

**UNITED STATES
PATENT AND TRADEMARK OFFICE**



PTAB Judicial Conference

Sharing Insights: From Bench to Bar
and Bar to Bench

UNITED STATES
PATENT AND TRADEMARK OFFICE



Welcome

UNITED STATES
PATENT AND TRADEMARK OFFICE

uspto

Program Overview

Time	Topic	Sharing Insights
9:00 to 9:10 am	Opening Remarks	From Bench to Bar
9:10 to 9:20 am	Director Remarks	
9:20 to 10:00 am	Judges Panel: Best Practices for Written and Oral Advocacy	
10:00 to 11:00 am	Practicum: Written Advocacy	
11 am to 11:15 am	BREAK	
11:15 am to 12:15 pm	Practicum: Oral Advocacy	
12:15 to 1:30 pm	LUNCH	
1:30 to 2:00 pm	State of the Board	From Bar to Bench
2:00 to 2:50 pm	Hot Topic 1: Patent Eligible Subject Matter Under Section 101	
2:50 to 3:00 pm	BREAK	
3:00 to 3:50 pm	Hot Topic 2: Motions to Amend in AIA Trial Proceedings	
3:50 to 4:30 pm	Interview with the Chief	



Best Practices for Written and Oral Advocacy

UNITED STATES
PATENT AND TRADEMARK OFFICE

uspto



Written Advocacy Practicum

UNITED STATES
PATENT AND TRADEMARK OFFICE



Purpose & Approach

- What: Enhance written advocacy skills
- How: Review real life examples of the most common mistakes in appeal briefs and petitions
- Who: Each table will consider one example
- When: Right now!!

Examples

- Example 1: Obviousness in General
- Examples 2 and 3: Motivation to Combine
- Example 4: Teaching Away
- Example 5: Analogous Art
- Example 6: Arguing the Claims
- Example 7: Arguing the Rejection

Small Group Discussion



Example 1: Obviousness



IPR Facts

- Patent concerned a process “to analyze and display human skin images”
- Claim: **[1]** acquire a first image of a face; **[2]** identify landmarks on the first image; **[3]** determine a sub-image based on the landmarks; and **[4]** analyze the sub-image to locate defect areas that include a visual defect and are less than 10% the size of the first image

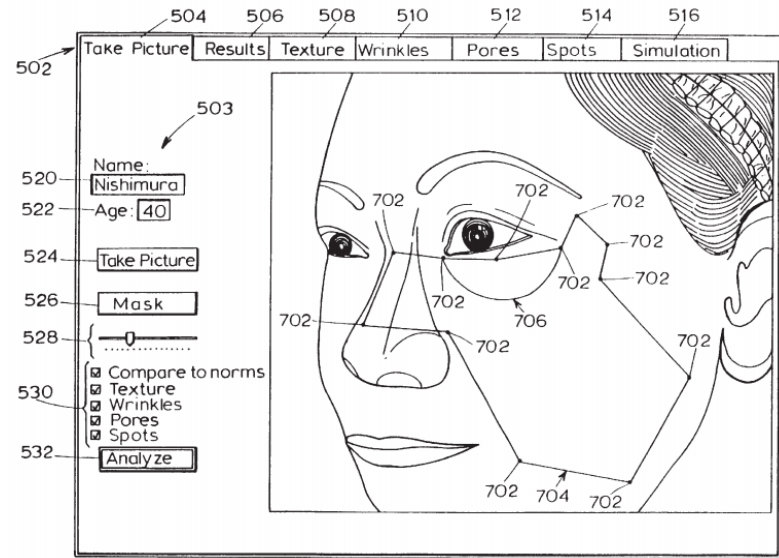

Petitioner's Argument

"Step [1] is taught by Arrow, steps [2] and [3] are taught by Bow, and step [4] is taught by Arrow. All the steps of claim 1 being taught by or obvious in view of the prior art, claim 1 is unpatentable under 35 U.S.C. § 103 over Arrow combined with Bow."

Was the Petition's Argument Successful?





PTAB Result

“Petitioner’s conclusory assertion fails to address in a meaningful way the manner in which the teachings of the references are combined, the reasons for doing so, or whether a reasonable expectation of success would have been present.”



A Better Argument

“Step [1] is taught by Arrow, steps [2] and [3] are taught by Bow, and step [4] is taught by Arrow. **An artisan would have modified Arrow to add Bow’s sub-image, because Bow teaches that using a smaller image would reduce processing time.”**

General Obviousness Tips

- Do **not** rely on the Board to fill gaps
- **Do** check that **every** limitation of **every** claim is accounted for in the references
- **Do** check that every combination is supported by a **specific** rationale that would have prompted the modification
- Address dependent claims too



Example 2: Motivation to Combine



IPR Facts

- Claims directed to a method for making a high voltage **tantalum anode** for a capacitor
- Anodized to a formation voltage of **at least 300V**

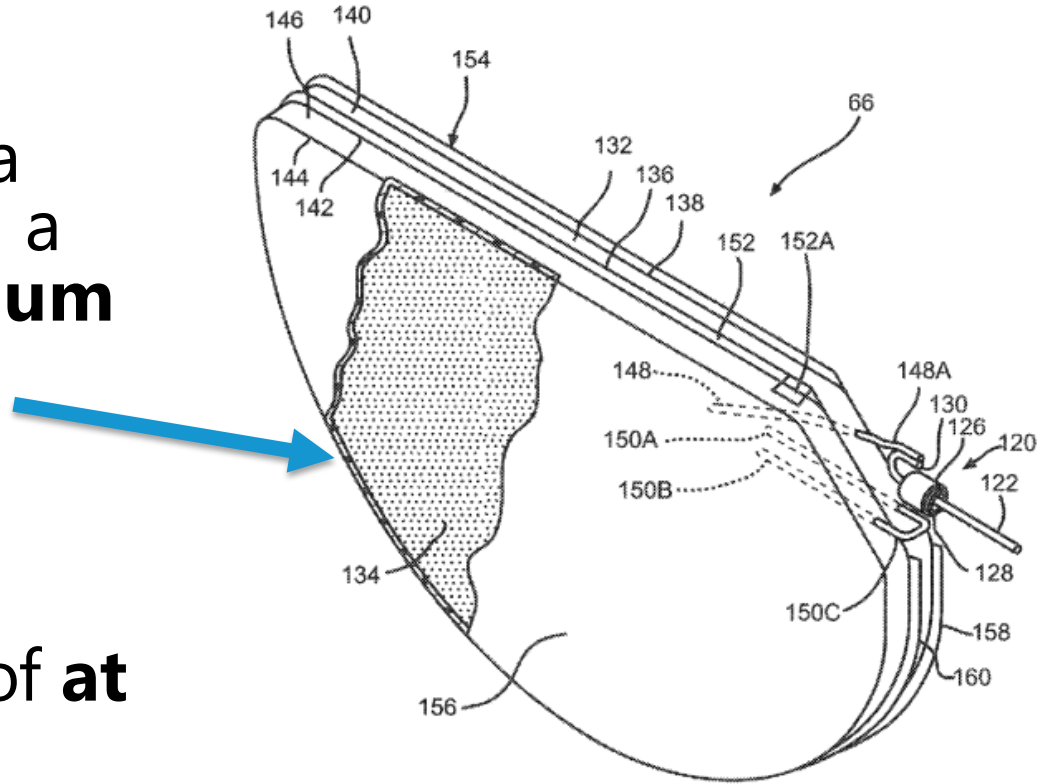

IPR Facts

- Petitioner sought to combine references Marian and Richard
- Marian disclosed **tantalum fibers** for use in **capacitors** with a formation voltage of up to 100V
- Richard disclosed capacitors formed using a voltage level **up to 450V**



Petitioner's Argument

"One would have been motivated to anodize the sintered tantalum pellet of Marian to a formation voltage of at least 300 V, because Marian and Richard both relate to the production of tantalum capacitors and because both references are applicant admitted prior art mentioned in the specification of the patent."



Was the Petition's Argument Successful?





PTAB Result

- “[T]he fact that two references relate to the same general subject matter is not itself sufficient to explain why one would have sought to modify; it shows at most that the two references are in the same field of endeavor.”
- “Nor is an alleged admission that they are prior art sufficient to explain why they would be combined in a manner necessary to arrive at the claimed invention.”



A Better Argument

“One would have had a reason to anodize the sintered tantalum pellet of Marian to a formation voltage of at least 300 V

because Richard teaches a formation voltage above 300 V and also that higher voltage advantageously results in a longer lasting material.”

Tips: Establishing a Rationale

- Provide a **specific, technical** reason
- Think **carefully** about whether it would have made sense, and **explain it to us**
- That the art is in the same field, or even very similar, is not enough



Example 3: More Motivation to Combine



Ex Parte Appeal Facts

Claim 1 was directed to a respiratory mask having [1] a mask body and [2] an articulated connector, where [3] "a **mechanical key system** is provided for joining the mask body and the connector."

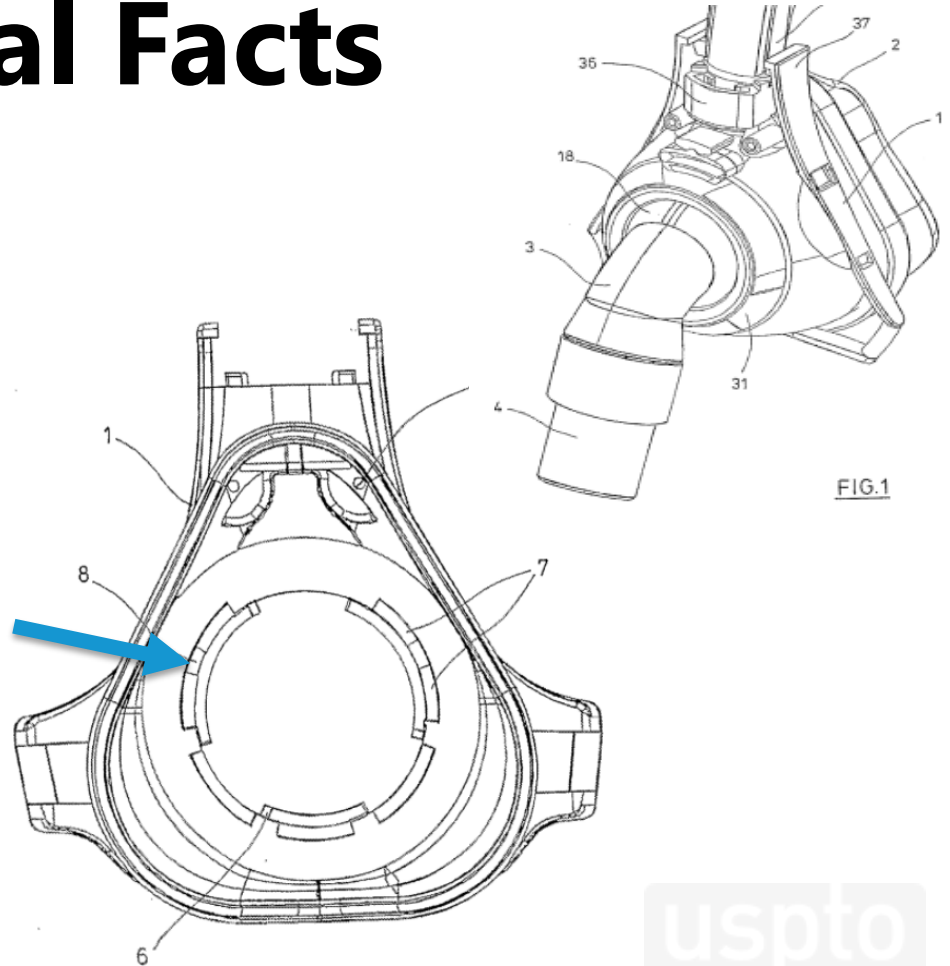

Ex Parte Appeal Facts

Rejected by
the Examiner
as obvious in
view of Robin
in combination
with Hood

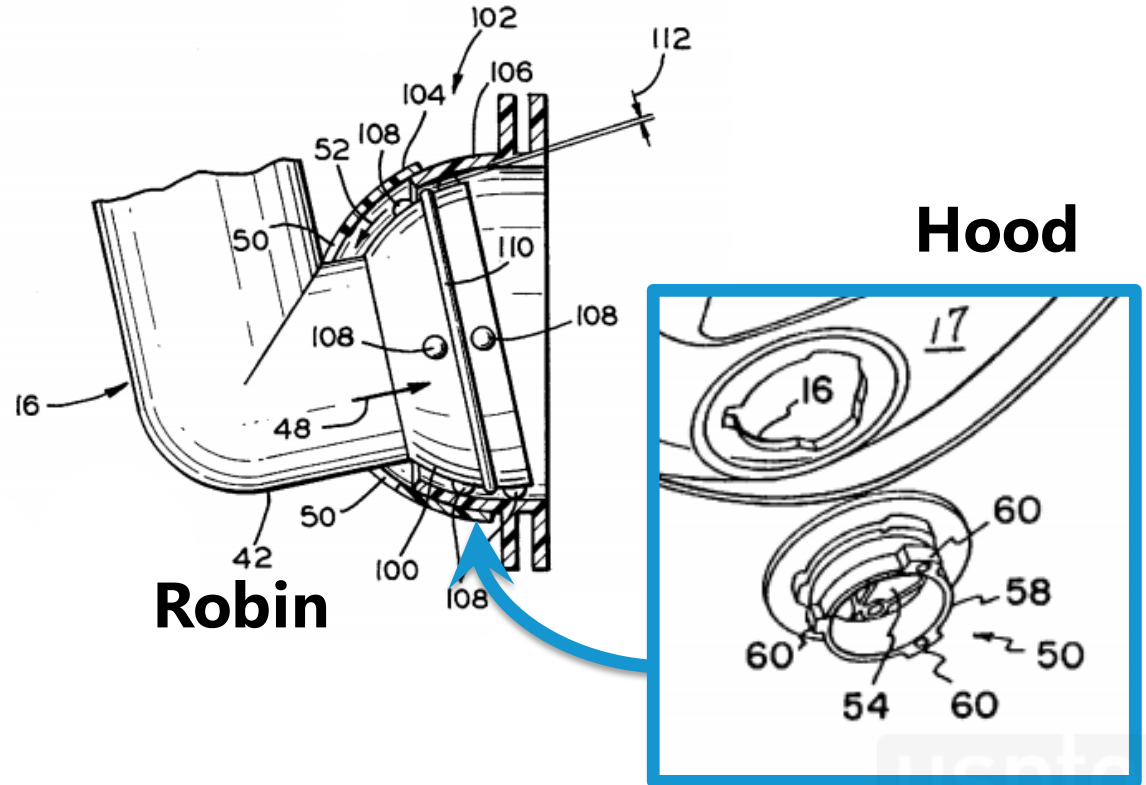

Appellant's Argument

- "In Hood, the keying provides for automatically aligning and orienting air filter cartridges, as some cartridges may be non-symmetrical or otherwise require a specific orientation."
- "But since Robin does not use any air filter cartridges, let alone non-symmetrical air filter cartridges, there would be no reason for providing mechanical keying in the modified mask of Robin envisioned by the Examiner."

Was the Appellant's Argument Successful?





uspto

PTAB Result

“Although we appreciate that Hood’s keyed connector is a type known in the art, in this case, modifying Robin’s connection to be a keyed connection without offering an explanation of why **Robin’s respiratory mask, generally, or the connection, specifically,** would benefit from being mechanically keyed suggests that the Examiner's reasoning suffers from impermissible hindsight.”



Why Successful?

- “In Hood, **the keying provides for automatically aligning and orienting air filter cartridges**, as some cartridges may be non-symmetrical or otherwise require a specific orientation.”
- “But since **Robin does not use any air filter cartridges, let alone non-symmetrical air filter cartridges**, there would be no reason for providing mechanical keying in the modified mask of Robin envisioned by the Examiner.”

Tips: Contesting a Rationale

- Think **carefully** about why it would not have made sense, and explain why
- A **generic** motivation (cheaper, faster, etc.) can be overcome with an appropriate technical argument
- In *ex parte* appeals, do not fail to address the Examiner's stated motivation



Example 4: Teaching Away



Facts

- A method for "calibrating and de-warping" a camera
- The claim required "mounting the camera to a translational stage and moving the camera along the stage to different locations along an optical axis"

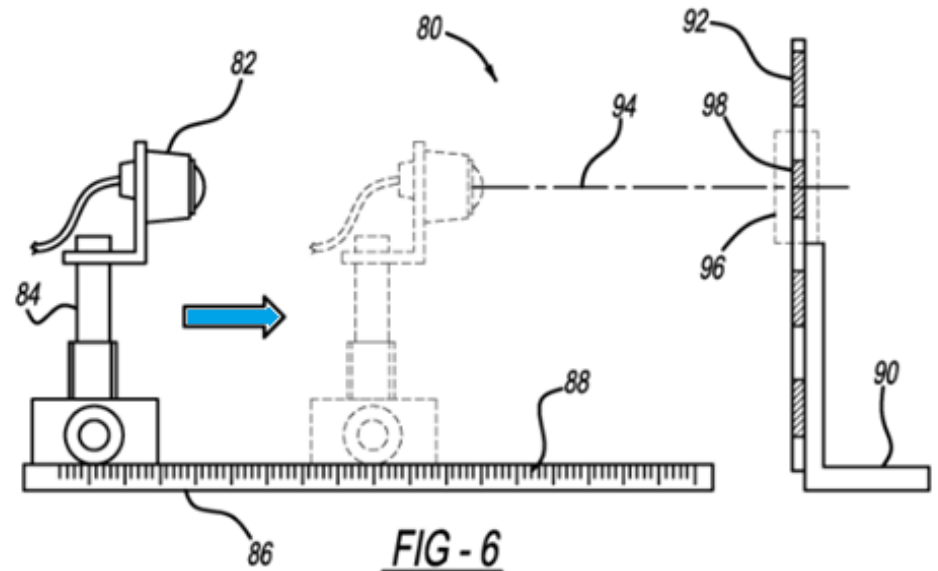

Facts

- Claims rejected as unpatentable over Arthur combined with Tuck
- Arthur described camera calibration with a camera mounted on a **stationary** tripod, using images taken at different focal lengths
- The Examiner cited Tuck for **moving** the camera

Appellant's Argument

"[W]here Arthur describes using the tripod to aid in taking a series of images at different focal lengths of a zoom lens, he is **teaching away** from Appellants' claimed method of estimating the focal length (of a fixed focal length camera) by using the translational stage."



Was the Appellant's Argument Successful?





PTAB Result

- “Appellants do not provide evidence that Arthur **criticizes, discredits, discourages, or would lead away** from moving the camera along a rail, as taught by Tuck.”
- “Appellants simply argue Arthur does not teach the limitation, which is not sufficient to show it teaches away from the limitation.”



A Better Argument

“[W]here Arthur describes **that the camera must be a stationary platform in order to obtain consistent results**, he is **teaching away** from Appellants’ claimed method of estimating the focal length (of a fixed focal length camera) by using the translational stage.”

Tips: Teaching Away

- A reference teaching X is **not** the same as the reference teaching away from Y
- Ensure that the reference suggests—either explicitly or implicitly—**not doing** what the applicant did
- Explain in detail what leads to that conclusion



Example 5: Analogous Art



IPR Facts

- Claim directed to a semiconductor memory module
- Requires that “the memory chips in each row are arranged in an **alternating sequence of opposite orientations**”

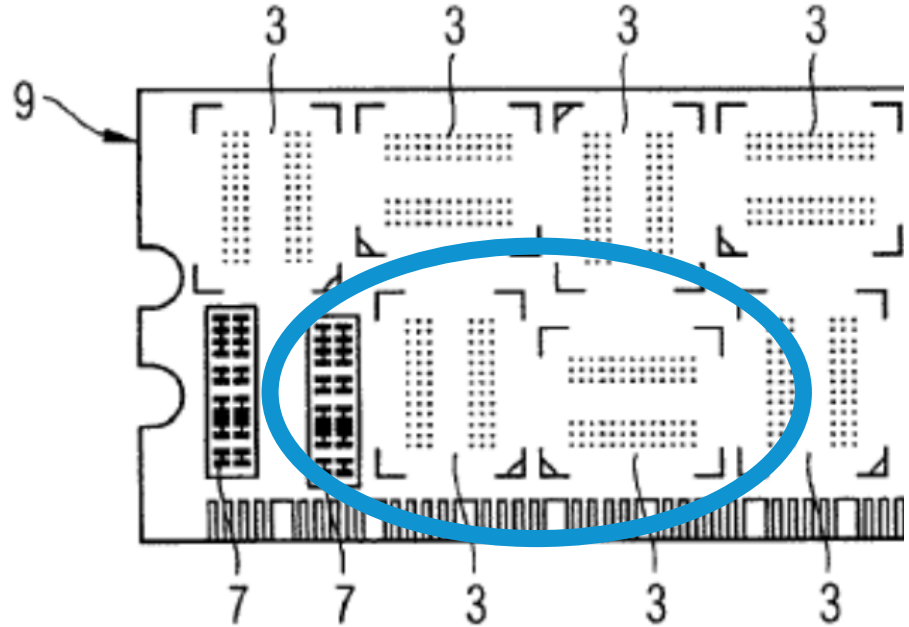

IPR Petition

- “Sherwood’s book, Ceramic Tile Setting, illustrates geometric tile patterns that would have been well-known.”
- “The problem addressed by the patent is not a highly technical problem related to semiconductor manufacturing, but a problem common to many human experiences related to arranging regularly shaped items in a pre-defined area.”

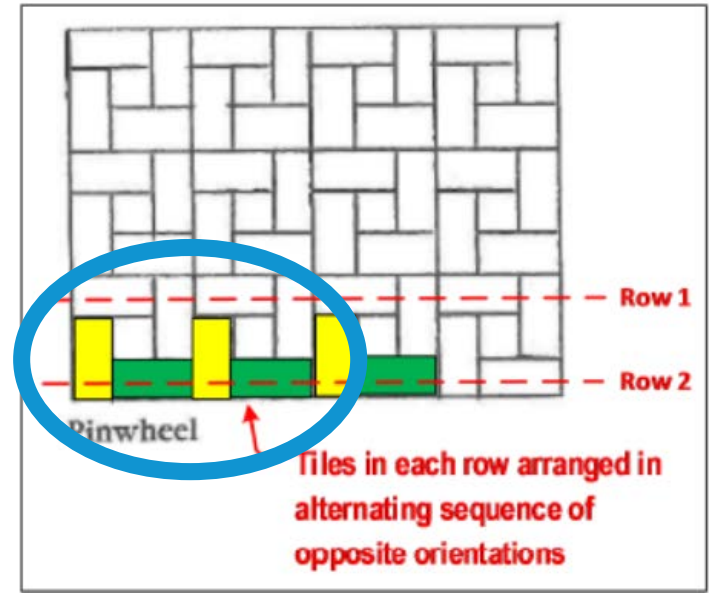

Patent Owner's Argument

- "The argument that a ceramic tile book is relevant is based upon the flawed notion that memory module design is nothing more than moving abstract geometrical objects around."
- "This fundamentally misstates the goals of the patent, as one of its 'core objectives' is ensuring that 'signal propagation times are as uniform as possible' and that the 'conductor track lengths are, to the greatest extent possible, identical length' and 'as short as possible.'"



Was Patent Owner's Argument Successful?





uspto

PTAB Result

“We find that Sherwood—a ceramic tile setting book—is not analogous art to the patent, and we find that one of ordinary skill in the field of semiconductor memory design would not have turned to Sherwood for any teachings as to the layout of memory chips on a circuit board.”



Tips: Analogous Art

- Address **both** prongs: (1) same field of endeavor and (2) reasonably pertinent to the problem faced by the inventor
- Many arguments fail on the **second prong**—think carefully about that one
- Also, make sure your argument is not undercut by the Specification, including the Background and Field of Endeavor

Example 6: Arguing the Claims



IPR Facts

- An expandable wellbore casing with one or more tubes
- A layer of lubricant on the interior surfaces of tubes
- The lubricant provides a coefficient of dynamic friction of between about 0.08 to 0.

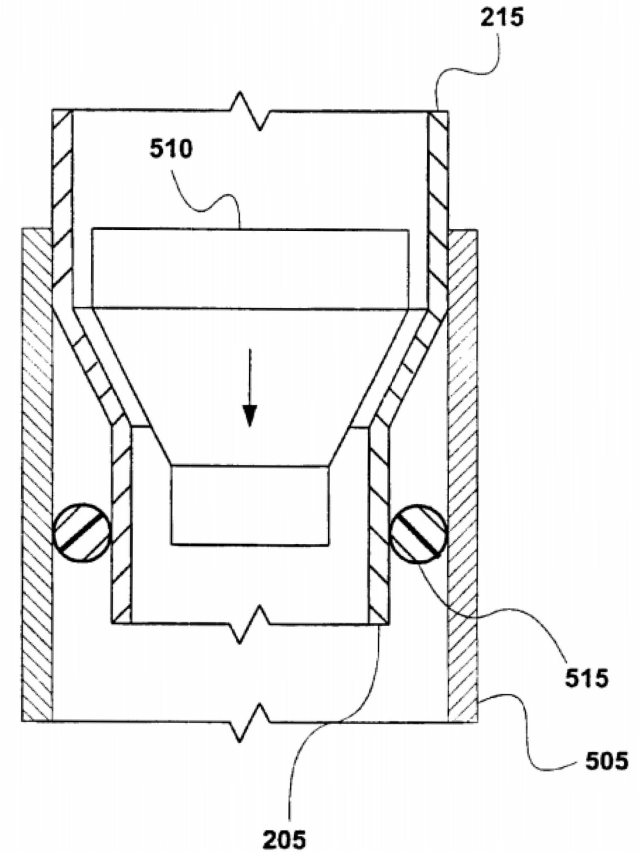

Petitioner's Argument

- Scarlet taught expanding a tube inside another with vegetable oil as a lubricant
- "One of ordinary skill in the art would know that vegetable oil used as a lubricant between hard steel and hard steel results in a coefficient of sliding friction of 0.08."

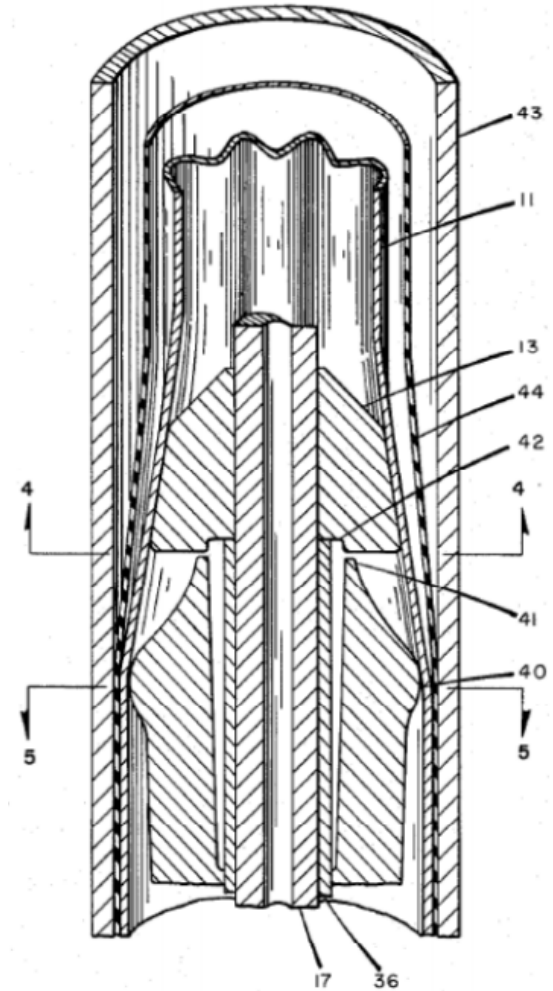

FIG. 3

Patent Owner's Argument

A POSITA "would understand that a sliding coefficient of friction is determined by testing done under very specific conditions and that a coefficient of friction determined under one set of conditions could be significantly different from one determined under a different set of conditions."



Was the Patent Owner's Argument Successful?





PTAB Result

- “The claims do not specify the materials or any particular circumstances for which the lubricant provides the coefficient of friction.”
- “Each challenged claim recites only that the lubricant provides a certain range of coefficients of friction.”
- “A lubricant would meet the claims if it provides the claimed ranges of coefficients of friction between hard steel and hard steel.”

Tips: Arguing a Claim

- This is a common issue, often arising in appeals, where the applicant seeks to import subject matter from the Specification
- Make sure you identify **why** the **specific terms** in the claims have a meaning that distinguishes over the art
- If your argument requires a specific claim construction, make that clear, and support it

Example 7: Arguing the Rejection



Facts

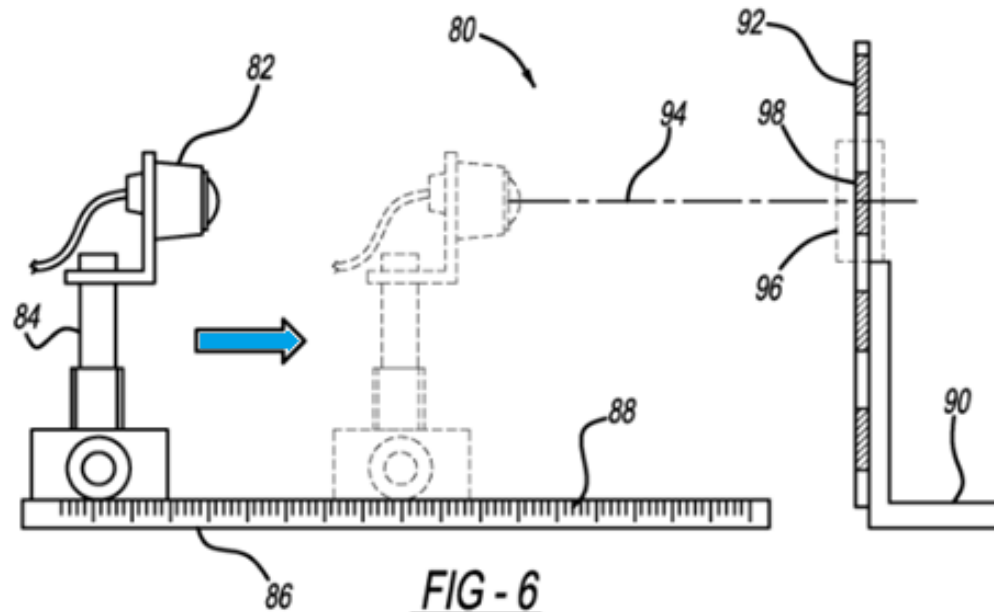

Claim: "mounting the camera to a translational stage and moving the camera along the stage to different locations along an optical axis"



Facts

- Examiner: unpatentable over Arthur in combination with Tuck
- Arthur described camera calibration with a camera mounted on a **stationary** tripod, using images taken at different focal lengths
- Tuck cited for **moving** the camera



Appellant's Argument

- "Arthur clearly does not teach moving the camera along the optical axis"
- "Tuck teaches only lens adjustment, not determining focal length and image center."

Was the Appellant's Argument Successful?





PTAB Result

- “Appellants argue the references individually, but do not address the combination as relied upon by the Examiner.”
- “The Examiner does not rely on Arthur to teach the camera moving along the optical axis, but rather, relies on Tuck.”

Tips: Arguing a Rejection

- Be **certain** that you are addressing the rejection that was **actually made**.
- If the combination is A+B, and the Examiner finds a feature in A, it does not matter that the feature is not in B.



Quick Tips



Quick Tips: Appeals

- Don't just quote or paraphrase claim language.
- Be careful with unsupported attorney argument.
- Minimize repetitive arguments; don't repeat the same arguments in a reply.
- Don't argue examiner guidance is binding.

Quick Tips: Trials

- Be careful with conclusory statements; have support and citations for all arguments.
- Acknowledge and address the weaknesses in your argument.
- Know and follow the rules.
- Cite to case law thoughtfully.
- Ensure that your arguments are internally consistent.

Break

UNITED STATES
PATENT AND TRADEMARK OFFICE



Board Communication and Oral Advocacy Practicum

UNITED STATES
PATENT AND TRADEMARK OFFICE



Purpose & Approach

- What: Enhance oral advocacy skills
- How: Review real life examples
- Who: Audience will identify strengths and points for improvement
- When: Right now!!

Examples

- Act 1: Email Request for Conference Call
- Act 2: Conference Call
- Act 3: Oral Argument

Act One: Email Request for Conference Call



When to Request a Conference Call

- Seek authorization to file a motion
 - “A motion will not be entered without Board authorization. Authorization may be provided in an order of general applicability of during the proceeding.” 37 C.F.R. § 42.20(b).
- File a motion to amend
 - “A patent owner may file one motion to amend a patent, but only after conferring with the Board.” 37 C.F.R. §§ 42.121(a), 42.221(a)
- Have an initial conference call to introduce yourself to the panel, resolve any initial issues, answer procedural questions, seek authorization for motions at start of proceeding, etc.
- Resolve any procedural disputes that arise during trial, such as location or timing of a deposition

Before Requesting A Call

- Parties should discuss and attempt to come to agreement with each other before requesting a call with the Board.

Email Requesting A Call

- Email requesting a conference call should:
 - copy the other party (37 C.F.R. § 42.5(d) prohibits *ex parte* communications)
 - indicate generally the relief being requested or the subject matter of the conference call
 - state whether the opposing party opposes the request
 - include multiple times when all parties are available
- Email requesting a conference call should NOT:
 - include attachments
 - include substantive communications to the Board (i.e., no arguments).



Timely Seek Relief

- “A party should seek relief promptly after the need for relief is identified. Delay in seeking relief may justify a denial of relief sought.” 37 C.F.R. § 42.25(b).

PTAB Response to Request

- Panel may schedule a conference call or grant/deny the request by email
- In deciding, PTAB may consider whether the request:
 - is joint, opposed, or unopposed
 - is ministerial
 - for example, unopposed request to correct typographical errors in a filing or a unopposed request to expunge a duplicate filing
 - will have impact on a decision
 - for example, a request to file a motion when a decision to deny institution based on an unrelated issue will be entered shortly
 - can be otherwise satisfied
 - for example, a request to file a motion to dismiss where the argument could be made in a preliminary response



Example Request

From: Sally Smith <ssmith@petitioner.com>

Sent: May 30, 2018 4:41 PM

To: Trials <Trials@USPTO.GOV>

Subject: IPR2018-12345 Late Filing

To the Patent Trial and Appeal Board:

Paper 22 (Petitioner's Objection to Evidence) was due May 1. Paper 22 was finalized and dated for May 1 on both the paper and on the certificate of service. We intended and believed that the document would be filed and served. Due to an internal mix-up by our paralegal, it appears that the document did not actually get filed until slightly after midnight May 2 and the document did not get served to opposing counsel until 12:17 AM on May 2. This mistake should not be held against my client.

Regards,
Sally Smith



Problem Free?

uspto



Problems with Example Request

- Sally Smith's email does NOT:
 - copy Petitioner Bob Baxter
 - include a request for a conference call
 - indicate the relief being sought and any applicable Board Rules providing for such relief
 - indicate if the parties conferred or reasonably attempted to confer
 - indicate whether Petitioner Bob Baxter opposed the relief
 - provide the parties' availability for a conference call



Problems with Example Request

- Sally Smith's email may not have been timely sent to the Board
 - "**Late action.** A late action will be excused on a showing of good cause or upon a Board decision that consideration on the merits would be in the interest of justice." 37 C.F.R. § 42.5(c)(3).

Improved Example Request

From: Sally Smith <ssmith@petitioner.com>
Sent: May 2, 2018 4:41 PM
To: Trials <Trials@USPTO.GOV>
Cc: Bob Baxter <bbaxter@patentowner.com>
Subject: IPR2018-12345 Late Filing

Petitioner requests a conference call to seek authorization to file a motion to excuse late action pursuant to 37 C.F.R. § 42.5(c)(3). Paper 22 (Petitioner's Objection to Evidence) was due May 1, but was filed and served late, slightly after midnight May 2.

Petitioner and Patent Owner have conferred. Patent Owner opposes Petitioner's filing of a motion to excuse.

Petitioner and Patent Owner are available May 3rd and 4th between 12:00 p.m. and 4:00 p.m. eastern time and May 7th between 8:00 a.m. and 12:00 p.m. eastern time.

Regards,
Sally Smith



Act Two: Conference Call



Video Clip

uspto

Problem Free?

uspto



Example Conference Call Transcript

Judge Harding: Ms. Smith, you requested the conference call. We will hear from you first.

Sally Smith: Thank you. Our Objections to Evidence were due May 1. We finalized and dated the Objections for May 1 on both the paper and the certificate of service. We intended to file and serve the Objections that day, but due to an internal mix-up by our paralegal, the document did not actually get filed until slightly after midnight May 2 and did not get served to opposing counsel until 12:17 AM. This mistake should not be held against my client.

Problems with Example Conference Call

- Sally Smith did NOT
 - articulate the relief being sought
 - request authorization to file a motion



Video Clip



Problem Free?





Example Conference Call Transcript

Bob Baxter: Petitioner's Objection was filed and served late. It doesn't matter that it was only 17 minutes late. The Board should not excuse the late filing because Petitioner waited too long to ask for the Board to excuse the late filing

Sally Smith (interrupting): It was only 17 minutes. . .

Bob Baxter (responding to Ms. Smith): Please let me finish!

Sally Smith (interrupting): You could not have been prejudiced . . .

Judge Harding: Ms. Smith, its Mr. Baxter's turn to speak. You will have another turn to speak after Mr. Baxter is done. Please address your remarks to the Board, not to each other. Ms. Smith, and continue.



Problems with Example Conference Call

- Sally Smith spoke over Bob Baxter.
- Bob Baxter responded back to Sally Smith instead of the Board.
- Sally Smith spoke over the Judge.



Video Clip

uspto

Problem Free?





Example Conference Call Transcript

Judge Harding: Ms. Smith, we will hear your response now. When did you become aware the Objections were filed and served late? Why did you wait 28 days to request to file a motion to excuse?

Ms. Smith: I am not prepared to answer that question. I cannot recall right now. I did not know that Patent Owner was going to make the timeliness of my request an issue.

Judge Harding: Ms. Smith, did you attempt to confer with Patent Owner before requesting the conference call to find out if and why Patent Owner would oppose?

Ms. Smith: No, your honor.



Problems with Example Conference Call

- Sally Smith did not confer with Bob Baxter before requesting a conference call and attempt to come to agreement with each other.
- Sally Smith was unprepared to answer the Board's questions.
 - If the parties had conferred, Sally would have realized that Bob Baxter objected to her delay in seeking to file a motion to excuse.



Act Three: Oral Argument



Video Clip



Problem Free?





Example Oral Argument Transcripts

Judge Hodge: How does Peters' $\frac{3}{4}$ layer teach a layer that extends just to the-ball-of-the-foot? I am specifically asking about Peter's teaching.

Ms. Smith: A person of ordinary skill in the art would have known to extend Jones' thermoplastic layer just to the-ball-of-the-foot, because that is where the arches of the foot are located and the foot needs the most support.

Judge Hodge: Ms. Smith you didn't answer my question. I asked how does Peters' $\frac{3}{4}$ layer teach a layer that extends just to the-ball-of-the-foot? How does a $\frac{3}{4}$ layer equate to a layer that extends to just to the-ball-of-the-foot.

Ms. Smith: One of ordinary skill would know that the-ball-of-the-foot is located $\frac{3}{4}$ of the way down the foot on at least some people.

Example Oral Argument Transcripts

Judge Theaker: Could you point to the evidence of record that shows that?

Ms. Smith: I think our declarant did testify on that point, but I am not sure where that testimony is in the record. Nonetheless, one of ordinary skill in the art would know. Plus, Matthews talks about the need to support the foot's arches.

Judge Theaker: Ms. Smith, did you discuss Matthew's teachings in the substantive papers? If so, where in the record?

Ms. Smith: No. We did not discuss Matthews.



Problems with Example Oral Argument

- Sally Smith put off the Judge's question. The Judges are seeking information they need to make a decision.
- Sally Smith's answer was conclusory. Know the record as best you can. Point to argument or evidence in the record that supports your argument.
- Sally Smith raised new argument and evidence.



Quick Tips



Quick Tips on Requesting a Call

- Before requesting a conference call, parties should confer and attempt to come to agreement with each other.
- An email requesting a conference call should:
 - copy the other party;
 - indicate the relief being requested or the subject matter of the conference call;
 - state whether the opposing party opposes the request; and
 - include multiple times when all parties are available.



Quick Tips for Conducting a Conference Call

- Don't speak over the Judges.
- Be prepared to answer the Judges' questions.
- Answer the Judges' questions.
- Each party will be given a chance to speak. Generally, the party requesting relief will speak first, then the opposing party, and then again the requesting party.
- Don't speak over the other party.
- Clearly articulate the relief being requested or the reasons the relief is opposed.

Quick Tips for Oral Argument

- Answer the Judges question as best you can.
- Know the record. Avoid conclusory answers by pointing to evidence in the record for support.
- Remember new arguments and new evidence are not permitted at oral argument.



Lunch

UNITED STATES
PATENT AND TRADEMARK OFFICE



The background of the slide is a light gray technical drawing of a mechanical assembly, possibly a shaft or a component of a machine. It features various parts with hatching and is annotated with numerous numerical callouts such as 18, 22, 24, 26, 30, 32, 34, 40, 42, 44, 46, 48, 50, 52, 54, 56, 58, 60, 62, 64, 66, 68, 70, 72, 74, 76, 78, 80, 82, 84, 86, and 88. The drawing is oriented diagonally across the slide.

State of the Board

UNITED STATES
PATENT AND TRADEMARK OFFICE

uspto

Ex Parte Appeal Statistics

UNITED STATES
PATENT AND TRADEMARK OFFICE



Pending Appeals

(FY10 to FY18: 9/30/10 to 3/31/18)

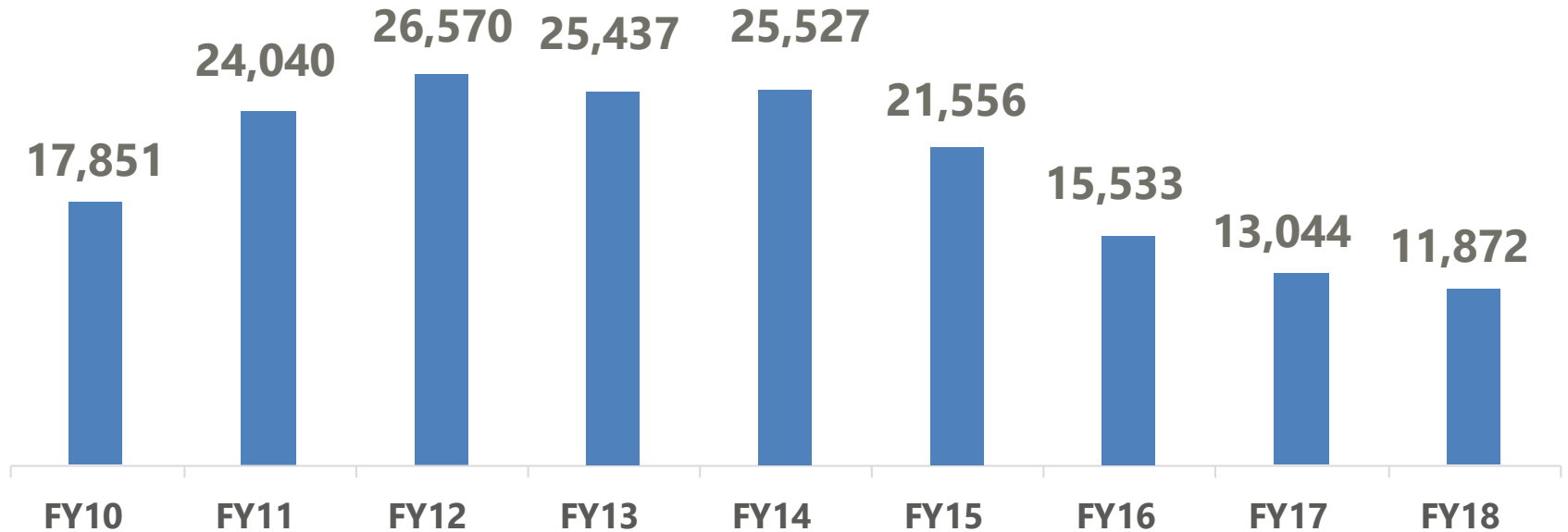

Note: FY17 pending changed from 13,034 to 13,044 due to an internal end of FY18 Q1 audit.

Pendency of Decided Appeals in FY17 and FY18

(Pendency of appeals decided in February 2017 compared to March 2018 in months)

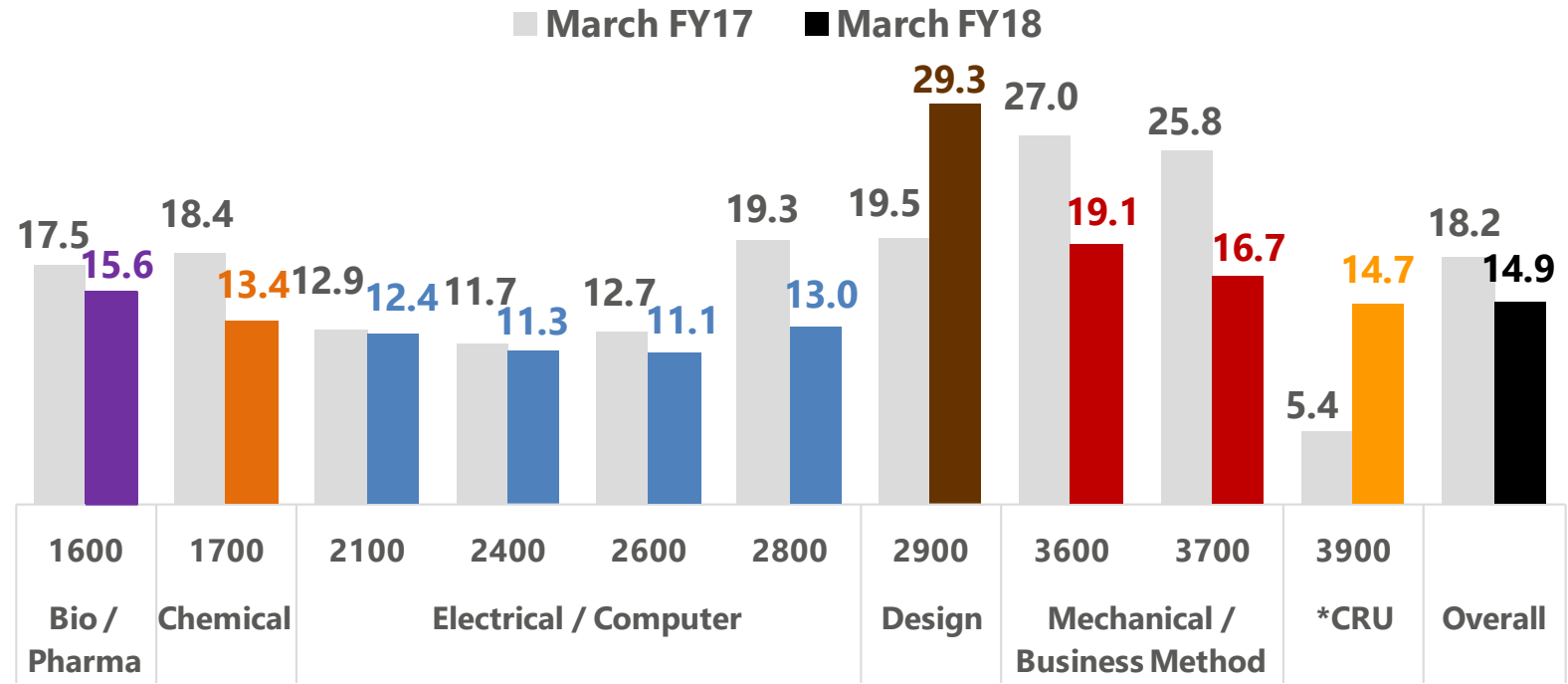

Pendency is calculated as average months from Board receipt date to final decision.
 *CRU (Central Reexamination Unit) includes ex parte reexams, inter partes reexams, supplemental examination reviews and reissues from all technologies.



AIA Trial Statistics

UNITED STATES
PATENT AND TRADEMARK OFFICE



Status of Petitions

(All Time: 9/16/12 to 5/31/18)

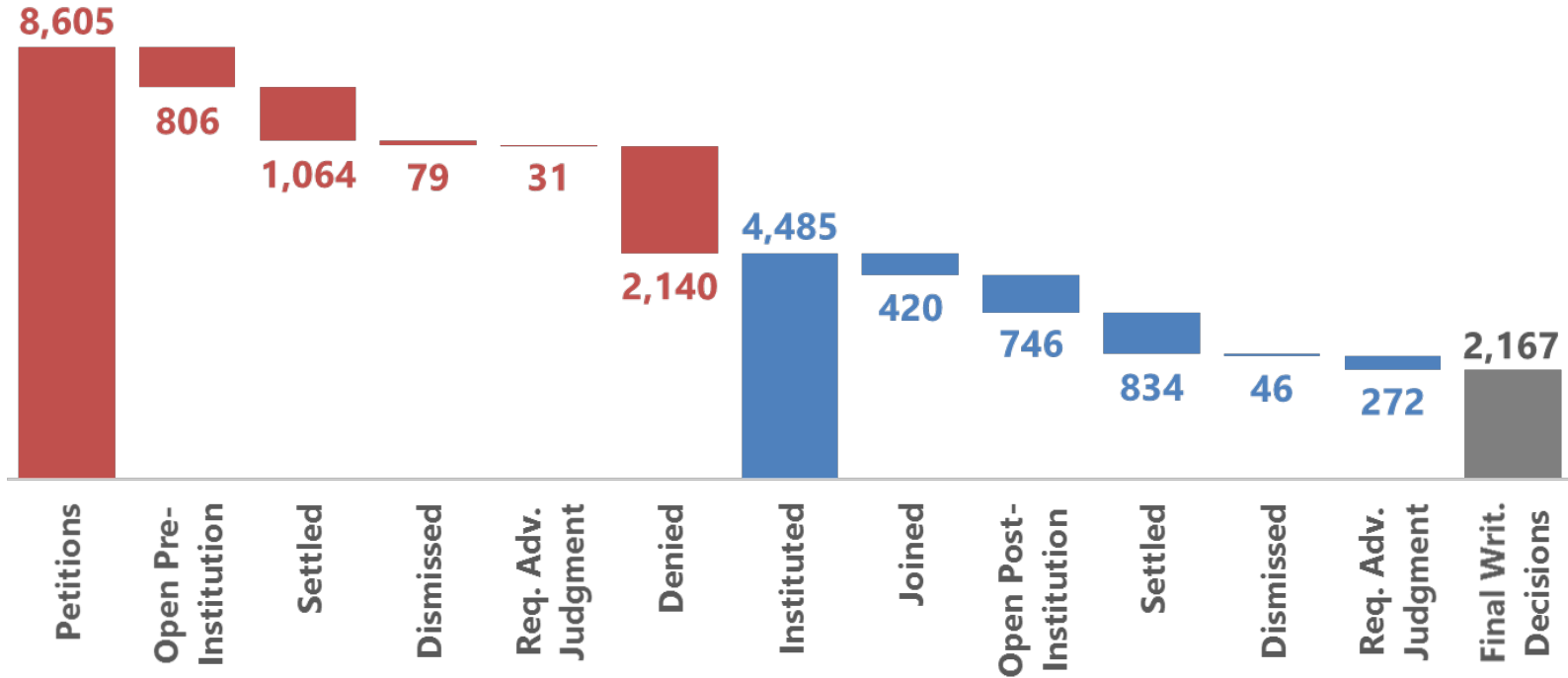

These figures reflect the latest status of each petition. The outcomes of decisions on institution responsive to requests for rehearing are incorporated. Once joined to a base case, a petition remains in the Joined category regardless of subsequent outcomes.



Institution Rates

(FY13 to FY18: 10/1/12 to 5/31/18)

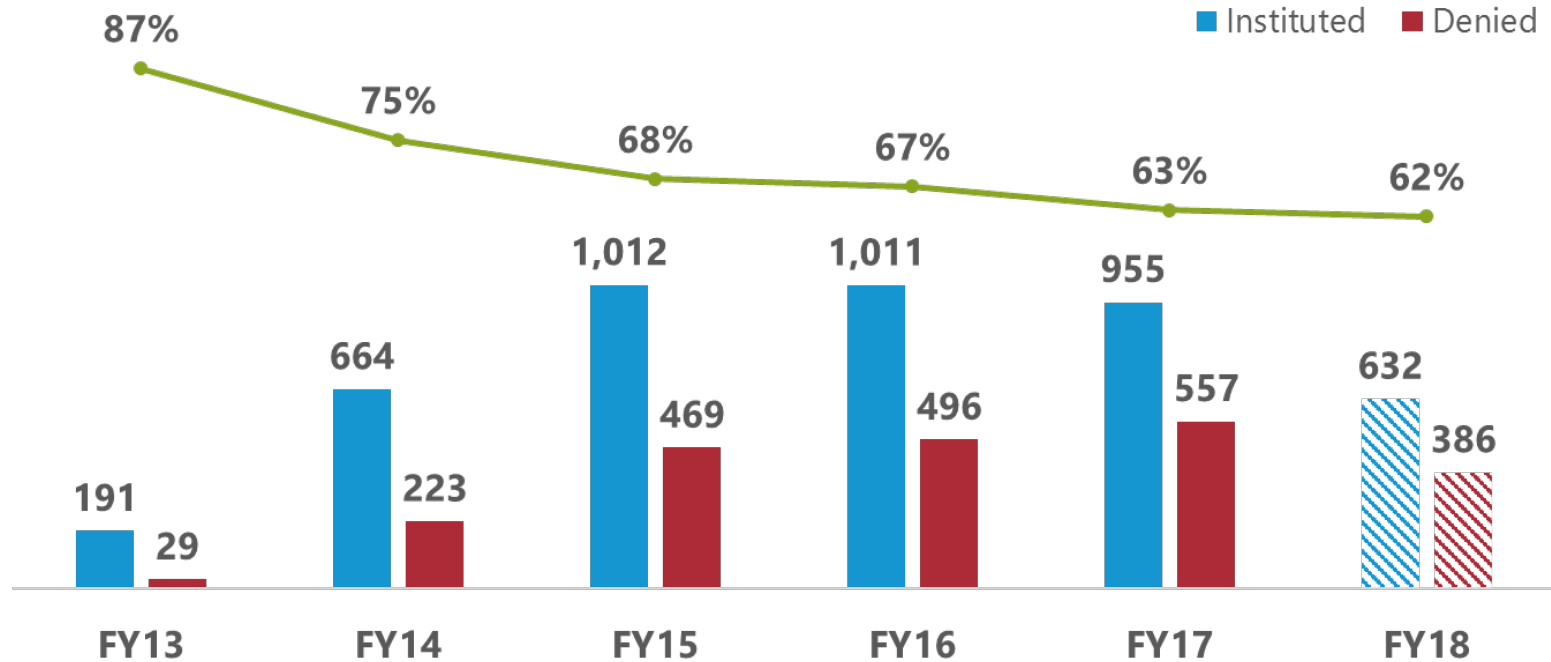

Institution rate for each fiscal year is calculated by dividing petitions instituted by decisions on institution (i.e., petitions instituted plus petitions denied). The outcomes of decisions on institution responsive to requests for rehearing are excluded.

Final Written Decisions

Percent of Decisions by Instituted Claims Remaining Patentable
(FY14 to FY17: 10/1/13 to 9/30/17)

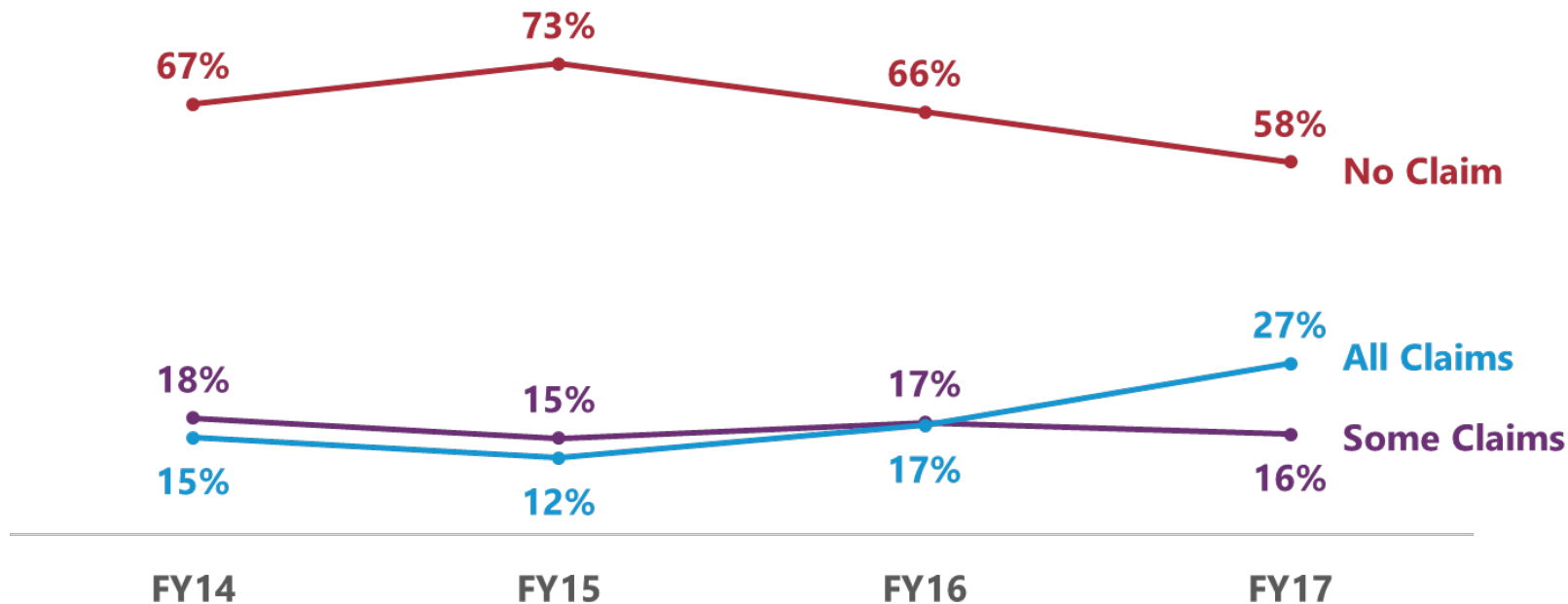

Joined cases are excluded.



Final Written Decisions

Percent of Decisions by Instituted Claims Remaining Patentable
(FY14 to FY17: 10/1/13 to 9/30/17)

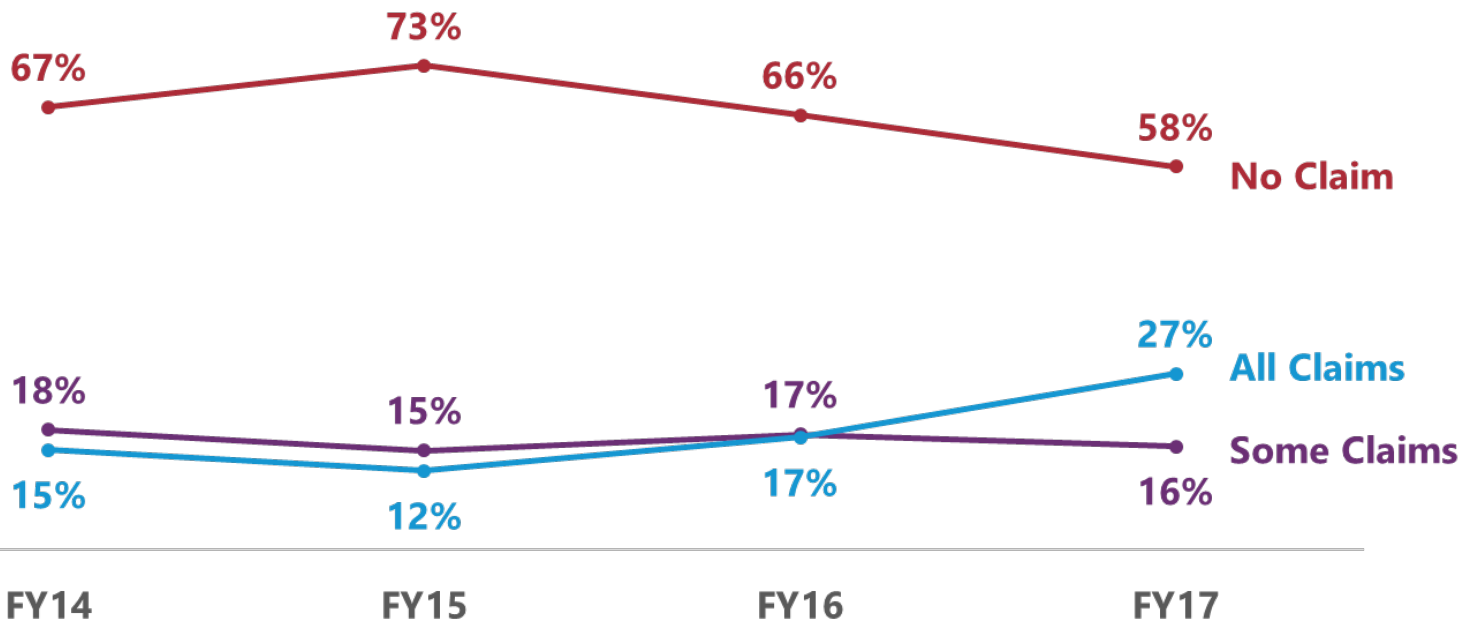

Joined cases are excluded.



Multiple Petition Study

Ultimate Outcome

- 69% of all petitions result in a patent being unchanged; 58% of patents are unchanged at the end of one or more AIA proceedings
- “By patent” accounts for whether any one petition against particular patent results in any unpatentable claims
- “By petition” accounts for whether a particular petition results in any unpatentable claims

Data Through 6/30/17

Outcomes in AIA Trials

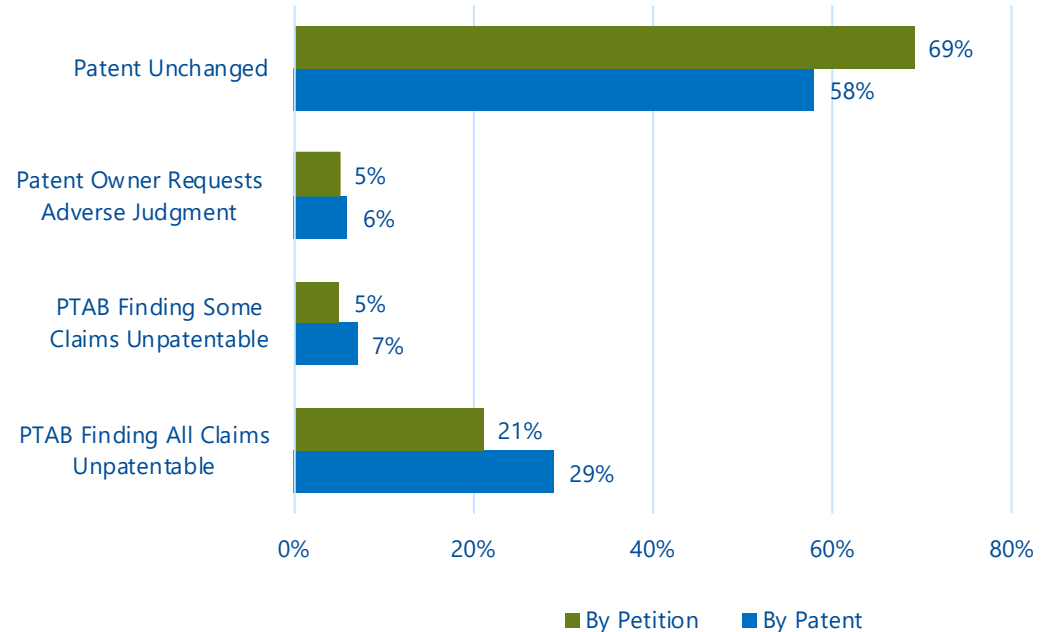

SAS

UNITED STATES
PATENT AND TRADEMARK OFFICE

uspto

SAS Guidance

Guidance on the impact of SAS on AIA trial proceedings

Release date: April 26, 2018

On April 24, 2018, the U.S. Supreme Court issued *SAS Institute Inc. v. Iancu*, 2018 WL 1914661, (U.S. Apr. 24, 2018). In light of this decision, the Patent Trial and Appeal Board (PTAB) will proceed in the following fashion at this time. The PTAB will continue to assess the impact of this decision on its operations and will provide further guidance in the future if appropriate.

As required by the decision, the PTAB will institute as to all claims or none. At this time, if the PTAB institutes a trial, the PTAB will institute on all challenges raised in the petition.

For pending trials in which a panel has instituted trial on all of the challenges raised in the petition, the panel will continue with the proceeding in the normal course. By contrast, for pending trials in which a panel has instituted trial only on some of the challenges raised in the petition (as opposed to all challenges raised in the petition), the panel may issue an order supplementing the institution decision to institute on all challenges raised in the petition.

Additionally, for pending trials in which a panel enters an order supplementing the institution decision pursuant to this notice, the panel may take further action to manage the trial proceeding, including, for example, permitting additional time, briefing, discovery, and/or oral argument, depending on various circumstances and the stage of the proceeding. For example, if the panel has instituted a trial and the case is near the end of the time allotted for filing the Patent Owner Response, the panel may extend the due date for the Patent Owner Response to enable the patent owner to address any additional challenges added to the proceeding.

Implementation of SAS

- PTAB will institute on all challenges raised in the petition or not institute at all (i.e., binary decision)
- If panel has issued a decision on institution (DI) instituting on all challenges, panel will proceed as normal
- If panel has issued a DI denying institution on all challenges, no additional action

Implementation of SAS

- If panel has instituted on only some challenges raised in the petition, panel may at this time:
 - Issue order instituting on all challenges;
 - Receive joint request filed by the parties to terminate as to certain challenges

Notice of Proposed Rulemaking (NPRM) for Claim Construction

UNITED STATES
PATENT AND TRADEMARK OFFICE



Claim Construction NPRM

83 Fed. Reg. 21,221 (May 9, 2018)

Proposed 42.100(b), 42.200(b), 42.300(b):

“In an [AIA trial] proceeding, a claim of a patent, or a claim proposed in a motion to amend under § 42.121, shall be construed using the same claim construction standard that would be used to construe such claim in a civil action to invalidate a patent under 35 U.S.C. 282(b), including construing the claim in accordance with the ordinary and customary meaning of such claim as understood by one of ordinary skill in the art and the prosecution history pertaining to the patent.

Any prior claim construction determination concerning a term of the claim in a civil action, or a proceeding before the International Trade Commission, that is timely⁴⁵ made of record in the inter partes review proceeding will be considered.”

Claim Construction NPRM

83 Fed. Reg. 21,221 (May 9, 2018)

- USPTO intends that any proposed rule changes adopted in a final rule would be applied to all pending AIA trial proceedings
- Public comments due on or before July 9 to:
PTABNPR2018@uspto.gov
- Comments are posted on the PTAB website and accessible at
<https://www.uspto.gov/patents-application-process/patent-trial-and-appeal-board/comments-changes-claim-construction>
- Federal Register Notice: <https://www.federalregister.gov/documents/2018/05/09/2018-09821/changes-to-the-claim-construction-standard-for-interpreting-claims-in-trial-proceedings-before-the>

New PTAB Website

UNITED STATES
PATENT AND TRADEMARK OFFICE



New PTAB Website

uspto UNITED STATES PATENT AND TRADEMARK OFFICE

About Us Jobs Contact Us MyUSPTO

Search uspto.gov

Patents Trademarks IP Policy Learning and Resources Quick Links

Home / Patents / Application Process / Patent Trial and Appeal Board

Patent Trial and Appeal Board

The Patent Trial and Appeal Board (PTAB) conducts trials, including inter partes, post-grant, and covered business method patent review and derivation proceedings; hears appeals from adverse examiner decisions in patent applications and reexamination proceedings; and renders decisions in interferences.



Trials

Information about proceedings conducted by the Patent Trial and Appeal Board, including inter partes review, post-grant review, the transitional post-grant review for...



Appeals

Information about ex parte appeals conducted by the Patent Trial and Appeal Board from adverse decisions of examiners in patent applications, reissue applications, and...



Decisions

Browse public final agency decisions of PTAB, including decisions designated as precedential or informative.



Hearings

Review guidance, schedules, and incumbent weather advisories for oral arguments for appeals, interferences, and trials.



Resources

Learn about the Patent Trial and Appeal Board or find key policies, procedures, forms, and guidance.



Statistics

View performance benchmarks of the PTAB, including dispositions, pendency, inventory, and other tracking measures.



PTAB Data Tools and IT Systems

Stay informed regarding maintenance events, obtain direct access to PTAB automated information sharing platforms, subscribe for updates, or provide feedback.



PTAB Events

Find where our Judges are speaking and learn more about events sponsored by PTAB.



About PTAB

The Patent Trial and Appeal Board is created by statute, and includes statutory members and Administrative Patent Judges. The PTAB is charged with rendering decisions on...

Upcoming PTAB events

PTAB/TTAB Stadium Tour at University of San Diego School of Law
Sep 20, 2018 10:00 AM PT
San Diego, CA

[See the full events calendar](#)

Find other events near you or online.

[View the PTAB event calendar](#)

Now Hiring

Are you interested in learning more about being a judge or applying for a position at the Patent Trial and Appeal Board?

PTAB tools and links

- [Patent Trial and Appeal Board End to End \(PTAB E2E\)](#)
- [AIA Review Decisions](#)
- [PTAB bulk data](#)
- [API page](#)
- [USPTO systems statuses](#)
- [Patent and Trial Appeal fees](#)
- [Request a PTAB speaker](#)





Tools & links

[About EFS-Web](#)

[Check application status](#)

[Fees and payment](#)

[Patent Trial & Appeal Board](#)

[Global Dossier](#)

[More tools & links](#)

Suggestion Box

Please send any suggestions regarding PTAB E2E to the [PTAB E2E Admin mailbox](#).

Please send any suggestions regarding the Appeals Process to the Board at [PTAB Appeals Suggestions](#).

Please send any suggestions regarding the Trials Process to the Board at [PTABAIATrialSuggestions@uspto.gov](#).

If you have suggestions for other topics that you would like to see covered by the PTAB in a future Outreach event, please email your suggestions to [PTABOutreach@uspto.gov](#).

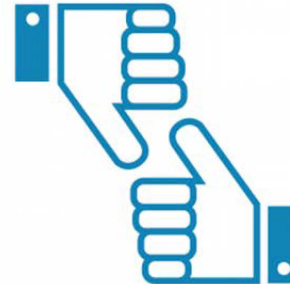

Accessible via the public PTAB Website at the following address:
<https://www.uspto.gov/patents-application-process/patent-trial-and-appeal-board/suggestion-box>

uspto

USPTO Subscription Center

Subscribe to our email newsletters or update your subscriptions

Provide your email address to get started with any of our newsletters or email alerts:

- USPTO Press Releases
- USPTO Director's Forum Blog
- USPTO Monthly Review
- FYI at the USPTO
- Inventors Eye
- Patents Alerts
- Trademarks Alerts
- Copyright Alerts
- Patent Trials and Appeal Board
- Intellectual Property for K-12 Educators

Email address (required)

SUBMIT

CANCEL

Accessible via the public PTAB Website at the following address:

<https://public.govdelivery.com/accounts/USPTO/subscriber/new>

uspto

101 Subject Matter Eligibility Analysis Framework (MPEP 2106)

- Step 1: Is the claim directed to a statutory class?
- Step 2A: Is the claim directed to judicial exception (e.g., abstract idea)?
- Step 2B: Does the claim recite additional elements that amount to significantly more than the abstract idea?

Step 2A: Vanda Pharm. Inc. v. West-Ward Pharm., 887 F.3d 1117 (Fed. Cir. 2018)

- Invention relates to a method of treating a patient having schizophrenia with iloperidone.
- Iloperidone is a drug known to cause disruption of the heart's normal rhythm (QTc prolongation) in patients having a particular genotype associated with poor drug metabolism.
- The genotype is referred to as a CYP2D6 poor metabolizer.

Step 2A: Vanda Pharm. Inc. v. West-Ward Pharm., 887 F.3d 1117 (Fed. Cir. 2018)

- Step 2A: claims "are directed to a method of using iloperidone to treat schizophrenia," rather than being "directed to" a judicial exception.
- Federal Circuit did not consider whether or not the treatment steps were routine or conventional when making its "directed to" determination.
- The claim was determined eligible in the step 2A "directed to" part of the test, so there was no need to conduct a step 2B analysis.



Vanda Guidance Memorandum

- Memorandum from Robert W. Bahr, Deputy Commissioner for Patent Examination Policy to Patent Examining Corps Issued June 7, 2018
- *search terms: uspto; vanda; memo*
- “method of treatment” claims that practically apply natural relationships should be considered patent eligible under Step 2A
- not necessary for such “method of treatment” claims to include non-routine or unconventional steps to be considered eligible

**Step 2B: Berkheimer v. HP, Inc.,
881 F.3d 1360 (Fed. Cir. 2018)**

- Invention relates to digitally processing and archiving files in a digital asset management system
- Step 2A: abstract ideas of parsing and comparing data (claims 1-3 and 9), parsing, comparing, and storing data (claim 4), and parsing, comparing, storing, and editing data (claims 5-7)

**Step 2B: Berkheimer v. HP, Inc.,
881 F.3d 1360 (Fed. Cir. 2018)**

- Claims 1-3 and 9: ineligible because no limitations that realized the purported improvements in the specification.
- Claims 4-7: contained limitations directed to those improvements; genuine issue of material fact as to whether those improvements were more than well-understood, routine, conventional activity.
- Mere fact that something disclosed in prior art does not make it well-understood, routine, conventional.

Berkheimer Guidance Memorandum

- Memorandum from Robert W. Bahr, Deputy Commissioner for Patent Examination Policy to Patent Examining Corps Issued April 19, 2018; *search terms: uspto; berkheimer*
- Does not change subject matter eligibility framework
- Clarifies when it is appropriate to conclude that an additional element represents “well-understood, routine, conventional activity”
 - Disclosure in prior art insufficient; “widely prevalent or in common use in the relevant industry”
 - Conclusion must be based upon a factual determination

Berkheimer Guidance Memorandum

- “Well-understood, routine, conventional activity” factual determination can be supported by:
 - express statement in the specification or to a statement made by an applicant during prosecution
 - one or more of the court decisions discussed in MPEP § 2106.05(d)(II)
 - a publication that demonstrates the well-understood, routine, conventional nature
 - official notice



Small Group Discussion



Question 1: Step 2A

- a. In your opinion, how should the PTAB determine how broadly or narrowly to formulate what the claims are “directed to” in analyzing whether they are directed to an abstract idea?
- b. What should the PTAB look to in determining what the claims are directed to?
- c. How (if at all) does the *Vanda* case, which did not consider whether the treatment steps were routine or conventional in Step 2A, affect your answers?



Question 2: Step 2B

- a. What type of evidence should be sufficient to show that something is a well-understood, routine and conventional activity?
- b. For statements in the specification or during prosecution, what must an applicant say for the statement to be considered an admission that something is well-understood, routine and conventional activity? “well known”? “known”? “commonplace”?
- c. If the specification identifies an element as being in a commercially available product, is that standing alone sufficient to show that element is well-understood, routine and conventional?
- d. For publications, in considering the “nature of publication” and description in the publication, can the fact that an element is described in an authoritative source (e.g., a treatise) standing alone be sufficient, or does the treatise still need to describe the element in such a way that it’s clear the element is well-understood, routine and conventional activity?
- e. For AIA proceedings, can an expert declaration from the Petitioner (absent persuasive rebuttal evidence) be sufficient to establish something is well understood, routine, and conventional?



Next Steps

- Thank you for the feedback
- Stay tuned for more developments

Break

UNITED STATES
PATENT AND TRADEMARK OFFICE

uspto

Hot Topic: Motions to Amend in AIA Trial Proceedings

UNITED STATES
PATENT AND TRADEMARK OFFICE



Motions to Amend

Current Procedure

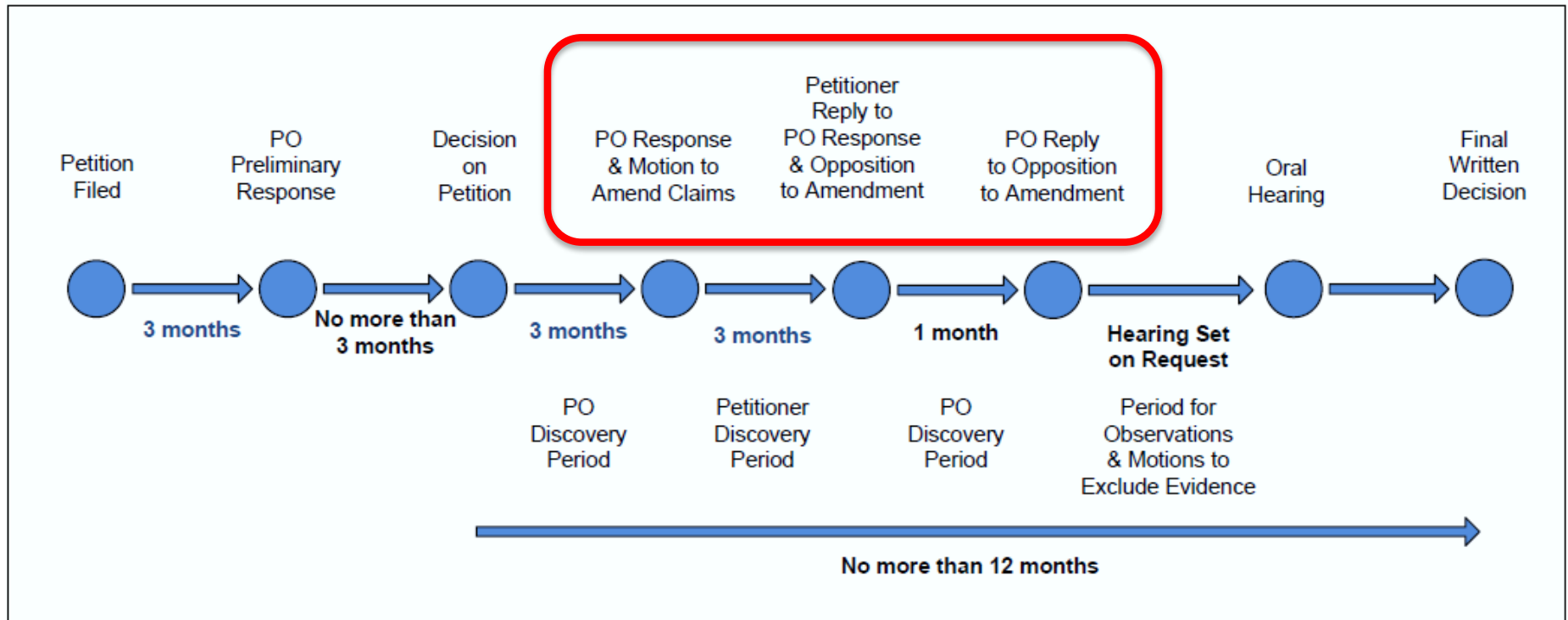

Motions to Amend

- *Aqua Products, Inc. v. Matal*, 872 F.3d 1290 (Fed. Cir. 2017) and subsequent Federal Circuit case law
- Guidance on Motions to Amend in view of *Aqua Products* (Nov. 21, 2017)
 - https://www.uspto.gov/sites/default/files/documents/guidance_on_motions_to_amend_11_2017.pdf
- *Western Digital Corp. v. SPEX Techs., Inc.*, IPR2018-00082 (Paper 13) (PTAB April 25, 2018) (Information and Guidance on Motions to Amend)

Western Digital v. SPEX Techs.

IPR2018-00082 -00084 (PTAB Apr. 25, 2018) (Paper 13) (Informative)

- Order provides guidance and information regarding statutory and regulatory requirements for a motion to amend in light of Federal Circuit case law (e.g., *Aqua Products*)
- Designated informative at the Board on June 1, 2018, after de-designation of *MasterImage* as precedential and *Idle Free* as informative



Western Digital v. SPEX Techs.

IPR2018-00082 -00084 (PTAB Apr. 25, 2018) (Paper 13) (Informative)

Order provides guidance and information, including on:

- Contingency
- Burden of persuasion regarding patentability of substitute claims
- Reasonable number of substitute claims
- Responding to a ground of unpatentability involved in the trial
- Scope of proposed substitute claims
 - May not enlarge scope of claims of challenged patent
 - May not introduce new subject matter
- Claim listing
- Default page limits
- Duty of candor



Motions to Amend

Burden of Persuasion

- Patent Owner does not bear the burden of persuasion to demonstrate the patentability of proposed substitute claims.
- Burden of persuasion ordinarily lies with petitioner, but the Board itself also may justify any finding of unpatentability by reference to evidence of record, as it must do when a petitioner ceases to participate.
- *See Aqua Products, Inc. v. Matal*, 872 F.3d 1290 (Fed. Cir. 2017); *Bosch Auto. Serv. Sols., LLC v. Iancu*, Order on Petition for Panel Rehearing, No. 2015-1928 (Fed. Cir. Mar. 15, 2018).
- Guidance on Motions to Amend in view of *Aqua Products* (Nov. 21, 2017)



Motions to Amend

Requirements under 35 U.S.C. 316(d); 37 C.F.R. 42.121, 42.221

- Motion must propose a reasonable number of substitute claims (rebuttable presumption of one-for-one claim substitution)
- Amendment must respond to a ground of unpatentability
 - Additional modifications addressing potential § 101 or § 112 issues are not precluded
- May not enlarge scope of claims or introduce new matter
 - Substitute claim must narrow scope of the challenged claim it replaces
 - Motion must set forth written description support for each proposed substitute claim

Motion to Amend Study

Update through March 31, 2018



Number of Motion to Amend Filings (FY13 to FY18: 10/1/2012-3/31/2018)

How Many Motions to Amend Are Filed?

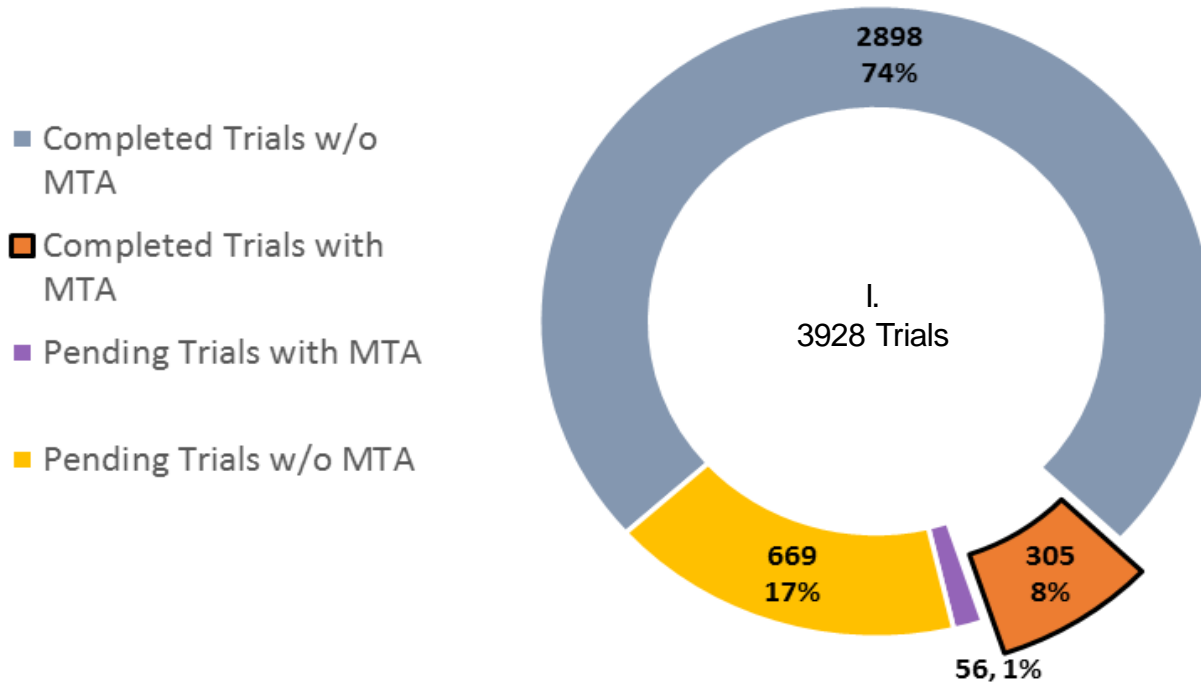

Subsequent Developments of Motions to Amend

(FY13 to FY18: 10/1/2012-3/31/2018)

Subsequent Developments of the Motions to Amend

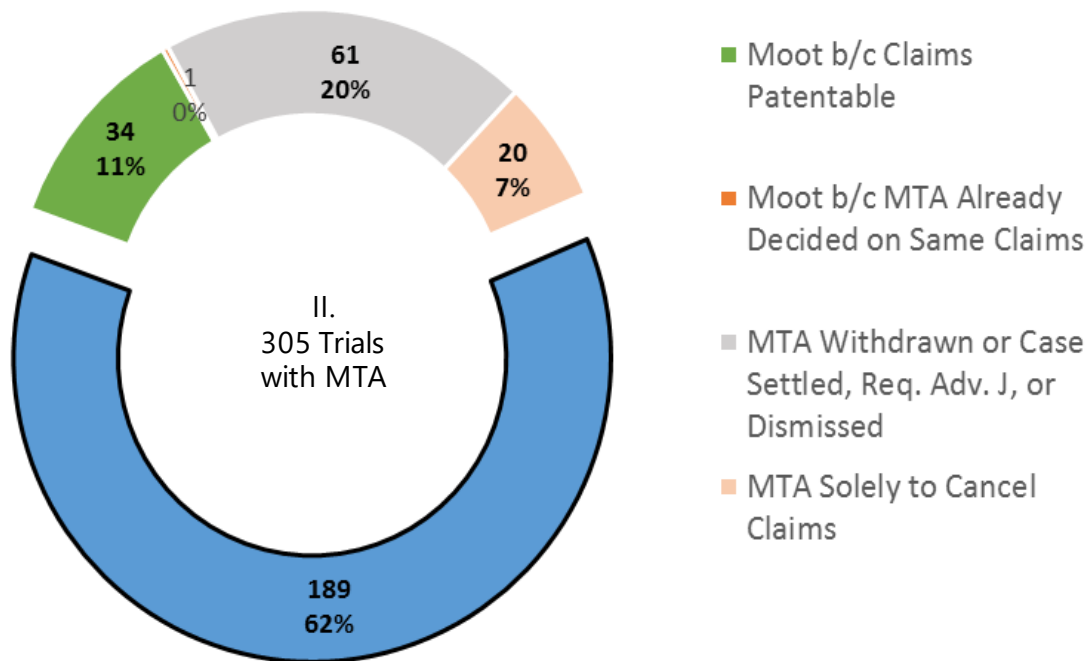

Disposition of Motions to Amend (FY13 to FY18: 10/1/2012-3/31/2018)

How Many Motions to Amend Substituting Claims
Are Granted?

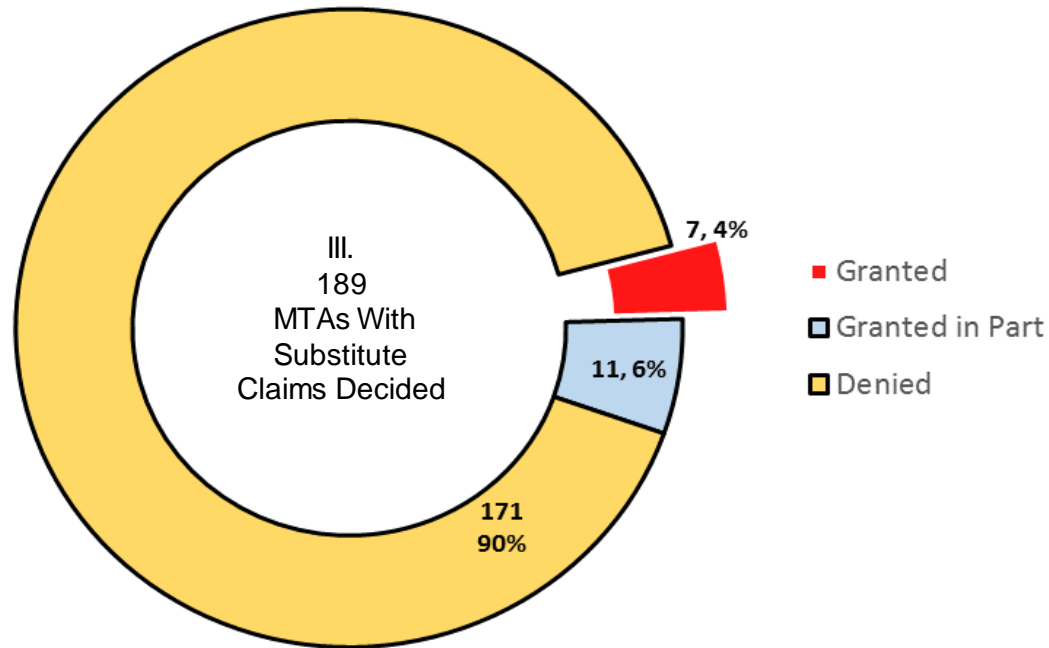

Reasons for Denying Entry of Substitute Claims

(FY13 to FY18: 10/1/2012-3/31/2018)

All Reasons

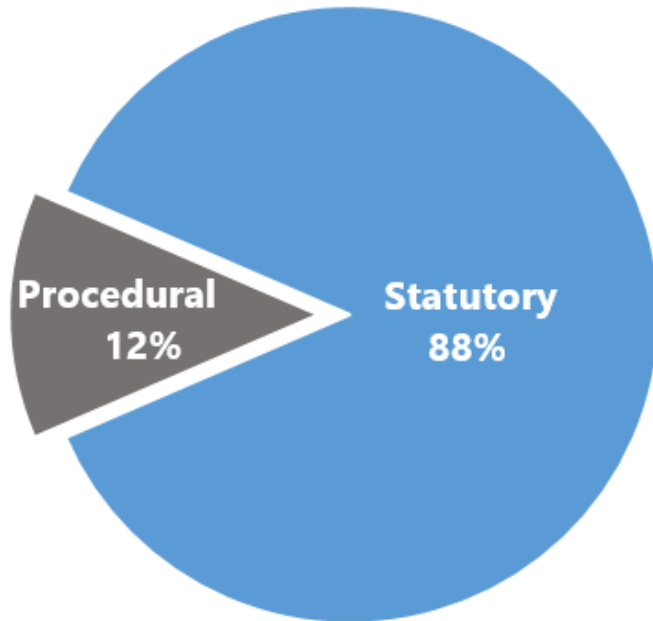

Statutory Reasons

Statutory Reasons

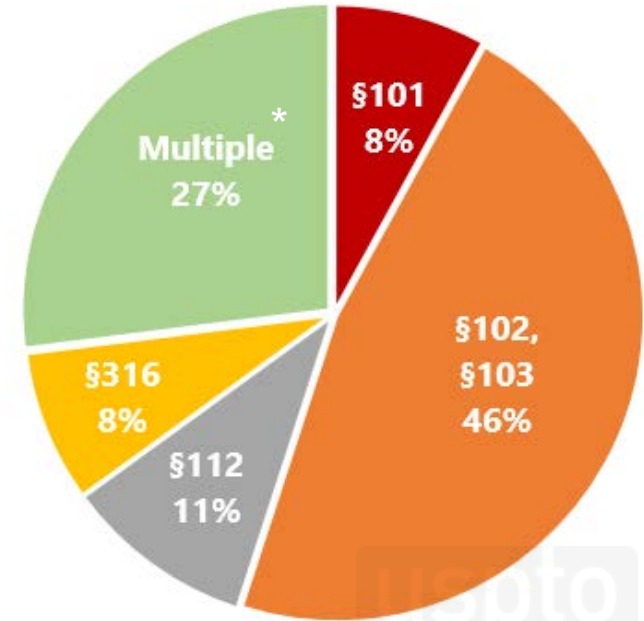

* All but one of the cases in which multiple statutory reasons were provided for denying entry of substitute claims included §§ 102, 103 and/or 112 as a reason for denial.

Motions to Amend Filed by Fiscal Year

(FY13 to FY18: 10/1/12 to 3/31/18)

Filings in the first half of FY18 (post-Aqua Products) have exceeded the entire previous fiscal year.

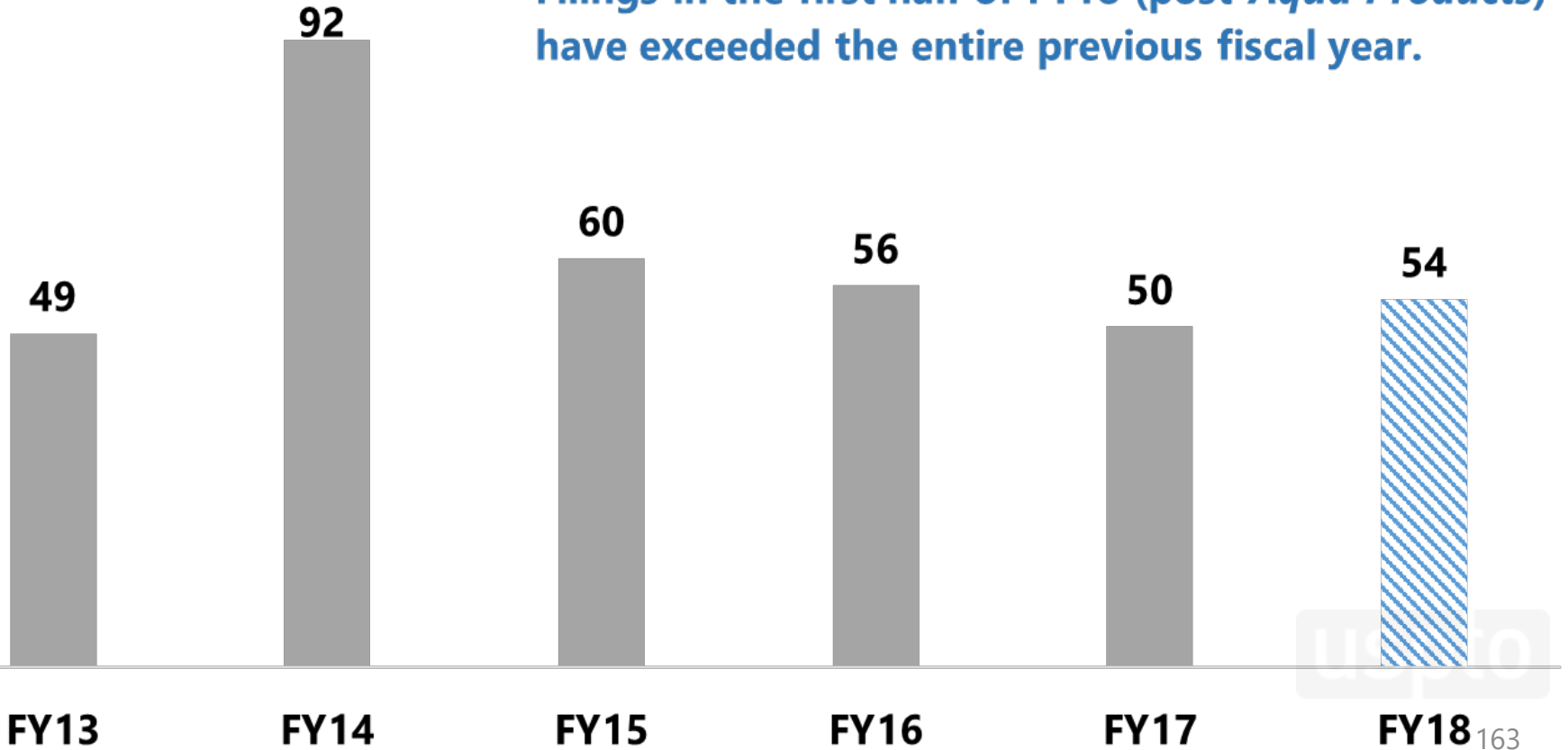

Apple Inc. v. Realtime Data LLC, IPR2016-01737

A Successful Motion to Amend

Why was this motion to amend successful?

- Patent Owner requested to replace 55 unpatentable claims for 55 substitute claims
- Patent Owner proposed a narrowing limitation in each substitute claim in direct response to the grounds of unpatentability involved in the trial
- Patent Owner identified support in the specification for the narrowing limitations

118. A method for providing accelerated loading of an operating system in a computer system, the method comprising:
preloading a portion of boot data in a compressed form into a volatile memory, the portion of boot data in the compressed form being associated that is with a portion of a boot data list for booting the computer system into a memory, wherein the preloading comprises transferring the portion of boot data in the compressed form into the volatile memory, and wherein the preloading occurs during the same boot sequence in which a boot device controller receives a command over a computer bus to load the portion of boot data;
accessing the preloaded portion of the boot data in the compressed form from the volatile memory;
decompressing . . . ;
and updating . . .



Small Group Discussion



Question 1: Examination of Substitute Claims

- a. Do you think patent examiners should be involved in assisting the Board in addressing motions to amend in AIA proceedings? Why or why not?
- b. If an examiner is involved, should it be required or only invoked upon request? By either or both parties?
- c. If an examiner is involved, what procedures should be used? For example, how should the trial schedule in relation to a motion to amend be modified to allow for examiner involvement?

Question 1: Examination of Substitute Claims

- d. What type of information should an examiner provide to the Board?
- e. Should an examiner conduct a search or only consider art of record? Should an examiner consider other papers or evidence beyond those directly involved in the amendment process?
- f. Should parties be able to respond to information provided by an examiner, and if so, in what way?
- g. What weight should the Board give information provided by an examiner in relation to a motion to amend?
- h. Do you have any other thoughts or suggestions on how patent examiners should be involved with motions to amend?



Question 2: MTA Considerations

- a. What considerations go into deciding whether to file a motion to amend?
- b. Have those considerations changed based on the recent case law and PTAB guidance?
- c. Would an indication from the Board that a challenged claim is likely to be found unpatentable make you more likely to file a motion to amend? Why or why not?
- d. Should motions to amend be contingent or non-contingent? Would your answer change if examiners are involved in assisting the Board in addressing motions to amend?



Next Steps

- Thank you for the feedback
- Stay tuned for more developments

A background of a technical drawing, likely a patent illustration, showing a cross-section of a mechanical assembly. The drawing is rendered in light gray lines on a white background. It features various components, some of which are labeled with numbers such as 18, 80, 40, 36, 34, 32, 52, 84, and 86. The drawing is oriented diagonally across the page.

Interview of the Chief Judge

UNITED STATES
PATENT AND TRADEMARK OFFICE

uspto

Slides and Materials

<https://www.uspto.gov/patents-application-process/patenttrialandappealboard>

[Home](#) / [Patents: Application Process](#) / [Patent Trial and Appeal Board](#)

Patent Trial and Appeal Board

The Patent Trial and Appeal Board (PTAB) conducts trials, including inter partes, post-grant, and covered business method patent reviews and derivation proceedings; hears appeals from adverse examiner decisions in patent applications and reexamination proceedings; and renders decisions in interferences.



Trials

Manage or review pending inter parte review, post-grant review, covered business method, derivation, and interference proceedings.



Appeals

Manage or review proceedings directed to adverse decisions of examiners in patent applications, reissue applications, and reexaminations of issued patents.



Decisions

Browse public final agency decisions of PTAB, including decisions designated as precedential or informative.



Hearings

Review guidance, schedules, and inclement weather advisories for oral arguments for appeals, interferences, and trials.



Resources and guidance

Learn about the Patent Trial and Appeal Board or find key policies, procedures, forms, and guidance.



Statistics

View performance benchmarks of the PTAB, including dispositions, pendency, inventory, and other tracking measures.



PTAB Data Tools and IT Systems

Stay informed regarding maintenance events, obtain direct access to PTAB automated information sharing platforms, subscribe for updates, or provide feedback.



PTAB Events

Find where our judges are speaking and learn more about events sponsored by PTAB.



About PTAB

Discover the history of the PTAB and map out its modern structure and mission.

Guidance on SAS NEW

[Notice of Proposed Rulemaking of Claim Construction Standard used in PTAB AIA Trial Proceedings](#) NEW

Upcoming PTAB events

[Impact of SAS, Motion to Amend Practice, and Claim Construction in Trial Proceedings](#)

Jun 5, 2018 12:00 PM ET

[Motions to Exclude and Motions to Strike in AIA Trial Proceedings](#)

Jun 7, 2018 12:00 PM ET

[PTAB/TTAB Stadium Tour at University of San Diego School of Law](#)

Sep 20, 2018 10:00 AM PT
San Diego, CA



Thank You



