



WELCOME
May 4th 2023

Please send questions to the DesignDay@uspto.gov mailbox.





Welcome

Lakiya Rogers, Technology Center Operations Manager, USPTO

Elizabeth Ferrill, Partner, Finnegan LLP

Please send questions to the DesignDay@uspto.gov mailbox.



Hosts *Lakiya Rogers, Technology Center 2900 Operations Manager, USPTO*
Elizabeth Ferrill, Partner, Finnegan LLP

SCHEDULE

9:30 – 10:00 **Registration/Coffee**
Sponsor: AIPLA/IPO

10:00 –10:15 **Welcome and Kick-off**
Lakiya Rogers, TC 2900 Operations Manager, USPTO
Elizabeth Ferrill, Partner, Finnegan LLP

10:15 – 10:35 **State of the Design Technology Center**
Karen Young, Director TC 2900 USPTO

10:35 – 11:05 **International Perspectives: the growing impacts of international forums, international developments, and user engagement**
Courtney Stopp, Patent Attorney, Office of Policy and International Affairs, USPTO

11:05 – 11:55 **Similarities & Differences between Utility & Design Patents -- Prosecution & Litigation**
Lakiya Rogers, TC 2900 Operations Manager, USPTO
Daniel Spillman, Associate VP-Assistant General Patent Counsel, Eli Lilly
Margaret Polson, Founder and Senior Partner, Polson IP Law

11:55-1:00 **Lunch & Interaction**

Please see nearby lunch options on separate flyer. We suggest placing an order for pick-up.

1:00 – 1:20 **Message from the Deputy Under Secretary**
Derrick Brent, Deputy Under Secretary of Commerce for Intellectual Property and Director of the United States Patent and Trademark Office

1:20 – 2:05 **Anatomy of a Design Patent Litigation**
Elizabeth Ferrill, Partner, Finnegan LLP
Christopher Carani, Partner, McAndrews, Held & Malloy Ltd.

2:05 – 3:30 **Intersection of Patents, Trademarks, and Copyright**
Damian Porcari, USPTO Regional Director, Midwest Regional Office
John S. Artz, Partner, Dickinson Wright PLLC
Susan B. Allen, Attorney Advisor, Office of Policy and International Affairs, USPTO
David Gearhart, Senior Staff Attorney, Office of Trademark Quality Review and Training, USPTO

3:30-3:45 **Break & Interaction**
Sponsor: AIPLA/IPO

3:45-4:15 **Spotlight on a Major Design Patent Case**
Brendan O'Dea, Partner, Womble Bond Dickinson

4:15 – 4:50 **Report from the Front Line: A Summary of Recent Decisions**
Rebekah Holtz, Associate, Sterne Kessler, Goldstein & Fox

4:50 –5:00 **Closing**

Any legal opinions expressed at this event do not necessarily represent USPTO policy. USPTO employees are reminded that the discussions at this event are not a substitute for formal USPTO legal training, and that they are not being educated as to what the law is and how it should be applied in examination.



State of the Design Technology Center

Karen M. Young, Director, Technology Center 2900

Please send questions to the DesignDay@uspto.gov mailbox.



Design filings

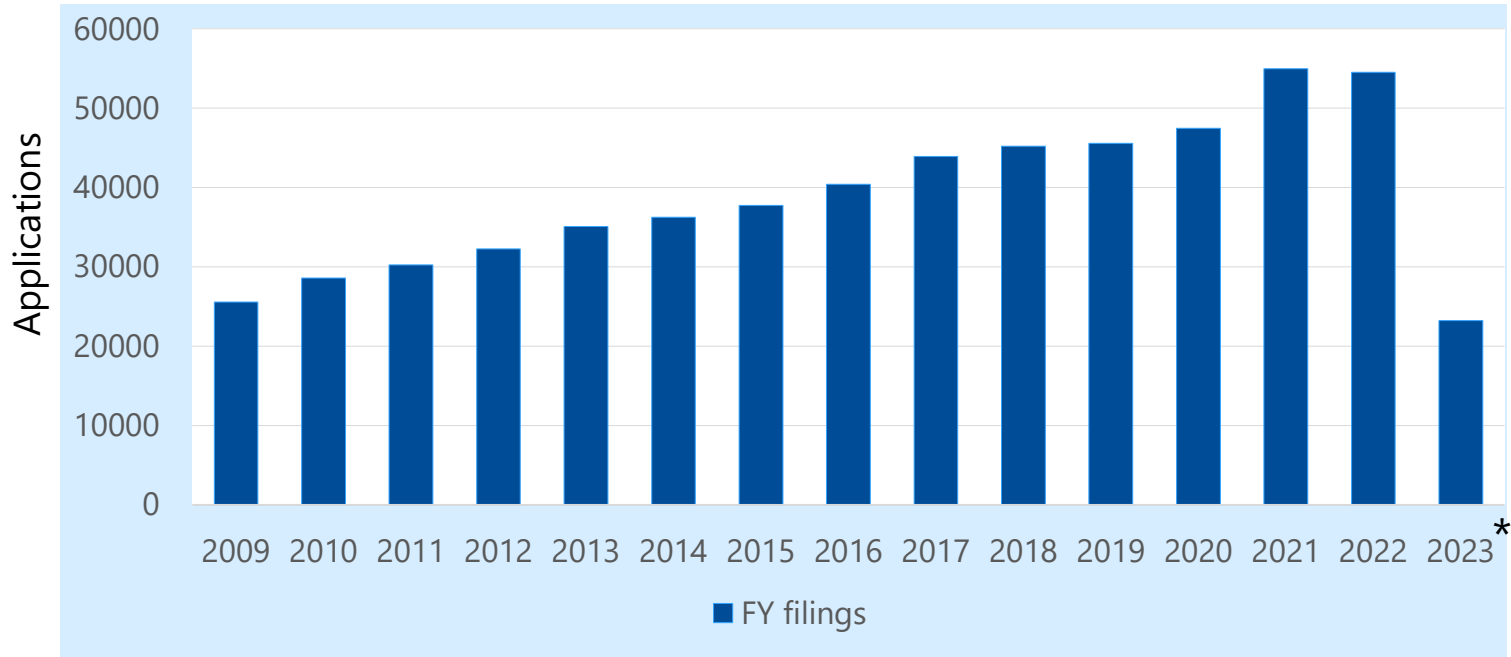

**Filings through fiscal year 2023 (FY23) quarter 2 (Q2) – 23,201*

Please send questions to the DesignDay@uspto.gov mailbox.

Design filings by class

CLASS	2019	2020	2021	2022	2023*	CLASS NAME
D01	89	72	216	60	66	EDIBLE PRODUCTS
D02	1068	1186	1247	1284	1237	APPAREL AND HABERDASHERY
D03	681	736	701	812	662	TRAVEL GOODS AND PERSONAL BELONGINGS
D04	189	189	188	201	155	BRUSHWARE
D05	62	84	45	35	31	TEXTILE OR PAPER YARD GOODS; SHEET MATERIAL
D06	1165	1270	1571	1776	1551	FURNISHINGS
						EQUIPMENT FOR PREPARING OR SERVING FOOD OR DRINK NOT ELSEWHERE SPECIFIED
D07	995	1041	1246	1438	1170	
D08	917	1082	1040	1184	1095	TOOLS AND HARDWARE
D09	899	918	785	754	724	PACKAGES AND CONTAINERS FOR GOODS
D10	503	625	589	576	510	MEASURING, TESTING, OR SIGNALLING INSTRUMENTS (1) (2)
D11	383	463	518	504	483	JEWELRY, SYMBOLIC INSIGNIA, AND ORNAMENTS
D12	1475	1653	1378	1792	1488	TRANSPORTATION
						EQUIPMENT FOR PRODUCTION, DISTRIBUTION, OR TRANSFORMATION OF ENERGY
D13	985	1039	1095	1109	1143	
						RECORDING, COMMUNICATION, OR INFORMATION RETRIEVAL EQUIPMENT
D14	2768	2975	2890	3696	2679	
D15	588	602	602	642	560	MACHINES NOT ELSEWHERE SPECIFIED
D16	493	444	594	499	441	PHOTOGRAPHY AND OPTICAL EQUIPMENT

* Filings through FY23 Q2

Design filings by class - continued

CLASS	2019	2020	2021	2022	2023*	CLASS NAME
D17	50	63	71	58	46	MUSICAL INSTRUMENTS
D18	134	119	103	100	95	PRINTING AND OFFICE MACHINERY
D19	173	178	201	290	185	OFFICE SUPPLIES; ARTISTS` AND TEACHERS` MATERIALS
D20	67	87	111	93	63	SALES AND ADVERTISING EQUIPMENT
D21	1014	1017	1282	1415	1171	GAMES, TOYS, AND SPORTS GOODS
D22	318	247	293	322	276	ARMS, PYROTECHNCIS, HUNTING AND FISHING EQUIPMENT
D23	940	1112	1253	1271	1143	ENVIRONMENTAL HEATING AND COOLING; FLUID HANDLING AND SANITARY EQUIPMENT
D24	1291	1388	1606	1432	1166	MEDICAL AND LABORATORY EQUIPMENT
D25	348	359	311	335	388	BUILDING UNITS AND CONSTRUCTION ELEMENTS
D26	914	932	1321	1391	1157	LIGHTING
D27	230	248	168	246	219	TOBACCO AND SMOKERS' SUPPLIES
D28	282	416	459	405	452	COSMETIC PRODUCTS AND TOILET ARTICLES
D29	143	131	162	129	118	EQUIPMENT FOR SAFETY, PROTECTION, AND RESCUE (1)
D30	249	261	351	506	489	ANIMAL HUSBANDRY
D32	298	366	244	363	327	WASHING, CLEANING, OR DRYING MACHINE
D34	150	178	163	171	145	MATERIAL OR ARTICLE HANDLING EQUIPMENT
D99	67	73	113	109	191	MISCELLANEOUS

* Filings through FY23 Q2

Design unexamined application inventory

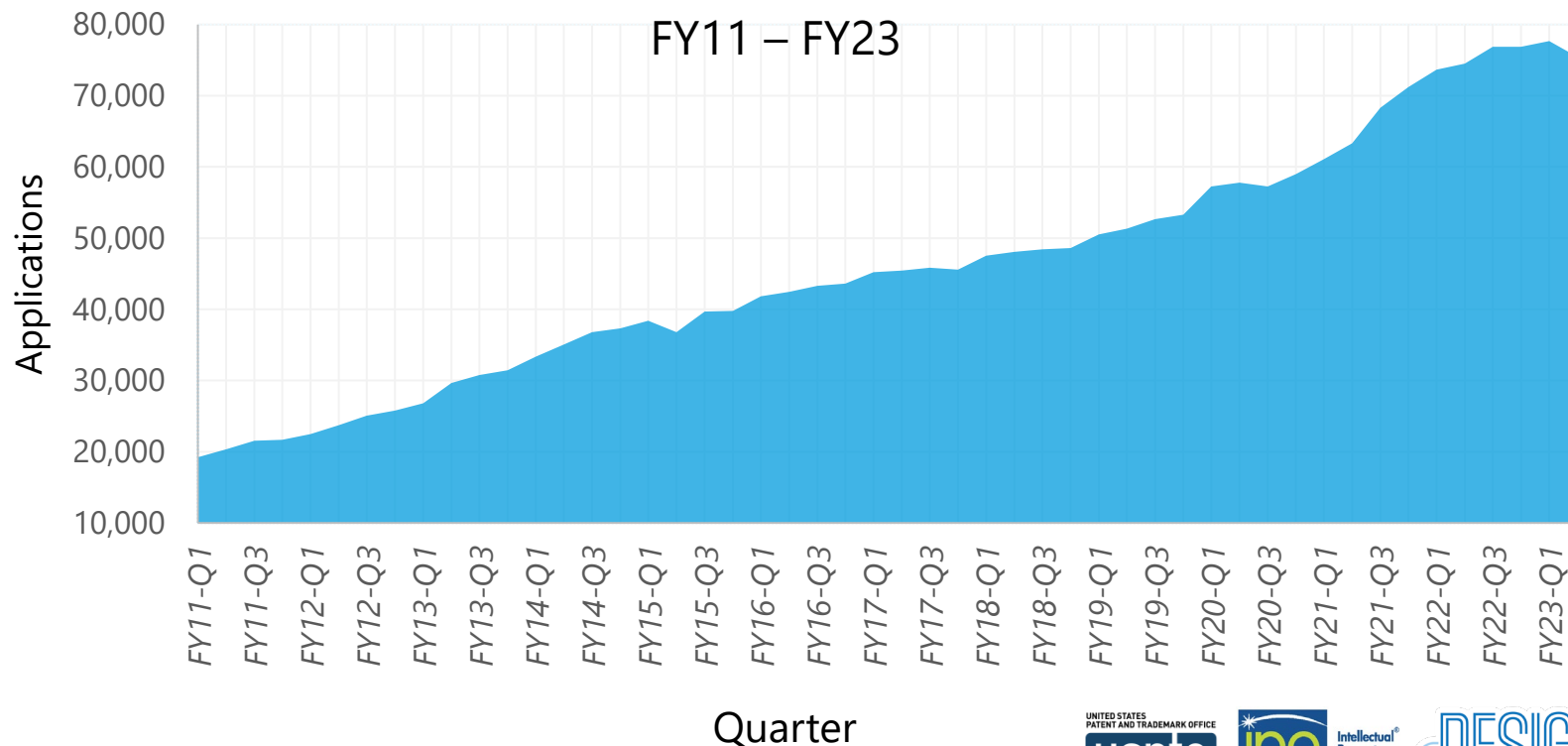

Please send questions to the DesignDay@uspto.gov mailbox.



First action and total pendency

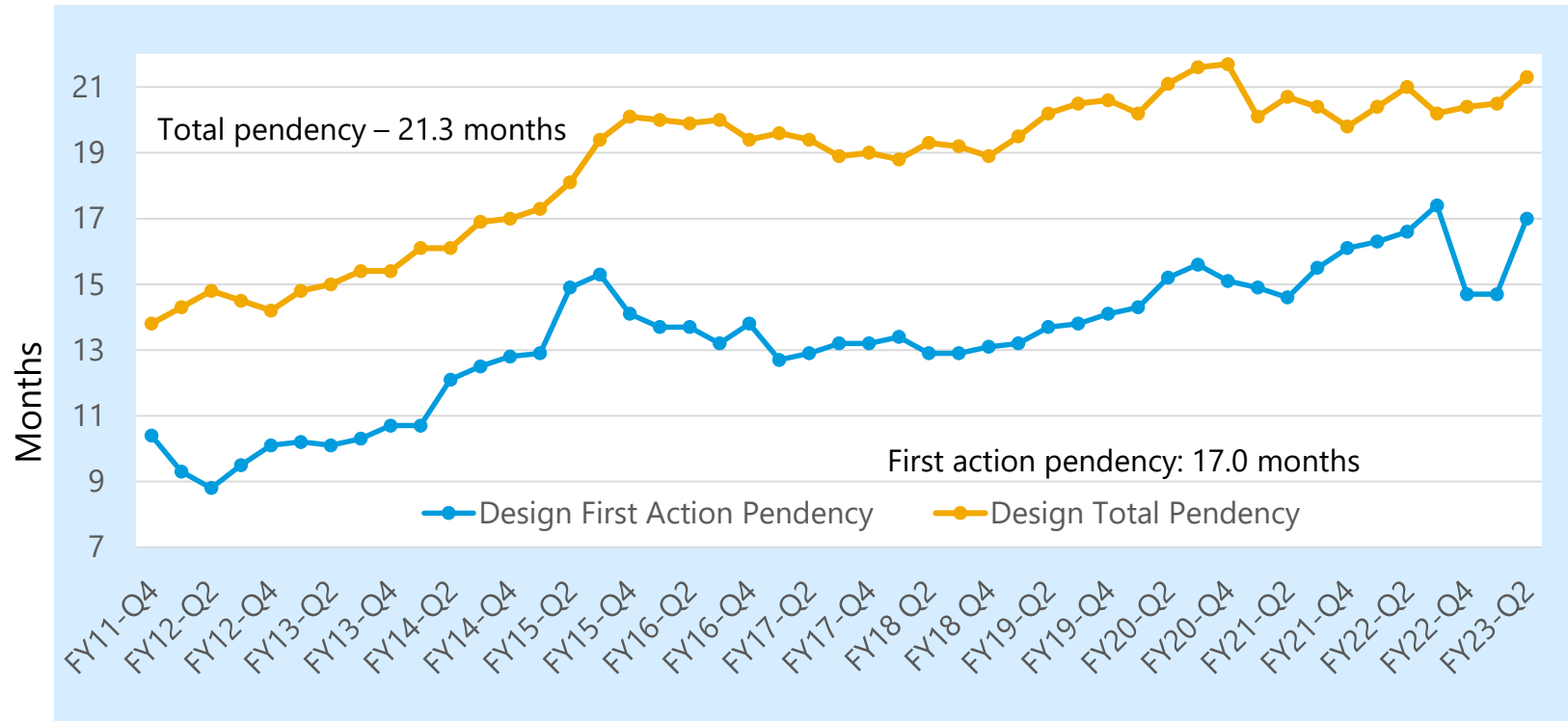

First actions – 14,124

Total actions – 21,784

Please send questions to the DesignDay@uspto.gov mailbox.

First action and total actions

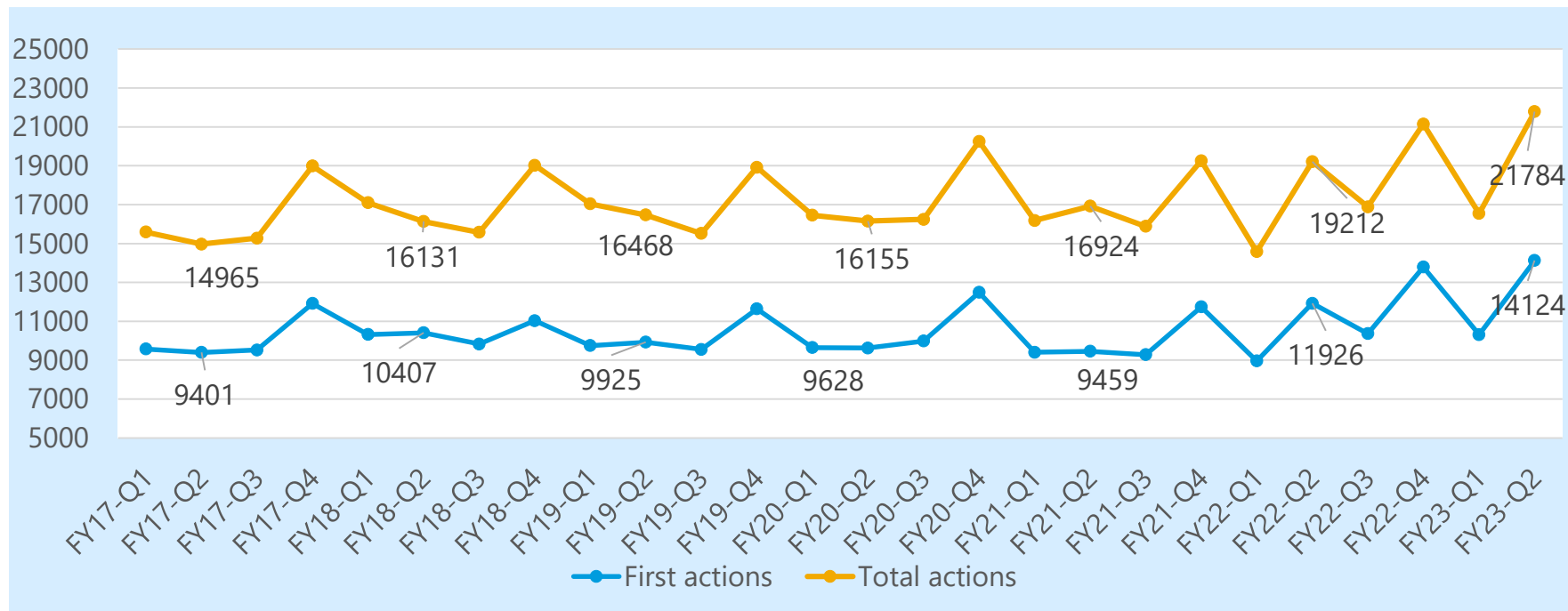

Please send questions to the DesignDay@uspto.gov mailbox.

Design patents issued

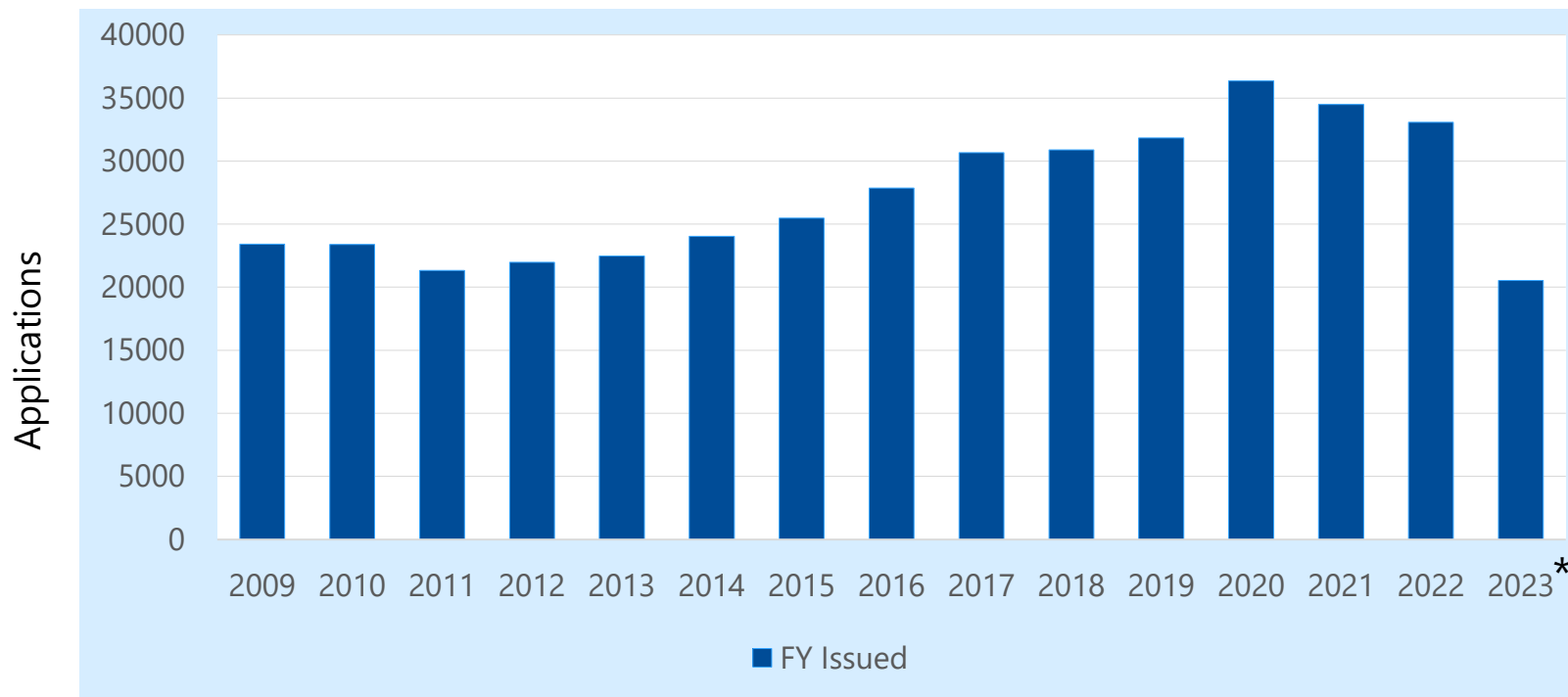

* Issued through FY23 Q2

Please send questions to the DesignDay@uspto.gov mailbox.

Yearly Hague applications

Fiscal year	Number of applications received by USPTO
2023	1,416*
2022	2,677
2021	2,248
2020	2,213
2019	2,415
2018	2,150
2017	2,048

**Filings through FY23 Q2*

Please send questions to the DesignDay@uspto.gov mailbox.



FY 2023 first office actions by type

U.S. design applications

<u>Type of action</u>	<u>Percent</u>
1st action rejection	39%
1st action allowance	40%
1st action restriction	8%
1st action Quayle	13%

Hague applications

<u>Type of Action</u>	<u>Percent</u>
1st action rejection	42%
1st action allowance	27%
1st action restriction	23%
1st action Quayle	8%

Please send questions to the DesignDay@uspto.gov mailbox.

Rocket docket

- Establishes an expedited procedure for design applications under 37 CFR 1.155, including applications filed via the Hague system
- Examined with priority and undergo expedited processing through the entire course of prosecution in the office

Please send questions to the DesignDay@uspto.gov mailbox.



Rocket docket filings

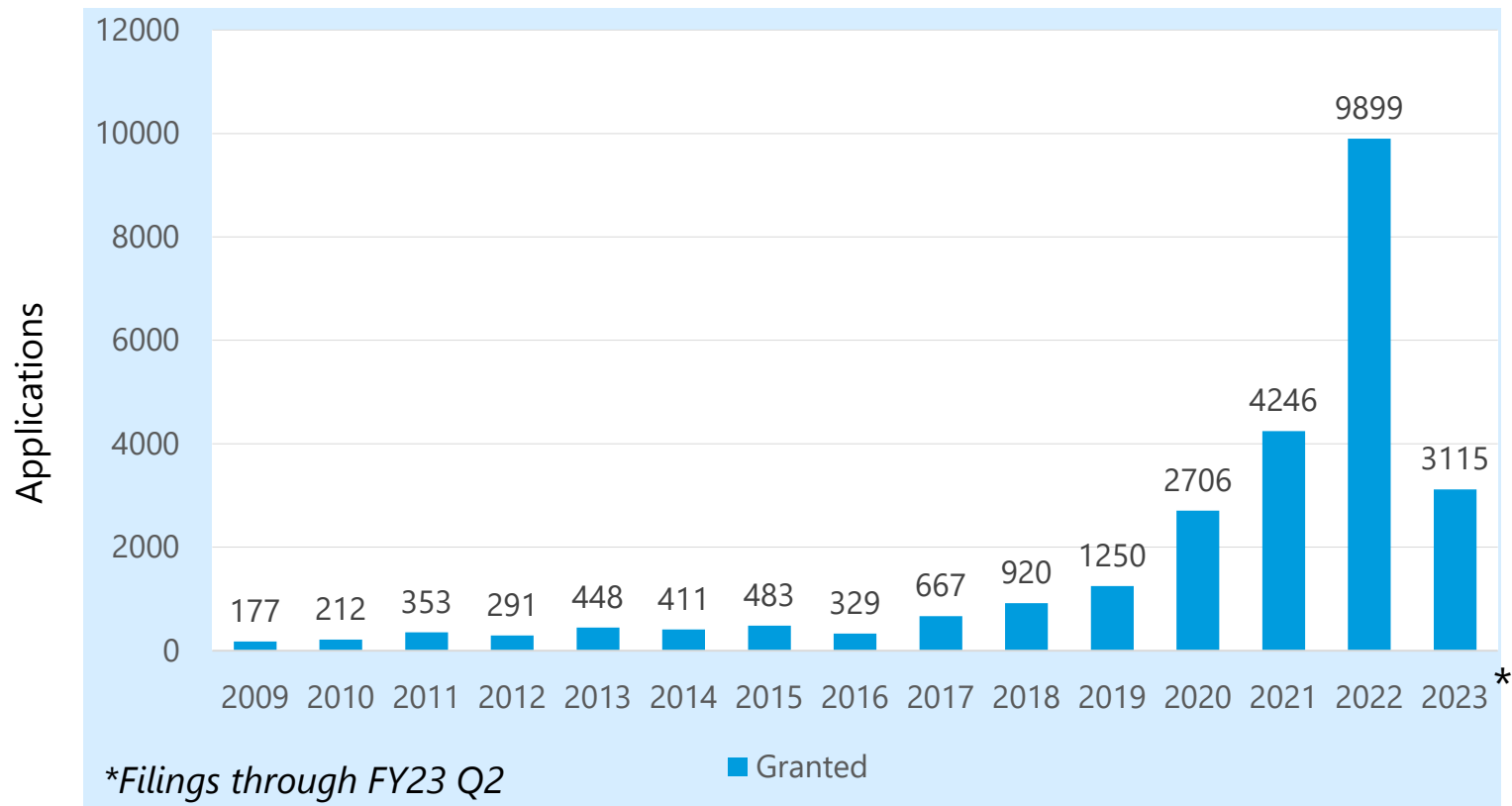

Please send questions to the DesignDay@uspto.gov mailbox.



Attribute time

- Attribute time related to Hague and Rocket Docket cases accounts for a significant portion of available examining resources – about 8% of current capacity

FISCAL YEAR	HAGUE HOURS	ROCKET DOCKET HOURS
2021	7437	11271
2022	7359	24516
2023*	4275	12978

**Attribute hours through FY23 Q2*

Please send questions to the DesignDay@uspto.gov mailbox.

Design staffing*

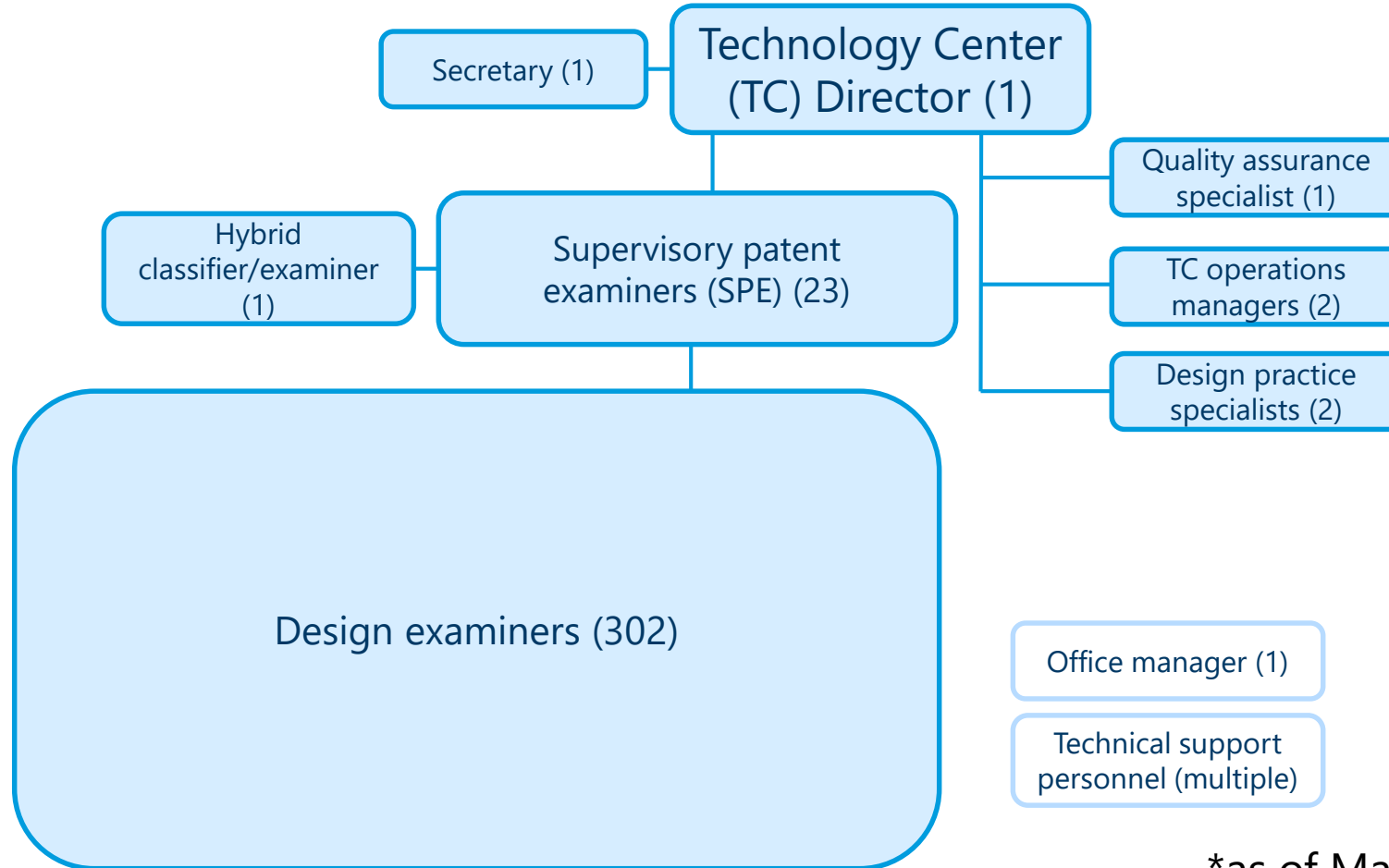

*as of May 4, 2023

Examiner experience level

Experience level	Number of examiners
GS-14	122
GS-13	5
GS-12	25
GS-11	20
GS-9	60
GS-7	71

Please send questions to the DesignDay@uspto.gov mailbox.

Now hiring design examiners!

- Total number of design examiners has increased 67% from FY18 to FY22, from 178 to 294

Fiscal year	Examiners hired
2022	82
2021	46
2020	38
2019	0
2018	0

Please send questions to the DesignDay@uspto.gov mailbox.



Now hiring design examiners!

MAY 18, 2023 – UPCOMING WEBINAR

[Become a design patent examiner](#)

By attending this event you will learn more about the agency and the design patent examiner position, meet with the USPTO team, and learn more about our tremendous benefits and why employees love to work here.

<https://www.uspto.gov/jobs/become-design-patent-examiner>

Please send questions to the DesignDay@uspto.gov mailbox.



New design examiners!



Please send questions to the DesignDay@uspto.gov mailbox.

Thank you

Karen M. Young
Director
Technology Center 2900

Please send questions to the DesignDay@uspto.gov mailbox.





International perspectives: the growing impacts of international forums

Courtney Stopp, USPTO – Office of Policy and International Affairs

Please send questions to the DesignDay@uspto.gov mailbox.



Overview

- The Hague System & Hague Working Group
- WIPO- SCT & DLT
- WIPO DAS
- ID5

Please send questions to the DesignDay@uspto.gov mailbox.



Hague System & Hague Working Group

Please send questions to the DesignDay@uspto.gov mailbox.



The Hague System

- A single international application for a single international registration
 - Designating one or more contracting parties
 - 79 contracting parties covering 93 countries (as of April 2023)
- Register up to 100 industrial design with a single application
 - All designs must belong to the same Locarno class
- If no refusal, the resulting international registration has the effect of a grant of protection in each designated contracting party

Please send questions to the DesignDay@uspto.gov mailbox.



The Hague System

- The Hague System is primarily a procedural treaty, and it does not determine:
 - The conditions for protection or
 - The rights which result from protection
- These issues are governed by the law of each contracting party designated in an international registration

Please send questions to the DesignDay@uspto.gov mailbox.



The Hague System

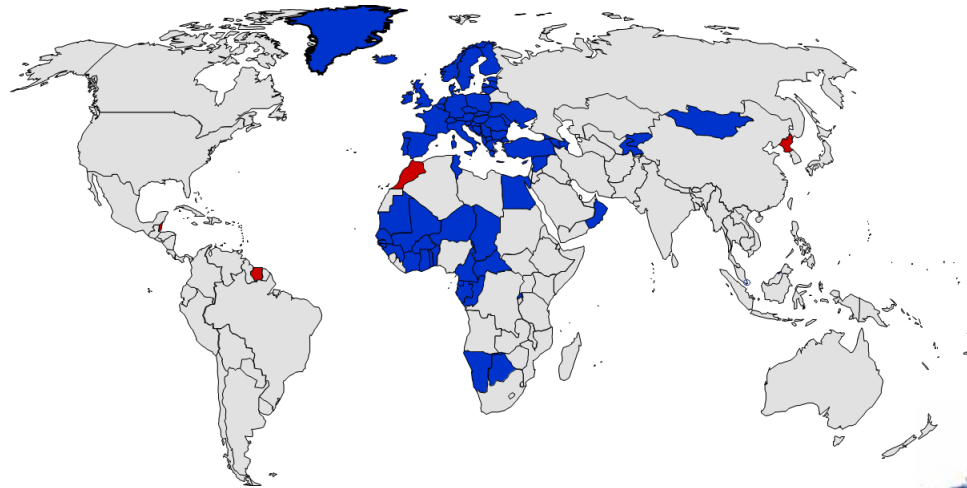

Hague Union 2014



Hague Union 2023

The Hague System

International applications grew by 15.7% in 2021 – the fastest growth since 2016.

1. International applications, 2007–2021

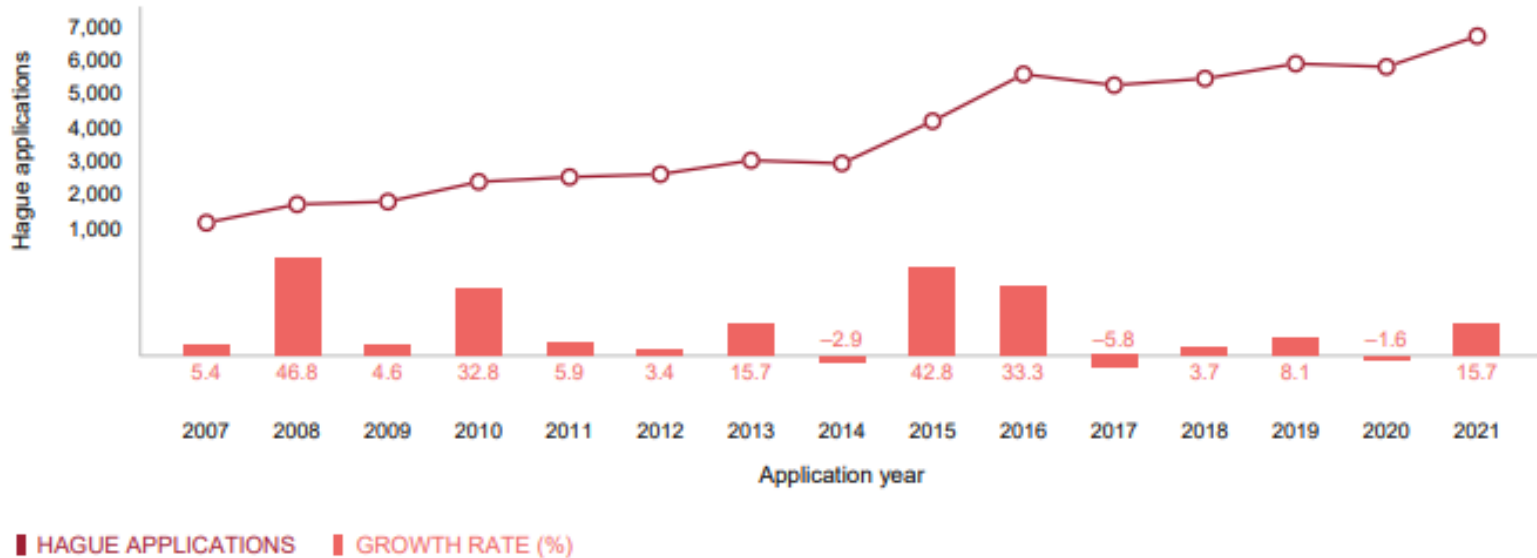

Source: WIPO Statistics Database, February 2022.

Please send questions to the DesignDay@uspto.gov mailbox.

The Hague System

The majority of the top 20 origins reported double-digit growth in number of designs in 2021.

9. Designs contained in international applications for the top 20 origins, 2021

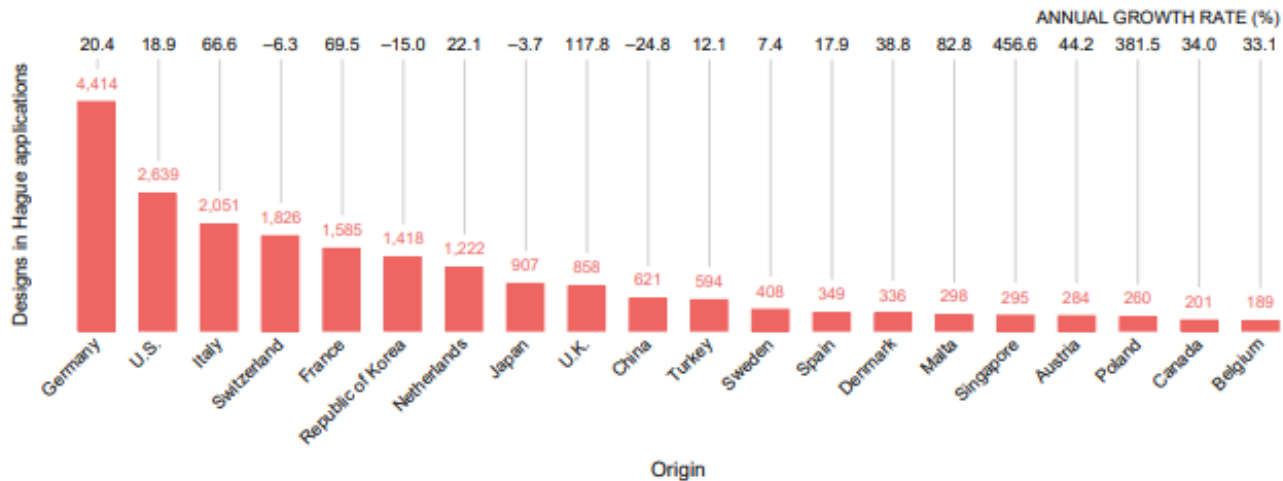

Note: The origin of an application is defined as the country/territory of the stated address of residence of the applicant. Applicants residing in a non-member country can file applications for international registrations, if they have a real and effective industrial or commercial establishment within the jurisdiction of a Hague member. For example, China was not a member of the Hague System in 2021, but ranked tenth, with 621 designs.

Source: WIPO Statistics Database, February 2022.

Please send questions to the DesignDay@uspto.gov mailbox.



The Hague System

Designs related to means of transport (9.7%) accounted for the largest share of total designs in 2021.

26. Designs contained in international applications by class, 2018–2021

Class	2018	2019	2020	2021	Growth rate (%): 2020–2021	2021 share of total (%)
Class 12: Means of transport or hoisting	1,662	2,075	1,895	2,179	15.0	9.7
Class 14: Recording, communication or information retrieval equipment	2,031	2,970	1,644	2,154	31.0	9.6
Class 9: Packages and containers for the transport or handling of goods	1,220	1,442	1,572	1,847	17.5	8.2
Class 6: Furnishing	2,352	2,187	1,385	1,548	11.8	6.9
Class 26: Lighting apparatus	1,196	1,357	1,303	1,457	11.8	6.5
Class 28: Pharmaceutical and cosmetic products, toilet articles and apparatus	785	542	772	1,283	66.2	5.7
Class 23: Fluid distribution equipment, sanitary, heating, ventilation and air-conditioning equipment, solid fuel	1,064	1,173	1,000	1,122	12.2	5.0
Class 2: Articles of clothing and haberdashery	698	949	635	1,120	76.4	5.0
Class 11: Articles of adornment	866	960	1,008	1,103	9.4	4.9
Class 21: Games, toys, tents and sports goods	561	695	612	898	46.7	4.0

Please send questions to the DesignDay@uspto.gov mailbox.

The Hague Working Group

- HWG 11 (December 12-14, 2022):
 - Potential addition of languages and/or schemes
 - Filing, publication, publication/office communication, working language
 - Cost implications and technical feasibility of the introduction of additional languages into the Hague System
 - Criteria for the selection of additional languages for introduction into the Hague System
- HWG 12 (December 4-6, 2023)

Please send questions to the DesignDay@uspto.gov mailbox.



WIPO SCT & DLT

Please send questions to the DesignDay@uspto.gov mailbox.



WIPO SCT

Standing Committee on the Law of Trademarks, Industrial Designs and Geographical Indications (SCT)

- A forum to discuss issues, facilitate coordination and provide guidance on the progressive development of international law on trademarks, industrial designs and geographic indications, including the harmonization of national laws and procedures.
 - Membership in the SCT is open to all member states of WIPO or the Paris Union for the Protection of Industrial Property.
 - A special rule of procedure extends membership without the right to vote to the European Union.



[This Photo](#) by Unknown Author is licensed under [CC BY-NC-ND](#)

Please send questions to the DesignDay@uspto.gov mailbox.

WIPO SCT

- Graphical User Interface (GUI), icons, typefont
 - Longterm efforts led by the United States (and others) to identify the scope and availability of design protections for GUIs, icons, and typefonts around the globe
 - Building off data collected throughout 2017-2019, the United States (and others) are working together to promote the development of recommended practices for protecting GUIs
 - As of 11/2022, the joint recommendation has gained the support of a significant number of countries and is now additionally co-sponsored by Canada, the EU, Israel, Japan, Korea, and the UK



Please send questions to the DesignDay@uspto.gov mailbox.

WIPO SCT

- **Design Law Treaty (DLT)**
 - Special session of the SCT and Preparatory Meetings – Oct 2023
 - Diplomatic Conference – No later than the end of 2024
- **Draft Design Law Treaty (DLT)**
 - Application (Art 3)
 - Filing Date (Art 5)
 - Grace Period (Art 6)
 - Relief - Time Limits (Art 12)
 - Reinstatement of Rights (Art 13)
 - Correction or Addition of Priority Claim (Art 14)
- **Remaining Issues:**
 - Disclosure Requirement
 - Technical Assistance



Please send questions to the DesignDay@uspto.gov mailbox.



WIPO SCT

- DLT Timeline
 - July 2022
 - Decision to convene a diplomatic conference
 - October 2023
 - Special planning session for the DLT
 - Late 2024
 - Diplomatic conference



Please send questions to the DesignDay@uspto.gov mailbox.



WIPO Digital Access Service (DAS)

Please send questions to the DesignDay@uspto.gov mailbox.



WIPO DAS

- The WIPO Digital Access Service (DAS) is an electronic system that facilitates the secure exchange of priority and similar documents between participating intellectual property offices.
 - The system enables applicants and offices to meet the requirements of the Paris Convention for certification of documents in an electronic environment.
- Offices participate as depositing offices and/or accessing offices.
 - Hague applications & national industrial applications
 - PCT applications & national patent applications
 - National trademark applications

www.wipo.int/das/en/

Please send questions to the DesignDay@uspto.gov mailbox.



WIPO DAS for industrial designs:

- Australia
 - Austria
 - Brazil†
 - Canada*
 - Chile
 - China*
 - Colombia
 - Eurasian Patent Organization*
 - European Union Intellectual Property Office*
 - France†
 - Georgia*
 - India
 - Ireland‡
 - Israel*
 - Italy†
 - Japan*
 - Mexico*
 - Monaco
 - Norway*
 - Poland‡*
 - Republic of Korea*
 - Spain*
 - Turkey†
 - United States of America*
 - WIPO
- Depositing Office for Hague international applications

www.wipo.int/das/en/participating_offices/

Please send questions to the DesignDay@uspto.gov mailbox.

Country / Organization	Name	Depositing office	Accessing office
Australia	IP Australia	Patent applications PCT international applications filed with the office as a PCT receiving office	Patent applications
Brazil	National Institute of Industrial Property	Patent applications PCT international applications filed with the office as a PCT receiving office	Patent applications
Canada	Canadian Intellectual Property Office	Industrial design applications	Industrial design applications
Chile	National Institute of Industrial Property	Industrial design applications Patent applications PCT international applications filed with the office as a PCT receiving office Utility model applications	Patent applications

National industrial design applications

† Depositing Office only

‡ Accessing Office only

*** Accessing Office for Hague international applications**

ID5 – Industrial Design Forum

Please send questions to the DesignDay@uspto.gov mailbox.



ID5

- A key mechanism for implementing global best practices benefiting U.S. innovative design applicants by effectively and efficiently protecting their designs around the world
 - Helping ensure effective protection for industrial designs in all technologies
 - Furthering consistency in design registration/examination policies and practices
 - Focusing global efforts to identify the needs of the design community through stakeholder outreach and information sharing

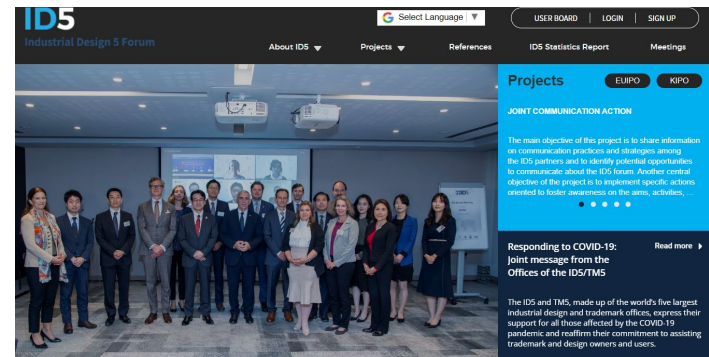

Please send questions to the DesignDay@uspto.gov mailbox.

ID5

- Established in 2015, ID5 is a framework for cooperation among the 5 largest IP offices for industrial designs
 - Intended to improve industrial design systems through greater awareness, improved work efficiency, increased quality, and user-friendliness
- Reference materials for applicants, recommended design practices, electronic exchange, etc.
 - Available at <http://id-five.org/>

Please send questions to the DesignDay@uspto.gov mailbox.



ID5 - Projects

- Active projects
 - Development of an e-learning platform
 - Informative user guide for the view and drawing requirements
 - Exchange of information regarding new technologies
 - WIPO DAS quick reference guide
 - Focus on designs and practices in light of the metaverse
 - Study on indications of registered/patented designs
 - Assessment on the scope of design protection

Please send questions to the DesignDay@uspto.gov mailbox.



Thank you

Courtney Stopp
Office of Policy and International Affairs - USPTO
Courtney.stopp@uspto.gov

Please send questions to the DesignDay@uspto.gov mailbox.





Prosecuting Design vs. Utility Applications

May 4, 2023

Please send questions to the DesignDay@uspto.gov mailbox.



How is the design patent practice different than the utility patent practice?

First Office Allowance

Patent Term

Priority

Inventorship

Publication

Functionality

Claiming

Obviousness

IDS practice

Continued Prosecution

Reissue

Fees

Please send questions to the DesignDay@uspto.gov mailbox.

US design patents

- Most issue on first action
 - Very different interactions with examiners for the most part
- Short pendency
- Shorter term – 15 years from grant vs. 20 years from filing

Please send questions to the DesignDay@uspto.gov mailbox.



The basics

35 U.S.C. 171 Patents for designs.

- Whoever invents any new, original and ornamental design for an article of manufacture may obtain a patent therefor, subject to the conditions and requirements of this title.
- The provisions of this title relating to patents for inventions shall apply to patents for designs, except as otherwise provided

Please send questions to the DesignDay@uspto.gov mailbox.



The basics

- MPEP Chapter 1500
- Different Rules for the Specification
- Different Rules for Amendments

Please send questions to the DesignDay@uspto.gov mailbox.



Priority

35 U.S.C. 172 Right of priority.

- The right of priority provided for by subsections (a) through (d) of section 119 of this title and the time specified in section 102(d) shall be six months in the case of designs.
- The right of priority provided for by section 119(e) of this title shall not apply to designs.
- Grace period foreign

Please send questions to the DesignDay@uspto.gov mailbox.



Priority

- 35 U.S.C. 120 Benefit of earlier filing date in the United States.
- A design patent can be a continuation or a divisional of a prior application, the prior application can be either a design or a utility application (including off a PCT/US National Stage)
- A design patent application probably cannot effectively be a continuation in part

Please send questions to the DesignDay@uspto.gov mailbox.



Munchkin, Inc. v Luv N' Care, Ltd

- D617,465, IPR2013-0072
- Application 29/292,909 filed 10/31/2007
- The '465 patent claims the benefit of application 10/536,106 which is the national stage of PCT/US03/24400 filed 8/5/2003 published as US2007/0221604 (Hakim '604)

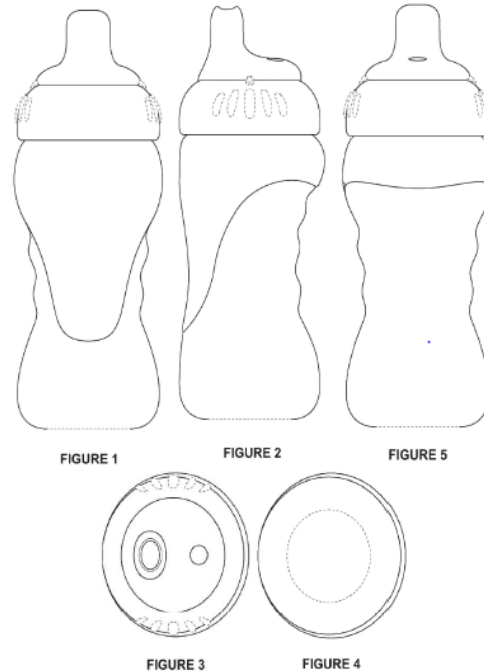

Please send questions to the DesignDay@uspto.gov mailbox.

Munchkin, Inc. v Luv N' Care, Ltd

- Entitled to claim benefit?

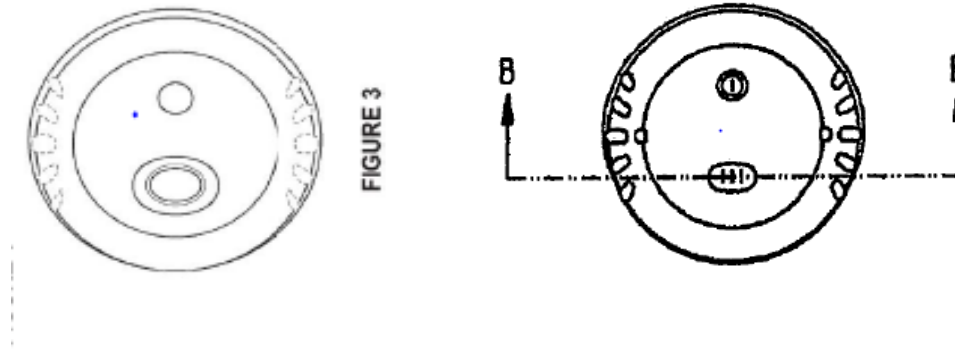

- For example, the '106 Application, which shows a racetrack-shaped spout tip, does not disclose the claimed oval-shaped spout tip of the '465 Patent. Also, the '106 Application, which shows slits in the openings of the spout tip and vent, does not disclose the broader design of the '465 Patent, which lacks any such slits.

Please send questions to the DesignDay@uspto.gov mailbox.

Munchkin, Inc. v Luv N' Care, Ltd

- Obvious over Hakim '604

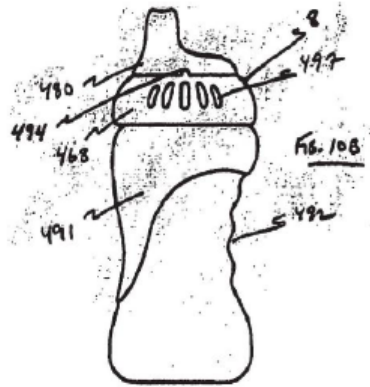

Please send questions to the DesignDay@uspto.gov mailbox.

Munchkin, Inc. v Luv N' Care, Ltd

- US 6,994,225 to Hakim (Hakim '225)

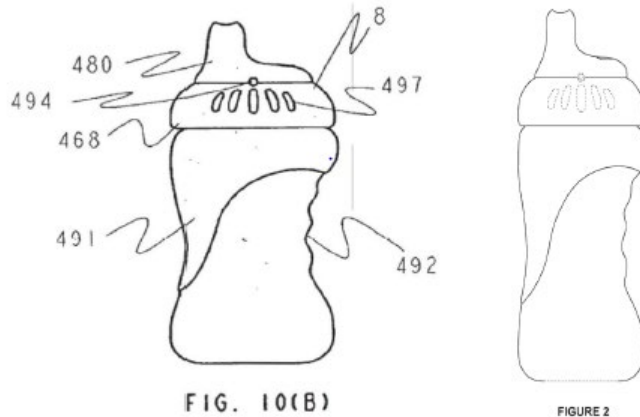

Please send questions to the DesignDay@uspto.gov mailbox.

Designer inventors

- Anyone who contributed to the ornamental appearance of the article is one of the inventors
- The inventor list for the design may be different than for a related utility patent
- Duty of disclosure applies, but remember you only care about what LOOKS like the claimed item, not what it does

Please send questions to the DesignDay@uspto.gov mailbox.



Publication

- Utility applications are automatically published 18 months after the earliest filing date (see 35 U.S.C. 122, MPEP 1120), unless:
 - Expressly abandoned prior to publication
 - National security or subject to secrecy
 - Nonpublication request in compliance with 37 CFR 1.213(a)
- Design applications are not published prior to grant
 - Expedited prosecution procedures are available if sooner publication via grant of the design is desired.
 - Jurisdictions outside of US allow for publications much sooner than in US

Please send questions to the DesignDay@uspto.gov mailbox.



Functionality doctrine

- Utility patent must have utility vs. abstract
- Design patent must be not be solely functional
- If you have both on the same article, be careful what you include in the utility patent
- This goes double if you might ever want a trade dress

Please send questions to the DesignDay@uspto.gov mailbox.

Figures – claiming and limitations

Design patents

- The article of manufacture depicted in the Figures can define the scope of the claim. *Curver Luxembourg, SARL, v. Home Expressions, Inc.*,
- Notwithstanding, the words in the title and claims in the written portion can further limit the scope
 - Limit prior art in procurement of the design. *In re SurgiSil, L.L.P.*, 14 F. 4th 1380 (Fed. Cir. 2021)
 - Limit targets in enforcement of the design. *Curver Luxembourg, SARL, v. Home Expressions, Inc.*, 938 F.3d 1334 (Fed. Cir. 2019)

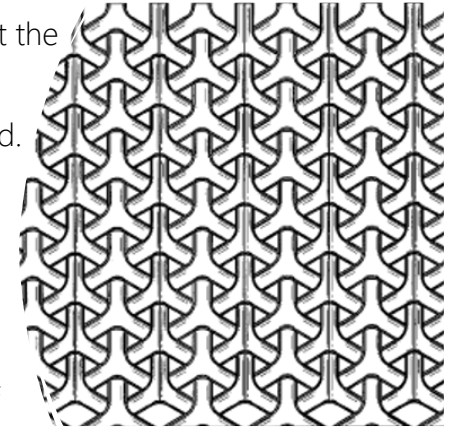

Utility patents

- Figures are part of the specification and can be useful for written description support of claims, enablement and best mode support, when each feature of the figures are not explicitly described
 - Increase claiming opportunities in patent procurement
 - Compared with Figures in Design Patents – limited to what is shown or where a boundary line would have been recognized by a designer of skill but is not claimed. *In re Owens*, Appeal No. 2012-1261 (Fed. Cir. Mar. 26, 2013)
- Claims with means plus function limitations may be likely defined by what is shown in the Figures

In re SurgiSil, LLC

- 14 F.4th 1380 (2021) October 4, 2021
- Question: Is prior art limited to analogous art for novelty?
- Claim was to a lip implant
- Prior art was an art tool
- Board "it is appropriate to ignore the identification of the article of manufacture in the claim language." "whether a reference is analogous art is irrelevant to whether that reference anticipates." Id. (quoting [In re Schreiber, 128 F.3d 1473, 1478 \(Fed. Cir. 1382*1382 1997\)](#))

Please send questions to the DesignDay@uspto.gov mailbox.

In re SurgiSil

- Drawing of application

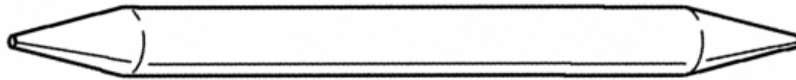

- Examiner's prior art



Please send questions to the DesignDay@uspto.gov mailbox.

In re SurgiSil

- “Federal Circuit: “Here, the claim identifies a lip implant. The claim language recites “a lip implant,” and the Board found that the application's figure depicts a lip implant. As such, the claim is limited to lip implants and does not cover other articles of manufacture. There is no dispute that Blick discloses an art tool rather than a lip implant. The Board's anticipation finding therefore rests on an erroneous interpretation of the claim's scope.”
- “We have considered the cases cited by the Director, and they do not support the Director's position. Because the Board erred in holding that the claimed design is not limited to lip implants, we reverse.”

Please send questions to the DesignDay@uspto.gov mailbox.



Obviousness in design patents

- “the ultimate inquiry under section 103 is whether the claimed design would have been obvious to a designer of ordinary skill who designs articles of the type involved.” *Durling v. Spectrum Furniture Co.*, 101 F.3d 100, 103 (Fed. Cir. 1996) (citing *In re Rosen*, 673 F.2d 388, 390 (CCPA 1982))
- “whether one of ordinary skill would have combined teachings of the prior art to create the same overall visual appearance as the claimed design,” *id.* (citing *In re Borden*, 90 F.3d 1570, 1574 (Fed Cir 1996))

Please send questions to the DesignDay@uspto.gov mailbox.



Obviousness in design patents

- “one must find a single reference, ‘a something in existence, the design characteristics of which are basically the same as the claimed design.’” Id. (quoting *In re Rosen*, 673 F.2d at 391)
- Once the primary reference is found, other “secondary” references “may be used to modify it to create a design that has the same overall visual appearance as the claimed design.” Id.

Please send questions to the DesignDay@uspto.gov mailbox.



Obviousness in design patents

Further, these secondary references must be “so related [to the primary reference] that the appearance of certain ornamental features in one would suggest the application of those features to the other.” *Id.* (quoting *In re Borden*, 90 F.3d at 1575)

Please send questions to the DesignDay@uspto.gov mailbox.



Obviousness in design patents

In making this determination, a primary reference must first be located. The trial court must: “(1) discern the correct visual impression created by the patented design as a whole; and (2) determine whether there is a single reference that creates ‘basically the same’ visual impression.” *Durling v. Spectrum Furniture Co.*, 101 F.3d 100, 103 (Fed. Cir. 1996). “A finding of obviousness cannot be based on selecting features from the prior art and assembling them to form an article similar in appearance to the claimed design.” *In re Borden*, 90 F.3d 1570, 1574 (Fed. Cir. 1996)

Please send questions to the DesignDay@uspto.gov mailbox.



Vanguard Identification Sys, Inc. v. Bank of America Appeal No. 2009-002973 (BPAI July 31, 2009)

- Applying the foregoing principles, the BPAI has held that a credit card that includes an aperture is non-obvious over prior art designs that did not include an aperture. *Id.* at 11. Figure 1 of U.S. Des. Pat. No. D467,247 ("'247 Patent"), the patent at issue in Vanguard, is reproduced below:

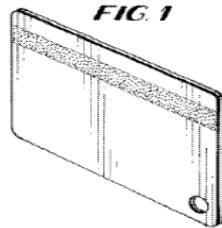

- The '247 Patent contained a total of four embodiments with the circular aperture located in different locations on the data card

Please send questions to the DesignDay@uspto.gov mailbox.

- The prior art cited against the '247 Patent included U.S. Pat. No. 6,196,594 to Keller ("Keller")

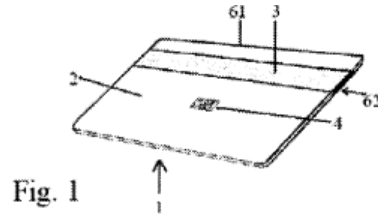

- The prior art cited against the '247 Patent also included U.S. Pat. No. 4,711,996 to Drexler ("Drexler")

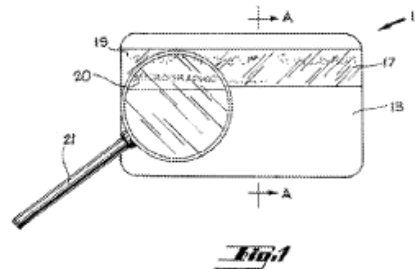

Please send questions to the DesignDay@uspto.gov mailbox.

IDS practice

- More art outside of patent literature
- Send in your client's catalogs and competitors catalogs, probably more relevant than most patents
- The examiner look for Social media posts, talk to your clients about what posting they have done
- If your client made public disclosures on social media before the filing date, file screens shots and include and affidavit that it is Applicant's device to avoid a 102 rejection

Please send questions to the DesignDay@uspto.gov mailbox.



IDS example

US006544094B1

(12) **United States Patent**
Maddocks et al.

(10) **Patent No.:** US 6,544,094 B1
(45) **Date of Patent:** Apr. 8, 2003

- (54) **TOY WITH SKIN COUPLED TO MOVABLE PART**
- (75) **Inventors:** Richard Maddocks, Barrington, RI (US); Peter Hall, Norfolk (GB); Adam B. Craft, Mansfield, MA (US); Jeffrey H. Olson, Pawtucket, RI (US)
- (73) **Assignee:** Hasbro, Inc., Pawtucket, RI (US)
- (*) **Notice:** Subject to any disclaimer, the term of this patent is extended or adjusted under 35 U.S.C. 154(b) by 0 days.

4,451,911 A	5/1984	Klose et al.
4,516,950 A	5/1985	Berman et al.
4,591,248 A	5/1986	Freeman
4,605,380 A *	8/1986	Camm et al.
4,654,659 A	3/1987	Kubo
4,659,919 A	4/1987	Price
4,665,640 A	5/1987	Forsse et al.
4,673,371 A	6/1987	Furukawa
4,675,519 A	6/1987	Price
4,696,653 A	9/1987	McKeefery
4,740,186 A	4/1988	Sirota
4,754,133 A		
4,799,171 A		
4,802,879 A		
4,809,335 A		

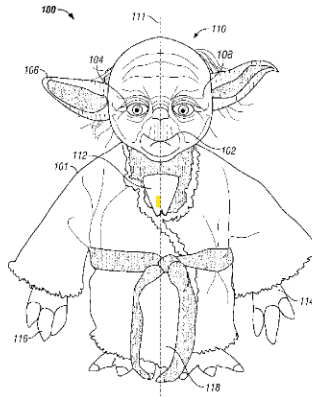

United States Patent [19]
Lucas, Jr. et al.

[11] **Des. 265,754**
[45] ** **Aug. 10, 1982**

- [54] **TOY FIGURE**
- [75] **Inventors:** George W. Lucas, Jr., San Anselmo; Ralph McQuarrie, Berkeley; Joseph E. Johnston, Fairfax, all of Calif.; Stuart Freeborn, Esher, England
- [73] **Assignee:** Lucasfilm, Ltd., San Rafael, Calif.
- [**] **Term:** 14 Years
- [21] **Appl. No.:** 141,597
- [22] **Filed:** Apr. 18, 1980

OTHER PUBLICATIONS

Sears 1978 Xmas Book, p. 574, Illustration No. 13, left figure, Jawa.

Primary Examiner—Melvin B. Feifer
Attorney, Agent, or Firm—Townsend and Townsend

[57] **CLAIM**

The ornamental design for a toy figure, substantially as shown.

- [51] **Int. Cl.:** D21-01
- [52] **U.S. Cl.:** D21/180; D21/171; D21/186
- [58] **Field of Search:** D21/180, 177, 166, 171, D21/186; D11/160

DESCRIPTION

FIG. 1 is a perspective front view of a toy figure illustrating the new design.

FIG. 2 is a perspective rear view thereof.

FIG. 3 is a front elevational view thereof.

FIG. 4 is a left side elevational view thereof.

FIG. 5 is a right side elevational view thereof.

FIG. 6 is a rear elevational view thereof.

FIG. 7 is a top plan view thereof.

FIG. 8 is a bottom view thereof.

- [56] **References Cited**
- U.S. PATENT DOCUMENTS**
- D. 164,463 9/1951 White D21/186

Please send questions to the DesignDay@uspto.gov mailbox.

Cited in design patent

Sept. 4, 1951

C. R. WHITE

Des. 164,463

TOY FIGURINE OR SIMILAR ARTICLE

Filed Nov. 9, 1950

Fig. 1.



Fig. 2.



Please send questions to the DesignDay@uspto.gov mailbox.

Cited in the utility patent

U.S. Patent Feb. 10, 1981

Sheet 1 of 2

4,249,338

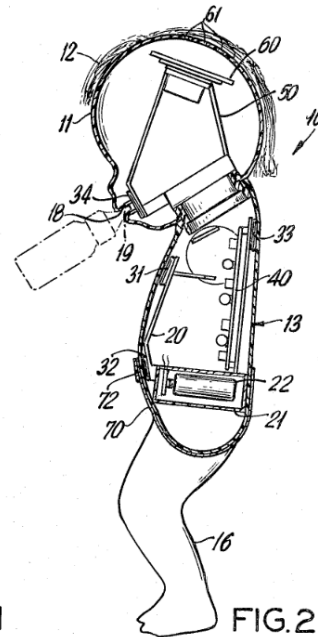
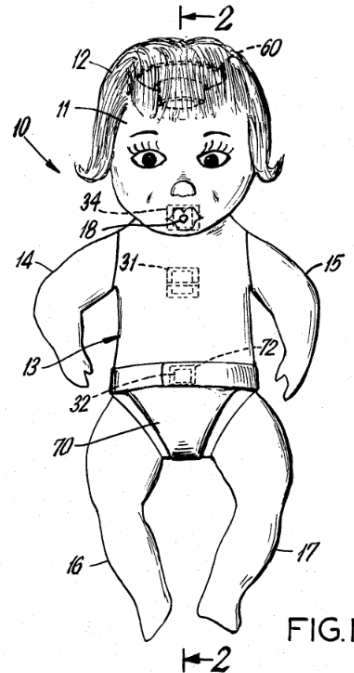

Please send questions to the DesignDay@uspto.gov mailbox.

Cited in the utility patent

United States Patent [19]
Freeman

[11] **Patent Number:** **4,591,248**
[45] **Date of Patent:** **May 27, 1986**

[54] **DYNAMIC AUDIENCE RESPONSIVE
MOVIE SYSTEM**
[76] **Inventor:** **Michael J. Freeman, 31 Cornwall
La., Sands Point, N.Y. 11050**
[21] **Appl. No.:** **489,170**

Primary Examiner—Monroe H. Hayes
*Attorney, Agent, or Firm—Stiefel, Gross, Kurland &
Pavane*

[57] **ABSTRACT**
A movie changeover system (20,200,2004,400) capable

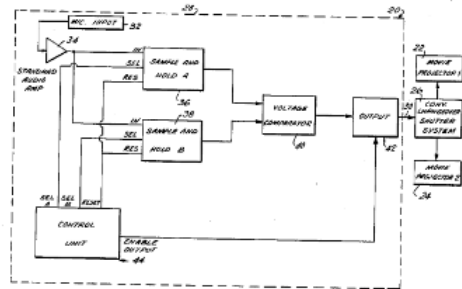

Please send questions to the DesignDay@uspto.gov mailbox.

IDS takeaways

IDS citations impact examination efficiency

- The number of citations
- Consider the relevancy to the claimed design

Please send questions to the DesignDay@uspto.gov mailbox.



Continuing prosecution

- You cannot file an RCE in a design application see MPEP 201.06(d)
- Which means you cannot use QPIDS: see MPEP 706.07(h)
- You have to file a CPA (continuing prosecution application)
- If it is Hague application, you cannot file a CPA, you must file a continuation application

Please send questions to the DesignDay@uspto.gov mailbox.



Drafting

- Sometimes a narrow patent is a good thing
- Harder to invalidate
- Easy to enforce

Please send questions to the DesignDay@uspto.gov mailbox.





US00D487014S

(12) **United States Design Patent** (10) **Patent No. US D487,014 S**
(45) **Date of Patent: ** *Feb. 24, 2004**

(54) **CURVED HEART SHAPED CARABINER**

Primary Examiner—Doris V. Coles
Assistant Examiner—Elizabeth A. Albert
(74) *Attorney, Agent, or Firm*—Rick Martin; Patent Law Offices of Rick Martin P.C.

(75) **Inventor: Brian James Kelleghan**, Longmont, CO (US)

(73) **Assignee: Bison Designs, L.L.C.**, Longmont, CO (US)

(57) **CLAIM**

The ornamental design for a curved heart shaped carabiner, as shown and described.

(*) **Notice:** This patent is subject to a terminal disclaimer.

(**) **Term:** 14 Years

(21) **Appl. No.:** 29/173,268

(22) **Filed:** Dec. 23, 2002

(51) **LOC (7) Cl.:** 08-05

(52) **U.S. Cl.:** D8/356

(58) **Field of Search:** D1/104, 120, 126; D8/333, 356, 367, 370, 383; D11/103, 133, 157, 200, 211; 24/583.1, 587.1, 588.1, 588.11, 594.11, 598.1, 598.2, 598.3, 598.4, 599.1, 599.2, 599.3, 599.5, 599.6, 599.7, 599.8, 599.9, 600.1, 600.3, 600.9, 601.5; 248/231.9, 231.91, 925; 294/82.17, 82.19, 82.2; 428/7, 13, 28

(56) **References Cited**

U.S. PATENT DOCUMENTS

D33,634 S	* 12/1900	Lord, Jr.	D8/38
D302,831 S	* 8/1989	Lau	D19/65
5,329,675 A	7/1994	McLean et al.	
5,390,510 A	* 2/1995	Irino-Cloonan	63/1.15
D447,932 S	* 9/2001	Kelleghan	D8/356
D454,054 S	3/2002	Kelleghan	
D465,146 S	* 11/2002	Kopplin	D8/356

* cited by examiner

1 Claim, 2 Drawing Sheets

DESCRIPTION

FIG. 1 is a top or bottom plan view, which are mirror images, of my new design for a curved heart shaped carabiner.

FIG. 2 is a right elevation view of the carabiner shown in FIG. 1.

FIG. 3 is a left side elevation view of the carabiner shown in FIG. 1.

FIG. 4 is a front side elevation view of the carabiner shown in FIG. 1.

FIG. 5 is a rear side elevation view of the carabiner shown in FIG. 1.

FIG. 6 is a top perspective view of the carabiner shown in FIG. 1.

FIG. 7 is a top or bottom plan view, which are mirror images, of an alternate embodiment of my new design for a curved heart shaped carabiner.

FIG. 8 is a right elevation view of the carabiner shown in FIG. 7.

FIG. 9 is a left elevation view of the carabiner shown in FIG. 7.

FIG. 10 is a front elevation view of the carabiner shown in FIG. 7.

FIG. 11 is a rear elevation view of the carabiner shown in FIG. 7; and,

FIG. 12 is a top perspective view of the carabiner shown in FIG. 7.

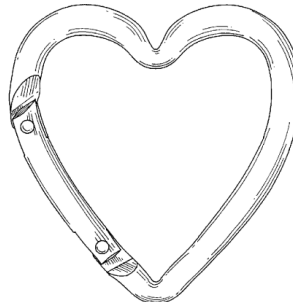

Please send questions to the DesignDay@uspto.gov mailbox.





US00D466793S

(12) **United States Design Patent** (10) **Patent No.:** **US D466,793 S**
Kelleghan (45) **Date of Patent:** **** Dec. 10, 2002**

(54) **WIDE ANGLE STAR SHAPED CARABINER**

(75) Inventor: **Brian James Kelleghan**, Longmont, CO (US)

(73) Assignee: **Bison Designs, LLC**, Longmont, CO (US)

(**) Term: **14 Years**

(21) Appl. No.: **29/158,809**

(22) Filed: **Apr. 10, 2002**

(51) **LOC (7) Cl.** **08-05**

(52) **U.S. Cl.** **D8/356**

(58) **Field of Search** D8/333, 356, 367, D8/370, 382; D11/48, 99; 24/115 R, 582.13, 583.11, 583.11, 587.1, 588.11, 594.11, 598.1, 598.2, 599.1, 599.2, 599.5, 599.6, 599.7, 599.8, 599.9, 600.1, 600.3, 600.9; 248/925; 294/82.1, 82.14; 411/400; D19/65; D1/106

(56) **References Cited**

U.S. PATENT DOCUMENTS

D37,049 S	*	7/1904 Forster	D8/356
2,152,075 A	*	3/1939 Melech	D8/370
D304,205 S	*	10/1989 Lorber et al.	D19/65
5,329,675 A	*	7/1994 McLean et al.	
5,463,798 A	*	11/1995 Wurzer	
D377,196 S	*	1/1997 Sheppard, Jr.	D8/370
5,878,834 A	*	3/1999 Brainerd et al.	
D426,670 S	*	7/2000 Tsai	D8/370
D454,054 S	*	10/2000 Kelleghan	
D456,693 S	*	2/2001 Kelleghan	
D441,638 S	*	5/2001 Kelleghan	
D447,680 S	*	9/2001 Kelleghan	
D447,932 S	*	9/2001 Kelleghan	
D447,933 S	*	9/2001 Kelleghan	

OTHER PUBLICATIONS

U.S. patent application Ser. No. 29/127,750, Brian James Kelleghan, filed Aug. 11, 2000.

U.S. patent application Ser. No. 29/128,297, Brian James Kelleghan, filed Aug. 22, 2000.

U.S. patent application Ser. No. 29/135,353, Brian James Kelleghan, filed Jan. 10, 2001.

U.S. patent application Ser. No. 29/154,974, Brian James Kelleghan, filed Jul. 1, 2002.

* cited by examiner

Primary Examiner—Doris V. Coles

Assistant Examiner—Elizabeth A. Albert

(74) *Attorney, Agent, or Firm*—Margaret Polson; Patent Law Offices of Rick Martin, P.C.

(57) **CLAIM**

The ornamental design for a wide angle star shaped carabiner, as shown and described.

DESCRIPTION

FIG. 1 is a top plan view of my new design for a wide angle star shaped carabiner, it being understood that the bottom view is identical;

FIG. 2 is a front elevational view of the wide angle star shaped carabiner shown in FIG. 1;

FIG. 3 is a rear elevational view of the wide angle star shaped carabiner shown in FIG. 1;

FIG. 4 is a right side elevational view of the wide angle star shaped carabiner shown in FIG. 1;

FIG. 5 is a left side elevational view of the wide angle star shaped carabiner shown in FIG. 1; and,

FIG. 6 is a top perspective view of the wide angle star shaped carabiner shown in FIG. 1.

1 Claim, 1 Drawing Sheet

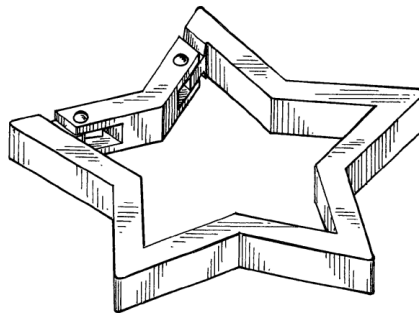

Please send questions to the DesignDay@uspto.gov mailbox.





US000454054S

(12) **United States Design Patent** (10) **Patent No.: US D454,054 S**
Kellegan (45) **Date of Patent: ** Mar. 5, 2002**

(54) **CIRCLE CARABINER**
 (75) Inventor: **Brian James Kellegan**, Longmont, CO (US)
 (73) Assignee: **Bison Designs, L.L.C.**, Longmont, CO (US)
 (**) Term: **14 Years**
 (21) Appl. No.: **29/131,501**
 (22) Filed: **Oct. 23, 2000**
 (51) **LOC (7) Cl.** **08-05**
 (52) **U.S. Cl.** **D8/356**
 (58) **Field of Search** D8/356, 367, 368, D8/349, 382, 343, 370, 333; D19/65, 86; 24/573.5, 599.1, 552; 411/400, 401; 294/82.1, 82.14; 248/925

(56) **References Cited**
 U.S. PATENT DOCUMENTS
 D32,654 S * 5/1900 Kroder D8/367

1,187,289 A * 6/1916 Ebersole 24/598.3
 1,399,207 A * 12/1921 Goozney 24/598.3
 D317,177 S * 5/1991 Wandenberg-Boschetti . D19/65
 D430,304 S * 8/2000 Berracasa D19/32

* cited by examiner
Primary Examiner—Pamela Burgess
 (74) *Attorney, Agent, or Firm*—Rick Martin; Patent Law Offices of Rick Martin

CLAIM
 (57)
 The ornamental design for a circle carabiner, as shown and described.

DESCRIPTION
 FIG. 1 is a top plan view of a circle carabiner showing my new design, the undisclosed bottom being a mirror image; FIG. 2 is a front elevational view thereof; FIG. 3 is a rear elevational view thereof; FIG. 4 is a left side elevational view thereof; FIG. 5 is a right side elevational view thereof; and, FIG. 6 is a top perspective view thereof.

1 Claim, 1 Drawing Sheet

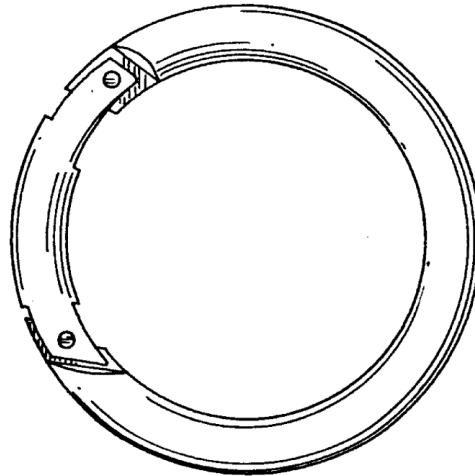

Please send questions to the DesignDay@uspto.gov mailbox.



Drafting best practices

- The conventional approach of having 6 views and at least one perspective is a good starting point.
 - In some situations, additional views may be needed for a clear disclosure of the invention
- Surface shading is not required, but it is often helpful. Surface shading:
 - Shows surface contours and character (e.g. reflective surfaces)
 - Clarifies openings on surfaces
 - Clarifies scope (i.e. where does the claim start and stop)
- Clear line quality

Please send questions to the DesignDay@uspto.gov mailbox.

Reissue

Please send questions to the DesignDay@uspto.gov mailbox.



Reissue - basics

- A **reissue application** is an application that is filed to correct an error in a patent that has not expired. See [35 USC §251](#). The error must have been made without any deceptive intention and must be an error that renders the patent wholly or partly inoperative or invalid. See, for example, [MPEP 1410, 1410.01, and 1411](#)

Requirements:

- A defective specification or drawing, or by reason of the patentee claiming more or less than he had a right to claim in the patent
- A surrender of the original patent
- A payment of the fee
- No new matter shall be introduced into the application for reissue

Please send questions to the DesignDay@uspto.gov mailbox.



Reissue – design patent exceptions

There are a few procedures specific to design reissue applications (MPEP 1457).

1. Expedited Examination (37 CFR 1.155, MPEP 1504.30)
2. Design Reissue Fee (no excess claim fees)
3. Multiple Design Reissue Applications

A. The error - A reissue design application claiming both the entire article and the patentably distinct subcombination or segregable part would be proper under [35 U.S.C. 251](#), if such a reissue application is filed within two years of the issuance of the design patent, because it is considered a broadening of the scope of the patent claim.

4. No conversion to Utility Patent or vice versa

Please send questions to the DesignDay@uspto.gov mailbox.



Reissue – typical process

Applicant action

USPTO action

Original Design Patent with A

File Design Reissue with A + A-B

File Request for Exp. Examination

USPTO – Rejection b/c No Error

File Response to Office Action

File Divisional Reissue Patent App with A-B

File Request to Suspend Action 1.103

USPTO Examines Div. Reissue Pat. App with A-B, and if Allowable

File 1.183 Petition Requesting Waiver of 1.153

Request of Merger of A-B with Org. Reissue of A

USPTO issues Design Reissue Patent with A + A- B

Reissue – An Example

US D706,448
Iss:
03JUN2014
Handrail

(12) **United States Design Patent**
Laitta et al.

(10) Patent No.: **US D706,448 S**
(45) Date of Patent: **Jun. 3, 2014**

(54) **HANDBRAIL**

(71) Applicant: **S.R. Smith, LLC**, Canby, OR (US)

(72) Inventor: **Richard F. Laitta**, Lake Oswego, OR (US); **Darrin Johnson**, Portland, TN (US)

(73) Assignee: **S. R. Smith, LLC**, Canby, OR (US)

(*) Term: **14 Years**

(21) Appl. No.: **29043,445**

(22) Filed: **Jan. 17, 2013**

(51) **IPC CL** (Int. Cl.): **25-02**

(52) **U.S. CL** (Class. Code): **D2541.1**

(56) **Field of Classification Search**
USPC: D2541.1; 2509; 63; 64; 4511; 506
See application file for complete search history.

(57) **References Cited**

U.S. PATENT DOCUMENTS

4,073,173 A * 3/1976 Bonaldi 02/169A
4,487,333 A * 12/1989 DeVine et al. 4/377A
5,727,204 A * 3/1998 Craig et al. 4/409

(10) Patent No.: **US D706,448 S**
(45) Date of Patent: **Jun. 3, 2014**

(54) **HANDBRAIL**

(71) Applicant: **S.R. Smith, LLC**, Canby, OR (US)

(72) Inventor: **Richard F. Laitta**, Lake Oswego, OR (US); **Darrin Johnson**, Portland, TN (US)

(73) Assignee: **S. R. Smith, LLC**, Canby, OR (US)

(*) Term: **14 Years**

(21) Appl. No.: **29043,445**

(22) Filed: **Jan. 17, 2013**

(51) **IPC CL** (Int. Cl.): **25-02**

(52) **U.S. CL** (Class. Code): **D2541.1**

(56) **Field of Classification Search**
USPC: D2541.1; 2509; 63; 64; 4511; 506
See application file for complete search history.

(57) **References Cited**

U.S. PATENT DOCUMENTS

4,073,173 A * 3/1976 Bonaldi 02/169A
4,487,333 A * 12/1989 DeVine et al. 4/377A
5,727,204 A * 3/1998 Craig et al. 4/409

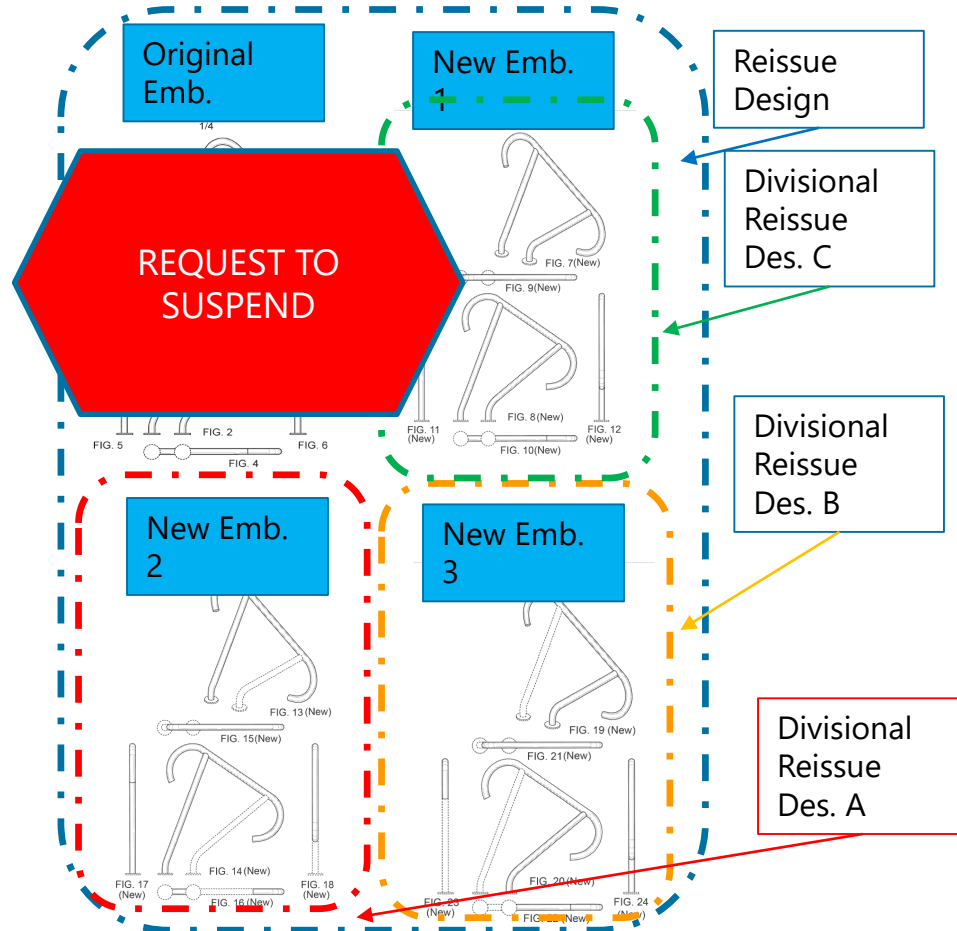
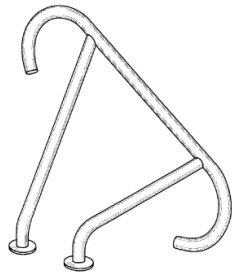

Reissue – an example

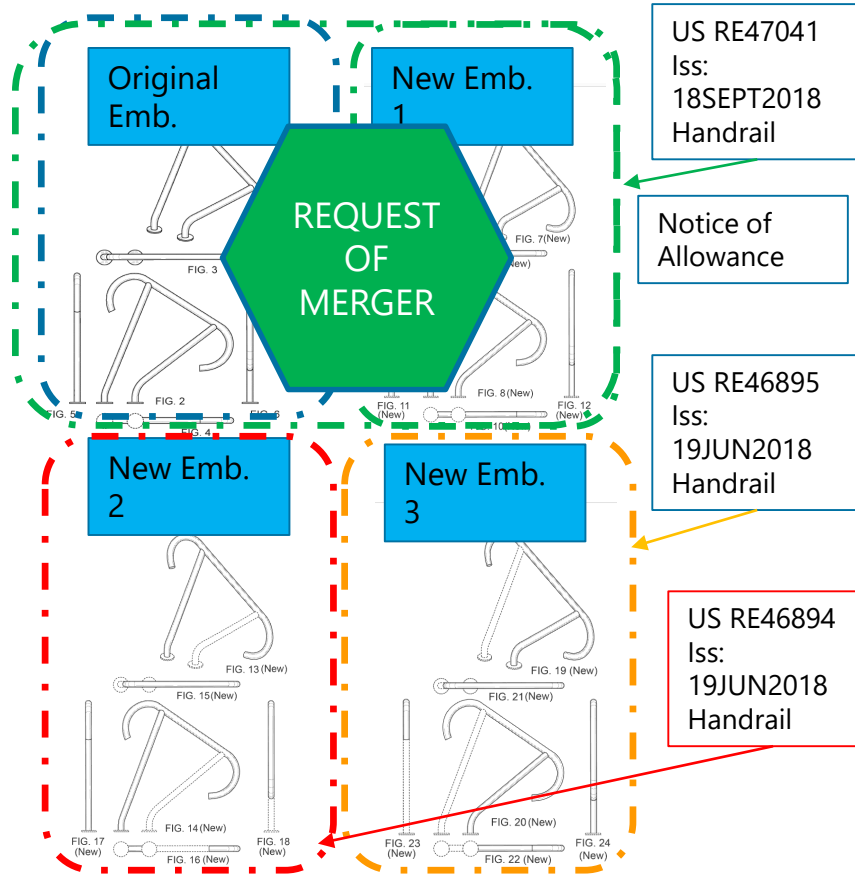

US RE47041
Iss:
18SEPT2018
Handrail

Notice of
Allowance

US RE46895
Iss:
19JUN2018
Handrail

US RE46894
Iss:
19JUN2018
Handrail



US00RE47041E

(10) **United States**
(12) **Reissued Patent**
Laitta et al.

(10) **Patent Number:** US RE47,041 E
(45) **Date of Reissued Patent:** Sep. 18, 2018

(54) **HANDRAIL** (74) Attorney, Agent, or Firm—Steel Pipes LLP

(71) Applicant: S.R. Smith, LLC, Canby, OR (US)

(72) Inventors: Richard P. Laitta, Lake Oswego, OR (US); Darrin Johnson, Portland, TN (US)

(73) Assignee: S.R. Smith, LLC, Canby, OR (US)

(21) Appl. No.: 29566,803

(22) Filed: Jun. 2, 2016

Related U.S. Patent Documents

(64) Patent No.: Des. 706,448
Issued: Jun. 3, 2014
App. No.: 29443,445
Filed: Jan. 17, 2013

(51) LOC (11) CL: 25-02

(52) U.S. CL: D25041.1

(58) **Field of Classification Search**
USPC: D2578.1, 41.1; D8700, 300, 307, 310, D8311, 313-317; D23504 (Continued)

(56) **References Cited**
U.S. PATENT DOCUMENTS
D984355 * * 3/10/13 Pinar D21414
4,077,373 A * 3/1978 Rozanski S2109.8 (Continued)

OTHER PUBLICATIONS

Stainless Handrails (Australia) photo of stainless metal handrail <http://www.stainless.com.au/gallery/2014-2-stainless-metal-handrails-visited-May-16-2016>

(Continued)

Primary Examiner—Darlington Ly

(74) Attorney, Agent, or Firm—Steel Pipes LLP

(57) **CLAIM**
We claim the ornamental design for a handrail, as shown and described.

DESCRIPTION

This application is a broadening reissue of U.S. Pat. No. D706,448 which issued Jun. 3, 2014 from application Ser. No. 29443,445 filed Jan. 17, 2013.

Notice: More than one reissue application has been filed for the reissue of U.S. Pat. No. D706,448. The reissue applications are application Ser. No. 29566,813 (the present application), divisional application Ser. No. 29607,133 filed Jan. 9, 2017, and divisional application Ser. No. 29607,140 filed Jan. 9, 2017.

[FIG. 1 is a perspective view of a handrail.]
[FIG. 2 is a front elevation view of the handrail of FIG. 1. The opposing rear elevation view is a mirror image of the illustrated view.]
[FIG. 3 is a top plan view of the handrail of FIG. 1.]
[FIG. 4 is a bottom plan view of the handrail of FIG. 1.]
[FIG. 5 is a left side elevation view of the handrail of FIG. 1, and]
[FIG. 6 is a right side elevation view of the handrail of FIG. 1.]
[FIG. 7 is a perspective view of a handrail showing our new design.]
[FIG. 8 is a front elevation view of the handrail of FIG. 7. The rear elevation view is a mirror image thereof.]
[FIG. 9 is a top plan view of the handrail of FIG. 7.]
[FIG. 10 is a bottom plan view of the handrail of FIG. 7.]
[FIG. 11 is a left side elevation view of the handrail of FIG. 7, and]
[FIG. 12 is a right side elevation view of the handrail of FIG. 7.]
[In FIG. 4, the portion of the bottom view bounded by the broken lines is for illustrative purposes only and Form] (Continued)



Reissue pitfalls

1. Improper error statements in the reissue oath/declaration
2. Asserted error is not able to be corrected in a reissue
3. Improper broadening reissue after 2 years from issuance of patent
4. Failure to meet the original patent requirement

Please send questions to the DesignDay@uspto.gov mailbox.



Fees

Please send questions to the DesignDay@uspto.gov mailbox.



Fees

Fee	Design (USD)	Utility (USD)
Basic Filing Fee	\$220	\$320
Search Fee	\$160	\$700
Examination Fee	\$640	\$800
CPA	Repeat fees above \$1020	
RCE		\$1360 (1 st Req.) \$2000 (later Reqs.)
Issue Fee	\$740	\$1200
Maintenance Fee	\$0	\$2000 @3.5 yrs. \$3760 @7.5 yrs. \$7700 @11.5 yrs.

Thank you

Margret Polson
Polson IP Law

Daniel Spillman
Eli Lilly and Company

Lakiya Rogers
US Patent and Trademark Office

Please send questions to the DesignDay@uspto.gov mailbox.





A Message from

Derrick Brent

*Deputy Under Secretary of Commerce for Intellectual Property and
Deputy Director of the United States Patent and Trademark Office*

Please send questions to the DesignDay@uspto.gov mailbox.



Droids, stormtrooper, light saber

Des. 265,330

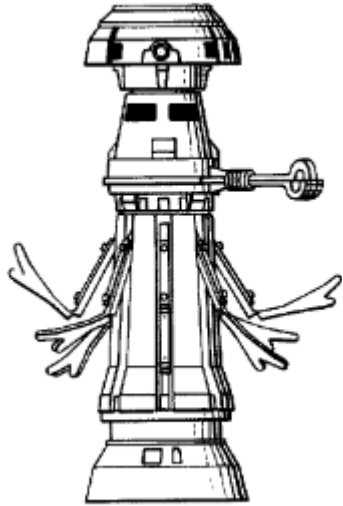

Des. 265,332

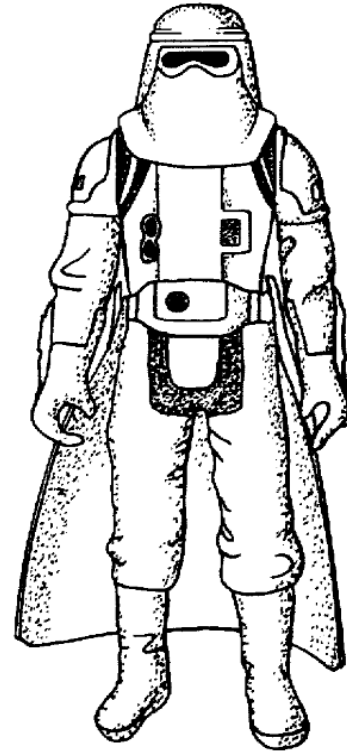

Des. 251,628

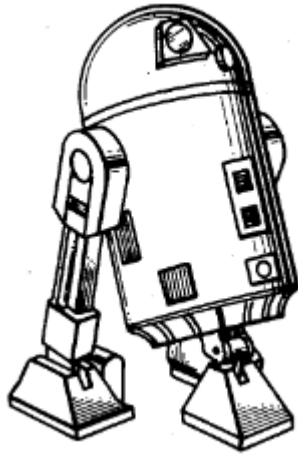

Des. 256,485



Boba Fett, AT-AT Walker, Jabba the Hutt, and Yoda

Des. 264,109

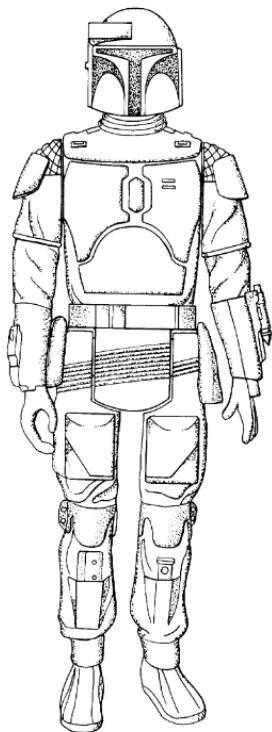

Des. 266,777

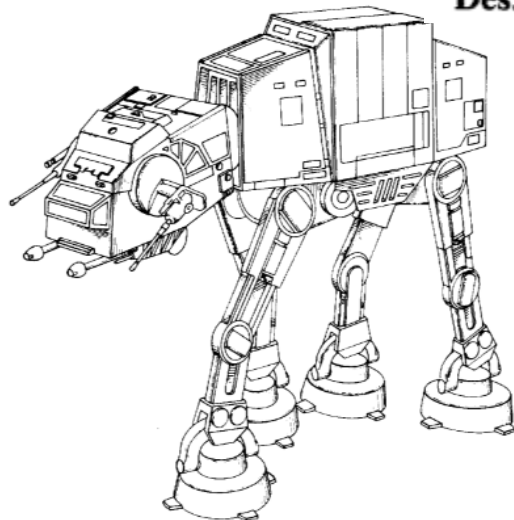

Des. 265,754



Des. 277,211

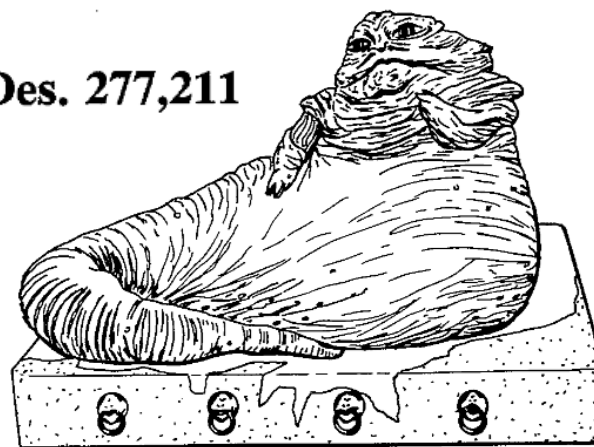

Thank you

Derrick Brent

**Deputy Under Secretary of Commerce for Intellectual Property and
Deputy Director of the United States Patent and Trademark Office**

Please send questions to the DesignDay@uspto.gov mailbox.





Anatomy of a Design Patent Litigation

Elizabeth D. Ferrill, Finnegan LLP

Christopher Carani, McAndrews, Held & Malloy Ltd.

Please send questions to the DesignDay@uspto.gov mailbox.



Life of a Design Patent Litigation

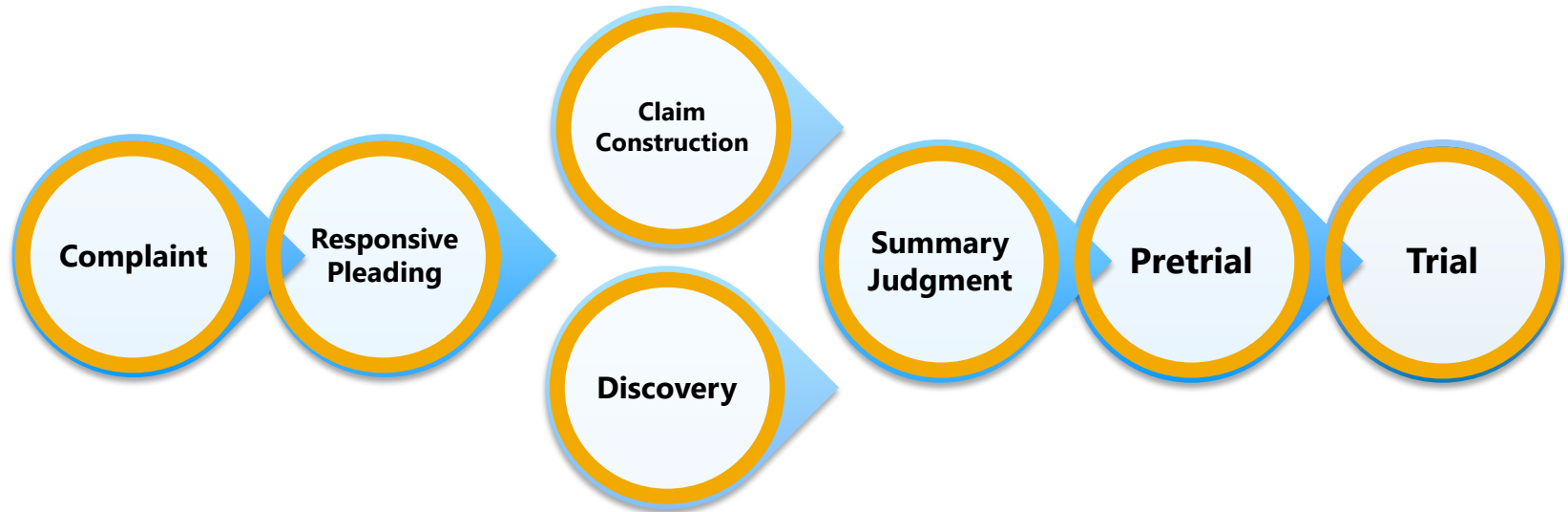

Please send questions to the DesignDay@uspto.gov mailbox.

Design Patent Trial

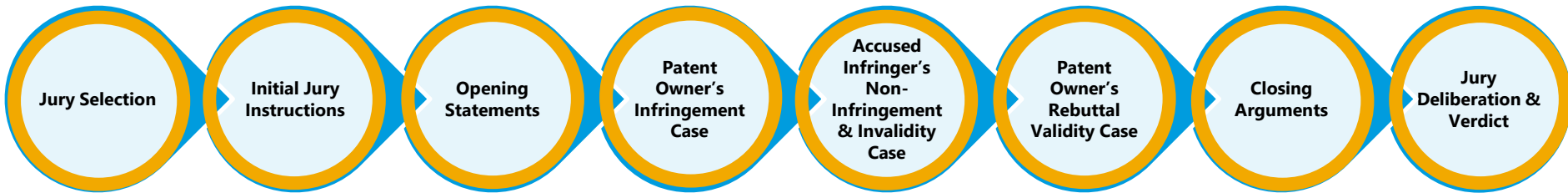

Please send questions to the DesignDay@uspto.gov mailbox.

Thank you

Christopher Carani
Partner
McAndrews, Held & Malloy Ltd.
ccarani@mcandrews-ip.com

Elizabeth D. Ferrill
Partner
Finnegan LLP
elizabeth.ferrill@finnegan.com

Please send questions to the DesignDay@uspto.gov mailbox.





Intersection of Patent, Trademark and Copyright

Damian Porcari, Midwest Regional Office

Please send questions to the DesignDay@uspto.gov mailbox.



Overview

1. Patents
2. Three dimensional Trademarks and Trade Dress
3. Copyright
4. Intersection and Panel Discussion

Please send questions to the DesignDay@uspto.gov mailbox.



Patents

Please send questions to the DesignDay@uspto.gov mailbox.



Requirements for design patents

- Whoever invents any new, original and ornamental design for an article of manufacture may obtain a patent therefor, subject to the conditions and requirements of this title
 - 35 USC 171a
- A design patent protects the way an article looks.
 - The ornamental appearance for an article includes its shape/configuration or surface ornamentation applied to the article, or both

Please send questions to the DesignDay@uspto.gov mailbox.



Patent examination for functionality

- To be patentable, a design must be “primarily ornamental.” “In determining whether a design is *primarily functional* or *primarily ornamental* the claimed design is viewed in its entirety
- To properly reject a claimed design under 35 U.S.C. 171 on the basis of a lack of ornamentality, an examiner must make a prima facie showing that the claimed design lacks ornamentality and provide a sufficient evidentiary basis for factual assumptions relied upon in such showing
- Examples of proper evidentiary basis for a rejection under 35 USC 171 that a claim is lacking in ornamentality would be: (A) common knowledge in the art; (B) the appearance of the design itself; (C) the specification of a related utility patent; or (D) information provided in the specification
 - MPEP 1504.01 (c)

Please send questions to the DesignDay@uspto.gov mailbox.



Overcoming a rejection for lack of ornamentality

- An affidavit or declaration design concerns enhancing the saleable value or increasing demand for the article a concern primarily for the esthetic appearance of the article;
- Advertisements which emphasize the ornamentality;
- Evidence of distinctness from the prior art;
- Evidence of motivating factors behind the creation of the design;
- Possible alternative designs which could have served the same function indicating that the appearance of the claimed design was not purely dictated by function;
- The nature of its visibility at some point between its manufacture or assembly and its ultimate use.

Please send questions to the DesignDay@uspto.gov mailbox.



Application of Carletti, Gasket CCPA (1964)

- The PTAB affirmed the decision of the examiner to reject the claim of a design patent application for a gasket used for 55 gallon drums, which was appealed to the CCPA.
- The CCPA upheld the USPTO rejection:
 - “It is clear that appellants never invented an "ornamental design." The appearance of appellants' gasket seems as much dictated by functional considerations as is the appearance of a piece of rope, which, too, has ribs and grooves nicely arranged. The fact that it is attractive or pleasant to behold is not enough. Many well-constructed articles of manufacture whose configurations are dictated solely by function are pleasing to look upon, for example a hex-nut, a ball bearing, a golf club, or a fishing rod, the pleasure depending largely on one's interests. But it has long been settled that when a configuration is the result of functional considerations only, the resulting design is not patentable as an ornamental design for the simple reason that it is not "ornamental" — was not created for the purpose of ornamenting.”

Please send questions to the DesignDay@uspto.gov mailbox.



Alternative Designs - Bergstrom v. Sears, Roebuck (D. Minn. 1980)

- The evidence undeniably establishes that there are numerous possible design solutions for tubular fireplace grates which operate on convective heat principles. The vast difference in appearance of the prior art patents support this conclusion, and presumably these prior art designs performed the task of heating as well as the Thermograte.
- Moreover, Bergstrom's testimony established that his three initial design solutions performed equally well, yet the appearance of these grates differed substantially.
- The myriad of alternatives in terms of the appearance of fireplace grate designs, and the variables which exist in terms of the elements which comprise the overall design, compel the conclusion that the Bergstrom patent is not invalid for functionality.

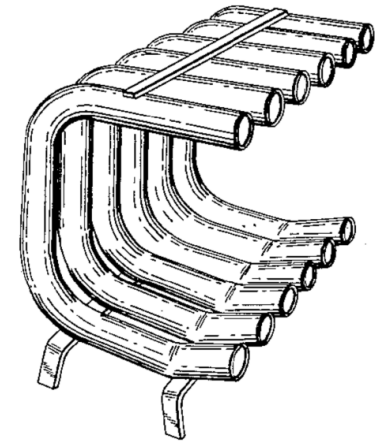

Please send questions to the DesignDay@uspto.gov mailbox.

Interoperability - Best Lock Corp. v. Ilco Unican Corp. (Fed. Cir. 1996)

- The claim of the design patent was limited to a blank key blade; the entire key was not claimed
- **Majority:** “The parties do not dispute that the key blade must be designed as shown in order to perform its intended function — to fit into its corresponding lock’s keyway. An attempt to create a key blade with a different design would necessarily fail because no alternative blank key blade would fit the corresponding lock.”
- **Judge Newman dissent:** “The design of the key profile is not removed from access to the design statute because the key fits a matching keyway. That two articles are designed in harmony does not deprive the design of access to the design patent law. The design of the key profile is not determined by the function of the key to fit the lock. In the case at bar there are said to be “thousands” of alternative key blade profiles.”



FIG 1

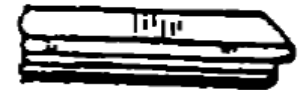

FIG 2

Please send questions to the DesignDay@uspto.gov mailbox.

Aesthetic Exhaustion - Autobody v. Ford (Fed. Cir. 2018)

- Consumer preference for a particular design to match other parts of a whole is inadequate to render that design functional.
- But regardless of the market advantage conferred by a patented appearance, competitors may not utilize a protected design during the patent's life.
- To hold that designs that derive commercial value from their aesthetic appeal are functional and ineligible for protection, as ABPA asks, would gut these principles.

Vehicle Hood," claims "[t]he ornamental design for exterior of vehicle hood." Figure 1, below, illustrates the hood.

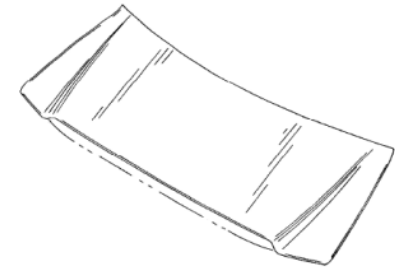
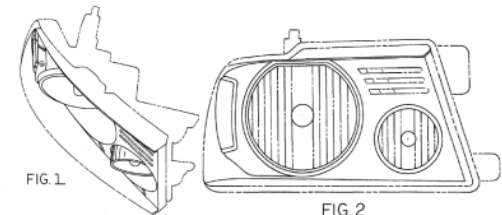

FIG. 1

The D'685 patent, titled "Vehicle Head Lamp," claims "[t]he ornamental design for a vehicle head lamp," as shown in Figures 1 and 2, reproduced below.



Please send questions to the DesignDay@uspto.gov mailbox.

Questions and Contact

- Damian Porcari
- dporcari@uspto.gov
- 313-446-4877

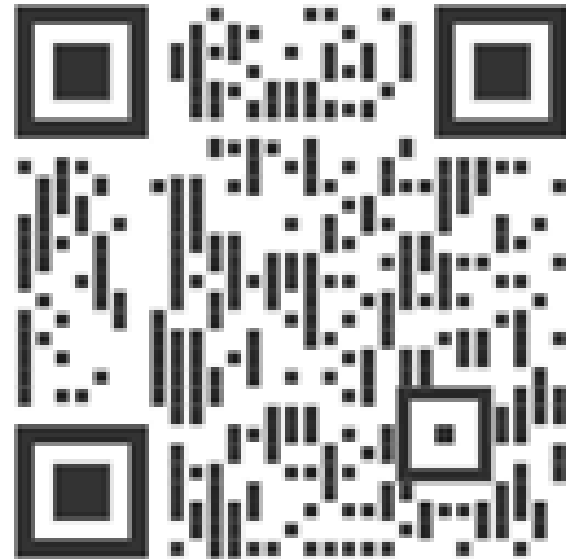

Please send questions to the DesignDay@uspto.gov mailbox.



Trademarks and Trade Dress

Please send questions to the DesignDay@uspto.gov mailbox.



Intersection of Patent, Trademark and Copyright

Trademarks

David Gearhart

Senior Staff Attorney

Office of Trademark Quality Review and Training

Three-Dimensional Marks 1202.02(c)(iv)

- In an application to register a mark with three-dimensional features, the applicant must submit a drawing that depicts the mark in a single rendition.
- To accurately reflect the exact nature of the mark, the mark description must state that the mark is three-dimensional in nature. This three-dimensional feature of the mark must be shown in the supporting specimens of use, in order for the drawing to comprise a substantially exact representation of the mark as actually used.

Please send questions to the DesignDay@uspto.gov mailbox.



Functionality and distinctiveness

- Where product design is refused on functionality, registration must also be refused on ground of nondistinctiveness –product design is **never** inherently distinctive
- Since product packaging may be inherently distinctive, where refused as functional, registration should also be refused on ground that proposed mark is nondistinctive

Traffix Devices, Inc. v. Mktg. Displays, Inc., 58 USPQ2d 1001, 1004-1005 (2001); *Two Pesos*, 23 USPQ2d at 1086; *In re Morton-Norwich Prods., Inc.*, 213 USPQ 9, 17 (CCPA 1982)

Please send questions to the DesignDay@uspto.gov mailbox.



Functionality: factors

- **Utility patents** disclosing utilitarian advantages
- **Advertising materials** touting utilitarian advantages
- Availability of functionally **equivalent designs**
- Comparatively simple or **cheap method** of manufacture

In re Becton, Dickinson & Co., 102 USPQ2d 1372 (Fed. Cir. 2012)

Valu Eng'g, Inc. v. Rexnord Corp., 61 USPQ2d 1422 (Fed. Cir. 2002)

In re Morton-Norwich Products, Inc., 213 USPQ 9 (CCPA 1982)

Please send questions to the DesignDay@uspto.gov mailbox.



Functionality . . . alternative designs

- May overcome functionality
- If evidence shows existence of number of functionally equivalent alternative designs that work "equally well," such that competitors do not need applicant's design to compete effectively, this factor may not support functionality

Please send questions to the DesignDay@uspto.gov mailbox.



TM examination - Utility patents

- The TM Examiner must consider the issue of distinctiveness and functionality. If it is determined that the subject trade dress is functional, the mark will be refused on both the Principal Register and the Supplemental Register, even if it can be proven that it has acquired distinctiveness.
 - See *In re Pingel Enterprise Inc.*, 46 U.S.P.Q.2d 1811, 1998 WL 320157 (TTAB 1998).

Please send questions to the DesignDay@uspto.gov mailbox.



TM examination - Design patents

- A design patent is a factor that weighs against a finding of functionality, because design patents by definition protect only ornamental and nonfunctional features. However, ownership of a design patent does not in itself establish that a product feature is nonfunctional, and can be outweighed by other evidence supporting the functionality determination.

Please send questions to the DesignDay@uspto.gov mailbox.



TM examination - Utility patents

Design shown in utility patent. TMEP 1202.02(a)(v)(A) *TrafFix Devices, Inc. v. Mktg. Displays, Inc.*, 532 U.S. 23, 29-30, 58 USPQ2d 1001, 1005 (2001), the Supreme Court resolved a circuit split regarding the proper weight to be afforded a utility patent in the functionality determination, stating:

“A utility patent is strong evidence that the features therein claimed are functional. If trade dress protection is sought for those features the strong evidence of functionality based on the previous patent adds great weight to the statutory presumption that features are deemed functional until proved otherwise by the party seeking trade dress protection. Where the expired patent claimed the features in question, one who seeks to establish trade dress protection must carry the heavy burden of showing that the feature is not functional, for instance by showing that it is merely an ornamental, incidental, or arbitrary aspect of the device.”

Please send questions to the DesignDay@uspto.gov mailbox.



Morton-Norwich Factors

1. The existence of a utility patent that discloses the utilitarian advantages of the design sought to be registered;
2. Advertising by the applicant that touts the utilitarian advantages of the design;
3. Facts pertaining to the availability of alternative designs; and
4. Facts pertaining to whether the design results from a comparatively simple or inexpensive method of manufacture.

Please send questions to the DesignDay@uspto.gov mailbox.



In re Hershey Chocolate and Confectionary Corp. Serial No. 77809223 (TTAB 2012) [not precedential]

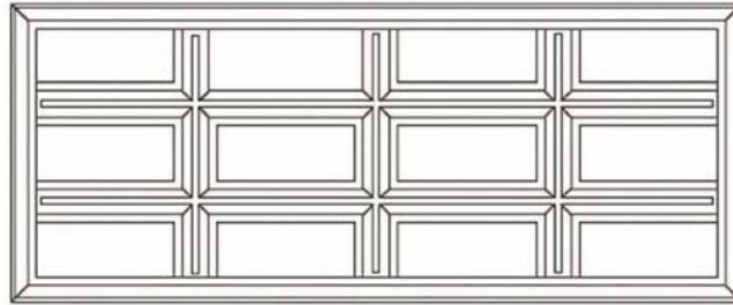

Configuration of a candy bar with 12 equally-sized recessed rectangular panels arranged in a 4 panel x 3 panel format with each panel having its own raised border within a large rectangle.

Please send questions to the DesignDay@uspto.gov mailbox.

In re Hershey

- [w]henever a proposed mark includes both functional and non-functional features . . . critical question is the degree of utility present in the overall design of the mark

In re Becton, Dickinson and Co., 675 F.3d 1368, 102 USPQ2d 1372, 1376 (Fed. Cir. 2012)

Please send questions to the DesignDay@uspto.gov mailbox.



In re Hershey

Record shows dozens of numerical combinations of segments in a variety of shapes and patterns such as the following:

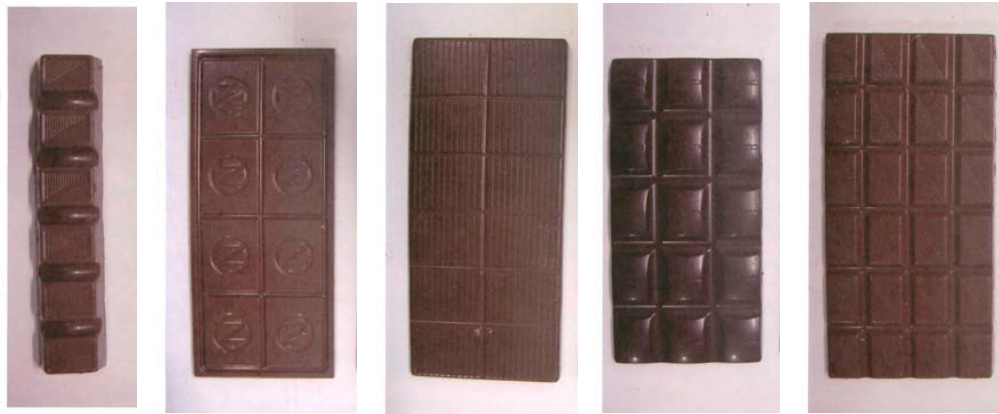

Please send questions to the DesignDay@uspto.gov mailbox.

In re Hershey

- Candy bar segmentation is a functional feature of candy bars
- Most candy bars have rectangular shape
- But, Hershey is seeking to register candy bar having:
 - 12 equally-sized recessed rectangular panels
 - arranged in a 4 panel x 3 panel format
 - each panel having its own raised border within a large rectangle

Please send questions to the DesignDay@uspto.gov mailbox.

In re Hershey

- Must balance functional rectangular shapes for candy bars which cannot be registered against non-functional elements to determine whether mark as a whole is essentially functional
- Raised border rectangles form a prominent part of Hershey's mark
- No evidence that Hershey's combination of recessed rectangles with raised border is used by others or that overall design is functional

Please send questions to the DesignDay@uspto.gov mailbox.

In re Hershey

- Even if certain features in Hershey's candy bar design are functional and common to other candy bars, does not follow that **overall** appearance of Hershey's candy bar configuration is functional
- Candy bar configuration mark **NOT** functional

to be continued . . .

Please send questions to the DesignDay@uspto.gov mailbox.

Grote Indus. v. Truck-Lite

Utility patent

Claims require at least 1 light emitting diode

Specific pattern of lights **not** claimed

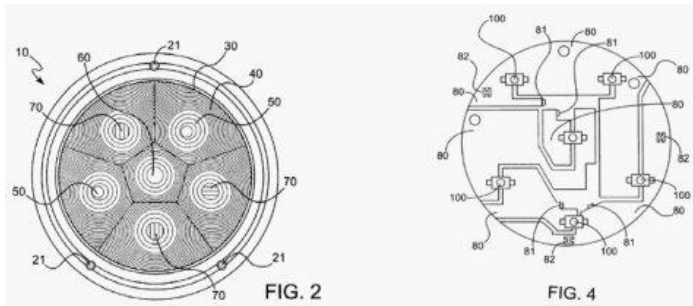

Provisional application

Configuration of the lights corresponding to the Penta-Star Pattern is described as "the **most preferred embodiment.**"

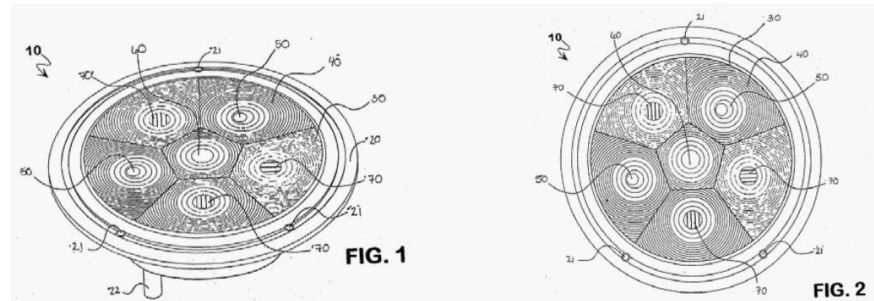

Please send questions to the DesignDay@uspto.gov mailbox.

Grote Indus. v. Truck-Lite

Functionality:

- Utility patent (including the provisional patent application) makes clear that although the design is “preferred embodiment” for the light, any number of diodes can be used
- Nowhere in the patent are any advantages of six-diode design specifically disclosed
- Truck-Lite's patent doesn't show that Penta-Star Pattern is essential to use or purpose of the article

Please send questions to the DesignDay@uspto.gov mailbox.



Grote Indus. v. Truck-Lite

- Advertising does not tout design's utilitarian advantages
- Availability of functionally equivalent designs satisfying federal regulations, found to be neutral
- Record suggests use of Penta-Star Pattern makes Truck-Lite's product more expensive and complex to manufacture

∴ design found non-functional

Please send questions to the DesignDay@uspto.gov mailbox.



Grote Indus. v. Truck-Lite

- Aesthetic Functionality
 - Equivalent lights with many diverse designs available
 - Grote not proved Penta-Star Pattern serves an aesthetic purpose independent of source identification
- No competitive need for design established, therefore not Aesthetic Functional

Please send questions to the DesignDay@uspto.gov mailbox.



Grote Indus. v. Truck-Lite

- Acquired Distinctiveness
 - in minds of public, primary significance of mark is to identify the source of the product rather than product itself
- Party seeking cancellation bears initial burden to “establish a prima facie case of no acquired distinctiveness”

Please send questions to the DesignDay@uspto.gov mailbox.

Grote Indus. v. Truck-Lite

- Review entire record pertaining to acquired distinctiveness
 - all evidence during prosecution
 - any additional evidence submitted during *inter partes* case
- Acquired distinctiveness may be determined at time of registration or trial in cancellation
- Here, proper timeframe to **assess** acquired distinctiveness is at **time of trial**

Please send questions to the DesignDay@uspto.gov mailbox.

Grote Indus. v. Truck-Lite

- Sold 13.8M lamps with trade dress for \$192M (numbers are even higher for 2016)
- Attends 40-50 trade shows/yr.
- Print ads, catalogs, website reach 400,000+ customers/yr.
 - No “look for” advertising calling attention to trade dress in record

Please send questions to the DesignDay@uspto.gov mailbox.



Grote Indus. v. Truck-Lite

Board's **assessment** of relevant evidence on **acquired distinctiveness**:

- Because the configuration is product design, it is not inherently distinctive
- Stop/turn/tail lights serve crucial non-source-identifying purposes
- Numerous third parties make same type of goods serving same purpose with various LED patterns, including very similar design by 3rd party
- Declarations from two Defendant executives and two 3rd parties have little persuasive value
- Sales success alone not probative of purchaser recognition of configuration as indication of source, may simply indicate popularity of product itself
- No "look for" advertising

Insufficient evidence in the record as a whole to show that the design by itself indicates source, or that consumers recognize it as such.

Please send questions to the DesignDay@uspto.gov mailbox.



Grote Indus. v. Truck-Lite

Orders Are Now Being Accepted For the

ALL NEW

Truck-Lite

6-DIODE SUPER 44
LED Stop / Turn / Tail Lamp



Effective immediately, Customer Service is accepting orders for the **NEW 6-Diode Super 44 LED Stop / Turn / Tail Lamp** for shipment on and after **September 1, 2000**.

The NEW 6-Diode Super 44 LED Lamp is the MOST ADVANCED LED S/T/T lamp design in the world! It is also the MOST AFFORDABLE LED S/T/T lamp we have ever produced.

Now, the ALL NEW 6-Diode SUPER 44 LED is EVEN MORE AFFORDABLE! If you act fast, you'll save EVEN MORE with our

6-Diode SUPER 44 LED
EARLY BIRD PROMO!

All orders placed on August 7, 2000 through September 30, 2000 will receive an **EXTRA 5% OFF** Our Low Standard Carton Price (Green Sheet pricing effective 9/1/00). All other discounts still apply! SEE BACK FOR QUALIFYING PART NUMBERS, PROMO PRICES and GUIDELINES

You have it all with our NEW Super 44. Latest high performance LED technology, Truck-Lite's exclusive Limited Lifetime Warranty and the lowest prices we have ever published!

For more information or to place your order, call or FAX: Customer Service (800) 562-5012, FAX (800) 685-6412
Western Division Customers contact Customer Service at (800) 266-1094 or FAX (800) 785-3481

Only same ad in each file:

- shows design having 6 diodes
- does not mention configuration or inform consumers to “look for” the pattern
- does not promote design as a mark

Please send questions to the DesignDay@uspto.gov mailbox.

Copyrights

Please send questions to the DesignDay@uspto.gov mailbox.



Copyright Protection for Designs in the United States

Susan Allen, Attorney Advisor, USPTO
Office of Policy and International Affairs
(OPIA) (Copyright Team)

Protected works of expression

- Copyright, in general, is meant to protect original works of expression. See 17 U.S.C. § 102.
- Such works include novels, poems, paintings, sculptures, and photographs.



Images credit: Wellcome Collection, CC BY. Folio books in strong rooms; Murumuru palm tree water color after C. Goodall, 1846; Sculpture hall of the Wellcome Historical Medical Museum.

Thresholds for protection

- A work of expression may qualify for copyright protection when: (1) the work is **original** [the work was created by the author instead of merely copied from another source];
- (2) the work is **fixed** in a concrete or tangible medium of expression [the novel, painting, etc., is manifest, for example, on a canvas or is expressed on paper]; and
- (3) the work exhibits a **minimum level of creativity** [some amount of human intellect and ingenuity has been applied to create the work, since the copyright law does not protect mere facts or ideas, but may protect the unique expression of facts or ideas.]

What Is not protected by Copyright?

- Ideas, procedures, methods, systems, processes, concepts, principles, or discoveries
- Works that are not fixed in a tangible form (such as a choreographic work that has not been notated or recorded or an improvisational speech that has not been written down)
- Titles, names, short phrases, and slogans
- Familiar symbols or designs
- Mere variations of typographic ornamentation, lettering, or coloring
- Mere listings of ingredients or contents
- **Useful articles**
- For more information, see Works Not Protected by Copyright ([Circular 33](#))

H.R.Rep. No. 1476, at 55 (legislative history of Copyright Act of 1976)

- “Although the shape of an industrial product may be aesthetically satisfying and valuable, the Committee’s intention is not to offer it copyright protection under the bill. Unless the shape of an automobile, airplane, ladies’ dress, food processor, television set, or any other industrial product contains some element that, physically or conceptually, can be identified as separate from the utilitarian aspects of that article, the design would not be copyrighted under the bill. The test of separability and independence from ‘the utilitarian aspects of the article’ does not depend upon the nature of the design – that is, even if the appearance of the article is determined by aesthetic (as opposed to functional) considerations, only elements, if any, which can be identified separately from the **useful articles** as such are copyrightable.”

Takeaways

- Is it original?
- Is it fixed?
- Is it creative?
- Is it a useful article?

Varsity Brands, Inc. v. Star Athletica (US 2017)



Copyright Office Compendium

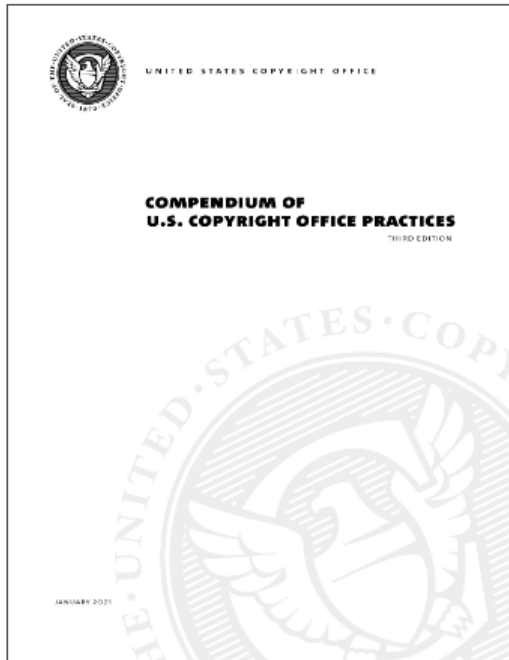

COMPENDIUM: Chapter 900

Visual Art Works

901	What This Chapter Covers.....	4
902	Visual Arts Division.....	5
903	What Is a Visual Art Work?	5
903.1	Pictorial, Graphic, and Sculptural Works.....	5
903.2	Architectural Works	6
904	Fixation of Visual Art Works	6
905	Copyrightable Authorship in Visual Art Works	7
906	Uncopyrightable Material.....	8
906.1	Common Geometric Shapes.....	9
906.2	Familiar Symbols and Designs.....	10
906.3	Colors, Coloring, and Coloration	11
906.4	Typeface, Typefont, Lettering, Calligraphy, and Typographic Ornamentation.....	12
906.5	Spatial Format and Layout Design	14

Intersection and Panel Discussion

Please send questions to the DesignDay@uspto.gov mailbox.



Hypothetical protection example

- Jedi Inc. future product – Lightsaber
- Technical Design by Bix Caleejn
- Lightsaber beam designer – Ralph McQuarrie
- Marketing Manger – Azmorigan
- VP of Product Development - Yoda

Please send questions to the DesignDay@uspto.gov mailbox.





“Invented a compact weapon deactivating an opponent we have. Lightsaber we call it. A Jedi-energy source it has, producing a retractable beam. One imperial unit it extends, and severing an opponent it can. Article of Manufacture and fixed in a tangible medium under Galactic Republic laws beam it is.”

Yoda, VP of Jedi Inc. Product Development

Please send questions to the DesignDay@uspto.gov mailbox.

This product design was selected for production after consumer market testing

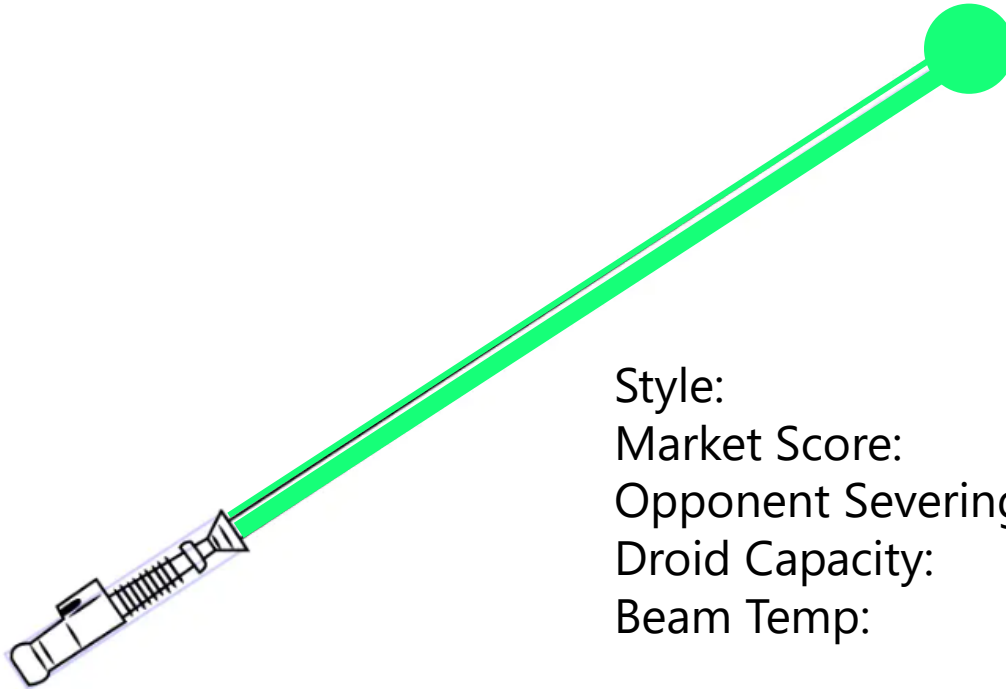

Style:	Green Split beam with globe
Market Score:	99%
Opponent Severing:	1.2 droids per second
Droid Capacity:	53
Beam Temp:	10 million caldera

Please send questions to the DesignDay@uspto.gov mailbox.

This product design was not selected even though it had superior performance

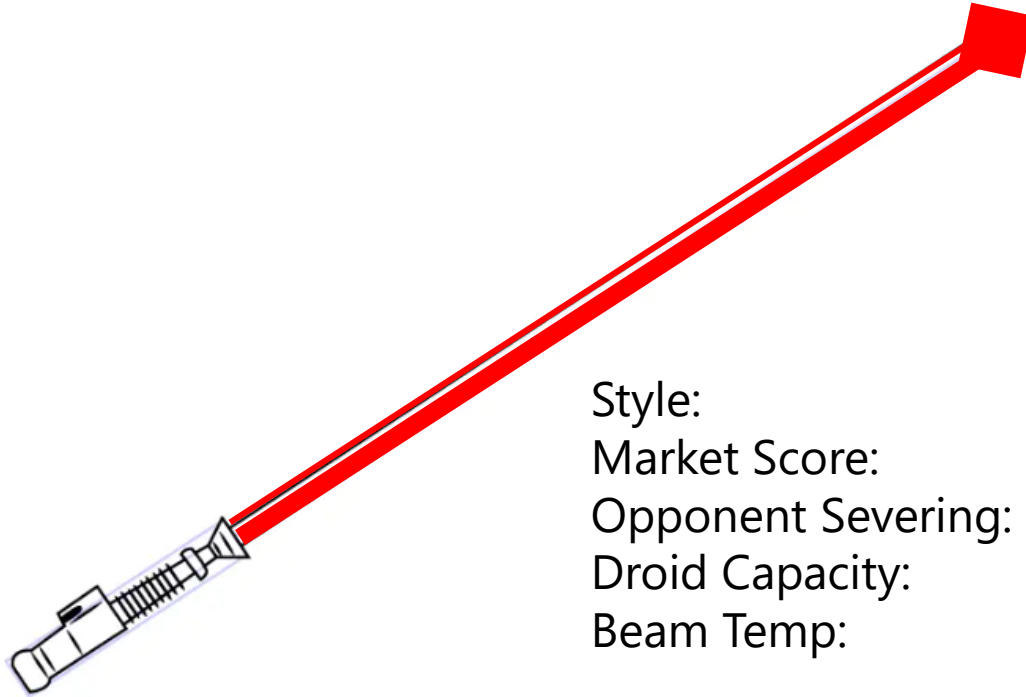

Style:	Red split beam with diamond
Market Score:	89%
Opponent Severing:	2.2 droids per second
Droid Capacity:	88
Beam Temp:	20 million caldera

Please send questions to the DesignDay@uspto.gov mailbox.

This product design was not selected even though it had the best performance

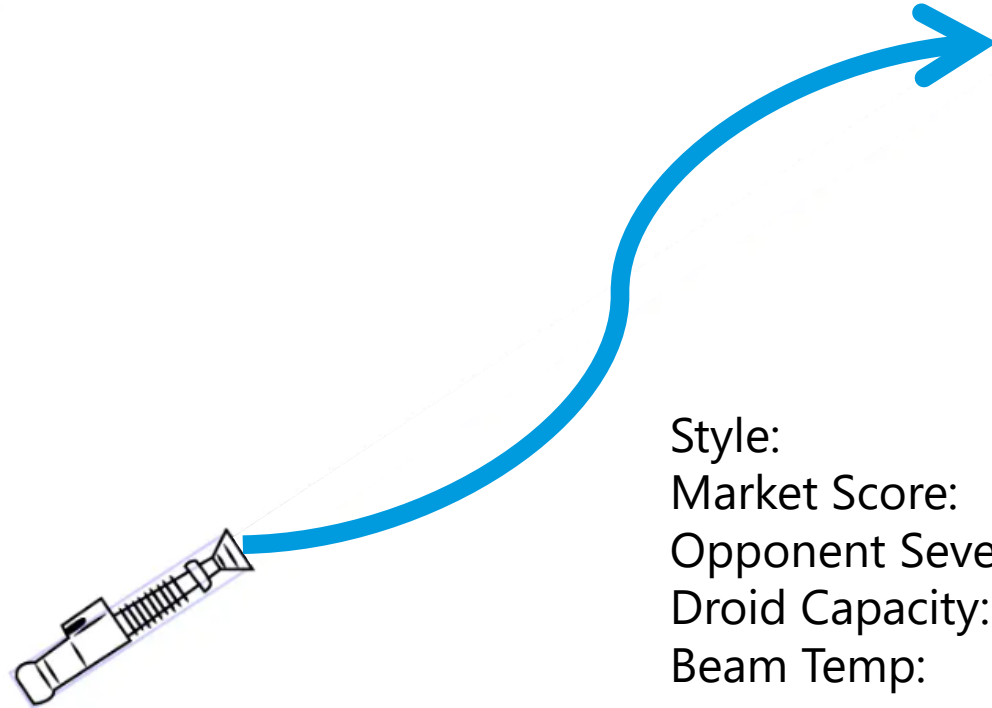

Style:	Blue curved beam with arrow
Market Score:	30%
Opponent Severing:	55 droids per second
Droid Capacity:	1112
Beam Temp:	130 million caldera

Please send questions to the DesignDay@uspto.gov mailbox.

Light Saber: Copyright protection?

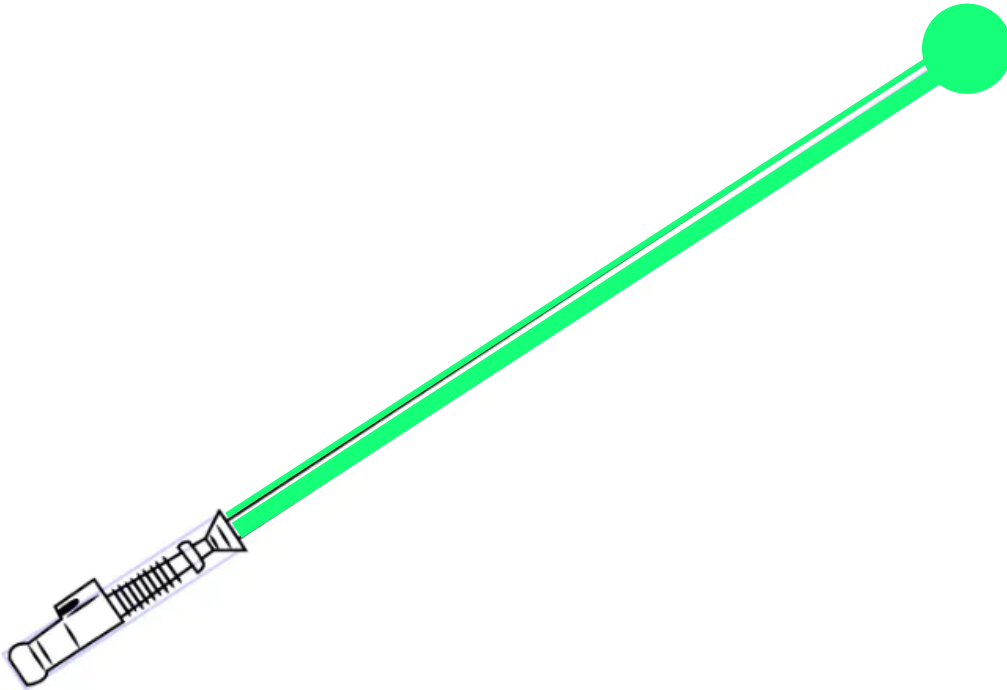

Drawing for utility patent application filed in the Galactic Republic Patent and Trademark Office

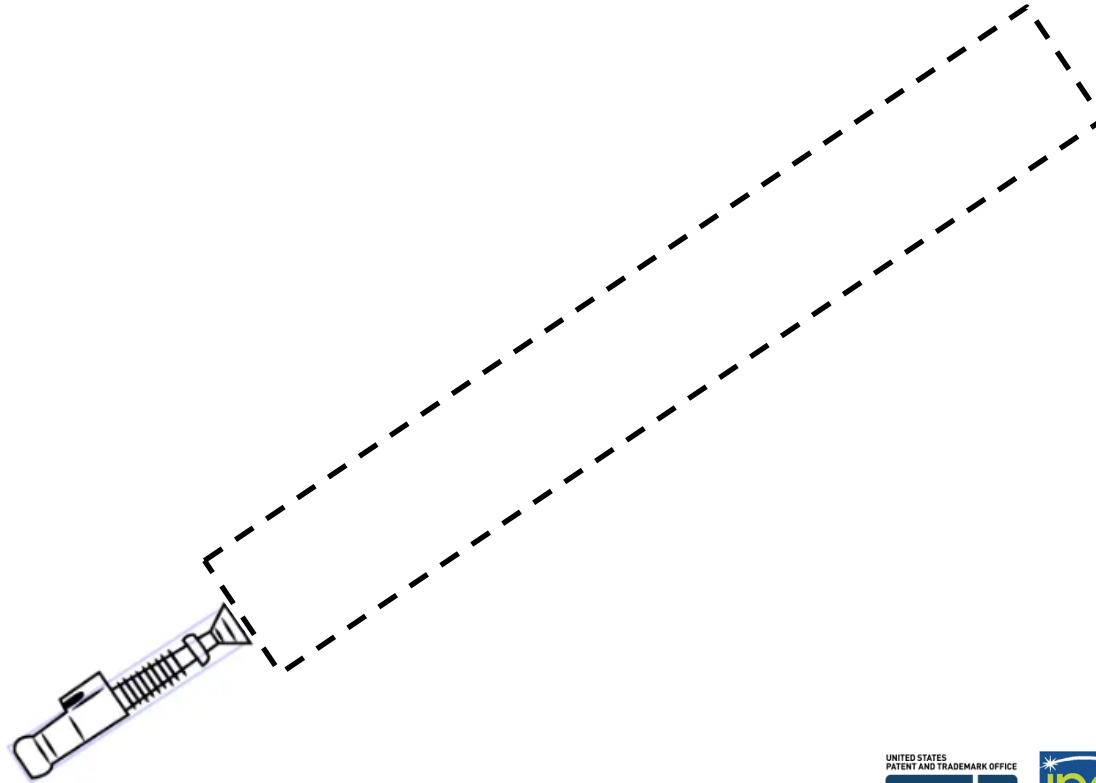

Please send questions to the DesignDay@uspto.gov mailbox.



Thank you

Damian Porcari
Regional Director, Midwest Regional Office
303-446-4877

Please send questions to the DesignDay@uspto.gov mailbox.





2023 USPTO DESIGN DAY

Car Wars

***(LKQ Corp. et al. v. GM Global
Technology Operations LLC
and its Implications)***

Brendan T. O'Dea, Esq.
Womble Bond Dickinson (US) LLP



A few months ago, in a court not
far away...

LKQ Corp. et al. v. GM Global Technology Operations LLC

It is a time of uncertainty in the design patent galaxy. The FEDERAL CIRCUIT, affirming a PTAB determination of nonobviousness in two GM-owned design patents, has elected not to overturn the current design patent nonobviousness test.

However, the final word on design patent nonobviousness may not yet have been spoken, as different factions now consider the question and its implications...

LKQ Corp. et al. v. GM Global Technology Operations LLC
Background

- GM owns two U.S. design patents at issue
 - USD855,508: “Vehicle Front Skid Bar”
 - USD797,625: “Vehicle Front Fender”

LKQ Corp. et al. v. GM Global Technology Operations LLC
Background

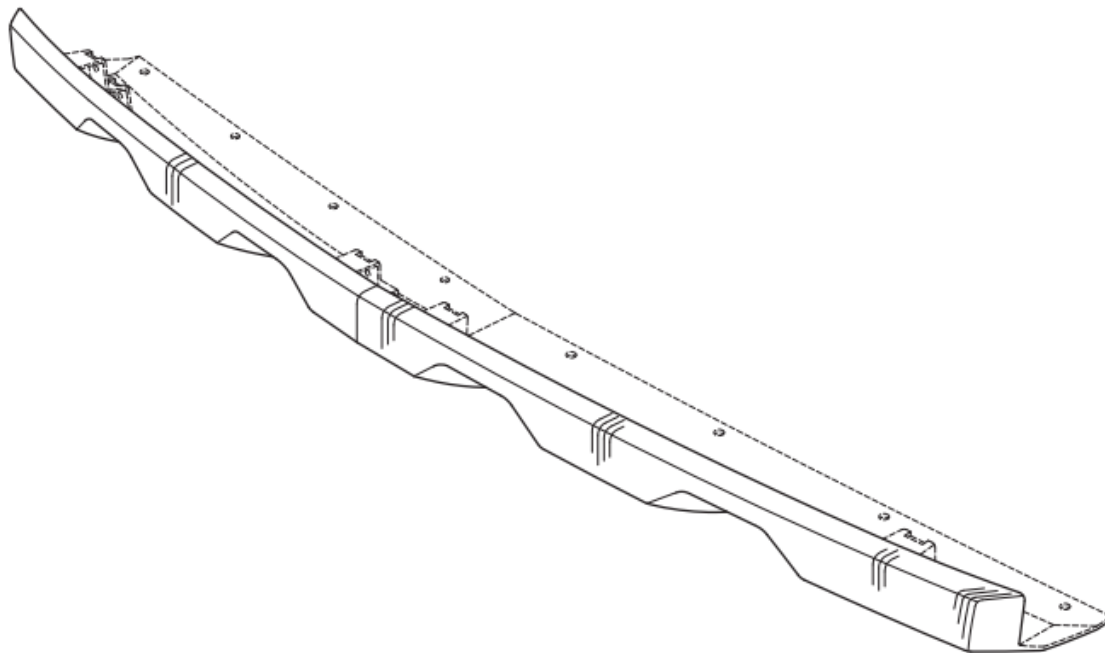

FIG. 1 OF D855,508 – “VEHICLE FRONT SKID BAR”

LKQ Corp. et al. v. GM Global Technology Operations LLC
Background

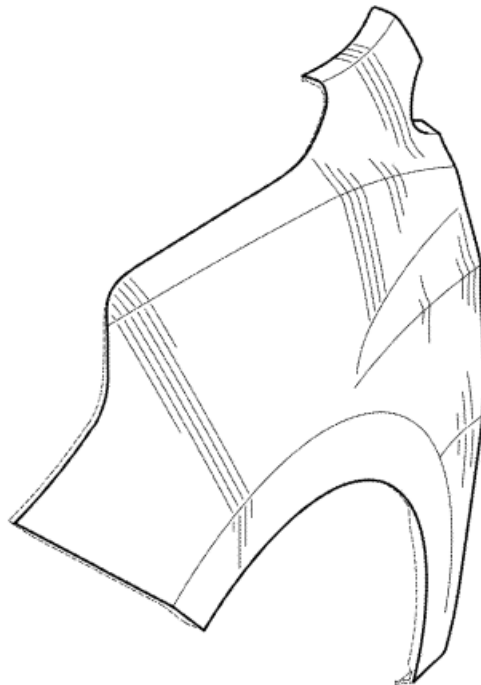

FIG. 1 OF D797,625 – “VEHICLE FRONT FENDER”

LKQ Corp. et al. v. GM Global Technology Operations LLC

Background

- LKQ Corp. is an aftermarket auto parts provider, and was accused of infringement on the '508 and '625 patents after prior licenses with GM expired.
- LKQ counters with a PGR of the '508 patent and an IPR of the '625 patent.
- In each proceeding, LKQ asserts that the patents are invalid over two prior art car designs.

LKQ Corp. et al. v. GM Global Technology Operations LLC

PGR – USD855,508

Fig. 1 of USD855,508

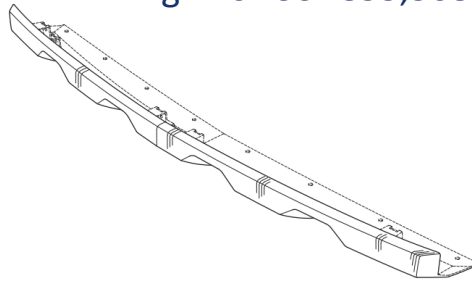





2015 Changfeng Leopard CS10



2012 Chevrolet Equinox

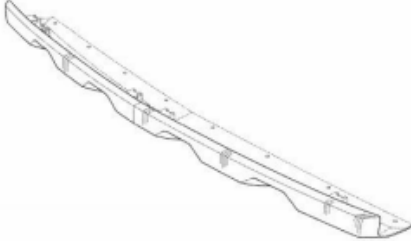

LKQ Corp. et al. v. GM Global Technology Operations LLC
PGR – USD855,508

'508 PATENT	LEOPAARD
 <p data-bbox="625 628 846 699">FIG. 1 Ex. 1001, FIG. 1</p>	 <p data-bbox="1078 647 1460 718">Ex. 1006, at 1; Ex. 1008, at 1 (cropped).</p>
 <p data-bbox="614 868 838 936">FIG. 2 Ex. 1001, FIG. 2</p>	 <p data-bbox="1078 952 1460 1023">Ex. 1007, at 1; Ex. 1009, at 1 (cropped).</p>

LKQ Corp. et al. v. GM Global Technology Operations LLC
PGR – USD855,508

- “A designer of ordinary skill would have been motivated to modify the skid bar of the Leopaard to have the vertical side edges taught by Patent Owner’s Equinox so that the Leopaard’s skid bar could fit on the Patent Owner’s Equinox or other vehicles with straight-lined, vertical bumper features leading to the skid bar.” PGR petition, p. 58.

LKQ Corp. et al. v. GM Global Technology Operations LLC
IPR – USD797,625

Fig. 1 of USD797,625

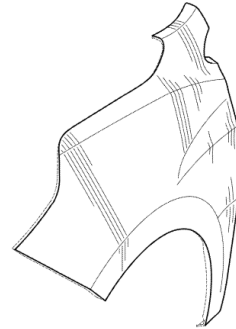

LIAN





2010 HYUNDAI TUCSON

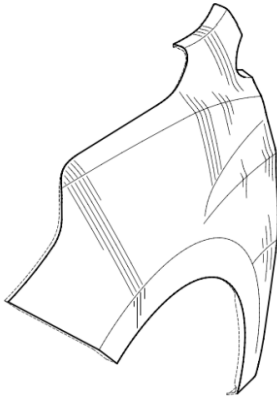

LKQ Corp. et al. v. GM Global Technology Operations LLC

IPR – USD797,625

'625 PATENT	LIAN (PRIMARY)
 <p data-bbox="614 1000 815 1030">Ex. 1001, FIG. 1</p>	 <p data-bbox="981 1000 1433 1030">Ex. 1006, FIG. 6 (cropped, annotated)</p>

LKQ Corp. et al. v. GM Global Technology Operations LLC
IPR – USD797,625

- LKQ, in one argument, asserts that that Lian only differs from the '625 patent in:
 - Wheel arch shape
 - Lower rear terminus of fender panel
- “The application of these features to Lian would have been suggested by the relatedness of the designs of the Hyundai Tucson and Lian and the similarity between their overall designs and doing so would have required no more than the exercise of ordinary skill.” IPR petition, p. 74.

LKQ Corp. et al. v. GM Global Technology Operations LLC
IPR – USD797,625

- With regard to obviousness, the PTAB held that there were a greater number of differences between Lian and the ‘625 patent than set forth by LQK, and that it did not properly qualify as a *Rosen* reference.
- “[a] preponderance of the evidence supports a conclusion that LKQ fails to identify “a single reference that creates ‘basically the same’ visual impression” as the patented design”. IPR decision, p. 58, citing *Durling*.

LKQ Corp. et al. v. GM Global Technology Operations LLC

PTAB RULINGS – *Durling* test (Prong I)

- With regard to obviousness, the PTAB applies the two-part test set forth in *Durling v. Spectrum Furniture*, 101 F.3d 100 (Fed. Cir. 1996):

“First, it must be determined whether a primary reference, also known as a Rosen reference, exists with characteristics “basically the same” as the claimed design by discerning the visual impression of the design as a whole.”

- *Durling v. Spectrum Furniture Co., Inc.*, 101 F.3d 100 (Fed. Cir. 1996); *In re Rosen*, 673 F.2d 388 (C.C.P.A. 1982)

LKQ Corp. et al. v. GM Global Technology Operations LLC
PTAB RULINGS – *Durling* test (Prong II)

“Second, if a satisfactory primary reference exists, the court must consider whether an ordinary designer would have modified the primary reference to create a design with the same overall visual appearance as the claimed design.”

- *Durling*, 101 F.3d at 103; *Rosen*, 673 F.2d at 390–91.

LKQ Corp. et al. v. GM Global Technology Operations LLC **PTAB RULINGS – *Durling* test (Prong II)**

“These secondary references may only be used to modify the primary reference if they are "so related [to the primary reference] that the appearance of certain ornamental features in one would suggest the application of those features to the other.””

-*Id.*, citing *In re Borden*, 90 F.3d at 1575, 39 U.S.P.Q.2D (BNA) at 1526-27.





LKQ Corp. et al. v. GM Global Technology Operations LLC

PTAB RULINGS

- With regard to obviousness, the PTAB held that there were a greater number of differences between Lian and the ‘625 patent and between Leopaard and the ‘508 patent than set forth by LQK, such that Lian and Leopaard did not properly qualify as *Rosen* references
- “[a] preponderance of the evidence supports a conclusion that LKQ fails to identify “a single reference that creates ‘basically the same’ visual impression” as the patented design”. IPR decision, p. 58, citing *Durling*.

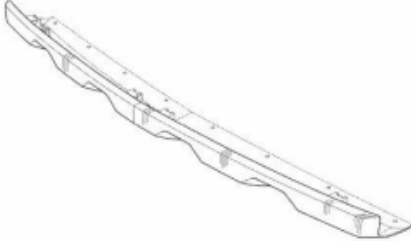

LKQ Corp. et al. v. GM Global Technology Operations LLC

PTAB RULINGS

'508 PATENT	LEOPAARD
 <p data-bbox="625 627 846 695">FIG. 1 Ex. 1001, FIG. 1</p>	 <p data-bbox="1078 647 1460 716">Ex. 1006, at 1; Ex. 1008, at 1 (cropped).</p>
 <p data-bbox="620 864 838 933">FIG. 2 Ex. 1001, FIG. 2</p>	 <p data-bbox="1078 948 1460 1017">Ex. 1007, at 1; Ex. 1009, at 1 (cropped).</p>

LKQ Corp. et al. v. GM Global Technology Operations LLC

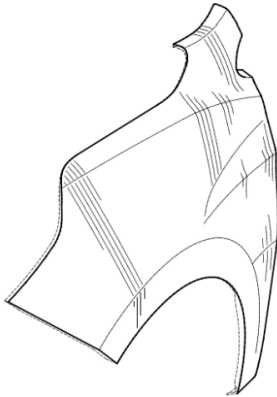
PTAB RULINGS

'625 PATENT	LIAN (PRIMARY)
 <p data-bbox="614 996 815 1033">Ex. 1001, FIG. 1</p>	 <p data-bbox="981 996 1433 1033">Ex. 1006, FIG. 6 (cropped, annotated)</p>

LKQ Corp. et al. v. GM Global Technology Operations LLC

Fed. Cir. Appeals

- LKQ appeals both PTAB decisions and argues, among other things, that the *Durling* test was not the proper analysis that should have been applied at the PTAB
- Instead, LKQ argues that the Supreme Court's ruling in *KSR* implicitly overruled *Rosen/Durling*

LKQ Corp. et al. v. GM Global Technology Operations LLC
KSR Int'l Co. v. Teleflex, Inc.

Teleflex's invention:

- Combining adjustable pedal assembly with electronic throttle control

Trial court

- Summary judgment of obviousness

Federal Circuit

- Teaching-Motivation-Suggestion required, leading PHOSITA to combine prior art as claimed (reversed the trial court)

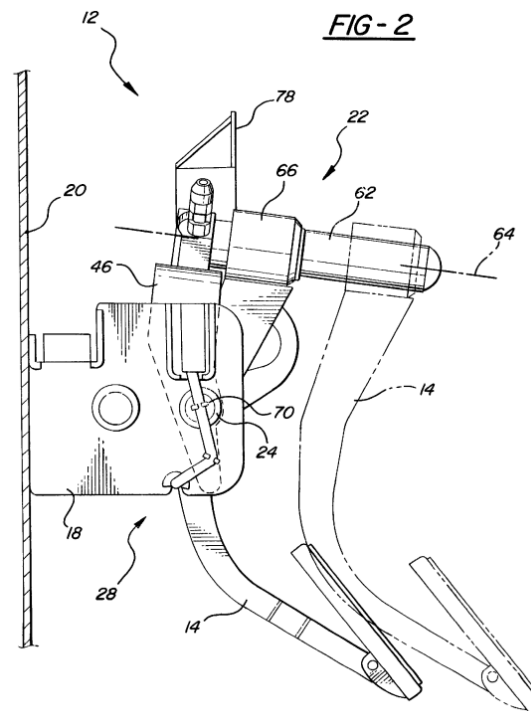

LKQ Corp. et al. v. GM Global Technology Operations LLC
KSR Int'l Co. v. Teleflex, Inc.

U.S. Supreme Court:

- Federal Circuit's TSM test too rigid
- Moved instead to a “flexible” and “functional” approach. Provided example rationales for findings of obviousness:
- Combining prior art elements according to known methods to yield predictable results
- Simple substitution of one known, equivalent element for another to obtain predictable results

LKQ Corp. et al. v. GM Global Technology Operations LLC
KSR Int'l Co. v. Teleflex, Inc.

- Use of known technique to improve similar devices (methods, or products) in the same way
- Applying a known technique to a known device (method, or product) ready for improvement to yield predictable results.
- “Obvious to try” – choosing from a finite number of predictable solutions

LKQ Corp. et al. v. GM Global Technology Operations LLC
KSR Int'l Co. v. Teleflex, Inc.

- Known work in one field of endeavor may prompt variations of it for use in either the same field or a different one based on design incentives or other market forces if the variations would have been predictable to one of ordinary skill in the art.
- The TSM Test

LKQ Corp. et al. v. GM Global Technology Operations LLC **Fed. Cir. Appeals – LKQ Arguments**

- LKQ argues that *KSR* stands for eliminating rigid tests for determining obviousness, and that *Rosen/Durling* is such a test so as to be inconsistent with *KSR*
- Notes that 35 U.S.C. § 103 does not create any test for nonobviousness different from utility patent subject matter.
- The *Rosen* requirement reduces the ordinary designer to an automaton lacking creativity
- The current standard conflates anticipation and obviousness determinations

LKQ Corp. et al. v. GM Global Technology Operations LLC **Fed. Cir. Appeals – *Per Curiam* Opinions**

- Fed. Cir. panel cannot overrule *Rosen/Durling*
 - Would need to be done *en banc* or under directive from the Supreme Court

- “We, as a panel, cannot overrule *Rosen* or *Durling* without a clear directive from the Supreme Court.” Citing *Deckers Corp. v. United States*, 752 F.3d 949, 965 (Fed. Cir. 2016)

LKQ Corp. et al. v. GM Global Technology Operations LLC
Fed. Cir. Appeals – *Per Curiam* Opinions

- Panel affirms the PTAB finding of nonobviousness under the *Rosen/Durling* dichotomy
 - Neither primary reference asserted by LKQ was sufficient to establish a *Rosen* reference

LKQ Corp. et al. v. GM Global Technology Operations LLC

Fed. Cir. Appeals – Additional Views

Judge Lourie writes separately on the *Rosen* question:

- *KSR* did not involve design patents, in which claim construction is significantly different
 - Usefulness (35 U.S.C. § 101) vs. ornamentality (35 U.S.C. § 171)

LKQ Corp. et al. v. GM Global Technology Operations LLC
Fed. Cir. Appeals – Additional Views

- Obviousness in a design context requires different considerations
 - Utility patents: unexpected properties, utility, function
 - “Functional utility is objective”
 - Design patents: ornamentality
 - “Ornament is in the eyes of the beholder”
- *KSR* did not address any of these considerations

LKQ Corp. et al. v. GM Global Technology Operations LLC **Fed. Cir. Appeals – Additional Views**

- “*Rosen* may have overstated its point . . . that the primary reference must have design characteristics that are ‘basically the same’ as those of the claimed design.”
- BUT, concludes that *Rosen* is not essentially wrong nor so rigid a test to run afoul of *KSR*’s flexible guidance.
 - “One has to start from somewhere.”

LKQ Corp. et al. v. GM Global Technology Operations LLC

Fed. Cir. Appeals – Concurring Opinions

Judge Stark concurs in the judgment and in part with the majority opinion:

- *LKQ* did not properly raise the *Rosen* issue before the PTAB, and should not have been addressed on appeal
- Agrees that it is not clear that *KSR* overturned *Rosen/Durling*
- Also writes that there is “substantial tension” between *KSR* and the *Durling* test

LKQ Corp. et al. v. GM Global Technology Operations LLC **Fed. Cir. Appeals – Concurring Opinions**

- A “strong case” can be made that the first prong of *Rosen/Durling* is the type of rigid rule that *KSR* addressed
- May stop the analysis before other important factors are considered:
 - Interrelated teachings
 - Effects of demands to the design community/marketplace
 - Background knowledge possessed by a POSITA

LKQ Corp. et al. v. GM Global Technology Operations LLC **Fed. Cir. Appeals – Concurring Opinions**

- Stopping the analysis at the *Rosen* inquiry can ignore ordinary designer’s creativity
- Also believes that the “so related” requirement in the second prong of *Rosen/Durling* is rigid
- Can see how one might argue design and utility patents are so fundamentally different so as to warrant their own tests for nonobviousness...

LKQ Corp. et al. v. GM Global Technology Operations LLC

Outstanding Questions

- *LKQ v. GM* ultimately dodged addressing the validity of *Rosen/Durling* head on, but laid out a roadmap for future challenges
 - A full *en banc* ruling?
 - Guidance from the Supreme Court
- How do applicants and patent owners now brace for a potential change?

Questions?

Brendan T. O’Dea, Esq.
Womble Bond Dickinson (US) LLP
Brendan.odea@wbd-us.com

“Womble Bond Dickinson,” the “law firm” or the “firm” refers to the network of member firms of Womble Bond Dickinson (International) Limited, consisting of Womble Bond Dickinson (UK) LLP and Womble Bond Dickinson (US) LLP. Each of Womble Bond Dickinson (UK) LLP and Womble Bond Dickinson (US) LLP is a separate legal entity operating as an independent law firm. Womble Bond Dickinson (International) Limited does not practice law. Please see www.womblebonddickinson.com/us/legal-notice for further details.

Information contained in this document is intended to provide general information about significant legal developments and should not be construed as legal advice on any specific facts and circumstances, nor should they be construed as advertisements for legal services.





Report from the Front Lines

Design Patent Decisions from the
Federal Circuit, District Courts, and PTAB

Rebekah Holtz

May 4, 2023

Technical Minds. Legal Muscle.



Wepay Global Payments LLC

Wepay Global Payments LLC

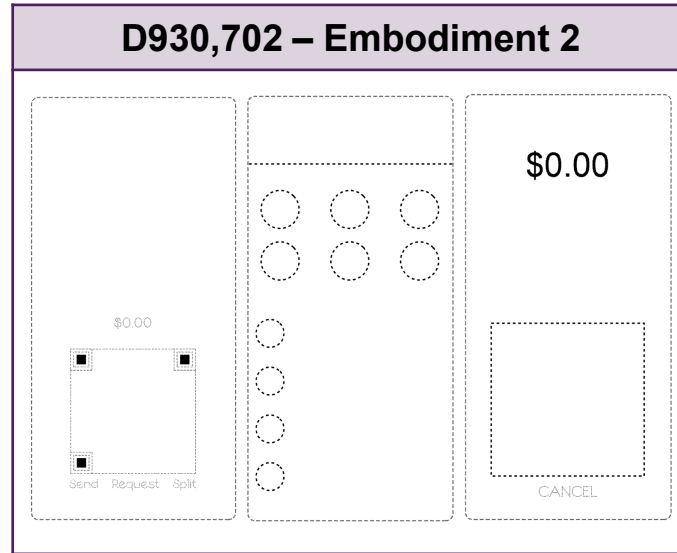
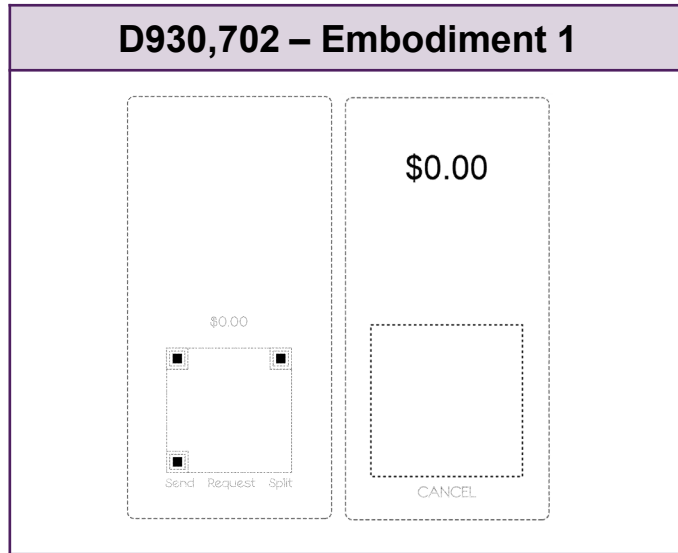

Wepay Global Payments LLC

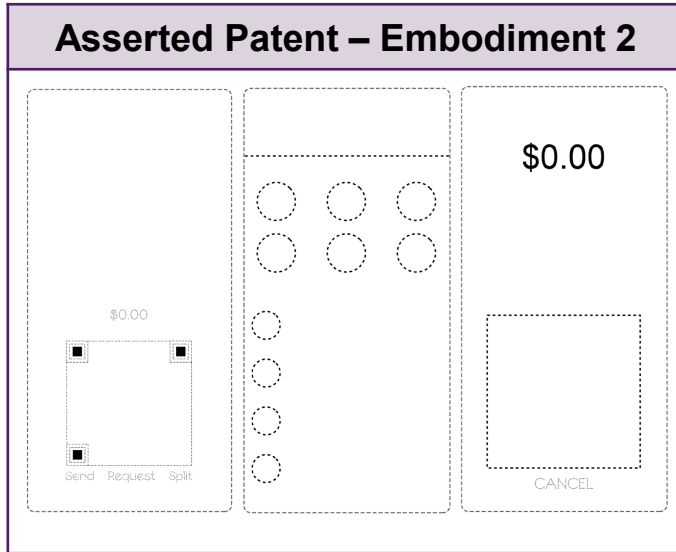

District Court

- Amazon.com, Inc., 1-22-cv-01061 (NDIL)
- Apple Inc., 6-22-cv-00223 (WDTX)
- Bank of America, NA, 1-22-cv-00105 (NDIL)
- JPMorgan Chase Bank, NA, 1-22-cv-00103 (NDIL)
- McDonald's Corporation, 1-22-cv-01064 (NDIL)
- PayPal, Inc., 6-21-cv-01094 (WDTX)
- PNC Bank, N.A., 2-22-cv-00592 (WDPA)
- Samsung Electronics Co., 6-21-cv-01095 (WDTX)
- Tesla, Inc., 6-22-cv-00224 (WDTX)
- Wal-Mart Stores, Inc., 1-22-cv-01062 (NDIL)
- Wells Fargo Bank NA, 6-22-cv-00363 (WDTX)

Wepay Global Payments LLC

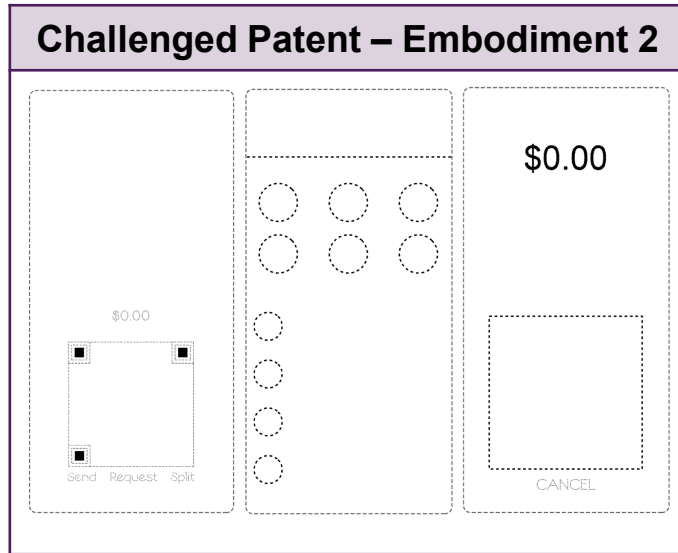

Petitions for Post Grant Review

- Early Warning Services, LLC v. Wepay Global Payments LLC, PGR2022-00031
- Samsung Electronics Co., Ltd. v. Wepay Global Payments LLC, PGR2022-00045

Wepay Global Payments LLC v. PNC Bank N.A. No. 2:22-CV-00592-MJH (W.D. Pa. June 1, 2022)

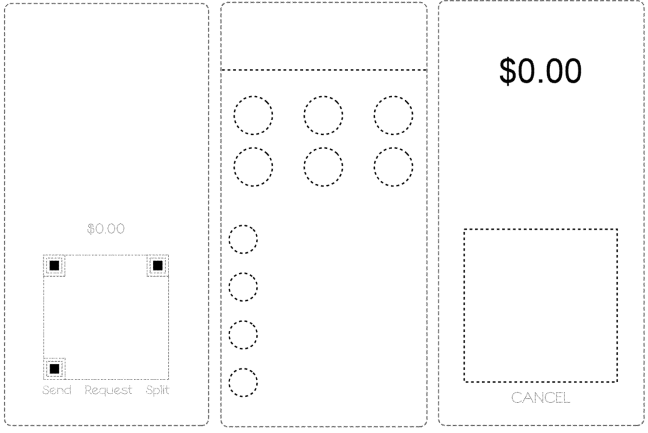
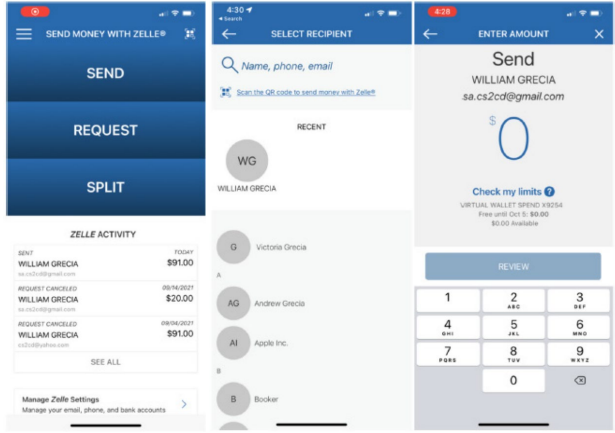
Asserted Patent – Embodiment 2	Accused Product
 <p>The diagram illustrates the asserted patent embodiment 2, showing a mobile application interface divided into three main sections. The left section, labeled 'SEND', features a large '\$0.00' amount and three buttons: 'Send', 'Request', and 'Split'. The middle section, labeled 'REQUEST', contains six circular icons arranged in two columns of three. The right section, labeled 'CANCEL', shows a '\$0.00' amount and a 'CANCEL' button. The entire interface is enclosed in a dashed-line border.</p>	 <p>The accused product is shown as a mobile application interface for Zelle payments. It consists of three sequential screens: 1. 'SEND MONEY WITH ZELLE' with 'SEND', 'REQUEST', and 'SPLIT' buttons. 2. 'SELECT RECIPIENT' with a search bar and a list of recent recipients including 'WILLIAM GRECIA'. 3. 'ENTER AMOUNT' with a 'Send' button, a large '0' input field, and a numeric keypad. The interface includes various status indicators like 'ZELLE ACTIVITY' and 'Check my limits'.</p>

Wepay Global Payments LLC v. PNC Bank N.A. No. 2:22-CV-00592-MJH (W.D. Pa. June 1, 2022)

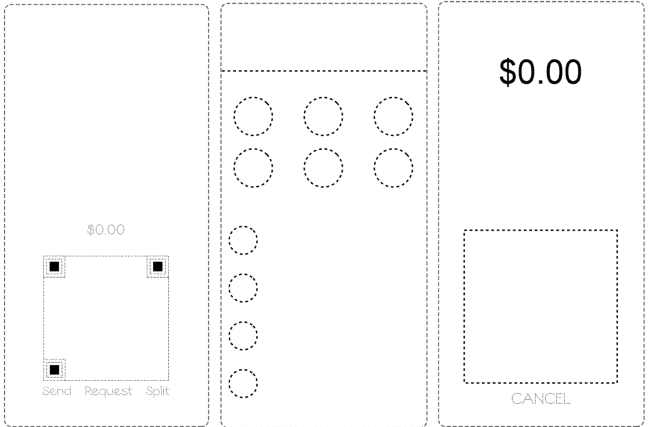
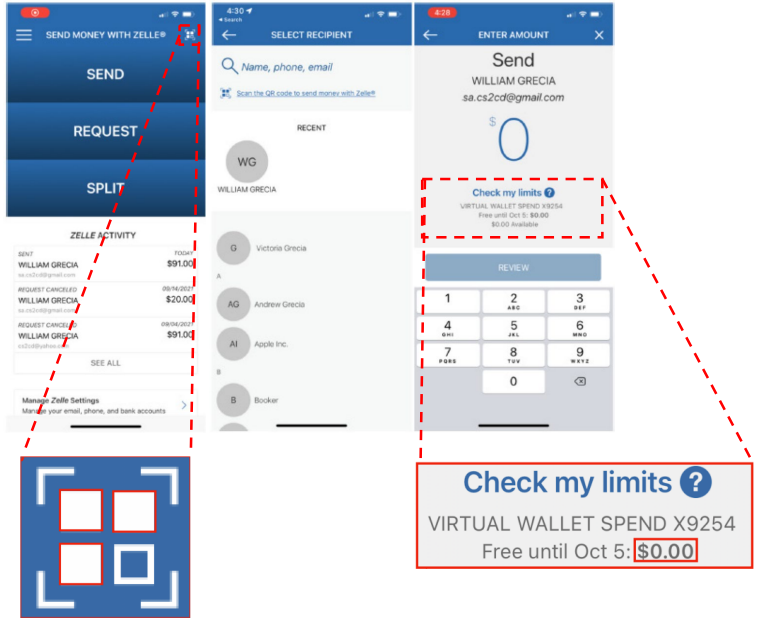
Asserted Patent – Embodiment 2	Accused Product
 <p>The diagram illustrates the asserted patent embodiment 2, showing a mobile application interface. It features three main sections: a left section with a '\$0.00' display and 'Send', 'Request', and 'Split' buttons; a middle section with six circular icons arranged in two columns of three; and a right section with a '\$0.00' display and a 'CANCEL' button. A dashed red line indicates a zoomed-in view of the 'Send' button area, which is shown as a blue square with four smaller squares inside, representing a QR code.</p>	 <p>The accused product is shown as a mobile application interface for 'SEND MONEY WITH ZELLE'. It consists of three screens: 1. 'SEND MONEY WITH ZELLE' screen with 'SEND', 'REQUEST', and 'SPLIT' buttons. 2. 'SELECT RECIPIENT' screen with a search bar and a list of recent recipients including 'WILLIAM GRECIA'. 3. 'ENTER AMOUNT' screen with a 'Send' button, recipient name, and a numeric keypad. A dashed red line highlights the 'Check my limits' link on the 'ENTER AMOUNT' screen, which is shown in a zoomed-in view below. The zoomed-in view displays: 'Check my limits ?' (with a question mark icon), 'VIRTUAL WALLET SPEND X9254', and 'Free until Oct 5: \$0.00' (with '\$0.00' circled in red).</p>

Wepay Global Payments LLC v. PNC Bank N.A. **No. 2:22-CV-00592-MJH (W.D. Pa. June 1, 2022)**

“[A] side-by-side comparison of WPG’s Asserted Design and PNC’s Accused Design demonstrates that they are ‘sufficiently distinct’ and ‘plainly dissimilar’ such that **no reasonable factfinder could find infringement**. Any similarity between the two designs is limited to basic geometric shapes, but with notable differences in shape size and spacing such that no ordinary observer would mistake the Accused Design with the Asserted Design or vice versa”

Wepay Global Payments LLC

D930,702 – Embodiment 1



D930,702 – Embodiment 2

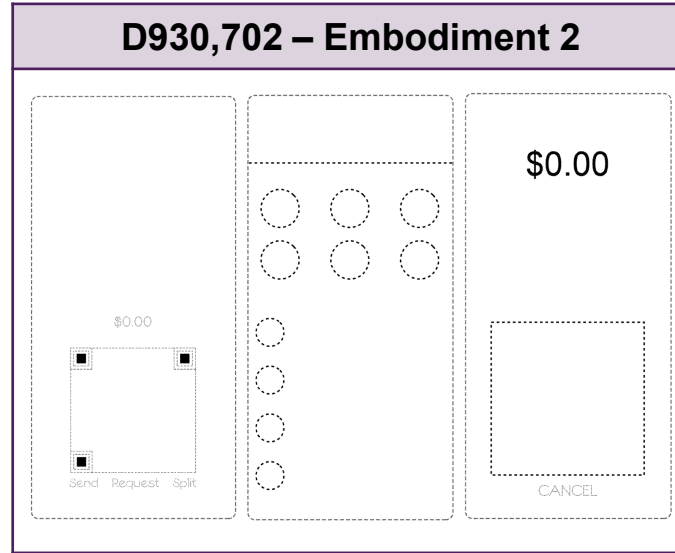

Wepay Global Payments LLC

D930,702 – Embodiment 1



D930,702 – Embodiment 2

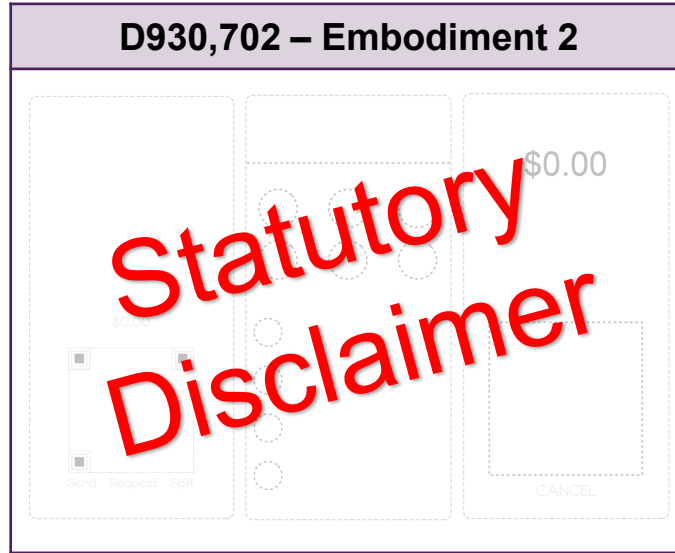

Early Warning Services, LLC and Samsung Electronics Co., Ltd. v. Wepay Global Payments LLC (PTAB February 9, 2023)

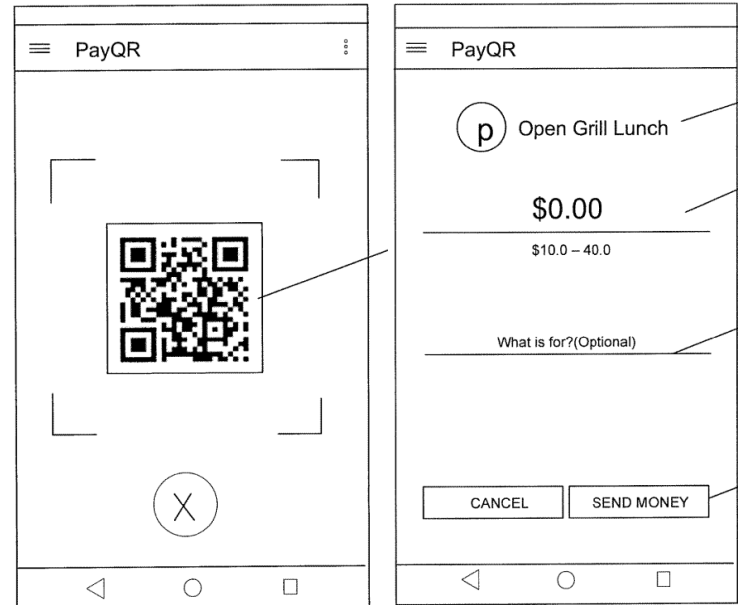

- Patent Owner, by disclaiming all figures and embodiments described in the '702 patent, disclaimed the entire scope of the sole design claim at issue, such that no challenged claim remains.
- The subject matter of the sole claim of the '702 patent is anticipated by, or obvious over, the disclosure of Reddy.





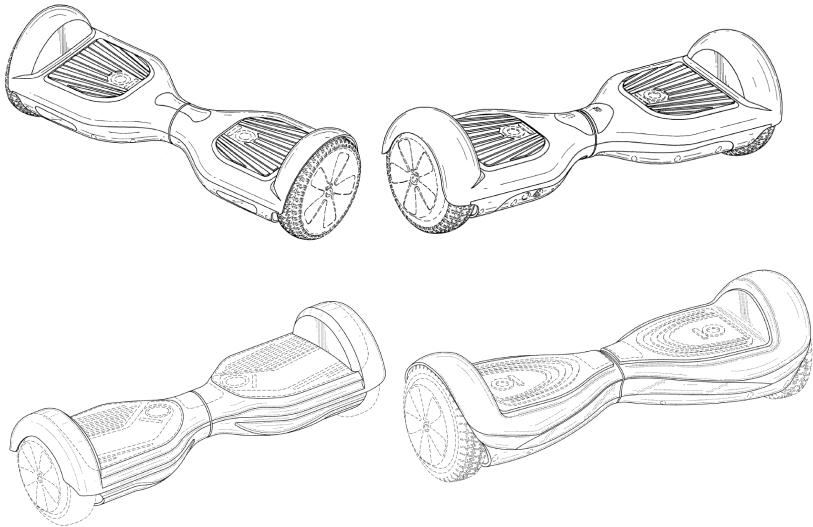

***ABC Corp. v.
Partnership and
Unincorporated
Associations***

ABC Corp. v. Partnership and Unincorporated Ass'ns 52 F.4th 934 (Fed. Cir. 2022)

Asserted Patents	Accused Products
	

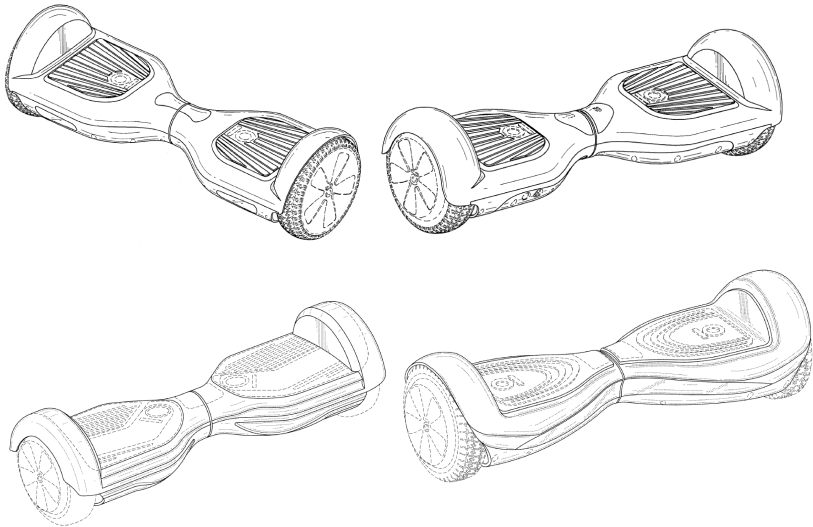
ABC Corp. v. Partnership and Unincorporated Ass'ns 52 F.4th 934 (Fed. Cir. 2022)

Asserted Patents	Accused Products
	

ABC Corp. v. Partnership and Unincorporated Ass'ns **52 F.4th 934 (Fed. Cir. 2022)**

Federal Circuit reverses, holding:

1. The district court applied, at least in part, the wrong legal standard.
2. The district court was required to conduct the ordinary observer analysis through the lens of the prior art.
3. The district court failed to apply the ordinary observer test on a product-by-product basis.
4. Even if the district court were to find a likelihood of success as to infringement, the language of the injunction is overbroad.

ABC Corp. v. Partnership and Unincorporated Ass'ns 52 F.4th 934 (Fed. Cir. 2022)

District Court – Plaintiffs' Expert Report

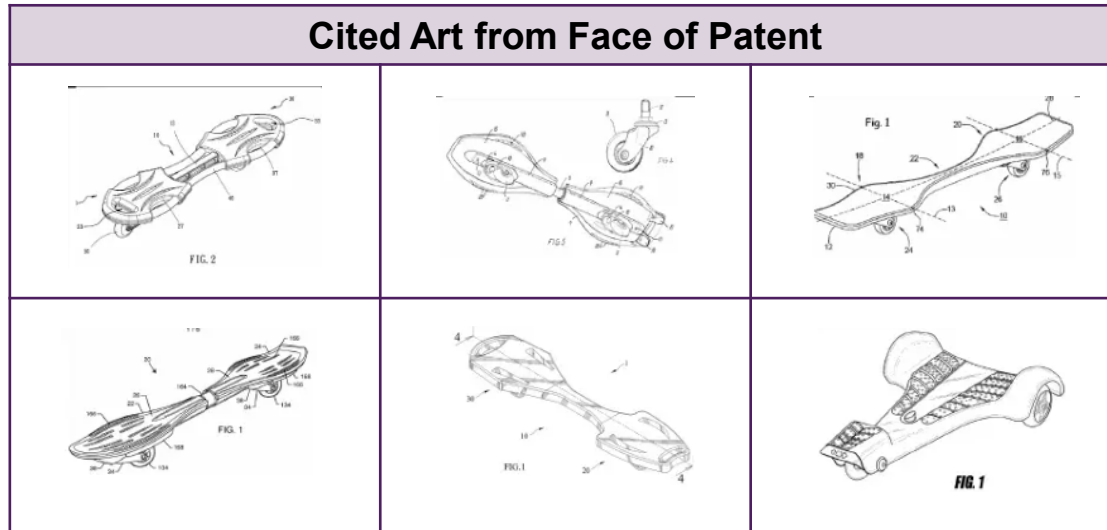

“The prior art is vastly different” and therefore the patent “enjoy[s] a very broad scope”

ABC Corp. v. Partnership and Unincorporated Ass'ns 52 F.4th 934 (Fed. Cir. 2022)

District Court – Plaintiffs' Expert Report

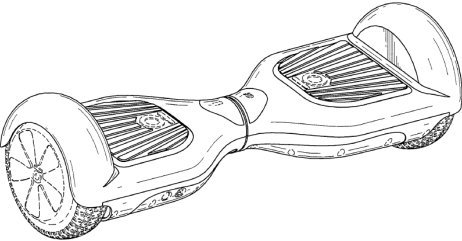
Accused Products	Asserted Patent
	

“In the eyes of the ordinary observer, the claimed design of the ‘723 [Patent] is substantially the same as the overall visual impression presented by the Accused Products.”

“Unlike the cited prior art . . . the claimed design of the ‘723 Patent and the Accused Products share the same overall impression and have an integrated ‘hourglass’ body with a relatively flat surface across the top of the main body, arched covers over the wheel area, larger radii on the front and back of the underside, and elongated light panels on the front surface.”

ABC Corp. v. Partnership and Unincorporated Ass'ns 52 F.4th 934 (Fed. Cir. 2022)

Federal Circuit – Conduct the ordinary observer analysis through the lens of the prior art.

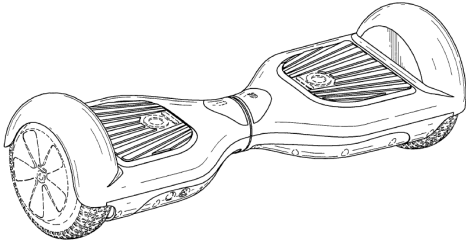
Accused Products	Asserted Patent
	

ABC Corp. v. Partnership and Unincorporated Ass'ns 52 F.4th 934 (Fed. Cir. 2022)

Federal Circuit – Conduct the ordinary observer analysis through the lens of the prior art.

Prior Art	Accused Products	Asserted Patent
		

ABC Corp. v. Partnership and Unincorporated Ass'ns 52 F.4th 934 (Fed. Cir. 2022)

District Court – Plaintiffs' Expert Report

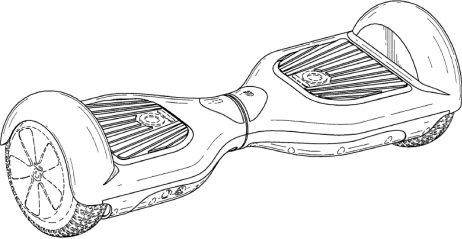
Accused Products	Asserted Patent
	

“In the eyes of the ordinary observer, the claimed design of the ‘723 [Patent] is substantially the same as the overall visual impression presented by the Accused Products.”

“Unlike the cited prior art . . . the claimed design of the ‘723 Patent and the Accused Products share the same overall impression and have an integrated ‘hourglass’ body with a relatively flat surface across the top of the main body, arched covers over the wheel area, larger radii on the front and back of the underside, and elongated light panels on the front surface.”

ABC Corp. v. Partnership and Unincorporated Ass'ns 52 F.4th 934 (Fed. Cir. 2022)

Federal Circuit – Apply the ordinary observer test on a product-by-product basis.

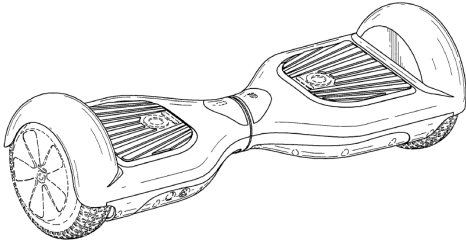
Accused Products	Asserted Patent
	

ABC Corp. v. Partnership and Unincorporated Ass'ns **52 F.4th 934 (Fed. Cir. 2022)**

Federal Circuit – Apply the ordinary observer test on a product-by-product basis.

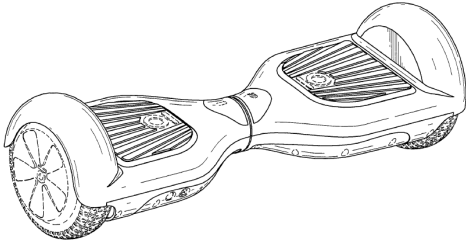
Accused Product	Asserted Patent
	

ABC Corp. v. Partnership and Unincorporated Ass'ns 52 F.4th 934 (Fed. Cir. 2022)

Federal Circuit – Conduct the ordinary observer analysis through the lens of the prior art & apply the ordinary observer test on a product-by-product basis.

Prior Art	Accused Product	Asserted Patent
		

ABC Corp. v. Partnership and Unincorporated Ass'ns **52 F.4th 934 (Fed. Cir. 2022)**

District Court – Defendants' Expert Report

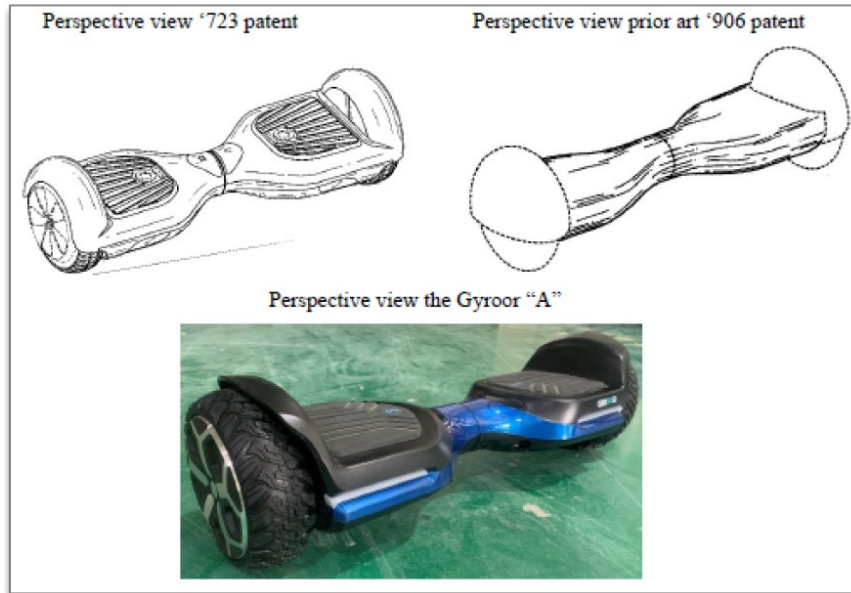





***Think Green Ltd. v.
Medela AG***

Think Green Ltd. v. Medela AG

No. 21 C 5445 (N.D. Ill. Oct. 7, 2022)

Accused Product	Asserted Patent
	

Think Green Ltd. v. Medela AG

No. 21 C 5445 (N.D. Ill. Oct. 7, 2022)

Drawings

- Oblique line shading is used to show transparent, translucent and highly polished or reflective surfaces.
- An inventor intending not to claim any particular material type would use a line drawing with a blank surface, free of anything but contour lines, thereby claiming both an opaque and transparent surface.

Think Green Ltd. v. Medela AG

No. 21 C 5445 (N.D. Ill. Oct. 7, 2022)

Drawings	Photographs
<ul style="list-style-type: none">• Oblique line shading is used to show transparent, translucent and highly polished or reflective surfaces.• An inventor intending not to claim any particular material type would use a line drawing with a blank surface, free of anything but contour lines, thereby claiming both an opaque and transparent surface.	<ul style="list-style-type: none">• Depiction of surface characteristics and material is inherent in a photograph of an actual, existing object.• Photographs strictly limit the design claim to the specific incarnation depicted in the photograph.



Think Green Ltd. v. Medela AG

No. 21 C 5445 (N.D. Ill. Oct. 7, 2022)

Drawings	Photographs	Computer-generated image
<ul style="list-style-type: none"> Oblique line shading is used to show transparent, translucent and highly polished or reflective surfaces. An inventor intending not to claim any particular material type would use a line drawing with a blank surface, free of anything but contour lines, thereby claiming both an opaque and transparent surface. 	<ul style="list-style-type: none"> Depiction of surface characteristics and material is inherent in a photograph of an actual, existing object. Photographs strictly limit the design claim to the specific incarnation depicted in the photograph. 	<ul style="list-style-type: none"> Like a photograph, the computer-generated image constitutes a choice of surface material.

Think Green Ltd. v. Medela AG

No. 21 C 5445 (N.D. Ill. Oct. 7, 2022)

Accused Product	Asserted Patent
	

“Think Green's patent must be interpreted to claim an opaque object to the exclusion of translucent or transparent objects.”

“Even if Medela's product were exactly the same as Think Green's design in all other aspects, . . . an ordinary observer would not find the translucent object to be substantially the same as the opaque object. **Opaque and translucent objects are categorically different such that they are ‘plainly dissimilar’ and could not be confused by an ordinary observer.**”



Ex parte Grede et al.

Ex parte Grede et al. (PTAB September 29, 2022)

Claimed Design	102 Rejection Based on Keltner Figure 7
	 <p style="text-align: center;"><i>Fig. 7.</i></p>

Figure 7 described as “a *fragmentary*, front view of the right stocking unit.”

Stocking unit 110a described as “worn over bare skin from the waist to the feet.”

Ex parte Grede et al. (PTAB September 29, 2022)

Claimed Design	102 Rejection Based on Keltner Figure 7
	 <p style="text-align: center;"><i>Fig. 7.</i></p>

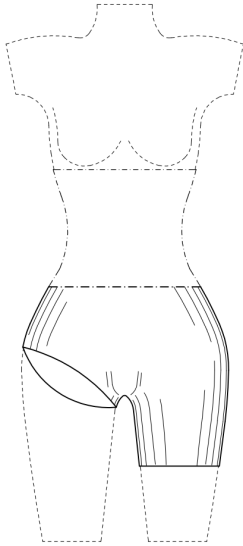
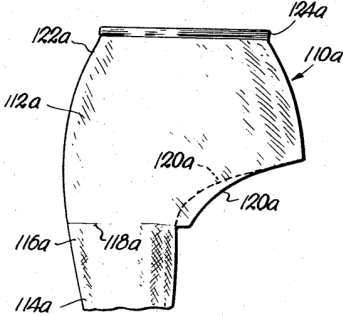
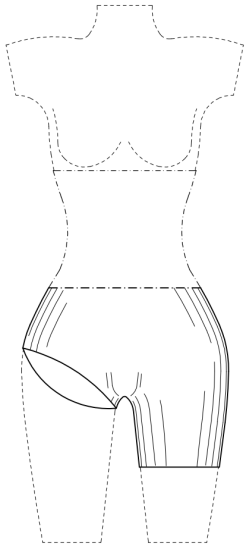
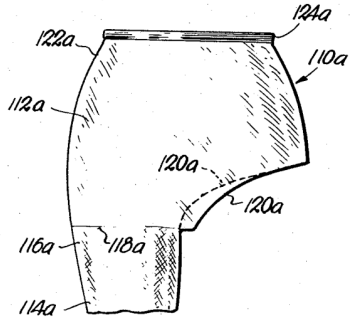
Appellant here is claiming the entire article of manufacture. Thus, it is appropriate to **compare Appellant's claimed design with an entire prior art article of manufacture.**

A skilled artisan, considering Keltner's right stocking unit 110a **as a whole**, would understand that its design includes a hose section 114a that extends all the way to the feet.



Ex parte Timothy Smith

Ex parte Timothy Smith (PTAB January 31, 2022)

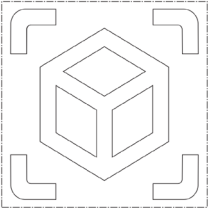
Claimed Design	103 Rejection Icon Finder in view of Park and Icons Website
	<div data-bbox="510 426 707 633"> </div> <div data-bbox="745 426 954 633"> </div> <div data-bbox="1000 426 1190 640"> </div> <p data-bbox="568 687 1163 750">Examiner's composite illustration of Icon Finder as modified by Park and Icons Website:</p> <div data-bbox="753 775 958 975"> </div>

Ex parte Timothy Smith (PTAB January 31, 2022)

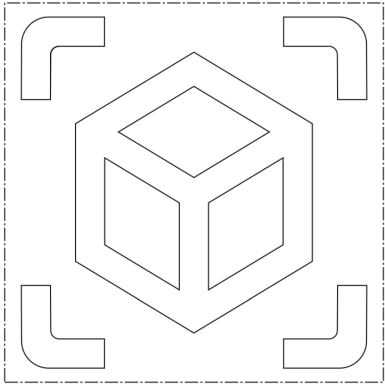
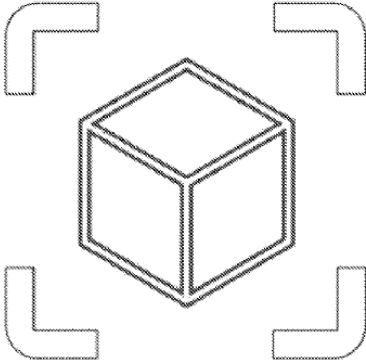
Claimed Design	Composite Illustration
	

Examiner:

The double-lines defining the edges of the cube are closer together in the composite illustration, but “mere variations in orientation, dimension, proportion, and spacing do not make the claimed design sufficiently different in ornamental appearance.”

The interior corners of the elbow brackets are slightly rounded in the claimed design, but “rounded corners . . . have been held to be an obvious expedient in designs.”

Ex parte Timothy Smith (PTAB January 31, 2022)

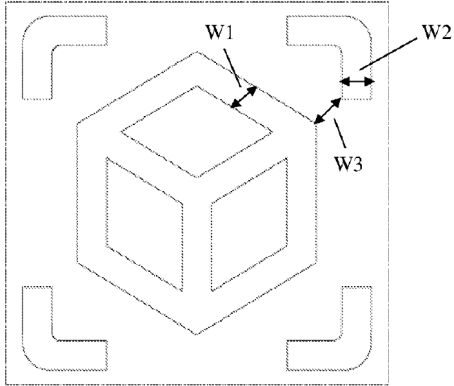
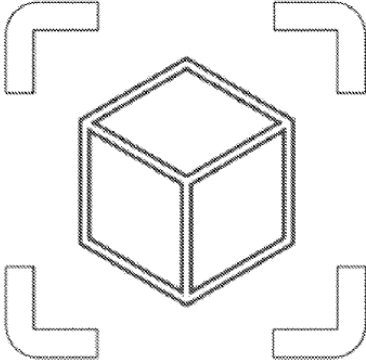
Claimed Design	Composite Illustration
	

Appellant:

The differences acknowledged by the Examiner are important design characteristics, which results in a combination that does not have ‘substantially the same’ overall visual appearance as the claimed design.

There is a third difference between the composite illustration and the claimed design. In the claimed design $W1 \approx W2 \approx W3$, providing “a consistency of sizing and spacing to create a ‘balanced and integrated design.’”

Ex parte Timothy Smith (PTAB January 31, 2022)

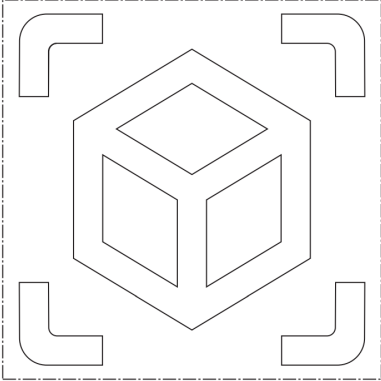
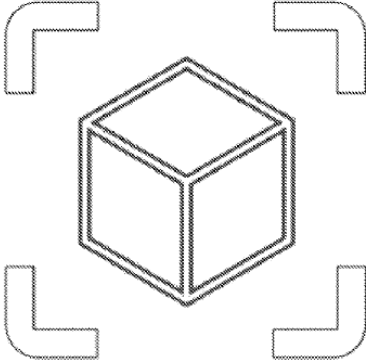
Claimed Design	Composite Illustration
	

Board:

There is a marked difference in the separation of the double-lines defining the edges of the cube. This difference is further emphasized when the cube is considered in combination with the bracket.

Ex parte Timothy Smith (PTAB January 31, 2022)

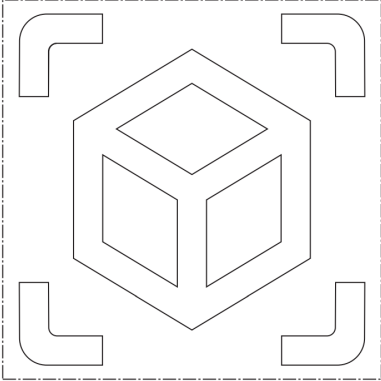
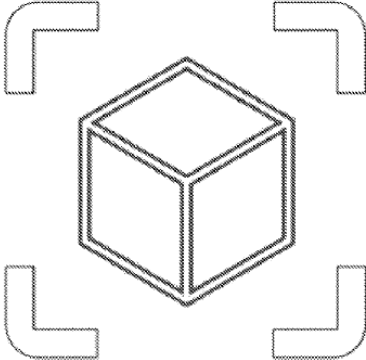
Claimed Design	Composite Illustration
	

Board:

To the extent the Examiner is attempting to extract from *King* a hard and fast rule that all changes in dimension are *per se* unpatentable advances, the Examiner's reliance upon this authority is misplaced.

To the extent the Examiner is attempting to extract from *Stevens* a hard and fast rule that all changes in proportion are *per se* unpatentable advances, the Examiner's reliance upon this authority is misplaced.



***Ideavillage Products
Corp. v. Koninklijke
Philips NV***

Ideavillage Products Corp. v. Koninklijke Philips NV (PTAB October 25, 2022)

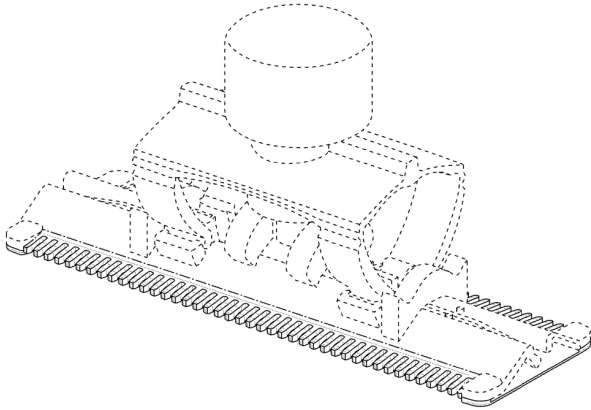
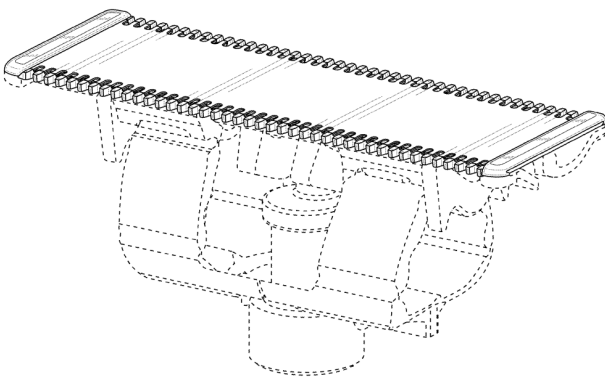

Ideavillage Products Corp. v. Koninklijke Philips NV (PTAB October 25, 2022)

Ground	35 U.S.C.	Reference(s) / Basis
1	102(a)(1)	Philips OneBlade
2	103	Andersson US, alone or in combination with Philips OneBlade, Philips RCD, Stapelbroek PCT, Stapelbroek EP, Feijen US, or Feijen PCT
3	103	Philips RCD, alone or in combination with Philips OneBlade, Andersson US, Stapelbroek PCT, Stapelbroek EP, Feijen US, or Feijen PCT
4	103	Stapelbroek PCT, alone or in combination with Philips OneBlade, Andersson US, Philips RCD, Stapelbroek EP, or Feijen US or Feijen PCT
5	103	Stapelbroek EP, alone or in combination with Philips OneBlade, Andersson US, Philips RCD, Stapelbroek PCT, Feijen US, or Feijen PCT
6	103	Feijen US, alone or in combination with Philips OneBlade, Andersson US, Philips RCD, Stapelbroek PCT, Stapelbroek EP, or Feijen PCT
7	103	Feijen PCT, alone or in combination with Philips OneBlade, Andersson US, Philips RCD, Stapelbroek PCT, Stapelbroek EP, or Feijen US

Ideavillage Products Corp. v. Koninklijke Philips NV (PTAB October 25, 2022)

Ground	35 U.S.C.	Reference(s) / Basis
1	102(a)(1)	Philips OneBlade
2	103	Andersson US, alone or in combination with Philips OneBlade, Philips RCD, Stapelbroek PCT, Stapelbroek EP, Feijen US, or Feijen PCT
3	103	Philips RCD, alone or in combination with Philips OneBlade, Andersson US, Stapelbroek PCT, Stapelbroek EP, Feijen US, or Feijen PCT
4	103	Stapelbroek PCT, alone or in combination with Philips OneBlade, Andersson US, Philips RCD, Stapelbroek EP, or Feijen US or Feijen PCT
5	103	Stapelbroek EP, alone or in combination with Philips OneBlade, Andersson US, Philips RCD, Stapelbroek PCT, Feijen US, or Feijen PCT
6	103	Feijen US, alone or in combination with Philips OneBlade, Andersson US, Philips RCD, Stapelbroek PCT, Stapelbroek EP, or Feijen PCT
7	103	Feijen PCT, alone or in combination with Philips OneBlade, Andersson US, Philips RCD, Stapelbroek PCT, Stapelbroek EP, or Feijen US

6
 single-reference
 obviousness challenges

+

36
 two-reference
 obviousness challenges

=

42
 discrete obviousness
 challenges

Ideavillage Products Corp. v. Koninklijke Philips NV (PTAB October 25, 2022)

- “None of the 42 obviousness challenges advanced in the Petition is supported by an adequate analysis. . . . In particular, none sufficiently discusses **both** the differences between the claimed and prior art designs and **how** any primary reference would have been modified (alone or in view of any other reference) to have the same visual appearance as the claimed design.”

Ideavillage Products Corp. v. Koninklijke Philips NV **(PTAB October 25, 2022)**

1. Find a primary reference (a single reference, a something in existence, the design characteristics of which are basically the same as the claimed design)
2. Use secondary reference(s) to modify the primary reference to create a design that has the same overall visual appearance as the claimed design

Ideavillage Products Corp. v. Koninklijke Philips NV (PTAB October 25, 2022)

1. Find a primary reference (a single reference, a something in existence, the design characteristics of which are basically the same as the claimed design)
 - BUT also provide an explanation as to **how** the primary reference is basically the same as the claimed design despite particular differences between the two designs
2. Use secondary reference(s) to modify the primary reference to create a design that has the same overall visual appearance as the claimed design
 - BUT also provide an explanation as to **how** and **why** the primary reference(s) would have been modified to arrive at a design that has the same overall visual appearance as the claimed design



Questions?

Final Remarks

Karen Young

Please send questions to the DesignDay@uspto.gov mailbox.



DESIGN 20 DAY 23

Thank you for attending!