

Chapter 1800 Patent Cooperation Treaty

- | | | | |
|---------|--|------|---|
| 1801 | Basic PCT Principles | 1870 | Administrative Instructions Annexes |
| 1802 | PCT Definitions | 1871 | Administrative Instructions Appendixes |
| 1803 | Reservations under the PCT taken by the United States of America | 1872 | International-type search |
| 1805 | Who may file in the United States Receiving Office | 1875 | International Bureau Procedures |
| 1807 | Agent or Common Representative | 1877 | International Publication |
| 1808 | Revocation of the appointment of an agent or a common representative | 1885 | Receipt of the International Application by the Designated Offices |
| 1810 | Filing date requirements | 1887 | Entry into the National (or Regional) Phase Before the Designated Offices |
| 1812 | Elements of the International Application | 1889 | Representation Before the Designated Office |
| 1815 | Formal Requirements of an International Application | 1890 | Requirements to Enter National Stage in United States of America |
| 1820 | The Request | 1895 | Review Under PCT Article 25 |
| 1820.01 | Title of the Invention | 1896 | Effect of U.S. Patent Issued on an International Application |
| 1820.02 | Applicant | 1897 | Filing and Prior Art Effect in United States |
| 1820.03 | Inventor | | |
| 1820.04 | Agent or Common Representative (if any) | | |
| 1820.05 | Designation of States | | |
| 1820.06 | Priority | | |
| 1820.07 | Parent Application or Grant | | |
| 1820.08 | Earlier International or International-Type Search | | |
| 1820.09 | Different Applicants for Different Designated States | | |
| 1820.10 | Different Inventors for Different Designated States | | |
| 1820.11 | Signature of Applicant | | |
| 1820.12 | Check List | | |
| 1823 | The Description | | |
| 1824 | The Claims | | |
| 1825 | The Drawings | | |
| 1826 | The Abstract | | |
| 1827 | Fees | | |
| 1828 | Priority Document | | |
| 1830 | PCT International Application Transmittal Letter | | |
| 1832 | License Request for Foreign Filing Under the PCT | | |
| 1840 | International Stage Time Limits | | |
| 1845 | Receiving Office Procedure | | |
| 1845.01 | Transmittal of Record Copy | | |
| 1845.02 | Correction of Defects before the Receiving Office | | |
| 1845.03 | Correction of Obvious Errors of Transcription | | |
| 1860 | The International Searching Authority | | |
| 1862 | The International Search | | |
| 1863 | The International Search Report | | |
| 1865 | Time Limit for Establishing the International Search Report | | |
| 1867 | Refund of International Search Fee | | |
| 1868 | Unity of Invention | | |

1801 Basic PCT Principles

MAJOR CONCEPTS

The Patent Cooperation Treaty (PCT) is an international agreement to which the United States of America is a party, which provides for the filing of patent applications on the same invention in a number of countries. The PCT enables the U.S. applicant to file one application, "an international application", in a standardized format in English in the Receiving Office (the U.S. Patent and Trademark Office), and have that application acknowledged as a regular national filing in as many member countries to the PCT as the applicant "designates" that is, names, as countries in which patent protection is desired. The PCT also provides that the application will be subjected to a search for published disclosures which are capable of assisting in the determination of whether the invention disclosed in the application is new and unobvious. Upon payment of national fees and the furnishing of a translation, usually some twenty months after the filing of the earliest application for the invention, the application will be subjected to national procedures in each of the designated countries.

The PCT offers an alternative route to filing patent applications directly in those countries which are members of the PCT. It does not preclude taking advantage of the priority rights and other advantages provided under the Paris convention (PCT Article 1). The PCT provides

an additional and optional foreign filing route to United States applicants.

PCT ARTICLE 1

Establishment of a Union

(1) The States party to this Treaty (hereinafter called "the Contracting States") constitute a Union for cooperation in the filing, searching, and examination, of applications for the protection of inventions, and for rendering special technical services. The Union shall be known as the International Patent Cooperation Union.

(2) No provision of this Treaty shall be interpreted as diminishing the rights under the Paris Convention for the Protection of any county party to that Convention.

The PCT has also substantially harmonized the formal requirements of applications for the member countries and the European Patent Convention (EPC).

The PCT also provides new filing and searching procedures whereby much of the processing and transmittal of papers is done for the applicant by the various national patent offices acting as international authorities and the International Bureau (IB) of the World Intellectual Property Organization (WIPO) in Geneva, Switzerland, which administers the Treaty.

BASIC FLOW

To understand the PCT, it is important to know the basic flow of an international application under the PCT. This flow is illustrated on the next page.

It is expected that, in most instances a national U.S. application (NA) will be filed first since the applicant can obtain a search for a relatively low U.S. filing fee. An international application for the same subject matter will then be filed subsequently within the priority year provided by the Paris Convention and claim the priority benefit of the U.S. national application filing date.

RECEIVING OFFICE (RO)

The international application (IA) must be filed in a Receiving Office (RO) (PCT Article 10). The United States Patent and Trademark Office will act as a Receiving Office for United States residents and nationals (35 USC 361 (a)). The Receiving Office functions as the filing and formalities review organization for international applications. International applications *must contain upon filing* the designation of those countries in which patent protection is desired and must meet certain standards for completeness and formality (PCT Articles 11 (1) and 14(1)).

Where a priority claim is made, the date of the earlier filed national application is used as the date for determining the timing of international processing, including the various transmittals, the payment of certain international and national fees, and publication of the application. Where no priority claim is made, the international filing date will be considered to be the "priority date" for timing purposes (PCT Article 2(xi)).

The international application is subject to the payment of certain fees upon filing and at the expiration of 12 months from the priority date (PCT Article 11(3) and 35 USC 363). The Receiving Office will grant an international filing date to the application, collect fees, handle informalities directly with the applicant, and monitor all corrections, 35 USC 361(d). By 13 months from the priority date, the Receiving Office is required to prepare and transmit a copy of the international application, called the Search Copy (SC), to the International Searching Authority (ISA); and another copy, called the Record Copy (RC), to the International Bureau (PCT Rules 22.1 and 23). A third copy of the international application, the Home Copy (HC), remains in the Receiving Office (PCT Article 12(1)). Once the Receiving Office has transmitted copies of the application, the International Searching Authority becomes the focus of international processing.

INTERNATIONAL SEARCHING AUTHORITY (ISA)

The basic function of the International Searching Authority (ISA) is to conduct a prior art search of inventions claimed in international applications; it does this by searching in at least the minimum documentation defined by the Treaty (PCT Articles 15 and 16 and PCT Rule 34). The U.S. Patent and Trademark Office acts as an International Searching Authority for U.S. residents and nationals. The International Searching Authority is also responsible for checking the content of the title and abstract (PCT Rules 37.2 and 38.2). An International Search Report (SR) will normally be issued by the International Searching Authority within three months from the receipt of the Search Copy (usually 16 months after the priority date) (PCT Rule 42). Copies of the International Search Report and prior art cited will be sent to the applicant and the International Bureau (PCT Rules 43 and 44.1). The Search Report will contain a listing of those documents found to be relevant and will identify the claims in the application to which they are pertinent; however, no judgments or statements as to patentability will be made (PCT Rule 43.10). Once the International Search Re-

port has been completed and transmitted, international processing continues before the International Bureau.

INTERNATIONAL BUREAU (IB)

The basic functions of the International Bureau (IB) are to maintain the master file of all international applications and to act as the publisher and central coordinating body under the Treaty. The World Intellectual Property Organization in Geneva, Switzerland performs the duties of the International Bureau.

If the applicant has not filed a certified copy of the priority document in the Receiving Office with the international application, or requested upon filing that the Receiving Office prepare and transmit to the International Bureau a copy of the prior U.S. national application, the priority of which is claimed, the applicant must submit such a document directly to the International Bureau not later than 16 months after the priority date.

The applicant has normally two months from the date of transmittal of the International Search Report to amend the claims by filing an amendment directly with the International Bureau (PCT Article 19 and PCT Rule 46). The International Bureau will then normally publish (P) the international application along with the Search Report and any amendment (Amdt) at the expiration of 18 months from the priority date (PCT Article 21). The international publication will be in pamphlet form

with a front page containing bibliographical data, the abstract, and a figure of the drawing (PCT Rule 48). The pamphlet will also contain the search report and any amendments to the claims submitted by the applicant. If the application is published in a language other than English, the search report and abstract are also published in English. The International Bureau will also publish a Gazette in the French and English languages which will contain information similar to that on the front pages of international applications, various indexes, and announcements (PCT Rule 86). The International Bureau will also transmit copies of the international application to all the Designated Offices (PCT Article 20 and PCT Rule 47).

DESIGNATED OFFICE (DO)

Twenty months from the priority date of the international application, the applicant must send to each Designated Office any required translations and the appropriate national or regional filing fees unless the individual Designated Office grants additional time (PCT Article 20). The applicant also has the right to amend his application within one month after the payment of his national fees. After this month has expired (PCT Article 28 and PCT Rule 52), each Designated Office will make its own determination as to the patentability of the application based upon its own specific national or regional laws (PCT Article 27(5)).

BASIC FLOW OF AN INTERNATIONAL APPLICATION

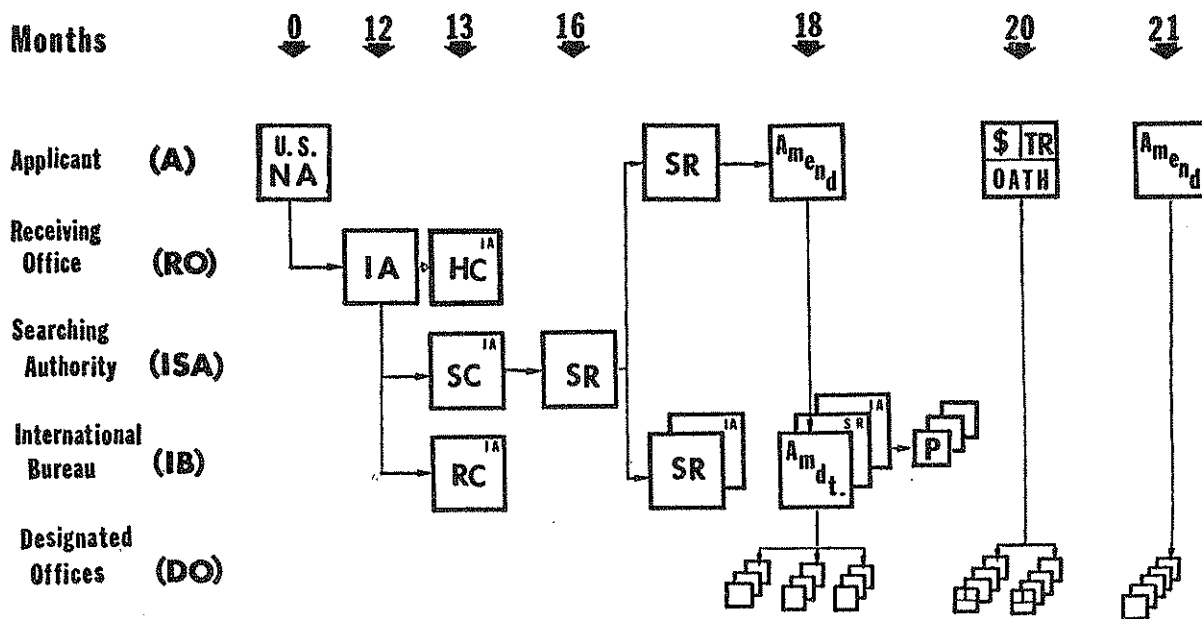

1802 PCT Definitions

ARTICLE 2

Definitions

For the purpose of this Treaty and the Regulations and unless expressly stated otherwise:

- (i) "application" means an application for the protection of an invention; references to an "application" shall be construed as references to applications for patents for inventions, inventors' certificates, utility certificates, utility models, patents or certificates of addition, inventors' certificates of addition, and utility certificates of addition;
- (ii) references to a "patent" shall be construed as references to patents for inventions, inventors' certificates, utility certificates, utility models, patents or certificates of addition, inventors' certificates of addition, and utility certificates of addition;
- (iii) "national patent" means a patent granted by a national authority;
- (iv) "regional patent" means a patent granted by a national or an intergovernmental authority having the power to grant patents effective in more than one State;
- (v) "regional application" means an application for a regional patent;
- (vi) references to a "national application" shall be construed as references to applications for national patents and regional patents, other than applications filed under this Treaty;
- (vii) "international application" means an application filed under this Treaty;
- (viii) references to an "application" shall be construed as references to international applications and national applications;
- (ix) references to a "patent" shall be construed as references to national patents and regional patents;
- (x) references to "national law" shall be construed as references to the national law of a Contracting State or, where a regional application or a regional patent is involved, to the treaty providing for the filing of regional applications or the granting of regional patents;
- (xi) "priority date," for the purposes of computing time limits, means:
- (a) where the international application contains a priority claim under Article 8, the filing date of the application whose priority is so claimed;
- (b) where the international application contains several priority claims under Article 8, the filing date of the earliest application whose priority is so claimed;
- (c) where the international application does not contain any priority claim under Article 8, the international filing date of such application;
- (xii) "national Office" means the government authority of a Contracting State entrusted with the

granting of patents; references to a "national Office" shall be construed as referring also to any intergovernmental authority which several States have entrusted with the task of granting regional patents, provided that at least one of those States is a Contracting State, and provided that the said States have authorized that authority to assume the obligations and exercise the powers which this Treaty and the Regulations provide for in respect of national Offices;

(xiii) "designated Office" means the national Office of or acting for the State designated by the applicant under Chapter I of this Treaty;

(xiv) "elected Office" means the national Office of or acting for the State elected by the applicant under Chapter II of this Treaty;

(xv) "receiving Office" means the national Office or the intergovernmental organization with which the international application has been filed;

(xvi) "Union" means the International Patent Cooperation Union;

(xvii) "Assembly" means the Assembly of the Union;

(xviii) "Organization" means the World Intellectual Property Organization;

(xix) "International Bureau" means the International Bureau of the Organization and, as long as it subsists, the United International Bureaux for the Protection of Intellectual Property (BIRPI);

(xx) "Director General" means the Director General of the Organization and, as long as BIRPI subsists, the Director of BIRPI.

PCT RULE 2

Interpretation of Certain Words

2.1 "Applicant"

Whenever the word "applicant" is used, it shall be construed as meaning also the agent or other representative of the applicant, except where the contrary clearly follows from the wording or the nature of the provision or the context in which the word is used, such as, in particular, where the provision refers to the residence or nationality of the applicant.

2.2 "Agent"

Whenever the word "agent" is used, it shall be construed as meaning any person who has the right to practice before international authorities as defined in Article 49 and, unless the contrary clearly follows from the wording or the nature of the provision, or the context in which the word is used, also the common representative referred to in Rule 4.8.

2.3 "Signature"

Whenever the word "signature" is used, it shall be understood that, if the national law applied by the receiving Office or the competent International Searching or Preliminary Examining Authority requires the use of a seal instead of a signature, the word, for the purposes of that Office or Authority, shall mean seal.

35 U.S.C. 351 Definitions. When used in this part unless the context otherwise indicates—

(a) The term 'treaty' means the Patent Cooperation Treaty done at Washington, on June 19, 1970, excluding chapter II thereof.

(b) The term 'Regulations', when capitalized, means the Regulations under the treaty excluding part C thereof, done at Washington on the same date as the treaty. The term 'regulations', when not capitalized, means the regulations established by the Commissioner under this title.

(c) The term 'international application' means an application filed under the treaty.

(d) The term 'international application originating in the United States' means an international application filed in the Patent Office when it is acting as a Receiving Office under the treaty, irrespective of whether or not the United States has been designated in that international application.

(e) The term 'international application designating the United States' means an international application specifying the United States as a country in which a patent is sought, regardless where such international application is filed.

(f) The term 'Receiving Office' means a national patent office or intergovernmental organization which receives and processes international applications as prescribed by the treaty and the Regulations.

(g) The term 'International Searching Authority' means a national patent office or intergovernmental organization as appointed under the treaty which processes international applications as prescribed by the treaty and the Regulations.

(h) The term 'International Bureau' means the international intergovernmental organization which is recognized as the coordinating body under the treaty and the Regulations.

(i) Terms and expressions not defined in this part are to be taken in the sense indicated by the treaty and the Regulations.

37 CFR 1.401 Definitions of terms under the Patent Cooperation Treaty. (a) The abbreviation "PCT" and the term "Treaty" mean the Patent Cooperation Treaty.

(b) "International Bureau" means the World Intellectual Property Organization located in Geneva, Switzerland.

(c) "Administrative Instructions" means that body of instructions for operating under the Patent Cooperation Treaty referred to in PCT Rule 89.

(d) "Request", when capitalized, means that element of the international application described in PCT Rules 3 and 4.

(e) "International application", as used in this Subchapter is defined in § 1.9(b).

(f) "Priority date" for the purpose of computing time limits under the Patent Cooperation Treaty is defined in PCT Art. 2(xi). Note also § 1.465.

(g) Other terms and expressions in this Subpart C not defined in this section are to be taken in the sense indicated in PCT Act. 2 and 35 U.S.C. 351.

1803 Reservations Under the PCT Taken by the United States of America

ARTICLE 64

Reservations

(1) (a) Any State may declare that it shall not be bound by the provisions of Chapter II.

(b) States making a declaration under subparagraph (a) shall not be bound by the provisions of Chapter II and the corresponding provisions of the Regulations.

(2) (a) Any State not having made a declaration under paragraph (1) (a) may declare that:

(i) it shall not be bound by the provisions of Article 39(1) with respect to the furnishing of a copy of the international application and a translation thereof (as prescribed),

(ii) the obligation to delay national processing, as provided for under Article 40, shall not prevent publication, by or through its national Office, of the international application or a translation thereof, it being understood, however, that it is not exempted from the limitations provided for in Articles 30 and 38.

(b) States making such a declaration shall be bound accordingly.

(3) (a) Any State may declare that, as far as it is concerned, international publication of international applications is not required.

(b) Where, at the expiration of 18 months from the priority date, the international application contains the designation only of such States as have made declarations under subparagraph (a), the international application shall not be published by virtue of Article 21(2).

(c) Where the provisions of subparagraph (b) apply, the international application shall nevertheless be published by the International Bureau:

(i) at the request of the applicant, as provided in the Regulations,

(ii) when a national application or a patent based on the international application is published by or on behalf of the national Office of any designated State having made a declaration under subparagraph (a), promptly after such publication but not before the expiration of 18 months from the priority date.

(4) (a) Any State whose national law provides for prior art effect of its patents as from a date before publication, but does not equate for prior art purposes the priority date claimed under the Paris Convention for the Protection of Industrial Property to the actual filing date in that State, may declare that the filing outside that State of an international application desig-

nating that State is not equated to an actual filing in that State for prior art purposes.

(b) Any State making a declaration under subparagraph (a) shall to that extent not be bound by the provisions of Article 11(3).

(c) Any State making a declaration under subparagraph (a) shall, at the same time, state in writing the date from which, and the conditions under which, the prior art effect of any international application designating that State becomes effective in that State. This statement may be modified at any time by notification addressed to the Director General.

(5) Each State may declare that it does not consider itself bound by Article 59. With regard to any dispute between any Contracting State having made such a declaration and any other Contracting State, the provisions of Article 59 shall not apply.

(6) (a) Any declaration made under this Article shall be made in writing. It may be made at the time of signing this Treaty, at the time of depositing the instrument of ratification or accession, or, except in the case referred to in paragraph (5), at any later time by notification addressed to the Director General. In the case of the said notification, the declaration shall take effect six months after the day on which the Director General has received the notification, and shall not affect international applications filed prior to the expiration of the said six-month period.

(b) Any declaration made under this Article may be withdrawn at any time by notification addressed to the Director General. Such withdrawal shall take effect three months after the day on which the Director General has received the notification and, in the case of the withdrawal of a declaration made under paragraph (3), shall not affect international applications filed prior to the expiration of the said three-month period.

(7) No reservations to this Treaty other than the reservations under paragraphs (1) to (5) are permitted.

The United States of America has declared that it is not bound by Chapter II (Article 64(1)).

It has also declared that, as far as the United States of America is concerned that international publication is not required (Article 64(3)).

The third reservation which the United States of America made was under Article 64(4) which relates to the prior art effective date of a U.S. patent issuing from an international application.

1805 Who May File in the United States Receiving Office

PCT ARTICLE 9

The Applicant

(1) Any resident or national of a Contracting State may file an international application.

(2) The Assembly may decide to allow the residents and the nationals of any country party to the Paris Convention for the Protection of Industrial Property which is not party to this Treaty to file international applications.

(3) The concepts of residence and nationality, and the application of those concepts in cases where there are several applicants or where the applicants are not the same for all the designated States, are defined in the Regulations.

PCT RULE 18

The Applicant

18.1 Residence

(a) Subject to the provisions of paragraph (b), the question whether an applicant is a resident of the Contracting State of which he claims to be a resident shall depend on the national law of that State and shall be decided by the receiving Office.

(b) In any case, possession of a real and effective industrial or commercial establishment in a Contracting State shall be considered residence in that State.

18.2 Nationality

(a) Subject to the provisions of paragraph (b), the question whether an applicant is a national of the Contracting State of which he claims to be a national shall depend on the national law of that State and shall be decided by the receiving Office.

(b) In any case, a legal entity constituted according to the national law of a Contracting State shall be considered a national of that State.

18.3 Several Applicants: Same for All Designated States

If all the applicants are applicants for the purposes of all designated States, the right to file an international application shall exist if at least one of them is entitled to file an international application according to Article 9.

18.4 Several Applicants: Different for Different Designated States

(a) The international application may indicate different applicants for the purposes of different designated States, provided that, in respect of each designated State, at least one of the applicants indicated for the purposes of that State is entitled to file an international application according to Article 9.

(b) If the condition referred to in paragraph (a) is not fulfilled in respect of any designated State, the designation of that State shall be considered not to have been made.

(c) The International Bureau shall, from time to time, publish information on the various national laws in respect of the question who is qualified (inventor, successor in title of the inventor, owner of the invention, or other) to file a national application and shall accompany such information by a warning that the effect of the international application in any designated State may depend on whether the person designated in

the international application as applicant for the purposes of that State is a person who, under the national law of that State, is qualified to file a national application.

→ PCT RULE 19

The Competent Receiving Office

19.1 *Where to File*

(a) Subject to the provisions of paragraph (b), the international application shall be filed, at the option of the applicant, with the national Office of or acting for the Contracting State of which the applicant is a resident or with the national Office of or acting for the Contracting State of which the applicant is a national.

(b) Any Contracting State may agree with another Contracting State or any intergovernmental organization that the national Office of the latter State or the intergovernmental organization shall, for all or some purposes, act instead of the national Office of the former State as receiving Office for applicants who are residents or nationals of that former State. Notwithstanding such agreement, the national Office of the former State shall be considered the competent receiving Office for the purposes of Article 15(5).

(c) In connection with any decision made under Article 9(2), the Assembly shall appoint the national Office or the intergovernmental organization which will act as receiving Office for applications of residents or nationals of States specified by the Assembly. Such appointment shall require the previous consent of the said national Office or intergovernmental organization.

19.2 *Several Applicants*

→ If there are several applicants, the requirements of Rule 19.1 shall be considered to be met if the national Office with which the international application is filed is the national Office of or acting for a Contracting State of which at least one of the applicants is a resident or national.
↳

19.3 *Publication of Fact of Delegation of Duties of Receiving Office*

(a) Any agreement referred to in Rule 19.1(b) shall be promptly notified to the International Bureau by the Contracting State which delegates the duties of the receiving Office to the national Office of or acting for another Contracting State or an intergovernmental organization.

(b) The International Bureau shall, promptly upon receipt, publish the notification in the Gazette.

PCT ADMINISTRATIVE INSTRUCTION SECTION 317

Procedure in the Case of the Designation of a State being Considered Not To Have Been Made

Where the receiving Office finds that, under Rule 18.4(b), the designation of a State is to be considered as not having been made, it shall indicate that fact in the international application by enclosing the designation of that State within square brackets and entering the words "CONSIDERED NOT TO HAVE BEEN

MADE," or their equivalent in the language of the international application, in the margin, and shall promptly notify the applicant accordingly. If copies of the international application have already been sent to the International Bureau and the International Searching Authority, the receiving Office shall also notify promptly that Bureau and that Authority.

35 U.S.C. 361 *Receiving Office.* (a) The Patent Office shall act as a Receiving Office for international applications filed by nationals or residents of the United States. In accordance with any agreement made between the United States and another country, the Patent Office may also act as a Receiving Office for international applications filed by residents or nationals of such country who are entitled to file international applications.

(b) The Patent Office shall perform all acts connected with the discharge of duties required of a Receiving Office, including the collection of international fees and their transmittal to the International Bureau.

(c) International applications filed in the Patent Office shall be in the English language.

(d) The basic fee portion of the international fee, and the transmittal and search fees prescribed under section 376(a) of this part, shall be paid on filing of an international application. Payment of designation fees may be made on filing and shall be made not later than one year from the priority date of the international application.

35 U.S.C. 373 *Improper applicant.* An international application designating the United States, shall not be accepted by the Patent Office for the national stage if it was filed by anyone not qualified under chapter 11 of this title to be an applicant for the purpose of filing a national application in the United States. Such international applications shall not serve as the basis for the benefit of an earlier filing date under section 120 of this title in a subsequently filed application, but may serve as the basis for a claim of the right of priority under section 119 of this title, if the United States was not the sole country designated in such international application.

37 CFR 1.421 *Applicant for international application.* (a) Only residents or nationals of the United States of America may file international applications in the United States Receiving Office.

(b) Although the United States Receiving Office will accept international applications filed by any resident or national of the United States of America for international processing, an international application designating the United States of America will be accepted by the Patent and Trademark Office for the national stage only if filed by the inventor or as provided in §§ 1.422, 1.423 or 1.425.

(c) International applications which do not designate the United States of America may be filed by the assignee or owner.

(d) The attorney or agent of the applicant may sign the international application Request and file the inter-

national application for the applicant if the international application when filed is accompanied by a separate power of attorney to that attorney or agent from the applicant. The separate power of attorney from the applicant may be submitted after filing if sufficient cause is shown for not submitting it at the time of filing. Note that paragraph (b) of this section requires that the applicant be the inventor if the United States of America is designated.

(e) Any indication of different applicants for the purpose of different Designated Offices must be shown on the Request portion of the international application.

(f) Changes in the person, name, or address of the applicant of an international application shall be made in accordance with PCT Rule 18.5.

37 CFR 1.422 When the inventor is dead. In case of the death of the inventor, the legal representative (executor, administrator, etc.) of the deceased inventor may file an international application which designates the United States of America.

37 CFR 1.423 When the inventor is insane or legally incapacitated. In case an inventor is insane or otherwise legally incapacitated, the legal representative (guardian, conservator, etc.) of such inventor may file an international application which designates the United States of America.

37 CFR 1.424 Joint inventors. Joint inventors must jointly file an international application which designates the United States of America; the signature of either of them alone, or less than the entire number will be insufficient for an invention invented by them jointly, except as provided in § 1.425.

37 CFR 1.425 Filing by other than inventor. (a) If a joint inventor refuses to join in an international application which designates the United States of America or cannot be found or reached after diligent effort, the international application which designates the United States of America may be filed by the other inventor on behalf of himself or herself and the omitted inventor. Such an international application which designates the United States of America must be accompanied by proof of the pertinent facts and must state the last known address of the omitted inventor. The Patent and Trademark Office shall forward notice of the filing of the international application to the omitted inventor at said address.

(b) Whenever an inventor refuses to execute an international application which designates the United States of America, or cannot be found or reached after diligent effort, a person to whom the inventor has assigned or agreed in writing to assign the invention or who otherwise shows sufficient proprietary interest in the matter justifying such action may file the international application on behalf of and as agent for the inventor. Such an international application which designates the United States of America must be accompanied by proof of the pertinent facts and a showing that such action is necessary to preserve the rights of the parties or to prevent irreparable damage, and must state the last known address of the inventor. The assignment, written agreement to assign or other evi-

dence of proprietary interest, or a verified copy thereof, must be filed in the Patent and Trademark Office. The Office shall forward notice of the filing of the application to the inventor at the address stated in the application.

Any resident or national of the United States of America may file an international application in the United States Receiving Office (PCT Article 9(1) and (3), PCT Rule 19.1, 35 U.S.C. 361(a) and 37 CFR 1.412, 1.421). The concepts of residence and nationality are defined in PCT Rules 18.1 and 18.2. For the purpose of filing an international application, the applicant may be either the inventor or the successor in title of the inventor (assignee or owner). See also § 1820.02.

However, the laws of the various Designated countries regarding the requirements for applicants must also be considered when filing an international application. For example, the patent law of the United States of America requires that, for the purposes of designating the United States of America, the applicant(s) must be the inventor(s) (35 U.S.C. 373, PCT Article 27(3)).

Where there are different applicants for different States, at least one applicant designated for each State must be entitled to file an international application under PCT Article 9, and PCT Rule 18.4. See § 1820.09.

PCT Rule 19.2 relates to the situation where there are several applicants for all the Designated States. [R-3]

1807 Agent or Common Representative [R-3]

PCT ARTICLE 49

Right To Practice Before International Authorities

Any attorney, patent agent, or other person, having the right to practice before the national Office with which the international application was filed, shall be entitled to practice before the International Bureau and the competent International Searching Authority and competent International Preliminary Examining Authority in respect of that application.

PCT RULE 2

Interpretation of Certain Words

2.1 "Applicant"

Whenever the word "applicant" is used, it shall be construed as meaning also the agent or other representative of the applicant, except where the contrary clearly follows from the wording or the nature of the provision or the context in which the word is used such as in particular, where the provision refers to the residence or nationality of the applicant.

2.2 "Agent"

Whenever the word "agent" is used, it shall be construed as meaning any person who has the right to practice before international authorities as defined in Article 49 and, unless the contrary clearly follows from the wording or the nature of the provision, or the context in which the word is used, also the common representative referred to in Rule 4.8.

2.3 "Signature"

Whenever the word "signature" is used, it shall be understood that, if the national law applied by the receiving Office or the competent International Searching or Preliminary Examining Authority requires the use of a seal instead of a signature, the word, for the purposes of that Office or Authority, shall mean seal.

PCT RULE 83**Right To Practice Before International Authorities****83.1 Proof of Right**

The International Bureau, the competent International Searching Authority, and the competent International Preliminary Examining Authority, may require the production of proof of the right to practice referred to in Article 49.

83.2 Information

(a) The national Office or the intergovernmental organization which the interested person is alleged to have a right to practice before shall, upon request, inform the International Bureau, the competent International Searching Authority, or the competent International Preliminary Examining Authority, whether such person has the right to practice before it.

(b) Such information shall be binding upon the International Bureau, the International Searching Authority, or the International Preliminary Examining Authority, as the case may be.

PCT RULE 90**Representation****90.1 Definitions**

For the purposes of Rule 90.2 and Rule 90.3:

- (i) "agent" means any of the persons referred to in Article 49;
- (ii) "common representative" means the applicant referred to in Rule 4.8.

90.2 Effects

(a) Any act by or in relation to an agent shall have the effect of an act by or in relation to the applicant or applicants having appointed the agent.

(b) Any act by or in relation to a common representative or his agent shall have the effect of an act by or in relation to all the applicants.

(c) If there are several agents appointed by the same applicant or applicants, any act by or in relation to any of the several agents shall have the effect of an act by or in relation to the said applicant or applicants.

(d) The effects described in paragraphs (a), (b), and (c), shall apply to the processing of the international application before the receiving Office, the International Bureau, the International Searching Authority, and the International Preliminary Examining Authority.

90.3 Appointment

(a) Appointment of any agent, or of any common representative within the meaning of Rule 4.8(a), shall be effected by each applicant, at his choice, either by signing the request in which the agent or common representative is designated or by a separate power of attorney (i.e., a document appointing an agent or common representative).

(b) The power of attorney may be submitted to the receiving Office or the International Bureau. Whichever of the two is the recipient of the power of attorney submitted shall immediately notify the other and the interested International Preliminary Examining Authority.

(c) If the separate power of attorney is not signed as provided in paragraph (a), or if the required separate power of attorney is missing, or if the indication of the name or address of the appointed person does not comply with Rule 4.4, the power of attorney shall be considered non-existent unless the defect is corrected.

(d) A general power of attorney may be deposited with the receiving Office for purposes of the processing of the international application as defined in Rule 90.2 (d). Reference may be made in the request to such general power of attorney, provided that a copy thereof is attached to the request by the applicant.

90.4 Revocation

(a) Any appointment may be revoked by the persons who have made the appointment or their successors in title.

(b) Rule 90.3 shall apply, *mutatis mutandis*, to the document containing the revocation.

37 CFR 1.155 Representation in international applications. (a) Applicants of international applications may be represented by attorneys or agents licensed to practice before the Patent and Trademark Office or by a common representative (PCT Art. 49, Rules 4.8 and 90 and § 1.341).

(b) Appointment of an agent, attorney or common representative (PCT Rule 4.8) must be effected either in the Request form, signed by all applicants, or in a separate power of attorney submitted either to the United States Receiving Office or to the International Bureau.

(c) Powers of attorney and revocations thereof should be submitted to the United States Receiving Office until the issuance of the international search report.

(d) The addressee for correspondence will be as indicated in Section 108 of the Administrative Instructions.

PCT ADMINISTRATIVE INSTRUCTION SECTION 106

Common Agent for Several Applicants

(a) In the case of several applicants, any agent designated under Rule 4.7 in the request signed by all the applicants, or appointed under Rule 90.3 in a separate power of attorney signed by all the applicants, shall be considered a common agent.

(b) Where the international application is filed with reference to a general power of attorney not signed by all the applicants, it shall be sufficient for the purpose of appointment of a common agent under Rule 90.3, if the request or a separate power of attorney is signed by the applicant, who did not sign the general power of attorney.

PCT ADMINISTRATIVE INSTRUCTION SECTION 108

Correspondence Intended for the Applicant

(a) Any correspondence from an International Authority intended for the applicant, or, in the case of several applicants, the applicants, shall be addressed as follows:

(i) Where the applicant has designated or appointed one agent, correspondence shall be addressed to that agent. Where, in the case of several applicants, the applicants are represented by a common representative or a common agent, correspondence shall be addressed to that representative or that agent.

(ii) Where the applicant has designated several agents in the request, correspondence shall be addressed to the agent first mentioned therein. Where, in the case of several applicants, the applicants have designated several common agents in the request, correspondence shall be addressed to the common agent first mentioned therein.

(iii) Where the applicant has appointed several agents in one or more separate powers of attorney, correspondence shall be addressed to the agent first mentioned in the earliest filed and still valid separate power of attorney. Where, in the case of several applicants, the applicants have appointed several common agents in one or more separate powers of attorney, correspondence shall be addressed to the common agent first mentioned in the earliest filed and still valid separate power of attorney.

(b) Any correspondence from an International Authority to the applicant or his agent shall be marked with the file reference, composed either of letters or numbers, or both, of the applicant or the agent, if so indicated on the request Form, provided this reference does not exceed ten characters.

PCT ADMINISTRATIVE INSTRUCTION SECTION 206

Common Representative Designated in the Request

If the applicants designate a common representative in accordance with Rule 4.8(a), such common representative shall be indicated on the front page of the request Form. The indication of the common representa-

tive shall take the form of a statement designating the named applicant to act as the common representative on behalf of all the applicants.

Any act by or in relation to an agent has the effect of an act by or in relation to the applicant or applicants who have designated the agent; any act by or in relation to a common representative has the effect of an act by or in relation to all the applicants; the foregoing applies to the international phase (37 CFR 1.421(d) and 1.435).

In the national (or regional) phase, other agents usually have to be appointed (PCT Rule 90.2). The national laws of the designated states govern the appointment of agents or attorneys in the national stage.

Any attorney or agent registered to practice before the United States Patent and Trademark Office may be appointed as an agent under the Patent Cooperation Treaty to file applications in the United States Receiving Office (PCT Article 49 and PCT Rule 83).

The document containing the revocation must be signed by the applicant or, where there are several applicants, by all the applicants. It must be submitted to the Receiving Office or the International Bureau (PCT Rule 90.4).

Powers of attorney and revocations should be submitted to the United States Receiving Office until the Search Report has issued in order that communications may be correctly addressed. After the Search Report has issued, powers of attorney and revocations should be submitted to the International Bureau.

General powers of attorney are recognized for the purpose of filing and prosecuting an international application before the international authorities. The original general power of attorney should be deposited with the PCT Division in the Patent and Trademark Office and any applications relying thereon must include a copy thereof. A general power of attorney form is in Annex M2 of the "PCT Applicant's Guide."

See also § 1820.04 for the power of attorney on the Request form.

1808 Revocation of the Appointment of an Agent or a Common Representative

37 CFR 1.475 Changes in person, name, or address of applicants and inventors. All requests for a change in person, name or address of applicants and inventor be sent to the United States Receiving Office until the time of issuance of the international search report. Thereafter requests for such changes should be submitted to the International Bureau.

1810 Filing Date Requirements

PCT ARTICLE 11

Filing Date and Effects of the International Application

(1) The receiving Office shall accord as the international filing date the date of receipt of the international application, provided that that Office has found that, at the time of receipt:

- (i) the applicant does not obviously lack, for reasons of residence or nationality, the right to file an international application with the receiving Office,
- (ii) the international application is in the prescribed language,
- (iii) the international application contains at least the following elements:

(a) an indication that it is intended as an international application.

(b) the designation of at least one Contracting State,

(c) the name of the applicant, as prescribed,

(d) a part which on the face of it appears to be a description,

(e) a part which on the face of it appears to be a claim or claims.

(2) (a) If the receiving Office finds that the international application did not, at the time of receipt, fulfill the requirements listed in paragraph (1), it shall, as provided in the Regulations, invite the applicant to file the required correction.

(b) If the applicant complies with the invitation, as provided in the Regulations, the receiving Office shall accord as the international filing date the date of receipt of the required correction.

(3) Subject to Article 64(4), any international application fulfilling the requirements listed in items (i) to (iii) of paragraph (1) and accorded an international filing date shall have the effect of a regular national application in each designated State as of the international filing date, which date shall be considered to be the actual filing date in each designated State.

(4) Any international application fulfilling the requirements listed in items (i) to (iii) of paragraph (1) shall be equivalent to a regular national filing within the meaning of the Paris Convention for the Protection of Industrial Property.

35 U.S.C. 363 International application designating the United States: Effect. An international application designating the United States shall have the effect, from its international filing date under article 11 of the treaty, of a national application for patent regularly filed in the Patent Office except as otherwise provided in section 102(e) of this title.

35 U.S.C. 376 Fees. (a) The required payment of the international fee, which amount is specified in the Regulations, shall be paid in United States currency. The Patent Office may also charge the following fees:

- (1) A transmittal fee (see section 361(d));
- (2) A search fee (see section 361(d));

(3) A supplemental search fee (to be paid when required);

(4) A national fee (see section 371(c));

(5) A special fee (to be paid when required; see section 372(c));

(6) Such other fees as established by the Commissioner.

(b) The amounts of fees specified in subsection (a) of this section, except the international fee, shall be prescribed by the Commissioner. He may refund any sum paid by mistake or in excess of the fees so specified, or if required under the treaty and the Regulations. The Commissioner may also refund any part of the search fee, where he determines such refund to be warranted.

37 CFR 1.431 International application requirements.

(a) An international application shall contain, as specified in the Treaty and the Regulations, a Request, a description, one or more claims, an abstract, and one or more drawings (where required). (PCT Art. 3(2) and Section 207 of the Administrative Instructions.)

(b) An international filing date will be accorded by the United States Receiving Office, at the time of receipt of the international application, provided that:

(1) The applicant is a United States resident or national (35 U.S.C. 361(a), PCT Art. 11(1)(i)).

(2) The international application is in the English language (35 U.S.C. 361(c), PCT Art. 11(1)(ii)).

(3) The international application contains at least the following elements (PCT Art. 11(1)(iii)):

(i) an indication that it is intended as an international application (PCT Rule 4.2);

(ii) the designation of at least one Contracting State of the International Patent Cooperation Union;

(iii) the name of the applicant, as prescribed (note § 1.422);

(iv) a part which on the face of it appears to be a description; and

(v) a part which on the face of it appears to be a claim.

(c) Payment of the basic portion of the international fee (PCT Rule 15.2) and the transmittal and search fees (§ 1.445) shall be made in full at the time the international application papers required by paragraph (b) of this section are deposited. Failure to make full payment on the same date as the deposit of the international application papers required by subparagraph (b) of this section will result in the international application being considered withdrawn (PCT Art. 14(3)(a)).

37 CFR 1.445 International application filing and processing fees. (a) The following fees and charges are established by the Patent and Trademark Office under the authority of 35 U.S.C. 376:

(1) A transmittal fee (see 35 U.S.C. 361(d) and PCT Rule 14)—\$35.00.

(2) A search fee (see 35 U.S.C. 361(d) and PCT Rule 16)—\$300.00.

(3) A supplemental search fee when required (see

PCT Art. 17(3) (a) and PCT Rule 40.2)—\$200.00 per additional invention.

(4) The national fee, that is, the amount set forth as the filing fee under 35 U.S.C. 41 (a) (1).

(5) A special fee when required (see 35 U.S.C. 372(c))—\$10.00 per claim.

(b) The basic fee and designation fee portions of the international fee shall be as prescribed in PCT Rule 15.

THE "INTERNATIONAL FILING DATE"

An international filing date is accorded on the date on which the international application was received by the Receiving Office or—pursuant to the correction of defects—on a later date (PCT Articles 11(1) and 11(2) (b) and PCT Rules 20.1, 20.3, 20.4(a), 20.5, and 20.6) : in the former case, the international filing date will be the date on which the international application was received by the Receiving Office; in the latter case, the international filing date will be the date on which the correction was received by the Receiving Office. Any correction has to be submitted by the applicant within certain time limits. Where all the sheets pertaining to the same international application are not received on the same day by the Receiving Office, in most instances, the date of receipt of the application will be amended to reflect the date on which the last missing sheets were received. As an amended date of receipt may cause the priority claim to be forfeited, applicants should assure that all sheets of the application are deposited with the Receiving Office on the same day. For particulars see PCT Rule 20.2.

CONDITIONS THAT MUST BE FULFILLED FOR THE INTERNATIONAL APPLICATION TO BE ENTITLED TO AN "INTERNATIONAL FILING DATE"

An "international filing date" will be accorded to the international application by the United States Receiving Office if it finds that the conditions of PCT Art. 11(1) and 37 CFR 1.431 are fulfilled.

NON-PAYMENT, INCOMPLETE PAYMENT OR LATE PAYMENT OF FEES EFFECT ON THE "INTERNATIONAL FILING DATE"

The non-payment, incomplete or late payment of the fees does not affect the filing date since the payment of fees is not an Article 11(1) requirement. However, non-payment or incomplete payment of fees on filing will result in the Receiving Office declaring that the international application is considered withdrawn, except where only the designation fees are missing (PCT Article 14(3) (a), PCT Rule 27.1(a) and 35 U.S.C. 361(d)). Although an international application which has not received an international filing date and an international applica-

tion which is considered to be withdrawn are both excluded from further processing in the international phase, an international application which fulfills the requirements necessary for being accorded an international filing date may be invoked as a priority application under the Paris Convention (PCT Article 11(4)) (if the conditions set by that Convention are fulfilled) even where it will be considered as withdrawn for non-payment of fees or other reasons.

1812 Elements of the International Application [R-3]

PCT ARTICLE 3

The International Application

(1) Applications for the protection of inventions in any of the Contracting States may be filed as international applications under this Treaty.

(2) An international application shall contain, as specified in this Treaty and the Regulations, a request, a description, one or more claims, one or more drawings (where required), and an abstract.

(3) The abstract merely serves the purpose of technical information and cannot be taken into account for any other purpose, particularly not for the purpose of interpreting the scope of the protection sought.

(4) The international application shall :

(i) be in a prescribed language;

(ii) comply with the prescribed physical requirements;

(iii) comply with the prescribed requirement of unity of invention;

(iv) be subject to the payment of the prescribed fees.

PCT RULE 9

Expressions, etc., Not To Be Used

9.1 Definition

The international application shall not contain :

(i) expressions or drawings contrary to morality;

(ii) expressions or drawings contrary to public order;

(iii) statements disparaging the products or processes of any particular person other than the applicant, or the merits or validity of applications or patents of any such person (mere comparisons with the prior art shall not be considered disparaging *per se*);

(iv) any statement or other matter obviously irrelevant or unnecessary under the circumstances.

9.2 Noting of Lack of Compliance

The receiving Office and the International Searching Authority may note lack of compliance with the prescriptions of Rule 9.1 and may suggest to the applicant that he voluntarily correct his international application accordingly. If the lack of compliance was noted by the receiving Office, that Office shall inform the com-

petent International Searching Authority and the International Bureau; if the lack of compliance was noted by the International Searching Authority, that Authority shall inform the receiving Office and the International Bureau.

9.3 Reference to Article 21(6)

"Disparaging statements," referred to in Article 21(6), shall have the meaning as defined in Rule 9.1 (iii).

PCT RULE 10

Terminology and Signs

10.1 Terminology and Signs

(a) Units of weights and measures shall be expressed in terms of the metric system, or also expressed in such terms if first expressed in terms of a different system.

→ (b) Temperatures shall be expressed in degrees Celsius, or also expressed in degrees Celsius, if first expressed in a different manner.

→ (c) (deleted)

(d) For indications of heat, energy, light, sound and magnetism, as well as for mathematical formulae and electrical units, the rules of international practice shall be observed; for chemical formulae the symbols, atomic weights, and molecular formulae, in general use, shall be employed.

(e) In general, only such technical terms, signs and symbols should be used as are generally accepted in the art.

(f) When the international application or its translation is in English or Japanese, the beginning of any decimal fraction shall be marked by a period, whereas, when the international application or its translation is in a language other than English or Japanese, it shall be marked by a comma.

10.2 Consistency

The terminology and the signs shall be consistent throughout the international application.

PCT RULE 12

Language of the International Application

12.1 The International Application

Any international application shall be filed in the language, or one of the languages, specified in the agreement concluded between the International Bureau and the International Searching Authority competent for the international searching of that application, provided that, if the agreement specifies several languages, the receiving Office may prescribe among the specified languages that language in which or those languages in one of which the international application must be filed.

12.2 Changes in the International Application

Any changes in the international application, such as amendments and corrections, shall be in the same language as the said application (cf. Rule 66.5).

PCT ADMINISTRATIVE INSTRUCTION SECTION 207

Arrangement of Elements and Numbering of Sheets of the International Application

(a) In effecting the sequential numbering of the sheets of the international application in accordance with Rule 11.7, the elements of the international application shall be placed in the following order: the request, the description, the claims, the abstract, the drawings.

(b) The sequential numbering of the sheets shall be effected by using three separate series of numbering, the first series applying to the request only and commencing with the first sheet of the request, the second series commencing with the first sheet of the description and continuing through the claims until the last sheet of the abstract, and the third series being applicable to the sheets of the drawings only and commencing with the first sheet of the drawings.

Any international application must contain the following elements: Request, description, claim or claims, abstract and one or more drawings (where drawings are necessary for the understanding of the invention (PCT Article 3(2) and PCT Article 7(2))). The elements of the international application are to be arranged in the following order: the Request, the description, the claims, the abstract, and the drawings (PCT Administrative Instructions, Section 207 (a)). All the sheets contained in the international application must be numbered in consecutive Arabic numerals by using three separate series of numbers; the first applying to the Request, the second to the description, claims and abstract, and the third to the drawings (PCT Rule 11.7 and PCT Administrative Instructions Section 207(b)). Only one copy of the international application need be filed in the United States Receiving Office (37 CFR 1.433(a)).

1815 Formal Requirements of an International Application [R-3] ←

PCT RULE 11

Physical Requirements of the International Application

11.1 Number of Copies

(a) Subject to the provisions of paragraph (b), the international application and each of the documents referred to in the check list (Rule 3.3(a)(ii)) shall be filed in one copy.

(b) Any receiving Office may require that the international application and any of the documents referred to in the check list (Rule 3.3(a)(ii)), except the receipt for the fees paid or the check for the payment of the fees, be filed in two or three copies. In that case, the receiving Office shall be responsible for verifying the identity of the second and the third copies with the record copy.

11.2 Fitness for Reproduction

(a) All elements of the international application (i.e., the request, the description, the claims, the drawings, and the abstract) shall be so presented as to admit of direct reproduction by photography, electrostatic processes, photo offset, and microfilming, in any number of copies.

(b) All sheets shall be free from creases and cracks; they shall not be folded.

(c) Only one side of each sheet shall be used.

(d) Subject to Rule 11.10(d) and Rule 11.13(j), each sheet shall be used in an upright position (i.e., the short sides at the top and bottom).

11.3 Material to be Used

All elements of the international application shall be on paper which shall be flexible, strong, white, smooth, non-shiny, and durable.

11.4 Separate Sheets, Etc.

(a) Each element (request, description, claims, drawings, abstract) of the international application shall commence on a new sheet.

(b) All sheets of the international application shall be so connected that they can be easily turned when consulted, and easily separated and joined again if they have been separated for reproduction purposes.

11.5 Size of Sheets

The size of the sheets shall be A4 (29.7 cm. x 21 cm.). However, any receiving Office may accept international applications on sheets of other sizes provided that the record copy, as transmitted to the International Bureau, and, if the competent International Searching Authority so desires, the search copy, shall be of A4 size.

11.6 Margins

(a) The minimum margins of the sheets containing the request, the description, the claims, and the abstract, shall be as follows:

- top: 2 cm.
- left side: 2.5 cm.
- right side: 2 cm.
- bottom: 2 cm.

(b) The recommended maximum, for the margins provided for in paragraph (a), is as follows:

- top: 4 cm.
- left side: 4 cm.
- right side: 3 cm.
- bottom: 3 cm.

(c) On sheets containing drawings, the surface usable shall not exceed 26.2 cm. x 17.0 cm. The sheets shall not contain frames around the usable or used surface. The minimum margins shall be as follows:

- top: 2.5 cm.
- left side: 2.5 cm.
- right side: 1.5 cm.

—bottom: 1.0 cm.

(d) The margins referred to in paragraphs (a) to (c) apply to A4-size sheets, so that, even if the receiving Office accepts other sizes, the A4-size record copy and, when so required, the A4-size search copy shall leave the aforesaid margins.

(e) The margins of the international application, when submitted, must be completely blank.

11.7 Numbering of Sheets

(a) All the sheets contained in the international application shall be numbered in consecutive arabic numerals.

(b) The numbers shall be placed at the top of the sheet, in the middle, but not in the margin.

11.8 Numbering of Lines

(a) It is strongly recommended to number every fifth line of each sheet of the description, and of each sheet of claims.

(b) The numbers should appear on the left side, to the right of the margin.

11.9 Writing of Text Matter

(a) The request, the description, the claims and the abstract shall be typed or printed.

(b) Only graphic symbols and characters, chemical or mathematical formulae, and certain characters in the Japanese language may, when necessary, be written by hand or drawn.

(c) The typing shall be 1½-spaced.

(d) All text matter shall be in characters the capital letters of which are not less than 0.21 cm. high, and shall be in a dark, indelible color, satisfying the requirements specified in Rule 11.2.

(e) As far as the spacing of the typing and the size of the characters are concerned, paragraphs (c) and (d) shall not apply to texts in the Japanese language.

11.10 Drawings, Formulae, and Tables, in Text Matter

(a) The request, the description, the claims and the abstract shall not contain drawings.

(b) The description, the claims and the abstract may contain chemical or mathematical formulae.

(c) The description and the abstract may contain tables; any claim may contain tables only if the subject matter of the claim makes the use of tables desirable.

(d) Tables and chemical or mathematical formulae may be placed sideways on the sheet if they cannot be presented satisfactorily in an upright position thereon; sheets on which tables or chemical or mathematical formulae are presented sideways shall be so presented that the tops of the tables or formulae are at the left side of the sheet.

11.11 Words in Drawings

(a) The drawings shall not contain text matter, except a single word or words, when absolutely indispensable, such as "water," "steam," "open," "closed," "section on AB," and, in the case of electric circuits

and block schematic or flow sheet diagrams, a few short catch words indispensable for understanding.

(b) Any words used shall be so placed that, if translated, they may be pasted over without interfering with any lines of the drawings.

11.12 Alterations, etc.

Each sheet shall be reasonably free from erasures and shall be free from alterations, overwritings, and interlineations. Non-compliance with this Rule may be authorized if the authenticity of the content is not in question and the requirements for good reproduction are not in jeopardy.

11.13 Special Requirements for Drawings

(a) Drawings shall be executed in durable, black, sufficiently dense and dark, uniformly thick and well-defined, lines and strokes without colorings.

(b) Cross-sections shall be indicated by oblique hatching which should not impede the clear reading of the reference signs and leading lines.

(c) The scale of the drawings and the distinctness of their graphical execution shall be such that a photographic reproduction with a linear reduction in size to two-thirds would enable all details to be distinguished without difficulty.

(d) When, in exceptional cases, the scale is given on a drawing, it shall be represented graphically.

(e) All numbers, letters, and reference lines, appearing on the drawings, shall be simple and clear. Brackets, circles or inverted commas shall not be used in association with numbers and letters.

(f) All lines in the drawings shall, ordinarily, be drawn with the aid of drafting instruments.

(g) Each element of each figure shall be in proper proportion to each of the other elements in the figure, except where the use of a different proportion is indispensable for the clarity of the figure.

(h) The height of the numbers and letters shall not be less than 0.32 cm. For the lettering of drawings, the Latin and, where customary, the Greek alphabets shall be used.

(i) The same sheet of drawings may contain several figures. Where figures on two or more sheets form in effect a single complete figure, the figures on the several sheets shall be so arranged that the complete figure can be assembled without concealing any part of any of the figures appearing on the various sheets.

(j) The different figures shall be arranged on a sheet or sheets without wasting space, preferably in an upright position, clearly separated from one another.

Where the figures are not arranged in an upright position, they shall be presented sideways with the top of the figures at the left side of the sheet.

(k) The different figures shall be numbered in arabic numerals consecutively and independently of the numbering of the sheets.

(l) Reference signs not mentioned in the description shall not appear in the drawings, and vice versa.

(m) The same features, when denoted by reference

signs, shall, throughout the international application, be denoted by the same signs.

(n) If the drawings contain a large number of reference signs, it is strongly recommended to attach a separate sheet listing all reference signs and the features denoted by them.

11.14 Later Documents

Rules 10, 11.1 to 11.13 also apply to any document—for example, corrected pages, amended claims—submitted after the filing of the international application.

11.15 Translations

No designated Office shall require that the translations of an international application filed with it comply with requirements other than those prescribed for the international application as filed.

37 CFR 1.433 *Physical requirements of international application.* (a) The international application and each of the documents that may be referred to in the check list of the Request (PCT Rule 3.3(a)(ii)) shall be filed in one copy only.

(b) All sheets of the international application must be on A4 size paper (21.0 x 29.7 cm.).

(c) Other physical requirements for international applications are set forth in PCT Rule 11 and Sections 201-207 of the Administrative Instructions.

The international application must comply with certain physical requirements, e.g., requirements concerning: fitness for reproduction (PCT Rule 11.2), the size of the sheets (PCT Rule 11.5), the margin sizes (PCT Rule 11.6), the numbering of the lines in the description and claims (PCT Rule 11.8), the writing of text materials (PCT Rule 11.9), etc. The specifics of each of these requirements are set forth in PCT Rule 11; however, two major requirements in application format are to be especially noted. The first requirement is that all papers in the international applications be "A4" size, which is 29.7 cm. by 21 cm. (PCT Rule 11.5) (approximately 11-11/16 inches by 8-1/4 inches), and the second is the requirement that the typing in the application be at 1 1/2 spacing (PCT Rule 11.9(c)). The international application must also be drafted to satisfy certain other formal requirements. It must not contain matter contrary to morality or public order, disparaging statements, or obviously irrelevant or unnecessary matter (PCT Rule 9). Units of weights, measures and density should be expressed in terms of the metric system, and temperatures in terms of degrees Centigrade (PCT Rule 10). The general rule with respect to terminology and signs is: only such technical terms, signs and symbols should be used as are generally accepted in the art. An international application filed in the United States Receiving Office must be in the English language (PCT Rule 12.1 and 35 U.S.C. 361(c)). International applications which comply with the PCT

formal requirements are acceptable by all PCT member States (PCT Article 27(1)).

→ 1820 The Request [R-3]

PCT ARTICLE 4

The Request

(1) The request shall contain :

(i) a petition to the effect that the international application be processed according to this Treaty ;

(ii) the designation of the Contracting State or States in which protection for the invention is desired on the basis of the international application ("designated States") ; if for any designated State a regional patent is available and the applicant wishes to obtain a regional patent rather than a national patent, the request shall so indicate ; if, under a treaty concerning a regional patent, the applicant cannot limit his application to certain of the States party to that treaty, designation of one of those States and the indication of the wish to obtain the regional patent shall be treated as designation of all the States party to that treaty ; if, under the national law of the designated State, the designation of that State has the effect of an application for a regional patent, the designation of the said State shall be treated as an indication of the wish to obtain the regional patent ;

(iii) the name of and other prescribed data concerning the applicant and the agent (if any) ;

(iv) the title of the invention ;

(v) the name of and other prescribed data concerning the inventor where the national law of at least one of the designated States requires that these indications be furnished at the time of filing a national application. Otherwise, the said indications may be furnished either in the request or in separate notices addressed to each designated office whose national law requires the furnishing of the said indications but allows that they be furnished at a time later than that of the filing of a national application.

(2) Every designation shall be subject to the payment of the prescribed fee within the prescribed time limit.

(3) Unless the applicant asks for any of the other kinds of protection referred to in Article 43, designation shall mean that the desired protection consists of the grant of a patent by or for the designated State. For the purposes of this paragraph, Article 2(ii) shall not apply.

(4) Failure to indicate in the request the name and other prescribed data concerning the inventor shall have no consequence in any designated State whose national law requires the furnishing of the said indications but allows that they be furnished at a time later than that of the filing of a national application. Failure to furnish the said indications in a separate notice shall have no consequence in any designated

State whose national law does not require the furnishing of the said indications.

PCT RULE 3

The Request (Form)

3.1 Printed Form

The request shall be made on a printed form.

3.2 Availability of Forms

Copies of the printed form shall be furnished free of charge to the applicants by the receiving Office, or, if the receiving Office so desires, by the International Bureau.

3.3 Check List

(a) The printed form shall contain a list which, when filled in, will show :

(i) the total number of sheets constituting the international application and the number of the sheets of each element of the international application (request, description, claims, drawings, abstract),

(ii) whether or not the international application as filed is accompanied by a power of attorney (i.e., a document appointing an agent or a common representative), a priority document, a receipt for the fees paid or a check for the payment of the fees, an international or an international-type search report, a document in evidence of the fact that the applicant is the successor in title of the inventor, and any other document (to be specified in the check list),

(iii) the number of that figure of the drawings which the applicant suggests should accompany the abstract when the abstract is published on the front page of the pamphlet and in the Gazette ; in exceptional cases, the applicant may suggest more than one figure.

(b) The list shall be filled in by the applicant, failing which the receiving Office shall fill it in and make the necessary annotations, except that the number referred to in paragraph (a) (iii) shall not be filled in by the receiving Office.

3.4 Particulars

Subject to Rule 3.3, particulars of the printed form shall be prescribed by the Administrative Instructions.

PCT RULE 4

The Request (Contents)

4.1 Mandatory and Optional Contents; Signature

(a) The request shall contain :

(i) a petition,

(ii) the title of the invention,

(iii) indications concerning the applicant and the agent, if there is an agent,

(iv) the designation of States,

(v) indications concerning the inventor where the national law of at least one of the designated States requires that the name of the inventor be furnished at the time of filing a national application.

(b) The request shall, where applicable, contain:

- (i) a priority claim,
- (ii) a reference to any earlier international, international-type or other search.
- (iii) choices of certain kinds of protection.
- (iv) an indication that the applicant wishes to obtain a regional patent and the names of the designated States for which he wishes to obtain such a patent,
- (v) a reference to a parent application or parent patent.

(c) The request may contain indications concerning the inventor where the national law of none of the designated States requires that the name of the inventor be furnished at the time of filing a national application.

(d) The request shall be signed.

4.2 The Petition

The petition shall be to the following effect and shall preferably be worded as follows: "The undersigned requests that the present international application be processed according to the Patent Cooperation Treaty."

* * * * *

(See §§ 1820.01-1820.11 for PCT Rules 4.3-4.15)

* * * * *

4.16 Transliteration or Translation of Certain Words

(a) Where any name or address is written in characters other than those of the Latin alphabet, the same shall also be indicated in characters of the Latin alphabet either as a mere transliteration or through translation into English. The applicant shall decide which words will be merely transliterated and which words, will be so translated.

(b) The name of any country written in characters other than those of the Latin alphabet shall also be indicated in English.

4.17 No Additional Matter

(a) The request shall contain no matter other than that specified in Rules 4.1 to 4.16.

37 CFR 1.434 The request. (a) The request shall be made on a standardized printed form (PCT Rules 3 and 4). Copies of such printed Request forms are available from the Patent and Trademark Office. Letters requesting such forms should be marked "Box PCT."

(b) The Check List portion of the Request form should indicate each document accompanying the international application on filing.

(c) All information, for example, addresses, names of States and dates, shall be indicated in the Request as required by PCT Rule 4 and Administrative Instructions 110 and 201.

(d) International applications which designate the United States of America shall include:

(1) The name, address and signature of the inventor, except as provided by §§ 1.421(d), 1.422, 1.423 and 1.425;

(2) A reference to any copending national application or international application designating the

United States of America, if the benefit of the filing date for the prior copending application is to be claimed.

PCT ADMINISTRATIVE INSTRUCTION SECTION 303

Deletion of Additional Matter in the Request

Where, under Rule 4.17(b), the receiving Office deletes *ex officio* any matter contained in the request, it shall do so by placing such matter between square brackets and entering the word "DELETED," or its equivalent in the language of the international application, in the right-hand margin adjacent to the matter so placed between brackets, and shall notify the applicant accordingly. If copies of the international application have already been sent to the International Bureau and the International Searching Authority, the receiving Office shall also notify that Bureau and that Authority.

The Request contain a petition to the effect that the international application be processed according to the PCT; it must contain certain bibliographic information (PCT Article 4(1), PCT Rules 3 and 4 and 37 CFR 1.434). The Request must be made on a printed form (PCT/RO/101) to be filled in with the required information (PCT Rules 3.1, 3.2 and Administrative Instruction Section 102(b)). Any prospective applicant may obtain English language Request forms free of charge from the United States Patent and Trademark Office, Box PCT, Washington, D.C. 20231. The PCT sets forth specific requirements for each element of bibliographic information on the Request form. The Request may not contain any matter that is not specified in PCT Rule 4. Any additional material will be deleted *ex-officio* (Administrative Instruction Section 303).

APPLICANT OR AGENT'S FILE REFERENCE

The applicant or agent may use a file reference composed either of letters or numbers or both, provided the file reference does not exceed ten characters. If a file reference is indicated on the Request form, any correspondence from an International Authority to the applicant or agent will include it (Administrative Instructions Section 108).

SUPPLEMENTAL BOX

This box is used for any material which cannot be placed in one of the previous boxes because of space limitations. The supplemental information placed in this box should be clearly entitled with the Box number from which it is continued, e.g., III. Inventor (Continued). If the supplemental box does not contain sufficient space, the material should be continued on an additional plain sheet of A4 size paper. If such a continuation sheet is used, it is numbered as an additional page 4 of the Request and counted

accordingly in the total number of sheets for fee calculation purposes. The sheet should be entitled "Continuation Sheet to the Request".

1820.01 Title of the Invention

PCT Rule 4.3 Title of the Invention

The title of the invention shall be short (preferably from two to seven words when in English or translated into English) and precise.

The Request must contain the title of the invention; the title must be short (preferably 2 to 7 words) and precise (PCT Rule 4.3). The title in Box I of the Request is considered to be the title of the application. The title appearing on the first page of the description (PCT Rule 5.1(a)) and on the page containing the abstract should be consistent with the title indicated in Box I of the Request form.

1820.02 Applicant

PCT Rule 4.4 Names and Addresses

(a) Names of natural persons shall be indicated by the person's family name and given name(s), the family name being indicated before the given name(s).

(b) Names of legal entities shall be indicated by their full, official designations.

(c) Addresses shall be indicated in such a way as to satisfy the customary requirements for prompt postal delivery at the indicated address and, in any case, shall consist of all the relevant administrative units up to, and including the house number, if any. Where the national law of the designated State does not require the indication of the house number, failure to indicate such number shall have no effect in that State. It is recommended to indicate any telegraphic and teleprinter address and telephone number.

(d) For each applicant, inventor, or agent, only one address may be indicated.

PCT Rule 4.5 The Applicant

(a) The request shall indicate the name, address, nationality and residence of the applicant or, if there are several applicants, of each of them.

(b) The applicant's nationality shall be indicated by the name of the State of which he is a national.

(c) The applicant's residence shall be indicated by the name of the State of which he is a resident.

PCT ADMINISTRATIVE INSTRUCTION SECTION 306

Change in the Person, Name or Address of the Applicant

Any request for the recording of any changes in the person or name of the applicant referred to in Rule 18.5 or Rule 54.4, or of any change in the address of the applicant shall be signed by the applicant or, if the receiving Office requested such change under Rule 18.5 or Rule 54.4, by the receiving Office. The request

shall indicate the name or address of the applicant for which the change is requested.

The names of natural persons must be given with the family name being indicated before the given name (PCT Rule 4.4). The names of legal entities should be given in full. All addresses should be spelled out in full and include the name of the country in order to assure correct publication of the information. If the United States of America is designated, the applicant must be the inventor at the time of filing (35 U.S.C. 373). PCT Rule 18.5 may not be used to name the inventor as the applicant for the United States of America after the international application has been filed.

The applicant of an international application for Designated Office other than the United States of America may be either the inventor or the owner of the invention. In cases where the inventor is the applicant for certain designated countries and the owner or assignee is the applicant for other designated countries, the names and other identifying information of both must appear under Box II. As only one name should be listed in this box, additional applicants should be listed in the "supplemental box" on page 3 of the Request form. All information required in Box II should be given for applicants named in the Supplemental Box, including residence and nationality.

It should be noted that at least one of the inventors must be a resident or national of a PCT Member country in order for the application to enter the national stage in the United States of America. This point involves two basic issues which must be addressed separately. One issue relates to the requirements for a valid designation of the United States of America. The other issue relates to the requirements of the U.S. national law in order for the U.S. Patent and Trademark Office to accept the international application for the national stage. As to the first issue, PCT Rules 18.3 and 18.4 require that *at least one* of the applicants for each designated State must be a resident or national of a member country of the PCT Union in order for the designation to be valid. As to the second issue, although the designation of the United States of America may be valid for PCT international procedure, the international application will not be accepted at the United States national stage unless the applicant is the inventor (PCT Article 27(3) and 35 U.S.C. 111 and 373). Therefore, at least one of the inventors must be a resident of a PCT member country in order for the international application to enter the national stage in the United States of America.

It should be noted, however, that if the owner or assignee is a resident or national of a PCT member country, the owner can be the sole ap-

applicant and file an international application designating all current PCT member countries other than the United States of America. Any invalid designation of States for which at least one applicant is not a resident or national of a Contracting State will be deleted by the Receiving Office.

1820.03 Inventor

PCT Rule 4.6 The Inventor

(a) Where Rule 4.1(a)(v) applies, the request shall indicate the name and address of the inventor or, if there are several inventors, of each of them.

(b) If the applicant is the inventor, the request, in lieu of the indication under paragraph (a), shall contain a statement to that effect or shall repeat the applicant's name in the space reserved for indicating the inventor.

(c) The request may, for different designated States, indicate different persons as inventors where, in this respect, the requirements of the national laws of the designated States are not the same. In such a case, the request shall contain a separate statement for each designated State or group of States in which a particular person, or the same person, is to be considered the inventor, or in which particular persons, or the same persons, are to be considered the inventors.

For purposes of the designated countries, the name and address of the inventor must be indicated either in the Request or later at some other point in the procedure (PCT Article 4(1)(v), 4(4), and 22(1); and PCT Rules 4.1(a)(v) and 4.6(a)). If all applicants are the inventors, the small box indicating that "Applicant is the inventor" may be checked. Otherwise, the name and address of the inventor(s) should be placed in Box III if any of the designated countries require the inventor to be named on filing. Only one inventor should be named in Box III; additional inventors should be identified in the "supplemental box" on page 3 of the Request form. Names should be indicated with the family name preceding the given name, and addresses should be spelled out in full, including both the zip code and country.

1820.04 Agent or Common Representative (if any) [R-3]

PCT Rule 4.7 The Agent

If agents are designated, the request shall so indicate, and shall state their names and addresses.

PCT Rule 4.8 Representation of Several Applicants Not Having Common Agent

(a) If there is more than one applicant and the request does not refer to an agent representing all the applicants ("a common agent"), the request shall des-

ignate one of the applicants who is entitled to file an international application according to Article 9 as their common representative.

(b) If there is more than one applicant and the request does not refer to an agent representing all the applicants and it does not comply with the requirement of designating one of the applicants as provided in paragraph (a), the common representative shall be the applicant first named in the request who is entitled to file an international application with the receiving Office with which the international application was filed (Rule 19.1(a)).

Any attorney or agent registered to practice before the Patent and Trademark Office may act as an agent for the applicant in an international application filed in the United States Receiving Office. Sub-box A of Box IV may be checked and the Request form then becomes a power of attorney document. In this case, all the applicants must sign the Request form at Box XI. If all signatures will not fit in Box XI, the "supplemental box" on page 3 of the Request may be used. When Box B is checked, all applicants must sign the separate power of attorney document and the attorney may sign the Request at Box XI.

It should be noted that under PCT there is no provision for correspondence addresses or associate attorneys. The first-named attorney or agent will receive correspondence (PCT Administrative Instructions Section 108(a)). If the power of attorney is found to be defective, the first-named applicant will receive any correspondence.

Joint applicants may also designate one of the applicants to be a common representative under PCT Rule 4.8(a). If a common representative is desired, the applicant so named should be placed in Box IV (Administrative Instruction Section 206).

1820.05 Designation of States [R-3]

PCT ARTICLE 43

Seeking Certain Kinds of Protection

In respect of any designated or elected State whose law provides for the grant of inventors' certificates, utility certificates, utility models, patents or certificates of addition, inventors' certificates of addition, or utility certificates of addition, the applicant may indicate, as prescribed in the Regulations, that his international application is for the grant, as far as that State is concerned, of an inventor's certificate, a utility certificate, or a utility model, rather than a patent, or that it is for the grant of a patent or certificate of addition, an inventor's certificate of addition, or a utility certificate of addition, and the ensuing effect shall be governed by the applicant's choice. For the purposes of this Article and any Rule thereunder, Article 2(ii) shall not apply.

PCT ARTICLE 44

Seeking Two Kinds of Protection

In respect of any designated or elected State whose law permits an application, while being for the grant of a patent or one of the other kinds of protection referred to in Article 43, to be also for the grant of another of the said kinds of protection, the applicant may indicate, as prescribed in the Regulations, the two kinds of protection he is seeking, and the ensuing effect shall be governed by the applicant's indications. For the purposes of this Article, Article 2(ii) shall not apply.

PCT ARTICLE 45

Regional Patent Treaties

(1) Any treaty providing for the grant of regional patents ("regional patent treaty"), and giving to all persons who, according to Article 9, are entitled to file international applications the right to file applications for such patents, may provide that international applications designating or electing a State party to both the regional patent treaty and the present Treaty may be filed as applications for such patents.

(2) The national law of the said designated or elected State may provide that any designation or election of such State in the international application shall have the effect of an indication of the wish to obtain a regional patent under the regional patent treaty.

PCT Rule 4.9 Designation of States

Contracting States shall be designated in the request by their names.

* * * * *

PCT Rule 4.12 Choice of Certain Kinds of Protection

(a) If the applicant wishes his international application to be treated, in any designated State, as an application not for a patent but for the grant of any of the other kinds of protection specified in Article 43, he shall so indicate in the request. For the purposes of this paragraph, Article 2(ii) shall not apply.

(b) In the case provided for in Article 44, the applicant shall indicate the two kinds of protection sought, or, if one of two kinds of protection is primarily sought, he shall indicate which kind is sought primarily and which kind is sought subsidiarily.

37 CFR 1.432 Designation of States and payment of designation fees. (a) The names of Designated States shall appear in the Request upon filing and must be indicated as set forth in Section 201 of the Administrative Instructions.

(b) The designation fees may be paid upon filing of the international application, but must be paid at the latest before the expiration of one year from the priority date (PCT Rule 15.4(b)). Failure to timely pay the designation fee for a particular Designated State will result in the withdrawal of that designation (PCT Art. 14(3)(b)). Failure to timely pay at least one designation fee will result in the withdrawal of the international application (PCT Art. 14(3)(a)).

PCT ADMINISTRATIVE INSTRUCTION SECTION 201

Names of States: Cancellation of Designations

(a) The name of any State referred to in the request shall be indicated either by the full name of the State or by a generally accepted short title which, if the indications are in English or French, shall be as appears in *Annex A*. The receiving Office, or the International Bureau where the receiving Office fails to do so, shall insert, in the appropriate space provided for in the request form, the two-letter country code as appears in *Annex B* (for example, where France is the third designated State in Box V of the request Form, "FR 3. France" or "FR 3. French Republic").

(b) The receiving Office shall cancel *ex-officio* the designation of States other than Contracting States, and inform the applicant promptly of such action. If the international application has already been sent to the International Bureau and the International Searching Authority, the receiving Office shall also notify promptly that Bureau and that Authority. In any event, the International Bureau shall, where the receiving Office fails to do so, cancel *ex-officio* the designation of States other than Contracting States and inform the applicant, the receiving Office and the International Searching Authority promptly of such action.

PCT ADMINISTRATIVE INSTRUCTION SECTION 202

Kind of Protection

(a) Where the applicant wishes his application to be treated in any designated State as an application not for a patent but for the grant of another kind of protection referred to in Article 43, he shall make the indication in the request referred to in Rule 4.12(a) by inserting the words "inventor's certificate," "utility certificate," "utility model," "patent of addition," "certificate of addition," "inventor's certificate of addition" or "utility certificate of addition," or their equivalent in the language of the international application, immediately after the indication of the said State.

(b) Where the applicant is seeking two kinds of protection under Article 44, he shall make the indication in the request referred to in Rule 4.12(b) by inserting, immediately after the indication of the said State and in the language of the international application, either.

(i) any two of the following terms connected by the word "and": "patent," "inventor's certificate," "utility certificate," "utility model," "patent of addition," "certificate of addition," "inventor's certificate of addition," "utility certificate of addition;" or

(ii) any two of the terms indicated in (i) above, one of them preceded by the word "primarily" and the other by the word "subsidiarily."

PCT ADMINISTRATIVE INSTRUCTION SECTION 203

Regional Patents

(1) Where the applicant wishes to obtain a regional patent in respect of any designated State, he shall, sub-

ject to paragraphs (2) and (3), make the indication in the request referred to in Rule 4.1(b)(iv) by inserting the words "regional patent," or their equivalent in the language of the international application, immediately after the indication of the said State or, where an indication has been made under Section 202, after that indication, provided that:

(i) where Article 4(1)(ii), third clause applies, and not all the States party to the regional treaty have been designated, the international application shall be treated as if all those States had been designated and as if the designations of all such States contained the said words, whether the said designations contained an indication of the wish to obtain a regional patent or, according to Article 4(1)(ii), fourth clause, are to be treated as containing such indication;

(ii) where the national law of any designated State contains a provision as referred to in Article 45(2), the International Bureau shall, according to Article 4(1)(ii), fourth clause, treat the designation as if it contained the said words even where the applicant failed to indicate them.

(2) The applicant may, instead of the words "regional patent" referred to in paragraph (1), use other words to the same effect; such words may include a reference to a patent to be granted by the European Patent Office under the Convention on the Grant of European Patents done at Munich on October 5, 1973 ("European patent"), where the regional patent which the applicant wishes to obtain is a European patent.

(3) An indication, in respect of the designation of Liechtenstein or Switzerland, or both, of the wish to obtain a regional patent shall be taken as indicating a wish to obtain a European patent in respect of those States, whereas the absence of any indication of the wish to obtain a regional patent in respect of such a designation shall be taken as indicating a wish to obtain a patent granted by the Swiss Intellectual Property Office in respect of those States.

PCT ADMINISTRATIVE INSTRUCTION SECTION 203bis

National and Regional Patents

Where the request of the international application contains a designation of a Contracting State without an indication of the wish to obtain a regional patent and also a designation of the same Contracting State with an indication of the wish to obtain a regional patent and the national law of the Contracting State does not contain a provision referred to in Article 45(2), the receiving Office shall calculate the designation fees on the basis that a separate fee is payable in respect of the designation of the Contracting State in addition to the designation fee payable in respect of that Contracting State as a Contracting State or as one of a group of Contracting States for which a regional patent is sought.

All designated States *must* be named in the Request for filing. It is not possible to add desig-

nations of countries to an international application after it is filed. Only those countries for which the PCT has come into effect at the time the international application is filed may be designated. The Request form, as filed, must contain the names of all designated countries in which protection is desired (PCT Article 4(1)(ii), PCT Rules 4.1(a)(iv), and 4.9, and 37 CFR 1.432. However, since the designation fees are not required until one year after the priority date, or if no priority is claimed the actual international application date (PCT Rule 15.4(b)), applicants may initially designate all PCT countries in which they may have an interest and later only pay designation fees for those countries in which patent protection is seriously desired. Any designated country for which a designation fee is not timely paid is considered withdrawn.

States must be designated in Box V by their official names or accepted short titles (Administrative Instructions Section 201). The official names and short titles appear in Annex A of the PCT Administrative Instructions. An indication of the applicant's desire (if any) to obtain a regional (rather than a national) patent where in respect of the designated State such a choice is available must be clearly expressed in Box V. In order to indicate that EPC regional protection is desired for certain States, the words "Regional Patent" must be placed after the name of the designated State in Box V, e.g., "United Kingdom, Regional Patent", (PCT Administrative Instructions, Section 203). A choice between a national patent and a regional patent is available for States that are members of both the PCT and a regional patent convention. In the case of the EPC, regional or national protection is available for Austria, the Federal Republic of Germany, Luxembourg, The Netherlands, Sweden, Switzerland, Liechtenstein, or the United Kingdom. However, where France is designated, the application will be treated as an application for a European patent with effect for France.

Belgium and Italy, although members of the EPC, cannot be designated in a PCT international application since they have not yet ratified the PCT.

It should be noted that Article 1 of the French national law No. 77-682, of June 30, 1977 states that only EPC regional patent protection is available for France if PCT is used. The English translation of this law, prepared by the International Bureau, reads as follows:

"Art. 1—Where an international application for the protection of an invention made pursuant to the Patent Cooperation treaty done at Washington on June 19, 1970, contains the designation or election of France, the said ap-

LIST OF PCT MEMBER STATES

State	Ratification or Accession	Date of Ratification or Accession	Date From Which State May Be Designated
(1) Central African Empire*	Accession	15 September 1971	01 June 1978
(2) Senegal*	Ratification	08 March 1972	01 June 1978
(3) Madagascar	Ratification	27 March 1972	01 June 1978
(4) Malawi	Accession	16 May 1972	01 June 1978
(5) Cameroon*	Accession	15 March 1973	01 June 1978
(6) Chad*	Accession	12 February 1974	01 June 1978
(7) Togo*	Ratification	28 January 1975	01 June 1978
(8) Gabon*	Accession	06 March 1975	01 June 1978
(9) United States of America	Ratification	26 November 1975	01 June 1978
(10) Germany, Federal Republic of**	Ratification	19 July 1976	01 June 1978
(11) Congo*	Accession	08 August 1977	01 June 1978
(12) Switzerland**	Ratification	14 September 1977	01 June 1978
(13) United Kingdom**	Ratification	24 October 1977	01 June 1978
(14) France**	Ratification	25 November 1977	01 June 1978
(15) Soviet Union	Ratification	29 December 1977	01 June 1978
(16) Brazil	Ratification	09 January 1978	01 June 1978
(17) Luxembourg**	Ratification	31 January 1978	01 June 1978
(18) Sweden**	Ratification	17 February 1978	01 June 1978
(19) Japan	Ratification	01 July 1978	01 October 1978
(20) Denmark	Ratification	01 September 1978	01 December 1978
(21) Austria**	Ratification	23 January 1979	23 April 1979
(22) Monaco	Ratification	22 March 1979	22 June 1979
(23) Netherlands**	Ratification	10 April 1979	10 July 1979
(24) Romania	Accession	23 April 1979	23 July 1979
(25) Norway	Ratification	01 October 1979	01 January 1980
(26) Liechtenstein**	Accession	19 December 1979	19 March 1980
(27) Australia	Accession	31 December 1979	31 March 1980
(28) Hungary	Ratification	27 March 1980	27 June 1980
(29) Democratic People's Republic of Korea (North Korea)	Accession	08 April 1980	08 July 1980
(30) Finland	Ratification	01 July 1980	01 October 1980

*Members of African Intellectual Property Organization (OAPI) regional patent system. Only regional patent protection is available for OAPI member states. A designation of any state is an indication that all OAPI states have been designated. Note: only one designation fee is due regardless of the number of OAPI member states designated.

**Members of European Patent Convention (EPC) regional patent system. Either national patents or European patents for member States are available through PCT, *except for France*, for which only European patents are available if PCT is used. If regional protection is desired for one or more States, the indication "regional patent" must follow the designation of the State or States. Note: only one designation fee is due if the regional patent protection is sought for several States.

plication shall have the effect of an application for a European Patent as governed by the provisions of the Convention of the Grant of European Patents done at Munich on October 5, 1973." The United States Receiving Office will treat the designation of France as the wish to obtain EPC regional patent protection for France, even if the indication "Regional Patent" is missing (PCT Administrative Instructions, Section 203). However, if the European Patent Office is not yet examining the subject matter to which the invention relates, the applicant will be permitted to convert the European application to a French national application once the national (regional) phase before the European Patent Office has begun.

The designation of any State is treated as an expression of the wish to obtain a patent in the designated State. However, if the applicant wishes his international application to be treated

in any designated States (whose national law knows that kind of protection) as an application not for a patent but for an inventor's certificate, a utility certificate, a utility model, a patent of addition, a certificate of addition, an inventor's certificate of addition or a utility certificate of addition, he must indicate his desire in Box V of the Request by indicating the kind of protection immediately after the indication of the State (Administrative Instruction Section 202 (a)), and his application will be dealt with accordingly in that State (PCT Articles 4.1(b) (iii) and 4.12). Annex F indicates, in respect of each Contracting State, the kinds of protection available.

The applicant may, in respect of any designated State (whose national law knows the kinds of protection involved and admits the possibility of seeking two kinds of protection), mention in the Request two kinds of protection

(Box V), together with an indication of the one he prefers, and his application will be dealt with accordingly in that State (PCT Article 44 and PCT Rule 4.12(b)). Annex I indicates, in respect of each Contracting State, whether this possibility is available.

The indication of the type of protection desired is placed directly after the name of the State, e.g., "Federal Republic of Germany, patent and utility model" (PCT Administrative Instructions, Section 202(b)). Where a title (patent, certificate, inventor's certificate, utility certificate) of addition, is sought, or where the applicant wishes the international application to be treated in any designated State as an application for a continuation or a continuation-in-part, the fact must be indicated together with the parent application (PCT Rules 4.(b)(v), 4.13 and 4.14). This indication is placed in Box VII. See § 1820.07.

→ 1820.06 Priority [R-3]

PCT ARTICLE 8

Claiming Priority

(1) The international application may contain a declaration, as prescribed in the Regulations, claiming the priority of one or more earlier applications filed in or for any country party to the Paris Convention for the Protection of Industrial Property.

(2) (a) Subject to the provisions of subparagraph (b), the conditions for, and the effect of, any priority claim declared under paragraph (1) shall be as provided in Article 4 of the Stockholm Act of the Paris Convention for the Protection of Industrial Property.

(b) The international application for which the priority of one or more earlier applications filed in or for a Contracting State is claimed may contain the designation of that State. Where, in the international application, the priority of one or more national applications filed in or for a designated State is claimed, or where the priority of an international application having designated only one State is claimed, the conditions for, and the effect of, the priority claim in that State shall be governed by the national law of that State.

PCT Rule 4.10 Priority Claim

(a) The declaration referred to in Article 8(1) shall be made in the request; it shall consist of a statement to the effect that the priority of an earlier application is claimed and shall indicate:

(i) when the earlier application is not a regional or an international application, the country in which it was filed; when the earlier application is a regional or an international application, the country or countries for which it was filed,

(ii) the date on which it was filed,

(iii) the number under which it was filed, and

(iv) when the earlier application is a regional or an international application, the national Office or intergovernmental organization with which it was filed.

(b) If the request does not indicate both

(i) when the earlier application is not a regional or an international application, the country in which it was filed; when the earlier application is a regional or an international application, at least one country for which it was filed, and

(ii) the date on which it was filed,

the priority claim shall, for the purposes of the procedure under the Treaty, be considered not to have been made except where, resulting from an obvious error of transcription, the indication of the said country or the said date is missing or is erroneous; whenever the identity or correct identity of the said country, or the said date or the correct date, may be established on the basis of the copy of the earlier application which the receiving Office receives before it transmits the record copy to the International Bureau, the error shall be considered as an obvious error.

(c) If the application number of the earlier application is not indicated in the request but is furnished by the applicant to the International Bureau prior to the expiration of the 18th month from the priority date, it shall be considered by all designated States to have been furnished in time. If it is furnished after the expiration of that time limit, the International Bureau shall inform the applicant and the designated Office of the date on which the said number was furnished to it. The International Bureau shall indicate that date in the international publication of the international application, or, if at the time of the international publication, the said number has not been furnished to it, shall indicate that fact in the international publication.

(d) If the filing date of the earlier application as indicated in the request does not fall within the period of one year preceding the international filing date, the receiving Office, or, if the receiving Office has failed to do so, the International Bureau, shall invite the applicant to ask either for the cancellation of the declaration made under Article 8(1) or, if the date of the earlier application was indicated erroneously, for the correction of the date so indicated. If the applicant fails to act accordingly within 1 month from the date of the invitation, the declaration made under Article 8(1) shall be cancelled ex officio. The receiving Office effecting the correction or cancellation shall notify the applicant accordingly and, if copies of the international application have already been sent to the International Bureau and the International Searching Authority, that Bureau and that Authority. If the correction or cancellation is effected by the International Bureau, the latter shall notify the applicant and the International Searching Authority accordingly.

(e) Where the priorities of several earlier applications are claimed, the provisions of paragraphs (a) to (d) shall apply to each of them.

PCT RULE 32BIS

Withdrawal of the Priority Claim

Rule 32bis.1 Withdrawals

(a) The applicant may withdraw the priority claim made in the international application under Article 8(1) at any time before the international publication of the international application.

(b) Where the international application contains more than one priority claim, the applicant may exer-

cise the right provided for in paragraph (a) in respect of one or more or all of them.

(c) Where the withdrawal of the priority claim, or in the case of more than one such claim, the withdrawal of any of them, causes a change in the priority date of the international application, any time limit which is computed from the original priority date and which has not already expired shall be computed from the priority date resulting from that change. In the case of the time limit of 18 months referred to in Article 21(2) (a), the International Bureau may nevertheless proceed with the international publication on the basis of the said time limit as computed from the original priority date if the withdrawal is effected during the period of 15 days preceding the expiration of that time limit.

(d) For any withdrawal under paragraph (a), the provisions of Rule 32.1(c) and (d) and Rule 74bis.1 shall apply *mutatis mutandis*.

PCT ADMINISTRATIVE INSTRUCTION SECTION 302

Notification of Priority Claim Considered Not To Have Been Made

Where, owing to failure to meet the requirements of Rule 4.10(b), the priority claim is, for the purposes of procedure under the Treaty, considered not to have been made, the receiving Office shall indicate that fact in the international application by marking over the box in the request Form which provides for the information concerning the priority claim, the words "NOT TO BE CONSIDERED FOR PCT PROCEDURE" or its equivalent in the language of the international application. The receiving Office shall notify the applicant accordingly. If copies of the international application have already been sent to the International Bureau and the International Searching Authority, the receiving Office shall also notify that Bureau and that Authority.

SECTION 314

Manner of Indicating Correction of the Priority Date or Cancellation of the Priority Claim

(a) Where, under Rule 4.10(d), the applicant corrects the erroneously indicated filing date of any earlier application, the receiving Office shall enter the corrected date in the request and draw a line through the previously entered date while still leaving it legible.

(b) Where, under Rule 4.10(d), the receiving Office cancels the declaration made under Article 8(1), that Office shall mark over the said declaration the words "CANCELLED ON REQUEST OF APPLICANT" or "CANCELLED EX OFFICIO BY RO," or their equivalent in the language of the international application, as the case may be.

SECTION 402

Notification of Correction of the Priority Date or Cancellation of the Priority Claim

Where, under Rule 4.10(d), the correction of the priority date or the cancellation of the priority claim

is effected by the International Bureau, the manner of indicating the correction or cancellation set forth in Section 314 shall apply *mutatis mutandis*. The receiving Office, in addition to the applicant and the International Searching Authority, shall be notified accordingly by the International Bureau.

SECTION 408

Priority Application Number

(a) If the application number of the earlier application referred to in Rule 4.10(c) (priority application number) is furnished to the International Bureau within the prescribed time limit, that Bureau shall enter the said number in the space provided therefor in the request Form.

(b) If the priority application number is furnished after the expiration of the prescribed time limit, the International Bureau shall indicate, in the international publication, the date on which the said number was furnished, by including on the front page of the pamphlet next to the priority application number the words "FURNISHED LATE ON . . . (date)," and their equivalent in the language of the international application, provided that language is French, German, Japanese or Russian.

(c) If the priority application number has not been furnished at the time of the international publication, the International Bureau shall indicate that fact by including on the front page of the pamphlet in the space provided for the priority application number the words "NOT FURNISHED AT TIME OF THIS PUBLICATION," and their equivalent in the language of the international application, provided that language is French, German, Japanese or Russian.

SECTION 409

Notification of Priority Claim Considered not to have been Made

Where the International Bureau notes that the receiving Office has failed to notify the applicant as provided in Section 302, it shall send a notification to the same effect to the applicant, the receiving Office and the International Searching Authority.

35 U.S.C. 365 Right of priority; benefit of the filing date of a prior application. (a) In accordance with the conditions and requirements of section 119 of this title, a national application shall be entitled to the right of priority based on a prior filed international application which designated at least one country other than the United States.

(b) In accordance with the conditions and requirement of the first paragraph of section 119 of this title and the treaty and the Regulations, an international application designating the United States shall be entitled to the right of priority based on a prior foreign application, or a prior international application designating at least one country other than the United States.

(c) In accordance with the conditions and requirements of section 120 of this title, an international

application designating the United States shall be entitled to the benefit of the filing date of a prior national application or a prior international application designating the United States, and a national application shall be entitled to the benefit of the filing date of a prior international application designating the United States. If any claim for the benefit of an earlier filing date is based on a prior international application which designated but did not originate in the United States, the Commissioner may require the filing in the Patent Office of a certified copy of such application together with a translation thereof into the English language, if it was filed in another language.

An applicant who claims the priority of one or more earlier national or international applications for the same invention must indicate, in the Request at the time of filing the international application, the country in or for which the application was filed, the date on which it was filed, and its application number. (PCT Article 8 and PCT Rule 4.10) When the earlier application is a regional or an international application, the applicant must also indicate the national Office or intergovernmental organization with which it was filed. If the number cannot be indicated in the Request at the time of filing of the international application, it must be furnished to the International Bureau at the latest by the expiration of sixteen months from the priority date.

If the applicant files a copy of the priority document, certified by the county or authority with which it was originally filed, at the time of filing the international application in the U.S. Patent and Trademark Office as a Receiving Office, the priority document will be included as part of the "Record Copy" of the international application and forwarded therewith to the International Bureau before the expiration of thirteen months from the priority date (PCT Rules 17 and 22). Also, under 37 CFR 1.451, upon filing the international application, the applicant may request the U.S. Patent and Trademark Office to prepare a copy of the U.S. national application whose priority is claimed and the United States Receiving Office will forward the copy to the International Bureau. If, however, the certified copy of the priority document is not submitted to the Receiving Office at the time of filing the international application or if no request under 37 CFR 1.451 is received upon filing, the applicant himself must submit a certified copy of the priority document to the International Bureau not later than sixteen months after the priority date. Otherwise, any designated State may disregard the claim for priority.

The applicant may withdraw any priority claim made in the international application until the international publication of the in-

ternational application (PCT Rule 32*bis*). The signed notice containing the withdrawal of any priority claim causes a change in the priority date of the international application (for the definition of "priority date," see PCT Article 2(xi)), any time limit which is computed from the original priority date and which has not yet expired—for example, the time limit before which processing in the national phase cannot start—is computed from the priority date resulting from the said change. Further details are provided in PCT Rule 32*bis*.

The date of the filing of the priority application should be given by indicating the number of the day by two digits, the name of the month spelled out in full and the number of the year in four digits, for example, 05 October 1978 (PCT Administrative Instruction, Section 110). The name of the country of filing should be either the official name or accepted short title listed in Annex A of the PCT Administrative Instructions. 35 U.S.C. 365 provides for recognition of priority claims in international applications.

1820.07 Parent Application or Grant

PCT Rule 4.13 Identification of Parent Application or Parent Grant

If the applicant wishes his international application to be treated, in any designated State, as an application for a patent or certificate of addition, inventor's certificate of addition, or utility certificate of addition, he shall identify the parent application or the parent patent, parent inventor's certificate, or parent utility certificate to which the patent or certificate of addition, inventor's certificate of addition, or utility certificate of addition, if granted, relates. For the purposes of this paragraph, Article 2(ii) shall not apply.

PCT Rule 4.14 Continuation or Continuation-in-Part

If the applicant wishes his international application to be treated, in any designated State, as an application for a continuation or a continuation-in-part of an earlier application, he shall so indicate in the request and shall identify the parent application involved.

Box VII may be used where the applicant has an earlier application in a country designated in the international application and where special title or treatment of the international application is desired. For example, if the applicant has a pending United States application, the international application could contain additional subject matter and be treated as a continuation-in-part in the United States, if the United States is designated in the international application (PCT Rule 4.14). In this example, the entries to be placed in Box VII would be as follows: "United States; con-

tinuation-in-part; U.S.S.N. 999,999, Pipe Clamp; 07 February 1978".

1820.08 Earlier International or International-Type Search [R-3]

PCT Rule 4.11 Reference to Earlier Search

If an international or international-type search has been requested on an application under Article 15(5) or if the applicant wishes the International Searching Authority to base the international search report wholly or in part on the results of a search, other than an international or international-type search, made by the national Office or intergovernmental organization which is the International Searching Authority competent for the international application, the request shall contain a reference to that fact. Such reference shall either identify the application (or its translation, as the case may be) in respect of which the earlier search was made by indicating country, date and number, or the said search by indicating, where applicable, date and number of the request for such search.

The United States Patent and Trademark Office performs an international-type search on all U.S. national applications filed on and after June 1, 1978. No specific request by the applicant is required and no number identifying the international-type search is assigned by the Office. All earlier U.S. applications referred to in Box VI for priority purposes as well as all U.S. applications referred to in separate transmittal letters will be considered by the Office for fee refund purposes under 37 CFR 1.446.

Box VIII should be used only to identify related international applications and U.S. national applications filed on and after June 1, 1978.

1820.09 Different Applicants for Different Designated States

In any international application, different applicants may be indicated for different designated States. This possibility is of great practical importance since, for the purposes of the United States of America, the applicant must be the inventor, whereas, for the purposes of the other countries currently members of the Treaty, no such requirement exists (PCT Article 9(3), PCT Rules 4.6(c) and 18.4 and 35 U.S.C. 373). Where there are several applicants, at least one of them must qualify to file an international application for each designated State (PCT Rules 18.3, 18.4 (a) and (b)).

If it is desired that different applicants be indicated for different designated countries, for example, in an application designating the United States, Sweden and Switzerland, for the

purposes of the United States, the inventor must be the applicant. If the invention has been assigned, the assignee may wish to be the applicant for Sweden and Switzerland. If in this example, "A" is the assignee and "B" is the inventor, "A" and "B" must both be indicated as applicants, one in Box II and the other in in the "supplemental box" on page 3 of the Request form. A check mark should be placed in the small box following the phrase "additional information is contained in supplemental box." The information placed in the supplemental box should be clearly labeled "II (Applicant) "B" as the inventor would also be named in Box III of the Request. Box IX, on page 2 of the Request, is then used to identify different applicants for different designated countries. In Box IX, "B" would be indicated as the applicant for the United States of America and "A" would be indicated as the applicant for Sweden and Switzerland. It should be noted that both "A" and "B" must also sign the Request form or a power of attorney if the Request is signed by an attorney or agent.

The names of all applicants indicated in Box II must be placed in Box IX opposite the names of the designated States for which they are to be considered as applicants. The names of applicants should be placed in the order, family name first. The names of States should be the full official titles or the accepted short titles as listed in Annex A to the PCT Administrative Instructions.

1820.10 Different Inventors for Different Designated States

Where, because of the provisions of the national law in the different designated States, it is necessary to indicate different inventors for different designated States, such information should be placed in Box X (PCT Rule, 4.6(c)). Names of inventors should be indicated family name first. The States should be named by official titles or accepted short titles as listed in Annex A to the PCT Administrative Instructions.

1820.11 Signature of Applicant

PCT Rule 4.15 Signature

The request shall be signed by the applicant.

The Request form of an international application must be signed either by *all* the applicants (PCT Rule 4.15) or the attorney or agent of all the applicants. In the later case, a power of attorney signed by all applicants is filed with the international application in the Receiving Office (PCT Rule 2.1). The supplemental box may be used if Box XI has insufficient room for all signatures.

1820.12 Check List

SECTION 313

Manner of Making the Necessary Annotations in the Check List

Where, under Rule 3.3(b), the receiving Office itself fills in the check list, that Office shall mark, next to such check list, the words "FILLED IN BY RO," or their equivalent in the language of the international application. Where only some of the indications are filled in by the receiving Office, the said words and each indication filled in by that Office shall be identified by an asterisk.

Part A—When calculating the list of pages, the Notes to the Request and the fee calculation sheet, form PCT/RO/101 Annex are not counted. Any supplemental sheet used for continuing material, however, is counted.

Part B—Items which accompany the international application should be identified in this portion. If transmittal form PTO-1382 is used, it should be referred to as "transmittal letter" under item 8 in Box XII, B.

Part C—The figure of drawing which applicant considers to best illustrate the invention should be identified in Box XII, C for publication in the Gazette and on the front page of the pamphlet. The figure selection will be reviewed by the International Searching Authority. When the international application contains only one figure which the applicant wishes to have published, the word "sole" should be typed in the space.

Part D—Part D is to be filled in by the Receiving Office only to indicate whether drawings are missing upon filing. (PCT Administrative Instructions, Section 310(a).)

ASSIGNMENT DOCUMENT

An assignment document, or a copy thereof, may be filed with the International application. The Check List of the Request form, Box XII, Item B.7, should be marked to indicate that an assignment document has accompanied the International application on filing. (PCT Rule 3.3(ii)) The assignment document will be transmitted with the Record Copy of the application to the International Bureau.

It should be noted that U.S. Patent and Trademark Office records assignments *only* for International applications in which the United States is named as a designated State. (37 CFR 1.331).

The assignment instrument for an International application must include the indication that the application to which it relates is an international application designating the United States. The assignment instrument and the pre-

scribed fee for recording (37 CFR 1.21) may be filed together with the International application. The Receiving Office will route the instrument and fee to the appropriate organizations for recording. Assignment instruments for International applications in which the United States is not designated will be returned.

→ 1823 The Description [R-3]

PCT ARTICLE 5

The Description

The description shall disclose the invention in a manner sufficiently clear and complete for the invention to be carried out by a person skilled in the art.

PCT RULE 5

The Description

5.1 Manner of the Description

(a) The description shall first state the title of the invention as appearing in the request and shall:

- (i) specify the technical field to which the invention relates;
 - (ii) indicate the background art which, as far as known to the applicant, can be regarded as useful for the understanding, searching and examination of the invention, and preferably, cite the documents reflecting such art;
 - (iii) disclose the invention, as claimed, in such terms that the technical problem (even if not expressly stated as such) and its solution can be understood, and state the advantageous effects, if any, of the invention with reference to the background art;
 - (iv) briefly describe the figures in the drawings, if any;
 - (v) set forth at least the best mode contemplated by the applicant for carrying out the invention claimed; this shall be done in terms of examples, where appropriate, and with reference to the drawings, if any; where the national law of the designated State does not require the description of the best mode but is satisfied with the description of any mode (whether it is the best contemplated or not), failure to describe the best mode contemplated shall have no effect in that State;
 - (vi) indicate explicitly, when it is not obvious from the description or nature of the invention, the way in which the invention is capable of exploitation in industry and the way in which it can be made and used, or, if it can only be used, the way in which it can be used; the term "industry" is to be understood in its broadest sense as in the Paris Convention for the Protection of Industrial Property.
- (b) The manner and order specified in paragraph (a) shall be followed except when, because of the nature of the invention, a different manner or a different order

would result in a better understanding and a more economic presentation.

(c) Subject to the provisions of paragraph (b), each of the parts referred to in paragraph (a) shall preferably be preceded by an appropriate heading as suggested in the Administrative Instructions.

37 CFR 1.435 The description. (a) Requirements as to the content and form of the description are set forth in PCT Rules 5, 9, 10 and 11 and Administrative Instruction 204, and shall be adhered to.

(b) In international applications designating the United States the description must contain upon filing an indication of the best mode contemplated by the inventor for carrying out the claimed invention.

PCT ADMINISTRATIVE INSTRUCTION SECTION 204

Headings of the Parts of the Description

The headings referred to Rule 5.1(c) should be as follows:

- (i) for matter referred to in Rule 5.1(a)(i), "Technical Field;"
- (ii) for matter referred to in Rule 5.1(a)(ii), "Background Art;"
- (iii) for matter referred to in Rule 5.1(a)(iii), "Disclosure of Invention."
- (iv) for matter referred to in Rule 5.1(a)(iv), "Brief Description of Drawings;"
- (v) for matter referred to in Rule 5.1(a)(v), "Best Mode for Carrying Out the Invention, or, where appropriate, "Mode(s) for Carrying Out the Invention";
- (vi) for matter referred to in Rule 5.1(a)(vi), "Industrial Applicability."

The description must "disclose the invention in a manner sufficiently clear and complete for the invention to be carried out by a person skilled in the art" (PCT Article 5). PCT Rule 5 contains detailed requirements as to the "manner and order" of the description, which, generally, should consist of six parts under the following headings: "Technical Field," "Background Art," "Disclosure of Invention," "Brief Description of Drawings," "Best Mode of Carrying Out the Invention," "Industrial Applicability." (PCT Administrative Instruction Section 204). The description must begin with the title of the invention as stated in Box I of the Request. (PCT Rule 5.) Every fifth line of typing may be numbered along the left hand side but not in the margin. (PCT Rule 11.8.) The page numbers must be placed at the top of the page but not in the top margin. (PCT Rule 11.6 (e).) If the United States of America is designated, the best mode contemplated by the inventor for carrying out the invention must be included in the description (37 CFR 1.435).

1823.01 Reference to Deposited Microorganism [R-3]

PCT RULE 13BIS

Microbiological Inventions

13bis.1 Definition

For the purposes of this Rule, "reference to a deposited microorganism" means particulars given in an international application with respect to the deposit of a microorganism with a depositary institution or to the microorganism so deposited.

13bis.2 References (General)

Any reference to a deposited microorganism shall be made in accordance with this Rule and, if so made, shall be considered as satisfying the requirements of the national law of each designated State.

13bis.3 References: Contents; Failure To Include Reference or Indication

(a) A reference to a deposited microorganism shall indicate,

(i) the name and address of the depositary institution with which the deposit was made;

(ii) the date of deposit of the microorganism with that institution;

(iii) the accession number given to the deposit by that institution; and

(iv) any additional matter of which the International Bureau has been notified pursuant to Rule 13bis.7(a) (1), provided that the requirement to indicate that matter was published in the Gazette in accordance with Rule 13bis.7(c) at least two months before the filing of the international application.

(b) Failure to include a reference to a deposited microorganism or failure to include, in a reference to a deposited microorganism, an indication in accordance with paragraph (a), shall have no consequence in any designated State whose national law does not require such reference or such indication in a national application.

13bis.4 References: Time of Furnishing Indications

If any of the indications referred to in Rule 13bis.3

(a) is not included in a reference to a deposited microorganism in the international application as filed but is furnished by the applicant to the International Bureau within 16 months after the priority date, the indication shall be considered by any designated Office to have been furnished in time unless its national law requires the indication to be furnished at an earlier time in the case of a national application and the International Bureau has been notified of such requirement pursuant to Rule 13bis.7(ii), provided that the International Bureau has published such requirement in the Gazette in accordance with Rule 13bis.7(c) at least two months before the filing of the international application. In the event that the applicant makes a request for early publication under Article 21(2) (b), however, any designated Office may consider any indication not

furnished by the time such request is made as not having been furnished in time. Irrespective of whether the applicable time limit under the preceding sentences has been observed, the International Bureau shall notify the applicant and the designated Offices of the date on which it has received any indication not included in the international application as filed. The International Bureau shall indicate that date in the international publication of the international application if the indication has been furnished to it before the completion of technical preparations for international publication.

13bis.5 References and Indications for the Purposes of One or More Designated States; Different Deposits for Different Designated States; Deposits with Depositary Institutions other than Those Notified

(a) A reference to a deposited microorganism shall be considered to be made for the purposes of all designated States, unless it is expressly made for the purposes of certain of the designated States only; the same applies to the indications included in the reference.

(b) References to different deposits of the microorganism may be made for different designated States.

(c) Any designated Office shall be entitled to disregard a deposit made with a depositary institution other than one notified by it under Rule 13bis.7(b).

13bis.6 Furnishing of Samples

(a) Where the international application contains a reference to a deposited microorganism, the applicant shall, upon the request of the International Searching Authority or the International Preliminary Examining Authority, authorize and assure the furnishing of a sample of that microorganism by the depositary institution to the said Authority, provided that the said Authority has notified the International Bureau that it may require the furnishing of samples and that such samples will be used solely for the purposes of international search or international preliminary examination, as the case may be, and such notification has been published in the Gazette.

(b) Pursuant to Articles 23 and 40, no furnishing of samples of the deposited microorganism to which a reference is made in an international application shall, except with the authorization of the applicant, take place before the expiration of the applicable time limits after which national processing may start under the said Articles. However, where the applicant performs the acts referred to in Articles 22 or 39 after international publication but before the expiration of the said time limits, the furnishing of samples of the deposited microorganism may take place, once the said acts have been performed. Notwithstanding the previous provision, the furnishing of samples from the deposited microorganism may take place under the national law applicable for any designated Office as soon as, under that law, the international publication has the effects of the compulsory national publication of an unexamined national application.

13bis.7 *National Requirements: Notification and Publication*

(a) Any national Office may notify the International Bureau of any requirement of the national law,

(i) that any matter specified in the notification, in addition to those referred to in Rule 13bis.3(a) (i), (ii) and (iii), is required to be included in a reference to a deposited microorganism in a national application;

(ii) that one or more of the indications referred to in Rule 13bis.3(a) are required to be included in a national application as filed or are required to be furnished at a time specified in the notification which is earlier than 16 months after the priority date.

(b) Each national Office shall notify the International Bureau a first time before entry into force of this Rule and then each time a change occurs of the depositary institutions with which the national law permits deposits of microorganisms to be made for the purposes of patent procedure before that Office or, if the national law does not provide for or permit such deposits, of that fact.

(c) The International Bureau shall promptly publish in the Gazette requirements notified to it under paragraph (a) and information notified to it under paragraph (b).

(PCT Rule 13bis becomes effective on January 1, 1981)

1824 **The Claims [R-3]**

PCT ARTICLE 6

The Claims

The claim or claims shall define the matter for which protection is sought. Claims shall be clear and concise. They shall be fully supported by the description.

PCT RULE 6

The Claims

6.1 *Number and Numbering of Claims*

(a) The number of the claims shall be reasonable in consideration of the nature of the invention claimed.

(b) If there are several claims, they shall be numbered consecutively in arabic numerals.

(c) The method of numbering in the case of the amendment of claims shall be governed by the Administrative Instructions.

6.2 *References to Other Parts of the International Application*

(a) Claims shall not, except where absolutely necessary, rely, in respect of the technical features of the invention, on references to the description or drawings. In particular, they shall not rely on such references as: "as described in part . . . of the description," or "as illustrated in figure . . . of the drawings."

PCT ADMINISTRATIVE INSTRUCTIONS SECTION 205

Numbering of Claims upon Amendment

(a) Any claim submitted after the filing date of the international application and which is not identical with the claims previously appearing in the international application shall, at the choice of the applicant, be submitted either:

(i) as an amended claim, in which case, it shall bear the same number as the previous claim it amends; that number shall be followed by the word "(amended)" or its equivalent in the language of the international application; or

(ii) as a new claim, in which case it shall bear the next number after the highest previously numbered claim; that number shall be followed by the word "(new)" or its equivalent in the language of the international application; where the consecutive order of claims requires that a new claim be given a number lower than the highest previously numbered claim, the claims following the new claim shall be renumbered; any new number shall be followed by the words "(Original claim No.*)" or an equivalent of these words in the language of the international application and an indication of the original number of the renumbered claim.

(b) The deletion of any claim previously appearing in the international application shall be made by indicating the number of the previous claim followed by the word "(cancelled)" or its equivalent in the language of the international application.

37 CFR 1.436 *The claims.* The requirements as to the content and format of claims are set forth in PCT Art. 6 and PCT Rules 6, 9, 10 and 11 and shall be adhered to. The number of the claims shall be reasonable, considering the nature of the invention claimed.

The *claim* or *claims* must "define the matter for which protection is sought. Claims shall be clear and concise. They shall be fully supported by the description" (PCT Article 6). PCT Rule 6 contains detailed requirements as to the number and numbering of claims, the extent to which any claim may refer to other parts of the international application, the manner of claiming and dependent claims. As to the manner of claiming, generally and wherever appropriate, the claims must consist of two distinct parts, the statement of the prior art and the statement of the features for which protection is sought ("the characterizing portion").

Multiple dependent claims are permitted in international applications if they are in the alternative only and do not serve as a basis for any other multiple dependent claim (PCT Rule 6.4(a), 35 U.S.C. 112). The claims, being an element of the application, should start on a new page (PCT Rule 11.4). Page numbers and

line numbers must not be placed in the margins (PCT Rule 11.6(e)).

The number of claims shall be reasonable, considering the nature of the invention claimed (37 CFR 1.436).

1825 The Drawings

PCT ARTICLE 7

The Drawings

(1) Subject to the provisions of paragraph (2) (ii), drawings shall be required when they are necessary for the understanding of the invention.

(2) Where, without being necessary for the understanding of the invention, the nature of the invention admits of illustration by drawings:

(i) the applicant may include such drawings in the international application when filed.

(ii) any designated Office may require that the applicant file such drawings with it within the prescribed time limit.

PCT RULE 7

The Drawings

7.1 Flow Sheets and Diagrams

Flow sheets and diagrams are considered drawings.

7.2 Time Limit

The time limit referred to in Article 7(2) (ii) shall be reasonable under the circumstances of the case and shall, in no case, be shorter than 2 months from the date of the written invitation requiring the filing of drawings or additional drawings under the said provision.

PCT ADMINISTRATIVE INSTRUCTION SECTION 310

Procedure in the Case of Missing Drawings

(a) Where the international application refers to drawings which in fact are not included in that application, the receiving Office shall make the indication referred to in Rule 26.6(a) by an appropriate marking of the request Form.

(b) Section 309(a) shall apply also in the case of drawings received by the receiving Office on a date later than the date on which sheets were first received by that Office.

(c) The receiving Office shall, in the case of missing drawings received within the time limit referred to in Rule 20.2(a) (iii):

(i) effect the required correction of the international filing date, or, where no international filing date has yet been accorded, of the date of receipt of the purported international application, and delete the indication made under paragraph (a) above;

(ii) notify the applicant of the correction effected under item (i), above;

(iii) where transmittals under Article 12(1) have already been made, notify the International Bureau and the International Searching Authority of any correction effected under item (i), above, by transmitting a copy of the corrected first page of the request, and forward copies of the later submitted drawings to the said Bureau and the said Authority;

(iv) where transmittals under Article 12(1) have not yet been made, attach a copy of the later submitted drawings to the record copy and the search copy.

(d) The receiving Office shall, in the case of missing drawings received after the expiration of the time limit referred to in Rule 20.2(a) (iii) :

(i) notify the applicant of the fact and of the date of receipt of the later submitted drawings;

(ii) where transmittals under Article 12(1) have already been made, forward a copy of the later submitted drawings to the International Bureau with the indication that such drawings and any reference to such drawings are not to be taken into consideration for the purposes of international processing;

(iii) where transmittals under Article 12(1) have not yet been made, attach a copy of the later submitted drawings to the record copy with the indication that such drawings and any reference to such drawings are not to be taken into consideration for the purposes of international processing.

37 CFR 1.437 The drawings. (a) Subject to paragraph (b) of this section, when drawings are necessary for the understanding of the invention, or are mentioned in the description, they must be part of an international application as originally filed in the United States Receiving Office in order to maintain the international filing date during the national stage (PCT Art. 7).

(b) Drawings missing from the application upon filing will be accepted if such drawings are received within 30 days of the date of first receipt of the incomplete papers. If the missing drawings are received within the 30-day period, the international filing date shall be the date on which such drawings are received. If such drawings are not timely received, all references to drawings in the international application shall be considered non-existent (PCT Art. 14(2), Administrative Instruction 310).

(c) The physical requirements for drawings are set forth in PCT Rule 11 and shall be adhered to.

Any international application must contain *drawings* "when they are necessary for the understanding of the invention" (PCT Article 7(1), 37 CFR 1.437)). However, even where, without being necessary for the understanding of the invention, the nature of the invention admits of illustration by drawings, the applicant *may* include such drawings and any designated

Office *may* require the applicant to file such drawings during the national (or regional) phase. Flow sheets and diagrams are considered drawings (PCT Rule 7.1). The drawing sheets must be numbered in a separate series either as $\frac{1}{3}$, $\frac{2}{3}$, $\frac{3}{3}$ or 1, 2, 3. The drawings in an international application must be on A4 size sheets of paper which must be flexible, strong, white, smooth, non-shiny and durable (PCT Rules 11.3 and 11.5). The space used for illustration on each sheet must not exceed 26.2 cm. by 17.0 cm. (PCT Rule 11.6(c)). One figure of the drawings should be designed for use on the front page of the published application to accompany the abstract (PCT Rules 33(a) (iii) and 48.2(d)).

1826 The Abstract

PCT RULE 8

The Abstract

8.1 Contents and Form of the Abstract

(a) The abstract shall consist of the following :

(i) a summary of the disclosure as contained in the description, the claims, and any drawings; the summary shall indicate the technical field to which the invention pertains and shall be drafted in a way which allows the clear understanding of the technical problem, the gist of the solution of that problem through the invention, and the principal use or uses of the invention;

(ii) where applicable, the chemical formula which, among all the formulae contained in the international application, best characterizes the invention.

(b) The abstract shall be as concise as the disclosure permits (preferably 50 to 150 words if it is English or when translated into English).

(c) The abstract shall not contain statements on the alleged merits or value of the claimed invention or on its speculative application.

(d) Each main technical feature mentioned in the abstract and illustrated by a drawing in the international application shall be followed by a reference sign, placed between parentheses.

8.2 Failure to Suggest a Figure to be Published with the Abstract

If the applicant fails to make the indication referred to in Rule 3.3(a) (iii), or if the International Searching Authority finds that a figure or figures other than that figure or those figures suggested by the applicant would, among all the figures of all the drawings, better characterize the invention, it shall indicate the figure or figures which it so considers. Publications by the International Bureau shall then use the figure or figures so indicated by the International Searching Authority. Otherwise, the figure or figures suggested by the applicant shall be used in the said publications.

8.3 Guiding Principles in Drafting

The abstract shall be so drafted that it can efficiently serve as a scanning tool for purposes of searching in the particular art, especially by assisting the scientist, engineer or researcher in formulating an opinion on whether there is a need for consulting the international application itself.

37 CFR 1.438 *The abstract.* (a) Requirements as to the content and form of the abstract are set forth in PCT Rule 8, and shall be adhered to.

(b) Lack of an abstract upon filing of an international application will not affect the granting of a filing date. However, failure to furnish an abstract within one month from the date of the notification by the Receiving Office will result in the international application being declared withdrawn.

The abstract must begin on a new sheet following the claims (PCT Administrative Instruction Section 207). It must consist of a summary of the disclosure as contained in the description, the claims and any drawings (PCT Article 3(3)). Where applicable, it must also contain the most characteristic chemical formula. The abstract must be as concise as the disclosure permits (preferably 50 to 150 words in English). It must be so drafted that it can efficiently serve as a scanning tool for the purposes of searching in the particular art. These and other requirements concerning the abstract are spelled out in detail in PCT Rule 8 (37 CFR 1.438).

SUMMARY OF ABSTRACT REQUIREMENTS

Preferably 50–150 words, but not more than 250.

Should contain—

1. Indication of field of invention.
2. Clear indication of the technical *problem*.
3. *Gist* of invention's *solution* of the problem.
4. Principal use or uses of the invention.
5. Reference numbers of the main technical features.
6. Where applicable, *chemical formula* which best characterizes the invention.

Should *not* contain—

1. Superfluous language.
2. Legal phraseology such as "said" and "means."
3. Statements of alleged merit or speculative application.
4. Prohibited items as defined in PCT Rule 9.

1827 Fees

PCT RULE 14

The Transmittal Fee

14.1 *The Transmittal Fee*

(a) Any receiving Office may require that the applicant pay a fee to it, for its own benefit, for receiving

the international application, transmitting copies to the International Bureau and the competent International Searching Authority, and performing all the other tasks which it must perform in connection with the international application in its capacity of receiving Office ("transmittal fee").

(b) The amount and the due date of the transmittal fee, if any, shall be fixed by the receiving Office.

PCT RULE 15

The International Fee

15.1 *Basic Fee and Designation Fee*

Each international application shall be subject to the payment of a fee for the benefit of the International Bureau ("international fee") to be collected by the receiving Office and consisting of.

(i) a "basic fee," and

(ii) as many "designation fees" as there are national patents and regional patents sought by the applicant in the international application, except that, where Article 44 applies in respect of a designation, only one designation fee shall be due.

15.2 *Amounts*

(a) The amounts of the basic fee and of the designation fee are as set out in the Schedule of Fees.

(b) The amounts of the basic fee and of the designation fee shall be established, for each receiving Office which, under Rule 15.3, prescribes the payment of those fees in a currency or currencies other than Swiss currency, by the Director General after consultation with that Office and in the currency or currencies prescribed by that Office ("prescribed currency"). The amounts in each prescribed currency shall be the equivalent, in round figures, of the amounts in Swiss currency set out in the Schedule of Fees. They shall be published in the Gazette.

(c) Where the amounts of the fees set out in the Schedule of Fees are changed, the corresponding amounts in the prescribed currencies shall be applied from the same date as the amounts set out in the amended Schedule of Fees.

(d) Where the exchange rate between Swiss currency and any prescribed currency becomes different from the exchange rate last applied, the Director General shall establish new amounts in the prescribed currency according to directives given by the Assembly. The newly established amounts shall become applicable two months after the date of their publication in the Gazette, provided that the interested Office and the Director General may agree on a date falling during the said two-month period in which case the said amounts shall become applicable for that Office from that date.

15.3 *Mode of Payment*

The international fee shall be payable in the currency or currencies prescribed by the receiving Office, it being understood that, when transferred by the re-

ceiving Office to the International Bureau, the amount transferred shall be freely convertible into Swiss currency.

15.4 Time of Payment

(a) Subject to paragraph (c), the basic fee shall be due on the date of receipt of the international application.

(b) Subject to paragraph (c), the designation fee shall be paid on the date of receipt of the international application or on any later date prior to the expiration of one year from the priority date.

(c) The receiving Office may permit applicants to pay either the basic fee or the designation fee or both of the fees later than on the dates provided for in paragraphs (a) and (b), provided that:

(i) permission shall not be given to pay the basic fee or the designation fee later than one month after the date of receipt of the international application;

(ii) permission may not be subject to any extra charge.

Such later payment of the said fees shall be without loss, in the case of the basic fee, of the international filing date, or, in the case of the designation fee, of the designations to which the payment relates.

15.5 (Deleted)

15.6 Refund

(a) The international fee shall be refunded to the applicant if the determination under Article 11(1) is negative.

(b) In no other case shall the international fee be refunded.

PCT RULE 16

The Search Fee

16.1 Right to Ask for a Fee

(a) Each International Searching Authority may require that the applicant pay a fee ("search fee") for its own benefit for carrying out the international search and for performing all other tasks entrusted to International Searching Authorities by the Treaty and these Regulations.

(b) The search fee shall be collected by the receiving Office. The said fee shall be payable in the currency or currencies prescribed by that Office ("the receiving Office currency"), it being understood that, if any receiving Office currency is not that, or one of those, in which the International Searching Authority has fixed the said fee ("the fixed currency or currencies"), it shall, when transferred by the receiving Office to the International Searching Authority, be freely convertible into the currency of the State in which the International Searching Authority has its headquarters ("the headquarters currency"). The amount of the search fee in any receiving Office currency, other than the fixed currency or currencies, shall be established by the Director General after consultation with that Office. The amounts so established shall be the equivalents, in round figures, of the amount established by

the International Searching Authority in the headquarters currency. They shall be published in the Gazette.

(c) Where the amount of the search fee in the headquarters currency is changed, the corresponding amounts in the receiving Office currencies, other than the fixed currency or currencies, shall be applied from the same date as the changed amount in the headquarters currency.

(d) Where the exchange rate between the headquarters currency and any receiving Office currency, other than the fixed currency or currencies, becomes different from the exchange rate last applied, the Director General shall establish the new amount in the said receiving Office currency according to directives given by the Assembly. The newly established amount shall become applicable two months after its publication in the Gazette, provided that any interested receiving Office and the Director General may agree on a date falling during the said two-month period in which case the said amount shall become applicable for that Office from that date.

(e) Where, in respect of the payment of the search fee in a receiving Office currency, other than the fixed currency or currencies, the amount actually received by the International Searching Authority in the headquarters currency is less than that fixed by it, the difference will be paid to the International Searching Authority by the International Bureau, whereas, if the amount actually received is more, the difference will belong to the International Bureau.

(f) As to the time of payment of the search fee, the provisions of Rule 15.4 relating to the basic fee shall apply.

16.2 Refund

The search fee shall be refunded to the applicant if the determination under Article 11(1) is negative.

16.3 Partial Refund

Where the international application claims the priority of an earlier international application which has been the subject of an international search by the same International Searching Authority, that Authority shall refund the search fee paid in connection with the later international application to the extent and under the conditions provided for in the agreement under Article 16(3)(b), if the international search report on the later international application could wholly or partly be based on the results of the international search effected on the earlier international application.

PCT RULE 27

Lack of Payment of Fees

27.1 Fees

(a) For the purposes of Article 14(3)(a), "fees prescribed under Article 3(4)(iv)" means; the transmittal fee (Rule 14), the basic fee part of the international fee (Rule 15.1(i)), and the search fee (Rule 16).

(b) For the purposes of Article 14(3)(a) and (b), "the fee prescribed under Article 4(2)" means the

designation fee part of the international fee (Rule 15.1(ii)).

PCT RULE 96

*The Schedule of Fees*96.1 *Schedule of Fees Annexed to Regulations*

The amounts of the fees referred to in Rules 15 and 57 shall be expressed in Swiss currency. They shall be specified in the Schedule of Fees which is annexed to these Regulations and forms an integral part thereof.

SCHEDULE OF FEES

(Effective January 1, 1981)

<i>Kind of Fee</i>	<i>Amount</i>
1. Basic Fee:	
(Rule 15.2(a))	
if the international application contains not more than 30 sheets.....	432 Swiss francs
if the international application contains more than 30 sheets	432 Swiss francs plus 8 Swiss francs for each sheet in excess of 30 sheets
2. Designation Fee:	
(Rule 15.2 (a))	104 Swiss francs
* * * * *	* * * * *
<i>Surcharges</i>	
5. Surcharge for late payment:	
(Rule 16bis.2(a))	Minimum: 200 Swiss francs
	Maximum: 500 Swiss francs

→ Note that effective May 19, 1981, the "prescribed currency" and amounts for filing in the United States Receiving Office are in U.S. dollars as follows (PCT Rule 15.2(b)):

→ Basic Fee application up to 30 sheets	\$215.00
→ Fee for each sheet in excess of 30 sheets	\$4.00
→ Designation Fee.....	\$50.00

Applicants should check the most recent issue of the Official Gazette for any changes in the amounts of the fees.

Fees Associated with International Applications.—There are three kinds of fees which must be paid to the United States Patent and Trademark Office in connection with the filing and processing of international applications in the United States Receiving Office:

A transmittal fee—for the benefit of the Receiving Office for receiving, processing, and transmitting copies of the international applications (PCT Rule 14);

A search fee—for the benefit of the International Searching Authority for carrying

out the international search and preparing an international search report (PCT Rule 16); and

An international fee which includes a basic fee portion and a designation fee portion for each State designated—for the benefit of the International Bureau for performing the tasks required of it under the PCT (PCT Rule 15).

When an international application is filed with the U.S. Patent and Trademark Office as a Receiving Office, the transmittal fee, the search fee, and the basic fee portion of the international fee are due *upon filing* of the application (35 U.S.C. 361(d)). The designation fee portion of the international fee must be paid within one year of the priority date.

The amounts of the transmittal fee (PCT Rule 14.1) and the search fee (PCT Rule 16.1) set forth in 37 CFR 1.445 are intended to cover the costs of performing the required functions in the U.S. Patent and Trademark Office and are as follows:

Transmittal fee.....	\$ 35.00
Search fee.....	\$300.00

The amount of the basic fee portion of the international fee is to be \$215.00 for an international application containing up to thirty sheets, with an additional charge of \$4.00 per sheet for each sheet in excess of thirty (PCT Rule 15.2(b)). Although all designated States must be named at the time the international application is filed, the payment of the designation fee portion of the international fee need not be paid on filing but must be paid to the Receiving Office, at the latest, within one year of the priority date. The designation fee portion of the international fee is \$50.00 for each State or group of designated States for which the same regional patent is sought (PCT Rule 15.2(b)). In other words, only one \$50.00 designation fee is due for all countries for which European patent protection is desired.

Fees may be paid by check (37 CFR 1.23) or be charged against a Patent and Trademark Office Deposit Account (37 CFR 1.25).

REFUND OF FEES

There is no provision in the PCT concerning the possibility of asking for a refund of the transmittal fee. The search fee and the international fee (both the basic fee and the designation fees) will be refunded where the Receiving Office refuses to "accord" an "international filing date" (PCT Rules 15.6 and 16.2). Such refusal will occur, generally speaking, where the international application is defective in certain respects. Where a (later) international application claims the priority of another (earlier)

U.S. national or international application which has been the subject of an international search by the same International Searching Authority which will have to carry out the search on the later application, a partial refund of the search fee paid in respect of the later application may be possible (PCT Rules 16.2 and 16.3).

FEE CALCULATION SHEET (FORM
PCT/RO/101 ANNEX

This sheet is not counted as a part of the international application for purposes of determining the amount of the Basic International fee (PCT Rule 15.2(a)).

The instructions for use of this form are printed on the reverse side of the form. When calculating fees, the latest issue of the *Official Gazette* should be consulted to determine the current level of the PCT fees.

➤ 1827.01 Advance for Unpaid Fees
[R-3]

PCT RULE 16BIS

Advancing Fees by the International Bureau

16bis.1 Guarantee by the International Bureau

(a) Where, by the time they are due under Rule 14.1 (b), Rule 15.4(a) or (c) and Rule 16.1(f), the receiving Office finds that in respect of an international application no fees were paid to it by the applicant, or that the amount paid to it by the applicant is less than what is necessary to cover the transmittal fee, the basic fee and the search fee, the receiving Office shall charge the amount required to cover those fees, or the missing part thereof, to the International Bureau and shall consider the said amount as if it had been paid by the applicant at the due time.

(b) Where, by the time it or they are due under Rule 15.4(b) or (c), the receiving Office finds that in respect of an international application the payment made by the applicant is insufficient to cover the designation fees necessary to cover all the designations, the receiving Office shall charge the amount required to cover those fees to the International Bureau and shall consider that amount as if it had been paid by the applicant at the due time.

(c) The International Bureau shall transfer from time to time to each receiving Office an amount which is expected to be necessary for covering any charges that the receiving Office has to make under paragraphs (a) and (b). The amount and the time of such transfers shall be determined by each receiving Office according to its own wish. The charging of any amount under paragraphs (a) and (b) shall not require any advance notice to, or any agreement by, the International Bureau.

➤ (d) Each month, the receiving Office shall inform the International Bureau of the charges, if any, made under paragraphs (a) and (b).

16bis.2 Obligations of the Applicant, etc.

← (a) The International Bureau shall promptly notify the applicant of any amount by which it was charged under Rule 16bis.1(a) and (b) and shall invite him to pay to it, within one month from the date of the notification, the said amount augmented by a surcharge of 50%, provided that the surcharge will not be less, and will not be more, than the amounts indicated in the Schedule of Fees. The notification may refer to the charges made both under Rule 16bis.1(a) and (b) or, at the discretion of the International Bureau, there may be two separate notifications, one referring to charges made under Rule 16bis.1(a), the other referring to charges made under Rule 16bis.1(b).

(b) If the applicant fails to pay, within the said time limit, to the International Bureau the amount claimed, or pays less than what is needed to cover the transmittal fee, the basic fee, the search fee, one designation fee and the surcharge, the International Bureau shall notify the receiving Office accordingly and the receiving Office shall declare the international application withdrawn under Article 14(3) (a) and the receiving Office and the International Bureau shall proceed as provided in Rule 29.

(c) If the applicant pays, within the said time limit, to the International Bureau an amount which is more than what is needed to cover the fees and surcharges referred to in paragraph (b) but less than what is needed to cover all the designations maintained, the International Bureau shall notify the receiving Office accordingly and the receiving Office shall apply the amount paid in excess of what is needed to cover the fees and surcharge referred to in paragraph (b) in an order which shall be established as follows:

(i) where the applicant indicates to which designation or designations the amount is to be applied, it shall be applied accordingly but, if the amount received is insufficient to cover the designations indicated, it shall be applied to as many designations as are covered by it in the order chosen by the applicant in indicating the designations;

(ii) to the extent that the applicant has not given the indications under item (i), the amount or the balance thereof shall be applied to the designations in the order in which they appear in the international application;

(iii) where the designation of a State is for the purposes of a regional patent and provided that the required designation fee is, under the preceding provisions, available for that designation, the designation of any further States for which the same regional patent is sought shall be considered as covered by that fee.

The receiving Office shall declare any designation not covered by the amount paid withdrawn under Article 14(3) (b) and the receiving Office and the International Bureau shall proceed as provided in Rule 29.

← (d) The receiving Office shall not return to the International Bureau any amount that it has charged to that Bureau for covering the transmittal fee.

(e) Where the international application is considered withdrawn, any amount charged to the International Bureau, other than the amount needed to cover the transmittal fee and the search fee transferred by the receiving Office to the International Searching Authority, shall be returned by the receiving Office to the International Bureau.

(f) Where the international application is considered withdrawn, any search fee charged by the receiving Office and transferred to the International Searching Authority shall be transferred by that Authority to the International Bureau unless the said Authority has already started the international search.

(g) Where paragraph (c) applies, the amount charged by the receiving Office to the International Bureau for designations which, as a consequence of the application of the order under that paragraph, are not maintained, shall be returned to the International Bureau by the receiving Office.

16bis.3 Notifications

(a) Any receiving Office may exclude the application of Rules 16bis.1 and 16bis.2 by a written notification to that effect given to the International Bureau by September 1, 1980. Such notification may be withdrawn at any time. The International Bureau shall publish all such notifications and withdrawals in the Gazette.

(b) Former Rule 15.5* remains applicable in respect of any receiving Office giving a notification under paragraph (a).

**Former Rule 15.5 Partial Payment*

(a) Where the amount of the international fee received by the receiving Office is not less than that of the basic fee and at least one designation fee but less than the amount required to cover the basic fee and all the designations made in the international application, the amount received shall be applied as follows:

(i) to cover the basic fee, and

(ii) to cover as many designation fees as, after deduction of the basic fee may be covered in full by the amount received in the order indicated in paragraph (b).

(b) The order in which the said amount shall be applied to the designations shall be established as follows:

(i) where the applicant indicates to which designation or designations the amount is to be applied, it shall be applied accordingly but, if the amount received is insufficient to cover the designations indicated, it shall be applied to as many designations as are covered by it in the order chosen by the applicant in indicating the designations;

(ii) to the extent that the applicant has not given the indications under item (i), the amount or the balance thereof shall be applied to the designations in the order in which they appear in the international application;

(iii) where the designation of a State is for the purposes of a regional patent and provided that the required designation fee is, under the preceding provisions, available for that designation, the desig-

nation of any further States for which the same regional patent is sought shall be considered as covered by that fee.

New Rule 16bis was added to provide greater security to the applicant and his professional representative in the case of a mistake (as to the prescribed amount) or delay (beyond the prescribed time limit) in the payment of fees to the receiving Office (transmittal fee, search fee, basic fee and designation fees). The system introduced by the new Rule guarantees that any such mistake or delay will not result in a loss of rights without the International Bureau of WIPO first having issued an invitation to the applicant to pay any amount that was missing when the time for payment expired. Payment pursuant to such an invitation will be subject to a surcharge which in general will be equal to 50% of the missing amount but which will have an upper limit of 500 Swiss francs and a lower limit of 200 Swiss francs. Any payment made in conformity with such an invitation will be regarded as if it had been made within the prescribed—but, in fact, missed—time limit.

The new system operates in the following fashion. Where the receiving Office finds the amount paid to be insufficient to cover all fees due, the receiving Office will charge the International Bureau with the amount due. The International Bureau will then notify the applicant of the amount it has advanced and will invite the applicant to pay the International Bureau the amount advanced together with a 50% surcharge, provided that the surcharge cannot be less than 200 Swiss francs or more than 500 Swiss francs (see the Schedule of Fees.) If the applicant does not timely pay the required amount to the International Bureau, the International Bureau will notify the receiving Office which will then declare the international application or certain designations withdrawn.

If applicant decides not to pay certain designation fees, it is requested that a letter be sent to the receiving Office specifically withdrawing such designations. If no such withdrawal letter is received and some designations remain unpaid one year after the priority date, the procedure under Rule 16bis will be used.

1828 Priority Document [R-3]

PCT RULE 17

The Priority Document

17.1 Obligation to Submit Copy of Earlier National Application

(a) Where the priority of an earlier national application is claimed under Article 8 in the international

application, a copy of the said national application, certified by the authority with which it was filed ("the priority document"), shall, unless already filed with the receiving Office, together with the international application, be submitted by the applicant to the International Bureau or to the receiving Office not later than 16 months after the priority date or, in the case referred to in Article 23(2), not later than at the time the processing or examination is requested. Where submitted to the receiving Office, the priority document shall be transmitted by that Office to the International Bureau together with the record copy or promptly after having been received by that Office. In the latter case, the receiving Office shall indicate to the International Bureau the date on which it received the priority document.

(b) Where the priority document is issued by the receiving Office, the applicant may, instead of submitting the priority document, request the receiving Office to transmit the priority document to the International Bureau. Such a request shall be made not later than the expiration of the applicable time limit referred to under paragraph (a) and may be subjected by the receiving Office to the payment of a fee. The receiving Office shall, promptly after receipt of such request, and, where applicable, the payment of such fee, transmit the priority document to the International Bureau with an indication of the date of receipt of such request.

(c) If the requirements of neither of the two preceding paragraphs are complied with, any designated State may disregard the priority claim.

(d) The International Bureau shall record the date on which the priority document has been received by it or by the receiving Office. Where applicable, the date of receipt by the receiving Office of a request referred to under paragraph (b) shall be recorded as the date of receipt of the priority document. The International Bureau shall notify the applicant and the designated Offices accordingly.

17.2 Availability of Copies

(a) The International Bureau shall, at the specific request of the designated Office, promptly but not before the expiration of the time limit fixed in Rule 17.1(a), furnish a copy of the priority document to that Office. No such Office shall ask the applicant himself to furnish it with a copy, except where it requires the furnishing of a copy of the priority document together with a certified translation thereof. The applicant shall not be required to furnish a certified translation to the designated Office before the expiration of the applicable time limit under Article 22.

(b) The International Bureau shall not make copies of the priority document available to the public prior to the international publication of the international application.

(c) Paragraphs (a) and (b) shall apply also to any earlier international application whose priority is claimed in the subsequent international application.

PCT ADMINISTRATIVE INSTRUCTION SECTION 411

Notification That the Certified Copy of the Priority Document Has Not Been Submitted

Where the time limit under Rule 17.1(a) has expired and the International Bureau has not received a certified copy of the priority document, it shall notify the applicant and the designated Offices accordingly.

37 CFR 1.451 *The priority claims and priority document in an international application.* (a) The claim for priority must be made on the Request (PCT Rule 4.10) in a manner complying with Sections 110 and 201 of the Administrative Instructions.

(b) Whenever the priority of an earlier United States national application is claimed in an international application, the applicant may request in a letter of transmittal accompanying the international application upon filing with the United States Receiving Office, that the Patent and Trademark Office prepare a certified copy of the national application for transmittal to the International Bureau (PCT Art. 8 and PCT Rule 17). The fee for preparing a certified copy is stated in § 1.21(b) and 35 U.S.C. 41(11).

(c) If a certified copy of the priority document is not submitted together with the international application on filing, or, if the priority application was filed in the United States and a request and appropriate payment for preparation of such a certified copy do not accompany the international application on filing, the certified copy of the priority document must be transmitted directly by the applicant to the International Bureau within the time limit specified in PCT Rule 17.1(a).

Under the PCT procedure, the applicant may file the certified copy of the earlier filed national application together with the international application in the Receiving Office for transmittal with the Record Copy, or alternatively the certified copy may be submitted directly by the applicant to the International Bureau not later than 16 months after the priority date of, if the applicant has requested early processing in any designated Office, not later than the time such processing or examination is requested. The International Bureau will notify the applicant and the designated Offices of the date on which the certified copy was received. The International Bureau will normally furnish copies of the certified copy to the various designated Offices on request so that the applicant will not normally be required to submit certified copies to each designated Office.

Under 37 CFR 1.451, a third alternative for transmittal of the certified copy of the priority document exists. The applicant may request, on filing the international application, that the United States Receiving Office prepare and transmit a certified copy of a U.S. national application, the priority of which is claimed, to the International Bureau. The United States

Receiving Office will prepare and transmit the certified copy provided that the fees for copying and certification are paid. See § 1830, item (1).

1830 PCT International Application Transmittal Letter

A PCT international application transmittal letter, form PTO-1382, is available free of charge for applicants to use when filing PCT international applications with the United States Receiving Office. The form is intended to simplify the filing of PCT international applications by providing a one-page letter which covers the most common requests and concerns of applicants. Specifically covered are:

(1) Requests under 37 CFR 1.451 for preparation and transmittal to the International Bureau of certified copies of the U.S. national applications, the priority of which is claimed in international applications;

(2) Requests for transmittal of the Record Copy by the applicant to the International Bureau under 37 CFR 1.461;

(3) Authorizations for any required additional search fees to be charged to a deposit account subject to oral confirmation of the authorization;

(4) Statements of preference and authorization for any refund or reimbursement of the search fee or additional (supplemental) search fee to be credited to a deposit account or to be refunded by U.S. Treasury Department check;

(5) Indications of information concerning differences in disclosure, if any, between the international application and related applications to assist in determining any foreign transmittal licensing requirements as well as for other purposes; and

(6) Requests for foreign transmittal license.

1832 License Request for Foreign Filing Under the PCT

A license for foreign filing is not required to file an international application in the United States Receiving Office but may be required before the applicant or the U.S. Receiving Office can forward a copy of the international application to a foreign patent office, the International Bureau or other foreign authority (35 U.S.C. 368, 37 CFR, 5.1 and 5.11). A foreign filing license to permit transmittal to a foreign office or international authority is not required if the international application does not disclose subject matter in addition to that disclosed in a prior U.S. national application filed more than six months prior to the filing of the international application (37 CFR 5.11(a)(2)).

In all other instances, the applicant should petition for a license for foreign filing (transmittal) (37 CFR 5.12) and if appropriate, identify any additional subject matter in the international application which was not in the earlier U.S. national application (37 CFR 5.14 (e)). This request and disclosure information may be supplied on the PCT international application transmittal letter form, PTO-1382, which is reproduced below.

If no petition or request for a foreign filing license is included in the international application, and it is clear that a license is required because of the designation of foreign countries and the time at which the Record Copy must be transmitted, it is current Office practice to construe the filing of such an international application to include a request for a foreign filing license. If the license can be granted it will be issued without further correspondence. If no license can be issued, or further information is required, applicant will be contacted. The automatic request for a foreign filing license does not apply to the filing of a foreign application outside the PCT.

EFFECT OF SECRECY ORDER

If a secrecy order is applied to an international application, the application will not be forwarded to the International Bureau as long as the secrecy order remains in effect (PCT Article 27(8) and 35 U.S.C. 368). If the secrecy order remains in effect at the end of the 14th month after the priority date of the international application, the international application will be declared withdrawn (abandoned) because the Record Copy of the international application was not received in time by the International Bureau (37 CFR 5.3(d), PCT Article 12(3), and PCT Rule 22.3). It is, however, possible to save the U.S. filing date, if the United States of America has been designated, by fulfilling the requirements of 35 U.S.C. 371(c) prior to the end of the 14th month.

1840 International Stage Time Limits [R-3]

PCT ARTICLE 47

Time Limits

(1) The details for computing time limits referred to in this Treaty are governed by the Regulations.

(2) (a) All time limits fixed in Chapters I and II of this Treaty may, outside any revision under Article 60, be modified by a decision of the Contracting States.

(b) Such decisions shall be made in the Assembly or through voting by correspondence and must be unanimous.

(c) The details of the procedure are governed by the Regulations.

PCT ARTICLE 48

Delay in Meeting Certain Time Limits

(1) Where any time limit fixed in this Treaty or the Regulations is not met because of interruption in the mail service or unavoidable loss or delay in the mail, the time limit shall be deemed to be met in the cases and subject to the proof and other conditions prescribed in the Regulations.

(2) (a) Any Contracting State shall, as far as that State is concerned, excuse, for reasons admitted under its national law, any delay in meeting any time limit.

(b) Any Contracting State may, as far as that State is concerned, excuse, for reasons other than those referred to in subparagraph (a), any delay in meeting any time limit.

PCT RULE 79

*Calendar**79.1 Expressing Dates*

Applicants, national Offices, receiving Offices, International Searching and Preliminary Examining Authorities, and the International Bureau, shall, for the purposes of the Treaty and the Regulations, express any date in terms of the Christian era and the Gregorian calendar, or, if they use other eras and calendars, they shall also express any date in terms of the Christian era and the Gregorian calendar.

PCT RULE 80

*Computation of Time Limits**80.1 Periods Expressed in Years*

When a period is expressed as one year or a certain number of years, computation shall start on the day following the day on which the relevant event occurred, and the period shall expire in the relevant subsequent year in the month having the same name and on the day having the same number as the month and the day on which the said event occurred provided that if the relevant subsequent month has no day with the same number the period shall expire on the last day of that month.

80.2 Periods Expressed in Months

When a period is expressed as one month or a certain number of months, computation shall start on the day following the day on which the relevant event occurred, and the period shall expire in the relevant subsequent month on the day which has the same number as the day on which the said event occurred, provided that if the relevant subsequent month has no day with the same number the period shall expire on the last day of that month.

80.3 Periods Expressed in Days

When a period is expressed as a certain number of days, computation shall start on the day following the day on which the relevant event occurred, and the period shall expire on the day on which the last day of the count has been reached.

80.4 Local Dates

(a) The date which is taken into consideration as the starting date of the computation of any period shall be the date which prevails in the locality at the time when the relevant event occurred.

(b) The date on which any period expires shall be the date which prevails in the locality in which the required document must be filed or the required fee must be paid.

80.5 Expiration on a Non-Working Day

If the expiration of any period during which any document or fee must reach a national Office or intergovernmental organization falls on a day on which such Office or organization is not open to the public for the purposes of the transaction of official business, or on which ordinary mail is not delivered in the locality in which such Office or organization is situated, the period shall expire on the next subsequent day on which neither of the said two circumstances exists.

80.6 Date of Documents

(a) Where a period starts on the day of the date of a document or letter emanating from a national Office or intergovernmental organization, any interested party may prove that the said document or letter was mailed on a day later than the date it bears, in which case the date of actual mailing shall, for the purposes of computing the period, be considered to be the date on which the period starts. Irrespective of the date on which such a document or letter was mailed, if the applicant offers to the national Office or intergovernmental organization evidence which satisfies the national Office or intergovernmental organization that the document or letter was received more than 7 days after the date it bears, the national Office or intergovernmental organization shall treat the period starting from the date of the document or letter as expiring later by an additional number of days which is equal to the number of days which the document or letter was received later than 7 days after the date it bears.

(b) Any receiving Office may exclude the application of the second sentence of paragraph (a) by a written notification to that effect given to the International Bureau by September 1, 1980. Such notification may be withdrawn at any time. The International Bureau shall publish all such notifications and withdrawals in the Gazette.

80.7 End of Working Day

(a) A period expiring on a given day shall expire at the moment the national Office or intergovernmental organization with which the document must be filed or to which the fee must be paid closes for business on that day.

(b) Any Office or organization may depart from the provisions of paragraph (a) up to midnight on the relevant day.

(c) The International Bureau shall be open for business until 6 p.m.

PCT RULE 82

*Irregularities in the Mail Service***82.1 Delay or Loss in Mail**

(a) Any interested party may offer evidence that he has mailed the document or letter 5 days prior to the expiration of the time limit. Except in cases where surface mail normally arrives at its destination within 2 days of mailing, or where no airmail service is available, such evidence may be offered only if the mailing was by airmail. In any case, evidence may be offered only if the mailing was by mail registered by the postal authorities.

(b) If such mailing is proven to the satisfaction of the national Office or intergovernmental organization which is the addressee, delay in arrival shall be excused, or, if the document or letter is lost in the mail, substitution for it of a new copy shall be permitted, provided that the interested party proves to the satisfaction of the said Office or organization that the document or letter offered in substitution is identical with the document or letter lost.

(c) In the cases provided for in paragraph (b), evidence of mailing within the prescribed time limit, and, where the document or letter was lost, the substitute document or letter as well, shall be submitted within 1 month after the date on which the interested party noticed—or with due diligence should have noticed—the delay or the loss, and in no case later than 6 months after the expiration of the time limit applicable in the given case.

82.2 Interruption in the Mail Service

(a) Any interested party may offer evidence that on any of the 10 days preceding the day of expiration of the time limit the postal service was interrupted on account of war, revolution, civil disorder, strike, natural calamity, or other like reason, in the locality where the interested party resides or has his place of business or is staying.

(b) If such circumstances are proved to the satisfaction of the national Office or intergovernmental organization which is the addressee, delay in arrival shall be excused, provided that the interested party proves to the satisfaction of the said Office or organization that he effected the mailing within 5 days after the mail service was resumed. The provisions of Rule 82.1(c) shall apply *mutatis mutandis*.

PCT ADMINISTRATIVE INSTRUCTIONS SECTION 110

Dates

Any date in the international application, or used in any correspondence emanating from International Authorities relating to the international application, shall be indicated by the Arabic number of the day, by the name of the month, and by the Arabic number of the year. The receiving Office, where the applicant has not done so, or the International Bureau, where the applicant has not done so and the receiving Office fails to do so, shall, after or below any date indicated by the

applicant in the request, repeat the date, in parenthesis, by indicating it by two-digit Arabic numerals each for the number of the day, for the number of the month and for the last two numbers of the year, in that order and with a period after the digit pairs of the day and of the month (for example, "30 March 1978 (30.03.78)").

35 U.S.C. 364. International stage: Procedure. (a) International applications shall be processed by the Patent Office when acting as a Receiving Office or International Searching Authority, or both, in accordance with the applicable provisions of the treaty, the Regulations, and this title.

(b) An applicant's failure to act within prescribed time limits in connection with requirements pertaining to a pending international application may be excused upon a showing satisfactory to the Commissioner of unav avoidable delay, to the extent not precluded by the treaty and the Regulations, and provided the conditions imposed by the treaty and the Regulations regarding the excuse of such failure to act are complied with.

37 CFR 1.465 Timing of application processing based on the priority date. (a) For the purpose of computing time limits under the Treaty, the priority date shall be defined as in PCT Art. 2(xi).

(b) When a claimed priority date is cancelled under PCT Rule 4.10(d), or considered not to have been made under PCT Rule 4.10(b), the priority date for the purposes of computing time limits will be the date of the earliest valid remaining priority claim of the international application, or if none, the international filing date.

(c) When corrections under PCT Art. 11(2), Art. 14(2) or PCT Rule 20.2(a) (i) or (iii) are timely submitted, and the date of receipt of such corrections falls later than one year from the claimed priority date or dates, the Receiving Office shall proceed under PCT Rule 4.10(d).

37 CFR 1.468 Delays in meeting time limits. Delays in meeting time limits during international processing of international applications may only be excused as provided in PCT Rule 82. For delays in meeting time limits in a national application, see § 1.137. [R-4]

1845 Receiving Office Procedure [R-3]

PCT ARTICLE 10

The Receiving Office

The international application shall be filed with the prescribed receiving Office, which will check and process it as provided in this Treaty and the Regulations.

PCT RULE 20

*Receipt of the International Application***20.1 Date and Number**

(a) Upon receipt of papers purporting to be an international application, the receiving Office shall in-

delibly mark the date of actual receipt in the space provided for that purpose in the request form of each copy received and one of the numbers assigned by the International Bureau to that Office on each sheet of each copy received.

(b) The place on each sheet where the date or number shall be marked, and other details, shall be specified in the Administrative Instructions.

20.2 Receipt on Different Days

(a) In cases where all the sheets pertaining to the same purported international application are not received on the same day by the receiving Office, that Office shall correct the date marked on the request (still leaving legible, however, the earlier date or dates already marked) so that it indicates the day on which the papers completing the international application were received, provided that:

(i) where no invitation under Article 11(2) (a) to correct was sent to the applicant, the said papers are received within 30 days from the date on which sheets were first received;

(ii) where an invitation under Article 11(2) (a) to correct was sent to the applicant, the said papers are received within the applicable time limit under Rule 20.6;

(iii) in the case of Article 14(2), the missing drawings are received within 30 days from the date on which the incomplete papers were filed;

(iv) the absence or later receipt of any sheet containing the abstract or part thereof shall not, in itself, require any correction of the date marked on the request.

(b) Any sheet received on a date later than the date on which sheets were first received shall be marked by the receiving Office with the date on which it was received.

20.3 Corrected International Application

In the case referred to in Article 11(2) (b), the receiving Office shall correct the date marked on the request (still leaving legible, however, the earlier date or dates already marked) so that it indicates the day on which the last required correction was received.

→ 20.3bis Manner of Carrying Out Corrections

The Administrative Instructions prescribe the manner in which corrections required under Article 11(2)

(a) shall be presented by the applicant and the manner in which they shall be entered in the file of the international application.

↳ 20.4 Determination under Article 11(1)

(a) Promptly after receipt of the papers purporting to be an international application, the receiving Office shall determine whether the papers comply with the requirements of Article 11(1).

(b) For the purposes of Article 11(1) (iii) (c), it shall be sufficient to indicate the name of the applicant in a way which allows his identity to be established even if the name is misspelled, the given names are not

fully indicated, or, in the case of legal entities, the indication of the name is abbreviated or incomplete.

20.5 Positive Determination

(a) If the determination under Article 11(1) is positive, the receiving Office shall stamp in the space provided for that purpose in the request form the name of the receiving Office and the words "PCT International Application," or "Demande internationale PCT." If the official language of the receiving Office is neither English nor French, the words "International Application" or "Demande internationale" may be accompanied by a translation of these words in the official language of the receiving Office.

(b) The copy whose request sheet has been so stamped shall be the record copy of the international application.

(c) The receiving Office shall promptly notify the applicant of the international application number and the international filing date.

20.6 Invitation to Correct

(a) The invitation to correct under Article 11(2) shall specify the requirement provided for under Article 11(1) which, in the opinion of the receiving Office, has not been fulfilled.

(b) The receiving Office shall promptly mail the invitation to the applicant and shall fix a time limit, reasonable under the circumstances of the case, for filing the correction. The time limit shall not be less than 10 days, and shall not exceed 1 month, from the date of the invitation. If such time limit expires after the expiration of 1 year from the filing date of any application whose priority is claimed, the receiving Office may call this circumstance to the attention of the applicant.

20.7 Negative Determination

If the receiving Office does not, within the prescribed time limit, receive a reply to its invitation to correct, or if the correction offered by the applicant still does not fulfill the requirements provided for under Article 11(1), it shall:

(i) promptly notify the applicant that his application is not and will not be treated as an international application and shall indicate the reasons therefor,

(ii) notify the International Bureau that the number it has marked on the papers will not be used as an international application number,

(iii) keep the papers constituting the purported international application and any correspondence relating thereto as provided in Rule 93.1, and

(iv) send a copy of the said papers to the International Bureau where, pursuant to a request by the applicant under Article 25(1), the International Bureau needs such a copy and specially asks for it.

20.8 Error by the Receiving Office

If the receiving Office later discovers, or on the basis of the applicant's reply realizes, that it has erred in

issuing an invitation to correct since the requirements provided for under Article 11(1) were fulfilled when the papers were received, it shall proceed as provided in Rule 20.5.

20.9 Certified Copy for the Applicant

Against payment of a fee, the receiving Office shall furnish to the applicant, on request, certified copies of the international application as filed and of any corrections thereto.

PCT RULE 26

Checking and Correcting Certain Elements of the International Application

26.1 Time Limit for Check

(a) The receiving Office shall issue the invitation to correct provided for in Article 14(1)(b) as soon as possible, preferably within 1 month from the receipt of the international application.

(b) If the receiving Office issues an invitation to correct the defect referred to in Article 14(1)(a)(iii) or (iv) (missing title or missing abstract), it shall notify the International Searching Authority accordingly.

26.2 Time Limit for Correction

The time limit referred to in Article 14(1)(b) shall be reasonable under the circumstances of the particular case and shall be fixed in each case by the receiving Office. It shall not be less than 1 month and normally not more than 2 months from the date of the invitation to correct.

26.3 Checking of Physical Requirements under Article 14(1)(a)(v)

The physical requirements referred to in Rule 11 shall be checked to the extent that compliance therewith is necessary for the purpose of reasonably uniform international publication.

26.4 Procedure

(a) Any correction offered to the receiving Office may be stated in a letter addressed to that Office if the correction is of such a nature that it can be transferred from the letter to the record copy without adversely affecting the clarity and the direct reproducibility of the sheet on to which the correction is to be transferred; otherwise, the applicant shall be required to submit a replacement sheet embodying the correction and the letter accompanying the replacement sheet shall draw attention to the differences between the replaced sheet and the replacement sheet.

(b) The receiving Office shall mark on each replacement sheet the international application number, the date on which it was received, and the stamp identifying the Office. It shall keep in its files a copy of the letter containing the correction or, when the correction is contained in a replacement sheet, the replaced sheet, the letter accompanying the replacement sheet, and a copy of the replacement sheet.

(c) The receiving Office shall promptly transmit the letter and any replacement sheet to the International Bureau. The International Bureau shall transfer to the record copy the corrections requested in a letter, together with the indication of the date of its receipt by the receiving Office, and shall insert any replacement sheet in the record copy. The letter and any replaced sheet shall be kept in the files of the International Bureau.

(d) The receiving Office shall promptly transmit a copy of the letter and any replacement sheet to the International Searching Authority.

26.5 Correction of Certain Elements

(a) The receiving Office shall decide whether the applicant has submitted the correction within the prescribed time limit. If the correction has been submitted within the prescribed time limit, the receiving Office shall decide whether the international application so corrected is or is not to be considered withdrawn.

(b) The receiving Office shall mark on the papers containing the correction the date on which it received such papers.

26.6 Missing Drawings

(a) If, as provided in Article 14(2), the international application refers to drawings which in fact are not included in that application, the receiving Office shall so indicate in the said application.

(b) The date on which the applicant receives the notification provided for in Article 14(2) shall have no effect on the time limit fixed under Rule 20.2(a)(iii).

35 U.S.C. 361. Receiving Office. (a) The Patent Office shall act as a Receiving Office for international applications filed by nationals or residents of the United States. In accordance with any agreement made between the United States and another country, the Patent Office may also act as a Receiving Office for international applications filed by residents or nationals of such country who are entitled to file international applications.

(b) The Patent Office shall perform all acts connected with the discharge of duties required of a Receiving Office, including the collection of international fees and their transmittal to the International Bureau.

(c) International applications filed in the Patent Office shall be in the English language.

(d) The basic fee portion of the international fee, and the transmittal and search fees prescribed under section 376(a) of this part, shall be paid on filing of an international application. Payment of designation fees may be made on filing and shall be made not later than one year from the priority date of the international application.

37 CFR 1.412 The United States Receiving Office. (a) The United States Patent and Trademark Office is a Receiving Office only for applicants who are residents or nationals of the United States of America.

(b) The Patent and Trademark Office, when acting as a Receiving Office, will be identified by the full title

"United States Receiving Office" or by the abbreviation "RO/US."

(c) The major functions of the Receiving Office include:

(1) According of international filing dates to international applications meeting the requirements of PCT Art. 11(1), and PCT Rule 20;

(2) Assuring that international applications meet the standards for format and content of PCT Art. 14(1), PCT Rule 9, 26, 29.1, 37, 38, 91, and portions of PCT Rules 3 through 11;

(3) Collecting and, when required, transmitting fees due for processing international applications (PCT Rule 14, 15, 16);

(4) Transmitting the record and search copies to the International Bureau and International Searching Authority, respectively (PCT Rules 22 and 23); and

(5) Determining compliance with applicable requirements of Part 5 of this chapter.

PCT ADMINISTRATIVE INSTRUCTIONS SECTION 105

Several Applicants

Where any international application indicates as applicants several persons, it shall be sufficient, for the purpose of identifying that application, to indicate, in

any Form or correspondence relating to such application, the name of the applicant first named in the request.

PCT ADMINISTRATIVE INSTRUCTIONS SECTION 301

Notification of Receipt of Purported International Application

Any receiving Office may notify the applicant of the receipt of the purported international application. The notification should indicate the date of actual receipt, the international application number of the purported international application referred to in Section 307 and the applicant's file reference, where available, as well as, where useful for purposes of identification, the title of the invention.

PCT ADMINISTRATIVE INSTRUCTIONS SECTION 305

Identifying the Copies of the International Application

(a) Where, under Rule 11.1(a), the international application has been filed in one copy, the receiving Office shall, after preparing under Rule 21.1(a) the additional copies required under Article 12(1), mark,

(i) the words "RECORD COPY" in the upper left-hand corner of the first page of the original copy,

(ii) in the same space on one additional copy, the words "SEARCH COPY," and

(iii) in the same space on the other such copy, the words "HOME COPY," or their equivalent in the language of the international application.

(b) Where, under Rule 11.1(b), the international application has been filed in more than one copy, the receiving Office shall choose the copy most suitable for reproduction purposes, and mark the words "RECORD COPY," in the upper left-hand corner of its first page. After verifying the identity of any additional copies and, if applicable, preparing under Rule 21.1(b) the home copy, it shall mark, in the upper left-hand corner of the first page of one such copy, the words "SEARCH COPY," and, in the same space on the other such copy, the words "HOME COPY," or their equivalent in the language of the international application.

PCT ADMINISTRATIVE INSTRUCTIONS SECTION 307

System of Numbering International Applications

Papers purporting to be an international application under Rule 20.1 shall be marked with the international application number, consisting of the letters "PCT," a slant, the two-letter code, as in *Annex B*, indicating the receiving Office, a two-digit indication of the last two numbers of the year in which such papers were first received, a slant and a five-digit number, allotted in sequential order corresponding to the order in which the international applications are received (e.g., "PCT/SU78/00001"). However, if a negative determination is made under Rule 20.7 or a declaration is made under Article 14(4), the letters "PCT" shall be deleted by the receiving Office from the indication of the international application number on any papers marked previously with that number, and the said number shall be used without such letters in any future correspondence relating to the purported international application.

PCT ADMINISTRATIVE INSTRUCTIONS SECTION 308

Marking of the Sheets of the International Application

(a) The receiving Office shall indelibly mark, so as to admit of direct reproduction in any of the manners set forth in Rule 11.2(a), the international application number referred to in Section 307 in the upper right-hand corner of each sheet of each copy of the purported international application.

(b) The data to be indicated on any replacement sheet under Rule 26.4(b) shall be indelibly marked by the receiving Office, so as to admit of direct reproduction in any of the manners set forth in Rule 11.2(a), in the upper right-hand corner of each replacement sheet.

PCT ADMINISTRATIVE INSTRUCTION SECTION 316

Procedure in the Case where the International Application Lacks the Prescribed Signature

Where, under Article 14(1)(a)(i), the receiving Office finds that any international application is defective in that it lacks the prescribed signature, that Office

shall send to the applicant, together with the invitation to correct under Article 14(1)(b), a copy of the request part of the international application. The applicant shall, within the prescribed time limit, return said copy after affixing thereto the prescribed signature.

The main procedural steps that any international application goes through in the United States Receiving Office are the following:

(i) the international application and the related fees are received by the Receiving Office (PCT Article 10);

(ii) the international application is checked by the Receiving Office to determine whether it meets the requirements prescribed by the PCT as to whether a filing date may be granted, fees due on filing are paid in full, whether the priority claim is acceptable, and whether any pages or drawings are missing (PCT Article 11(1), PCT Rule 4.10 and 35 U.S.C. 361(d)). The checks performed by the Receiving Office are of a formal nature and do not go into the substance of the invention;

(iii) where the checks by the United States Receiving Office show that the international application does not meet the requirements for a filing date or other matters are missing, that Office immediately communicates with the applicant in order to obtain any possible necessary corrections (PCT Articles 11(2)(a) and 14(3) and PCT Rules 4.10 and 20).

(iv) where—possibly after correction—the relevant checks by the Receiving Office show that the international application meets the requirements for the granting of a filing date, an international filing date is accorded to the international application by the Receiving Office (PCT Articles 11(1) and 11(2)(b), and PCT Rules 20.3, 20.4, and 20.5);

(v) the United States Receiving Office contacts the applicant or agent by telephone and discusses any formal defects and necessary corrections. Receiving Office checks do not go into the substance of the invention when defects under Article 14(1) exist, the Receiving Office will set a time limit for response, which is usually one month.

(vi) copies of the international application and other documents related thereto are prepared and transmitted by the United States Receiving Office to the International Searching Authority and to the International Bureau so that these Authorities may carry out the procedural steps for which they are responsible in the further processing of the international application (PCT Article 12 and PCT Rules 22, 23, 24, and 25).

WHERE TO FILE

The United States Receiving Office is located in Crystal Plaza, Arlington, Virginia, Building 2, Room 4-C-08. International applications and related papers may be deposited directly with the United States Receiving Office or mailed to: Commissioner of Patents and Trademarks, Box PCT, Washington, D.C. 20231. It should be noted that the Certificate of mailing practice does not relate to the filing of International applications or related papers 37 CFR 1.8). The United States Receiving Office staff is available to offer guidance on PCT requirements and procedures. In person, telephone or written inquiries are welcome. Telephone inquiries should be directed to (703)557-2003. Written inquiries should be addressed to: Commissioner of Patents and Trademarks, Box PCT, Washington, D.C. 20231.

1845.01 Transmittal of Record Copy

PCT ARTICLE 12

Transmittal of the International Application to the International Bureau and the International Searching Authority

(1) One copy of the international application shall be kept by the receiving Office ("home copy"), one copy ("record copy") shall be transmitted to the International Bureau, and another copy ("search copy") shall be transmitted to the competent International Searching Authority referred to in Article 16, as provided in the Regulations.

(2) The record copy shall be considered the true copy of the international application.

(3) The international application shall be considered withdrawn if the record copy has not been received by the International Bureau within the prescribed time limit.

PCT RULE 21

*Preparation of Copies**21.1 Responsibility of the Receiving Office*

(a) Where the international application is required to be filed in one copy, the receiving Office shall be responsible for preparing the home copy and the search copy required under Article 12(1).

(b) Where the international application is required to be filed in two copies, the receiving Office shall be responsible for preparing the home copy.

(c) If the international application is filed in less than the number of copies required under Rule 11.1(b), the receiving Office shall be responsible for the prompt preparation of the number of copies required, and shall have the right to fix a fee for performing that task and to collect such fee from the applicant.

PCT RULE 22

*Transmittal of the Record Copy**22.1 Procedure*

(a) If the determination under Article 11(1) is positive, and unless prescriptions concerning national security prevent the international application from being treated as such, the receiving Office shall transmit the record copy to the International Bureau. Such transmittal shall be effected promptly after receipt of the international application or, if a check to preserve national security must be performed, as soon as the necessary clearance has been obtained. In any case, the receiving Office shall transmit the record copy in time for it to reach the International Bureau by the expiration of the 13th month from the priority date. If the transmittal is effected by mail, the receiving Office shall mail the record copy not later than 5 days prior to the expiration of the 13th month from the priority date.

(b) If the applicant is not in possession of the notification of receipt sent by the International Bureau under Rule 24.2(a) by the expiration of 13 months and 10 days from the priority date, he shall have the right to ask the receiving Office to give him the record copy or, should the receiving Office allege that it has transmitted the record copy to the International Bureau, a certified copy based on the home copy.

(c) The applicant may transmit the copy he has received under paragraph (b) to the International Bureau. Unless the record copy transmitted by the receiving Office has been received by the International Bureau before the receipt by that Bureau of the copy transmitted by the applicant, the latter copy shall be considered the record copy.

22.2 Alternative Procedure

(a) Notwithstanding the provisions of Rule 22.1, any receiving Office may provide that the record copy of any international application filed with it shall be transmitted, at the option of the applicant, by the receiving Office or through the applicant. The receiving Office shall inform the International Bureau of the existence of any such provision.

(b) The applicant shall exercise the option through a written notice, which he shall file together with the international application. If he fails to exercise the said option, the applicant shall be considered to have opted for transmittal by the receiving Office.

(c) Where the applicant opts for transmittal by the receiving Office, the procedure shall be the same as that provided for in Rule 22.1.

(d) Where the applicant opts for transmittal through him, he shall indicate in the notice referred to in paragraph (b) whether he wishes to collect the record copy at the receiving Office or wishes the receiving Office to mail the record copy to him. If the applicant expresses the wish to collect the record copy, the receiving Office shall hold that copy at the disposal of the applicant as soon as the clearance referred to in

Rule 22.1(a) has been obtained and, in any case, including the case where a check for such clearance must be performed, not later than 10 days before the expiration of 13 months from the priority date. If, by the expiration of the time limit for receipt of the record copy by the International Bureau, the applicant has not collected that copy, the receiving Office shall notify the International Bureau accordingly. If the applicant expresses the wish that the receiving Office mail the record copy to him or fails to express the wish to collect the record copy, the receiving Office shall mail that copy to the applicant as soon as the clearance referred to in Rule 22.1(a) has been obtained and, in any case, including the case where a check for such clearance must be performed, not later than 15 days before the expiration of 13 months from the priority date.

(e) Where the receiving Office does not hold the record copy at the disposal of the applicant by the date fixed in paragraph (d), or where, after having asked for the record copy to be mailed to him, the applicant has not received that copy at least 10 days before the expiration of 13 months from the priority date, the applicant may transmit a copy of his international application to the International Bureau. This copy ("provisional record copy") shall be replaced by the record copy or, if the record copy has been lost, by a substitute record copy certified by the receiving Office on the basis of the home copy, as soon as practicable and, in any case, before the expiration of 15 months from the priority date.

22.3 Time Limit under Article 12(3)

(a) The time limit referred to in Article 12(3) shall be:

- (i) where the procedure under Rule 22.1 or Rule 22.2(c) applies, 15 months from the priority date;
- (ii) where the procedure under Rule 22.2(d) applies, 14 months from the priority date, except that, where a provisional record copy is filed under Rule 22.2(e), it shall be 14 months from the priority date for the filing of the provisional record copy, and 15 months from the priority date for the filing of the record copy.

22.4 Statistics Concerning Non-Compliance with Rules 22.1 and 22.2

The number of instances in which, according to the knowledge of the International Bureau, any receiving Office has not complied with the requirements of Rules 22.1 and/or 22.2 shall be indicated, once a year, in the Gazette.

22.5 Documents Filed with the International Application

Any power of attorney and any priority document filed with the international application referred to in Rule 3.3(a) (ii) shall accompany the record copy; any

other document referred to in that Rule shall be sent only at the specific request of the International Bureau. If any document referred to in Rule 3.3(a) (ii) which is indicated in the check list as accompanying the international application is not, in fact, filed at the latest by the time the record copy leaves the receiving Office, that Office shall so note on the check list and the said indication shall be considered as if it had not been made.

PCT RULE 23

Transmittal of the Search Copy

23.1 Procedure

(a) The search copy shall be transmitted by the receiving Office to the International Searching Authority at the latest on the same day as the record copy is transmitted to the International Bureau or, under Rule 22.2(d), to the applicant.

(b) If the International Bureau has not received, within 10 days from the receipt of the record copy, information from the International Searching Authority that that Authority is in possession of the search copy, the International Bureau shall promptly transmit a copy of the international application to the International Searching Authority. Unless the International Searching Authority has erred in alleging that it was not in possession of the search copy by the expiration of the 13th month from the priority date, the cost of making a copy for that Authority shall be reimbursed by the receiving Office to the International Bureau.

(c) The number of instances in which, according to the knowledge of the International Bureau, any receiving Office has not complied with the requirement of Rule 23.1(a) shall be indicated, once a year, in the Gazette.

PCT ADMINISTRATIVE INSTRUCTIONS SECTION 315

Notification of Non-Collection of Record Copy

Where, under Rule 22.2(d), the receiving Office has, in accordance with the applicant's wish, held the record copy at the disposal of the applicant, and the applicant has not collected that copy by the expiration of the time limit for receipt of that copy by the International Bureau, the receiving Office shall notify the applicant accordingly.

37 CFR 1.461 Procedures for transmittal of record copy to the International Bureau. (a) Transmittal of the record copy of the international application to the International Bureau shall be made, at the option of the applicant, either by the United States Receiving Office or by the applicant. Subject to paragraph (b) of this section, any applicant who chooses to make such transmittal personally shall notify the United States Receiving Office to that effect in writing, by way of a notice filed together with the international application. Such notice shall also state whether the applicant wishes to collect the record copy at the United States Receiving Office or to have the record copy mailed directly to him. The record copy of an

international application which was filed without being accompanied by such notice will be transmitted to the International Bureau by the United States Receiving Office (PCT Rule 22).

(b) An applicant may transmit the record copy to the International Bureau as provided in PCT Rule 22.2 only if the international application is filed with the United States Receiving Office before the expiration of 11 months from the priority date.

(c) No copy of an international application may be transmitted to the International Bureau, a foreign Designated Office, or other foreign authority by the United States Receiving Office or the applicant, unless the applicable requirements of Part 5 of this chapter have been satisfied.

The PCT provides for two alternative procedures for the transmittal of the record copy. For full details see PCT Rules 22.1 and 22.2.

(i) Under the first alternative, which constitutes the normal procedure, the transmittal of the record copy and documents filed therewith (PCT Rule 22.5) are effected by the United States Receiving Office, which notifies the applicant of the date of transmittal on form PCT/RO/132. The International Bureau, upon receipt of the Record Copy, promptly notifies the applicant using form (PCT/1B/301) that it has received the record copy (PCT Article 12(1) and PCT Rules 22.1 and 24.2(a)).

(ii) Under the second alternative, only applied in the case of international applications filed prior to the expiration of 11 months from the priority date, the applicant may, at his option, effect the transmittal of the record copy himself (PCT Rule 22.2 and 37 CFR 1.461(a) and (b)).

If the applicant has not received notification from the International Bureau that the record copy has been received within 13 months and 10 days from the priority date, he may assume that the record copy has not reached the International Bureau and he may ask the Receiving Office to give him the record copy or a certified copy based on the home copy and send it himself to the International Bureau (PCT Rules 22.1(b) and (c)). The record copy must, in this case too, reach the International Bureau not later than 15 months from the priority date (PCT Rule 22.3). Under this alternative the Record Copy must be made available to the applicant to send to the International Bureau within time limits specified in PCT Rule 22.2(d). The applicant must assure that the Record Copy or an acceptable substitute, specified in PCT Rule 22.2(d) is received by the International Bureau by 13 months after the expiration of the priority date. In most instances, if a substitute Record Copy has been filed with the

International Bureau, the Record Copy itself must also be filed before the expiration of 15 months from the priority date.

(iii) The international fees will also be forwarded to the International Bureau by the Receiving Office (35 U.S.C. 42). Since the applicant is required to file only one copy of the international application in the United States Receiving Office (37 CFR 1.433), the United States Receiving Office will prepare the "Search Copy" for the International Searching Authority and the "Home Copy" for its own records (PCT Rule 21.1 and Administrative Instructions Section 305(a)).

SAFEGUARDS FOR ASSURING TIMELY RECEIPT OF THE RECORD COPY

The following steps are being taken by the United States Receiving Office to insure timely receipt of the Record Copy by the International Bureau.

(i) The Record Copy is sent by Registered Airmail to the International Bureau with transmittal letter listing contents.

(ii) A copy of the Transmittal letter is mailed separately to the International Bureau in a business size envelope.

(iii) The Applicant is informed of the date of mailing of the Record Copy by letter from the United States Receiving Office.

(iv) A Telex is sent to the International Bureau in Geneva giving notice of mailing and the Mail Registration number.

(v) The International Bureau immediately acknowledges receipt of the Telex by return Telex to the United States Receiving Office.

(vi) The Applicant is informed of receipt of Record Copy by the International Bureau.

(vii) The United States Receiving Office is in telephone contact with the International Bureau in Geneva at least once a week, at which time questions are handled and records are coordinated.

If for some reason, the Record Copy is not received by the International Bureau by the expiration of the 13th month from the priority date, the applicant and the Receiving Office have two additional months under PCT Rule 22.3(a) to provide a copy to the International Bureau before the application is withdrawn under PCT Article 12(3). [R-4]

1845.02 Correction of Defects Before the Receiving Office [R-3]

PCT ARTICLE 14

Certain Defects in the International Application

(1) (a) The receiving Office shall check whether the international application contains any of the following defects, that is to say:

- (i) it is not signed as provided in the Regulations;
- (ii) it does not contain the prescribed indications concerning the applicant;
- (iii) it does not contain a title;
- (iv) it does not contain an abstract;
- (v) it does not comply to the extent provided in the Regulations with the prescribed physical requirements.

(b) If the receiving Office finds any of the said defects, it shall invite the applicant to correct the international application within the prescribed time limit, failing which that application shall be considered withdrawn and the receiving Office shall so declare.

(2) If the international application refers to drawings which, in fact, are not included in that application, the receiving Office shall notify the applicant accordingly and he may furnish them within the prescribed time limit and, if he does, the international filing date shall be the date on which the drawings are received by the receiving Office. Otherwise, any reference to the said drawings shall be considered non-existent.

(3) (a) If the receiving Office finds that, within the prescribed time limits, the fees prescribed under Article 3(4) (iv) have not been paid, or no fee prescribed under Article 4(2) has been paid in respect of any of the designated States, the international application shall be considered withdrawn and the receiving Office shall so declare.

(b) If the receiving Office finds that the fee prescribed under Article 4(2) has been paid in respect of one or more (but less than all) designated States within the prescribed time limit, the designation of those States in respect of which it has not been paid within the prescribed time limit shall be considered withdrawn and the receiving Office shall so declare.

(4) If, after having accorded an international filing date to the international application, the receiving Office finds, within the prescribed time limit, that any of the requirements listed in items (i) to (iii) of Article 11(1) was not complied with at that date, the said application shall be considered withdrawn and the receiving Office shall so declare.

PCT RULE 29

International Applications or Designations Considered Withdrawn under Article 14(1), (3) or (4)

29.1 Finding by Receiving Office

(a) If the receiving Office declares, under Article 14(1) (b) and Rule 26.5 (failure to correct certain defects), or under Article 14(3) (a) (failure to pay the prescribed fees under Rule 27.1(a)), or under Article 14(4) (later finding of non-compliance with the requirements listed in items (i) to (iii) of Article 11(1)), that the international application is considered withdrawn:

- (i) the receiving Office shall transmit the record copy (unless already transmitted), and any correction offered by the applicant, to the International Bureau;

(ii) the receiving Office shall promptly notify both the applicant and the International Bureau of the said declaration, and the International Bureau shall in turn notify the interested designated Offices;

(iii) the receiving Office shall not transmit the search copy as provided in Rule 23, or, if such copy has already been transmitted, it shall notify the International Searching Authority of the said declaration;

(iv) the International Bureau shall not be required to notify the applicant of the receipt of the record copy.

(b) If the receiving Office declares under Article 14(3) (b) (failure to pay the prescribed designation fee under Rule 27.1(b)) that the designation of any given State is considered withdrawn, the receiving Office shall promptly notify both the applicant and the International Bureau of the said declaration. The International Bureau shall in turn notify the interested national Office.

29.2 Finding by Designated Office

Where the effect of the international application ceases in any designated State by virtue of Article 24(1) (iii), or where such effect is maintained in any designated State by virtue of Article 24(2), the competent designated Office shall promptly notify the International Bureau accordingly.

29.3 Calling Certain Facts to the Attention of the Receiving Office

If the International Bureau or the International Searching Authority considers that the receiving Office should make a finding under Article 14(4), it shall call the relevant facts to the attention of the receiving Office.

29.4 Notification of Intent to Make Declaration under Article 14(4)

Before the receiving Office issues any declaration under Article 14(4), it shall notify the applicant of its intent to issue such declaration and the reasons therefor. The applicant may, if he disagrees with the tentative finding of the receiving Office, submit arguments to that effect within 1 month from the notification.

PCT RULE 30

Time Limit Under Article 14(4)

30.1 Time Limit

The time limit referred to in Article 14(4) shall be 4 months from the international filing date. ←

PCT RULE 32

Withdrawal of the International Application or of Designations

32.1 Withdrawals

(a) The applicant may withdraw the international application prior to the expiration of 20 months from the priority date except as to any designated State in which national processing or examination has already

started. He may withdraw the designation of any designated State prior to the date on which processing or examination may start in that State.

(b) Withdrawal of the designation of all designated States shall be treated as withdrawal of the international application.

(c) Withdrawal shall be effected by a signed notice from the applicant to the International Bureau or, if the record copy has not yet been sent to the International Bureau, to the receiving Office. In the case of Rule 4.8(b), the notice shall require the signature of all the applicants.

(d) Where the record copy has already been sent to the International Bureau, the fact of withdrawal, together with the date of receipt of the notice effecting withdrawal, shall be recorded by the International Bureau and promptly notified by it to the receiving Office, the applicant, the designated Offices affected by the withdrawal, and, where the withdrawal concerns the international application and where the international search report or the declaration referred to in Article 17(2)(a) has not yet issued, the International Searching Authority.

PCT ADMINISTRATIVE INSTRUCTIONS SECTION 304

Corrections Submitted to the Receiving Office Concerning Expressions, etc., not to be used in the International Application

Where the applicant submits corrections to the receiving Office aimed at complying with the prescriptions of Rule 9.1, that Office shall, if copies of the international application have not yet been transmitted to the International Bureau and the International Searching Authority, attach copies of such corrections to the international application. If copies of the international application have already been transmitted, the receiving Office shall transmit copies of such corrections to the said Bureau and the said Authority.

PCT ADMINISTRATIVE INSTRUCTIONS SECTION 309

Procedure in the Case of Later Submitted Sheets

(a) The receiving Office shall indelibly mark, so as to admit of direct reproduction in any of the manners set forth in Rule 11.2(a), any sheet received on a date later than the date on which sheets were first received with the date on which it received that sheet, inserted immediately below the international application number referred to in Section 307.

(b) The receiving Office shall, in the case of later submitted sheets received within the time limits referred to in Rule 20.2(a) (i) and (ii) :

(i) effect the required correction of the international filing date, or, where no international filing date has yet been accorded, of the date of receipt of the purported international application ;

(ii) notify the applicant of the correction effected under item (i) above ;

(iii) where transmittals under Article 12(1) have already been made, notify the International Bureau

and the International Searching Authority of any correction effected under item (i) above, by transmitting a copy of the corrected first page of the request, and forward copies of the later submitted sheets to the said Bureau and the said Authority ;

(iv) where transmittals under Article 12(1) have not yet been made, attach a copy of the later submitted sheets to the record copy and the search copy.

(c) The receiving Office shall, in the case of later submitted sheets received after the expiration of the time limits referred to in Rule 20.2(a) (i) and (ii) ;

(i) notify the applicant of that fact and of the date of receipt of the later submitted sheets ;

(ii) where transmittals under Article 12(1) have already been made, forward a copy of the later submitted sheets to the International Bureau with the indication that such sheets are not to be taken into consideration for the purposes of international processing ;

(iii) where transmittals under Article 12(1) have not yet been made, attach a copy of the later submitted sheets to the record copy with the indication that such sheets are not to be taken into consideration for the purposes of international processing.

PCT ADMINISTRATIVE INSTRUCTIONS SECTION 311

Renumbering of Sheets of the International Application

(a) The receiving Office shall, subject to Section 207, sequentially renumber the sheets of the international application when necessitated by the addition of any new sheet, the deletion of entire sheets, a change in the order of the sheets or any other reason.

(b) The sheets of the international application shall be provisionally renumbered in the following manner :

(i) when a sheet is deleted, the receiving Office shall either include a blank sheet with the same number and with the word "deleted," or its equivalent in the language of the international application, below the number, or insert, in brackets, below the number of the following sheet, the number of the deleted sheet with the word "deleted" or its equivalent in the language of the international application ;

(ii) when a sheet is substituted, the receiving Office shall write below the number of the new sheet the word "substitute" or its equivalent in the language of the international application ;

(iii) when one or more sheets are added, each sheet shall be identified by the number of the preceding sheet followed by an oblique stroke and then by a natural number series, starting always with number one for the first sheet added after an unchanged sheet (e.g., 10/1, 15/1, 15/2, 15/3, etc.). When later additions of sheets to an existing series of added sheets are necessary, an extra digit shall be used for identifying the further additions (e.g. 15/1, 15/1/1, 15/1/2, 15/2, etc.).

(c) In the cases mentioned in (i) and (iii) above, it is recommended that the receiving Office should write, below the number of the last sheet, the total number of

the sheets of the international application followed by the words "TOTAL OF SHEETS" or their equivalent in the language of the international application. It is further recommended that, at the bottom of any last sheet added, the words "LAST ADDED SHEET" or their equivalent in the language of the international application should be inserted.

PCT ADMINISTRATIVE INSTRUCTIONS SECTION 312

Notification of Decision not to Issue Declaration that the International Application is Considered Withdrawn

Where the receiving Offices, after having notified the applicant under Rule 29.4 of its intent to issue a declaration under Article 14(4), decides not to issue such a declaration, it shall notify the applicant accordingly.

37 CFR 1.471 *Corrections and amendments during international processing.* (a) All corrections submitted to the United States Receiving Office must be in the form of replacement sheets and be accompanied by a letter that draws attention to the differences between the replaced sheets and the replacement sheets, except that the deletion of lines of text, the correction of simple typographical errors, and one addition or change of not more than five words per sheet may be stated in a letter and the United States Receiving Office will make the deletion or transfer the correction to the international application, provided that such corrections do not adversely affect the clarity and direct reproducibility of the application (PCT Rule 26.4).

(b) Amendments of claims submitted to the International Bureau shall be as prescribed by PCT Rule 46.

DEFECTS IN THE INTERNATIONAL APPLICATION WHICH MAY BE CORRECTED

The following defects must be corrected before an international filing date can be accorded. Form PCT/RO/103 is used to call applicant's attention to these defects and to invite correction thereof. The time limit for filing the correction is fixed by the Receiving Office. It cannot be less than 10 days or more than one month from the date of the invitation to correct (PCT Rule 20.6(b)).

(i) The International application *does not designate at least one Contracting State.*

(ii) The international application does not contain the name of the applicant or does not contain at least those minimal indications concerning the name of the applicant which are indicated in PCT Article 11(1)(iii)(c) and PCT Rule 20.4(b).

(iii) The international application does not contain a part which, on the face of it, appears to be a description or a part which, on the face of it, appears to be a claim or claims (PCT Article 11(1)(iii)(d) and (e)).

(iv) The applicant obviously lacks, for reasons of not being a resident or national of the United States of America, the right to file an international application with the United States Receiving Office (PCT Article 11(1)(i)).

(v) The international application is not in the English language which must be used for international applications filed with the United States Receiving Office (PCT Article 11(1)(ii)).

(vi) The international application does not contain an indication that it is intended as an international application (PCT Article 11(1)(iii)(a)).

The following defects must be corrected within the time period set by the United States Receiving Office in the invitation to correct (form PCT/RO/106) to prevent withdrawal of the international application (PCT Rule 26.5). If the correction is timely presented the filing date will not be changed and the application will not be withdrawn.

(i) Where the Receiving Office finds that the international application *is not signed* (PCT Article 14(1)(a)(i) and PCT Rules 2, 3, 4.1(d) and 4.15). The time limit for correction is fixed by the Receiving Office. It must be reasonable under the circumstances; it cannot be less than one month and normally not more than two months from the date of the invitation to correct. Such invitation together with a copy of the unsigned Request are issued by the Receiving Office as soon as possible after the receipt of international application (PCT Article 14(1)(b), PCT Rule 26.2) and Administrative Instructions Section 316.

(ii) The applicant must return the copy of the Request, properly signed, within the prescribed time limit. Where the Receiving Office finds that the international application does not contain the name of the applicant in the prescribed way or the prescribed indications concerning the applicant (other than those specified in Rule 20.4(b)(ii)). These indications include, in particular, the applicant's address, residence and nationality (PCT Article 14(1)(a)(ii) and PCT Rules 4.4 and 4.5).

(iii) Where the Receiving Office finds that the international application does not contain a title (that is, a title for the claimed invention) (PCT Article 14(1)(a)(iv) and PCT Rule 26.1(b)).

(iv) Where the Receiving Office finds that the international application does not contain an abstract (PCT Article 14(1)(a)(iv) and PCT Rule 26.1(b)).

(v) Where the Receiving Office finds that the international application does not comply, to the extent provided for in the Regulations, with

the prescribed physical requirements (PCT Article 14(1)(a)(v) and PCT Rules 11 and 26.3). The physical requirements are provided for in detail in PCT Rule 11. Compliance with them must be checked to the extent that compliance therewith is necessary for the purpose of reasonably uniform international publication.

(vi) Where the Receiving Office finds that any of the drawings referred to in the international application are, in fact, not included in that application (PCT Article 14(2) and PCT Rule 26.6), the time limit for furnishing such drawings is 30 days from the date on which incomplete papers were received by the Receiving Office (PCT Rule 20.2(a)(iii)). It should be carefully noted that when missing drawings are received within 30 days they will be entered into the application papers, *however, the date of receipt of the application will be amended to reflect the date on which the missing drawings were received.* The United States Receiving Office will notify the applicant of any missing drawings on form PCT/RO/107. Detailed procedures in the case where drawings are missing are set forth in Section 310 of the PCT Administrative Instructions.

(vii) Where the Receiving Office finds that sheets of the description or claims are missing, the procedures are similar to those in (vi) above; and are set forth in detail in PCT Rule 20 and Section 309 of the PCT Administrative Instructions.

(viii) If the Receiving Office finds that the priority claim fails to meet the requirements of Rule 4.10(b) in that the name of the country of filing or the date of filing of the earlier application are missing, the priority claim is considered not to have been made and the applicant is notified accordingly on form PCT/RO/121, (PCT Administrative Instructions Section 302).

(ix) If the Receiving Office finds that the claimed priority date does not fall within the period of one year preceding the International filing date, it will invite the applicant to amend or cancel the priority claim using form PCT/RO/110 (PCT Rule 4.10(d)). The applicant has one month to respond by amending or canceling the priority claim. If no response is timely received, the Receiving Office will cancel the priority claim *ex officio* (Administrative Instructions Section 314). The amendment or cancellation of the priority claim will be acknowledged using forms PCT/RO/111.

PRESENTATION OF CORRECTIONS

According to the nature of the defect, the correction may be stated in a letter only or may have to be filed in the form of a replacement sheet or replacement sheets accompanied by a

letter (37 CFR 1.471). The details are provided for in PCT Rule 26.4. Any correction must be in the English language (PCT Rule 12.2). As to the signature and other requirements of such letters, see PCT Rule 92.1. The Receiving Office must inform, and where necessary, transmit copies of replacement sheets to the International Searching Authority.

CONSEQUENCES OF THE CORRECTION OF DEFECTS

Where the correction is filed with the Receiving Office within the prescribed time limit and is found acceptable, the international application will be considered valid (PCT article 11(2)(b)). If the correction relates to any of the defects referred to in PCT Article 11(1) and 14(2), the international filing date will be the date on which the correction was received; if it relates only to any of the defects referred to in Article 14(1), the international filing date will be the date on which the international application was received by the Receiving Office.

CONSEQUENCES OF NOT CORRECTING DEFECTS

Where an acceptable response or correction is not filed within the prescribed time limit, the international application:

(i) will not be treated as an international application (and, consequently will not be accorded an international filing date) if the defect is one of those referred to in PCT Article 11(1) and PCT Rule 20.7;

(ii) will be treated as withdrawn if the defect is one of those referred to in PCT Article 14(1) and PCT Rule 26.5. In the case of a defect of this kind referred to in PCT Article 14(2), which remains uncorrected, the reference to the (missing) drawing(s) in the international application will be considered non-existent. Missing sheets will not be entered into the application if not received within 30 days of the receipt of incomplete papers (PCT Rule 20.2(a)(i) and PCT Administrative Instructions Section 309);

(iii) if the priority claim fails to meet the requirements of PCT Rule 4.10(b), the priority claim is considered not to have been made and the applicant is notified accordingly (Administrative Instructions Section 302).

1845.03 Correction of Obvious Errors of Transcription

PCT RULE 91

Obvious Errors of Transcription

91.1 Rectification

(a) Subject to paragraphs (b) to (g), obvious errors of transcription in the international application or

other papers submitted by the applicant may be rectified.

(b) Errors which are due to the fact that something other than what was obviously intended was written in the international application or other paper shall be regarded as obvious errors of transcription. The rectification itself shall be obvious in the sense that anyone would immediately realize that nothing else could have been intended than what is offered as rectification.

(c) Omissions of entire elements or sheets of the international application, even if clearly resulting from inattention, at the stage, for example, of copying or assembling sheets, shall not be rectifiable.

(d) Rectification may be made on the request of the applicant. The authority having discovered what appears to be an obvious error of transcription may invite the applicant to present a request for rectification as provided in paragraphs (e) to (g).

(e) No rectification shall be made except with the express authorization:

(i) of the receiving Office if the error is in the request.

(ii) of the International Searching Authority if the error is in any part of the international application other than the request or in any paper submitted to that Authority.

(iii) of the International Preliminary Examining Authority if the error is in any part of the international application other than the request or in any paper submitted to that Authority, and

(iv) of the International Bureau if the error is in any paper, other than the international application or amendments or corrections to that application, submitted to the International Bureau.

(f) The date of the authorization shall be recorded in the files of the international application.

(g) The authorization for rectification referred to in paragraph (e) may be given until the following events occur:

(i) in the case of authorization given by the receiving Office and the International Bureau, the communication of the international application under Article 20;

(ii) in the case of authorization given by the International Searching Authority, the establishment of the international search report or the making of a declaration under Article 17(2) (a);

(iii) in the case of authorization given by the International Preliminary Examining Authority, the establishment of the international preliminary examination report.

(h) Any authority, other than the International Bureau, which authorizes any rectification shall promptly inform the International Bureau of such rectification.

91.2 Manner of Carrying Out Rectifications

The Administrative Instructions prescribe the manner in which rectifications of obvious errors of transcription shall be made and the manner in which they

shall be entered in the file of the international application.

PCT RULE 92

Correspondence

92.1 Need for Letter and for Signature

(a) Any paper submitted by the applicant in the course of the international procedure provided for in the Treaty and these Regulations, other than the international application itself, if not itself in the form of a letter, be accompanied by a letter identifying the international application to which it relates. The letter shall be signed by the applicant.

(b) If the requirements provided for in paragraph (a) are not complied with, the applicant shall be informed as to the non-compliance and invited to remedy the omission within a time limit fixed in the invitation. The time limit so fixed shall be reasonable in the circumstances; even where the time limit so fixed expires later than the time limit applying to the furnishing of the paper (or even if the latter time limit has already expired), it shall not be less than 10 days and not more than one month from the mailing of the invitation. If the omission is remedied within the time limit fixed in the invitation, the omission shall be disregarded; otherwise, the applicant shall be informed that the paper has been disregarded.

(c) Where non-compliance with the requirements provided for in paragraph (a) has been overlooked and the paper taken into account in the international procedure, the non-compliance shall be disregarded.

92.2 Language

(a) Subject to the provisions of paragraph (b) and (c), any letter or document submitted by the applicant to the International Searching Authority or the International Preliminary Examining Authority shall be in the same language as the international application to which it relates.

(b) Any letter from the applicant to the International Searching Authority or the International Preliminary Examining Authority may be in a language other than that of the international application, provided the said Authority authorizes the use of such language.

(c) When a translation is required under Rule 55.2, the International Preliminary Examining Authority may require that any letter from the applicant to the said Authority be in the language of that translation.

(d) Any letter from the applicant to the International Bureau shall be in English or French.

(e) Any letter or notification from the International Bureau to the applicant or to any national Office shall be in English or French.

92.3 Mailings by National Offices and Intergovernmental Organizations

Any document or letter emanating from or transmitted by a national Office or an intergovernmental organization and constituting an event from the date of which any time limit under the Treaty or these Regulations commences, to run shall be sent by regis-

tered air mail, provided that surface mail may be used instead of air mail in cases where surface mail normally arrives at its destination within 2 days from mailing or where air mail service is not available.

92.4 *Use of Telegraph, Teleprinter, etc.*

(a) Notwithstanding the provisions of Rules 11.14 and 92.1(a), but subject to paragraph (b), below, any document (including any drawing) subsequent to the international application may be sent by telegraph or teleprinter or other like means of communication producing a printed or written document. Any such document so sent shall be considered to have been submitted in a form complying with the requirements of the said Rules on the day on which it was communicated by the means mentioned above, provided that, within 14 days after being so communicated, its contents are furnished in that form; otherwise, the telegraphic, teleprinter or other communication shall be considered not to have been made.

(b) Each national Office or intergovernmental organization shall promptly notify the International Bureau of any means referred to in paragraph (a) by which it is prepared to receive documents referred to in that paragraph. The International Bureau shall publish the information so received in the Gazette as well as information concerning the means referred to in paragraph (a) by which the International Bureau is prepared to receive any such document. Paragraph (a) shall apply with respect to any national Office or intergovernmental organization only to the extent the said information has been so published with respect to it. The International Bureau shall publish, from time to time, in the Gazette, changes in the information previously published.

PCT ADMINISTRATIVE INSTRUCTIONS SECTION 109

Notification of Authorization or Refusal of Rectification

Any International Authority which authorizes or refuses rectification of obvious errors of transcription under Rule 91 shall promptly inform the applicant of such authorization or refusal and, in the case of refusal, of the reasons therefor.

Obvious errors of transcription may be rectified (PCT Rule 91) The Receiving Office of Searching Authority will inform the applicant of obvious errors of transcription using form PCT/RO/108 or PCT ISA/216, respectively. The form will indicate to which Authority the applicant may request rectification of the error. In general the Receiving Office may authorize rectification of errors in the Request only. The Searching Authority may authorize rectification of errors in the description, claims, abstract or drawings. The applicant, upon noticing an error of transcription, may spontaneously present a request for rectification to the appropriate authority. The Authority will promptly inform the applicant of the authorization or the

refusal to authorize the rectification of obvious errors (PCT Administration Instruction Section 109). The forms used by the United States Receiving Office and the Searching Authority for authorization or refusal are PCT/RO/109 and PCT/ISA/217.

1845.04 Changes in Certain Indications in the Request [R-3]

PCT RULE 92BIS

Changes in Certain Indications in the Request or the Demand

92bis.1 *Recording of Changes by the International Bureau*

The International Bureau shall, on the request of the applicant or the receiving Office, record changes in the following indications appearing in the request or demand:

- (i) person, name, residence, nationality or address of the applicant,
- (ii) person, name or address of the agent, the common representative or the inventor.

92bis.2 *Notifications*

(a) The International Bureau shall give notifications concerning changes recorded by it:

- (i) to the receiving Office where the change has been recorded on the request of the applicant,
- (ii) as long as the international search report or the declaration referred to in Article 17(2) has not yet issued, to the International Searching Authority,
- (iii) until the expiration of the time limit referred to in Article 22(1), to the designated Offices,
- (iv) as long as the preliminary examination report has not yet issued, to the International Preliminary Examining Authority,
- (v) until the expiration of the time limit referred to in Article 39(1) (a), to the elected Offices.

(b) A copy of each notification sent under paragraph (a) shall be sent to the applicant by the International Bureau.

PCT ADMINISTRATIVE INSTRUCTION SECTION 111

Changes in Certain Indications in the Request and the Demand

Any request for the recording of any changes referred to under Rule 92bis shall be signed by the applicant or, if the receiving Office requested such change, by the receiving Office. The request shall clearly identify the indications the change of which is requested.

1860 The International Searching Authority

PCT ARTICLE 16

The International Searching Authority

(1) International search shall be carried out by an International Searching Authority, which may be either

a national Office or an intergovernmental organization, such as the International Patent Institute, whose tasks include the establishing of documentary search reports on prior art with respect to inventions which are the subject of applications.

(2) If, pending the establishment of a single International Searching Authority, there are several International Searching Authorities, each receiving Office shall, in accordance with the provisions of the applicable agreement referred to in paragraph (3)(b), specify the International Searching Authority or Authorities competent for the searching of international applications filed with such Office.

(3) (a) International Searching Authorities shall be appointed by the Assembly. Any national Office and any intergovernmental organization satisfying the requirements referred to in subparagraph (c) may be appointed as International Searching Authority.

(b) Appointment shall be conditional on the consent of the national Office or intergovernmental organization to be appointed and the conclusion of an agreement, subject to approval by the Assembly, between such Office or organization and the International Bureau. The agreement shall specify the rights and obligations of the parties, in particular, the formal undertaking by the said Office or organization to apply and observe all the common rules of international search.

(c) The Regulations prescribe the minimum requirements, particularly as to manpower and documentation, which any Office or organization must satisfy before it can be appointed and must continue to satisfy while it remains appointed.

(d) Appointment shall be for a fixed period of time and may be extended for further periods.

(e) Before the Assembly makes a decision on the appointment of any national Office or intergovernmental organization, or on the extension of its appointment, or before it allows any such appointment to lapse, the Assembly shall hear the interested Office or organization and seek the advice of the Committee for Technical Cooperation referred to in Article 56 once that Committee has been established.

PCT ARTICLE 17

Procedure Before the International Searching Authority

(1) Procedure before the International Searching Authority shall be governed by the provisions of this

Treaty, the Regulations, and the agreement which the International Bureau shall conclude, subject to this Treaty and the Regulations, with the said Authority.

(2) (a) If the International Searching Authority considers:

(i) that the international application relates to a subject matter which the International Searching Authority is not required, under the Regulations, to search, and in the particular case decides not to search, or

(ii) that the description, the claims, or the drawings, fail to comply with the prescribed requirements to such an extent that a meaningful search could not be carried out,

the said Authority shall so declare and shall notify the applicant and the International Bureau that no international search report will be established.

(b) If any of the situations referred to in subparagraph (a) is found to exist in connection with certain claims only, the international search report shall so indicate in respect of such claims, whereas, for the other claims, the said report shall be established as provided in Article 18.

(3) (a) If the International Searching Authority considers that the international application does not comply with the requirement of unity of invention as set forth in the Regulations, it shall invite the applicant to pay additional fees. The International Searching Authority shall establish the international search report on those parts of the international application which relate to the invention first mentioned in the claims ("main invention") and, provided the required additional fees have been paid within the prescribed time limit, on those parts of the international application which relate to inventions in respect of which the said fees were paid.

(b) The national law of any designated State may provide that, where the national Office of that State finds the invitation, referred to in subparagraph (a), of the International Searching Authority justified and where the applicant has not paid all additional fees, those parts of the international application which consequently have not been searched shall, as far as effects in that State are concerned, be considered withdrawn unless a special fee is paid by the applicant to the national Office of that State.

PCT RULE 25

*Receipt of the Search Copy by the International Searching Authority***25.1 Notification of Receipt of the Search Copy**

The International Searching Authority shall promptly notify the International Bureau, the applicant, and—unless the International Searching Authority is the same as the receiving Office—the receiving Office, of the fact and the date of receipt of the search copy.

PCT RULE 28

*Defects Noted by the International Bureau or the International Searching Authority***28.1 Note on Certain Defects**

(a) If, in the opinion of the International Bureau or of the International Searching Authority, the international application contains any of the defects referred to in Article 14(1)(a) (i), (ii), or (v), the International Bureau or the International Searching Authority, respectively, shall bring such defects to the attention of the receiving Office.

(b) The receiving Office shall, unless it disagrees with the said opinion, proceed as provided in Article 14(1)(b) and Rule 26.

PCT RULE 35

*The Competent International Searching Authority***35.1 When Only One International Searching Authority is Competent**

Each receiving Office shall, in accordance with the terms of the applicable agreement referred to in Article 16(3)(b), inform the International Bureau which International Searching Authority is competent for the searching of the international applications filed with it, and the International Bureau shall promptly publish such information.

35.2 When Several International Searching Authorities are Competent

(a) Any receiving Office may, in accordance with the terms of the applicable agreement referred to in Article 16(3)(b), specify several International Searching Authorities:

(i) by declaring all of them competent for any international application filed with it, and leaving the choice to the applicant, or

(ii) by declaring one or more competent for certain kinds of international applications filed with it, and declaring one or more others competent for other kinds of international applications filed with it, provided that, for those kinds of international applications for which several International Searching Authorities are declared to be competent, the choice shall be left to the applicant.

(b) Any receiving Office availing itself of the faculty provided in paragraph (a) shall promptly inform the International Bureau, and the International Bureau shall promptly publish such information.

35 U.S.C. 362 International Searching Authority. The Patent Office may act as an International Searching Authority with respect to international applications in accordance with the terms and conditions of an agreement which may be concluded with the International Bureau.

37 CFR 1.418 The United States International Searching Authority. (a) Pursuant to appointment by the Assembly, the United States Patent and Trademark Office will act as an International Searching Authority for international applications filed in the United States Receiving Office and in other Receiving Offices as may be agreed upon by the Commissioner, in accordance with agreement between the Patent and Trademark Office and the International Bureau (PCT Art. 16(3)(b)).

(b) The Patent and Trademark Office, when acting as an International Searching Authority, will be identified by the full title "United States International Searching Authority" or by the abbreviation "ISA/US."

(c) The major functions of the International Searching Authority include:

(1) Approving or establishing the title and abstract;

(2) Considering the matter of unity of invention;

(3) Conducting international and international-type searches and preparing international and international-type search reports (PCT Art. 15, 17 and 18, and PCT Rules 25, 33 to 45 and 47); and

(4) Transmitting the international search report to the applicant and the International Bureau.

TRANSMITTAL OF THE "SEARCH COPY" TO THE INTERNATIONAL SEARCHING AUTHORITY

The "search copy" is transmitted by the Receiving Office to the International Searching Authority (PCT Article 12(1)), the details of transmittal are provided in PCT Rule 23.

THE MAIN PROCEDURAL STEPS IN THE INTERNATIONAL SEARCHING AUTHORITY

The main procedural steps that any international application goes through in the United States International Searching Authority are the following:

(i) the making of the international search (PCT Article 15), and

(ii) the preparing of the international search report (PCT Article 18 and PCT Rule 43)

COMPETENT INTERNATIONAL SEARCHING AUTHORITY

In respect of international applications filed with the U.S. Receiving Office, the United States International Searching Authority, which is the Examining Corps of the United States Patent and Trademark Office, is competent to carry out the international search (PCT

Article 16, PCT Rules 35 and 36, 35 U.S.C. 362 and 37 CFR 1.413).

1862 The International Search

ARTICLE 15

The International Search

(1) Each international application shall be the subject of international search.

(2) The objective of the international search is to discover relevant prior art.

(3) International search shall be made on the basis of the claims, with due regard to the description and the drawings (if any).

(4) The International Searching Authority referred to in Article 16 shall endeavor to discover as much of the relevant prior art as its facilities permit, and shall, in any case, consult the documentation specified in the Regulations.

(5) (a) If the national law of the Contracting States so permits, the applicant who files a national application with the national Office of or acting for such State may, subject to the conditions provided for in such law, request that a search similar to an international search ("international-type search") be carried out on such application.

(b) If the national law of the Contracting State so permits, the national Office of or acting for such State may subject any national application filed with it to an international-type search.

(c) The international-type search shall be carried out by the International Searching Authority referred to in Article 16 which would be competent for an international search if the national application were an international application and were filed with the Office referred to in subparagraphs (a) and (b). If the national application is in a language which the International Searching Authority considers it is not equipped to handle, the international-type search shall be carried out on a translation prepared by the applicant in a language prescribed for international applications and which the International Searching Authority has undertaken to accept for international applications. The national application and the translation, when required, shall be presented in the form prescribed for international applications.

PCT RULE 33

Relevant Prior Art for the International Search

33.1 Relevant Prior Art for the International Search

(a) For the purposes of Article 15(2), relevant prior art shall consist of everything which has been made available to the public anywhere in the world by means of written disclosure (including drawings and other illustrations) and which is capable of being of assistance in determining that the claimed invention is or is not new and that it does or does not involve an inventive step (i.e., that it is or is not obvious), pro-

vided that the making available to the public occurred prior to the international filing date.

(b) When any written disclosure refers to an oral disclosure, use, exhibition, or other means whereby the contents of the written disclosure were made available to the public, and such making available to the public occurred on a date prior to the international filing date, the international search report shall separately mention that fact and the date on which it occurred if the making available to the public of the written disclosure occurred on a date posterior to the international filing date.

(c) Any published application or any patent whose publication date is later but whose filing date, or, where applicable, claimed priority date, is earlier than the international filing date of the international application searched, and which would constitute relevant prior art for the purposes of Article 15(2) had it been published prior to the international filing date, shall be specially mentioned in the international search report.

33.2 Fields to be Covered by the International Search

(a) The international search shall cover all those technical fields, and shall be carried out on the basis of all those search files, which may contain material pertinent to the invention.

(b) Consequently, not only shall the art in which the invention is classifiable be searched but also analogous arts regardless of where classified.

(c) The question what arts are, in any given case, to be regarded as analogous shall be considered in the light of what appears to be the necessary essential function or use of the invention and not only the specific functions expressly indicated in the international application.

(d) The international search shall embrace all subject matter that is generally recognized as equivalent to the subject matter of the claimed invention for all or certain of its features, even though, in its specifics, the invention as described in the international application is different.

33.3 Orientation of the International Search

(a) International search shall be made on the basis of the claims, with due regard to the description and the drawings (if any) and with particular emphasis on the inventive concept toward which the claims are directed.

(b) Insofar as possible and reasonable, the international search shall cover the entire subject matter to which the claims are directed or to which they might reasonably be expected to be directed after they have been amended.

PCT RULE 34

Minimum Documentation

34.1 Definition

(a) The definitions contained in Article 2 (i) and (ii) shall not apply for the purposes of this Rule.

(b) The documentation referred to in Article 15(4) ("minimum documentation") shall consist of:

(i) the "national patent documents" as specified in paragraph (c).

(ii) the "national patent documents" as specified in paragraph (c),

(ii) the published international (PCT) applications, the published regional applications for patents and inventors' certificates, and the published regional patents and inventors' certificates,

(iii) such other published items of non-patent literature as the International Searching Authorities shall agree upon and which shall be published in a list by the International Bureau when agreed upon for the first time and whenever changed.

(c) Subject to paragraphs (d) and (e), the "national patent documents" shall be the following:

(i) the patents issued in and after 1920 by France, the former *Reichpatentamt* of Germany, Japan, the Soviet Union, Switzerland (in French and German languages only), the United Kingdom, and the United States of America;

(ii) the patents issued by the Federal Republic of Germany,

(iii) the patent applications, if any, published in and after 1920 in the countries referred to in items (i) and (ii),

(iv) the inventors' certificates issued by the Soviet Union,

(v) the utility certificates issued by, and the published applications for utility certificates of, France,

(vi) such patents issued by, and such patent applications published in, any other country after 1920 as are in the English, French, or German language and in which no priority is claimed, provided that the national Office of the interested country sorts out these documents and places them at the disposal of each International Searching Authority.

(d) Where an application is republished once (for example, an *Offenlegungsschrift* as an *Auslegeschrift*) or more than once, no International Searching Authority shall be obliged to keep all versions in its documentation; consequently, each such Authority shall be entitled not to keep more than one version. Furthermore, where an application is granted and is issued in the form of a patent or a utility certificate (France), no International Searching Authority shall be obliged to keep both the application and the patent or utility certificate (France) in its documentation; consequently, each such Authority shall be entitled to keep either the application only or the patent or utility certificate (France) only.

(e) Any International Searching Authority whose official language, or one of whose official languages, is not Japanese or Russian is entitled not to include in its documentation those patent documents of Japan and the Soviet Union, respectively, for which no abstracts in the English language are generally available. English abstracts becoming generally available after the date of entry into force of these Regulations shall

require the inclusion of the patent documents to which the abstracts refer no later than 6 months after such abstracts become generally available. In case of the interruption of abstracting services in English in technical fields in which English abstracts were formerly generally available, the Assembly shall take appropriate measures to provide for the prompt restoration of such services in the said fields.

(f) For the purposes of this Rule, applications which have only been laid open for public inspection are not considered published applications.

PCT RULE 36

Minimum Requirements for International Searching Authorities

36.1 Definition of Minimum Requirements

The minimum requirements referred to in Article 16(3) (c) shall be the following:

(i) the national Office or intergovernmental organization must have at least 100 full-time employees with sufficient technical qualifications to carry out searches;

(ii) that Office or organization must have in its possession at least the minimum documentation referred to in Rule 34, properly arranged for search purposes;

(iii) that Office or organization must have a staff which is capable of searching the required technical fields and which has the language facilities to understand at least those languages in which the minimum documentation referred to in Rule 34 is written or is translated.

PCT RULE 39

Subject Matter Under Article 17(2) (a) (i)

39.1 Definition

No International Searching Authority shall be required to search an international application if, and to the extent to which, its subject matter is any of the following:

(i) scientific and mathematical theories,

(ii) plant or animal varieties or essentially biological processes for the production of plants and animals, other than microbiological processes and the products of such processes,

(iii) schemes, rules or methods of doing business, performing purely mental acts or playing games,

(iv) methods for treatment of the human or animal body by surgery or therapy, as well as diagnostic methods,

(v) mere presentations of information,

(vi) computer programs to the extent that the International Searching Authority is not equipped to search prior art concerning such programs.

PCT ADMINISTRATIVE INSTRUCTIONS SECTION 501
Corrections Submitted to the International Searching Authority Concerning Expressions, etc., not to be used in the International Application

Where the applicant submits corrections to the In-

ternational Searching Authority aimed at complying with the prescription of Rule 9.1, that Authority shall transmit copies of such corrections to the receiving Office and the International Bureau.

The objective of the international search is to discover relevant prior art (PCT Article 15 (2)). "Prior art" consists of everything which has been made available to the public anywhere in the world by means of written disclosure (including drawings and other illustrations); it is "relevant" in respect of the international application if it is capable of being of assistance in determining that the claimed invention is or is not new and that the claimed invention does or does not involve an inventive step (i.e., that it is or is not obvious), and if the making available to the public occurred prior to the international filing date, for further details see PCT Rule 33. The international search is made on the basis of the claims, with due regard to the description and the drawings (if any) contained in the international application (PCT Article 15(3)).

DOCUMENTS SEARCHED BY THE INTERNATIONAL SEARCHING AUTHORITY

The International Searching Authority must endeavor to discover as much of the relevant prior art as its facilities permit (PCT Article 15(4)), and, in any case, must consult the so-called "minimum documentation" (PCT Rule 34).

CERTAIN SUBJECT MATTER NEED NOT BE SEARCHED

No International Searching Authority is required to perform an international search where the international application relates to any of the following subject matters: (i) scientific and mathematical theories, (ii) plant or animal varieties or essentially biological processes for the production of plants and animals, other than microbiological processes and the products of such processes, (iii) schemes, rules or methods of doing business, performing purely mental acts or playing games, (iv) methods for treatment of the human or animal body by surgery or therapy, as well as diagnostic methods, (v) mere presentation of information, and (vi) computer programs to the extent that it, the said Authority) is not equipped to search prior art (PCT Article 17(2)(a)(i) and PCT Rule 39). The applicant planning to file an international application may be well advised not to file one if the subject matter of the application falls into one of the above mentioned areas; if he still does file, the United States International Searching Authority may declare that it will not establish an international search report. It is to be noted

nevertheless that the lack of the international search report in such case will not have, in itself, any influence on the validity of the international application and the latter's processing will continue, including its communication to the designated Offices.

NO SEARCH REQUIRED IF CLAIMS ARE UNCLEAR

If the International Searching Authority considers that the description, the claims, or the drawings fail to comply with the prescribed requirements to such an extent that a meaningful search could not be carried out, it may declare that it will not establish a search report (PCT Article 17(2)(a)(ii) and (b)). Such declaration may also be made in respect of some of the claims only. This may be particularly the case where the description or the claims are unclear. The lack of the international search report will not, in itself, have any influence on the validity of the international application and the latter's processing will continue, including its communication to the designated Offices. Where only some of the claims are found to be "unsearchable," the International Searching Authority will not search them, but will search the rest of the international application. Any unsearched claims will be indicated in the Search Report.

1863 The International Search Report

PCT ARTICLE 18

The International Search Report

(1) The international search report shall be established within the prescribed time limit and in the prescribed form.

(2) The international search report shall, as soon as it has been established, be transmitted by the International Searching Authority to the applicant and the International Bureau.

(3) The international search report or the declaration referred to in Article 17(2)(a) shall be translated as provided in the Regulations. The translations shall be prepared by or under the responsibility of the International Bureau.

PCT RULE 37

Missing or Defective Title

37.1 Lack of Title

If the international application does not contain a title and the receiving Office has notified the International Searching Authority that it has invited the applicant to correct such defect, the International Searching Authority shall proceed with the international search unless and until it receives notification that the said application is considered withdrawn.

37.2 Establishment of Title

If the international application does not contain a title and the International Searching Authority has not received a notification from the receiving Office to the effect that the applicant has been invited to furnish a title, or if the said Authority finds that the title does not comply with Rule 4.3, it shall itself establish a title.

PCT RULE 38*Missing Abstract***38.1 Lack of Abstract**

If the international application does not contain an abstract and the receiving Office has notified the International Searching Authority that it has invited the applicant to correct such defect, the International Searching Authority shall proceed with the international search unless and until it receives notification that the said application is considered withdrawn.

38.2 Establishment of Abstract

(a) If the international application does not contain an abstract and the International Searching Authority has not received a notification from the receiving Office to the effect that the applicant has been invited to furnish an abstract, or if the said Authority finds that the abstract does not comply with Rule 8, it shall itself establish an abstract (in the language in which the international application is published). In the latter case, it shall invite the applicant to comment on the abstract established by it within 1 month from the date of the invitation.

(b) The definitive contents of the abstract shall be determined by the International Searching Authority.

PCT RULE 43*The International Search Report***43.1 Identifications**

The international search report shall identify the International Searching Authority which established it by indicating the name of such Authority, and the international application by indicating the international application number, the name of the applicant, the name of the receiving Office, and the international filing date.

43.2 Dates

The international search report shall be dated and shall indicate the date on which the international search was actually completed. It shall also indicate the filing date of any earlier application whose priority is claimed.

43.3 Classification

(a) The international search report shall contain the classification of the subject matter at least according to the International Patent Classification.

(b) Such classification shall be effected by the International Searching Authority.

43.4 Language

Every international search report and any declaration made under Article 17(2)(a) shall be in the language in which the international application to which it relates is published.

43.5 Citations

(a) The international search report shall contain the citations of the documents considered to be relevant.

(b) The method of identifying any cited document shall be regulated by the Administrative Instructions.

(c) Citations of particular relevance shall be specially indicated.

(d) Citations which are not relevant to all the claims shall be cited in relation to the claim or claims to which they are relevant.

(e) If only certain passages of the cited document are relevant or particularly relevant, they shall be identified, for example, by indicating the page, the column, or the lines, where the passage appears.

43.6 Fields Searched

(a) The international search report shall list the classification identification of the fields searched. If that identification is effected on the basis of a classification other than the International Patent Classification, the International Searching Authority shall publish the classification used.

(b) If the international search extended to patents, inventors' certificates, utility certificates, utility models, patents or certificates of addition, inventors' certificates of addition, utility certificates of addition, or published applications for any of those kinds of protection, of States, periods, or languages, not included in the minimum documentation as defined in Rule 34, the international search report shall, when practicable, identify the kinds of documents, the States, the periods, and the languages to which it extended. For the purposes of this paragraph, Article 2(ii) shall not apply.

43.7 Remarks Concerning Unity of Invention

If the applicant paid additional fees for the international search, the international search report shall so indicate. Furthermore, where the international search was made on the main invention only (Article 17(3)(a)), the international search report shall indicate what parts of the international application were and what parts were not searched.

43.8 Signature

The international search report shall be signed by an authorized officer of the International Searching Authority.

43.9 No Other Matter

The international search report shall contain no matter other than that enumerated in Rules 33.1(b) and (c), 43.1, 2, 3, 5, 6, 7 and 8, and 44.2(a) and (b), and the indication referred to in Article 17(2)

(b). In particular, it shall contain no expressions of opinion, reasoning, arguments, or explanations.

43.10 Form

The physical requirements as to the form of the international search report shall be prescribed by the Administrative Instructions.

PCT RULE 44

Transmittal of the International Search Report, etc.

44.1 Copies of Report or Declaration

The International Searching Authority shall, on the same day, transmit one copy of the international search report or the declaration referred to in Article 17(2) (a) to the International Bureau and one copy to the applicant.

44.2 Title or Abstract

(a) Subject to paragraphs (b) and (c), the international search report shall either state that the International Searching Authority approves the title and the abstract as submitted by the applicant or be accompanied by the text of the title and/or abstract as established by the International Searching Authority under Rules 37 and 38.

(b) If, at the time the international search is completed, the time limit allowed for the applicant to comment on any suggestion of the International Searching Authority in respect of the abstract has not expired, the international search report shall indicate that it is incomplete as far as the abstract is concerned.

(c) As soon as the time limit referred to in paragraph (b) has expired, the International Searching Authority shall notify the abstract approved or established by it to the International Bureau and to the applicant.

44.3 Copies of Cited Documents

(a) The request referred to in Article 20(3) may be presented any time during 7 years from the international filing date of the international application to which the international search report relates.

(b) The International Searching Authority may require that the party (applicant or designated Office) presenting the request pay to it the cost of preparing and mailing the copies. The level of the cost of preparing copies shall be provided for in the agreements referred to in Article 16(3)(b) between the International Searching Authorities and the International Bureau.

(c) Any International Searching Authority not wishing to send copies direct to any designated Office shall send a copy to the International Bureau and the International Bureau shall then proceed as provided in paragraphs (a) and (b).

(d) Any International Searching Authority may perform the obligations referred to in (a) to (c) through another agency responsible to it.

PCT ADMINISTRATIVE INSTRUCTIONS SECTION 503

Method of Identifying Documents Cited in the International Search Report

Identification of any document cited in the international search report referred in Rule 43.5(b) shall be made by indicating the following elements in the order in which they are listed:

(a) *In the case of any patent document* (patent documents being patents within the meaning of Article 2(ii) as well as published applications relating thereto):

(i) the Office that issued the document, by the two-letter code as in *Annex B*;

(ii) the kind of document, by the appropriate symbols as in *Annex C*;

(iii) the number of the document as given to it by the Office that issued it (for Japanese patent documents the indication of the year of the reign of the Emperor must precede the serial number of the patent document);

(iv) the date of publication of the cited patent document as indicated thereon;

(v) where applicable, the pages, columns or lines where the relevant passages appear, or the relevant figures of the drawings; and

(vi) the name of the patentee or applicant.

(The following example illustrates the citation of a patent document according to paragraph (a) above: JP, B, 5014535, published 28 May 1975, see column 4, lines 3 to 27, NCR Corporation.)

(b) *In the case of any book or other separately issued publication:*

(i) the name of the author;

(ii) the title (including, where applicable, the number of the edition and/or volume);

(iii) the year of publication (when this coincides with the year of the international application or of the priority claim, the International Searching Authority shall endeavor to determine the month and, if necessary, the day of publication and to indicate these data in the international search report);

(iv) the name of the publisher;

(v) as far as available, the place of publication where only the location of the publisher appears on the book or other separately issued publication, then that location shall be indicated as the place of publication; and

(vi) where applicable, the pages, columns or lines where the relevant passages appear, or the relevant figures of the drawings.

(The following example illustrates the citation of a book or other separately issued publication according to paragraph (b) above:

H. Walton, "Microwave Quantum Theory," Volume 2, published 1973, by Sweet and Maxwell (London), see pages 138 to 192, especially pages 146 to 148.)

(c) *In the case of any article published in a periodical or other serial publication:*

(i) the title of the periodical or other serial publication;

(ii) the number of the volume and the date of the issue in which the article appears;

(iii) as far as available, the place of publication (where only the location of the publisher appears in the periodical or other serial publication, then that location shall be indicated as the place of publication);

(iv) the author and the title of the article and the number of the page both on which the article starts and ends; and

(v) where applicable, the pages, columns or lines where the relevant passages appear, or the relevant figures of the drawings.

(The following example illustrates the citation of an article published in a periodical or other serial publication according to paragraph (c) above:

IBM Technical Disclosure Bulletin, Volume 17 No. 5, issued October 1974 (Armonk, New York), J. G. Drop, "Integrated Circuit Personalization at the Module Level" see pages 1344 to 1345.)

(d) *In the case of abstracts:*

(i) the identification of the document containing the abstract in the manner set forth in paragraphs (a), (b) and (c) respectively, depending upon whether the abstract is contained in a patent document, in a book or other separately issued publication, or in an article published in a periodical or other serial publication;

(ii) in the case where the abstract is not published together with the full text document which served as its basis, the identification of both abstract and full text document on the basis of whatever bibliographic data may be available in respect thereto.

(The following example illustrates the citation of an abstract according to paragraph (d) (ii) above:

Chemical Abstracts, Volume 75, No. 20, issued 15 November 1971 (Columbus, Ohio, U.S.A.), D. I. Shetulov, "Surface Effects During Mental Fatigue," see page 163, column 1, the abstract No. 120718k, Fiz.-Khim. Mekh. Mater. 1971, 7(2), 7-11. (Russ.)

PCT ADMINISTRATIVE INSTRUCTIONS SECTION 504

Classification of the Subject Matter of the International Application

(a) Where the subject matter of the international application is such that classification thereof requires more than one classification symbol according to the principles to be followed in the application of the International Patent Classification to any given patent document, the international search report shall indicate all such symbols.

(b) Where any national classification system is used, the international search report may indicate all the applicable classification symbols also according to that system.

(c) Where the subject matter of the international application is classified both according to the International Patent Classification and to any national classification system, the international search report shall, wherever possible, indicate the corresponding symbols of both classifications opposite each other.

PCT ADMINISTRATIVE INSTRUCTIONS SECTION 505

Indication of Citations of Particular Relevance in the International Search Report

Where any document cited in the international search report is of particular relevance, the special indication required by Rule 43.5(c) shall consist of the letter "X" placed next to the citation of the said document.

PCT ADMINISTRATIVE INSTRUCTIONS SECTION 507

Manner of Indicating Certain Special Categories of Documents Cited in the International Search Report

(a) Where any document cited in the international search report refers to an oral disclosure, use, exhibition, or other means referred to in Rule 33.1(b), the separate indication required by that Rule shall consist of the letter "O" placed next to the citation of the said document.

(b) Where any document cited in the international search report is a published application or patent as defined in Rule 33.1(c), the special mention required by that Rule shall consist of the letter "E" placed next to the citation of the said document.

(c) Where any document cited in the international search report is a document which defines the general state of the art, it shall be indicated by the letter "A" placed next to the citation of the said document.

(d) Where any document cited in the international search report is a document whose publication date occurred earlier than the international filing date of the international application, but later than the priority date claimed in that application, it shall be indicated by the letter "P" next to the citation of the said document.

(e) Where any document cited in the international search report is a document whose publication date occurred after the filing date or the priority date of the international application and is not in conflict with the said application, but is cited for the principle or theory underlying the invention, which may be useful for a better understanding of the invention, or is cited to show that the reasoning or the facts underlying the invention are incorrect, it shall be indicated by the letter "T" next to the citation of the document.

(f) Where in the international search report any document is cited for reasons other than those referred to in the preceding paragraphs, such document shall be indicated by the letter "L" next to the citation of the document.

PCT ADMINISTRATIVE INSTRUCTIONS SECTION 508

Manner of Indicating the Claims to which the Documents Cited in the International Search Report are Relevant

The claims to which cited documents are relevant shall be indicated by placing in the appropriate column of the international search report:

(i) where the cited document is relevant to one claim, the number of that claim; for example (2) or (17);

(ii) where the cited document is relevant to two or more claims numbered in consecutive order, the numbers of the first and last claims of the series connected by a hyphen; for example, (1-15) or (2-3);

(iii) where the cited document is relevant to two or more claims that are not numbered in consecutive order, the number of each claim placed in ascending order and separated by a comma or comma; for example (1, 6) or (1, 7, 10);

(iv) where the cited document is relevant to more than one series of claims under (ii) above, or to claims of both categories (ii) and (iii) above, the series or individual claim numbers and series placed in ascending order using commas to separate the several series, or to separate the numbers of individual claims and each series of claims; for example, (1-6, 9-10, 12-15) or (1, 3-4, 6, 9-11).

CONTENTS OF THE INTERNATIONAL SEARCH REPORT

The international search report (PCT Rule 43) contains, among other things, the citations of the documents considered to be relevant (PCT Rule 43.5 and Administrative Instructions Section 503), the classification of the subject matter of the invention (PCT Rule 43.3 and Administrative Instruction Section 504) and an indication of the fields searched (PCT Rule 43.6). Citations of particular relevance must be specially indicated (Administrative Instruction Section 505); citations of certain specific categories of documents are also indicated (Administrative Instructions Section 507); citations which are not relevant to all the claims must be cited in relation to the claim or claims to which they are relevant (Administrative Instruction Section 508); if only certain passages of the cited document are particularly relevant, they must be identified, for example, by indicating the page, the column or the lines, where the passage appears. The international search report form, PCT/ISA/210 appears in Annex O. It is important to note that an international search report must not contain any expression of opinion, reasoning, argument or ex-

planation of any kind whatsoever relating to patentability.

TRANSMITTAL OF THE INTERNATIONAL SEARCH REPORT

The United States International Searching Authority transmits, on the same day, a copy of the international search report together with a copy of all the prior art cited or, where no search report is established, the declaration to that effect, to the applicant and the International Bureau (PCT Article 18(2) and PCT Rule 44.1). The International Bureau uses the search report for publication and communication to the designated Offices.

TITLE OF THE INVENTION OR ABSTRACT MISSING OR DEFECTIVE

If the title of the invention or the abstract are missing or defective, the International Searching Authority will establish a proper title or abstract. When the International Searching Authority finds that the abstract is defective, it will prepare a new abstract and allow the applicant 30 days to comment. For further details, see PCT Rules 37, 38, and 44.2

1865 Time Limit for Establishing the International Search Report

PCT RULE 42

*Time Limits for International Search*42.1 *Time Limit for International Search*

All agreements concluded with International Searching Authorities shall provide for the same time limit for establishing the international search report or the declaration referred to in Article 17(2) (a). This time limit shall not exceed 3 months from the receipt of the search copy by the International Searching Authority, or 9 months from the priority date, whichever time limit expires later. For a transitional period of 3 years from the entry into force of the Treaty, time limits for the agreement with any International Searching Authority may be individually negotiated, provided that such time limits shall not extend by more than 2 months the time limits referred to in the preceding sentence and in any case shall not go beyond the expiration of the 18th month after the priority date.

The international search report should, as a general rule, be established within three months from the receipt of the search copy by the International Searching Authority, or within nine months from the priority date (for the definition of "priority date", see PCT Article 2(xi), whichever time limit expires later (PCT Article 18(1) and PCT Rule 42).

INTERNATIONAL SEARCH REPORT

International Application No **PCT/US78/00002**

I. CLASSIFICATION OF SUBJECT MATTER (if several classification symbols apply, indicate all) ⁵		
According to International Patent Classification (IPC) or to both National Classification and IPC		
INT. CL. ² B23K 37/04, 37/00; B25B 05/00, 13/40		
U.S. CL. 269/228; 81/91B; 269/238		
II. FIELDS SEARCHED		
Minimum Documentation Searched ⁴		
Classification System	Classification Symbols	
U.S.	269/228, 238 81/91B 157/1.28, 1.31	
Documentation Searched other than Minimum Documentation to the Extent that such Documents are Included in the Fields Searched ⁵		
III. DOCUMENTS CONSIDERED TO BE RELEVANT ¹⁴		
Category ⁶	Citation of Document, ¹⁶ with Indication, where appropriate, of the relevant passages ¹⁷	Relevant to Claim No. ¹⁸
X	JP, B, 34-6199, Published 16 July 1959	1, 3, 5
X,P	US, A, 4,046,363, Published 06 September 1977, See Col. 1, lines 10-19, Whitley	1
A,E	SU, A, 401460, Published 02 June 1978	1
A	JP, A, 50-154134, Published 11 December 1975	2
A	US, A, 3,619,891, Published 16 November 1971, Harrison	1
A,P	DE, A, 2607986, Published 01 September 1977	1-2
A	N, American Machinist, issued 29 August 1946, James Taylor, Long-Extension Adjustable Toggle Moves Heavy Slabs Smoothly, See Page 123	1-4
<p>⁶ Special categories of cited documents: ¹⁶</p> <p>"A" document defining the general state of the art</p> <p>"E" earlier document but published on or after the International filing date</p> <p>"L" document cited for special reason other than those referred to in the other categories</p> <p>"O" document referring to an oral disclosure, use, exhibition or other means</p> <p>"P" document published prior to the International filing date but on or after the priority date claimed</p> <p>"T" later document published on or after the International filing date or priority date and not in conflict with the application, but cited to understand the principle or theory underlying the invention</p> <p>"X" document of particular relevance</p>		
IV. CERTIFICATION		
Date of the Actual Completion of the International Search ³	Date of Mailing of this International Search Report ³	
03 August 1978	(Mailed by PCT Central)	
International Searching Authority ¹	Signature of Authorized Officer ²⁰	
ISA/US	<i>John F. Pitrelli</i> John F. Pitrelli	

1867 Refund of International Search Fee

37 CFR 1.446 Refund of international application filing and processing fees. (a) Money paid for international application fees, where paid by actual mistake or in excess, such as a payment not required by law or Treaty and its Regulations, will be refunded.

(b) Refunds of a portion of the search fee may be made if the international search report is wholly or partly based on an earlier international or international-type search (PCT Rules 16 and 41). The amount of the refund will be as determined by the examiner according to the value of the prior international-type search or international search as 90%, 45% or 0% of the international search fee. If the amount of the refund is not a multiple of \$5.00, it will be rounded to the next higher multiple of \$5.00. See § 1.26 for refund of a portion of the international search fee during subsequent national examination of the application.

(c) Refund of the supplemental search fees will be made if such refund is determined to be warranted by the Commissioner or the Commissioner's designee acting under PCT Rule 40.2(c).

(d) The international and search fees will be refunded if no international filing date is accorded (PCT Rules 15.6 and 16.2).

The applicant may be entitled to a refund of the search fee by the United States International Searching Authority where the invention claimed in a later filed international application has been the subject of an international search by the United States International Searching Authority on an earlier filed international application. Another possibility of a search fee refund arises when an earlier search is conducted by the U.S. Patent and Trademark Office on a national application (37 CFR 1.26 and 1.446).

EXTENT AND CONDITIONS OF REFUNDS OF THE SEARCH FEE

Refunds of a portion of the search fee may be made if the international search report is wholly or partly based on an earlier international or international-type search conducted by the United States Patent and Trademark Office (PCT Rules 16 and 41). The amount of the refund will be as determined by the examiner according to the value of the prior international-type search or international search as 90%, 45% or 0% of the international search fee.

The criteria for refunds of the indicated percentages are as follows:

	Percent
A. The prior search was substantially complete; only an updating search or short search for an additional detail was required-----	90

	Percent
B. The prior search was of some significant benefit but not enough to justify a 90% refund-----	45
C. The prior search was of very little or no value-----	0

Refund of the supplemental search fees will be made if such refund is determined to be warranted by the Commissioner of Patents and Trademarks or his designee acting under Rule 40.2(c).

1868 Unity of Invention

PCT RULE 40

Lack of Unity of Invention (International Search)

40.1 Invitation to Pay

The invitation to pay additional fees provided for in Article 17(3)(a) shall specify the reasons for which the international application is not considered as complying with the requirement of unity of invention and shall indicate the amount to be paid.

40.2 Additional Fees

(a) The amount of the additional fee due for searching under Article 17(3)(a) shall be determined by the competent International Searching Authority.

(b) The additional fee due for searching under Article 17(3)(a) shall be payable direct to the International Searching Authority.

(c) Any applicant may pay the additional fee under protest, that is, accompanied by a reasoned statement to the effect that the international application complies with the requirement of unity of invention or that the amount of the required additional fee is excessive. Such protest shall be examined by a three-member board or other special instance of the International Searching Authority or any competent higher authority, which, to the extent that it finds the protest justified, shall order the total or partial reimbursement to the applicant of the additional fee. On the request of the applicant, the text of both the protest and the decision thereon shall be notified to the designated Offices together with the international search report. The applicant shall submit any translation thereof with the furnishing of the translation of the international application required under Article 22.

(d) The three-member board, special instance or competent higher authority, referred to in paragraph (c), shall not comprise any person who made the decision which is the subject of the protest.

40.3 Time Limit

The time limit provided for in Article 17(3)(a) shall be fixed, in each case, according to the circumstances of the case, by the International Searching Authority; it shall not be shorter than 15 or 30 days, respectively, depending on whether the applicant's address is in the same country as or in a different country from that in which the International Searching

Authority is located, and it shall not be longer than 45 days, from the date of the invitation.

PCT ADMINISTRATIVE INSTRUCTIONS SECTION 502

Protest Against Payment of Additional Fee and Decision Thereon

The International Searching Authority shall transmit to the applicant, at the latest, together with the international search report, any decision which it has taken under Rule 40.2(c) on the protest of the applicant against the payment of the additional fee. At the same time, it shall transmit to the International Bureau a copy of both the protest and the decision thereon, as well as any request by the applicant to forward the texts of both the protest and the decision thereon to any of the designated Offices.

37 CFR 1.481 Determination of unity of invention before the International Searching Authority. (a) Before establishing the international search report, the International Searching Authority shall determine whether the international application complies with the requirement of unity of invention as set forth in PCT Rule 13 and as set forth in §§ 1.141 and 1.146 except as modified below in this section.

(b) If the International Searching Authority considers that the international application does not comply with the requirement of unity of invention, it shall inform the applicant accordingly and invite the payment of additional fees (note § 1.445 and PCT Art. 17(3)(a) and PCT Rule 40). The applicant will be given a time period in accordance with PCT Rule 40.3 to pay the additional fees due.

(c) In the case of non-compliance with unity of invention and where no additional fees are paid, the international search will be performed on the invention first mentioned ("main invention") in the claims.

(d) Lack of unity of invention may be directly evident before considering the claims in relation to any prior art, or after taking the prior art into consideration, as where a document discovered during the search shows the invention claimed in a generic or linking claim lacks novelty or is clearly obvious, leaving two or more claims joined thereby without a common inventive concept. In such a case the International Searching Authority may raise the objection of lack of unity of invention.

37 CFR 1.482 Protest to lack of unity of invention.

(a) If the applicant disagrees with the holding of lack of unity of invention by the International Searching Authority, additional fees may be paid under protest, accompanied by a request for refund and a statement setting forth reasons for disagreement or why the required additional fees are considered excessive, or both (PCT Rule 40.2(c)).

(b) Protest under paragraph (c) of this section will be examined by the Commissioner or the Commissioner's designee. In the event that the applicant's protest is determined to be justified, the additional fees or a portion thereof will be refunded.

(c) An applicant who desires that a copy of the protest and the decision thereon accompany the international search report when forwarded to the Designated Offices, may notify the International Searching Authority to that effect any time prior to the issuance of the international search report. Thereafter, such notification should be directed to the International Bureau (PCT Rule 40.2(c)).

THE REQUIREMENT FOR "UNITY OF INVENTION"

Any international application must relate to one invention only or to a group of inventions so linked as to form a single general inventive concept (PCT Article 3(4)(iii), PCT Rule 13.1, and 37 CFR 1.481). The construction of this principle is laid down in PCT Rule 13.2, 13.3, and 13.4. Observance of this requirement is checked by the International Searching Authority and may be relevant in the national (or regional) phase.

LACK OF UNITY OF INVENTION

The search fee which the applicant is required to pay is intended to compensate the International Searching Authority for carrying out an international search on the international application, but only where the international application meets the "requirement of unity of invention". That means that the international application must relate to only one invention or must relate to a group of inventions which are so linked as to form a single general inventive concept (PCT Articles 3(4)(iii) and 17(3)(a)).

If the International Searching Authority finds that the international application does not comply with the requirement of unity of invention, the applicant will be invited to pay additional search fees. The International Searching Authority will specify the reasons for its finding and indicate the number of additional fees to be paid (PCT Rules 40.1, 40.2(a) and (b)). Such additional fees are payable directly to the Patent and Trademark Office within the time limit fixed, which must not be shorter than 15 days, if the applicant's address is in the United States; or 30 days, if applicant's address is in a country different than the United States; and not longer than 45 days from the date of the invitation (PCT Rule 40.3). The amount of the additional search fee per additional invention charged by the U.S. International Searching Authority is \$200 per invention (37 CFR 1.445(a)(3)).

The United States International Searching Authority will establish the international search report on those parts of international application which relate to the "main invention", that is, the invention or the group of inventions so

linked as to form a single general inventive concept first mentioned in the claims (PCT Article 17(3)(a)). Moreover, the international search report will be established also on those parts of the international application which relate to any invention (or any group of inventions so linked as to form a single general inventive concept) in respect of which the applicant has paid any additional fee within the prescribed time limits.

Any applicant may pay the additional fee under protest, that is, accompanied by a reasoned statement to the effect that the international application complies with the requirement of unity of invention or that the amount of the required additional fee is excessive (PCT Rule 40.2(c)). Any such protest will be examined and decided by the Group Director (37 CFR 1.482(b)). To the extent that the applicant's protest is found to be justified, total or partial reimbursement of the additional fee will be made. On the request of the applicant, the text of both the protest and the decision thereon is sent to the designated Offices together with the international search report (37 CFR 1.482(c)).

Where, within the prescribed time limit, the applicant does not pay any additional fees or only pays some of the additional fees indicated, certain parts of the international application will consequently not be searched. The lack of an international search report in respect of such parts of the international application will, in itself have no influence on the validity of the international application and processing of the international application will continue, both in the international and in the national (regional) phases. Nevertheless, the U.S. national law provides that such unsearched parts of the international application will be considered withdrawn as far as the United States as a designated Office is concerned, unless a special fee for each claim is paid by the applicant upon request (PCT Article 17(3)(b), 35 U.S.C. 372(c), 376(a) 5, 37 CFR 1.445(a)(5)).

1870 Administrative Instructions Annexes

ANNEX B

CODE FOR IDENTIFYING STATES AND ORGANIZATIONS

AR	Argentina	CF	Central African Empire
AT	Austria	CG	Congo
AU	Australia	CH	Switzerland
BE	Belgium	CI	Ivory Coast
BG	Bulgaria	CM	Cameroon
BJ	Benin (Dahomey)	CS	Czechoslovakia
BR	Brazil	CU	Cuba
BS	Bahamas	CY	Cyprus
CA	Canada	DD	German Democratic Republic
		DE	Germany, Federal Republic of
		DK	Denmark
		DO	Dominican Republic
		DZ	Algeria
		EG	Egypt
		ES	Spain
		FI	Finland
		FR	France
		GA	Gabon
		GB	United Kingdom
		GH	Ghana
		GR	Greece
		HT	Haiti
		HU	Hungary
		HV	Upper Volta
		ID	Indonesia
		IE	Ireland
		IL	Israel
		IQ	Iraq
		IR	Iran
		IS	Iceland
		IT	Italy
		JO	Jordan
		JP	Japan
		KE	Kenya
		LB	Lebanon
		LI	Liechtenstein
		LK	Sri Lanka
		LU	Luxembourg
		LY	Socialist People's Libyan Arab Jamahiriya
		MA	Morocco
		MC	Monaco
		MG	Madagascar
		MR	Mauritania
		MT	Malta
		MU	Mauritius
		MW	Malawi
		MX	Mexico
		NE	Niger
		NG	Nigeria
		NL	Netherlands
		NO	Norway
		NZ	New Zealand
		PH	Philippines
		PL	Poland
		PT	Portugal
		RH	Southern Rhodesia
		RO	Romania
		SE	Sweden
		SM	San Marino
		SN	Senegal

SR	Surinam
SU	Soviet Union
SY	Syrian Arab Republic
TD	Chad
TG	Togo
TN	Tunisia
TR	Turkey
TT	Trinidad and Tobago
TZ	United Republic of Tanzania
UG	Uganda
US	United States of America
UY	Uruguay
VA	Vatican City State (Holy See)
VN	Viet Nam, Socialist Republic of
YU	Yugoslavia
ZA	South Africa
ZM	Zambia
ZR	Zaire
OA	African Intellectual Property Organization
EP	European Patent Office
WO	International Bureau of WIPO

ANNEX C

STANDARD CODE FOR IDENTIFICATION OF DIFFERENT KINDS
OF PATENT DOCUMENTS*Introduction*

1. The recommendation provides for groups of letter codes in order to distinguish patent documents. The letter codes also facilitate the storage and retrieval of such documents.

2. If any Office wants to amplify the information contained in the letter code, this letter code may be optionally associated with a numerical code. The meaning of such numerical code should then be defined by each Patent Office availing itself of this option.

3. The code also provides for a letter for non-patent literature documents (N) and for documents to be restricted to the internal use of Patent Offices (X) (e.g., confidential documents, not to be disclosed outside the Office). See in this respect also SI.1 (ICIREPAT Manual pages 4.3.1.1 to 4.3.1.4).

Definitions

4. For the purposes of this recommendation, the expression "patent documents" includes patents for inventions, inventors' certificates, utility certificates, utility models, patents or certificates of addition, inventors' certificates of addition, utility certificates of addition, plant patents and published applications therefor.

5. For the purposes of this recommendation, the term "entry in an official gazette" means at least one comprehensive announcement in an official gazette regarding the making available to the public of the complete text, claims (if any) and drawings (if any) of a patent document.

6. For the purposes of this recommendation, the terms "publication" and "published" are used in the sense of making available

(i) a patent document to the public for inspection or supplying a copy on request

(ii) multiple copies of a patent document produced by printing or like process

Explanation: If, at a particular procedural stage, a copy of the document is first made available to the public for inspection or copying and is then, *at the same procedural stage*, made available in multiple copies produced by printing or like process, only a single publication is considered to have occurred. If, on the other hand, multiple reproduction results from a new procedural stage, this reproduction is considered to be a further publication of the document, even if the texts at the two stages are identical.

7. According to certain national patent laws or regulations, the same patent application may be published at various procedural stages. For the purposes of this recommendation, a publication level is defined as the level corresponding to a procedural stage at which normally a document is published under a given national patent law.

Recommendation

8. It is recommended that the code:

(a) be used for the recording of the "kind of document" in machine-readable data carriers, such as 80-column punched cards, magnetic tapes, aperture cards, etc.;

(b) be used in the first page of patent documents, preferably near the document number, if these have been published in the sense of paragraph 6;

(c) be used in entries in official gazettes or, if all entries in a section of the Gazette relate to the same kind of a document at the beginning of such a section.

(d) be used for the identification of patent documents cited in "Search Reports" and "Lists of References" in patent documents (INID Number 56).

9. Code

The Code is subdivided into *mutually exclusive* groups of letters. The groups characterize patent documents and documents specified in paragraph 3. Groups 1-5 comprise one or several letters enabling identification of documents pertaining to different publication levels.

Group 1 Use for primary or major series of patent documents

- A First publication level
- B Second publication level
- C Third publication level

Group 2 Use for secondary series of patent documents

- E First publication level
- F Second publication level
- G Third publication level

- Group 3* Use for further series of patent documents, as the special requirements of each Office may be
- H
I
- Group 4* Use for major special types of patent documents
- M Medicament patent documents
P Plant patent documents
S Design patent
- Group 5* Use for utility model documents having a numbering series other than the documents of Group 1
- U First publication level
Y Second publication level
Z Third publication level
- Group 6* Other (see paragraph 3)
- N Non-patent literature documents
X Documents restricted to the internal use of Offices

10. It is understood that documents resulting from a patent application and being identified as the major series will fall under Group 1 (e.g. DT Offenlegungsschrift, Auslegungsschrift and Patentschrift). However,

documents identified as a secondary series will fall under Group 2 (e.g., FR patent of addition under old law, U.S. reissue). In exceptional cases of need for a further series, Group 3 is reserved for such purposes (e.g., U.S. defensive publication). Group 4 applies only, at present, to special documents concerning the medicament patents published in France and the plant patents published in the United States of America. In any country publishing similar documents, Group 4 should then be used.

11. As indicated in paragraph 2, the above letter code may optionally be associated with a numerical code to amplify the information represented by the letter code. For this numerical code only digits 1 to 9 should be used. The significance of this code will be defined by any national Office applying such code and communicated to the International Bureau, which will publicize this information. The numerical code must always be interpreted in conjunction with the country code and the above letter code.

12. As an appendix to this recommendation a list of patent documents, past and currently published, and intended to be published in the future, divided in accordance with the code, is given.

1871 Administrative Instructions Appendixes

APPENDIX I

LIST OF PATENT DOCUMENTS, PAST AND CURRENTLY PUBLISHED, AND INTENDED TO BE PUBLISHED IN THE FUTURE, DIVIDED IN ACCORDANCE WITH THIS CODE

Code: A Patent Documents Numbered in Primary or Major Series—First Publication Level

Examples: Austria	Patent Application published in the sense of paragraph 6(i)
Belgium	Brevet d'invention/Uitvindingsoetrooti
Belgium	Brevet de perfectionnement/Verbeteringsoetrooti
Bulgaria	Opisanie na izobretenie po patent
Canada	Patent
Cuba	Patent Application published in the sense of paragraph 6(i)
Czechoslovakia	Patent Application published in the sense of paragraph 6(i)
Czechoslovakia	Inventor's Certificate Application published in the sense of paragraph 6(i)
Denmark	Patent Application published in the sense of paragraph 6(i)
Egypt	Patent specification
Europat	Document published after 18 months
Finland	Patent Application published in the sense of paragraph 6(i)
France	Brevet d'invention (old law)
France	Brevet d'invention, première et unique publication
France	Certificat d'addition à un brevet d'invention, première et unique publication
France	Certificat d'utilité, première et unique publication
France	Certificat d'addition à un certificat d'utilité, première et unique publication
France	Demande de brevet d'invention, première publication
France	Demande de certificat d'addition à un brevet d'invention, première publication
France	Demande de certificat d'utilité, première publication
France	Demande de certificat d'addition à un certificat d'utilité, première publication
German Democratic Republic	Patentschrift (Ausschlusspatent), granted in accordance with paragraph 5.1 of the Patent Amendment Act of the German Democratic Republic

Code: A Patent Documents Numbered in Primary or Major Series—First Publication Level—Continued

Examples: German Democratic Republic	Patentschrift (Wirtschaftspatent), granted in accordance with paragraph 5.1 of the Patent Amendment Act of the German Democratic Republic
Germany, Federal Republic of	Offenlegungsschrift
Hungary	Patent Application published in the sense of paragraph 6(i)
India	Patent specification
Ireland	Patent specification
Italy	Brevetto per invenzione industriale
Japan	Kokai tokkyo koho
Luxembourg	Brevet d'invention
Luxembourg	Certificat d'addition à un brevet d'invention
Netherlands	Ter inzage gelegde octrooiaanvraag
Norway	Patent Application published in the sense of paragraph 6(i)
Pakistan	Patent specification
PCT	Pamphlet published after 18 months
Poland	Opis patentowy
Romania	Descrierea invenției
Soviet Union	Opisanie izobreteniya k patentu
Soviet Union	Opisanie izobreteniya k avtorskomu svidetelstvu
Spain	Patente de invención
Sweden	Patent Application published in the sense of paragraph 6(i)
Switzerland	Auslegeschrift/Mémoire Exposé/Esposito Memoriale (Patent Application published in the sense of paragraphs 6(i) and 6(ii) pertaining to the technical fields for which search and examination as to novelty are made)
Switzerland	Patentschrift/Exposé d'invention/Esposito d'invenzione (Patent published in the sense of paragraph 6(ii) and pertaining to the technical fields for which neither search nor examination as to novelty are made)
United Kingdom	Patent specification
United States	Patent
Yugoslavia	Patentni spis

Code: B Patent Documents Numbered in Primary or Major Series—Second Publication Level

Examples: Australia	Patent specification
Austria	Patentschrift
Canada	Reissue
Cuba	Patente de invención
Czechoslovakia	Popis vynálezu k patentu
Czechoslovakia	Popis vynálezu k autorskému osvědčení
Denmark	Fremlaeggelseskraft
Finland	Kuulutusjulkaisu—Utläggningsskrift
France	Brevet d'invention, deuxième publication de l'invention
France	Certificat d'addition à un brevet d'invention, deuxième publication de l'invention
France	Certificat d'utilité, deuxième publication de l'invention
France	Certificat d'addition à un certificat d'utilité, deuxième publication de l'invention
German Democratic Republic	Patentschrift (Ausschlusspatent), granted in accordance with paragraph 29 of the Patent Act of the German Democratic Republic
German Democratic Republic	Patentschrift (Wirtschaftspatent), granted in accordance with paragraph 29 of the Patent Act of the German Democratic Republic
Germany, Federal Republic of	Auslegeschrift
Hungary	Szabadalmi leiras
Japan	Tokkyo koho
Netherlands	Openbaar gemaakte octrooiaanvraag
Norway	Utlægningsskrift
Sweden	Utläggningsskrift

Code: B Patent Documents Numbered in Primary or Major Series—Second Publication Level—Continued

Examples: Switzerland	Patentschrift/Exposé d'invention/Esposito d'invenzione (Patent published in the sense of paragraph 6(ii) and pertaining to the technical fields for which search and examination as to the novelty are made)
United Kingdom	Amended Patent Specification

Code: C Patent Documents Numbered in Primary or Major Series—Third Publication Level

Examples: Denmark	Patent
Finland	Patentti—Patent
Germany, Federal Republic of	Patentschrift
Netherlands	Octrooi
Norway	Patent
Sweden	Patentskrift

Code: E Patent Documents Numbered in Secondary Series—First Publication Level

Examples: France	Certificat d'addition à brevet d'invention (old law)
United States	Reissue

Code: H Patent Documents numbered in further series

Example: United States	Defensive publication
------------------------	-----------------------

Code: M Medicament Patent Documents

Examples: France	Brevet spécial de médicament
France	Addition à un brevet spécial de médicament

Code: P Plant Patent Documents

Example: United States	Plant patent
------------------------	--------------

Code: U Utility Model Documents Numbered in Series other than the Documents of Group I—First Publication Level

Examples: Germany, Federal Republic of	Gebrauchsmuster
Japan	Kokai jitsuyo shinan koho
Spain	Utility Model Application published in the sense of paragraph 6(i)

Code: Y Utility Model Documents Numbered in Series other than the Documents of Group I—Second Publication Level

Examples: Japan	Jitsuyo shinan koho
Spain	Modelo de utilidad

Appendix II

List of Patent Documents, Past and Currently Published,
broken down by issuing country and coded in accordance with the SI.8 Code

Issuing country	Kind of published patent document			Letter code	Associated numerical code (when defined)
	Designation in language of issuing country (and, if required, transliteration in Latin characters)	Translation into English (when needed)	Identification of document		
Australia	Unexamined complete specification open to public inspection (not marked on document) Patent specification		Unexamined Patent Application published in the sense of paragraph 6(i)	A	
			Patent published in the sense of paragraph 6(ii)	B	
Austria	Aufgebot (not marked on document but indicated as such in the Official Gazette) Patentschrift	Document laid open Patent specification	Patent Application published in the sense of paragraph 6(i)	A	
			Patent published in the sense of paragraph 6(ii)	B	
Belgium	Brevet d'invention/ Uitvindingsoctrooi Brevet de perfectionnement/ Verbeteringsoctrooi Brevet d'importation/ Invoeringsoctrooi	Patent of invention Patent of improvement Patent of importation	Patent published in the sense of paragraph 6(ii)	A	
			Patent of improvement published in the sense of paragraph 6(ii)	A	
			Patent of importation published in the sense of paragraph 6(ii)	A	
Bulgaria	ОПИСАНИЕ НА ИЗОБРЕТЕНИЕ ПО ПАТЕНТ (Opisanie na izobretenie po patent) ОПИСАНИЕ НА ИЗОБРЕТЕНИЕ ПО АВТОРСКО СВИДЕТЕЛСТВО (Opisanie na izobretenie po avtorsko svidetelstvo)	Description of invention for a patent Description of invention for an author's certificate	Patent published in the sense of paragraph 6(ii)	A	
			Inventor's certificate published in the sense of paragraph 6(ii)	A	
Canada	Patent/Brevet Reissue Patent/Brevet de redélivrance		Patent published in the sense of paragraph 6(ii)	A	
			Patent reissued and republished in the sense of paragraph 6(ii)	B	
Cuba	Publicación de la solicitud (not marked on document) Patente de invención	Publication of the application Patent of invention	Patent application published in the sense of paragraph 6(i)	A	
			Patent published in the sense of paragraph 6(ii)	B	

Issuing country	Kind of published patent document			Letter code	Associated numerical code (when defined)
	Designation in language of issuing country (and, if required, transliteration in Latin characters)	Translation into English (when needed)	Identification of document		
Czechoslovakia	Příhláška vynálezu (se žádostí o autorské osvědčení)	Application for an invention asking for author's certificate	Application for inventor's certificate published in the sense of paragraph 6(i), in accordance with Law No. 84 of 01.11.1972	A	1
	Příhláška vynálezu (se žádostí o patent)	Application for an invention asking for a patent	Patent application published in the sense of paragraph 6(i), in accordance with Law No. No. 84 of 01.11.1972	A	2
	Patentová přihláška or Příhláška vynálezu	Patent application or Application for invention	Patent application published in the sense or paragraph 6(i) up to patent No. 149260 (granted before the entry into force of Law No. 84 of 01.11.1972)	A	5
	Popis vynálezu k autorskému osvědčení	Description of an invention for an author's certificate	Inventor's certificate published in the sense of paragraph 6(ii), granted in accordance with Law No. 84 of 01.11.1972	B	1
	Popis vynálezu k patentu	Description of an invention for a patent	Patent published in the sense of paragraph 6(ii), granted in accordance with Law No. 84 of 01.11.1972	B	2
	Popis vynálezu k autorskému osvědčení	Description of an invention for an author's certificate	Dependant author's certificate published in the sense of paragraph 6(ii), granted in accordance with Law No. 84 of 01.11.1972	B	3
	Popis vynálezu k patentu	Description of an invention for a patent	Dependent patent published in the sense of paragraph 6(ii), granted in accordance with Law No. 84 of 01.11.1972	B	4
	Patentový spis	Patent specification	Patent published in the sense of paragraph 6(ii), up to No. 149 260, granted before the entry into force of Law No. 84 of 01.11.1972	B	5
Denmark	Almindelig tilgængelig patentansøgning	Patent application accessible to the public	Patent application published in the sense of paragraph 6(i)	A	
	Fremlaeggelseskraft	Document laid open	Patent application published after examination as to novelty in the sense of paragraph 6(ii)	B	

Issuing country	Kind of published patent document			Letter code	Associated numerical code (when defined)
	Designation in language of issuing country (and, if required, transliteration in Latin characters)	Translation into English (when needed)	Identification of document		
Denmark (cont'd)	Patent	Patent	Patent published in the sense of paragraph 6(ii)	C	
Egypt	إدارة براءات الاختراع (Idarat bara'at alikhtirah)	Authority for Patent Delivery	Patent published in the sense of paragraph 6(ii)	A	
Finland	Julkiseksi tullut patenttihakemus (not marked on the document)	Patent application made accessible to the public	Patent application published in the sense of paragraph 6(i)	A	
	Kuulutusjulkaisu – Utläggningsskrift	Document laid open	Patent application published after examination as to novelty in the sense of paragraphs 6(i) and 6(ii)	B	
	Patentti-Patent	Patent	Patent published in the sense of paragraph 6(ii)	C	
France	Demande de brevet d'invention	Application for patent of invention	Patent application, first publication, published in the sense of paragraph 6(ii)	A	1
	Demande de certificat d'addition à un brevet d'invention	Application for a certificate of addition to a patent of invention	Application for a certificate of addition, first publication, published in the sense of paragraph 6(ii)	A	2
	Demande de certificat d'utilité	Application for certificate of utility	Utility certificate application, first publication, published in the sense of paragraph 6(ii)	A	3
	Demande de certificat d'addition à un certificat d'utilité	Application for a certificate of addition to a certificate of utility	Application for a certificate of addition to a utility certificate, first publication, published in the sense of paragraph 6(ii)	A	4
	Brevet d'invention	Patent of invention	Patent, first and only publication, published in the sense of paragraph 6(ii)	A	5
	Certificat d'addition à un brevet d'invention	Certificate of addition to a patent of invention	Certificate of addition to a patent, first and only publication, published in the sense of paragraph 6(ii)	A	6
	Certificat d'utilité	Certificate of utility	Utility certificate, first and only publication, published in the sense of paragraph 6(ii)	A	7

Issuing country	Kind of published patent document			Letter code	Associated numerical code (when defined)
	Designation in language of issuing country (and, if required, transliteration in Latin characters)	Translation into English (when needed)	Identification of document		
France (cont'd)	Certificat d'addition à un certificat d'utilité	Certificate of addition to a certificate of utility	Certificate of addition to a utility certificate, first and only publication, published in the sense of paragraph 6(ii)	A	8
	Brevet d'invention	Patent of invention	Patent, second publication, published in the sense of paragraph 6(ii)	B	1
	Certificat d'addition à un brevet d'invention	Certificate of addition to a patent of invention	Certificate of addition to a patent, second publication, published in the sense of paragraph 6(ii)	B	2
	Certificat d'utilité	Certificate of utility	Utility certificate, second publication, published in the sense of paragraph 6(ii)	B	3
	Certificat d'addition à un certificat d'utilité	Certificate of addition to a certificate of utility	Certificate of addition to a utility certificate, second publication, published in the sense of paragraph 6(ii)	B	4
	Brevet d'invention	Patent of invention	Patent (old law) published in the sense of paragraph 6(ii)	A	
	Certificat d'addition à un brevet d'invention	Certificate of addition to a patent of invention	Certificate of addition to a patent (old law) published in the sense of paragraph 6(ii)	E	
	Brevet spécial de médicament	Special patent for medicament	Medicament patent (old law) published in the sense of paragraph 6(ii)	M	
Certificat d'addition à un brevet spécial de médicament	Certificate of addition to a special patent for medicament	Certificate of addition to a medicament patent (old law) published in the sense of paragraph 6(ii)	M		
German Democratic Republic	Patentschrift (Ausschliessungspatent)	Patent specification (Exclusive Patent)	Exclusive patent, granted in accordance with paragraph 5.1 of the Patent Amendment Act of the German Democratic Republic, published in the sense of paragraph 6(ii)	A	
	Patentschrift (Wirtschaftspatent)	Patent specification (Economic Patent)	Industrial patent, granted in accordance with paragraph 5.1 of the Patent Amendment Act of the German Democratic Republic, published in the sense of paragraph 6(ii)	A	

Issuing country	Kind of published patent document			Letter code	Associated numerical code (when defined)
	Designation in language of issuing country (and, if required, transliteration in Latin characters)	Translation into English (when needed)	Identification of document		
German Democratic Republic (cont'd)	Patentschrift (Ausschliessungspatent)	Patent specification (Exclusive Patent)	Exclusive patent granted in accordance with paragraph 29 of the Patent Act of the German Democratic Republic, (2nd publication after examination as to novelty whenever this examination is effected), published in the sense of paragraph 6(ii)	B	
	Patentschrift (Wirtschaftspatent)	Patent specification (Economic Patent)	Industrial patent granted in accordance with paragraph 29 of the Patent Act of the German Democratic Republic (2nd publication after examination as to novelty whenever this examination is effected), published in the sense of paragraph 6(ii)	B	
	Berichtigte Patentschrift (Ausschliessungspatent)	Corrected patent specification (Exclusive Patent)	Corrected patent (Exclusive patent) published in the sense of paragraph 6(ii)	C	
	Berichtigte Patentschrift (Wirtschaftspatent)	Corrected patent specification (Economic Patent)	Corrected patent (Industrial patent) published in the sense of paragraph 6(ii)	C	
Germany (Federal Republic of)	Offenlegungsschrift	Document open for inspection	Patent application published, before examination as to novelty, in the sense of paragraph 6(ii)	A	
			- 1st publication	A	1
			- 2nd publication. Modified reprint following A1 Offenlegungsschrift or B1 Auslegeschrift	A	2
	Auslegeschrift	Document laid open	- 3rd publication. Modified reprint following A2 Offenlegungsschrift or B2 Auslegeschrift	A	3
			Patent application published, after examination as to novelty, in the sense of paragraph 6(ii)	B	
			- 1st publication. Offenlegungsschrift not yet published	B	1
		- 2nd publication. Normally following an A1 Offenlegungsschrift or B1 Auslegeschrift	B	2	

Issuing country	Kind of published patent document			Letter code	Associated numerical code (when defined)
	Designation in language of issuing country (and, if required, transliteration in Latin characters)	Translation into English (when needed)	Identification of document		
Germany (Federal Republic of) (cont'd)	Patentschrift	Patent specification	- 3rd publication. Following an A2 Offenlegungsschrift or B2 Auslegeschrift	B	3
			- 4th publication. Following an A3 Offenlegungsschrift or B3 Auslegeschrift	B	4
			Patent published in the sense of paragraph 6(ii)	C	
			- 1st publication. Offenlegungsschrift and Auslegeschrift not published	C	1
			- 2nd publication. Modified reprint normally following a B1 Auslegeschrift or C1 Patentschrift	C	2
			- 3rd publication. Normally following a B2 Auslegeschrift and an A1 Offenlegungsschrift or following a B2 Auslegeschrift with a preceding B1 Auslegeschrift as well	C	3
			- 4th publication. Following a B3 Auslegeschrift or C3 Patentschrift	C	4
	- 5th publication. Following a B4 Auslegeschrift or a C4 Patentschrift	C	5		
Gebrauchsmuster	Utility model	Utility model published in the sense of paragraph 6(ii)	U		
Hungary	Közzétett szabadalmi bejelentés	Published patent application	Patent application published in the sense of paragraph 6(i)	A	
	Szabadalmi leírás	Patent specification	Patent published in the sense of paragraph 6(ii)	B	
India	Patent specification		Patent published in the sense of paragraph 6(ii)	A	
Ireland	Patent specification		Patent published in the sense of paragraph 6(ii)	A	
Italy	Brevetto per invenzione industriale	Patent for industrial invention	Patent published in the sense of paragraph 6(ii)	A	

Issuing country	Kind of published patent document			Letter code	Associated numerical code (when defined)
	Designation in language of issuing country (and, if required, transliteration in Latin characters)	Translation into English (when needed)	Identification of document		
Japan	公開特許公報 (Kōkai tokkyo kōhō)	Published unexamined patent application	Patent application published before examination as to novelty in the sense of paragraphs 6(i) and 6(ii).	A	
	特許公報 (Tokkyo kōhō)	Published examined patent application	Patent application published after examination as to novelty in the sense of paragraphs 6(i) and 6(ii). - 1st publication. A Kōkai tokkyo kōhō not published. "T" headed the numerical number of Tokkyo kōhō published from 1922 to 1926. - 2nd publication. Normally following an A Kōkai tokkyo kōhō.	B 1	
	特許発明明細書 (Tokkyo hatsumei meisaisyō)	Patent specification	Patent (old law) published in the sense of paragraphs 6(i) and 6(ii). - 1st publication. Tokkyo kōhō not published. - 2nd publication. Normally following a B 1 Tokkyo kōhō.	C 1	
	特許審判請求公告 (Tokkyo shinpan Seikyū kōkoku)	Corrected patent specification	Corrected patent published in the sense of paragraphs 6(i) and 6(ii).	C 2	
	意匠公報 (Isyō kōhō)	Registered design publication	Registered design application published after examination as to novelty in the sense of paragraphs 6(i) and 6(ii).	H	
	公開実用新案公報 (Kōkai jitsuyō shinan kōhō)	Published unexamined utility model application	Utility model application published before examination as to novelty in the sense of paragraphs 6(i) and 6(ii)	S	
				U	

Issuing country	Kind of published patent document			Letter code	Associated numerical code (when defined)
	Designation in language of issuing country (and, if required, transliteration in Latin characters)	Translation into English (when needed)	Identification of document		
Japan (contd)	実用新案公報 (Jitsuyō shinan kōhō)	Published examined utility model application	Utility model application published after examination as to novelty in the sense of paragraphs 6(i) and 6(ii) - 1st publication. U Kōkai jitsuyō shinan kōhō not published. "T" headed the numerical number of Jitsuyō shinan kōhō published from 1922 to 1926. - 2nd publication. Normally following a U Kōkai jitsuyō shinan kōhō.	Y	1
	登録実用新案 (Tōroku jitsuyō shinan)	Registered utility model specification	Registered utility model published in the sense of paragraphs 6(i) and 6(ii) - 1st publication Jitsuyō shinan kōhō not published - 2nd publication. Normally following a Y 1 Jitsuyō shinan kōhō.	Y	2
	登録実用新案審判請求公告 (Tōroku jitsuyō shinan shinpan seikyū kōkoku)	Corrected registered utility model specification	Corrected registered utility model published in the sense of paragraphs 6(i) and 6(ii).	Z	1
				Z	2
Luxembourg	Brevet d'invention	Patent of invention	Patent published in the sense of paragraph 6(ii)	A	
	Certificat d'addition à un brevet d'invention	Certificate of addition to a patent of invention	Certificate of addition to a patent published in the sense of paragraph 6(ii)	A	
Monaco	Brevet d'invention	Patent of invention	Patent published in the sense of paragraph 6(ii)	A	
Netherlands	Terinzagelegging	Patent application laid open	Patent application published in the sense of paragraphs 6(i) and 6(ii)	A	
	Openbaarmaking	Published patent application	Patent application published after examination in the sense of paragraphs 6(i) and 6(ii)	B	
	Octrooi	Patent	Patent published in the sense of paragraph 6(ii)	C	
Norway	Ailment tilgjengelige patentsøknader (not marked on the document)	Patent application accessible to the public	Patent application published in the sense of paragraph 6(i)	A	
	Utlegningskrift	Document laid open	Patent application published after examination as to novelty in the sense of paragraph 6(ii)	B	

Issuing country	Kind of published patent document			Letter code	Associated numerical code (when defined)
	Designation in language of issuing country (and, if required, transliteration in Latin characters)	Translation into English (when needed)	Identification of document		
Norway (cont'd)	Patent	Patent	Patent published in the sense of paragraph 6(ii)	C	
Pakistan	Patent specification		Patent published in the sense of paragraph 6(ii)	A	
Poland	Opis patentowy Patentu tymczasowego	Description of patent	Patent application published in the sense of paragraph 6(i)	A	
			Patent published in the sense of paragraph 6(ii)	B	
Romania	Descrierea invenției	Description of the invention	Patent published in the sense of paragraph 6(ii)	A	
Soviet Union	ОПИСАНИЕ ИЗОБРЕТЕНИЯ К ПАТЕНТУ (Opisanie izobreteniya k patentu) ОПИСАНИЕ ИЗОБРЕТЕНИЯ К АВТОРСКОМУ СВИДЕТЕЛЬСТВУ (Opisanie izobreteniya k avtorskomu svidetelstvu)	Description of the invention for a patent Description of the invention for an author's certificate	Patent published in the sense of paragraph 6(ii)	A	
			Inventor's certificate published in the sense of paragraph 6(ii)	A	
Spain	Patente de invención	Patent of invention	Patent published in the sense of paragraph 6(i)	A	
	Patente de introducción	Patent of introduction	Patent of importation published in the sense of paragraph 6(i)	A	
	Certificado de adición	Certificate of addition	Certificate of addition published in the sense of paragraph 6(i)	A	
	Solicitud de Modelo de Utilidad	Application for a utility model	Utility Model Application published in the sense of paragraph 6(i)	U	
	Modelo de Utilidad	Utility Model	Utility Model published in the sense of paragraph 6(i)	Y	
Sweden	Allmänt tillgänglig patentansökan	Patent application accessible to the public	Patent Application published in the sense of paragraph 6(i)	A	
	Utläggningsskrift	Document laid open	Patent Application published after examination as to novelty in the sense of paragraphs 6(i) and 6(ii)	B	

Issuing country	Kind of published patent document			Letter code	Associated numerical code (when defined)
	Designation in language of issuing country (and, if required, transliteration in Latin characters)	Translation into English (when needed)	Identification of document		
Sweden (cont'd)	Patentskrift	Patent document	Patent published in the sense of paragraph 6(ii)	C	
Switzerland	Auslegeschrift/Mémoire Exposé/Esposito Memoriale	Document laid open	Patent Application published after examination as to novelty in the sense of paragraphs 6(i) and 6(ii), and pertaining to the technical fields for which examination as to novelty is made, issued since 1959	A	4
	Patentschrift/Exposé d'invention/Esposito d'invenzione	Patent specification	Patent published in the sense of paragraph 6(ii) and pertaining to the technical fields for which no examination as to novelty is made, issued since 1959	A	5
	Patentschrift/Exposé d'invention/Esposito d'invenzione	Patent specification	Patent published in the sense of paragraph 6(ii) and pertaining to technical fields for which examination as to novelty is made, issued since 1959	B	5
	Patentschrift/Exposé d'invention/Esposito d'invenzione (Hauptpatent/Brevet principal/Brevetto principale)	Patent specification (Main patent)	Patent published in the sense of paragraph 6(ii), issued from 1888 to 1959	A	
	Patentschrift/Exposé d'invention/Esposito d'invenzione (Zusatzpatent/Brevet additionnel/Brevetto addizionale)	Patent specification (Additional patent)	Patent of addition published in the sense of paragraph 6(ii), issued from 1907 to 1959	A	
	Patentschrift/Exposé d'invention/Esposito d'invenzione (Zusatzpatent/Brevet additionnel/Brevetto addizionale)	Patent specification (Additional patent)	Patent of addition published in the sense of paragraph 6(ii) in secondary series from 1888 to 1907	E	
United Kingdom	Patent Specification		Examined Patent Application published in the sense of paragraph 6(ii). Grant of letters Patent usually occurs 3 months after publication.	A	

Issuing country	Kind of published patent document			Letter code	Associated numerical code (when defined)
	Designation in language of issuing country (and, if required, transliteration in Latin characters)	Translation into English (when needed)	Identification of document		
United Kingdom (cont'd)	Amended Patent Specification		Amended Specification of a Granted Patent published in the sense of paragraph 6(ii)	B	
United States of America	Patent Plant Patent Design Patent		Patent published in the sense of paragraph 6(ii)	A P S	
	Reissue Patent		Patent reissued and republished in the sense of paragraph 6(ii)	E	
	Defensive Publication		Patent application published without examination or assertion as to novelty, in the sense of paragraph 6(i)	H	
	Defensive Publication		Patent document published in the sense of paragraph 5: Entry of an abstract of the application in the Official Gazette	H	
Yugoslavia	Patentni spis	Patent specification	Accepted Patent Application published in the sense of paragraph 6(i)	A	
			Patent published in the sense of paragraph 6(ii)	B	

1872 International-Type Search [R-3]

PCT RULE 41

Earlier Search other than International Search

41.1 Obligation to Use Results; Refund of Fee

If reference has been made in the request, in the form provided for in Rule 4.11, to an international-type search carried out under the conditions set out in Article 15(5) or to a search other than an international or international-type search, the International Searching Authority shall, to the extent possible, use the results of the said search in establishing the international search report on the international application. The International Searching Authority shall refund the search fee, to the extent and under the conditions provided for in the agreement under Article 16(3)(b) or in a communication addressed to and published in the Gazette by the International Bureau, if the international search report could wholly or partly, be based on the results of the international-type search.

37 CFR 1.21 Patent and miscellaneous fees and charges.

* * * * *

(w) For preparing an international-type search report of an international-type search made at the time of the first action on the merits in a national patent application ----- \$25.00

NOTE: The Patent and Trademark Office does not require that a formal report be prepared of an international-type search in order to obtain a search fee refund in a later filed international application. For fees relating to processing of international applications, see § 1.445.

37 CFR 1.104 Nature of examination; examiner's action.

* * * * *

(c) An international-type search will be made in all national applications filed on and after June 1, 1978.

(d) Any national application may also have an international-type search report prepared thereon at the time of the national examination on the merits, upon specific written request therefor and payment of the international-type search report fee. See § 1.21(w) for amount of fee for preparation of international-type search report.

NOTE: The Patent and Trademark Office does not require that a formal report of an international-type search be prepared in order to obtain a search fee refund in a later filed international application.

PCT Rule 41 provides that the applicant may request in a later filed international application that the report of the results of the international-type search, i.e., a search similar to an international search, but carried out on a national application (37 CFR 1.104(c) and (d)), be used in establishing an international search report on such international application. A partial refund of the search fee in the international application may be possible to the extent that the international search report could wholly or partially be based upon the results of the international-type search (37 CFR 1.446). An international-type search is conducted on all U.S. national applications filed after June 1, 1978. Upon specific request at the time of the examination of a U.S. national application and provided that the payment of a \$25.00 international-type search report fee has been made (37 CFR 1.21(w)) an international-type search report form (PCT/ISA/201) will also be prepared.

Whether or not an international-type search report form is prepared, the amount of the refund of the search fee of an international application depends upon the extent to which the results of that earlier U.S. search can be used.

1875 International Bureau Procedures [R-3]

PCT ARTICLE 19

Amendment of the Claims Before the International Bureau

(1) The applicant shall, after having received the international search report, be entitled to one opportunity to amend the claims of the international application by filing amendments with the International Bureau within the prescribed time limit. He may, at the same time, file a brief statement, as provided in the Regulations, explaining the amendments and indicating any impact that such amendments might have on the description and the drawings.

(2) The amendments shall not go beyond the disclosure in the international application as filed.

(3) If the national law of any designated State permits amendments to go beyond the said disclosure, failure to comply with paragraph (2) shall have no consequence in that State.

PCT RULE 24

Receipt of the Record Copy by the International Bureau

24.1 Recording of Date of Receipt of the Record Copy

The International Bureau shall, upon receipt of the record copy, mark on the request sheet the date of receipt and on all sheets of the international application the stamp of the International Bureau.

24.2 Notification of Receipt of the Record Copy

(a) Subject to the provisions of paragraph (b), the International Bureau shall promptly notify the applicant, the receiving Office, the International Searching Authority, and all designated Offices, of the fact and the date of receipt of the record copy. The notification shall identify the international application by its number, the international filing date, the name of the applicant, and the name of the receiving Office, and shall indicate the filing date of any earlier application whose priority is claimed. The notification sent to the applicant shall also contain the list of the designated Offices which have been notified under this paragraph, and shall, in respect of each designated Office, indicate any applicable time limit under Article 22(3).

(b) If the record copy is received after the expiration of the time limit fixed in Rule 22.3, the International Bureau shall promptly notify the applicant, the receiving Office, and the International Searching Authority, accordingly.

PCT RULE 46

Amendment of Claims Before the International Bureau

46.1 Time Limit

The time limit referred to in Article 19 shall be 2 months from the date of transmittal of the international search report to the International Bureau and to the applicant by the International Searching Authority or, when such transmittal takes place before

the expiration of 14 months from the priority date, 3 months from the date of such transmittal.

46.2 Dating of Amendments

The date of receipt of any amendment shall be recorded by the International Bureau, which shall also notify the applicant of the date and indicate the date in any publication or copy issued by it.

46.3 Language of Amendments

If the international application has been filed in a language other than the language in which it is published by the International Bureau, any amendment made under Article 19 shall be both in the language in which the international application has been filed and in that in which it is published.

46.4 Statement

(a) The statement referred to in Article 19(1) shall be in the language in which the international application is published and shall not exceed 500 words if in the English language or if translated into that language.

(b) The statement shall contain no comments on the international search report or the relevance of the citations contained in that report. The statement may refer to a citation contained in the international search report only in order to indicate that a specific amendment of the claims is intended to avoid the document cited.

46.5 Form of Amendments

(a) The applicant shall be required to submit a replacement sheet for every sheet of the claims which, on account of an amendment or amendments under Article 19, differs from the sheet originally filed. The letter accompanying the replacement sheet shall draw attention to the differences between the replaced sheets and the replacement sheets. To the extent that any amendment results in the cancellation of an entire sheet, that amendment shall be communicated in a letter.

(b) The International Bureau shall mark on each replacement sheet the international application number, the date on which it was received, and the stamp identifying the International Bureau. It shall keep in its files any replaced sheet, the letter accompanying the replacement sheet or sheets, and any letter referred to in the last sentence of paragraph (a).

(c) The International Bureau shall insert any replacement sheet in the record copy and, in the case referred to in the last sentence of paragraph (a), shall indicate the cancellations in the record copy.

37 CFR 1.415 The International Bureau. (a) The International Bureau is the World Intellectual Property Organization located at Geneva, Switzerland. It is the international intergovernmental organization which acts as the coordinating body under the Treaty and the Regulations (PCT Art. 2(xix) and 35 U.S.C. 351(h)).

(b) The major functions of the International Bureau include:

(1) Publishing of international applications and the International Gazette;

- (2) Transmitting copies of international applications to Designated Offices;
- (3) Storing and maintaining record copies; and
- (4) Transmitting information to authorities pertinent to the processing of specific international applications.

1877 International Publication

PCT ARTICLE 21

International Publication

(1) The International Bureau shall publish international applications.

(2) (a) Subject to the exceptions provided for in subparagraph (b) and in Article 64(3), the international publication of the international application shall be effected promptly after the expiration of 18 months from the priority date of that application.

(b) The applicant may ask the International Bureau to publish his international application any time before the expiration of the time limit referred to in subparagraph (a). The International Bureau shall proceed accordingly, as provided in the Regulations.

(3) The international search report or the declaration referred to in Article 17(2)(a) shall be published as prescribed in the Regulations.

(4) The language and form of the international publication and other details are governed by the Regulations.

(5) There shall be no international publication if the international application is withdrawn or is considered withdrawn before the technical preparations for publication have been completed.

(6) If the international application contains expressions or drawings which, in the opinion of the International Bureau, are contrary to morality or public order, or if, in its opinion, the international application contains disparaging statements as defined in the Regulations, it may omit such expressions, drawings, and statements, from its publications, indicating the place and number of words or drawings omitted, and furnishing, upon request, individual copies of the passages omitted.

PCT ARTICLE 29

Effects of the International Publication

(1) As far as the protection of any rights of the applicant in a designated State is concerned, the effects, in that State, of the international publication of an international application shall, subject to the provisions of paragraphs (2) to (4), be the same as those which the national law of the designated State provides for the compulsory national publication of unexamined national applications as such.

(2) If the language in which the international publication has been effected is different from the language in which publications under the national law are effected in the designated State, the said national law

may provide that the effects provided for in paragraph (1) shall be applicable only from such time as:

(i) a translation into the latter language has been published as provided by the national law, or

(ii) a translation into the latter language has been made available to the public, by laying open for public inspection as provided by the national law, or

(iii) a translation into the latter language has been transmitted by the applicant to the actual or prospective unauthorized user of the invention claimed in the international application, or

(iv) both the acts described in (i) and (iii), or both the acts described in (ii) and (iii), have taken place.

(3) The national law of any designated State may provide that, where the international publication has been effected, on the request of the applicant, before the expiration of 18 months from the priority date, the effects provided for in paragraph (1) shall be applicable only from the expiration of 18 months from the priority date.

(4) The national law of any designated State may provide that the effects provided for in paragraph (1) shall be applicable only from the date on which a copy of the international application as published under Article 21 has been received in the national Office of or acting for such State. The said Office shall publish the date of receipt in its gazette as soon as possible.

PCT RULE 48

International Publication

48.1 Form

(a) The international application shall be published in the form of a pamphlet.

(b) The particulars regarding the form of the pamphlet and the method of reproduction shall be governed by the Administrative Instructions.

48.2 Contents

(a) The pamphlet shall contain:

(i) a standardized front page,

(ii) the description,

(iii) the claims,

(iv) the drawings, if any,

(v) subject to paragraph (g), the international search report or the declaration under Article 17(2)

(a); the publication of the international search report in the pamphlet shall, however, not be required to include the part of the international search report which contains only matter referred to in Rule 43 already appearing on the front page of the pamphlet,

(vi) any statement filed under Article 19(1), unless the International Bureau finds that the statement does not comply with the provisions of Rule 46.4.

(b) Subject to paragraph (c), the front page shall include:

(i) data taken from the request sheet and such other data as are prescribed by the Administrative Instructions,

(ii) a figure or figures where the international application contains drawings,

(iii) the abstract; if the abstract is both in English and in another language, the English text shall appear first.

(c) Where a declaration under Article 17(2)(a) has issued, the front page shall conspicuously refer to that fact and need include neither a drawing nor an abstract.

(d) The figure or figures referred to in paragraph (b)(ii) shall be selected as provided in Rule 8.2. Reproduction of such figure or figures on the front page may be in a reduced form.

(e) If there is not enough room on the front page for the totality of the abstract referred to in paragraph (b)(iii), the said abstract shall appear on the back of the front page. The same shall apply to the translation of the abstract when such translation is required to be published under Rule 48.3(c).

(f) If the claims have been amended under Article 19, the publication shall contain either the full text of the claims both as filed and as amended or the full text of the claims as filed and specify the amendments. Any statement referred to in Article 19(1) shall be included as well, unless the International Bureau finds that the statement does not comply with the provisions of Rule 46.4. The date of receipt of the amended claims by the International Bureau shall be indicated.

(g) If, at the time when publication is due, the international search report is not yet available (for example, because of publication on the request of the applicant as provided in Articles 21(2)(b) and 64(3)(c)(i)), the pamphlet shall contain, in place of the international search report, an indication to the effect that that report was not available and that either the pamphlet (then also including the international search report) will be republished or the international search report (when it becomes available) will be separately published.

(h) If, at the time when publication is due, the time limit for amending the claims under Article 19 has not expired, the pamphlet shall refer to that fact and indicate that, should the claims be amended under Article 19, then, promptly after such amendments, either the pamphlet (containing the claims as amended) will be republished or a statement reflecting all the amendments will be published. In the latter case, at least the front page and the claims shall be republished and, if a statement under Article 19(1) has been filed, that statement shall be published as well, unless the International Bureau finds that the statement does not comply with the provisions of Rule 46.4.

(i) The Administrative Instructions shall determine the cases in which the various alternatives referred to in paragraphs (g) and (h) shall apply. Such determination shall depend on the volume and complexity of the amendments and/or the volume of the international applications and the cost factors.

48.3 Language

(a) If the international application is filed in English, French, German, Japanese, or Russian, that application shall be published in the language in which it was filed.

(b) If the international application is filed in a language other than English, French, German, Japanese, or Russian, that application shall be published in English translation. The translation shall be prepared under the responsibility of the International Searching Authority, which shall be obliged to have it ready in time to permit the communication under Article 20 by the prescribed date, or, if the international publication is due at an earlier date than the said communication, to permit international publication by the prescribed date. Notwithstanding Rule 16.1(a), the International Searching Authority may charge a fee for the translation to the applicant. The International Searching Authority shall give the applicant an opportunity to comment on the draft translation. The International Searching Authority shall fix a time limit reasonable under the circumstances of the case for such comments. If there is no time to take the comments of the applicant into account before the translation is communicated or if there is a difference of opinion between the applicant and the said Authority as to the correct translation, the applicant may send a copy of his comments, or what remains of them, to the International Bureau and each designated Office to which the translation was communicated. The International Bureau shall publish the essence of the comments together with the translation of the International Searching Authority or subsequently to the publication of such translation.

(c) If the international application is published in a language other than English, the international search report to the extent that it is published under Rule 48.2(a)(v), or the declaration referred to in Article 17(2)(a), and the abstract shall be published both in that language and in English. The translations shall be prepared under the responsibility of the International Bureau.

48.4 Earlier Publication on the Applicant's Request

(a) Where the applicant asks for publication under Articles 21(2)(b) and 64(3)(c)(i) and the international search report, or the declaration referred to in Article 17(2)(a), is not yet available for publication together with the international application, the International Bureau shall collect a special publication fee whose amount shall be fixed in the Administrative Instructions.

(b) Publication under Articles 21(2)(b) and 64(3)(c)(i) shall be effected by the International Bureau promptly after the applicant has asked for it and, where a special fee is due under paragraph (a), after receipt of such fee.

48.5 Notification of National Publication

Where the publication of the international application by the International Bureau is governed by Article 64(3)(c)(ii), the national Office concerned shall, promptly after effecting the national publication referred to in the said provision, notify the International Bureau of the fact of such national publication.

48.6 Announcing of Certain Facts

(a) If any notification under Rule 29.1(a)(ii) reaches the International Bureau at a time later than that at which it was able to prevent the international publication of the international application, the International Bureau shall promptly publish a notice in the Gazette reproducing the essence of such notification.

(b) The essence of any notification under Rules 29.2 or 51.4 shall be published in the Gazette and, if the notification reaches the International Bureau before preparations for the publication of the pamphlet have been completed, also in the pamphlet.

(c) If the international application is withdrawn after its international publication, this fact shall be published in the Gazette.

PCT RULE 86*The Gazette**86.1 Contents*

The Gazette referred to in Article 55(4) shall contain:

(i) for each published international application, data specified by the Administrative Instructions taken from the front page of the pamphlet published under Rule 48, the drawing (if any) appearing on the said front page, and the abstract,

(ii) the schedule of all fees payable to the receiving Offices, the International Bureau, and the International Searching and Preliminary Examining Authorities,

(iii) notices the publication of which is required under the Treaty or these Regulations,

(iv) information, if and to the extent furnished to the International Bureau by the designated or elected Offices, on the question whether the requirements provided for in Articles 22 or 39 have been complied with in respect of the international applications designating or electing the Office concerned,

(v) any other useful information prescribed by the Administrative Instructions, provided access to such information is not prohibited under the Treaty or these Regulations.

86.2 Languages

(a) The Gazette shall be published in an English-language edition and a French-language edition. It shall also be published in editions in any other language, provided the cost of publication is assured through sales or subventions.

(b) The Assembly may order the publication of the Gazette in languages other than those referred to in paragraph (a).

86.3 Frequency

(a) Subject to paragraph (b), the Gazette shall be published once a week.

(b) For a transitional period after the entry into force of the Treaty terminating upon a date fixed by the Assembly, the Gazette may be published at such times as the Director General considers appropriate having regard to the number of international applications and the amount of other material required to be published.

86.4 Sale

(a) Subject to paragraph (b), the subscription and other sale prices of the Gazette shall be fixed in the Administrative Instructions.

(b) For a transitional period after the entry into force of the Treaty terminating upon a date fixed by the Assembly, the Gazette may be distributed on such terms as the Director General considers appropriate having regard to the number of international applications and the amount of other material published therein.

86.5 Title

The title of the Gazette shall be "Gazette of International Patent Applications," and "Gazette des Demandes internationales de brevets," respectively.

86.6 Further Details

Further details concerning the Gazette may be provided for in the Administrative Instructions.

PCT ADMINISTRATIVE INSTRUCTIONS SECTION 404*International Publication Number*

The International Bureau shall assign to each published international application an international publication number which shall be different from the international application number. The international publication number shall be used on the pamphlet and in the Gazette entry. It shall consist of the two-letter code "WO" followed by a two-digit designation of the last two numbers of the year of publication, a slant, and a serial number consisting of five digits (e.g., "WO78/12345").

35 U.S.C. 374 Publication of international application: Effect. The publication under the treaty of an international application shall confer no rights and shall have no effect under this title other than that of a printed publication.

37 CFR 1.318 Notification of national publication of a patent based on an international application. The Office will notify the International Bureau when a patent is issued on an application filed under 35 U.S.C. 371, and there has been no previous international publication.

1885 Receipt of the International Application by the Designated Offices [R-3]

PCT ARTICLE 20

Communication to Designated Offices

(1) (a) The international application, together with the international search report (including any indication referred to in Article 17(2) (b)) or the declaration referred to in Article 17(2) (a), shall be communicated to each designated Office, as provided in the Regulations, unless the designated Office waives such requirement in its entirety or in part.

(b) The communication shall include the translation (as prescribed) of the said report or declaration.

(2) If the claims have been amended by virtue of Article 19(1), the communication shall either contain the full text of the claims both as filed and as amended or shall contain the full text of the claims as filed and specify the amendments, and shall include the statement, if any, referred to in Article 19(1).

(3) At the request of the designated Office or the applicant, the International Searching Authority shall send to the said Office or the applicant, respectively, copies of the documents cited in the international search report, as provided in the Regulations.

PCT RULE 47

Communication to Designated Offices

47.1 Procedure

(a) The communication provided for in Article 20 shall be effected by the International Bureau.

(b) Such communication shall be effected promptly after the international publication of the international application and, in any event, by the end of the 19th month after the priority date. Where the time limit under Rule 46.1 has not expired when the communication is effected and the International Bureau has neither received amendments from the applicant nor a declaration that the applicant does not wish to make amendments before the International Bureau, the International Bureau shall, at the time of the communication, notify the applicant and the designated Offices accordingly; it shall, immediately after receipt, communicate any amendment received subsequently to the designated Offices and notify the applicant accordingly. Where, under Article 17(2) (a), the International Searching Authority has made a declaration that no international search report will be established, the communication shall be effected, unless the international application is withdrawn, within 1 month from the date on which the International Bureau has been notified of the said declaration by the International Searching Authority; such communication shall be accompanied by an indication of the date of the notification sent to the applicant under Article 17(2) (a).

(c) The International Bureau shall send a notice to the applicant indicating the designated Offices to which

the communication has been effected and the date of such communication. Such notice shall be sent on the same day as the communication. Each designated Office shall be informed, separately from the communication, about the sending and the date of mailing of the notice. The notice shall be accepted by all designated Offices as conclusive evidence that the communication has duly taken place on the date specified in the notice.

(d) Each designated Office shall, when it so requires, receive the international search reports and the declarations referred to in Article 17(2) (a) also in the translation referred to in Rule 45.1.

(e) Where any designated Office has waived the requirement provided under Article 20, the copies of the documents which otherwise would have been sent to that Office shall, at the request of that Office or the applicant, be sent to the applicant at the time of the notice referred to in paragraph (c).

47.2 Copies

(a) The copies required for communication shall be prepared by the International Bureau.

(b) They shall be in sheets of A4 size.

47.3 Languages

The international application communicated under Article 20 shall be in the language in which it is published provided that if that language is different from the language in which it was filed it shall, on the request of the designated Office, be communicated in either or both of these languages.

37 CFR 1.414 The United States Designated Office. (a) The United States Patent and Trademark Office will act as a Designated Office for international applications in which the United States of America has been designated as a State in which patent protection is desired.

(b) The Patent and Trademark Office, when acting as a Designated Office during international processing will be identified by the full title "United States Designated Office" or by the abbreviation "DO/US."

(c) The major functions of the United States Designated Office in respect to international applications in which the United States of America has been designated, include:

(1) Receiving various notifications throughout the international stage;

(2) Accepting for regular national patentability examination international applications which satisfy the requirements of 35 U.S.C. 371; and

(3) Conducting reviews under PCT Article 25 for those international applications declared withdrawn.

The International Bureau communicates a copy of the international application to each designated Office, except the United States Patent and Trademark Office where that Office is not only a designated Office but was also the Receiving Office and International Searching Authority (35 U.S.C. 371(a)). The copy is pre-

pared by the International Bureau and it is accompanied by a copy of any amendments to the claims, and a copy of the international search report or the declaration by the International Searching Authority to the effect that no international search report will be established (PCT Article 20(1)(a) and (2) and PCT Rules 47.1(a) and 47.2). The International Bureau also sends a notice to the applicant (from PCT/1B/308) informing him of those Offices to which it has sent the copies and the date on which it was sent (PCT Rule 47.1(c)).

The International Bureau effects the said communication of the international application to the designated Offices promptly after publication.

The applicant may, if he so desires, transmit, or ask the International Bureau to transmit, at any time, a copy of his international application to any designated Office.

Further details may be found in PCT Article 13 and PCT Rule 31. It is to be noted that any transmittal of this kind does not, in the absence of an express request from the applicant, entitle the designated Office to start processing the international application in that Office. At the express request of the applicant, however, any designated Office may start processing or examining the international application earlier (PCT Article 23(2)).

1887 Entry into the National (or Regional) Phase Before the Designated Offices [R-3]

PCT ARTICLE 22

Copy, Translation, and Fee, to Designated Offices

(1) The applicant shall furnish a copy of the international application (unless the communication provided for in Article 20 has already taken place) and a translation thereof (as prescribed), and pay the national fee (if any), to each designated Office not later than at the expiration of 20 months from the priority date. Where the national law of the designated State requires the indication of the name of and other prescribed data concerning the inventor but allows that these indications be furnished at a time later than that of the filing of a national application, the applicant shall, unless they were contained in the request, furnish the said indications to the national Office of or acting for that State not later than at the expiration of 20 months from the priority date.

(2) Notwithstanding the provisions of paragraph (1), where the International Searching Authority makes a declaration, under Article 17(2)(a), that no international search report will be established, the time limit for performing the acts referred to in paragraph

(1) of this Article shall be two months from the date of the notification sent to the applicant of the said declaration.

(3) Any national law may, for performing the acts referred to in paragraphs (1) or (2), fix time limits which expire later than the time limit provided for in those paragraphs.

PCT ARTICLE 23

Delaying of National Procedure

(1) No designated Office shall process or examine the international application prior to the expiration of the applicable time limit under Article 22.

(2) Notwithstanding the provisions of paragraph (1), any designated Office may, on the express request of the applicant, process or examine the international application at any time.

PCT ARTICLE 24

Possible Loss of Effect in Designated States

(1) Subject, in case (ii) below, to the provisions of Article 25, the effect of the international application provided for in Article 11(3) shall cease in any designated State with the same consequences as the withdrawal of any national application in that State:

(i) if the applicant withdraws his international application or the designation of that State;

(ii) if the international application is considered withdrawn by virtue of Articles 12(3), 14(1)(b), 14(3)(a), or 14(4), or if the designation of that State is considered withdrawn by virtue of Article 14(3)(b);

(iii) if the applicant fails to perform the acts referred to in Article 22 within the applicable time limit.

(2) Notwithstanding the provisions of paragraph (1), any designated Office may maintain the effect provided for in Article 11(3) even where such effect is not required to be maintained by virtue of Article 25(2).

PCT ARTICLE 26

Opportunity to Correct Before Designated Offices

No designated Office shall reject an international application on the grounds of non-compliance with the requirements of this Treaty and the Regulations without first giving the applicant the opportunity to correct the said application to the extent and according to the procedure provided by the national law for the same or comparable situations in respect of national applications.

PCT ARTICLE 27

National Requirements

(1) No National law shall require compliance with requirements relating to the form or contents of the

international application different from or additional to those which are provided for in this Treaty and the Regulations.

(2) The provisions of paragraph (1) neither affect the application of the provisions of Article 7(2) nor preclude any national law from requiring, once the processing of the international application has started in the designated Office, the furnishing:

(i) when the applicant is a legal entity, of the name of an officer entitled to represent such legal entity,

(ii) of documents not part of the international application but which constitute proof of allegations or statements made in that application, including the confirmation of the international application by the signature of the applicant when that application, as filed, was signed by his representative or agent.

(3) Where the applicant, for the purposes of any designated State, is not qualified according to the national law of that State to file a national application because he is not the inventor, the international application may be rejected by the designated Office.

(4) Where the national law provides, in respect of the form or contents of national applications, for requirements which, from the viewpoint of applicants, are more favorable than the requirements provided for by this Treaty and the Regulations in respect of international applications, the national Office, the courts and any other competent organs of or acting for the designated State may apply the former requirements, instead of the latter requirements, to international applications, except where the applicant insists that the requirements provided for by this Treaty and the Regulations be applied to his international application.

(5) Nothing in this Treaty and the Regulations is intended to be construed as prescribing anything that would limit the freedom of each Contracting State to prescribe such substantive conditions of patentability as it desires. In particular, any provision in this Treaty and the Regulations concerning the definition of prior art is exclusively for the purposes of the international procedure and, consequently, any Contracting State is free to apply, when determining the patentability of an invention claimed in an international application, the criteria of its national law in respect of prior art and other conditions of patentability not constituting requirements as to the form and contents of applications.

(6) The national law may require that the applicant furnish evidence in respect of any substantive condition of patentability prescribed by such law.

(7) Any receiving Office or, once the processing of the international application has started in the designated Office, that Office may apply the national law as far as it relates to any requirement that the applicant be represented by an agent having the right to represent applicants before the said Office and/or that the applicant have an address in the designated State for the purpose of receiving notifications.

(8) Nothing in this Treaty and the Regulations is intended to be construed as limiting the freedom of any Contracting State to apply measures deemed necessary for the preservation of its national security or to limit, for the protection of the general economic interests of that State, the right of its own residents or nationals to file international applications.

PCT ARTICLE 28

Amendment of the Claims, the Description, and the Drawings, Before Designated Offices

(1) The applicant shall be given the opportunity to amend the claims, the description, and the drawings, before each designated Office within the prescribed time limit. No designated Office shall grant a patent, or refuse the grant of a patent, before such time limit has expired except with the express consent of the applicant.

(2) The amendments shall not go beyond the disclosure in the international application as filed unless the national law of the designated State permits them to go beyond the said disclosure.

(3) The amendments shall be in accordance with the national law of the designated State in all respects not provided for in this Treaty and the Regulations.

(4) Where the designated Office requires a translation of the international application, the amendments shall be in the language of the translation.

PCT RULE 49

Languages of Translations and Amounts of Fees Under Article 22(1) and (2)

49.1 Notification

(a) Any Contracting State requiring the furnishing of a translation or the payment of a national fee, or both, under Article 22, shall notify the International Bureau of:

- (i) the languages from which and the language into which it requires translation,
- (ii) the amount of the national fee.

(b) Any notification received by the International Bureau under paragraph (a) shall be promptly published by the International Bureau in the Gazette.

(c) If the requirements under paragraph (a) change later, such changes shall be notified by the Contracting State to the International Bureau and that Bureau shall promptly publish the notification in the Gazette. If the change means that translation is required into a language which, before the change, was not required, such change shall be effective only with respect to international applications filed later than 2 months after the publication of the notification in the Gazette. Otherwise, the effective date of any change shall be determined by the Contracting State.

49.2 Languages

The language into which translation may be required must be an official language of the designated Office. If there are several of such languages, no translation may be required if the international application is in one of them. If there are several official languages and a translation must be furnished, the applicant may choose any of those languages. Notwithstanding the foregoing provisions of this paragraph, if there are several official languages but the national law prescribes the use of one such language for foreigners, a translation into that language may be required.

49.3 Statements under Article 19

For the purposes of Article 22 and the present Rule, any statement made under Article 19(1) and any indication furnished under Rule 13bis.4 shall be considered part of the international application.

PCT RULE 50

Faculty Under Article 22(3)

50.1 Exercise of Faculty

(a) Any Contracting State allowing a time limit expiring later than the time limits provided for in

Article 22(1) or (2) shall notify the International Bureau of the time limits so fixed.

(b) Any notification received by the International Bureau under paragraph (a) shall be promptly published by the International Bureau in the Gazette.

(c) Notifications concerning the shortening of the previously fixed time limit shall be effective in relation to international applications filed after the expiration of 3 months computed from the date on which the notification was published by the International Bureau.

(d) Notifications concerning the lengthening of the previously fixed time limit shall become effective upon publication by the International Bureau in the Gazette in respect of international applications pending at the time or filed after the date of such publication, or, if the Contracting State effecting the notification fixes some later date, as from the latter date.

PCT RULE 52

Amendment of the Claims, the Description, and the Drawings, before Designated Offices

52.1 Time Limit

(a) In any designated State in which processing or examination starts without special request, the applicant shall, if he so wishes, exercise the right under Article 28 within one month from the fulfillment of the requirements under Article 22, provided that, if the communication under Rule 47.1 has not been effected by the expiration of the time limit applicable under Article 22, he shall exercise the said right not later than 4 months after such expiration date. In either case, the applicant may exercise the said right at any other time if so permitted by the national law of the said State.

(b) In any designated State in which the national law provides that examination starts only on special request, the time limit within or the time at which the applicant may exercise the right under Article 28 shall be the same as that provided by the national law for the filing of amendments in the case of the examination, on special request, of national applications, provided that such time limit shall not expire prior to, or such time shall not come before, the expiration of the time limit applicable under paragraph (a).

In order that his application may be processed by the Office (national or regional) which grants (or refuses the grant of) a national (or regional) patent, the applicant must, subject to the exceptions stated in this paragraph, do the following things:

(i) The applicant must pay the national fee to each designated Office not later than at the expiration of 20 months from the priority date (PCT Article 22(1)), unless more time is allowed by the Designated Office.

(ii) Depending on the language of the international application, the applicant may have to furnish a translation of the international application to the designated Office. The preparation

of the translation is the applicant's responsibility. The translation must reach the designated Office not later than at the expiration of 20 months from the priority date (PCT Article 22(1) and 35 U.S.C. 371(c)(2)). Where the applicant has amended the claims by filing amendments with the International Bureau, he will have to furnish the translation also of the original claims, and if he has filed a statement explaining the amendments, a translation of that statement into the same language as that into which the international application is translated must be attached to the translation of the international application (PCT Article 28(4) and PCT Rules 49.1(a)(i) and 49.2).

(iii) Where the International Bureau has not yet communicated a copy of the international application to the designated Office, the applicant must furnish a copy of the international application (that is, a copy in its original language) to the designated Office not later than at the expiration of 20 months from the priority date. The applicant will receive form PCT/1B/308 from the International Bureau indicating the date of mailing of the communications as well as the designated Offices to which the communication of copies was effected (PCT Rule 47.1(c)).

(iv) In respect of certain designated Offices, the applicant must furnish, if it is not already contained in the "Request" part of the international application, the name and certain other data concerning the inventor (PCT Articles 4(1)(v) and 4(4)).

AMENDMENT OF THE INTERNATIONAL APPLICATION IN THE "NATIONAL PHASE"

The applicant is permitted to amend the claims, the description and the drawings before the designated Offices. Any such amendments must be submitted within the given time limit, generally within one month of the payment of the national fees and the furnishing of a translation, if necessary (PCT Article 28 and PCT Rule 52). The amendments must not go beyond the disclosure in the international application as filed except where the law of the designated State permits them to go beyond the said disclosure. The amendments must be in accordance with the law of the designated State in all respects not provided for in the PCT. The amendments must be presented in the language of the translation of the international application, if a translation was required.

1889 Representation Before the Designated Office

Any designated Office may, once the processing of the international application has started

in that Office, apply the national (regional) law as far as it relates to any requirement that the applicant be represented by an agent having the right to represent applicants before the said Office and/or that the applicant have an address in the designated State for the purpose of receiving notifications (PCT Article 27(7)).

1890 Requirements To Enter Stage in United States of America

35 U.S.C. 371 National stage: Commencement. (a) Receipt from the International Bureau of copies of international applications with amendments to the claims, if any, and international search reports is required in the case of all international applications designating the United States, except those filed in the Patent Office.

(b) Subject to subsection (f) of this section, the national stage shall commence with the expiration of the applicable time limit under article 22 (1) or (2) of the treaty, at which time the applicant shall have complied with the applicable requirements specified in subsection (c) of this section.

(c) The applicant shall file in the Patent Office—

(1) the national fee prescribed under section 376 (a) (4) of this part;

(2) a copy of the international application, unless not required under subsection (a) of this section or already received from the International Bureau, and a verified translation into the English language of the international application, if it was filed in another language;

(3) amendments, if any, to the claims in the international application, made under article 19 of the treaty, unless such amendments have been communicated to the Patent Office by the International Bureau, and a translation into the English language if such amendments were made in another language;

(4) an oath or declaration of the inventor (or other person authorized under chapter 11 of this title) complying with the requirements of section 115 of this title) and with regulations prescribed for oaths or declarations of applicants.

(d) Failure to comply with any of the requirements of subsection (c) of this section, within the time limit provided by article 22 (1) or (2) of the treaty shall result in abandonment of the international application.

(e) After an international application has entered the national stage, no patent may be granted or refused thereon before the expiration of the applicable time limit under article 28 of the treaty, except with the express consent of the applicant. The applicant may present amendments to the specification, claims, and drawings of the application after the national stage has commenced.

(f) At the express request of the applicant, the national stage of processing may be commenced at any

time at which the application is in order for such purpose and the applicable requirements of subsection (c) of this section have been complied with.

35 U.S.C. 372 National stage: Requirements and procedure. (a) All questions of substance and, within the scope of the requirements of the treaty and Regulations, procedure in an international application designating the United States shall be determined as in the case of national applications regularly filed in the Patent Office.

(b) In case of international applications designating but not originating in, the United States—

(1) the Commissioner may cause to be reexamined questions relating to form and contents of the application in accordance with the requirements of the treaty and the Regulations;

(2) the Commissioner may cause the question of unity of invention to be reexamined under section 121 of this title, within the scope of the requirements of the treaty and the Regulations.

“(c) Any claim not searched in the international stage in view of a holding, found to be justified by the Commissioner upon review, that the international application did not comply with the requirement for unity of invention under the treaty and the Regulations, shall be considered canceled, unless payment of a special fee is made by the applicant. Such special fee shall be paid with respect to each claim not searched in the international stage and shall be submitted not later than one month after a notice was sent to the applicant informing him that the said holding was deemed to be justified. The payment of the special fee shall not prevent the Commissioner from requiring that the international application be restricted to one of the inventions claimed therein under section 121 of this title, and within the scope of the requirements of the treaty and the Regulations.

37 CFR 1.61 Filing of application in the United States of America as a Designated Office. (a) To maintain the benefit of the international filing date and obtain an examination as to the patentability of the invention in the United States, the applicant shall furnish to the U.S. Patent and Trademark Office not later than the expiration of 20 months from the priority date: (1) A copy of the international application with any amendments, unless it has been previously furnished by the International Bureau or unless it was originally filed in the U.S. Patent and Trademark Office; (2) a verified translation of the international application and a translation of any amendments into the English language, if originally filed elsewhere in another language; (3) the national fee (see § 1.445(a)(4)); and (4) an oath or declaration of the inventor (see § 1.70).

(b) Where an International Searching Authority has made a declaration that no international search report will be established because the international application relates to subject matter which it is not required to search, or because the application fails to comply with the prescribed requirements to such an

extent that a meaningful search could not be carried out, the time for performing the acts referred to in paragraph (a) of this section is 2 months from the mailing date of the declaration to the applicant.

37 CFR 1.70 Content of oath or declaration relating to content of and amendments to an application under 35 U.S.C. 371(c)(4). (a) (1) When an applicant of an international application, if the inventor, desires to enter the national stage under 35 U.S.C. 371, he or she must specifically identify the international application and any amendments thereto and state that he or she has reviewed the referred to application and any amendments, and that he or she verily believes himself or herself to be the original and first inventor or discoverer of the process, machine, manufacturer, composition of matter, or improvement thereof, for which he or she solicits a patent; that he or she does not know and does not believe that the same was ever known or used in the United States of America before his or her invention or discovery thereof, and shall state of what country he or she is a citizen and where he or she resides and whether he or she is a sole or joint inventor of the invention claimed in his or her international application as filed or as amended. In every application the applicant must distinctly state that to the best of his or her knowledge and belief the invention has not been in public use or on sale in the United States of America more than one year prior to his or her international application, or patented or described in any printed publication in any country before his or her invention or more than one year prior to his or her international application, or patented or made the subject of an inventor's certificate in any foreign country prior to the date of his or her international application on an application filed by himself or herself or his or her legal representatives or assigns more than twelve months prior to his or her international application. He or she must acknowledge a duty to disclose information he or she is aware of which is material to the examination of the application. He or she shall state whether or not any application for patent or inventor's certificate on the same invention has been filed in any foreign country, either by himself or herself, or by his or her legal representatives or assigns. If any such application has been filed, the applicant shall name the country in which the earliest such application was filed, and shall give the day, month, and year of its filing; he or she shall also identify by country and by day, month, and year of filing, every such foreign application filed more than twelve months before the filing of the international application.

(2) This statement (i) must be subscribed to by the applicant, and (ii) must either (a) be sworn to (or affirmed) as provided in § 1.66, or (b) include the personal declaration of the applicant as prescribed in § 1.68.

(b) If the international application was made as provided in §§ 1.422, 1.423 or 1.425, the applicant shall state his or her relationship to the inventor and, upon

information and belief, the facts which the inventor is required by this section to state.

37 CFR 3.56 Oath to be filed with the United States Designated Office under 35 U.S.C. 371(c)(4). As a below named inventor, being duly sworn (or affirmed), I depose and say that:

My residence, post office address, and citizenship are as stated below next to my name;

I verily believe I am the original, first and sole inventor (if only one name is listed below) or a joint inventor (if plural inventors are named below) of the invention entitled:

described and claimed in international application No. _____ filed _____, and as amended on _____ (if any), which I have reviewed and for which I solicit a patent;

I do not know and do not believe the same was ever known or used in the United States of America before my or our invention thereof, or patented or described in any printed publication in any country before my or our invention thereof or more than one year prior to my international application, that the same was not in public use or on sale in the United States of America more than one year prior to my international application, that the invention has not been patented or made the subject of an inventor's certificate issued before the date of my international application in any country foreign to the United States of America on an application filed by me or my legal representatives or assigns more than twelve months prior to my international application, that I acknowledge my duty to disclose information of which I am aware which is material to the examination of this application, and that no application for patent or inventor's certificate on this invention has been filed in any country foreign to the United States of America prior to this application by me or my legal representatives or assigns except as follows:

Full name of sole or first inventor	-----
Inventor's signature	-----
	Date
Residence	-----
Citizenship	-----
Post office address	-----
Full name of second joint inventor, if any	-----
Second Inventor's signature	-----
	Date
Residence	-----
Citizenship	-----
Post office address	-----

(Supply similar information and signature for third and subsequent joint inventors)

ss:

Sworn to and subscribed before me this _____ day of _____, 19____.

(Signature of notary or officer)

[Seal]

(Official character)

37 CFR 3.57 Declaration to be filed with United States Designated Office under 35 U.S.C. 371(c) (4).
As a below named inventor, I hereby declare that:

My residence, post office address and citizenship are as stated below next to my name;

I verily believe I am the original, first and sole inventor (if only one name is listed below) or a joint inventor (if plural inventors are named below) of the invention entitled:

described and claimed in international application No. _____ filed _____ and as amended on _____ (if any), which I have reviewed and for which I solicit a patent;

I do not know and do not believe the same was ever known or used in the United States of America before my or our invention thereof, or patented or described in any printed publication in any country before my or our invention thereof or more than one year prior to my international application, that the same was not in public use or on sale in the United States of America more than one year prior to my international application, that the invention has not been patented or made the subject of an inventor's certificate issued before the date of my international application in any country foreign to the United States of America on an application filed by me or my legal representatives or assigns more than twelve months prior to my international application, that I acknowledge my duty to disclose information of which I am aware which is material to the examination of this application, and that no application for patent or inventor's certificate on this invention has been filed in any country foreign to the United States of America prior to this application by me or my legal representatives or assigns, except as follows:

I hereby declare that all statements made herein of my knowledge are true and that all statements made on information and belief are believed to be true; and further that these statements were made with the knowledge that willful false statements and the like so made are punishable by fine or imprisonment, or both, under Section 1001 of Title 18 of the United States Code and that such willful false statements may

jeopardize the validity of the application or any patent issued thereon.

Full name of sole or first inventor _____
Inventor's signature _____
Date _____

Residence _____
Citizenship _____
Post office address _____

Full name of second joint inventor, if any _____

Second Inventor's signature _____
Date _____

Residence _____
Citizenship _____
Post office address _____

(Supply similar information and signature for third and subsequent joint inventors.)

The United States national stage commencement requirements are set forth in 35 U.S.C. 371 and 372. In order to retain the international filing date and enter the national stage in the United States, and unless the international application was filed in the United States Receiving Office or was already received from the International Bureau, the applicant, who must be the inventor for the United States (35 U.S.C. 373), must timely file in the Patent and Trademark Office (37 CFR 1.414) the following items:

- (i) a copy of the international application and a verified English translation thereof, if necessary,
- (ii) Amendments to the claims which were made before the International Bureau, if any, and an English translation thereof, if necessary,
- (iii) an oath or declaration of the inventor (37 CFR 1.70, 3.56 and 3.57) and
- (iv) the national filing fee (35 U.S.C. 41(a) (1), 376 (4)) and 37 CFR 1.445(a) (4).

The applicant must submit these items not later than the expiration of 20 months from the priority date to avoid abandonment of the application (35 U.S.C. 371(d) and PCT Article 22). At 20 months the applicant may also file copies of the prior art cited in the Search Report.

After filing, the applicant has the right to amend the application before the Designated Office within one month after entry into the national state. The amendment may effect the description, claims and drawings, but may not add new matter. It should be noted that the time

limit of 20 months from the priority date applies irrespective of whether the international search report is available.

It should be noted that the 20 months indicated in items (i), (ii) and (iv) above, expires earlier where the International Searching Authority makes a declaration to the effect that no international search report will be established (PCT Article 17(2)(a)); such a declaration is notified to the application by the International Searching Authority; the time limit is then two months from the date of the notification of the said declaration sent to the applicant (PCT Article 22(2), PCT Rule 44.1 and 37 CFR 1.61).

Entry into the national stage may also occur earlier at the express request of the applicant under the provisions of 35 U.S.C. 371(f). In order that earlier entry into the national stage may take place, the applicable requirements of 35 U.S.C. 371(c) must be received by the United States Patent and Trademark Office. Requirements such as the Search Report and any amendments to the claims must be submitted promptly after they are made available, if not submitted with the other requirements of 35 U.S.C. 371(c).

EARLY PROCESSING OF APPLICATION AT THE U.S. NATIONAL STAGE

National stage processing in the United States Patent and Trademark Office will normally not begin until after the expiration of the applicable time limit under PCT Article 22 (35 U.S.C. 371(b)).

This is true even if the applicant fulfills the requirements of 35 U.S.C. 371(c), paragraphs (1), (2), and (4) to obtain an early prior art date well before the expiration of the above mentioned time limit.

Applicants may, however, expressly request early processing at any time after the applicable requirements of 35 U.S.C. 371(c) have been compiled with. If a proper express request for early processing is received, the international application will promptly be assigned a national serial number and be forwarded for examination.

PRIOR ART STATEMENT REQUIREMENT FOR UNITED STATES

If the United States of America is designated, a prior art statement under 37 CFR 1.97 and 1.98 should be filed at the time of entering the national state (35 U.S.C. 371(b) or (f)) or within three months thereafter. For purposes of 37 CFR 1.97(a) the date of entry into the national stage is considered to be "the time of filing the application".

UNITED STATES DRAWING REQUIREMENTS

When the nature of the subject matter of the invention admits of illustration by the drawing and the applicant has not furnished such a drawing, the Commissioner of Patents and Trademarks may require the submission of such a drawing within a time period of not less than two months from the sending of a notice to the applicant (35 U.S.C. 113, and 37 CFR 1.81 and 83). Accordingly, whenever filing international applications which designate the United States, applicants may wish to routinely furnish a drawing with each application in which the subject matter "admits of illustration by a drawing" even though the drawing is not deemed necessary for the understanding of the invention.

1895 Review Under PCT Article 25

PCT ARTICLE 25

Review by Designated Offices

(1) (a) Where the receiving Office has refused to accord an international filing date or has declared that the international application is considered withdrawn, or where the International Bureau has made a finding under Article 12(3), the International Bureau shall promptly send, at the request of the applicant, copies of any document in the file to any of the designated Offices named by the applicant.

(b) Where the receiving Office has declared that the designation of any given State is considered withdrawn, the International Bureau shall promptly send, at the request of the applicant, copies of any document in the file to the national Office of such State.

(c) The request under subparagraphs (a) or (b) shall be presented within the prescribed time limit.

(2) (a) Subject to the provisions of subparagraph (b), each designated Office shall, provided that the national fee (if any) has been paid and the appropriate translation (as prescribed) has been furnished within the prescribed time limit, decide whether the refusal, declaration, or finding, referred to in paragraph (1) was justified under the provisions of this Treaty and the Regulations, and, if it finds that the refusal or declaration was the result of an error or omission on the part of the receiving Office or that the finding was the result of an error or omission on the part of the International Bureau, it shall, as far as effects in the State of the designated Office are concerned, treat the international application as if such error or omission had not occurred.

(b) Where the record copy has reached the International Bureau after the expiration of the time limit prescribed under Article 12(3) on account of any error or omission on the part of the applicant, the provisions of subparagraph (a) shall apply only under the circumstances referred to in Article 48(2).

PCT RULE 51

*Review by Designated Offices***51.1 Time Limit for Presenting the Request to Send Copies**

The time limit referred to in Article 25(1) (c) shall be 2 months computed from the date of the notification sent to the applicant under Rules 20.7 (i), 24.2 (b), 29.1 (a) (ii), or 29.1 (b).

51.2 Copy of the Notice

Where the applicant, after having received a negative determination under Article 11(1), requests the International Bureau, under Article 25(1), to send copies of the file of the purported international application to any of the named Offices he has attempted to designate, he shall attach to his request a copy of the notice referred to in Rule 20.7 (i).

51.3 Time Limit for Paying National Fee and Furnishing Translation

The time limit referred to in Article 25(2) (a) shall expire at the same time as the time limit prescribed in Rule 51.1.

51.4 Notification to the International Bureau

Where, under Article 25(2), the competent designated Office decides that the refusal, declaration or finding referred to in Article 25(1) was not justified, it shall promptly notify the International Bureau that it will treat the international application as if the error or omission referred to in Article 25(2) had not occurred.

35 U.S.C. 366 Withdrawn international application. Subject to section 367 of this part, if an international application designating the United States is withdrawn or considered withdrawn, either generally or as to the United States, under the conditions of the treaty and the Regulations, before the applicant has complied with the applicable requirements prescribed by section 371 (c) of this part, the designation of the United States shall have no effect and shall be considered as not having been made. However, such international application may serve as the basis for a claim of priority under section 365 (a) and (b) of this part, if it designated a country other than the United States.

35 U.S.C. 367 Actions of other authorities: Review. (a) Where a Receiving Office other than the Patent Office has refused to accord an international filing date to an international application designating the United States or where it has held such application to be withdrawn either generally or as to the United States, the applicant may request review of the matter by the Commissioner, on compliance with the requirements of and within the time limits specified by the treaty and the Regulations. Such review may result in a determination that such application be considered as pending in the national stage.

(b) The review under subsection (a) of this section, subject to the same requirements and conditions, may

also be requested in those instances where an international application designating the United States is considered withdrawn due to a finding by the International Bureau under Article 12(3) of the treaty.

PCT Article 25 and 35 U.S.C. 367 provide for review by the United States Designated Office of decisions by another Receiving Office (1) refusing to grant a filing date or (2) withdrawing the international application or the designation of the United States of America.

1896 Effect of U.S. Patent Issued on an International Application

PCT ARTICLE 46

Incorrect Translation of the International Application

If, because of an incorrect translation of the international application, the scope of any patent granted on that application exceeds the scope of the international application in its original language, the competent authorities of the Contracting State concerned may accordingly and retroactively limit the scope of the patent, and declare it null and void to the extent that its scope has exceeded the scope of the international application in its original language.

35 U.S.C. 375 Patent issued on international application: Effect. (a) A patent may be issued by the Commissioner based on an international application designating the United States, in accordance with the provisions of this title. Subject to section 102(e) of this title, such patent shall have the force and effect of a patent issued on a national application filed under the provisions of chapter 11 of this title.

(b) Where due to an incorrect translation the scope of a patent granted on an international application designating the United States, which was not originally filed in the English language, exceeds the scope of the international application in its original language, a court of competent jurisdiction may retroactively limit the scope of the patent, by declaring it unenforceable to the extent that it exceeds the scope of the international application in its original language.

A patent issued on an international application has the same force and effect as a patent issued on a national application except that a court may retroactively limit the scope of a patent if it is too broad because of an incorrect translation, 35 U.S.C. 375.

1897 Filing and Prior Art Effect in United States of America

35 U.S.C. 363 International application designating the United States: Effect. An international application designating the United States shall have the effect, from its international filing date under article 11 of

the treaty, of a national application for patent regularly filed in the Patent Office except as otherwise provided in section 102(e) of this title.

37 CFR 1.55 Serial number and filing date of application.

* * * * *

(d) The filing date of an international application designating the United States of America shall be treated as the filing date in the United States of America under PCT Article 11(3), except as provided in 35 U.S.C. 102(e).

The prior art effect under 35 U.S.C. 102(e) begins on the date the applicant has fulfilled the requirements of 35 U.S.C. 371(c), (1), (2) and (4). These requirements are that the national filing fee, a copy of the international application and a verified English translation thereof, if it was filed in another language, and an oath or declaration be filed in the Patent and Trademark Office. The international application also becomes prior art when it is published promptly after the expiration of 18 months from the priority date, or earlier at applicant's request.