

CLASS 126, STOVES AND FURNACES**SECTION I - CLASS DEFINITION**

This class includes, generally, apparatus for the application of heat. It comprises cooking and heating stoves, hot-air furnaces, and accessories; hot-air radiators and heating drums; open liquid heaters, steaming apparatus, dampers, fireplaces, and stovepipes. It includes the fuel burner when combined with the stove or furnace structure; combinations of a particular stove or furnace structure of the type classified in this class (126) with a closed liquid heater or steam generator; liquid heaters of only the nonpressure type unless they are structurally tied to the stove or furnace or form a necessary part thereof, and grates of general use in stoves, hot-air furnaces, or boiler furnaces.

SECTION II - REFERENCES TO OTHER CLASSES**SEE OR SEARCH CLASS:**

- | | |
|--|--|
| <p>44, Fuel and Related Compositions, subclass 540 for a fuel composition combined with an incombustible carrier, e.g., a torch, etc.</p> <p>49, Movable or Removable Closures, appropriate subclasses for closures of the type provided for and see the search notes thereto in section IV of Class 49 for the loci of closures in other classes.</p> <p>68, Textiles: Fluid Treating Apparatus, having significant structure for fluid treatment of a textile, subclass 15 for a textile fluid treating machine combined with a tank heater or subclass 222 for an implement to apply steam to a textile.</p> <p>99, Foods and Beverages: Apparatus, takes food support means, peculiar to a food, shape, or condition, (e.g., can, jar, bottle, or slice holders, spits, griddles, waffle irons, sandwich grills, article confining or conforming supports), including a mechanism for manipulating food during cooking, other than mere agitation or stirring (e.g., conveying or bodily moving), or including a mechanism for treating food (e.g., basting, compressing, molding, drip, or gravy segregating), and, in any case, irrespective of whether or not a heat, steam, or vapor generator or enclosure is claimed; subclasses 293+ for a steamer or condenser type of beverage infuser, subclass 311 for a gravity feed beverage infuser with force feed fountain type recycling or reprecipitating supply having</p> | <p>110, Furnaces, for the broad art of combustion of solid or combined solid and fluid fuel.</p> <p>122, Liquid Heaters and Vaporizers, for a closed or pressurized liquid heater or vaporizer for other than a stove or furnace.</p> <p>160, Flexible or Portable Closure, Partition, or Panel, for devices (1) in the form of panels in which flexible fabrics or other flexible sheet material forms the panel portion, (2) in the form of panel units formed of plural strips, slats or panels interconnected for relative motion (excluding those connected only by a common operator or mounted on a common support), (3) panels in the form of portable partitions or (4) parts (1)-(3) combined with each other or with rigid closures or other rigid panels, even though combined with only those features of the fire place, stove or furnace which pertain to the mounting and for operating of the flexible or portable panels.</p> <p>219, Electric Heating, for the generation of heat by electricity, and the utilization of the heat similarly to this class (126) as in fluid, oven, tool, etc., heating wherein there is involved electrical characteristics or structure.</p> <p>236, Automatic Temperature and Humidity Regulation, for means to accomplish the function of the class wherein there is not involved structure which forms the basis of classification in this class (126).</p> <p>237, Heating Systems, for an apparatus or process of heating an enclosure, subclass 7 for a combined radiator and boiler having automatic control, or subclasses 16-18 for a combined boiler and radiator.</p> <p>264, Plastic and Nonmetallic Article Shaping or Treating: Processes, subclass 30 for furnace lining formation or repair and see the notes thereto.</p> <p>431, Combustion, appropriate subclass for a residual combustion apparatus or process, per se.</p> <p>432, Heating, appropriate subclass for the apparatus or method for the application of heat to materials not specifically provided for in the subclasses of Class 126, or elsewhere.</p> <p>588, Hazardous or Toxic Waste Destruction or Containment, subclasses 313 through 320 for processes wherein toxic or hazardous waste is burned in a stove or furnace. See cross-reference art collection, subclass 900, for apparatus</p> |
|--|--|

useful in the destruction of hazardous or toxic waste.

SUBCLASSES

1

Cooking:

This subclass is indented under the unnumbered subclass, STOVES. Subject matter generally of cast or sheet metal, wire, or rod construction, adapted to culinary heating purposes.

SEE OR SEARCH THIS CLASS, SUBCLASS:

- 19.5, for combustion engine heated cooking stoves and ovens.
- 100, for cooking stoves combined with hot air furnaces.
- 218, for attachments used on the top of heating stoves adapting such stoves to cooking.
- 222+, for trash burning cooking stoves.
- 263.01+, for cooking stoves in which heat is generated by noncombustion chemical reactions.
- 506, for cooking or oven attachments used in fireplaces.

SEE OR SEARCH CLASS:

- 99, Foods and Beverages: Apparatus, subclasses 324+ for mass or machine type cookers and for vessels with heating means, which are particularly adapted to the cooking of foods or the preparation of beverages.

2

Double fire pot:

This subclass is indented under subclass 1. Cooking stoves that have two or more fire pots related to a single structure.

SEE OR SEARCH THIS CLASS, SUBCLASS:

- 111, for this structure in a hot air furnace.

3

Cooking and heating:

This subclass is indented under subclass 2. Devices comprising a combined cooking and heating stove.

4

Combined cooking and heating stove:

This subclass is indented under subclass 1. Cooking stoves adapted to heating for purposes other than cooking. In this subclass will be found what are generally known as "parlor cooking stoves".

SEE OR SEARCH THIS CLASS, SUBCLASS:

- 3, for such stoves having double fire pots.
- 100, for hot air furnaces adapted to cooking.
- 218, for heating stoves having lid or tops or attachments for the lid or top to adapt it for cooking.

5

Steam or water generators:

This subclass is indented under subclass 4. Combined cooking and heating stoves provided with steam or hot water generators for house heating, power, or cooking.

SEE OR SEARCH THIS CLASS, SUBCLASS:

- 344 through 363.1, for a liquid heater that may include a kettle, a steam generator, stove pipe for use with a stove, a domestic water heater or boiler (e.g., kitchen boiler, range boiler, etc.) for use with a stove or furnace.

6

Air-heating:

This subclass is indented under subclass 4. Combined cooking and heating stoves which have means for heating and circulating a current of air.

SEE OR SEARCH THIS CLASS, SUBCLASS:

- 58+, for detail air heating features.

7

Magazine:

This subclass is indented under subclass 4. Combined cooking and heating stoves which contain a magazine or self-feeder.

SEE OR SEARCH THIS CLASS, SUBCLASS:

- 10, and see the notes thereunder, for other magazine feeds.

- 8 Brick set:**
This subclass is indented under subclass 1. Subject matter in a masonry setting, permanent in character.
- 9 Knockdown or separable:**
This subclass is indented under subclass 1. Devices structurally adapted to be folded or the several parts separated, so as to allow for its easy transportation from place to place. The stoves in this class are usually termed "portable furnaces".
- SEE OR SEARCH THIS CLASS, SUB-CLASS:
25+, 59 and 275, for other stoves having knock-down or separable features.
- 10 Magazine:**
This subclass is indented under subclass 1. Devices that are provided with magazines or self-feeding coal devices.
- SEE OR SEARCH THIS CLASS, SUB-CLASS:
7, 68, 73, 74, 107, and 501, for other stoves having magazine feed.
- SEE OR SEARCH CLASS:
110, Furnaces, subclasses 293+ for magazine fed furnaces.
- 11 Portable:**
This subclass is indented under subclass 10. Subject matter in which the magazine or coal-receptacle is removably placed in the stove-holes and provided with means for feeding the coal to the fire-pot.
- 12 Hearths:**
This subclass is indented under subclass 1. Subject matter relating to hearths and to means for attaching the hearth to the stove.
- 13 Fire pot:**
This subclass is indented under subclass 12. Devices that are provided with fire pots for cooking or broiling purposes.
- 14 Broiling attachments:**
This subclass is indented under subclass 1. Subject matter including attachments for broiling purposes which are inseparable from the stove structure.
- SEE OR SEARCH THIS CLASS, SUB-CLASS:
41, for gas stove broilers.
- SEE OR SEARCH CLASS:
99, Foods and Beverages: Apparatus, subclasses 385, 444, 450, and any indented subclasses for food broiling apparatus.
219, Electric Heating, subclass 450.1 for an exposed planar support surface for material to be heated (e.g., hot plate, etc.) for contact with food (e.g., grill, griddle, etc.).
- 15 Feeding air:**
This subclass is indented under subclass 1. Subject matter including means for the preliminary heating of air before its introduction into the combustion chamber or flues.
- SEE OR SEARCH CLASS:
110, Furnaces, subclass 201 for a locomotive furnace provided with an air preheater; subclass 254 for a refuse incinerator provided with an air preheater; and subclasses 302+ for other types of solid fuel furnaces provided with an air preheater.
- 16 Flue cleaners:**
This subclass is indented under subclass 1. Subject matter with means for cleaning the flues, also combined scrapers and soot-receptacles applicable to this class of stove.
- SEE OR SEARCH THIS CLASS, SUB-CLASS:
280, for forms of soot-receptacles.
- SEE OR SEARCH CLASS:
15, Brushing, Scrubbing, and General Cleaning, appropriate subclasses for a flue cleaner, particularly subclasses 104.066+ for a brush or broom implement; subclasses 104.068+ for a scraper flue implement; subclass

249.1 for a brush or broom implement intended to be left attached (i.e., at work and at rest) to a flue; subclasses 249.2+ for a scraper implement intended to be left attached (i.e., at work and at rest) to a flue.

17 Smoke pipe-heated:

This subclass is indented under the unnumbered subclass, Elevated ovens. Subject matter that have ovens supported by a stove-pipe above the top plate of the stove and heated thereby. In this subclass will be found warming-ovens that are stovepipe heated.

18 Top plate-supported:

This subclass is indented under the unnumbered subclass, Elevated ovens. Subject matter in which an oven is elevated above and supported by the stove-top.

19 Ovens:

This subclass is indented under subclass 1. Subject matter relating to the structure of the chamber used for baking or roasting.

SEE OR SEARCH THIS CLASS, SUBCLASS:

19.5, for ovens heated by the waste heat of combustion engines.

273+, for various species of ovens as indicated by the subclass titles.

SEE OR SEARCH CLASS:

428, Stock Material or Miscellaneous Articles, subclasses 606+ for metallic stock material in the form of foil.

19.5 COMBUSTION ENGINE-HEATED COOKING STOVES, OVEN OR HEATING VESSELS:

This subclass is indented under the class definition. Subject matter consisting of domestic heating vessels and/or heat exchangers used for heating in the manner of a cooking stove or oven which are heated by the waste heat of a combustion engine as contained in its exhaust products or cooling fluid.

SEE OR SEARCH THIS CLASS, SUBCLASS:

271.1+, for surfaced heaters, some of which utilize heat from the exhaust or cooling fluid of engines.

SEE OR SEARCH CLASS:

60, Power Plants, subclasses 320+ for an internal combustion engine in which an exhaust system element is nominal means for heating.

237, Heating Systems, subclasses 12.1+ for heating systems utilizing the waste heat of power plants.

20 Steam or hot water:

This subclass is indented under subclass 19. Subject matter in which the oven is heated by steam or hot water, either where the steam or hot water surrounds the oven or where the steam enters the oven.

SEE OR SEARCH THIS CLASS, SUBCLASS:

369 through 369.3, for a liquid heating steam chamber for food.

377.1 through 392.1, for an open-top liquid heating vessel that may include a lid having a confining, directing, or shielding feature for a liquid or steam used to heat the vessel.

20.1 Plural:

This subclass is indented under subclass 20. Devices consisting of two or more compartments each (1) constituting a distinct oven or (2) having separate means of access thereto.

20.2 Selective supply:

This subclass is indented under subclass 20.1. Devices in which means are provided to control the supply of heating fluid, at will, to less than all of the ovens.

SEE OR SEARCH THIS CLASS, SUBCLASS:

369.3, for a steaming chamber for food having selective supply.

21 Ventilated:

This subclass is indented under subclass 19. Subject matter where means are provided for heating a current of air, circulating it through the oven, and usually feeding it to the combustion chamber or flues.

- 22 Protector plate:**
This subclass is indented under subclass 19. Subject matter including devices to be used in the oven for the purpose of protecting articles to be baked therein. Some of these devices are provided with air-moistening means.
- 23 Reversible:**
This subclass is indented under subclass 1. Subject matter that are convertible into a right and left hand stove; also, where the smoke-collar is interchangeable from the back to the top plate, or vice versa.
- 24 Ship's galley:**
This subclass is indented under subclass 1. Cooking stoves counterbalanced or suspended to maintain their equilibrium.
- SEE OR SEARCH CLASS:
114, Ships, subclasses 188+ for ships furnishings which may include stoves of this type limited to ship board use.
- 25 Summer:**
This subclass is indented under subclass 1. Subject matter that is portable in character, usually employed in outdoor work, and adapted to burn charcoal or light fuel. These stoves are frequently called "braziers".
- SEE OR SEARCH THIS CLASS, SUB-CLASS:
9, for other knockdown or portable stoves.
227, 230, and 236, for similar devices for heating flat irons or soldering irons respectively.
- 26 Detachable fire pot:**
This subclass is indented under subclass 25. Subject matter comprising fire-pot structures adapted to be supported in and cooperate with the stove-hole of ordinary cooking stoves.
- 27 Stove top-supported:**
This subclass is indented under subclass 25. Subject matter designed to be supported upon the top plate of an ordinary kitchen-stove, with the smoke-outlet in communication with the stove proper through the medium of the stove-lid opening. These devices are frequently termed "portable furnaces".
- SEE OR SEARCH THIS CLASS, SUB-CLASS:
26, for field cooking stoves with detachable fire pots.
- 28 Stove flue-connected:**
This subclass is indented under subclass 27. Devices in which the smoke-outlet has direct connection with the stove-pipe or smoke-flue of the stove.
- 29 Field:**
This subclass is indented under subclass 25. Stoves designed to be employed in the open air and are what may be termed "bottomless", the fire being built upon the ground.
- SEE OR SEARCH THIS CLASS, SUB-CLASS:
59, for camp heating stoves.
- SEE OR SEARCH CLASS:
110, Furnaces, subclass 239 for stoves to be placed around a stump to burn it.
- 30 Supporting frame:**
This subclass is indented under subclass 29. Devices in the nature of supports and tripods designed to suspend or support cooking utensils over the fire.
- SEE OR SEARCH CLASS:
248, Supports, subclasses 146 through 154 for a stationary receptacle stand.
- 31 Flue extension:**
This subclass is indented under the unnumbered subclass, Water-heating. Stoves in which a tank containing water to be heated is placed in an extension-chamber through which the products of combustion pass. This type of stove is generally known as "reservoir cooking-stove".
- SEE OR SEARCH THIS CLASS, SUB-CLASS:
364.1, 365.1, for a liquid heater and stove-pipe.
- 32 Spittoon attachments:**
This subclass is indented under subclass 1. Subject matter in the nature of attachments for spittoons.

SEE OR SEARCH CLASS:

- 4, Baths, Closets, Sinks, and Spittoons, subclasses 258+ for spittoons.

33 Tables, steam-heated:

This subclass is indented under subclass 1. Devices that are in the form of shallow chambers provided with means for causing a circulation of steam or hot water therein, whereby the top plates or receptacles placed thereon are heated, e.g., candy-tables, carving-tables, food-warming vessels, and similar devices.

SEE OR SEARCH THIS CLASS, SUBCLASS:

- 369 through 369.3, for a steam chamber for food.
377.1 through 392.1, for an open-top liquid heating vessel that may include a lid having a confining, directing, or shielding feature for a liquid or steam used to heat the vessel.

34 Water backs:

This subclass is indented under subclass 1. Stoves provided with generators, steam or hot-water, located in or adjacent to the combustion-chamber.

SEE OR SEARCH THIS CLASS, SUBCLASS:

- 5, for a steam or hot water generator for house heating, power, or cooking.
53, for a fluid fueled cooking stove providing a water back to heat water for a domestic purpose.
361.1 through 363.1, for a boiler receiving hot liquid or steam from a stove or furnace (e.g., kitchen boiler, range boiler, etc.).

35 Safety devices:

This subclass is indented under subclass 34. Stoves provided with means for preventing the bursting of the water-back, due to excessive internal pressure as the result of overheating or the freezing of the water.

SEE OR SEARCH CLASS:

- 122, Liquid Heaters and Vaporizers, subclasses 504+ for safety devices on steam generators in general.

- 137, Fluid Handling, subclasses 59+ for valves controlled by means sensing freezing conditions, subclasses 67+ for valves controlled by a destructible element, and subclasses 455+ for valves responsive to changes in line conditions, particularly subclasses 457 and 468 responsive to a change in thermal condition.

- 220, Receptacles, subclasses 366.1 and 367.1+ for vent means in a closure.

36 Combined coal and gas:

This subclass is indented under the unnumbered subclass, Liquid or gaseous fuel. Subject matter comprising combined coal and gas stoves where the gas-stove is a permanent part of the cooking stove or range.

37 Cabinet:

This subclass is indented under the unnumbered subclass, Liquid or gaseous fuel. Subject matter comprising cabinets or inclosing casings that are structurally designed to inclose or conceal gas or liquid-fuel stoves when not in use. The cabinets are usually provided with compartments wherein articles of food and the like may be placed.

SEE OR SEARCH CLASS:

- 312, Supports: Cabinet Structure, subclass 236 for cabinets having both storage space and a stove where no structural characteristics of the stove or the control thereof are claimed.

38 Folding or nesting kit:

This subclass is indented under the unnumbered subclass, Liquid or gaseous fuel. Devices adapted to be folded or slipped together and designed as such to contain the heating element and as a rule, the article acted upon by the heating element. These devices are frequently termed "pocket-stoves".

39 Gas:

This subclass is indented under the unnumbered subclass, Liquid or gaseous fuel. Subject matter comprising improvements in the ordinary commercial gas-stove.

- 40 Burner stands:**
This subclass is indented under subclass 39. Devices in the nature of combined burner and stand, that are portable in character, and as such are designed to be placed upon a table or similar article of support. These devices are usually of the "single-burner" variety.
- 41 Broilers:**
This subclass is indented under subclass 39. Devices comprising gas-stove structures with broiling attachments.
- SEE OR SEARCH THIS CLASS, SUB-CLASS:
14, for other broiling attachments.
- SEE OR SEARCH CLASS:
99, Foods and Beverages: Apparatus, subclasses 385+, 444+ and 450 for food broilers designed to treat the food by more or other than mere heating.
- 42 Safety attachments:**
This subclass is indented under subclass 39. Devices that are designed to simultaneously close the valves in branch pipes when the valve in the main gas supply is closed, also valve-locking means that will prevent the accidental opening of the valves.
- SEE OR SEARCH THIS CLASS, SUB-CLASS:
351.1, for a fluid fuel burner other than a top-accessible liquid heating vessel and a condition responsive feature.
374.1, for an open-top liquid heating vessel that may include a lid and a condition responsive feature.
- SEE OR SEARCH CLASS:
70, Locks, subclass 178 for valve encasing locks designed to prevent unauthorized operation of the encased valve.
431, Combustion, subclass 153 for residual combustion apparatus having structure preventing the feeding of gaseous or liquid fuel when the apparatus is in a condition in which operation would be unsafe.
- 43 Alcohol:**
This subclass is indented under the unnumbered subclass, Liquid. Subject matter which employ alcohol burners.
- 44 Vapor:**
This subclass is indented under the unnumbered subclass, Liquid. Subject matter comprising liquid-fuel cooking-stoves of the well known retort vapor-burner type.
- 45 Wick:**
This subclass is indented under the unnumbered subclass, Liquid. Subject matter comprising liquid-fuel cooking-stoves of the wick burner type.
- 46 Extension top:**
This subclass is indented under subclass 45. Liquid-fuel wick-type stoves where the improvement resides in the means for giving the top an enlarged or extended cooking-surface.
- SEE OR SEARCH THIS CLASS, SUB-CLASS:
216, for other domestic heaters which burn gas or liquid fuel and have an extended top.
- 47 Lamp type:**
This subclass is indented under subclass 45. Devices where the heater is of the ordinary lamp or illuminating type structure.
- 48 Combined top, chimney and burner:**
This subclass is indented under subclass 47. Devices having a combined top, chimney, and burner. These devices are frequently termed "drums" in the art.
- 49 Reservoir supporting top and burner:**
This subclass is indented under subclass 45. Liquid-fuel wick-stove in which a combined supporting-top and burner are supported in an elevated position from and above the oil-reservoir.
- 50 Supporting frame:**
This subclass is indented under the unnumbered subclass, Liquid or gaseous fuel. Subject matter comprising gas, liquid-fuel, and vapor stove frames, usually of skeleton form,

- provided with liquid or gaseous fuel heating-burners and designed to support the ordinary kitchen utensils.
- SEE OR SEARCH THIS CLASS, SUB-CLASS:
211+, especially subclass 215 for elevated supports for other fluid fuel stoves.
- 51 Drip pan or receptacle:**
This subclass is indented under the unnumbered subclass Liquid. Devices that are in the form of pans or receptacles so attached to liquid or vapor stove supporting frames that they will catch the oil dripping or overflowing from a burner or burners. Means are sometimes provided for conducting the accumulated oil from the pans to a receptacle.
- 52 Valve mechanism, article-controlled:**
This subclass is indented under the unnumbered subclass, Liquid or gaseous fuel. Subject matter burning fluid fuel and having fuel control valves that are opened by the weight of the article to be heated and closed through the medium of a weight or spring.
- SEE OR SEARCH THIS CLASS, SUB-CLASS:
234, and 238, for stove shelves which may operate valves.
- 53 Water backs:**
This subclass is indented under the unnumbered subclass, Liquid or gaseous fuel. Subject matter comprising gas or vapor stove structures that are provided with water-backs designed to heat water for domestic purposes.
- SEE OR SEARCH THIS CLASS, SUB-CLASS:
34, for a cooking stove having a water back.
39 through 51, for an improvement in a gas cooking stove.
44, for a liquid fueled cooking stove of retort vapor-burner type.
361.1 through 363.1, for a boiler receiving hot liquid or steam from a stove or furnace (e.g., kitchen boiler, range boiler, etc.).
- 54 Combined burner and water back:**
This subclass is indented under subclass 53. Subject matter in which the burner structures and water-heating means are integral.
- 55 Combined base and hot closet:**
This subclass is indented under subclass 1. Subject matter comprising devices that are designed to support the stove or range from the floor. It is usual to provide the base with what may be termed a warming or hot closet.
- SEE OR SEARCH THIS CLASS, SUB-CLASS:
277, and 305, for other platforms and base supports respectively.
- 56 Car:**
This subclass is indented under the unnumbered subclass, STOVES. Subject matter comprising stoves that are specially designed for use on railroad-cars and similar structures.
- 57 Protective casings:**
This subclass is indented under subclass 56. Car-stoves wherein the improvement resides in means to make it safe in case of derailment, collision, or other accident to the car. The means may be an inclosing casing, an automatically-operated closing casing, or automatic means for closing the inlet and outlet openings of the stove.
- SEE OR SEARCH THIS CLASS, SUB-CLASS:
544, through 551, for fire screen and guards, per se.
- 58 Heating:**
This subclass is indented under the class definition. Subject matter relating to usually cast or sheet metal, heat generators that are direct-heat radiating.
- 59 Camp:**
This subclass is indented under subclass 58. Heating stoves of the knock-down type, specially designed for tent heating.
- SEE OR SEARCH THIS CLASS, SUB-CLASS:
9, for other knock-down stoves.
65+, for other sheet metal stoves.

59.5 Orchard:

This subclass is indented under subclass 58. Portable devices for generating heat or smoke for protecting orchards from frost.

SEE OR SEARCH CLASS:

- 47, Plant Husbandry, subclass 2 for frost preventing means for plants, not otherwise provided for.
- 99, Foods and Beverages: Apparatus, subclasses 467+ for smoke generators combined with food treating apparatus.
- 110, Furnaces, appropriate subclasses, where the invention is merely a means for combustion of solid fuel.
- 431, Combustion, subclasses 331+ for a pot forming a liquid fuel holding and burning unit not having a stove or heat transfer feature.

60 Horizontal body:

This subclass is indented under subclass 58. Heating stoves having horizontally elongated fire-boxes or combustion-chambers.

61 Hot air:

This subclass is indented under subclass 60. Devices which are provided with means for heating and circulating a current or air.

64 Panel:

This subclass is indented under subclass 58. Heating stoves having walls or earthenware refractory material.

SEE OR SEARCH THIS CLASS, SUBCLASS:

- 98, and 119, for related subject matter, involving stove or hot air furnace joints.

65 Sheet metal:

This subclass is indented under subclass 58. Heating stoves the outer walls of which are formed of sheet metal. These stoves are of the wood-burning type, having generally no separate or distinct fire-pot.

66 Hot air:

This subclass is indented under subclass 65. Devices provided with air heating and circulating features.

67 Hot air:

This subclass is indented under subclass 58. Heating stoves which are provided with means for heating and circulating a current of air and are not more specifically classified.

SEE OR SEARCH THIS CLASS, SUBCLASS:

- 6, for combined cooking and hot air stoves.
- 61, for horizontal body hot air stoves.
- 66, for sheet metal wood burning hot air stoves.
- 88, through 90, for gas burning hot air stoves.
- 93, through 97, for liquid fuel burning hot air stoves.
- 99, through 119, for hot air furnaces and see the notes thereunder to Class 432, Heating.
- 500, through 555, for hot air fireplaces, especially subclasses 506, 524, and 531, and see the notes thereunder.

68 Magazine:

This subclass is indented under subclass 67. Devices provided with magazines or self-feeders.

SEE OR SEARCH THIS CLASS, SUBCLASS:

- 10, for other magazine feeds.

69 Revertible draft, base-heating:

This subclass is indented under subclass 67. Devices provided with means for giving the products a direct or indirect course to the outlet-flue. When an indirect course is employed, it heats the base of the stove.

SEE OR SEARCH THIS CLASS, SUBCLASS:

- 74, and 75, for revertible-draft features.

70 Internal air chamber:

This subclass is indented under subclass 67. Devices in which the air heating chamber is located centrally relative to the combustion chamber.

- SEE OR SEARCH THIS CLASS, SUB-CLASS:
71, for hot air radiating stoves in which the air heating chamber is a central, vertical tube.
- 71 Central air tube:**
This subclass is indented under subclass 67. Devices in which an air-tube passes vertically and centrally through the heater.
- SEE OR SEARCH THIS CLASS, SUB-CLASS:
70, for central chamber hot air radiating stoves.
72, for tubular chamber hot air radiating stoves.
109, for hot air furnaces having tubular air passages.
- 72 Tubular air heaters:**
This subclass is indented under subclass 67. Devices provided with a series of air-tubes which are passed vertically, horizontally, or diagonally through the combustion chamber.
- SEE OR SEARCH THIS CLASS, SUB-CLASS:
70, for central chamber hot air radiating stoves.
71, for hot air radiating stoves having central, vertical tubes.
109, for hot air furnaces having tubular air passages.
- 73 Magazine:**
This subclass is indented under subclass 58. Heating stoves that are provided with magazines or self-feeders.
- SEE OR SEARCH THIS CLASS, SUB-CLASS:
10, for other magazine feeds.
- SEE OR SEARCH CLASS:
110, Furnaces, subclasses 255+ for a refuse incinerator provided with feeding means; and subclasses 267+ for a furnace provided with fuel feeding means.
- 74 Reversible draft, base-heating:**
This subclass is indented under subclass 73. Devices that are provided with a direct or indirect course to the outlet-flue. When an indirect course is employed, it heats the base of the stove.
- SEE OR SEARCH THIS CLASS, SUB-CLASS:
69, and 75, for other reversible draft features.
- 75 Reversible draft, base-heating:**
This subclass is indented under subclass 58. Heating stoves having means to give a direct or an indirect course to the products of combustion. The indirect course causes the heating of the base.
- SEE OR SEARCH THIS CLASS, SUB-CLASS:
69, and 74, for other reversible-draft features.
- 76 Downdraft:**
This subclass is indented under subclass 58. Heating stoves in which the draft is downward through the fuel.
- 77 Feeding air:**
This subclass is indented under subclass 58. Heating stoves having means for heating and introducing air to the zone of combustion.
- SEE OR SEARCH THIS CLASS, SUB-CLASS:
15, for air feeding cooking stoves.
112, for air feeding means for hot air furnaces.
146, for firepots provided with air feeding means.
163, for grates having air feeding features.
193, for stove doors and windows having air feeding provisions.
- SEE OR SEARCH CLASS:
110, Furnaces, subclass 201 for a locomotive furnace provided with an air preheater; subclass 254 for an incinerator provided with an air preheater; and subclasses 302+ for other types of solid fuel furnaces provided with air preheaters.

- 78 Feeding steam:**
This subclass is indented under subclass 58. Heating stoves having steam feeding devices that are specially applicable and structurally related to such stoves.
- SEE OR SEARCH CLASS:
110, Furnaces, appropriate subclasses for steam and air feeding devices.
- 79 Smoke and gas returning:**
This subclass is indented under subclass 58. Heating-stoves that are provided with means for returning the gases or products of combustion from the smoke-outlet to the combustion-chamber of the stove.
- SEE OR SEARCH CLASS:
110, Furnaces, particularly subclasses 203+ for furnaces having similar means.
362, Illumination, subclasses 171+ for lanterns in which a portion of the products of combustion is led back to the flame.
- 80 Ventilating attachments:**
This subclass is indented under subclass 58. Heating-stoves that are provided with special ventilating attachments or features.
- SEE OR SEARCH THIS CLASS, SUB-CLASS:
21, 84, 198, 293, and 316, for stoves having ventilating features.
- SEE OR SEARCH CLASS:
454, Ventilation, particularly subclasses 1+ for other ventilating means associated with heaters.
- 81 Stove plates:**
This subclass is indented under subclass 58. Heating-stoves having ornamental and name plates; and means employed for attaching them to the outer surfaces of stove-bodies.
- 82 Adjustable pipe collar:**
This subclass is indented under subclass 58. Heating-stoves having a back plate carrying the pipe-collar, and capable of variable adjustments relative to the flue-opening.
- SEE OR SEARCH THIS CLASS, SUB-CLASS:
315, for adjustable flue collars.
- 83 Deflector plate:**
This subclass is indented under subclass 58. Heating-stoves having retarding plates so formed and arranged as to give the products of combustion a circuitous course to the exit flue.
- 84 Combined heating and ventilating:**
This subclass is indented under the unnumbered subclass, Liquid or gaseous fuel. Heating-stoves of the liquid and gaseous fuel type that are structurally adapted to both heat and ventilate the room in which they are located.
- SEE OR SEARCH THIS CLASS, SUB-CLASS:
80, 94 and 97, for related subject matter.
- 85 Gas:**
This subclass is indented under the unnumbered subclass, Liquid or gaseous fuel. Heating-stoves of the gaseous fuel type that do not fall under more specific subclasses.
- 86 Open front:**
This subclass is indented under subclass 85. Devices of the open-front type that are adapted for the burning of gaseous fuel.
- SEE OR SEARCH THIS CLASS, SUB-CLASS:
97, and 512, for related subject matter.
- 87 Asbestos fireback:**
This subclass is indented under subclass 86. Devices where the back plate or wall is provided with asbestos fiber and adapted to be heated to incandescence.
- SEE OR SEARCH THIS CLASS, SUB-CLASS:
400, for heat accumulator structures.
- 88 Hot air:**
This subclass is indented under subclass 87. Devices that are provided with specific air heating features.

- SEE OR SEARCH THIS CLASS, SUB-CLASS:
512, for asbestos fire-backs of the liquid or gaseous type for fireplaces.
- 89 Hot air:**
This subclass is indented under subclass 86. Devices that are provided with specific air heating features.
- 90 Hot air:**
This subclass is indented under subclass 85. Devices that are provided with various forms of air heating means.
- 91 Radiator type:**
This subclass is indented under subclass 85. Devices that have the structural form of tubular radiators.
- SEE OR SEARCH CLASS:
219, Electric Heating, subclasses 375 through 378 for electrically heated radiators.
- 92 Incandescent fire grate:**
This subclass is indented under subclass 85. Devices that are adapted to receive or hold substances which are heated to incandescence by gas or similar burners. These devices are usually employed in fireplaces or in open-front heaters.
- SEE OR SEARCH THIS CLASS, SUB-CLASS:
86+, for related subject matter.
- SEE OR SEARCH CLASS:
431, Combustion, subclasses 326+ for a radiant surface burner and subclasses 347+ for a burner having an incandescing or reflecting component.
- 93 Liquid:**
This subclass is indented under the unnumbered subclass, Liquid or gaseous fuel. Heating stoves that are structurally adapted for the burning of liquid fuel.
- 94 Flue-connected:**
This subclass is indented under subclass 93. Devices that are provided with means for connecting them with chimney or flue openings.
- SEE OR SEARCH THIS CLASS, SUB-CLASS:
84, for liquid and gaseous fuel heating stoves having heating and ventilating provisions.
- 95 Vapor:**
This subclass is indented under subclass 93. Devices that are provided with liquid-fuel retort vapor-burners.
- 96 Wick:**
This subclass is indented under subclass 93. Devices that are of the wick type and those that are provided with specific air heating features. These devices are usually termed "lamp-stoves".
- 97 Heating and illuminating:**
This subclass is indented under subclass 96. Devices in which the stove proper is provided with an open front and adapted to receive an illuminating-lamp as the heater.
- SEE OR SEARCH THIS CLASS, SUB-CLASS:
86+, 294 and 512, for detail stove features.
248, for drum features.
- 98 Joints:**
This subclass is indented under subclass 58. Heating-stoves comprising the structural features of stove joints.
- SEE OR SEARCH THIS CLASS, SUB-CLASS:
64, and 119, for similar structures.
- 99 HOT-AIR FURNACES:**
This subclass is indented under the class definition. Subject matter relating to furnaces which heat air in an inclosing case or jacket to be distributed to points remote from the furnace.
- SEE OR SEARCH THIS CLASS, SUB-CLASS:
6, for combined cooking and hot air stoves.
67+, for hot air stoves.
500+, for hot air fireplaces.

- SEE OR SEARCH CLASS:
432, Heating, subclasses 222+ for means heating air by mixing it with combustion products, and subclass 219 for a residual apparatus for heating a gaseous or liquid material.
- 100 Combined with cooking stove:**
This subclass is indented under subclass 99. Hot air furnaces that are provided with cooking-stove or oven attachments.
- 101 Combined with boiler:**
This subclass is indented under subclass 99. Hot air furnaces combined with steam, or water heaters, generally known in the art as "hot-air furnaces, steam".
- 102 Circular radiating drum:**
This subclass is indented under subclass 99. Hot air furnaces in which the radiating drum encircles the fire-pot or combustion-chamber.
- 103 Downdraft:**
This subclass is indented under subclass 99. Hot air furnaces in which the products of combustion are caused to pass in a downward direction through the fuel.
- 104 Horizontal combustion chamber:**
This subclass is indented under subclass 99. Hot air furnaces which are provided with horizontal or elongated fire-boxes or combustion-chambers.
- SEE OR SEARCH THIS CLASS, SUB-CLASS:
60, 61 and 108, for related subject matter.
- 105 Hot-air equalizers:**
This subclass is indented under subclass 99. Hot air furnaces having devices for equally distributing heated air to the several apartments of a building.
- 106 Internal air chamber:**
This subclass is indented under subclass 99. Hot air furnaces in which an air heating chamber is centrally situated as respects the combustion-chamber and provided with passages which connect the chamber with the space formed by the inclosing case or jacket.
- SEE OR SEARCH THIS CLASS, SUB-CLASS:
70, 71 and 109, for air heating structures.
- 107 Magazine:**
This subclass is indented under subclass 99. Hot air furnaces that are provided with magazines or self-feeders.
- SEE OR SEARCH THIS CLASS, SUB-CLASS:
10, for other magazine feeds.
- SEE OR SEARCH CLASS:
110, Furnaces, subclasses 255+ for an incinerator provided with feed means; and subclasses 267+ for other solid fuel furnaces provided with feed means.
- 108 Secondary heating chamber horizontally arranged:**
This subclass is indented under subclass 99. Hot air furnaces in which the radiating devices are located at the rear of the furnace proper and within the air-casing.
- SEE OR SEARCH THIS CLASS, SUB-CLASS:
104, for related subject matter.
- 109 Tubular air heater:**
This subclass is indented under subclass 99. Hot air furnaces which have air-tubes passed vertically, horizontally, or diagonally through the combustion-chamber and which communicate with the space formed by the inclosing case or jacket.
- SEE OR SEARCH THIS CLASS, SUB-CLASS:
71, 72 and 106, for similar air heating arrangements.
- SEE OR SEARCH CLASS:
454, Ventilation, appropriate subclasses for building ventilation, per se.
- 110 Compressed air:**
This subclass is indented under subclass 99. Hot air furnaces for heating air under compression, as distinguished from devices for compressing the air to heat it.

- 111 Double fire pot:**
This subclass is indented under subclass 99. Hot air furnaces that are provided with two or more firepots and structural features by which the firepots are capable of separate or joint use.
- SEE OR SEARCH THIS CLASS, SUB-CLASS:
2, for double fire-pot cooking stoves.
- SEE OR SEARCH CLASS:
110, Furnaces, subclasses 208+ for multiple firebox furnaces provided with exhaust gas treatment means; and subclasses 295+ for other types of multiple firebox solid fuel furnaces.
- 112 Feeding air:**
This subclass is indented under subclass 99. Hot air furnaces having devices formed and arranged for heating and introducing air into the combustion-chamber.
- SEE OR SEARCH THIS CLASS, SUB-CLASS:
15, 77, 78, 146, and 193, for related subject matter.
- SEE OR SEARCH CLASS:
110, Furnaces, subclass 201 for a locomotive type furnace provided with an air preheater; subclass 254 for an incinerator provided with an air preheater; and subclasses 302+ for other types of solid fuel furnaces provided with air preheaters.
- 113 Air moisteners:**
This subclass is indented under subclass 99. Hot air furnaces having a water pan so formed and arranged as to produce vapor which moistens the air heated by the furnace.
- 114 Casings:**
This subclass is indented under subclass 99. Hot air furnaces having an inclosing furnace-casing.
- SEE OR SEARCH THIS CLASS, SUB-CLASS:
117, for preliminary air heating devices.
- 115 Dust flue:**
This subclass is indented under subclass 99. Hot air furnaces provided with means for conveying the dust resultant from raking the fire to the smoke-pipe or fire-pot.
- 116 Liquid or gaseous fuel:**
This subclass is indented under subclass 99. Hot-air furnaces in which the heating agent is either a liquid or gaseous fuel burner or combined coal and liquid or gaseous fuel burner. Also included here are attachments independent of the main furnace, but connected thereto, and floor-register attachments.
- SEE OR SEARCH CLASS:
454, Ventilation, subclasses 284+ for register features.
- 117 Preliminary air heater:**
This subclass is indented under subclass 99. Hot air furnaces having devices for heating the air before it is conveyed to the space formed by the surrounding jacket or casing of a furnace.
- SEE OR SEARCH THIS CLASS, SUB-CLASS:
114, for hot air furnace casings.
- 118 Radiating flanges:**
This subclass is indented under subclass 99. Hot air furnaces having flanges or pins which are attached to furnace sections and drums for increasing their radiating-surfaces.
- 119 Joints:**
This subclass is indented under subclass 99. Hot air furnaces comprising the structure of the joints of the furnace or casing.
- SEE OR SEARCH THIS CLASS, SUB-CLASS:
64, and 98, for joints in heating stoves.
- 144 FIRE POTS AND LININGS:**
This subclass is indented under the class definition. Subject matter relating to firepots and linings.
- SEE OR SEARCH THIS CLASS, SUB-CLASS:
152+, for grates.

- SEE OR SEARCH CLASS:
110, Furnaces, subclasses 317+ for solid fuel furnace firebox structure.
- 145 Adjustable:**
This subclass is indented under subclass 144. Subject matter adapted to be adjusted so as to fit stoves of various sizes; includes linings that are provided with breakable grooves.
- 146 Feeding air:**
This subclass is indented under subclass 144. Subject matter provided with air-feeding means.
- SEE OR SEARCH THIS CLASS, SUB-CLASS:
15, 77 and 112, for similar air feeding means.
- 147 Divided:**
This subclass is indented under subclass 144. Subject matter that is provided with means to divide them or adjust the fuel capacity of the fire-pot.
- SEE OR SEARCH THIS CLASS, SUB-CLASS:
25+, for summer cooking stoves.
154, for vertically adjustable grates.
- 148 Fire plate:**
This subclass is indented under subclass 144. Subject matter that is provided with plates to limit or confine the fuel-space, and thereby regulate the combustion.
- 149 Horizontal axis:**
This subclass is indented under the unnumbered subclass, Rotary. Subject matter relating to fire boxes adapted to inclose the fuel, whereby the fire box can be given a complete rotation on a horizontal axis.
- SEE OR SEARCH THIS CLASS, SUB-CLASS:
181, for horizontal axis rotary grates.
- 150 Vertical axis:**
This subclass is indented under the unnumbered subclass, Rotary. Subject matter relating to firepots that are provided with means for imparting to the fire-pot a complete rotation on a vertical axis.
- SEE OR SEARCH THIS CLASS, SUB-CLASS:
170, for vertical axis oscillatory grates.
- 151 Sectional:**
This subclass is indented under subclass 144. Subject matter composed of sections.
- SEE OR SEARCH THIS CLASS, SUB-CLASS:
145, for adjustable firepots.
- 152 GRATES:**
This subclass is indented under the class definition. Subject matter relating to furnace, stove and range grates that do not fall under more specific subclasses, and not specifically classified in other classes. Includes all grate structures, per se, that are of general application to furnaces and stoves.
- (1) Note. For grates that are adapted to specific application of the heat of combustion, search should be made in the class including such applications.
- SEE OR SEARCH CLASS:
110, Furnaces, subclasses 267+ for progressive feed grates, and subclass 298 for hollow air-cooled grates.
122, Liquid Heaters and Vaporizers, subclasses 371+, and the subclasses referred to in the notes thereunder, for water grates.
241, Solid Material Comminution or Disintegration, appropriate subclasses, especially subclasses 198.1+, for similar structures functioning as comminutors but which have no burning charge or fuel supporting function.
- 153 Adjustable:**
This subclass is indented under subclass 152. Devices adapted to fit different-sized firepots.
- SEE OR SEARCH THIS CLASS, SUB-CLASS:
144, for fire pots and linings.

- SEE OR SEARCH CLASS:
110, Furnaces, subclass 320 for adjustable fire box furnace structure.
- 154 Vertically:**
This subclass is indented under subclass 153. Devices adapted to vertical adjustment.
- SEE OR SEARCH THIS CLASS, SUB-CLASS:
159, for pocket agitating grates.
- 155 Agitating:**
This subclass is indented under subclass 152. Devices adapted to be shaken or agitated for the clearance of ashes.
- 156 Alternate ends:**
This subclass is indented under subclass 155. Devices that are provided with means for imparting vibrating or rocking motion in opposite directions to adjacent grate-bars.
- 157 Alternate bar:**
This subclass is indented under subclass 155. Devices that are constructed with alternate immovable and movable grate-bars and means for imparting vertical motion to the alternate movable bars.
- SEE OR SEARCH THIS CLASS, SUB-CLASS:
173, for raking attachments.
- 158 Dumping:**
This subclass is indented under subclass 155. Devices that are provided with dumping means or sections.
- SEE OR SEARCH THIS CLASS, SUB-CLASS:
162, for other dumping grates.
- 159 Pocket:**
This subclass is indented under subclass 155. Devices that are provided with means for giving a varying depth to the fuel over the grate-surface. The means employed are usually pockets or depressions in the grate surface.
- SEE OR SEARCH THIS CLASS, SUB-CLASS:
154, for vertically adjustable grates.
- 160 Closures:**
This subclass is indented under subclass 152. Devices provided with means for regulating the grate-openings, whereby the draft may be full, reduced, or closed.
- 161 Cut-off:**
This subclass is indented under subclass 152. Devices provided with means closely related to the grate structure for retaining a portion of the fuel in the fire-pot, thus permitting the removal of the bottom portion or ash.
- SEE OR SEARCH CLASS:
110, Furnaces, subclasses 117 and 118 for similar furnace fuel feeders.
- 162 Dumping:**
This subclass is indented under subclass 152. Devices that are provided with special dumping means.
- SEE OR SEARCH CLASS:
110, Furnaces, subclasses 268 through 285 for a furnace provided with a movable grate.
- 163 Feeding air:**
This subclass is indented under subclass 152. Devices provided with air feeding features.
- SEE OR SEARCH CLASS:
110, Furnaces, subclasses 182, 270+ and 288 for similar furnace air feeding structure.
- 166 Fuel cut-off:**
This subclass is indented under subclass 152. Devices that are designed to be passed through or inserted in the fuel above the grate in order to sustain the main body of the fuel, and thus permit the removal of ashes and cinders. These devices are independent of the fuel-support or grate.
- SEE OR SEARCH THIS CLASS, SUB-CLASS:
161, for cut off grates.

- 167 Grate bar:**
This subclass is indented under subclass 152. Subject matter relating to the form of the bar. These bars are known as stationary or immovable.
- SEE OR SEARCH THIS CLASS, SUBCLASS:
179, for this structure in a rocking bar grate.
- 168 Removable fuel support:**
This subclass is indented under subclass 167. Devices that are provided with removable fuel-supporting devices.
- 169 Operating mechanism:**
This subclass is indented under subclass 152. Devices designed for the operation or moving of the grates and grate-bar structures in general.
- SEE OR SEARCH CLASS:
110, Furnaces, subclasses 268 through 285 for a furnace provided with a movable grate; and subclasses 328-330 for movable grate structure, per se.
- 170 Vertical axis:**
This subclass is indented under the unnumbered subclass, OSCILLATORY. Devices arranged horizontally on a vertical axis and adapted to be given a to-and-fro motion. These structures are sometimes termed "rotary".
- 171 Dumping section:**
This subclass is indented under subclass 170. Devices that are provided with a pivoted dumping section or sections.
- 172 Sliding section:**
This subclass is indented under subclass 170. Devices that are provided with a sliding ash-discharge section.
- 173 Raking attachments:**
This subclass is indented under subclass 152. Subject matter relating to attachments to grates designed to rake and free the grate from ashes and clinkers. As a rule these devices are inseparable from the grate structure.
- SEE OR SEARCH CLASS:
48, Gas: Heating and Illuminating, subclass 85.2 for cupola gas generators with fuel stirrers.
110, Furnaces, subclass 285 for a solid fuel furnace provided with a raking grate.
- 174 Reciprocating:**
This subclass is indented under subclass 152. Devices designed to be given a horizontal to-and-fro end movement, as distinguished from the oscillatory or rotary type.
- SEE OR SEARCH CLASS:
110, Furnaces, subclasses 281+ for solid fuel furnaces provided with reciprocating grates; and subclass 328 for movable grate structure, per se.
- 175 Alternate bar:**
This subclass is indented under subclass 174. Devices where the alternate bars are given an opposite to-and-fro end movement or where the bars are moved in reverse horizontal direction.
- 176 Rocking bar:**
This subclass is indented under subclass 152. Devices in which the grates and grate bars are horizontally-pivoted and are provided with means for giving them a to-and-fro or rocking motion, but not adapted to be given a complete rotation or revolution.
- SEE OR SEARCH CLASS:
110, Furnaces, subclass 278 for a solid fuel furnace provided with a rocking grate; and subclass 328 for movable grate structure, per se.
- 177 Dumping:**
This subclass is indented under subclass 176. Devices that are provided with dumping means or dumping-sections.
- 178 Duplex:**
This subclass is indented under subclass 176. Devices where different fuel-supporting faces may be employed; includes grates designed for the burning of coal or wood combining coal and wood bearing faces.

SEE OR SEARCH THIS CLASS, SUB-CLASS:

181, for horizontal axis rotary grates.

179 Grate bar:

This subclass is indented under subclass 176. Subject matter relating to the form or character of the rocking bar.

SEE OR SEARCH THIS CLASS, SUB-CLASS:

167+, for other grate bars.

SEE OR SEARCH CLASS:

110, Furnaces, subclass 278 for a solid fuel furnace provided with a rocking grate; and subclass 328 for movable grate structure, per se.

180 Removing fuel support:

This subclass is indented under subclass 179. Devices provided with removable fuel-bearing faces.

181 Horizontal axis:

This subclass is indented under the unnumbered subclass, Rotary. Devices that are horizontally pivoted and are structurally adapted to be given a complete rotary motion; also, means for imparting this motion.

SEE OR SEARCH THIS CLASS, SUB-CLASS:

176, for rocking bar grates.

SEE OR SEARCH CLASS:

110, Furnaces, subclass 226 for an incinerator provided with preliminary refuse dryer in the form of a rotary drum; subclass 246 for an incinerator in the form of a rotary drum; and subclass 276 for a solid fuel furnace provided with a horizontal rotary grate.

182 Vertical axis:

This subclass is indented under the unnumbered subclass, Rotary. Devices that are horizontally arranged, mounted upon a vertical pivot, and means for imparting to the grate a full and complete revolution upon its axis or pivot.

SEE OR SEARCH THIS CLASS, SUB-CLASS:

150, for vertical axis rotary fire pots and linings.

170+, for vertical axis oscillatory grates.

SEE OR SEARCH CLASS:

110, Furnaces, subclass 247 for an incinerator in the form of a vertical axially mounted rotary grate; and subclasses 275 and 277 for a solid fuel furnace provided with a vertically mounted rotary grate.

190 STOVE DOORS AND WINDOWS:

This subclass is indented under the class definition. Subject matter relating to stove doors and windows applicable to heating and cooking stoves.

SEE OR SEARCH CLASS:

49, Movable or Removable Closures, appropriate subclasses for closures of the type provided for and see the search notes thereto in section IV of Class 49 for the loci of closures in other classes.

110, Furnaces, subclasses 173+ for furnace doors.

374, Thermal Measuring and Testing, subclass 149 for stove doors or windows combined with and modified to receive thermometers, and wherein no more of the door or window is claimed than is necessary to provide a locus or support for the thermometer.

191 Balanced:

This subclass is indented under subclass 190. Devices that are provided with weights or springs designed to aid in opening or closing the door; also, to prevent the sudden closing of the door.

192 Door-operator:

This subclass is indented under subclass 190. Devices provided with door opening or closing devices. Devices known in the art as "kicker-latches".

- SEE OR SEARCH CLASS:
49, Movable or Removable Closures, subclasses 324+ for other closure operators.
- 193 Feeding air:**
This subclass is indented under subclass 190. Devices designed to admit a current of air into the combustion chamber above the fuel-level. In some instances the object sought is to prevent the blackening of the transparent door-panel.
- SEE OR SEARCH THIS CLASS, SUB-CLASS:
163, for air feeding grates.
- 194 Hinges:**
This subclass is indented under subclass 190. Subject matter relating to hinges that are peculiarly applicable to domestic stoves and furnaces.
- SEE OR SEARCH CLASS:
16, Miscellaneous Hardware (e.g., Bushing, Carpet Fastener, Caster, Door Closer, Panel Hanger, Attachable or Adjunct Handle, Hinge, Window Sash Balance, etc.), subclasses 221 through 392 for other hinges.
- 197 Combined latch and operator:**
This subclass is indented under the unnumbered subclass, Latches. Subject matter, including a latch and an operator.
- 198 Oven doors, ventilating:**
This subclass is indented under subclass 190. Devices comprising oven-doors provided with means for ingress and egress of air.
- SEE OR SEARCH THIS CLASS, SUB-CLASS:
193, for feeding air features in other doors.
- 200 Transparent panel:**
This subclass is indented under subclass 190. Devices that have a glass or mica panel therein.
- (1) Note. This subclass does not include illuminating devices in bakers' ovens and similar devices, or what is known in the art as "peep-holes".
- SEE OR SEARCH THIS CLASS, SUB-CLASS:
193, for feeding air-doors. 213, for illuminating stove tops.
- SEE OR SEARCH CLASS:
99, Foods and Beverages: Apparatus, subclass 341 for food cooking apparatus combined with observation means.
220, Receptacles, subclasses 662 through 665, and see the notes thereto, for structures wherein a transparent panel is mounted in a wall.
362, Illumination, subclasses 92+ for oven illuminating means.
- 201 FENDERS:**
This subclass is indented under the class definition. Subject matter relating to guards and protectors. Includes stove foot rails or guards.
- SEE OR SEARCH THIS CLASS, SUB-CLASS:
298, for fire dogs.
- 204 BODY WARMERS:**
This subclass is indented under the class definition. Subject matter relating to body, hand and foot warmers.
- SEE OR SEARCH THIS CLASS, SUB-CLASS:
263.01+, for chemical or lime heaters.
- SEE OR SEARCH CLASS:
36, Boots, Shoes, and Leggings, subclass 2.6 for boots, or shoes having heating means designed to warm the foot.
165, Heat Exchange, subclass 46 for a flexible envelope or cover type of heat exchanger.
215, Bottles and Jars, appropriate subclasses, for receptacles of glass, ceramic or similar material for retaining and heating or cooling medium.
219, Electric Heating, subclass 211 for electrically heated devices for applying heat to the body.
220, Receptacles, subclass 577 for a rigid heat transfer container.
383, Flexible Bags, subclass 901 for bags of flexible materials known in the art as hot-water and ice bags.

- 205 Bed heaters:**
This subclass is indented under subclass 204. Body warmers adapted for heating beds, and analogous devices.
- SEE OR SEARCH CLASS:
4, Baths, Closets, Sinks, and Spittoons, subclasses 529+ for vapor and hot air baths which accommodate the user in a recumbent position.
5, Beds, subclass 284 for bedsteads with heating or cooling means, subclasses 421+ for heating means, and subclass 422 for heating a waterbed mattress.
- 206 Composition fuel:**
This subclass is indented under subclass 204. Body warmers structurally adapted to burn composition fuel, notably what is known in the art as "Japanese punk".
- 207 Heated block:**
This subclass is indented under subclass 204. Body warmers structurally adapted to be heated by a hot blank, such as iron, soapstone, and similar substances.
- SEE OR SEARCH THIS CLASS, SUB-CLASS:
246, for dish heaters.
400, for heat accumulator blocks, per se.
- 208 Liquid or gaseous fuel:**
This subclass is indented under subclass 204. Body warmers structurally adapted for the burning of liquid or gaseous fuel.
- SEE OR SEARCH CLASS:
122, Liquid Heaters and Vaporizers, subclass 26 for friction generators.
- 209 Combined heater and lantern:**
This subclass is indented under subclass 208. Devices adapted to be employed both as heater and lantern.
- (1) Note. This is a combined subclass, and the detail features of both heater and lantern should be searched for in appropriate classes and subclasses.
- SEE OR SEARCH THIS CLASS, SUB-CLASS:
267, for combined lunch bucket and lantern burning liquid or gaseous fuel.
- 210 Water heater:**
This subclass is indented under subclass 208. Devices that are structurally related to or are combined with water heating devices.
- SEE OR SEARCH CLASS:
237, Heating Systems, subclass 12.3 for vehicle heating systems.
- 211 STOVE LIDS AND TOPS:**
This subclass is indented under the class definition. Subject matter relating to improvements on the top plate of stoves.
- SEE OR SEARCH THIS CLASS, SUB-CLASS:
227, and 230, for flatiron heaters.
338, for a rotary oven, shelf or rack.
- SEE OR SEARCH CLASS:
219, Electric Heating, subclasses 452.11+ for an exposed planar support surface for material to be heated (e.g., hot plate, etc.) for a particular frame, casing or housing for a heating unit (e.g., range top, stove top, countertop, etc.).
- 212 Centers or cross pieces:**
This subclass is indented under subclass 211. Subject matter relating to improvements on stove centers or cross-pieces, generally employed in cooking-stoves.
- 213 Illuminating:**
This subclass is indented under subclass 211. Subject matter relating to illuminating and heat-reflecting devices placed on or secured to the top portion of a stove.
- SEE OR SEARCH THIS CLASS, SUB-CLASS:
200, for stove doors with a transparent panel.
- 214 Liquid or gaseous fuel:**
This subclass is indented under subclass 211. Subject matter which are peculiarly adapted to the burning of liquid or gaseous fuel.

- 215 Elevating support:**
This subclass is indented under subclass 214. Devices designed to be placed on the stove top for supporting the ordinary kitchen utensil or article spaced from the top.
- SEE OR SEARCH THIS CLASS, SUB-CLASS:
50, for other utensil supports.
- 216 Extension top:**
This subclass is indented under subclass 214. Subject matter in which the tops are designed to have an enlarged working surface. In most instances they are adapted to utilize the heat from a single burner.
- SEE OR SEARCH THIS CLASS, SUB-CLASS:
46, for extension tops on liquid fuel wick-type cooking stoves.
- 217 Heating stove:**
This subclass is indented under subclass 211. Subject matter relating to heating stoves. As a rule they relate to the means for opening or closing the magazine feed-opening.
- SEE OR SEARCH THIS CLASS, SUB-CLASS:
335, for door operated drop shelves for stoves.
- 218 Cooking attachments:**
This subclass is indented under subclass 217. Heating-stove tops that are provided with means to adapt them to be employed in cooking.
- 219 Ornaments and urns:**
This subclass is indented under subclass 217. Subject matter pertaining to top ornaments and urns.
- 220 Lids:**
This subclass is indented under subclass 211. Subject matter relating to improvements in the lids.
- SEE OR SEARCH THIS CLASS, SUB-CLASS:
227+, and 230, for attachments for heating flatirons.
- 221 Stove mats:**
This subclass is indented under subclass 211. Subject matter relating to mats designed to be placed upon the stove-top, usually formed of asbestos and metal, or asbestos having metal-bound edges.
- 222 Cooking stoves:**
This subclass is indented under the unnumbered subclass, TRASH BURNERS. Subject matter relating to cooking-stoves adapted for the burning of straw, hay, sawdust, and similar material as fuel.
- SEE OR SEARCH CLASS:
110, Furnaces, subclasses 196 and 197 for furnaces employing straw as a fuel, and fuel feeders therefor.
- 223 Feeding attachments:**
This subclass is indented under subclass 222. Subject matter relating to the fuel feeding attachments, usually of magazine form.
- SEE OR SEARCH THIS CLASS, SUB-CLASS:
11, for portable coal magazines for cooking stoves.
- 224 Domestic-refuse burners:**
This subclass is indented under the unnumbered subclass, TRASH BURNERS. Subject matter relating to refuse or "garbage" burner attachments structurally related to the cooking or heating stove art.
- SEE OR SEARCH THIS CLASS, SUB-CLASS:
11, for portable magazines for cooking stoves.
- SEE OR SEARCH CLASS:
110, Furnaces, subclasses 235+ for a refuse incinerator not structurally related to cooking or heating stoves.
- 225 Heating stoves:**
This subclass is indented under the unnumbered subclass, TRASH BURNERS. Subject matter relating to heating-stoves structurally adapted for the burning of hay, straw, sawdust and similar material.

- SEE OR SEARCH CLASS:
110, Furnaces, subclasses 196 and 197 for furnaces employing straw as a fuel, and fuel feeders therefor.
- 226 TOOL HEATERS:**
This subclass is indented under the class definition. Subject matter designed for the heating of various types of tools.
- 227 Flatiron:**
This subclass is indented under subclass 226. Subject matter specially designed for the heating of flatirons or "sadirons".
- SEE OR SEARCH THIS CLASS, SUBCLASS:
25, for portable cooking stoves.
- SEE OR SEARCH CLASS:
38, Textiles: Ironing or Smoothing, subclasses 74+ for sadirons and flatirons.
- 228 Attachments:**
This subclass is indented under subclass 227. Devices relating to portable or independent heating devices structurally designed to be employed in connection with stove structures.
- SEE OR SEARCH THIS CLASS, SUBCLASS:
211+, for stove lids and tops.
505, for shelves adapted to fireplace grates.
540+, for fireplace grates.
- 229 Liquid or gaseous fuel:**
This subclass is indented under subclass 226. Devices adapted to the burning of gaseous or liquid fuel.
- 230 Flatiron:**
This subclass is indented under subclass 229. Devices specially designed for the heating of flatirons or "sadirons".
- SEE OR SEARCH THIS CLASS, SUBCLASS:
227, for other flatiron heaters.
- 231 Gas burner attachments:**
This subclass is indented under subclass 229. Devices designed to be attached to gas-brackets. This subclass includes mainly curling iron heaters.
- SEE OR SEARCH THIS CLASS, SUBCLASS:
235, for tool heating devices adapted to be attached to lamps.
- 232 Combined lighting and heating:**
This subclass is indented under subclass 231. Devices in which the heating-burner is supplied with gas through the medium of a bypass without affecting the operation of the lighting burner. As a rule one may be employed to the exclusion of the other, or both at one and the same time.
- SEE OR SEARCH THIS CLASS, SUBCLASS:
254, for heating and lighting burners used in connection with a gas bracket attachment.
- SEE OR SEARCH CLASS:
239, Fluid Sprinkling, Spraying, and Diffusing, subclasses 390+ for a fluid distributor having plural interchangeable discharge modifiers, outlet arrangements or coupling means, and subclasses 436+ for a fluid distributor having selectively usable or variable diverse terminal outlets, even though the distributor may be disclosed as a burner.
- 233 Jet mixer:**
This subclass is indented under subclass 231. Devices provided with specific gas and air mixing means whereby the illuminating-flame is converted into a heating-flame.
- 234 Tool-controlled valve:**
This subclass is indented under subclass 231. Devices provided with tool controlled valve mechanism.
- SEE OR SEARCH THIS CLASS, SUBCLASS:
52, for article controlled valve mechanism.

- 238, for soldering iron controlled valve mechanism.
- 235 Lamp attachments:**
This subclass is indented under subclass 229. Devices designed to be attached to lamps, but mainly the lamp chimney. In this subclass will be found curling iron heaters.
- SEE OR SEARCH THIS CLASS, SUB-CLASS:
231, for gas burner attachments.
- 236 Soldering iron:**
This subclass is indented under subclass 226. Devices that are portable in character and provided with special means for retaining a soldering iron in the furnace.
- SEE OR SEARCH THIS CLASS, SUB-CLASS:
25, for portable cooking stoves.
- 237 Gas heaters:**
This subclass is indented under subclass 236. Devices heated by gaseous fuel.
- 238 Tool-controlled valve:**
This subclass is indented under subclass 237. Devices provided with special forms of automatic gas supply and cut-off devices.
- SEE OR SEARCH THIS CLASS, SUB-CLASS:
52, for article controlled valve mechanism.
234, for other tool controlled valve mechanism.
- 239 Liquid fuel:**
This subclass is indented under subclass 236. Devices heated by liquid fuel.
- 240 Combined heater and solder pot:**
This subclass is indented under subclass 239. Devices designed for the combined heating of soldering irons and the melting or solder pot.
- 241 Lamp:**
This subclass is indented under subclass 239. Devices in which the heating means employed is a lamp.
- 242 ASH DISCHARGE AND COLLECTING:**
This subclass is indented under the class definition. Subject matter designed for the handy removal and collection of ashes from domestic stoves and furnaces. In most instances the devices have direct connection with the stove ash-pit and are in the form of chutes leading to receptacles and provided with gravity-traps. The chutes may also be provided with screens for separating the cinders from the ashes. Includes also receptacles and ash-pit-attaching means and means for removing ashes from the pit into the receptacle.
- SEE OR SEARCH CLASS:
110, Furnaces, subclasses 165+ for ash receiving and handling devices of that class.
193, Conveyors, Chutes, Skids, Guides, and Ways, subclass 34 for vertical wall chutes.
209, Classifying, Separating, and Assorting Solids, subclasses 233+ for sifters.
220, Receptacles, appropriate subclasses for containers of more general utility.
- 243 Ash pans:**
This subclass is indented under subclass 242. Devices employed in stove or furnace ashpits.
- SEE OR SEARCH CLASS:
110, Furnaces, subclass 166 for other ash-pans.
- 244 Sifting:**
This subclass is indented under subclass 243. Devices provided with sifting means.
- SEE OR SEARCH CLASS:
209, Classifying, Separating, and Assorting Solids, particularly subclasses 376 and 377 for other sifters.
- 245 Combined stove and ash pan:**
This subclass is indented under subclass 242. Devices that include some special feature of stove structure which cooperates with the pan to produce the intended result.

- 246 Dish:**
This subclass is indented under the unnumbered subclass, HEATERS. Heaters for warming dishes or other articles or for keeping warm food-containing vessels after removal from the stove and in which a heat-retaining substance, either liquid or solid, adapted to be preheated is employed.
- SEE OR SEARCH THIS CLASS, SUBCLASS:
33, for steam tables.
207, for block heated body warmers.
262, for combined lunch can and heater.
400, for heat accumulator blocks, per se.
- 247 Frictional:**
This subclass is indented under the unnumbered subclass, HEATERS. Heaters designed to generate heat by friction.
- 248 Drum:**
This subclass is indented under the unnumbered subclass, Attachments. Subject matter relating to drum attachments adapted for use with heating or illuminating burners.
- SEE OR SEARCH THIS CLASS, SUBCLASS:
97, for heating and illuminating liquid fuel stoves.
- 249 Gas jet:**
This subclass is indented under the unnumbered subclass, Attachments. Subject matter relating to attachments in the form of brackets or supports not directly supported by a gas-bracket designed to sustain articles over a flame.
- SEE OR SEARCH CLASS:
248, Supports, appropriate subclasses for mere supports and brackets not limited by structure to use in supporting articles over a flame, even though disclosed as for supporting an article over a flame.
362, Illumination, subclasses 453+ for combined socket attached shade and bowl supports.
- 250 Air:**
This subclass is indented under subclass 249. Devices relating to air heating attachments adapted for use with the ordinary house gas-bracket.
- SEE OR SEARCH THIS CLASS, SUBCLASS:
248, for drum attachments.
- 251 Jet mixer:**
This subclass is indented under subclass 250. Devices provided with means for mixing gas and air in advance of the flame-point.
- 252 Article support:**
This subclass is indented under subclass 249. Devices directly attached or connected to the ordinary gas-bracket.
- 253 Jet mixer:**
This subclass is indented under subclass 252. Devices provided with means for mixing gas and air in advance of the flame-point.
- SEE OR SEARCH THIS CLASS, SUBCLASS:
233, and 251, for other jet mixers.
- 254 Combined:**
This subclass is indented under subclass 249. Devices relating to combined heating or lighting burners which are so related that they can be used jointly or separately.
- SEE OR SEARCH THIS CLASS, SUBCLASS:
232, for other combined lighting and heating.
- SEE OR SEARCH CLASS:
239, Fluid Sprinkling, Spraying, and Diffusing, subclasses 390+ for a fluid distributor having plural interchangeable discharge modifiers, outlet arrangements or coupling means, and subclasses 436+ for a fluid distributor having selectively usable or variable diverse terminal outlets, even though the distributor may be disclosed as a burner.

- 255 Lamp:**
This subclass is indented under the unnumbered subclass, Attachments. Subject matter relating to attachments designed for use with lamp or wick burners.
- 256 Article support:**
This subclass is indented under subclass 255. Devices relating to article supporting attachments that are supported upon the lamp-body independent of the lamp-chimney.
- SEE OR SEARCH CLASS:
248, Supports, appropriate subclasses for mere supports and brackets not limited by structure to use with a lamp.
- 257 Air:**
This subclass is indented under the unnumbered subclass, Chimney heaters. Devices relating to air-heaters, usually of drum form, specially applicable to lamp-chimneys.
- SEE OR SEARCH THIS CLASS, SUBCLASS:
248, for drum heater attachments.
- 258 Article support:**
This subclass is indented under the unnumbered subclass, Chimney heaters. Devices relating to article supporting brackets that are specially designed to be supported upon lamp-chimneys.
- SEE OR SEARCH THIS CLASS, SUBCLASS:
235, for other lamp attachments.
- 259 Air heaters:**
This subclass is indented under the unnumbered subclass, Stands. Devices relating to air or drum heaters that are supported by stands, over and independent of the lamp structure.
- 260 Article support:**
This subclass is indented under the unnumbered subclass, Stands. Devices relating to article supporting stands that are employed in connection with lamp-heaters, and they are independent of the form or character of the heater.
- SEE OR SEARCH CLASS:
248, Supports, subclasses 127+ for stands not limited by structure to the above, even though disclosed as for use in supporting articles over a lamp.
- 261 Lunch:**
This subclass is indented under the unnumbered subclass, HEATERS. Heaters designed for warming and keeping warm articles of food. Includes nursery or hot-water bags provided with bottle receptacles or pockets combined with heating means.
- SEE OR SEARCH CLASS:
383, Flexible Bags, subclass 901 for hot water bags.
- 262 Combined can and heater:**
This subclass is indented under subclass 261. Devices relating to closed receptacles containing food products that are provided with permanently attached heaters.
- 263.01 Chemical:**
This subclass is indented under the unnumbered subclass, HEATERS. Subject matter comprising an apparatus for applying heat resulting from a first substance being brought into contact with a second substance, thereby, generates a chemical reaction which produces heat without producing a flame.
- SEE OR SEARCH THIS CLASS, SUBCLASS:
204+, for body warmers, the containers of which are of particular configuration or structure for adaptation to the body.
- SEE OR SEARCH CLASS:
44, Fuel and Related Compositions, subclasses 250+ for flammables or glowless fuel compositions, per se, and in containers used for packaging or transportation only and subclasses 901+ for a collection of patents having heating means combined with exemplary material to be heated.
62, Refrigeration, subclass 4 for means using a chemical reaction to produce a refrigeration effect.

- 122, Liquid Heaters and Vaporizers, subclass 21 for boilers having chemical heaters.
- 132, Toilet, subclass 220 for hair curlers including chemical heaters.
- 149, Explosive and Thermic Compositions or Charges, appropriate subclasses for explosive compositions and particularly subclasses 37+ for compositions containing a metallic fuel and an oxygen supplying compound.
- 166, Wells, subclass 58 for a chemical heater adapted for use in a well.
- 228, Metal Fusion Bonding, subclasses 56.1+ for a single or plural layer metal article useful as a filler material in a metal fusion bonding operation combined with a thermic segment.
- 252, Compositions, subclass 70 for reversibly exothermic-endothermic compositions, per se, and in containers used for packaging or transportation only.
- 426, Food or Edible Material: Processes, Compositions, and Products, subclasses 113+ for a package of food combined with means to heat the food.
- 263.02 Oxidation with air:**
This subclass is indented under subclass 263.01. Subject matter wherein the first substance is brought into contact with oxygen of the atmosphere, thereby, generating the chemical reaction which produces heat without producing the flame.
- 263.03 Crystallization of supercooled liquid:**
This subclass is indented under subclass 263.01. Subject matter wherein the first substance is in a liquid state and when it is cooled below its freezing temperature and the second substance is brought into contact with it, the first substance changes to crystals.
- 263.04 By escape of reactant from container within liquid:**
This subclass is indented under subclass 263.03. Subject matter wherein the second substance is located within a container and the crystallization is caused by the second substance escaping from the container into the liquid while the container is located within the liquid.
- 263.05 Liquid in contact with solid (e.g., water and lime):**
This subclass is indented under subclass 263.01. Subject matter wherein the first substance which is in a liquid state such as water brought into contact with the second substance which is a solid-state such as lime, thereby, generating the chemical reaction which produces heat without producing the flame.
- 263.06 Including separate solid and liquid compartments:**
This subclass is indented under subclass 263.05. Subject matter wherein the liquid substance and the solid substance are kept in separate containers.
- 263.07 Flexible wall compartment (e.g., flexible plastic bag):**
This subclass is indented under subclass 263.06. Subject matter wherein a portion of an outer wall of one of the containers for the solid and the liquid substances is made of a pliable material.
- 263.08 Including means to rupture or open solid or liquid compartment:**
This subclass is indented under subclass 263.07. Subject matter wherein one of the containers includes a device which is capable of piercing or opening the outer wall of the container so as to bring the solid substance into contact with the liquid substance to generate a chemical reaction.
- (1) Note. This subclass is intended to include means other than merely a characteristic of the flexible material which can cause rupture or opening of the container. The container merely having a weakened area of the flexible material which is joined with glue or such similar material is not included in this subclass.
- SEE OR SEARCH THIS CLASS, SUBCLASS:
263.09, for means to rupture or open a compartment of a solid or liquid substance.

263.09 Including means to rupture or open solid or liquid compartment:

This subclass is indented under subclass 263.06. Subject matter wherein one of the containers includes a device which is capable of piercing or opening an outer wall of one of the containers so as to bring the solid substance into contact with the liquid substance.

SEE OR SEARCH THIS CLASS, SUB-CLASS:

263.08, for means to rupture or open a compartment having a flexible wall.

263.1 Including time release coating on solid in contact with liquid:

This subclass is indented under subclass 263.06. Subject matter wherein the solid substance includes a covering made of material which when brought into contact with the liquid substance slows down a rate of penetration of the liquid substance into the solid substance, thereby, prolonging a duration of release of heat.

265 Liquid or gaseous fuel:

This subclass is indented under subclass 261. Devices employing liquid or gaseous fuel as the heating medium.

266 Dinner buckets:

This subclass is indented under subclass 265. Devices known as dinner pail or buckets.

267 Combined bucket and lantern:

This subclass is indented under subclass 266. Devices structurally adapted to be employed as lanterns.

SEE OR SEARCH THIS CLASS, SUB-CLASS:

209, for liquid or gaseous fuel burning body warmers adapted to be employed both as heater and lantern.

SEE OR SEARCH CLASS:

362, Illumination, appropriate subclasses for other combined light and structure devices.

268 Wagon:

This subclass is indented under subclass 261. Devices relating to vehicles, sometimes designated "caterers' wagons", designed to keep food at a predetermined temperature while conveying the same to customers or dining room.

SEE OR SEARCH THIS CLASS, SUB-CLASS:

276, for ovens adapted to be mounted on wheeled structures.

269 Powder:

This subclass is indented under the unnumbered subclass, HEATERS. Devices specially adapted for the thawing of explosives, such as powder, dynamite, etc.

SEE OR SEARCH THIS CLASS, SUB-CLASS:

284, for glue pots.

377.1 through 392.1, for an open-top liquid heating vessel that may include a lid having a confining, directing, or shielding feature for a liquid or steam used to heat the vessel.

SEE OR SEARCH CLASS:

220, Receptacles, subclasses 573.4 and 573.5 for double boiler-type receptacles.

271.1 Surface:

This subclass is indented under the unnumbered subclass, HEATERS. Miscellaneous devices for applying heat to surfaces and generally adapted to be moved over the surface. Includes devices for heating surfaces by steam, that either comes in contact with the surface to be heated or is applied by a radiator. Includes devices for thawing frozen earth in placer mining, melting snow and ice, burning weeds or stubble, heating ground for cultivation, and solid fuel paint breamers.

SEE OR SEARCH CLASS:

37, Excavating, subclasses 227+ for devices for excavating and melting the excavated snow.

43, Fishing, Trapping, and Vermin Destroying, subclass 144 for surface heaters having added features for seeking out insects for destruction,

and even though additionally disclosed as weed burners.

239, Fluid Sprinkling, Spraying, and Diffusing, subclasses 128+ and 146+ for wheeled carts having a heating means and a nozzle structure for discharging steam or a heated fluid, and see the class definition of Class 239, section III (h), for the line between Classes 126 and 239.

404, Road Structure, Process, or Apparatus, subclass 77 for a process of in situ heating of earth or road surface, subclasses 79+, a process of heating earth or road surface and subclass 95 for means to heat earth or road surface.

271.2 Fluid fuel:

This subclass is indented under subclass 271.1. Devices for applying the products of combustion of fluid fuel, hot air heated by fluid fuel, steam in combination with either the products of combustion or hot air.

SEE OR SEARCH CLASS:

431, Combustion, subclass 344 for a flame holder-fuel tank assembly not particularly adapted for heating a surface (e.g., gasoline blow torch, etc.) and subclass 345 for a flame holder having an attached handle.

271.3 Solid fuel:

This subclass is indented under subclass 271.1. Devices for applying the products of combustion of solid fuel or the radiant heat thereof, of hot air, or steam in combination with products of combustion or hot air.

273 Domestic:

This subclass is indented under the unnumbered subclass, OVENS. Devices comprising ovens of the household type that do not fall under more specific classes and subclasses.

SEE OR SEARCH THIS CLASS, SUBCLASS:

3, 4, 9, 19, 19.5, 198, 218, 337, and 506, for other devices including oven structure.

SEE OR SEARCH CLASS:

219, Electric Heating, subclass 391 for electrically heated ovens.

273.5 With heat accumulator, e.g., fireless:

This subclass is indented under subclass 273. Ovens provided with means to store or retain a substantial quantity of heat to be given up to the contents of the oven over an extended period of time. So called "Fireless Cookers" are here classified. The oven is frequently heat insulated to conserve heat.

SEE OR SEARCH THIS CLASS, SUBCLASS:

207, for heated block type of body warmer.
375.1, for an open-top liquid heating vessel that may include a lid having a heat accumulator.
400, for heat accumulator blocks, per se.

SEE OR SEARCH CLASS:

220, Receptacles, subclasses 560.12+, 592.01+, and 903 for insulated vessels in general.

274 Dutch:

This subclass is indented under subclass 273. Domestic ovens, portable in character, having an open side and adapted to receive radiated heat from an open fireplace or stove.

275 Portable:

This subclass is indented under subclass 273. Domestic ovens structurally independent of stove structure and designed to be placed upon stove-surfaces. This subclass includes those devices that are known in the trade as portable gas and vapor stove ovens.

SEE OR SEARCH THIS CLASS, SUBCLASS:

369 through 369.3, for a steam chamber for food that may include a chamber placed over a steam generator.

276 Wagon:

This subclass is indented under the unnumbered subclass, OVENS. Ovens specially adapted to be mounted upon wheeled structures. These devices are usually termed traveling kitchens.

- SEE OR SEARCH THIS CLASS, SUB-CLASS:
268, for vehicles, for keeping food warm while conveying same to customers or dining room.
- 277 PLATFORMS:**
This subclass is indented under the class definition. Devices, usually platforms, designed to support stove-bodies. The platform may be provided with means for sustaining it in an elevated position.
- SEE OR SEARCH THIS CLASS, SUB-CLASS:
55, and 305, for other structures for supporting stoves.
- 278 Stove boards:**
This subclass is indented under subclass 277. Platforms designed to rest flat upon the floor-surface and to protect the floor from the heat of a stove resting thereon.
- 279 Ventilating:**
This subclass is indented under subclass 278. Devices so constructed as to allow for a free circulation of air beneath or through them.
- SEE OR SEARCH THIS CLASS, SUB-CLASS:
500+, for fireplace bases or hearths having air feeding or ventilating features therein.
- 280 SOOT CATCHERS:**
This subclass is indented under the class definition. Devices comprising receptacles designed to be so placed or suspended that they will catch or receive the soot falling from stovepipe or chimney openings.
- 281 DOUGH RAISERS:**
This subclass is indented under the class definition. Devices comprising pans or trays designed for the raising of dough and usually provided with means for heating and maintaining the heat of the pan or tray at a uniform temperature in excess of that of the surrounding atmosphere.
- SEE OR SEARCH THIS CLASS, SUB-CLASS:
377.1 through 392.1, for an open-top liquid heating vessel that may include a lid having a confining, directing, or shielding feature for a liquid or steam used to heat the vessel.
- SEE OR SEARCH CLASS:
312, Supports: Cabinet Structure, subclass 236 for cabinets having both storage and heating means not special to this class.
- 282 Lamp type:**
This subclass is indented under subclass 281. Dough-raising devices, having a heater of the liquid-fuel-burner type.
- 283 FUEL BOXES:**
This subclass is indented under the class definition. Devices comprising fuel-holding cabinets provided with means for permitting the withdrawal of small quantities of fuel.
- SEE OR SEARCH CLASS:
209, Classifying, Separating, and Assorting, Solids, subclass 377 for enclosed sifters adapted for operation in connection with or within stoves or furnaces.
312, Supports: Cabinet Structure, subclass 236 for cabinets having both storage and heating means not special to this class.
- 284 GLUE POTS:**
This subclass is indented under the class definition. Devices primarily designed for the melting of glue and analogous substances. The pots are usually water or steam jacketed.
- SEE OR SEARCH THIS CLASS, SUB-CLASS:
33, for a cooking stove having a table heated by steam or hot water.
282, for a dough raiser heated by a liquid fuel burner.
377.1 through 392.1, for an open-top liquid heating vessel that may include a lid having a confining, directing, or shielding feature for a liquid or steam used to heat the vessel.

285 DAMPERS:

This subclass is indented under the class definition. Devices comprising miscellaneous dampers not classifiable otherwise.

SEE OR SEARCH CLASS:

110, Furnaces, subclass 192 for a solid fuel furnace or incinerator provided with a timer to control all or a portion of the furnace or incinerator.
454, Ventilation, subclasses 322+ for damper details of registers.

285.5 Timer-controlled:

This subclass is indented under subclass 285. Device comprising means controlling time as which the damper is either opened or closed, or the length of time between the opening and closing of the damper.

SEE OR SEARCH CLASS:

110, Furnaces, subclass 192 for a solid fuel furnace or incinerator provided with a timer to control all or a portion of the furnace or incinerator.

286 Distance operating devices:

This subclass is indented under subclass 285. Devices including operating means located at a distance and designed to operate smoke, air-flue, and stove draft-dampers.

287 Door-operated:

This subclass is indented under subclass 286. Damper-operating devices, that are coupled up or connected to stove-doors and designed to operate the damper upon the opening or closing of the stove-door.

SEE OR SEARCH CLASS:

110, Furnaces, subclass 158 for devices for admitting air to a furnace smoke box where the air opening valve is controlled by movement of the furnace door.

287.5 Fusible release:

This subclass is indented under subclass 285. Dampers for stoves or furnaces with fusible means for holding them in inoperative position, but which when the temperature reaches a certain limit fuses and allows the damper to move in position to check the fire.

SEE OR SEARCH CLASS:

137, Fluid Handling, subclasses 72+ for valves controlled by a fusible or heat destructible element.

289 Stove:

This subclass is indented under subclass 285. Dampers structurally adapted for use with heating or cooking stoves.

290 Draft:

This subclass is indented under subclass 289. Dampers designed to control the admission of air to the combustion-chamber.

SEE OR SEARCH THIS CLASS, SUBCLASS:

193, for doors designed to admit a current of air into the combustion chamber above the fuel level.

291 Repair:

This subclass is indented under subclass 289. Dampers designed to replace broken or worn-out dampers and adjustable to stoves of different sizes.

SEE OR SEARCH THIS CLASS, SUBCLASS:

145, for adjustable stove linings.
153, for adjustable grates.

292 Stovepipe:

This subclass is indented under subclass 285. Devices comprising miscellaneous stovepipe and air-flue dampers.

293 Combined damper and ventilator:

This subclass is indented under subclass 292. Damper devices where the smoke-controlling damper and the ventilating-damper are so connected that the movement of one operates to move the other.

294 Cone:

This subclass is indented under subclass 292. Dampers in the form of a sectional truncated cone. One or both of its sides are usually movable, so as to cause direct or retarded draft in the pipe.

- fumes, vapors, steam, dust, etc., from various places.
- 295 Lock and indicator:**
This subclass is indented under subclass 292. Dampers provided with means for locking or holding the damper in a predetermined position, also devices for indicating their position.
- 296 Multiple:**
This subclass is indented under subclass 292. Dampers composed of two or more plates connected by a common operating-rod, so as to receive simultaneous action, thereby affecting the direct or indirect draft of the pipe.
- 297 Sinuous passage:**
This subclass is indented under subclass 292. Devices comprising single-spindle-operating pipe-dampers that have retarding means for giving a circuitous course to the products.
- 298 FIRE DOGS:**
This subclass is indented under the class definition. Devices generally known as andirons. Some of these devices are provided with a shelf or support, also a fender.
- SEE OR SEARCH THIS CLASS, SUB-CLASS:
505, for shelves adapted to fireplace grates or any open grate structure.
544+, for fireplace screens, guards and hearth structure.
- 299 STOVE HOODS:**
This subclass is indented under the class definition. Miscellaneous devices, commonly known as stove-hoods, designed to carry off odors from kitchen ranges, etc.
- SEE OR SEARCH THIS CLASS, SUB-CLASS:
389.1, for an open-top liquid heating vessel that may include a lid having a vent for steam emitted from the liquid that may be a passageway to a stove hole in a stove top.
- SEE OR SEARCH CLASS:
104, Railways, subclass 52 for smoke removers for use in roundhouses and locomotive sheds over locomotive smoke stacks.
454, Ventilation, subclasses 49+ for hoods and off takes for conducting away
- 300 Stove discharge:**
This subclass is indented under subclass 299. Stove-hoods that discharge into the stove-body proper.
- 301 Stovepipe discharge:**
This subclass is indented under subclass 299. Stove-hoods provided with means for connecting them with stovepipes and flues.
- SEE OR SEARCH THIS CLASS, SUB-CLASS:
312, for stovepipes with ventilators.
- 302 Stove casing:**
This subclass is indented under subclass 301. Stove-hoods designed to inclose a stove; the casing acts as a heat-fender and is provided with ventilating means.
- SEE OR SEARCH THIS CLASS, SUB-CLASS:
544+, for devices designed to screen and guard stove and fireplace openings.
- 303 Top plate casing:**
This subclass is indented under subclass 301. Stove-hoods, designed to inclose the top plate of a stove. The casing is usually provided with ventilating means.
- 304 STOVE LEGS:**
This subclass is indented under the class definition. Subject matter comprising stove-legs and the means for attaching them to stove-bodies.
- SEE OR SEARCH CLASS:
4, Baths, Closets, Sinks, and Spittoons, subclass 594 for bath tub legs.
248, Supports, subclasses 188.2+ for furniture leveling devices and subclasses 188.8+ for pads and feet for furniture.
- 305 Base supports:**
This subclass is indented under subclass 304. Devices in the form of a ring or base, to which the stove-leg is attached, and designed to support the stove-body.

- SEE OR SEARCH THIS CLASS, SUB-CLASS:
55, and 277+, for other supporting structures for stoves and subclass 57, for protective casings for car stoves.
- 306 Sheet metal:**
This subclass is indented under subclass 304. Devices comprising sheet-metal stove-legs.
- 307 STOVEPIPES:**
This subclass is indented under the class definition. Devices comprising miscellaneous smoke-flues, designed to convey smoke and waste gases from the fire-pot.
- SEE OR SEARCH CLASS:
138, Pipes and Tubular Conduits, appropriate subclasses for pipe and conduit structures generally.
- 312 Ventilation:**
This subclass is indented under subclass 307. Subject matter having devices designed to carry off vitiated air and odors.
- SEE OR SEARCH THIS CLASS, SUB-CLASS:
293, for damper devices where the smoke controlling damper and the ventilating damper are interconnected.
301, for stove hoods with means connecting them with stove pipes or flues.
- SEE OR SEARCH CLASS:
454, Ventilation, subclass 43 for ventilating devices for buildings in which an outlet current of air is heated to increase its velocity.
- 313 Air-moistening attachments:**
This subclass is indented under subclass 307. Devices including open vessels containing a liquid and so connected to a stovepipe as to be heated thereby and designed to moisten the air in the room.
- SEE OR SEARCH CLASS:
454, Ventilation, subclasses 110, 157, 223, 291, 328, and 337 for analogous devices for moistening air in ventilating structures.
- 314 STOVEPIPE THIMBLES:**
This subclass is indented under the class definition. Devices adapted to be applied to flue and similar openings, forming a lining therefor, and designed to receive a stove or similar pipe.
- SEE OR SEARCH CLASS:
301, Land Vehicles: Wheels and Axles, subclasses 108.1+ for vehicle wheels provided with hub caps.
- 315 Adjustable flue collar:**
This subclass is indented under subclass 314. Devices capable of vertical adjustment to suit the height of a stovepipe to obviate the necessity of cutting the same to fix the stove-hole of the chimney; also adjustable thimbles adapted to receive different-size stove-pipes.
- SEE OR SEARCH THIS CLASS, SUB-CLASS:
82, for stoves in which the back plate carries a pipe collar which is capable of adjustment relative to the flue opening.
- 316 Combined thimble and ventilator:**
This subclass is indented under subclass 314. Devices comprising thimbles designed to ventilate.
- 317 Floor or ceiling plates:**
This subclass is indented under subclass 314. Devices comprising collar and thimble devices designed for use in connection with pipes which pass through the floors or ceilings of buildings.
- SEE OR SEARCH CLASS:
362, Illumination, subclasses 404+ for similar devices adapted to be applied to the pipe or conduit of brackets or chandeliers where they are secured to a wall or ceiling in order to hide the juncture.
- 318 Stovepipe anchor or lock:**
This subclass is indented under subclass 314. Devices for locking the inserted end of a stovepipe in a flue or thimble opening.

- SEE OR SEARCH CLASS:
285, Pipe Joints or Couplings, subclasses 189+ for sheet metal pipe to plate joints generally.
- 319 Flue stoppers:**
This subclass is indented under subclass 314. Devices designed to close flue and thimble openings.
- 332 STOVE SHELVES:**
This subclass is indented under the class definition. Devices comprising shelves or racks peculiarly applicable to stoves and as a rule self-supporting.
- SEE OR SEARCH THIS CLASS, SUB-CLASS:
190, for miscellaneous stove doors and windows.
214, for lid and top structure for liquid or gaseous fuel burning stoves.
- SEE OR SEARCH CLASS:
312, Supports: Cabinet Structure, subclass 351 for cabinets with fixed or removable shelves or other article supports.
- 333 Brackets or stands:**
This subclass is indented under subclass 332. Stove-shelves supported by a bracket or stand above the stove-top.
- SEE OR SEARCH CLASS:
248, Supports, appropriate subclasses for mere stands or brackets for supporting a stove shelf, unless limited by structure to use with a stove.
312, Supports: Cabinet Structure, subclass 280 for cabinets with continuously external racks or shelves.
- 334 Drop:**
This subclass is indented under subclass 332. Shelves so hung as to form when in operative position an extension of the stove top or oven-bottom.
- SEE OR SEARCH THIS CLASS, SUB-CLASS:
190, for stove doors and windows.
- 335 Door-operated:**
This subclass is indented under subclass 334. Shelves so hung as to form an extension of the oven-bottom when the oven-door is open and thrown into operative or inoperative position by the opening or closing of the oven door.
- 337 Oven shelf or rack:**
This subclass is indented under subclass 332. Subject matter comprising improvements in the form of the oven-rack or shelf.
- SEE OR SEARCH THIS CLASS, SUB-CLASS:
273, for miscellaneous domestic ovens.
- 338 Rotary:**
This subclass is indented under subclass 337. Oven shelves or racks adapted to be revolved or rotated in the oven.
- SEE OR SEARCH CLASS:
312, Supports: Cabinet Structure, subclass 305 for cabinets with continuously housed rotary shelves or racks.
- 339 Sliding:**
This subclass is indented under subclass 337. Oven shelves or racks, adapted to be withdrawn from the oven and means for holding the shelf in its extended horizontal position.
- SEE OR SEARCH CLASS:
312, Supports: Cabinet Structure, subclasses 330.1+ for cabinets with sliding shelves or racks.
- 340 Door-operated:**
This subclass is indented under subclass 339. Sliding oven shelves or racks moved out or in by the opening or closing of the oven-door.
- SEE OR SEARCH CLASS:
312, Supports: Cabinet Structure, subclass 273 for cabinets with horizontally slidable shelves or racks interconnected with a rigid housing wall or closure for relative motion.
- 343.5 MELTING FURNACES:**
This subclass is indented under the class definition. Heaters specially adapted for melting substances by the application of heat to a

receptacle, conduit, or support for the material to be melted.

SEE OR SEARCH THIS CLASS, SUB-CLASS:

271.1+, for portable apparatus for applying heat to surfaces generally, whether for the purpose of melting snow and ice, thawing frozen ground, burning weeds or stubble, or preparing ground for cultivation.

SEE OR SEARCH CLASS:

37, Excavating, subclasses 227+ for analogous construction.
 239, Fluid Sprinkling, Spraying, and Diffusing, subclasses 128+ and 146+ for wheeled carts having a heating means and a nozzle structure for discharging steam or a heated fluid, and see the class definition of Class 239, section III(h), for the line between Classes 126 and 239.
 423, Chemistry of Inorganic Compounds, subclass 13 for a residual process of melting material.

344 LIQUID HEATER:

This subclass is indented under the class definition. Subject matter comprising means to add thermal energy to a fluid that is shapeless, virtually incompressible, and has a definite volume (e.g., water, etc.).

(1) Note. This may include a solid within the liquid.

SEE OR SEARCH THIS CLASS, SUB-CLASS:

5, for combined cooking and heating stoves with steam or hot-water generators.
 20, for ovens of the cooking stove type heated by steam or hot water.
 31, for cooking stoves having a water tank in an extension chamber through which products of combustion pass.
 33, for shallow chambers (steam tables) provided with means for circulating steam or hot water therein.
 34, for cooking stoves provided with steam or hot water generators located in or adjacent the combustion chamber.

53, for gas or vapor fuel cooking stoves that have water backs.
 101, for hot air furnaces combined with boilers.
 113, for hot air furnaces with water pans.
 210, for body warmers having liquid or gaseous fuel water heaters.
 508, for air moistening attachments to fireplaces or open front heaters.
 513+, for fireplaces having water or steam generating backs.
 561+, and 569+, for devices for heating water by solar energy.

SEE OR SEARCH CLASS:

122, Liquid Heaters and Vaporizers, for a closed or pressurized liquid heater or vaporizer for other than a stove or furnace.
 165, Heat Exchange, for a residual heat transfer apparatus or process.
 392, Electric Resistance Heating Devices, subclass 308 for a heating device combined with other than electrical heating means (e.g., gas, etc.) for heating liquid, subclasses 311-338 for electrically heated water heaters, or subclasses 441-464 for a tank- or container-type liquid heater.

345 Kettle furnace:

This subclass is indented under subclass 344. Subject matter wherein the liquid heater has an open tank or receptacle for the liquid intended to cook food.

(1) Note. This type of liquid heater is also called an "agricultural boiler".

SEE OR SEARCH CLASS:

99, Foods and Beverages: Apparatus, subclass 453 for temperature modification of dairy foods.
 159, Concentrating Evaporators, subclasses 32+ for open pan liquid concentrators.

346 Canning:

This subclass is indented under subclass 345. Subject matter wherein the kettle furnace has a tray having elevating and lowering means, and means for treating a food product other than in the art of preserving.

SEE OR SEARCH CLASS:

99, Foods and Beverages: Apparatus, subclasses 359+ for heated receptacles modified to contain jars or cans of food, and subclasses 403+ for heated vessels modified to contact a food material with a heated liquid contained therein.

347 Horizontal combustion chamber:

This subclass is indented under subclass 345. Subject matter wherein the kettle furnace has an enclosed structure for the fuel burner that extends parallel to, in the plane of, or operating in a plane parallel to the horizon.

348 Steam generator and cooker:

This subclass is indented under subclass 345. Subject matter wherein the kettle furnace heats the liquid until vapor is emitted which is used to prepare food for eating.

SEE OR SEARCH THIS CLASS, SUBCLASS:

360.1, 360.2, for a submerged fluid fuel burner other than a top-accessible liquid heating vessel.
 368.1, for a liquid heater having a solid fuel burner submerged underneath the surface of the liquid that may be held in an open-top vessel.
 373.1 through 390.1, for a liquid heater having an open-top vessel that may have a heating means submerged under the liquid.

SEE OR SEARCH CLASS:

122, Liquid Heaters and Vaporizers, for a closed or pressurized liquid heater or vaporizer for other than a stove or furnace.

349 Tilting:

This subclass is indented under subclass 345. Subject matter wherein the kettle furnace has means permitting the kettle to move or shift so as to lean or incline.

SEE OR SEARCH CLASS:

222, Dispensing, subclasses 164+ for dispensing vessels which are tiltably supported.

350.1 Fluid fuel burner for other than top-accessible vessel:

This subclass is indented under subclass 344. Subject matter wherein the liquid heater has a fuel burner that burns fuel having physical properties of a gas or liquid to generate heat for the liquid in other than a receptacle having an entrance at its uppermost.

SEE OR SEARCH THIS CLASS, SUBCLASS:

373.1 through 390.1, for an open-top liquid heating vessel that may include a lid.

SEE OR SEARCH CLASS:

122, Liquid Heaters and Vaporizers, for a closed or pressurized liquid heater or vaporizer for other than a stove or furnace, subclasses 13.01 through 19.2 for a stand boiler (e.g., water heater, etc.) that provides hot water for domestic or household use (e.g., cooking, cleaning, washing, bathing, space heating, etc.) that may be in other than a house or home (e.g., apartment building, office building, restaurant, laundry, recreational vehicle, etc.).
 123, Internal-Combustion Engines, subclass 142.5 for an engine combined with external means to heat the engine or an adjunct of it (e.g., radiator, etc.), or the engine having means to exchange heat from one part to another part.

350.2 Vaporizer or humidifier:

This subclass is indented under subclass 350.1. Subject matter wherein the liquid heater converts the liquid into a gaseous state for delivery outside the liquid heater.

(1) Note. This vapor may be used to create a fog, control the humidity in a room, or for inhalation.

SEE OR SEARCH THIS CLASS, SUBCLASS:

113, for a hot air furnace having an air moistening means.

SEE OR SEARCH CLASS:

- 4, Baths, Closets, Sinks, and Spittoons, subclasses 524 through 534 for a vapor or heat in a bath (e.g., sauna, steam bath, or sudatorium, etc.) or subclasses 535-537 for means for applying vapor or hot air directly to the body of a user.
- 29, Metal Working, subclass 890.07 for a method of making a condenser, evaporator, or vaporizer.
- 128, Surgery, subclasses 203.26 and 203.27 for a respiratory method or device to mix and heat a treating agent or a respiratory gas, or a mixture of both.
- 261, Gas and Liquid Contact Apparatus, digest 65 for a vaporizer.
- 392, Electric Resistance Heating Devices, subclasses 394 through 406 for a liquid vaporizer.

351.1 And condition responsive feature:

This subclass is indented under subclass 350.1. Subject matter and means to sense a state or change in state of the liquid heater or the liquid heated by the liquid heater to effect a change in operation of the liquid heater or the heated liquid.

SEE OR SEARCH THIS CLASS, SUBCLASS:

- 42, for a gas fueled cooking stove having a safety attachment.
- 374.1, for an open-top liquid heating vessel that may include a lid and a condition responsive feature.

SEE OR SEARCH CLASS:

- 99, Foods and Beverages: Apparatus, for apparatus combined with a food treating feature that is more than mere heating, subclasses 325 through 336 for automatic control of cooking apparatus.
- 122, Liquid Heaters and Vaporizers, for a closed or pressurized liquid heater or vaporizer for other than a stove or furnace, subclasses 14.1 through 14.31 for a stand boiler (e.g., water heater, etc.) having a condition responsive feature.

- 236, Automatic Temperature and Humidity Regulation, subclasses 20 through 33 for an automatic temperature control for a closed fluid heater.

355.1 And liquid dripping from plate, pan, or suspended strip:

This subclass is indented under subclass 350.1. Subject matter and a smooth, flat, thin piece of material, a broad, shallow, open-top vessel or a long, narrow piece of material hung to be free on all sides, except at the point of support, for the liquid to fall downward by gravity in drops to mix with rising exhaust from the burner.

- (1) Note. The pan is within a tank that is open to the atmosphere.
- (2) Note. The plate, pan, or suspended strip may be perforated.
- (3) Note. The liquid is heated by contact with the heated plate, pan or suspended strip, or by direct contact by the dripping liquid with the rising exhaust from the burner.

SEE OR SEARCH THIS CLASS, SUBCLASS:

- 359.1, for a fluid fuel burner other than a top-accessible liquid heating vessel where the liquid flows down a cylindrical or conical surface.

357.1 And separable heat exchanger to heat the liquid:

This subclass is indented under subclass 350.1. Subject matter and means that can be separated or dissociated from the burner without materially mixing the liquid with exhaust from the burner.

- (1) Note. The heat exchanger may be intended for fluid communication with a vessel.

358.1 Wick lamp type:

This subclass is indented under subclass 350.1. Subject matter wherein the fluid fueled burner is structurally related to those using a bundle of fibers or a loosely twisted, braided, or woven cord, tape, or tube usually of soft spun cotton threads to draw up liquid fuel steadily, by cap-

illary attraction, from a reservoir to be burned to produce light.

SEE OR SEARCH THIS CLASS, SUB-CLASS:

- 47, 48, for a liquid fueled wick lamp-type cooking stove.
 96, 97, for a liquid fueled wick lamp-type air heating stove.
 255 through 256, for an attachment to a liquid or gaseous fueled lamp- or wick-type burner.

SEE OR SEARCH CLASS:

- 431, Combustion, a residual process or apparatus of combustion or combustion starting, subclass 120 for a wick trimming, treating, inserting, or removing means; or subclasses 298-325 for a fibrous wick-type flame holder.
 502, Catalyst, Solid Sorbent, or Support Therefor: Product or Process of Making, subclasses 400 through 438 for a solid sorbent.

359.1 And the liquid flows down a cylindrical or conical surface:

This subclass is indented under subclass 350.1. Subject matter and means to pour the liquid over an upper exterior or interior of a cylinder or cone-shaped part.

SEE OR SEARCH THIS CLASS, SUB-CLASS:

- 355.1, for a fluid fuel burner other than a top-accessible liquid heating vessel where the liquid drips from a plate, pan, or suspended strip.

SEE OR SEARCH CLASS:

- 122, Liquid Heaters and Vaporizers, for a closed or pressurized liquid heater or vaporizer for other than a stove or furnace, subclass 39 for a boiler having a liquid film flowing over a heating surface.

360.1 And liquid heater is submerged under the liquid:

This subclass is indented under subclass 350.1. Subject matter wherein the liquid heater is covered by and beneath the surface of the liquid.

SEE OR SEARCH THIS CLASS, SUB-CLASS:

- 367.1, 368.1, for a liquid heater having a solid fuel burner submerged underneath the surface of the liquid that may be held in an open-top vessel.

360.2 Direct contact of the liquid by exhaust:

This subclass is indented under subclass 360.1. Subject matter wherein the fluid fueled burner generates a hot gaseous product submerged under the surface of and put into immediate connection with the liquid.

SEE OR SEARCH CLASS:

- 261, Gas and Liquid Contact Apparatus, subclass 77 for a submerged blast injector device providing intimate contact between a gas and liquid.

361.1 Boiler receiving hot liquid or steam from stove or furnace (e.g., kitchen boiler, range boiler, etc.):

This subclass is indented under subclass 344. Subject matter wherein the liquid heater is closed and intended to receive hot liquid heated or vapor emitted from liquid heated from the stove or furnace for heating or storage.

SEE OR SEARCH THIS CLASS, SUB-CLASS:

- 53, 54, for a fluid fueled cook stove having a water back.

SEE OR SEARCH CLASS:

- 122, Liquid Heaters and Vaporizers, for a closed or pressurized liquid heater or vaporizer for other than a stove or furnace, subclass 18.5 for a stand boiler (e.g., water heater, etc.) that provides hot water for domestic or household use (e.g., cooking, cleaning, washing, bathing, space heating, etc.) that may be found in other than a house or home (e.g., apartment building, office building, restaurant, laundry, etc.) having a fluid fueled burner and an external water tank.
 220, Receptacles, subclass 567.3 for a stationary tank for a hot water heater or boiler.

362.1 Having means to circulate the liquid:

This subclass is indented under subclass 361.1. Subject matter including means to provide a liquid flow path inside or outside the boiler.

SEE OR SEARCH THIS CLASS, SUBCLASS:

365.1, for a liquid heater and stovepipe having liquid circulation means.

SEE OR SEARCH CLASS:

122, Liquid Heaters and Vaporizers, for a closed or pressurized liquid heater or vaporizer for other than a stove or furnace, for a stand boiler (e.g., water heater, etc.) that provides hot water for domestic or household use (e.g., cooking, cleaning, washing, bathing, space heating, etc.) that may be in other than a house or home (e.g., apartment building, office building, restaurant, laundry, recreational vehicle, etc.), subclass 13.3 having a delivery means to a dispensing feature or subclass 19.1 having a water containing chamber or external tank including a flow feature within.

392, Electric Resistance Heating Devices, subclass 452 for a line connected tank- or container-type liquid heater having an immersion heating element and a baffle or guard to direct the liquid.

363.1 Support:

This subclass is indented under subclass 361.1. Subject matter including means to hold up or serve as a foundation or prop for the boiler.

SEE OR SEARCH CLASS:

248, Supports, subclasses 128 through 145.6 for a movable receptacle stand or subclasses 146-154 for a stationary receptacle stand.

364.1 And stovepipe:

This subclass is indented under subclass 344. Subject matter wherein the liquid heater is part of and has means to transfer heat from the stovepipe to the liquid.

365.1 Having means to circulate the liquid:

This subclass is indented under subclass 364.1. Subject matter including means to provide a liquid flow path inside or outside the liquid heating stovepipe.

SEE OR SEARCH THIS CLASS, SUBCLASS:

362.1, for a boiler receiving hot liquid or steam from a stove or furnace (e.g., kitchen boiler, range boiler, etc.) having liquid circulation means.

SEE OR SEARCH CLASS:

122, Liquid Heaters and Vaporizers, for a closed or pressurized liquid heater or vaporizer for other than a stove or furnace, for a stand boiler (e.g., water heater, etc.) that provides hot water for domestic or household use (e.g., cooking, cleaning, washing, bathing, space heating, etc.) that may be in other than a house or home (e.g., apartment building, office building, restaurant, laundry, recreational vehicle, etc.), subclass 13.3 having a delivery means to a dispensing feature or subclass 19.1 having a water containing chamber or external tank including a flow feature within.

392, Electric Resistance Heating Devices, subclass 452 for a line connected tank- or container-type liquid heater having an immersion heating element and a baffle or guard to direct the liquid.

367.1 Solid fuel burner and submerged under the liquid:

This subclass is indented under subclass 344. Subject matter wherein the liquid heater has a fuel burner that burns fuel having physical properties other than a gas or liquid (e.g., coal, wood, etc.) and covered by and beneath the surface of the liquid.

SEE OR SEARCH THIS CLASS, SUBCLASS:

360.1, 360.2, for a submerged fluid fuel burner other than a top-accessible liquid heating vessel.

373.1 through 390.1, for a liquid heater having an open-top vessel that may

include a lid or has a heating means submerged under the liquid.

SEE OR SEARCH CLASS:

122, Liquid Heaters and Vaporizers, for a closed or pressurized liquid heater or vaporizer for other than a stove or furnace, subclass 16.1 for a stand boiler (e.g., water heater, etc.) that provides hot water for domestic or household use (e.g., cooking, cleaning, washing, bathing, space heating, etc.) that may be in other than a house or home (e.g., apartment building, office building, restaurant, laundry, recreational vehicle, etc.) having a solid fuel burner.

368.1 United to vessel containing the liquid:

This subclass is indented under subclass 367.1. Subject matter including a container for the liquid wherein the liquid heater and the container form a whole.

369 Steam chamber for food:

This subclass is indented under subclass 344. Subject matter wherein the liquid heater heats the liquid until vapor is emitted for use in an enclosed space for receiving a comestible.

SEE OR SEARCH THIS CLASS, SUBCLASS:

20, for cooking ovens heated by steam or hot water.

SEE OR SEARCH CLASS:

34, Drying and Gas or Vapor Contact With Solids, for analogous devices used for drying.

99, Foods and Beverages: Apparatus, for apparatus combined with a food treating feature that is more than mere heating, subclass 293 and 294 for a steamer- or condenser-type beverage infuser or subclasses 359-371 for filled receptacle-type cooking apparatus (e.g., can processor, bottle pasteurizer, food jar canning apparatus, etc.).

131, Tobacco, subclasses 300+ for tobacco steaming apparatus.

369.1 With additional heating fluid:

This subclass is indented under subclass 369. Subject matter wherein the steam chamber includes means for using another heating fluid

(e.g., combustion exhaust, etc.), other than the steam on the food.

(1) Note. The steam or the additional fluid may be used together or separately on the food.

369.2 Plural steam chambers:

This subclass is indented under subclass 369. Subject matter including two or more distinct steam chambers, or the steam chamber is divided into two or more compartments having separate means of access thereto.

SEE OR SEARCH THIS CLASS, SUBCLASS:

20.1+, for plural steam ovens.

369.3 Selective supply:

This subclass is indented under subclass 369.2. Subject matter wherein the plural steam chambers have means to control which chamber or chambers are provided with steam.

SEE OR SEARCH THIS CLASS, SUBCLASS:

20.2, for the selective supply of steam to a plurality of steam ovens.

373.1 Open-top vessel may include lid:

This subclass is indented under subclass 344. Subject matter wherein the liquid heater is a receptacle for holding the liquid for heating that is accessible at its uppermost and may include a movable cover.

(1) Note. This may include a thermal energy generating means for the vessel.

(2) Note. The heater for the vessel is claimed or disclosed as a "tank heater", "immersion heater", "immersible heater", "submersion heater" or "submersible heater".

SEE OR SEARCH THIS CLASS, SUBCLASS:

350.1 through 350.2, for a fluid fuel burner other than a top-accessible liquid heating vessel.

368.1, for a liquid heater having a solid fuel burner submerged underneath the surface of the liquid that may be held in an open-top vessel.

SEE OR SEARCH CLASS:

- 99, Foods and Beverages: Apparatus, for apparatus combined with a food treating feature that is more than mere heating, subclasses 316 through 322 for a beverage infusor having a space or support for an infusible material or subclasses 403-418 for a boiler or a deep fat fryer-type cooker.
- 220, Receptacles, subclasses 573.1 through 573.5 for cookware (e.g., pot, baking pan, etc.), subclasses 592.22 and 592.23 for a thermally insulated receptacle for heated contents (e.g., fireless cooker, etc.), or subclass 592.28 for a receptacle for use with a heated fluent medium (e.g., hot air, hot water, steam, etc.).
- 392, Electric Resistance Heating Devices, subclasses 449 through 464 for a line connected tank or container-type liquid heater.

374.1 And condition responsive feature:

This subclass is indented under subclass 373.1. Subject matter and means to sense a state or change in state of the open-top vessel or the liquid heated by the open-top vessel to effect a change in operation of the open-top vessel or the heated liquid.

SEE OR SEARCH THIS CLASS, SUBCLASS:

- 42, for a gas fueled cooking stove having a safety attachment.
- 351.1, for a liquid heater and stovepipe having liquid circulation means.

SEE OR SEARCH CLASS:

- 99, Foods and Beverages: Apparatus, for apparatus combined with a food treating feature that is more than mere heating, subclasses 325 through 336 for automatic control of cooking apparatus.
- 119, Animal Husbandry, for residual apparatus to care for a living animal, subclass 73 for a temperature-controlled watering or liquid-feeding apparatus, subclass 77 for a watering fountain or trough having a barometrically controlled supply, or subclass 78 for a

watering fountain or trough having a float-controlled supply.

- 122, Liquid Heaters and Vaporizers, for a closed or pressurized liquid heater or vaporizer for other than a stove or furnace, subclasses 14.1 through 14.31 for a stand boiler (e.g., water heater, etc.) having a condition responsive feature.
- 137, Fluid Handling, subclasses 386 through 454 for apparatus that is condition responsive to a liquid level or maintains a liquid level.
- 417, Pumps, subclasses 36 through 41 for a pump drive motor that is condition responsive to accumulated liquid pumped into a receiver.

375.1 Heat accumulator:

This subclass is indented under subclass 373.1. Subject matter including means to store thermal energy for delivery to the liquid in the vessel.

SEE OR SEARCH THIS CLASS, SUBCLASS:

- 273.5, for a domestic oven using a heat accumulator (e.g., fireless cooker, etc.).

376.1 Heating fluid confining, directing, or shielding feature:

This subclass is indented under subclass 373.1. Subject matter including enclosing, guiding, or protecting means for regulating a hot liquid or gas used in heating the vessel or the liquid in the vessel.

SEE OR SEARCH THIS CLASS, SUBCLASS:

- 390.1, for an open-top liquid heating vessel that may include a lid having a heating wall structure.

SEE OR SEARCH CLASS:

- 99, Foods and Beverages: Apparatus, for apparatus combined with a food treating feature that is more than mere heating, subclass 447 for a cooking apparatus having a heat distributor.
- 122, Liquid Heaters and Vaporizers, for a closed or pressurized liquid heater or vaporizer for other than a stove or furnace, subclasses 18.1 through 18.4 for a stand boiler (e.g., water heater,

etc.) having a fluid fuel burner and heat exchange feature.

377.1 Heating fluid is a liquid or steam:

This subclass is indented under subclass 376.1. Subject matter wherein the heating fluid is a liquid (e.g., water, etc.) or a vapor emitted from a heated liquid.

- (1) Note. The heating liquid or steam may be the same as, separate from, or distinct from the liquid in the vessel.

SEE OR SEARCH THIS CLASS, SUBCLASS:

- 20 through 20.2, for a cooking stove having an oven heated by steam or hot water.
33, for a cooking stove having a table heated by steam or hot water.
281, 282, for a dough raiser that may be heated by steam or hot water.
284, for a glue pot that may be heated by steam or hot water.

SEE OR SEARCH CLASS:

- 220, Receptacles, subclass 23.91 for a receptacle having rigid, removable external jacket or casing or subclasses 62.11-62.22 for a receptacle side wall made of two or more layers of permanently attached material.

378.1 In closed chamber or coiled pipe to heat the liquid:

This subclass is indented under subclass 377.1. Subject matter including an enclosed space or cavity, or a conduit formed into a loop to transfer heat from the liquid or steam heating fluid to the liquid in the vessel.

- (1) Note. The term "closed" means the heating liquid or steam is separate from the liquid in the vessel and out of contact with the atmosphere.
(2) Note. This includes two or more vessels fitted together to form a closed chamber (e.g., double boiler, etc.).

SEE OR SEARCH CLASS:

- 392, Electric Resistance Heating Devices, subclasses 451 through 457 for a line connected tank or container-type liq-

uid heater having an immersion heating element or subclass 496 for continuous flow-type fluid heater using a fluid heated by the heating element for subsequent transmission to the flow path.

379.1 Steam jet directed into the liquid of vessel:

This subclass is indented under subclass 377.1. Subject matter wherein the liquid heater heats the liquid until vapor is emitted, then the confining or directing means ejects the vapor as a stream into the liquid of the vessel.

SEE OR SEARCH THIS CLASS, SUBCLASS:

- 348, for a liquid heating-type steam generator and cooker kettle furnace.

SEE OR SEARCH CLASS:

- 99, Foods and Beverages: Apparatus, for apparatus combined with a food treating feature that is more than mere heating, subclasses 467 through 482 for subjecting food to an enclosed modified atmosphere or subclasses 516-536 for means to treat food by applying a fluid.
261, Gas and Liquid Contact Apparatus, subclass 77 for a submerged blast injector device providing intimate contact between a gas and liquid.

380.1 And supply of the liquid to vessel:

This subclass is indented under subclass 373.1. Subject matter including means to store and dispense the liquid to the vessel.

- (1) Note. The liquid usually replaces that lost from the vessel by evaporation or is used to condense vapors within the vessel.
(2) Note. The supply of liquid to the vessel is other than returned condensed steam, boil over, or spatter from the liquid in the vessel.

SEE OR SEARCH THIS CLASS, SUBCLASS:

- 381.1, 382.1, for an open-top liquid heating vessel that may include a lid having a condenser for steam from the vessel.

383.1 through 386.1, for an open-top liquid heating vessel that may include a lid having a collecting, directing, or shielding feature for overflow or spatter of the liquid.

SEE OR SEARCH CLASS:

119, Animal Husbandry, for residual apparatus to care for a living animal, subclasses 74 through 81 for a watering fountain or trough having a supply.

122, Liquid Heaters and Vaporizers, for a closed or pressurized liquid heater or vaporizer for other than a stove or furnace, subclasses 451 through 458 for a water feeder combined with a boiler.

196, Mineral Oils: Apparatus, subclass 135 for special means for feeding oil to a vaporizer.

202, Distillation: Apparatus, a residual class, subclasses 262 and 263 for means to feed material in or discharge residue from a still or retort.

381.1 And condenser for steam from vessel:

This subclass is indented under subclass 373.1. Subject matter and means to convert vapor emitted from the heated liquid in the vessel back into the liquid.

SEE OR SEARCH THIS CLASS, SUBCLASS:

380.1, for an open-top liquid heating vessel that may include a lid and a supply of liquid to the vessel.

SEE OR SEARCH CLASS:

29, Metal Working, subclass 890.07 for a method of making a condenser, evaporator, or vaporizer.

99, Foods and Beverages: Apparatus, for apparatus combined with a food treating feature that is more than mere heating, subclasses 293 and 294 for a steamer- or condenser-type beverage infuser or subclass 347 for a condensing or self-basting cooker.

202, Distillation: Apparatus, a residual class, subclasses 185.1 through 196 for a still having a condenser.

382.1 Condenser is confined body of liquid:

This subclass is indented under subclass 381.1. Subject matter wherein the condenser is a contained bulk of fluid that is shapeless, virtually incompressible, and has a definite volume (e.g., water, etc.).

383.1 Collecting, directing, or shielding feature for overflow or spatter of the liquid:

This subclass is indented under subclass 373.1. Subject matter including amassing, guiding, or protecting means for regulating the liquid when it flows over the brim of or spurts forth in scattered drops from the vessel.

SEE OR SEARCH THIS CLASS, SUBCLASS:

380.1, for an open-top liquid heating vessel that may include a lid having a supply of liquid to the vessel.

387.1, for an open-top liquid heating vessel that may include a lid having an agitator or circulator using the heated liquid within the vessel and may prevent boil over.

389.1, for an open-top liquid heating vessel that may include a lid having a vent for steam emitted from the liquid that may be a passageway to a stove hole in a stove top.

SEE OR SEARCH CLASS:

99, Foods and Beverages: Apparatus, for apparatus combined with a food treating feature that is more than mere heating, subclass 375 for an opposed heated mold or surface-type (e.g., waffle iron, etc.) cooking apparatus having a drip or waste receptor, director, or trimmer.

220, Receptacles, subclass 4.03 for a container constructed of separate and distinct sections provided with an additional section to form an extension of its sidewall, subclass 571.1 for a drain or a drip pan attachable to a bucket or paint can, or subclasses 694-89.4 for a container attachment or adjunct.

384.1 And in closure for vessel (e.g., lid, etc.):

This subclass is indented under subclass 383.1. Subject matter wherein the open-top vessel and means to close or obstruct the opening having the collecting, directing, or shielding feature for the overflow or spatter of the liquid.

- (1) Note. The closure (e.g., a lid, etc.) may have more than one hole through it.

385.1 Annular receptacle for vessel:

This subclass is indented under subclass 383.1. Subject matter wherein the collecting, directing, or shielding feature is a channel or container encircling the vessel for the overflow or spatter of the liquid.

386.1 Restoring overflow or spatter to vessel:

This subclass is indented under subclass 385.1. Subject matter wherein the annular receptacle for the vessel includes means to return the overflowed or spattered liquid back into the vessel.

SEE OR SEARCH THIS CLASS, SUBCLASS:

- 384.1, for an open-top liquid heating vessel that may include a lid and a closure for the vessel having a collecting, directing, or shielding feature for overflow of the liquid.

387.1 Agitator or circulator using the heated liquid within:

This subclass is indented under subclass 373.1. Subject matter including means using thermal energy of the liquid heated within the vessel to cause stirring, shaking, or flowing of the liquid within the vessel.

- (1) Note. The agitating or circulating means may prevent boil over or burning of the liquid.

SEE OR SEARCH CLASS:

- 99, Foods and Beverages: Apparatus, for apparatus combined with a food treating feature that is more than mere heating, subclass 287 for a beverage infusor having means to agitate or compact the infusible material during infusion or subclass 348 for cooking

apparatus having means to stir the food during cooking.

- 165, Heat Exchange, for a residual heat transfer apparatus or process, subclass 108 for a heat exchanger having a delineated recirculation path between its discharge and inlet.
- 366, Agitating, subclasses 144 through 149 for agitating combined with heating or cooling.

388.1 And indicator or signaler feature:

This subclass is indented under subclass 373.1. Subject matter and means to display, notify, or warn of a condition or function of the liquid heater.

SEE OR SEARCH CLASS:

- 99, Foods and Beverages: Apparatus, for apparatus combined with a food treating feature that is more than mere heating, subclass 285 for a beverage infusor having signal, indicator, or observation means; or subclasses 342-344 for cooking apparatus having a signal, indicator, or tester means.
- 116, Signals and Indicators, for a general mechanical means to signal or indicate a condition or function.
- 206, Special Receptacle or Package, subclass 459.1 for a container with an indicator (i.e., variable information exhibiting means).

389.1 Vent for steam emitted from the liquid:

This subclass is indented under subclass 373.1. Subject matter wherein the open-top vessel that may include the lid has an opening for a vapor, arising from the liquid heated in the vessel, to escape.

- (1) Note. In the newer, 1960s and later patents, the vent is usually for pressure relief, while in the older patents, the vent is a passageway to a stove hole in a stove top usually for disposing of disagreeable cooking odors.

SEE OR SEARCH THIS CLASS, SUBCLASS:

- 299 through 303, for a stove hood designed to carry off an odor from a stove.

383.1 through 386.1, for an open-top liquid heating vessel that may include a lid having a collecting, directing, or shielding feature for overflow or spatter of the liquid.

390.1 Heating wall structure:

This subclass is indented under subclass 373.1. Subject matter wherein the vessel has a material layer makeup or arrangement between the liquid in the vessel and the thermal energy from the liquid heater.

- (1) Note. This heating wall may modify conduction, area, or distribution of the heat within the vessel.
- (2) Note. This heating wall may be separable from the vessel.

SEE OR SEARCH THIS CLASS, SUBCLASS:

376.1 through 391.1, for an open-top liquid heating vessel that may include a lid having a heating fluid confining, directing, or shielding feature.

SEE OR SEARCH CLASS:

- 99, Foods and Beverages: Apparatus, for apparatus combined with a food treating feature that is more than mere heating, subclass 447 for a cooking apparatus having a heat distributor.
- 122, Liquid Heaters and Vaporizers, for a closed or pressurized liquid heater or vaporizer for other than a stove or furnace, subclasses 18.1 through 18.4 for a stand boiler (e.g., water heater, etc.) having a fluid fueled burner and heat exchange feature.
- 165, Heat Exchange, for a residual heat transfer apparatus or process that may include a heating wall structure.

391.1 Flue penetrates wall of vessel into the liquid:

This subclass is indented under subclass 376.1. Subject matter wherein the confining or directing means is a pipe or passageway for exhausting flame or smoke, passing through a side of the vessel into the liquid.

392.1 The liquid circulating between external heating tube and vessel:

This subclass is indented under subclass 377.1. Subject matter wherein the confining or directing means is a fluid flow circuit including the liquid in the vessel and a thermal energy receiving hollow elongated cylinder outside the vessel.

400 HEAT ACCUMULATOR STRUCTURES:

This subclass is indented under the class definition. Devices consisting of bodies which are so constituted or constructed as to be capable of absorbing quantities of heat energy large relative to their mass or volume and being adapted for use as either a source or reservoir of heat energy. These bodies are frequently the heat sources in so-called "Fireless Cookers" and body warmers.

SEE OR SEARCH THIS CLASS, SUBCLASS:

- 39, for gas stoves combined with "Fireless Cookers".
- 87+, 92 and 512, for gas or liquid burning heating stoves or fireplaces having heating elements against which the flames impinge.
- 204, and 263.01-263.1, for heating devices including means undergoing a chemical change, other than combustion, to give off heat.
- 207, for block type body warmers.
- 246, for dishes having heat accumulators, either liquid or solid.
- 273.5, for fireless cookers.
- 375.1, for heat accumulator bodies incorporated in a liquid heater.

SEE OR SEARCH CLASS:

- 62, Refrigeration, subclass 293 for a hand manipulable cooling tool, subclass 437 for a refrigeration system with a nonliquid heat accumulator, and subclass 530 for an envelope type refrigerant container.
- 110, Furnaces, subclasses 322+ for baffles and heat retainers.
- 132, Toilet, subclass 117 for toilet combs with a removable heat accumulator, and subclasses 233+ for hair curlers comprising a tube acting as a mandrel around which hair is wound, a jaw

- clamping the hair to the mandrel, and a rod separately heatable and insertable in the mandrel to heat it.
- 165, Heat Exchange, subclasses 4+ for a regenerative heat exchange having heat accumulator structure.
- 237, Heating Systems, subclasses 44 and 75 for car heating systems and steam radiators with heat accumulators.
- 252, Compositions, subclasses 67+, 70 and 71+ for compositions which absorb and give off heat without undergoing a chemical change.
- 431, Combustion, subclass 170 for a furnace in which the fuel nozzle feeds into a permeable mass within the furnace.
- 501, Compositions: Ceramic, subclasses 94+ for refractory compositions.
- 401 TOOL HAVING FLUID FUEL BURNER:**
This subclass is indented under the class definition. Miscellaneous tool having a work engaging member which is heated by a fluid fuel combustion device integral with the work engaging member.
- 402 Branding iron:**
This subclass is indented under subclass 401. Tool adapted to making distinctive marks by burning a surface.
- 403 Gas:**
This subclass is indented under subclass 402. Branding iron employing gaseous fuel.
- 404 Hydrocarbon reservoir:**
This subclass is indented under subclass 402. Branding iron provided with a liquid fuel holding receptacle, usually in the handle, for supplying fuel to the heating burner.
- 405 Burning tool:**
This subclass is indented under subclass 401. Tool employed in the burning of wood and other substances.
- 406 Gas:**
This subclass is indented under subclass 405. Tool burning gas.
- 407 Hydrocarbon reservoir:**
This subclass is indented under subclass 405. Tool provided with a liquid holding receptacle for supplying fuel to the heating burner.
- 408 Curling iron:**
This subclass is indented under subclass 401. Tool used to set the curl in hair by heat.
- 409 Hydrocarbon reservoir:**
This subclass is indented under subclass 408. Curling iron provided with means to utilize liquid fuel as a heating agent.
- 410 Roll heating type:**
This subclass is indented under subclass 401. Subject matter including a burner combined with and heating and ironing roll, burnishing-machine, or similar structure.
- SEE OR SEARCH CLASS:
492, Roll or Roller, for a roll, per se, not elsewhere provided for, and see the notes thereunder.
- 411 Sadiron:**
This subclass is indented under subclass 401. Subject matter comprising a movable heavy smooth planar surface adapted to be heated and used for "pressing".
- SEE OR SEARCH CLASS:
38, Textiles: Ironing or Smoothing, subclasses 74+, and the notes thereunder, for other flatirons.
- 412 Hydrocarbon reservoir:**
This subclass is indented under subclass 411. Sadiron structurally adapted to the use of liquid fuel and provided with an attached liquid fuel reservoir.
- 413 Soldering iron:**
This subclass is indented under subclass 401. Tool adapted to melt solder and apply it between surfaces of parts to joint them.
- SEE OR SEARCH CLASS:
219, Electric Heating, subclasses 227+ for a soldering iron having electrical structure or characteristics.
228, Metal Fusion Bonding, subclass 53 for a soldering iron having means to

heat the iron and combined with means to handle flux or solder.

414 Hydrocarbon reservoir:

This subclass is indented under subclass 413. Soldering iron provided with a liquid fuel holding receptacle, usually in the handle, for supplying fuel to the heating burner.

500 FIREPLACES OR ACCESSORIES:

This subclass is indented under the class definition. Subject matter comprising structure for providing a flame within an inhabitable enclosure and which, in one condition of operation, provides visibility of the flame to inhabitants in the enclosure; or auxiliary devices particularly intended to be used with such structure.

SEE OR SEARCH THIS CLASS, SUBCLASS:
298, for andirons used in a fireplace.

501 Hopper feed of solid fuel:

This subclass is indented under subclass 500. Subject matter wherein means are provided to dispense solid combustible material to the flame from a receptacle spaced from the flame.

SEE OR SEARCH THIS CLASS, SUBCLASS:
10, and see the notes thereunder for other hopper feeds.

502 Condition responsive control:

This subclass is indented under subclass 500. Subject matter including means to sense a condition or change of condition in the environment or in the operation of said structure or device; and said means effects a control function on the operation of said structure or device.

503 Of fluid fuel feed:

This subclass is indented under subclass 502. Subject matter wherein a combustible material providing the flame is a liquid or gas, and wherein said control function affects the rate of flow of said liquid or gas.

504 Of flue damper:

This subclass is indented under subclass 502. Subject matter including an adjustable closure plate in a channel leading from the flame to the exterior of the enclosure, and wherein said con-

trol function affects the degree of closure of said channel by said plate.

505 With article warming shelf on grate:

This subclass is indented under subclass 500. Subject matter including a ledge for supporting an object, said ledge being attached to means for holding solid fuel so that said object may be heated by the flame.

506 With food cooker:

This subclass is indented under subclass 500. Subject matter including means supporting or otherwise facilitating the heating of a solid edible material by said flame.

SEE OR SEARCH THIS CLASS, SUBCLASS:

505, for a shelf attached to a grate to heat objects placed on the shelf.

507 With filter:

This subclass is indented under subclass 500. Subject matter including means to separate solid particles from a fluid entering or leaving the vicinity of the flame.

508 With room humidifier:

This subclass is indented under subclass 500. Subject matter including means to add moisture in the form of vapor to the environment within said inhabitable enclosure.

SEE OR SEARCH THIS CLASS, SUBCLASS:

113, and 313, for other air moistening devices.

SEE OR SEARCH CLASS:

261, Gas and Liquid Contact Apparatus, for humidifiers, per se.

509 For heating plural rooms:

This subclass is indented under subclass 500. Subject matter including means to direct heat from said flame to another inhabitable enclosure.

510 Fireplace in dividing wall:

This subclass is indented under subclass 509. Subject matter wherein said flame is located in a partition separating said inhabitable enclosures.

- 511 Rotatable fire chamber:**
This subclass is indented under subclass 510. Subject matter wherein means supporting said flame is movable about a vertical axis to permit said flame to be viewed selectively by inhabitants in one or the other of said inhabitable enclosures.
- 512 Fluid fuel:**
This subclass is indented under subclass 500. Subject matter wherein a primary combustible material providing said flame is in the form of a liquid or gas.
- (1) Note. While many of the patents relating to open front liquid and gaseous fuel heating stoves in subclasses 86+ and 93+ of this class (126) may belong under subclasses 500+ of this class in a hierarchical placement of patents, subclasses 86+ and 93+ were not made a part of or screened in this project gathering art relating to fireplaces. Thus, subclasses 86+ and 93+ must be searched for patents relating to viewable fires having a liquid or gaseous fuel.
- SEE OR SEARCH THIS CLASS, SUBCLASS:
503, for condition responsive control of the rate of flow of fluid fuel.
- 513 With liquid heater:**
This subclass is indented under subclass 500. Subject matter wherein means to hold a liquid is located near the vicinity of said flame to heat said liquid.
- SEE OR SEARCH THIS CLASS, SUBCLASS:
508, for a heated liquid holder to add humidity to a room.
- 514 And means conducting liquid to room heater:**
This subclass is indented under subclass 513. Subject matter including a conduit providing a flow path for said liquid from said flame vicinity to a heat exchanger located within said inhabitable enclosure.
- SEE OR SEARCH THIS CLASS, SUBCLASS:
509+, for structure for heating plural rooms by a liquid heated in a fireplace.
- 515 Inlet air supply from outside fireplace room:**
This subclass is indented under subclass 500. Subject matter including means providing a flow path for air leading to the vicinity of said flame from a location remote from said inhabitable enclosure.
- 516 With air pump:**
This subclass is indented under subclass 515. Subject matter including a device for moving the air along said flow path.
- 517 And air flow regulator:**
This subclass is indented under subclass 516. Subject matter including means to control the amount of air reaching same flame from said flow path.
- 518 With air flow regulator:**
This subclass is indented under subclass 515. Subject matter including means to control the amount of air reaching same flame from said flow path.
- SEE OR SEARCH THIS CLASS, SUBCLASS:
517, for a flow regulator associated with a pump supplying exterior air.
- 519 Circular viewability of flame:**
This subclass is indented under subclass 500. Subject matter wherein same flame is viewable by inhabitants within said enclosure at any point along a 360° arc surrounding the flame.
- 520 Insertable into existing window:**
This subclass is indented under subclass 500. Subject matter including means accommodating a firebox structure for positioning it in a pre-existing opening constructed to admit light or air to said inhabitable enclosure.
- 521 With air pump:**
This subclass is indented under subclass 500. Subject matter including a device for moving air from an air inlet to the vicinity of the flame.

- SEE OR SEARCH THIS CLASS, SUB-CLASS:
516, for an air pump associated with a remote air supply.
- 522 Tubular heat exchanger:**
This subclass is indented under subclass 521. Subject matter including a conduit, generally circular or square in cross-section, in fluid flow communication with same device; said conduit being positioned in proximity to said flame or to hot combustion gases to provide heat exchange between said flame and air flowing through said conduit.
- 523 With heat exchanger for room heating air:**
This subclass is indented under subclass 500. Subject matter including structure for directing inlet air along a defined flow path in contact with a surface heated by the flame or combustion gases, then directing the heated air to the inhabitable enclosure; or structure for directing hot combustion gases through a conduit within the inhabitable enclosure to a heat transmitting surface remote from the flame.
- SEE OR SEARCH THIS CLASS, SUB-CLASS:
521+, for heat exchangers associated with an air pump.
- 524 Tubular:**
This subclass is indented under subclass 523. Subject matter wherein said heated surface is generally circular or square in cross-section.
- 525 Secondary outlet leads air to flame:**
This subclass is indented under subclass 524. Subject matter including means defining an opening along said flow path in the vicinity of the flame for injecting air into the flame to aid in combustion.
- 526 With air flow regulator:**
This subclass is indented under subclass 524. Subject matter including means to control the amount of air flowing through said flow path.
- 527 Secondary outlet leads air to flame:**
This subclass is indented under subclass 523. Subject matter including means defining an opening along said flow path in the vicinity of
- the flame for injecting air into the flame to aid in combustion.
- SEE OR SEARCH THIS CLASS, SUB-CLASS:
525, for secondary outlet associated with a tubular heat exchanger.
- 528 Air flow path between exterior surface of heat exchanger and facing building surface:**
This subclass is indented under subclass 523. Subject matter wherein said heated surface is positioned in a location opposite a building wall surface so that said flow path is defined by the building wall surface and the heated surface.
- 529 And additional flow path through hollow walled heat exchanger:**
This subclass is indented under subclass 528. Subject matter wherein structure around said flame includes a wall having plates spaced apart from each other to define a conduit for receiving air from said flow path and directing the air to flow between the plates.
- 530 With air flow regulator:**
This subclass is indented under subclass 528. Subject matter including means to control the amount of air flowing through said flow path.
- 531 Hollow side walls in heat exchanger:**
This subclass is indented under subclass 523. Subject matter wherein said structure includes spaced apart plates along each side of the flame, and said spaced apart plates define a flow path for air along opposite sides of the flame.
- 532 With means facilitating ash removal:**
This subclass is indented under subclass 523. Subject matter and further including a device to facilitate the removal of solid products of combustion from a location beneath the flame.
- 533 With air flow regulator:**
This subclass is indented under subclass 523. Subject matter including means to control the amount of air flowing through said flow path.

- SEE OR SEARCH THIS CLASS, SUB-CLASS:
517, 518, 526, and 530, for air flow regulation in the specific structure provided for therein.
- 534 And adjustable flue damper:**
This subclass is indented under subclass 533. Subject matter, and further including a closure plate in a channel leading from the flame to the exterior of the enclosure, and wherein means is provided for moving said plate to affect the amount of combusted gases passing through said channel.
- 535 And adjustable flue damper:**
This subclass is indented under subclass 523. Subject matter and further including a closure plate in a channel leading from the flame to the exterior of the enclosure, and wherein means is provided for moving said plate to affect the amount of combusted gases passing through said channel.
- SEE OR SEARCH THIS CLASS, SUB-CLASS:
534, for an adjustable flue damper combined with an air flow regulator.
- 536 Adjustable flue damper:**
This subclass is indented under subclass 500. Subject matter including a closure plate in a channel leading from the flame to the exterior of the enclosure, and means for moving said closure plate to affect the amount of combusted gases passing around said plate.
- SEE OR SEARCH THIS CLASS, SUB-CLASS:
504, for a condition responsive flue damper; and subclasses 534 and 535 for an adjustable flue damper associated with a fireplace having a heat exchanger.
- 537 Screw operator:**
This subclass is indented under subclass 536. Subject matter wherein said means for moving said closure plate comprises interengaging helical threads relatively rotatable by an inhabitant in said closure.
- 538 Variable predetermined positions:**
This subclass is indented under subclass 536. Subject matter including means holding said closure plate in a plurality of preset positions.
- 539 From exterior of front face of fireplace:**
This subclass is indented under subclass 536. Subject matter wherein said means for moving same closure plate extends into said closure plate extends into said inhabitable enclosure from a position in said channel.
- 540 Grate structure:**
This subclass is indented under subclass 500. Subject matter including means to support a solid combustible material above a floor beneath the flame.
- 541 Relatively movable parts:**
This subclass is indented under subclass 540. Subject matter wherein said combustible material support is formed of plural parts movable with respect to each other for assembly of said support or for adjusting the position or size of said support; or wherein said support is mounted so as to facilitate movement of said support relative to said floor.
- 542 Including means facilitating ash removal:**
This subclass is indented under subclass 541. Subject matter wherein said parts are movable to and fro to dislodge solid products of combustion from said support; or wherein said support is mounted in a manner capable of being tilted to dislodge the products of combustion.
- SEE OR SEARCH THIS CLASS, SUB-CLASS:
532, for means facilitating ash removal in combination with heat exchanger structure in a fireplace.
- 543 With removable ash pan:**
This subclass is indented under subclass 542. Subject matter including a receptacle slidable into and out of a position below the combustible material support to facilitate removal of the solid products of combustion.
- 544 Front barrier or guard:**
This subclass is indented under subclass 500. Subject matter including protection means positioned between the flame and the inhabit-

- able enclosure to protect the inhabitable enclosure or inhabitant thereof from the flame, smoke or embers.
- SEE OR SEARCH THIS CLASS, SUB-CLASS:
298, for andirons used in a fireplace.
- SEE OR SEARCH CLASS:
160, Flexible or Portable Closure, Partition, or Panel, appropriate subclasses for barriers or partitions wherein specific fireplace features or relationships are not claimed.
- 545 With particular seal:**
This subclass is indented under subclass 544. Subject matter wherein significance is attributed to means for preventing air or smoke seepage between abutting surfaces on said protection means and structure surrounding said flame.
- 546 Vertically adjustable:**
This subclass is indented under subclass 544. Subject matter wherein said protective means is provided with structure to alter the vertical distance between a bottom edge of said protective means and a hearth portion extending from beneath the flame.
- 547 Solid front cover:**
This subclass is indented under subclass 544. Subject matter wherein said protection means comprises an imperforate barrier between the flame and the inhabitable enclosure.
- 548 And perforated screen:**
This subclass is indented under subclass 547. Subject matter and further comprising an apertured barrier between the flame and the inhabitable enclosure.
- 549 And auxiliary air flow adjuster:**
This subclass is indented under subclass 547. Subject matter wherein a wall portion beneath said imperforate barrier includes means to regulate the amount of air admitted to the flame when the barrier is closed.
- SEE OR SEARCH THIS CLASS, SUB-CLASS:
517, and 518, for air flow regulators used in conjunction with exterior air, and subclasses 526, 530 and 533+ for air regulators used to adjust flow through a heat exchanger.
- 550 Smoke collecting hood:**
This subclass is indented under subclass 544. Subject matter wherein said protection means comprises means extending into the inhabitable enclosure from the front, upper face of structure surrounding the flame to prevent smoke from dispersing into the enclosure.
- 551 Screen slidable on track:**
This subclass is indented under subclass 544. Subject matter wherein said protection means comprises a barrier supported for opening and closing movement along a horizontally extending guideway.
- 552 Heat reflecting structure:**
This subclass is indented under subclass 500. Subject matter wherein significance is attributed to the material or configuration of a wall surface for throwing heat from the flame into the inhabitable enclosure.
- 553 Adjustable:**
This subclass is indented under subclass 552. Subject matter wherein said wall surface is movable into any of a plurality of positions.
- 554 With means facilitating ash removal:**
This subclass is indented under subclass 500. Subject matter including a device to facilitate removal of solid products of combustion from a location beneath the flame.
- SEE OR SEARCH THIS CLASS, SUB-CLASS:
532, for ash removal facilities in a heat exchanger fireplace environment, and subclasses 542+ for ash removal facilities in combination with a grate.
- 555 Removable ash pan:**
This subclass is indented under subclass 554. Subject matter wherein said device comprises a receptacle slidable into and out of a position below the flame.

561 SOLAR HEAT COLLECTOR FOR POND OR POOL:

This subclass is indented under the class definition. Apparatus wherein a device to collect the heat of solar radiation includes means to transfer the heat from the device to an open body of liquid in the ground (i.e., pond) or to a body of water normally used for swimming (i.e., pool).

SEE OR SEARCH CLASS:

4, Baths, Closets, Sinks, and Spitoons, subclasses 487 and 488+ for pool structure, per se.

562 Including auxiliary source for adding heat to pool:

This subclass is indented under subclass 561. Apparatus and further including a heater other than solar for providing additional heat to water in the pool.

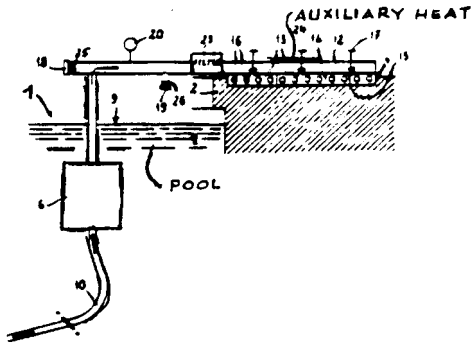

563 Remotely located from pool:

This subclass is indented under subclass 561. Apparatus in which the device is spaced away from the pool.

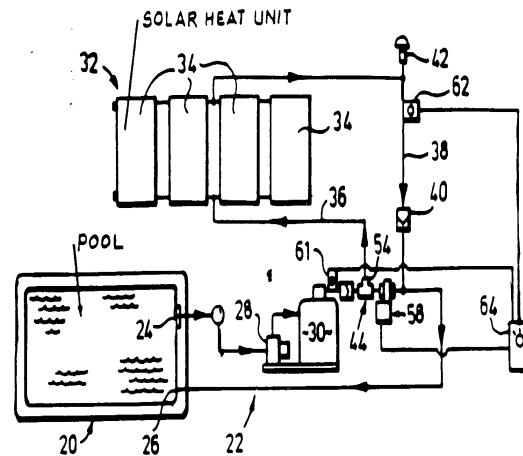

A solar heating system for a swimming pool and the like is disclosed. The system includes a circulation circuit having a pump by which water is withdrawn from the pool, passed through a filter, and returned to the pool. A solar collector assembly is provided and has flow and return lines connected in said circuit.

564 Within pool water:

This subclass is indented under subclass 561. Apparatus wherein the device is totally submerged in the pool water.

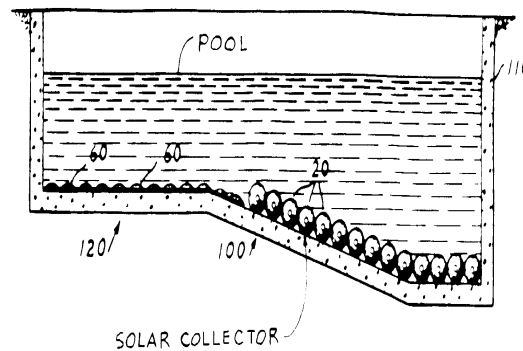

565 On pool water surface:

This subclass is indented under subclass 561. Apparatus wherein at least a portion of the device contacts the surface of the pool water.

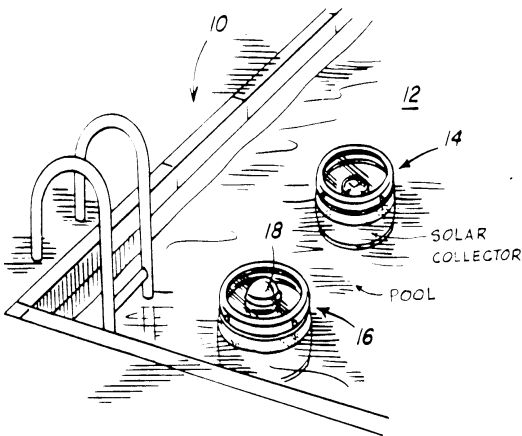

566 Pool cover is collector:

This subclass is indented under subclass 565. Apparatus wherein the device serves an additional function of concealing or protecting the pool.

- (1) Note. Pool cover may cover or protect only part of the pool area.

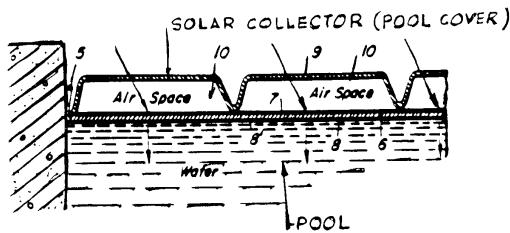

SEE OR SEARCH CLASS:

- 4, Baths, Closets, Sinks, and Spitoons, subclasses 498+ for pool cover, per se.

567 With means to extract heat from pond liquid:

This subclass is indented under subclass 561. Apparatus and further including means to transfer heat from the liquid in the pond to a heat utilization area.

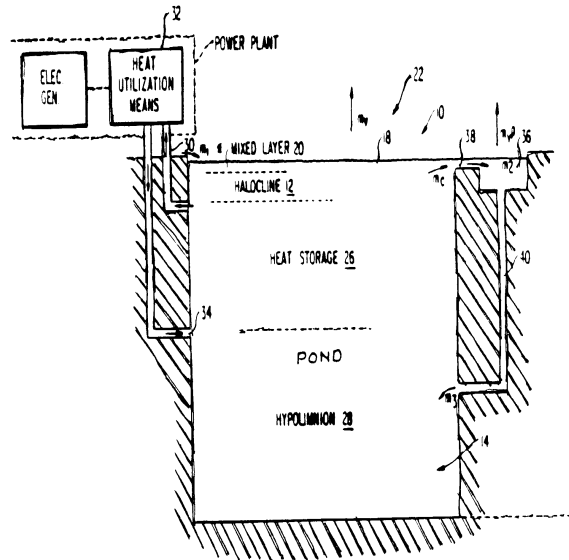

568 In contact with pond liquid:

This subclass is indented under subclass 561. Apparatus wherein the device touches the liquid in the pond.

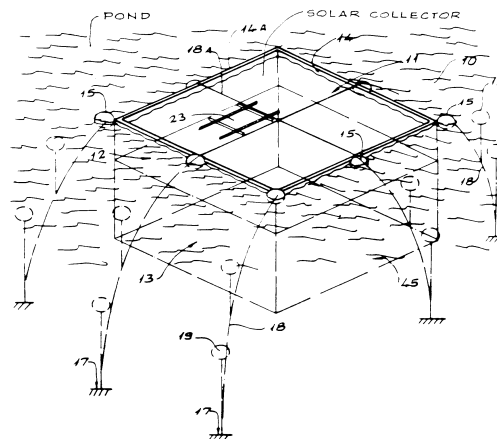

569 SOLAR HEAT COLLECTOR:

This subclass is indented under the class definition. Apparatus having (1) means to direct solar radiation and support means for an article to be heated by the directed radiation or (2) means to convert solar radiation to heat.

- (1) Note. The "means" of clause (2) may be combined with (a) means to concentrate or direct solar radiation to the converting means, or (b) a spaced cover or enclosure.

sure for the converting means, or (c) a means to utilize the heat to heat a fluent medium (i.e., a gas, liquid, or a flowable solid), or (d) a support for the converting means.

SEE OR SEARCH THIS CLASS, SUB-CLASS:

400, for means, per se, for storing heat which may have been derived from a solar collector.

SEE OR SEARCH CLASS:

23, Chemistry: Physical Processes, subclass 295 for subject matter utilizing solar energy for crystallizing a substance.

29, Metal Working, subclass 890.033 for making solar energy device.

34, Drying and Gas or Vapor Contact With Solids, subclass 93 for subject matter utilizing solar energy to dry material.

47, Plant Husbandry, subclasses 17, 59, and 65 for a greenhouse or other structure with specific means for holding or growing a plant in combination with solar heating means for the greenhouse or plant.

52, Static Structures (e.g., Buildings), for a building structure, per se.

60, Power Plants, subclasses 641.1+ for a power plant operated by means of heat from the sun.

62, Refrigeration, subclass 235.1 for a refrigeration system utilizing solar energy.

136, Batteries: Thermoelectric and Photoelectric, subclass 206 for electric power generator utilizing solar energy; and subclasses 243+ for a solar concentrator, orientator, or reflector in combination therewith which changes solar radiation into electrical energy. Where the sole disclosure of the collector is a Class 136 device and is claimed broadly, classification is in Class 136. For a disclosure of diverse collectors classifiable in different classes and claimed merely as a collector, classification is in Class 126. When a Class 136 collector is claimed, classification is in Class 136.

159, Concentrating Evaporators, subclasses 1.1 and 902+ for a concentrator utilizing solar energy.

165, Heat Exchange, especially subclasses 48.1 and 48.2 for a combined heating and cooling means which utilizes solar energy.

202, Distillation: Apparatus, subclass 234 for distillation by solar energy.

203, Distillation: Processes, Separatory, Digest 1 and subclasses 10 and 100 for a distillation process utilizing solar energy.

237, Heating Systems, for a method, apparatus for heating a room, chamber, house, or other enclosing structure wherein the source of heat claimed is other than a solar collector.

244, Aeronautics and Astronautics, subclass 168 for control of attitude of a spacecraft by solar pressure.

323, Electricity: Power Supply or Regulation Systems, subclass 906 for subject matter utilizing solar energy.

359, Optical: Systems and Elements, subclasses 619+ and 642+ for a lense; and subclasses 871+ for a reflector, per se, used to concentrate solar energy.

422, Chemical Apparatus and Process Disinfecting, Deodorizing, Preserving, or Sterilizing, subclasses 22+ for subject matter utilizing solar energy.

428, Stock Material or Miscellaneous Articles, for a particular coating or surface preparation for absorbing solar energy.

570 Having external damage preventer:

This subclass is indented under subclass 569. Apparatus having a structure designed to withstand or otherwise obstruct the impact of a means external of the converting means which might damage the converting means were it not for the presence of the structure.

SEE OR SEARCH THIS CLASS, SUB-CLASS:

572+, for internal damage prevention, e.g., pressure, temperature, etc.

571 Comprising movable support:

This subclass is indented under subclass 570. Apparatus wherein the structure to withstand or otherwise obstruct impact carries the weight of the converting means and is designed to permit physical adjustment of the converting means.

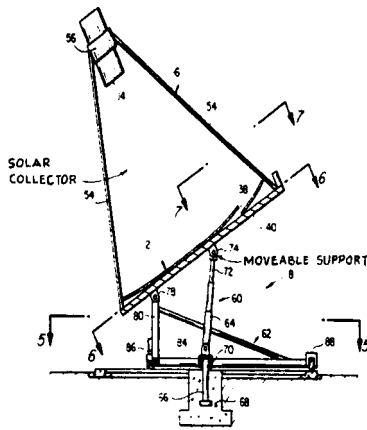

A solar concentrator is disclosed herein and includes a modularized point focusing solar concentrating panel which is movably mounted to track the sun. This panel has an overall parabolic reflecting surface and a triangular or approximately triangular configuration which improves structural integrity, minimizes wind resistance, and permits rapid and easy stowing.

572 With control means energized in response to actuator stimulated by condition sensor:

This subclass is indented under subclass 569. Apparatus having a device for sensing ambient condition, condition within the converting means, or sensing a condition of a fluent medium as it passes into, through, or from the converting means and operates to affect the fluent in some manner (e.g., as by affecting its flow, pressure, or temperature) or to operate a structure to block or permit more or less of the available solar radiation to reach the converting means or to move the converting means depending on the position of the sun.

573 Including sun position tracking sensor:

This subclass is indented under subclass 572. Apparatus including a supporting base wherein the sensing means is adapted to follow the sun and activate structure to move the converting means with respect to the base according to the position of the sun.

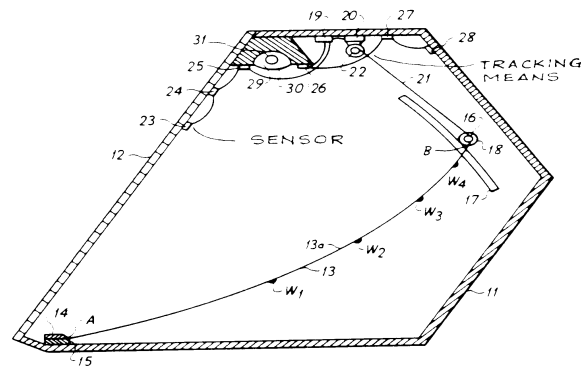

A focusing solar collector which utilizes an elongated parabolic shaped mirror made from a sheet of drapable material so that when draped in a catenary-like curved configuration, the sun's rays may be focused on a linear target which is axially aligned with the axis of the mirror. Means are provided for adjusting the angle of the drape of the catenary-like curve in order to maintain the focus of the sun's rays on the linear target as the relative diurnal positions of the sun to the collector changes. The optimum catenary like curve for the range of the drape angles involved is achieved by using a nonlinear distribution of weight along the cross-section of the draped mirror material.

SEE OR SEARCH THIS CLASS, SUB-CLASS:

600, for a device for repositioning of solar collector for optimum radiation exposure without a condition responsive control.

SEE OR SEARCH CLASS:

250, Radiant Energy, subclass 203.4 for a tracking system, per se, which may be used for moving a solar collector to follow the sun.

353, Optics: Image Projectors, subclass 3 for a heliostat.

574 With computer:

This subclass is indented under subclass 573. Apparatus which further includes a unit capable of processing, retrieving, and storing programmed information.

575 With timer:

This subclass is indented under subclass 573. Apparatus which further includes an instrument for measuring intervals of time to move the converting means.

576 With motor:
This subclass is indented under subclass 573. Apparatus wherein means to operate the structure includes an engine.

577 With gear:
This subclass is indented under subclass 576. Apparatus wherein means to operate the structure includes an input member which transmits motion to an output member by rolling contact between surfaces of the members, and wherein the input member is driven by an engine.

578 Electronic sensor:
This subclass is indented under subclass 573. Apparatus wherein the sensing means includes a device that determines or measures change in the electrical property of a material.

579 Fluid expansion sensor:
This subclass is indented under subclass 573. Apparatus wherein the sensing means includes a device which detects change in volume of a liquid or gas.

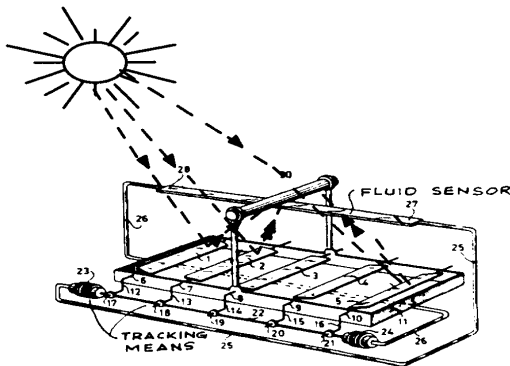

A solar collector includes a plurality of elongated parallel reflectors mounted for rotation about their respective longitudinal axes, together with mechanism coupled to the reflectors for simultaneously rotating the same. An elongated absorber is arranged parallel to the reflectors for collecting solar radiation focussed thereon by the reflectors. Tracking means including two solar sensor reservoirs containing a vaporizable/condensable liquid working medium is provided for rotation of the reflectors to control the focussing of solar radiation on the absorber.

580 Gas:
This subclass is indented under subclass 579. Apparatus wherein the device detects change in volume of a gas.

581 Solid expansion sensor:
This subclass is indented under subclass 573. Apparatus wherein the sensing means includes a device which detects change in the volume of a solid material.

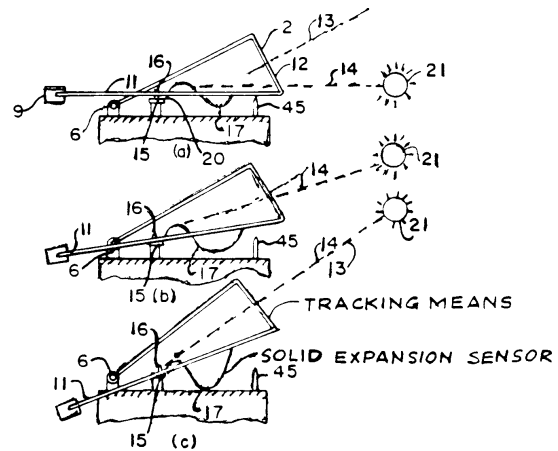

A solar energy conversion device is provided with simplified means for tracking a source of solar energy. In the preferred embodiment, the tracking means is a predeterminedly shaped, heat expandable device operatively connected to an energy concentrator. The energy concentrator is movably mounted and is adapted to direct concentrated energy either towards a suitable energy conversion means in those positions in which the concentration is aligned with respect to the solar energy source, or towards the expandable device in those positions in which the concentrator is misaligned with respect to the solar energy source. Application of concentrated solar energy to the expandable device causes its expansion, which expansion is utilized to move the concentrator into alignment with the energy source. At alignment, concentrated energy is directed from the expandable device toward the energy conversion means.

582 Phase change sensor:
This subclass is indented under subclass 573. Apparatus wherein the sensing means includes a device which detects a transformation of state of substance (e.g., from solid to liquid or from liquid to gas).

- 583 Of fluent medium:**
This subclass is indented under subclass 572. Apparatus wherein the sensing means operates a device to affect the fluent medium.
- 584 Pressure responsive:**
This subclass is indented under subclass 583. Apparatus wherein the sensed condition is the pressure of the fluent medium.
- 585 Temperature responsive:**
This subclass is indented under subclass 583. Apparatus wherein the sensed condition is the temperature of the fluent medium.
- 586 Set point control:**
This subclass is indented under subclass 585. Apparatus wherein at a predetermined temperature of the fluent medium, the fluent affecting device is operated.
- 587 Differential temperature control:**
This subclass is indented under subclass 585. Apparatus wherein a difference between two temperatures is measured and in response to such measurement, a device is actuated to such measurement, a device is actuated to operate a function of the converting means.

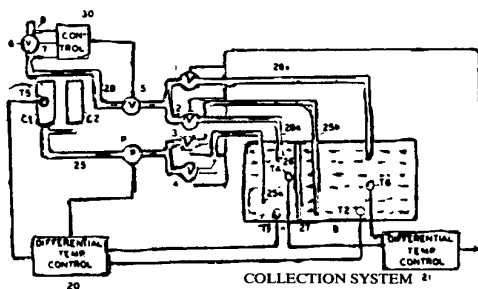

Solar heating system. A solar connector. A double storage device connected to the collector to provide coolest possible heat transport medium at beginning of each day's collection and to control collector input temperature hence maximum collection efficiency. The first storage device has a capacity for approximately one day's operation. The second storage device has a capacity for several days' operation. The operation of the storage devices are controlled so that the first storage device is heated first and when the first storage device is heated sufficiently then the second storage device is heated. The operation of the storage device is used first

for heating and when the first storage device is depleted of useable heat then the second storage device is used.

- 588 Freezing prevention:**
This subclass is indented under subclass 585. Apparatus wherein in response to the sensed temperature condition, a device is actuated to prevent the fluent medium from changing to its solid state.

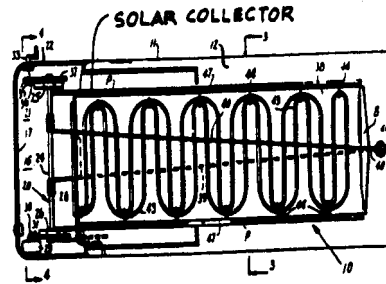

A self-storing solar heater is disclosed installed on a house trailer with the heater being extendable over a portion of the roof of the trailer to receive the rays of the sun during the day and is stored in a heated compartment on cold days and nights to prevent the water in the solar heater from freezing. A thermostatically controlled motor driven reel retracts the solar heater into the heated storage compartment and a pulley system actuated by the same motor extends the solar heater when heating rays are available from the sun.

- 589 Overheating prevention:**
This subclass is indented under subclass 585. Apparatus wherein in response to the sensed temperature condition, a device is actuated to prevent the fluent medium from getting overheated.
- 590 Fluid level responsive:**
This subclass is indented under subclass 583. Apparatus wherein the sensed condition is the location of the surface of the fluent medium relative to its container.

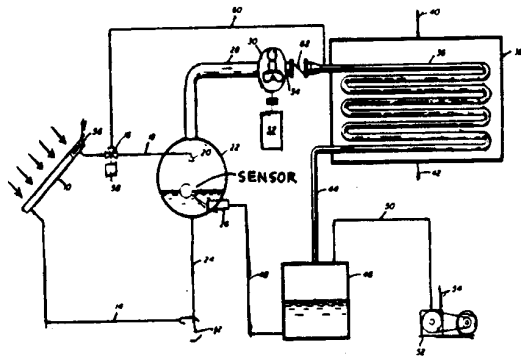

591 Of fluid flow:
 This subclass is indented under subclass 583. Apparatus wherein in response to the sensed condition the fluid is affected in some manner (e.g., as by affecting its flow or temperature or pressure).

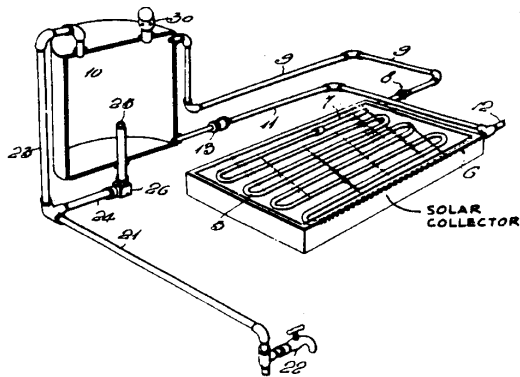

592 Liquid:
 This subclass is indented under subclass 591. Apparatus wherein the fluent medium is liquid.

593 Of collector:
 This subclass is indented under subclass 572. Apparatus wherein the sensing means operates a device to affect the solar heat unit.

594 Pressure responsive:
 This subclass is indented under subclass 593. Apparatus wherein the sensed condition is the pressure within the apparatus.

595 Temperature responsive:
 This subclass is indented under subclass 593. Apparatus wherein the sensed condition is the temperature within the apparatus.

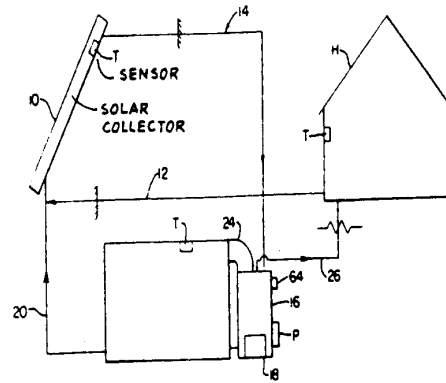

596 Set point control:
 This subclass is indented under subclass 595. Apparatus wherein at a predetermined temperature within the apparatus, the apparatus affecting device is operated.

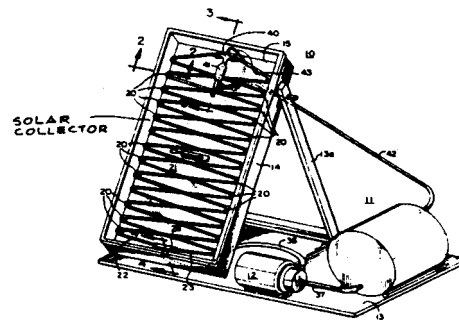

A solar heating system is provided which utilizes the sun's rays to heat fluid in a solar panel, which heated fluid is released to a storage tank when it reaches a predetermined temperature, and where it is available for withdrawal from the tank for heat exchange as desired.

597 Differential temperature control:
 This subclass is indented under subclass 595. Apparatus wherein a difference between two temperatures is measured and in response to such measurement, a device is actuated to operate a function of the apparatus.

598 Freezing prevention:

This subclass is indented under subclass 595. Apparatus wherein in response to the sensed temperature condition, a device is actuated to protect the apparatus against damage due to cold weather.

599 Overheating prevention:

This subclass is indented under subclass 595. Apparatus wherein in response to the sensed temperature condition, a device is actuated to protect the apparatus from damage due to excessive heat build-up within the apparatus.

600 With means to reposition solar collector for optimum radiation exposure:

This subclass is indented under subclass 569. Apparatus wherein an actuating device moves the apparatus to permit a desired amount of solar radiation to be received by the apparatus.

- (1) Note. The actuating device does not include sensor.

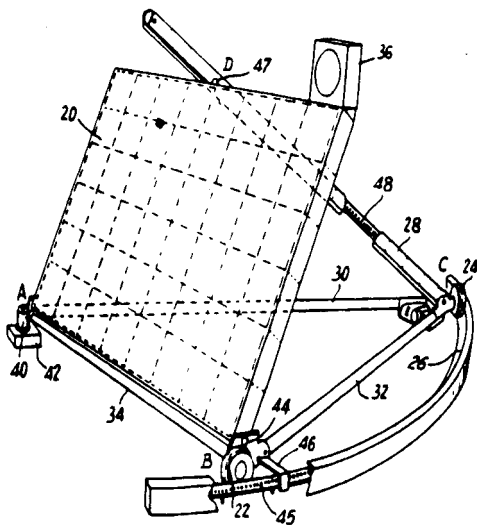

A heliostat comprises a tubular chassis having a triangular base mounted to pivot about a substantially vertical axis and provided with an oblique support mounted at a point of the triangular base in order to pivot about a horizontal axis. A reflecting panel is pivoted on the base and is slidably attached to an oblique bar in order to fix the panel to the base and orientate the latter as regards altitude. Wheels are provided on the base to enable the chassis to travel

on a circular track for orientation as regards azimuth. An application for the heliostat is the recovery of solar energy.

SEE OR SEARCH THIS CLASS, SUB-CLASS:

573, for sun's position tracking using sensor.

SEE OR SEARCH CLASS:

250, Radiant Energy, subclass 203.4 for tracking systems, per se, which may be used for moving a solar collector to follow the sun.

353, Optics: Image Projectors, subclass 3 for a heliostat.

601 Computer:

This subclass is indented under subclass 600. Apparatus wherein the actuating device is a unit which is capable of processing, retrieving, and storing programmed information.

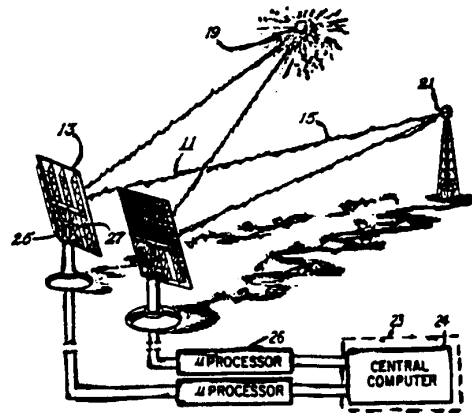

A central computer calculates a commanded position for particular time of particular day for the particular location of the body. A microprocessor incorporating respective software and hardware then calculates the position for the heliostat.

602 Timer:

This subclass is indented under subclass 600. Apparatus wherein the actuating device includes an instrument which measures interval of time to move the apparatus an incremented amount.

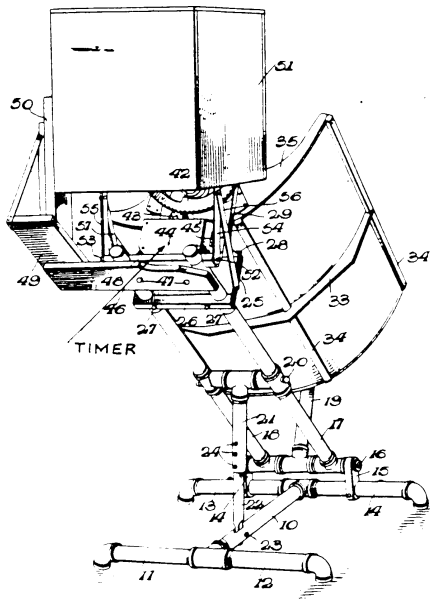

The present invention relates to automatic thermal/hydraulic logic system for continuously positioning a heliostat in alignment with the sun in both horizontal and vertical planes. Solar radiation is monitored by phials which produce signal pressures of a magnitude that varies with phial exposure to the rays of the sun. The produced signal pressures are directed to thermally controlled valves which are compared with mechanically controlled valves of similar design feature. These control valves are centered so long as hydraulic fluid pressure signals on each end of a control valve are equal, but the valve spool is displaced to the left or to the right if and when a pressure differential is created (improper alignment). When a specific differential sets in, a mechanical action takes place which moves the heliostat to its proper concentrating position. Movement ceases when the differential disappears (proper alignment).

603 Electric:
This subclass is indented under subclass 602. Apparatus wherein the instrument is powered by electricity.

605 Motor:
This subclass is indented under subclass 600. Apparatus wherein the actuating device includes an engine.

604 Having fluid power:
This subclass is indented under subclass 600. Apparatus wherein the force for moving the actuating device is from a liquid or gas.

606 Gearing:
This subclass is indented under subclass 605. Apparatus wherein the actuating device includes an input member which transmits motion to an output member by rolling contact between surfaces of the members, and wherein the input member is driven by an engine.

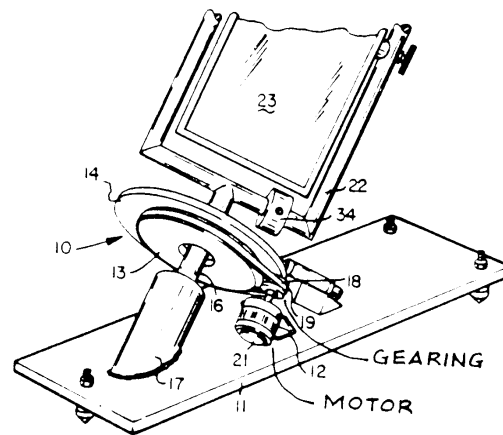
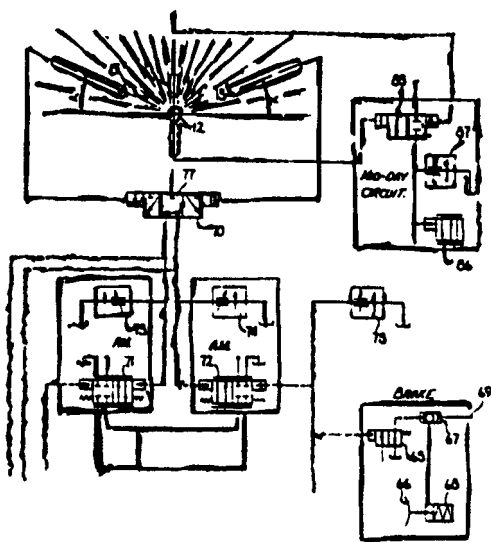

607 Gearing:
This subclass is indented under subclass 600. Apparatus wherein the actuating device includes an input member which transmits motion to an output member by rolling contact between surfaces of the members.

608 Manual:

This subclass is indented under subclass 600. Apparatus wherein the actuating device is operated through application of force exerted by a human operator.

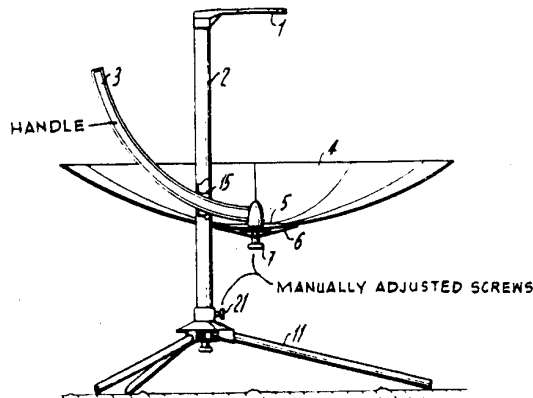
**609 With auxiliary heat source for fluent medium:**

This subclass is indented under subclass 569. Apparatus which further includes a heater other than solar to add thermal energy to the fluent medium.

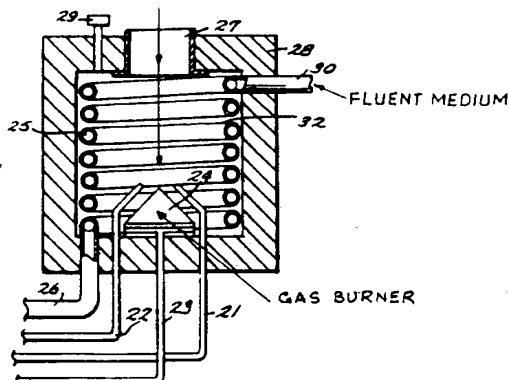
**SEE OR SEARCH CLASS:**

62, Refrigeration, subclass 235.1 for a solar heater providing a heat sink for a heat pump or providing a heat source required for refrigeration (e.g., boils refrigerant in an absorption system).

165, Heat Exchange, subclasses 48.1-48.2 and other appropriate subclasses for a combined heating and cooling means wherein the heating means may be a solar heater.

237, Heating Systems, subclass 1 for methods and apparatus for heating rooms, chambers, houses, and other enclosing structures where the source of heat claimed is other than a solar collector.

610 In a tank:

This subclass is indented under subclass 609. Apparatus wherein the heater is located within a storage reservoir containing the fluent medium.

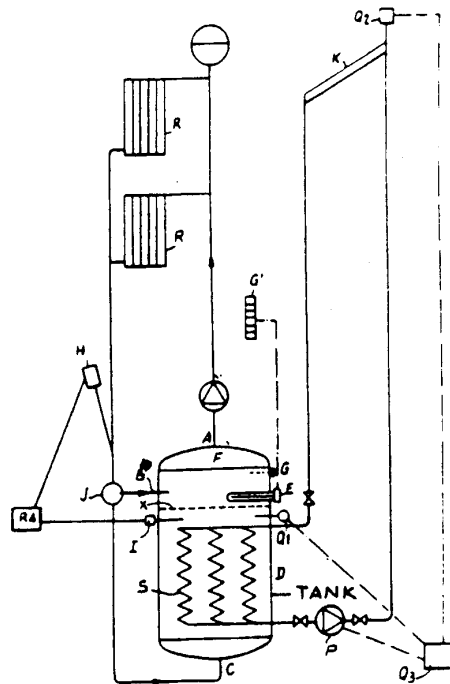

Heater comprises a container divided into upper and lower chambers by a perforated plate. The container is connected to receive heated liquid from a solar collector and deliver it to radiators or the like. The container is equipped with an electrical heating coil for further heating the liquid when the solar heat supply is inadequate.

611 In a heat exchanger:

This subclass is indented under subclass 609. Apparatus wherein the heater is located within a device that transfers heat from one fluid to another without mixture of the fluids.

612 In the collector:

This subclass is indented under subclass 609. Apparatus wherein the heater is located within the enclosure for the converting means.

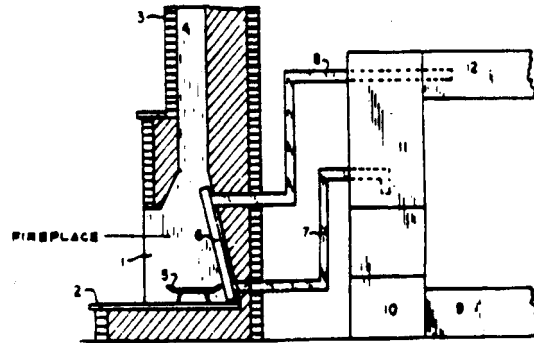
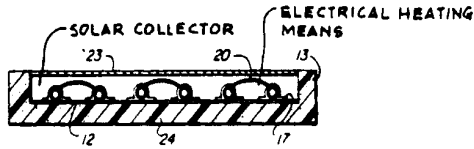

613 Heat pump:

This subclass is indented under subclass 609. Apparatus wherein the heater is a device that has both a refrigerating mode and a heating mode, and the heating mode of the device is used as the heater for the fluent medium.

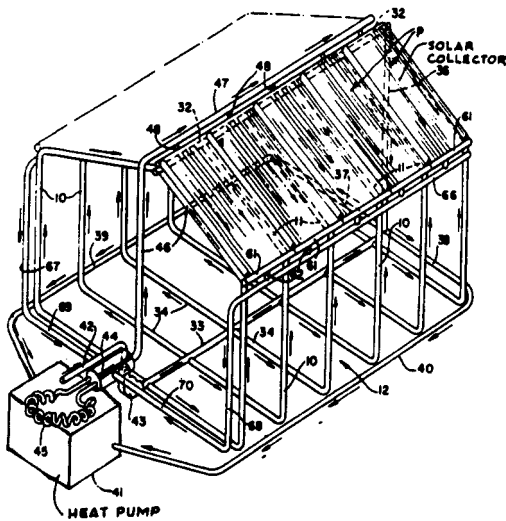

615 Water heater:

This subclass is indented under subclass 609. Apparatus wherein the heater is a device that has an additional function of providing heated water for heating an inhabitable enclosure.

616 Hot air furnace:

This subclass is indented under subclass 609. Apparatus wherein the heater is a device which has an additional function of providing heated air for heating an inhabitable enclosure.

617 With heat storage mass:

This subclass is indented under subclass 569. Apparatus which further includes a quantity of solid material which is heated by the fluent medium during periods when solar radiation is received and which, in turn, liberates its heat at other periods of time.

618 Phase change:

This subclass is indented under subclass 617. Apparatus wherein the material undergoes change in state from solid to liquid or from liquid to solid.

614 Fireplace:

This subclass is indented under subclass 609. Apparatus wherein the heater includes structure for providing a flame within an inhabitable enclosure and which, in one condition of operation, provides visibility of the flame to inhabitants in the enclosure and heat to the fluent medium.

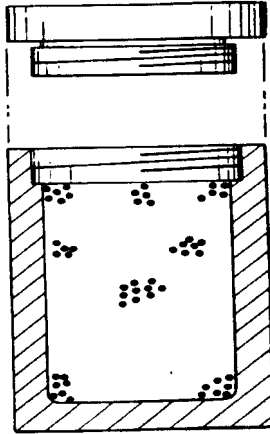

A thermal energy storage system comprising a germanium phase change material and a graphite container.

619 Specific chemical:

This subclass is indented under subclass 617. Apparatus wherein significance is attributed to the elemental composition of the material.

- (1) Note. A patent proper for this subclass will have at least one claim wherein the material is identified by its chemical name.

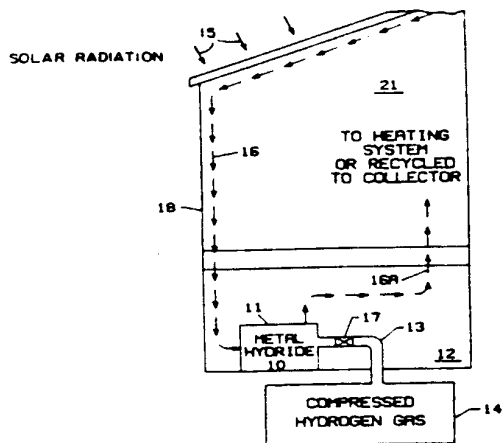

Thermal energy storage systems employing metal hydrides are useful for storing thermal energy produced, for example, by solar radiation. The metal hydrides, examples of which include FeTiH and the VH-VH₂ reaction system, evidence ease of reversibility of the metal

hydrogen reaction and have relatively high heats of formation. An additional advantage of the metal hydrides over other thermal storage materials is that the metal hydrides permit a greater degree of control to be exercised over the rate of heat evolution when needed.

620 Rocks or soil:

This subclass is indented under subclass 617. Apparatus wherein the material includes a relatively hard naturally formed mass of mineral or petrified matter or earth.

- (1) Note. A patent proper for this subclass will have at least one claim wherein the material is identified as being rocks or stones, or being a combination, or fragmented rocks (i.e., sand or gravel), or soil.

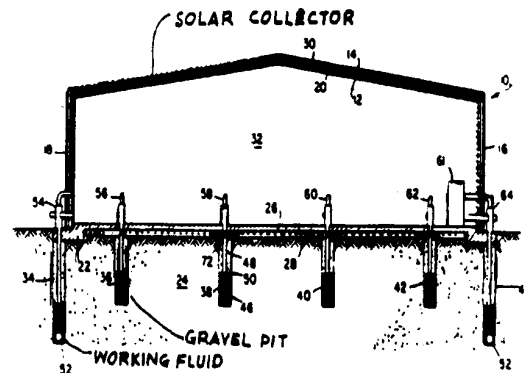

A double-walled structure utilizes air as the heat transfer medium between solar-heated outer walls and either the interior space or heat storage means beneath the structure. A load-bearing layer of gravel supporting the floor and subterranean gravel pits form the heat storage means. In summer, during the day, solar-heated air gives up heat to the storage means; at night, heat is radiated to the atmosphere and thus-cooled air is used for daytime cooling by storage either in the gravel pits or the gravel layer supporting the building floor. In winter, air is heated in the storage means for interior circulation and, when available during daylight hours, solar-heated air may be used directly or temporarily stored for nighttime use. Cold air can also be stored during winter months in separate storage means for additional summer cooling capacity.

- 621 Solar collector forms part of building roof:**
 This subclass is indented under subclass 569. Apparatus wherein the converting means is made an integral part of a structure which provides a top cover of a building.

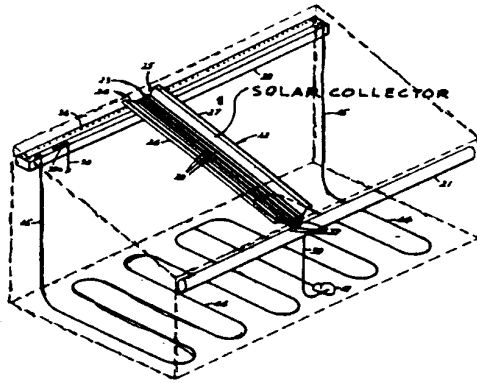

Solar heating system, wherein solar heating assemblies are adapted to form the roof of a structure. The solar heating assemblies may not occupy the entire surface area of a roof, but the upper sheathing elements of the solar heating assemblies may extend over the entire roof area so that no other provision for roofing of the structure is necessary.

- 622 Solar collector includes roof shingles or tiles:**
 This subclass is indented under subclass 621. Apparatus wherein the structure includes a plurality of overlapping pieces of material laid in rows.

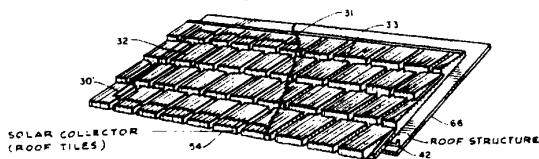

A form-molded synthetic foam roofing section or structure having a solar-collecting insert or panel incorporated therein with a relatively broad undersurface and an exposed surface configured to resemble interlocked and overlapping roofing shingles which are united to support a surface such as wood, metal, etc. during the molding process. The roofing structure may be affixed by any conventional means, such as nails or adhesives, to roof boards, rafters, or over old existing roof structure with adjacent roofing section interconnected by appropriate inlets and outlets for the solar panel insert. Solar

heat-collecting fluid may be circulated through the solar panel inserts in a conventional manner. Connecting tubes are provided for connecting the solar panel inserts in adjacent roofing sections and terminal connectors are compatible with all circulating systems.

- 623 Solar collector supported on existing roof structure:**
 This subclass is indented under subclass 569. Apparatus wherein the converting means is completely mounted on a roof exterior of the building.

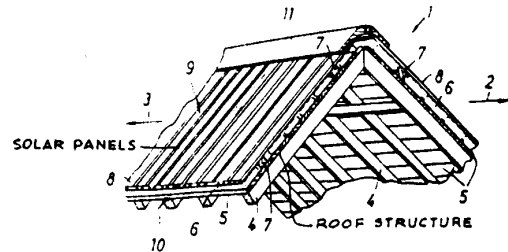

The invention relates to a roof and wall covering, in particular for heat-insulating house walls or roofs, consisting of board-like hollow plastic sections with several through profile chambers extending in longitudinal direction and of edge profiles insertable flush into each other.

- 624 Rollable or foldable collector unit of non-rigid material:**
 This subclass is indented under subclass 569. Apparatus wherein the converting means is made of a pliable material which may be overlapped upon itself for storage.

- 625 Fluent medium is gas:**
 This subclass is indented under subclass 624. Apparatus wherein the fluent medium is a gaseous substance.

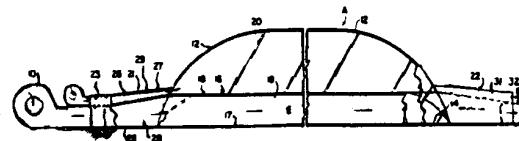

Method and apparatus for converting solar radiation to thermal energy for heating a gaseous stream such as air to be used for heating or drying purposes. The air or other gaseous passage defined by plastic film formed of solar radiation absorbing or opaque (black) material and

the film is inflated by the fluid pressure for the gaseous stream passing therethrough.

626 Fluent medium is water:

This subclass is indented under subclass 624. Apparatus wherein the fluent medium is water.

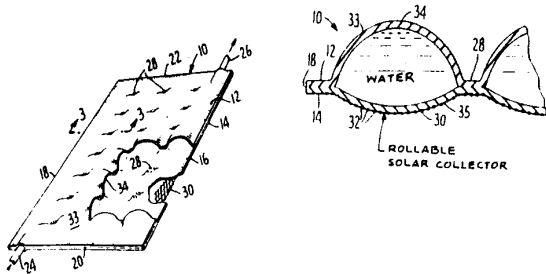

627 Foldable collector unit of rigid material:

This subclass is indented under subclass 569. Apparatus wherein adjacent parts of the converting means are made of inflexible material and are connected to each other, and having structure permitting the parts to be doubled upon themselves for storage.

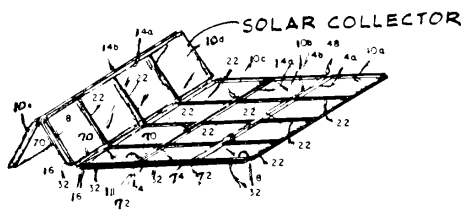

628 Including means to utilize fluent medium from collector to heat interior of building:

This subclass is indented under subclass 569. Apparatus having a means by which the heat of solar radiation is transferred via the fluent medium to heat the space enclosed by a building.

629 With device to circulate air from room of building through collector:

This subclass is indented under subclass 628. Apparatus which includes a machine to move air from the space enclosed by the building through the converting means.

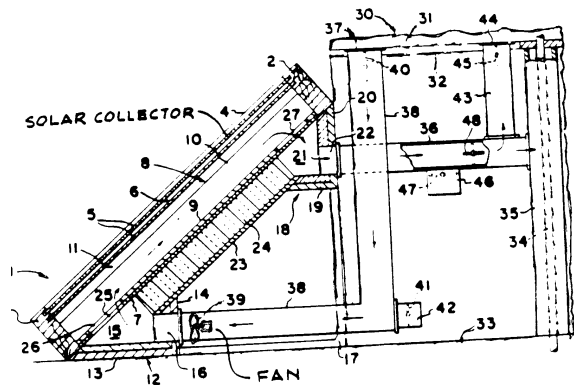

630 Plural circulators:

This subclass is indented under subclass 629. Apparatus which includes more than one machine.

631 Circulator located in collector:

This subclass is indented under subclass 629. Apparatus wherein the machine is located within an enclosure for the converting means.

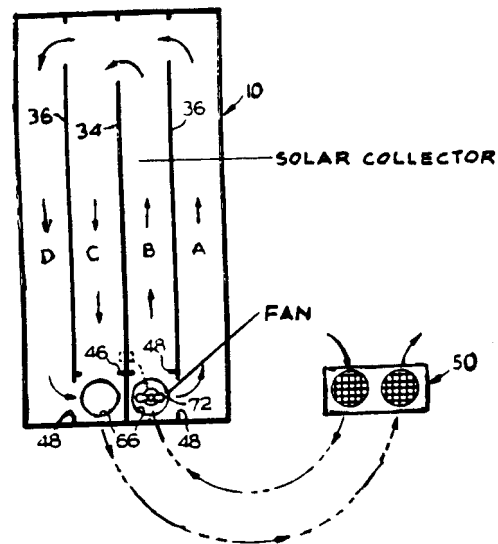

632 Circulator located in building:

This subclass is indented under subclass 629. Apparatus wherein the machine is located within the building.

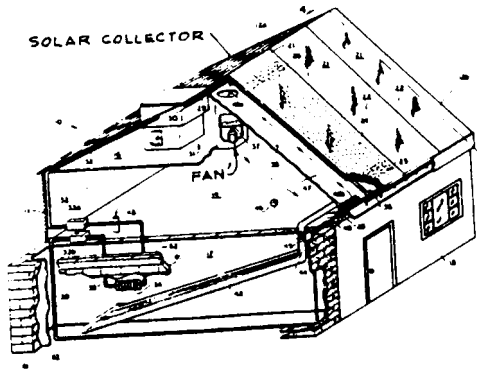

633 With fluent medium passage in floor or wall of room:

This subclass is indented under subclass 628. Apparatus in which a conduit is provided in a floor or wall of a building, and the fluent medium is moved through the conduit for the purpose of heating the enclosed building space.

634 With means to convey fluent medium through collector:

This subclass is indented under subclass 569. Apparatus having means by which the fluent medium is moved through the converting means and in doing so absorbs heat to be transferred elsewhere.

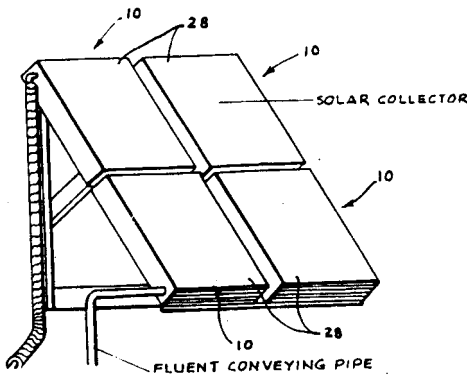

635 Having evaporator and condenser sections (e.g., heat pipe):

This subclass is indented under subclass 634. Apparatus having a closed conduit to convey the fluent medium between a section heated by solar radiation and a cooled section whereby it

is caused to change from liquid to gaseous state because of the absorption of solar radiation and subsequently change back to its liquid state as the heat of the gas is dissipated in the cooled section.

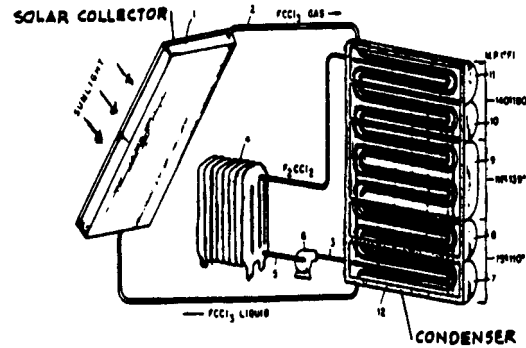

SEE OR SEARCH CLASS:

- 60, Power Plants, subclasses 641.1+ for a power plant operating by means of heat evolved from the sun.
- 165, Heat Exchange, subclasses 104.21+ for a condensing and evaporating heat exchange system.

636 Particular fluid:

This subclass is indented under subclass 635. Apparatus wherein significance is attributed to a specific kind of fluent medium.

637 Gas:

This subclass is indented under subclass 636. Apparatus wherein the fluent medium is a gas.

638 Thermosiphonic fluid circulation:

This subclass is indented under subclass 634. Apparatus in which the fluent medium is a fluid which completely fills a closed circuitous conduit extending between a low and a high elevation, and having a first section which passes through the converting means whereby the fluent medium is heated and rises in the conduit from the low to the high elevation, and a second section wherein the heat of the fluent medium is dissipated causing the cooled medium to descend into the second section and return to the first section.

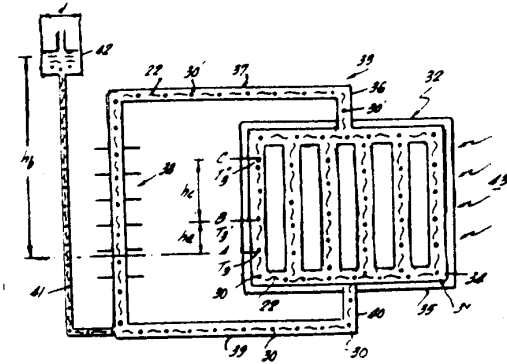

A solar heating system in which the heating transfer medium is circulated from the heat absorbing member through the heat exchange area by means of gravitational forces which are augmented by the use of a transfer medium containing additives which change in state from fluid to gaseous as they move through the system.

639 Liquid:

This subclass is indented under subclass 638. Apparatus wherein the fluent medium is a liquid.

640 With storage tank for fluent medium:

This subclass is indented under subclass 634. Apparatus having a container in which the fluent medium from the converting means is accumulated.

641 Having heat exchanger within storage tank:

This subclass is indented under subclass 640. Apparatus which includes a device that transfers heat from one fluid to another fluid without mixture of the fluids and is positioned inside the container.

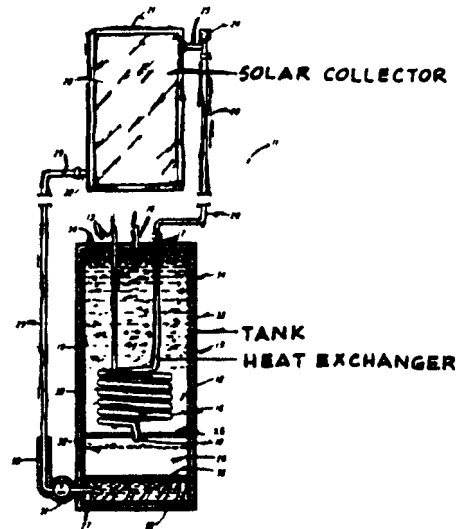

642 Tank is heat exchanger:

This subclass is indented under subclass 640. Apparatus wherein the heat is transferred from the fluent medium via a wall of the fluent container to a heat utilization location.

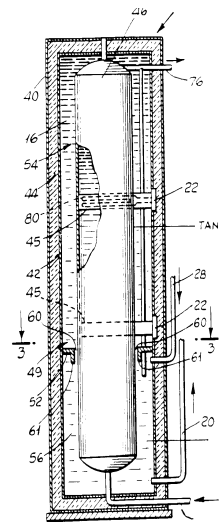

Fluent medium

643 With heat exchanger:

This subclass is indented under subclass 634. Apparatus which includes a device that transfers heat from one fluent medium to another fluent without mixture of the fluents.

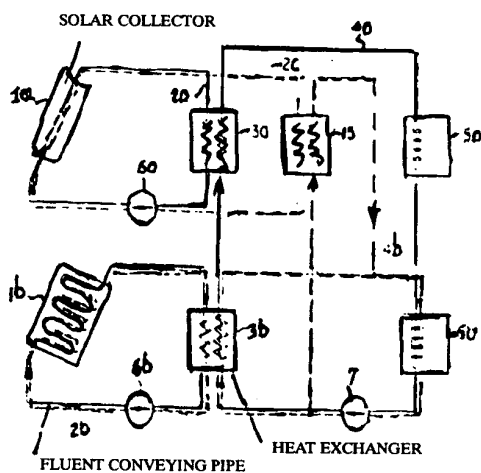

644 With solid phase change:
 This subclass is indented under subclass 643. Apparatus wherein the fluent medium in the heat transferring device undergoes change in state from fluent to solid.

645 With liquid phase change:
 This subclass is indented under subclass 643. Apparatus wherein the fluent medium in the heat transferring device undergoes change in the state from solid or gas to liquid.

646 Pump:
 This subclass is indented under subclass 634. Apparatus including a machine for forcing the fluent medium through the converting means.

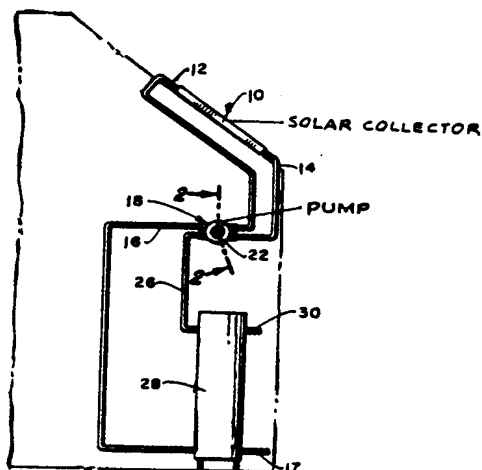

647 Blower:
 This subclass is indented under subclass 646. Apparatus wherein the machine is a gas-moving device.

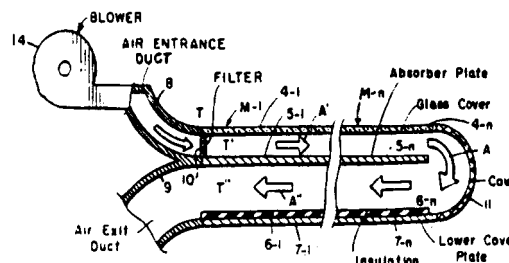

648 With radiation trap:
 This subclass is indented under subclass 634. Apparatus having a device which captures randomly reflected solar radiation which would otherwise escape or unintentionally be directed away from that portion of the converting means where the radiation is to be absorbed by the converting means.

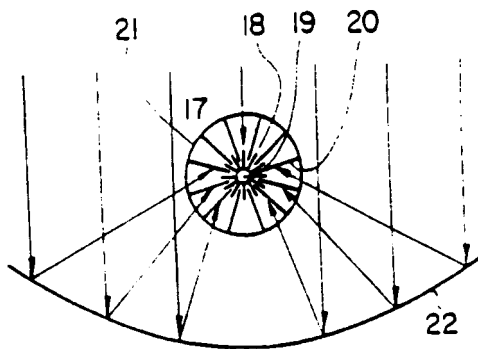

A device called Solar Trap for concentrating and collecting the solar energy is disclosed. Said Solar Trap employs, firstly, the principle of the light funneling as means for concentrating the sunlight and secondly, the principle of the repeated incidence as means for enhancing the absorption of the concentrated sunlight.

649 Plural traps:
 This subclass is indented under subclass 648. Apparatus and further including another device which captures randomly reflected solar radiation which would otherwise escape or unintentionally be directed away from that portion of

the converting means where the radiation is to be absorbed by the fluent medium.

650 Particular material:

This subclass is indented under subclass 648. Apparatus wherein significance is attributed to a substance from which the device is made.

651 Conduit absorber structure:

This subclass is indented under subclass 634. Apparatus wherein the fluent medium is located within a fluent confining means which surrounds and provides an axial flowpath for the fluent medium through the converting means.

652 Surrounded by transparent enclosure:

This subclass is indented under subclass 651. Apparatus having a transparent means which completely envelops, in spaced relation to, and extends along an axial length of the fluent confining means.

653 Sealed chamber between enclosure and absorber contains vacuum promoter (e.g., getter):

This subclass is indented under subclass 652. Apparatus wherein a negative pressure exists in a space between an enclosure and an absorber conduit and wherein a substance is added to enhance the negative pressure.

654 Sealed chamber between enclosure and absorber contains gas for promoting heat transfer:

This subclass is indented under subclass 652. Apparatus wherein a sealed chamber between an enclosure and an absorber conduit contains a gaseous fluid which enhances the conduction of heat between the enclosure and the absorber conduit.

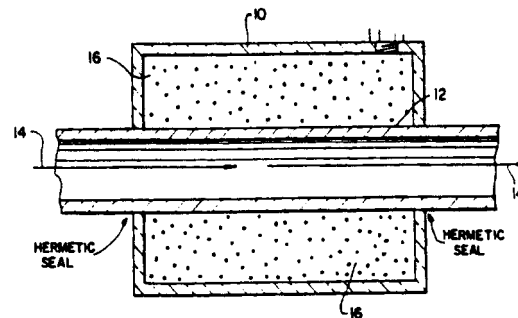

The disclosure relates to a solar radiation converting method and means whereby the addition of a halogen within a hermetically sealed space receives and converts solar or synthetic radiant spectra into heat energy; its principal advantage being the conversion of the visible portion of the light spectra into additional heat.

655 Plurality of conduit absorbers:

This subclass is indented under subclass 652. Apparatus which includes more than one fluent confining means.

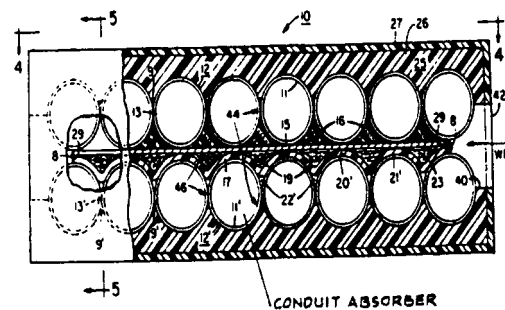

656 Axis of conduit is curved (e.g., helical or serpentine):

This subclass is indented under subclass 652. Apparatus wherein the fluent confining means is shaped in such a manner that the fluid follows a circuitous path.

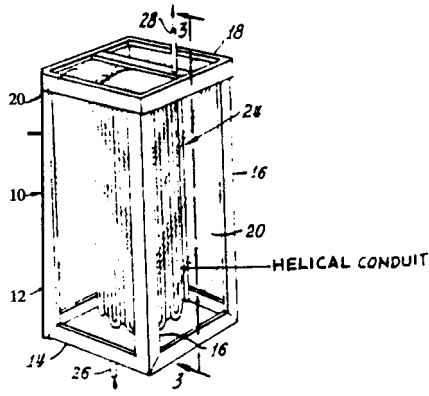

657 With reflector:
 This subclass is indented under subclass 652. Apparatus which further includes a nontransparent surface to redirect solar radiation as the solar radiation travels toward the fluent confining means.

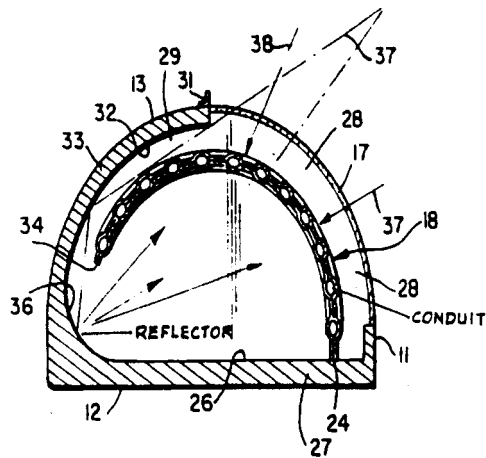

658 Having heat-absorbing fin or plate:
 This subclass is indented under subclass 651. Apparatus having a projecting vane or a sheet secured to or integrally formed with the fluent confining means to effectively increase the heat transfer area beyond that which the confining means would otherwise have available.

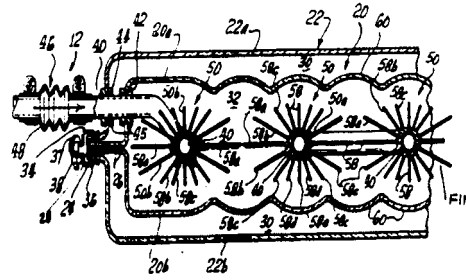

659 With fastener to secure fin to conduit:
 This subclass is indented under subclass 658. Apparatus wherein an attaching device is used to connect the vane to the fluent confining means.

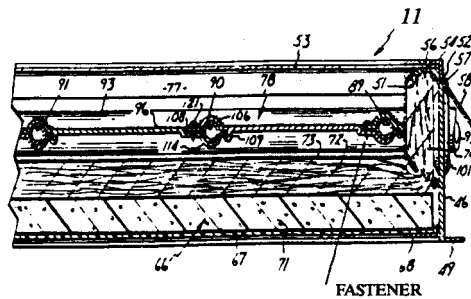

660 Plate integral with conduit:
 This subclass is indented under subclass 658. Apparatus wherein the sheet is manufactured simultaneously as a complete unit with the fluent confining means.

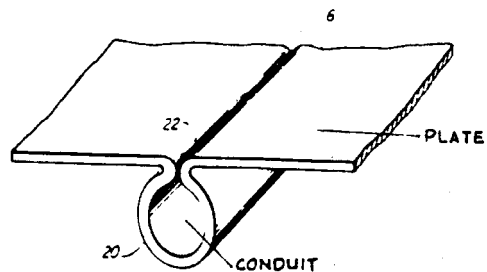

A solar collector which includes a radiation-absorbing panel having a surface provided with integral fluid-conducting conduits whereby heat absorbed by the panel may be efficiently transferred directly to fluid circulating in the conduits.

- 661 Plate surface with conduit secured thereto:**
This subclass is indented under subclass 658. Apparatus which includes means for connecting the fluent confining means to the sheet.

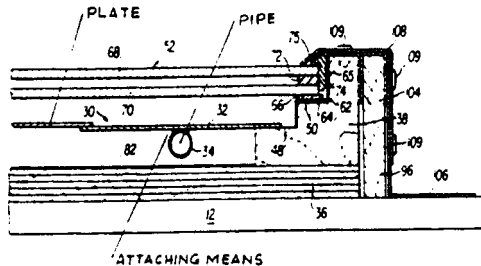

- 662 Conduit positioned in a groove in the plate:**
This subclass is indented under subclass 658. Apparatus wherein the sheet is provided with a channel to receive the fluent confining means.

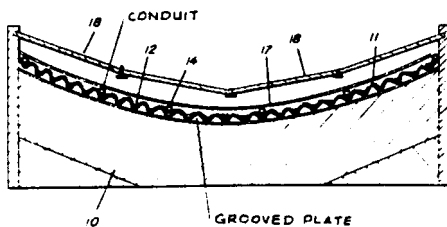

- 663 Plural conduits:**
This subclass is indented under subclass 651. Apparatus wherein the fluent confining means provides two or more side by side axial flow-paths for either series or parallel flow of the fluent medium.

- 664 Noncircular conduit:**
This subclass is indented under subclass 663. Apparatus wherein the fluent confining means defines a flowpath which has a cross-sectional shape other than a circle.

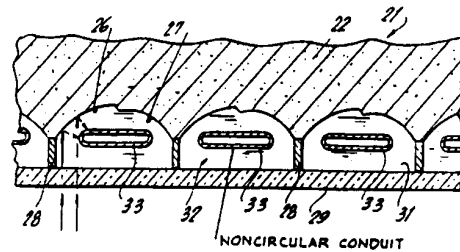

- 665 Flexible conduit:**
This subclass is indented under subclass 663. Apparatus wherein the fluent confining means is formed of a pliable material.

- 666 Rectangular metallic conduit:**
This subclass is indented under subclass 651. Apparatus wherein the fluent confining means is made of metal and defines a flow chamber which has a rectangular cross-sectional shape.

- 667 Having internal partition:**
This subclass is indented under subclass 666. Apparatus in which the flow chamber includes a baffle which redirects the flow through the chamber.

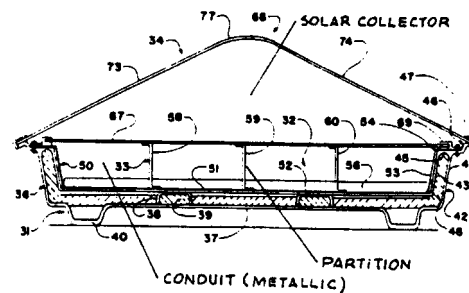

- 668 Rectangular nonmetallic conduit:**
This subclass is indented under subclass 651. Apparatus wherein the fluent confining means is made of material other than metal and defines a flow chamber which has a rectangular cross-sectional shape.

- 669 Having internal partition:**
This subclass is indented under subclass 668. Apparatus in which the fluent chamber includes a baffle which redirects the flow through the chamber.

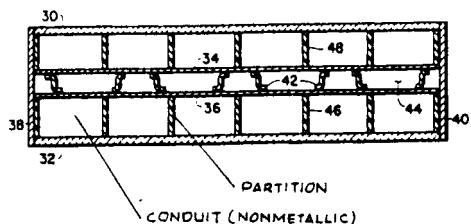
**670 Circular metallic conduit:**

This subclass is indented under subclass 651. Apparatus wherein the fluent confining means is made of metal and defines a flow chamber which has a circular cross-sectional shape.

671 Having internal partition:

This subclass is indented under subclass 670. Apparatus in which the fluent chamber includes a baffle which redirects the flow through the chamber.

672 Circular nonmetallic conduit:

This subclass is indented under subclass 651. Apparatus wherein the fluent confining means is made of material other than metal and defines a flow chamber which has a circular cross-sectional shape.

673 Having internal partition:

This subclass is indented under subclass 672. Apparatus in which the fluid chamber includes a baffle which redirects the flow through the chamber.

674 Absorber having extended surface:

This subclass is indented under subclass 651. Apparatus wherein the fluent confining means is formed so that it has a heat exchange surface area which is greater than that which would be formed by a fluent confining means having a smooth surface and occupying a similar area of the converting means.

675 Corrugated surface:

This subclass is indented under subclass 674. Apparatus wherein the heat exchange surface is formed into parallel and alternating ridges and grooves.

676 Particular absorber material:

This subclass is indented under subclass 651. Apparatus wherein significance is attributed to a substance from which the fluent confining means is made.

677 Metal:

This subclass is indented under subclass 676. Apparatus wherein the fluent confining means is made of metal.

678 Particular fluent medium including radiation absorbing material:

This subclass is indented under subclass 569. Apparatus wherein significance is attributed to the material forming the fluent medium and especially to properties of the material which enhance heat transfer.

679 Specific chemical:

This subclass is indented under subclass 678. Apparatus wherein significance is attributed to the elemental composition of the matter.

(1) Note. A patent proper for this subclass will have at least one claim wherein the matter is identified by its chemical name.

680 Energy concentrator with support for material heated:

This subclass is indented under subclass 569. Apparatus having means to carry the weight of an article to be heated and having means to focus solar radiation on the article.

SEE OR SEARCH THIS CLASS, SUBCLASS:

684, for a reflector.

698, for a lens for concentrating solar energy on an absorber for heating a fluid.

681 Solar oven:

This subclass is indented under subclass 680. Apparatus wherein the article to be heated is within an enclosed compartment.

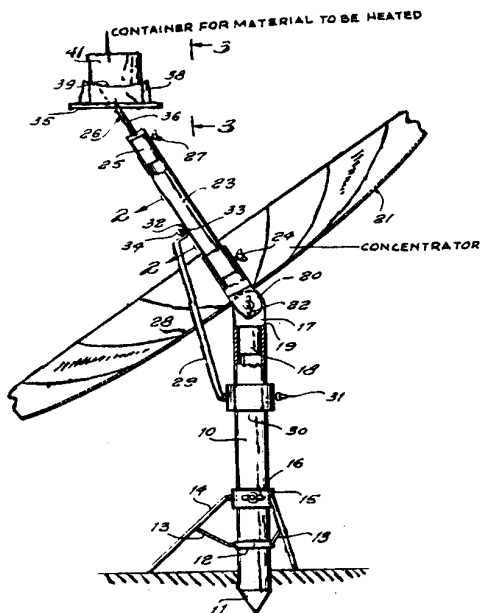

682 Having foldable energy concentrator:

This subclass is indented under subclass 681. Apparatus wherein the focusing means has structure permitting it to be doubled upon itself.

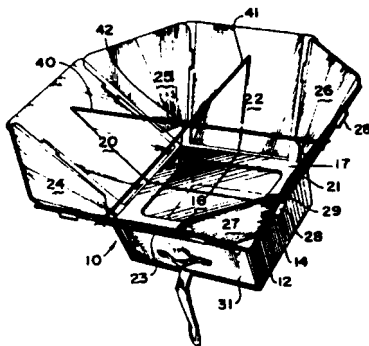

A solar stove having a casing with four rectangular reflective panels foldably attached and surrounding the perimeter of the upper edge of the casing, the panels being foldable against the casing to form a neat package. Each panel is attached to an opposite panel by a flexible cord, the cords crossing each other when the panels are opened to aid the user in aiming the solar stove directly into the sun. Triangular panels are removably attached to the side of adjacent rectangular panels to fill the space created when the rectangular panels are opened to approximately 45° past vertical. The oven is a drawer

fitting in the casing and removable either horizontally or vertically, the drawer having multiple layer construction for heat retention and a dark interior surface for converting solar rays to heat.

683 With concentrating reflector and concentrating lens:

This subclass is indented under subclass 569. Apparatus wherein said concentrating or directing means includes a first nontransparent surface which acts to redirect the solar radiation and increases the brightness of solar radiation and also includes a refractor; the combination of the nontransparent surface and the refractor causes the solar radiation to converge to the converting means.

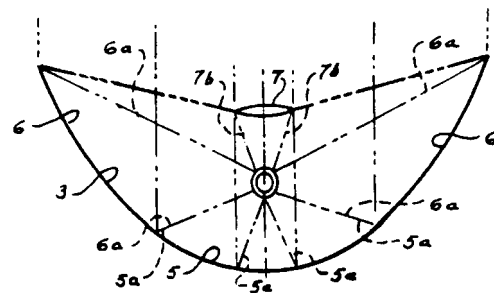

SEE OR SEARCH THIS CLASS, SUB-CLASS:

680, for energy concentrator with support for material heated.

684 With concentrating reflector:

This subclass is indented under subclass 569. Apparatus wherein said means to concentrate or direct solar radiation includes a first non-transparent surface which acts to increase the brightness of the solar radiation and directs the solar radiation to the converting means.

SEE OR SEARCH THIS CLASS, SUB-CLASS:

680, for energy concentrator with support for material heated.

685 Plural reflectors in optical series:

This subclass is indented under subclass 684. Apparatus which further includes an additional nontransparent surface to receive solar radiation from the first surface and wherein said

additional surface and first surface redirect the solar radiation to the converting means.

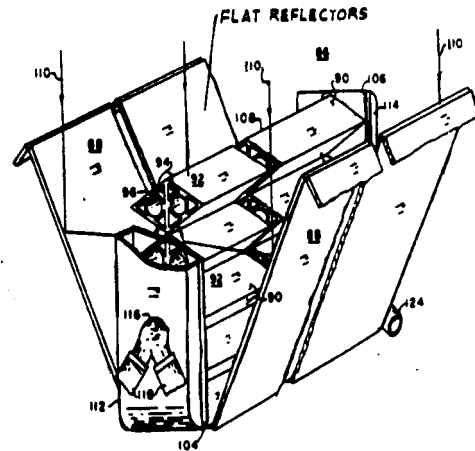
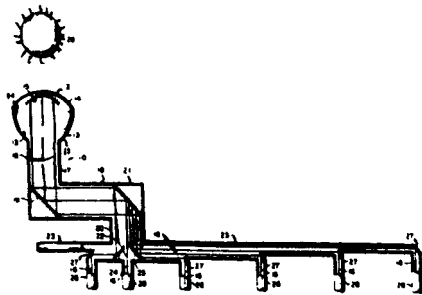

686 Flat and curved:

This subclass is indented under subclass 685. Apparatus wherein one of said surfaces is planar and wherein the other of said surfaces deviates from planarity in a smooth, continuous way.

688 Spot focus:

This subclass is indented under subclass 684. Apparatus wherein the first surface is arranged to concentrate the solar radiation at a point.

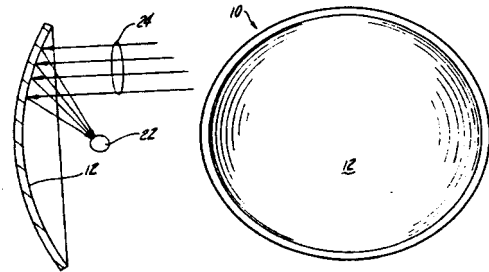
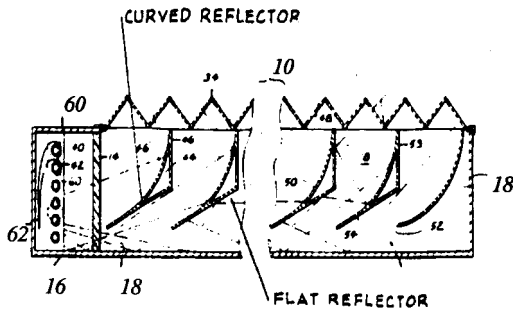

687 Flat:

This subclass is indented under subclass 685. Apparatus wherein one of said surfaces is planar.

689 Spherical:

This subclass is indented under subclass 688. Apparatus wherein the first surface is shaped in a manner that all points on the surface are equidistant from a fixed point.

690 Parabolic:

This subclass is indented under subclass 688. Apparatus wherein the first surface is shaped like a plane curve generated by a point so moving that its distance from a fixed point divided by its distance from a fixed line is equal to one.

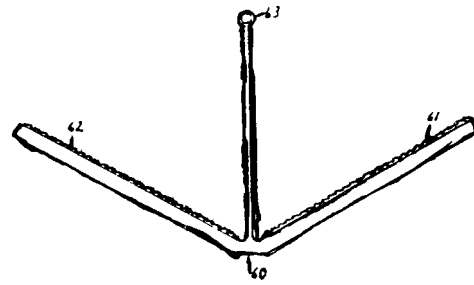
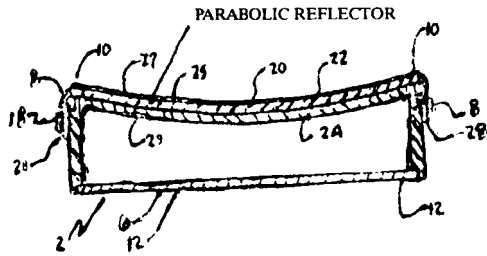
**691 Elliptical:**

This subclass is indented under subclass 688. Apparatus wherein the first surface is shaped like a closed plane curve generated by a point so moving that its distance from a fixed point divided by its distance from a fixed line is a positive constant less than one.

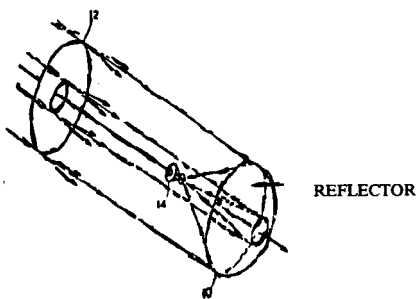

A solar dish concentrator is provided having a rotationally symmetrical elliptical shape for focusing a uniform flux density of solar radiation on a receiver. The solar flux pattern reflected to the receiver is evenly distributed over the four quadrants of the receiver without containing any hot spots.

692 Line focus:

This subclass is indented under subclass 684. Apparatus wherein the first surface has a length larger than the width and is arranged to direct solar radiation at a series of spot foci located along a line.

A solar concentrator with wide effective aperture is disclosed, which comprises at least one linear echelon reflector element which is inclined with respect to the direction of incident solar radiation to direct incident solar radiation to a line focus.

693 Circular:

This subclass is indented under subclass 692. Apparatus wherein perimeter of the first surface forms a circle.

694 Parabolic:

This subclass is indented under subclass 692. Apparatus wherein the first surface is shaped like a plane curve generated by a point so moving that its distance from a fixed point divided by its distance from a fixed line is equal to one.

695 Elliptical:

This subclass is indented under subclass 692. Apparatus wherein the first surface is shaped like a closed plane curve generated by a point so moving that its distance from a fixed point divided by its distance from a fixed line is a positive constant less than one.

696 Reflector support:

This subclass is indented under subclass 684. Apparatus wherein a structure is provided to carry the weight of the first surface.

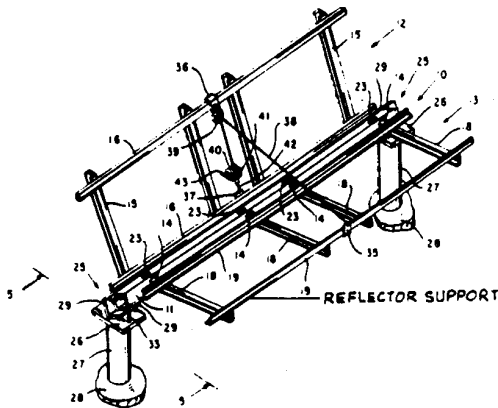

SEE OR SEARCH THIS CLASS, SUB-CLASS:
700, for lens support.

697 Inflatable reflector:

This subclass is indented under subclass 684. Apparatus wherein the first surface is made of a material which expands when filled with fluid.

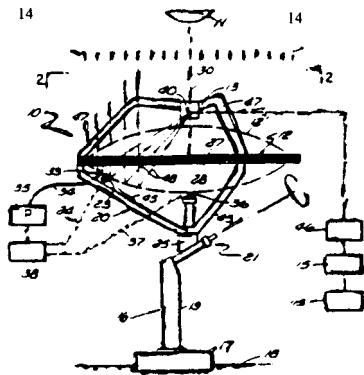

698 With concentrating lens:

This subclass is indented under subclass 569. Apparatus wherein said concentrating or directing means includes a refractor to receive solar radiation and causes the solar radiation to converge or diverge as the solar radiation travels to the converting means.

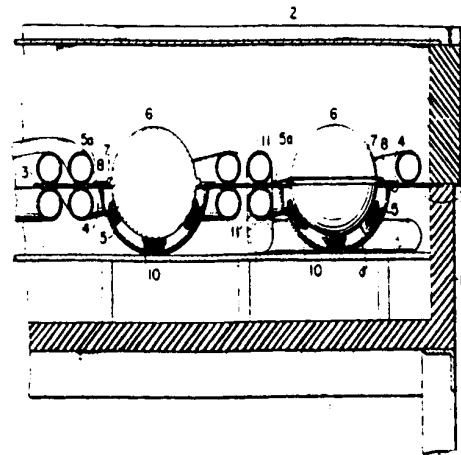

An apparatus for heating water by solar rays in which a plurality of spherical lenses are used to enable solar rays to be converged whenever there is sunlight present. Also incorporating a superheat resisting carbon impregnated cloth to cover that area of metal which is subjected to the intensive heat of the focused rays.

SEE OR SEARCH THIS CLASS, SUB-CLASS:
680, for energy concentrators with support for material heated.

699 Circular lens:

This subclass is indented under subclass 698. Apparatus wherein the perimeter of the refractor forms a circle.

700 Lens support:

This subclass is indented under subclass 698. Apparatus wherein a structure is provided to carry the weight of the refractor.

SEE OR SEARCH THIS CLASS, SUB-CLASS:
696, for reflector support

701 Controlling solar radiation:

This subclass is indented under subclass 569. Apparatus wherein said means to concentrate or direct solar radiation includes a device which regulates the amount of solar radiation received by the converting means.

- 702 Interconnected slats (e.g., blinds, shutters):**
This subclass is indented under subclass 701. Apparatus wherein the device includes a plurality of thin strips joined with one another by a linking mechanism.

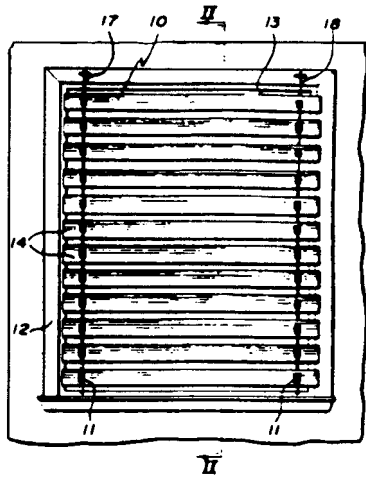

Converter for use in a location adjacent to the inside of a window to receive solar energy and change it to useful heat.

- 703 Manual:**
This subclass is indented under subclass 701. Apparatus wherein the device is operated through application of force exerted by human operator.
- 704 Collector housing:**
This subclass is indented under subclass 569. Apparatus having an enclosure for the converting means.

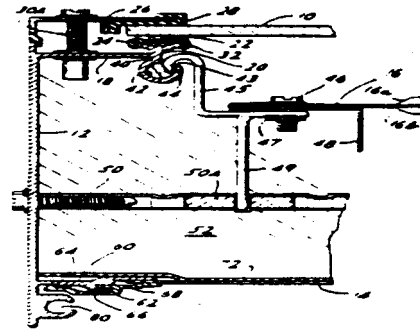

Solar energy collector assembly including a solar energy collector in an enclosed space housing with bottom closure member secured by a snap-fit spring channel and low thermal conductivity mating projection therefor, a collector member securing means comprising a plurality of stiff low thermal conductivity wire retainers and top cover securing and sealing means comprising a seal and clamp engaging the top cover just inward of its periphery, to prevent intrusion of condensate in the enclosed space of the housing.

- 705 Cover:**
This subclass is indented under subclass 704. Apparatus wherein significance is attributed to a structure that forms the uppermost part of the enclosure.
- 706 Insulation:**
This subclass is indented under subclass 705. Apparatus wherein the structure includes or is formed of a material that precludes escape of heat from the space within the enclosure.
- 707 Plastic:**
This subclass is indented under subclass 705. Apparatus wherein the structure is made of polymeric material.
- 708 Glass:**
This subclass is indented under subclass 705. Apparatus wherein the structure is made of glass.
- 709 Insulation:**
This subclass is indented under subclass 704. Apparatus wherein the enclosure includes or is formed of a material that precludes escape of heat from space within the enclosure.

- 710 Particular material:**
This subclass is indented under subclass 704. Apparatus wherein significance is attributed to a specific kind of material from which the enclosure is made.
- 711 Plastic:**
This subclass is indented under subclass 710. Apparatus wherein the enclosure is made of polymeric material.
- 712 Glass:**
This subclass is indented under subclass 710. Apparatus wherein the enclosure is made of glass.
- 713 Metal:**
This subclass is indented under subclass 710. Apparatus wherein the enclosure is made of metal.
- 714 PROCESS OF HEATING BY USING SOLAR HEAT:**
This subclass is indented under the class definition. Methods of heating by use of solar heat.

CROSS-REFERENCE ART COLLECTIONS

- 903 SOLAR COLLECTOR CLEANING DEVICE:**
A collection of patents disclosing means by which a solar collector is kept free from dirt or foreign matter.
- 904 ARRANGEMENTS FOR SEALING SOLAR COLLECTOR:**
A collection of patents disclosing a structure for preventing foreign matter from entering a housing of a solar collector.
- 905 PREVENTING CONDENSING OF MOISTURE IN SOLAR COLLECTOR:**
A collection of patents disclosing means to keep dew from forming or means to remove dew from a structure of a solar collector.
- 906 CONNECTING PLURAL SOLAR COLLECTORS AS A UNIT:**
A collection of patents disclosing means by which at least two solar collectors, each of which could function individually, are fluidly connected to operate together so as to increase the capacity.

- 907 ABSORBER COATING:**
A collection of patents disclosing coatings for use on a collector surface to convert solar radiation into heat.
- 908 Particular chemical:**
This subclass is indented under subclass 907. A collection of patents wherein a specific chemical or chemical composition is named as forming a part of the coating.
- 909 LINEAR CONCENTRATING LENS:**
A collection of patents disclosing a refractor which receives solar radiation and causes the solar radiation to converge or diverge as the solar radiation travels to the converting means, and the refractor has a length much greater than its width, and the length extends along an axis perpendicular to the axis along which the solar radiation travels.
- 910 HEAT STORAGE LIQUID:**
A collection of patents disclosing a liquid which remains in a compartment and is heated by the fluent medium during periods when solar radiations are received and which, in turn, liberates its heat at other periods of time.

FOREIGN ART COLLECTIONS

The definitions below correspond to abolished subclasses from which these collections were formed. See the Foreign Art Collection schedule of this class for specific correspondences. [Note: The titles and definitions for indented art collections include all the details of the one(s) that are hierarchically superior.]

- FOR 100 Stand boilers:**
Foreign art collection for devices comprising water-holding tanks or boilers, indirectly associated with significant burner and/or burner control structure. These devices are termed generally "kitchen-range boilers", or "stand boilers".
- FOR 101 Circulation:**
Foreign art collection for devices where the improvements reside in specific water-circulating means.
- FOR 102 Supports:**
Foreign art collection for devices relating to their supports.

FOR 103 Stovepipe:

Foreign art collection for devices through which some portion of a stove smoke-pipe passes to heat the water therein.

FOR 104 Circulation:

Foreign art collection for devices which are provided with circulation-pipes between the heater and an adjacent tank or reservoir. These heaters have the character and function of "water-backs" .

FOR 105 Portable:

Foreign art collection for devices comprising solid-fuel stove structures designed to be submerged in an open tank of liquid for heating the same. The stove structure does not form a permanent part of the tank, but is readily removable from the tank.

FOR 106 Closed systems pipes:

Foreign art collection for devices comprising steam or hot-water pipes submerged in a closed liquid-heating system and designed to heat the same.

FOR 107 Stationary:

Foreign art collection for devices comprising solid-fuel stove structures adapted to be submerged in an open tank of liquid for heating the same.

FOR 108 Vessels:

Foreign art collection for devices adapted to contain an unconfined bulk of fluent material and modified to facilitate the heat treatment of the contents thereof. The heat generator may or may not be included.

FOR 109 With automatic control:

Foreign art collection for devices provided with means to sense a change of condition and to initiate, maintain, and/or terminate the heating of the liquid upon the change of condition.

FOR 110 With heat accumulator:

Foreign art collection for devices in which means are provided to retain or store heat to be given up to the contents of the vessel over a period of time.

FOR 111 Fluid-heated:

Foreign art collection for devices in which the means to facilitate the heat treatment includes apparatus for confining or directing a confined heated fluid or vapor about or into the vessel or a space in heat exchange relationship with the contents of the vessel or for shielding all or a portion of the contents from the action of the heated fluid.

FOR 112 Steam- or water-heated:

Foreign art collection for devices in which the fluid or vapor is steam or a heated liquid.

FOR 113 Closed chamber or coil:

Foreign art collection for devices in which the steam or heated liquid is in, or passes through, a chamber or coil which is in heat exchange relationship with the contents of the vessel.

FOR 114 Jet:

Foreign art collection for devices arranged to direct steam into the body of liquid contained in the vessel.

FOR 115 With liquid supply:

Foreign art collection for devices provided with a source of liquid and means for delivering the liquid to the heating vessel. The added liquid is usually to replace that lost from the vessel by evaporation or is that used to condense vapors within the vessel.

FOR 116 With condenser:

Foreign art collection for devices combined with structure providing a heat exchange relationship between the vapors evolved in the vessel and a cooler body or fluid.

FOR 117 Condensing liquid:

Foreign art collection for devices in which the evolved vapors are in heat exchange relationship with a body of confined liquid.

FOR 118 Overflow directors or receptors:

Foreign art collection for devices in which there is provided means to collect and/or dispose of fluent material escaping from the confines of the vessel.

FOR 119 In vessel closure:

Foreign art collection for devices in which the collection or disposal means is located in the lid or cover of the vessel.

FOR 120 Annular receptor:

Foreign art collection for devices which are provided with a trough or receptacle encircling an opening of the vessel to receive the material which overflows or which would otherwise overflow from the vessel.

FOR 121 With return:

Foreign art collection for devices provided with means to conduct the overflowed material back to the vessel.

FOR 122 With heat-type agitator or circulator:

Foreign art collection for devices including means for vibrating, or creating or directing fluid currents within, the contents of the vessel by means of a thermosiphonic or other heat resultant condition of the contents.

FOR 123 With signal or indicator:

Foreign art collection for devices including means for signalling or indicating the existence or occurrence of some condition, usually related to the heating operation.

FOR 124 With vent passage:

Foreign art collection for devices provided with means establishing communication between the interior of the vessel, above the material therein, and an exterior remote point. The purpose of the communication means may be to direct fluid or vapor either to or from the vessel and is usually arranged to terminate exteriorly of the bottom of the vessel adjacent a heating surface or for communication with a stove hole.

FOR 125 Heating-surface construction and arrangement:

Foreign art collection for devices in which the bottom or walls of the vessel are so constituted, configured, or disposed as to modify the heat conductivity, heating area or heat distribution of the vessel relative to an unconfined heating fluid or a primary source of heat. Included in this subclass are arrangements for the transmission or distribution of heat through an extended surface of a material heating plate or vessel, not necessarily a part of a liquid containing vessel, such as a hot plate or griddle.

FOR 126 Fire tube type:

Foreign art collection for devices, including a reentrant tube or passage for the heating fluid completely encircled by the fluent contents of the vessel.

FOR 127 Water tube type:

Foreign art collection for devices including a projecting tube or hollow leg containing the fluent material to be heated and completely encircled by the heating fluid.

FOR 128 Liquid and gaseous fuel:

Foreign art collection for miscellaneous devices that are heated by liquid or gaseous fuel burners.

FOR 129 Automatic:

Foreign art collection for devices in which the flow of fluid fuel to the burner is automatically cut off when the temperature of the water reaches a certain limit. The device ordinarily must be reset by hand.

FOR 130 Drip plate:

Foreign art collection for devices in which the water is admitted into the top portion of the heater and descends to the bottom portion thereof through the medium of shallow pans or suspended metal strips, the water coming in direct contact with the ascending gaseous product of combustion.

FOR 131 Hinged or separable:

Foreign art collection for devices in the nature of water-backs and designed to be employed with liquid or gaseous fuel cooking-stoves. These devices may be hinged to or be a separate part of the stove proper.

FOR 132 Lamp type:

Foreign art collection for devices which are structurally related to the lamp or wick type burners. The chimney or combustion flue of lamps is as a rule surrounded by the water or liquid contained vessel.

FOR 133 Overflow:

Foreign art collection for devices comprising portable water heaters in which the supply-pipe leads into and discharges in the upper portion of the water receptacle or heater and the water is sprayed and caused to flow downward over the heated cylinders and in a reverse direction to the flame.

FOR 134 Submerged:

Foreign art collection for devices comprising submerged heaters. This subclass includes both the stationary and portable type of heater.

END