

CLASS 234, SELECTIVE CUTTING (E.G., PUNCHING)

SECTION I - CLASS DEFINITION

This is a restricted class for the art of selective cutting as defined below. For placement of a patent as an original in this class, the claimed subject matter should meet the minimum requirements of the class definition, and should not extend beyond the general boundaries expressed in the Scope of the Class, and Lines with Other Classes, below, which concern mainly the combination of selective cutting with other subject matter elsewhere classified.

SCOPE OF THE CLASS

The subject matter of Class 234 relates to means for, or steps of, accomplishing the selection, or selection and actuation, of one or a group of less than the total number of cutting tool pairs from a given number of such tool pairs which are constantly available for selection and actuation. The great preponderance of patent disclosures of selective cutting or punching also include means for, or methods of, handling the work to be cut, or handling the product after cutting. Many of such patents further disclose other treatment of the work (e.g., printing, cutting to size, or punching feed holes), or non manufacturing operations such as computation of input data or verification of output data which is related in some degree to the selection of tools.

The sole requirement for placement of a patent in Class 234 is that the means for or method of selection of tools be included in the claimed subject matter. Patents which meet this requirement may, however, be excluded from this class because of the claimed inclusion of other subject matter for which there are existing classes. Specific cases may be decided as indicated in the following section, entitled LINES WITH OTHER CLASSES AND WITHIN THIS CLASS.

In general, a patent which is restricted to means for, or steps of, accomplishing the selection of one or more cutting tools as outlined in the class definition, will be placed in this class. Additionally claimed ancillary features such as work holding, feeding, handling (e.g., counting or sorting), detection of malfunction of machine, handling of pattern, provision of specific data input arrangements and other specific data input arrangements and other features, normally to be found in a complete machine are also accommodated in this class. Exclusion of a patent from Class 234, although cutting tool selection is claimed, is generally based upon

additional recitation of (a) certain other treatment of the work, (b) certain handling or treatment of the control data or (c) other methods or devices which are elsewhere provided for.

In general, a patent will not be originally placed in Class 234, if in addition to selective cutting means, it includes a device which does not contribute to the ease or effectiveness of operation of the cutting machine, or to a general awareness (on the part of an attendant) of the conditions or the results of its operation. The only exception to this general exclusion rule is in the case of a patent to the combination of selective with nonselective cutting means, which will be placed originally in Class 234 (see "Relationship to Other Classes, Including, per se, Cutting or Other Treatment of Work--The Class of Cutting," below).

A number of terms currently used in the art have been selected for definition in the Glossary of this class, and will be identified by an asterisk (*) hereinafter.

The accompanying diagrams represent simple embodiments of the various concepts treated. The elements most commonly found in such mechanisms are uniformly designated in the diagrams as follows:

W = workpiece* (typically a sheet or web)

P = pattern* (typically a marked or perforated sheet or web)

T = active cutting tool

D = die, or cooperating tool

H = tool-actuating hammer or press ram (reciprocable)

I = interposer*

K = key (representative of a keyboard)

Other elements necessary to the disclosures are designated, where feasible, by terms commonly used in the art, and are discussed in the individual diagram notes. Where only a single tool of a selective cutting device is shown, it is to be taken as representative of a plurality of such tools, arranged in a row or as a bank (plurality of rows) in proximity to a workpiece.

The placement of a patent as an original in this class will hereinafter be referred to as "placement".

This class is restricted to:

(A) That kind of cutting device which is characterized by the inclusion of a plurality of cutting tool pairs and an actuating power train for each pair (one power train may be common to all), so that power may be delivered to any or all pairs for any cutting cycle, and wherein each tool pair assembled in the machine is constantly available to be chosen for cutting or noncutting in any desired number or combination of pairs (from one to the total number available) by:

(1) a pattern*,

(2) combinational-coding-means*, or

(3) means not a part of the tool-actuating power train and which does not partake of all the movements of either tool of the pair, which pattern or means conditions each pair so chosen as to (a) enable, or (b) prevent, a cutting operation thereby when its driving power train is actuated; and to:

(B) That type of procedure not elsewhere classified which comprises (1) the step of selecting one or more cutting tool pairs from a constantly available plurality of tool pairs, or (2) the step of utilizing a selective cutting device as defined above.

- (1) Note. Placement in this class requires the claimed recital of structure or method step set forth above.
- (2) Note. Figures 1, 2 and 3 illustrate approximately the minimum requirements for placement in this class, in the three correspondingly numbered categories (1, 2, 3) of the class definition. Each figure indicates a plurality of independently movable tools and mechanism for effecting the actuation of some or all of the tools, in any desired number and arrangement (the number of keys, positions, tools, etc., would in actual practice be many times the limited number shown in the diagrams).

Fig. 1 represents a pattern-controlled cutting device, classifiable in subclass 77 of this schedule, wherein pattern P acts similarly to a stencil, in that it blocks the effectiveness of the nonselected tools T, while other tools pass through holes in P and perforate the work W, upon downward movement of hammer or tool-head H and consequent compression of the springs.

Fig. 2 represents a single form of combinational-coding, which may be termed "coded direct punching" (subclass 106). Note that an individual tool may be actuated, at different times, as a part of several distinct subgroups (e.g., to perforate distinctive code symbols) in response to the depression of different keys; this is in contrast to the individual, independent key linkages indicated in the nonselective device of Fig. 6, wherein a given tool responds only to the depression of its own associated key.

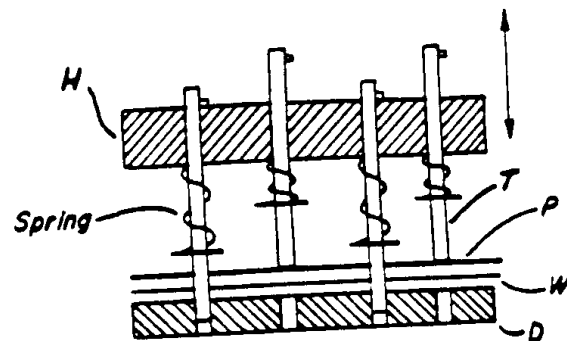

Fig. 1. SELECTIVE CUTTING, PATTERN CONTROLLED. (subclass 77)

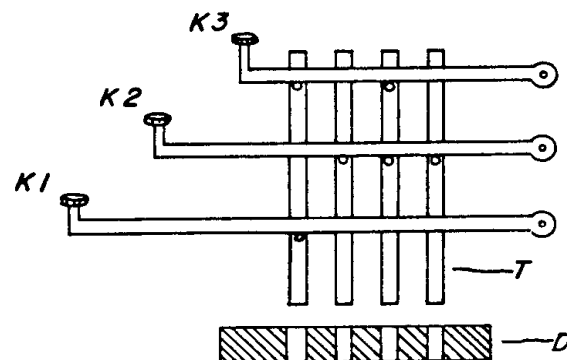

Fig. 2. SELECTIVE CUTTING, CODED DIRECT ACTUATION (subclass 106)

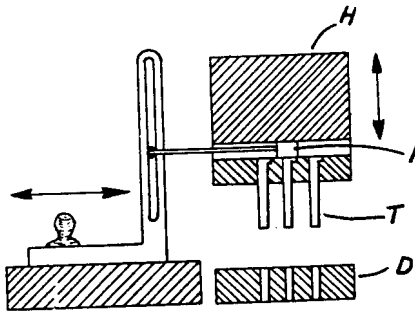

Fig. 3. SELECTIVE CUTTING, BY INTER-POSER (subclass 112)

Fig. 3 represents mechanism of the subclass 112 type, wherein the gag or interposer* I is positioned by means (shown as a manually slidable block on the machine frame) which is not a part of the tool drive train and which does not move in unison with the selected tool. (If the interposer I of Fig. 3 were manipulable directly, as by a knob fastened to its extending rod and thus vertically reciprocable with the tool-head H, the device would fail to meet the definition of Class 234, and would instead be classifiable in Class 83, Cutting, subclass 573, as a hand-actuated means to connect or disconnect a tool and its continuously moving drive means).

Fig. 4 is presented further to illustrate the line between this class and Class 83. The hand-manipulable interposer I does not meet the limitations of part (3) of the class definition, above, but it does qualify as combinational-coding-means* under part (2) of the definition, and specifically as a differential interposer (234-98). This line has been developed as a practical measure to distinguish most of the (generally) production-type cutting machines of Class 83.

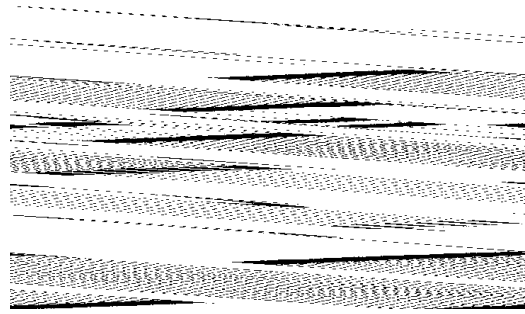

Fig. 4. SELECTIVE CUTTING, BY CODED INTERPOSER. (subclass 98) (see (3) Note below)

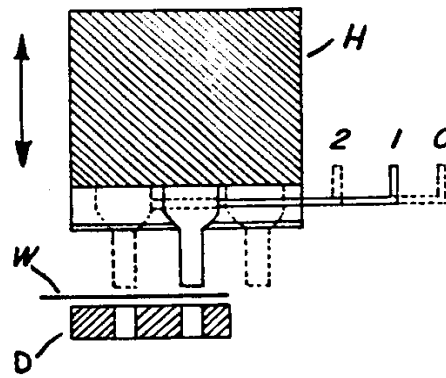

Fig. 5. NONSELECTIVE CUTTING, Class 83 type. (see (4) Note below)

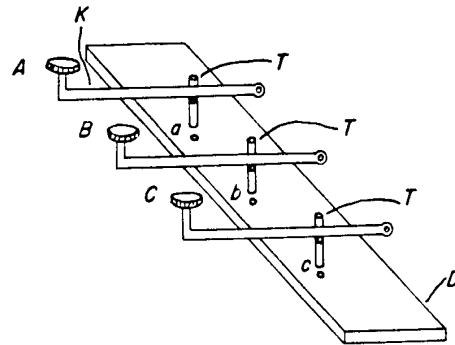

Fig. 6. NONSELECTIVE CUTTING, Class 83 type.

From the (generally) data-handling selective cutting machines of Class 234. The availability of two or more sub-groups of tools in Fig. 4 makes the device selective under the class definition.

- (3) Note. Specifically excluded from this class is a patent to a cutting method or apparatus which concerns the production of distinctive cutting operations solely by varying the position, the cutting stroke, or the time of actuation of a single tool (or a group of tools driven always as a unit). Fig. 5 represents such a device having a single tool, adjustable in position on a reciprocable ram; there is no "selection" from among a number of tools, but a mere adjustment of one tool. Also excluded is a patent to apparatus having a turret of tools, wherein the positioning of one tool for a cutting operation necessitates the movement of the other tools away from their effective positions.
- (4) Note. Further excluded is a patent to cutting apparatus in which the distinctive cutting operations are effected by direct (manual or power) actuation of one or more independently drivable tools at the will of an operative. Fig. 6 illustrates the excluded combination of tools, each driven by an independent key linkage, which is classifiable in Class 83, subclass 633, as a reciprocable tool driven by a fixed-axis lever. Fig. 7 illustrates the excluded combination of tools which lack a common power train or individual power trains for all tools; the single driving cam, shiftable along the rod, places this combination in Class 83, subclass 549. (see (4) Note in section II)

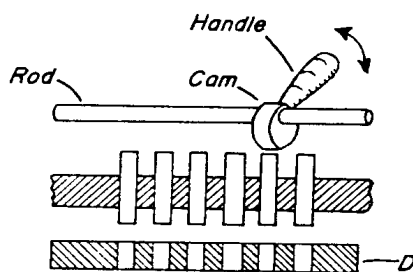

Fig. 7. NONSELECTIVE CUTTING, Class 83 type.

SECTION II - LINES WITH OTHER CLASSES AND WITHIN THIS CLASS

A. THE CLASS OF CUTTING IMPLEMENTS, CLASS 30.

A patent to a selective cutting or punching device will not be barred from original placement in Class 234 by reason of the fact that the device is intended to be hand-held and/or hand-actuated and/or work-supported.

B. THE CLASS OF SEVERING BY TEARING OR BREAKING, CLASS 225.

A patent to the combination of selective cutting means with means to sever (the work or product) by tearing or breaking will be placed originally in Class 234. The combination of tearing or breaking means with other (i.e., nonselective) severing means is found in Class 225, subclass 7.

C. THE CLASS OF CUTTING, CLASS 83.

Class 83 is an elemental or basic class. That is, its subject matter is restricted (so far as possible) to means for, or steps of, accomplishing the following functions: cutting something (the "work"); or cutting and handling the work to be cut; or cutting and handling the product of the cutting operation. Class 234 being superior to Class 83, a patent for the combination of a cutting device or method classifiable, per se, in Class 83 and a selective cutting device or method will be placed originally in Class 234. For a complete statement of the relationship between Class 83 and Class 234, see the class definition of Class 83.

D. THE CLASS OF PRINTING, CLASS 101.

Generally speaking, the recording or alphabetic or numeric characters by cutting is proper subject matter for Class 101, Printing. More particularly, individual cases of selective cutting may be tested for aptness to Class 101 by reference to the following statements:

(1) If in addition to a selective cutting machine or process of Class 234 there is claimed a means or step peculiar to Class 101 (e.g., the application of ink to the cutting tool to additionally outline or mark an aperture made by the punch, or the printing or embossing of characters or designs by means other than the cutting tools), the patent directed to such combination will be placed in Class 101.

(2) A patent directed to the selective cutting of a letter, number or aesthetic design will be placed in Class 101, subclass 18.

- (1) Note. The term “design” in this instance denotes a picture, a decorative or artistic arrangement of perforations or cut edges, or direct intelligence-bearing perforations or cuts; as distinguished from coded symbols. In case of doubt as to whether a patent discloses direct intelligence-bearing or codes symbols, placement will be in this class (234).

(3) A patent directed to the selective embossing of a letter, coded symbol, character or design will be placed in Class 101, subclass 18. (Such a patent would a priori be excluded from Class 234 on the ground that it is not concerned with cutting).

E. THE CLASS OF TYPEWRITING MACHINES, CLASS 400.

Patents for key-operated machines for the simultaneous composition and production of printed matter generally, are placed in Class 400, Typewriting Machines. The combination of typing and selective punching will in all cases be placed in Class 400, subject to the following qualifying statements:

(1) If only so much typing structure is claimed as is necessary to constitute a completely operative selective punching machine, the patent will be placed originally in Class 234 on the ground that the combination with typing is not positively claimed. (e.g., the recitation of typewriter keys, key levers, type bars, and means responsive to actuation of the type bars to select cutting tools is not considered sufficient for placement of the patent in Class 400 unless the structure claimed is sufficient to effect actual character production on the work; nor is the further recitation of escapement means and a movable paper carriage, if it appears that the carriage exerts a control on some function of the cutting mechanism, such as the feed of a card relative to the cutting tool station).

(2) The nominal recitation of a typewriter in combination with specific selective punching machine is not considered sufficient for placement of a patent to the combination in Class 400.

(3) A patent directed to the production of printed matter through the agency of a paper tape perforated under control of a keyboard will be placed in Class 400.

F. THE CLASS OF RECORDERS, CLASS 346.

A process or apparatus which would be otherwise proper for Class 346, Recorders, will not be removed from the scope of that class merely by virtue of the fact that the recording, as claimed, is accomplished by a selective cutting mechanism or method step.

RELATIONSHIP TO OTHER CLASSES INCLUDING, PER SE, HANDLING OR TREATMENT OF DATA

A. THE CLASS OF TELEGRAPHY, CLASS 178.

A process or apparatus which would be otherwise proper for Class 178, Telegraphy, will not be removed from the scope of that class merely by virtue of the fact that the recording of the transmitted message, as claimed, is accomplished by a selective cutting mechanism or method step.

In general, a recording or “printing” telegraph of Class 178 is distinguished from a selective punching machine of Class 234 by comprising one or a limited number of electrical input channels through which messages, unlimited with respect to the variety or extent of information they are adapted to convey, are transmitted from a distant point, the elements of the messages being selected according to a prearranged code. The claimed inclusion of a distant transmitter, or of means to decode electrical impulses originating at a distant point and conveyed over a relatively small number of channels, exemplifies the type of subject matter which would be placed in Class 178 rather than in Class 234, even though the recording may be accomplished by selective punching mechanism.

B. THE CLASS OF REGISTERS, CLASS 235.

There are generally three types of disclosure which contain subject matter common to Class 235, Registers, and Class 234, as follows:

(1) A patent directed to a calculating machine combined with selective mechanism for punching the data set up or the results, or both, which would be placed in Class 235.

(2) A patent directed to a selective punching machine combined with a register to ascertain the number of machine operations

or number of workpieces treated, which would be placed in Class 234.

(3) A patent for a keyboard controlled selective punching machine combined with a register for totalizing incremental quantities (e.g., type-widths and interword-spaces) related to the key-selected data, and means to indicate the approach of the total toward a predetermined quantity (e.g., the required length of a completed line of type composed according to the key-selected data), which would be placed in Class 234, subclass 4.

RELATIONSHIP TO OTHER MATERIAL HANDLING CLASSES

This class (234) receives original patents claiming significantly both a selective cutting or punching device and (a) means to separate or assort portions of the product resulting from the cutting operation, or (b) means to move or feed work, or (c) means to hold or move a pattern* or copy*. For the placing of patents which refer more broadly to a cutting tool or operation in combination with work or product handling, see the class definition of Class 83, Cutting.

SECTION III - GLOSSARY

ACTUATION

The application of operating energy to a mechanism to cause the latter to perform its appointed function.

ARRAY

A plurality of tools or sensing elements arranged to be driven as a group by a common actuator.

AUXILIARY-OPERATION

Any of the functions to be found in a selective cutting machine other than the selection* of tools, (e.g., tool actuation*, feed* of pattern or workpiece, change of code*, shift of control to or from a keyboard or pattern-senser*, starting or stopping of any portion of the machine, etc.).

CODE

A system of symbols arbitrarily used to represent directions, words, letters, or numerical values. In this class,

the term "code" wherever employed without further limitation should be regarded as meaning Combinational-Code*.

CODED-INTERPOSER

An element which is movable to and from an effective position in which position portions of said element engage tools of a plurality of tool pairs, thereby completing a drive train for the subsequent effective transmission of actuating power to the corresponding tool pairs. (Cf. Interposer).

CODED-SELECTOR-MEANS

An element which is movable to and from an effective position in which it determines the selection of a plurality of tool pairs by other mechanism. (Note. This element differs from a coded-interposer* in that (a) it does not engage the selected tools, and (b) it has only one effective position, as distinguished from the differentially positionable coded-interposer* found in subclass 98).

COMBINATIONAL-CODE

A system of symbols each comprising two or more marks or perforations which by their number and/or position arbitrarily represent bits of information. (Cf. one-hole- code*, defined below).

COMBINATIONAL-CODING-MEANS

Means which is differentially responsive to distinguishable forces or input-impulses* to prepare corresponding predetermined distinct combinations of less than the total number of tool pairs for actuation. (Note. This is the subject matter of subclass 94 of this class).

COPY (N.)

A tangible object which carries or exhibits a picture, design, or record of data, for the guidance or direction of an operative or attendant of a selective cutting machine. (Cf. pattern*).

FEED (OF PATTERN, CARD, WEB, ETC.)

The progressive advancement of an object through a tool field and/or a field of pattern-sensers*, as distinguished from the mere presentation of an object to a machine.

FULL-BANK

An assemblage of elements (e.g., tools or pattern-sensors*), which covers all significant points of an area to be operated on, usually in one cycle.

INDICIUM

A mark or configuration exhibited or carried by an object (such as a pattern* or token) intended for use in the control of a machine.

INPUT-IMPULSE

A force or stimulus applied to a machine from an external source (such as the hand of an operative, or the output mechanism of a calculator, etc.) or which originates from the sensing of a pattern* presented to the machine, and which is capable of controlling tool selection and/or auxiliary-operations*. (Cf. input-means*).

INPUT-MEANS

An instrumentality which is effective to exert control over the operation of tool-selecting mechanism and/or mechanism to perform an auxiliary-operation*, in response to the application of an input-impulse* to such input-means, (e.g., a keyboard, a dial, a pattern-sensing unit, etc.)

INTERPOSER

An element which is movable to and from two or more positions, in one or more of which positions it is effective to condition a tool pair for actuation by its engagement with a tool of said pair and by thus completing a drive train for transmission of actuating force to the tool pair (either by the transmission of energy to an active tool element, or by blocking an inactive tool element in effective position).

JUSTIFICATION

The computation or assignment of interword-spaces and/or type-widths, or symbols representative of such spaces or type-widths, in connection with the composition of a line of type or the production of an instrumentality (perforated tape, etc.) for the control of a type-setting machine, for the purpose of predetermining the exact length of a completed line of type.

NOTCHING

The cutting of a discrete product from a workpiece through the thickness of the workpiece with the line of

cut starting at an edge of the workpiece and returning to the same edge.

ONE-HOLE-CODE

A system of single-hole symbols each distinguished only by its position with respect to a datum line.

ONE-STROKE-STORAGE

Usually a misnomer, denoting merely a one-cycle delay in the actuation of selected tools. (See subclass 91 for examples; also cf. Storage*).

PATTERN

A tangible object, which, when temporarily presented to a suitable machine of the class type, affects the control of tool selection. (The workpiece itself may function as a pattern).

PATTERN-FIELD

A complete pattern or any part thereof which may be chosen to supply input data for any purpose.

PATTERN-SENSER

One or more elements which are capable of responding to certain indicia or characteristics of a pattern* presented to a machine, which response may be utilized to exert a control function on some portion of the machine.

PRODUCT

A workpiece* which has been completely processed by a device of the Class 234 type.

PROGRAM

A predetermined timed sequence of auxiliary-operations* of a Class 234 machine (i.e., not directly including the selection of tools, but it may include a changeover from one code* system to another; cf. Auxiliary-operation*).

READ-IN (N.)

The transfer of data to a storage* device.

READ-OUT (N.)

The transfer of data from a storage device or other means, to tool selection mechanism.

SELECTION

The conditioning by a device of one or more of a number of available elements. (In this class, the term "selection" is usually employed with reference to tools; tool selection is independent of tool actuation*).

SHIFT (N.)

A change in the relative position of data, indicia, etc., incidental to its transfer from one record or medium to another (e.g., data in columns 1-5 of a pattern card may be caused to appear in columns 16-19 and 21 of a newly made card).

SKIP (N.)

A suspension of cutting and/or pattern-sensing operations, accompanied by a predetermined amount of feed* of a workpiece or pattern, for the purpose of omitting operations on a portion thereof.

SLITTING

The cutting of a narrow incision by a single straight or curved cutting edge, the incision extending through the thickness of a workpiece, being of finite length, and having distinct ends (i.e., not a punched hole).

STORAGE

The temporary retention, in a portion of machine, of input data, after cessation of the input-impulse* and before a corresponding initiation of tool selection*.

TOOL-FIELD

An area embracing all the points which can be operated upon in one cycle of actuation of a given plurality of tools.

WORKPIECE

The object which is cut or punched (before, during, or after such operation is effected). Cf. Product*.

SUBCLASSES**1 METHODS:**

This subclass is indented under the class definition. A procedure which comprises the step of selecting one or more cutting tools or utilizing a selective cutting device.

2 Comprising utilization of a pattern:

This subclass is indented under subclass 1. Procedure which comprises the step of detecting the indicia or the characteristics of a pattern.

3 And modification of the pattern or its effectiveness:

This subclass is indented under subclass 2. Procedure which comprises the step of varying (1) the characteristics of a pattern or (2) the response of a machine to pattern characteristics.

4 WITH TYPE-WIDTH AND INTER-WORD-SPACE TOTALIZER OR INDICATOR (I.E., FOR JUSTIFICATION):

This subclass is indented under the class definition. Device comprising means to cut character and space-representing code perforations successively in a strip of material and, substantially simultaneously, to cut other perforations representative of incremental quantities related to said characters (e.g., their widths when set up in type), and further comprising means to totalize said quantities (by means of a counter or measuring unit) and means to indicate the approach of said total toward a predetermined quantity (i.e., the length of a completed line of type).

(1) Note. A patent directed to a device for punching a typographical-machine-controlling strip will not be placed in this or the indented subclasses unless all or a significant portion of a justification-space counter and/or indicator or associated structure pertaining to justification is claimed. Other features, such as repeat key systems, may be found in appropriate subclasses herebelow, in devices which could conceivably be utilized as composing machines.

(2) Note. Some patents have been cross-referenced to this subclass on the basis of disclosed features deemed important to selective typographical punching machines even though the disclosures are not clearly of the selective type.

SEE OR SEARCH THIS CLASS, SUB-CLASS:

125, for a “repeat key” mechanism on a composing machine or other selective punching device.

SEE OR SEARCH CLASS:

400, Typewriting Machines, subclasses 1+ and 77+ for a “composing machine” which prints code symbols on a tape, and comprises some justification structure.

5 **Embodying exchangeable sub-assembly unit for font change:**

This subclass is indented under subclass 4. Device which includes a portion that can be removed and replaced by another assembly having characteristics related to a different size or style of type which alters the selection of tools in response to a given input impulse.

- (1) Note. Usual examples are interchangeable keyboards or permutation-bar units, usable to adapt a single machine for composing matter in different fonts or type styles. Provision is thus made for suitably altering the selection of punches and the drive to the justification counter and/or indicator.

SEE OR SEARCH THIS CLASS, SUB-CLASS:

14, for programmed means to alter a code.

69, for code production or conversion means associated with a pattern-controlled punching device.

96, for means in a selective cutting device for changing a code or facilitating change thereof.

6 **Embodying means to facilitate error correction:**

This subclass is indented under subclass 4. Device which includes a modification adapted to simplify or reduce the number of operations required to effect the cancellation of a portion of the series of perforations made in previous cycles of the machine.

- (1) Note. Such a device usually operates in two general steps: (1) to restore the justi-

fication counter and indicator to the conditions they occupied prior to the punching of the canceled subject matter; and (2) to overpunch the matter to be canceled, or to insert an error symbol in appropriate position to be sensed by the type-casting machine for which the tape is intended to be used.

7 **Embodying means to tabulate or to adjust line length:**

This subclass is indented under subclass 4. Device including means effective to provide subtotalization of said incremental quantities at a plurality of predetermined points in the composed line, or means to effect alteration in the length of line to be composed.

- (1) Note. A device of this subclass type facilitates the composition of printed lines of different lengths, and the composition of tubular matter (i.e., in vertical columns).

8 **Embodying means to insert justification symbol:**

This subclass is indented under subclass 4. Device including means for cutting in said strip one or more perforations which represent the widths of interword-spaces so selected at the completion of each line as to cause the completed line (when set in type by a machine not claimed here) to be of a predetermined length.

- (1) Note. Actuation of the selected tools to produce justification indicia in the control strip may be effected manually (by special key or incidental to another manual operation such as line feed), or may be automatic.

9 **With means to effect selection of justification tools:**

This subclass is indented under subclass 8. Device including means responsive to justification conditions as determined by a justification counter or indicator to control the conditioning of tools without the intervention of an operative.

10 With means to insert justification symbol at other than end of line:

This subclass is indented under subclass 9. Device, including means to insert the justification symbol or symbols at the beginning of a line or in interword-spaces.

- (1) Note. The more conventional system is to insert justification symbols at the end of the line, which usually requires later that the control tape be fed backward into the typesetting machine; for which see subclasses 8 and 9.

11 Embodying means to drive totalizer:

This subclass is indented under subclass 4. Device including means to advance the counter or measuring unit.

- (1) Note. Also included are arrangements for altering or adjusting (rather than exchanging) the counter drive to accommodate different type fonts or to space the letters of words.

SEE OR SEARCH THIS CLASS, SUBCLASS:

- 4, for a machine including a mere justification indicator (i.e., which does not totalize or compute justification data).
5, for a machine with exchangeable parts to accommodate different fonts.
7, for a machine with provision for altering the counter or measuring unit drive incidental to tabulating or line length adjustment.

12 "Unit-Wheel" type of counter:

This subclass is indented under subclass 11. Device wherein the counter consists of a toothed wheel driven through assigned increments of rotation by one or more toothed racks.

- (1) Note. Counters of this type, termed "unit-wheel", are in wide use (see Patent No. 663, 996, granted December 18, 1900, to T. Lanston).

13 WITH MEANS TO IMPOSE PROGRAMMED CONTROL OF AUXILIARY-OPERATION:

This subclass is indented under the class definition. Device which performs a plurality of operations in sequence and which comprises means effective at a predetermined point in said sequence to modify or render effective or ineffective certain machine controlling impulses other than those impulses which directly control the selection of tools.

- (1) Note. For example, the changeover from one code system to another, and the shift of control from one input source to another, are merely preparatory to subsequent tool selection operations, hence they are regarded as "auxiliary-operations", rather than as constituting direct control of tool selection. The term auxiliary-operation* implies any action, operation, or change of condition of a device or part thereof, other than the actual selection of tools for cutting or noncutting action in any cycle of tool actuation. For further examples of auxiliary-operations, see Definitions of Terms.

- (2) Note. The term "programmed" implies that any of the actions or changes of conditions referred to in (1) Note, above is the result of a prearranged timing schedule and thus occurs at one or more fixed points in the timed sequence of a machine operation, as against any random time dependent upon the receipt of signals from an external source (e.g., actuation of a keyboard by an operative), or upon the occurrence of a condition which is not definitely related to any particular cycle of operation of the machine (e.g., the occurrence of a misfeed overload, or other malfunction).

- (3) Note. Programming may be effected by sensing a card, tape, or other medium while at rest or while progressing through the machine. Such a card or tape is distinguishable from a "pattern" card or tape by the fact that a programming medium controls auxiliary-operations of the machine. If it further contains tool-selection-controlling data, it is a com-

bined program-pattern element, and the programming feature would prevail in the original classification of a patent to the combination.

- (4) Note. Certain conventional features commonly found in card punches, namely: the so-called “last-column contact” circuits, or automatic card-feed and card-eject devices in general, are not deemed as of sufficient interest in this class to warrant cross-referencing into subclass 13 unless included in the claimed invention.

14 **Embodying means to change code:**

Device under subclass 13 wherein the program means modifies a code* or substitutes one code for another.

- (1) Note. The program means found in this subclass does not select tools directly, but effects a change in the system of tool selection (i.e., a change of code, such for example as the substitution, at certain points only in the sequence of operations, of a “space” symbol for a “zero” in response to a “zero” impulse).
- (2) Note. The automatic insertion of zeros or suppression of zeros while punching numerical data is an example of “change of code”. This auxiliary-operation, if arranged to occur only at predetermined points in the sequence of machine cycles, is said to be “programmed”; if, however, it takes place whenever a certain condition or combination of conditions should arise (e.g., upon detection of an initial zero in numerical data received from a keyboard or a pattern-reader) it is a randomly effected change of code, classifiable in subclasses 22+.

SEE OR SEARCH THIS CLASS, SUBCLASS:

- 24, for means to automatically insert or to suppress the punching of a zero symbol, under the control of randomly effective operating conditions.
- 96, for means to change or facilitate change of code, in a selective cutting device.

15 **Embodying means to afford choice of programs:**

This subclass is indented under subclass 13. Device wherein additional means is provided for conditioning the device to follow one of a plurality of distinct predetermined sequences of operations.

16 **Embodying means to shift control between plural input sources:**

This subclass is indented under subclass 13. Device wherein the program means terminates the transmission of machine-controlling impulses from one specified portion of the device and effects initiation of transmission of such impulses from another specified portion of the device.

- (1) Note. For original placement in this subclass, a patent must claim means to connect a second input means, as well as means to disconnect a first input means. The mere addition of an overriding control of a single input means (e.g., the operation of keys by a pattern-responsive mechanism at certain times) is found in subclass 20.

17 **Diverse sources:**

This subclass is indented under subclass 16. Device wherein the two specified portions of the device differ in both structure and function.

- (1) Note. Such portions may be, for example, a keyboard and a pattern-senser or data storage device.

18 **Embodying means to effect selection or shift or skip of field:**

This subclass is indented under subclass 13. Device wherein said program means effects a predetermined change in the location of a cutting tool pair with respect to work and/or in the location of the effective portion of a pattern-sensing mechanism with respect to a pattern.

- (1) Note. Patents in this subclass disclose means for altering, at predetermined times, the relative recorded positions of data being read from a pattern or storage means, or being supplied from a keyboard or other input means.

SEE OR SEARCH THIS CLASS, SUB-CLASS:

72+, for means to effect field selection, skip, elimination, or shift, in a pattern controlled device.

19 With change in feed of pattern or work:

This subclass is indented under subclass 18. Device including means effective during a predetermined time interval to speed up, slow-down, or temporarily block the progressive movement of work or pattern past the zone of cutting or sensing operations.

(1) Note. "Skip bar" controls are found in this subclass, also arrangements for permitting "multiple punching" in given columns.

SEE OR SEARCH THIS CLASS, SUB-CLASS:

28+, for randomly controlled changes in feed of pattern or work.

72+, for alteration of the effect of pattern data which may involve changes in feed.

20 For start or stop of control from given input source:

This subclass is indented under subclass 13. Device, wherein the program means effects initiation or termination of transmission of machine-controlling impulses from a specified portion of the device.

(1) Note. Included here is the conventional "column cutout bar" control which starts and stops duplicating operations at predetermined card columns, permitting an operative to insert manually keyed data in certain fields of a card.

21 For stopping after predetermined number of operations:

This subclass is indented under subclass 13. Device provided with means to bring one or more parts to a halt after the completion of a fixed plurality of cycles of operation of the device or of any portion thereof which is periodically actuated.

(1) Note. This subclass does not include "repeat key" mechanisms, for their actu-

ation is manually initiated at random times (i.e., at the will of an operative), for which see the Search This Class, Subclass note below.

SEE OR SEARCH THIS CLASS, SUB-CLASS:

51, for means to effect unicyclic tool actuation.

125, for repeat key mechanism, and see (1) Note, above.

22 WITH MEANS TO IMPOSE RANDOMLY ACTUATED CONTROL OF AUXILIARY-OPERATION:

This subclass is indented under the class definition. Device provided with means for initiating, modifying, or terminating the functional effect of some portion of the device other than or in addition to the tool selecting mechanism, per se; such control-imposing means acting in response to a signal or impulse which cannot be predicted to occur during any particular one of a number of recurring cycles of operation (either of the machine as a whole, of a tool, or of any part of the machine which has a cyclic law of operation).

(1) Note. Such means may comprise, for example, a device effective to stop a selective cutting machine upon the detection of a jam in the work feed mechanism, or to start such a machine upon the presentation thereto of a pattern or a workpiece, or to temporarily suspend tool actuation during the passage of a particularly identified card through the punching station or to cause automatic change of code under certain operating conditions which occur at random times.

(2) Note. The claimed combination of pattern-sensing means and tool-selecting means controlled thereby is found in subclass 59, below. The selection of tools being in the main characteristic of Class 234, it is not included in the meaning of the term

(3) Note. In general, an operation which is specifically voluntarily initiated, as by the depression of a claimed special key on a keyboard, is not regarded as a random operation within the meaning of

this subclass definition. The term “random” is applied in Class 234 to operations which occur in response to given conditions or otherwise without voluntary initiation by an operative. Means for performing a given operation at the will of an operative or attendant will generally be found in a subclass relating generally to means for performing the pertinent operation, or in the keyboard subclasses 123+.

SEE OR SEARCH THIS CLASS, SUBCLASS:

- 13+, for programmed control of auxiliary-operation.
- 59+, for pattern control of tool selection.
- 124+, for keyboard control of an auxiliary-operation, (e.g., workfeed, repeat operations, column skipping, etc.).

23 **Embodying means to detect order of occurrence of input data:**

This subclass is indented under subclass 22. Device provided with additional means which is differentially responsive, to two or more diverse bits of data which control the selection of tools in the device, in such manner that a certain time sequence of transmission of such bits makes said additional means effective to transmit said signal or impulse to the control-imposing means.

- (1) Note. For example, a device in this subclass may effect an automatic change of code, sometimes involving the punching of “letters shift” or “figures shift” symbols at appropriate locations in an output tape. The control-imposing means does not select tools, but establishes or selects the system by which tool selections are governed, during the existence of a given operating condition.

SEE OR SEARCH THIS CLASS, SUBCLASS:

- 14, for means to perform a similar operation under programmed control.

24 **Zero suppression or insertion:**

This subclass is indented under subclass 23. Device wherein the additional means is differentially responsive to the occurrence of a zero or a significant digit, and the control-imposing

means is capable of determining the actuation or nonactuation of a tool or group of tools (which has been selected by other means) to represent a zero symbol.

- (1) Note. The systematic substitution of a “zero” for a space or other character, or substitution of a “space” for a zero, at every occurrence, is simply a change of code. A device having this function would be classified in one of the appropriate subclasses relating to “coded” punching (see the Search This Class, Subclass note below, for example).

SEE OR SEARCH THIS CLASS, SUBCLASS:

- 14, for programmed means to change code.
- 69+, for change of code in a pattern-controlled selective cutting device (see (1) Note above).
- 96, for means to change or facilitate change of code in a selective cutting device.

25 **Embodying means to detect indicium in work or pattern:**

This subclass is indented under subclass 22. Device provided with additional means which is capable of sensing data or a characteristic of a pattern* or workpiece* and initiating the control-imposing signal or impulse in response to the sensing of a predetermined symbol or characteristic.

- (1) Note. See (2) Note under subclass 22.

SEE OR SEARCH THIS CLASS, SUBCLASS:

- 33+, for a control which may be initiated jointly by work-sensing means and other means.
- 63+, for means to control tool selection by detection of indicia in workpiece.

26 **With group number control of recording:**

This subclass is indented under subclass 25. Device wherein said control-imposing means governs the transfer or nontransfer of data from a pattern to a workpiece, the device being further provided with a comparator effective to compare data sensed by such additional means with other data stored in the device or concur-

rently sensed from a pattern or workpiece, and means to initiate the control-imposing signal or impulse under a given condition of correspondence or noncorrespondence of said compared data.

- (1) Note. The auxiliary-operation controlled in this case is the tool actuation (as distinct from tool selection) or the transmission of selection impulses to the tool-selection means.

SEE OR SEARCH THIS CLASS, SUBCLASS:

63, for control of data reproduction by detection of indicia in a workpiece.

27 With control of feed of pattern and/or work:
This subclass is indented under subclass 26. Device including means responsive to the control-imposing signal or impulse to regulate the feed of pattern and/or work.

28 With means to control feed:
This subclass is indented under subclass 25. Device wherein the control-imposing means is for starting, stopping, or modifying the progress of a pattern and/or workpiece through the device.

- (1) Note. The usual function characterizing the devices of this subclass is pattern-controlled skipping of pattern and/or work fields.

SEE OR SEARCH THIS CLASS, SUBCLASS:

19, for programmed control of pattern or work feed.

72+, for broadly, means to alter the effect of pattern data by transposition, shift, or suppression field.

29 Control of pattern feed:
This subclass is indented under subclass 28. Device wherein said control-imposing means regulates the progressive movement of a pattern with respect to pattern-sensing means.

30 Stopping means:
This subclass is indented under subclass 22. Device wherein said control-imposing means operates by bringing any or all of the moving

parts of the device to a halt or by terminating an auxiliary-operation (e.g., tool actuation).

- (1) Note. It is not a bar to original placement of a patent in this subclass, that the claimed power train disrupting, breaking, or other "stopping" means may be activated at a time when the part to be halted is, purely adventitiously, at a standstill due to its normal cyclic operation.

- (2) Note. Patents in this subclass (30) may claim the combination, in a selective cutting device, of stopping means initiated by sensing the absence of work or pattern, or sensing misplaced or defective work, etc., wherein the occurrence of such condition, as disclosed, is not by reason of defect or malfunction of the device, for which latter condition, see subclass indented hereunder.

SEE OR SEARCH THIS CLASS, SUBCLASS:

22, for random control which may include, but is not limited to stopping (e.g., means to start a machine upon presentation of work or pattern which may be combined with means to stop the machine upon withdrawal of work or pattern).

32 Upon detection of machine defect or misoperation:

This subclass is indented under subclass 30. Device provided with additional means responsive to a failure of a machine part, or to an abnormal position or functioning thereof, to initiate said signal or impulse.

- (1) Note. Random stopping means which responds to absence or abnormal position of a pattern or workpiece, irrespective of the cause for such condition, will be found in subclass 30.

33 With means to check on tool actuation:

This subclass is indented under subclass 32. Device provided with means which responds to tool actuation or senses characteristics of the workpiece subsequent to tool actuation and which initiates said signal or impulse in response to (1) a failure of the device to follow

a predetermined type of tool operation, or (2) the correct completion of such operation, which signal or impulse governs the continuance of operation of the machine or of a part thereof.

- (1) Note. For example, the means may be used to check the presence of a punched hole in each column of a card before it leaves a card punch machine.
- (2) Note. A check on tool actuation includes, but does not require, verification of the correctness of the punching operations, for which see subclass 34, indented hereunder.
- (3) Note. The term "stopping" in subclasses 30+ is broadly construed to embrace a change in the mode of operation of the device which involves the cessation of a particular function even though parts concerned may still have motion.

34 With verifier (data comparator):

This subclass is indented under subclass 33. Device in which the signal- or impulse-generating means responds to a disparity between the selection control impulses received by the device and the consequent operations performed by the device.

35 WITH INPUT MEANS COMMON TO TOOL SELECTOR AND PRINTER:

This subclass is indented under the class definition. Device including input-means* which means affects both mechanism for selective cutting as well as mechanism for applying embossed or visibly tinted character-representing symbols to a workpiece.

- (1) Note. The printing and cutting operations may be applied to the same or to different workpieces, and either simultaneously or nonsimultaneously.
- (2) Note. The claimed inclusion of any specific element of a printing device, which element is not a necessary part of the control or actuating mechanism of the selective cutting device, is a bar to placement of the patent in this class. For example, a patent to a combined "typewriter-punch" wherein the typewriter

key levers actuate punch-selection mechanisms and the paper-carriage movement controls feed of a card to the punching station, would be placed as an original in Class 400, Typewriting Machines, if the claims referred also to "types", or ribbon feed or line-feed mechanism, etc.

- (3) Note. For the relationship of this group of subclasses to other work-treating classes, see the class definition section entitled "Relationship to Other Classes Including, Per Se, Cutting or Other Treatment of Work".

36 Step by step printer:

This subclass is indented under subclass 35. Device wherein the printing means is disclosed as being effective to applying printed symbols in sequential order.

- (1) Note. Typographical punching machines commonly include step-by-step printing incidental to the production of a perforated control strip for typesetting purposes.

SEE OR SEARCH THIS CLASS, SUBCLASS:

- 4, for a typographical punching machine with incidental step-by-step printing.

SEE OR SEARCH CLASS:

- 101, Printing, for the combination of specific printing means with selective cutting means.
- 400, Typewriting Machines, for the combination of step-by-step printing means and work-feed means with selective cutting means.

37 On same workpiece:

This subclass is indented under subclass 36. Device wherein the printing means is disclosed as being effective to treat the workpiece upon which the cutting tool pairs are effective.

38 WITH NONSELECTIVE CUTTING OR PUNCHING MEANS:

This subclass is indented under the class definition. Device which includes cutting or punching mechanism which is not selective in terms of the class definition.

- (1) Note. Disclosures of a selective cutting machine combined with feed-hole punching mechanism or a work-trimming cutter are found in this or the indented subclass.

39 Work sizing or cyclic (e.g., feed hole) punching:

This subclass is indented under subclass 38. Device wherein the nonselective mechanism is effective to cut the workpiece or product to size or to perforate it at regular intervals.

40 WITH SORTING MEANS OR COPY HOLDER:

This subclass is indented under the class definition. Device in combination with (1) means to systematically distribute the products from the cutting device, or (2) means to support and exhibit a record or data source for the convenience of an operative using the device.

- (1) Note. A patent to a selective punching device comprising a manually movable stylus to control tool selection, and a holder for a drawing or design to be traced by such stylus, will be placed as an original in this subclass.
- (2) Note. The terms copy* and "data source" do not imply direct control of a machine therefrom, as in the case of a pattern* or a "program device", but merely afford information for the guidance of an operative or attendant, who in turn controls the selection of tools.

SEE OR SEARCH THIS CLASS, SUBCLASS:

- 13, and 22, for respectively, programmed control or random control of auxiliary-operation, which latter may include sorting as well as interfiling, segregating, counting, etc.

41 CONVERTIBLE:

This subclass is indented under the class definition. Device provided with means which, when rendered effective, alters the device from the selective cutting device to a device lying outside the scope of the class definition.

- (1) Note. Example: A card punch machine which by the manipulation of a control switch is usable as a verifying machine, or as a card sorter.

SEE OR SEARCH CLASS:

- 73, Measuring and Testing, subclass 156, statistical record verifying, for a verifying device, per se.
- 83, Cutting, subclasses 204 and 574 for a device which is convertible within that class.

42 PLURAL TOOL FIELDS:

This subclass is indented under the class definition. Device which comprises two or more distinct arrays of selectively controlled tools, or one array composed of distinct groups of tools controlled by separate tool selection mechanism.

- (1) Note. A device in this subclass may consist of a plurality of virtually complete selective cutting machines interconnected to some degree as by control means or common drive means; or it may be in effect one cutting machine provided with distinct arrays of tools and conforming with the above definition.
- (2) Note. The plural tool fields need not be spaced apart physically: tools of the several fields may be adjacent (or even intermingled) if there are distinct actuating means and/or distinct selecting means for each field.
- (3) Note. The conventional Powers-type card punch, having a full bank of punch elements connectable column-by-column to a single input means (keyboard and pin-setting carriage) does not constitute a plural tool field selective punching device, for the selection means, as well as the actuating means is common to all columns of punches.
- (4) Note. The addition of a second input means, such as a serial numbering attachment, to a selective punching device to control the punching in certain columns of a card will not of itself effect patent placement in this subclass.

- SEE OR SEARCH THIS CLASS, SUB-CLASS:
 38, for a combination of devices which may comprise plural tool fields, one of which is not selective.
 61, for a patent disclosing plural tool fields, one field being devoted to serial numbering, and see (4) Note above.
 91, for a device of the Powers type referred to in (3) Note above.
- 43 With means to select a given field:**
 This subclass is indented under subclass 42. Device provided with means to determine which one or more of the arrays of tools shall be operative.
- SEE OR SEARCH THIS CLASS, SUB-CLASS:
 18, for programmed control of field selection.
 22, for control of field selection by random means (e.g., sensed data).
- 44 By manually settable means:**
 This subclass is indented under subclass 43. Device wherein the field-selection means is controllable at the will of an operative.
- SEE OR SEARCH THIS CLASS, SUB-CLASS:
 124+, for control of auxiliary-operation by keyboard means in a selective cutting device.
- 45 With independent manual input means:**
 This subclass is indented under subclass 42. Device including distinct means separately controllable at the will of an operative to select tools in each of two or more arrays.
- 46 NOTCHING OR SLITTING MEANS:**
 This subclass is indented under the class definition. Device in which each tool pair is arranged to effect (1) a notching* operation or (2) a slitting* operation.
- (1) Note. Included in this and indented subclasses are for instance, patents directed to selective cutting machines for (a) notching the edges of cards, (b) machines for partially or completely severing a workpiece along a particular contour or line of cut, and (c) machines for cutting U-shaped slits to constitute "chainless apertures".
- 47 Notching:**
 This subclass is indented under subclass 46. Device wherein the tool pairs are arranged to perform notching operations only.
- SEE OR SEARCH CLASS:
 83, Cutting, subclass 917, and other appropriate subclasses for a notching device in general.
- 48 Uniform depth:**
 This subclass is indented under subclass 47. Device comprising means to cause selected tools to make cuts of equal maximum extent (measured along a line normal to the edge of the workpiece) from portions of the periphery of a properly positioned workpiece.
- SEE OR SEARCH THIS CLASS, SUB-CLASS:
 47, for a device adapted to cut both deep and shallow notches in combination as required in some card coding systems.
- 49 MEANS FOR CUTTING MOVING WORK:**
 This subclass is indented under the class definition. Device including means to advance the workpiece at an angle to the direction of motion of the tool(s) during the actuation of the selected tool(s).
- (1) Note. This subclass does not include patent for a device wherein the only movement of the work is incidental to the approach of one tool to its cooperating tool, (e.g., work carried by a moving die plate against fixed punches).
- (2) Note. This subclass contains, for example, patents directed to means for recording the actuations of piano keys by selectively punching a moving paper strip.

SEE OR SEARCH CLASS:

- 83, Cutting, subclasses 284+ and 350+ for tool-cutting moving work, in general.
- 84, Music, subclasses 461+ for means to record movements of piano keys, other than by perforating a sheet; and see (2) Note, above.

50 Flying cutter:

This subclass is indented under subclass 49. Device wherein the acutated tools have a component of motion parallel to the direction of work advance.

- (1) Note. The component of motion of tools in the direction of work advance may be obtained by so mounting the tools that they may be carried along by their engagement with the moving work.

SEE OR SEARCH CLASS:

- 83, Cutting, subclasses 284+ for a flying cutter of more general utility.

51 EMBODYING UNICYCLIC TOOL ACTUATING MEANS:

This subclass is indented under the class definition. Device provided with means to bring the tool drive train to an ineffective condition after the occurrence of one actuation of the selected tool or tools, which condition persists at least until the transmission of a subsequent control impulse to the tool selection means.

- (1) Note. The type of mechanism found in this subclass is frequently termed "non-repeat".

SEE OR SEARCH THIS CLASS, SUBCLASS:

- 21, for means to bring part or all of a selective cutting device to a halt after a predetermined number of operations.

SEE OR SEARCH CLASS:

- 83, Cutting, subclasses 203+, 484, 524+ for unicyclic operation of a cutting tool, in general.

52 WITH INTERLOCK BETWEEN TOOL ACTUATOR AND SELECTOR:

This subclass is indented under the class definition. Device provided with means in addition to the tool selecting and tool actuating power trains, which means positively prevents operation of the tool-actuating power train in the event of partial or incomplete operation of the tool selecting means, or vice versa.

SEE OR SEARCH CLASS:

- 83, Cutting, subclasses 221, 380 and 399+ for an interlock device in a cutting machine.

53 WITH MEANS TO ESTABLISH CONTROL PATH, FROM ONE OF A PLURALITY OF INPUT SOURCES, TO TOOL SELECTION MEANS:

This subclass is indented under the class definition. Device provided with two or more distinct and independent means capable of receiving input-impulses* and initiating or transmitting tool-selection control impulses in accordance therewith, and further means for determining which of such distinct and independent means should be effective.

SEE OR SEARCH THIS CLASS, SUBCLASS:

- 16+, for programmed means to select from a plurality of input sources.
- 22+, for randomly-controlled shift from one input means to another.
- 65, for joint control of tool selection by pattern senser and other input means.

54 Diverse input sources:

This subclass is indented under subclass 53. Device wherein the distinct and independent receiving means are dissimilar in general structure and function.

SEE OR SEARCH THIS CLASS, SUBCLASS:

- 17, for programmed means to select from a plurality of diverse input sources.

55 WITH MEANS TO STORE AND RETRIEVE INPUT DATA AFTER REMOVAL OF INPUT-IMPULSE:

This subclass is indented under the class definition. Device provided with means effective to receive a signal or impulse transmitted from an input-means* and to register and retain a distinctive record thereof, after cessation thereof and further means effective to read said record and to transmit a corresponding control impulse to the tool selection means.

- (1) Note. For inclusion in this or an indented subclass, a patent must claim means which is selectively conditioned by a signal or impulse transmitted by an input-means and which, at some time thereafter, takes part in the generation or transmission of another signal or impulse, representative of the first, as determined by such selective conditioning.
- (2) Note. To constitute data storage there must be retention of distinctive information after removal of the input-impulse (e.g., retraction of the depressed key) and before the corresponding tool selection has been effected.
- (3) Note. Storage may be effected by a recording mechanism, (such as a tape punch), and a sensing means, so arranged that data stored in the tape is later utilized to control tool selection.
- (4) Note. Fig. 8 illustrates the essentials of one type of storage system. Depression of any key K energizes an associated storage relay SR, which remains energized over a circuit including its hold contacts a. When at some later time, read-out contacts R-O are closed, circuits are completed through contacts b of all energized relays, thus energizing the associated magnets M and positioning interposers I in readiness to actuate tools T upon the next stroke of ram H. (In practice, relays SR would ordinarily be restored after the read-out, by opening their holding circuits).

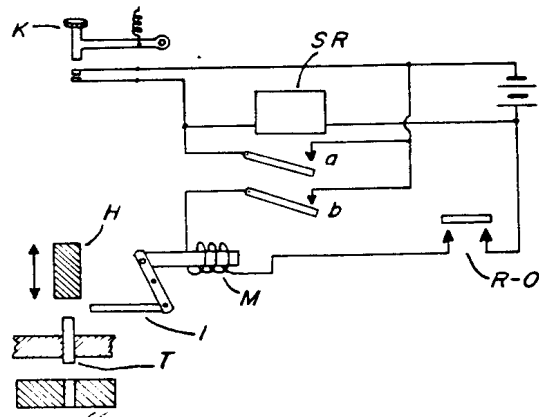

SEE OR SEARCH THIS CLASS, SUB-CLASS:

- 25+, for control of auxiliary mechanism by detection of predetermined indicia, which may involve storage of such indicia.
- 26, for comparison of "group numbers" for auxiliary control purposes, which may involve storage of such numbers for control purposes rather than for read-out to recording means.
- 90, for means to delay the effectiveness of tool selection; e.g., the so-called "one-stroke storage" feature.
- 92+, for means optionally settable to retain or clear a selection of tools after their actuation.

SEE OR SEARCH CLASS:

- 235, Registers, appropriate subclasses for a calculating machine having data storage and output punching features.
- 365, Static Information Storage and Retrieval, appropriate subclasses for electrical means to store data.

56 With read-out in different order:

This subclass is indented under subclass 55. Device comprising a plurality of said receiving means effective to register and retain a plurality of such records, and the transmitting means being effective to transmit two or more control impulses to the tool selecting means in altered sequence from that in which the corresponding records are registered.

- (1) Note. Within the meaning of the subclass definition, either the read-in* or the

read-out* may be simultaneous, if the other is in timed sequence.

- (2) Note. As methods of achieving a different sequence, for example, input data may be entered in parallel and read-out serially, or vice versa, or data may be entered in column-by-column order and read-out row-by-row.

57 With optionally settable means to clear storage upon read-out:

This subclass is indented under subclass 55. Device provided with mechanism capable of being moved or adjusted from one position or condition to another, said mechanism in the one position being effective to prevent restoration of the registering means to its idle or empty condition, but in the other position being effective to cause such restoration in response to transmission of the selection control impulse from the registering means.

- (1) Note. A device of this type is, in other words, capable of either "destructive" or "nondestructive" read-out.

SEE OR SEARCH THIS CLASS, SUBCLASS:

92+, for means optionally settable to retain a selection of tools after their actuation.

58 With serial read-out from storage:

This subclass is indented under subclass 55. Device including mechanism to effect the transmission of control impulses from the registering means in a timed sequence.

- (1) Note. A common example of serial read-out is a column-by-column read-out to a card or tape punch from a bank of storage relays.

SEE OR SEARCH THIS CLASS, SUBCLASS:

66, for means to read-out data in sequence from pattern-sensors.

59 WITH MEANS TO INITIATE TOOL SELECTION BY SENSING PATTERN

INDICIA OR CONFIGURED MACHINE ELEMENT:

This subclass is indented under the class definition. Device which comprises means for sensing indicia or characteristics of a pattern*, or means for sensing a specially-configured cylindrically effective portion of the device, and means responsive to such sensing to cause actuation of one or more tools, or to tool selection only, or to control both selection and actuation of tools.

- (1) Note. Some instance of pattern control are found in preceding subclasses (e.g., as specific phases of "program control"; and as phases of "randomly actuated" control of auxiliary-operations).

- (2) Note. Fig. 9 illustrates a card or sheet which bears indicia such as marks or perforations, appearing, for example, in five columns (A-E) and comprising four index points per column (in practice, the usual number of columns may be 45 or 80, with 6 to 12 index points per column). Fig. 10 illustrates a card which has been punched from the pattern of Fig. 9, without alteration of the position or the significance of any of the data.

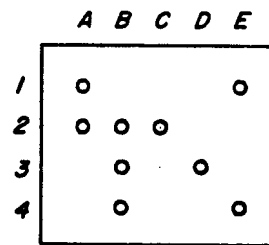

Fig. 9 A marked or punched card usable as a pattern. (subclasses 59+)

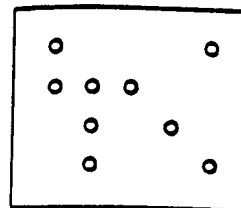

Fig. 10 A card cut from the pattern of Fig. 9. (subclasses 59+)

SEE OR SEARCH THIS CLASS, SUBCLASS:

13+, for a disclosure of a program card or tape which may resemble a pattern, but is utilized to control auxiliary-operation(s) instead of, or in addition to, tool selection.

25+, for a device wherein pattern sensors control auxiliary mechanism.

60 Means to sense cyclically movable machine element:

This subclass is indented under subclass 59. Device which comprises means responsive to the detection of a portion of the device which portion has periodic motion, for selection or varying the existing selection of tools.

(1) Note. Sensing may occur while the periodically moving portion is at rest.

(2) Note. The aforementioned means is entirely a portion of the machine proper, thus excluding pattern-sensing mechanism.

SEE OR SEARCH THIS CLASS, SUBCLASS:

62, through 89, for pattern-controlled selective cutting, in general.

SEE OR SEARCH CLASS:

83, Cutting, subclasses 76.1+ for a pattern-controlled cutting machine, in general.

61 Serial number punching of work:

This subclass is indented under subclass 60. Device in which said responsive means periodically effects the selection of tools for cutting successive workpieces or predetermined groups of workpieces with coded representations of consecutive numbers.

62 With repeated sensing of same pattern field:

This subclass is indented under subclass 59. Device including means for causing said sensing means to act a plurality of times in succession with respect to a given portion of said pattern, or wherein plural sensing means are provided and so arranged that two or more

sensing means act successively with respect to a given portion of said pattern, during operations on one workpiece.

63 Pattern indicia carried by work:

This subclass is indented under subclass 59. Device wherein said sensing means is caused to act with respect to a workpiece* presented to the device for cutting by the tools thereof.

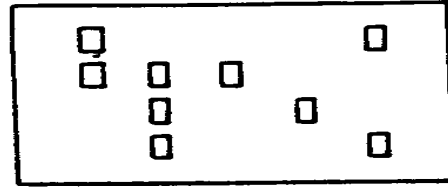

Fig. 11 Reperforated or overpunched card. (subclass 63)

(1) Note. Within the scope of this subclass, the work may be sensed prior to, during, or after its treatment.

(2) Note. Fig. 11 illustrates an application of the mechanism of this subclass; a marked or punched card is sensed and punched, to change marks to holes, or to convert small holes to large ones, etc.

SEE OR SEARCH THIS CLASS, SUBCLASS:

25, for control of an auxiliary function of a device instead of or in addition to control of tool selection, by sensing the workpiece.

64 Processed work as pattern for following work:

This subclass is indented under subclass 63. Device wherein said sensing means is so arranged as to act upon a product which has been previously subjected to cutting operations in the device.

(1) Note. In the card punching art, the use of a newly-processed card as a pattern for the following card is commonly referred to as "gang-punching".

65 Including plural input means, jointly effective:

This subclass is indented under subclass 59. Device further provided with input-means* in addition to said sensing means, and means for enabling effective transmission of signals or impulses from both said input-means during the same operating cycle of the machine.

- (1) Note. The additional input-means may also be pattern-sensing mechanisms thus affording tool selection control by two or more patterns.
- (2) Note. Disclosures in this subclass include "edited" or supervised selective punching, wherein a pattern-sensing mechanism imposes restrictions on the selection of punches by other means (e.g., keyboard).

SEE OR SEARCH THIS CLASS, SUBCLASS:

- 16+, and 53+, for means to shift control from one input source to another, which may include pattern-control means.
- 67+, for means in general to modify the effect of pattern data.

66 Serial read-out from full bank of pattern-sensors:

This subclass is indented under subclass 59. Device which includes a plurality of sensing means arranged to coact simultaneously with all significant points of a pattern field, and further including means effective to establish, in sequence, a plurality of signal or impulse transmission channels, each extending from a group of such sensing means to the tool selecting means or to a portion thereof.

- (1) Note. Fig. 15 illustrates typical mechanism found in a device of this subclass. A pattern card is clamped in a sensing unit which may comprise a full bank of spring-biased sensing pins. Movement of the sensing unit and pattern past a microswitch causes successive positionings of interposer I corresponding to those sensing pins which have entered holes in the pattern and are thus misaligned with the others. Storage* is not

involved here, for the input-impulses* are retained (by the positioned sensing pins) until tool selection has been effected.

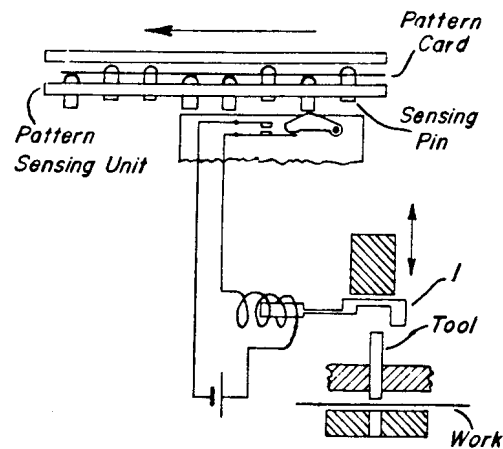

Fig. 15. FULL-BANK SENSING, READ-OUT STEP-BY-STEP. (subclass 66)

67 With means to modify effect of pattern data:

This subclass is indented under subclass 59. Device provided with means to effect significant alteration, in any one cutting cycle, of the relative positions of the selected cutting tool pairs with respect to the positions of corresponding control indicia or characteristics in the pattern.

- (1) Note. The general effect produced by a device of this type is to make a product which has cut or punched portions, not all of which correspond in spatial position or arrangement to their related pattern indicia.
- (2) Note. Included here are some patents which claim such arrangements of tools, control means, and/or pattern sensors as to enable the use of smaller, cheaper, or more simplified mechanisms than could be achieved with the use of "facsimile" patterns.
- (3) Note. Included in this and indented subclasses are, for example, disclosures of means to effect one or more of the following functions: to produce a combinational-code*, to decode such a code into a single cutting operation, to convert from one code to another, to produce a

complementary or “inverse” duplicate of a field of perforations, to reproduce only selected fields of a pattern, or to shift the relative positions of data being reproduced.

SEE OR SEARCH THIS CLASS, SUBCLASS:

- 3, for a method comprising the step of modifying the effectiveness of a pattern.
- 29, and 43, for other instances of modified reproduction of pattern data.
- 65, for joint control of tool selection by a pattern reader and other means, which control may modify the effect of the pattern data.

68 By inversion of pattern data:

This subclass is indented under subclass 67. Device wherein the altering means is effective to cause nonselection of a cutting tool in response to sensing of a pattern indicium, and to cause selection of a cutting tool when no such indicium is sensed.

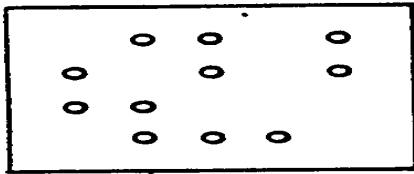

Fig. 12 Inverse or complementary punching from pattern of Fig. 9 (subclass 68)

- (1) Note. A device of this subclass produces the “inverse” or “physical complement” of the pattern field.
- (2) Note. A device which produces the “code complement” of a code symbol is not classifiable here but in subclass 69 as an instance of code conversion, rather than inversion. The code complement of a code symbol may bear no physical resemblance to the “inverse” of the group of perforations which constitute the symbol.
- (3) Note. Fig. 12 illustrates a card which has been punched with the inverse or com-

plement of the indicia from the pattern card of Fig. 9.

69 Code conversion:

This subclass is indented under subclass 67. Device wherein the altering means effects a change from a code* exhibited by the pattern to a different code cut into the workpiece.

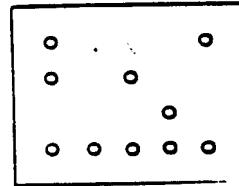

Fig. 13 With code conversion. (subclass 69)

- (1) Note. Any device of this type effects “code conversion”. In some instances it would appear instead that a code is being “generated” (as when alphabetical or numerical characters are sensed to control the selection of linearly arranged tools), but the operation is always basically the same, i.e., the transfer or intelligence from one record to another, with a systematic change from one set of arbitrary symbols to another.
- (2) Note. Basic mechanisms of the so-called “tape-to-card” or “card-to-tape” record-controlled duplicating machines are found here, for different codes are ordinarily employed in the two record media.
- (3) Note. A device which, upon reading the symbol of a digit in a pattern, effects the punching of the symbol of the “tens complement” or “nines complement” of that digit, may be found in this subclass. See (2) Note under subclass 68.
- (4) Note. Fig. 13 illustrates code conversion. The data from the pattern of Fig. 9 has been reproduced, but the four-element code symbols appearing in the pattern have been altered to conform to a different code (in this example, another four-element code). In practice, the change may be from one statistical system to another, or from Morse to Cable Code,

five-channel tape code to seven-channel code, etc.

SEE OR SEARCH THIS CLASS, SUBCLASS:

5, 14 and 96, for code-changing means not limited to a pattern-controlled device.

SEE OR SEARCH CLASS:

341, Coded Data Generation or Conversion, appropriate subclass for means to change or convert one electrical code into another (and see search notes under said subclass).

70 Combinational-code to or from one-hole-code:

This subclass is indented under subclass 69. Device wherein said altering means is systematically effective (a) to cause the selection of two or more tools in response to the sensing of one pattern indicium, or (2) to cause the selection of one tool in response to the sensing of two or more pattern indicia.

(1) Note. A device of this subclass converts a combinational-code* to or from a one-hole-code*.

71 Means for timing the tool actuation:

This subclass is indented under subclass 67. Device in which the alteration is brought about by means effective to interpose variable time delays between the pattern-sensing and tool-actuating functions in successive cycles.

(1) Note. The subject matter of this subclass (71) and the following subclass (72) concerns generally the relocation (or suppression) of data from certain portions of a pattern, while preceding subclasses 68 and 69 deal generally with modification of the significance of the data itself (e.g., the relocation of punched holes in a column).

(2) Note. A typical device of this subclass effects the "standardization" of a perforated music roll such that all perforations in the reproduced roll have locations and lengths expressible in whole multiples of a unit space.

72 Means for transposition, shift or suppression of field:

This subclass is indented under subclass 67. Device wherein the alteration is brought about by varying the effect of the sensing means (of the device of subclass 59) with respect to a pre-determined portion of a pattern, as follows: (1) disablement of the sensing means, (2) interruption of the transmission of tool-selecting control impulses from the sensing means to corresponding tool-selecting means, or (3) establishment of an alternate or an additional channel for transmission of such control impulses to other tool-selecting means.

(1) Note. See (1) Note under subclass 71, above.

(2) Note. The functions found in machines of this type include the "skipping" of a pattern-field* or a zone of a workpiece (i.e., omission to sense and/or to punch the field or zone in question), and the "transposition" or "shift" of fields (i.e., changing their effective position, as by sensing two such fields in altered sequence.

(3) Note. Fig. 14 illustrates shift of data fields, without alteration of the significance of the data. Columns A-E of the pattern (Fig. 9) now appear in the order C, D, E, A, and B respectively, which may be appropriate to a different form of business record.

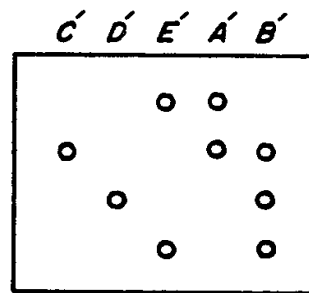

Fig. 14 With shift of pattern fields. (subclass 72)

SEE OR SEARCH THIS CLASS, SUBCLASS:

13+, for programmed means which can modify the effect of a pattern data (as

- by skipping over certain fields of data in a pattern).
- 25+, and 53, for other instances of pattern-controlled operations which may include field suppression, selection, or shift.
- 73 By adjustable electrical means:**
This subclass is indented under subclass 72. Device wherein the means to alter the effect of pattern data comprises electrical circuitry with shiftable connections or characteristics.
- (1) Note. The devices in this subclass include plugboards, multi-position switches, and the like, for facilitating changes in machine set-ups.
- SEE OR SEARCH THIS CLASS, SUBCLASS:
13+, 22+, for disclosures of such equipment and devices with automatic, programmed, or randomly actuated, auxiliary functions.
- 74 By a senser with more than two output signals:**
This subclass is indented under subclass 59. Device wherein the sensing means is capable of generating any one of a plurality of signals or impulses distinct in degree or character, in response to different sizes or kinds of pattern indicia or characteristics being sensed, and including means to select distinct tools or combinations of tools corresponding to such distinct signals or impulses.
- (1) Note. For example, the pattern senser may distinguish between larger and smaller pattern holes to cause the selection of different tools or combination of tools.
- 75 Pattern or senser in motion during sensing:**
This subclass is indented under subclass 59. Device comprising means for effecting relative progressive movement between the pattern and the sensing means during the sensing operation.
- (1) Note. Either or both of the pattern or the sensing means may move (e.g., pattern card or tape sensed while in motion through the device, or a stationary record "scanned" by moving pattern sensors).
- (2) Note. As an alternative to moving the pattern or the sensors, all points of a stationary pattern may be sensed simultaneously and the data may be read out in steps (e.g., column-by-column) to the tool-selecting means, over a system of shiftable connections (see subclass 66).
- SEE OR SEARCH THIS CLASS, SUBCLASS:
25, for pattern-sensing means which may be disclosed as operating upon a moving pattern.
64, for a gang-punching* machine which may disclose the sensing of a card in motion.
66, for means to read data in sequential steps from a full bank of pattern sensors, and see (2) Note, above.
- 76 Sensing by tool directly engageable with pattern:**
This subclass is indented under subclass 59. Device including means to bring a portion of a tool into position of contact with said pattern, whereby said tool functions as a sensing means.
- (1) Note. Selected tools may be latched in position to relieve the pattern of tool-driving stresses, after the pattern has effected preliminary tool positioning.
- 77 Tool actuation blocked by pattern:**
This subclass is indented under subclass 76. Device including yieldable individual tool-actuating power trains so arranged that the tools which do not contact said pattern are forced into cutting relationship with a work-piece.
- (1) Note. The pattern functions as a mask or stencil to block the operation of unselected tools.
- (2) Note. See Fig. 1 (described in section II, (2) Note) for illustrative mechanism.

78 Tool actuating force transmitted by pattern:

This subclass is indented under subclass 76. Device including individual tool-actuating power trains, said power trains comprising spaced driving and driven elements with lost motion or misalignment therebetween, and means to support said pattern generally between said driving and driven elements so that portions of the pattern serve to complete the driving power trains to the so-selected tools.

- (1) Note. The pattern has the form of an inverse stencil (i.e., having blank areas corresponding to holes to be punched, and holes corresponding to areas to be left unpunched).

79 With means to feed pattern or pattern sensing means:

This subclass is indented under subclass 59. Device provided with mechanism to impart progressive relative movement between the pattern and said sensing means between successive sensing operations.

- (1) Note. Feed* means is to be distinguished from means which merely initially presents the pattern to the sensors, or vice versa. In the majority of pattern-controlled selective cutting machines, the pattern is advanced continuously or intermittently during successive sensing and cutting or punching cycles.

SEE OR SEARCH THIS CLASS, SUBCLASS:

- 19, for programmed means to alter the feed of a pattern.
 27, and 29, for randomly-actuated control of pattern feed.
 66, for a machine having serial read-out to the tool selectors from a full bank of sensors (as an alternative to pattern feed means).
 75, for means to effect relative movement between pattern and sensors during the sensing operation.

80 With means to adjust pattern position or feed, or senser:

This subclass is indented under subclass 79. Device wherein means is provided for (1) changing the position of the pattern relative to the sensing means, or vice versa, (2) altering the rate of progress of the pattern relative to the sensing means, or (3) altering the effectiveness of the sensing means in degree or mode of operation.

SEE OR SEARCH THIS CLASS, SUBCLASS:

- 3, for a method comprising the step of modifying the effectiveness of a pattern.
 53+, for means to select from among a plurality of input sources, some of which may be pattern-sensing devices.

81 Senser moves tool into position to receive actuating force:

This subclass is indented under subclass 79. Device in which the sensing means, in response to detection of a pattern indicium or characteristic, moves a selected tool, or initiates the transmission of force from a source of energy to move said tool, into such position that (1) an actuating power train is completed to drive said tool through its working stroke, or (2) a latching or blocking mechanism is caused to hold said tool in operative position while a cooperating tool is actuated.

- (1) Note. No interposer* is employed in mechanism of this type.

SEE OR SEARCH THIS CLASS, SUBCLASS:

- 117+, for a tool selection means in general which effects completion of a power drive train to a selected tool without the use of an interposer.

82 Senser controls effectiveness of actuating force to selected tool pair only:

This subclass is indented under subclass 79. Device wherein the sensing means directly initiates or permits the application of energy to a selected complete individual tool-actuating power train.

- (1) Note. A device classifiable in this subclass is termed "direct-acting" in that the senser, although it does not transmit tool-actuating force, controls and determines the application of actuating force from a power source to a tool, without the use of an interposer or other selecting means.
- (2) Note. For example, the pattern-senser may comprise a contact brush which completes an energizing circuit for a tool-driving magnet upon detection of a hole in the pattern; or the senser, upon detection of a pattern indicium, may release a latch or restraining device for a yieldably-biased tool, freeing the latter for actuation.

SEE OR SEARCH THIS CLASS, SUBCLASS:

- 106+, for a device effective to cause the actuation of a plurality of selected tools, without interposers (coded direct punching).
- 117+, for means to select a single tool by moving an element of the tool drive train into power-transmitting relationship with a drive means.

83 **Senser actuates tool:**

This subclass is indented under subclass 82. Device wherein the indicia-detecting means itself constitutes drive means for the selected tool or tools.

SEE OR SEARCH THIS CLASS, SUBCLASS:

- 78, for a device wherein the selected tool is driven by a power train which comprises the pattern and a senser-like portion of the tool itself.
- 81, for a device wherein the selected tool is latched in power-receiving position after having been moved thereto preliminarily by the sensing means.

84 **Interposer movable by senser:**

This subclass is indented under subclass 79. Device wherein the sensing means in response to the detection of indicia effects the movement of an interposer*.

- (1) Note. In a device of this type, the pattern-senser generally controls the motion of the interposer, even though a specific arrangement of biasing springs or weights may tend to obscure this relationship.

85 **Integral or fixed thereto:**

This subclass is indented under subclass 84. Device wherein said interposer moves bodily with and is effectively unitary with said sensing means.

86 **Biased interposer and senser:**

This subclass is indented under subclass 84. Device including means which continually tends to move an interposer* toward or from its effective position and simultaneously to move the associated sensing means toward its most advanced (i.e., indicium-responsive) position.

- (1) Note. The mechanism typically comprises cyclically-actuated means to retract the sensers from engagement with the pattern, against the force of the biasing means.
- (2) Note. Fig. 16 illustrates typical mechanism of this subclass. Pattern P and workpiece W are usually advanced in step-by-step manner past the senser(s) S and tool(s) T. S is biased by a weak spring toward contact with P, and is retracted therefrom after each sensing operation by a reciprocating bail B. When, in any cycle of operation, senser S detects a hole in P (by entry therein) it causes sufficient movement of its interconnected interposer I to control the conditioning of tool T for cutting or noncutting, as desired.

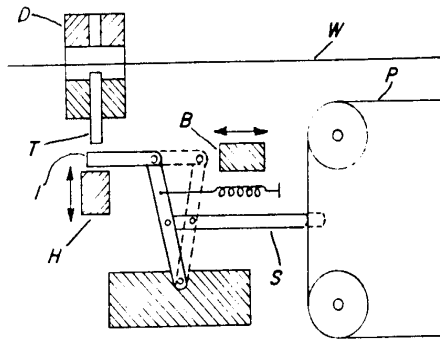

Fig. 16. BIASED INTERPOSER AND SENSER (subclass 86).

87 Senser controls application of power to interposer:

This subclass is indented under subclass 79. Device including means responsive to actuation of the sensing means to initiate or terminate the transmission of force from a power drive train for moving an interposer* from one of its two (effective, ineffective) positions to the other position.

- (1) Note. Typical mechanism is illustrated in Fig. 17, wherein the progressively advance pattern P is sensed by a contact brush to control a circuit for the positioning magnet of an interposer I.

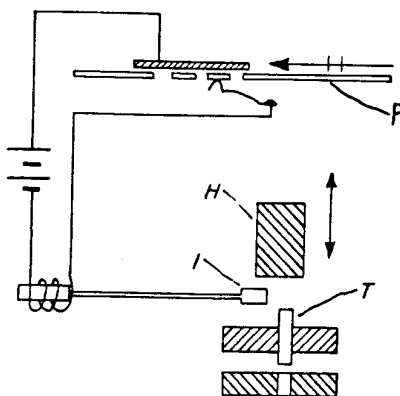

Fig. 17 SENSER CONTROLS POWER TO MOVE INTERPOSER (subclass 87).

88 Connects or disconnects interposer linkage and cyclically movable actuator:

This subclass is indented under subclass 87. Device wherein said force-transmission initiating or terminating means functions by coupling or uncoupling the interposer* (or a driving element connected thereto) to or from the power drive train, which drive train operates periodically.

89 Pattern or record and/or sensing means per se:

This subclass is indented under subclass 59. Device (and not classifiable in any other class) wherein the invention relates to the pattern or record to be used with the device and/or the mechanism for reading or sensing a pattern or record.

- (1) Note. A patent to a pattern-controlled selective cutting device may be placed as an original in this subclass if it discloses but does not claim specific pattern-controlled means for selecting tools.
- (2) Note. A pattern or a senser for use in the control of auxiliary mechanism not claimed, may be found in this subclass.
- (3) Note. A patent which is originally classified elsewhere in this class should be cross-referenced in subclass 89 if it discloses novel pattern or senser structure not elsewhere provided for in the schedule.

SEE OR SEARCH THIS CLASS, SUBCLASS:

- 13+, for disclosure of a program card or tape, and for a combined program and pattern medium, in connection with the device utilizing it.
- 23+, 25+, 53+, and 59-88, for disclosures of pattern media.
- 74, for a differentially responsive sensing means.
- 75, for means to sense a moving record or to scan a stationary record.

90 WITH MEANS TO CAUSE DELAYED ACTUATION OF SELECTED TOOL:

This subclass is indented under the class definition. Device including means responsive to a tool-selecting operation to partially condition a power drive train for subsequent actuation of a selected tool, and means responsive to a subsequent tool-selecting operation, or to the passage of time, to complete such conditioning of the power drive train.

- (1) Note. A common purpose for such a device is to provide what is loosely termed one-stroke storage*, thus affording the operative of a keyboard machine an opportunity of rectifying an error if it is perceived before the next key has been struck.
- (2) Note. Storage* is not necessarily involved in machines of this type.

SEE OR SEARCH THIS CLASS, SUB-CLASS:

23+, for randomly-controlled means which, under certain conditions, will delay the punching of input data until a required "letters" or "figures" shift symbol has been inserted.

91 With plurality of selecting means sequentially controlled by one input means:

This subclass is indented under subclass 90. Device comprising an input-means*, a plurality of groups of tools and associated selecting mechanisms, and means responsive to the operation of a selecting mechanism of one group to shift operating connections from the input-means to another group of selecting mechanisms.

- (1) Note. The typical disclosure of this subclass comprises a keyboard, a pin-setting carriage, a full bank of selecting pins and associated punches, and means to step the carriage along column-by-column as selections are made. Punching is effected after all of a predetermined group of columns have been set, and may be manually initiated.

SEE OR SEARCH THIS CLASS, SUB-CLASS:

92, for a similar disclosure wherein the input-means and shiftable operating connections are not claimed.

92 WITH OPTIONALLY SETTABLE MEANS TO CLEAR TOOL SELECTION:

This subclass is indented under the class definition. Device including means movable or adjustable from one position or condition to another; such means, while in the one position, being effective to prevent restoration (i.e., return to idle or nonselecting condition) of the tool-selection means and, in the other position, being effective to cause or permit such restoration.

SEE OR SEARCH THIS CLASS, SUB-CLASS:

57, for optionally-settable means to clear a storage instrumentality upon read-out therefrom.

93 Effective on portion of tool field:

This subclass is indented under subclass 92. Device including a plurality of such movable or adjustable means, each operative on the selection means of a distinct group of tools.

- (1) Note. A device of this type usually enables retention of data or clearing (at will) of individual columns, as when punching cards with some fixed and some variable data. For a device in which all the columns are treated simultaneously as a group, see subclass 92, generic hereto.

SEE OR SEARCH THIS CLASS, SUB-CLASS:

91, for a device of the column-by-column setting type provided with selective column clearing means.

92, for means to clear all the selection means.

94 WITH SPECIFIC MEANS TO SELECT A PLURALITY OF TOOLS (I.E., COMBINATIONAL CODING MEANS:

This subclass is indented under the class definition. Device provided with mechanism to condition a plurality of tool pairs in response to an input-impulse.*

- (1) Note. Tool acutation may follow as a result of selection, or may be effected by independent means (e.g., by hand lever) after one or more selections have been made.
- (2) Note. Means to select a plurality of tool pairs in response to a single input-impulse constitutes a combinational-coding means*, as distinguished from means to produce a one-hole-(or positional) code.
- (3) Note. For original placement in subclass 94, a patent must claim specific tool-selection mechanism, i.e., such mechanism must be recited in terms of structural relationships.
- (4) Note. Fig. 18 illustrates a form of combinational-coding means wherein a coding member CSM is pivotally mounted to swing in either direction from its neutral position upon depression of either key K or K'. In either of its actuated positions, member CSM closes circuits to move interposers I to condition a group of tools (not shown) to perforate a distinctive code symbol in a workpiece.

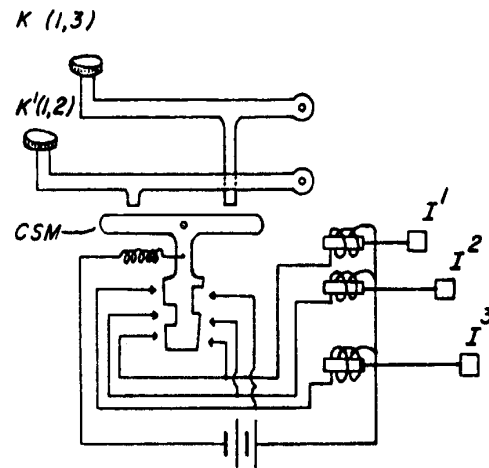

Fig.18.COMBINATIONAL-CODING MEANS (subclass 94).

SEE OR SEARCH THIS CLASS, SUBCLASS:

- 59+, for pattern-controlled means to select tool pairs.
- 109+, for means to select a single tool pair, and see (2) Note, above.

95 Successively:

This subclass is indented under subclass 94. Device wherein the mechanism is effective to condition a plurality of tool pairs in timed sequence in response to such input-impulse.

96 With means to change or facilitate change of code:

This subclass is indented under subclass 94. Device provided with means to modify a code or substitute one code for another, or means to reduce or simplify the operations required for such modification or substitution.

- (1) Note. A shift key or equivalent mechanism may be found in this subclass if it alters the selection of type bars or the like; but not if it merely shifts the bars so that a different portion of the same bars becomes effective.
- (2) Note. Exemplary devices of this type usually comprise a plurality of such parts associated with different portions of the input means.

SEE OR SEARCH THIS CLASS, SUB-CLASS:

- 14, for a programmed means to change code.
24, for a randomly-actuated means to change code.

97 Coded interposer:

This subclass is indented under subclass 94. Device wherein the conditioning mechanism comprises a coded-interposer*.

- (1) Note. The interposer when in effective position, serves either (1) as the last link of the power train to the driven tools of the selected pairs, or (2) as blocking means to hold the "fixed" tools in effective position to cooperate with their associated driven tools.
(2) Note. One of a plurality of elements which is movable into an active position to control the selecting of a plurality of tool pairs, but which does not contact the tools, may constitute a coded selector member*, for which see subclass 102.

98 Differentially positioned:

This subclass is indented under subclass 97. Device wherein the interposer has a plurality of effective positions in each of which it engages a different combination or group of tools.

- (1) Note. See Fig. 4 (described in the class definition) for illustrative mechanism.

99 Turret of interposers:

This subclass is indented under subclass 98. Device wherein a plurality of interposers are movable as a unit to and between said effective positions by rotation of said unit.

100 Power transmitting:

This subclass is indented under subclass 99. Device in which the turret of interposers constitutes a part of the drive train to the selected tool pairs.

- (1) Note. The interposers in this subclass function as power-transmitting elements of the tool-driving train, as distinguished from other interposers which serve merely to block the "fixed" tools of the

selected pairs and thus do not transmit power.

- (2) Note. Fig. 19 illustrates mechanism exemplary of this subclass. The turret of interposers is adjustable to three positions, in each of which a different combination of tools is conditioned for actuation by the press ram acting through the tool-aligned interposer lugs.

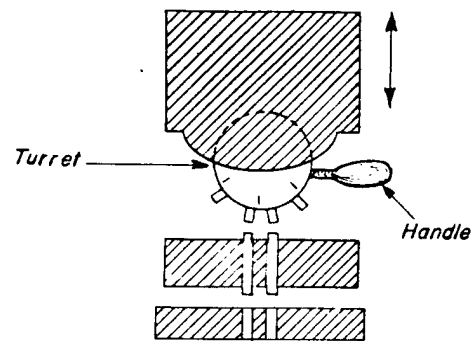

Fig. 19, TURRET OF ACTIVE INTERPOSERS (subclass 100).

101 Power driven:

This subclass is indented under subclass 97. Device provided with means to move the interposer other than by effort exerted by an operative.

102 Coded selector means:

This subclass is indented under subclass 94. Device wherein the tool-conditioning mechanisms comprise a plurality of independent elements each movable, in response to an input-impulse*, from an ineffective position to an effective position in which it initiates the selection of a plurality of tool pairs for actuation by other means.

- (1) Note. A coded selector member differs from a coded interposer in that (1) it does not engage the selected tools, and (2) it has only one effective position (as distinguished from the differentially-positioned interposer of subclass 98). See Fig. 20 (under subclass 105) for a specific example of a coded selector member.

103 Actuates contacts:

This subclass is indented under subclass 102. Device in which the movable element in effective position closes a selection-controlling circuit.

104 Paired bars:

This subclass is indented under subclass 102. Device wherein each independent element has a companion element connected thereto for movement thereby in the opposite direction, said elements being so arranged that either one or the other element will always be in position to respond to an input-impulse*.

- (1) Note. Mechanism of the subclass type affords fast and positive response, and eliminates the need for restoring springs.

105 Selector means drives interposers:

This subclass is indented under subclass 102. Device provided with means connecting a plurality of interposers to each selector element to be moved to effective position by the movement of a selector element.

- (1) Note. Mechanism of this subclass type differs from that found in subclass 97 above, in that it includes some form of power drive trains between the coded element and a number of a single interposers (i.e., each interposer controls a single tool pair), while the coded interposer of subclass 97 consists of a unitary element which is engageable with a plurality of tools to control a plurality of tool pairs.
- (2) Note. Fig. 20 represents typical basic mechanism of this subclass. The differently positioned lugs on the levers of keys A and B, constitute, with their levers, coded-selector-means which are adapted to drive distinct groups of interposers.

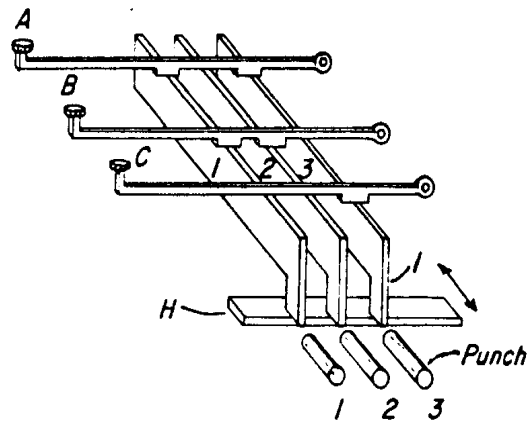

Fig. 20. CODED SELECTOR MEANS COMBINED WITH INTERPOSERS (subclass 105).

106 Direct punching (coded actuation):

This subclass is indented under subclass 94. Device wherein the tool-conditioning mechanism is constituted solely of means to drive a plurality of tools through their cutting stroke, or to directly initiate the transmission of actuation force to a plurality of tools from a source of power.

- (1) Note. A device of this type performs "coded direct punching", by utilizing the movement of a key-lever or the like, either to drive certain of the tools directly or to actuate valves, clutches, or electrical contacts to apply power to certain tools.
- (2) Note. In this case the tool "selecting means" is not distinct from the tool "actuating means"; tool "selection" is achieved by applying power to a predetermined group of tools; in other words, tool selection and actuation are effected simultaneously by a common impulse through a common channel.
- (3) Note. See Fig. 2 (described in the class definition) for an illustrative example of mechanism classifiable in this subclass. Compare Fig. 6 (independent tool-actuating linkages lying side-by-side; no coding mechanism present).

107 With power means to actuate tools:

This subclass is indented under subclass 106. Device wherein the means directly controls the transmission of actuating force to a plurality of tools from a source of power.

108 Individual electrical drives:

This subclass is indented under subclass 107. Device wherein the means controls the application of electrical power to electromechanical transducers associated with the tool pairs to drive the same.

- (1) Note. Fig. 21 illustrates circuitry and mechanism typical of this subclass. Depression of a key closes circuits to energize a group of tool-actuating solenoids.

(The lowermost key (D) is shown as controlling only one tool, but at least two other keys control distinct subgroups of the total number of tools, thus constituting combinational-coding-means* under the class definition).

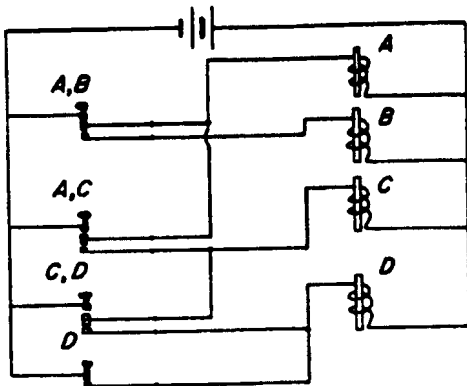

Fig. 21. DIRECT CODED ACTUATION, INDIVIDUAL ELECTRIC DRIVES (subclass 108).

109 WITH SPECIFIC MEANS TO SELECT A SINGLE TOOL:

This subclass is indented under the class definition. Device provided with mechanism to condition one tool pair.

- (1) Note. This subclass (109) includes devices wherein a member, when in

effective position, engages and blocks actuation of an associated tool. Such a blocking member is not an interposer*, for it does not “engage a tool---for actuation”.

- (2) Note. For original placement in subclass 109, a patent must claim specific tool-selection mechanism.

SEE OR SEARCH THIS CLASS, SUBCLASS:

- 59+, for pattern-controlled means to select one or more tool pairs.
94+, for means to select a plurality of tool pairs (i.e., combinational-coding-means).

110 By immobilizing a portion of an element in tool drive train:

This subclass is indented under subclass 109. Device wherein the tool pair and its actuating power train are permanently connected by actuating linkage having a portion which normally has idling motion rendering the linkage ineffective to transmit power to the tool, and wherein the conditioning mechanism comprises an element movable into blocking engagement with said portion to furnish a fulcrum therefor, whereby said linkage is made effective to actuate said tool.

- (1) Note. Fig. 22 illustrates basic mechanism of this subclass. A continuously rotating crankshaft carries a crankpin which is slidable in a longitudinal slot in the actuating lever. The lever is restrained against longitudinal movement by suitable guides, not shown, so that it oscillates idly in a vertical plane during the normal or retracted condition of the latch. Depression of key K projects the latch into the path of idle movement of the lever, constraining the latter to pivot about the latch as a fulcrum and thus to drive tool T downwardly upon each rotation of the crankshaft.

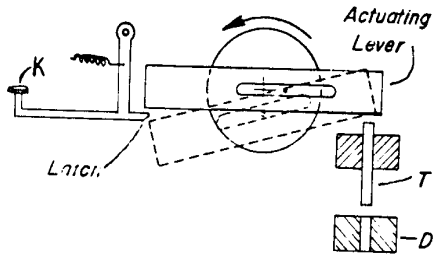

Fig. 22 Typical Mechanism of subclass 110.

111 Interposer:

This subclass is indented under subclass 109. Device wherein the tool- conditioning mechanism comprises an interposer*.

112 Differentially positioned:

This subclass is indented under subclass 111. Device wherein the interposer is movable to a plurality of effective positions in each of which it engages and effects selection of a different tool.

- (1) Note. See Fig. 3 (described in the class definition), for illustrative mechanism.

113 Turret of interposers:

This subclass is indented under subclass 112. Device wherein a plurality of interposers are movable as a unit to and between said effective positions by rotation of said unit.

114 Power driven:

This subclass is indented under subclass 111. Device including a source of mechanical energy and means effective to transmit or make available said energy to move the interposer to or from its effective position.

115 By individual electric means:

This subclass is indented under subclass 114. Device in which the source of energy comprises an electro-mechanical transducer for each interposer.

116 Reciprocable in a straight line:

This subclass is indented under subclass 111. Device in which the interposer in moving to and from an effective position moves rectilinearly.

117 Means to move an element of the tool drive train into power transmitting relationship with a power source:

This subclass is indented under subclass 109. Device in which said tool-conditioning mechanism comprises means capable of moving a tool or an element of a tool-actuating drive train into power receiving engagement with a movable actuator.

- (1) Note. The mechanism of this subclass is distinguishable from the interposer mechanism of subclass 111 in that the movable element is at all times drivingly connected to its associated tool.
- (2) Note. Fig. 23 illustrates typical mechanism of this subclass. A dog or link, pivotally attached to tool T, is movable into and out of alignment with reciprocable hammer H, by positioning-linkage controlled by a key or other means.

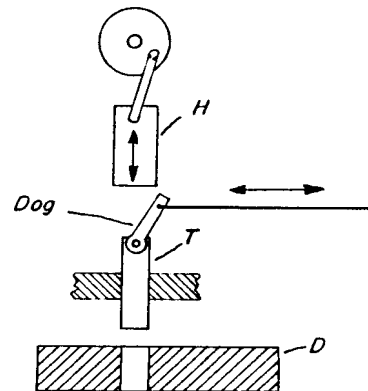

Fig. 23. Typical Mechanism of subclass 117.

118 Shiftable element is the tool:

This subclass is indented under subclass 117. Device wherein said moving means effects the movement of at least a portion of a tool into such position that an actuating drive train for the tool is completed.

119 Continuously rotating actuator:

This subclass is indented under subclass 117. Device wherein the movable actuator has continuous rotary motion.

120 WITH INPUT MEANS OTHER THAN PATTERN SENSER TO CONTROL TOOL SELECTION:

This subclass is indented under the class definition. Device including means not provided for in the preceding subclasses, which is responsive to a signal or impulse originating externally of the device or from an unspecified source, to control a disclosed tool-selecting mechanism.

- (1) Note. A patent to the combination of an input-means* (e.g., keyboard) and a specific tool selecting mechanism is placed as an original in subclass 94 or 109 in accordance with the type of selecting mechanism claimed. For original placement in subclass 120, a patent should be drawn to a specific input-means associated with a selective cutting device whereof the selecting mechanism is disclosed but not significantly claimed.

SEE OR SEARCH THIS CLASS, SUBCLASS:

- 59, for an input-means of the pattern sensing type.

121 Differentially positionable input element (e.g., lever):

This subclass is indented under subclass 120. Device wherein the responsive means comprises a member which is capable of adjustment to two or more positions, in each of which positions it generates a distinct signal or impulse effective to control the selection of tools to be actuated.

- (1) Note. A differentially-positionable input element is typically a slide bar, a drum or a pivoted lever, by means of which a plurality of distinct tool-selection controls may be obtained, as distinguished from a simple key or pushbutton which has only one effective or control position.
- (2) Note. The control signal or impulse of the subclass definition is to be distinguished from the input-impulse* which effects adjustment of the movable input member.

- (3) Note. In many cases, a visual guide such as a numbered scale, or a design to be reproduced, is associated with the positionable input device but does not of itself exert a control on the positioning of the input member (i.e., it is not a pattern*).

SEE OR SEARCH THIS CLASS, SUBCLASS:

- 40, for means to hold a picture or design to be traced by a manually-movable stylus controlling tool selections.
- 74, for a differentially-responsive pattern sener.

122 Plural input channels:

This subclass is indented under subclass 120. Device wherein the responsive means consists of a number of distinct mechanisms or electrical circuits each responsive to such signal or impulse from an external or unspecified source.

- (1) Note. A number of patents which disclose plural input channels are originally classified in subclass 121.

SEE OR SEARCH THIS CLASS, SUBCLASS:

- 45, for a device having independent manual input means for a plurality of tool fields.
- 121, for a disclosure of plural input means of the differentially-positionable type.

123 Keyboard:

This subclass is indented under subclass 122. Device wherein the distinct mechanisms comprise manually-actuatable levers or push-buttons.

- (1) Note. In general, the actuatable levers or push-buttons found in this subclass have only one effective position and one ineffective position, as distinguished from the differentially positionable elements of subclass 121.
- (2) Note. A patent disclosing novelty in keyboard or key-linkage structure, or in the connections therefrom to a tool-selecting mechanism, and not classifiable in a

preceding subclass, may be placed as an original in this subclass. The broad recitation or disclosure of a key or keyboard is insufficient for this purpose.

SEE OR SEARCH THIS CLASS, SUBCLASS:

106, for an example of a keyboard-controlled coded direct punching device.

124 With auxiliary function control means:

This subclass is indented under subclass 123. Device including means, responsive to actuation of such keyboard means to initiate, terminate, or modify an operation of the device other than the selection of tools.

- (1) Note. This feature, particularly with reference to auxiliary keys for controlling the advance of a workpiece, is disclosed in many of the more complex machines classified in preceding subclasses.

SEE OR SEARCH THIS CLASS, SUBCLASS:

36+, for a combined printing and punching machine which may be of the keyboard type having "space bar" or "space key" mechanism.

91, for a conventional back-spacing and/or canceling key mechanism in a column-by-column keyboard selective punch device.

125 Repeat key:

This subclass is indented under subclass 124. Device in which the keyboard means is capable of causing a plurality of actuations of tools which have been selected by other means.

- (1) Note. The mechanism of this subclass is commonly known as a "repeat key mechanism". The key may be arranged to effect, at each operation, an unlimited or a predetermined number of repetitions.

SEE OR SEARCH THIS CLASS, SUBCLASS:

21, for means to stop a machine or portion thereof after a predetermined number of operations.

126 WITH MEANS TO VARY WORK FEED INCREMENT:

This subclass is indented under the class definition. Device provided with mechanism effective to advance a workpiece* relative to a tool station with continuous or intermittent motion and means for changing the rate of advance or length of workpiece fed from one tool cycle to another.

- (1) Note. A patent will be placed in an appropriate preceding subclass if it includes claimed specific tool-selection mechanism or input means.

SEE OR SEARCH CLASS:

83, Cutting, subclasses 241+ for means to vary work feed increment in a cutting machine.

226, Advancing Material of Indeterminate Length, subclasses 139+ for a means to vary feed increments of an advancing web.

127 Dependent upon tool(s) selected:

This subclass is indented under subclass 126. Device including means responsive to the selection of a particular tool, or to the number or combinational arrangement of the tools chosen for a cycle of actuation, to control the work-feed varying means.

- (1) Note. For example, in a selective tape punch which records symbols of varying length (e.g., Morse or cable code characters), the increment of tape feed after each punching cycle may be made equal to the length of tape occupied by the character punched.

SEE OR SEARCH THIS CLASS, SUBCLASS:

8, for means to insert justification symbols related to the widths of characters represented by punched symbols.

128 WITH WORK HOLDER OR MOVER:

This subclass is indented under the class definition. Device provided with mechanism for advancing a workpiece* into position to be acted upon at a tool station and/or for retaining a workpiece in such position.

- (1) Note. The feeding, clamping, or other handling of work is included in the term auxiliary-operation*.

SEE OR SEARCH THIS CLASS, SUB-CLASS:

46+, for a card notching device, which includes means for holding a card in fixed position.

126+, for means to vary work feed increment in a selective cutting machine.

SEE OR SEARCH CLASS:

83, Cutting, appropriate subclasses, for a work mover or work holder associated with a cutting or punching device.

269, Work Holders, for means to hold or support work during treatment thereof.

129 With reversible work-feed (e.g., with back spacer):

This subclass is indented under subclass 128. Device provided with means capable of advancing a workpiece relative to a tool field in either of two opposed directions.

- (1) Note. The "back spacing" mechanism on a card or tape punch is an example of such a device.

- (2) Note. The work advance in this subclass (129) is preparatory to a cutting operation, i.e., not the ejection of work from the machine.

SEE OR SEARCH CLASS:

83, Cutting, subclass 220 for means to advance work in opposite directions, intermittently, in a cutting machine.

226, Advancing Material of Indeterminate Length, subclasses 49+ for selectively-operated means to reverse the direction of motion of a web.

130 With cyclically advanced work carrier:

This subclass is indented under subclass 128. Device wherein the mechanism comprises a holder which moves progressively with the work in timed relation to successive cutting operations.

SEE OR SEARCH CLASS:

83, Cutting, subclasses 276+ for work feed means which advances intermittently with the work in timed relation to cutting operations in a cutting machine.

131 MISCELLANEOUS:

This subclass is indented under the class definition. Device which comprises a feature not provided for in any prior subclass in this schedule.

- (1) Note. A patent to indicating mechanism associated with tool-selecting mechanism will be placed originally in subclasses 94+ or 109+, and cross-referenced into subclass 131. If, however, the selecting mechanism is only nominally or incompletely claimed, the patent should be placed originally in subclass 131.

SEE OR SEARCH CLASS:

116, Signals and Indicators, for an indicating device of more general application.

END