

CLASS 336, INDUCTOR DEVICES**SECTION I - CLASS DEFINITION**

This is the generic class for the structure of inductor devices of the passive type.

SECTION II - LINES WITH OTHER CLASSES AND WITHIN THIS CLASS**A. INDUCTOR DEVICES HAVING CAPACITANCE OR RESISTANCE:****1. With Capacitance:**

As pointed out above, this class provides for inductor devices wherein the inherent capacitive reactance of the inductor does not resonate with the inductance of the inductor within the frequency range of the electric current adapted to flow therethrough. Where the inductance of the inductor resonates with its inherent capacitive reactance, the device is excluded from this class and will be found in Class 333, Wave Transmission Lines and Networks, subclasses 24+, as a coupling network, (e.g., filter, delay networks, equalizers, coupling transformers), or in Class 334, Tuners, appropriate subclasses as a tuner.

2. With Resistance:

This class provides for all inductor devices having appreciable inductive reactance regardless of the value of the inherent resistance of the device within the frequency range of the electric current adapted to flow therethrough. This class does not provide for resistors which may have an incidental or undesired inherent inductive reactance and which are designed to be used only as resistive impedances. For such excluded resistors, see Class 338, Electrical Resistors, especially subclasses 61+ for resistors with inductance reducing means.

3. Inductor Devices in Combination with Separate Capacitors or Resistors:

This class does not provide for the combination of inductor devices and separate capacitors and/or resistors irrespective of whether such combined devices are in mere structural arrangement or in circuit arrangement with each other. For the excluded subject matter, see Class 361, Electricity: Electrical Systems and Devices, subclasses 268+, especially subclass 270 for the combination of a transformer and capacitor, subclasses 331+

for the structure of switchboards and analogous devices including the structural combination of plural diverse impedance elements, e.g., inductors and capacitors, inductors and resistors, capacitors and resistors or any combination of two or more of such elements for which provision has not been made elsewhere. See also the search notes below for other classes providing for inductor, inductor and capacitor or resistor combinations.

B. INDUCTOR DEVICE STRUCTURE CLASSIFIED ELSEWHERE:**1. Stationary Inductor Devices:**

Inductor device coil and core structure will be found in Class 361, Electricity: Electrical Systems and Devices, subclasses 268+ for induction or spark coils with capacitors and/or circuit makers and breakers of the periodically operated type, subclasses 331+.

2. Transmission Line Sections with Distributed Parameters:

Transmission line sections where the line has distributed inductance and capacity with or without effective distributed resistance are classified in Class 333, Wave Transmission Lines and Networks, subclasses 219+ and 245+. Note that in subclasses 245+ are resonant long line sections (i.e., with distributed inductance and capacity) which are designed to be operated at other than resonant frequency for producing the effect of an inductance. For example, a short-circuited quarter-wave length line operated at less than resonant frequency or an open-circuited line greater than a quarter-wave length but less than a half wave length of wave energy acts as an inductance. Also note that subclasses 24+ of Class 333 contains some patents relating to adjustable inductor devices which have an appreciable inherent capacity.

3. Electromagnets with Armatures:

Electromagnets of the tractive type which include an armature for converting electrical energy into mechanical work through the agency of electromagnetic induction are classified in Class 335, Electricity: Magnetically Operated Switches, Magnets, and Electromagnets, subclasses 220+ for electromagnets with armatures. Note that also, Class 335, Electricity: Magnetically Operated Switches, Magnets, and Electromagnets, subclasses 2+ provides for electromagnetically actuated electric switches.

4. Loading Coils:

Class 178, Telegraphy, subclass 46, provides for inductor coil structure designed for use in long electric wave transmission lines to modify the electric wave propagation characteristics of the lines.

5. Telephone Inductor Coils:

Class 379, Telephonic Communications, subclasses 443+ and the subclasses specified in the notes thereto provide for inductor coils combined with the structure of telephone instruments.

6. Loop Antennas:

Class 343, Communications: Radio Wave Antennas, subclasses 700+, and especially subclasses 726, 728, 741+, 748, 764, 788, 842, 855, and 866+, provides for the structure of inductor coil devices for radiating or intercepting radio wave energy in free space.

7. Dynamo Electric Machines:

Class 310, Electrical Generator or Motor Structure, appropriate subclasses for the structure of electric motors and generators including synchronous condensers, synchronous motors, induction motors, dynamotors, rotary converters, metadynes, balancer sets and the like.

8. Electromagnetic Electro-acoustical Wave Transducers and Sound Pick-ups:

Devices which include an electromagnetic device for converting electrical energy to sound energy, or vice versa, or which are used in electrically recording and/or reproducing sound records or which are used to convert the vibrations of a musical instrument into modified electric currents, are classified as follows:

Music instrument transducers, Class 84, Music, subclasses 725 to 729.

Audible electrical signal producers such as bells, whistles, etc., Class 340, Communications: Electrical, subclasses 384+.

Magnetic recording or reproducing devices, Class 360, Dynamic Magnetic Information Storage or Retrieval, subclasses 110+.

Electro-mechanical sound recording and/or reproducing devices having a stylus for actuating, or actuated by, the electromagnetic device, Class 369, Dynamic Information Storage or Retrieval, subclasses 146+.

Telephone transmitters or receivers, Class 379, Telephonic Communications, subclasses 419-427.

9. Signal Transmitters Using Variable Inductor Devices:

For devices designed to be selectively actuated to transmit an undulating current for signaling purpose and which include means, such as a pendulum, reed, or similar vibrating member to vary the inductance of a variable inductor device, see References to Other Classes, below.

10. Goniometers:

For Goniometers see Class 343 in References to Other Class, below.

11. Inductor Devices with Rotatable Element Recited By Name Only in Combination with Positioning Means:

Class 74, subclasses 10+ and the subclasses specified in the notes thereto provides for the combination of a transformer or inductive reactor having an element (e.g., coil or core) designed to be angularly movable in combination with specific mechanical means for rotating a shaft for positioning the movable element, where no significant structure of the transformer or reactor other than that it has an angularly movable part is recited in the claim. Where the means for moving the shaft is not solely mechanical see the search notes to subclass 10 of Class 74 for the other classes which provide for the combination. Where significant reactor or transformer structure is claimed, classification is in this class (336).

12. Inductor Devices or Systems Utilizing High Temperature Superconducting Material:

For Inductor Devices or Systems Utilizing High Temperature Superconducting Material, see Class 505 in References to Other Classes, below.

C. PATTERN CONTROLLED VARIABLE INDUCTOR DEVICES AND PATTERN TRACING DEVICES WHICH ACTUATE VARIABLE INDUCTOR DEVICES:

In many of the arts, especially in the machine tool arts, there are machines and apparatus designed to be controlled in accordance with a pattern. The control pattern may be facsimile of the article to be made or may be a code-type pattern or other type of record. Many of these apparatuses and machines disclose that the pattern actuates a variable inductor device to modify the electric

current in the control system. A substantially complete listing of all the arts which involve pattern control may be found in the search notes to Class 178, Telegraphy, subclass 3. Also see this class definition with reference to variable inductor devices designed for use in reproducing sound records (e.g., phonograph pick-ups). See References to Other Classes, below, for classes and subclasses that are considered to be most likely to include pattern controlled variable inductors.

D. VARIABLE INDUCTOR DEVICES OPERATED BY A CONDITION SENSITIVE MEANS:

This class provides for adjustable inductor devices where the movement of the inductance varying means is operated by a device which responds to a condition, such as pressure responsive inductor devices, temperature responsive inductor devices, etc., in subclasses 30+.

There are many classes which provide for such condition responsive devices in combination with the electrical system. See above for the classification of adjustable inductor devices which have their inductance varied in response to sound waves or which are designed for use in reproducing sound from a sound record, or which are designed to convert the vibrations of a musical instrument to modified electric current. Also see above for a reference to pattern controlled variable inductor devices.

For other classes which should be searched for condition responsive inductor device systems see References to Other Classes, below.

E. ELECTROMAGNETS AND PERMANENT MAGNETS:

Electromagnets and permanent magnets of general application and electromagnet coils and cores, per se, are classified in Class 335, Electricity: Magnetically Operated Switches, Magnets, and Electromagnets, subclasses 209+ for general application of magnets and electromagnets, electromagnetic coils and cores, per se, subclasses 285+ for lifting and holding electro and permanent magnets (e.g., magnetic chucks). See Class 414, Material or Article Handling, subclasses 606 and 737 for the provision of a load-engaging magnet on certain types of load raising or lowering devices, and Class 294, Handling: Hand and Hoist-Line Implements, subclass 65.5 for hand and hoist-line implements having a magnetic means for holding or attaching the material to be lifted to the lifting handle or hoist-line.

Electromagnetic devices for heating (e.g., by induction heating) are classified in Class 373, Industrial Electric

Heating Furnaces, subclasses 138+ when combined with furnace structure, and Class 219, Electric Heating, subclasses 600+ for inductive heating, subclasses 678+ for microwave heating, and subclasses 764+ for capacitive dielectric heating.

Class 128, Surgery, subclasses 1.3+ provides for electromagnetic devices for surgical purposes, including magnetic probes and such magnetic devices as are designed to induce electric currents in the human body.

F. INDUCTOR DEVICE SYSTEMS:

1. Current, Voltage And/Or Phase Control Systems:

This class does not provide for systems which include an inductive regulator device as a part thereof. Class 323, Electricity: Power Supply or Regulation Systems, is the generic class for systems for controlling the voltage and/or current in the system and/or for systems for controlling the phase angle between the voltage or current in the system. See the search notes to the class definition of Class 323 for the other classes which provide for electrical regulating systems and for systems which include as a part thereof a regulating device.

2. Miscellaneous Transformer and Inductor Device Systems:

Class 323, Electricity: Power Supply or Regulation Systems, is the generic class for transformer and impedance systems. See subclass 355 and the subclasses specified in the notes thereto for the miscellaneous inductive reactor device systems.

3. Inductive Loaded Transmission Lines:

Class 178, Telegraphy, subclass 45 is the miscellaneous subclass for inductivity loaded transmission line systems of the type used signaling systems, and Class 379, Telephonic Communications, subclasses 414+ provide for inductively loaded telephone lines.

4. Inductively Coupled Signaling Systems:

For signaling systems provided with means for transmitting the signaling energy through space by electromagnetic induction (e.g., using transformer coils) see References to Other Classes, below.

5. Transmitting Power To Vehicles:

For transmitting power to vehicles, see References to Other Classes, below.

G. ANTI-INDUCTIVE DEVICES AND SYSTEMS:

For Anti-Inductive Devices and Systems, see References to Other Classes, below.

SECTION III - REFERENCES TO OTHER CLASSES

SEE OR SEARCH CLASS:

- 72, Metal Deforming, subclass 7 for a metal shaping machine controlled by a pattern-actuated sensor means, and subclass 81 for a direct pattern controlled sheet metal spinning machine. (See Lines With Other Classes and Within This Class, C, Pattern Controlled Variable Inductor Devices and Pattern Tracing Devices Which Actuate Variable Inductor Devices, above.)
- 73, Measuring and Testing, appropriate subclasses, for miscellaneous apparatus and systems for making nonelectrical, nonchemical and nonoptical measurements and tests. In Class 73, the sensing or measuring means may actuate an electrical device, as a resistance or inductor device. In Class 73, the apparatus and systems are classified on the basis of the measurement or test made rather than upon the basis that electrical means are used. See subclasses 763+ for stress or strain measuring apparatus wherein the value of an electric current is modified (such as by varying an adjustable inductor), particularly subclass 779 for such apparatus with specified inductive sensor structure, subclass 301 for liquid level or depth gauges of the hydrostatic pressure type having an electrical means (such as a variable inductor) actuated by the pressure, subclass 308 for float type liquid level or depth gauges which actuate an electro-responsive device, subclass 313 for other type liquid level or depth gauges which actuate an electro responsive device, subclasses 722 and 728 for fluid pressure gauges which include pressure responsive means for actuating a variable inductor device. (See Lines With Other Classes and Within This Class, D, Variable Inductor Devices Operated By a Condition Sensitive Means, above.)
- 74, Machine Element or Mechanism, subclass 5.6 for gyroscopes with means (including electrical devices) controlled by the gyroscope for sensing the position of the gyroscope and/or its gimbals. (See Lines With Other Classes and Within This Class, D, Variable Inductor Devices Operated By a Condition Sensitive Means, above.)
- 82, Turning, subclasses 11.1+, for pattern controlled turning apparatus (e.g., lathes). (See Lines With Other Classes and Within This Class, C, Pattern Controlled Variable Inductor Devices and Pattern Tracing Devices Which Actuate Variable Inductor Devices, above.)
- 83, Cutting, subclass 71, for cutting machine control devices which are responsive to tape or card-carried indicia. (See Lines With Other Classes and Within This Class, D, Variable Inductor Devices Operated By a Condition Sensitive Means, above.)
- 102, Ammunition and Explosives, appropriate subclasses for firing devices for explosive devices which are actuated by the effect of a magnetic field, see subclasses 390+ for marine type drop bombs with such ignition means, subclasses 416+ for marine mines with such firing devices, subclass 427 for other mines with such firing devices and subclasses 209 and 211 for the miscellaneous explosive devices with such firing devices. (See Lines With Other Classes and Within This Class, D, Variable Inductor Devices Operated By a Condition Sensitive Means, above.)
- 118, Coating Apparatus, subclasses 211+ and 323 for pattern controlled coating apparatus. (See Lines With Other Classes and Within This Class, C, Pattern Controlled Variable Inductor Devices and Pattern Tracing Devices Which Actuate Variable Inductor Devices, above.)
- 142, Wood Turning, the subclasses indented under the title "copying" and subclasses 21, 22, 24, 27+, 30, 37, 38+, 41, and 43+ for pattern controlled wood-turning machines. (See Lines With Other Classes and Within This Class, C, Pattern Controlled Variable Inductor Devices and Pattern Tracing Devices Which Actuate Variable Inductor Devices, above.)
- 144, Woodworking, subclasses 144.1+ and 145.1+ for a pattern controlled wood working machine.
- 174, Electricity: Conductors and Insulators, subclasses 32+ for conductor systems having means for reducing or preventing the detrimental effects due to either the self inductance of a single conductor or mutual inductance between plural conductors. See the search notes to these subclasses for related fields of search. (Lines With Other Classes and Within This Class, G, Anti-Inductive Devices and Systems)

- 178, Telegraphy, subclass 69 for telegraph systems with means, such as an inductor device, to prevent or reduce inductive effects. (See Lines With Other Classes and Within This Class, G, Anti-Inductive Devices and Systems, above.)
- 178, Telegraphy, subclass 43 for telegraph systems. (See Lines With Other Classes and Within This Class, Inductor Devices Systems, 4, above.)
- 178, Telegraphy, subclasses 47+ for such devices used in telegraph multiplex systems and for the multiplex systems. (See Lines With Other Classes, Signal Transmitters Using Variable Inductor Devices, above.)
- 191, Electricity: Transmission to Vehicles, subclass 10 for induction systems for transmitting electric power to a vehicle. (See Lines With Other Classes, F, Inductor Device Systems, above.)
- 209, Classifying, Separating, and Assorting Solids, subclass 212, and 213+ for apparatus for separating solid materials and assorting or segregating them according to their diamagnetic or magnetic properties, see subclass 212 for the apparatus designed to operate due to the diamagnetic properties and subclasses 213+ for the apparatus designed to operate due to the magnetic properties. (See Lines With Other Classes and Within This Class, D, Variable Inductor Devices Operated By a Condition Sensitive Means, above.)
- 246, Railway Switches and Signals, subclass 8, 63, 194, for railway switch and signal systems having inductive means for transmitting the signals to or from moving trains. (See Lines With Other Classes and Within This Class, Inductor Devices Systems, 4, above.)
- 266, Metallurgical Apparatus, subclasses 58+ for pattern controlled metal cutting torches (e.g., oxy-acetylene torches). (See Lines With Other Classes and Within This Class, C, Pattern Controlled Variable Inductor Devices and Pattern Tracing Devices Which Actuate Variable Inductor Devices, above.)
- 307, Electrical Transmission or Interconnection Systems, subclasses 89+ for systems having means for preventing induction or coupling with other electrical systems. (See Lines With Other Classes and Within This Class, G, Anti-Inductive Devices and Systems, above.)
- 324, Electricity: Measuring and Testing, subclasses 1+ for electrically operated ore detectors (e.g., explosive mine detectors) which use an inductor device as the sensing means (e.g., the inductance is varied by the presence of a magnetic body), and subclasses 34+ and 59 for miscellaneous electrical testing apparatus using a variable inductor device as the sensing element (e.g., the material to be tested varies the inductance of the inductor device and magnetic field strength testing). (See Lines With Other Classes and Within This Class, D, Variable Inductor Devices Operated By a Condition Sensitive Means, above.)
- 333, Wave Transmission Lines and Networks, subclasses 213+ for reactance networks, which may be inductive, of the active element type.
- 340, Communications: Electrical, subclasses 1.1 through 16.1 for selective controlling systems, some of which may utilize variable inductor devices as transmitters (note particularly subclasses 13.1-13.38); subclasses 500-693.12 for condition responsive signaling systems (e.g., alarms, etc.) (see Lines With Other Classes and Within This Class, D, Variable Inductor Devices Operated By a Condition Sensitive Means, in this class (336)); and subclasses 870.31-870.36 for telemetering systems utilizing variable inductor devices (e.g., flux valve, etc.) as transmitters (see Lines With Other Classes and Within This Class, B, 9, Signal Transmitters Using Variable Inductor Devices in this class (336)).
- 343, Communications: Radio Wave Antennas, subclass 431 and 441 for goniometer devices for use in direction finding radio systems. A goniometer is an inductor device with three windings, two of which are fixed, and one of which is movable, so that the two fixed coils may induce a current into the movable coil. See this Class, 336, subclasses 115+ for similar devices used as induction regulators. (See Lines With Other Classes and Within This Class, Goniometers, above.)
- 374, Thermal Measuring and Testing, subclass 184 for a thermometer having a reactive sensing element, and subclass 188 for thermometer with a mechanical sensor varying an electrical signal. (See Lines With Other Classes and Within This Class, D, Variable Inductor Devices Operated By a Condition Sensitive Means, above.)
- 379, Telephonic Communications, subclasses 251+ and 352+ for such devices designed for use as calling devices for telephone systems. (See Lines With Other Classes, Signal Transmitters Using Variable Inductor Devices, above.)

- 379, Telephonic Communications, subclass 55.1 for telephone systems. (See Lines With Other Classes and Within This Class, Inductor Devices Systems, 4, above.)
- 379, Telephonic Communications, subclass 398 and 415 for telephone systems having means, such as an inductor device, to prevent or reduce inductive effects. (See Lines With Other Classes and Within This Class, G, Anti-Inductive Devices and Systems, above.)
- 409, Gear Cutting, Milling, or Planing, subclasses 2+ for a pattern controlled gear cutting machine; subclasses 79+ for a pattern controlled milling machine; subclasses 125+ for a templet or tracer adapted to be used with a milling machine; and subclasses 289+ for a pattern controlled planing machine. (See Lines With Other Classes and Within This Class, C, Pattern Controlled Variable Inductor Devices and Pattern Tracing Devices Which Actuate Variable Inductor Devices, above.)
- 428, Stock Material or Miscellaneous Articles, subclasses 544+ for stock materials, e.g., of indefinite length, which are all metal or have adjacent metal components, particularly subclasses 592 for stock material in the form of a helix or having a helical component.
- 446, Amusement Devices: Toys, subclasses 129+ for a toy which involves magnetic phenomena in its operation.
- 451, Abrading, subclass 237 for a pattern controlled, rotary type of abrading machine. (See Lines With Other Classes and Within This Class, C, Pattern Controlled Variable Inductor Devices and Pattern Tracing Devices Which Actuate Variable Inductor Devices, above.)
- 455, Telecommunications, subclasses 67.11 through 67.7 for measuring a testing devices used for testing the operating conditions of the systems; and subclasses 226.1-226.4 for measuring or testing devices for particular use with radio receivers. (See Lines With Other Classes and Within This Class, D, Variable Inductor Devices Operated By a Condition Sensitive Means, above.)
- 505, Superconductor Technology: Apparatus, Material, Process, subclasses 150+ for devices or systems utilizing high temperature ($T_c > 30$ K) superconducting material, particularly subclasses 211+ for inductors using high temperature superconducting material.
- 600, Surgery, subclasses 407+ for electric diagnostic instruments for use with humans and which include an inductor device designed to have its

inductance varied by a condition. (See Lines With Other Classes and Within This Class, D, Variable Inductor Devices Operated By a Condition Sensitive Means, above.)

SECTION IV - GLOSSARY

ADJUSTABLE INDUCTOR

A passive inductor wherein the inductor device includes a movable element which may be adjusted to different positions or adjusted to vary its physical dimensions to change the effective inductance from one value to another.

Examples of such movable elements are: a tap changing switch, a distortable coil or core, coil length varying means, a movable core and movable coupled coils.

Inductor devices designed to change inductance (a) as a function of the current flowing through the inductor winding, or (b) in accordance with a magnetic bias applied to the core of the device, or (c) as a function of the ambient temperature of the device, and wherein no physical elements of the inductor are moved to effect such change in inductance, are not considered adjustable under the above definition. Such variable inductors will be found in subclasses 155+ of this class for magnetically saturable or high leakage reactance type devices and subclass 179 of this class for devices responsive to changes in ambient temperature.

CLOSED COIL

is a coil which is not designed to be connected to an external source or to a circuit, but which has the ends of the coil connected together so that a magnetic field can induce current therein which current flows in the closed path formed by the closed coil and generates a magnetic field in opposition to the current inducing field.

COIL

A conductor which creates a magnetic field due to the flow of current therein. It may be formed into one or more convolutions or turns, or have only a partial turn, or be straight.

COIL AXIS

That path along which a unit magnetic pole would experience a maximum force when a current is caused to flow in the coil conductor. For example, in a long, uni-

form, single layer cylindrical coil, the coil axis corresponds to the geometrical axis of the coil.

CONDUCTOR

A body designed to have an electric current flowing therein. For the purpose of classification, a magnetic core is distinguished from a conductor. A conductor is designed to be connected to a source of electromotive force, or to have induced therein a voltage by inductive coupling from a current carrying conductor. A conductor, when used as a coil, and connected either directly or by mutual inductance to a source of electromotive force, creates a magnetic field due to the flow of current in the conductor. See the definition of core.

CORE

A magnetic or magnetizable body having a magnetic permeability greater than one. The proximate purpose of a core is to increase the inductance of an associated coil by increasing the number of magnetic flux interlinkages of the coil. Although the material of the core is electrically conductive such electrical conductivity is usually minimized by using magnetic material of high resistivity in the form of bundles of fine wires, stacks of thin laminations insulated from each other or a suspension of iron powder in an electrically insulating binder.

INDUCTIVE COUPLING

The coupling between separate coils or windings due to the electromagnetic induction between the coils or windings.

INDUCTOR

An impedance device comprising a coil means with or without core means for introducing inductance into an electric circuit and wherein the inherent capacitive reactance thereof does not resonate with the inductance of the coil within the frequency range of the electric current adapted to flow therethrough. Both transformers and inductive reactors are included within the meaning of "inductor". Excluded are inductor devices that are designed to do more than introduce inductance into a circuit. Examples are: inductor devices particularly designed to produce a magnetic field which radiates energy which is not returned to the device, or devices designed to produce external mechanical work by electromagnetic action.

MAGNETIC BODY

Same as "CORE" above.

PASSIVE INDUCTOR

An inductor device which contains no source or sink of energy (i.e., an active element). A "sink of energy" as used in this definition is an element or network which is designed to absorb energy, by converting electrical energy into another form of energy. Excluded, therefore, are variable or adjustable inductance devices in which the change in inductance is effected, at least in part, by an active element such as, by way of example, continuously rotating machinery (i.e., synchronous or asynchronous phase modifier or phase advancer machines) or reactance tube systems having space discharge devices with electrode biasing potential sources.

TRANSFORMER

An inductor having a plurality of coils or windings in mutually inductive relation.

WINDING

A coil or plurality of coils which are interconnected, or designed to be interconnected, having terminal means adapted to be connected to an external source of current, to an output or load circuit, or to some other circuit.

SUBCLASSES

5

POLYPHASE:

This subclass is indented under the class definition. Inductor devices comprising plural inductor means arranged structurally and/or by internal connection for use in a two or more phase electrical system.

- (1) Note. The claims must limit the device to use in a polyphase system by including some structure or electrical connection which is not of general utility but is specifically for use in a polyphase system to be classified herein.
- (2) Note. The search should extend to the appropriate subclasses below for inductor structure which may be used with polyphase current but which is of general utility (e.g., multiple coil reactors and transformers with plural primary and secondary windings).

SEE OR SEARCH CLASS:

- 307, Electrical Transmission or Interconnection Systems, subclasses 13+ for plural load systems of the polyphase type.
- 310, Electrical Generator or Motor Structure, appropriate subclasses under subclass 10 for dynamoelectric machine structure of the polyphase type.
- 323, Electricity: Power Supply or Regulation Systems, appropriate subclasses for systems in which a single source of supply is connected to a single output circuit and the system includes means for controlling only the magnitude of the current, the voltage and/or the phase angle between the current or voltage in the system. The single source of supply may be a polyphase source. Also see subclasses 44+ for miscellaneous polyphase transformer systems, and subclasses 63+ for the miscellaneous polyphase impedance (including inductive impedance) systems.
- 331, Oscillators, subclass 45 for polyphase output oscillator systems utilizing polyphase inductor structure.
- 363, Electric Power Conversion Systems, especially subclasses 152+ for induction type (e.g., transformer) phase conversion systems.

10 Adjustable inductor:

This subclass is indented under subclass 5. Subject matter wherein the inductor has means for adjusting its inductance.

- (1) Note. The claims must limit the device to use in a polyphase system by including some structure or electrical connection which is not of general utility but is specifically for use in a polyphase system to be classified herein.
- (2) Note. The search should extend to the appropriate subclasses below for adjustable inductor structure which may be used with polyphase current but which is of general utility (e.g., multiple coil reactors and transformers with plural primary and secondary windings).

SEE OR SEARCH CLASS:

- 307, Electrical Transmission or Interconnection Systems, subclass 104 for systems having means for controlling the same under highly inductive conditions.
- 323, Electricity: Power Supply or Regulation Systems, appropriate subclasses, for systems in which a single source of supply is connected to a single output circuit and the system includes means for controlling only the magnitude of the current, the voltage and/or the phase angle between the current or voltage in the system. The single source of supply may be a polyphase source.
- 335, Electricity: Magnetically Operated Switches, Magnets, and Electromagnets, subclasses 220+ for structure of polyphase induction devices without inductance varying means.

12 Interconnected windings:

This subclass is indented under subclass 5. Subject matter wherein the claimed subject matter sets forth specific electrical connections between plural inductor devices which devices comprise a structural unit, so that the devices may be incorporated in a plural phase system as an operating unit.

15 WITH COIL WINDING AND/OR UNWINDING:

This subclass is indented under the class definition. Adjustable inductor devices in which the number of effective turns of a coil is changed by winding or unwinding the conductor forming the coil.

- (1) Note. The following is an illustrative example:

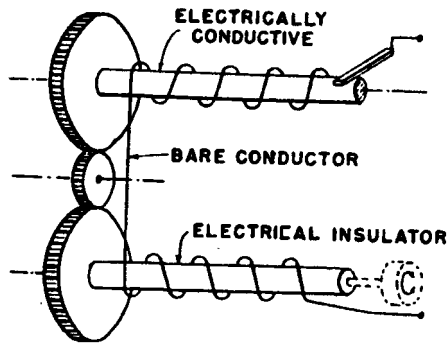

SEE OR SEARCH THIS CLASS, SUB-CLASS:

- 20, for adjustable inductor devices wherein the inductance change is effected by distorting or misshaping a coil conductor and/or core of the regulator.
- 116, and 137+, for other adjustable inductor devices wherein the inductive change is effected by altering the effective length of the coil conductor by means other than winding and/or unwinding the conductor.
- 184, for inductor devices with coils having different axis or on different core legs.

SEE OR SEARCH CLASS:

- 74, Machine Element or Mechanism, subclasses 10+ and the subclasses specified in the notes thereto for mechanical mechanism for rotating a shaft including such mechanism designed for use with an adjustable inductor device. Also see the search notes to subclass 10 of Class 74 for the classification of other rotary shaft moving mechanism and for the line between Class 336 and Class 74.
- 191, Electricity: Transmission to Vehicles, subclasses 12.2+ for an electric current supply conductor and reel means upon which the conductor may be wound.
- 242, Winding, Tensioning, or Guiding, subclasses 370+ for a reeling device of general use.
- 334, Tuners, subclass 38 for tuners having a reactor element which is adapted to

be wound or unwound upon a core or form.

- 338, Electrical Resistors, subclass 79 for mechanically variable electric resistors in which the resistance value is varied by winding the resistance element from one core to another.
- 343, Communications: Radio Wave Antennas, subclasses 700+ for radio antennae in which the effective length of the antenna is changed by winding the radiating element of the antenna in or out.

20 WITH DEFORMABLE OR DISTORTIBLE COIL AND/OR CORE:

This subclass is indented under the class definition. Adjustable inductor devices wherein the inductance variation is attained by changing the physical shape of either the coil or core or both, usually by physically displacing portions of the coil or core relative to other portions of the coil or core respectively, by bending, twisting or stretching.

(1) Note. The following are illustrative examples:

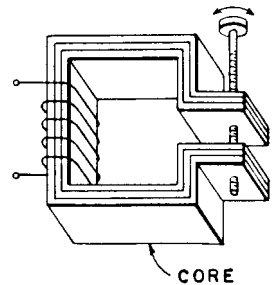

(a) The core is deformed.

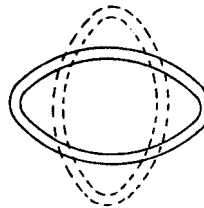

(b) The coil is deformed.

(2) Note. This subclass includes variable inductor devices having a core or core part formed of magnetostrictive material

which material exhibits a change in volume and in magnetizing properties when placed under mechanical stress.

SEE OR SEARCH THIS CLASS, SUBCLASS:

- 15, for adjustable inductor devices wherein the deformation or distortion of the coil conductor is that caused by winding and/or unwinding the conductor.
- 115+, for inductor devices having two or more coils which are movable relative to each other.
- 130, for inductor devices having a relatively movable magnetic core and coil.

SEE OR SEARCH CLASS:

- 331, Oscillators, subclass 157 for oscillator systems having a frequency determining element comprising electromechanical resonator of the magnetostrictive type.
- 343, Communications: Radio Wave Antennas, subclass 868 for loop type antennas with an adjustable configuration, area, or coil length.
- 367, Communications, Electrical: Acoustic Wave Systems and Devices, subclass 168 for magnetostrictive electroacoustic or electro-vibrational transducers.
- 369, Dynamic Information Storage or Retrieval, subclasses 146+ for magnetostrictive transducers for electromechanical recording or reproducing.
- 381, Electrical Audio Signal Processing Systems and Devices, subclasses 150+ for electro-acoustical transducers of the magnetostrictive type for use in telephony. Subclasses 150+ includes transmitters and receivers.

30 WITH CONDITION-RESPONSIVE INDUCTANCE ADJUSTING MEANS (E.G., BY ELECTROMAGNET):

This subclass is indented under the class definition. Adjustable inductor devices where the change in inductance is effected by adjusting or varying the inductance changing elements of the device in response to a condition by condition sensing means external to the device.

- (1) Note. The inductance varying element may be a thermally responsive element (including those for temperature compensations; however, where compensation is effected by the internal structure of the device, classification is not herein but in subclass 179), a fluid pressure diaphragm (e.g., a barometer), a centrifugal device, or any other device or means responsive to a condition.

- (2) Note. The following are illustrative examples:

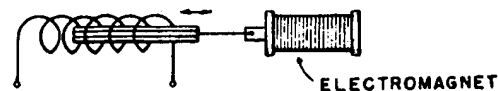
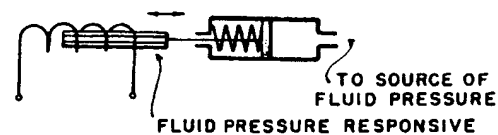

- (3) Note. See section VI of the class definition for a listing of other classes which have condition response variable inductor devices.

SEE OR SEARCH THIS CLASS, SUBCLASS:

179, and see (1) Note, above.

SEE OR SEARCH CLASS:

- 307, Electrical Transmission or Interconnection Systems, appropriate subclasses, for automatically controlled systems of general application involving two or more sources or input circuits and/or two or more output or load circuits.
- 323, Electricity: Power Supply or Regulation Systems, for single load regulation systems in which the regulation is controlled by a condition.
- 331, Oscillators, subclasses 65+ for oscillator systems combined with a device responsive to an external physical condition and wherein a frequency determining element (inductor or

capacitor) of the oscillator is varied by the condition sensing device.

333, Wave Transmission Lines and Networks, subclasses 2+ and 17.1+ for wave transmission lines and networks including an adjustable inductor with automatic control, and subclasses 15 and 16 for pilot line and pilot current control systems respectively which may include an adjustable inductor with automatic control.

334, Tuners, subclass 4 for magnetic responsive tuners; subclasses 5+ for tuners responsive to an external condition; subclass 13 for tuners having a saturable core type element and means to automatically center the frequency of the circuit; subclass 16 for a tuner utilizing a reactance tube tuner combined with automatic frequency centering circuit means, and subclasses 26+ for a tuner having an electromagnetic operator with automatic frequency centering means.

455, Telecommunications, subclass 257 for receivers with automatic frequency control and subclasses 150.1+ for particular frequency selection means in radio receivers.

40 ADJUSTABLE BY MAGNETIC FORCE BETWEEN RELATIVELY MOVABLE PARTS OF THE INDUCTOR:

This subclass is indented under the class definition. Adjustable inductor devices in which the inductance varying element is adjusted in response to the magnetic force existing between the magnetic elements (e.g., between the core and coil or between coils) of the inductor device.

(1) Note. Illustrative examples are:

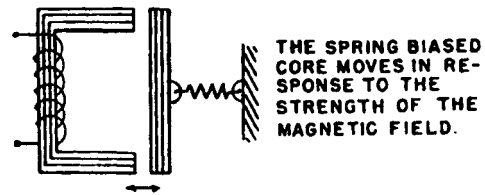

THE SPRING BIASED CORE MOVES IN RESPONSE TO THE STRENGTH OF THE MAGNETIC FIELD.

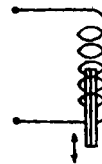

THE COIL IS MOVED AGAINST THE FORCE OF GRAVITY DUE TO THE CHANGE IN MAGNETIC FIELD.

(2) Note. This subclass includes inductor devices such as are used in constant current systems.

SEE OR SEARCH CLASS:

323, Electricity: Power Supply or Regulation Systems, subclass 305 for single source to single load type constant current regulation systems.

41 Weight-counterbalanced coil or core:

This subclass is indented under subclass 40. Subject matter in which the weight of one of the elements which is moved by the magnetic force is counterbalanced at least in part by a counterbalanced weight so that the magnetic force needed to move the movable element is either less than or more than the weight of the movable element.

(1) Note. Where the inductor has a plurality of movable inductance changing elements (e.g., a movable coil and a movable core) one of the movable elements may be used as a counterbalance for the others and vice versa.

(2) Note. An illustrative example is:

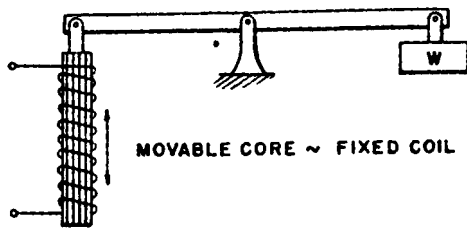

SEE OR SEARCH CLASS:

- 248, Supports, appropriate subclasses for counterbalanced movable supports of general application. Note subclass 364 of Class 248 and also see the Index to the Manual of Classification of Patents under the titles 'Weights' and 'Counterweights' for counterbalance weights.

45 WITH MOVABLE ELEMENT POSITION INDICATOR:

This subclass is indented under the class definition. Adjustable inductor devices in which means are provided for showing the displacement of an inductance changing element of the inductor device relative to some fixed part of the device.

SEE OR SEARCH CLASS:

- 116, Signals and Indicators, subclasses 241+, for miscellaneous position indicators other than the electrically actuated or controlled type.
- 331, Oscillators, subclass 64 for oscillators having means for indicating the position or setting of an adjustable frequency determining element of the oscillator, such as a variable inductor or capacitor.
- 340, Communications: Electrical, appropriate subclasses for electrically actuated or controlled signals and indicators, especially subclasses 870.31+ for telemetric systems.

55 WITH MOVABLE ELEMENT POSITION INDICATOR:

This subclass is indented under the class definition. Inductor devices wherein means are provided for modifying or for controlling the temperature of the inductor device.

SEE OR SEARCH THIS CLASS, SUBCLASS:

- 179, for inductor devices whose inherent construction is such as to maintain their inductance at a constant value, or which permits their inductance to vary in a predetermined manner with changes in temperature of the device.

SEE OR SEARCH CLASS:

- 62, Refrigeration, appropriate subclasses for miscellaneous refrigeration apparatus, particularly subclasses 259.1+ for refrigeration means installed in structures having other functions.
- 165, Heat Exchange, appropriate subclasses for heat exchange apparatus combined with a device to be cooled or heated thereby, if no structure of such device is included other than that necessary for cooperation with the heat exchange device.
- 174, Electricity: Conductors and Insulators, subclasses 15.1+ for a mere housing, casing or envelope for an electrical device where no significant structure of the device is claimed with means for modifying the temperature of the device.
- 310, Electrical Generator or Motor Structure, subclass 16 and 52+ for reciprocating and rotary dynamoelectric machines, respectively, with cooling or temperature modification means.
- 315, Electric Lamp and Discharge Devices: Systems, particularly subclass 50 for combined structure of a space discharge device and impedance means, which means may be an inductor, and which means is constructed to modify the temperature of the load device.
- 331, Oscillators, subclasses 69 and 70 for oscillator systems with means for modifying or controlling the temperature of the oscillator or an element, such as a tank circuit inductor, of the oscillator.
- 454, Ventilation, appropriate subclasses for miscellaneous ventilating apparatus.

57 With inductor insulating fluid circulating means:

This subclass is indented under subclass 55. Subject matter in which the inductor device has a circumambient liquid or gaseous insulating medium in contact with its coil or core and wherein means, such as a pump or fan, is included to force the medium to circulate for the purpose of effecting a heat exchange between the medium and the inductor device.

SEE OR SEARCH CLASS:

- 62, Refrigeration, particularly subclasses 304+ for material cooling means including a gas-liquid contactor, subclasses 373+ for a cooler in which a liquid contacts a discrete commodity, and subclasses 403+ for a system for cooling a gas and controlling or directing it, e.g., with an air pump.
- 165, Heat Exchange, subclasses 104.22+ for a heat exchange device in which mechanically impelled fluent material picks up heat at one point in a circuit and discharges it at another.
- 174, Electricity: Conductors and Insulators, subclass 15.1 for fluid feeding, circulating or distributing for cooling electrical equipment generally and indented subclass 16.1 for such having ventilation and/or gas circulation.
- 310, Electrical Generator or Motor Structure, subclasses 58+ for cooling or fluid contact means for rotary dynamo electric machinery which includes means to circulate a coolant.

58 Liquid insulating medium:

This subclass is indented under subclass 55. Subject matter wherein the inductor device is immersed in a heat exchanging medium comprising an insulating liquid.

- (1) Note. If the insulating liquid in which the inductor is immersed is not specifically disclosed or claimed as a heat exchange medium for the device classification is not herein but rather in subclass 94 below.

SEE OR SEARCH CLASS:

- 208, Mineral Oils: Processes and Products, subclass 14 for an insulating oil comprising only mineral oil components.
- 252, Compositions, subclasses 570+ for fluent dielectric compositions containing a nonhydrocarbon material.
- 585, Chemistry of Hydrocarbon Compounds, subclasses 6.3+ for an all-hydrocarbon insulating oil containing more than mineral oil fractions.

59 Vented casing:

This subclass is indented under subclass 55. Subject matter wherein the inductor has a housing or casing which is provided with apertures (usually open to the atmosphere) to allow circulation of air over selected surfaces of the contained inductor.

SEE OR SEARCH CLASS:

- 165, Heat Exchange, subclasses 128+ for a heat exchange structure having a thermosyphonic flue.
- 174, Electricity: Conductors and Insulators, subclass 16.1 for a mere housing or casing for an electrical device, where no significant structure of the device is claimed, with means to provide for ventilation of the interior of the casing.
- 454, Ventilation, appropriate subclasses for miscellaneous ventilating structure such as cowls, hoods and louvers.

60 Ventilating passages (e.g., by coil section or core part spacers):

This subclass is indented under subclass 55. Subject matter comprising passages between or through various components of the inductor structure so that a cooling fluid may circulate therethrough.

- (1) Note. The passageways may be formed by coil or winding and/or core part spacers.

SEE OR SEARCH THIS CLASS, SUBCLASS:

- 185, for windings formed of multiple coils with spacers therebetween.

196+, for spacing means between coil and core.

199+, for spacing means between coils or coil turns.

SEE OR SEARCH CLASS:

310, Electrical Generator or Motor Structure, subclass 65 for rotary dynamoelectric machine structure wherein spacers are provided between motor core laminations or coils to effect a heat exchange between a fluid medium and the core or coils.

61 Heat exchanging surfaces:

This subclass is indented under subclass 55. Subject matter wherein a heat exchanging surface is structurally combined with the coil or winding or the core of the inductor, or the coil or winding or the core is especially adapted by its structure to have a heat exchanging surface.

- (1) Note. The heat exchanging surface is not limited to heat radiating surfaces but the heat exchange may take place by conduction or convection or a combination of the various types of heat transfer, the essential element required for this subclass being a surface, adapted for heat transfer in intimate relationship with the coil or winding or the core of the inductor.

SEE OR SEARCH CLASS:

165, Heat Exchange, subclass 185 for a heat transmitter, per se.

310, Electrical Generator or Motor Structure, subclasses 64+ for heat exchanging surfaces in rotary dynamoelectric machines.

62 Hollow conductor coil:

This subclass is indented under subclass 55. Subject matter wherein at least one coil of the inductor device is formed of a tubular conductor which is designed to convey a temperature modifying fluid therethrough.

SEE OR SEARCH THIS CLASS, SUBCLASS:

223, for windings having conductors of a particular shape including tubular.

SEE OR SEARCH CLASS:

138, Pipes and Tubular Conduits, appropriate subclasses for miscellaneous pipe and tubular conduit structure.

174, Electricity: Conductors and Insulators, subclasses 28+ for co-axial type conductors with fluid or vacuum insulation, subclass 102 for conductors formed as tubular sheaths for other conductors, and subclasses 126.1+, and especially indented subclasses 130 and 131 for hollow electric conductors of the stranded type.

219, Electric Heating, subclasses 600+ for inductive heating, note subclasses 628+ for an inductor structure having a fluid flow; subclasses 678+ for microwave heating; and subclasses 764+ for capacitive dielectric heating.

65 WITH MOUNTING OR SUPPORTING MEANS (E.G., BASE):

This subclass is indented under the class definition. Inductor devices having exterior means to support the entire inductor structure.

- (1) Note. A support is defined as a device or means which carries the weight of the inductor device or otherwise hold or steady it against the pull of gravity.

(2) Note. Means for supporting parts or elements of the inductor device with respect to each other are not considered support or mounting means for classification in this subclass.

(3) Note. A mere casing or housing for the inductor device is not considered to be a supporting means within the definition of this subclass. However, if the casing or housing is provided with means for supporting the casing or housing such as being mounted on supporting legs or wheels or has legs extending from the casing so that casing can be mounted on a panel or wall, the structure is considered to be supporting structure for this subclass.

SEE OR SEARCH THIS CLASS, SUB-CLASS:

- 92, for inductor devices provided with means to support the inductor device within the casing.
- 185, for supports or spacers for the coils of a winding.
- 195, for one coil supported by another coil.
- 196+, for supporting or spacing means between coil and core.
- 199+, for coil or coil turn supports.
- 210+, for core clamps, wedges or fasteners.

SEE OR SEARCH CLASS:

- 174, Electricity: Conductors and Insulators, subclass 37 for underground supports for electrical devices; subclass 40 for overhead supports for electrical devices; subclasses 50-64, particularly subclasses 58 and 63, for means to mount or support a casing or housing for an electrical device; and subclasses 480-507 for means for mounting miscellaneous casings or housings for electrical devices on or within a wall of a building structure.
- 248, Supports, appropriate subclasses for miscellaneous supports.
- 310, Electrical Generator or Motor Structure, subclass 91 for dynamoelectric machines combined with supporting means therefor.
- 343, Communications: Radio Wave Antennas, subclass 869 for loop type antennas with a rotatable support.
- 361, Electricity: Electrical Systems and Devices, subclasses 600+ for mounting means for switchboards or plural diverse.

66 Handle:

This subclass is indented under subclass 65. Subject matter provided with means to manually hold or support the inductor device.

SEE OR SEARCH CLASS:

- 16, Miscellaneous Hardware (e.g., Bushing, Carpet Fastener, Caster, Door Closer, Panel Hanger, Attachable or Adjunct Handle, Hinge, Window Sash Balance, etc.), subclasses 110.1 through 430 for handles in general.

- 174, Electricity: Conductors and Insulators, subclass 46 for handles restricted by structure to use with electrical apparatus in general. The Notes listed under subclass 46 of Class 174 indicate other fields of search for devices with handles.

- 310, Electrical Generator or Motor Structure, subclass 50 for rotary dynamoelectric machines of the portable or hand tool type.

67 Bracket:

This subclass is indented under subclass 65. Subject matter provided with means to rigidly attach and support the inductor on or to a supporting surface. Usually the support is adapted to be fastened to a wall and projects therefrom to support the inductor in cantilever fashion.

SEE OR SEARCH CLASS:

- 174, Electricity: Conductors and Insulators, particularly subclasses 480 through 507 for wall-mounted conduits or housings.
- 248, Supports, appropriate subclasses for object supporting brackets of general application, see particularly subclasses 200+.

68 Suspension:

This subclass is indented under subclass 65. Subject matter provided with mechanical coupling means by means of which the inductor may be hung from an overhead position.

SEE OR SEARCH CLASS:

- 248, Supports, appropriate subclasses for object supporting suspension type supports, see particularly subclasses 317+.

69 WITH COIL CAPACITANCE MODIFYING MEANS:

This subclass is indented under the class definition. Inductor devices comprising means to modify the inherent capacitive effects between (a) adjacent turns of a winding, or (b) between adjacent windings, or (c) between windings or turns and adjacent structure such as a core or casing therefor.

- (1) Note. The modification of the capacitive effects may be accomplished, for exam-

ple, by the provision of appropriately placed shield members, or open-circuited auxiliary coils, or by use of a dielectric of graded thickness or composition.

- (2) Note. The capacitive effect modifying means may be, for example, to eliminate undesired coupling between windings, or to protect the inductor from breakdown of the insulation on the occurrence of high amplitude transient potentials at the inductor terminals (see indented subclass 70 for such transient control).
- (3) Note. Mere arrangement of the conductor winding pattern to prevent undesired coupling between coils is not subject matter for this subclass. Such subject matter may be found in the appropriate subclass for the structure involved.

SEE OR SEARCH CLASS:

- 178, Telegraphy, appropriate subclasses for telegraph systems with inductors and capacity balancing means, especially subclass 45 for loading coils, and subclasses 63 and 69 for cable or line capacity correction.
- 307, Electrical Transmission or Interconnection Systems, subclasses 89+ for anti-inductive systems in general.
- 333, Wave Transmission Lines and Networks, appropriate subclasses for wave transmission lines and networks having inductor elements including means to balance the capacitance of the elements with respect to a particular potential plane, see particularly subclasses 4+, 117+ and 25+.
- 361, Electricity: Electrical Systems and Devices, subclass 270 for structural combinations of an inductor and a capacitor.
- 379, Telephonic Communications, appropriate subclasses for telephone systems with inductors and capacity balancing means, especially subclass 398 and 415 for anti-inductive telephone devices.

70 With surge potential gradient modifying means:

This subclass is indented under subclass 69. Subject matter wherein the inherent inductor capacitance relationships are modified by additional means which change the potential gradient distribution through at least part of the inductor, and which may include, in addition, connections to various fixed or other potential points in the inductor, or a rearrangement of coils or terminals to attain a potential gradient distribution which will minimize the deleterious effect of surge or transient electrical pulses or waves to which the inductor may be subjected.

SEE OR SEARCH THIS CLASS, SUBCLASS:

- 84, for inductors with electric or magnetic shielding means for shielding the inductor from stray fields or for preventing radiation of undesired electric or magnetic field energy.

SEE OR SEARCH CLASS:

- 174, Electricity: Conductors and Insulators, subclass 127 for conductor structure which prevents corona discharge, including such structure which performs this function by preventing high electrostatic stress at any point; and subclasses 140+ for insulators, including those combined with conductive means which function together to control the voltage gradient, particularly subclass 143 for bushing type insulators with alternating rings or cylinders of conductive and insulating material which exert a modifying effect on the capacitance between inner and outer conductors of the bushing, particularly for voltage stress distribution.
- 307, Electrical Transmission or Interconnection Systems, subclass 327 for protective systems for surge, transient or parasitic current suppression in general.
- 310, Electrical Generator or Motor Structure, subclass 196 for dynamoelectric machine armature or primary winding structure including corona discharge prevention means.

73 WITH CLOSED COIL OR CONDUCTOR MEMBER:

This subclass is indented under the class definition. Inductor devices which include a coil and a member which has at least a portion of the member formed of nonmagnetic electrically conductive material, the member being shaped so that it provides a closed electrical circuit for current induced therein.

- (1) Note. The conductive member may be a closed coil, a plate, bar or slug, and need not be formed wholly of nonmagnetic material (see indented subclass 77 for relatively movable members of such construction).

SEE OR SEARCH THIS CLASS, SUB-CLASS:

- 84+, for electric and/or magnetic shields which may be disclosed as closed conductive members.

SEE OR SEARCH CLASS:

- 310, Electrical Generator or Motor Structure, subclasses 182+ and 197 for short-circuited windings or conductors in field or armature windings, respectively, for rotary dynamoelectric machines.

75 Movable with respect to another coil:

This subclass is indented under subclass 73. Subject matter wherein the coil and the conductive member are relatively movable with respect to each other.

- (2) Note. Illustrative examples are:

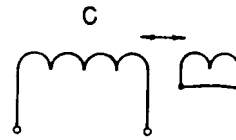
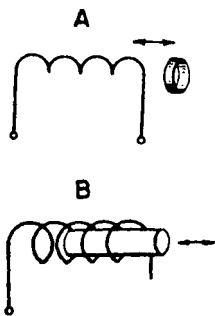

SEE OR SEARCH THIS CLASS, SUB-CLASS:

- 138, and 144, for adjustable inductor devices which have closed coils or short-circuited turns which are fixed in position relative to the coil or coils of the inductor device.

SEE OR SEARCH CLASS:

- 331, Oscillators, subclass 181 for oscillator systems with a variable inductance frequency determining means, which variable inductance may be of the angularly adjustable vane type.

77 With magnetic portion:

This subclass is indented under subclass 75. Devices in which a portion of the member is formed of magnetic material.

- (1) Note. An illustrative example is:

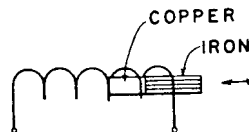

SEE OR SEARCH THIS CLASS, SUB-CLASS:

- 117+, for inductor devices having relatively movable coils and a core, at least one of the coils and the core being relatively movable, see indented subclass 119 where a coil and the core are movable as a unit with respect to another coil.
- 130+, for inductor devices having one or more coils and a core, the core and a coil being relatively movable with respect to each other.
- 221, for inductor devices comprising miscellaneous core and coil combinations.

79 Angularly movable:

This subclass is indented under subclass 75. Devices in which the member is movable about an axis of rotation.

(1) Note. An illustrative example is:

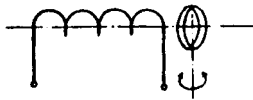

SEE OR SEARCH THIS CLASS, SUBCLASS:

120+, for inductor devices having relatively movable coils and a core, a coil and a core being relatively movable as a unit about an axis of rotation.

122+, and the subclasses specified in the Notes thereto for inductor devices having relatively movable coils, one of the coils being movable about an axis of rotation.

SEE OR SEARCH CLASS:

74, Machine Element or Mechanism, subclasses 10+ and the subclasses specified in the Notes thereto for mechanical mechanism for rotating a shaft including such mechanism designed for use with an adjustable inductor device. Also see the search notes to subclass 10 of Class 74 for the classification of other rotary shaft moving mechanism and for the line between Class 336 and Class 74.

310, Electrical Generator or Motor Structure, subclasses 105+ for induced or eddy current magnetic field type of torque transmitting clutch or brake which have a rotating short-circuited or conducting disc member, and subclasses 210+ for dynamoelectric machines with secondary windings or conductors which may include such of the short-circuited coil or disc conductor type.

324, Electricity: Measuring and Testing, subclasses 137+ for meters with eddy current rotors.

335, Electricity: Magnetically Operated Switches, Magnets, and Electromagnets, subclass 225 for magneto-mechanical motive devices with relatively, movable members of the induced current type, (e.g., rotary disk); and subclass 226 specifically for such with short-circuited coils.

82 COIL FORMS PROTECTIVE CASING:

This subclass is indented under the class definition. Inductor devices wherein a coil or winding of the inductor consists of a solid, unitary preformed casing which substantially completely encloses the rest of the inductor structure. A wound coil such as a toroidal or spherical coil which completely encloses another coil and/or core is excluded from this subclass and may be found in the appropriate structural subclasses below.

SEE OR SEARCH CLASS:

333, Wave Transmission Lines and Networks, subclasses 222+ for high frequency resonators of the distributed parameter type which may include a rigid external conductive casing.

334, Tuners, subclasses 41+ for resonant line tuning units wherein the tuning capacitor may be enclosed in a rigid conductive casing comprising the tuner inductor, and subclass 85 for a tuner having shielding or housing means which may be a rigid conductive casing which serves as an inductance element.

83 CORE FORMS CASING:

This subclass is indented under the class definition. Inductor devices wherein the coils or windings are substantially completely enclosed by the core structure except for such apertures in the core structure necessary to allow passage of the coil or winding leads.

(1) Note. If a casing or housing having an inductor therein serves as a portion of the magnetic path of the inductor, classification is herein rather than in subclasses 90+.

SEE OR SEARCH THIS CLASS, SUB-CLASS:

214+, for inductors with cores wherein multiple separate magnetic paths are provided in the core structure.

84 WITH ELECTRIC AND/OR MAGNETIC SHIELDING MEANS:

This subclass is indented under the class definition. Inductor devices provided with means for shielding at least part of the inductor device from external electric or magnetic fields, or with means to protect parts of the device from undesired electric or magnetic fields originating in another part of the device, or with means to prevent the inductor device from emanating undesired electric or magnetic fields.

SEE OR SEARCH THIS CLASS, SUB-CLASS:

69+, for inductive devices having coil capacitance modifying means and in which electrostatic shields are associated with the coil means to shield coils from each other, or in special arrangements for balancing coil capacitances, or to modify the coil surge potential gradient.

73+, for inductive devices having a closed or short-circuited coil which is often in the form of a conductive screen or plate of the electrostatic shield type, and indented subclasses 75+ for inductor devices having a movable nonmagnetic conductive screen or shield which is used to vary the effective inductance of the inductor device.

82, for inductive devices wherein a coil, formed as a solid, unitary structure of conductive material, forms the casing of the inductive device and may function in part like an electrostatic shield.

83, for inductive devices wherein the coil or winding thereof is totally enclosed by a magnetic core (so-called 'iron-clad' cores) which structure tends to confine the electromagnetic field within the bounds of the inductor.

90+, for inductor devices with casings or housings not limited by claimed subject matter to electric or magnetic shielding.

SEE OR SEARCH CLASS:

174, Electricity: Conductors and Insulators, subclasses 32 through 397 for miscellaneous anti-inductive structures, particularly subclasses 350-397 for miscellaneous electrical shields and screen structures not elsewhere classifiable. The search notes to subclasses 32-397 indicate further fields of search for anti-inductive and shielding structure.

307, Electrical Transmission or Interconnection Systems, subclasses 39+ for anti-inductive means to prevent or modify the coupling between electrical systems, particularly subclass 91 for 'shielding means.'

310, Electrical Generator or Motor Structure, subclass 256 for stray field flux loss prevention by shielding means in rotary dynamoelectric machines.

330, Amplifiers, subclass 68 for amplifiers combined with significant details of shielding structure, generally, subclass 170 for amplifiers having transformer coupling including shielding means involved in such transformer coupling.

331, Oscillators, subclass 67 for oscillator systems provided with an electromagnetic or electrostatic shield. The shield may be for an element (such as an inductor) of the oscillator system.

333, Wave Transmission Lines and Networks, subclass 12 for transmission line inductive or radiation interference reduction systems which include shielding means for the purpose.

343, Communications: Radio Wave Antennas, subclass 842 for loop type antennas with an electrical shield.

361, Electricity: Electrical Systems and Devices, subclasses 268+ for inductors with integral switch or capacitor means, particularly subclass 270 for those inductive devices structurally combined with a capacitor.

87 Adjustable inductor:

This subclass is indented under subclass 84. Subject matter wherein means for adjustment of the inductance of the inductor device are included.

90 WITH OUTER CASING OR HOUSING:

This subclass is indented under the class definition. Inductor devices provided with a casing or housing to enclose the inductor device.

- (1) Note. The casing or housing surrounding the inductor device in the patents of this and indented subclasses is disclosed primarily as a mechanical protection for, or to contain an insulating medium around, the inductor.
- (2) Note. If the casing or housing is claimed as an electric or magnetic shield, the patent is excluded and classified in subclasses 84+.
- (3) Note. For classification in this or indented subclasses some detail of the inductor device such as a winding must be claimed. If the recitation in the claim of an inductor device is by name only, the patent is not classified herein but rather in the appropriate subclasses in Class 174.

SEE OR SEARCH THIS CLASS, SUBCLASS:

- 55+, for inductor devices having casings combined with means to modify the temperature of the inductor. See especially subclass 59 for vented casings.
- 65+, for inductor devices having casings with external mounting means.
- 82, for inductor devices wherein a unitary preformed coil or winding forms the casing.
- 83, for inductor devices wherein the core forms a casing for the windings.

SEE OR SEARCH CLASS:

- 174, Electricity: Conductors and Insulators, for miscellaneous casings and housings for electrical devices including such casings and housings, in combination with an electrical device recited by name only, particularly subclasses 8+ for such devices intended to be used with a fluid or vacuum; subclasses 37+ for underground vaults for electrical devices; and subclasses 50+ for such devices of general utility.

220, Receptacles, appropriate subclasses for miscellaneous box, housing or casing structure of general utility.

324, Electricity: Measuring and Testing, subclass 156 for casings for electrical measuring instruments.

361, Electricity: Electrical Systems and Devices, subclasses 600+ for housings and mounting assemblies with plural diverse electrical components.

92 Internal inductor support:

This subclass is indented under subclass 90. Subject matter wherein means are provided within the casing to maintain the inductor device in a predetermined relation to the casing.

SEE OR SEARCH THIS CLASS, SUBCLASS:

- 65+, for the combination of an inductor with means to support it with respect to its environment. Housed inductor devices with means external of the housing for supporting the device are in subclasses 65+.

94 Fluid insulation:

This subclass is indented under subclass 90. Subject matter wherein the housing or casing containing the inductor contains an insulating fluid in which the inductor is immersed.

(1) Note. If means are provided for circulating the insulating fluid, for cooling purposes, the patent is not classified herein but rather in subclass 57.

(2) Note. If the insulating fluid comprises a liquid and is provided for a cooling effect, classification is not herein but rather in subclass 58.

(3) Note. For the locus of patents to insulating fluids, per se, see the search notes in subclass 58.

96 Potted type:

This subclass is indented under subclass 90. Subject matter wherein the space between the casing or housing and the inductor and its interstices is occupied by a semisolid or solidified mass of insulating material such as sand or asphalt (or other plastic material).

SEE OR SEARCH THIS CLASS, SUB-CLASS:

58, and 94, for inductors immersed in an insulating medium which is in a fluid state.

98 Exposed core portions:

This subclass is indented under subclass 90. Subject matter wherein a portion of the inductor core protrudes from the casing or housing, e.g., a transformer with 'end bells' covering only the windings and a portion of the core.

100 WITH VIBRATION CONTROL:

This subclass is indented under the class definition. Inductor devices which are especially designed or provided with some structure to inhibit or reduce the vibration, to prevent failure from the vibration or to eliminate or reduce the effects upon the device of the vibration caused by the fluctuations in magnetic flux.

SEE OR SEARCH CLASS:

74, Machine Element or Mechanism, subclass 574.1 for flywheel with electrical or magnetic damping; subclass 574.2 for damping using swinging masses, e.g., pendulum type for damping, etc.; subclass 574.3 for damping by increasing frictional force; and subclass 574.4 for damping by absorbing the vibration force (via rubber, elastomeric material, etc.).

188, Brakes, subclasses 371+ for braking devices which use plastic deformation or breakage of a retarder element to dissipate motion; subclasses 378+ for braking devices which use the inertia of a damping mass; subclasses 266+ for internal resistance type braking devices or vibration damping means; and subclass 381 for vibration dampers which use friction between damper elements.

248, Supports, subclasses 560+ for resilient supports.

267, Spring Devices, appropriate subclasses, for miscellaneous spring structures.

310, Electrical Generator or Motor Structure, subclass 51 for miscellaneous vibration suppression means utilized in rotary dynamoelectric machinery,

subclass 93 for electrodynamic brakes utilized to damp out vibrations.

464, Rotary Shafts, Gudgeons, Housings, and Flexible Couplings for Rotary Shafts, subclasses 127 and 180 for shaft couplings and shafting having vibration dampening characteristics.

105 COMBINED:

This subclass is indented under the class definition. Inductor devices combined with structure other than the coil structure or the core structure or the supporting and spacing structure for mounting the coils and/or cores with respect to each other, or the structure or means for electrically insulating the coil and core structure, and which are not classified in any of the subclasses in this class preceding this subclass.

(1) Note. If the other structure is a switch for varying the inductance of the device, as a tap changing switch, the patent is excluded from this subclass, and will be found in subclass 150 of this class or one of the subclasses specified in the Notes to that subclass. If the switch interrupts or completes the line circuit to the inductor, the patent is excluded and may be found in Class 361, Electricity: Electrical Systems and Devices, subclass 157.6.

(2) Note. An illustrative example is:



107 With connector:

This subclass is indented under subclass 105. Subject matter combined with means to complete an external electrical circuit connection to the inductor, said means comprising readily-detachable, interengaging friction or screw held, or pressure-exerting, coupling elements.

SEE OR SEARCH THIS CLASS, SUB-CLASS:

192, for inductor devices with terminals adapted to make permanent or semi-permanent connections with an external electrical circuit (e.g., solder lugs).

SEE OR SEARCH CLASS:

- 343, Communications: Radio Wave Antennas, subclass 870 for loop type antennas with a connector or terminals.
- 439, Electrical Connectors, appropriate subclasses for an electrical connector, per se, generally.

110 WITH PERMANENT MAGNET:

This subclass is indented under the class definition. Inductor devices which are provided with a permanent magnet to modify the magnetic flux distribution.

- (1) Note. An illustrative example is:

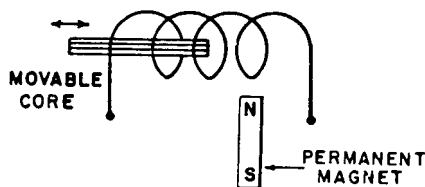
**SEE OR SEARCH THIS CLASS, SUBCLASS:**

- 155+, for inductor devices having a winding adapted to be energized by direct current to modify the magnetic flux distribution of the device.

SEE OR SEARCH CLASS:

- 323, Electricity: Power Supply or Regulation Systems, subclasses 250, 330, and 362 for miscellaneous inductive reactor systems where the reactor includes a permanent magnet as a part thereof.
- 343, Communications: Radio Wave Antennas, subclass 788 for loop type antennas with magnetic material.

115 RELATIVELY MOVABLE COILS:

This subclass is indented under the class definition. Inductor devices having two coils which are relatively movable with respect to each other.

- (1) Note. Illustrative examples are:

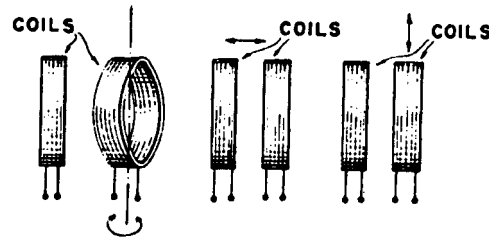
**SEE OR SEARCH THIS CLASS, SUBCLASS:**

- 75+, for inductor devices having a coil and a closed coil which are relatively movable with respect to each other.
- 170+, 180+, 188, and 220, for inductor devices having plural, nonrelatively movable coils or windings.
- 323, Electricity: Power Supply or Regulation Systems, subclasses 216, 264, and 347 for inductor systems with movable structure or windings.
- 330, Amplifiers, subclasses 65+ for amplifiers combined with significant structural detail of any of the circuit elements which may include inductor structure; subclasses 171, 190, and 197 for amplifiers having transformer coupling including significant details of the transformer structure, subclass 169 for amplifiers having transformer coupling including means for adjusting such inductive coupling.
- 333, Wave Transmission Lines and Networks, subclasses 24+ for coupling networks, including filters, equalizers, and delay networks, having relatively movable coils, and especially subclasses 177+ for transformer coupled wave filters.
- 334, Tuners, subclasses 59+ for tuners having tuned transformer circuits which are substituted by switching in which the primary may remain stationary while the secondary is moved relative to the primary, and subclasses 61+ for tuners having mutual inductance variable means which may be relatively displaceable coils.
- 428, Stock Material or Miscellaneous Articles, subclass 591 for metallic stock

having parts which are relatively movable with respect to each other.

116 With means to change coil length and/or connections:

This subclass is indented under subclass 115. Subject matter wherein one of the coils is provided with means (a) to change the physical length of the coil which is effective as an inductive component, (b) to add or cut out turns or coils or to substitute a coil section or component of different characteristics or position for a coil or (c) to change the direction of current flow through at least a portion of the coil conductor.

(1) Note. Illustrative examples are:

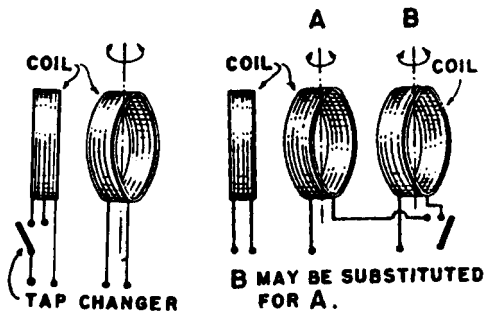

SEE OR SEARCH THIS CLASS, SUBCLASS:

15, for adjustable inductor devices having means for varying the number of turns of the coil by winding or unwinding the coil.

137+, for other inductor devices wherein the inductance change is effected by changing the effective coil length and/or coil connections.

SEE OR SEARCH CLASS:

323, Electricity: Power Supply or Regulation Systems, subclasses 255 and 340 for transformer systems with tapped windings.

117 With core:

This subclass is indented under subclass 115. Subject matter wherein one of the coils is provided with a core.

(1) Note. The core may extend through the fixed and movable coil (e.g., the movable coil may slide along the core), or one coil may be provided with a core fixed in relation thereto and the other coil may be relatively movable with respect to the fixed coil and core, or each coil may be mounted on respective complementary portions of a two part core.

(2) Note. Illustrative examples are:

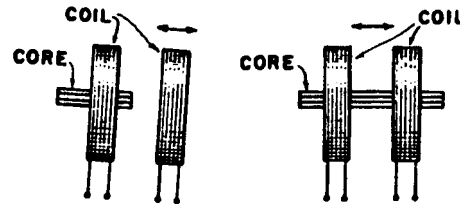

SEE OR SEARCH THIS CLASS, SUBCLASS:

40+, for adjustable inductor devices having relatively movable coils and a core where the movement of the movable core is effected by the change in magnetic force between the two coils (e.g., constant current devices).

130+, where the inductor device has a core movable with respect to one or more coils.

333, Wave Transmission Lines and Networks, subclasses 177+ for transformer coupled wave filters with magnetic core inductances.

118 Relatively movable core and coils:

This subclass is indented under subclass 117. Subject matter, wherein the core is relatively movable with respect to the two coils which are movable with respect to each other.

(1) Note. Illustrative examples are:

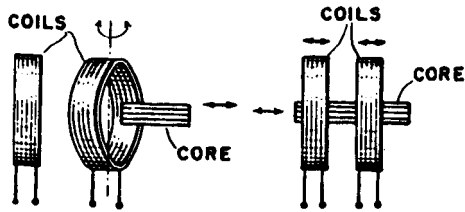
**119 Coil and core movable as a unit:**

This subclass is indented under subclass 117. Subject matter wherein a core and a coil which are fixed with respect to each other are movable as a unit relative to another coil.

(1) Note. An illustrative example is:

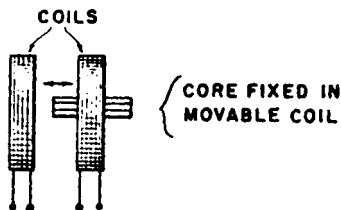

SEE OR SEARCH THIS CLASS, SUBCLASS:

77, for adjustable inductor devices having a coil and a closed coil (e.g., short circuit coil) or conductive member which are relatively movable with respect to each other, the closed coil or conductive member having a portion formed of magnetic material.

212, for inductor devices having core comprising plural parts formed of unitary assemblages.

120 Angularly movable:

This subclass is indented under subclass 119. Subject matter wherein the fixed core and coil unit is movable about an axis of rotation.

SEE OR SEARCH THIS CLASS, SUBCLASS:

122+, for adjustable inductor devices having relatively movable coils, the movable coil being movable about an axis of rotation.

SEE OR SEARCH CLASS:

74, Machine Element or Mechanism, subclasses 10+ and the subclasses specified in the Notes thereto for mechanical mechanism for rotating a shaft including such mechanism designed for use with an adjustable inductor device. Also see the search notes to subclass 10 of Class 74 for the classification of other rotary shaft moving mechanism and for the line between Class 336 and Class 74.

121 Angularly and linearly movable coils:

This subclass is indented under subclass 115. Subject matter wherein a coil is movable about an axis of rotation and is also movable in a linear path or wherein one coil is movable about an axis of rotation and another coil is movable in a linear path.

(1) Note. Illustrative examples are:

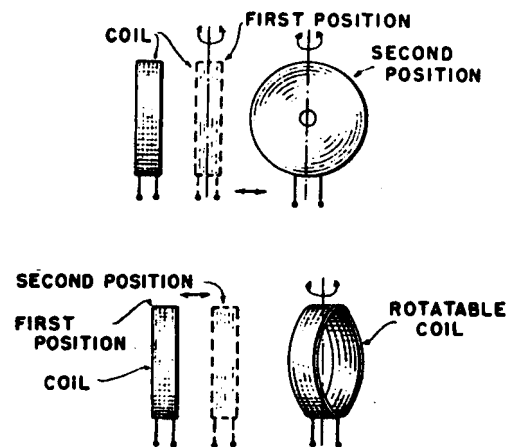

SEE OR SEARCH THIS CLASS, SUBCLASS:

115, for relatively movable coil inductor devices where one coil is movable only in a linear path which is not parallel to the coil axis of the other coil.

122, for relatively movable coil inductor devices where a coil is movable only about an axis of rotation.

129, for relatively movable coil inductor devices where one coil is movable only in a linear path which is parallel

to and usually coincident with the coil axis of another coil.

122 Angularly movable:

This subclass is indented under subclass 115. Subject matter wherein a coil is movable about an axis of rotation.

(1) Note. Illustrative examples are:

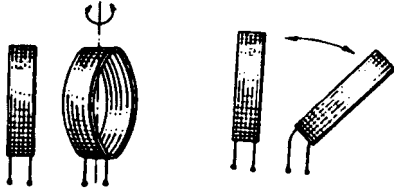

SEE OR SEARCH THIS CLASS, SUBCLASS:

- 79, for inductor devices which include a short-circuited coil which is movable about an axis of rotation.
- 120, where the inductor device is provided with a core for a movable coil, the core and coil being angularly movable as a unit with respect to another coil.
- 121, where the coil is movable about an axis of rotation and is also linearly movable or where a coil is movable about an axis of rotation and another coil is linearly movable.

SEE OR SEARCH CLASS:

- 74, Machine Element or Mechanism, subclasses 10+ and the subclasses specified in the Notes thereto for mechanical mechanism for rotating a shaft including such mechanism designed for use with an adjustable inductor device. Also see the search notes to subclass 10 of Class 74 for the classification of other rotary shaft moving mechanism and for the line between Class 336 and Class 74.

123 About axis parallel to or coaxial with the other coil axis:

This subclass is indented under subclass 122. Subject matter wherein the axis of rotation of the movable coil is coincident with or parallel to the axis of the other coil.

(1) Note. An illustrative example is:

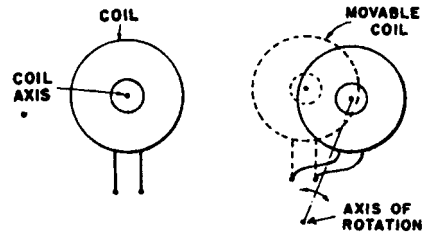

124 Nonsymmetrically pivoted coil movable on axis transverse to other coil axis:

This subclass is indented under subclass 122. Subject matter wherein the movable coil is movable about an axis of rotation which is offset with respect to center of coil, the axis of rotation of the movable coil being inclined at an angle with respect to the axis of the other coil.

(1) Note. Illustrative examples are:

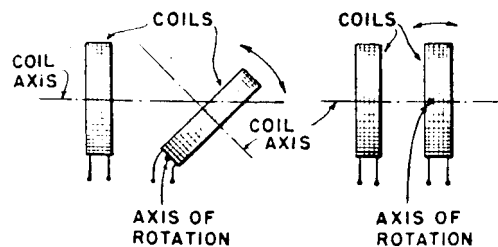

125 About axis normal to other coil axis:

This subclass is indented under subclass 122. Subject matter wherein the movable coil is movable about an axis of rotation which passes through the center of the coil and which is perpendicular to the axis of the other coil.

(1) Note. An illustrative example is:

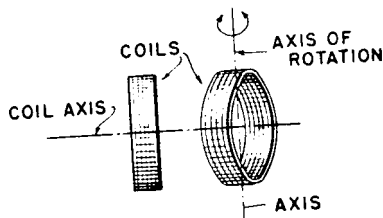

SEE OR SEARCH THIS CLASS, SUB-CLASS:

122, where the movable coil is movable about an axis of rotation which passes through the center of the coil, the axis of rotation being transverse to, but not normal to, the axis of the other coil.

126 Plural coils movable with respect to a coil:

This subclass is indented under subclass 125. Subject matter having three or more coils, at least two of the coils being angularly movable with respect to each other and with respect to another coil.

(1) Note. The plural movable coils may be angularly movable about the same or different axis of rotation.

(2) Note. Illustrative examples are:

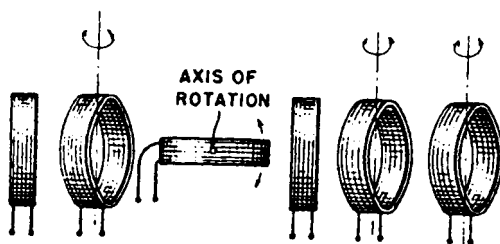

SEE OR SEARCH THIS CLASS, SUB-CLASS:

170+, for inductors having three or more nonmovable windings.

127 Similar spherical-shaped coils:

This subclass is indented under subclass 125. Subject matter wherein the coils are similar and have a spherical shape.

(1) Note. The coil winding need not form a complete sphere, but may only be a portion of a sphere.

SEE OR SEARCH THIS CLASS, SUB-CLASS:

230, for the structure of spherical coils.

128 Tubular stationary coil:

This subclass is indented under subclass 125. Subject matter wherein the stationary coil has a tubular shape.

(1) Note. A tubular coil is a coil having a rectilinear coil axis and having its windings extending along the coil axis for a distance usually greater than the cross-sectional dimensions (e.g., the diameter in the case of round tubular coils) of the coil. The cross-sectional shape or area usually is uniform along the coil axis. The cross-sectional shape may be circular, oval, square, polygonal or the like. Coils of spherical, toroidal, or pancake form, for example, are not considered to be tubular coils for this subclass.

(2) Note. An illustrative example is:

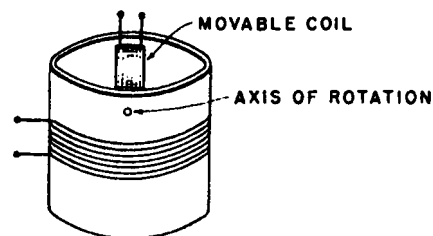

SEE OR SEARCH THIS CLASS, SUB-CLASS:

199+, for the structure of coils on a form and especially subclass 208 for coil forms.

225+, for the structure of coils having a special configuration.

129 Movable along or parallel to other coil axis:

This subclass is indented under subclass 115. Subject matter wherein the coil is movable along a linear axis which is either coincident with or parallel to the coil axis of the other coil.

(1) Note. An illustrative example is:

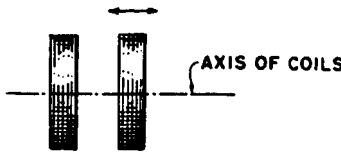

SEE OR SEARCH THIS CLASS, SUB-CLASS:

- 119, for inductor devices having relatively movable coils, the movable coil being provided with a core, the core and coil being movable as a unit along an axis coincident with or parallel to the axis of the other coil.
- 121, for inductor devices having relatively movable coils wherein a coil is movable about an axis of rotation and is also movable in a linear path or wherein one coil is movable about an axis of rotation and another coil is movable in a linear path.

130 RELATIVELY MOVABLE CORE AND COIL:

This subclass is indented under the class definition. Adjustable inductor devices having a core and a coil which are relatively movable with respect to each other so that the effective inductance of the device may be varied.

(1) Note. Illustrative examples are:

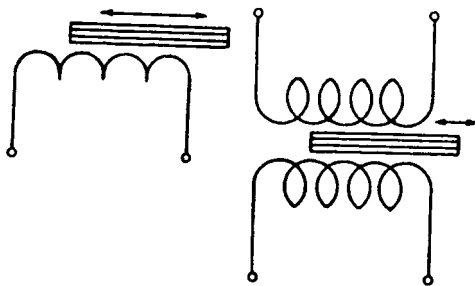

SEE OR SEARCH THIS CLASS, SUB-CLASS:

- 20, where the inductor device has a deformable or distortable coil or core.

- 40, where the movement between the coil and core is due to the magnetic force existing between the coil and core.
- 77, where the core is a portion of a short-circuited conductor or conductive member which is movable with respect to the coil.
- 117+, where the inductor device includes two coils which are movable relative to each other, the core being movable relative to at least one of the coils.
- 221, for the structure of coil and core not elsewhere provided for.

SEE OR SEARCH CLASS:

- 74, Machine Element or Mechanism, subclasses 10+ and the subclasses specified in the Notes thereto for mechanical mechanism for rotating a shaft including such mechanism designed for use with an adjustable inductor device. Also see the search notes to subclass 10 of Class 74 for the classification of other rotary shaft moving mechanism and for the line between Class 336 and Class 74.
- 323, Electricity: Power Supply or Regulation Systems, subclasses 216, 264, and 347 for miscellaneous inductive reactor systems where the reactor includes a relatively movable core and coil.
- 330, Amplifiers, subclass 169 for amplifiers having transformer coupling including means for adjusting inductive coupling of the transformer.
- 334, Tuners, appropriate subclasses for tuned networks for use in wave energy apparatus and comprising inductance and capacitance elements in circuit arrangement to form a resonant circuit and in which structure is provided for adjusting one or both of these elements for changing the mean resonant frequency of the circuit. The adjustable inductance is usually of the movable core type.
- 343, Communications: Radio Wave Antennas, subclass 748 for loop type antennas with a variable reactance for tuning the antenna.

131 Plural coils with plural cores:

This subclass is indented under subclass 130. Subject matter which includes a plurality of coils, each of the coils being provided with a core which is relatively movable with respect to the coil with which it is associated.

- (1) Note. The several coils may or may not be in inductive relation to each other.
- (2) Note. Illustrative examples are:

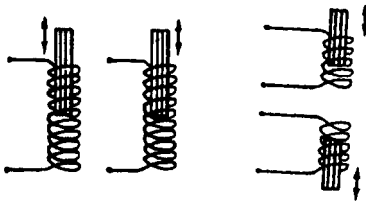

SEE OR SEARCH THIS CLASS, SUBCLASS:

170+, 182+, 188, and 220, for the structure of nonadjustable inductive devices having plural windings (e.g., transformers).

SEE OR SEARCH CLASS:

333, Wave Transmission Lines and Networks, subclasses 24+ for coupling networks including plural coils with plural cores, and particularly subclasses 177+ for transformer coupled wave filters with magnetic core inductance.

334, Tuners, subclass 77 for tuners having variable inductors which are gang operated.

132 Plural relatively movable core parts:

This subclass is indented under subclass 130. Subject matter wherein the core is formed of a plurality of separate parts, one of the parts being movable relative to the other part.

- (1) Note. The core part which is movable with respect to the other core part may be movable with respect to the coil, or the other core part may be movable with respect to the coil.

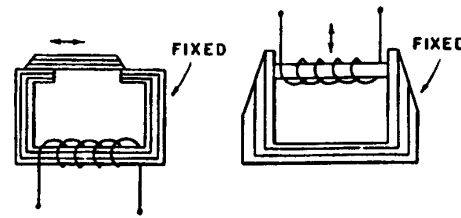

- (2) Note. Illustrative examples are:

SEE OR SEARCH THIS CLASS, SUBCLASS:

221, for inductive devices with plural part cores in general.

133 Adjustable magnetic shunt:

This subclass is indented under subclass 132. Subject matter wherein the inductor device is provided with at least two coils, one of the core portions forming a continuous flux path inductively coupling the two coils, the movable magnetic core portion being arranged between the two coils so as to provide an adjustable shunt for shunting some of the magnetic flux from the core portion forming the continuous flux path so that one of the coils may be linked by a different amount of magnetic flux than that which links the other coil.

- (1) Note. An illustrative example is:

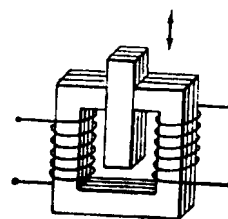

MOVABLE CORE SHUNTS FLUX GENERATED BY ONE COIL FROM OTHER COIL.

- (2) Note. The following illustrated types of inductor devices, below, are not included in this subclass. For the below excluded types of inductor devices, see subclasses 134+ where there is an adjustable air gap and subclass 132 for such devices without an adjustable air gap.

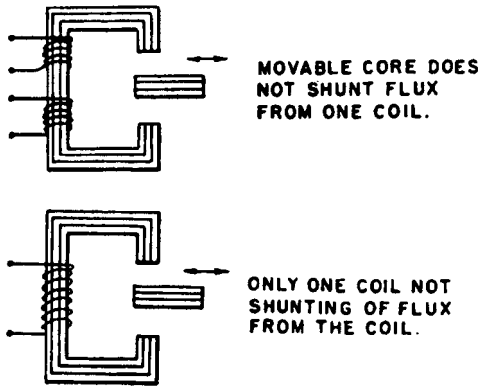

SEE OR SEARCH THIS CLASS, SUB-CLASS:

160, for inductive regulators, without relatively movable parts, having a magnetic shunt.

134 Adjustable air gap:

This subclass is indented under subclass 132. Subject matter wherein the movable core portion in at least one of the positions to which it may be moved provides an air gap between itself and the other core portion.

(1) Note. The movable core portion may provide an air gap between itself and the other core portion in all of the positions to which it may be moved.

(2) Note. Illustrative examples are:

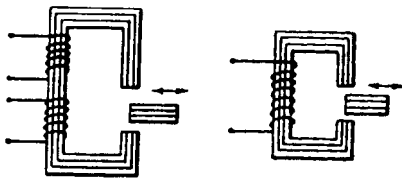

SEE OR SEARCH THIS CLASS, SUB-CLASS:

155+, for inductive regulators, with no relatively moving parts having an air gap.
178, for inductive devices with a closed core interrupted by an air gap, generally.

135 Angularly movable:

This subclass is indented under subclass 134. Subject matter wherein the movable core portion is movable about an axis of rotation.

(1) Note. An illustrative example is:

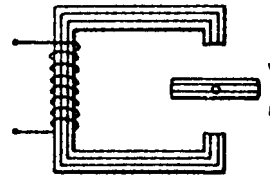

SEE OR SEARCH THIS CLASS, SUB-CLASS:

120, for inductor devices having a core and coil which are movable as a unit about an axis of rotation to effect movement between the core and coil unit and another coil.

SEE OR SEARCH CLASS:

74, Machine Element or Mechanism, subclasses 10+ and the subclasses specified in the notes thereto for mechanical mechanism for rotating a shaft including such mechanism designed for use with an adjustable inductor device. Also see the search notes to subclass 10 of Class 74 for the classification of other rotary shaft moving mechanism and for the line between Class 336 and Class 74.

136 Telescoping magnetic body and coil:

This subclass is indented under subclass 130. Subject matter in which the core and a coil are relatively movable in the direction of the axis of the coil and in variable amount of overlapping relation.

(1) Note. In the devices in this subclass, the core may be 'telescoped' within the coil, or the coil may be telescoped within the core.

(2) Note. An illustrative example is:

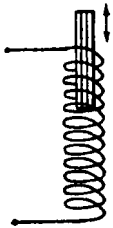

137 WITH MEANS TO CHANGE COIL LENGTH OR CONNECTIONS:

This subclass is indented under the class definition. Inductor devices wherein a coil is provided with means (a) to change the physical length of the coil which is effective as an inductive component, or (b) to add or cut out turns or coils or to substitute a coil section or component of different characteristics or position for a coil or (c) to change the direction of current flow through at least a portion of the coil conductor.

(1) Note. Illustrative examples are:

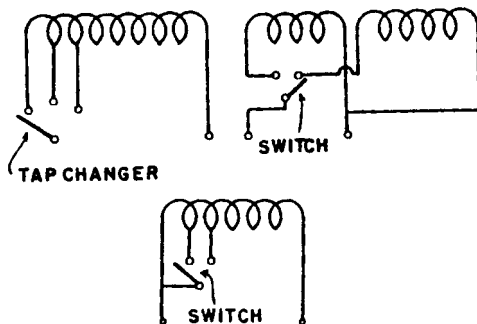

SEE OR SEARCH THIS CLASS, SUBCLASS:

15, where the effective number of turns of the coil is varied by winding or unwinding the coil conductor.

116, where one of the coils is also movable with respect to another of the coils.

SEE OR SEARCH CLASS:

74, Machine Element or Mechanism, subclasses 10+ and the subclasses specified in the notes thereto for mechanical mechanism for rotating a shaft including such mechanism designed

for use with an adjustable inductor device. Also see the search notes to subclass 10 of Class 74 for the classification of other rotary shaft moving mechanism and for the line between Class 336 and Class 74.

323, Electricity: Power Supply or Regulation Systems, subclasses 255 and 340 for transformer systems with tapped windings.

334, Tuners, subclasses 47+ for tuners of the switch type and especially subclasses 56+ for a switch type tuner in which the inductor only is modified or substituted by switching.

343, Communications: Radio Wave Antennas, subclass 748 for loop type antennas with a variable reactance for tuning the antenna; and subclass 868 for loop type antennas having means for adjusting the coil length.

138 Parallel-spaced conductors or coils bridged by movable connector:

This subclass is indented under subclass 137. Subject matter comprising conductors (which may be coils) lying in side by side relation, or having a common axis, and bridged by a conducting member, which member is movable along the conductors to include equivalent portions of both conductors in each of its various positions.

(1) Note. Illustrative examples are:

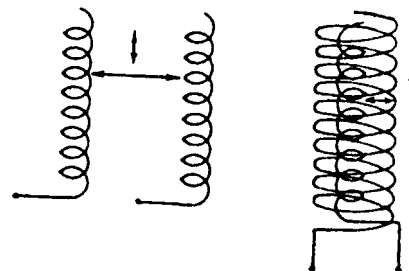

SEE OR SEARCH THIS CLASS, SUBCLASS:

184, for nonadjustable plural coil winding inductive devices where coils have different axes or are mounted on different core legs.

SEE OR SEARCH CLASS:

333, Wave Transmission Lines and Networks, subclasses 219+ for resonators of the distributed electrical parameter type, which structurally may be parallel transmission lines joined by a movable shorting bar, and subclasses 245+ for similar distributed electrical parameter lines which are operated at other than their resonant frequency thereby effecting an inductive or capacitive reactance at the terminals thereof.

139 Contactor following helical conductor:

This subclass is indented under subclass 137. Subject matter wherein the coil is formed of a helically or spirally wound conductor, a movable contactor being provided to make contact with the coil, the conductor contact being movable along the length of the helical or spiral conductor and maintaining a continuous contact with the conductor during such movement so that the conductor contact of the contactor travels in the helical or spiral path defined by the conductor and so that in the range of adjustment of the contactor the change in effective impedance is continuously changing (as distinguished from a step-by-step change).

(1) Note. If the device is also provided with means so that the contact can be moved out of contact with the conductor to make a large discontinuous change in inductance, this will not exclude the patent from this subclass.

(2) Note. An illustrative example is:

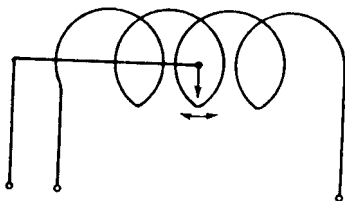

SEE OR SEARCH CLASS:

74, Machine Element or Mechanism, subclasses 10+ and the subclasses specified in the Notes thereto for mechanical mechanism for rotating a shaft

including such mechanism designed for use with an adjustable inductor device. Also see the search notes to subclass 10 of Class 74 for the classification of other rotary shaft moving mechanism and for the line between Class 336 and Class 74.

334, Tuners, subclasses 72+ for tuners having a variable inductor of the type in which a movable contact is adjusted over the length of the inductor.

338, Electrical Resistors, subclasses 143+ for mechanically variable electrical resistors in which the contact terminal moves along the turns of the helical resistance element.

140 Plural movable contactors:

This subclass is indented under subclass 139. Subject matter having a plurality of contactors for contacting the helical or spiral conductor of the coil, or having a plurality of spiral or helical coils with a contactor, which follows and makes continuous contact with the conductor for each coil, the plural contactors being capable of being moved separately or differentially with respect to one another.

(1) Note. Illustrative examples are:

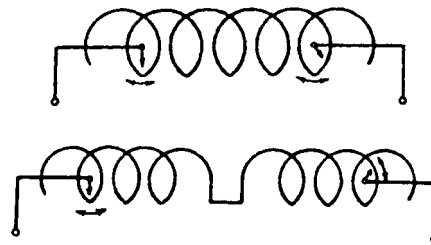

141 With contactor guide track:

This subclass is indented under subclass 139. Subject matter having the movable contactor movably mounted on and/or guided by an elongated bar or track member, the bar or track member extending parallel to or being co-incident with the coil axis.

(1) Note. an illustrative example is:

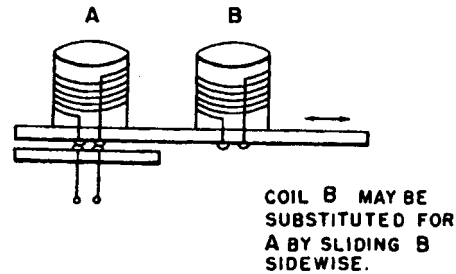
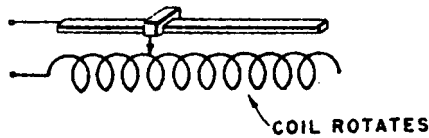

142 Coil connections changed by moving coil (e.g., coil substitution):

This subclass is indented under subclass 137. Subject matter wherein the inductor device includes a plurality of coils with separate electrical contacts or a coil having contact means (e.g., taps) for making contact with the coil at different places and a supporting structure for the coils or coil, the supporting structure being provided with electrical contacts for making contact with less than all of the coils or with means for making contact at different places on the coil, the plurality of coils or the tapped coil being movably supported with respect to the supporting structure, and the coils or coil and supporting structure being designed so that as the coils or coil is moved, different coils or coil contacts can be moved into circuit making relation with the contacts in the supporting structure.

- (1) Note. In the devices in this and the indented subclass, the structure is designed for changing coils in the circuit or for varying the amount of coil conductor in the circuit. The distinguishing feature is that the coil change or conductor length is changed by moving the coils or coil, rather than by having the coils or coil stationary and moving a contactor (e.g., switch into contact with the coil terminals or along the coil.
- (2) Note. Where the device has a plurality of coils, the coils must be arranged so as not to be movable with respect to each other when in circuit making relation with the contacts so as to vary the effective inductance of the device. If the effective inductance of the device can be changed by moving the coils relative to each other, see subclasses 115+ above.
- (3) Note. An illustrative example is:

SEE OR SEARCH THIS CLASS, SUBCLASS:

- 15, for inductor devices where the length of the coil conductor is changed by winding or unwinding the conductor on the coil.
- 115+, for inductor devices which are provided with relatively movable coils for changing the effective inductance of the device.
- 149, for inductor devices where the effective length of the coil conductor is changed by sliding a contactor along the coil winding.
- 150, for inductor devices wherein the inductor is provided with taps and a tap changing switch is provided.

SEE OR SEARCH CLASS:

- 323, Electricity: Power Supply or Regulation Systems, subclasses 255, 340, and 354 for miscellaneous impedance systems wherein a plurality of impedances (e.g., inductor devices) are provided and means are provided for selecting the impedance which may be included in the circuit.
- 331, Oscillators, subclass 179 for oscillator systems wherein the generated oscillation frequency may be changed in discrete steps by inductance coil substitution.
- 334, Tuners, subclasses 47+ for switch type tuners.

143 With connection reversing means:

This subclass is indented under subclass 137. Subject matter wherein the inductor device is provided with a plurality of coil sections or a coil having means (e.g., taps) for making contact with the coil conductor at different places,

the inductor device including means (e.g., a switch) to reverse the inductive effect of one coil section or part with respect to another coil section or part, and to thereby change the effective inductance of the inductor device.

(1) Note. An illustrative example is:

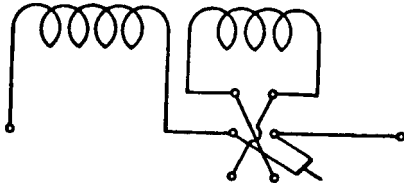

144 With variable number of short-circuited turns:

This subclass is indented under subclass 137. Subject matter having adjustable means to selectively form a closed circuit with one or more turns of the coil.

(1) Note. An illustrative example is:

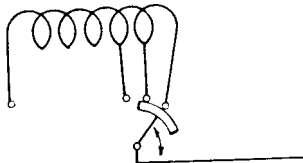

SEE OR SEARCH THIS CLASS, SUBCLASS:

- 15, for inductor devices in which the number of effective turns of a coil is changed by winding or unwinding the coil conductors upon a short circuiting member.
- 73+, for inductor devices with closed coil, particularly indented subclasses 75+ where the closed coil (e.g., the short circuited turns) is movable relative to the coil.
- 138, for similar adjustable inductor devices having a plurality of parallel spaced coil members, a bridging member being movable along the coils to short circuit equivalent portions of both coils.

145 Plural coils (e.g., transformers):

This subclass is indented under subclass 137. Subject matter wherein the inductor device is provided with a plurality of coils in mutually inductive relation.

(1) Note. See the Notes to the class definition for the other classes which provide for plural coil inductive reactors and transformers.

SEE OR SEARCH THIS CLASS, SUBCLASS:

- 116, where the coils are also movable relative to each other.
- 138, where the coils are spaced in parallel relationship and a movable contactor contacts both coils to include an equivalent portion of both coils in circuit.
- 170+, 182+, 188, and 220, for the structure of nonadjustable inductive devices having plural windings (e.g., transformers).

SEE OR SEARCH CLASS:

- 330, Amplifiers, subclass 169 for amplifiers having transformer coupling including means to adjust the inductive coupling.

146 Inductance change in plural coils:

This subclass is indented under subclass 145. Subject matter having means for changing the coil length and/or connections of a plurality of the coils.

SEE OR SEARCH THIS CLASS, SUBCLASS:

- 138, where the coils are spaced in parallel relationship and a movable contactor contacts both coils to include an equivalent portion of both coils in circuit.
- 143, where one of the coils is provided with connection reversing means.
- 144, where one of the coils is provided with means to vary the number of short-circuited turns.

147 Plural coils or coil portions connected in parallel or in series and parallel:

This subclass is indented under subclass 145. Subject matter in which there are a plurality of coils or coil portions which are connected in parallel relation with respect to each other, means being provided to change the coil length or connections of the parallel connected coils or coil portions.

- (1) Note. The change may be to change the coils or coil portions from parallel relation to series relation.
- (2) Note. The device may also include coils or coil portions connected in series with the parallel connected coils or coil portions.
- (3) Note. Illustrative examples are:

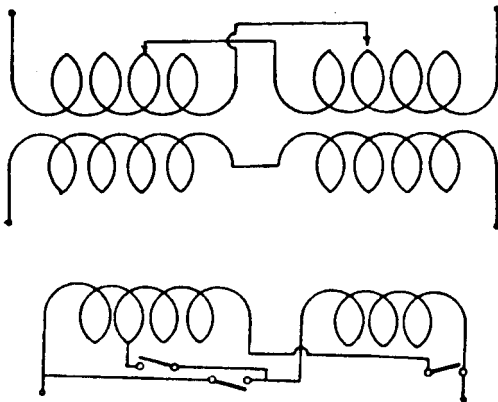

SEE OR SEARCH CLASS:

- 323, Electricity: Power Supply or Regulation Systems, subclass 346 for miscellaneous transformer systems where the transformer is provided with windings which may be selectively connected wither in series or parallel.

148 Autotransformers:

This subclass is indented under subclass 145. Subject matter in which a coil portion forms at least a part of a plurality of coils.

- (1) Note. Included in this subclass are autotransformers.

- (2) Note. An illustrative example is:

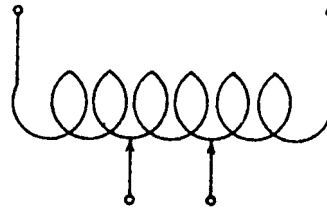

149 Contactor slidable on coil winding:

This subclass is indented under subclass 137. Subject matter comprising a coil and a contactor which travels on and across the successive conductor turns of the coil, making direct contact with the coil conductor.

SEE OR SEARCH THIS CLASS, SUBCLASS:

- 138, for inductor devices having a plurality of parallel spaced coils, a movable contactor being provided to contact both coils to include an equivalent portion of both coils in circuit.
- 139, where the coil is a helical coil or spiral and the contactor follows the conductor so as to make continuous contact with the coil conductor.
- 150, for inductor devices with a tap changing switch.

150 Series change (e.g., tap change):

This subclass is indented under subclass 137. Subject matter wherein the inductor coil is provided with a plurality of contact means so that the change in inductance can be effected by adding or subtracting turns or coil portions in series to the portion of the coil connected in the circuit.

- (1) Note. An illustrative example is:

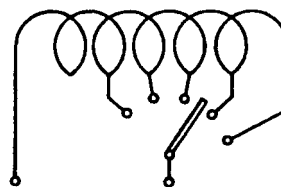

SEE OR SEARCH THIS CLASS, SUB-CLASS:

- 139, where the coil is a helical coil or spiral, and the contactor follows the conductor so as to make continuous contact with the coil conductor.
- 142, where the connections to the coil are changed by moving the coil (i.e., movable coil and fixed contacts).
- 149, where a contactor slides along the coil conductor, making direct contact with the coil conductor.

SEE OR SEARCH CLASS:

- 307, Electrical Transmission or Interconnection Systems, subclass 50 for tap changing means associated with a multi-cell battery which floats across another source of electrical energy.
- 310, Electrical Generator or Motor Structure, subclass 189 for tapped field or excitation windings of dynamoelectric machines, and subclass 200 for tapped armature or primary windings of dynamoelectric machines.
- 323, Electricity: Power Supply or Regulation Systems, subclasses 255 and 340 for transformer systems with tapped windings.

155 INDUCTIVE REGULATORS WITH NO RELATIVELY MOVING PARTS:

This subclass is indented under the class definition. Inductor devices comprising an inductor with no relatively movable parts wherein (a) the inductance thereof is variable in response to current flow therethrough or (b) a magnetic shunt or air gap is provided to cause a high leakage reactance between at least two magnetically coupled windings, or (c) the core saturation of the device is controlled by an auxiliary bias means such as a DC control winding.

- (1) Note. A disclosure in the specification of any of the above enumerated subject matter is sufficient to cause classification in this or indented subclasses of any patent that would otherwise be classified in the succeeding subclasses of this class.

SEE OR SEARCH THIS CLASS, SUB-CLASS:

- 110, for inductor devices having a magnetic bias produced by a permanent magnet.
- 178, for closed type cores with their magnetic path interrupted by an air gap.

SEE OR SEARCH CLASS:

- 310, Electrical Generator or Motor Structure, appropriate subclasses, particularly subclasses 179+ for analogous generator or motor structure, and especially indented subclass 193 for generator or motor structure having nonmagnetic inserts or air gaps.
- 315, Electric Lamp and Discharge Devices: Systems, particularly subclass 282 for discharge device with a regulating transformer in the supply circuit.
- 318, Electricity: Motive Power Systems, subclass 513 for electric motor armature circuit control systems utilizing a saturable reactor.
- 322, Electricity: Single Generator Systems, particularly subclass 57 for dynamoelectric generators with means to saturate a portion of the generator magnetic structure.
- 323, Electricity: Power Supply or Regulation Systems, subclass 56 for current and/or voltage magnitude control systems where the control means is a saturable transformer, and subclass 89 where the control means is a saturable reactor.
- 330, Amplifiers, subclass 8 for magnetic amplifiers (having a saturable reactor active element).
- 331, Oscillators, subclass 181 for oscillator systems having an oscillation frequency determining element comprising a variable inductance, which inductance may be of the saturable core type.
- 332, Modulators, particularly subclass 173 for amplitude modulators which may utilize saturable inductors.

160 With magnetic shunt to increase leakage reactance:

This subclass is indented under subclass 155. Subject matter comprising two or more magnetically coupled windings or coils mounted on a core having at least one auxiliary magnetic path which serves to divert a portion of the flux emanating from one or more of the windings or coils so as to prevent the said flux portion from linking one or more of the other windings or coils.

SEE OR SEARCH CLASS:

- 310, Electrical Generator or Motor Structure, particularly subclass 190 for rotary dynamoelectric machine field structure having magnetic shunts for shifting the field flux.
- 322, Electricity: Single Generator Systems, particularly subclass 50 for dynamoelectric generator control means including a magnetic shunt for the field flux.

165 Air gap in magnetic shunt:

This subclass is indented under subclass 160. Subject matter having an air gap in the auxiliary magnetic path.

- (1) Note. The air gap may interrupt the auxiliary magnetic path partially or completely, and may constitute a nonmagnetic spacer or filler material.

SEE OR SEARCH THIS CLASS, SUBCLASS:

- 134+, for relatively movable core and coil inductor apparatus having an adjustable air gap.
- 178, for closed type cores interrupted by an air gap wherein the purpose of the air gap is not disclosed as subject matter for subclasses 155+.

SEE OR SEARCH CLASS:

- 310, Electrical Generator or Motor Structure, subclass 192 for generator or motor winding and core structure having nonmagnetic inserts or gaps.

170 THREE OR MORE WINDINGS:

This subclass is indented under the class definition. Inductor devices comprising three or more windings, not elsewhere provided for.

SEE OR SEARCH THIS CLASS, SUBCLASS:

- 5+, for inductors with polyphase windings which may have three or more windings.
- 73+, for inductors which may have two or more windings and in addition a closed or short circuited coil or winding.
- 115+, for inductive devices with relatively movable coils which may have three or more windings.
- 130+, for inductive devices having relatively movable core and coil, which may have three or more windings. See particularly indented subclass 131 for inductors including plural cores and plural coils or windings.
- 137+, for inductive devices with means to change coil lengths or connections which may have three or more windings. See particularly indented subclasses 145+ for transformers with plural windings or coils.
- 155+, for inductive regulators which have plural windings.
- 182+, for inductor devices with two windings at least one of which is a plural coil winding.
- 188, for inductor devices having two windings with mutually crossed turns.
- 214+, for inductive devices having multiple magnetic paths which includes subject matter where such multiple magnetic paths have or are adapted to have three or more windings distributed thereon.
- 220, for inductive devices having two windings, not elsewhere provided for.

SEE OR SEARCH CLASS:

- 310, Electrical Generator or Motor Structure, subclasses 184+ and 198+ for plural field windings and plural armature or primary windings, respectively, for rotary dynamoelectric machines.

- 323, Electricity: Power Supply or Regulation Systems, particularly subclasses 48+ for transformer systems with plural primary and/or secondary windings, and subclasses 83+ for inductor systems in general having plural windings.
- 330, Amplifiers, subclasses 165+, 188+, and 195+ for amplifier systems having transformer coupling, particularly subclasses 171, 190, and 197 where transformer structure is involved.
- 335, Electricity: Magnetically Operated Switches, Magnets, and Electromagnets, subclass 291 for electromagnets of the lifting, traction and related types.
- 343, Communications: Radio Wave Antennas, subclass 867 for plural loop type antennas.

171 Noninductively related windings:

This subclass is indented under subclass 170. Subject matter wherein the inductor device and its windings are so constructed, positioned, arranged, and/or connected that at least one of the windings is electromagnetically decoupled with respect to the other windings.

SEE OR SEARCH THIS CLASS, SUBCLASS:

- 184, for inductor devices having a winding with plural coils, so constructed or arranged that the axis of at least one coil is not coincident with the axes of the other coils.

SEE OR SEARCH CLASS:

- 333, Wave Transmission Lines and Networks, for wave transmission systems utilizing hybrid or three winding transformers wherein at least one winding is magnetically decoupled from the other windings.

172 COIL TURN LINKS PORTION OF CORE ACROSS SECTION (E.G., FRACTIONAL TURN):

This subclass is indented under the class definition. Inductor devices wherein the inductor comprises a coil or winding having a turn or series of full turns which embrace the full transverse section of the core and which includes, in addition, one or more shorter turns

which embrace only a portion of the transverse section of the core. The core flux path may be a single solid or laminated core leg with a small piece thereof cut out to permit the 'partial turns' to enclose a smaller cross-section of the core flux path than is enclosed by the full turns; or the core flux path may consist of two or more parallel core legs of a single core or of two independently constructed cores with the full turns enclosing the core legs in cross-section, and the 'partial turns' enclosing in like manner fewer core legs than those enclosed by the full turns.

SEE OR SEARCH THIS CLASS, SUBCLASS:

- 73, for closed or short-circuited turns enclosing less cross-section of a flux path than those enclosed by full turns of the inductor.
- 133, and 160+, for inductor devices of the adjustable or regulating type having core structures including a separate and distinct shunt magnetic path structure.

173 INTERLINKED COILS OR WINDINGS (E.G., CURRENT TRANSFORMER):

This subclass is indented under the class definition. Inductor devices in which two or more coils or windings of the device, as defined by the limiting or boundary surfaces of their turns, cross each other so as to be interlinking.

SEE OR SEARCH THIS CLASS, SUBCLASS:

- 73+, for closed or short-circuited coils which may interlink with another coil or winding.
- 82, for inductors where a coil forms the casing thereof and which may involve interlinked coils.
- 175+, for a core surrounding a linear conductor.
- 180+, for inductors with plural coil windings where single turns of different coils may cross at one or more points.
- 187, for coils formed of plural parallel conductors which are transposed.
- 188, for inductors in which the individual turns of two or more coils or windings mutually cross each other.
- 189+, for single coils with crossed turns.

195, for inductors where one coil has a conductor which receives another coil in a groove, recess, or hollow space of such conductor.

SEE OR SEARCH CLASS:

310, Electrical Generator or Motor Structure, subclasses 179+ for winding and core structures for rotary dynamoelectric machines, appropriate subclasses of which may have interlinking coils.

324, Electricity: Measuring and Testing, subclass 127 for means for measuring, testing, or sensing electricity, per se, having a transformer coupling which may be of the type having interlinking coils or windings (e.g., current or potential instrument transformers).

174 Coil surrounding linear conductor:

This subclass is indented under subclass 173. Subject matter wherein one of the interlinking coils is a linear conductor and is surrounded by another coil.

(1) Note. The linear conductor referred to above is regarded as a segment of a circular coil of infinite radius thereby bringing such subject matter within the definition of subclass 173 under which this subclass is indented.

SEE OR SEARCH THIS CLASS, SUBCLASS:

175+, for linear conductors surrounded by magnetic cores.

175 CORE SURROUNDING LINEAR CONDUCTOR:

This subclass is indented under the class definition. Inductor devices in which a linear conductor comprising the inductor winding or coil is surrounded by a magnetic core.

(1) Note. Where both a coil and core surround a linear conductor the subject matter is classified above in subclass 174 of this class.

SEE OR SEARCH THIS CLASS, SUBCLASS:

173+, for inductors with interlinked coils or windings (e.g., current transformers).

221, for the combination of a core and coil in general and not elsewhere classified.

233, for magnetic core structure in general not elsewhere classified.

SEE OR SEARCH CLASS:

324, Electricity: Measuring and Testing, subclass 127 for means for measuring, testing, or sensing electricity, per se, having transformer coupling means, some of which are current transformers having a winding or coil comprised of a linear conductor.

176 Hinged core:

This subclass is indented under subclass 175. Subject matter in which the magnetic core surrounding the linear conductor comprises plural parts which are hinged at some point, usually to facilitate placing the core about the conductor.

SEE OR SEARCH THIS CLASS, SUBCLASS:

132+, for inductors with relatively movable core parts for varying the inductance of the inductor.

210, for inductors with core clamps, wedges or fasteners.

212, for inductor cores formed of plural parts.

216+, for joint structure of cores.

177 WITH COIL OR MAGNETIC MATERIAL:

This subclass is indented under the class definition. Inductor devices wherein the conductor of a coil of the device is constructed in whole or in part of magnetic material.

SEE OR SEARCH THIS CLASS, SUBCLASS:

213, for cores formed of wound strip or filamentary material.

222+, for windings of inductors generally, including windings whose conductors are constructed of a special material.

233+, for magnetic cores of inductors generally, particularly for cores of special materials.

SEE OR SEARCH CLASS:

- 252, Compositions, subclasses 62.51+ for the compositions of magnetic materials generally.
- 428, Stock Material or Miscellaneous Articles, subclasses 544+ for stock material or intermediate articles which are all metal or have adjacent metal components, particularly subclasses 615+ for metallic composites defined in terms of the composition of their components, and subclass 928 for metallic stock having magnetic properties.

178 WITH CLOSED CORE INTERRUPTED BY AN AIR GAP:

This subclass is indented under the class definition. Inductor devices comprising a structure having a closed core which is partially or completely interrupted at one or more points by nonmagnetic separators or air gaps.

- (1) Note. If the purpose of the nonmagnetic separator or gap is for the purpose of causing a leakage reactance which is usually a function of the load current of the device, the patent is not classified herein but rather in subclasses 155+.

SEE OR SEARCH CLASS:

- 310, Electrical Generator or Motor Structure, subclass 192 for electric generator or motor winding and core structure having nonmagnetic inserts or air gaps.

179 COILS WITH TEMPERATURE COMPENSATING MEANS:

This subclass is indented under the class definition. Inductor devices wherein the coil or winding and/or supporting structure thereof is so constructed as to maintain the inductance of the device constant over a predetermined range of ambient temperature, or wherein the device is designed to follow a predetermined law of variation of inductance with ambient temperature.

- (1) Note. The inductance of the device may be maintained constant by (a) utilizing structural components having equal compensatory temperature coefficients, or (b) utilizing winding and/or support-

ing structure members having constant temperature coefficients.

SEE OR SEARCH THIS CLASS, SUBCLASS:

- 30, for inductor devices controlled by an external temperature sensitive element.

SEE OR SEARCH CLASS:

- 252, Compositions, subclass 70 for compositions having specific temperature response characteristics.
- 324, Electricity: Measuring and Testing, subclasses 105+ for electric meters with thermal compensation means.
- 334, Tuners, subclasses 5+ for condition responsive tuners which may involve coils with temperature compensating means.
- 361, Electricity: Electrical Systems and Devices, subclass 140 for electromagnet circuits having means for compensating for thermal changes, and subclasses 158 and 161+ for electromagnet systems that are thermally responsive.
- 428, Stock Material or Miscellaneous Articles, subclasses 616+ for a metallic composite which is arcuately deflectable by a temperature change.

180 WINDING FORMED OF PLURAL COILS (SERIES OR PARALLEL):

This subclass is indented under the class definition. Inductor devices wherein the device is comprised of at least one winding having a plurality of coils which are connected or are specifically designed to be connected together.

SEE OR SEARCH THIS CLASS, SUBCLASS:

- 5, for inductors of the polyphase type which may include windings with plural coils.
- 73+, and 115+, for relatively movable coils which may include windings with plural coils.
- 131, for relatively movable core and coil which may include windings with plural coils.
- 137, for inductors with means to change coil length or connections which may include windings with plural coils.

- 155+, for inductive regulators which may have windings with plural coils.
- 170+, for inductors with three or more windings wherein at least one of said windings may be comprised of plural coils.

SEE OR SEARCH CLASS:

- 310, Electrical Generator or Motor Structure, subclasses 179+ for winding and core structure for dynamoelectric machines, appropriate subclasses of which may include windings having plural coils.
- 323, Electricity: Power Supply or Regulation Systems, subclasses 44+ for transformer systems, and subclasses 82+ for reactors appropriate subclasses of which may include windings with plural coils.
- 335, Electricity: Magnetically Operated Switches, Magnets, and Electromagnets, subclasses 291+ for structure of lifting, holding and similar magnets, appropriate subclasses of which may include windings with plural coils.

181 Wound to reduce external magnetic field (i.e., fieldless winding):

This subclass is indented under subclass 180. Subject matter in which the coils of the winding are so positioned, constructed and connected that the resultant external magnetic field set up, when current is caused to flow in each of the coils, is substantially reduced or cancelled (i.e., so-called 'fieldless' coils).

SEE OR SEARCH THIS CLASS, SUBCLASS:

- 83, for inductors completely enclosed by a core.
- 84, for inductors with electric and/or magnetic shielding means.
- 189+, for coils with crossed turns, which may be wound to reduce external fields.
- 225+, for coils of special configuration some of whose shapes may be of significance in reducing external fields, particularly subclass 229, toroidal coils, indented thereunder which are known to reduce external fields.

182 Two windings (e.g., transformer):

This subclass is indented under subclass 180. Subject matter in which the inductor includes two windings, at least one of which is formed of plural coils.

SEE OR SEARCH THIS CLASS, SUBCLASS:

- 5+, for inductors with two or more windings adapted for polyphase use.
- 170+, for inductors with three or more windings.
- 220, for inductors having two windings wherein each winding consists of a single coil. Note particularly the subclasses of this class and the outside classes specified in the Notes to subclass 220 as to other fields of search for plural winding inductors wherein at least one of the windings may include plural coils.

SEE OR SEARCH CLASS:

- 330, Amplifiers, subclasses 165+, 188+, and 195+ for amplifier systems having transformer coupling, particularly subclasses 171, 190, and 197 where transformer structure is involved.

183 Coils of different windings interposed:

This subclass is indented under subclass 182. Subject matter in which at least one coil of one winding is positioned between separate coils of another winding.

SEE OR SEARCH THIS CLASS, SUBCLASS:

- 69+, for inductors with coil balancing means which may also have plural coil windings with interposed coils.

184 Coils having different axis or on different core legs:

This subclass is indented under subclass 180. Subject matter wherein the coils of an inductor winding are distributed on different legs of the inductor core means, or wherein at least two coils of an inductor winding are so positioned that their axes do not coincide.

- (1) Note. For relevant material in other classes see the search notes to other

classes under subclasses 180 and 182 of this class.

SEE OR SEARCH THIS CLASS, SUBCLASS:

- 15, for adjustable inductors wherein a coil conductor is wound from one coil supporting form to another having a different axis.
- 69+, for inductors with coil capacitance balancing means which also may have a winding with plural coils distributed on different axes or different core legs.
- 115+, for relatively movable coils particularly subclasses 121 and 122+ which may have plural windings distributed on different axes or core legs.
- 131, for relatively movable core and coil with plural coils and plural cores which may have a winding with plural coils distributed on different axes of core legs.
- 137+, for inductors with means to change coil length or connections which may have windings with plural coils distributed on different axes or core legs.
- 155+, for inductive regulators with no movable parts which may have plural coils of a winding distributed on different core legs or wherein the axes of the coils of a winding do not coincide.
- 170+, for inductors with three or more windings of which one may be plural coil with the coils distributed on different axes or core legs.

SEE OR SEARCH CLASS:

- 310, Electrical Generator or Motor Structure, particularly subclasses 184+ for rotary dynamo-electric machine field structures having plural field coils on separate poles and which may be connected to form a single winding.

185 Coil supports or spacers:

This subclass is indented under subclass 180. Subject matter comprising preformed supporting, holding or spacing means which supports, holds or maintains in spaced apart relationship a plurality of coils of a winding.

SEE OR SEARCH THIS CLASS, SUBCLASS:

- 60, for inductors with ventilating passages, particularly for structure establishing such passages by spacing apart coils of a plural coil winding or wherein such passages are a part of the coil supporting structure.
- 65+, for supports for inductors in general designed to support the inductor with respect to its environment.
- 92, for supports for inductors with casing where the support is specifically adapted to maintain the inductor fixed relative to the casing.
- 195, for inductors wherein one coil having a grooved, hollow or recessed conductor portion supports another coil within said portion.
- 196+, for supporting or spacing means between coil and core of an inductor, particularly subclass 198 indented thereunder for preformed insulation between coil and core.
- 199+, for supports for the closely similar organization of plural windings not involving a plural coil winding.
- 209, for inductor coils with outer windings or binders.

186 COIL FORMED OF PARALLEL CONNECTED CONDUCTORS:

This subclass is indented under the class definition. Inductor devices comprising a coil having convolutions or turns formed of plural strand or multiple type conductors, which strands or conductors are electrically connected in parallel.

- (1) Note. The subject matter of this subclass is distinguished from that of subclass 180 of this class in that, of the parallel connected plural coils which may be found therein, each coil is a separate entity, as established in the definition of coil immediately under the class definition, whereas in this subclass (186) each of the plural conductors is not constructed to function as a separate inductor coil, but all the parallel connected conductors together are constructed and arranged to function as a single coil.

SEE OR SEARCH THIS CLASS, SUB-CLASS:

- 138, for inductors with parallel spaced conductors or coils bridged by a movable connector.
- 147, for inductors having plural coils or windings connected in parallel or series and parallel.
- 180, and see (1) Note, above.

SEE OR SEARCH CLASS:

- 174, Electricity: Conductors and Insulators, particularly subclasses 24+, and 68.1+ for plural conductor cables or conductors, especially subclasses 113+ indented under subclass 68.1 for multiple conductors wherein the individual conductors are insulated from each other, and subclasses 128+ indented under subclass 68 for plural strand conductors wherein the individual strands are uninsulated.

187 Crossed or transposed conductors:

This subclass is indented under subclass 186. Subject matter in which the plural conductors comprising the coil are transposed in positional relationship to each other at a plurality of points.

SEE OR SEARCH THIS CLASS, SUB-CLASS:

- 188, for plural windings with mutually crossed turns.
- 189+, for a coil with crossed turns.

SEE OR SEARCH CLASS:

- 174, Electricity: Conductors and Insulators, particularly subclass 34 for multiple conductor or cable structure wherein the conductors are transposed in relative position, usually for the purpose of reducing the effect of mutual inductance between the conductors.

188 TWO WINDINGS WITH MUTUALLY CROSSED WINDING TURNS:

This subclass is indented under the class definition. Inductor devices wherein the device comprises two windings whose respective turns are mutually crossed at a plurality of points.

SEE OR SEARCH THIS CLASS, SUB-CLASS:

- 75+, and 115+, for inductors with relatively movable coils whose respective conductors may cross at different positional adjustments of the coils.
- 173+, for interlinking coils. The coils do not have mutually crossed turns but the coils as a whole are interlinking. Subclass 174 indented under 173 has a linear conductor as one coil.
- 182+, for plural windings with plural coils.
- 189+, for coils wherein the coil conductor crosses at a plurality of points in successive convolutions of the coil conductor.

189 COIL WITH CROSSED TURNS:

This subclass is indented under the class definition. Inductor devices comprising inductor coils in which the conductor thereof is in crossed relationship with itself at a plurality of points in its length.

SEE OR SEARCH THIS CLASS, SUB-CLASS:

- 172, for inductors wherein the winding or coil has at least one turn of reduced length which links only a portion of the flux path and which turn may cross the remaining full turns of the winding or coil.
- 173, for inductors with interlinked coils.
- 187, for transposed parallel connected conductors.
- 188, for plural windings with mutually crossed turns.

SEE OR SEARCH CLASS:

- 310, Electrical Generator or Motor Structure, appropriate subclasses under 179+, which include coils and windings with crossed turns particularly subclasses 206 and 207 for lap and wave windings.
- 335, Electricity: Magnetically Operated Switches, Magnets, and Electromagnets, subclasses 291+ for magnets and electromagnets structure of the lifting, holding or tractive type which may include coils of the bank-wound or other cross-wound types. See subclass 210 for electronic and ionic

beam deflecting coils which are usually of the scramble-wound type.

190 Bank or universal wound coils (e.g., honeycomb, random wound):

This subclass is indented under subclass 189. Subject matter wherein the inductor comprises a coil of more than one layer of conductor (e.g., honeycomb and random or scramble wound coils).

SEE OR SEARCH THIS CLASS, SUBCLASS:

75, and 115+, for inductors with relatively movable coils and wherein the conductors of the coil conductors may mutually cross.

188, for inductors with plural windings having mutually crossed turns.

SEE OR SEARCH CLASS:

428, Stock Material or Miscellaneous Articles, subclass 593 for metallic stock material of honeycomb configuration.

191 Basket weave (single layer):

This subclass is indented under subclass 189. Subject matter wherein the inductor comprises a single layer coil of the basket weave type. This subclass includes basket weave coils where the layer is concentric to the coil axis and spider web coils where the layer lies in a surface normal to the coil axis.

SEE OR SEARCH THIS CLASS, SUBCLASS:

232, for disc type coils.

192 WINDING WITH TERMINALS, TAPS, OR COIL CONDUCTOR END ANCHORING MEANS:

This subclass is indented under the class definition. Inductor devices comprising inductors with means, such as terminal lugs, for effecting external electrical connection to the inductor coil conductor ends, or wherein means are provided to effect electrical connection intermediate the coil conductor ends (e.g., tap connections), and/or wherein means are provided to fasten or tie in the end turn or turns of the coil conductor to prevent loosening or unravelling thereof.

SEE OR SEARCH THIS CLASS, SUBCLASS:

15, for coil end holding means associated with coil winding or unwinding.

107, for terminal connectors of the quick detachable type (e.g., plug and socket type) when combined with an inductor device.

185, for coil supports and spacers for plural coil windings, particularly for coil end or connecting means between coils having such supports or spacers.

199+, for coil turn supports or spacers, particularly indented subclass 200 for coated conductive means used as a terminal or tap, indented subclass 205 for coil terminals, taps or end means embedded in plastic material, and indented subclass 206 for flexible filaments, strip or sheet insulation used to anchor coil terminal ends.

223, for inductor windings with coil conductor of particular shape.

SEE OR SEARCH CLASS:

24, Buckles, Buttons, Clasps, etc., subclasses 115+ for cord and rope holders particularly indented subclasses 122.3 and 122.6 for holders for sheathed strand and plural-strand cord or rope (which includes similarly constructed electrical conductors where no electrical features are claimed.)

29, Metal Working, appropriate subclasses for methods of manufacture and special apparatus for assembly and disassembly of metal articles and the like, generally particularly subclasses 874+ for methods of manufacture of contacts and terminals, subclasses 602.1+ methods of manufacture of electromagnets, transformers, and inductances, especially subclass 605 with winding and coiling which includes the anchoring of coil ends.

156, Adhesive Bonding and Miscellaneous Chemical Manufacture, subclasses 47+ for methods of making electrical conductors of indefinite length, noting subclass 49, indented thereunder, which is specific to splicing. See also appropriate subclasses

- in this class (156) for apparatus and methods involving winding and wrapping.
- 174, Electricity: Conductors and Insulators, appropriate subclasses for electrical conductor and insulator structure in general, particularly, subclasses 19+ for conduit or cable end structure with fluid or vacuum and subclasses 21+ for conduit or cable joint structure with fluid or vacuum, subclasses 68.1+ for conduit, cable and conductor structure in general, especially indented subclasses 71+ for branched structures, indented subclass 73 for joint and end structure and subclasses 84+ for joint structure.
- 191, Electricity: Transmission to Vehicles, particularly subclasses 12.2+ for flexible electrical conductors having an end secured to a reel structure and adapted to be wound thereon.
- 242, Winding, Tensioning, or Guiding, subclasses 379+ and 125+ for means to connect an end of an elongated material to a spool or core.
- 248, Supports, for supports of general application, particularly subclasses 49+ for pipe or cable supports, and subclasses 329+ for cord supported reels.
- 310, Electrical Generator or Motor Structure, particularly subclasses 40+ for rotary dynamoelectric machines, especially subclass 71 of such machines combined with connectors, terminals or lead-ins, subclass 234 for commutators having winding connectors, subclass 260 for stator structure with end turn supports and subclass 270 for rotor structure with end turn supports.
- 343, Communications: Radio Wave Antennas, subclass 867 for loop type antennas with plural taps or tapped coils.
- 439, Electrical Connectors, appropriate subclasses for electrical connectors, generally. Search especially subclasses 1+ for a pair of relatively movable electrical connectors; subclasses 445+ for an electrical connectors with a pivoted guard for the line cord; subclasses 449+ for an electrical connectors with a stress relieving means; and subclasses 877+ for a metallic connector or contact also having securing part adapted to be crimped, deformed or bent onto a conductor.
- 195 COIL SUPPORTED WITHIN GROOVED OR HOLLOW COIL CONDUCTOR OF ANOTHER COIL:**
This subclass is indented under the class definition. Inductor devices wherein one coil conductor supports another coil conductor in specifically provided channels, grooves, recesses, or hollow spaces within such supporting coil conductor.
- (1) Note. Where one coil merely supports another without especially designed spaces within the coil conductor for receiving the supported coil, such subject matter is not in this subclass, but will be found in subclass 185 where plural coil windings are involved or in subclass 208 of this class where one coil forms a preformed support for another.
- (2) Note. Where a supporting coil completely encloses the supported coil such subject matter is not in this subclass but will be found in subclass 82 of this class.
- SEE OR SEARCH THIS CLASS, SUBCLASS:**
- 62, for inductors with hollow conductors adapted for passage of cooling fluid there-through.
- 65+, for inductors with means to support them relative to their environment.
- 82, for inductors where coil forms casing. See (2) Note above.
- 92, for inductors with means to support them relative to an enclosing casing.
- 185, for inductor coil supports or spacers for plural coil windings. See also (1) Note, above.
- 199+, for inductor coil or coil turn supports.
- 220, for inductors with plural windings generally not elsewhere provided for.
- 223, for windings having a coil conductor of particular shape.

SEE OR SEARCH CLASS:

174, Electricity: Conductors and Insulators, particularly subclasses 28+ for co-axial or concentric conductors, subclasses 102+ for conductors with conductive armor or sheath, subclasses 113+ for electrical conductor structure, per se.

428, Stock Material or Miscellaneous Articles, subclasses 544+ for stock materials, e.g., of indefinite length which are all metal or have adjacent metal components.

196 WITH SUPPORTING AND/OR SPACING MEANS BETWEEN COIL AND CORE:

This subclass is indented under the class definition. Inductor devices comprising the combination of coil and core with means to hold the coil and core in fixed relative relation to each other or wherein electrical insulating material is interposed between the core and coil.

SEE OR SEARCH THIS CLASS, SUBCLASS:

20, 30+, 60, 77, 83, 100, 110, 117+, 130+, 155+, 175+, 178, 184, and 185 for combinations of coil and core which may include electrical insulating material between coil and core or which may have means to support or space the coil relative to the core. See also the comprehensive list of search notes appended to subclass 221 of this class as to other fields of search for the combination of coil and core which may include structure falling within the definition of this subclass.

SEE OR SEARCH CLASS:

310, Electrical Generator or Motor Structure, subclasses 179+ for windings and core structure for rotary dynamoelectric machines, particularly subclass 215 for core slot liners for insulating winding conductors from the core.

197 Coil clamps or wedges:

This subclass is indented under subclass 196. Subject matter wherein the means for holding the coil relative to the core includes a clamping or wedging means.

SEE OR SEARCH THIS CLASS, SUBCLASS:

210, for inductors having means to clamp, wedge, or otherwise fasten elements of the core, such as magnetic laminations, together.

SEE OR SEARCH CLASS:

248, Supports, subclass 499 for tie downs and subclasses 500+ for holddowns of general application.

310, Electrical Generator or Motor Structure, especially subclass 214 for coil retainers or slot closers for holding dynamoelectric machine windings fixed relative to their associated core means.

198 Preformed insulation between coil and core (e.g., spool):

This subclass is indented under subclass 196. Subject matter wherein there is a structure of predetermined shape (e.g., a spool) of electrically insulating material interposed between coil and core.

(1) Note. Ordinary stock material which is not preformed especially to adapt it to its separating and insulating function in the particular coil and core combination involved is not in this subclass but in subclass 196 above.

SEE OR SEARCH THIS CLASS, SUBCLASS:

60, for preformed spacing means to establish ventilating passages inside an inductor for cooling.

185, for preformed coil spacing and support means in plural coil windings.

199+, for coil or coil turn support spacers, particularly indented subclass 208 for coils on preformed supports or mounts.

209, for inductors with outer coil wrappers or binders.

219, for core insulation between laminations or core parts.

SEE OR SEARCH CLASS:

310, Electrical Generator or Motor Structure, particularly subclass 194 for dynamoelectric machine field or exci-

tation coil supports or spools, usually of preformed insulating material, and subclass 215 for core slot liners of preformed insulating material for insulating the core from the coil.

199 COIL OR COIL TURN SUPPORTS OR SPACERS:

This subclass is indented under the class definition. Inductor devices comprising supports or forms for coils, coil conductors or coil conductor turns, or means to space coil conductors, coil conductor turns, or spacers and supports for more than one coil (each said one coil constituting a separate independent winding) and which support or spacing means is not provided for in any of the preceding subclasses.

SEE OR SEARCH THIS CLASS, SUBCLASS:

- 60, for ventilated inductors with spacing means to provide passageways between coils or windings for cooling fluids.
- 65+, for coils and means to support them relative to their environment.
- 82, for coils which form a casing for the inductor.
- 92, for coil supports where the inductor is specifically supported within and relative to a casing.
- 107, for coil support features included in or in combination with terminals of the quick detachable type.
- 179, for coil supports including temperature compensation means (e.g., coils on temperature invariant coil forms).
- 185, for spacers between separate coils of a plural coil winding and supports for plural coil windings.
- 192, for such coil support features associated with coil and anchoring means, terminals or taps.
- 195, for coils supported in a grooved or hollow conductor.
- 196+, for coil turn supports or spacer means associated with support or spacing between coil and core.

SEE OR SEARCH CLASS:

- 29, Metal Working, particularly subclasses 602.1+ for processes of manufacture of inductor devices in general, and note especially the comprehensive

list of classes referred to under 'SEARCH CLASS' of this subclass as to other product, manufacturing or process classes which may include processes for making inductors having particular coil supports, coil spacers or coil conductor turn spacers, or the resulting product.

- 310, Electrical Generator or Motor Structure, particularly subclasses 179+ for windings and core structure for rotary dynamoelectric machines, especially indented subclass 194 for field winding supports and spools, and indented subclass 209 for armature coil structure, per se.
- 335, Electricity: Magnetically Operated Switches, Magnets, and Electromagnets, subclasses 291+ for the structure including coil, coil conductor supports or spacers, for electromagnets of the lifting, holding or tractive type.
- 343, Communications: Radio Wave Antennas, subclasses 866+ for loop type antennas with coil or coil turn supports or spacers.

200 Printed circuit-type coil:

This subclass is indented under subclass 199. Subject matter wherein the inductor coil structure comprises a conductive coating material on a base. For example, such as produced by a printing, painting, spraying, electro-deposition or similar coating method, or by the removal of adherent conducting material from an insulating base by etching, grinding, or the like.

SEE OR SEARCH CLASS:

- 29, Metal Working, especially subclasses 602.1+ for processes of manufacture of inductor devices in general. See the comprehensive list of classes referred to under 'SEARCH CLASS,' of subclasses 602.1+ of Class 29, as to other classes which may include processes for making printed circuit type electrical devices or the resulting products.
- 101, Printing, appropriate subclasses for apparatus and processes for producing characters or designs on surfaces by impression of type or dies or by applying coating material to a surface

- through openings in a pattern sheet (e.g., stenciling).
- 156, Adhesive Bonding and Miscellaneous Chemical Manufacture, subclasses 2+ for etching processes of producing surface effects, subclass 154 for abrading or grinding of a laminated product and subclass 155 for removal or destruction of transitory material by dissolving or melting, etc.
- 204, Chemistry: Electrical and Wave Energy, appropriate subclasses for apparatus and processes utilizing electrical energy or wave energy, either electromagnetic or mechanical, for forming particular shapes or coating surfaces, such as printed circuit type configurations.
- 361, Electricity: Electrical Systems and Devices, subclasses 748+ for structural combinations of diverse impedance elements such as inductors, capacitors or resistors not elsewhere classifiable and which may be of the printed circuit type.
- 439, Electrical Connectors, especially subclasses 55+ for an electrical connector combined with a preformed panel circuit arrangement (e.g., printed circuit board).
- 451, Abrading, subclasses 28+ for a process for producing a surface effect by abrading.
- 455, Telecommunications, subclasses 334+ for components restricted to use in radio apparatus and which may be of the printed circuit type.
- 205 Coil turns cemented to support or embedded in plastic:**
This subclass is indented under subclass 199. Subject matter wherein the conductor forming the coil is wholly or partially embedded in plastic supporting or adhesive electrically insulating material, which material holds or supports the adjacent coil conductor portions in spaced apart relation.
- SEE OR SEARCH THIS CLASS, SUBCLASS:
- 96, for potted-type inductors wherein the preformed inductor is embedded in plastic, electrically insulating material.
- 189+, for coil structures with crossed turns, including bank wound and basket weave coils, wherein the coil conductor turns may be held in position by plastic or adhesive material.
- SEE OR SEARCH CLASS:
- 29, Metal Working, especially subclasses 602.1+ for the process of manufacture of inductor devices, not elsewhere classifiable, and which may include the step of adhering coil conductor turns to a base member or the step of molding plastic material about coil conductor turns to hold them in fixed relation to each other.
- 156, Adhesive Bonding and Miscellaneous Chemical Manufacture, subclasses 52+ for covering of electrical conductors of indefinite length with preformed material. See other appropriate subclasses in this class for methods and apparatus for manufacture of laminated materials and analogous structures not provided for elsewhere.
- 174, Electricity: Conductors and Insulators, particularly subclass 96 for plural conduit-ducts or conductors or subclass 98 for conduit-duct or conductors that are embedded in material which may be plastic.
- 264, Plastic and Nonmetallic Article Shaping or Treating: Processes, appropriate subclasses, for processes within the class definition, for molding or shaping plastic materials. See particularly subclasses 272.11+ which pertain particularly to electrical component encapsulating.
- 338, Electrical Resistors, subclasses 226+ for electrical resistors embedded, incased or housed, and especially subclasses 262+ and 275 wherein the casing is formed as a coating on or molded on the resistance element.
- 425, Plastic Article or Earthenware Shaping or Treating: Apparatus, subclasses 110+ for a molding apparatus combined with means to feed or support a preform in a molding cavity for encapsulation thereof, see especially subclasses 123+ for such apparatus

including means to support plural pre-forms.

- 206 Flexible filament, strip or sheet insulation:**
This subclass is indented under subclass 199. Subject matter wherein flexible filament, strip, or sheet insulation holds, supports or maintains in spaced apart relation adjacent coil conductor portions, coil layers, or coils.

SEE OR SEARCH THIS CLASS, SUBCLASS:

- 185, for separate coils separated by insulation, which coils form part of a single winding.
191, for basket weave type coils wherein flexible filament or strip material is interwoven with the coil conductor.
205, for similar coil structures wherein the coil conductors or coils are cemented to or embedded in the flexible filament, strip or sheet insulation.
209, for coils wherein the flexible insulating material forms only the outer wrapper or binder for the coil.

SEE OR SEARCH CLASS:

- 29, Metal Working, particularly subclasses 602.1+ for processes of manufacture assembly or disassembly of inductor devices including the utilization of flexible insulating material in the manufacture thereof.
156, Adhesive Bonding and Miscellaneous Chemical Manufacture, appropriate subclasses for methods and apparatus for manufacture of laminated materials and analogous structures not provided for elsewhere, e.g., by winding.
174, Electricity: Conductors and Insulators, particularly subclasses 120+ and 124, for conductors covered with flexible sheet insulating material, and subclass 143 for condenser type bushings utilizing flexible sheet insulating material.
242, Winding, Tensioning, or Guiding, subclasses 430+ for a process or apparatus for forming an article by winding material (e.g., wire and tape) onto a core, subclasses 444.1+ for simultaneously winding electrically conductive and nonconductive strips on a

core to form an article, usually a capacitor, and subclasses 602+ for a spool having structure to maintain coil convolutions or layers in spaced apart relationship.

207 With coil turn spacer:

This subclass is indented under subclass 199. Subject matter wherein means are provided for maintaining coil turns or adjacent portions of the coil conductor in spaced apart relation. The means, by way of example, may be individual spacers or coil conductor holding grooves of a coil supporting form.

SEE OR SEARCH THIS CLASS, SUBCLASS:

- 60, for coil turn or coil spacing means which forms spacers for passage of ventilating or cooling fluids.
62, for spacers to separate or support the turns of hollow conductors (adapted for flow of cooling fluid through the conductor).
135, for coil turn spacing or coil spacing means or support means for plural coil windings.
136+, for coil spacing means or supports associated with parallel connected conductors.
138, for plural windings with mutually crossed turns including coil conductor spacing means.
139+, for coils with crossed turns which include coil conductor spacing means or wherein the crossed turns inherently act as spacers.
179, for coil turn spacing means associated with means for compensating for inductance changes caused by temperature changes.
195, for coils with grooved or hollow conductors for supporting and spacing a conductor of another coil.
196+, for the combination of coil and core having spacing or supporting means between coil and core.
200, for printed circuit type coils.
205, for coils wherein the coil turns are cemented to a support or are embedded in a plastic material.
206, for coils or coil conductor turns separated by flexible filament strip or sheet insulation.

208 Coil on a preformed support or mount:

This subclass is indented under subclass 199. Subject matter comprising coil supports having a definite shape and which are not provided for in any of the preceding subclasses.

SEE OR SEARCH THIS CLASS, SUBCLASS:

- 173+, for interlinked coils having preformed supporting means.
- 179, for coils having supports or forms adapted to remain invariant in dimensions or which compensate for changes in ambient temperature of the device.
- 185, for preformed supports for plural coil windings.
- 195, for coils with grooved or hollow conductors for supporting the conductor of another coil.
- 196+, particularly indented subclass 198 for preformed electrical insulation between a coil and associated core.

SEE OR SEARCH CLASS:

- 191, Electricity: Transmission to Vehicles, particularly subclasses 12.2+ for flexible electrical conductors and combined take up reels.
- 242, Winding, Tensioning, or Guiding, subclasses 600+ and 118+ for spool construction of general use.
- 310, Electrical Generator or Motor Structure, particularly subclass 194 for field coil supports and spools for rotary type dynamoelectric machines.

209 COIL WRAPPER ON BINDER:

This subclass is indented under the class definition. Inductor devices comprising coils or windings externally wrapped or bound with flexible insulating sheet or tape and not previously provided for in any of the subclasses above.

SEE OR SEARCH THIS CLASS, SUBCLASS:

- 90, for inductors with casings or housings.
- 185, for coil structures wherein flexible filament, strip, or sheet insulation is employed to hold, support, or separate

adjacent coil conductor portions, coil layers or coils.

- 192, for windings with terminals, taps or coil end anchoring means which may utilize flexible sheet or strip insulation.
- 206, for coils separated by insulation forming part of a single winding. See also the search notes appended to this subclass (206) as to further fields of search for subject matter similar to that provided for in subclass 209.

210 WITH CORE CLAMPS, WEDGES OR FASTENERS:

This subclass is indented under the class definition. Inductor devices comprising inductor core structure with means for fastening plural parts of the core or the core laminations into a single integral core.

- (1) Note. Cores wherein the core parts are held together by interfitting or interlocking portions of the core parts or by adhesive material, such as cement, are excluded from this subclass. For such subject matter search the subclasses below, particularly subclasses 212, 216+, 219, and 233+.

SEE OR SEARCH THIS CLASS, SUBCLASS:

- 20, for inductors with means to deform or distort the core to adjust its inductance.
- 65+, for inductors having means for supporting the inductor relative to its environment.
- 92, for inductor with casing or housing means with means to support the inductor with respect to such casing or housing.
- 96, for inductor with casing or housing means wherein the inductor is embedded in plastic material.
- 98, for inductors with casings and wherein the core is clamped between portions of the casing so that a portion of the core is exposed.
- 100, for inductors with means, in addition to the core part fastening means, for inhibiting or damping core vibrations.
- 132+, for adjustable inductor structures with relatively movable core parts and hav-

- ing means for holding the plural parts of the core with respect to each other.
- 176, for inductors having a core with a pivot or hinge between elements thereof.
- 196+, for supporting and spacing means between coil and core.
- 212, for inductors wherein the core is comprised of plural parts which have interlocking or interfitting portions.
- 214+, for multiple magnetic path cores.
- 216+, for inductors having cores with particular joint structure.
- 219, for inductors with core insulation (e.g., between laminations).
- 233, for core structure generally, especially indented subclass 234 for laminated core structure.

SEE OR SEARCH CLASS:

- 24, Buckles, Buttons, Clasps, etc., appropriate subclasses for various types of fastening means in general (e.g., clasps, bale and package ties, strap fasteners and the like).
- 248, Supports, appropriate subclasses for article supports in general, particularly subclass 361 for holddowns.
- 310, Electrical Generator or Motor Structure, particularly subclasses 216.113 through 216.065, for core structure for a rotary type dynamoelectric machine with means for securing core elements into an integral unit.
- 335, Electricity: Magnetically Operated Switches, Magnets, and Electromagnets, subclasses 291+ for lifting, holding or traction magnets which may include means for fastening core parts together.
- 403, Joints and Connections, appropriate subclasses for joints of general utility.

211 CONCENTRIC OR NESTED CORE ELEMENTS:

This subclass is indented under the class definition. Inductor devices comprising inductor core structure formed of concentric, nested, or telescoped core elements of magnetic material.

SEE OR SEARCH THIS CLASS, SUBCLASS:

- 83, for inductors where the core forms the casing of the device.

- 84+, for inductors having magnetic shielding means which may be of the concentric type.
- 177, for inductors having coils with coil conductors of magnetic material.
- 213, for wound cores.
- 233+, for general core structure not elsewhere provided for, particularly subclass 234 indented thereunder for laminated cores.

SEE OR SEARCH CLASS:

- 310, Electrical Generator or Motor Structure, subclasses 10+ for dynamoelectric machine structure, particularly indented subclasses 14, 23+, 30, and 34+, for nonrotary type machines having concentric element core structures wherein one of the elements is a plunger armature, and subclasses 40+, appropriate subclasses, for rotary type machines with concentric type relatively rotatable core elements.
- 335, Electricity: Magnetically Operated Switches, Magnets, and Electromagnets, subclasses 256+ for concentric core structure for plunger type armatures and subclasses 291+ for lifting, holding or tractive type magnets with diverse core elements wherein one of the elements is a plunger armature.

212 PLURAL PART CORE:

This subclass is indented under the class definition. Inductor devices comprising a core of preformed parts, each part of which may be a single integral structure of magnetic material or wherein each part may be built up of separate sheets or wires of magnetic material (e.g., and assemblage of preformed laminated magnetic leg or yoke members).

SEE OR SEARCH THIS CLASS, SUBCLASS:

- 10, 20, 40+, 60, 61, 77, 83, 84+, 98, 100, 110, 117+, 130+, 155+, 172, 175+, 177, 178, 184, 196+, 210, and 211, for combinations of coil and core wherein the core may be of the plural part type. See particularly subclass 176, above, for plural part cores which are hinged for relative angular movement to permit insertion of a coil or coil conductor, and see also, subclass 210

above for plural part cores combined with means such as a clamp or wedging means, to hold the core parts together.

- 233, for core structure in general and note especially the search notes listed thereunder as to other fields of search for core structure including plural part core structure.

SEE OR SEARCH CLASS:

- 310, Electrical Generator or Motor Structure, particularly subclasses 216.001 through 216.014, for dynamoelectric machine core structure, including plural part cores; subclass 254.1, for stator structure; and subclass 261.1, for rotor structure.
- 335, Electricity: Magnetically Operated Switches, Magnets, and Electromagnets, subclasses 296+ for various core structures wherein one section may be an operator for an electric circuit breaker.

213 WOUND CORE:

This subclass is indented under the class definition. Inductor devices comprising inductor core structure formed of a continuous, wound strip or filament of magnetic material.

SEE OR SEARCH THIS CLASS, SUBCLASS:

- 177, for inductors wherein the coil conductor is of magnetic material.
- 211, for inductor cores formed of separate concentric or nested core elements.

SEE OR SEARCH CLASS:

- 29, Metal Working, particularly subclass 605 for inductor assembly including winding or coiling of core material and subclass 609 for laminating core material, including winding and coiling, in general.
- 72, Metal Deforming, subclasses 66, 135+ and 146+ for a method of or a means for bending metal into helical or spiral coil form.
- 140, Wireworking, appropriate subclasses for methods and apparatus for winding and for shaping wire of magnetic material to form cores.

- 148, Metal Treatment, appropriate subclasses, particularly subclasses 100+ for working, including winding and coiling, and heat treatment of magnetic core materials.

- 156, Adhesive Bonding and Miscellaneous Chemical Manufacture, appropriate subclasses for processes and apparatus for making laminated products not provided for elsewhere, e.g., by assembling, winding, wrapping, folding, etc., of filaments, sheets or webs.

- 242, Winding, Tensioning, or Guiding, subclasses 430+ for a process or apparatus for forming an article by winding material onto a core.

- 428, Stock Material or Miscellaneous Articles, appropriate subclasses, for a stock material product in the form of a single or plural layer web or sheet not elsewhere provided for, and especially subclasses 364+ for a structurally defined or coated rod, strand, fiber or filament, which may be of a magnetic material.

214 MULTIPLE MAGNETIC PATHS:

This subclass is indented under the class definition. Inductor devices comprising inductor core structure with more than one independent and distinct closed loop of magnetic material, the loops forming closed magnetic circuits adapted to thread through and about the coil means of the inductor.

SEE OR SEARCH THIS CLASS, SUBCLASS:

- 5+, for similar structures limited by claimed subject matter to polyphase inductor structure.
- 83, for inductors wherein the coil means is totally enclosed within the core means, except for openings for the coil leads.
- 155+, particularly 160+, for inductors of the saturable or high leakage reactance type having cores with multiple magnetic paths.
- 184, for inductors with plural coil windings wherein the coils may be on different core legs.

- 211, for inductors with concentric or nested core elements which may form separate magnetic loops.
- 212, for inductors having plural part cores, e.g., separate preformed leg and yoke members forming separate magnetic loops.
- 213, for inductors having a core comprising separate loops each formed of wound magnetic material.

SEE OR SEARCH CLASS:

- 310, Electrical Generator or Motor Structure, particularly subclasses 216.001 through 216.014, for dynamoelectric machine core structure, including a core with plural magnetic paths; subclass 254.1, for stator structure, and subclass 261.1, for rotor structure.
- 335, Electricity: Magnetically Operated Switches, Magnets, and Electromagnets, subclasses 289+ for lifting, holding and tractive electromagnets in general which may have plural separate magnetic paths.

215 Three or more:

This subclass is indented under subclass 214. Subject matter wherein the number of independent and distinct closed loops of magnetic material is three or more.

SEE OR SEARCH THIS CLASS, SUBCLASS:

- 5+, for similar structures limited by claimed subject matter to polyphase inductor structure which may have three or more separate magnetic paths relative to a particular coil.

216 CORE JOINT STRUCTURE:

This subclass is indented under the class definition. Inductor device comprising the particular core structure at the point of juncture of magnetic elements or parts of the core. The elements or parts are usually the leg and yoke members of the core.

SEE OR SEARCH THIS CLASS, SUBCLASS:

- 132+, for inductors having plural joined core parts with means to permit relative movement therebetween for adjusting the inductance of the device.

- 165, and 178, for inductor cores having a high reluctance gap in the magnetic circuit, which gap may be bridged by nonmagnetic material to effect a joint between the two opposed parts of the core.
- 173, for inductors having a core with a joint comprising hinged parts to permit clamping of the core about a conductor or coil means.
- 210, for inductor core joint structure with means, in addition to the core elements themselves, to clamp, wedge or otherwise hold the core elements together.
- 212, for inductor cores comprising an assemblage of preformed core parts (such as leg sections and yoke sections) which include significant joint structure between the parts.
- 213, for inductor cores having joints between core elements of coiled or wound magnetic material.
- 214+, for inductor cores with core elements providing multiple magnetic paths and having significant joint structure between the elements.

SEE OR SEARCH CLASS:

- 29, Metal Working, subclasses 602.1+ for processes of manufacture assembly of inductor devices, especially indented subclass 606 for assembly of coil and core, and subclasses 607+ for core assembly. Apparatus for assembling an electrical inductor device may be found in subclasses 729+, and a device for securing parts together by a hollow rivet, when not elsewhere classifiable, may be found in subclass 243.52.
- 228, Metal Fusion Bonding, subclasses 101+ for a process of metallurgically bonding an electrical connection and especially subclasses 179+ for a process of a metallurgically bonding plural joints of electrical devices. See the search notes in Class 228 for other classes and subclasses providing for making electrical joint structure.
- 310, Electrical Generator or Motor Structure, particularly subclasses 216.001 through 216.014, for dynamoelectric machine core structure, including core

- joint structure; subclass 254.1, for stator structure, and subclass 261.1, for rotor structure.
- 403, Joints and Connections, appropriate subclasses for joints of general utility.
- 217 Overlapping laminations (e.g., 'break joint'):**
This subclass is indented under subclass 216. Subject matter wherein the elements or parts comprising the core joint consists of groups of plates or laminations of magnetic material, which are interleaved at the core joint.
- SEE OR SEARCH THIS CLASS, SUBCLASS:
- 210, for inductor cores, usually of the laminated type, with clamps, wedges or fasteners to hold the laminations together at the core joint.
- 211, for inductor cores comprising concentric or nested core elements with joint structure between elements.
- 213, for inductor cores comprising wound magnetic material with joint structure between core elements.
- 214+, for inductor cores with core elements, usually of the laminated type, providing multiple magnetic paths, the laminations of different core elements being interleaved to form joints.
- SEE OR SEARCH CLASS:
- 29, Metal Working, particularly subclass 609 for the process of manufacture assembly or disassembly of inductor cores of the laminated type including the interleaving of core laminations to form core joints.
- 310, Electrical Generator or Motor Structure, particularly subclasses 216.001 through 216.014, for dynamoelectric machine core structure, including core joint structure; especially subclasses 2161.004-216.014, for laminated core; subclass 254.1, for stator structure, and subclass 261.1, for rotor structure.
- 218 MAGNETIC ORIENTATION (I.E., DIRECTIONALLY PRESTRESSED CORE MATERIAL):**
This subclass is indented under the class definition. Inductor devices wherein the core is built up of elements of directionally prestressed material so arranged as to exhibit desired directional magnetic and/or electric properties. Usually the desired directional property is produced by taking advantage of the anisotropy of the crystal structure of the magnetic material by rolling and then heating to orient the grain structure, the permeability of the resultant product being a maximum in the direction of rolling.
- SEE OR SEARCH THIS CLASS, SUBCLASS:
- 20, for inductors wherein a change in inductance is effected by physically distorting the core.
- SEE OR SEARCH CLASS:
- 29, Metal Working, especially subclasses 607+ for the process of manufacture, assembly or disassembly of inductor cores in general, and indented subclass 609 for laminated cores in particular, which cores may include grain oriented magnet material.
- 148, Metal Treatment, subclasses 100+ for processes of altering the internal structure of metalliferous materials to influence their magnetic properties, particularly subclass 104 relating to the production of dust cores, and subclasses 300+ for magnetic stock resulting from such processes.
- 428, Stock Material or Miscellaneous Articles, subclasses 554+ for stock material or intermediate articles which are all metal or have adjacent metal components, particularly subclasses 615+ for metallic composites defined in terms of the composition of their components, and subclass 928 for metallic stock having magnetic properties.
- 219 CORE INSULATION (E.G., BETWEEN CORE PARTS):**
This subclass is indented under the class definition. Inductor devices comprising a core built up of elements of magnetic material separated

from each other by elements of electrically insulating material. Laminated cores with electrical insulation between the magnetic laminations of the core are in this subclass.

- (1) Note. For other classes providing for processes of forming laminations, laminating, or to the resulting products, see classes listed under 'SEARCH CLASS', of subclass 234 of this class.

SEE OR SEARCH THIS CLASS, SUBCLASS:

- 60, for core structure having insulating spacers between core parts to provide ventilating passages for the core.
- 61, for core structure having heat exchanging surfaces between core parts and insulated therefrom.
- 100, for inductors wherein the core parts may be separated by resilient insulating material to damp out electro-mechanical vibrations produced by the inductor.
- 134+, for inductors with an adjustable air gap between relatively movable core parts.
- 165, for inductors of the high leakage reactance type wherein the core has a shunt path with an air gap.
- 177, for inductors with a coil formed of an electrically insulated conductor of magnetic material.
- 178, for inductors with a closed type core having an air gap.
- 198, for inductors with preformed electrical insulation between coil and core.
- 211, for inductors with a core comprising concentric or nested magnetic elements with electrical insulation between elements.
- 212, for inductors with plural part cores (e.g., an assemblage of preformed leg and yoke portions) with electrical insulation between core parts.
- 213, for inductors with a core formed of a continuous, wound strip of magnetic material with electrical insulation between turns.
- 216+, for inductors having core joint structure wherein electrical insulation may be disposed between the core parts of the joint.

- 234, for the structure of laminated cores in general.

SEE OR SEARCH CLASS:

- 29, Metal Working, subclasses 602.1+ for processes of manufacture, assembly or disassembly of electromagnets, transformers and inductances, particularly indented subclass 609 for laminated core manufacture.

220 TWO WINDINGS:

This subclass is indented under the class definition. Inductor devices comprising an inductor having two windings, each winding constituting a coil adapted to be connected to an external circuit and not provided for in any of the preceding subclasses.

- (1) Note. Plural coils adapted to be connected in series and/or parallel are not considered to constitute plural windings for classification in this subclass, but are considered a single winding formed of plural coils and are classifiable, in particular in subclasses 145+, especially indented subclass 147, for such combinations with coil length or connection changing means, and subclasses 180+ for such combinations where no inductance adjusting means is claimed.

SEE OR SEARCH THIS CLASS, SUBCLASS:

- 5+, for inductors having polyphase windings.
- 73+, 115+, for inductors having two or more relatively movable coils, each coil acting as a separate winding.
- 130+, for inductors having relatively movable core and coil means, wherein the coil means may be two or more windings. In particular, indented subclass 131 provides for plural coils (or windings) with plural cores.
- 137+, for inductors with means to change coil length or connections and wherein two or more coils constituting separate windings may be included (see (1) Note, above).
- 155+, for saturable core or high leakage reactance type inductors, especially subclasses 160+ for transformers with

- primary and secondary windings with a magnetic shunt therebetween.
- 170+, for inductors with three or more windings.
- 173+, for inductors with at least two coils or windings which are physically interlinked.
- 180+, for inductors with at least one winding formed of plural coils, particularly subclasses 182+, for plural windings at least one of which is formed of plural coils. See also the reference to subclasses 180+ in (1) Note above.
- 188, for inductors having plural windings with mutually crossed turns.
- 195, for inductors wherein a coil or winding is supported within the grooved or hollow conductor of another coil or winding.
- 199+, for inductors having particular coil turn or coil or winding supports or spacers.
- SEE OR SEARCH CLASS:**
- 178, Telegraphy, subclass 43 for systems utilizing plural windings for transmitting and receiving telegraph signals through appreciable space by means of an inductive field, subclass 49 for transformers or reactors utilized for superposed current signaling and subclass 64 for coil transformers employed in telegraph systems.
- 191, Electricity: Transmission to Vehicles, subclass 10 for inductively coupled means comprising a winding mounted on one body and another winding mounted on another body, the bodies being relatively movable, electric power being transmitted from one winding to the other wholly through the induction field.
- 219, Electric Heating, subclasses 50+, especially subclass 116, for metal heating systems utilizing plural winding transformers.
- 246, Railway Switches and Signals, subclasses 8 and 29 for railway signaling systems utilizing transmitting and receiving windings mutually coupled through appreciable space by means of the induction field.
- 307, Electrical Transmission or Interconnection Systems, appropriate subclasses for miscellaneous electrical systems using plural winding inductors, note particularly subclasses 7, 17, and 83 for systems utilizing transformers.
- 310, Electrical Generator or Motor Structure, subclasses 10+ for dynamoelectric machine structure, especially subclasses 179+ for winding and core structure, indented subclasses 184+ being directed to plural field windings and indented subclasses 198+ to plural armature or primary windings.
- 313, Electric Lamp and Discharge Devices, particularly subclass 62, and 153+, 413, 421+, 442 for coil structures which may involve plural windings, combined with electric lamps and space discharge devices.
- 315, Electric Lamp and Discharge Devices: Systems, appropriate subclasses for lamp and space discharge device systems utilizing inductors which may have plural windings, particularly subclasses 4+, 27, 39, 40, 41+, 50, 54, 70, 141+, 177, 206, 212+, 219+, 239, 254+, 262, 266, 274, 276+, 354, 368.28, and 382.
- 318, Electricity: Motive Power Systems, appropriate subclasses for electric motors and control systems therefor including plural windings inductors.
- 322, Electricity: Single Generator Systems, appropriate subclasses for single electrical generators and control systems therefor including plural winding inductors.
- 323, Electricity: Power Supply or Regulation Systems, subclasses 206, 214, 215+, 232, 247+, 301+, and 328+ for systems employing transformers or other plural winding inductors.
- 324, Electricity: Measuring and Testing, subclass 55 for transformer testing systems, subclass 59 for inductance measuring systems and subclass 127 for measuring systems with coupling transformers.
- 333, Wave Transmission Lines and Networks, particularly subclasses 100+ and 24+ for electric wave coupling systems including plural winding

- inductors, note especially subclasses 177+ for transformer coupled wave filters.
- 334, Tuners, appropriate subclasses for tuners which may employ inductors with plural windings.
- 335, Electricity: Magnetically Operated Switches, Magnets, and Electromagnets, subclasses 289+ for structure of electromagnets of the holding, lifting or tractive type.
- 340, Communications: Electrical, especially subclasses 870.31+ for plural winding inductors employed in telemetering systems.
- 343, Communications: Radio Wave Antennas, subclass 855 for plural loop type antennas with a coupling network; and subclass 867 for plural loop type antennas including plural or tapped coils.
- 361, Electricity: Electrical Systems and Devices, subclasses 35+ for transformer protection circuits, subclasses 139+ for electric circuits for relays or electromagnets which may be of the plural winding type.
- 363, Electric Power Conversion Systems, appropriate subclasses for current, frequency, or phase conversion systems utilizing plural winding inductors, particularly subclasses 5, 64, 152+, and 170+ for systems with transformers.
- 379, Telephonic Communications, particularly subclass 443 for induction coils combined with telephones, subclass 55.1 for separate windings inductively coupled through appreciable space to transmit and receive telephone signals, and appropriate subclasses for induction coils restricted to use in telephone systems.
- 221 COIL AND CORE:**
This subclass is indented under the class definition. Inductor devices comprising the combination of coil and core in general and which is not provided for in any of the preceding subclasses.
- SEE OR SEARCH THIS CLASS, SUBCLASS:
- 20, for the combination of coil and core where the coil and/or core are distortable to effect an inductance change.
- 30+, for an inductor comprising coil and core means wherein the inductance thereof is changed by physically displacing parts of the inductor relative to each other in response to some condition.
- 60, for inductor structure with ventilating passages therethrough (e.g., by coil section or core part spacers).
- 61, for inductor structure with heat exchanging surfaces associated with the coil and/or core thereof.
- 77, for relatively movable coil and closed coil or conductor member wherein a portion of the closed coil or conductor member is formed of magnetic material.
- 83, for inductor structure wherein the core forms a casing for the coil (e.g., iron clad coil).
- 98, for incased inductor structure with exposed core portions.
- 100, for inductor structures with means to prevent vibration or shattering of core parts caused by varying currents in the coil conductor.
- 110, for inductor structure including a permanent magnet.
- 117+, for inductor structure involving relatively movable coils and associated core.
- 130+, for inductor structures comprising relatively movable coil and core.
- 155+, for inductive regulator structure of the saturable core or high leakage reactance type.
- 172, for coil and core wherein at least one coil turn is shorter than the other turns and links only part of the core cross section.
- 175+, for inductor structure comprising a linear conductor surrounded by a core.
- 177, for inductor structure having a coil conductor of magnetic material.
- 178, for coil with a substantially closed core having an air gap.

- 184, for winding formed of plural coils disposed on different core legs.
- 196+, for inductor structure with supporting and spacing means between coil and core.
- 210, for coil with core having core clamps, wedges of fasteners.
- 211, for coil with concentric core elements.
- 212, for coil with plural part core.
- 213, for coil with wound core.
- 214+, for coil with core having multiple magnetic paths.
- 216+, for coil with core having novel joint structure.
- 218, for coil with core of directionally prestressed material (i.e., grain oriented).
- 219, for coil with core having insulation between core parts.
- SEE OR SEARCH CLASS:**
- 29, Metal Working, subclasses 602.1+ for the process of manufacture, assembly and disassembly of electromagnets and inductors in general particularly subclass 606 for assembling coil and core. See, also, the comprehensive search notes appended to subclasses 602.1+ of Class 29 as to other classes providing for inductors and inductor manufacture.
- 178, Telegraphy, subclass 46 for the coil and core combinations designed to electrically load electrically long telegraph lines and subclass 64 for telegraph systems utilizing coil transformers.
- 219, Electric Heating, subclasses 50+, especially indented subclass 116, for metal heating systems utilizing transformers; subclasses 600+ for inductive heating, note subclasses 672+ for a specific heating inductor configuration; subclasses 678+ for microwave heating; and subclasses 764+ for capacitive dielectric heating, note subclass 780 for a specific heating electrode configuration.
- 307, Electrical Transmission or Interconnection Systems, appropriate subclasses, for miscellaneous electrical systems utilizing transformers or other inductor devices.
- 310, Electrical Generator or Motor Structure, subclasses 10+ for dynamoelectric machine structure, especially subclasses 179+ for windings and core structure.
- 313, Electric Lamp and Discharge Devices, particularly subclass 62, and 153+, 413, 421+, 442 for coil and core structures combined with electric lamps or space discharge devices.
- 314, Electric Lamp and Discharge Devices: Consumable Electrodes, particularly subclass 20 for consumable electrode devices with electromagnetic discharge influencing means.
- 315, Electric Lamp and Discharge Devices: Systems, particularly subclasses 4+, 27, 39, 40, 41, and 382 for inductor means associated with lamps and space discharge device in structural and system relationship.
- 318, Electricity: Motive Power Systems, appropriate subclasses for inductor structure utilized in controlling electric motors.
- 322, Electricity: Single Generator Systems, particularly subclasses 75+ and 95+ for impedance systems including inductors, for controlling single electrical generators.
- 323, Electricity: Power Supply or Regulation Systems, subclasses 206, 214, 215, 247+, 301, 305+, and 328+ for power supply or regulation systems utilizing inductors classifiable in class 336.
- 324, Electricity: Measuring and Testing, particularly 200+, 253+ subclasses for electromagnetic and magnetic testing systems, subclass 55 for transformer testing, subclasses 57+ (especially indented subclass 59) for measuring inductive reactance, and subclasses 76.51, 87, 117, 126+, and 144+ for electrical measuring or testing systems or devices utilizing inductor means.
- 332, Modulators, particularly subclasses 132, 133, 141+, 172, 173, and 175 for modulators employing inductor means.

- 333, Wave Transmission Lines and Networks, particularly subclasses 24+ for coupling networks for transmitting electric wave energy, especially indented subclasses 148 and 186+ for coupling systems utilizing electro-mechanical transducers, and indented subclasses 177+ for transformer coupled filters (indented subclasses 177+ providing for such transformers with magnetic core).
- 334, Tuners, appropriate subclasses for coil and core structure used in tuner circuits.
- 335, Electricity: Magnetically Operated Switches, Magnets, and Electromagnets, subclasses 1+ for combined diverse switches, and subclasses 291+ for structure of lifting, holding or tractive magnets.
- 340, Communications: Electrical, subclasses 870.31+ for inductor type telemetering transmitters, and subclasses 384.1+ for electromagnetically operated audible signal generators.
- 343, Communications: Radio Wave Antennas, particularly subclass 431 and 441 for the structure of goniometers used in direction finding receivers, subclass 748 for loop type antennas with variable reactance for tuning; and subclass 788 for loop type antennas including magnetic material.
- 360, Dynamic Magnetic Information Storage or Retrieval, subclasses 110+, for inductive heads used in magnetic recording or reproducing.
- 361, Electricity: Electrical Systems and Devices, subclasses 1+ for electromagnetic devices with protective means, especially indented subclasses 38+ for structurally combined transformers and protective devices; subclasses 117+ for high voltage dissipators, especially indented subclass 118 for surge preventing choke coils and indented subclasses 133+ for such dissipators with magnetic means (e.g., electromagnet); subclasses 139+ for electric circuits for relays and electromagnets; subclasses 268+ for subject matter of Class 336 combined with integral switch, capacitor or lock means; and subclasses 331+ for plural
- different components such as inductors and capacitors, or inductors and resistors structurally related with each other and not classified elsewhere.
- 363, Electric Power Conversion Systems, particularly subclasses 5, 26, 75, 82, 90, 140, 152+, and 170+ for inductors employed in current, phase, or frequency conversion systems.
- 365, Static Information Storage and Retrieval, appropriate subclass for electromagnetic storage systems, subclasses 185.01+ for floating gate memory storage (e.g., flash memory).
- 367, Communications, Electrical: Acoustic Wave Systems and Devices, subclass 168 for magnetostrictive acoustic wave transducers.
- 373, Industrial Electric Heating Furnaces, subclasses 138+ for induction furnaces wherein the furnace charge may be of magnetic material.
- 379, Telephonic Communications, subclasses 414+ for loaded telephone lines, subclass 443 for telephones combined with induction coils, and appropriate subclasses for induction coils adapted for use in telephone systems.
- 381, Electrical Audio Signal Processing Systems and Devices, subclasses 150+ for audio transducers.
- 222 WINDINGS:**
This subclass is indented under the class definition. Inductor devices comprising an inductor winding structure not provided for in any of the preceding subclasses. For example, windings having coil conductors made of a particular composition, other than magnetic material, are in this subclass.
- SEE OR SEARCH THIS CLASS, SUBCLASS:**
- 5+, for polyphase winding structures.
- 15, for the structure of coils whose conductors may be wound or unwound to change the coil inductance.
- 20, for the structure of coils adapted to be distorted to change the coil inductance.
- 69+, for coil structure having means to modify its capacitance with respect to a given potential plane.

- 73+, for inductors with closed coil or conductor member.
- 107, for coil structure combined with quick detachable coil terminal connector means.
- 115+, for relatively movable coils.
- 130+, for relatively movable coil and core.
- 137+, for coil structures with means to change the effective coil length or connections.
- 155+, for high leakage reactance type inductors.
- 170+, for inductors with three or more windings.
- 172, for coils having one or more full turns and including at least one short turn linking a part of the total coil flux.
- 173, for interlinked coils.
- 175, for an inductor comprising a straight conductor surrounded by a core.
- 177, for inductors wherein the coil conductor is of magnetic material.
- 179, for coils with means to compensate for changes in inductance with temperature.
- 180+, for windings formed of plural coils.
- 186+, for coil formed of parallel connected conductors.
- 188, for plural windings with mutually crossed winding turns.
- 189+, for coils with crossed turns.
- 192, for windings with terminals, taps or coil conductor and anchoring means.
- 196+, for coil and core and supporting and spacing means therebetween.
- 199+, for coil or coil turn supports or spacers.
- 209, for coils with specific wrapper or binder.
- 220, for plural windings in general.
- 221, for the combination of coil and core in general.
- 225+, for coils of special configuration.
- SEE OR SEARCH CLASS:
- 29, Metal Working, subclasses 602.1+ for processes of manufacture of electromagnets, transformers and inductances, particularly subclass 605 for winding or coiling. See the comprehensive list under 'SEARCH CLASS,' subclasses 602.1+ of Class 29, as to other classes providing for coils and coil making.
- 178, Telegraphy, subclass 46 for the structure of inductors specifically designed to be inserted at predetermined points along an electric wave transmitting line (i.e., for loading the line to change its impedance characteristics).
- 219, Electric Heating, particularly subclasses 663+ for the structure of inductational heating coils.
- 310, Electrical Generator or Motor Structure, subclasses 10+ for the structure of dynamoelectric machines in general, especially subclasses 179+ for windings or coil structure.
- 313, Electric Lamp and Discharge Devices, subclass 62 for cyclotron structures having particular coil means for influencing the path of charged particles within the device, subclasses 413, 421+, and 442 for magnetic field producing coils combined with cathode-ray tube structure, and subclasses 153+ for lamp or space discharge mean in general having an inductor coil means structurally associated therewith.
- 315, Electric Lamp and Discharge Devices: Systems, subclasses 4+ for systems including cathode-ray tubes combined with inductor or resonator means, subclass 27 for cathode-ray tube systems wherein coils are used to deflect the cathode ray, subclass 40 for space discharge devices having an inductive electrode, and subclass 41 for such devices with an inductor connected between electrodes.
- 323, Electricity: Power Supply or Regulation Systems, appropriate subclasses for systems utilizing transformers or inductors in general particularly subclasses 215, 247+, 301+, 305+, and 328+ for transformer systems and 206, 214, 249+, and 329+ for systems involving inductive reactors.
- 324, Electricity: Measuring and Testing, appropriate subclasses for coils used in electrical measuring and testing systems, especially subclasses 256+ for coils used in magnetic testing, and subclass 55 for testing transformers, and subclass 59 for determining inductive reactance of coils.

- 333, Wave Transmission Lines and Networks, appropriate subclasses for wave transmission lines and networks utilizing inductor coils as elements thereof.
- 334, Tuners, appropriate subclass for a coil utilized as an element of a tuned circuit.
- 335, Electricity: Magnetically Operated Switches, Magnets, and Electromagnets, subclasses 299+ for structure of coils for electromagnetic devices.
- 338, Electrical Resistors, especially subclasses 267+ for electrical resistors having structure analogous to inductors.
- 343, Communications: Radio Wave Antennas, subclasses 726, 728, 748, 764, 788, 842, and 866+ for the structure of inductors designed for the radiation or reception of radio waves.
- 373, Industrial Electric Heating Furnaces, subclasses 152+ and 160 for electric furnaces including the structure of windings for inductively heating a furnace charge.
- 381, Electrical Audio Signal Processing Systems and Devices, subclasses 150+ for an electro-acoustic transducer involving magnetism.
- 600, Surgery, subclasses 9+ for coil structures designed to subject the human or lower animal body to a magnetic field for therapeutic purposes.
- 223 Having conductor of particular shape (e.g., tapered longitudinally or of noncircular cross section):**
This subclass is indented under subclass 222. Subject matter wherein the coil is formed of a conductor having cross-sectional dimensions of different values along the length of the conductor and/or wherein the cross-sectional configuration of the conductor is other than circular.
- SEE OR SEARCH THIS CLASS, SUBCLASS:
- 61, for coils formed of conductors having heat exchanging surfaces incorporated therein.
- 62, for coils formed of conductors which are hollow to permit the flow of cooling fluid therethrough.
- 82, for coil structure which forms the casing for the inductor device.
- 195, for coils formed of grooved or hollow conductors and wherein another coil conductor is supported within the grooved or hollow portion.
- SEE OR SEARCH CLASS:
- 174, Electricity: Conductors and Insulators, appropriate subclasses for the structure of electric cables and conductors, per se, particularly subclass 114 for insulated multi-conductor cables with split conductors, subclass 115 wherein the conductors are of different size, shape, insulation or other characteristic, subclass 117 for conductor assemblies of noncircular section, subclasses 126.1+ for conductor structure, per se, especially subclass 133 for conductor strands of noncircular cross section.
- 219, Electric Heating, subclasses 600+ for inductive heating, subclasses 678+ for microwave heating, and subclasses 764+ for capacitive dielectric heating.
- 315, Electric Lamp and Discharge Devices: Systems, subclasses 4+ for cathode-ray tubes having structurally combined inductive impedance or resonator means of particular shape, and subclass 40 for space discharge devices having electrodes of particular shape formed as an inductive impedance.
- 332, Modulators, particularly subclass 133 for frequency modulators utilizing inductive or resonator elements of particular shape (e.g., Klystron).
- 333, Wave Transmission Lines and Networks, appropriate subclasses for wave transmission elements having inductive elements of particular shape, particularly subclass 13 for resonator type breakdown discharge systems, subclass 34 for impedance matching coupling networks utilizing tapered conductors, and subclasses 219+ for resonators of the distributed parameter type.

224 Nonuniformly spaced turns:

This subclass is indented under subclass 222. Subject matter wherein the distance between adjacent turns of the coil conductor changes along the coil winding.

SEE OR SEARCH THIS CLASS, SUBCLASS:

- 20, for coils wherein the distance between adjacent turns is adjusted by distorting the coil.
- 70, for coils wherein the spacing between end turns of the coil may be different than that of the body of the coil (in combination with other structure) for the purpose of modifying the surge potential gradient of the coil.
- 172, for a coil wherein at least one turn is shorter in length than the rest of the turns.
- 185, for a winding of plural coils which coils may be unequally spaced by support or spacer structure.
- 199+, for coil or coil turn supports or spacers in general, particularly indented subclass 207 for coils with coil turn spacers.

SEE OR SEARCH CLASS:

- 333, Wave Transmission Lines and Networks, particularly subclass 34 for impedance matching networks having a transmission line element which may be coiled with unequal spacing between successive turns.

225 COILS OF SPECIAL CONFIGURATION:

This subclass is indented under the class definition. Inductor devices wherein the coils forming the winding or the coil, per se, has a distinctive external contour or shape.

SEE OR SEARCH THIS CLASS, SUBCLASS:

- 20, for coil structures which are adapted to be deformed to change the inductance thereof.
- 60, for coils having ventilating passages therethrough.
- 61, for coils having their external surface modified by additional heat exchanging surfaces.

- 82, for inductors having a coil forming the external casing of the inductor.
- 127, for relatively movable spherically shaped coils.
- 128, for relatively movable coils one of which is tubular.
- 195, for grooved or hollow coil conductors for supporting another coil conductor therein.
- 199+, for coil turn supports, particularly subclass 208 for preformed coil supports or mounts.

SEE OR SEARCH CLASS:

- 219, Electric Heating, subclasses 600+ for inductive heating, note subclasses 672+ for a specific heating inductor configuration and subclasses 635+ for a heater adapted to heat articles of specific shape; subclasses 678+ for microwave heating; and subclasses 764+ for capacitive dielectric heating.
- 310, Electrical Generator or Motor Structure, especially subclasses 179+ for dynamoelectric machine windings of particular shape.
- 313, Electric Lamp and Discharge Devices, subclass 413, especially subclass 433, for electromagnetic coils of particular shape for deflecting and electron beam, subclass 442 for beam, and subclasses 153+ for windings of distinctive shape structurally associated with a space discharge device.
- 315, Electric Lamp and Discharge Devices: Systems, subclasses 4+ for inductor structure of particular shape combined structurally with a cathode ray tube, and subclass 40 for a space discharge device having an electrode formed of an inductive impedance of distinctive shape.
- 333, Wave Transmission Lines and Networks, particularly subclasses 13, 21, 22, 26, 33+, 109+, 117+, 125+, 156+, 202+, 219+, and 245+ for wave transmission networks having resonant line sections of distinctive shape.
- 334, Tuners, subclass 75 for a variable inductor tuner in which the inductor is wound in a particular shape.

- 335, Electricity: Magnetically Operated Switches, Magnets, and Electromagnets, subclasses 291+ for lifting, holding or tractive electromagnetic structure and specifically subclass 213 for electronic and ionic beam deflecting coil structure.
- 343, Communications: Radio Wave Antennas, subclasses 866+ for loop type antennas which may have a special shape.
- 428, Stock Material or Miscellaneous Articles, subclasses 544+ for stock materials, e.g., of indefinite length, which are all metal or have adjacent metal components, particularly subclasses 557+ for an intermediate metallic article, and 592 for stock which is helical or has a helical component.
- 600, Surgery, subclasses 13+ for magnet coils of specific configuration adapted to therapeutic uses.
- D13, Equipment for Production, Distribution, or Transformation of Energy, subclass 117 for design patents relating to coil shapes.
- 226 Figure '8' section:**
This subclass is indented under subclass 225. Subject matter wherein the coil conductor has a 'figure 8' shape in a plane transverse to the coil axis.
- 227 Polyhedral section:**
This subclass is indented under subclass 225. Subject matter wherein the coil conductor has a polygonal shape in a plane transverse to the coil axis.
- 228 'D' section:**
This subclass is indented under subclass 225. Subject matter wherein the coil conductor has a 'D' shape in a plane transverse to the coil axis.
- 229 Toroidal:**
This subclass is indented under subclass 225. Subject matter wherein the coil axis describes a closed curve (e.g., a circle).
- 230 Spherical:**
This subclass is indented under subclass 225. Subject matter wherein the coil has an external surface similar to that generated by a circle rotated about a diameter.
- SEE OR SEARCH THIS CLASS, SUB-CLASS:
127, for relatively movable spherical coils.
- 231 Conical:**
This subclass is indented under subclass 225. Subject matter wherein the coil has an external surface similar to that generated by a right triangle rotated about a side.
- SEE OR SEARCH CLASS:
333, Wave Transmission Lines and Networks, subclass 34 for impedance matching networks utilizing tapered or conically shaped inductive elements.
- 232 Planar type:**
This subclass is indented under subclass 225. Subject matter wherein the coil turns lie substantially in a plane.
- SEE OR SEARCH THIS CLASS, SUB-CLASS:
191, for basket weave coils of the spider web type.
- SEE OR SEARCH CLASS:
242, Winding, Tensioning, or Guiding, subclasses 430+ for a process or apparatus for forming an article by winding material onto a core.
- 233 CORE (E.G., COMPRESSED POWDER):**
This subclass is indented under the class definition. Inductor devices comprising the structure of the magnetic body of the inductor device.
- SEE OR SEARCH THIS CLASS, SUB-CLASS:
20, for deformable or distortable core structure.
31, for counterbalanced core adjustable in response to a condition.
77, for relatively movable coil and closed coil or conductor member having a magnetic portion.
83, for core structure entirely enclosing the inductor winding.
84, for structure for magnetically shielding the inductor device.
98, for encased inductors leaving a portion of the core exposed.

- 100, for core structures having means to inhibit or damp core vibrations caused by fluctuations in magnetic flux therein.
- 110, for core structures which comprise or include a permanent magnet.
- 117+, for inductors with relatively movable coils having a core portion.
- 130+, for relatively movable coil and core.
- 155+, for inductors of the high leakage reactance type having saturable cores or cores with magnetic shunts.
- 172, for core structures provided with a portion linked by a partial or shorter length coil turn.
- 175+, for inductor comprising a core surrounding a linear conductor.
- 177, for inductor with coil conductor formed of magnetic material.
- 178, for closed type core with an air gap.
- 184, for conductor coils disposed on different core legs.
- 196, for inductor structures having supporting and/or spacing means between coil and core.
- 210, for cores with clamps, wedges or fasteners.
- 211, for concentric or nested core elements.
- 212, for plural part cores.
- 213, for wound cores.
- 214+, for cores with multiple magnetic paths.
- 216+, for cores with specific joint structure.
- 218, for cores whose magnetic properties are determined at least in part, by oriented magnetic particles or grain structure of the core material.
- 219, for cores having electrical insulation between core parts (e.g., between laminations).
- 221, for the combination of coil and core in general.
- SEE OR SEARCH CLASS:**
- 29, Metal Working, subclasses 602.1+ for processes of manufacture, assembly and disassembly of electromagnets, transformers and inductances. See particularly subclass 606 for the process of assembling coil and core, and subclasses 607+ for the process of manufacture of permanent magnets and cores. Note under subclasses 602.1+ under 'SEARCH CLASS', as to other fields of search and the line between Class 29 and other classes.
- 33, Geometrical Instruments, subclasses 355+, for magnetic compasses.
- 106, Compositions: Coating or Plastic, appropriate subclasses for mixtures of powdered materials such as magnetic particles, plus a binder material.
- 148, Metal Treatment, subclasses 100+ for processes of altering the internal structure of metalliferous materials to influence their magnetic properties, particularly subclass 104 relating to the production of dust cores. Subclasses 300+ for magnetic stock material made by a subclasses 100+ process or claimed in terms of significant magnetic properties.
- 204, Chemistry: Electrical and Wave Energy, subclasses 194+ for electrolytic apparatus, in general.
- 205, Electrolysis: Processes, Compositions Used Therein, and Methods of Preparing the Compositions, appropriate subclasses for electrolytic processes, in general.
- 252, Compositions, subclasses 62.51+ for the composition of magnetic materials not classified elsewhere. See the search notes to this subclass as to the line between Class 252 and Classes 29, 75, 106, 148, 260, and 317.
- 310, Electrical Generator or Motor Structure, particularly subclasses 216.001 through 216.014, for dynamoelectric machine core structure; subclass 261.1, for stator structure; and subclass 261.1, for rotor structure.
- 324, Electricity: Measuring and Testing, subclasses 244+ for apparatus or methods for determining the characteristics of magnetic fields or the magnetic properties of materials.
- 335, Electricity: Magnetically Operated Switches, Magnets, and Electromagnets, subclasses 285+ for structure of holding, lifting magnets and electromagnets. Note particularly subclasses 302+ for permanent magnets in general.

- 361, Electricity: Electrical Systems and Devices, subclass 267 for process or apparatus for demagnetizing magnetized bodies.
- 381, Electrical Audio Signal Processing Systems and Devices, subclass 177 for structure of a magnet in an acoustic microphone; subclasses 396+ for the structure of a magnet in an acoustic reproducer, such as an earphone or loudspeaker.
- 419, Power Metallurgy Processes, appropriate subclasses for processes of producing articles, which may be magnetic bodies, form particulate materials including sintering.
- 420, Alloys or Metallic Compositions, appropriate subclasses for alloys which are broadly as 'magnetic,' 'magnetized' or 'permanent magnet' or alloys defined only in terms of their composition which are inherently magnetic. See the definition to Class 148 subclasses 300+ for the line between magnetic alloys classifiable in Class 420 and magnetic stock proper for Class 148.
- 428, Stock Material or Miscellaneous Articles, subclasses 544+ for stock materials, e.g., of indefinite length, which are all metal or have adjacent metal components, particularly subclasses 546+ for such stock distinguished by a magnetic feature.
- 520, Synthetic Resins or Natural Rubbers, particularly Classes 523 and 524 for a composition containing a resin or natural rubber and a nonmagnetic metal or alloy.
- 234 Laminated type (includes bundles of rods or wires):**
This subclass is indented under subclass 233. Inductor devices having a core or magnetic body comprising superimposed bundles or layers of magnetic material in the form of sheets, rods, or wires. Single sheets, punchings, rods or wires which have such configuration that they are of no utility except in building up a core for use in an inductor device falling within the class definition are classified in this subclass.
- SEE OR SEARCH THIS CLASS, SUB-CLASS:
60, for laminated core structures having spaces between groups of laminations to provide ventilating passages for cooling the core and/or coil structure.
61, for laminated core structures having heat exchanging surfaces interleaved between laminations for the purpose of conducting heat energy away from the core.
84, for core structure including electric or magnetic shields between laminations.
177, for inductors having a coil conductor of magnetic material.
210, for laminated core structures wherein clamps, wedges or other fasteners are utilized to hold the laminations together.
211, for cores consisting of concentric or nested elements.
212, for plural part core (e.g., an assemblage of preformed leg and yoke portions).
213, for inductor cores comprising a continuous strip of magnetic material wound to form a core.
217, for inductor cores of the laminated type wherein the core joints comprise alternately overlapping laminations.
218, for laminated inductor core structures wherein the material of the core laminations has been treated to orient its crystalline grain structure to modify its magnetic characteristics.
219, for inductor core structures with electrical insulation between core parts, particularly between core laminations.
- SEE OR SEARCH CLASS:
29, Metal Working, subclasses 602.1+, particularly subclass 605, for inductor assembly including winding or coiling of core material, and subclass 609 for the assembly of laminated cores in general. See the comprehensive search notes listed under 'SEARCH CLASS,' of subclasses 602.1+ of Class 29, relative to other product, manufacturing or process classes for electromagnets and transformers.

- 72, Metal Deforming, subclasses 66, 135+ and 146+, for a method of or an apparatus for bending metal into a helical or spiral coil form.
- 83, Cutting, appropriate subclasses for processes and apparatus for cutting or punching blanks for forming laminated cores, particularly subclass 32 which provides for cutting interdigitating produces, and subclass 40 which provides for plural steps of blanking and cutting.
- 140, Wireworking, appropriate subclasses, for methods and apparatus for winding and for shaping wire of magnetic material to form cores.
- 156, Adhesive Bonding and Miscellaneous Chemical Manufacture, appropriate subclasses for processes and apparatus for making laminated products, e.g., by assembling winding, wrapping, folding, etc., of filaments, sheets or webs.
- 205, Electrolysis: Processes, Compositions Used Therein, and Methods of Preparing the Compositions, especially subclasses 76+ for the product and process for making sheets, webs, wires or filaments electrolytically, and subclasses 138+ and 152 for electrolytically coating sheets, webs, wires and filaments constituting an electrically conducting base.
- 242, Winding, Tensioning, or Guiding, subclasses 430+ for a process or apparatus for forming an article by winding material onto a core.
- 310, Electrical Generator or Motor Structure, subclasses 10+, appropriate indented subclasses, for the structure of laminated cores for dynamo electric machines.
- 428, Stock Material or Miscellaneous Articles, appropriate subclasses, for a metallic or nonmetallic stock material product in the form of a single or plural layer web or sheet not elsewhere provided for, and especially subclasses 364+ for a structurally defined or coated rod, strand, fiber or filament, which may be of a magnetic material, and subclass 621 for metallic composite stock comprising plural adjacent metal layers and an additional nonmetal layer; subclasses 577+ for metal blanks of definite shape; subclasses 548+ for metal particle containing composite material (i.e., plural metallic layers); and subclasses 615+ for composite metal materials in general.

END