

## CLASS 410, FREIGHT ACCOMMODATION ON FREIGHT CARRIER

### SECTION I - CLASS DEFINITION

A. This is the generic class for the accommodation of discrete units of freight which have been loaded on board a freight carrier for transportation, the freight accommodation being to assure the integrity of the load unit against the hazards of dynamic forces incident to transit

The class comprehends:

Means, entitled "accommodating means" in direct contact with a load unit to inhibit untoward shifting relative to the carrier that would be hazardous to the integrity of the unit. The term "accommodating means" is the generic term therefor.

Load unit accommodation on a freight carrier is recognized by the provision of:

1. An accommodating means detail in the construction of the load-supporting section of a freight carrier;
2. Means, per se, installable or otherwise put to use on a freight carrier (like dunnage which is merely inserted between load units);
3. Particular means on an exterior surface of the load unit (usually, of the load bearer type) itself; particularly provided, that is, to contact and thereby to cooperate with a corresponding construction of the freight carrier to achieve the accommodation of the load unit thereon;
4. An arrangement of an article of freight or the grouping of articles in such a way or to assure the integrity of the load against untoward shifting on board the freight carrier. Accommodating means may, but need not necessarily be required nor used to effect the arrangement; or
5. Freight accommodating methods, namely (a) associating a load unit present on the freight carrier with the appropriate accommodating means or (b) arranging (e.g., grouping) a load unit on the freight carrier.

- (1) Note. Cautionary note: A step of loading onto or of unloading a load unit from a freight carrier places the combination beyond the limits of this class; for which greater combination see the material or article handling class.

B. Present the critical element of load unit accommodation as herein defined, placement in the class is on a predominant disclosure basis. An invention will be found herein when the subject matter of the invention, regardless of breadth is disclosed as:

1. A support or receptacle which has a use as a freight carrier vehicle body part, e.g., an on-and-off container or other load bearer provided with the accommodating means referred to above.

2. Article securing or bracing structure which in use is attached to, installed on, or even merely placed on board a freight carrier for freight accommodation (e.g., dunnage).

3. Structure concerning which the advance in the state of the art has caused to be recognized as uniquely suitable to freight accommodation on a freight carrier. The emphasis in the disclosure of load unit accommodation on freight carrier for this class should be on a level equivalent to a principal embodiment description. However, as to the state of the art test, a presumption of load unit accommodation on a freight carrier not negated in the disclosure will serve for inclusion of the document in this class (410). In fact, except where clearly negated by the detailed description, this class is available as a depository for such state of the art structure as dunnage structures for load bracing and twist lock devices for load bearer retention even when not pinpointed in the description for use on a freight carrier.

4. A load bearer which is a shipping support on which a single article is secured for on-and-off stowage aboard a freight carrier. This subject matter is provided for in this class, even when the shipping support load bearer does not include the accommodating means cooperating with the freight carrier. This is so because the state of the art recognition of the equivalency in the art of the shipping support load bearer, whether or not provided with such cooperating means, has become so integrated at the time of the inception of this class (410) that the search for both has been quite merged.

- (1) Note. Cautionary note: A shipping support lacking the accommodating means and supporting a group of articles on a freight car-

rier has not been classified in this class (410) but will be found elsewhere. A freight container absent the accommodating structure cooperating between the container and the freight carrier will also be found elsewhere. See References to Other Classes.

A term which is defined in this class (410) definition, and is limited to a single word, is identified by an asterisk. Where a group of words defines the term, parentheses are used to identify the beginning and end of the term; and this is followed by an asterisk.

## SECTION II - LINES WITH OTHER CLASSES AND WITHIN THIS CLASS

### INTERNAL PLAN OF THIS CLASS

A. Class 410 consists of three major groupings, as follows:

1. Particular Article Accommodation, (see Subclass References to the Current Class, for the location of the definition of this term) - subclass 2+
2. Load Bearer Accommodation, (see Subclass References to the Current Class, for the location of the definition of this term) - 52+
3. Subcombinational Subject Matter, namely (a) Load Lashing - 96+; and (b) Load Bracing, i.e., Yieldable Brace - 117+, and Load Bracing - 121 (generally). (see Subclass References to the Current Class, for the location of the definition of these terms)

The accommodation to the shape of the particular article in this first group being of essence and the disclosure being almost inevitably to such a detail, inventions limited to the subcombination will nevertheless be uniformly classified in that superior locus (subclasses 2+) and will be found as a cross-reference only in the subcombinational loci, subclasses 96+ or, in particular, subclasses 117+ and 121+.

B. Search Time And Storage Economization: Search Units.

1. Economy in search time and retrieval efficiency and in search area storage space has been incorporated in the internal plan of this class. This was done by the abstraction from the more generalized art of some particular

subclasses certain subjects matter meriting low priority as the depository of the original (as opposed to the cross-reference copy) of a document in the classification schedule. As a result, subclasses of such low priority subject matter recur as indents under classified loci of higher priority (typically as subcombinations in different superior and separately classified combinations). Recurring sets of extractions or "break outs" have thus been developed out of separate but mutually related indented subclasses. They are usually quite small. A one "break out" readily matches a second (sometimes also a third) freed from the disclosures in principal subclasses entirely extraneous to the particular search needs for which "search units" have been devised.

2. Search Units: Where these "break out" pairs (or triplets) most closely coincide in extensiveness and analogousness further economy is achieved by emphatic discouragement of cross-referencing internally of one another but rather, are singled out and can be identified as constituting search units. They are easily recognized and identifiable in the Class 410 schedule.

3. The vehicle classes: The vehicle classes involved in the haulage of freight, absent the freight accommodation feature(s) as defined in section I, above, are:

### RELATIONSHIP TO THE VEHICLE CLASSES

The vehicle classes involved in the haulage of freight, absent the freight accommodation features as defined in the Class Definition, above, are found in References to Other Classes below.

Excluded from this class (410) are (a) haulage of material in bulk, whether fluid, aggregate, particulate or in any bulk form. However, a rigid-wall receptacle which contains fluent or other bulk material qualifies as a load unit (of the load bearer type) for this class (410); and (b) very short distance movement of articles on a vehicle propelled by a walking attendant handler (e.g., from a building to a moving van); for which see References to Other Classes, below.

Securement means for articles on a pleasure vehicle for the pleasure or convenience of the occupant(s), particularly, are provided for elsewhere.

### RELATIONSHIP TO THE RECEPTACLE AND SUPPORT CLASSES:

The receptacle and support classes include disclosures for the provision of securement or bracing of an object or of a group of objects intended for shipment together

as a unit, but excluded from the instant class (410) because of absence of accommodating means cooperating with a freight carrier. The receptacle classes of this description may be found in References to Other Classes below.

The support classes are found in Reference to Other Classes, below.

The receptacle and support classes are in particular related to subclass(es) 52+ of the instant class (410) in that a receptacle or support is recognized as a load bearer when conforming to the limitations set forth in the Class Definition; i.e., having means cooperating with a freight carrier to effect the accommodation thereof on the freight carrier. Placement in the instant

Class 410 is in no way barred because of further inclusion of details of receptacle or support structures. This class is the appropriate locus too, for a receptacle or support disclosed as being, in fact (a) a freight carrier body part, and (b) provided with accommodating means for a stowed load unit, e.g., the particular article under subclasses 2+.

#### RELATIONSHIP TO ARTICLE HANDLING CLASSES

See References to Other Classes for the generic article handling class, which provides for the means and method of loading and unloading freight on-and-off a freight carrier.

See References to Other classes for article handling classes that provide for means for tautening flexible material about a load of objects--absent the attachment of the load to the freight carrier--and that provide for container lift loading and unloading devices of the spreader frame type. (This type lift device includes latch elements akin to the retainers of of the instant class (410), particularly akin to the twist lock type found in Class 410).

#### RELATIONSHIP TO ATTACHMENT DEVICE SUB-COMBINATIONS, ELEMENTS:

See References to Other Classes, below, for attachment devices used to secure objects to one another only, to make up a load unit found on a freight carrier, but which devices do not couple the load unit to the freight carrier.

Class 188 Brakes, subclass 32 is the generic locus for a wheel chock, recognized as a brake on the ground whereas the instant Class 410 is the locus for such a

device used on board a freight carrier to stabilize freight; compare with instant Class 410, subclass 30 for a wheel chock for a stowed vehicle; and subclasses 49+ for a chock for stowed cylindrical article, generally. Compare, too, with instant subclass 62 for fore-and-aft accommodation of a stowed vehicle where the aft-end accommodating means may be a wheel chock. (Attachment Device Class)

#### RELATIONSHIP TO STOCK MATERIAL CLASSES

The locus for members of indeterminate shape, as for load bracing, e.g., dunnaging, is found elsewhere. When in fact of such a shape so as to be beyond the scope of that class, a bracing member will be found in the instant class (410) in subclasses 117+ when of flexible (i.e., flexible wall) material; subclass 121 being the principal subclass for load bracing; and subclasses 154 and 155 for, respectively, edge around and honeycomb dunnage. Subclass References to the Current Class of this class (410) is particularly relevant as a guide to the location of dunnage in the instant Class 410. (Stock Material Class)

#### SECTION III - SUBCLASS REFERENCES TO THE CURRENT CLASS

##### SEE OR SEARCH THIS CLASS, SUBCLASS:

- 2, for definition of the term Particular Article.
- 52, for definition of the term Load Bearer.
- 68, for a load unit of the load bearer type.
- 71, for definition of Corner Pedestal.
- 77, for definition of Retainer.
- 77, (1) Note, for definition of Retainer, Rigid Or Hold-down Type.
- 82+, for twist lock type retainers.
- 96, for Load Lashing.
- 97, for definition of Wraparound Lashing
- 101+, for anchor part which directly engages the end of a flaccid material member to secure that end at an anchor location whereby to define the point from which the member diverges from the freight carrier surface.
- 106, for the anchor-array one-piece member shaped or arranged to require no tie piece.
- 107, see Tie Piece in the Glossary below.
- 117, for definition of Yieldable Brace (i.e., flaccid or deformable).
- 121, for definition of Brace and Load Bracing.
- 154, 155, for dunnage, species thereof.

**SECTION IV - REFERENCES TO OTHER CLASSES**

SEE OR SEARCH CLASS:

- 24, Buckles, Buttons, Clasps, etc., include attachment devices used to secure objects to one another only, to make up a load unit found on a freight carrier, but which devices do not couple the load unit to the freight carrier. The class includes, for example, fasteners for coupling containers to one another; for which see subclass 287 for container-to-container locking devices including those of the twist lock type which operate like those of the instant class (410). (Attachment Device Class)
- 105, Railway Rolling Stock, 239+ for dumping car bodies; and subclasses 358+ for tank cars; subclasses 355+ for freight car bodies; and subclasses 404+ for freight car frames and other structure. (Vehicle class involved in haulage of freight)
- 108, Horizontally Supported Planar Surfaces, see, particularly, subclasses 51.11+ for pallets; (Support Class)
- 114, Ships, subclasses 72+ for freighters; subclasses 73+ for bulk cargo freighters. (Vehicle class involved in haulage of freight)
- 180, Motor Vehicles, (Vehicle class involved in haulage of freight)
- 188, Brakes, subclass 32 is the generic locus for a wheel chock, recognized as a brake on the ground whereas the instant Class 410 is the locus for such a device used on board a freight carrier to stabilize freight. See Lines With Other Classes, for a further discussion of the line (Attachment Device Class)
- 206, Special Receptacle or Package, for shipping support lacking the accommodating means and supporting a group of articles on a freight carrier.
- 206, Special Receptacle or Package, appropriate subclass, frequently according to the specifically provided for article; (Receptacle Class)
- 211, Supports: Racks, (support class)
- 220, Receptacles, see particularly subclasses 1.5+ for freight container, including invention in locking on-and-off containers to one another. (Receptacle Class)
- 224, Package and Article Carriers, subclasses 400+ for securement means for articles on a pleasure vehicle for the pleasure or convenience of the occupant(s). (Vehicle class involved in haulage of freight)
- 244, Aeronautics and Astronautics, subclasses 118.1+ for cargo planes; (Vehicle class involved in haulage of freight)
- 248, Supports, (support class)
- 254, Implements or Apparatus for Applying Pushing or Pulling Force, subclasses 199+ provide for means for tautening flexible material about a load of objects---absent the attachment of the load to the freight carrier. The more comprehensive combination (including freight accommodation on the freight carrier) is proper for the instant class (410), for which see subclasses 34+, when the load consists of a tautened group of particular articles; and subclasses 96+ for load lashing of indiscriminate articles of freight. (Article Handling Class)
- 280, Land Vehicles, for example, subclasses 423.1+ for semitrailers (Vehicle class involved in haulage of freight)
- 280, Land Vehicles, for very short distance movement of articles on a vehicle propelled by a walking attendant handler (e.g., from a building to a moving van); subclasses 47.131+ (for a two-wheel or other type unstable vehicle), and subclasses 47.17+, and 47.34+. (Vehicle class)
- 294, Handling: Hand and Hoist-Line Implements, subclass 81 provides for container lift loading and unloading devices of the spreader frame type. This type lift device includes latch elements akin to the retainers of of the instant class (410), particularly akin to the twist lock type found in lass 410). (Article Handling Class)
- 296, Land Vehicles: Bodies and Tops, (Vehicle class involved in haulage of freight)
- 298, Land Vehicles: Dumping, (Vehicle class)
- 414, Material or Article Handling, is the generic article handling class. The class provides for the means and method of loading and unloading freight on-and-off a freight carrier. The relevant loci in that class (the article handling vehicle search areas) include subclasses 333, 334+, 337, 338, 339, 340+, 349+, 352+, 354+, and 373+ for various combinations of one or more moving or stationary freight carrier(s) and an external means of some nature for loading or unloading, or cooperating in the loading or unloading thereof. (Article Handling Class)
- 428, Stock Material or Miscellaneous Articles, is the locus for members of indeterminate shape, as for load bracing, e.g., dunnaging. (Stock Material Class)

## SECTION V - GLOSSARY

Also see Subclass References To The Current Class, above, for the location of the definition of other Glossary terms.

### CUSHIONING MEANS:

Fore-and-aft slide cushioning means - Load unit protection means supplementing load accommodation. The effect of inadvertently inertial forces which could cause damage to the load unit is mitigated by means so supplementing accommodation as to permit such an extent of reactive movement of the load unit or the accommodating means, or both as to be adequate to prevent damage that could occur were the load rigidly fixed to the freight carrier. When the forces guarded against and the reactive movement acts in the direction along the longitudinal axis of the freight carrier, this is recognized as fore-and-aft direction slide cushioning. The effect of only mere compression-relaxation of a resilient block is not intended to be included in the cushioning concept.

### LOAD LASHING RETAINER

Retainer which includes flaccid material accommodating means, the virtue of the flaccidity being in its infinite deflective capacity so that the means can (inter alia) (a) closely conform to exterior configurations of load units, (b) extend in guided changes in direction from the locus of securement to the freight carrier to that of the retentive engagement with the load unit, and (c) most particularly, under subjection to force multiplying means, be so tightly engaged with the load unit, and over such critical configurations of the load unit surface that the engagement of this nature constitutes load unit retention. A load lashing retainer may consist of a combination of rigid material and flaccid material elements provided that the flaccid material element (or member) is significant in the combination. Significance is present when the flaccid material element member is used (a) to attach the load lashing retainer to the freight carrier or retentively to connect with the load unit, or (b) to extend between the freight carrier attachment member and load unit securement member (one or both of which members are rigid) to impart to the load lashing retainer made up of these members unique advantages of flaccidity described in the preceding paragraph. Not all flaccid load unit accommodating relationships are, in fact, retentive. Tight encirclement of the load (i.e., wrap-around lashing) tautened engagement with the load under the effect of force multiplying means, and a

tiedown (defined hereinbelow) do, however, invariably accomplish load lashing retention.

### TIE PIECE

The anchor part which directly engages the end of a flaccid material member to secure that end at an anchor location whereby to define the point from which the member diverges from the freight carrier surface. The term is used in the context of bi-partite construction in that the tie piece is an add-on (e.g., welded on) part, the other part of the anchor being the mounting for freight carrier attachment. Commonly, the mounting is a one-piece member shaped or otherwise so constructed or arranged on a freight carrier as to define an array of anchor locations, at one or more of which the add-on tie piece is attached. See Subclass References To The Current Class, above.

### TIEDOWN

A load lashing retainer which diverges from the freight carrier surface whereat it is attached and extends and terminates at the point or localized area of attachment to the load units.

## SUBCLASSES

### 1 INCLUDING TURNTABLE FOR LOAD, E.G., FOR SEMITRAILER:

This subclass is indented under the class definition. Structure in which the freight carrier has a supporting surface which is rotatable to turn lading which it underlies (typically, a semitrailer or other wheeled vehicle for transshipment) between positions (a) for loading and unloading, and (b) for transit aboard the freight carrier.

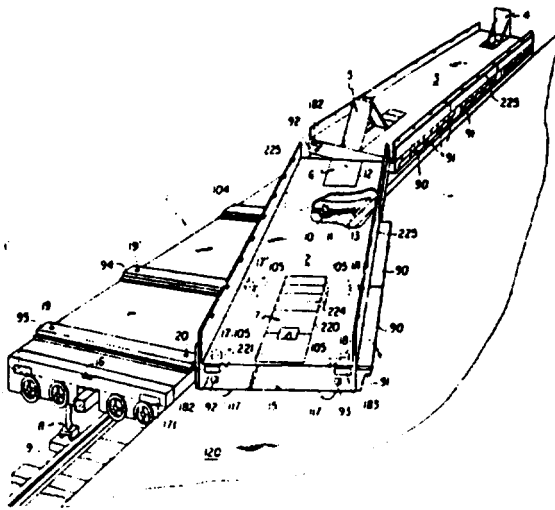

## 2 PARTICULAR ARTICLE ACCOMMODATION:

This subclass is indented under the class definition. Structure for accommodating, by direct contact, an article of the type which satisfies a particular need elsewhere (i.e., is not merely a bearer for the load in shipment, like a container or pallet), which structure is designed, in its contact with the lading, to take advantage of a particular configuration of the lading, or one of its parts, to minimize a carrying problem arising from such particular configuration, e.g., tendency of a cylindrical article to roll.

- (1) Note. Included herein (see indented subclasses 31+) is the accommodation of articles by their having been grouped in a particular way or by having been otherwise so arranged on the freight carrier that a foreseeable problem in transit is minimized.
- (2) Note. The class definition section, Internal Plan of This Class relating to this and the indented subclasses is reviewed, as follows: placement in this and indented subclasses is on a predominant disclosure basis, which means that, in the absence of a controlling claim barring such placement or an overwhelming emphasis in the total disclosure to that same effect, this is the locus (subclasses 2+) for the original placement of an invention to accommodating means for the particular article. Accordingly: a. A

generic invention to structure disclosed as accommodating a semitrailer or container (ordinarily classified under subclasses 52+) and equally applicable to the accommodation of a particular article (a farm tractor in transit, for example) will be classified as an original in subclasses 2+ and will appear in subclass(es) 52+ only as a cross-reference where necessary. b. Subclasses 2+ will take an invention to a load lashing means or load bracing means subcombination for a particular article or group of articles and only a cross-reference will be placed in subclasses 96+, load lashing, or subclasses 121+, load bracing means; the locus for the lashing or bracing subcombinations, respectively, of general freight.

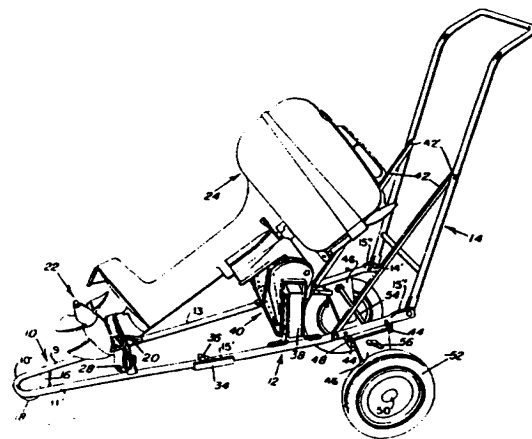

SEE OR SEARCH THIS CLASS, SUBCLASS:

- 35, for a group of articles stowed on board a freight carrier together with an on-and-off base.
- 46, for a shipping support onto which a single article only has been secured for on-and-off storage on board a freight carrier.

## 3 Wheeled vehicle:

This subclass is indented under subclass 2. Structure in which the freight carrier is particularly designed or equipped to accommodate that class of article which, in its normal use, moves along a land surface by means of its

underlying supporting structure which rolls along that surface.

- (1) Note. This (the principal) subclass includes inventions for bicycle stowage.
- (2) Note. Semitrailers are presumed to be load bearers, not, in themselves, particular articles of freight.

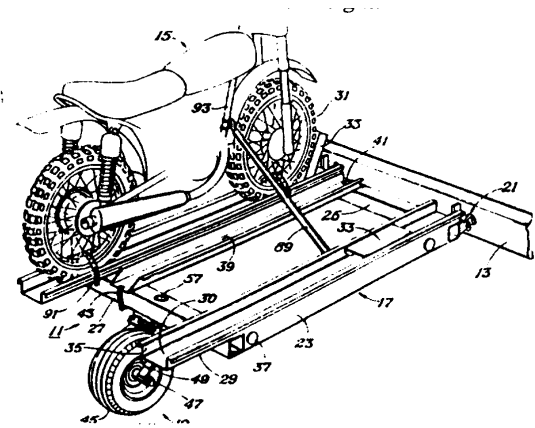

SEE OR SEARCH THIS CLASS, SUBCLASS:  
56+, for the stowage of freight-laden semitrailers.

- 4 **Four-wheeled vehicle accommodation:**  
This subclass is indented under subclass 3. Structure in which the freight carrier is particularly designed or equipped to accommodate such a wheeled vehicle as has sets of running gear from corner-to-corner across the forward and the rear ends.

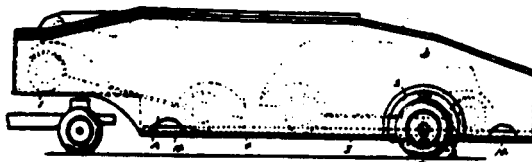

SEE OR SEARCH CLASS:  
206, Special Receptacle or Package, subclass 335 for a four-wheel vehicle or group of vehicles preassembled in an on-and-off container for shipment on a freight carrier, absent means for interengagement with the freight car-

rier for accommodation against the hazards of transportation.

- 5 This subclass is indented under subclass 4. Overturned or on-edge vehicle arrangement: Structure for retaining the stowed vehicle upon the carrier at an attitude substantially 905 or 1805 from the road condition attitude.

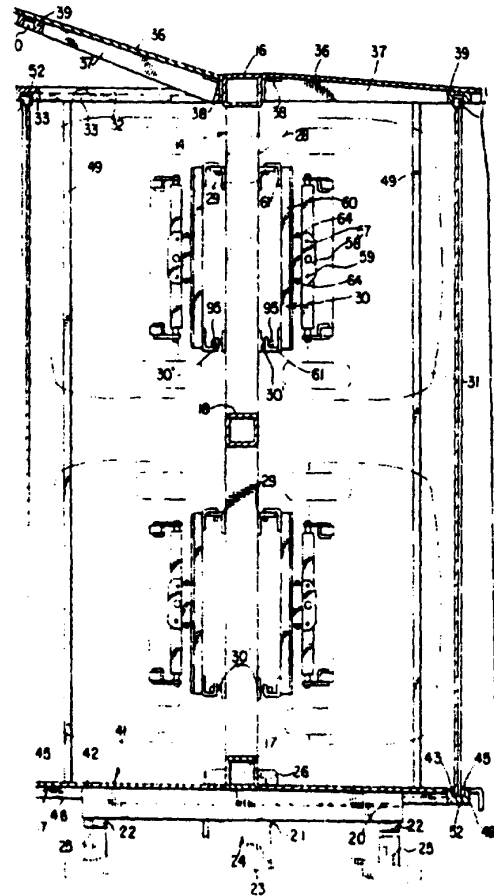

SEE OR SEARCH THIS CLASS, SUBCLASS:

- 3, (the principle subclass) for an upended arrangement in the stowage of bicycles.
- 13+, for four-wheel vehicles stowage structure in which an end only of the stowed vehicle is raised to maintain it at an inclination of approximately 455.
- 24+, for slanted deck structure to support stowed vehicles at about a 455 angle.

**6 Ramp becomes vehicle sustainer:**

This subclass is indented under subclass 5. Structure including panel means constituting a vertical panel at the side edge of the freight carrier and mounted for swinging movement outboard thereof for rolling or placement of a vehicle thereonto for stowage, and means for securing the vehicle to the panel whereby, when the panel is then swung to its vertical position upward from the edge of the carrier the panel means further functions to sustain the stowed vehicle attached thereto at substantially 90° to its normal road use attitude.

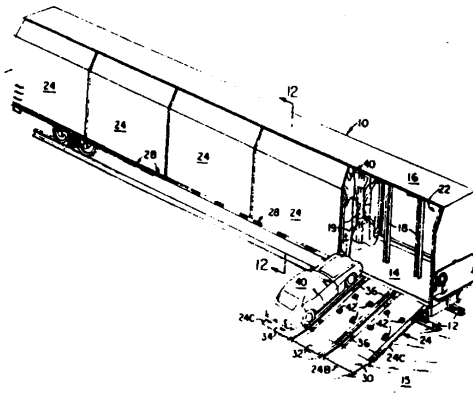
**7 Vehicle retainer\*:**

This subclass is indented under subclass 4. Structure including a retainer\*; i.e., member(s) secured to the carrier and particularly constructed for direct securement engagement with a part of the stowed vehicle

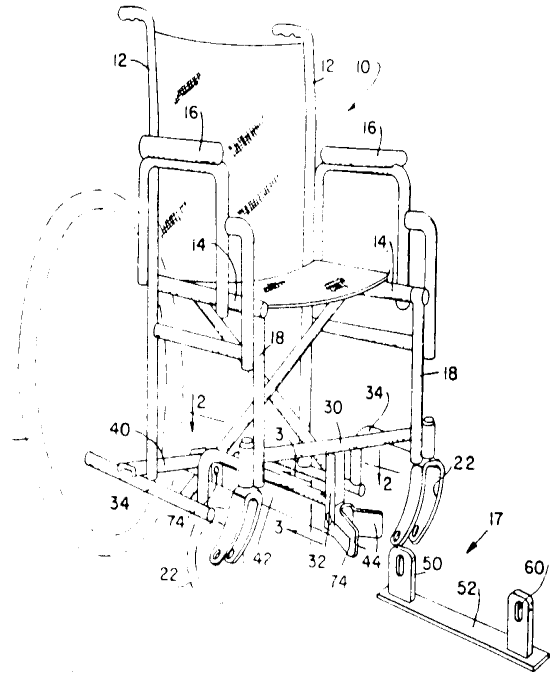
**8 Multipositionable; i.e., along array strip or track:**

This subclass is indented under subclass 7. Structure in which the carrier is further provided with an elongated mounting member which has retainer positioning locations therealong; and in which (a) the retainer engageable with the stowed vehicle part extends from the location selected as being the suitable one for retaining the vehicle on the freight carrier, or (b) the elongated mounting member is shaped to guide the vehicle retainer for sliding movement therealong to the selected location.



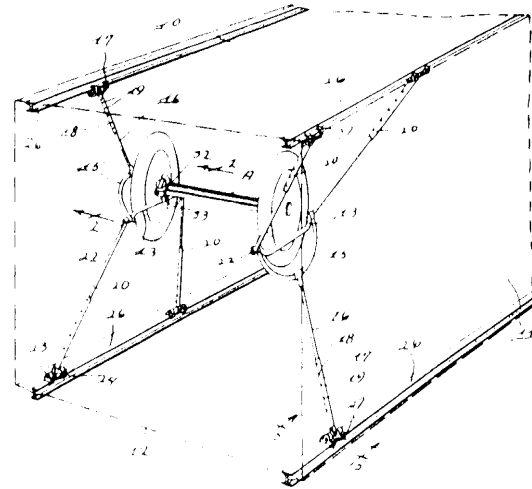
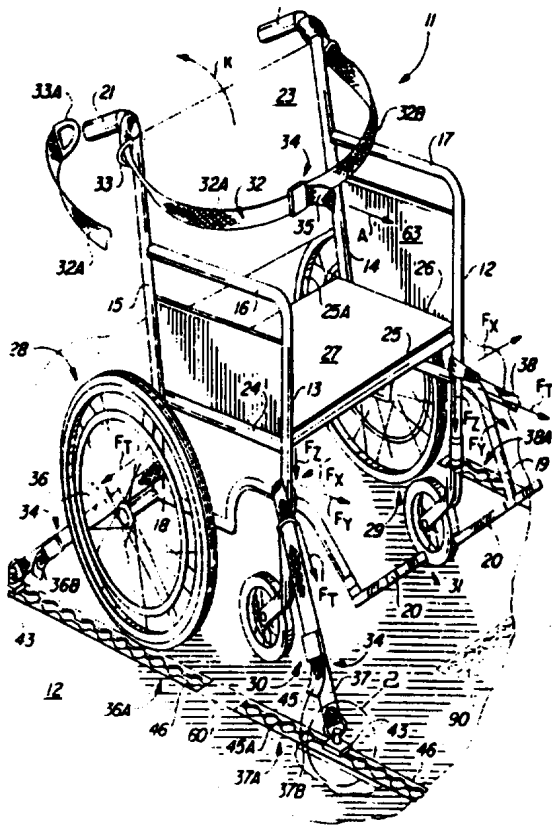

**10 Tiedown\*:**  
 This subclass is indented under subclass 9.  
 Structure in which the retainer\* for the stowed vehicle is a tiedown\*.

SEE OR SEARCH THIS CLASS, SUB-CLASS:

- 104+, for a track to guide a load lashing anchor to the suitable location on the freight carrier.
- 108+, 113+ and 115, for an array of anchors.
- 150, for a track to guide a brace bar along a freight carrier to its load bracing position.

**9 Wheel hub, or axle retainer\*:**  
 This subclass is indented under subclass 8.  
 Structure in which the retainer\* retentively engages that particular functional part of the stowed vehicle, i.e., a wheel, which rolls along the land surface in the normal road use of the vehicle; or that particular functional part which provides, or from which extends the road-use bearing axis for the rolling part.

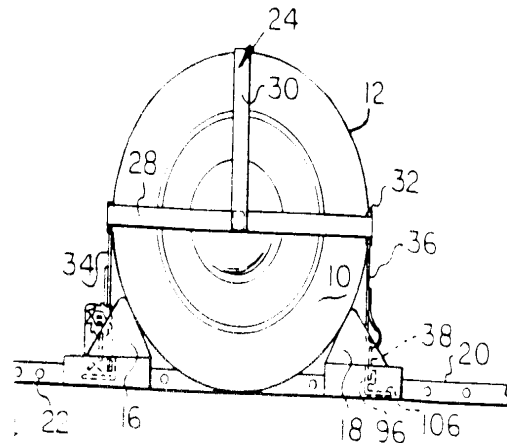

**11 Tiedown\*:**  
 This subclass is indented under subclass 8.  
 Structure in which the retainer\* for the stowed vehicle is a tiedown\*.

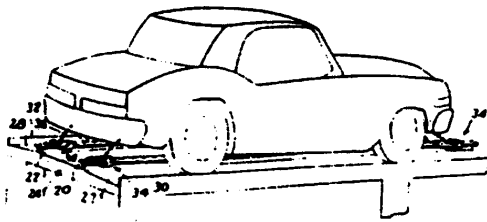

**12 Including force-multiplying takeup or tensioning means:**

This subclass is indented under subclass 11. Structure which includes tautening means effective to multiply the force applied to the tiedown and thence to the stowed vehicle over that of a mere straight-line pull, e.g., drum or winch, turnbuckle, jack strew, but not mere linkage.

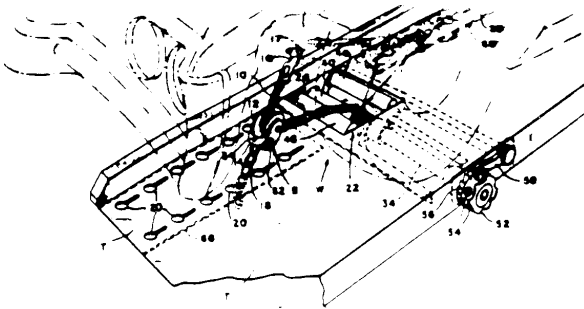

SEE OR SEARCH THIS CLASS, SUBCLASS:

38+, for force-multiplying means for forcing articles in a group into compactly close proximity.

103, for a load-lashing anchor incorporating force-multiplying means.

**13 In arrangement in which the vehicle end, at least, is raised to hood section height:**

This subclass is indented under subclass 7. Structure including means maintaining at least one end of a stowed vehicle supported at a level above the freight carrier floor a distance not less than the anticipatable conventional hood section height of a stowed vehicle.

(1) Note. The arrangement of this subclass, typically, is for overlapping with another vehicle intended to be transported.

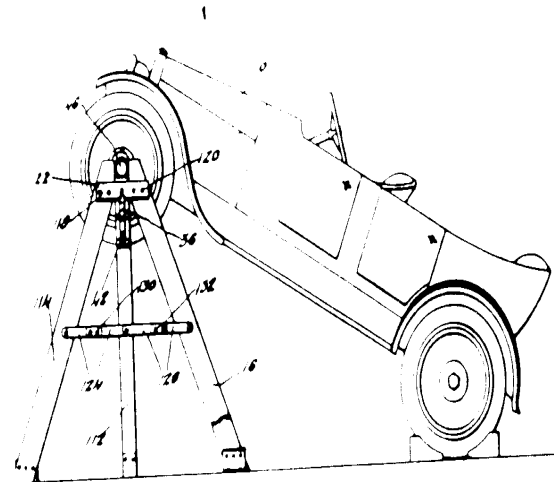

**14** This subclass is indented under subclass 13. Elevatable deck suspended from hoist line: Structure including support member(s) directly underlyingly engaging four-wheels of a stowed vehicle and mounted on the freight carrier for movement between raised transport position and lowered loading position; and means including a flexible member, e.g., chain, cable for raising the support member(s) and maintaining the member(s) higher than the carrier floor.

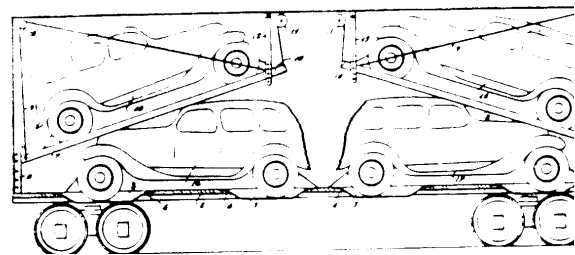

**15 Lift simultaneously erects pivoted prop:** This subclass is indented under subclass 14. Structure including leg means hinged at its ends to the carrier floor and to the vehicle-underlying support member(s) so as to be raised along with the elevatable deck members from prone position to an erect position to cooperate in sustaining the deck.

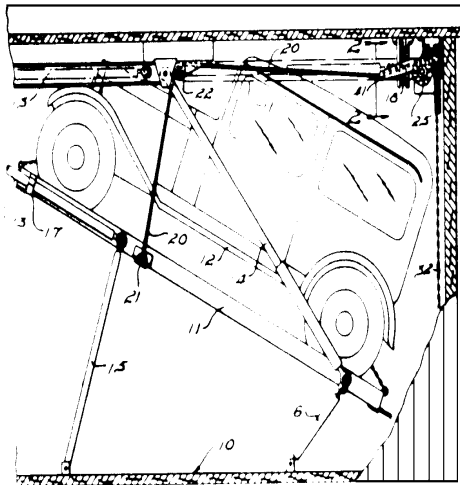

**16 Including wheel-straddling member which is a retainer\* or retainer\* adjunct:**

This subclass is indented under subclass 13. Structure in which the member in direct securement engagement with the stowed vehicle is effective either (a) by engagement with the vehicle wheel, which engagement is uninterruptedly across a wheel dimension transverse to the circumference, i.e., substantially from sidewall to sidewall, or (b) by extension from wheel straddling structure to a location in securement engagement with another functional part of the stowed vehicle.

- (1) Note. Accommodating structure such as a straddle or cradle does not constitute retentive securement where only the lower wheel quadrant is engaged; whereas retention amounting to securement necessarily is effected when similar structure encompasses the upper wheel quadrant(s).

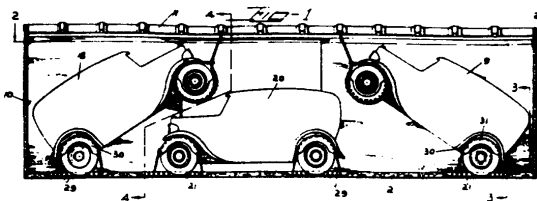

**17 Including suspended retainer\* member or prop:**

This subclass is indented under subclass 13. Structure in which the freight carrier is a walled vehicle and in which an elongate arm or flexible means depends from substantially the highest portion of the carrier interior either (a) to bring a retainer\* member into its direct, retentive contact with a vehicle part, or (b) to abut and thereby brace either the retained vehicle or some part of the retainer\*.

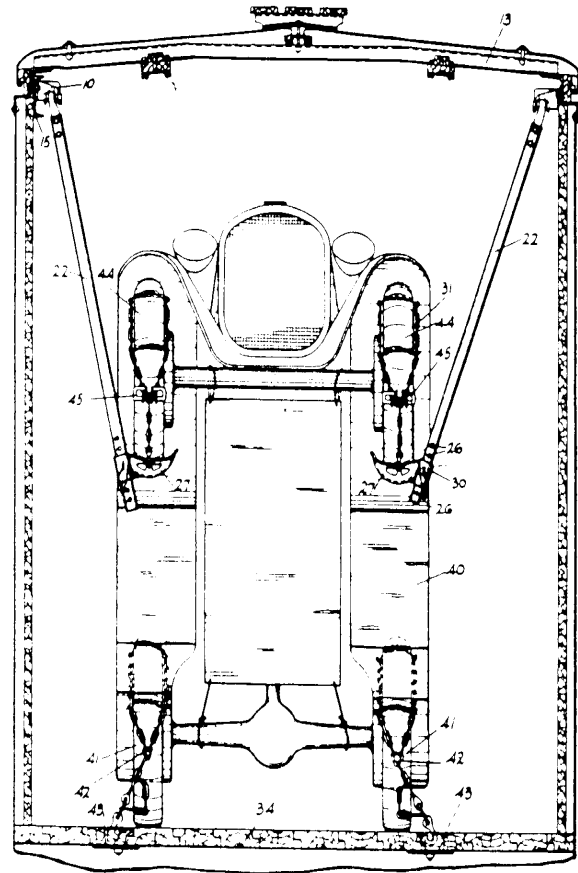

**18 Retainer\* arm or prop extending from freight carrier wall:**

This subclass is indented under subclass 13. Structure in which is included a rigid, elongate member extending from a vertical surface of the freight carrier either (a) to bring a retainer\* member into direct retentive contact with a stowed vehicle part, the retainer member being at the distal end of said elongate member, or (b) to abut and thereby brace either the stowed vehicle or some part of the retainer\* structure.

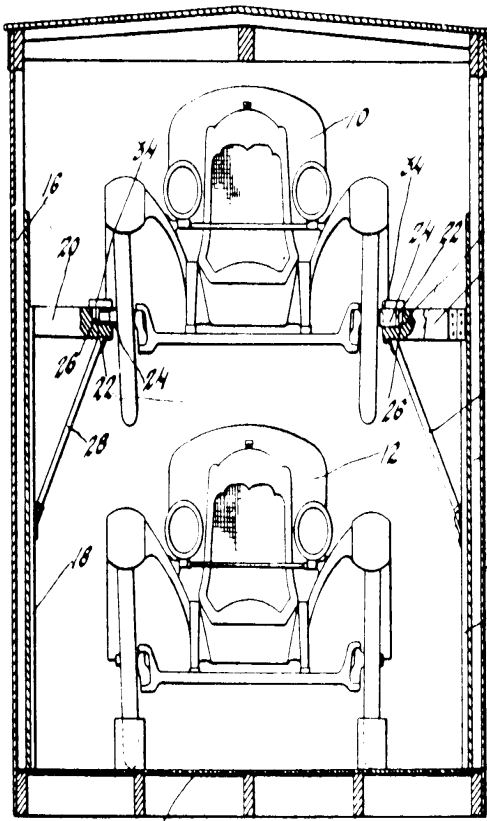

**19 For wheel, hub, or axle shaft:**  
 This subclass is indented under subclass 7. Structure in which a retainer\* member(s) is retentively attachable to the stowed vehicle functional part that rolls along the land surface in the normal road use of the vehicle; or to that particular functional part that provides or from which extends the road-use bearing axis for the rolling member.

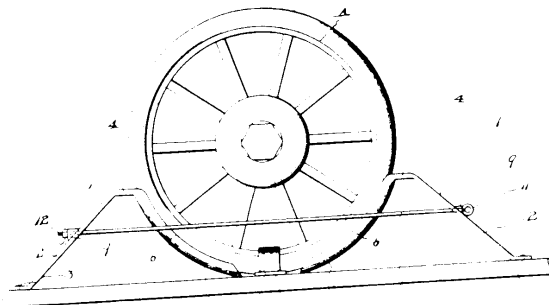

SEE OR SEARCH THIS CLASS, SUB-CLASS:

- 9+, for a multipositionable (e.g., track-mounted) wheel, hub, or axle retainer.
- 16, for a wheel straddling retainer in a raised vehicle arrangement.

**20 Wheel wraparound\*:**  
 This subclass is indented under subclass 19. Structure in which the retainer\* is a wrap-around\* in tight encirclement about the upper quadrants of a wheel.

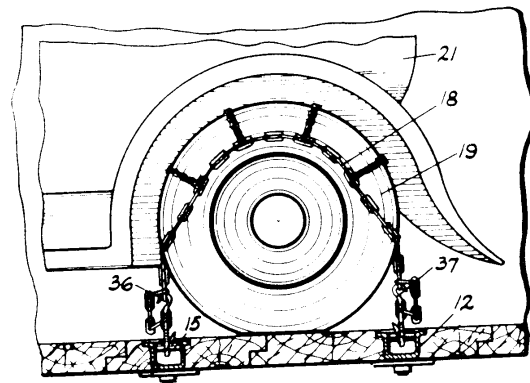

SEE OR SEARCH THIS CLASS, SUB-CLASS:

- 9+, for a wheel, hub, or axle shaft retainer in a raised vehicle arrangement.

**21 (Load lashing retainer)\*:**  
 This subclass is indented under subclass 19. Structure in which the retainer\* is a (load lashing retainer)\*.

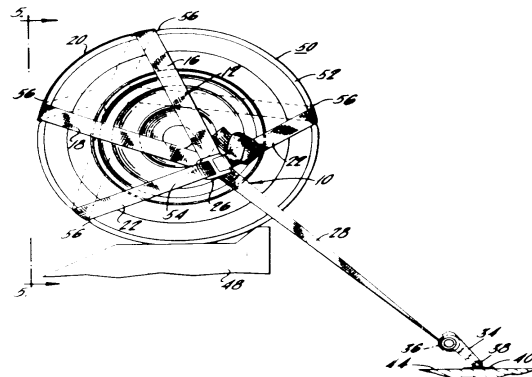

SEE OR SEARCH THIS CLASS, SUB-CLASS:

- 15, for disclosed but not claimed hub or axle retainer structure quite commonly mounted on a "semi-decking" frame (an art term for the angularly propped vehicle sustaining deck).
- 48, for a rigid retainer effective by contact with the core or hub of a cylindrical article, e.g., reel, or wheel not mounted to a vehicle.

**22 Hub or axle shaft retainer\*:**

This subclass is indented under subclass 19. Structure in which a retainer\* member is retentively attachable to that particular functional part of the stowed vehicle that provides, or from which extends the road-use bearing axis for the vehicle wheel.

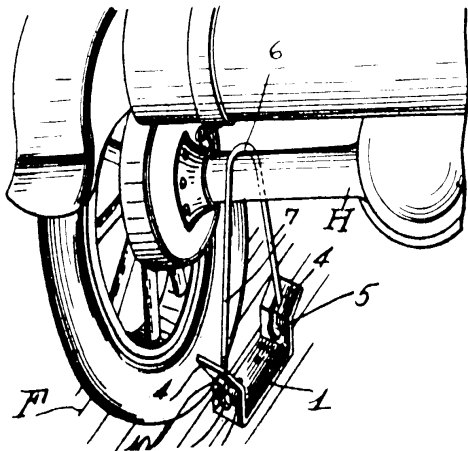

**23 Tiedown\*:**

This subclass is indented under subclass 7. Structure in which the retainer\* is a tiedown\*.

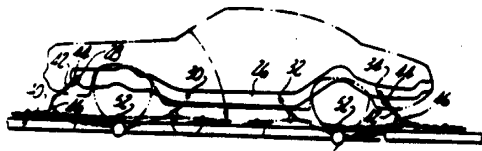

**24 Raised vehicle arrangement:**

This subclass is indented under subclass 4. Structure comprising means for supporting at least one end of the stowed vehicle above the freight carrier floor at a height at least that of

the anticipatable conventional hood section height.

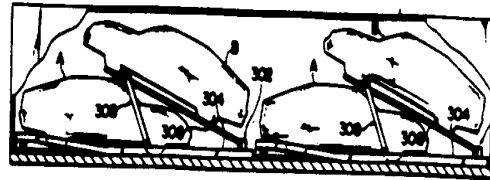

SEE OR SEARCH THIS CLASS, SUB-CLASS:

- 13+, for a raised vehicle arrangement in which is included a retainer for the stowed vehicle.

**24.1 Including above-cab stowage:**

This subclass is indented under subclass 24. Structure including means so located and constructed as to support at least one end section of a stowed vehicle directly over the compartment of the freight carrier operator.

- (1) Note. The support means may be, or may include the vehicle cab roof to provide elevated height stowage.

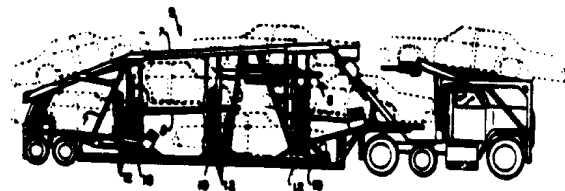

**25 Interrupted or recessed wheel support:**

This subclass is indented under subclass 24. Raised vehicle arrangement structure in which spaced supporting portions or members engage respective lower quadrant portions of a stowed vehicle wheel perimeter, whereby the intervening perimetral portion, which normally sustains the vehicle mass, as during road use, is uncontacted by said member or portions.

- (1) Note. Another sunken and upwardly concave member may, however, span the space between the member or portions to substantially conform to and contact the lower half perimeter of the wheel.

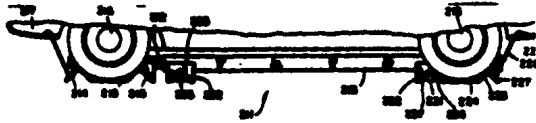

SEE OR SEARCH THIS CLASS, SUBCLASS:

- 26, for a raised vehicle arrangement wherein the underlying support, in the raised vehicle arrangement, is planar so as to contact the vehicle wheel at that point at which it normally sustains the vehicle mass.
- 30, for wheel chock or cradle means to inhibit the rolling tendency of a vehicle wheel.
- 49+, for similar means to inhibit the rolling tendency of any other cylindrical article.
- 57, for the fore-and-aft accommodation of a semitrailer which could include similar sunken area structure for accommodating the rear wheels.
- 65, for a rear wheel accommodating sunken area accommodating the stowage of a semitrailer.

**26 Multilevel deck; i.e., four-wheel support:**

This subclass is indented under subclass 24. Structure including one or more planar members supporting the stowed vehicle entirely above the carrier floor by direct underlying engagement with all four-wheels of said vehicle, whereby the freight carrier floor sustains a vehicle at the requisite height above a lower level.

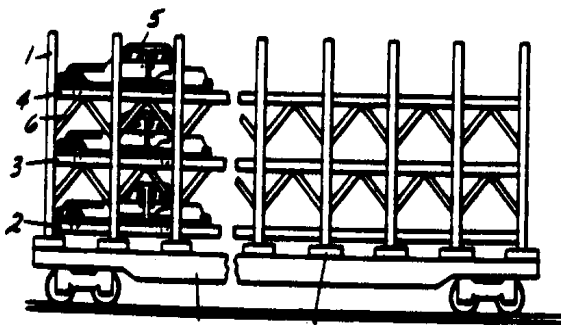

SEE OR SEARCH CLASS:

- 105, Railway Rolling Stock, subclasses 371+ for a railway freight carrier convertible to multideck structure for hauling indiscriminate freight.
- 206, Special Receptacle or Package, subclass 335 for a multilevel deck, on-and-off shipping container for delivery and shipment of vehicles on board a freight carrier.

**27 Including interdeck transfer way:**

This subclass is indented under subclass 26. Structure including further structure underlyingly receiving the vehicle wheel(s) thereupon and constituting either an elevator or inclined ramp for transit of vehicles between the vertically spaced decks.

- (1) Note. Elevating structure, per se, and nothing more, is proper for this subclass only when, either in itself or together with another elevator(s), it provides a substantially continuous elevated support for a plurality of vehicles at least temporarily, for loading and unloading. The elevator or ramp must be in addition to, and for service between, a plurality of decks level. Absent the above, see principal subclass 26 for an inclined fixed height structure sustaining the four-wheels of a single stowed vehicle and subclasses 14+ for such a structure which is adjustable, e.g., elevatable.

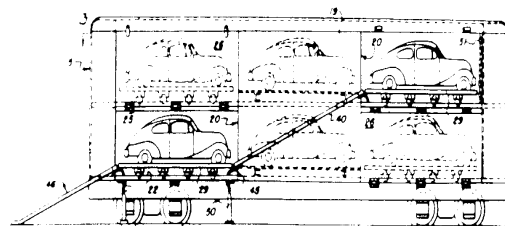

**28 On dropped-center car:**

This subclass is indented under subclass 27. Structure in which the freight carrier floor which underlyingly supports the vehicle wheels is of an extent to include a center area lower than the freight carrier running gear supports and another area extending therefrom to a

level to support a part, at least, of a stowed vehicle directly above a running gear support.

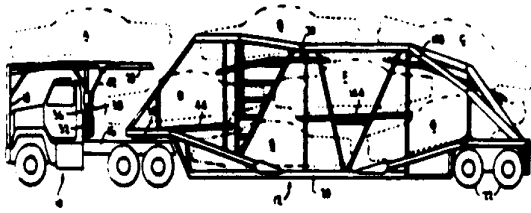

**28.1 On dropped section freight carrier:**

This subclass is indented under subclass 26. Structure in which the freight carrier floor includes longitudinally contiguous areas, namely, a relatively high area at an end section of the freight carrier and a relatively lower area longitudinally inward thereof, whereby a vehicle may be towed athwart the areas at an incline with respective ends thereof supported at the corresponding floor areas.

- (1) Note. The freight carrier of this subclass is of the type which is wheeled and is for highway travel and includes a floor section inward of the running gear used to advantage in freight haulage in being constructed lower than the running gear height.
- (2) Note. The stowed vehicle may be supported, front and rear, directly on respective floor sections, or on structure supported by and straddling the floor sections.

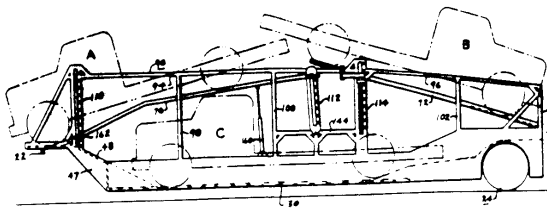

**29 Vertically swingable from hinge at freight carrier wall:**

This subclass is indented under subclass 26. Structure in which the deck structure is pivotally mounted at the freight carrier wall for vertical swinging movement.

- (1) Note. The hinged deck structure may include a plurality of members, of which each, or a pair of each extends from opposite walls of the freight carrier for supporting corresponding pairs of the supported vehicle wheels.

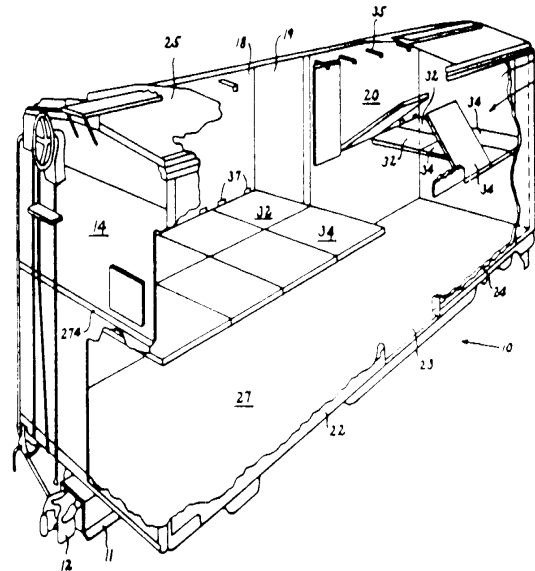

**29.1 Higher level deck positioned, then sustained by power cylinder:**

This subclass is indented under subclass 26. Structure in which the member which underlyingly supports the stowed vehicle by its wheels is vertically adjustable and in which piston and cylinder telescoping tube means has one end attached to the member and the other end to a point on the freight carrier, the telescoping tube means being subject to the influence of force from a fluid source to effect elongation thereof to position the wheel support member at the requisite height, or attitude at which the piston and cylinder means cooperates in retaining the vehicle support means.

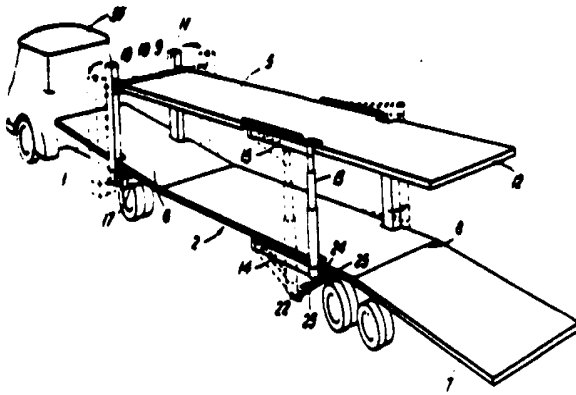

**30 Wheel cradle, chock, or well:**

This subclass is indented under subclass 4. Structure wherein the means to accommodate the stowed vehicle engages the wheel(s) thereof at location(s) extending to, but not beyond both lower quadrants of the wheel periphery; or along, but not beyond, a substantial perimetral length of a lower wheel quadrant.

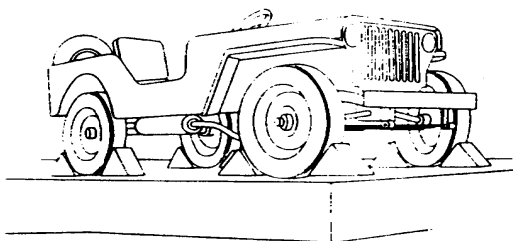

SEE OR SEARCH THIS CLASS, SUBCLASS:

49, for cradle structure accommodating a cylindrical article other than a wheel mounted on a vehicle.

SEE OR SEARCH CLASS:

188, Brakes, subclass 32 for a chock, recognized as a brake on the ground for that class and subclass, and which may be used to chock a vehicle wheel on a surface other than that of a freight carrier.

**31 Grouped:**

This subclass is indented under subclass 2. Structure particularly designed for accommodating a number of articles as a load unit, or an arrangement of such a number of articles.

(1) Note. This (the principal) subclass includes inventions particularly designed for accommodation of groups of engines, also racks or hanging hooks for meat carcasses.

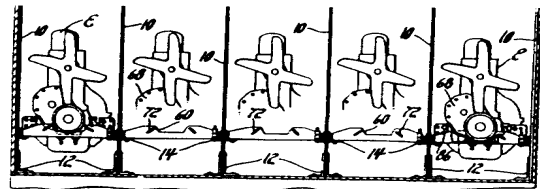

SEE OR SEARCH CLASS:

206, Special Receptacle or Package, appropriate subclass for a group of articles which is prepackaged possibly for stowage as a load unit on board a freight carrier.

**32 Group of articles which are, predominantly, regularly contoured; i.e., are rodlike, panel shaped, blocks, or analogous forms:**

This subclass is indented under subclass 31. Structure or arrangement wherein the accommodated load unit consists of articles which are substantially the same in cross section throughout at least nearly all of their length.

(1) Note. The article, under the instant definition, may have a localized irregularity (for which, see subclass 31, indented hereunder) but remains, on the whole, "predominantly" regularly contoured, as the title to this subclass phrases it.

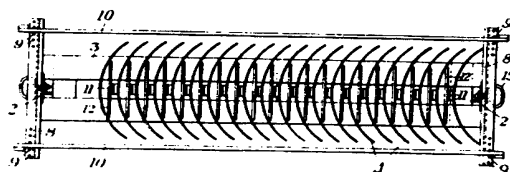



- 33 Articles with protuberance or flange:**  
 This subclass is indented under subclass 32. Structure or arrangement particularly designed to establish a load unit of articles shaped with a localized right-angled extension from each of their otherwise regular contours.

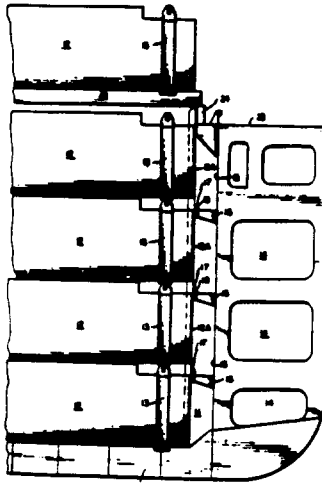

- 34** This subclass is indented under subclass 32. Grouped by load binder or press means: Structure including means firmly forcing the articles into compact proximity.

- (1) Note. The means of this subclass may be firmly forced against the group of articles by muscle power or by force multiplying means associated with said first-named means (for which latter, see indented subclasses 38+).

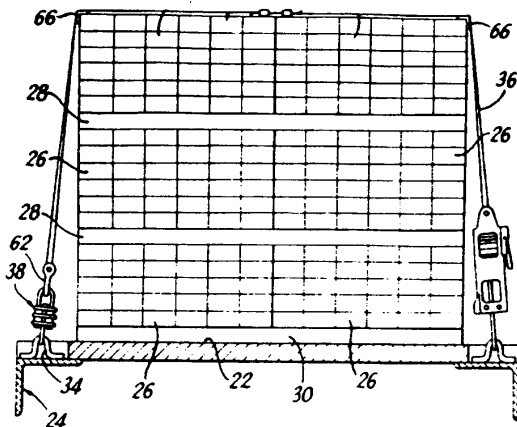

SEE OR SEARCH CLASS:

- 24, Buckles, Buttons, Clasps, etc., subclasses 16+ for a wraparound load binder for a group of articles having no parts connected to a freight carrier; see, too, indented subclasses 19+ wherein the load binder includes a tightener; and see subclasses 68+ for a tightener, per se.

- 35 Grouped together with on-and-off base:**  
 This subclass is indented under subclass 34. Structure further including underlying support structure for the load unit and united therewith by the load binder or press means for and throughout the loading and unloading sequences.

- (1) Note. A rigid member underlying a load unit may be merely an element of the press means of principal subclass 34 when its dimensions are not substantially different from the remaining (side and top) press means member; rather than being so substantially dimensioned as to be clearly recognizable as a supporting base for the load unit.

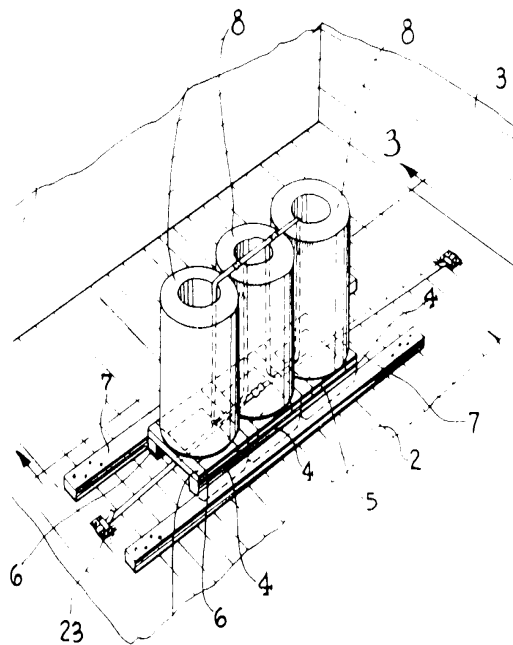

## SEE OR SEARCH CLASS:

206, Special Receptacle or Package, subclass 386 for a group of articles pre-packaged on an on-and-off base for stowage for shipment on board a freight carrier, absent means in interengagement with the freight carrier for accommodation against the hazards of transportation.

**36 Cylindrical article group:**

This subclass is indented under subclass 34. Structure in which the means firmly maintains or urges articles of substantially circular cross section into the compact proximity.

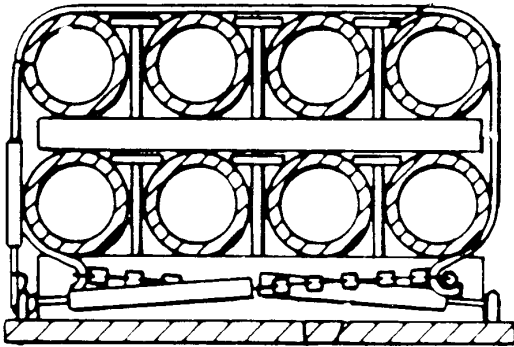
**37 Log load:**

This subclass is indented under subclass 36. Structure or arrangement in which the load unit consists of hewn tree trunks in compact proximity.

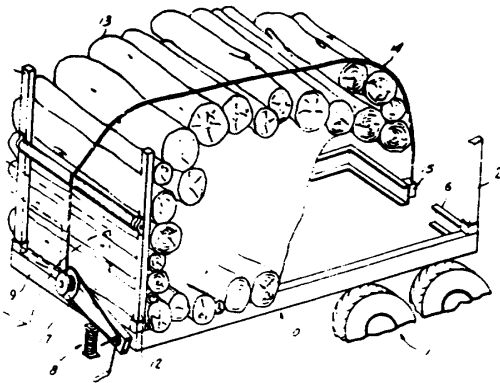
**38 Press:**

This subclass is indented under subclass 34. Structure comprising rigid means which contactingly bounds a side, at least, of the group and force multiplying means associated therewith whereby the rigid means is in itself adjustable for movement against the side of the group or includes an adjustable member for such movement under influence of means which multiplies the force of compaction against said group.

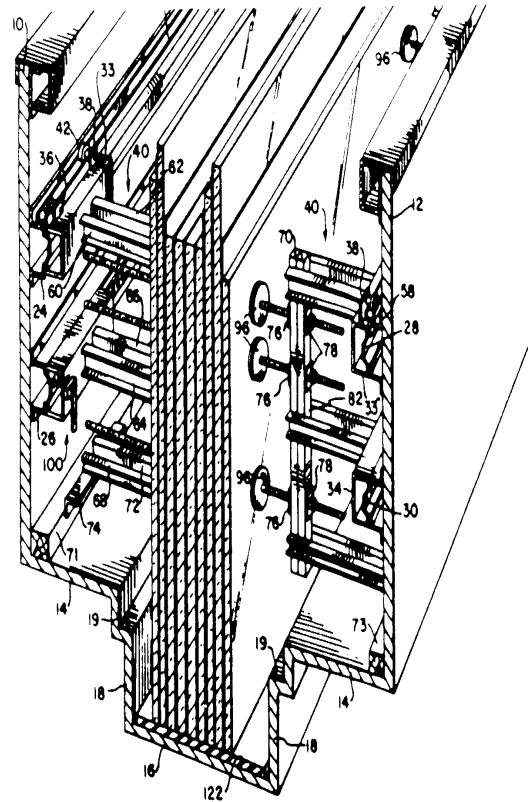

## SEE OR SEARCH THIS CLASS, SUBCLASS:

12, for force multiplying means used with a tiedown\* for retaining a four-wheel vehicle on a freight carrier.

**39 Including spacer:**

This subclass is indented under subclass 38. Structure further including means intervening between articles in the group or between and setting off one group of articles from another.

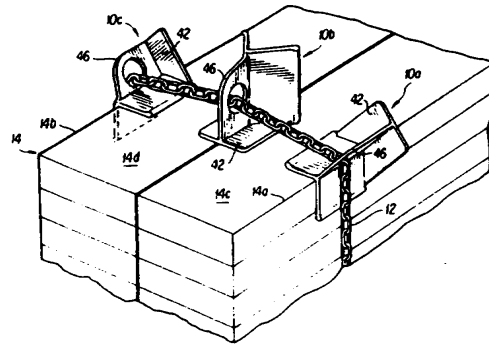
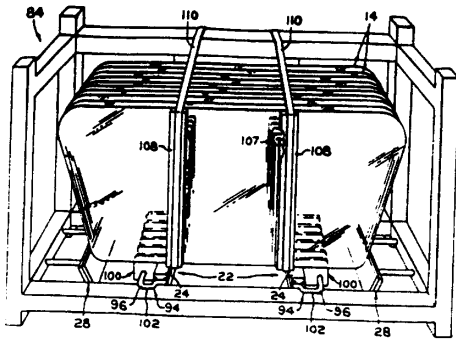

**40 Between groups:**  
 This subclass is indented under subclass 39. Structure in which the intervening means is between and sets off one group of articles from another.

**42 Cylindrical article group:**  
 This subclass is indented under subclass 32. Structure in which the accommodated load unit consists of articles of substantially circular cross section.

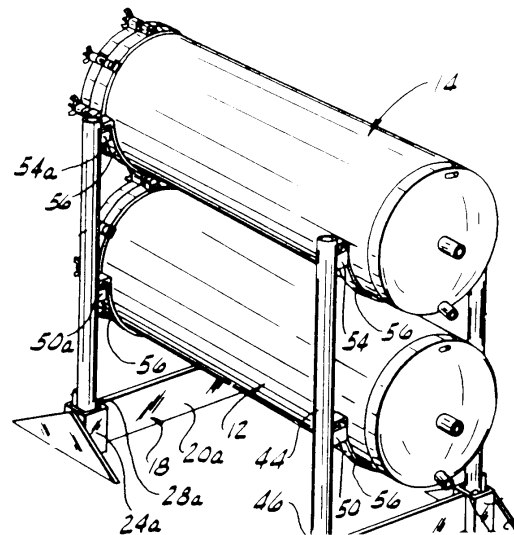
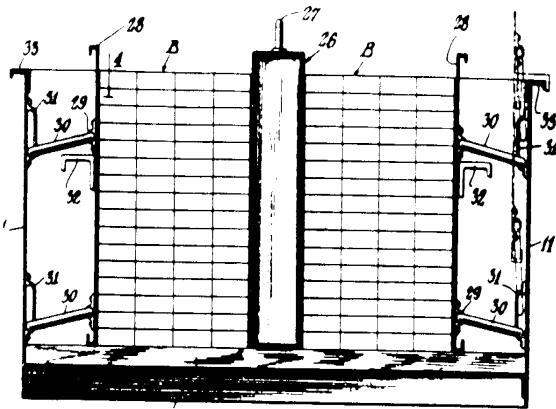

**41 Including angle overlay, e.g., corner guard:**  
 This subclass is indented under subclass 34. Structure in which the articles of the group are of such shape that the group is configured as to provide an abrupt, substantially 90 degree change of direction along the outside surface of the group; and in which a rigid member is of such shape as to be in overlying contact with said outside surface through said change in direction.

**43 Vehicle body part group:**  
 This subclass is indented under subclass 31. Structure or arrangement particularly designed to accommodate articles consisting of frame or shell parts for vehicle manufacture or assembly.

(1) Note. In this way, frequently, the outside corner article is protected from the bend of a taut lashing member.

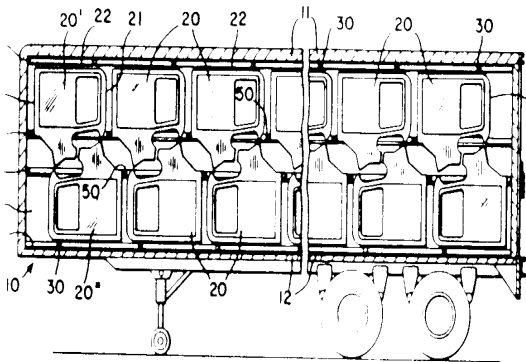

**44 Accommodation of article which is massive relative to the freight carrier:**

This subclass is indented under subclass 2. Structure particularly designed to accommodate a single article (a) of such dimensions as to occupy substantially the entire space of the freight carrier or to extend beyond an edge thereof (e.g., onto a second carrier), or (b) of such height as to require that the freight carrier load-support area surface area on which the article rests be between and lower than the height of the top of the carrier trucks.

- (1) Note. A truck is considered to be a freight carrier for this subclass so that an article bridging a pair of trucks are properly classifiable therein. The article may in itself, or together with on-and-off base, be the sole structure bridging the pair of trucks; for which see indented subclass 45.

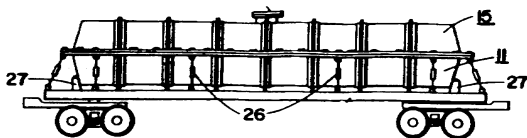

**45 Stowed as a bridge between trucks, or across cars, or on drop-center (schnabel type) car:**

This subclass is indented under subclass 44. Structure or arrangement (a) in which the article, either by itself alone or together with an on-and-off underlying support, is mounted at each end onto separate, spaced apart freight carrier running gear structures to constitute the sole connection between those structures while so mounted, or (b) in which the article staddles

a plurality of horizontally swingingly related freight carriers, or (c) in which the freight carrier load-support area is between and lower than the height of the freight carrier running gear supports.

- (1) Note. With respect to part (b) of the above definition, each of the separate spaced running gear structures (i.e., trucks) constitutes, in itself, a freight carrier and the article, extending from the one to the other extends beyond either one of them. The requirement for placement in subclass 44, under (1) Note of the definition thereof, is there by met.

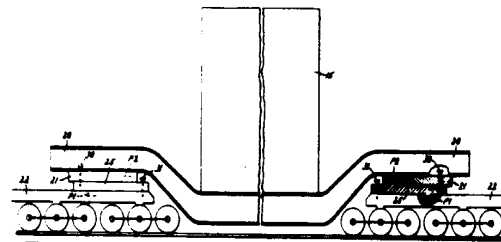

SEE OR SEARCH THIS CLASS, SUB-CLASS:

- 53, for a load bearer, e.g., semitrailer, stowed as a bridge between trucks.

SEE OR SEARCH CLASS:

- 296, Land Vehicles: Bodies and Tops, subclass 25 for a dropped center highway vehicle, e.g., semitrailer, absent the provision thereon of load accommodating structure.

**46 On supporting on-and-off base:**

This subclass is indented under subclass 2. Structure comprising underlying structure for an article and means for effecting the immobilization of the article on the structure for and through the loading and unloading sequences of accommodation on a freight carrier.

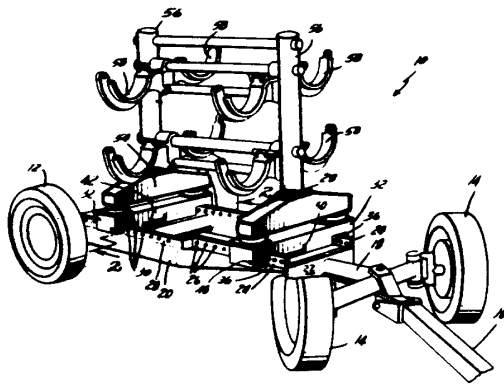

SEE OR SEARCH THIS CLASS, SUBCLASS:

35, for an on-and-off base stowed together with its article load on board a freight carrier by the use of accommodating (usually retainer)\* means.

SEE OR SEARCH CLASS:

206, Special Receptacle or Package, appropriate subclass for an article pre-assembled on an on-and-off container to constitute a shipping unit, but lacking means interengageable with a freight carrier for accommodation against the hazards of transportation.  
220, Receptacles, subclasses 1.5+ for a freight container.

**47 Cylindrical article accommodation:**

This subclass is indented under subclass 2. Structure particularly designed to accommodate an elongate article of substantially circular cross section; i.e., to utilize a structural feature of, or nullify a particular problem inherent in, the shape of the article.

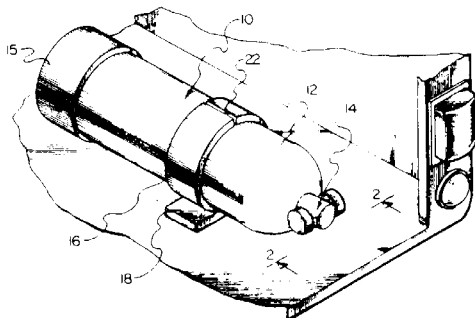

**48 Rigid retainer\* acting as, or retentively contacting a core or hub:**

This subclass is indented under subclass 47. Structure including rigid means retentively engaging the article along its longitudinal axis, or retentively engaging a member axially related to (generally, an axial part of) the article.

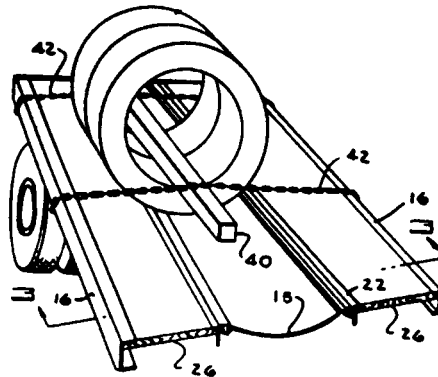

**49 Cradle or chock:**

This subclass is indented under subclass 47. Structure in which the accommodating means defines an upwardly facing concavity or upwardly diverging angle(s), whether continuous or interrupted, in either case to engage one or both lower quadrants of the cylindrical article periphery and thereby inhibit rolling.

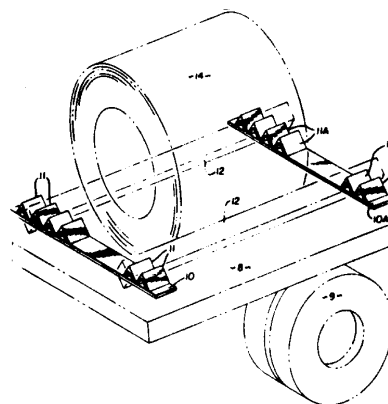

SEE OR SEARCH CLASS:

188, Brakes, subclass 32 for a chock recognized as a brake on the ground for that class distinguishing over the

instant subclass in that it is applied to a surface other than that of a freight carrier.

**50 And wraparound\* lashing:**

This subclass is indented under subclass 49. Structure further including a wraparound\* (load lashing retainer)\* attached at its ends to the freight carrier and drawn securely about or through the article to secure it against a contour-complementing surface of the accommodating means.

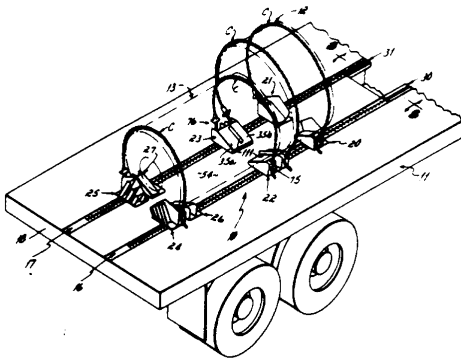

SEE OR SEARCH THIS CLASS, SUBCLASS:

20, for a wraparound for securing the wheel of a stowed four-wheel vehicle to the freight carrier; and subclasses 97+ for a wraparound for lashing a load unit to a freight carrier, generally.

**51 DRAFT (INCLUDING PUSHED) FREIGHT CARRIER, I. E., WAGON, HAND TRUCK:**

This subclass is indented under the class definition. Structure particularly designed to accommodate a load unit on a freight carrier the motive force for which is intended to be entirely biologically muscular.

(1) Note. Included herein are horse drawn wagons designed for such facile removal of the load bearer structure from running gear as is common to the more contemporary load carrier stowage technology of subclasses 52+. Because of such commonality that has been brought about by the advance in the state of the art, this type of support or container is

classified with more contemporary on-and-off load bearers of this class (410).

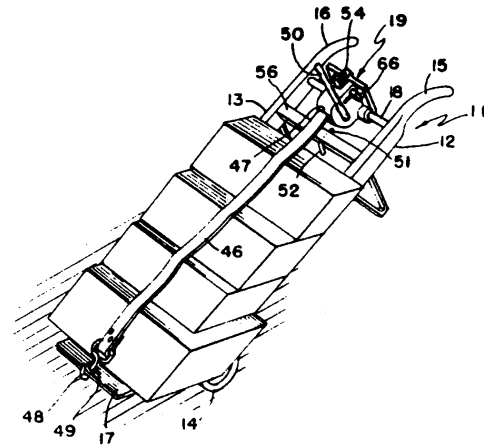

SEE OR SEARCH CLASS:

280, Land Vehicles, subclasses 47.131+ for an inherently unstable vehicle to which an article may be attached, and which may be propelled by a walking attendant. Transportation (a) for a insignificant distance, as within a supermarket or from a building to a curbside moving van, or (b) by a non-commercial user, e.g., a shopper or a boatman trailering his own boat would be appropriate for that Class 280, subclass 47.131 rather than the instant class and subclass 51.

**52 LOAD BEARER ACCOMMODATION:**

This subclass is indented under the class definition. Structure particularly designed to accommodate an on-and-off freight support base or receptacle; i.e., such as underlying support or such an enclosure as presumably receives freight thereon or therein prior to being loaded on the carrier and is unloaded from the carrier together with the freight.

(1) Note. A base (pallet) or enclosure (container), per se, is herein included when provided with externally carried means specifically for cooperation with mating means on the freight carrier for the accommodation of said base or enclosure and will be found in the particular subclass provided for that particular

accommodation. The means, per se, specifically for cooperation with mating means on the freight carrier for the accommodation of said base or enclosure and will be found in the particular subclass provided for that particular accommodation. The means, per se, found in subclasses 96+ is also herein provided.

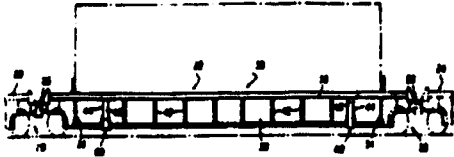

SEE OR SEARCH CLASS:

294, Handling: Hand and Hoist-Line Implements, subclasses 67.1+ for a frame or a load bearer particularly designed (as by being provided with corner fittings) for cooperating with hoist equipment for loading onto or unloading from a freight carrier.

**53 Stowed as a bridge between trucks:**

This subclass is indented under subclass 52. Structure or arrangement in which the load bearer is mounted at each end onto separate spaced apart freight carrier running gear structures to constitute the sole connection between them.

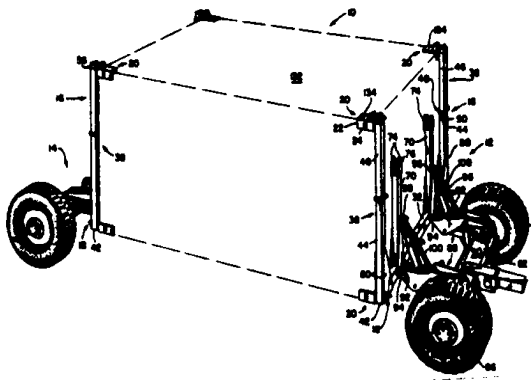

SEE OR SEARCH THIS CLASS, SUBCLASS:

45, for a particular article so massive as to be accommodated as a bridge between trucks.

SEE OR SEARCH CLASS:

105, Railway Rolling Stock, subclasses 270+ for a tank pivoted between railway trucks in order to orient its outlet for pouring.

**54 Diverse load accommodation, e.g., convertible between semitrailer and container accommodation:**

This subclass is indented under subclass 52. Structure in which the freight carrier is particularly designed simultaneously or alternatively to accommodate load units of diverse construction, e.g., container and/or pallet and/or semitrailer, and, therefore, necessitating mutually distinct stowage structures or arrangements to be present on or be assembled to or arranged on the freight carrier.

(1) Note. These subclasses (54+) require a positive structural detail of each of the accommodations; the plurality of accommodating means or, at least, structure particularly provided to cooperate with each of them. Mere retractability for getting accommodation means of a one type out of the way, and going no further than to prepare the freight carrier for an alternative accommodation is inadequate for this subclass.

(2) Note. The original document to structure designed to accommodate a particular article, as defined in subclass 2, and also, alternatively or additionally, a load bearer defined in principal subclass 52 will be classified in the superior subclasses 2+ and should be crossed in this instant subclass (54).

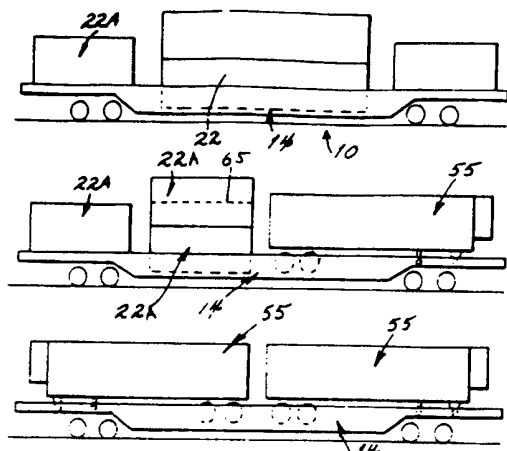

**55 Retainer including load lashing anchor capability:**

This subclass is indented under subclass 54. Structure appropriate for retentive engagement with a load bearer is combined with (e.g., has attached thereto) or is convertible to structure for the attachment device used in load lashing.

- (1) Note. See subclass 101 for the definition of a load lashing anchor, and search indented subclass 102 for other diverse use devices including an anchor.

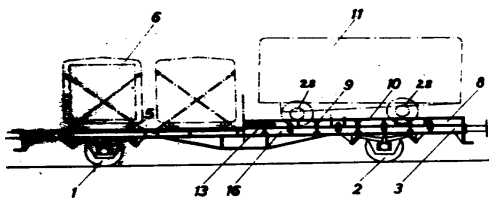

**56 Semitrailer accommodation:**

This subclass is indented under subclass 52. Structure in which the accommodated load bearer is of the type provided with running gear at a location limited to the rear portion thereof.

- (1) Note. An arrangement of wheels at the front end to facilitate stowage (e.g., guidance) on the carrier will bar placement in this subclass, even though the wheels are nonroadable and have no other use than said storage facilitation

[See (1) Note in subclass 66]. Mere lowering of the semitrailer landing gear does not, however, constitute stowage (e.g., guidance) facilitation to make said bar to placement herein operative.

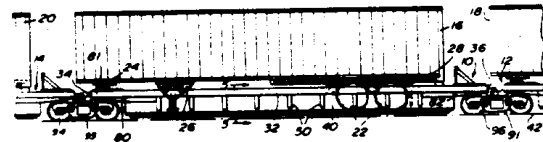

**SEE OR SEARCH THIS CLASS, SUB-CLASS:**

- 1, for the inclusion of a turntable mounted on a semitrailer-accommodating freight carrier for stowing the trailer on board the carrier.
- 53, for a semitrailer stowed as a bridge between railway trucks; in fact, constituting the sole structure linking the spaced trucks.

**SEE OR SEARCH CLASS:**

- 280, Land Vehicles, subclasses 414.1+ for a boat carrying, articulated vehicle, e.g., semitrailer.

**57 Fore-and-aft accommodation:**

This subclass is indented under subclass 56. Structure including accommodating means engaging forward and rear sections of the stowed semitrailer.

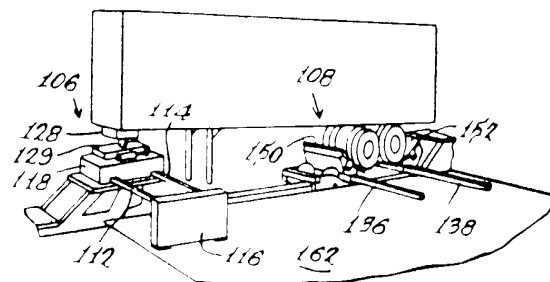

**SEE OR SEARCH THIS CLASS, SUB-CLASS:**

- 58+, for a stand collapsibly mounted on a freight carrier for accommodating a semitrailer at its front end.



64, for details of the kingpin retaining latch of such a stand.

**58 Collapsible and erectable stand:**

This subclass is indented under subclass 56. Structure including a support to maintain the fore end of a stowed semitrailer raised above the freight carrier bed and means so linking the support to the freight carrier bed as to be extensible to a raised, supporting position and foldable to a lowered position on or below the bed.

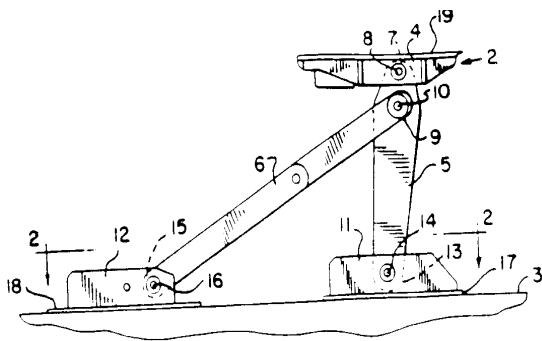

SEE OR SEARCH THIS CLASS, SUBCLASS:

57, for semitrailer stowage structure including the fore-end stand and means accommodating the rear end of the semitrailer.

**59 Tractor operated:**

This subclass is indented under subclass 58. Structure wherein the supporting stand is provided with means engageable with a loading or unloading tractor so as to utilize the tractor force for the extensible raising or the collapsed lowering operation.



**60 Cushioned:**

This subclass is indented under subclass 59. Structure including recoverable means, other than merely a resilient block, which is yieldable under the influence of an excessive or inadvertent force whereby to interveningly

receive and thereby ward off the undesirable effect of the force upon the stand or the stowed trailer; which means tends to be restored to its prior state upon, and as a consequence of, the cessation of that force.

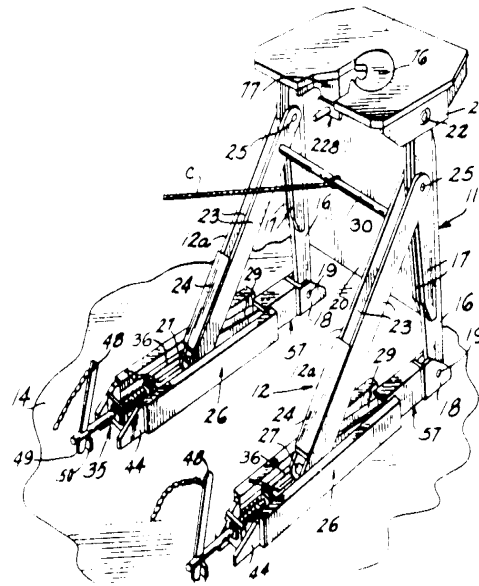

**61 Jack screw erected:**

This subclass is indented under subclass 58. Structure in which the mounting means for the fore-end stand includes threaded means operable to obtain a force multiplying advantage effective to facilitate raising of the stand and with it, presumably, the mass of the supported fraction of the load.

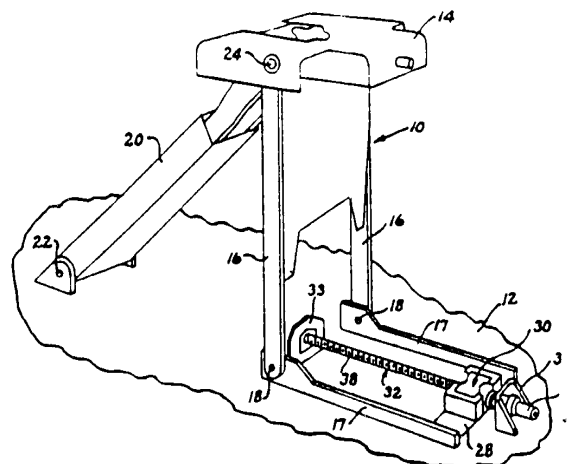

**62 (Fore-and-aft direction slide cushioning means)\*:**

This subclass is indented under subclass 58. Structure wherein the mounting means for the trailer support includes a base portion installed along the carrier floor for movement parallel to the longitudinal axis of the carrier under the influence of (fore-and-aft direction slide cushioning means)\*.

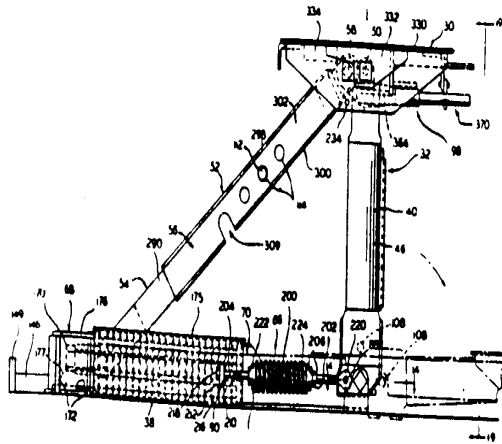

**63 Cushioned cylinder strut:**

This subclass is indented under subclass 58. Structure wherein the mounting means for the trailer support comprises underlying leg means including a leg consisting of hollow interfitting parts which enclose means which render them yieldable for telescopic movement in response to inadvertent force incident to freight transportation and recoverable to the earlier state upon and as a consequence of cessation of the force.

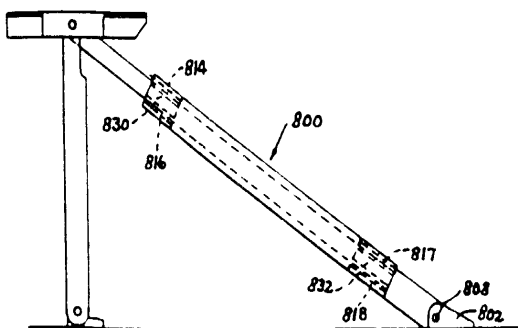

**64 King pin latch:**

This subclass is indented under subclass 58. Structure in which the trailer fore-end support includes means particularly designed for releasable retentive connection with a post extending downward from the underside of the fore end of the trailer, which post is analogously employed to join the trailer to the tractor during road use.

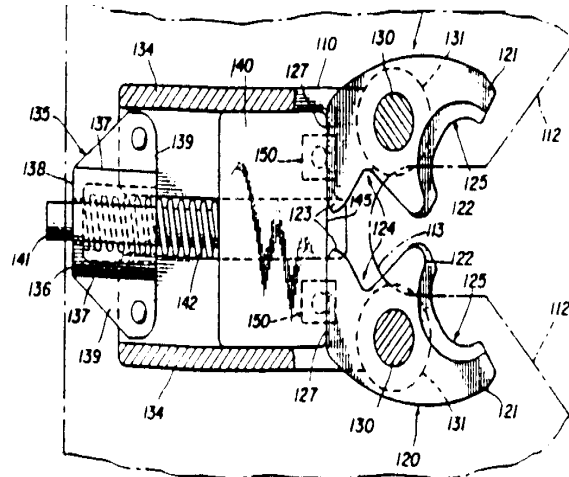

**65 Accommodation means conforms to wheel sidewall during guidance or rest condition, e.g., rub rail or wheel well:**

This subclass is indented under subclass 56. Structure in which the freight carrier support surface is provided with accommodation means of such configuration as to be in engagement with a sidewall of the semitrailer wheel during its movement along the freight carrier to a stowed location or when it is at that location, whereby lateral movement of the semitrailer is thereby prevented.

- (1) Note. The mere lowering of the wheeled landing gear on a deck surface is not considered to convert a semitrailer to a four-wheeled vehicle to bar placement in this subclass in favor of lower subclasses 66+. However, additional (e.g., fore-end) wheels to facilitate guidance for stowage on the freight carrier, even though such additional wheels are non-roadable and have only that stowage facilitation use and capability, is subject matter for that inferior subclass and will be found therein rather than in the instant

subclass. See (1) Note in principal subclass 56.

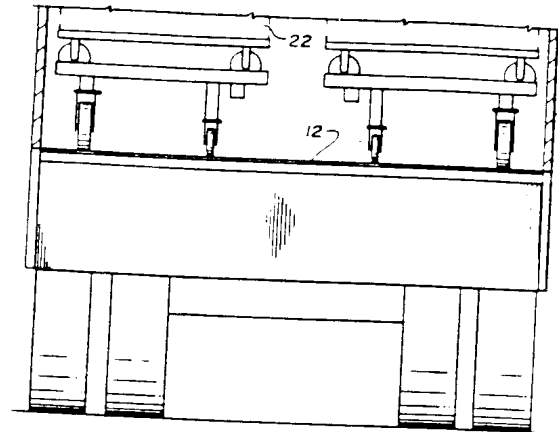
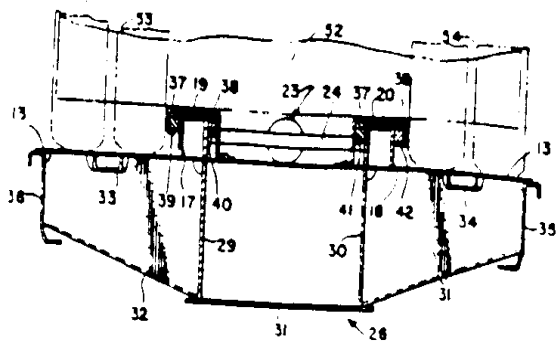

SEE OR SEARCH THIS CLASS, SUBCLASS:

- 57, for a freight carrier provided with rub rail or sunken area structure accommodating the rear wheels of a stowed semitrailer and also with means accommodating the fore end of the semitrailer.
- 67, for rub rail or sunken area structure accommodating a four-wheeled load bearer.

SEE OR SEARCH THIS CLASS, SUBCLASS:

- 1, for a freight-carrier-mounted turntable for stowing a wheeled vehicle, typically a semitrailer, on board; and wherein wheel guide structure (e.g., track) is mounted on the turntable and wherein, moreover, mating guide (track) structure may further be mounted on the freight carrier.

**66 Wheeled load bearer accommodation:**  
This subclass is indented under subclass 52. Structure particularly designed to accommodate such a load bearer as includes rolling support means.

- (1) Note. The "rolling support means" commonly but not necessarily constitutes the running gear for road use; see indented subclass 67 however, wherein are to be found four-wheel vehicles having roller support structure having utility for facilitating stowage, but impractical for road use.

**67 Including wheel guide:**  
This subclass is indented under subclass 66. Structure in which the freight carrier floor structure is provided with means contacting the rolling support members for guiding or for accommodating the supported load unit to or at its stowed position.

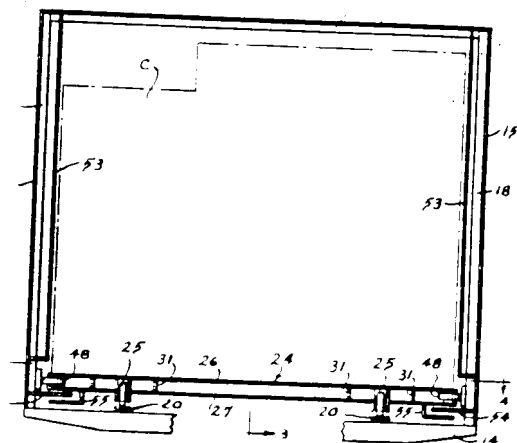

SEE OR SEARCH THIS CLASS, SUB-CLASS:

- 57, for a freight carrier provided with such structure and also with structure accommodating the fore end of the stowed semitrailer.
- 65, for wheel guides of the rub rail type for accommodating a semitrailer.

**68 Accommodation of rigid wall container for bulk material:**

This subclass is indented under subclass 52. Structure particularly designed to accommodate such an enclosure as (a) is form sustaining, and (b) contains fluent, particulate, or aggregate material.

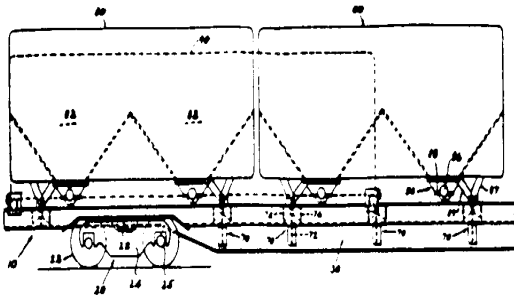

SEE OR SEARCH CLASS:

- 105, Railway Rolling Stock, subclass 270 for a container for fluids pivoted on its axis between railway trucks so as to reorient the outlet for pouring; and subclasses 358+ for tank cars.

**69 Load bearer tripped retainer\*:**

This subclass is indented under subclass 52. Structure including a retainer for the load bearer including a part so mounted and so positioned on the freight carrier as to be moved as a result of contact with a load bearer which is being stowed on the freight carrier.

- (1) Note. The contact-induced movement may be of the reset type; i.e., undergoing displacement to permit the load carrier to move therepast to be finally positioned, provided that the displacement is followed by spring, gravity, etc., induced

resetting for ultimate retentive engagement.

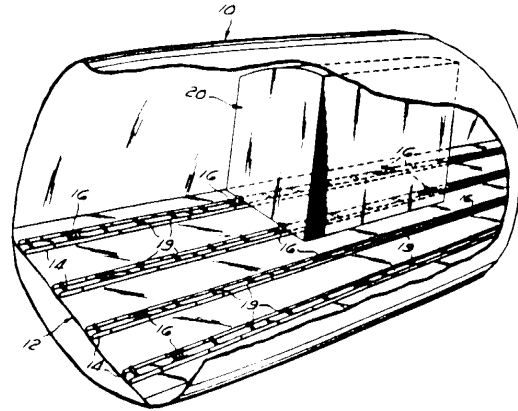

- 70** This subclass is indented under subclass 69. Retainer\* mounted on (corner pedestal)\*: Structure in which a load bearer retainer\* is installed to extend and move through a wall of a (corner pedestal)\* so as to be load tripped upon the load bearer corner(s) mating therewith.

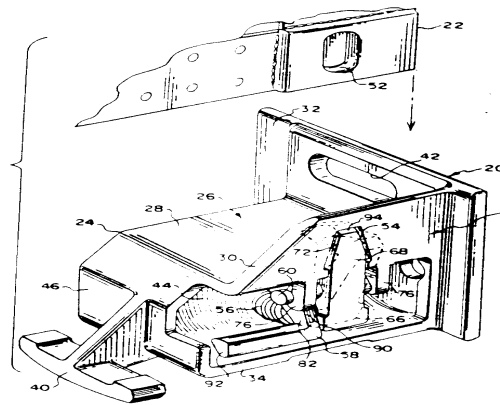

**71 Corner pedestal:**

This subclass is indented under subclass 52. Structure including a horizontal member engaging the meeting edges of a corner of a load bearer and vertical members upstanding from the outer edges of the horizontal member in position to engage corresponding vertical surfaces of said load bearer meeting edges to inhibit horizontal displacement of the load bearer on the freight carrier in the direction both longitudinally and transversely of the freight carrier; the accommodating structure

being positioned to maintain the load bearer somewhat raised from the freight carrier surface.

- (1) Note. The presence of the horizontal member merely upon the upper surface of the freight carrier floor is adequate to satisfy the "somewhat raised" requirement of this instant subclass definition.
- (2) Note. The disclosure is commonly directed, of course, to a set of four corner pedestals for the respective four corners of the load bearer.

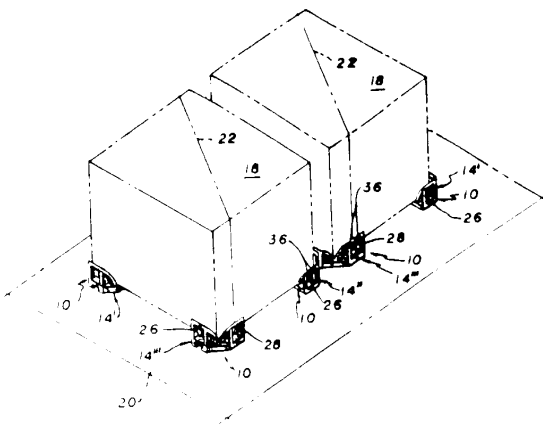

**72 Vertically displaceable, e.g., on horizontal axis:**

This subclass is indented under subclass 71. Structure including mounting means which permits displacement of the corner pedestal between an upper position to maintain the load bearer somewhat raised and a lower, generally nonuse, position of the pedestal.

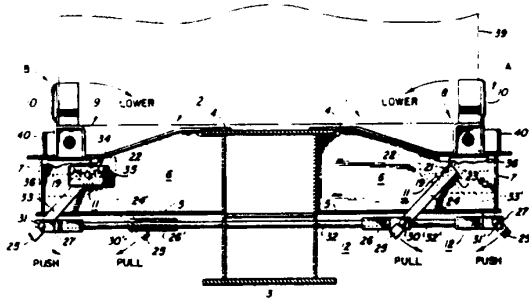

**73 Including male-female retainer\*:**

This subclass is indented under subclass 72. Structure in which the corner pedestal is provided with, or is constructed to mount a retainer\*, which is effective within the confines of the vertical and horizontal pedestal members, to penetrate a load bearer corner aperture.

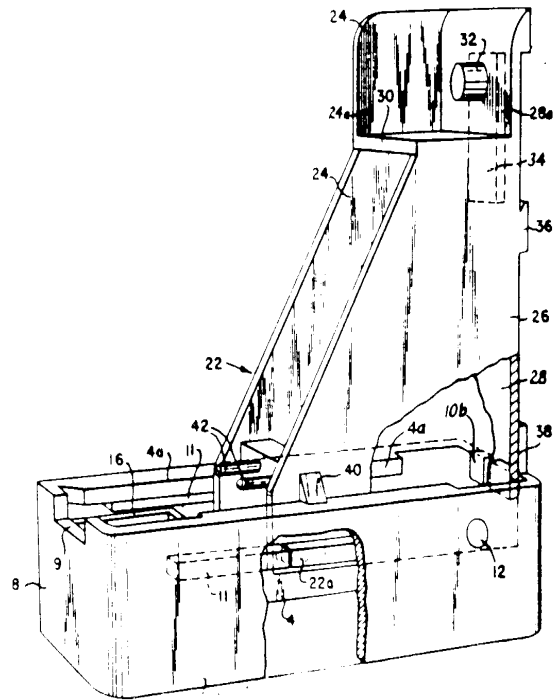

**74 Mounted on pedestal which is also slidable along track:**

This subclass is indented under subclass 73. Structure in which the corner pedestal which is provided with or which mounts the retainer\* is itself mounted on guide means for movement toward or away from the location the corner of a stowed load bearer is intended to occupy.

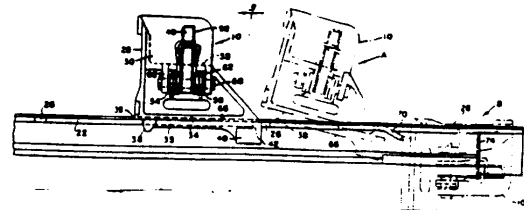

**75 And slidable along track:**

This subclass is indented under subclass 72. Structure in which the freight carrier is provided with guide means constraining the corner pedestal for movement there along-toward and away from an intended location relative to the corner of a stowed load bearer.

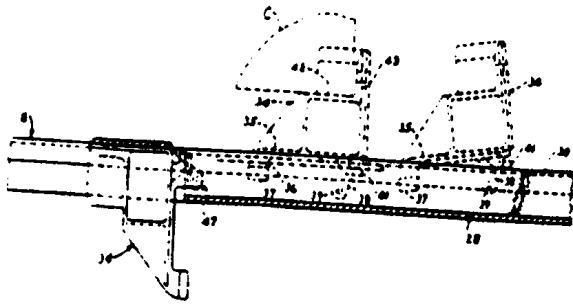
**76 Including male-female retainer\*:**

This subclass is indented under subclass 71. Structure in which the corner pedestal is provided with, or is constructed to mount a retainer\*, effective within the confines of the horizontal and vertical pedestal members, to penetrate within a load bearer corner recess.

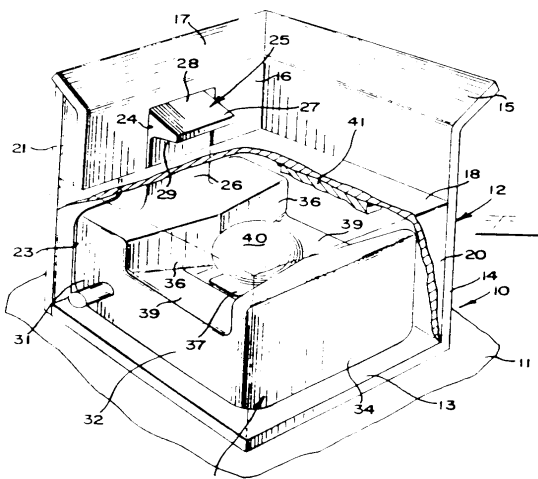
**77 Retainer:**

This subclass is indented under subclass 52. Structure in which the accommodating means is attached to the freight carrier and engages a part of the stowed load bearer adequately to effect securement thereto; i.e., to inhibit displacement of the load carrier on the freight carrier in both the lateral and vertical direction.

- (1) Note. Inhibition of displacement in the lateral direction is presumed when means inhibiting displacement in the vertical direction is brought into play. However, merely inhibiting displacement in the lateral direction will not be assumed to constitute, in itself, retainer structure as herein defined but will be recognized only as generic accommodating means. Rigid material hold-down structure of the hold-down type is predominantly the expedient by which to inhibit vertical displacement of a load--and, typically, lateral displacement as well (note, however, the load bearer (load lashing retainer)\* in subclass 85). The basics of a hold-down is paraphrased from the definition of Class 248, Supports, subclass 501, as follows: --form-sustaining structure having an undersurface portion for engaging an upwardly facing portion of a article to retain the article on a support surface--; to wit, in the instant context, a load bearer on a freight carrier surface.

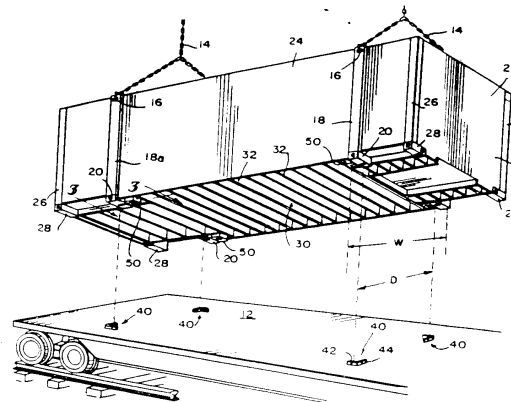

SEE OR SEARCH THIS CLASS, SUB-CLASS:

- 57, for the accommodation of a semi-trailer on a freight carrier by means cooperating with fore and with aft sections of the semitrailer, which means may be retainer\*.
- 64, for the retention of a semitrailer on a freight carrier by latch means on a stand retentively engaging the king

pin at the fore end of the semitrailer supported on the stand.

**78 Multiunit retainer:**

This subclass is indented under subclass 77. Structure in which (a) the retainer includes parts particularly interrelated for retaining a corresponding plurality of stowed load bearers, or (b) there is further provided a common operator to associate or disassociate a plurality of retainers with respect to a corresponding plurality of load bearer units.

- (1) Note. Consonant with the scope thereof, the above definition does not comprehend the customary plurality of retainers which, in fact, act independently of one another in their engagement with load bearers. Nor does this subclass include the plurality of retainers; however, inter-related in operation, for cooperating in retentively engaging different parts of but a single load unit.

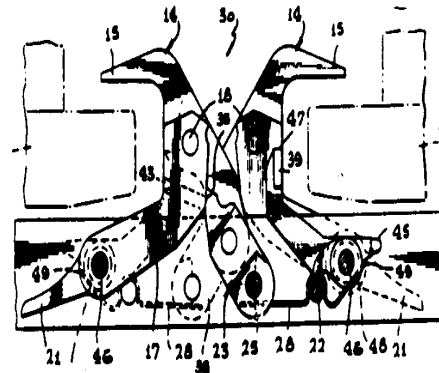

**80 Load bearer understructure retention, e.g., leg engaging:**

This subclass is indented under subclass 77. Structure including a part mounted on the freight carrier and retentively engaging such a load bearer part as is positioned or projects below the load-support surface thereof.

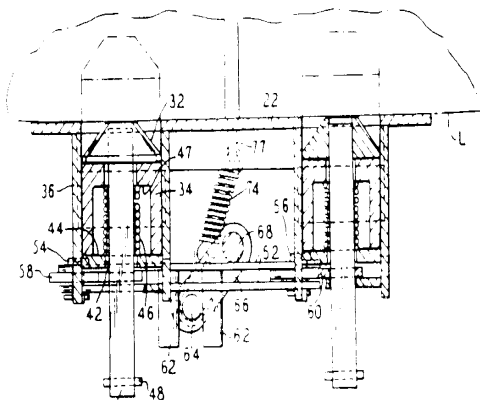

**79 Oppositely directed latch pair to retain contiguous load bearers:**

This subclass is indented under subclass 78. Structure in which the retainer is provided with lateral projections extending in opposite directions and parallel to the surface on which the load bearers are supported so as to be in retentive engagement with a respective pair of side-by-side load bearers.

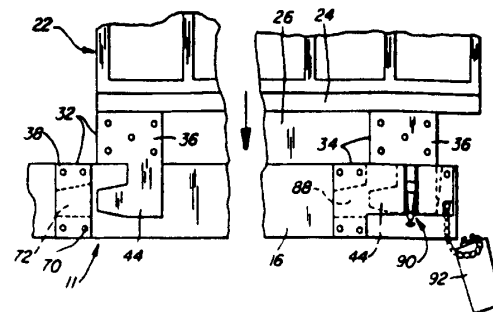

**81 By insertion of completely separable retainer, e.g., bolt, through aligned aperture:**

This subclass is indented under subclass 80. Structure wherein the retention is effected by the passage of a hitherto independent elongated fastener through coaxial apertures through each of the freight carrier and load bearer parts.

- (1) Note. The fastener was “hitherto independent” when carried upon the person for use as a retainer. It is also considered “hitherto independent” when hung from a chain or the like at a convenient spot on the load bearer or freight carrier surface.

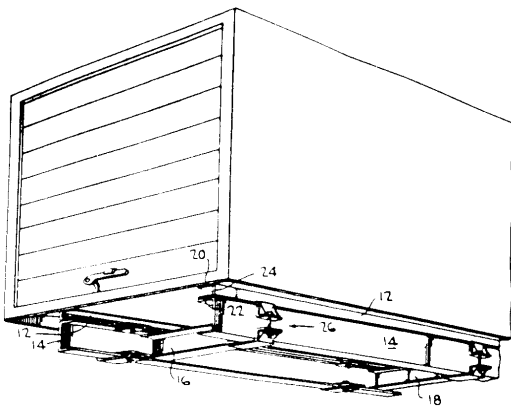
**82 Twist lock:**

This subclass is indented under subclass 77. Structure comprising a flanged shift the flange of which enters a load bearer fitting past a restriction which partially blocks egress, the shaft being then rotatable about its axis whereby to turn the flange behind the ingress-blocking restriction whereby to lock and retain the load bearer on the freight carrier.

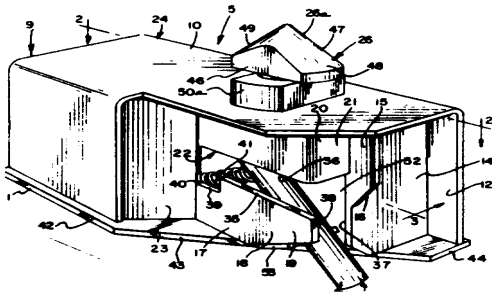
**SEE OR SEARCH CLASS:**

- 24, Buckles, Buttons, Clasps, etc., subclass 287 for a twist lock joining adjacent load bearers; frequently when on a freight carrier.
- 294, Handling: Hand and Hoist-Line Implements, subclass 81 for a handling device equipped with twist lock terminals to enter the corner fittings of a load bearer for the handling thereof, i.e., to load a load bearer on, or unload one from a freight carrier.

**83 Project-retract mounting:**

This subclass is indented under subclass 82. Structure including means which is on, or parallel to the support surface of the load bearer on the freight carrier, which means mounts the retainer for displacement between (a) an operative position for entry into a load bearer fitting, and (b) a nonuse position locating the retainer flange below the level of that support surface.

- (1) Note. The load bearer support surface could be the floor or a bolster of the freight carrier or could be a floor- or bolster-attached housing for the twist lock flanged member.

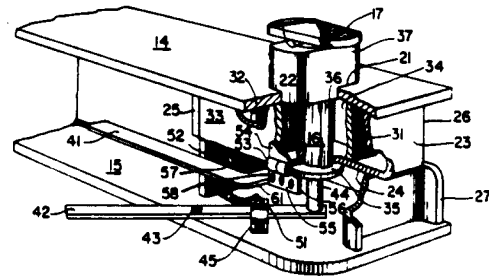
**84 Load bearer mounts active retainer received by static freight carrier keeper:**

This subclass is indented under subclass 77. Structure in which the freight carrier includes a fixed member and the load bearer is equipped with retainer structure including a part movable into retentive engagement with said carrier fixed member.

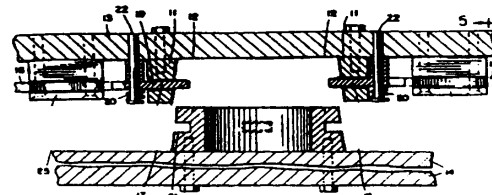



- 85 Load bearer (load lashing retainer)\*:**  
 This subclass is indented under subclass 77. Structure in which the accommodating means is a (load lashing retainer)\*.

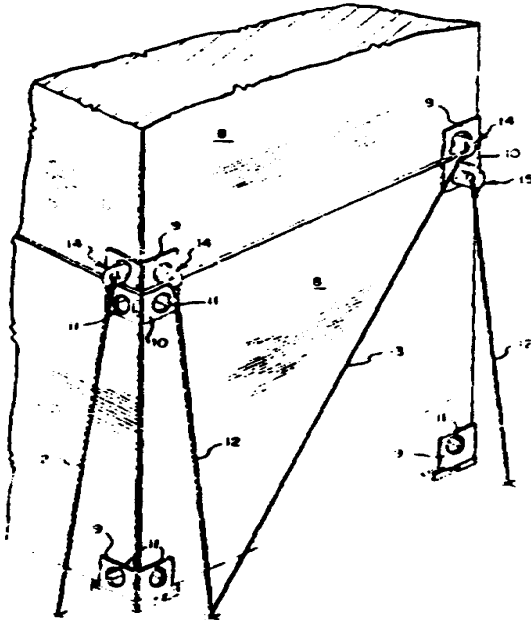

- 86 Including load bearer cushioning means:**  
 This subclass is indented under subclass 77. Structure comprising means so retaining the load bearer or so related to the load bearer support or retaining structure as to impart thereto recoverable movability so as to be movably yieldable under an excessive or undesirable force and thereby ward off the undesirable effect of that force.

(1) Note. The mere compression of a solid block is not herein provided for.

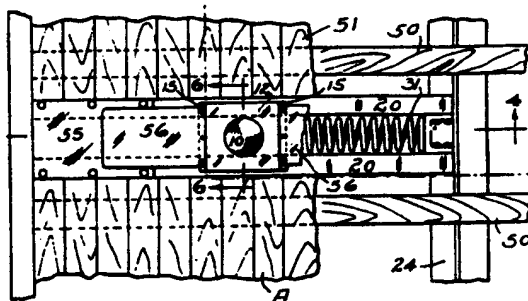

- 87 Cushioned accommodation:**  
 This subclass is indented under subclass 52. Structure comprising means so participating in the accommodation of the load bearer as to impart to the load bearer recoverable movability so as to be yieldable under an excessive or inadvertent force and thereby ward off the undesirable effect of that force upon the load unit.

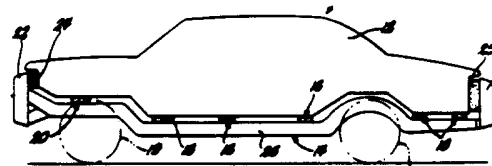

SEE OR SEARCH THIS CLASS, SUB-CLASS:

117+, for a yieldable brace for a load unit, generally.

- 88 (Fore-and-aft direction slide cushioning means)\*:**  
 This subclass is indented under subclass 87. Structure so related to the load bearer as to constitute (fore-and-aft direction slide cushioning means)\* therefor.

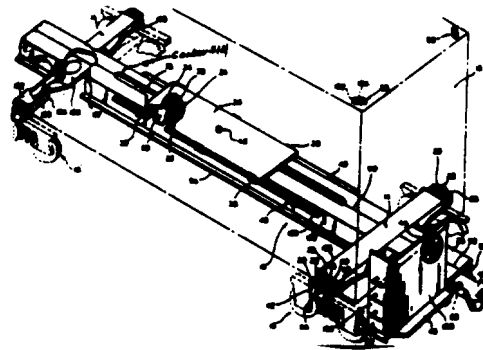

SEE OR SEARCH THIS CLASS, SUB-CLASS:

62, for (fore-and-aft direction slide cushioning means)\* for semitrailer stand-support accommodation.

**89 Wall-to-wall socket-entering load bearer:**

This subclass is indented under subclass 52. Structure in which a wall of the freight carrier is provided with means defining a recess, matched by a corresponding recess means on an opposed wall, and the load bearer is provided with a projection mating with said means for accommodation of the load bearer on the freight carrier.

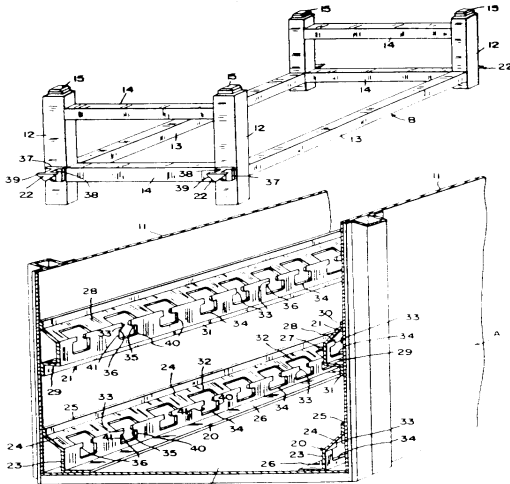

SEE OR SEARCH THIS CLASS, SUB-CLASS:

- 54, for a wall-to-wall socketed load bearer convertible to a brace panel by being repositioned to extend wall-to-wall, but vertically.
- 132+, and 142, for a freight carrier having a wall-to-wall brace panel with pin-in-socket panel-to-wall association.
- 144+, for projection-in-aperture association of a wall-to-wall brace bar with the freight carrier wall.

**90 Load bearer accommodation by underside socketing:**

This subclass is indented under subclass 52. Structure in which, at the common plane whereat the load bearer undersurface rests on the freight carrier floor, a projection extends from one of these and enters a recess of the other to inhibit lateral shifting of the load bearer on the floor.

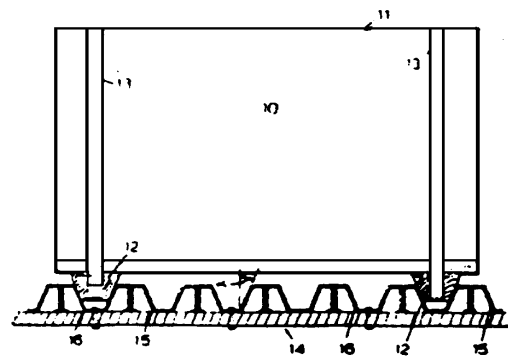
**91 Pin-socket accommodation:**

This subclass is indented under subclass 90. Structure in which the projection is a localized male post member and the recess is an aperture surrounding the member.

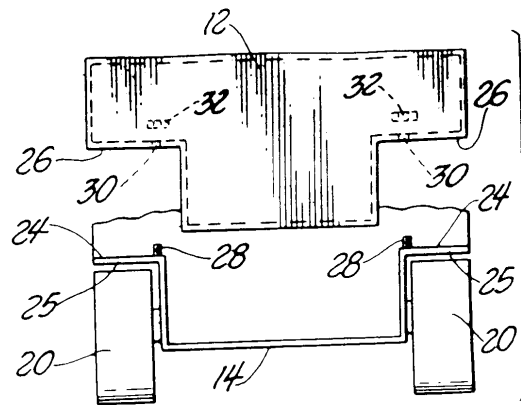

SEE OR SEARCH THIS CLASS, SUB-CLASS:

- 81, for a projection-in-fitting retainer\* arrangement wherein both projection and fitting are apertured and wherein the apertures are alignable so as to receive a bolt or boltlike member to retain the load bearer unit on the freight carrier.

**92 Rollerway:**

This subclass is indented under subclass 52. Structure including an assemblage of members each of which is so mounted along the load-supporting surface of the freight carrier as to be rotatable about its own individual axis, or center for a sphere, and so projecting or projectable from that surface as to be engageable with the undersurface of a load bearer to facilitate

movement thereof to an appropriate location on the freight carrier.

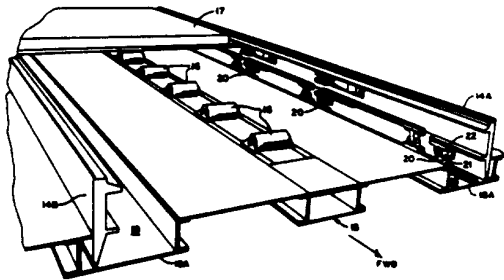

**93 Drop side car, side converts to ramp:**  
 This subclass is indented under subclass 52. Structure comprising a freight carrier component, usually side wall member, hinged at an outside edge of the freight carrier floor for swinging movement between (a) vertically upstanding position constituting a barrier to the shifting movement of the load unit past the freight carrier, and (b) a lowered position to permit loading or unloading of the load unit thereacross; the component being one in a parallel array along said edge to substantially coincide with the edge widths of load bearers intended to be arrayed along the freight carrier.

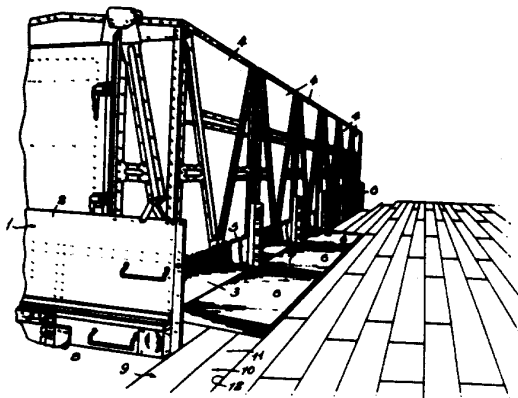

SEE OR SEARCH CLASS:  
 244, Aeronautics and Astronautics, subclass 118.3 for an aircraft closure panel swingably displaceable outwardly and downwardly to constitute an on-ground loading ramp.

**94 Load bearer abutment:**  
 This subclass is indented under subclass 52. Structure comprising a rigid member connected to and upstanding from the floor of a freight carrier to engage and prevent lateral movement of a stowed load bearer there past.

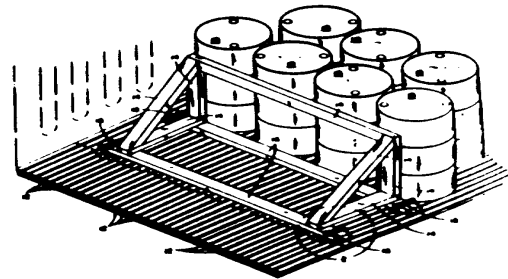

SEE OR SEARCH THIS CLASS, SUB-CLASS:  
 121, 154 and 155, for dunnage members; i.e., free standing and unconnected to the freight carrier to fill in spaces between load units.

**95 Between load bearer units:**  
 This subclass is indented under subclass 94. Structure in which the rigid upstanding member spans the space between and thereby abuttingly separates adjacent load bearers on the freight carrier.

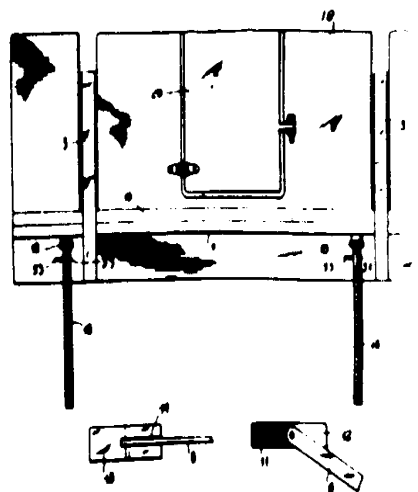

**96 LOAD LASHING RETAINER OR LOAD LASHING ADJUNCT:**

This subclass is indented under the class definition. Structure including (a) flexible member means to engage lading on a freight carrier to control the lading against inadvertent shifting during transportation, or (b) means attachable to the freight carrier for securement of the flexible member means thereto and, thereby, to the freight carrier, or (c) an arrangement of lading, including the use of flexible member means, to accomplish the purpose hereinabove defined.

- (1) Note. Attention is directed to the (1) Note proviso in the definition of indented subclass 101 that an anchor (or equivalent hardware) for a flexible member disclosed as merely bracing the lading (along only one edge, as under subclass(es) 117) is not barred from placement therein (subclasses 101+).

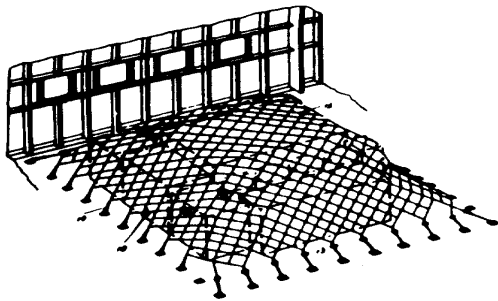

**97 Wraparound:**

This subclass is indented under subclass 96. Structure wherein the flexible means encircles the lading to effect retention thereof on the freight carrier.

- (1) Note. 270° of encirclement will suffice for this subclass only when a wall or other car surface panel structure, e.g., bulkhead, or car side, completes the remaining 90° encirclement.

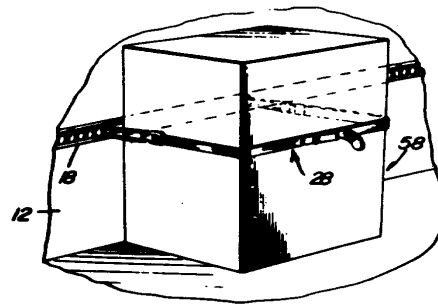

SEE OR SEARCH THIS CLASS, SUBCLASS:

- 120, for a wraparound\*-type retainer consisting however, of an assembly of rigid material rod members (as opposed to chain links) joined angularly and end-to-end to tightly encompass a lading unit.

SEE OR SEARCH CLASS:

- 224, Package and Article Carriers, subclasses 309+ for wraparound means for securing an article, e.g., package, to the roof of a passenger vehicle.

**98 Method:**

This subclass is indented under subclass 97. Process including the use of a wraparound\* to retain lading on a freight carrier to control inadvertent shifting thereof during transportation.

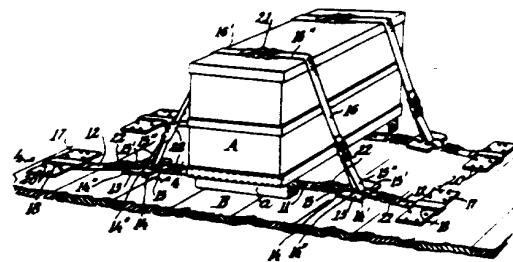

**99 Including angular surface guard, e.g., edge-around:**

This subclass is indented under subclass 97. Subject matter in which the encircled load unit has a rectangular or an arcuate dimension and,

therefor, includes a corner or a curved outer surface location and in which the rigid material member protectively intervenes at that location either (a) between the lading and the flexible means encircling it, or (b) as a connector between adjacent ends of flexible means members.

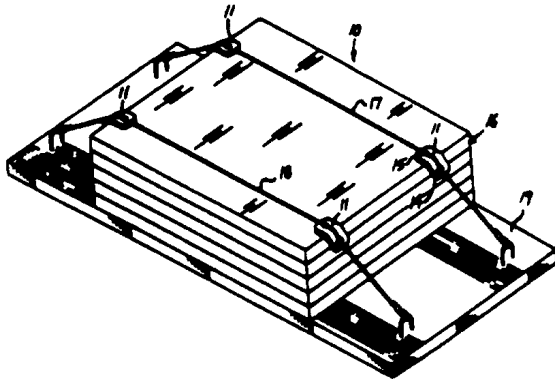

**100 Including tightener or tensioner:**  
 This subclass is indented under subclass 97. Structure including force-multiplying means to draw the flexible member means in tight encirclement about lading, e.g., winch, turnbuckle, jack screw, (but not mere linkage) or spring means connected to the flexible member means in intervening relation between the lading and the freight carrier to provide a force constantly urging the flexible member means into tight compaction about the lading.

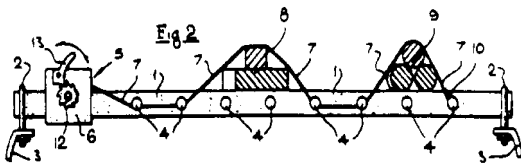

**101 Anchor:**  
 This subclass is indented under subclass 96. Structure comprising an attachment device secured to a freight carrier surface at a location (usually one of a number of locations) for securing an end of a flexible member thereto to leave the remainder thereof available for use in constraining lading against inadvertent shifting during transport on board the carrier.

(1) Note. Disclosure that the attached flexible member is used merely for bracing, as defined in subclass 117, will not bar placement of the anchor subcombination in this locus (subclasses 101+).

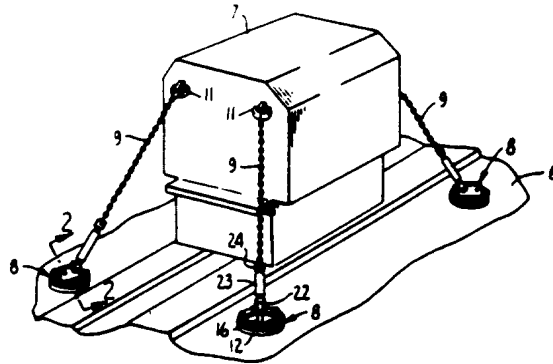

**102 Multipurpose, e.g., combined, convertible:**  
 This subclass is indented under subclass 101. Structure in which the anchor location is both the tie piece\* locus and also the locus for structure which serves another purpose, e.g., hold down, bracket, brace bar receiver, even for retaining a second flexible member.

(1) Note. The plural uses may be simultaneous or alternative and may, but need not necessarily, involve rearrangement, modification, or substitution of parts.

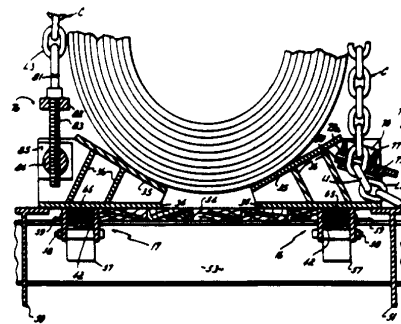

**103 Including winch or tensioner:**  
 This subclass is indented under subclass 101. Structure in which the device is provided with tautening means which is effective either by taking up a turn on the flexible member, e.g., drum, or by augmenting the force applied through the (tie piece)\*.

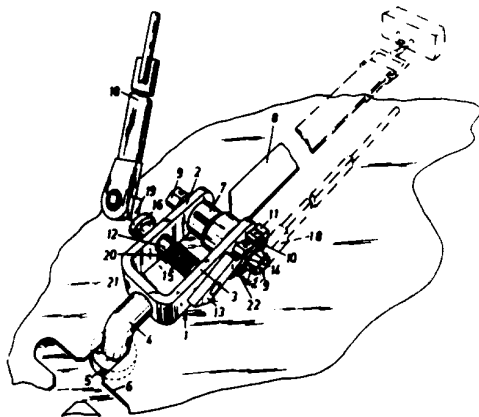

## SEE OR SEARCH CLASS:

254, Implements or Apparatus for Applying Pushing or Pulling Force, subclasses 199+ and 213+ for a cable tautening device, including a tie piece to retain the end of a load lashing or binding cable.

**104 Track-guided anchor:**

This subclass is indented under subclass 101. Structure including an elongated member fixed to a surface of the freight carrier and constructed to mount a tie piece\* for guided sliding movement to one of a plurality of locations along the length of said member most suitable for the instant load retaining arrangement.

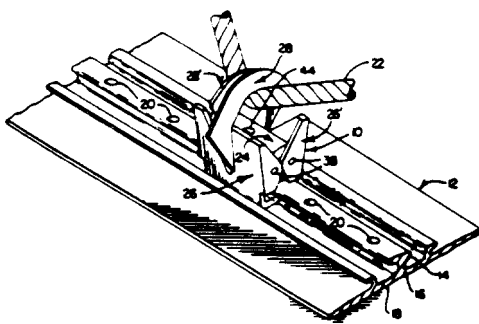

## SEE OR SEARCH THIS CLASS, SUBCLASS:

10, and 11, for tiedown structure to retain a four-wheel vehicle on a freight carrier, which structure includes track-guided anchor structure; and for track-

guided anchor structure, per se, limited to this use.

115, for an elongated member which in itself provides an array of anchor locations or which is provided with an array of locations to which tie pieces are mounted; there being no guide structure for communication between the locations.

**105 Anchor-admitting cross-slotted track:**

This subclass is indented under subclass 104. Structure in which the elongated mounting member is formed with passage means having at least one communicating side recess and the flexible-member-retaining device is formed at its end with a correspondingly relatively wide mounting portion receivable through said side recess but too large for entry or escape through any other part of the passage.

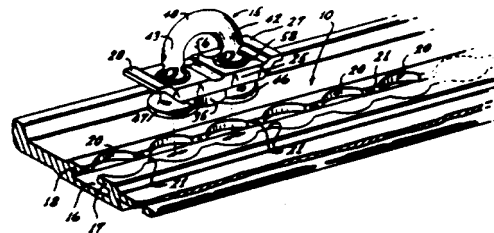

## SEE OR SEARCH THIS CLASS, SUBCLASS:

150, for a cross-slotted track for slidably guiding and selectively locating the end of a brace bar along a freight carrier wall.

**106 Mounted on exposed and bordering structural member:**

This subclass is indented under subclass 101. Structure in which the device is affixed to or formed from a single elongated structural member, e.g., top chord or bulb angle, side sill of flat car, incorporated in and recognized as basic carrier structure for the framing of the cargo space available to the ambient, or to a door post of a box car.

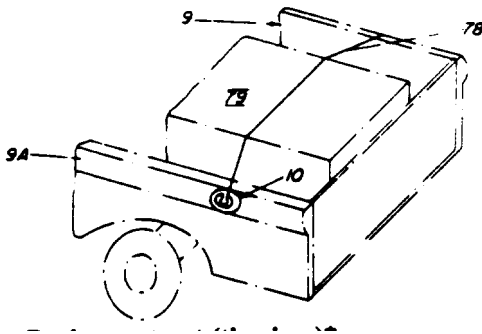

**107 Project-retract (tie piece)\*:**  
 This subclass is indented under subclass 106. Structure in which the device includes a (tie piece)\* mounted for movement from a nonuse position within the bounds of the exposed surface configuration of the structural member to a position maintained exposed therepast, as by force exerted on the attached lading-engaging flexible member.

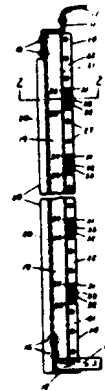

**109 And inboard-mounted anchor, e.g., recessed in car facing:**  
 This subclass is indented under subclass 108. Structure further including another flexible-member-retaining device secured to the carrier within the confines (though not necessarily the plane) of the framework.

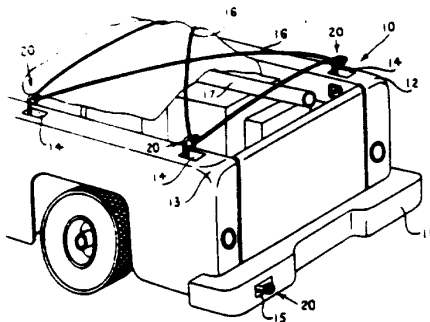

**108 In exposed array therealong:**  
 This subclass is indented under subclass 106. Structure in which a row of (tie piece)\* or anchor formations is mounted or arranged on the framing member at loci whereat all are substantially bordering the freight carrier contour and available to the ambient.

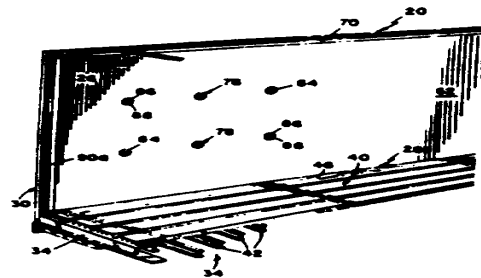

**110 Atop wall of open top freight carrier, e.g., bulb-angle mounted:**  
 This subclass is indented under subclass 108. Structure in which a row of (tie pieces)\* or anchor formations is arranged along, or adjacent and parallel to, the uppermost edge of the vertical body member of the freight carrier and thereby in an exposed and bordering array because the freight carrier has no top wall structure to thwart access thereto.

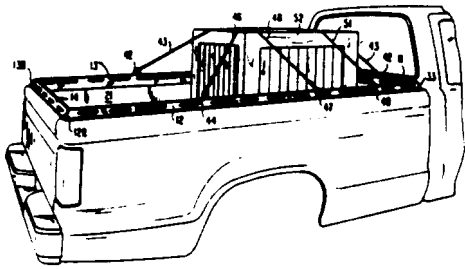

**111 Project-retract (tie piece)\*:**

This subclass is indented under subclass 101. Subject matter in which the (tie piece)\* is mounted so as to be recessed within the bounds of the mounting structure in the nonuse position thereof and be shiftable to extend therebeyond and be maintained in that position under the force applied to the attached flexible, lading engaging member.

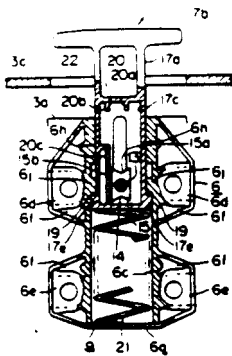

**112 Recessed in car facing:**

This subclass is indented under subclass 101. Structure in which covering material is so formed or so mounted on a surface of the freight carrier exposed to lading as to define an inset at or along that surface; and in which anchor structure, either the entire anchor or only the (tie piece)\* thereof, is so mounted as to be available only at the inset and to be confined within the plane defined by the exposed surface of the covering material.

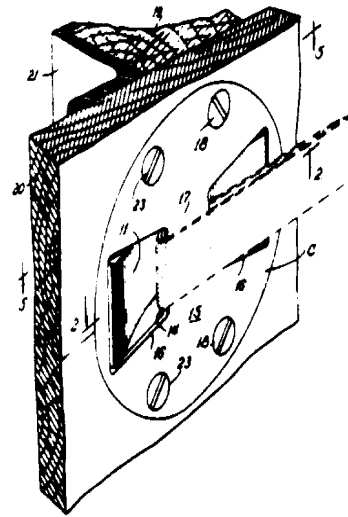

SEE OR SEARCH THIS CLASS, SUBCLASS:

- 107, for such a project-retract tie piece on a bordering surface of a freight carrier open to the ambient.
- 111, for a project-retract tie piece which is recessed in freight carrier facing in its nonuse position.

**113 Recessed anchor array:**

This subclass is indented under subclass 112. Structure in which the attachment device for the flexible material member essentially is, or includes elongated member means having a row of anchor locations therealong, the anchor locations being provided by (a) spaced formations shaped from (e.g., stricken from) the elongated member means to provide access thereto for the end of the flexible member, or (b) the arrangement of an elongated member and such backing, support, or other adjacent freight carrier interior structure as defines such spaced access formation, or (c) a spaced row of (tie pieces)\* added on (e.g., welded on) to the elongated member means; the attachment device in any of these constructions or arrangements being so surrounded by adjacent structural details as to be accessible only at or within the plane defined thereby.



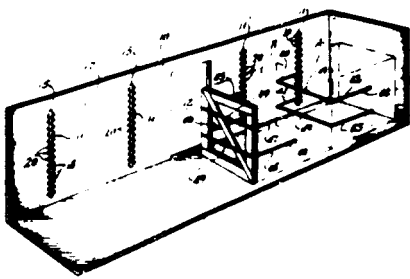

**114 Of attached (tie pieces)\*, e.g., welded:**

This subclass is indented under subclass 113. Structure in which the anchor locations are defined by a row of individual (tie pieces)\* mounted along the elongated anchor array member means at the anchor intervals and contained within the exposed plane of the covering means.

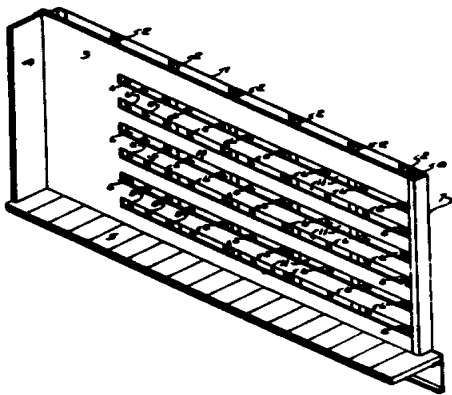

SEE OR SEARCH THIS CLASS, SUBCLASS:

113, the principal subclass, for the anchor array provided by the elongated anchor member itself by means of formations therealong at the anchor intervals and unitary therewith; or by the way it is mounted and related to adjacent freight carrier structure.

**115 Array strip or formation:**

This subclass is indented under subclass 101. Structure comprising elongated member means, e.g., bar, strip, post; and see (1) Note, below, fixed to the freight carrier surface and provided at intervals along the length thereof either (a) with the individual tie pieces\*, or (b) with a row of unitary formations or arrange-

ments for the direct connection thereto of the end of a lading engaging member.

- (1) Note. The “elongated member means” herein defined may be, in fact, part of wider panel structure (e.g., edge, flange; see subclass 108) only when it is unmistakably distinct from the rest of the panel and so narrow as hardly to permit more than a single anchoring to occur at a single location along the row (two would be rare and could occur only under the limitations of subclass 102).

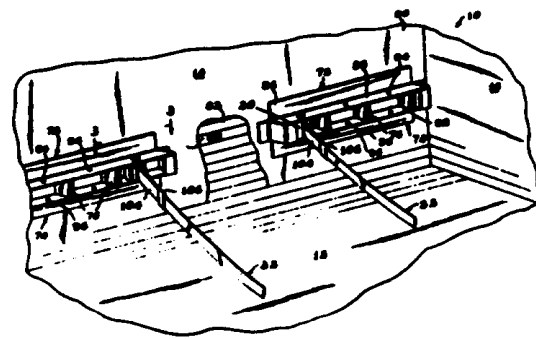

**116 Including mounting means for facile assembly or removal of (tie piece)\*:**

This subclass is indented under subclass 101. Structure in which the attachment device includes a (tie piece)\* provided with means mounting the device for ready securement to and disengagement from the freight carrier.

- (1) Note. The requirement for either facile securement or disengagement is met where either is disclosed and it is obvious that a reverse manipulation will complete both. Facility in assembling and removal is presumably negated by the necessity to use a tool: but not necessarily. Delivering a light blow to unwedge the device, for example, need not necessarily negate operational facility.
- (2) Note. Performance of facile assembly and removal may occur for the tie piece and anchor mounting as a unit; or by association and disassociation of the tie piece alone from the means which

mounts it on the anchor receiver and remains with it.

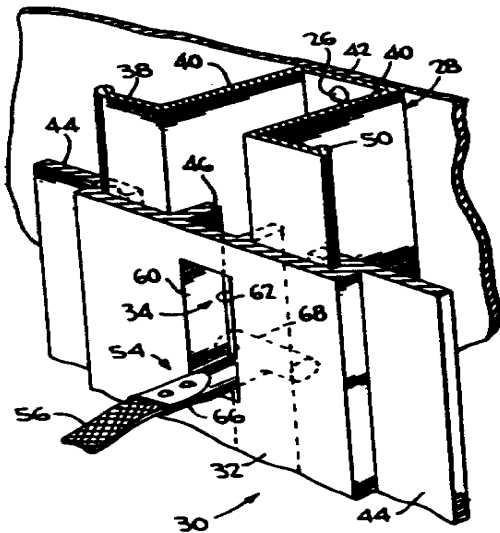

#### 117 YIELDABLE BRACE:

This subclass is indented under the class definition. Structure comprising accommodating means which (a) is in whole or in part of flaccid material so as to yield upon application against lading when the means is installed on the freight carrier, or (b) subsequent to positioning or installation on the freight carrier is in such direct engagement with the load unit and is of such deformable construction that it will undergo a change of shape upon receiving force from lading disturbed by untoward occurrence during shipment.

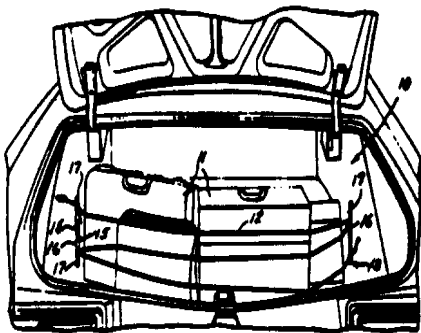

#### 118 Panel:

This subclass is indented under subclass 117. Structure in which the accommodating means is a deformable member of significant length and breadth conformingly to engage a surface area of the load unit.

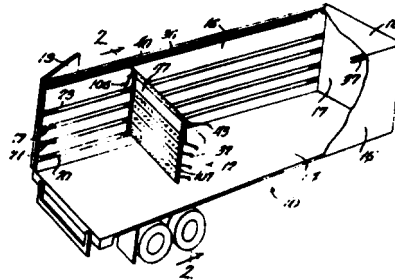

SEE OR SEARCH THIS CLASS, SUBCLASS:

121+, (e.g., 123+, indented thereunder), for load bracing panel means in which the member directly engaging a surface of the load unit is rigid and essentially nondeformable but is provided with yieldable means urging the panel into bracing augmentation with the load unit, compare, for example, subclass 119 indented hereunder, with subclass 125, indented under 123.

SEE OR SEARCH CLASS:

150, Purses, Wallets, and Protective Covers, subclasses 154+ for flexible covers for the protection of articles, generally.

#### 119 Inflated or inflatable:

This subclass is indented under subclass 118. Structure wherein the load unit engaging member is a wall of a bag which is filled with fluid or is in communication with a fluid source of reception of filling fluid for its accommodating function.

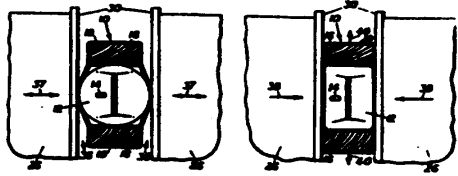

SEE OR SEARCH THIS CLASS, SUB-CLASS:

- 119, for a squeeze device; i.e., an inflated or inflatable bag for exerting lading-engaging force upon a pair of brace panels on opposite sides of the bag.
- 128, for pneumatic means including a bag between a brace panel and a freight carrier compartment wall for exerting lading-engaging force upon the panel.

SEE OR SEARCH CLASS:

- 280, Land Vehicles, subclasses 728+ for a passenger restraint inflatable bag in a land vehicle.

**120 RIGID MEMBER RETAINER, E.G., WRAP-AROUND TYPE:**

This subclass is indented under the class definition. Structure comprising a rigid material retainer\*, e.g., form-sustaining, elongate rod members, as opposed to chain links, articulatively or angularly joined to one another at their ends to pass over and to encompass a load unit in tight encirclement thereof.

- (1) Note. 270 encompassment against a planar freight carrier surface is adequate for this subclass definition.

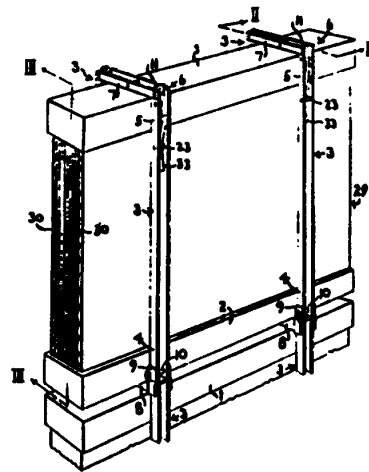

SEE OR SEARCH THIS CLASS, SUB-CLASS:

- 97+, for chain means for flexibly encircling lading or for the combination of flexible and rigid wraparound members, in either case to constitute a flexible (retainer)\* (wraparound)\*.

**121 LOAD BRACING MEANS:**

This subclass is indented under the class definition. Structure comprising a brace; i.e., rigid member means for contacting a vertical side of lading on a freight carrier to block inadvertent lateral shifting of the lading in transit.

- (1) Note. This (the principal) subclass contains dunnage members; i.e., freely insertable elements between and in contact with adjacent load units to fill the intervening space.

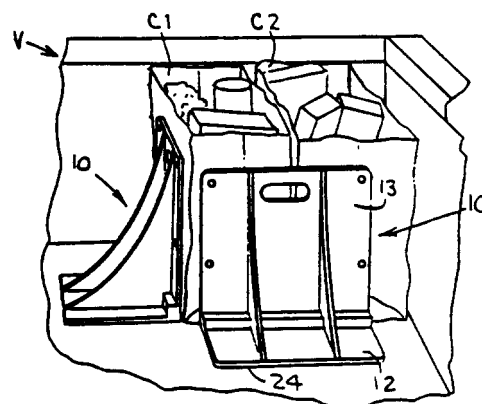

SEE OR SEARCH THIS CLASS, SUB-CLASS:

- 154, for honeycomb-shaped dunnage.
- 155, for dunnage elements shaped to contact angularly related load unit surfaces.

**122 Bifacial brace:**

This subclass is indented under subclass 121. Structure in which the lading-engaging member means includes a pair of rigid lading-engaging panels or frames provided with means interconnecting them for movement away from one another and for maintaining them thus apart in either spaced parallelism or opposite divergence; the bi-member means thereby constituted being locatable in a space between adjacent load units with each member in blocking engagement with a respective confronting side of each load unit.

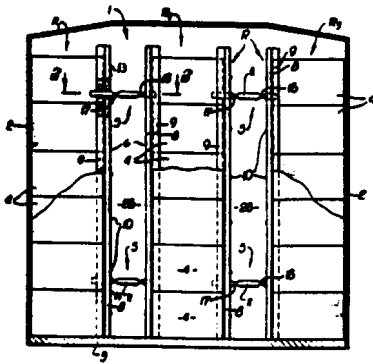
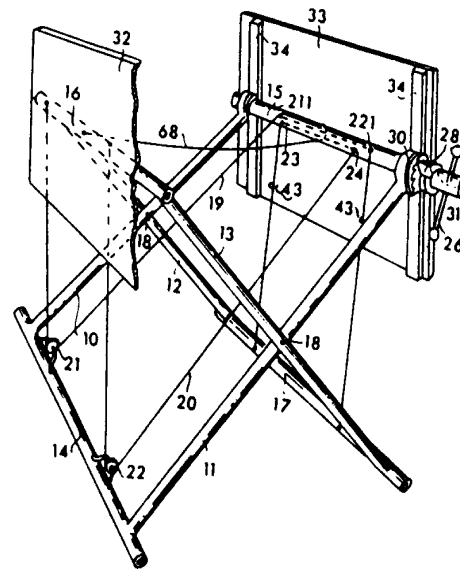

**123 Squeeze:**

This subclass is indented under subclass 122. Structure further including fluid pressure, electrically powered or force-multiplying means, e.g., jack screw, ratchet, (but not mere linkage means) operative between the lading-engaging members to urge them apart for augmenting the blocking force on the lading.

**124 Powered or pressurized:**

This subclass is indented under subclass 123. Structure wherein the means to urge the blocking member apart to augment the blocking force on the lading is fluid pressure or electrically powered means.

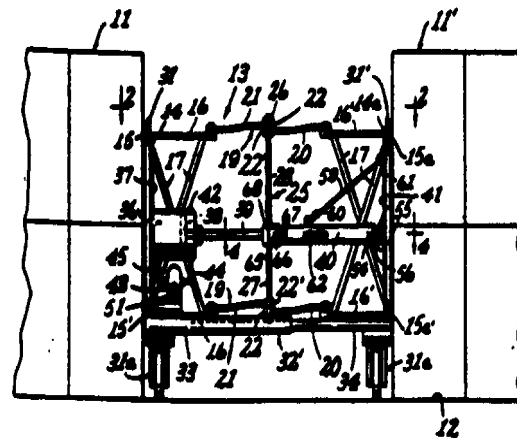

**125 Intervening squeeze bag:**

This subclass is indented under subclass 124. Structure including a closed, flexible, fluid-filled container in intervening contact with and between the blocking members and of a dimension at least approaching that of the area or length of the members.

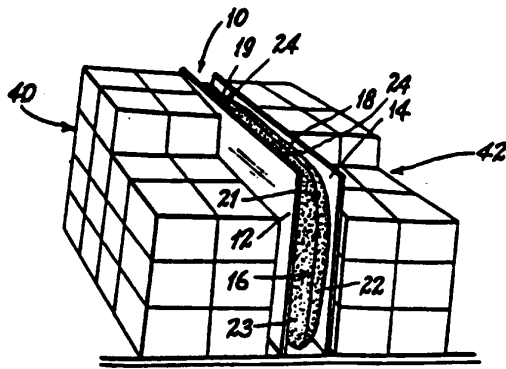

**126 Track guided:**

This subclass is indented under subclass 123. Structure (a) including means installed on the freight carrier and extending longitudinally therealong, (b) and in engagement with a conformingly shaped edge portion or added-on part of at least one of the lading-engaging members, (c) to constrain longitudinal movement of a member along the freight carrier to a position effective for lading-blocking engagement.

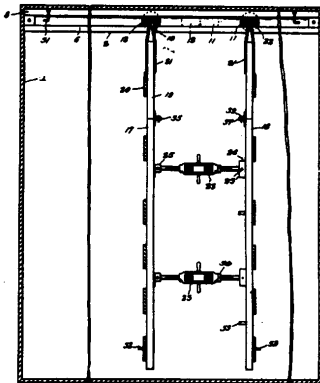

SEE OR SEARCH THIS CLASS, SUBCLASS:

125, for squeeze structure of the construction which includes an intervening squeeze bag and which may be track mounted.

**127 Brace panel with wall-to-lading adjustment means:**

This subclass is indented under subclass 121. Structure comprising a rigid, planar-face lading engaging and bracing member and means at, or

adjacent to the wall of a freight carrier so movably related to the member and to the wall as to displace the member, upon movement thereof, into load bracing contact therewith, or into enhancement of such contact

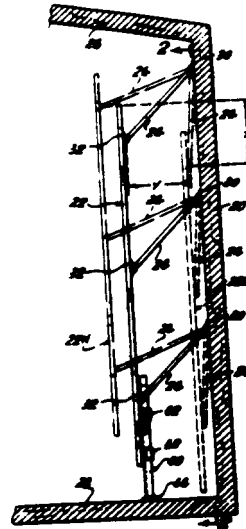

**128 Forcing, e.g., motorized, pressurized, or adjusted by force-multiplying means:**

This subclass is indented under subclass 127. Structure further including means urged by fluid pressure or motive power or through the provision of force multiplying structure, e.g., turnbuckle, jack screw, but excluding mere linkage, to compel the shifting of the lading engaging and bracing member to its operative position abutting the lading.

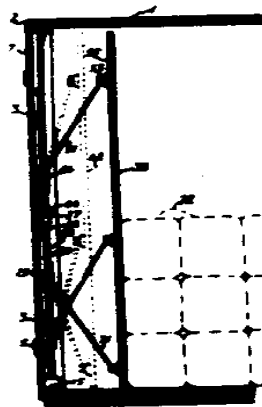

SEE OR SEARCH THIS CLASS, SUB-CLASS:

123, and 126, indented thereunder, for force multiplying means for urging the individual panels of a bifacial brace in the directions away from one another more tightly to brace load units at either side of the respective panels.

124+, indented under 123, for motor powered or fluid pressure means for effecting the same.

**129 Panel or frame, wall-to-wall:**

This subclass is indented under subclass 121. Structure in which the rigid member means has a planar contour of such width and height dimensions as to be capable of substantially spanning the transverse dimension of the freight carrier, in the horizontal dimension of said means, and to extend to significant height vertically.

- (1) Note. Frame structure defining a substantially planar contour is considered to constitute a panel under the above definition.
- (2) Note. The rigid member means in this and the indented subclasses is referred to in disclosures classified hereunder as a bracing member, at other times as a bulkhead. In either case the member is assumed to be effective for bracing a load unit, in any event, to be so similarly shaped and installed as to be classified together regardless of how referred to and, by implication, used. Some few such panel or frame members are herein classified even when not positioned wall-to-wall recognizing, for example, that dimensions appropriately "wall-to-wall" in a freight car do not aptly apply to the hold of a ship, where the panel member may be installed post to post.

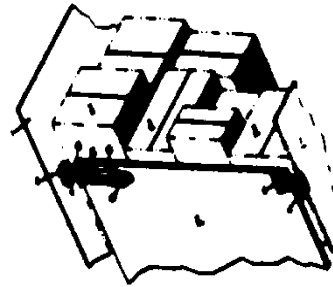

SEE OR SEARCH THIS CLASS, SUB-CLASS:

54, for a brace panel convertible to wall-to-wall socket-entering load bearer by being repositioned from the vertical bracing position to the horizontal load bearer supporting position.

**130 Track mounted:**

This subclass is indented under subclass 129. Structure in which the planar-face member means is provided with a projection (usually roller equipped), and in which the freight carrier is equipped with means extending along the length thereof which is shaped to captively guide the extension for sliding or rolling movement therealong to position said member means at a selected one of a number of compartment-spanning positions intermediate the ends of the freight carrier.

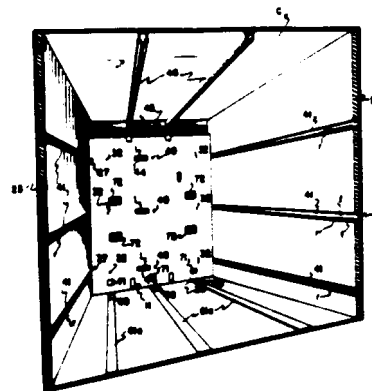

SEE OR SEARCH THIS CLASS, SUB-CLASS:

125, for bifacial squeeze structure commonly track mounted and extending wall-to-wall, which latter squeeze

structure includes an intervening air bag.

126, for a track mounted bifacial squeeze intervening, commonly wall-to-wall, between adjacent load units.

**131 Wall-to-wall pair, oppositely swinging:**

This subclass is indented under subclass 130. Structure in which the planar face member means comprises a pair of planar members of a width substantially half that of the transverse dimension of the freight carrier interior, the members being turnably mounted on respective individual pivots between positions (a) defining a common plane transversely spanning said interior, and (b) spaced substantial parallelism to one another and adjacent parallelism to each respective freight carrier side wall.

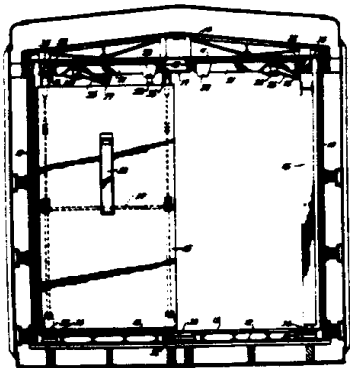

**132 Including pin-in-aperture latch:**

This subclass is indented under subclass 130. Structure in which the planar face member means is provided with a pin-shaped element extending or extensible from an edge thereof and the freight carrier is provided with a series of conformingly shaped openings; i.e., holes or slots, extending along the length thereof for the selective reception of the pin-shaped element to fixedly lock the planar member means at a selected position along the length of the freight carrier.

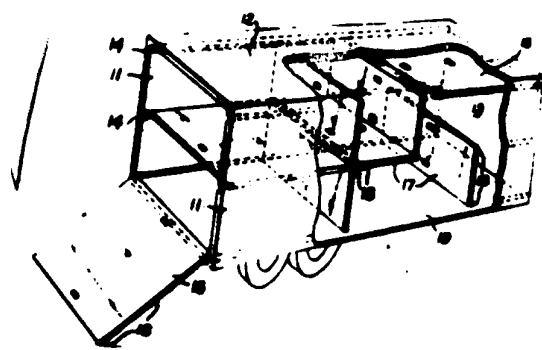

**133 Track is apertured to defined both (a) a sprocket wheel rack, and (b) a series of latch pin receivers:**

This subclass is indented under subclass 132. Structure in which the guide for the movement of the planar face member means, or immediately adjacent structure fixedly secured to the guide, is provided with (a) a series of openings therealong to cooperate with sprocket means rolling therealong, and (b) with another series of openings to define lock pin receivers.

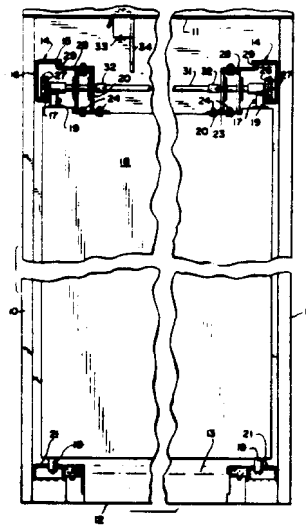

**134 Gang-operated latch pins:**

This subclass is indented under subclass 133. Structure including operating means so linked to a spaced plurality of lock elements as sequentially or simultaneously to move them into or out of lock position with respective lock apertures.

freight carrier walls to out-of-way adjacency parallel to these walls.

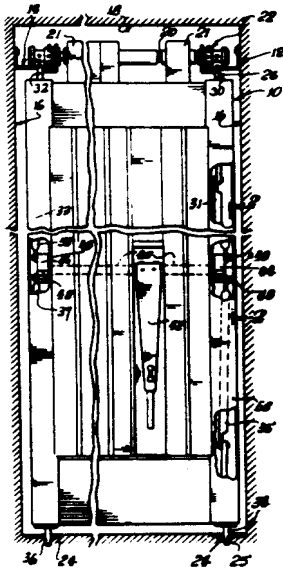

**135 Panel movable to out-of-way position:**

This subclass is indented under subclass 132. Structure in which the planar face member means is shiftable to a nonblocking position close to and substantially parallel to one of the freight carrier interior surfaces.

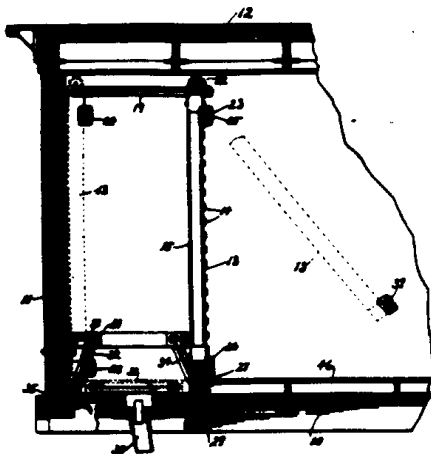

SEE OR SEARCH THIS CLASS, SUBCLASS:

131, for panel structure constituted from a pair member which is positionable to complement one another for the wall-to-wall arrangement and are individually and oppositely swingable about respective hinges adjacent opposite

**136 Winched:**

This subclass is indented under subclass 135. Structure including cable and pulley means, the pulley being attached to the freight carrier and the cable extending from the pulley and attached adjacent the distal end of the pivoted panel or frame member for turning it about the pivot at its other end to an out-of-the way position adjacent and parallel to a freight carrier, usually the upper surface thereof.

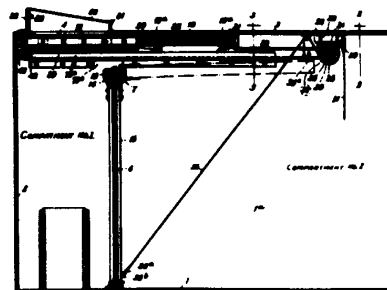

**137 Gang-operated latch pins:**

This subclass is indented under subclass 132. Structure including operating means so linked to a spaced plurality of lock elements as sequentially or simultaneously to move them into or out of locking engagement with the respective lock apertures.

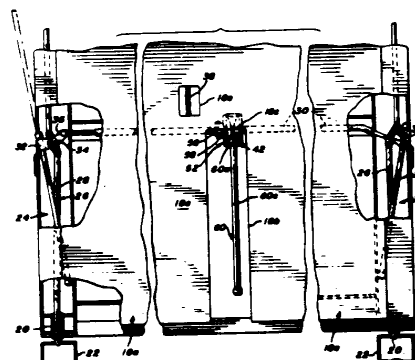

**138 Including pin which latches into track aperture:**

This subclass is indented under subclass 137. Structure in which the spaced plurality of members includes one which is movable into or out of lock engagement with one of the lock



openings which is in a series formed along the panel-movement-controlling guide.

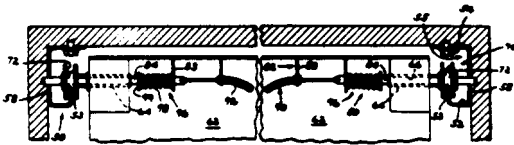

- 139 Track is apertured to receive latch pin:**  
 This subclass is indented under subclass 132. Structure in which the guide for the sliding movement of the planar face member means is provided with a series of openings along the length thereof for the selective reception of the pin-shaped lock element.

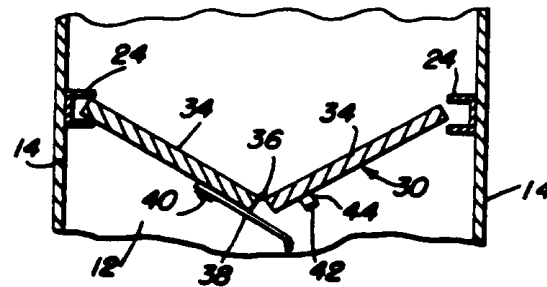

- 141 Latched to side wall aperture or slot:**  
 This subclass is indented under subclass 140. Structure in which the parts are installed by the reception of a projection at their ends into an opening of a receiver therefor mounted at or formed from a side wall of the freight carrier.
- (1) Note. The projection-receiving opening may be defined by an endless or discontinued wall configuration.

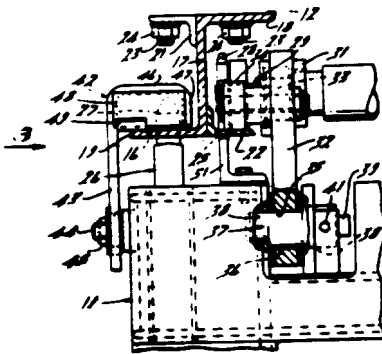

- 140 Deployed structure or comprising individually installed parts:**  
 This subclass is indented under subclass 129. Structure in which the planar face rigid member means consists of a number of parts (e.g., planking, linked members) and in which (a) each part is sequentially installed along a common vertical plane in wall-to-wall spanning arrangement to define, in the composite, the planar face panel structure, or (b) members are so pivotally linked to one another as to be installed by extending them from substantially side-by-side parallelism to compartment-spanning configuration.

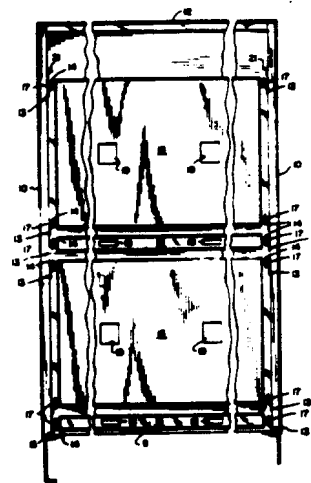

- 142 Having aperture-entering latch pin:**  
 This subclass is indented under subclass 129. Structure in which the planar face rigid member means is provided with a pin-shaped element extending or extensible from an edge thereof receivable in a conformingly shaped opening formed at a freight carrier surface to fixedly lock said member means in the substantially wall-to-wall position at a location intermediate the end walls of the freight carrier.

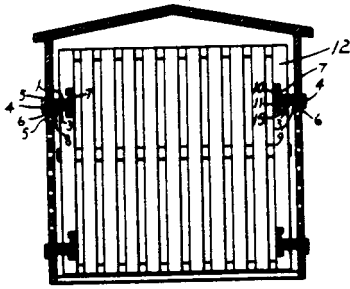

**143 Brace bar, wall-to-wall:**

This subclass is indented under subclass 121. Structure for use in a freight carrier having opposed side walls between its ends; and in which the rigid member means constitutes an elongate compartment-spanning member provided with end means for securement to the opposed side walls of the freight carrier at the location where it abuts lading and inhibits shifting thereof during transit.

- (1) Note. A brace bar receiver either installed along or formed from the opposed side walls and cooperating with the end means of the spanning member for its securement is provided for hereunder (for which see indented subclass 152).
- (2) Note. The limitation "end means" is limited to one of the usual pair of structures under the subclass definition to function at one of the pair of brace bar ends.

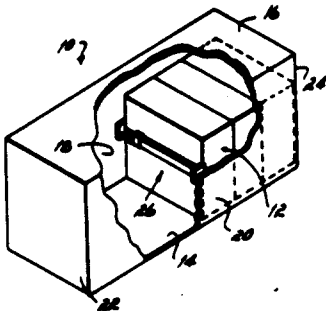

SEE OR SEARCH THIS CLASS, SUBCLASS:

129+, for a wall-to-wall brace panel at times referred to as a "bulkhead".

**144 Aperature-entering wall-to-wall connection at the end:**

This subclass is indented under subclass 143. Structure in which one of (a) the end means, or (b) the brace bar receiver is provided with a passage and the other includes a member (or members) which enters, substantially fills, and is blockingly bounded on all sides of the passage.

- (1) Note. This subclass has been defined to provide for such a passage as has an endless border completely to block movement of the contained member laterally therepast. Hence, the passage is not a slot or any other formation which has a discontinuity negating such endless border configuration. See subclass 150 for an end-fitting-receiving passage which is a cross slot in open communication with an elongated passage constituting a track; hence, not provided for in subclasses 144+.

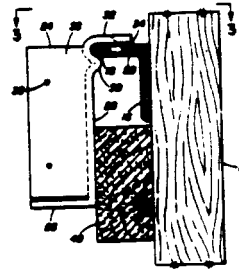

SEE OR SEARCH THIS CLASS, SUBCLASS:

132+, and 142, for a brace panel installed wall-to-wall by the use of aperture-entering latch pin.

**145 Axially adjustable toward wall, e.g., telescopic:**

This subclass is indented under subclass 144. Structure in which the compartment-spanning member includes a part which is shiftable relative to the remainder in the direction of the longitudinal axis of the whole to compensate for

differences in space between opposed receivers therefor, or otherwise to facilitate compartment-spanning installation.

- (1) Note. The shiftable part is commonly an end fitting which mounts the end means or itself constitutes end means in that it includes a projection; i.e., pin or hook member, which enters the aperture of the brace bar receiver for installation between the freight carrier walls.

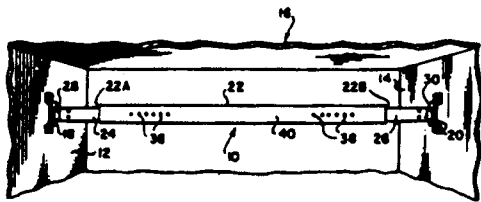

**146 Axially adjustable end fitting, with pivoted aperture-entering part:**

This subclass is indented under subclass 145. Structure in which the projection (pin or hook) is swingably mounted on the end fitting for entry of the projection through the passage in the brace bar receiver mounted on the freight carrier wall.

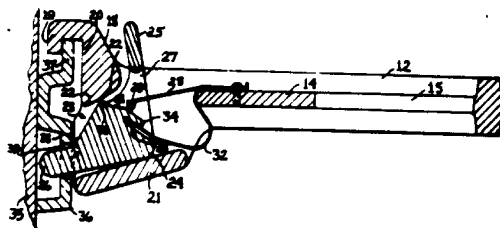

**147 Aperture-entering duo:**

This subclass is indented under subclass 146. Structure in which the swingably mounted projection is one of a pair of aperture-entering projections.

- (1) Note. In this subclass (a) each aperture-entering projection of the pair may be mounted on its own swinging part, (b) both mounted on the same swinging part, (c) one of the pair not swingably mounted on the end fitting at all, or (d)

any arrangement of an aperture-entering pair of projections, provided that one of the pair swingably enters the aperture, as hereinabove defined. The projections may both enter the same aperture or each enter a separate aperture.

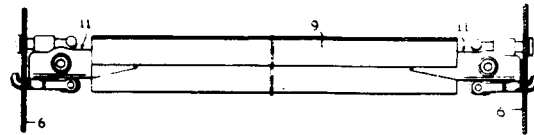

**148 Axially adjustable end fitting has integral aperture-entering part and pivotally mounted cooperating latch part:**

This subclass is indented under subclass 145. Structure in which the end fitting is an attachment member which includes (a) a projecting part (pin or hook) shiftable as a unit therewith for entry into a receiver aperture, and (b) another part mounted adjacent thereto for swinging movement toward the free end of said first part to a position contiguous with the receiver surface to interfere with the removal of the said first part from the receiver aperture.

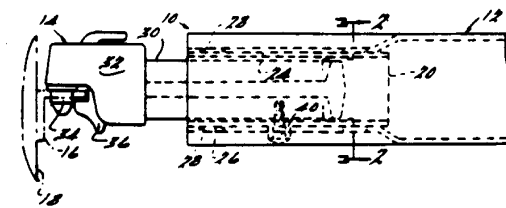

**149 Spring biased:**

This subclass is indented under subclass 145. Structure including resilient means effective between the relatively shiftable parts to urge them apart or together and thereby toward or away from the freight carrier side wall.

- (1) Note. The direction in which the parts are urged is usually toward the freight carrier wall and the installed receiver; however, an opposite bias relation and effect (away from the wall and receiver) is herein also provided; to tighten an end part hook portion against an inside wall of a receiver aperture after installation of the hooked end therein.

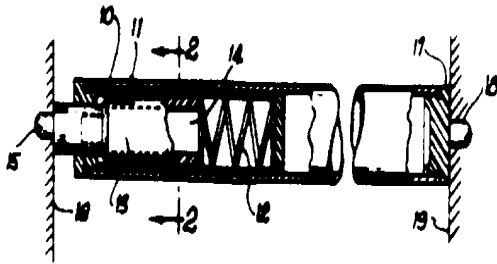

**150 Track mounted, for slidable adjustment along the car wall:**

This subclass is indented under subclass 143. Structure in which the brace bar receiver extends longitudinally a substantial distance between the ends of the freight carrier and is configured to cooperate with the end means of the compartment-spanning member to guide the member for displacement within the freight carrier through said distance.

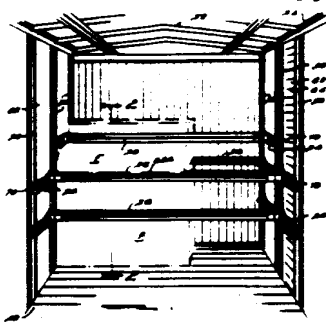

SEE OR SEARCH THIS CLASS, SUB-CLASS:

- 8+, for track-mounted structure for a retainer for a stowed vehicle.
- 74, and 75, for a track-mounted corner pedestal on which a load bearer is retained or merely accommodated, respectively.
- 104+, for a track-mounted load lashing anchor.
- 130+, for track-mounted brace panel structure.

**151 Wall-to-wall force fit; or having wall-piercing end:**

This subclass is indented under subclass 143. Structure in which the compartment-spanning member is retained between the side walls either (a) by the tightness of the engagement therewith, or (b) by means of a wall-piercing prong or nail.

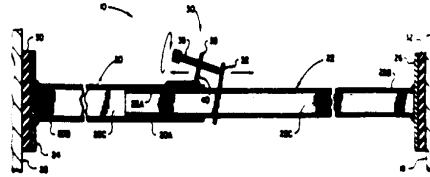

**152 Brace bar receiver:**

This subclass is indented under subclass 143. Structure comprising means either installed along or formed from opposed side walls of the freight carrier for cooperating with the end means of the elongate spanning member for securing of one to the other.

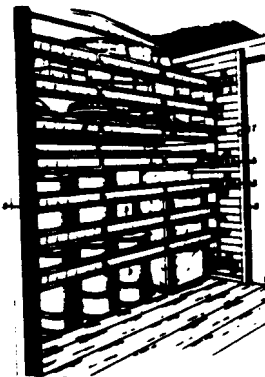

**153 Brace post:**

This subclass is indented under subclass 121. Structure in which the rigid member means is an elongated, vertically upstanding member, or group of members unattached to one another; and in which the freight carrier includes means or formations for the attachment or positioning of the member thereon in load accommodating juxtapositioning

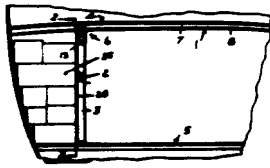

SEE OR SEARCH CLASS:

- 105, Railway Rolling Stock, subclasses 380+ for stakes for bracing lading at the edge of a freight car; and subclasses 390+ for stake pockets.
- 296, Land Vehicles: Bodies and Tops, subclass 43 for a land vehicle body having a stake to hold its load in place.

**154 Honeycomb:**

This subclass is indented under subclass 121. Structure which is free-standing, i.e., unconnected to the freight carrier and abuts lading to fill otherwise unoccupied space, the structure defining a parallel array, or arrays, of formations of endless configuration constituted from interconnected sets of thin panel portions with faces spaced from one another except at their serially interconnected edges.

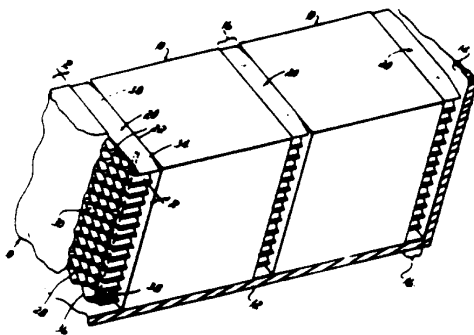

SEE OR SEARCH CLASS:

- 428, Stock Material or Miscellaneous Articles, subclasses 116+ for nonmetallic honeycomb stock material; and subclass 593 for metallic honeycomb stock material.

**155 Edge-around dunnage brace:**

This subclass is indented under subclass 121. Structure the unit of which is a member freely intervening, i.e., unconnected to the carrier, between load units of angular configuration, the member defining a part or spaced parts of complementing angular configuration whereby contactively to extend about both sides of the edge defining the angular configuration.

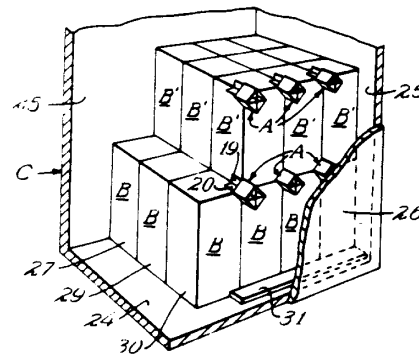

SEE OR SEARCH THIS CLASS, SUB-CLASS:

- 41, for an edge-around corner guard used in a lashed-together group of regularly contoured articles.
- 90, for the edge-around guard used in wraparound lashing of indiscriminate freight.

**156 MISCELLANEOUS:**

This subclass is indented under the class definition. Structure not provided in for in any other preceding subclass.

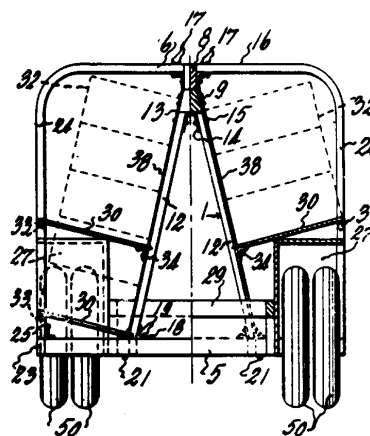

END