

**CLASS 560, ORGANIC COMPOUNDS -- PART  
OF THE CLASS 532-570 SERIES**

SUBCLASSES

**1 Carboxylic acid esters:**

This subclass is indented under subclass 1. Compounds under Class 532, ... wherein the acid function entering into the formation of the esters is a carboxyl group.

- (1) Note. The traditional manner of naming esters has been to define the acid and alcohol moieties that are interrelated. The basis for classifying esters in this class has been the acid moiety. In this reclassification, the use of the acid moiety as the primary basis for classification has been retained. However, whenever it was determined that no further subdivision of a body of patents could be established based upon variants of the acid moiety and consistent with good classification practice, further subdivision has been made on the characteristics of the alcohol moiety. To avoid any confusion, the schedule of subclass titles specifically points out that a particular characteristic pertains to the acid moiety or the alcohol moiety. This factor, combined with the complexity of the compounds which involve pluralities of acid and alcohol moieties, has made it essential to establish a set of rules to determine which acid moiety and which alcohol moiety is to control the classification.

**RULES FOR CLASSIFYING CARBOXYLIC ESTERS**

**A. Compounds**

**I. General**

- (1) The first step in determining the classification of a compound is to resolve it into the several acidic and alcoholic moieties.
- (2) If there is more than one acid moiety, the general rule of superiority is applied to determine the acid moiety which will control classification.

(3) Thereafter, the rule applied is that only those alcohol moieties which esterify the selected acid moiety are considered for classification.

(4) Where there is more than one alcohol moiety esterifying a controlling acid moiety and it is necessary to determine which alcohol moiety will control classification, the general rules of superiority are applied.

The following examples illustrate these rules:

(a) Polyoxy alcohol B and two carboxylic acids, A and D  $AC(=O)OBO(O=)CD$  Determine which of acids A or D has priority to decide the classification.

(b) Polycarboxylic acid A and two alcohols B and D  $BO(O)CAC(=O)OD$  If necessary, determine which of alcohols B and D has priority to decide the classification.

(c) Oxy acid B, acylating acid A and alcohol D  $AC(=O)OBC(=O)OD$  Determine which of acids A and B has priority. If acid A has priority, then oxy acid B serves as the alcohol moiety and D is ignored for classification. If oxy acid B has priority, then alcohol D is considered for classification and acid A is ignored.

(d) Polycarboxylic acid A, monocarboxylic acid E, polyoxy alcohol D and monooxy alcohol B  $BO(O=)CAC(=O)ODO(O=)CE$  Determine which of acids A and E takes priority. If acid A has priority, then alcohols B and D are considered and acid E is ignored. If necessary, determine priority as between alcohols B and D to establish classification. If acid E has priority, consider only alcohol D for classification and ignore acid A and alcohol B.

(e) Polycarboxylic acid A, oxy acid B, monocarboxylic acid E, monooxy alcohol F and polyoxy alcohol D  $FO(O=)CAC(=O)OBC(=O)ODO(O=)CE$  Determine priority among acid moi-

eties A, B and E. If polycarboxylic acid A has priority, then consider only F and B as the alcohol moieties and ignore D and E. If necessary, determine priority between F and B as alcohol moieties for classification. If oxy acid B has priority, then only alcohol D is considered for classification, ignoring F, A and E. If acid E has priority, consider only alcohol D for classification, ignoring F, A and B.

## II. Polycarboxylic Acid Esters

The treatment of polycarboxylic acid esters has not changed in this reclassification. However, since it presents potential pitfalls for classification and search, the problems are summarized here.

Esters of polycarboxylic acids where one or more of the carboxyl groups are unesterified are classified with the polycarboxylic acid esters where all carboxyl groups may be in the free acid form or may be present as salts or as acid halides.

When the unesterified carboxyl is reacted with an amine to form an amide, the compound is classified in the appropriate subclass of the group of esters containing nitrogen.

Since an acid halide group on an acid moiety which contains an esterified carboxyl is the function which makes it a polycarboxylic acid ester, such compound is not considered to be halogenated, for classification purposes. However, when the acid halide group is on an acid moiety which serves as the alcohol portion of an ester of an acid with higher priority, this restriction no longer applies and it may be considered as a halogenated alcohol.

An anhydride of a half ester of a dicarboxylic acid with a monocarboxylic acid is regarded for classification purposes, as a monocarboxylic acid ester, e.g.,  $\text{BO}(\text{O}=\text{C})\text{AC}(\text{=O})\text{O}(\text{O}=\text{C})\text{CD}$  and the final classification will be determined by the functional groups present on both A and D which form the entire acid moiety.

An anhydride of a half ester of a dicarboxylic acid with another dicarboxylic acid or half ester will be considered as a polycarboxylic acid, e.g.,  $\text{BO}(\text{O}=\text{C})\text{CAC}(\text{=O})\text{O}(\text{O}=\text{C})\text{CDC}(\text{=O})\text{OH}$ .

Here too, the final classification will be determined by the functional groups present on both A and D which form the entire acid moiety.

## III. Phenolic Esters

The only exception to the rules set forth in I. above, is that of phenolic esters of acyclic carboxylic acids. Here, the primary basis of classification is the phenolic moiety, with the acids providing a secondary basis when all classifiable characteristics of the phenolic moiety have been exhausted. As a further exception to this case, carbamic acid esters of phenols have been made special and appear before all other categories.

## IV. Salts

As a general rule, a salt forming moiety will not be considered as significant for classifying a carboxylic acid ester, unless it is, per se, an ester classifiable in this area, in which case its acid group will compete for priority with the acid group of the ester to which it is ionically bound. In this case, classification will be based solely on that ionic moiety which is superior.

### B. Processes

The rules of classification with respect to processes follow the general rules as set forth in the class definition. Since processes may appear in three different positions within the schedule, this rule is amplified to cover the three situations.

(a) When a process subclass appears as a first line indent to a residual subclass and is ahead of and coordinate with a series of product subclasses, it is considered as referring to the subject matter of the

residual subclass as well as the coordinate product subclasses.

(1) If the claims are drawn to a product classifiable in the residual subclass and a process classifiable in a process subclass, the original patent is placed in the residual subclass and cross referenced to the appropriate process subclass.

(2) If the claims are drawn to products classifiable in a coordinate product subclass as well as process claims classifiable in a process subclass, the original patent is placed in the appropriate process subclass and cross referenced to the product subclass.

(3) If all the claims are drawn to a process classifiable in a process subclass, the original is placed in the appropriate process subclass.

(b) When a process subclass appears as an indent to a product subclass it refers only to the subject of that product subclass.

(1) When the patent contains claims classifiable both in the product and the process subclass, the patent is placed as an original in the product subclass and cross referenced to the process subclass.

(2) If all the claims are drawn to a process classifiable in the process subclass, the original patent is placed in the process subclass.

(c) When process subclasses appear as a first line indent, but below a series of coordinate product subclasses, then they refer only to subject matter classifiable in the residual subclass.

(1) If the patent contains claims to a product classifiable in the residual subclass and claims classifiable in a process subclass, the original patent is placed in the residual subclass and cross referenced to the process subclass.

(2) If the claims are all drawn to a process classifiable in a process subclass,

the original patent is placed in the process subclass.

(d) Where a patent has claims drawn only to a process for which no subclass is provided, in all cases the patent is placed in the subclass appropriate to the product being produced.

(2) Note. This is the residual subclass for esters of alicyclic carboxylic acids not specifically provided for in subclasses (114-128) inclusive.

(3) Note. This subclass contains, for example: esters of naphthenic acids and

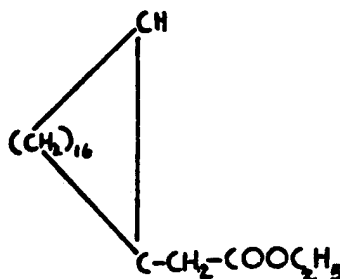
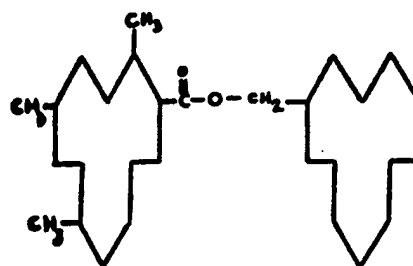

## 2 With preservative:

This subclass is indented under subclass 1. Products wherein the ester is mixed with a preserving agent whose sole function is to prevent physical or chemical change.

## 3 Aromatic polycarboxylic acid esters:

This subclass is indented under subclass 2. Products wherein the ester is an aromatic polycarboxylic acid ester.

**4 Acyclic unsaturated monocarboxylic acid esters:**

This subclass is indented under subclass 2. Products wherein the ester is an acyclic unsaturated monocarboxylic acid ester.

**5 Hydrophenanthrene in acid moiety:**

This subclass is indented under subclass 1. Compounds wherein the acid radical contains a hydrophenanthrene nucleus not provided for above.

(1) Note. Patents are placed here when directed to compounds, wherein the acid radical is that of a free natural resin acid of known chemical structure which contains the hydrophenanthrene nucleus.

(2) Note. This subclass contains, for example:

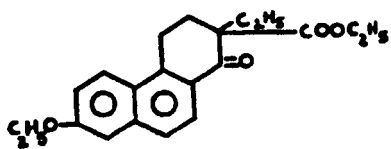
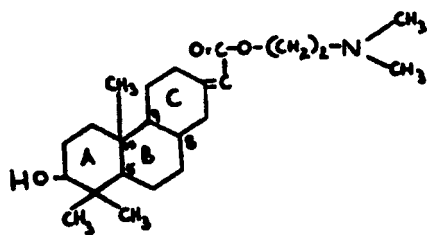

**SEE OR SEARCH CLASS:**

530, Chemistry: Natural Resins or Derivatives; Peptides or Proteins; Lignins or Reaction Products Thereof, subclasses 200+, for esters of natural resin acids obtained by treatment of the natural resin and wherein the esters are not separated as single compounds of known chemical structure.

See particularly subclasses 215, 216, 217, and 218.

**6 Polycyclo ring system having the hydrophenanthrene and at least one additional ring as cyclos:**

This subclass is indented under subclass 5. Compounds wherein the hydrophenanthrene nucleus contains additional rings formed by ortho fusion or by a bridge.

(1) Note. This subclass contains, for example:

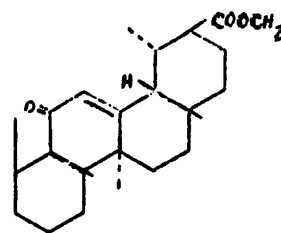
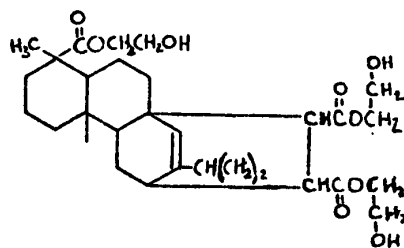

**7 1, 4a-dimethylhydrophenanthrene - 1 carboxylic acid:**

This subclass is indented under subclass 5. Compounds which contain the nucleus 1, 4a-dimethylhydrophenanthrene -1 carboxylic acid.

(1) Note. This subclass contains, for example:

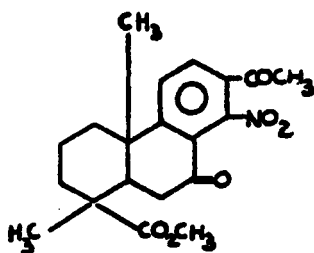
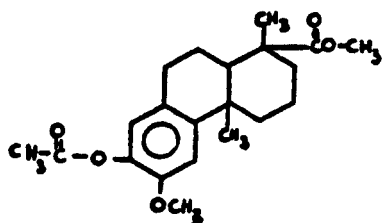

8

**Aromatic acid moiety:**

This subclass is indented under subclass 1. Compounds wherein the acid radical contains a benzene or other carbocyclic aromatic group.

- (1) Note. This subclass contains, for example:

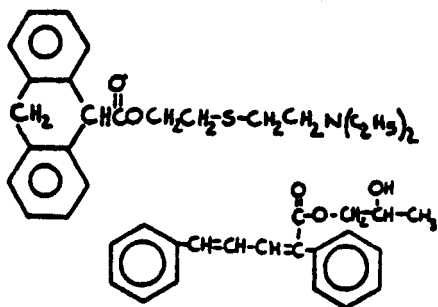

SEE OR SEARCH THIS CLASS, SUBCLASS:

- 5+, for esters of carboxylic acids containing a hydrophenanthrene nucleus and having a known chemical structure, not provided for above, for example, the esters of abietic acid, dehydroabietic acid and pimaric acid.

SEE OR SEARCH CLASS:

- 588, Hazardous or Toxic Waste Destruction or Containment, subclasses 405 through 409 for the chemical destruction of organic hazardous or toxic waste containing halogen, chalcogen, nitrogen, phosphorus, or metals.

9

**Sulfur in acid moiety:**

This subclass is indented under subclass 8. Compounds wherein the acid radical contains sulfur covalently bonded.

- (1) Note. This subclass contains, for example:

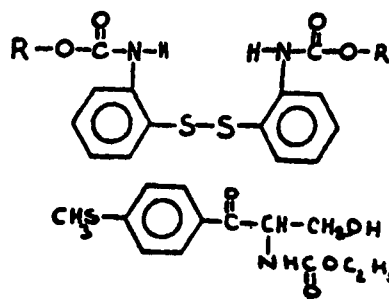

10

**Ortho fused rings in acid moiety:**

This subclass is indented under subclass 9. Compounds wherein the acid radical contains two or more carbocyclic nuclei joined through two ortho positioned nuclear carbon atoms.

- (1) Note. This subclass contains, for example:

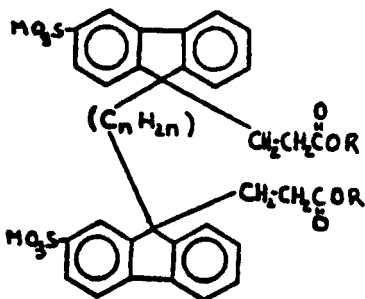
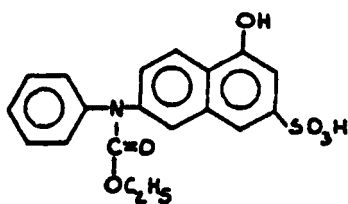

- 11 **Sulfoxy in acid moiety:**  
This subclass is indented under subclass 9.  
Compounds wherein the acid radical contains sulfur bonded to oxygen.

(1) Note. This subclass contains, for example:

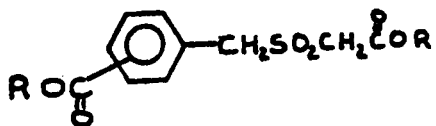
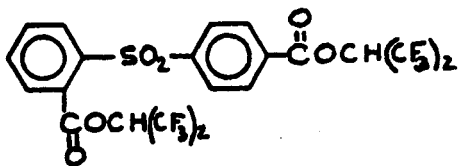

- 12 **Nitrogen in acid moiety:**  
This subclass is indented under subclass 11.  
Compounds wherein the acid radical contains nitrogen covalently bonded.

(1) Note. Amine salts of sulfonic acid containing carboxylic acid esters are not considered as nitrogen containing for this subclass. See section A. IV or (1) Note in subclass 1.

(2) Note. This subclass contains, for example:

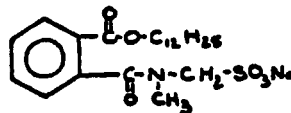

- 13 **Plural nitrogens in acid moiety:**  
This subclass is indented under subclass 12.  
Compounds wherein the acid radical contains more than one nitrogen.

(1) Note. This subclass contains, for example:

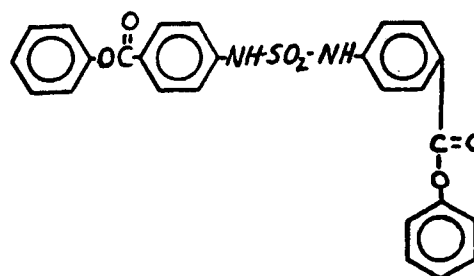
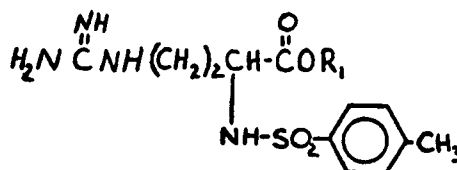

- 14 **Sulfonic acids, salts or acid halides:**  
This subclass is indented under subclass 11.  
Compounds wherein the acid radical contains the group, shown below, or its salts or acid halides.

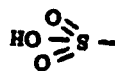

(1) Note. This subclass contains, for example:

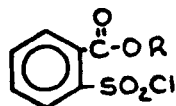
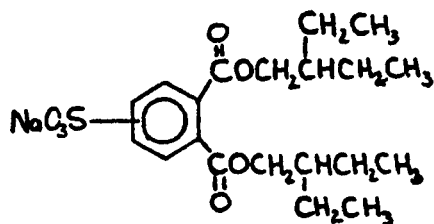

15 **Sulfur, not bonded directly to a ring, in same side chain as ester function:**

This subclass is indented under subclass 9. Compounds wherein the esterified carboxylic acid function is on a side chain containing sulfur in or attached to the chain, but not directly bonded to a carbon of a carbocyclic nucleus.

- (1) Note. In this and subsequent subclasses where the term "side chain" is used, it is intended to mean an acyclic chain uninterrupted by a cyclic formation.
- (2) Note. When the same sulfur atom is directly attached to one carbocyclic nucleus and indirectly attached to a second carbocyclic nucleus, it will always be considered as directly attached for classification, e.g.,

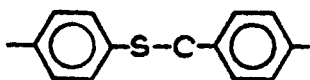

- (3) Note. This subclass contains, for example:

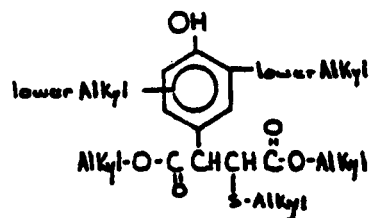
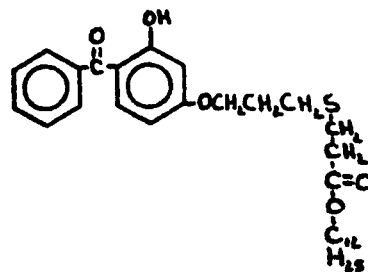

16 **Nitrogen in acid moiety:**

This subclass is indented under subclass 15. Compounds wherein the acid radical also contains nitrogen covalently bonded.

- (1) Note. This subclass contains, for example:

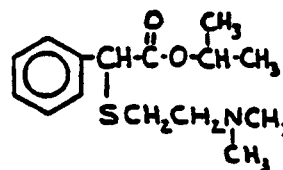
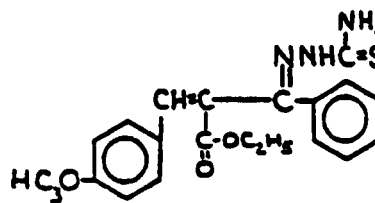

17 **Sulfur, bonded directly to a ring, in same side chain as ester function:**

This subclass is indented under subclass 9. Compounds wherein the esterified carboxylic acid function is on a side chain which contains

sulfur directly bonded to a carbon of a carbocyclic nucleus.

- (1) Note. This subclass contains, for example:

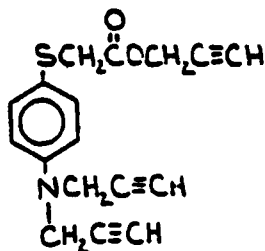

**18 Ester function attached directly to a ring:**

This subclass is indented under subclass 9. Compounds wherein the esterified carboxylic acid function is directly bonded to a carbon of a carbocyclic nucleus.

- (1) Note. This subclass contains, for example:

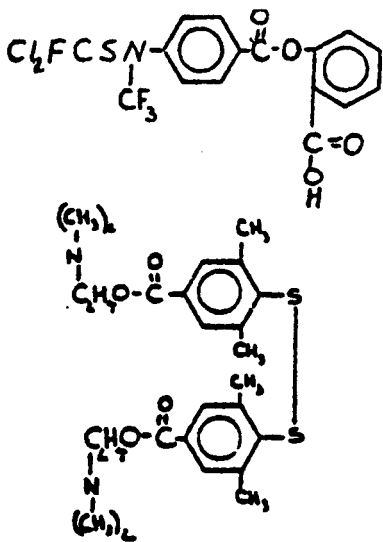

**19 Nitrogen in acid moiety other than as nitroso or isocyanate (e.g., amino acid esters, etc.):**

This subclass is indented under subclass 8. Compounds wherein the acid radical contains covalently bonded nitrogen other than in the form of an isocyanate or nitroso group.

- (1) Note. Compounds containing an isocyanate or a nitroso group are not per se excluded from this subclass, provided that the compounds also contain nitrogen in another form.

- (2) Note. This subclass contains, for example:

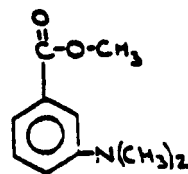
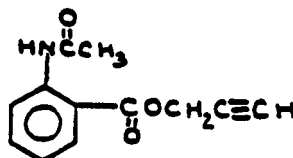

**20 Nitro bonded to carbon in acid moiety:**

This subclass is indented under subclass 19. Compounds wherein the acid radical contains the group  $-N(=O)_2$  bonded to carbon.

- (1) Note. This subclass contains, for example:

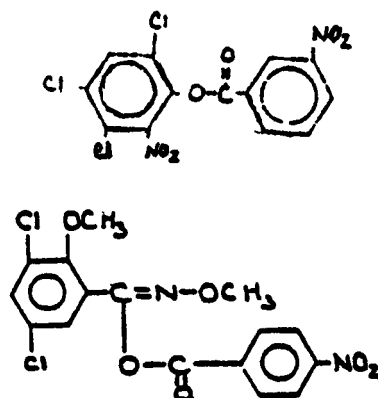



**21 Plural rings in acid moiety:**

This subclass is indented under subclass 20. Compounds wherein the acid radical contains more than one carbocyclic group.

- (1) Note. This subclass contains, for example:

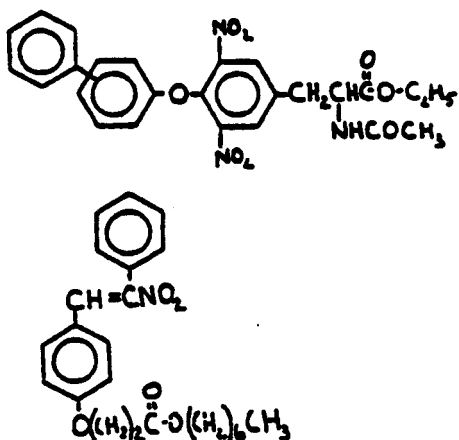
**22 Additional nitrogen in acid moiety:**

This subclass is indented under subclass 20. Compounds wherein the acid radical contains an additional nitrogen covalently bonded.

- (1) Note. The additional nitrogen may be in the form of a nitro, isocyanate or nitroso group.
- (2) Note. This subclass contains, for example:

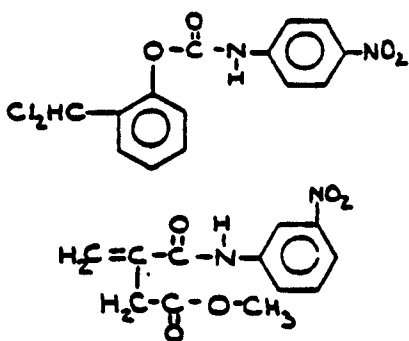
**23 Oxy, aldehyde or ketone group in acid moiety:**

This subclass is indented under subclass 20. Compounds wherein the acid radical contains a carbonyl group bonded to C and X where X is carbon or hydrogen; or an -OX group bonded to a noncarbonylic C where X is C, H, an alcoholate forming group not provided for above, or an acyl group not provided for above.

- (1) Note. This subclass contains, for example:

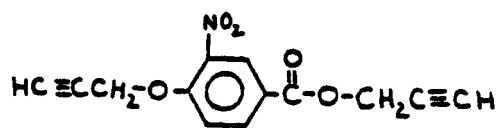
**24 Carbamic acid:**

This subclass is indented under subclass 19. Compounds wherein the acid radical contains nitrogen directly bonded to the carbon of the esterified carboxyl group.

- (1) Note. This subclass contains, for example:

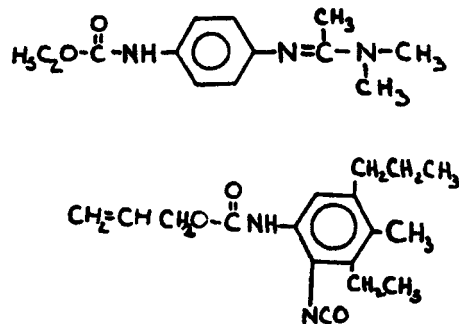
**25 Polycarbamic:**

This subclass is indented under subclass 24. Compounds wherein the acid radical contains more than one carbamic acid group, at least one of which is esterified.

- (1) Note. This subclass also contains compounds where an unesterified carbamic acid has been converted into a salt or an acid halide. Where an unesterified car-

bamic acid group has been converted into an amide and only one esterified carbamic acid group is present, the compound is classified in the appropriate subclass dealing with monocarbamic acid esters.

- (2) Note. This subclass contains, for example:

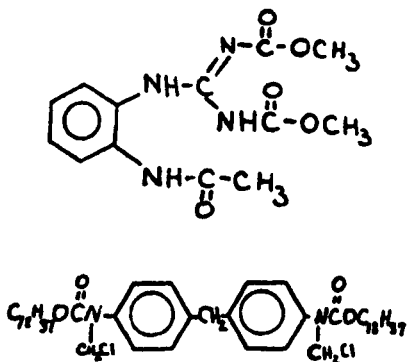

**26 Polyoxy alcohol moiety:**

This subclass is indented under subclass 25. Compounds wherein the alcohol moiety contains in addition to an esterified hydroxyl, another -OX group attached to a noncarbonylic C where X is H, C, an alcoholate forming group not provided for above, or an acyl group not provided for above.

- (1) Note. This subclass contains, for example:

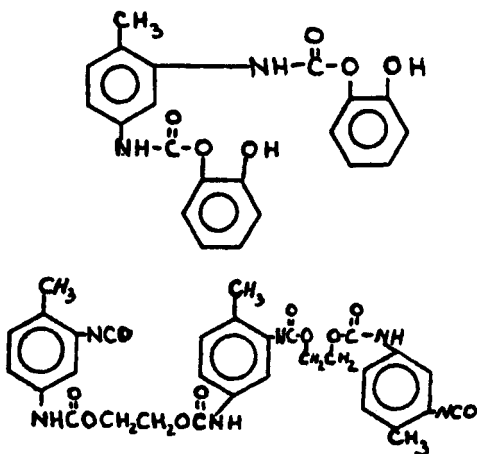

**27 Plural rings in acid moiety:**

This subclass is indented under subclass 24. Compounds wherein the acid radical contains more than one carbocyclic group.

- (1) Note. This subclass contains, for example:

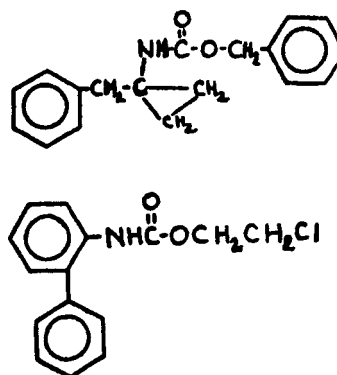

**28 Ortho fused:**

This subclass is indented under subclass 27. Compounds wherein at least two carbocyclic groups are joined through two ortho positioned carbon atoms.

- (1) Note. This subclass contains, for example:

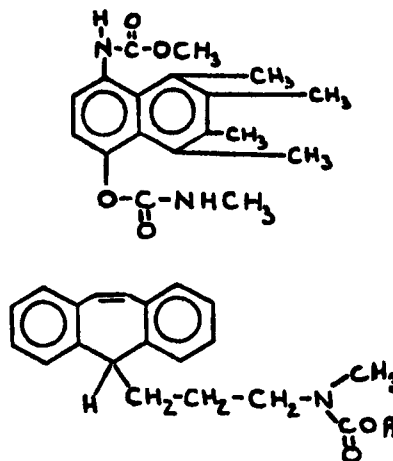

**29 Oxy in acid moiety:**

This subclass is indented under subclass 24. Compounds wherein the acid radical contains the -OX group attached to a noncarbonylic C where X is C, H, an alcoholate forming group not provided for above, or an acyl group not provided for above.

(1) Note. This subclass contains, for example:

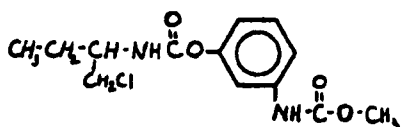
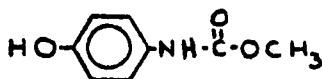
**30 Halogen in acid moiety:**

This subclass is indented under subclass 24. Compounds wherein the acid radical contains a covalently bonded halogen.

(1) Note. This subclass contains, for example:

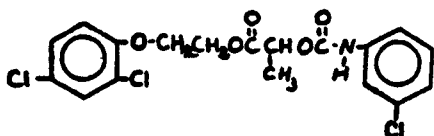
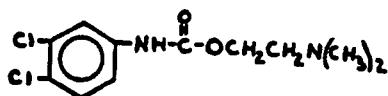
**31 Ring in alcohol moiety:**

This subclass is indented under subclass 30. Compounds wherein the alcohol moiety of the ester contains a carbocyclic nucleus.

(1) Note. This subclass contains, for example:

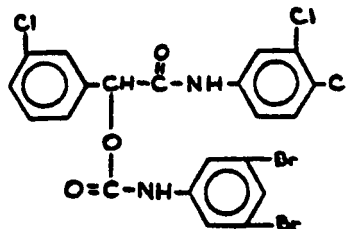
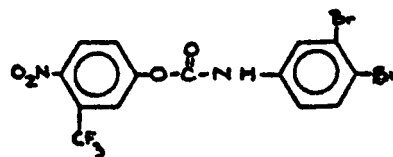
**32 Ring in alcohol moiety:**

This subclass is indented under subclass 24. Compounds wherein the alcohol moiety of the ester contains a carbocyclic nucleus.

(1) Note. This subclass contains, for example:

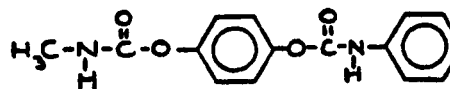
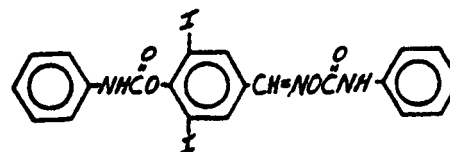
**33 Sulfur, nitrogen, halogen or additional oxy in alcohol moiety:**

This subclass is indented under subclass 24. Compounds wherein the alcohol moiety contains sulfur, nitrogen or halogen covalently bonded or in addition to the esterified hydroxyl, an -OX group attached to a noncarbonylic C where X is C, H, an alcoholate forming group not provided for above, or an acyl group not provided for above.

(1) Note. This subclass contains, for example:

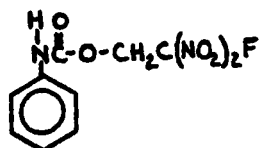
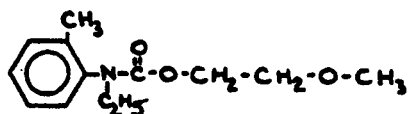
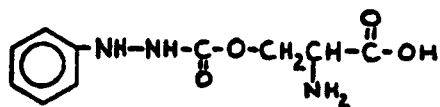

34 **Ureido, guanido or hydrazino in acid moiety:**

This subclass is indented under subclass 19. Compounds wherein the acid radical contains a ureido group  $>NC(=O)N<<$  or a guanido group  $>NC(=N)N<<$  or a hydrazo group  $>NN<<$ .

(1) Note. This subclass contains, for example:

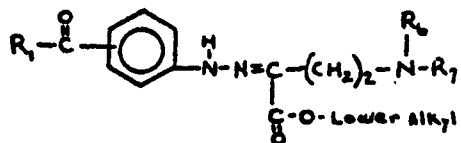
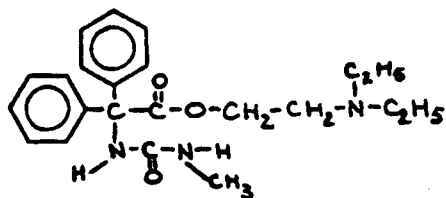

35 **Amidine, azomethine, ketimine or oxime in acid moiety:**

This subclass is indented under subclass 19. Compounds containing the grouping  $-C=N-$ , including amidines not provided for above or compounds equivalent in structure to those formed by reacting an aldehyde or a ketone with ammonia or an amine.

(1) Note. This subclass contains, for example:

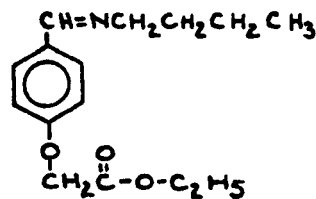
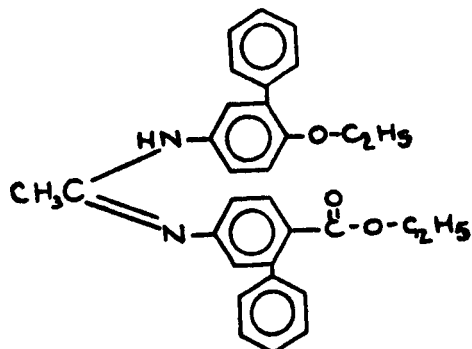

36 **Plural rings bonded directly to the same carbon in acid moiety:**

This subclass is indented under subclass 19. Compounds wherein the acid radical contains two carbocyclic nuclei attached to a methylene or carbonyl group.

(1) Note. This subclass contains, for example:

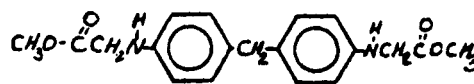

37 **The nitrogen is not bonded directly to a ring:**

This subclass is indented under subclass 19. Compounds wherein the acid radical contains nitrogen which is not directly attached to a carbocyclic nucleus.

(1) Note. When the same N atom is directly attached to one carbocyclic nucleus and indirectly attached to a second carbocyclic nucleus, it will always be considered

as directly attached for classification,  
e.g.,

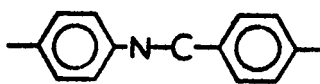

- (2) Note. This subclass contains, for example:

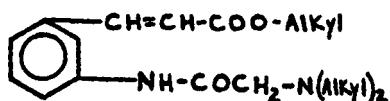
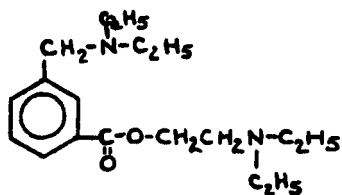

**38 The nitrogen is in same side chain as ester function:**

This subclass is indented under subclass 37. Compounds wherein the acid radical contains nitrogen in or attached to the same side chain which contains the carboxylic acid ester function.

- (1) Note. This subclass contains, for example:

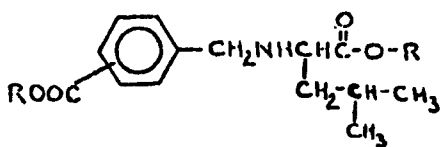
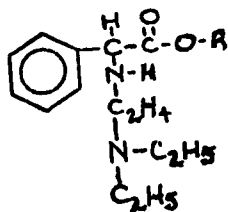

**39 Oxy in acid moiety:**

This subclass is indented under subclass 38. Compounds wherein the acid radical also contains the group -OX attached to a noncarbonylic C where X is C, H, an alcoholate forming group not provided for above, or an acyl group not provided for above.

- (1) Note. This subclass contains, for example:

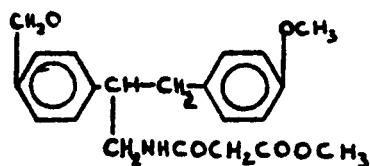
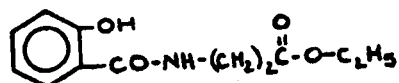

**40 Phenylalanines:**

This subclass is indented under subclass 39. Compounds wherein the acid radical contains a phenylalanine group.

- (1) Note. This subclass contains, for example:

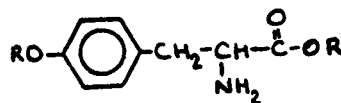
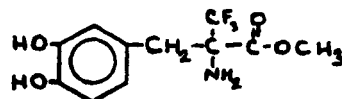

**41 Amide in acid moiety:**

This subclass is indented under subclass 38. Compounds wherein the acid radical contains an acyl group, not provided for above, attached to the nitrogen to form an amide.

- (1) Note. This subclass contains, for example:

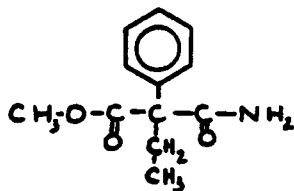
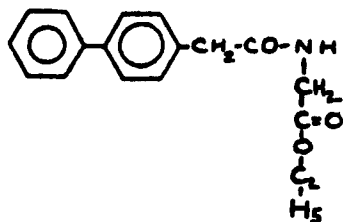
42 **Oxy in acid moiety:**

Compounds under subclass 37 wherein the acid radical also contains the group -OX attached to a noncarbonylic C where X is C, H, an alcoholate forming group not provided for above, or an acyl group not provided for above.

- (1) Note. This subclass contains, for example:

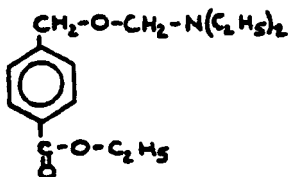
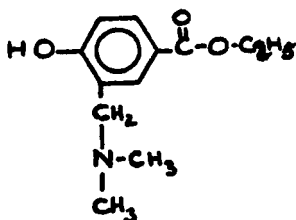
43 **The nitrogen is bonded directly to a ring and is in same side chain as ester function:**

This subclass is indented under subclass 19. Compounds wherein the acid radical has the ester function on a side chain attached to nitro-

gen, which is directly attached to a carbocyclic nucleus.

- (1) Note. This subclass contains, for example:

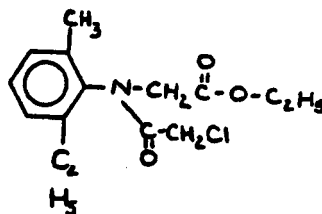
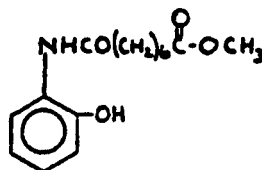
44 **Polycarboxylic acid:**

This subclass is indented under subclass 43. Compounds wherein the acid radical has more than one carboxyl group, at least one of which is esterified.

- (1) Note. This subclass also contains compounds wherein an unesterified carboxyl has been converted into a salt or an acid halide, or may be in the free acid form. Where the unesterified carboxyl is converted into an amide, the compound is classified in subclass 43.
- (2) Note. This subclass contains, for example:

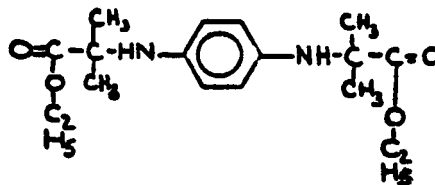

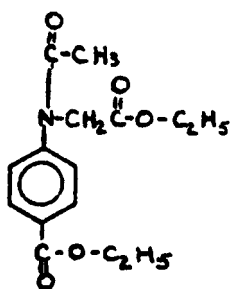
**45 Oxy in acid moiety:**

This subclass is indented under subclass 19. Compounds wherein the acid radical contains an -OX group attached to a noncarbonylic C where X is C, H, an alcoholate forming group not provided for above, or an acyl group not provided for above.

- (1) Note. This subclass contains, for example:

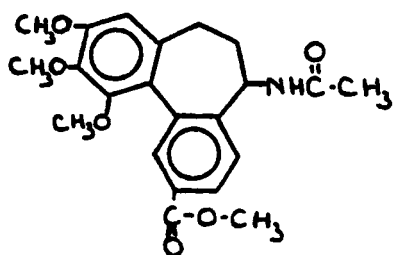
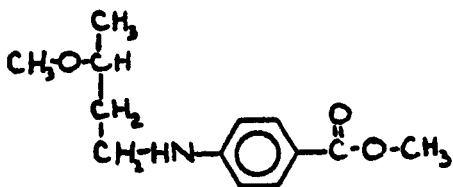
**46 Benzoic acid substituted on ring with oxy and nitrogen:**

This subclass is indented under subclass 45. Compounds wherein the acid radical has an esterified carboxyl group, nitrogen and an -OX group all directly attached to the benzene ring, wherein X is C, H, and alcoholate forming group not provided for above, or an acyl group not provided for above.

- (1) Note. This subclass contains, for example:

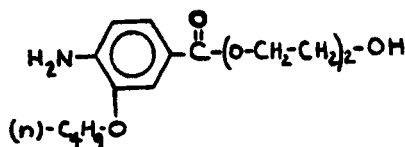
**47 Halogen in acid moiety:**

This subclass is indented under subclass 19. Compounds wherein the acid radical contains a covalently bonded halogen.

- (1) Note. This subclass contains, for example:

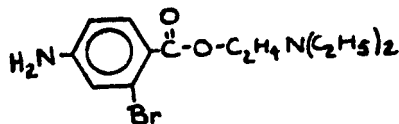
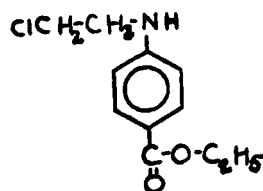
**48 Plural rings in acid moiety with nitrogen bonded directly to at least one of the rings:**

This subclass is indented under subclass 19. Compounds wherein the acid radical contains more than one carbocyclic group with nitrogen directly attached to at least one carbocyclic group.

- (1) Note. This subclass contains, for example:

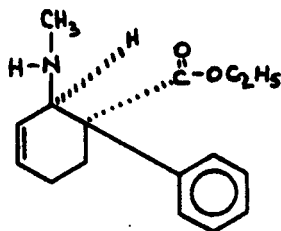
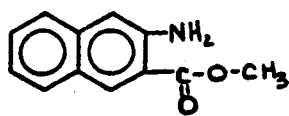

**49 Nitrogen in alcohol moiety:**

This subclass is indented under subclass 19. Compounds wherein the alcohol moiety contains nitrogen covalently bonded.

- (1) Note. This subclass contains, for example:

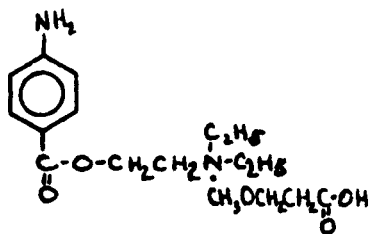
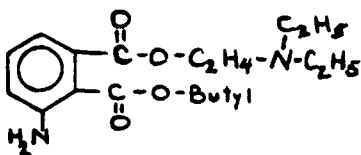

**50 Polyoxy alcohol moiety:**

This subclass is indented under subclass 19. Compounds wherein the alcohol moiety contains in addition to the esterified hydroxyl group, an -OX group attached to a noncarbonylic C where X is C, H, an alcoholate forming group not provided for above, or an acyl group not provided for above.

- (1) Note. This subclass contains, for example:

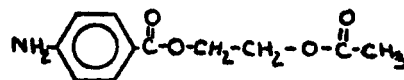
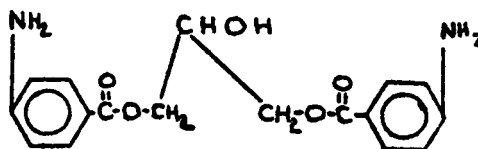

**51 Aldehyde or ketone group in acid moiety:**

This subclass is indented under subclass 8. Compounds wherein the acid radical contains the group -C(=O)X bonded to carbon and X is C or H, i.e., aldehyde or ketone group containing esters.

- (1) Note. This subclass contains, for example:

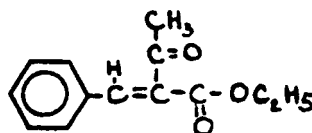
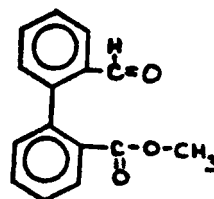

**52 Plural rings bonded directly to the same carbonyl in acid moiety:**

This subclass is indented under subclass 51. Compounds wherein the acid radical contains two carbocyclic nuclei directly attached to a carbonyl group.

- (1) Note. This subclass contains, for example:



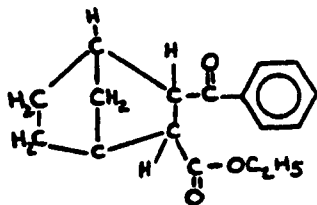
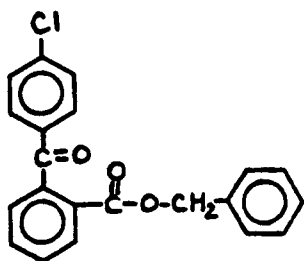

53

**Oxy in acid moiety:**

This subclass is indented under subclass 51. Compounds wherein the acid radical also contains the group -OX attached to a noncarbonylic C and X is C, H, an alcoholate forming group not provided for above, or an acyl group not provided for above.

- (1) Note. This subclass contains, for example:

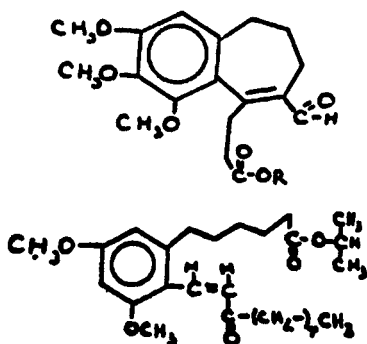

54

**Polycarboxylic acid:**

This subclass is indented under subclass 51. Compounds wherein the acid radical contains more than one carboxyl group, at least one of which is esterified.

- (1) Note. This subclass contains compounds wherein an unesterified carboxyl may be present in free acid form or in the form

of a salt or an acid halide. When the unesterified carboxyl is converted into an amide, the compound is classifiable in the appropriate subclass under (19).

- (2) Note. This subclass contains, for example:

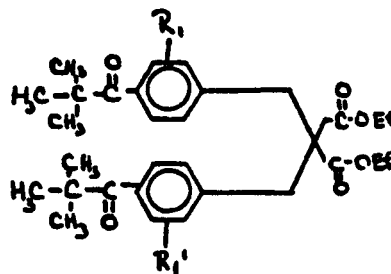
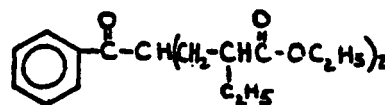

55

**Oxy in acid moiety:**

This subclass is indented under subclass 8. Compounds wherein the acid radical contains the -OX group attached to a noncarbonylic C where X may be C, H, an alcoholate forming group not provided for above, or an acyl group not provided for above.

- (1) Note. This subclass contains, for example:

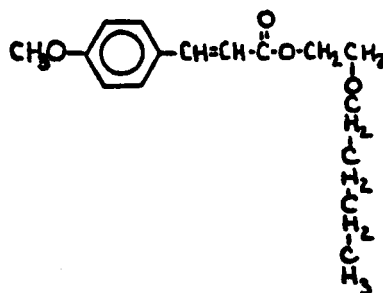

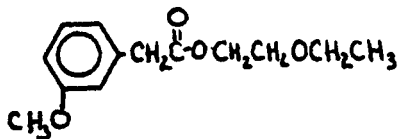

**56 Ortho fused rings in acid moiety:**

This subclass is indented under subclass 55. Compounds wherein the acid radical contains two or more carbocyclic nuclei joined through a pair of ortho positioned carbon atoms.

- (1) Note. This subclass contains, for example:

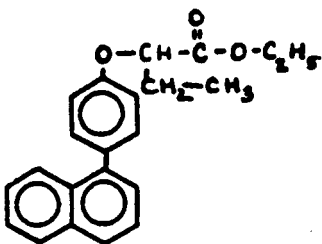
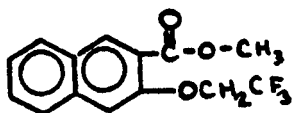

**57 Plural rings bonded directly to the same carbon in acid moiety:**

This subclass is indented under subclass 55. Compounds wherein the acid radical contains two carbocyclic nuclei attached to a methylene group.

- (1) Note. This subclass contains, for example:

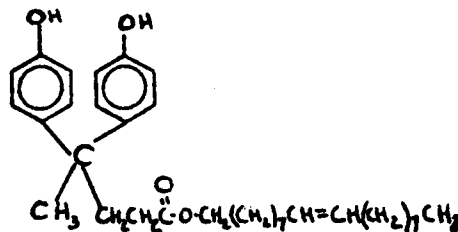
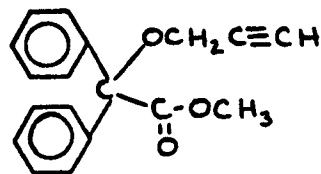

**58 Nitrogen in alcohol moiety:**

This subclass is indented under subclass 57. Compounds wherein the alcohol moiety contains nitrogen covalently bonded.

- (1) Note. This subclass contains, for example:

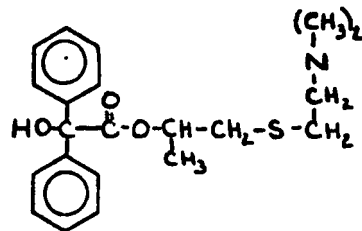

**59 Rings bonded directly to each other in acid moiety:**

This subclass is indented under subclass 55. Compounds wherein the acid radical contains two carbocyclic groups joined through a covalent bond.

- (1) Note. This subclass contains, for example:

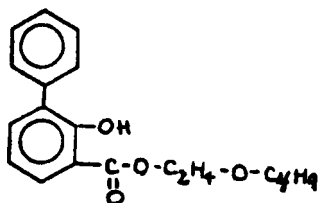
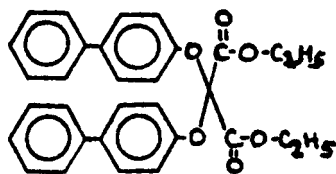

**60 Oxy, not bonded directly to a ring, in same side chain as ester function:**

This subclass is indented under subclass 55. Compounds wherein the esterified acid function is on a side chain containing an oxy group attached to or in the chain, but not attached to a carbocyclic nucleus.

- (1) Note. When the same oxygen atom is directly attached to one carbocyclic nucleus and indirectly attached to a second carbocyclic nucleus, it will always be considered as directly attached for classification, e.g.,

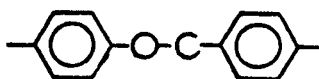

- (2) Note. This subclass contains, for example:

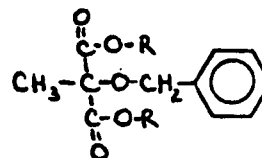
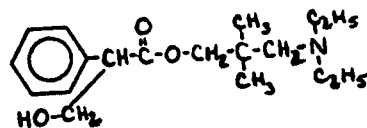

**61 Oxy, bonded directly to a ring, in same side chain as ester function:**

This subclass is indented under subclass 55. Compounds wherein the esterified acid function is on side chain containing an oxy group which is directly attached to a carbocyclic nucleus.

- (1) Note. This subclass contains, for example:

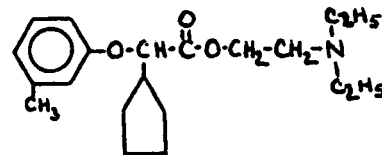
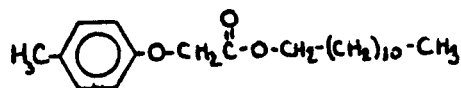

**62 Halogen in acid moiety:**

This subclass is indented under subclass 61. Compounds wherein the acid radical also contains covalently bonded halogen.

- (1) Note. This subclass contains, for example:

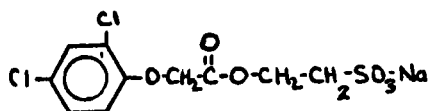
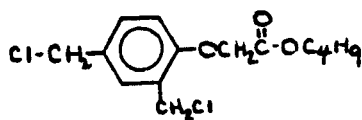

**63 Polyoxy alcohol moiety:**

This subclass is indented under subclass 62. Compounds wherein the alcohol moiety contains in addition to the esterified hydroxyl, an -OX group attached to a noncarbonylic C where X may be C, H, an alcoholate forming group not provided for above, or an acyl group not provided for above.

- (1) Note. This subclass contains, for example:

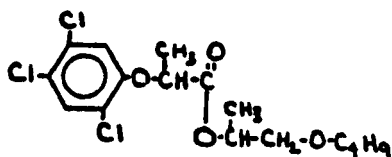
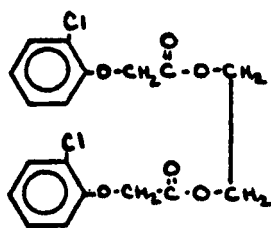

**64 Ester function attached directly to a ring:**

This subclass is indented under subclass 55. Compounds wherein the esterified acid function is directly attached to a carbocyclic nucleus.

- (1) Note. This subclass contains, for example:

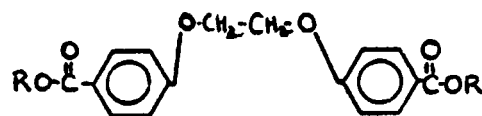
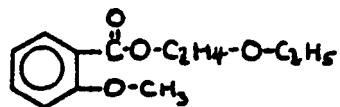

**65 Halogen in acid moiety:**

This subclass is indented under subclass 64. Compounds wherein the acid function contains a covalently bonded halogen.

- (1) Note. This subclass contains, for example:

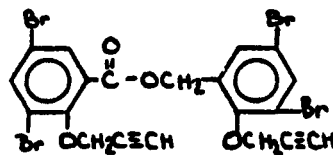
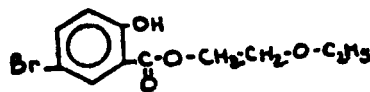

**66 Acylated:**

This subclass is indented under subclass 64. Compounds wherein a hydroxy group of the esterified acid radical has been esterified by an acyl group not provided for above.

- (1) Note. This subclass contains, for example:

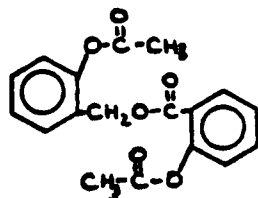
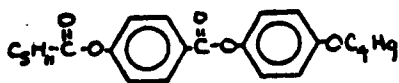

**67 Phenolic hydroxy or metallate:**

This subclass is indented under subclass 64. Compounds wherein the acid function contains an -OX group, where X is H or an alcoholate forming group not provided for above, directly attached to the carbon of a benzene ring.

- (1) Note. This subclass contains, for example:

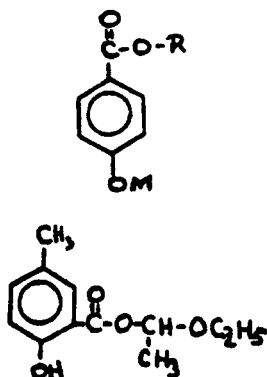

**68 Tannins and reaction products thereof:**

This subclass is indented under subclass 67. Products and their processes which are known as tannins or tannic acids. Chemically they appear to be esters of gallic acid in which the carboxyl group thereof is esterified by the hydroxyl group of a second molecule of gallic acid, or glucosides thereof.

- (1) Note. This subclass includes, for example, tannin extracts together with their preparation, treatment and purification. Many of these extracts are useful as tanning or mordanting agents. Where the

tannin extract is admixed with other ingredients to form a composition having an art use provided for elsewhere, the patent is placed in the other class and cross referenced to this class when desirable. For example, tanning compositions and mordanting compositions are in Class 8, Bleaching and Dyeing: Fluid Treatment and Chemical Modification of Textiles and Fibers.

**69 Extraction from bark or vegetable material:**

This subclass is indented under subclass 68. Processes which are directed to or include the treatment of bark, shell galls, or other vegetable material to remove tannins therefrom.

**70 Polyphenolic hydroxy or metallate:**

This subclass is indented under subclass 67. Compounds wherein the acid function contains more than one -OX group attached to a carbon of a benzene ring, where X is H or an alcoholate forming group not provided for above.

- (1) Note. This subclass contains, for example:

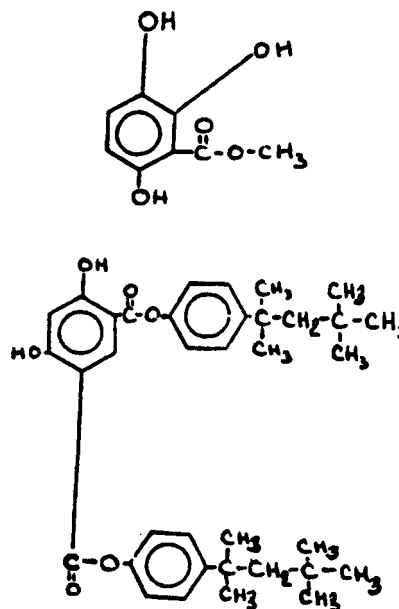

**71 Salicyclic acid:**

This subclass is indented under subclass 67. Compounds wherein the acid radical is derived from the compound known as salicyclic acid, e.g., salol, oil of wintergreen.

(1) Note. This subclass is limited to esters of salicyclic acid, per se. Esters of acylated salicyclic acid are found in subclass 64 and salicyclic acid acylated with acyclic carboxylic acids are in subclass 143.

(2) Note. This subclass contains, for example:

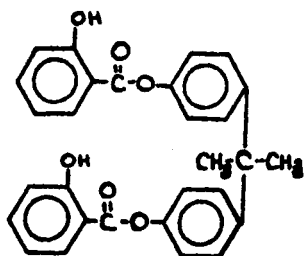
**72 Ring in alcohol moiety:**

This subclass is indented under subclass 67. Compounds wherein the alcohol moiety contains a carbocyclic nucleus.

(1) Note. This subclass contains, for example:

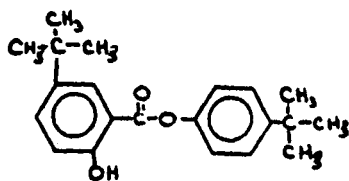
**73 Ring in alcohol moiety:**

This subclass is indented under subclass 64. Compounds wherein the alcohol moiety contains a carbocyclic nucleus.

(1) Note. This subclass contains, for example:

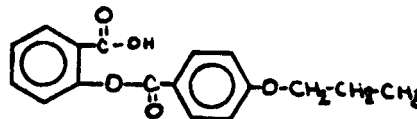
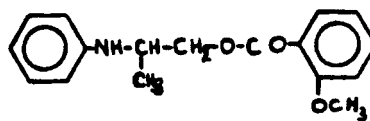
**74 Nitrogen in alcohol moiety:**

This subclass is indented under subclass 64. Compounds wherein the alcohol moiety contains nitrogen covalently bonded.

(1) Note. This subclass contains, for example:

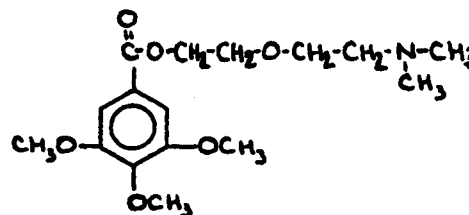
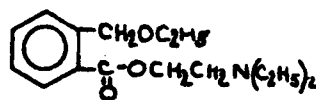
**75 Phenolic hydroxy or metallate:**

This subclass is indented under subclass 55. Compounds wherein the acid function contains an -OX group, where X is H or an alcoholate forming group not provided for above, directly attached to a benzene ring.

(1) Note. This subclass contains, for example:

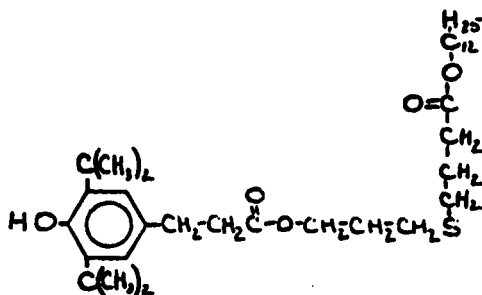
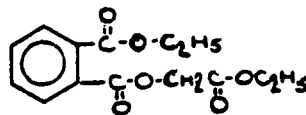
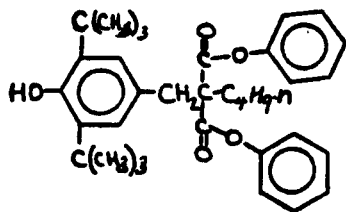
**76 Polycarboxylic acid:**

This subclass is indented under subclass 8. Compounds wherein the acid radical contains more than one carboxyl group, at least one of which is esterified.

- (1) Note. This subclass also contains compounds wherein an unesterified carboxyl may be present in free acid form or in the form of a salt or an acid halide. Where an unesterified carboxyl has been converted into an amide, the compound is classifiable in the appropriate subclass under (19).
- (2) Note. This subclass contains, for example:

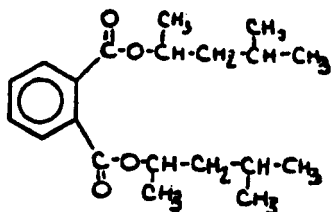
**77 Producing carboxyl group by oxidation:**

This subclass is indented under subclass 76. Processes wherein at least one of the carboxyl groups of the acid is formed by oxidizing an aromatic material.

- (1) Note. This subclass includes, for example, the oxidation of xylene or toluic acid either in the presence of an alcohol or with a subsequent esterification to form the dicarboxylic acid esters.

**78 Purification or recovery:**

This subclass is indented under subclass 76. Processes which are directed to the purification, separation or recovery of aromatic polycarboxylic acid esters.

**79 Of esters of polyoxy alcohols:**

This subclass is indented under subclass 78. Processes wherein the compounds treated are polyoxy alcohol esters.

**80 Ortho fused rings in acid moiety:**

This subclass is indented under subclass 76. Compounds wherein the acid radical contains two or more carbocyclic nuclei joined through ortho positioned nuclear carbons.

- (1) Note. This subclass contains, for example:

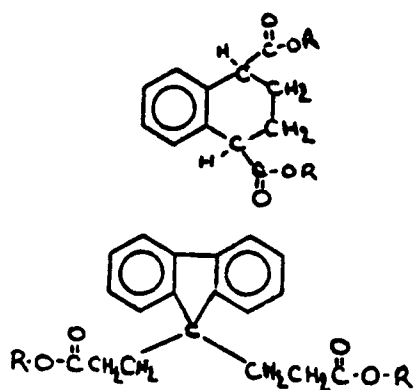

**81 Esterified carboxy not bonded directly to a ring:**

This subclass is indented under subclass 76. Compounds wherein an esterified carboxyl group of the acid radical is not directly bonded to a nuclear carbon of a carbocyclic group.

- (1) Note. This subclass contains, for example:

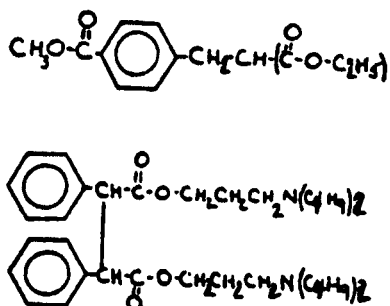

**82 Malonates:**

This subclass is indented under subclass 81. Compounds in which the methylene group of a malonic acid ester contains an aromatic substituent.

- (1) Note. This subclass contains, for example:

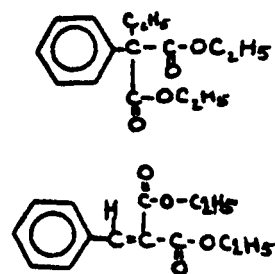

**83 Halogen in acid moiety:**

This subclass is indented under subclass 76. Compounds wherein the acid radical contains covalently bonded halogen.

- (1) Note. Compounds wherein the only halogen is present in the form of a carboxylic acid halide are not considered halogenated acids for this subclass.

- (2) Note. This subclass contains, for example:

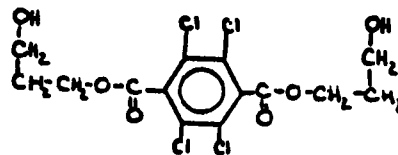

**84 Ring in alcohol moiety:**

This subclass is indented under subclass 76. Compounds wherein the alcohol moiety contains a carbocyclic nucleus.

- (1) Note. This subclass contains, for example:

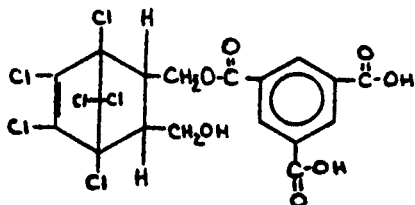
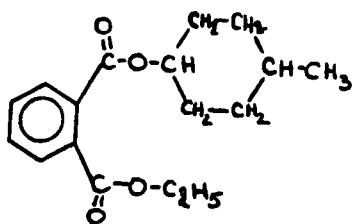

**85 Aromatic alcohol moiety:**

This subclass is indented under subclass 84. Compounds wherein the carbocyclic nucleus is aromatic.

- (1) Note. This subclass contains, for example:

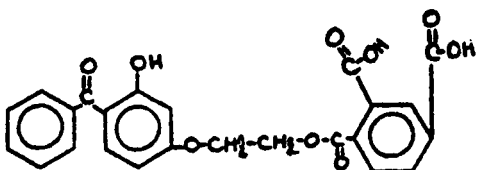
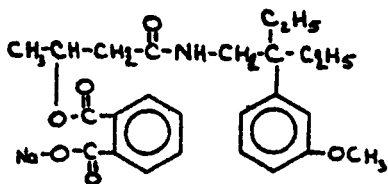
**86 Esterified phenolic hydroxy:**

This subclass is indented under subclass 85. Compounds wherein the ester is formed with a phenolic hydroxyl group.

- (1) Note. This subclass contains, for example:

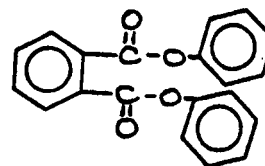
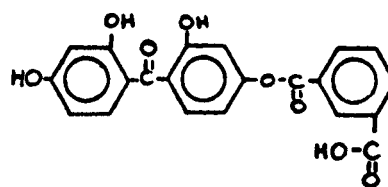
**87 Sulfur or halogen in alcohol moiety:**

This subclass is indented under subclass 76. Compounds wherein the alcohol moiety contains sulfur or a halogen covalently bonded.

- (1) Note. This subclass contains, for example:

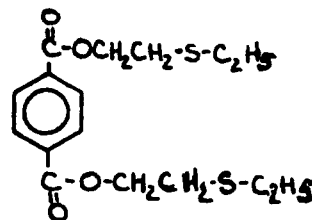
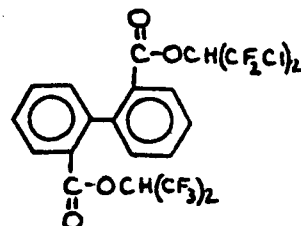
**88 Nitrogen in alcohol moiety:**

This subclass is indented under subclass 76. Compounds wherein the alcohol moiety contains nitrogen covalently bonded.

- (1) Note. This subclass contains, for example:

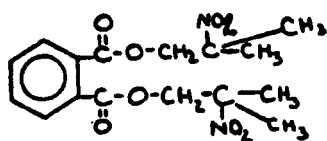

89

**Polyoxy alcohol moiety:**

This subclass is indented under subclass 76. Compounds wherein the alcohol moiety contains in addition to the esterified hydroxyl group, an -OX group attached to a noncarbonylic C where X may be H, C, an acyl radical not provided for above, or an alcoholate forming group not provided for above.

(1) Note. This subclass contains, for example:

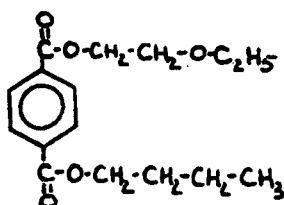
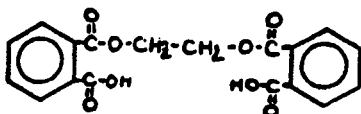

90

**Additional esterifying acid:**

This subclass is indented under subclass 89. Compounds wherein the polyoxy alcohol is additionally esterified by a different carboxylic acid not provided for above.

(1) Note. This subclass contains, for example:

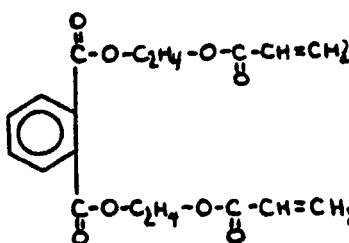
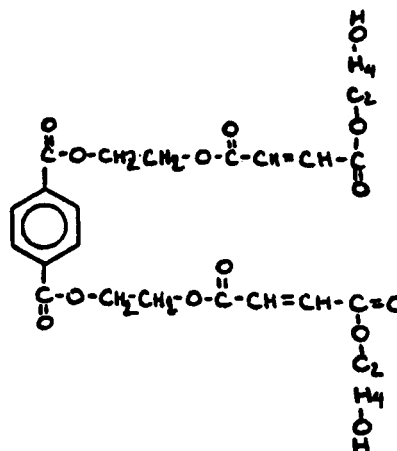

91

**Polyoxyalkylene alcohol moiety:**

This subclass is indented under subclass 89. Compounds wherein the polyoxy alcohol moiety has the structure-O-(C<sub>n</sub>H<sub>2n</sub>)<sub>m</sub>, where n and m are positive integers and m>1.

(1) Note. This subclass contains, for example:

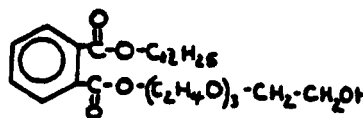

92

**Preparing esters by ester interchange:**

This subclass is indented under subclass 89. Processes wherein the ester is prepared by reacting an ester with another ester, acid or alcohol, to produce a different ester.

**93 Preparing esters from alkylene oxides:**  
This subclass is indented under subclass 89. Processes wherein the esters are prepared from alkylene oxides.

**94 Preparing esters from acid or from nitrile and diol:**  
This subclass is indented under subclass 89. Processes wherein the esters are prepared by reaction of a carboxylic acid or a nitrile with a diol.

**95 Unsaturation in alcohol moiety:**  
This subclass is indented under subclass 76. Compounds wherein the alcohol moiety is acyclic and contains an ethylenic double bond or a triple bond.

(1) Note. This subclass contains, for example:

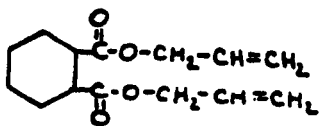

**96 Processes:**  
This subclass is indented under subclass 76. Processes for preparing compounds classifiable in that subclass.

(1) Note. When a patent contains claims to both a product classifiable in subclass 76 and a process, the patent is placed as an original in subclass 76 and cross referenced to this subclass. When the claims are directed solely to a process of preparing a compound classifiable in subclass 76, it is placed as an original in this subclass.

**97 Carbonylation:**  
This subclass is indented under subclass 96. Processes wherein the ester is prepared through formation of a carboxyl group on a starting material by reacting with a carbonylating agent such as carbon monoxide in the presence of an alcohol or by subsequent esterification.

**98 Esterification of acid, salt, acid halide or anhydride with alcohol:**  
This subclass is indented under subclass 96. Processes in which the compounds are prepared by reacting an alcohol with a carboxylic acid or its salt, acid halide or anhydride.

**99 Metal containing catalyst utilized:**  
This subclass is indented under subclass 98. Processes wherein the esterification reaction is carried out in the presence of a metal containing catalyst.

**100 Naphthyl in acid moiety:**  
This subclass is indented under subclass 8. Compounds wherein the acid radical contains the naphthyl group.

(1) Note. This subclass contains, for example:

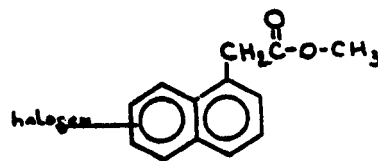
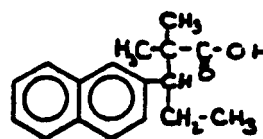

**101 Plural rings bonded directly to the same carbon in acid moiety:**  
This subclass is indented under subclass 8. Compounds wherein the acid radical contains two carbocyclic nuclei attached to a noncarbonylic methylene group.

(1) Note. Compounds wherein two carbocyclic nuclei are attached to a carbonyl group are classified in subclass 52.

(2) Note. This subclass contains, for example:

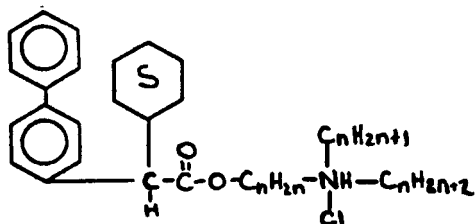
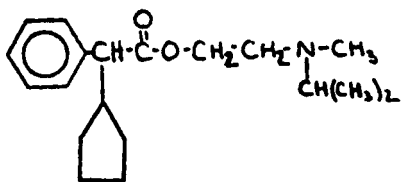

**102 Rings bonded directly to each other in acid moiety:**

This subclass is indented under subclass 8. Compounds wherein the acid radical contains a carbocyclic nucleus directly linked to another carbocyclic nucleus through a covalent bond.

(1) Note. This subclass contains, for example:

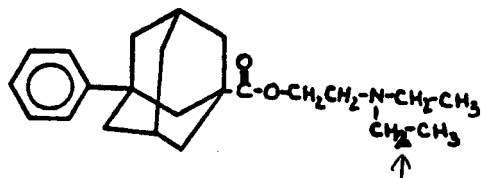
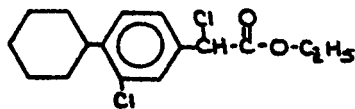

**103 Monocyclic acid moiety:**

This subclass is indented under subclass 8. Compounds wherein the acid radical contains only one carbocyclic group.

(1) Note. This subclass contains, for example:

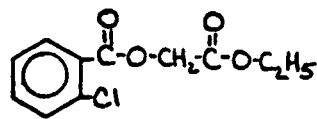

**104 Additional unsaturation in acid moiety:**

This subclass is indented under subclass 103. Compounds wherein the acid radical contains an ethylenic double bond or a triple bond.

(1) Note. This subclass contains, for example:

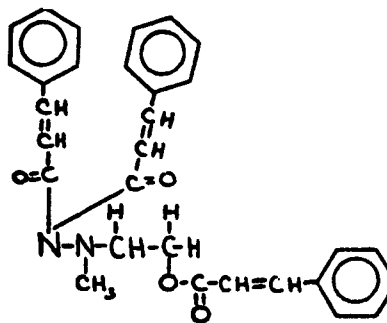
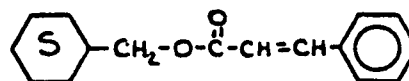

**105 Carboxyl, not bonded directly to a ring, in acid moiety:**

This subclass is indented under subclass 103. Compounds wherein the carboxyl group of the acid radical is not directly attached to the carbocyclic group.

(1) Note. This subclass contains, for example:

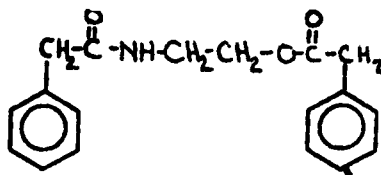

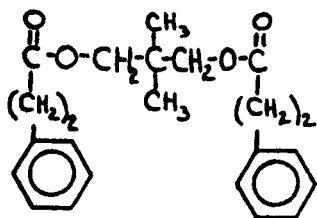
**106 Ring in alcohol moiety:**

This subclass is indented under subclass 103. Compounds wherein the alcohol moiety contains a carbocyclic group.

- (1) Note. This subclass contains, for example:

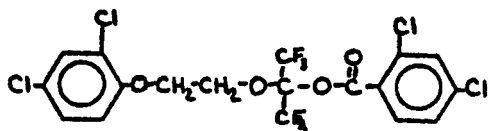
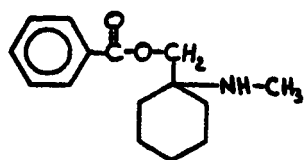
**107 Plural rings in alcohol moiety:**

This subclass is indented under subclass 106. Compounds wherein the alcohol moiety contains more than one carbocyclic group.

- (1) Note. This subclass contains, for example:

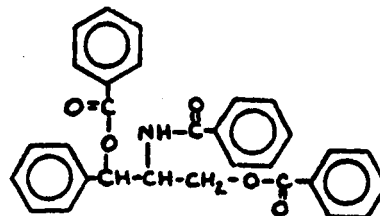
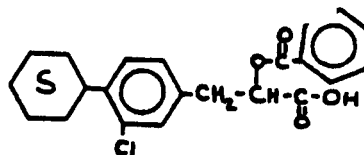

SEE OR SEARCH CLASS:

552, Organic Compounds, subclass 653 for esters of Vitamin D compounds, cholecalciferols, activated 7-dehydrocholesterols, dihydrotachysterols, 3-5 cyclovitamin D compounds, etc.

**108 Esterified phenolic hydroxy:**

This subclass is indented under subclass 107. Compounds wherein the ester function is formed with a phenolic OH group.

- (1) Note. This subclass contains, for example:

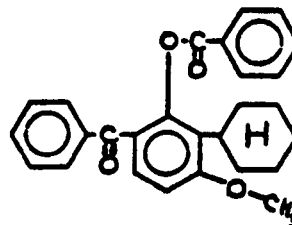
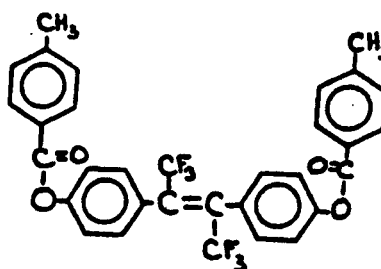

**109 Esterified phenolic hydroxy:**

This subclass is indented under subclass 106. Compounds in which the ester function is formed with a phenolic OH group.

- (1) Note. This subclass contains, for example:

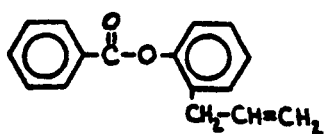
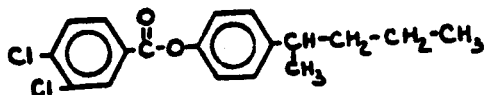
**110 Nitrogen in alcohol moiety:**

This subclass is indented under subclass 103. Compounds wherein the alcohol moiety contains nitrogen covalently bonded.

- (1) Note. This subclass contains, for example:

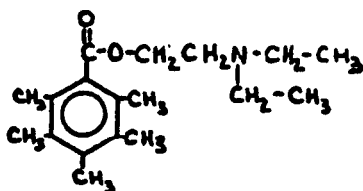
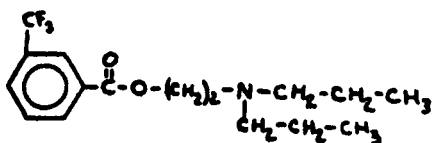
**111 Halogen in alcohol moiety:**

This subclass is indented under subclass 103. Compounds wherein the alcohol moiety contains a covalently bonded halogen.

- (1) Note. This subclass contains, for example:

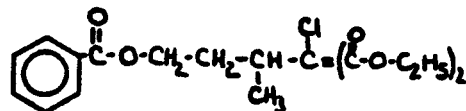
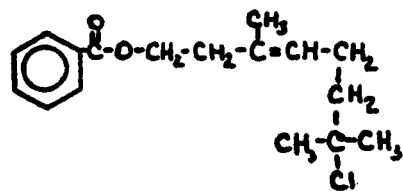
**112 Polyoxy alcohol moiety:**

This subclass is indented under subclass 103. Compounds wherein the alcohol moiety is an acyclic polyoxy alcohol, which in addition to the esterified PH, contains at least one other oxy group, -OX wherein X may be C, H, an alcoholate forming group not provided for above, or an acyl group not provided for above.

- (1) Note. This subclass contains, for example:

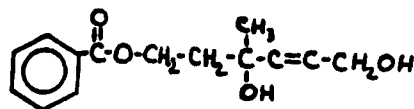
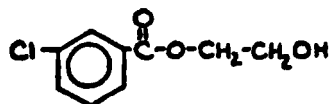
**113 Unsaturation in alcohol moiety:**

This subclass is indented under subclass 103. Compounds wherein the alcohol moiety contains an ethylenic double bond or a triple bond.

- (1) Note. This subclass contains, for example:

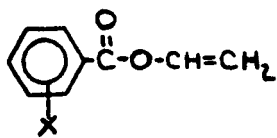

**114 Preparing alicyclic acid esters by carbonylation:**

This subclass is indented under subclass 1. Processes wherein an alicyclic acid ester is prepared through formation of a carboxyl group on a starting material by reaction with a carbonylating agent such as carbon monoxide in the presence of an alcohol or through subsequent esterification.

**115 Alicyclic carbamates:**

This subclass is indented under subclass 1. Compounds in which the acid radical contains an alicyclic nucleus and a nitrogen directly attached to the carbon of an esterified carboxyl group.

(1) Note. This subclass contains, for example:

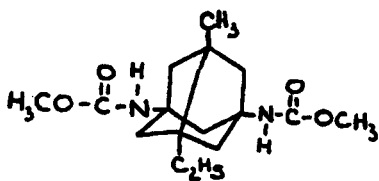
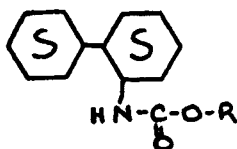

**116 Plural alicyclic rings in acid moiety:**

This subclass is indented under subclass 1. Compounds in which the acid radical contains more than one alicyclic group.

(1) Note. Compounds containing the hydrophenanthrene nucleus are placed in subclasses 5+.

(2) Note. This subclass contains, for example:

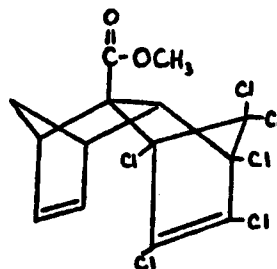
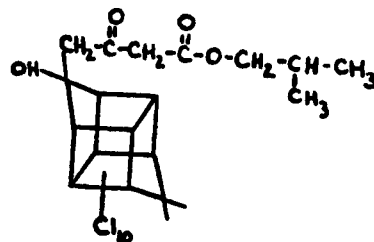

**117 Tricyclo ring system in acid moiety:**

This subclass is indented under subclass 116. Compounds in which the acid radical contains three alicyclic groups which are joined to each other either through ortho fusion or by a bridge.

(1) Note. This subclass contains, for example:

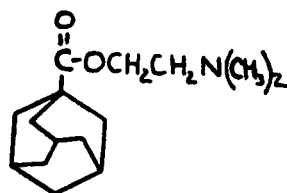
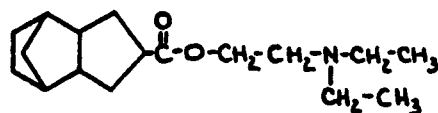

**118 Two rings only in acid moiety:**

This subclass is indented under subclass 116. Compounds in which the acid radical contains two alicyclic groups.

- (1) Note. This subclass contains, for example:

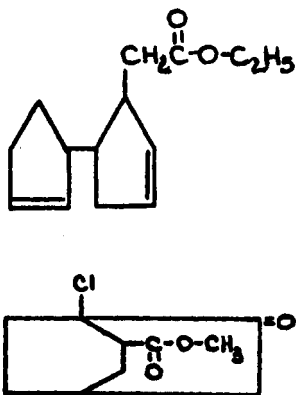

**119 Ortho fused:**

This subclass is indented under subclass 118. Compounds in which the acid radical contains two alicyclic groups joined through two ortho positioned carbon atoms.

- (1) Note. This subclass contains, for example:

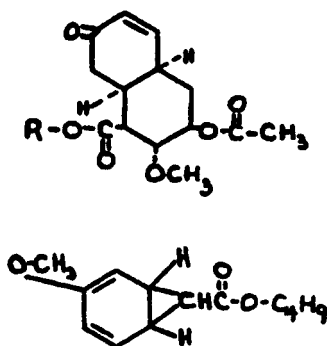

**120 2,2,1-bicyclo:**

This subclass is indented under subclass 118. Compounds in which the acid radical contains a 2,2,1-bicyclo nucleus.

- (1) Note. This subclass contains, for example:

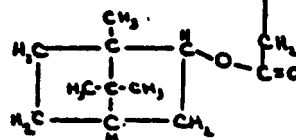
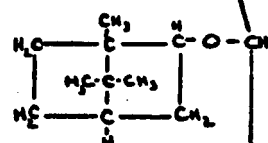
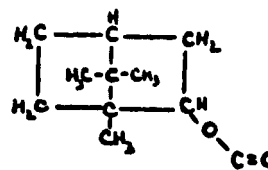
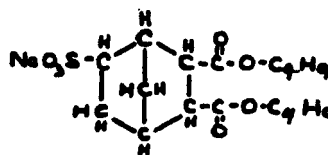

**121 Cyclopentyl in acid moiety (e.g., prostaglandins, etc.):**

This subclass is indented under subclass 1. Compounds in which the acid radical contains a cyclopentyl group.

- (1) Note. This subclass contains the class of compounds known as prostaglandins.
- (2) Note. This subclass contains, for example:





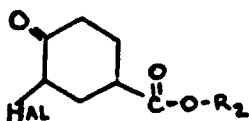
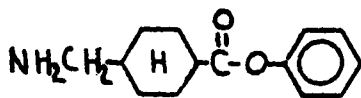

**126 Alicyclic acid moiety containing oxy, aldehyde or ketone group:**

This subclass is indented under subclass 1. Compounds wherein the acid radical contains an alicyclic nucleus not provided for above and contains the group-C(=O)X bonded to carbon, where X is C or H; or the group -OX attached to a noncarbonylic carbon where X is C, H, an alcoholate forming group not provided for above, or an acyl group not provided for above.

- (1) Note. This subclass contains, for example:

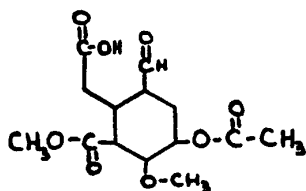
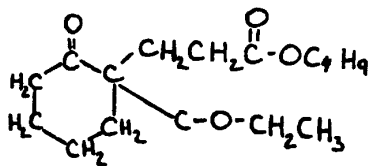

**127 Alicyclic polycarboxylic acid moiety:**

This subclass is indented under subclass 1. Compounds which contain an alicyclic nucleus not provided for above and contain more than one carboxyl group, at least one of which is esterified.

- (1) Note. This subclass also includes compounds wherein any unesterified carboxyl group may be present as a free acid or has been converted into a salt or

acid halide. However, those compounds wherein a carboxyl group has been converted into an amide group are found in subclass 125.

- (2) Note. This subclass contains, for example:

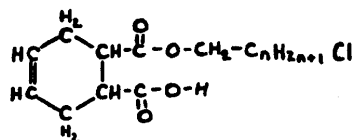
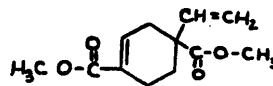

**128 Alicyclic acid moiety containing unsaturation:**

This subclass is indented under subclass 1. Compounds wherein the acid radical contains an alicyclic nucleus not provided for above and contains an ethylenic double bond or a triple bond.

- (1) Note. This subclass contains, for example:

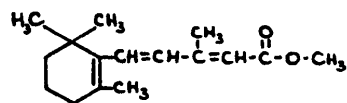
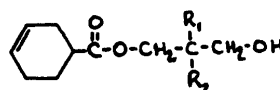

**129 Acyclic acid moiety:**

This subclass is indented under subclass 1. Compounds wherein the acid radical contains no carbocyclic nucleus.

- (1) Note. For esters of higher fatty acids, see Class 260, subclasses 398+, particularly subclasses 410+.
- (2) Note. For synthetic resins which are esters, see appropriate subclasses in Class 526, particularly subclass 309.

- (3) Note. This subclass contains, for example:

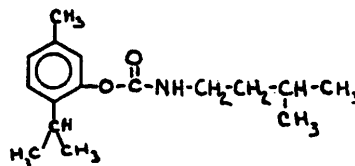
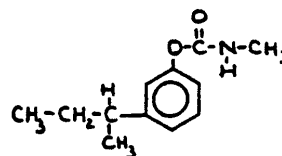
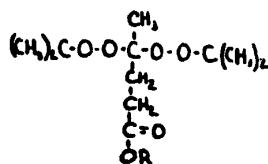
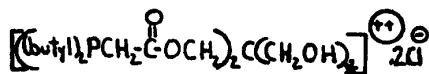

**130 Esterified phenolic hydroxy:**

This subclass is indented under subclass 129. Compounds wherein the carboxyl group is esterified by a phenolic hydroxyl group.

- (1) Note. This subclass contains, for example:

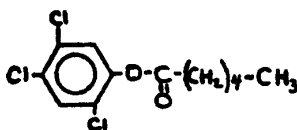
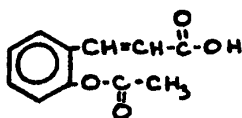

**131 Preparing esters by oxidation:**

This subclass is indented under subclass 130. Processes whereby phenolic esters are produced by the reaction of a starting material with oxygen or an oxygen producing material.

**132 Carbamic acid:**

This subclass is indented under subclass 130. Compounds wherein the acid radical contains nitrogen directly attached to the carbon of an esterified carboxyl group.

- (1) Note. This subclass contains, for example:

**133 Plural rings in phenolic moiety:**

This subclass is indented under subclass 132. Compounds wherein the phenolic moiety contains more than one carbocyclic group.

- (1) Note. This subclass contains, for example:

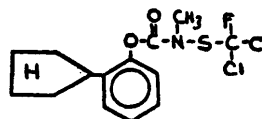
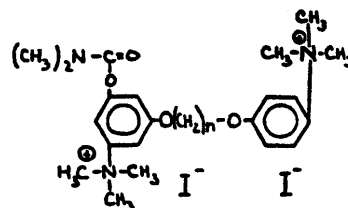

**134 Ortho fused:**

This subclass is indented under subclass 133. Compounds wherein the carbocyclic groups are joined through two ortho positioned carbon atoms.

- (1) Note. This subclass contains, for example:

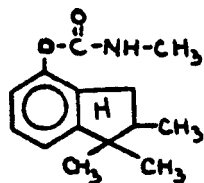
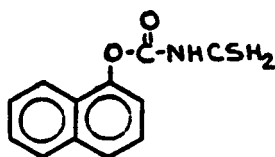

**135 Sulfur in phenolic moiety:**

This subclass is indented under subclass 132. Compounds wherein the phenolic moiety contains sulfur covalently bonded.

- (1) Note. This subclass contains, for example:

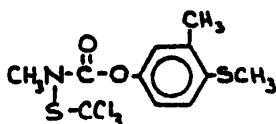
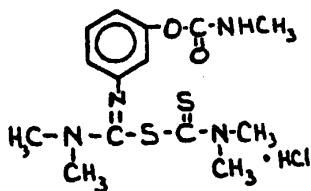

**136 Nitrogen in phenolic moiety:**

This subclass is indented under subclass 132. Compounds wherein the phenolic moiety contains nitrogen covalently bonded.

- (1) Note. This subclass contains, for example:

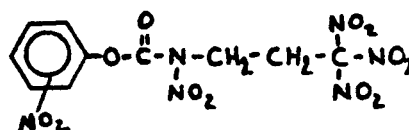
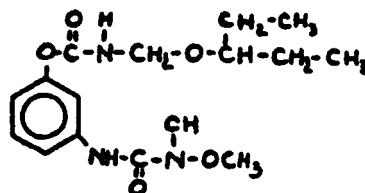

**137 Sulfur, halogen or additional nitrogen or oxygen in carbamic acid moiety:**

This subclass is indented under subclass 132. Compounds wherein the acid radical contains sulfur, halogen or nitrogen or oxygen in addition to that present in the carbamic acid group.

- (1) Note. This subclass contains, for example:

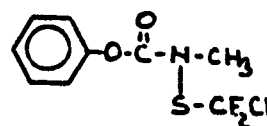
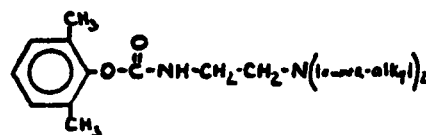

**138 Plural rings in phenolic moiety:**

This subclass is indented under subclass 130. Compounds wherein the phenolic moiety contains more than one carbocyclic group.

- (1) Note. See subclasses 133+ for polycyclic phenolic esters of carbamic acids.
- (2) Note. This subclass contains, for example:

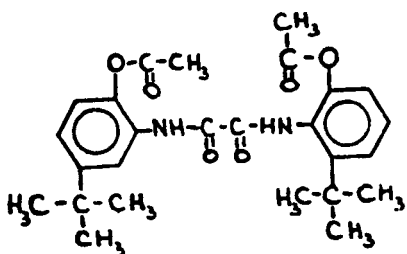
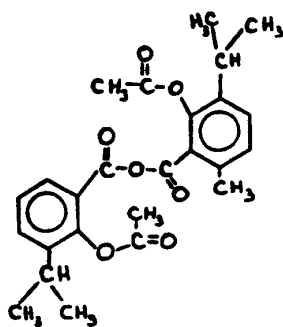

**139 Ortho fused:**

This subclass is indented under subclass 138. Compounds wherein the carbocyclic groups of the phenolic moiety are joined through two ortho positioned carbon atoms.

(1) Note. This subclass contains, for example:

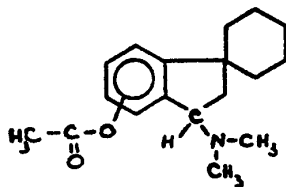
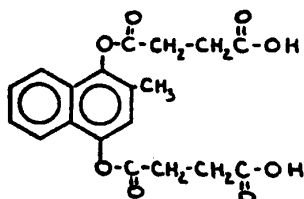

**140 Plural rings bonded directly to the same carbon in phenolic moiety:**

This subclass is indented under subclass 138. Compounds wherein the phenolic moiety contains two carbocyclic groups attached to a methylene or carbonyl group.

(1) Note. This subclass contains, for example:

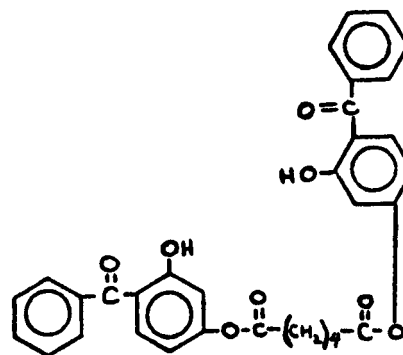
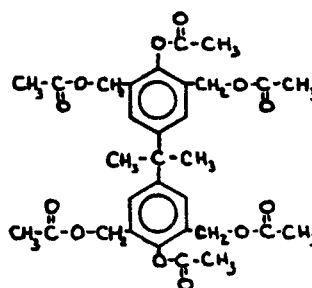

**141 Rings bonded directly to each other in phenolic moiety:**

This subclass is indented under subclass 138. Compounds wherein the phenolic moiety contains two carbocyclic groups joined to each other through a covalent bond.

(1) Note. This subclass contains, for example:

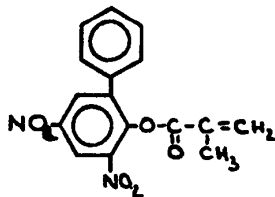
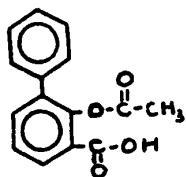

- 142 Nitrogen or sulfur in phenolic moiety:**  
This subclass is indented under subclass 130. Compounds wherein the phenolic moiety contains sulfur or nitrogen covalently bonded.

- (1) Note. This subclass contains, for example:

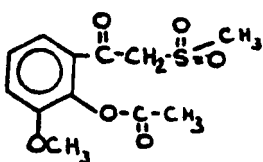
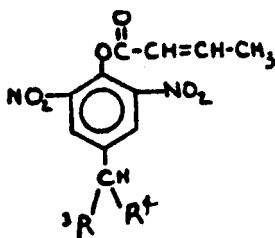

- 143 Salicylic acid or functional derivative:**  
This subclass is indented under subclass 130. Compounds wherein the phenolic moiety is salicylic acid, its salts, acid halides or anhydrides not provided for above.

- (1) Note. See subclass 142 for acylated salicylic acid amides.

- (2) Note. See subclass 71 for esters for salicylic acid.
- (3) Note. See subclass 138 for esters of salicylic acid anhydride per se and substituted derivatives thereof.
- (4) Note. This subclass contains, for example:

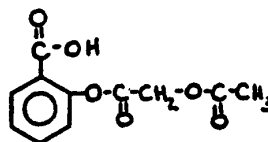
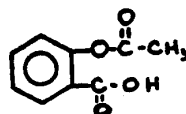

- 144 Polyoxy phenolic moiety:**  
This subclass is indented under subclass 130. Compounds wherein the phenolic moiety contains, in addition to the esterified hydroxyl group, an -OX group attached to a noncarbonylic carbon, where X is C, H, an alcoholate forming group not provided for above, or an acyl group not provided for above.

- (1) Note. This subclass includes, for example:

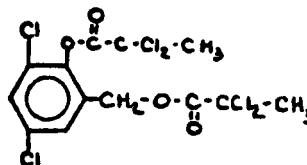
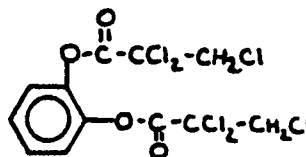

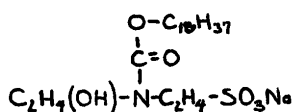
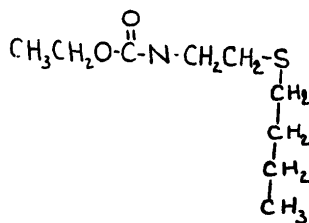

**149 Sulfoxo in acid moiety:**

This subclass is indented under subclass 147. Compounds wherein the acid radical contains sulfur bonded to oxygen.

- (1) Note. This subclass contains compounds which have a sulfonic acid moiety or its salt or acid halide.
- (2) Note. This subclass contains, for example:

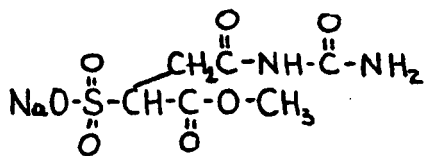
**150 Sulfonyl or sulfinyl in acid moiety:**

This subclass is indented under subclass 149. Compounds wherein the acid radical contains the sulfinyl group, R-S(=O)-R or the sulfonyl group, R-S(=O)<sub>2</sub>R.

- (1) Note. This subclass contains, for example:

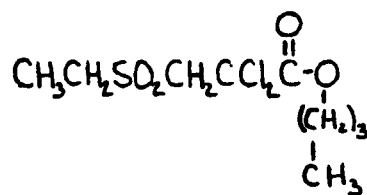
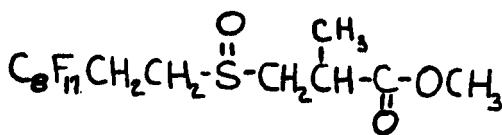
**151 Polycarboxylic acid:**

This subclass is indented under subclass 149. Compounds wherein the acid radical contains more than one carboxyl group, at least one of which is esterified.

- (1) Note. This subclass also contains compounds wherein an unesterified carboxyl group may appear in free acid form or has been converted into a salt or an acid halide. Where an unesterified carboxyl has been converted into an amide, see subclass 149 or subclass 150 above.
- (2) Note. This subclass contains, for example:

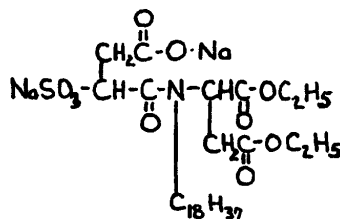
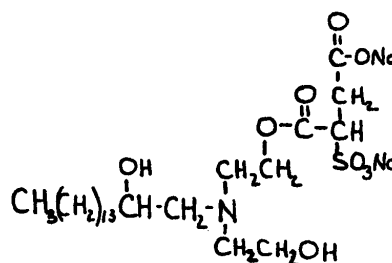
**152 Thio ether in acid moiety:**

This subclass is indented under subclass 147. Compounds wherein the acid radical contains the group, R-S-R.



- (1) Note. This subclass contains, for example:

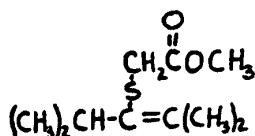
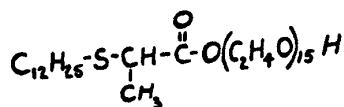

- 153 Nitrogen or halogen in acid moiety:**  
This subclass is indented under subclass 152. Compounds wherein the acid radical contains nitrogen or halogen covalently bonded.

- (1) Note. This subclass contains, for example:

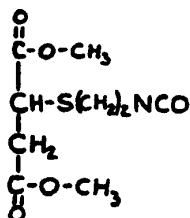
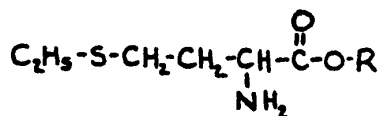

- 154 Polycarboxylic acid:**  
This subclass is indented under subclass 152. Compounds wherein the acid radical contains more than one carboxyl group, at least one of which is esterified.

- (1) Note. This subclass also contains compounds wherein an unesterified carboxyl may appear in the form of a free acid or has been converted into a salt or an acid halide. Where an unesterified carboxyl has been converted into an amide, see subclass 153 above.

- (2) Note. This subclass contains, for example:

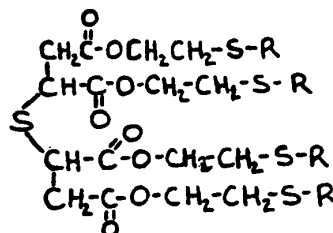
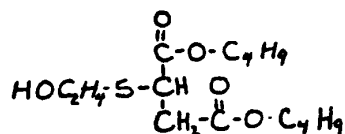

- 155 Nitrogen in acid moiety other than as nitroso or isocyanate (e.g., amino acid esters, etc.):**

This subclass is indented under subclass 129. Compounds wherein the acid radical contains covalently bonded nitrogen other than in the form of isocyanate or nitroso groups.

- (1) Note. This subclass contains, for example:

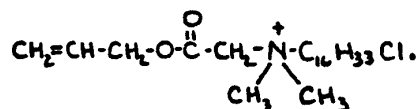
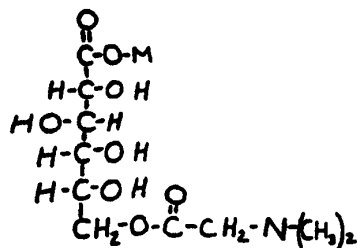

- 156 Nitro bonded to carbon in acid moiety:**  
This subclass is indented under subclass 155. Compounds wherein the acid radical contains the group -N(=O)<sub>2</sub> bonded to carbon.

- (1) Note. This subclass contains, for example:

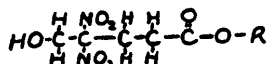
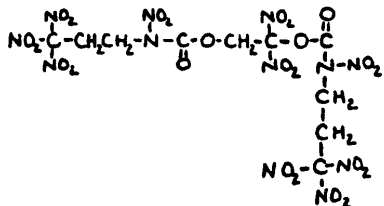

**157 Carbamic acid:**

This subclass is indented under subclass 155. Compounds wherein the acid radical contains a nitrogen directly attached to the carbon of an esterified carboxyl group.

- (1) Note. This subclass contains, for example:

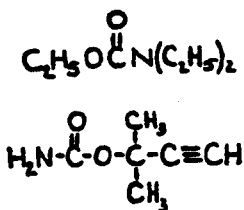

**158 Polycarbamic:**

This subclass is indented under subclass 157. Compounds wherein the acid radical contains more than one carbamic acid group.

- (1) Note. This subclass also contains compounds, where an unesterified carbamic acid group may appear in the form of a free acid or may be converted into a salt or acid halide. Where an unesterified carbamic acid group has been converted into an amide and only one esterified carbamic acid group is present, the compound is placed in the appropriate subclass dealing with monocarbamic acid esters.

**159 Addition nitrogen in acid moiety:**

This subclass is indented under subclass 157. Compounds wherein the acid radical contains covalently bonded nitrogen in addition to that present in the carbamic acid group.

- (1) Note. The additional nitrogen may be present in the form of an isocyanate or nitroso group.
- (2) Note. See subclass 156 for nitro containing carbamic acid esters.
- (3) Note. This subclass contains, for example:

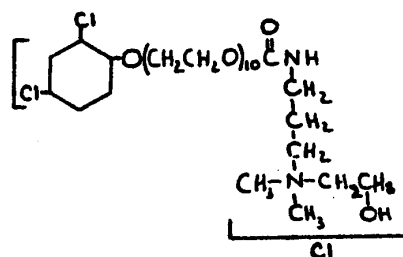

**160 Oxy in acid moiety:**

This subclass is indented under subclass 157. Compounds wherein the acid radical contains an -OX group attached to a noncarbonylic carbon, where X=C, H, an alcoholate forming group not provided for above.

- (1) Note. This subclass contains, for example:

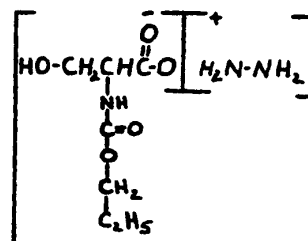
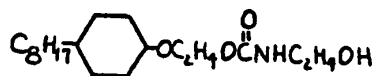

**161 Halogen in acid moiety:**

This subclass is indented under subclass 157. Compounds wherein the acid radical contains covalently bonded halogen.

- (1) Note. This subclass contains, for example:

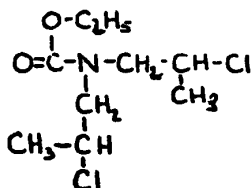
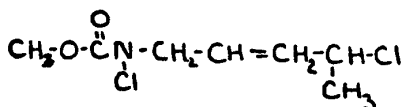
**162 Cyclic alcohol moiety:**

This subclass is indented under subclass 157. Compounds wherein the alcohol moiety contains a carbocyclic group.

- (1) Note. This subclass contains, for example:

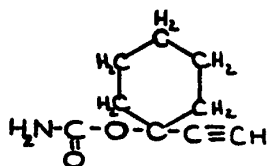
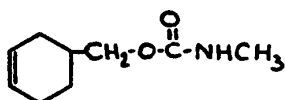
**163 Aromatic alcohol moiety:**

This subclass is indented under subclass 162. Compounds wherein the alcohol moiety of the ester contains an aromatic group.

- (1) Note. This subclass contains, for example:

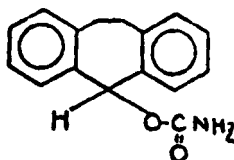
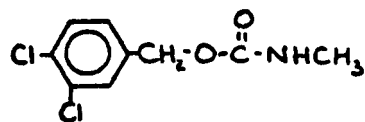
**164 Polyoxy alcohol moiety:**

This subclass is indented under subclass 163. Compounds wherein the alcohol moiety of the ester contains in addition to the esterified OH group, at least one other -OX group attached to a noncarbonylic carbon, where X may be C, H, an alcoholate forming group not provided for above, or an acyl group not provided for above.

- (1) Note. This subclass contains, for example:

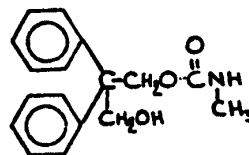
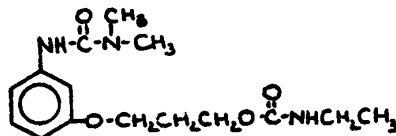

This subclass is indented under subclass 162. Compounds wherein the alcohol moiety of the ester contains an aromatic group.

- (1) Note. This subclass contains, for example:

**165 Sulfur or nitrogen in alcohol moiety:**

This subclass is indented under subclass 157. Compounds wherein the alcohol moiety of the ester contains covalently bonded nitrogen or sulfur.

- (1) Note. This subclass contains, for example:



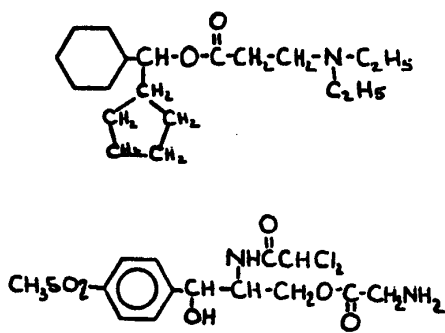

**174 Aldehyde or ketone group in acid moiety:**

This subclass is indented under subclass 129. Compounds wherein the acid radical contains the group  $-C(=O)X$  attached to carbon, where X is C or H.

- (1) Note. This subclass contains, for example:

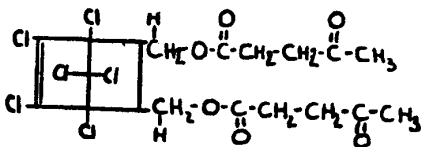
**175 Preparing esters by carbonylation:**

This subclass is indented under subclass 174. Processes wherein the ester is prepared through formation of a carboxyl group of a starting material by reaction with a carbonylating agent such as carbon monoxide either in the presence of an alcohol or by subsequent esterification of the formed acid.

**176 Polycarboxylic acid:**

This subclass is indented under subclass 174. Compounds wherein the acid radical contains more than one carboxyl group, at least one of which is esterified.

- (1) Note. This subclass also includes compounds wherein any unesterified carboxyl group may be present in free acid form or has been converted into a salt or acid halide. Where the carboxyl group has been converted into an amide, the

compound is classified in subclasses 155+.

- (2) Note. This subclass contains, for example:

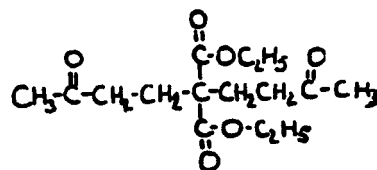
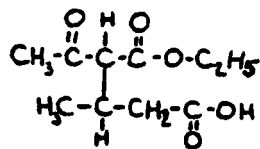
**177 Aldehyde group in acid moiety:**

This subclass is indented under subclass 174. Compounds wherein the acid radical contains the aldehyde group  $-C(=O)H$ .

- (1) Note. This subclass contains, for example:

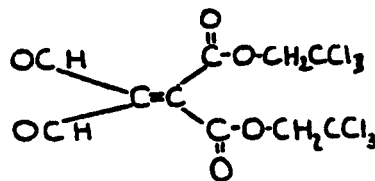
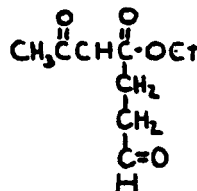
**178 Acetoacetic acid:**

This subclass is indented under subclass 174. Compounds which are esters of acetoacetic acid, per se.

- (1) Note. For substituted derivatives of acetoacetic acid esters, see the appropriate subclasses above.
- (2) Note. This subclass contains, for example:

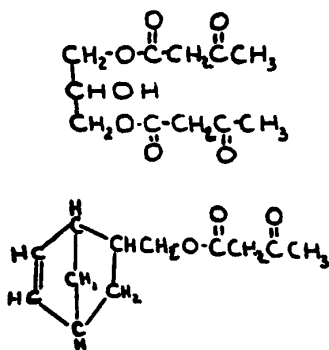

### 179 Oxy in acid moiety:

This subclass is indented under subclass 129. Compounds wherein the acid radical contains the -OX group attached to a noncarbonylic carbon, where X may be C, H, an alcoholate forming group not provided for above, or an acyl group not provided for above.

- (1) Note. This subclass contains, for example:

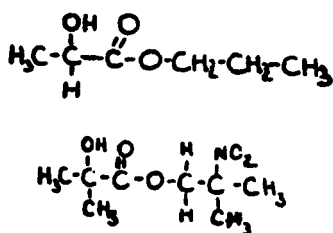

### 180 Polycarboxylic acid:

This subclass is indented under subclass 179. Compounds wherein the acid radical contains more than one carboxyl group, at least one of which is esterified.

- (1) Note. This subclass also contains compounds wherein an unesterified carboxyl may appear in free acid form or

has been converted into a salt or acid halide. Where the carboxyl group has been converted into an amide, the compound is classified in subclasses 155+.

- (2) Note. This subclass contains, for example:

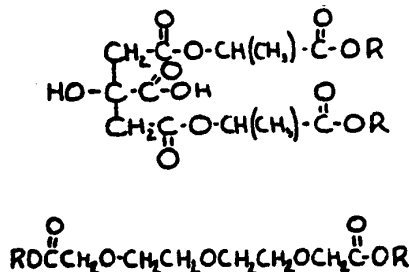

### 181 Unsaturation in acid moiety:

This subclass is indented under subclass 180. Compounds wherein the acid radical contains an ethylenic double bond or a triple bond.

- (1) Note. This subclass contains, for example:

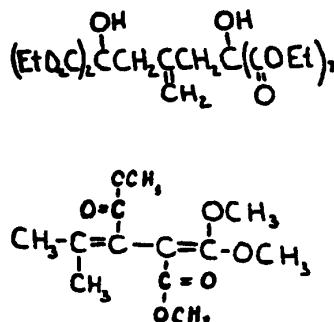

### 182 Polyoxy alcohol moiety:

This subclass is indented under subclass 180. Compounds wherein the alcohol moiety of the ester contains in addition to the esterified OH group, an -OX group attached to a noncarbonylic carbon, wherein X may be C, H, an alcoholate forming group not provided for above, or an acyl group not provided for above.

- (1) Note. This subclass contains, for example:

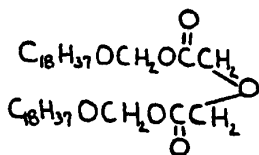
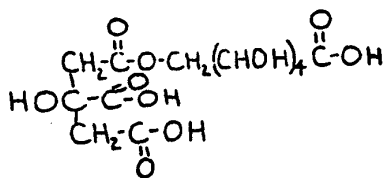
**183 Unsaturation in acid moiety:**

This subclass is indented under subclass 179. Compounds wherein the acid radical contains an ethylenic double bond or a triple bond.

- (1) Note. This subclass contains, for example:

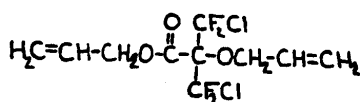
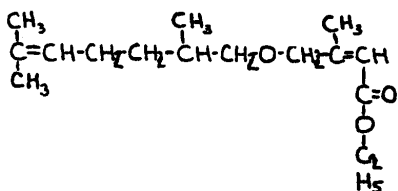
**184 Halogen in acid moiety:**

This subclass is indented under subclass 179. Compounds wherein the acid radical contains covalently bonded halogen.

- (1) Note. This subclass contains, for example:

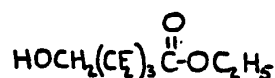
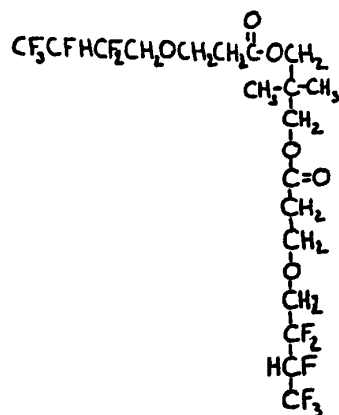
**185 Acylated oxy in acid moiety:**

This subclass is indented under subclass 179. Compounds wherein a hydroxy group of the esterified acid radical has been esterified by an acyl group not provided for above.

- (1) Note. Lactyl lactate is classified in subclass 179, but lactyl acetoxy lactate is placed here.
- (2) Note. This subclass contains, for example:

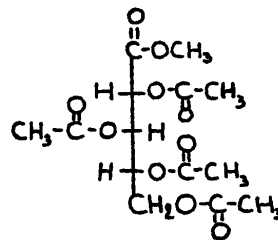
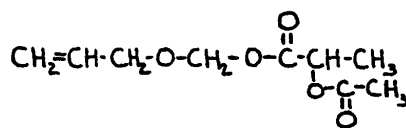
**186 Polyoxy acid moiety:**

This subclass is indented under subclass 179. Compounds wherein the acid radical contains more than one oxy group.



- (1) Note. This subclass contains, for example:

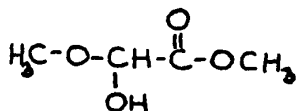
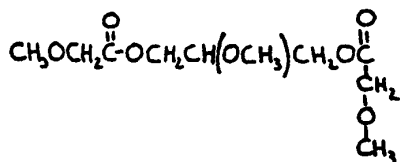

**187 Alkoxy in acid moiety:**

This subclass is indented under subclass 179. Compounds wherein the X of the -OX group in the acid radical is C which is part of an alkyl group.

- (1) Note. This subclass contains, for example:

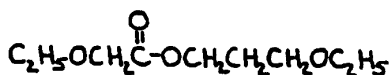
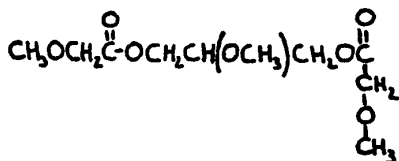

**188 Cyclic alcohol moiety:**

This subclass is indented under subclass 179. Compounds wherein the alcohol moiety of the ester contains a carbocyclic group.

- (1) Note. This subclass contains, for example:

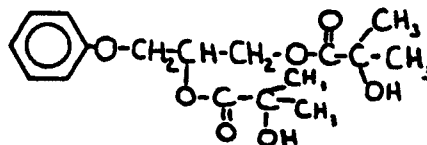

**189 Polyoxy alcohol moiety:**

This subclass is indented under subclass 179. Compounds wherein the alcohol moiety of the ester contains, in addition to the esterified OH, another -OX group attached to a noncarbonylic C, where X may be C, H, an alcoholate forming group not provided for above, or an acyl group not provided for above.

- (1) Note. This subclass contains, for example:

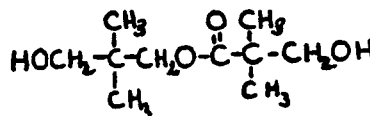
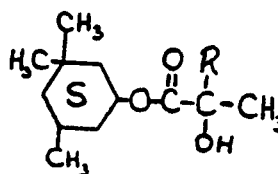

**190 Polycarboxylic acid:**

This subclass is indented under subclass 129. Compounds which contain more than one carboxyl group, at least one of which is esterified.

- (1) Note. This subclass also contains compounds wherein an unesterified carboxyl may be present in free acid form or has been converted into a salt or an acid halide. Where an unesterified carboxyl has been converted into an amide, see subclasses 155+.

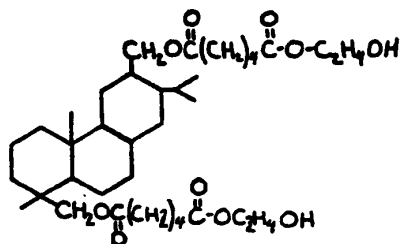
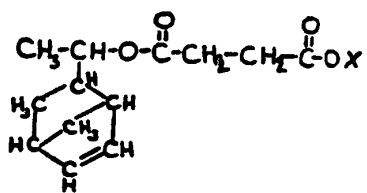

**195 Phosphorus or sulfur in alcohol moiety:**

This subclass is indented under subclass 190. Compounds wherein the alcohol moiety of the ester contains sulfur or phosphorus covalently bonded.

- (1) Note. This subclass contains, for example:

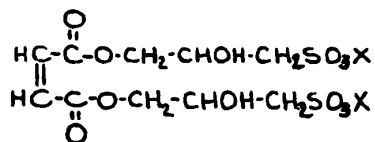
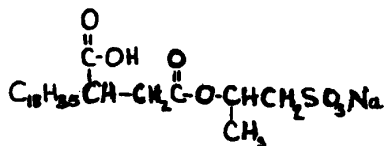
**196 Nitrogen in alcohol moiety:**

This subclass is indented under subclass 190. Compounds wherein the alcohol moiety of the ester contains nitrogen covalently bonded.

- (1) Note. This subclass contains, for example:

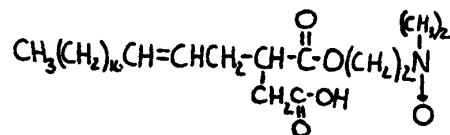
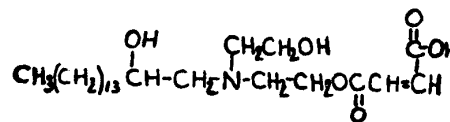
**197 Halogen in alcohol moiety:**

This subclass is indented under subclass 190. Compounds wherein the alcohol moiety of the ester contains halogen covalently bonded.

- (1) Note. This subclass contains, for example:

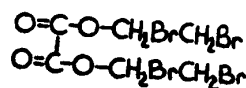
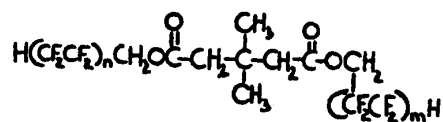
**198 Polyoxy alcohol moiety:**

This subclass is indented under subclass 190. Compounds wherein the alcohol moiety of the ester contains, in addition to the esterified OH, an -OX attached to a noncarbonylic C, where X may be C, H, and alcoholate forming group not provided for above, or an acyl group not provided for above.

- (1) Note. This subclass contains, for example:

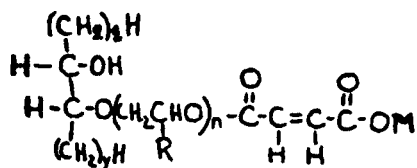

**199 Additional monooxy alcohol or monocarboxylic acid (e.g., complex esters, etc.):**

This subclass is indented under subclass 198. Compounds in which an additional monohydric alcohol or monocarboxylic acid or both have been reacted.

- (1) Note. This subclass includes the so-called "complex esters" which fall into the following three categories:

I. Monocarboxylic acid - polyhydric alcohol - (polycarboxylic acid - polyhydric alcohol)<sub>x</sub> - Monocarboxylic acid.

II. Monohydric alcohol - polycarboxylic acid - (polyhydric alcohol - polycarboxylic acid)<sub>x</sub> - Monohydric alcohol.

III. Monohydric alcohol - (polycarboxylic acid - polyhydric alcohol)<sub>x</sub> - Monocarboxylic acid.

- (2) Note. This subclass includes, for example:

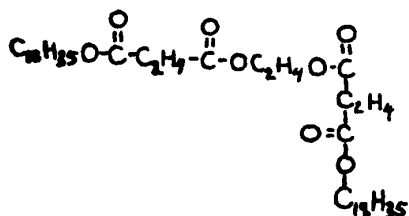

**200 Preparing esters from alkylene oxides:**

This subclass is indented under subclass 198. Processes in which an acyclic polycarboxylic acid ester is produced by reaction with an alkylene oxide.

**201. Unsaturation in alcohol moiety:**

This subclass is indented under subclass 190. Compounds wherein the alcoholic moiety of the ester contains an ethylenic double bond or a triple bond.

- (1) Note. This subclass contains, for example:

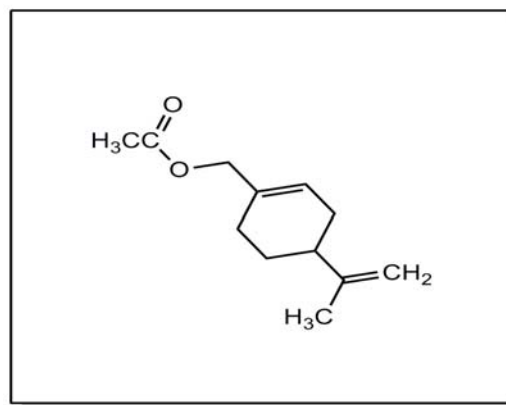

SEE OR SEARCH THIS CLASS, SUBCLASS:

130, through 146, for esters of unsubstituted acids of the acetic acid series with phenols.

**202. Preparing esters for oligomerization:**

This subclass is indented under subclass 190. Processes in which a polycarboxylic acid ester is prepared by interacting two to four monomeric units.

- (1) Note. This subclass also includes, for example, processes known as reductive coupling.

**203. Preparing esters by alkylation or isomerization:**

This subclass is indented under subclass 190. Processes in which a polycarboxylic acid ester is produced (a) by introducing an alkyl or alkylidene radical on the acid moiety, or (b) by forming an isomer of the starting material.

**204. Preparing esters by esterification or carbonylation:**

This subclass is indented under subclass 190. Processes in which a polycarboxylic acid ester is produced (a) by a reaction which forms an

ester linkage, or (b) by formation of a carboxyl group on a starting material by reaction with a carbonylating agent such as carbon monoxide with simultaneous or subsequent esterification of the acid with an alcohol.

**205. Unsaturation in acid moiety:**

This subclass is indented under subclass 129. Compounds wherein the acid radical contains an ethylenic double bond or a triple bond.

- (1) Note. This subclass contains, for example:

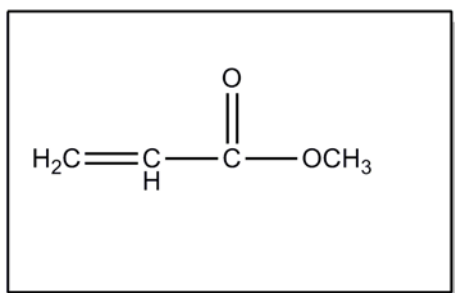

**206. Preparing esters for carbonylation:**

This subclass is indented under subclass 205. Processes wherein an unsaturated acid ester is prepared through formation of a carboxyl group on a starting material by reaction with carbonylating agent such as carbon monoxide in the presence of an alcohol or by subsequent esterification of the formed acid.

**207. Group VIII noble metal catalyst utilized:**

This subclass is indented under subclass 206. Processes wherein the carbonylating is carried out in the presence of a catalyst which contains a noble metal from Group VIII, i.e., iridium, osmium, palladium, platinum, rhodium, or rubidium.

**208. Formation of carboxyl group by oxidation:**

This subclass is indented under subclass 205. Processes wherein the ester is produced by treatment of a starting material, such as an olefin or an aldehyde with oxygen or an oxygen producing material and esterifying the resulting acid.

**209. Preparing esters from alkylene oxides:**

This subclass is indented under subclass 205. Processes wherein the ester is produced by a reaction, where one of the reactants is an alkylene oxide.

**210. Preparing esters from aldehydes:**

This subclass is indented under subclass 205. Processes wherein the ester is prepared from an aldehyde.

- (1) Note. This subclass contains, for example, processes of condensing an unsaturated aldehyde with a metal alcoholate or a saturated monocarboxylic acid ester.

SEE OR SEARCH THIS CLASS, SUBCLASS:

208, for processes involving the oxidation of an aldehyde.

**211. Formation of ethylenic unsaturation:**

This subclass is indented under subclass 205. Processes wherein the ester is produced by treating a monocarboxylic acid or ester to introduce unsaturation and may include subsequent esterification.

**212. By dehydration or dealcoholization:**

This subclass is indented under subclass 211. Processes wherein unsaturation is introduced by removal of an -OX group, where X is H or C.

**213. By dehalogenation or dehydrohalogenation:**

This subclass is indented under subclass 211. Processes wherein unsaturation is introduced by removal of a halogen or a hydrohalide.

**214. By dehydrogenation:**

This subclass is indented under subclass 211. Processes wherein unsaturation is introduced by removal of hydrogen.

**215. Preparing esters from nitriles or amides:**

This subclass is indented under subclass 205. Processes wherein the ester is produced by reaction of a nitrile or an amide.

**216. Preparing esters by depolymerization:**

This subclass is indented under subclass 205. Processes wherein the ester is produced by changing the state of a polymeric material to

that of a lower polymeric form or to a monomer.

**217. Preparing esters by ester interchange:**

This subclass is indented under subclass 205. Processes wherein the ester is produced by reaction of an ester with an alcohol, an acid or an ester to produce a different ester.

- (1) Note. This subclass includes processes where a sulfonic acid ester is used as the source of a replacing alcohol moiety, but does not include those processes wherein the sulfate is produced as a transitory intermediate in sulfuric acid catalyzed reactions.

**218. Purification or recovery:**

This subclass is indented under subclass 205. Processes which are directed to the purification, recovery or separation of acyclic, unsaturated monocarboxylic acid esters.

**219. Halogen in acid moiety:**

This subclass is indented under subclass 205. Compounds wherein the acid radical contains covalently bonded halogen.

- (1) Note. This subclass contains for example:

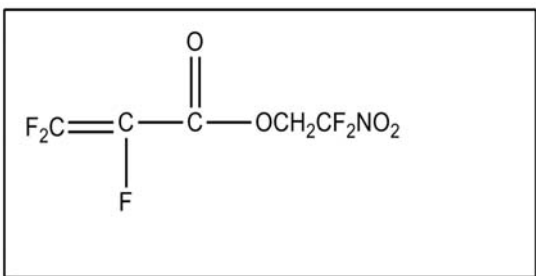
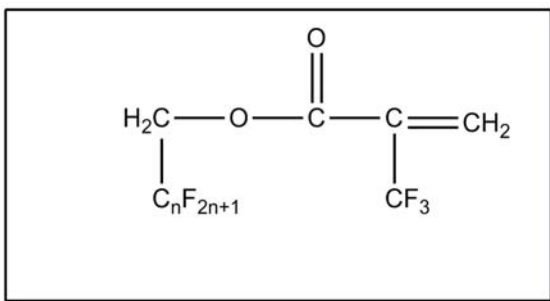

**220. Cyclic alcohol moiety:**

This subclass is indented under subclass 205. Compounds wherein the alcohol moiety of the ester contains a carbocyclic group.

- (1) Note. This subclass contains, for example:

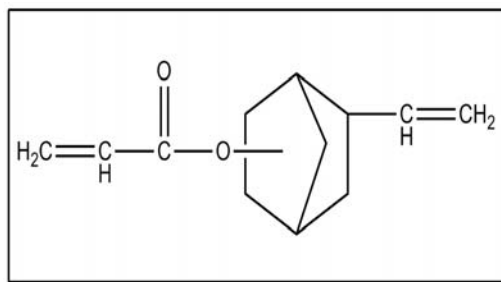
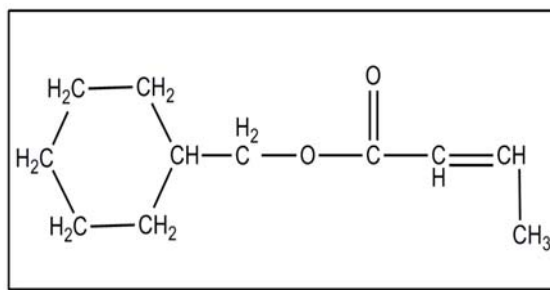

**221. Aromatic alcohol moiety:**

This subclass is indented under subclass 220. Compounds wherein the carbocyclic group of the alcohol moiety is aromatic.

- (1) Note: This subclass contains, for example:

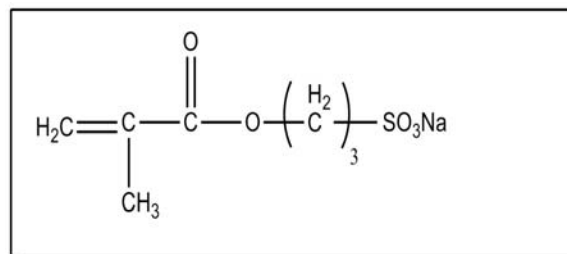
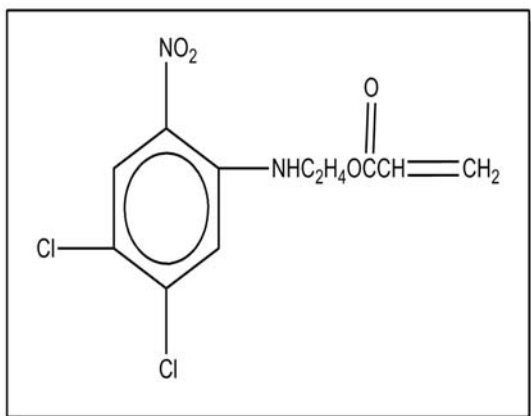
**223. Halogen in alcohol moiety:**

This subclass is indented under subclass 205. Compounds wherein the alcohol moiety contains covalently bonded halogen.

- (1) Note. This subclass contains, for example:

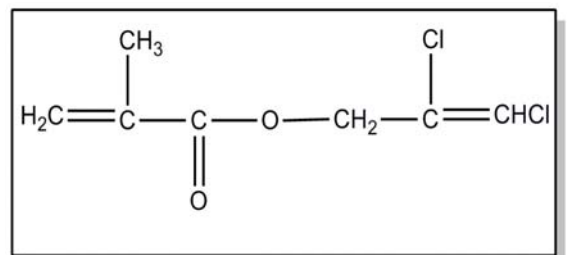
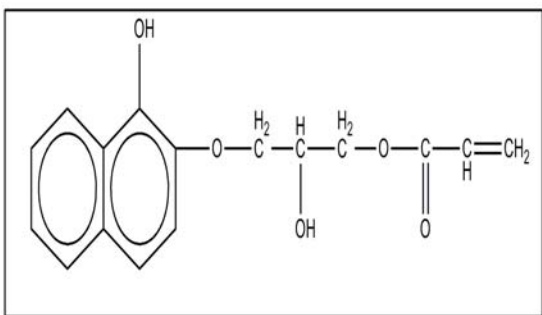
**222. Phosphorus, sulfur or nitrogen in alcohol moiety:**

This subclass is indented under subclass 205. Compound wherein the alcohol moiety contains phosphorus or sulfur or nitrogen covalently bonded.

- (1) Note. This subclass contains, for example:

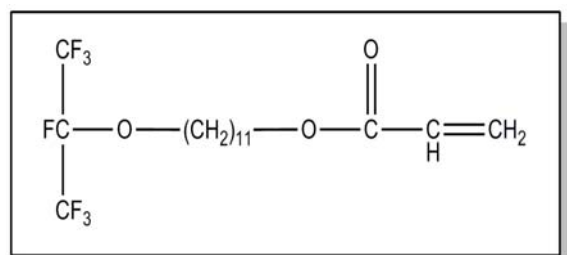
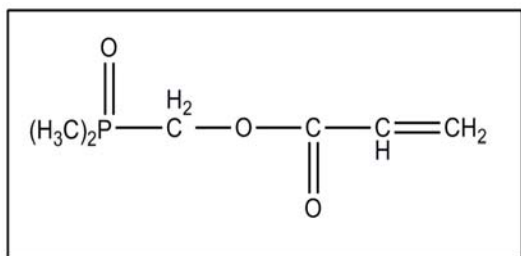
**224. Polyoxy alcohol moiety:**

This subclass is indented under subclass 205. Compounds wherein the alcohol moiety contains in addition to the esterified hydroxyl group, an -OX group attached to a noncarbonylic carbon, where X may be C, H, an alcohol-forming group not provided for above, or an acyl group not provided for above.

- (1) Note. This subclass contains, for example:

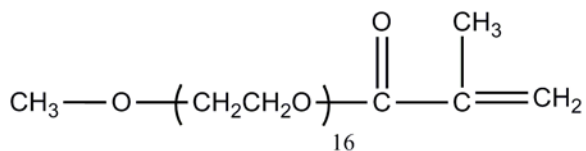
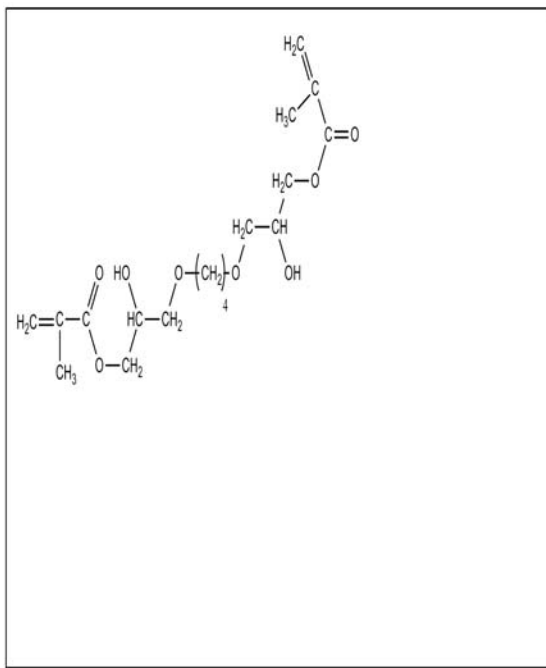
**225. Unsaturation in alcohol moiety:**

This subclass is indented under subclass 205. Compounds wherein the alcohol moiety contains an ethylenic double bond or a triple bond.

- (1) Note. This subclass contains, for example:

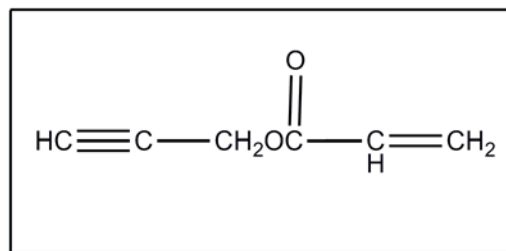
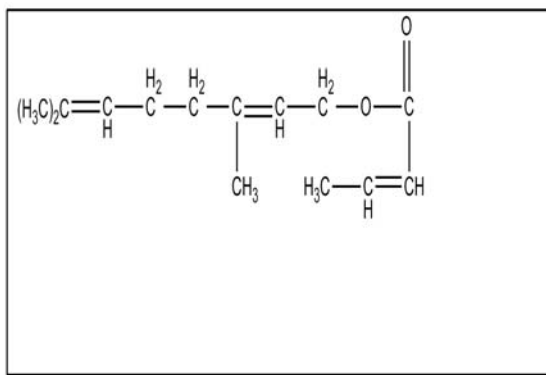
**226. Halogen in acid moiety:**

This subclass is indented under subclass 129. Compounds wherein the acid radical contains covalently bonded halogen.

- (1) Note. This subclass contains, for example:

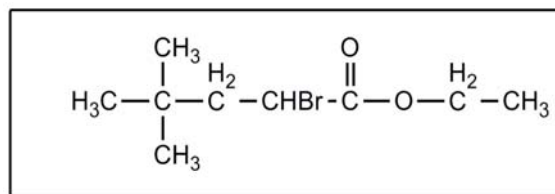
**227. Fluorine in acid moiety:**

This subclass is indented under subclass 226. Compounds wherein the halogen is fluorine.

- (1) Note. This subclass contains, for example:

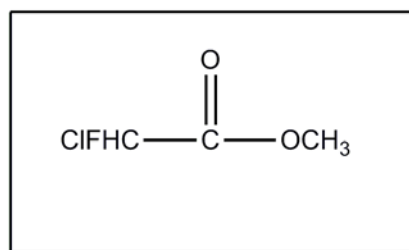

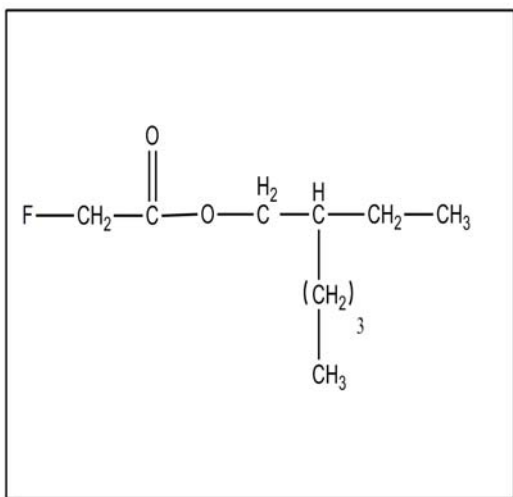

**228. Cyclic alcohol moiety:**

This subclass is indented under subclass 226. Compounds wherein the alcohol moiety contains a carbocyclic group.

- (1) Note. This subclass contains, for example:

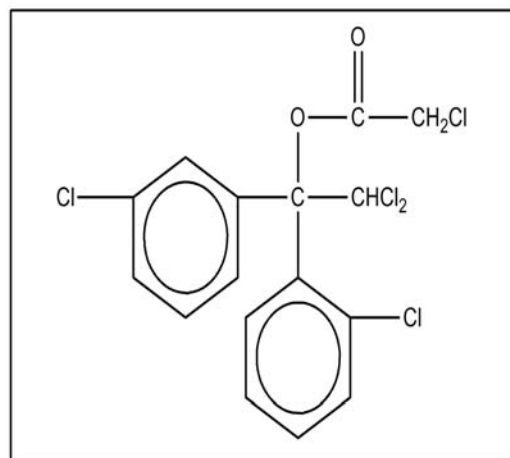
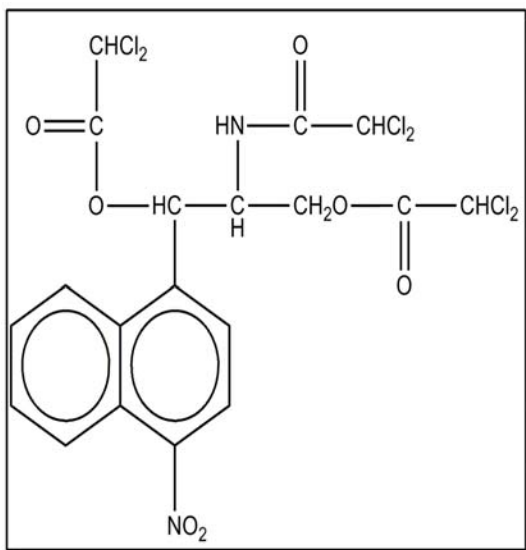
**229. Halogen in alcohol moiety:**

This subclass is indented under subclass 226. Compounds wherein the alcohol moiety contains covalently bonded halogen.

- (1) Note. This subclass contains, for example:

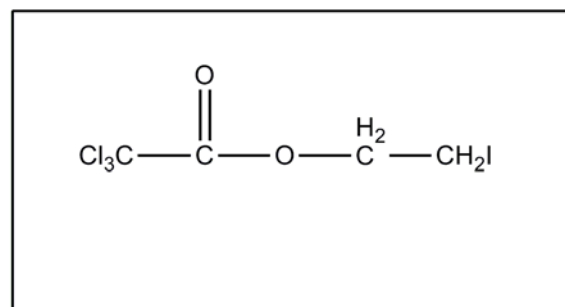
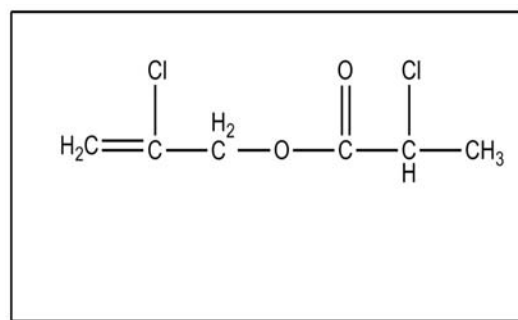

**230. Polyoxyl alcohol moiety:**

This subclass is indented under subclass 226. Compounds wherein the alcohol moiety contains, in addition to the esterified hydroxyl, an -OX group attached to noncarbonylic carbon, where X is C, H, an alcoholate forming group not provided for above, or an acyl group not provided for above.

- (1) Note. This subclass contains, for example:

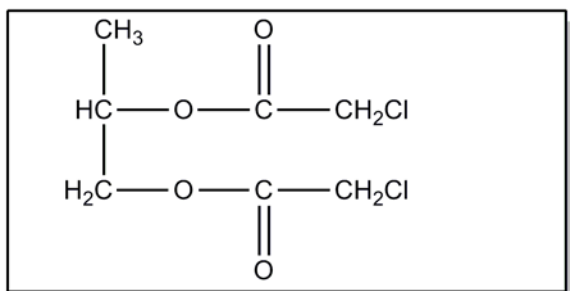
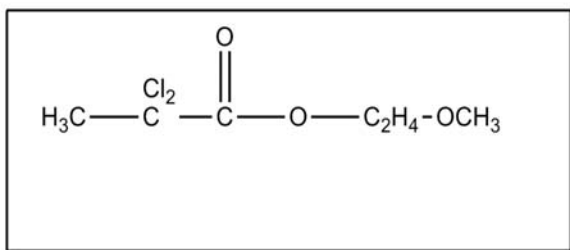
**231. Unsubstituted acids of the acetic series:**

This subclass is indented under subclass 129. Compounds wherein the acid radical is saturated, unsubstituted, contains less than seven carbon atoms in an unbroken chain attached to a carboxyl group, and has the formula C<sub>n</sub>H<sub>2n+1</sub>COOR.

- (1) Note. This subclass contains, for example:

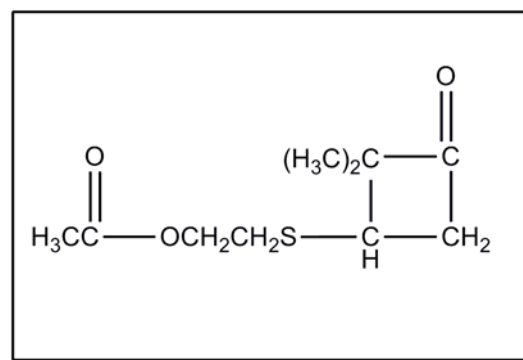
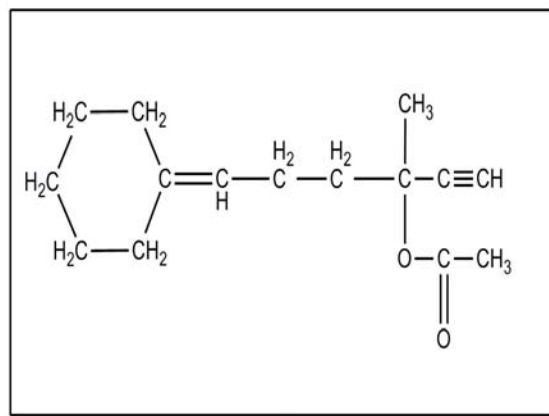
**SEE OR SEARCH CLASS:**

554, Organic Compounds, subclasses 1 through 231, for esters of higher fatty acids.

**232. Preparing esters by carbonylation:**

This subclass is indented under subclass 231. Processes wherein the ester is prepared through formation of a carboxyl group on a starting material by reaction with a carbonylating agent such as carbon monoxide in the presence of an alcohol or by subsequent esterification.

**233. Of olefins:**

This subclass is indented under subclass 232. Processes wherein the starting material is an olefin.

**234. Preparing esters by ester interchange:**

This subclass is indented under subclass 231. Processes wherein the ester is produced by reacting an ester with an alcohol, an acid or another ester to produce a different ester.

- (1) Note. This subclass includes, for example:

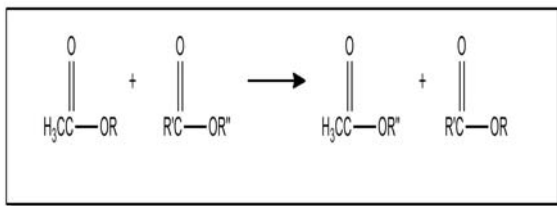
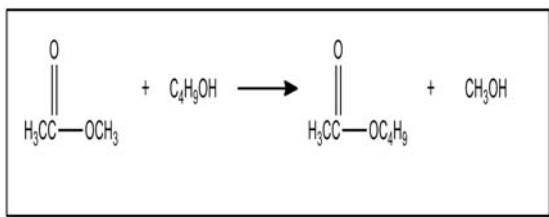

**235. From alkyl sulfates:**

This subclass is indented under subclass 234. Processes wherein an alkyl sulfate is used as the source of another alcohol.

- (1) Note. This subclass contains, for example:

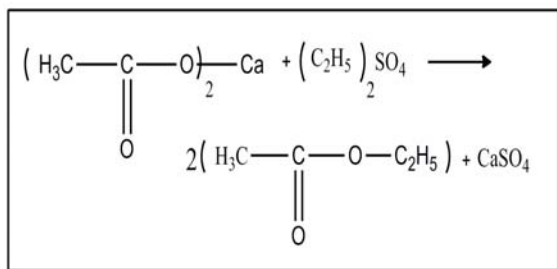

**236. Preparing esters from halogenated hydrocarbons:**

This subclass is indented under subclass 231. Processes wherein the ester is prepared from a halogenated hydrocarbon.

- (1) Note. This subclass contains, for example:

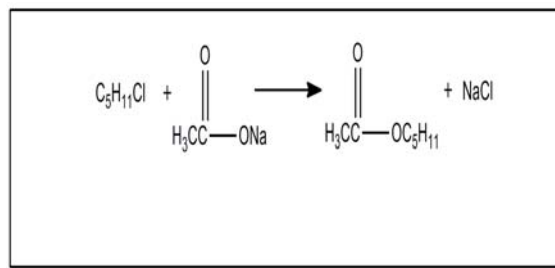

**237. From alkenyl halides:**

This subclass is indented under subclass 236. Processes wherein the halogenated hydrocarbon is an alkenyl halide, e.g., vinyl chloride, etc.

- (1) Note. This subclass includes, for example:

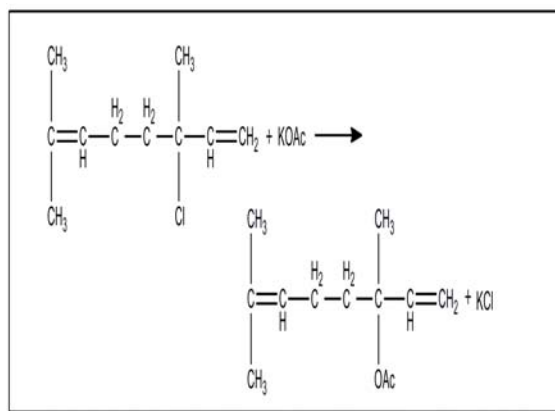

**238. Preparing esters from aldehydes:**

This subclass is indented under subclass 231. Processes wherein the ester is prepared from an aldehyde.

- (1) Note. This subclass includes, for example:

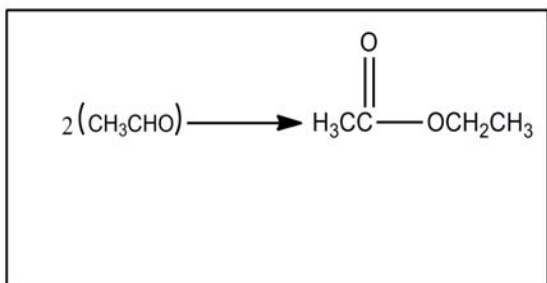

**239. Preparing esters by dehydrogenation of alcohols:**

This subclass is indented under subclass 231. Processes wherein the ester is prepared by dehydrogenation of an alcohol.

- (1) Note. This subclass includes, for example:

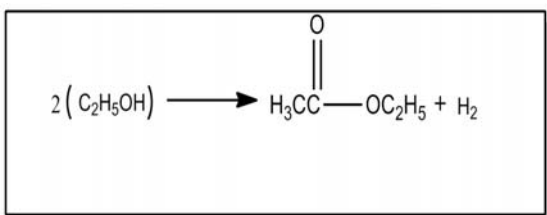

**240. Preparing esters from ethers:**

This subclass is indented under subclass 231. Processes wherein the ester is prepared from an ether, including cyclic ethers.

- (1) Note. This subclass contains, for example:

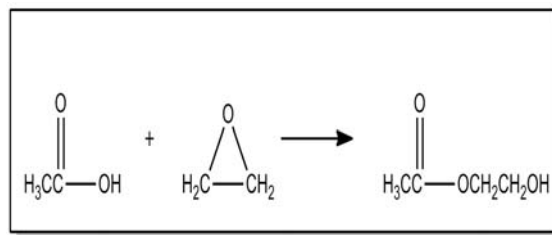
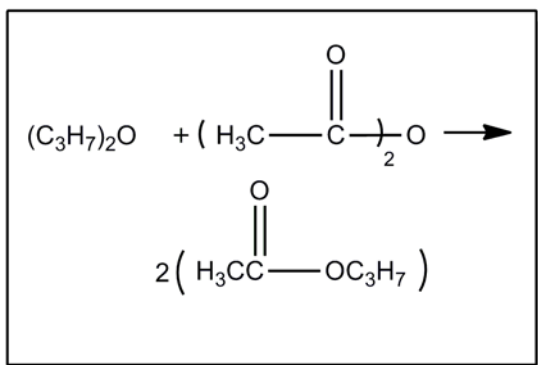

**241. Preparing esters from hydrocarbons:**

This subclass is indented under subclass 231. Processes wherein the ester is prepared from a hydrocarbon.

**241.1 By oxidation of hydrocarbon mixtures:**

This subclass is indented under subclass 241. Processes wherein the ester is prepared by oxidizing a mixture of hydrocarbons.

**242. From acetylenic hydrocarbons:**

This subclass is indented under subclass 241. Processes wherein the hydrocarbon contains a triple bond.

- (1) Note. This subclass contains, for example:

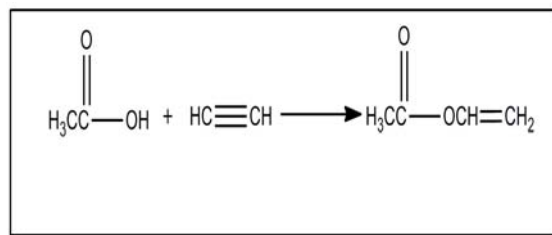

**243. From olefins utilizing Group VIII noble metal catalyst:**

This subclass is indented under subclass 241. Processes wherein the hydrocarbon is an olefin and the reaction is carried out in the presence of a catalyst containing a Group VIII noble metal.

- (1) Note. Group VIII noble metals are iridium, osmium, palladium, platinum, rhodium and rutherfordium.

**244. From polyolefins:**

This subclass is indented under subclass 243. Processes wherein the olefin contains more than one double bond, e.g., butadiene, etc.

**245. Gas phase:**

This subclass is indented under subclass 243. Processes wherein the reaction is carried out in a gas or vapor phase.

**246. Preparing polyoxy alcohol esters from olefins:**

This subclass is indented under subclass 241. Processes wherein the ester is prepared from an olefin and is equivalent in structure to an ester prepared from a polyoxy alcohol.

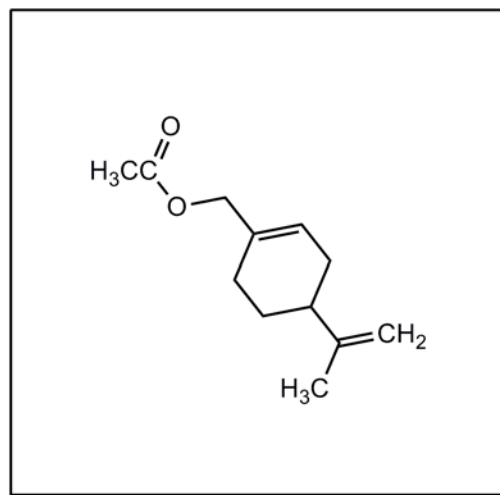
**247. Preparing alkyl esters from olefins:**

This subclass is indented under subclass 241. Processes wherein the ester is prepared from an olefin and is equivalent in structure to an ester prepared from an acyclic saturated monoxy alcohol.

**248. Purification or recovery:**

This subclass is indented under subclass 231. Processes which are directed to the purification, separation, or recovery of esters of unsubstituted acids of the acetic acid series.

**249. Terpene alcohol moiety:**

This subclass is indented under subclass 231. Processes in which alcohol moiety of the ester is a terpene.

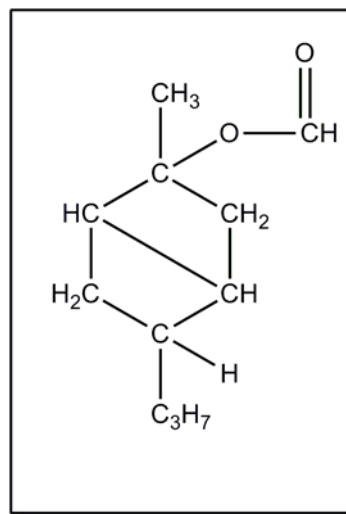

(1) Note. This subclass contains, for example:

**250. Nitrogen is alcohol moiety other than as nitro, nitroso or isocyanate:**

This subclass is indented under subclass 231. Compounds in which alcohol moiety contains nitrogen other than in the form of an isocyanate, nitroso, or nitro group.

(1) Note. This subclass contains, for example:

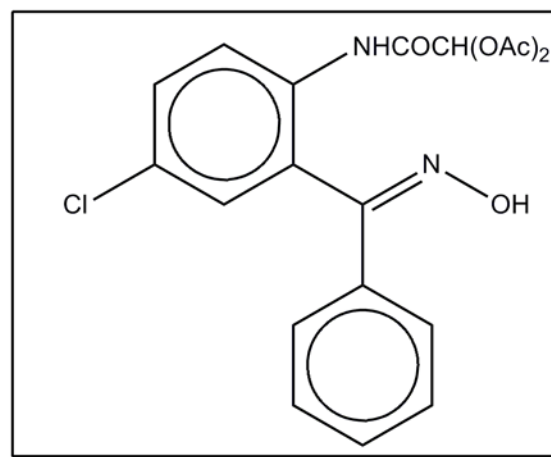
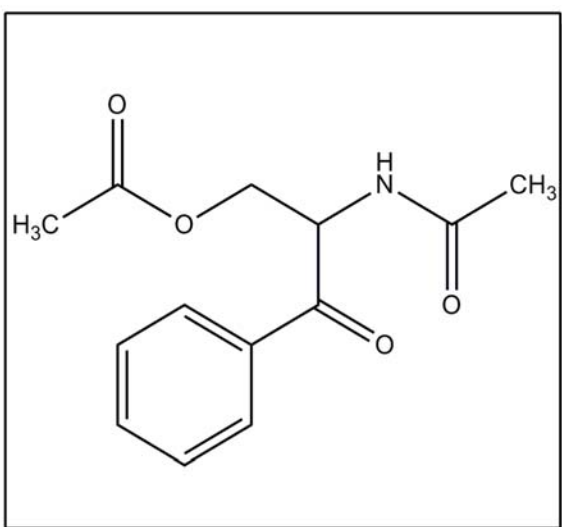
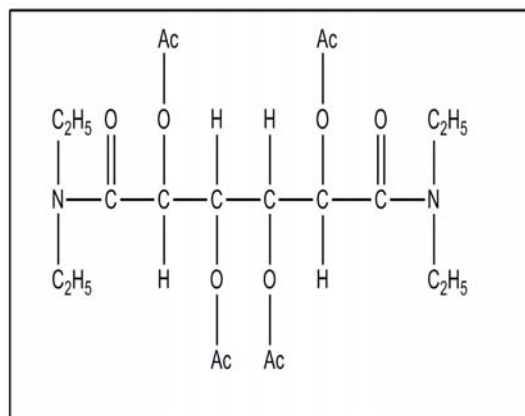
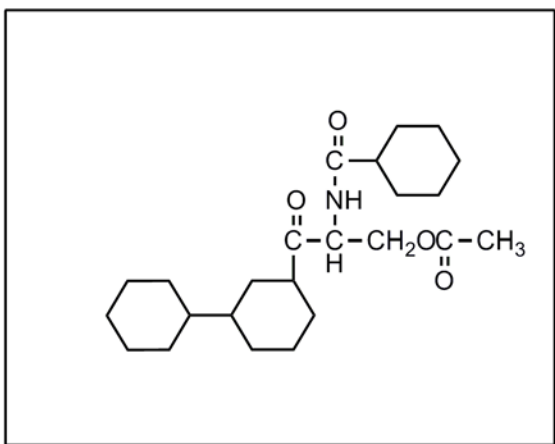

**251. Plural nitrogens in alcohol moiety:**

This subclass is indented under subclass 250. Compounds wherein the alcohol moiety contains more than one nitrogen.

- (1) Note. The additional nitrogen may be in the form of an isocyanate, nitroso, or nitro group.
- (2) Note. This subclass contains, for example:

**252. Polyoxy alcohol moiety:**

This subclass is indented under subclass 250. Processes in which alcohol moiety contains, in addition to the esterified OH group, another -OX group attached to a noncarbonylic C, where X may be C, H, an alcoholate forming group not provided for above, or an acyl group not provided for above.

- (1) Note. This subclass contains, for example:

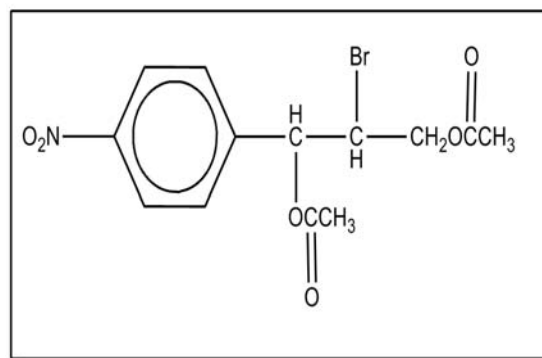
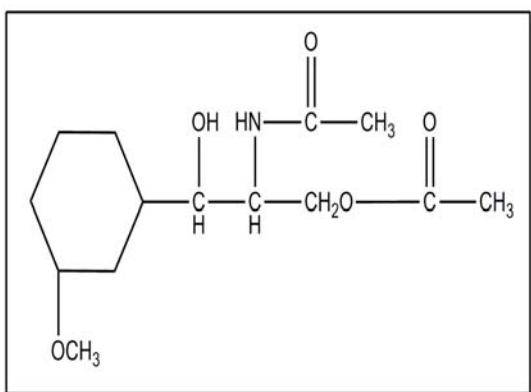
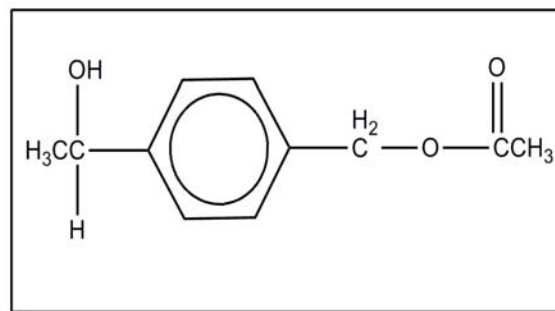
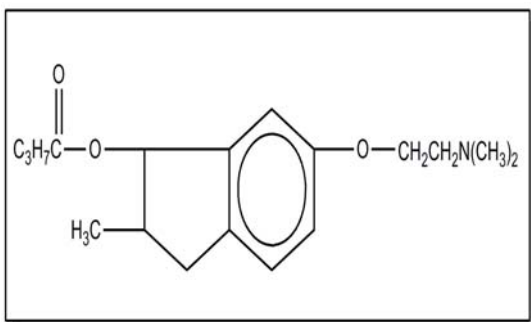
**253. Acyclic alcohol moiety:**

This subclass is indented under subclass 250. Processes in which alcohol moiety is acyclic.

- (1) Note. This subclass contains, for example:

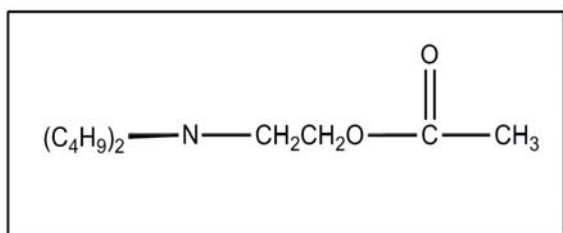
**254. Aromatic alcohol moiety:**

This subclass is indented under subclass 231. Processes in which alcohol moiety contains a benzene ring and is not provided for above.

**255. Plural rings in alcohol moiety:**

This subclass is indented under subclass 254. Compounds wherein the alcohol moiety contains at least one additional carbocyclic group.

- (1) Note. This subclass contains, for example:

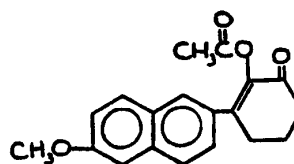
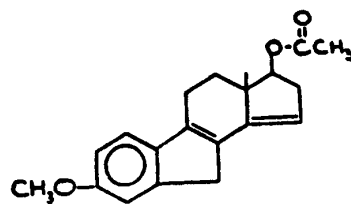

**256 Polycyclo - alicyclic ring system in alcohol moiety:**

This subclass is indented under subclass 231. Compounds wherein the alcohol moiety contains a polyalicyclic nucleus in which the rings are joined either through two ortho positioned carbons or through a carbon bridge or both.

(1) Note. This subclass contains, for example:

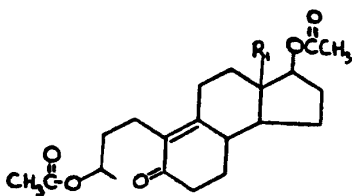
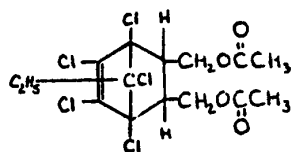

SEE OR SEARCH CLASS:

552, Organic Compounds, subclass 653 for esters of Vitamin D compounds, cholecalciferols, activated 7-dehydrocholesterols, dihydrotachysterols, 3-5 cyclovitamin D compounds, etc.

**257 Nor- or homo-cyclopentanohydrophenanthenes:**

This subclass is indented under subclass 256. Compounds wherein the alcohol moiety contains the structure, illustrated below, wherein is 0-2, but all n's may not be equal to 1 at the same time.

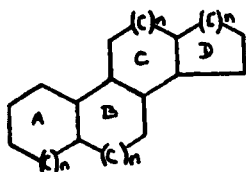

(1) Note. For compounds where all n's are equal to 1, see Class 552, subclasses 502+.

(2) Note. This subclass contains, for example:

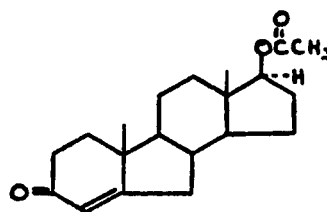
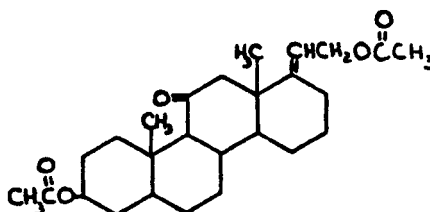

**258 Nor-a ring:**

This subclass is indented under subclass 257. Compounds wherein n=0 in the A ring.

(1) Note. This subclass contains, for example:

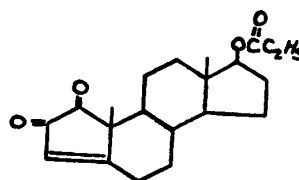
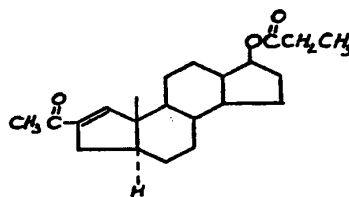



**259 2, 6, 6-trialkyl cyclohexenyl in alcohol moiety:**

This subclass is indented under subclass 231. Compounds wherein the alcohol moiety is characterized by the presence of a 2, 6, 6-trialkyl cyclohexenyl group, e.g., carotenes.

- (1) Note. This subclass contains, for example:

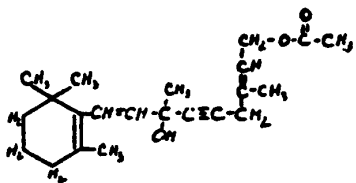
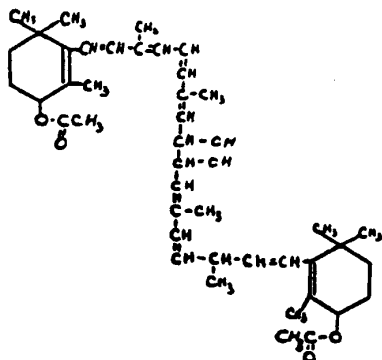

**260 Vitamin a alcohol moiety:**

This subclass is indented under subclass 259. Compounds wherein the alcohol moiety is Vitamin A.

- (1) Note. This subclass contains, for example:

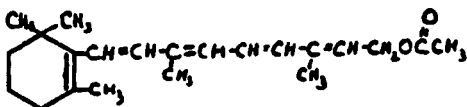

**261 Acyclic alcohol moiety having unsaturation:**

This subclass is indented under subclass 231. Compounds wherein the alcohol moiety is acyclic and contains an ethylenic double bond or a triple bond.

- (1) Note. This subclass contains, for example:

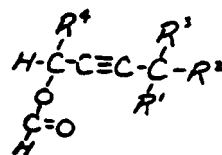
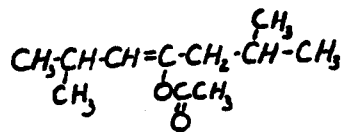

**262 Substituted:**

This subclass is indented under subclass 261. Compounds wherein the alcohol moiety contains a substituent other than a hydrocarbon and is not provided for above.

- (1) Note. This subclass contains, for example:

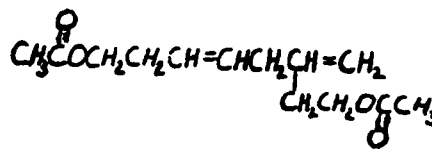
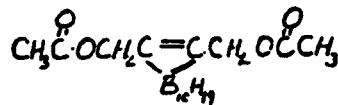

**263 Acyclic polyoxy alcohol moiety:**

This subclass is indented under subclass 231. Compounds wherein the alcohol moiety is acyclic and contains in addition to the esterified OH group, another -OX group attached to a noncarbonylic C, where X may be C, H, an alcoholate forming group not provided for above, or an acyl group not provided for above.

- (1) Note. This subclass contains, for example:

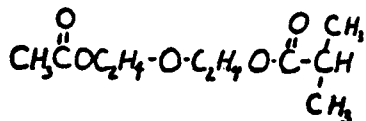
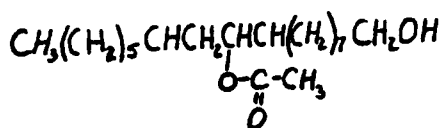
**264 Substituted:**

This subclass is indented under subclass 263. Compounds wherein the alcohol moiety contains a substituent other than a hydrocarbon and is not provided for above.

- (1) Note. This subclass contains, for example:

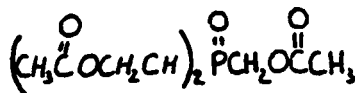
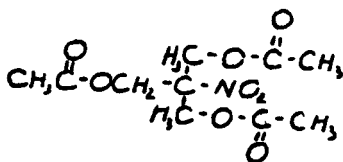
**265 Acyclic monohydric alcohol moiety:**

This subclass is indented under subclass 231. Compounds wherein the alcohol moiety is acyclic, saturated and has no oxy group other than the one which is esterified.

- (1) Note. This subclass contains, for example:

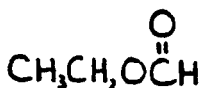
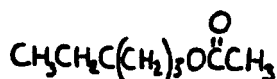
**266 Substituted:**

This subclass is indented under subclass 265. Compounds wherein the alcohol moiety contains a substituent other than a hydrocarbon and is not provided for above.

- (1) Note. This subclass contains, for example:

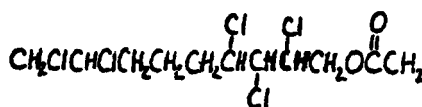

**300** This subclass is indented under subclass 1. Compounds under Class 532, ... wherein the hypohalite group, -O-halo, or the perhypohalite group, -O-O-halo, is bonded directly to carbon, which carbon may be single bonded to any atom but may be multiple bonded only to carbon.

- (1) Note. Examples of compounds provided for herein are:

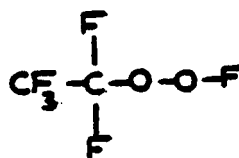
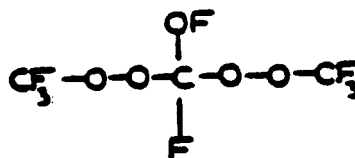
**SEE OR SEARCH CLASS:**

588, Hazardous or Toxic Waste Destruction or Containment, subclass 406 for the chemical destruction of organic hazardous or toxic waste containing halogen.

**301** This subclass is indented under subclass 1. Compounds under Class 532, ... wherein the cyanate group, -O-C N is bonded directly to carbon, which carbon may be single bonded to any atom but may be multiple bonded only to carbon.

(1) Note. An example of a compound provided for herein is:

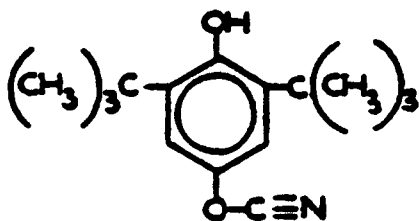

SEE OR SEARCH CLASS:

588, Hazardous or Toxic Waste Destruction or Containment, subclasses 408 and 409 for the chemical destruction of organic hazardous or toxic waste containing oxygen and nitrogen.

**302** This subclass is indented under subclass 1. Compounds under Class 532, ... having the group -C(=X)-X-nX-, wherein the X's may be the same or diverse chalcogens (i.e., oxygen, sulfur, selenium or tellurium), nX is a divalent chalcogen or a chain of divalent chalcogens, and a single bonded X is bonded directly to carbon, which carbon may be single bonded to any atom but may be multiple bonded only to carbon.

(1) Note. Examples of compounds provided for herein are:

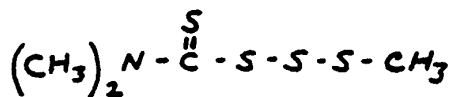
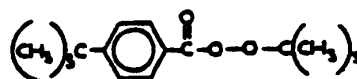
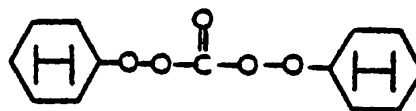
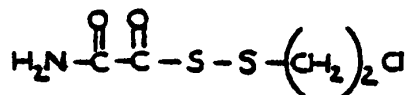

SEE OR SEARCH CLASS:

588, Hazardous or Toxic Waste Destruction or Containment, subclasses 408 and 409 for the chemical destruction of organic hazardous or toxic waste containing chalcogens or nitrogen.

**303** This subclass is indented under subclass 1. Compounds under Class 532, ... having the sulfohydroxamate group or a chalcogen analogue thereof, -S(=O)(=O)-NH-X-wherein X is chalcogen (i.e., oxygen, sulfur, selenium or tellurium) and substitution may be made for hydrogen only, and wherein the X is bonded directly to carbon, which carbon may be single bonded to any atom but may be multiple bonded only to carbon.

(1) Note. Examples of compounds provided for herein are:

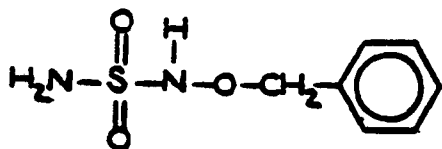
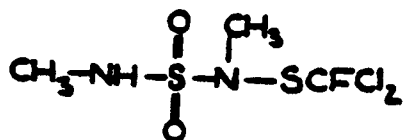

## SEE OR SEARCH CLASS:

588, Hazardous or Toxic Waste Destruction or Containment, subclasses 406, 408 and 409 for the chemical destruction of organic hazardous or toxic waste containing halogen, chalcogen, or nitrogen.

- 304** This subclass is indented under subclass 1. Compounds under Class 532, ... wherein the peroxyne group, -O-O-N(=O)(=O), is bonded directly to carbon, which carbon may be single bonded to any atom but may be multiple bonded only to carbon.

(1) Note. An example of a compound provided for herein is:

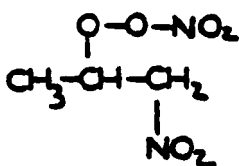

## SEE OR SEARCH CLASS:

588, Hazardous or Toxic Waste Destruction or Containment, subclasses 408 and 409 for the chemical destruction of organic hazardous or toxic waste containing oxygen or nitrogen.

- 305** This subclass is indented under subclass 1. Compounds under Class 532, ... having the -X-X- group, wherein the X's are the same or

diverse chalcogens (i.e., oxygen, sulfur, selenium or tellurium), bonded directly to boron and to carbon, which carbon may be single bonded to any atom but may be multiple bonded only to carbon.

(1) Note. An example of a compound provided for herein is:

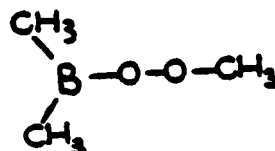

## SEE OR SEARCH CLASS:

588, Hazardous or Toxic Waste Destruction or Containment, subclass 409 for the chemical destruction of organic hazardous or toxic waste containing chalcogens.

- 306** This subclass is indented under subclass 1. Compounds under Class 532, ... wherein the perhalate group, -O-halo(=O)(=O)(=O), is bonded directly to carbon which carbon may be single bonded to any atom but may be multiple bonded only to carbon.

(1) Note. An example of a compound provided for herein is:

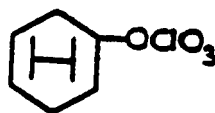

## SEE OR SEARCH CLASS:

588, Hazardous or Toxic Waste Destruction or Containment, subclass 409 for the chemical destruction of organic hazardous or toxic waste containing oxygen.

- 307** This subclass is indented under subclass 1. Compounds under Class 532, ... having the -S(=O)(=O)-S- group wherein the divalent sulfur is bonded directly to carbon, which carbon

may be single bonded to any atom but may be multiple bonded only to carbon.

- (1) Note. An example of a compound provided for herein is:

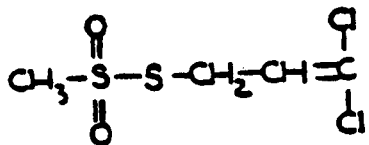

SEE OR SEARCH CLASS:

588, Hazardous or Toxic Waste Destruction or Containment, subclasses 406 and 409 for the chemical destruction of organic hazardous or toxic waste containing halogens or chalcogens.

- 308** This subclass is indented under subclass 307. Compounds wherein the hexavalent sulfur of the  $-S(=O)(=O)-S-$  group is bonded directly to oxygen.

- (1) Note. An example of a compound provided for herein is:

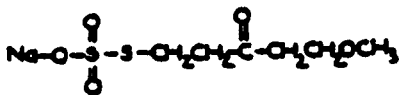

- 309** This subclass is indented under subclass 308. Compound wherein the  $-S(=O)(=O)-S-$  group is attached indirectly to nitrogen by nonionic bonding.

- (1) Note. An example of a compound provided for herein is:

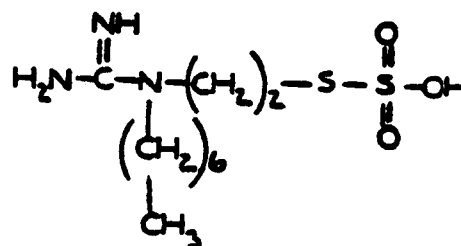

- 310** This subclass is indented under subclass 1. Compounds under Class 532, ... having the  $-S(=O)-S-$  group wherein the divalent sulfur is bonded directly to carbon, which carbon may be single bonded to any atom but may be multiple bonded only to carbon.

- (1) Note. Examples of compounds provided for herein are:

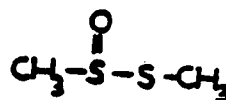
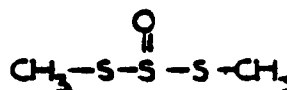

SEE OR SEARCH CLASS:

588, Hazardous or Toxic Waste Destruction or Containment, subclass 409 for the chemical destruction of organic hazardous or toxic waste containing chalcogens.

- 311** This subclass is indented under subclass 1. Compounds under Class 532, ... having the perhydroxamate group or a chalcogen analogue thereof,  $-C(=X)-NH-X-X-$ , wherein the X's may be the same or diverse chalcogens (i.e., oxygen, sulfur, selenium or tellurium) and substitution may be made for hydrogen only, and wherein the single bonded X is bonded directly to carbon, which carbon may be single bonded to any atom but may be multiple bonded only to carbon.

- (1) Note. An example of a compound provided for herein is:

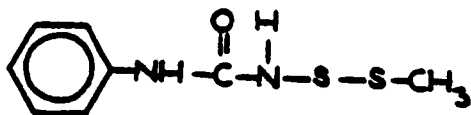

SEE OR SEARCH CLASS:

588, Hazardous or Toxic Waste Destruction or Containment, subclasses 408 and 409 for the chemical destruction of organic hazardous or toxic waste containing chalcogen and nitrogen.

- 312** This subclass is indented under subclass 1. Compounds under Class 532, ... having the hydroxamate group or a chalcogen analogue thereof,  $-C(=X)-NH-X-$ , wherein the X's may be the same or diverse chalcogens (i.e., oxygen, sulfur, selenium or tellurium) and substitution may be made for hydrogen only, and wherein the single bonded X is bonded directly to carbon, which carbon may be single bonded to any atom but may be multiple bonded only to carbon.

- (1) Note. Examples of compounds provided for herein are:

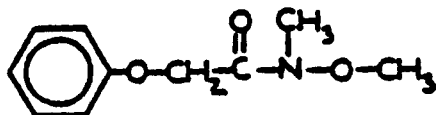
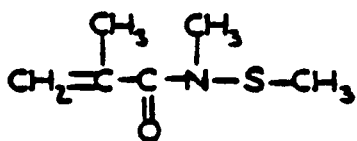

SEE OR SEARCH CLASS:

588, Hazardous or Toxic Waste Destruction or Containment, subclasses 408 and 409 for the chemical destruction of organic hazardous or toxic waste containing oxygen or nitrogen.

- 313** This subclass is indented under subclass 312. Compounds wherein the carbon of the  $-C(=X)-NH-X-$  group is bonded directly to nitrogen.

- (1) Note. An example of a compound provided for herein is:

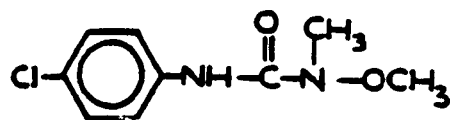

- 314** This subclass is indented under subclass 313. Compounds wherein the substituent nitrogen is bonded directly to acyclic or alicyclic carbon, or wherein the single bonded X is sulfur.

- (1) Note. Examples of compounds provided for herein are:

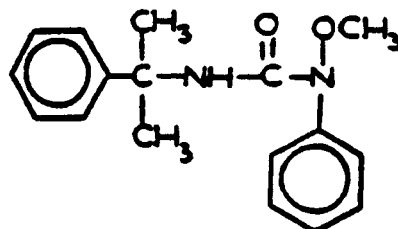
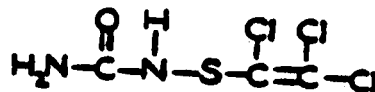

- 315** This subclass is indented under subclass 312. Compounds wherein the carbon of the  $-C(=X)-NH-X-$  group is bonded directly to a carbocyclic ring.

- (1) Note. Examples of compounds provided for herein are:

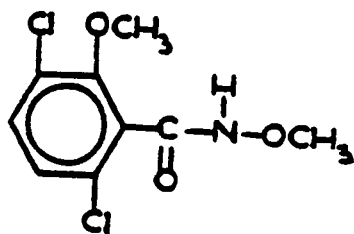
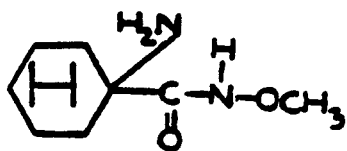

- 316** This subclass is indented under subclass 1. Compounds under Class 532, ... wherein the hyponitrite group,  $-O-N=N-O-$ , is bonded directly to carbon, which carbon may be single bonded to any atom but may be multiple bonded only to carbon.

(1) Note. An example of a compound provided for herein is:

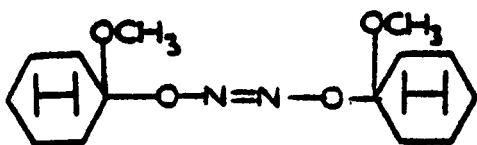

SEE OR SEARCH CLASS:

588, Hazardous or Toxic Waste Destruction or Containment, subclasses 408 and 409 for the chemical destruction of organic hazardous or toxic waste containing oxygen or nitrogen.

- 317** This subclass is indented under subclass 1. Compounds under Class 532, ... wherein the  $-N=S=O$  group is bonded directly to carbon, which carbon may be single bonded to any atom but may be multiple bonded only to carbon.

(1) Note. An example of a compound provided for herein is:



SEE OR SEARCH CLASS:

588, Hazardous or Toxic Waste Destruction or Containment, subclasses 406, 408 and 409 for the chemical destruction of organic hazardous or toxic waste containing halogen, sulfur, oxygen, or nitrogen.

- 318** This subclass is indented under subclass 1. Compounds under Class 532, ... wherein the terminal oxygen of a  $-S(=O)(=O)-O-O-$  group is bonded directly to carbon, which carbon may be single bonded to any atom but may be multiple bonded only to carbon.

(1) Note. An example of a compound provided for herein is:

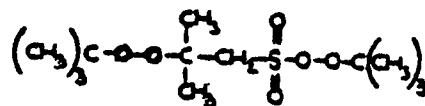

SEE OR SEARCH CLASS:

588, Hazardous or Toxic Waste Destruction or Containment, subclass 409 for the chemical destruction of organic hazardous or toxic waste containing sulfur and oxygen.

- 319** This subclass is indented under subclass 1. Compounds under Class 532, ... wherein the perthioimidate group,  $HN=CH-S-S-$ , may be single bonded directly to any atom but may be multiple bonded only to carbon, and substitution may be made for hydrogen only.

(1) Note. An example of a compound provided for herein is:

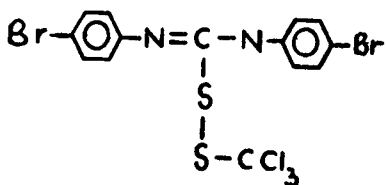

## SEE OR SEARCH CLASS:

588, Hazardous or Toxic Waste Destruction or Containment, subclasses 406, 408 and 409 for the chemical destruction of organic hazardous or toxic waste containing halogen, sulfur, or nitrogen.

- 330** This subclass is indented under subclass 1. Compounds under Class 532, ... wherein the isocyanate group,  $-N=C=O$ , is bonded directly to carbon, which carbon may be single bonded to any atom but may be multiple bonded only to carbon.

(1) Note. An example of a compound provided for herein is:

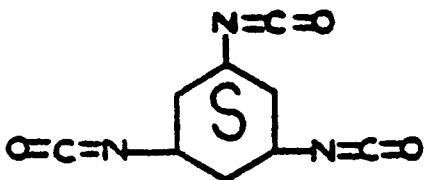

## SEE OR SEARCH CLASS:

588, Hazardous or Toxic Waste Destruction or Containment, subclasses 406, 408, and 409 for the chemical destruction of organic hazardous or toxic waste containing, halogen, oxygen, sulfur, phosphorus, or nitrogen.

- 331** This subclass is indented under subclass 330. Products which contain an isocyanate ester in admixture with a preserving or stabilizing agent whose sole function is to prevent physical or chemical change.

- 332** This subclass is indented under subclass 331. Products wherein the preserving or stabilizing agent contains nitrogen.

- 333** This subclass is indented under subclass 331. Products wherein the preserving or stabilizing agent contains phosphorus, silicon or a phenolic hydroxy group.

- 334** This subclass is indented under subclass 330. Compounds which contain the carbodiimide group,  $-N=C=N-$ .

(1) Note. An example of a compound provided for herein is:



- 335** This subclass is indented under subclass 330. Compounds which contain the biuret group,  $-NH-C(=O)-NH-C(=O)-NH-$ , wherein substitution may be made for hydrogen only.

(1) Note. An example of a compound provided for herein is:

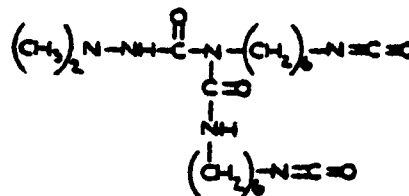

- 336** This subclass is indented under subclass 330. Processes which are directed to the preparation, purification, recovery, or treatment in any way of an isocyanate ester.

- 337** This subclass is indented under subclass 336. Processes wherein isocyanic acid,  $H-N=C=O$ , or a salt thereof, is employed as a reactant.

- 338** This subclass is indented under subclass 336. Processes which involve the formation of the isocyanate group,  $-N=C=O$ .



**339** This subclass is indented under subclass 338. Processes wherein there is utilized a reactant which contains the cyanate group,  $-O-C=N$ .

**340** This subclass is indented under subclass 338. Processes wherein there is utilized a reactant which contains a hetero ring.

**341** This subclass is indented under subclass 338. Processes wherein carbon monoxide is utilized in any way.

**342** This subclass is indented under subclass 341. Processes wherein there is utilized a reactant which contains a nitro group bonded directly to carbon.

(1) Note. An example of a process provided for herein is:

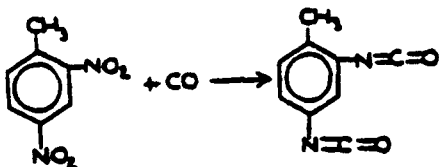

**343** This subclass is indented under subclass 338. Processes wherein there is utilized a reactant that contains the azide group,  $-N_3$ .

**344** This subclass is indented under subclass 338. Processes wherein there is utilized a reactant that contains the  $-NH-C(=O)-NH-$  group, wherein substitution may be made for hydrogen only.

**345** This subclass is indented under subclass 338. Processes wherein there is utilized a reactant that contains the carbamate group,  $-O-C(=O)-NH$ , wherein substitution may be made for hydrogen only.

**346** This subclass is indented under subclass 338. Processes wherein there is utilized a reactant that contains carbon double or triple bonded to nitrogen.

**347** This subclass is indented under subclass 338. Processes wherein there is utilized a carbonyl dihalide reactant,  $X-C(=O)-X$ , wherein X represents halogen.

(1) Note. The classical isocyanate synthesis phosgenation of an amine, is provided for herein.

**348** This subclass is indented under subclass 338. Processes wherein there is utilized a carbamyl halide reactant, halo- $C(=O)-NH-$ , wherein substitution may be made for hydrogen only.

**349** This subclass is indented under subclass 336. Processes wherein an isocyanate ester is halogenated.

**350** This subclass is indented under subclass 336. Processes wherein an isocyanate group on one reactant and a different functional group on a second reactant undergo an exchange reaction.

(1) Note. An example of a process provided for herein is:

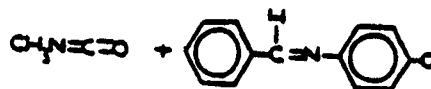
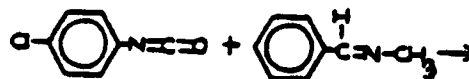

**351** This subclass is indented under subclass 336. Processes wherein an isocyanate ester of known structure is reacted to yield products of indeterminate structure.

**352** This subclass is indented under subclass 336. Processes wherein an isocyanate ester is separated from impurities, or from the reaction medium.

**353** This subclass is indented under subclass 352. Processes wherein a metal or an epoxy compound is utilized.

354 This subclass is indented under subclass 330. Compounds which contain a polycyclic ring system having an alicyclic ring as one of the cycles.

(1) Note. Examples of compounds provided for herein are:

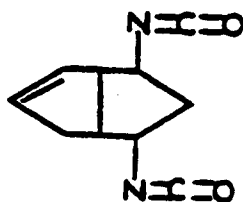
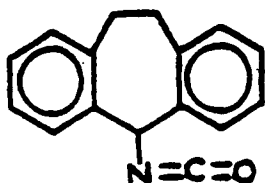

355 This subclass is indented under subclass 330. Compounds wherein the isocyanate group is bonded directly to an acyclic carbon.

(1) Note. Example of compounds provided for herein are:

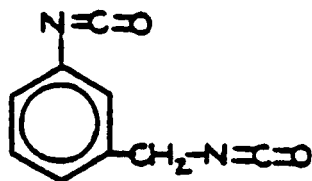
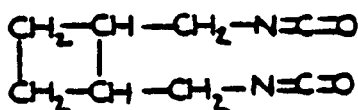

356 This subclass is indented under subclass 355. Compounds wherein the isocyanate group is attached indirectly to halogen by acyclic non-ionic bonding.

(1) Note. An example of a compound provided for herein is:

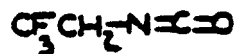

357 This subclass is indented under subclass 355. Compounds wherein the isocyanate group is attached indirectly by acyclic nonionic bonding to chalcogen, which is single bonded directly to carbon.

(1) Note. An example of a compound provided for herein is:

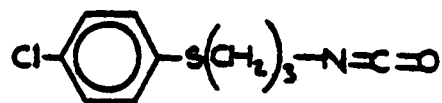

358 This subclass is indented under subclass 330. Compounds wherein the isocyanate group is bonded directly to a benzene ring.

(1) Note. An example of a compound provided for herein is:

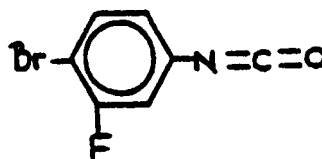

359 This subclass is indented under subclass 358. Compounds wherein isocyanate groups are bonded directly to more than one benzene ring.

(1) Note. An example of a compound provided for herein is:

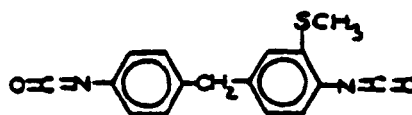

**360** This subclass is indented under subclass 358. Compounds wherein plural isocyanate groups are bonded directly to the same benzene ring.

- (1) Note. An example of a compound provided for herein is:

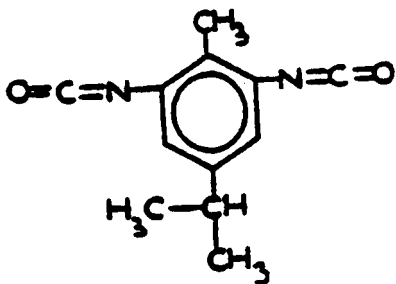

END