

MARKS PUBLISHED FOR OPPOSITION

The following marks are published in compliance with section 12(a) of the Trademark Act of 1946. Applications for the registration of marks in more than one class have been filed as provided in section 30 of said act as amended by Public Law 772, 87th Congress, approved Oct. 9, 1962, 76 Stat. 769. Opposition under section 13 may be filed within thirty days of the date of this publication. See rules 2.101 to 2.105.

A separate fee of two hundred dollars for opposing each mark in each class must accompany the opposition.

SECTION 1.— INTERNATIONAL CLASSIFICATION

The short titles associated below with the international class numbers are terms designed merely for quick identification and are not an official part of the international classification. The full names of international classes are given in section 6.1 of the trademark rules of practice.

The designation "U.S. Cl." appearing in this section refers to the U.S. class in effect prior to Sep. 1, 1973 rather than the international class which applies to applications filed on or after that date. For adoption of international classification see notice in the OFFICIAL GAZETTE of Jun. 26, 1973 (911 O.G. TM 210).

Application in more than one class

SN 76-335,456. NUCRYST PHARMACEUTICALS CORP., ALBERTA T8L 3W4, CANADA, FILED 11-8-2001.

SN 76-428,398. HUSKY OF TOSTOCK LIMITED, IPSWICH, SUFFOLK IP8 4AN, UNITED KINGDOM, FILED 7-9-2002.



SILCRYST

OWNER OF ERPN CMNTY TM OFC REG. NO. 003213576, DATED 2-17-2005, EXPIRES 6-5-2013.
OWNER OF U.S. REG. NOS. 1,439,262, 2,256,220 AND 2,256,221.
COLOR IS NOT CLAIMED AS A FEATURE OF THE MARK.

PRIORITY CLAIMED UNDER SEC. 44(D) ON CANADA APPLICATION NO. 1119114, FILED 10-25-2001, REG. NO. TMA621,855, DATED 10-6-2004, EXPIRES 10-6-2019.

CLASS 2—PAINTS

FOR (BASED ON 44(E)) METAL COATINGS AND METAL POWDERS USED TO PREVENT THE GROWTH OF MICROBES FOR USE IN THE FIELD OF MEDICINE (U.S. CLS. 6, 11 AND 16).

CLASS 5—PHARMACEUTICALS

FOR (BASED ON USE IN COMMERCE AND 44(E)) MEDICAL AND SURGICAL WOUND AND BURN DRESSINGS UTILIZING ANTIMICROBIAL COATINGS (U.S. CLS. 6, 18, 44, 46, 51 AND 52).
FIRST USE 3-12-2004; IN COMMERCE 3-12-2004.
JULIE WATSON, EXAMINING ATTORNEY

CLASS 9—ELECTRICAL AND SCIENTIFIC APPARATUS

FOR SPECTACLES; SUNGLASSES; ANTI-GLARE EYEGLASSES; CASES FOR EYEGLASSES, SPECTACLES AND SUNGLASSES; AND FRAMES FOR EYEGLASSES AND SUNGLASSES (U.S. CLS. 21, 23, 26, 36 AND 38).

CLASS 18—LEATHER GOODS

FOR ARTICLES MADE FROM LEATHER AND IMITATIONS OF LEATHER, NAMELY, HANDBAGS, WALLET, PURSES, CREDIT CARD HOLDERS, ALL PURPOSE SPORTS BAGS AND SUITCASES (U.S. CLS. 1, 2, 3, 22 AND 41).

CLASS 25—CLOTHING

FOR MEN'S, WOMEN'S AND CHILDREN'S CLOTHING; NAMELY, SPORTSWEAR AND LEISUREWEAR, NAMELY, COATS, JACKETS, WAISTCOATS, SHIRTS, SHORTS, TROUSERS, DRESSING GOWNS, JUMPERS, CARDIGANS, PULLOVERS, SWEATERS AND LEG WARMERS; HEADWEAR, NAMELY, ANTI-GLARE VISORS AND SUN VISORS; AND FOOTWEAR, NAMELY, SHOES (U.S. CLS. 22 AND 39).
BILL DAWE, EXAMINING ATTORNEY

SN 76-548,261. BESSON, CYNTHIA, SAN JOSE, CA. FILED 10-1-2003.

SN 76-672,189. NOTTINGHAM SPIRK DESIGN ASSOCIATES, CLEVELAND, OH. AND INTERNATIONAL FLAVORS & FRAGRANCES INC., NEW YORK, NY. FILED 2-2-2007.

LEANRTEEN GENERATION

CLASS 5—PHARMACEUTICALS

FOR DIETETIC FOOD FOR MEDICALLY RESTRICTED DIETS, NAMELY, FOOD BARS, SHAKES, DRINKS, FROZEN FOODS, CHIPS, CANDY (U.S. CLS. 6, 18, 44, 46, 51 AND 52).

CLASS 16—PAPER GOODS AND PRINTED MATTER

FOR JOURNAL, DIARY, NOTEBOOKS, STATIONERY, BINDERS (U.S. CLS. 2, 5, 22, 23, 29, 37, 38 AND 50).

CLASS 25—CLOTHING

FOR SHIRTS, SHOES, PANTS, SWEATSHIRTS, HATS, T-SHIRTS, TANK TOPS (U.S. CLS. 22 AND 39).
RONALD AIKENS, EXAMINING ATTORNEY

SN 76-596,933. INTERNATIONAL PROFIT ASSOCIATES, INC., BUFFALO GROVE, IL. FILED 6-14-2004.

IPA BENCHMARKS

THE MARK CONSISTS OF STANDARD CHARACTERS WITHOUT CLAIM TO ANY PARTICULAR FONT, STYLE, SIZE, OR COLOR.

CLASS 35—ADVERTISING AND BUSINESS

FOR BUSINESS CONSULTATION, NAMELY, BUSINESS CONSULTATION SERVICES, BUSINESS DEVELOPMENT SERVICES, NAMELY, PROVIDING START-UP SUPPORT FOR BUSINESSES OF OTHERS, BUSINESS MANAGEMENT AND CONSULTATION, BUSINESS MANAGEMENT PLANNING, PROFIT SURVEY AND ANALYSIS, BUSINESS MARKETING CONSULTATION SERVICES, BUSINESS ORGANIZATIONAL CONSULTATION, BUSINESS PLANNING, PREPARING BUSINESS REPORTS, PROVIDING BUSINESS MARKETING INFORMATION, BUSINESS AUDITING, BUSINESS ACQUISITION AND MERGER CONSULTATION, ACCOUNTING SERVICES, AND COST ACCOUNTING (U.S. CLS. 100, 101 AND 102).

CLASS 36—INSURANCE AND FINANCIAL

FOR FINANCIAL CONSULTATION, NAMELY, FINANCIAL CONSULTATION SERVICES, FINANCIAL ANALYSIS, FINANCIAL MANAGEMENT, FINANCIAL PLANNING, FINANCIAL PORTFOLIO MANAGEMENT, AND FINANCIAL RESEARCH (U.S. CLS. 100, 101 AND 102).

WILLIAM P. SHANAHAN, EXAMINING ATTORNEY

FRESH FLUSH

THE MARK CONSISTS OF STANDARD CHARACTERS WITHOUT CLAIM TO ANY PARTICULAR FONT, STYLE, SIZE, OR COLOR.

CLASS 5—PHARMACEUTICALS

FOR AIR FRESHENING PREPARATIONS FOR USE IN BATTERY-OPERATED AIR FRESHENING UNITS WHICH ARE ACTIVATED BY A DECREASE IN WATER LEVEL CAUSED BY FLUSHING OF A TOILET (U.S. CLS. 6, 18, 44, 46, 51 AND 52).

CLASS 11—ENVIRONMENTAL CONTROL APPARATUS

FOR BATTERY-OPERATED DISPENSING UNITS FOR AIR FRESHENERS WHICH ARE ACTIVATED BY A DECREASE IN WATER LEVEL CAUSED BY FLUSHING OF A TOILET (U.S. CLS. 13, 21, 23, 31 AND 34).
ALEXANDER L. POWERS, EXAMINING ATTORNEY

SN 76-677,221. TEKRA CORPORATION, NEW BERLIN, WI. FILED 5-21-2007.

PROTEK

THE MARK CONSISTS OF STANDARD CHARACTERS WITHOUT CLAIM TO ANY PARTICULAR FONT, STYLE, SIZE, OR COLOR.

CLASS 17—RUBBER GOODS

FOR PROTECTIVE COATINGS, NAMELY, PREMIUM HARD COAT POLYCARBONATE PLASTIC AND POLYESTER PLASTIC FILMS FOR PRINTING ON SUBSTRATES FOR OPTO-ELECTRIC APPLICATIONS, NAMELY, APPLICATION TO FLAT PANEL OR LCD DISPLAYS (U.S. CLS. 1, 5, 12, 13, 35 AND 50).
FIRST USE 11-20-2001; IN COMMERCE 11-20-2001.

CLASS 40—MATERIAL TREATMENT

FOR APPLICATION OF PROTECTIVE COATINGS, NAMELY, PLASTIC FILMS TO PLASTIC AND PAPER SUBSTRATES FOR OTHERS (U.S. CLS. 100, 103 AND 106).
TRACY WHITTAKER-BROWN, EXAMINING ATTORNEY

SN 76-677,231. TEKRA CORPORATION, NEW BERLIN, WI.
FILED 5-21-2007.

CLASS 17—RUBBER GOODS

FOR PROTECTIVE COATINGS, NAMELY, PREMIUM HARD COAT POLYCARBONATE PLASTIC AND POLYESTER PLASTIC FILMS FOR PRINTING ON SUBSTRATES FOR OPTO-ELECTRIC APPLICATIONS, NAMELY, APPLICATION TO FLAT PANEL OR LCD DISPLAYS (U.S. CLS. 1, 5, 12, 13, 35 AND 50).
FIRST USE 11-21-2001; IN COMMERCE 11-21-2001.

CLASS 40—MATERIAL TREATMENT

FOR APPLICATION OF PROTECTIVE COATINGS, NAMELY, PLASTIC FILMS TO PLASTIC AND PAPER SUBSTRATES FOR OTHERS (U.S. CLS. 100, 103 AND 106).

FIRST USE 11-21-2001; IN COMMERCE 11-21-2001.
TRACY WHITTAKER-BROWN, EXAMINING ATTORNEY

SN 76-681,068. STEALTHBITS TECHNOLOGIES, INC., GLEN ROCK, NJ. FILED 8-23-2007.

THE MARK CONSISTS OF STANDARD CHARACTERS WITHOUT CLAIM TO ANY PARTICULAR FONT, STYLE, SIZE, OR COLOR.

CLASS 9—ELECTRICAL AND SCIENTIFIC APPARATUS

FOR COMPUTER HARDWARE; COMPUTER SOFTWARE USED FOR COLLECTING AND ANALYZING DATA, TO IDENTIFY, ASSESS AND MANAGE RISKS, MANAGE NETWORK DEVICES, ENFORCE POLICIES, DEPLOY CHECKS AND CONTROLS, ASSESS VULNERABILITIES, MANAGE COMPLIANCE, ALL IN THE AREA OF ENTERPRISE INFORMATION TECHNOLOGY; COMPUTER SOFTWARE FOR MANAGEMENT AND ADMINISTRATION OF REGULATORY, SECURITY, AUDIT, LEGAL, AND CORPORATE COMPLIANCE REQUIREMENTS; COMPUTER SOFTWARE TO AUTOMATE, CONTROL, IMPROVE, MANAGE AND ADMINISTER COMPUTER SECURITY AND COMPLIANCE; COMPUTER SOFTWARE FOR INFORMATION TECHNOLOGY RISK AND COMPLIANCE, AND INFORMATION TECHNOLOGY GOVERNANCE; AND COMPUTER SOFTWARE TO MANAGE CONFIGURATION OF COMPUTERS, SOFTWARE, AND NETWORK DEVICES (U.S. CLS. 21, 23, 26, 36 AND 38).
FIRST USE 10-9-2001; IN COMMERCE 10-9-2001.

CLASS 42—SCIENTIFIC AND COMPUTER SERVICES

FOR COMPUTER PROGRAMMING SERVICES; TECHNICAL AND STRATEGIC CONSULTATION IN THE FIELD OF COMPUTER SOFTWARE, NETWORK MANAGEMENT AND NETWORK SECURITY, AND INFORMATION TECHNOLOGY GOVERNANCE; AND TECHNICAL SUPPORT SERVICES, NAMELY, PROVIDING UPDATES TO SOFTWARE APPLICATIONS, BUILDING AND CREATING CUSTOM SOLUTIONS UTILIZING TECHNIQUES AND OPERATIONS PROVIDED WITHIN SOFTWARE APPLICATIONS, AND PROVIDING ASSISTANCE IN THE NATURE OF TROUBLESHOOTING SOFTWARE PROBLEMS FOR USERS OF SOFTWARE APPLICATIONS VIA THE WORLD WIDE WEB, INTERNET, AND/OR TELEPHONE (U.S. CLS. 100 AND 101).

FIRST USE 10-9-2001; IN COMMERCE 10-9-2001.
PRISCILLA MILTON, EXAMINING ATTORNEY

SN 76-681,069. STEALTHBITS TECHNOLOGIES, INC., GLEN ROCK, NJ. FILED 8-23-2007.

THE MARK CONSISTS OF STANDARD CHARACTERS WITHOUT CLAIM TO ANY PARTICULAR FONT, STYLE, SIZE, OR COLOR.

CLASS 9—ELECTRICAL AND SCIENTIFIC APPARATUS

FOR COMPUTER HARDWARE; COMPUTER SOFTWARE USED FOR COLLECTING AND ANALYZING DATA, TO IDENTIFY, ASSESS AND MANAGE RISKS, MANAGE NETWORK DEVICES, ENFORCE POLICIES, DEPLOY CHECKS AND CONTROLS, ASSESS VULNERABILITIES, MANAGE COMPLIANCE, ALL IN THE AREA OF ENTERPRISE INFORMATION TECHNOLOGY; COMPUTER SOFTWARE FOR MANAGEMENT AND ADMINISTRATION OF REGULATORY, SECURITY, AUDIT, LEGAL, AND CORPORATE COMPLIANCE REQUIREMENTS; COMPUTER SOFTWARE TO AUTOMATE, CONTROL, IMPROVE, MANAGE AND ADMINISTER COMPUTER SECURITY AND COMPLIANCE; COMPUTER SOFTWARE FOR INFORMATION TECHNOLOGY RISK AND COMPLIANCE, AND INFORMATION TECHNOLOGY GOVERNANCE; AND COMPUTER SOFTWARE TO MANAGE CONFIGURATION OF COMPUTERS, SOFTWARE, AND NETWORK DEVICES (U.S. CLS. 21, 23, 26, 36 AND 38).

FIRST USE 10-9-2001; IN COMMERCE 10-9-2001.

CLASS 42—SCIENTIFIC AND COMPUTER SERVICES

FOR COMPUTER PROGRAMMING SERVICES; TECHNICAL AND STRATEGIC CONSULTATION IN THE FIELD OF COMPUTER SOFTWARE, NETWORK MANAGEMENT AND NETWORK SECURITY, AND INFORMATION TECHNOLOGY GOVERNANCE; AND TECHNICAL SUPPORT SERVICES, NAMELY, PROVIDING UPDATES TO SOFTWARE APPLICATIONS, BUILDING AND CREATING CUSTOM SOLUTIONS UTILIZING TECHNIQUES AND OPERATIONS PROVIDED WITHIN SOFTWARE APPLICATIONS, AND PROVIDING ASSISTANCE IN THE NATURE OF TROUBLESHOOTING SOFTWARE PROBLEMS FOR USERS OF SOFTWARE APPLICATIONS VIA THE WORLD WIDE WEB, INTERNET, AND/OR TELEPHONE (U.S. CLS. 100 AND 101).

FIRST USE 10-9-2001; IN COMMERCE 10-9-2001.
PRISCILLA MILTON, EXAMINING ATTORNEY

SN 76-682,166. AFFINITY DESIGN COMPANY LIMITED, SHEUNG WAN, HONG KONG, FILED 9-21-2007.



ICRYSTAL

PRIORITY CLAIMED UNDER SEC. 44(D) ON HONG KONG APPLICATION NO. 300945658, FILED 9-3-2007, REG. NO. 300945658, DATED 9-3-2007, EXPIRES 9-3-2017. OWNER OF HONG KONG REG. NO. 300993042, DATED 11-14-2007, EXPIRES 11-14-2017.

THE COLOR(S) PINK, GRAY AND BLACK IS/ARE CLAIMED AS A FEATURE OF THE MARK.

THE MARK CONSISTS OF THE COLOR PINK APPEARING IN THE OUTLINE OF THE CAT DESIGN, GRAY APPEARING IN THE DIAMOND SHAPED CRYSTAL AT THE CAT'S NECK, AND THE WORD "ICRYSTAL" SHOWN IN BLACK UNDER THE CAT DESIGN. THE COLOR WHITE REPRESENTS TRANSPARENT BACKGROUND AND IS NOT CLAIMED AS A FEATURE OF THE MARK.

CLASS 9—ELECTRICAL AND SCIENTIFIC APPARATUS

FOR SUNGLASSES DECORATED WITH CRYSTALS (U.S. CLS. 21, 23, 26, 36 AND 38).

CLASS 14—JEWELRY

FOR WATCHES AND JEWELRY, DECORATED WITH CRYSTALS (U.S. CLS. 2, 27, 28 AND 50).

CLASS 18—LEATHER GOODS

FOR HANDBAGS; COIN BAGS; PURSES; DECORATED WITH CRYSTALS (U.S. CLS. 1, 2, 3, 22 AND 41). JENNIFER DIXON, EXAMINING ATTORNEY

SN 76-683,985. ENVIPCO HOLDING N.V., NL-1015 DE AMSTERDAM, NETHERLANDS, FILED 11-13-2007.

BULKMASTER

THE MARK CONSISTS OF STANDARD CHARACTERS WITHOUT CLAIM TO ANY PARTICULAR FONT, STYLE, SIZE, OR COLOR.

PRIORITY CLAIMED UNDER SEC. 44(D) ON ERP CMNTY TM OFC APPLICATION NO. 006154561, FILED 7-31-2007, REG. NO. 006154561, DATED 7-3-2008, EXPIRES 7-31-2017.

CLASS 7—MACHINERY

FOR MACHINES AND MACHINE TOOLS, NAMELY, MACHINES FOR COUNTING, SORTING, SEPARATING, AND CONVEYING CONTAINERS (U.S. CLS. 13, 19, 21, 23, 31, 34 AND 35).

CLASS 9—ELECTRICAL AND SCIENTIFIC APPARATUS

FOR REVERSE VENDING MACHINES, NAMELY, AUTOMATIC MACHINES FOR RECEIVING BEVERAGE CONTAINERS FROM CONSUMERS, ACCOUNTING FOR CONTAINERS PROCESSED, AND REFUNDING DEPOSITS TO CONSUMERS OR PROVIDING RECEIPTS FOR CONSUMERS TO OBTAIN DEPOSIT REFUNDS (U.S. CLS. 21, 23, 26, 36 AND 38).

MELVIN AXILBUND, EXAMINING ATTORNEY

SN 76-685,762. FORDIA GROUP INC., SAINT-LAURENT, QUEBEC, CANADA, FILED 1-14-2008.



PRIORITY CLAIMED UNDER SEC. 44(D) ON CANADA APPLICATION NO. 1,361,249, FILED 8-27-2007, REG. NO. TMA721974, DATED 8-26-2008, EXPIRES 8-26-2023.

THE GREY TONES IN THE DRAWING ARE TO SHOW SHADING NOT COLOR.

THE WORDING "FORDIA" HAS NO MEANING IN A FOREIGN LANGUAGE.

CLASS 35—ADVERTISING AND BUSINESS

FOR RETAIL STORE SERVICES FEATURING DRILLING TOOLS; WHOLESALE DISTRIBUTORSHIPS FEATURING DRILLING TOOLS (U.S. CLS. 100, 101 AND 102).

CLASS 40—MATERIAL TREATMENT

FOR MANUFACTURING SERVICES FOR OTHERS IN THE FIELD OF DRILLING TOOLS (U.S. CLS. 100, 103 AND 106).

JAMES LOVELACE, EXAMINING ATTORNEY

SN 76-686,115. STOGIRL ENTERPRISES, LLC, CINCINNATI, OH. FILED 1-25-2008.

**COLLEGE HILL COFFEE CO.
AND CASUAL GOURMET**

NO CLAIM IS MADE TO THE EXCLUSIVE RIGHT TO USE "COFFEE CO. AND CASUAL GOURMET", APART FROM THE MARK AS SHOWN.

SEC. 2(F).

CLASS 18—LEATHER GOODS

FOR TOTE BAGS (U.S. CLS. 1, 2, 3, 22 AND 41). FIRST USE 1-1-2006; IN COMMERCE 1-1-2006.

CLASS 25—CLOTHING

FOR T-SHIRTS, BABY SHIRTS, HATS, SWEAT SHIRTS (U.S. CLS. 22 AND 39).
FIRST USE 1-1-2006; IN COMMERCE 1-1-2006.

SN 76-692,598. ALCORN STATE UNIVERSITY, ALCORN STATE, MS. FILED 9-5-2008.

CLASS 30—STAPLE FOODS

FOR CANDY IN TUBES, COFFEE, COFFEE BEANS, TEA (U.S. CL. 46).
FIRST USE 1-1-2006; IN COMMERCE 1-1-2006.

CLASS 43—HOTEL AND RESTAURANT SERVICES

FOR RESTAURANT SERVICES (U.S. CLS. 100 AND 101).
FIRST USE 1-1-2006. THE MARK WAS FIRST USED ANYWHERE IN A DIFFERENT FORM OTHER THAN THAT SOUGHT TO BE REGISTERED ON 01/00/1999.; IN COMMERCE 1-1-2006, THE MARK WAS FIRST USED IN COMMERCE IN A DIFFERENT FORM OTHER THAN THAT SOUGHT TO BE REGISTERED ON 01/00/1999..
MICHELE SWAIN, EXAMINING ATTORNEY



OWNER OF U.S. REG. NOS. 3,113,561 AND 3,376,841.
THE MARK CONSISTS OF A CAPITAL "A" WITH THE WORD "ALCORN" COMPRISING THE HORIZONTAL LINE OF THE "A".

CLASS 16—PAPER GOODS AND PRINTED MATTER

FOR PRINTED MATERIALS, NAMELY, DECALS, STICKERS, BUMPER STICKERS, STATIONERY, BINDERS, NOTEBOOKS, ATHLETIC EVENT MEDIA GUIDES, ATHLETIC EVENT PROGRAMS, ATHLETIC EVENT BROCHURES, ATHLETIC EVENT POSTERS (U.S. CLS. 2, 5, 22, 23, 29, 37, 38 AND 50).
FIRST USE 6-18-2004; IN COMMERCE 6-18-2004.

SN 76-690,066. AMERICAN MENSA, LTD., ARLINGTON, TX. FILED 5-28-2008.

MENSA PROCESS

THE MARK CONSISTS OF STANDARD CHARACTERS WITHOUT CLAIM TO ANY PARTICULAR FONT, STYLE, SIZE, OR COLOR.
OWNER OF U.S. REG. NOS. 938,219, 1,492,188 AND OTHERS.
NO CLAIM IS MADE TO THE EXCLUSIVE RIGHT TO USE "PROCESS", APART FROM THE MARK AS SHOWN.
THE ENGLISH TRANSLATION OF THE LATIN WORD "MENSA" IN THE MARK IS "TABLE".

CLASS 25—CLOTHING

FOR CLOTHING, NAMELY, SHORT SLEEVED T-SHIRTS, LONG-SLEEVED T-SHIRTS, JERSEYS, SHIRTS, SWEATSHIRTS, SWEATPANTS, PANTS, SHORTS, HEADWEAR, CAPS, HATS, NECKWEAR AND OUTERWEAR, NAMELY, JACKETS, VESTS, COATS, AND ANORAKS (U.S. CLS. 22 AND 39).
FIRST USE 6-18-2004; IN COMMERCE 6-18-2004.

CLASS 41—EDUCATION AND ENTERTAINMENT

FOR ENTERTAINMENT SERVICES, NAMELY, ARRANGING AND CONDUCTING UNIVERSITY LEVEL MEN'S AND WOMEN'S ATHLETIC EXHIBITIONS, CONFERENCES, EVENTS, GAMES, TOURNAMENTS; ATHLETIC TICKET AGENCY SERVICES; ENTERTAINMENT, NAMELY, LIVE MUSIC CONCERTS (U.S. CLS. 100, 101 AND 107).
FIRST USE 6-18-2004; IN COMMERCE 6-18-2004.
FRED CARL, EXAMINING ATTORNEY

CLASS 35—ADVERTISING AND BUSINESS

FOR BUSINESS CONSULTATION SERVICES IN THE NATURE OF CONSULTATION ON THE DEVELOPMENT OF MARKETING, ADVERTISING, AND PROMOTIONAL CAMPAIGNS FOR OTHERS; CONCEPT AND BRAND DEVELOPMENT SERVICES FOR CORPORATE CLIENTS (U.S. CLS. 100, 101 AND 102).
FIRST USE 0-0-2001; IN COMMERCE 0-0-2001.

SN 76-694,045. WALLS INDUSTRIES, INC., CLEBURNE, TEXAS, CLEBURNE, TX. FILED 11-5-2008.

STORM DUCK

CLASS 42—SCIENTIFIC AND COMPUTER SERVICES

FOR DEVELOPING AND DESIGNING NEW PRODUCTS FOR OTHERS (U.S. CLS. 100 AND 101).
FIRST USE 0-0-2001; IN COMMERCE 0-0-2001.
MAYUR VAGHANI, EXAMINING ATTORNEY

THE MARK CONSISTS OF STANDARD CHARACTERS WITHOUT CLAIM TO ANY PARTICULAR FONT, STYLE, SIZE, OR COLOR.
NO CLAIM IS MADE TO THE EXCLUSIVE RIGHT TO USE "STORM", APART FROM THE MARK AS SHOWN.

CLASS 9—ELECTRICAL AND SCIENTIFIC APPARATUS

FOR PROTECTIVE CLOTHING (U.S. CLS. 21, 23, 26, 36 AND 38).

CLASS 25—CLOTHING

FOR CLOTHING, NAMELY, SHIRTS, PANTS, SHORTS, JACKETS, FOUL WEATHER GEAR, WIND-COATS, WIND JACKETS, RAIN JACKETS, RAINCOATS (U.S. CLS. 22 AND 39).

TINA BROWN, EXAMINING ATTORNEY

SN 76-694,909. BETTEREARTH GREEN ENERGY, INC., DIAMOND BAR, CA. FILED 12-19-2008.

BetterEarth Green Energy

THE MARK CONSISTS OF STANDARD CHARACTERS WITHOUT CLAIM TO ANY PARTICULAR FONT, STYLE, SIZE, OR COLOR.

NO CLAIM IS MADE TO THE EXCLUSIVE RIGHT TO USE "GREEN ENERGY", APART FROM THE MARK AS SHOWN.

CLASS 4—LUBRICANTS AND FUELS

FOR BIODIESEL FUEL; BIODIESEL FUEL DERIVED FROM JATROPHA CURCAS SEEDS; OILS, FATS, AND LIPIDS FOR USE IN THE MANUFACTURE OF OTHER PRODUCTS, NAMELY, BIODIESEL FUEL; BIOFUELS; BIOFUELS DERIVED FROM JATROPHA CURCAS SEEDS; FUELS FROM JATROPHA SEED OIL; FUEL OIL; FUELS; FOSSIL FUEL SUBSTITUTES, NAMELY, BIOFUELS; FUELS FOR MOTOR VEHICLES, NAMELY, BIODIESEL FUEL; FUELS FOR MOTOR VEHICLES, NAMELY, BIODIESEL FUEL DERIVED FROM JATROPHA CURCAS SEEDS; JATROPHA CURCAS OIL FOR USE IN FURTHER MANUFACTURE OF ALTERNATIVE FUELS; PLANT DERIVED FUEL OIL (U.S. CLS. 1, 6 AND 15).

CLASS 31—NATURAL AGRICULTURAL PRODUCTS

FOR AGRICULTURAL SEEDS; AGRICULTURAL SEEDS, NAMELY, JATROPHA CURCAS; LIVING TREES, NAMELY, JATROPHA CURCAS; SEEDS FOR AGRICULTURAL PURPOSES; LIVE PLANTS, NAMELY, JATROPHA CURCAS; AGRICULTURAL PRODUCTS, NAMELY, JATROPHA SEEDS; UNPROCESSED JATROPHA CURCAS SEEDS FOR AGRICULTURAL USE; AGRICULTURAL PRODUCTS, NAMELY, SOWING SEEDS (U.S. CLS. 1 AND 46).

CLASS 40—MATERIAL TREATMENT

FOR PRODUCTION, TREATMENT AND REFINEMENT OF FUEL, DIESEL FUEL, BIOFUEL AND BIODIESEL FUEL FOR OTHERS; PRODUCTION, TREATMENT AND REFINEMENT OF JATROPHA OIL FOR OTHERS; PRODUCTION, TREATMENT AND REFINEMENT OF JATROPHA SEEDS TO PRODUCE BIODIESEL AND BIOFUELS (U.S. CLS. 100, 103 AND 106).

DAVID MURRAY, EXAMINING ATTORNEY

SN 76-694,910. BETTEREARTH GREEN ENERGY, INC., DIAMOND BAR, CA. FILED 12-19-2008.

Power this Generation and Beyond

THE MARK CONSISTS OF STANDARD CHARACTERS WITHOUT CLAIM TO ANY PARTICULAR FONT, STYLE, SIZE, OR COLOR.

CLASS 4—LUBRICANTS AND FUELS

FOR BIODIESEL FUEL; BIODIESEL FUEL DERIVED FROM JATROPHA CURCAS SEEDS; OILS, FATS, AND LIPIDS FOR USE IN THE MANUFACTURE OF OTHER PRODUCTS, NAMELY, BIODIESEL FUEL; BIOFUELS; BIOFUELS DERIVED FROM JATROPHA CURCAS SEEDS; FUELS FROM JATROPHA SEED OIL; FUEL OIL; FUELS; FOSSIL FUEL SUBSTITUTES, NAMELY, BIOFUELS; FUELS FOR MOTOR VEHICLES, NAMELY, BIODIESEL FUEL; FUELS FOR MOTOR VEHICLES, NAMELY, BIODIESEL FUEL DERIVED FROM JATROPHA CURCAS SEEDS; JATROPHA CURCAS OIL FOR USE IN FURTHER MANUFACTURE OF ALTERNATIVE FUELS; PLANT DERIVED FUEL OIL (U.S. CLS. 1, 6 AND 15).

CLASS 31—NATURAL AGRICULTURAL PRODUCTS

FOR AGRICULTURAL SEEDS; AGRICULTURAL SEEDS, NAMELY, JATROPHA CURCAS; LIVING TREES, NAMELY, JATROPHA CURCAS; SEEDS FOR AGRICULTURAL PURPOSES; LIVE PLANTS, NAMELY, JATROPHA CURCAS; AGRICULTURAL PRODUCTS, NAMELY, JATROPHA SEEDS; UNPROCESSED JATROPHA CURCAS SEEDS FOR AGRICULTURAL USE; AGRICULTURAL PRODUCTS, NAMELY, SOWING SEEDS (U.S. CLS. 1 AND 46).

CLASS 40—MATERIAL TREATMENT

FOR PRODUCTION, TREATMENT AND REFINEMENT OF FUEL, DIESEL FUEL, BIOFUEL AND BIODIESEL FUEL FOR OTHERS; PRODUCTION, TREATMENT AND REFINEMENT OF JATROPHA OIL FOR OTHERS; PRODUCTION, TREATMENT AND REFINEMENT OF JATROPHA SEEDS TO PRODUCE BIODIESEL AND BIOFUELS (U.S. CLS. 100, 103 AND 106).

DAVID MURRAY, EXAMINING ATTORNEY

SN 77-000,589. MANKOVITZ, ROY J., MONTECITO, CA. FILED 9-15-2006.

THE MONTECITO DIET

THE MARK CONSISTS OF STANDARD CHARACTERS WITHOUT CLAIM TO ANY PARTICULAR FONT, STYLE, SIZE, OR COLOR.

NO CLAIM IS MADE TO THE EXCLUSIVE RIGHT TO USE "DIET", APART FROM THE MARK AS SHOWN.

CLASS 16—PAPER GOODS AND PRINTED MATTER

FOR PRINTED PUBLICATIONS, NAMELY, BOOKS, MAGAZINES, NEWSLETTERS, BROCHURES, AND PAMPHLETS CONCERNING HEALTH, NUTRITION, ILLNESS PREVENTION, DETOXIFICATION, DIET AND LIFESTYLE CHOICES (U.S. CLS. 2, 5, 22, 23, 29, 37, 38 AND 50).

CLASS 41—EDUCATION AND ENTERTAINMENT

FOR ON-LINE JOURNALS, NAMELY, BLOGS FEATURING INFORMATION IN THE FIELD OF HEALTH, NUTRITION, ILLNESS PREVENTION, DETOXIFICATION, AND DIET AND LIFESTYLE CHOICES (U.S. CLS. 100, 101 AND 107).

CLASS 44—MEDICAL, BEAUTY AND AGRICULTURAL SERVICES

FOR PROVIDING HEALTH INFORMATION; PROVIDING INFORMATION IN THE FIELD OF NUTRITIONAL COUNSELING; PROVIDING INFORMATION IN THE FIELD OF ILLNESS PREVENTION, DIET, DETOXIFICATION, AND LIFESTYLE WELLNESS CHOICES; PROVIDING GLOBAL COMPUTER WEBSITES FEATURING INFORMATION IN THE FIELD OF HEALTH, NUTRITION, ILLNESS PREVENTION, DETOXIFICATION, AND DIET AND LIFESTYLE WELLNESS CHOICES (U.S. CLS. 100 AND 101).

JOHN WILKE, EXAMINING ATTORNEY

SN 77-010,137. SIRS-LAB GMBH, JENA, FED REP GERMANY, FILED 9-28-2006.

MAGNIFECT

THE MARK CONSISTS OF STANDARD CHARACTERS WITHOUT CLAIM TO ANY PARTICULAR FONT, STYLE, SIZE, OR COLOR.

OWNER OF ERPN CMNTY TM OFC REG. NO. 004600771, DATED 9-28-2006, EXPIRES 9-28-2016.

CLASS 1—CHEMICALS

FOR CHEMICALS USED IN INDUSTRY AND SCIENCE; DIAGNOSTIC PREPARATIONS USED IN SCIENCE; AUTOMATED SCALABLE AND FLEXIBLE NUCLEIC ACID ISOLATION DIAGNOSTIC, THERAPY MONITORING AND SAMPLE PREPARATION KITS COMPRISED OF COMBINATIONS OF BUFFERS, REAGENTS, ENZYMES, AND PROTEINS IMMOBILIZED ON SOLID SUPPORT OR PLASTIC CONSUMABLES FOR SCIENTIFIC OR RESEARCH USE; AUTOMATED SCALABLE AND FLEXIBLE LIQUID HANDLING AND/OR MAGNETIC-BEAD-BASED NUCLEIC ACID ISOLATION DIAGNOSTIC, THERAPY MONITORING AND SAMPLE PREPARATION KITS COMPRISED OF COMBINATIONS OF BUFFERS, REAGENTS, ENZYMES, AND PROTEINS IMMOBILIZED ON BEADS OF POROUS MATERIALS, PLASTIC CONSUMABLES OR FILTER MEMBRANES, FOR SCIENTIFIC OR RESEARCH USE (U.S. CLS. 1, 5, 6, 10, 26 AND 46).

CLASS 5—PHARMACEUTICALS

FOR DIAGNOSTIC PREPARATIONS USED IN MEDICINE; AUTOMATED SCALABLE AND FLEXIBLE NUCLEIC ACID ISOLATION DIAGNOSTIC, THERAPY MONITORING AND SAMPLE PREPARATION KITS COMPRISED OF COMBINATIONS OF BUFFERS, REAGENTS, ENZYMES, AND PROTEINS IMMOBILIZED ON SOLID SUPPORT OR PLASTIC CONSUMABLES FOR MEDICAL OR VETERINARY USE; AUTOMATED SCALABLE AND FLEXIBLE LIQUID HANDLING AND/OR MAGNETIC-BEAD-BASED NUCLEIC ACID ISOLATION DIAGNOSTIC, THERAPY MONITORING AND SAMPLE PREPARATION KITS COMPRISED OF COMBINATIONS OF BUFFERS, REAGENTS, ENZYMES, AND PROTEINS IMMOBILIZED ON BEADS OF POROUS MATERIALS, PLASTIC CONSUMABLES OR FILTER MEMBRANES FOR MEDICAL OR VETERINARY USE (U.S. CLS. 6, 18, 44, 46, 51 AND 52).

CLASS 9—ELECTRICAL AND SCIENTIFIC APPARATUS

FOR SCIENTIFIC MEASURING AND CONTROL APPARATUS AND INSTRUMENTS, NAMELY, DEVICES FOR DIAGNOSIS, THERAPY MONITORING AND SAMPLE PREPARATION, IN PARTICULAR FOR PATHOGEN DETECTION, NUCLEIC ACID ISOLATION, GENE ACTIVITY MEASUREMENT, AND SNP-PROFILING, NOT FOR MEDICAL PURPOSES, NAMELY, APPARATUS IN THE NATURE OF HOMOGENISERS FOR THE PURPOSE OF BREAKING UP CELL WALLS AND MEMBRANES AND MIXING THE RESULTING LIQUIDS, VACUUM VALVES FOR CONTROLLING AND REGULATING THE FLOW OF GASSES OR LIQUIDS NOT BEING PART OF PLUMBING, HEATING, COOLING INSTALLATIONS OR MACHINES FOR THE PURPOSE OF PERMITTING THE OPERATION OF LABORATORY PROCESSES UNDER SUB-ATMOSPHERIC PRESSURE, LABORATORY EQUIPMENT FOR ROBOTIC LIQUID HANDLING, NAMELY, MICROPLATES, REACTION TUBES, PIPETTE TIPS, SAMPLE CONTAINERS, REAGENT HOLDERS; AND APPARATUS AND DEVICES IN THE NATURE OF LIQUID HANDLING LABORATORY ROBOTS COMPRISED OF MICROPLATES, REACTION TUBES, PIPETTE TIPS, SAMPLE CONTAINERS, AND/OR REAGENT HOLDERS, AND/OR CENTRIFUGES, HOMOGENISERS FOR THE PURPOSE OF BREAKING UP CELL WALLS AND MEMBRANES AND MIXING THE RESULTING LIQUIDS, VACUUM VALVES FOR THE PURPOSE OF PERMITTING THE OPERATION OF LABORATORY PROCESSES UNDER SUB-ATMOSPHERIC PRESSURE, FOR LYSING SAMPLES, PIPETTING AND MIXING REAGENTS, AND BINDING AND/OR ELUTING NUCLEIC ACID; MEDICAL LABORATORY EQUIPMENT FOR ROBOTIC LIQUID HANDLING, NAMELY, MICROPLATES, REACTION TUBES, PIPETTE TIPS, SAMPLE CONTAINERS, AND/OR REAGENT HOLDERS; APPARATUS AND DEVICES IN THE NATURE OF LIQUID HANDLING MEDICAL LABORATORY ROBOTS COMPRISED OF MICROPLATES, REACTION TUBES, PIPETTE TIPS, SAMPLE CONTAINERS, AND/OR REAGENT HOLDERS, AND/OR CENTRIFUGES, HOMOGENISERS FOR THE PURPOSE OF BREAKING UP CELL WALLS AND MEMBRANES AND MIXING THE RESULTING LIQUIDS, VACUUM VALVES FOR THE PURPOSE OF PERMITTING THE OPERATION OF LABORATORY PROCESSES UNDER SUB-ATMOSPHERIC PRESSURE, FOR LYSING SAMPLES, PIPETTING AND MIXING REAGENTS, AND BINDING AND/OR ELUTING NUCLEIC ACID (U.S. CLS. 21, 23, 26, 36 AND 38).

CLASS 10—MEDICAL APPARATUS

FOR MEDICAL DEVICES FOR DIAGNOSIS, THERAPY MONITORING AND SAMPLE PREPARATION, IN PARTICULAR FOR PATHOGEN DETECTION, NUCLEIC ACID ISOLATION, GENE ACTIVITY MEASUREMENTS AND SNP-PROFILING, FOR MEDICAL PURPOSES, NAMELY, APPARATUS IN THE NATURE OF HOMOGENISERS FOR THE PURPOSE OF BREAKING UP CELL WALLS AND MEMBRANES AND MIXING THE RESULTING LIQUIDS, VACUUM VALVES FOR CONTROLLING AND REGULATING THE FLOW OF GASSES OR LIQUIDS NOT BEING PART OF PLUMBING, HEATING, COOLING INSTALLATIONS OR MACHINES FOR THE PURPOSE OF PERMITTING THE OPERATION OF MEDICAL LABORATORY PROCESSES UNDER SUB-ATMOSPHERIC PRESSURE (U.S. CLS. 26, 39 AND 44).

CLASS 40—MATERIAL TREATMENT

FOR CONSULTATION ON THE MANUFACTURE OF ANALYTICAL AND DIAGNOSTIC EQUIPMENT (U.S. CLS. 100, 103 AND 106).

CLASS 42—SCIENTIFIC AND COMPUTER SERVICES

FOR SCIENTIFIC CONSULTATION ON THE PREPARATION OF DIAGNOSTIC AGENTS; EFFECTING CHEMICAL ANALYSES; SERVICES OF A CHEMICAL LABORATORY; RESEARCH IN THE MEDICAL FIELD; SERVICES OF A MEDICAL LABORATORY (U.S. CLS. 100 AND 101).

CLASS 44—MEDICAL, BEAUTY AND AGRICULTURAL SERVICES

FOR EFFECTING MEDICAL DIAGNOSES, NAMELY, DIAGNOSING DISEASES; CONSULTATION ON ISSUES OF MEDICAL AND SCIENTIFIC DIAGNOSES AND ANALYSES, NAMELY, DISEASE DIAGNOSIS CONSULTATION; CONSULTATION IN HEALTH MANAGEMENT, NAMELY, CONSULTATION REGARDING MAINTAINING AND IMPROVING INDIVIDUAL HEALTH (U.S. CLS. 100 AND 101).

ROBERT STRUCK, EXAMINING ATTORNEY

SN 77-023,574. ELIZABETH BRADLEY DESIGN (2006) LIMITED, BIRMINGHAM, UNITED KINGDOM, FILED 10-18-2006.

ELIZABETH BRADLEY

THE MARK CONSISTS OF STANDARD CHARACTERS WITHOUT CLAIM TO ANY PARTICULAR FONT, STYLE, SIZE, OR COLOR.

PRIORITY CLAIMED UNDER SEC. 44(D) ON ERP CMNTY TM OFC APPLICATION NO. 005397443, FILED 10-18-2006, REG. NO. 005397443, DATED 9-12-2007, EXPIRES 10-18-2016.

THE NAME "ELIZABETH BRADLEY" IDENTIFIES A LIVING INDIVIDUAL WHOSE CONSENT IS OF RECORD.

CLASS 16—PAPER GOODS AND PRINTED MATTER

FOR PAPER, CARDBOARD AND GOODS MADE FROM THESE MATERIALS, NOT INCLUDED IN OTHER CLASSES, NAMELY, PRINTED MATTER IN THE NATURE OF PRINTED LESSONS ON DECORATION, HOME DECORATION, SEWING, NEEDLEWORK, TAPESTRY, STITCHING AND KNITTING, BROCHURES, NEWSLETTERS, MAGAZINES, LEAFLETS, BOOKLETS, INSTRUCTIONS, ALL IN THE FIELD OF DECORATION, HOME DECORATION, SEWING, NEEDLEWORK, TAPESTRY, STITCHING AND KNITTING; BOOK BINDING TAPE AND WIRE, CLOTH FOR BOOK-BINDING; PHOTOGRAPHS; STATIONERY; ADHESIVES FOR STATIONERY OR HOUSEHOLD PURPOSES; ARTISTS' MATERIALS, NAMELY, BRUSHES, PASTELS, PENCILS, PENS, CANVAS; PAINT BRUSHES; TYPEWRITERS AND OFFICE REQUISITES, EXCEPT FURNITURE, NAMELY, STAPLERS, RUBBERS BANDS, PUNCHES, ADHESIVE TAPE, ADHESIVE TAPE DISPENSERS; PRINTED INSTRUCTIONAL AND TEACHING MATERIAL IN THE FIELD OF DECORATION, HOME DECORATION, SEWING, NEEDLEWORK, TAPESTRY, STITCHING AND KNITTING; PLASTIC MATERIALS FOR PACKAGING, NAMELY, BAGS, PLASTIC BUBBLE PACKS; PRINTERS' TYPE; PRINTING BLOCKS; PATTERNS FOR SEWING AND FOR NEEDLEWORK; BOOKS IN THE FIELD OF SEWING AND NEEDLE WORK; STATIONERY (U.S. CLS. 2, 5, 22, 23, 29, 37, 38 AND 50).

CLASS 20—FURNITURE AND ARTICLES NOT OTHERWISE CLASSIFIED

FOR FURNITURE, MIRRORS, PICTURE FRAMES; STOOLS; GOODS OF WOOD, CORK, TEED, CANE, WICKER, HORN, BONE, IVORY, WHALEBONE, SHELL, AMBER, MOTHER-OF-PEARL, MEERSCHAURN AND SUBSTITUTES FOR ALL THESE MATERIALS, OR OF PLASTICS, NAMELY, DRAWER PULLS, INTERIOR WINDOW BLINDS, ORNAMENTS EXCLUDING CHRISTMAS TREE ORNAMENTS, SCULPTURES, STATUETTES, STATUES (U.S. CLS. 2, 13, 22, 25, 32 AND 50).

CLASS 22—CORDAGE AND FIBERS

FOR ROPES, STRING, BUTTERFLY NETS, TENTS, AWNINGS, TARPAULINS, SAILS, SACKS AND BAGS FOR THE TRANSPORTATION OR STORAGE OF MATERIALS IN BULK; PADDING AND STUFFING MATERIALS NOT OF RUBBER OR PLASTIC; RAW FIBROUS TEXTILE MATERIALS; WOOL (U.S. CLS. 1, 2, 7, 19, 22, 42 AND 50).

CLASS 24—FABRICS

FOR TEXTILES AND TEXTILE GOODS, NAMELY, UPHOLSTERY FABRICS, TRACED CLOTH FOR EMBROIDERY, BED SHEETS, BED SPREADS, BED SKIRTS, BED LINEN, TABLE CLOTHS NOT OF PAPER, COVERS FOR CUSHIONS, CURTAIN LOOPS OF TEXTILE MATERIAL, UNFITTED FURNITURE COVERINGS OF TEXTILE, TABLE RUNNERS, CURTAINS OF TEXTILE, TAPESTRIES; CANVAS FOR TAPESTRY OR EMBROIDERY (U.S. CLS. 42 AND 50).

CLASS 26—FANCY GOODS

FOR LACE AND EMBROIDERY, RIBBONS AND BRAID; BUTTONS FOR CLOTHING, HOOKS AND EYES, SEWING PINS AND SEWING NEEDLES; ARTIFICIAL FLOWERS (U.S. CLS. 37, 39, 40, 42 AND 50).

CLASS 27—FLOOR COVERINGS

FOR CARPETS, RUGS, MATS AND MATTING, LINOLEUM AND OTHER MATERIALS FOR COVERING EXISTING FLOORS, NAMELY, CORK FOR USE AS A FLOOR COVERING, VINYL FLOOR COVERINGS; CARPET BORDERS, NAMELY, CARPET UNDERLINING; NON-TEXTILE WALL HANGINGS (U.S. CLS. 19, 20, 37, 42 AND 50).

SUNG IN, EXAMINING ATTORNEY

SN 77-031,139. STORA ENSO OYJ, HELSINKI, FINLAND,
FILED 10-27-2006.

CDM

THE MARK CONSISTS OF STANDARD CHARACTERS WITHOUT CLAIM TO ANY PARTICULAR FONT, STYLE, SIZE, OR COLOR.

PRIORITY CLAIMED UNDER SEC. 44(D) ON ERPNTY TM OFC APPLICATION NO. 005070131, FILED 5-11-2006, REG. NO. 005070131, DATED 2-13-2008, EXPIRES 5-11-2016.

CLASS 6—METAL GOODS

FOR GENERAL PURPOSE CONTAINERS MADE OF METAL, INDUSTRIAL PACKAGING CONTAINERS MADE OF METAL, CONTAINERS MADE OF METAL FOR TRANSPORT, ALL OF THE FOREGOING HAVING ACTIVE AND ELECTRIC DELAMINATING PROPERTIES (U.S. CLS. 2, 12, 13, 14, 23, 25 AND 50).

CLASS 9—ELECTRICAL AND SCIENTIFIC APPARATUS

FOR APPARATUS AND INSTRUMENTS FOR CONDUCTING, SWITCHING, TRANSFORMING, ACCUMULATING, REGULATING AND/OR CONTROLLING LOW-VOLTAGE ELECTRICITY, NAMELY, ELECTRICAL CONDUCTORS, TRANSFORMERS, ACCUMULATORS, ELECTRIC CURRENT SWITCHES, VOLTAGE REGULATORS FOR ELECTRIC POWER AND ELECTRIC DISTRIBUTION PANELS; ELECTRONIC SWITCHBOARDS AND CIRCUITS; ELECTRONIC CIRCUITS FOR CONDUCTING AND CONTROLLING LOW-VOLTAGE ELECTRICITY, ALL OF THE FOREGOING ENABLING ACTIVE AND ELECTRIC DELAMINATION (U.S. CLS. 21, 23, 26, 36 AND 38).

CLASS 16—PAPER GOODS AND PRINTED MATTER

FOR PAPER, CARDBOARD AND GOODS MADE FROM THESE MATERIALS, NOT INCLUDED IN OTHER CLASSES, NAMELY, PRINTED MATTER, NAMELY, BUSINESS CARDS, GREETING CARDS; STATIONERY; ADHESIVES FOR STATIONERY OR HOUSEHOLD PURPOSES; PRINTED INSTRUCTIONAL AND TEACHING MATERIAL IN THE FIELD OF MANUFACTURE AND DEVELOPMENT OF PACKAGING SOLUTIONS; PLASTIC MATERIALS FOR PACKAGING, NAMELY, WRAPS AND BAGS; PAPER, FLUTING PAPER, PACKAGING PAPER, PACKAGING CARDBOARD, PACKAGING PAPERBOARD, CARDBOARD FOR PACKAGING LIQUIDS, FOLDING BOXBOARD, CARDBOARD, LAMINATED PAPER AND CARDBOARD, CORRUGATED CARDBOARD AND PAPER, PAPER AND CARDBOARD COATED WITH POLYTHENE OR PLASTIC MATERIALS; CORRUGATED PAPER, MILLBOARD, LINER PAPER, CARDBOARD FOR GRAPHICS AND PRINTING; GOODS MADE FROM THE AFORESAID MATERIALS, NAMELY, BOXES AND CONTAINERS OF CARDBOARD, PACKAGING FOR FOOD AND DRINK, BLISTER PACKS, COLLAPSIBLE PACKAGING, PACKAGING FOR AUDIO AND VIDEO DISCS, COVERS AND INSERTS FOR CDS AND DVDS; PLASTIC MATERIAL FOR PACKAGING, NAMELY, PLASTIC BAGS, PLASTIC SACKS; PROTECTIVE PLASTIC FILMS NOT FOR COMMERCIAL OR INDUSTRIAL USE AND PROTECTIVE PLASTIC FOILS FOR PACKAGING, ALL OF THE FOREGOING BEING PRODUCTS FOR ACTIVE AND ELECTRIC DELAMINATION OR HAVING ACTIVE AND ELECTRIC DELAMINATION PROPERTIES (U.S. CLS. 2, 5, 22, 23, 29, 37, 38 AND 50).

CLASS 40—MATERIAL TREATMENT

FOR TREATMENT OF MATERIALS, NAMELY, SHAPING, FOLDING AND TREATMENT OF CARDBOARD AND PAPER TO IMPROVE PROTECTION FROM THE DELAMINATION OF BOXES AND CONTAINERS (U.S. CLS. 100, 103 AND 106).

CLASS 42—SCIENTIFIC AND COMPUTER SERVICES

FOR RESEARCH AND DEVELOPMENT OF PACKAGING SOLUTIONS; SCIENTIFIC AND TECHNOLOGICAL SERVICES IN THE FIELD OF PACKAGES AND PACKAGING SOLUTIONS, AND RESEARCH AND DESIGN RELATING THERETO; INDUSTRIAL ANALYSIS AND RESEARCH SERVICES; DESIGN AND DEVELOPMENT OF COMPUTER HARDWARE AND SOFTWARE; LEGAL SERVICES; INDUSTRIAL DESIGN; PACKAGING DESIGN FOR OTHERS, ALL OF THE FOREGOING BEING IN THE FIELD OF ACTIVE AND ELECTRIC DELAMINATION (U.S. CLS. 100 AND 101).
PRISCILLA MILTON, EXAMINING ATTORNEY

SN 77-043,292. SONY COMPUTER ENTERTAINMENT EUROPE LIMITED, LONDON, ENGLAND, FILED 11-14-2006.

SingStore

OWNER OF GREAT BRITAIN REG. NO. 2421004, DATED 5-4-2006, EXPIRES 5-4-2016.

CLASS 9—ELECTRICAL AND SCIENTIFIC APPARATUS

FOR COMPUTER SOFTWARE FOR USE IN AUTHORIZING, DOWNLOADING, TRANSMITTING, RECEIVING, EDITING, EXTRACTING, ENCODING, DECODING, PLAYING, STORING AND ORGANIZING AUDIO AND VIDEO DATA (U.S. CLS. 21, 23, 26, 36 AND 38).

CLASS 35—ADVERTISING AND BUSINESS

FOR RETAIL STORE SERVICES IN THE FIELD OF ENTERTAINMENT, NAMELY, MOVIES, MUSICAL AND AUDIOVISUAL WORKS AND RELATED MERCHANDISE, PROVIDED VIA THE INTERNET AND OTHER COMPUTER AND ELECTRONIC COMMUNICATION NETWORKS (U.S. CLS. 100, 101 AND 102).

CLASS 36—INSURANCE AND FINANCIAL

FOR ELECTRONIC PAYMENT SERVICES, NAMELY, THE COLLECTION OF PAYMENTS FOR AUDIO AND VIDEO RECORDINGS (U.S. CLS. 100, 101 AND 102).

CLASS 38—COMMUNICATION

FOR PROVIDING ELECTRONIC TRANSMISSION OF MUSIC FOR DOWNLOADING VIA THE INTERNET; PROVIDING ELECTRONIC ACCESS TO MUSIC VIA THE INTERNET (U.S. CLS. 100, 101 AND 104).

CLASS 41—EDUCATION AND ENTERTAINMENT

FOR PROVIDING AN ONLINE COMPUTER GAME; ENTERTAINMENT INFORMATION SERVICES AND ON-LINE INFORMATION SERVICES IN THE FIELDS OF MUSIC; DIGITAL IMAGING SERVICES; PROVIDING A WEBSITE FEATURING AUDIO, VIDEO, GRAPHICS, TEXT AND OTHER MULTIMEDIA CONTENT IN THE FIELDS OF MUSIC, ENTERTAINMENT RELATED TO MUSIC AND ARTS AND LEISURE VIA COMMUNICATIONS NETWORKS (U.S. CLS. 100, 101 AND 107).
ANGELA M. MICHELI, EXAMINING ATTORNEY

SN 77-049,885. PROVENTIA AMERICAS LLC, WILMINGTON, DE. FILED 11-22-2006.



THE MARK CONSISTS OF THE WORDS "PROVENTIA" IN STYLIZED FORMAT ACCOMPANIED BY A WHIRLWIND DESIGN REPRESENTING THE DOT OVER THE LETTER "I".

CLASS 1—CHEMICALS

FOR CHEMICALS AND ENVIRONMENTAL CATALYSTS USED IN INDUSTRY AND FOR PURPOSES OF ENVIRONMENTAL TECHNOLOGY AND OTHER SUSTAINABLE DEVELOPMENT TECHNOLOGY (U.S. CLS. 1, 5, 6, 10, 26 AND 46).

CLASS 7—MACHINERY

FOR EXHAUST SYSTEMS FOR LAND, AIR AND WATER VEHICLES, CONSISTING OF EXHAUST PIPES, EXHAUST SILENCERS, AFTER-TREATMENT COMPONENTS IN THE NATURE OF CATALYTIC CONVERTERS, PARTICULATE FILTERS, AFTER-TREATMENT REAGENT STORAGE TANKS, DOSING AND ELECTRONIC CONTROLLERS, AND ELECTRONIC CONTROLLERS TO ENGINE TO REDUCE EMISSIONS, ALL SOLD AS A UNIT; CATALYTIC CONVERTERS FOR MOTORS AND ENGINES; EMISSION CONTROL SYSTEMS FOR VEHICLES, MACHINES AND EQUIPMENT SUCH AS ENGINES, MOTORS, FACTORIES, POWER PLANTS, AND GEN SETS (GENERATOR SETS), CONSISTING OF EXHAUST PIPES, EXHAUST SILENCERS AND AFTER-TREATMENT COMPONENTS OF SUCH SYSTEMS, NAMELY, CATALYST SUBSTRATE COMPRISED OF CATALYST WASHCOAT AND CATALYST COATING, CATALYST SUBSTRATE HOUSING, CATALYST SUBSTRATE CANNING, ELECTRIC HEATING ELEMENTS FOR EXHAUST GAS AND/OR CATALYST SUBSTRATE, DIESEL PARTICULATE FILTER, PARTICULATE FILTER, CATALYTIC BURNERS AND/OR FUEL BURNERS; EMISSION CONTROL SYSTEMS FOR VEHICLES, MACHINES AND EQUIPMENT, NAMELY, AFTER-TREATMENT REAGENT STORAGE COMPONENTS USED FOR NOX (NITROGEN OXIDES) REDUCTION OR DIESEL PARTICULATE FILTER REGENERATION IN THE NATURE OF REAGENT TANKS, REAGENT INJECTORS, REAGENT PUMPS, REAGENT PIPES, REAGENT FILTERS AND REAGENT TANK TEMPERATURE CONTROL HEATER/COOLER; EMISSION CONTROL SYSTEMS FOR VEHICLES, MACHINES AND EQUIPMENT, NAMELY, AFTER-TREATMENT DOSING AND CONTROL SYSTEM USED FOR NOX (NITROGEN OXIDES) REDUCTION OR DIESEL PARTICULATE FILTER REGENERATION CONSISTING OF EXHAUST GAS SENSOR, EXHAUST AND/OR INTAKE FLOW METERS, REAGENT INJECTORS, REAGENT PUMPS, REAGENT FILTERS AND REAGENT CLOSER CONTROL UNIT; EMISSION CONTROL SYSTEMS FOR VEHICLES, MACHINES AND EQUIPMENT, NAMELY, CATALYTIC CONVERTERS, DIESEL PARTICULATE FILTERS,

FLOW THROUGH FILTERS, FUEL ADDITIVE TANKS AND DOSERS, SELECTIVE CATALYTIC REDUCTION (SCR) AND NITROGEN OXIDES REDUCTION (DENOX) CATALYSTS, SELECTIVE CATALYTIC REDUCTION (SCR) REAGENT INJECTION CONTROL PUMP AND ELECTRONIC CONTROL MODULE; EMISSION CONTROL SYSTEMS FOR VEHICLES, MACHINES AND EQUIPMENT, NAMELY, DIESEL PARTICULATE FILTER REGENERATION SYSTEM CONSISTING OF ELECTRIC HEATERS, FUEL BURNERS AND HYDROCARBON (HG) INJECTORS; EMISSION CONTROL SYSTEMS FOR VEHICLES, MACHINES AND EQUIPMENT, NAMELY, ENGINE INTAKE THROTTLING COMPONENTS IN THE NATURE OF THROTTLE VALVES AND CONTROLLERS AND AIR INTAKE FLOW METERS; EMISSION CONTROL SYSTEMS FOR VEHICLES, MACHINES AND EQUIPMENT, NAMELY, ELECTRONIC CONTROL SYSTEMS INCORPORATING ALGORITHMS USED TO REDUCE ENGINE EMISSIONS, CONSISTING OF ENGINE INJECTION, TURBOCHARGER AND COMBUSTION PRESSURE SENSORS, ENGINE INTAKE AND EXHAUST GAS PRESSURE SENSORS, TEMPERATURE AND EXHAUST GAS SENSORS AND ENGINE COOLING CONTROLLERS; RECYCLING AUTOMATION SYSTEMS CONSISTING OF MACHINES FOR RECYCLING OF MONITORS AND TELEVISIONS AND ELECTRONICS DEVICES; INDUSTRIAL AUTOMATION MACHINES AND SYSTEMS FOR TRANSPORTING, ASSEMBLING, PACKING, GRINDING, FAIRING CONSISTING OF ROBOTS, CONVEYORS AND PARTS THEREOF; MACHINE TOOLS FOR THE CUTTING AND FORMING OF RESIN AND OTHER SURFACE MATERIAL AND SURFACES; GAS AND/OR ELECTRIC WELDING AND MOLDING MACHINES; SORTING AND PACKING MACHINES IN USE IN INDUSTRIAL MANUFACTURING (U.S. CLS. 13, 19, 21, 23, 31, 34 AND 35).

CLASS 9—ELECTRICAL AND SCIENTIFIC APPARATUS

FOR ELECTRONIC QUALITY CONTROL EQUIPMENT AND OTHER MEASURING AND ELECTRONIC CONTROL EQUIPMENTS FOR INDUSTRIAL MANUFACTURING, NAMELY, ROBOT AND SYSTEM CONTROLS AND 2D AND 3D MACHINE VISION SYSTEMS; COMPUTER PROGRAMS FOR INDUSTRIAL AUTOMATION MACHINES USED IN THE FIELD OF ENVIRONMENTAL TECHNOLOGY AND CLEAN TECHNOLOGY, AS WELL AS IN THE FIELD OF INFORMATION TECHNOLOGY RELATING TO ENVIRONMENTAL AND/OR CLEAN TECHNOLOGY, FOR CONTROLLING THE OPERATION OF INDUSTRIAL ROBOTS, MACHINES, SYSTEMS, USER INTERFACES AND VISION SYSTEMS, EXCLUDING COMPUTER PROGRAMS IN THE FIELD OF DATA SECURITY, NETWORK SECURITY AND OTHER INDUSTRIAL SECURITY (U.S. CLS. 21, 23, 26, 36 AND 38).

CLASS 11—ENVIRONMENTAL CONTROL APPARATUS

FOR WATER PURIFICATION UNITS (U.S. CLS. 13, 21, 23, 31 AND 34).

CLASS 35—ADVERTISING AND BUSINESS

FOR BUSINESS MANAGEMENT; BUSINESS MANAGEMENT COUNSELING AND CONSULTATION CONNECTED WITH ENVIRONMENTAL MANAGEMENT (U.S. CLS. 100, 101 AND 102).

CLASS 37—CONSTRUCTION AND REPAIR

FOR INSTALLATION, MAINTENANCE AND REPAIR OF CATALYTIC CONVERTERS, EMISSION CONTROL SYSTEMS, SYSTEMS RELATING TO WASTE MANAGEMENT AND RECYCLING, MACHINES, MACHINE TOOLS, INDUSTRIAL AUTOMATION MACHINES AND SYSTEMS (U.S. CLS. 100, 103 AND 106).

CLASS 39—TRANSPORTATION AND STORAGE

FOR COUNSELING AND CONSULTATION CONNECTED WITH TRANSPORTATION AND STORAGE OF GOODS RELATING TO WASTE MANAGEMENT AND RECYCLING OF MATERIALS (U.S. CLS. 100 AND 105).

SN 77-061,008. CYBER COLORS LIMITED, ROAD TOWN TORTOLA, BR.VIRGIN ISLANDS, FILED 12-11-2006.

CYBER COLORS**CLASS 40—MATERIAL TREATMENT**

FOR TREATMENT OF WASTE; COUNSELING AND CONSULTATION CONNECTED WITH TREATMENT OF MATERIALS OF RECYCLING AUTOMATION SYSTEMS AND INDUSTRIAL AUTOMATION SYSTEMS (U.S. CLS. 100, 103 AND 106).

THE MARK CONSISTS OF STANDARD CHARACTERS WITHOUT CLAIM TO ANY PARTICULAR FONT, STYLE, SIZE, OR COLOR.

OWNER OF HONG KONG REG. NO. 300799561, DATED 1-18-2007, EXPIRES 1-18-2017.

OWNER OF HONG KONG REG. NO. 1999B00170, DATED 8-1-1999, EXPIRES 7-23-2014.

NO CLAIM IS MADE TO THE EXCLUSIVE RIGHT TO USE "COLORS" WITH RESPECT TO THE GOODS IN CLASSES 3 AND 5, APART FROM THE MARK AS SHOWN.

CLASS 41—EDUCATION AND ENTERTAINMENT

FOR PROVIDING EDUCATION AND TRAINING CONNECTED WITH ENVIRONMENTAL AND OTHER SUSTAINABLE DEVELOPMENT TECHNOLOGY, ENVIRONMENTAL MANAGEMENT AND FINANCING IN THE FORM OF SEMINARS AND WORKSHOPS (U.S. CLS. 100, 101 AND 107).

CLASS 3—COSMETICS AND CLEANING PREPARATIONS

FOR COSMETICS, CREAMS, MILKS, LOTIONS, GELS AND POWDERS FOR THE FACE, THE BODY AND THE HANDS; LIPSTICKS; MASCARAS; TONERS; MAKE-UP; MAKE-UP PREPARATIONS; MAKE-UP REMOVING PREPARATIONS; COSMETIC PREPARATIONS FOR SLIMMING PURPOSES; SUNTAN PREPARATIONS; COSMETIC PENCILS; NAIL CARE PREPARATIONS; NAIL CARE VARNISH; NAIL POLISH; FALSE NAILS; COTTON STICKS AND WOOL FOR COSMETIC PURPOSES; SHAVING PREPARATIONS; SHAMPOOS; HAIR CONDITIONERS; GELS, SPRAYS, MOUSSES AND BALMS FOR HAIR STYLING AND HAIR CARE; HAIR LACQUERS; HAIR COLOURING AND HAIR DECOLORANT PREPARATIONS; HAIR PERMANENT WAVING AND CURLING PREPARATIONS; NON-MEDICATED SKIN CARE PREPARATIONS; NON-MEDICATED HAIR CARE PREPARATIONS; BEAUTY MASKS; NON-MEDICATED TOILETRIES; MINERAL WATER SPRAYS FOR COSMETIC PURPOSES; SHOWER GELS; BODY WASHES; BODY PREPARATIONS, NAMELY, BODY SOAPS, BODY EMULSIONS, AND BODY SCRUBS; MANICURE PREPARATIONS; TANNING AND AFTER-SUN MILKS, GELS AND OILS; BODY DEODORANTS; PERFUMERY; TOILET WATER; ESSENTIAL OILS; SOAPS; ANTI-PERSPIRANTS; TOOTHPASTES; COSMETIC PREPARATIONS FOR THE CARE OF TEETH; TOOTH CLEANING PREPARATIONS; DENTIFRICES; COSMETIC SKIN PREPARATIONS FOR USE IN SKIN CARE; PUMICE STONE FOR PERSONAL USE (U.S. CLS. 1, 4, 6, 50, 51 AND 52).

CLASS 42—SCIENTIFIC AND COMPUTER SERVICES

FOR SCIENTIFIC RESEARCH RELATING TO ENVIRONMENTAL AND CLEAN TECHNOLOGY AND THE AUTOMATION INDUSTRY; TECHNOLOGICAL SERVICES, NAMELY, PRODUCT RESEARCH AND DESIGN RELATING TO ENVIRONMENTAL AND CLEAN TECHNOLOGY AND THE AUTOMATION INDUSTRY; DESIGN OF PRODUCTS AND SERVICES OF ENVIRONMENTAL AND OTHER SUSTAINABLE DEVELOPMENT TECHNOLOGY, RELATING TO INDUSTRIAL AUTOMATION SYSTEMS AND MACHINE TOOLS; DESIGN OF COMPUTER HARDWARE AND SOFTWARE RELATING THERETO USED IN THE FIELD OF ENVIRONMENTAL TECHNOLOGY AND CLEAN TECHNOLOGY, AS WELL AS IN THE FIELD OF INFORMATION TECHNOLOGY RELATING TO ENVIRONMENTAL AND/OR CLEAN TECHNOLOGY, AS WELL AS COUNSELLING AND CONSULTATION CONNECTED WITH ALL THE ABOVE MENTIONED SERVICES FOR ENVIRONMENTAL TECHNOLOGY, NAMELY, SOFTWARE SYSTEMS FOR ENVIRONMENTAL AND SUSTAINABILITY REPORTING, ANALYZING, CONSOLIDATION, COLLECTION, PUBLISHING AND OTHER PROCESSING OF SUCH INFORMATION BY SOFTWARE AND HARDWARE AND EXCLUDING SERVICES RELATING TO HARDWARE OR COMPUTER PROGRAMS IN THE FIELD OF DATA SECURITY, NETWORK SECURITY AND OTHER INDUSTRIAL SECURITY; DESIGN OF SYSTEMS AND PROCESSING PLANTS FOR RECYCLING OF ELECTRONICS WASTE AND TRASH AND COUNSELLING AND CONSULTATION CONNECTED THEREWITH (U.S. CLS. 100 AND 101).

BRIAN PINO, EXAMINING ATTORNEY

CLASS 5—PHARMACEUTICALS

FOR PHARMACEUTICAL AND MEDICATED PREPARATIONS AND SUBSTANCES FOR SKIN CARE AND HAIR CARE; MEDICATED MOUTH CARE PREPARATIONS (U.S. CLS. 6, 18, 44, 46, 51 AND 52).

CLASS 8—HAND TOOLS

FOR HAND-OPERATED HAND TOOLS AND IMPLEMENTS, NAMELY, SHARPENING INSTRUMENTS, NEEDLE FILES, STAMPS, NAIL EXTRACTORS, CUTICLE NIPPERS, CUTICLE TWEEZERS, CUTTING TOOLS, NAIL CLIPPERS, FINGERNAIL POLISHERS, HAIR CLIPPERS FOR PERSONAL USE, HAIR-REMOVING TWEEZERS, EYELASH CURLERS, EYEBROW TWEEZERS, NAIL FILES, ELECTRIC NAIL FILES, NAIL DRAWERS FOR KEEPING HANDING TOOLS, NAIL CLIPPERS, PEDICURE SETS, MANICURE SETS, RAZOR CASES, RAZOR BLADES, RAZORS, BEARD CLIPPERS, ELECTRIC AND NON-ELECTRIC SHAVERS FOR MEN, LADY SHAVERS, SCISSORS (U.S. CLS. 23, 28 AND 44).

CLASS 9—ELECTRICAL AND SCIENTIFIC APPARATUS

FOR HAND IMPLEMENTS FOR HAIR CURLING, NAMELY, ELECTRIC CURLING IRONS, ELECTRIC ROTARY HAIR STYLING BRUSHES, ELECTRIC CURLERS (U.S. CLS. 21, 23, 26, 36 AND 38).

CLASS 18—LEATHER GOODS

FOR ANIMAL SKINS, HIDES, TRUNKS AND TRAVELING BAGS, UMBRELLAS, PARASOLS AND WALKING STICKS, WHIPS, HARNESS AND SADDLERY, ALL PURPOSE SPORTS BAGS, WALLETS, BUSINESS CASES, LUGGAGE, POUCHES OF LEATHER, BACKPACKS, GARMENT BAGS FOR TRAVEL, MESH SHOPPING BAGS, CANES, CARD CASES FOR HOLDING NAME CARDS, BUSINESS CARDS, CREDIT CARDS; COLLARS FOR ANIMALS OR PETS, KEY CASES, VANITY CASES SOLD EMPTY, SCHOOL SATCHELS, SUITCASE HANDLES, SUITCASES, TRAVELING SETS COMPRISED OF COORDINATED LUGGAGE PIECES; TRAVELING TRUNKS, UMBRELLA COVERS, UMBRELLA HANDLES, WALKING STICK SEATS, LUGGAGE BELTS, BEACH BAGS, BRIEFCASES, CASES OF LEATHER, BOXES OF LEATHER FOR USE IN HOLDING HATS FOR TRAVEL, STORING GREETING CARDS, NAME CARDS, BUSINESS CARDS AND CREDIT CARDS; HANDBAGS, LEATHER STRAPS, MOUNTAINEERING STICKS, RUCKSACKS, SCHOOL BAGS, BAGS, ENVELOPES AND POUCHES OF LEATHER FOR PACKAGING; HANDBAG FRAMES; SLING BAGS FOR CARRYING INFANTS; NET BAGS FOR SHOPPING; WHEELED SHOPPING BAGS; WATCH BANDS OF LEATHER; SHAVING CASES, SOLD EMPTY (U.S. CLS. 1, 2, 3, 22 AND 41).

CLASS 21—HOUSEWARES AND GLASS

FOR BRUSHES FOR HAIR, EYE LASH AND COSMETIC USE; COMB CASES; COMBS; COMBS FOR THE HAIR; COSMETIC UTENSILS, NAMELY, SPONGES, BRUSHES, PADS; EYEBROW BRUSHES; NAIL BRUSHES; PADS FOR CLEANING PURPOSES; PERFUME SPRAYERS; PERFUME VAPORIZERS SOLD EMPTY; POWDER COMPACTS, NOT OF PRECIOUS METALS; POWDER PUFFS; SCRUBBING BRUSHES; SPONGES FOR COSMETIC PURPOSES; FACE SCRUBBING PUFF; SPONGE FOR FACE; CREAM BOXES SOLD EMPTY; FOOT-SCRUBBING BRUSHES INCORPORATING A PUMICE STONE FOR PERSONAL USE; FITTED VANITY CASES (U.S. CLS. 2, 13, 23, 29, 30, 33, 40 AND 50).

ELLEN BURNS, EXAMINING ATTORNEY

SN 77-062,701. HEALTHCARE NEWS NETWORK, LLC., CAPE CORAL, FL. FILED 12-12-2006.

HNN

THE MARK CONSISTS OF STANDARD CHARACTERS WITHOUT CLAIM TO ANY PARTICULAR FONT, STYLE, SIZE, OR COLOR.

CLASS 35—ADVERTISING AND BUSINESS

FOR PRODUCTION AND DISTRIBUTION OF TELEVISION COMMERCIALS AND PUBLIC SERVICE ANNOUNCEMENTS; POST-PRODUCTION EDITING SERVICES FOR VIDEO AND AUDIO COMMERCIALS; PRODUCTION OF ORIGINAL PUBLIC SERVICE ANNOUNCEMENTS AND COMMERCIALS; AND PROVIDING ADVERTISING, MARKETING AND PROMOTIONAL SERVICES FOR THE PHARMACEUTICAL AND MEDICAL INDUSTRY; PRODUCING AUDIO OR VIDEO INFOMERCIALS (U.S. CLS. 100, 101 AND 102).

CLASS 41—EDUCATION AND ENTERTAINMENT

FOR SPECIALTY TELEVISION AND CABLE TELEVISION PROGRAMMING TAILORED TO SPECIFIC HOSPITAL AND/OR USER; CABLE TELEVISION PROGRAMMING; ENTERTAINMENT IN THE NATURE OF TELEVISION NEWS SHOWS; ENTERTAINMENT IN THE NATURE OF ON-GOING TELEVISION PROGRAMS IN THE FIELD OF HEALTHCARE; ENTERTAINMENT, NAMELY, CONTINUING VARIETY AND NEWS SHOWS BROADCAST OVER TELEVISION; PRODUCTION OF CABLE TELEVISION PROGRAMS; TELEVISION SCHEDULING; TELEVISION SHOW PRODUCTION; NEWS REPORTING SERVICES; DISTRIBUTION OF TELEVISION PROGRAMMING TO CABLE TELEVISION SYSTEMS; PHOTOGRAPHIC AND VIDEO SERVICES, NAMELY, PHOTOGRAPHIC AND VIDEO CAPTURE; AND PRODUCTION OF ORIGINAL TELEVISION PROGRAMS AND DOCUMENTARIES (U.S. CLS. 100, 101 AND 107).

MICHAEL WEBSTER, EXAMINING ATTORNEY

SN 77-068,562. SHANGRI-LA INTERNATIONAL HOTEL MANAGEMENT LIMITED, TORTOLA, BR.VIRGIN ISLANDS, FILED 12-20-2006.

HOTEL JEN

THE MARK CONSISTS OF STANDARD CHARACTERS WITHOUT CLAIM TO ANY PARTICULAR FONT, STYLE, SIZE, OR COLOR.

OWNER OF HONG KONG REG. NO. 300783919, DATED 12-20-2006, EXPIRES 12-19-2016.

NO CLAIM IS MADE TO THE EXCLUSIVE RIGHT TO USE "HOTEL" FOR INTERNATIONAL CLASS 35 AND CLASS 43, APART FROM THE MARK AS SHOWN.

CLASS 35—ADVERTISING AND BUSINESS

FOR RETAIL FLORIST SHOPS; BUSINESS MANAGEMENT OF HOTELS AND TEMPORARY ACCOMMODATIONS; PROVISION OF BUSINESS CONSULTANCY, ADVISORY AND BUSINESS INFORMATION SERVICES FOR OTHERS IN THE FIELDS OF HOTELS, FRACTIONAL OWNERSHIP RESIDENCES, COMMERCIAL AND RETAIL PROPERTY, APARTMENTS, CONDOMINIUMS, GUEST HOUSE / ACCOMMODATION; ADVERTISING SERVICES; DISSEMINATION OF ADVERTISING MATTER; SHOP WINDOW DRESSING AND DISPLAY ARRANGEMENT SERVICES; UPDATING OF ADVERTISING MATERIAL; RENTAL OF ADVERTISING SPACE; PROFESSIONAL BUSINESS CONSULTANCY; BUSINESS RESEARCH; SALES PROMOTION SERVICES (U.S. CLS. 100, 101 AND 102).

CLASS 43—HOTEL AND RESTAURANT SERVICES

SN 77-089,861. PRADA S.P.A., MILANO, ITALY, FILED 1-24-2007.

FOR HOTELS, NAMELY, PROVIDING TEMPORARY ACCOMMODATIONS; HOTEL ACCOMMODATION RESERVATIONS FOR OTHERS; RESTAURANT AND CATERING SERVICES; PROVIDING FACILITIES FOR CONFERENCES AND EXHIBITS; PROVIDING ADVICE TO TOURISTS AND BUSINESS TRAVELERS ON THE BOOKING OF TEMPORARY ACCOMMODATIONS; TRAVEL AGENCY SERVICES FOR THE BOOKING OF TEMPORARY ACCOMMODATIONS; PROVISION OF FOOD AND BEVERAGES SERVICES, NAMELY, SERVING OF FOODS AND BEVERAGES; PREPARATION OF FOOD AND DRINK, SELF-SERVICE AND FAST FOOD RESTAURANT SERVICES; PROVIDING INFORMATION RELATING TO HOTEL SERVICES ON-LINE FROM A COMPUTER DATABASE OR VIA THE INTERNET OR EXTRANETS (U.S. CLS. 100 AND 101).

CLASS 44—MEDICAL, BEAUTY AND AGRICULTURAL SERVICES

FOR HEALTH AND BEAUTY SPA SERVICES, NAMELY, PROVISION OF SAUNA, SOLARIUM AND SUN DECK FACILITIES, PEDICURE AND MANICURE SERVICES, SKIN CARE TREATMENT SERVICES, MASSAGE SERVICES; FLOWER ARRANGING SERVICES; BEAUTY SALON SERVICES, HAIRDRESSING SERVICES; HEALTH CARE SERVICES, NAMELY, DIETARY, NUTRITIONAL, WEIGHT LOSS, WEIGHT GAIN AND WEIGHT CONTROL AND WELLNESS COUNSELING AND ADVISORY SERVICES (U.S. CLS. 100 AND 101).

JESSICA FATHY, EXAMINING ATTORNEY

GIORGIO MORETTO

SN 77-085,283. STONES THROW RECORDS, LLC, LOS ANGELES, CA. FILED 1-18-2007.



THE MARK CONSISTS OF A CIRCULAR RECORD IN THE BACKGROUND WITH THE NAME "STONES THROW" ON TOP OF THE RECORD.

CLASS 9—ELECTRICAL AND SCIENTIFIC APPARATUS

FOR MUSICAL SOUND RECORDINGS; DOWNLOADABLE MUSICAL SOUND RECORDINGS; MUSICAL VIDEO RECORDINGS (U.S. CLS. 21, 23, 26, 36 AND 38).
FIRST USE 4-1-1996; IN COMMERCE 4-1-1996.

CLASS 25—CLOTHING

FOR CLOTHING, NAMELY, SHIRTS, HATS AND SWEATSHIRTS (U.S. CLS. 22 AND 39).
FIRST USE 4-1-1996; IN COMMERCE 4-1-1996.
LINDSEY RUBIN, EXAMINING ATTORNEY

THE MARK CONSISTS OF STANDARD CHARACTERS WITHOUT CLAIM TO ANY PARTICULAR FONT, STYLE, SIZE, OR COLOR.

OWNER OF ERPN CMNTY TM OFC REG. NO. 758722, DATED 8-16-1999, EXPIRES 2-24-2018.

OWNER OF U.S. REG. NO. 1,422,851.

THE NAME "GIORGIO MORETTO" IDENTIFIES A LIVING INDIVIDUAL WHOSE CONSENT IS OF RECORD.

CLASS 18—LEATHER GOODS

FOR BAGS, NAMELY, HANDBAGS, TOTE BAGS, LUGGAGE, SUITCASES, AND BRIEFCASES (U.S. CLS. 1, 2, 3, 22 AND 41).

CLASS 25—CLOTHING

FOR COATS, JACKETS, ALL-WEATHER-COATS, SHIRTS, SWEATERS, WAISTCOATS, SKIRTS, TROUSERS, BATHING SUITS, BATH GOWNS, SHAWLS, FOULARDS, TIES, BELTS, BOOTS, SHOES, SLIPPERS, GLOVES, HATS, UNDERWEAR, DRESSING GOWNS, SCARVES (U.S. CLS. 22 AND 39).

CURTIS FRENCH, EXAMINING ATTORNEY

SN 77-123,510. KABUSHIKI KAISHA HITACHI SEISAKUSHO, DBA HITACHI, LTD., TOKYO, JAPAN, FILED 3-6-2007.

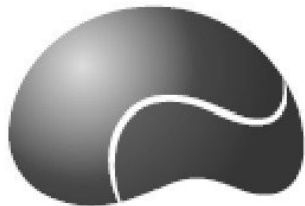

CLASS 9—ELECTRICAL AND SCIENTIFIC APPARATUS

FOR OPTICAL TOPOGRAPHY APPARATUS FOR NON-MEDICAL DIAGNOSIS AND RESEARCH PURPOSES, OPTICAL APPARATUS AND INSTRUMENTS, NAMELY, OPTICAL LENSES, SPECTACLES, TELESCOPES, MICROSCOPES, COLOR FILTERS FOR TELEVISION AND MOTION PICTURE FILM CAMERAS, MEASURING APPARATUS AND INSTRUMENTS, NAMELY, BALANCES AND SCALES, THERMOMETERS NOT FOR MEDICAL PURPOSES, GAS METERS, WATER METERS, SPEEDOMETERS, PRESSURE METERS, PHOTOMETERS, LUMINOFLEX METERS, HYGROMETERS, CALORIMETERS, FLOW METERS LEVEL GAUGES, GRAVIMETERS, VISCOMETERS, CLINOMETERS, SURFACE ROUGHNESS TESTERS, FLATNESS TESTING UNITS, STRAIGHTNESS TESTING UNITS, PHYSICAL OR CHEMICAL APPARATUS FOR LABORATORY AUTOMATION AND EXPERIMENTAL PURPOSES, NAMELY, THERMOSTATS, HYGROSTATS, GLASSWARE FOR LABORATORY EXPERIMENTS, PORCELAIN WARE FOR LABORATORY EXPERIMENTS, DOWNLOADABLE COMPUTER GAMES AND COMPUTER PROGRAMS FOR USE IN CONNECTION WITH OPTICAL TOPOGRAPHY, COMPUTER GAME SOFTWARE, VIDEO GAME SOFTWARE, AND SOFTWARE FOR HAND-HELD ELECTRONIC GAMES ALL ADAPTED FOR USE WITH AN EXTERNAL DISPLAY SCREEN OR MONITOR, ELECTRONIC CIRCUITS AND CD-ROMS RECORDED WITH COMPUTER SOFTWARE GAME PROGRAMS FOR HAND-HELD GAMES WITH LIQUID CRYSTAL DISPLAYS, ARCADE GAMES ADAPTED FOR USE WITH AN EXTERNAL DISPLAY SCREEN OR MONITOR (U.S. CLS. 21, 23, 26, 36 AND 38).

CLASS 10—MEDICAL APPARATUS

FOR MEDICAL APPARATUS AND INSTRUMENTS, NAMELY, OPTICAL TOPOGRAPHY APPARATUS FOR MEDICAL DIAGNOSIS AND RESEARCH PURPOSES, MRI APPARATUS, X-RAY DIAGNOSTIC APPARATUS, MOUNTS FOR MEDICAL X-RAY NEGATIVES, X-RAY PHOTOGRAPHS FOR MEDICAL PURPOSES, ULTRASOUND DIAGNOSTIC APPARATUS, RADIOLOGICAL APPARATUS FOR MEDICAL PURPOSES, POSITRON EMISSION TOMOGRAPHY DIAGNOSTIC IMAGING APPARATUS AND COMPONENTS THEREFORE SOLD TOGETHER AS A UNIT (U.S. CLS. 26, 39 AND 44).

CLASS 30—STAPLE FOODS

FOR EXTRACTS NOT PREPARED FROM ESSENTIAL OILS USED AS FLAVORINGS AND SYRUPS FOR FOODSTUFFS, TEA, COFFEE, COCOA, ICE, SEASONINGS, FERMENTED SOYBEAN PASTE, NAMELY, MISO, WORCESTERSHIRE SAUCE, MEAT GRAVIES, KETCHUP, SOY SAUCE, VINEGAR, VINEGAR MIXES, SALAD DRESSINGS, WHITE SAUCE MADE WITH FLOUR, BUTTER, MILK AND SEASONINGS, MAYONNAISE, SAUCES FOR BARBECUED MEAT, CUBE SUGAR, SUGAR AND SUGAR SUBSTITUTES FOR FOOD, NAMELY, FRUCTOSE, MALTOSE AND GLUCOSE, CRYSTAL SUGAR THAT IS NOT CONFECTIONERY, HONEY FOR FOOD, POWDERED STARCH SYRUP FOR FOOD, STARCH SYRUP FOR FOOD, TABLE SALT MIXED WITH SESAME SEEDS, COOKING SALT ROASTED AND GROUP SESAME SEED, CELERY SALT, CHEMICAL SEASONINGS, NAMELY, GLUTAMIC ACID SOLUTION FOR FOOD PURPOSES, SPICES, ICE CREAM MIXES, SHERBET MIXES, UNPROCESSED UNROASTED COFFEE (U.S. CL. 46).

CLASS 32—LIGHT BEVERAGES

FOR BEER, NON-ALCOHOLIC CARBONATED BEVERAGES, NON-ALCOHOLIC FRUIT JUICE BEVERAGES, EXTRACTS OF HOPS FOR MAKING BEER, WHEY BEVERAGES, VEGETABLE JUICES THAT ARE BEVERAGES, SYRUPS FOR MAKING BEVERAGES (U.S. CLS. 45, 46 AND 48).

CLASS 41—EDUCATION AND ENTERTAINMENT

FOR PROVIDING ON-LINE, NON-DOWNLOADABLE COMPUTER GAMES (U.S. CLS. 100, 101 AND 107).

CLASS 42—SCIENTIFIC AND COMPUTER SERVICES

FOR RENTAL OF OPTICAL TOPOGRAPHY SYSTEM FOR RESEARCH OR LABORATORY PURPOSES; RENTAL OF OPTICAL APPARATUS AND INSTRUMENTS FOR RESEARCH OR LABORATORY PURPOSES; RENTAL OF MEASURING OR TESTING MACHINES AND INSTRUMENTS, RENTAL OF LABORATORY APPARATUS AND INSTRUMENTS, RENTAL OF COMPUTERS, PROVIDING ON-LINE, NON-DOWNLOADABLE SOFTWARE FOR USE IN CONNECTION WITH OPTICAL TOPOGRAPHY, TESTING, INSPECTION OR RESEARCH OF PHARMACEUTICALS, COSMETICS OR FOODSTUFF (U.S. CLS. 100 AND 101).

JACQUELINE A. LAVINE, EXAMINING ATTORNEY

SN 77-131,857. METALFRIO SOLUTIONS LTDA., SÃO PAULO, BRAZIL, FILED 3-15-2007.



THE MARK CONSISTS OF A SNOW FLAKE WITH THE WORDING "METALFRIO".

CLASS 11—ENVIRONMENTAL CONTROL APPARATUS

FOR BEVERAGE REFRIGERATION AND DISPENSING MACHINES, ICE CREAM FREEZERS, ICE MAKERS AND ICE DISPENSING MACHINES, FREEZERS AND WINE COOLERS, NAMELY, REFRIGERATED CABINETS CONTAINING RACKS AND STORAGE SHELVES FOR WINE BOTTLES (U.S. CLS. 13, 21, 23, 31 AND 34).

CLASS 37—CONSTRUCTION AND REPAIR

FOR INSTALLATION AND REPAIR OF BEVERAGE REFRIGERATION AND DISPENSING MACHINES, ICE CREAM FREEZERS, ICE MAKERS AND ICE DISPENSING MACHINES, FREEZERS AND WINE COOLERS IN THE NATURE OF REFRIGERATED CABINETS (U.S. CLS. 100, 103 AND 106).

RAMONA ORTIGA, EXAMINING ATTORNEY

SN 77-131,859. METALFRIO SOLUTIONS LTDA., SÃO PAULO, BRAZIL, FILED 3-15-2007.



THE MARK CONSISTS OF A SNOW FLAKE WITH THE WORDING "METALFRIO", A VERTICAL LINE AND THE WORD "SOLUTIONS".

CLASS 11—ENVIRONMENTAL CONTROL APPARATUS

FOR BEVERAGE REFRIGERATION AND DISPENSING MACHINES, ICE CREAM FREEZERS, ICE MAKERS AND ICE DISPENSING MACHINES, FREEZERS AND WINE COOLERS, NAMELY, REFRIGERATED CABINETS CONTAINING RACKS AND STORAGE SHELVES FOR WINE BOTTLES (U.S. CLS. 13, 21, 23, 31 AND 34).

CLASS 37—CONSTRUCTION AND REPAIR

FOR INSTALLATION AND REPAIR OF BEVERAGE REFRIGERATION AND DISPENSING MACHINES, ICE CREAM FREEZERS, ICE MAKERS AND ICE DISPENSING MACHINES, FREEZERS AND WINE COOLERS IN THE NATURE OF REFRIGERATED CABINETS (U.S. CLS. 100, 103 AND 106).

RAMONA ORTIGA, EXAMINING ATTORNEY

SN 77-147,725. FORENSIC SCIENCE SERVICE LTD, SOLIHULL, UNITED KINGDOM, FILED 4-3-2007.

DNAbost

THE MARK CONSISTS OF STANDARD CHARACTERS WITHOUT CLAIM TO ANY PARTICULAR FONT, STYLE, SIZE, OR COLOR.

PRIORITY CLAIMED UNDER SEC. 44(D) ON UNITED KINGDOM APPLICATION NO. 2434369, FILED 10-3-2006, REG. NO. 2434369, DATED 10-12-2007, EXPIRES 10-3-2016.

CLASS 9—ELECTRICAL AND SCIENTIFIC APPARATUS

FOR COMPUTER SOFTWARE FOR ENTERING, COLLECTING, TRANSMITTING, PROCESSING, ANALYZING, INTERPRETATION AND PRESENTING DATA, INFORMATION, EVIDENCE, IMAGES AND DNA PROFILES IN THE FIELD OF FORENSIC SCIENCE; SCIENTIFIC, ELECTRONIC AND ELECTRICAL APPARATUS AND INSTRUMENTS, NAMELY, AMPLIFIERS, SEPARATORS AND SEQUENCERS FOR DNA, COMPUTER HARDWARE, COMPUTER PRINTERS, AND PORTABLE DATA STORAGE DEVICES, NAMELY, MAGNETIC DATA CARRIERS, MAGNETIC COMPUTER TAPES FOR STORAGE OF COMPUTER DATA, DIGITAL DATA MEDIA, NAMELY, DIGITAL AUDIO TAPES, CD-ROMS AND FLASH MEMORY CARDS, ALL PRE-RECORDED WITH COMPUTER SOFTWARE AND INFORMATION FOR USE IN THE FIELD OF FORENSIC SCIENTIFIC INTELLIGENCE AND CORROBORATION FOR THE SCIENTIFIC INVESTIGATION SERVICES AND TOXICOLOGY SERVICES, USED FOR ENTERING, COLLECTING, TRANSMITTING, PROCESSING, ANALYZING, INTERPRETING AND PRESENTING DATA, INFORMATION, EVIDENCE, IMAGES AND DNA IN THE FIELD OF FORENSIC SCIENCE; AND PRE-RECORDED VIDEOS AND CD-ROMS FEATURING INFORMATION IN THE FIELD OF FORENSIC SCIENCE (U.S. CLS. 21, 23, 26, 36 AND 38).

CLASS 37—CONSTRUCTION AND REPAIR

FOR MAINTENANCE AND UPDATING OF COMPUTERS, COMPUTER HARDWARE, AND COMPUTER PERIPHERALS FOR POLICE FORCES, LAW ENFORCEMENT AGENCIES, INSURANCE AGENCIES, FORENSIC INVESTIGATORS, AND LABORATORIES OR RELATING TO FORENSIC SCIENCE SERVICES, LEGAL SERVICES AND ANALYTICAL SERVICES (U.S. CLS. 100, 103 AND 106).

CLASS 42—SCIENTIFIC AND COMPUTER SERVICES

FOR INVESTIGATION, SAMPLING, EXAMINATION, ANALYSIS AND EVALUATION OF BODY FLUIDS, BLOOD, SEMEN, BUCCAL SWABS, CRIME STAINS, PAINT, EXPLOSIVES, DRUGS, DNA, DNA PROFILE RESULTS, FINGERPRINTS, HAIR, FIBRES, CLOTHING, FOOTWEAR, GRAPHS, TACHOGRAPHS, PARTICULATE DEBRIS, DOCUMENTS, LETTERS, STATISTICS, HANDWRITING, FOOTPRINTS, TOOL MARKS, WEAPONS, FIREARMS, AMMUNITION, DISCHARGE RESIDUES, FIRE SCENES, THEFT SCENES AND VIDEOS, PRODUCT COUNTERFEITING, PRODUCT ADULTERATION, PRODUCT CONTAMINATION, ALL FOR THE PURPOSE OF FORENSIC SCIENTIFIC INTELLIGENCE AND CORROBORATION; FORENSIC TOXICOLOGY, NAMELY, SCREENING FOR DRUGS AND ALCOHOL; DETECTION OF FRAUD, ARSON, FIRES, MALICIOUS DAMAGE AND COUNTERFEITING, ALL FOR THE PURPOSE OF FORENSIC SCIENTIFIC INTELLIGENCE AND CORROBORATION; SCIENTIFIC SERVICES RELATING TO VIDEO FORMAT CONVERSION, VIDEO ENHANCEMENT, VIDEO TAPE REPAIR, NAMELY, FORENSIC VIDEO ANALYSIS; CONFIRMATION AND EVALUATION OF IDENTITY, PATERNITY, MATERNITY; COMPUTER DATABASE SERVICES, NAMELY, FORENSIC BIOLOGY; FORENSIC SCIENCE SERVICES, NAMELY, SCIENTIFIC INVESTIGATION SERVICES, TOXICOLOGY SERVICES, FORENSIC EXAMINATION OF COMPUTERS, COMPUTER SOFTWARE AND COMPUTER RECORDS, FORENSIC INVESTIGATION OF COMPUTER CRIME; DESIGN AND CREATION OF TELECOMMUNICATIONS SUPPORT FACILITIES, INTERNET SITES, WORLD WIDE WEB SITES, ELECTRONIC LINK FACILITIES, ON-LINE ACCESS FACILITIES, E-COMMERCE NETWORKS, WEB LINKS, FOR OTHERS, PARTICULARLY FOR POLICE FORCES, LAW ENFORCEMENT AGENCIES, INSURANCE AGENCIES, FORENSIC INVESTIGATORS, LABORATORIES; COMPUTER SERVICES, NAMELY, COMPUTER PROGRAMMING, MAINTENANCE, DESIGN, AND UPDATING OF COMPUTER SOFTWARE, COMPUTER LINKS AND DATABASES, AND COMPUTER SYSTEM DESIGN, ALL FOR OTHERS, PARTICULARLY FOR POLICE FORCES, LAW ENFORCEMENT AGENCIES, INSUR-

ANCE AGENCIES, FORENSIC INVESTIGATORS AND LABORATORIES; SCIENTIFIC INVESTIGATION SERVICES, NAMELY, FORENSIC SCIENCE; SCIENTIFIC, MEASURING, CHECKING AND MONITORING SERVICES, NAMELY, ACCESSING, READING, COPYING AND ANALYZING DATA FROM INSTRUMENTS FOR USE IN FORENSIC SCIENCE INVESTIGATIONS, NAMELY, MOBILE PHONES, PERSONAL DIGITAL ASSISTANCE AND PORTABLE DATA STORAGE DEVICES; CONSULTING SERVICES IN THE FIELD OF FORENSIC SCIENCE (U.S. CLS. 100 AND 101).
JIM RINGLE, EXAMINING ATTORNEY

SN 77-158,183. T-SOLAR GLOBAL, S.A., VIGO (PONTEVEDRA), SPAIN, FILED 4-17-2007.



PRIORITY CLAIMED UNDER SEC. 44(D) ON ERP CMNTY TM OFC APPLICATION NO. 005825617, FILED 4-12-2007, REG. NO. 005825617, DATED 12-16-2008, EXPIRES 4-12-2017.

THE COLOR(S) ORANGE AND RED IS/ARE CLAIMED AS A FEATURE OF THE MARK.

THE MARK CONSISTS OF THE WORD "T SOLAR" WITH A RAISED PERIOD BETWEEN THE LETTERS "T" AND "S", A FANCIFUL LETTER "O" WITH ONLY THE TOP PORTION SHOWN, AND A CURVED LINE BENEATH THE WORDS, ALL IN ORANGE. THE LETTERS "T" AND "S" AND "LAR" ALL ARE IN RED.

SN 77-155,101. NYC & COMPANY, INC., NEW YORK, NY. FILED 4-12-2007.

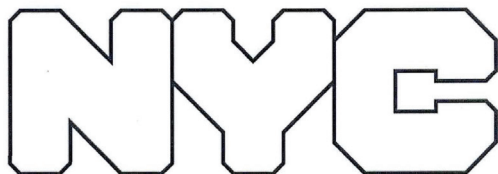

CLASS 7—MACHINERY

FOR ELECTRICAL GENERATORS, INCLUDING WIND-POWERED ELECTRIC GENERATORS (U.S. CLS. 13, 19, 21, 23, 31, 34 AND 35).

CLASS 11—ENVIRONMENTAL CONTROL APPARATUS

FOR PHOTOVOLTAICS SOLAR HEAT COLLECTION PANELS (U.S. CLS. 13, 21, 23, 31 AND 34).
CHRISIE B. KING, EXAMINING ATTORNEY

SN 77-179,157. KYOWA HAKKO KIRIN CO., LTD., CHIYODA-KU, TOKYO, JAPAN, FILED 5-11-2007.

OWNER OF U.S. REG. NOS. 2,510,974, 3,574,986 AND OTHERS.
THE MARK CONSISTS OF STYLIZED "NYC" DESIGN.
SEC. 2(F).

COMPLEGENT

CLASS 35—ADVERTISING AND BUSINESS

FOR PROMOTING BUSINESS AND TOURISM IN THE NEW YORK METROPOLITAN AREA, NAMELY, PROMOTING THE SERVICES OF OTHERS IN THE FIELDS OF TOURISM, CONVENTIONS, RESTAURANTS, RETAIL STORES, CULTURAL ACTIVITIES, BUSINESS AND BUSINESS INVESTMENT IN NEW YORK CITY THROUGH THE DISTRIBUTION OF PRINTED, VIDEO, ONLINE, AND AUDIO PROMOTIONAL MATERIALS, PRESS RELEASES, PRESS CONFERENCES, AND THE RENDERING OF SALES PROMOTION ADVICE; PROVIDING PROMOTION OF SPECIAL EVENTS (U.S. CLS. 100, 101 AND 102).
FIRST USE 4-0-2007; IN COMMERCE 4-0-2007.

CLASS 41—EDUCATION AND ENTERTAINMENT

FOR ENTERTAINMENT, NAMELY, PRODUCTION AND PRESENTATION OF EVENTS IN THE NATURE OF LIVE SHOW PERFORMANCES, LIVE MUSIC CONCERTS, LIVE MUSICAL PERFORMANCES AND CULTURAL EVENTS (U.S. CLS. 100, 101 AND 107).
FIRST USE 4-0-2007; IN COMMERCE 4-0-2007.
DAVID COLLIER, EXAMINING ATTORNEY

THE MARK CONSISTS OF STANDARD CHARACTERS WITHOUT CLAIM TO ANY PARTICULAR FONT, STYLE, SIZE, OR COLOR.

PRIORITY CLAIMED UNDER SEC. 44(D) ON JAPAN APPLICATION NO. 2007041645, FILED 4-25-2007, REG. NO. 5184022, DATED 11-28-2008, EXPIRES 11-28-2018.

CLASS 5—PHARMACEUTICALS

FOR HOST CELLS FOR MEDICAL OR CLINICAL USE; CELLS THAT MANUFACTURE ANTIBODIES, FRAGMENTS OF ANTIBODIES OR DERIVATIVES OF ANTIBODIES FOR MEDICAL OR CLINICAL USE; TRANSFECTED CELLS THAT MANUFACTURE ANTIBODIES, FRAGMENTS OF ANTIBODIES OR DERIVATIVES OF ANTIBODIES FOR MEDICAL OR CLINICAL USE; PHARMACEUTICALS, NAMELY, CENTRAL NERVOUS SYSTEM DEPRESSANTS, PREPARATIONS FOR OPHTHALMIC USE, ANTI-HISTAMINICS, CARDIOTONICS, ARRHYTHMIA TREATING AGENTS, DIURETICS, HYPOTENSORS, PROPHYLACTIC FOR THE TREATMENT OF ASTHMA, ANTITUSSIVES AND EXPECTORANTS, STOMACHICS AND DIGESTIVES, ANTACIDS, HORMONES, NAMELY, PITUITARY HORMONES FOR THE TREATMENT OF INFERTILITY, THYROID HORMONES FOR THE TREATMENT OF HYPERTHYROIDISM, ANABOLIC HORMONES FOR

THE TREATMENT OF APLASTIC ANEMIA AND OSTEOPOROSIS, CORTICOSTEROIDS FOR TREATMENT OF HYPOPITUITARISM, CONGENITAL ADRENAL HYPERPLASIA, RHEUMATOID ARTHRITIS, RHEUMATIC FEVER, CROHN'S DISEASE, AND CHRONIC ACTIVE HEPATITIS, ESTROGEN AND PROGESTERONE USED AS COMBINED ORAL CONTRACEPTIVES, URINARY ANTISEPTICS, ANALGESICS, ANTI-ITCHING AGENTS, CATAPLASMS FOR THE TREATMENT OF BRUISES, LUMBAGO AND STIFF SHOULDER, PHARMACEUTICAL PREPARATIONS USED TO TREAT HAIR DISORDERS, VITAMIN PREPARATIONS, FOOD ENRICHING AGENTS FOR TREATING VITAMIN DEFICIENCIES, ANTI-COAGULANTS, ENZYME PREPARATIONS FOR CONTROL OF MALABSORPTION AND DIARRHEA, ANTI-CANCER PREPARATIONS, ANTI-SARCOMA PREPARATIONS, ANTIBIOTICS AND THEIR PREPARATIONS FOR THE TREATMENT OF INFECTIOUS DISEASES, ANTITUBERCULOTIC AGENTS, INFLUENZA VACCINES, DIPHTHERIA VACCINES, TETANUS VACCINES, GAS GANGRENE VACCINES, JAPANESE ENCEPHALITIS VACCINES, IN VITRO TETRODOTOXINS FOR MEDICAL USE, ANTIPROTOZOALS FOR THE TREATMENT OF TRICHOMONIASIS AND DERMATOPHYTOSIS, ANTHELMINTICS FOR THE TREATMENT OF THREADWORM AND TOXOPLASMAOSIS, NATURALLY OCCURRING DRUGS FOR TREATING PEPTIC ULCERS, CHARRED DRUGS FOR TREATING PEPTIC ULCERS, MOXA FOR TREATING PEPTIC ULCERS, VETERINARY DRUGS FOR THE TREATMENT OF DISTEMPER IN DOGS, DISTOMATOSIS IN DOGS, COCCIDIAN IN CHICKENS, AND DYSENTERY IN PIGS, GERMINATION CONTROLLERS AND PLANT REARING AGENTS, NAMELY, HERBICIDES, FUNGICIDES, INSECTICIDES, BACTERICIDES AND RODENTICIDES FOR DOMESTIC AND OR AGRICULTURAL USE, ANTISEPTICS, DRUGS FOR ARTERIOSCLEROSIS, ONCOSTATIC DRUGS FOR THE TREATMENT FOR CANCER, MULTIENZYME DIGESTANTS FOR IN VIVO USE, ANTIFUNGAL ANTIBIOTICS FOR TREATING TRICHOMONIASIS AND DERMATOPHYTOSIS, ANTI PARKINSONISM DRUGS, MINOR TRANQUILIZERS, AND ANTI ANXIETY AGENTS, MEDICINAL PREPARATIONS FOR THE TREATMENT OF THE CENTRAL NERVOUS SYSTEM, THE RESPIRATORY TRACT AND THE CARDIOVASCULAR SYSTEM, ANTI-BACTERIAL PREPARATIONS, MONOLITHIC PREPARATIONS, MEDICINAL PREPARATIONS FOR THE TREATMENT OF PEPTIC ULCERS, ANTI-INFLAMMATORY PREPARATIONS, ANALGESIC PREPARATIONS, CEPHALOSPORIN, COCARBOXYLASE PREPARATIONS, GLUTATHIONE PREPARATIONS, PREPARATIONS FOR IMPROVING THE METABOLISM AND THE PERIPHERAL CIRCULATION, PLASMA SUBSTITUTES AND EXTRACORPOREAL CIRCULATION FLOW IMPROVEMENT PREPARATIONS, DIURETIC AND ANTI-HYPERTENSIVE PREPARATIONS, IN VITRO DIAGNOSTIC REAGENTS FOR MEDICAL USE, IN VITRO EXTRA CORPOREAL DIAGNOSTIC REAGENTS FOR MEDICAL USE, IN VITRO X-RAY CONTRAST AGENTS FOR MEDICAL USE, IN VITRO DIAGNOSTIC MEDIA, PHARMACEUTICAL PREPARATIONS FOR THE TREATMENT OF INSOMNIA AND OTHER SLEEP RELATED DISEASES (U.S. CLS. 6, 18, 44, 46, 51 AND 52).

CLASS 40—MATERIAL TREATMENT

FOR CONTRACT MANUFACTURING SERVICE IN THE FIELD OF ANTIBODIES, FRAGMENTS OF ANTIBODIES, AND DERIVATIVES OF ANTIBODIES; CONTRACT MANUFACTURING SERVICE IN THE FIELD OF CELLS THAT MANUFACTURE ANTIBODIES, FRAGMENTS OF ANTIBODIES, AND DERIVATIVES OF ANTIBODIES; CONTRACT MANUFACTURING SERVICE IN THE FIELD OF TRANSFECTED CELLS THAT MANUFACTURE ANTIBODIES, FRAGMENTS OF ANTIBODIES, AND DERIVATIVES OF ANTIBODIES; CONTRACT MANUFACTURING SERVICE IN THE FIELD OF HOST CELLS; CONTRACT EXTRACTING, REFINING, SYNTHESIZING, MANUFACTURING AND PREPARING PHARMACEUTICALS, AGRICULTURAL CHEMICALS, AND CHEMICALS; PROVIDING INFORMATION IN THE FIELD OF MANUFACTURING TECHNOLOGY IN THE FIELD OF ANTIBODIES, FRAGMENTS OF ANTIBODIES, AND DERIVATIVES OF ANTIBODIES; TECHNICAL CONSULTATION IN THE FIELD OF MANUFACTURING TECHNOLOGY IN THE FIELD OF ANTIBODIES, FRAGMENTS OF ANTI-

BODIES, AND DERIVATIVES OF ANTIBODIES; PROVIDING INFORMATION IN THE FIELD OF MANUFACTURING TECHNOLOGY IN THE FIELD OF CELLS THAT MANUFACTURE ANTIBODIES, FRAGMENTS OF ANTIBODIES, AND DERIVATIVES OF ANTIBODIES; TECHNICAL CONSULTATION IN THE FIELD OF MANUFACTURING TECHNOLOGY IN THE FIELD OF CELLS THAT MANUFACTURE ANTIBODIES, FRAGMENTS OF ANTIBODIES, AND DERIVATIVES OF ANTIBODIES; PROVIDING INFORMATION IN THE FIELD OF MANUFACTURING TECHNOLOGY IN THE FIELD OF TRANSFECTED CELLS THAT MANUFACTURE ANTIBODIES, FRAGMENTS OF ANTIBODIES, AND DERIVATIVES OF ANTIBODIES; TECHNICAL CONSULTATION IN THE FIELD OF MANUFACTURING TECHNOLOGY IN THE FIELD OF TRANSFECTED CELLS THAT MANUFACTURE ANTIBODIES, FRAGMENTS OF ANTIBODIES, AND DERIVATIVES OF ANTIBODIES; PROVIDING INFORMATION IN THE FIELD OF MANUFACTURING TECHNOLOGY IN THE FIELD OF HOST CELLS; TECHNICAL CONSULTATION IN THE FIELD OF MANUFACTURING TECHNOLOGY IN THE FIELD OF EXTRACTING, REFINING, SYNTHESIZING, MANUFACTURING AND PREPARING PHARMACEUTICALS, AGRICULTURAL CHEMICALS, AND CHEMICALS TECHNICAL CONSULTATION IN THE FIELD OF EXTRACTING, REFINING, SYNTHESIZING, MANUFACTURING AND PREPARING PHARMACEUTICALS, AGRICULTURAL CHEMICALS, AND CHEMICALS (U.S. CLS. 100, 103 AND 106).

CLASS 42—SCIENTIFIC AND COMPUTER SERVICES

FOR DEVELOPMENT OF NEW PRODUCTS FOR OTHERS IN THE FIELD OF ANTIBODIES, FRAGMENTS OF ANTIBODIES, DERIVATIVES OF ANTIBODIES, CELLS THAT MANUFACTURE ANTIBODIES, FRAGMENTS OF ANTIBODIES, AND DERIVATIVES OF ANTIBODIES, TRANSFECTED CELLS THAT MANUFACTURE ANTIBODIES, FRAGMENTS OF ANTIBODIES, AND DERIVATIVES OF ANTIBODIES, AND HOST CELLS; PROVIDING TECHNICAL INFORMATION IN THE FIELD OF DEVELOPMENT OF NEW PRODUCTS IN THE FIELD OF ANTIBODIES, FRAGMENTS OF ANTIBODIES, DERIVATIVES OF ANTIBODIES, CELLS THAT MANUFACTURE ANTIBODIES, FRAGMENTS OF ANTIBODIES, AND DERIVATIVES OF ANTIBODIES, TRANSFECTED CELLS THAT MANUFACTURE ANTIBODIES, FRAGMENTS OF ANTIBODIES, AND DERIVATIVES OF ANTIBODIES, AND HOST CELLS; TECHNICAL CONSULTATION IN THE FIELD OF DEVELOPMENT OF NEW PRODUCTS IN THE FIELD OF ANTIBODIES, FRAGMENTS OF ANTIBODIES, DERIVATIVES OF ANTIBODIES, CELLS THAT MANUFACTURE ANTIBODIES, FRAGMENTS OF ANTIBODIES, AND DERIVATIVES OF ANTIBODIES, TRANSFECTED CELLS THAT MANUFACTURE ANTIBODIES, FRAGMENTS OF ANTIBODIES, AND DERIVATIVES OF ANTIBODIES, AND HOST CELLS (U.S. CLS. 100 AND 101).

PAUL E. FAHRENKOPF, EXAMINING ATTORNEY

SN 77-182,932. NEXON PUBLISHING NORTH AMERICA INC., BRITISH COLUMBIA, VANCOUVER, CANADA, FILED 5-16-2007.

MOTO LOCO

THE MARK CONSISTS OF STANDARD CHARACTERS WITHOUT CLAIM TO ANY PARTICULAR FONT, STYLE, SIZE, OR COLOR.

PRIORITY CLAIMED UNDER SEC. 44(D) ON CANADA APPLICATION NO. 1346529, FILED 5-8-2007, REG. NO. TMA712220, DATED 4-17-2008, EXPIRES 4-17-2023.

CLASS 9—ELECTRICAL AND SCIENTIFIC APPARATUS

FOR VIDEO GAME SOFTWARE FOR PLAY ON PERSONAL COMPUTERS; COMPUTER PROGRAMS FOR PRE-RECORDED VIDEO GAMES; PRE-RECORDED COMPACT DISCS CONTAINING VIDEO GAME AND COMPUTER GAME SOFTWARE AND AUDIO CONTENT RELATING TO COMPUTER GAMES AND VIDEO GAMES; ELECTRONIC AMUSEMENT APPARATUS, NAMELY, ELECTRONIC GAME MACHINES FOR PLAYING VIDEO GAMES, VIDEO GAME CARTRIDGES, VIDEO GAME MACHINES FOR USE WITH AN EXTERNAL DISPLAY SCREEN OR MONITOR, AND PARTS THEREFORE, NAMELY, CONTROLLERS FOR CONTROLLING THE LOCATION OF ELEMENTS OF A VIDEO GAME DISPLAY, AND INTERACTIVE TOY ROBOTS AND TOY LIGHT GUNS SOLD ONLY AS COMPONENTS OF THE VIDEO GAMES; COMPUTER MOUSE PADS; REFRIGERATOR MAGNETS (U.S. CLS. 21, 23, 26, 36 AND 38).

CLASS 16—PAPER GOODS AND PRINTED MATTER

FOR STATIONERY, NAMELY, WRITING PAPER AND ENVELOPES; PENS AND PENCILS; AND POSTERS (U.S. CLS. 2, 5, 22, 23, 29, 37, 38 AND 50).

CLASS 21—HOUSEWARES AND GLASS

FOR SOUVENIR CUPS, DRINKING GLASSES, AND PLASTIC COASTERS (U.S. CLS. 2, 13, 23, 29, 30, 33, 40 AND 50).

CLASS 25—CLOTHING

FOR CLOTHING, NAMELY, HATS, T-SHIRTS (U.S. CLS. 22 AND 39).

CLASS 28—TOYS AND SPORTING GOODS

FOR HAND-HELD UNIT FOR PLAYING VIDEO GAMES; CARD GAMES, TOYS, NAMELY, HAND-HELD ELECTRONIC TOYS; NON-ELECTRONIC BOARD GAMES; NON-ELECTRONIC HAND-HELD GAMES (U.S. CLS. 22, 23, 38 AND 50).

CLASS 38—COMMUNICATION

FOR PROVIDING ON-LINE CHAT ROOMS FOR TRANSMISSION OF MESSAGES AMONG COMPUTER USERS CONCERNING TOPICS OF COMPUTER GAMING EQUIPMENT; AND PROVIDING ON-LINE ELECTRONIC BULLETIN BOARDS FOR TRANSMISSION OF MESSAGES AMONG COMPUTER USERS CONCERNING TOPICS OF COMPUTER GAMING ENTERTAINMENT (U.S. CLS. 100, 101 AND 104).

CLASS 41—EDUCATION AND ENTERTAINMENT

FOR ENTERTAINMENT SERVICES, NAMELY, PROVIDING AN ON-LINE COMPUTER GAME; PROVIDING ON-LINE INFORMATION IN THE FIELD OF COMPUTER GAMING ENTERTAINMENT (U.S. CLS. 100, 101 AND 107).

TINA L. SNAPP, EXAMINING ATTORNEY

SN 77-185,833. SELECT EMPORIUM LIMITED (A BRITISH CORPORATION), BIRMINGHAM, ENGLAND, FILED 5-21-2007.

DEMAND

THE MARK CONSISTS OF STANDARD CHARACTERS WITHOUT CLAIM TO ANY PARTICULAR FONT, STYLE, SIZE, OR COLOR.

CLASS 3—COSMETICS AND CLEANING PREPARATIONS

FOR COSMETICS AND PERFUMERY (U.S. CLS. 1, 4, 6, 50, 51 AND 52).

CLASS 9—ELECTRICAL AND SCIENTIFIC APPARATUS

FOR SUNGLASSES (U.S. CLS. 21, 23, 26, 36 AND 38).

CLASS 18—LEATHER GOODS

FOR HANDBAGS, LADIES HANDBAGS, SCHOOL BAGS (U.S. CLS. 1, 2, 3, 22 AND 41).

CLASS 25—CLOTHING

FOR CLOTHING, NAMELY, GLOVES, COATS, DRESSES, SOCKS, GOWNS, SCARVES, SWEAT BAND, JACKETS, SUITS, HOODED SWEATSHIRTS AND HOODED PULLOVERS, SHAWLS, SKIRTS, JUMPERS, SWEATERS, SWIMWEAR, T-SHIRTS, VESTS, TROUSERS, SHORTS, KNICKERS, PAJAMAS, TIES, JEANS, TRACKSUITS, WAISTCOATS, BRAS AND NIGHT-SHIRTS; HEADGEAR, NAMELY, CAPS, HATS AND BEANIE CAPS; AND, FOOTWEAR, NAMELY, LACE-UP BOOTS, SANDALS, TRAINERS, SHOES, SLIPPERS, PULL-ON BOOTS, FLIP-FLOPS (U.S. CLS. 22 AND 39).

RUDY R. SINGLETON, EXAMINING ATTORNEY

SN 77-195,788. GENERAL DYNAMICS INFORMATION TECHNOLOGY, FAIRFAX, VA. FILED 6-1-2007.

STRONG IT

THE MARK CONSISTS OF STANDARD CHARACTERS WITHOUT CLAIM TO ANY PARTICULAR FONT, STYLE, SIZE, OR COLOR.

NO CLAIM IS MADE TO THE EXCLUSIVE RIGHT TO USE "IT", APART FROM THE MARK AS SHOWN.

CLASS 35—ADVERTISING AND BUSINESS

FOR LOGISTICS MANAGEMENT IN THE FIELD OF GOVERNMENT DEFENSE, GOVERNMENT INTELLIGENCE, AND NON-DEFENSE CIVILIAN AGENCIES TO ASSIST WITH NATIONAL SECURITY, INTELLIGENCE AND MILITARY OPERATIONS, CUSTOMS AND IMMIGRATION ENFORCEMENT, AND NATIONAL DEFENSE AND HOMELAND SECURITY; PROCUREMENT, NAMELY, PURCHASING OF COMPUTER REPLACEMENT PARTS, COMPUTER LAPTOPS, COMPUTER HARDWARE, COMPUTER SOFTWARE, COMPUTER SERVERS, RADIO-FREQUENCY IDENTIFICATION (RFID) CHIPS, HANDHELD COMPUTERS AND PERSONAL DIGITAL ASSISTANT DEVICES, COMMON ACCESS CARDS, ROUTERS, SOFTWARE UPGRADES, PATCH PANELS, WIRELESS NETWORK CARDS AND EQUIPMENT, VIDEO AND AUDIO RECORDERS, DIGITAL VERSATILE DISC ("DVD") PLAYERS AND CAMERAS FOR OTHERS; BUSINESS RECORDS MANAGEMENT, AND INVENTORY CONTROL FOR GOVERNMENT DEFENSE, INTELLIGENCE, AND NON-DEFENSE AGENCIES TO ASSIST WITH INTELLIGENCE AND MILITARY OPERATIONS, CUSTOMS AND IMMIGRATION ENFORCEMENT, AND NATIONAL DEFENSE AND HOMELAND SECURITY; COMPUTERIZED DATA MANAGEMENT AND BUSINESS PROCESS OUTSOURCING SERVICES TO ASSIST GOVERNMENT DEFENSE, INTELLIGENCE, AND NON-DEFENSE AGENCIES TO MANAGE MILITARY AND INTELLIGENCE COMMAND CENTERS, MILITARY AND INTELLIGENCE OPERATIONS; REQUISITION AND PURCHASING OPERATIONS, SERVICE DESK OPERATIONS, AND RECORDS MANAGEMENT; BUSINESS SERVICES, NAMELY, FACILITIES MANAGEMENT OF TECHNICAL OPERATIONS; BUSINESS PROCESS RE-ENGINEERING SERVICES (U.S. CLS. 100, 101 AND 102).

CLASS 41—EDUCATION AND ENTERTAINMENT

FOR PROVIDING CUSTOMIZED ON-SITE AND DISTANCE COMPUTER TRAINING AND TRAINING ASSISTANCE; COMPUTER SOFTWARE TRAINING; EDUCATIONAL SERVICES, NAMELY, CONDUCTING PROGRAMS IN THE FIELD OF PLANNING, DESIGNING, DEVELOPING AND IMPLEMENTING COMPUTER SOFTWARE AND SYSTEMS; TRAINING IN THE USE AND OPERATION OF COMPUTER SOFTWARE AND SYSTEMS (U.S. CLS. 100, 101 AND 107).

CLASS 42—SCIENTIFIC AND COMPUTER SERVICES

FOR ENGINEERING, DESIGN, INTEGRATION AND IMPLEMENTATION SERVICES, NAMELY, PLANNING, DESIGN, DEVELOPMENT AND TESTING OF SOFTWARE PROGRAMS AND INTEGRATION OF NEW TECHNOLOGIES WITH EXISTING SOFTWARE PROGRAMS FOR GOVERNMENT MILITARY AND CIVILIAN AGENCIES FOR USE IN WARGAMING AND BATTLE SIMULATION, COALITION OPERATIONS-INTELLIGENCE SYSTEMS, COUNTER TERRORISM, COMMUNICATIONS FOR BOTH TACTICAL AND NON-TACTICAL SYSTEMS, ELECTRONIC RECORDS MANAGEMENT AND STORAGE, PREPARATION OF EMERGENCY RESPONSE PLANS, FLEET MANAGEMENT, SERVICE DESK MANAGEMENT, INTEGRATION OF EXISTING SOFTWARE APPLICATIONS AND SERVER ADMINISTRATION; PROVIDING DESIGN, ENGINEERING, TESTING AND EVALUATION OF ELECTRONIC SYSTEMS FOR OTHERS; INTEGRATION AND DESIGN OF TELECOMMUNICATIONS NETWORKS, NAMELY SOFTWARE INTEGRATION AND DEVELOPMENT SERVICES; SOFTWARE TESTING AND EVALUATION SERVICES; PROVIDING INFORMATION SYSTEMS DESIGN SERVICES, NAMELY, DEFINING CLIENT REQUIREMENTS, ANALYZING DESIGN ALTERNATIVES AND PLANNING IMPLEMENTATION OF INFORMATION SYSTEMS; TECHNICAL SUPPORT SERVICES, NAMELY DEVELOPING AND PROVIDING SYS-

TEM LIFE CYCLE SUPPORT FOR CUSTOM COMPUTER SOFTWARE APPLICATIONS SYSTEMS FOR OTHERS; PROVIDING DESIGN AND DEVELOPMENT OF COMPUTER HARDWARE AND SOFTWARE PROGRAMS IN THE FIELDS OF NATIONAL DEFENSE AND SECURITY SYSTEMS AND PROVIDING COMPUTER SIMULATION, MODELING AND/OR ANALYSIS FOR INFORMATION SYSTEMS AND GOVERNMENT SYSTEMS FOR OTHERS; COMPUTER SERVICES, NAMELY, DATA RECOVERY SERVICES; COMPUTER SECURITY SERVICES, NAMELY HARD DRIVE ERASURE (U.S. CLS. 100 AND 101).

CLASS 45—PERSONAL AND LEGAL SERVICES

FOR NETWORK SECURITY SERVICES, MONITORING OF COMPUTER SYSTEMS FOR SECURITY PURPOSES; COMPUTER SECURITY SERVICES IN THE NATURE OF PROVIDING AN INTERNET TRUST CENTER, NAMELY, COMPUTER SECURITY ASSURANCE AND ADMINISTRATION OF DIGITAL KEYS AND DIGITAL CERTIFICATES, ELECTRONIC MONITORING SERVICES OF SECURE WIRELESS NETWORKS, WIDE AREA NETWORKS, LOCAL AREA NETWORKS, DATA AND VOICE COMMUNICATIONS, AND NETWORK SWITCH CONFIGURATIONS FOR GOVERNMENT DEFENSE, INTELLIGENCE, AND NON-DEFENSE AGENCIES TO ENSURE NETWORK AND COMPUTER SYSTEM SECURITY (U.S. CLS. 100 AND 101).

LOURDES AYALA, EXAMINING ATTORNEY

SN 77-197,304. JAVACHEFF, JEANNE-CLAUDE, NEW YORK, NY. AND JAVACHEFF, CHRISTO, NEW YORK, NY. AND CVJ CORPORATION, NEW YORK, NY. FILED 6-4-2007.

CHRISTO AND JEANNE-CLAUDE:
THE MASTABA, PROJECT FOR
THE UNITED ARAB EMIRATES

THE MARK CONSISTS OF STANDARD CHARACTERS WITHOUT CLAIM TO ANY PARTICULAR FONT, STYLE, SIZE, OR COLOR.

NO CLAIM IS MADE TO THE EXCLUSIVE RIGHT TO USE "THE MASTABA, PROJECT FOR THE UNITED ARAB EMIRATES", APART FROM THE MARK AS SHOWN.

CLASS 16—PAPER GOODS AND PRINTED MATTER

FOR SERIES OF BOOKS RELATING TO ART AND SCULPTURE AND THE PUBLIC EXHIBITION AND DEMONSTRATION OF ART AND SCULPTURE; POSTERS; POSTCARDS; PRINTS (U.S. CLS. 2, 5, 22, 23, 29, 37, 38 AND 50).

CLASS 41—EDUCATION AND ENTERTAINMENT

FOR ENTERTAINMENT AND EXHIBITION SERVICES, NAMELY, PUBLIC DEMONSTRATION OF SCULPTURE AND OTHER WORKS OF ART (U.S. CLS. 100, 101 AND 107).

CARRIE GENOVESE, EXAMINING ATTORNEY

SN 77-202,581. NOLAN, THADY, NICE, FRANCE, FILED 6-11-2007.



PRIORITY CLAIMED UNDER SEC. 44(D) ON ERP N CMNTY TM OFC APPLICATION NO. 005563267, FILED 12-18-2006, REG. NO. 005563267, DATED 4-10-2008, EXPIRES 12-18-2016.

NO CLAIM IS MADE TO THE EXCLUSIVE RIGHT TO USE "IRISH PUB", APART FROM THE MARK AS SHOWN.

THE NAME(S), PORTRAIT(S), AND/OR SIGNATURE(S) SHOWN IN THE MARK DOES NOT IDENTIFY A PARTICULAR LIVING INDIVIDUAL.

THE COLOR(S) BLACK, ORANGE, YELLOW AND WHITE IS/ARE CLAIMED AS A FEATURE OF THE MARK.

THE COLOR BLACK APPEARS IN THE BACKGROUND OF THE RECTANGLE DESIGN; THE COLOR ORANGE APPEARS IN THE WORDING "MA NOLANS" AND IN PART OF THE SPIRAL DESIGN COMPRISING THE LETTER "O" OF THE WORD "NOLANS"; THE COLOR YELLOW APPEARS IN PART OF THE SPIRAL DESIGN COMPRISING THE LETTER "O" OF THE WORD "NOLANS"; AND THE COLOR WHITE APPEARS IN THE WORDING "IRISH PUB" OF THE MARK. THE MARK CONSISTS OF THE STYLIZED WORDING "MA NOLANS IRISH PUB" WITHIN A RECTANGULAR DESIGN.

CLASS 25—CLOTHING

FOR CLOTHING, NAMELY, PULLOVERS, CARDIGANS, SWEATERS, TROUSERS, SKIRTS, JACKETS, BLOUSES, SHIRTS, JEANS, SWEATPANTS, SHORTS, SWEATSHIRTS, SUITS, DRESSES, OVERCOATS, COATS, RAINCOATS, BELTS, JERSEYS, NECKWEAR, SOCKS AND STOCKINGS, TIGHTS, VESTS, WAISTCOATS, JUMPERS, TRACKSUITS, BLOUSONS, GYM SUITS, KNICKERS, T-SHIRTS, ANORAKS, LOUNGEWEAR, OVERALLS, UNDERWEAR, BEACHWEAR, SLEEPWEAR, HEADWEAR, HATS AND CAPS, SCARVES, GLOVES, SHOES, SANDALS, BOOTS AND SLIPPERS (U.S. CLS. 22 AND 39).

CLASS 41—EDUCATION AND ENTERTAINMENT

FOR ENTERTAINMENT SERVICES, NAMELY, PRESENTATION OF LIVE SHOW PERFORMANCES FEATURING COMEDIANS, IMPERSONATORS AND IMPRESSIONISTS; PROVISION OF LIVE MUSIC SHOWS; PRODUCTION OF LIVE SHOWS FEATURING COMEDIANS, IMPERSONATORS; ORGANIZATION OF SPORTS COMPETITIONS AND EVENTS; PROVIDING FACILITIES FOR RECREATION ACTIVITIES; AMUSEMENT SERVICES, NAMELY, PROVISION OF LIVE MUSIC, COMICS AND BURLSQUE SHOWS; CINEMA THEATRES AND PROVIDING FACILITIES FOR PRODUCTION OF TELEVISION SHOWS; ENTERTAINMENT CLUB SERVICES, NAMELY, NIGHTCLUBS; OPERATING A DISCOTEQUE; GAMING SERVICES, NAMELY, THE PROVISION OF CASINO FACILITIES; PARTY PLANNING; PROVISION OF INFORMATION RELATING TO ENTERTAINMENT AND SPORTS; PROVIDING ADVICE, INFORMATION AND CONSULTATION SERVICES RELATING TO ALL THE AFORESAID SERVICES (U.S. CLS. 100, 101 AND 107).

CLASS 43—HOTEL AND RESTAURANT SERVICES

FOR BAR, PUBLIC HOUSE AND RESTAURANT SERVICES; CATERING FOR THE PROVISION OF FOOD AND DRINK; CATERING SERVICES; CAFES, CAFETERIAS, CANTEENS, SNACK-BARS, WINE BARS, BRASSERIE, COFFEE SHOP, BISTRO AND RESTAURANT SERVICES; PROVISION OF MEALS FOR CONSUMPTION ON AND OFF THE PREMISES; PREPARATION OF FOODSTUFFS OR MEALS FOR CONSUMPTION ON AND OFF THE PREMISES; COCKTAIL LOUNGE SERVICES; HOTEL AND MOTEL SERVICES; PROVIDING ADVICE, INFORMATION AND CONSULTATION SERVICES RELATING TO ALL THE AFORESAID SERVICES (U.S. CLS. 100 AND 101).

ANDREW RHIM, EXAMINING ATTORNEY

SN 77-204,993. BIOMÉRIEUX, MARCY L'ETOILE, FRANCE, FILED 6-13-2007.



OWNER OF FRANCE REG. NO. 023198902, DATED 12-11-2002, EXPIRES 12-10-2012.

THE COLOR(S) GREY, BLACK, BLUE, GREEN AND YELLOW IS/ARE CLAIMED AS A FEATURE OF THE MARK.

THE MARK CONSISTS OF THE WORDING "BIOMERIEUX" WITH A STYLIZED CIRCLE AND VERTICAL SLASH THROUGH THE CIRCLE ABOVE THE WORDING. THE COLOR GREY APPEARS IN THE WORDING "BIO". THE COLOR BLACK APPEARS IN THE WORDING "MERIEUX". THE COLOR BLUE APPEARS IN THE CIRCLE. THE COLOR GREEN APPEARS IN THE TOP AND BOTTOM OF THE SLASH. THE COLOR YELLOW APPEARS IN THE MIDDLE OF THE SLASH.

THE WORD "BIOMERIEUX" HAS NO MEANING IN A FOREIGN LANGUAGE.

CLASS 1—CHEMICALS

FOR CHEMICALS FOR USE IN INDUSTRY AND SCIENCE; REAGENTS AND MEDIA TO CONTROL AND DETECT CONTAMINATING SUBSTANCES IN INDUSTRIAL, AGRICULTURAL, COSMETIC AND PHARMACEUTICAL PRODUCTS (U.S. CLS. 1, 5, 6, 10, 26 AND 46).

CLASS 5—PHARMACEUTICALS

FOR REAGENTS AND MEDIA FOR MEDICAL AND VETERINARY DIAGNOSIS (U.S. CLS. 6, 18, 44, 46, 51 AND 52).

CLASS 9—ELECTRICAL AND SCIENTIFIC APPARATUS

FOR SCIENTIFIC APPARATUS AND INSTRUMENTS FOR CONTROLLING AND DETECTING CONTAMINATING SUBSTANCES IN INDUSTRIAL, AGRO-FOODSTUFF, COSMETIC AND PHARMACEUTICAL PRODUCTS, NAMELY, IMMUNO ANALYSERS, NUCLEIC ACID ANALYSERS, BACTERIOLOGIC ANALYSERS, MICROBIOLOGIC ANALYSERS; DIAGNOSIS APPARATUS AND INSTRUMENTS, NOT FOR MEDICAL USE, NAMELY, EQUIPMENTS AND DEVICES IN THE NATURE OF IMMUNO ANALYSERS, BACTERIOLOGIC AND MICROBIOLOGIC ANALYSERS, MOLECULAR ANALYSERS, BIOCHEMISTRY ANALYSERS, USED FOR THE ISOLATION, IDENTIFICATION, QUANTIFICATION, REVELATION, CONTROL AND DETECTION OF CONTAMINATING SUBSTANCES USED FOR TESTING OR FOR MANUAL OR AUTOMATED TESTING IN INDUSTRIAL APPLICATIONS, NAMELY, FOR THE ANALYSIS OF AN INDUSTRIAL SAMPLE, A COSMETIC SAMPLE, OR AN ENVIRONMENTAL SAMPLE TO DETERMINE CONTAMINANTS, TO DETERMINE COMPOSITION, AND TO CONTROL QUALITY; SOFTWARE USED TO PROCESS AND INTERPRET THE RESULTS OF ABOVE TESTS (U.S. CLS. 21, 23, 26, 36 AND 38).

CLASS 10—MEDICAL APPARATUS

FOR APPARATUS AND INSTRUMENTS FOR MEDICAL AND VETERINARY DIAGNOSIS, NAMELY, EQUIPMENTS AND DEVICES IN THE NATURE OF IMMUNO ANALYSERS, NUCLEIC ACID ANALYSERS, BACTERIOLOGIC ANALYSERS, MICROBIOLOGIC ANALYSERS USED FOR TESTING OR FOR MANUAL OR FOR AUTOMATED TESTING IN MEDICAL AND CLINICAL APPLICATIONS (U.S. CLS. 26, 39 AND 44).

TINA BROWN, EXAMINING ATTORNEY

SN 77-207,173. EK SPI DISH EN LLC, LONGMONT, CO. FILED 6-15-2007.

5 MINUTES TO POWER

THE MARK CONSISTS OF STANDARD CHARACTERS WITHOUT CLAIM TO ANY PARTICULAR FONT, STYLE, SIZE, OR COLOR.

CLASS 41—EDUCATION AND ENTERTAINMENT

FOR EDUCATIONAL SERVICES, NAMELY, TRAINING COURSES, WORKSHOPS, AND SEMINARS FOR BUSINESS AND INDIVIDUALS IN THE FIELD OF SAFETY, HEALTH, WELLNESS, AND WEIGHT LOSS (U.S. CLS. 100, 101 AND 107).

FIRST USE 2-15-1999; IN COMMERCE 2-15-1999.

CLASS 44—MEDICAL, BEAUTY AND AGRICULTURAL SERVICES

FOR PROVIDING INFORMATION ON AWARENESS, SOLUTIONS, AND CONCERNS REGARDING PREVENTION IN THE FIELD OF HEALTH, WELLNESS, AND WEIGHT LOSS (U.S. CLS. 100 AND 101).

FIRST USE 2-15-1999; IN COMMERCE 2-15-1999.

CLASS 45—PERSONAL AND LEGAL SERVICES

FOR PROVIDING INFORMATION ON AWARENESS, SOLUTIONS, AND CONCERNS REGARDING PREVENTION IN THE FIELD OF JOBSITE SAFETY (U.S. CLS. 100 AND 101).

FIRST USE 2-15-1999; IN COMMERCE 2-15-1999.

SARA THOMAS, EXAMINING ATTORNEY

SN 77-209,512. VAN ZANDT, STEVEN, NEW YORK, NY. FILED 6-19-2007.

ROCKY RIALTO

THE MARK CONSISTS OF STANDARD CHARACTERS WITHOUT CLAIM TO ANY PARTICULAR FONT, STYLE, SIZE, OR COLOR.

THE NAME(S), PORTRAIT(S), AND/OR SIGNATURE(S) SHOWN IN THE MARK DOES NOT IDENTIFY A PARTICULAR LIVING INDIVIDUAL.

CLASS 9—ELECTRICAL AND SCIENTIFIC APPARATUS

FOR AUDIO, VISUAL AND AUDIOVISUAL RECORDINGS IN ALL FORMATS AND CONFIGURATIONS CONTAINING MUSIC, VOCAL, DRAMATIC AND COMEDIC PERFORMANCES (U.S. CLS. 21, 23, 26, 36 AND 38).

CLASS 16—PAPER GOODS AND PRINTED MATTER

FOR PRINTED AND RELATED MATTER, NAMELY, POSTERS, CALENDARS, TEMPORARY TATTOOS, STICKERS, DECALS, IRON-ON AND PLASTIC TRANSFERS, BUMPER STICKERS, NOTE CARDS, POSTCARDS, PICTURE POSTCARDS, GREETING CARDS, MUSICAL GREETING CARDS, PRINTED GREETING CARDS WITH ELECTRONIC INFORMATION STORED THEREIN, GIFT CARDS, OCCASION CARDS, SOCIAL NOTE CARDS, MOTIVATIONAL CARDS, CARDS BEARING UNIVERSAL GREETINGS, BLANK CARDS, BLANK NOTE CARDS, PLACE CARDS, BLANK AND PARTIALLY PRINTED CARDS, RECORD CARDS, SCORE CARDS, TRADING CARDS, SCRAPBOOKS, STATIONERY, NOTE PADS, PAPER NOTE TABLETS, WRITING TABLETS, NOTEBOOKS, FOLDERS, FILE FOLDERS, STATIONERY FOLDERS, BOOKMARKS, PAPER PENNANTS, BINDERS, WRITING PAPER, ENVELOPES, APPOINTMENT BOOKS, ADDRESS BOOKS, DESK PADS AND PAPER TAGS; PASSPORT HOLDERS, PERSONAL ORGANIZERS, DESK TOP ORGANIZERS, ORGANIZERS FOR STATIONERY USE AND STATIONERY-TYPE PORTFOLIOS, PAPER FLAGS, MOUNTS FOR STAMPS, RUBBER STAMPS, RUBBER DOCUMENT STAMPS, STAMP ALBUMS, STAMP PAD INKS, STAMP PADS, SLEEVES FOR HOLDING AND PROTECTING STAMPS, PAPER BANNERS, HOLDERS FOR DESK ACCESSORIES, LETTER OPENERS, LETTER TRAYS, LETTER RACKS, PEN AND PENCIL CUPS, PENS, PENCILS, MARKERS, PEN AND PENCIL SETS, STICK MARKERS, ERASERS, DRAWING AND DRAFTING RULERS, PENCIL SHARPENERS, BOOK ENDS, BOOK COVERS, CHECKBOOK COVERS, BOOK HOLDERS, PHOTOGRAPH AND COIN ALBUMS; BULLETIN BOARDS; PHOTOGRAPH MOUNTS; PHOTOGRAPHIC OR ART MOUNTS; PHOTOGRAPHIC PRINTS; PHOTOGRAPHS; LITHOGRAPHS; DECORATIVE PAPER CENTERPIECES; DECORATIVE PENCIL-TOP ORNAMENTS; PICTURE BOOKS; PAPER AND CARDBOARD PICTURE MOUNTS; GLOBES; PAPERWEIGHTS; PAPER CLIP HOLDERS; PAPER SIGN HOLDERS; PRINTED PAPER SIGNS; CLIP BOARDS; TOUR BOOKS AND FOLIOS; CONCERT

PROGRAMS; BOOKS, MAGAZINES, LEAFLETS, JOURNALS, NEWSLETTERS, BOOKLETS, PAMPHLETS AND BROCHURES, ALL IN THE FIELD OF MUSIC (U.S. CLS. 2, 5, 22, 23, 29, 37, 38 AND 50).

CLASS 25—CLOTHING

FOR CLOTHING, NAMELY, SHIRTS, T-SHIRTS, UNDERSHIRTS, NIGHT SHIRTS, RUGBY SHIRTS, POLO SHIRTS, JERSEYS, UNIFORMS, PANTS, TROUSERS, SLACKS, JEANS, DENIM JEANS, OVERALLS, COVERALLS, JUMPERS, JUMP SUITS, SHORTS, BOXER SHORTS, TOPS, TANK TOPS, HALTER TOPS, SWEAT SHIRTS, SWEAT SHORTS, SWEAT PANTS, WARM-UP SUITS, JOGGING SUITS, BLOUSES, SKIRTS, DRESSES, SWEATERS, VESTS, FLEECE VESTS, PULLOVERS, FLEECE PULLOVERS, SNOW SUITS, PARKAS, PONCHOS, JACKETS, DINNER JACKETS, SPORTS JACKETS, COATS, BLAZERS, SUITS, TURTLENECKS, SWIMWEAR, BEACHWEAR, CAPS, BERETS, HATS, HEADBANDS, WRIST BANDS, HEADWEAR, EAR MUFFS, APRONS, SCARVES, BANDANAS, BELTS, SUSPENDERS, NECKWEAR, NECKTIES, TIES, UNDERWEAR, BRIEFS, TRUNKS, BRAS, SPORTS BRAS, SINGLETS, SOCKS, LOUNGEWEAR, ROBES, BATH-ROBES, PAJAMAS, SLEEPWEAR, NIGHTGOWNS, LINGERIE, CAMISOLES, SLIPS, LEG WARMERS, BODYSUITS, TIGHTS, LEOTARDS, UNITARDS, GLOVES, MITTENS, FOOTWEAR, SHOES, SNEAKERS, BOOTS, GALOSHES, SANDALS, SLIPPERS AND RAINWEAR (U.S. CLS. 22 AND 39).

CLASS 35—ADVERTISING AND BUSINESS

FOR RETAIL STORE SERVICES, WHOLESALE STORE SERVICES, MAIL ORDER SERVICES, ON-LINE ORDERING SERVICES AND ON-LINE RETAIL STORE SERVICES, ELECTRONIC RETAIL STORE SERVICES VIA COMPUTERS, AND RETAIL STORE SERVICES AVAILABLE THROUGH COMPUTER COMMUNICATIONS AND INTERACTIVE TELEVISION, ALL OF THE AFORESAID FEATURING COSMETICS, HAIR, NAIL, BATH AND BODY PRODUCTS, RECORDED PRODUCT, MUSIC RELATED ITEMS, PROMOTIONAL ITEMS SUCH AS MOUSE PADS, MAGNETS, PAPER WEIGHTS, TRANSPORT CASES, MUGS, GLASSES AND COASTERS, COMPUTER GOODS, SOFTWARE, GAMES, TOYS AND PLAYTHINGS, PLUSH TOYS, TEDDY BEARS AND ACCESSORIES THEREFOR, DOLLS AND ACCESSORIES THEREFOR, SPORTING GOODS AND EQUIPMENT, BAGS AND ACCESSORIES THEREFOR, CLOTHING AND ACCESSORIES THEREFOR, FOOTWEAR, EYEWEAR AND ACCESSORIES THEREFOR, JEWELRY AND WATCHES AND ACCESSORIES THEREFOR, CLOCKS, PRINTED PROMOTIONAL MATTER SUCH AS POSTERS, CALENDARS, STICKERS, STATIONERY AND RELATED MATTER, BOOKS AND PUBLICATIONS, NOVELTY ITEMS AND ORNAMENTS, HAIR ACCESSORIES, PICTURE FRAMES, HOUSEHOLD ITEMS, BEDDING AND LINENS; DISTRIBUTORSHIP SERVICES IN THE FIELD OF MUSICAL AUDIO AND VIDEO RECORDINGS (U.S. CLS. 100, 101 AND 102).

CLASS 41—EDUCATION AND ENTERTAINMENT

FOR ENTERTAINMENT SERVICES, NAMELY, RECORD PRODUCTION; RECORD MASTER PRODUCTION; MUSIC PRODUCTION; AUDIO RECORDING AND PRODUCTION; VIDEOTAPE PRODUCTION; MOTION PICTURE PRODUCTION; PRODUCTION OF VIDEO DISCS FOR OTHERS; RECORDING STUDIOS; ENTERTAINMENT SERVICES, NAMELY, PRODUCING MUSICAL AUDIO AND VIDEO RECORDINGS; MUSIC COMPOSITION FOR OTHERS; SONG WRITING SERVICES; MUSIC PUBLISHING SERVICES; ENTERTAINMENT IN THE NATURE OF A LIVE MUSICAL PERFORMER, MUSICAL BAND AND MUSICAL GROUP; ENTERTAINMENT IN THE NATURE OF LIVE PERFORMANCES BY A MUSICAL ARTIST, MUSICAL GROUP AND MUSICAL BAND; ENTERTAINMENT IN THE NATURE OF LIVE VISUAL AND AUDIO PERFORMANCES BY A MUSICAL ARTIST, MUSICAL GROUP AND MUSICAL BAND; ENTERTAINMENT, NAMELY, LIVE MUSIC CONCERTS; ENTERTAINMENT, NAMELY, PERSONAL APPEARANCES BY A MUSI-

CIAN, MUSICAL GROUP AND MUSICAL BAND; ENTERTAINMENT, NAMELY, PROVIDING A WEB SITE FEATURING MUSICAL PERFORMANCES, MUSICAL VIDEOS, RELATED FILM CLIPS, PHOTOGRAPHS, AND OTHER MULTIMEDIA MATERIALS; ENTERTAINMENT SERVICES, NAMELY, PROVIDING PRERECORDED MUSIC, INFORMATION IN THE FIELD OF MUSIC AND DANCE, COMMENTARY AND ARTICLES ABOUT MUSIC, ALL ONLINE VIA THE INTERNET; TELEVISION AND RADIO PRODUCTION; TELEVISION SHOW PRODUCTION; CABLE TELEVISION SHOW PRODUCTION; RADIO ENTERTAINMENT PRODUCTION; MOTION PICTURE FILM PRODUCTION AND DISTRIBUTION; ENTERTAINMENT IN THE NATURE OF ONGOING TELEVISION, RADIO PROGRAMS FEATURING MUSICAL, DANCE, COMEDIC AND DRAMATIC ACTS; TELEVISION PROGRAMS FEATURING MUSIC, DANCE, DRAMA AND COMEDY; PROVIDING AN ONGOING VARIETY SHOW DISTRIBUTED OVER TELEVISION, RADIO, SATELLITE, AUDIO AND VIDEO MEDIA; THEATRE PRODUCTIONS; ENTERTAINMENT IN THE NATURE OF LIVE TRAVELING TOURS FEATURING MUSIC, DANCE, DRAMA AND COMEDY AND ORGANIZING AND PRESENTING MUSICAL COMPETITIONS (U.S. CLS. 100, 101 AND 107).

CLASS 43—HOTEL AND RESTAURANT SERVICES

FOR HOTEL, BAR AND RESTAURANT SERVICES (U.S. CLS. 100 AND 101).
ERNEST SHOSHO, EXAMINING ATTORNEY

SN 77-217,668. CABLE & WIRELESS U.K., BERKSHIRE, UNITED KINGDOM, FILED 6-28-2007.

A NEW WAY EVERYWHERE

THE MARK CONSISTS OF STANDARD CHARACTERS WITHOUT CLAIM TO ANY PARTICULAR FONT, STYLE, SIZE, OR COLOR.

PRIORITY CLAIMED UNDER SEC. 44(D) ON ERPN CMNTY TM OFC APPLICATION NO. 005898771, FILED 5-11-2007, REG. NO. 005898771, DATED 4-11-2008, EXPIRES 5-11-2017.

CLASS 9—ELECTRICAL AND SCIENTIFIC APPARATUS

FOR APPARATUS FOR RECORDING, TRANSMISSION OR REPRODUCTION OF SOUND OR IMAGES; BLANK MAGNETIC DATA CARRIERS, BLANK RECORDING DISCS; CALCULATORS AND DATA PROCESSORS; COMPUTER PROGRAMS AND SOFTWARE FOR MANAGING AND IMPLEMENTING COMMUNICATIONS BY AND BETWEEN COMPONENTS OF A TELECOMMUNICATIONS NETWORK, FOR PROVIDING ACCESS TO LOCAL, WIDE AREA AND GLOBAL COMMUNICATIONS NETWORKS, FOR PROVIDING ACCESS TO BILLING INFORMATION AND FOR PROVIDING DATA COLLECTION STORAGE AND TRANSMISSION IN THE FIELD OF TELECOMMUNICATIONS; COMPUTER E-COMMERCE SOFTWARE TO ALLOW USERS TO PERFORM ELECTRONIC BUSINESS TRANSACTIONS VIA A GLOBAL COMPUTER NETWORK OR THE INTERNET; DOWNLOADABLE COMPUTER SOFTWARE SUPPLIED FROM COMPUTER NETWORKS OR THE INTERNET FOR CONNECTING COMPUTER NETWORK USERS TO PAGES AND SITES ON THE WORLD WIDE WEB; DOWNLOADABLE COMPUTER SOFTWARE SUPPLIED FROM COMPUTER NETWORKS OR THE INTERNET FOR BROWSING AND SEARCHING DATA, OR ENABLING BROWSING AND SEARCHING, ON A COMPUTER NETWORK OR THE INTERNET; DOWNLOADABLE ELECTRONIC PUBLICATIONS, NAMELY, PAMPHLETS, BROCHURES, NEWSLETTERS,

JOURNALS AND MAGAZINES IN THE FIELD OF TELECOMMUNICATIONS, INFORMATION TECHNOLOGY, AND ENGINEERING DESIGN SERVICES; TELECOMMUNICATIONS APPARATUS AND INSTRUMENTS, NETWORKS AND CIRCUITRY FOR ENABLING, FACILITATING AND ROUTING CONNECTIONS TO DATABASES, COMPUTER NETWORKS AND THE INTERNET, NAMELY, MODEMS, COMPUTER NETWORK HUBS, SWITCHES AND ROUTERS; TELEPHONES, TELEPRINTERS, AND ELECTRONIC DATA COMMUNICATIONS APPARATUS AND INSTRUMENTS, NAMELY, TELECOMMUNICATIONS ENCODERS AND DECODERS, INTERCOMS, CELLULAR TELEPHONES, RADIO TELEPHONES, MODEMS; RADIO-PAGERS; RADIO-TELEPHONES. ELECTRONIC APPARATUS AND INSTRUMENTS, NAMELY, COMPUTER HARDWARE AND SOFTWARE, ALL FOR THE MANAGEMENT AND/OR PERFORMANCE AND ANALYSIS OF TELECOMMUNICATIONS AND DATA COMMUNICATIONS NETWORKS AND CIRCUITS; OPTICAL AND ELECTRO-OPTICAL APPARATUS AND EQUIPMENT FOR SENDING, TRANSMITTING AND RECEIVING DATA, INFORMATION, PICTURES, IMAGES AND SOUNDS, NAMELY, OPTICAL DISK COMPUTERS AND SCANNERS; CABLES FOR TELECOMMUNICATIONS; DISPERSION SHIFTED OPTICAL FIBRES, NON-LINEAR OPTICAL FIBRES, AND POLARISATION MAINTAINING OPTICAL FIBRES; ELECTRONIC APPARATUS AND INSTRUMENTS, NAMELY, COMPUTER HARDWARE AND SOFTWARE, FOR THE RETRIEVAL, COLLECTION, PROCESSING, LOGGING, STORING, TRANSMITTING, RECEPTION, DISPLAY AND/OR PRINTING OUT OF COMMUNICATION SIGNALS, DATA AND INFORMATION; APPARATUS AND INSTRUMENTS FOR RECORDING, RECEIVING AND TRANSMITTING VIDEO AND SOUND SIGNALS, DATA AND INFORMATION, NAMELY, VIDEO RECORDERS, TELEVISION RECEIVERS, COMBINED TELEVISION RECEIVERS AND VIDEO RECORDERS; INTERACTIVE ELECTRONIC APPARATUS AND INSTRUMENTS FOR TELECOMMUNICATION, TRANSMISSION AND RECEPTION OF DATA, PICTURES AND/OR SOUNDS AND FOR ORDERING GOODS AND/OR SERVICES, NAMELY, COMPUTER HARDWARE, SOFTWARE AND PERIPHERALS AND PLATFORM SOFTWARE FOR ACCESS TO THE WORLD WIDE WEB; APPARATUS AND INSTRUMENTS FOR DEBITING OR CREDITING FINANCIAL ACCOUNTS AND FOR PAYING FOR GOODS OR SERVICES, NAMELY, AUTOMATIC TELLER MACHINES (ATMS) AND CREDIT CARD READERS; MAGNETICALLY ENCODED PRE-PAID CARDS FOR DEBITING OR CREDITING FINANCIAL ACCOUNTS AND FOR PAYING FOR GOODS OR SERVICES; MAGNETICALLY ENCODED, MACHINE-READABLE DEBIT CARDS, CREDIT CARDS, AND CHARGE CARDS; APPARATUS AND INSTRUMENTS, NAMELY, TRANSCEIVERS, TRANSDUCERS AND RESPONDERS, AND COMPUTER SOFTWARE FOR COMMUNICATING WITH AND IN COMPUTER NETWORKS; TELECOMMUNICATIONS SOFTWARE FOR MANAGING AND IMPLEMENTING COMMUNICATIONS BY AND BETWEEN COMPONENTS OF A TELECOMMUNICATIONS NETWORK, AND FOR TRANSMITTING PAYMENT INFORMATION TO GLOBAL NETWORKS, TELEVISION, RADIO, VIDEO AND AUDIO APPARATUS, EQUIPMENT AND DEVICES, NAMELY, TELEVISIONS, RADIOS, VIDEO RECEIVERS AND TRANSMITTERS, COMBINED TELEVISION AND VIDEO RECEIVERS AND TRANSMITTERS, CASSETTE PLAYERS, RECORD PLAYERS, COMPACT DISK PLAYERS, CD-ROM PLAYERS, MP3 PLAYERS, DVD PLAYERS, VIDEO RECORDERS, VIDEO CAMERAS; ELECTRONIC UNITS FOR ENCRYPTING AND DECRYPTING ELECTRONIC, VIDEO, AND SOUND SIGNALS AND DATA; DOWNLOADABLE DIGITAL MUSIC PROVIDED FROM COMPUTER NETWORKS OR FROM INTERNET WEB-SITES; AND PARTS AND FITTINGS FOR ALL THE AFORESAID GOODS (U.S. CLS. 21, 23, 26, 36 AND 38).

CLASS 37—CONSTRUCTION AND REPAIR

FOR REPAIR SERVICES RELATING TO COMPUTER HARDWARE AND TELECOMMUNICATIONS APPARATUS AND EQUIPMENT; INFORMATION SERVICES PROVIDED ON-LINE FROM A DATABASE ON A COMPUTER NETWORK OR THE INTERNET RELATING TO REPAIR OF COMPUTER HARDWARE AND TELECOMMUNICATIONS APPARATUS AND EQUIPMENT; INFORMATION SERVICES PROVIDED ON-LINE FROM A DATABASE ON A COMPUTER NETWORK OR THE INTERNET RELATING TO INSTALLATION, REPAIR AND MAINTENANCE OF TELECOMMUNICATION APPARATUS, COMPUTER HARDWARE, BROADCASTING, BROADCAST RECEIVING, MESSAGE SENDING AND MESSAGE RECEIVING EQUIPMENT AND APPARATUS (U.S. CLS. 100, 103 AND 106).

CLASS 38—COMMUNICATION

FOR TELECOMMUNICATION SERVICES, NAMELY, PROVIDING LOCAL AND LONG-DISTANCE TRANSMISSION OF VOICE, DATA AND GRAPHICS BY MEANS OF TELEPHONE, TELEGRAPHIC, CABLE, SATELLITE AND INTERNET TRANSMISSIONS, AND PROVIDING FIBRE OPTIC NETWORK SERVICES; VOICE OVER INTERNET PROTOCOL (VOIP) SERVICES; TELECOMMUNICATIONS NETWORK SERVICE, NAMELY, PROVIDING TELECOMMUNICATIONS CONNECTIONS AND ACCESS TO A GLOBAL COMPUTER NETWORK; PROVIDING TELECOMMUNICATION CONNECTIONS TO A GLOBAL COMPUTER NETWORK, TO THE INTERNET AND TO DATABASES THEREON; PROVIDING MULTIPLE USER ACCESS TO THE INTERNET AND TO A GLOBAL COMPUTER NETWORK; ELECTRONIC TRANSMISSION OF INFORMATION, COMPUTER PROGRAMS, AND DATA BY COMPUTER TERMINALS, TELEPHONE, AND TELEVISION AND VIDEO BROADCASTING; PROVIDING TELECOMMUNICATION ACCESS SERVICES TO A COMPUTER NETWORK OR TO THE INTERNET; PROVIDING ACCESS TO DIGITAL MUSIC WEBSITES ON THE INTERNET; TRANSMISSION OF DIGITAL MUSIC, IMAGES, VOICE AND DATA BY TELECOMMUNICATIONS, NAMELY, TELEPHONE, TELEGRAPHIC, CABLE, SATELLITE AND INTERNET TRANSMISSION; ELECTRONIC TRANSMISSION OF VOICE, DATA AND INFORMATION; VOIP, LOCAL, LONG DISTANCE, INTERNATIONAL AND TOLL FREE TELEPHONE SERVICES; AUTOMATED VOICE RESPONSE SERVICES; CALL ROUTING SERVICES; FRAME RELAY SERVICES; ATM (ASYNCHRONOUS TRANSFER MODE) SERVICES; ISDN (INTEGRATED SERVICES DIGITAL NETWORK) SERVICES; ELECTRONIC MESSAGING AND MAIL SERVICES; LEASING AND RENTAL SERVICES IN CONNECTION WITH COMMUNICATIONS APPARATUS AND EQUIPMENT; ELECTRONIC TRANSMISSION OF RECORDED SOUND AND IMAGES; BROADCASTING AND TRANSMISSION OF RADIO, TELEVISION AND CABLE TELEVISION AND RADIO PROGRAMMES; PROVIDING TELEPHONE CONFERENCING, VIDEO CONFERENCING, AND WEB CONFERENCING SERVICES; CABLE TELEVISION BROADCASTING; PROVIDING TELECOMMUNICATIONS ACCESS TO ELECTRONIC DATA, DATABASES, BULLETIN BOARDS AND PUBLICATIONS ON REMOTE COMPUTERS OR VIA COMPUTER NETWORKS; TRANSMISSION OF WRITTEN AND DIGITAL COMMUNICATION OF MATHEMATICAL AND STATISTICAL DATA; PROVIDING ON-LINE CHAT ROOMS FOR TRANSMISSION OF MESSAGES AMONG COMPUTER USERS CONCERNING TOPICS OF GENERAL INTEREST; ADVISORY, INFORMATION, CONSULTANCY SERVICES RELATING TO THE AFOREMENTIONED SERVICES; TECHNICAL PROJECT STUDIES, NAMELY, CONSULTATION IN THE FIELD OF TELECOMMUNICATIONS (U.S. CLS. 100, 101 AND 104).

CLASS 41—EDUCATION AND ENTERTAINMENT

FOR EDUCATION AND ENTERTAINMENT SERVICES, NAMELY, CABLE TELEVISION PROGRAMMING; CONDUCTING DISTANCE LEARNING INSTRUCTION AT THE SECONDARY, COLLEGE AND GRADUATE LEVELS IN THE FIELD OF TELECOMMUNICATIONS, INFORMATION TECHNOLOGY AND BUSINESS MANAGEMENT; ELECTRONIC PUBLISHING SERVICES, NAMELY, PUBLICATION OF TEXT AND GRAPHIC WORKS OF OTHERS VIA A GLOBAL COMPUTER IN THE FIELD OF TELECOMMUNICATIONS, INFORMATION TECHNOLOGY AND BUSINESS MANAGEMENT; TRAINING SERVICES IN THE FIELD OF TELECOMMUNICATIONS, INFORMATION TECHNOLOGY AND BUSINESS MANAGEMENT; ARRANGEMENT OF ENTERTAINMENT AND CULTURAL EVENTS, NAMELY, ART EXHIBITIONS, MUSIC EVENTS, SOUND AND LIGHT DISPLAYS; ARRANGING EDUCATIONAL CONFERENCES AND MEETINGS; EDUCATION SERVICES, NAMELY, PROVIDING LIVE AND ON-LINE CLASSES, SEMINARS AND WORKSHOPS IN THE FIELD OF TELECOMMUNICATIONS, INFORMATION TECHNOLOGY AND BUSINESS MANAGEMENT; TELEVISION, VIDEO AND ENTERTAINMENT SERVICES, NAMELY, TELEVISION PRODUCTION, RECORD PRODUCTION, AND LIVE PERFORMANCES BY MUSICAL GROUPS; INFORMATION RELATING TO ENTERTAINMENT AND EDUCATION PROVIDED ON-LINE FROM A DATABASE ON A COMPUTER NETWORK OR THE INTERNET; ELECTRONIC GAMES SERVICES PROVIDED BY MEANS OF A COMPUTER NETWORK OR THE INTERNET; PROVIDING NON-DOWNLOADABLE DIGITAL MUSIC FROM WEBSITES ON THE INTERNET; INFORMATION AND ADVISORY SERVICES RELATING TO THE AFOREMENTIONED SERVICES (U.S. CLS. 100, 101 AND 107).

CLASS 42—SCIENTIFIC AND COMPUTER SERVICES

FOR SCIENTIFIC RESEARCH SERVICES; INDUSTRIAL RESEARCH SERVICES IN THE FIELD OF TELECOMMUNICATIONS; TECHNICAL PROJECT STUDIES, NAMELY, TECHNICAL PLANNING AND RESEARCH IN THE FIELD OF TELECOMMUNICATIONS; COMPUTER CONSULTATION SERVICES, NAMELY, ADVISORY SERVICES WITH REGARD TO THE OPERATION OF COMPUTER HARDWARE; COMPUTER PROGRAMMING; CONSULTING SERVICES IN THE FIELD OF ENGINEERING AND SOFTWARE DESIGN SERVICES; COMPUTER RENTAL; DESIGN OF INTERNET HOMEPAGES AND WEB-SITES; SEARCHING AND RETRIEVING INFORMATION, SITES, AND OTHER RESOURCES AVAILABLE ON COMPUTER NETWORKS FOR OTHERS; CREATING AND MAINTAINING WEBSITES FOR OTHERS; HOSTING THE WEBSITES OF OTHERS; INSTALLATION AND MAINTENANCE OF COMPUTER SOFTWARE; CREATING INDEXES OF INFORMATION, DATA AND SITES AVAILABLE ON COMPUTER NETWORKS; COMPUTER SERVICES, NAMELY, PROVIDING SEARCH ENGINES FOR OBTAINING DATA ON A GLOBAL COMPUTER NETWORK (U.S. CLS. 100 AND 101).

BARBARA GAYNOR, EXAMINING ATTORNEY

SN 77-218,138. KALKMAN, LUCIA M., NAPERVILLE, IL.
FILED 6-28-2007.



THE COLOR(S) BLUE, GREEN, RED, ORANGE, GRAY, YELLOW, WHITE, BLACK, PINK, BROWN, AND PEACH IS/ ARE CLAIMED AS A FEATURE OF THE MARK.

THE COLORS BLUE, BLACK AND WHITE APPEAR IN THE WORDS "CREATE-A-HABITAT". THE COLOR GREEN APPEARS IN THE GRASS, THE COLOR BLUE APPEARS IN THE WATER, THE COLORS YELLOW AND WHITE APPEAR IN THE FLOWERS, THE COLOR BROWN APPEARS IN THE LOGS, THE COLORS PEACH AND GRAY APPEAR IN THE GROUND AND ROCKS AND THE COLORS RED, GRAY, WHITE, BROWN, GREEN, YELLOW, ORANGE, PINK APPEAR IN THE ANIMALS.

CLASS 28—TOYS AND SPORTING GOODS

FOR ACTION FIGURES; ACTION FIGURES AND ACCESSORIES THEREFOR; ACTION SKILL GAMES; ANIMAL ATTRACTANT SCENTS; BATHTUB TOYS; BEACH BALLS; BEAN BAG DOLLS; BEAN BAGS; BIRD CALLS; BOARD GAMES; BUBBLE MAKING WAND AND SOLUTION SETS; CARD GAMES; CAT TOYS; CHECKER SETS; CHESS SETS; CHILDREN'S MULTIPLE ACTIVITY TOYS; CONSTRUCTION TOYS; COSTUME MASKS; DOLL ACCESSORIES; DOLL CLOTHING; DOLL COSTUMES; DOLLS; DOLLS FOR PLAYING; ELECTRIC ACTION TOYS; ELECTRONIC ACTION TOYS; ELECTRONIC EDUCATIONAL GAME MACHINES FOR CHILDREN; ELECTRONIC LEARNING TOYS; ELECTRONIC TOY BUILDING BLOCKS THAT LIGHT UP AS A NIGHT LIGHT; ELECTRONIC TOY VEHICLES; ELECTRONICALLY OPERATED TOY MOTOR VEHICLES; FANTASY CHARACTER TOYS; FISHING REELS; FISHING RODS; FISHING TACKLE; FISHING TACKLE BOXES; HAND BALLS; HAND HELD UNIT FOR PLAYING ELECTRONIC GAMES; HAND HELD UNIT FOR PLAYING VIDEO GAMES; HAND PUPPETS; HAND-HELD FISHING NETS; HAND-HELD FISHING NETS FOR SPORTSMEN; HEADGEAR FOR DOLLS; INFLATABLE BATH TOYS; INFLATABLE RIDE-ON TOYS; INFLATABLE THIN RUBBER TOYS; INFLATABLE TOYS; JIGSAW PUZZLES; JUMP ROPES; KITES; MAGIC TRICKS; MANIPULATIVE PUZZLES; MARBLES; MARIONETTE PUPPETS; MECHANICAL ACTION TOYS; MECHANICAL TOYS; MEMORY GAMES; MODEL CARS; MODELED PLASTIC TOY FIGURINES; PET TOYS; PET TOYS CONTAINING CATNIP; PET TOYS MADE OF ROPE; PLAY TENTS; PLAY WANDS; PLUSH TOYS; PULL TOYS; PUNCHING TOYS; PUPPETS; PUSH TOYS; PUZZLES; RADIO CONTROLLED MODEL VEHICLES; RAG DOLLS; RUBBER BALLS; SAND TOYS; SANDBOX TOYS; STUFFED PUPPETS; STUFFED TOY ANIMALS; STUFFED TOY BEARS; STUFFED TOYS; TALKING TOYS; TEDDY BEARS; TOY CHRISTMAS TREES; TOY ACTION FIGURES; TOY ACTION FIGURES AND ACCESSORIES THEREFOR; TOY AIRPLANES; TOY ANIMALS AND ACCESSORIES THEREFOR; TOY ARMOR; TOY ARTIFICIAL FINGERNAILS; TOY BAKEWARE AND COOKWARE; TOY BANKS; TOY BOWS AND ARROWS; TOY BOXES; TOY BUILDING BLOCKS; TOY BUILDING BLOCKS CAPABLE OF INTERCONNECTION; TOY BUILDINGS AND ACCESSORIES THEREFOR; TOY BUTTERFLY NETS; TOY CAP PISTOLS; TOY CLOCKS AND WATCHES; TOY CONSTRUCTION BLOCKS; TOY CONSTRUCTION SETS; TOY FIGURES; TOY FILM CARTRIDGES AND VIEWERS; TOY FURNITURE; TOY GLIDERS; TOY GLOCKENSPIELS; TOY GUNS; TOY HARMONICAS; TOY HOLSTERS; TOY HOOP SETS; TOY HOUSES; TOY MAIL BOXES; TOY MASKS; TOY MOBILES; TOY MODEL CARS; TOY MODEL HOBBY-CRAFT KITS; TOY MODEL KIT CARS; TOY MODEL TRAIN SETS; TOY MODEL VEHICLES AND RELATED ACCESSORIES SOLD AS UNITS; TOY MODELING DOUGH; TOY MUSIC BOXES; TOY NOISEMAKERS; TOY PIANOS; TOY PIANOS, SOLD AS A UNIT WITH PRINTED BOOKS IN THE FIELD OF MUSIC EDUCATION; TOY PISTOLS; TOY PRISM GLASSES; TOY

PUTTY; TOY RECORD PLAYERS; TOY ROBOTS; TOY ROCKETS; TOY SCOOTERS; TOY SETS OF CARPENTERS' TOOLS; TOY SNOW GLOBES; TOY STAMPS; TOY SWORDS; TOY TRAINS AND PARTS AND ACCESSORIES THEREFOR; TOY VEHICLE TRACK SETS AND ROADWAYS AND ACCESSORIES THEREFOR; TOY VEHICLES; TOY VEHICLES AND ACCESSORIES THEREFOR; TOY VEHICLES WITH TRANSFORMING PARTS; TOY WATCHES; TOY WATER GLOBES; TOY WEAPONS; TOY WIND SOCKS; TOY XYLOPHONES; TOY ZIP GUNS; TOY, NAMELY, BATTERY-POWERED COMPUTER GAME WITH LCD SCREEN WHICH FEATURES ANIMATION AND SOUND EFFECTS; TOYS, NAMELY, A DISK TO TOSS IN PLAYING A GAME WHEREIN OTHER DISKS ARE FLIPPED AND COLLECTED; WATER PISTOLS (U.S. CLS. 22, 23, 38 AND 50).

CLASS 31—NATURAL AGRICULTURAL PRODUCTS

FOR BIRD SEED; BRINE SHRIMP FOR FISH FOOD; CAT FOOD; CAT TREATS; CLAMS; CRABS; DIGESTIBLE CHEWING BONES FOR DOGS; DOG BISCUITS; DOG FOOD; FISH FOOD; FOOD FOR ANIMALS; FOOD FOR RODENTS; LIVE ANIMALS; LIVE ANIMALS, NAMELY, FISH, HERMIT CRABS, TURTLES, FROGS, TADPOLES, WORMS, CRICKETS, WALKING STICKS, LIZARDS, SNAKES, RATS, MICE, HAMSTERS, PET BIRDS, SNAILS, ANTS, LIVE BUTTERFLIES, BUTTERFLY EGGS, REPTILES, LIVE BIRDS, NAMELY, PET BIRDS; LIVE BUTTERFLIES; LIVE FISH; LIVE FISH FOR FOOD PURPOSES; LIVE PLANTS; LIVE PLANTS USED AS AQUARIUM LANDSCAPES; LIVESTOCK, NAMELY, FISH, HERMIT CRABS, TURTLES, FROGS, TADPOLES, WORMS, CRICKETS, WALKING STICKS, LIZARDS, SNAKES, RATS, MICE, HAMSTERS, PET BIRDS, SNAILS, ANTS, LIVE BUTTERFLIES, BUTTERFLY EGGS, REPTILES, LOBSTERS; SHRIMP; SHRIMPS, PRAWNS AND LOBSTERS; SILKWORM EGGS; TOP SOIL (U.S. CLS. 1 AND 46).

CLASS 35—ADVERTISING AND BUSINESS

FOR COMPUTER SERVICES, NAMELY, PROVIDING CONSUMER INFORMATION IN THE FIELD OF ANIMALS AND PETS RELATING TO PET PRODUCTS, PET TREATS AND PET TOYS; RETAIL PET STORES; ONLINE RETAIL STORE SERVICES FEATURING PETS, PET FOOD, PET SUPPLIES, PET ACCESSORIES, GENERAL TOYS, NATURE TOYS, ANIMAL TOYS, APPAREL; OPERATING AN ONLINE SHOPPING SITE IN THE FIELD OF TOYS, PETS, PET SUPPLIES, APPAREL; RETAIL APPAREL STORES; RETAIL CLOTHING STORES; RETAIL STORE SERVICES FEATURING PETS, TOYS, APPAREL; RETAIL STORES FEATURING PETS, PET FOOD, PET SUPPLIES, PET ACCESSORIES, GENERAL TOYS, NATURE TOYS, ANIMAL TOYS, APPAREL (U.S. CLS. 100, 101 AND 102).

SANI KHOURI, EXAMINING ATTORNEY

SN 77-219,078. YMC LIMITED, LONDON, UNITED KINGDOM, FILED 6-29-2007.

YMC - YOUMUSTCREATE

THE MARK CONSISTS OF STANDARD CHARACTERS WITHOUT CLAIM TO ANY PARTICULAR FONT, STYLE, SIZE, OR COLOR.

CLASS 18—LEATHER GOODS

FOR BAGS, NAMELY, HOLDALL BAGS, SACHEL BAGS, DUFFLE BAGS, RUCKSACKS, COURIER AND MESSENGER BAGS, ALL PURPOSE ATHLETIC BAGS AND HANDBAGS (U.S. CLS. 1, 2, 3, 22 AND 41).
FIRST USE 0-0-1996; IN COMMERCE 0-0-1998.

CLASS 25—CLOTHING

FOR CLOTHING, NAMELY, JACKETS, COATS, TROUSERS, SHIRTS, SWEATSHIRTS, SWEAT PANTS, T-SHIRTS, BELTS, SCARVES, KNITWEAR, NAMELY, SWEATERS, SCARVES AND GLOVES, HEADGEAR, NAMELY, HATS AND FOOTWEAR, NAMELY, SHOES AND BOOTS (U.S. CLS. 22 AND 39).
FIRST USE 0-0-1996; IN COMMERCE 0-0-1998.
JESSICA FATHY, EXAMINING ATTORNEY

SN 77-224,780. HEALTHWAYS, INC., NASHVILLE, TN. FILED 7-9-2007.

HEALTHWAYS

THE MARK CONSISTS OF STANDARD CHARACTERS WITHOUT CLAIM TO ANY PARTICULAR FONT, STYLE, SIZE, OR COLOR.
OWNER OF U.S. REG. NOS. 3,226,699 AND 3,294,917.

CLASS 9—ELECTRICAL AND SCIENTIFIC APPARATUS

FOR COMPUTER SOFTWARE FOR USE IN DATABASE MANAGEMENT FOR MEDICAL RECORDS (U.S. CLS. 21, 23, 26, 36 AND 38).
FIRST USE 9-0-2005; IN COMMERCE 9-0-2005.

CLASS 42—SCIENTIFIC AND COMPUTER SERVICES

FOR APPLICATION SERVICE PROVIDER SERVICES, FEATURING SOFTWARE FOR USE IN DATABASE MANAGEMENT FOR MEDICAL RECORDS (U.S. CLS. 100 AND 101).
FIRST USE 9-0-2005; IN COMMERCE 9-0-2005.
DEZMONA MIZELLE, EXAMINING ATTORNEY

SN 77-233,632. CONSEAL INTERNATIONAL INCORPORATED, NORWOOD, MA. FILED 7-19-2007.

HOT SHOTS

THE MARK CONSISTS OF STANDARD CHARACTERS WITHOUT CLAIM TO ANY PARTICULAR FONT, STYLE, SIZE, OR COLOR.

CLASS 5—PHARMACEUTICALS

FOR NUTRITIONALLY-FORTIFIED WATER; VITAMIN-ENRICHED WATER; NUTRITIONALLY-FORTIFIED BEVERAGES, NAMELY, HERBAL SUPPLEMENT BEVERAGES AND NUTRITIONAL SUPPLEMENT BEVERAGES (U.S. CLS. 6, 18, 44, 46, 51 AND 52).

FIRST USE 7-10-2007; IN COMMERCE 7-10-2007.

CLASS 30—STAPLE FOODS

FOR HERBAL FOOD BEVERAGES IN THE NATURE OF HERBAL SUPPLEMENT BEVERAGES (U.S. CL. 46).

FIRST USE 7-10-2007; IN COMMERCE 7-10-2007.
BRIAN CALLAGHAN, EXAMINING ATTORNEY

CLASS 30—STAPLE FOODS

FOR FOOD FLAVOURINGS AND SEASONINGS; HERBAL FOOD BEVERAGES; FLAVOURINGS FOR BEVERAGES; COFFEE, MIXTURES OF COFFEE AND CHICORY, COFFEE ESSENCES; COFFEE EXTRACTS; COFFEE SUBSTITUTES, COFFEE PREPARATIONS, NAMELY, COFFEE BASED BEVERAGES; DRINKS CONTAINING COFFEE; CHICORY AND CHICORY MIXTURES, ALL FOR USE AS SUBSTITUTES FOR COFFEE; COCOA, COCOA PRODUCTS, COCOA POWDER, DRINKING CHOCOLATE, BEVERAGES MADE FROM OR CONTAINING CHOCOLATE, BEVERAGES MADE FROM OR CONTAINING COCOA, PREPARATIONS FOR MAKING CHOCOLATE OR COCOA BASED DRINKS; TEA, HERBAL TEA, TEA, BLACK TEA, GREEN TEA, FRUIT TEA, FRUIT AND HERBAL FLAVOURED TEA, TEA ESSENCES, TEA EXTRACTS, INSTANT TEA, TEA MIXTURES; COFFEE, COCOA, DRINKING CHOCOLATE; HERBAL INFUSIONS FOR MAKING BEVERAGES; CUSTARD POWDER; BLANCMANGE; BAKING POWDER; FLOUR, FLOUR CONCENTRATE, BRAN, WHEATGERM; YEAST; RUSKS; CEREALS AND PREPARATIONS MADE FROM CEREALS, BREAKFAST CEREAL BARS; BREAD, BREAD CRUMBS, PASTRY; BAKERY PRODUCTS, FARINACEOUS PRODUCTS AND PREPARATIONS; PASTRIES AND CONFECTIONERY, NAMELY, PASTILLES; GRANOLA BASED SNACK BARS; CHEWING GUM; TARTS; BISCUITS; COOKIES, CAKES; PREPARED MEALS CONSISTING PRIMARILY OF PASTA OR RICE; CEREAL BASED SNACK FOOD; CHOCOLATE, CHOCOLATE BARS, CHOCOLATES AND CONFECTIONERY, NAMELY, PASTILLES; PROCESSED CULINARY HERBS, SPICES; SUGAR, RICE, TAPIOCA, SAGO; FRUIT ICES; HONEY; TREACLE; SALT, MUSTARD, PEPPER, VINEGAR, SAUCES; ICE; ICE CREAM, ICE CREAM CONFECTIONS; WATER ICES AND FROZEN CONFECTIONS; ICED TEA, CARBONATED TEA, TEA-BASED BEVERAGES; TEA-BASED BEVERAGES WITH FRUIT FLAVORING (U.S. CL. 46).

SN 77-240,138. QUERCEGEN PHARMA LLC, NEWTON, MA. FILED 7-26-2007.

QB3C

THE MARK CONSISTS OF STANDARD CHARACTERS WITHOUT CLAIM TO ANY PARTICULAR FONT, STYLE, SIZE, OR COLOR.

CLASS 5—PHARMACEUTICALS

FOR DIETETIC FOOD SUPPLEMENTS, FOOD AND NUTRITIONAL SUPPLEMENTS, VITAMINS, MINERAL SUPPLEMENTS, HERBAL SUPPLEMENTS; DIETARY SUPPLEMENTAL DRINKS; DIETARY SUPPLEMENTS; HOMEOPATHIC SUPPLEMENTS; MEAL REPLACEMENT AND DIETARY SUPPLEMENT DRINK MIXES; MEAL REPLACEMENT BARS; MEAL REPLACEMENT DRINKS; NUTRACEUTICALS FOR USE AS A DIETARY SUPPLEMENT; NUTRITIONAL ADDITIVES FOR MEDICAL PURPOSES FOR USE IN FOODS AND DIETARY SUPPLEMENTS FOR HUMAN CONSUMPTION; NUTRITIONAL DRINK MIX FOR USE AS A MEAL REPLACEMENT; SOY PROTEIN FOR USE AS A NUTRITIONAL INGREDIENT; MEDICATED CONFECTIONERY, MEDICATED CHEWING GUM; HERBAL TEA FOR MEDICINAL PURPOSES; MEDICATED BEVERAGES; NUTRITIONALLY FORTIFIED BEVERAGES; NUTRITIONAL ADDITIVES FOR MEDICAL PURPOSES FOR USE IN BEVERAGES FOR HUMAN CONSUMPTION (U.S. CLS. 6, 18, 44, 46, 51 AND 52).

CLASS 32—LIGHT BEVERAGES

FOR BREWED MALT-BASED ALCOHOLIC BEVERAGES IN THE NATURE OF A BEER, PREPARATIONS FOR MAKING MALTED BEVERAGES; NON-ALCOHOLIC FRUIT JUICE BEVERAGES; AERATED WATERS, TABLE WATERS, MINERAL WATERS; FRUIT JUICES, FRUIT BEVERAGES, NON-ALCOHOLIC BEVERAGES, NAMELY, SPORTS DRINKS, SOFT DRINKS, CARBONATED BEVERAGES AND SOY-BASED BEVERAGES NOT BEING MILK SUBSTITUTES; ENERGY DRINKS; PREPARATIONS FOR MAKING FRUIT BEVERAGES, ENERGY DRINKS, SOFT DRINKS, SPORTS BEVERAGES AND NON-ALCOHOLIC BEVERAGES WITH TEA FLAVOR; NON-ALCOHOLIC MALT BEVERAGES; PREPARATIONS FOR MAKING MALTED BEVERAGES; NON-ALCOHOLIC FRUIT JUICE-BASED BEVERAGES (U.S. CLS. 45, 46 AND 48).

LESLIE RICHARDS, EXAMINING ATTORNEY

SN 77-250,122. PARTNERSHIP PROPERTIES INCORPORATED, DBA THE RAYMOND AARON GROUP, RICHMOND HILL, CANADA, FILED 8-8-2007.

MAINLY

THE MARK CONSISTS OF STANDARD CHARACTERS WITHOUT CLAIM TO ANY PARTICULAR FONT, STYLE, SIZE, OR COLOR.

PRIORITY CLAIMED UNDER SEC. 44(D) ON CANADA APPLICATION NO. 1334620, FILED 2-8-2007, REG. NO. TMA714582, DATED 5-16-2008, EXPIRES 5-16-2023.

CLASS 9—ELECTRICAL AND SCIENTIFIC APPARATUS

FOR PRE-RECORDED DVDS, CDS, VIDEO AND AUDIO TAPES, FEATURING INFORMATION IN THE FIELDS OF SELF-HELP, SELF-IMPROVEMENT, PERSONAL GROWTH, BUSINESS GROWTH, AND FINANCIAL SECURITY (U.S. CLS. 21, 23, 26, 36 AND 38).

CLASS 16—PAPER GOODS AND PRINTED MATTER

FOR PRINTED PUBLICATIONS, NAMELY, PRINTED FORMS, WORKBOOKS, ARTICLES, BOOKS, AND MANUALS ALL IN THE FIELDS OF SELF-HELP, SELF-IMPROVEMENT, PERSONAL GROWTH, BUSINESS GROWTH, AND FINANCIAL SECURITY (U.S. CLS. 2, 5, 22, 23, 29, 37, 38 AND 50).

CLASS 35—ADVERTISING AND BUSINESS

FOR BUSINESS CONSULTATION SERVICES REGARDING BUSINESS GROWTH (U.S. CLS. 100, 101 AND 102).

CLASS 41—EDUCATION AND ENTERTAINMENT

FOR EDUCATIONAL AND ENTERTAINMENT SERVICES, NAMELY, LIVE PRESENTATIONS, LECTURES, AND SEMINARS IN THE FIELDS OF PERSONAL GROWTH, BUSINESS GROWTH, CAREER BUILDING, SELF IMPROVEMENT, AND PERSONAL EXCELLENCE; CAREER COUNSELING SERVICES (U.S. CLS. 100, 101 AND 107).

CLASS 45—PERSONAL AND LEGAL SERVICES

FOR COUNSELING REGARDING PERSONAL GROWTH, SELF-IMPROVEMENT, AND PERSONAL EXCELLENCE; PROVIDING INFORMATION REGARDING PERSONAL GROWTH, SELF-IMPROVEMENT, AND PERSONAL EXCELLENCE AND COUNSELING RELATED THERETO VIA THE INTERNET (U.S. CLS. 100 AND 101).

NORA BUCHANAN WILL, EXAMINING ATTORNEY

SN 77-250,238, AUSTRALASIAN CONFERENCE ASSOCIATION LIMITED, NEW SOUTH WALES, AUSTRALIA, FILED 8-8-2007.

EARTHSOWN

THE MARK CONSISTS OF STANDARD CHARACTERS WITHOUT CLAIM TO ANY PARTICULAR FONT, STYLE, SIZE, OR COLOR.

PRIORITY CLAIMED UNDER SEC. 44(D) ON AUSTRALIA APPLICATION NO. 1189832, FILED 7-27-2007, REG. NO. 1189832, DATED 7-27-2007, EXPIRES 7-27-2017.

CLASS 29—MEATS AND PROCESSED FOODS

FOR FOOD SPREADS, NAMELY, CHEESE SPREADS, FRUIT-BASED SPREADS, GARLIC-BASED SPREAD, HAZELNUT SPREAD, MEAT-BASED SPREADS, VEGETABLE-BASED SPREADS; PEANUT BUTTER; NUT BUTTERS; NUT CHEESE; SOY BASED SPREADS AND DIPS; NUT AND SEED SPREADS; PREPARED NUTS; NUT MEAT; NUT EXTRACTS; ROASTED NUTS; FLAVOURED NUTS; MALTED NUT POWDER; NUT PRODUCTS, NAMELY, NUT FLOUR, NUT TOPPINGS, NUT-BASED MILK, CANDIED NUTS; MEAT; FISH; POULTRY; GAME; MEAT EXTRACTS; MEAT SUBSTITUTES; FISH SUBSTITUTES; POULTRY SUBSTITUTES; GAME SUBSTITUTES; MEAT EXTRACT SUBSTITUTES; DAIRY PRODUCTS EXCLUDING ICE CREAM, ICE MILK AND FROZEN YOGURT; MILK; MILK BASED BEVERAGES CONTAINING FRUIT JUICE, FRUITS, SOY, OR CEREALS; MILK PRODUCTS, NAMELY, CONDENSED MILK, EVAPORATED MILK, FERMENTED MILK, HALF AND HALF, MILK POWDER; YOGHURT; YOGHURT SPREAD; WHEY; DAIRY SUBSTITUTES, NAMELY, SOY BASED DAIRY SUBSTITUTES, DAIRY SUBSTITUTES MADE PRIMARILY FROM SOY, DAIRY SUBSTITUTES MADE PRIMARILY FROM NUTS, DAIRY SUBSTITUTES MADE PRIMARILY FROM CEREALS, DAIRY SUBSTITUTES MADE PRIMARILY FROM RICE; MILK SUBSTITUTES, NAMELY, HEMP MILK, RICE MILK, OAT MILK; SOY BASED BEVERAGES, NAMELY, SOY BASED BEVERAGES FOR USE AS A MILK SUBSTITUTE, SOY BASED BEVERAGES CONTAINING FRUIT, SOY BASED BEVERAGES CONTAINING CEREALS, SOY BASED BEVERAGES CONTAINING RICE; SOY MILK; TOFU; PRODUCTS MADE FROM TOFU, NAMELY, FREEZE-DRIED TOFU PIECES, FRIED TOFU PIECES; PRESERVED SOY BEANS AND PRODUCTS MADE FROM PRESERVED SOY BEANS, NAMELY, SOY BEAN OIL, SOY BEAN PASTE; EGGS; EGG PRODUCTS, NAMELY, DRIED EGGS, EGG YOLKS, EGG WHITES; TOMATO JUICE FOR COOKING; TOMATO PUREE; VEGETABLE JUICE FOR COOKING; SOUP, BOUILLON, BEEF STOCK, FISH STOCK, VEAL STOCK, CHICKEN STOCK, VEGETABLE STOCK, BROTH AND PREPARATIONS FOR MAKING SOUP, BOUILLON, BEEF STOCK, FISH STOCK, VEAL STOCK, CHICKEN STOCK, VEGETABLE STOCK, BROTH; EDIBLE OILS; EDIBLE FATS; PROTEIN BEING FOODSTUFFS FOR HUMAN CONSUMPTION; TEXTURED VEGETABLE PROTEIN FOR USE AS A MEAT EXTENDER; SOY PROTEIN FOR USE AS A FOOD ADDITIVE; PREPARED MEALS CONSISTING PRIMARILY OF MEAT, FISH, POULTRY, VEGETABLES, SOY; FOOD BEVERAGES, NAMELY, DAIRY BASED FOOD BEVERAGES, FRUIT BASED FOOD BEVERAGES, VEGETABLE BASED FOOD BEVERAGES, PEANUT BASED FOOD BEVERAGES, SOY BASED FOOD BEVERAGES; CRYSTALLISED FRUIT; PRODUCTS MADE FROM POTATOES, NAMELY, FRIED POTATOES, POTATO CHIPS, POTATO CRISPS, POTATO DUMPLINGS, POTATO FRITTERS, POTATO PANCAKES, POTATO BASED GNOCCHI; BEVERAGES, NAMELY, DAIRY-BASED BEVERAGES, MILK BEVERAGES WITH HIGH MILK CONTENT, SOY BASED BEVERAGES; FRUIT BASED BEVERAGES; VEGETABLE BASED BEVERAGES; FRUIT BASED SPREADS; JELLIES; JAMS; COMPOTES; FRUIT SAUCES, NAMELY, APPLESAUCE AND CRANBERRY SAUCE; COOKED, DRIED, FROZEN, CRYSTALLISED, PROCESSED OR PRESERVED FRUITS; COOKED, DRIED, FROZEN, PROCESSED OR PRESERVED VEGETABLES; SNACKS PREPARED FROM FRUIT, NAMELY, CANDIED FRUIT SNACKS, DEHYDRATED FRUIT SNACKS, FRUIT BASED SNACK FOOD, FRUIT BASED FOOD BARS, FRUIT CHIPS, POTATO-BASED SNACK FOOD, VEGETABLE-BASED SNACK FOOD, CHEESE-BASED SNACK FOOD AND MEAT-BASED SNACK FOOD; COOKED, DRIED, FROZEN OR PRESERVED MEALS PREPARED FROM MEAT, FISH, POULTRY, GAMES, FRUITS AND VEGETABLES; VEGETABLE EXTRACTS; MIXTURES COMPRISED PRIMARILY OF DRIED FRUITS, PREPARED NUTS, SEEDS, MILK PRODUCTS, YOGURT, DAIRY SUBSTITUTES IN ANY COMBINATION OF THE FOREGOING, NAMELY, SNACK MIX CONSISTING PRIMARILY OF DRIED FRUITS, NUTS, SEEDS OR DAIRY SUBSTITUTES; PRESERVED LENTILS; VEGETARIAN CROQUETTES; VEGETARIAN MEALS CONSISTING PRIMARILY OF VEGETABLES, NOODLES OR SOY; PREPARED MEALS CONSISTING PRIMARILY OF VEGETABLES, NOODLES

OR SOY; SNACK FOODS, NAMELY, SOY-BASED FOOD BARS ALSO CONTAINING GRAIN, DRIED FRUIT, NUTS; MALTED NUT POWDER (U.S. CL. 46).

SN 77-250,853. IP4L PTY LTD, KIRRA, AUSTRALIA, FILED 8-9-2007.

LOCAL KNOWLEDGE

CLASS 30—STAPLE FOODS

FOR BREAKFAST CEREAL; CEREAL PREPARATIONS, NAMELY, CEREAL-BASED SNACK FOODS, READY-TO-EAT CEREALS, READY-TO-EAT CEREAL DERIVED FOOD BARS; PROCESSED CEREALS; FLOUR; BISCUITS; PASTRIES; COOKIES; CRACKERS; BREAD; CAKES; PREPARATIONS FOR MAKING CAKES IN THE NATURE OF CAKE MIXES; COFFEE; ARTIFICIAL COFFEE; COFFEE SUBSTITUTES; TEA; ARTIFICIAL TEA; COCOA; CHOCOLATE-BASED BEVERAGES NOT BEING DAIRY BASED OF VEGETABLE BASED; COCOA-BASED BEVERAGES; COFFEE-BASED BEVERAGES; SUGAR; HONEY; TREACLE; GOLDEN SYRUP; YEAST; BAKING POWDER; CORNFLAKES; CONFECTIONERY, NAMELY, EDIBLE ICES, FROZEN CONFECTIONERY, FRUIT JELLIES; CEREAL-BASED ENERGY BARS AND SNACK FOODS; RICE-BASED ENERGY BARS AND SNACK FOODS; FROZEN YOGURT; ICE CREAM; OAT FLAKES; PEANUT CONFECTIONERY; RICE; RICE CAKES; RICE PRODUCTS, NAMELY, RICE-BASED BEVERAGES, RICE NOODLES, RICE PUDDING, RICE-BASED SNACK FOODS; RICE MILK; SOY-BASED PRODUCTS, NAMELY, SOY-BASED ICE CREAM SUBSTITUTE, SOY SAUCE, SOY BEAN PASTE; YEAST EXTRACTS; YEAST SPREADS; PUFFED CORN SNACKS; CEREAL BASED SNACKS; CEREAL EXTRACTS; CEREAL-BASED BEVERAGES; CUSTARD; ICES; ICE; CONDIMENTS IN THE NATURE OF SAUCES; MUSTARD; GRAVY; MALT EXTRACT FOR FOOD; SEASONINGS OTHER THAN ESSENTIAL OILS; SPICES; FLAVOURINGS OTHER THAN ESSENTIAL OILS; FLAVOURINGS FOR BEVERAGES OTHER THAN ESSENTIAL OILS; CONDIMENTS, NAMELY, PEPPER SAUCE, PEPPER OIL; SALT, VINEGAR, PUDDINGS; COMBINED NUT AND CEREAL FOODS, NAMELY, BREAKFAST CEREALS, CEREAL DERIVED FOOD BARS; PREPARED FOODSTUFFS CONSISTING OF OR MADE SUBSTANTIALLY OF LEGUMES; MALTED WHEAT EXTRACT; FARINACEOUS FOODS, NAMELY, FARINA; FARINACEOUS FOOD PASTES FOR HUMAN CONSUMPTION; SNACK FOODS, NAMELY, WHEAT-BASED SNACK FOODS, CORN-BASED SNACK FOODS, GRAIN-BASED SNACK FOODS, RICE-BASED SNACK FOODS; PRESERVED GARDEN HERBS; SOY BEAN PASTE; SOY FLOUR; PASTA; NOODLES; PROCESSED SEMOLINA; SAGO; SUGAR AND NATURAL SWEETENERS; TAPIOCA; SALAD DRESSINGS; PREPARED MEALS CONSISTING PRIMARILY OF PASTA OR RICE; VEGETARIAN MEALS CONSISTING PRIMARILY OF PASTA AND VEGETABLES; VEGETARIAN MEALS CONSISTING PRIMARILY OF RICE; ALMOND PASTE; BEAN MEAL; FOOD BEVERAGES, NAMELY, HERBAL FOOD BEVERAGES, GRAIN-BASED FOOD BEVERAGES, CHOCOLATE FOOD BEVERAGES NOT BEING DAIRY BASED OR VEGETABLE BASED (U.S. CL. 46).

CLASS 32—LIGHT BEVERAGES

FOR SOY-BASED BEVERAGES NOT BEING A MILK SUBSTITUTE; SOY-BASED BEVERAGES CONTAINING FRUIT JUICE; SOY-BASED BEVERAGES CONTAINING FRUIT EXTRACTS; FRUIT JUICE; FRUIT NECTAR; TOMATO JUICE; VEGETABLE JUICE; SMOOTHIES; SPARKLING GRAPE JUICE; WATER; FRUIT WATER; AERATED WATER; FLAVOURED WATER; WHEY BEVERAGES; LEMONADE; SELTZER WATER; CARBONATED BEVERAGES; MINERAL WATER; FRUIT DRINKS; SYRUPS FOR MAKING BEVERAGES AND OTHER PREPARATIONS FOR MAKING FRUIT DRINKS, ISOTONIC BEVERAGES, FLAVOURED WATER, LEMONADE, SMOOTHIES, SPARKLING GRAPE JUICE, FRUIT WATER, WHEY BEVERAGES (U.S. CLS. 45, 46 AND 48).

PRISCILLA MILTON, EXAMINING ATTORNEY

THE MARK CONSISTS OF STANDARD CHARACTERS WITHOUT CLAIM TO ANY PARTICULAR FONT, STYLE, SIZE, OR COLOR.

PRIORITY CLAIMED UNDER SEC. 44(D) ON AUSTRALIA APPLICATION NO. 1161500, FILED 2-14-2007, REG. NO. 1161500, DATED 2-14-2007, EXPIRES 2-14-2017.

CLASS 3—COSMETICS AND CLEANING PREPARATIONS

FOR SOAPS, PERFUMERY, ESSENTIAL OILS, COSMETICS, NON-MEDICATED SKIN CARE PREPARATIONS AND HAIR LOTIONS (U.S. CLS. 1, 4, 6, 50, 51 AND 52).

CLASS 14—JEWELRY

FOR PRECIOUS METALS AND THEIR ALLOYS; GOODS OF PRECIOUS METALS AND THEIR ALLOYS, GOODS OF IMITATION PRECIOUS METALS, OR COATED THEREWITH, NAMELY, JEWELLERY, WATCHES AND CLOCKS; JEWELLERY; COSTUME JEWELLERY, EARRINGS; NECKLACES; JEWELLERY CHAINS; JEWELLERY AMULETS; JEWELLERY ANKLETS; BROOCHES, RINGS, CHARMS, JEWELLERY TRINKETS, NAMELY, EARRINGS, NECKLACES, ANKLETS, BROOCHES, RINGS AND CHARMS; JEWELLERY ORNAMENTS, NAMELY, PENDANTS, ORNAMENTAL PINS AND STUDS, CUFFLINKS, WRIST BANDS, COLLAR TIPS, BOOT CHAINS; PRECIOUS STONES AND SEMI-PRECIOUS STONES; HOROLOGICAL AND CHRONOMETRIC INSTRUMENTS, WATCHES AND CLOCKS, AND OTHER TIMEPIECES, AND PARTS OF THE AFOREGOING GOODS; WATCH ACCESSORIES, NAMELY, WATCH BANDS, WATCH CHAINS, WATCH STRAPS AND WATCH CASES; JEWELLERY CASES, JEWELLERY BOXES AND JEWELLERY POUCHES; MEDALLIONS, BADGES OF PRECIOUS METAL OR COATED THEREWITH; KEYRINGS, KEY CHAINS, KEY CASES, KEY TAGS AND KEY FOBs ALL OF PRECIOUS METAL; AND COASTERS OF PRECIOUS METAL; ALARM CLOCKS, TIE CLIPS, CLOCKS, ELECTRIC CLOCKS AND WATCHES, LIQUID CRYSTAL DISPLAY WATCHES, MOULDED FLIP TOP LIQUID CRYSTAL DISPLAY WATCHES, QUARTZ ANALOGUE WATCHES, GOLD AND SILVER GOODS, NAMELY, JEWELLERY, WATCHES AND CLOCKS; HAT ORNAMENTS OF PRECIOUS METAL, HOUSEHOLD CONTAINERS OF PRECIOUS METAL, HOUSEHOLD UTENSILS OF PRECIOUS METAL, NAMELY, BOTTLE STOPPERS; OBJECTS OF IMITATION GOLD, NAMELY, JEWELLERY, WATCHES AND CLOCKS; KEY RINGS, NECKLACES, ORNAMENTAL PINS, ORNAMENTS, JEWELLERY PINS, TIE PINS, PLATED ARTICLES, NAMELY, JEWELLERY, WATCHES AND CLOCKS; RINGS, STOPWATCHES (U.S. CLS. 2, 27, 28 AND 50).

CLASS 18—LEATHER GOODS

FOR GOODS MADE OF LEATHER, ANIMAL SKINS AND HIDES, AND IMITATIONS OF THE AFOREGOING MATERIALS, NAMELY, BAGS; CHAMOIS LEATHER OTHER THAN FOR CLEANING PURPOSES; BAGS, NAMELY, BEACH BAGS, SPORTS BAGS, ATHLETIC BAGS, BARREL BAGS, TOTE BAGS, BAGS OF LEATHER, ANIMAL SKINS AND HIDES, AND BAGS MADE OF IMITATIONS OF THE AFOREGOING MATERIALS, SHOPPING BAGS OF TEXTILE MATERIALS, CARRY-ALL BAGS, SHOPPING BAGS OF LEATHER, TEXTILE OR MESH, LEATHER BAGS FOR MERCHANDISE PACKAGING, TRAVEL GOODS, NAMELY, TRAVEL BAGS, GARMENT BAGS FOR TRAVEL, TRUNKS, LUGGAGE; LUGGAGE ARTICLES, NAMELY, LUG-

GAGE TAGS OF LEATHER AND LUGGAGE STRAPS, STRAPS FOR CARRYING SKIS, KNAPSACKS, BACKPACKS, WAISTPACKS, SCHOOL BAGS, SATCHELS, SHOULDER BAGS, WAIST BAGS, HAND BAGS, CLUTCH BAGS, WALLETS, PURSES; CASES, NAMELY, TRAVEL CASES, OVERNIGHT CASES, BRIEF CASES, DOCUMENT CASES, CREDIT CARD CASES, BUSINESS CARD CASES, COSMETIC, TOILETRY AND VANITY CASES ALL SOLD EMPTY, JEWELLERY ORGANIZERS FOR TRAVEL, KEY CASES, KEY HOLDERS, KEY FOBs, AND KEY TAGS, KEY RINGS, ALL BEING OF LEATHER, ANIMAL HIDES AND IMITATIONS THEREOF IN THIS CLASS; UMBRELLAS AND UMBRELLA COVERS (U.S. CLS. 1, 2, 3, 22 AND 41).

CLASS 24—FABRICS

FOR TEXTILE FABRICS FOR MANUFACTURING CLOTHING; FABRICS FOR TEXTILE USE; GOODS OF PLASTIC MATERIAL AS A SUBSTITUTE FOR FABRICS, NAMELY, SEMI-FINISHED PLASTIC PRODUCTS, NAMELY, WOVEN ARAMID FABRICS FOR USE IN THE MANUFACTURE OF PROTECTIVE CLOTHING AND HELMETS AND IN HARD ARMOUR; GOODS OF TEXTILES, FABRIC OR PLASTIC MATERIALS, NAMELY, TOWELS, BATH LINEN AND BED LINEN; TEXTILE LABELS LININGS OF TEXTILE FOR GARMENTS; TOWELS, NAMELY, BEACH TOWELS; BATH LINEN, BED LINEN, LINEN BED AND TABLE COVERS; TABLE LINEN, NAMELY, TABLE CLOTHS, PLACE-MATS, SERVIETTES AND NAPKINS; CLOTH COASTERS; UNFITTED FABRIC FURNITURE COVERINGS; CUSHION COVERS; FABRIC WINDOW COVERINGS, CURTAINS, BLINDS; BANNERS; FABRIC FLAGS; TEXTILE LABELS; WASHING MITTS; NONE OF THE FOREGOING GOODS BEING WALL HANGINGS (U.S. CLS. 42 AND 50).

CLASS 25—CLOTHING

FOR CLOTHING, OUTWEAR AND UNDERWEAR FOR MEN, WOMEN, CHILDREN AND INFANTS, NAMELY, SURFWEAR, SKIWEAR AND SNOWBOARD WEAR; CLOTHING FOR SKATEBOARDING, NAMELY, SKATE BOARDING WEAR IN THE NATURE OF BEANIES, HATS, SHOES, SOCKS, SHIRTS, SWEATSHIRTS, JACKETS, SHORTS, PANTS, JEANS, SKIRTS AND DRESSES; BODYSUITS, TRACKSUITS, TRACKSUIT TOPS AND TRACKSUIT TROUSERS; SWEAT TOPS, SWEAT BANDS, BEACHWEAR, SWIMWEAR, BATHROBES, UNDERWEAR AND SLEEPWEAR, HOSIERY; FASHION ACCESSORIES, NAMELY, BELTS, GLOVES AND MITTENS, SCARVES, TIES, DECORATIVE STRAPS FOR BRAS; FOOTWEAR, NAMELY, SOCKS, SHOES, BOOTS, SANDALS, THONGS, SLIDES AND SLIPPERS, PARTS OF FOOTWEAR, NAMELY, TRACTION AND NON SLIP DEVICES FOR BOOTS AND SHOES; HEADGEAR, NAMELY, HATS, CAPS, BEANIES, BANDANAS, HEADBANDS, PEAKS AND VISORS; RASH GUARDS, NAMELY, RASH SHIRTS AND RASH VESTS; WETSUITS, WETSUIT VESTS, WETSUIT BOOTS, WETSUIT GLOVES, WETSUIT HOODS, WETSUIT SHORTS AND WETSUIT TOPS, MONEY BELTS (U.S. CLS. 22 AND 39).

CLASS 28—TOYS AND SPORTING GOODS

FOR SPORTING GOODS, NAMELY, SURFBOARDS, BODYBOARDS, KNEEBOARDS, WAKEBOARDS, SAILBOARDS AND KITEBOARDS, SNOWBOARDS AND SKIS, PARTS AND FITTINGS FOR THE AFORESAID GOODS; FINS AND FIN BOXES FOR SURFBOARDS, DECKGRIPS FOR SURFBOARDS, BAGS AND COVERS SPECIFICALLY DESIGNED FOR SURFBOARDS; BAGS FOR BODYBOARDS, KNEEBOARDS, WAKEBOARDS, SAILBOARDS AND KITEBOARDS, SNOWBOARDS AND SKIS; SKI AND SURFBOARD WAX; LEASHES FOR SURFBOARDS, BODYBOARDS, KNEEBOARDS, WAKEBOARDS, SAILBOARDS AND KITEBOARDS; SPORTS GUARDS, NAMELY, ELBOW GUARDS, KNEE GUARDS, WRIST GUARDS, PROTECTIVE PADDING FOR PLAYING CRICKET, BASKETBALL, SOCCER AND FOOTBALL; GAMES, NAMELY, FINGERBOARDS, NOVELTY TOYS, NAMELY, FAKE TEETH; REMOTE CONTROL TOYS, NAMELY, CARS, RACE CARS, BOATS, AEROPLANES AND HELICOPTERS; MECHANICAL NOVELTY TOYS AND MECHANICAL TOYS COMPRISING GAMES; COIN OPERATED VIDEO

GAMES; ELECTRONIC GAMES, NAMELY, ELECTRONIC DART GAMES, ELECTRONIC EDUCATION GAMES AND MACHINES FOR CHILDREN; ELECTRONIC GAME TOY, NAMELY, BATTERY-POWERED COMPUTER GAME WITH LCD SCREEN WHICH FEATURES ANIMATION AND SOUND EFFECTS; PORTABLE GAMES THAT INCLUDE A BUILT-IN DISPLAY; BOARD GAMES; BALLS FOR GAMES AND SPORTS; PUZZLES, NAMELY, JIGSAW PUZZLES; TARGETS; YO YOS; SPINNING TOPS; FLYING DISCS AND SAUCERS, PLAYING CARDS; TOY MASKS; BALLOONS; TOY MOBILE; KITES; PARTS AND FITTINGS FOR ALL OF THE AFOREGOING GOODS; NONE OF THE AFOREGOING GOODS BEING STUFFED TOYS OR GOODS MADE FROM ANIMAL FUR (U.S. CLS. 22, 23, 38 AND 50).

CLASS 32—LIGHT BEVERAGES

FOR NON-ALCOHOLIC BEVERAGES, NAMELY, DRINKING WATER, FLAVOURED WATER, FLAVOURED COCONUT MILK, FRUIT JUICES, VEGETABLE JUICES, SODA POPS (U.S. CLS. 45, 46 AND 48).
CAROLINE WOOD, EXAMINING ATTORNEY

SN 77-260,089. CYTIVA SOFTWARE INC., EMERYVILLE, CA. FILED 8-20-2007.

SONICPERFORM

THE MARK CONSISTS OF STANDARD CHARACTERS WITHOUT CLAIM TO ANY PARTICULAR FONT, STYLE, SIZE, OR COLOR.

PRIORITY CLAIMED UNDER SEC. 44(D) ON CANADA APPLICATION NO. 1349154, FILED 5-28-2007, REG. NO. TMA722,020, DATED 8-26-2008, EXPIRES 8-26-2023.

CLASS 9—ELECTRICAL AND SCIENTIFIC APPARATUS

FOR DOWNLOADABLE COMPUTER SOFTWARE FOR THE PURPOSE OF PERSONNEL MANAGEMENT, MANAGEMENT OF STAFF PERFORMANCE, MANAGEMENT OF HUMAN RESOURCES DEPARTMENT PERFORMANCE, KNOWLEDGE MANAGEMENT IN THE FIELD OF HUMAN RESOURCES THEORY, PRACTICE, AND DOCUMENT MANAGEMENT; COMPUTER SOFTWARE FOR DATABASE MANAGEMENT USED TO ELECTRONICALLY DISSEMINATE CLIENT PROFILES OVER THE INTERNET IN THE FIELD OF HUMAN RESOURCES MANAGEMENT; COMPUTER SOFTWARE FOR HOSTING CORPORATE CAREER WEBSITES (U.S. CLS. 21, 23, 26, 36 AND 38).

CLASS 35—ADVERTISING AND BUSINESS

FOR PROVIDING A WEBSITE FEATURING BUSINESS INFORMATION IN THE FIELD OF HUMAN RESOURCES MANAGEMENT; PROVIDING BUSINESS INFORMATION IN THE FIELD OF HUMAN RESOURCES MANAGEMENT, NAMELY, SYSTEMATIZATION OF INFORMATION INTO COMPUTER DATABASES; CONSULTANCY IN THE FIELD OF BUSINESS SYSTEMS ANALYSIS AND DESIGN; CONSULTANCY IN THE FIELD OF HUMAN RESOURCES; BUSINESS RESEARCH AND ANALYSIS IN THE FIELD OF HUMAN RESOURCES MANAGEMENT; DATABASE COMPILATION AND MANAGEMENT (U.S. CLS. 100, 101 AND 102).

CLASS 42—SCIENTIFIC AND COMPUTER SERVICES

FOR PROVIDING ONLINE NON-DOWNLOADABLE COMPUTER SOFTWARE FOR PERSONNEL MANAGEMENT, MANAGEMENT OF STAFF PERFORMANCE, MANAGEMENT OF HUMAN RESOURCES DEPARTMENT PERFORMANCE, KNOWLEDGE MANAGEMENT IN THE FIELD OF HUMAN RESOURCES THEORY, PRACTICE, AND DOCUMENT MANAGEMENT; INFORMATION TECHNOLOGY SYSTEMS CONSULTATION; APPLICATION SERVICE PROVIDER FEATURING SOFTWARE FOR MANAGING PERSONNEL DATA FOR USE IN HUMAN RESOURCES MANAGEMENT (U.S. CLS. 100 AND 101).

DAVID TOOLEY, EXAMINING ATTORNEY

SN 77-260,449. BAUMER HOLDING AG, FRAUENFELD, SWITZERLAND, FILED 8-21-2007.

VeriFlash

THE MARK CONSISTS OF STANDARD CHARACTERS WITHOUT CLAIM TO ANY PARTICULAR FONT, STYLE, SIZE, OR COLOR.

PRIORITY CLAIMED UNDER SEC. 44(D) ON ERP N CMNTY TM OFC APPLICATION NO. 005708731, FILED 2-22-2007, REG. NO. 005708731, DATED 1-25-2008, EXPIRES 2-22-2017.

SN 77-260,395. HLS ECOLO INC., TORONTO, CANADA, FILED 8-21-2007.



PRIORITY CLAIMED UNDER SEC. 44(D) ON CANADA APPLICATION NO. 1337057, FILED 2-26-2007, REG. NO. TMA729,677, DATED 11-27-2008, EXPIRES 11-27-2023.

OWNER OF U.S. REG. NO. 1,636,633.

NO CLAIM IS MADE TO THE EXCLUSIVE RIGHT TO USE "SYSTEMS INC. COMPANY", APART FROM THE MARK AS SHOWN.

THE STIPPLING IS A FEATURE OF THE MARK AND DOES NOT INDICATE COLOR.

THE MARK CONSISTS OF THE PHRASE "HLS ECOLO" WRITTEN WITHIN AN OVAL. THE LEFT SIDE OF THE OVAL IS WHITE AND THE RIGHT SIDE IS BLACK; THE TWO ELEMENTS ARE SEPARATED BY A CIRCLE-OVAL DESIGN. THE PHRASE "A HYDRALOGIC SYSTEMS INC. COMPANY" IS WRITTEN IN SMALLER LETTERS UNDERNEATH THE OVAL.

THE WORDING "ECOLO" HAS NO MEANING IN A FOREIGN LANGUAGE.

CLASS 5—PHARMACEUTICALS

FOR ALL PURPOSE DEODORIZING PREPARATIONS FOR COMMERCIAL USE (U.S. CLS. 6, 18, 44, 46, 51 AND 52).

FIRST USE 2-23-2006; IN COMMERCE 2-23-2006.

CLASS 11—ENVIRONMENTAL CONTROL APPARATUS

FOR DEODORIZING MACHINES FOR COMMERCIAL USE (U.S. CLS. 13, 21, 23, 31 AND 34).

FIRST USE 2-23-2006; IN COMMERCE 2-23-2006.

CLASS 37—CONSTRUCTION AND REPAIR

FOR SERVICING OF DEODORIZING MACHINES FOR COMMERCIAL USE (U.S. CLS. 100, 103 AND 106).

FIRST USE 2-23-2006; IN COMMERCE 2-23-2006.

CLASS 40—MATERIAL TREATMENT

FOR CONSULTATION SERVICES IN THE FIELD OF ODOR CONTROL (U.S. CLS. 100, 103 AND 106).

FIRST USE 2-23-2006; IN COMMERCE 2-23-2006.

NATALIE POLZER, EXAMINING ATTORNEY

CLASS 9—ELECTRICAL AND SCIENTIFIC APPARATUS

FOR APPARATUS AND INSTRUMENTS FOR WEAK-CURRENT ENGINEERING, NAMELY, APPARATUS FOR TELECOMMUNICATIONS, HIGH-FREQUENCY ENGINEERING AND CONTROL ENGINEERING, NAMELY, CHANGE-OVER SWITCHES, COMPUTER HARDWARE, ELECTRIC CAPACITORS, ELECTRIC RESISTORS, ELECTRICAL TRANSFORMERS, FUSES, INDICATOR LIGHTS, MICROPHONES, MOUNTING RACKS FOR TELECOMMUNICATIONS HARDWARE, PICKUPS, SIGNAL BAND SEPARATORS, CABLES, EXCHANGERS, SWITCHES, TOWERS, TRANSMITTERS, ELECTRONIC TEST AND MEASUREMENT DEVICES FOR USE IN THE FIELDS OF NETWORKS AND TELECOMMUNICATIONS, NAMELY, INSTRUMENTATION USED TO TEST AND CERTIFY NEW AND EXISTING DATA AND VOICE COMMUNICATION CABLE AND COAXIAL CABLE, ELECTRONIC TESTING EQUIPMENT, NAMELY, TELECOMMUNICATION LINE INTEGRITY TESTING APPARATUS, TELECOMMUNICATIONS AND DATA NETWORKING HARDWARE, NAMELY, DEVICES FOR TRANSPORTING AND AGGREGATING VOICE, DATA, AND VIDEO COMMUNICATIONS ACROSS MULTIPLE NETWORK INFRASTRUCTURES AND COMMUNICATIONS PROTOCOLS, HIGH FREQUENCY SWITCHES, HIGH FREQUENCY SWITCHING POWER SUPPLIES, AUTOMATED PROCESS CONTROL SYSTEM, NAMELY, MICROPROCESSOR BASED HARDWARE AND SOFTWARE USED TO MONITOR THE STATUS OF INDUSTRIAL PROCESSES AND/OR MACHINERY, NAMELY, TURBINES, GENERATORS, COMPRESSORS, POWER GENERATION, ELECTRICAL DISTRIBUTION, MATERIALS PROCESSING, PACKAGING AND HANDLING, ELECTRONIC CONTROL SYSTEMS FOR MACHINES; DIGITAL CAMERAS, DIGITAL SENSORS; DATA PROCESSORS, COMPUTERS, PCI INTERFACE BOARDS, COMPUTER SOFTWARE IN THE FIELD OF CONTROL ENGINEERING, MEASURING TECHNIQUES, TELECOMMUNICATIONS; DRIVERS, IN PARTICULAR FOR SENSORS AND ACTUATORS, CONTROLLING SOFTWARE FOR MACHINES AND ROBOTS, SOFTWARE FOR TRANSMISSION OF SIGNALS, OPERATING SYSTEMS FOR MACHINES; ANALOG AND DIGITAL SENSORS, IN PARTICULAR PRESSURE SENSORS, FORCE SENSORS, STRAIN SENSORS, STRAIN TRANSFORMERS, STRAIN MEASURING DEVICES, NAMELY, STRAIN GAUGES AND APPARATUS FOR PHOTO ELASTICITY; SURFACE STRAIN SENSORS, PRESSURE TRANSDUCERS, PRESSURE TRANSMITTERS, TRANSVERSE STRAIN MEASURING DEVICES, PRESSURE SWITCHES, EXTENSOMETERS, PIEZOELECTRIC SENSORS, BRIDGE AMPLIFIERS; INDUCTIVE SENSORS, PROXIMITY SWITCHES, MAGNETIC FIELD SENSORS, HALL-EFFECT SENSORS, INDUCTIVE CODE READERS, HIGH TEMPERATURE SENSORS; DISPLACEMENT SENSORS, DISPLACEMENT TRANSDUCERS, DISPLACEMENT TRANSMITTERS, INDUCTIVE DISPLACEMENT TRANSDUCERS, DISTANCE SENSORS; CAPACITIVE SENSORS, CAPACITIVE PROXIMITY SWITCHES, CAPACITIVE LEVEL SENSORS, CAPACITIVE HIGH TEMPERATURE SENSORS; ACTUATORS, POSITION DRIVES; OPTICAL SENSORS, LASER SCANNERS, REFLECTION LIGHT SCANNERS, LASER SENSORS, DISTANCE SENSORS; RETRO-REFLECTIVE

SENSORS, THROUGH BEAM SENSORS, FORKED SENSORS; LIGHT GUIDE APPARATUS, FIBER-OPTIC LIGHT GUIDES AND PLASTIC LIGHT GUIDES, ALL BEING LIGHT CONDUCTING FILAMENTS; LASER COPY COUNTERS, COLOR SENSORS, LINE SENSORS, ELECTRIC SHAPE CONVERTERS; ROTARY ENCODERS, MAGNETIC ROTARY ENCODERS, MULTITURN ROTARY ENCODERS, MAGNETIC SENSORS, ABSOLUTE ROTARY ENCODERS, ANGLE SENSORS, HOLLOW SHAFT ROTARY ENCODERS, SHAFT ROTARY ENCODERS, LINEAR DISPLACEMENT TRANSDUCERS, ELECTRONIC INTERPOLATION SYSTEMS, NAMELY, FOR SENSORS AND ACTUATOR DRIVES; ELECTRICAL CONTROLLERS, ELECTRICAL PROCESS CONTROLLERS, ELECTRICAL PRECISION SWITCHES, PRECISION SCANNERS; IDENTIFICATION SENSORS FOR RECORDING THE LOCATION, POSITION, MOVEMENT OR SIZE OF PERSONS, OBJECTS AND EQUIPMENT; IDENTIFICATION SENSORS FOR RECORDING ENCODED DATA, INFORMATION AND SIGNALS; IDENTIFICATION SENSORS FOR RECORDING CHARACTERS AND IMAGES (U.S. CLS. 21, 23, 26, 36 AND 38).

CLASS 42—SCIENTIFIC AND COMPUTER SERVICES

FOR SCIENTIFIC AND INDUSTRIAL RESEARCH AND DEVELOPMENT IN THE FIELD OF SENSOR TECHNOLOGY AND OPTICAL INFORMATION CAPTURE AND PROCESSING; COMPUTER PROGRAMMING, IN PARTICULAR FOR DIGITAL INFORMATION CAPTURE BY MEANS OF SENSORS AND THE ACTIVATION OF ACTUATORS; TECHNICAL CONSULTANCY IN THE FIELDS OF SENSOR TECHNOLOGY, AUTOMATION TECHNOLOGY (U.S. CLS. 100 AND 101).

PAUL F. GAST, EXAMINING ATTORNEY

SN 77-274,473. AMERICAN ASSOCIATION FOR DENTAL RESEARCH, ALEXANDRIA, VA. FILED 9-7-2007.



THE MARK CONSISTS OF A DESIGN FEATURED TO THE LEFT OF THE LETTERS "AADR" AND ABOVE THE WORDS "AMERICAN ASSOCIATION FOR DENTAL RESEARCH"; THE DESIGN ELEMENT OF THE MARK IS AN INCOMPLETE TRIANGLE FEATURING ANGLES, AKIN TO A CHEVRON, WITH TWO CURVED BARS OR SWIRLS, THE COMPLETE DESIGN ELEMENT OF THE MARK BEING A ROUGH GEOMETRIC FIGURE REPRESENTING OR FORMING THE LETTER "A".

SEC. 2(F).

CLASS 35—ADVERTISING AND BUSINESS

FOR ASSOCIATION SERVICES, NAMELY, PROMOTING SCIENTIFIC RESEARCH IN ALL BRANCHES OF DENTAL AND RELATED SCIENCES (U.S. CLS. 100, 101 AND 102).

CLASS 42—SCIENTIFIC AND COMPUTER SERVICES

FOR PROVIDING, WITHIN THE SCIENTIFIC COMMUNITY, THE DENTAL PROFESSIONS AND THE PUBLIC, RESEARCH RESULTS AND OTHER SCIENTIFIC INFORMATION IN CONNECTION WITH SCIENTIFIC RESEARCH IN ALL BRANCHES OF DENTAL AND RELATED SCIENCES (U.S. CLS. 100 AND 101).

DEZMONA MIZELLE, EXAMINING ATTORNEY

SN 77-282,154. FORE! CME, LLC, WESTON, FL. FILED 9-18-2007.

FORECME

THE MARK CONSISTS OF STANDARD CHARACTERS WITHOUT CLAIM TO ANY PARTICULAR FONT, STYLE, SIZE, OR COLOR.

CLASS 35—ADVERTISING AND BUSINESS

FOR BUSINESS MEETING PLANNING; DISPLAYING ADVERTISING FOR OTHERS; DIRECT MARKETING ADVERTISING, DISSEMINATION OF ADVERTISING FOR OTHERS VIA THE INTERNET; DISSEMINATION OF ADVERTISING MATERIAL; ELECTRONIC BILLBOARD ADVERTISING; PLACING ADVERTISEMENTS FOR OTHERS; PREPARING AND PLACING ADVERTISEMENTS FOR OTHERS; TRAVEL MANAGEMENT; ARRANGING AND CONDUCTING BUSINESS CONFERENCES FOR PHYSICIANS AND OTHER MEDICAL PROFESSIONALS; ARRANGING AND CONDUCTING BUSINESS CONFERENCES VIA GLOBAL COMPUTER NETWORKS FOR PHYSICIANS AND OTHER MEDICAL PROFESSIONALS; AND CONSULTING SERVICES IN THE FIELD OF HIGHER EDUCATION ADMINISTRATION (U.S. CLS. 100, 101 AND 102).

CLASS 41—EDUCATION AND ENTERTAINMENT

FOR SPECIAL EVENT PLANNING; SPECIAL EVENT CONSULTATION AND COORDINATION SERVICES; EDUCATIONAL SERVICES, NAMELY, PROVIDING ONE-ON-ONE MENTORING, MENTORING, TUTORING AND TUTORIAL SESSIONS IN THE FIELDS OF MEDICINE, TRAVEL, BUSINESS AND CONTINUING MEDICAL EDUCATION; EDUCATION SERVICES, NAMELY, PROVIDING CLASSES, SEMINARS, WORKSHOPS, AND PROGRAMS IN THE FIELD OF MEDICINE, TRAVEL AND BUSINESS; PHYSICAL EDUCATION SERVICES; MEDICAL EDUCATION SERVICES, NAMELY, ONE-ON-ONE MENTORING, MENTORING, TUTORING, TUTORIAL SESSIONS, COURSES, WORKSHOPS, SEMINARS AND CONTINUING EDUCATION COURSES; CONTINUING EDUCATION SERVICES, NAMELY, ONE-ON-ONE MENTORING, MENTORING, TUTORING, TUTORIAL SESSIONS, COURSES, WORKSHOPS, SEMINARS, AND PROGRAMS IN THE FIELD OF MEDICINE, TRAVEL AND BUSINESS; ARRANGING AND CONDUCTING EDUCATIONAL BUSINESS SYMPOSIUMS, SEMINARS AND PRESENTATIONS VIA GLOBAL COMPUTER NETWORKS FOR PHYSICIANS AND OTHER MEDICAL PROFESSIONALS IN THE FIELD OF HIGHER EDUCATION MANAGEMENT (U.S. CLS. 100, 101 AND 107).

KELLY BOULTON, EXAMINING ATTORNEY

SN 77-284,915. AMT SOLUTIONS, INC., DBA E-MDS, AUSTIN, TX. FILED 9-20-2007.

e-MDs

THE MARK CONSISTS OF STANDARD CHARACTERS WITHOUT CLAIM TO ANY PARTICULAR FONT, STYLE, SIZE, OR COLOR.

OWNER OF U.S. REG. NO. 2,569,571.

CLASS 9—ELECTRICAL AND SCIENTIFIC APPARATUS

FOR COMPUTER SOFTWARE FOR MEDICAL PRACTICE MANAGEMENT (U.S. CLS. 21, 23, 26, 36 AND 38).
FIRST USE 2-0-2000; IN COMMERCE 2-0-2000.

CLASS 42—SCIENTIFIC AND COMPUTER SERVICES

FOR CUSTOMIZATION OF COMPUTER SOFTWARE; CUSTOM DESIGN OF COMPUTER SOFTWARE FOR USE IN THE HEALTH CARE INDUSTRY; DEVELOPMENT, UPDATING AND MAINTENANCE OF SOFTWARE AND DATABASES; TECHNICAL SUPPORT SERVICES, NAMELY, TROUBLESHOOTING OF COMPUTER SOFTWARE PROBLEMS (U.S. CLS. 100 AND 101).
FIRST USE 2-0-2000; IN COMMERCE 2-0-2000.

CLASS 44—MEDICAL, BEAUTY AND AGRICULTURAL SERVICES

FOR PROVIDING A DATABASE OF MEDICAL TERMINOLOGY VIA THE INTERNET (U.S. CLS. 100 AND 101).
FIRST USE 2-0-2000; IN COMMERCE 2-0-2000.
RAUL CORDOVA, EXAMINING ATTORNEY

SN 77-303,383. GREEN MOUNTAIN PHASES, NEW YORK, NY. FILED 10-12-2007.

Green Mountain Phases

THE MARK CONSISTS OF STANDARD CHARACTERS WITHOUT CLAIM TO ANY PARTICULAR FONT, STYLE, SIZE, OR COLOR.

CLASS 35—ADVERTISING AND BUSINESS

FOR CONCEPT AND BRAND DEVELOPMENT SERVICES IN THE FIELD OF VIDEO PRODUCTION (U.S. CLS. 100, 101 AND 102).
FIRST USE 6-1-1999; IN COMMERCE 6-1-1999.

CLASS 41—EDUCATION AND ENTERTAINMENT

FOR PUBLISHING OF BOOKS, MAGAZINES ; PHOTOGRAPHY SERVICES ; MOTION PICTURE FILM PRODUCTION (U.S. CLS. 100, 101 AND 107).
FIRST USE 6-1-1999; IN COMMERCE 6-1-1999.
JENNIFER VASQUEZ, EXAMINING ATTORNEY

SN 77-306,149. FLORACRAFT CORPORATION, LUDINGTON, MI. FILED 10-17-2007.



OWNER OF U.S. REG. NO. 2,660,536.
NO CLAIM IS MADE TO THE EXCLUSIVE RIGHT TO USE "FLORAL", APART FROM THE MARK AS SHOWN.
THE MARK CONSISTS OF THE WORDS "FLORAL NECESSITIES" IN A RECTANGLE WITH A DEPICTION OF THREE FLOWERS IN A CONTAINER AND ONE FLOWER OUTSIDE OF THE CONTAINER IN THE UPPER LEFT CORNER OF THE RECTANGLE.

CLASS 16—PAPER GOODS AND PRINTED MATTER

FOR FLORAL AND CRAFT SUPPLIES SUITABLE FOR USE IN MAKING FLORAL ARRANGEMENTS, NAMELY, FLORAL CLAY, MOLDING CLAY, ADHESIVE TAPE, FLORIST WIRE, AND FLORAL PICKS (U.S. CLS. 2, 5, 22, 23, 29, 37, 38 AND 50).

CLASS 21—HOUSEWARES AND GLASS

FOR PLASTIC FLORAL CONTAINERS (U.S. CLS. 2, 13, 23, 29, 30, 33, 40 AND 50).
JENNY PARK, EXAMINING ATTORNEY

SN 77-313,234. INTS IT IS NOT THE SAME, GMBH, ZUG, SWITZERLAND, FILED 10-25-2007.

Dezigual

PRIORITY CLAIMED UNDER SEC. 44(D) ON SPAIN APPLICATION NO. 2769646, FILED 4-27-2007, REG. NO. 2.769.646/4, DATED 9-4-2007, EXPIRES 9-4-2017.

OWNER OF U.S. REG. NO. 2,088,319.
THE FOREIGN WORDING IN THE MARK TRANSLATES INTO ENGLISH AS UNEQUAL.

CLASS 3—COSMETICS AND CLEANING PREPARATIONS

FOR BLEACHING PREPARATIONS FOR HOUSEHOLD USE AND OTHER SUBSTANCES, NAMELY, LAUNDRY DETERGENT FOR LAUNDRY USE; CLEANING, POLISHING, SCOURING AND ABRASIVE PREPARATIONS; SOAPS; PERFUMERY, ESSENTIAL OILS, COSMETICS, HAIR LOTIONS; DENTIFRICES (U.S. CLS. 1, 4, 6, 50, 51 AND 52).

CLASS 9—ELECTRICAL AND SCIENTIFIC APPARATUS

FOR SUNGLASSES, SPECTACLE CASES, SPECTACLE FRAMES, SPORTS GLASSES, CONTACT LENSES, CASES FOR CONTACT LENSES, CHAINS AND CORDS FOR GLASSES, NAMELY, PINCE-NEZ; SCIENTIFIC, NAUTICAL, SURVEYING, PHOTOGRAPHIC, CINEMATOGRAPHIC, OPTICAL, WEIGHING, MEASURING, SIGNALING, CHECKING, SUPERVISION, LIFE-SAVING AND TEACHING APPARATUS AND INSTRUMENTS, NAMELY, SENSING AND SIGNALING DEVICES FOR MEASUREMENT AND QUALITY CONTROL OF MATERIALS PROCESSING BY LASER; APPARATUS AND INSTRUMENTS FOR CONDUCTING, SWITCHING, TRANSFORMING, ACCUMULATING, REGULATING OR CONTROLLING ELECTRICITY, NAMELY, SPLICES FOR ELECTRICAL TRANSMISSION LINES, POWER-LINE TRANSMISSION MACHINES AND APPARATUS; APPARATUS FOR RECORDING, TRANSMISSION OR REPRODUCTION OF SOUND OR IMAGES; BLANK MAGNETIC DATA CARRIERS, BLANK RECORD DISCS; AUTOMATIC VENDING MACHINES AND MECHANISMS FOR COIN-OPERATED APPARATUS; CASH REGISTERS, CALCULATING MACHINES, DATA PROCESSING EQUIPMENT AND COMPUTERS; FIRE-EXTINGUISHING APPARATUS (U.S. CLS. 21, 23, 26, 36 AND 38).

CLASS 18—LEATHER GOODS

FOR HANDBAGS, PURSES, TRAVELING BAGS, BACKPACKS, HAVERSACKS, TRAVELING SETS MADE OF LEATHER, NAMELY, SUITCASES; TRUNKS; UMBRELLAS; PARASOLS AND WALKING STICKS; PURSES MADE OF LEATHER; WHIPS, HARNESSES AND SADDLERY; WALLETS MADE OF LEATHER (U.S. CLS. 1, 2, 3, 22 AND 41).

CLASS 25—CLOTHING

FOR READY-MADE CLOTHING FOR WOMEN, MEN AND CHILDREN, NAMELY, PANTS, SHORTS, SHIRTS, T-SHIRTS, JACKETS, BLOUSES, SKIRTS, DRESSES; FOOTWEAR; HEADGEAR, NAMELY, HATS AND CAPS (U.S. CLS. 22 AND 39).

JESSICA A. POWERS, EXAMINING ATTORNEY

SN 77-314,651. DEJAJUJU, LLC, PINE, CO. FILED 10-26-2007.

DEJAJUJU

THE MARK CONSISTS OF STANDARD CHARACTERS WITHOUT CLAIM TO ANY PARTICULAR FONT, STYLE, SIZE, OR COLOR.

CLASS 17—RUBBER GOODS

FOR SEMI-FINISHED MODULAR AND SCALABLE ART BOARDS OF ACRYLIC MOLDED PLASTIC FOR FURTHER MANUFACTURE (U.S. CLS. 1, 5, 12, 13, 35 AND 50).

CLASS 21—HOUSEWARES AND GLASS

FOR WORKS OF ART CONSISTING OF DECORATIVE CERAMIC, GLASS, AND ACRYLIC GLASS TILES SOLD SEPARATELY AND TOGETHER WITH A MODULAR AND SCALABLE ART BOARD (U.S. CLS. 2, 13, 23, 29, 30, 33, 40 AND 50).

JILL PRATER, EXAMINING ATTORNEY

SN 77-315,758. ELSEVIER PROPERTIES S.A., NEUCHÂTEL, SWITZERLAND, FILED 10-29-2007.

THE LANCET

THE MARK CONSISTS OF STANDARD CHARACTERS WITHOUT CLAIM TO ANY PARTICULAR FONT, STYLE, SIZE, OR COLOR.

OWNER OF SWITZERLAND REG. NO. 505917, DATED 8-16-2002, EXPIRES 8-16-2012.

OWNER OF U.S. REG. NO. 1,471,389.

CLASS 9—ELECTRICAL AND SCIENTIFIC APPARATUS

FOR PRERECORDED CD-ROMS CONTAINING COMPUTER SOFTWARE AND PROGRAMS AND DOWNLOADABLE COMPUTER SOFTWARE FROM THE INTERNET BOTH USED FOR SEARCHING DATABASES IN THE FIELDS OF MEDICINE, HEALTH SCIENCES, SURGERY, HEALTHCARE AND NUTRITION; ELECTRONIC PERIODICAL PUBLICATIONS, NAMELY, MAGAZINES, JOURNALS, REVIEWS, BOOKS AND DIARIES IN THE FIELD OF HEALTH SCIENCE AND MEDICINE IN ELECTRONIC, DIGITAL, MICRO PHOTOGRAPHIC, MAGNETIC OR OPTICAL FORM ON TAPES, DISCS, FILMS, MICRO FICHES, MAGNETIC CARDS, DIGITAL VERSATILE DISCS AND DVDS; DOWNLOADABLE PERIODICAL PUBLICATIONS, MAGAZINES, JOURNALS, REVIEWS, BOOKS AND DIARIES IN THE FIELD OF HEALTH SCIENCE AND MEDICINE PROVIDED ON-LINE AS DOWNLOADS FROM DATABASES, FROM FACILITIES PROVIDED ON THE INTERNET OR FROM OTHER NETWORKS AND WEBSITES; ELECTRONIC DOWNLOADABLE PERIODICAL PUBLICATIONS, MAGAZINES, JOURNALS, REVIEWS, BOOKS AND DIARIES IN THE FIELD OF HEALTH SCIENCE AND MEDICINE (U.S. CLS. 21, 23, 26, 36 AND 38).

CLASS 41—EDUCATION AND ENTERTAINMENT

FOR ELECTRONIC PUBLICATION OF TEXTS, MAGAZINES, JOURNALS, REVIEWS, AND BOOKS IN THE FIELD OF SCIENCE AND MEDICINE, AVAILABLE ONLINE OR VIA PRERECORDED CD-ROMS OR E-MAIL TEXTS; PROVIDING PUBLICATIONS ON THE INTERNET WHICH MAY BE BROWSED, NAMELY, TEXTS, MAGAZINES, REVIEWS, JOURNALS AND BOOKS IN THE FIELD OF HEALTH SCIENCE AND MEDICINE; PROVIDING INFORMATION, CONSULTANCY AND ADVISORY SERVICES IN THE FIELD OF PUBLISHING TO ON-LINE PUBLISHERS OF SCIENTIFIC AND HEALTH INFORMATION; EDUCATIONAL SERVICES, NAMELY, CONDUCTING LIVE TRAINING COURSES, CONFERENCES, SEMINARS AND PROFESSIONAL WORKSHOPS IN THE FIELD OF HEALTH SCIENCE AND MEDICINE; EDUCATIONAL SERVICES, NAMELY, CONDUCTING ON-LINE TRAINING COURSES, CONFERENCES, SEMINARS AND PROFESSIONAL WORKSHOPS IN THE FIELD OF HEALTH SCIENCE AND MEDICINE; EDUCATIONAL SERVICES, NAMELY, PROVIDING MENTORING IN THE FIELD OF HEALTH SCIENCE AND MEDICINE; EDUCATIONAL SERVICES, NAMELY, PROVIDING TUTORING IN THE FIELD OF HEALTH SCIENCE AND MEDICINE; EDUCATIONAL SERVICES, NAMELY, DEVELOPING, ARRANGING, AND CONDUCTING EDUCATIONAL CONFERENCES AND PROGRAMS AND PROVIDING COURSES OF INSTRUCTION IN THE FIELD OF HEALTH SCIENCE AND MEDICINE; EDUCATIONAL SERVICES, NAMELY, DEVELOPING CURRICULUM FOR OTHERS IN THE FIELD OF HEALTH SCIENCE AND MEDICINE; ORGANIZATION OF CONFERENCES AND SYMPOSIA IN THE FIELD OF HEALTH SCIENCE AND MEDICINE; ORGANIZATION OF SEMINARS, WORKING GROUPS, RESEARCH GROUPS AND CONVENTIONS, IN THE FIELD OF HEALTH SCIENCE AND MEDICINE; PROVIDING PHYSICAL FITNESS INFORMATION FOR OTHERS ACCESSED VIA THE INTERNET AND WEBSITES (U.S. CLS. 100, 101 AND 107).

CLASS 44—MEDICAL, BEAUTY AND AGRICULTURAL SERVICES

FOR PROVIDING HEALTH AND SURGICAL INFORMATION AND INFORMATION ABOUT HEALTH, HEALTH CARE AND NUTRITION FOR ACCESSING VIA COMMUNICATION AND COMPUTER NETWORKS AND/OR VIA THE INTERNET; PROVIDING SURGICAL AND HEALTH INFORMATION AND INFORMATION ABOUT HEALTH, HEALTH CARE AND NUTRITION PROVIDED IN THE FORM OF WEBSITES (U.S. CLS. 100 AND 101).

RONALD DELGIZZI, EXAMINING ATTORNEY

SN 77-318,541. THE INSTITUTE OF MATERIALS, MINERALS AND MINING, LONDON, UNITED KINGDOM, FILED 10-31-2007.



OWNER OF ERPN CMNTY TM OFC REG. NO. 005770722, DATED 1-23-2008, EXPIRES 3-7-2017.

NO CLAIM IS MADE TO THE EXCLUSIVE RIGHT TO USE "MATERIALS", APART FROM THE MARK AS SHOWN.

THE MARK CONSISTS OF THE WORD "MATERIALS" IN CAPITAL LETTERS AND SMALLER FONT OVER THE WORD "WORLD" IN LOWER CASE LETTERS AND LARGER FONT WHEREIN THE LETTER "O" IN THE WORD "WORLD" IS A STYLIZED GLOBE.

CLASS 9—ELECTRICAL AND SCIENTIFIC APPARATUS

FOR SCIENTIFIC, NAUTICAL, SURVEYING, PHOTOGRAPHIC, CINEMATOGRAPHIC, OPTICAL, WEIGHING, MEASURING, SIGNALING, CHECKING, TEACHING APPARATUS AND INSTRUMENTS, NAMELY, TENSILE EQUIPMENT TO MEASURE STRENGTH AND ELASTICITY, SPECIFICALLY STATIC PROPERTIES, TOGETHER WITH ELECTRONIC FATIGUE AND CREEP TESTING EQUIPMENT TO MEASURE THE RESISTANCE TO FAILURE OF MATERIALS UNDER CYCLIC LOADS AND ELECTRONIC TESTING EQUIPMENT FOR THE ASSESSMENT OF MATERIALS HARDNESS AND DENSITY ON MELTING POINT AND RELATED PHYSICAL PROPERTIES; APPARATUS AND INSTRUMENTS FOR ANALYZING MATERIALS EXTRACTED IN THE MINING PROCESS AND MINERALS; APPARATUS AND INSTRUMENTS FOR CONDUCTING, SWITCHING, TRANSFORMING, ACCUMULATING, REGULATING OR CONTROLLING ELECTRICITY; APPARATUS FOR RECORDING, TRANSMISSION OR REPRODUCTION OF SOUND OR IMAGES; PRERECORDED MEDIA, NAMELY, MAGNETIC DATA CARRIERS, RECORDING DISCS, DVDS, CDS, CASSETTES AND MP3S FEATURING INFORMATION IN THE FIELD OF MATERIALS SCIENCE, MINERALS AND MINING; DATA PROCESSING EQUIPMENT AND COMPUTERS; COMPUTER SOFTWARE FOR COLLATING, MANIPULATING, ANALYZING AND STORING DATA; DOWNLOADABLE ELECTRONIC PUBLICATIONS IN THE NATURE OF PERIODICALS, JOURNALS, BOOKS AND ARTICLES IN THE FIELD OF MATERIALS SCIENCE, MINERALS AND MINING; DIGITALLY PRINTED PUBLICATIONS IN ELECTRONICALLY READABLE FORM, NAMELY, CDS, DVDS AND DOWNLOADABLE AUDIO AND AUDIO-VISUAL FILES FEATURING PUBLICATIONS IN THE FIELD OF MATERIALS SCIENCE, MINERALS AND MINING (U.S. CLS. 21, 23, 26, 36 AND 38).

CLASS 16—PAPER GOODS AND PRINTED MATTER

FOR PAPER, CARDBOARD, AND GOODS MADE FROM THESE MATERIALS, NAMELY, DOCUMENT FILES, FOLDERS AND DOCUMENT FOLDERS IN THE FORM OF WALLETS, FILE INDEX DIVIDERS, FILE SUBJECT DIVIDERS, HANGING FOLDERS SUSPENSION FILES, PRESENTATION AND DISPLAY ALBUMS, FOLDERS AND BINDERS; PRINTED MATTER, NAMELY, MAGAZINES, PERIODICALS, JOURNALS AND BOOKS FEATURING MATERIALS SCIENCE, MINERALS AND MINING; BOOK BINDING MATERIAL; PHOTOGRAPHS, STATIONERY; ADHESIVE FOR STATIONERY OR HOUSEHOLD PURPOSES; OFFICE REQUISITES, NAMELY, DOCUMENT FILES, FOLDERS AND DOCUMENT FOLDERS IN THE FORM OF WALLETS, FILE INDEX DIVIDERS AND SUBJECT DIVIDERS, HANGING FOLDERS, FILE BOXES FOR STORAGE OF BUSINESS AND PERSONAL RECORDS, PAPER EXPANDING FILES, RING BINDERS, LEVER ARCH BINDERS, PRESENTATION AND DISPLAY ALBUMS, BINDERS AND FILE POCKETS, DOCUMENT, LETTER AND MAGAZINE TRAYS AND RACKS, DESKTOP BUSINESS CARD HOLDERS AND BOOKS FOR BUSINESS CARDS, PEN HOLDERS, DRY ERASE WHITEBOARDS, CHALK BOARDS, STAPLERS AND HOLE PUNCHES; PRINTED INSTRUCTIONAL AND TEACHING MATERIALS IN THE FIELD OF MATERIALS SCIENCE, MINERALS AND MINING; PLASTIC MATERIALS, NAMELY, PLASTIC BAGS AND PLASTIC BUBBLE PACKS FOR PACKAGING (U.S. CLS. 2, 5, 22, 23, 29, 37, 38 AND 50).

CLASS 35—ADVERTISING AND BUSINESS

FOR ARRANGING, ORGANIZING AND CONDUCTING OF BUSINESS CONFERENCES; ARRANGING, ORGANIZING AND CONDUCTING OF EXHIBITIONS FOR COMMERCIAL AND ADVERTISING PURPOSES (U.S. CLS. 100, 101 AND 102).

CLASS 41—EDUCATION AND ENTERTAINMENT

FOR PROVIDING ON-LINE PUBLICATIONS IN THE NATURE OF MAGAZINES, BOOKS, JOURNALS AND ARTICLES IN THE FIELD OF MATERIALS SCIENCE, MINERALS AND MINING; EDUCATION, NAMELY, ARRANGING AND CONDUCTING OF WORKSHOPS, SEMINARS, COURSES AND EXHIBITIONS IN THE FIELD OF MINERALS AND MINING, PROVIDING OF TRAINING IN THE FIELD OF MATERIALS SCIENCE, MINERALS AND MINING; PROVISION OF ENTERTAINMENT SERVICES THROUGH THE MEDIA PUBLICATIONS, NAMELY, MULTI-MEDIA PUBLISHING OF BOOKS, MAGAZINES, JOURNALS, SOFTWARE, GAMES, MUSIC AND ELECTRONIC PUBLICATIONS (U.S. CLS. 100, 101 AND 107).

HEATHER BIDDULPH, EXAMINING ATTORNEY

SN 77-329,992. SYNnex CORPORATION, FREMONT, CA. FILED 11-15-2007.

VARNEX

THE MARK CONSISTS OF STANDARD CHARACTERS WITHOUT CLAIM TO ANY PARTICULAR FONT, STYLE, SIZE, OR COLOR.

CLASS 35—ADVERTISING AND BUSINESS

FOR ARRANGING AND CONDUCTING TRADE SHOWS FOR RESELLERS AND INFORMATION TECHNOLOGY MANUFACTURERS AND VENDORS IN THE FIELDS OF COMPUTERS, COMPUTER HARDWARE, COMPUTER AND NETWORK SOFTWARE, COMPUTER AND NETWORK COMPONENTS, COMPUTER AND NETWORK PERIPHERALS, TELEPHONY AND INFORMATION TECHNOLOGY PRODUCTS AND SERVICES AND BUSINESS PROCESS SERVICES; PROVISION OF END-USER MARKETING SERVICES IN CONJUNCTION WITH RESELLER AND VENDOR INITIATIVES; SALES PROMOTION SERVICES AND DEMAND GENERATION SERVICES FOR OTHERS; SALES PROMOTION SERVICES AND DEMAND GENERATION SERVICES, NAMELY, ARRANGING JOINT SALES CALLS BETWEEN RESELLERS AND VENDOR SALES REPRESENTATIVES; BUSINESS CONSULTATION SERVICES; PROMOTING COLLABORATION AND THE EXCHANGE OF INFORMATION AMONG A NETWORK OF RESELLERS IN THE FIELDS OF COMPUTERS, COMPUTER HARDWARE, COMPUTER AND NETWORK SOFTWARE, COMPUTER AND NETWORK COMPONENTS, COMPUTER AND NETWORK PERIPHERALS, TELEPHONY AND INFORMATION TECHNOLOGY PRODUCTS AND SERVICES AND BUSINESS PROCESS SERVICES; PROVIDING INFORMATION ABOUT ONLINE ORDERING, ONLINE SHIPMENT TRACKING AND BILLING, ORDER PROCESSING AND TRACKING, DISTRIBUTION TO OTHERS, MATERIALS MANAGEMENT, FREIGHT LOGISTICS, AND COMPONENT SOURCING AND PROCUREMENT (U.S. CLS. 100, 101 AND 102).

CLASS 38—COMMUNICATION

FOR PROVISION OF ACCESS TO A WEBSITE ENABLING RESELLERS TO COMMUNICATE WITH EACH OTHER; PROVISION OF ACCESS TO AN ONLINE NETWORK OF RESELLERS IN THE FIELDS OF COMPUTERS, COMPUTER HARDWARE, COMPUTER AND NETWORK SOFTWARE, COMPUTER AND NETWORK COMPONENTS, COMPUTER AND NETWORK PERIPHERALS, TELEPHONY AND INFORMATION TECHNOLOGY PRODUCTS AND SERVICES AND BUSINESS PROCESS SERVICES (U.S. CLS. 100, 101 AND 104).

CLASS 41—EDUCATION AND ENTERTAINMENT

FOR PROVISION OF EDUCATIONAL SERVICES, NAMELY, CONFERENCES, CLASSES, SEMINARS, TRAINING SESSIONS, AND WORKSHOPS, FEATURING INFORMATION ABOUT COMPUTERS, COMPUTER HARDWARE, COMPUTER SOFTWARE, COMPUTER AND NETWORK COMPONENTS, COMPUTER AND NETWORK PERIPHERALS, TELEPHONE SYSTEMS, CONSUMER ELECTRONICS, INFORMATION TECHNOLOGY PRODUCTS AND SERVICES AND BUSINESS PROCESS SERVICES AND DISTRIBUTION OF COURSE MATERIAL IN CONNECTION THEREWITH (U.S. CLS. 100, 101 AND 107).

CLASS 42—SCIENTIFIC AND COMPUTER SERVICES

FOR PROVISION OF TECHNICAL CONSULTATION AND INFORMATION IN THE FIELDS OF COMPUTERS, COMPUTER HARDWARE, COMPUTER SOFTWARE, COMPUTER NETWORKS, COMPUTER TELEPHONY, AND COMPUTER-RELATED SERVICES (U.S. CLS. 100 AND 101).

RONALD AIKENS, EXAMINING ATTORNEY

SN 77-330,267. GRETTA ENTERPRISES, LLC, NEEDHAM, MA. FILED 11-15-2007.

GLUXE

THE MARK CONSISTS OF STANDARD CHARACTERS WITHOUT CLAIM TO ANY PARTICULAR FONT, STYLE, SIZE, OR COLOR.

OWNER OF U.S. REG. NOS. 2,711,186, 2,821,023 AND 2,987,939.

CLASS 3—COSMETICS AND CLEANING PREPARATIONS

FOR SKIN CARE PREPARATIONS, NAMELY, SKIN CLEANSERS, FACIAL, BODY, FOOT AND HAND SCRUBS, NON-MEDICATED SKIN CARE TONICS, BEAUTY, FACIAL AND BODY MASQUES, NON-MEDICATED PEELS, MOISTURIZERS AND HYDRATORS IN THE NATURE OF LOTIONS, CREAMS, NON-MEDICATED GELS, SUN TANNING AND NON-MEDICATED SUN CARE PREPARATIONS, SKIN GELS FOR ACCELERATING, ENHANCING OR EXTENDING TANS, LIGHTENERS, BRIGHTENERS IN THE NATURE OF LIGHTENERS, LOTIONS, MAKEUP REMOVERS, BODY SPRITZ IN THE NATURE OF A SPRAY AND BODY OIL, SKIN CONCEALERS, COSMETIC PREPARATIONS FOR SKIN RENEWAL, SKIN EXFOLIANTS, SKIN MOUSSE, NON-MEDICATED SKIN CARE PREPARATIONS, NON-MEDICATED SKIN-SERUM, SKIN CLARIFIERS, SKIN CLEANSING CREAM, SKIN CLEANSING LOTION, SKIN CONDITIONERS, SKIN EMOLLIENTS, SKIN SOAP, TOPICAL SKIN SPRAYS FOR COSMETIC PURPOSES, WRINKLE REMOVING SKIN CARE PREPARATIONS; COSMETICS; FRAGRANCES FOR PERSONAL USE; HAIR CARE PREPARATIONS; NAIL POLISH AND NAIL POLISH REMOVER (U.S. CLS. 1, 4, 6, 50, 51 AND 52).

CLASS 9—ELECTRICAL AND SCIENTIFIC APPARATUS

FOR EYEGLASS CASES (U.S. CLS. 21, 23, 26, 36 AND 38).

CLASS 14—JEWELRY

FOR JEWELRY (U.S. CLS. 2, 27, 28 AND 50).

SN 77-330,596. GRETTA ENTERPRISES, LLC, NEEDHAM, MA. FILED 11-15-2007.

CLASS 18—LEATHER GOODS

FOR TOILETRY AND COSMETIC BAGS SOLD EMPTY, HAND BAGS, TOTE BAGS, BUCKET-SHAPED BAGS IN THE NATURE OF SACHELS, CLUTCH BAGS, SLING BAGS, BUCKET-SHAPED HANDBAGS, PURSES, CHANGE PURSES, ALL PURPOSE ATHLETIC BAGS, CARRY-ON BAGS, DIAPER BAGS, DUFFEL BAGS, GARMENT BAGS FOR TRAVEL, GYM BAGS, LEATHER SHOPPING BAGS, MESH SHOPPING BAGS, SCHOOL BAGS, SHOULDER BAGS, SUIT BAGS, TEXTILE SHOPPING BAGS, WRIST-MOUNTED CARRY-ALL BAGS, BRIEF CASES, KNAP SACKS, BACK PACKS, WAIST PACKS AND FASHION ACCESSORIES, NAMELY, WALLET, KEY CASES (U.S. CLS. 1, 2, 3, 22 AND 41).

CLASS 21—HOUSEWARES AND GLASS

FOR COSMETIC APPLICATORS AND ACCESSORIES, NAMELY, BRUSHES, MAKEUP FACIAL SPONGES, POWDER PUFFS, FACIAL PADS IN THE NATURE OF SPONGES AND APPLICATOR STICKS FOR APPLYING MAKEUP AND EYE BROW AND EYELASH COMBS; HAIR BRUSHES AND COMBS (U.S. CLS. 2, 13, 23, 29, 30, 33, 40 AND 50).

CLASS 25—CLOTHING

FOR CLOTHING, NAMELY, BLOUSES, SHIRTS, T-SHIRTS, JERSEYS, SWEATERS, JACKETS, SUITS, UNDERGARMENTS, SOCKS, PANTS, SLACKS, JEANS, SHOES, HATS, BATHING SUITS, BODY SUITS, GYM, JOGGING, SWEAT AND WARM-UP SUITS, COATS, GLOVES, BELTS, HOSIERY, DRESSES, SKIRTS, SCARVES, FURS, NAMELY, COATS, JACKETS, STOLE AND HATS, SLIPS, PANTIES, TEDDIES, CAPS, WRAP-AROUNDS, SHAWLS, PAJAMAS AND ROBES (U.S. CLS. 22 AND 39).

CLASS 26—FANCY GOODS

FOR HAIR ACCESSORIES, NAMELY, BANDS, BARRETTES, PINS, HAIR CLIPS, CLAW CLIPS, CURL CLIPS, BOWS, BUCKLES, EXTENSION PIECES, HAIR ELASTIC BANDS, RIBBONS AND SCRUNCHIES (U.S. CLS. 37, 39, 40, 42 AND 50).

CLASS 35—ADVERTISING AND BUSINESS

FOR RETAIL STORE SERVICES FEATURING HAIR AND SKIN CARE PREPARATIONS, COSMETICS, COSMETIC APPLICATORS, FRAGRANCES, HAIR ACCESSORIES, HAIR COMBS AND BRUSHES, TOILETRY AND COSMETIC BAGS SOLD EMPTY, JEWELRY, CLOTHING, SHOES, BAGS AND FASHION ACCESSORIES (U.S. CLS. 100, 101 AND 102).

CLASS 44—MEDICAL, BEAUTY AND AGRICULTURAL SERVICES

FOR HAIR SALON AND BEAUTY SPA SERVICES, NAMELY, COSMETIC BODY CARE (U.S. CLS. 100 AND 101).

Laura Hammel, Examining Attorney

GRETTALUXE

THE MARK CONSISTS OF STANDARD CHARACTERS WITHOUT CLAIM TO ANY PARTICULAR FONT, STYLE, SIZE, OR COLOR.

OWNER OF U.S. REG. NOS. 2,821,023, 2,980,421 AND 3,245,037.

CLASS 3—COSMETICS AND CLEANING PREPARATIONS

FOR SKIN CARE PREPARATIONS, NAMELY, SKIN CLEANSERS, FACIAL, BODY, FOOT AND HAND SCRUBS, TONICS IN THE NATURE OF TONERS, BEAUTY, FACIAL AND BODY MASQUES, NON-MEDICATED PEELS, MOISTURIZERS AND HYDRATORS IN THE NATURE OF LOTIONS, CREAMS, NON-MEDICATED GELS, SUN TANNING AND NON-MEDICATED SUN CARE PREPARATIONS, SKIN GELS FOR ACCELERATING, ENHANCING OR EXTENDING TANS, LIGHTENERS, BRIGHTENERS IN THE NATURE OF LIGHTENERS, LOTIONS, MAKEUP REMOVERS, BODY SPRITZ IN THE NATURE OF SPRAY AND BODY OIL, SKIN CONCEALERS, COSMETIC PREPARATIONS FOR SKIN RENEWAL, SKIN EXFOLIANTS, SKIN MOUSSE, NON-MEDICATED SKIN CARE PREPARATIONS, NON-MEDICATED SKIN-SERUM, SKIN CLARIFIERS, SKIN CLEANSING CREAM, SKIN CLEANSING LOTION, SKIN CONDITIONERS, SKIN EMOLLIENTS, SKIN SOAP, TOPICAL SKIN SPRAYS FOR COSMETIC PURPOSES, WRINKLE REMOVING SKIN CARE PREPARATIONS; COSMETICS; FRAGRANCES FOR PERSONAL USE; HAIR CARE PREPARATIONS; NAIL POLISH AND NAIL POLISH REMOVER (U.S. CLS. 1, 4, 6, 50, 51 AND 52).

CLASS 9—ELECTRICAL AND SCIENTIFIC APPARATUS

FOR EYEGLASS AND SUNGLASS CASES (U.S. CLS. 21, 23, 26, 36 AND 38).

CLASS 14—JEWELRY

FOR JEWELRY (U.S. CLS. 2, 27, 28 AND 50).

CLASS 18—LEATHER GOODS

FOR TOILETRY AND COSMETIC BAGS SOLD EMPTY, HAND BAGS, TOTE BAGS, BUCKET-SHAPED BAGS IN THE NATURE OF SACHELS, CLUTCH BAGS, SLING BAGS, BUCKET-SHAPED HANDBAGS, PURSES, CHANGE PURSES, ALL PURPOSE ATHLETIC BAGS, CARRY-ON BAGS, DIAPER BAGS, DUFFEL BAGS, GARMENT BAGS FOR TRAVEL, GYM BAGS, LEATHER SHOPPING BAGS, MESH SHOPPING BAGS, SCHOOL BAGS, SHOULDER BAGS, SUIT BAGS, TEXTILE SHOPPING BAGS, WRIST-MOUNTED CARRY-ALL BAGS, BRIEF CASES, KNAP SACKS, BACK PACKS, WAIST PACKS AND ACCESSORIES, NAMELY, WALLET AND KEY CASES (U.S. CLS. 1, 2, 3, 22 AND 41).

CLASS 21—HOUSEWARES AND GLASS

FOR COSMETIC APPLICATORS AND ACCESSORIES, NAMELY, BRUSHES, MAKEUP SPONGES FOR APPLYING MAKEUP, POWDER PUFFS, FACIAL PADS IN THE NATURE OF SPONGES AND APPLICATOR STICKS FOR APPLYING MAKEUP AND EYE BROW AND EYELASH COMBS; HAIR BRUSHES AND COMBS (U.S. CLS. 2, 13, 23, 29, 30, 33, 40 AND 50).

CLASS 25—CLOTHING

FOR CLOTHING, NAMELY, BLOUSES, SHIRTS, T-SHIRTS, JERSEYS, SWEATERS, JACKETS, SUITS, UNDERGARMENTS, SOCKS, PANTS, SLACKS, JEANS, SHOES, HATS, BATHING SUITS, BODY SUITS, GYM, JOGGING, SWEAT AND WARM-UP SUITS, COATS, GLOVES, BELTS, HOSIERY, DRESSES, SKIRTS, SCARVES, FURS, NAMELY, COATS, JACKETS, STOLES AND HATS, SLIPS, PANTIES, TEDDIES, CAPS, WRAP-AROUNDS, SHAWLS, PAJAMAS AND ROBES (U.S. CLS. 22 AND 39).

CLASS 26—FANCY GOODS

FOR HAIR ACCESSORIES, NAMELY, BANDS, BARR-ETTES, PINS, HAIR CLIPS, CLAW CLIPS, CURL CLIPS, BOWS, BUCKLES, EXTENSION PIECES, RIBBONS, HAIR ELASTIC BANDS AND SCRUNCHIES (U.S. CLS. 37, 39, 40, 42 AND 50).

Laura Hammel, Examining Attorney

SN 77-333,963. WORLD DATA PRODUCTS, INC., MINNE-
TONKA, MN. FILED 11-20-2007.



NO CLAIM IS MADE TO THE EXCLUSIVE RIGHT TO USE "DATA PRODUCTS" AND "HARDWARE LIFECYCLE MANAGEMENT" AND "PLAN" AND "PURCHASE" AND "LEASE" AND "DEPLOY" AND "INSTALL" AND "MAIN-TAIN" AND "UPGRADE" AND "PARTS" AND "REPAIR" AND "BUY BACK" AND "TRADE IN" AND "DISPOSE" AND "RECYCLE", APART FROM THE MARK AS SHOWN.

SN 77-333,136. BARNES, MARC, WASHINGTON, DC. FILED
11-19-2007.

THE PARK AT FOURTEENTH

THE MARK CONSISTS OF STANDARD CHARACTERS WITHOUT CLAIM TO ANY PARTICULAR FONT, STYLE, SIZE, OR COLOR.

NO CLAIM IS MADE TO THE EXCLUSIVE RIGHT TO USE "AT FOURTEENTH", APART FROM THE MARK AS SHOWN.

**CLASS 41—EDUCATION AND ENTERTAIN-
MENT**

FOR NIGHTCLUB SERVICES (U.S. CLS. 100, 101 AND 107).

FIRST USE 10-30-2007; IN COMMERCE 10-30-2007.

**CLASS 43—HOTEL AND RESTAURANT SER-
VICES**

FOR RESTAURANT SERVICES; BAR SERVICES (U.S. CLS. 100 AND 101).

FIRST USE 10-30-2007; IN COMMERCE 10-30-2007.
MARIAM MAHMOUDI, EXAMINING ATTORNEY

**CLASS 9—ELECTRICAL AND SCIENTIFIC
APPARATUS**

FOR COMPUTER HARDWARE (U.S. CLS. 21, 23, 26, 36 AND 38).

CLASS 35—ADVERTISING AND BUSINESS

FOR RETAIL AND WHOLESALE DISTRIBUTORSHIPS IN THE FIELD OF REFURBISHED, USED, AND NEW SERVER, STORAGE AND COMPUTER NETWORK HARDWARE; HARDWARE AND SOFTWARE INVENTO- RY MANAGEMENT; PROCUREMENT, NAMELY, PURCHASING SERVER SYSTEMS AND COMPUTER COMPONENTS FOR OTHERS (U.S. CLS. 100, 101 AND 102).

CLASS 36—INSURANCE AND FINANCIAL

FOR BUSINESS LIQUIDATION SERVICES FOR DATA CENTER ASSETS COMPRISED OF USED SERVER SYS- TEMS AND COMPUTER COMPONENTS (U.S. CLS. 100, 101 AND 102).

CLASS 37—CONSTRUCTION AND REPAIR

FOR MAINTENANCE AND REPAIR OF COMPUTER HARDWARE; REFURBISHMENT OF COMPUTER HARDWARE, NAMELY, UPGRADING AND REPAIR- ING COMPUTER HARDWARE FOR RESALE (U.S. CLS. 100, 103 AND 106).

**CLASS 42—SCIENTIFIC AND COMPUTER
SERVICES**

FOR LEASING OF COMPUTER HARDWARE AND SOFTWARE; CONSULTING SERVICES IN THE FIELD OF DESIGN, SELECTION, IMPLEMENTATION AND USE OF COMPUTER HARDWARE AND SOFTWARE SYSTEMS FOR OTHERS; MANAGEMENT OF COMPU- TER HARDWARE AND SOFTWARE SYSTEMS FOR OTHERS, NAMELY, PROVIDING PLANNING, DESIGN, DEVELOPMENT, AND TECHNICAL SUPPORT OF COM- PUTEER NETWORK SYSTEMS; RECOVERY OF COMPU- TER DATA; COMPUTER DISASTER RECOVERY PLANNING; COMPUTER SECURITY SERVICE, NAMELY, HARD DRIVE ERASURE (U.S. CLS. 100 AND 101).

Ira J. Goodsaid, Examining Attorney

SN 77-333,981. WORLD DATA PRODUCTS, INC., MINNETONKA, MN. FILED 11-20-2007.

SN 77-335,641. BRANDS BEYOND BORDERS, LLC, CARLSBAD, CA. FILED 11-21-2007.

StyleXplorers

WORLD DATA PRODUCTS

THE MARK CONSISTS OF STANDARD CHARACTERS WITHOUT CLAIM TO ANY PARTICULAR FONT, STYLE, SIZE, OR COLOR.

NO CLAIM IS MADE TO THE EXCLUSIVE RIGHT TO USE "DATA PRODUCTS", APART FROM THE MARK AS SHOWN.

CLASS 9—ELECTRICAL AND SCIENTIFIC APPARATUS

FOR COMPUTER HARDWARE (U.S. CLS. 21, 23, 26, 36 AND 38).

FIRST USE 0-0-1987; IN COMMERCE 0-0-1987.

CLASS 35—ADVERTISING AND BUSINESS

FOR RETAIL AND WHOLESALE DISTRIBUTORSHIPS IN THE FIELD OF REFURBISHED, USED, AND NEW SERVER, STORAGE AND COMPUTER NETWORK HARDWARE; HARDWARE AND SOFTWARE INVENTORY MANAGEMENT; PROCUREMENT, NAMELY, PURCHASING SERVER SYSTEMS AND COMPUTER COMPONENTS FOR OTHERS (U.S. CLS. 100, 101 AND 102).

FIRST USE 0-0-1987; IN COMMERCE 0-0-1987.

CLASS 36—INSURANCE AND FINANCIAL

FOR BUSINESS LIQUIDATION SERVICES FOR DATA CENTER ASSETS COMPRISED OF USED SERVER SYSTEMS AND COMPUTER COMPONENTS (U.S. CLS. 100, 101 AND 102).

CLASS 37—CONSTRUCTION AND REPAIR

FOR MAINTENANCE AND REPAIR OF COMPUTER HARDWARE; REFURBISHMENT OF COMPUTER HARDWARE, NAMELY, UPGRADING AND REPAIRING COMPUTER HARDWARE FOR RESALE (U.S. CLS. 100, 103 AND 106).

FIRST USE 0-0-1987; IN COMMERCE 0-0-1987.

CLASS 42—SCIENTIFIC AND COMPUTER SERVICES

FOR LEASING OF COMPUTER HARDWARE AND SOFTWARE; CONSULTING SERVICES IN THE FIELD OF DESIGN, SELECTION, IMPLEMENTATION AND USE OF COMPUTER HARDWARE AND SOFTWARE SYSTEMS FOR OTHERS; MANAGEMENT OF COMPUTER HARDWARE AND SOFTWARE SYSTEMS FOR OTHERS, NAMELY, PROVIDING PLANNING, DESIGN, DEVELOPMENT, AND TECHNICAL SUPPORT OF COMPUTER NETWORK SYSTEMS; RECOVERY OF COMPUTER DATA; COMPUTER DISASTER RECOVERY PLANNING; COMPUTER SECURITY SERVICE, NAMELY, HARD DRIVE ERASURE (U.S. CLS. 100 AND 101).

FIRST USE 0-0-1987; IN COMMERCE 0-0-1987.
IRA J. GOODSAD, EXAMINING ATTORNEY

THE MARK CONSISTS OF STANDARD CHARACTERS WITHOUT CLAIM TO ANY PARTICULAR FONT, STYLE, SIZE, OR COLOR.

CLASS 35—ADVERTISING AND BUSINESS

FOR BUSINESS SERVICES, NAMELY, ADVERTISING SERVICES AND PUBLIC RELATIONS; PROMOTION AND MARKETING SERVICES, NAMELY, PROMOTING AND MARKETING THE GOODS AND SERVICES OF OTHERS THROUGH ALL PUBLIC COMMUNICATION MEANS; DEVELOPMENT OF MARKETING STRATEGIES AND CONCEPTS; MARKETING CONSULTING; CONSUMER MARKETING RESEARCH; ON-LINE ADVERTISING AND MARKETING SERVICES; CROWDSOURCING SERVICES, NAMELY, INVOLVING CUSTOMERS IN THE ASSESSMENT, ANALYSIS AND DEVELOPMENT OF PRODUCTS AND TECHNOLOGIES (U.S. CLS. 100, 101 AND 102).

FIRST USE 10-18-2007; IN COMMERCE 10-18-2007.

CLASS 42—SCIENTIFIC AND COMPUTER SERVICES

FOR HOSTING ONLINE COMMUNITY WEBSITES FEATURING ADVERTISING, MARKETING AND PROMOTIONAL MATERIAL FOR OTHERS; PROVIDING AN ONLINE WEBSITE IN THE NATURE OF A VIRTUAL COMMUNITY FEATURING ADVERTISING, MARKETING AND PROMOTIONAL MATERIAL FOR OTHERS; COMPUTER SERVICES, NAMELY, CREATING AN ONLINE COMMUNITY FOR USERS TO PARTICIPATE IN COMPETITIONS, SHOWCASE THEIR SKILLS, GET FEEDBACK FROM THEIR PEERS, FORM VIRTUAL COMMUNITIES, ENGAGE IN SOCIAL NETWORKING (U.S. CLS. 100 AND 101).

FIRST USE 10-18-2007; IN COMMERCE 10-18-2007.
ALYSSA STEEL, EXAMINING ATTORNEY

SN 77-336,318. THE VILLAGE COMPANY, LLC, CHASKA, MN. FILED 11-25-2007.



OWNER OF U.S. REG. NO. 3,033,177.
THE MARK CONSISTS OF A STYLIZED LETTER "V" AND VINE DESIGN WITHIN A SQUARE BORDER.

CLASS 3—COSMETICS AND CLEANING PREPARATIONS

FOR BATH, SHOWER AND PERSONAL CARE PRODUCTS, NAMELY, HAND AND BODY SALT SCRUB; HAND AND BODY SUGAR SCRUB; NON-MEDICATED BATH SALTS, TABLETS AND BEADS; BUBBLE BATH; FOAM BATH; MILK BATH; LIQUID BATH AND SHOWER GELS; SKIN CLEANSING LIQUID; EXFOLIATING BODY WASH; SKIN MOISTURIZING LOTIONS, BODY OILS AND SPRAYS; FACIAL CREAMS; BODY AND FACIAL BAR SOAP; LIQUID HAND SOAP; FOAMY HAND SOAP; HAIR SHAMPOO; HAIR CONDITIONER; HAIR STYLING GEL; HAIR STYLING MOUSSE; HAIR SPRAY; HAIR DETANGLING SOLUTION; NON-MEDICATED FOOT CARE PRODUCTS, NAMELY, FOOT SOAK, FOOT SCRUB, FOOT CREAMS, FOOT POWDER, FOOT DEODORANT, FOOT EXFOLIANTS, FOOT GELS, FOOT OILS, FOOT SPRAYS, BATH SALTS FOR THE FEET, BATH FIZZERS FOR THE FEET, NAMELY, EFFERVESCENT BATH POWDERS FOR THE FEET; LIP BALMS AND LIP CONDITIONERS (U.S. CLS. 1, 4, 6, 50, 51 AND 52).

CLASS 5—PHARMACEUTICALS

FOR MEDICATED BATH SALTS, TABLETS AND BEADS (U.S. CLS. 6, 18, 44, 46, 51 AND 52).
JILL PRATER, EXAMINING ATTORNEY

SN 77-336,320. THE VILLAGE COMPANY, LLC, CHASKA, MN. FILED 11-25-2007.



OWNER OF U.S. REG. NOS. 1,085,243, 2,981,702 AND 3,033,177.

NO CLAIM IS MADE TO THE EXCLUSIVE RIGHT TO USE "COMPANY", APART FROM THE MARK AS SHOWN.

THE MARK CONSISTS OF THE WORDING "THE VILLAGE COMPANY" IN STYLIZED LETTERING WITH THE LETTER "V" AND A VINE DESIGN ENCOMPASSED WITHIN A SQUARE BORDER.

CLASS 3—COSMETICS AND CLEANING PREPARATIONS

FOR BATH, SHOWER AND PERSONAL CARE PRODUCTS, NAMELY, HAND AND BODY SALT SCRUB; HAND AND BODY SUGAR SCRUB; NON-MEDICATED BATH SALTS, TABLETS AND BEADS; BUBBLE BATH; FOAM BATH; MILK BATH; LIQUID BATH AND SHOWER GELS; SKIN CLEANSING LIQUID; EXFOLIATING BODY WASH; SKIN MOISTURIZING LOTIONS, BODY OILS AND SPRAYS; FACIAL CREAMS; BODY AND FACIAL BAR SOAP; LIQUID HAND SOAP; FOAMY HAND SOAP; HAIR SHAMPOO; HAIR CONDITIONER; HAIR STYLING GEL; HAIR STYLING MOUSSE; HAIR SPRAY; HAIR DETANGLING SOLUTION; NON-MEDICATED FOOT CARE PRODUCTS, NAMELY, FOOT SOAK, FOOT SCRUB, FOOT CREAMS, FOOT POWDER, FOOT DEODORANT, FOOT EXFOLIANTS, FOOT GELS, FOOT OILS, FOOT SPRAYS, BATH SALTS FOR THE FEET, BATH FIZZERS FOR THE FEET, NAMELY, EFFERVESCENT BATH POWDERS FOR THE FEET; LIP BALMS AND LIP CONDITIONERS (U.S. CLS. 1, 4, 6, 50, 51 AND 52).

CLASS 5—PHARMACEUTICALS

FOR MEDICATED BATH SALTS, TABLETS AND BEADS (U.S. CLS. 6, 18, 44, 46, 51 AND 52).
JILL PRATER, EXAMINING ATTORNEY

SN 77-336,978. FIELDTURF TARKETT INC., TMR-MONTREAL, CANADA, FILED 11-26-2007.



PRIORITY CLAIMED UNDER SEC. 44(D) ON CANADA APPLICATION NO. 1371329, FILED 11-8-2007, REG. NO. TMA730660, DATED 12-10-2008, EXPIRES 12-10-2023.
THE MARK CONSISTS OF THE LETTERS "FTTK".

CLASS 19—NON-METALLIC BUILDING MATERIALS

FOR FLOOR UNDERLAY; VINYL, SYNTHETIC, Poured, MULTIPURPOSE AND HARDWOOD FLOORING FOR BASKETBALL, VOLLEYBALL AND BADMINTON; SYNTHETIC GRASS, TEXTILE, CLAY AND HARD COURT SURFACES FOR TENNIS; OUTDOOR RUNNING TRACKS FOR TRACK AND FIELD (U.S. CLS. 1, 12, 33 AND 50).

CLASS 27—FLOOR COVERINGS

FOR SYNTHETIC GRASS SYSTEMS FOR THE PLAYING OF SOCCER, AMERICAN FOOTBALL, LACROSSE, FIELD HOCKEY, CRICKET, GOLF AND OTHER ATHLETIC ACTIVITIES AND FOR USE ALONGSIDE AIRPORT RUNWAYS AND FOR LANDSCAPING; VINYL FLOOR COVERINGS AND CARPETS FOR GYMNASIUMS (U.S. CLS. 19, 20, 37, 42 AND 50).

CLASS 37—CONSTRUCTION AND REPAIR

FOR INSTALLATION OF SYNTHETIC GRASS SYSTEMS FOR THE PLAYING OF SOCCER, AMERICAN FOOTBALL, LACROSSE, FIELD HOCKEY, CRICKET, GOLF AND OTHER ATHLETIC ACTIVITIES AND FOR USE ALONGSIDE AIRPORT RUNWAYS AND FOR LANDSCAPING; INSTALLATION OF FLOOR UNDERLAY; INSTALLATION OF VINYL, SYNTHETIC, Poured, MULTIPURPOSE AND HARDWOOD FLOORING FOR BASKETBALL, VOLLEYBALL AND BADMINTON; INSTALLATION OF VINYL SHEETS AND CARPETS FOR GYMNASIUMS; INSTALLATION OF SYNTHETIC GRASS, TEXTILE, CLAY AND HARD COURT SURFACES FOR TENNIS; INSTALLATION OF OUTDOOR RUNNING TRACKS FOR TRACK AND FIELD (U.S. CLS. 100, 103 AND 106).

AISHA CLARKE, EXAMINING ATTORNEY

SN 77-338,008. NOT-NOT, INC., TEMPLE TERRACE, FL.
FILED 11-27-2007.

SN 77-338,114. NOT-NOT, INC., TEMPLE TERRACE, FL.
FILED 11-27-2007.

NOT-NOT

THE MARK CONSISTS OF STANDARD CHARACTERS WITHOUT CLAIM TO ANY PARTICULAR FONT, STYLE, SIZE, OR COLOR.

CLASS 14—JEWELRY

FOR JEWELRY (U.S. CLS. 2, 27, 28 AND 50).

CLASS 16—PAPER GOODS AND PRINTED MATTER

FOR PRINTED MATTER; NAMELY, BOOKS IN THE FIELDS OF CREATIVITY, IDEATION, PERCEPTION, OUT OF THE BOX THINKING, FAITH, SPIRITUALITY, ROMANCE, MUSIC, ART, LAW, PHILOSOPHY, HISTORY, FAMILY, HEALTH, COOKING, HOME AND GARDEN, NATURE, TRAVEL, HUMOR AND SPORTS; NOTEBOOKS, NOTEPADS, MEMO PADS, STATIONARY, ADHESIVE NOTE PAPER; DECALS; BUMPER STICKERS; POSTERS, TEMPORARY TATTOOS (U.S. CLS. 2, 5, 22, 23, 29, 37, 38 AND 50).

CLASS 21—HOUSEWARES AND GLASS

FOR COFFEE MUGS; BEVERAGE GLASSWARE (U.S. CLS. 2, 13, 23, 29, 30, 33, 40 AND 50).

CLASS 25—CLOTHING

FOR CLOTHING, NAMELY, HATS, SHIRTS, UNDERWEAR, SOCKS AND TIES (U.S. CLS. 22 AND 39).

CLASS 26—FANCY GOODS

FOR EMBROIDERED PATCHES FOR CLOTHING (U.S. CLS. 37, 39, 40, 42 AND 50).

CLASS 35—ADVERTISING AND BUSINESS

FOR PROVIDING AND RENTAL OF ADVERTISING SPACE ON THE INTERNET; ONLINE RETAIL STORE SERVICES FEATURING GENERAL CONSUMER MERCHANDISE, CLOTHING, HATS, PATCHES, DECALS, BUMPER STICKERS, OFFICE REQUISITES, PRINTED MATTER, POSTERS, TEMPORARY TATTOOS, JEWELRY, TOYS, GLASSWARE, CUPS, MUGS (U.S. CLS. 100, 101 AND 102).

CLASS 41—EDUCATION AND ENTERTAINMENT

FOR PROVIDING A WEBSITE FEATURING TRIVIA, PUZZLES, RIDDLES, WORD GAMES, DIGITAL IMAGES, FICTIONAL AND NON-FICTIONAL STORIES AND INFORMATION AND LINKS IN THE FIELDS OF MUSIC, ART, HUMOR AND SPORTS (U.S. CLS. 100, 101 AND 107).

DAVID I, EXAMINING ATTORNEY

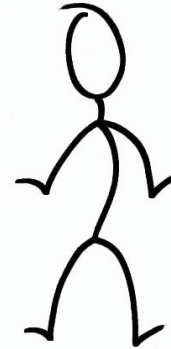

THE MARK CONSISTS OF A FANCIFUL DESIGN OF A HUMAN.

CLASS 14—JEWELRY

FOR JEWELRY (U.S. CLS. 2, 27, 28 AND 50).

CLASS 16—PAPER GOODS AND PRINTED MATTER

FOR PRINTED MATTER, NAMELY, BOOKS IN THE FIELDS OF CREATIVITY, IDEATION, PERCEPTION, OUT OF THE BOX THINKING, FAITH, SPIRITUALITY, ROMANCE, MUSIC, ART, PHILOSOPHY, HISTORY, FAMILY, NATURE, TRAVEL, HUMOR AND SPORTS; NOTEBOOKS, NOTEPADS, MEMO PADS, STATIONARY, ADHESIVE NOTE PAPER; DECALS; BUMPER STICKERS; POSTERS, TEMPORARY TATTOOS (U.S. CLS. 2, 5, 22, 23, 29, 37, 38 AND 50).

CLASS 21—HOUSEWARES AND GLASS

FOR COFFEE MUGS; BEVERAGE GLASSWARE (U.S. CLS. 2, 13, 23, 29, 30, 33, 40 AND 50).

CLASS 25—CLOTHING

FOR CLOTHING, NAMELY, HATS, SHIRTS, UNDERWEAR, SOCKS AND TIES (U.S. CLS. 22 AND 39).

CLASS 26—FANCY GOODS

FOR EMBROIDERED PATCHES FOR CLOTHING (U.S. CLS. 37, 39, 40, 42 AND 50).

CLASS 35—ADVERTISING AND BUSINESS

FOR PROVIDING AND RENTAL OF ADVERTISING SPACE ON THE INTERNET; ONLINE RETAIL STORE SERVICES FEATURING GENERAL CONSUMER MERCHANDISE, CLOTHING, HATS, PATCHES, DECALS, BUMPER STICKERS, OFFICE REQUISITES, PRINTED MATTER, POSTERS, TEMPORARY TATTOOS, JEWELRY, TOYS, GLASSWARE, CUPS, MUGS (U.S. CLS. 100, 101 AND 102).

CLASS 41—EDUCATION AND ENTERTAINMENT

FOR PROVIDING A WEBSITE FEATURING TRIVIA, PUZZLES, RIDDLES, WORD GAMES, DIGITAL IMAGES, FICTIONAL AND NON-FICTIONAL STORIES AND INFORMATION AND LINKS IN THE FIELDS OF MUSIC, ART, HUMOR AND SPORTS (U.S. CLS. 100, 101 AND 107).

DAVID I, EXAMINING ATTORNEY

SN 77-338,352. SOCIALVIBE, INC., CAMARILLO, CA. FILED 11-27-2007.

ARCHETYPE MEDIA

THE MARK CONSISTS OF STANDARD CHARACTERS WITHOUT CLAIM TO ANY PARTICULAR FONT, STYLE, SIZE, OR COLOR.

NO CLAIM IS MADE TO THE EXCLUSIVE RIGHT TO USE "MEDIA", APART FROM THE MARK AS SHOWN.

CLASS 35—ADVERTISING AND BUSINESS

FOR ELECTRONIC COMMERCE SERVICES, NAMELY, PROVIDING INFORMATION ABOUT PRODUCTS VIA TELECOMMUNICATION NETWORKS FOR ADVERTISING AND SALES PURPOSES; PROMOTING THE GOODS AND SERVICES OF OTHERS BY PROVIDING A COMMUNITY-DRIVEN WEBSITE FEATURING USER-SUBMITTED CONTENT IN THE NATURE OF COUPONS, REBATES, PRICE-COMPARISON INFORMATION, PRODUCT REVIEWS, LINKS TO THE RETAIL WEBSITES OF OTHERS, AND DISCOUNT INFO; PROVIDING AN ONLINE DIRECTORY INFORMATION SERVICE FEATURING INFORMATION REGARDING LIFESTYLE AND SOCIAL NETWORKING ISSUES; PROVIDING INFORMATION IN THE FIELD OF MARKETING AND ON-LINE MARKETING MEDIA VIA THE INTERNET (U.S. CLS. 100, 101 AND 102).

CLASS 42—SCIENTIFIC AND COMPUTER SERVICES

FOR COMPUTER SERVICES, NAMELY, CREATING AN ONLINE COMMUNITY FOR REGISTERED USERS TO PARTICIPATE IN COMPETITIONS, SHOWCASE THEIR SKILLS, GET FEEDBACK FROM THEIR PEERS, FORM VIRTUAL COMMUNITIES, ENGAGE IN SOCIAL NETWORKING AND IMPROVE THEIR TALENT (U.S. CLS. 100 AND 101).

DOMINIC J. FERRAIUOLO, EXAMINING ATTORNEY

SN 77-338,785. KALTURA, INC., BROOKLYN, NY. FILED 11-28-2007.

KALTURA

THE MARK CONSISTS OF STANDARD CHARACTERS WITHOUT CLAIM TO ANY PARTICULAR FONT, STYLE, SIZE, OR COLOR.

THE MARK HAS NO MEANING IN A FOREIGN LANGUAGE.

CLASS 9—ELECTRICAL AND SCIENTIFIC APPARATUS

FOR DOWNLOADABLE COMPUTER SOFTWARE AND DOWNLOADABLE SOFTWARE DEVELOPMENT TOOLS TO CREATE COMMUNITY AND COLLABORATIVE PLATFORMS, SHARED DATA AND WEB BASED CONTENT NETWORKS, AND MULTIMEDIA DATABASES FOR EDITING AND PROCESSING OF MULTIMEDIA CONTENT OF OTHERS (U.S. CLS. 21, 23, 26, 36 AND 38).

FIRST USE 9-17-2007; IN COMMERCE 9-17-2007.

CLASS 42—SCIENTIFIC AND COMPUTER SERVICES

FOR PROVIDING TEMPORARY USE OF ONLINE NON-DOWNLOADABLE SOFTWARE IN THE FORM OF WEB BASED COLLABORATIVE PLATFORMS AND COMMUNITY PLATFORMS FOR MULTI-USER PROJECT DEVELOPMENT, UPLOADING, EDITING, REMIXING AND SHARING PHOTOGRAPHS, MUSIC, AND MULTIMEDIA CONTENT, SUCH AS AUDIO CLIPS AND DIGITAL VIDEO CONTENT; PROVIDING TEMPORARY USE OF ONLINE NON-DOWNLOADABLE SOFTWARE IN THE FORM OF A WEB BASED INTERFACE FOR THE MANAGEMENT OF WEB BASED COMMUNITIES, INFORMATION, MULTIMEDIA MATERIALS AND AUDIO AND VISUAL CONTENT BY OTHERS; PROVIDING TEMPORARY USE OF ONLINE NON-DOWNLOADABLE SOFTWARE AND ONLINE NON-DOWNLOADABLE SOFTWARE DEVELOPMENT TOOLS TO CREATE COMMUNITY AND COLLABORATIVE PLATFORMS, SHARED DATA AND WEB BASED CONTENT NETWORKS, AND MULTIMEDIA DATABASES FOR EDITING AND PROCESSING OF MULTIMEDIA CONTENT OF OTHERS (U.S. CLS. 100 AND 101).

FIRST USE 5-19-2007; IN COMMERCE 5-19-2007.

HENRY S. ZAK, EXAMINING ATTORNEY

SN 77-339,533. FRENCH PHARMACIE, LLC, INDIANAPOLIS, IN. FILED 11-28-2007.

ARE YOU CHIC ENOUGH?

THE MARK CONSISTS OF STANDARD CHARACTERS WITHOUT CLAIM TO ANY PARTICULAR FONT, STYLE, SIZE, OR COLOR.

CLASS 3—COSMETICS AND CLEANING PREPARATIONS

FOR COSMETICS, BODY SOAPS, HAIR CARE PREPARATIONS, BODY LOTIONS, BODY CLEANSERS, BODY MOISTURIZERS, FACE TONICS, FACE MASKS, FACE POWDER, BATH POWDER, FOUNDATION, BLUSHERS, MASCARA, EYE SHADOW, EYELINER, EYE MAKEUP REMOVER, LIPSTICK, LIP PENCIL, NAIL ENAMEL, NAIL CARE PREPARATIONS, SUN BLOCK, AFTER-SUN BALM, HAIR SHAMPOO, HAIR CREAM RINSE, HAIRSPRAY, PERSONAL DEODORANTS, ANTI-PERSPIRANT, PERFUME AND PERFUMERY, EAU DE COLOGNE (U.S. CLS. 1, 4, 6, 50, 51 AND 52).

CLASS 20—FURNITURE AND ARTICLES NOT OTHERWISE CLASSIFIED

FOR FURNITURE, PICTURE FRAMES, WINDOW BLINDS, VENETIAN BLINDS, PAPER BLINDS, PLASTIC BOXES, WOODEN BOXES, NONMETAL CAPS FOR BOTTLES, JEWELRY BOXES NOT OF METAL, CURTAIN RODS, NONMETAL CURTAIN RINGS, CUSHIONS, ROOM DIVIDERS, DRINKING STRAWS, FITTED FABRIC FURNITURE COVERS, FIRE SCREENS FOR DOMESTIC USE, GIFT PACKAGE DECORATIONS OF PLASTIC, HAMPERS, CLOTHES HANGERS, NONMETAL HOUSE NUMBERS, INFANT CRADLES, INFANT WALKERS, NONMETAL AND NONLEATHER KEY CHAIN TAGS, PLASTIC PENNANTS, NONMETAL KEY HOLDERS, NONMETAL KEY RINGS, PLASTIC KEY TAGS, KITCHEN CABINETS, PLASTIC KNOBS, WOOD KNOBS, NONMETAL LADDERS, NONMETAL LATCH BARS, NONMETAL LATCHES, LAWN FURNITURE, LECTERNS, PLASTIC LETTER BOXES, WOOD LETTER BOXES, PLASTIC NOVELTY LICENSE PLATES, PLASTIC LIDS, PLASTIC LIDS FOR CANS, PLASTIC DRAWER LINING MATERIAL, LIVING ROOM FURNI-

TURE, NONMETAL LOCK BOXES, LOCKERS, LOVE SEATS, PLASTIC LUGGAGE LINING MATERIAL, NONMETAL MAILBOXES, MANNEQUINS, PLASTIC MEDICATION CONTAINERS, MEDICINE CABINETS, HAND-HELD MIRRORS, FURNITURE MIRRORS, DECORATIVE MOBILES, PICTURE FRAME MOLDINGS, NONMETAL MONEY BOXES, NONMETAL MONEY CLIPS, PLASTIC NAME BADGES, NONMETAL NAME PLATES, OFFICE FURNITURE, PLASTER ORNAMENTS, PLASTIC ORNAMENTS, WAX ORNAMENTS, WOOD ORNAMENTS, OTTOMANS, CHAIR PADS, NONMETAL PALLETS, NONMETAL TENT PEGS, NONMETAL PEGS, PLASTIC PILLBOXES, PILLOWS, PLAQUES MADE OF WOOD, FITTED PLASTIC INSERTS FOR USE AS CONTAINER LINERS, PLATE RACKS, PLAYPENS, DISPLAY RACKS, WIND CHIMES, FREESTANDING NONMETAL TOOL RACKS, MAGAZINE RACKS, NONMETAL HAT RACKS, STORAGE RACKS, WALL-MOUNTED NONMETAL TOOL RACKS, CURTAIN RAILS, FURNITURE RECLINERS, HAND-OPERATED NONMETAL GARDEN HOSE REELS, PLASTIC KEY RINGS, NONMETAL SAFES, FURNITURE SCREENS, NONMETAL EXPANDING SLEEVES FOR AFFIXING SCREWS, NONMETAL SCREWS, SOFT SCULPTURE WALL DECORATIONS, PLASTER SCULPTURES, PLASTIC SCULPTURES, WAX SCULPTURES, WOOD SCULPTURES, SEASHELLS, SEAT CUSHIONS, BOOSTER SEATS, SEATS FOR FURNITURE, SETTEES, WINDOW SHADES, PLASTIC SHELF LINING MATERIAL, SHELVES, SHELVING, SIDEBOARDS, WOODEN SIGNBOARDS, PLASTIC SIGNBOARDS, WOOD SIGNBOARDS, PLASTIC HOLDERS FOR SIGNS, SOFAS, UMBRELLA STANDS, PLASTER STATUES, PLASTIC STATUES, WAX STATUES, WOOD STATUES, PLASTER STATUETTES, PLASTIC STATUETTES, WAX STATUETTES, WOOD STATUETTES, STOOLS, PLASTIC STORAGE DRUMS, STUFFED ANIMALS WHICH ARE NOT TOYS, TRESTLE TABLES, WOOD CHOPPING BLOCK TABLES, FURNITURE TABLES, TEA CARTS, NONMETAL THREADED FASTENERS, NONMETAL TIME CAPSULES, NONMETAL TOOL BOXES USED AS FURNITURE, NONMETAL TOOL CHESTS USED AS FURNITURE, NONMETAL FIXED TOWEL DISPENSERS, TOY BOXES USED AS FURNITURE, TOY CHESTS, TRESTLES FOR SUPPORTING NONMETAL TABLES, NONMETAL TROPHIES, NONMETAL TROPHY COLUMNS, PLASTIC TUBS NOT USED FOR BATHING, WOODEN TUBS NOT USED FOR BATHING, NONMETAL WEATHER VANES, WALL UNITS USED AS FURNITURE, WARDROBES, WOOD BARRELS, WOOD CRATES, WOOD DOORKNOBS, WOOD DOOR HANDLES, WOOD BROOM HANDLES, WOOD TOOL HANDLES, WOOD SIGNS, WORK BENCHES, GLASS CASTERS, DECORATIVE NONMETAL LETTERBOXES (U.S. CLS. 2, 13, 22, 25, 32 AND 50).

CLASS 25—CLOTHING

FOR APPAREL, NAMELY, HATS, T-SHIRTS, PANTS, SHORTS, SOCKS, SCARVES, GLOVES, FOOTWEAR, UNDERGARMENTS (U.S. CLS. 22 AND 39).

JACQUELINE A. LAVINE, EXAMINING ATTORNEY

SN 77-339,574. ZEALAND PHARMA A/S, GLOSTRUP, DENMARK, FILED 11-29-2007.

Slimatide

THE MARK CONSISTS OF STANDARD CHARACTERS WITHOUT CLAIM TO ANY PARTICULAR FONT, STYLE, SIZE, OR COLOR.

PRIORITY CLAIMED UNDER SEC. 44(D) ON DENMARK APPLICATION NO. VA200704720, FILED 11-29-2007, REG. NO. VR200800818, DATED 2-21-2008, EXPIRES 2-21-2018.

CLASS 1—CHEMICALS

FOR (BASED ON INTENT TO USE) BIOMEDICAL COMPOUNDS, NAMELY, PEPTIDE SUBSTRATES USED IN ANALYZING AND DETECTING CERTAIN TOXINS FOR LABORATORY OR RESEARCH USE (U.S. CLS. 1, 5, 6, 10, 26 AND 46).

CLASS 5—PHARMACEUTICALS

FOR (BASED ON INTENT TO USE) (BASED ON 44(D) PRIORITY APPLICATION) SYNTHETIC PEPTIDES FOR PHARMACEUTICAL PURPOSES (U.S. CLS. 6, 18, 44, 46, 51 AND 52).

ANTHONY RINKER, EXAMINING ATTORNEY

SN 77-341,134. ZIH CORP., HAMILTON HM 08, BERMUDA, FILED 11-30-2007.



OWNER OF U.S. REG. NOS. 1,360,141, 3,043,780 AND OTHERS.

THE MARK CONSISTS OF A STYLIZED VERSION OF THE RIGHT SIDE OF THE HEAD AND UPPER NECK OF A ZEBRA.

CLASS 9—ELECTRICAL AND SCIENTIFIC APPARATUS

FOR COMPUTER SOFTWARE, NAMELY, SOFTWARE FOR USE IN CONNECTION WITH SUPPLY CHAIN MANAGEMENT AND EXECUTION; SOFTWARE FOR MANAGING LOGISTICS, REVERSE LOGISTICS, SUPPLY CHAIN SERVICES, SUPPLY CHAIN VISIBILITY AND SYNCHRONIZATION, SUPPLY AND DEMAND FORECASTING AND PRODUCT DISTRIBUTION PROCESSES FOR OTHERS; COMPUTER SOFTWARE FOR USE IN MANAGEMENT AND OPERATION OF MANUFACTURING AND SHIPPING CONTAINER DEPOTS AND LOGISTICS CENTERS; COMPUTER SOFTWARE FOR TRACKING AND POSITIONING OF SHIPPING CONTAINERS, FOR USE BY MARINE TERMINAL OPERATORS, AIRPORT OPERATORS, RAIL TERMINALS OR INTER-MODAL TERMINALS; COMPUTER HARDWARE AND SOFTWARE FOR IDENTIFYING, LOCATING OR TRACKING ASSETS, EQUIPMENT OR PEOPLE; COMPUTER HARDWARE AND SOFTWARE FOR REAL-TIME LOCATION SYSTEMS; READERS AND TAGS FOR REAL-TIME LOCATION SYSTEMS; COMPUTER SOFTWARE FOR ACCESSING AND MANAGING MARINE, AIRPORT, RAIL, OR INTER-MODAL TERMINAL DATA; COMPUTER HARDWARE; COMPUTER PROGRAMS, NAMELY, SOFTWARE FOR DESIGNING, PRINTING, AND CREATING BAR CODE LABELS, TAGS, TICKETS, CARDS, OR WRISTBANDS; COMPUTER PROGRAM FOR OPERATING PRINTERS, COMPUTER PROGRAMS EMBODIED IN PRINTERS OR PRINT SERVERS; COMPUTER PROGRAMS FOR MANAGING PRINTER OPERATION, MAINTENANCE OR SUPPLIES REPLENISHMENT; ELECTRONIC USER MANUALS SOLD THEREWITH (U.S. CLS. 21, 23, 26, 36 AND 38).

CLASS 16—PAPER GOODS AND PRINTED MATTER

FOR PRINTED MATTER AND PRINTED PUBLICATIONS, NAMELY, INSTRUCTION AND USER MANUALS FOR COMPUTER SOFTWARE, COMPUTER HARDWARE, REAL TIME LOCATION SYSTEMS, AND PRINTERS (U.S. CLS. 2, 5, 22, 23, 29, 37, 38 AND 50).

CLASS 35—ADVERTISING AND BUSINESS

FOR COMPUTERIZED DATABASE MANAGEMENT SERVICES; INFORMATION MANAGEMENT SERVICES, NAMELY, SHIPMENT PROCESSING, PREPARING SHIPPING DOCUMENTS AND INVOICES, TRACKING DOCUMENTS, PACKAGES AND FREIGHT OVER COMPUTER NETWORKS, INTRANET, AND INTERNET; AND BUSINESS CONSULTING SERVICES IN THE FIELD OF COMPUTER-BASED PRINTING, COMPUTER SOFTWARE AND COMPUTER PRODUCTS, PRINTERS, DATA SECURITY, ACCESS CONTROL DEVICES, MEMBERSHIP CARDS, GIFT CARDS, AND FINANCIAL CARDS; BUSINESS CONSULTING SERVICES TO MANUFACTURERS OR SHIPPING TERMINAL OPERATORS REGARDING PRODUCTIVITY, EFFICIENCY, INVENTORY CONTROL, OPERATIONAL PROCEDURES, AND EQUIPMENT PURCHASES (U.S. CLS. 100, 101 AND 102).

CLASS 41—EDUCATION AND ENTERTAINMENT

FOR EDUCATION AND TRAINING SERVICES, NAMELY, ARRANGING AND CONDUCTING CLASSES, SEMINARS, WORKSHOPS, COLLOQUIUMS, CONFERENCES, AND CONGRESSES IN THE FIELD OF REAL TIME LOCATION SYSTEMS, COMPUTER-BASED PRINTING, COMPUTER SOFTWARE AND COMPUTER PRODUCTS, PRINTERS, DATA SECURITY, ACCESS CONTROL DEVICES, MEMBERSHIP CARDS, GIFT CARDS, AND FINANCIAL CARDS (U.S. CLS. 100, 101 AND 107).

CLASS 42—SCIENTIFIC AND COMPUTER SERVICES

FOR CUSTOM DESIGN AND DEVELOPMENT OF COMPUTER HARDWARE, COMPUTER SOFTWARE; NON-DOWNLOADABLE SOFTWARE SERVICES, NAMELY, PROVIDING TEMPORARY USE OF NON-DOWNLOADABLE SOFTWARE FOR REAL-TIME LOCATION SYSTEM; PROVIDING TEMPORARY USE OF NON-DOWNLOADABLE SOFTWARE FOR USE IN MANAGEMENT AND OPERATION OF MANUFACTURING AND SHIPPING CONTAINER DEPOTS, LOGISTICS CENTERS, RAIL TERMINALS, INTERMODAL TERMINALS OR AIRPORTS (U.S. CLS. 100 AND 101).
THEODORE MCBRIDE, EXAMINING ATTORNEY

CLASS 9—ELECTRICAL AND SCIENTIFIC APPARATUS

FOR COMPUTER SOFTWARE, NAMELY, SOFTWARE FOR USE IN CONNECTION WITH SUPPLY CHAIN MANAGEMENT AND EXECUTION; SOFTWARE FOR MANAGING LOGISTICS, REVERSE LOGISTICS, SUPPLY CHAIN SERVICES, SUPPLY CHAIN VISIBILITY AND SYNCHRONIZATION, SUPPLY AND DEMAND FORECASTING AND PRODUCT DISTRIBUTION PROCESSES FOR OTHERS; COMPUTER SOFTWARE FOR USE IN MANAGEMENT AND OPERATION OF MANUFACTURING AND SHIPPING CONTAINER DEPOTS AND LOGISTICS CENTERS; COMPUTER SOFTWARE FOR TRACKING AND POSITIONING OF SHIPPING CONTAINERS, FOR USE BY MARINE TERMINAL OPERATORS, AIRPORT OPERATORS, RAIL TERMINALS OR INTER-MODAL TERMINALS; COMPUTER HARDWARE AND SOFTWARE FOR IDENTIFYING, LOCATING OR TRACKING ASSETS, EQUIPMENT OR PEOPLE; COMPUTER HARDWARE AND SOFTWARE FOR REAL-TIME LOCATION SYSTEMS; READERS AND TAGS FOR REAL-TIME LOCATION SYSTEMS; COMPUTER SOFTWARE FOR ACCESSING AND MANAGING MARINE, AIRPORT, RAIL, OR INTER-MODAL TERMINAL DATA; COMPUTER HARDWARE; COMPUTER PROGRAMS, NAMELY, SOFTWARE FOR DESIGNING, PRINTING, AND CREATING BAR CODE LABELS, TAGS, TICKETS, CARDS, OR WRISTBANDS; COMPUTER PROGRAM FOR OPERATING PRINTERS, COMPUTER PROGRAMS EMBODIED IN PRINTERS OR PRINT SERVERS; COMPUTER PROGRAMS FOR MANAGING PRINTER OPERATION, MAINTENANCE OR SUPPLIES REPLENISHMENT; ELECTRONIC USER MANUALS SOLD THEREWITH (U.S. CLS. 21, 23, 26, 36 AND 38).

CLASS 16—PAPER GOODS AND PRINTED MATTER

FOR PRINTED MATTER AND PRINTED PUBLICATIONS, NAMELY, INSTRUCTION AND USER MANUALS FOR COMPUTER SOFTWARE, COMPUTER HARDWARE, REAL TIME LOCATION SYSTEMS, AND PRINTERS (U.S. CLS. 2, 5, 22, 23, 29, 37, 38 AND 50).

CLASS 35—ADVERTISING AND BUSINESS

FOR COMPUTERIZED DATABASE MANAGEMENT SERVICES; INFORMATION MANAGEMENT SERVICES, NAMELY, SHIPMENT PROCESSING, PREPARING SHIPPING DOCUMENTS AND INVOICES, TRACKING DOCUMENTS, PACKAGES AND FREIGHT OVER COMPUTER NETWORKS, INTRANET, AND INTERNET; AND BUSINESS CONSULTING SERVICES IN THE FIELD OF COMPUTER-BASED PRINTING, COMPUTER SOFTWARE AND COMPUTER PRODUCTS, PRINTERS, DATA SECURITY, ACCESS CONTROL DEVICES, MEMBERSHIP CARDS, GIFT CARDS, AND FINANCIAL CARDS; BUSINESS CONSULTING SERVICES TO MANUFACTURERS OR SHIPPING TERMINAL OPERATORS REGARDING PRODUCTIVITY, EFFICIENCY, INVENTORY CONTROL, OPERATIONAL PROCEDURES, AND EQUIPMENT PURCHASES (U.S. CLS. 100, 101 AND 102).

CLASS 41—EDUCATION AND ENTERTAINMENT

FOR EDUCATION AND TRAINING SERVICES, NAMELY, ARRANGING AND CONDUCTING CLASSES, SEMINARS, WORKSHOPS, COLLOQUIUMS, CONFERENCES, AND CONGRESSES IN THE FIELD OF REAL TIME LOCATION SYSTEMS, COMPUTER-BASED PRINTING, COMPUTER SOFTWARE AND COMPUTER PRODUCTS, PRINTERS, DATA SECURITY, ACCESS CONTROL DEVICES, MEMBERSHIP CARDS, GIFT CARDS, AND FINANCIAL CARDS (U.S. CLS. 100, 101 AND 107).

SN 77-341,143. ZIH CORP., HAMILTON HM 08, BERMUDA,
FILED 11-30-2007.

ZEBRA

THE MARK CONSISTS OF STANDARD CHARACTERS WITHOUT CLAIM TO ANY PARTICULAR FONT, STYLE, SIZE, OR COLOR.

OWNER OF U.S. REG. NOS. 1,566,752, 3,043,779 AND OTHERS.

CLASS 42—SCIENTIFIC AND COMPUTER SERVICES

FOR CUSTOM DESIGN AND DEVELOPMENT OF COMPUTER HARDWARE, COMPUTER SOFTWARE; NON-DOWNLOADABLE SOFTWARE SERVICES, NAMELY, PROVIDING TEMPORARY USE OF NON-DOWNLOADABLE SOFTWARE FOR REAL-TIME LOCATION SYSTEM; PROVIDING TEMPORARY USE OF NON-DOWNLOADABLE SOFTWARE FOR USE IN MANAGEMENT AND OPERATION OF MANUFACTURING AND SHIPPING CONTAINER DEPOTS, LOGISTICS CENTERS, RAIL TERMINALS, INTERMODAL TERMINALS OR AIRPORTS (U.S. CLS. 100 AND 101).
THEODORE MCBRIDE, EXAMINING ATTORNEY

SN 77-343,007. PARTNERS IN LEADERSHIP IP II, LLC, TEMECULA, CA. FILED 12-3-2007.

INPUT/OUTPUT CHANGE MODEL

THE MARK CONSISTS OF STANDARD CHARACTERS WITHOUT CLAIM TO ANY PARTICULAR FONT, STYLE, SIZE, OR COLOR.
NO CLAIM IS MADE TO THE EXCLUSIVE RIGHT TO USE "CHANGE MODEL", APART FROM THE MARK AS SHOWN.

CLASS 35—ADVERTISING AND BUSINESS

FOR BUSINESS SERVICES, NAMELY, BUSINESS CONSULTATION SERVICES (U.S. CLS. 100, 101 AND 102).

CLASS 41—EDUCATION AND ENTERTAINMENT

FOR EDUCATIONAL AND TRAINING SERVICES, NAMELY, CONSULTING SEMINARS, WORKSHOPS AND ONE-ON-ONE TRAINING IN THE FIELDS OF BUSINESS MANAGEMENT AND BUSINESS OPERATIONS AND DISTRIBUTION OF COURSE MATERIAL IN CONNECTION THEREWITH (U.S. CLS. 100, 101 AND 107).
SEAN CROWLEY, EXAMINING ATTORNEY

SN 77-343,816. AGRECOL CORPORATION, MADISON, WI. FILED 12-4-2007.

ENVIROLOK

THE MARK CONSISTS OF STANDARD CHARACTERS WITHOUT CLAIM TO ANY PARTICULAR FONT, STYLE, SIZE, OR COLOR.

CLASS 19—NON-METALLIC BUILDING MATERIALS

FOR (BASED ON USE IN COMMERCE) EARTH RETAINING WALLS AND MATERIALS THEREFOR, NAMELY, CONTAINMENT BAGS FILLED WITH SOIL AND SELECTIVELY SECURED IN HORIZONTAL AND OVERLAPPING ABUTMENT BY STABILIZER STRIPS OF GEOTEXTILE MATERIALS, RIGID SOIL STABILIZER BODIES AND VEGETATION EXTENDING WITHIN AND BETWEEN ABUTTING BAGS FOR THE PURPOSES OF DRAINAGE CONFINEMENT, STABILIZING INCLINES, PLANT SUPPORT, ABSORPTION, FILTRATION, SEPARATION, STABILIZATION AND REINFORCEMENT OF THE SOIL (U.S. CLS. 1, 12, 33 AND 50).
FIRST USE 10-1-2005; IN COMMERCE 10-1-2005.

CLASS 31—NATURAL AGRICULTURAL PRODUCTS

FOR (BASED ON USE IN COMMERCE) NATIVE LIVE PLANTS AND PLANT SEEDS (U.S. CLS. 1 AND 46).
FIRST USE 10-1-2005; IN COMMERCE 10-1-2005.

CLASS 37—CONSTRUCTION AND REPAIR

FOR (BASED ON INTENT TO USE) INSTALLATION AND RESTORATION OF EARTH RETAINING WALLS (U.S. CLS. 100, 103 AND 106).

CLASS 42—SCIENTIFIC AND COMPUTER SERVICES

FOR (BASED ON INTENT TO USE) CONSULTING SERVICES IN THE FIELD OF ENVIRONMENTAL ASSESSMENT, COMPLIANCE AND PLANNING IN THE FIELD OF SOIL EROSION CONTROL; ENVIRONMENTAL SERVICES, NAMELY, TECHNICAL CONSULTATION IN THE FIELD OF ENVIRONMENTAL SCIENCE, ENGINEERING SERVICES, SITE MANAGEMENT SERVICES AND DESIGN FOR OTHERS IN THE FIELD OF ENVIRONMENTAL ENGINEERING, ALL IN THE FIELD OF SOIL EROSION CONTROL; ENVIRONMENTAL ENGINEERING SERVICES IN THE FIELD OF SOIL EROSION CONTROL (U.S. CLS. 100 AND 101).
WENDY GOODMAN, EXAMINING ATTORNEY

SN 77-349,417. SIR GROUT AND TILE SERVICES, LLC, ALPHARETTA, GA. FILED 12-11-2007.



OWNER OF U.S. REG. NO. 3,223,414.
NO CLAIM IS MADE TO THE EXCLUSIVE RIGHT TO USE "GROUT", APART FROM THE MARK AS SHOWN.
THE NAME "SIR GROUT" DOES NOT IDENTIFY A LIVING INDIVIDUAL.
THE MARK CONSISTS OF "SIR GROUT" AND A DEPICTION OF THE HELMET OF A KNIGHT WITH THE FACEPLATE CLOSED AND A FEATHER ON THE TOP.

CLASS 3—COSMETICS AND CLEANING PREPARATIONS

FOR CLEANERS FOR USE ON TILE AND GROUT; FLOOR STRIPPING/CLEANING PREPARATIONS AND FLOOR WAX REMOVERS (U.S. CLS. 1, 4, 6, 50, 51 AND 52).

FIRST USE 2-25-2009; IN COMMERCE 2-25-2009.

CLASS 17—RUBBER GOODS

FOR GROUT SEALANT (U.S. CLS. 1, 5, 12, 13, 35 AND 50).

FIRST USE 3-4-2009; IN COMMERCE 3-4-2009.
MAUREEN DALL, EXAMINING ATTORNEY

SN 77-350,245. ENDEMOL ENTERTAINMENT B.V., 1217 SC HILVERSUM, NETHERLANDS, FILED 12-12-2007.

THE LUCKY CASE GAME

THE MARK CONSISTS OF STANDARD CHARACTERS WITHOUT CLAIM TO ANY PARTICULAR FONT, STYLE, SIZE, OR COLOR.

NO CLAIM IS MADE TO THE EXCLUSIVE RIGHT TO USE "GAME", APART FROM THE MARK AS SHOWN.

CLASS 9—ELECTRICAL AND SCIENTIFIC APPARATUS

FOR APPARATUS FOR RECORDING, TRANSMISSION OR REPRODUCTION OF SOUND AND IMAGES; PRERECORDED MAGNETIC DATA CARRIERS AND DIGITAL RECORDING DISCS FEATURING TELEVISION GAME PROGRAMS; ELECTRONIC PUBLICATIONS, NAMELY, MAGAZINES FEATURING A TELEVISION GAME SHOW AND NEWS ITEMS RECORDED ON COMPUTER MEDIA; INTERACTIVE HAND-HELD COMPUTER GAME PROGRAMS; GAME CONSOLES FOR USE WITH AN EXTERNAL DISPLAY SCREEN OR MONITOR; INTERACTIVE ELECTRONIC GAME SOFTWARE AND PROGRAMS; INTERACTIVE COMPUTER GAME SOFTWARE AND PROGRAMS; DOWNLOADABLE INTERNET GAME SOFTWARE FOR USE ON MOBILE PHONES; WIRELESS COMMUNICATION DEVICES FEATURING VOICE AND DATA TRANSMISSION, INTERACTIVE MOBILE TELEPHONE DEVICE DATA TRANSMISSION AND TEXT MESSAGING FOR MOBILE PHONES AND VIA THE INTERNET; SOFTWARE FOR DOWNLOADING RING TONES, GAMES, GAMING INFORMATION, SCREENSAVERS, AND WALLPAPER; COMPUTER APPLICATION SOFTWARE FOR MOBILE PHONES, NAMELY, FOR DOWNLOADING AND STORING LOGOS AND PHOTOGRAPHS, SHORT VIDEOS AND MOVIES AND GRAPHICS; COMPUTER SOFTWARE FOR WIRELESS CONTENT DELIVERY WHICH CONTENT IS OFFERED AND COMMUNICATED AND EXAMINED BY CONSUMERS AND USERS, AND ORDERED AND DOWNLOADED VIA THE INTERNET OR OTHER ELECTRONIC MEANS, INCLUDING PSMS (PREMIUM SHORT MESSAGE SERVICE), MOBILE PHONES AND COMPUTERS; AMUSEMENT MACHINES AND SLOT MACHINES ADAPTED FOR USE WITH AN EXTERNAL DISPLAY SCREEN OR MONITOR (U.S. CLS. 21, 23, 26, 36 AND 38).

CLASS 28—TOYS AND SPORTING GOODS

FOR COMPUTER GAMES, NAMELY, ARCADE-TYPE ELECTRONIC VIDEO GAMES (U.S. CLS. 22, 23, 38 AND 50).

CLASS 41—EDUCATION AND ENTERTAINMENT

FOR EDUCATIONAL AND ENTERTAINMENT SERVICES, NAMELY, PRODUCTION OF TELEVISION AND RADIO PROGRAMS; PRODUCTION OF MOVIES; GAMBLING SERVICES; THEATRE PRODUCTION, NAMELY, STAGE PRODUCTIONS AND PRODUCTIONS OF MUSICALS; ORGANIZING AND CONDUCTING MUSIC EVENTS AND CONCERTS; PROVIDING INFORMATION IN THE FIELD OF RADIO AND TELEVISION PROGRAM SCHEDULING AND SHOW CONTENTS; SERVICES OF PERFORMING ARTISTS, NAMELY, ENTERTAINMENT IN THE NATURE OF VISUAL AND AUDIO PERFORMANCES COMPRISING MUSIC AND DANCE PERFORMANCES; ARRANGING AND CONDUCTING CONCERT PERFORMANCES; GAME SERVICES PROVIDED ONLINE, VIA THE INTERNET AND VIA PSMS (PREMIUM SHORT MESSAGE SERVICE), NAMELY, PROVIDING AN INTERACTIVE GAME; ENTERTAINMENT SERVICES PROVIDED VIA THE INTERNET, MOBILE TELEPHONES AND OTHER ELECTRONIC MEANS, NAMELY, PRODUCTION AND DISTRIBUTION OF A GAME SHOW; PRODUCTION OF MUSIC AND AUDIOVISUAL MATERIAL, NAMELY, PHOTOGRAPHS, SHORT VIDEOS AND MOVIES FOR USE AS RING TONES, SCREENSAVERS AND LOGOS; PROVIDING INFORMATION, NEWS AND COMMENTARY IN THE FIELD OF ARTISTS AND ENTERTAINMENT; PRODUCTION OF GAMES VIA THE INTERNET; PROVIDING OF GAMES VIA THE INTERNET (U.S. CLS. 100, 101 AND 107).

HANNO RITTNER, EXAMINING ATTORNEY

SN 77-351,178. MITSUBISHI GAS CHEMICAL COMPANY, INC., CHIYODA-KU, TOKYO, JAPAN, FILED 12-13-2007.

BIOPQQ

THE MARK CONSISTS OF STANDARD CHARACTERS WITHOUT CLAIM TO ANY PARTICULAR FONT, STYLE, SIZE, OR COLOR.

CLASS 1—CHEMICALS

FOR CHEMICALS FOR USE IN INDUSTRY; SULPHATES; AMMONIUM PERSULFATE; NITRATES, NAMELY, LEAD NITRATE, SODIUM NITRATE; OXIDES; ALCOHOLS, NAMELY, ETHYL ALCOHOL AND METHYL ALCOHOL; GLYCOL; ETHERS, NAMELY, BENZYL ETHERS, CHLOROMETHYL ETHERS; ALDEHYDES; KETONES; ESTERS, NAMELY, METHYL ESTERS; ADHESIVES FOR USE IN INDUSTRY; PLANT GROWTH REGULATING PREPARATIONS; FERTILIZERS; CERAMIC GLAZINGS; NON-METALLIC MINERALS, NAMELY, SULPHUR (U.S. CLS. 1, 5, 6, 10, 26 AND 46).

CLASS 3—COSMETICS AND CLEANING PREPARATIONS

FOR ANTI-STATIC PREPARATIONS FOR HOUSEHOLD PURPOSES; DE-GREASING PREPARATIONS FOR HOUSEHOLD PURPOSES; RUST REMOVING PREPARATIONS; STAIN REMOVERS CONTAINING BENZINE; FABRIC SOFTENERS FOR LAUNDRY USE; LAUNDRY BLEACH; ADHESIVES FOR AFFIXING FALSE HAIR; ADHESIVES FOR AFFIXING FALSE EYELASHES; LAUNDRY STARCH; POLISHING PREPARATIONS; SOAPS AND DETERGENTS; DENTIFRICES; COSMETICS AND NON-MEDICATED TOILETRIES; NATURAL PERFUMERY MADE FROM PLANTS; NATURAL PERFUMERY PREPARED FROM ANIMAL EXTRACTS; SYNTHETIC PERFUMERY; COMPOUND PERFUMERY; FOOD FLAVORINGS PREPARED FROM ESSENTIAL OILS; INCENSES AND FRAGRANCES; ABRASIVE PAPER, NAMELY, SANDPAPER; ABRASIVE CLOTH; ABRASIVE SAND; ARTIFICIAL PUMICE STONE FOR PERSONAL USE; POLISHING PAPER; POLISHING CLOTH, NAMELY, IMPREGNATED CLOTHS FOR POLISHING; HYDROGEN PEROXIDE FOR USE ON THE HAIR (U.S. CLS. 1, 4, 6, 50, 51 AND 52).

CLASS 5—PHARMACEUTICALS

FOR PHARMACEUTICAL PREPARATIONS FOR THE TREATMENT OF CATARACT; DIETETIC BEVERAGES FOR MEDICAL USE; DIETETIC FOOD FOR MEDICAL USE; NUTRITIONAL SUPPLEMENTS; DIETETIC FOOD PREPARATIONS FOR MEDICAL USE; PRODUCTS FOR USE IN BODY MAINTENANCE AND WEIGHT CONTROL, NAMELY, THERAPEUTIC AGENTS; DIETETIC FOOD FOR MEDICAL USE IN BODY MAINTENANCE AND WEIGHT CONTROL; NUTRITIONAL DRINKS IN POWDER MIX AND LIQUID FORMS; HYDROGEN PEROXIDE FOR MEDICAL PURPOSES; NUTRITIONALLY FORTIFIED BEVERAGE; NUTRITIONALLY FORTIFIED PROCESSED FOODS IN POWDER MIX AND LIQUID FORM, NAMELY, MEAL REPLACEMENT MIXES MAINLY MADE OF RICE, HUSKED BARLEY, HUSKED OATS, AND FLOUR CEREAL (U.S. CLS. 6, 18, 44, 46, 51 AND 52).

CLASS 29—MEATS AND PROCESSED FOODS

FOR FRESH, CHILLED, AND FROZEN MEAT FOR HUMAN CONSUMPTION; CHILLED AND FROZEN, NOT LIVE, EDIBLE AQUATIC ANIMALS, NAMELY, FISH; MEAT EXTRACTS; FROZEN VEGETABLES; FROZEN FRUITS; PROCESSED MEAT AND PROCESSED MEAT PRODUCTS, NAMELY, HAM, TURKEY, LAMB, AND VEAL; PROCESSED FISHERIES PRODUCTS, NAMELY, FISH; STEW AND SOUP MIXES; VEGETABLE JUICES FOR COOKING; PROCESSED VEGETABLES AND FRUITS; EDIBLE OILS AND FATS; MILK PRODUCTS EXCLUDING ICE CREAM, MILK AND FROZEN YOGURT; EGGS; BLOCKS OF BOILED, SMOKED AND THEN DRIED BONITOS (KATSUO-BUSHI); FRESH AND DRIED PIECES OF AGAR JELLY (KANTEN); FLAKES OF DRIED FISH MEAT (KEZURI-BUSHI); FISHMEAL FOR HUMAN CONSUMPTION; EDIBLE SHAVINGS OF DRIED KELP (TORORO-KOMBU); SHEETS OF DRIED LAYER (HOSHI-NORI); DRIED BROWN ALGA (HOSHI-HIJKI); DRIED EDIBLE SEAWEED (HOSHI-WAKAME); TOASTED SHEETS OF LAYER (YAKI-NORI); FRIED TOFU PIECES (ABURA-AGE); FREEZE-DRIED TOFU PIECES (KOHRI-DOFU); JELLY MADE FROM DEVILS' TONGUE ROOT (KONNYAKU); MILK SUBSTITUTE, NAMELY, SOYA MILK; TOFU; FERMENTED SOYBEANS (NATTO); PROCESSED EGGS; DRIED FLAKES OF LAYER FOR SPRINKLING ON RICE IN HOT WATER (OCHAZUKE-NORI); SEASONED POWDER FOR SPRINKLING ON RICE (FURI-KAKE); SIDE-DISH MADE OF FERMENTED SOYBEAN (NAME-MONO); RAW PULSES; PROTEIN FOR HUMAN CONSUMPTION, NAMELY, MILK PROTEINS; SOUP MIXES FEATURING NUTRITION-SUPPLEMENTS IN THE FORM OF POWDER OR LIQUID; PREPARED MEALS CONSISTING PRIMARILY OF VEGETABLES OR FRUIT AS THE MAIN MATERIALS; NUTRITIONALLY FORTIFIED SOUPS IN LIQUID OR POWDER; PREPARATIONS FOR MAKING SOUPS; PROCESSED FOODS IN LIQUID OR SOLID, NAMELY, PREPARED MEALS CONSISTING PRIMARILY OF VEGETABLES AND FRUITS; PRO-

CESSSED FOODS IN LIQUID OR SOLID, NAMELY, PREPARED MEALS CONSISTING PRIMARILY OF MEAT; PROCESSED FOODS IN LIQUID OR SOLID, NAMELY, PREPARED MEALS CONSISTING PRIMARILY OF FISH AND SEAFOOD; YOGURTS (U.S. CL. 46).

CLASS 30—STAPLE FOODS

FOR COFFEE; TEA; COCOA; SUGAR; RICE; TAPIOCA; SAGO; ARTIFICIAL COFFEE; FLOUR; PASTRY; BREAD; CONFECTIONERY, NAMELY, GUM CANDY; FROZEN BREAD AND FROZEN CONFECTIONERY; FLAVORS FOR CAKES, NAMELY, FLAVORINGS OTHER THAN ESSENTIAL OILS; FLAVORINGS FOR DRINKS; FROZEN YOGURT; BISCUITS; ICE CREAMS; ICE CREAMS BASED ON FROZEN FRUIT JUICES; POWDER FOR USE IN MAKING ICE CREAM; CHEWING GUM; HONEY; TREACLE; YEAST; BAKING POWDER; SALT; MUSTARD; VINEGAR; SAUCES; SPICES; ICE; CURRY (U.S. CL. 46).

CLASS 32—LIGHT BEVERAGES

FOR MINERAL WATER; CARBONATED SOFT DRINKS; NON-ALCOHOLIC FRUIT JUICE BEVERAGES; PREPARATIONS FOR MAKING BEVERAGES, NAMELY, FRUIT DRINKS; SPARKLING NON-ALCOHOLIC DRINKS WITH TEA FLAVOR; BEER; EXTRACTS OF HOPS FOR MAKING BEER; WHEY BEVERAGES; VEGETABLE JUICES; FRUIT DRINKS AND FRUIT JUICES; SYRUPS FOR MAKING BEVERAGES; CARBONATED SOFT DRINKS CONTAINING NUTRITIONAL FORTIFICATION; NON-ALCOHOLIC FRUIT JUICE BEVERAGES, VEGETABLE JUICES AND WHEY BEVERAGES IN POWDER MIX AND LIQUID FORM (U.S. CLS. 45, 46 AND 48).

LESLIE RICHARDS, EXAMINING ATTORNEY

SN 77-351,226. THE BLUES BBQ CO., LLC, ROANOKE, VA. FILED 12-13-2007.

IT'S ALL ABOUT THE LOVE

THE MARK CONSISTS OF STANDARD CHARACTERS WITHOUT CLAIM TO ANY PARTICULAR FONT, STYLE, SIZE, OR COLOR.

CLASS 25—CLOTHING

FOR CLOTHING, NAMELY, T-SHIRTS, SWEATSHIRTS, GOLF SHIRTS, HATS AND SHORTS (U.S. CLS. 22 AND 39).

FIRST USE 12-1-2006; IN COMMERCE 12-1-2006.

CLASS 43—HOTEL AND RESTAURANT SERVICES

FOR RESTAURANT, NAMELY, A FULL SERVICE RESTAURANT SERVING PREPARED FOOD AND DRINK FOR ON-SITE CONSUMPTION AND TAKE AWAY (U.S. CLS. 100 AND 101).

FIRST USE 12-1-2006; IN COMMERCE 12-1-2006.
DAWN FELDMAN, EXAMINING ATTORNEY

SN 77-351,282. MITSUBISHI GAS CHEMICAL COMPANY, INC., CHIYODA-KU, TOKYO, JAPAN, FILED 12-13-2007.

NEUROQUIN

THE MARK CONSISTS OF STANDARD CHARACTERS WITHOUT CLAIM TO ANY PARTICULAR FONT, STYLE, SIZE, OR COLOR.

CLASS 1—CHEMICALS

FOR CHEMICALS FOR USE IN INDUSTRY; SULPHATES; AMMONIUM PERSULFATE; NITRATES, NAMELY, LEAD NITRATE, SODIUM NITRATE; OXIDES; HYDROGEN PEROXIDE; ALCOHOLS, NAMELY, ETHYL ALCOHOL AND METHYL ALCOHOL; GLYCOL; ETHERS, NAMELY, BENZYL ETHERS, CHLOROMETHYL ETHERS; ALDEHYDES; KETONES; ESTERS, NAMELY, METHYL ESTERS; ADHESIVES FOR USE IN INDUSTRY; PLANT GROWTH REGULATING PREPARATIONS; FERTILIZERS; CERAMIC GLAZINGS; NON-METALLIC MINERALS, NAMELY, SULPHUR; PHOTOGRAPHIC SUPPLIES, NAMELY, CHEMICALS AND DEVELOPERS; CHEMICAL TEST PAPER; ARTIFICIAL SWEETENERS; FLOUR, NAMELY, WOOD FLOUR FOR USE AS A FILLER IN THE MANUFACTURE OF PLASTICS; STARCH FOR INDUSTRIAL PURPOSES, NAMELY, FOR USE IN THE MANUFACTURE OF PAPER AND TEXTILES (U.S. CLS. 1, 5, 6, 10, 26 AND 46).

CLASS 3—COSMETICS AND CLEANING PREPARATIONS

FOR ANTI-STATIC PREPARATIONS FOR HOUSEHOLD PURPOSES; DE-GREASING PREPARATIONS FOR HOUSEHOLD PURPOSES; RUST REMOVING PREPARATIONS; STAIN REMOVERS CONTAINING BENZINE; FABRIC SOFTENERS FOR LAUNDRY USE; LAUNDRY BLEACH; ADHESIVES FOR AFFIXING FALSE HAIR; ADHESIVES FOR AFFIXING FALSE EYELASHES; LAUNDRY STARCH; POLISHING PREPARATIONS; SOAPS AND DETERGENTS; DENTIFRICES; COSMETICS AND NON-MEDICATED TOILETRIES; NATURAL PERFUMERY MADE FROM PLANTS; NATURAL PERFUMERY PREPARED FROM ANIMAL EXTRACTS; SYNTHETIC PERFUMERY; COMPOUND PERFUMERY; FOOD FLAVORINGS PREPARED FROM ESSENTIAL OILS; INCENSES AND FRAGRANCES; ABRASIVE PAPER, NAMELY, SANDPAPER; ABRASIVE CLOTH; ABRASIVE SAND; ARTIFICIAL PUMICE STONE FOR PERSONAL USE; POLISHING PAPER; POLISHING CLOTH, NAMELY, IMPREGNATED CLOTHS FOR POLISHING; HYDROGEN PEROXIDE FOR USE ON THE HAIR (U.S. CLS. 1, 4, 6, 50, 51 AND 52).

CLASS 5—PHARMACEUTICALS

FOR PHARMACEUTICAL PREPARATIONS FOR THE TREATMENT OF CATARACT; DIETETIC BEVERAGES FOR MEDICAL USE; DIETETIC FOOD FOR MEDICAL USE; NUTRITIONAL SUPPLEMENTS; DIETETIC FOOD PREPARATIONS FOR MEDICAL USE; PRODUCTS FOR USE IN BODY MAINTENANCE AND WEIGHT CONTROL, NAMELY, THERAPEUTIC AGENTS; DIETETIC FOOD FOR MEDICAL USE IN BODY MAINTENANCE AND WEIGHT CONTROL; NUTRITIONAL DRINKS IN POWDER MIX AND LIQUID FORMS; HYDROGEN PEROXIDE FOR MEDICAL PURPOSES; NUTRITIONALLY FORTIFIED BEVERAGE; NUTRITIONALLY FORTIFIED PROCESSED FOODS IN POWDER MIX AND LIQUID FORM, NAMELY, MEAL REPLACEMENT MIXES MAINLY MADE OF RICE, HUSKED BARLEY, HUSKED OATS, AND FLOUR CEREAL (U.S. CLS. 6, 18, 44, 46, 51 AND 52).

CLASS 29—MEATS AND PROCESSED FOODS

FOR FRESH, CHILLED, AND FROZEN MEAT FOR HUMAN CONSUMPTION; CHILLED AND FROZEN, NOT LIVE, EDIBLE AQUATIC ANIMALS, NAMELY, FISH; MEAT EXTRACTS; FROZEN VEGETABLES; FROZEN FRUITS; PROCESSED MEAT AND PROCESSED MEAT PRODUCTS, NAMELY, HAM, TURKEY, LAMB, AND VEAL; PROCESSED FISHERIES PRODUCTS, NAMELY, FISH; STEW AND SOUP MIXES; VEGETABLE JUICES FOR COOKING; PROCESSED VEGETABLES AND FRUITS; EDIBLE OILS AND FATS; MILK PRODUCTS EXCLUDING ICE CREAM, MILK AND FROZEN YOGURT; EGGS; BLOCKS OF BOILED, SMOKED AND THEN DRIED BONITOS (KATSUO-BUSHI); FRESH AND DRIED PIECES OF AGAR JELLY (KANTEN); FLAKES OF DRIED FISH MEAT (KEZURI-BUSHI); FISHMEAL FOR HUMAN CONSUMPTION; EDIBLE SHAVINGS OF DRIED KELP (TORORO-KOMBU); SHEETS OF DRIED LAYER (HOSHI-NORI); DRIED BROWN ALGA (HOSHI-HIJKI); DRIED EDIBLE SEAWEED (HOSHI-WAKAME); TOASTED SHEETS OF LAVER (YAKI-NORI); FRIED TOFU PIECES (ABURA-AGE); FREEZE-DRIED TOFU PIECES (KOHRI-DOFU); JELLY MADE FROM DEVILS' TONGUE ROOT (KONNYAKU); MILK SUBSTITUTE, NAMELY, SOYA MILK; TOFU; FERMENTED SOYBEANS (NATTO); PROCESSED EGGS; DRIED FLAKES OF LAVER FOR SPRINKLING ON RICE IN HOT WATER (OCHAZUKE-NORI); SEASONED POWDER FOR SPRINKLING ON RICE (FURI-KAKE); SIDE-DISH MADE OF FERMENTED SOYBEAN (NAME-MONO); RAW PULSES; PROTEIN FOR HUMAN CONSUMPTION, NAMELY, MILK PROTEINS; SOUP MIXES FEATURING NUTRITION-SUPPLEMENTS IN THE FORM OF POWDER OR LIQUID (U.S. CL. 46).

CLASS 30—STAPLE FOODS

FOR COFFEE; TEA; COCOA; SUGAR; RICE; TAPIOCA; SAGO; ARTIFICIAL COFFEE; FLOUR; PASTRY; BREAD; CONFECTIONERY, NAMELY, GUM CANDY; FROZEN BREAD AND FROZEN CONFECTIONERY; FLAVORS FOR CAKES, NAMELY, FLAVORINGS OTHER THAN ESSENTIAL OILS; FLAVORINGS FOR DRINKS; FROZEN YOGURT; BISCUITS; ICE CREAMS; ICE CREAMS BASED ON FROZEN FRUIT JUICES; POWDER FOR USE IN MAKING ICE CREAM; CHEWING GUM; HONEY; TREACLE; YEAST; BAKING POWDER; SALT; MUSTARD; VINEGAR; SAUCES; SPICES; ICE; CURRY (U.S. CL. 46).

CLASS 32—LIGHT BEVERAGES

FOR MINERAL WATER; CARBONATED SOFT DRINKS; NON-ALCOHOLIC FRUIT JUICE BEVERAGES; PREPARATIONS FOR MAKING BEVERAGES, NAMELY, FRUIT DRINKS; SPARKLING NON-ALCOHOLIC DRINKS WITH TEA FLAVOR; BEER; EXTRACTS OF HOPS FOR MAKING BEER; WHEY BEVERAGES; VEGETABLE JUICES; FRUIT DRINKS AND FRUIT JUICES; SYRUPS FOR MAKING BEVERAGES; CARBONATED SOFT DRINKS CONTAINING NUTRITIONAL FORTIFICATION; NON-ALCOHOLIC FRUIT JUICE BEVERAGES, VEGETABLE JUICES AND WHEY BEVERAGES IN POWDER MIX AND LIQUID FORM (U.S. CLS. 45, 46 AND 48).

LESLIE RICHARDS, EXAMINING ATTORNEY

SN 77-351,313. PITTSBURGH STEELERS SPORTS, INC.,
PITTSBURGH, PA. FILED 12-13-2007.

SN 77-351,359. PITTSBURGH STEELERS SPORTS, INC.,
PITTSBURGH, PA. FILED 12-13-2007.



OWNER OF U.S. REG. NOS. 1,233,083 AND 1,235,468.
NO CLAIM IS MADE TO THE EXCLUSIVE RIGHT TO
USE THE SHAPE OF A JERSEY, APART FROM THE MARK
AS SHOWN.

THE COLOR(S) BLACK, YELLOW, AND WHITE IS/ARE
CLAIMED AS A FEATURE OF THE MARK.

THE MARK CONSISTS OF A CONFIGURATION OF A
PROFESSIONAL FOOTBALL JERSEY CONSISTING OF
THE COLOR COMBINATION OF BLACK, YELLOW AND
WHITE AND A DESIGN PATTERN COMPRISING A SERIES
OF STRIPES. THE STRIPE DESIGN COMPRISES A CENTRAL
WIDE YELLOW STRIPE, A THINNER WHITE
STRIPE OUTLINED BY BLACK LINES ADJOINING EACH
SIDE OF THE WIDE YELLOW STRIPE, ALL BOUNDED BY
A YELLOW STRIPE ALSO OUTLINED IN BLACK LINES SO
AS FORM A SINGLE BAND IN APPEARANCE. THE BAND
APPEARS ON EACH SLEEVE OF THE JERSEY AND WRAPS
DIAGONALLY AROUND EACH SLEEVE TO JOIN THE
BODY OF THE JERSEY, WHICH IS BLACK. THE BROKEN
LINES IN THE DRAWING DEPICT ELEMENTS NOT BEING
CLAIMED AS FEATURES OF THE MARK BUT SERVE TO
IDENTIFY THE MARK AS A PROFESSIONAL FOOTBALL
JERSEY AND TO SHOW PLACEMENT.

SEC. 2(F).

CLASS 25—CLOTHING

FOR JERSEYS (U.S. CLS. 22 AND 39).
FIRST USE 9-0-1999; IN COMMERCE 9-0-1999.

CLASS 41—EDUCATION AND ENTERTAINMENT

FOR EDUCATION AND ENTERTAINMENT SERVICES
IN THE NATURE OF ORGANIZING AND PRESENTING
PROFESSIONAL FOOTBALL GAMES AND EXHIBITIONS;
PROVIDING SPORTS AND ENTERTAINMENT
INFORMATION VIA A GLOBAL COMPUTER NETWORK OR
A COMMERCIAL ON-LINE SERVICE; ORGANIZATION OF
SPORTS EVENTS; FAN CLUB SERVICES; EDUCATIONAL
SERVICES, NAMELY, PHYSICAL EDUCATION PROGRAMS
AND SEMINARS IN THE FIELD OF FOOTBALL; FOOTBALL
GAMES, EXHIBITIONS, COMPETITIONS AND MUSICAL,
COMEDY AND DANCE PERFORMANCES PERFORMED
BEFORE LIVE AUDIENCES AND BROADCAST VIA
TELEVISION, CABLE TELEVISION, SATELLITE
TELEVISION AND RADIO BROADCAST (U.S. CLS. 100,
101 AND 107).

FIRST USE 9-0-1999; IN COMMERCE 9-0-1999.
HANNO RITTNER, EXAMINING ATTORNEY

OWNER OF U.S. REG. NOS. 1,233,083 AND 1,235,468.
NO CLAIM IS MADE TO THE EXCLUSIVE RIGHT TO
USE THE SHAPE OF A JERSEY, APART FROM THE MARK
AS SHOWN.

THE COLOR(S) BLACK, YELLOW AND WHITE IS/ARE
CLAIMED AS A FEATURE OF THE MARK.

THE MARK CONSISTS OF A CONFIGURATION OF A
PROFESSIONAL FOOTBALL JERSEY CONSISTING OF
THE COLOR COMBINATION OF BLACK, YELLOW AND
WHITE AND A DESIGN PATTERN COMPRISING A SERIES
OF STRIPES. THE STRIPE DESIGN COMPRISES A CENTRAL
WIDE YELLOW STRIPE, A THINNER WHITE
STRIPE OUTLINED BY BLACK LINES ADJOINING EACH
SIDE OF THE WIDE YELLOW STRIPE, ALL BOUNDED BY
A YELLOW STRIPE ALSO OUTLINED IN BLACK LINES SO
AS FORM A SINGLE BAND IN APPEARANCE. THE BAND
APPEARS ON EACH SLEEVE OF THE JERSEY AND WRAPS
DIAGONALLY AROUND EACH SLEEVE TO JOIN THE
BODY OF THE JERSEY, WHICH IS WHITE. THE BROKEN
LINES IN THE DRAWING DEPICT ELEMENTS NOT BEING
CLAIMED AS FEATURES OF THE MARK BUT SERVE TO
IDENTIFY THE MARK AS A PROFESSIONAL FOOTBALL
JERSEY AND TO SHOW PLACEMENT.

SEC. 2(F).

CLASS 25—CLOTHING

FOR JERSEYS (U.S. CLS. 22 AND 39).
FIRST USE 9-0-1999; IN COMMERCE 9-0-1999.

CLASS 41—EDUCATION AND ENTERTAINMENT

FOR EDUCATION AND ENTERTAINMENT SERVICES
IN THE NATURE OF ORGANIZING AND PRESENTING
PROFESSIONAL FOOTBALL GAMES AND EXHIBITIONS;
PROVIDING SPORTS AND ENTERTAINMENT
INFORMATION VIA A GLOBAL COMPUTER NETWORK OR
A COMMERCIAL ON-LINE SERVICE; ORGANIZATION OF
SPORTS EVENTS; FAN CLUB SERVICES; EDUCATIONAL
SERVICES, NAMELY, PHYSICAL EDUCATION PROGRAMS
AND SEMINARS IN THE FIELD OF FOOTBALL; FOOTBALL
GAMES, EXHIBITIONS, COMPETITIONS AND MUSICAL,
COMEDY AND DANCE PERFORMANCES PERFORMED
BEFORE LIVE AUDIENCES AND BROADCAST VIA
TELEVISION, CABLE TELEVISION, SATELLITE
TELEVISION AND RADIO BROADCAST (U.S. CLS. 100,
101 AND 107).

FIRST USE 9-0-1999; IN COMMERCE 9-0-1999.
HANNO RITTNER, EXAMINING ATTORNEY

SN 77-355,557. CLEAR LAM PACKAGING, INC., ELK GROVE VILLAGE, IL. FILED 12-19-2007.



NO CLAIM IS MADE TO THE EXCLUSIVE RIGHT TO USE "CLEAR PACKAGING", APART FROM THE MARK AS SHOWN.

THE MARK CONSISTS OF A BOX AND A LEAF AND LITERAL ELEMENTS INSIDE OF CIRCLE.

CLASS 17—RUBBER GOODS

FOR PLASTIC PACKAGING, NAMELY, FLEXIBLE AND RIGID FILMS FOR PACKAGING FOOD, ELECTRONICS, AND PERSONAL HEALTH CARE PRODUCTS (U.S. CLS. 1, 5, 12, 13, 35 AND 50).

CLASS 20—FURNITURE AND ARTICLES NOT OTHERWISE CLASSIFIED

FOR PLASTIC PACKAGING, NAMELY, THERMOFORMED CONTAINERS AND LIDS FOR PACKAGING FOOD, ELECTRONICS, AND PERSONAL HEALTH CARE PRODUCTS (U.S. CLS. 2, 13, 22, 25, 32 AND 50).
JEFF DEFORD, EXAMINING ATTORNEY

SN 77-357,192. CLEANTECH NETWORK LLC, HOWELL, MI. FILED 12-20-2007.

CLEANTECH ACCELERATOR

THE MARK CONSISTS OF STANDARD CHARACTERS WITHOUT CLAIM TO ANY PARTICULAR FONT, STYLE, SIZE, OR COLOR.

OWNER OF U.S. REG. NOS. 3,347,821, 3,347,823 AND 3,351,886.

CLASS 35—ADVERTISING AND BUSINESS

FOR ASSISTANCE IN MANAGEMENT OF BUSINESS ACTIVITIES; BUSINESS CONSULTATION SERVICES; BUSINESS MANAGEMENT; CONSULTING SERVICES IN THE AREA OF SUSTAINABLE BUSINESS SOLUTIONS; PROVIDING INFORMATION RELATING TO BUSINESS MANAGEMENT AND BUSINESS CONSULTATION IN THE FIELD OF RENEWABLE ENERGY (U.S. CLS. 100, 101 AND 102).

FIRST USE 10-25-2007; IN COMMERCE 10-25-2007.

CLASS 42—SCIENTIFIC AND COMPUTER SERVICES

FOR COMPUTER SERVICES, NAMELY, HOSTING AND MAINTAINING AN ON-LINE WEB SITE FOR OTHERS WHEREIN INFORMATION IN THE NATURE OF DESCRIPTIONS OF BUSINESS NEEDS RELATING TO SUSTAINABLE BUSINESS PRACTICES TO LESSEN ENVIRONMENTAL IMPACT ARE POSTED AND WHERE USERS CAN SUBMIT INFORMATION ON PROPOSED SOLUTIONS TO THE BUSINESS NEEDS (U.S. CLS. 100 AND 101).

FIRST USE 10-25-2007; IN COMMERCE 10-25-2007.

SHAUNIA CARLYLE, EXAMINING ATTORNEY

SN 77-358,071. FRED'S CAPITAL MANAGEMENT COMPANY, WILMINGTON, DE. FILED 12-21-2007.

JOYFUL TRADITIONS

THE MARK CONSISTS OF STANDARD CHARACTERS WITHOUT CLAIM TO ANY PARTICULAR FONT, STYLE, SIZE, OR COLOR.

CLASS 11—ENVIRONMENTAL CONTROL APPARATUS

FOR ELECTRIC LIGHTS FOR CHRISTMAS TREES; DECORATIVE STRING AND ROPE LIGHTS; CHRISTMAS NIGHT LIGHTS; CHRISTMAS LIGHTS, NAMELY, CANDOLIERS (U.S. CLS. 13, 21, 23, 31 AND 34).

CLASS 26—FANCY GOODS

FOR ARTIFICIAL WREATHS; CHRISTMAS DECORATIONS, NAMELY, RIBBONS AND BOWS; ARTIFICIAL GARLAND (U.S. CLS. 37, 39, 40, 42 AND 50).

CLASS 28—TOYS AND SPORTING GOODS

FOR ARTIFICIAL CHRISTMAS TREES; ARTIFICIAL CHRISTMAS WREATHS; CHRISTMAS TREE ORNAMENT CLIPS AND ORNAMENT HOOKS; CHRISTMAS TREE ORNAMENTS AND DECORATIONS, NAMELY, TREE TOPPERS, CHRISTMAS BALLS, PORCELAIN/CERAMIC HOUSES, PORCELAIN/CERAMIC FIGURES, FIGURINES, SANTAS AND SNOWMEN; ARTIFICIAL ICICLES FOR DECORATING CHRISTMAS TREES; OUTDOOR CHRISTMAS DECORATIONS AND ORNAMENTS IN THE NATURE OF INFLATABLE FIGURES; CHRISTMAS STOCKINGS; CHRISTMAS TREE STANDS AND SKIRTS (U.S. CLS. 22, 23, 38 AND 50).

CLASS 31—NATURAL AGRICULTURAL PRODUCTS

FOR LIVE CHRISTMAS WREATHS; LIVE AND CUT CHRISTMAS TREES (U.S. CLS. 1 AND 46).

SUNG IN, EXAMINING ATTORNEY

SN 77-359,151. REDHORSE CO., LTD., TOKYO, JAPAN,
FILED 12-25-2007.

Redhorse

THE MARK CONSISTS OF STANDARD CHARACTERS WITHOUT CLAIM TO ANY PARTICULAR FONT, STYLE, SIZE, OR COLOR.

CLASS 35—ADVERTISING AND BUSINESS

FOR ISSUANCE OF TRADING STAMPS, NAMELY, THE ISSUANCE OF STAMPS THAT CAN BE EXCHANGED FOR GOODS, GIVEN BY THE MEMBER STORES TO CUSTOMERS; EMPLOYMENT AGENCIES; AUCTIONEERING; GOODS IMPORT-EXPORT AGENCIES; PROVIDING EMPLOYMENT INFORMATION, NAMELY, EMPLOYEE RELATIONS INFORMATION SERVICES (U.S. CLS. 100, 101 AND 102).

CLASS 36—INSURANCE AND FINANCIAL

FOR AGENCIES IN THE FIELD OF BONDS AND OTHER SECURITIES, NAMELY, ACCEPTANCE OF DEPOSITS, INCLUDING SUBSTITUTE BOND ISSUANCE, AND ACCEPTANCE OF FIXED INTERVAL INSTALLMENT DEPOSITS; LOANS AND DISCOUNT OF BILLS; LIABILITY GUARANTEE AND ACCEPTANCE OF BILLS, NAMELY, FINANCIAL GUARANTEE AND SURETY; SECURITIES LENDING, NAMELY, MORTGAGING OF SECURITIES FOR OTHERS; ACQUISITION AND TRANSFER OF MONETARY CLAIMS; SAFE DEPOSIT BOX SERVICES; CURRENCY EXCHANGE; TRUSTEE SERVICES FOR FINANCIAL FUTURES CONTRACTS; TRUSTEE SERVICES FOR MONEY, SECURITIES, MONEY CLAIMS, PERSONAL PROPERTY, LAND, RIGHTS ON LAND FIXTURES, SURFACE RIGHTS OR LEASE ON LAND; AGENCIES FOR BOND SUBSCRIPTIONS; FOREIGN EXCHANGE TRANSACTIONS; LETTER-OF-CREDIT RELATED SERVICES, NAMELY, ISSUING OF LETTER OF CREDIT; BROKERAGE FOR HIRE-PURCHASE; ISSUE OF TOKENS OF VALUE; BUYING AND SELLING OF SECURITIES, NAMELY, SECURITIES BROKERAGE; AGENCIES OR BROKERAGE FOR TRADING OF SECURITIES INDEX FUTURES; AGENCIES OR BROKERAGE FOR TRADING OF SECURITIES OPTIONS; AGENCIES OR BROKERAGE FOR TRADING OF OVERSEAS MARKET SECURITIES FUTURES; AGENCIES OR BROKERAGE FOR TRADING OF SECURITIES INDEX FUTURES, SECURITIES OPTIONS, AND OVERSEAS MARKET SECURITIES FUTURES; AGENCIES OR BROKERAGE FOR ENTRUSTING AGENTS WITH ON-COMMISSION TRADING IN DOMESTIC MARKETS OF SECURITIES, SECURITIES INDEX FUTURES AND SECURITIES OPTIONS; AGENCIES OR BROKERAGE FOR ENTRUSTING AGENTS WITH ON-COMMISSION TRADING IN OVERSEAS MARKETS OF SECURITIES, AND SECURITIES INDEX FUTURES; AGENCIES OR BROKERAGE FOR FORWARD AGREEMENT OF SECURITIES, FOR FORWARD AGREEMENT OF SECURITIES INDEX FUTURES, FOR FORWARD AGREEMENT OF SECURITIES OPTIONS, SPOT AND FORWARD TRANSACTION OF SECURITIES INDEX FUTURES; BROKERAGE FOR SECURITIES LIQUIDATION; FINANCIAL INVESTMENT SERVICES, NAMELY, ADMINISTERING THE UNDERWRITING OF SECURITIES; SECURITIES OFFERING SERVICES, NAMELY, ADMINISTERING THE ISSUANCE OF SERVICES; TRANSACTION OF SECURITIES SUBSCRIPTION OR OFFERING, NAMELY, THE ADMINISTERING THE ISSUANCE, UNDERWRITING AND DISTRIBUTION OF SECURITIES; PROVIDING STOCK MARKET INFORMATION; AGENCIES FOR COMMODITY FUTURES TRADING; LIFE INSURANCE BROKERAGE; LIFE INSURANCE UNDERWRITING; AGENCIES FOR NON-LIFE INSURANCE, NAMELY, INSURANCE AGENCY SERVICES EXCEPT FOR LIFE INSURANCE; CLAIM ADJUSTMENT IN THE FIELD OF INSURANCE EXCEPT FOR LIFE INSURANCE; INSURANCE UNDERWRITING FOR ALL TYPES OF INSURANCE EXCEPT LIFE INSURANCE; INSURANCE PREMIUM RATE COMPUTING; MANAGEMENT OF BUILDINGS; AGENCIES OR BROKERAGE FOR RENTING OF BUILDINGS; LEASING OR RENTING OF BUILDINGS; PURCHASE AND SALE OF BUILDINGS; REAL ESTATE BROKERAGE, NAMELY, BROKERAGE FOR PURCHASE AND SALE OF BUILDINGS; REAL ESTATE APPRAISAL; REAL ESTATE MANAGEMENT, NAMELY, LAND MANAGEMENT; AGENCIES OR BROKERAGE FOR LEASING OR RENTING OF LAND; LEASING OF LAND; PURCHASE AND SALE OF LAND; REAL ESTATE BROKERAGE, NAMELY, BROKERAGE FOR PURCHASE AND SALE OF LAND; REAL ESTATE AGENCIES, NAMELY, AGENCY FOR PURCHASE OR SALES OF LAND; PROVIDING INFORMATION IN THE FIELD OF BUILDINGS, LAND AND REAL ESTATE AFFAIRS; COMMODITY INVESTMENT ADVICE, NAMELY, PROVIDING INFORMATION ON COMMODITY SALES (U.S. CLS. 100, 101 AND 102).

ANCE EXCEPT LIFE INSURANCE; INSURANCE PREMIUM RATE COMPUTING; MANAGEMENT OF BUILDINGS; AGENCIES OR BROKERAGE FOR RENTING OF BUILDINGS; LEASING OR RENTING OF BUILDINGS; PURCHASE AND SALE OF BUILDINGS; REAL ESTATE BROKERAGE, NAMELY, BROKERAGE FOR PURCHASE AND SALE OF BUILDINGS; REAL ESTATE APPRAISAL; REAL ESTATE MANAGEMENT, NAMELY, LAND MANAGEMENT; AGENCIES OR BROKERAGE FOR LEASING OR RENTING OF LAND; LEASING OF LAND; PURCHASE AND SALE OF LAND; REAL ESTATE BROKERAGE, NAMELY, BROKERAGE FOR PURCHASE AND SALE OF LAND; REAL ESTATE AGENCIES, NAMELY, AGENCY FOR PURCHASE OR SALES OF LAND; PROVIDING INFORMATION IN THE FIELD OF BUILDINGS, LAND AND REAL ESTATE AFFAIRS; COMMODITY INVESTMENT ADVICE, NAMELY, PROVIDING INFORMATION ON COMMODITY SALES (U.S. CLS. 100, 101 AND 102).

CLASS 42—SCIENTIFIC AND COMPUTER SERVICES

FOR ARCHITECTURAL DESIGN; SURVEYING; DESIGNING OF MACHINES, APPARATUS, INSTRUMENTS INCLUDING THEIR PARTS, OR SYSTEMS COMPOSED OF SUCH MACHINES, APPARATUS AND INSTRUMENTS; GRAPHIC ARTS DESIGNING; RESEARCH ON BUILDING CONSTRUCTION OR CITY PLANNING; TESTING OR RESEARCH ON PREVENTION OF POLLUTION; TESTING OR RESEARCH ON ELECTRICITY; TESTING OR RESEARCH ON CIVIL ENGINEERING; RENTAL OF COMPUTERS (U.S. CLS. 100 AND 101).

CLASS 43—HOTEL AND RESTAURANT SERVICES

FOR PRESCHOOLER AND INFANT CARE AT DAY-CARE CENTERS; RETIREMENT HOME; PROVIDING CONFERENCE ROOMS; PROVIDING FACILITIES FOR EXHIBITIONS; RENTAL OF CURTAINS; RENTAL OF FURNITURE; RENTAL OF WALL HANGINGS; RENTAL OF FLOOR COVERINGS (U.S. CLS. 100 AND 101).
MICHAEL WIENER, EXAMINING ATTORNEY

SN 77-360,962. SUBBIAN, RABINDAR, DBA CARING COUNSELORS, ANN ARBOR, MI. FILED 12-28-2007.

Caring Counselors

THE MARK CONSISTS OF STANDARD CHARACTERS WITHOUT CLAIM TO ANY PARTICULAR FONT, STYLE, SIZE, OR COLOR.

NO CLAIM IS MADE TO THE EXCLUSIVE RIGHT TO USE "COUNSELORS", APART FROM THE MARK AS SHOWN.

CLASS 44—MEDICAL, BEAUTY AND AGRICULTURAL SERVICES

FOR COUNSELING SERVICES IN THE FIELDS OF HEALTH, NUTRITION AND LIFESTYLE WELLNESS; MENTAL HEALTH COUNSELING AND PSYCHOTHERAPY AS IT RELATES TO RELATIONSHIPS; PROVIDING WELLNESS SERVICES, NAMELY, PERSONAL ASSESSMENTS, PERSONALIZED ROUTINES, MAINTENANCE SCHEDULES, AND COUNSELING; PSYCHOLOGICAL COUNSELING; PSYCHOTHERAPY AND PSYCHOTHERAPY COUNSELING FOR CHILDREN AND ADULTS IN INDIVIDUAL AND FAMILY SESSIONS; PSYCHOTHERAPY SERVICES; CONSULTING SERVICES IN THE FIELD OF MENTAL FITNESS; CONSULTING SERVICES IN THE FIELD OF MENTAL HEALTH AND WELLNESS (U.S. CLS. 100 AND 101).

FIRST USE 9-1-2005; IN COMMERCE 9-1-2006.

CLASS 45—PERSONAL AND LEGAL SERVICES

FOR GRIEF COUNSELING; MARRIAGE COUNSELING; PROVIDING COUNSELING FOR VICTIMS OF BATTERY OR ABUSE COMPRISING INTERVIEWING THE VICTIM, IDENTIFYING WHAT THE PROBLEM IS AND SUGGESTING WHERE HELP CAN BE OBTAINED (U.S. CLS. 100 AND 101).

FIRST USE 9-1-2005; IN COMMERCE 9-1-2006.
JENNIFER MARTIN, EXAMINING ATTORNEY

CLASS 9—ELECTRICAL AND SCIENTIFIC APPARATUS

FOR APPARATUS FOR WIRELESS TRANSMISSION OF ACOUSTIC INFORMATION; CELLULAR PHONES; COMMUNICATIONS COMPUTERS; COMMUNICATIONS SERVERS; COMMUNICATIONS SOFTWARE FOR CONNECTING COMPUTER NETWORK USERS; COMPUTER HARDWARE AND SOFTWARE USED FOR THE CONTROL OF VOICE CONTROLLED INFORMATION AND COMMUNICATION DEVICES; COMPUTER SOFTWARE FOR COMMUNICATING WITH USERS OF HAND-HELD COMPUTERS; COMPUTER SOFTWARE FOR WIRELESS CONTENT DELIVERY; DEVICES FOR WIRELESS RADIO TRANSMISSION; DIGITAL CELLULAR PHONES; DOWNLOADABLE MUSIC VIA THE INTERNET AND WIRELESS DEVICES; ELECTRONIC AND OPTICAL COMMUNICATIONS INSTRUMENTS AND COMPONENTS, NAMELY, DIGITAL TRANSMITTERS; INTEGRATED CIRCUITS AND INTEGRATED CIRCUIT CORES FOR USE IN WIRELESS COMMUNICATIONS AND WIRELESS COMMUNICATION EQUIPMENT AND APPARATUS AND DIGITAL SIGNAL PROCESSORS (DSP); MOBILE COMPUTING AND OPERATING PLATFORMS CONSISTING OF DATA TRANSCEIVERS, WIRELESS NETWORKS AND GATEWAYS FOR COLLECTION AND MANAGEMENT OF DATA; MODEMS; MP3 PLAYERS; TELECOMMUNICATIONS AND DATA NETWORKING HARDWARE, NAMELY, DEVICES FOR TRANSPORTING AND AGGREGATING VOICE, DATA, AND VIDEO COMMUNICATIONS ACROSS MULTIPLE NETWORK INFRASTRUCTURES AND COMMUNICATIONS PROTOCOLS; TELEMATICS APPARATUS, NAMELY, WIRELESS INTERNET DEVICES WHICH PROVIDE TELEMATIC SERVICES AND HAVE A CELLULAR PHONE FUNCTION; WIRELESS TELEPHONES; COMPUTER HARDWARE, NAMELY, A HANDHELD DEVICE THAT CAN COMMUNICATE PHYSICALLY WITH A WIRELESS NETWORK DEVICE; COMPUTER HARDWARE, NAMELY, A WIRELESS ENABLING DEVICE THAT CAN COMMUNICATE PHYSICALLY WITH A PLURALITY OF DEVICES (U.S. CLS. 21, 23, 26, 36 AND 38).

CLASS 38—COMMUNICATION

FOR CELLULAR TELEPHONE SERVICES; COMMUNICATIONS SERVICES, NAMELY, ELECTRONIC TRANSMISSION OF DATA AND DOCUMENTS AMONG USERS OF COMPUTERS AND WIRELESS DEVICES; COMMUNICATIONS BY COMPUTER TERMINALS; COMMUNICATIONS SERVICES, NAMELY, TRANSMITTING STREAMED SOUND AND AUDIO-VISUAL RECORDINGS VIA THE INTERNET; COMPUTER AIDED TRANSMISSION OF INFORMATION AND IMAGES; MOBILE TELEPHONY; ELECTRONIC MAIL SERVICES; ELECTRONIC MESSAGE TRANSMISSION; MOBILE MEDIA SERVICES IN THE NATURE OF ELECTRONIC TRANSMISSION OF ENTERTAINMENT MEDIA CONTENT; PROVISION OF ACCESS TO THE INTERNET (U.S. CLS. 100, 101 AND 104).

KATHRYN COWARD, EXAMINING ATTORNEY

SN 77-361,971. MODU LTD., KEFAR SABA, ISRAEL, FILED 12-31-2007.

MODU

SN 77-363,618. HUBBS, CHARLIE, DALTON, GA. FILED 1-3-2008.

SIL-AIR

THE MARK CONSISTS OF STANDARD CHARACTERS WITHOUT CLAIM TO ANY PARTICULAR FONT, STYLE, SIZE, OR COLOR.

PRIORITY CLAIMED UNDER SEC. 44(D) ON ISRAEL APPLICATION NO. 206723, FILED 12-18-2007, REG. NO. 206723, DATED 3-12-2009, EXPIRES 12-18-2017.

PRIORITY CLAIMED UNDER SEC. 44(D) ON ISRAEL APPLICATION NO. 206721, FILED 12-18-2007, REG. NO. 206721, DATED 3-12-2009, EXPIRES 12-18-2017.

THE MARK CONSISTS OF STANDARD CHARACTERS WITHOUT CLAIM TO ANY PARTICULAR FONT, STYLE, SIZE, OR COLOR.

CLASS 18—LEATHER GOODS

FOR SADDLE PADS AND SADDLE COMPONENTS, NAMELY, SADDLE GIRTHS, CINCHES AND SURCINGLES; SADDLE BLANKETS, SADDLE COVERS AND SADDLE BAGS (U.S. CLS. 1, 2, 3, 22 AND 41).

SN 77-365,886. LINWOOD HOMES, LTD., DELTA, CANADA, FILED 1-7-2008.

CLASS 20—FURNITURE AND ARTICLES NOT OTHERWISE CLASSIFIED

FOR MATTRESSES, FURNITURE CUSHIONS, SEATING CUSHIONS AND WHEELCHAIR CUSHIONS (U.S. CLS. 2, 13, 22, 25, 32 AND 50).

SITE SPECIFIC DESIGN

THE MARK CONSISTS OF STANDARD CHARACTERS WITHOUT CLAIM TO ANY PARTICULAR FONT, STYLE, SIZE, OR COLOR.

NO CLAIM IS MADE TO THE EXCLUSIVE RIGHT TO USE "DESIGN", APART FROM THE MARK AS SHOWN.

CLASS 25—CLOTHING

FOR SHOE INSERTS FOR PRIMARILY NON-ORTHOPEDIC PURPOSES AND SHOE CUSHIONS FOR PRIMARILY NON-ORTHOPEDIC PURPOSES (U.S. CLS. 22 AND 39).

BRENDAN REGAN, EXAMINING ATTORNEY

CLASS 19—NON-METALLIC BUILDING MATERIALS

FOR PREPACKAGED HOMES (U.S. CLS. 1, 12, 33 AND 50).

SN 77-364,073. BOERNER KUNSTSTOFF- UND METALLWARENFABRIK GMBH, LANDSCHEID-NIEDERKAIL, FED REP GERMANY, FILED 1-4-2008.

CLASS 36—INSURANCE AND FINANCIAL

FOR REAL ESTATE SERVICES, NAMELY, SELLING PREPACKAGED HOMES (U.S. CLS. 100, 101 AND 102).

CLASS 37—CONSTRUCTION AND REPAIR

FOR CONSTRUCTION SERVICES, NAMELY, PLANNING AND CONSTRUCTION OF PREPACKAGED HOMES (U.S. CLS. 100, 103 AND 106).

CLASS 41—EDUCATION AND ENTERTAINMENT

FOR EDUCATIONAL AND TRAINING SERVICES, NAMELY, PROVIDING CLASSES, SEMINARS, WORKSHOPS IN THE FIELDS OF HOME PLANNING AND CONSTRUCTION OF PREPACKAGED HOMES (U.S. CLS. 100, 101 AND 107).

JAY FLOWERS, EXAMINING ATTORNEY

BÖRNER

THE MARK CONSISTS OF STANDARD CHARACTERS WITHOUT CLAIM TO ANY PARTICULAR FONT, STYLE, SIZE, OR COLOR.

OWNER OF U.S. REG. NOS. 1,501,746, 3,022,466 AND OTHERS.
SEC. 2(F).

CLASS 8—HAND TOOLS

FOR SMALL HAND-OPERATED HOUSEHOLD AND KITCHEN UTENSILS, NAMELY, FOOD CUTTERS, SLICERS, NON-ELECTRIC FRUIT AND VEGETABLE PEELERS, CHOPPERS, VEGETABLE SHREDDERS, KNIFE BLADE GUARDS, NUT CRACKERS, KNIVES, SPOONS, FORKS; WALL-MOUNTED HOLDERS FOR THE AFORESAID KITCHEN AND HOUSEHOLD ITEMS (U.S. CLS. 23, 28 AND 44).

SN 77-367,151. EZNAILS, INC, GARDEN GROVE, CA. FILED 1-9-2008.



THE COLOR(S) BLACK AND BLUE IS/ARE CLAIMED AS A FEATURE OF THE MARK.

THE MARK CONSISTS OF A BLUE BOX CONTAINING AN UPPER CASE LETTER "E" IN BLACK ABOVE THE WORDING "EZNAI LS" IN BLACK.

CLASS 21—HOUSEWARES AND GLASS

FOR SMALL HAND-OPERATED HOUSEHOLD AND KITCHEN UTENSILS, NAMELY, GRATERS, NOODLE PRESSES, GARLIC PRESSES; JAR OPENERS, HOUSEHOLD UTENSILS NAMELY KITCHEN TONGS, PEPPER MILLS, MANUAL JUICE SQUEEZERS; CONTAINERS FOR HOUSEHOLD OR KITCHEN USE NOT MADE OF PRECIOUS METAL, NAMELY, FOOD CONTAINERS, JUICE CONTAINERS; BEVERAGE GLASSWARE FOR HOUSEHOLD AND KITCHEN USE; MUGS, PLATES AND DINNERWARE OF PORCELAIN FOR HOUSEHOLD AND KITCHEN USE; MUGS, PLATES AND DINNERWARE OF STONWARE FOR HOUSEHOLD AND KITCHEN USE; WALL-MOUNTED HOLDERS FOR THE AFORESAID KITCHEN AND HOUSEHOLD ITEMS (U.S. CLS. 2, 13, 23, 29, 30, 33, 40 AND 50).

RONALD MCMORROW, EXAMINING ATTORNEY

CLASS 3—COSMETICS AND CLEANING PREPARATIONS

FOR FALSE NAILS (U.S. CLS. 1, 4, 6, 50, 51 AND 52).
FIRST USE 10-1-1997; IN COMMERCE 10-1-1997.

CLASS 8—HAND TOOLS

FOR PEDICURE IMPLEMENTS, NAMELY, NAIL FILES, NAIL CLIPPERS, CUTICLE PUSHERS, TWEEZERS, NAIL CLIPPERS AND CUTICLE SCISSORS (U.S. CLS. 23, 28 AND 44).
FIRST USE 10-1-1997; IN COMMERCE 10-1-1997.

CLASS 21—HOUSEWARES AND GLASS

FOR NAIL BRUSHES (U.S. CLS. 2, 13, 23, 29, 30, 33, 40 AND 50).
FIRST USE 10-1-1997; IN COMMERCE 10-1-1997.
ANTHONY RINKER, EXAMINING ATTORNEY

CLASS 37—CONSTRUCTION AND REPAIR

FOR CONSTRUCTION SERVICES, NAMELY, PLANNING, MANAGEMENT, SUPERVISION, AND CONSTRUCTION OF BUILDINGS FOR OTHERS; LAND DEVELOPMENT SERVICES, NAMELY, PLANNING AND LAYING OUT OF BUILDINGS FOR OTHERS; TECHNICAL CONSULTATION IN THE FIELD OF CONSTRUCTION (U.S. CLS. 100, 103 AND 106).

CLASS 42—SCIENTIFIC AND COMPUTER SERVICES

FOR ARCHITECTURAL DESIGN OF BUILDINGS, CONSTRUCTION DRAFTING, ENGINEERING SERVICES AND TECHNICAL CONSULTATION IN THE FIELDS OF ENGINEERING AND ARCHITECTURE (U.S. CLS. 100 AND 101).
MICHAEL KEATING, EXAMINING ATTORNEY

SN 77-367,575. FACILITY HOLDINGS CORP., SMYRNA, GA. FILED 1-9-2008.



OWNER OF U.S. REG. NO. 2,448,912.
THE MARK CONSISTS OF A WINDOWS LOGO WITH THE WORDS "FACILITY GROUP".
SEC. 2(F) AS TO "FACILITY GROUP".

SN 77-368,508. BEGGS, JIM, CARDIFF BY THE SEA, CA. AND CALEM, JUDY, CARDIFF BY THE SEA, CA. FILED 1-10-2008.

CLASS 37—CONSTRUCTION AND REPAIR

FOR CONSTRUCTION SERVICES, NAMELY, PLANNING, MANAGEMENT, SUPERVISION, AND CONSTRUCTION OF BUILDINGS FOR OTHERS; LAND DEVELOPMENT SERVICES, NAMELY, PLANNING AND LAYING OUT OF BUILDINGS FOR OTHERS; TECHNICAL CONSULTATION IN THE FIELD OF CONSTRUCTION (U.S. CLS. 100, 103 AND 106).

PARADOX PLAYGROUND

THE MARK CONSISTS OF STANDARD CHARACTERS WITHOUT CLAIM TO ANY PARTICULAR FONT, STYLE, SIZE, OR COLOR.

CLASS 42—SCIENTIFIC AND COMPUTER SERVICES

FOR ARCHITECTURAL DESIGN OF BUILDINGS, CONSTRUCTION DRAFTING, ENGINEERING SERVICES AND TECHNICAL CONSULTATION IN THE FIELDS OF ENGINEERING AND ARCHITECTURE (U.S. CLS. 100 AND 101).
MICHAEL KEATING, EXAMINING ATTORNEY

CLASS 9—ELECTRICAL AND SCIENTIFIC APPARATUS

FOR PRE-RECORDED CDS FEATURING MUSIC; DOWNLOADABLE PRE-RECORDED MUSIC FILES; MAGNETIC DATA CARRIERS WITH PRE-RECORDED MUSIC; DOWNLOADABLE MULTIMEDIA FILES FEATURING MUSIC (U.S. CLS. 21, 23, 26, 36 AND 38).
FIRST USE 5-0-2003; IN COMMERCE 1-0-2004.

SN 77-367,597. FACILITY HOLDINGS CORP., SMYRNA, GA. FILED 1-9-2008.

CLASS 38—COMMUNICATION

FOR STREAMING MUSIC ON THE INTERNET (U.S. CLS. 100, 101 AND 104).
FIRST USE 5-0-2003; IN COMMERCE 1-0-2004.



OWNER OF U.S. REG. NO. 2,448,912.
THE MARK CONSISTS OF A WINDOWS LOGO WITH THE WORDS "FACILITY GROUP" ALL UNDER THE WORD "ONESOURCE".
SEC. 2(F) AS TO "FACILITY GROUP".

CLASS 41—EDUCATION AND ENTERTAINMENT

FOR SONGWRITING SERVICES FOR OTHERS; MUSIC COMPOSITION SERVICES FOR OTHERS; AUDIO RECORDING AND PRODUCTION SERVICES; ENTERTAINMENT SERVICES, NAMELY, LIVE PERFORMANCES BY A MUSICAL GROUP AND PROVIDING NON-DOWNLOADABLE MUSIC VIA THE INTERNET (U.S. CLS. 100, 101 AND 107).
FIRST USE 5-0-2003; IN COMMERCE 1-0-2004.
AMEETA JORDAN, EXAMINING ATTORNEY

SN 77-370,065. DIRECTLY SOUTH LLC, SAN FRANCISCO, CA. FILED 1-11-2008.

SOUTH

THE MARK CONSISTS OF STANDARD CHARACTERS WITHOUT CLAIM TO ANY PARTICULAR FONT, STYLE, SIZE, OR COLOR.

CLASS 29—MEATS AND PROCESSED FOODS

FOR CONDIMENTS, NAMELY, JAMS AND EDIBLE OILS, NAMELY, AVOCADO OIL (U.S. CL. 46).

CLASS 30—STAPLE FOODS

FOR CONDIMENTS, NAMELY, SAUCES AND MARINADES; SPICES, SALT, PEPPER (U.S. CL. 46).
INGRID C. EULIN, EXAMINING ATTORNEY

SN 77-371,206. LASHER, DANA J. DBA GET READY GIRLS, DOYLESTOWN, PA. FILED 1-14-2008.



THE COLOR(S) PINK, BLACK AND WHITE IS/ARE CLAIMED AS A FEATURE OF THE MARK.

THE MARK CONSISTS OF THE WORDING "GET READY GIRLS" IN BLACK ON A PINK BACKGROUND INSIDE A BLACK LINED OVAL WHICH IS ITSELF PLACED ON A WHITE BACKGROUND INSIDE A PINK OVAL.

CLASS 18—LEATHER GOODS

FOR PURSES AND WALLETS (U.S. CLS. 1, 2, 3, 22 AND 41).

CLASS 25—CLOTHING

FOR WOMEN'S SHOES; BATH SLIPPERS; CANVAS SHOES; CLOGS; FLIP FLOPS; FOOTWEAR; SANDALS; AND SNEAKERS (U.S. CLS. 22 AND 39).
RAUL CORDOVA, EXAMINING ATTORNEY

SN 77-372,111. ALTICOR INC., ADA, MI. FILED 1-15-2008.

AMWAY ONE BY ONE

THE MARK CONSISTS OF STANDARD CHARACTERS WITHOUT CLAIM TO ANY PARTICULAR FONT, STYLE, SIZE, OR COLOR.

CLASS 35—ADVERTISING AND BUSINESS

FOR PHILANTHROPIC SERVICES, NAMELY, ORGANIZING AND CONDUCTING VOLUNTEER PROGRAMS AND COMMUNITY SERVICE PROJECTS (U.S. CLS. 100, 101 AND 102).

FIRST USE 10-21-2002; IN COMMERCE 10-21-2002.

CLASS 36—INSURANCE AND FINANCIAL

FOR CHARITABLE FUND-RAISING (U.S. CLS. 100, 101 AND 102).

FIRST USE 10-21-2002; IN COMMERCE 10-21-2002.

SUE LAWRENCE, EXAMINING ATTORNEY

SN 77-372,880. ALTICOR INC., ADA, MI. FILED 1-16-2008.



NO CLAIM IS MADE TO THE EXCLUSIVE RIGHT TO USE "CAMPAIGN FOR CHILDREN", APART FROM THE MARK AS SHOWN.

THE MARK CONSISTS OF FIGURE OF A PERSON WITH STYLIZED WORDING AS INDICATED IN LITERAL ELEMENT.

CLASS 35—ADVERTISING AND BUSINESS

FOR PHILANTHROPIC SERVICES, NAMELY, ORGANIZING AND CONDUCTING VOLUNTEER PROGRAMS AND COMMUNITY SERVICE PROJECTS (U.S. CLS. 100, 101 AND 102).

FIRST USE 10-21-2002; IN COMMERCE 10-21-2002.

CLASS 36—INSURANCE AND FINANCIAL

FOR CHARITABLE FUND-RAISING (U.S. CLS. 100, 101 AND 102).

FIRST USE 10-21-2002; IN COMMERCE 10-21-2002.

SUE LAWRENCE, EXAMINING ATTORNEY

SN 77-374,896. HOUSEWARES AMERICA, INC., ISELIN, NJ. FILED 1-18-2008.

THE ORIGINAL GREEN LADY

THE MARK CONSISTS OF STANDARD CHARACTERS WITHOUT CLAIM TO ANY PARTICULAR FONT, STYLE, SIZE, OR COLOR.

NO CLAIM IS MADE TO THE EXCLUSIVE RIGHT TO USE "ORIGINAL", APART FROM THE MARK AS SHOWN.

CLASS 3—COSMETICS AND CLEANING PREPARATIONS

FOR CLEANING PREPARATIONS FOR FOOD; CLEANING PREPARATIONS FOR PRODUCE (U.S. CLS. 1, 4, 6, 50, 51 AND 52).

CLASS 5—PHARMACEUTICALS

FOR FOOD SANITIZERS; PRODUCE SANITIZERS; SANITIZING PREPARATIONS FOR FOOD; SANITIZING PREPARATIONS FOR PRODUCE; PREPARATION FOR KILLING BACTERIA AND VIRUSES ON FOOD; PREPARATION FOR KILLING BACTERIA AND VIRUSES ON PRODUCE; SPRAY PREPARATION FOR KILLING BACTERIA AND VIRUSES ON FOOD; SPRAY PREPARATION FOR KILLING BACTERIA AND VIRUSES ON PRODUCE (U.S. CLS. 6, 18, 44, 46, 51 AND 52).

CLASS 16—PAPER GOODS AND PRINTED MATTER

FOR PLASTIC FOOD STORAGE BAGS; PLASTIC STORAGE BAGS FOR HOUSEHOLD USE; PLASTIC STORAGE BAGS FOR KITCHEN USE; PAPER WRAPPINGS FOR STORING FOOD; PLASTIC WRAPPINGS FOR STORING FOOD; PLASTIC BAGS FOR HOUSEHOLD USE; PLASTIC BAGS FOR KITCHEN USE; PAPER BAGS FOR HOUSEHOLD USE; PAPER BAGS FOR KITCHEN USE (U.S. CLS. 2, 5, 22, 23, 29, 37, 38 AND 50).

CLASS 21—HOUSEWARES AND GLASS

FOR HOUSEHOLD FOOD STORAGE CONTAINERS; PLASTIC HOUSEHOLD STORAGE CONTAINERS; PLASTIC CONTAINERS AND COVERS SOLD AS A UNIT FOR HOUSEHOLD USE; CONTAINERS FOR HOUSEHOLD OR KITCHEN USE NOT OF PRECIOUS METAL; PLASTIC HOUSEHOLD CONTAINERS AND COVERS SOLD AS A UNIT FOR FOOD STORAGE; NON-ELECTRIC KITCHEN AND HOUSEHOLD CONTAINERS NOT MADE OF PRECIOUS METAL; PORTABLE PLASTIC CONTAINERS FOR STORING HOUSEHOLD AND KITCHEN GOODS; CONTAINERS FOR HOUSEHOLD OR KITCHEN USE (U.S. CLS. 2, 13, 23, 29, 30, 33, 40 AND 50).

RONALD AIKENS, EXAMINING ATTORNEY

CLASS 9—ELECTRICAL AND SCIENTIFIC APPARATUS

FOR AUTOMATED PROCESS CONTROL SYSTEM TO CONTROL SOLAR-POWERED ELECTRICITY GENERATORS, HORIZONTAL-AXIS WIND TURBINES, VERTICAL-AXIS WIND TURBINES, WIND-POWERED ELECTRICITY GENERATORS, SOLAR COLLECTORS, SOLAR ENERGY BASED COOLING APPARATUS, SOLAR HEAT COLLECTION PANELS AND PROPELLERS FOR WIND POWERED GENERATORS, NAMELY, MICRO-PROCESSOR BASED HARDWARE AND SOFTWARE USED TO MONITOR THE STATUS OF SOLAR-POWERED ELECTRICITY GENERATORS, WIND TURBINES, WIND-POWERED ELECTRICITY GENERATORS, SOLAR COLLECTORS, SOLAR ENERGY BASED COOLING APPARATUS, SOLAR HEAT COLLECTION PANELS AND PROPELLERS FOR WIND POWERED GENERATORS AND ACCESSORIES THEREOF; ELECTRICAL CONTROLLING DEVICES FOR SOLAR-POWERED ELECTRICITY GENERATORS, HORIZONTAL-AXIS WIND TURBINES, VERTICAL-AXIS WIND TURBINES, WIND-POWERED ELECTRICITY GENERATORS, SOLAR COLLECTORS, SOLAR ENERGY BASED COOLING APPARATUS, SOLAR HEAT COLLECTION PANELS AND PROPELLERS FOR WIND POWERED GENERATORS AND ACCESSORIES THEREOF; ELECTRONIC CONTROL SYSTEMS FOR SOLAR-POWERED ELECTRICITY GENERATORS, HORIZONTAL-AXIS WIND TURBINES, VERTICAL-AXIS WIND TURBINES, WIND-POWERED ELECTRICITY GENERATORS, SOLAR COLLECTORS, SOLAR ENERGY BASED COOLING APPARATUS, SOLAR HEAT COLLECTION PANELS AND PROPELLERS FOR WIND POWERED GENERATORS AND ACCESSORIES THEREOF (U.S. CLS. 21, 23, 26, 36 AND 38).

CLASS 11—ENVIRONMENTAL CONTROL APPARATUS

FOR SOLAR COLLECTORS; SOLAR ENERGY BASED COOLING APPARATUS; SOLAR HEAT COLLECTION PANELS; PROPELLERS FOR WIND POWERED GENERATORS (U.S. CLS. 13, 21, 23, 31 AND 34).

NAPOLÉON SHARMA, EXAMINING ATTORNEY

SN 77-377,676. AMERICAIR CORPORATION, MISSISSAUGA, CANADA, FILED 1-22-2008.

SN 77-378,532. AIR PRODUCTS AND CHEMICALS, INC., ALLENTOWN, PA. FILED 1-23-2008.

GUS



THE MARK CONSISTS OF STANDARD CHARACTERS WITHOUT CLAIM TO ANY PARTICULAR FONT, STYLE, SIZE, OR COLOR.

THE MARK CONSISTS OF AVATAR (E-PERSON) GRAPHIC.

CLASS 7—MACHINERY

FOR SOLAR-POWERED ELECTRICITY GENERATORS; HORIZONTAL-AXIS WIND TURBINES; VERTICAL-AXIS WIND TURBINES; WIND-POWERED ELECTRICITY GENERATORS (U.S. CLS. 13, 19, 21, 23, 31, 34 AND 35).

CLASS 1—CHEMICALS

FOR INDUSTRIAL GASES IN THE NATURE OF NITROGEN, HYDROGEN, CARBON DIOXIDE; CHEMICALS FOR USE IN INDUSTRY (U.S. CLS. 1, 5, 6, 10, 26 AND 46).

CLASS 9—ELECTRICAL AND SCIENTIFIC APPARATUS

FOR APPARATUS FOR RECORDING, TRANSMISSION OR REPRODUCTION OF SOUND OR IMAGES; PRERECORDED MAGNETIC DATA CARRIERS FEATURING A FEMALE AVATAR TO COMMUNICATE THE ROLE, THE EXPERIENCE AND THE FUTURE OF AN ALTERNATIVE FUEL; PRERECORDED RECORDING DISCS FEATURING A FEMALE AVATAR TO COMMUNICATE THE ROLE, THE EXPERIENCE AND THE FUTURE OF AN ALTERNATIVE FUEL; PRERECORDED COMPACT DISCS FOR VIEWING SOUND AND PICTURES FEATURING A FEMALE AVATAR TO COMMUNICATE THE ROLE, THE EXPERIENCE AND THE FUTURE OF AN ALTERNATIVE FUEL; PRERECORDED DVDS FEATURING A FEMALE AVATAR TO COMMUNICATE THE ROLE, THE EXPERIENCE AND THE FUTURE OF AN ALTERNATIVE FUEL; PRERECORDED FILMS FEATURING A FEMALE AVATAR TO COMMUNICATE THE ROLE, THE EXPERIENCE AND THE FUTURE OF AN ALTERNATIVE FUEL; PRERECORDED VIDEO CASSETTES FEATURING A FEMALE AVATAR TO COMMUNICATE THE ROLE, THE EXPERIENCE AND THE FUTURE OF AN ALTERNATIVE FUEL; VIDEO GAME SOFTWARE (U.S. CLS. 21, 23, 26, 36 AND 38).

CLASS 16—PAPER GOODS AND PRINTED MATTER

FOR PAPER, CARDBOARD AND GOODS MADE FROM THESE MATERIALS, NAMELY, LABELS, STICKERS, INFORMATIONAL BROCHURES FEATURING A FEMALE AVATAR TO COMMUNICATE THE ROLE, THE EXPERIENCE AND THE FUTURE OF AN ALTERNATIVE FUEL, BANNERS, POSTERS (U.S. CLS. 2, 5, 22, 23, 29, 37, 38 AND 50).

CLASS 35—ADVERTISING AND BUSINESS

FOR ADVERTISING AND PROMOTION SERVICES; PROVIDING EDUCATIONAL BUSINESS INFORMATION ON INDUSTRIAL GAS BUSINESS (U.S. CLS. 100, 101 AND 102).

CLASS 42—SCIENTIFIC AND COMPUTER SERVICES

FOR INDUSTRIAL RESEARCH SERVICES IN THE FIELD OF INDUSTRIAL GASES (U.S. CLS. 100 AND 101).
LAURIE MAYES, EXAMINING ATTORNEY

SN 77-384,258. ADAMS MAGNETIC PRODUCTS CO., SONOMA, CA. FILED 1-30-2008.

ADAMS MAGNETIC PRODUCTS

THE MARK CONSISTS OF STANDARD CHARACTERS WITHOUT CLAIM TO ANY PARTICULAR FONT, STYLE, SIZE, OR COLOR.

OWNER OF U.S. REG. NO. 3,539,731.
NO CLAIM IS MADE TO THE EXCLUSIVE RIGHT TO USE "MAGNETIC PRODUCTS", APART FROM THE MARK AS SHOWN.
SEC. 2(F).

CLASS 35—ADVERTISING AND BUSINESS

FOR RETAIL STORE SERVICES, WHOLESALE STORES AND ONLINE RETAIL STORE SERVICES VIA THE INTERNET, ALL FEATURING INDUSTRIAL MAGNETIC PRODUCTS AND ACCESSORIES THEREFOR (U.S. CLS. 100, 101 AND 102).
FIRST USE 0-0-1950; IN COMMERCE 0-0-1950.

CLASS 40—MATERIAL TREATMENT

FOR MANUFACTURE OF INDUSTRIAL MAGNETIC PRODUCTS AND ACCESSORIES THEREFOR, TO THE ORDER AND SPECIFICATION OF OTHERS (U.S. CLS. 100, 103 AND 106).
FIRST USE 0-0-1950; IN COMMERCE 0-0-1950.
ANDREW RHIM, EXAMINING ATTORNEY

SN 77-385,459. MOHEGAN TRIBAL GAMING AUTHORITY, UNCASVILLE, CT. FILED 1-31-2008.

SUNRISE SQUARE

THE MARK CONSISTS OF STANDARD CHARACTERS WITHOUT CLAIM TO ANY PARTICULAR FONT, STYLE, SIZE, OR COLOR.

CLASS 41—EDUCATION AND ENTERTAINMENT

FOR GAMBLING SERVICES (U.S. CLS. 100, 101 AND 107).
FIRST USE 5-1-2007; IN COMMERCE 8-10-2007.

CLASS 43—HOTEL AND RESTAURANT SERVICES

FOR RESTAURANT (U.S. CLS. 100 AND 101).
FIRST USE 5-1-2007; IN COMMERCE 8-10-2007.
LESLEY LAMOTHE, EXAMINING ATTORNEY

SN 77-386,067. JAKKS PACIFIC, INC., MALIBU, CA. FILED 1-31-2008.



OWNER OF U.S. REG. NO. 2,083,189.
THE MARK CONSISTS OF THE DESIGN OF A COMPASS UNDER THE STYLIZED WORDING "FLYING COLORS".

CLASS 16—PAPER GOODS AND PRINTED MATTER

FOR STAMP ALBUMS; STICKER ALBUMS; ART MATERIALS, NAMELY, ART PAPER, CRAFT PAPER, DRAWING PAPER, CONSTRUCTION PAPER, PRINTS, ARTISTS' BRUSHES, DRAWING BRUSHES, PAINT BRUSHES, WRITING BRUSHES, PENS, WRITING INK, PENCILS, CRAYONS, MARKERS, PASTELS, PAINTING SETS FOR CHILDREN; ARTS AND CRAFT PAINT KITS AND ARTS AND CRAFT CLAY KITS; BALL POINT PENS; BINDERS; BLANK CARDS; PAPER LABELS; BLANK JOURNAL BOOKS; BOOK COVERS; BOOKMARKS; CHALK; CHILDREN'S BOOKS; COLOR PENS AND PENCILS; CORKBOARD PINS; PENCIL ORNAMENTS; ENVELOPES; ERASER; PORTABLE AND LAP DESKS; LUNCH BAGS; RUBBER STAMPS; PHOTO ALBUMS; MODELING MATERIALS AND COMPOUNDS FOR USE BY CHILDREN; NOTE BOOKS; NOTE PADS; MEMO PADS; PENCIL AND PEN CASES; PEN HOLDER; PENCIL LEAD; PUSH PINS, SCHOOL SUPPLY KITS CONTAINING VARIOUS COMBINATIONS OF SELECTED SCHOOL SUPPLIES, NAMELY, STENCILS, STICKERS AND WRITING INSTRUMENTS; CALENDARS; CARDS, NAMELY, GIFT CARDS, NOTE CARDS, BLANK CARDS, GREETING CARDS, HOLIDAY CARDS (U.S. CLS. 2, 5, 22, 23, 29, 37, 38 AND 50).

CLASS 28—TOYS AND SPORTING GOODS

FOR TOYS, GAMES AND PLAYTHINGS, NAMELY, CHILDREN'S PLAY COSMETICS, TOY COSMETIC MAKING KITS, TOY TOILETRY SETS, TOY JEWELRY, TOY MAKEUP KITS FOR CHILDREN, TOY PERFUME KITS FOR CHILDREN, TOY PERFUME MAKING KITS FOR CHILDREN; TOY BAKEWARE AND ACCESSORIES THEREFOR, TOY COOKWARE AND ACCESSORIES THEREFOR, TOY FOOD DECORATING KITS, TOY FROSTING DISPENSERS, TOY ICING DISPENSERS, TOY SPRINKLES DISPENSERS, AND RELATED GOODS, NAMELY, TOY BAKING UTENSILS AND BAKERY MIXES FOR USE BY CHILDREN IN PLAYING WITH SAID TOY BAKING UTENSILS, SOLD AS A UNIT; TOY CANDY MAKING UTENSILS AND CANDY MIXES FOR USE BY CHILDREN IN PLAYING WITH SAID TOY CANDY UTENSILS (U.S. CLS. 22, 23, 38 AND 50).

MAUREEN DALL, EXAMINING ATTORNEY

SN 77-391,245, SUCCESS RESOURCES PTE LTD, SINGAPORE, SINGAPORE, FILED 2-7-2008.

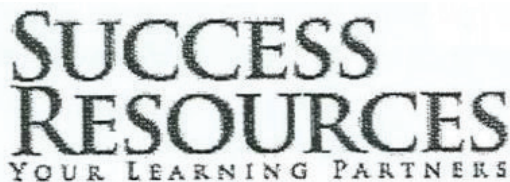

**SUCCESS
RESOURCES**
YOUR LEARNING PARTNERS

PRIORITY CLAIMED UNDER SEC. 44(D) ON SINGAPORE APPLICATION NO. T08/00624Z, FILED 1-18-2008, REG. NO. T08/00624Z, DATED 1-18-2008, EXPIRES 1-18-2018.

PRIORITY CLAIMED UNDER SEC. 44(D) ON SINGAPORE APPLICATION NO. T08/00623A, FILED 1-18-2008, REG. NO. T08/00623A, DATED 1-18-2008, EXPIRES 1-18-2018.

NO CLAIM IS MADE TO THE EXCLUSIVE RIGHT TO USE "RESOURCES" AND "LEARNING", APART FROM THE MARK AS SHOWN.

CLASS 16—PAPER GOODS AND PRINTED MATTER

FOR PRINTED INSTRUCTIONAL AND TEACHING MATERIALS IN THE FIELD OF BUSINESS AND PERSONAL DEVELOPMENT PROGRAMS; PRINTED MATTER, NAMELY, BROCHURES, PAMPHLETS, SYMPOSIA IN THE FIELD OF BUSINESS AND PERSONAL DEVELOPMENT PROGRAMS; BOOKS IN THE FIELDS OF BUSINESS AND PERSONAL DEVELOPMENT; BOOKLETS IN THE FIELDS OF PERSONAL DEVELOPMENT, INSTRUCTION MANUALS RELATING TO TRAINING SEMINARS IN THE FIELDS OF BUSINESS AND PERSONAL DEVELOPMENT; MANUALS FOR BUSINESS TRAINING COURSES; PRINTED TRAINING GUIDES IN THE FIELDS OF BUSINESS AND PERSONAL DEVELOPMENT; PRINTED TRAINING BOOKLETS IN THE FIELD OF BUSINESS AND PERSONAL DEVELOPMENT PROGRAMS; PRINTED TRAINING MATERIALS IN THE NATURE OF BOOKS, NOTES, PRINTED DIAGRAMS IN THE FIELDS OF BUSINESS AND PERSONAL DEVELOPMENT PROGRAMS; HANDOUTS IN THE FIELD OF BUSINESS AND PERSONAL DEVELOPMENT PROGRAMS; PRINTED MATERIALS IN THE NATURE OF BOOKS, NOTES, DIAGRAMS, HANDOUTS TO ACCOMPANY AUDIOVISUAL PRESENTATION IN THE FIELD OF BUSINESS AND PERSONAL DEVELOPMENT PROGRAMS; PRINTED EDUCATIONAL MATERIALS IN THE NATURE OF BOOKS, BOOKLETS, NOTES, DIAGRAMS, HANDOUTS FOR USE IN TEACHING IN THE FIELD OF BUSINESS AND PERSONAL DEVELOPMENT PROGRAMS; EDUCATIONAL MATERIALS IN PRINTED AND WRITTEN FORM IN THE NATURE OF NOTES, DIAGRAMS, HANDOUTS IN THE FIELD OF BUSINESS AND PERSONAL DEVELOPMENT PROGRAMS; PRINTED COURSE MATERIALS IN THE NATURE OF BOOKS, BOOKLETS, NOTES IN THE FIELD OF BUSINESS AND PERSONAL DEVELOPMENT PROGRAMS; PRINTED DISCUSSION NOTES IN THE FIELD OF BUSINESS AND PERSONAL DEVELOPMENT PROGRAMS; CATALOGUES IN THE FIELD OF BUSINESS AND PERSONAL DEVELOPMENT PROGRAMS; PRINTED DIAGRAMS; ENVELOPES; PRINTED GRAPHIC REPRODUCTIONS IN THE FIELD OF BUSINESS AND PERSONAL DEVELOPMENT PROGRAMS; PRINTED MANUALS, HANDBOOKS, INDEXES, LETTERS, NEWSLETTERS IN THE FIELD OF BUSINESS AND PERSONAL DEVELOPMENT PROGRAMS; PRINTED PUBLICATIONS IN THE NATURE OF BOOKS, BOOKLETS, MAGAZINES IN THE FIELD OF BUSINESS AND PERSONAL DEVELOPMENT PROGRAMS; EDUCATIONAL PAMPHLETS IN THE FIELD OF BUSINESS AND PERSONAL DEVELOPMENT PROGRAMS; ADHESIVE TAPES FOR STATIONERY OR HOUSEHOLD PURPOSES; DOCUMENT FILES; FOLDERS; GLUE FOR STATIONERY OR HOUSEHOLD PURPOSES; DRAWING INSTRUMENTS IN THE NATURE OF PENS, PENCILS, MARKERS, CRAYONS; DRAWING MATERIALS IN THE NATURE OF COLOR PENCILS, CRAYONS, MARKER PENS; NOTE BOOKS; PAPER SHEETS; STATIONERY; POSTERS; PLASTIC MATERIALS FOR PACKAGING, NAMELY, BAGS AND BUBBLE PACKS; BOOKMARKERS; CALENDARS; COASTERS OF PAPER; BLANK WRITING PADS; PERIODICAL MAGAZINES IN THE FIELD OF BUSINESS AND PERSONAL DEVELOPMENT PROGRAMS; PICTURES; CARDS, NAMELY, FLASH CARDS, HOLIDAY CARDS; PAPER WEIGHTS; RUBBER ERASERS; PEN CASES; PENS AND PENCILS (U.S. CLS. 2, 5, 22, 23, 29, 37, 38 AND 50).

CLASS 41—EDUCATION AND ENTERTAINMENT

FOR EDUCATIONAL SERVICES, NAMELY, PRACTICAL TRAININGS AND DEMONSTRATIONS IN THE FIELD OF BUSINESS AND PERSONAL DEVELOPMENT PROGRAMS; TEACHING, NAMELY, PROVIDING COURSES AND WORKSHOPS IN THE FIELD OF MANAGEMENT AND PERSONAL DEVELOPMENT PROGRAMS; INSTRUCTION SERVICES, NAMELY, PROVIDING COURSES AND WORKSHOPS IN THE FIELD OF BUSINESS AND PERSONAL DEVELOPMENT PROGRAMS; ARRANGING AND CONDUCTING EDUCATIONAL CONFERENCES, WORKSHOPS, SEMINARS, SYMPOSIUMS AND CONGRESSES; TRAINING SERVICES, NAMELY, PROVIDING COURSES AND WORKSHOPS IN THE FIELD OF BUSINESS AND PERSONAL DEVELOPMENT PROGRAMS; PROVISION OF EDUCA-

TIONAL INFORMATION, NAMELY, CONSULTATION IN THE FIELD OF BUSINESS AND PERSONAL DEVELOPMENT PROGRAMS; ORGANIZATION OF EDUCATIONAL OR ENTERTAINMENT COMPETITIONS; EDUCATIONAL SERVICES, NAMELY, PROVIDING COURSES AND WORKSHOPS IN THE FIELD OF BUSINESS AND PERSONAL DEVELOPMENT PROGRAMS; CORRESPONDENCE COURSES IN THE FIELD OF BUSINESS AND PERSONAL DEVELOPMENT PROGRAMS; ONLINE COURSES FOR EDUCATION IN THE FIELD OF BUSINESS AND PERSONAL DEVELOPMENT COURSES; PROVISION OF EDUCATIONAL INFORMATION ONLINE FROM A COMPUTER DATABASE OR ON THE GLOBAL COMMUNICATIONS NETWORK IN THE FIELD OF BUSINESS AND PERSONAL DEVELOPMENT PROGRAMS; PROVISION OF INSTRUCTIONAL SERVICES ONLINE FROM A COMPUTER DATABASE OR ON THE GLOBAL COMMUNICATIONS NETWORK IN THE FIELD OF BUSINESS AND PERSONAL DEVELOPMENT PROGRAMS; PUBLICATION OF NEWS, TEXT, BOOKS AND JOURNALS OTHER THAN PUBLICITY TEXT BY ELECTRONIC OR DIGITAL MEANS IN THE FIELD OF BUSINESS AND PERSONAL DEVELOPMENT PROGRAMS; PROVIDING NON-DOWNLOADABLE ONLINE ELECTRONIC PUBLICATIONS IN THE FORM OF ELECTRONIC BOOKS, NEWSLETTERS IN THE FIELD OF BUSINESS AND PERSONAL DEVELOPMENT PROGRAMS; CONSULTANCY SERVICES RELATING TO TRAINING AND EDUCATION; CONSULTANCY SERVICES RELATING TO THE ANALYSIS OF TRAINING REQUIREMENTS AND THE DESIGNING OF TRAINING COURSES; NON-DOWNLOADABLE GAME SERVICES PROVIDED ON-LINE FROM A COMPUTER NETWORK IN THE NATURE OF A COMPUTER GAME; PRODUCTION AND RENTAL OF SOUND AND VIDEO RECORDINGS; PERSONAL DEVELOPMENT COURSES AND TRAINING; ORGANIZATION OF GROUP RECREATIONAL ACTIVITIES IN THE FIELD OF TEAM-BUILDING GAMES, HIKING (U.S. CLS. 100, 101 AND 107).

ANDREA HACK, EXAMINING ATTORNEY

SN 77-395,803. TRICO MARINE SERVICES, INC., HOUSTON, TX. FILED 2-13-2008.

TRICO MARINE

THE MARK CONSISTS OF STANDARD CHARACTERS WITHOUT CLAIM TO ANY PARTICULAR FONT, STYLE, SIZE, OR COLOR.

OWNER OF U.S. REG. NO. 2,685,835.

NO CLAIM IS MADE TO THE EXCLUSIVE RIGHT TO USE "MARINE", APART FROM THE MARK AS SHOWN.

CLASS 37—CONSTRUCTION AND REPAIR

FOR MARINE CONSTRUCTION; INSTALLATION, MAINTENANCE, AND REMOVAL OF OFFSHORE FACILITIES, NAMELY, DEMOLITION AND CLEAN UP SERVICES; AND SUBSEA CONSTRUCTION (U.S. CLS. 100, 103 AND 106).

FIRST USE 12-31-1993; IN COMMERCE 12-31-1993.

CLASS 39—TRANSPORTATION AND STORAGE

FOR MARINE TRANSPORTATION SERVICES FOR TRANSPORTING OIL AND GAS INDUSTRY DRILLING MATERIALS, SUPPLIES AND CREWS, BY MARINE VESSELS, TO DRILLING RIGS AND OTHER OFFSHORE FACILITIES; AND MARINE TRANSPORTATION SERVICES FOR TOWING DRILLING RIGS AND DRILLING RIG EQUIPMENT TO OFFSHORE LOCATIONS (U.S. CLS. 100 AND 105).

FIRST USE 12-31-1993; IN COMMERCE 12-31-1993.
JENNIFER VASQUEZ, EXAMINING ATTORNEY

SN 77-396,510. PATCHIN PICTURES, LLC, LAS VEGAS, NV. FILED 2-13-2008.



NO CLAIM IS MADE TO THE EXCLUSIVE RIGHT TO USE "PICTURES", APART FROM THE MARK AS SHOWN. THE COLOR(S) GREEN, BLUE, BLACK, PURPLE, GREY, AND WHITE IS/ARE CLAIMED AS A FEATURE OF THE MARK.

THE MARK CONSISTS OF A STYLIZED LETTER "P" IN BLACK AND GREEN AND THE WORDS "PATCHIN PICTURES" IN BLACK LETTERING OVER AN IMAGE OF A BLUE, GREEN, GREY, AND PURPLE STYLIZED IMAGE OF A DVD, WITH THE OUTLINING SURROUNDING THE STYLIZED LETTER "P" AND LETTERING IN WHITE.

CLASS 9—ELECTRICAL AND SCIENTIFIC APPARATUS

FOR PRE-RECORDED VIDEOTAPES AND DVDS FEATURING EDUCATIONAL AND ENTERTAINMENT CONTENT IN THE NATURE OF INSTRUCTIONAL VIDEOS, BIOGRAPHIES, FAMILY AND BUSINESS HISTORIES (U.S. CLS. 21, 23, 26, 36 AND 38).

FIRST USE 6-1-1997; IN COMMERCE 7-1-1997.

CLASS 35—ADVERTISING AND BUSINESS

FOR CUSTOM AUDIO AND VISUAL SERVICES, NAMELY, PRODUCTION OF BUSINESS PROMOTIONAL VIDEO (U.S. CLS. 100, 101 AND 102).

FIRST USE 6-1-1997; IN COMMERCE 7-1-1997.

CLASS 41—EDUCATION AND ENTERTAINMENT

FOR COMPLETE VIDEO PRODUCTION SERVICES, MEDIA PRODUCTION SERVICES, NAMELY, PRODUCTION OF VIDEOS, VIDEO EDITING; PHOTOGRAPHY; CUSTOM AUDIO AND VIDEO SERVICES, NAMELY, ALL STAGES OF VIDEO PRODUCTION, INCLUDING CONCEPT, SCRIPTING, RECORDING, EDITING, AND FINISHING TO DVD, HI DENSITY DVD, OTHER TAPE FORMATS, AND DIGITAL FILES, FOR PERSONAL AND BUSINESS PURPOSES; PRODUCTION OF FAMILY HISTORY VIDEOS THROUGH CONVERSION OF PHOTOS, SLIDES, AND VIDEOS TO DVD, HI DENSITY DVD AND OTHER TAPE FORMATS AND DIGITAL FILES (U.S. CLS. 100, 101 AND 107).

FIRST USE 6-1-1997; IN COMMERCE 7-1-1997.

DAVID COLLIER, EXAMINING ATTORNEY

SN 77-397,114. SNAP-ON EQUIPMENT GMBH, 64319 PFUNGSTADT, FED REP GERMANY, FILED 2-14-2008.

QUADRIGA

THE MARK CONSISTS OF STANDARD CHARACTERS WITHOUT CLAIM TO ANY PARTICULAR FONT, STYLE, SIZE, OR COLOR.

OWNER OF ERPN CMNTY TM OFC REG. NO. 005734215, DATED 1-22-2008, EXPIRES 2-21-2017.

CLASS 7—MACHINERY

FOR TIRE CHANGER MACHINES (U.S. CLS. 13, 19, 21, 23, 31, 34 AND 35).

SN 77-398,171. DENTAL SLEEP SOLUTIONS, LLC, HOLMES BEACH, FL. FILED 2-15-2008.

CLASS 37—CONSTRUCTION AND REPAIR

FOR TIRE SERVICES IN VEHICLE SERVICE STATIONS, NAMELY, TIRE ROTATING, TIRE BALANCING, TIRE REPAIR AND TIRE MAINTENANCE (U.S. CLS. 100, 103 AND 106).

MELISSA VALLILLO, EXAMINING ATTORNEY



NO CLAIM IS MADE TO THE EXCLUSIVE RIGHT TO USE "DENTAL SLEEP", APART FROM THE MARK AS SHOWN.

THE MARK CONSISTS OF AN OUTLINE OF A QUARTER MOON WITH FACE, THREE STARS AND THE WORDS "DENTAL SLEEP" WITH A CURVED LINE THEREUNDER BELOW THE LINE BEING THE WORD "SOLUTIONS".

SN 77-397,369. ZHU AND CO., LLC, BEDMINSTER, NJ. FILED 2-14-2008.

CLASS 40—MATERIAL TREATMENT

FOR CUSTOM CONSTRUCTION OF INDIVIDUALIZED ORTHOTIC APPLIANCES TO BE WORN WHILE SLEEPING FOR THE TREATMENT OF SLEEP APNEA AND SNORING (U.S. CLS. 100, 103 AND 106).

FIRST USE 5-15-2005; IN COMMERCE 5-15-2005.

Cabrie

CLASS 44—MEDICAL, BEAUTY AND AGRICULTURAL SERVICES

FOR DENTAL SERVICES, NAMELY, FITTING OF INDIVIDUALIZED ORTHOTIC APPLIANCES TO BE WORN WHILE SLEEPING FOR THE TREATMENT OF SLEEP APNEA AND SNORING (U.S. CLS. 100 AND 101).

FIRST USE 5-15-2005; IN COMMERCE 5-15-2005.

APRIL ROACH, EXAMINING ATTORNEY

THE MARK CONSISTS OF STANDARD CHARACTERS WITHOUT CLAIM TO ANY PARTICULAR FONT, STYLE, SIZE, OR COLOR.

THE WORDING "CABRIE" HAS NO MEANING IN A FOREIGN LANGUAGE.

SN 77-398,757. VISION MECHANIX, LLC, HOOD RIVER, OR. FILED 2-15-2008.

CLASS 24—FABRICS

FOR KNITTED FABRIC; KNITTED FABRICS; KNITTED FABRICS OF CHEMICAL-FIBER YARN; KNITTED FABRICS OF COTTON YARN; KNITTED FABRICS OF SILK YARN; KNITTED FABRICS OF WOOL YARN; SILK BASE MIXED FABRICS; EIDER-DOWNS; QUILTS; QUILTS OF TEXTILE; TRICOT QUILTS; TROWS DESIGNED TO ALSO BE WRAPPED AROUND A PERSON (U.S. CLS. 42 AND 50).

QUIETSPACING

THE MARK CONSISTS OF STANDARD CHARACTERS WITHOUT CLAIM TO ANY PARTICULAR FONT, STYLE, SIZE, OR COLOR.

CLASS 25—CLOTHING

FOR EVENING DRESSES; DRESS SHIRTS; DRESS SUITS; DRESSES; SKIRTS AND DRESSES; BALLOON PANTS; CAPRI PANTS; CARGO PANTS; DENIMS; JOGGING PANTS; LEATHER PANTS; LOUNGE PANTS; PANTS; PETTI-PANTS; SKI PANTS; SNOW PANTS; SNOWBOARD PANTS; STRETCH PANTS; SWEAT PANTS; TAP PANTS; TOBOGGAN HATS, PANTS AND CAPS; TRACK PANTS; WATERPROOF JACKETS AND PANTS; WIND PANTS; YOGA PANTS; QUILTED VESTS; BELTS; CAPS; LEATHER BELTS; TIES; WRAPS (U.S. CLS. 22 AND 39).

MELISSA VALLILLO, EXAMINING ATTORNEY

CLASS 9—ELECTRICAL AND SCIENTIFIC APPARATUS

FOR PRE-RECORDED DVDS, CDS, AND OTHER PRE-RECORDED DIGITAL AND ELECTRONIC MEDIA, AND DOWNLOADABLE WEB-BASED AUDIO AND VISUAL MATERIALS IN THE NATURE OF WRITTEN MANUSCRIPTS, AUDIO/VISUAL SCRIPTS, WORKSHEETS, BOOKS, HANDOUTS, INSTRUCTION AND EVALUATION SHEETS, PRESENTATION SLIDWARE, FLASH-BASED PRESENTATIONS, VIDEO RECORDINGS AND AUDIO RECORDINGS IN THE FIELD OF PRODUCTIVITY, IMPROVING WORK HABITS, AND INDIVIDUAL PERFORMANCE (U.S. CLS. 21, 23, 26, 36 AND 38).

CLASS 41—EDUCATION AND ENTERTAINMENT

FOR CONDUCTING SEMINARS AND WORKSHOPS RELATING TO PRODUCTIVITY, IMPROVING WORK HABITS, AND INDIVIDUAL PERFORMANCE; EDUCATIONAL SERVICES RELATED TO PRODUCTIVITY, NAMELY, ONE-ON-ONE AND GROUP CONSULTING CLASSES AND PERSONAL AND GROUP COACHING; AND DISTRIBUTING MATERIALS IN CONNECTION THEREWITH (U.S. CLS. 100, 101 AND 107).

CLASS 42—SCIENTIFIC AND COMPUTER SERVICES

FOR NON-DOWNLOADABLE WEB-BASED SOFTWARE FEATURING AUDIO AND VISUAL MATERIALS IN THE NATURE OF WRITTEN MANUSCRIPTS, AUDIO/VISUAL SCRIPTS, WORKSHEETS, BOOKS, HANDOUTS, INSTRUCTION AND EVALUATION SHEETS, PRESENTATION SLIDWARE, FLASH-BASED PRESENTATIONS, VIDEO RECORDINGS AND AUDIO RECORDINGS IN THE FIELD OF PRODUCTIVITY, IMPROVING WORK HABITS, AND INDIVIDUAL PERFORMANCE (U.S. CLS. 100 AND 101).

LINDSEY RUBIN, EXAMINING ATTORNEY

SN 77-399,744. SPERIAN PROTECTION EUROPE, VILLEPINTE, FRANCE, FILED 2-18-2008.

PROTECTION YOU CAN TRUST

THE MARK CONSISTS OF STANDARD CHARACTERS WITHOUT CLAIM TO ANY PARTICULAR FONT, STYLE, SIZE, OR COLOR.

PRIORITY CLAIMED UNDER SEC. 44(D) ON FRANCE APPLICATION NO. 073545799, FILED 12-21-2007, REG. NO. 073545799, DATED 12-21-2007, EXPIRES 12-21-2017.

CLASS 9—ELECTRICAL AND SCIENTIFIC APPARATUS

FOR RESPIRATORS OTHER THAN FOR ARTIFICIAL RESPIRATION AND RESPIRATORY MASKS FOR NON-MEDICAL PURPOSES; RESPIRATORS FOR FILTERING AIR NOT FOR MEDICAL USE; FILTERS FOR NON-MEDICAL RESPIRATORY MASKS; OPTO-ELECTRONIC, NAMELY, PROTECTIVE MASKS NOT FOR MEDICAL PURPOSES; PROTECTIVE OPTICAL INSTRUMENTS, NAMELY, PROTECTIVE EYEWEAR; SPECTACLES, OPTICAL LENSES, NON-MEDICAL PROTECTIVE MASKS FOR EYES; SPECTACLES; FACE-PROTECTING WELDING SHIELDS; SHIELDS, FILMS, FILTERS AND SHEETS FOR EYE PROTECTION FROM ULTRA-VIOLET LIGHT AND LASERS FOR NON-MEDICAL USE; PROTECTIVE HELMETS; WORKMEN'S PROTECTIVE FACE AND EYE SHIELDS; DEVICES FOR EAR PROTECTION, NAMELY, SAFETY EARMUFFS, EARPLUGS AND HEADBANDS; AUTOMATIC DISTRIBUTION MACHINES FOR DEVICES FOR EAR PROTECTION, NAMELY, DISPENSERS OF EAR PLUGS AND EAR MUFFS; SAFETY EQUIPMENT AND EQUIPMENT FOR PROTECTION AGAINST FALLS, NAMELY, HARNESSSES, LINES, FALL-ARREST LIFE LINES, LANYARDS, BARS, ANCHORS; SAFETY RESTRAINTS OTHER THAN FOR VEHICLE SEATS AND SPORTS EQUIPMENT; SAFETY BELTS NOT FOR VEHICLE SEATS OR SPORTS EQUIPMENT; SAFETY CORDONS NOT FOR VEHICLE SEATS AND SPORTS EQUIPMENT; SAFETY STRAPS FOR HARNESSSES AND RESTRAINTS; LIFTING BELTS AND SAFETY HARNESSSES NOT FOR VEHICLE SEATS AND SPORTS EQUIPMENT; CLOTHING, HEADGEAR AND NON-ORTHOPEDIC FOOTWEAR FOR PROTECTION AGAINST ACCIDENTS, RADIATION AND FIRE; GLOVES FOR PROTECTION AGAINST ACCIDENTS, X-RAYS AND CHEMICAL AND BACTERIOLOGICAL RISKS; APPARATUS AND DEVICES FOR GAS TESTING AND TESTING EQUIPMENT FOR INDEPENDENT RESPIRATORY ASSISTANCE APPARATUS, NAMELY, GAS DETECTORS, APPARATUS FOR TESTING THE EFFICIENCY OF INDEPENDENT RESPIRATORY ASSISTANCE APPARATUS; DEVICES

FOR PERSONAL PROTECTION FROM ACCIDENTS, NAMELY, PROTECTIVE CLOTHING, PROTECTIVE HEADGEAR, PROTECTIVE EAR COVERINGS, PROTECTIVE WORK GLOVES, PROTECTIVE FOOTWEAR, PROTECTIVE FOOTWEAR COVERINGS; PROTECTIVE HELMETS; HARD HATS; PROTECTIVE HOODS; EQUIPMENT FOR PROTECTION AGAINST FALLS DURING SPORT, NAMELY, HARNESSSES, BELTS, DESCENDERS, LIFELINES, LANYARDS, CARABINERS, CLAMPING WEDGES; SAFETY DEVICES FOR SPORT, NAMELY, SAFETY HARNESSSES, SAFETY RESTRAINTS, HELMETS; SAFETY BELTS FOR USE IN SPORTS (U.S. CLS. 21, 23, 26, 36 AND 38).

CLASS 10—MEDICAL APPARATUS

FOR DEVICES FOR HEARING PROTECTION, NAMELY, HEAD BANDS, EARPLUGS AND EARMUFFS USED TO PROTECT EARS FOR MEDICAL AND PROPHYLACTIC PURPOSES; PROTECTIVE MASKS, CAPS, GLOVES, CLOTHING USED BY MEDICAL, SURGICAL AND DENTAL PERSONNEL; SURGICAL STERILE SHEETS; DEVICES AND INSTRUMENTS FOR EYE CLEANING, NAMELY, EYEWASH STATIONS CONSISTING OF EYE FLUSHING DEVICE, EYEWASH, AND EYE DECONTAMINATION SHOWERS (U.S. CLS. 26, 39 AND 44).

CLASS 25—CLOTHING

FOR CLOTHING, NAMELY, PANTS, SHIRTS, COATS; GLOVES; FOOTWEAR; COVERINGS FOR SHOES AND BOOTS NOT FOR MEDICAL OR PROTECTIVE PURPOSES; NON-ORTHOPEDIC PARTS OF FOOTWEAR, NAMELY, HEEL PIECES, SHOE SOLES AND PROTECTIVE TOE CAPS, REMOVABLE OR OTHERWISE, IN LEATHER, RUBBER, OR ANY OTHER MATERIAL; SOCKS, BOOT SOCKS, SLIPPERS, BOOTS, HALF-BOOTS, WOODEN SHOES, NON-SLIPPING DEVICES FOR FOOTWEAR; HEADGEAR, NAMELY, HATS, CAPS; APRONS; BIBS NOT OF CLOTH OR PAPER (U.S. CLS. 22 AND 39).

CLASS 28—TOYS AND SPORTING GOODS

FOR CLIMBERS' HARNESSSES; CORDONS FOR USE IN SPORTS, NAMELY, STRAPS FOR MOUNTAINEERING; STRAPS FOR USE IN SPORTS, NAMELY, BINDING STRAPS (U.S. CLS. 22, 23, 38 AND 50).

CLASS 35—ADVERTISING AND BUSINESS

FOR WHOLESALE STORES AND RETAIL STORES FEATURING CLOTHING AND DEVICES FOR PERSONAL PROTECTION AGAINST ACCIDENTS, RADIATION, CHEMICAL AND BACTERIOLOGICAL CONTAMINATION, FIRE AND AURAL ATTACKS (U.S. CLS. 100, 101 AND 102).

ALYSSA STEEL, EXAMINING ATTORNEY

SN 77-402,369. YAKABOD, FREDERICK, MD. FILED 2-21-2008.

Do stuff that matters.

THE MARK CONSISTS OF STANDARD CHARACTERS WITHOUT CLAIM TO ANY PARTICULAR FONT, STYLE, SIZE, OR COLOR.

CLASS 9—ELECTRICAL AND SCIENTIFIC APPARATUS

FOR COMPUTER SOFTWARE FOR MANAGING, SHARING, AND PROTECTING BUSINESS INFORMATION (U.S. CLS. 21, 23, 26, 36 AND 38).
FIRST USE 2-15-2008; IN COMMERCE 2-15-2008.

SN 77-405,582. GERDING/EDLEN DEVELOPMENT COMPANY, LLC, PORTLAND, OR. FILED 2-25-2008.

CLASS 42—SCIENTIFIC AND COMPUTER SERVICES

FOR COMPUTER SERVICE, NAMELY, ACTING AS AN APPLICATION SERVICE PROVIDER IN THE FIELD OF KNOWLEDGE MANAGEMENT TO HOST COMPUTER APPLICATION SOFTWARE FOR THE COLLECTION, EDITING, ORGANIZING, MODIFYING, BOOK MARKING, TRANSMISSION, STORAGE AND SHARING OF DATA AND INFORMATION (U.S. CLS. 100 AND 101).
FIRST USE 2-15-2008; IN COMMERCE 2-15-2008.
JOHN SCHUYLER YARD, EXAMINING ATTORNEY

Gerding Edlen Development

THE MARK CONSISTS OF STANDARD CHARACTERS WITHOUT CLAIM TO ANY PARTICULAR FONT, STYLE, SIZE, OR COLOR.
NO CLAIM IS MADE TO THE EXCLUSIVE RIGHT TO USE "DEVELOPMENT", APART FROM THE MARK AS SHOWN.
THE SURNAMES "GERDING" AND "EDLEN" IDENTIFY LIVING INDIVIDUALS WHOSE CONSENTS ARE OF RECORD.

CLASS 36—INSURANCE AND FINANCIAL

FOR REAL ESTATE INVESTMENT SERVICES (U.S. CLS. 100, 101 AND 102).
FIRST USE 2-2-1996; IN COMMERCE 2-2-1996.

SN 77-402,824. TURNTO NETWORKS, INC., NEW YORK, NY. FILED 2-21-2008.

CLASS 37—CONSTRUCTION AND REPAIR

FOR LAND DEVELOPMENT SERVICES, NAMELY, PLANNING AND LAYING OUT OF RESIDENTIAL AND COMMERCIAL BUILDINGS; CONSTRUCTION SERVICES IN THE FIELD OF SUSTAINABLE BUILDING AND DEVELOPMENT (U.S. CLS. 100, 103 AND 106).
FIRST USE 2-2-1996; IN COMMERCE 2-2-1996.

TURNTO

CLASS 42—SCIENTIFIC AND COMPUTER SERVICES

FOR PLANNING OF BUILDING INFRASTRUCTURES; ENVIRONMENTAL SUSTAINABILITY SERVICES, NAMELY, DESIGN OF SUSTAINABLE BUILDINGS AND DEVELOPMENT AND IMPLEMENTATION OF SUSTAINABLE STRATEGIES FOR EXISTING BUILDINGS AND BUILDINGS IN DESIGN (U.S. CLS. 100 AND 101).
FIRST USE 2-2-1996; IN COMMERCE 2-2-1996.
LINDA ESTRADA, EXAMINING ATTORNEY

THE MARK CONSISTS OF STANDARD CHARACTERS WITHOUT CLAIM TO ANY PARTICULAR FONT, STYLE, SIZE, OR COLOR.

CLASS 42—SCIENTIFIC AND COMPUTER SERVICES

FOR HOSTED COMPUTER SERVICES FOR OTHERS, NAMELY, HOSTING A WEB-ACCESSIBLE DATABASE AND WEBSITE INTERFACE ENABLING USERS TO CREATE AND MAINTAIN INFORMATION ON CONNECTIONS BETWEEN THEMSELVES AND OTHER USERS, AND ENABLING WEB SITES AND ON-LINE SERVICE PROVIDERS, SUCH AS ADVERTISERS AND DIRECT MARKETERS, TO ACCESS THIS DATA (U.S. CLS. 100 AND 101).
FIRST USE 7-30-2008; IN COMMERCE 7-30-2008.

SN 77-411,854. LENDER PROCESSING SERVICES, INC., JACKSONVILLE, FL. FILED 3-3-2008.

LPS

CLASS 45—PERSONAL AND LEGAL SERVICES

FOR INTERNET-BASED SOCIAL NETWORKING SERVICES (U.S. CLS. 100 AND 101).
FIRST USE 7-30-2008; IN COMMERCE 7-30-2008.
PRISCILLA MILTON, EXAMINING ATTORNEY

THE MARK CONSISTS OF STANDARD CHARACTERS WITHOUT CLAIM TO ANY PARTICULAR FONT, STYLE, SIZE, OR COLOR.

CLASS 35—ADVERTISING AND BUSINESS

FOR INVOICE MANAGEMENT SERVICES, NAMELY, ACCOUNTS RECEIVABLE AND BILLING SERVICES; REAL ESTATE PROPERTY TAX PAYMENT TRACKING SERVICES; SERVICES RELATING TO ADVISORY AND MANAGEMENT SERVICES FOR COORDINATION OF REAL ESTATE OWNED TRANSACTIONS FOR FINANCIAL INSTITUTIONS, FINANCIAL SERVICE PROVIDERS AND INVESTORS, NAMELY, ARRANGING FOR BUILDING MAINTENANCE AND REPAIR SERVICES FOR LENDERS; SERVICES RELATING TO ADVISORY AND MANAGEMENT SERVICES FOR COORDINATION OF REAL ESTATE OWNED TRANSACTIONS FOR FINANCIAL INSTITUTIONS, FINANCIAL SERVICE PROVIDERS AND INVESTORS, NAMELY, ARRANGING FOR REAL ESTATE HOUSE INSPECTION SERVICES (U.S. CLS. 100, 101 AND 102).

FIRST USE 2-29-2008; IN COMMERCE 2-29-2008.

CLASS 36—INSURANCE AND FINANCIAL

FOR SERVICES FOR USE BY FINANCIAL INSTITUTIONS, FINANCIAL SERVICE PROVIDERS AND INVESTORS IN THE NATURE OF PROVIDING SERVICES IN THE NATURE OF MORTGAGE ORIGINATION AND TRANSACTION PROCESSING SERVICES, LOAN FULFILLMENT MANAGEMENT AND PROCESSING SERVICES, AND MORTGAGE SERVICING MANAGEMENT AND PROCESSING SERVICES; LOAN DEFAULT MANAGEMENT SERVICES FOR LENDERS AND BANKS; LOAN PORTFOLIO SERVICES FEATURING DOCUMENT PREPARATION; FINANCIAL SERVICES, NAMELY, LOSS MITIGATION SERVICES FOR UNDEROR NON-PERFORMING MORTGAGE LOANS; INSURANCE AGENCIES IN THE FIELD OF REAL PROPERTY TITLE; REAL ESTATE TRUSTEE SERVICES IN THE NATURE OF SERVICES TO ACT AS AGENT OR TRUSTEE TO FACILITATE THE PROCESSING OF REAL PROPERTY LIEN RELEASE AND LIEN ASSIGNMENT; PROVIDING REAL ESTATE VALUATION AND APPRAISAL SERVICES; COLLATERAL REAL ESTATE ASSESSMENT SERVICES; RATING THE ACCURACY OF REAL ESTATE APPRAISERS; TRACKING AND MONITORING INSURANCE COMPLIANCE SERVICES IN REGARD TO FLOOD ZONES; PROVIDING A SEARCHABLE ONLINE DATABASE IN THE FIELD OF REAL ESTATE PUBLIC PROPERTY RECORDS; REAL ESTATE SERVICES IN THE NATURE OF PROVIDING REAL PROPERTY PROFILES AND PROVIDING REAL PROPERTY TRANSACTION HISTORIES; SERVICES RELATING TO ADVISORY AND MANAGEMENT SERVICES FOR COORDINATION OF REAL ESTATE OWNED TRANSACTIONS FOR FINANCIAL INSTITUTIONS, FINANCIAL SERVICE PROVIDERS AND INVESTORS, NAMELY, ARRANGING FOR THE BROKERAGE OF REAL ESTATE; PROVIDING LOAN PREPAYMENT AND DEFAULT PREDICTIVE MODELS TO FINANCIAL INSTITUTIONS, FINANCIAL SERVICE PROVIDERS AND INVESTORS TO PRICE, FUND, TRADE AND HEDGE MORTGAGES, MORTGAGE BACKED SECURITIES AND COLLATERALIZED MORTGAGE OBLIGATIONS; PROVIDING FIXED-INCOME ANALYTICAL SERVICES AND PORTFOLIO MANAGEMENT ANALYTICAL SERVICES TO FINANCIAL INSTITUTIONS, FINANCIAL SERVICE PROVIDERS AND INVESTORS TO PRICE, FUND, TRADE AND HEDGE MORTGAGES, MORTGAGE BACKED SECURITIES AND COLLATERALIZED MORTGAGE OBLIGATIONS; PROVIDING FINANCIAL DUE DILIGENCE TO FINANCIAL INSTITUTIONS, FINANCIAL SERVICE PROVIDERS AND INVESTORS TO PRICE, FUND, TRADE AND HEDGE MORTGAGES, MORTGAGE BACKED SECURITIES AND COLLATERALIZED MORTGAGE OBLIGATIONS; AND PROVIDING A NON-AGENCY COLLATERALIZED MORTGAGE OBLIGATION LOAN LEVEL DATABASE TO FINANCIAL INSTITUTIONS, FINANCIAL SERVICE PROVIDERS AND INVESTORS TO PRICE, FUND, TRADE AND HEDGE MORTGAGES, MORTGAGE BACKED SECURITIES AND COLLATERALIZED MORTGAGE OBLIGATIONS (U.S. CLS. 100, 101 AND 102).

FIRST USE 2-29-2008; IN COMMERCE 2-29-2008.

CLASS 42—SCIENTIFIC AND COMPUTER SERVICES

FOR DESIGN, DEVELOPMENT AND IMPLEMENTATION OF SOFTWARE; APPLICATION SERVICE PROVIDER SERVICES, NAMELY, DEVELOPING AND PROVIDING COMPUTER SOFTWARE PROGRAMS AND HOSTING SUCH SOFTWARE PROGRAMS ONLINE FOR LENDERS, BANKS AND MORTGAGE SERVICERS IN THE REAL ESTATE INDUSTRY; DATA CONVERSION OF COMPUTER PROGRAM DATA OR INFORMATION SERVICES (U.S. CLS. 100 AND 101).

FIRST USE 2-29-2008; IN COMMERCE 2-29-2008.

CLASS 45—PERSONAL AND LEGAL SERVICES

FOR REAL ESTATE SETTLEMENT SERVICES; REAL ESTATE CLOSING SERVICES; PROVIDING REAL ESTATE TITLE SEARCHES; PROVIDING REAL ESTATE TITLE ABSTRACTS; PROVIDING THE STATUS OF REAL ESTATE TITLE IN A TITLE COMMITMENT; PROVIDING REAL ESTATE TITLE EXCEPTION RESOLUTION; PROVIDING REAL ESTATE CHAIN-OF-TITLE HISTORIES; PROVIDING REVIEW, PREPARATION OF REAL ESTATE CLOSING AND POST CLOSING DOCUMENTS; PUBLIC REAL ESTATE DOCUMENT FILING SERVICES; MORTGAGE COMPLIANCE CONSULTING SERVICES CONCERNING MORTGAGE-RELATED LAWS FOR MORTGAGE LENDERS AND SERVICERS AND MORTGAGE BROKERS (U.S. CLS. 100 AND 101).

FIRST USE 2-29-2008; IN COMMERCE 2-29-2008.

HOWARD B. LEVINE, EXAMINING ATTORNEY

SN 77-412,056. LENDER PROCESSING SERVICES, INC., JACKSONVILLE, FL. FILED 3-4-2008.



THE MARK CONSISTS OF THE LETTERS "LPS" SURROUNDED BY TWO CURVED STYLIZED LINES.

CLASS 35—ADVERTISING AND BUSINESS

FOR INVOICE MANAGEMENT SERVICES, NAMELY, ACCOUNTS RECEIVABLE AND BILLING SERVICES; REAL ESTATE PROPERTY TAX PAYMENT TRACKING SERVICES; SERVICES RELATING TO ADVISORY AND MANAGEMENT SERVICES FOR COORDINATION OF REAL ESTATE OWNED TRANSACTIONS FOR FINANCIAL INSTITUTIONS, FINANCIAL SERVICE PROVIDERS AND INVESTORS, NAMELY, ARRANGING FOR BUILDING MAINTENANCE AND REPAIR SERVICES FOR LENDERS; SERVICES RELATING TO ADVISORY AND MANAGEMENT SERVICES FOR COORDINATION OF REAL ESTATE OWNED TRANSACTIONS FOR FINANCIAL INSTITUTIONS, FINANCIAL SERVICE PROVIDERS AND INVESTORS, NAMELY, ARRANGING FOR REAL ESTATE HOUSE INSPECTION SERVICES (U.S. CLS. 100, 101 AND 102).

FIRST USE 7-2-2008; IN COMMERCE 7-2-2008.

CLASS 36—INSURANCE AND FINANCIAL

FOR SERVICES FOR USE BY FINANCIAL INSTITUTIONS, FINANCIAL SERVICE PROVIDERS AND INVESTORS IN THE NATURE OF PROVIDING SERVICES IN THE NATURE OF MORTGAGE ORIGATION AND TRANSACTION PROCESSING SERVICES, LOAN FULFILLMENT MANAGEMENT AND PROCESSING SERVICES, AND MORTGAGE SERVICING MANAGEMENT AND PROCESSING SERVICES; LOAN DEFAULT MANAGEMENT SERVICES FOR LENDERS AND BANKS; LOAN PORTFOLIO SERVICES FEATURING DOCUMENT PREPARATION; FINANCIAL SERVICES, NAMELY, LOSS MITIGATION SERVICES FOR UNDEROR NON-PERFORMING MORTGAGE LOANS; INSURANCE AGENCIES IN THE FIELD OF REAL PROPERTY TITLE; REAL ESTATE TRUSTEE SERVICES IN THE NATURE OF SERVICES TO ACT AS AGENT OR TRUSTEE TO FACILITATE THE PROCESSING OF REAL PROPERTY LIEN RELEASE AND LIEN ASSIGNMENT; PROVIDING REAL ESTATE VALUATION AND APPRAISAL SERVICES; COLLATERAL REAL ESTATE ASSESSMENT SERVICES; RATING THE ACCURACY OF REAL ESTATE APPRAISERS; TRACKING AND MONITORING INSURANCE COMPLIANCE SERVICES IN REGARD TO FLOOD ZONES; PROVIDING A SEARCHABLE ONLINE DATABASE IN THE FIELD OF REAL ESTATE PUBLIC PROPERTY RECORDS; REAL ESTATE SERVICES IN THE NATURE OF PROVIDING REAL PROPERTY PROFILES AND PROVIDING REAL PROPERTY TRANSACTION HISTORIES; SERVICES RELATING TO ADVISORY AND MANAGEMENT SERVICES FOR COORDINATION OF REAL ESTATE OWNED TRANSACTIONS FOR FINANCIAL INSTITUTIONS, FINANCIAL SERVICE PROVIDERS AND INVESTORS, NAMELY, ARRANGING FOR THE BROKERAGE OF REAL ESTATE; PROVIDING LOAN PREPAYMENT AND DEFAULT PREDICTIVE MODELS TO FINANCIAL INSTITUTIONS, FINANCIAL SERVICE PROVIDERS AND INVESTORS TO PRICE, FUND, TRADE AND HEDGE MORTGAGES, MORTGAGE BACKED SECURITIES AND COLLATERALIZED MORTGAGE OBLIGATIONS, PROVIDING FIXED-INCOME ANALYTICAL SERVICES AND PORTFOLIO MANAGEMENT ANALYTICAL SERVICES TO FINANCIAL INSTITUTIONS, FINANCIAL SERVICE PROVIDERS AND INVESTORS TO PRICE, FUND, TRADE AND HEDGE MORTGAGES, MORTGAGE BACKED SECURITIES AND COLLATERALIZED MORTGAGE OBLIGATIONS; PROVIDING FINANCIAL DUE DILIGENCE TO FINANCIAL INSTITUTIONS, FINANCIAL SERVICE PROVIDERS AND INVESTORS TO PRICE, FUND, TRADE AND HEDGE MORTGAGES, MORTGAGE BACKED SECURITIES AND COLLATERALIZED MORTGAGE OBLIGATIONS; AND PROVIDING A NON-AGENCY COLLATERALIZED MORTGAGE OBLIGATION LOAN LEVEL DATABASE TO FINANCIAL INSTITUTIONS, FINANCIAL SERVICE PROVIDERS AND INVESTORS TO PRICE, FUND, TRADE AND HEDGE MORTGAGES, MORTGAGE BACKED SECURITIES AND COLLATERALIZED MORTGAGE OBLIGATIONS (U.S. CLS. 100, 101 AND 102).

FIRST USE 7-2-2008; IN COMMERCE 7-2-2008.

CLASS 42—SCIENTIFIC AND COMPUTER SERVICES

FOR DESIGN, DEVELOPMENT AND IMPLEMENTATION OF SOFTWARE; APPLICATION SERVICE PROVIDER SERVICES, NAMELY, DEVELOPING AND PROVIDING COMPUTER SOFTWARE PROGRAMS AND HOSTING SUCH SOFTWARE PROGRAMS ONLINE FOR LENDERS, BANKS AND MORTGAGE SERVICERS IN THE REAL ESTATE INDUSTRY; DATA CONVERSION OF COMPUTER PROGRAM DATA OR INFORMATION SERVICES (U.S. CLS. 100 AND 101).

FIRST USE 7-2-2008; IN COMMERCE 7-2-2008.

CLASS 45—PERSONAL AND LEGAL SERVICES

FOR REAL ESTATE SETTLEMENT SERVICES; REAL ESTATE CLOSING SERVICES; PROVIDING REAL ESTATE TITLE SEARCHES; PROVIDING REAL ESTATE TITLE ABSTRACTS; PROVIDING THE STATUS OF REAL ESTATE TITLE IN A TITLE COMMITMENT; PROVIDING REAL ESTATE TITLE EXCEPTION RESOLUTION; PROVIDING REAL ESTATE CHAIN-OF-TITLE HISTORIES; PROVIDING REVIEW, PREPARATION OF REAL ESTATE CLOSING AND POST CLOSING DOCUMENTS; PUBLIC REAL ESTATE DOCUMENT FILING SERVICES; MORTGAGE COMPLIANCE CONSULTING SERVICES CONCERNING MORTGAGE-RELATED LAWS FOR MORTGAGE LENDERS AND SERVICERS AND MORTGAGE BROKERS (U.S. CLS. 100 AND 101).

FIRST USE 7-2-2008; IN COMMERCE 7-2-2008.

HOWARD B. LEVINE, EXAMINING ATTORNEY

SN 77-415,711. EASYGROUP IP LICENSING LIMITED, LONDON NW1 7DL, UNITED KINGDOM, FILED 3-7-2008.

EASYJET GIFTS

THE MARK CONSISTS OF STANDARD CHARACTERS WITHOUT CLAIM TO ANY PARTICULAR FONT, STYLE, SIZE, OR COLOR.

OWNER OF UNITED KINGDOM REG. NO. 2253810, DATED 5-31-2002, EXPIRES 11-22-2010.

OWNER OF U.S. REG. NOS. 2,197,131, 2,694,614 AND 3,147,540.

NO CLAIM IS MADE TO THE EXCLUSIVE RIGHT TO USE "GIFTS" FOR INTERNATIONAL CLASS 16 AND 35, APART FROM THE MARK AS SHOWN.

CLASS 3—COSMETICS AND CLEANING PREPARATIONS

FOR HAIR CARE, RELAXING, BLEACHING, STRAIGHTENING AND STYLING PREPARATIONS; SKIN ABRASIVE PREPARATIONS; NAIL CARE AND BUFFING PREPARATIONS; COSMETICS; PERFUME; COLOGNE; SCENTED BODY SPRAYS; SOAPS; SHAMPOO; HAIR CONDITIONER; SKIN MOISTENERS; DEPLATORIES; SUN SCREEN AND SUN TANNING PREPARATIONS; DEODORANTS AND ANTIPERSPIRANTS; ESSENTIAL OILS FOR PERSONAL USE; AND ESSENTIAL OILS FOR USE IN THE MANUFACTURE OF SCENTED PRODUCTS (U.S. CLS. 1, 4, 6, 50, 51 AND 52).

CLASS 9—ELECTRICAL AND SCIENTIFIC APPARATUS

FOR CAMERAS; COMPUTER SOFTWARE AND FIRMWARE FOR USE IN DATABASE MANAGEMENT, FOR USE AS A SPREADSHEET AND FOR WORD PROCESSING, ALL RELATING TO TRAVEL, EDUCATION AND/OR ENTERTAINMENT; COMPUTER HARDWARE; COMPUTER GAMES SOFTWARE, PERSONAL RADIOS, PERSONAL COMPUTER HARDWARE, PERSONAL CASSETTE RECORDERS; PRE-RECORDED DIGITAL AUDIO TAPES FEATURING MUSIC; VIDEO RECORDINGS FEATURING FILMS; MUSICAL SOUND RECORDINGS; VIDEO CASSETTE RECORDERS; DIGITAL AUDIO TAPE PLAYERS; TELEVISION SETS; MOTION PICTURE FILMS FOR ENTERTAINMENT PURPOSES; PHOTOGRAPHIC SLIDE TRANSPARENCIES; MAGNETIC CODED CARDS FOR USE AS BANK CARDS, ATM CARDS, CREDIT AND DEBIT CARDS, LOYALTY CARDS, TELEPHONE CALLING CARDS, MEMBERSHIP CARDS, ELECTRONIC BENEFIT TRANSFER CARDS AND GIFT VOUCHER CARDS; SUNGLASSES; MOUSE PADS AND PROTECTIVE CLOTHING (U.S. CLS. 21, 23, 26, 36 AND 38).

CLASS 12—VEHICLES

FOR BICYCLES AND MOTORIZED SCOOTERS; NON-MOTORIZED SCOOTERS; TRAVELING BAGS SPECIFICALLY INTENDED FOR ATTACHING TO BICYCLES (U.S. CLS. 19, 21, 23, 31, 35 AND 44).

CLASS 14—JEWELRY

FOR JEWELRY, CLOCKS, HOROLOGICAL INSTRUMENTS, NAMELY, WATCHES (U.S. CLS. 2, 27, 28 AND 50).

CLASS 16—PAPER GOODS AND PRINTED MATTER

FOR PRINTED MATTER AND PRINTED PUBLICATIONS, NAMELY, PERIODICALS, BOOKS, MANUALS, PAMPHLETS, NEWSLETTERS, BROCHURES, PHOTOGRAPH ALBUMS, NEWSPAPERS AND MAGAZINES, ALL RELATING TO GENERAL INTEREST SUBJECT MATTERS INCLUDING TRAVEL, ENTERTAINMENT, AND CURRENT AFFAIRS; PRINTED TICKETS, PRINTED VOUCHERS, PRINTED COUPONS; TRAVELER IDENTIFICATION CARDS, NOT MAGNETICALLY ENCODED, PRINTED LABELS NOT OF TEXTILE AND PAPER TAGS; POSTERS; POSTCARDS, STATIONERY, WRITING INSTRUMENTS, WRAPPING AND PACKAGING, NAMELY, WRAPPING PAPER AND BAGS OF PAPER OR PLASTICS, CALENDARS, DIARIES, MOUNTED AND UNMOUNTED PHOTOGRAPHS, GIFT CARDS, GREETING CARDS, PRINTED INSTRUCTIONAL, EDUCATIONAL AND TEACHING MATERIALS IN THE FIELD OF MATH, SCIENCE, ENGLISH, AND HISTORY; ARTISTS' MATERIALS, NAMELY, DRAWING INSTRUMENTS (U.S. CLS. 2, 5, 22, 23, 29, 37, 38 AND 50).

CLASS 18—LEATHER GOODS

FOR TRUNKS, TRAVELING BAGS, PURSES, WALLETS, FELT POUCHES, HANDBAGS, LUGGAGE, SPORTS BAGS, BACKPACKS, UMBRELLAS, PARASOLS, HARNESSES, AND SADDLERY, ALL AFORESAID GOODS MADE OF LEATHER AND IMITATION LEATHER, AND ANIMAL SKINS AND HIDES (U.S. CLS. 1, 2, 3, 22 AND 41).

CLASS 28—TOYS AND SPORTING GOODS

FOR BOARD GAMES, FOOTBALLS, BASKETBALLS, BASEBALLS, RUBBER BALLS, BEACH BALLS AND RUGBY BALLS; ARCADE GAMES; CHRISTMAS TREE DECORATIONS; SCALE MODEL AIRPLANES, TOY SCOOTERS; TEDDY BEARS AND GOLF BALLS (U.S. CLS. 22, 23, 38 AND 50).

CLASS 29—MEATS AND PROCESSED FOODS

FOR CHEESE, BUTTER, YOGURTS AND MARGARINE; PREPARED MEALS CONSISTING PRIMARILY OF MEAT, FISH, POULTRY, OR VEGETABLES; CANDIED FRUIT SNACKS, AND FRUIT SNACK FOODS; MEAT; FISH; POULTRY; EDIBLE OILS AND FATS; EGGS; MILK; JELLIES; JAMS; AND PRESERVED, DRIED, AND COOKED FRUITS AND VEGETABLES; FRUIT SAUCES IN THE NATURE OF APPLESAUCE AND CRANBERRY SAUCE (U.S. CL. 46).

CLASS 30—STAPLE FOODS

FOR COFFEE; TEA; COCOA; SUGAR; RICE; TAPIOCA; SAGO; ARTIFICIAL COFFEE; FLOUR; HONEY; TREACLE; YEAST; BAKING POWDER; SALT; CONDIMENTS, NAMELY, PEPPER AND MUSTARD; VINEGAR, SAUCES; SPICES; PREPARED MEALS CONSISTING PRIMARILY OF RICE AND PASTA; WHEAT, CEREAL, RICE, AND GRANOLA BASED SNACK FOODS; PUFFED CORN SNACK FOODS; CONFECTIONERY, NAMELY, CANDY AND CHIPS FOR BAKING; FLAVORED ICES; AND CHOCOLATE; FRUIT SAUCES EXCLUDING CRANBERRY SAUCE AND APPLESAUCE (U.S. CL. 46).

CLASS 32—LIGHT BEVERAGES

FOR MINERAL AND AERATED WATERS; BEER; FRUIT DRINKS; FRUIT JUICE; AND SYRUPS AND OTHER PREPARATIONS FOR MAKING FRUIT DRINKS (U.S. CLS. 45, 46 AND 48).

CLASS 33—WINES AND SPIRITS

FOR ALCOHOLIC DRINKS, NAMELY, WINES, LIQUEURS, ALCOHOLIC COCKTAILS, PREPARED WINE COCKTAILS, AND POTABLE, DISTILLED, AND BRANDY SPIRITS (U.S. CLS. 47 AND 49).

CLASS 34—SMOKERS' ARTICLES

FOR CIGARETTES; CIGARS, SNUFF; TOBACCO; CIGARETTE LIGHTERS NOT OF PRECIOUS METAL; AND MATCHES; CIGARETTE LIGHTERS OF PRECIOUS METAL (U.S. CLS. 2, 8, 9 AND 17).

CLASS 35—ADVERTISING AND BUSINESS

FOR ADVERTISING AGENCIES; COOPERATIVE ADVERTISING AND MARKETING SERVICES; PUBLICITY AGENT SERVICES; DISSEMINATION OF ADVERTISING, MARKETING, AND PUBLICITY MATERIALS; BUSINESS MANAGEMENT OF RETAIL OUTLETS; BUSINESS ADMINISTRATION, NAMELY, BUSINESS CONSULTATION FOR RETAIL OUTLETS; BUSINESS MANAGEMENT AND CONSULTATION; PURCHASING AGENT; PRODUCT DEMONSTRATIONS; RETAIL STORE SERVICES FEATURING TOYS, CLOTHING AND STATIONERY; ONLINE RETAIL STORE SERVICES FEATURING TOYS, CLOTHING AND STATIONERY; MAIL ORDER SERVICES FEATURING TOYS, CLOTHING AND STATIONERY; ADVERTISING INFORMATION AND BUSINESS INFORMATION SERVICES IN RELATION TO THE AFORESAID SERVICES VIA THE INTERNET FROM AN ONLINE COMPUTER DATABASE; HOTEL MANAGEMENT SERVICES FOR OTHERS (U.S. CLS. 100, 101 AND 102).

CLASS 38—COMMUNICATION

FOR RADIO, TELEPHONE, MOBILE RADIO, AND TELEGRAM COMMUNICATIONS; TELEVISION BROADCASTING; ELECTRONIC MESSAGE AND DATA TRANSMISSION; PROVISION OF ACCESS TO COMPUTERS AND THE INTERNET, NAMELY, PROVIDING MULTIPLE-USER ACCESS TO A GLOBAL COMPUTER INFORMATION NETWORK, AND COMMUNICATIONS CONSULTATION AND INFORMATION SERVICES IN RELATION TO THE AFORESAID SERVICES VIA THE INTERNET FROM AN ONLINE COMPUTER DATABASE (U.S. CLS. 100, 101 AND 104).

CLASS 39—TRANSPORTATION AND STORAGE

FOR TRANSPORTATION OF GOODS, PASSENGERS AND TRAVELERS BY AIR; FREIGHT TRANSPORT BY AIR AND BOAT; AIRPORT CHECK-IN SERVICES; ARRANGING OF TRANSPORTATION OF GOODS, PASSENGERS AND TRAVELERS BY LAND AND SEA; AIRLINE SERVICES; CARGO HANDLING, BAGGAGE HANDLING IN THE NATURE OF PASSENGER BAGGAGE HANDLING, AND FREIGHT BROKERAGE SERVICES; ARRANGING TRAVEL TOURS, CRUISES, EXCURSIONS AND VACATIONS; CHARTERING OF AIRCRAFT; RENTAL OF VEHICLES, BOATS AND AIRCRAFT; VEHICLE PARKING SERVICES, NAMELY, CAR AND AIRCRAFT PARKING SERVICES; TRAVEL AGENCY AND TOURIST OFFICE SERVICES, NAMELY, MAKING RESERVATIONS AND BOOKINGS FOR TRANSPORTATION; TRAVEL INFORMATION SERVICES IN RELATION TO THE AFORESAID SERVICES AND INFORMATION FOR RELATED TRANSPORTATION SERVICES INCLUDING VIA INTERNET FROM AN ONLINE COMPUTER DATABASE; PROVISION OF TRAVEL INFORMATION (U.S. CLS. 100 AND 105).

CLASS 41—EDUCATION AND ENTERTAINMENT

FOR PROVIDING EDUCATIONAL AND ENTERTAINMENT INFORMATION, NAMELY, INFORMATION CONCERNING ENTERTAINMENT EVENTS, HISTORY, ART AND CURRENT AFFAIRS, PROVIDED ONLINE FROM A COMPUTER DATABASE OR THE INTERNET; ENTERTAINMENT SERVICES PROVIDED ONLINE FROM A COMPUTER DATABASE OR INTERNET, NAMELY, PROVIDING ONLINE COMPUTER GAMES; EDUCATIONAL INFORMATION PROVIDED ONLINE FROM A COMPUTER DATABASE OR THE INTERNET, NAMELY, DEVELOPMENT AND DISSEMINATION OF EDUCATIONAL MATERIALS OF OTHERS IN THE FIELD OF ART AND HISTORY; ENTERTAINMENT SERVICES, NAMELY, PROVIDING ENTERTAINMENT INFORMATION AND PROVIDING ONLINE GAMES, AND AMUSEMENT SERVICES TO ENTERTAIN PASSENGERS, INCLUDING THE SHOWING OF FILMS/TV PROGRAMS AND PROVIDING THE FACILITIES FOR PLAYING COMPUTER GAMES; EDUCATIONAL SERVICES, NAMELY, PROVIDING CLASSES IN THE SUBJECTS OF ART, HISTORY, GENERAL INTEREST TOPICS AND TRAVEL; RENTAL OF COMPUTER GAME PROGRAMS AND RELATED TOYS FOR ENTERTAINMENT AND CHILD AMUSEMENT PURPOSES (U.S. CLS. 100, 101 AND 107).

CLASS 42—SCIENTIFIC AND COMPUTER SERVICES

FOR PROVIDING METEOROLOGICAL INFORMATION SERVICES; DESIGN OF COMPUTER SOFTWARE FOR OTHERS; COMPUTER PROGRAMMING FOR OTHERS; COMPUTER CONSULTATION; SOFTWARE, HARDWARE, FIRMWARE AND INFORMATION TECHNOLOGY CONSULTATION AND DESIGN; RENTAL OF ELECTRIC AND ELECTRONIC GOODS, NAMELY, RENTAL OF COMPUTERS AND COMPUTER SOFTWARE; PROVIDING INFORMATION IN THE FIELD OF INFORMATION TECHNOLOGY, AND THE AFORESAID SERVICES VIA THE INTERNET FROM AN ONLINE COMPUTER DATABASE (U.S. CLS. 100 AND 101).

CLASS 43—HOTEL AND RESTAURANT SERVICES

FOR PROVIDING TEMPORARY HOUSING ACCOMMODATION, CATERING, HOTEL, RESTAURANT, CAFE AND BAR SERVICES; TRAVEL AGENCY SERVICES, NAMELY, RESERVATIONS AND BOOKINGS FOR TEMPORARY LODGING AND HOTEL ACCOMMODATION, PROVISION OF GENERAL PURPOSE FACILITIES FOR EXHIBITIONS AND CONFERENCES (U.S. CLS. 100 AND 101).

CLASS 44—MEDICAL, BEAUTY AND AGRICULTURAL SERVICES

FOR HAIRDRESSING, HAIR CUTTING, HAIR STYLING AND BEAUTY SALON SERVICES; HEALTH CARE; COUNSELING IN THE FIELD OF HEALTH (U.S. CLS. 100 AND 101).

CLASS 45—PERSONAL AND LEGAL SERVICES

FOR LICENSING OF COMPUTER SOFTWARE, FIRMWARE AND HARDWARE TO OTHERS; RENTAL OF CLOTHING; PROVIDING INFORMATION IN THE FIELD OF LAW AND INTELLECTUAL PROPERTY COUNSELING AND LICENSING; BAGGAGE HANDLING INSPECTIONS FOR AIRLINES (U.S. CLS. 100 AND 101).

SEAN CROWLEY, EXAMINING ATTORNEY

SN 77-417,675. TSX INC., TORONTO, CANADA, FILED 3-10-2008.

TSX TECHNOLOGIES

THE MARK CONSISTS OF STANDARD CHARACTERS WITHOUT CLAIM TO ANY PARTICULAR FONT, STYLE, SIZE, OR COLOR.

OWNER OF CANADA REG. NO. TMA727993, DATED 11-6-2008, EXPIRES 11-6-2023.

OWNER OF U.S. REG. NOS. 2,986,091, 3,030,003 AND OTHERS.

NO CLAIM IS MADE TO THE EXCLUSIVE RIGHT TO USE "TECHNOLOGIES", APART FROM THE MARK AS SHOWN.

CLASS 9—ELECTRICAL AND SCIENTIFIC APPARATUS

FOR COMPUTER SOFTWARE FOR TRADING IN FINANCIAL INSTRUMENTS AND SECURITIES AND RECORDING, COMPUTING, ANALYSIS AND REPORTING OF INFORMATION REGARDING TRADING IN FINANCIAL INSTRUMENTS AND SECURITIES (U.S. CLS. 21, 23, 26, 36 AND 38).

CLASS 36—INSURANCE AND FINANCIAL

FOR RECORDING, COMPUTING, ANALYSIS AND REPORTING OF INFORMATION REGARDING TRADING OF FINANCIAL INSTRUMENTS AND SECURITIES; OPERATION OF A STOCK EXCHANGE AND STOCK MARKET FOR TRADING IN FINANCIAL INSTRUMENTS AND SECURITIES; ESTABLISHING AND ISSUING FINANCIAL INSTRUMENTS AND SECURITIES FOR OTHERS; ANALYSIS AND REPORTING INFORMATION RELATING TO SUCH TRADING AND ONLINE FINANCIAL INFORMATION SERVICES; FACILITATION OF ON-LINE TRADING OF FINANCIAL INSTRUMENTS AND SECURITIES, NAMELY, PROVIDING TRADERS WITH THE ABILITY TO COMPLETE TRADES ON VARIOUS EXCHANGES WITHIN THE STOCK MARKET (U.S. CLS. 100, 101 AND 102).

TARA PATE, EXAMINING ATTORNEY

SN 77-417,733. TSX INC., TORONTO, CANADA, FILED 3-10-2008.

TSX MARKET ON CLOSE

THE MARK CONSISTS OF STANDARD CHARACTERS WITHOUT CLAIM TO ANY PARTICULAR FONT, STYLE, SIZE, OR COLOR.

OWNER OF CANADA REG. NO. TMA727995, DATED 11-6-2008, EXPIRES 11-6-2023.

OWNER OF U.S. REG. NOS. 2,986,091, 3,030,003 AND OTHERS.

NO CLAIM IS MADE TO THE EXCLUSIVE RIGHT TO USE "MARKET ON CLOSE", APART FROM THE MARK AS SHOWN.

CLASS 9—ELECTRICAL AND SCIENTIFIC APPARATUS

FOR COMPUTER SOFTWARE FOR TRADING IN FINANCIAL INSTRUMENTS AND SECURITIES AND RECORDING, COMPUTING, ANALYSIS AND REPORTING OF INFORMATION REGARDING TRADING IN FINANCIAL INSTRUMENTS AND SECURITIES (U.S. CLS. 21, 23, 26, 36 AND 38).

CLASS 36—INSURANCE AND FINANCIAL

FOR RECORDING, COMPUTING, ANALYSIS AND REPORTING OF INFORMATION REGARDING TRADING OF FINANCIAL INSTRUMENTS AND SECURITIES; OPERATION OF A STOCK EXCHANGE AND STOCK MARKET FOR TRADING IN FINANCIAL INSTRUMENTS AND SECURITIES; ESTABLISHING AND ISSUING FINANCIAL INSTRUMENTS AND SECURITIES FOR OTHERS; ANALYSIS AND REPORTING INFORMATION RELATING TO SUCH TRADING AND ON-LINE FINANCIAL INFORMATION SERVICES; FACILITATION OF ON-LINE TRADING OF FINANCIAL INSTRUMENTS AND SECURITIES, NAMELY, PROVIDING TRADERS WITH THE ABILITY TO COMPLETE TRADES ON VARIOUS EXCHANGES WITHIN THE STOCK MARKET (U.S. CLS. 100, 101 AND 102).

TARA PATE, EXAMINING ATTORNEY

SN 77-417,812. TSX INC., TORONTO, CANADA, FILED 3-10-2008.



OWNER OF CANADA REG. NO. TMA725207, DATED 10-2-2008, EXPIRES 10-2-2023.

OWNER OF U.S. REG. NOS. 2,986,091, 3,030,003 AND OTHERS.

THE MARK CONSISTS OF THE TERM "QUANTUM" POSITIONED BETWEEN THE TERMS "TSX" AND "THE SPEED OF TRADE" WITH A CURVED LINE SEGMENT PASSING THERETHROUGH.

CLASS 9—ELECTRICAL AND SCIENTIFIC APPARATUS

FOR COMPUTER SOFTWARE FOR TRADING IN FINANCIAL INSTRUMENTS AND SECURITIES AND RECORDING, COMPUTING, ANALYSIS AND REPORTING OF INFORMATION REGARDING TRADING IN FINANCIAL INSTRUMENTS AND SECURITIES (U.S. CLS. 21, 23, 26, 36 AND 38).

CLASS 36—INSURANCE AND FINANCIAL

FOR RECORDING, COMPUTING, ANALYSIS AND REPORTING OF INFORMATION REGARDING TRADING OF FINANCIAL INSTRUMENTS AND SECURITIES; OPERATION OF A STOCK EXCHANGE AND STOCK MARKET FOR TRADING IN FINANCIAL INSTRUMENTS AND SECURITIES; ESTABLISHING AND ISSUING FINANCIAL INSTRUMENTS AND SECURITIES FOR OTHERS; ANALYSIS AND REPORTING INFORMATION RELATING TO SUCH TRADING AND ON-LINE FINANCIAL INFORMATION SERVICES; FACILITATION OF ON-LINE TRADING OF FINANCIAL INSTRUMENTS AND SECURITIES, NAMELY, PROVIDING TRADERS WITH THE ABILITY TO COMPLETE TRADES ON VARIOUS EXCHANGES WITHIN THE STOCK MARKET (U.S. CLS. 100, 101 AND 102).

TARA PATE, EXAMINING ATTORNEY

SN 77-419,649. BUSINESSSTONE LLC, NEW YORK, NY. FILED 3-12-2008.

ESPRESSO LEGEND

THE MARK CONSISTS OF STANDARD CHARACTERS WITHOUT CLAIM TO ANY PARTICULAR FONT, STYLE, SIZE, OR COLOR.

OWNER OF ITALY REG. NO. 770715, DATED 2-1-1999, EXPIRES 5-28-2016.

CLASS 25—CLOTHING

FOR SPORTS CLOTHING, NAMELY, T-SHIRTS, SHIRTS, TROUSERS, SKIRTS, TIGHTS, COATS, SKI AND SNOWBOARD WEAR, JACKETS, PANTS, SWEAT-PANTS, SHORTS, SWEATSHIRTS, SOCKS; TRACK-SUITS, GLOVES, HATS, CAPS, BERETS, HOSIERY, FOOTWEAR; SKI BOOT CARRYING CASES (U.S. CLS. 22 AND 39).

CLASS 28—TOYS AND SPORTING GOODS

FOR SKATEBOARDS, SNOWBOARDS, SURFBOARDS, ROLLER SKATES, PADDLEBALL AND BADMINTON RACKETS, SNOW SKIS, SKI CARRYING CASES, SKI BINDINGS, SNOWBOARD BINDINGS, SNOWBOARD CARRYING CASES (U.S. CLS. 22, 23, 38 AND 50).

ALICE BENMAMAN, EXAMINING ATTORNEY

SN 77-424,227. MOOD AUSTRALIA PTY LTD, PETERSHAM NSW 2049, AUSTRALIA, FILED 3-17-2008.

MOOD

THE MARK CONSISTS OF STANDARD CHARACTERS WITHOUT CLAIM TO ANY PARTICULAR FONT, STYLE, SIZE, OR COLOR.

CLASS 14—JEWELRY

FOR CLOCKS; KEY RINGS OF PRECIOUS METAL; BOXES OF PRECIOUS METAL; CHRONOGRAPHS FOR USE AS WATCHES; CHRONOMETERS, CHRONOMETRICAL INSTRUMENTS OTHER THAN CHRONOGRAPHS FOR USE AS SPECIALIZED TIME RECORDING APPARATUSES, CHRONOSCOPES; ORNAMENTS OF PRECIOUS METAL, NAMELY, SILVER ORNAMENTS; STATUES AND STATUETTES OF PRECIOUS METAL; JEWELRY CASES, NOT OF PRECIOUS METAL (U.S. CLS. 2, 27, 28 AND 50).

CLASS 20—FURNITURE AND ARTICLES NOT OTHERWISE CLASSIFIED

FOR ANIMAL HORN AND ANTLERS; STAG ANTLERS; ANIMAL HORN, UNWORKED OR SEMI-WORKED; BONE HANDLES FOR FURNITURE, DOORS, CABINETS, CUPBOARDS, BOXES AND DRAWERS, HORN HANDLES FOR FURNITURE, DOORS, CABINETS, CUPBOARDS, BOXES AND DRAWERS; NON-METAL CABINET HARDWARE, NAMELY, NON-METAL HANDLES, NON-METAL HINGES AND KNOBS OF PLASTIC AND WOOD; NON-METAL CLOSURES AND STOPPERS FOR BOTTLES AND CONTAINERS; WOOD HANDLES FOR KNIVES AND TOOLS; NON-METAL DOOR FITTINGS, FURNITURE FITTINGS AND WINDOW FITTINGS; BOTTLE CAPS, NOT OF METAL; WIND CHIMES FOR DECORATION; CUPBOARDS; PICTURE FRAMES; FURNITURE; MIRRORS; MAGAZINE RACKS; SIDEBOARDS; STATUES AND STATUETTES OF WOOD, WAX, PLASTER OR PLASTIC; STOOLS; UMBRELLA STANDS; WORKS OF ART, MADE OF WOOD, WAX, PLASTER OR PLASTIC (U.S. CLS. 2, 13, 22, 25, 32 AND 50).

LYDIA BELZER, EXAMINING ATTORNEY

SN 77-427,740. SEIKO EPSON KABUSHIKI KAISHA (ALSO TRADING AS SEIKO EPSON CORPORATION), TOKYO, JAPAN, FILED 3-20-2008.



Greenmethod

THE MARK CONSISTS OF TWO CURVED LINES OVER THE WORDING "GREENMETHOD".

CLASS 9—ELECTRICAL AND SCIENTIFIC APPARATUS

FOR GLOBAL GREENHOUSE GASES MEASURING APPARATUS, NAMELY, MEASURING APPARATUS FOR GREENHOUSE GAS LEVELS IN GASES AND SOLID SUBSTANCES, AND THEIR PARTS (U.S. CLS. 21, 23, 26, 36 AND 38).

CLASS 36—INSURANCE AND FINANCIAL

FOR EMISSIONS TRADING OF GLOBAL GREENHOUSE GASES; AGENCIES OR BROKERAGE FOR EMISSIONS TRADING OF GLOBAL GREENHOUSE GASES (U.S. CLS. 100, 101 AND 102).

CLASS 42—SCIENTIFIC AND COMPUTER SERVICES

FOR PROVIDING TECHNICAL ADVICE AND INFORMATION RELATING TO GLOBAL GREENHOUSE GASES MEASURING AND TESTING MACHINES AND INSTRUMENTS; MEASUREMENT AND EVALUATION OF GLOBAL GREENHOUSE GASES; PROVIDING INFORMATION IN THE FIELD OF MEASURING GLOBAL GREENHOUSE GASES; MEASURING, TESTING OR RESEARCH RELATING TO AIR QUALITY; TESTING OR RESEARCH ON ENVIRONMENTAL TECHNOLOGY; PROVIDING ENVIRONMENTAL ANALYSIS, SURVEYS OR RESEARCH OF OTHERS FOR THE PURPOSE OF EMISSIONS TRADING OF GLOBAL GREENHOUSE GASES; RENTAL OF MEASURING APPARATUS (U.S. CLS. 100 AND 101).

SUNG IN, EXAMINING ATTORNEY

SN 77-428,184. ANIMATORS AT LAW, INC., ALEXANDRIA, VA. FILED 3-21-2008.



THE STIPPLING IS A FEATURE OF THE MARK AND DOES NOT INDICATE COLOR.

THE MARK CONSISTS OF A SCALE DESIGN WITH A STRIP OF MOVIE FILM ON THE LEFT; UNDERNEATH THE RIGHT PART OF THE SCALE IS THE WORD "ANIMATORS", AND UNDERNEATH THAT ARE THE WORDS "AT LAW".

CLASS 41—EDUCATION AND ENTERTAINMENT

FOR LITIGATION TECHNOLOGY SERVICES, NAMELY, ANIMATION PRODUCTION AND DIGITAL IMAGING SERVICES IN THE FIELD OF LITIGATION (U.S. CLS. 100, 101 AND 107).

FIRST USE 10-20-1995; IN COMMERCE 10-20-1995.

CLASS 42—SCIENTIFIC AND COMPUTER SERVICES

FOR GRAPHIC ILLUSTRATION AND DESIGN SERVICES IN THE FIELD OF LITIGATION; LITIGATION TECHNOLOGY SERVICES, NAMELY, ANIMATION AND SPECIAL EFFECTS DESIGN FOR OTHERS IN THE FIELD OF LITIGATION, ASSISTING OTHERS WITH THE PRODUCTION OF ELECTRONIC DISCOVERY, SOFTWARE DESIGN AND DEVELOPMENT OF PRE-TRIAL AND TRIAL IMAGE PROCESSING SOFTWARE AND HARDWARE, DOCUMENT DATA TRANSFER FROM ONE COMPUTER FORMAT TO ANOTHER, DESIGNING AND PREPARING DOCUMENTS, GRAPHICS, VIDEO TESTIMONY AND OTHER EXHIBITS IN DIGITAL FORMAT FOR TRIAL PRESENTATION; TRIAL TECHNOLOGY SUPPORT, NAMELY, PROVIDING CONSULTING SERVICES TO ATTORNEYS, PARALEGALS AND COURT PERSONNEL THAT RELATE TO TECHNOLOGY ISSUES NEEDED DURING THE COURSE OF A TRIAL; ELECTRONIC LEGAL DISCOVERY CONSULTING SERVICES (U.S. CLS. 100 AND 101).
FIRST USE 10-20-1995; IN COMMERCE 10-20-1995.

CLASS 45—PERSONAL AND LEGAL SERVICES

FOR LITIGATION CONSULTING SERVICES (U.S. CLS. 100 AND 101).
FIRST USE 10-20-1995; IN COMMERCE 10-20-1995.
BRIAN CALLAGHAN, EXAMINING ATTORNEY

SN 77-429,024. MICHELLE BARON HAGEMAN, LORAIN, OH. FILED 3-23-2008.

Green Body and Soul

THE MARK CONSISTS OF STANDARD CHARACTERS WITHOUT CLAIM TO ANY PARTICULAR FONT, STYLE, SIZE, OR COLOR.

NO CLAIM IS MADE TO THE EXCLUSIVE RIGHT TO USE "GREEN", APART FROM THE MARK AS SHOWN.

CLASS 3—COSMETICS AND CLEANING PREPARATIONS

FOR CAKES OF TOILET SOAP; CLEANER FOR USE ON SKIN, BODY, HAIR, NAILS, AND FEET; CONDITIONERS; COSMETIC PREPARATIONS FOR THE CARE OF MOUTH AND TEETH; COSMETIC PRODUCTS IN THE FORM OF AEROSOLS FOR SKIN CARE; COSMETIC PRODUCTS IN THE FORM OF AEROSOLS FOR SKINCARE; COSMETIC PRODUCTS TAKEN ORALLY, NAMELY, PILLS THAT INDUCE BRONZING OF THE SKIN; DENTIFRICES IN THE FORM OF CHEWING GUM; ESSENTIAL OILS FOR USE IN MANUFACTURING OF HAIR CARE PRODUCTS AND SKIN CARE PRODUCTS; ESSENTIAL OILS FOR USE IN THE MANUFACTURE OF SCENTED PRODUCTS; HAIR STYLING FIXATIVE IN THE NATURE OF HAIR WAX; MAKE-UP KITS COMPRISED OF LIPSTICK, LOTION, CREAM, FOUNDATION, AND LIP GLOSS; MINERAL SALT IN THE NATURE OF BATH SALTS NOT FOR MEDICAL PURPOSES; NON-MEDICATED GROOMING PREPARATIONS FOR CATS, DOGS, AND PETS, NAMELY, SHAMPOOS, CONDITIONERS, LOTIONS, AND CREAMS; NON-MEDICATED OINTMENTS FOR THE PREVENTION AND TREATMENT OF SUNBURN; NON-MEDICATED PREPARATIONS ALL FOR THE CARE OF SKIN, HAIR AND SCALP; 3-IN-1 HAIR CONDITIONERS; 3-IN-1 HAIR SHAMPOOS; ADHESIVES FOR AFFIXING FALSE HAIR; ADHESIVES FOR FALSE EYELASHES, HAIR AND NAILS; AROMATHERAPY BODY CARE PRODUCTS, NAMELY, BODY LOTION, SHOWER GEL, CUTICLE CREAM, SHAMPOO, CONDI-

TIONER, NON-MEDICATED LIP BALM, SOAP, BODY POLISH, BODY AND FOOT SCRUB AND NON-MEDICATED FOOT CREAM; BABY HAIR CONDITIONER; CLEANING AND POLISHING PAPER; CLEANING AND POLISHING PREPARATIONS; CLEANING, POLISHING AND SCOURING PREPARATIONS; CLEANING, SCOURING AND POLISHING PREPARATIONS AND SUBSTANCES; CLEANING, WASHING AND POLISHING PREPARATIONS; CLEANSING AND POLISHING PREPARATIONS; EXFOLIANTS FOR HAIR, SKIN, AND NAILS; FLOOR POLISH; FLOOR POLISHES; FURNITURE POLISH; FURNITURE POLISHES; GEL FOR HAIR, SCULPTING, NAILS, AND CUTICLES; GENERAL PURPOSE CLEANING, POLISHING, AND ABRASIVE LIQUIDS AND POWDERS; HAIR BALSAM; HAIR BLEACH; HAIR BLEACHES; HAIR BLEACHING PREPARATIONS; HAIR CARE CREAMS; HAIR CARE KITS COMPRISING NON-MEDICATED HAIR CARE PREPARATIONS, NAMELY, SHAMPOO, CONDITIONER, GEL, MOUSSE, AND HAIRSPRAY; HAIR CARE LOTIONS; HAIR CARE PREPARATIONS; HAIR CLEANING PREPARATIONS; HAIR COLOR; HAIR COLOR REMOVERS; HAIR COLORANTS; HAIR COLORING PREPARATIONS; HAIR COLORANTS; HAIR COLORING PREPARATIONS; HAIR CONDITIONER; HAIR CONDITIONERS; HAIR CONDITIONERS FOR BABIES; HAIR CREAMS; HAIR DECOLORANTS; HAIR DRESSINGS FOR MEN; HAIR DRESSINGS FOR WOMEN; HAIR DYE; HAIR DYES; HAIR EMOLLIENTS; HAIR FIXERS; HAIR FROSTS; HAIR GEL; HAIR GEL AND HAIR MOUSSE; HAIR GELS; HAIR LACQUERS; HAIR LIGHTENERS; HAIR LOTION; HAIR LOTIONS; HAIR MAS-CARA; HAIR MOUSSE; HAIR MOUSSES; HAIR NOURISHERS; HAIR OILS; HAIR PIECE BONDING GLUE; HAIR POMADES; HAIR RELAXERS; HAIR RELAXING PREPARATIONS; BABY LOTION; BABY OIL; BABY OILS; BABY POWDER; BABY POWDERS; BABY SHAMPOO; BABY WIPES; BOOT POLISH; DEODORIZERS FOR PETS; FOAMS CONTAINING COSMETICS AND SUNSCREENS; HAIR REMOVING CREAM; HAIR RINSES; HAIR RINSES; HAIR SHAMPOO; HAIR SHAMPOOS AND CONDITIONERS; HAIR SPRAY; HAIR SPRAYS; HAIR SPRAYS AND HAIR GELS; HAIR STRAIGHTENING PREPARATIONS; HAIR STYLING GEL; HAIR STYLING PREPARATIONS; HAIR STYLING SPRAY; HAIR TONIC; HAIR TONICS; HAIR WAVING LOTION; HAIR WAVING PREPARATIONS; HAIR WAX; HAIR-WASHING POWDER; HYDROGEN PEROXIDE FOR USE ON THE HAIR; IMPREGNATED CLEANING, DUSTING OR POLISHING CLOTHS; IMPREGNATED CLOTHS FOR POLISHING; JAPANESE HAIR FIXING OIL (BINTSUKE-ABURA); LEATHER POLISHES; LIP POLISHER; LOTIONS FOR SKIN, HAIR, BODY, NAILS, FACE, HANDS, AND FEET; MASSAGE CREAMS; MASSAGE OIL; MASSAGE OILS; MOUSSE FOR SKIN, HAIR, BODY, FACE, FEET, HANDS, NAILS, AND FEET; NAIL POLISH; NAIL POLISH BASE COAT; NAIL POLISH REMOVER; NAIL POLISH REMOVERS; NAIL POLISH TOP COAT; NAIL-POLISH REMOVERS; NON-MEDICATED HAIR RESTORATION LOTIONS; OIL BATHS FOR HAIR CARE; OILS FOR HAIR CONDITIONING; PERFUME OILS FOR THE MANUFACTURE OF COSMETIC PREPARATIONS; PET CARE KITS COMPRISING SHAMPOO, CONDITIONER, BODY SPRAY; PET FRAGRANCES; PET ODOR REMOVERS; PET SHAMPOO; PET STAIN REMOVERS; POLISHING POWDERS; POLISHING PREPARATIONS; POLISHING STONES; POLISHING WAX; POLISHING, SCOURING AND ABRASIVE PREPARATIONS; PREPARATIONS TO MAKE THE LEAVES OF PLANTS SHINY; SANDING APPARATUS IN THE FORM OF A GLOVE; SHAMPOOS FOR BABIES; SHAVING SPRITZ IN THE NATURE OF A MOISTURIZING SOLUTION FOR SHAVING; SHINING PREPARATIONS; SHOE AND BOOT POLISH; SHOE BLACK; SHOE CREAMS AND POLISHES; SHOE POLISH; SHOE POLISH AND CREAMS; SHOE POLISH APPLICATORS CONTAINING SHOE POLISH; SKIN CARE PREPARATION, NAMELY, BODY POLISH; SKIN POLISHING RICE BRAN (ARAI-NUKA); SOAPS; STONE POLISHERS; STONE POLISHES; STONE POLISHING PREPARATIONS; SUNSCREEN CREAM; SUNSCREEN CREAMS; TONERS; TOOTH POLISH; WATERLESS SPRAY FOR THE CLEANING AND WAXING OF VEHICLES; WAX FOR REMOVING BODY HAIR; WAX STRIPS FOR REMOVING BODY HAIR; AFTER-SHAVE LOTIONS; AFTER-SUN LOTIONS; AFTER-SUN OILS; AGE RETARDANT LOTION; AROMATHERAPY INHALER SOLD FILLED WITH AROMATHERAPY ESSENTIAL OILS; AROMATHERAPY LOTIONS;

AROMATHERAPY OILS; BATH LOTION; BATH OIL; BATH OILS; BATH OILS AND BATH SALTS; BATH OILS FOR COSMETIC PURPOSES; BATHING LOTIONS; BEAUTY LOTIONS; BERGAMOT OIL; BODY LOTION; BODY LOTIONS; BODY MASK LOTION; BODY OIL; BODY OILS; COSMETIC OILS; COSMETIC OILS FOR THE EPIDERMIS; COSMETIC OLIVE OIL FOR THE FACE AND BODY; COSMETIC SUNTAN LOTIONS; ESSENTIAL OILS; ESSENTIAL OILS AS PERFUME FOR LAUNDRY PURPOSES; ESSENTIAL OILS FOR FLAVORING BEVERAGES; ESSENTIAL OILS FOR FOOD FLAVORINGS; ESSENTIAL OILS FOR HOUSEHOLD USE; ESSENTIAL OILS FOR PERSONAL USE; ETHEREAL OILS; EYE LOTIONS; FACE AND BODY LOTIONS; FACE MILK AND LOTIONS; FACIAL LOTION; FOOD FLAVORING, BEING ESSENTIAL OILS; FOOD FLAVORINGS PREPARED FROM ESSENTIAL OILS; MAKE-UP REMOVING LOTIONS; MAKE-UP REMOVING MILK, GEL, LOTIONS AND CREAMS; NATURAL ESSENTIAL OILS; NON-MEDICATED DIAPER RASH OINTMENTS AND LOTIONS; NON-MEDICATED FOOT LOTIONS; NON-MEDICATED SKIN CARE PREPARATIONS, NAMELY, CREAMS, LOTIONS, GELS, TONERS, CLEANERS AND PEELS; NON-MEDICATED STIMULATING LOTIONS FOR THE SKIN; NUTRITIONAL OILS FOR COSMETIC PURPOSES; OILS FOR CLEANING PURPOSES; OILS FOR COSMETIC PURPOSES; OILS FOR PERFUMES AND SCENTS; OILS FOR TOILETRY PURPOSES; PERFUME OILS; POMADES FOR HAIR, LIPS, AND SKIN; ROSE OIL FOR COSMETIC PURPOSES; SCENTED BODY LOTIONS AND CREAMS; SCENTED OILS USED TO PRODUCE AROMAS WHEN HEATED; SHAVING LOTION; SHAVING LOTIONS; SKIN AND BODY TOPICAL LOTIONS, CREAMS AND OILS FOR COSMETIC USE; SKIN CLEANSING LOTION; SKIN LOTION; STYLING LOTIONS; SUN CARE LOTIONS; SUN TAN LOTION; SUN TAN OIL; SUN-BLOCK LOTIONS; SUN-TANNING OILS; SUN-TANNING OILS AND LOTIONS; TANNING AND AFTER-SUN MILKS, GELS AND OILS; TANNING OILS; TEETH CLEANING LOTIONS; TISSUES IMPREGNATED WITH COSMETIC LOTIONS; TOILET WATER CONTAINING SNAKE OIL; TONING LOTION, FOR THE FACE, BODY AND HANDS; LOTIONS FOR BEARDS; LOTIONS FOR COSMETIC PURPOSES; LOTIONS FOR FACE AND BODY CARE; LOTIONS FOR STRENGTHENING THE NAILS; SKIN LOTIONS; CREAMY FOUNDATION; FOUNDATION; FOUNDATION MAKE-UP (U.S. CLS. 1, 4, 6, 50, 51 AND 52).

CLASS 16—PAPER GOODS AND PRINTED MATTER

FOR A SERIES OF BOOKS AND WRITTEN ARTICLES IN THE FIELD OF HEALTH, EMOTION, ENVIRONMENT, BODY, AND COOKBOOKS; A SERIES OF BOOKS, WRITTEN ARTICLES, HANDOUTS AND WORKSHEETS IN THE FIELD OF EMOTION, BODY, ENVIRONMENT, HEALTH, AND COOKBOOKS; BABY BOOKS; BOOKS IN THE FIELD OF HEALTH, EMOTION, ENVIRONMENT, BODY, AND COOKBOOKS; BOTTLE WRAPPERS OF CARDBOARD OR PAPER; BOXES OF CARDBOARD OR PAPER; BOXES OF PAPER; BOXES OF PAPER OR CARDBOARD; COFFEE TABLE BOOKS FEATURING BODY, EMOTION, HEALTH, AND HOME; CONTAINERS FOR ICE MADE OF PAPER OR CARDBOARD; COVERS OF PAPER FOR FLOWER POTS; CUSHIONING OR PADDING MADE OF PAPER FOR PACKING PURPOSES; DISPOSABLE HOUSEBREAKING PADS FOR PETS; DISPOSABLE PAPER SHEETS FOR PERSONAL HYGIENIC USE IN THE NATURE OF DISPOSABLE HEADREST COVERS NOT FOR MEDICAL USE; EDUCATIONAL PUBLICATIONS, NAMELY, EDUCATIONAL LEARNING CARDS, FLASH CARDS, ACTIVITY CARDS, WORKBOOKS, TEXTBOOKS, ACTIVITY BOOKS, STORY BOOKS, PUZZLE BOOKS, PRINTED PUZZLES, TEACHER GUIDES, MANUALS, POSTERS, EDUCATIONAL CARD GAMES AND EDUCATIONAL BOOKLETS IN THE FIELD OF ENVIRONMENT, HEALTH, AND EMOTION; EDUCATIONAL PUBLICATIONS, NAMELY, TRAINING MANUALS IN THE FIELD OF ENVIRONMENT, HEALTH, AND EMOTION; FACE TOWELS OF PAPER; GARBAGE BAGS OF PAPER; GARBAGE BAGS OF PAPER; GARBAGE BAGS OF PLASTIC; GARBAGE BAGS OF PLASTICS; HALLOWEEN GOODIE BAGS OF PAPER OR PLASTIC; HAND TOWELS OF PAPER; HANDKERCHIEFS OF PAPER; HAT BOXES OF CARDBOARD; HAT BOXES

OF PAPER; INDUSTRIAL PACKAGING CONTAINERS OF PAPER; LAMINATED PAPERS TO BE AFFIXED TO THE SURFACE OF FURNITURE; LETTER OPENERS OF PRECIOUS METAL; LITHOGRAPHIC WORKS OF ART; LUNCH BAGS MADE OF TEXTILE; MARKING INK CONTAINING BIOLOGICS FOR USE IN AUTHENTICATION OF OBJECTS; NAPKINS OF PAPER FOR REMOVING MAKE-UP; PACKAGING AND CONTAINERS COMPRISED OF STARCH-BASED MATERIALS IN THE NATURE OF A PAPER SUBSTITUTE FOR FOOD, BEVERAGES AND CONSUMER PRODUCTS; PACKAGING CONTAINERS OF PAPER; PAINT APPLICATORS IN THE NATURE OF SPONGES; PAPER BABY BIBS; PAPER PACKAGING AND CONTAINERS FOR FOOD AND BEVERAGES COMPRISED OF MATERIALS DESIGNED TO LESSEN ADVERSE EFFECTS ON THE ENVIRONMENT; PAPER PET CRATE MATS; PARTY GOODIE BAGS OF PAPER OR PLASTIC; PARTY ORNAMENTS OF PAPER; PENNANTS OF PAPER; PLACE MATS OF PAPER; PLASTIC BAGS FOR DISPOSING OF PET WASTE (U.S. CLS. 2, 5, 22, 23, 29, 37, 38 AND 50).

CLASS 44—MEDICAL, BEAUTY AND AGRICULTURAL SERVICES

FOR DAY SPA SERVICES, NAMELY, NAIL CARE, MANICURES, PEDICURES AND NAIL ENHANCEMENTS; DEPILATORY HAIR REMOVAL SERVICES; HAIR CUTTING; HAIR IMPLANTATION; HAIR REPLACEMENT; HAIR REPLACEMENT, HAIR ADDITION, AND HAIR EXTENSION SERVICES; HAIR SALON SERVICES; HAIR SALON SERVICES, NAMELY, HAIR CUTTING, STYLING, COLORING, AND HAIR EXTENSION SERVICES; HAIR SALON SERVICES, NAMELY, TREATMENTS TO PROTECT HAIR FROM EFFECTS OF EXPOSURE TO SUNLIGHT, HEAT, HUMIDITY AND CHLORINATED WATER; HAIR STYLING; INFORMATION RELATING TO MASSAGE; MANICURE SERVICES; MANICURING; MASSAGE; MASSAGE AND THERAPEUTIC SHIATSU MASSAGE; MASSAGES; PEDICURE SERVICES; PERMANENT HAIR REMOVAL AND REDUCTION SERVICES; PET CARE SERVICES, NAMELY, DOG WALKING, DOG BATHING AND NON-MEDICATED PET GROOMING; SALON SERVICES, NAMELY, FACIALS, MANICURES AND MASSAGES THAT ARE PROVIDED IN A TRAILER OUTFITTED WITH CHAIR, TABLE AND SINK ACCESSORIES; VITAMIN THERAPY (U.S. CLS. 100 AND 101).
HEATHER SAPP, EXAMINING ATTORNEY

SN 77-431,060. STANLEY LOGISTICS, L.L.C., NEW BRITAIN, CT. FILED 3-25-2008.

VIDMAR

THE MARK CONSISTS OF STANDARD CHARACTERS WITHOUT CLAIM TO ANY PARTICULAR FONT, STYLE, SIZE, OR COLOR.

OWNER OF U.S. REG. NO. 867,159.
SEC. 2(F).

CLASS 6—METAL GOODS

FOR METAL PALLETS; HOSE AND CORD REELS, BOTH IN THE NATURE OF HAND OPERATED HOSE AND CABLE REELS COMPRISED SOLELY OR PRIMARILY OF METAL; METAL STAIRS; METAL BUILDING MATERIALS, NAMELY, STATIONARY PREFABRICATED METAL WALKWAYS, METAL RAILS; METAL TOOLBOXES; METAL BINS; METAL STORAGE BIN ORGANIZER FOR ORGANIZING TOOLS, THEIR PARTS AND TOOL SUPPLIES; METAL GUARD BARRIERS FOR PROTECTING STORAGE RACKS (U.S. CLS. 2, 12, 13, 14, 23, 25 AND 50).

CLASS 7—MACHINERY

FOR POWER-OPERATED LIFTS USED TO TRANSPORT, PLACE, AND RETRIEVE STORAGE CONTAINERS; POWER-OPERATED LIFT CONTROLS, NAMELY, HYDRAULIC AND PNEUMATIC LIFT CONTROLS FOR MACHINES; MOTORIZED BRIDGES IN THE NATURE OF ELEVATING WORK PLATFORMS USED TO BRIDGE OTHER WORK AREAS (U.S. CLS. 13, 19, 21, 23, 31, 34 AND 35).

CLASS 12—VEHICLES

FOR CARTS (U.S. CLS. 19, 21, 23, 31, 35 AND 44).

CLASS 20—FURNITURE AND ARTICLES NOT OTHERWISE CLASSIFIED

FOR NON-METAL BINS, NON-METAL STORAGE BIN ORGANIZERS FOR TOOLS, PARTS AND SUPPLIES; NON-METAL STORAGE PALLETS; METAL STORAGE RACKS; METAL WALL-MOUNTED TOOL RACKS; METAL FREE-STANDING TOOL RACKS; METAL WORK-BENCHES; METAL STORAGE CABINETS; AND METAL WORKSTATIONS HAVING MULTI-USE WORK SURFACES FOR USE IN A WIDE VARIETY OF FIELDS (U.S. CLS. 2, 13, 22, 25, 32 AND 50).

MAUREEN DALL, EXAMINING ATTORNEY

SN 77-431,279. SPINACT, LLC, EASTON, PA. FILED 3-25-2008.

KNOWLEDGE AS A SERVICE

THE MARK CONSISTS OF STANDARD CHARACTERS WITHOUT CLAIM TO ANY PARTICULAR FONT, STYLE, SIZE, OR COLOR.

CLASS 41—EDUCATION AND ENTERTAINMENT

FOR PROVIDING ON-LINE TRAINING, NAMELY, COURSES, SEMINARS, AND WORKSHOPS IN THE FIELDS OF INFORMATION TECHNOLOGY, SOFTWARE, ENGINEERING, BIO INFORMATICS, BIO INFORMATION TECHNOLOGY, MEDICINE, PERSONAL DEVELOPMENT, BUSINESS MANAGEMENT, FINANCIAL SERVICES, LAW, MARKETING; PROVIDING EDUCATIONAL INFORMAL ON-LINE PROGRAMS IN THE NATURE OF ONLINE MEETINGS, GATHERINGS, INTERACTIVE DISCUSSIONS, AND VIDEO CONFERENCES IN THE FIELD OF INFORMATION TECHNOLOGY, SOFTWARE, ENGINEERING, BIO INFORMATICS, BIO INFORMATION TECHNOLOGY, MEDICINE, PERSONAL DEVELOPMENT, BUSINESS MANAGEMENT, FINANCIAL SERVICES, LAW, MARKETING, AND PROFESSIONAL SKILLS BUILDING (U.S. CLS. 100, 101 AND 107).

CLASS 42—SCIENTIFIC AND COMPUTER SERVICES

FOR PRODUCT DEVELOPMENT (U.S. CLS. 100 AND 101).

BARNEY CHARLON, EXAMINING ATTORNEY

SN 77-434,986. SMILEY MILEY, INC., LOS ANGELES, CA. FILED 3-28-2008.

MILEY

THE MARK CONSISTS OF STANDARD CHARACTERS WITHOUT CLAIM TO ANY PARTICULAR FONT, STYLE, SIZE, OR COLOR.

THE NAME(S), PORTRAIT(S), AND/OR SIGNATURE(S) SHOWN IN THE MARK IDENTIFIES MILEY RAY CYRUS, WHOSE CONSENT(S) TO REGISTER IS SUBMITTED.

CLASS 25—CLOTHING

FOR MEN'S, WOMEN'S AND CHILDREN'S WEARING APPAREL, NAMELY, TOPS, BOTTOMS, VESTS, COATS, JACKETS, BLAZERS, SCARVES, SWEATERS, SWEAT-SHIRTS, HOODED SWEATSHIRTS, SWEATPANTS, T-SHIRTS, POLO SHIRTS, TANK TOPS, SHIRTS, BLOUSES, PANTS, JEANS, SHORTS, SLACKS, CAPRIS, DRESSES, SKIRTS, ROBES, COVER-UPS, TUNICS, BELTS, GLOVES, APRONS, BOAS, BANDANAS, WRAPS, HEADBANDS, WRISTBANDS, SWEATBANDS, PAJAMAS, DANCE COSTUMES, HALLOWEEN COSTUMES, MASQUERADE COSTUMES, COSTUMES FOR USE IN ROLE-PLAYING GAMES, SPORT JERSEYS, WARM-UP SUITS, AND UNIFORMS; HEADWEAR, FOOTWEAR, SWIMWEAR, BEACHWEAR, UNDERWEAR, LOUNGEWEAR, SLEEPWEAR, NIGHTWEAR, INFANTWEAR, RAINWEAR, SKIWEAR, SURFWEAR, AND NECKWEAR (U.S. CLS. 22 AND 39).

CLASS 28—TOYS AND SPORTING GOODS

FOR TOY ARTIFICIAL FINGERNAILS; TOY NOVELTY ITEMS, NAMELY, DIE AGITATOR PROVIDED WITH A WINDOW FOR VIEWING PIECES CONTAINING POSITIVE OR NEGATIVE ANSWERS TO PREVIOUSLY ASKED QUESTIONS; JUMP ROPES; KITES; MARBLES; MUSIC BOX TOYS; MUSICAL TOYS; TOY MUSICAL INSTRUMENTS; FLYING DISCS; PUZZLES; ELECTRIC ACTION TOYS; BATTERY OPERATED ACTION TOYS AND ACTION FIGURES; INFANT TOYS; PET TOYS; BATH TOYS; BENDABLE TOYS; CHILDREN'S MULTIPLE ACTIVITY TOYS; PRINTING TOYS; DRAWING TOYS; MECHANICAL TOYS; POSITIONABLE TOY FIGURES; PLASTIC CHARACTER TOYS; RIDE-ON TOYS; SAND TOYS; STUFFED TOYS; WIND-UP TOYS; ACTION FIGURES AND ACCESSORIES THEREFOR; TOY VEHICLES AND ACCESSORIES THEREFOR; BOBBLE HEAD DOLLS; BEAN BAGS; ELECTRONIC LEARNING TOYS; MOLDED TOY FIGURES; TOY ANIMALS; TOY BOXES; TOY STAMPS; TOY BUILDING BLOCKS; TOY BUTTERFLY NETS; TOY AND NOVELTY FACE MASKS; TOY FILM CARTRIDGES AND VIEWERS; TOY FURNITURE; TOY MOBILES; TOY PUTTY; TOY SCOOTERS; TOY SNOW GLOBES; TOY WATCHES AND CLOCKS; TOY WIND-SOCKS; TOY ROBOTS; TOY CHRISTMAS TREES; TOY BAKEWARE AND COOKWARE; BALLOONS; CASES FOR PLAY ACCESSORIES; PUPPETS; KALEIDOSCOPES; POKER CHIPS; STREAMERS; GAME TABLES; BOARD GAMES; ACTION SKILL GAMES; DICE; DICE GAMES; PARTY GAMES; PINBALL MACHINES; ROLE-PLAYING GAMES; TABLETOP GAMES; PARLOR GAMES; CARD GAMES; MEMORY GAMES; TARGET GAMES; ARCADE GAMES; HORSESHOE GAMES; SWIM FLOATS FOR RECREATIONAL USE; INFLATABLE SWIMMING POOLS; SWIMMING FLIPPERS; YOGA MATS; PERSONAL EXERCISE MATS; PORTABLE SUPPORT STRUCTURES FOR DANCE AND OTHER EXERCISES; IN-LINE SKATES; ICE SKATES; BODY BOARDS; WAKE BOARDS; SURFBOARDS; SURFBOARD LEASHES; AEROBIC STEPS; ATHLETIC SPORTING GOODS, NAMELY, ATHLETIC WRIST AND JOINT SUPPORTS; ATHLETIC TAPE; BAGS SPECIALLY ADAPTED FOR SPORTS EQUIPMENT; BASEBALL GLOVES; SOFTBALL GLOVES; BATTING GLOVES; BASKETBALL HOOPS; BILLIARD TABLES; BILLIARD EQUIPMENT; BODY TRAINING APPARATUS; BOCCE BALLS; CROQUET

SETS; EXERCISE MACHINES; EXERCISE PLATFORMS; EXERCISE WEIGHTS; FISHING RODS; FISHING TACKLE; FISHING LINES; FISHING REELS; FISHING TACKLE BOXES; GOLF BAGS; GOLF BALLS; GOLF CLUBS; GOLF CLUB COVERS; GOLF TEES; GYMNAS-TIC APPARATUS; SCUBA FINS; SCUBA FLIPPERS; SHIN GUARDS FOR ATHLETIC USE; WORK-OUT GLOVES; WATER SKIS; SKIS; SKI POLES; SKI BAGS; SNOWBOARDS; TABLE-TENNIS TABLES; TABLE TEN-NIS PADDLES; PADDLES FOR USE IN PADDLE BALL GAMES; BOUNCING BALLS; BEACH BALLS; TETHER BALLS; BALLS FOR GAMES; BALLS FOR SPORTS; BATS FOR GAMES; RACQUETS FOR TENNIS, SQUASH, BADMINTON, AND RACQUETBALL; RACKETS; PLUSH TOYS; PLAY COSMETICS; DOLLS AND ACCESSORIES THEREFOR; DOLL PLAY SETS; DOLL CLOTHES; DOLL COSTUMES; DOLL FURNITURE; ELECTRONIC DART GAMES; ELECTRONIC EDUCATIONAL GAME MA-CHINES FOR CHILDREN; ELECTRONIC GAMES OTHER THAN THOSE ADAPTED FOR USE WITH TELEVISION RECEIVERS ONLY; STAND ALONE VI-DEO GAME MACHINES; HAND HELD UNIT FOR PLAYING ELECTRONIC GAMES; MAGIC TRICKS; PARTY FAVORS, NAMELY, PAPER PARTY HATS AND PARTY GAMES; BLOW OUTS; PARTY FAVORS IN THE NATURE OF CRACKERS, NOISEMAKERS, AND SMALL TOYS; CHRISTMAS TREE DECORA-TIONS; INFLATABLE TOYS; PLAYING CARDS; SKATE-BOARDS; ROLLER SKATES; MODEL MAKING KITS; YO-YOS; BADMINTON SETS; DART SETS (U.S. CLS. 22, 23, 38 AND 50).

HENRY S. ZAK, EXAMINING ATTORNEY

CLASS 21—HOUSEWARES AND GLASS

FOR MUGS; JUGS; PORTABLE BEVERAGE COOLERS; BEVERAGE GLASSWARE; SPORTS BOTTLES SOLD EMPTY; PORTABLE BEVERAGE DISPENSERS; BEVER-AGEWARE; THERMAL INSULATED WRAP FOR CANS TO KEEP THE CONTENTS HOT OR COLD; CAKE PANS; CAKE MOLDS; CAKE SERVERS; COOKIE JARS; COO-KIE CUTTERS; FIGURINES OF CHINA, CRYSTAL, EARTHENWARE, GLASS, PORCELAIN, TERRA COTTA, CERAMIC, FIBERGLASS, AND STAINED GLASS; BOT-TLE OPENERS; COMB CASES; HAIR BRUSHES; HAIR COMBS; LUNCH BOXES; NAPKIN HOLDERS; PAPER CUPS; PLASTIC CUPS; DECANTERS; DECORATIVE PLATES; DINNERWARE DISHES; ICE BUCKETS; ICE CHESTS; DECORATIVE CUPS NOT OF PRECIOUS METAL; VACUUM BOTTLES; COMMEMORATIVE PLATES; ALL-PURPOSE PORTABLE HOUSEHOLD CONTAINERS; TOOTHBRUSHES; WASTEPAPER BAS-KETS; CAMPING EQUIPMENT, NAMELY, CAMPING GRILLS (U.S. CLS. 2, 13, 23, 29, 30, 33, 40 AND 50).

CLASS 24—FABRICS

FOR BLANKETS; BLANKET THROWS; BATH LINEN; BED LINEN; DINING LINEN; HOUSEHOLD LINEN; LINEN; LINEN CLOTH; TABLE LINEN; BEDDING, NAMELY, BED BLANKETS, BED CANOPIES, BED COVERS, BED PADS, BED SHEETS, BED SKIRTS, BED SPREADS, PILLOW CASES, PILLOW COVERS, PILLOW SHAMS, SHAMS, DUVET, DUVET COVERS, COMFOR-TERS, QUILTS, DUST RUFFLES, FUTON COVERS NOT OF PAPER, COVERLETS, FABRIC HEADBOARD COV-ERS, MATTRESS COVERS, AND MATTRESS PADS; TOWELS (U.S. CLS. 42 AND 50).

HENRY S. ZAK, EXAMINING ATTORNEY

SN 77-434,989. SMILEY MILEY, INC., LOS ANGELES, CA. FILED 3-28-2008.

SN 77-435,917. MONACO COACH CORPORATION, CO-BURG, OR. FILED 3-31-2008.

MILEY

SIGNATURE RESORTS

THE MARK CONSISTS OF STANDARD CHARACTERS WITHOUT CLAIM TO ANY PARTICULAR FONT, STYLE, SIZE, OR COLOR.

THE NAME SHOWN IN THE MARK IDENTIFIES MILEY RAY CYRUS WHOSE CONSENT IS OF RECORD.

CLASS 20—FURNITURE AND ARTICLES NOT OTHERWISE CLASSIFIED

FOR INDOOR AND OUTDOOR FURNITURE; FURNI-TURE, NAMELY, BED HEADBOARDS; CAMPING EQUIPMENT, NAMELY, AIR MATTRESSES, INFLATA-BLE MATTRESSES, CAMPING FURNITURE, AND SLEEPING BAGS; PLASTIC PENNANTS; DECORATIVE MOBILES; DRINKING STRAWS; NON-METAL AND NON-LEATHER KEY CHAINS, KEY FOBS AND KEY RINGS; NON-METAL PICTURE FRAMES AND PLASTIC NOVELTY LICENSE PLATES; NON-METAL PILLBOXES; GIFT PACKAGE DECORATIONS MADE OF PLASTIC; FIGURES AND FIGURINES OF COLD CAST RESIN, FABRIC, BONE, IVORY, PLASTER, PLASTIC, WAX, WOOD, AND POLYMER CLAY; HAND FANS; HAND-HELD MIRRORS; VENETIAN BLINDS; WIND CHIMES; BEDDING, NAMELY, PILLOWS (U.S. CLS. 2, 13, 22, 25, 32 AND 50).

THE MARK CONSISTS OF STANDARD CHARACTERS WITHOUT CLAIM TO ANY PARTICULAR FONT, STYLE, SIZE, OR COLOR.

NO CLAIM IS MADE TO THE EXCLUSIVE RIGHT TO USE "RESORTS", APART FROM THE MARK AS SHOWN.

CLASS 37—CONSTRUCTION AND REPAIR

FOR REAL ESTATE DEVELOPMENT SERVICES; RE-SORT DEVELOPMENT SERVICES (U.S. CLS. 100, 103 AND 106).

CLASS 41—EDUCATION AND ENTERTAINMENT

FOR RECREATIONAL, SPORTS AND ENTERTAIN-MENT FACILITIES, NAMELY, POOLS, TENNIS COURTS, GOLF COURSES AND GOLF CLUB SER-VICES, MOVIE THEATERS AND PHYSICAL FITNESS CLUB FACILITIES (U.S. CLS. 100, 101 AND 107).

CLASS 43—HOTEL AND RESTAURANT SERVICES

FOR MOTORHOME RESORT LODGING; PROVIDING LODGING FACILITIES FOR OTHERS, NAMELY, RESTAURANTS, BARS, PROVIDING LAND LOTS FOR USE OF RECREATIONAL VEHICLES ON SITE; MOTORHOME RESORT RENTAL AND RESERVATION SERVICES, NAMELY, PROVIDING LOTS FOR USING RECREATIONAL VEHICLES ON SITE (U.S. CLS. 100 AND 101).

RONALD AIKENS, EXAMINING ATTORNEY

SN 77-446,665. PAYEASE CORP., SANTA CLARA, CA. FILED 4-11-2008.

E.T

THE MARK CONSISTS OF STANDARD CHARACTERS WITHOUT CLAIM TO ANY PARTICULAR FONT, STYLE, SIZE, OR COLOR.

CLASS 36—INSURANCE AND FINANCIAL

FOR FINANCIAL TRANSACTION SERVICES, NAMELY, PROVIDING SECURE COMMERCIAL TRANSACTIONS AND PAYMENT OPTIONS FOR ONLINE AND OFFLINE PURCHASES USING MOBILE ELECTRONIC DEVICES AND ELECTRONIC AND OPTICAL COMMUNICATIONS NETWORKS (U.S. CLS. 100, 101 AND 102).

CLASS 38—COMMUNICATION

FOR PROVIDING ELECTRONIC AND OPTICAL TRANSMISSION OF FINANCIAL TRANSACTION AND PAYMENT DATA VIA A GLOBAL COMPUTER NETWORK; PROVIDING E-MAIL SERVICES; PROVIDING MULTIPLE-USER ACCESS TO A GLOBAL COMPUTER INFORMATION NETWORK; INFORMATION ABOUT TELECOMMUNICATIONS; PROVIDING ACCESS TO TELECOMMUNICATIONS NETWORKS; PROVIDING ELECTRONIC BULLETIN BOARDS FOR TRANSMISSION OF MESSAGES AMONG COMPUTER USERS CONCERNING FINANCIAL TRANSACTIONS (U.S. CLS. 100, 101 AND 104).

MICHAEL TANNER, EXAMINING ATTORNEY

SN 77-448,768. MAGNOMATICS LIMITED, SHEFFIELD, UNITED KINGDOM, FILED 4-15-2008.

PDD

THE MARK CONSISTS OF STANDARD CHARACTERS WITHOUT CLAIM TO ANY PARTICULAR FONT, STYLE, SIZE, OR COLOR.

PRIORITY CLAIMED UNDER SEC. 44(D) ON ERPNCMNTY TM OFC APPLICATION NO. 6483796, FILED 12-4-2007, REG. NO. 6483796, DATED 9-29-2008, EXPIRES 12-4-2017.

CLASS 7—MACHINERY

FOR MACHINES AND MACHINE TOOLS, NAMELY, DRILLING MACHINES, CLOTHES WASHING MACHINES, WIND TURBINES; MINING MACHINES AND INDUSTRIAL MACHINES, NAMELY, LIFTING HOISTS AND WINCHES, BALL MILLS, GRINDING MILLS FOR USE WITH CHEMICAL AND/OR MINERAL PROCESSING OR ROCK CRUSHING, EARTH MOVING EXCAVATORS, CONE CRUSHERS, GYRATORY CRUSHERS, HAMMERMILLS, IMPACT CRUSHERS, JAW CRUSHERS, ROCK BREAKERS, ROLL CRUSHERS, ROTARY CRUSHERS; INDUSTRIAL ROBOTS, PUMPS, NAMELY, COMPRESSED AIR PUMPS, ELECTRIC PUMPS, HYDRAULIC PUMPS, COMPRESSORS, NAMELY, AIR COMPRESSORS, COMPRESSORS FOR MACHINES, POWER TOOLS, NAMELY, DRILLS, ROUTERS, CIRCULAR SAWS; MOTORS AND ENGINES SPECIFICALLY FOR AIRPLANES, HELICOPTERS, SPACECRAFT, AIRSHIPS, BOATS, SHIPS; TURBINES OTHER THAN FOR LAND VEHICLES; TURBINES FOR POWER GENERATION, NOT FOR LAND VEHICLES; GENERATORS OF ELECTRICITY; ELECTRIC GENERATORS; AUXILIARY POWER UNITS FOR SUPPLYING ELECTRICAL POWER TO HEAT AND POWER GENERATORS; PARTS AND FITTINGS FOR THE AFORESAID, NAMELY, GEARS FOR INDUSTRIAL MACHINERY, GEARBOXES NOT FOR LAND VEHICLES, CLUTCHES FOR MACHINES, BRAKES FOR MACHINES, DIFFERENTIALS NOT FOR LAND VEHICLES, TURBINES, SHAFTS FOR PUMPS, AXLES FOR MACHINES, PUMPS, NAMELY, CENTRIFUGAL PUMPS, ELECTRIC PUMPS, COMPRESSORS, NAMELY, AIR COMPRESSORS, ELECTRIC COMPRESSORS; CONSTRUCTION MACHINES, NAMELY, FRONT LOADERS, EXCAVATORS AND CONCRETE CONSTRUCTION MACHINES; MOBILE CRANES (U.S. CLS. 13, 19, 21, 23, 31, 34 AND 35).

CLASS 42—SCIENTIFIC AND COMPUTER SERVICES

FOR SCIENTIFIC AND TECHNOLOGY SERVICES, NAMELY, NEW PRODUCT DEVELOPMENT IN THE FIELD OF GEARS, GEARBOXES, LOW RATIO MAGNETIC GEARS AND GEARBOXES; SCIENTIFIC RESEARCH AND DESIGN FOR OTHERS IN THE FIELD OF GEARS, GEARBOXES, LOW RATIO MAGNETIC GEARS AND GEARBOXES; INDUSTRIAL ANALYSIS AND RESEARCH SERVICES, NAMELY, INDUSTRIAL RESEARCH IN THE FIELD OF GEARS, GEARBOXES, LOW RATIO MAGNETIC GEARS AND GEARBOXES; MECHANICAL RESEARCH, PRODUCT DEVELOPMENT, PRODUCT TESTING AND PRODUCT DEVELOPMENT CONSULTATION IN THE FIELD OF GEARS, GEARBOXES, LOW RATIO MAGNETIC GEARS AND GEARBOXES; PROVIDING INFORMATION IN THE FIELD OF NEW PRODUCT DEVELOPMENT AND DESIGN, SCIENTIFIC AND INDUSTRIAL AND MECHANICAL RESEARCH, AND PRODUCT TESTING, ALL RELATING TO GEARS, GEARBOXES, LOW RATIO MAGNETIC GEARS AND GEARBOXES; TECHNOLOGY CONSULTATION IN THE FIELD OF GEARS, GEARBOXES, LOW RATIO MAGNETIC GEARS AND GEARBOXES (U.S. CLS. 100 AND 101).

JOHN DWYER, EXAMINING ATTORNEY

SN 77-450,703. 15°71' AMAZON LLC, SAN JOSE, CA. FILED 4-17-2008.

SN 77-454,652. DAHLMAN INSTITUTE, INC., RANCHO PALOS VERDES, CA. FILED 4-22-2008.

15°71° AMAZON

CLASS 5—PHARMACEUTICALS

FOR NATURAL AND ORGANIC MEDICINAL HERBAL EXTRACTS FOR MEDICAL PURPOSES, MEDICINAL AND HERBAL DRINKS AND HERBS IN DRIED OR PRESERVED FOR MEDICINAL USE (U.S. CLS. 6, 18, 44, 46, 51 AND 52).

CLASS 30—STAPLE FOODS

FOR VINEGARS, SPICES, SALTS, TEAS AND TEA EXTRACTS AND COCOA EXTRACTS FOR HUMAN CONSUMPTION (U.S. CL. 46).
DEZMONA MIZELLE, EXAMINING ATTORNEY

SN 77-450,987. CDG CONSULTING LLC, DBA RISK ASSESSMENT & TRANSFER INTERNATIONAL, CHICAGO, IL. FILED 4-17-2008.



NO CLAIM IS MADE TO THE EXCLUSIVE RIGHT TO USE "RISK ASSESSMENT & TRANSFER INTERNATIONAL", APART FROM THE MARK AS SHOWN.

THE COLOR(S) BLUE, WHITE, AND BLACK IS/ARE CLAIMED AS A FEATURE OF THE MARK.

THE MARK CONSISTS OF A BLUE BORDER SURROUNDING A BLACK BORDER SURROUNDING A WHITE RECTANGLE CONTAINING TEXT AND A WHITE, BLUE, AND BLACK GEOMETRIC DESIGN. THE FIRST WORD OF THE TEXT IS "RISK" AND IS IN ALL CAPITAL BLACK LETTERS, THE WORD "RISK" IS FOLLOWED BY THE WORDS "ASSESSMENT & TRANSFER" WHICH ARE IN BLUE ITALICS, BELOW THIS TEXT IS THE WORD "INTERNATIONAL" WHICH IS IN ALL CAPITAL BLACK LETTERS. THE AFOREMENTIONED GEOMETRIC DESIGN HAS A BLUE SPHERE CONTAINED IN A WHITE AND BLACK SQUARE BORDER, AND THE SPHERE IS INTERSECTED WITH A BLACK HORIZONTAL LINE AND A BLACK VERTICAL LINE.

CLASS 35—ADVERTISING AND BUSINESS

FOR BUSINESS RISK MANAGEMENT; BUSINESS RISK MANAGEMENT CONSULTATION (U.S. CLS. 100, 101 AND 102).

FIRST USE 3-1-2008; IN COMMERCE 3-1-2008.

CLASS 36—INSURANCE AND FINANCIAL

FOR FINANCIAL RISK MANAGEMENT; FINANCIAL RISK MANAGEMENT CONSULTATION (U.S. CLS. 100, 101 AND 102).

FIRST USE 3-1-2008; IN COMMERCE 3-1-2008.
JAMES A. RAUEN, EXAMINING ATTORNEY

PROJECT OPTIMAL

THE MARK CONSISTS OF STANDARD CHARACTERS WITHOUT CLAIM TO ANY PARTICULAR FONT, STYLE, SIZE, OR COLOR.

NO CLAIM IS MADE TO THE EXCLUSIVE RIGHT TO USE "PROJECT", APART FROM THE MARK AS SHOWN.

CLASS 9—ELECTRICAL AND SCIENTIFIC APPARATUS

FOR INTERACTIVE COMPUTER SOFTWARE FOR THE ASSESSMENT AND INDIVIDUALIZED EDUCATION OF CHILDREN WITH AUTISM AND DEVELOPMENTAL DISORDERS (U.S. CLS. 21, 23, 26, 36 AND 38).

CLASS 41—EDUCATION AND ENTERTAINMENT

FOR TRAINING PROGRAMS FOR EDUCATORS AND CARE PROVIDERS TO PROVIDE STRATEGIES, TECHNIQUES AND SKILLS FOR THE EDUCATION OF CHILDREN WITH AUTISM AND DEVELOPMENTAL DISORDERS; PROVIDING AN INTERACTIVE COMPUTER DATABASE PROVIDING INFORMATION FOR THE EDUCATIONAL ASSESSMENT AND INDIVIDUALIZED EDUCATION OF CHILDREN WITH AUTISM AND DEVELOPMENTAL DISORDERS (U.S. CLS. 100, 101 AND 107).

CLASS 42—SCIENTIFIC AND COMPUTER SERVICES

FOR AUTISM RESEARCH SERVICES; INTERACTIVE ONLINE NON-DOWNLOADABLE COMPUTER SOFTWARE FOR THE ASSESSMENT AND INDIVIDUALIZED EDUCATION OF CHILDREN WITH AUTISM AND DEVELOPMENTAL DISORDERS (U.S. CLS. 100 AND 101).

CLASS 44—MEDICAL, BEAUTY AND AGRICULTURAL SERVICES

FOR BEHAVIOR THERAPY AND BEHAVIORAL TREATMENT AND CONSULTING SERVICES FOR PERSONS WITH AUTISM, DEVELOPMENTAL DISABILITIES AND LEARNING DISORDERS; MENTAL HEALTH SERVICES, NAMELY, PROVIDING EARLY INTERVENTION SERVICES IN THE NATURE OF MENTAL HEALTH EARLY DETECTION AND TREATMENT, PSYCHIATRIC TESTING AND CONSULTATION AND COUNSELING SERVICES FOR INDIVIDUALS HAVING AUTISM, MENTAL ILLNESS, MENTAL RETARDATION, ATTENTION DEFICIT DISORDERS, PHYSICAL DISABILITIES AND PHYSICAL AND MENTAL DEVELOPMENTAL DELAYS; PROVIDING INFORMATION AND CONSULTATION SERVICES TO INDIVIDUALS AFFECTED WITH OR WORKING IN THE FIELD OF AUTISM, SPECTRUM DISORDERS AND DEVELOPMENTAL DISORDERS; PROVIDING INFORMATION AND CONSULTATION RELATING TO AUTISM SPECTRUM DISORDER AND DEVELOPMENTAL DISORDERS BY MEANS OF A GLOBAL COMMUNICATION NETWORK; PROVIDING A DATABASE AND ONLINE RESOURCE CENTER, NAMELY, A WEBSITE FEATURING INFORMATION IN THE FIELD OF AUTISM; PROVIDING AUTISM TREATMENT INFORMATION (U.S. CLS. 100 AND 101).

EDWARD NELSON, EXAMINING ATTORNEY

SN 77-454,730. DAHLMAN INSTITUTE, INC., RANCHO PALOS VERDES, CA. FILED 4-22-2008.

SN 77-454,897. WHITE, RON, TORONTO, ONTARIO, CANADA, FILED 4-22-2008.

OPTIMAL AID

THE MARK CONSISTS OF STANDARD CHARACTERS WITHOUT CLAIM TO ANY PARTICULAR FONT, STYLE, SIZE, OR COLOR.

NO CLAIM IS MADE TO THE EXCLUSIVE RIGHT TO USE "AID", APART FROM THE MARK AS SHOWN.

CLASS 9—ELECTRICAL AND SCIENTIFIC APPARATUS

FOR INTERACTIVE COMPUTER SOFTWARE FOR THE ASSESSMENT AND INDIVIDUALIZED EDUCATION OF CHILDREN WITH AUTISM AND DEVELOPMENTAL DISORDERS (U.S. CLS. 21, 23, 26, 36 AND 38).

CLASS 41—EDUCATION AND ENTERTAINMENT

FOR TRAINING PROGRAMS FOR EDUCATORS AND CARE PROVIDERS TO PROVIDE STRATEGIES, TECHNIQUES AND SKILLS FOR THE EDUCATION OF CHILDREN WITH AUTISM AND DEVELOPMENTAL DISORDERS; PROVIDING AN INTERACTIVE COMPUTER DATABASE PROVIDING INFORMATION FOR THE EDUCATIONAL ASSESSMENT AND INDIVIDUALIZED EDUCATION OF CHILDREN WITH AUTISM AND DEVELOPMENTAL DISORDERS (U.S. CLS. 100, 101 AND 107).

CLASS 42—SCIENTIFIC AND COMPUTER SERVICES

FOR INTERACTIVE ONLINE NON-DOWNLOADABLE COMPUTER SOFTWARE FOR THE ASSESSMENT AND INDIVIDUALIZED EDUCATION OF CHILDREN WITH AUTISM AND DEVELOPMENTAL DISORDERS (U.S. CLS. 100 AND 101).

CLASS 44—MEDICAL, BEAUTY AND AGRICULTURAL SERVICES

FOR PROVIDING INFORMATION AND CONSULTATION SERVICES TO INDIVIDUALS AFFECTED WITH OR WORKING IN THE FIELD OF AUTISM, SPECTRUM DISORDERS AND DEVELOPMENTAL DISORDERS; PROVIDING INFORMATION AND CONSULTATION RELATING TO AUTISM SPECTRUM DISORDER AND DEVELOPMENTAL DISORDERS BY MEANS OF A GLOBAL COMMUNICATION NETWORK; PROVIDING A DATABASE AND ONLINE RESOURCE CENTER, NAMELY, A WEBSITE FEATURING INFORMATION IN THE FIELD OF AUTISM; PROVIDING AUTISM TREATMENT INFORMATION (U.S. CLS. 100 AND 101).
EDWARD NELSON, EXAMINING ATTORNEY

SHOERU

THE MARK CONSISTS OF STANDARD CHARACTERS WITHOUT CLAIM TO ANY PARTICULAR FONT, STYLE, SIZE, OR COLOR.

CLASS 35—ADVERTISING AND BUSINESS

FOR RETAIL STORE SERVICES FEATURING FOOTWEAR, NAMELY, SHOES, SANDALS AND BOOTS (U.S. CLS. 100, 101 AND 102).

CLASS 45—PERSONAL AND LEGAL SERVICES

FOR PROVIDING ON-LINE INFORMATION IN THE FIELD OF FASHION AND FOOTWEAR, NAMELY, SHOES, SANDALS AND BOOTS (U.S. CLS. 100 AND 101).
WARREN L. OLANDRIA, EXAMINING ATTORNEY

SN 77-455,510. MORTON INTERNATIONAL, INC., CHICAGO, IL. FILED 4-23-2008.

MORTON HELPS YOUR HOME WORK BETTER

THE MARK CONSISTS OF STANDARD CHARACTERS WITHOUT CLAIM TO ANY PARTICULAR FONT, STYLE, SIZE, OR COLOR.

OWNER OF U.S. REG. NOS. 1,400,005, 3,062,506 AND OTHERS.

CLASS 1—CHEMICALS

FOR SALT, NAMELY, SODIUM CHLORIDE; POTASSIUM CHLORIDE PELLETS FOR WATER TREATMENT; SALT FOR WATER SOFTENING; WATER TREATMENT CHEMICAL PREPARATIONS FOR DISSOLVING AND REMOVING RUST FROM WATER SOFTENERS (U.S. CLS. 1, 5, 6, 10, 26 AND 46).

CLASS 3—COSMETICS AND CLEANING PREPARATIONS

FOR RUST REMOVING PREPARATIONS FOR USE IN REMOVING RUST FROM FABRICS, PORCELAIN, ENAMEL, GLASS, CONCRETE AND METAL SURFACES (U.S. CLS. 1, 4, 6, 50, 51 AND 52).
BERYL GARDNER, EXAMINING ATTORNEY

SN 77-456,811. NARVA ENTERPRISES LLC, DBA AED AUTHORITY, MORRISON, CO. FILED 4-24-2008.

AED AUTHORITY

THE MARK CONSISTS OF STANDARD CHARACTERS WITHOUT CLAIM TO ANY PARTICULAR FONT, STYLE, SIZE, OR COLOR.

NO CLAIM IS MADE TO THE EXCLUSIVE RIGHT TO USE "AED", APART FROM THE MARK AS SHOWN.

CLASS 35—ADVERTISING AND BUSINESS

FOR MANAGING AN AUTOMATIC EXTERNAL DEFIBRILLATOR PROGRAM, NAMELY, TRACKING THE STATUS, SERIAL NUMBERS, AND EXACT LOCATIONS OF AEDS, TRACKING THE EXPIRATION DATES OF AED DISPOSABLE ITEMS, NAMELY, BATTERIES AND ELECTRODES, AND TRACKING THE TRAINING CERTIFICATIONS OF CPR AND AED CERTIFIED PERSONNEL (U.S. CLS. 100, 101 AND 102).

FIRST USE 1-25-2008; IN COMMERCE 1-25-2008.

CLASS 42—SCIENTIFIC AND COMPUTER SERVICES

FOR PROVIDING WEB BASED AUTOMATIC EXTERNAL DEFIBRILLATOR TRACKING AND MANAGEMENT SERVICES, NAMELY, PROVIDING TEMPORARY USE OF ONLINE NON-DOWNLOADABLE SOFTWARE USED TO ENTER AND EDIT DATA AND GENERATE REPORTS PERTAINING TO AEDS, MONITOR THE EXPIRATION DATES OF BATTERIES AND PADS, AND SEND OUT E-MAIL NOTIFICATIONS WHEN BATTERIES OR PADS ARE NEAR EXPIRATION, OR WHEN EMPLOYEES ARE TO BE SCHEDULED FOR RECERTIFICATION (U.S. CLS. 100 AND 101).

FIRST USE 1-25-2008; IN COMMERCE 1-25-2008.

THOMAS MANOR, EXAMINING ATTORNEY

SN 77-457,974. S. LAEUCHLI CONSULTING GMBH, FORMERLY S. LAEUCHLI CONSULTING, MR. SIMON LAU-CHLI, PFAEFFKON SZ, SWITZERLAND, FILED 4-25-2008.

fanpastico

THE MARK CONSISTS OF STANDARD CHARACTERS WITHOUT CLAIM TO ANY PARTICULAR FONT, STYLE, SIZE, OR COLOR.

OWNER OF SWITZERLAND REG. NO. 566004, DATED 8-13-2007, EXPIRES 8-13-2017.

CLASS 30—STAPLE FOODS

FOR ALIMENTARY PASTA; DOUGH-BASED POCKETS WITH FILLING CONSISTING PRIMARILY OF PASTA OR RICE; DRIED PASTA; FRESH PASTA; PASTA; PASTA AND NOODLES; PASTA FOR SOUPS; PASTA SALAD; PASTA SAUCE; PASTA SHELLS; PASTA-WRAPPINGS FOR GYOZA; PREPARED PASTA; FROZEN OR PREPARED OR PACKAGED ENTREES CONSISTING PRIMARILY OF PASTA OR RICE; FROZEN OR PREPARED OR PACKAGED MEALS CONSISTING PRIMARILY OF PASTA OR RICE; MIX FOR MAKING COMBINED NOODLE AND SAUCE DISH; NOODLES AND SAUCE MIXES COMBINED IN UNITARY PACKAGES; NOODLES, SAUCE, AND SEASONING TOPPINGS COMBINED IN UNITARY PACKAGES; NOODLES, SAUCE, AND TOPPING COMBINED IN UNITARY PACKAGES; NOODLES, SAUCE, DEHYDRATED VEGETABLES, AND TOPPING COMBINED IN UNITARY PACKAGES; READY-MADE SAUCES; SAUCE MIXES; SAUCES; SPAGHETTI SAUCE; TOMATO SAUCE (U.S. CL. 46).

CLASS 35—ADVERTISING AND BUSINESS

FOR ADVERTISING SERVICES, NAMELY, PROMOTING AND MARKETING THE GOODS AND SERVICES OF OTHERS IN THE FIELD OF UPSCALE CHOICES SUCH AS CULTURAL EVENTS, RESTAURANTS, SHOPPING, AND TRAVEL VIA PRINT AND ELECTRONIC MEDIA; ASSOCIATION SERVICES, NAMELY, PROMOTING DIVERSITY IN THE RESTAURANT AND HOTEL INDUSTRIES ON BEHALF OF EMPLOYEES, VENDORS, MANAGEMENT, AND OWNERS; FRANCHISING, NAMELY, OFFERING TECHNICAL ASSISTANCE IN THE ESTABLISHMENT AND/OR OPERATION OF RESTAURANTS; OFFERING TECHNICAL ASSISTANCE IN THE ESTABLISHMENT AND/OR OPERATION OF RESTAURANTS; ON-LINE ORDERING SERVICES IN THE FIELD OF RESTAURANT TAKE-OUT AND DELIVERY; RESTAURANT FRANCHISING; RESTAURANT MANAGEMENT FOR OTHERS; ADVERTISING, INCLUDING PROMOTION OF PRODUCTS AND SERVICES OF THIRD PARTIES THROUGH SPONSORING ARRANGEMENTS AND LICENCE AGREEMENTS RELATING TO INTERNATIONAL SPORTS' EVENTS; ARRANGING AND CONDUCTING MARKETING PROMOTIONAL EVENTS FOR OTHERS; PROMOTING SPORTS COMPETITIONS AND/OR EVENTS OF OTHERS; PROMOTING THE PARTIES AND SPECIAL EVENTS OF OTHERS; PROVIDING CONSUMER INFORMATION SERVICES AND MAKING REFERRALS IN THE FIELD OF ENTERTAINMENT SERVICES FOR PRODUCTS, SERVICES, EVENTS, ACTIVITIES, FACILITIES AND LOCATIONS; PROVIDING INFORMATION ABOUT AND MAKING REFERRALS IN THE FIELD OF CONSUMER PRODUCTS AND SERVICES FOR RETAIL SERVICES CONCERNING PRODUCTS, SERVICES, EVENTS, ACTIVITIES, ATTRACTIONS AND FACILITIES IN PARTICULAR GEOGRAPHIC LOCATIONS; PROVIDING MARKETING AND PROMOTION OF SPECIAL EVENTS (U.S. CLS. 100, 101 AND 102).

CLASS 43—HOTEL AND RESTAURANT SERVICES

FOR BAR AND RESTAURANT SERVICES; CAFE AND RESTAURANT SERVICES; CAFE-RESTAURANTS; CAFETERIA AND RESTAURANT SERVICES; CARRY-OUT RESTAURANTS; DELICATESSENS; FAST FOOD AND NON-STOP RESTAURANT SERVICES; FAST-FOOD RESTAURANTS; FAST-FOOD RESTAURANTS AND SNACKBARS; HOTEL AND RESTAURANT RESERVATION SERVICES; HOTEL AND RESTAURANT SERVICES; HOTEL, BAR AND RESTAURANT SERVICES; HOTEL, MOTEL, RESTAURANT, BAR AND CATERING SERVICES; HOTEL, RESTAURANT AND BAR SERVICES; HOTEL, RESTAURANT AND CATERING SERVICES; ICE CREAM SHOP SERVICES IN THE NATURE OF A RESTAURANT; PROVIDING ADVICE TO TOURISTS AND BUSINESS TRAVELERS ON HOTEL AND RESTAURANT DESTINATIONS; PROVIDING PROGRESSIVE DINNER EVENTS WHERE PARTICIPANTS SAMPLE MEALS AND DRINKS AT A SERIES OF RESTAURANTS; PROVISION OF FOOD AND DRINK

IN RESTAURANTS; RESTAURANT; RESTAURANT AND BAR SERVICES; RESTAURANT AND CAFE SERVICES; RESTAURANT AND CATERING SERVICES; RESTAURANT AND HOTEL SERVICES; RESTAURANT SERVICES; RESTAURANT SERVICES FEATURING SANDWICHES; RESTAURANT SERVICES, INCLUDING SIT-DOWN SERVICE OF FOOD AND TAKE-OUT RESTAURANT SERVICES; RESTAURANT, BAR AND CATERING SERVICES; RESTAURANTS; RESTAURANTS FEATURING HOME DELIVERY; SELF SERVICE RESTAURANTS; SELF-SERVICE RESTAURANTS; TAKE-OUT RESTAURANT SERVICES (U.S. CLS. 100 AND 101).
WILLIAM P. SHANAHAN, EXAMINING ATTORNEY

CLASS 35—ADVERTISING AND BUSINESS

FOR BUSINESS CONSULTATION, BUSINESS MANAGEMENT CONSULTING IN THE FIELD OF TEAM DEVELOPMENT, PROVIDING CAREER CONSULTATION AND CONFLICT MANAGEMENT; PSYCHOLOGICAL TESTING FOR THE SELECTION OF PERSONNEL, PSYCHOMETRIC TESTING SERVICES, NAMELY, DEVELOPMENT AND APPLICATION OF STANDARDIZED, STATISTICALLY BASED PROTOCOLS FOR THE QUANTITATIVE MEASUREMENT, PROFILING AND ANALYSIS OF COGNITIVE AND PROBLEM SOLVING ABILITY, PSYCHOLOGICAL AND PERSONALITY TRAITS, OCCUPATIONAL COMPETENCIES, APTITUDE AND WORK PREFERENCES, ALL FOR USE IN THE RECRUITMENT, SELECTION, PLACEMENT, RETENTION AND PROFESSIONAL DEVELOPMENT AND ENHANCEMENT OF PERSONNEL, AND BUSINESS MANAGEMENT CONSULTING WITH RELATION TO STRATEGY AND SALES, PARTICULARLY SPECIALIZING IN THE USE OF ANALYTIC AND STATISTIC MODELS FOR THE UNDERSTANDING AND PREDICTING OF CONSUMERS, BUSINESSES AND MARKET TRENDS AND ACTIONS (U.S. CLS. 100, 101 AND 102).

SN 77-464,183. THE INSIGHTS GROUP LIMITED, DUNDEE, UNITED KINGDOM, FILED 5-2-2008.

CLASS 41—EDUCATION AND ENTERTAINMENT

FOR ORGANIZATION AND ARRANGING OF EDUCATIONAL SEMINARS, WORKSHOPS, TRAINING SESSIONS, CONFERENCES, SYMPOSIUMS, CONGRESSES AND COLLOQUIUMS; EDUCATIONAL SERVICES, NAMELY, PROVIDING EDUCATIONAL SEMINARS, WORKSHOPS, TRAINING SESSIONS, CONFERENCES, SYMPOSIUMS, CONGRESSES AND COLLOQUIUMS, WHICH PROVIDE EDUCATIONAL INFORMATION IN THE FIELD OF EMPLOYEE, PERSONAL AND ORGANIZATIONAL ASSESSMENT AND/OR DEVELOPMENT, PUBLICATION OF BOOKS AND TEXTS, ALL THE AFOREMENTIONED IN THE FIELD OF EMPLOYEE, PERSONAL AND ORGANIZATIONAL ASSESSMENT AND/OR DEVELOPMENT, BUT NOT PERSONAL RELATIONSHIP, AND BUSINESS TRAINING (U.S. CLS. 100, 101 AND 107).

DAVID COLLIER, EXAMINING ATTORNEY

INSIGHTS NAVIGATOR

THE MARK CONSISTS OF STANDARD CHARACTERS WITHOUT CLAIM TO ANY PARTICULAR FONT, STYLE, SIZE, OR COLOR.

CLASS 9—ELECTRICAL AND SCIENTIFIC APPARATUS

FOR DOWNLOADABLE ELECTRONIC PUBLICATIONS IN THE NATURE OF PERIODICAL PUBLICATIONS, MAGAZINES, BOOKS AND NEWSLETTERS IN THE FIELD OF EMPLOYEE, PERSONAL AND ORGANIZATIONAL ASSESSMENT AND/OR DEVELOPMENT, AND COMPUTER SOFTWARE FOR USE IN EMPLOYEE AND PERSONAL ASSESSMENT AND ORGANIZATIONAL DEVELOPMENT (U.S. CLS. 21, 23, 26, 36 AND 38).

CLASS 16—PAPER GOODS AND PRINTED MATTER

FOR PRINTED MATTER IN THE NATURE OF PERIODICAL PUBLICATIONS, MAGAZINES, BOOKS, BOOKLETS AND CATALOGUES IN THE FIELD OF EMPLOYEE, PERSONAL AND ORGANIZATIONAL ASSESSMENT AND/OR DEVELOPMENT, BLANK CARDS, BUSINESS CARDS, STATIONERY, OFFICE REQUISITES IN THE NATURE OF FOLDERS, CALENDARS, DIARIES, NOTEPADS, PENS, PENCILS, ERASERS, PENCIL SHARPENERS, PENCIL CASES, RULERS, BOXES FOR PENS, BOOK MARKERS, DRAWING MATERIALS FOR BLACKBOARDS, PRINTED INSTRUCTIONAL, EDUCATIONAL TEACHING MATERIALS IN THE FIELD OF EMPLOYEE, PERSONAL AND ORGANIZATIONAL ASSESSMENT AND/OR DEVELOPMENT (U.S. CLS. 2, 5, 22, 23, 29, 37, 38 AND 50).

SN 77-464,450. UNITED BIOSOURCE CORPORATION, BETHESDA, MD. FILED 5-2-2008.

EXACT-PRO INITIATIVE

THE MARK CONSISTS OF STANDARD CHARACTERS WITHOUT CLAIM TO ANY PARTICULAR FONT, STYLE, SIZE, OR COLOR.

CLASS 16—PAPER GOODS AND PRINTED MATTER

FOR PRINTED MATERIAL, NAMELY, SURVEYS AND ASSESSMENTS IN THE FIELD OF MEDICINE (U.S. CLS. 2, 5, 22, 23, 29, 37, 38 AND 50).
FIRST USE 12-0-2005; IN COMMERCE 12-0-2005.

CLASS 42—SCIENTIFIC AND COMPUTER SERVICES

FOR MEDICAL AND SCIENTIFIC RESEARCH, NAMELY, CLINICAL TRIALS, BASIC AND CLINICAL RESEARCH IN THE FIELD OF HEALTH CARE AND MEDICINE (U.S. CLS. 100 AND 101).
FIRST USE 12-0-2005; IN COMMERCE 12-0-2005.
CHRISTINA SOBRAL, EXAMINING ATTORNEY

SN 77-464,457. UNITED BIOSOURCE CORPORATION,
BETHESDA, MD. FILED 5-2-2008.



THE MARK CONSISTS OF A SWIRL WITHIN A SEMI-CIRCLE AND THE WORDING "EXACT-PRO INITIATIVE" WITHIN THE SEMI-CIRCLE.

CLASS 16—PAPER GOODS AND PRINTED MATTER

FOR PRINTED MATERIAL, NAMELY, SURVEYS AND ASSESSMENTS IN THE FIELD OF MEDICINE (U.S. CLS. 2, 5, 22, 23, 29, 37, 38 AND 50).
FIRST USE 12-0-2005; IN COMMERCE 12-0-2005.

CLASS 42—SCIENTIFIC AND COMPUTER SERVICES

FOR MEDICAL AND SCIENTIFIC RESEARCH, NAMELY, CLINICAL TRIALS, BASIC AND CLINICAL RESEARCH IN THE FIELD OF HEALTH CARE AND MEDICINE (U.S. CLS. 100 AND 101).
FIRST USE 12-0-2005; IN COMMERCE 12-0-2005.
CHRISTINA SOBRAL, EXAMINING ATTORNEY

SN 77-464,604. WORLD GAMES 2010 FOUNDATION, INC.,
LEXINGTON, KY. FILED S.R. 5-2-2008; AM. P.R. 2-5-2009.

WORLD EQUESTRIAN GAMES

THE MARK CONSISTS OF STANDARD CHARACTERS WITHOUT CLAIM TO ANY PARTICULAR FONT, STYLE, SIZE, OR COLOR.

NO CLAIM IS MADE TO THE EXCLUSIVE RIGHT TO USE "EQUESTRIAN" IN CLASS 16 ONLY, APART FROM THE MARK AS SHOWN.

CLASS 16—PAPER GOODS AND PRINTED MATTER

FOR PRINTED MATERIALS, NAMELY, PRINTED CALENDARS, BOOKS ABOUT HORSES, POSTERS AND STATIONERY (U.S. CLS. 2, 5, 22, 23, 29, 37, 38 AND 50).
FIRST USE 12-2-2008; IN COMMERCE 12-2-2008.

CLASS 21—HOUSEWARES AND GLASS

FOR BEVERAGE CONTAINERS, NAMELY, BEVERAGEWARE; DESKTOP STATUARY MADE OF GLASS AND CERAMICS (U.S. CLS. 2, 13, 23, 29, 30, 33, 40 AND 50).
FIRST USE 5-24-2007; IN COMMERCE 5-24-2007.

CLASS 25—CLOTHING

FOR CLOTHING, NAMELY, SHIRTS, JACKETS AND HEADWEAR (U.S. CLS. 22 AND 39).
FIRST USE 5-24-2007; IN COMMERCE 5-24-2007.
JAMES LOVELACE, EXAMINING ATTORNEY

SN 77-466,743. MCGOVERN, KEVIN M., NEW YORK, NY.
FILED 5-6-2008.

TWI

THE MARK CONSISTS OF STANDARD CHARACTERS WITHOUT CLAIM TO ANY PARTICULAR FONT, STYLE, SIZE, OR COLOR.

CLASS 40—MATERIAL TREATMENT

FOR PROVIDING INFORMATION AND CONSULTATION CONCERNING WATER FILTRATION AND WATER FILTERING UNITS FOR NON-INDUSTRIAL, HOUSEHOLD, OFFICE AND PERSONAL USES (U.S. CLS. 100, 103 AND 106).

CLASS 42—SCIENTIFIC AND COMPUTER SERVICES

FOR TECHNOLOGY CONSULTATION IN THE FIELD OF WATER FILTRATION AND WATER FILTERING UNITS (U.S. CLS. 100 AND 101).
DAWN HAN, EXAMINING ATTORNEY

SN 77-467,153. HITECH FLUID SYSTEMS LTD., CALGARY,
CANADA, FILED 5-6-2008.

HITECH FLUID SYSTEMS

THE MARK CONSISTS OF STANDARD CHARACTERS WITHOUT CLAIM TO ANY PARTICULAR FONT, STYLE, SIZE, OR COLOR.

NO CLAIM IS MADE TO THE EXCLUSIVE RIGHT TO USE "FLUID SYSTEMS", APART FROM THE MARK AS SHOWN.

CLASS 4—LUBRICANTS AND FUELS

FOR OIL-BASED DRILLING FLUID USED IN SERVING OF OIL AND GAS WELLS; OIL-BASED DRILLING FLUID USED IN EXPLORATORY AND PRODUCTION DRILLING FOR OIL AND GAS WELLS (U.S. CLS. 1, 6 AND 15).

CLASS 37—CONSTRUCTION AND REPAIR

FOR MAINTENANCE AND REPAIR OF OIL AND GAS WELLS; OIL AND GAS WELL CASING; PERFORATING SERVICES FOR OIL AND GAS WELLS; PERFORATING SERVICES, NAMELY, PERFORATION OF OIL AND GAS WELLS; CONSULTATION IN THE USE OF DRILLING FLUIDS FOR OIL AND GAS WELL DRILLING (U.S. CLS. 100, 103 AND 106).

CLASS 42—SCIENTIFIC AND COMPUTER SERVICES

FOR WELL LOGGING AND SURVEYING; GEOLOGICAL SURVEYS OR RESEARCH, NAMELY, ANALYSIS, TESTING, AND SAMPLING OF GEOLOGICAL FORMULATIONS; MONITORING THE PERFORMANCE OF DRILLING FLUID (U.S. CLS. 100 AND 101).

ROSELLE HERRERA, EXAMINING ATTORNEY

SN 77-467,221. HITECH FLUID SYSTEMS LTD., CALGARY, CANADA, FILED 5-6-2008.



SN 77-467,187. HITECH FLUID SYSTEMS LTD., CALGARY, CANADA, FILED 5-6-2008.

THE MARK CONSISTS OF A DIAMOND SPIRAL HAVING A DROPLET OF FLUID DRIPPING OFF OF THE OPEN END OF THE DIAMOND SPIRAL AND A MAPLE LEAF DRIPPING OFF OF THE CLOSED END OF THE DIAMOND SPIRAL BEING LOCATED IN THE MIDDLE OF THE DIAMOND SPIRAL.

THE BALANCE IS ALWAYS IN
THE SERVICE

CLASS 4—LUBRICANTS AND FUELS

FOR OIL-BASED DRILLING FLUID USED IN SERVICING OF OIL AND GAS WELLS; OIL-BASED DRILLING FLUID USED IN EXPLORATORY AND PRODUCTION DRILLING FOR OIL AND GAS WELLS (U.S. CLS. 1, 6 AND 15).

CLASS 37—CONSTRUCTION AND REPAIR

FOR MAINTENANCE AND REPAIR OF OIL AND GAS WELLS; OIL AND GAS WELL CASING; PERFORATING SERVICES FOR OIL AND GAS WELLS; PERFORATING SERVICES, NAMELY, PERFORATION OF OIL AND GAS WELLS; CONSULTATION IN THE USE OF DRILLING FLUIDS FOR OIL AND GAS WELL DRILLING (U.S. CLS. 100, 103 AND 106).

CLASS 42—SCIENTIFIC AND COMPUTER SERVICES

FOR WELL LOGGING AND SURVEYING; GEOLOGICAL SURVEYS OR RESEARCH, NAMELY, ANALYSIS, TESTING, AND SAMPLING OF GEOLOGICAL FORMULATIONS; MONITORING THE PERFORMANCE OF DRILLING FLUID (U.S. CLS. 100 AND 101).

ROSELLE HERRERA, EXAMINING ATTORNEY

THE MARK CONSISTS OF STANDARD CHARACTERS WITHOUT CLAIM TO ANY PARTICULAR FONT, STYLE, SIZE, OR COLOR.

CLASS 4—LUBRICANTS AND FUELS

FOR OIL-BASED DRILLING FLUID USED IN SERVICING OF OIL AND GAS WELLS; OIL-BASED DRILLING FLUID USED IN EXPLORATORY AND PRODUCTION DRILLING FOR OIL AND GAS WELLS (U.S. CLS. 1, 6 AND 15).

CLASS 37—CONSTRUCTION AND REPAIR

FOR MAINTENANCE AND REPAIR OF OIL AND GAS WELLS; OIL AND GAS WELL CASING; PERFORATING SERVICES FOR OIL AND GAS WELLS; PERFORATING SERVICES, NAMELY, PERFORATION OF OIL AND GAS WELLS; CONSULTATION IN THE USE OF DRILLING FLUIDS FOR OIL AND GAS WELL DRILLING (U.S. CLS. 100, 103 AND 106).

CLASS 42—SCIENTIFIC AND COMPUTER SERVICES

FOR WELL LOGGING AND SURVEYING; GEOLOGICAL SURVEYS OR RESEARCH, NAMELY, ANALYSIS, TESTING, AND SAMPLING OF GEOLOGICAL FORMULATIONS; MONITORING THE PERFORMANCE OF DRILLING FLUID (U.S. CLS. 100 AND 101).

ROSELLE HERRERA, EXAMINING ATTORNEY

SN 77-468,777. ARTIFICIAL LIFE, INC., SANTA MONICA, CA. FILED 5-8-2008.

Bustin' Balls

THE MARK CONSISTS OF STANDARD CHARACTERS WITHOUT CLAIM TO ANY PARTICULAR FONT, STYLE, SIZE, OR COLOR.

CLASS 9—ELECTRICAL AND SCIENTIFIC APPARATUS

FOR ELECTRONIC GAME SOFTWARE FOR CELLULAR TELEPHONES (U.S. CLS. 21, 23, 26, 36 AND 38).

CLASS 38—COMMUNICATION

FOR TRANSMISSION AND RECEPTION OF DATABASE INFORMATION VIA THE TELECOMMUNICATION NETWORK (U.S. CLS. 100, 101 AND 104).

SN 77-473,855. NEW KINGDOM, INC., DBA SUE DEVITT STUDIO, NEW YORK, NY. FILED 5-14-2008.

CLASS 41—EDUCATION AND ENTERTAINMENT

FOR EDUCATIONAL SERVICES, NAMELY, CONDUCTING INFORMAL ON-LINE PROGRAMS IN THE FIELDS OF GAMES FOR CELLULAR PHONES, USING ON-LINE ACTIVITIES AND INTERACTIVE EXHIBITS, AND PRINTABLE MATERIALS DISTRIBUTED THEREWITH (U.S. CLS. 100, 101 AND 107).

MATTHEW KLINE, EXAMINING ATTORNEY

BECAUSE BEAUTY IS MORE
THAN SKIN DEEP

THE MARK CONSISTS OF STANDARD CHARACTERS WITHOUT CLAIM TO ANY PARTICULAR FONT, STYLE, SIZE, OR COLOR.

CLASS 24—FABRICS

FOR BED LINENS, BATH LINENS, TABLE LINENS (U.S. CLS. 42 AND 50).

CLASS 25—CLOTHING

FOR FOOTWEAR (U.S. CLS. 22 AND 39).
DAVID HOFFMAN, EXAMINING ATTORNEY

SN 77-470,757. RAMESH RICHARD EVANGELISM AND CHURCH HEALTH, PLANO, TX. FILED 5-9-2008.



R E A C H

Ramesh Richard Evangelism and Church Health

SN 77-475,783. PATTON, MICHAEL L., SAN ANTONIO, TX. FILED 5-15-2008.

OWNER OF U.S. REG. NO. 1,989,485.
NO CLAIM IS MADE TO THE EXCLUSIVE RIGHT TO USE "EVANGELISM AND CHURCH HEALTH", APART FROM THE MARK AS SHOWN.

THE NAME(S), PORTRAIT(S), AND/OR SIGNATURE(S) SHOWN IN THE MARK IDENTIFIES "RAMESH RICHARD", WHOSE CONSENT(S) TO REGISTER IS MADE OF RECORD.

THE MARK CONSISTS OF A STYLIZED GLOBE AND STYLIZED CROSS CONSISTING OF CURVED, INTERSECTING LINES WITHIN A SQUARE. TO THE RIGHT OF THE DESIGN ARE THE STACKED WORDS "RREACH" AND "RAMESH RICHARD EVANGELISM AND CHURCH HEALTH" SEPARATED BY A HORIZONTAL LINE

GOOD TASTE WITH TANJI

THE MARK CONSISTS OF STANDARD CHARACTERS WITHOUT CLAIM TO ANY PARTICULAR FONT, STYLE, SIZE, OR COLOR.

THE NAME "TANJI" IDENTIFIES A LIVING INDIVIDUAL WHOSE CONSENT IS OF RECORD.

CLASS 41—EDUCATION AND ENTERTAINMENT

FOR EDUCATIONAL SERVICES, NAMELY, PROVIDING PASTORAL TRAINING AND TEACHING IN THE NATURE OF CONDUCTING LECTURES, CLASSES AND SEMINARS FOR MINISTERS OR PRIESTS IN THE FIELDS OF MINISTRY AND PASTORAL TRAINING, AND DISTRIBUTION OF BOOKS IN CONNECTION THEREWITH; PROVIDING A WEB SITE FEATURING ON-LINE PUBLICATIONS IN THE FIELDS OF DEVOTIONALS AND ARTICLES IN THE FIELDS OF RELIGION AND SPIRITUALITY; PROVIDING PUBLIC SPEAKING SERVICES, NAMELY, SERMONS, LECTURES, AND TELECLASSES IN THE FIELDS OF RELIGION AND SPIRITUALITY (U.S. CLS. 100, 101 AND 107).

FIRST USE 5-1-2007; IN COMMERCE 5-1-2007.

CLASS 45—PERSONAL AND LEGAL SERVICES

FOR EVANGELISTIC MINISTERIAL SERVICES; PREACHING SERVICES (U.S. CLS. 100 AND 101).

FIRST USE 5-1-2007; IN COMMERCE 5-1-2007.
CARYN GLASSER, EXAMINING ATTORNEY

CLASS 41—EDUCATION AND ENTERTAINMENT

FOR ENTERTAINMENT SERVICES, NAMELY, AN ON-GOING AUDIO-VISUAL PROGRAM DISTRIBUTED OVER AUDIO AND VISUAL MEDIA IN THE FIELDS OF WINE, FOOD, COOKING, RECIPES, RESTAURANTS, TRAVEL, ENTERTAINING AND THE CULINARY ARTS; ON-LINE JOURNALS, NAMELY, BLOGS FEATURING WINE, FOOD, AND RESTAURANT REVIEWS AND RECOMMENDATIONS; INFORMATION RELATING TO ENTERTAINMENT AND EDUCATION, PROVIDED ON-LINE FROM A COMPUTER DATABASE OR THE INTERNET; PROVIDING A WEB SITE FEATURING ON-LINE PUBLICATIONS IN THE NATURE OF NEWSLETTERS AND ARTICLES IN THE FIELD OF WINE, COOKING, ENTERTAINING, RESTAURANTS AND THE CULINARY ARTS; CONSULTING SERVICES IN THE FIELD OF ENTERTAINING, NAMELY, ARRANGING, ORGANIZING, AND HOSTING SPECIAL EVENTS, GET-TOGETHERS, AND PARTIES FOR NON-BUSINESS PURPOSES; PROVIDING A WEB SITE FEATURING INFORMATION IN THE FIELD OF ENTERTAINING, NAMELY, ARRANGING, ORGANIZING, AND HOSTING SPECIAL EVENTS, GET-TOGETHERS, AND PARTIES FOR NON-BUSINESS PURPOSES (U.S. CLS. 100, 101 AND 107).

FIRST USE 6-25-2008; IN COMMERCE 6-25-2008.

CLASS 43—HOTEL AND RESTAURANT SERVICES

FOR PROVIDING INFORMATION AND ADVICE IN THE FIELD OF COOKING, WINE CHARACTERISTICS, WINE PAIRINGS, RECIPES, RESTAURANTS AND THE CULINARY ARTS; PROVIDING ONLINE REVIEWS OF RESTAURANTS, WINES AND FOOD; CONSULTING SERVICES IN THE FIELD OF WINE CHARACTERISTICS, WINE PAIRINGS AND THE CULINARY ARTS; ENTERTAINMENT SERVICES, NAMELY, PROVIDING ON-LINE REVIEWS OF WINE, RESTAURANTS, AND FOOD; PROVIDING A WEB SITE FEATURING INFORMATION IN THE FIELD OF WINE CHARACTERISTICS, WINE PAIRINGS, COOKING, RESTAURANTS AND THE CULINARY ARTS (U.S. CLS. 100 AND 101).

FIRST USE 6-25-2008; IN COMMERCE 6-25-2008.
JULIE GUTTADAURO, EXAMINING ATTORNEY

CLASS 16—PAPER GOODS AND PRINTED MATTER

FOR MARKERBOARDS IN THE NATURE OF PRESENTATION BOARDS, GRAPHIC MARKERBOARDS IN THE NATURE OF PRESENTATION BOARDS, COMBINATION BOARDS, NAMELY, PRESENTATION BOARDS COMPRISED OF BLACKBOARDS AND BULLETIN BOARDS, LAPBOARDS FOR READING AND WRITING, RESURFACING PANELS, NAMELY, SELF-ADHESIVE DRY ERASE PANELS THAT RESTORE OLD CHALKBOARDS OR WHITEBOARDS, MARKER AND CHALK BOARD ACCESSORIES, NAMELY, MAP RAILS, EXHIBIT RAILS, MAP HOOKS, FLAG HOLDERS, MAP WINDERS, SEAM STRIPS FOR FILLING GAPS BETWEEN WHITEBOARD OR CHALKBOARD PANELS, MARKERS, AND ERASERS (U.S. CLS. 2, 5, 22, 23, 29, 37, 38 AND 50).

CLASS 20—FURNITURE AND ARTICLES NOT OTHERWISE CLASSIFIED

FOR BULLETIN BOARDS (U.S. CLS. 2, 13, 22, 25, 32 AND 50).

ADA HAN, EXAMINING ATTORNEY

SN 77-477,615. JOHNSON & JOHNSON, NEW BRUNSWICK, NJ. FILED 5-19-2008.

ACTIV-FLEX

THE MARK CONSISTS OF STANDARD CHARACTERS WITHOUT CLAIM TO ANY PARTICULAR FONT, STYLE, SIZE, OR COLOR.

CLASS 3—COSMETICS AND CLEANING PREPARATIONS

FOR NON-MEDICATED PREPARATIONS FOR PREVENTING AND TREATING BLISTERS ON THE FEET AND HANDS (U.S. CLS. 1, 4, 6, 50, 51 AND 52).

CLASS 5—PHARMACEUTICALS

FOR FINGER-WRAP BANDAGES, ADHESIVE BANDAGES, AND MEDICAL TAPES (U.S. CLS. 6, 18, 44, 46, 51 AND 52).

CLASS 28—TOYS AND SPORTING GOODS

FOR ATHLETIC TAPE (U.S. CLS. 22, 23, 38 AND 50).
MIDGE BUTLER, EXAMINING ATTORNEY

SN 77-478,939. 2AM GROUP, LLC, DBA 2AM GROUP, LLC, DUNCAN, SC. FILED 5-20-2008.



NO CLAIM IS MADE TO THE EXCLUSIVE RIGHT TO USE "AUTOMOTIVE, AEROSPACE, MARINE", APART FROM THE MARK AS SHOWN.

THE MARK CONSISTS OF "2AM" (WITH A STYLIZED "A") OVER THE WORDS "AUTOMOTIVE AEROSPACE MARINE", THOSE WORDS BEING SEPARATED BY TYPOGRAPHICAL "BULLETS". "2AM" INDICATES THE TWO LETTERS "A" AND THE SINGLE LETTER "M" THAT ARE THE ACRONYM FOR THE THREE WORDS UNDERNEATH.

CLASS 35—ADVERTISING AND BUSINESS

FOR FOREIGN TRADE ZONE INFORMATION AND CONSULTATION; CUSTOMS CLEARANCE SERVICES; LOGISTICS SERVICES, NAMELY, INVENTORY MANAGEMENT (U.S. CLS. 100, 101 AND 102).

FIRST USE 3-10-2006; IN COMMERCE 3-10-2006.

SN 77-478,118. GLENROY, INC., MENOMONEE FALLS, WI. FILED 5-19-2008.

EVERPRODUCTS

THE MARK CONSISTS OF STANDARD CHARACTERS WITHOUT CLAIM TO ANY PARTICULAR FONT, STYLE, SIZE, OR COLOR.

CLASS 37—CONSTRUCTION AND REPAIR

FOR REPAIR, REWORKING AND CUSTOMIZATION OF AUTOMOBILES, AIRCRAFT AND MARINE CRAFT; AUTOMOTIVE, AEROSPACE AND MARINE CONVERSION SERVICES, NAMELY, INSTALLATING SPECIALTY PARTS, COMPONENTS AND EQUIPMENT IN AUTOMOBILES, AIRCRAFT AND MARINE CRAFT; TECHNICAL SUPPORT SERVICES, NAMELY, PROVIDING TECHNICAL ADVICE IN THE FIELDS OF AUTOMOTIVE, AEROSPACE AND MARINE CONSTRUCTION AND REPAIR (U.S. CLS. 100, 103 AND 106).

FIRST USE 3-10-2006; IN COMMERCE 3-10-2006.

CLASS 39—TRANSPORTATION AND STORAGE

FOR SUPPLY CHAIN, LOGISTICS AND REVERSE LOGISTICS SERVICES, NAMELY, STORAGE, TRANSPORTATION AND DELIVERY OF DOCUMENTS, PACKAGES, RAW MATERIALS, AND OTHER FREIGHT FOR OTHERS BY AIR, RAIL, SHIP OR TRUCK (U.S. CLS. 100 AND 105).

FIRST USE 3-10-2006; IN COMMERCE 3-10-2006.

CLASS 40—MATERIAL TREATMENT

FOR MANUFACTURING SERVICES FOR OTHERS IN THE FIELDS OF AUTOMOTIVE, AEROSPACE AND MARINE MANUFACTURING AND CONSTRUCTION; TECHNICAL SUPPORT SERVICES, NAMELY, PROVIDING TECHNICAL ADVICE IN THE FIELD OF AUTOMOTIVE, AEROSPACE AND MARINE MANUFACTURE (U.S. CLS. 100, 103 AND 106).

FIRST USE 3-10-2006; IN COMMERCE 3-10-2006.

CLASS 42—SCIENTIFIC AND COMPUTER SERVICES

FOR PRODUCT INSPECTIONS FOR OTHERS IN THE FIELDS OF AUTOMOTIVE, AEROSPACE AND MARINE MANUFACTURING AND CONSTRUCTION; PRODUCT DEVELOPMENT FOR OTHERS IN THE FIELDS OF AUTOMOTIVE, AEROSPACE AND MARINE MANUFACTURING AND CONSTRUCTION; ENGINEERING SERVICES FOR OTHERS IN THE FIELDS OF AUTOMOTIVE, AEROSPACE AND MARINE MANUFACTURING AND CONSTRUCTION; ENGINEERING SERVICES FOR THE DESIGN OF MANUFACTURING PROCESSES IN THE FIELDS OF AUTOMOTIVE, AEROSPACE AND MARINE MANUFACTURING AND CONSTRUCTION; TECHNICAL SUPPORT SERVICES, NAMELY, PROVIDING TECHNICAL ADVICE IN THE FIELD OF AUTOMOTIVE, AEROSPACE AND MARINE DESIGN (U.S. CLS. 100 AND 101).

FIRST USE 3-10-2006; IN COMMERCE 3-10-2006.
ALICE BENMAMAN, EXAMINING ATTORNEY

SN 77-479,011. MID-AMERICAN CONFERENCE, CLEVELAND, OH. FILED 5-20-2008.



**MID-AMERICAN
CONFERENCE**

NO CLAIM IS MADE TO THE EXCLUSIVE RIGHT TO USE "1946" AND "CONFERENCE", APART FROM THE MARK AS SHOWN.

THE MARK CONSISTS OF A 3-SIDED HEATER SHIELD BEARING THE NUMBERS "1946" INSIDE THE SHIELD ALONG THE TOP-CENTER AND THE LETTERS "MAC" THROUGH THE INSIDE MIDDLE OF THE SHIELD AND A SOLID 5-POINTED STAR INSIDE THE SHIELD ALONG THE BOTTOM-MIDDLE. CENTERED AND BELOW THE SHIELD ARE THE WORDS "MID-AMERICAN." CENTERED AND BELOW THE WORDS "MID-AMERICAN" IS THE WORD "CONFERENCE".

CLASS 16—PAPER GOODS AND PRINTED MATTER

FOR PUBLICATIONS, NAMELY, BOOKS, PAMPHLETS, BROCHURES, NEWSLETTERS, JOURNALS, MAGAZINES, HANDBOOKS, MANUALS AND PROGRAMS IN THE FIELDS OF ATHLETIC ACTIVITIES (U.S. CLS. 2, 5, 22, 23, 29, 37, 38 AND 50).

CLASS 25—CLOTHING

FOR SPORTS JERSEYS; WARM UP SUITS; SHIRTS; SHORTS; JACKETS; INFANTWEAR; SLEEPWEAR; PANTS; SHOES; MITTENS; SCARVES; SOCKS (U.S. CLS. 22 AND 39).

CLASS 41—EDUCATION AND ENTERTAINMENT

FOR ENTERTAINMENT IN THE NATURE OF COMPETITIONS IN THE FIELD OF SPORTING ACTIVITIES, NAMELY, COLLEGIATE SPORTING EVENTS AND SPORT EXHIBITION EVENTS (U.S. CLS. 100, 101 AND 107).

RAMONA ORTIGA, EXAMINING ATTORNEY

SN 77-480,577. COMPOSITE COOLING SOLUTIONS, L.P., FORT WORTH, TX. FILED 5-21-2008.

PEGASUS

THE MARK CONSISTS OF STANDARD CHARACTERS WITHOUT CLAIM TO ANY PARTICULAR FONT, STYLE, SIZE, OR COLOR.

CLASS 11—ENVIRONMENTAL CONTROL APPARATUS

FOR COOLING TOWERS, TOWER STRUCTURES AND SUPPORT STRUCTURES (U.S. CLS. 13, 21, 23, 31 AND 34).

CLASS 37—CONSTRUCTION AND REPAIR

FOR CONSTRUCTION OF TOWERS, TOWER STRUCTURES, SUPPORT STRUCTURES AND COOLING TOWERS TO THE ORDER AND SPECIFICATION OF OTHERS (U.S. CLS. 100, 103 AND 106).

KELLY BOULTON, EXAMINING ATTORNEY

SN 77-480,673. SHIRTS AND CAPS, INC., ZEPHYRHILLS, FL. FILED 5-21-2008.

CLASSB

THE MARK CONSISTS OF STANDARD CHARACTERS WITHOUT CLAIM TO ANY PARTICULAR FONT, STYLE, SIZE, OR COLOR.

CLASS 9—ELECTRICAL AND SCIENTIFIC APPARATUS

FOR PRERECORDED AUDIO TAPES, CASSETTES, AUDIO AND VIDEO DISCS, VIDEO TAPES, COMPACT DISCS, CD-ROM'S AND DVD'S FEATURING INSTRUCTION AND EDUCATION IN THE FIELD OF OUTDOOR ACTIVITIES, CAMPING, CRAFTS, SPORTS, SCOUTING ACTIVITIES AND THE REQUIREMENTS, ADVANCEMENT AND AWARD EARNINGS WITHIN A SCOUTING ORGANIZATION; COMPUTER SOFTWARE FOR USE IN CREATING WEBSITE TEMPLATES, DESKTOP WALL-PAPER PICTURES, AND PATCH SHAPE TEMPLATES (U.S. CLS. 21, 23, 26, 36 AND 38).

FIRST USE 4-14-2000; IN COMMERCE 4-14-2000.

CLASS 16—PAPER GOODS AND PRINTED MATTER

FOR PRINTED MATTER, NAMELY, ACTIVITY, RESOURCE AND GUIDE BOOKS, MANUALS AND CHARTS FEATURING INSTRUCTION AND EDUCATION IN THE FIELD OF OUTDOOR ACTIVITIES, CAMPING, CRAFTS, SPORTS, SCOUTING ACTIVITIES AND THE REQUIREMENT, ADVANCEMENT AND AWARD EARNINGS WITHIN A SCOUTING ORGANIZATION; DRAWING TEMPLATES FOR CREATING PATCHES (U.S. CLS. 2, 5, 22, 23, 29, 37, 38 AND 50).

FIRST USE 4-14-2000; IN COMMERCE 4-14-2000.

CLASS 40—MATERIAL TREATMENT

FOR SCREEN PRINTING SERVICES (U.S. CLS. 100, 103 AND 106).

FIRST USE 4-14-2000; IN COMMERCE 4-14-2000.

PAM WILLIS, EXAMINING ATTORNEY

SN 77-481,960. MID-AMERICAN CONFERENCE, CLEVELAND, OH. FILED 5-23-2008.



NO CLAIM IS MADE TO THE EXCLUSIVE RIGHT TO USE "1946" AND "CONFERENCE", APART FROM THE MARK AS SHOWN.

THE MARK CONSISTS OF AN OBLONG SHAPE THAT RUNS FROM LEFT TO RIGHT. A SMALL HEATER-STYLE SHIELD, WITH THE NUMBERS "1946" RUNNING THROUGH THE MIDDLE OF THE SHIELD, IS PLACED INSIDE THE OBLONG SHAPE AND IS POSITIONED TO THE FAR LEFT. TO THE RIGHT OF THE HEATER-STYLE SHIELD AND INSIDE THE OBLONG SHAPE ARE THE STYLIZED CAPITAL LETTERS "MAC." OUTSIDE OF THE OBLONG SHAPE AND CENTERED BELOW THE OBLONG SHAPE ARE STYLIZED CAPITAL LETTERS WHICH SAY "MID-AMERICAN." CENTERED BELOW "MID-AMERICAN" ARE STYLIZED CAPITAL LETTERS WHICH SAY "CONFERENCE".

CLASS 16—PAPER GOODS AND PRINTED MATTER

FOR PUBLICATIONS, NAMELY, BOOKS, PAMPHLETS, BROCHURES, NEWSLETTERS, JOURNALS, MAGAZINES, HANDBOOKS, MANUALS AND PROGRAMS IN THE FIELDS OF ATHLETIC ACTIVITIES (U.S. CLS. 2, 5, 22, 23, 29, 37, 38 AND 50).

CLASS 25—CLOTHING

FOR INFANTWEAR; JACKETS; MITTENS; PANTS; SCARVES; SHIRTS; SHOES; SHORTS; SLEEPWEAR; SOCKS; SPORTS JERSEYS; WARM UP SUITS (U.S. CLS. 22 AND 39).

CLASS 41—EDUCATION AND ENTERTAINMENT

FOR ENTERTAINMENT IN THE NATURE OF COMPETITIONS IN THE FIELD OF SPORTING ACTIVITIES, NAMELY, COLLEGIATE SPORTING EVENTS AND SPORT EXHIBITION EVENTS (U.S. CLS. 100, 101 AND 107).

RAMONA ORTIGA, EXAMINING ATTORNEY

SN 77-482,016. MID-AMERICAN CONFERENCE, CLEVELAND, OH. FILED 5-23-2008.



NO CLAIM IS MADE TO THE EXCLUSIVE RIGHT TO USE "CONFERENCE", APART FROM THE MARK AS SHOWN.

THE MARK CONSISTS OF THREE STYLIZED CAPITAL LETTERS SPELLING "MAC." CENTERED AND BELOW THE WORD "MAC" ARE THE WORDS "MID-AMERICAN," CONSISTING OF THE SAME STYLIZED CAPITAL LETTERS AS "MAC." BUT IN A SMALLER SIZED FONT. CENTERED AND BELOW THE WORDS "MID-AMERICAN" IS THE WORD "CONFERENCE," CONSISTING OF SAME STYLIZED CAPITAL LETTERS AND FONT SIZE AS "MID-AMERICAN".

CLASS 16—PAPER GOODS AND PRINTED MATTER

FOR PUBLICATIONS, NAMELY, BOOKS, PAMPHLETS, BROCHURES, NEWSLETTERS, JOURNALS, MAGAZINES, HANDBOOKS, MANUALS AND PROGRAMS IN THE FIELDS OF ATHLETIC ACTIVITIES (U.S. CLS. 2, 5, 22, 23, 29, 37, 38 AND 50).

CLASS 25—CLOTHING

FOR INFANTWEAR; JACKETS; MITTENS; PANTS; SCARVES; SHIRTS; SHOES; SHORTS; SLEEPWEAR; SOCKS; SPORTS JERSEYS; WARM UP SUITS (U.S. CLS. 22 AND 39).

CLASS 41—EDUCATION AND ENTERTAINMENT

FOR ENTERTAINMENT IN THE NATURE OF COMPETITIONS IN THE FIELD OF SPORTING ACTIVITIES, NAMELY, COLLEGIATE SPORTING EVENTS AND SPORT EXHIBITION EVENTS (U.S. CLS. 100, 101 AND 107).

RAMONA ORTIGA, EXAMINING ATTORNEY

SN 77-482,596. KOZY SHACK, INC, HICKSVILLE, NY.
FILED 5-23-2008.

Simply Well

THE MARK CONSISTS OF STANDARD CHARACTERS WITHOUT CLAIM TO ANY PARTICULAR FONT, STYLE, SIZE, OR COLOR.

CLASS 29—MEATS AND PROCESSED FOODS

FOR DAIRY BASED BEVERAGES (U.S. CL. 46).

CLASS 30—STAPLE FOODS

FOR REFRIGERATED DESSERTS, NAMELY, PUD-
DINGS, FLANS, AND FLAVORED AND SWEETENED
GELATINS (U.S. CL. 46).

CLASS 32—LIGHT BEVERAGES

FOR BEVERAGES, NAMELY, NON-ALCOHOLIC BEV-
ERAGES CONTAINING FRUIT JUICE AND PROTEIN,
SMOOTHIES, WHEY BEVERAGES (U.S. CLS. 45, 46 AND
48).

EDWARD FENNESSY, EXAMINING ATTORNEY

SN 77-484,141. AMERICAN ASSOCIATION FOR THE AD-
VANCEMENT OF SCIENCE, WASHINGTON, DC. FILED
5-27-2008.

EUREKALERT!

THE MARK CONSISTS OF STANDARD CHARACTERS WITHOUT CLAIM TO ANY PARTICULAR FONT, STYLE, SIZE, OR COLOR.

CLASS 35—ADVERTISING AND BUSINESS

FOR PROVIDING A WEBSITE FOR USE BY THE
MEDIA AND JOURNALISTS FEATURING NEWS, RE-
SEARCH INFORMATION AND IMAGES RELATED
THERETO IN THE FIELDS OF SOCIAL SCIENCE,
NAMELY, ECONOMICS, PUBLIC POLICY, SOCIAL POL-
ICY, POLITICS AND DEMOGRAPHIC STUDIES VIA A
GLOBAL COMPUTER NETWORK (U.S. CLS. 100, 101
AND 102).

FIRST USE 10-31-1996; IN COMMERCE 4-28-2008.

CLASS 39—TRANSPORTATION AND STO- RAGE

FOR PROVIDING A WEBSITE FOR USE BY THE
MEDIA AND JOURNALISTS FEATURING NEWS, RE-
SEARCH INFORMATION, AND IMAGES RELATED
THERETO IN THE FIELDS OF SOCIAL SCIENCE,
NAMELY, GEOGRAPHIC INFORMATION IN THE NATURE
OF MAPS VIA A GLOBAL COMMUNICATIONS
NETWORK (U.S. CLS. 100 AND 105).

FIRST USE 10-31-1996; IN COMMERCE 3-9-2009.

CLASS 41—EDUCATION AND ENTERTAIN- MENT

FOR PROVIDING INFORMATION FOR USE BY THE
MEDIA AND JOURNALISTS FEATURING NEWS, RE-
SEARCH INFORMATION, AND IMAGES RELATED
THERETO FEATURING RESEARCH IN THE FIELDS
OF MATH AND SOCIAL SCIENCES, NAMELY, HIS-
TORY, ARCHEOLOGY, VIA A GLOBAL COMPUTER
NETWORK (U.S. CLS. 100, 101 AND 107).

FIRST USE 10-31-1996; IN COMMERCE 3-9-2009.

CLASS 42—SCIENTIFIC AND COMPUTER SERVICES

FOR PROVIDING MATHEMATICAL AND TECHNO-
LOGICAL INFORMATION FOR USE BY THE MEDIA
AND JOURNALISTS AND IMAGES RELATED THER-
TO OF VIA A GLOBAL COMPUTER NETWORK (U.S.
CLS. 100 AND 101).

FIRST USE 10-31-1996; IN COMMERCE 3-9-2009.

CLASS 44—MEDICAL, BEAUTY AND AGRI- CULTURAL SERVICES

FOR PROVIDING A WEBSITE FOR USE BY THE
MEDIA AND JOURNALISTS FEATURING NEWS, RE-
SEARCH INFORMATION, AND IMAGES RELATED
THERETO IN THE FIELDS OF MEDICINE, HEALTH
SCIENCES AND AGRICULTURE VIA A GLOBAL COM-
MUNICATIONS NETWORK (U.S. CLS. 100 AND 101).

FIRST USE 10-31-1996; IN COMMERCE 3-9-2009.

FRED CARL, EXAMINING ATTORNEY

SN 77-486,806. O'BRIEN, PAUL W., TUNKHANNOCK, PA.
FILED 5-29-2008.

FRAGRANT RAIN

THE MARK CONSISTS OF STANDARD CHARACTERS WITHOUT CLAIM TO ANY PARTICULAR FONT, STYLE, SIZE, OR COLOR.

NO CLAIM IS MADE TO THE EXCLUSIVE RIGHT TO
USE "FRAGRANT", APART FROM THE MARK AS
SHOWN.

CLASS 3—COSMETICS AND CLEANING PRE- PARATIONS

FOR BATH SALTS, BATH OILS, BATH GELS, BODY
WASHES, SKIN CONDITIONERS, HAIR AND BODY
RINSES, PERFUMES AND SKIN LOTIONS (U.S. CLS. 1,
4, 6, 50, 51 AND 52).

CLASS 21—HOUSEWARES AND GLASS

FOR DISPENSERS FOR HOUSEHOLD AND COM-
MERCIAL USE FOR ADDING BATH SALTS, BATH
OILS, BATH GELS, BODY WASHES, SKIN CONDI-
TIONERS, HAIR AND BODY RINSES, PERFUMES,
AND SKIN LOTIONS AND THE LIKE INTO THE PATH
OF A WATER OUTLET STREAM SUCH AS A SHOWER
HEAD, SHOWER MASSAGER, FAUCET OR HOSE (U.S.
CLS. 2, 13, 23, 29, 30, 33, 40 AND 50).

MARY BOAGNI, EXAMINING ATTORNEY

SN 77-487,603. BODY BY JAKE, INC., LOS ANGELES, CA.
FILED 5-30-2008.



OWNER OF U.S. REG. NOS. 1,373,726, 1,877,452 AND 2,848,325.

"JAKE" REFERS TO "JAKE STEINFELD," WHO IS A LIVING INDIVIDUAL WHOSE CONSENT IS OF RECORD.

THE MARK CONSISTS OF AN OVAL AROUND THE WORDS "BODY BY JAKE."

CLASS 9—ELECTRICAL AND SCIENTIFIC APPARATUS

FOR AUDIO AND VIDEO RECORDINGS IN THE FIELDS OF HEALTH, FITNESS, MOTIVATION, EXERCISE, WELLNESS, NUTRITION AND HEALTHY LIFESTYLES; MUSICAL SOUND RECORDINGS; DVDS AND CDS FEATURING INFORMATION IN THE FIELDS OF HEALTH, FITNESS, MOTIVATION, EXERCISE, WELLNESS, NUTRITION AND HEALTHY LIFESTYLES; DOWNLOADABLE ELECTRONIC NEWSLETTERS IN THE FIELDS OF HEALTH, FITNESS, MOTIVATION, EXERCISE, WELLNESS, NUTRITION AND HEALTHY LIFESTYLES; DOWNLOADABLE AUDIO AND VIDEO RECORDINGS IN THE FIELDS OF HEALTH, FITNESS, MOTIVATION, EXERCISE, WELLNESS, NUTRITION AND HEALTHY LIFESTYLES; CDS AND DVDS FEATURING MUSIC; DOWNLOADABLE AUDIO AND VIDEO FILES FEATURING MUSIC; DOWNLOADABLE WEBCASTS IN THE FIELDS OF HEALTH, FITNESS, MOTIVATION, EXERCISE, WELLNESS, NUTRITION AND HEALTHY LIFESTYLES; SPORTING EQUIPMENT, NAMELY, SPORTS HELMETS, SPORTS EYEWEAR, SPORTS GOGGLES, PROTECTIVE HEADGEAR FOR SPORTS; ELECTRONIC EDUCATIONAL COMPUTER GAME PROGRAMS FOR CHILDREN (U.S. CLS. 21, 23, 26, 36 AND 38).

CLASS 16—PAPER GOODS AND PRINTED MATTER

FOR BOOKS, NEWSLETTERS, ARTICLES, PAMPHLETS, MANUALS, HAND-OUTS, JOURNALS, WORKBOOKS, WORKSHEETS, BROCHURES, BOOKLETS, MAGAZINES IN THE FIELDS OF HEALTH, FITNESS, MOTIVATION, EXERCISE, WELLNESS, NUTRITION AND HEALTHY LIFESTYLES; CALENDARS, STICKERS, STATIONERY; LOG BOOKS, PAPER, PAPER BANNERS, PAPER PENNANTS, APPOINTMENT BOOKS, ADDRESS BOOKS, DIARIES, DECALS, WRAPPING PAPER, NOTEBOOKS, NOTE PADS, POSTERS, PRINTS, GREETING CARDS, BOOK COVERS, BLANK JOURNALS, DAY PLANNERS; EXERCISE BOOKS; CARTOON PRINTS; CARTOON STRIPS; EDUCATIONAL PRODUCTS, NAMELY, PRINTED EDUCATIONAL MATERIALS IN THE FIELDS OF HEALTH, FITNESS, MOTIVATION, EXERCISE, WELLNESS, NUTRITION AND HEALTHY LIFESTYLES (U.S. CLS. 2, 5, 22, 23, 29, 37, 38 AND 50).

CLASS 21—HOUSEWARES AND GLASS

FOR PLASTIC WATER BOTTLES SOLD EMPTY; MUGS; CONTAINERS FOR HOUSEHOLD USE (U.S. CLS. 2, 13, 23, 29, 30, 33, 40 AND 50).

CLASS 25—CLOTHING

FOR CLOTHING, NAMELY, TOPS; BOTTOMS; SHIRTS; PANTS; SHORTS; HEADWEAR; FOOTWEAR; UNDERWEAR; COATS, JACKETS, SCARVES, GLOVES, MITTENS, VESTS, SWEATERS, SWEATSHIRTS, HOODED SWEATSHIRTS, PARKAS, PULLOVERS; SWIM WEAR; SWEAT BANDS, WRIST BANDS, HEAD BANDS, BANDANAS, BELTS, HATS, CAPS, AND NECKWEAR (U.S. CLS. 22 AND 39).

CLASS 28—TOYS AND SPORTING GOODS

FOR EXERCISE MACHINES; EXERCISE WEIGHTS; EXERCISE BARS, EXERCISE BENCHES, EXERCISE BALLS, EXERCISE PLATFORMS, EXERCISE TABLES, PERSONAL EXERCISE MATS, STATIONARY EXERCISE BICYCLES, EXERCISE TREADMILLS, EXERCISE WEIGHT CUFFS, EXERCISE RESISTANCE BANDS, EXERCISE RESISTANCE CORDS, JUMP ROPES, MEDICINE BALLS, AEROBIC STEP MACHINES, AEROBIC STEPS, ANKLE AND WRIST WEIGHTS FOR EXERCISE, DUMBBELLS, BARBELLS, EXERCISE ROWING MACHINES, EXERCISE TRAMPOLINES, EXERCISE GLOVES, WORK-OUT GLOVES, WEIGHT LIFTING BELTS, YOGA MATS, BAGS SPECIALLY ADAPTED FOR EXERCISE EQUIPMENT; BALLS FOR SPORTS, HANDBALLS, BOXING GLOVES, BOXING BAGS, TRAINING APPARATUS FOR BOXING, MARTIAL ARTS AND SIMILAR SPORTS, PUNCHING BALLS, ELBOW PADS FOR ATHLETIC USE, HAND PADS FOR ATHLETIC USE, KNEE PADS FOR ATHLETIC USE, SHIN PADS FOR ATHLETIC USE, BAGS SPECIALLY ADAPTED FOR SPORTS EQUIPMENT, ELECTRONIC SPORTS TRAINING SIMULATORS, NETS FOR SPORTS, BATS FOR GAMES, LACROSSE BALL BAGS, LACROSSE BALLS, LACROSSE GLOVES, LACROSSE STICK HANDLES, LACROSSE STICK HEADS, LACROSSE STICKS, GYMNASIUM APPARATUS; FLYING DISCS, BENDABLE TOYS, CHILDREN'S MULTIPLE ACTIVITY TOYS, TOY FIGURES, CONSTRUCTION TOYS, DISC TOSS TOYS, ELECTRIC ACTION TOYS, INFLATABLE TOYS, MECHANICAL TOYS, MUSICAL TOYS, PUSH TOYS, PULL TOYS, WATER SQUIRTING TOYS, SAND TOYS, TOY VEHICLES, STACKING TOYS, TALKING TOYS, TOY SCOOTERS, WIND-UP TOYS, ACTION SKILL GAMES, ARCADE GAMES, BOARD GAMES, CARD GAMES, COIN-OPERATED VIDEO GAMES, ELECTRONIC EDUCATIONAL GAME MACHINES FOR CHILDREN, GAME TABLES, MANIPULATIVE GAMES, PARLOR GAMES, PARTY GAMES, PINBALL GAMES, PLAYING CARDS, PUZZLES, TARGET GAMES, TRADING CARD GAMES, STAND ALONE VIDEO GAME MACHINES, BEACH BALLS, BALLOONS, JUNGLE GYMS; PLAYGROUND EQUIPMENT, NAMELY, PLAYGROUND BALLS, PLAYGROUND CLIMBING UNITS, PLAYGROUND SAND BOXES, PLAYGROUND SLIDES, PLAYGROUND SWING SETS (U.S. CLS. 22, 23, 38 AND 50).

CLASS 41—EDUCATION AND ENTERTAINMENT

FOR PHYSICAL FITNESS TRAINING SERVICES; SPORTS TRAINING SERVICES; PROVIDING INFORMATION IN THE FIELD OF EXERCISE TRAINING; PROVIDING INFORMATION IN THE FIELDS OF FITNESS, FITNESS MOTIVATION, AND EXERCISE; BOOK PUBLISHING SERVICES; MAGAZINE PUBLISHING SERVICES; PUBLISHING OF ELECTRONIC PUBLICATIONS; DIGITAL VIDEO, AUDIO, AND MULTIMEDIA PUBLISHING SERVICES; PROVIDING A WEBSITE FEATURING ONLINE RESOURCE GUIDES IN THE FIELDS OF FITNESS, FITNESS MOTIVATION, AND EXERCISE; PROVIDING A WEBSITE FEATURING AUDIO, VIDEO, WEBCASTS, PODCASTS, PHOTOGRAPHS, GAMES, AND OTHER MULTIMEDIA MATERIALS IN THE FIELDS OF FITNESS, FITNESS MOTIVATION, AND EXERCISE; PHYSICAL FITNESS INSTRUCTION; PROVIDING MOTIVATIONAL SPEAKERS; PERSONAL APPEARANCES BY A FITNESS TRAINER; MUSIC PUBLISHING SERVICES; AUDIO AND VIDEO RECORDING SERVICES; AUDIO AND VIDEO PRODUCTION SERVICES; MUSIC VIDEO PRODUCTION; PROVIDING A WEBSITE IN THE FIELD OF MUSIC; EDUCATIONAL SEMINARS, CONFERENCES, CLASSES, AND WORKSHOPS IN THE FIELDS OF HEALTH, FITNESS, MOTIVATION, EXERCISE, WELL-

NESS, NUTRITION AND HEALTHY LIFESTYLES, AND DISTRIBUTING COURSE MATERIALS IN CONNECTION THEREWITH; TELEVISION SHOW PRODUCTION; ENTERTAINMENT IN THE NATURE OF AN ON-GOING VARIETY, NEWS, MUSIC OR COMEDY SHOW ABOUT HEALTH, FITNESS, MOTIVATION, EXERCISE, WELLNESS, NUTRITION AND HEALTHY LIFESTYLES BROADCAST OVER TELEVISION, SATELLITE, AUDIO, AND VIDEO MEDIA; ENTERTAINMENT SERVICES, NAMELY, A MULTIMEDIA PROGRAM SERIES FEATURING INSTRUCTION, COMEDY, ACTION AND ADVENTURE DISTRIBUTED VIA VARIOUS PLATFORMS ACROSS MULTIPLE FORMS OF TRANSMISSION MEDIA; DISTRIBUTION OF TELEVISION PROGRAMS FOR OTHERS; DISTRIBUTION OF MOTION PICTURE FILMS; FILM PRODUCTION; ENTERTAINMENT SERVICES, NAMELY, PRODUCTION AND DISTRIBUTION OF A TELEVISION SHOWS AND FILMS (U.S. CLS. 100, 101 AND 107).

CLASS 44—MEDICAL, BEAUTY AND AGRICULTURAL SERVICES

FOR PROVIDING INFORMATION IN THE FIELDS OF HEALTH, WELLNESS, NUTRITION, AND HEALTHY LIFESTYLES (U.S. CLS. 100 AND 101).

CLASS 45—PERSONAL AND LEGAL SERVICES

FOR PROVIDING INFORMATION IN THE FIELD OF PERSONAL MOTIVATION; PROVIDING A WEBSITE FEATURING ONLINE RESOURCE GUIDES IN THE FIELD OF PERSONAL MOTIVATION; PROVIDING A WEBSITE FEATURING AUDIO, VIDEO, WEBCASTS, PODCASTS, PHOTOGRAPHS, GAMES, AND OTHER MULTIMEDIA MATERIALS IN THE FIELD OF PERSONAL MOTIVATION (U.S. CLS. 100 AND 101).

LEIGH CAROLINE CASE, EXAMINING ATTORNEY

SN 77-487,606. BODY BY JAKE, INC., LOS ANGELES, CA.
FILED 5-30-2008.



OWNER OF U.S. REG. NO. 1,486,704.
THE MARK CONSISTS OF THE WORDS "DON'T QUIT"
SURROUNDED BY AN OVAL.

CLASS 9—ELECTRICAL AND SCIENTIFIC APPARATUS

FOR AUDIO AND VIDEO RECORDINGS IN THE FIELDS OF HEALTH, FITNESS, MOTIVATION, EXERCISE, WELLNESS, NUTRITION AND HEALTHY LIFESTYLES; MUSICAL SOUND RECORDINGS; DVDS AND CDS FEATURING INFORMATION IN THE FIELDS OF HEALTH, FITNESS, MOTIVATION, EXERCISE, WELLNESS, NUTRITION AND HEALTHY LIFESTYLES; DOWNLOADABLE ELECTRONIC NEWSLETTERS IN THE FIELDS OF HEALTH, FITNESS, MOTIVATION, EXERCISE, WELLNESS, NUTRITION AND HEALTHY LIFESTYLES; DOWNLOADABLE AUDIO AND VIDEO RECORDINGS IN THE FIELDS OF HEALTH, FITNESS, MOTIVATION, EXERCISE, WELLNESS, NUTRITION AND HEALTHY LIFESTYLES; CDS AND DVDS FEATURING MUSIC; DOWNLOADABLE AUDIO AND VIDEO FILES FEATURING MUSIC; DOWNLOADABLE WEBCASTS IN THE FIELDS OF HEALTH, FITNESS, MOTIVATION, EXERCISE, WELLNESS, NUTRITION AND HEALTHY LIFESTYLES; DOWNLOADABLE TELEVISION SHOWS ABOUT HEALTH, FITNESS, MOTIVATION, EXERCISE, WELLNESS, NUTRITION AND HEALTHY LIFESTYLES; SPORTING EQUIPMENT, NAMELY, SPORTS HELMETS, SPORTS EYEWEAR, SPORTS GOGGLES, PROTECTIVE HEADGEAR FOR SPORTS; ELECTRONIC EDUCATIONAL COMPUTER GAME PROGRAMS FOR CHILDREN (U.S. CLS. 21, 23, 26, 36 AND 38).

CLASS 16—PAPER GOODS AND PRINTED MATTER

FOR BOOKS, NEWSLETTERS, ARTICLES, PAMPHLETS, MANUALS, HAND-OUTS, JOURNALS, WORKBOOKS, WORKSHEETS, BROCHURES, BOOKLETS, MAGAZINES IN THE FIELDS OF HEALTH, FITNESS, MOTIVATION, EXERCISE, WELLNESS, NUTRITION AND HEALTHY LIFESTYLES; CALENDARS, STICKERS, STATIONERY; LOG BOOKS, PAPER, PAPER BANNERS, PAPER PENNANTS, APPOINTMENT BOOKS, ADDRESS BOOKS, DIARIES, DECALS, WRAPPING PAPER, NOTEBOOKS, NOTE PADS, POSTERS, PRINTS, GREETING CARDS, BOOK COVERS, BLANK JOURNALS, DAY PLANNERS; EXERCISE BOOKS; CARTOON PRINTS; CARTOON STRIPS; EDUCATIONAL PRODUCTS, NAMELY, PRINTED EDUCATIONAL MATERIALS IN THE FIELDS OF HEALTH, FITNESS, MOTIVATION, EXERCISE, WELLNESS, NUTRITION AND HEALTHY LIFESTYLES (U.S. CLS. 2, 5, 22, 23, 29, 37, 38 AND 50).

CLASS 21—HOUSEWARES AND GLASS

FOR PLASTIC WATER BOTTLES SOLD EMPTY; MUGS, CONTAINERS FOR HOUSEHOLD USE (U.S. CLS. 2, 13, 23, 29, 30, 33, 40 AND 50).

CLASS 25—CLOTHING

FOR CLOTHING, NAMELY, TOPS; BOTTOMS; SHIRTS; PANTS; SHORTS; HEADWEAR; FOOTWEAR; UNDERWEAR; COATS, JACKETS, SCARVES, GLOVES, MITTENS, VESTS, SWEATERS, SWEATSHIRTS, HOODED SWEATSHIRTS, PARKAS, PULLOVERS; SWIMWEAR; SWEAT BANDS, WRIST BANDS, HEAD BANDS, BANDANAS, BELTS, HATS, CAPS, AND NECKWEAR (U.S. CLS. 22 AND 39).

CLASS 26—FANCY GOODS

FOR ORNAMENTAL BUTTONS AND PINS (U.S. CLS. 37, 39, 40, 42 AND 50).

CLASS 28—TOYS AND SPORTING GOODS

FOR EXERCISE MACHINES; EXERCISE WEIGHTS; EXERCISE BARS, EXERCISE BENCHES, EXERCISE BALLS, EXERCISE PLATFORMS, EXERCISE TABLES, PERSONAL EXERCISE MATS, STATIONARY EXERCISE BICYCLES, EXERCISE TREADMILLS, EXERCISE WEIGHT CUFFS, EXERCISE RESISTANCE BANDS, EXERCISE RESISTANCE CORDS, JUMP ROPES, MEDICINE BALLS, AEROBIC STEP MACHINES, AEROBIC STEPS, ANKLE AND WRIST WEIGHTS FOR EXERCISE, DUMBBELLS, BARBELLS, EXERCISE ROWING MACHINES, EXERCISE TRAMPOLINES, EXERCISE GLOVES, WORK-OUT GLOVES, WEIGHT LIFTING BELTS, YOGA MATS, BAGS SPECIALLY ADAPTED FOR EXERCISE EQUIPMENT; BALLS FOR SPORTS, HANDBALLS, BOXING GLOVES, BOXING BAGS, TRAINING APPARATUS FOR BOXING, MARTIAL ARTS AND SIMILAR SPORTS, PUNCHING BALLS, ELBOW PADS FOR ATHLETIC USE, HAND PADS FOR ATHLETIC USE, KNEE PADS FOR ATHLETIC USE, SHIN PADS FOR ATHLETIC USE, BAGS SPECIALLY ADAPTED FOR SPORTS EQUIPMENT, ELECTRONIC SPORTS TRAINING SIMULATORS, NETS FOR SPORTS, BATS FOR GAMES, LACROSSE BALL BAGS, LACROSSE BALLS, LACROSSE GLOVES, LACROSSE STICK HANDLES, LACROSSE STICK HEADS, LACROSSE STICKS, GYMNAS TIC APPARATUS; FLYING DISCS, BENDABLE TOYS, CHILDREN'S MULTIPLE ACTIVITY TOYS, TOY FIGURES, CONSTRUCTION TOYS, DISC TOSS TOYS, ELECTRIC ACTION TOYS, INFLATABLE TOYS, MECHANICAL TOYS, MUSICAL TOYS, PUSH TOYS, PULL TOYS, WATER SQUIRTING TOYS, SAND TOYS, TOY VEHICLES, STACKING TOYS, TALKING TOYS, TOY SCOOTERS, WIND-UP TOYS, ACTION SKILL GAMES, ARCADE GAMES, BOARD GAMES, CARD GAMES, COIN-OPERATED VIDEO GAMES, ELECTRONIC EDUCATIONAL GAME MACHINES FOR CHILDREN, GAME TABLES, MANIPULATIVE GAMES, PARLOR GAMES, PARTY GAMES, PINBALL GAMES, PLAYING CARDS, PUZZLES, TARGET GAMES, TRADING CARD GAMES, STAND ALONE VIDEO GAME MACHINES, BEACH BALLS, BALLOONS, JUNGLE GYMS; PLAYGROUND EQUIPMENT, NAMELY, PLAYGROUND BALLS, PLAYGROUND CLIMBING UNITS, PLAYGROUND SAND BOXES, PLAYGROUND SLIDES, PLAYGROUND SWING SETS (U.S. CLS. 22, 23, 38 AND 50).

CLASS 29—MEATS AND PROCESSED FOODS

FOR BEEF; BUTTER; BUTTER SUBSTITUTES; CHEESE; CHICKEN; CHILI; COOKING OIL; DAIRY-BASED BEVERAGES; DAIRY PRODUCTS EXCLUDING ICE CREAM, ICE MILK AND FROZEN YOGURT; DIPS; EDIBLE OILS; FISH; FRUIT PRESERVES; FRUIT-BASED FOOD BEVERAGES; FRUIT-BASED SNACK FOODS; FRUIT-BASED SPREADS; JAMS; JELLIES; JERKY; MEAT; MILK; OLIVE OIL; PEANUT BUTTER; POULTRY; PROCESSED FRUITS; PROCESSED VEGETABLES; SALADS EXCEPT MACARONI, RICE, AND PASTA SALAD; SEAFOOD; SHELLFISH; SNACK MIX CONSISTING PRIMARILY OF PROCESSED FRUITS, PROCESSED NUTS AND/OR RAISINS; SOUPS; SOY PROTEIN FOR USE AS A FOOD ADDITIVE; SOY-BASED FOOD BARS; SOY-BASED SNACK FOODS; SOY MILK; TOFU; TURKEY; VEAL; VEGETABLE-BASED FOOD BEVERAGES; VEGETABLE-BASED MEAT SUBSTITUTES; VEGETABLE-BASED SNACK FOODS; VEGETABLE-BASED SPREADS; WHEY; WHIPPED TOPPING; YOGURT; YOGURT DRINKS; FROZEN, PREPARED OR PACKAGED MEALS CONSISTING PRIMARILY OF MEAT, FISH, POULTRY OR VEGETABLES (U.S. CL. 46).

CLASS 30—STAPLE FOODS

FOR BREAKFAST CEREALS; READY TO EAT, CEREAL DERIVED FOOD BARS CEREAL-BASED ENERGY BARS; CEREAL-BASED SNACK FOODS; PROCESSED CEREALS; BAKERY PRODUCTS; BREAD; CANDY; CHEWING GUM; CHOCOLATE; COFFEE; DOUGH; FLAVORED ICES; FLAVOURINGS; FLOUR; FROZEN YOGURT; FRUIT ICES; GLUTEN; GRAIN-BASED BEVERAGES; GRAIN-BASED FOOD BEVERAGES; GRAIN-BASED SNACK FOODS; GRANOLA; GRANOLA SNACKS; HONEY; ICE; ICE CREAM; ICE CREAM DRINKS; ICING; MARINADES; MIXES FOR BAKERY GOODS; NOODLES; OATMEAL; PASTA; PASTRIES; POPCORN; PRETZELS; PROCESSED GRAINS; PROCESSED HERBS; RICE; SALT; PEPPER; SALAD DRESSING; SANDWICHES; SALSA; SAUCES; SEASONING; SHAKES; SHERBETS; SORBET; SPICES; SUGAR; SUGAR SUBSTITUTES; SUGAR FREE CANDIES; SUGAR FREE CHEWING GUM; SUSHI; SWEETS; SUGAR FREE SWEETS; TEA; VANILLA; VINEGAR; YEAST; YERBA MATE; FROZEN, PREPARED OR PACKAGED MEALS CONSISTING PRIMARILY OF PASTA OR RICE (U.S. CL. 46).

CLASS 32—LIGHT BEVERAGES

FOR FRUIT JUICES; SMOOTHIES; VEGETABLE JUICES; WHEY BEVERAGES; DRINKING WATERS; ENERGY DRINKS; FLAVORED WATERS; HERBAL JUICES; ISOTONIC BEVERAGES; MINERAL WATERS; SPARKLING WATERS; SPORTS DRINKS; SOFT DRINKS; SODA WATER (U.S. CLS. 45, 46 AND 48).

CLASS 35—ADVERTISING AND BUSINESS

FOR PROMOTING PUBLIC AWARENESS OF ISSUES RELATING TO HEALTH, FITNESS, MOTIVATION, EXERCISE, WELLNESS, NUTRITION, AND HEALTHY LIFESTYLES; ONLINE RETAIL STORE SERVICES, ONLINE ORDERING SERVICES, AND MAIL ORDER SERVICES FEATURING AUDIO AND VIDEO RECORDINGS, PAPER GOODS AND PRINTED MATTER, ELECTRONIC MEDIA, CLOTHING, CLOTHING ACCESSORIES, EXERCISE AND FITNESS PRODUCTS, SPORTING EQUIPMENT, TOYS, GAMES, AND PLAYTHINGS, KEY CHAINS, HOUSEHOLD GOODS, FOOD AND BEVERAGE, CONSUMER ELECTRONICS, AND GENERAL CONSUMER MERCHANDISE; ONLINE RETAIL STORE SERVICES FEATURING DOWNLOADABLE PRE-RECORDED MUSIC AND VIDEO; ADVERTISING AND PROMOTIONAL SERVICES; PUBLIC SERVICE PROGRAMS IN THE NATURE OF ORGANIZING AND CONDUCTING VOLUNTEER PROGRAMS (U.S. CLS. 100, 101 AND 102).

CLASS 38—COMMUNICATION

FOR PROVIDING ONLINE CHAT ROOMS AND ELECTRONIC BULLETIN BOARDS FOR TRANSMISSION OF MESSAGES AMONG USERS IN THE FIELDS OF HEALTH, FITNESS, MOTIVATION, EXERCISE, WELLNESS, NUTRITION AND HEALTHY LIFESTYLES; ELECTRONIC TRANSMISSION OF MESSAGES; INTERNET BROADCASTING SERVICES; ONLINE AUDIO AND VIDEO STREAMING SERVICES; AUDIO BROADCASTING; VIDEO BROADCASTING (U.S. CLS. 100, 101 AND 104).

CLASS 41—EDUCATION AND ENTERTAINMENT

FOR PHYSICAL FITNESS TRAINING SERVICES; SPORTS TRAINING SERVICES; PROVIDING INFORMATION IN THE FIELD OF EXERCISE TRAINING; PROVIDING INFORMATION IN THE FIELDS OF FITNESS, FITNESS MOTIVATION, AND EXERCISE; BOOK PUBLISHING SERVICES; MAGAZINE PUBLISHING SERVICES; PUBLISHING OF ELECTRONIC PUBLICATIONS; DIGITAL VIDEO, AUDIO, AND MULTIMEDIA PUBLISHING SERVICES; PROVIDING A WEBSITE FEATURING ONLINE RESOURCE GUIDES IN THE FIELDS OF FITNESS, FITNESS MOTIVATION, AND EXERCISE; PROVIDING A WEBSITE FEATURING AUDIO, VIDEO, WEBCASTS, PODCASTS, PHOTO-

GRAPHS, GAMES, AND OTHER MULTIMEDIA MATERIALS IN THE FIELDS OF FITNESS, FITNESS MOTIVATION, AND EXERCISE; PHYSICAL FITNESS INSTRUCTION; PROVIDING MOTIVATIONAL SPEAKERS; PERSONAL APPEARANCES BY A FITNESS TRAINER; MUSIC PUBLISHING SERVICES; AUDIO AND VIDEO RECORDING SERVICES; AUDIO AND VIDEO PRODUCTION SERVICES; MUSIC VIDEO PRODUCTION; PROVIDING A WEBSITE IN THE FIELD OF MUSIC; EDUCATIONAL SEMINARS, CONFERENCES, CLASSES, AND WORKSHOPS IN THE FIELDS OF HEALTH, FITNESS, MOTIVATION, EXERCISE, WELLNESS, NUTRITION AND HEALTHY LIFESTYLES, AND DISTRIBUTING COURSE MATERIALS IN CONNECTION THEREWITH; TELEVISION SHOW PRODUCTION; ENTERTAINMENT IN THE NATURE OF AN ON-GOING VARIETY, NEWS, MUSIC OR COMEDY SHOW ABOUT HEALTH, FITNESS, MOTIVATION, EXERCISE, WELLNESS, NUTRITION AND HEALTHY LIFESTYLES BROADCAST OVER TELEVISION, SATELLITE, AUDIO, AND VIDEO MEDIA; ENTERTAINMENT SERVICES, NAMELY, A MULTIMEDIA PROGRAM SERIES FEATURING INSTRUCTION, COMEDY, ACTION AND ADVENTURE DISTRIBUTED VIA VARIOUS PLATFORMS ACROSS MULTIPLE FORMS OF TRANSMISSION MEDIA; DISTRIBUTION OF TELEVISION PROGRAMS FOR OTHERS; DISTRIBUTION OF MOTION PICTURE FILMS; FILM PRODUCTION; ENTERTAINMENT SERVICES, NAMELY, PRODUCTION AND DISTRIBUTION OF A TELEVISION SHOWS AND FILMS (U.S. CLS. 100, 101 AND 107).

CLASS 44—MEDICAL, BEAUTY AND AGRICULTURAL SERVICES

FOR PROVIDING INFORMATION IN THE FIELDS OF HEALTH, WELLNESS, NUTRITION, AND HEALTHY LIFESTYLES; PROVIDING A WEBSITE FEATURING ONLINE RESOURCE GUIDES IN THE FIELDS OF HEALTH, WELLNESS, NUTRITION, AND HEALTHY LIFESTYLES; PROVIDING A WEBSITE FEATURING AUDIO, VIDEO, WEBCASTS, PODCASTS, PHOTOGRAPHS, GAMES, AND OTHER MULTIMEDIA MATERIALS IN THE FIELDS OF HEALTH, WELLNESS, NUTRITION, AND HEALTHY LIFESTYLES (U.S. CLS. 100 AND 101).

CLASS 45—PERSONAL AND LEGAL SERVICES

FOR PERSONAL GROWTH AND MOTIVATION CONSULTING SERVICES; PROVIDING INFORMATION IN THE FIELD OF PERSONAL MOTIVATION; PROVIDING A WEBSITE FEATURING ONLINE RESOURCE GUIDES IN THE FIELD OF PERSONAL MOTIVATION; PROVIDING A WEBSITE FEATURING AUDIO, VIDEO, WEBCASTS, PODCASTS, PHOTOGRAPHS, GAMES, AND OTHER MULTIMEDIA MATERIALS IN THE FIELD OF PERSONAL MOTIVATION (U.S. CLS. 100 AND 101).
LEIGH CAROLINE CASE, EXAMINING ATTORNEY

SN 77-489,381. STRYKER SPINE, CESTAS, FRANCE, FILED 6-3-2008.

UNILIF

THE MARK CONSISTS OF STANDARD CHARACTERS WITHOUT CLAIM TO ANY PARTICULAR FONT, STYLE, SIZE, OR COLOR.

CLASS 5—PHARMACEUTICALS

FOR ORTHOPEDIC IMPLANTS MADE OF NATURAL TISSUE OR DERIVATIVES THEREOF, NAMELY, HUMAN ALLOGRAFT AND XENOGRIFT IMPLANTS (U.S. CLS. 6, 18, 44, 46, 51 AND 52).

CLASS 10—MEDICAL APPARATUS

FOR ORTHOPEDIC IMPLANTS MADE OF ARTIFICIAL MATERIALS AND ORTHOPEDIC INSTRUMENTS TO FACILITATE THE IMPLANTATION OF ORTHOPEDIC IMPLANTS (U.S. CLS. 26, 39 AND 44).
JILL C. ALT, EXAMINING ATTORNEY

SN 77-489,461. SOCIÉTÉ INDUSTRIELLE LIMOUSINE D'APPLICATION BIOLOGIQUE, DBA SILAB S.A., OBJAT, FRANCE, FILED 6-3-2008.



OWNER OF ERPN CMNTY TM OFC REG. NO. 006489959, DATED 11-27-2008, EXPIRES 11-27-2018.

THE COLOR(S) WHITE AND GREEN IS/ARE CLAIMED AS A FEATURE OF THE MARK.

THE MARK CONSISTS OF GRASSES IN WHITE ON A GREEN RECTANGULAR BACKGROUND WITH THE WORDING, "NATURE-SCIENCE-BEAUTY SUSTAINABLE ALLIANCE".

CLASS 1—CHEMICALS

FOR PRIMARY MATERIALS FOR THE PRODUCTION OF COSMETIC PREPARATIONS, NAMELY, RAW MATERIALS, ADDITIVES AND ACTIVE MATERIALS BASED ON CONCENTRATES OF CONCENTRATED NATURAL SUBSTANCES AND HIGHLY CONCENTRATED NATURAL SUBSTANCES, NAMELY, SUBSTANCES EXTRACTED FROM PLANTS; ENZYMATIC PREPARATIONS AND ENZYME ADAPTED FOR THE PRODUCTION OF COSMETIC PREPARATIONS (U.S. CLS. 1, 5, 6, 10, 26 AND 46).

CLASS 3—COSMETICS AND CLEANING PREPARATIONS

FOR COSMETIC ARTICLES, NAMELY, COSMETIC PRODUCTS FOR THE CARE OF THE SKIN AND FOR THE BEAUTY, NAMELY, ANTI-AGING, FIRING, HYDRATING, ANTI-WRINKLE, RESTRUCTURING, DEPIGMENTING PREPARATIONS IN THE NATURE OF MILKS, CREAMS, LOTIONS, OILS AND POWDERS; BRONZING PRODUCTS AND FOR SOLAR PROTECTION FOR COSMETIC USE, NAMELY, SUNSCREEN IN THE NATURE OF MILKS, CREAMS, GELS, OILS AND LOTIONS AND SUNLESS TANNING BRONZER IN THE NATURE OF MILKS, CREAMS, LOTIONS, OILS AND POWDERS ; HAIR PRODUCTS, NAMELY, SHAMPOOS, CONDITIONERS, AND GELS, CREAMS, LOTIONS, SPRAYS AND OILS FOR USE IN STYLING HAIR AND REPAIRING DAMAGED HAIR; COSMETIC BODY DEODORANT (U.S. CLS. 1, 4, 6, 50, 51 AND 52).

CLASS 5—PHARMACEUTICALS

FOR DERMATOLOGICAL PRODUCTS, NAMELY, ANTI-AGING, FIRING, HYDRATING, ANTI-WRINKLE, RESTRUCTURING, DEPIGMENTING PREPARATIONS, NAMELY, PRODUCTS IN THE NATURE OF MILKS, CREAMS, LOTIONS, OILS AND POWDERS (U.S. CLS. 6, 18, 44, 46, 51 AND 52).
RICHARD A. STRASER, EXAMINING ATTORNEY

SN 77-489,847. THE ALLIANCE FOR CLIMATE PROTECTION, MENLO PARK, CA. FILED 6-3-2008.



THE MARK CONSISTS OF THE LITERAL ELEMENT "WE" ENCLOSED WITHIN A SOLID CIRCLE.

CLASS 41—EDUCATION AND ENTERTAINMENT

FOR EDUCATIONAL SERVICES, NAMELY, ORGANIZING AND CONDUCTING CLASSES, COURSES, CONFERENCES, WORKSHOPS, SEMINARS AND CULTURAL ACTIVITIES THAT PROMOTE EDUCATION AND AWARENESS ABOUT GLOBAL WARMING AND CLIMATE CHANGE (U.S. CLS. 100, 101 AND 107).

CLASS 42—SCIENTIFIC AND COMPUTER SERVICES

FOR PROVIDING ONLINE INFORMATION IN THE FIELDS OF CLIMATE CHANGE AND GLOBAL WARMING (U.S. CLS. 100 AND 101).
FIRST USE 4-2-2008; IN COMMERCE 4-2-2008.
BRIAN NEVILLE, EXAMINING ATTORNEY

SN 77-489,934. MODAVOX, INC., PHOENIX, AZ. FILED 6-3-2008.

BOOMBOX

THE MARK CONSISTS OF STANDARD CHARACTERS WITHOUT CLAIM TO ANY PARTICULAR FONT, STYLE, SIZE, OR COLOR.

OWNER OF U.S. REG. NO. 2,397,385.

CLASS 38—COMMUNICATION

FOR ENTERTAINMENT SERVICES FEATURING MOVIES VIA THE INTERNET, NAMELY, VIDEO STREAMING SERVICES FEATURING MOVIES, ALL VIA THE INTERNET; ENTERTAINMENT SERVICES FEATURING MOVIES PROVIDED VIA THE WEB, NAMELY, AUDIO-VISUAL BROADCASTING SERVICES OVER THE INTERNET FEATURING MOVIES (U.S. CLS. 100, 101 AND 104).

FIRST USE 6-23-2008; IN COMMERCE 6-23-2008.

CLASS 41—EDUCATION AND ENTERTAINMENT

FOR ENTERTAINMENT SERVICES, NAMELY, PROVIDING NEWS IN THE NATURE OF CURRENT EVENTS REPORTING VIA THE INTERNET; ENTERTAINMENT SERVICES, NAMELY, PROVIDING AN ON-GOING VARIETY TALK SHOW BROADCAST VIA THE INTERNET; ENTERTAINMENT SERVICES IN THE NATURE OF MUSIC AND VIDEO CONTENT VIA THE INTERNET, NAMELY, TELEVISION COMEDY SHOWS BROADCAST VIA THE INTERNET, TELEVISION SHOWS FEATURING LIVE THEATER PRODUCTIONS BROADCAST VIA THE INTERNET, TELEVISION SHOWS FEATURING LIVE MUSICAL PERFORMANCES BROADCAST VIA THE INTERNET, TELEVISION NEWS SHOWS FEATURING VIDEO NEWS REPORTS BROADCAST VIA THE INTERNET; ENTERTAINMENT SERVICES FEATURING TELEVISION SHOWS, NAMELY, CONTINUING VARIETY, COMEDY, AND NEWS TELEVISION SHOWS BROADCAST VIA THE INTERNET; ENTERTAINMENT SERVICES FEATURING TELEVISION SHOWS, NAMELY, CONTINUING TELEVISION SHOWS FEATURING COMMENTARY IN THE FIELD OF ENTERTAINMENT BROADCAST VIA THE INTERNET; MUSICAL ENTERTAINMENT BROADCAST VIA THE INTERNET, NAMELY, AN ON-GOING SERIES FEATURING MUSICAL PERFORMANCES BY INDIVIDUAL ARTISTS, THEATRICAL GROUPS AND BANDS PROVIDED THROUGH WEBCASTS (U.S. CLS. 100, 101 AND 107).

FIRST USE 6-23-2008; IN COMMERCE 6-23-2008.
MAUREEN DALL, EXAMINING ATTORNEY

SN 77-490,576. AVID MEDICAL, INC., TOANO, VA. FILED 6-4-2008.

AVID MEDICAL

THE MARK CONSISTS OF STANDARD CHARACTERS WITHOUT CLAIM TO ANY PARTICULAR FONT, STYLE, SIZE, OR COLOR.

OWNER OF U.S. REG. NO. 2,766,180.

NO CLAIM IS MADE TO THE EXCLUSIVE RIGHT TO USE "MEDICAL", APART FROM THE MARK AS SHOWN.

CLASS 10—MEDICAL APPARATUS

FOR SURGICAL AND MEDICAL PROCEDURE TRAYS (U.S. CLS. 26, 39 AND 44).

CLASS 42—SCIENTIFIC AND COMPUTER SERVICES

FOR CUSTOM DESIGN OF SURGICAL AND MEDICAL PROCEDURE TRAYS TO THE ORDER AND SPECIFICATION OF OTHERS (U.S. CLS. 100 AND 101).

JENNIFER DIXON, EXAMINING ATTORNEY

SN 77-491,307. GHOSN, TIKI, DBA K. TIKI GHOSN, HUNTINGTON BEACH, CA. FILED 6-4-2008.

SN 77-492,331. CALIBRA MEDICAL, INC., REDWOOD CITY, CA. FILED 6-5-2008.



OWNER OF U.S. REG. NO. 3,178,791.
NO CLAIM IS MADE TO THE EXCLUSIVE RIGHT TO USE "ULTIMATE TRAINING CENTER" FOR INTERNATIONAL CLASS 41, APART FROM THE MARK AS SHOWN.
THE MARK CONSISTS OF THE STYLIZED LETTERS "HB" CENTERED ABOVE THE PHRASE "ULTIMATE TRAINING CENTER".

SEC. 2(F) AS TO "HB ULTIMATE TRAINING CENTER".

CLASS 25—CLOTHING

FOR ATHLETIC FOOTWEAR; BELTS; BOXER SHORTS; CAPS; CLOTHING FOR WEAR IN WRESTLING GAMES; FLEECE PULLOVERS; FOOTWEAR; GYM SHORTS; HATS; HEADGEAR, NAMELY, BEANIES, BANDANAS, CAPS, BASEBALL CAPS; HOODED PULLOVERS; HOODED SWEAT SHIRTS; JACKETS; JERSEYS; KNIT SHIRTS; LONG-SLEEVED SHIRTS; MARTIAL ARTS UNIFORMS; MOISTURE-WICKING SPORTS SHIRTS; PULLOVERS; SHIRTS; SHORT-SLEEVED OR LONG-SLEEVED T-SHIRTS; SHORT-SLEEVED SHIRTS; SHORTS; SPORTS JACKETS; SPORTS JERSEYS; SPORTS SHIRTS; SWEAT JACKETS; SWEAT SHIRTS; SWEAT SHORTS; T-SHIRTS; TANK TOPS; TOPS; TRAINING SHOES; TRAINING SUITS; TROUSERS; TRUNKS (U.S. CLS. 22 AND 39).

CLASS 41—EDUCATION AND ENTERTAINMENT

FOR ENTERTAINMENT SERVICES IN THE NATURE OF LIVE MIXED MARTIAL ARTS (MMA) EVENTS; GYMNASIUMS; ORGANIZING LIVE MIXED MARTIAL ARTS EVENTS AND COMPETITIONS; PERSONAL TRAINING SERVICES, NAMELY, STRENGTH AND CONDITIONING TRAINING; PHYSICAL FITNESS TRAINING SERVICES; PRESENTATION OF MIXED MARTIAL ARTS (MMA) EVENTS; PROVIDING GYMNASIUMS; PROVIDING INFORMATION IN THE FIELD OF EXERCISE TRAINING; PROVIDING INFORMATION ON PHYSICAL EXERCISE; SPORTS TRAINING SERVICES; TRAINING SERVICES IN THE FIELD OF MIXED MARTIAL ARTS (MMA) (U.S. CLS. 100, 101 AND 107).

FIRST USE 10-28-2002; IN COMMERCE 10-28-2002.
JASON BLAIR, EXAMINING ATTORNEY

CALIBRA

THE MARK CONSISTS OF STANDARD CHARACTERS WITHOUT CLAIM TO ANY PARTICULAR FONT, STYLE, SIZE, OR COLOR.

THE ENGLISH TRANSLATION OF "CALIBRA" IN THE MARK IS IT CALIBRATES.

CLASS 10—MEDICAL APPARATUS

FOR PORTABLE APPARATUS FOR TRANSDERMAL ADMINISTRATION OF MEDICAMENTS; MOISTURE INSULATORS AND THERMAL INSULATORS USED AS PARTS FOR THE PORTABLE APPARATUS FOR TRANSDERMAL MEDICAMENT ADMINISTRATION SOLD AS A UNIT WITH THE APPARATUS AND SOLD SEPARATELY; MEDICAL DEVICES, NAMELY, ELECTRONIC MEDICAMENT ADMINISTRATION MONITORS THAT UTILIZE ALERTS AND REMINDERS; MEDICAL DEVICES FOR TRANSDERMAL ADMINISTRATION OF MEDICAMENTS, NAMELY, PORTABLE APPARATUS FOR TRANSDERMAL ADMINISTRATION OF MEDICAMENTS; PARTS FOR MEDICAL DEVICES CONSISTING OF COMPONENTS FOR CANULA PLACEMENT SOLD AS A UNIT WITH THE MEDICAL APPARATUS AND SOLD SEPARATELY; USER INSTRUCTIONS, MANUALS, AND INFORMATIONAL BROCHURES AND REPORTS FOR MEDICAL APPARATUS FOR TRANSDERMAL MEDICAMENT ADMINISTRATION SOLD AS A UNIT WITH THE APPARATUS (U.S. CLS. 26, 39 AND 44).

CLASS 16—PAPER GOODS AND PRINTED MATTER

FOR PAPER GOODS, NAMELY, USER INSTRUCTIONS AND MANUALS, INFORMATIONAL BROCHURES AND REPORTS (U.S. CLS. 2, 5, 22, 23, 29, 37, 38 AND 50).

ANDREA HACK, EXAMINING ATTORNEY

SN 77-492,339. THOMSON, BOULOGNE-BILLANCOURT, FRANCE, FILED 6-5-2008.

mp3D

THE MARK CONSISTS OF STANDARD CHARACTERS WITHOUT CLAIM TO ANY PARTICULAR FONT, STYLE, SIZE, OR COLOR.

OWNER OF FRANCE REG. NO. 073543656, DATED 12-11-2007, EXPIRES 12-11-2017.

CLASS 9—ELECTRICAL AND SCIENTIFIC APPARATUS

FOR APPARATUS FOR RECORDING, TRANSMISSION, REPRODUCTION OF SOUND AND IMAGES; TELEPHONE APPARATUS; CELL PHONES; AUDIO AND VIDEO DISK READERS; AUDIO AND VIDEO DISK RECORDERS; RADIOS; AUDIO AND VIDEO RECEIVERS; AUDIO AND VIDEO CASSETTE READERS AND RECORDERS; TELEVISION APPARATUS; LOUD SPEAKERS; MICROPHONES; BLANK MAGNETIC DATA CARRIERS; BLANK COMPACT DISKS; BLANK CD ROMS; BLANK AUDIO AND VIDEO CASSETTES; DIGITAL PERSONAL ASSISTANTS; COMPUTER MATERIAL, NAMELY, COMPUTERS, COMPUTER PERIPHERALS; SOFTWARE FOR RECORDING, TRANSMISSION AND REPRODUCTION OF SOUND (U.S. CLS. 21, 23, 26, 36 AND 38).

CLASS 38—COMMUNICATION

FOR TELECOMMUNICATION SERVICES, NAMELY, BROADCASTING, TRANSMISSION AND DISTRIBUTION OF SOUNDS, IMAGES AND DATA BY SATELLITE, CABLE AND AERIALS (U.S. CLS. 100, 101 AND 104).

APRIL ROACH, EXAMINING ATTORNEY

SN 77-493,675. TURBO HOLDINGS INC, SAYREVILLE, NJ. FILED 6-8-2008.

makatto

THE MARK CONSISTS OF STANDARD CHARACTERS WITHOUT CLAIM TO ANY PARTICULAR FONT, STYLE, SIZE, OR COLOR.

CLASS 35—ADVERTISING AND BUSINESS

FOR OPERATING ON-LINE MARKETPLACES FOR SELLERS OF GOODS AND/OR SERVICES; PROMOTING THE GOODS AND SERVICES OF OTHERS BY MEANS OF OPERATING AN ON-LINE SHOPPING MALL WITH LINKS TO THE RETAIL WEB SITES OF OTHERS (U.S. CLS. 100, 101 AND 102).

CLASS 42—SCIENTIFIC AND COMPUTER SERVICES

FOR COMPUTER SERVICES IN THE NATURE OF CUSTOMIZED WEB PAGES FEATURING USER-DEFINED INFORMATION, PERSONAL PROFILES AND INFORMATION; COMPUTER SERVICES, NAMELY, INTERACTIVE HOSTING SERVICES WHICH ALLOW THE USER TO PUBLISH AND SHARE THEIR OWN CONTENT AND IMAGES ON-LINE (U.S. CLS. 100 AND 101).

WON TEAK OH, EXAMINING ATTORNEY

SN 77-492,551. ROHM AND HAAS COMPANY, PHILADELPHIA, PA. FILED 6-6-2008.

FLOVITRO

SN 77-494,062. AUGUSTA LLC, MIAMI, FL. FILED 6-9-2008.

CONTINENTAL GREEN

THE MARK CONSISTS OF STANDARD CHARACTERS WITHOUT CLAIM TO ANY PARTICULAR FONT, STYLE, SIZE, OR COLOR.

CLASS 9—ELECTRICAL AND SCIENTIFIC APPARATUS

FOR APPARATUS FOR TESTING, INSPECTION OR RESEARCH OF PHARMACEUTICALS OR FOODSTUFF (U.S. CLS. 21, 23, 26, 36 AND 38).

CLASS 42—SCIENTIFIC AND COMPUTER SERVICES

FOR TESTING, INSPECTION OR RESEARCH OF PHARMACEUTICALS OR FOODSTUFF (U.S. CLS. 100 AND 101).

CLASS 45—PERSONAL AND LEGAL SERVICES

FOR LICENSING OF PROCEDURE FOR TESTING, INSPECTION OR RESEARCH OF PHARMACEUTICALS OR FOODSTUFF OF OTHERS (U.S. CLS. 100 AND 101).

PAUL E. FAHRENKOPF, EXAMINING ATTORNEY

THE MARK CONSISTS OF STANDARD CHARACTERS WITHOUT CLAIM TO ANY PARTICULAR FONT, STYLE, SIZE, OR COLOR.

NO CLAIM IS MADE TO THE EXCLUSIVE RIGHT TO USE "GREEN", APART FROM THE MARK AS SHOWN.

CLASS 7—MACHINERY

FOR SMALL HOUSEHOLD APPLIANCES, NAMELY, ELECTRIC FOOD BLENDERS, ELECTRIC MIXERS FOR HOUSEHOLD PURPOSES, ELECTRIC HAND MIXERS, STAND MIXERS, ELECTRIC CAN OPENERS (U.S. CLS. 13, 19, 21, 23, 31, 34 AND 35).

CLASS 11—ENVIRONMENTAL CONTROL APPARATUS

FOR ELECTRIC COFFEE MAKERS, ELECTRIC TOASTERS, ELECTRIC TOASTER OVENS (U.S. CLS. 13, 21, 23, 31 AND 34).

ASMAT KHAN, EXAMINING ATTORNEY

SN 77-496,684. PLANETWIDE GAMES, INC., ALISO VIEJO, CA. FILED 6-11-2008.

MASHON

THE MARK CONSISTS OF STANDARD CHARACTERS WITHOUT CLAIM TO ANY PARTICULAR FONT, STYLE, SIZE, OR COLOR.

OWNER OF U.S. REG. NO. 3,481,929.

CLASS 9—ELECTRICAL AND SCIENTIFIC APPARATUS

FOR COMPUTER GAME SOFTWARE; COMPUTER GRAPHICS SOFTWARE; COMPUTER SOFTWARE FOR MANIPULATING DIGITAL AUDIO INFORMATION FOR USE IN AUDIO MEDIA APPLICATIONS; COMPUTER SOFTWARE FOR ORGANIZING AND VIEWING DIGITAL IMAGES AND PHOTOGRAPHS; DESKTOP PUBLISHING SOFTWARE (U.S. CLS. 21, 23, 26, 36 AND 38).

FIRST USE 9-11-2007; IN COMMERCE 1-15-2008.

CLASS 25—CLOTHING

FOR BEACHWEAR; FOOTWEAR; GLOVES; HATS; MUSCLE TOPS; PANTS; SHIRTS; SHORT-SLEEVED OR LONG-SLEEVED T-SHIRTS; SWEAT SHIRTS; SWEAT-BANDS; SWIM WEAR; TANK TOPS (U.S. CLS. 22 AND 39).

LINDA LAVACHE, EXAMINING ATTORNEY

SN 77-497,242. GOLF-RESORT "TERRE BLANCHE" SAS, TOURETTES, FRANCE, FILED 6-12-2008.

DOMAINE DE TERRE BLANCHE
golf club resort

PRIORITY CLAIMED UNDER SEC. 44(D) ON ERPNTY TM OFC APPLICATION NO. 006565865, FILED 12-13-2007, REG. NO. 006565865, DATED 1-12-2009, EXPIRES 12-13-2017.

NO CLAIM IS MADE TO THE EXCLUSIVE RIGHT TO USE "GOLF CLUB RESORT", APART FROM THE MARK AS SHOWN.

THE MARK CONSISTS OF THE WORDING "DOMAINE DE TERRE BLANCHE" ABOVE THE WORDING "GOLF CLUB RESORT". ABOVE THE WORDING "DOMAINE DE TERRE BLANCHE" IS A HALF SUN DESIGN. UNDERNEATH THE WORDING "GOLF CLUB RESORT" IS A HALF FLOWER DESIGN.

THE ENGLISH TRANSLATION OF "DOMAINE DE TERRE BLANCHE" IN THE MARK IS DOMAIN OF WHITE LAND.

CLASS 36—INSURANCE AND FINANCIAL

FOR REAL ESTATE AFFAIRS; NAMELY, REAL ESTATE AGENCIES; REAL ESTATE MANAGEMENT; RENTAL OF RESIDENTIAL HOUSING, SHORT TERM FURNISHED APARTMENTS, VACATION HOMES, AND CONDOMINIUMS, AND MANSIONS; LEASING OF REAL ESTATE; REAL-ESTATE BROKERAGE SERVICES (U.S. CLS. 100, 101 AND 102).

CLASS 41—EDUCATION AND ENTERTAINMENT

FOR TRAINING IN THE FIELD OF GOLF; ARRANGING AND CONDUCTING OF COURSES IN THE FIELD OF GOLF; INSTRUCTION IN TRAINING TECHNIQUES IN THE FIELD OF GOLF AND FITNESS; OPERATING GOLF SCHOOLS; OPERATING GOLF DRIVING RANGES AND GOLF CLUBS (U.S. CLS. 100, 101 AND 107).

CLASS 43—HOTEL AND RESTAURANT SERVICES

FOR HOTEL SERVICES; PROVIDING HOTEL ACCOMMODATION; ARRANGING TEMPORARY HOUSING ACCOMMODATIONS; PROVIDING TEMPORARY ACCOMMODATION; CATERING FOR GUESTS (U.S. CLS. 100 AND 101).

JANICE KIM, EXAMINING ATTORNEY

SN 77-497,640. MUELLER INDUSTRIES, INC., MEMPHIS, TN. FILED 6-12-2008.

ProLine
SERIES

NO CLAIM IS MADE TO THE EXCLUSIVE RIGHT TO USE "SERIES", APART FROM THE MARK AS SHOWN.

THE MARK CONSISTS OF THE STYLIZED WORDS "PROLINE SERIES" WITH A HORIZONTAL BAR THROUGH THE WORD "PROLINE" AND THE WORD "SERIES" APPEARING WITHIN THE HORIZONTAL BAR.

CLASS 6—METAL GOODS

FOR METAL PIPE WITH THREADS; METAL PIPE FITTINGS; NONE FOR USE WITH FLUID AND CORROSIVE HANDLING APPLICATIONS (U.S. CLS. 2, 12, 13, 14, 23, 25 AND 50).

CLASS 17—RUBBER GOODS

FOR FLEXIBLE PLASTIC PIPE WITH THREADS; NONE FOR USE WITH FLUID AND CORROSIVE HANDLING APPLICATIONS (U.S. CLS. 1, 5, 12, 13, 35 AND 50).

CLASS 19—NON-METALLIC BUILDING MATERIALS

FOR RIGID PLASTIC PIPE WITH THREADS; NONE FOR USE WITH FLUID AND CORROSIVE HANDLING APPLICATIONS (U.S. CLS. 1, 12, 33 AND 50).

KELLY MCCOY, EXAMINING ATTORNEY

SN 77-497,682. SOMOSTV LLC, CORAL GABLES, FL. FILED 6-12-2008.



THE MARK CONSISTS OF SEEDLING WITH SPROUT ATTACHED TO TOP OF SEEDLING FORMING THE LETTER "S" AND STYLIZED LOWER CASE FORMING LETTERS "EMILLITAS".

THE ENGLISH TRANSLATION OF THE WORD "EMILLITAS" IN THE MARK IS "LITTLE SEEDS".

CLASS 38—COMMUNICATION

FOR TELEVISION BROADCASTING SERVICES (U.S. CLS. 100, 101 AND 104).

CLASS 41—EDUCATION AND ENTERTAINMENT

FOR ENTERTAINMENT SERVICES IN THE NATURE OF ONGOING TELEVISION PROGRAMS IN THE FIELD OF CHILDREN'S ENTERTAINMENT (U.S. CLS. 100, 101 AND 107).

HOWARD SMIGA, EXAMINING ATTORNEY

CLASS 1—CHEMICALS

FOR CHEMICAL PREPARATIONS FOR SCIENTIFIC PURPOSES, NAMELY, FOR LABORATORY ANALYSIS IN THE FIELD OF BIOTECHNOLOGY, DRUG DISCOVERY, GENOMICS, MOLECULAR BIOLOGY AND MICROBIOLOGY; CHEMICAL PREPARATIONS FOR SCIENTIFIC PURPOSES IN THE FIELD OF BIOTECHNOLOGY, DRUG DISCOVERY, GENOMICS, MOLECULAR BIOLOGY AND MICROBIOLOGY; BACTERIA PREPARATIONS FOR USE IN FOOD MANUFACTURE, WASTE WATER TREATMENT, FERMENTATION, RESEARCH, MANUFACTURE OF COSMETICS, MANUFACTURE OF SCIENTIFIC COMPOUNDS, AND MANUFACTURE OF PHARMACEUTICAL COMPOUNDS; BACTERIOLOGICAL PREPARATIONS FOR USE IN FOOD MANUFACTURE, WASTE WATER TREATMENT, FERMENTATION, RESEARCH, MANUFACTURE OF COSMETICS, MANUFACTURE OF SCIENTIFIC COMPOUNDS, AND MANUFACTURE OF PHARMACEUTICAL COMPOUNDS; MICROORGANISM CULTURES FOR USE IN FOOD MANUFACTURE, WASTE WATER TREATMENT, FERMENTATION, RESEARCH, MANUFACTURE OF COSMETICS, MANUFACTURE OF SCIENTIFIC COMPOUNDS, MANUFACTURE OF PHARMACEUTICAL COMPOUNDS; BIOCHEMICAL CATALYSTS FOR USE IN FOOD MANUFACTURE, WASTE WATER TREATMENT, FERMENTATION, RESEARCH, MANUFACTURE OF COSMETICS, MANUFACTURE OF SCIENTIFIC COMPOUNDS, MANUFACTURE OF PHARMACEUTICAL COMPOUNDS; BIOLOGICAL MATERIALS FOR CLINICAL, SCIENTIFIC, RESEARCH AND MEDICAL LABORATORIES, NAMELY, PROTEINS, DNA, RNA AND MODIFICATIONS THEREOF; DIAGNOSTIC MATERIALS FOR CLINICAL, SCIENTIFIC, RESEARCH AND MEDICAL LABORATORY PURPOSES, NAMELY, PROTEINS, DNA, RNA AND MODIFICATIONS THEREOF; ENZYMES AND ENZYME PREPARATIONS FOR USE IN THE FIELD OF FOOD MANUFACTURE, WASTE TREATMENT, FERMENTATION, MANUFACTURE OF COSMETICS, MANUFACTURE OF SCIENTIFIC COMPOUNDS, AND MANUFACTURE OF PHARMACEUTICAL COMPOUNDS; BIOLOGICAL MATERIALS FOR MEDICAL DIAGNOSTIC LABORATORY USE, NAMELY, PROTEINS, DNA, RNA AND MODIFICATIONS THEREOF; DIAGNOSTIC MATERIALS FOR CLINICAL AND MEDICAL LABORATORY PURPOSES, NAMELY, PROTEINS, DNA, RNA AND MODIFICATIONS THEREOF; DEOXYRIBONUCLEIC ACID, ESPECIALLY DEOXYRIBONUCLEIC ACID COMPRISING 80 TO 150 BASE PAIRS FOR SCIENTIFIC AND RESEARCH PURPOSES; AND GENES, NAMELY, GENES COMPRISING 80 TO 150 BASE PAIRS FOR SCIENTIFIC AND RESEARCH PURPOSES (U.S. CLS. 1, 5, 6, 10, 26 AND 46).

SN 77-497,882. GENEART AG, REGENSBURG, FED REP GERMANY, FILED 6-12-2008.

GENEART - THE PROTEIN OF
YOUR CHOICE

THE MARK CONSISTS OF STANDARD CHARACTERS WITHOUT CLAIM TO ANY PARTICULAR FONT, STYLE, SIZE, OR COLOR.

PRIORITY CLAIMED UNDER SEC. 44(D) ON FED REP GERMANY APPLICATION NO. 302008016844, FILED 5-27-2008, REG. NO. 302008016844, DATED 8-4-2008, EXPIRES 8-4-2018.

OWNER OF U.S. REG. NO. 2,751,683.

CLASS 5—PHARMACEUTICALS

FOR MEDICINES FOR HUMAN-MEDICAL PURPOSES, NAMELY, ANTIBIOTICS, ANTIBODIES, DNA, RNA, VACCINES, BLOOD-PRODUCING PREPARATIONS, HORMONES AND ENZYMES FOR USE IN THE TREATMENT OF CANCER, DIABETES, ALZHEIMER'S AND INFECTIOUS DISEASES; MEDICINES FOR DENTAL PURPOSES, NAMELY, ANTIBIOTICS, ANTIBODIES, DNA, RNA, VACCINES, BLOOD-PRODUCING PREPARATIONS, HORMONES AND ENZYMES FOR USE IN THE TREATMENT OF CANCER, ALZHEIMER'S AND INFECTIOUS DISEASES; MEDICINES FOR VETERINARY PURPOSES, NAMELY, ANTIBIOTICS, ANTIBODIES, DNA, RNA, VACCINES, BLOOD-PRODUCING PREPARATIONS, HORMONES AND ENZYMES FOR USE IN THE TREATMENT OF CANCER, DIABETES, ALZHEIMER'S AND INFECTIOUS DISEASES; BACTERIOLOGICAL PREPARATIONS FOR MEDICAL AND VETERINARY PURPOSES FOR USE IN THE TREATMENT OF CANCER, HIGH BLOOD PRESSURE, DIARRHEA, SKIN IRRITATIONS, INFECTIONS, DIABETES, AUTOIMMUNE DISEASES AND ARTHRITIS AS WELL AS FOR USE IN GENE THERAPY; BIOLOGICAL PREPARATIONS FOR MEDICAL PURPOSES, NAMELY, ANTIBIOTICS, ANTIBODIES, DNA, RNA, VACCINES, BLOOD-PRODUCING PREPARATIONS, HORMONES AND ENZYMES FOR USE IN THE TREATMENT OF CANCER, DIABETES, ALZHEIMER'S AND INFECTIOUS DISEASES; BIOLOGICAL PREPARATIONS FOR VETERINARY PURPOSES, NAMELY, ANTIBIOTICS, ANTIBODIES, DNA, RNA, VACCINES, BLOOD-PRODUCING

PREPARATIONS, HORMONES AND ENZYMES FOR USE IN THE TREATMENT OF CANCER, DIABETES, ALZHEIMER'S AND INFECTIOUS DISEASES; GERMICIDES FOR MEDICAL AND LABORATORY EQUIPMENT AND FOR INSTITUTIONAL AND DOMESTIC USES; VERMICIDES FOR MEDICAL AND LABORATORY EQUIPMENT AND FOR INSTITUTIONAL, DOMESTIC, AND RESIDENTIAL USES; FUNGICIDES FOR MEDICAL AND LABORATORY EQUIPMENT AND FOR INSTITUTIONAL AND DOMESTIC USES; DEOXYRIBONUCLEIC ACID, NAMELY, DEOXYRIBONUCLEIC ACID COMPRISING 80 TO 150 BASE PAIRS FOR DIAGNOSTIC MEDICAL PURPOSES; AND GENES, NAMELY, GENES COMPRISING 80 TO 150 BASE PAIRS FOR MEDICAL DIAGNOSTIC PURPOSES (U.S. CLS. 6, 18, 44, 46, 51 AND 52).

CLASS 7—MACHINERY

FOR FILLING MACHINES; MACHINE PARTS, NAMELY, MACHINE HOUSINGS; MEMBRANES SPECIALLY DESIGNED FOR ELECTRIC PUMPS; MIXERS; PUMPS, NAMELY, ELECTRIC PUMPS; REGULATORS BEING PARTS OF MACHINES; INDUSTRIAL ROBOTS; SEPARATORS, NAMELY, CENTRIFUGAL SEPARATORS (U.S. CLS. 13, 19, 21, 23, 31, 34 AND 35).

CLASS 9—ELECTRICAL AND SCIENTIFIC APPARATUS

FOR SCIENTIFIC AND LABORATORY EQUIPMENT, NAMELY, AUTOMATIC MACHINES FOR THE SYNTHESIS OF DEOXYRIBONUCLEIC ACIDS; ROBOT MACHINES FOR LABORATORY PURPOSES; COMPUTER TERMINALS; COMPUTER PROGRAMS FOR USE AS TOOLS FOR DESIGN AND SYNTHESIS OF DEOXYRIBONUCLEIC ACIDS, GENES AND PROTEINS; COMPUTER SOFTWARE TO INCREASE POTENCY OF ENZYMES AND ENZYME PREPARATIONS, BACTERIA PREPARATIONS, BACTERIOLOGICAL PREPARATIONS, MICRO-ORGANISM CULTURES, BIOLOGICAL PREPARATIONS AND DIAGNOSTIC PREPARATIONS; COMPUTER OPERATING PROGRAMS; COMPUTER PERIPHERAL DEVICES; COMPUTER KEYBOARDS; BLANK MAGNETIC DATA CARRIERS; BLANK OPTICAL DISKS; DATA PROCESSING APPARATUS, NAMELY, DATA PROCESSORS; COMPUTER MEMORIES; BLANK FLOPPY COMPUTER DISKS; BLANK HARD DRIVES FOR COMPUTERS; PRINTERS FOR USE WITH COMPUTERS; COMPUTER INTERFACES; LAPTOP COMPUTERS; DATA PROCESSORS, NAMELY, READERS AND SCANNERS; COMPUTER MOUSE; MICROPROCESSORS IN THE NATURE OF SEMICONDUCTORS; COMPUTER MODEMS; COMPUTER MONITORS; COMPUTER HARDWARE; AND NOTEBOOK COMPUTERS (U.S. CLS. 21, 23, 26, 36 AND 38).

CLASS 42—SCIENTIFIC AND COMPUTER SERVICES

FOR COMPUTER SERVICES, NAMELY, UPDATING OF COMPUTER SOFTWARE FOR OTHERS, CONSULTING IN THE FIELD OF BIOTECHNOLOGY, DESIGNING COMPUTER SOFTWARE FOR OTHERS, MAINTENANCE OF COMPUTER SOFTWARE FOR OTHERS, RENTAL OF COMPUTER SOFTWARE, COMPUTER PROGRAMMING FOR OTHERS, LEASING OF COMPUTERS, AND RECONSTRUCTION OF COMPUTER DATA FOR OTHERS; CHEMICAL ANALYSIS FOR OTHERS; RESEARCH FOR OTHERS IN THE FIELDS OF BACTERIOLOGY, BIOLOGY, CHEMISTRY, PHYSICS, GENEALOGY, COSMETICS, GENETIC ENGINEERING, AND MACHINE ENGINEERING; MEDICAL LABORATORY SERVICES FOR OTHERS IN THE FIELDS OF BACTERIOLOGY AND CHEMISTRY; CONSULTATION IN THE FIELDS OF BACTERIOLOGY, BIOLOGY, CHEMISTRY, PHYSICS, GENEALOGY, COSMETICS RESEARCH, EN-

GINEERING AND MACHINE ENGINEERING; CONSULTATION IN THE FIELD OF PHARMACOLOGY; MEASURING CALIBRATION FOR OTHERS; DEVELOPMENT AND RESEARCH OF NEW PRODUCTS FOR OTHERS; TECHNICAL CONSULTATION IN THE FIELD OF ENVIRONMENTAL PROTECTION; TECHNICAL PROJECT PLANNING AND TECHNOLOGY CONSULTING SERVICES IN THE FIELDS OF BACTERIOLOGY, BIOLOGY, CHEMISTRY, PHYSICS, GENEALOGY, COSMETICS RESEARCH, ENGINEERING, AND MACHINE ENGINEERING; AND QUALITY CONTROL FOR OTHERS (U.S. CLS. 100 AND 101).

ROBIN MITTLER, EXAMINING ATTORNEY

SN 77-498,301. KONAMI DIGITAL ENTERTAINMENT CO., LTD., TOKYO, JAPAN, FILED 6-13-2008.



THE MARK CONSISTS OF THE LETTERS "PES" IN STYLIZED FONT. THE LETTER "E" IS UNDERLINED AND FEATURES A CROWN ABOVE.

CLASS 9—ELECTRICAL AND SCIENTIFIC APPARATUS

FOR VIDEO GAME SOFTWARE; VIDEO GAME PROGRAMS; COMPUTER GAME SOFTWARE; COMPUTER GAME PROGRAMS; ELECTRONIC GAME PROGRAMS; ARCADE GAMES ADAPTED FOR USE WITH AN EXTERNAL DISPLAY SCREEN OR MONITOR (U.S. CLS. 21, 23, 26, 36 AND 38).

CLASS 41—EDUCATION AND ENTERTAINMENT

FOR ENTERTAINMENT SERVICES, NAMELY, PROVIDING ONLINE COMPUTER GAMES ACCESSIBLE VIA VIDEO GAME MACHINES, MOBILE PHONES AND COMPUTERS; PROVIDING ONLINE COMPUTER GAMES VIA NETWORK BETWEEN COMMUNICATIONS NETWORKS AND COMPUTERS, AND WHICH MAY BE ACCESSED NETWORK-WIDE BY NETWORK USERS; ENTERTAINMENT SERVICES, NAMELY, PROVIDING INFORMATION TO VIDEO AND COMPUTER GAME PLAYERS ABOUT THE RANKING OF THEIR SCORES OF GAMES VIA THE INTERNET; ENTERTAINMENT SERVICES, NAMELY, PROVIDING INFORMATION, GRAPHICS, AND SOUND IN THE FIELD OF VIDEO AND COMPUTER GAMES (U.S. CLS. 100, 101 AND 107).

REBECCA POVARCHUK, EXAMINING ATTORNEY

SN 77-498,665. VALIANT LLC, THOUSAND OAKS, CA. FILED 6-13-2008.

MINISTRY OF CULTURE

THE MARK CONSISTS OF STANDARD CHARACTERS WITHOUT CLAIM TO ANY PARTICULAR FONT, STYLE, SIZE, OR COLOR.

CLASS 25—CLOTHING

FOR CLOTHING, NAMELY, BRIEFS AND BOXER BRIEFS, BOARD SHORTS, NECK TIES, COATS, COVERUPS, CREWNECKS, DENIM JACKETS, DENIM PANTS, DRESS SHIRTS, FABRIC BELTS, FLEECE PULLOVERS, FLEECE JACKETS, JACKETS, JEANS, KNIT SHIRTS, JUMPSUITS, LEATHER JACKETS, LEATHER PANTS, LOUNGE WEAR, TROUSERS, VESTS, NIGHTWEAR, OUTDOOR GLOVES, PARKAS, PAJAMAS, PONCHOS, POLO SHIRTS, RAINCOATS, ROBES, SCARVES, SHIRTS, SHORTS, SLEEPWEAR, SNOW BOARDING SUITS, SOCKS, SWEAT SUITS, SWEAT SHIRTS, SWEAT PANTS, SWIMWEAR, TANK TOPS, T-SHIRTS, UNDERGARMENTS, WRISTBANDS; HEADGEAR, NAMELY, CAPS, HATS AND VISORS; FOOTWEAR, NAMELY, FLIP FLOPS, RUBBER SHOES, SANDALS, CANVAS SHOES, LEATHER SHOES AND BOOTS; INSOLES FOR SHOES (U.S. CLS. 22 AND 39).

CLASS 41—EDUCATION AND ENTERTAINMENT

FOR EDUCATION AND ENTERTAINMENT SERVICES, NAMELY, PROVIDING A WEBSITE FEATURING AUDIO CLIPS, VIDEO CLIPS, MUSICAL PERFORMANCES, MUSICAL VIDEOS, FILM CLIPS, PHOTOGRAPHS, OTHER MULTIMEDIA MATERIALS, AND INFORMATION IN THE FIELD OF AUDIO CLIPS, VIDEO CLIPS, MUSICAL PERFORMANCES, MUSICAL VIDEOS, FILM CLIPS, PHOTOGRAPHS, AND OTHER MULTIMEDIA MATERIALS; BLOGS FEATURING INFORMATION IN THE FIELD OF AUDIO CLIPS, VIDEO CLIPS, MUSICAL PERFORMANCES, MUSICAL VIDEOS, FILM CLIPS, PHOTOGRAPHS, AND OTHER MULTIMEDIA MATERIALS. ENTERTAINMENT SERVICES, NAMELY, PRODUCTION OF THEATRICAL SHOWS; PRODUCTION OF DVD'S, USB DRIVES, VIDEOTAPES AND TELEVISION PROGRAMS FEATURING ACTION SPORTS, LIFESTYLE, MUSIC, PARTIES, CULTURAL EVENTS PLUS RELATED REALITY, LIFESTYLE AND CULTURAL THEMES (U.S. CLS. 100, 101 AND 107).
DORITT L. CARROLL, EXAMINING ATTORNEY

SN 77-498,742. GENTLE GIANT MOVING CO., INC., SOMERVILLE, MA. FILED 6-13-2008.



OWNER OF U.S. REG. NO. 2,123,585.
NO CLAIM IS MADE TO THE EXCLUSIVE RIGHT TO USE "MOVING COMPANY", APART FROM THE MARK AS SHOWN.

THE COLOR(S) PURPLE, GOLD, GREEN AND WHITE IS/ARE CLAIMED AS A FEATURE OF THE MARK.

THE MARK CONSISTS OF TWO GOLD LEGS IN SHOES, ALL WITH GREEN SHADOWING, DEPICTED AGAINST A PURPLE BACKGROUND, AND WITH WHITE LETTERING.

CLASS 35—ADVERTISING AND BUSINESS

FOR MOVING AND RELOCATION SERVICES, NAMELY, PLANNING AND IMPLEMENTING MOVES OF HOMES AND OFFICES; MOVING AND RELOCATION CONSULTATION, NAMELY, PLANNING AND IMPLEMENTING MOVES OF HOMES AND OFFICES (U.S. CLS. 100, 101 AND 102).

CLASS 39—TRANSPORTATION AND STORAGE

FOR LOCAL, INTERSTATE AND INTERNATIONAL SERVICES, NAMELY, PACKING FOR TRANSPORTATION OR STORAGE, MOVING TRANSPORTATION OF GOODS, AND STORAGE OF GOODS; MOVING TRANSPORTATION CONSULTATION; VEHICLE RELOCATION SERVICES; AND PROVIDING INFORMATION IN THE FIELD OF MOVING TRANSPORTATION, PACKING ARTICLES FOR TRANSPORTATION OR STORAGE, AND STORAGE OF GOODS (U.S. CLS. 100 AND 105).
LESLIE RICHARDS, EXAMINING ATTORNEY

SN 77-499,403. TRAN, CASSIDY, WESTMINSTER, CA. FILED 6-16-2008.

Tainted Kiss

THE MARK CONSISTS OF STANDARD CHARACTERS WITHOUT CLAIM TO ANY PARTICULAR FONT, STYLE, SIZE, OR COLOR.

CLASS 25—CLOTHING

FOR BLOUSES; CAPRI PANTS; CARGO PANTS; DENIMS; DRESS SHIRTS; DRESS SUITS; DRESSES; EVENING DRESSES; INFANT AND TODDLER ONE PIECE CLOTHING; INFANT CLOTH DIAPERS; JEANS; JERSEYS; JOGGING PANTS; LEATHER BELTS; LEATHER PANTS; LEOTARDS AND TIGHTS FOR WOMEN, MEN AND CHILDREN OF NYLON, COTTON OR OTHER TEXTILE FIBERS; LINGERIE ACCESSORIES, NAMELY, REMOVABLE SILICONE BREAST ENHANCER PADS USED IN A BRA; LOUNGE PANTS; MEN'S AND WOMEN'S JACKETS, COATS, TROUSERS, VESTS; MEN'S SUITS, WOMEN'S SUITS; PANTS; PARTS OF CLOTHING, NAMELY, GUSSETS FOR TIGHTS, GUSSETS FOR STOCKINGS, GUSSETS FOR BATHING SUITS, GUSSETS FOR UNDERWEAR, GUSSETS FOR LEOTARDS AND GUSSETS FOR FOOTLETS; PERSPIRATION ABSORBENT UNDERWEAR CLOTHING; SHOES; SHORT SETS; SHOULDER WRAPS; SKIRT SUITS; SKIRTS; SKIRTS AND DRESSES; STRETCH PANTS; SWEAT PANTS; TOPS; UNDERGARMENT ACCESSORIES, NAMELY, REMOVABLE SILICONE BUTTOCK ENHANCER PADS; WEARABLE GARMENTS AND CLOTHING, NAMELY, SHIRTS; WOMEN'S CEREMONIAL DRESSES; WOMEN'S SHOES; WOMEN'S UNDERWEAR; WRAPS; YOGA PANTS (U.S. CLS. 22 AND 39).

FIRST USE 4-1-2008; IN COMMERCE 4-1-2008.

CLASS 35—ADVERTISING AND BUSINESS

FOR MAIL ORDER CATALOG SERVICES FEATURING WOMEN'S CLOTHING AND ACCESSORIES; MAIL ORDER SERVICES FEATURING WOMEN'S CLOTHING AND ACCESSORIES; RETAIL APPAREL STORES; RETAIL CLOTHING BOUTIQUES; RETAIL CLOTHING STORES; RETAIL STORES FEATURING WOMEN'S CLOTHING; RETAIL WOMEN'S CLOTHING STORES (U.S. CLS. 100, 101 AND 102).

FIRST USE 4-1-2008; IN COMMERCE 4-1-2008.

GIANCARLO CASTRO, EXAMINING ATTORNEY

SN 77-499,693. BAILAC, LLC, TOOLE, UT. FILED 6-16-2008.

BAILAC

THE MARK CONSISTS OF STANDARD CHARACTERS WITHOUT CLAIM TO ANY PARTICULAR FONT, STYLE, SIZE, OR COLOR.

CLASS 9—ELECTRICAL AND SCIENTIFIC APPARATUS

FOR COMPUTER SOFTWARE FOR MANAGING THE LIFECYCLE OF INDUSTRIAL TIRES, RIMS, AND CHAINS (U.S. CLS. 21, 23, 26, 36 AND 38).

CLASS 35—ADVERTISING AND BUSINESS

FOR SCHEDULING REPAIRS, ROTATION AND REPLACEMENT OF TIRES FOR OTHERS (U.S. CLS. 100, 101 AND 102).

CLASS 42—SCIENTIFIC AND COMPUTER SERVICES

FOR TIRE MAINTENANCE SERVICES, NAMELY, TRACKING TIRE PRESSURE, TIRE TREAD DEPTH, TIRE TEMPERATURE, AND DAMAGE TO TIRES FOR THIRD PARTIES FOR PURPOSES OF DETERMINING WHEN TIRES NEED REPAIR, ROTATION AND REPLACEMENT; PROVIDING TEMPORARY USE OF ONLINE, NON-DOWNLOADABLE SOFTWARE FOR MANAGING THE LIFECYCLE OF INDUSTRIAL TIRES, RIMS, AND CHAINS THROUGH A WEBSITE (U.S. CLS. 100 AND 101).

JOHN DWYER, EXAMINING ATTORNEY

SN 77-499,948. TENCENT HOLDINGS LIMITED, GEORGE TOWN, CAYMAN ISLANDS, FILED 6-16-2008.



OWNER OF U.S. REG. NOS. 2,938,524, 3,159,635 AND OTHERS.

NO CLAIM IS MADE TO THE EXCLUSIVE RIGHT TO USE "CHESS", APART FROM THE MARK AS SHOWN.

THE MARK CONSISTS OF A CROWN AND THE LETTERS "QQ" ABOVE THE WORD "CHESS".

CLASS 9—ELECTRICAL AND SCIENTIFIC APPARATUS

FOR DOWNLOADABLE COMPUTER PROGRAMS FOR USE IN TELECOMMUNICATIONS, NAMELY, TELECOMMUNICATIONS SOFTWARE FOR PROVIDING SINGLE USER AND MULTIPLE USER ACCESS TO A GLOBAL COMPUTER NETWORK; DOWNLOADABLE COMPUTER SOFTWARE FOR PLAYING COMPUTER GAMES; DOWNLOADABLE COMPUTER SOFTWARE FEATURING ANIMATED CARTOONS (U.S. CLS. 21, 26, 36 AND 38).

CLASS 41—EDUCATION AND ENTERTAINMENT

FOR ENTERTAINMENT AND EDUCATION SERVICES, NAMELY, PROVIDING ONLINE GAMES IN THE NATURE OF COMPUTER CONTESTS; PROVIDING ONLINE COMPUTER GAMES (U.S. CLS. 100, 101 AND 107).

ROBIN MITTLER, EXAMINING ATTORNEY

SN 77-500,003. TENCENT HOLDINGS LIMITED, GEORGE TOWN, CAYMAN ISLANDS, FILED 6-16-2008.



OWNER OF U.S. REG. NOS. 2,938,524, 3,159,635 AND OTHERS.

NO CLAIM IS MADE TO THE EXCLUSIVE RIGHT TO USE "HEARTS", APART FROM THE MARK AS SHOWN.

THE MARK CONSISTS OF THE LETTERS "QQ" IN STYLIZED FORM ABOVE THE TERM "HEARTS" IN STYLIZED FORM. NEXT TO THE LETTERS "QQ" IS AN ACE OF HEARTS CARD ON TOP OF ANOTHER CARD.

CLASS 9—ELECTRICAL AND SCIENTIFIC APPARATUS

FOR DOWNLOADABLE COMPUTER PROGRAMS FOR USE IN TELECOMMUNICATIONS, NAMELY, TELECOMMUNICATIONS SOFTWARE FOR PROVIDING SINGLE USER AND MULTIPLE USER ACCESS TO A GLOBAL COMPUTER NETWORK; DOWNLOADABLE COMPUTER SOFTWARE FOR PLAYING COMPUTER GAMES; DOWNLOADABLE COMPUTER SOFTWARE FEATURING ANIMATED CARTOONS (U.S. CLS. 21, 26, 36 AND 38).

CLASS 41—EDUCATION AND ENTERTAINMENT

FOR ENTERTAINMENT AND EDUCATION SERVICES, NAMELY, PROVIDING ONLINE GAMES IN THE NATURE OF COMPUTER CONTESTS; PROVIDING ONLINE COMPUTER GAMES (U.S. CLS. 100, 101 AND 107).

ROBIN MITTLER, EXAMINING ATTORNEY

SN 77-501,633. GLOBAL CONTENT & RESEARCH LTD., TORTOLA, BR. VIRGIN ISLANDS, FILED 6-18-2008.

ECOSEED

THE MARK CONSISTS OF STANDARD CHARACTERS WITHOUT CLAIM TO ANY PARTICULAR FONT, STYLE, SIZE, OR COLOR.

CLASS 35—ADVERTISING AND BUSINESS

FOR INTERNET CONTENT MANAGEMENT, NAMELY, PROVIDING BUSINESS INFORMATION ON THE WORLD WIDE WEB RELATED TO ECOLOGY; BUSINESS SERVICES IN THE AREA OF ECOLOGY, NAMELY, BUSINESS CONSULTING IN THE AREA OF ECOLOGY, AND MATCHING INDIVIDUALS WISHING TO PURCHASE ECOLOGICALLY-FRIENDLY PRODUCTS AND SERVICES WITH ENTITIES WISHING TO SELL SUCH GOODS AND SERVICES (U.S. CLS. 100, 101 AND 102).

CLASS 38—COMMUNICATION

FOR INTERNET CONTENT MANAGEMENT, NAMELY, STREAMING VIDEOS OF SPEECHES AND NEWS EVENTS IN THE AREA OF ECOLOGY VIA THE INTERNET (U.S. CLS. 100, 101 AND 104).

CLASS 41—EDUCATION AND ENTERTAINMENT

FOR INTERNET PUBLISHING, NAMELY, ON-LINE PUBLICATION OF TEXT AND GRAPHIC WORKS OF OTHERS IN THE FIELD OF ECOLOGY (U.S. CLS. 100, 101 AND 107).

MAUREEN DALL, EXAMINING ATTORNEY

SN 77-502,691. FAIRWAY BUILDING PRODUCTS, LP, MOUNT JOY, PA. FILED 6-19-2008.

LANDMARKE

THE MARK CONSISTS OF STANDARD CHARACTERS WITHOUT CLAIM TO ANY PARTICULAR FONT, STYLE, SIZE, OR COLOR.

CLASS 6—METAL GOODS

FOR METALLIC FENCING SYSTEMS COMPRISED OF GATES AND FENCES, FENCE POSTS, POST CAPS, FENCE RAILS, AND FENCE PANELS (U.S. CLS. 2, 12, 13, 14, 23, 25 AND 50).

FIRST USE 3-26-2008; IN COMMERCE 6-4-2008.

CLASS 19—NON-METALLIC BUILDING MATERIALS

FOR NON-METALLIC FENCING SYSTEMS COMPRISED OF VINYL GATES AND FENCES, FENCE POSTS, POST CAPS, FENCE RAILS, AND FENCE PANELS (U.S. CLS. 1, 12, 33 AND 50).

FIRST USE 3-26-2008; IN COMMERCE 4-1-2008.
STEVEN R. FINE, EXAMINING ATTORNEY

SN 77-505,235. SONY ONLINE ENTERTAINMENT LLC, SAN DIEGO, CA. FILED 6-23-2008.

SOE

THE MARK CONSISTS OF STANDARD CHARACTERS WITHOUT CLAIM TO ANY PARTICULAR FONT, STYLE, SIZE, OR COLOR.

OWNER OF U.S. REG. NOS. 2,591,884, 2,612,892 AND 3,114,636.

CLASS 35—ADVERTISING AND BUSINESS

FOR PROMOTING THE GOODS AND SERVICES OF OTHERS BY PREPARING AND DISSEMINATING ADVERTISEMENTS ACCESSED THROUGH A GLOBAL COMPUTER NETWORK; ONLINE RETAIL STORE SERVICES VIA COMPUTER IN THE FIELD OF COMPUTER GAMES AND ENTERTAINMENT IN THE NATURE OF SOFTWARE PROGRAMS (U.S. CLS. 100, 101 AND 102).

FIRST USE 9-7-2001; IN COMMERCE 9-7-2001.

CLASS 38—COMMUNICATION

FOR PROVIDING ON-LINE FACILITIES FOR REAL-TIME INTERACTION WITH OTHER COMPUTER USERS CONCERNING TOPICS OF GENERAL INTEREST (U.S. CLS. 100, 101 AND 104).

FIRST USE 9-7-2001; IN COMMERCE 9-7-2001.

CLASS 41—EDUCATION AND ENTERTAINMENT

FOR PROVIDING INFORMATION IN THE FIELD OF ENTERTAINMENT BY MEANS OF A GLOBAL COMPUTER NETWORK AND OTHER COMPUTER NETWORKS (U.S. CLS. 100, 101 AND 107).

FIRST USE 9-7-2001; IN COMMERCE 9-7-2001.

KATHRYN COWARD, EXAMINING ATTORNEY

SN 77-505,294. CONSTELLATION BUSINESS GROUP, INC., FORT LEE, NJ. FILED 6-23-2008.

شبكة جهانی آریانا

OWNER OF U.S. REG. NOS. 3,462,368, 3,472,332 AND OTHERS.

NO CLAIM IS MADE TO THE EXCLUSIVE RIGHT TO USE NON-LATIN CHARACTERS THAT MEAN "INTERNATIONAL NETWORK", APART FROM THE MARK AS SHOWN.

THE MARK CONSISTS OF STYLIZED ARABIC WRITING.

THE FOREIGN WORDING IN THE MARK MEANS "ARIANA INTERNATIONAL NETWORK" IN ENGLISH.

THE NON-LATIN CHARACTERS IN THE MARK TRANSLITERATE TO "SHABIKIH JAHAANI ARIANA".

CLASS 38—COMMUNICATION

FOR TELEVISION AND RADIO BROADCASTING (U.S. CLS. 100, 101 AND 104).

CLASS 41—EDUCATION AND ENTERTAINMENT

FOR TELEVISION AND RADIO PROGRAMMING; ENTERTAINMENT IN THE NATURE OF ON-GOING TELEVISION AND RADIO PROGRAMS FEATURING SOAP OPERAS, SITCOMS, NEWS AND ENTERTAINMENT MAGAZINE FORMATS, GAME SHOWS, MUSIC BASED SHOWS, CURRENT AFFAIRS SHOWS, NEWS, AND CHILDREN'S SHOWS (U.S. CLS. 100, 101 AND 107).
COLLEEN DOMBROW, EXAMINING ATTORNEY

SN 77-505,412. SONY ONLINE ENTERTAINMENT LLC, SAN DIEGO, CA. FILED 6-23-2008.



OWNER OF U.S. REG. NOS. 2,591,884, 2,612,892 AND 3,114,636.

THE MARK CONSISTS OF THE STYLIZED LETTERS "SOE" CONTAINED WITHIN A RECTANGLE WITH CURVED CORNERS.

CLASS 35—ADVERTISING AND BUSINESS

FOR PROMOTING THE GOODS AND SERVICES OF OTHERS BY PREPARING AND DISSEMINATING ADVERTISEMENTS ACCESSED THROUGH A GLOBAL COMPUTER NETWORK; ONLINE RETAIL STORE SERVICES VIA COMPUTER IN THE FIELD OF COMPUTER GAMES AND ENTERTAINMENT IN THE NATURE OF SOFTWARE PROGRAMS (U.S. CLS. 100, 101 AND 102).
FIRST USE 9-7-2001; IN COMMERCE 9-7-2001.

CLASS 38—COMMUNICATION

FOR PROVIDING ON-LINE FACILITIES FOR REAL-TIME INTERACTION WITH OTHER COMPUTER USERS CONCERNING TOPICS OF GENERAL INTEREST (U.S. CLS. 100, 101 AND 104).
FIRST USE 9-7-2001; IN COMMERCE 9-7-2001.

CLASS 41—EDUCATION AND ENTERTAINMENT

FOR PROVIDING INFORMATION IN THE FIELD OF ENTERTAINMENT BY MEANS OF A GLOBAL COMPUTER NETWORK AND OTHER COMPUTER NETWORKS (U.S. CLS. 100, 101 AND 107).
FIRST USE 9-7-2001; IN COMMERCE 9-7-2001.
KATHRYN COWARD, EXAMINING ATTORNEY

SN 77-505,665. AUSTRALIAN MERINO PTY. LTD., SYDNEY NEW SOUTH WALES, AUSTRALIA, FILED 6-23-2008.

MERINOEASYCLEAN

THE MARK CONSISTS OF STANDARD CHARACTERS WITHOUT CLAIM TO ANY PARTICULAR FONT, STYLE, SIZE, OR COLOR.

CLASS 24—FABRICS

FOR WOVEN FABRICS FOR MEN'S AND WOMEN'S FORMAL AND INFORMAL JACKETS, TROUSERS AND SKIRTS, ALL MADE IN WHOLE OR SUBSTANTIALLY IN PART OF MERINO WOOL AND SOLD SEPARATELY FROM THE CLOTHING ITEMS (U.S. CLS. 42 AND 50).

CLASS 25—CLOTHING

FOR MEN'S AND WOMEN'S FORMAL AND INFORMAL JACKETS, TROUSERS AND SKIRTS, ALL MADE IN WHOLE OR SUBSTANTIALLY IN PART OF MERINO WOOL (U.S. CLS. 22 AND 39).
CHRISTINE BLOMQUIST, EXAMINING ATTORNEY

SN 77-506,878. BARA ISHIDU INTERNATIONAL CORPORATION, LYFORD CAY, BAHAMAS, FILED 6-24-2008.



OWNER OF U.S. REG. NOS. 3,018,388, 3,220,511 AND OTHERS.

NO CLAIM IS MADE TO THE EXCLUSIVE RIGHT TO USE "CUP", APART FROM THE MARK AS SHOWN.

THE MARK CONSISTS OF "TAVISTOCK CUP" OVER A SWINGING GOLFER ON A GOLF BALL WITH A BORDER CONSISTING OF FIVE SIDES.

CLASS 9—ELECTRICAL AND SCIENTIFIC APPARATUS

FOR PRERECORDED AUDIO AND VIDEO TAPES, AUDIO AND VIDEO CASSETTES, COMPACT DISCS, DIGITAL VIDEO DISCS CONTAINING INFORMATION PERTAINING TO THE GAME OF GOLF; COMPUTER GAME SOFTWARE AND COMPUTER GAME DISCS PERTAINING TO GOLF; COMPUTER SOFTWARE FOR ISSUING GOLF TICKETS; COMPUTER MOUSE PADS; COMPUTER SCREEN SAVER SOFTWARE; DECORATIVE MAGNETS; SUNGLASSES (U.S. CLS. 21, 23, 26, 36 AND 38).

CLASS 18—LEATHER GOODS

FOR UMBRELLAS AND GOLF UMBRELLAS; ATHLETIC BAGS, TOTE BAGS, SHOE BAGS FOR TRAVEL, BACK PACKS, LEATHER BILLFOLDS, LEATHER KEY CHAINS; ATTACHE CASES AND BRIEFCASES; HANDBAGS AND WALLETS (U.S. CLS. 1, 2, 3, 22 AND 41).

CLASS 20—FURNITURE AND ARTICLES NOT OTHERWISE CLASSIFIED

FOR GOLF STOOLS AND CHAIRS (U.S. CLS. 2, 13, 22, 25, 32 AND 50).

CLASS 21—HOUSEWARES AND GLASS

FOR BEVERAGE GLASSWARE; PLASTIC CUPS AND MUGS; PEWTER MUGS; ORNAMENTAL DECORATIVE TABLE ACCESSORIES, NAMELY, BOWLS WITH AND WITHOUT LIDS, MADE OF GLASS, CRYSTAL AND CHINA (U.S. CLS. 2, 13, 23, 29, 30, 33, 40 AND 50).

CLASS 28—TOYS AND SPORTING GOODS

FOR GOLF EQUIPMENT AND ACCESSORIES, NAMELY, GOLF BAGS, GOLF BAG COVERS, GOLF BALLS, GOLF CLUBS, GOLF CLUB COVERS, GOLF FLAGS, GOLF BALL MARKERS, DIVOT REPAIR TOOLS (U.S. CLS. 22, 23, 38 AND 50).
DAWN HAN, EXAMINING ATTORNEY

SN 77-507,564. RUSSELL, JOHN F., LYNN, MA. FILED 6-25-2008.

Buginface

THE MARK CONSISTS OF STANDARD CHARACTERS WITHOUT CLAIM TO ANY PARTICULAR FONT, STYLE, SIZE, OR COLOR.

CLASS 16—PAPER GOODS AND PRINTED MATTER

FOR STICKERS, DECORATIVE STICKERS FOR HELMETS (U.S. CLS. 2, 5, 22, 23, 29, 37, 38 AND 50).

CLASS 25—CLOTHING

FOR CLOTHING, NAMELY, T-SHIRTS, TANK TOPS, HATS, SWEAT SHIRTS, BANDANNAS, SCARVES, LEATHER SCARVES, LEATHER GLOVES, LEATHER JACKETS, LEATHER CHAPS, AND LEATHER VESTS (U.S. CLS. 22 AND 39).

THEODORE MCBRIDE, EXAMINING ATTORNEY

SN 77-507,961. BEARING TECHNOLOGIES, LTD., AVON, OH. FILED 6-25-2008.



The logo for Bearingtech features the word "bearingtech" in a lowercase, sans-serif font. The letter "b" is stylized, with a circular graphic element that resembles a bearing or a gear, partially overlapping the letter. The "b" and the circular graphic are underlined.

NO CLAIM IS MADE TO THE EXCLUSIVE RIGHT TO USE "BEARING TECH", APART FROM THE MARK AS SHOWN.

THE MARK CONSISTS OF A GRAPHIC OF THE LETTER "B" SURROUNDED BY A SERIES OF SMALLER CIRCLES THAT ARE INLAID WITHIN THE CIRCUMFERENCE OF A LARGER CIRCLE; THE WORDS "BEARING TECH" WHICH ARE UNDERLINED.

CLASS 7—MACHINERY

FOR WHEEL BEARINGS FOR LAND VEHICLES, DRIVE SHAFT CENTER SUPPORT BEARINGS, CLUTCH RELEASE BEARINGS FOR LAND VEHICLES, WHEEL HUBS FOR LAND VEHICLES (U.S. CLS. 13, 19, 21, 23, 31, 34 AND 35).

CLASS 12—VEHICLES

FOR INDUSTRIAL BEARINGS IN THE NATURE OF MACHINE PARTS, NAMELY, ROLLER BEARINGS (U.S. CLS. 19, 21, 23, 31, 35 AND 44).

FIRST USE 6-20-2008; IN COMMERCE 6-20-2008.
ELISSA GARBER KON, EXAMINING ATTORNEY

SN 77-508,005. BARA ISHIDU INTERNATIONAL CORPORATION, LYFORD CAY, BAHAMAS, FILED 6-25-2008.



OWNER OF U.S. REG. NOS. 3,018,388, 3,220,511 AND OTHERS.

NO CLAIM IS MADE TO THE EXCLUSIVE RIGHT TO USE "CUP", APART FROM THE MARK AS SHOWN.

THE MARK CONSISTS OF "TAVISTOCK CUP" OVER A SWINGING GOLFER ON A GOLF BALL WITH A BORDER CONSISTING OF FIVE SIDES.

CLASS 6—METAL GOODS

FOR METAL MONEY CLIPS (U.S. CLS. 2, 12, 13, 14, 23, 25 AND 50).

FIRST USE 9-1-2007; IN COMMERCE 11-10-2007.

CLASS 16—PAPER GOODS AND PRINTED MATTER

FOR BOOKS, SOUVENIR PROGRAMS, JOURNALS, AND MANUALS PERTAINING TO THE GAME OF GOLF AND TO GOLF TOURNAMENTS; PAIRING SHEETS, NAMELY, GOLF SCORE CARDS; POSTERS AND LITHOGRAPHIC PRINTS; CALENDARS; STATIONERY; DESK SETS AND PAPERWEIGHTS; PENS AND PENCILS (U.S. CLS. 2, 5, 22, 23, 29, 37, 38 AND 50).

FIRST USE 9-1-2007; IN COMMERCE 11-10-2007.

CLASS 24—FABRICS

FOR GOLF TOWELS; SOUVENIR PENNANTS AND FLAGS MADE OF CLOTH (U.S. CLS. 42 AND 50).

FIRST USE 9-1-2007; IN COMMERCE 11-10-2007.

CLASS 25—CLOTHING

FOR HEADWEAR, CLOTHING AND ACCESSORIES, NAMELY, T-SHIRTS, COLLARED SHIRTS, SWEATERS, JACKETS, COATS, PANTS, SHORTS, RAINSUITS, HATS, SUN VISORS, BELTS (U.S. CLS. 22 AND 39).

FIRST USE 9-1-2007; IN COMMERCE 11-10-2007.

CLASS 41—EDUCATION AND ENTERTAINMENT

FOR ENTERTAINMENT SERVICES IN THE NATURE OF ORGANIZING AND CONDUCTING GOLF TOURNAMENTS WHICH ARE TELEvised FOR THE ENJOYMENT OF A WORLDWIDE AUDIENCE (U.S. CLS. 100, 101 AND 107).

FIRST USE 9-1-2007; IN COMMERCE 11-10-2007.
DAWN HAN, EXAMINING ATTORNEY

SN 77-508,085. PHOENIX INTERNATIONAL HOLDINGS, INC., DBA PHOENIX INTERNATIONAL, INC., LARGO, MD. FILED 6-25-2008.

xBot

THE MARK CONSISTS OF STANDARD CHARACTERS WITHOUT CLAIM TO ANY PARTICULAR FONT, STYLE, SIZE, OR COLOR.

CLASS 12—VEHICLES

FOR REMOTELY OPERATED VEHICLE SYSTEMS, NAMELY, A VEHICLE SYSTEM COMPRISED OF A PLATFORM CAPABLE OF UNMANNED, REMOTELY OPERATED TRAVEL UNDERWATER USED TO CARRY INSTRUMENTS FOR EXPLORATION AND COLLECTION OF DATA FOR UNDERWATER SEARCH, INVESTIGATION, INSPECTION, OPTICAL DOCUMENTATION, SAMPLE COLLECTION AND OBJECT RETRIEVAL OF CULTURAL ARTIFACTS, MARINE RESOURCES, GEOLOGICAL FORMATIONS AND ENVIRONMENTAL CONDITIONS AS WELL AS TEMPORARY AND PERMANENT MAN-MADE STRUCTURES (U.S. CLS. 19, 21, 23, 31, 35 AND 44).
FIRST USE 4-30-2003; IN COMMERCE 4-30-2003.

CLASS 42—SCIENTIFIC AND COMPUTER SERVICES

FOR UNDERWATER EXPLORATION AND STRUCTURAL INSPECTION SERVICES (U.S. CLS. 100 AND 101).
FIRST USE 4-30-2003; IN COMMERCE 4-30-2003.
INGRID C. EULIN, EXAMINING ATTORNEY

SN 77-508,996. TLV CO., LTD., HYOGO-KEN, JAPAN, FILED 6-26-2008.

CDL

THE MARK CONSISTS OF STANDARD CHARACTERS WITHOUT CLAIM TO ANY PARTICULAR FONT, STYLE, SIZE, OR COLOR.

CLASS 37—CONSTRUCTION AND REPAIR

FOR MAINTENANCE AND REPAIR OF STEAM SYSTEMS FOR HEATING AND COOLING AND PARTS THEREFOR (U.S. CLS. 100, 103 AND 106).

CLASS 42—SCIENTIFIC AND COMPUTER SERVICES

FOR TECHNICAL SUPPORT SERVICES, NAMELY, MONITORING, INSPECTION, SURVEY AND DIAGNOSTIC SERVICES FOR STEAM SYSTEMS FOR HEATING AND COOLING; ENGINEERING AND DESIGN FOR OTHERS OF STEAM SYSTEMS FOR HEATING AND COOLING; TECHNOLOGICAL CONSULTATION IN THE FIELD OF STEAM SYSTEMS FOR HEATING AND COOLING; DESIGN PLANNING AND ADVISORY SERVICES RELATED TO THE DESIGN OF STEAM SYSTEMS FOR HEATING AND COOLING OF STEAM SYSTEMS FOR HEATING AND COOLING (U.S. CLS. 100 AND 101).

ANDREA SAUNDERS, EXAMINING ATTORNEY

SN 77-509,004. TLV CO., LTD., HYOGO-KEN, JAPAN, FILED 6-26-2008.

ZRM

THE MARK CONSISTS OF STANDARD CHARACTERS WITHOUT CLAIM TO ANY PARTICULAR FONT, STYLE, SIZE, OR COLOR.

CLASS 37—CONSTRUCTION AND REPAIR

FOR MAINTENANCE AND REPAIR OF STEAM SYSTEMS FOR HEATING AND COOLING AND PARTS THEREFOR (U.S. CLS. 100, 103 AND 106).

CLASS 42—SCIENTIFIC AND COMPUTER SERVICES

FOR TECHNICAL SUPPORT SERVICES, NAMELY, MONITORING, INSPECTION, SURVEY AND DIAGNOSTIC SERVICES FOR STEAM SYSTEMS FOR HEATING AND COOLING; ENGINEERING AND DESIGN FOR OTHERS OF STEAM SYSTEMS FOR HEATING AND COOLING; TECHNOLOGICAL CONSULTATION IN THE FIELD OF STEAM SYSTEMS FOR HEATING AND COOLING; DESIGN, TECHNICAL PLANNING AND ADVISORY SERVICES RELATED TO THE DESIGN OF STEAM SYSTEMS FOR HEATING AND COOLING (U.S. CLS. 100 AND 101).
ANDREA SAUNDERS, EXAMINING ATTORNEY

SN 77-509,507. INTIMATE-INFINITY LLC, DBA DESIGN-NET, EMERYVILLE, CA. FILED 6-27-2008.



design.net

NO CLAIM IS MADE TO THE EXCLUSIVE RIGHT TO USE "DESIGN.NET" AND "LLC", APART FROM THE MARK AS SHOWN.

THE MARK CONSISTS OF 8 STYLIZED OBJECTS FORMING A PERSON OR A DOG. EACH FIGURE HAS 2 CIRCULAR EYES, AND 2 LEGS EXCEPT FOR ONE DOG WITH 4 LEGS. EACH REPRESENTS DIFFERENT OBJECTS, SPECIFICALLY, A DOG, A SHOPPING BAG, THE LETTER

"G", A BUBBLE, A COMPACT DISK, A CAMERA, A TRIANGLE AND A VIDEO GAME CONTROLLER. TWO LARGE HOLLOW LETTERS "II" PLACED NEXT TO EACH OTHER WITH LEFT HOLLOW LETTER CONSISTING OF SMALL LETTERS "II" AND RIGHT HOLLOW LETTER CONSISTING SMALL LETTERS "LLC" PLACED ON THE OUTSIDE RIGHT OF HOLLOW LETTERS FORMING "II LLC" TOGETHER. THE WORDS "DESIGN.NET" APPEAR BELOW THE HIGHLY STYLIZED DESIGN PORTION OF THE MARK.

CLASS 9—ELECTRICAL AND SCIENTIFIC APPARATUS

FOR COMPUTER APPLICATION SOFTWARE FOR MOBILE PHONES; INTERACTIVE MULTIMEDIA COMPUTER GAME PROGRAM; INTERACTIVE VIDEO GAME PROGRAMS; INTERACTIVE VIDEO GAMES OF VIRTUAL REALITY COMPRISED OF COMPUTER HARDWARE AND SOFTWARE; VIDEO AND COMPUTER GAME PROGRAMS; VIDEO GAME SOFTWARE (U.S. CLS. 21, 23, 26, 36 AND 38).

FIRST USE 4-26-2008; IN COMMERCE 5-26-2008.

CLASS 28—TOYS AND SPORTING GOODS

FOR ACTION FIGURES; COLLECTIBLE TOY FIGURES; INFLATABLE TOYS; MODELED PLASTIC TOY FIGURINES; MOLDED TOY FIGURES; POSITIONABLE THREE DIMENSIONAL TOYS FOR USE IN GAMES; POSITIONABLE TOY FIGURES; POSITIONABLE TWO DIMENSIONAL TOYS FOR USE IN GAMES (U.S. CLS. 22, 23, 38 AND 50).

FIRST USE 4-26-2008; IN COMMERCE 5-26-2008.

CLASS 42—SCIENTIFIC AND COMPUTER SERVICES

FOR ARCHITECTURAL DESIGN; COMMERCIAL ART DESIGN; COMPUTER GRAPHICS SERVICES; CONSULTING SERVICES IN THE FIELD OF ARCHITECTURAL DESIGN; DESIGN AND DEVELOPMENT OF MULTIMEDIA PRODUCTS; DESIGN AND DEVELOPMENT OF ON-LINE COMPUTER SOFTWARE SYSTEMS; DESIGN OF HOME PAGES; DESIGNING AND DEVELOPING COMPUTER GAME SOFTWARE AND VIDEO GAME SOFTWARE FOR USE WITH COMPUTERS, VIDEO GAME PROGRAM SYSTEMS AND COMPUTER NETWORKS; DESIGNING AND MODIFYING COMPUTER PROGRAMS AND VIDEO GAMES FOR OTHERS; DESIGNING WEB SITES FOR ADVERTISING PURPOSES; GRAPHIC ART DESIGN; GRAPHIC DESIGN; GRAPHIC DESIGN SERVICES; GRAPHIC ILLUSTRATION AND DRAWING SERVICES, NAMELY, PROVIDING GRAPHIC ILLUSTRATIONS AND DRAWINGS OF COMMERCIAL AND INDUSTRIAL BUILDING DESIGNS, AND CONVERTING BUILDING DESIGNS OR MARKUPS TO ELECTRONIC CAD DRAWINGS; GRAPHIC ILLUSTRATION SERVICES FOR OTHERS; INDUSTRIAL DESIGN; INDUSTRIAL DESIGN SERVICES; INTERIOR DESIGN SERVICES; LANDSCAPE ARCHITECTURAL DESIGN (U.S. CLS. 100 AND 101).

FIRST USE 4-26-2008; IN COMMERCE 4-26-2008.

DAVID COLLIER, EXAMINING ATTORNEY

SN 77-509,546. FLEETPRIDE, INC., THE WOODLANDS, TX. FILED 6-27-2008.

WE LIVE AND BREATHE HEAVY
DUTY

THE MARK CONSISTS OF STANDARD CHARACTERS WITHOUT CLAIM TO ANY PARTICULAR FONT, STYLE, SIZE, OR COLOR.

CLASS 35—ADVERTISING AND BUSINESS

FOR TRUCK AND TRAILER SERVICES FOR TRUCK AND TRAILER REPAIR BUSINESSES, NAMELY, ADVERTISING SERVICES IN THE NATURE OF PROMOTING THE GOODS AND SERVICES OF TRUCK AND TRAILER REPAIR BUSINESSES BY PROVIDING IN-STORE ADVERTISING MATERIALS, PROVIDING PRESS RELEASES, PROVIDING TRADE JOURNAL ADVERTISEMENTS, PARTICIPATING IN INDUSTRY TRADE SHOWS, PROVIDING MARKETING SERVICES IN THE NATURE OF DIRECT MARKETING ADVERTISING FOR OTHERS, AND PROVIDING REBATE PROGRAMS IN THE NATURE OF PROCESSING MANUFACTURER'S REBATES; TRUCK AND TRAILER SERVICES FOR TRUCK AND TRAILER REPAIR BUSINESSES, NAMELY, PROVIDING BUSINESS INFORMATION RELATING TO TRUCK AND TRAILER REPAIR SERVICE BUSINESSES (U.S. CLS. 100, 101 AND 102).

FIRST USE 12-0-2005; IN COMMERCE 12-0-2005.

CLASS 36—INSURANCE AND FINANCIAL

FOR TRUCK AND TRAILER SERVICES FOR TRUCK AND TRAILER REPAIR BUSINESSES, NAMELY, PROVIDING WARRANTIES ON PARTS PURCHASED FROM TRADEMARK OWNER AND INSTALLED AS PART OF TRUCK AND TRAILER REPAIRS (U.S. CLS. 100, 101 AND 102).

FIRST USE 12-0-2005; IN COMMERCE 12-0-2005.

MELISSA VALLILLO, EXAMINING ATTORNEY

SN 77-509,900. PRESTOLITE WIRE LLC, SOUTHFIELD, MI. FILED 6-27-2008.

MALLORY

THE MARK CONSISTS OF STANDARD CHARACTERS WITHOUT CLAIM TO ANY PARTICULAR FONT, STYLE, SIZE, OR COLOR.

OWNER OF U.S. REG. NOS. 1,244,189 AND 3,224,074.

CLASS 4—LUBRICANTS AND FUELS

FOR LUBRICANTS FOR MOTOR VEHICLES (U.S. CLS. 1, 6 AND 15).

FIRST USE 0-0-2004; IN COMMERCE 0-0-2004.

CLASS 8—HAND TOOLS

FOR HAND TOOLS FOR USE ON MOTOR VEHICLE AND MOTOR VEHICLE PRODUCTS, NAMELY, WIRE STRIPPERS, PLIERS, WRENCHES AND CABLE TIE TENSION AND REMOVAL TOOLS (U.S. CLS. 23, 28 AND 44).

FIRST USE 0-0-1940; IN COMMERCE 0-0-1940.

CLASS 12—VEHICLES

FOR HOUSE MARK FOR DRIVE SYSTEM PARTS FOR MOTOR VEHICLES (U.S. CLS. 19, 21, 23, 31, 35 AND 44).

FIRST USE 0-0-2002; IN COMMERCE 0-0-2002.

RENEE SERVANCE, EXAMINING ATTORNEY

SN 77-511,796. HASKELL, GLORIA THOMPSON, CHAPEL HILL, NC. AND HASKELL, GREGORY EDWARD, CHAPEL HILL, NC. FILED 6-30-2008.



GREEN HILL DESIGNS

NO CLAIM IS MADE TO THE EXCLUSIVE RIGHT TO USE "DESIGNS", APART FROM THE MARK AS SHOWN.

THE COLOR(S) GREEN AND WHITE IS/ARE CLAIMED AS A FEATURE OF THE MARK.

THE MARK CONSISTS THE WORDING "GREEN HILL DESIGNS" IN GREEN AND THE DESIGN OF A GREEN CIRCLE AND A WHITE, CURVED VINE-LIKE MOTIF AND TWO WHITE LEAVES. ONE LEAF HAS A SMALL WHITE CIRCLE NEXT TO IT, AND THE OTHER LEAF HAS TWO SMALL WHITE CIRCLES NEXT TO IT, ONE LARGER THAN THE OTHER.

CLASS 16—PAPER GOODS AND PRINTED MATTER

FOR BUSINESS CARDS; OFFICE STATIONARY; CARDBOARD TRADE SHOW DISPLAY UNITS FOR MERCHANDISING PRODUCTS; BUSINESS ENVELOPES; CARDBOARD PACKAGING; PAPER STICKERS TO ACT AS LABELS; CARDBOARD TAGS AND PAPER TAGS TO GO ON STRING TO BE PLACED AROUND OBJECTS (U.S. CLS. 2, 5, 22, 23, 29, 37, 38 AND 50).

CLASS 35—ADVERTISING AND BUSINESS

FOR ON-LINE RETAIL STORE SERVICES FEATURING CUSTOM CRAFTED FURNITURE (U.S. CLS. 100, 101 AND 102).
MARGARET POWER, EXAMINING ATTORNEY

SN 77-511,804. ARCTIC CIRCLE ENTERPRISES LLC, ANCHORAGE, AK. FILED 6-30-2008.



NO CLAIM IS MADE TO THE EXCLUSIVE RIGHT TO USE "ALASKA", APART FROM THE MARK AS SHOWN.

THE MARK CONSISTS OF THE WORD "ALASKA" WITH THE WORD "SUMMIT" DIRECTLY BELOW, WITH A STYLIZED MOUNTAIN TO THE RIGHT OF THE ENDING "A" IN "ALASKA" AND THE "T" IN "SUMMIT".

CLASS 6—METAL GOODS

FOR METAL KEY CHAINS (U.S. CLS. 2, 12, 13, 14, 23, 25 AND 50).

CLASS 9—ELECTRICAL AND SCIENTIFIC APPARATUS

FOR MAGNETS (U.S. CLS. 21, 23, 26, 36 AND 38).

CLASS 18—LEATHER GOODS

FOR LUGGAGE AND TRAVEL BAGS; BACKPACKS; DUFFEL BAGS (U.S. CLS. 1, 2, 3, 22 AND 41).

CLASS 21—HOUSEWARES AND GLASS

FOR MUGS AND CUPS; PLASTIC WATER BOTTLES SOLD EMPTY; METAL WATER BOTTLES SOLD EMPTY (U.S. CLS. 2, 13, 23, 29, 30, 33, 40 AND 50).

CLASS 25—CLOTHING

FOR CLOTHING, NAMELY, JACKETS, SOCKS AND STOCKINGS, HATS, CAPS AND HEADWEAR, SWEATSHIRTS AND T-SHIRTS (U.S. CLS. 22 AND 39).

MARGARET POWER, EXAMINING ATTORNEY

SN 77-512,207. CHRISTIN, JULIE, LEMONT, IL. FILED 7-1-2008.

JULIE-MARIE

THE MARK CONSISTS OF STANDARD CHARACTERS WITHOUT CLAIM TO ANY PARTICULAR FONT, STYLE, SIZE, OR COLOR.

CLASS 18—LEATHER GOODS

FOR ALL-PURPOSE DRAWSTRING BAGS; MAKE-UP BAGS SOLD EMPTY; TOTE BAGS; PURSES; COIN PURSES; ALL-PURPOSE CARRYING BAGS FOR ATTACHMENT TO WHEELCHAIRS (U.S. CLS. 1, 2, 3, 22 AND 41).

FIRST USE 4-2-2008; IN COMMERCE 4-2-2008.

CLASS 21—HOUSEWARES AND GLASS

FOR INSULATING FABRIC SLEEVE HOLDERS FOR COFFEE CUPS; FACIAL TISSUE HOLDERS (U.S. CLS. 2, 13, 23, 29, 30, 33, 40 AND 50).

FIRST USE 4-2-2008; IN COMMERCE 4-2-2008.
KIMBERLY FRYE, EXAMINING ATTORNEY

SN 77-512,384. TASTI D-LITE LLC, FRANKLIN, TN. FILED 7-1-2008.

SN 77-512,902. HAYNES, VIRGINIA, DBA WYLIES BAIT & TACKLE, MALIBU, CA. FILED 7-1-2008.

tasti D-fense

THE MARK CONSISTS OF STANDARD CHARACTERS WITHOUT CLAIM TO ANY PARTICULAR FONT, STYLE, SIZE, OR COLOR.

OWNER OF U.S. REG. NOS. 1,525,999, 3,301,896 AND 3,334,587.

NO CLAIM IS MADE TO THE EXCLUSIVE RIGHT TO USE "TASTY", APART FROM THE MARK AS SHOWN.

CLASS 5—PHARMACEUTICALS

FOR VITAMIN-FORTIFIED, HERB-FORTIFIED, AND NUTRIENT-FORTIFIED BEVERAGES (U.S. CLS. 6, 18, 44, 46, 51 AND 52).

CLASS 30—STAPLE FOODS

FOR HERBAL FOOD BEVERAGES (U.S. CL. 46).
WON TEAK OH, EXAMINING ATTORNEY

WYLIES

THE MARK CONSISTS OF STANDARD CHARACTERS WITHOUT CLAIM TO ANY PARTICULAR FONT, STYLE, SIZE, OR COLOR.

SEC. 2(F).

CLASS 25—CLOTHING

FOR PROMOTIONAL CLOTHING, NAMELY, CAPS, HATS, T-SHIRTS AND SWEATSHIRTS (U.S. CLS. 22 AND 39).

FIRST USE 0-0-1959; IN COMMERCE 0-0-1959.

CLASS 35—ADVERTISING AND BUSINESS

FOR RETAIL STORE SERVICES FEATURING FISHING GEAR, TIDE BOOKLETS AND CLOTHING (U.S. CLS. 100, 101 AND 102).

FIRST USE 0-0-1946; IN COMMERCE 0-0-1946.
SANJEEV VOHRA, EXAMINING ATTORNEY

SN 77-512,896. VIRGINIA HAYNES, DBA WYLIES BAIT & TACKLE, MALIBU, CA. FILED 7-1-2008.

SN 77-513,500. LIGHTHOUSE TECHNOLOGIES LIMITED, SHATIN, HONG KONG, FILED 7-2-2008.

WYLIE'S

THE MARK CONSISTS OF STANDARD CHARACTERS WITHOUT CLAIM TO ANY PARTICULAR FONT, STYLE, SIZE, OR COLOR.

SEC. 2(F).

CLASS 16—PAPER GOODS AND PRINTED MATTER

FOR PRINTED PUBLICATIONS, NAMELY, A HIGH AND LOW TIDES BOOKLET (U.S. CLS. 2, 5, 22, 23, 29, 37, 38 AND 50).

FIRST USE 0-0-1953; IN COMMERCE 0-0-1953.

CLASS 28—TOYS AND SPORTING GOODS

FOR FISH HOOKS AND LEADERS (U.S. CLS. 22, 23, 38 AND 50).

FIRST USE 0-0-1946; IN COMMERCE 0-0-1946.
SANJEEV VOHRA, EXAMINING ATTORNEY

VELOS

THE MARK CONSISTS OF STANDARD CHARACTERS WITHOUT CLAIM TO ANY PARTICULAR FONT, STYLE, SIZE, OR COLOR.

THE ENGLISH TRANSLATION OF "VELOS" IN THE MARK IS SPEED.

CLASS 9—ELECTRICAL AND SCIENTIFIC APPARATUS

FOR APPARATUS FOR RECORDATION, TRANSMISSION AND REPRODUCTION OF SOUND AND IMAGES; SCREENS, NAMELY, PROJECTION SCREENS, VIDEO SCREENS AND LIGHT EMITTING DIODE (LED) SCREENS; TELEVISION PROJECTION APPARATUS; LED DISPLAYS; LED MODULAR VIDEO PANELS; MONITORS, NAMELY, TELEVISION MONITORS, LED MONITORS, COMPUTER MONITORS AND LED COMPUTER MONITORS; TELEVISIONS; LED TELEVISIONS; LED FOR USE IN TELEVISIONS, SCREENS, MONITORS AND COMPUTER MONITORS; LED SIGNAGE; AND STRUCTURAL PARTS AND FITTINGS THEREFOR, ALL THESE GOODS FOR INDOOR AND OUTDOOR USES (U.S. CLS. 21, 23, 26, 36 AND 38).

CLASS 11—ENVIRONMENTAL CONTROL APPARATUS

FOR INSTALLATIONS, APPARATUS AND INSTRUMENTS FOR LIGHTING, NAMELY, ARCHITECTURAL LIGHTING INSTALLATIONS AND LANDSCAPE LIGHTING INSTALLATIONS; ELECTRIC LIGHTING FIXTURES; LED LIGHTING FIXTURES FOR USE IN DISPLAY, COMMERCIAL, INDUSTRIAL, RESIDENTIAL, AND ARCHITECTURAL ACCENT LIGHTING APPLICATIONS; LED LIGHTING FIXTURES FOR INDOOR AND OUTDOOR LIGHTING APPLICATIONS; LAMPS AND LAMP FITTINGS; AND STRUCTURAL PARTS AND FITTINGS FOR ALL THE AFORESAID GOODS (U.S. CLS. 13, 21, 23, 31 AND 34).

CLASS 11—ENVIRONMENTAL CONTROL APPARATUS

FOR INSTALLATIONS, APPARATUS AND INSTRUMENTS FOR LIGHTING, NAMELY, ARCHITECTURAL LIGHTING INSTALLATIONS AND LANDSCAPE LIGHTING INSTALLATIONS; ELECTRIC LIGHTING FIXTURES; LED LIGHTING FIXTURES FOR USE IN DISPLAY, COMMERCIAL, INDUSTRIAL, RESIDENTIAL, AND ARCHITECTURAL ACCENT LIGHTING APPLICATIONS; LED LIGHTING FIXTURES FOR INDOOR AND OUTDOOR LIGHTING APPLICATIONS; LAMPS AND LAMP FITTINGS; AND STRUCTURAL PARTS AND FITTINGS FOR ALL THE AFORESAID GOODS (U.S. CLS. 13, 21, 23, 31 AND 34).

CLASS 37—CONSTRUCTION AND REPAIR

FOR INSTALLATION, MAINTENANCE AND REPAIR OF APPARATUS FOR RECORDATION, TRANSMISSION AND REPRODUCTION OF SOUND AND IMAGES, HOME THEATER PRODUCTS, ENTERTAINMENT SYSTEMS, CONSUMER ELECTRONIC PRODUCTS, SCREENS, PROJECTION SCREENS, VIDEO SCREENS, LIGHT EMITTING DIODE (LED) SCREENS, PROJECTION APPARATUS, LED DISPLAYS, LED MODULAR VIDEO PANELS, MONITORS, LED MONITORS, TELEVISIONS, LED TELEVISIONS, LED FOR TELEVISIONS, SCREENS, MONITORS AND COMPUTER MONITORS, VIDEO SYSTEMS, AND LED SIGNAGE FOR INDOOR AND OUTDOOR USES; INSTALLATION OF INDOOR AND OUTDOOR HOME THEATERS AND RELATED STRUCTURAL WIRING (U.S. CLS. 100, 103 AND 106).
JOHN WILKE, EXAMINING ATTORNEY

CLASS 37—CONSTRUCTION AND REPAIR

FOR INSTALLATION, MAINTENANCE AND REPAIR OF APPARATUS FOR RECORDATION, TRANSMISSION AND REPRODUCTION OF SOUND AND IMAGES, HOME THEATER PRODUCTS, ENTERTAINMENT SYSTEMS, CONSUMER ELECTRONIC PRODUCTS, SCREENS, PROJECTION SCREENS, VIDEO SCREENS, LIGHT EMITTING DIODE (LED) SCREENS, PROJECTION APPARATUS, LED DISPLAYS, LED MODULAR VIDEO PANELS, MONITORS, LED MONITORS, TELEVISIONS, LED TELEVISIONS, LED FOR TELEVISIONS, SCREENS, MONITORS AND COMPUTER MONITORS, VIDEO SYSTEMS, AND LED SIGNAGE FOR INDOOR AND OUTDOOR USES; INSTALLATION OF INDOOR AND OUTDOOR HOME THEATERS AND RELATED STRUCTURAL WIRING (U.S. CLS. 100, 103 AND 106).
JOHN WILKE, EXAMINING ATTORNEY

SN 77-513,528. LIGHTHOUSE TECHNOLOGIES LIMITED, SHATIN, HONG KONG, FILED 7-2-2008.



THE MARK CONSISTS OF THE LETTER "V" AS A BIRD-LIKE DESIGN WITH THE NAME "VELOS" BELOW. THE ENGLISH TRANSLATION OF "VELOS" IN THE MARK IS SPEED.

CLASS 9—ELECTRICAL AND SCIENTIFIC APPARATUS

FOR APPARATUS FOR RECORDATION, TRANSMISSION AND REPRODUCTION OF SOUND AND IMAGES; SCREENS, NAMELY, PROJECTION SCREENS, VIDEO SCREENS AND LIGHT EMITTING DIODE (LED) SCREENS; TELEVISION PROJECTION APPARATUS; LED DISPLAYS; LED MODULAR VIDEO PANELS; MONITORS, NAMELY, TELEVISION MONITORS, LED MONITORS, COMPUTER MONITORS AND LED COMPUTER MONITORS; TELEVISIONS; LED TELEVISIONS; LED FOR USE IN TELEVISIONS, SCREENS, MONITORS AND COMPUTER MONITORS; LED SIGNAGE; AND STRUCTURAL PARTS AND FITTINGS THEREFOR, ALL THESE GOODS FOR INDOOR AND OUTDOOR USES (U.S. CLS. 21, 23, 26, 36 AND 38).

SN 77-513,535. LIGHTHOUSE TECHNOLOGIES LIMITED, SHATIN, HONG KONG, FILED 7-2-2008.



OWNER OF U.S. REG. NO. 2,537,687.
THE MARK CONSISTS OF THE LETTER "V" AS A BIRD-LIKE DESIGN WITH THE NAME "VELOS LIGHTHOUSE" BELOW. THE ENGLISH TRANSLATION OF "VELOS" IN THE MARK IS SPEED.

CLASS 9—ELECTRICAL AND SCIENTIFIC APPARATUS

FOR APPARATUS FOR RECORDATION, TRANSMISSION AND REPRODUCTION OF SOUND AND IMAGES; SCREENS, NAMELY, PROJECTION SCREENS, VIDEO SCREENS AND LIGHT EMITTING DIODE (LED) SCREENS; TELEVISION PROJECTION APPARATUS; LED DISPLAYS; LED MODULAR VIDEO PANELS; MONITORS, NAMELY, TELEVISION MONITORS, LED MONITORS, COMPUTER MONITORS AND LED COMPUTER MONITORS; TELEVISIONS; LED TELEVISIONS; LED FOR USE IN TELEVISIONS, SCREENS, MONITORS AND COMPUTER MONITORS; LED SIGNAGE; AND STRUCTURAL PARTS AND FITTINGS THEREFOR, ALL THESE GOODS FOR INDOOR AND OUTDOOR USES (U.S. CLS. 21, 23, 26, 36 AND 38).

CLASS 11—ENVIRONMENTAL CONTROL APPARATUS

FOR INSTALLATIONS, APPARATUS AND INSTRUMENTS FOR LIGHTING, NAMELY, ARCHITECTURAL LIGHTING INSTALLATIONS AND LANDSCAPE LIGHTING INSTALLATIONS; ELECTRIC LIGHTING FIXTURES; LED LIGHTING FIXTURES FOR USE IN DISPLAY, COMMERCIAL, INDUSTRIAL, RESIDENTIAL, AND ARCHITECTURAL ACCENT LIGHTING APPLICATIONS; LED LIGHTING FIXTURES FOR INDOOR AND OUTDOOR LIGHTING APPLICATIONS; LAMPS AND LAMP FITTINGS; AND STRUCTURAL PARTS AND FITTINGS FOR ALL THE AFORESAID GOODS (U.S. CLS. 13, 21, 23, 31 AND 34).

CLASS 37—CONSTRUCTION AND REPAIR

FOR INSTALLATION, MAINTENANCE AND REPAIR OF APPARATUS FOR RECORDATION, TRANSMISSION AND REPRODUCTION OF SOUND AND IMAGES, HOME THEATER PRODUCTS, ENTERTAINMENT SYSTEMS, CONSUMER ELECTRONIC PRODUCTS, SCREENS, PROJECTION SCREENS, VIDEO SCREENS, LIGHT EMITTING DIODE (LED) SCREENS, PROJECTION APPARATUS, LED DISPLAYS, LED MODULAR VIDEO PANELS, MONITORS, LED MONITORS, TELEVISIONS, LED TELEVISIONS, LED FOR TELEVISIONS, SCREENS, MONITORS AND COMPUTER MONITORS, VIDEO SYSTEMS, AND LED SIGNAGE FOR INDOOR AND OUTDOOR USES; INSTALLATION OF INDOOR AND OUTDOOR HOME THEATERS AND RELATED STRUCTURAL WIRING (U.S. CLS. 100, 103 AND 106).
JOHN WILKE, EXAMINING ATTORNEY

SN 77-513,722. MODERN BREWERY AGE LLC, WESTON, CT. FILED 7-2-2008.

MODERN BREWERY AGE

THE MARK CONSISTS OF STANDARD CHARACTERS WITHOUT CLAIM TO ANY PARTICULAR FONT, STYLE, SIZE, OR COLOR.

NO CLAIM IS MADE TO THE EXCLUSIVE RIGHT TO USE "BREWERY", APART FROM THE MARK AS SHOWN.

CLASS 9—ELECTRICAL AND SCIENTIFIC APPARATUS

FOR ELECTRONIC DOWNLOADABLE NEWSLETTERS FEATURING INFORMATION ON THE BEER INDUSTRY AND ELECTRONIC TRADE DIRECTORIES FEATURING INFORMATION ABOUT THE BEER INDUSTRY RECORDED ON COMPUTER MEDIA (U.S. CLS. 21, 23, 26, 36 AND 38).

FIRST USE 3-30-1998; IN COMMERCE 3-30-1998.

CLASS 16—PAPER GOODS AND PRINTED MATTER

FOR PRINTED PUBLICATIONS, NAMELY, MAGAZINES AND TRADE DIRECTORIES BOTH FEATURING INFORMATION ABOUT THE BEER INDUSTRY (U.S. CLS. 2, 5, 22, 23, 29, 37, 38 AND 50).

FIRST USE 3-1-1940; IN COMMERCE 3-1-1940.
ALICE BENMAMAN, EXAMINING ATTORNEY

SN 77-513,983. MCGRATH RENTCORP, LIVERMORE, CA. FILED 7-2-2008.



THE MARK CONSISTS OF AN IMAGE IN THE SHAPE OF A PLUS SIGN TO THE RIGHT OF THE LETTERS "ACCU". BEHIND THE IMAGE IS A SHADOW ALSO IN THE SHAPE OF A PLUS SIGN. THE WORD "PLUS" IS SPELLED OUT IN THE IMAGE OF THE PLUS SIGN, WITH A DASH (-) BEFORE THE WORD "PLUS".

CLASS 35—ADVERTISING AND BUSINESS

FOR RETAIL STORE SERVICES IN THE FIELD OF USED ELECTRONIC TEST EQUIPMENT; COMPUTERIZED ON-LINE ORDERING SERVICES IN THE FIELD OF USED ELECTRONIC TEST EQUIPMENT; TELEPHONE ORDERING SERVICES IN THE FIELD OF USED ELECTRONIC TEST EQUIPMENT (U.S. CLS. 100, 101 AND 102).

CLASS 37—CONSTRUCTION AND REPAIR

FOR REFURBISHMENT OF USED ELECTRONIC TEST EQUIPMENT (U.S. CLS. 100, 103 AND 106).

CLASS 42—SCIENTIFIC AND COMPUTER SERVICES

FOR CERTIFICATION OF USED ELECTRONIC TEST EQUIPMENT, NAMELY, TESTING, ANALYSIS AND EVALUATION OF THE USED ELECTRONIC TEST EQUIPMENT OF OTHERS FOR THE PURPOSE OF CERTIFICATION (U.S. CLS. 100 AND 101).

YAT SYE, LEE, EXAMINING ATTORNEY

SN 77-514,222. REVANCE THERAPEUTICS, INC., MOUNTAIN VIEW, CA. FILED 7-3-2008.

TRANSMTS

THE MARK CONSISTS OF STANDARD CHARACTERS WITHOUT CLAIM TO ANY PARTICULAR FONT, STYLE, SIZE, OR COLOR.

CLASS 1—CHEMICALS

FOR PEPTIDE COMPOUNDS FOR USE IN THE MANUFACTURE OF PHARMACEUTICAL AND COSMETIC PREPARATIONS; CHEMICALS, NAMELY, PEPTIDE SUBSTRATES USED IN SCIENTIFIC AND MEDICINAL RESEARCH AS OR TO DELIVER TREATMENTS TOPICALLY THROUGH THE SKIN (U.S. CLS. 1, 5, 6, 10, 26 AND 46).

CLASS 3—COSMETICS AND CLEANING PREPARATIONS

FOR COSMETICS AND SKIN CREAMS COMPRISING PEPTIDE COMPOUNDS (U.S. CLS. 1, 4, 6, 50, 51 AND 52).

CLASS 5—PHARMACEUTICALS

FOR DRUG DELIVERY AGENTS CONSISTING OF COMPOUNDS THAT FACILITATE DELIVERY OF A WIDE RANGE OF PHARMACEUTICALS; PHARMACEUTICAL PREPARATIONS, NAMELY, PEPTIDE SUBSTRATES FOR USE IN THE TREATMENT OF NEUROLOGICAL DISORDERS, MUSCLE DYSTONIAS, SMOOTH MUSCLE DISORDERS, AUTONOMIC NERVE DISORDERS, HEADACHES, WRINKLES, HYPERHIDROSIS, SPORTS INJURIES, CEREBRAL PALSY, SPASMS, TREMORS AND PAIN (U.S. CLS. 6, 18, 44, 46, 51 AND 52).

SUNG IN, EXAMINING ATTORNEY

SN 77-514,514. LUCASFILM ENTERTAINMENT COMPANY LTD., SAN FRANCISCO, CA. FILED 7-3-2008.

THE OLD REPUBLIC

THE MARK CONSISTS OF STANDARD CHARACTERS WITHOUT CLAIM TO ANY PARTICULAR FONT, STYLE, SIZE, OR COLOR.

OWNER OF U.S. REG. NO. 2,823,910.

CLASS 9—ELECTRICAL AND SCIENTIFIC APPARATUS

FOR INTERACTIVE ENTERTAINMENT SOFTWARE AND ACCOMPANYING INSTRUCTION MANUALS SOLD AS A UNIT, NAMELY, COMPUTER GAME SOFTWARE AND MANUALS SOLD AS A UNIT; VIDEO GAME SOFTWARE AND MANUALS SOLD AS A UNIT; VIDEO GAME SOFTWARE, COMPUTER GAME SOFTWARE, AND PRE-RECORDED CD-ROMS AND DVDS FEATURING GAMES, FILMS, MUSIC, COMPUTER GAME SOFTWARE, AND VIDEO GAME SOFTWARE; DOWNLOADABLE VIDEO GAME SOFTWARE AND DOWNLOADABLE COMPUTER GAME SOFTWARE (U.S. CLS. 21, 23, 26, 36 AND 38).

CLASS 41—EDUCATION AND ENTERTAINMENT

FOR ENTERTAINMENT SERVICES PROVIDED ONLINE BY MEANS OF GLOBAL AND LOCAL AREA NETWORKS, NAMELY, PROVIDING INTERACTIVE COMPUTER GAMES AND INTERACTIVE VIDEO GAMES, ALL ON-LINE BY MEANS OF GLOBAL AND LOCAL AREA NETWORKS; PROVIDING NEWS AND INFORMATION IN THE FIELD OF ENTERTAINMENT RELATING TO INTERACTIVE COMPUTER GAME SOFTWARE AND INTERACTIVE VIDEO GAME SOFTWARE OVER AN ELECTRONIC NETWORK; ENTERTAINMENT IN THE NATURE OF ON-GOING TELEVISION PROGRAMS IN THE FIELD OF ENTERTAINMENT NEWS RELATING TO SCIENCE FICTION OVER AN ELECTRONIC NETWORK; FAN CLUB SERVICES (U.S. CLS. 100, 101 AND 107).

AISHA SALEM, EXAMINING ATTORNEY

SN 77-514,622. FIDUCIARY ASSET MANAGEMENT, LLC, ST. LOUIS, MO. FILED 7-3-2008.



OWNER OF U.S. REG. NOS. 2,544,450, 2,966,315 AND OTHERS.

THE COLOR(S) BLUE AND WHITE IS/ARE CLAIMED AS A FEATURE OF THE MARK.

THE MARK CONSISTS OF A DESIGN OF A WHITE TRIANGLE AND 3 WHITE LINES WITHIN A BLUE RECTANGLE, TWO OF THE WHITE LINES ARE DASHED AND ONE OF THE WHITE LINES IS SOLID. TO THE RIGHT OF THE DESIGN IS THE WORDING "FAMCO FIDUCIARY ASSET MANAGEMENT" IN BLUE, THE WORDING "FIDUCIARY ASSET MANAGEMENT" APPEARS BELOW A SOLID BLUE LINE AND ABOVE A SOLID BLUE LINE.

SEC. 2(F) AS TO "FIDUCIARY ASSET MANAGEMENT".

CLASS 35—ADVERTISING AND BUSINESS

FOR COST CONTROL, NAMELY, COST CONTAINMENT IN THE FIELD OF FUND INVESTMENT AND INVESTMENT PORTFOLIO CONSTRUCTION (U.S. CLS. 100, 101 AND 102).

CLASS 36—INSURANCE AND FINANCIAL

FOR FINANCIAL INVESTMENT SERVICES, NAMELY, FINANCIAL MANAGEMENT OF INVESTMENTS; FUND INVESTMENT CONSULTATION; INVESTMENT CONSULTATION; INVESTMENT ADVICE; FUNDS INVESTMENT; FINANCIAL ANALYSIS AND CONSULTATION; PROVIDING INFORMATION ON THE TOPICS OF FUND INVESTMENT CONSULTATION, INVESTMENT CONSULTATION, INVESTMENT ADVICE, FUNDS INVESTMENT, FINANCIAL ANALYSIS AND CONSULTATION VIA A GLOBAL COMPUTER NETWORK; INVESTMENT PORTFOLIO CONSTRUCTION; FINANCIAL RISK MANAGEMENT; FINANCIAL PORTFOLIO RISK MANAGEMENT; MUTUAL FUND INVESTMENT; AND PROVIDING INFORMATION IN THE FIELD OF MUTUAL FUNDS AND MUTUAL FUND INVESTMENT; MUTUAL FUND INVESTMENT CONSULTATION, ADVICE AND ANALYSIS; FINANCIAL RISK MANAGEMENT CONSULTATION; AND FINANCIAL ANALYSIS AND CONSULTATION, NAMELY, MACROECONOMIC ANALYSIS STRATEGY (U.S. CLS. 100, 101 AND 102).

KATHLEEN LORENZO, EXAMINING ATTORNEY

SN 77-514,870. ECD SYSTEMS, INC., MARSTON MILLS, MA. FILED 7-3-2008.



THE MARK CONSISTS OF THE FORMATIVE "FAIRSHARE" UNDER TWO HANDS FACING OPPOSITE DIRECTIONS.

CLASS 9—ELECTRICAL AND SCIENTIFIC APPARATUS

SN 77-515,668. CUP-A-CCINO, LLC, MATTHEWS, NC. FILED 7-7-2008.

FOR COMPUTER SOFTWARE TO ALLOW SOFTWARE DEVELOPERS, PUBLISHERS AND CONSUMERS TO REGULATE ACCESS TO AND SHARING OF COPIES OF PROTECTED AUDIO, AUDIO-VIDEO AND SOFTWARE CONTENT FOR EVALUATION PRIOR TO PURCHASE (U.S. CLS. 21, 23, 26, 36 AND 38).



CLASS 42—SCIENTIFIC AND COMPUTER SERVICES

FOR CONSULTING SERVICES IN THE FIELD OF DESIGN, IMPLEMENTATION AND USE OF COMPUTER SOFTWARE TO ALLOW SOFTWARE DEVELOPERS, PUBLISHERS AND CONSUMERS TO PROTECT AGAINST UNAUTHORIZED COPYING OR REDISTRIBUTION OF AUDIO-VIDEO AND SOFTWARE CONTENT FOR EVALUATION; CONSULTING SERVICES IN THE FIELD OF DESIGN, IMPLEMENTATION AND USE OF COMPUTER SOFTWARE TO ALLOW SOFTWARE DEVELOPERS, PUBLISHERS, AND CONSUMERS TO ALLOW REGULATED SHARING OF AUDIO, AUDIO-VIDEO, AND SOFTWARE CONTENT FOR EVALUATION PRIOR TO PURCHASE (U.S. CLS. 100 AND 101).

STEVEN JACKSON, EXAMINING ATTORNEY

NO CLAIM IS MADE TO THE EXCLUSIVE RIGHT TO USE "GOURMET GIVING", APART FROM THE MARK AS SHOWN.

THE MARK CONSISTS OF AN IMAGE OF A STEAMING HOT BEVERAGE ON TOP OF A SAUCER BELOW THE WORDS "CUP-A-CCINO" IN A DISTINCTIVE FONT, AND ABOVE THE WORDS "GOURMET GIVING" IN A DISTINCTIVE FONT.

SN 77-515,621. CUP-A-CCINO, LLC, MATTHEWS, NC. FILED 7-7-2008.

CUP-A-CCINO

THE MARK CONSISTS OF STANDARD CHARACTERS WITHOUT CLAIM TO ANY PARTICULAR FONT, STYLE, SIZE, OR COLOR.

CLASS 35—ADVERTISING AND BUSINESS

FOR PROVIDING AUTOMATED VENDING MACHINE SERVICES FOR THE DISPENSING OF COFFEE AND OTHER HOT BEVERAGES; VENDING MACHINE RENTAL AND STOCKING OF VENDING MACHINES RELATED TO THE ABOVE VENDING ITEMS (U.S. CLS. 100, 101 AND 102).

FIRST USE 7-7-2008; IN COMMERCE 7-7-2008.

CLASS 36—INSURANCE AND FINANCIAL

FOR CHARITABLE FUND RAISING SERVICES, NAMELY, FACILITATING CHARITABLE DONATIONS ON BEHALF OF THIRD PARTIES THROUGH DONATING A PORTION OF REVENUES COLLECTED FROM VENDING MACHINES LOCATED AT THE WORKPLACES OF SUCH THIRD PARTIES TO CHARITIES DESIGNATED BY SUCH THIRD PARTIES (U.S. CLS. 100, 101 AND 102).

FIRST USE 7-7-2008; IN COMMERCE 7-7-2008.

ALICE BENMAMAN, EXAMINING ATTORNEY

CLASS 35—ADVERTISING AND BUSINESS

SN 77-515,863. FLEETPRIDE, INC., THE WOODLANDS, TX. FILED 7-7-2008.

FOR PROVIDING AUTOMATED VENDING MACHINE SERVICES FOR THE DISPENSING OF COFFEE AND OTHER HOT BEVERAGES; VENDING MACHINE RENTAL AND STOCKING OF VENDING MACHINES RELATED TO THE ABOVE VENDING ITEMS (U.S. CLS. 100, 101 AND 102).

FIRST USE 7-7-2008; IN COMMERCE 7-7-2008.

CLASS 36—INSURANCE AND FINANCIAL

COUNT ON US

FOR CHARITABLE FUND RAISING SERVICES, NAMELY, FACILITATING CHARITABLE DONATIONS ON BEHALF OF THIRD PARTIES THROUGH DONATING A PORTION OF REVENUES COLLECTED FROM VENDING MACHINES LOCATED AT THE WORKPLACES OF SUCH THIRD PARTIES TO CHARITIES DESIGNATED BY SUCH THIRD PARTIES (U.S. CLS. 100, 101 AND 102).

FIRST USE 7-7-2008; IN COMMERCE 7-7-2008.

ALICE BENMAMAN, EXAMINING ATTORNEY

THE MARK CONSISTS OF STANDARD CHARACTERS WITHOUT CLAIM TO ANY PARTICULAR FONT, STYLE, SIZE, OR COLOR.

CLASS 35—ADVERTISING AND BUSINESS

FOR TRUCK AND TRAILER SERVICES FOR TRUCK AND TRAILER REPAIR BUSINESSES, NAMELY, ADVERTISING SERVICES IN THE NATURE OF PROMOTING THE GOODS AND SERVICES OF TRUCK AND TRAILER REPAIR BUSINESSES BY PROVIDING IN-STORE ADVERTISING MATERIALS, PROVIDING PRESS RELEASES, PROVIDING TRADE JOURNAL ADVERTISEMENTS, PARTICIPATING IN INDUSTRY TRADE SHOWS, PROVIDING MARKETING SERVICES IN THE NATURE OF DIRECT MARKETING ADVERTISING FOR OTHERS, AND PROVIDING REBATE PROGRAMS IN THE NATURE OF PROCESSING MANUFACTURER'S REBATES; TRUCK AND TRAILER SERVICES FOR TRUCK AND TRAILER REPAIR BUSINESSES, NAMELY, PROVIDING BUSINESS INFORMATION RELATING TO TRUCK AND TRAILER REPAIR SERVICE BUSINESSES (U.S. CLS. 100, 101 AND 102).

FIRST USE 11-0-2005; IN COMMERCE 11-0-2005.

CLASS 36—INSURANCE AND FINANCIAL

FOR TRUCK AND TRAILER SERVICES FOR TRUCK AND TRAILER REPAIR BUSINESSES, NAMELY, PROVIDING WARRANTIES ON PARTS PURCHASED FROM TRADEMARK OWNER AND INSTALLED AS PART OF TRUCK AND TRAILER REPAIRS (U.S. CLS. 100, 101 AND 102).

FIRST USE 11-0-2005; IN COMMERCE 11-0-2005.

CLASS 41—EDUCATION AND ENTERTAINMENT

FOR TRUCK AND TRAILER SERVICES FOR TRUCK AND TRAILER REPAIR BUSINESSES, NAMELY, TRAINING OTHERS HOW TO REPAIR TRUCKS (U.S. CLS. 100, 101 AND 107).

FIRST USE 11-0-2005; IN COMMERCE 11-0-2005.
MELISSA VALLILLO, EXAMINING ATTORNEY

SN 77-516,149. E.LAND WORLD LIMITED, SEOUL, REPUBLIC OF KOREA, FILED 7-7-2008.

EBLIN

THE MARK CONSISTS OF STANDARD CHARACTERS WITHOUT CLAIM TO ANY PARTICULAR FONT, STYLE, SIZE, OR COLOR.

CLASS 18—LEATHER GOODS

FOR ALL-PURPOSE CARRYING BAGS; ATHLETIC BAGS; BACKPACKS; HANDBAGS; KEY CASES; POUCHES OF LEATHER; PURSES; SHOULDER BAGS; SLING BAGS; SPORTS BAGS; TOTE BAGS; TRAVEL BAGS; AND WALLETS (U.S. CLS. 1, 2, 3, 22 AND 41).

CLASS 25—CLOTHING

FOR PANTS; SHIRTS; T-SHIRTS; SWEATERS; SWEATSHIRTS; JACKETS; COATS; VESTS; HEADWEAR; BELTS; FOOTWEAR; SOCKS; BABY TOPS; SHORTS; BOTTOMS; DRESSES; JEANS; LOUNGEWEAR; PAJAMAS; PULLOVERS; SKIRTS; SWIMWEAR; UNDERWEAR; AND SWEAT SUITS (U.S. CLS. 22 AND 39).

RON FAIRBANKS, EXAMINING ATTORNEY

SN 77-516,186. E.LAND WORLD LIMITED, SEOUL, REPUBLIC OF KOREA, FILED 7-7-2008.



THE NAME "LITTLE BRENN" DOES NOT IDENTIFY A LIVING INDIVIDUAL.

THE MARK CONSISTS OF THE LETTERERS "LB" INSIDE OF A SWIRL DESIGN AND THE WORDING "LITTLE BRENN".

CLASS 18—LEATHER GOODS

FOR ALL-PURPOSE CARRYING BAGS; ATHLETIC BAGS; BACKPACKS; HANDBAGS; KEY CASES; POUCHES OF LEATHER; PURSES; SHOULDER BAGS; SLING BAGS; SPORTS BAGS; TOTE BAGS; TRAVEL BAGS; AND WALLETS (U.S. CLS. 1, 2, 3, 22 AND 41).

CLASS 25—CLOTHING

FOR PANTS; SHIRTS; T-SHIRTS; SWEATERS; SWEATSHIRTS; JACKETS; COATS; VESTS; HEADWEAR; BELTS; FOOTWEAR; SOCKS; BABY TOPS; SHORTS; BOTTOMS; DRESSES; JEANS; LOUNGEWEAR; PAJAMAS; PULLOVERS; SKIRTS; SWIMWEAR; UNDERWEAR; AND SWEAT SUITS (U.S. CLS. 22 AND 39).

RON FAIRBANKS, EXAMINING ATTORNEY

SN 77-516,726. THE TRANZONIC COMPANIES, HIGHLAND HEIGHTS, OH. FILED 7-8-2008.



OWNER OF U.S. REG. NOS. 1,470,577 AND 2,809,689.

NO CLAIM IS MADE TO THE EXCLUSIVE RIGHT TO USE "HEALTHY", "SAFE", AND "CLEAN", APART FROM THE MARK AS SHOWN.

THE MARK CONSISTS OF THE WORDING "HOSPECO", "HEALTHY, SAFE" AND "CLEAN" AND A DESIGN FEATURE. THE DESIGN ELEMENT CONSISTS OF A CROSS INSIDE OF A CIRCLE. INSIDE THE CROSS THE TERM "HOSPECO" IS DEPICTED ALONG EACH LINE OF THE CROSS WITH THE TERMS INTERSECTING AT THE LETTER "P". THE WORDINGS "HEALTHY, SAFE" AND "CLEAN" ARE DEPICTED ON THE RIGHT OF THE DESIGN FEATURE AND EACH TERM IS SEPARATED BY A VERTICAL LINE.

CLASS 3—COSMETICS AND CLEANING PREPARATIONS

FOR SOAPS FOR HAND, FACE, AND BODY (U.S. CLS. 1, 4, 6, 50, 51 AND 52).

CLASS 5—PHARMACEUTICALS

FOR TAMPONS; SANITARY NAPKINS; ADULT INCONTINENCE UNDERGARMENTS; MATERNITY SANITARY PADS; FIRST AID KITS; WOUND DRESSINGS; CARPET AND ROOM DEODORIZERS; BIO-ENZYME AIR DEODORIZERS; AIR FRESHENERS; AND AROMATIC WICK AIR FRESHENERS; BREAST PADS (U.S. CLS. 6, 18, 44, 46, 51 AND 52).

CLASS 6—METAL GOODS

FOR FIXED DISPENSERS MADE OF METAL FOR TAMPONS, TOILET TISSUE, TOILET SEAT COVERS, PAPER TOWELS, FEMININE NAPKINS, CONDOMS, BABY DIAPERS, AND HAND SOAP (U.S. CLS. 2, 12, 13, 14, 23, 25 AND 50).

CLASS 9—ELECTRICAL AND SCIENTIFIC APPARATUS

FOR GLOVES FOR PROTECTION AGAINST ACCIDENTS; PROTECTIVE GLOVES FOR INDUSTRIAL USE; PROTECTIVE WORK GLOVES; BREATHING PROTECTION APPARATUS, NAMELY, RESPIRATORS AND RESPIRATOR CARTRIDGES, NOT FOR ARTIFICIAL RESPIRATION; EYE PROTECTION APPARATUS, NAMELY, SAFETY GLASSES AND SAFETY GOGGLES; HEARING PROTECTION APPARATUS, NAMELY, EAR-PLUGS FOR NON-MEDICAL PURPOSES AND SAFETY EAR COVERINGS, NAMELY, EARMUFFS; HEAD PROTECTION APPARATUS, NAMELY, HARD HATS; PROTECTIVE CLOTHING, NAMELY, SAFETY VESTS, DISPOSABLE COVERALLS, BOUFFANT CAPS, BOOT AND SHOE COVERS, DISPOSABLE SLEEVES, AND DISPOSABLE APPAREL (U.S. CLS. 21, 23, 26, 36 AND 38).

CLASS 10—MEDICAL APPARATUS

FOR CONDOMS (U.S. CLS. 26, 39 AND 44).

CLASS 11—ENVIRONMENTAL CONTROL APPARATUS

FOR URINAL SCREENS; AIR FRESHENER DISPENSERS; ELECTRIC HOT AIR HAND DRYERS (U.S. CLS. 13, 21, 23, 31 AND 34).

CLASS 16—PAPER GOODS AND PRINTED MATTER

FOR PAPER TOILET SEAT COVERS; DISPOSABLE DIAPERS; AND RECEPTACLE LINERS, NAMELY, TRASH CAN LINERS (U.S. CLS. 2, 5, 22, 23, 29, 37, 38 AND 50).

CLASS 20—FURNITURE AND ARTICLES NOT OTHERWISE CLASSIFIED

FOR NON-METAL FIXED DISPENSERS FOR TAMPONS, TOILET TISSUE, TOILET SEAT COVERS, PAPER TOWELS, FEMININE NAPKINS, CONDOMS, BABY DIAPERS, AND HAND SOAP (U.S. CLS. 2, 13, 22, 25, 32 AND 50).

SHARON MEIER, EXAMINING ATTORNEY

SN 77-517,264, PAGE, JEAN REYNOLDS, MERCER ISLAND, WA. FILED 7-9-2008.

BOUNDTRACK

THE MARK CONSISTS OF STANDARD CHARACTERS WITHOUT CLAIM TO ANY PARTICULAR FONT, STYLE, SIZE, OR COLOR.

CLASS 9—ELECTRICAL AND SCIENTIFIC APPARATUS

FOR PRERECORDED MUSIC, NAMELY, DOWNLOADABLE AUDIO FILES FEATURING MUSIC AND COMPACT DISCS FEATURING MUSIC (U.S. CLS. 21, 23, 26, 36 AND 38).

CLASS 16—PAPER GOODS AND PRINTED MATTER

FOR PRINTED MATTER, NAMELY, NOVELS AND SERIES OF FICTION BOOKS AND SHORT STORIES FEATURING MUSIC THAT INSPIRED, REPRESENT, OR CONNECT TO THE CHARACTERS IN THE NOVELS AND SERIES OF FICTION BOOKS AND SHORT STORIES (U.S. CLS. 2, 5, 22, 23, 29, 37, 38 AND 50).

CLASS 41—EDUCATION AND ENTERTAINMENT

FOR ENTERTAINMENT SERVICES, NAMELY, PROVIDING A WEB SITE FEATURING MUSIC THAT INSPIRED, REPRESENT, OR CONNECT TO THE CHARACTERS IN NOVELS AND A SERIES OF FICTION BOOKS AND SHORT STORIES; PROVIDING PRERECORDED MUSIC AND INFORMATION, COMMENTARY, AND ARTICLES ABOUT THE PRERECORDED MUSIC VIA A GLOBAL COMPUTER NETWORK (U.S. CLS. 100, 101 AND 107).

CLASS 42—SCIENTIFIC AND COMPUTER SERVICES

FOR COMPUTER SERVICES, NAMELY, PROVIDING ON-LINE FACILITIES, VIA A GLOBAL COMPUTER NETWORK, TO ENABLE USERS TO ACQUIRE DOWNLOADABLE AUDIO FILES FEATURING MUSIC (U.S. CLS. 100 AND 101).

MARK PILARO, EXAMINING ATTORNEY

SN 77-518,225, WORDLOCK, INC., SANTA CLARA, CA. FILED 7-9-2008.

USE WORDS NOT NUMBERS

THE MARK CONSISTS OF STANDARD CHARACTERS WITHOUT CLAIM TO ANY PARTICULAR FONT, STYLE, SIZE, OR COLOR.

CLASS 6—METAL GOODS

FOR METAL COMBINATION LOCKS; METAL PAD-LOCKS; METAL BICYCLE LOCKS; METAL LUGGAGE LOCKS; METAL LOCKS FOR LOCKERS; METAL BACKPACK LOCKS; METAL COMPUTER AND LAPTOP LOCKS; METAL SKI AND SNOWBOARD LOCKS; METAL CASH BOXES; METAL LOCK BOXES (U.S. CLS. 2, 12, 13, 14, 23, 25 AND 50).

FIRST USE 7-9-2008; IN COMMERCE 7-9-2008.

CLASS 12—VEHICLES

FOR LOCKS FOR AUTOMOTIVE USE, NAMELY, ANTI-THEFT LOCKS FOR USE ON AUTOMOBILE STEERING WHEELS (U.S. CLS. 19, 21, 23, 31, 35 AND 44).

CLASS 18—LEATHER GOODS

FOR SUITCASES; LUGGAGE; BRIEFCASES (U.S. CLS. 1, 2, 3, 22 AND 41).

CLASS 20—FURNITURE AND ARTICLES NOT OTHERWISE CLASSIFIED

FOR NON-METAL CASH BOXES; NON-METAL LOCK BOXES (U.S. CLS. 2, 13, 22, 25, 32 AND 50).
BRENDAN REGAN, EXAMINING ATTORNEY

SN 77-519,146. HERBALSCIENCE GROUP, LLC, NAPLES, FL. FILED 7-10-2008.

MOVEMENTHEALTH

THE MARK CONSISTS OF STANDARD CHARACTERS WITHOUT CLAIM TO ANY PARTICULAR FONT, STYLE, SIZE, OR COLOR.

SN 77-518,377. EICKMAN, PAULETTE, SEATTLE, WA. FILED 7-9-2008.



THE MARK CONSISTS OF THE WORD "TWIGS" IN A STYLIZED FONT, WITH A CAPITAL LETTER "T" AND THE LETTER "I" BEING REPRESENTED BY AN IMAGE OF A SIMPLE CURVED TREE TRUNK WITH TWO SMALL BARE BRANCHES.

CLASS 21—HOUSEWARES AND GLASS

FOR MOLDS FOR CHOCOLATES (U.S. CLS. 2, 13, 23, 29, 30, 33, 40 AND 50).

CLASS 29—MEATS AND PROCESSED FOODS

FOR FRUIT-BASED ORGANIC FOOD BARS; DRIED FRUITS; PROCESSED NUTS; PROCESSED EDIBLE SEEDS; SOY-BASED FOOD BARS ALSO CONTAINING GRAIN (U.S. CL. 46).

CLASS 30—STAPLE FOODS

FOR PROCESSED GRAINS; CHOCOLATE; CHOCOLATE BARS; CHOCOLATE CANDIES; CHOCOLATE COVERED NUTS; CHOCOLATE COVERED RAISINS; CHOCOLATE TRUFFLES; CHOCOLATE AND CHOCOLATE-BASED READY-TO-EAT CANDIES AND SNACKS; CHOCOLATE-BASED READY-TO-EAT FOOD BARS; FILLED CHOCOLATE; GRAIN-BASED FOOD BARS ALSO CONTAINING SOY; CHOCOLATE COVERED FRUIT STICKS; CHOCOLATE COVERED COOKIES; CRACKERS AND BISCUITS; MOLDED CHOCOLATES WITH AND WITHOUT FRUIT AND NUT FILLINGS; BISCUITS; BISCUITS AND BREAD; BUTTER BISCUITS; SAVORY AND SALTED BISCUITS; CANDY; CANDIES; CANDY BARS; CANDY CONTAINING ALCOHOLIC BEVERAGE CONTENT AND FLAVOR; CANDY MINTS; CANDY WITH CARAMEL; CANDY WITH COCOA; GIFT BASKETS CONTAINING CANDY (U.S. CL. 46).

CLASS 31—NATURAL AGRICULTURAL PRODUCTS

FOR RAW NUTS (U.S. CLS. 1 AND 46).
ZHALEH DELANEY, EXAMINING ATTORNEY

CLASS 1—CHEMICALS

FOR BOTANICAL EXTRACTS FOR USE IN THE MANUFACTURE OF NUTRACEUTICALS; EXTRACTS FOR USE IN THE MANUFACTURE OF PHARMACEUTICAL PREPARATIONS IN THE FORM OF PREPARATIONS IN THE FORM OF LOTIONS, CREAMS, AND TOPICAL ANALGESICS AND ANESTHETICS, TABLETS, CAPSULES, PILLS, TINCTURE, SUPPOSITORIES AND AMPULE FOR INJECTION; BOTANICAL EXTRACTS FOR USE IN THE MANUFACTURE OF PHARMACEUTICALS; CHEMICAL EXTRACTS EXTRACTED FROM MEDICINAL PLANTS FOR USE IN THE MANUFACTURE OF NUTRACEUTICALS AND PHARMACEUTICALS; CHEMICAL EXTRACTS EXTRACTED FROM MEDICINAL PLANTS FOR USE IN THE PHARMACEUTICAL INDUSTRY, NAMELY, CHEMICAL AGENTS MADE FROM BOTANICAL EXTRACTS OR ASSOCIATION OF CHEMICAL EXTRACTS FOR USE IN THE MANUFACTURE OF PHARMACEUTICAL OR NUTRACEUTICAL PRODUCTS; BOTANICAL EXTRACTS USED IN THE MANUFACTURE OF PREPARATIONS IN THE FORM OF LOTIONS, CREAMS, AND TOPICAL ANALGESICS AND ANESTHETICS, TABLETS, CAPSULES, PILLS, LOZENGES, INHALERS, TINCTURE, SUPPOSITORIES AND AMPULE FOR INJECTION; BOTANICALS AND BOTANICAL BLENDS, HERBS AND HERBAL BLENDS, BOTANICAL EXTRACTS AND BOTANICAL EXTRACT BLENDS, FLAVOR EXTRACTS AND FLAVOR EXTRACT BLENDS, ALGAL EXTRACTS AND ALGAL EXTRACT BLENDS, ALL FOR USE IN THE MANUFACTURE OF NUTRITIONAL SUPPLEMENTS AND VITAMINS; HERBAL EXTRACTS AND BLENDS FOR USE IN MANUFACTURING FUNCTIONAL FOODS OR BEVERAGES; HERBAL EXTRACTS AND BLENDS FOR USE IN MANUFACTURING MEDICINAL FOODS OR BEVERAGES; BOTANICAL EXTRACTS AND BLENDS FOR USE IN MANUFACTURING FUNCTIONAL FOODS OR BEVERAGES; BOTANICAL EXTRACTS AND BLENDS FOR USE IN MANUFACTURING MEDICINAL FOODS OR BEVERAGES; HERBAL PREPARATIONS AND EXTRACTS FOR USE AS INGREDIENTS IN MANUFACTURING IN THE FOOD, NUTRITION, NUTRACEUTICAL AND/OR PHARMACEUTICAL INDUSTRIES (U.S. CLS. 1, 5, 6, 10, 26 AND 46).

CLASS 5—PHARMACEUTICALS

FOR NUTRITIONAL SUPPLEMENTS; HERBAL PRODUCTS, NAMELY, MEDICATED SKIN AND LIP BALMS; HERBAL PRODUCTS, NAMELY, OINTMENTS, OILS, DRINKS, INFUSIONS, SYRUPS, HERBAL EXTRACTS, POISONS, AND TINCTURES FOR MEDICAL USE IN THE TREATMENT OF STROKES, INFARCTS AND OTHER CARDIOVASCULAR AND CEREBRUM DISEASES; HERBAL PRODUCTS, NAMELY, OINTMENTS, OILS, NAMELY, MINERAL OIL FOR USE AS A LAXATIVE; DRINKS, NAMELY, MEAL REPLACEMENT DRINKS, DIETARY SUPPLEMENT DRINKS, MEDICINAL DRINKS, AND FISH OIL FOR USE AS A DIETARY SUPPLEMENT OR NUTRACEUTICAL; INFUSIONS AND SYRUPS, NAMELY, COUGH SYRUPS; HERBAL PRODUCTS FOR MEDICINAL PURPOSES, NAMELY, HERBAL EXTRACTS FOR USE AS NUTRITIONAL AND DIETARY SUPPLEMENTS; HERBAL PRODUCTS FOR MEDICINAL PURPOSES, NAMELY, HERBAL EXTRACTS AND SYRUPS; MEDICINAL HERB EXTRACTS; MEDICINAL HERB EXTRACTS FOR MEDICAL PURPOSES; PLANT EXTRACTS FOR MEDICAL, PHARMACEUTICAL, NUTRACEUTICAL AND NUTRI-

TIONAL PURPOSES; MEDICINAL EXTRACTS IN THE FORM OF LOTIONS, CREAMS, TOPICAL ANALGESICS AND ANESTHETICS, TABLETS, CAPSULES, PILLS, TINCTURE, SUPPOSITORIES AND AMPULE FOR INJECTION, MEDICINAL HERBAL EXTRACTS IN THE FORM OF LOTIONS, CREAMS, TOPICAL ANALGESICS AND ANESTHETICS, TABLETS, CAPSULES, PILLS, TINCTURE, SUPPOSITORIES AND AMPULE FOR INJECTION, AND MEDICINAL BOTANICAL EXTRACTS IN THE FORM OF LOTIONS, CREAMS, TOPICAL ANALGESICS AND ANESTHETICS, TABLETS, CAPSULES, PILLS, TINCTURE, SUPPOSITORIES AND AMPULE FOR INJECTION USED TO TREAT SKIN AILMENTS, FOR INFECTION, DEGENERATIVE, MUSCULAR, PULMONARY, SKELETAL, ENDOCRINE, IMMUNE, NEUROLOGICAL, CARDIOVASCULAR, METABOLIC, INFLAMMATORY, CANCER AND RELATED CONDITIONS; YEAST EXTRACTS FOR MEDICAL, PHARMACEUTICAL OR NUTRACEUTICAL PURPOSES; HERBAL PRODUCTS, NAMELY, HERBAL POWDERS FOR NUTRITIONAL PURPOSES; HERBAL PRODUCTS, NAMELY, HERBAL MEAL REPLACEMENT POWDERS FOR DIETARY AND NUTRITIONAL PURPOSES; HERBAL PRODUCTS, NAMELY, AROMATHERAPY PACKS CONTAINING HERBS USED FOR RELIEF FROM HEADACHES, INSOMNIA AND SINUS DISCOMFORT; HERBAL PRODUCTS, NAMELY, HERBAL POWDERS SOLD AS AN INTEGRAL INGREDIENT OF NUTRITIONAL SUPPLEMENT DRINK MIX FOR NUTRITIONAL PURPOSES; PHARMACEUTICALS AND NUTRACEUTICALS, NAMELY, VITAMINS AND FOOD SUPPLEMENTS; PHARMACEUTICAL PREPARATIONS, NAMELY, APPETITE SUPPRESSANTS AND LIPID LOWERING AGENTS; FOOD FOR DIABETICS, INFANTS AND ENTERAL FEEDING; BOTANICAL EXTRACTS FOR NUTRITIONAL USE; BOTANICAL EXTRACTS FOR MEDICAL, VETERINARY, NUTRACEUTICAL AND PHARMACEUTICAL PURPOSES; DESIGNER EXTRACTS, NAMELY, HERBAL EXTRACTS FOR MEDICAL, VETERINARY AND PHARMACEUTICAL PURPOSES; BOTANICAL EXTRACTS FOR NUTRITIONAL SUPPLEMENTS, NUTRACEUTICALS AND PHARMACEUTICALS; NUTRITIONAL DIETARY SUPPLEMENTS; ORAL PREPARATIONS CONTAINING HERBS OR HERBAL EXTRACTS USED TO MAINTAIN HEALTH AND FOR A WIDE VARIETY OF PHYSICAL CONDITIONS; VITAMIN AND MINERAL PREPARATIONS INTENDED FOR USE AS DIETARY SUPPLEMENTS; VITAMINS; NUTRACEUTICALS, NAMELY, VITAMINS AND FOOD SUPPLEMENTS; FOOD FOR MEDICALLY RESTRICTED DIETS; SUPPLEMENTS, NAMELY, LIPID CONCENTRATES FOR USE AS A DIETARY FOOD SUPPLEMENT OR FOR PHARMACEUTICAL OR MEDICINAL PURPOSES; FOOD SUPPLEMENTS, NAMELY, ANTI-OXIDANTS; BOTANICALS AND BOTANICAL BLENDS, HERBALS AND HERBAL BLENDS, BOTANICAL EXTRACTS AND BOTANICAL EXTRACT BLENDS, FLAVOR EXTRACTS AND FLAVOR EXTRACT BLENDS, ALL SOLD AS NUTRITIONAL SUPPLEMENTS AND VITAMINS; NUTRITIONAL OILS NOT FOR COSMETIC PURPOSES; FOOD SUPPLEMENTS, NAMELY, LIPID CONCENTRATES FOR USE AS A DIETARY FOOD SUPPLEMENT OR FOR PHARMACEUTICAL OR MEDICINAL PURPOSES; ANTI-COUGH DROPS; COUGH DROPS; COUGH EXPECTORANTS; THROAT LOZENGES; COUGH LOZENGES; COUGH TREATMENT PREPARATIONS; COLD SORE TREATMENT PREPARATIONS; PHARMACEUTICAL ANTITUSSIVE-COLD PREPARATIONS; PREPARATIONS FOR TREATING COLDS; ANALGESIC PREPARATIONS; ANALGESICS; ANTIPIRETIC ANALGESICS; IBUPROFEN FOR USE AS AN ORAL ANALGESIC; MULTIPURPOSE MEDICATED ANTIBIOTIC CREAM, ANALGESIC BALM AND MENTHOLATED SALVE; ORAL ANALGESICS; TOPICAL ANALGESICS; PHARMACEUTICAL PREPARATIONS FOR THE TREATMENT AND PREVENTION OF HERPES; VACCINES FOR THE TREATMENT AND PREVENTION OF HERPES; BIOLOGICAL PREPARATIONS FOR THE TREATMENT AND PREVENTION OF HERPES; PHARMACEUTICAL PREPARATIONS FOR THE TREATMENT OF HERPES SIMPLEX INFECTION; PHARMACEUTICAL CAPSULES FOR THE TREATMENT OF HERPES SIMPLEX INFECTION; HOMEOPATHIC PREPARATIONS FOR THE TREATMENT OF HERPES AND COLD SORES; PHARMACEUTICAL PREPARATIONS FOR THE TREATMENT OF HERPES VIRUSES; MEDICATED TOPICAL CLEAR FLUORIDE GEL FOR THE TREATMENT OF HERPES VIRUS DURING THE PHYSICAL MANI-

FESTATION OF THE VIRUS; PHARMACEUTICAL PREPARATIONS FOR THE TREATMENT OF HERPES SIMPLEX VIRUS TYPE I OR TYPE II OR HERPES ZOSTER VIRUS, NOT IN INTRAVENOUS FORM; PLANT-BASED ANTIVIRALS; OVER-THE-COUNTER TOPICAL ANTIVIRALS; PHARMACEUTICAL PREPARATION WITH ANTIVIRAL AND/OR ANTIMICROBIAL PROPERTIES FOR USE IN THE TREATMENT OF HERPETIC KERATITIS, CONJUNCTIVITIS, HIV RETINOPATHY, VIRAL INFLUENZA "FLU", HERPES SIMPLEX VIRUS 1, HERPES SIMPLEX VIRUS 2, VARICELLA ZOSTER VIRUS "HERPES ZOSTER" OR "SHINGLES", CYTOMEGALOVIRUS, VIRAL PARAINFLUENZA, ADENOVIRUS, VIRAL ENCEPHALITIS, VIRAL MENINGITIS, ARBOVIRUS, ARENAVIRUS, PICORNAVIRUS, CORONAVIRUS, SYNTIALVIRUS, VIRAL INFECTIONS, COMMON COLDS CAUSED BY VIRUSES, COLD SORES, HUMAN IMMUNODEFICIENCY VIRUS "HIV", ROSEOLA INFANTUM, HUMAN HERPES IV; PHARMACEUTICAL PREPARATIONS FOR THE TREATMENT OF VIRAL DISEASES AND DISORDERS, NAMELY, HERPES; PHARMACEUTICAL PREPARATIONS FOR TREATING IMMUNE DISEASES INDUCED BY VIRUS, NAMELY, HERPES, HERPES ZOSTER AND AIDS; ALGAL PRODUCTS FOR MEDICINAL PURPOSES, NAMELY, ALGAL EXTRACTS OR ALGAL EXTRACT BLENDS FOR USE AS NUTRITIONAL AND DIETARY SUPPLEMENTS; ALGAL PRODUCTS, NAMELY, ALGAL POWDERS SOLD AS AN INTEGRAL INGREDIENT OF NUTRITIONAL SUPPLEMENT DRINK MIX FOR NUTRITIONAL PURPOSES; ALGAL PRODUCTS, NAMELY, ALGAL POWDERS FOR NUTRITIONAL PURPOSES; ALGAL EXTRACTS OR ALGAL EXTRACT BLENDS FOR MEDICAL OR PHARMACEUTICAL PURPOSES; FUNCTIONAL FOODS, NAMELY, DIETETIC FOODS ADAPTED FOR MEDICAL PURPOSES; FUNCTIONAL BEVERAGES, NAMELY, NUTRITIONALLY FORTIFIED BEVERAGES; MEDICINAL FOODS, NAMELY, PROCESSED FOOD FOR MEDICAL PURPOSES; ANIMAL HEALTH PRODUCTS, NAMELY, ANIMAL FEED SUPPLEMENTS, MEDICATED ANIMAL FEED, MICRO-NUTRIENT ANIMAL FEED, DIETARY SUPPLEMENTS FOR ANIMALS, NON-MEDICATED ADDITIVES FOR ANIMAL FEED FOR USE AS NUTRITIONAL SUPPLEMENTS, NUTRITIONAL DRINKS FOR ANIMALS, PHARMACEUTICAL PREPARATIONS FOR ANIMAL SKINCARE; PLANT EXTRACTS FOR MEDICAL, VETERINARY AND PHARMACEUTICAL PURPOSES; HERBAL EXTRACTS FOR MEDICAL, VETERINARY AND PHARMACEUTICAL PURPOSES; DESIGNER EXTRACTS, NAMELY, PLANT, HERBAL AND BOTANICAL EXTRACTS FOR MEDICAL, VETERINARY AND PHARMACEUTICAL PURPOSES; AND BIODEFENSE PRODUCTS, NAMELY, MEDICINAL PREPARATIONS FOR THE TREATMENT OF INFECTIOUS DISEASES AND ADVERSE HUMAN HEALTH CONDITIONS, NAMELY, INFECTION, DEGENERATIVE, MUSCULAR, PULMONARY, SKELETAL, ENDOCRINE, IMMUNE, NEUROLOGICAL, CARDIOVASCULAR, METABOLIC, INFLAMMATORY, CANCER AND RELATED CONDITIONS; MUSHROOM, FUNGUS, OR SPORE EXTRACTS OR BLENDS AS SUPPLEMENTS, NUTRITION, NUTRACEUTICALS AND/OR PHARMACEUTICALS; BOTANICAL EXTRACTS FOR NUTRITIONAL USE; NUTRITIONALLY FORTIFIED BEVERAGES; NUTRITIONALLY FORTIFIED BEVERAGES FOR IMMUNE ENHANCEMENT, AND NUTRITIONALLY FORTIFIED BEVERAGES WITH RICE BRAN AND WHEAT BRAN; MEDICINAL BEVERAGES; SOY PROTEIN FOR USE AS A NUTRITIONAL SUPPLEMENT; ACTIVE PRINCIPLES EXTRACTED FROM MEDICINAL PLANTS FOR USE IN THE MANUFACTURE OF NUTRACEUTICALS AND PHARMACEUTICALS; ACTIVE PRINCIPLES EXTRACTED FROM MEDICINAL PLANTS FOR USE IN THE MANUFACTURE OF PHARMACEUTICAL OR NUTRACEUTICAL PRODUCTS; NUTRITIONAL ADDITIVES FOR MEDICAL OR NONMEDICAL PURPOSES FOR USE IN MANUFACTURING FOODS AND DIETARY SUPPLEMENTS FOR HUMAN CONSUMPTION (U.S. CLS. 6, 18, 44, 46, 51 AND 52).

HEATHER THOMPSON, EXAMINING ATTORNEY

SN 77-519,154. HERBALSCIENCE GROUP, LLC, NAPLES, FL. FILED 7-10-2008.

MOVEMENTPOWER

THE MARK CONSISTS OF STANDARD CHARACTERS WITHOUT CLAIM TO ANY PARTICULAR FONT, STYLE, SIZE, OR COLOR.

CLASS 1—CHEMICALS

FOR BOTANICAL EXTRACTS FOR USE IN THE MANUFACTURE OF NUTRACEUTICALS; EXTRACTS FOR USE IN THE MANUFACTURE OF PHARMACEUTICAL PREPARATIONS IN THE FORM OF PREPARATIONS IN THE FORM OF LOTIONS, CREAMS, AND TOPICAL ANALGESICS AND ANESTHETICS, TABLETS, CAPSULES, PILLS, TINCTURE, SUPPOSITORIES AND AMPULE FOR INJECTION; BOTANICAL EXTRACTS FOR USE IN THE MANUFACTURE OF PHARMACEUTICALS; CHEMICAL EXTRACTS EXTRACTED FROM MEDICINAL PLANTS FOR USE IN THE MANUFACTURE OF NUTRACEUTICALS AND PHARMACEUTICALS; CHEMICAL EXTRACTS EXTRACTED FROM MEDICINAL PLANTS FOR USE IN THE PHARMACEUTICAL INDUSTRY, NAMELY, CHEMICAL AGENTS MADE FROM BOTANICAL EXTRACTS OR ASSOCIATION OF CHEMICAL EXTRACTS FOR USE IN THE MANUFACTURE OF PHARMACEUTICAL OR NUTRACEUTICAL PRODUCTS; BOTANICAL EXTRACTS USED IN THE MANUFACTURE OF PREPARATIONS IN THE FORM OF LOTIONS, CREAMS, AND TOPICAL ANALGESICS AND ANESTHETICS, TABLETS, CAPSULES, PILLS, LOZENGES, INHALERS, TINCTURE, SUPPOSITORIES AND AMPULE FOR INJECTION; BOTANICALS AND BOTANICAL BLENDS, HERBS AND HERBAL BLENDS, BOTANICAL EXTRACTS AND BOTANICAL EXTRACT BLENDS, FLAVOR EXTRACTS AND FLAVOR EXTRACT BLENDS, ALGAL EXTRACTS AND ALGAL EXTRACT BLENDS, ALL FOR USE IN THE MANUFACTURE OF NUTRITIONAL SUPPLEMENTS AND VITAMINS; HERBAL EXTRACTS AND BLENDS FOR USE IN MANUFACTURING FUNCTIONAL FOODS OR BEVERAGES; HERBAL EXTRACTS AND BLENDS FOR USE IN MANUFACTURING MEDICINAL FOODS OR BEVERAGES; BOTANICAL EXTRACTS AND BLENDS FOR USE IN MANUFACTURING FUNCTIONAL FOODS OR BEVERAGES; BOTANICAL EXTRACTS AND BLENDS FOR USE IN MANUFACTURING MEDICINAL FOODS OR BEVERAGES; HERBAL PREPARATIONS AND EXTRACTS FOR USE AS INGREDIENTS IN MANUFACTURING IN THE FOOD, NUTRITION, NUTRACEUTICAL AND/OR PHARMACEUTICAL INDUSTRIES (U.S. CLS. 1, 5, 6, 10, 26 AND 46).

CLASS 5—PHARMACEUTICALS

FOR NUTRITIONAL SUPPLEMENTS; HERBAL PRODUCTS, NAMELY, MEDICATED SKIN AND LIP BALMS; HERBAL PRODUCTS, NAMELY, OINTMENTS, OILS, DRINKS, INFUSIONS, SYRUPS, HERBAL EXTRACTS, POISONS, AND TINCTURES FOR MEDICAL USE IN THE TREATMENT OF STROKES, INFARCTS AND OTHER CARDIOVASCULAR AND CEREBRUM DISEASES; HERBAL PRODUCTS, NAMELY, OINTMENTS, OILS, NAMELY, MINERAL OIL FOR USE AS A LAXATIVE; DRINKS, NAMELY, MEAL REPLACEMENT DRINKS, DIETARY SUPPLEMENT DRINKS, MEDICINAL DRINKS, AND FISH OIL FOR USE AS A DIETARY SUPPLEMENT OR NUTRACEUTICAL; INFUSIONS AND SYRUPS, NAMELY, COUGH SYRUPS; HERBAL PRODUCTS FOR MEDICINAL PURPOSES, NAMELY, HERBAL EXTRACTS FOR USE AS NUTRITIONAL AND DIETARY SUPPLEMENTS; HERBAL PRODUCTS FOR MEDICINAL PURPOSES, NAMELY, HERBAL EXTRACTS AND SYRUPS; MEDICINAL HERB EXTRACTS; MEDICINAL HERB EXTRACTS FOR MEDICAL PURPOSES; PLANT EXTRACTS FOR MEDICAL, PHARMACEUTICAL, NUTRACEUTICAL AND NUTRI-

TIONAL PURPOSES; MEDICINAL EXTRACTS IN THE FORM OF LOTIONS, CREAMS, TOPICAL ANALGESICS AND ANESTHETICS, TABLETS, CAPSULES, PILLS, TINCTURE, SUPPOSITORIES AND AMPULE FOR INJECTION, MEDICINAL HERBAL EXTRACTS IN THE FORM OF LOTIONS, CREAMS, TOPICAL ANALGESICS AND ANESTHETICS, TABLETS, CAPSULES, PILLS, TINCTURE, SUPPOSITORIES AND AMPULE FOR INJECTION, AND MEDICINAL BOTANICAL EXTRACTS IN THE FORM OF LOTIONS, CREAMS, TOPICAL ANALGESICS AND ANESTHETICS, TABLETS, CAPSULES, PILLS, TINCTURE, SUPPOSITORIES AND AMPULE FOR INJECTION USED TO TREAT SKIN AILMENTS, FOR INFECTION, DEGENERATIVE, MUSCULAR, PULMONARY, SKELETAL, ENDOCRINE, IMMUNE, NEUROLOGICAL, CARDIOVASCULAR, METABOLIC, INFLAMMATORY, CANCER AND RELATED CONDITIONS; YEAST EXTRACTS FOR MEDICAL, PHARMACEUTICAL OR NUTRACEUTICAL PURPOSES; HERBAL PRODUCTS, NAMELY, HERBAL POWDERS FOR NUTRITIONAL PURPOSES; HERBAL PRODUCTS, NAMELY, HERBAL MEAL REPLACEMENT POWDERS FOR DIETARY AND NUTRITIONAL PURPOSES; HERBAL PRODUCTS, NAMELY, AROMATHERAPY PACKS CONTAINING HERBS USED FOR RELIEF FROM HEADACHES, INSOMNIA AND SINUS DISCOMFORT; HERBAL PRODUCTS, NAMELY, HERBAL POWDERS SOLD AS AN INTEGRAL INGREDIENT OF NUTRITIONAL SUPPLEMENT DRINK MIX FOR NUTRITIONAL PURPOSES; PHARMACEUTICALS AND NUTRACEUTICALS, NAMELY, VITAMINS AND FOOD SUPPLEMENTS; PHARMACEUTICAL PREPARATIONS, NAMELY, APPETITE SUPPRESSANTS AND LIPID LOWERING AGENTS; FOOD FOR DIABETICS, INFANTS AND ENTERAL FEEDING; BOTANICAL EXTRACTS FOR NUTRITIONAL USE; BOTANICAL EXTRACTS FOR MEDICAL, VETERINARY, NUTRACEUTICAL AND PHARMACEUTICAL PURPOSES; DESIGNER EXTRACTS, NAMELY, HERBAL EXTRACTS FOR MEDICAL, VETERINARY AND PHARMACEUTICAL PURPOSES; BOTANICAL EXTRACTS FOR NUTRITIONAL SUPPLEMENTS, NUTRACEUTICALS AND PHARMACEUTICALS; NUTRITIONAL DIETARY SUPPLEMENTS; ORAL PREPARATIONS CONTAINING HERBS OR HERBAL EXTRACTS USED TO MAINTAIN HEALTH AND FOR A WIDE VARIETY OF PHYSICAL CONDITIONS; VITAMIN AND MINERAL PREPARATIONS INTENDED FOR USE AS DIETARY SUPPLEMENTS; VITAMINS; NUTRACEUTICALS, NAMELY, VITAMINS AND FOOD SUPPLEMENTS; FOOD FOR MEDICALLY RESTRICTED DIETS; SUPPLEMENTS, NAMELY, LIPID CONCENTRATES FOR USE AS A DIETARY FOOD SUPPLEMENT OR FOR PHARMACEUTICAL OR MEDICINAL PURPOSES; FOOD SUPPLEMENTS, NAMELY, ANTI-OXIDANTS; BOTANICALS AND BOTANICAL BLENDS, HERBALS AND HERBAL BLENDS, BOTANICAL EXTRACTS AND BOTANICAL EXTRACT BLENDS, FLAVOR EXTRACTS AND FLAVOR EXTRACT BLENDS, ALL SOLD AS NUTRITIONAL SUPPLEMENTS AND VITAMINS; NUTRITIONAL OILS NOT FOR COSMETIC PURPOSES; FOOD SUPPLEMENTS, NAMELY, LIPID CONCENTRATES FOR USE AS A DIETARY FOOD SUPPLEMENT OR FOR PHARMACEUTICAL OR MEDICINAL PURPOSES; ANTI-COUGH DROPS; COUGH DROPS; COUGH EXPECTORANTS; THROAT LOZENGES; COUGH LOZENGES; COUGH TREATMENT PREPARATIONS; COLD SORE TREATMENT PREPARATIONS; PHARMACEUTICAL ANTITUSSIVE-COLD PREPARATIONS; PREPARATIONS FOR TREATING COLDS; ANALGESIC PREPARATIONS; ANALGESICS; ANTIPYRETIC ANALGESICS; IBUPROFEN FOR USE AS AN ORAL ANALGESIC; MULTIPURPOSE MEDICATED ANTIBIOTIC CREAM, ANALGESIC BALM AND MENTHOLATED SALVE; ORAL ANALGESICS; TOPICAL ANALGESICS; PHARMACEUTICAL PREPARATIONS FOR THE TREATMENT AND PREVENTION OF HERPES; VACCINES FOR THE TREATMENT AND PREVENTION OF HERPES; BIOLOGICAL PREPARATIONS FOR THE TREATMENT AND PREVENTION OF HERPES; PHARMACEUTICAL PREPARATIONS FOR THE TREATMENT OF HERPES SIMPLEX INFECTION; PHARMACEUTICAL CAPSULES FOR THE TREATMENT OF HERPES SIMPLEX INFECTION; HOMEOPATHIC PREPARATIONS FOR THE TREATMENT OF HERPES AND COLD SORES; PHARMACEUTICAL PREPARATIONS FOR THE TREATMENT OF HERPES VIRUSES; MEDICATED TOPICAL CLEAR FLUORIDE GEL FOR THE TREATMENT OF HERPES VIRUS DURING THE PHYSICAL MANI-

FESTATION OF THE VIRUS; PHARMACEUTICAL PREPARATIONS FOR THE TREATMENT OF HERPES SIMPLEX VIRUS TYPE I OR TYPE II OR HERPES ZOSTER VIRUS, NOT IN INTRAVENOUS FORM; PLANT-BASED ANTIVIRALS; OVER-THE-COUNTER TOPICAL ANTIVIRALS; PHARMACEUTICAL PREPARATION WITH ANTIVIRAL AND/OR ANTIMICROBIAL PROPERTIES FOR USE IN THE TREATMENT OF HERPETIC KERATITIS, CONJUNCTIVITIS, HIV RETINOPATHY, VIRAL INFLUENZA "FLU", HERPES SIMPLEX VIRUS 1, HERPES SIMPLEX VIRUS 2, VARICELLA ZOSTER VIRUS "HERPES ZOSTER" OR "SHINGLES", CYTOMEGALOVIRUS, VIRAL PARAINFLUENZA, ADENOVIRUS, VIRAL ENCEPHALITIS, VIRAL MENINGITIS, ARBOVIRUS, ARENAVIRUS, PICORNAVIRUS, CORONAVIRUS, SYNTIALVIRUS, VIRAL INFECTIONS, COMMON COLDS CAUSED BY VIRUSES, COLD SORES, HUMAN IMMUNODEFICIENCY VIRUS "HIV", ROSEOLA INFANTUM, HUMAN HERPES IV; PHARMACEUTICAL PREPARATIONS FOR THE TREATMENT OF VIRAL DISEASES AND DISORDERS, NAMELY, HERPES; PHARMACEUTICAL PREPARATIONS FOR TREATING IMMUNE DISEASES INDUCED BY VIRUS, NAMELY, HERPES, HERPES ZOSTER AND AIDS; ALGAL PRODUCTS FOR MEDICINAL PURPOSES, NAMELY, ALGAL EXTRACTS OR ALGAL EXTRACT BLENDS FOR USE AS NUTRITIONAL AND DIETARY SUPPLEMENTS; ALGAL PRODUCTS, NAMELY, ALGAL POWDERS SOLD AS AN INTEGRAL INGREDIENT OF NUTRITIONAL SUPPLEMENT DRINK MIX FOR NUTRITIONAL PURPOSES; ALGAL PRODUCTS, NAMELY, ALGAL POWDERS FOR NUTRITIONAL PURPOSES; ALGAL EXTRACTS OR ALGAL EXTRACT BLENDS FOR MEDICAL OR PHARMACEUTICAL PURPOSES; FUNCTIONAL FOODS, NAMELY, DIETETIC FOODS ADAPTED FOR MEDICAL PURPOSES; FUNCTIONAL BEVERAGES, NAMELY, NUTRITIONALLY FORTIFIED BEVERAGES; MEDICINAL FOODS, NAMELY, PROCESSED FOOD FOR MEDICAL PURPOSES; ANIMAL HEALTH PRODUCTS, NAMELY, ANIMAL FEED SUPPLEMENTS, MEDICATED ANIMAL FEED, MICRO-NUTRIENT ANIMAL FEED, DIETARY SUPPLEMENTS FOR ANIMALS, NON-MEDICATED ADDITIVES FOR ANIMAL FEED FOR USE AS NUTRITIONAL SUPPLEMENTS, NUTRITIONAL DRINKS FOR ANIMALS, PHARMACEUTICAL PREPARATIONS FOR ANIMAL SKINCARE; PLANT EXTRACTS FOR MEDICAL, VETERINARY AND PHARMACEUTICAL PURPOSES; HERBAL EXTRACTS FOR MEDICAL, VETERINARY AND PHARMACEUTICAL PURPOSES; DESIGNER EXTRACTS, NAMELY, PLANT, HERBAL AND BOTANICAL EXTRACTS FOR MEDICAL, VETERINARY AND PHARMACEUTICAL PURPOSES; AND BIODEFENSE PRODUCTS, NAMELY, MEDICINAL PREPARATIONS FOR THE TREATMENT OF INFECTIOUS DISEASES AND ADVERSE HUMAN HEALTH CONDITIONS, NAMELY, INFECTION, DEGENERATIVE, MUSCULAR, PULMONARY, SKELETAL, ENDOCRINE, IMMUNE, NEUROLOGICAL, CARDIOVASCULAR, METABOLIC, INFLAMMATORY, CANCER AND RELATED CONDITIONS; MUSHROOM, FUNGUS, OR SPORE EXTRACTS OR BLENDS AS SUPPLEMENTS, NUTRITION, NUTRACEUTICALS AND/OR PHARMACEUTICALS; BOTANICAL EXTRACTS FOR NUTRITIONAL USE; NUTRITIONALLY FORTIFIED BEVERAGES; NUTRITIONALLY FORTIFIED BEVERAGES FOR IMMUNE ENHANCEMENT, AND NUTRITIONALLY FORTIFIED BEVERAGES WITH RICE BRAN AND WHEAT BRAN; MEDICINAL BEVERAGES; SOY PROTEIN FOR USE AS A NUTRITIONAL SUPPLEMENT; ACTIVE PRINCIPLES EXTRACTED FROM MEDICINAL PLANTS FOR USE IN THE MANUFACTURE OF NUTRACEUTICALS AND PHARMACEUTICALS; ACTIVE PRINCIPLES EXTRACTED FROM MEDICINAL PLANTS FOR USE IN THE MANUFACTURE OF PHARMACEUTICAL OR NUTRACEUTICAL PRODUCTS; NUTRITIONAL ADDITIVES FOR MEDICAL OR NONMEDICAL PURPOSES FOR USE IN MANUFACTURING FOODS AND DIETARY SUPPLEMENTS FOR HUMAN CONSUMPTION (U.S. CLS. 6, 18, 44, 46, 51 AND 52).

HEATHER THOMPSON, EXAMINING ATTORNEY

SN 77-519,163. HERBALSCIENCE GROUP, LLC, NAPLES, FL. FILED 7-10-2008.

MOVEMENTEASE

THE MARK CONSISTS OF STANDARD CHARACTERS WITHOUT CLAIM TO ANY PARTICULAR FONT, STYLE, SIZE, OR COLOR.

CLASS 1—CHEMICALS

FOR BOTANICAL EXTRACTS FOR USE IN THE MANUFACTURE OF NUTRACEUTICALS; EXTRACTS FOR USE IN THE MANUFACTURE OF PHARMACEUTICAL PREPARATIONS IN THE FORM OF PREPARATIONS IN THE FORM OF LOTIONS, CREAMS, AND TOPICAL ANALGESICS AND ANESTHETICS, TABLETS, CAPSULES, PILLS, TINCTURE, SUPPOSITORIES AND AMPULE FOR INJECTION; BOTANICAL EXTRACTS FOR USE IN THE MANUFACTURE OF PHARMACEUTICALS; CHEMICAL EXTRACTS EXTRACTED FROM MEDICINAL PLANTS FOR USE IN THE MANUFACTURE OF NUTRACEUTICALS AND PHARMACEUTICALS; CHEMICAL EXTRACTS EXTRACTED FROM MEDICINAL PLANTS FOR USE IN THE PHARMACEUTICAL INDUSTRY, NAMELY, CHEMICAL AGENTS MADE FROM BOTANICAL EXTRACTS OR ASSOCIATION OF CHEMICAL EXTRACTS FOR USE IN THE MANUFACTURE OF PHARMACEUTICAL OR NUTRACEUTICAL PRODUCTS; BOTANICAL EXTRACTS USED IN THE MANUFACTURE OF PREPARATIONS IN THE FORM OF LOTIONS, CREAMS, AND TOPICAL ANALGESICS AND ANESTHETICS, TABLETS, CAPSULES, PILLS, LOZENGES, INHALERS, TINCTURE, SUPPOSITORIES AND AMPULE FOR INJECTION; BOTANICALS AND BOTANICAL BLENDS, HERBS AND HERBAL BLENDS, BOTANICAL EXTRACTS AND BOTANICAL EXTRACT BLENDS, FLAVOR EXTRACTS AND FLAVOR EXTRACT BLENDS, ALGAL EXTRACTS AND ALGAL EXTRACT BLENDS, ALL FOR USE IN THE MANUFACTURE OF NUTRITIONAL SUPPLEMENTS AND VITAMINS; HERBAL EXTRACTS AND BLENDS FOR USE IN MANUFACTURING FUNCTIONAL FOODS OR BEVERAGES; HERBAL EXTRACTS AND BLENDS FOR USE IN MANUFACTURING MEDICINAL FOODS OR BEVERAGES; BOTANICAL EXTRACTS AND BLENDS FOR USE IN MANUFACTURING FUNCTIONAL FOODS OR BEVERAGES; BOTANICAL EXTRACTS AND BLENDS FOR USE IN MANUFACTURING MEDICINAL FOODS OR BEVERAGES; HERBAL PREPARATIONS AND EXTRACTS FOR USE AS INGREDIENTS IN MANUFACTURING IN THE FOOD, NUTRITION, NUTRACEUTICAL AND/OR PHARMACEUTICAL INDUSTRIES (U.S. CLS. 1, 5, 6, 10, 26 AND 46).

CLASS 5—PHARMACEUTICALS

FOR NUTRITIONAL SUPPLEMENTS; HERBAL PRODUCTS, NAMELY, MEDICATED SKIN AND LIP BALMS; HERBAL PRODUCTS, NAMELY, OINTMENTS, OILS, DRINKS, INFUSIONS, SYRUPS, HERBAL EXTRACTS, POISONS, AND TINCTURES FOR MEDICAL USE IN THE TREATMENT OF STROKES, INFARCTS AND OTHER CARDIOVASCULAR AND CEREBRUM DISEASES; HERBAL PRODUCTS, NAMELY, OINTMENTS, OILS, NAMELY, MINERAL OIL FOR USE AS A LAXATIVE; DRINKS, NAMELY, MEAL REPLACEMENT DRINKS, DIETARY SUPPLEMENT DRINKS, MEDICINAL DRINKS, AND FISH OIL FOR USE AS A DIETARY SUPPLEMENT OR NUTRACEUTICAL; INFUSIONS AND SYRUPS, NAMELY, COUGH SYRUPS; HERBAL PRODUCTS FOR MEDICINAL PURPOSES, NAMELY, HERBAL EXTRACTS FOR USE AS NUTRITIONAL AND DIETARY SUPPLEMENTS; HERBAL PRODUCTS FOR MEDICINAL PURPOSES, NAMELY, HERBAL EXTRACTS AND SYRUPS; MEDICINAL HERB EXTRACTS; MEDICINAL HERB EXTRACTS FOR MEDICAL PURPOSES; PLANT EXTRACTS FOR MEDICAL, PHARMACEUTICAL, NUTRACEUTICAL AND NUTRI-

TIONAL PURPOSES; MEDICINAL EXTRACTS IN THE FORM OF LOTIONS, CREAMS, TOPICAL ANALGESICS AND ANESTHETICS, TABLETS, CAPSULES, PILLS, TINCTURE, SUPPOSITORIES AND AMPULE FOR INJECTION, MEDICINAL HERBAL EXTRACTS IN THE FORM OF LOTIONS, CREAMS, TOPICAL ANALGESICS AND ANESTHETICS, TABLETS, CAPSULES, PILLS, TINCTURE, SUPPOSITORIES AND AMPULE FOR INJECTION, AND MEDICINAL BOTANICAL EXTRACTS IN THE FORM OF LOTIONS, CREAMS, TOPICAL ANALGESICS AND ANESTHETICS, TABLETS, CAPSULES, PILLS, TINCTURE, SUPPOSITORIES AND AMPULE FOR INJECTION USED TO TREAT SKIN AILMENTS, FOR INFECTION, DEGENERATIVE, MUSCULAR, PULMONARY, SKELETAL, ENDOCRINE, IMMUNE, NEUROLOGICAL, CARDIOVASCULAR, METABOLIC, INFLAMMATORY, CANCER AND RELATED CONDITIONS; YEAST EXTRACTS FOR MEDICAL, PHARMACEUTICAL OR NUTRACEUTICAL PURPOSES; HERBAL PRODUCTS, NAMELY, HERBAL POWDERS FOR NUTRITIONAL PURPOSES; HERBAL PRODUCTS, NAMELY, HERBAL MEAL REPLACEMENT POWDERS FOR DIETARY AND NUTRITIONAL PURPOSES; HERBAL PRODUCTS, NAMELY, AROMATHERAPY PACKS CONTAINING HERBS USED FOR RELIEF FROM HEADACHES, INSOMNIA AND SINUS DISCOMFORT; HERBAL PRODUCTS, NAMELY, HERBAL POWDERS SOLD AS AN INTEGRAL INGREDIENT OF NUTRITIONAL SUPPLEMENT DRINK MIX FOR NUTRITIONAL PURPOSES; PHARMACEUTICALS AND NUTRACEUTICALS, NAMELY, VITAMINS AND FOOD SUPPLEMENTS; PHARMACEUTICAL PREPARATIONS, NAMELY, APPETITE SUPPRESSANTS AND LIPID LOWERING AGENTS; FOOD FOR DIABETICS, INFANTS AND ENTERAL FEEDING; BOTANICAL EXTRACTS FOR NUTRITIONAL USE; BOTANICAL EXTRACTS FOR MEDICAL, VETERINARY, NUTRACEUTICAL AND PHARMACEUTICAL PURPOSES; DESIGNER EXTRACTS, NAMELY, HERBAL EXTRACTS FOR MEDICAL, VETERINARY AND PHARMACEUTICAL PURPOSES; BOTANICAL EXTRACTS FOR NUTRITIONAL SUPPLEMENTS, NUTRACEUTICALS AND PHARMACEUTICALS; NUTRITIONAL DIETARY SUPPLEMENTS; ORAL PREPARATIONS CONTAINING HERBS OR HERBAL EXTRACTS USED TO MAINTAIN HEALTH AND FOR A WIDE VARIETY OF PHYSICAL CONDITIONS; VITAMIN AND MINERAL PREPARATIONS INTENDED FOR USE AS DIETARY SUPPLEMENTS; VITAMINS; NUTRACEUTICALS, NAMELY, VITAMINS AND FOOD SUPPLEMENTS; FOOD FOR MEDICALLY RESTRICTED DIETS; SUPPLEMENTS, NAMELY, LIPID CONCENTRATES FOR USE AS A DIETARY FOOD SUPPLEMENT OR FOR PHARMACEUTICAL OR MEDICINAL PURPOSES; FOOD SUPPLEMENTS, NAMELY, ANTI-OXIDANTS; BOTANICALS AND BOTANICAL BLENDS, HERBALS AND HERBAL BLENDS, BOTANICAL EXTRACTS AND BOTANICAL EXTRACT BLENDS, FLAVOR EXTRACTS AND FLAVOR EXTRACT BLENDS, ALL SOLD AS NUTRITIONAL SUPPLEMENTS AND VITAMINS; NUTRITIONAL OILS NOT FOR COSMETIC PURPOSES; FOOD SUPPLEMENTS, NAMELY, LIPID CONCENTRATES FOR USE AS A DIETARY FOOD SUPPLEMENT OR FOR PHARMACEUTICAL OR MEDICINAL PURPOSES; ANTI-COUGH DROPS; COUGH DROPS; COUGH EXPECTORANTS; THROAT LOZENGES; COUGH LOZENGES; COUGH TREATMENT PREPARATIONS; COLD SORE TREATMENT PREPARATIONS; PHARMACEUTICAL ANTITUSSIVE-COLD PREPARATIONS; PREPARATIONS FOR TREATING COLDS; ANALGESIC PREPARATIONS; ANALGESICS; ANTI-PYRETIC ANALGESICS; IBUPROFEN FOR USE AS AN ORAL ANALGESIC; MULTIPURPOSE MEDICATED ANTIBIOTIC CREAM, ANALGESIC BALM AND MENTHOLATED SALVE; ORAL ANALGESICS; TOPICAL ANALGESICS; PHARMACEUTICAL PREPARATIONS FOR THE TREATMENT AND PREVENTION OF HERPES; VACCINES FOR THE TREATMENT AND PREVENTION OF HERPES; BIOLOGICAL PREPARATIONS FOR THE TREATMENT AND PREVENTION OF HERPES; PHARMACEUTICAL PREPARATIONS FOR THE TREATMENT OF HERPES SIMPLEX INFECTION; PHARMACEUTICAL CAPSULES FOR THE TREATMENT OF HERPES SIMPLEX INFECTION; HOMEOPATHIC PREPARATIONS FOR THE TREATMENT OF HERPES AND COLD SORES; PHARMACEUTICAL PREPARATIONS FOR THE TREATMENT OF HERPES VIRUSES; MEDICATED TOPICAL CLEAR FLUORIDE GEL FOR THE TREATMENT OF HERPES VIRUS DURING THE PHYSICAL MANI-

FESTATION OF THE VIRUS; PHARMACEUTICAL PREPARATIONS FOR THE TREATMENT OF HERPES SIMPLEX VIRUS TYPE I OR TYPE II OR HERPES ZOSTER VIRUS, NOT IN INTRAVENOUS FORM; PLANT-BASED ANTIVIRALS; OVER-THE-COUNTER TOPICAL ANTIVIRALS; PHARMACEUTICAL PREPARATION WITH ANTIVIRAL AND/OR ANTIMICROBIAL PROPERTIES FOR USE IN THE TREATMENT OF HERPETIC KERATITIS, CONJUNCTIVITIS, HIV RETINOPATHY, VIRAL INFLUENZA "FLU", HERPES SIMPLEX VIRUS 1, HERPES SIMPLEX VIRUS 2, VARICELLA ZOSTER VIRUS "HERPES ZOSTER" OR "SHINGLES", CYTOMEGALOVIRUS, VIRAL PARAINFLUENZA, ADENOVIRUS, VIRAL ENCEPHALITIS, VIRAL MENINGITIS, ARBOVIRUS, ARENAVIRUS, PICORNAVIRUS, CORONAVIRUS, SYNTIALVIRUS, VIRAL INFECTIONS, COMMON COLDS CAUSED BY VIRUSES, COLD SORES, HUMAN IMMUNODEFICIENCY VIRUS "HIV", ROSEOLA INFANTUM, HUMAN HERPES IV; PHARMACEUTICAL PREPARATIONS FOR THE TREATMENT OF VIRAL DISEASES AND DISORDERS, NAMELY, HERPES; PHARMACEUTICAL PREPARATIONS FOR TREATING IMMUNE DISEASES INDUCED BY VIRUS, NAMELY, HERPES, HERPES ZOSTER AND AIDS; ALGAL PRODUCTS FOR MEDICINAL PURPOSES, NAMELY, ALGAL EXTRACTS OR ALGAL EXTRACT BLENDS FOR USE AS NUTRITIONAL AND DIETARY SUPPLEMENTS; ALGAL PRODUCTS, NAMELY, ALGAL POWDERS SOLD AS AN INTEGRAL INGREDIENT OF NUTRITIONAL SUPPLEMENT DRINK MIX FOR NUTRITIONAL PURPOSES; ALGAL PRODUCTS, NAMELY, ALGAL POWDERS FOR NUTRITIONAL PURPOSES; ALGAL EXTRACTS OR ALGAL EXTRACT BLENDS FOR MEDICAL OR PHARMACEUTICAL PURPOSES; FUNCTIONAL FOODS, NAMELY, DIETETIC FOODS ADAPTED FOR MEDICAL PURPOSES; FUNCTIONAL BEVERAGES, NAMELY, NUTRITIONALLY FORTIFIED BEVERAGES; MEDICINAL FOODS, NAMELY, PROCESSED FOOD FOR MEDICAL PURPOSES; ANIMAL HEALTH PRODUCTS, NAMELY, ANIMAL FEED SUPPLEMENTS, MEDICATED ANIMAL FEED, MICRO-NUTRIENT ANIMAL FEED, DIETARY SUPPLEMENTS FOR ANIMALS, NON-MEDICATED ADDITIVES FOR ANIMAL FEED FOR USE AS NUTRITIONAL SUPPLEMENTS, NUTRITIONAL DRINKS FOR ANIMALS, PHARMACEUTICAL PREPARATIONS FOR ANIMAL SKINCARE; PLANT EXTRACTS FOR MEDICAL, VETERINARY AND PHARMACEUTICAL PURPOSES; HERBAL EXTRACTS FOR MEDICAL, VETERINARY AND PHARMACEUTICAL PURPOSES; DESIGNER EXTRACTS, NAMELY, PLANT, HERBAL AND BOTANICAL EXTRACTS FOR MEDICAL, VETERINARY AND PHARMACEUTICAL PURPOSES; AND BIODEFENSE PRODUCTS, NAMELY, MEDICINAL PREPARATIONS FOR THE TREATMENT OF INFECTIOUS DISEASES AND ADVERSE HUMAN HEALTH CONDITIONS, NAMELY, INFECTION, DEGENERATIVE, MUSCULAR, PULMONARY, SKELETAL, ENDOCRINE, IMMUNE, NEUROLOGICAL, CARDIOVASCULAR, METABOLIC, INFLAMMATORY, CANCER AND RELATED CONDITIONS; MUSHROOM, FUNGUS, OR SPORE EXTRACTS OR BLENDS AS SUPPLEMENTS, NUTRITION, NUTRACEUTICALS AND/OR PHARMACEUTICALS; BOTANICAL EXTRACTS FOR NUTRITIONAL USE; NUTRITIONALLY FORTIFIED BEVERAGES; NUTRITIONALLY FORTIFIED BEVERAGES FOR IMMUNE ENHANCEMENT, AND NUTRITIONALLY FORTIFIED BEVERAGES WITH RICE BRAN AND WHEAT BRAN; MEDICINAL BEVERAGES; SOY PROTEIN FOR USE AS A NUTRITIONAL SUPPLEMENT; ACTIVE PRINCIPLES EXTRACTED FROM MEDICINAL PLANTS FOR USE IN THE MANUFACTURE OF NUTRACEUTICALS AND PHARMACEUTICALS; ACTIVE PRINCIPLES EXTRACTED FROM MEDICINAL PLANTS FOR USE IN THE MANUFACTURE OF PHARMACEUTICAL OR NUTRACEUTICAL PRODUCTS; NUTRITIONAL ADDITIVES FOR MEDICAL OR NONMEDICAL PURPOSES FOR USE IN MANUFACTURING FOODS AND DIETARY SUPPLEMENTS FOR HUMAN CONSUMPTION (U.S. CLS. 6, 18, 44, 46, 51 AND 52).

HEATHER THOMPSON, EXAMINING ATTORNEY

SN 77-519,191. HERBALSCIENCE GROUP, LLC, NAPLES, FL. FILED 7-10-2008.

SN 77-519,241. HERBALSCIENCE GROUP, LLC, NAPLES, FL. FILED 7-10-2008.

MOTIONASSIST

THE MARK CONSISTS OF STANDARD CHARACTERS WITHOUT CLAIM TO ANY PARTICULAR FONT, STYLE, SIZE, OR COLOR.

CLASS 1—CHEMICALS

FOR BOTANICAL EXTRACTS FOR USE IN THE MANUFACTURE OF NUTRACEUTICALS; EXTRACTS FOR USE IN THE MANUFACTURE OF PHARMACEUTICAL PREPARATIONS IN THE FORM OF PREPARATIONS IN THE FORM OF LOTIONS, CREAMS, AND TOPICAL ANALGESICS AND ANESTHETICS, TABLETS, CAPSULES, PILLS, TINCTURE, SUPPOSITORIES AND AMPULE FOR INJECTION; BOTANICAL EXTRACTS FOR USE IN THE MANUFACTURE OF PHARMACEUTICALS; CHEMICAL EXTRACTS EXTRACTED FROM MEDICINAL PLANTS FOR USE IN THE MANUFACTURE OF NUTRACEUTICALS AND PHARMACEUTICALS; CHEMICAL EXTRACTS, NAMELY, CHEMICAL AGENTS MADE FROM BOTANICAL EXTRACTS OR ASSOCIATION OF CHEMICAL EXTRACTS FOR USE IN THE MANUFACTURE OF PHARMACEUTICAL OR NUTRACEUTICAL PRODUCTS; BOTANICAL EXTRACTS USED IN THE MANUFACTURE OF PREPARATIONS IN THE FORM OF LOTIONS, CREAMS, AND TOPICAL ANALGESICS AND ANESTHETICS, TABLETS, CAPSULES, PILLS, LOZENGES, INHALERS, TINCTURE, SUPPOSITORIES AND AMPULE FOR INJECTION; BOTANICALS AND BOTANICAL BLENDS, HERBS AND HERBAL BLENDS, BOTANICAL EXTRACTS AND BOTANICAL EXTRACT BLENDS, FLAVOR EXTRACTS AND FLAVOR EXTRACT BLENDS, ALGAL EXTRACTS AND ALGAL EXTRACT BLENDS, ALL FOR USE IN THE MANUFACTURE OF NUTRITIONAL SUPPLEMENTS AND VITAMINS; HERBAL EXTRACTS AND BLENDS FOR USE IN MANUFACTURING FUNCTIONAL FOODS OR BEVERAGES; HERBAL EXTRACTS AND BLENDS FOR USE IN MANUFACTURING MEDICINAL FOODS OR BEVERAGES; BOTANICAL EXTRACTS AND BLENDS FOR USE IN MANUFACTURING FUNCTIONAL FOODS OR BEVERAGES; BOTANICAL EXTRACTS AND BLENDS FOR USE IN MANUFACTURING MEDICINAL FOODS OR BEVERAGES; HERBAL PREPARATIONS AND EXTRACTS FOR USE AS INGREDIENTS IN MANUFACTURING IN THE FOOD, NUTRITION, NUTRACEUTICAL AND/OR PHARMACEUTICAL INDUSTRIES (U.S. CLS. 1, 5, 6, 10, 26 AND 46).

CLASS 5—PHARMACEUTICALS

FOR NUTRITIONAL ADDITIVES FOR MEDICAL OR NONMEDICAL PURPOSES FOR USE IN MANUFACTURING FOODS AND DIETARY SUPPLEMENTS FOR HUMAN CONSUMPTION; ACTIVE PRINCIPLES EXTRACTED FROM MEDICINAL PLANTS FOR USE IN THE MANUFACTURE OF NUTRACEUTICALS AND PHARMACEUTICALS; ACTIVE PRINCIPLES EXTRACTED FROM MEDICINAL PLANTS FOR USE IN THE MANUFACTURE OF PHARMACEUTICAL OR NUTRACEUTICAL PRODUCTS (U.S. CLS. 6, 18, 44, 46, 51 AND 52).

HEATHER THOMPSON, EXAMINING ATTORNEY

THINKINGFAST

THE MARK CONSISTS OF STANDARD CHARACTERS WITHOUT CLAIM TO ANY PARTICULAR FONT, STYLE, SIZE, OR COLOR.

CLASS 1—CHEMICALS

FOR BOTANICAL EXTRACTS FOR USE IN THE MANUFACTURE OF NUTRACEUTICALS; EXTRACTS FOR USE IN THE MANUFACTURE OF PHARMACEUTICAL PREPARATIONS IN THE FORM OF PREPARATIONS IN THE FORM OF LOTIONS, CREAMS, AND TOPICAL ANALGESICS AND ANESTHETICS, TABLETS, CAPSULES, PILLS, TINCTURE, SUPPOSITORIES AND AMPULE FOR INJECTION; BOTANICAL EXTRACTS FOR NUTRITIONAL USE; BOTANICAL EXTRACTS FOR USE IN THE MANUFACTURE OF NUTRACEUTICALS AND PHARMACEUTICALS; BOTANICAL EXTRACTS FOR USE IN NUTRACEUTICALS AND PHARMACEUTICALS; CHEMICAL EXTRACTS AND ACTIVE PRINCIPLES EXTRACTED FROM MEDICINAL PLANTS FOR USE IN THE MANUFACTURE OF NUTRACEUTICALS AND PHARMACEUTICALS; BOTANICAL EXTRACTS USED IN PREPARATIONS IN THE FORM OF LOTIONS, CREAMS, AND TOPICAL ANALGESICS AND ANESTHETICS, TABLETS, CAPSULES, PILLS, LOZENGES, INHALERS, TINCTURE, SUPPOSITORIES AND AMPULE FOR INJECTION; BOTANICAL EXTRACTS FOR USE IN THE MANUFACTURE OF PREPARATIONS IN THE FORM OF LOTIONS, CREAMS, AND TOPICAL ANALGESICS AND ANESTHETICS, TABLETS, CAPSULES, PILLS, LOZENGES, INHALERS, TINCTURE, SUPPOSITORIES AND AMPULE FOR INJECTION; BOTANICAL EXTRACTS USED IN PHARMACEUTICAL PREPARATIONS IN THE FORM OF LOTIONS, CREAMS, AND TOPICAL ANALGESICS AND ANESTHETICS, TABLETS, CAPSULES, PILLS, TINCTURE, SUPPOSITORIES AND AMPULE FOR INJECTION; BOTANICAL EXTRACTS FOR USE IN THE MANUFACTURE OF PHARMACEUTICAL PREPARATIONS IN THE FORM OF LOTIONS, CREAMS, AND TOPICAL ANALGESICS AND ANESTHETICS, TABLETS, CAPSULES, PILLS, TINCTURE, SUPPOSITORIES AND AMPULE FOR INJECTION; BOTANICALS AND BOTANICAL BLENDS, HERBS AND HERBAL BLENDS, BOTANICAL EXTRACTS AND BOTANICAL EXTRACT BLENDS, FLAVOR EXTRACTS AND FLAVOR EXTRACT BLENDS, ALGAL EXTRACTS AND ALGAL EXTRACT BLENDS, ALL FOR USE IN THE MANUFACTURE OF NUTRITIONAL SUPPLEMENTS AND VITAMINS (U.S. CLS. 1, 5, 6, 10, 26 AND 46).

CLASS 5—PHARMACEUTICALS

FOR HERBAL EXTRACTS AND BLENDS FOR USE IN FUNCTIONAL FOODS OR BEVERAGES; HERBAL EXTRACTS AND BLENDS FOR USE IN MEDICINAL FOODS OR BEVERAGES; BOTANICAL EXTRACTS AND BLENDS FOR USE IN FUNCTIONAL FOODS OR BEVERAGES; BOTANICAL EXTRACTS AND BLENDS FOR USE IN MEDICINAL FOODS OR BEVERAGES; HERBAL PRODUCTS, NAMELY, AROMATHERAPY PACKS FILLED WITH HERBS FOR USE IN AROMATHERAPY; AND PRE-MOISTENED NON-MEDICATED PERSONAL HYGIENE WIPES, NAMELY, HERPES RELIEF WIPES; HERBAL EXTRACTS FOR COSMETIC USE, ALGAL EXTRACTS OR ALGAL EXTRACT BLENDS FOR COSMETIC USE, ESSENTIAL OILS; FRAGRANCES; FRAGRANCES FOR PERSONAL USE; NUTRITIONAL SUPPLEMENTS; HERBAL PRODUCTS, NAMELY, MEDICATED SKIN AND LIP BALMS; HERBAL PRODUCTS, NAMELY, OINTMENTS, OILS; DRINKS, INFUSIONS, SYRUPS, HERBAL EXTRACTS, POISONS, TINCTURES FOR MEDICAL USE IN THE TREATMENT OF STROKES, INFARCTS AND OTHER CARDIOVASCULAR AND CEREBRUM DIS-

EASES; HERBAL PRODUCTS, NAMELY, OINTMENTS, OILS, NAMELY, MINERAL OIL FOR USE AS A LAXATIVE, DRINKS, NAMELY, MEAL REPLACEMENT DRINKS, DIETARY SUPPLEMENT DRINKS, MEDICINAL DRINKS, AND FISH OIL FOR USE AS A DIETARY SUPPLEMENT OR IN A NUTRACEUTICAL, INFUSIONS, SYRUPS, NAMELY, COUGH SYRUPS; HERBAL PRODUCTS FOR MEDICINAL PURPOSES, NAMELY, HERBAL EXTRACTS FOR USE AS NUTRITIONAL AND DIETARY SUPPLEMENTS; HERBAL PRODUCTS FOR MEDICINAL PURPOSES, NAMELY, HERBAL EXTRACTS AND SYRUPS; MEDICINAL HERB EXTRACTS; MEDICINAL HERB EXTRACTS FOR MEDICAL PURPOSES; PLANT EXTRACTS FOR MEDICAL OR PHARMACEUTICAL PURPOSES; PLANT EXTRACTS FOR MEDICAL AND NUTRITIONAL PURPOSES; PLANT EXTRACTS FOR MEDICAL AND PHARMACEUTICAL PURPOSES; PLANT EXTRACTS FOR MEDICAL OR NUTRACEUTICAL PURPOSES; PLANT EXTRACTS FOR MEDICAL AND NUTRACEUTICAL PURPOSES; MEDICINAL EXTRACTS USED IN PREPARATIONS IN THE FORM OF LOTIONS, CREAMS, AND TOPICAL ANALGESICS AND ANESTHETICS, TABLETS, CAPSULES, PILLS, LOZENGES, INHALERS, TINCTURE, SUPPOSITORIES AND AMPULE FOR INJECTION; MEDICINAL EXTRACTS USED IN PHARMACEUTICAL PREPARATIONS IN THE FORM OF LOTIONS, CREAMS, AND TOPICAL ANALGESICS AND ANESTHETICS, TABLETS, CAPSULES, PILLS, TINCTURE, SUPPOSITORIES AND AMPULE FOR INJECTION; MEDICINAL HERBAL EXTRACTS USED AS COMPONENT INGREDIENTS OF PHARMACEUTICAL PREPARATIONS IN THE FORM OF LOTIONS, CREAMS, AND TOPICAL ANALGESICS AND ANESTHETICS, TABLETS, CAPSULES, PILLS, TINCTURE, SUPPOSITORIES AND AMPULE FOR INJECTION; BOTANICAL EXTRACTS USED AS COMPONENT INGREDIENTS OF PHARMACEUTICAL PREPARATIONS IN THE FORM OF LOTIONS, CREAMS, AND TOPICAL ANALGESICS AND ANESTHETICS, TABLETS, CAPSULES, PILLS, TINCTURE, SUPPOSITORIES AND AMPULE FOR INJECTION USED TO TREAT SKIN AILMENTS, FOR INFECTION, DEGENERATIVE, MUSCULAR, PULMONARY, SKELETAL, ENDOCRINE, IMMUNE, NEUROLOGICAL, CARDIOVASCULAR, METABOLIC, INFLAMMATORY, CANCER AND RELATED CONDITIONS; YEAST EXTRACTS FOR MEDICAL OR PHARMACEUTICAL PURPOSES; YEAST EXTRACTS FOR MEDICAL OR NUTRACEUTICAL PURPOSES; HERBAL EXTRACTS FOR COSMETIC USE; HERBAL PRODUCTS, NAMELY, HERBAL POWDERS FOR NUTRITIONAL PURPOSES; HERBAL PRODUCTS, NAMELY, HERBAL MEAL REPLACEMENT POWDERS FOR DIETARY AND NUTRITIONAL PURPOSES; HERBAL PRODUCTS, NAMELY, AROMA THERAPY PACKS FILLED WITH HERBS FOR USE IN AROMA THERAPY; HERBAL PRODUCTS, NAMELY, AROMATHERAPY PACKS CONTAINING HERBS USED FOR RELIEF FROM HEADACHES, INSOMNIA AND SINUS DISCOMFORT; HERBAL PRODUCTS, NAMELY, HERBAL POWDERS SOLD AS AN INTEGRAL INGREDIENT OF NUTRITIONAL SUPPLEMENT DRINK MIX FOR NUTRITIONAL PURPOSES; PHARMACEUTICALS AND NUTRACEUTICALS, NAMELY, VITAMINS AND FOOD SUPPLEMENTS; PHARMACEUTICAL PREPARATIONS, NAMELY, APPETITE SUPPRESSANTS AND LIPID LOWERING AGENTS; FOOD FOR DIABETICS, INFANTS AND ENTERAL FEEDING; BOTANICAL EXTRACTS FOR NUTRITIONAL USE; BOTANICAL EXTRACTS FOR USE IN NUTRACEUTICALS; BOTANICAL EXTRACTS FOR NUTRITIONAL USE; BOTANICAL EXTRACTS USED AS INGREDIENTS IN PHARMACEUTICAL PREPARATIONS IN THE FORM OF LOTIONS, CREAMS, AND TOPICAL ANALGESICS AND ANESTHETICS, TABLETS, CAPSULES, PILLS, TINCTURE, SUPPOSITORIES AND AMPULE FOR INJECTION; AND BOTANICAL EXTRACTS FOR USE IN NUTRACEUTICALS AND PHARMACEUTICALS; BOTANICAL EXTRACTS FOR MEDICAL, VETERINARY, NUTRACEUTICAL AND PHARMACEUTICAL PURPOSES; DESIGNER EXTRACTS, NAMELY, HERBAL EXTRACTS FOR MEDICAL, VETERINARY AND PHARMACEUTICAL PURPOSES; BOTANICAL EXTRACTS SOLD AS AN INTEGRAL INGREDIENT OF NUTRITIONAL SUPPLEMENTS, NUTRACEUTICALS AND PHARMACEUTICALS; BOTANICAL EXTRACTS SOLD AS AN INTEGRAL INGREDIENT OF NUTRITIONAL SUPPLEMENTS AND NUTRACEUTICALS; HERBAL PREPARATIONS AND EXTRACTS FOR USE AS INGRE-

DIENTS IN THE FOOD, NUTRITION, NUTRACEUTICAL AND/OR PHARMACEUTICAL INDUSTRY; NUTRITIONAL DIETARY SUPPLEMENTS; ORAL PREPARATIONS; ORAL PREPARATIONS CONTAINING HERBS OR HERBAL EXTRACTS USED TO MAINTAIN HEALTH AND FOR A WIDE VARIETY OF PHYSICAL CONDITIONS; VITAMIN AND MINERAL PREPARATIONS INTENDED FOR USE AS DIETARY SUPPLEMENTS; VITAMINS; FOOD SUPPLEMENTS; NUTRACEUTICALS, NAMELY, VITAMINS AND FOOD SUPPLEMENTS; FOOD FOR MEDICALLY RESTRICTED DIETS; SUPPLEMENTS, NAMELY, LIPID CONCENTRATES FOR USE AS A DIETARY FOOD SUPPLEMENT OR FOR PHARMACEUTICAL OR MEDICINAL PURPOSES; FOOD SUPPLEMENTS, NAMELY, ANTI-OXIDANTS; BOTANICALS AND BOTANICAL BLENDS, HERBALS AND HERBAL BLENDS, BOTANICAL EXTRACTS AND BOTANICAL EXTRACT BLENDS, FLAVOR EXTRACTS AND FLAVOR EXTRACT BLENDS, ALL SOLD AS COMPONENTS OF NUTRITIONAL SUPPLEMENTS AND VITAMINS; NUTRITIONAL OILS NOT FOR COSMETIC PURPOSES; FOOD SUPPLEMENTS, NAMELY, LIPID CONCENTRATES FOR USE AS A DIETARY FOOD SUPPLEMENT OR FOR PHARMACEUTICAL OR MEDICINAL PURPOSES; ANTI-COUGH DROPS; COUGH DROPS; COUGH EXPECTORANTS; THROAT LOZENGES; COUGH LOZENGES; COUGH SYRUPS; COUGH TREATMENT PREPARATIONS; COLD SORE TREATMENT PREPARATIONS; PHARMACEUTICAL ANTITUSSIVE-COLD PREPARATIONS; PREPARATIONS FOR TREATING COLDS; ANALGESIC PREPARATIONS; ANALGESICS; ANTIPYRETIC ANALGESICS; IBUPROFEN FOR USE AS AN ORAL ANALGESIC; MULTIPURPOSE MEDICATED ANTIBIOTIC CREAM, ANALGESIC BALM AND MENTHOLATED SALVE; ORAL ANALGESICS; TOPICAL ANALGESICS; PHARMACEUTICAL PREPARATIONS FOR THE TREATMENT AND PREVENTION OF HERPES; VACCINES FOR THE TREATMENT AND PREVENTION OF HERPES; BIOLOGICAL PREPARATIONS FOR THE TREATMENT AND PREVENTION OF HERPES; PHARMACEUTICAL PREPARATIONS FOR THE TREATMENT OF HERPES SIMPLEX INFECTION; PHARMACEUTICAL CAPSULES FOR THE TREATMENT OF HERPES SIMPLEX INFECTION; HOMEOPATHIC PREPARATIONS FOR THE TREATMENT OF HERPES AND COLD SORES; PHARMACEUTICAL PREPARATIONS FOR THE TREATMENT OF HERPES VIRUSES; MEDICATED TOPICAL CLEAR FLUORIDE GEL FOR THE TREATMENT OF HERPES VIRUS DURING THE PHYSICAL MANIFESTATION OF THE VIRUS; PHARMACEUTICAL PREPARATIONS FOR THE TREATMENT OF HERPES SIMPLEX VIRUS TYPE I OR TYPE II OR HERPES ZOSTER VIRUS, NOT IN INTRAVENOUS FORM; PLANT BASED ANTIVIRALS; OVER-THE-COUNTER TOPICAL ANTIVIRALS; PHARMACEUTICAL PREPARATION WITH ANTIVIRAL AND/OR ANTIMICROBIAL PROPERTIES FOR USE IN THE TREATMENT OF HERPATIC KERATITIS, CONJUNCTIVITIS, HIV RETINOPATHY, VIRAL INFLUENZA "FLU", HERPES SIMPLEX VIRUS 1, HERPES SIMPLEX VIRUS 2, VARICELLA ZOSTER VIRUS "HERPES ZOSTER" "SHINGLES", CYTOMEGALOVIRUS, VIRAL PARAINFLUENZA, ADENOVIRUS, VIRAL ENCEPHALITIS, VIRAL MENINGITIS, ARBOVIRUS, ARENAVIRUS, PICORNAVIRUS, CORONAVIRUS, SYNTIALVIRUS, VIRAL INFECTIONS, COMMON COLDS CAUSED BY VIRUSES, COLD SORES, HUMAN IMMUNODEFICIENCY VIRUS "HIV", ROSEOLA INFANTUM, HUMAN HERPES IV; PHARMACEUTICAL PREPARATIONS FOR THE TREATMENT OF VIRAL DISEASES AND DISORDERS, NAMELY, HERPES; PHARMACEUTICAL PREPARATIONS FOR TREATING IMMUNE DISEASES INDUCED BY VIRUS, NAMELY, HERPES, HERPES ZOSTER AND AIDS; AND PRE-MOISTENED NON-MEDICATED PERSONAL HYGIENE WIPES, NAMELY, HERPES RELIEF WIPES; ALGAL PRODUCTS FOR MEDICINAL PURPOSES, NAMELY, ALGAL EXTRACTS OR ALGAL EXTRACT BLENDS FOR USE AS NUTRITIONAL AND DIETARY SUPPLEMENTS; ALGAL PRODUCTS, NAMELY, ALGAL POWDERS SOLD AS AN INTEGRAL INGREDIENT OF NUTRITIONAL SUPPLEMENT DRINK MIX FOR NUTRITIONAL PURPOSES; ALGAL PRODUCTS, NAMELY, ALGAL POWDERS FOR NUTRITIONAL PURPOSES; ALGAL EXTRACTS OR ALGAL EXTRACT BLENDS FOR MEDICAL OR PHARMACEUTICAL PURPOSES; FUNCTIONAL FOODS; FUNCTIONAL FOODS, NAMELY, DIETETIC FOODS ADAPTED FOR MEDICAL PURPOSES, FOOD FOR

DIABETICS, INFANTS AND ENTERAL FEEDING, FOOD FOR MEDICALLY RESTRICTED DIETS; FUNCTIONAL BEVERAGES, NAMELY, NUTRITIONALLY FORTIFIED BEVERAGES; MEDICINAL FOODS, NAMELY, PROCESSED FOOD FOR MEDICAL PURPOSES; ANIMAL HEALTH PRODUCTS, NAMELY, ANIMAL FEED SUPPLEMENTS, MEDICATED ANIMAL FEED, MICRO-NUTRIENT ANIMAL FEED, DIETARY SUPPLEMENTS FOR ANIMALS, NON-MEDICATED ADDITIVES FOR ANIMAL FEED FOR USE AS NUTRITIONAL SUPPLEMENTS, NUTRITIONAL DRINKS FOR ANIMALS, PHARMACEUTICAL PREPARATIONS FOR ANIMAL SKIN CARE; PLANT EXTRACTS FOR MEDICAL, VETERINARY AND PHARMACEUTICAL PURPOSES; BOTANICAL EXTRACTS FOR MEDICAL, VETERINARY AND PHARMACEUTICAL PURPOSES; HERBAL EXTRACTS FOR MEDICAL, VETERINARY AND PHARMACEUTICAL PURPOSES; DESIGNER EXTRACTS, NAMELY, PLANT, HERBAL AND BOTANICAL EXTRACTS FOR MEDICAL, VETERINARY AND PHARMACEUTICAL PURPOSES; AND BIODEFENSE PRODUCTS, NAMELY, MEDICINAL PREPARATIONS FOR THE TREATMENT OF INFECTIOUS DISEASES AND ADVERSE HUMAN HEALTH CONDITIONS; MUSHROOM, FUNGUS, OR SPORE EXTRACTS OR BLENDS FOR USE AS INGREDIENTS IN FOOD, SUPPLEMENT, NUTRITION, NUTRACEUTICAL AND/OR PHARMACEUTICAL PRODUCTS; CHEMICAL EXTRACTS AND ACTIVE PRINCIPLES EXTRACTED FROM MEDICINAL PLANTS FOR USE IN THE PHARMACEUTICAL INDUSTRY, NAMELY, CHEMICAL AGENTS MADE FROM BOTANICAL EXTRACTS OR ASSOCIATION OF CHEMICAL EXTRACTS FOR USE IN THE MANUFACTURE OF PHARMACEUTICAL OR NUTRACEUTICAL PRODUCTS; NUTRITIONAL ADDITIVES FOR MEDICAL OR NONMEDICAL PURPOSES FOR USE IN FOODS AND DIETARY SUPPLEMENTS FOR HUMAN CONSUMPTION (U.S. CLS. 6, 18, 44, 46, 51 AND 52).

DORITT L. CARROLL, EXAMINING ATTORNEY

CLASS 1—CHEMICALS

FOR BOTANICAL EXTRACTS FOR USE IN THE MANUFACTURE OF NUTRACEUTICALS; EXTRACTS FOR USE IN THE MANUFACTURE OF PHARMACEUTICAL PREPARATIONS IN THE FORM OF PREPARATIONS IN THE FORM OF LOTIONS, CREAMS, AND TOPICAL ANALGESICS AND ANESTHETICS, TABLETS, CAPSULES, PILLS, TINCTURE, SUPPOSITORIES AND AMPULE FOR INJECTION; BOTANICAL EXTRACTS FOR USE IN THE MANUFACTURE OF PHARMACEUTICALS; CHEMICAL EXTRACTS EXTRACTED FROM MEDICINAL PLANTS FOR USE IN THE MANUFACTURE OF NUTRACEUTICALS AND PHARMACEUTICALS; CHEMICAL EXTRACTS, NAMELY, CHEMICAL AGENTS MADE FROM BOTANICAL EXTRACTS OR ASSOCIATION OF CHEMICAL EXTRACTS FOR USE IN THE MANUFACTURE OF PHARMACEUTICAL OR NUTRACEUTICAL PRODUCTS; BOTANICAL EXTRACTS USED IN THE MANUFACTURE OF PREPARATIONS IN THE FORM OF LOTIONS, CREAMS, AND TOPICAL ANALGESICS AND ANESTHETICS, TABLETS, CAPSULES, PILLS, LOZENGES, INHALERS, TINCTURE, SUPPOSITORIES AND AMPULE FOR INJECTION; BOTANICALS AND BOTANICAL BLENDS, HERBS AND HERBAL BLENDS, BOTANICAL EXTRACTS AND BOTANICAL EXTRACT BLENDS, FLAVOR EXTRACTS AND FLAVOR EXTRACT BLENDS, ALGAL EXTRACTS AND ALGAL EXTRACT BLENDS, ALL FOR USE IN THE MANUFACTURE OF NUTRITIONAL SUPPLEMENTS AND VITAMINS; HERBAL EXTRACTS AND BLENDS FOR USE IN MANUFACTURING FUNCTIONAL FOODS OR BEVERAGES; HERBAL EXTRACTS AND BLENDS FOR USE IN MANUFACTURING MEDICINAL FOODS OR BEVERAGES; BOTANICAL EXTRACTS AND BLENDS FOR USE IN MANUFACTURING MEDICINAL FOODS OR BEVERAGES; HERBAL PREPARATIONS AND EXTRACTS FOR USE AS INGREDIENTS IN MANUFACTURING IN THE FOOD, NUTRITION, NUTRACEUTICAL AND/OR PHARMACEUTICAL INDUSTRIES (U.S. CLS. 1, 5, 6, 10, 26 AND 46).

CLASS 5—PHARMACEUTICALS

FOR NUTRITIONAL SUPPLEMENTS; HERBAL PRODUCTS, NAMELY, MEDICATED SKIN AND LIP BALMS; HERBAL PRODUCTS, NAMELY, OINTMENTS, OILS, DRINKS, INFUSIONS, SYRUPS, HERBAL EXTRACTS, POISONS, AND TINCTURES FOR MEDICAL USE IN THE TREATMENT OF STROKES, INFARCTS AND OTHER CARDIOVASCULAR AND CEREBRUM DISEASES; HERBAL PRODUCTS, NAMELY, OINTMENTS, OILS, NAMELY, MINERAL OIL FOR USE AS A LAXATIVE; DRINKS, NAMELY, MEAL REPLACEMENT DRINKS, DIETARY SUPPLEMENT DRINKS, MEDICINAL DRINKS, AND FISH OIL FOR USE AS A DIETARY SUPPLEMENT OR IN A NUTRACEUTICAL; INFUSIONS AND SYRUPS, NAMELY, COUGH SYRUPS; HERBAL PRODUCTS FOR MEDICINAL PURPOSES, NAMELY, HERBAL EXTRACTS FOR USE AS NUTRITIONAL AND DIETARY SUPPLEMENTS; HERBAL PRODUCTS FOR MEDICINAL PURPOSES, NAMELY, HERBAL EXTRACTS AND SYRUPS; MEDICINAL HERB EXTRACTS; MEDICINAL HERB EXTRACTS FOR MEDICAL PURPOSES; PLANT EXTRACTS FOR MEDICAL, PHARMACEUTICAL, NUTRACEUTICAL AND NUTRITIONAL PURPOSES; MEDICINAL EXTRACTS USED IN PREPARATIONS IN THE FORM OF LOTIONS, CREAMS, AND TOPICAL ANALGESICS AND ANESTHETICS, TABLETS, CAPSULES, PILLS, LOZENGES, INHALERS, TINCTURE, SUPPOSITORIES AND AMPULE FOR INJECTION; MEDICINAL EXTRACTS IN THE FORM OF LOTIONS, CREAMS, AND TOPICAL ANALGESICS AND ANESTHETICS, TABLETS, CAPSULES, PILLS, TINCTURE, SUPPOSITORIES AND AMPULE FOR INJECTION; MEDICINAL BOTANICAL EXTRACTS IN THE FORM OF LOTIONS, CREAMS, AND TOPICAL ANALGESICS AND ANESTHETICS, TABLETS, CAPSULES, PILLS, TINCTURE, SUPPOSITORIES AND AMPULE FOR INJECTION USED TO TREAT SKIN AILMENTS, FOR INFECTION, DEGENERATIVE, MUS-

SN 77-519,247. HERBALSCIENCE GROUP, LLC, NAPLES, FL. FILED 7-10-2008.

ULTRAPOWER ENERGY

THE MARK CONSISTS OF STANDARD CHARACTERS WITHOUT CLAIM TO ANY PARTICULAR FONT, STYLE, SIZE, OR COLOR.

NO CLAIM IS MADE TO THE EXCLUSIVE RIGHT TO USE "ENERGY", APART FROM THE MARK AS SHOWN.

CULAR, PULMONARY, SKELETAL, ENDOCRINE, IMMUNE, NEUROLOGICAL, CARDIOVASCULAR, METABOLIC, INFLAMMATORY, CANCER AND RELATED CONDITIONS; YEAST EXTRACTS FOR MEDICAL, PHARMACEUTICAL OR NUTRACEUTICAL PURPOSES; HERBAL PRODUCTS, NAMELY, HERBAL POWDERS FOR NUTRITIONAL PURPOSES; HERBAL PRODUCTS, NAMELY, HERBAL MEAL REPLACEMENT POWDERS FOR DIETARY AND NUTRITIONAL PURPOSES; HERBAL PRODUCTS, NAMELY, AROMATHERAPY PACKS CONTAINING HERBS USED FOR RELIEF FROM HEADACHES, INSOMNIA AND SINUS DISCOMFORT; HERBAL PRODUCTS, NAMELY, HERBAL POWDERS SOLD AS AN INTEGRAL INGREDIENT OF NUTRITIONAL SUPPLEMENT DRINK MIX FOR NUTRITIONAL PURPOSES; PHARMACEUTICALS AND NUTRACEUTICALS, NAMELY, VITAMINS AND FOOD SUPPLEMENTS; PHARMACEUTICAL PREPARATIONS, NAMELY, APPETITE SUPPRESSANTS AND LIPID LOWERING AGENTS; FOOD FOR DIABETICS, INFANTS AND ENTERAL FEEDING; BOTANICAL EXTRACTS FOR NUTRITIONAL USE; BOTANICAL EXTRACTS FOR MEDICAL, VETERINARY, NUTRACEUTICAL AND PHARMACEUTICAL PURPOSES; DESIGNER EXTRACTS, NAMELY, HERBAL EXTRACTS FOR MEDICAL, VETERINARY AND PHARMACEUTICAL PURPOSES; BOTANICAL EXTRACTS FOR NUTRITIONAL SUPPLEMENTS, NUTRACEUTICALS AND PHARMACEUTICALS; NUTRITIONAL DIETARY SUPPLEMENTS; ORAL PREPARATIONS CONTAINING HERBS OR HERBAL EXTRACTS USED TO MAINTAIN HEALTH AND FOR A WIDE VARIETY OF PHYSICAL CONDITIONS; VITAMIN AND MINERAL PREPARATIONS INTENDED FOR USE AS DIETARY SUPPLEMENTS; VITAMINS; FOOD SUPPLEMENTS; NUTRACEUTICALS, NAMELY, VITAMINS AND FOOD SUPPLEMENTS; FOOD FOR MEDICALLY RESTRICTED DIETS; SUPPLEMENTS, NAMELY, LIPID CONCENTRATES FOR USE AS A DIETARY FOOD SUPPLEMENT OR FOR PHARMACEUTICAL OR MEDICINAL PURPOSES; FOOD SUPPLEMENTS, NAMELY, ANTI-OXIDANTS; BOTANICALS AND BOTANICAL BLENDS, HERBALS AND HERBAL BLENDS, BOTANICAL EXTRACTS AND BOTANICAL EXTRACT BLENDS, FLAVOR EXTRACTS AND FLAVOR EXTRACT BLENDS, ALL SOLD AS COMPONENTS OF NUTRITIONAL SUPPLEMENTS AND VITAMINS; NUTRITIONAL OILS NOT FOR COSMETIC PURPOSES; FOOD SUPPLEMENTS, NAMELY, LIPID CONCENTRATES FOR USE AS A DIETARY FOOD SUPPLEMENT OR FOR PHARMACEUTICAL OR MEDICINAL PURPOSES; ANTI-COUGH DROPS; COUGH DROPS; COUGH EXPECTORANTS; THROAT LOZENGES; COUGH LOZENGES; COUGH SYRUPS; COUGH TREATMENT PREPARATIONS; COLD SORE TREATMENT PREPARATIONS; PHARMACEUTICAL ANTITUSSIVE-COLD PREPARATIONS; PREPARATIONS FOR TREATING COLDS; ANALGESIC PREPARATIONS; ANALGESICS; ANTIPIRETTIC ANALGESICS; IBUPROFEN FOR USE AS AN ORAL ANALGESIC; MULTIPURPOSE MEDICATED ANTIBIOTIC CREAM, ANALGESIC BALM AND MENTHOLATED SALVE; ORAL ANALGESICS; TOPICAL ANALGESICS; PHARMACEUTICAL PREPARATIONS FOR THE TREATMENT AND PREVENTION OF HERPES; VACCINES FOR THE TREATMENT AND PREVENTION OF HERPES; BIOLOGICAL PREPARATIONS FOR THE TREATMENT AND PREVENTION OF HERPES; PHARMACEUTICAL PREPARATIONS FOR THE TREATMENT OF HERPES SIMPLEX INFECTION; PHARMACEUTICAL CAPSULES FOR THE TREATMENT OF HERPES SIMPLEX INFECTION; HOMEOPATHIC PREPARATIONS FOR THE TREATMENT OF HERPES AND COLD SORES; PHARMACEUTICAL PREPARATIONS FOR THE TREATMENT OF HERPES VIRUSES; MEDICATED TOPICAL CLEAR FLUORIDE GEL FOR THE TREATMENT OF HERPES VIRUS DURING THE PHYSICAL MANIFESTATION OF THE VIRUS; PHARMACEUTICAL PREPARATIONS FOR THE TREATMENT OF HERPES SIMPLEX VIRUS TYPE I OR TYPE II OR HERPES ZOSTER VIRUS, NOT IN INTRAVENOUS FORM; PLANT-BASED ANTIVIRALS; OVER-THE-COUNTER TOPICAL ANTIVIRALS; PHARMACEUTICAL PREPARATION WITH ANTIVIRAL AND/OR ANTIMICROBIAL PROPERTIES FOR USE IN THE TREATMENT OF HERPESIC KERATITIS, CONJUNCTIVITIS, HIV RETINOPATHY, VIRAL INFLUENZA "FLU", HERPES SIMPLEX VIRUS 1, HERPES SIMPLEX VIRUS 2, VARICELLA ZOSTER VIRUS "HERPES ZOSTER" OR "SHINGLES", CYTOMEGALOVIRUS, VIRAL PARAIN-

FLUENZA, ADENOVIRUS, VIRAL ENCEPHALITIS, VIRAL MENINGITIS, ARBOVIRUS, ARENAVIRUS, PICORNAVIRUS, CORONAVIRUS, SYNTIAL VIRUS, VIRAL INFECTIONS, COMMON COLDS CAUSED BY VIRUSES, COLD SORES, HUMAN IMMUNODEFICIENCY VIRUS "HIV", ROSEOLA INFANTUM, HUMAN HERPES IV; PHARMACEUTICAL PREPARATIONS FOR THE TREATMENT OF VIRAL DISEASES AND DISORDERS, NAMELY, HERPES; PHARMACEUTICAL PREPARATIONS FOR TREATING IMMUNE DISEASES INDUCED BY VIRUS, NAMELY, HERPES, HERPES ZOSTER AND AIDS; ALGAL PRODUCTS FOR MEDICINAL PURPOSES, NAMELY, ALGAL EXTRACTS OR ALGAL EXTRACT BLENDS FOR USE AS NUTRITIONAL AND DIETARY SUPPLEMENTS; ALGAL PRODUCTS, NAMELY, ALGAL POWDERS SOLD AS AN INTEGRAL INGREDIENT OF NUTRITIONAL SUPPLEMENT DRINK MIX FOR NUTRITIONAL PURPOSES; ALGAL PRODUCTS, NAMELY, ALGAL POWDERS FOR NUTRITIONAL PURPOSES; ALGAL EXTRACTS OR ALGAL EXTRACT BLENDS FOR MEDICAL OR PHARMACEUTICAL PURPOSES; FUNCTIONAL FOODS, NAMELY, DIETETIC FOODS ADAPTED FOR MEDICAL PURPOSES; FUNCTIONAL BEVERAGES, NAMELY, NUTRITIONALLY FORTIFIED BEVERAGES; MEDICINAL FOODS, NAMELY, PROCESSED FOOD FOR MEDICAL PURPOSES; ANIMAL HEALTH PRODUCTS, NAMELY, ANIMAL FEED SUPPLEMENTS, MEDICATED ANIMAL FEED, MICRO-NUTRIENT ANIMAL FEED, DIETARY SUPPLEMENTS FOR ANIMALS, NON-MEDICATED ADDITIVES FOR ANIMAL FEED FOR USE AS NUTRITIONAL SUPPLEMENTS, NUTRITIONAL DRINKS FOR ANIMALS, PHARMACEUTICAL PREPARATIONS FOR ANIMAL SKINCARE; PLANT EXTRACTS FOR MEDICAL, VETERINARY AND PHARMACEUTICAL PURPOSES; HERBAL EXTRACTS FOR MEDICAL, VETERINARY AND PHARMACEUTICAL PURPOSES; DESIGNER EXTRACTS, NAMELY, PLANT, HERBAL AND BOTANICAL EXTRACTS FOR MEDICAL, VETERINARY AND PHARMACEUTICAL PURPOSES; AND BIODEFENSE PRODUCTS, NAMELY, MEDICINAL PREPARATIONS FOR THE TREATMENT OF INFECTIOUS DISEASES AND ADVERSE HUMAN HEALTH CONDITIONS, NAMELY, INFECTION, DEGENERATIVE, MUSCULAR, PULMONARY, SKELETAL, ENDOCRINE, IMMUNE, NEUROLOGICAL, CARDIOVASCULAR, METABOLIC, INFLAMMATORY, CANCER AND RELATED CONDITIONS; MUSHROOM, FUNGUS, OR SPORE EXTRACTS OR BLENDS AS SUPPLEMENTS, NUTRITION, NUTRACEUTICALS AND/OR PHARMACEUTICALS; BOTANICAL EXTRACTS FOR NUTRITIONAL USE; NUTRITIONALLY FORTIFIED BEVERAGES; NUTRITIONALLY FORTIFIED BEVERAGES FOR IMMUNE ENHANCEMENT, AND NUTRITIONALLY FORTIFIED BEVERAGES WITH RICE BRAN AND WHEAT BRAN; MEDICINAL BEVERAGES; SOY PROTEIN FOR USE AS A NUTRITIONAL SUPPLEMENT; NUTRITIONAL ADDITIVES FOR MEDICAL OR NONMEDICAL PURPOSES FOR USE IN MANUFACTURING FOODS AND DIETARY SUPPLEMENTS FOR HUMAN CONSUMPTION; ACTIVE PRINCIPLES EXTRACTED FROM MEDICINAL PLANTS FOR USE IN THE MANUFACTURE OF NUTRACEUTICALS AND PHARMACEUTICALS; ACTIVE PRINCIPLES EXTRACTED FROM MEDICINAL PLANTS FOR USE IN THE MANUFACTURE OF PHARMACEUTICAL OR NUTRACEUTICAL PRODUCTS (U.S. CLS. 6, 18, 44, 46, 51 AND 52).

CLASS 30—STAPLE FOODS

FOR HERBAL FOOD BEVERAGES; BEVERAGES, NAMELY, GRAIN-BASED BEVERAGES AND GRAIN-BASED FOOD BEVERAGES; PROCESSED HERBS; ORGANIC FOODS, NAMELY, CHOCOLATE, DAIRY-FREE CHOCOLATE, REDUCED FAT CHOCOLATE, REDUCED CALORIE CHOCOLATE, COCOA, CHOCOLATE CHIPS, CHOCOLATE FONDUE, CHOCOLATE TOPPING, REDUCED FAT CANDY, BAKERY PRODUCTS, NAMELY, CAKES AND PIES, CRACKERS, BISCUITS, READY-TO-EAT CEREAL-DERIVED FOOD BARS, PRETZELS, CHEWING GUM, FROZEN YOGURT, FROZEN CUSTARD, FRUIT ICES, PANCAKE AND WAFFLE MIXES, SALAD DRESSING, PASTA AND PASTA MIXES, RICE, CORNMEAL AND WHEAT-BASED SNACK FOODS; FOOD BEVERAGES, NAMELY, CHOCOLATE FOOD BEVERAGES NOT BEING DAIRY-BASED OR VEGETABLE BASED, AND GRAIN-BASED FOOD BEVERAGES; FUNCTIONAL FOODS, NAMELY, CHOCOLATE,

DAIRY-FREE CHOCOLATE, REDUCED FAT CHOCOLATE, REDUCED CALORIE CHOCOLATE, COCOA, CHOCOLATE CHIPS, CHOCOLATE FONDUE, CHOCOLATE TOPPING, REDUCED FAT CANDY, BAKERY PRODUCTS, NAMELY, CAKES AND PIES, CRACKERS, BISCUITS, READY-TO-EAT CEREAL-DERIVED FOOD BARS, PRETZELS, CHEWING GUM, FROZEN YOGURT, FROZEN CUSTARD, FRUIT ICES, PANCAKE AND WAFFLE MIXES, SALAD DRESSING, PASTA AND PASTA MIXES, RICE, CORNMEAL AND WHEAT BASED SNACK FOODS; BREAKFAST CEREALS; FUNCTIONAL BEVERAGES, NAMELY, GRAIN BASED FOOD BEVERAGES CONTAINING OATS OR OAT EXTRACTS, HERBAL FOOD BEVERAGES; FOOD FLAVORINGS; AND WHEAT BRAN-BASED SNACKS AND SNACK FOODS, RICE BRAN-BASED SNACKS AND SNACK FOODS; PROCESSED WHEAT AND RICE BRAN (U.S. CL. 46).

CLASS 32—LIGHT BEVERAGES

FOR ORGANIC BEVERAGES, NAMELY, FRUIT DRINKS, FRUIT-FLAVORED BEVERAGES, VEGETABLE-FLAVORED BEVERAGES, SOFT DRINKS, DRINKING WATER, FRUIT JUICES AND VEGETABLE JUICES; FUNCTIONAL BEVERAGES, NAMELY, FRUIT DRINKS, FRUIT-FLAVORED BEVERAGES, VEGETABLE-FLAVORED BEVERAGES, SOFT DRINKS, DRINKING WATER AND FRUIT JUICES AND VEGETABLE JUICES (U.S. CLS. 45, 46 AND 48).

HEATHER THOMPSON, EXAMINING ATTORNEY

SN 77-519,256, HERBALSCIENCE GROUP, LLC, NAPLES, FL, FILED 7-10-2008.

ENERGY ULTRAPOWER

THE MARK CONSISTS OF STANDARD CHARACTERS WITHOUT CLAIM TO ANY PARTICULAR FONT, STYLE, SIZE, OR COLOR.

NO CLAIM IS MADE TO THE EXCLUSIVE RIGHT TO USE "ENERGY", APART FROM THE MARK AS SHOWN.

CLASS 1—CHEMICALS

FOR BOTANICAL EXTRACTS FOR USE IN THE MANUFACTURE OF NUTRACEUTICALS; EXTRACTS FOR USE IN THE MANUFACTURE OF PHARMACEUTICAL PREPARATIONS IN THE FORM OF PREPARATIONS IN THE FORM OF LOTIONS, CREAMS, AND TOPICAL ANALGESICS AND ANESTHETICS, TABLETS, CAPSULES, PILLS, TINCTURE, SUPPOSITORIES AND AMPULE FOR INJECTION; BOTANICAL EXTRACTS FOR USE IN THE MANUFACTURE OF PHARMACEUTICALS; CHEMICAL EXTRACTS EXTRACTED FROM MEDICINAL PLANTS FOR USE IN THE MANUFACTURE OF NUTRACEUTICALS AND PHARMACEUTICALS; CHEMICAL EXTRACTS, NAMELY, CHEMICAL AGENTS MADE FROM BOTANICAL EXTRACTS OR ASSOCIATION OF CHEMICAL EXTRACTS FOR USE IN THE MANUFACTURE OF PHARMACEUTICAL OR NUTRACEUTICAL PRODUCTS; BOTANICAL EXTRACTS USED IN THE MANUFACTURE OF PREPARATIONS IN THE FORM OF LOTIONS, CREAMS, AND TOPICAL ANALGESICS AND ANESTHETICS, TABLETS, CAPSULES, PILLS, LOZENGES, INHALERS, TINCTURE, SUPPOSITORIES AND AMPULE FOR INJECTION; BOTANICALS AND BOTANICAL BLENDS, HERBS AND HERBAL BLENDS, BOTANICAL EXTRACTS AND BOTANICAL EXTRACT BLENDS, FLAVOR EXTRACTS AND FLAVOR EXTRACT BLENDS, ALGAL EXTRACTS AND ALGAL EXTRACT BLENDS, ALL FOR USE IN THE MANUFACTURE OF NUTRITIONAL SUPPLEMENTS AND VITAMINS; HERBAL EXTRACTS AND BLENDS FOR USE IN MANUFACTURING FUNCTIONAL FOODS OR BEVERAGES; HERBAL EXTRACTS AND BLENDS FOR USE IN MANUFACTURING MEDICINAL FOODS OR BEVERAGES; BOTANICAL EXTRACTS AND BLENDS FOR USE IN MANUFACTURING FUNCTIONAL FOODS OR BEVERAGES; BOTANICAL EXTRACTS AND BLENDS FOR USE IN MANUFACTURING MEDICINAL FOODS OR BEVERAGES; HERBAL PREPARATIONS AND EXTRACTS FOR USE AS INGREDIENTS IN MANUFACTURING IN THE FOOD, NUTRITION, NUTRACEUTICAL AND/OR PHARMACEUTICAL INDUSTRIES (U.S. CLS. 1, 5, 6, 10, 26 AND 46).

CLASS 3—COSMETICS AND CLEANING PREPARATIONS

FOR HERBAL PRODUCTS, NAMELY, AROMATHERAPY PACKS FILLED WITH HERBS FOR USE IN AROMATHERAPY; PRE-MOISTENED NON-MEDICATED PERSONAL HYGIENE WIPES, NAMELY, HERPES RELIEF WIPES; HERBAL AND BOTANICAL EXTRACTS FOR COSMETIC USE; ALGAL EXTRACTS OR ALGAL EXTRACT BLENDS FOR COSMETIC USE; ESSENTIAL OILS; FRAGRANCES; FRAGRANCES FOR PERSONAL USE; FOOD FLAVORINGS PREPARED FROM ESSENTIAL OILS (U.S. CLS. 1, 4, 6, 50, 51 AND 52).

CLASS 5—PHARMACEUTICALS

FOR NUTRITIONAL SUPPLEMENTS; HERBAL PRODUCTS, NAMELY, MEDICATED SKIN AND LIP BALMS; HERBAL PRODUCTS, NAMELY, OINTMENTS, OILS, DRINKS, INFUSIONS, SYRUPS, HERBAL EXTRACTS, POISONS, AND TINCTURES FOR MEDICAL USE IN THE TREATMENT OF STROKES, INFARCTS AND OTHER CARDIOVASCULAR AND CEREBRUM DISEASES; HERBAL PRODUCTS, NAMELY, OINTMENTS, OILS, NAMELY, MINERAL OIL FOR USE AS A LAXATIVE; DRINKS, NAMELY, MEAL REPLACEMENT DRINKS, DIETARY SUPPLEMENT DRINKS, MEDICINAL DRINKS, AND FISH OIL FOR USE AS A DIETARY SUPPLEMENT OR IN A NUTRACEUTICAL; INFUSIONS AND SYRUPS, NAMELY, COUGH SYRUPS; HERBAL PRODUCTS FOR MEDICINAL PURPOSES, NAMELY, HERBAL EXTRACTS FOR USE AS NUTRITIONAL AND DIETARY SUPPLEMENTS; HERBAL PRODUCTS FOR MEDICINAL PURPOSES, NAMELY, HERBAL EXTRACTS AND SYRUPS; MEDICINAL HERB EXTRACTS; MEDICINAL HERB EXTRACTS FOR MEDICAL PURPOSES; PLANT EXTRACTS FOR MEDICAL, PHARMACEUTICAL, NUTRACEUTICAL AND NUTRITIONAL PURPOSES; MEDICINAL EXTRACTS USED IN PREPARATIONS IN THE FORM OF LOTIONS, CREAMS, AND TOPICAL ANALGESICS AND ANESTHETICS,

TABLETS, CAPSULES, PILLS, LOZENGES, INHALERS, TINCTURE, SUPPOSITORIES AND AMPULE FOR INJECTION; MEDICINAL EXTRACTS IN THE FORM OF LOTIONS, CREAMS, AND TOPICAL ANALGESICS AND ANESTHETICS, TABLETS, CAPSULES, PILLS, TINCTURE, SUPPOSITORIES AND AMPULE FOR INJECTION; MEDICINAL HERBAL EXTRACTS IN THE FORM OF LOTIONS, CREAMS, AND TOPICAL ANALGESICS AND ANESTHETICS, TABLETS, CAPSULES, PILLS, TINCTURE, SUPPOSITORIES AND AMPULE FOR INJECTION; MEDICINAL BOTANICAL EXTRACTS IN THE FORM OF LOTIONS, CREAMS, AND TOPICAL ANALGESICS AND ANESTHETICS, TABLETS, CAPSULES, PILLS, TINCTURE, SUPPOSITORIES AND AMPULE FOR INJECTION USED TO TREAT SKIN AILMENTS, FOR INFECTION, DEGENERATIVE, MUSCULAR, PULMONARY, SKELETAL, ENDOCRINE, IMMUNE, NEUROLOGICAL, CARDIOVASCULAR, METABOLIC, INFLAMMATORY, CANCER AND RELATED CONDITIONS; YEAST EXTRACTS FOR MEDICAL, PHARMACEUTICAL OR NUTRACEUTICAL PURPOSES; HERBAL PRODUCTS, NAMELY, HERBAL POWDERS FOR NUTRITIONAL PURPOSES; HERBAL PRODUCTS, NAMELY, HERBAL MEAL REPLACEMENT POWDERS FOR DIETARY AND NUTRITIONAL PURPOSES; HERBAL PRODUCTS, NAMELY, AROMATHERAPY PACKS CONTAINING HERBS USED FOR RELIEF FROM HEADACHES, INSOMNIA AND SINUS DISCOMFORT; HERBAL PRODUCTS, NAMELY, HERBAL POWDERS SOLD AS AN INTEGRAL INGREDIENT OF NUTRITIONAL SUPPLEMENT DRINK MIX FOR NUTRITIONAL PURPOSES; PHARMACEUTICALS AND NUTRACEUTICALS, NAMELY, VITAMINS AND FOOD SUPPLEMENTS; PHARMACEUTICAL PREPARATIONS, NAMELY, APPETITE SUPPRESSANTS AND LIPID LOWERING AGENTS; FOOD FOR DIABETICS, INFANTS AND ENTERAL FEEDING; BOTANICAL EXTRACTS FOR NUTRITIONAL USE; BOTANICAL EXTRACTS FOR MEDICAL, VETERINARY, NUTRACEUTICAL AND PHARMACEUTICAL PURPOSES; DESIGNER EXTRACTS, NAMELY, HERBAL EXTRACTS FOR MEDICAL, VETERINARY AND PHARMACEUTICAL PURPOSES; BOTANICAL EXTRACTS FOR NUTRITIONAL SUPPLEMENTS, NUTRACEUTICALS AND PHARMACEUTICALS; NUTRITIONAL DIETARY SUPPLEMENTS; ORAL PREPARATIONS CONTAINING HERBS OR HERBAL EXTRACTS USED TO MAINTAIN HEALTH AND FOR A WIDE VARIETY OF PHYSICAL CONDITIONS; VITAMIN AND MINERAL PREPARATIONS INTENDED FOR USE AS DIETARY SUPPLEMENTS; VITAMINS; FOOD SUPPLEMENTS; NUTRACEUTICALS, NAMELY, VITAMINS AND FOOD SUPPLEMENTS; FOOD FOR MEDICALLY RESTRICTED DIETS; SUPPLEMENTS, NAMELY, LIPID CONCENTRATES FOR USE AS A DIETARY FOOD SUPPLEMENT OR FOR PHARMACEUTICAL OR MEDICINAL PURPOSES; FOOD SUPPLEMENTS, NAMELY, ANTI-OXIDANTS; BOTANICALS AND BOTANICAL BLENDS, HERBALS AND HERBAL BLENDS, BOTANICAL EXTRACTS AND BOTANICAL EXTRACT BLENDS, FLAVOR EXTRACTS AND FLAVOR EXTRACT BLENDS, ALL SOLD AS COMPONENTS OF NUTRITIONAL SUPPLEMENTS AND VITAMINS; NUTRITIONAL OILS NOT FOR COSMETIC PURPOSES; FOOD SUPPLEMENTS, NAMELY, LIPID CONCENTRATES FOR USE AS A DIETARY FOOD SUPPLEMENT OR FOR PHARMACEUTICAL OR MEDICINAL PURPOSES; ANTI-COUGH DROPS; COUGH DROPS; COUGH EXPECTORANTS; THROAT LOZENGES; COUGH LOZENGES; COUGH SYRUPS; COUGH TREATMENT PREPARATIONS; COLD SORE TREATMENT PREPARATIONS; PHARMACEUTICAL ANTITUSSIVE-COLD PREPARATIONS; PREPARATIONS FOR TREATING COLDS; ANALGESIC PREPARATIONS; ANALGESICS; ANTIPIRETTIC ANALGESICS; IBUPROFEN FOR USE AS AN ORAL ANALGESIC; MULTIPURPOSE MEDICATED ANTIBIOTIC CREAM, ANALGESIC BALM AND MENTHOLATED SALVE; ORAL ANALGESICS; TOPICAL ANALGESICS; PHARMACEUTICAL PREPARATIONS FOR THE TREATMENT AND PREVENTION OF HERPES; VACCINES FOR THE TREATMENT AND PREVENTION OF HERPES; BIOLOGICAL PREPARATIONS FOR THE TREATMENT AND PREVENTION OF HERPES; PHARMACEUTICAL PREPARATIONS FOR THE TREATMENT OF HERPES SIMPLEX INFECTION; PHARMACEUTICAL CAPSULES FOR THE TREATMENT OF HERPES SIMPLEX INFECTION; HOMEOPATHIC PREPARATIONS FOR THE TREATMENT OF HERPES AND COLD SORES; PHARMACEUTICAL PREPARATIONS FOR THE

TREATMENT OF HERPES VIRUSES; MEDICATED TOPICAL CLEAR FLUORIDE GEL FOR THE TREATMENT OF HERPES VIRUS DURING THE PHYSICAL MANIFESTATION OF THE VIRUS; PHARMACEUTICAL PREPARATIONS FOR THE TREATMENT OF HERPES SIMPLEX VIRUS TYPE I OR TYPE II OR HERPES ZOSTER VIRUS, NOT IN INTRAVENOUS FORM; PLANT-BASED ANTIVIRALS; OVER-THE-COUNTER TOPICAL ANTIVIRALS; PHARMACEUTICAL PREPARATION WITH ANTIVIRAL AND/OR ANTIMICROBIAL PROPERTIES FOR USE IN THE TREATMENT OF HERPETHIC KERATITIS, CONJUNCTIVITIS, HIV RETINOPATHY, VIRAL INFLUENZA "FLU", HERPES SIMPLEX VIRUS 1, HERPES SIMPLEX VIRUS 2, VARICELLA ZOSTER VIRUS "HERPES ZOSTER" OR "SHINGLES", CYTOMEGALOVIRUS, VIRAL PARAINFLUENZA, ADENOVIRUS, VIRAL ENCEPHALITIS, VIRAL MENINGITIS, ARBOVIRUS, ARENAVIRUS, PICORNAVIRUS, CORONAVIRUS, SYNTIALVIRUS, VIRAL INFECTIONS, COMMON COLDS CAUSED BY VIRUSES, COLD SORES, HUMAN IMMUNODEFICIENCY VIRUS "HIV", ROSEOLA INFANTUM, HUMAN HERPES IV; PHARMACEUTICAL PREPARATIONS FOR THE TREATMENT OF VIRAL DISEASES AND DISORDERS, NAMELY, HERPES; PHARMACEUTICAL PREPARATIONS FOR TREATING IMMUNE DISEASES INDUCED BY VIRUS, NAMELY, HERPES, HERPES ZOSTER AND AIDS; ALGAL PRODUCTS FOR MEDICINAL PURPOSES, NAMELY, ALGAL EXTRACTS OR ALGAL EXTRACT BLENDS FOR USE AS NUTRITIONAL AND DIETARY SUPPLEMENTS; ALGAL PRODUCTS, NAMELY, ALGAL POWDERS SOLD AS AN INTEGRAL INGREDIENT OF NUTRITIONAL SUPPLEMENT DRINK MIX FOR NUTRITIONAL PURPOSES; ALGAL PRODUCTS, NAMELY, ALGAL POWDERS FOR NUTRITIONAL PURPOSES; ALGAL EXTRACTS OR ALGAL EXTRACT BLENDS FOR MEDICAL OR PHARMACEUTICAL PURPOSES; FUNCTIONAL FOODS, NAMELY, DIETETIC FOODS ADAPTED FOR MEDICAL PURPOSES; FUNCTIONAL BEVERAGES, NAMELY, NUTRITIONALLY FORTIFIED BEVERAGES; MEDICINAL FOODS, NAMELY, PROCESSED FOOD FOR MEDICAL PURPOSES; ANIMAL HEALTH PRODUCTS, NAMELY, ANIMAL FEED SUPPLEMENTS, MEDICATED ANIMAL FEED, MICRO-NUTRIENT ANIMAL FEED, DIETARY SUPPLEMENTS FOR ANIMALS, NON-MEDICATED ADDITIVES FOR ANIMAL FEED FOR USE AS NUTRITIONAL SUPPLEMENTS, NUTRITIONAL DRINKS FOR ANIMALS, PHARMACEUTICAL PREPARATIONS FOR ANIMAL SKINCARE; PLANT EXTRACTS FOR MEDICAL, VETERINARY AND PHARMACEUTICAL PURPOSES; HERBAL EXTRACTS FOR MEDICAL, VETERINARY AND PHARMACEUTICAL PURPOSES; DESIGNER EXTRACTS, NAMELY, PLANT, HERBAL AND BOTANICAL EXTRACTS FOR MEDICAL, VETERINARY AND PHARMACEUTICAL PURPOSES; AND BIODEFENSE PRODUCTS, NAMELY, MEDICINAL PREPARATIONS FOR THE TREATMENT OF INFECTIOUS DISEASES AND ADVERSE HUMAN HEALTH CONDITIONS, NAMELY, INFECTION, DEGENERATIVE, MUSCULAR, PULMONARY, SKELETAL, ENDOCRINE, IMMUNE, NEUROLOGICAL, CARDIOVASCULAR, METABOLIC, INFLAMMATORY, CANCER AND RELATED CONDITIONS; MUSHROOM, FUNGUS, OR SPORE EXTRACTS OR BLENDS AS SUPPLEMENTS, NUTRITION, NUTRACEUTICALS AND/OR PHARMACEUTICALS; BOTANICAL EXTRACTS FOR NUTRITIONAL USE; NUTRITIONALLY FORTIFIED BEVERAGES; NUTRITIONALLY FORTIFIED BEVERAGES FOR IMMUNE ENHANCEMENT, AND NUTRITIONALLY FORTIFIED BEVERAGES WITH RICE BRAN AND WHEAT BRAN; MEDICINAL BEVERAGES; SOY PROTEIN FOR USE AS A NUTRITIONAL SUPPLEMENT; NUTRITIONAL ADDITIVES FOR MEDICAL OR NONMEDICAL PURPOSES FOR USE IN MANUFACTURING FOODS AND DIETARY SUPPLEMENTS FOR HUMAN CONSUMPTION; ACTIVE PRINCIPLES EXTRACTED FROM MEDICINAL PLANTS FOR USE IN THE MANUFACTURE OF NUTRACEUTICALS AND PHARMACEUTICALS; ACTIVE PRINCIPLES EXTRACTED FROM MEDICINAL PLANTS FOR USE IN THE MANUFACTURE OF PHARMACEUTICAL OR NUTRACEUTICAL PRODUCTS (U.S. CLS. 6, 18, 44, 46, 51 AND 52).

CLASS 29—MEATS AND PROCESSED FOODS

FOR BEVERAGES, NAMELY, YOGURT-BASED BEVERAGES; FOOD BEVERAGES, NAMELY, DAIRY-BASED FOOD BEVERAGES, FRUIT-BASED FOOD BEVERAGES, VEGETABLE-BASED FOOD BEVERAGES, DAIRY-BASED CHOCOLATE FOOD BEVERAGES, SOY-BASED FOOD BEVERAGE USED AS A MILK SUBSTITUTE, VEGETABLE-BASED CHOCOLATE FOOD BEVERAGES AND PEANUT-BASED FOOD BEVERAGES; MILK BEVERAGES; MILK BEVERAGES, NAMELY, MILK, MILK BEVERAGES CONTAINING FRUITS, MILK BEVERAGES WITH HIGH MILK CONTENT, MILK BASED BEVERAGES CONTAINING FRUIT JUICE AND MILK BEVERAGES CONTAINING COFFEE; MILK POWDER; MILK POWDER FOR NUTRITIONAL PURPOSES; POWDERED MILK FOR FOOD PURPOSES; FUNCTIONAL FOODS, NAMELY, DAIRY-BASED FOOD BEVERAGES, FRUIT-BASED FOOD BEVERAGES, VEGETABLE-BASED FOOD BEVERAGES, DAIRY-BASED CHOCOLATE FOOD BEVERAGES, SOY-BASED FOOD BEVERAGE USED AS A MILK SUBSTITUTE, VEGETABLE-BASED CHOCOLATE FOOD BEVERAGES, NUT-BASED FOOD BEVERAGES, MILK, MILK BEVERAGES CONTAINING FRUITS, MILK BEVERAGES WITH HIGH MILK CONTENT, MILK BASED BEVERAGES CONTAINING FRUIT JUICE, AND MILK BEVERAGES CONTAINING COFFEE; EDIBLE OILS, NAMELY, OMEGA OIL EXTRACTS AND FISH OIL EXTRACTS; SOY PROTEIN FOR USE AS A FOOD ADDITIVE; MUSHROOM, FUNGUS, OR SPORE EXTRACTS OR BLENDS THEREOF FOR USE AS FOOD ADDITIVES (U.S. CL. 46).

CLASS 30—STAPLE FOODS

FOR HERBAL FOOD BEVERAGES; BEVERAGES, NAMELY, GRAIN-BASED BEVERAGES AND GRAIN-BASED FOOD BEVERAGES; PROCESSED HERBS; ORGANIC FOODS, NAMELY, CHOCOLATE, DAIRY-FREE CHOCOLATE, REDUCED FAT CHOCOLATE, REDUCED CALORIE CHOCOLATE, COCOA, CHOCOLATE CHIPS, CHOCOLATE FONDUE, CHOCOLATE TOPPINGS, REDUCED FAT CANDY, BAKERY PRODUCTS, NAMELY, CAKES AND PIES, CRACKERS, BISCUITS, READY-TO-EAT CEREAL-DERIVED FOOD BARS, PRETZELS, CHEWING GUM, FROZEN YOGURT, FROZEN CUSTARD, FRUIT ICES, PANCAKE AND WAFFLE MIXES, SALAD DRESSING, PASTA AND PASTA MIXES, RICE, CORNMEAL AND WHEAT-BASED SNACK FOODS; FOOD BEVERAGES, NAMELY, CHOCOLATE FOOD BEVERAGES NOT BEING DAIRY-BASED OR VEGETABLE BASED, AND GRAIN-BASED FOOD BEVERAGES; FUNCTIONAL FOODS, NAMELY, CHOCOLATE, DAIRY-FREE CHOCOLATE, REDUCED FAT CHOCOLATE, REDUCED CALORIE CHOCOLATE, COCOA, CHOCOLATE CHIPS, CHOCOLATE FONDUE, CHOCOLATE TOPPINGS, REDUCED FAT CANDY, BAKERY PRODUCTS, NAMELY, CAKES AND PIES, CRACKERS, BISCUITS, READY-TO-EAT CEREAL-DERIVED FOOD BARS, PRETZELS, CHEWING GUM, FROZEN YOGURT, FROZEN CUSTARD, FRUIT ICES, PANCAKE AND WAFFLE MIXES, SALAD DRESSING, PASTA AND PASTA MIXES, RICE, CORNMEAL AND WHEAT BASED SNACK FOODS; BREAKFAST CEREALS; FUNCTIONAL BEVERAGES, NAMELY, GRAIN BASED FOOD BEVERAGES CONTAINING OATS OR OAT EXTRACTS, HERBAL FOOD BEVERAGES; FOOD FLAVORINGS; AND WHEAT BRAN-BASED SNACKS AND SNACK FOODS, RICE BRAN-BASED SNACKS AND SNACK FOODS; PROCESSED WHEAT AND RICE BRAN (U.S. CL. 46).

CLASS 32—LIGHT BEVERAGES

FOR ORGANIC BEVERAGES, NAMELY, FRUIT DRINKS, FRUIT-FLAVORED BEVERAGES, VEGETABLE-FLAVORED BEVERAGES, SOFT DRINKS, DRINKING WATER, FRUIT JUICES AND VEGETABLE JUICES; FUNCTIONAL BEVERAGES, NAMELY, FRUIT DRINKS, FRUIT-FLAVORED BEVERAGES, VEGETABLE-FLAVORED BEVERAGES, SOFT DRINKS, DRINKING WATER AND FRUIT JUICES AND VEGETABLE JUICES (U.S. CLS. 45, 46 AND 48).

HEATHER THOMPSON, EXAMINING ATTORNEY

SN 77-519,257, ULTIMATE RESORT HOLDINGS, LLC, KISSIMMEE, FL. FILED 7-10-2008.

IT'S THE ULTIMATE WAY TO
BRING FAMILY AND FRIENDS
TOGETHER.

THE MARK CONSISTS OF STANDARD CHARACTERS WITHOUT CLAIM TO ANY PARTICULAR FONT, STYLE, SIZE, OR COLOR.

OWNER OF U.S. REG. NOS. 3,223,509, 3,489,964 AND OTHERS.

CLASS 41—EDUCATION AND ENTERTAINMENT

FOR COUNTRY CLUB SERVICES (U.S. CLS. 100, 101 AND 107).

FIRST USE 9-1-2007; IN COMMERCE 9-1-2007.

CLASS 43—HOTEL AND RESTAURANT SERVICES

FOR RESORT LODGING SERVICES (U.S. CLS. 100 AND 101).

FIRST USE 9-1-2007; IN COMMERCE 9-1-2007.

LESLIE RICHARDS, EXAMINING ATTORNEY

SN 77-519,271, HERBALSCIENCE GROUP, LLC, NAPLES, FL. FILED 7-10-2008.

MATÉHEALTH

THE MARK CONSISTS OF STANDARD CHARACTERS WITHOUT CLAIM TO ANY PARTICULAR FONT, STYLE, SIZE, OR COLOR.

USED TO MAINTAIN HEALTH AND FOR A WIDE VARIETY OF PHYSICAL CONDITIONS; VITAMIN AND MINERAL PREPARATIONS INTENDED FOR USE AS DIETARY SUPPLEMENTS; VITAMINS; FOOD SUPPLEMENTS; NUTRACEUTICALS, NAMELY, VITAMINS AND FOOD SUPPLEMENTS; FOOD FOR MEDICALLY RESTRICTED DIETS; SUPPLEMENTS, NAMELY, LIPID CONCENTRATES FOR USE AS A DIETARY FOOD SUPPLEMENT OR FOR PHARMACEUTICAL OR MEDICINAL PURPOSES; FOOD SUPPLEMENTS, NAMELY, ANTI-OXIDANTS; BOTANICALS AND BOTANICAL BLENDS, HERBALS AND HERBAL BLENDS, BOTANICAL EXTRACTS AND BOTANICAL EXTRACT BLENDS, FLAVOR EXTRACTS AND FLAVOR EXTRACT BLENDS, ALL SOLD AS COMPONENTS OF NUTRITIONAL SUPPLEMENTS AND VITAMINS; NUTRITIONAL OILS NOT FOR COSMETIC PURPOSES; FOOD SUPPLEMENTS, NAMELY, LIPID CONCENTRATES FOR USE AS A DIETARY FOOD SUPPLEMENT OR FOR PHARMACEUTICAL OR MEDICINAL PURPOSES; ANTI-COUGH DROPS; COUGH DROPS; COUGH EXPECTORANTS; THROAT LOZENGES; COUGH LOZENGES; COUGH SYRUPS; COUGH TREATMENT PREPARATIONS; COLD SORE TREATMENT PREPARATIONS; PHARMACEUTICAL ANTITUSSIVE-COLD PREPARATIONS; PREPARATIONS FOR TREATING COLDS; ANALGESIC PREPARATIONS; ANALGESICS; ANTI-PYRETIC ANALGESICS; IBUPROFEN FOR USE AS AN ORAL ANALGESIC; MULTIPURPOSE MEDICATED ANTIBIOTIC CREAM, ANALGESIC BALM AND MENTHOLATED SALVE; ORAL ANALGESICS; TOPICAL ANALGESICS; PHARMACEUTICAL PREPARATIONS FOR THE TREATMENT AND PREVENTION OF HERPES; VACCINES FOR THE TREATMENT AND PREVENTION OF HERPES; BIOLOGICAL PREPARATIONS FOR THE TREATMENT AND PREVENTION OF HERPES; PHARMACEUTICAL PREPARATIONS FOR THE TREATMENT OF HERPES SIMPLEX INFECTION; PHARMACEUTICAL CAPSULES FOR THE TREATMENT OF HERPES SIMPLEX INFECTION; HOMEOPATHIC PREPARATIONS FOR THE TREATMENT OF HERPES AND COLD SORES; PHARMACEUTICAL PREPARATIONS FOR THE TREATMENT OF HERPES VIRUSES; MEDICATED TOPICAL CLEAR FLUORIDE GEL FOR THE TREATMENT OF HERPES VIRUS DURING THE PHYSICAL MANIFESTATION OF THE VIRUS; PHARMACEUTICAL PREPARATIONS FOR THE TREATMENT OF HERPES SIMPLEX VIRUS TYPE I OR TYPE II OR HERPES ZOSTER VIRUS, NOT IN INTRAVENOUS FORM; PLANT BASED ANTIVIRALS; OVER-THE-COUNTER TOPICAL ANTIVIRALS; PHARMACEUTICAL PREPARATION WITH ANTIVIRAL OR ANTIMICROBIAL PROPERTIES FOR USE IN THE TREATMENT OF HERPATIC KERATITIS, CONJUNCTIVITIS, HIV RETINOPATHY, VIRAL INFLUENZA (FLU), HERPES SIMPLEX VIRUS 1, HERPES SIMPLEX VIRUS 2, VARICELLA ZOSTER VIRUS (HERPES ZOSTER OR SHINGLES), CYTOMEGALOVIRUS, VIRAL PARAINFLUENZA, ADENOVIRUS, VIRAL ENCEPHALITIS, VIRAL MENINGITIS, ARBOVIRUS, ARENAVIRUS, PICORNAVIRUS, CORONAVIRUS, SYNTIALVIRUS, VIRAL INFECTIONS, COMMON COLDS CAUSED BY VIRUSES, COLD SORES, HUMAN IMMUNODEFICIENCY VIRUS (HIV), ROSEOLA INFANTUM, HUMAN HERPES IV; PHARMACEUTICAL PREPARATIONS FOR THE TREATMENT OF VIRAL DISEASES AND DISORDERS, NAMELY, HERPES; PHARMACEUTICAL PREPARATIONS FOR TREATING IMMUNE DISEASES INDUCED BY VIRUS, NAMELY, HERPES, HERPES ZOSTER AND AIDS; ALGAL PRODUCTS FOR MEDICINAL PURPOSES, NAMELY, ALGAL EXTRACTS OR ALGAL EXTRACT BLENDS FOR USE AS NUTRITIONAL AND DIETARY SUPPLEMENTS; ALGAL PRODUCTS, NAMELY, ALGAL POWDERS SOLD AS AN INTEGRAL INGREDIENT OF NUTRITIONAL SUPPLEMENT DRINK MIX FOR NUTRITIONAL PURPOSES; ALGAL NUTRITIONAL SUPPLEMENT PRODUCTS, NAMELY, ALGAL POWDERS FOR USE AS A NUTRITIONAL SUPPLEMENT; ALGAL EXTRACTS OR ALGAL EXTRACT BLENDS FOR MEDICAL OR PHARMACEUTICAL PURPOSES; FUNCTIONAL FOODS, NAMELY, DIETETIC FOODS ADAPTED FOR MEDICAL PURPOSES, FOOD FOR DIABETICS, INFANTS AND ENTERAL FEEDING, FOOD FOR MEDICALLY RESTRICTED DIETS; FUNCTIONAL BEVERAGES, NAMELY, NUTRITIONALLY FORTIFIED BEVERAGES; MEDICINAL FOODS, NAMELY, PROCESSED FOOD FOR MEDICAL PURPOSES; ANIMAL HEALTH PRODUCTS, NAMELY, ANI-

MAL FEED SUPPLEMENTS, MEDICATED ANIMAL FEED, MICRO-NUTRIENT ANIMAL FEED, DIETARY SUPPLEMENTS FOR ANIMALS, NON-MEDICATED ADDITIVES FOR ANIMAL FEED FOR USE AS NUTRITIONAL SUPPLEMENTS, NUTRITIONAL DRINKS FOR ANIMALS, PHARMACEUTICAL PREPARATIONS FOR ANIMAL SKINCARE; PLANT EXTRACTS FOR MEDICAL, VETERINARY AND PHARMACEUTICAL PURPOSES; BOTANICAL EXTRACTS FOR MEDICAL, VETERINARY AND PHARMACEUTICAL PURPOSES; HERBAL EXTRACTS FOR MEDICAL, VETERINARY AND PHARMACEUTICAL PURPOSES; DESIGNER EXTRACTS, NAMELY, PLANT, HERBAL AND BOTANICAL EXTRACTS FOR MEDICAL, VETERINARY AND PHARMACEUTICAL PURPOSES; AND BIODEFENSE PRODUCTS, NAMELY, MEDICINAL PREPARATIONS FOR THE TREATMENT OF, OR RELIEF OF SYMPTOMS IN, INFECTIOUS DISEASES AND ADVERSE HUMAN HEALTH CONDITIONS, NAMELY, INFECTION, DEGENERATIVE, MUSCULAR, PULMONARY, SKELETAL, ENDOCRINE, IMMUNE, NEUROLOGICAL, CARDIOVASCULAR, METABOLIC, INFLAMMATORY, CANCER AND RELATED CONDITIONS; MUSHROOM, FUNGUS, OR SPORE EXTRACTS OR BLENDS FOR USE AS INGREDIENTS IN FUNCTIONAL FOODS, NUTRACEUTICAL OR PHARMACEUTICAL PREPARATIONS; FUNCTIONAL FOODS FOR USE AS DIETARY OR NUTRITIONAL SUPPLEMENTS, NAMELY, EDIBLE PRODUCTS IN CONVENTIONAL FOOD FORM FORTIFIED WITH VITAMINS, MINERALS AND OTHER NUTRIENTS OR FIBER; NUTRITIONALLY FORTIFIED FOOD BEVERAGES; NUTRITIONALLY FORTIFIED BEVERAGES; FUNCTIONAL FOODS, NAMELY, DAIRY-BASED FOOD BEVERAGES, FRUIT-BASED FOOD BEVERAGES, VEGETABLE-BASED FOOD BEVERAGES, DAIRY-BASED CHOCOLATE FOOD BEVERAGES, SOY-BASED FOOD BEVERAGE USED AS A MILK SUBSTITUTE, VEGETABLE-BASED CHOCOLATE FOOD BEVERAGES, NUT-BASED FOOD BEVERAGES, MILK, MILK BEVERAGES CONTAINING FRUITS, MILK BEVERAGES WITH HIGH MILK CONTENT, MILK BASED BEVERAGES CONTAINING FRUIT JUICE, AND MILK BEVERAGES CONTAINING COFFEE, OMEGA-3 OIL EXTRACTS; FISH OIL EXTRACTS; SOY PROTEIN AS A NUTRITIONAL SUPPLEMENT; WHEAT BRAN AND RICE BRAN AS NUTRITIONAL SUPPLEMENTS IN MEDICINAL AND FUNCTIONAL FOODS AND BEVERAGES; MEDICINAL BEVERAGES (U.S. CLS. 6, 18, 44, 46, 51 AND 52).

CLASS 29—MEATS AND PROCESSED FOODS

FOR FOOD BEVERAGES, NAMELY, DAIRY-BASED FOOD BEVERAGES, FRUIT-BASED FOOD BEVERAGES, VEGETABLE-BASED FOOD BEVERAGES, DAIRY-BASED CHOCOLATE FOOD BEVERAGES, SOY-BASED FOOD BEVERAGE USED AS A MILK SUBSTITUTE, VEGETABLE-BASED CHOCOLATE FOOD BEVERAGES AND PEANUT-BASED FOOD BEVERAGES; MILK BEVERAGES, NAMELY, MILK, MILK BEVERAGES CONTAINING FRUITS, MILK BEVERAGES WITH HIGH MILK CONTENT, MILK BASED BEVERAGES CONTAINING FRUIT JUICE; MILK BEVERAGES CONTAINING COFFEE; MILK POWDER FOR NUTRITIONAL PURPOSES; POWDERED MILK FOR FOOD PURPOSES; NUT-BASED FOOD BEVERAGES; OILS, NAMELY, EDIBLE OILS, EDIBLE OIL EXTRACTS, OMEGA-3 OIL EXTRACTS (U.S. CL. 46).

CLASS 30—STAPLE FOODS

FOR HERBAL FOOD BEVERAGES; MEDICINAL BEVERAGES FOR IMMUNITY ENHANCEMENT; NUTRITIONALLY FORTIFIED BEVERAGES FOR IMMUNITY ENHANCEMENT; GRAIN-BASED BEVERAGES WITH RICE BRAN; GRAIN-BASED BEVERAGES WITH WHEAT BRAN; MEDICINAL HERBS, NAMELY, PROCESSED HERBS; NUTRITIONALLY FORTIFIED ORGANIC FOODS, NAMELY, CHOCOLATE, DAIRY-FREE CHOCOLATE, REDUCED FAT CHOCOLATE, REDUCED CALORIE CHOCOLATE, COCOA, CHOCOLATE CHIPS, CHOCOLATE FONDUE, CHOCOLATE TOPPINGS, REDUCED FAT CANDY, BAKERY PRODUCTS, NAMELY, COOKIES, CAKES, PIES AND MUFFINS, CRACKERS, BISCUITS, READY-TO-EAT CEREAL-DERIVED FOOD BARS, PRETZELS, CHEWING GUM, FROZEN YOGURT, FROZEN CUSTARD, FRUIT ICES, PANCAKE, WAFFLE

AND BREAD MIXES, SALAD DRESSING, PASTA AND PASTA MIXES, RICE, CORNMEAL AND WHEAT BASED SNACK FOODS; FOOD BEVERAGES, NAMELY, CHOCOLATE FOOD BEVERAGES NOT BEING DAIRY-BASED OR VEGETABLE BASED, HERBAL FOOD BEVERAGES, AND GRAIN-BASED FOOD BEVERAGES; FUNCTIONAL FOODS, NAMELY, CHOCOLATE, DAIRY-FREE CHOCOLATE, REDUCED FAT CHOCOLATE, REDUCED CALORIE CHOCOLATE, COCOA, CHOCOLATE CHIPS, CHOCOLATE FONDUE, CHOCOLATE TOPPINGS, REDUCED FAT CANDY, BAKERY PRODUCTS, NAMELY, COOKIES, CAKES, PIES AND MUFFINS, CRACKERS, BISCUITS, READY-TO-EAT CEREAL-DERIVED FOOD BARS, PRETZELS, CHEWING GUM, FROZEN YOGURT, FROZEN CUSTARD, FRUIT ICES, PANCAKE, WAFFLE AND BREAD MIXES, SALAD DRESSING, PASTA AND PASTA MIXES, RICE, CORNMEAL AND WHEAT BASED SNACK FOODS, BREAD, BREAKFAST CEREALS; FUNCTIONAL BEVERAGES, NAMELY, GRAIN BASED FOOD BEVERAGES CONTAINING OATS OR OAT EXTRACTS, HERBAL FOOD BEVERAGES; FOOD BEVERAGES, NAMELY, CHOCOLATE FOOD BEVERAGES NOT BEING DAIRY-BASED OR VEGETABLE BASED, HERBAL FOOD BEVERAGES, AND GRAIN-BASED FOOD BEVERAGES; FOOD FLAVORINGS; AND WHEAT BRAN BASED FOODS AND SNACKS; RICE BRAN BASED FOOD AND SNACKS; AND FOOD FLAVORINGS PREPARED FROM HERBAL OR BOTANICAL EXTRACTS OR BLENDS; HERBAL INFUSIONS (U.S. CL. 46).

CLASS 32—LIGHT BEVERAGES

FOR ORGANIC BEVERAGES, NAMELY, FRUIT DRINKS, SOFT DRINKS, DRINKING WATER AND FRUIT AND VEGETABLE JUICES; FUNCTIONAL BEVERAGES, NAMELY, FRUIT DRINKS, SOFT DRINKS, DRINKING WATER AND FRUIT AND VEGETABLE JUICES (U.S. CLS. 45, 46 AND 48).

TINA KUAN, EXAMINING ATTORNEY

SN 77-519,288. CEMENTOS LIMA S.A., LIMA 35, PERU, FILED 7-10-2008.



OWNER OF PERU REG. NO. 49218, DATED 1-1-2008, EXPIRES 1-1-2018.

OWNER OF PERU REG. NO. 49196, DATED 1-1-2008, EXPIRES 1-1-2018.

OWNER OF PERU REG. NO. 134348, DATED 1-11-2008, EXPIRES 1-11-2018.

OWNER OF PERU REG. NO. 134847, DATED 2-1-2008, EXPIRES 2-1-2018.

NO CLAIM IS MADE TO THE EXCLUSIVE RIGHT TO USE "CEMENTOS LIMA S.A. - LIMA PERU", APART FROM THE MARK AS SHOWN.

THE COLOR(S) GREEN IS/ARE CLAIMED AS A FEATURE OF THE MARK.

THE MARK CONSISTS OF A CIRCULAR FIGURE INSIDE OF WHICH IS THE DENOMINATION "CEMENTOS LIMA S.A. - LIMA PERU", AS WELL AS THE DENOMINATION "SOL" WITHIN AN IRREGULAR FIGURE WHICH IS SUPERIMPOSED OVER THE STYLIZED REPRESENTATION OF A SUN; ALL IN GREEN COLOR.

THE FOREIGN WORDING IN THE MARK TRANSLATES INTO ENGLISH AS SUN AND CEMENT.

CLASS 16—PAPER GOODS AND PRINTED MATTER

FOR PAPER, CARDBOARD, STATIONERY; PAPER BAGS; CARDBOARD BOXES AND BAGS; PAPER FOR PACKAGING, PLASTIC BAGS AND BUBBLE PACKS AND CARDBOARD FOR PACKAGING (U.S. CLS. 2, 5, 22, 23, 29, 37, 38 AND 50).

CLASS 19—NON-METALLIC BUILDING MATERIALS

FOR CEMENTS IN GENERAL, NAMELY, PORTLAND TYPE CEMENTS AND PUZZOLANIC TYPE CEMENTS (U.S. CLS. 1, 12, 33 AND 50).

CLASS 37—CONSTRUCTION AND REPAIR

FOR BUILDING CONSTRUCTION; RENTAL OF CONSTRUCTION HAND AND POWER TOOLS, MATERIALS AND MACHINES FOR BUILDING CONSTRUCTION, QUARRYING AND MINING EXTRACTION (U.S. CLS. 100, 103 AND 106).

CLASS 39—TRANSPORTATION AND STORAGE

FOR SUPPLY CHAIN, LOGISTICS AND REVERSE LOGISTICS SERVICES, NAMELY, TRANSPORT, PACKAGING FOR TRANSPORTATION AND STORAGE OF CEMENTS IN GENERAL, INCLUDING IN BULK AND/OR IN BAGS; RENTAL OF WAREHOUSES FOR STORAGE OF CEMENTS IN GENERAL, INCLUDING CEMENTS IN BULK AND/OR IN BAGS (U.S. CLS. 100 AND 105).

THOMAS MANOR, EXAMINING ATTORNEY

SN 77-519,311. HERBALSCIENCE GROUP, LLC, NAPLES, FL. FILED 7-10-2008.

ULTRAPOWER MEMORY

THE MARK CONSISTS OF STANDARD CHARACTERS WITHOUT CLAIM TO ANY PARTICULAR FONT, STYLE, SIZE, OR COLOR.

NO CLAIM IS MADE TO THE EXCLUSIVE RIGHT TO USE "MEMORY", APART FROM THE MARK AS SHOWN.

CLASS 1—CHEMICALS

FOR BOTANICAL EXTRACTS FOR USE IN THE MANUFACTURE OF NUTRACEUTICALS; EXTRACTS FOR USE IN THE MANUFACTURE OF PHARMACEUTICAL PREPARATIONS IN THE FORM OF PREPARATIONS IN THE FORM OF LOTIONS, CREAMS, AND TOPICAL ANALGESICS AND ANESTHETICS, TABLETS, CAPSULES, PILLS, TINCTURE, SUPPOSITORIES AND AMPULE FOR INJECTION; BOTANICAL EXTRACTS FOR USE IN THE MANUFACTURE OF PHARMACEUTICALS; CHEMICAL EXTRACTS EXTRACTED FROM MEDICINAL PLANTS FOR USE IN THE MANUFACTURE OF NUTRACEUTICALS AND PHARMACEUTICALS; CHEMICAL EXTRACTS, NAMELY, CHEMICAL AGENTS MADE FROM BOTANICAL EXTRACTS OR ASSOCIATION OF CHEMICAL EXTRACTS FOR USE IN THE MANUFACTURE OF PHARMACEUTICAL OR NUTRACEUTICAL PRODUCTS; BOTANICAL EXTRACTS USED IN THE MANUFACTURE OF PREPARATIONS IN THE FORM OF LOTIONS, CREAMS, AND TOPICAL ANALGESICS AND ANESTHETICS, TABLETS, CAPSULES, PILLS, LOZENGES, INHALERS, TINCTURE, SUPPOSITORIES AND AMPULE FOR INJECTION; BOTANICALS AND BOTANICAL BLENDS, HERBS AND HERBAL BLENDS, BOTANICAL EXTRACTS AND BOTANICAL EXTRACT BLENDS, FLAVOR EXTRACTS AND FLAVOR EXTRACT BLENDS, ALGAL EXTRACTS AND ALGAL EXTRACT BLENDS, ALL FOR USE IN THE MANUFACTURE OF NUTRITIONAL SUPPLEMENTS AND VITAMINS; HERBAL EXTRACTS AND BLENDS FOR USE IN MANUFACTURING FUNCTIONAL FOODS OR BEVERAGES; HERBAL EXTRACTS AND BLENDS FOR USE IN MANUFACTURING MEDICINAL FOODS OR BEVERAGES; BOTANICAL EXTRACTS AND BLENDS FOR USE IN MANUFACTURING FUNCTIONAL FOODS OR BEVERAGES; BOTANICAL EXTRACTS AND BLENDS FOR USE IN MANUFACTURING MEDICINAL FOODS OR BEVERAGES; HERBAL PREPARATIONS AND EXTRACTS FOR USE AS INGREDIENTS IN MANUFACTURING IN THE FOOD, NUTRITION, NUTRACEUTICAL AND/OR PHARMACEUTICAL INDUSTRIES (U.S. CLS. 1, 5, 6, 10, 26 AND 46).

CLASS 5—PHARMACEUTICALS

FOR NUTRITIONAL SUPPLEMENTS; HERBAL PRODUCTS, NAMELY, MEDICATED SKIN AND LIP BALMS; HERBAL PRODUCTS, NAMELY, OINTMENTS, OILS, DRINKS, INFUSIONS, SYRUPS, HERBAL EXTRACTS, POISONS, AND TINCTURES FOR MEDICAL USE IN THE TREATMENT OF STROKES, INFARCTS AND OTHER CARDIOVASCULAR AND CEREBRUM DISEASES; HERBAL PRODUCTS, NAMELY, OINTMENTS, OILS, NAMELY, MINERAL OIL FOR USE AS A LAXATIVE; DRINKS, NAMELY, MEAL REPLACEMENT DRINKS, DIETARY SUPPLEMENT DRINKS, MEDICINAL DRINKS, AND FISH OIL FOR USE AS A DIETARY SUPPLEMENT OR IN A NUTRACEUTICAL; INFUSIONS AND SYRUPS, NAMELY, COUGH SYRUPS; HERBAL PRODUCTS FOR MEDICINAL PURPOSES, NAMELY, HERBAL EXTRACTS FOR USE AS NUTRITIONAL AND DIETARY SUPPLEMENTS; HERBAL PRODUCTS FOR MEDICINAL PURPOSES, NAMELY, HERBAL EXTRACTS AND SYRUPS; MEDICINAL HERB EXTRACTS; MEDICINAL HERB EXTRACTS FOR MEDICAL PURPOSES; PLANT EXTRACTS FOR MEDICAL, PHARMACEUTICAL, NUTRACEUTICAL AND NUTRI-

TIONAL PURPOSES; MEDICINAL EXTRACTS USED IN PREPARATIONS IN THE FORM OF LOTIONS, CREAMS, AND TOPICAL ANALGESICS AND ANESTHETICS, TABLETS, CAPSULES, PILLS, LOZENGES, INHALERS, TINCTURE, SUPPOSITORIES AND AMPULE FOR INJECTION; MEDICINAL EXTRACTS IN THE FORM OF LOTIONS, CREAMS, AND TOPICAL ANALGESICS AND ANESTHETICS, TABLETS, CAPSULES, PILLS, TINCTURE, SUPPOSITORIES AND AMPULE FOR INJECTION; MEDICINAL BOTANICAL EXTRACTS IN THE FORM OF LOTIONS, CREAMS, AND TOPICAL ANALGESICS AND ANESTHETICS, TABLETS, CAPSULES, PILLS, TINCTURE, SUPPOSITORIES AND AMPULE FOR INJECTION USED TO TREAT SKIN AILMENTS, FOR INFECTION, DEGENERATIVE, MUSCULAR, PULMONARY, SKELETAL, ENDOCRINE, IMMUNE, NEUROLOGICAL, CARDIOVASCULAR, METABOLIC, INFLAMMATORY, CANCER AND RELATED CONDITIONS; YEAST EXTRACTS FOR MEDICAL, PHARMACEUTICAL OR NUTRACEUTICAL PURPOSES; HERBAL PRODUCTS, NAMELY, HERBAL POWDERS FOR NUTRITIONAL PURPOSES; HERBAL PRODUCTS, NAMELY, HERBAL MEAL REPLACEMENT POWDERS FOR DIETARY AND NUTRITIONAL PURPOSES; HERBAL PRODUCTS, NAMELY, AROMATHERAPY PACKS CONTAINING HERBS USED FOR RELIEF FROM HEADACHES, INSOMNIA AND SINUS DISCOMFORT; HERBAL PRODUCTS, NAMELY, HERBAL POWDERS SOLD AS AN INTEGRAL INGREDIENT OF NUTRITIONAL SUPPLEMENT DRINK MIX FOR NUTRITIONAL PURPOSES; PHARMACEUTICALS AND NUTRACEUTICALS, NAMELY, VITAMINS AND FOOD SUPPLEMENTS; PHARMACEUTICAL PREPARATIONS, NAMELY, APPETITE SUPPRESSANTS AND LIPID LOWERING AGENTS; FOOD FOR DIABETICS, INFANTS AND ENTERAL FEEDING; BOTANICAL EXTRACTS FOR NUTRITIONAL USE; BOTANICAL EXTRACTS FOR MEDICAL, VETERINARY, NUTRACEUTICAL AND PHARMACEUTICAL PURPOSES; DESIGNER EXTRACTS, NAMELY, HERBAL EXTRACTS FOR MEDICAL, VETERINARY AND PHARMACEUTICAL PURPOSES; BOTANICAL EXTRACTS FOR NUTRITIONAL SUPPLEMENTS, NUTRACEUTICALS AND PHARMACEUTICALS; NUTRITIONAL DIETARY SUPPLEMENTS; ORAL PREPARATIONS CONTAINING HERBS OR HERBAL EXTRACTS USED TO MAINTAIN HEALTH AND FOR A WIDE VARIETY OF PHYSICAL CONDITIONS; VITAMIN AND MINERAL PREPARATIONS INTENDED FOR USE AS DIETARY SUPPLEMENTS; VITAMINS; FOOD SUPPLEMENTS; NUTRACEUTICALS, NAMELY, VITAMINS AND FOOD SUPPLEMENTS; FOOD FOR MEDICALLY RESTRICTED DIETS; SUPPLEMENTS, NAMELY, LIPID CONCENTRATES FOR USE AS A DIETARY FOOD SUPPLEMENT OR FOR PHARMACEUTICAL OR MEDICINAL PURPOSES; ANTI-OXIDANTS; BOTANICALS AND BOTANICAL BLENDS, HERBALS AND HERBAL BLENDS, BOTANICAL EXTRACTS AND BOTANICAL EXTRACT BLENDS, FLAVOR EXTRACTS AND FLAVOR EXTRACT BLENDS, ALL SOLD AS COMPONENTS OF NUTRITIONAL SUPPLEMENTS AND VITAMINS; NUTRITIONAL OILS NOT FOR COSMETIC PURPOSES; FOOD SUPPLEMENTS, NAMELY, LIPID CONCENTRATES FOR USE AS A DIETARY FOOD SUPPLEMENT OR FOR PHARMACEUTICAL OR MEDICINAL PURPOSES; ANTI-COUGH DROPS; COUGH DROPS; COUGH EXPECTORANTS; THROAT LOZENGES; COUGH LOZENGES; COUGH SYRUPS; COUGH TREATMENT PREPARATIONS; COLD SORE TREATMENT PREPARATIONS; PHARMACEUTICAL ANTITUSSIVE-COLD PREPARATIONS; PREPARATIONS FOR TREATING COLDS; ANALGESIC PREPARATIONS; ANALGESICS; ANTIPIRETIC ANALGESICS; IBUPROFEN FOR USE AS AN ORAL ANALGESIC; MULTIPURPOSE MEDICATED ANTIBIOTIC CREAM, ANALGESIC BALM AND MENTHOLATED SALVE; ORAL ANALGESICS; TOPICAL ANALGESICS; PHARMACEUTICAL PREPARATIONS FOR THE TREATMENT AND PREVENTION OF HERPES; VACCINES FOR THE TREATMENT AND PREVENTION OF HERPES; BIOLOGICAL PREPARATIONS FOR THE TREATMENT AND PREVENTION OF HERPES; PHARMACEUTICAL PREPARATIONS FOR THE TREATMENT OF HERPES SIMPLEX INFECTION; PHARMACEUTICAL CAPSULES FOR THE TREATMENT OF HERPES

SIMPLEX INFECTION; HOMEOPATHIC PREPARATIONS FOR THE TREATMENT OF HERPES AND COLD SORES; PHARMACEUTICAL PREPARATIONS FOR THE TREATMENT OF HERPES VIRUSES; MEDICATED TOPICAL CLEAR FLUORIDE GEL FOR THE TREATMENT OF HERPES VIRUS DURING THE PHYSICAL MANIPULATION OF THE VIRUS; PHARMACEUTICAL PREPARATIONS FOR THE TREATMENT OF HERPES SIMPLEX VIRUS TYPE I OR TYPE II OR HERPES ZOSTER VIRUS, NOT IN INTRAVENOUS FORM; PLANT-BASED ANTIVIRALS; OVER-THE-COUNTER TOPICAL ANTIVIRALS; PHARMACEUTICAL PREPARATION WITH ANTIVIRAL AND/OR ANTIMICROBIAL PROPERTIES FOR USE IN THE TREATMENT OF HERPETIC KERATITIS, CONJUNCTIVITIS, HIV RETINOPATHY, VIRAL INFLUENZA "FLU", HERPES SIMPLEX VIRUS 1, HERPES SIMPLEX VIRUS 2, VARICELLA ZOSTER VIRUS "HERPES ZOSTER" OR "SHINGLES", CYTOMEGALOVIRUS, VIRAL PARAINFLUENZA, ADENOVIRUS, VIRAL ENCEPHALITIS, VIRAL MENINGITIS, ARBOVIRUS, ARENAVIRUS, PICORNAVIRUS, CORONAVIRUS, SYNTIALVIRUS, VIRAL INFECTIONS, COMMON COLDS CAUSED BY VIRUSES, COLD SORES, HUMAN IMMUNODEFICIENCY VIRUS "HIV", ROSEOLA INFANTUM, HUMAN HERPES IV; PHARMACEUTICAL PREPARATIONS FOR THE TREATMENT OF VIRAL DISEASES AND DISORDERS, NAMELY, HERPES; PHARMACEUTICAL PREPARATIONS FOR TREATING IMMUNE DISEASES INDUCED BY VIRUS, NAMELY, HERPES, HERPES ZOSTER AND AIDS; ALGAL PRODUCTS FOR MEDICINAL PURPOSES, NAMELY, ALGAL EXTRACTS OR ALGAL EXTRACT BLENDS FOR USE AS NUTRITIONAL AND DIETARY SUPPLEMENTS; ALGAL PRODUCTS, NAMELY, ALGAL POWDERS SOLD AS AN INTEGRAL INGREDIENT OF NUTRITIONAL SUPPLEMENT DRINK MIX FOR NUTRITIONAL PURPOSES; ALGAL PRODUCTS, NAMELY, ALGAL POWDERS FOR NUTRITIONAL PURPOSES; ALGAL EXTRACTS OR ALGAL EXTRACT BLENDS FOR MEDICAL OR PHARMACEUTICAL PURPOSES; FUNCTIONAL FOODS, NAMELY, DIETETIC FOODS ADAPTED FOR MEDICAL PURPOSES; FUNCTIONAL BEVERAGES, NAMELY, NUTRITIONALLY FORTIFIED BEVERAGES; MEDICINAL FOODS, NAMELY, PROCESSED FOOD FOR MEDICAL PURPOSES; ANIMAL HEALTH PRODUCTS, NAMELY, ANIMAL FEED SUPPLEMENTS, MEDICATED ANIMAL FEED, MICRO-NUTRIENT ANIMAL FEED, DIETARY SUPPLEMENTS FOR ANIMALS, NON-MEDICATED ADDITIVES FOR ANIMAL FEED FOR USE AS NUTRITIONAL SUPPLEMENTS, NUTRITIONAL DRINKS FOR ANIMALS, PHARMACEUTICAL PREPARATIONS FOR ANIMAL SKINCARE; PLANT EXTRACTS FOR MEDICAL, VETERINARY AND PHARMACEUTICAL PURPOSES; HERBAL EXTRACTS FOR MEDICAL, VETERINARY AND PHARMACEUTICAL PURPOSES; DESIGNER EXTRACTS, NAMELY, PLANT, HERBAL AND BOTANICAL EXTRACTS FOR MEDICAL, VETERINARY AND PHARMACEUTICAL PURPOSES; AND BIODEFENSE PRODUCTS, NAMELY, MEDICINAL PREPARATIONS FOR THE TREATMENT OF INFECTIOUS DISEASES AND ADVERSE HUMAN HEALTH CONDITIONS, NAMELY, INFECTION, DEGENERATIVE, MUSCULAR, PULMONARY, SKELETAL, ENDOCRINE, IMMUNE, NEUROLOGICAL, CARDIOVASCULAR, METABOLIC, INFLAMMATORY, CANCER AND RELATED CONDITIONS; MUSHROOM, FUNGUS, OR SPORE EXTRACTS OR BLENDS AS SUPPLEMENTS, NUTRITION, NUTRACEUTICALS AND/OR PHARMACEUTICALS; BOTANICAL EXTRACTS FOR NUTRITIONAL USE; NUTRITIONALLY FORTIFIED BEVERAGES; NUTRITIONALLY FORTIFIED BEVERAGES FOR IMMUNE ENHANCEMENT, AND NUTRITIONALLY FORTIFIED BEVERAGES WITH RICE BRAN AND WHEAT BRAN; MEDICINAL BEVERAGES; SOY PROTEIN FOR USE AS A NUTRITIONAL SUPPLEMENT; NUTRITIONAL ADDITIVES FOR MEDICAL OR NONMEDICAL PURPOSES FOR USE IN MANUFACTURING FOODS AND DIETARY SUPPLEMENTS FOR HUMAN CONSUMPTION; ACTIVE PRINCIPLES EXTRACTED FROM MEDICINAL PLANTS FOR USE IN THE MANUFACTURE OF NUTRACEUTICALS AND PHARMACEUTICALS; ACTIVE PRINCIPLES EXTRACTED FROM MEDICINAL PLANTS FOR USE IN THE MANUFACTURE OF PHARMACEUTICAL OR NUTRACEUTICAL PRODUCTS (U.S. CLS. 6, 18, 44, 46, 51 AND 52).

HEATHER THOMPSON, EXAMINING ATTORNEY

SN 77-519,320. HERBALSCIENCE GROUP, LLC, NAPLES, FL. FILED 7-10-2008.

MEMORY ULTRAPOWER

THE MARK CONSISTS OF STANDARD CHARACTERS WITHOUT CLAIM TO ANY PARTICULAR FONT, STYLE, SIZE, OR COLOR.

NO CLAIM IS MADE TO THE EXCLUSIVE RIGHT TO USE "MEMORY", APART FROM THE MARK AS SHOWN.

CLASS 1—CHEMICALS

FOR BOTANICAL EXTRACTS FOR USE IN THE MANUFACTURE OF NUTRACEUTICALS; EXTRACTS FOR USE IN THE MANUFACTURE OF PHARMACEUTICAL PREPARATIONS IN THE FORM OF PREPARATIONS IN THE FORM OF LOTIONS, CREAMS, AND TOPICAL ANALGESICS AND ANESTHETICS, TABLETS, CAPSULES, PILLS, TINCTURE, SUPPOSITORIES AND AMPULE FOR INJECTION; BOTANICAL EXTRACTS FOR USE IN THE MANUFACTURE OF PHARMACEUTICALS; CHEMICAL EXTRACTS EXTRACTED FROM MEDICINAL PLANTS FOR USE IN THE MANUFACTURE OF NUTRACEUTICALS AND PHARMACEUTICALS; CHEMICAL EXTRACTS, NAMELY, CHEMICAL AGENTS MADE FROM BOTANICAL EXTRACTS OR ASSOCIATION OF CHEMICAL EXTRACTS FOR USE IN THE MANUFACTURE OF PHARMACEUTICAL OR NUTRACEUTICAL PRODUCTS; BOTANICAL EXTRACTS USED IN THE MANUFACTURE OF PREPARATIONS IN THE FORM OF LOTIONS, CREAMS, AND TOPICAL ANALGESICS AND ANESTHETICS, TABLETS, CAPSULES, PILLS, LOZENGES, INHALERS, TINCTURE, SUPPOSITORIES AND AMPULE FOR INJECTION; BOTANICALS AND BOTANICAL BLENDS, HERBS AND HERBAL BLENDS, BOTANICAL EXTRACTS AND BOTANICAL EXTRACT BLENDS, FLAVOR EXTRACTS AND FLAVOR EXTRACT BLENDS, ALGAL EXTRACTS AND ALGAL EXTRACT BLENDS, ALL FOR USE IN THE MANUFACTURE OF NUTRITIONAL SUPPLEMENTS AND VITAMINS; HERBAL EXTRACTS AND BLENDS FOR USE IN MANUFACTURING FUNCTIONAL FOODS OR BEVERAGES; HERBAL EXTRACTS AND BLENDS FOR USE IN MANUFACTURING MEDICINAL FOODS OR BEVERAGES; BOTANICAL EXTRACTS AND BLENDS FOR USE IN MANUFACTURING FUNCTIONAL FOODS OR BEVERAGES; BOTANICAL EXTRACTS AND BLENDS FOR USE IN MANUFACTURING FUNCTIONAL FOODS OR BEVERAGES; BOTANICAL EXTRACTS AND BLENDS FOR USE IN MANUFACTURING FUNCTIONAL FOODS OR BEVERAGES; HERBAL PREPARATIONS AND EXTRACTS FOR USE AS INGREDIENTS IN MANUFACTURING IN THE FOOD, NUTRITION, NUTRACEUTICAL AND/OR PHARMACEUTICAL INDUSTRIES (U.S. CLS. 1, 5, 6, 10, 26 AND 46).

CLASS 5—PHARMACEUTICALS

FOR NUTRITIONAL SUPPLEMENTS; HERBAL PRODUCTS, NAMELY, MEDICATED SKIN AND LIP BALMS; HERBAL PRODUCTS, NAMELY, OINTMENTS, OILS, DRINKS, INFUSIONS, SYRUPS, HERBAL EXTRACTS, POISONS, AND TINCTURES FOR MEDICAL USE IN THE TREATMENT OF STROKES, INFARCTS AND OTHER CARDIOVASCULAR AND CEREBRUM DISEASES; HERBAL PRODUCTS, NAMELY, OINTMENTS, OILS, NAMELY, MINERAL OIL FOR USE AS A LAXATIVE; DRINKS, NAMELY, MEAL REPLACEMENT DRINKS, DIETARY SUPPLEMENT DRINKS, MEDICINAL DRINKS, AND FISH OIL FOR USE AS A DIETARY SUPPLEMENT OR IN A NUTRACEUTICAL; INFUSIONS AND SYRUPS, NAMELY, COUGH SYRUPS; HERBAL PRODUCTS FOR MEDICINAL PURPOSES, NAMELY, HERBAL EXTRACTS FOR USE AS NUTRITIONAL AND DIETARY SUPPLEMENTS; HERBAL PRODUCTS FOR MEDICINAL PURPOSES, NAMELY, HERBAL EXTRACTS AND SYRUPS; MEDICINAL HERB EXTRACTS; MEDICINAL HERB EXTRACTS FOR MEDICAL PURPOSES; PLANT EXTRACTS FOR MEDICAL, PHARMACEUTICAL, NUTRACEUTICAL AND NUTRI-

TIONAL PURPOSES; MEDICINAL EXTRACTS USED IN PREPARATIONS IN THE FORM OF LOTIONS, CREAMS, AND TOPICAL ANALGESICS AND ANESTHETICS, TABLETS, CAPSULES, PILLS, LOZENGES, INHALERS, TINCTURE, SUPPOSITORIES AND AMPULE FOR INJECTION; MEDICINAL EXTRACTS IN THE FORM OF LOTIONS, CREAMS, AND TOPICAL ANALGESICS AND ANESTHETICS, TABLETS, CAPSULES, PILLS, TINCTURE, SUPPOSITORIES AND AMPULE FOR INJECTION; MEDICINAL HERBAL EXTRACTS IN THE FORM OF LOTIONS, CREAMS, AND TOPICAL ANALGESICS AND ANESTHETICS, TABLETS, CAPSULES, PILLS, TINCTURE, SUPPOSITORIES AND AMPULE FOR INJECTION USED TO TREAT SKIN AILMENTS, FOR INFECTION, DEGENERATIVE, MUSCULAR, PULMONARY, SKELETAL, ENDOCRINE, IMMUNE, NEUROLOGICAL, CARDIOVASCULAR, METABOLIC, INFLAMMATORY, CANCER AND RELATED CONDITIONS; YEAST EXTRACTS FOR MEDICAL, PHARMACEUTICAL OR NUTRACEUTICAL PURPOSES; HERBAL PRODUCTS, NAMELY, HERBAL POWDERS FOR NUTRITIONAL PURPOSES; HERBAL PRODUCTS, NAMELY, HERBAL MEAL REPLACEMENT POWDERS FOR DIETARY AND NUTRITIONAL PURPOSES; HERBAL PRODUCTS, NAMELY, AROMATHERAPY PACKS CONTAINING HERBS USED FOR RELIEF FROM HEADACHES, INSOMNIA AND SINUS DISCOMFORT; HERBAL PRODUCTS, NAMELY, HERBAL POWDERS SOLD AS AN INTEGRAL INGREDIENT OF NUTRITIONAL SUPPLEMENT DRINK MIX FOR NUTRITIONAL PURPOSES; PHARMACEUTICALS AND NUTRACEUTICALS, NAMELY, VITAMINS AND FOOD SUPPLEMENTS; PHARMACEUTICAL PREPARATIONS, NAMELY, APPETITE SUPPRESSANTS AND LIPID LOWERING AGENTS; FOOD FOR DIABETICS, INFANTS AND ENTERAL FEEDING; BOTANICAL EXTRACTS FOR NUTRITIONAL USE; BOTANICAL EXTRACTS FOR MEDICAL, VETERINARY, NUTRACEUTICAL AND PHARMACEUTICAL PURPOSES; DESIGNER EXTRACTS, NAMELY, HERBAL EXTRACTS FOR MEDICAL, VETERINARY AND PHARMACEUTICAL PURPOSES; BOTANICAL EXTRACTS FOR NUTRITIONAL SUPPLEMENTS, NUTRACEUTICALS AND PHARMACEUTICALS; NUTRITIONAL DIETARY SUPPLEMENTS; ORAL PREPARATIONS CONTAINING HERBS OR HERBAL EXTRACTS USED TO MAINTAIN HEALTH AND FOR A WIDE VARIETY OF PHYSICAL CONDITIONS; VITAMIN AND MINERAL PREPARATIONS INTENDED FOR USE AS DIETARY SUPPLEMENTS; VITAMINS; FOOD SUPPLEMENTS; NUTRACEUTICALS, NAMELY, VITAMINS AND FOOD SUPPLEMENTS; FOOD FOR MEDICALLY RESTRICTED DIETS; SUPPLEMENTS, NAMELY, LIPID CONCENTRATES FOR USE AS A DIETARY FOOD SUPPLEMENT OR FOR PHARMACEUTICAL OR MEDICINAL PURPOSES; FOOD SUPPLEMENTS, NAMELY, ANTI-OXIDANTS; BOTANICALS AND BOTANICAL BLENDS, HERBALS AND HERBAL BLENDS, BOTANICAL EXTRACTS AND BOTANICAL EXTRACT BLENDS, FLAVOR EXTRACTS AND FLAVOR EXTRACT BLENDS, ALL SOLD AS COMPONENTS OF NUTRITIONAL SUPPLEMENTS AND VITAMINS; NUTRITIONAL OILS NOT FOR COSMETIC PURPOSES; FOOD SUPPLEMENTS, NAMELY, LIPID CONCENTRATES FOR USE AS A DIETARY FOOD SUPPLEMENT OR FOR PHARMACEUTICAL OR MEDICINAL PURPOSES; ANTI-COUGH DROPS; COUGH DROPS; COUGH EXPECTORANTS; THROAT LOZENGES; COUGH LOZENGES; COUGH SYRUPS; COUGH TREATMENT PREPARATIONS; COLD SORE TREATMENT PREPARATIONS; PHARMACEUTICAL ANTITUSSIVE-COLD PREPARATIONS; PREPARATIONS FOR TREATING COLDS; ANALGESIC PREPARATIONS; ANALGESICS; ANTIPIRETTIC ANALGESICS; IBUPROFEN FOR USE AS AN ORAL ANALGESIC; MULTIPURPOSE MEDICATED ANTIBIOTIC CREAM, ANALGESIC BALM AND MENTHOLATED SALVE; ORAL ANALGESICS; TOPICAL ANALGESICS; PHARMACEUTICAL PREPARATIONS FOR THE TREATMENT AND PREVENTION OF HERPES; VACCINES FOR THE TREATMENT AND PREVENTION OF HERPES; BIOLOGICAL PREPARATIONS FOR THE TREATMENT AND PREVENTION OF HERPES; PHARMACEUTICAL PREPARATIONS FOR THE TREATMENT OF HERPES SIMPLEX INFECTION; PHARMACEUTICAL CAPSULES FOR THE TREATMENT OF HERPES

SIMPLEX INFECTION; HOMEOPATHIC PREPARATIONS FOR THE TREATMENT OF HERPES AND COLD SORES; PHARMACEUTICAL PREPARATIONS FOR THE TREATMENT OF HERPES VIRUSES; MEDICATED TOPICAL CLEAR FLUORIDE GEL FOR THE TREATMENT OF HERPES VIRUS DURING THE PHYSICAL MANIFESTATION OF THE VIRUS; PHARMACEUTICAL PREPARATIONS FOR THE TREATMENT OF HERPES SIMPLEX VIRUS TYPE I OR TYPE II OR HERPES ZOSTER VIRUS, NOT IN INTRAVENOUS FORM; PLANT-BASED ANTIVIRALS; OVER-THE-COUNTER TOPICAL ANTIVIRALS; PHARMACEUTICAL PREPARATION WITH ANTIVIRAL AND/OR ANTIMICROBIAL PROPERTIES FOR USE IN THE TREATMENT OF HERPETIC KERATITIS, CONJUNCTIVITIS, HIV RETINOPATHY, VIRAL INFLUENZA "FLU", HERPES SIMPLEX VIRUS 1, HERPES SIMPLEX VIRUS 2, VARICELLA ZOSTER VIRUS "HERPES ZOSTER" OR "SHINGLES", CYTOMEGALOVIRUS, VIRAL PARAINFLUENZA, ADENOVIRUS, VIRAL ENCEPHALITIS, VIRAL MENINGITIS, ARBOVIRUS, ARENAVIRUS, PICORNAVIRUS, CORONAVIRUS, SYNTIALVIRUS, VIRAL INFECTIONS, COMMON COLDS CAUSED BY VIRUSES, COLD SORES, HUMAN IMMUNODEFICIENCY VIRUS "HIV", ROSEOLA INFANTUM, HUMAN HERPES IV; PHARMACEUTICAL PREPARATIONS FOR THE TREATMENT OF VIRAL DISEASES AND DISORDERS, NAMELY, HERPES; PHARMACEUTICAL PREPARATIONS FOR TREATING IMMUNE DISEASES INDUCED BY VIRUS, NAMELY, HERPES, HERPES ZOSTER AND AIDS; ALGAL PRODUCTS FOR MEDICINAL PURPOSES, NAMELY, ALGAL EXTRACTS OR ALGAL EXTRACT BLENDS FOR USE AS NUTRITIONAL AND DIETARY SUPPLEMENTS; ALGAL PRODUCTS, NAMELY, ALGAL POWDERS SOLD AS AN INTEGRAL INGREDIENT OF NUTRITIONAL SUPPLEMENT DRINK MIX FOR NUTRITIONAL PURPOSES; ALGAL PRODUCTS, NAMELY, ALGAL POWDERS FOR NUTRITIONAL PURPOSES; ALGAL EXTRACTS OR ALGAL EXTRACT BLENDS FOR MEDICAL OR PHARMACEUTICAL PURPOSES; FUNCTIONAL FOODS, NAMELY, DIETETIC FOODS ADAPTED FOR MEDICAL PURPOSES; FUNCTIONAL BEVERAGES, NAMELY, NUTRITIONALLY FORTIFIED BEVERAGES; MEDICINAL FOODS, NAMELY, PROCESSED FOOD FOR MEDICAL PURPOSES; ANIMAL HEALTH PRODUCTS, NAMELY, ANIMAL FEED SUPPLEMENTS, MEDICATED ANIMAL FEED, MICRO-NUTRIENT ANIMAL FEED, DIETARY SUPPLEMENTS FOR ANIMALS, NON-MEDICATED ADDITIVES FOR ANIMAL FEED FOR USE AS NUTRITIONAL SUPPLEMENTS, NUTRITIONAL DRINKS FOR ANIMALS, PHARMACEUTICAL PREPARATIONS FOR ANIMAL SKINCARE; PLANT EXTRACTS FOR MEDICAL, VETERINARY AND PHARMACEUTICAL PURPOSES; HERBAL EXTRACTS FOR MEDICAL, VETERINARY AND PHARMACEUTICAL PURPOSES; DESIGNER EXTRACTS, NAMELY, PLANT, HERBAL AND BOTANICAL EXTRACTS FOR MEDICAL, VETERINARY AND PHARMACEUTICAL PURPOSES; AND BIODEFENSE PRODUCTS, NAMELY, MEDICINAL PREPARATIONS FOR THE TREATMENT OF INFECTIOUS DISEASES AND ADVERSE HUMAN HEALTH CONDITIONS, NAMELY, INFECTION, DEGENERATIVE, MUSCULAR, PULMONARY, SKELETAL, ENDOCRINE, IMMUNE, NEUROLOGICAL, CARDIOVASCULAR, METABOLIC, INFLAMMATORY, CANCER AND RELATED CONDITIONS; MUSHROOM, FUNGUS, OR SPORE EXTRACTS OR BLENDS AS SUPPLEMENTS, NUTRITION, NUTRACEUTICALS AND/OR PHARMACEUTICALS; BOTANICAL EXTRACTS FOR NUTRITIONAL USE; NUTRITIONALLY FORTIFIED BEVERAGES; NUTRITIONALLY FORTIFIED BEVERAGES FOR IMMUNE ENHANCEMENT, AND NUTRITIONALLY FORTIFIED BEVERAGES WITH RICE BRAN AND WHEAT BRAN; MEDICINAL BEVERAGES; SOY PROTEIN FOR USE AS A NUTRITIONAL SUPPLEMENT; NUTRITIONAL ADDITIVES FOR MEDICAL OR NONMEDICAL PURPOSES FOR USE IN MANUFACTURING FOODS AND DIETARY SUPPLEMENTS FOR HUMAN CONSUMPTION; ACTIVE PRINCIPLES EXTRACTED FROM MEDICINAL PLANTS FOR USE IN THE MANUFACTURE OF NUTRACEUTICALS AND PHARMACEUTICALS; ACTIVE PRINCIPLES EXTRACTED FROM MEDICINAL PLANTS FOR USE IN THE MANUFACTURE OF PHARMACEUTICAL OR NUTRACEUTICAL PRODUCTS (U.S. CLS. 6, 18, 44, 46, 51 AND 52).

CLASS 29—MEATS AND PROCESSED FOODS

FOR BEVERAGES, NAMELY, YOGURT-BASED BEVERAGES; FOOD BEVERAGES, NAMELY, DAIRY-BASED FOOD BEVERAGES, FRUIT-BASED FOOD BEVERAGES, VEGETABLE-BASED FOOD BEVERAGES, DAIRY-BASED CHOCOLATE FOOD BEVERAGES, SOY-BASED FOOD BEVERAGE USED AS A MILK SUBSTITUTE, VEGETABLE-BASED CHOCOLATE FOOD BEVERAGES AND PEANUT-BASED FOOD BEVERAGES; MILK BEVERAGES; MILK BEVERAGES, NAMELY, MILK, MILK BEVERAGES CONTAINING FRUITS, MILK BEVERAGES WITH HIGH MILK CONTENT, MILK BASED BEVERAGES CONTAINING FRUIT JUICE AND MILK BEVERAGES CONTAINING COFFEE; MILK POWDER; MILK POWDER FOR NUTRITIONAL PURPOSES; POWDERED MILK FOR FOOD PURPOSES; FUNCTIONAL FOODS, NAMELY, DAIRY-BASED FOOD BEVERAGES, FRUIT-BASED FOOD BEVERAGES, VEGETABLE-BASED FOOD BEVERAGES, DAIRY-BASED CHOCOLATE FOOD BEVERAGES, SOY-BASED FOOD BEVERAGE USED AS A MILK SUBSTITUTE, VEGETABLE-BASED CHOCOLATE FOOD BEVERAGES, NUT-BASED FOOD BEVERAGES, MILK, MILK BEVERAGES CONTAINING FRUITS, MILK BEVERAGES WITH HIGH MILK CONTENT, MILK BASED BEVERAGES CONTAINING FRUIT JUICE, AND MILK BEVERAGES CONTAINING COFFEE; EDIBLE OILS, NAMELY, OMEGA OIL EXTRACTS AND FISH OIL EXTRACTS; SOY PROTEIN FOR USE AS A FOOD ADDITIVE; MUSHROOM, FUNGUS, OR SPORE EXTRACTS OR BLENDS THEREOF FOR USE AS FOOD ADDITIVES (U.S. CL. 46).
 HEATHER THOMPSON, EXAMINING ATTORNEY

CLASS 1—CHEMICALS

FOR BOTANICAL EXTRACTS FOR USE IN THE MANUFACTURE OF NUTRACEUTICALS; EXTRACTS FOR USE IN THE MANUFACTURE OF PHARMACEUTICAL PREPARATIONS IN THE FORM OF PREPARATIONS IN THE FORM OF LOTIONS, CREAMS, AND TOPICAL ANALGESICS AND ANESTHETICS, TABLETS, CAPSULES, PILLS, TINCTURE, SUPPOSITORIES AND AMPULE FOR INJECTION; BOTANICAL EXTRACTS FOR USE IN THE MANUFACTURE OF PHARMACEUTICALS; CHEMICAL EXTRACTS EXTRACTED FROM MEDICINAL PLANTS FOR USE IN THE MANUFACTURE OF NUTRACEUTICALS AND PHARMACEUTICALS; CHEMICAL EXTRACTS, NAMELY, CHEMICAL AGENTS MADE FROM BOTANICAL EXTRACTS OR ASSOCIATION OF CHEMICAL EXTRACTS FOR USE IN THE MANUFACTURE OF PHARMACEUTICAL OR NUTRACEUTICAL PRODUCTS; BOTANICAL EXTRACTS USED IN THE MANUFACTURE OF PREPARATIONS IN THE FORM OF LOTIONS, CREAMS, AND TOPICAL ANALGESICS AND ANESTHETICS, TABLETS, CAPSULES, PILLS, LOZENGES, INHALERS, TINCTURE, SUPPOSITORIES AND AMPULE FOR INJECTION; BOTANICALS AND BOTANICAL BLENDS, HERBS AND HERBAL BLENDS, BOTANICAL EXTRACTS AND BOTANICAL EXTRACT BLENDS, FLAVOR EXTRACTS AND FLAVOR EXTRACT BLENDS, ALGAL EXTRACTS AND ALGAL EXTRACT BLENDS, ALL FOR USE IN THE MANUFACTURE OF NUTRITIONAL SUPPLEMENTS AND VITAMINS; HERBAL EXTRACTS AND BLENDS FOR USE IN MANUFACTURING FUNCTIONAL FOODS OR BEVERAGES; HERBAL EXTRACTS AND BLENDS FOR USE IN MANUFACTURING MEDICINAL FOODS OR BEVERAGES; BOTANICAL EXTRACTS AND BLENDS FOR USE IN MANUFACTURING FUNCTIONAL FOODS OR BEVERAGES; BOTANICAL EXTRACTS AND BLENDS FOR USE IN MANUFACTURING MEDICINAL FOODS OR BEVERAGES; HERBAL PREPARATIONS AND EXTRACTS FOR USE AS INGREDIENTS IN MANUFACTURING IN THE FOOD, NUTRITION, NUTRACEUTICAL AND/OR PHARMACEUTICAL INDUSTRIES (U.S. CLS. 1, 5, 6, 10, 26 AND 46).

SN 77-519,332. HERBALSCIENCE GROUP, LLC, NAPLES, FL. FILED 7-10-2008.

ULTRAPOWER BRAIN

THE MARK CONSISTS OF STANDARD CHARACTERS WITHOUT CLAIM TO ANY PARTICULAR FONT, STYLE, SIZE, OR COLOR.
 NO CLAIM IS MADE TO THE EXCLUSIVE RIGHT TO USE "BRAIN", APART FROM THE MARK AS SHOWN.

CLASS 5—PHARMACEUTICALS

FOR NUTRITIONAL SUPPLEMENTS; HERBAL PRODUCTS, NAMELY, MEDICATED SKIN AND LIP BALMS; HERBAL PRODUCTS, NAMELY, OINTMENTS, OILS, DRINKS, INFUSIONS, SYRUPS, HERBAL EXTRACTS, POISONS, AND TINCTURES FOR MEDICAL USE IN THE TREATMENT OF STROKES, INFARCTS AND OTHER CARDIOVASCULAR AND CEREBRUM DISEASES; HERBAL PRODUCTS, NAMELY, OINTMENTS, OILS, NAMELY, MINERAL OIL FOR USE AS A LAXATIVE; DRINKS, NAMELY, MEAL REPLACEMENT DRINKS, DIETARY SUPPLEMENT DRINKS, MEDICINAL DRINKS, AND FISH OIL FOR USE AS A DIETARY SUPPLEMENT OR IN A NUTRACEUTICAL; INFUSIONS AND SYRUPS, NAMELY, COUGH SYRUPS; HERBAL PRODUCTS FOR MEDICINAL PURPOSES, NAMELY, HERBAL EXTRACTS FOR USE AS NUTRITIONAL AND DIETARY SUPPLEMENTS; HERBAL PRODUCTS FOR MEDICINAL PURPOSES, NAMELY, HERBAL EXTRACTS AND SYRUPS; MEDICINAL HERB EXTRACTS; MEDICINAL HERB EXTRACTS FOR MEDICAL PURPOSES; PLANT EXTRACTS FOR MEDICAL, PHARMACEUTICAL, NUTRACEUTICAL AND NUTRITIONAL PURPOSES; MEDICINAL EXTRACTS USED IN PREPARATIONS IN THE FORM OF LOTIONS, CREAMS, AND TOPICAL ANALGESICS AND ANESTHETICS, TABLETS, CAPSULES, PILLS, LOZENGES, INHALERS, TINCTURE, SUPPOSITORIES AND AMPULE FOR INJECTION; MEDICINAL EXTRACTS IN THE FORM OF LOTIONS, CREAMS, AND TOPICAL ANALGESICS AND ANESTHETICS, TABLETS, CAPSULES, PILLS, TINCTURE, SUPPOSITORIES AND AMPULE FOR INJECTION; MEDICINAL BOTANICAL EXTRACTS IN THE FORM OF LOTIONS, CREAMS, AND TOPICAL ANALGESICS AND ANESTHETICS, TABLETS, CAPSULES, PILLS, TINCTURE, SUPPOSITORIES AND AMPULE FOR INJECTION USED TO TREAT SKIN AILMENTS, FOR INFECTION, DEGENERATIVE, MUS-

CULAR, PULMONARY, SKELETAL, ENDOCRINE, IMMUNE, NEUROLOGICAL, CARDIOVASCULAR, METABOLIC, INFLAMMATORY, CANCER AND RELATED CONDITIONS; YEAST EXTRACTS FOR MEDICAL, PHARMACEUTICAL OR NUTRACEUTICAL PURPOSES; HERBAL PRODUCTS, NAMELY, HERBAL POWDERS FOR NUTRITIONAL PURPOSES; HERBAL PRODUCTS, NAMELY, HERBAL MEAL REPLACEMENT POWDERS FOR DIETARY AND NUTRITIONAL PURPOSES; HERBAL PRODUCTS, NAMELY, AROMATHERAPY PACKS CONTAINING HERBS USED FOR RELIEF FROM HEADACHES, INSOMNIA AND SINUS DISCOMFORT; HERBAL PRODUCTS, NAMELY, HERBAL POWDERS SOLD AS AN INTEGRAL INGREDIENT OF NUTRITIONAL SUPPLEMENT DRINK MIX FOR NUTRITIONAL PURPOSES; PHARMACEUTICALS AND NUTRACEUTICALS, NAMELY, VITAMINS AND FOOD SUPPLEMENTS; PHARMACEUTICAL PREPARATIONS, NAMELY, APPETITE SUPPRESSANTS AND LIPID LOWERING AGENTS; FOOD FOR DIABETICS, INFANTS AND ENTERAL FEEDING; BOTANICAL EXTRACTS FOR NUTRITIONAL USE; BOTANICAL EXTRACTS FOR MEDICAL, VETERINARY, NUTRACEUTICAL AND PHARMACEUTICAL PURPOSES; DESIGNER EXTRACTS, NAMELY, HERBAL EXTRACTS FOR MEDICAL, VETERINARY AND PHARMACEUTICAL PURPOSES; BOTANICAL EXTRACTS FOR NUTRITIONAL SUPPLEMENTS, NUTRACEUTICALS AND PHARMACEUTICALS; NUTRITIONAL DIETARY SUPPLEMENTS; ORAL PREPARATIONS CONTAINING HERBS OR HERBAL EXTRACTS USED TO MAINTAIN HEALTH AND FOR A WIDE VARIETY OF PHYSICAL CONDITIONS; VITAMIN AND MINERAL PREPARATIONS INTENDED FOR USE AS DIETARY SUPPLEMENTS; VITAMINS; FOOD SUPPLEMENTS; NUTRACEUTICALS, NAMELY, VITAMINS AND FOOD SUPPLEMENTS; FOOD FOR MEDICALLY RESTRICTED DIETS; SUPPLEMENTS, NAMELY, LIPID CONCENTRATES FOR USE AS A DIETARY FOOD SUPPLEMENT OR FOR PHARMACEUTICAL OR MEDICINAL PURPOSES; FOOD SUPPLEMENTS, NAMELY, ANTI-OXIDANTS; BOTANICALS AND BOTANICAL BLENDS, HERBALS AND HERBAL BLENDS, BOTANICAL EXTRACTS AND BOTANICAL EXTRACT BLENDS, FLAVOR EXTRACTS AND FLAVOR EXTRACT BLENDS, ALL SOLD AS COMPONENTS OF NUTRITIONAL SUPPLEMENTS AND VITAMINS; NUTRITIONAL OILS NOT FOR COSMETIC PURPOSES; FOOD SUPPLEMENTS, NAMELY, LIPID CONCENTRATES FOR USE AS A DIETARY FOOD SUPPLEMENT OR FOR PHARMACEUTICAL OR MEDICINAL PURPOSES; ANTI-COUGH DROPS; COUGH DROPS; COUGH EXPECTORANTS; THROAT LOZENGES; COUGH LOZENGES; COUGH SYRUPS; COUGH TREATMENT PREPARATIONS; COLD SORE TREATMENT PREPARATIONS; PHARMACEUTICAL ANTITUSSIVE-COLD PREPARATIONS; PREPARATIONS FOR TREATING COLDS; ANALGESIC PREPARATIONS; ANALGESICS; ANTIPIRETTIC ANALGESICS; IBUPROFEN FOR USE AS AN ORAL ANALGESIC; MULTIPURPOSE MEDICATED ANTIBIOTIC CREAM, ANALGESIC BALM AND MENTHOLATED SALVE; ORAL ANALGESICS; TOPICAL ANALGESICS; PHARMACEUTICAL PREPARATIONS FOR THE TREATMENT AND PREVENTION OF HERPES; VACCINES FOR THE TREATMENT AND PREVENTION OF HERPES; BIOLOGICAL PREPARATIONS FOR THE TREATMENT AND PREVENTION OF HERPES; PHARMACEUTICAL PREPARATIONS FOR THE TREATMENT OF HERPES SIMPLEX INFECTION; PHARMACEUTICAL CAPSULES FOR THE TREATMENT OF HERPES SIMPLEX INFECTION; HOMEOPATHIC PREPARATIONS FOR THE TREATMENT OF HERPES AND COLD SORES; PHARMACEUTICAL PREPARATIONS FOR THE TREATMENT OF HERPES VIRUSES; MEDICATED TOPICAL CLEAR FLUORIDE GEL FOR THE TREATMENT OF HERPES VIRUS DURING THE PHYSICAL MANIFESTATION OF THE VIRUS; PHARMACEUTICAL PREPARATIONS FOR THE TREATMENT OF HERPES SIMPLEX VIRUS TYPE I OR TYPE II OR HERPES ZOSTER VIRUS, NOT IN INTRAVENOUS FORM; PLANT-BASED ANTIVIRALS; OVER-THE-COUNTER TOPICAL ANTIVIRALS; PHARMACEUTICAL PREPARATION WITH ANTIVIRAL AND/OR ANTIMICROBIAL PROPERTIES FOR USE IN THE TREATMENT OF HERPESIC KERATITIS, CONJUNCTIVITIS, HIV RETINOPATHY, VIRAL INFLUENZA "FLU", HERPES SIMPLEX VIRUS 1, HERPES SIMPLEX VIRUS 2, VARICELLA ZOSTER VIRUS "HERPES ZOSTER" OR "SHINGLES", CYTOMEGALOVIRUS, VIRAL PARAIN-

FLUENZA, ADENOVIRUS, VIRAL ENCEPHALITIS, VIRAL MENINGITIS, ARBOVIRUS, ARENAVIRUS, PICORNAVIRUS, CORONAVIRUS, SYNTIALVIRUS, VIRAL INFECTIONS, COMMON COLDS CAUSED BY VIRUSES, COLD SORES, HUMAN IMMUNODEFICIENCY VIRUS "HIV", ROSEOLA INFANTUM, HUMAN HERPES IV; PHARMACEUTICAL PREPARATIONS FOR THE TREATMENT OF VIRAL DISEASES AND DISORDERS, NAMELY, HERPES; PHARMACEUTICAL PREPARATIONS FOR TREATING IMMUNE DISEASES INDUCED BY VIRUS, NAMELY, HERPES, HERPES ZOSTER AND AIDS; ALGAL PRODUCTS FOR MEDICINAL PURPOSES, NAMELY, ALGAL EXTRACTS OR ALGAL EXTRACT BLENDS FOR USE AS NUTRITIONAL AND DIETARY SUPPLEMENTS; ALGAL PRODUCTS, NAMELY, ALGAL POWDERS SOLD AS AN INTEGRAL INGREDIENT OF NUTRITIONAL SUPPLEMENT DRINK MIX FOR NUTRITIONAL PURPOSES; ALGAL PRODUCTS, NAMELY, ALGAL POWDERS FOR NUTRITIONAL PURPOSES; ALGAL EXTRACTS OR ALGAL EXTRACT BLENDS FOR MEDICAL OR PHARMACEUTICAL PURPOSES; FUNCTIONAL FOODS, NAMELY, DIETETIC FOODS ADAPTED FOR MEDICAL PURPOSES; FUNCTIONAL BEVERAGES, NAMELY, NUTRITIONALLY FORTIFIED BEVERAGES; MEDICINAL FOODS, NAMELY, PROCESSED FOOD FOR MEDICAL PURPOSES; ANIMAL HEALTH PRODUCTS, NAMELY, ANIMAL FEED SUPPLEMENTS, MEDICATED ANIMAL FEED, MICRO-NUTRIENT ANIMAL FEED, DIETARY SUPPLEMENTS FOR ANIMALS, NON-MEDICATED ADDITIVES FOR ANIMAL FEED FOR USE AS NUTRITIONAL SUPPLEMENTS, NUTRITIONAL DRINKS FOR ANIMALS, PHARMACEUTICAL PREPARATIONS FOR ANIMAL SKINCARE; PLANT EXTRACTS FOR MEDICAL, VETERINARY AND PHARMACEUTICAL PURPOSES; HERBAL EXTRACTS FOR MEDICAL, VETERINARY AND PHARMACEUTICAL PURPOSES; DESIGNER EXTRACTS, NAMELY, PLANT, HERBAL AND BOTANICAL EXTRACTS FOR MEDICAL, VETERINARY AND PHARMACEUTICAL PURPOSES; AND BIODEFENSE PRODUCTS, NAMELY, MEDICINAL PREPARATIONS FOR THE TREATMENT OF INFECTIOUS DISEASES AND ADVERSE HUMAN HEALTH CONDITIONS, NAMELY, INFECTION, DEGENERATIVE, MUSCULAR, PULMONARY, SKELETAL, ENDOCRINE, IMMUNE, NEUROLOGICAL, CARDIOVASCULAR, METABOLIC, INFLAMMATORY, CANCER AND RELATED CONDITIONS; MUSHROOM, FUNGUS, OR SPORE EXTRACTS OR BLENDS AS SUPPLEMENTS, NUTRITION, NUTRACEUTICALS AND/OR PHARMACEUTICALS; BOTANICAL EXTRACTS FOR NUTRITIONAL USE; NUTRITIONALLY FORTIFIED BEVERAGES; NUTRITIONALLY FORTIFIED BEVERAGES FOR IMMUNE ENHANCEMENT, AND NUTRITIONALLY FORTIFIED BEVERAGES WITH RICE BRAN AND WHEAT BRAN; MEDICINAL BEVERAGES; SOY PROTEIN FOR USE AS A NUTRITIONAL SUPPLEMENT; NUTRITIONAL ADDITIVES FOR MEDICAL OR NONMEDICAL PURPOSES FOR USE IN MANUFACTURING FOODS AND DIETARY SUPPLEMENTS FOR HUMAN CONSUMPTION; ACTIVE PRINCIPLES EXTRACTED FROM MEDICINAL PLANTS FOR USE IN THE MANUFACTURE OF NUTRACEUTICALS AND PHARMACEUTICALS; ACTIVE PRINCIPLES EXTRACTED FROM MEDICINAL PLANTS FOR USE IN THE MANUFACTURE OF PHARMACEUTICAL OR NUTRACEUTICAL PRODUCTS (U.S. CLS. 6, 18, 44, 46, 51 AND 52).

HEATHER THOMPSON, EXAMINING ATTORNEY

SN 77-519,342. HERBALSCIENCE GROUP, LLC, NAPLES, FL. FILED 7-10-2008.

BRAIN ULTRAPOWER

THE MARK CONSISTS OF STANDARD CHARACTERS WITHOUT CLAIM TO ANY PARTICULAR FONT, STYLE, SIZE, OR COLOR.

NO CLAIM IS MADE TO THE EXCLUSIVE RIGHT TO USE "BRAIN", APART FROM THE MARK AS SHOWN.

CLASS 1—CHEMICALS

FOR BOTANICAL EXTRACTS FOR USE IN THE MANUFACTURE OF NUTRACEUTICALS; EXTRACTS FOR USE IN THE MANUFACTURE OF PHARMACEUTICAL PREPARATIONS IN THE FORM OF PREPARATIONS IN THE FORM OF LOTIONS, CREAMS, AND TOPICAL ANALGESICS AND ANESTHETICS, TABLETS, CAPSULES, PILLS, TINCTURE, SUPPOSITORIES AND AMPULE FOR INJECTION; BOTANICAL EXTRACTS FOR USE IN THE MANUFACTURE OF PHARMACEUTICALS; CHEMICAL EXTRACTS EXTRACTED FROM MEDICINAL PLANTS FOR USE IN THE MANUFACTURE OF NUTRACEUTICALS AND PHARMACEUTICALS; CHEMICAL EXTRACTS, NAMELY, CHEMICAL AGENTS MADE FROM BOTANICAL EXTRACTS OR ASSOCIATION OF CHEMICAL EXTRACTS FOR USE IN THE MANUFACTURE OF PHARMACEUTICAL OR NUTRACEUTICAL PRODUCTS; BOTANICAL EXTRACTS USED IN THE MANUFACTURE OF PREPARATIONS IN THE FORM OF LOTIONS, CREAMS, AND TOPICAL ANALGESICS AND ANESTHETICS, TABLETS, CAPSULES, PILLS, LOZENGES, INHALERS, TINCTURE, SUPPOSITORIES AND AMPULE FOR INJECTION; BOTANICALS AND BOTANICAL BLENDS, HERBS AND HERBAL BLENDS, BOTANICAL EXTRACTS AND BOTANICAL EXTRACT BLENDS, FLAVOR EXTRACTS AND FLAVOR EXTRACT BLENDS, ALGAL EXTRACTS AND ALGAL EXTRACT BLENDS, ALL FOR USE IN THE MANUFACTURE OF NUTRITIONAL SUPPLEMENTS AND VITAMINS; HERBAL EXTRACTS AND BLENDS FOR USE IN MANUFACTURING FUNCTIONAL FOODS OR BEVERAGES; HERBAL EXTRACTS AND BLENDS FOR USE IN MANUFACTURING MEDICINAL FOODS OR BEVERAGES; BOTANICAL EXTRACTS AND BLENDS FOR USE IN MANUFACTURING FUNCTIONAL FOODS OR BEVERAGES; BOTANICAL EXTRACTS AND BLENDS FOR USE IN MANUFACTURING MEDICINAL FOODS OR BEVERAGES; HERBAL PREPARATIONS AND EXTRACTS FOR USE AS INGREDIENTS IN MANUFACTURING IN THE FOOD, NUTRITION, NUTRACEUTICAL AND/OR PHARMACEUTICAL INDUSTRIES (U.S. CLS. 1, 5, 6, 10, 26 AND 46).

CLASS 5—PHARMACEUTICALS

FOR NUTRITIONAL SUPPLEMENTS; HERBAL PRODUCTS, NAMELY, MEDICATED SKIN AND LIP BALMS; HERBAL PRODUCTS, NAMELY, OINTMENTS, OILS, DRINKS, INFUSIONS, SYRUPS, HERBAL EXTRACTS, POISONS, AND TINCTURES FOR MEDICAL USE IN THE TREATMENT OF STROKES, INFARCTS AND OTHER CARDIOVASCULAR AND CEREBRUM DISEASES; HERBAL PRODUCTS, NAMELY, OINTMENTS, OILS, NAMELY, MINERAL OIL FOR USE AS A LAXATIVE; DRINKS, NAMELY, MEAL REPLACEMENT DRINKS, DIETARY SUPPLEMENT DRINKS, MEDICINAL DRINKS, AND FISH OIL FOR USE AS A DIETARY SUPPLEMENT OR IN A NUTRACEUTICAL; INFUSIONS AND SYRUPS, NAMELY, COUGH SYRUPS; HERBAL PRODUCTS FOR MEDICINAL PURPOSES, NAMELY, HERBAL EXTRACTS FOR USE AS NUTRITIONAL AND DIETARY SUPPLEMENTS; HERBAL PRODUCTS FOR MEDICINAL PURPOSES, NAMELY, HERBAL EXTRACTS AND SYRUPS; MEDICINAL HERB EXTRACTS; MEDICINAL HERB EXTRACTS FOR MEDICAL PURPOSES; PLANT EXTRACTS FOR MEDICAL, PHARMACEUTICAL, NUTRACEUTICAL AND NUTRI-

TIONAL PURPOSES; MEDICINAL EXTRACTS USED IN PREPARATIONS IN THE FORM OF LOTIONS, CREAMS, AND TOPICAL ANALGESICS AND ANESTHETICS, TABLETS, CAPSULES, PILLS, LOZENGES, INHALERS, TINCTURE, SUPPOSITORIES AND AMPULE FOR INJECTION; MEDICINAL EXTRACTS IN THE FORM OF LOTIONS, CREAMS, AND TOPICAL ANALGESICS AND ANESTHETICS, TABLETS, CAPSULES, PILLS, TINCTURE, SUPPOSITORIES AND AMPULE FOR INJECTION; MEDICINAL BOTANICAL EXTRACTS IN THE FORM OF LOTIONS, CREAMS, AND TOPICAL ANALGESICS AND ANESTHETICS, TABLETS, CAPSULES, PILLS, TINCTURE, SUPPOSITORIES AND AMPULE FOR INJECTION USED TO TREAT SKIN AILMENTS, FOR INFECTION, DEGENERATIVE, MUSCULAR, PULMONARY, SKELETAL, ENDOCRINE, IMMUNE, NEUROLOGICAL, CARDIOVASCULAR, METABOLIC, INFLAMMATORY, CANCER AND RELATED CONDITIONS; YEAST EXTRACTS FOR MEDICAL, PHARMACEUTICAL OR NUTRACEUTICAL PURPOSES; HERBAL PRODUCTS, NAMELY, HERBAL POWDERS FOR NUTRITIONAL PURPOSES; HERBAL PRODUCTS, NAMELY, HERBAL MEAL REPLACEMENT POWDERS FOR DIETARY AND NUTRITIONAL PURPOSES; HERBAL PRODUCTS, NAMELY, AROMATHERAPY PACKS CONTAINING HERBS USED FOR RELIEF FROM HEADACHES, INSOMNIA AND SINUS DISCOMFORT; HERBAL PRODUCTS, NAMELY, HERBAL POWDERS SOLD AS AN INTEGRAL INGREDIENT OF NUTRITIONAL SUPPLEMENT DRINK MIX FOR NUTRITIONAL PURPOSES; PHARMACEUTICALS AND NUTRACEUTICALS, NAMELY, VITAMINS AND FOOD SUPPLEMENTS; PHARMACEUTICAL PREPARATIONS, NAMELY, APPETITE SUPPRESSANTS AND LIPID LOWERING AGENTS; FOOD FOR DIABETICS, INFANTS AND ENTERAL FEEDING; BOTANICAL EXTRACTS FOR NUTRITIONAL USE; BOTANICAL EXTRACTS FOR MEDICAL, VETERINARY, NUTRACEUTICAL AND PHARMACEUTICAL PURPOSES; DESIGNER EXTRACTS, NAMELY, HERBAL EXTRACTS FOR MEDICAL, VETERINARY AND PHARMACEUTICAL PURPOSES; BOTANICAL EXTRACTS FOR NUTRITIONAL SUPPLEMENTS, NUTRACEUTICALS AND PHARMACEUTICALS; NUTRITIONAL DIETARY SUPPLEMENTS; ORAL PREPARATIONS CONTAINING HERBS OR HERBAL EXTRACTS USED TO MAINTAIN HEALTH AND FOR A WIDE VARIETY OF PHYSICAL CONDITIONS; VITAMIN AND MINERAL PREPARATIONS INTENDED FOR USE AS DIETARY SUPPLEMENTS; VITAMINS; FOOD SUPPLEMENTS; NUTRACEUTICALS, NAMELY, VITAMINS AND FOOD SUPPLEMENTS; FOOD FOR MEDICALLY RESTRICTED DIETS; SUPPLEMENTS, NAMELY, LIPID CONCENTRATES FOR USE AS A DIETARY FOOD SUPPLEMENT OR FOR PHARMACEUTICAL OR MEDICINAL PURPOSES; FOOD SUPPLEMENTS, NAMELY, ANTI-OXIDANTS; BOTANICALS AND BOTANICAL BLENDS, HERBALS AND HERBAL BLENDS, BOTANICAL EXTRACTS AND BOTANICAL EXTRACT BLENDS, FLAVOR EXTRACTS AND FLAVOR EXTRACT BLENDS, ALL SOLD AS COMPONENTS OF NUTRITIONAL SUPPLEMENTS AND VITAMINS; NUTRITIONAL OILS NOT FOR COSMETIC PURPOSES; FOOD SUPPLEMENTS, NAMELY, LIPID CONCENTRATES FOR USE AS A DIETARY FOOD SUPPLEMENT OR FOR PHARMACEUTICAL OR MEDICINAL PURPOSES; ANTI-COUGH DROPS; COUGH DROPS; COUGH EXPECTORANTS; THROAT LOZENGES; COUGH LOZENGES; COUGH SYRUPS; COUGH TREATMENT PREPARATIONS; COLD SORE TREATMENT PREPARATIONS; PHARMACEUTICAL ANTITUSSIVE-COLD PREPARATIONS; PREPARATIONS FOR TREATING COLDS; ANALGESIC PREPARATIONS; ANALGESICS; ANTIPIRETTIC ANALGESICS; IBUPROFEN FOR USE AS AN ORAL ANALGESIC; MULTIPURPOSE MEDICATED ANTIBIOTIC CREAM, ANALGESIC BALM AND MENTHOLATED SALVE; ORAL ANALGESICS; TOPICAL ANALGESICS; PHARMACEUTICAL PREPARATIONS FOR THE TREATMENT AND PREVENTION OF HERPES; VACCINES FOR THE TREATMENT AND PREVENTION OF HERPES; BIOLOGICAL PREPARATIONS FOR THE TREATMENT AND PREVENTION OF HERPES; PHARMACEUTICAL PREPARATIONS FOR THE TREATMENT OF HERPES SIMPLEX INFECTION; PHARMACEUTICAL CAPSULES FOR THE TREATMENT OF HERPES

SIMPLEX INFECTION; HOMEOPATHIC PREPARATIONS FOR THE TREATMENT OF HERPES AND COLD SORES; PHARMACEUTICAL PREPARATIONS FOR THE TREATMENT OF HERPES VIRUSES; MEDICATED TOPICAL CLEAR FLUORIDE GEL FOR THE TREATMENT OF HERPES VIRUS DURING THE PHYSICAL MANIFESTATION OF THE VIRUS; PHARMACEUTICAL PREPARATIONS FOR THE TREATMENT OF HERPES SIMPLEX VIRUS TYPE I OR TYPE II OR HERPES ZOSTER VIRUS, NOT IN INTRAVENOUS FORM; PLANT-BASED ANTIVIRALS; OVER-THE-COUNTER TOPICAL ANTIVIRALS; PHARMACEUTICAL PREPARATION WITH ANTIVIRAL AND/OR ANTIMICROBIAL PROPERTIES FOR USE IN THE TREATMENT OF HERPETIC KERATITIS, CONJUNCTIVITIS, HIV RETINOPATHY, VIRAL INFLUENZA "FLU", HERPES SIMPLEX VIRUS 1, HERPES SIMPLEX VIRUS 2, VARICELLA ZOSTER VIRUS "HERPES ZOSTER" OR "SHINGLES", CYTOMEGALOVIRUS, VIRAL PARAINFLUENZA, ADENOVIRUS, VIRAL ENCEPHALITIS, VIRAL MENINGITIS, ARBOVIRUS, ARENAVIRUS, PICORNAVIRUS, CORONAVIRUS, SYNTIALVIRUS, VIRAL INFECTIONS, COMMON COLDS CAUSED BY VIRUSES, COLD SORES, HUMAN IMMUNODEFICIENCY VIRUS "HIV", ROSEOLA INFANTUM, HUMAN HERPES IV; PHARMACEUTICAL PREPARATIONS FOR THE TREATMENT OF VIRAL DISEASES AND DISORDERS, NAMELY, HERPES; PHARMACEUTICAL PREPARATIONS FOR TREATING IMMUNE DISEASES INDUCED BY VIRUS, NAMELY, HERPES, HERPES ZOSTER AND AIDS; ALGAL PRODUCTS FOR MEDICINAL PURPOSES, NAMELY, ALGAL EXTRACTS OR ALGAL EXTRACT BLENDS FOR USE AS NUTRITIONAL AND DIETARY SUPPLEMENTS; ALGAL PRODUCTS, NAMELY, ALGAL POWDERS SOLD AS AN INTEGRAL INGREDIENT OF NUTRITIONAL SUPPLEMENT DRINK MIX FOR NUTRITIONAL PURPOSES; ALGAL PRODUCTS, NAMELY, ALGAL POWDERS FOR NUTRITIONAL PURPOSES; ALGAL EXTRACTS OR ALGAL EXTRACT BLENDS FOR MEDICAL OR PHARMACEUTICAL PURPOSES; FUNCTIONAL FOODS, NAMELY, DIETETIC FOODS ADAPTED FOR MEDICAL PURPOSES; FUNCTIONAL BEVERAGES, NAMELY, NUTRITIONALLY FORTIFIED BEVERAGES; MEDICINAL FOODS, NAMELY, PROCESSED FOOD FOR MEDICAL PURPOSES; ANIMAL HEALTH PRODUCTS, NAMELY, ANIMAL FEED SUPPLEMENTS, MEDICATED ANIMAL FEED, MICRO-NUTRIENT ANIMAL FEED, DIETARY SUPPLEMENTS FOR ANIMALS, NON-MEDICATED ADDITIVES FOR ANIMAL FEED FOR USE AS NUTRITIONAL SUPPLEMENTS, NUTRITIONAL DRINKS FOR ANIMALS, PHARMACEUTICAL PREPARATIONS FOR ANIMAL SKINCARE; PLANT EXTRACTS FOR MEDICAL, VETERINARY AND PHARMACEUTICAL PURPOSES; HERBAL EXTRACTS FOR MEDICAL, VETERINARY AND PHARMACEUTICAL PURPOSES; DESIGNER EXTRACTS, NAMELY, PLANT, HERBAL AND BOTANICAL EXTRACTS FOR MEDICAL, VETERINARY AND PHARMACEUTICAL PURPOSES; AND BIODEFENSE PRODUCTS, NAMELY, MEDICINAL PREPARATIONS FOR THE TREATMENT OF INFECTIOUS DISEASES AND ADVERSE HUMAN HEALTH CONDITIONS, NAMELY, INFECTION, DEGENERATIVE, MUSCULAR, PULMONARY, SKELETAL, ENDOCRINE, IMMUNE, NEUROLOGICAL, CARDIOVASCULAR, METABOLIC, INFLAMMATORY, CANCER AND RELATED CONDITIONS; MUSHROOM, FUNGUS, OR SPORE EXTRACTS OR BLENDS AS SUPPLEMENTS, NUTRITION, NUTRACEUTICALS AND/OR PHARMACEUTICALS; BOTANICAL EXTRACTS FOR NUTRITIONAL USE; NUTRITIONALLY FORTIFIED BEVERAGES; NUTRITIONALLY FORTIFIED BEVERAGES FOR IMMUNE ENHANCEMENT, AND NUTRITIONALLY FORTIFIED BEVERAGES WITH RICE BRAN AND WHEAT BRAN; MEDICINAL BEVERAGES; SOY PROTEIN FOR USE AS A NUTRITIONAL SUPPLEMENT; NUTRITIONAL ADDITIVES FOR MEDICAL OR NONMEDICAL PURPOSES FOR USE IN MANUFACTURING FOODS AND DIETARY SUPPLEMENTS FOR HUMAN CONSUMPTION; ACTIVE PRINCIPLES EXTRACTED FROM MEDICINAL PLANTS FOR USE IN THE MANUFACTURE OF NUTRACEUTICALS AND PHARMACEUTICALS; ACTIVE PRINCIPLES EXTRACTED FROM MEDICINAL PLANTS FOR USE IN THE MANUFACTURE OF PHARMACEUTICAL OR NUTRACEUTICAL PRODUCTS (U.S. CLS. 6, 18, 44, 46, 51 AND 52).

CLASS 29—MEATS AND PROCESSED FOODS

FOR BEVERAGES, NAMELY, YOGURT-BASED BEVERAGES; FOOD BEVERAGES, NAMELY, DAIRY-BASED FOOD BEVERAGES, FRUIT-BASED FOOD BEVERAGES, VEGETABLE-BASED FOOD BEVERAGES, DAIRY-BASED CHOCOLATE FOOD BEVERAGES, SOY-BASED FOOD BEVERAGE USED AS A MILK SUBSTITUTE, VEGETABLE-BASED CHOCOLATE FOOD BEVERAGES AND PEANUT-BASED FOOD BEVERAGES; MILK BEVERAGES; MILK BEVERAGES, NAMELY, MILK, MILK BEVERAGES CONTAINING FRUITS, MILK BEVERAGES WITH HIGH MILK CONTENT, MILK BASED BEVERAGES CONTAINING FRUIT JUICE AND MILK BEVERAGES CONTAINING COFFEE; MILK POWDER; MILK POWDER FOR NUTRITIONAL PURPOSES; POWDERED MILK FOR FOOD PURPOSES; FUNCTIONAL FOODS, NAMELY, DAIRY-BASED FOOD BEVERAGES, FRUIT-BASED FOOD BEVERAGES, VEGETABLE-BASED FOOD BEVERAGES, DAIRY-BASED CHOCOLATE FOOD BEVERAGES, SOY-BASED FOOD BEVERAGE USED AS A MILK SUBSTITUTE, VEGETABLE-BASED CHOCOLATE FOOD BEVERAGES, NUT-BASED FOOD BEVERAGES, MILK, MILK BEVERAGES CONTAINING FRUITS, MILK BEVERAGES WITH HIGH MILK CONTENT, MILK BASED BEVERAGES CONTAINING FRUIT JUICE, AND MILK BEVERAGES CONTAINING COFFEE; EDIBLE OILS, NAMELY, OMEGA OIL EXTRACTS AND FISH OIL EXTRACTS; SOY PROTEIN FOR USE AS A FOOD ADDITIVE; MUSHROOM, FUNGUS, OR SPORE EXTRACTS OR BLENDS THEREOF FOR USE AS FOOD ADDITIVES (U.S. CL. 46).
HEATHER THOMPSON, EXAMINING ATTORNEY

SN 77-519,377. HERBALSCIENCE GROUP, LLC, NAPLES, FL. FILED 7-10-2008.

ULTRAPOWER JOINT

THE MARK CONSISTS OF STANDARD CHARACTERS WITHOUT CLAIM TO ANY PARTICULAR FONT, STYLE, SIZE, OR COLOR.

NO CLAIM IS MADE TO THE EXCLUSIVE RIGHT TO USE "JOINT", APART FROM THE MARK AS SHOWN.

CLASS 1—CHEMICALS

FOR BOTANICAL EXTRACTS FOR USE IN THE MANUFACTURE OF NUTRACEUTICALS; EXTRACTS FOR USE IN THE MANUFACTURE OF PHARMACEUTICAL PREPARATIONS IN THE FORM OF PREPARATIONS IN THE FORM OF LOTIONS, CREAMS, AND TOPICAL ANALGESICS AND ANESTHETICS, TABLETS, CAPSULES, PILLS, TINCTURE, SUPPOSITORIES AND AMPULE FOR INJECTION; BOTANICAL EXTRACTS FOR USE IN THE MANUFACTURE OF PHARMACEUTICALS; CHEMICAL EXTRACTS EXTRACTED FROM MEDICINAL PLANTS FOR USE IN THE MANUFACTURE OF NUTRACEUTICALS AND PHARMACEUTICALS; CHEMICAL EXTRACTS, NAMELY, CHEMICAL AGENTS MADE FROM BOTANICAL EXTRACTS OR ASSOCIATION OF CHEMICAL EXTRACTS FOR USE IN THE MANUFACTURE OF PHARMACEUTICAL OR NUTRACEUTICAL PRODUCTS; BOTANICAL EXTRACTS USED IN THE MANUFACTURE OF PREPARATIONS IN THE FORM OF LOTIONS, CREAMS, AND TOPICAL ANALGESICS AND ANESTHETICS, TABLETS, CAPSULES, PILLS, LOZENGES, INHALERS, TINCTURE, SUPPOSITORIES AND AMPULE FOR INJECTION; BOTANICALS AND BOTANICAL BLENDS, HERBS AND HERBAL BLENDS, BOTANICAL EXTRACTS AND BOTANICAL EXTRACT BLENDS, FLAVOR EXTRACTS AND FLAVOR EXTRACT BLENDS, ALGAL EXTRACTS AND ALGAL EXTRACT BLENDS, ALL FOR USE IN THE MANUFACTURE OF NUTRITIONAL SUPPLEMENTS AND VITAMINS; HERBAL EXTRACTS AND BLENDS FOR USE IN MANUFACTURING FUNCTIONAL FOODS OR BEVERAGES; HERBAL EXTRACTS AND BLENDS FOR USE IN MANUFACTURING MEDICINAL FOODS OR BEVERAGES; BOTANICAL EXTRACTS AND BLENDS FOR USE IN MANUFACTURING FUNCTIONAL FOODS OR BEVERAGES; BOTANICAL EXTRACTS AND BLENDS FOR USE IN MANUFACTURING MEDICINAL FOODS OR BEVERAGES; HERBAL PREPARATIONS AND EXTRACTS FOR USE AS INGREDIENTS IN MANUFACTURING IN THE FOOD, NUTRITION, NUTRACEUTICAL AND/OR PHARMACEUTICAL INDUSTRIES (U.S. CLS. 1, 5, 6, 10, 26 AND 46).

CLASS 5—PHARMACEUTICALS

FOR NUTRITIONAL SUPPLEMENTS; HERBAL PRODUCTS, NAMELY, MEDICATED SKIN AND LIP BALMS; HERBAL PRODUCTS, NAMELY, OINTMENTS, OILS, DRINKS, INFUSIONS, SYRUPS, HERBAL EXTRACTS, POISONS, AND TINCTURES FOR MEDICAL USE IN THE TREATMENT OF STROKES, INFARCTS AND OTHER CARDIOVASCULAR AND CEREBRUM DISEASES; HERBAL PRODUCTS, NAMELY, OINTMENTS, OILS, NAMELY, MINERAL OIL FOR USE AS A LAXATIVE; DRINKS, NAMELY, MEAL REPLACEMENT DRINKS, DIETARY SUPPLEMENT DRINKS, MEDICINAL DRINKS, AND FISH OIL FOR USE AS A DIETARY SUPPLEMENT OR IN A NUTRACEUTICAL; INFUSIONS AND SYRUPS, NAMELY, COUGH SYRUPS; HERBAL PRODUCTS FOR MEDICINAL PURPOSES, NAMELY, HERBAL EXTRACTS FOR USE AS NUTRITIONAL AND DIETARY SUPPLEMENTS; HERBAL PRODUCTS FOR MEDICINAL PURPOSES, NAMELY, HERBAL EXTRACTS AND SYRUPS; MEDICINAL HERB EXTRACTS; MEDICINAL HERB EXTRACTS FOR MEDICAL PURPOSES; PLANT EXTRACTS FOR MEDICAL, PHARMACEUTICAL, NUTRACEUTICAL AND NUTRITIONAL PURPOSES; MEDICINAL EXTRACTS USED IN PREPARATIONS IN THE FORM OF LOTIONS, CREAMS, AND TOPICAL ANALGESICS AND ANESTHETICS, TABLETS, CAPSULES, PILLS, LOZENGES, INHALERS, TINCTURE, SUPPOSITORIES AND AMPULE FOR INJECTION; MEDICINAL EXTRACTS IN THE FORM OF LOTIONS, CREAMS, AND TOPICAL ANALGESICS AND ANESTHETICS, TABLETS, CAPSULES, PILLS, TINCTURE, SUPPOSITORIES AND AMPULE FOR INJECTION; MEDICINAL BOTANICAL EXTRACTS IN THE FORM OF LOTIONS, CREAMS, AND TOPICAL ANALGESICS AND ANESTHETICS, TABLETS, CAPSULES, PILLS, TINCTURE, SUPPOSITORIES AND AMPULE FOR INJECTION USED TO TREAT SKIN AILMENTS, FOR INFECTION, DEGENERATIVE, MUS-

CULAR, PULMONARY, SKELETAL, ENDOCRINE, IMMUNE, NEUROLOGICAL, CARDIOVASCULAR, METABOLIC, INFLAMMATORY, CANCER AND RELATED CONDITIONS; YEAST EXTRACTS FOR MEDICAL, PHARMACEUTICAL OR NUTRACEUTICAL PURPOSES; HERBAL PRODUCTS, NAMELY, HERBAL POWDERS FOR NUTRITIONAL PURPOSES; HERBAL PRODUCTS, NAMELY, HERBAL MEAL REPLACEMENT POWDERS FOR DIETARY AND NUTRITIONAL PURPOSES; HERBAL PRODUCTS, NAMELY, AROMATHERAPY PACKS CONTAINING HERBS USED FOR RELIEF FROM HEADACHES, INSOMNIA AND SINUS DISCOMFORT; HERBAL PRODUCTS, NAMELY, HERBAL POWDERS SOLD AS AN INTEGRAL INGREDIENT OF NUTRITIONAL SUPPLEMENT DRINK MIX FOR NUTRITIONAL PURPOSES; PHARMACEUTICALS AND NUTRACEUTICALS, NAMELY, VITAMINS AND FOOD SUPPLEMENTS; PHARMACEUTICAL PREPARATIONS, NAMELY, APPETITE SUPPRESSANTS AND LIPID LOWERING AGENTS; FOOD FOR DIABETICS, INFANTS AND ENTERAL FEEDING; BOTANICAL EXTRACTS FOR NUTRITIONAL USE; BOTANICAL EXTRACTS FOR MEDICAL, VETERINARY, NUTRACEUTICAL AND PHARMACEUTICAL PURPOSES; DESIGNER EXTRACTS, NAMELY, HERBAL EXTRACTS FOR MEDICAL, VETERINARY AND PHARMACEUTICAL PURPOSES; BOTANICAL EXTRACTS FOR NUTRITIONAL SUPPLEMENTS, NUTRACEUTICALS AND PHARMACEUTICALS; NUTRITIONAL DIETARY SUPPLEMENTS; ORAL PREPARATIONS CONTAINING HERBS OR HERBAL EXTRACTS USED TO MAINTAIN HEALTH AND FOR A WIDE VARIETY OF PHYSICAL CONDITIONS; VITAMIN AND MINERAL PREPARATIONS INTENDED FOR USE AS DIETARY SUPPLEMENTS; VITAMINS; FOOD SUPPLEMENTS; NUTRACEUTICALS, NAMELY, VITAMINS AND FOOD SUPPLEMENTS; FOOD FOR MEDICALLY RESTRICTED DIETS; SUPPLEMENTS, NAMELY, LIPID CONCENTRATES FOR USE AS A DIETARY FOOD SUPPLEMENT OR FOR PHARMACEUTICAL OR MEDICINAL PURPOSES; FOOD SUPPLEMENTS, NAMELY, ANTI-OXIDANTS; BOTANICALS AND BOTANICAL BLENDS, HERBALS AND HERBAL BLENDS, BOTANICAL EXTRACTS AND BOTANICAL EXTRACT BLENDS, FLAVOR EXTRACTS AND FLAVOR EXTRACT BLENDS, ALL SOLD AS COMPONENTS OF NUTRITIONAL SUPPLEMENTS AND VITAMINS; NUTRITIONAL OILS NOT FOR COSMETIC PURPOSES; FOOD SUPPLEMENTS, NAMELY, LIPID CONCENTRATES FOR USE AS A DIETARY FOOD SUPPLEMENT OR FOR PHARMACEUTICAL OR MEDICINAL PURPOSES; ANTI-COUGH DROPS; COUGH DROPS; COUGH EXPECTORANTS; THROAT LOZENGES; COUGH LOZENGES; COUGH SYRUPS; COUGH TREATMENT PREPARATIONS; COLD SORE TREATMENT PREPARATIONS; PHARMACEUTICAL ANTITUSSIVE-COLD PREPARATIONS; PREPARATIONS FOR TREATING COLDS; ANALGESIC PREPARATIONS; ANALGESICS; ANTIPIRETIC ANALGESICS; IBUPROFEN FOR USE AS AN ORAL ANALGESIC; MULTIPURPOSE MEDICATED ANTIBIOTIC CREAM, ANALGESIC BALM AND MENTHOLATED SALVE; ORAL ANALGESICS; TOPICAL ANALGESICS; PHARMACEUTICAL PREPARATIONS FOR THE TREATMENT AND PREVENTION OF HERPES; VACCINES FOR THE TREATMENT AND PREVENTION OF HERPES; BIOLOGICAL PREPARATIONS FOR THE TREATMENT AND PREVENTION OF HERPES; PHARMACEUTICAL PREPARATIONS FOR THE TREATMENT OF HERPES SIMPLEX INFECTION; PHARMACEUTICAL CAPSULES FOR THE TREATMENT OF HERPES SIMPLEX INFECTION; HOMEOPATHIC PREPARATIONS FOR THE TREATMENT OF HERPES AND COLD SORES; PHARMACEUTICAL PREPARATIONS FOR THE TREATMENT OF HERPES VIRUSES; MEDICATED TOPICAL CLEAR FLUORIDE GEL FOR THE TREATMENT OF HERPES VIRUS DURING THE PHYSICAL MANIFESTATION OF THE VIRUS; PHARMACEUTICAL PREPARATIONS FOR THE TREATMENT OF HERPES SIMPLEX VIRUS TYPE I OR TYPE II OR HERPES ZOSTER VIRUS, NOT IN INTRAVENOUS FORM; PLANT-BASED ANTIVIRALS; OVER-THE-COUNTER TOPICAL ANTIVIRALS; PHARMACEUTICAL PREPARATION WITH ANTIVIRAL AND/OR ANTIMICROBIAL PROPERTIES FOR USE IN THE TREATMENT OF HERPESIC KERATITIS, CONJUNCTIVITIS, HIV RETINOPATHY, VIRAL INFLUENZA "FLU", HERPES SIMPLEX VIRUS 1, HERPES SIMPLEX VIRUS 2, VARICELLA ZOSTER VIRUS "HERPES ZOSTER" OR "SHINGLES", CYTOMEGALOVIRUS, VIRAL PARAIN-

FLUENZA, ADENOVIRUS, VIRAL ENCEPHALITIS, VIRAL MENINGITIS, ARBOVIRUS, ARENAVIRUS, PICORNAVIRUS, CORONAVIRUS, SYNTIALVIRUS, VIRAL INFECTIONS, COMMON COLDS CAUSED BY VIRUSES, COLD SORES, HUMAN IMMUNODEFICIENCY VIRUS "HIV", ROSEOLA INFANTUM, HUMAN HERPES IV; PHARMACEUTICAL PREPARATIONS FOR THE TREATMENT OF VIRAL DISEASES AND DISORDERS, NAMELY, HERPES; PHARMACEUTICAL PREPARATIONS FOR TREATING IMMUNE DISEASES INDUCED BY VIRUS, NAMELY, HERPES, HERPES ZOSTER AND AIDS; ALGAL PRODUCTS FOR MEDICINAL PURPOSES, NAMELY, ALGAL EXTRACTS OR ALGAL EXTRACT BLENDS FOR USE AS NUTRITIONAL AND DIETARY SUPPLEMENTS; ALGAL PRODUCTS, NAMELY, ALGAL POWDERS SOLD AS AN INTEGRAL INGREDIENT OF NUTRITIONAL SUPPLEMENT DRINK MIX FOR NUTRITIONAL PURPOSES; ALGAL PRODUCTS, NAMELY, ALGAL POWDERS FOR NUTRITIONAL PURPOSES; ALGAL EXTRACTS OR ALGAL EXTRACT BLENDS FOR MEDICAL OR PHARMACEUTICAL PURPOSES; FUNCTIONAL FOODS, NAMELY, DIETETIC FOODS ADAPTED FOR MEDICAL PURPOSES; FUNCTIONAL BEVERAGES, NAMELY, NUTRITIONALLY FORTIFIED BEVERAGES; MEDICINAL FOODS, NAMELY, PROCESSED FOOD FOR MEDICAL PURPOSES; ANIMAL HEALTH PRODUCTS, NAMELY, ANIMAL FEED SUPPLEMENTS, MEDICATED ANIMAL FEED, MICRO-NUTRIENT ANIMAL FEED, DIETARY SUPPLEMENTS FOR ANIMALS, NON-MEDICATED ADDITIVES FOR ANIMAL FEED FOR USE AS NUTRITIONAL SUPPLEMENTS, NUTRITIONAL DRINKS FOR ANIMALS, PHARMACEUTICAL PREPARATIONS FOR ANIMAL SKINCARE; PLANT EXTRACTS FOR MEDICAL, VETERINARY AND PHARMACEUTICAL PURPOSES; HERBAL EXTRACTS FOR MEDICAL, VETERINARY AND PHARMACEUTICAL PURPOSES; DESIGNER EXTRACTS, NAMELY, PLANT, HERBAL AND BOTANICAL EXTRACTS FOR MEDICAL, VETERINARY AND PHARMACEUTICAL PURPOSES; AND BIODEFENSE PRODUCTS, NAMELY, MEDICINAL PREPARATIONS FOR THE TREATMENT OF INFECTIOUS DISEASES AND ADVERSE HUMAN HEALTH CONDITIONS, NAMELY, INFECTION, DEGENERATIVE, MUSCULAR, PULMONARY, SKELETAL, ENDOCRINE, IMMUNE, NEUROLOGICAL, CARDIOVASCULAR, METABOLIC, INFLAMMATORY, CANCER AND RELATED CONDITIONS; MUSHROOM, FUNGUS, OR SPORE EXTRACTS OR BLENDS AS SUPPLEMENTS, NUTRITION, NUTRACEUTICALS AND/OR PHARMACEUTICALS; BOTANICAL EXTRACTS FOR NUTRITIONAL USE; NUTRITIONALLY FORTIFIED BEVERAGES; NUTRITIONALLY FORTIFIED BEVERAGES FOR IMMUNE ENHANCEMENT, AND NUTRITIONALLY FORTIFIED BEVERAGES WITH RICE BRAN AND WHEAT BRAN; MEDICINAL BEVERAGES; SOY PROTEIN FOR USE AS A NUTRITIONAL SUPPLEMENT; NUTRITIONAL ADDITIVES FOR MEDICAL OR NONMEDICAL PURPOSES FOR USE IN MANUFACTURING FOODS AND DIETARY SUPPLEMENTS FOR HUMAN CONSUMPTION; ACTIVE PRINCIPLES EXTRACTED FROM MEDICINAL PLANTS FOR USE IN THE MANUFACTURE OF NUTRACEUTICALS AND PHARMACEUTICALS; ACTIVE PRINCIPLES EXTRACTED FROM MEDICINAL PLANTS FOR USE IN THE MANUFACTURE OF PHARMACEUTICAL OR NUTRACEUTICAL PRODUCTS (U.S. CLS. 6, 18, 44, 46, 51 AND 52).

CLASS 30—STAPLE FOODS

FOR HERBAL FOOD BEVERAGES; BEVERAGES, NAMELY, GRAIN-BASED BEVERAGES AND GRAIN-BASED FOOD BEVERAGES; PROCESSED HERBS; ORGANIC FOODS, NAMELY, CHOCOLATE, DAIRY-FREE CHOCOLATE, REDUCED FAT CHOCOLATE, REDUCED CALORIE CHOCOLATE, COCOA, CHOCOLATE CHIPS, CHOCOLATE FONDUE, CHOCOLATE TOPPING, REDUCED FAT CANDY, BAKERY PRODUCTS, NAMELY, CAKES AND PIES, CRACKERS, BISCUITS, READY-TO-EAT CEREAL-DERIVED FOOD BARS, PRETZELS, CHEWING GUM, FROZEN YOGURT, FROZEN CUSTARD, FRUIT ICES, PANCAKE AND WAFFLE MIXES, SALAD DRESSING, PASTA AND PASTA MIXES, RICE, CORNMEAL AND WHEAT-BASED SNACK FOODS; FOOD BEVERAGES, NAMELY, CHOCOLATE FOOD BEVERAGES NOT BEING DAIRY-BASED OR VEGETABLE BASED, AND GRAIN-BASED FOOD BEVERAGES; FUNCTIONAL FOODS, NAMELY, CHOCOLATE,

DAIRY-FREE CHOCOLATE, REDUCED FAT CHOCOLATE, REDUCED CALORIE CHOCOLATE, COCOA, CHOCOLATE CHIPS, CHOCOLATE FONDUE, CHOCOLATE TOPPING, REDUCED FAT CANDY, BAKERY PRODUCTS, NAMELY, CAKES AND PIES, CRACKERS, BISCUITS, READY-TO-EAT CEREAL-DERIVED FOOD BARS, PRETZELS, CHEWING GUM, FROZEN YOGURT, FROZEN CUSTARD, FRUIT ICES, PANCAKE AND WAFFLE MIXES, SALAD DRESSING, PASTA AND PASTA MIXES, RICE, CORNMEAL AND WHEAT BASED SNACK FOODS; BREAKFAST CEREALS; FUNCTIONAL BEVERAGES, NAMELY, GRAIN BASED FOOD BEVERAGES CONTAINING OATS OR OAT EXTRACTS, HERBAL FOOD BEVERAGES; FOOD FLAVORINGS; AND WHEAT BRAN-BASED SNACKS AND SNACK FOODS, RICE BRAN-BASED SNACKS AND SNACK FOODS; PROCESSED WHEAT AND RICE BRAN (U.S. CL. 46).

HEATHER THOMPSON, EXAMINING ATTORNEY

SN 77-519,386. HERBALSCIENCE GROUP, LLC, NAPLES, FL. FILED 7-10-2008.

JOINT ULTRAPOWER

THE MARK CONSISTS OF STANDARD CHARACTERS WITHOUT CLAIM TO ANY PARTICULAR FONT, STYLE, SIZE, OR COLOR.

NO CLAIM IS MADE TO THE EXCLUSIVE RIGHT TO USE "JOINT", APART FROM THE MARK AS SHOWN.

CLASS 1—CHEMICALS

FOR BOTANICAL EXTRACTS FOR USE IN THE MANUFACTURE OF NUTRACEUTICALS; EXTRACTS FOR USE IN THE MANUFACTURE OF PHARMACEUTICAL PREPARATIONS IN THE FORM OF PREPARATIONS IN THE FORM OF LOTIONS, CREAMS, AND TOPICAL ANALGESICS AND ANESTHETICS, TABLETS, CAPSULES, PILLS, TINCTURE, SUPPOSITORIES AND AMPULE FOR INJECTION; BOTANICAL EXTRACTS FOR USE IN THE MANUFACTURE OF PHARMACEUTICALS; CHEMICAL EXTRACTS EXTRACTED FROM MEDICINAL PLANTS FOR USE IN THE MANUFACTURE OF NUTRACEUTICALS AND PHARMACEUTICALS; CHEMICAL EXTRACTS, NAMELY, CHEMICAL AGENTS MADE FROM BOTANICAL EXTRACTS OR ASSOCIATION OF CHEMICAL EXTRACTS FOR USE IN THE MANUFACTURE OF PHARMACEUTICAL OR NUTRACEUTICAL PRODUCTS; BOTANICAL EXTRACTS USED IN THE MANUFACTURE OF PREPARATIONS IN THE FORM OF LOTIONS, CREAMS, AND TOPICAL ANALGESICS AND ANESTHETICS, TABLETS, CAPSULES, PILLS, LOZENGES, INHALERS, TINCTURE, SUPPOSITORIES AND AMPULE FOR INJECTION; BOTANICALS AND BOTANICAL BLENDS, HERBS AND HERBAL BLENDS, BOTANICAL EXTRACTS AND BOTANICAL EXTRACT BLENDS, FLAVOR EXTRACTS AND FLAVOR EXTRACT BLENDS, ALGAL EXTRACTS AND ALGAL EXTRACT BLENDS, ALL FOR USE IN THE MANUFACTURE OF NUTRITIONAL SUPPLEMENTS AND VITAMINS; HERBAL EXTRACTS AND BLENDS FOR USE IN MANUFACTURING FUNCTIONAL FOODS OR BEVERAGES; HERBAL EXTRACTS AND BLENDS FOR USE IN MANUFACTURING MEDICINAL FOODS OR BEVERAGES; BOTANICAL EXTRACTS AND BLENDS FOR USE IN MANUFACTURING FUNCTIONAL FOODS OR BEVERAGES; BOTANICAL EXTRACTS AND BLENDS FOR USE IN MANUFACTURING MEDICINAL FOODS OR BEVERAGES; HERBAL PREPARATIONS AND EXTRACTS FOR USE AS INGREDIENTS IN MANUFACTURING IN THE FOOD, NUTRITION, NUTRACEUTICAL AND/OR PHARMACEUTICAL INDUSTRIES (U.S. CLS. 1, 5, 6, 10, 26 AND 46).

CLASS 5—PHARMACEUTICALS

FOR NUTRITIONAL SUPPLEMENTS; HERBAL PRODUCTS, NAMELY, MEDICATED SKIN AND LIP BALMS; HERBAL PRODUCTS, NAMELY, OINTMENTS, OILS, DRINKS, INFUSIONS, SYRUPS, HERBAL EXTRACTS, POISONS, AND TINCTURES FOR MEDICAL USE IN THE TREATMENT OF STROKES, INFARCTS AND OTHER CARDIOVASCULAR AND CEREBRUM DISEASES; HERBAL PRODUCTS, NAMELY, OINTMENTS, OILS, NAMELY, MINERAL OIL FOR USE AS A LAXATIVE; DRINKS, NAMELY, MEAL REPLACEMENT DRINKS, DIETARY SUPPLEMENT DRINKS, MEDICINAL DRINKS, AND FISH OIL FOR USE AS A DIETARY SUPPLEMENT OR IN A NUTRACEUTICAL; INFUSIONS AND SYRUPS, NAMELY, COUGH SYRUPS; HERBAL PRODUCTS FOR MEDICINAL PURPOSES, NAMELY, HERBAL EXTRACTS FOR USE AS NUTRITIONAL AND DIETARY SUPPLEMENTS; HERBAL PRODUCTS FOR MEDICINAL PURPOSES, NAMELY, HERBAL EXTRACTS AND SYRUPS; MEDICINAL HERB EXTRACTS; MEDICINAL HERB EXTRACTS FOR MEDICAL PURPOSES; PLANT EXTRACTS FOR MEDICAL, PHARMACEUTICAL, NUTRACEUTICAL AND NUTRITIONAL PURPOSES; MEDICINAL EXTRACTS USED IN PREPARATIONS IN THE FORM OF LOTIONS, CREAMS, AND TOPICAL ANALGESICS AND ANESTHETICS, TABLETS, CAPSULES, PILLS, LOZENGES, INHALERS, TINCTURE, SUPPOSITORIES AND AMPULE FOR INJECTION; MEDICINAL EXTRACTS IN THE FORM OF LOTIONS, CREAMS, AND TOPICAL ANALGESICS AND ANESTHETICS, TABLETS, CAPSULES, PILLS, TINCTURE, SUPPOSITORIES AND AMPULE FOR INJECTION; MEDICINAL HERBAL EXTRACTS IN THE FORM OF LOTIONS, CREAMS, AND TOPICAL ANALGESICS AND ANESTHETICS, TABLETS, CAPSULES, PILLS, TINCTURE, SUPPOSITORIES AND AMPULE FOR INJECTION USED TO TREAT SKIN AILMENTS, FOR INFECTION, DEGENERATIVE, MUSCULAR, PULMONARY, SKELETAL, ENDOCRINE, IMMUNE, NEUROLOGICAL, CARDIOVASCULAR, METABOLIC, INFLAMMATORY, CANCER AND RELATED CONDITIONS; YEAST EXTRACTS FOR MEDICAL, PHARMACEUTICAL OR NUTRACEUTICAL PURPOSES; HERBAL PRODUCTS, NAMELY, HERBAL POWDERS FOR NUTRITIONAL PURPOSES; HERBAL PRODUCTS, NAMELY, HERBAL MEAL REPLACEMENT POWDERS FOR DIETARY AND NUTRITIONAL PURPOSES; HERBAL PRODUCTS, NAMELY, AROMATHERAPY PACKS CONTAINING HERBS USED FOR RELIEF FROM HEADACHES, INSOMNIA AND SINUS DISCOMFORT; HERBAL PRODUCTS, NAMELY, HERBAL POWDERS SOLD AS AN INTEGRAL INGREDIENT OF NUTRITIONAL SUPPLEMENT DRINK MIX FOR NUTRITIONAL PURPOSES; PHARMACEUTICALS AND NUTRACEUTICALS, NAMELY, VITAMINS AND FOOD SUPPLEMENTS; PHARMACEUTICAL PREPARATIONS, NAMELY, APPETITE SUPPRESSANTS AND LIPID LOWERING AGENTS; FOOD FOR DIABETICS, INFANTS AND ENTERAL FEEDING; BOTANICAL EXTRACTS FOR NUTRITIONAL USE; BOTANICAL EXTRACTS FOR MEDICAL, VETERINARY, NUTRACEUTICAL AND PHARMACEUTICAL PURPOSES; DESIGNER EXTRACTS, NAMELY, HERBAL EXTRACTS FOR MEDICAL, VETERINARY AND PHARMACEUTICAL PURPOSES; BOTANICAL EXTRACTS FOR NUTRITIONAL SUPPLEMENTS, NUTRACEUTICALS AND PHARMACEUTICALS; NUTRITIONAL DIETARY SUPPLEMENTS; ORAL PREPARATIONS CONTAINING HERBS OR HERBAL EXTRACTS USED TO MAINTAIN HEALTH AND FOR A WIDE VARIETY OF PHYSICAL CONDITIONS; VITAMIN AND MINERAL PREPARATIONS INTENDED FOR USE AS DIETARY SUPPLEMENTS; VITAMINS; FOOD SUPPLEMENTS; NUTRACEUTICALS, NAMELY, VITAMINS AND FOOD SUPPLEMENTS; FOOD FOR MEDICALLY RESTRICTED DIETS; SUPPLEMENTS, NAMELY, LIPID CONCENTRATES FOR USE AS A DIETARY FOOD SUPPLEMENT OR FOR PHARMACEUTICAL OR MEDICINAL PURPOSES; FOOD SUPPLEMENTS, NAMELY, ANTI-OXIDANTS; BOTANICALS AND BOTANICAL BLENDS, HERBALS AND HERBAL BLENDS, BOTANICAL EXTRACTS AND BOTANICAL EXTRACT BLENDS, FLAVOR EXTRACTS AND FLAVOR EXTRACT BLENDS, ALL SOLD AS COMPONENTS OF NUTRITIONAL SUP-

PLEMENTS AND VITAMINS; NUTRITIONAL OILS NOT FOR COSMETIC PURPOSES; FOOD SUPPLEMENTS, NAMELY, LIPID CONCENTRATES FOR USE AS A DIETARY FOOD SUPPLEMENT OR FOR PHARMACEUTICAL OR MEDICINAL PURPOSES; ANTI-COUGH DROPS; COUGH DROPS; COUGH EXPECTORANTS; THROAT LOZENGES; COUGH LOZENGES; COUGH SYRUPS; COUGH TREATMENT PREPARATIONS; COLD SORE TREATMENT PREPARATIONS; PHARMACEUTICAL ANTITUSSIVE-COLD PREPARATIONS; PREPARATIONS FOR TREATING COLDS; ANALGESIC PREPARATIONS; ANALGESICS; ANTIPIRETTIC ANALGESICS; IBUPROFEN FOR USE AS AN ORAL ANALGESIC; MULTIPURPOSE MEDICATED ANTIBIOTIC CREAM, ANALGESIC BALM AND MENTHOLATED SALVE; ORAL ANALGESICS; TOPICAL ANALGESICS; PHARMACEUTICAL PREPARATIONS FOR THE TREATMENT AND PREVENTION OF HERPES; VACCINES FOR THE TREATMENT AND PREVENTION OF HERPES; BIOLOGICAL PREPARATIONS FOR THE TREATMENT AND PREVENTION OF HERPES; PHARMACEUTICAL PREPARATIONS FOR THE TREATMENT OF HERPES SIMPLEX INFECTION; PHARMACEUTICAL CAPSULES FOR THE TREATMENT OF HERPES SIMPLEX INFECTION; HOMEOPATHIC PREPARATIONS FOR THE TREATMENT OF HERPES AND COLD SORES; PHARMACEUTICAL PREPARATIONS FOR THE TREATMENT OF HERPES VIRUSES; MEDICATED TOPICAL CLEAR FLUORIDE GEL FOR THE TREATMENT OF HERPES VIRUS DURING THE PHYSICAL MANIFESTATION OF THE VIRUS; PHARMACEUTICAL PREPARATIONS FOR THE TREATMENT OF HERPES SIMPLEX VIRUS TYPE I OR TYPE II OR HERPES ZOSTER VIRUS, NOT IN INTRAVENOUS FORM; PLANT-BASED ANTIVIRALS; OVER-THE-COUNTER TOPICAL ANTIVIRALS; PHARMACEUTICAL PREPARATION WITH ANTIVIRAL AND/OR ANTIMICROBIAL PROPERTIES FOR USE IN THE TREATMENT OF HERPESIC KERATITIS, CONJUNCTIVITIS, HIV RETINOPATHY, VIRAL INFLUENZA "FLU", HERPES SIMPLEX VIRUS 1, HERPES SIMPLEX VIRUS 2, VARICELLA ZOSTER VIRUS "HERPES ZOSTER" OR "SHINGLES", CYTOMEGALOVIRUS, VIRAL PARAINFLUENZA, ADENOVIRUS, VIRAL ENCEPHALITIS, VIRAL MENINGITIS, ARBOVIRUS, ARENAVIRUS, PICORNAVIRUS, CORONAVIRUS, SYNTIAL VIRUS, VIRAL INFECTIONS, COMMON COLDS CAUSED BY VIRUSES, COLD SORES, HUMAN IMMUNODEFICIENCY VIRUS "HIV", ROSEOLA INFANTUM, HUMAN HERPES IV; PHARMACEUTICAL PREPARATIONS FOR THE TREATMENT OF VIRAL DISEASES AND DISORDERS, NAMELY, HERPES; PHARMACEUTICAL PREPARATIONS FOR TREATING IMMUNE DISEASES INDUCED BY VIRUS, NAMELY, HERPES, HERPES ZOSTER AND AIDS; ALGAL PRODUCTS FOR MEDICAL PURPOSES, NAMELY, ALGAL EXTRACTS OR ALGAL EXTRACT BLENDS FOR USE AS NUTRITIONAL AND DIETARY SUPPLEMENTS; ALGAL PRODUCTS, NAMELY, ALGAL POWDERS SOLD AS AN INTEGRAL INGREDIENT OF NUTRITIONAL SUPPLEMENT DRINK MIX FOR NUTRITIONAL PURPOSES; ALGAL PRODUCTS, NAMELY, ALGAL POWDERS FOR NUTRITIONAL PURPOSES; ALGAL EXTRACTS OR ALGAL EXTRACT BLENDS FOR MEDICAL OR PHARMACEUTICAL PURPOSES; FUNCTIONAL FOODS, NAMELY, DIETETIC FOODS ADAPTED FOR MEDICAL PURPOSES; FUNCTIONAL BEVERAGES, NAMELY, NUTRITIONALLY FORTIFIED BEVERAGES; MEDICINAL FOODS, NAMELY, PROCESSED FOOD FOR MEDICAL PURPOSES; ANIMAL HEALTH PRODUCTS, NAMELY, ANIMAL FEED SUPPLEMENTS, MEDICATED ANIMAL FEED, MICRO-NUTRIENT ANIMAL FEED, DIETARY SUPPLEMENTS FOR ANIMALS, NON-MEDICATED ADDITIVES FOR ANIMAL FEED FOR USE AS NUTRITIONAL SUPPLEMENTS, NUTRITIONAL DRINKS FOR ANIMALS, PHARMACEUTICAL PREPARATIONS FOR ANIMAL SKINCARE; PLANT EXTRACTS FOR MEDICAL, VETERINARY AND PHARMACEUTICAL PURPOSES; HERBAL EXTRACTS FOR MEDICAL, VETERINARY AND PHARMACEUTICAL PURPOSES; DESIGNER EXTRACTS, NAMELY, PLANT, HERBAL AND BOTANICAL EXTRACTS FOR MEDICAL, VETERINARY AND PHARMACEUTICAL PURPOSES; AND BIODEFENSE PRODUCTS, NAMELY, MEDICINAL PREPARATIONS FOR THE TREATMENT OF INFECTIOUS DISEASES AND ADVERSE HUMAN HEALTH CONDITIONS, NAMELY, INFECTION, DEGENERATIVE, MUSCULAR, PULMONARY, SKELETAL, ENDOCRINE, IMMUNE, NEUROLOGICAL, CARDIOVASCULAR, ME-

TABOLIC, INFLAMMATORY, CANCER AND RELATED CONDITIONS; MUSHROOM, FUNGUS, OR SPORE EXTRACTS OR BLENDS AS SUPPLEMENTS, NUTRITION, NUTRACEUTICALS AND/OR PHARMACEUTICALS; BOTANICAL EXTRACTS FOR NUTRITIONAL USE; NUTRITIONALLY FORTIFIED BEVERAGES; NUTRITIONALLY FORTIFIED BEVERAGES FOR IMMUNE ENHANCEMENT, AND NUTRITIONALLY FORTIFIED BEVERAGES WITH RICE BRAN AND WHEAT BRAN; MEDICINAL BEVERAGES; SOY PROTEIN FOR USE AS A NUTRITIONAL SUPPLEMENT; NUTRITIONAL ADDITIVES FOR MEDICAL OR NONMEDICAL PURPOSES FOR USE IN MANUFACTURING FOODS AND DIETARY SUPPLEMENTS FOR HUMAN CONSUMPTION; ACTIVE PRINCIPLES EXTRACTED FROM MEDICINAL PLANTS FOR USE IN THE MANUFACTURE OF NUTRACEUTICALS AND PHARMACEUTICALS; ACTIVE PRINCIPLES EXTRACTED FROM MEDICINAL PLANTS FOR USE IN THE MANUFACTURE OF PHARMACEUTICAL OR NUTRACEUTICAL PRODUCTS (U.S. CLS. 6, 18, 44, 46, 51 AND 52).

BARS, PRETZELS, CHEWING GUM, FROZEN YOGURT, FROZEN CUSTARD, FRUIT ICES, PANCAKE AND WAFFLE MIXES, SALAD DRESSING, PASTA AND PASTA MIXES, RICE, CORNMEAL AND WHEAT BASED SNACK FOODS; BREAKFAST CEREALS; FUNCTIONAL BEVERAGES, NAMELY, GRAIN BASED FOOD BEVERAGES CONTAINING OATS OR OAT EXTRACTS, HERBAL FOOD BEVERAGES; FOOD FLAVORINGS; AND WHEAT BRAN-BASED SNACKS AND SNACK FOODS, RICE BRAN-BASED SNACKS AND SNACK FOODS; PROCESSED WHEAT AND RICE BRAN (U.S. CL. 46).

HEATHER THOMPSON, EXAMINING ATTORNEY

SN 77-519,398. HERBALSCIENCE GROUP, LLC, NAPLES, FL. FILED 7-10-2008.

CLASS 29—MEATS AND PROCESSED FOODS

FOR BEVERAGES, NAMELY, YOGURT-BASED BEVERAGES; FOOD BEVERAGES, NAMELY, DAIRY-BASED FOOD BEVERAGES, FRUIT-BASED FOOD BEVERAGES, VEGETABLE-BASED FOOD BEVERAGES, DAIRY-BASED CHOCOLATE FOOD BEVERAGES, SOY-BASED FOOD BEVERAGE USED AS A MILK SUBSTITUTE, VEGETABLE-BASED CHOCOLATE FOOD BEVERAGES AND PEANUT-BASED FOOD BEVERAGES; MILK BEVERAGES; MILK BEVERAGES, NAMELY, MILK, MILK BEVERAGES CONTAINING FRUITS, MILK BEVERAGES WITH HIGH MILK CONTENT, MILK BASED BEVERAGES CONTAINING FRUIT JUICE AND MILK BEVERAGES CONTAINING COFFEE; MILK POWDER; MILK POWDER FOR NUTRITIONAL PURPOSES; POWDERED MILK FOR FOOD PURPOSES; FUNCTIONAL FOODS, NAMELY, DAIRY-BASED FOOD BEVERAGES, FRUIT-BASED FOOD BEVERAGES, VEGETABLE-BASED FOOD BEVERAGES, DAIRY-BASED CHOCOLATE FOOD BEVERAGES, SOY-BASED FOOD BEVERAGE USED AS A MILK SUBSTITUTE, VEGETABLE-BASED CHOCOLATE FOOD BEVERAGES, NUT-BASED FOOD BEVERAGES, MILK, MILK BEVERAGES CONTAINING FRUITS, MILK BEVERAGES WITH HIGH MILK CONTENT, MILK BASED BEVERAGES CONTAINING FRUIT JUICE, AND MILK BEVERAGES CONTAINING COFFEE; EDIBLE OILS, NAMELY, OMEGA OIL EXTRACTS AND FISH OIL EXTRACTS; SOY PROTEIN FOR USE AS A FOOD ADDITIVE; MUSHROOM, FUNGUS, OR SPORE EXTRACTS OR BLENDS THEREOF FOR USE AS FOOD ADDITIVES (U.S. CL. 46).

CLASS 30—STAPLE FOODS

FOR HERBAL FOOD BEVERAGES; BEVERAGES, NAMELY, GRAIN-BASED BEVERAGES AND GRAIN-BASED FOOD BEVERAGES; PROCESSED HERBS; ORGANIC FOODS, NAMELY, CHOCOLATE, DAIRY-FREE CHOCOLATE, REDUCED FAT CHOCOLATE, REDUCED CALORIE CHOCOLATE, COCOA, CHOCOLATE CHIPS, CHOCOLATE FONDUE, CHOCOLATE TOPPINGS, REDUCED FAT CANDY, BAKERY PRODUCTS, NAMELY, CAKES AND PIES, CRACKERS, BISCUITS, READY-TO-EAT CEREAL-DERIVED FOOD BARS, PRETZELS, CHEWING GUM, FROZEN YOGURT, FROZEN CUSTARD, FRUIT ICES, PANCAKE AND WAFFLE MIXES, SALAD DRESSING, PASTA AND PASTA MIXES, RICE, CORNMEAL AND WHEAT-BASED SNACK FOODS; FOOD BEVERAGES, NAMELY, CHOCOLATE FOOD BEVERAGES NOT BEING DAIRY-BASED OR VEGETABLE BASED, AND GRAIN-BASED FOOD BEVERAGES; FUNCTIONAL FOODS, NAMELY, CHOCOLATE, DAIRY-FREE CHOCOLATE, REDUCED FAT CHOCOLATE, REDUCED CALORIE CHOCOLATE, COCOA, CHOCOLATE CHIPS, CHOCOLATE FONDUE, CHOCOLATE TOPPINGS, REDUCED FAT CANDY, BAKERY PRODUCTS, NAMELY, CAKES AND PIES, CRACKERS, BISCUITS, READY-TO-EAT CEREAL-DERIVED FOOD

ULTRAPOWER HEART

THE MARK CONSISTS OF STANDARD CHARACTERS WITHOUT CLAIM TO ANY PARTICULAR FONT, STYLE, SIZE, OR COLOR.

NO CLAIM IS MADE TO THE EXCLUSIVE RIGHT TO USE "HEART", APART FROM THE MARK AS SHOWN.

CLASS 1—CHEMICALS

FOR BOTANICAL EXTRACTS FOR USE IN THE MANUFACTURE OF NUTRACEUTICALS; EXTRACTS FOR USE IN THE MANUFACTURE OF PHARMACEUTICAL PREPARATIONS IN THE FORM OF PREPARATIONS IN THE FORM OF LOTIONS, CREAMS, AND TOPICAL ANALGESICS AND ANESTHETICS, TABLETS, CAPSULES, PILLS, TINCTURE, SUPPOSITORIES AND AMPULE FOR INJECTION; BOTANICAL EXTRACTS FOR USE IN THE MANUFACTURE OF PHARMACEUTICALS; CHEMICAL EXTRACTS EXTRACTED FROM MEDICINAL PLANTS FOR USE IN THE MANUFACTURE OF NUTRACEUTICALS AND PHARMACEUTICALS; CHEMICAL EXTRACTS, NAMELY, CHEMICAL AGENTS MADE FROM BOTANICAL EXTRACTS OR ASSOCIATION OF CHEMICAL EXTRACTS FOR USE IN THE MANUFACTURE OF PHARMACEUTICAL OR NUTRACEUTICAL PRODUCTS; BOTANICAL EXTRACTS USED IN THE MANUFACTURE OF PREPARATIONS IN THE FORM OF LOTIONS, CREAMS, AND TOPICAL ANALGESICS AND ANESTHETICS, TABLETS, CAPSULES, PILLS, LOZENGES, INHALERS, TINCTURE, SUPPOSITORIES AND AMPULE FOR INJECTION; BOTANICALS AND BOTANICAL BLENDS, HERBS AND HERBAL BLENDS, BOTANICAL EXTRACTS AND BOTANICAL EXTRACT BLENDS, FLAVOR EXTRACTS AND FLAVOR EXTRACT BLENDS, ALGAL EXTRACTS AND ALGAL EXTRACT BLENDS, ALL FOR USE IN THE MANUFACTURE OF NUTRITIONAL SUPPLEMENTS AND VITAMINS; HERBAL EXTRACTS AND BLENDS FOR USE IN MANUFACTURING FUNCTIONAL FOODS OR BEVERAGES; HERBAL EXTRACTS AND BLENDS FOR USE IN MANUFACTURING MEDICINAL FOODS OR BEVERAGES; BOTANICAL EXTRACTS AND BLENDS FOR USE IN MANUFACTURING FUNCTIONAL FOODS OR BEVERAGES; BOTANICAL EXTRACTS AND BLENDS FOR USE IN MANUFACTURING MEDICINAL FOODS OR BEVERAGES; HERBAL PREPARATIONS AND EXTRACTS FOR USE AS INGREDIENTS IN MANUFACTURING IN THE FOOD, NUTRITION, NUTRACEUTICAL AND/OR PHARMACEUTICAL INDUSTRIES (U.S. CLS. 1, 5, 6, 10, 26 AND 46).

CLASS 5—PHARMACEUTICALS

FOR NUTRITIONAL SUPPLEMENTS; HERBAL PRODUCTS, NAMELY, MEDICATED SKIN AND LIP BALMS; HERBAL PRODUCTS, NAMELY, OINTMENTS, OILS, DRINKS, INFUSIONS, SYRUPS, HERBAL EXTRACTS, POISONS, AND TINCTURES FOR MEDICAL USE IN THE TREATMENT OF STROKES, INFARCTS AND OTHER CARDIOVASCULAR AND CEREBRUM DISEASES; HERBAL PRODUCTS, NAMELY, OINTMENTS, OILS, NAMELY, MINERAL OIL FOR USE AS A LAXATIVE; DRINKS, NAMELY, MEAL REPLACEMENT DRINKS, DIETARY SUPPLEMENT DRINKS, MEDICINAL DRINKS, AND FISH OIL FOR USE AS A DIETARY SUPPLEMENT OR IN A NUTRACEUTICAL; INFUSIONS AND SYRUPS, NAMELY, COUGH SYRUPS; HERBAL PRODUCTS FOR MEDICINAL PURPOSES, NAMELY, HERBAL EXTRACTS FOR USE AS NUTRITIONAL AND DIETARY SUPPLEMENTS; HERBAL PRODUCTS FOR MEDICINAL PURPOSES, NAMELY, HERBAL EXTRACTS AND SYRUPS; MEDICINAL HERB EXTRACTS; MEDICINAL HERB EXTRACTS FOR MEDICAL PURPOSES; PLANT EXTRACTS FOR MEDICAL, PHARMACEUTICAL, NUTRACEUTICAL AND NUTRITIONAL PURPOSES; MEDICINAL EXTRACTS USED IN PREPARATIONS IN THE FORM OF LOTIONS, CREAMS, AND TOPICAL ANALGESICS AND ANESTHETICS, TABLETS, CAPSULES, PILLS, LOZENGES, INHALERS, TINCTURE, SUPPOSITORIES AND AMPULE FOR INJECTION; MEDICINAL EXTRACTS IN THE FORM OF LOTIONS, CREAMS, AND TOPICAL ANALGESICS AND ANESTHETICS, TABLETS, CAPSULES, PILLS, TINCTURE, SUPPOSITORIES AND AMPULE FOR INJECTION; MEDICINAL HERB EXTRACTS IN THE FORM OF LOTIONS, CREAMS, AND TOPICAL ANALGESICS AND ANESTHETICS, TABLETS, CAPSULES, PILLS, TINCTURE, SUPPOSITORIES AND AMPULE FOR INJECTION USED TO TREAT SKIN AILMENTS, FOR INFECTION, DEGENERATIVE, MUSCULAR, PULMONARY, SKELETAL, ENDOCRINE, IMMUNE, NEUROLOGICAL, CARDIOVASCULAR, METABOLIC, INFLAMMATORY, CANCER AND RELATED CONDITIONS; YEAST EXTRACTS FOR MEDICAL, PHARMACEUTICAL OR NUTRACEUTICAL PURPOSES; HERBAL PRODUCTS, NAMELY, HERBAL POWDERS FOR NUTRITIONAL PURPOSES; HERBAL PRODUCTS, NAMELY, HERBAL MEAL REPLACEMENT POWDERS FOR DIETARY AND NUTRITIONAL PURPOSES; HERBAL PRODUCTS, NAMELY, AROMATHERAPY PACKS CONTAINING HERBS USED FOR RELIEF FROM HEADACHES, INSOMNIA AND SINUS DISCOMFORT; HERBAL PRODUCTS, NAMELY, HERBAL POWDERS SOLD AS AN INTEGRAL INGREDIENT OF NUTRITIONAL SUPPLEMENT DRINK MIX FOR NUTRITIONAL PURPOSES; PHARMACEUTICALS AND NUTRACEUTICALS, NAMELY, VITAMINS AND FOOD SUPPLEMENTS; PHARMACEUTICAL PREPARATIONS, NAMELY, APPETITE SUPPRESSANTS AND LIPID LOWERING AGENTS; FOOD FOR DIABETICS, INFANTS AND ENTERAL FEEDING; BOTANICAL EXTRACTS FOR NUTRITIONAL USE; BOTANICAL EXTRACTS FOR MEDICAL, VETERINARY, NUTRACEUTICAL AND PHARMACEUTICAL PURPOSES; DESIGNER EXTRACTS, NAMELY, HERBAL EXTRACTS FOR MEDICAL, VETERINARY AND PHARMACEUTICAL PURPOSES; BOTANICAL EXTRACTS FOR NUTRITIONAL SUPPLEMENTS, NUTRACEUTICALS AND PHARMACEUTICALS; NUTRITIONAL DIETARY SUPPLEMENTS; ORAL PREPARATIONS CONTAINING HERBS OR HERBAL EXTRACTS USED TO MAINTAIN HEALTH AND FOR A WIDE VARIETY OF PHYSICAL CONDITIONS; VITAMIN AND MINERAL PREPARATIONS INTENDED FOR USE AS DIETARY SUPPLEMENTS; VITAMINS; FOOD SUPPLEMENTS; NUTRACEUTICALS, NAMELY, VITAMINS AND FOOD SUPPLEMENTS; FOOD FOR MEDICALLY RESTRICTED DIETS; SUPPLEMENTS, NAMELY, LIPID CONCENTRATES FOR USE AS A DIETARY FOOD SUPPLEMENT OR FOR PHARMACEUTICAL OR MEDICINAL PURPOSES; FOOD SUPPLEMENTS, NAMELY, ANTI-OXIDANTS; BOTANICALS AND BOTANICAL BLENDS, HERBALS AND HERBAL BLENDS, BOTANICAL EXTRACTS AND BOTANICAL EXTRACT BLENDS, FLAVOR EXTRACTS AND FLAVOR EXTRACT BLENDS, ALL SOLD AS COMPONENTS OF NUTRITIONAL SUP-

PLEMENTS AND VITAMINS; NUTRITIONAL OILS NOT FOR COSMETIC PURPOSES; FOOD SUPPLEMENTS, NAMELY, LIPID CONCENTRATES FOR USE AS A DIETARY FOOD SUPPLEMENT OR FOR PHARMACEUTICAL OR MEDICINAL PURPOSES; ANTI-COUGH DROPS; COUGH DROPS; COUGH EXPECTORANTS; THROAT LOZENGES; COUGH LOZENGES; COUGH SYRUPS; COUGH TREATMENT PREPARATIONS; COLD SORE TREATMENT PREPARATIONS; PHARMACEUTICAL ANTITUSSIVE-COLD PREPARATIONS; PREPARATIONS FOR TREATING COLDS; ANALGESIC PREPARATIONS; ANALGESICS; ANTIPIRETTIC ANALGESICS; IBUPROFEN FOR USE AS AN ORAL ANALGESIC; MULTIPURPOSE MEDICATED ANTIBIOTIC CREAM, ANALGESIC BALM AND MENTHOLATED SALVE; ORAL ANALGESICS; TOPICAL ANALGESICS; PHARMACEUTICAL PREPARATIONS FOR THE TREATMENT AND PREVENTION OF HERPES; VACCINES FOR THE TREATMENT AND PREVENTION OF HERPES; BIOLOGICAL PREPARATIONS FOR THE TREATMENT AND PREVENTION OF HERPES; PHARMACEUTICAL PREPARATIONS FOR THE TREATMENT OF HERPES SIMPLEX INFECTION; PHARMACEUTICAL CAPSULES FOR THE TREATMENT OF HERPES SIMPLEX INFECTION; HOMEOPATHIC PREPARATIONS FOR THE TREATMENT OF HERPES AND COLD SORES; PHARMACEUTICAL PREPARATIONS FOR THE TREATMENT OF HERPES VIRUSES; MEDICATED TOPICAL CLEAR FLUORIDE GEL FOR THE TREATMENT OF HERPES VIRUS DURING THE PHYSICAL MANIFESTATION OF THE VIRUS; PHARMACEUTICAL PREPARATIONS FOR THE TREATMENT OF HERPES SIMPLEX VIRUS TYPE I OR TYPE II OR HERPES ZOSTER VIRUS, NOT IN INTRAVENOUS FORM; PLANT-BASED ANTIVIRALS; OVER-THE-COUNTER TOPICAL ANTIVIRALS; PHARMACEUTICAL PREPARATION WITH ANTIVIRAL AND/OR ANTIMICROBIAL PROPERTIES FOR USE IN THE TREATMENT OF HERPESIC KERATITIS, CONJUNCTIVITIS, HIV RETINOPATHY, VIRAL INFLUENZA "FLU", HERPES SIMPLEX VIRUS 1, HERPES SIMPLEX VIRUS 2, VARICELLA ZOSTER VIRUS "HERPES ZOSTER" OR "SHINGLES", CYTOMEGALOVIRUS, VIRAL PARAINFLUENZA, ADENOVIRUS, VIRAL ENCEPHALITIS, VIRAL MENINGITIS, ARBOVIRUS, ARENAVIRUS, PICORNAVIRUS, CORONAVIRUS, SYNTIAL VIRUS, VIRAL INFECTIONS, COMMON COLDS CAUSED BY VIRUSES, COLD SORES, HUMAN IMMUNODEFICIENCY VIRUS "HIV", ROSEOLA INFANTUM, HUMAN HERPES IV; PHARMACEUTICAL PREPARATIONS FOR THE TREATMENT OF VIRAL DISEASES AND DISORDERS, NAMELY, HERPES; PHARMACEUTICAL PREPARATIONS FOR TREATING IMMUNE DISEASES INDUCED BY VIRUS, NAMELY, HERPES, HERPES ZOSTER AND AIDS; ALGAL PRODUCTS FOR MEDICAL PURPOSES, NAMELY, ALGAL EXTRACTS OR ALGAL EXTRACT BLENDS FOR USE AS NUTRITIONAL AND DIETARY SUPPLEMENTS; ALGAL PRODUCTS, NAMELY, ALGAL POWDERS SOLD AS AN INTEGRAL INGREDIENT OF NUTRITIONAL SUPPLEMENT DRINK MIX FOR NUTRITIONAL PURPOSES; ALGAL PRODUCTS, NAMELY, ALGAL POWDERS FOR NUTRITIONAL PURPOSES; ALGAL EXTRACTS OR ALGAL EXTRACT BLENDS FOR MEDICAL OR PHARMACEUTICAL PURPOSES; FUNCTIONAL FOODS, NAMELY, DIETETIC FOODS ADAPTED FOR MEDICAL PURPOSES; FUNCTIONAL BEVERAGES, NAMELY, NUTRITIONALLY FORTIFIED BEVERAGES; MEDICINAL FOODS, NAMELY, PROCESSED FOOD FOR MEDICAL PURPOSES; ANIMAL HEALTH PRODUCTS, NAMELY, ANIMAL FEED SUPPLEMENTS, MEDICATED ANIMAL FEED, MICRO-NUTRIENT ANIMAL FEED, DIETARY SUPPLEMENTS FOR ANIMALS, NON-MEDICATED ADDITIVES FOR ANIMAL FEED FOR USE AS NUTRITIONAL SUPPLEMENTS, NUTRITIONAL DRINKS FOR ANIMALS, PHARMACEUTICAL PREPARATIONS FOR ANIMAL SKINCARE; PLANT EXTRACTS FOR MEDICAL, VETERINARY AND PHARMACEUTICAL PURPOSES; HERBAL EXTRACTS FOR MEDICAL, VETERINARY AND PHARMACEUTICAL PURPOSES; DESIGNER EXTRACTS, NAMELY, PLANT, HERBAL AND BOTANICAL EXTRACTS FOR MEDICAL, VETERINARY AND PHARMACEUTICAL PURPOSES; AND BIODEFENSE PRODUCTS, NAMELY, MEDICINAL PREPARATIONS FOR THE TREATMENT OF INFECTIOUS DISEASES AND ADVERSE HUMAN HEALTH CONDITIONS, NAMELY, INFECTION, DEGENERATIVE, MUSCULAR, PULMONARY, SKELETAL, ENDOCRINE, IMMUNE, NEUROLOGICAL, CARDIOVASCULAR, ME-

TABOLIC, INFLAMMATORY, CANCER AND RELATED CONDITIONS; MUSHROOM, FUNGUS, OR SPORE EXTRACTS OR BLENDS AS SUPPLEMENTS, NUTRITION, NUTRACEUTICALS AND/OR PHARMACEUTICALS; BOTANICAL EXTRACTS FOR NUTRITIONAL USE; NUTRITIONALLY FORTIFIED BEVERAGES; NUTRITIONALLY FORTIFIED BEVERAGES FOR IMMUNE ENHANCEMENT, AND NUTRITIONALLY FORTIFIED BEVERAGES WITH RICE BRAN AND WHEAT BRAN; MEDICINAL BEVERAGES; SOY PROTEIN FOR USE AS A NUTRITIONAL SUPPLEMENT; NUTRITIONAL ADDITIVES FOR MEDICAL OR NONMEDICAL PURPOSES FOR USE IN MANUFACTURING FOODS AND DIETARY SUPPLEMENTS FOR HUMAN CONSUMPTION; ACTIVE PRINCIPLES EXTRACTED FROM MEDICINAL PLANTS FOR USE IN THE MANUFACTURE OF NUTRACEUTICALS AND PHARMACEUTICALS; ACTIVE PRINCIPLES EXTRACTED FROM MEDICINAL PLANTS FOR USE IN THE MANUFACTURE OF PHARMACEUTICAL OR NUTRACEUTICAL PRODUCTS (U.S. CLS. 6, 18, 44, 46, 51 AND 52).

HEATHER THOMPSON, EXAMINING ATTORNEY

SN 77-519,404. HERBALSCIENCE GROUP, LLC, NAPLES, FL. FILED 7-10-2008.

HEART ULTRAPOWER

THE MARK CONSISTS OF STANDARD CHARACTERS WITHOUT CLAIM TO ANY PARTICULAR FONT, STYLE, SIZE, OR COLOR.

NO CLAIM IS MADE TO THE EXCLUSIVE RIGHT TO USE "HEART", APART FROM THE MARK AS SHOWN.

CLASS 1—CHEMICALS

FOR BOTANICAL EXTRACTS FOR USE IN THE MANUFACTURE OF NUTRACEUTICALS; EXTRACTS FOR USE IN THE MANUFACTURE OF PHARMACEUTICAL PREPARATIONS IN THE FORM OF PREPARATIONS IN THE FORM OF LOTIONS, CREAMS, AND TOPICAL ANALGESICS AND ANESTHETICS, TABLETS, CAPSULES, PILLS, TINCTURE, SUPPOSITORIES AND AMPULE FOR INJECTION; BOTANICAL EXTRACTS FOR USE IN THE MANUFACTURE OF PHARMACEUTICALS; CHEMICAL EXTRACTS EXTRACTED FROM MEDICINAL PLANTS FOR USE IN THE MANUFACTURE OF NUTRACEUTICALS AND PHARMACEUTICALS; CHEMICAL EXTRACTS, NAMELY, CHEMICAL AGENTS MADE FROM BOTANICAL EXTRACTS OR ASSOCIATION OF CHEMICAL EXTRACTS FOR USE IN THE MANUFACTURE OF PHARMACEUTICAL OR NUTRACEUTICAL PRODUCTS; BOTANICAL EXTRACTS USED IN THE MANUFACTURE OF PREPARATIONS IN THE FORM OF LOTIONS, CREAMS, AND TOPICAL ANALGESICS AND ANESTHETICS, TABLETS, CAPSULES, PILLS, LOZENGES, INHALERS, TINCTURE, SUPPOSITORIES AND AMPULE FOR INJECTION; BOTANICALS AND BOTANICAL BLENDS, HERBS AND HERBAL BLENDS, BOTANICAL EXTRACTS AND BOTANICAL EXTRACT BLENDS, FLAVOR EXTRACTS AND FLAVOR EXTRACT BLENDS, ALGAL EXTRACTS AND ALGAL EXTRACT BLENDS, ALL FOR USE IN THE MANUFACTURE OF NUTRITIONAL SUPPLEMENTS AND VITAMINS; HERBAL EXTRACTS AND BLENDS FOR USE IN MANUFACTURING FUNCTIONAL FOODS OR BEVERAGES; HERBAL EXTRACTS AND BLENDS FOR USE IN MANUFACTURING MEDICINAL FOODS OR BEVERAGES; BOTANICAL EXTRACTS AND BLENDS FOR USE IN MANUFACTURING FUNCTIONAL FOODS OR BEVERAGES; BOTANICAL EXTRACTS AND BLENDS FOR USE IN MANUFACTURING MEDICINAL FOODS OR BEVERAGES; HERBAL PREPARATIONS AND EXTRACTS FOR USE AS INGREDIENTS IN MANUFACTURING

IN THE FOOD, NUTRITION, NUTRACEUTICAL AND/OR PHARMACEUTICAL INDUSTRIES (U.S. CLS. 1, 5, 6, 10, 26 AND 46).

CLASS 5—PHARMACEUTICALS

FOR NUTRITIONAL SUPPLEMENTS; HERBAL PRODUCTS, NAMELY, MEDICATED SKIN AND LIP BALMS; HERBAL PRODUCTS, NAMELY, OINTMENTS, OILS, DRINKS, INFUSIONS, SYRUPS, HERBAL EXTRACTS, POISONS, AND TINCTURES FOR MEDICAL USE IN THE TREATMENT OF STROKES, INFARCTS AND OTHER CARDIOVASCULAR AND CEREBRUM DISEASES; HERBAL PRODUCTS, NAMELY, OINTMENTS, OILS, NAMELY, MINERAL OIL FOR USE AS A LAXATIVE; DRINKS, NAMELY, MEAL REPLACEMENT DRINKS, DIETARY SUPPLEMENT DRINKS, MEDICINAL DRINKS, AND FISH OIL FOR USE AS A DIETARY SUPPLEMENT OR IN A NUTRACEUTICAL; INFUSIONS AND SYRUPS, NAMELY, COUGH SYRUPS; HERBAL PRODUCTS FOR MEDICINAL PURPOSES, NAMELY, HERBAL EXTRACTS FOR USE AS NUTRITIONAL AND DIETARY SUPPLEMENTS; HERBAL PRODUCTS FOR MEDICINAL PURPOSES, NAMELY, HERBAL EXTRACTS AND SYRUPS; MEDICINAL HERB EXTRACTS; MEDICINAL HERB EXTRACTS FOR MEDICAL PURPOSES; PLANT EXTRACTS FOR MEDICAL, PHARMACEUTICAL, NUTRACEUTICAL AND NUTRITIONAL PURPOSES; MEDICINAL EXTRACTS USED IN PREPARATIONS IN THE FORM OF LOTIONS, CREAMS, AND TOPICAL ANALGESICS AND ANESTHETICS, TABLETS, CAPSULES, PILLS, LOZENGES, INHALERS, TINCTURE, SUPPOSITORIES AND AMPULE FOR INJECTION; MEDICINAL EXTRACTS IN THE FORM OF LOTIONS, CREAMS, AND TOPICAL ANALGESICS AND ANESTHETICS, TABLETS, CAPSULES, PILLS, TINCTURE, SUPPOSITORIES AND AMPULE FOR INJECTION; MEDICINAL HERBAL EXTRACTS IN THE FORM OF LOTIONS, CREAMS, AND TOPICAL ANALGESICS AND ANESTHETICS, TABLETS, CAPSULES, PILLS, TINCTURE, SUPPOSITORIES AND AMPULE FOR INJECTION; MEDICINAL BOTANICAL EXTRACTS IN THE FORM OF LOTIONS, CREAMS, AND TOPICAL ANALGESICS AND ANESTHETICS, TABLETS, CAPSULES, PILLS, TINCTURE, SUPPOSITORIES AND AMPULE FOR INJECTION USED TO TREAT SKIN AILMENTS, FOR INFECTION, DEGENERATIVE, MUSCULAR, PULMONARY, SKELETAL, ENDOCRINE, IMMUNE, NEUROLOGICAL, CARDIOVASCULAR, METABOLIC, INFLAMMATORY, CANCER AND RELATED CONDITIONS; YEAST EXTRACTS FOR MEDICAL, PHARMACEUTICAL OR NUTRACEUTICAL PURPOSES; HERBAL PRODUCTS, NAMELY, HERBAL POWDERS FOR NUTRITIONAL PURPOSES; HERBAL PRODUCTS, NAMELY, HERBAL MEAL REPLACEMENT POWDERS FOR DIETARY AND NUTRITIONAL PURPOSES; HERBAL PRODUCTS, NAMELY, AROMATHERAPY PACKS CONTAINING HERBS USED FOR RELIEF FROM HEADACHES, INSOMNIA AND SINUS DISCOMFORT; HERBAL PRODUCTS, NAMELY, HERBAL POWDERS SOLD AS AN INTEGRAL INGREDIENT OF NUTRITIONAL SUPPLEMENT DRINK MIX FOR NUTRITIONAL PURPOSES; PHARMACEUTICALS AND NUTRACEUTICALS, NAMELY, VITAMINS AND FOOD SUPPLEMENTS; PHARMACEUTICAL PREPARATIONS, NAMELY, APPETITE SUPPRESSANTS AND LIPID LOWERING AGENTS; FOOD FOR DIABETICS, INFANTS AND ENTERAL FEEDING; BOTANICAL EXTRACTS FOR NUTRITIONAL USE; BOTANICAL EXTRACTS FOR MEDICAL, VETERINARY, NUTRACEUTICAL AND PHARMACEUTICAL PURPOSES; DESIGNER EXTRACTS, NAMELY, HERBAL EXTRACTS FOR MEDICAL, VETERINARY AND PHARMACEUTICAL PURPOSES; BOTANICAL EXTRACTS FOR NUTRITIONAL SUPPLEMENTS, NUTRACEUTICALS AND PHARMACEUTICALS; NUTRITIONAL DIETARY SUPPLEMENTS; ORAL PREPARATIONS CONTAINING HERBS OR HERBAL EXTRACTS USED TO MAINTAIN HEALTH AND FOR A WIDE VARIETY OF PHYSICAL CONDITIONS; VITAMIN AND MINERAL PREPARATIONS INTENDED FOR USE AS DIETARY SUPPLEMENTS; VITAMINS; FOOD SUPPLEMENTS; NUTRACEUTICALS, NAMELY, VITAMINS AND FOOD SUPPLEMENTS; FOOD FOR MEDICALLY RESTRICTED DIETS; SUPPLEMENTS, NAMELY, LIPID CONCENTRATES FOR USE AS A DIETARY FOOD SUPPLEMENT OR FOR PHARMACEUTICAL OR MEDICINAL PURPOSES; FOOD SUPPLEMENTS, NAMELY, ANTI-OXI-

DANTS; BOTANICALS AND BOTANICAL BLENDS, HERBALS AND HERBAL BLENDS, BOTANICAL EXTRACTS AND BOTANICAL EXTRACT BLENDS, FLAVOR EXTRACTS AND FLAVOR EXTRACT BLENDS, ALL SOLD AS COMPONENTS OF NUTRITIONAL SUPPLEMENTS AND VITAMINS; NUTRITIONAL OILS NOT FOR COSMETIC PURPOSES; FOOD SUPPLEMENTS, NAMELY, LIPID CONCENTRATES FOR USE AS A DIETARY FOOD SUPPLEMENT OR FOR PHARMACEUTICAL OR MEDICINAL PURPOSES; ANTI-COUGH DROPS; COUGH DROPS; COUGH EXPECTORANTS; THROAT LOZENGES; COUGH LOZENGES; COUGH SYRUPS; COUGH TREATMENT PREPARATIONS; COLD SORE TREATMENT PREPARATIONS; PHARMACEUTICAL ANTITUSSIVE-COLD PREPARATIONS; PREPARATIONS FOR TREATING COLDS; ANALGESIC PREPARATIONS; ANALGESICS; ANTIPIRETTIC ANALGESICS; IBUPROFEN FOR USE AS AN ORAL ANALGESIC; MULTIPURPOSE MEDICATED ANTIBIOTIC CREAM, ANALGESIC BALM AND MENTHOLATED SALVE; ORAL ANALGESICS; TOPICAL ANALGESICS; PHARMACEUTICAL PREPARATIONS FOR THE TREATMENT AND PREVENTION OF HERPES; VACCINES FOR THE TREATMENT AND PREVENTION OF HERPES; BIOLOGICAL PREPARATIONS FOR THE TREATMENT AND PREVENTION OF HERPES; PHARMACEUTICAL PREPARATIONS FOR THE TREATMENT OF HERPES SIMPLEX INFECTION; PHARMACEUTICAL CAPSULES FOR THE TREATMENT OF HERPES SIMPLEX INFECTION; HOMEOPATHIC PREPARATIONS FOR THE TREATMENT OF HERPES AND COLD SORES; PHARMACEUTICAL PREPARATIONS FOR THE TREATMENT OF HERPES VIRUSES; MEDICATED TOPICAL CLEAR FLUORIDE GEL FOR THE TREATMENT OF HERPES VIRUS DURING THE PHYSICAL MANIFESTATION OF THE VIRUS; PHARMACEUTICAL PREPARATIONS FOR THE TREATMENT OF HERPES SIMPLEX VIRUS TYPE I OR TYPE II OR HERPES ZOSTER VIRUS, NOT IN INTRAVENOUS FORM; PLANT-BASED ANTIVIRALS; OVER-THE-COUNTER TOPICAL ANTIVIRALS; PHARMACEUTICAL PREPARATION WITH ANTIVIRAL AND/OR ANTIMICROBIAL PROPERTIES FOR USE IN THE TREATMENT OF HERPETIC KERATITIS, CONJUNCTIVITIS, HIV RETINOPATHY, VIRAL INFLUENZA "FLU", HERPES SIMPLEX VIRUS 1, HERPES SIMPLEX VIRUS 2, VARICELLA ZOSTER VIRUS "HERPES ZOSTER" OR "SHINGLES", CYTOMEGALOVIRUS, VIRAL PARAINFLUENZA, ADENOVIRUS, VIRAL ENCEPHALITIS, VIRAL MENINGITIS, ARBOVIRUS, ARENAVIRUS, PICORNAVIRUS, CORONAVIRUS, SYNTIALVIRUS, VIRAL INFECTIONS, COMMON COLDS CAUSED BY VIRUSES, COLD SORES, HUMAN IMMUNODEFICIENCY VIRUS "HIV", ROSEOLA INFANTUM, HUMAN HERPES IV; PHARMACEUTICAL PREPARATIONS FOR THE TREATMENT OF VIRAL DISEASES AND DISORDERS, NAMELY, HERPES; PHARMACEUTICAL PREPARATIONS FOR TREATING IMMUNE DISEASES INDUCED BY VIRUS, NAMELY, HERPES, HERPES ZOSTER AND AIDS; ALGAL PRODUCTS FOR MEDICINAL PURPOSES, NAMELY, ALGAL EXTRACTS OR ALGAL EXTRACT BLENDS FOR USE AS NUTRITIONAL AND DIETARY SUPPLEMENTS; ALGAL PRODUCTS, NAMELY, ALGAL POWDERS SOLD AS AN INTEGRAL INGREDIENT OF NUTRITIONAL SUPPLEMENT DRINK MIX FOR NUTRITIONAL PURPOSES; ALGAL PRODUCTS, NAMELY, ALGAL POWDERS FOR NUTRITIONAL PURPOSES; ALGAL EXTRACTS OR ALGAL EXTRACT BLENDS FOR MEDICAL OR PHARMACEUTICAL PURPOSES; FUNCTIONAL FOODS, NAMELY, DIETETIC FOODS ADAPTED FOR MEDICAL PURPOSES; FUNCTIONAL BEVERAGES, NAMELY, NUTRITIONALLY FORTIFIED BEVERAGES; MEDICINAL FOODS, NAMELY, PROCESSED FOOD FOR MEDICAL PURPOSES; ANIMAL HEALTH PRODUCTS, NAMELY, ANIMAL FEED SUPPLEMENTS, MEDICATED ANIMAL FEED, MICRO-NUTRIENT ANIMAL FEED, DIETARY SUPPLEMENTS FOR ANIMALS, NON-MEDICATED ADDITIVES FOR ANIMAL FEED FOR USE AS NUTRITIONAL SUPPLEMENTS, NUTRITIONAL DRINKS FOR ANIMALS, PHARMACEUTICAL PREPARATIONS FOR ANIMAL SKINCARE; PLANT EXTRACTS FOR MEDICAL, VETERINARY AND PHARMACEUTICAL PURPOSES; HERBAL EXTRACTS FOR MEDICAL, VETERINARY AND PHARMACEUTICAL PURPOSES; DESIGNER EXTRACTS, NAMELY, PLANT, HERBAL AND BOTANICAL EXTRACTS FOR MEDICAL, VETERINARY AND PHARMACEUTICAL PURPOSES; AND BIODEFENSE PRODUCTS, NAMELY, MEDICINAL PRE-

PARATIONS FOR THE TREATMENT OF INFECTIOUS DISEASES AND ADVERSE HUMAN HEALTH CONDITIONS, NAMELY, INFECTION, DEGENERATIVE, MUSCULAR, PULMONARY, SKELETAL, ENDOCRINE, IMMUNE, NEUROLOGICAL, CARDIOVASCULAR, METABOLIC, INFLAMMATORY, CANCER AND RELATED CONDITIONS; MUSHROOM, FUNGUS, OR SPORE EXTRACTS OR BLENDS AS SUPPLEMENTS, NUTRITION, NUTRACEUTICALS AND/OR PHARMACEUTICALS; BOTANICAL EXTRACTS FOR NUTRITIONAL USE; NUTRITIONALLY FORTIFIED BEVERAGES; NUTRITIONALLY FORTIFIED BEVERAGES FOR IMMUNE ENHANCEMENT, AND NUTRITIONALLY FORTIFIED BEVERAGES WITH RICE BRAN AND WHEAT BRAN; MEDICINAL BEVERAGES; SOY PROTEIN FOR USE AS A NUTRITIONAL SUPPLEMENT; NUTRITIONAL ADDITIVES FOR MEDICAL OR NONMEDICAL PURPOSES FOR USE IN MANUFACTURING FOODS AND DIETARY SUPPLEMENTS FOR HUMAN CONSUMPTION; ACTIVE PRINCIPLES EXTRACTED FROM MEDICINAL PLANTS FOR USE IN THE MANUFACTURE OF NUTRACEUTICALS AND PHARMACEUTICALS; ACTIVE PRINCIPLES EXTRACTED FROM MEDICINAL PLANTS FOR USE IN THE MANUFACTURE OF PHARMACEUTICAL OR NUTRACEUTICAL PRODUCTS (U.S. CLS. 6, 18, 44, 46, 51 AND 52).

CLASS 29—MEATS AND PROCESSED FOODS

FOR BEVERAGES, NAMELY, YOGURT-BASED BEVERAGES; FOOD BEVERAGES, NAMELY, DAIRY-BASED FOOD BEVERAGES, FRUIT-BASED FOOD BEVERAGES, VEGETABLE-BASED FOOD BEVERAGES, DAIRY-BASED CHOCOLATE FOOD BEVERAGES, SOY-BASED FOOD BEVERAGE USED AS A MILK SUBSTITUTE, VEGETABLE-BASED CHOCOLATE FOOD BEVERAGES AND PEANUT-BASED FOOD BEVERAGES; MILK BEVERAGES; MILK BEVERAGES, NAMELY, MILK, MILK BEVERAGES CONTAINING FRUITS, MILK BEVERAGES WITH HIGH MILK CONTENT, MILK BASED BEVERAGES CONTAINING FRUIT JUICE AND MILK BEVERAGES CONTAINING COFFEE; MILK POWDER; MILK POWDER FOR NUTRITIONAL PURPOSES; POWDERED MILK FOR FOOD PURPOSES; FUNCTIONAL FOODS, NAMELY, DAIRY-BASED FOOD BEVERAGES, FRUIT-BASED FOOD BEVERAGES, VEGETABLE-BASED FOOD BEVERAGES, DAIRY-BASED CHOCOLATE FOOD BEVERAGES, SOY-BASED FOOD BEVERAGE USED AS A MILK SUBSTITUTE, VEGETABLE-BASED CHOCOLATE FOOD BEVERAGES, NUT-BASED FOOD BEVERAGES, MILK, MILK BEVERAGES CONTAINING FRUITS, MILK BEVERAGES WITH HIGH MILK CONTENT, MILK BASED BEVERAGES CONTAINING FRUIT JUICE, AND MILK BEVERAGES CONTAINING COFFEE; EDIBLE OILS, NAMELY, OMEGA OIL EXTRACTS AND FISH OIL EXTRACTS; SOY PROTEIN FOR USE AS A FOOD ADDITIVE; MUSHROOM, FUNGUS, OR SPORE EXTRACTS OR BLENDS THEREOF FOR USE AS FOOD ADDITIVES (U.S. CL. 46).
HEATHER THOMPSON, EXAMINING ATTORNEY

SN 77-519,414, HERBALSCIENCE GROUP, LLC, NAPLES, FL. FILED 7-10-2008.

ULTRAPOWER CARDIO

THE MARK CONSISTS OF STANDARD CHARACTERS WITHOUT CLAIM TO ANY PARTICULAR FONT, STYLE, SIZE, OR COLOR.

NO CLAIM IS MADE TO THE EXCLUSIVE RIGHT TO USE "CARDIO", APART FROM THE MARK AS SHOWN.

CLASS 1—CHEMICALS

FOR BOTANICAL EXTRACTS FOR USE IN THE MANUFACTURE OF NUTRACEUTICALS; EXTRACTS FOR USE IN THE MANUFACTURE OF PHARMACEUTICAL PREPARATIONS IN THE FORM OF PREPARATIONS IN THE FORM OF LOTIONS, CREAMS, AND TOPICAL ANALGESICS AND ANESTHETICS, TABLETS, CAPSULES, PILLS, TINCTURE, SUPPOSITORIES AND AMPULE FOR INJECTION; BOTANICAL EXTRACTS FOR USE IN THE MANUFACTURE OF PHARMACEUTICALS; CHEMICAL EXTRACTS EXTRACTED FROM MEDICINAL PLANTS FOR USE IN THE MANUFACTURE OF NUTRACEUTICALS AND PHARMACEUTICALS; CHEMICAL EXTRACTS, NAMELY, CHEMICAL AGENTS MADE FROM BOTANICAL EXTRACTS OR ASSOCIATION OF CHEMICAL EXTRACTS FOR USE IN THE MANUFACTURE OF PHARMACEUTICAL OR NUTRACEUTICAL PRODUCTS; BOTANICAL EXTRACTS USED IN THE MANUFACTURE OF PREPARATIONS IN THE FORM OF LOTIONS, CREAMS, AND TOPICAL ANALGESICS AND ANESTHETICS, TABLETS, CAPSULES, PILLS, LOZENGES, INHALERS, TINCTURE, SUPPOSITORIES AND AMPULE FOR INJECTION; BOTANICALS AND BOTANICAL BLENDS, HERBS AND HERBAL BLENDS, BOTANICAL EXTRACTS AND BOTANICAL EXTRACT BLENDS, FLAVOR EXTRACTS AND FLAVOR EXTRACT BLENDS, ALGAL EXTRACTS AND ALGAL EXTRACT BLENDS, ALL FOR USE IN THE MANUFACTURE OF NUTRITIONAL SUPPLEMENTS AND VITAMINS; HERBAL EXTRACTS AND BLENDS FOR USE IN MANUFACTURING FUNCTIONAL FOODS OR BEVERAGES; HERBAL EXTRACTS AND BLENDS FOR USE IN MANUFACTURING MEDICINAL FOODS OR BEVERAGES; BOTANICAL EXTRACTS AND BLENDS FOR USE IN MANUFACTURING FUNCTIONAL FOODS OR BEVERAGES; BOTANICAL EXTRACTS AND BLENDS FOR USE IN MANUFACTURING MEDICINAL FOODS OR BEVERAGES; HERBAL PREPARATIONS AND EXTRACTS FOR USE AS INGREDIENTS IN MANUFACTURING IN THE FOOD, NUTRITION, NUTRACEUTICAL AND/OR PHARMACEUTICAL INDUSTRIES (U.S. CLS. 1, 5, 6, 10, 26 AND 46).

CLASS 5—PHARMACEUTICALS

FOR NUTRITIONAL SUPPLEMENTS; HERBAL PRODUCTS, NAMELY, MEDICATED SKIN AND LIP BALMS; HERBAL PRODUCTS, NAMELY, OINTMENTS, OILS, DRINKS, INFUSIONS, SYRUPS, HERBAL EXTRACTS, POISONS, AND TINCTURES FOR MEDICAL USE IN THE TREATMENT OF STROKES, INFARCTS AND OTHER CARDIOVASCULAR AND CEREBRUM DISEASES; HERBAL PRODUCTS, NAMELY, OINTMENTS, OILS, NAMELY, MINERAL OIL FOR USE AS A LAXATIVE; DRINKS, NAMELY, MEAL REPLACEMENT DRINKS, DIETARY SUPPLEMENT DRINKS, MEDICINAL DRINKS, AND FISH OIL FOR USE AS A DIETARY SUPPLEMENT OR IN A NUTRACEUTICAL; INFUSIONS AND SYRUPS, NAMELY, COUGH SYRUPS; HERBAL PRODUCTS FOR MEDICINAL PURPOSES, NAMELY, HERBAL EXTRACTS FOR USE AS NUTRITIONAL AND DIETARY SUPPLEMENTS; HERBAL PRODUCTS FOR MEDICINAL PURPOSES, NAMELY, HERBAL EXTRACTS AND SYRUPS; MEDICINAL HERB EXTRACTS; MEDICINAL HERB EXTRACTS FOR MEDICAL PURPOSES; PLANT EXTRACTS FOR MEDICAL, PHARMACEUTICAL, NUTRACEUTICAL AND NUTRITIONAL PURPOSES; MEDICINAL EXTRACTS USED IN PREPARATIONS IN THE FORM OF LOTIONS, CREAMS, AND TOPICAL ANALGESICS AND ANESTHETICS, TABLETS, CAPSULES, PILLS, LOZENGES, INHALERS, TINCTURE, SUPPOSITORIES AND AMPULE FOR INJECTION; MEDICINAL EXTRACTS IN THE FORM OF LOTIONS, CREAMS, AND TOPICAL ANALGESICS AND ANESTHETICS, TABLETS, CAPSULES, PILLS, TINCTURE, SUPPOSITORIES AND AMPULE FOR INJECTION; MEDICINAL BOTANICAL EXTRACTS IN THE FORM OF LOTIONS, CREAMS, AND TOPICAL ANALGESICS AND ANESTHETICS, TABLETS, CAPSULES, PILLS, TINCTURE, SUPPOSITORIES AND AMPULE FOR INJECTION USED TO TREAT SKIN AILMENTS, FOR INFECTION, DEGENERATIVE, MUS-

CULAR, PULMONARY, SKELETAL, ENDOCRINE, IMMUNE, NEUROLOGICAL, CARDIOVASCULAR, METABOLIC, INFLAMMATORY, CANCER AND RELATED CONDITIONS; YEAST EXTRACTS FOR MEDICAL, PHARMACEUTICAL OR NUTRACEUTICAL PURPOSES; HERBAL PRODUCTS, NAMELY, HERBAL POWDERS FOR NUTRITIONAL PURPOSES; HERBAL PRODUCTS, NAMELY, HERBAL MEAL REPLACEMENT POWDERS FOR DIETARY AND NUTRITIONAL PURPOSES; HERBAL PRODUCTS, NAMELY, AROMATHERAPY PACKS CONTAINING HERBS USED FOR RELIEF FROM HEADACHES, INSOMNIA AND SINUS DISCOMFORT; HERBAL PRODUCTS, NAMELY, HERBAL POWDERS SOLD AS AN INTEGRAL INGREDIENT OF NUTRITIONAL SUPPLEMENT DRINK MIX FOR NUTRITIONAL PURPOSES; PHARMACEUTICALS AND NUTRACEUTICALS, NAMELY, VITAMINS AND FOOD SUPPLEMENTS; PHARMACEUTICAL PREPARATIONS, NAMELY, APPETITE SUPPRESSANTS AND LIPID LOWERING AGENTS; FOOD FOR DIABETICS, INFANTS AND ENTERAL FEEDING; BOTANICAL EXTRACTS FOR NUTRITIONAL USE; BOTANICAL EXTRACTS FOR MEDICAL, VETERINARY, NUTRACEUTICAL AND PHARMACEUTICAL PURPOSES; DESIGNER EXTRACTS, NAMELY, HERBAL EXTRACTS FOR MEDICAL, VETERINARY AND PHARMACEUTICAL PURPOSES; BOTANICAL EXTRACTS FOR NUTRITIONAL SUPPLEMENTS, NUTRACEUTICALS AND PHARMACEUTICALS; NUTRITIONAL DIETARY SUPPLEMENTS; ORAL PREPARATIONS CONTAINING HERBS OR HERBAL EXTRACTS USED TO MAINTAIN HEALTH AND FOR A WIDE VARIETY OF PHYSICAL CONDITIONS; VITAMIN AND MINERAL PREPARATIONS INTENDED FOR USE AS DIETARY SUPPLEMENTS; VITAMINS; FOOD SUPPLEMENTS; NUTRACEUTICALS, NAMELY, VITAMINS AND FOOD SUPPLEMENTS; FOOD FOR MEDICALLY RESTRICTED DIETS; SUPPLEMENTS, NAMELY, LIPID CONCENTRATES FOR USE AS A DIETARY FOOD SUPPLEMENT OR FOR PHARMACEUTICAL OR MEDICINAL PURPOSES; FOOD SUPPLEMENTS, NAMELY, ANTI-OXIDANTS; BOTANICALS AND BOTANICAL BLENDS, HERBALS AND HERBAL BLENDS, BOTANICAL EXTRACTS AND BOTANICAL EXTRACT BLENDS, FLAVOR EXTRACTS AND FLAVOR EXTRACT BLENDS, ALL SOLD AS COMPONENTS OF NUTRITIONAL SUPPLEMENTS AND VITAMINS; NUTRITIONAL OILS NOT FOR COSMETIC PURPOSES; FOOD SUPPLEMENTS, NAMELY, LIPID CONCENTRATES FOR USE AS A DIETARY FOOD SUPPLEMENT OR FOR PHARMACEUTICAL OR MEDICINAL PURPOSES; ANTI-COUGH DROPS; COUGH DROPS; COUGH EXPECTORANTS; THROAT LOZENGES; COUGH LOZENGES; COUGH SYRUPS; COUGH TREATMENT PREPARATIONS; COLD SORE TREATMENT PREPARATIONS; PHARMACEUTICAL ANTITUSSIVE-COLD PREPARATIONS; PREPARATIONS FOR TREATING COLDS; ANALGESIC PREPARATIONS; ANALGESICS; ANTIPIRETIC ANALGESICS; IBUPROFEN FOR USE AS AN ORAL ANALGESIC; MULTIPURPOSE MEDICATED ANTIBIOTIC CREAM, ANALGESIC BALM AND MENTHOLATED SALVE; ORAL ANALGESICS; TOPICAL ANALGESICS; PHARMACEUTICAL PREPARATIONS FOR THE TREATMENT AND PREVENTION OF HERPES; VACCINES FOR THE TREATMENT AND PREVENTION OF HERPES; BIOLOGICAL PREPARATIONS FOR THE TREATMENT AND PREVENTION OF HERPES; PHARMACEUTICAL PREPARATIONS FOR THE TREATMENT OF HERPES SIMPLEX INFECTION; PHARMACEUTICAL CAPSULES FOR THE TREATMENT OF HERPES SIMPLEX INFECTION; HOMEOPATHIC PREPARATIONS FOR THE TREATMENT OF HERPES AND COLD SORES; PHARMACEUTICAL PREPARATIONS FOR THE TREATMENT OF HERPES VIRUSES; MEDICATED TOPICAL CLEAR FLUORIDE GEL FOR THE TREATMENT OF HERPES VIRUS DURING THE PHYSICAL MANIFESTATION OF THE VIRUS; PHARMACEUTICAL PREPARATIONS FOR THE TREATMENT OF HERPES SIMPLEX VIRUS TYPE I OR TYPE II OR HERPES ZOSTER VIRUS, NOT IN INTRAVENOUS FORM; PLANT-BASED ANTIVIRALS; OVER-THE-COUNTER TOPICAL ANTIVIRALS; PHARMACEUTICAL PREPARATION WITH ANTIVIRAL AND/OR ANTIMICROBIAL PROPERTIES FOR USE IN THE TREATMENT OF HERPESIC KERATITIS, CONJUNCTIVITIS, HIV RETINOPATHY, VIRAL INFLUENZA "FLU", HERPES SIMPLEX VIRUS 1, HERPES SIMPLEX VIRUS 2, VARICELLA ZOSTER VIRUS "HERPES ZOSTER" OR "SHINGLES", CYTOMEGALOVIRUS, VIRAL PARAIN-

FLUENZA, ADENOVIRUS, VIRAL ENCEPHALITIS, VIRAL MENINGITIS, ARBOVIRUS, ARENAVIRUS, PICORNAVIRUS, CORONAVIRUS, SYNTIALVIRUS, VIRAL INFECTIONS, COMMON COLDS CAUSED BY VIRUSES, COLD SORES, HUMAN IMMUNODEFICIENCY VIRUS "HIV", ROSEOLA INFANTUM, HUMAN HERPES IV; PHARMACEUTICAL PREPARATIONS FOR THE TREATMENT OF VIRAL DISEASES AND DISORDERS, NAMELY, HERPES; PHARMACEUTICAL PREPARATIONS FOR TREATING IMMUNE DISEASES INDUCED BY VIRUS, NAMELY, HERPES, HERPES ZOSTER AND AIDS; ALGAL PRODUCTS FOR MEDICINAL PURPOSES, NAMELY, ALGAL EXTRACTS OR ALGAL EXTRACT BLENDS FOR USE AS NUTRITIONAL AND DIETARY SUPPLEMENTS; ALGAL PRODUCTS, NAMELY, ALGAL POWDERS SOLD AS AN INTEGRAL INGREDIENT OF NUTRITIONAL SUPPLEMENT DRINK MIX FOR NUTRITIONAL PURPOSES; ALGAL PRODUCTS, NAMELY, ALGAL POWDERS FOR NUTRITIONAL PURPOSES; ALGAL EXTRACTS OR ALGAL EXTRACT BLENDS FOR MEDICAL OR PHARMACEUTICAL PURPOSES; FUNCTIONAL FOODS, NAMELY, DIETETIC FOODS ADAPTED FOR MEDICAL PURPOSES; FUNCTIONAL BEVERAGES, NAMELY, NUTRITIONALLY FORTIFIED BEVERAGES; MEDICINAL FOODS, NAMELY, PROCESSED FOOD FOR MEDICAL PURPOSES; ANIMAL HEALTH PRODUCTS, NAMELY, ANIMAL FEED SUPPLEMENTS, MEDICATED ANIMAL FEED, MICRO-NUTRIENT ANIMAL FEED, DIETARY SUPPLEMENTS FOR ANIMALS, NON-MEDICATED ADDITIVES FOR ANIMAL FEED FOR USE AS NUTRITIONAL SUPPLEMENTS, NUTRITIONAL DRINKS FOR ANIMALS, PHARMACEUTICAL PREPARATIONS FOR ANIMAL SKINCARE; PLANT EXTRACTS FOR MEDICAL, VETERINARY AND PHARMACEUTICAL PURPOSES; HERBAL EXTRACTS FOR MEDICAL, VETERINARY AND PHARMACEUTICAL PURPOSES; DESIGNER EXTRACTS, NAMELY, PLANT AND BOTANICAL EXTRACTS FOR MEDICAL, VETERINARY AND PHARMACEUTICAL PURPOSES; AND BIODEFENSE PRODUCTS, NAMELY, MEDICINAL PREPARATIONS FOR THE TREATMENT OF INFECTIOUS DISEASES AND ADVERSE HUMAN HEALTH CONDITIONS, NAMELY, INFECTION, DEGENERATIVE, MUSCULAR, PULMONARY, SKELETAL, ENDOCRINE, IMMUNE, NEUROLOGICAL, CARDIOVASCULAR, METABOLIC, INFLAMMATORY, CANCER AND RELATED CONDITIONS; MUSHROOM, FUNGUS, OR SPORE EXTRACTS OR BLENDS AS SUPPLEMENTS, NUTRITION, NUTRACEUTICALS AND/OR PHARMACEUTICALS; BOTANICAL EXTRACTS FOR NUTRITIONAL USE; NUTRITIONALLY FORTIFIED BEVERAGES; NUTRITIONALLY FORTIFIED BEVERAGES FOR IMMUNE ENHANCEMENT, AND NUTRITIONALLY FORTIFIED BEVERAGES WITH RICE BRAN AND WHEAT BRAN; MEDICINAL BEVERAGES; SOY PROTEIN FOR USE AS A NUTRITIONAL SUPPLEMENT; NUTRITIONAL ADDITIVES FOR MEDICAL OR NONMEDICAL PURPOSES FOR USE IN MANUFACTURING FOODS AND DIETARY SUPPLEMENTS FOR HUMAN CONSUMPTION; ACTIVE PRINCIPLES EXTRACTED FROM MEDICINAL PLANTS FOR USE IN THE MANUFACTURE OF NUTRACEUTICALS AND PHARMACEUTICALS; ACTIVE PRINCIPLES EXTRACTED FROM MEDICINAL PLANTS FOR USE IN THE MANUFACTURE OF PHARMACEUTICAL OR NUTRACEUTICAL PRODUCTS (U.S. CLS. 6, 18, 44, 46, 51 AND 52).

HEATHER THOMPSON, EXAMINING ATTORNEY

SN 77-519,415. HERBALSCIENCE GROUP, LLC, NAPLES, FL. FILED 7-10-2008.

CARDIO ULTRAPOWER

THE MARK CONSISTS OF STANDARD CHARACTERS WITHOUT CLAIM TO ANY PARTICULAR FONT, STYLE, SIZE, OR COLOR.

NO CLAIM IS MADE TO THE EXCLUSIVE RIGHT TO USE "CARDIO", APART FROM THE MARK AS SHOWN.

CLASS 1—CHEMICALS

FOR BOTANICAL EXTRACTS FOR USE IN THE MANUFACTURE OF NUTRACEUTICALS; EXTRACTS FOR USE IN THE MANUFACTURE OF PHARMACEUTICAL PREPARATIONS IN THE FORM OF PREPARATIONS IN THE FORM OF LOTIONS, CREAMS, AND TOPICAL ANALGESICS AND ANESTHETICS, TABLETS, CAPSULES, PILLS, TINCTURE, SUPPOSITORIES AND AMPULE FOR INJECTION; BOTANICAL EXTRACTS FOR USE IN THE MANUFACTURE OF PHARMACEUTICALS; CHEMICAL EXTRACTS EXTRACTED FROM MEDICINAL PLANTS FOR USE IN THE MANUFACTURE OF NUTRACEUTICALS AND PHARMACEUTICALS; CHEMICAL EXTRACTS, NAMELY, CHEMICAL AGENTS MADE FROM BOTANICAL EXTRACTS OR ASSOCIATION OF CHEMICAL EXTRACTS FOR USE IN THE MANUFACTURE OF PHARMACEUTICAL OR NUTRACEUTICAL PRODUCTS; BOTANICAL EXTRACTS USED IN THE MANUFACTURE OF PREPARATIONS IN THE FORM OF LOTIONS, CREAMS, AND TOPICAL ANALGESICS AND ANESTHETICS, TABLETS, CAPSULES, PILLS, LOZENGES, INHALERS, TINCTURE, SUPPOSITORIES AND AMPULE FOR INJECTION; BOTANICALS AND BOTANICAL BLENDS, HERBS AND HERBAL BLENDS, BOTANICAL EXTRACTS AND BOTANICAL EXTRACT BLENDS, FLAVOR EXTRACTS AND FLAVOR EXTRACT BLENDS, ALGAL EXTRACTS AND ALGAL EXTRACT BLENDS, ALL FOR USE IN THE MANUFACTURE OF NUTRITIONAL SUPPLEMENTS AND VITAMINS; HERBAL EXTRACTS AND BLENDS FOR USE IN MANUFACTURING FUNCTIONAL FOODS OR BEVERAGES; HERBAL EXTRACTS AND BLENDS FOR USE IN MANUFACTURING MEDICINAL FOODS OR BEVERAGES; BOTANICAL EXTRACTS AND BLENDS FOR USE IN MANUFACTURING FUNCTIONAL FOODS OR BEVERAGES; BOTANICAL EXTRACTS AND BLENDS FOR USE IN MANUFACTURING MEDICINAL FOODS OR BEVERAGES; HERBAL PREPARATIONS AND EXTRACTS FOR USE AS INGREDIENTS IN MANUFACTURING IN THE FOOD, NUTRITION, NUTRACEUTICAL AND/OR PHARMACEUTICAL INDUSTRIES (U.S. CLS. 1, 5, 6, 10, 26 AND 46).

CLASS 5—PHARMACEUTICALS

FOR NUTRITIONAL SUPPLEMENTS; HERBAL PRODUCTS, NAMELY, MEDICATED SKIN AND LIP BALMS; HERBAL PRODUCTS, NAMELY, OINTMENTS, OILS, DRINKS, INFUSIONS, SYRUPS, HERBAL EXTRACTS, POISONS, AND TINCTURES FOR MEDICAL USE IN THE TREATMENT OF STROKES, INFARCTS AND OTHER CARDIOVASCULAR AND CEREBRUM DISEASES; HERBAL PRODUCTS, NAMELY, OINTMENTS, OILS, NAMELY, MINERAL OIL FOR USE AS A LAXATIVE; DRINKS, NAMELY, MEAL REPLACEMENT DRINKS, DIETARY SUPPLEMENT DRINKS, MEDICINAL DRINKS, AND FISH OIL FOR USE AS A DIETARY SUPPLEMENT OR IN A NUTRACEUTICAL; INFUSIONS AND SYRUPS, NAMELY, COUGH SYRUPS; HERBAL PRODUCTS FOR MEDICINAL PURPOSES, NAMELY, HERBAL EXTRACTS FOR USE AS NUTRITIONAL AND DIETARY SUPPLEMENTS; HERBAL PRODUCTS FOR MEDICINAL PURPOSES, NAMELY, HERBAL EXTRACTS AND SYRUPS; MEDICINAL HERB EXTRACTS; MEDICINAL HERB EXTRACTS FOR MEDICAL PURPOSES; PLANT EXTRACTS FOR MEDICAL, PHARMACEUTICAL, NUTRACEUTICAL AND NUTRI-

TIONAL PURPOSES; MEDICINAL EXTRACTS USED IN PREPARATIONS IN THE FORM OF LOTIONS, CREAMS, AND TOPICAL ANALGESICS AND ANESTHETICS, TABLETS, CAPSULES, PILLS, LOZENGES, INHALERS, TINCTURE, SUPPOSITORIES AND AMPULE FOR INJECTION; MEDICINAL EXTRACTS IN THE FORM OF LOTIONS, CREAMS, AND TOPICAL ANALGESICS AND ANESTHETICS, TABLETS, CAPSULES, PILLS, TINCTURE, SUPPOSITORIES AND AMPULE FOR INJECTION; MEDICINAL HERBAL EXTRACTS IN THE FORM OF LOTIONS, CREAMS, AND TOPICAL ANALGESICS AND ANESTHETICS, TABLETS, CAPSULES, PILLS, TINCTURE, SUPPOSITORIES AND AMPULE FOR INJECTION USED TO TREAT SKIN AILMENTS, FOR INFECTION, DEGENERATIVE, MUSCULAR, PULMONARY, SKELETAL, ENDOCRINE, IMMUNE, NEUROLOGICAL, CARDIOVASCULAR, METABOLIC, INFLAMMATORY, CANCER AND RELATED CONDITIONS; YEAST EXTRACTS FOR MEDICAL, PHARMACEUTICAL OR NUTRACEUTICAL PURPOSES; HERBAL PRODUCTS, NAMELY, HERBAL POWDERS FOR NUTRITIONAL PURPOSES; HERBAL PRODUCTS, NAMELY, HERBAL MEAL REPLACEMENT POWDERS FOR DIETARY AND NUTRITIONAL PURPOSES; HERBAL PRODUCTS, NAMELY, AROMATHERAPY PACKS CONTAINING HERBS USED FOR RELIEF FROM HEADACHES, INSOMNIA AND SINUS DISCOMFORT; HERBAL PRODUCTS, NAMELY, HERBAL POWDERS SOLD AS AN INTEGRAL INGREDIENT OF NUTRITIONAL SUPPLEMENT DRINK MIX FOR NUTRITIONAL PURPOSES; PHARMACEUTICALS AND NUTRACEUTICALS, NAMELY, VITAMINS AND FOOD SUPPLEMENTS; PHARMACEUTICAL PREPARATIONS, NAMELY, APPETITE SUPPRESSANTS AND LIPID LOWERING AGENTS; FOOD FOR DIABETICS, INFANTS AND ENTERAL FEEDING; BOTANICAL EXTRACTS FOR NUTRITIONAL USE; BOTANICAL EXTRACTS FOR MEDICAL, VETERINARY, NUTRACEUTICAL AND PHARMACEUTICAL PURPOSES; DESIGNER EXTRACTS, NAMELY, HERBAL EXTRACTS FOR MEDICAL, VETERINARY AND PHARMACEUTICAL PURPOSES; BOTANICAL EXTRACTS FOR NUTRITIONAL SUPPLEMENTS, NUTRACEUTICALS AND PHARMACEUTICALS; NUTRITIONAL DIETARY SUPPLEMENTS; ORAL PREPARATIONS CONTAINING HERBS OR HERBAL EXTRACTS USED TO MAINTAIN HEALTH AND FOR A WIDE VARIETY OF PHYSICAL CONDITIONS; VITAMIN AND MINERAL PREPARATIONS INTENDED FOR USE AS DIETARY SUPPLEMENTS; VITAMINS; FOOD SUPPLEMENTS; NUTRACEUTICALS, NAMELY, VITAMINS AND FOOD SUPPLEMENTS; FOOD FOR MEDICALLY RESTRICTED DIETS; SUPPLEMENTS, NAMELY, LIPID CONCENTRATES FOR USE AS A DIETARY FOOD SUPPLEMENT OR FOR PHARMACEUTICAL OR MEDICINAL PURPOSES; FOOD SUPPLEMENTS, NAMELY, ANTI-OXIDANTS; BOTANICALS AND BOTANICAL BLENDS, HERBALS AND HERBAL BLENDS, BOTANICAL EXTRACTS AND BOTANICAL EXTRACT BLENDS, FLAVOR EXTRACTS AND FLAVOR EXTRACT BLENDS, ALL SOLD AS COMPONENTS OF NUTRITIONAL SUPPLEMENTS AND VITAMINS; NUTRITIONAL OILS NOT FOR COSMETIC PURPOSES; FOOD SUPPLEMENTS, NAMELY, LIPID CONCENTRATES FOR USE AS A DIETARY FOOD SUPPLEMENT OR FOR PHARMACEUTICAL OR MEDICINAL PURPOSES; ANTI-COUGH DROPS; COUGH DROPS; COUGH EXPECTORANTS; THROAT LOZENGES; COUGH LOZENGES; COUGH SYRUPS; COUGH TREATMENT PREPARATIONS; COLD SORE TREATMENT PREPARATIONS; PHARMACEUTICAL ANTITUSSIVE-COLD PREPARATIONS; PREPARATIONS FOR TREATING COLDS; ANALGESIC PREPARATIONS; ANALGESICS; ANTIPIRETTIC ANALGESICS; IBUPROFEN FOR USE AS AN ORAL ANALGESIC; MULTIPURPOSE MEDICATED ANTIBIOTIC CREAM, ANALGESIC BALM AND MENTHOLATED SALVE; ORAL ANALGESICS; TOPICAL ANALGESICS; PHARMACEUTICAL PREPARATIONS FOR THE TREATMENT AND PREVENTION OF HERPES; VACCINES FOR THE TREATMENT AND PREVENTION OF HERPES; BIOLOGICAL PREPARATIONS FOR THE TREATMENT AND PREVENTION OF HERPES; PHARMACEUTICAL PREPARATIONS FOR THE TREATMENT OF HERPES SIMPLEX INFECTION; PHARMACEUTICAL CAPSULES FOR THE TREATMENT OF HERPES

SIMPLEX INFECTION; HOMEOPATHIC PREPARATIONS FOR THE TREATMENT OF HERPES AND COLD SORES; PHARMACEUTICAL PREPARATIONS FOR THE TREATMENT OF HERPES VIRUSES; MEDICATED TOPICAL CLEAR FLUORIDE GEL FOR THE TREATMENT OF HERPES VIRUS DURING THE PHYSICAL MANIFESTATION OF THE VIRUS; PHARMACEUTICAL PREPARATIONS FOR THE TREATMENT OF HERPES SIMPLEX VIRUS TYPE I OR TYPE II OR HERPES ZOSTER VIRUS, NOT IN INTRAVENOUS FORM; PLANT-BASED ANTIVIRALS; OVER-THE-COUNTER TOPICAL ANTIVIRALS; PHARMACEUTICAL PREPARATION WITH ANTIVIRAL AND/OR ANTIMICROBIAL PROPERTIES FOR USE IN THE TREATMENT OF HERPETIC KERATITIS, CONJUNCTIVITIS, HIV RETINOPATHY, VIRAL INFLUENZA "FLU", HERPES SIMPLEX VIRUS 1, HERPES SIMPLEX VIRUS 2, VARICELLA ZOSTER VIRUS "HERPES ZOSTER" OR "SHINGLES", CYTOMEGALOVIRUS, VIRAL PARAINFLUENZA, ADENOVIRUS, VIRAL ENCEPHALITIS, VIRAL MENINGITIS, ARBOVIRUS, ARENAVIRUS, PICORNAVIRUS, CORONAVIRUS, SYNTIALVIRUS, VIRAL INFECTIONS, COMMON COLDS CAUSED BY VIRUSES, COLD SORES, HUMAN IMMUNODEFICIENCY VIRUS "HIV", ROSEOLA INFANTUM, HUMAN HERPES IV; PHARMACEUTICAL PREPARATIONS FOR THE TREATMENT OF VIRAL DISEASES AND DISORDERS, NAMELY, HERPES; PHARMACEUTICAL PREPARATIONS FOR TREATING IMMUNE DISEASES INDUCED BY VIRUS, NAMELY, HERPES, HERPES ZOSTER AND AIDS; ALGAL PRODUCTS FOR MEDICINAL PURPOSES, NAMELY, ALGAL EXTRACTS OR ALGAL EXTRACT BLENDS FOR USE AS NUTRITIONAL AND DIETARY SUPPLEMENTS; ALGAL PRODUCTS, NAMELY, ALGAL POWDERS SOLD AS AN INTEGRAL INGREDIENT OF NUTRITIONAL SUPPLEMENT DRINK MIX FOR NUTRITIONAL PURPOSES; ALGAL PRODUCTS, NAMELY, ALGAL POWDERS FOR NUTRITIONAL PURPOSES; ALGAL EXTRACTS OR ALGAL EXTRACT BLENDS FOR MEDICAL OR PHARMACEUTICAL PURPOSES; FUNCTIONAL FOODS, NAMELY, DIETETIC FOODS ADAPTED FOR MEDICAL PURPOSES; FUNCTIONAL BEVERAGES, NAMELY, NUTRITIONALLY FORTIFIED BEVERAGES; MEDICINAL FOODS, NAMELY, PROCESSED FOOD FOR MEDICAL PURPOSES; ANIMAL HEALTH PRODUCTS, NAMELY, ANIMAL FEED SUPPLEMENTS, MEDICATED ANIMAL FEED, MICRO-NUTRIENT ANIMAL FEED, DIETARY SUPPLEMENTS FOR ANIMALS, NON-MEDICATED ADDITIVES FOR ANIMAL FEED FOR USE AS NUTRITIONAL SUPPLEMENTS, NUTRITIONAL DRINKS FOR ANIMALS, PHARMACEUTICAL PREPARATIONS FOR ANIMAL SKINCARE; PLANT EXTRACTS FOR MEDICAL, VETERINARY AND PHARMACEUTICAL PURPOSES; HERBAL EXTRACTS FOR MEDICAL, VETERINARY AND PHARMACEUTICAL PURPOSES; DESIGNER EXTRACTS, NAMELY, PLANT, HERBAL AND BOTANICAL EXTRACTS FOR MEDICAL, VETERINARY AND PHARMACEUTICAL PURPOSES; AND BIODEFENSE PRODUCTS, NAMELY, MEDICINAL PREPARATIONS FOR THE TREATMENT OF INFECTIOUS DISEASES AND ADVERSE HUMAN HEALTH CONDITIONS, NAMELY, INFECTION, DEGENERATIVE, MUSCULAR, PULMONARY, SKELETAL, ENDOCRINE, IMMUNE, NEUROLOGICAL, CARDIOVASCULAR, METABOLIC, INFLAMMATORY, CANCER AND RELATED CONDITIONS; MUSHROOM, FUNGUS, OR SPORE EXTRACTS OR BLENDS AS SUPPLEMENTS, NUTRITION, NUTRACEUTICALS AND/OR PHARMACEUTICALS; BOTANICAL EXTRACTS FOR NUTRITIONAL USE; NUTRITIONALLY FORTIFIED BEVERAGES; NUTRITIONALLY FORTIFIED BEVERAGES FOR IMMUNE ENHANCEMENT, AND NUTRITIONALLY FORTIFIED BEVERAGES WITH RICE BRAN AND WHEAT BRAN; MEDICINAL BEVERAGES; SOY PROTEIN FOR USE AS A NUTRITIONAL SUPPLEMENT; NUTRITIONAL ADDITIVES FOR MEDICAL OR NONMEDICAL PURPOSES FOR USE IN MANUFACTURING FOODS AND DIETARY SUPPLEMENTS FOR HUMAN CONSUMPTION; ACTIVE PRINCIPLES EXTRACTED FROM MEDICINAL PLANTS FOR USE IN THE MANUFACTURE OF NUTRACEUTICALS AND PHARMACEUTICALS; ACTIVE PRINCIPLES EXTRACTED FROM MEDICINAL PLANTS FOR USE IN THE MANUFACTURE OF PHARMACEUTICAL OR NUTRACEUTICAL PRODUCTS (U.S. CLS. 6, 18, 44, 46, 51 AND 52).

CLASS 29—MEATS AND PROCESSED FOODS

FOR BEVERAGES, NAMELY, YOGURT-BASED BEVERAGES; FOOD BEVERAGES, NAMELY, DAIRY-BASED FOOD BEVERAGES, FRUIT-BASED FOOD BEVERAGES, VEGETABLE-BASED FOOD BEVERAGES, DAIRY-BASED CHOCOLATE FOOD BEVERAGES, SOY-BASED FOOD BEVERAGE USED AS A MILK SUBSTITUTE, VEGETABLE-BASED CHOCOLATE FOOD BEVERAGES AND PEANUT-BASED FOOD BEVERAGES; MILK BEVERAGES; MILK BEVERAGES, NAMELY, MILK, MILK BEVERAGES CONTAINING FRUITS, MILK BEVERAGES WITH HIGH MILK CONTENT, MILK BASED BEVERAGES CONTAINING FRUIT JUICE AND MILK BEVERAGES CONTAINING COFFEE; MILK POWDER; MILK POWDER FOR NUTRITIONAL PURPOSES; POWDERED MILK FOR FOOD PURPOSES; FUNCTIONAL FOODS, NAMELY, DAIRY-BASED FOOD BEVERAGES, FRUIT-BASED FOOD BEVERAGES, VEGETABLE-BASED FOOD BEVERAGES, DAIRY-BASED CHOCOLATE FOOD BEVERAGES, SOY-BASED FOOD BEVERAGE USED AS A MILK SUBSTITUTE, VEGETABLE-BASED CHOCOLATE FOOD BEVERAGES, NUT-BASED FOOD BEVERAGES, MILK, MILK BEVERAGES CONTAINING FRUITS, MILK BEVERAGES WITH HIGH MILK CONTENT, MILK BASED BEVERAGES CONTAINING FRUIT JUICE, AND MILK BEVERAGES CONTAINING COFFEE; EDIBLE OILS, NAMELY, OMEGA OIL EXTRACTS AND FISH OIL EXTRACTS; SOY PROTEIN FOR USE AS A FOOD ADDITIVE; MUSHROOM, FUNGUS, OR SPORE EXTRACTS OR BLENDS THEREOF FOR USE AS FOOD ADDITIVES (U.S. CL. 46).
HEATHER THOMPSON, EXAMINING ATTORNEY

SN 77-519,569. HERBALSCIENCE GROUP, LLC, NAPLES, FL. FILED 7-10-2008.

BALANCE ULTRAPOWER

THE MARK CONSISTS OF STANDARD CHARACTERS WITHOUT CLAIM TO ANY PARTICULAR FONT, STYLE, SIZE, OR COLOR.

CLASS 1—CHEMICALS

FOR BOTANICAL EXTRACTS FOR USE IN THE MANUFACTURE OF NUTRACEUTICALS; EXTRACTS FOR USE IN THE MANUFACTURE OF PHARMACEUTICAL PREPARATIONS IN THE FORM OF PREPARATIONS IN THE FORM OF LOTIONS, CREAMS, AND TOPICAL ANALGESICS AND ANESTHETICS, TABLETS, CAPSULES, PILLS, TINCTURE, SUPPOSITORIES AND AMPULE FOR INJECTION; BOTANICAL EXTRACTS FOR USE IN THE MANUFACTURE OF PHARMACEUTICALS; CHEMICAL EXTRACTS EXTRACTED FROM MEDICINAL PLANTS FOR USE IN THE MANUFACTURE OF NUTRACEUTICALS AND PHARMACEUTICALS; CHEMICAL EXTRACTS, NAMELY, CHEMICAL AGENTS MADE FROM BOTANICAL EXTRACTS OR ASSOCIATION OF CHEMICAL EXTRACTS FOR USE IN THE MANUFACTURE OF PHARMACEUTICAL OR NUTRACEUTICAL PRODUCTS; BOTANICAL EXTRACTS USED IN THE MANUFACTURE OF PREPARATIONS IN THE FORM OF LOTIONS, CREAMS, AND TOPICAL ANALGESICS AND ANESTHETICS, TABLETS, CAPSULES, PILLS, LOZENGES, INHALERS, TINCTURE, SUPPOSITORIES AND AMPULE FOR INJECTION; BOTANICALS AND BOTANICAL BLENDS, HERBS AND HERBAL BLENDS, BOTANICAL EXTRACTS AND BOTANICAL EXTRACT BLENDS, FLAVOR EXTRACTS AND FLAVOR EXTRACT BLENDS, ALGAL EXTRACTS AND ALGAL EXTRACT BLENDS, ALL FOR USE IN THE MANUFACTURE OF NUTRITIONAL SUPPLEMENTS AND VITAMINS; HERBAL EXTRACTS AND BLENDS FOR USE IN MANUFACTURING FUNCTIONAL FOODS OR BEVERAGES; HERBAL EXTRACTS AND BLENDS FOR USE IN MANUFACTURING MEDICINAL FOODS OR BEVERAGES; BOTANICAL EXTRACTS AND BLENDS FOR USE IN MANUFACTURING FUNCTIONAL FOODS OR BEVERAGES; BOTANICAL EXTRACTS AND BLENDS FOR USE IN MANUFACTURING MEDICINAL FOODS OR BEVERAGES; HERBAL PREPARATIONS AND EXTRACTS FOR USE AS INGREDIENTS IN MANUFACTURING IN THE FOOD, NUTRITION, NUTRACEUTICAL AND/OR PHARMACEUTICAL INDUSTRIES (U.S. CLS. 1, 5, 6, 10, 26 AND 46).

SN 77-519,488. BILLION 7 INTERNATIONAL, INC., NORTH HUMBERSIDE, UNITED KINGDOM, FILED 7-10-2008.

BILLION7

THE MARK CONSISTS OF STANDARD CHARACTERS WITHOUT CLAIM TO ANY PARTICULAR FONT, STYLE, SIZE, OR COLOR.

CLASS 35—ADVERTISING AND BUSINESS

FOR DISSEMINATION OF ADVERTISING FOR OTHERS VIA THE INTERNET, PROVIDING AND RENTAL OF ADVERTISING SPACE ON THE INTERNET (U.S. CLS. 100, 101 AND 102).
FIRST USE 1-8-2007; IN COMMERCE 1-8-2007.

CLASS 45—PERSONAL AND LEGAL SERVICES

FOR PROVIDING A SOCIAL NETWORKING WEBSITE FOR ENTERTAINMENT PURPOSES (U.S. CLS. 100 AND 101).
FIRST USE 1-8-2007; IN COMMERCE 1-8-2007.
ELLEN BURNS, EXAMINING ATTORNEY

CLASS 5—PHARMACEUTICALS

FOR NUTRITIONAL ADDITIVES FOR MEDICAL OR NONMEDICAL PURPOSES FOR USE IN MANUFACTURING FOODS AND DIETARY SUPPLEMENTS FOR HUMAN CONSUMPTION; ACTIVE PRINCIPLES EXTRACTED FROM MEDICINAL PLANTS FOR USE IN THE MANUFACTURE OF NUTRACEUTICALS AND PHARMACEUTICALS; ACTIVE PRINCIPLES EXTRACTED FROM MEDICINAL PLANTS FOR USE IN THE MANUFACTURE OF PHARMACEUTICAL OR NUTRACEUTICAL PRODUCTS (U.S. CLS. 6, 18, 44, 46, 51 AND 52).
HEATHER THOMPSON, EXAMINING ATTORNEY

SN 77-519,578. HERBALSCIENCE GROUP, LLC, NAPLES, FL. FILED 7-10-2008.

SN 77-519,584. HERBALSCIENCE GROUP, LLC, NAPLES, FL. FILED 7-10-2008.

BALANCEASSIST

THE MARK CONSISTS OF STANDARD CHARACTERS WITHOUT CLAIM TO ANY PARTICULAR FONT, STYLE, SIZE, OR COLOR.

CLASS 1—CHEMICALS

FOR BOTANICAL EXTRACTS FOR USE IN THE MANUFACTURE OF NUTRACEUTICALS; EXTRACTS FOR USE IN THE MANUFACTURE OF PHARMACEUTICAL PREPARATIONS IN THE FORM OF PREPARATIONS IN THE FORM OF LOTIONS, CREAMS, AND TOPICAL ANALGESICS AND ANESTHETICS, TABLETS, CAPSULES, PILLS, TINCTURE, SUPPOSITORIES AND AMPULE FOR INJECTION; BOTANICAL EXTRACTS FOR USE IN THE MANUFACTURE OF PHARMACEUTICALS; CHEMICAL EXTRACTS EXTRACTED FROM MEDICINAL PLANTS FOR USE IN THE MANUFACTURE OF NUTRACEUTICALS AND PHARMACEUTICALS; CHEMICAL EXTRACTS, NAMELY, CHEMICAL AGENTS MADE FROM BOTANICAL EXTRACTS OR ASSOCIATION OF CHEMICAL EXTRACTS FOR USE IN THE MANUFACTURE OF PHARMACEUTICAL OR NUTRACEUTICAL PRODUCTS; BOTANICAL EXTRACTS USED IN THE MANUFACTURE OF PREPARATIONS IN THE FORM OF LOTIONS, CREAMS, AND TOPICAL ANALGESICS AND ANESTHETICS, TABLETS, CAPSULES, PILLS, LOZENGES, INHALERS, TINCTURE, SUPPOSITORIES AND AMPULE FOR INJECTION; BOTANICALS AND BOTANICAL BLENDS, HERBS AND HERBAL BLENDS, BOTANICAL EXTRACTS AND BOTANICAL EXTRACT BLENDS, FLAVOR EXTRACTS AND FLAVOR EXTRACT BLENDS, ALGAL EXTRACTS AND ALGAL EXTRACT BLENDS, ALL FOR USE IN THE MANUFACTURE OF NUTRITIONAL SUPPLEMENTS AND VITAMINS; HERBAL EXTRACTS AND BLENDS FOR USE IN MANUFACTURING FUNCTIONAL FOODS OR BEVERAGES; HERBAL EXTRACTS AND BLENDS FOR USE IN MANUFACTURING MEDICINAL FOODS OR BEVERAGES; BOTANICAL EXTRACTS AND BLENDS FOR USE IN MANUFACTURING FUNCTIONAL FOODS OR BEVERAGES; BOTANICAL EXTRACTS AND BLENDS FOR USE IN MANUFACTURING MEDICINAL FOODS OR BEVERAGES; HERBAL PREPARATIONS AND EXTRACTS FOR USE AS INGREDIENTS IN MANUFACTURING IN THE FOOD, NUTRITION, NUTRACEUTICAL AND/OR PHARMACEUTICAL INDUSTRIES (U.S. CLS. 1, 5, 6, 10, 26 AND 46).

CLASS 5—PHARMACEUTICALS

FOR NUTRITIONAL ADDITIVES FOR MEDICAL OR NONMEDICAL PURPOSES FOR USE IN MANUFACTURING FOODS AND DIETARY SUPPLEMENTS FOR HUMAN CONSUMPTION; ACTIVE PRINCIPLES EXTRACTED FROM MEDICINAL PLANTS FOR USE IN THE MANUFACTURE OF NUTRACEUTICALS AND PHARMACEUTICALS; ACTIVE PRINCIPLES EXTRACTED FROM MEDICINAL PLANTS FOR USE IN THE MANUFACTURE OF PHARMACEUTICAL OR NUTRACEUTICAL PRODUCTS (U.S. CLS. 6, 18, 44, 46, 51 AND 52).

HEATHER THOMPSON, EXAMINING ATTORNEY

BALANCEENHANCE

THE MARK CONSISTS OF STANDARD CHARACTERS WITHOUT CLAIM TO ANY PARTICULAR FONT, STYLE, SIZE, OR COLOR.

CLASS 1—CHEMICALS

FOR BOTANICAL EXTRACTS FOR USE IN THE MANUFACTURE OF NUTRACEUTICALS; EXTRACTS FOR USE IN THE MANUFACTURE OF PHARMACEUTICAL PREPARATIONS IN THE FORM OF PREPARATIONS IN THE FORM OF LOTIONS, CREAMS, AND TOPICAL ANALGESICS AND ANESTHETICS, TABLETS, CAPSULES, PILLS, TINCTURE, SUPPOSITORIES AND AMPULE FOR INJECTION; BOTANICAL EXTRACTS FOR USE IN THE MANUFACTURE OF PHARMACEUTICALS; CHEMICAL EXTRACTS EXTRACTED FROM MEDICINAL PLANTS FOR USE IN THE MANUFACTURE OF NUTRACEUTICALS AND PHARMACEUTICALS; CHEMICAL EXTRACTS, NAMELY, CHEMICAL AGENTS MADE FROM BOTANICAL EXTRACTS OR ASSOCIATION OF CHEMICAL EXTRACTS FOR USE IN THE MANUFACTURE OF PHARMACEUTICAL OR NUTRACEUTICAL PRODUCTS; BOTANICAL EXTRACTS USED IN THE MANUFACTURE OF PREPARATIONS IN THE FORM OF LOTIONS, CREAMS, AND TOPICAL ANALGESICS AND ANESTHETICS, TABLETS, CAPSULES, PILLS, LOZENGES, INHALERS, TINCTURE, SUPPOSITORIES AND AMPULE FOR INJECTION; BOTANICALS AND BOTANICAL BLENDS, HERBS AND HERBAL BLENDS, BOTANICAL EXTRACTS AND BOTANICAL EXTRACT BLENDS, FLAVOR EXTRACTS AND FLAVOR EXTRACT BLENDS, ALGAL EXTRACTS AND ALGAL EXTRACT BLENDS, ALL FOR USE IN THE MANUFACTURE OF NUTRITIONAL SUPPLEMENTS AND VITAMINS; HERBAL EXTRACTS AND BLENDS FOR USE IN MANUFACTURING FUNCTIONAL FOODS OR BEVERAGES; HERBAL EXTRACTS AND BLENDS FOR USE IN MANUFACTURING MEDICINAL FOODS OR BEVERAGES; BOTANICAL EXTRACTS AND BLENDS FOR USE IN MANUFACTURING FUNCTIONAL FOODS OR BEVERAGES; BOTANICAL EXTRACTS AND BLENDS FOR USE IN MANUFACTURING MEDICINAL FOODS OR BEVERAGES; HERBAL PREPARATIONS AND EXTRACTS FOR USE AS INGREDIENTS IN MANUFACTURING IN THE FOOD, NUTRITION, NUTRACEUTICAL AND/OR PHARMACEUTICAL INDUSTRIES (U.S. CLS. 1, 5, 6, 10, 26 AND 46).

CLASS 5—PHARMACEUTICALS

FOR NUTRITIONAL ADDITIVES FOR MEDICAL OR NONMEDICAL PURPOSES FOR USE IN MANUFACTURING FOODS AND DIETARY SUPPLEMENTS FOR HUMAN CONSUMPTION; ACTIVE PRINCIPLES EXTRACTED FROM MEDICINAL PLANTS FOR USE IN THE MANUFACTURE OF NUTRACEUTICALS AND PHARMACEUTICALS; ACTIVE PRINCIPLES EXTRACTED FROM MEDICINAL PLANTS FOR USE IN THE MANUFACTURE OF PHARMACEUTICAL OR NUTRACEUTICAL PRODUCTS (U.S. CLS. 6, 18, 44, 46, 51 AND 52).

HEATHER THOMPSON, EXAMINING ATTORNEY

SN 77-519,596, HERBALSCIENCE GROUP, LLC, NAPLES, FL. FILED 7-10-2008.

ULTRAPOWER SLEEP

THE MARK CONSISTS OF STANDARD CHARACTERS WITHOUT CLAIM TO ANY PARTICULAR FONT, STYLE, SIZE, OR COLOR.

NO CLAIM IS MADE TO THE EXCLUSIVE RIGHT TO USE "SLEEP", APART FROM THE MARK AS SHOWN.

CLASS 1—CHEMICALS

FOR BOTANICAL EXTRACTS FOR USE IN THE MANUFACTURE OF NUTRACEUTICALS; EXTRACTS FOR USE IN THE MANUFACTURE OF PHARMACEUTICAL PREPARATIONS IN THE FORM OF PREPARATIONS IN THE FORM OF LOTIONS, CREAMS, AND TOPICAL ANALGESICS AND ANESTHETICS, TABLETS, CAPSULES, PILLS, TINCTURE, SUPPOSITORIES AND AMPULE FOR INJECTION; BOTANICAL EXTRACTS FOR USE IN THE MANUFACTURE OF PHARMACEUTICALS; CHEMICAL EXTRACTS EXTRACTED FROM MEDICINAL PLANTS FOR USE IN THE MANUFACTURE OF NUTRACEUTICALS AND PHARMACEUTICALS; CHEMICAL EXTRACTS, NAMELY, CHEMICAL AGENTS MADE FROM BOTANICAL EXTRACTS OR ASSOCIATION OF CHEMICAL EXTRACTS FOR USE IN THE MANUFACTURE OF PHARMACEUTICAL OR NUTRACEUTICAL PRODUCTS; BOTANICAL EXTRACTS USED IN THE MANUFACTURE OF PREPARATIONS IN THE FORM OF LOTIONS, CREAMS, AND TOPICAL ANALGESICS AND ANESTHETICS, TABLETS, CAPSULES, PILLS, LOZENGES, INHALERS, TINCTURE, SUPPOSITORIES AND AMPULE FOR INJECTION; BOTANICALS AND BOTANICAL BLENDS, HERBS AND HERBAL BLENDS, BOTANICAL EXTRACTS AND BOTANICAL EXTRACT BLENDS, FLAVOR EXTRACTS AND FLAVOR EXTRACT BLENDS, ALGAL EXTRACTS AND ALGAL EXTRACT BLENDS, ALL FOR USE IN THE MANUFACTURE OF NUTRITIONAL SUPPLEMENTS AND VITAMINS; HERBAL EXTRACTS AND BLENDS FOR USE IN MANUFACTURING FUNCTIONAL FOODS OR BEVERAGES; HERBAL EXTRACTS AND BLENDS FOR USE IN MANUFACTURING MEDICINAL FOODS OR BEVERAGES; BOTANICAL EXTRACTS AND BLENDS FOR USE IN MANUFACTURING FUNCTIONAL FOODS OR BEVERAGES; BOTANICAL EXTRACTS AND BLENDS FOR USE IN MANUFACTURING MEDICINAL FOODS OR BEVERAGES; HERBAL PREPARATIONS AND EXTRACTS FOR USE AS INGREDIENTS IN MANUFACTURING IN THE FOOD, NUTRITION, NUTRACEUTICAL AND/OR PHARMACEUTICAL INDUSTRIES (U.S. CLS. 1, 5, 6, 10, 26 AND 46).

CLASS 5—PHARMACEUTICALS

FOR NUTRITIONAL SUPPLEMENTS; HERBAL PRODUCTS, NAMELY, MEDICATED SKIN AND LIP BALMS; HERBAL PRODUCTS, NAMELY, OINTMENTS, OILS, DRINKS, INFUSIONS, SYRUPS, HERBAL EXTRACTS, POISONS, AND TINCTURES FOR MEDICAL USE IN THE TREATMENT OF STROKES, INFARCTS AND OTHER CARDIOVASCULAR AND CEREBRUM DISEASES; HERBAL PRODUCTS, NAMELY, OINTMENTS, OILS, NAMELY, MINERAL OIL FOR USE AS A LAXATIVE; DRINKS, NAMELY, MEAL REPLACEMENT DRINKS, DIETARY SUPPLEMENT DRINKS, MEDICINAL DRINKS, AND FISH OIL FOR USE AS A DIETARY SUPPLEMENT OR IN A NUTRACEUTICAL; INFUSIONS AND SYRUPS, NAMELY, COUGH SYRUPS; HERBAL PRODUCTS FOR MEDICINAL PURPOSES, NAMELY, HERBAL EXTRACTS FOR USE AS NUTRITIONAL AND DIETARY SUPPLEMENTS; HERBAL PRODUCTS FOR MEDICINAL PURPOSES, NAMELY, HERBAL EXTRACTS AND SYRUPS; MEDICINAL HERB EXTRACTS; MEDICINAL HERB EXTRACTS FOR MEDICAL PURPOSES; PLANT EXTRACTS FOR MEDICAL, PHARMACEUTICAL, NUTRACEUTICAL AND NUTRI-

TIONAL PURPOSES; MEDICINAL EXTRACTS USED IN PREPARATIONS IN THE FORM OF LOTIONS, CREAMS, AND TOPICAL ANALGESICS AND ANESTHETICS, TABLETS, CAPSULES, PILLS, LOZENGES, INHALERS, TINCTURE, SUPPOSITORIES AND AMPULE FOR INJECTION; MEDICINAL EXTRACTS IN THE FORM OF LOTIONS, CREAMS, AND TOPICAL ANALGESICS AND ANESTHETICS, TABLETS, CAPSULES, PILLS, TINCTURE, SUPPOSITORIES AND AMPULE FOR INJECTION; MEDICINAL BOTANICAL EXTRACTS IN THE FORM OF LOTIONS, CREAMS, AND TOPICAL ANALGESICS AND ANESTHETICS, TABLETS, CAPSULES, PILLS, TINCTURE, SUPPOSITORIES AND AMPULE FOR INJECTION USED TO TREAT SKIN AILMENTS, FOR INFECTION, DEGENERATIVE, MUSCULAR, PULMONARY, SKELETAL, ENDOCRINE, IMMUNE, NEUROLOGICAL, CARDIOVASCULAR, METABOLIC, INFLAMMATORY, CANCER AND RELATED CONDITIONS; YEAST EXTRACTS FOR MEDICAL, PHARMACEUTICAL OR NUTRACEUTICAL PURPOSES; HERBAL PRODUCTS, NAMELY, HERBAL POWDERS FOR NUTRITIONAL PURPOSES; HERBAL PRODUCTS, NAMELY, HERBAL MEAL REPLACEMENT POWDERS FOR DIETARY AND NUTRITIONAL PURPOSES; HERBAL PRODUCTS, NAMELY, AROMATHERAPY PACKS CONTAINING HERBS USED FOR RELIEF FROM HEADACHES, INSOMNIA AND SINUS DISCOMFORT; HERBAL PRODUCTS, NAMELY, HERBAL POWDERS SOLD AS AN INTEGRAL INGREDIENT OF NUTRITIONAL SUPPLEMENT DRINK MIX FOR NUTRITIONAL PURPOSES; PHARMACEUTICALS AND NUTRACEUTICALS, NAMELY, VITAMINS AND FOOD SUPPLEMENTS; PHARMACEUTICAL PREPARATIONS, NAMELY, APPETITE SUPPRESSANTS AND LIPID LOWERING AGENTS; FOOD FOR DIABETICS, INFANTS AND ENTERAL FEEDING; BOTANICAL EXTRACTS FOR NUTRITIONAL USE; BOTANICAL EXTRACTS FOR MEDICAL, VETERINARY, NUTRACEUTICAL AND PHARMACEUTICAL PURPOSES; DESIGNER EXTRACTS, NAMELY, HERBAL EXTRACTS FOR MEDICAL, VETERINARY AND PHARMACEUTICAL PURPOSES; BOTANICAL EXTRACTS FOR NUTRITIONAL SUPPLEMENTS, NUTRACEUTICALS AND PHARMACEUTICALS; NUTRITIONAL DIETARY SUPPLEMENTS; ORAL PREPARATIONS CONTAINING HERBS OR HERBAL EXTRACTS USED TO MAINTAIN HEALTH AND FOR A WIDE VARIETY OF PHYSICAL CONDITIONS; VITAMIN AND MINERAL PREPARATIONS INTENDED FOR USE AS DIETARY SUPPLEMENTS; VITAMINS; FOOD SUPPLEMENTS; NUTRACEUTICALS, NAMELY, VITAMINS AND FOOD SUPPLEMENTS; FOOD FOR MEDICALLY RESTRICTED DIETS; SUPPLEMENTS, NAMELY, LIPID CONCENTRATES FOR USE AS A DIETARY FOOD SUPPLEMENT OR FOR PHARMACEUTICAL OR MEDICINAL PURPOSES; FOOD SUPPLEMENTS, NAMELY, ANTI-OXIDANTS; BOTANICALS AND BOTANICAL BLENDS, HERBALS AND HERBAL BLENDS, BOTANICAL EXTRACTS AND BOTANICAL EXTRACT BLENDS, FLAVOR EXTRACTS AND FLAVOR EXTRACT BLENDS, ALL SOLD AS COMPONENTS OF NUTRITIONAL SUPPLEMENTS AND VITAMINS; NUTRITIONAL OILS NOT FOR COSMETIC PURPOSES; FOOD SUPPLEMENTS, NAMELY, LIPID CONCENTRATES FOR USE AS A DIETARY FOOD SUPPLEMENT OR FOR PHARMACEUTICAL OR MEDICINAL PURPOSES; ANTI-COUGH DROPS; COUGH DROPS; COUGH EXPECTORANTS; THROAT LOZENGES; COUGH LOZENGES; COUGH SYRUPS; COUGH TREATMENT PREPARATIONS; COLD SORE TREATMENT PREPARATIONS; PHARMACEUTICAL ANTITUSSIVE-COLD PREPARATIONS; PREPARATIONS FOR TREATING COLDS; ANALGESIC PREPARATIONS; ANALGESICS; ANTI-PYRETIC ANALGESICS; IBUPROFEN FOR USE AS AN ORAL ANALGESIC; MULTIPURPOSE MEDICATED ANTIBIOTIC CREAM, ANALGESIC BALM AND MENTHOLATED SALVE; ORAL ANALGESICS; TOPICAL ANALGESICS; PHARMACEUTICAL PREPARATIONS FOR THE TREATMENT AND PREVENTION OF HERPES; VACCINES FOR THE TREATMENT AND PREVENTION OF HERPES; BIOLOGICAL PREPARATIONS FOR THE TREATMENT AND PREVENTION OF HERPES; PHARMACEUTICAL PREPARATIONS FOR THE TREATMENT OF HERPES SIMPLEX INFECTION; PHARMACEUTICAL CAPSULES FOR THE TREATMENT OF HERPES

SIMPLEX INFECTION; HOMEOPATHIC PREPARATIONS FOR THE TREATMENT OF HERPES AND COLD SORES; PHARMACEUTICAL PREPARATIONS FOR THE TREATMENT OF HERPES VIRUSES; MEDICATED TOPICAL CLEAR FLUORIDE GEL FOR THE TREATMENT OF HERPES VIRUS DURING THE PHYSICAL MANIFESTATION OF THE VIRUS; PHARMACEUTICAL PREPARATIONS FOR THE TREATMENT OF HERPES SIMPLEX VIRUS TYPE I OR TYPE II OR HERPES ZOSTER VIRUS, NOT IN INTRAVENOUS FORM; PLANT-BASED ANTIVIRALS; OVER-THE-COUNTER TOPICAL ANTIVIRALS; PHARMACEUTICAL PREPARATION WITH ANTIVIRAL AND/OR ANTIMICROBIAL PROPERTIES FOR USE IN THE TREATMENT OF HERPETIC KERATITIS, CONJUNCTIVITIS, HIV RETINOPATHY, VIRAL INFLUENZA "FLU", HERPES SIMPLEX VIRUS 1, HERPES SIMPLEX VIRUS 2, VARICELLA ZOSTER VIRUS "HERPES ZOSTER" OR "SHINGLES", CYTOMEGALOVIRUS, VIRAL PARAINFLUENZA, ADENOVIRUS, VIRAL ENCEPHALITIS, VIRAL MENINGITIS, ARBOVIRUS, ARENAVIRUS, PICORNAVIRUS, CORONAVIRUS, SYNTIALVIRUS, VIRAL INFECTIONS, COMMON COLDS CAUSED BY VIRUSES, COLD SORES, HUMAN IMMUNODEFICIENCY VIRUS "HIV", ROSEOLA INFANTUM, HUMAN HERPES IV; PHARMACEUTICAL PREPARATIONS FOR THE TREATMENT OF VIRAL DISEASES AND DISORDERS, NAMELY, HERPES; PHARMACEUTICAL PREPARATIONS FOR TREATING IMMUNE DISEASES INDUCED BY VIRUS, NAMELY, HERPES, HERPES ZOSTER AND AIDS; ALGAL PRODUCTS FOR MEDICINAL PURPOSES, NAMELY, ALGAL EXTRACTS OR ALGAL EXTRACT BLENDS FOR USE AS NUTRITIONAL AND DIETARY SUPPLEMENTS; ALGAL PRODUCTS, NAMELY, ALGAL POWDERS SOLD AS AN INTEGRAL INGREDIENT OF NUTRITIONAL SUPPLEMENT DRINK MIX FOR NUTRITIONAL PURPOSES; ALGAL PRODUCTS, NAMELY, ALGAL POWDERS FOR NUTRITIONAL PURPOSES; ALGAL EXTRACTS OR ALGAL EXTRACT BLENDS FOR MEDICAL OR PHARMACEUTICAL PURPOSES; FUNCTIONAL FOODS, NAMELY, DIETETIC FOODS ADAPTED FOR MEDICAL PURPOSES; FUNCTIONAL BEVERAGES, NAMELY, NUTRITIONALLY FORTIFIED BEVERAGES; MEDICINAL FOODS, NAMELY, PROCESSED FOOD FOR MEDICAL PURPOSES; ANIMAL HEALTH PRODUCTS, NAMELY, ANIMAL FEED SUPPLEMENTS, MEDICATED ANIMAL FEED, MICRO-NUTRIENT ANIMAL FEED, DIETARY SUPPLEMENTS FOR ANIMALS, NON-MEDICATED ADDITIVES FOR ANIMAL FEED FOR USE AS NUTRITIONAL SUPPLEMENTS, NUTRITIONAL DRINKS FOR ANIMALS, PHARMACEUTICAL PREPARATIONS FOR ANIMAL SKINCARE; PLANT EXTRACTS FOR MEDICAL, VETERINARY AND PHARMACEUTICAL PURPOSES; HERBAL EXTRACTS FOR MEDICAL, VETERINARY AND PHARMACEUTICAL PURPOSES; DESIGNER EXTRACTS, NAMELY, PLANT, HERBAL AND BOTANICAL EXTRACTS FOR MEDICAL, VETERINARY AND PHARMACEUTICAL PURPOSES; AND BIODEFENSE PRODUCTS, NAMELY, MEDICINAL PREPARATIONS FOR THE TREATMENT OF INFECTIOUS DISEASES AND ADVERSE HUMAN HEALTH CONDITIONS, NAMELY, INFECTION, DEGENERATIVE, MUSCULAR, PULMONARY, SKELETAL, ENDOCRINE, IMMUNE, NEUROLOGICAL, CARDIOVASCULAR, METABOLIC, INFLAMMATORY, CANCER AND RELATED CONDITIONS; MUSHROOM, FUNGUS, OR SPORE EXTRACTS OR BLENDS AS SUPPLEMENTS, NUTRITION, NUTRACEUTICALS AND/OR PHARMACEUTICALS; BOTANICAL EXTRACTS FOR NUTRITIONAL USE; NUTRITIONALLY FORTIFIED BEVERAGES; NUTRITIONALLY FORTIFIED BEVERAGES FOR IMMUNE ENHANCEMENT, AND NUTRITIONALLY FORTIFIED BEVERAGES WITH RICE BRAN AND WHEAT BRAN; MEDICINAL BEVERAGES; SOY PROTEIN FOR USE AS A NUTRITIONAL SUPPLEMENT; NUTRITIONAL ADDITIVES FOR MEDICAL OR NONMEDICAL PURPOSES FOR USE IN MANUFACTURING FOODS AND DIETARY SUPPLEMENTS FOR HUMAN CONSUMPTION; ACTIVE PRINCIPLES EXTRACTED FROM MEDICINAL PLANTS FOR USE IN THE MANUFACTURE OF NUTRACEUTICALS AND PHARMACEUTICALS; ACTIVE PRINCIPLES EXTRACTED FROM MEDICINAL PLANTS FOR USE IN THE MANUFACTURE OF PHARMACEUTICAL OR NUTRACEUTICAL PRODUCTS (U.S. CLS. 6, 18, 44, 46, 51 AND 52).

CLASS 29—MEATS AND PROCESSED FOODS

FOR BEVERAGES, NAMELY, YOGURT-BASED BEVERAGES; FOOD BEVERAGES, NAMELY, DAIRY-BASED FOOD BEVERAGES, FRUIT-BASED FOOD BEVERAGES, VEGETABLE-BASED FOOD BEVERAGES, DAIRY-BASED CHOCOLATE FOOD BEVERAGES, SOY-BASED FOOD BEVERAGE USED AS A MILK SUBSTITUTE, VEGETABLE-BASED CHOCOLATE FOOD BEVERAGES AND PEANUT-BASED FOOD BEVERAGES; MILK BEVERAGES; MILK BEVERAGES, NAMELY, MILK, MILK BEVERAGES CONTAINING FRUITS, MILK BEVERAGES WITH HIGH MILK CONTENT, MILK BASED BEVERAGES CONTAINING FRUIT JUICE AND MILK BEVERAGES CONTAINING COFFEE; MILK POWDER; MILK POWDER FOR NUTRITIONAL PURPOSES; POWDERED MILK FOR FOOD PURPOSES; FUNCTIONAL FOODS, NAMELY, DAIRY-BASED FOOD BEVERAGES, FRUIT-BASED FOOD BEVERAGES, VEGETABLE-BASED FOOD BEVERAGES, DAIRY-BASED CHOCOLATE FOOD BEVERAGES, SOY-BASED FOOD BEVERAGE USED AS A MILK SUBSTITUTE, VEGETABLE-BASED CHOCOLATE FOOD BEVERAGES, NUT-BASED FOOD BEVERAGES, MILK, MILK BEVERAGES CONTAINING FRUITS, MILK BEVERAGES WITH HIGH MILK CONTENT, MILK BASED BEVERAGES CONTAINING FRUIT JUICE, AND MILK BEVERAGES CONTAINING COFFEE; EDIBLE OILS, NAMELY, OMEGA OIL EXTRACTS AND FISH OIL EXTRACTS; SOY PROTEIN FOR USE AS A FOOD ADDITIVE; MUSHROOM, FUNGUS, OR SPORE EXTRACTS OR BLENDS THEREOF FOR USE AS FOOD ADDITIVES (U.S. CL. 46).

HEATHER THOMPSON, EXAMINING ATTORNEY

SN 77-519,599. HERBALSCIENCE GROUP, LLC, NAPLES, FL. FILED 7-10-2008.

SLEEP ULTRAPOWER

THE MARK CONSISTS OF STANDARD CHARACTERS WITHOUT CLAIM TO ANY PARTICULAR FONT, STYLE, SIZE, OR COLOR.

NO CLAIM IS MADE TO THE EXCLUSIVE RIGHT TO USE "SLEEP", APART FROM THE MARK AS SHOWN.

CLASS 1—CHEMICALS

FOR BOTANICAL EXTRACTS FOR USE IN THE MANUFACTURE OF NUTRACEUTICALS; EXTRACTS FOR USE IN THE MANUFACTURE OF PHARMACEUTICAL PREPARATIONS IN THE FORM OF PREPARATIONS IN THE FORM OF LOTIONS, CREAMS, AND TOPICAL ANALGESICS AND ANESTHETICS, TABLETS, CAPSULES, PILLS, TINCTURE, SUPPOSITORIES AND AMPULE FOR INJECTION; BOTANICAL EXTRACTS FOR USE IN THE MANUFACTURE OF PHARMACEUTICALS; CHEMICAL EXTRACTS EXTRACTED FROM MEDICINAL PLANTS FOR USE IN THE MANUFACTURE OF NUTRACEUTICALS AND PHARMACEUTICALS; CHEMICAL EXTRACTS, NAMELY, CHEMICAL AGENTS MADE FROM BOTANICAL EXTRACTS OR ASSOCIATION OF CHEMICAL EXTRACTS FOR USE IN THE MANUFACTURE OF PHARMACEUTICAL OR NUTRACEUTICAL PRODUCTS; BOTANICAL EXTRACTS USED IN THE MANUFACTURE OF PREPARATIONS IN THE FORM OF LOTIONS, CREAMS, AND TOPICAL ANALGESICS AND ANESTHETICS, TABLETS, CAPSULES, PILLS, LOZENGES, INHALERS, TINCTURE, SUPPOSITORIES AND AMPULE FOR INJECTION; BOTANICALS AND BOTANICAL BLENDS, HERBS AND HERBAL BLENDS, BOTANICAL EXTRACTS AND BOTANICAL EXTRACT BLENDS, FLAVOR EXTRACTS AND FLAVOR EXTRACT BLENDS, ALGAL EXTRACTS AND ALGAL EXTRACT BLENDS, ALL FOR USE IN THE MANUFACTURE OF NUTRITIONAL SUPPLEMENTS AND VITAMINS; HERBAL EXTRACTS AND BLENDS FOR USE IN MANUFACTURING FUNCTIONAL FOODS OR BEVERAGES; HERBAL EXTRACTS AND BLENDS FOR USE IN MANUFACTURING MEDICINAL FOODS OR BEVERAGES; BOTANICAL EXTRACTS AND BLENDS FOR USE IN MANUFACTURING FUNCTIONAL FOODS OR BEVERAGES; BOTANICAL EXTRACTS AND BLENDS FOR USE IN MANUFACTURING MEDICINAL FOODS OR BEVERAGES; HERBAL PREPARATIONS AND EXTRACTS FOR USE AS INGREDIENTS IN MANUFACTURING IN THE FOOD, NUTRITION, NUTRACEUTICAL AND/OR PHARMACEUTICAL INDUSTRIES (U.S. CLS. 1, 5, 6, 10, 26 AND 46).

CLASS 3—COSMETICS AND CLEANING PREPARATIONS

FOR HERBAL PRODUCTS, NAMELY, AROMATHERAPY PACKS FILLED WITH HERBS FOR USE IN AROMATHERAPY; PRE-MOISTENED NON-MEDICATED PERSONAL HYGIENE WIPES, NAMELY, HERPES RELIEF WIPES; HERBAL AND BOTANICAL EXTRACTS FOR COSMETIC USE; ALGAL EXTRACTS OR ALGAL EXTRACT BLENDS FOR COSMETIC USE; ESSENTIAL OILS; FRAGRANCES; FRAGRANCES FOR PERSONAL USE; FOOD FLAVORINGS PREPARED FROM ESSENTIAL OILS (U.S. CLS. 1, 4, 6, 50, 51 AND 52).

CLASS 5—PHARMACEUTICALS

FOR NUTRITIONAL SUPPLEMENTS; HERBAL PRODUCTS, NAMELY, MEDICATED SKIN AND LIP BALMS; HERBAL PRODUCTS, NAMELY, OINTMENTS, OILS, DRINKS, INFUSIONS, SYRUPS, HERBAL EXTRACTS, POISONS, AND TINCTURES FOR MEDICAL USE IN THE TREATMENT OF STROKES, INFARCTS AND OTHER CARDIOVASCULAR AND CEREBRUM DISEASES; HERBAL PRODUCTS, NAMELY, OINTMENTS, OILS, NAMELY, MINERAL OIL FOR USE AS A LAXATIVE; DRINKS, NAMELY, MEAL REPLACEMENT DRINKS, DIETARY SUPPLEMENT DRINKS, MEDICINAL DRINKS, AND FISH OIL FOR USE AS A DIETARY SUPPLEMENT OR IN A NUTRACEUTICAL; INFUSIONS AND SYRUPS, NAMELY, COUGH SYRUPS; HERBAL PRODUCTS FOR MEDICINAL PURPOSES, NAMELY, HERBAL EXTRACTS FOR USE AS NUTRITIONAL AND DIETARY SUPPLEMENTS; HERBAL PRODUCTS FOR MEDICINAL PURPOSES, NAMELY, HERBAL EXTRACTS AND SYRUPS; MEDICINAL HERB EXTRACTS; MEDICINAL HERB EXTRACTS FOR MEDICAL PURPOSES; PLANT EXTRACTS FOR MEDICAL, PHARMACEUTICAL, NUTRACEUTICAL AND NUTRITIONAL PURPOSES; MEDICINAL EXTRACTS USED IN PREPARATIONS IN THE FORM OF LOTIONS, CREAMS, AND TOPICAL ANALGESICS AND ANESTHETICS,

TABLETS, CAPSULES, PILLS, LOZENGES, INHALERS, TINCTURE, SUPPOSITORIES AND AMPULE FOR INJECTION; MEDICINAL EXTRACTS IN THE FORM OF LOTIONS, CREAMS, AND TOPICAL ANALGESICS AND ANESTHETICS, TABLETS, CAPSULES, PILLS, TINCTURE, SUPPOSITORIES AND AMPULE FOR INJECTION; MEDICINAL HERBAL EXTRACTS IN THE FORM OF LOTIONS, CREAMS, AND TOPICAL ANALGESICS AND ANESTHETICS, TABLETS, CAPSULES, PILLS, TINCTURE, SUPPOSITORIES AND AMPULE FOR INJECTION; MEDICINAL BOTANICAL EXTRACTS IN THE FORM OF LOTIONS, CREAMS, AND TOPICAL ANALGESICS AND ANESTHETICS, TABLETS, CAPSULES, PILLS, TINCTURE, SUPPOSITORIES AND AMPULE FOR INJECTION USED TO TREAT SKIN AILMENTS, FOR INFECTION, DEGENERATIVE, MUSCULAR, PULMONARY, SKELETAL, ENDOCRINE, IMMUNE, NEUROLOGICAL, CARDIOVASCULAR, METABOLIC, INFLAMMATORY, CANCER AND RELATED CONDITIONS; YEAST EXTRACTS FOR MEDICAL, PHARMACEUTICAL OR NUTRACEUTICAL PURPOSES; HERBAL PRODUCTS, NAMELY, HERBAL POWDERS FOR NUTRITIONAL PURPOSES; HERBAL PRODUCTS, NAMELY, HERBAL MEAL REPLACEMENT POWDERS FOR DIETARY AND NUTRITIONAL PURPOSES; HERBAL PRODUCTS, NAMELY, AROMATHERAPY PACKS CONTAINING HERBS USED FOR RELIEF FROM HEADACHES, INSOMNIA AND SINUS DISCOMFORT; HERBAL PRODUCTS, NAMELY, HERBAL POWDERS SOLD AS AN INTEGRAL INGREDIENT OF NUTRITIONAL SUPPLEMENT DRINK MIX FOR NUTRITIONAL PURPOSES; PHARMACEUTICALS AND NUTRACEUTICALS, NAMELY, VITAMINS AND FOOD SUPPLEMENTS; PHARMACEUTICAL PREPARATIONS, NAMELY, APPETITE SUPPRESSANTS AND LIPID LOWERING AGENTS; FOOD FOR DIABETICS, INFANTS AND ENTERAL FEEDING; BOTANICAL EXTRACTS FOR NUTRITIONAL USE; BOTANICAL EXTRACTS FOR MEDICAL, VETERINARY, NUTRACEUTICAL AND PHARMACEUTICAL PURPOSES; DESIGNER EXTRACTS, NAMELY, HERBAL EXTRACTS FOR MEDICAL, VETERINARY AND PHARMACEUTICAL PURPOSES; BOTANICAL EXTRACTS FOR NUTRITIONAL SUPPLEMENTS, NUTRACEUTICALS AND PHARMACEUTICALS; NUTRITIONAL DIETARY SUPPLEMENTS; ORAL PREPARATIONS CONTAINING HERBS OR HERBAL EXTRACTS USED TO MAINTAIN HEALTH AND FOR A WIDE VARIETY OF PHYSICAL CONDITIONS; VITAMIN AND MINERAL PREPARATIONS INTENDED FOR USE AS DIETARY SUPPLEMENTS; VITAMINS; FOOD SUPPLEMENTS; NUTRACEUTICALS, NAMELY, VITAMINS AND FOOD SUPPLEMENTS; FOOD FOR MEDICALLY RESTRICTED DIETS; SUPPLEMENTS, NAMELY, LIPID CONCENTRATES FOR USE AS A DIETARY FOOD SUPPLEMENT OR FOR PHARMACEUTICAL OR MEDICINAL PURPOSES; FOOD SUPPLEMENTS, NAMELY, ANTI-OXIDANTS; BOTANICALS AND BOTANICAL BLENDS, HERBALS AND HERBAL BLENDS, BOTANICAL EXTRACTS AND BOTANICAL EXTRACT BLENDS, FLAVOR EXTRACTS AND FLAVOR EXTRACT BLENDS, ALL SOLD AS COMPONENTS OF NUTRITIONAL SUPPLEMENTS AND VITAMINS; NUTRITIONAL OILS NOT FOR COSMETIC PURPOSES; FOOD SUPPLEMENTS, NAMELY, LIPID CONCENTRATES FOR USE AS A DIETARY FOOD SUPPLEMENT OR FOR PHARMACEUTICAL OR MEDICINAL PURPOSES; ANTI-COUGH DROPS; COUGH DROPS; COUGH EXPECTORANTS; THROAT LOZENGES; COUGH LOZENGES; COUGH SYRUPS; COUGH TREATMENT PREPARATIONS; COLD SORE TREATMENT PREPARATIONS; PHARMACEUTICAL ANTITUSSIVE-COLD PREPARATIONS; PREPARATIONS FOR TREATING COLDS; ANALGESIC PREPARATIONS; ANALGESICS; ANTIPIRETTIC ANALGESICS; IBUPROFEN FOR USE AS AN ORAL ANALGESIC; MULTIPURPOSE MEDICATED ANTIBIOTIC CREAM, ANALGESIC BALM AND MENTHOLATED SALVE; ORAL ANALGESICS; TOPICAL ANALGESICS; PHARMACEUTICAL PREPARATIONS FOR THE TREATMENT AND PREVENTION OF HERPES; VACCINES FOR THE TREATMENT AND PREVENTION OF HERPES; BIOLOGICAL PREPARATIONS FOR THE TREATMENT AND PREVENTION OF HERPES; PHARMACEUTICAL PREPARATIONS FOR THE TREATMENT OF HERPES SIMPLEX INFECTION; PHARMACEUTICAL CAPSULES FOR THE TREATMENT OF HERPES SIMPLEX INFECTION; HOMEOPATHIC PREPARATIONS FOR THE TREATMENT OF HERPES AND COLD SORES; PHARMACEUTICAL PREPARATIONS FOR THE

TREATMENT OF HERPES VIRUSES; MEDICATED TOPICAL CLEAR FLUORIDE GEL FOR THE TREATMENT OF HERPES VIRUS DURING THE PHYSICAL MANIFESTATION OF THE VIRUS; PHARMACEUTICAL PREPARATIONS FOR THE TREATMENT OF HERPES SIMPLEX VIRUS TYPE I OR TYPE II OR HERPES ZOSTER VIRUS, NOT IN INTRAVENOUS FORM; PLANT-BASED ANTIVIRALS; OVER-THE-COUNTER TOPICAL ANTIVIRALS; PHARMACEUTICAL PREPARATION WITH ANTIVIRAL AND/OR ANTIMICROBIAL PROPERTIES FOR USE IN THE TREATMENT OF HERPETIC KERATITIS, CONJUNCTIVITIS, HIV RETINOPATHY, VIRAL INFLUENZA "FLU", HERPES SIMPLEX VIRUS 1, HERPES SIMPLEX VIRUS 2, VARICELLA ZOSTER VIRUS "HERPES ZOSTER" OR "SHINGLES", CYTOMEGALOVIRUS, VIRAL PARAINFLUENZA, ADENOVIRUS, VIRAL ENCEPHALITIS, VIRAL MENINGITIS, ARBOVIRUS, ARENAVIRUS, PICORNAVIRUS, CORONAVIRUS, SYNTIALVIRUS, VIRAL INFECTIONS, COMMON COLDS CAUSED BY VIRUSES, COLD SORES, HUMAN IMMUNODEFICIENCY VIRUS "HIV", ROSEOLA INFANTUM, HUMAN HERPES IV; PHARMACEUTICAL PREPARATIONS FOR THE TREATMENT OF VIRAL DISEASES AND DISORDERS, NAMELY, HERPES; PHARMACEUTICAL PREPARATIONS FOR TREATING IMMUNE DISEASES INDUCED BY VIRUS, NAMELY, HERPES, HERPES ZOSTER AND AIDS; ALGAL PRODUCTS FOR MEDICINAL PURPOSES, NAMELY, ALGAL EXTRACTS OR ALGAL EXTRACT BLENDS FOR USE AS NUTRITIONAL AND DIETARY SUPPLEMENTS; ALGAL PRODUCTS, NAMELY, ALGAL POWDERS SOLD AS AN INTEGRAL INGREDIENT OF NUTRITIONAL SUPPLEMENT DRINK MIX FOR NUTRITIONAL PURPOSES; ALGAL PRODUCTS, NAMELY, ALGAL POWDERS FOR NUTRITIONAL PURPOSES; ALGAL EXTRACTS OR ALGAL EXTRACT BLENDS FOR MEDICAL OR PHARMACEUTICAL PURPOSES; FUNCTIONAL FOODS, NAMELY, DIETETIC FOODS ADAPTED FOR MEDICAL PURPOSES; FUNCTIONAL BEVERAGES, NAMELY, NUTRITIONALLY FORTIFIED BEVERAGES; MEDICINAL FOODS, NAMELY, PROCESSED FOOD FOR MEDICAL PURPOSES; ANIMAL HEALTH PRODUCTS, NAMELY, ANIMAL FEED SUPPLEMENTS, MEDICATED ANIMAL FEED, MICRO-NUTRIENT ANIMAL FEED, DIETARY SUPPLEMENTS FOR ANIMALS, NON-MEDICATED ADDITIVES FOR ANIMAL FEED FOR USE AS NUTRITIONAL SUPPLEMENTS, NUTRITIONAL DRINKS FOR ANIMALS, PHARMACEUTICAL PREPARATIONS FOR ANIMAL SKINCARE; PLANT EXTRACTS FOR MEDICAL, VETERINARY AND PHARMACEUTICAL PURPOSES; HERBAL EXTRACTS FOR MEDICAL, VETERINARY AND PHARMACEUTICAL PURPOSES; DESIGNER EXTRACTS, NAMELY, PLANT, HERBAL AND BOTANICAL EXTRACTS FOR MEDICAL, VETERINARY AND PHARMACEUTICAL PURPOSES; AND BIODEFENSE PRODUCTS, NAMELY, MEDICINAL PREPARATIONS FOR THE TREATMENT OF INFECTIOUS DISEASES AND ADVERSE HUMAN HEALTH CONDITIONS, NAMELY, INFECTION, DEGENERATIVE, MUSCULAR, PULMONARY, SKELETAL, ENDOCRINE, IMMUNE, NEUROLOGICAL, CARDIOVASCULAR, METABOLIC, INFLAMMATORY, CANCER AND RELATED CONDITIONS; MUSHROOM, FUNGUS, OR SPORE EXTRACTS OR BLENDS AS SUPPLEMENTS, NUTRITION, NUTRACEUTICALS AND/OR PHARMACEUTICALS; BOTANICAL EXTRACTS FOR NUTRITIONAL USE; NUTRITIONALLY FORTIFIED BEVERAGES; NUTRITIONALLY FORTIFIED BEVERAGES FOR IMMUNE ENHANCEMENT, AND NUTRITIONALLY FORTIFIED BEVERAGES WITH RICE BRAN AND WHEAT BRAN; MEDICINAL BEVERAGES; SOY PROTEIN FOR USE AS A NUTRITIONAL SUPPLEMENT; NUTRITIONAL ADDITIVES FOR MEDICAL OR NONMEDICAL PURPOSES FOR USE IN MANUFACTURING FOODS AND DIETARY SUPPLEMENTS FOR HUMAN CONSUMPTION; ACTIVE PRINCIPLES EXTRACTED FROM MEDICINAL PLANTS FOR USE IN THE MANUFACTURE OF NUTRACEUTICALS AND PHARMACEUTICALS; ACTIVE PRINCIPLES EXTRACTED FROM MEDICINAL PLANTS FOR USE IN THE MANUFACTURE OF PHARMACEUTICAL OR NUTRACEUTICAL PRODUCTS (U.S. CLS. 6, 18, 44, 46, 51 AND 52).

CLASS 29—MEATS AND PROCESSED FOODS

FOR BEVERAGES, NAMELY, YOGURT-BASED BEVERAGES; FOOD BEVERAGES, NAMELY, DAIRY-BASED FOOD BEVERAGES, FRUIT-BASED FOOD BEVERAGES, VEGETABLE-BASED FOOD BEVERAGES, DAIRY-BASED CHOCOLATE FOOD BEVERAGES, SOY-BASED FOOD BEVERAGE USED AS A MILK SUBSTITUTE, VEGETABLE-BASED CHOCOLATE FOOD BEVERAGES AND PEANUT-BASED FOOD BEVERAGES; MILK BEVERAGES; MILK BEVERAGES, NAMELY, MILK, MILK BEVERAGES CONTAINING FRUITS, MILK BEVERAGES WITH HIGH MILK CONTENT, MILK BASED BEVERAGES CONTAINING FRUIT JUICE AND MILK BEVERAGES CONTAINING COFFEE; MILK POWDER; MILK POWDER FOR NUTRITIONAL PURPOSES; POWDERED MILK FOR FOOD PURPOSES; FUNCTIONAL FOODS, NAMELY, DAIRY-BASED FOOD BEVERAGES, FRUIT-BASED FOOD BEVERAGES, VEGETABLE-BASED FOOD BEVERAGES, DAIRY-BASED CHOCOLATE FOOD BEVERAGES, SOY-BASED FOOD BEVERAGE USED AS A MILK SUBSTITUTE, VEGETABLE-BASED CHOCOLATE FOOD BEVERAGES, NUT-BASED FOOD BEVERAGES, MILK, MILK BEVERAGES CONTAINING FRUITS, MILK BEVERAGES WITH HIGH MILK CONTENT, MILK BASED BEVERAGES CONTAINING FRUIT JUICE, AND MILK BEVERAGES CONTAINING COFFEE; EDIBLE OILS, NAMELY, OMEGA OIL EXTRACTS AND FISH OIL EXTRACTS; SOY PROTEIN FOR USE AS A FOOD ADDITIVE; MUSHROOM, FUNGUS, OR SPORE EXTRACTS OR BLENDS THEREOF FOR USE AS FOOD ADDITIVES (U.S. CL. 46).
HEATHER THOMPSON, EXAMINING ATTORNEY

SN 77-519,605, HERBALSCIENCE GROUP, LLC, NAPLES, FL. FILED 7-10-2008.

SLEEPHEALTH

THE MARK CONSISTS OF STANDARD CHARACTERS WITHOUT CLAIM TO ANY PARTICULAR FONT, STYLE, SIZE, OR COLOR.

CLASS 1—CHEMICALS

FOR BOTANICAL EXTRACTS FOR USE IN THE MANUFACTURE OF NUTRACEUTICALS; PLANT EXTRACTS FOR USE IN THE MANUFACTURE OF PHARMACEUTICAL PREPARATIONS IN THE FORM OF PREPARATIONS IN THE FORM OF LOTIONS, CREAMS, AND TOPICAL ANALGESICS AND ANESTHETICS, TABLETS, CAPSULES, PILLS, TINCTURE, SUPPOSITORIES AND AMPULE FOR INJECTION; BOTANICAL EXTRACTS FOR USE IN THE MANUFACTURE OF NUTRACEUTICALS AND PHARMACEUTICALS; CHEMICAL EXTRACTS AND ACTIVE PRINCIPLES EXTRACTED FROM MEDICINAL PLANTS FOR USE IN THE PHARMACEUTICAL INDUSTRY, NAMELY, CHEMICAL AGENTS MADE FROM BOTANICAL EXTRACTS OR ASSOCIATION OF CHEMICAL EXTRACTS FOR USE IN THE MANUFACTURE OF PHARMACEUTICAL OR NUTRACEUTICAL PRODUCTS; BOTANICAL EXTRACTS FOR USE IN THE MANUFACTURE OF PHARMACEUTICAL AND NUTRACEUTICAL PREPARATIONS, NAMELY, LOTIONS, CREAMS, AND TOPICAL ANALGESICS AND ANESTHETICS, TABLETS, CAPSULES, PILLS, LOZENGES, INHALERS, TINCTURE, SUPPOSITORIES AND AMPULE FOR INJECTION; BOTANICALS AND BOTANICAL BLENDS, HERBALS AND HERBAL BLENDS, BOTANICAL EXTRACTS AND BOTANICAL EXTRACT BLENDS, FLAVOR EXTRACTS AND FLAVOR EXTRACT BLENDS, ALGAL EXTRACTS AND ALGAL EXTRACT BLENDS, ALL FOR USE IN THE MANUFACTURE OF NUTRITIONAL SUPPLEMENTS AND VITAMIN; AND BOTANICAL EXTRACTS FOR USE IN MAKING COSMETICS (U.S. CLS. 1, 5, 6, 10, 26 AND 46).

CLASS 5—PHARMACEUTICALS

FOR BOTANICAL EXTRACTS FOR USE AS NUTRITIONAL SUPPLEMENTS; MEDICINAL HERBAL EXTRACTS AND BLENDS FOR USE IN FUNCTIONAL FOODS OR BEVERAGES; BOTANICAL EXTRACTS AND BLENDS FOR USE IN FUNCTIONAL FOODS OR BEVERAGES; BOTANICAL EXTRACTS AND BLENDS FOR USE IN MEDICINAL FOODS OR BEVERAGES; HERBAL PRODUCTS, NAMELY, AROMATHERAPY PACKS FILLED WITH HERBS; NUTRITIONAL SUPPLEMENTS; HERBAL PRODUCTS, NAMELY, MEDICATED SKIN AND LIP BALMS; HERBAL PRODUCTS, NAMELY, OINTMENTS, OILS, DRINKS, INFUSIONS, SYRUPS, HERBAL EXTRACTS, POISONS, TINCTURES FOR MEDICAL USE IN THE TREATMENT OF STROKES, INFARCTS AND OTHER CARDIOVASCULAR AND CEREBRUM DISEASES; HERBAL PRODUCTS, NAMELY, OINTMENTS, OILS, NAMELY, MINERAL OIL FOR USE AS A LAXATIVE, DRINKS, NAMELY, MEAL REPLACEMENT DRINKS, DIETARY SUPPLEMENT DRINKS, MEDICINAL DRINKS, AND FISH OIL FOR USE AS A DIETARY SUPPLEMENT OR IN A NUTRACEUTICAL, INFUSIONS, SYRUPS, NAMELY, COUGH SYRUPS; HERBAL PRODUCTS FOR MEDICINAL PURPOSES, NAMELY, HERBAL EXTRACTS FOR USE AS NUTRITIONAL AND DIETARY SUPPLEMENTS; HERBAL PRODUCTS FOR MEDICINAL PURPOSES, NAMELY, HERBAL EXTRACTS AND SYRUPS; MEDICINAL HERB EXTRACTS; MEDICINAL HERB EXTRACTS FOR MEDICAL PURPOSES; PLANT EXTRACTS FOR MEDICAL OR PHARMACEUTICAL PURPOSES; PLANT EXTRACTS FOR MEDICAL AND NUTRITIONAL PURPOSES; PLANT EXTRACTS FOR MEDICAL AND PHARMACEUTICAL PURPOSES; PLANT EXTRACTS FOR USE AS A NUTRACEUTICAL; TOPICAL ANALGESICS AND ANESTHETICS; MEDICINAL EXTRACTS USED IN PHARMACEUTICAL AND NUTRACEUTICAL PREPARATIONS IN THE FORM OF LOTIONS, CREAMS, AND TOPICAL ANALGESICS AND ANESTHETICS, TABLETS, CAPSULES, PILLS, LOZENGES, INHALERS, TINCTURE, SUPPOSITORIES AND AMPULE FOR INJECTION, FOR THE TREATMENT OF INFECTION, DEGENERATIVE, MUSCULAR, PULMONARY, SKELETAL, ENDOCRINE, IMMUNE, NEUROLOGICAL, CARDIOVASCULAR, METABOLIC, INFLAMMATORY, CANCER AND RELATED CONDITIONS; MEDICINAL HERBAL EXTRACTS USED AS COMPONENT INGREDIENTS OF PHARMACEUTICAL PREPARATIONS IN THE FORM OF LOTIONS, CREAMS, AND TOPICAL ANALGESICS AND ANESTHETICS, TABLETS, CAPSULES, PILLS, TINCTURE, SUPPOSITORIES AND AMPULE FOR INJECTION USED TO TREAT SKIN AILMENTS, FOR INFECTION, DEGENERATIVE, MUSCULAR, PULMONARY, SKELETAL, ENDOCRINE, IMMUNE, NEUROLOGICAL, CARDIOVASCULAR, METABOLIC, INFLAMMATORY, CANCER AND RELATED CONDITIONS; YEAST EXTRACTS FOR MEDICAL OR PHARMACEUTICAL PURPOSES; YEAST EXTRACTS FOR MEDICAL OR NUTRACEUTICAL PURPOSES; HERBAL EXTRACTS FOR COSMETIC USE; HERBAL PRODUCTS, NAMELY, HERBAL POWDERS FOR NUTRITIONAL PURPOSES; HERBAL PRODUCTS, NAMELY, HERBAL MEAL REPLACEMENT POWDERS FOR DIETARY AND NUTRITIONAL PURPOSES; HERBAL PRODUCTS, NAMELY, AROMA THERAPY PACKS FILLED WITH HERBS FOR USE IN AROMA THERAPY; HERBAL PRODUCTS, NAMELY, AROMATHERAPY PACKS CONTAINING HERBS USED FOR RELIEF FROM HEADACHES, INSOMNIA AND SINUS DISCOMFORT; HERBAL PRODUCTS, NAMELY, HERBAL POWDERS SOLD AS AN INTEGRAL INGREDIENT OF NUTRITIONAL SUPPLEMENT DRINK MIX FOR NUTRITIONAL PURPOSES; PHARMACEUTICALS AND NUTRACEUTICALS, NAMELY, VITAMINS AND FOOD SUPPLEMENTS; PHARMACEUTICAL PREPARATIONS, NAMELY, APPETITE SUPPRESSANTS AND LIPID LOWERING AGENTS; FOOD FOR DIABETICS, INFANTS AND ENTERAL FEEDING; BOTANICAL EXTRACTS FOR NUTRITIONAL USE; BOTANICAL EXTRACTS FOR USE IN NUTRACEUTICALS; BOTANICAL EXTRACTS FOR NUTRITIONAL USE; BOTANICAL EXTRACTS USED AS INGREDIENTS IN

PHARMACEUTICAL PREPARATIONS IN THE FORM OF LOTIONS, CREAMS, AND TOPICAL ANALGESICS AND ANESTHETICS, TABLETS, CAPSULES, PILLS, TINCTURE, SUPPOSITORIES AND AMPULE FOR INJECTION; AND BOTANICAL EXTRACTS FOR USE IN NUTRACEUTICALS AND PHARMACEUTICALS; BOTANICAL EXTRACTS FOR MEDICAL, VETERINARY, NUTRACEUTICAL AND PHARMACEUTICAL PURPOSES; DESIGNER EXTRACTS, NAMELY, HERBAL EXTRACTS FOR MEDICAL, VETERINARY AND PHARMACEUTICAL PURPOSES; BOTANICAL EXTRACTS SOLD AS AN INTEGRAL INGREDIENT OF NUTRITIONAL SUPPLEMENTS, NUTRACEUTICALS AND PHARMACEUTICALS; BOTANICAL EXTRACTS SOLD AS AN INTEGRAL INGREDIENT OF NUTRITIONAL SUPPLEMENTS AND NUTRACEUTICALS; HERBAL PREPARATIONS AND EXTRACTS FOR USE AS INGREDIENTS IN NUTRACEUTICALS, PHARMACEUTICALS AND FUNCTIONAL FOODS.; NUTRITIONAL DIETARY SUPPLEMENTS; ORAL PREPARATIONS, NAMELY, NUTRITIONAL SUPPLEMENTS USED TO MAINTAIN HEALTH AND FOR A WIDE VARIETY OF PHYSICAL CONDITIONS; VITAMIN AND MINERAL PREPARATIONS INTENDED FOR USE AS DIETARY SUPPLEMENTS; VITAMINS; FOOD SUPPLEMENTS; NUTRACEUTICALS, NAMELY, VITAMINS AND FOOD SUPPLEMENTS; FOOD FOR MEDICALLY RESTRICTED DIETS; FOOD SUPPLEMENTS, NAMELY, LIPID CONCENTRATES FOR USE AS A DIETARY FOOD SUPPLEMENT OR FOR PHARMACEUTICAL OR MEDICINAL PURPOSES; ANTI-COUGH DROPS; COUGH DROPS; COUGH EXPECTORANTS; THROAT LOZENGES; COUGH LOZENGES; COUGH SYRUPS; COUGH TREATMENT PREPARATIONS; COLD SORE TREATMENT PREPARATIONS; PHARMACEUTICAL ANTITUSSIVE-COLD PREPARATIONS; PREPARATIONS FOR TREATING COLDS; ANALGESIC PREPARATIONS; ANALGESICS; ANTI-PYRETIC ANALGESICS; IBUPROFEN FOR USE AS AN ORAL ANALGESIC; MULTIPURPOSE MEDICATED ANTIBIOTIC CREAM, ANALGESIC BALM AND MENTHOLATED SALVE FOR MEDICAL USE; ORAL ANALGESICS; TOPICAL ANALGESICS; PHARMACEUTICAL PREPARATIONS FOR THE TREATMENT AND PREVENTION OF HERPES; VACCINES FOR THE TREATMENT AND PREVENTION HERPES; BIOLOGICAL PREPARATIONS FOR THE TREATMENT AND PREVENTION OF HERPES; PHARMACEUTICAL PREPARATIONS FOR THE TREATMENT OF HERPES SIMPLEX INFECTION; PHARMACEUTICAL CAPSULES FOR THE TREATMENT OF HERPES SIMPLEX INFECTION; HOMEOPATHIC PREPARATIONS FOR THE TREATMENT OF HERPES AND COLD SORES; PHARMACEUTICAL PREPARATIONS FOR THE TREATMENT OF HERPES VIRUSES; MEDICATED TOPICAL CLEAR FLUORIDE GEL FOR THE TREATMENT OF HERPES VIRUS DURING THE PHYSICAL MANIFESTATION OF THE VIRUS; PHARMACEUTICAL PREPARATIONS FOR THE TREATMENT OF HERPES SIMPLEX VIRUS TYPE I OR TYPE II OR HERPES ZOSTER VIRUS, NOT IN INTRAVENOUS FORM; PLANT BASED ANTIVIRALS; OVER-THE-COUNTER TOPICAL ANTIVIRALS; PHARMACEUTICAL PREPARATION WITH ANTIVIRAL AND/OR ANTIMICROBIAL PROPERTIES FOR USE IN THE TREATMENT OF HERPETIC KERATITIS, CONJUNCTIVITIS, HIV RETINOPATHY, VIRAL INFLUENZA "FLU", HERPES SIMPLEX VIRUS 1, HERPES SIMPLEX VIRUS 2, VARICELLA ZOSTER VIRUS "HERPES ZOSTER" "SHINGLES", CYTOMEGALOVIRUS, VIRAL PARAINFLUENZA, ADENOVIRUS, VIRAL ENCEPHALITIS, VIRAL MENINGITIS, ARBOVIRUS, ARENAVIRUS, PICORNAVIRUS, CORONAVIRUS, SYNTIAL VIRUS, VIRAL INFECTIONS, COMMON COLDS CAUSED BY VIRUSES, COLD SORES, HUMAN IMMUNODEFICIENCY VIRUS "HIV", ROSEOLA INFANTUM, HUMAN HERPES IV; PHARMACEUTICAL PREPARATIONS FOR THE TREATMENT OF VIRAL DISEASES AND DISORDERS, NAMELY, HERPES; PHARMACEUTICAL PREPARATIONS FOR TREATING IMMUNE DISEASES

INDUCED BY VIRUS, NAMELY, HERPES, HERPES ZOSTER AND AIDS; ALGAL PRODUCTS FOR MEDICINAL PURPOSES, NAMELY, ALGAL EXTRACTS OR ALGAL EXTRACT BLENDS FOR USE AS NUTRITIONAL AND DIETARY SUPPLEMENTS; ALGAL PRODUCTS, NAMELY, ALGAL POWDERS SOLD AS AN INTEGRAL INGREDIENT OF NUTRITIONAL SUPPLEMENT DRINK MIX FOR NUTRITIONAL PURPOSES; ALGAL PRODUCTS, NAMELY, ALGAL POWDERS FOR USE AS A NUTRITIONAL SUPPLEMENT; ALGAL EXTRACTS OR ALGAL EXTRACT BLENDS FOR MEDICAL OR PHARMACEUTICAL PURPOSES; BOTANICAL EXTRACTS FOR USE IN FUNCTIONAL FOODS; FUNCTIONAL FOODS, NAMELY, DIETETIC FOODS ADAPTED FOR MEDICAL PURPOSES, FOOD FOR DIABETICS, INFANTS AND ENTERAL FEEDING, FOOD FOR MEDICALLY RESTRICTED DIETS; FUNCTIONAL BEVERAGES, NAMELY, NUTRITIONALLY FORTIFIED BEVERAGES; MEDICINAL FOODS, NAMELY, PROCESSED FOOD FOR MEDICAL PURPOSES; ANIMAL HEALTH PRODUCTS, NAMELY, ANIMAL FEED SUPPLEMENTS, MEDICATED ANIMAL FEED, MICRO-NUTRIENT ANIMAL FEED, DIETARY SUPPLEMENTS FOR ANIMALS, NON-MEDICATED ADDITIVES FOR ANIMAL FEED FOR USE AS NUTRITIONAL SUPPLEMENTS, NUTRITIONAL DRINKS FOR ANIMALS, PHARMACEUTICAL PREPARATIONS FOR ANIMAL SKIN CARE; PLANT EXTRACTS FOR MEDICAL, VETERINARY AND PHARMACEUTICAL PURPOSES; BOTANICAL EXTRACTS FOR MEDICAL, VETERINARY AND PHARMACEUTICAL PURPOSES; HERBAL EXTRACTS FOR MEDICAL, VETERINARY AND PHARMACEUTICAL PURPOSES; DESIGNER EXTRACTS, NAMELY, PLANT, HERBAL AND BOTANICAL EXTRACTS FOR MEDICAL, VETERINARY AND PHARMACEUTICAL PURPOSES; AND BIODEFENSE PRODUCTS, NAMELY, MEDICINAL PREPARATIONS FOR THE TREATMENT OF, OR RELIEF OF SYMPTOMS IN, INFECTIOUS DISEASES AND ADVERSE HUMAN HEALTH CONDITIONS, NAMELY, INFECTION, DEGENERATIVE, MUSCULAR, PULMONARY, SKELETAL, ENDOCRINE, IMMUNE, NEUROLOGICAL, CARDIOVASCULAR, METABOLIC, INFLAMMATORY, CANCER AND RELATED CONDITIONS; MUSHROOM, FUNGUS, OR SPORE EXTRACTS OR BLENDS FOR USE AS INGREDIENTS IN FUNCTIONAL FOODS, NUTRACEUTICAL OR PHARMACEUTICAL PREPARATIONS; CHEMICAL EXTRACTS AND ACTIVE PRINCIPLES EXTRACTED FROM MEDICINAL PLANTS FOR USE IN THE PHARMACEUTICAL INDUSTRY, NAMELY, CHEMICAL AGENTS MADE FROM BOTANICAL EXTRACTS OR ASSOCIATION OF CHEMICAL EXTRACTS FOR USE IN THE MANUFACTURE OF PHARMACEUTICAL OR NUTRACEUTICAL PRODUCTS; NUTRITIONAL ADDITIVES FOR MEDICAL OR NONMEDICAL PURPOSES FOR USE IN FOODS AND DIETARY SUPPLEMENTS FOR HUMAN CONSUMPTION (U.S. CLS. 6, 18, 44, 46, 51 AND 52).

DORITT L. CARROLL, EXAMINING ATTORNEY

SN 77-519,762. CEMENTOS LIMA S.A., LIMA 35, PERU, FILED 7-11-2008.

SOL

THE MARK CONSISTS OF STANDARD CHARACTERS WITHOUT CLAIM TO ANY PARTICULAR FONT, STYLE, SIZE, OR COLOR.

OWNER OF PERU REG. NO. 51115, DATED 6-4-2008, EXPIRES 6-4-2018.

OWNER OF PERU REG. NO. 51118, DATED 6-4-2008, EXPIRES 6-4-2018.

OWNER OF PERU REG. NO. 138854, DATED 5-30-2008, EXPIRES 5-30-2018.

THE FOREIGN WORDING IN THE MARK TRANSLATES INTO ENGLISH AS SUN.

CLASS 19—NON-METALLIC BUILDING MATERIALS

FOR CEMENTS IN GENERAL, NAMELY, PORTLAND TYPE CEMENTS AND PUZZOLANIC TYPE CEMENTS (U.S. CLS. 1, 12, 33 AND 50).

CLASS 37—CONSTRUCTION AND REPAIR

FOR BUILDING CONSTRUCTION; RENTAL OF CONSTRUCTION HAND AND POWER TOOLS, MATERIALS AND MACHINES FOR BUILDING CONSTRUCTION, QUARRYING AND MINING EXTRACTION (U.S. CLS. 100, 103 AND 106).

CLASS 39—TRANSPORTATION AND STORAGE

FOR SUPPLY CHAIN, LOGISTICS AND REVERSE LOGISTICS SERVICES, NAMELY, TRANSPORT, PACKAGING FOR TRANSPORTATION AND STORAGE OF CEMENTS IN GENERAL, INCLUDING IN BULK AND/OR IN BAGS; RENTAL OF WAREHOUSES FOR STORAGE OF CEMENTS IN GENERAL, INCLUDING CEMENTS IN BULK AND/OR IN BAGS (U.S. CLS. 100 AND 105).

THOMAS MANOR, EXAMINING ATTORNEY

SN 77-519,766. DAIMLER AG, 70327 STUTTGART, FED REP GERMANY, FILED 7-11-2008.

BLUEHYDRO

THE MARK CONSISTS OF STANDARD CHARACTERS WITHOUT CLAIM TO ANY PARTICULAR FONT, STYLE, SIZE, OR COLOR.

PRIORITY CLAIMED UNDER SEC. 44(D) ON FED REP GERMANY APPLICATION NO. 302008002953, FILED 1-17-2008, REG. NO. 302008002953, DATED 5-15-2008, EXPIRES 1-31-2018.

OWNER OF U.S. REG. NOS. 2,685,201 AND 3,224,057.

CLASS 9—ELECTRICAL AND SCIENTIFIC APPARATUS

FOR FUEL CELLS FOR VEHICLES; ELECTRIC BATTERIES FOR VEHICLES; TACHOGRAPHS FOR VEHICLES; SPEEDOMETERS; TACHOMETERS; RADIOS FOR VEHICLES; SIMULATORS FOR STEERING AND CONTROL OF VEHICLES; VOLTAGE REGULATORS FOR VEHICLES; THERMOSTATS FOR VEHICLES; WARNING TRIANGLES FOR VEHICLES (U.S. CLS. 21, 23, 26, 36 AND 38).

CLASS 12—VEHICLES

FOR AUTOMOBILES, TRUCKS, VANS, SPORT UTILITY VEHICLES AND BUSES AND THEIR STRUCTURAL PARTS; MOTORS FOR LAND VEHICLES (U.S. CLS. 19, 21, 23, 31, 35 AND 44).

CLASS 28—TOYS AND SPORTING GOODS

FOR TOY MODEL VEHICLES (U.S. CLS. 22, 23, 38 AND 50).

BARBARA RUTLAND, EXAMINING ATTORNEY

SN 77-519,790. FLEETPRIDE, INC., THE WOODLANDS, TX. FILED 7-11-2008.



OWNER OF U.S. REG. NO. 3,194,759. NO CLAIM IS MADE TO THE EXCLUSIVE RIGHT TO USE "FLEET CARE" AND "TRUCK SERVICE CENTER", APART FROM THE MARK AS SHOWN. THE COLOR(S) BLUE, WHITE AND RED IS/ARE CLAIMED AS A FEATURE OF THE MARK. THE MARK CONSISTS OF THE WORDING "FLEET-CARE" IN WHITE ON A BLUE QUADRILATERAL WITH A RED HORIZONTAL BAND AT THE BOTTOM, AND THE WORDING "TRUCK SERVICE CENTER" IN BLUE WITH A WHITE BACKGROUND CONSISTING OF A HORIZONTAL WHITE BAND THAT EXTENDS UPWARDS AND APPEARS AS A WHITE RECTANGLE BESIDE THE BLUE AND RED QUADRILATERAL.

CLASS 35—ADVERTISING AND BUSINESS

FOR TRUCK AND TRAILER SERVICES FOR TRUCK AND TRAILER REPAIR BUSINESSES, NAMELY, ADVERTISING SERVICES IN THE NATURE OF PROMOTING THE GOODS AND SERVICES OF TRUCK AND TRAILER REPAIR BUSINESSES BY PROVIDING IN-STORE ADVERTISING MATERIALS, PROVIDING PRESS RELEASES, PROVIDING TRADE JOURNAL ADVERTISEMENTS, PARTICIPATING IN INDUSTRY TRADE SHOWS, PROVIDING MARKETING SERVICES IN THE NATURE OF DIRECT MARKETING ADVERTISING FOR OTHERS, AND PROVIDING REBATE PROGRAMS IN THE NATURE OF PROCESSING MANUFACTURER'S REBATES; TRUCK AND TRAILER SERVICES FOR TRUCK AND TRAILER REPAIR BUSINESSES, NAMELY, PROVIDING BUSINESS INFORMATION RELATING TO TRUCK AND TRAILER REPAIR SERVICE BUSINESSES (U.S. CLS. 100, 101 AND 102). FIRST USE 12-0-2003; IN COMMERCE 12-0-2003.

CLASS 36—INSURANCE AND FINANCIAL

FOR TRUCK AND TRAILER SERVICES FOR TRUCK AND TRAILER REPAIR BUSINESSES, NAMELY, PROVIDING WARRANTIES ON PARTS PURCHASED FROM TRADEMARK OWNER AND INSTALLED AS PART OF TRUCK AND TRAILER REPAIRS (U.S. CLS. 100, 101 AND 102). FIRST USE 12-0-2003; IN COMMERCE 12-0-2003. MELISSA VALLILLO, EXAMINING ATTORNEY

SN 77-521,234. ARAMARK CORPORATION, PHILADELPHIA, PA. FILED 7-14-2008.

I IMPACT

THE MARK CONSISTS OF STANDARD CHARACTERS WITHOUT CLAIM TO ANY PARTICULAR FONT, STYLE, SIZE, OR COLOR.

CLASS 35—ADVERTISING AND BUSINESS

FOR MANAGEMENT OF HOSPITALS AND MEDICAL FACILITIES; EMPLOYMENT STAFFING IN THE FIELD OF MEDICAL AND HOSPITAL ORDERLIES (U.S. CLS. 100, 101 AND 102).

CLASS 37—CONSTRUCTION AND REPAIR

FOR BUILDING AND FACILITIES MAINTENANCE SERVICES (U.S. CLS. 100, 103 AND 106).

CLASS 41—EDUCATION AND ENTERTAINMENT

FOR EDUCATIONAL SERVICES, NAMELY, TRAINING SERVICES IN THE FIELDS OF FOOD SERVICES, JANITORIAL SERVICES, FACILITIES MAINTENANCE, AND FACILITIES MANAGEMENT SERVICES (U.S. CLS. 100, 101 AND 107).

CLASS 43—HOTEL AND RESTAURANT SERVICES

FOR RESTAURANTS; RESTAURANT SERVICES; CONTRACT FOOD SERVICES (U.S. CLS. 100 AND 101). JOHN GARTNER, EXAMINING ATTORNEY

SN 77-521,250. ARAMARK CORPORATION, PHILADELPHIA, PA. FILED 7-14-2008.

IT'S ALL CONNECTED

THE MARK CONSISTS OF STANDARD CHARACTERS WITHOUT CLAIM TO ANY PARTICULAR FONT, STYLE, SIZE, OR COLOR.

CLASS 35—ADVERTISING AND BUSINESS

FOR MANAGEMENT OF HOSPITALS AND MEDICAL FACILITIES; EMPLOYMENT STAFFING IN THE FIELD OF MEDICAL AND HOSPITAL ORDERLIES (U.S. CLS. 100, 101 AND 102).

CLASS 37—CONSTRUCTION AND REPAIR

FOR BUILDING AND FACILITIES MAINTENANCE SERVICES (U.S. CLS. 100, 103 AND 106).

CLASS 41—EDUCATION AND ENTERTAINMENT

FOR EDUCATIONAL SERVICES, NAMELY, TRAINING SERVICES IN THE FIELDS OF FOOD SERVICES, JANITORIAL SERVICES, FACILITIES MAINTENANCE, AND FACILITIES MANAGEMENT SERVICES (U.S. CLS. 100, 101 AND 107).

CLASS 43—HOTEL AND RESTAURANT SERVICES

FOR RESTAURANTS; RESTAURANT SERVICES; CONTRACT FOOD SERVICES (U.S. CLS. 100 AND 101). JOHN GARTNER, EXAMINING ATTORNEY

SN 77-521,657. COMERCIAL E INDUSTRIAL SOHO S.A., LAS CONDES, SANTIAGO, CHILE, FILED 7-14-2008.

FABRINI

THE MARK CONSISTS OF STANDARD CHARACTERS WITHOUT CLAIM TO ANY PARTICULAR FONT, STYLE, SIZE, OR COLOR.

CLASS 29—MEATS AND PROCESSED FOODS

FOR EDIBLE OILS, NAMELY, OLIVE OIL AND EDIBLE AVOCADO OIL (U.S. CL. 46).

CLASS 30—STAPLE FOODS

FOR SALAD DRESSINGS; BALSAMIC VINEGAR (U.S. CL. 46).
LAURIE MAYES, EXAMINING ATTORNEY

SN 77-521,663. COMERCIAL E INDUSTRIAL SOHO S.A., LAS CONDES, SANTIAGO, CHILE, FILED 7-14-2008.

SOL DE ACULEO

THE MARK CONSISTS OF STANDARD CHARACTERS WITHOUT CLAIM TO ANY PARTICULAR FONT, STYLE, SIZE, OR COLOR.

THE ENGLISH TRANSLATION OF "SOL DE" IN THE MARK IS "SUN OF". THE TERM "ACULEO" HAS NO ENGLISH TRANSLATION.

CLASS 29—MEATS AND PROCESSED FOODS

FOR EDIBLE OILS, NAMELY, OLIVE OIL AND EDIBLE AVOCADO OIL (U.S. CL. 46).

CLASS 30—STAPLE FOODS

FOR SALAD DRESSINGS; BALSAMIC VINEGAR (U.S. CL. 46).
LAURIE MAYES, EXAMINING ATTORNEY

SN 77-521,746. HUNGRY MACHINE, INC., WASHINGTON, DC, FILED 7-14-2008.

LIVINGSOCIAL

THE MARK CONSISTS OF STANDARD CHARACTERS WITHOUT CLAIM TO ANY PARTICULAR FONT, STYLE, SIZE, OR COLOR.

CLASS 38—COMMUNICATION

FOR PROVIDING ONLINE CHAT ROOMS FOR REGISTERED USERS FOR TRANSMISSION OF MESSAGES CONCERNING A VIRTUAL COMMUNITY RELATING TO SOCIAL NETWORKING (U.S. CLS. 100, 101 AND 104).

FIRST USE 2-1-2008; IN COMMERCE 2-1-2008.

CLASS 41—EDUCATION AND ENTERTAINMENT

FOR ELECTRONIC PUBLISHING SERVICES, NAMELY, PUBLISHING OF ONLINE WORKS OF OTHERS FEATURING USER-CREATED TEXT, AUDIO, VIDEO, AND GRAPHICS; PUBLISHING ON-LINE JOURNALS, BLOGS IN A WIDE VARIETY OF FIELDS AND WEB LOGS, ALL FEATURING USER-CREATED CONTENT (U.S. CLS. 100, 101 AND 107).

FIRST USE 2-1-2008; IN COMMERCE 2-1-2008.

CLASS 42—SCIENTIFIC AND COMPUTER SERVICES

FOR PROVIDING TEMPORARY USE OF NON-DOWNLOADABLE SOFTWARE APPLICATIONS FOR SOCIAL NETWORKING, BLOGGING, PHOTO SHARING, VIDEO SHARING, MUSIC SHARING, LITERATURE SHARING, INFORMATION SHARING, AND TRANSMISSION OF SAME; PROVIDING AN ONLINE VIRTUAL COMMUNITY FOR PURPOSES OF SOCIAL NETWORKING; PROVIDING INFORMATION ABOUT ONLINE VIRTUAL COMMUNITIES OFFERED FOR PURPOSES OF SOCIAL NETWORKING (U.S. CLS. 100 AND 101).

FIRST USE 2-1-2008; IN COMMERCE 2-1-2008.

REBECCA EISINGER, EXAMINING ATTORNEY

SN 77-521,925. EMAT CAPITAL MANAGEMENT, LLC, LOS ANGELES, CA, FILED 7-14-2008.

EMAT

THE MARK CONSISTS OF STANDARD CHARACTERS WITHOUT CLAIM TO ANY PARTICULAR FONT, STYLE, SIZE, OR COLOR.

CLASS 35—ADVERTISING AND BUSINESS

FOR BUSINESS MANAGEMENT AND CONSULTATION (U.S. CLS. 100, 101 AND 102).

CLASS 36—INSURANCE AND FINANCIAL

FOR INVESTMENT SERVICES, NAMELY, ASSET ACQUISITION, DEVELOPMENT AND MANAGEMENT SERVICES (U.S. CLS. 100, 101 AND 102).

DAVID H. STINE, EXAMINING ATTORNEY

SN 77-521,929. EMAT CAPITAL MANAGEMENT, LLC, LOS ANGELES, CA. FILED 7-14-2008.



THE COLOR(S) RED, GREEN, BLACK, LIGHT GREEN IS/ ARE CLAIMED AS A FEATURE OF THE MARK.

THE MARK CONSISTS OF THE TERM "EMAT" IN STYLIZED FORM WITH TWO VERTICAL LINES THROUGH THE LETTER "E." THE SHADOWING OF THE "M" IS RED, THE LETTERS ARE OUTLINED IN BLACK, AND THE REST OF THE LETTERS ARE GREEN; THE VERTICAL LINES THROUGH THE "E" ARE LIGHT GREEN.

CLASS 35—ADVERTISING AND BUSINESS

FOR BUSINESS MANAGEMENT AND CONSULTATION (U.S. CLS. 100, 101 AND 102).

CLASS 36—INSURANCE AND FINANCIAL

FOR INVESTMENT SERVICES, NAMELY, ASSET ACQUISITION, DEVELOPMENT AND MANAGEMENT SERVICES (U.S. CLS. 100, 101 AND 102).

DAVID H. STINE, EXAMINING ATTORNEY

SN 77-522,215. NOVA INNOVATIONS, LC, ST. LOUIS, MO. FILED 7-15-2008.



NO CLAIM IS MADE TO THE EXCLUSIVE RIGHT TO USE "LC", APART FROM THE MARK AS SHOWN.

THE MARK CONSISTS OF THE STYLIZED WORDS "NOVA INNOVATIONS, LC," WITH "NOVA" APPEARING 11 TIMES ABOVE "INNOVATIONS, LC" AND PROGRESSIVELY GETTING SMALLER, AND THE TERM "INNOVATIONS" APPEARING 3 TIMES BELOW "INNOVATIONS, LC" AND PROGRESSIVELY MOVING TO THE LEFT SO THAT THE BOTTOM TERM ONLY SHOWS A FRACTION OF THE LETTER "N" FOLLOWED BY "OVATIONS".

CLASS 9—ELECTRICAL AND SCIENTIFIC APPARATUS

FOR DECORATIVE MAGNETS; COMPUTER SCREEN SAVER SOFTWARE AND COMPUTER DESKTOP WALL-PAPER SOFTWARE (U.S. CLS. 21, 23, 26, 36 AND 38).

CLASS 16—PAPER GOODS AND PRINTED MATTER

FOR POSTERS; BUMPER STICKERS; CALENDARS AND DAY PLANNERS; PENCILS, PENS, AND MARKERS (U.S. CLS. 2, 5, 22, 23, 29, 37, 38 AND 50).

CLASS 20—FURNITURE AND ARTICLES NOT OTHERWISE CLASSIFIED

FOR DESK SIGNS AND PLAQUES MADE FROM PLASTIC OR WOOD WITH AND WITHOUT STANDS; DECORATIVE WALL PLAQUES MADE OF PLASTIC OR WOOD (U.S. CLS. 2, 13, 22, 25, 32 AND 50).

CLASS 26—FANCY GOODS

FOR ORNAMENTAL NOVELTY BUTTONS AND PINS (U.S. CLS. 37, 39, 40, 42 AND 50).

ALYSSA STEEL, EXAMINING ATTORNEY

SN 77-522,218. ALLIED GROUP HOLDINGS, LLC, DBA ALLIED NORTH AMERICA, JERICHO, NY. FILED 7-15-2008.

Not Just A Customer Promise - A Customer Commitment

THE MARK CONSISTS OF STANDARD CHARACTERS WITHOUT CLAIM TO ANY PARTICULAR FONT, STYLE, SIZE, OR COLOR.

CLASS 35—ADVERTISING AND BUSINESS

FOR BUSINESS RISK MANAGEMENT SERVICES OFFERED BY INSURANCE PROVIDERS (U.S. CLS. 100, 101 AND 102).

CLASS 36—INSURANCE AND FINANCIAL

FOR INSURANCE SERVICES, NAMELY, BROKERAGE SERVICES, SURETY BONDING, FINANCIAL RISK MANAGEMENT SERVICES; INSURANCE ADMINISTRATION, NAMELY, OF WRAP-UP INSURANCE PROGRAMS, AND CONTROLLED INSURANCE PROGRAMS, NAMELY, OWNER CONTROLLED INSURANCE PROGRAMS AND CONTRACTOR CONTROLLED INSURANCE PROGRAMS (U.S. CLS. 100, 101 AND 102).

HANNO RITTNER, EXAMINING ATTORNEY

SN 77-523,787. KESLASSY, DAVID, SAINT GILES BRUXELLES, BELGIUM, FILED 7-16-2008.

DJ LIFE

THE MARK CONSISTS OF STANDARD CHARACTERS WITHOUT CLAIM TO ANY PARTICULAR FONT, STYLE, SIZE, OR COLOR.

PRIORITY CLAIMED UNDER SEC. 44(D) ON ERPNCMNTY TM OFC APPLICATION NO. 006928691, FILED 5-22-2008, REG. NO. 006928681, DATED 3-12-2009, EXPIRES 3-12-2019.

CLASS 9—ELECTRICAL AND SCIENTIFIC APPARATUS

FOR COMPUTER AND VIDEO GAME SOFTWARE; COMPUTER AND VIDEO GAMES, NAMELY, COMPUTER AND VIDEO GAME CARTRIDGES AND DISCS; COMPUTER SOFTWARE FOR GAMES OF CHANCE FOR DEDICATED GAMING CONSOLES; MULTIMEDIA SOFTWARE RECORDED ON CD-ROM FEATURING GAMES; VIDEO GAME ENHANCERS, NAMELY, COMPUTER VIDEO GAME SOFTWARE FEATURING UPGRADES AND ADD-ONS (U.S. CLS. 21, 23, 26, 36 AND 38).

SN 77-524,455. AMERICAN COLLEGE OF PHYSICIANS, INC., PHILADELPHIA, PA. FILED 7-17-2008.

ACP AMERICAN COLLEGE OF PHYSICIANS INTERNAL MEDICINE DOCTORS FOR ADULTS

CLASS 41—EDUCATION AND ENTERTAINMENT

FOR ON LINE ENTERTAINMENT, NAMELY, PROVIDING ON LINE COMPUTER GAMES; PROVIDING ON LINE COMPUTER GAMES AND GAME SHOWS; PROVIDING INFORMATION ON LINE RELATING TO COMPUTER GAMES AND COMPUTER ENHANCEMENTS FOR GAMES; PROVIDING ON-LINE COMPUTER GAMES BY CELLULAR TELEPHONE COMMUNICATION (U.S. CLS. 100, 101 AND 107).
KAPIL BHANOT, EXAMINING ATTORNEY

THE MARK CONSISTS OF STANDARD CHARACTERS WITHOUT CLAIM TO ANY PARTICULAR FONT, STYLE, SIZE, OR COLOR.

OWNER OF U.S. REG. NOS. 2,407,388, 2,746,285 AND OTHERS.

NO CLAIM IS MADE TO THE EXCLUSIVE RIGHT TO USE "INTERNAL MEDICINE DOCTORS FOR ADULTS", APART FROM THE MARK AS SHOWN.

SEC. 2(F) AS TO "AMERICAN COLLEGE OF PHYSICIANS".

CLASS 35—ADVERTISING AND BUSINESS

FOR ASSOCIATION SERVICES, NAMELY, PROMOTING THE INTERESTS OF DOCTORS OF INTERNAL MEDICINE (U.S. CLS. 100, 101 AND 102).

FIRST USE 3-0-2003; IN COMMERCE 3-0-2003.

CLASS 41—EDUCATION AND ENTERTAINMENT

FOR EDUCATIONAL SERVICES, NAMELY, CONDUCTING EDUCATIONAL PROGRAMS ON ASPECTS OF INTERNAL MEDICINE (U.S. CLS. 100, 101 AND 107).

FIRST USE 3-0-2003; IN COMMERCE 3-0-2003.

KAPIL BHANOT, EXAMINING ATTORNEY

SN 77-524,075. FALCON GAS STORAGE COMPANY, INC., HOUSTON, TX. FILED 7-16-2008.

SN 77-524,748. WEALTH MASTERS LIVE LLC, PINELLAS PARK, FL. FILED 7-17-2008.



THE MARK CONSISTS OF A STYLIZED BEAKED FALCON BIRD FACING RIGHT WITH OUTSTRETCHED WINGS.

CLASS 4—LUBRICANTS AND FUELS

FOR NATURAL GAS; NATURAL GAS LIQUIDS (U.S. CLS. 1, 6 AND 15).
FIRST USE 10-0-2000; IN COMMERCE 10-0-2000.

WEALTH MASTERS LIVE

THE MARK CONSISTS OF STANDARD CHARACTERS WITHOUT CLAIM TO ANY PARTICULAR FONT, STYLE, SIZE, OR COLOR.

NO CLAIM IS MADE TO THE EXCLUSIVE RIGHT TO USE "WEALTH" AND "LIVE", APART FROM THE MARK AS SHOWN.

CLASS 35—ADVERTISING AND BUSINESS

FOR PROMOTING THE SERVICES OF OTHERS BY ADVERTISING AND MARKETING SEMINARS IN THE FIELD OF CREATING PERSONAL STRATEGIES TO ACHIEVE FINANCIAL INDEPENDENCE; PROMOTING THE SERVICES OF OTHERS BY MARKETING AND ADVERTISING SPEAKERS IN THE FIELD OF CREATING PERSONAL STRATEGIES TO ACHIEVE FINANCIAL INDEPENDENCE (U.S. CLS. 100, 101 AND 102).

CLASS 39—TRANSPORTATION AND STORAGE

FOR STORAGE, DISTRIBUTION, AND TRANSPORTATION OF NATURAL GAS AND NATURAL GAS LIQUIDS (U.S. CLS. 100 AND 105).
FIRST USE 3-0-2001; IN COMMERCE 3-0-2001.
ALEX KEAM, EXAMINING ATTORNEY

CLASS 41—EDUCATION AND ENTERTAINMENT

FOR ARRANGING EDUCATIONAL SEMINARS ON THE TOPICS OF CREATION OF PERSONALIZED STRATEGIES TO ACHIEVE FINANCIAL INDEPENDENCE (U.S. CLS. 100, 101 AND 107).
REBECCA SMITH, EXAMINING ATTORNEY

SN 77-525,246. REVSON, JENNIFER, RALEIGH, NC. FILED 7-17-2008.

SN 77-526,072. GLOBAL CONTENT & RESEARCH LTD., TORTOLA, BR.VIRGIN ISLANDS, FILED 7-18-2008.

SPEED WITH STYLE

THE MARK CONSISTS OF STANDARD CHARACTERS WITHOUT CLAIM TO ANY PARTICULAR FONT, STYLE, SIZE, OR COLOR.

CLASS 9—ELECTRICAL AND SCIENTIFIC APPARATUS

FOR HELMETS (U.S. CLS. 21, 23, 26, 36 AND 38).

CLASS 25—CLOTHING

FOR T-SHIRTS, SWEAT SHIRTS, JACKETS, CAPS, HATS, SHOES, ATHLETIC SHOES, WALKING SHOES, RUNNING SHOES, SWIMWEAR, RACING SUITS FOR USE IN AUTO RACING, RACING GLOVES, RACING SHOES (U.S. CLS. 22 AND 39).

MARGERY A. TIERNEY, EXAMINING ATTORNEY

SN 77-525,918. OCULUS INFO INC., TORONTO, CANADA, FILED 7-18-2008.

CONFIGURABLE SPACES

THE MARK CONSISTS OF STANDARD CHARACTERS WITHOUT CLAIM TO ANY PARTICULAR FONT, STYLE, SIZE, OR COLOR.

PRIORITY CLAIMED UNDER SEC. 44(D) ON CANADA APPLICATION NO. 1381286, FILED 1-30-2008, REG. NO. TMA737405, DATED 4-2-2009, EXPIRES 4-2-2024.

CLASS 9—ELECTRICAL AND SCIENTIFIC APPARATUS

FOR INTERACTIVE COMPUTER SOFTWARE FOR COMMERCIAL AND GOVERNMENT USE FOR THE DISPLAY AND MANIPULATION OF DIAGRAMMATIC ANALYTICAL TOOLS OVER TIME (U.S. CLS. 21, 23, 26, 36 AND 38).

FIRST USE 11-30-2005; IN COMMERCE 11-30-2005.

CLASS 42—SCIENTIFIC AND COMPUTER SERVICES

FOR COMPUTER SOFTWARE DEVELOPMENT (U.S. CLS. 100 AND 101).

FIRST USE 11-30-2005; IN COMMERCE 11-30-2005.
KATHERINE CHANG, EXAMINING ATTORNEY



NO CLAIM IS MADE TO THE EXCLUSIVE RIGHT TO USE "ECO", APART FROM THE MARK AS SHOWN.

THE MARK CONSISTS OF THE STYLIZED WORDS "ECO SEED". BETWEEN THE TWO WORDS IS THE DESIGN OF A SEED SUPERIMPOSED ON A GLOBE, WHICH IS ABOVE THE GLOBE'S SHADOW.

CLASS 35—ADVERTISING AND BUSINESS

FOR INTERNET CONTENT MANAGEMENT, NAMELY, PROVIDING BUSINESS INFORMATION ON THE WORLD WIDE WEB RELATED TO ECOLOGY; BUSINESS SERVICES IN THE AREA OF ECOLOGY; NAMELY, BUSINESS CONSULTING IN THE AREA OF ECOLOGY, AND MATCHING INDIVIDUALS WISHING TO PURCHASE ECOLOGICALLY-FRIENDLY PRODUCTS AND SERVICES WITH ENTITIES WISHING TO SELL SUCH GOODS AND SERVICES (U.S. CLS. 100, 101 AND 102).

CLASS 38—COMMUNICATION

FOR INTERNET CONTENT MANAGEMENT, NAMELY, STREAMING VIDEOS OF SPEECHES AND NEWS EVENTS IN THE AREA OF ECOLOGY VIA THE INTERNET (U.S. CLS. 100, 101 AND 104).

CLASS 41—EDUCATION AND ENTERTAINMENT

FOR INTERNET PUBLISHING, NAMELY, ON-LINE PUBLICATION OF TEXT AND GRAPHIC WORKS OF OTHERS IN THE FIELD OF ECOLOGY (U.S. CLS. 100, 101 AND 107).

MAUREEN DALL, EXAMINING ATTORNEY

SN 77-526,076. MANTECH INTERNATIONAL CORPORATION, FAIRFAX, VA. FILED 7-18-2008.

DECISIONPOINT

THE MARK CONSISTS OF STANDARD CHARACTERS WITHOUT CLAIM TO ANY PARTICULAR FONT, STYLE, SIZE, OR COLOR.

CLASS 9—ELECTRICAL AND SCIENTIFIC APPARATUS

FOR COMPUTER SOFTWARE USED IN THE FIELD OF CONTRACT MANAGEMENT, NAMELY, COMPUTER SOFTWARE FOR COLLABORATIVELY EVALUATING AND MANAGING COMPETITIVE SOLICITATION PROPOSALS TO SELECT AWARDEES (U.S. CLS. 21, 23, 26, 36 AND 38).

FIRST USE 4-0-1999; IN COMMERCE 7-0-1999.

CLASS 42—SCIENTIFIC AND COMPUTER SERVICES

FOR PROVIDING WEB-BASED NON-DOWNLOADABLE COMPUTER SOFTWARE FOR USE IN THE FIELD OF CONTRACT MANAGEMENT, NAMELY, COMPUTER SOFTWARE FOR COLLABORATIVELY EVALUATING AND MANAGING COMPETITIVE SOLICITATION PROPOSALS TO SELECT AWARDEES (U.S. CLS. 100 AND 101).

FIRST USE 4-0-1999; IN COMMERCE 7-0-1999.
DAWN FELDMAN, EXAMINING ATTORNEY

SN 77-526,154. SCALAR MEDIA PARTNERS LLC, NEW YORK, NY. FILED 7-18-2008.

SCALAR MEDIA

THE MARK CONSISTS OF STANDARD CHARACTERS WITHOUT CLAIM TO ANY PARTICULAR FONT, STYLE, SIZE, OR COLOR.

NO CLAIM IS MADE TO THE EXCLUSIVE RIGHT TO USE "MEDIA", APART FROM THE MARK AS SHOWN.

CLASS 35—ADVERTISING AND BUSINESS

FOR PROVIDING BUSINESS CONSULTING, BUSINESS MANAGEMENT, PROMOTION AND MARKETING SERVICES AND RELATED CONSULTING SERVICES TO MEDIA, ENTERTAINMENT, AND SPORTS COMPANIES (U.S. CLS. 100, 101 AND 102).

CLASS 36—INSURANCE AND FINANCIAL

FOR PROVIDING FINANCIAL CONSULTING SERVICES TO MEDIA, ENTERTAINMENT, AND SPORTS COMPANIES (U.S. CLS. 100, 101 AND 102).
AMY HELLA, EXAMINING ATTORNEY

SN 77-526,264. CROWN EQUIPMENT CORPORATION, NEW BREMEN, OH. FILED 7-18-2008.

ENCORE

THE MARK CONSISTS OF STANDARD CHARACTERS WITHOUT CLAIM TO ANY PARTICULAR FONT, STYLE, SIZE, OR COLOR.

THE WORDING "ENCORE" HAS NO MEANING IN A FOREIGN LANGUAGE.

CLASS 12—VEHICLES

FOR MATERIAL LIFTING, TRANSPORTING AND HANDLING EQUIPMENT, NAMELY, LIFT TRUCKS AND PALLET TRUCKS; TOWING TRACTORS; FORK LIFT TRUCKS; PLATFORM LIFT TRUCKS; SPECIAL APPLICATION LIFT TRUCKS; AND STOCK PICKER TRUCKS (U.S. CLS. 19, 21, 23, 31, 35 AND 44).

FIRST USE 12-0-2005; IN COMMERCE 12-0-2005.

CLASS 35—ADVERTISING AND BUSINESS

FOR DISTRIBUTORSHIP SERVICES IN THE FIELD OF PREVIOUSLY OWNED MATERIAL HANDLING EQUIPMENT (U.S. CLS. 100, 101 AND 102).

FIRST USE 12-0-2005; IN COMMERCE 12-0-2005.
WARREN L. OLANDRIA, EXAMINING ATTORNEY

SN 77-526,783. ISAAC'S JOURNEY . . . "WHERE HOPE BEGINS" FOUNDATION, SAUK CENTRE, MN. FILED 7-20-2008.



THE COLOR(S) BLUE, WHITE, YELLOW, AND GREEN IS/ARE CLAIMED AS A FEATURE OF THE MARK.

THE MARK CONSISTS OF A YELLOW RIBBON IN THE PLACE OF AN "I" IN THE WORDING "ISSAC'S JOURNEY" WITH "SSAC'S JOURNEY" IN GREEN. THE WORDING "WHERE HOPE BEGINS" WITH "WHERE H PE BEGINS" IN GREEN. THE "O" OF "HOPE" IS A YELL CIRCLE WITH A GREEN BUTTERFLY, AND THE DOT OF THE "I" OF "BEGINS" IS A YELLOW STAR OUTLINED IN GREEN. THE BACKGROUND IS BLUE SKY AND WHITE CLOUDS.

CLASS 25—CLOTHING

FOR SHIRTS (U.S. CLS. 22 AND 39).
FIRST USE 1-1-2008; IN COMMERCE 1-1-2008.

CLASS 36—INSURANCE AND FINANCIAL

FOR CHARITABLE FUND RAISING SERVICES, NAMELY, BY PROVIDING INDIVIDUALS WITH THE INFORMATION AND OPPORTUNITY TO MAKE MONETARY DONATIONS TO THEIR FAVORITE CHARITY (U.S. CLS. 100, 101 AND 102).

FIRST USE 1-1-2008; IN COMMERCE 1-1-2008.
GRETTA YAO, EXAMINING ATTORNEY

SN 77-526,864. ADVANSTAR COMMUNICATIONS INC., DULUTH, MN. FILED 7-21-2008.

OPTOMETRY TIMES

THE MARK CONSISTS OF STANDARD CHARACTERS WITHOUT CLAIM TO ANY PARTICULAR FONT, STYLE, SIZE, OR COLOR.

NO CLAIM IS MADE TO THE EXCLUSIVE RIGHT TO USE "OPTOMETRY", APART FROM THE MARK AS SHOWN.

CLASS 16—PAPER GOODS AND PRINTED MATTER

FOR PERIODICAL PUBLICATION, NAMELY, A MAGAZINE FEATURING INFORMATION IN THE FIELD OF OPTOMETRY (U.S. CLS. 2, 5, 22, 23, 29, 37, 38 AND 50).

CLASS 41—EDUCATION AND ENTERTAINMENT

FOR ONLINE MAGAZINE FEATURING INFORMATION IN THE FIELD OF OPTOMETRY (U.S. CLS. 100, 101 AND 107).

SETH A. RAPPAPORT, EXAMINING ATTORNEY

CLASS 41—EDUCATION AND ENTERTAINMENT

FOR EDUCATION SERVICES IN THE FIELD OF BUILDING AUTOMATION SYSTEMS, NAMELY, CONDUCTING CLASSES IN THE FIELD OF USING TECHNOLOGY IN BUSINESS RELATING TO ELECTRICAL AND ELECTRONIC DEVICES, BUILDING AUTOMATION SYSTEMS AND ELECTRONIC COMMUNICATION SERVICES; TRAINING IN THE USE AND OPERATION OF BUILDING AUTOMATION SYSTEMS AND ELECTRONIC COMMUNICATION SERVICES (U.S. CLS. 100, 101 AND 107).

CLASS 42—SCIENTIFIC AND COMPUTER SERVICES

FOR BUILDING AUTOMATION DESIGN SERVICES FOR OTHERS, NAMELY, ENGINEERING SERVICES, ARCHITECTURAL DESIGN SERVICES AND COMPUTER PROGRAMMING SERVICES FOR OTHERS ALL IN THE FIELD OF BUILDING AUTOMATION SYSTEMS (U.S. CLS. 100 AND 101).

JOHN GARTNER, EXAMINING ATTORNEY

SN 77-527,663. LEGRAND HOME SYSTEMS, INC., MIDDLETOWN, PA. FILED 7-21-2008.

SN 77-528,111. ARTSANA S.P.A., 22070 GRANDATE, COMO, ITALY, FILED 7-22-2008.

LIVING PERFECTION

THE MARK CONSISTS OF STANDARD CHARACTERS WITHOUT CLAIM TO ANY PARTICULAR FONT, STYLE, SIZE, OR COLOR.

CLASS 9—ELECTRICAL AND SCIENTIFIC APPARATUS

FOR ELECTRICAL AND ELECTRONIC DEVICES IN THE FIELD OF BUILDING AUTOMATION SYSTEMS, NAMELY, BUILDING AUTOMATION CONTROLLERS, TOUCHSCREENS, LIQUID CRYSTAL DISPLAYS, LCD CONTROL PANELS, KEYPADS, REMOTE CONTROLS, RS-232 SIGNAL INTERFACE DEVICES, ELECTRICAL AUDIO AND VIDEO SIGNAL DISTRIBUTION APPARATUS, THERMOSTATS, LIGHT SENSORS, MOTION SENSORS, PRESSURE SENSORS, ELECTRONIC COMMUNICATING THERMOSTAT STATIONS, ELECTRICAL RELAY STATIONS, ELECTRICAL INPUT STATIONS, ELECTRICAL OUTPUT STATIONS, ELECTRIC LIGHT DIMMING APPARATUS, REMOTE INFRARED RECEIVERS, WIRELESS TRANSCEIVERS, MODEMS, COMPUTERS AND COMPUTER SOFTWARE FOR OPERATING BUILDING AUTOMATION SYSTEMS, ENVIRONMENTAL CONDITION SYSTEMS, WATER SYSTEMS, AUDIO/VIDEO SYSTEMS, BUILDING MONITORING AND ACCESS SYSTEMS, AND BUILDING AMENITIES; AND COMPONENT AND REPLACEMENT PARTS FOR ALL THE AFORESAID GOODS (U.S. CLS. 21, 23, 26, 36 AND 38).

CLASS 37—CONSTRUCTION AND REPAIR

FOR BUILDING CONSTRUCTION AND REPAIR SERVICES IN THE FIELD OF BUILDING AUTOMATION SYSTEMS, NAMELY, INSTALLATION AND REPAIR OF BUILDING AUTOMATION SYSTEMS AND DEVICES, AND BUILDING ELECTRICAL AND ELECTRONIC DEVICES AND BUILDING AUTOMATION SYSTEMS (U.S. CLS. 100, 103 AND 106).

OWNER OF U.S. REG. NOS. 1,316,861 AND 1,325,862.

THE MARK CONSISTS OF AN OUTLINED RECTANGLE HAVING ROUNDED CORNERS DESIGN WITH THE WORDING "CHICCO" APPEARING IN STYLIZED FONT WITHIN THE RECTANGLE. A CIRCLE DESIGN REPRESENTS THE DOT IN THE LETTER "I".

THE ENGLISH TRANSLATION OF "CHICCO" IN THE MARK IS GRAIN, COFFEE BEAN, GRAPESTONE OR HALSTONE AND IS SOMETIMES THE NICKNAME OF ENRICO.

CLASS 3—COSMETICS AND CLEANING PREPARATIONS

FOR SOAPS; PERFUMERY, ESSENTIAL OILS, COSMETICS, HAIR LOTIONS; DENTIFRICES (U.S. CLS. 1, 4, 6, 50, 51 AND 52).

CLASS 16—PAPER GOODS AND PRINTED MATTER

FOR PAPER, CARDBOARD AND GOODS MADE FROM THESE MATERIALS, NAMELY, PAPER AND CARDBOARD BOXES; PRINTED MATTER, NAMELY, PRINTED FORMS; BOOKBINDING MATERIAL; PHOTOGRAPHS; STATIONERY; ADHESIVES FOR STATIONERY OR HOUSEHOLD PURPOSES; ARTISTS' MATERIALS, NAMELY, PENS, PENCILS, BALL PENS, FOUNTAIN PENS, FELT PENS, WATER COLOURS, TEMPERAS; PAINT BRUSHES; TYPEWRITERS; PRINTED INSTRUCTIONAL AND TEACHING MATERIAL IN THE FIELD OF BABIES, CHILDREN, TEENAGERS AND MATERNITY (U.S. CLS. 2, 5, 22, 23, 29, 37, 38 AND 50).

CLASS 18—LEATHER GOODS

FOR LEATHER AND IMITATIONS OF LEATHER, LEATHER BAGS, TRAVELING BAGS, DIAPER BAGS, BAGS FOR CARRYING BABIES, BEAUTY CASES, KNAP SACKS FOR CARRYING BABIES, SCHOOL BAGS AND KNAP SACKS, ANIMAL SKINS, HIDES; TRUNKS, UMBRELLAS, PARASOLS AND WALKING STICKS; WHIPS, HARNESS AND SADDLERY (U.S. CLS. 1, 2, 3, 22 AND 41).

SN 77-528,339. UNILEVER SUPPLY CHAIN, INC., CLINTON, CT. FILED 7-22-2008.



CLASS 35—ADVERTISING AND BUSINESS

FOR ADVERTISING; BUSINESS MANAGEMENT; BUSINESS ADMINISTRATION; OFFICE FUNCTIONS (U.S. CLS. 100, 101 AND 102).
CIMMERIAN COLEMAN, EXAMINING ATTORNEY

NO CLAIM IS MADE TO THE EXCLUSIVE RIGHT TO USE "PURITY GUARANTEED", APART FROM THE MARK AS SHOWN.

THE MARK CONSISTS OF THE A DESIGN WITH THREE DROPS AT THE CENTER OF TWO CONCENTRIC CIRCLES; TWO HORIZONTAL LINES SEPARATE THE DROPS FROM ONE ANOTHER; THE WORDING "TRIPLE PURIFICATION" IS POSITIONED ABOVE THE CENTRAL DESIGN AND THE WORDING "PURITY GUARANTEED" IS LOCATED BELOW THE DROP DESIGN.

SN 77-528,205. BRAINMASTER TECHNOLOGIES, INC., OAKWOOD VILLAGE, OH. FILED 7-22-2008.

BRAINTRACK

CLASS 3—COSMETICS AND CLEANING PREPARATIONS

FOR NON-MEDICATED BATH AND SHOWER PREPARATIONS, NAMELY, SHOWER GEL, BATH SOAK; BODY WASH; NON-MEDICATED SKIN CARE PREPARATIONS, NAMELY, OILS, CREAMS AND LOTIONS FOR THE SKIN; PETROLEUM JELLY FOR COSMETIC PURPOSES (U.S. CLS. 1, 4, 6, 50, 51 AND 52).

CLASS 5—PHARMACEUTICALS

FOR PHARMACEUTICAL PREPARATIONS, NAMELY, PREPARATIONS FOR ALLEVIATING SKIN CONDITIONS; DISINFECTANTS FOR USE IN DISINFECTING THE SKIN; ANTISEPTICS; PLASTERS; MEDICATED SKIN AND HAIR PREPARATIONS; MEDICATED PREPARATIONS FOR THE LIPS; PREPARATIONS FOR THE TREATMENT AND/OR ALLEVIATION OF SUNBURN; PETROLEUM JELLY FOR MEDICAL PURPOSES (U.S. CLS. 6, 18, 44, 46, 51 AND 52).
MELVIN AXILBUND, EXAMINING ATTORNEY

THE MARK CONSISTS OF STANDARD CHARACTERS WITHOUT CLAIM TO ANY PARTICULAR FONT, STYLE, SIZE, OR COLOR.

CLASS 9—ELECTRICAL AND SCIENTIFIC APPARATUS

FOR BIOFEEDBACK SYSTEM COMPRISED OF BRAIN-WAVE AND PHYSIOLOGICALLY CONTROLLED GAMES IN THE NATURE OF TOY VEHICLE TRACK SETS AND ROADWAYS AND ACCESSORIES THEREFOR AND BIOFEEDBACK SENSORS, NOT FOR MEDICAL PURPOSES (U.S. CLS. 21, 23, 26, 36 AND 38).
FIRST USE 5-1-2008; IN COMMERCE 5-1-2008.

SN 77-528,653. REIGN NET MEDIA, LLC, LA JOLLA, CA. FILED 7-22-2008.

CLASS 10—MEDICAL APPARATUS

FOR BIOFEEDBACK SYSTEM COMPRISED OF BRAIN-WAVE AND PHYSIOLOGICALLY CONTROLLED GAMES IN THE NATURE OF TOY VEHICLE TRACK SETS AND ROADWAYS AND ACCESSORIES THEREFOR AND BIOFEEDBACK SENSORS, FOR THE MEDICAL PURPOSE OF BIOFEEDBACK THERAPY (U.S. CLS. 26, 39 AND 44).
FIRST USE 5-1-2008; IN COMMERCE 5-1-2008.
BRIAN CALLAGHAN, EXAMINING ATTORNEY

National Football Post

THE MARK CONSISTS OF STANDARD CHARACTERS WITHOUT CLAIM TO ANY PARTICULAR FONT, STYLE, SIZE, OR COLOR.

NO CLAIM IS MADE TO THE EXCLUSIVE RIGHT TO USE "NATIONAL FOOTBALL", APART FROM THE MARK AS SHOWN.

CLASS 41—EDUCATION AND ENTERTAINMENT

FOR ENTERTAINMENT SERVICES IN THE NATURE OF FANTASY FOOTBALL LEAGUES (U.S. CLS. 100, 101 AND 107).

CLASS 42—SCIENTIFIC AND COMPUTER SERVICES

FOR HOSTING AN ONLINE WEBSITE FEATURING FOOTBALL INFORMATION AND OPINIONS (U.S. CLS. 100 AND 101).
HANNO RITTNER, EXAMINING ATTORNEY

SN 77-528,673. REIGN NET MEDIA, LLC, LA JOLLA, CA. FILED 7-22-2008.

N.F. Post

THE MARK CONSISTS OF STANDARD CHARACTERS WITHOUT CLAIM TO ANY PARTICULAR FONT, STYLE, SIZE, OR COLOR.

CLASS 41—EDUCATION AND ENTERTAINMENT

FOR ENTERTAINMENT SERVICES IN THE NATURE OF FANTASY FOOTBALL LEAGUES (U.S. CLS. 100, 101 AND 107).

CLASS 42—SCIENTIFIC AND COMPUTER SERVICES

FOR HOSTING AN ONLINE WEBSITE FEATURING FOOTBALL INFORMATION AND OPINIONS (U.S. CLS. 100 AND 101).
HANNO RITTNER, EXAMINING ATTORNEY

SN 77-528,933. LONGYEAR TM, INC., SOUTH JORDAN, UT. FILED 7-23-2008.

GROUTMASTER

THE MARK CONSISTS OF STANDARD CHARACTERS WITHOUT CLAIM TO ANY PARTICULAR FONT, STYLE, SIZE, OR COLOR.

CLASS 7—MACHINERY

FOR POWER OPERATED TOOLS FOR USE IN THE FIELD OF EARTH DRILLING, NAMELY, GROUT MIXING AND PUMPING UNITS AND PARTS THEREFOR (U.S. CLS. 13, 19, 21, 23, 31, 34 AND 35).

CLASS 42—SCIENTIFIC AND COMPUTER SERVICES

FOR CUSTOM DESIGN OF GROUT MIXING AND PUMPING UNITS FOR USE IN THE FIELD OF EARTH DRILLING (U.S. CLS. 100 AND 101).
SUSAN STIGLITZ, EXAMINING ATTORNEY

SN 77-529,133. MADDOCK DOUGLAS, INC., ELMHURST, IL. FILED 7-23-2008.

MADDOCK DOUGLAS

THE MARK CONSISTS OF STANDARD CHARACTERS WITHOUT CLAIM TO ANY PARTICULAR FONT, STYLE, SIZE, OR COLOR.

THE NAME "MADDOCK DOUGLAS" DOES NOT IDENTIFY A LIVING INDIVIDUAL.

CLASS 35—ADVERTISING AND BUSINESS

FOR ADVERTISING AGENCY SERVICES; ADVERTISING AGENCY SERVICES, NAMELY, CREATING CORPORATE AND BRAND IDENTITY FOR OTHERS (U.S. CLS. 100, 101 AND 102).
FIRST USE 2-13-1991; IN COMMERCE 5-1-1991.

CLASS 42—SCIENTIFIC AND COMPUTER SERVICES

FOR RESEARCH AND DEVELOPMENT OF NEW PRODUCTS FOR OTHERS; GRAPHIC ART DESIGN SERVICES (U.S. CLS. 100 AND 101).
FIRST USE 2-13-1991; IN COMMERCE 5-1-1991.
JANICE KIM, EXAMINING ATTORNEY

SN 77-529,642. FUNKY MONKEY CALIFORNIA LLC, SANTA ROSA, CA. FILED 7-23-2008.

THE FUNKY MONKEY

THE MARK CONSISTS OF STANDARD CHARACTERS WITHOUT CLAIM TO ANY PARTICULAR FONT, STYLE, SIZE, OR COLOR.

CLASS 41—EDUCATION AND ENTERTAINMENT

FOR ENTERTAINMENT SERVICES, NAMELY, FAMILY ENTERTAINMENT CENTERS (U.S. CLS. 100, 101 AND 107).
FIRST USE 0-0-1998; IN COMMERCE 1-0-2008.

CLASS 43—HOTEL AND RESTAURANT SERVICES

FOR RESTAURANT SERVICES (U.S. CLS. 100 AND 101).
FIRST USE 0-0-1998; IN COMMERCE 1-0-2008.
WILLIAM VERHOSEK, EXAMINING ATTORNEY

SN 77-529,656. FUNKY MONKEY CALIFORNIA LLC, SANTA ROSA, CA. FILED 7-23-2008.

WHERE KIDS GO BANANAS!

THE MARK CONSISTS OF STANDARD CHARACTERS WITHOUT CLAIM TO ANY PARTICULAR FONT, STYLE, SIZE, OR COLOR.

CLASS 41—EDUCATION AND ENTERTAINMENT

FOR ENTERTAINMENT SERVICES, NAMELY, FAMILY ENTERTAINMENT CENTERS (U.S. CLS. 100, 101 AND 107).

FIRST USE 0-0-1998; IN COMMERCE 1-0-2008.

CLASS 43—HOTEL AND RESTAURANT SERVICES

FOR RESTAURANT SERVICES (U.S. CLS. 100 AND 101).

FIRST USE 0-0-1998; IN COMMERCE 1-0-2008.
WILLIAM VERHOSEK, EXAMINING ATTORNEY

SN 77-529,796. REPUBLIC OF TEXAS BIKER RALLY, INC., AUSTIN, TX. FILED 7-23-2008.

Republic of Texas Biker Rally

THE MARK CONSISTS OF STANDARD CHARACTERS WITHOUT CLAIM TO ANY PARTICULAR FONT, STYLE, SIZE, OR COLOR.

NO CLAIM IS MADE TO THE EXCLUSIVE RIGHT TO USE "BIKER RALLY", APART FROM THE MARK AS SHOWN.

SEC. 2(F).

CLASS 25—CLOTHING

FOR CLOTHING AND CLOTHING ACCESSORIES, NAMELY, T-SHIRTS, KNIT SHIRTS, TANK TOPS, HALTER TOPS, SHORTS, SKIRTS, HATS, CAPS, BEANIES, DO RAGS, BANDANAS, SWEATSHIRTS, JACKETS AND VESTS (U.S. CLS. 22 AND 39).

FIRST USE 10-29-1996; IN COMMERCE 1-10-1997.

CLASS 35—ADVERTISING AND BUSINESS

FOR ADVERTISING AND PUBLICITY SERVICES, NAMELY, PROMOTING THE GOODS, SERVICES, BRAND IDENTITY AND COMMERCIAL INFORMATION AND NEWS OF THIRD PARTIES THROUGH PRINT, AUDIO, VIDEO, DIGITAL AND ON-LINE MEDIUM; PROMOTING MOTORCYCLE RALLIES AND CONFERENCES, EVENTS, FESTIVALS AND SEMINARS IN THE FIELDS OF MOTORCYCLES, MOTORCYCLE RIDING, MOTORCYCLE CONSTRUCTION, MAINTENANCE AND REPAIR, AND MOTORCYCLE LIFESTYLES (U.S. CLS. 100, 101 AND 102).

FIRST USE 10-29-1996; IN COMMERCE 1-10-1997.

CLASS 41—EDUCATION AND ENTERTAINMENT

FOR ENTERTAINMENT AND EDUCATIONAL SERVICES, NAMELY, ORGANIZING, ARRANGING, AND CONDUCTING MOTORCYCLE RALLIES AND CONFERENCES, EVENTS, FESTIVALS AND SEMINARS IN THE FIELDS OF MOTORCYCLES, MOTORCYCLE RIDING, MOTORCYCLE CONSTRUCTION, MAINTENANCE AND REPAIR, AND MOTORCYCLE LIFESTYLES (U.S. CLS. 100, 101 AND 107).

FIRST USE 10-29-1996; IN COMMERCE 1-10-1997.

GRETTA YAO, EXAMINING ATTORNEY

SN 77-530,471. KUNZE, PHILIP J., DBA PHILIP KUNZE AZO, KALAMAZOO, MI. FILED 7-24-2008.

TIMEANDPLACESTORIES

THE MARK CONSISTS OF STANDARD CHARACTERS WITHOUT CLAIM TO ANY PARTICULAR FONT, STYLE, SIZE, OR COLOR.

CLASS 35—ADVERTISING AND BUSINESS

FOR PROVIDING SPACE ON A WEBSITE FOR ADVERTISING GOODS AND SERVICES OF OTHERS (U.S. CLS. 100, 101 AND 102).

CLASS 42—SCIENTIFIC AND COMPUTER SERVICES

FOR PROVIDING AN INTERACTIVE WEBSITE THAT GIVES COMPUTER USERS THE ABILITY TO UPLOAD, TAG, BROWSE, EXCHANGE AND SHARE USER-DEFINED INFORMATION IN THE NATURE OF PHOTOS, VIDEOS, TEXT FILES AND SOUND FILES, AND THE ABILITY TO ORGANIZE SAID USER-DEFINED INFORMATION CHRONOLOGICALLY AND GEOGRAPHICALLY (U.S. CLS. 100 AND 101).

BRIAN CALLAGHAN, EXAMINING ATTORNEY

SN 77-531,329. ATOMPARK SOFTWARE, INC., ALEXANDRIA, VA. FILED 7-25-2008.

AtomPark

THE MARK CONSISTS OF STANDARD CHARACTERS WITHOUT CLAIM TO ANY PARTICULAR FONT, STYLE, SIZE, OR COLOR.

CLASS 9—ELECTRICAL AND SCIENTIFIC APPARATUS

FOR COMPUTER UTILITY SOFTWARE, DOWNLOADABLE COMPUTER SOFTWARE AND COMPUTER SOFTWARE FOR MANAGING MAILING LISTS AND BULK E-MAILING, PASSWORD RECOVERY, ACTIVITY MONITORING AND WEBSITE PROTECTION AND ENCRYPTION (U.S. CLS. 21, 23, 26, 36 AND 38).

FIRST USE 10-12-2001; IN COMMERCE 10-12-2001.

CLASS 42—SCIENTIFIC AND COMPUTER SERVICES

FOR APPLICATION SERVICE PROVIDER FEATURING SOFTWARE FOR MANAGING MAILING LISTS AND BULK E-MAILING, PASSWORD RECOVERY, ACTIVITY MONITORING AND WEBSITE PROTECTION AND ENCRYPTION; OPERATING A WEBSITE PROVIDING TECHNICAL OPERATING INFORMATION AND SUPPORT FOR THE SOFTWARE PROGRAMS FOR MANAGING MAILING LISTS AND BULK E-MAILING, PASSWORD RECOVERY, ACTIVITY MONITORING AND WEBSITE PROTECTION AND ENCRYPTION; OPERATING A WEBSITE FOR PROVIDING INTERACTIVE TECHNICAL SUPPORT SERVICES RELATING THERE-TO (U.S. CLS. 100 AND 101).

FIRST USE 10-12-2001; IN COMMERCE 10-12-2001.
KOURTNEE HODGES, EXAMINING ATTORNEY

SN 77-533,380. MENSA TECHNOLOGY CORPORATION, BANKS, OR. FILED 7-29-2008.

GUARDIAN GLO

THE MARK CONSISTS OF STANDARD CHARACTERS WITHOUT CLAIM TO ANY PARTICULAR FONT, STYLE, SIZE, OR COLOR.

NO CLAIM IS MADE TO THE EXCLUSIVE RIGHT TO USE "GLOW", APART FROM THE MARK AS SHOWN.

CLASS 11—ENVIRONMENTAL CONTROL APPARATUS

FOR FIBER OPTIC LIGHTING FIXTURES (U.S. CLS. 13, 21, 23, 31 AND 34).

CLASS 27—FLOOR COVERINGS

FOR FLOOR MATS (U.S. CLS. 19, 20, 37, 42 AND 50).
SAIMA MAKHDOOM, EXAMINING ATTORNEY

SN 77-532,213. THE NATIONAL WORLD WAR II MUSEUM, INC., NEW ORLEANS, LA. FILED 7-27-2008.



NO CLAIM IS MADE TO THE EXCLUSIVE RIGHT TO USE "CANTEEN", APART FROM THE MARK AS SHOWN.
THE MARK CONSISTS OF STYLIZED WORDS "STAGE DOOR CANTEEN".

CLASS 41—EDUCATION AND ENTERTAINMENT

FOR PROVIDING FACILITIES IN THE NATURE OF A LIVE PERFORMANCE THEATER FOR THE PURPOSE OF EDUCATIONAL INSTRUCTION IN THE FIELD OF HISTORY; PROVIDING FACILITIES IN THE NATURE OF A LIFE PERFORMANCE THEATER FOR PROVIDING ENTERTAINMENT IN THE NATURE OF FILMED THEATER PERFORMANCES AND LIVE THEATER PERFORMANCES; EDUCATIONAL SERVICES, NAMELY, DEVELOPING, ARRANGING AND CONDUCTING EDUCATIONAL PROGRAMS IN THE FIELD OF HISTORY; PROVIDING ENTERTAINMENT IN THE NATURE OF FILMED THEATER PERFORMANCES AND LIVE THEATER PERFORMANCES (U.S. CLS. 100, 101 AND 107).

CLASS 43—HOTEL AND RESTAURANT SERVICES

FOR PROVIDING BANQUET HALL FACILITIES FOR THE PROVISION OF REFRESHMENTS; PROVIDING RESTAURANT SERVICES FOR THE PURPOSE OF PROVIDING REFRESHMENTS (U.S. CLS. 100 AND 101).
BONNIE LUKEN, EXAMINING ATTORNEY

SN 77-533,473. INFINITY PROPERTY PARTNERS, LLC, BENTONVILLE, AR. FILED 7-29-2008.

ZEES

THE MARK CONSISTS OF STANDARD CHARACTERS WITHOUT CLAIM TO ANY PARTICULAR FONT, STYLE, SIZE, OR COLOR.

CLASS 20—FURNITURE AND ARTICLES NOT OTHERWISE CLASSIFIED

FOR MATTRESSES, MATTRESS FOUNDATIONS; BOX SPRINGS, AND PILLOWS (U.S. CLS. 2, 13, 22, 25, 32 AND 50).

CLASS 24—FABRICS

FOR MATTRESS PADS; BEDDING, NAMELY, COMFORTERS, QUILTS, BED SPREADS, BED SKIRTS, BED COVERS, DUVETS, DUVET COVERS, COMFORTER COVERS, COMFORTERS, BED BLANKETS, BED SHEETS, BED LINENS, DUST RUFFLES, PILLOW CASES, PILLOW SHAMS AND EUROPEAN SHAMS, FEATHER BEDS (U.S. CLS. 42 AND 50).
ELIZABETH KAJUBI, EXAMINING ATTORNEY

SN 77-533,479. SPRINGBOK SERVICES, INC., ENGLEWOOD, CO. FILED 7-29-2008.

SN 77-534,806. GLOBAL REPORTER INC., WINNIPEG, MANITOBA, CANADA, FILED 7-30-2008.

ASCEND

THE MARK CONSISTS OF STANDARD CHARACTERS WITHOUT CLAIM TO ANY PARTICULAR FONT, STYLE, SIZE, OR COLOR.

CLASS 36—INSURANCE AND FINANCIAL

FOR PROFESSIONAL FINANCIAL CONSULTING SERVICES IN THE FIELD OF PREPAID OR STORED VALUE CARD ISSUANCE, CARD TRANSACTION PROCESSING SERVICES AND RISK MANAGEMENT (U.S. CLS. 100, 101 AND 102).

CLASS 42—SCIENTIFIC AND COMPUTER SERVICES

FOR PROVIDING A WEB-BASED ON-LINE NON-DOWNLOADABLE INCENTIVE AND REWARD MANAGEMENT SOFTWARE PLATFORM FOR ORDERING AND ISSUING PREPAID AND STORED VALUE CARDS AND PROCESSING PREPAID AND STORED VALUE CARD TRANSACTIONS (U.S. CLS. 100 AND 101).
MICHELE SWAIN, EXAMINING ATTORNEY



SN 77-534,617. POLYBRITE INTERNATIONAL, INC., NAPERVILLE, IL. FILED 7-30-2008.

PAWBRITE

THE MARK CONSISTS OF STANDARD CHARACTERS WITHOUT CLAIM TO ANY PARTICULAR FONT, STYLE, SIZE, OR COLOR.

OWNER OF U.S. REG. NOS. 2,527,905 AND 2,572,125.

CLASS 9—ELECTRICAL AND SCIENTIFIC APPARATUS

FOR CELLPHONE POUCHES (U.S. CLS. 21, 23, 26, 36 AND 38).

CLASS 18—LEATHER GOODS

FOR HARNESES, HARNESS COVERS, ANIMAL LEASHES, HAND-FREE LEASHES FOR ANIMALS, BACKPACKS AND PET CARRIERS (U.S. CLS. 1, 2, 3, 22 AND 41).

CLASS 25—CLOTHING

FOR WAIST BELTS AND WRIST BANDS (U.S. CLS. 22 AND 39).

CLASS 26—FANCY GOODS

FOR ARM BANDS (U.S. CLS. 37, 39, 40, 42 AND 50).
KEVON CHISOLM, EXAMINING ATTORNEY

NO CLAIM IS MADE TO THE EXCLUSIVE RIGHT TO USE "GLOBAL REPORTER", APART FROM THE MARK AS SHOWN.

THE MARK CONSISTS OF A CAMERA WITH A MAP OF THE WORLD APPEARING WITHIN THE CAMERA LENS, AND THE WORDING "GLOBAL REPORTER" POSITIONED ABOVE, AND SEPARATED BY A LINE, FROM THE WORDING "WHERE YOU REPORT THE NEWS".

CLASS 35—ADVERTISING AND BUSINESS

FOR ARRANGING SUBSCRIPTIONS TO WEB-BASED ONLINE NEWS SERVICES OF OTHERS; PROVISION OF SPACE ON NEWS WEBSITES FOR ADVERTISING GOODS AND SERVICES; ON-LINE RETAIL STORE SERVICES AND MAIL ORDER SERVICES FEATURING PUBLICATIONS AND PRE-RECORDED DIGITAL MEDIA FEATURING STATISTICAL INFORMATION GENERATED FROM USER-SUBSCRIPTION LIST PROVIDED TO CONSUMERS DESIRING MARKET AND STATISTICAL RESEARCH AND INFORMATION (U.S. CLS. 100, 101 AND 102).

CLASS 38—COMMUNICATION

FOR STREAMING OF VIDEO MATERIAL ON THE INTERNET (U.S. CLS. 100, 101 AND 104).

CLASS 41—EDUCATION AND ENTERTAINMENT

FOR PROVIDING AN INTERNET NEWS PORTAL FEATURING LINKS TO NEWS ARTICLES, NEWS STORIES, INFORMATION AND COMMENTARY IN THE NATURE OF CURRENT EVENT REPORTING (U.S. CLS. 100, 101 AND 107).

ANDREA K. NADELMAN, EXAMINING ATTORNEY

SN 77-535,648. BOARD OF REGENTS OF THE UNIVERSITY SYSTEM OF GEORGIA, ATLANTA, GA. FILED 7-31-2008.

SN 77-535,849. SILVERMAN, JOEL, RANCHO SANTA MARGARITA, CA. FILED 7-31-2008.



OWNER OF U.S. REG. NOS. 1,298,360, 3,214,180 AND OTHERS.

NO CLAIM IS MADE TO THE EXCLUSIVE RIGHT TO USE "GWINNETT" AND "ESTABLISHED 2005" AS TO ALL CLASSES, AND "COLLEGE" AND "LEADERSHIP SERVICE SCHOLARSHIP CREATIVITY" AS TO CLASS 41 ONLY, APART FROM THE MARK AS SHOWN.

THE MARK CONSISTS OF FOUR CONCENTRIC CIRCLES, EACH SEPARATED BY A SINGLE LINE BORDER. THE OUTERMOST CIRCLE CONTAINS THE NAME "GEORGIA GWINNETT COLLEGE" ON THE TOP HALF OF THE CIRCLE, AND THE PHRASE "ESTABLISHED 2005" WITH A DOT ON EITHER SIDE OF THE PHRASE ON THE BOTTOM HALF OF THE CIRCLE. THE SECOND CIRCLE CONTAINS A BORDER DESIGN CONSISTING OF A DEPICTION OF STARS. THE THIRD CIRCLE IS SHADED AND CONTAINS THE WORDS "LEADERSHIP SERVICE SCHOLARSHIP CREATIVITY" WITH A DOT SEPARATING EACH WORD. THE INNERMOST CIRCLE IS ALSO SHADED AND CONTAINS A LOGO COMPRISING OF A DOUBLE LETTER "G".

SEC. 2(F) AS TO "GEORGIA".

CLASS 14—JEWELRY

FOR JEWELRY; PINS BEING JEWELRY (U.S. CLS. 2, 27, 28 AND 50).

FIRST USE 12-1-2007; IN COMMERCE 1-1-2008.

CLASS 16—PAPER GOODS AND PRINTED MATTER

FOR FOLDERS; NOTEPADS; PEN HOLDERS; PENS; STATIONERY; STATIONERY-TYPE PORTFOLIOS; TIME PLANNERS (U.S. CLS. 2, 5, 22, 23, 29, 37, 38 AND 50).

FIRST USE 12-1-2007; IN COMMERCE 1-1-2008.

CLASS 41—EDUCATION AND ENTERTAINMENT

FOR EDUCATIONAL SERVICES, NAMELY, PROVIDING COURSES OF INSTRUCTION AT THE COLLEGE LEVEL AND DISTRIBUTION OF COURSE MATERIAL IN CONNECTION THEREWITH; ENTERTAINMENT IN THE NATURE OF COMPETITIONS IN THE FIELD OF ATHLETIC EVENTS (U.S. CLS. 100, 101 AND 107).

FIRST USE 12-1-2007; IN COMMERCE 1-1-2008.
MARC LEIPZIG, EXAMINING ATTORNEY

JOEL SILVERMAN'S COMPANIONS FOR LIFE

THE MARK CONSISTS OF STANDARD CHARACTERS WITHOUT CLAIM TO ANY PARTICULAR FONT, STYLE, SIZE, OR COLOR.

THE NAME "JOEL SILVERMAN" IDENTIFIES A LIVING INDIVIDUAL WHOSE CONSENT IS OF RECORD.

CLASS 9—ELECTRICAL AND SCIENTIFIC APPARATUS

FOR ELECTRICAL MECHANISM FOR ATTRACTING AND TRAPPING FLEAS; WHISTLES FOR CALLING PETS, NAMELY, DOG WHISTLES; A SERIES OF PRE-RECORDED VIDEOTAPES AND AUDIO TAPES ABOUT BIRDS, CATS AND DOGS; AND COMPUTER AND VIDEO GAMES PROGRAMS ABOUT BIRDS, CATS AND DOGS (U.S. CLS. 21, 23, 26, 36 AND 38).

CLASS 21—HOUSEWARES AND GLASS

FOR BIRD CAGES AND THE STANDS THEREFOR; BIRD CAGE ACCESSORIES, NAMELY, SANDED PERCH COVERS AND GRAVEL PAPER FOR BIRD CAGES; CAGES FOR PETS; PET FEEDING BOWLS AND DISHES; GROOMING BRUSHES AND COMBS; ANIMAL LITTER BOXES AND ANIMAL LITTER PANS; PLASTIC WATER BOTTLES FOR PETS SOLD EMPTY; BIRD BATHS NOT BEING STRUCTURES, BIRD FOOD AND WATER CUPS (U.S. CLS. 2, 13, 23, 29, 30, 33, 40 AND 50).

CLASS 31—NATURAL AGRICULTURAL PRODUCTS

FOR LITTER FOR PETS; PET FOOD, EDIBLE PET TREATS AND DOG BISCUITS, EDIBLE PET SNACKS, PET BEVERAGES; CUTTLEBONE FOR BIRDS AND CEDAR WOOD SHAVINGS FOR USE AS ANIMAL LITTER AND BEDDING FOR PETS (U.S. CLS. 1 AND 46).

GINA FINK, EXAMINING ATTORNEY

SN 77-536,509. BODY BY JAKE, INC., LOS ANGELES, CA. FILED 7-31-2008.

DON'T QUIT!

THE MARK CONSISTS OF STANDARD CHARACTERS WITHOUT CLAIM TO ANY PARTICULAR FONT, STYLE, SIZE, OR COLOR.

OWNER OF U.S. REG. NO. 1,486,704.

CLASS 9—ELECTRICAL AND SCIENTIFIC APPARATUS

FOR AUDIO AND VIDEO RECORDINGS IN THE FIELDS OF HEALTH, FITNESS, MOTIVATION, EXERCISE, WELLNESS, NUTRITION AND HEALTHY LIFESTYLES; MUSICAL SOUND RECORDINGS; DVDS AND CDS FEATURING INFORMATION IN THE FIELDS OF HEALTH, FITNESS, MOTIVATION, EXERCISE, WELLNESS, NUTRITION AND HEALTHY LIFESTYLES; DOWNLOADABLE ELECTRONIC NEWSLETTERS IN THE FIELDS OF HEALTH, FITNESS, MOTIVATION, EXERCISE, WELLNESS, NUTRITION AND HEALTHY LIFESTYLES; DOWNLOADABLE AUDIO AND VIDEO RECORDINGS IN THE FIELDS OF HEALTH, FITNESS, MOTIVATION, EXERCISE, WELLNESS, NUTRITION AND HEALTHY LIFESTYLES; CDS AND DVDS FEATURING MUSIC; DOWNLOADABLE AUDIO AND VIDEO FILES FEATURING MUSIC; DOWNLOADABLE WEBCASTS IN THE FIELDS OF HEALTH, FITNESS, MOTIVATION, EXERCISE, WELLNESS, NUTRITION AND HEALTHY LIFESTYLES; DOWNLOADABLE TELEVISION SHOWS ABOUT HEALTH, FITNESS, MOTIVATION, EXERCISE, WELLNESS, NUTRITION AND HEALTHY LIFESTYLES; SPORTING EQUIPMENT, NAMELY, SPORTS HELMETS, SPORTS EYEWEAR, SPORTS GOGGLES, PROTECTIVE HEADGEAR FOR SPORTS; ELECTRONIC EDUCATIONAL COMPUTER GAME PROGRAMS FOR CHILDREN (U.S. CLS. 21, 23, 26, 36 AND 38).

CLASS 16—PAPER GOODS AND PRINTED MATTER

FOR BOOKS, NEWSLETTERS, ARTICLES, PAMPHLETS, MANUALS, HAND-OUTS, JOURNALS, WORKBOOKS, WORKSHEETS, BROCHURES, BOOKLETS, MAGAZINES IN THE FIELDS OF HEALTH, FITNESS, MOTIVATION, EXERCISE, WELLNESS, NUTRITION AND HEALTHY LIFESTYLES; CALENDARS, STICKERS, STATIONERY; LOG BOOKS, PAPER, PAPER BANNERS, PAPER PENNANTS, APPOINTMENT BOOKS, ADDRESS BOOKS, DIARIES, DECALS, WRAPPING PAPER, NOTEBOOKS, NOTE PADS, POSTERS, PRINTS, GREETING CARDS, BOOK COVERS, BLANK JOURNALS, DAY PLANNERS; EXERCISE BOOKS; CARTOON PRINTS; CARTOON STRIPS; EDUCATIONAL PRODUCTS, NAMELY, PRINTED EDUCATIONAL MATERIALS IN THE FIELDS OF HEALTH, FITNESS, MOTIVATION, EXERCISE, WELLNESS, NUTRITION AND HEALTHY LIFESTYLES (U.S. CLS. 2, 5, 22, 23, 29, 37, 38 AND 50).

CLASS 21—HOUSEWARES AND GLASS

FOR PLASTIC WATER BOTTLES SOLD EMPTY; MUGS, CONTAINERS FOR HOUSEHOLD USE (U.S. CLS. 2, 13, 23, 29, 30, 33, 40 AND 50).

CLASS 25—CLOTHING

FOR CLOTHING, NAMELY, TOPS; BOTTOMS; SHIRTS; PANTS; SHORTS; HEADWEAR; FOOTWEAR; UNDERWEAR; COATS, JACKETS, SCARVES, GLOVES, MITTENS, VESTS, SWEATERS, SWEATSHIRTS, HOODED SWEATSHIRTS, PARKAS, PULLOVERS; SWIM WEAR; SWEAT BANDS, WRIST BANDS, HEAD BANDS, BANDANAS, BELTS, HATS, CAPS, AND NECKWEAR (U.S. CLS. 22 AND 39).

CLASS 26—FANCY GOODS

FOR ORNAMENTAL BUTTONS AND PINS (U.S. CLS. 37, 39, 40, 42 AND 50).

CLASS 28—TOYS AND SPORTING GOODS

FOR EXERCISE MACHINES; EXERCISE WEIGHTS; EXERCISE BARS, EXERCISE BENCHES, EXERCISE BALLS, EXERCISE PLATFORMS, EXERCISE TABLES, PERSONAL EXERCISE MATS, STATIONARY EXERCISE BICYCLES, EXERCISE TREADMILLS, EXERCISE WEIGHT CUFFS, EXERCISE RESISTANCE BANDS, EXERCISE RESISTANCE CORDS, JUMP ROPES, MEDICINE BALLS, AEROBIC STEP MACHINES, AEROBIC STEPS, ANKLE AND WRIST WEIGHTS FOR EXERCISE, DUMBBELLS, BARBELLS, EXERCISE ROWING MACHINES, EXERCISE TRAMPOLINES, EXERCISE GLOVES, WORK-OUT GLOVES, WEIGHT LIFTING BELTS, YOGA MATS, BAGS SPECIALLY ADAPTED FOR EXERCISE EQUIPMENT; BALLS FOR SPORTS, HANDBALLS, BOXING GLOVES, BOXING BAGS, TRAINING APPARATUS FOR BOXING, MARTIAL ARTS AND SIMILAR SPORTS, PUNCHING BALLS, ELBOW PADS FOR ATHLETIC USE, HAND PADS FOR ATHLETIC USE, KNEE PADS FOR ATHLETIC USE, SHIN PADS FOR ATHLETIC USE, BAGS SPECIALLY ADAPTED FOR SPORTS EQUIPMENT, ELECTRONIC SPORTS TRAINING SIMULATORS, NETS FOR SPORTS, BATS FOR GAMES, LACROSSE BALL BAGS, LACROSSE BALLS, LACROSSE GLOVES, LACROSSE STICK HANDLES, LACROSSE STICK HEADS, LACROSSE STICKS, GYMNASIUM APPARATUS; FLYING DISCS, BENDABLE TOYS, CHILDREN'S MULTIPLE ACTIVITY TOYS, TOY FIGURES, CONSTRUCTION TOYS, DISC TOSS TOYS, ELECTRIC ACTION TOYS, INFLATABLE TOYS, MECHANICAL TOYS, MUSICAL TOYS, PUSH TOYS, PULL TOYS, WATER SQUIRTING TOYS, SAND TOYS, TOY VEHICLES, STACKING TOYS, TALKING TOYS, TOY SCOOTERS, WIND-UP TOYS, ACTION SKILL GAMES, ARCADE GAMES, BOARD GAMES, CARD GAMES, COIN-OPERATED VIDEO GAMES, ELECTRONIC EDUCATIONAL GAME MACHINES FOR CHILDREN, GAME TABLES, MANIPULATIVE GAMES, PARLOR GAMES, PARTY GAMES, PINBALL GAMES, PLAYING CARDS, PUZZLES, TARGET GAMES, TRADING CARD GAMES, STAND ALONE VIDEO GAME MACHINES, BEACH BALLS, BALLOONS, JUNGLE GYMS; PLAYGROUND EQUIPMENT, NAMELY, PLAYGROUND BALLS, PLAYGROUND CLIMBING UNITS, PLAYGROUND SAND BOXES, PLAYGROUND SLIDES, PLAYGROUND SWING SETS (U.S. CLS. 22, 23, 38 AND 50).

CLASS 29—MEATS AND PROCESSED FOODS

FOR BEEF; BUTTER; BUTTER SUBSTITUTES; CHEESE; CHICKEN; CHILI; COOKING OIL; DAIRY-BASED BEVERAGES; DAIRY PRODUCTS EXCLUDING ICE CREAM, ICE MILK AND FROZEN YOGURT; DIPS; EDIBLE OILS; FISH; FRUIT PRESERVES; FRUIT-BASED FOOD BEVERAGES; FRUIT-BASED SNACK FOODS; FRUIT-BASED SPREADS; JAMS; JELLIES; JERKY; MEAT; MILK; OLIVE OIL; PEANUT BUTTER; POULTRY; PROCESSED FRUITS; PROCESSED VEGETABLES; SALADS EXCEPT MACARONI, RICE, AND PASTA SALAD; SEAFOOD; SHELLFISH; SNACK MIX CONSISTING PRIMARILY OF PROCESSED FRUITS, PROCESSED NUTS AND/OR RAISINS; SOUPS; SOY PROTEIN FOR USE AS A FOOD ADDITIVE; SOY-BASED FOOD BARS; SOY-BASED SNACK FOODS; SOY MILK; TOFU; TURKEY; VEAL; VEGETABLE-BASED FOOD BEVERAGES; VEGETABLE-BASED MEAT SUBSTITUTES; VEGETABLE-BASED SNACK FOODS; VEGETABLE-BASED SPREADS; WHEY; WHIPPED TOPPING; YOGURT; YOGURT DRINKS; FROZEN, PREPARED OR PACKAGED MEALS CONSISTING PRIMARILY OF MEAT, FISH, POULTRY OR VEGETABLES (U.S. CL. 46).

CLASS 30—STAPLE FOODS

FOR BREAKFAST CEREALS; READY TO EAT, CEREAL DERIVED FOOD BARS, CEREAL-BASED ENERGY BARS; CEREAL-BASED SNACK FOODS; PROCESSED CEREALS; BAKERY PRODUCTS; BREAD; CANDY; CHEWING GUM; CHOCOLATE; COFFEE; DOUGH; FLAVORED ICES; FLAVOURINGS; FLOUR; FROZEN YOGURT; FRUIT ICES; GLUTEN; GRAIN-BASED BEVERAGES; GRAIN-BASED FOOD BEVERAGES; GRAIN-BASED SNACK FOODS; GRANOLA; GRANOLA SNACKS; HONEY; ICE; ICE CREAM; ICE CREAM DRINKS; ICING; MARINADES; MIXES FOR BAKERY GOODS; NOODLES; OATMEAL; PASTA; PASTRIES; POPCORN; PRETZELS; PROCESSED GRAINS; PROCESSED HERBS; RICE; SALT; PEPPER; SALAD DRESSING; SANDWICHES; SALSA; SAUCES; SEASONING; SHAKES; SHERBETS; SORBET; SPICES; SUGAR; SUGAR SUBSTITUTES; SUGARFREE CANDIES; SUGARFREE CHEWING GUM; SUSHI; SWEETS; SUGARFREE SWEETS; TEA; VANILLA; VINEGAR; YEAST; YERBA MATE; FROZEN, PREPARED OR PACKAGED MEALS CONSISTING PRIMARILY OF PASTA OR RICE (U.S. CL. 46).

CLASS 32—LIGHT BEVERAGES

FOR FRUIT JUICES; SMOOTHIES; VEGETABLE JUICES; WHEY BEVERAGES; DRINKING WATERS; ENERGY DRINKS; FLAVORED WATERS; HERBAL JUICES; ISOTONIC BEVERAGES; MINERAL WATERS; SPARKLING WATERS; SPORTS DRINKS; SOFT DRINKS; SODA WATER (U.S. CLS. 45, 46 AND 48).

CLASS 35—ADVERTISING AND BUSINESS

FOR PROMOTING PUBLIC AWARENESS OF ISSUES RELATING TO HEALTH, FITNESS, MOTIVATION, EXERCISE, WELLNESS, NUTRITION, AND HEALTHY LIFESTYLES; ONLINE RETAIL STORE SERVICES, ONLINE ORDERING SERVICES, AND MAIL ORDER SERVICES FEATURING AUDIO AND VIDEO RECORDINGS, PAPER GOODS AND PRINTED MATTER, ELECTRONIC MEDIA, CLOTHING, CLOTHING ACCESSORIES, EXERCISE AND FITNESS PRODUCTS, SPORTING EQUIPMENT, TOYS, GAMES, AND PLAYTHINGS, KEY CHAINS, HOUSEHOLD GOODS, FOOD AND BEVERAGE, CONSUMER ELECTRONICS, AND GENERAL CONSUMER MERCHANDISE; ONLINE RETAIL STORE SERVICES FEATURING DOWNLOADABLE PRE-RECORDED MUSIC AND VIDEO; ADVERTISING AND PROMOTIONAL SERVICES; PUBLIC SERVICE PROGRAMS IN THE NATURE OF ORGANIZING AND CONDUCTING VOLUNTEER PROGRAMS (U.S. CLS. 100, 101 AND 102).

CLASS 38—COMMUNICATION

FOR PROVIDING ONLINE CHAT ROOMS AND ELECTRONIC BULLETIN BOARDS FOR TRANSMISSION OF MESSAGES AMONG USERS IN THE FIELDS OF HEALTH, FITNESS, MOTIVATION, EXERCISE, WELLNESS, NUTRITION AND HEALTHY LIFESTYLES; ELECTRONIC TRANSMISSION OF MESSAGES; INTERNET BROADCASTING SERVICES; ONLINE AUDIO AND VIDEO STREAMING SERVICES; AUDIO BROADCASTING; VIDEO BROADCASTING (U.S. CLS. 100, 101 AND 104).

CLASS 41—EDUCATION AND ENTERTAINMENT

FOR PHYSICAL FITNESS TRAINING SERVICES; SPORTS TRAINING SERVICES; PROVIDING INFORMATION IN THE FIELD OF EXERCISE TRAINING; PROVIDING INFORMATION IN THE FIELDS OF FITNESS, FITNESS MOTIVATION, AND EXERCISE; BOOK PUBLISHING SERVICES; MAGAZINE PUBLISHING SERVICES; PUBLISHING OF ELECTRONIC PUBLICATIONS; DIGITAL VIDEO, AUDIO, AND MULTIMEDIA PUBLISHING SERVICES; PROVIDING A WEBSITE FEATURING ONLINE RESOURCE GUIDES IN THE FIELDS OF FITNESS, FITNESS MOTIVATION, AND EXERCISE; PROVIDING A WEBSITE FEATURING AUDIO, VIDEO, WEBCASTS, PODCASTS, PHOTO-

GRAPHS, GAMES, AND OTHER MULTIMEDIA MATERIALS IN THE FIELDS OF FITNESS, FITNESS MOTIVATION, AND EXERCISE; PHYSICAL FITNESS INSTRUCTION; PROVIDING MOTIVATIONAL SPEAKERS; PERSONAL APPEARANCES BY A FITNESS TRAINER; MUSIC PUBLISHING SERVICES; AUDIO AND VIDEO RECORDING SERVICES; AUDIO AND VIDEO PRODUCTION SERVICES; MUSIC VIDEO PRODUCTION; PROVIDING A WEBSITE IN THE FIELD OF MUSIC; EDUCATIONAL SEMINARS, CONFERENCES, CLASSES, AND WORKSHOPS IN THE FIELDS OF HEALTH, FITNESS, MOTIVATION, EXERCISE, WELLNESS, NUTRITION AND HEALTHY LIFESTYLES, AND DISTRIBUTING COURSE MATERIALS IN CONNECTION THEREWITH; TELEVISION SHOW PRODUCTION; ENTERTAINMENT IN THE NATURE OF AN ON-GOING VARIETY, NEWS, MUSIC OR COMEDY SHOW ABOUT HEALTH, FITNESS, MOTIVATION, EXERCISE, WELLNESS, NUTRITION AND HEALTHY LIFESTYLES BROADCAST OVER TELEVISION, SATELLITE, AUDIO, AND VIDEO MEDIA; ENTERTAINMENT SERVICES, NAMELY, A MULTIMEDIA PROGRAM SERIES FEATURING INSTRUCTION, COMEDY, ACTION AND ADVENTURE DISTRIBUTED VIA VARIOUS PLATFORMS ACROSS MULTIPLE FORMS OF TRANSMISSION MEDIA; DISTRIBUTION OF TELEVISION PROGRAMS FOR OTHERS; DISTRIBUTION OF MOTION PICTURE FILMS; FILM PRODUCTION; ENTERTAINMENT SERVICES, NAMELY, PRODUCTION AND DISTRIBUTION OF A TELEVISION SHOWS AND FILMS (U.S. CLS. 100, 101 AND 107).

CLASS 44—MEDICAL, BEAUTY AND AGRICULTURAL SERVICES

FOR PROVIDING INFORMATION IN THE FIELDS OF HEALTH, WELLNESS, NUTRITION, AND HEALTHY LIFESTYLES; PROVIDING A WEBSITE FEATURING ONLINE RESOURCE GUIDES IN THE FIELDS OF HEALTH, WELLNESS, NUTRITION, AND HEALTHY LIFESTYLES; PROVIDING A WEBSITE FEATURING AUDIO, VIDEO, WEBCASTS, PODCASTS, PHOTOGRAPHS, GAMES, AND OTHER MULTIMEDIA MATERIALS IN THE FIELDS OF HEALTH, WELLNESS, NUTRITION, AND HEALTHY LIFESTYLES (U.S. CLS. 100 AND 101).

CLASS 45—PERSONAL AND LEGAL SERVICES

FOR PERSONAL GROWTH AND MOTIVATION CONSULTING SERVICES; PROVIDING INFORMATION IN THE FIELD OF PERSONAL MOTIVATION; PROVIDING A WEBSITE FEATURING ONLINE RESOURCE GUIDES IN THE FIELD OF PERSONAL MOTIVATION; PROVIDING A WEBSITE FEATURING AUDIO, VIDEO, WEBCASTS, PODCASTS, PHOTOGRAPHS, GAMES, AND OTHER MULTIMEDIA MATERIALS IN THE FIELD OF PERSONAL MOTIVATION (U.S. CLS. 100 AND 101).

LEIGH CAROLINE CASE, EXAMINING ATTORNEY

SN 77-537,003. EXCHANGE MINERALS LIMITED, DUBAI, UNITED ARAB EMIR., FILED 8-1-2008.

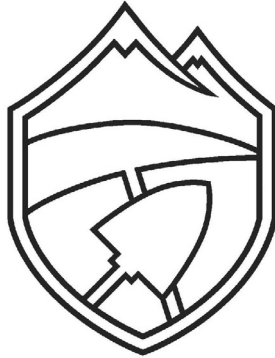

PRIORITY CLAIMED UNDER SEC. 44(D) ON UNITED KINGDOM APPLICATION NO. 2492939, FILED 7-17-2008.

THE MARK CONSISTS OF THE OUTLINE IMAGES OF A SHOVEL AND PICK INSIDE THE STYLIZED IMAGE OF A SHIELD; THE TOP OF THE SHIELD HAS TWO PEAKS SYMBOLIZING MOUNTAINS.

CLASS 36—INSURANCE AND FINANCIAL

FOR PROVISION OF FINANCIAL ANALYSES RELATING TO COMMODITIES AND COMMODITIES FINANCING RELATING TO THE ACQUISITION AND DEVELOPMENT OF MINERAL, OIL AND GAS RESOURCES; GEOLOGICAL ESTIMATION AND RESEARCH RELATING TO THE ACQUISITION AND DEVELOPMENT OF MINERAL, OIL AND GAS RESOURCES; EQUITY FINANCING RELATING TO THE ACQUISITION AND DEVELOPMENT OF MINERAL, OIL AND GAS RESOURCES (U.S. CLS. 100, 101 AND 102).

CLASS 42—SCIENTIFIC AND COMPUTER SERVICES

FOR RESEARCH RELATING TO MINERAL RESOURCES, NAMELY, TO THE ACQUISITION AND DEVELOPMENT OF MINERAL, OIL AND GAS RESOURCES; GEOLOGICAL ESTIMATION AND RESEARCH RELATING TO THE ACQUISITION AND DEVELOPMENT OF MINERAL, OIL AND GAS RESOURCES; METALLURGICAL ANALYSIS RELATING TO THE ACQUISITION AND DEVELOPMENT OF MINERAL, OIL AND GAS RESOURCES; ENGINEERING RESEARCH, SURVEYING, FEASIBILITY STUDIES AND CONSULTANCY RELATING TO THE ACQUISITION AND DEVELOPMENT OF MINERAL, OIL AND GAS RESOURCES (U.S. CLS. 100 AND 101).

DEIRDRE ROBERTSON, EXAMINING ATTORNEY

SN 77-537,090. CHARMIE INVESTMENTS LIMITED, ROAD TOWN, TORTOLA, BR. VIRGIN ISLANDS, FILED 8-1-2008.

PLUMA  DOWN

NO CLAIM IS MADE TO THE EXCLUSIVE RIGHT TO USE "PLUMA" AND "DOWN", APART FROM THE MARK AS SHOWN.

THE MARK CONSISTS OF THE WORDS "PLUMA DOWN" WITH A FEATHER DEVICE BETWEEN THESE TWO WORDS.

THE ENGLISH TRANSLATION OF "PLUMA" IN THE MARK IS FEATHER.

CLASS 20—FURNITURE AND ARTICLES NOT OTHERWISE CLASSIFIED

FOR BEDDING, NAMELY, BEDS AND MATTRESSES MADE OF FEATHER AND MADE IN WHOLE OR SUBSTANTIALLY IN PART OF DOWN (U.S. CLS. 2, 13, 22, 25, 32 AND 50).

CLASS 24—FABRICS

FOR FEATHER BEDS; COMFORTERS, AND DUVET COVERS, ALL MADE IN WHOLE OR SUBSTANTIALLY IN PART OF DOWN (U.S. CLS. 42 AND 50).

INGRID C. EULIN, EXAMINING ATTORNEY

SN 77-537,317. VISUAL HEALTH TOOLS, LLC, TUCSON, AZ. FILED 8-1-2008.

Wellness Color Score

THE MARK CONSISTS OF STANDARD CHARACTERS WITHOUT CLAIM TO ANY PARTICULAR FONT, STYLE, SIZE, OR COLOR.

NO CLAIM IS MADE TO THE EXCLUSIVE RIGHT TO USE "WELLNESS", APART FROM THE MARK AS SHOWN.

CLASS 16—PAPER GOODS AND PRINTED MATTER

FOR PRINTED CHARTS WITH PRINTED OR COMPUTER-GENERATED COLOR-CODED VALUES RESULTING FROM THE COMBINING OF ANSWERS TO QUESTIONS AND/OR SPECIFIC METRICS OF BODY SIZE BODILY FUNCTION AND/OR LABORATORY RESULT VALUES REPRESENTING AN OVERVIEW OF WHAT IS HAPPENING TO A PERSON'S BODY (U.S. CLS. 2, 5, 22, 23, 29, 37, 38 AND 50).

FIRST USE 4-30-2008; IN COMMERCE 4-30-2008.

CLASS 44—MEDICAL, BEAUTY AND AGRICULTURAL SERVICES

FOR PROVIDING ASSISTANCE, FITNESS EVALUATION AND CONSULTATION TO INDIVIDUALS TO HELP THEM MAKE HEALTH, WELLNESS AND NUTRITIONAL CHANGES IN THEIR DAILY LIVING TO IMPROVE HEALTH BY PROVIDING BUSINESSES AND INDIVIDUALS WITH A PRINTED OR COMPUTER-GENERATED COLOR CODED VALUES RESULTING FROM THE COMBINING OF ANSWERS TO QUESTIONS AND/OR SPECIFIC METRICS OF BODY SIZE BODILY FUNCTION AND/OR LABORATORY RESULT VALUES REPRESENTING AN OVERVIEW OF WHAT IS HAPPENING TO A PERSON'S BODY (U.S. CLS. 100 AND 101).

FIRST USE 4-30-2008; IN COMMERCE 4-30-2008.

KAPIL BHANOT, EXAMINING ATTORNEY

SN 77-537,703. LOCKHART UNLIMITED, INC., MARIETTA, GA. FILED 8-2-2008.

MOTOGOURMET

THE MARK CONSISTS OF STANDARD CHARACTERS WITHOUT CLAIM TO ANY PARTICULAR FONT, STYLE, SIZE, OR COLOR.

CLASS 35—ADVERTISING AND BUSINESS

FOR PROVIDING ON-LINE REVIEWS OF PRODUCTS AND COMPANIES (U.S. CLS. 100, 101 AND 102).

CLASS 41—EDUCATION AND ENTERTAINMENT

FOR ENTERTAINMENT SERVICES, NAMELY, CONTINUING VARIETY SHOWS BROADCASTING OVER TELEVISION, SATELLITE, RADIO, AUDIO, AND VIDEO MEDIA AND GLOBAL COMPUTER NETWORKS; PROVIDING ON-LINE PUBLICATIONS, NAMELY, NEWSLETTERS, BOOKS AND MAGAZINES IN THE FIELDS OF TRAVEL, VEHICLES, FOOD, COOKING, AND LIFESTYLE; PROVIDING AN ON-LINE DATABASE OF PRIVATE AND PUBLIC LEISURE FACILITIES AND EVENTS; PROVIDING ON-LINE REVIEWS OF COMPETITIONS AND EVENTS; CONDUCTING ON-LINE EXHIBITIONS AND DISPLAYS AND INTERACTIVE EXHIBITS; ARRANGING AND CONDUCTING FESTIVALS, EXHIBITIONS, FAIRS, EVENTS, AND OTHER RECREATIONAL ACTIVITIES EDUCATIONAL DEMONSTRATIONS, CONTESTS, COMPETITIONS, AND AWARD CEREMONIES, AND FAN CLUB SERVICES, ALL IN THE FIELDS OF TRAVEL, VEHICLES, FOOD, COOKING, AND LIFESTYLE (U.S. CLS. 100, 101 AND 107).

CLASS 42—SCIENTIFIC AND COMPUTER SERVICES

FOR HOSTING ON-LINE INTERNET COMMUNITIES FEATURING REVIEWS OF PRODUCTS AND COMPANIES, AND INFORMATION ON TRAVEL, VEHICLES, FOOD, COOKING, LIFESTYLE, PRIVATE AND PUBLIC LEISURE FACILITIES AND EVENTS, FESTIVALS AND RECREATIONAL ACTIVITIES (U.S. CLS. 100 AND 101).
KYLE PEETE, EXAMINING ATTORNEY

SN 77-538,610. COMPUTER SCIENCES CORPORATION, FALLS CHURCH, VA. FILED 8-4-2008.

TEAMRACK

THE MARK CONSISTS OF STANDARD CHARACTERS WITHOUT CLAIM TO ANY PARTICULAR FONT, STYLE, SIZE, OR COLOR.

CLASS 9—ELECTRICAL AND SCIENTIFIC APPARATUS

FOR COMPUTER NETWORK HARDWARE FOR COMPUTER SERVERS, NAMELY, ROUTERS, SWITCHES, NETWORK ADAPTERS, HUBS, MULTIPLEXERS, TERMINATORS, REPEATERS, AND TRANSCEIVERS (U.S. CLS. 21, 23, 26, 36 AND 38).

CLASS 42—SCIENTIFIC AND COMPUTER SERVICES

FOR COMPUTER SERVICES, NAMELY, CUSTOMIZATION AND INTEGRATION OF COMPUTER SERVERS AND APPLICATION SOFTWARE USED ON COMPUTER SERVERS (U.S. CLS. 100 AND 101).
JUSTINE D. PARKER, EXAMINING ATTORNEY

SN 77-538,629. TORAY KABUSHIKI KAISHA (TORAY INDUSTRIES, INC.), CHUO-KU, TOKYO, JAPAN, FILED 8-4-2008.

INNOVARAY

THE MARK CONSISTS OF STANDARD CHARACTERS WITHOUT CLAIM TO ANY PARTICULAR FONT, STYLE, SIZE, OR COLOR.

PRIORITY CLAIMED UNDER SEC. 44(D) ON JAPAN APPLICATION NO. 2008-059928, FILED 7-23-2008.

PRIORITY CLAIMED UNDER SEC. 44(D) ON JAPAN APPLICATION NO. 2008-053163, FILED 7-18-2008, REG. NO. 5212187, DATED 3-6-2009, EXPIRES 3-6-2019.

CLASS 24—FABRICS

FOR WOVEN AND KNITTED TEXTILE FABRICS MADE WHOLLY OR PARTLY OF SYNTHETIC FIBER AND USED FOR MANUFACTURE OF CLOTHING (U.S. CLS. 42 AND 50).

CLASS 25—CLOTHING

FOR CLOTHING, NAMELY, SHIRTS, DRESSES, PANTS, SUITS, COATS, JACKETS, JUMPERS, TROUSERS, SKIRTS, JERSEYS, BLOUSES, SKI WEAR, BIKE SUITS, TENNIS WEAR, WARM-UP SUITS, JUMP SUITS, ATHLETIC PANTS, SKATING OUTFITS, RAINWEAR, ANORAKS, ATHLETIC UNIFORMS, OUTDOOR WEAR, NAMELY, VESTS AND SHORTS, SWIM SUITS, SCHOOL UNIFORMS, SHORTS, TRUNKS, PAJAMAS, GOWNS, STOCKINGS, PANTY-STOCKINGS, PETTICOATS, SOCKS, TIGHTS, INFANT CLOTH DIAPERS AND INFANT DIAPER COVERS, UNDERWEAR; HEADWEAR AND FOOTWEAR (U.S. CLS. 22 AND 39).
BRENDAN REGAN, EXAMINING ATTORNEY

SN 77-538,763. ATLANTIC REPRESENTATIONS, INC., DBA ATLANTIC INC., SANTA FE SPRINGS, CA. FILED 8-4-2008.



OWNER OF U.S. REG. NO. 3,481,079.
NO CLAIM IS MADE TO THE EXCLUSIVE RIGHT TO USE "GAME", APART FROM THE MARK AS SHOWN.

THE MARK CONSISTS OF RECTANGLE COMPRISING THE STYLIZED WORDING "GAME KEEPER" AND A STYLIZED DEPICTION OF A CONTROLLER.

CLASS 9—ELECTRICAL AND SCIENTIFIC APPARATUS

FOR PROTECTIVE HARD AND SOFT NON-METAL CONTAINERS FOR VIDEO GAMES AND VIDEO GAME EQUIPMENT THAT ARE USED WITH AN EXTERNAL DISPLAY SCREEN OR MONITOR; PROTECTIVE CARRYING CASES SPECIALLY ADAPTED FOR VIDEO GAME INTERACTIVE HAND HELD REMOTE CONTROLS FOR PLAYING ELECTRONIC GAMES (U.S. CLS. 21, 23, 26, 36 AND 38).

SN 77-542,368. KT INDUSTRIES, INC., SHELDON, IA. FILED 8-8-2008.

**CLASS 20—FURNITURE AND ARTICLES NOT OTHERWISE CLASSIFIED**

FOR STORAGE RACKS AND CABINETS FOR VIDEO GAMES AND VIDEO GAME EQUIPMENT (U.S. CLS. 2, 13, 22, 25, 32 AND 50).

NO CLAIM IS MADE TO THE EXCLUSIVE RIGHT TO USE "INDUSTRIES INC.", APART FROM THE MARK AS SHOWN.

THE MARK CONSISTS OF THE WORDING, "KT INDUSTRIES INC.", AND RECTANGLE DESIGN.

CLASS 28—TOYS AND SPORTING GOODS

FOR PROTECTIVE CARRYING CASES SPECIALLY ADAPTED FOR HANDHELD VIDEO GAMES (U.S. CLS. 22, 23, 38 AND 50).

FRÉD MANDIR, EXAMINING ATTORNEY

CLASS 7—MACHINERY

FOR ELECTRIC WELDING MACHINES AND GAS WELDING MACHINES (U.S. CLS. 13, 19, 21, 23, 31, 34 AND 35).

FIRST USE 0-0-1987; IN COMMERCE 0-0-1987.

CLASS 8—HAND TOOLS

FOR HAND TOOLS, NAMELY, WRENCHES, SOCKETS AND RATCHETS, AND TOOLS FOR WELDING, NAMELY, TOOLS FOR MARKING, STRIKING, AND GRINDING (U.S. CLS. 23, 28 AND 44).

FIRST USE 0-0-1982; IN COMMERCE 0-0-1982.

RICHARD A. STRASER, EXAMINING ATTORNEY

SN 77-539,588. EZ TRIGGER, HOUSTON, TX. FILED 8-5-2008.

EZ TRIGGER

SN 77-543,439. TOKARIK, CRAIG, CREAM RIDGE, NJ. FILED 8-11-2008.

CAR DIAPER

THE MARK CONSISTS OF STANDARD CHARACTERS WITHOUT CLAIM TO ANY PARTICULAR FONT, STYLE, SIZE, OR COLOR.

NO CLAIM IS MADE TO THE EXCLUSIVE RIGHT TO USE "TRIGGER", APART FROM THE MARK AS SHOWN.

CLASS 7—MACHINERY

FOR DOWNHOLE OILFIELD TOOL FOR DOWNHOLE CONVEYANCE AND SETTING OF EQUIPMENT, NAMELY, WELL PACKERS AND BRIDGE PLUGS ADAPTED TO ISOLATE THE FLOW OF FLUIDS TO OR FROM GEOLOGIC FORMATIONS IN OIL AND GAS WELLS, AND WHICH CAN BE ACTUATED UPON RECEIPT OF A TRANSMITTED ELECTRIC CURRENT OR SIGNAL (U.S. CLS. 13, 19, 21, 23, 31, 34 AND 35).

THE MARK CONSISTS OF STANDARD CHARACTERS WITHOUT CLAIM TO ANY PARTICULAR FONT, STYLE, SIZE, OR COLOR.

NO CLAIM IS MADE TO THE EXCLUSIVE RIGHT TO USE "CAR", APART FROM THE MARK AS SHOWN.

CLASS 9—ELECTRICAL AND SCIENTIFIC APPARATUS

FOR DOWNHOLE OILFIELD TOOL FOR DOWNHOLE CONVEYANCE AND SETTING OF EQUIPMENT, NAMELY, DOWNHOLE SURVEY AND MEASUREMENT EQUIPMENT, FLOW REGULATORS USED IN OIL AND GAS WELLS, AND WHICH CAN BE ACTUATED UPON RECEIPT OF A TRANSMITTED ELECTRIC CURRENT OR SIGNAL (U.S. CLS. 21, 23, 26, 36 AND 38).

JOHN DWYER, EXAMINING ATTORNEY

CLASS 6—METAL GOODS

FOR REMOVABLE METAL PAN ATTACHED TO THE UNDERCARRIAGE OF A CAR TO COLLECT OIL DRIPPINGS (U.S. CLS. 2, 12, 13, 14, 23, 25 AND 50).

CLASS 20—FURNITURE AND ARTICLES NOT OTHERWISE CLASSIFIED

FOR REMOVABLE NON-METAL PAN ATTACHED TO THE UNDERCARRIAGE OF A CAR TO COLLECT OIL DRIPPINGS (U.S. CLS. 2, 13, 22, 25, 32 AND 50).

LIEF MARTIN, EXAMINING ATTORNEY

SN 77-543,820. AMERICAN EXPRESS MARKETING & DEVELOPMENT CORP., NEW YORK, NY. FILED 8-11-2008.

SN 77-544,057. TURTLE POND PUBLICATIONS LLC, NEW YORK, NY. FILED 8-11-2008.

NO DRAWING-SENSORY MARK

THE MARK IS A SOUND THAT CONSISTS OF THE THEME PLAYED BY BOTH VIOLIN AND CELLO AS FOLLOWS: FOUR CONSECUTIVE EIGHTH NOTES, A4, B4, C#5 AND E5, THE E5 TIED TO A HALF NOTE E5, WHICH IS FURTHER TIED TO A DOTTED QUARTER NOTE. THIS IS FOLLOWED BY THREE CONSECUTIVE EIGHTH NOTES, E4, B4 AND C#4. THIS IS FOLLOWED BY A QUARTER NOTE, A4 THAT IS TIED TO A A4 HALF NOTE WHICH FADES. THE CELLO PLAYS THE SAME NOTES AN OCTAVE LOWER. CHORDAL ACCOMPANIMENT UNDER THAT THEME IS AS FOLLOWS: THREE EIGHTH NOTES D MAJOR, TWO TIED EIGHTH NOTES FOLLOWED BY THREE UNTIED EIGHTH NOTES E MAJOR, THEN AN A MAJOR CHORD HELD FOR SIX BEATS INTO THE FADE.

CLASS 16—PAPER GOODS AND PRINTED MATTER

FOR PERIODIC MAGAZINES, NEWSLETTERS, BROCHURES AND LEAFLETS DEALING WITH TRAVEL, DINING AND HOTELS (U.S. CLS. 2, 5, 22, 23, 29, 37, 38 AND 50).

CLASS 35—ADVERTISING AND BUSINESS

FOR PROMOTING THE SALE OF GOODS AND SERVICES OF OTHERS BY AWARDED PURCHASE POINTS FOR CREDIT CARD USE (U.S. CLS. 100, 101 AND 102).

CLASS 36—INSURANCE AND FINANCIAL

FOR FINANCIAL SERVICES, NAMELY, CHARGE AND CREDIT CARD SERVICES; TRAVELERS CHECK ISSUANCE AND FINANCING SERVICES RELATED THERETO; BILL PAYMENT PROCESSING SERVICES; LIFE, HEALTH AND ACCIDENT INSURANCE UNDERWRITING SERVICES; INSURANCE ADMINISTRATION AND INSURANCE CLAIMS PROCESSING SERVICES; CREDIT CARD SERVICES, NAMELY, COMPUTERIZED CREDIT AUTHORIZATION (U.S. CLS. 100, 101 AND 102).

CLASS 39—TRANSPORTATION AND STORAGE

FOR TRAVEL AGENCY SERVICES, NAMELY, TRAVEL AND TOUR TICKET RESERVATION SERVICES; TOUR AND SIGHTSEEING RESERVATION SERVICES; ORGANIZING OF TOURS; ARRANGING THE TRANSPORTATION OF PASSENGERS BY LAND, AIR AND WATER; PERSONAL TOUR GUIDE SERVICES AND TOUR INFORMATION; ARRANGING FOR AUTOMOBILE AND BUS RENTALS (U.S. CLS. 100 AND 105).

CLASS 43—HOTEL AND RESTAURANT SERVICES

FOR MAKING HOTEL RESERVATIONS FOR OTHERS; RESERVATION OF HOTEL ROOMS FOR TRAVELERS (U.S. CLS. 100 AND 101).
JASON BLAIR, EXAMINING ATTORNEY

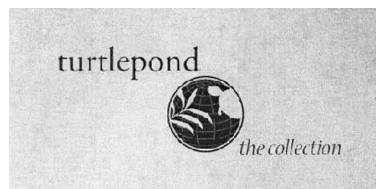

NO CLAIM IS MADE TO THE EXCLUSIVE RIGHT TO USE "COLLECTION", APART FROM THE MARK AS SHOWN.

THE MARK CONSISTS OF A GLOBE DESIGN WITH AN IMAGE OF A TURTLE AND A BRANCH WITH LEAVES UNDERNEATH THE WORD "TURTLEPOND" AND ABOVE THE WORDS "THE COLLECTION"; THE SHADED GRAY BACKGROUND IS NOT A FEATURE OF THE MARK.

CLASS 9—ELECTRICAL AND SCIENTIFIC APPARATUS

FOR DOWNLOADABLE SOFTWARE FOR INTERACTIVE STORYTELLING AND EDUCATIONAL GAMES AND ACTIVITIES FOR CHILDREN (U.S. CLS. 21, 23, 26, 36 AND 38).

CLASS 41—EDUCATION AND ENTERTAINMENT

FOR SERIES OF ANIMATIONS, NAMELY, ENTERTAINMENT SERVICES IN THE NATURE OF PROVIDING ONLINE ANIMATED PROGRAMS VIA THE INTERNET; ONLINE ENTERTAINMENT SERVICES IN THE NATURE OF STORYTELLING FOR CHILDREN; ONLINE ELECTRONIC PUBLISHING OF CHILDREN'S BOOKS, MAGAZINES AND PERIODICALS FEATURING CHILDREN'S ACTIVITIES AND STORIES (U.S. CLS. 100, 101 AND 107).

CLASS 42—SCIENTIFIC AND COMPUTER SERVICES

FOR PROVIDING ONLINE NON-DOWNLOADABLE SOFTWARE FOR INTERACTIVE STORYTELLING AND EDUCATIONAL GAMES AND ACTIVITIES FOR CHILDREN (U.S. CLS. 100 AND 101).

KAREN K. BUSH, EXAMINING ATTORNEY

SN 77-544,059. BIRST, INC., SAN FRANCISCO, CA. FILED 8-11-2008.

BIRST

THE MARK CONSISTS OF STANDARD CHARACTERS WITHOUT CLAIM TO ANY PARTICULAR FONT, STYLE, SIZE, OR COLOR.

CLASS 35—ADVERTISING AND BUSINESS

FOR BUSINESS MANAGEMENT SERVICES, NAMELY, PROVIDING BUSINESS INTELLIGENCE AND ANALYTICS MANAGEMENT SERVICES; BUSINESS MANAGEMENT CONSULTING SERVICES RELATING TO BUSINESS INTELLIGENCE, ANALYTICS, AND REPORTING; PROVIDING A WEBSITE WITH GENERAL INFORMATION OF INTEREST TO THE FIELDS OF BUSINESS INTELLIGENCE AND ANALYTICS (U.S. CLS. 100, 101 AND 102).

CLASS 41—EDUCATION AND ENTERTAINMENT

FOR EDUCATIONAL SERVICES, NAMELY, CONDUCTING SEMINARS, CONFERENCES, WORKSHOPS, AND WEB TRAINING IN THE FIELD OF BUSINESS INTELLIGENCE AND ANALYTICS; PROVIDING OF TRAINING IN THE FIELD OF BUSINESS INTELLIGENCE AND ANALYTICS; ARRANGING OF EDUCATIONAL EXHIBITIONS FOR EDUCATIONAL PURPOSES; ARRANGING AND HOLDING OF EDUCATIONAL CONFERENCES, CONGRESSES, AND SEMINARS IN THE FIELD OF BUSINESS INTELLIGENCE AND ANALYTICS; PUBLICATION OF NEWSPAPERS AND BOOKS; PUBLICATION OF TEXTS; ONLINE PUBLICATION OF BOOKS, MAGAZINES AND NEWSLETTERS IN THE FIELD OF BUSINESS INTELLIGENCE AND ANALYTICS SERVICES BY WAY OF INTERNATIONAL DATA NETWORKS (U.S. CLS. 100, 101 AND 107).

CLASS 42—SCIENTIFIC AND COMPUTER SERVICES

FOR PROVIDING TEMPORARY USE OF ON-LINE NON-DOWNLOADABLE SOFTWARE FOR STORING, MANAGING, TRACKING, ANALYZING, AND SHARING DATA IN THE FIELDS OF BUSINESS, MARKETING, SALES, BUSINESSES OPERATIONS, BUSINESS MANAGEMENT, FINANCE, ACADEMIA, PERSONAL DATA, AND GOVERNMENT; PROVIDING TEMPORARY USE OF ON-LINE NON-DOWNLOADABLE SOFTWARE TO CREATE AND SHARE STATISTICAL AND MANAGEMENT REPORTS AND CHARTS IN THE FIELDS OF BUSINESS, MARKETING, SALES, BUSINESSES OPERATIONS, BUSINESS MANAGEMENT, FINANCE, ACADEMIA, PERSONAL DATA, AND GOVERNMENT; TECHNICAL SUPPORT SERVICES FOR THE USE OF ON-LINE NON-DOWNLOADABLE SOFTWARE FOR STORING, MANAGING, TRACKING, ANALYZING, AND SHARING DATA THE FIELDS OF BUSINESS, MARKETING, SALES, BUSINESSES OPERATIONS, BUSINESS MANAGEMENT, FINANCE, ACADEMIA, PERSONAL DATA, AND GOVERNMENT (U.S. CLS. 100 AND 101).

KAREN K. BUSH, EXAMINING ATTORNEY

SN 77-545,316. ARAMARK CORPORATION, PHILADELPHIA, PA. FILED 8-12-2008.

IMPACT IN ACTION

THE MARK CONSISTS OF STANDARD CHARACTERS WITHOUT CLAIM TO ANY PARTICULAR FONT, STYLE, SIZE, OR COLOR.

CLASS 35—ADVERTISING AND BUSINESS

FOR MANAGEMENT OF HOSPITALS AND MEDICAL FACILITIES; EMPLOYMENT STAFFING IN THE FIELD OF MEDICAL AND HOSPITAL ORDERLIES (U.S. CLS. 100, 101 AND 102).

CLASS 37—CONSTRUCTION AND REPAIR

FOR BUILDING AND FACILITIES MAINTENANCE SERVICES (U.S. CLS. 100, 103 AND 106).

CLASS 41—EDUCATION AND ENTERTAINMENT

FOR EDUCATIONAL SERVICES, NAMELY, TRAINING SERVICES IN THE FIELDS OF FOOD SERVICES, JANITORIAL SERVICES, FACILITIES MAINTENANCE, AND FACILITIES MANAGEMENT SERVICES (U.S. CLS. 100, 101 AND 107).

CLASS 43—HOTEL AND RESTAURANT SERVICES

FOR RESTAURANTS; RESTAURANT SERVICES; CONTRACT FOOD SERVICES (U.S. CLS. 100 AND 101).
JOHN GARTNER, EXAMINING ATTORNEY

SN 77-547,337. NEXTENERGY, INC, ELMIRA, CANADA, FILED 8-14-2008.



THE MARK CONSISTS OF AN IMAGE OF A DISTANT HOUSE WITH A HEATING VENT IN THE LAWN IN THE FOREGROUND.

CLASS 11—ENVIRONMENTAL CONTROL APPARATUS

FOR GEOTHERMAL HEAT PUMPS (U.S. CLS. 13, 21, 23, 31 AND 34).

CLASS 35—ADVERTISING AND BUSINESS

FOR BUSINESS MARKETING SERVICES TO DEALERS OF GEOTHERMAL HEATING EQUIPMENT (U.S. CLS. 100, 101 AND 102).

DOUGLAS LEE, EXAMINING ATTORNEY

SN 77-547,347. NEXTENERGY, INC, ELMIRA, CANADA, FILED 8-14-2008.

**Geothermal Your Land.
Your Energy.**

THE MARK CONSISTS OF STANDARD CHARACTERS WITHOUT CLAIM TO ANY PARTICULAR FONT, STYLE, SIZE, OR COLOR.

NO CLAIM IS MADE TO THE EXCLUSIVE RIGHT TO USE "GEOTHERMAL", APART FROM THE MARK AS SHOWN.

**CLASS 11—ENVIRONMENTAL CONTROL AP-
PARATUS**

FOR GEOTHERMAL HEAT PUMPS (U.S. CLS. 13, 21,
23, 31 AND 34).

CLASS 35—ADVERTISING AND BUSINESS

FOR BUSINESS MARKETING SERVICES TO DEAL-
ERS OF GEOTHERMAL HEATING EQUIPMENT (U.S.
CLS. 100, 101 AND 102).

DOUGLAS LEE, EXAMINING ATTORNEY



SN 77-547,365. NEXTENERGY, INC, ELMIRA, CANADA,
FILED 8-14-2008.

Energy From the Ground Up

THE MARK CONSISTS OF STANDARD CHARACTERS
WITHOUT CLAIM TO ANY PARTICULAR FONT, STYLE,
SIZE, OR COLOR.

**CLASS 11—ENVIRONMENTAL CONTROL AP-
PARATUS**

FOR GEOTHERMAL HEAT PUMPS (U.S. CLS. 13, 21,
23, 31 AND 34).

CLASS 35—ADVERTISING AND BUSINESS

FOR BUSINESS MARKETING SERVICES TO DEAL-
ERS OF GEOTHERMAL HEATING EQUIPMENT (U.S.
CLS. 100, 101 AND 102).

DOUGLAS LEE, EXAMINING ATTORNEY



SN 77-547,378. NEXTENERGY, INC, ELMIRA, CANADA,
FILED 8-14-2008.



THE MARK CONSISTS OF TWO WAVY LINES.

**CLASS 11—ENVIRONMENTAL CONTROL AP-
PARATUS**

FOR GEOTHERMAL HEAT PUMPS (U.S. CLS. 13, 21,
23, 31 AND 34).

CLASS 35—ADVERTISING AND BUSINESS

FOR BUSINESS MARKETING SERVICES TO DEAL-
ERS OF GEOTHERMAL HEATING EQUIPMENT (U.S.
CLS. 100, 101 AND 102).

DOUGLAS LEE, EXAMINING ATTORNEY

SN 77-547,844. ARAMARK CORPORATION, PHILADEL-
PHIA, PA. FILED 8-15-2008.

**BEST CARE, BEST
ENVIRONMENTS**

THE MARK CONSISTS OF STANDARD CHARACTERS
WITHOUT CLAIM TO ANY PARTICULAR FONT, STYLE,
SIZE, OR COLOR.

OWNER OF U.S. REG. NO. 2,965,110.

CLASS 35—ADVERTISING AND BUSINESS

FOR MANAGEMENT OF HOSPITALS AND MEDICAL
FACILITIES; EMPLOYMENT STAFFING IN THE FIELD
OF MEDICAL AND HOSPITAL ORDERLIES (U.S. CLS.
100, 101 AND 102).

CLASS 37—CONSTRUCTION AND REPAIR

FOR BUILDING AND FACILITIES MAINTENANCE
SERVICES (U.S. CLS. 100, 103 AND 106).

**CLASS 41—EDUCATION AND ENTERTAIN-
MENT**

FOR EDUCATIONAL SERVICES, NAMELY, TRAIN-
ING SERVICES IN THE FIELDS OF FOOD SERVICES,
JANITORIAL SERVICES, FACILITIES MAINTENANCE,
AND FACILITIES MANAGEMENT SERVICES (U.S. CLS.
100, 101 AND 107).

**CLASS 43—HOTEL AND RESTAURANT SER-
VICES**

FOR RESTAURANTS; RESTAURANT SERVICES;
CONTRACT FOOD SERVICES (U.S. CLS. 100 AND 101).

JOHN GARTNER, EXAMINING ATTORNEY



SN 77-547,941. KNORR-NÄHRMITTEL AKTIENGE-
SELLSCHAFT, THAYNGEN, SWITZERLAND, FILED 8-
15-2008.

**CADA COMIDA ES UNA
OPORTUNIDAD**

THE MARK CONSISTS OF STANDARD CHARACTERS
WITHOUT CLAIM TO ANY PARTICULAR FONT, STYLE,
SIZE, OR COLOR.

THE ENGLISH TRANSLATION OF "CADA COMIDA ES
UNA OPORTUNIDAD" IN THE MARK IS EVERY MEAL IS
AN OPPORTUNITY.

CLASS 29—MEATS AND PROCESSED FOODS

FOR MEAT, FISH, POULTRY AND GAME; MEAT
EXTRACTS; PRESERVED, DRIED AND COOKED
FRUITS AND VEGETABLES; JELLIES, JAMS, COM-
POTES; EGGS, MILK AND MILK PRODUCTS, NAMELY,
MILK PRODUCTS EXCLUDING ICE CREAM, ICE MILK
AND FROZEN YOGURT; EDIBLE OILS AND FATS (U.S.
CL. 46).

CLASS 30—STAPLE FOODS

FOR COFFEE, TEA, COCOA, SUGAR, RICE, TAPIOCA, SAGO, ARTIFICIAL COFFEE; FLOUR, BREAD, ICES; HONEY, TREACLE; YEAST, BAKING-POWDER; SALT, MUSTARD; VINEGAR, SAUCES; CONDIMENTS, NAMELY, HERBS AND SEASONINGS, DIP SAUCES; SPICES; ICE (U.S. CL. 46).

MICHAEL ENGEL, EXAMINING ATTORNEY

SN 77-549,071. BHI ADVANCED INTERNET, EDEN PRAIRIE, MN. FILED 8-18-2008.

BHI

THE MARK CONSISTS OF STANDARD CHARACTERS WITHOUT CLAIM TO ANY PARTICULAR FONT, STYLE, SIZE, OR COLOR.

CLASS 38—COMMUNICATION

FOR ELECTRONIC MAIL AND MESSAGING SERVICES AND PROVISION OF ACCESS TO THE INTERNET (U.S. CLS. 100, 101 AND 104).

FIRST USE 5-31-2003; IN COMMERCE 5-31-2003.

CLASS 42—SCIENTIFIC AND COMPUTER SERVICES

FOR BACK-UP SERVICES FOR COMPUTER HARD DRIVE DATA, EXCLUDING DATA AND DOCUMENTS FOR USE IN THE HEALTHCARE FIELD; COMPUTER COLOCATION SERVICES, NAMELY, PROVIDING FACILITIES FOR THE LOCATION OF COMPUTER SERVERS WITH THE EQUIPMENT OF OTHERS; COMPUTER SECURITY SERVICES, NAMELY, RESTRICTING ACCESS TO AND BY COMPUTER NETWORKS TO AND OF UNDESIRE WEB SITES, MEDIA AND INDIVIDUALS AND FACILITIES; AND HOSTING THE WEB SITES OF OTHERS ON A COMPUTER SERVER FOR A GLOBAL COMPUTER NETWORK (U.S. CLS. 100 AND 101).

FIRST USE 5-31-2003; IN COMMERCE 5-31-2003.
PAUL CROWLEY, EXAMINING ATTORNEY

SN 77-549,074. BHI ADVANCED INTERNET, EDEN PRAIRIE, MN. FILED 8-18-2008.



NO CLAIM IS MADE TO THE EXCLUSIVE RIGHT TO USE "ADVANCED INTERNET SOLUTIONS", APART FROM THE MARK AS SHOWN.

THE COLOR(S) YELLOW AND BLACK IS/ARE CLAIMED AS A FEATURE OF THE MARK.

THE MARK CONSISTS OF A BLACK SPHERE SURROUNDED BY A YELLOW RING. TO THE RIGHT OF THE DESIGN IS THE WORDS "BHI" IN YELLOW. BELOW THE DESIGN AND "BHI" ARE THE WORDS "ADVANCED INTERNET SOLUTIONS" IN BLACK.

CLASS 38—COMMUNICATION

FOR ELECTRONIC MAIL AND MESSAGING SERVICES AND PROVISION OF ACCESS TO THE INTERNET (U.S. CLS. 100, 101 AND 104).

FIRST USE 5-31-2003; IN COMMERCE 5-31-2003.

CLASS 42—SCIENTIFIC AND COMPUTER SERVICES

FOR BACK-UP SERVICES FOR COMPUTER HARD DRIVE DATA, EXCLUDING DATA AND DOCUMENTS FOR USE IN THE HEALTHCARE FIELD; COMPUTER COLOCATION SERVICES, NAMELY, PROVIDING FACILITIES FOR THE LOCATION OF COMPUTER SERVERS WITH THE EQUIPMENT OF OTHERS; COMPUTER SECURITY SERVICES, NAMELY, RESTRICTING ACCESS TO AND BY COMPUTER NETWORKS TO AND OF UNDESIRE WEB SITES, MEDIA AND INDIVIDUALS AND FACILITIES; AND HOSTING THE WEB SITES OF OTHERS ON A COMPUTER SERVER FOR A GLOBAL COMPUTER NETWORK (U.S. CLS. 100 AND 101).

FIRST USE 5-31-2003; IN COMMERCE 5-31-2003.
PAUL CROWLEY, EXAMINING ATTORNEY

SN 77-549,422. FIRSTLINE MANUFACTURING CORPORATION, HOUSTON, TX. FILED 8-18-2008.

SLEEK

THE MARK CONSISTS OF STYLIZED RENDERING OF THE WORD "SLEEK".

CLASS 21—HOUSEWARES AND GLASS

FOR HAIR ACCESSORIES, NAMELY, HAIR COMBS AND HAIR BRUSHES (U.S. CLS. 2, 13, 23, 29, 30, 33, 40 AND 50).

CLASS 25—CLOTHING

FOR HAIR ACCESSORIES, NAMELY, SLEEP CAPS, SLEEP BONNETS, SHOWER CAPS, WRAP CAPS, BANDANAS, EXERCISE CAPS, HEAD BANDS, HEAD SCARVES; HEADWEAR, NAMELY, DO-RAGS AND STOCKING CAPS (U.S. CLS. 22 AND 39).

MARY CRAWFORD, EXAMINING ATTORNEY

SN 77-550,626. AARP, WASHINGTON, DC. FILED 8-19-2008.

**GROW OLD. EVERYBODY'S
DOING IT.**

THE MARK CONSISTS OF STANDARD CHARACTERS WITHOUT CLAIM TO ANY PARTICULAR FONT, STYLE, SIZE, OR COLOR.

CLASS 35—ADVERTISING AND BUSINESS

FOR ASSOCIATION SERVICES, NAMELY, PROMOTING THE INTERESTS OF MATURE INDIVIDUALS; PROMOTING PUBLIC AWARENESS AND ADVOCACY IN THE FIELDS OF CAREGIVING, CHILDCARE, EDUCATION, MEDICAL SERVICES, ELDERCARE, EMPLOYMENT, ASSISTED CARE FACILITIES, LEGAL ASSISTANCE, BUSINESS, INSURANCE, REAL ESTATE, TRAVEL, ELDER ASSISTANCE, RETIREMENT, MATURE OR RETIRED LIFESTYLES, FINANCE, HEALTH, AGING, FAMILY RELATIONSHIPS, VOLUNTEER ACTIVITIES, CONSUMER ISSUES, ECONOMIC SECURITY, WORK, INDEPENDENT LIVING, EXERCISE, FITNESS, ATHLETICS AND SPORTS; PROVIDING CONSUMER INFORMATION IN THE FIELDS OF INSURANCE, HEALTH CARE, DISCOUNT AND SAVINGS PLANS, ELDERCARE, MEDICAL PRODUCTS, PHARMACEUTICAL PRODUCTS AND SERVICES AND HEALTH PLANS; INCOME TAX PREPARATION SERVICES; ARRANGING, CONDUCTING AND ORGANIZING TRADE SHOWS IN THE FIELD OF MATURE PERSONS AND PERSONS PREPARING FOR RETIREMENT; AND ORGANIZING AND CONDUCTING COMMUNITY VOLUNTEER PROGRAMS; PROVIDING ONLINE MAGAZINES AND NEWSLETTERS PROMOTING THE INTERESTS OF MATURE INDIVIDUALS AND IN THE FIELDS OF CAREGIVING, CHILDCARE, EDUCATION, MEDICAL SERVICES, ELDERCARE, EMPLOYMENT, ASSISTED CARE FACILITIES, LEGAL ASSISTANCE, BUSINESS, INSURANCE, REAL ESTATE, TRAVEL, ELDER ASSISTANCE, RETIREMENT, MATURE OR RETIRED LIFESTYLES, FINANCE, HEALTH, AGING, FAMILY RELATIONSHIPS, VOLUNTEER ACTIVITIES, CONSUMER ISSUES, ECONOMIC SECURITY, WORK, INDEPENDENT LIVING, EXERCISE, FITNESS, ATHLETICS AND SPORTS (U.S. CLS. 100, 101 AND 102).

CLASS 41—EDUCATION AND ENTERTAINMENT

FOR EDUCATION AND TRAINING SERVICES, NAMELY, ARRANGING AND CONDUCTING CLASSES, ONLINE CLASSES, SEMINARS, CONFERENCES AND WORKSHOPS IN THE FIELDS OF CAREGIVING, CHILDCARE, EDUCATION, MEDICAL SERVICES, ELDERCARE, EMPLOYMENT, ASSISTED CARE FACILITIES, LEGAL ASSISTANCE, BUSINESS, INSURANCE, REAL ESTATE, TRAVEL, ELDER ASSISTANCE, RETIREMENT, MATURE OR RETIRED LIFESTYLES, FINANCE, HEALTH, AGING, FAMILY RELATIONSHIPS, VOLUNTEER ACTIVITIES, CONSUMER ISSUES, ECONOMIC SECURITY, WORK, INDEPENDENT LIVING, EXERCISE, FITNESS, ATHLETICS AND SPORTS, AND THE DISTRIBUTION OF COURSE MATERIALS IN CONNECTION THEREWITH; AND ARRANGING AND CONDUCTING EXERCISE, FITNESS, ATHLETIC AND SPORTS COMPETITIONS, CONTESTS, RACES AND EVENTS, AND CONSULTATION SERVICES PROVIDED IN CONNECTION THEREWITH (U.S. CLS. 100, 101 AND 107).

BRIDGETT SMITH, EXAMINING ATTORNEY

SN 77-551,333. SPINVOX LIMITED, MARLOW, ENGLAND, FILED 8-20-2008.

VOXU

THE MARK CONSISTS OF STANDARD CHARACTERS WITHOUT CLAIM TO ANY PARTICULAR FONT, STYLE, SIZE, OR COLOR.

CLASS 9—ELECTRICAL AND SCIENTIFIC APPARATUS

FOR COMPUTER SOFTWARE FOR USE IN PERFORMING VOICE TO TEXT CONVERSION PROCESSES AND TECHNIQUES (U.S. CLS. 21, 23, 26, 36 AND 38).

CLASS 35—ADVERTISING AND BUSINESS

FOR WHOLESALE AND RETAIL DISTRIBUTORSHIPS FEATURING PRODUCTS RELATING TO VOICE TO TEXT CONVERSION PROCESSES AND TECHNIQUES, NAMELY, INTERNET AND TELECOMMUNICATION TEXT BASED DEVICES (U.S. CLS. 100, 101 AND 102).

CLASS 38—COMMUNICATION

FOR TELECOMMUNICATION SERVICES, NAMELY, PROVIDING TRANSMISSION OF VOICE TO TEXT CONVERSION PROCESSES AND TECHNIQUES (U.S. CLS. 100, 101 AND 104).

CLASS 42—SCIENTIFIC AND COMPUTER SERVICES

FOR COMPUTER SERVICES, NAMELY, CROSS-PLATFORM VOICE TO TEXT CONVERSION PROCESSES AND TECHNIQUES (U.S. CLS. 100 AND 101).

ZACHARY BELLO, EXAMINING ATTORNEY

SN 77-551,532. RUSH FIELD HOCKEY, INC., ENCINITAS, CA. FILED 8-20-2008.

RUSH FIELD HOCKEY

THE MARK CONSISTS OF STANDARD CHARACTERS WITHOUT CLAIM TO ANY PARTICULAR FONT, STYLE, SIZE, OR COLOR.

NO CLAIM IS MADE TO THE EXCLUSIVE RIGHT TO USE "FIELD HOCKEY", APART FROM THE MARK AS SHOWN.

CLASS 35—ADVERTISING AND BUSINESS

FOR ASSOCIATION SERVICES, NAMELY, PROMOTING THE INTERESTS OF AMATEUR SPORTS TEAMS AND LEAGUES IN THE FIELD OF FIELD HOCKEY (U.S. CLS. 100, 101 AND 102).

FIRST USE 5-31-1998; IN COMMERCE 5-31-1998.

CLASS 41—EDUCATION AND ENTERTAINMENT

FOR ENTERTAINMENT SERVICES, NAMELY, PARTICIPATION IN VARIOUS SPORTS EVENTS IN THE FIELD OF FIELD HOCKEY; OPERATION OF SPORT CAMPS; ORGANIZING AND PROVIDING YOUTH SPORTS ACTIVITIES IN THE FORM OF TEAMS, LEAGUES, AND RELATED ACTIVITIES IN THE FIELD OF FIELD HOCKEY (U.S. CLS. 100, 101 AND 107).

FIRST USE 5-31-1998; IN COMMERCE 5-31-1998.

NICHOLAS COLEMAN, EXAMINING ATTORNEY

SN 77-553,823. JOSEPH SAYEGH, CORONA DEL MAR, CA.
FILED 8-22-2008.

ANTIQUERA

THE MARK CONSISTS OF STANDARD CHARACTERS WITHOUT CLAIM TO ANY PARTICULAR FONT, STYLE, SIZE, OR COLOR.

THE WORDING "ANTIQUERA" HAS NO MEANING IN A FOREIGN LANGUAGE.

CLASS 11—ENVIRONMENTAL CONTROL APPARATUS

FOR ORNAMENTAL FOUNTAINS, WATER FOUNTAINS (U.S. CLS. 13, 21, 23, 31 AND 34).

CLASS 19—NON-METALLIC BUILDING MATERIALS

FOR NON-METAL DOORS, NON-METAL TILES; SALVAGED NON-METAL ARCHITECTURAL COLUMNS; NON-METAL DECORATIVE MOLDINGS AND DECORATIVE TRIM FOR USE IN BUILDING CONSTRUCTION; WORKS OF ART OF STONE, MARBLE, AND GRANITE; STATUES AND SCULPTURES OF STONE (U.S. CLS. 1, 12, 33 AND 50).

CLASS 21—HOUSEWARES AND GLASS

FOR WORKS OF ART OF EARTHENWARE, PORCELAIN, TERRA COTTA; HEADS AND BUSTS OF EARTHENWARE, PORCELAIN, TERRA COTTA; STATUES AND SCULPTURES OF EARTHENWARE, PORCELAIN, AND TERRA COTTA (U.S. CLS. 2, 13, 23, 29, 30, 33, 40 AND 50).

VIVIAN MICZNIK FIRST, EXAMINING ATTORNEY

SN 77-554,724. ARROWPOINT CAPITAL CORP., CHARLOTTE, NC. FILED 8-25-2008.

ARROWPOINT ADVISORS

THE MARK CONSISTS OF STANDARD CHARACTERS WITHOUT CLAIM TO ANY PARTICULAR FONT, STYLE, SIZE, OR COLOR.

OWNER OF U.S. REG. NOS. 3,484,563 AND 3,484,564.

NO CLAIM IS MADE TO THE EXCLUSIVE RIGHT TO USE "ADVISORS", APART FROM THE MARK AS SHOWN.

CLASS 35—ADVERTISING AND BUSINESS

FOR CONSULTING SERVICES IN THE FIELD OF BUSINESS AUDITING AND INSURANCE CLAIMS AUDITING (U.S. CLS. 100, 101 AND 102).

CLASS 36—INSURANCE AND FINANCIAL

FOR INSURANCE SERVICES, NAMELY, WRITING PROPERTY CASUALTY INSURANCE; UNDERWRITING IN THE FIELDS OF PROPERTY AND CASUALTY INSURANCE; INSURANCE CLAIMS PROCESSING; INSURANCE CLAIMS SERVICING, NAMELY, CLAIMS ADMINISTRATION AND PREMIUM RATE COMPUTING; ACTUARIAL SERVICES; INSURANCE CONSULTING SERVICES; ADMINISTRATION OF AND CONSULTING IN THE FIELD OF EMPLOYEE RETIREMENT PLANS (U.S. CLS. 100, 101 AND 102).

CLASS 45—PERSONAL AND LEGAL SERVICES

FOR LITIGATION SUPPORT SERVICES, NAMELY, CONSULTING ON AND MANAGING INSURANCE-RELATED LITIGATION (U.S. CLS. 100 AND 101).

LINDA MICKLEBURGH, EXAMINING ATTORNEY

SN 77-555,179. TOYOTA JIDOSHA KABUSHIKI KAISHA, TA
TOYOTA MOTOR CORPORATION, TOYOTA-SHI, JAPAN, FILED 8-25-2008.

AVANZA CONFIADO

THE MARK CONSISTS OF STANDARD CHARACTERS WITHOUT CLAIM TO ANY PARTICULAR FONT, STYLE, SIZE, OR COLOR.

THE ENGLISH TRANSLATION OF "AVANZA CONFIADO" IN THE MARK IS ADVANCING TRUST, ADVANCING TRUSTING, MOVING FORWARD WITH CONFIDENCE, OR ADVANCING WITH CONFIDENCE.

CLASS 35—ADVERTISING AND BUSINESS

FOR PROVIDING CONSUMER PRODUCT INFORMATION VIA THE INTERNET (U.S. CLS. 100, 101 AND 102).
FIRST USE 9-30-2004; IN COMMERCE 9-30-2004.

CLASS 41—EDUCATION AND ENTERTAINMENT

FOR PROVIDING A WEB SITE FEATURING ARTICLES, NEWS, PHOTOGRAPHIC, AUDIO, AND VIDEO PRESENTATIONS ON THE SUBJECTS OF SPORTS, MOTORSPORTS, MUSIC, AND ENTERTAINMENT; PROVIDING INFORMATION VIA THE INTERNET ON THE SUBJECTS OF SPORTS, MOTORSPORTS, MUSIC, AND ENTERTAINMENT (U.S. CLS. 100, 101 AND 107).

FIRST USE 9-30-2004; IN COMMERCE 9-30-2004.
MARLENE BELL, EXAMINING ATTORNEY

SN 77-555,791, ALIBABA.COM LIMITED, GRAND CAYMAN, CAYMAN ISLANDS, FILED 8-26-2008.

GOLD SUPPLIER

THE MARK CONSISTS OF STANDARD CHARACTERS WITHOUT CLAIM TO ANY PARTICULAR FONT, STYLE, SIZE, OR COLOR.

NO CLAIM IS MADE TO THE EXCLUSIVE RIGHT TO USE "SUPPLIER", APART FROM THE MARK AS SHOWN.

CLASS 9—ELECTRICAL AND SCIENTIFIC APPARATUS

FOR APPARATUS FOR RECORDING, TRANSMISSION OR REPRODUCTION OF SOUND OR IMAGES; BLANK MAGNETIC DATA CARRIERS, RECORDING DISCS; AUTOMATIC VENDING MACHINES AND MECHANISMS FOR COIN-OPERATED APPARATUS; CASH REGISTERS, CALCULATING MACHINES, DATA PROCESSORS AND COMPUTERS; COMPUTERS; COMPUTER PROGRAMS AND COMPUTER SOFTWARE FOR BUSINESS MANAGEMENT, CUSTOMER RELATIONSHIP MANAGEMENT (CRM), INVENTORY MANAGEMENT, SALES FORCE MANAGEMENT, FINANCIAL TOOLS, AND MARKETING INFORMATION MANAGEMENT, ALL IN THE FIELD OF E-COMMERCE; COMPUTER PERIPHERALS; BLANK OPTICAL DISCS; ELECTRONIC POCKET TRANSLATORS; TELEPHONES; PUNCH CLOCKS; TIME RECORDING DEVICES, NAMELY, TIME CLOCKS; FACSIMILE MACHINES; WEIGHING APPARATUS AND INSTRUMENTS, NAMELY, SCALES AND BALANCES; SCALED RULERS; BLANK SOUND RECORDING STRIPS; NEON SIGNS; ELECTRONIC NOTICE BOARDS; TRANSPARENCY PROJECTION APPARATUS; ODOMETERS; TELESCOPES; ELECTRIC WIRES; ELECTRIC SWITCHES; POINT-OF-SALE TERMINALS; ELECTROPLATING APPARATUS, NAMELY, ELECTROPLATING MACHINES; FIRE EXTINGUISHERS; ELECTRIC WELDING APPARATUS, NAMELY, TORCHES; ACOUSTIC ALARMS, NAMELY, SMOKE AND FIRE ALARMS; EYEGASSES; BATTERIES; EXPOSED FILMS, NAMELY, EXPOSED CAMERA FILM; ELECTRIFIED FENCES, NAMELY, ELECTRIC FENCES; COMPUTER HARDWARE AND FIRMWARE FOR USE IN THE FIELD OF BUSINESS; COMPUTER SOFTWARE DOWNLOADABLE FROM THE INTERNET FOR BUSINESS MANAGEMENT, CUSTOMER RELATIONSHIP MANAGEMENT (CRM), INVENTORY MANAGEMENT, SALES FORCE MANAGEMENT, FINANCIAL TOOLS, AND MARKETING INFORMATION MANAGEMENT, ALL IN THE FIELD OF E-COMMERCE; COMPACT DISCS FEATURING COMPUTER PROGRAMS AND COMPUTER SOFTWARE FOR BUSINESS MANAGEMENT, CUSTOMER RELATIONSHIP MANAGEMENT (CRM), INVENTORY MANAGEMENT, SALES FORCE MANAGEMENT, FINANCIAL TOOLS, AND MARKETING INFORMATION MANAGEMENT, ALL IN THE FIELD OF E-COMMERCE; DIGITAL MUSIC DOWNLOADABLE FROM THE INTERNET; TELECOMMUNICATIONS APPARATUS FOR NETWORK TELEPHONING, ELECTRONIC FACSIMILE, ELECTRONIC MAIL, AND INSTANT MESSAGING COMMUNICATION; MOUSE MATS FOR COMPUTERS; MOBILE PHONE ACCESSORIES, NAMELY, BATTERY CHARGERS, CASES, COVERS, EAR PHONES AND DEVICES FOR HANDS-FREE USE OF MOBILE PHONES; SPECTACLES AND SUNGLASSES (U.S. CLS. 21, 23, 26, 36 AND 38).

CLASS 35—ADVERTISING AND BUSINESS

FOR ADVERTISING VIA ELECTRONIC MEDIA AND SPECIFICALLY VIA THE INTERNET; BUSINESS MANAGEMENT IN THE FIELD OF E-COMMERCE; BUSINESS ADMINISTRATION IN THE FIELD OF E-COMMERCE; COMMERCIAL INFORMATION AGENCIES; BUSINESS RESEARCH; BUSINESS INVESTIGATIONS; ORGANIZATION OF TRADE FAIRS FOR COMMERCIAL OR ADVERTISING PURPOSES; AUCTIONEERING; PERSONNEL MANAGEMENT CONSULTANCY; RELOCATION SERVICES FOR BUSINESSES; COMPILATION OF INFORMATION INTO COMPUTER DATABASES; CONDUCTING DATA SEARCHES FOR THE GOODS AND SERVICES OF OTHERS IN COMPUTER FILES FOR OTHERS; ACCOUNTING; RENTAL OF VENDING MACHINES; PUBLICATION OF PUBLICITY TEXTS; ADVERTISING; RENTAL OF ADVERTISING SPACE; ADVERTISING AGENCIES; ON-LINE ADVERTISING ON A COMPUTER NETWORK (U.S. CLS. 100, 101 AND 102).

CLASS 36—INSURANCE AND FINANCIAL

FOR INSURANCE AND FINANCIAL INFORMATION AND CONSULTANCY SERVICES; INSURANCE ADMINISTRATION; ASSESSMENT AND MANAGEMENT OF REAL ESTATE; PROVIDING INFORMATION IN THE FIELD OF REAL ESTATE VIA THE INTERNET; REAL ESTATE BROKERAGE; BANKING AND FINANCING SERVICES; FINANCIAL ANALYSIS; ART APPRAISAL; SURETY SERVICES; CHARITABLE FUND RAISING; ELECTRONIC FUNDS TRANSFER SERVICES; CAPITAL INVESTMENT; FIDUCIARY REPRESENTATIVES; PAWN BROKERAGE (U.S. CLS. 100, 101 AND 102).

CLASS 38—COMMUNICATION

FOR TELECOMMUNICATION SERVICES, NAMELY, NETWORK TELEPHONE, ELECTRONIC FACSIMILE, ELECTRONIC MAIL AND INSTANT MESSAGING; NEWS AGENCIES, NAMELY, TRANSMISSION OF NEWS ITEMS TO NEWS REPORTING ORGANIZATIONS; ELECTRONIC MESSAGE SENDING; CELLULAR TELEPHONE COMMUNICATION; COMPUTER AIDED TRANSMISSION OF MESSAGES AND IMAGES; ELECTRONIC MAIL SERVICES; ELECTRONIC BULLETIN BOARD SERVICES, NAMELY, PROVIDING ONLINE ELECTRONIC BULLETIN BOARDS FOR TRANSMISSION OF MESSAGES AMONG USERS IN THE FIELD OF GENERAL INTEREST; PROVIDING TELECOMMUNICATIONS CONNECTIONS TO A GLOBAL COMPUTER NETWORK; TELECONFERENCING SERVICES; PROVIDING USER ACCESS TO A GLOBAL COMPUTER NETWORK; PROVIDING INFORMATION ABOUT TELECOMMUNICATIONS (U.S. CLS. 100, 101 AND 104).

CLASS 41—EDUCATION AND ENTERTAINMENT

FOR EDUCATIONAL SERVICES, NAMELY, CONDUCTING SEMINARS AND CONFERENCES IN THE FIELD OF BUSINESS AND E-COMMERCE; PROVIDING TRAINING COURSES IN THE FIELD OF BUSINESS; ENTERTAINMENT SERVICES, NAMELY, PROVIDING ON-LINE COMPUTER GAMES; ARRANGING AND CONDUCTING OF EDUCATIONAL CONFERENCES IN THE FIELD OF BUSINESS AND E-COMMERCE; LENDING LIBRARIES; PUBLICATION OF ELECTRONIC BOOKS AND JOURNALS ON-LINE IN THE FIELDS OF BUSINESS AND E-COMMERCE; GAME SERVICES PROVIDED ON-LINE FROM A COMPUTER NETWORK; DIGITAL IMAGING SERVICES; TRANSLATION SERVICES; PROVIDING ON-LINE ELECTRONIC PUBLICATIONS IN THE NATURE OF BLOGS, ONLINE NEWSLETTERS AND EDITORIALS IN THE FIELD OF BUSINESS; HEALTH CLUB SERVICES, NAMELY, PROVIDING INSTRUCTION AND EQUIPMENT IN THE FIELD OF PHYSICAL EXERCISE; OPERATING LOTTERIES FOR OTHERS (U.S. CLS. 100, 101 AND 107).

CLASS 42—SCIENTIFIC AND COMPUTER SERVICES

FOR PROVIDING USE OF ONLINE NON-DOWNLOADABLE SOFTWARE FOR BUSINESS MANAGEMENT, CUSTOMER RELATIONSHIP MANAGEMENT (CRM), INVENTORY MANAGEMENT, SALES FORCE MANAGEMENT, FINANCIAL TOOLS, AND MARKETING INFORMATION MANAGEMENT, ALL IN THE FIELD OF E-COMMERCE; SCIENTIFIC AND TECHNOLOGICAL SERVICES AND RESEARCH AND DESIGN IN CONNECTION WITH SOFTWARE SYSTEMS FOR BUSINESS MANAGEMENT, CUSTOMER RELATIONSHIP MANAGEMENT (CRM), INVENTORY MANAGEMENT, SALES FORCE MANAGEMENT, FINANCIAL TOOLS, AND MARKETING INFORMATION MANAGEMENT, ALL IN THE FIELD OF E-COMMERCE; INDUSTRIAL ANALYSIS AND RESEARCH SERVICES IN THE FIELD OF BUSINESS MANAGEMENT, CUSTOMER RELATIONSHIP MANAGEMENT (CRM), INVENTORY MANAGEMENT, SALES FORCE MANAGEMENT, FINANCIAL TOOLS AND MARKETING INFORMATION MANAGEMENT FOR E-COMMERCE; DESIGN AND DEVELOPMENT OF COMPUTER HARDWARE AND SOFTWARE FOR BUSINESS USE; DATA CONVERSION OF COMPUTER PROGRAMS AND DATA; COMPUTER SYSTEM DESIGN; DUPLICATION OF COMPUTER PROGRAMS; CONVERSION OF DATA OR DOCUMENTS FROM PHYSICAL TO ELECTRONIC MEDIA; CREATING, MAINTAINING AND HOSTING WEB SITES FOR OTHERS; COMPUTER SOFTWARE DESIGN; RENTAL OF CD CONTAINING SOFTWARE FOR BUSINESS AND FINANCIAL INFO; PRODUCT RESEARCH AND DEVELOPMENT SERVICES FOR OTHERS; QUALITY SYSTEM AUTHENTICATION, NAMELY, QUALITY ASSURANCE SERVICES IN THE FIELD OF COMPUTER SOFTWARE; INDUSTRIAL DESIGN (U.S. CLS. 100 AND 101).

SHAILA SETTLES, EXAMINING ATTORNEY

SN 77-557,369. SAWYER, GARY, SPOKANE, WA. FILED 8-27-2008.

Tom Sawyer Country Coffee

THE MARK CONSISTS OF STANDARD CHARACTERS WITHOUT CLAIM TO ANY PARTICULAR FONT, STYLE, SIZE, OR COLOR.

NO CLAIM IS MADE TO THE EXCLUSIVE RIGHT TO USE "COFFEE", APART FROM THE MARK AS SHOWN. "TOM SAWYER" IDENTIFIES A LIVING INDIVIDUAL WHOSE CONSENT IS OF RECORD.

CLASS 30—STAPLE FOODS

FOR COFFEE; FLAVORING SYRUP; ROASTED COFFEE BEANS (U.S. CL. 46).

CLASS 35—ADVERTISING AND BUSINESS

FOR WHOLESALE AND RETAIL STORE SERVICES FEATURING COFFEE AND COFFEE RELATED PRODUCTS (U.S. CLS. 100, 101 AND 102).
MICHAEL ENGEL, EXAMINING ATTORNEY

SN 77-557,704. COMMISSION ON PRESIDENTIAL DEBATES, WASHINGTON, DC. FILED 8-28-2008.

COMMISSION ON PRESIDENTIAL DEBATES

THE MARK CONSISTS OF STANDARD CHARACTERS WITHOUT CLAIM TO ANY PARTICULAR FONT, STYLE, SIZE, OR COLOR.

OWNER OF U.S. REG. NO. 1,555,375.

NO CLAIM IS MADE TO THE EXCLUSIVE RIGHT TO USE "DEBATES", APART FROM THE MARK AS SHOWN. SEC. 2(F).

CLASS 9—ELECTRICAL AND SCIENTIFIC APPARATUS

FOR DOWNLOADABLE ELECTRONIC PUBLICATIONS IN THE NATURE OF GUIDES FEATURING INFORMATION ABOUT SPONSORING, ORGANIZING, AND HOSTING DEBATES (U.S. CLS. 21, 23, 26, 36 AND 38).

FIRST USE 0-0-2000; IN COMMERCE 0-0-2000.

CLASS 41—EDUCATION AND ENTERTAINMENT

FOR ARRANGING AND SPONSORING DEBATES AMONG CANDIDATES FOR PRESIDENT AND VICE PRESIDENT OF THE UNITED STATES AND DISTRIBUTION OF DEBATE MATERIALS IN CONNECTION THEREWITH; PUBLISHING OF ELECTRONIC PUBLICATIONS IN THE NATURE OF GUIDES FEATURING INFORMATION ABOUT SPONSORING, ORGANIZING, AND HOSTING DEBATES (U.S. CLS. 100, 101 AND 107).

FIRST USE 2-18-1987; IN COMMERCE 2-18-1987.

EDWARD FENNESSY, EXAMINING ATTORNEY

SN 77-557,742. BATH & BODY WORKS BRAND MANAGEMENT, INC., REYNOLDSBURG, OH. FILED 8-28-2008.

POWER UP FRAGRANCE EXPERIENCE

THE MARK CONSISTS OF STANDARD CHARACTERS WITHOUT CLAIM TO ANY PARTICULAR FONT, STYLE, SIZE, OR COLOR.

NO CLAIM IS MADE TO THE EXCLUSIVE RIGHT TO USE "FRAGRANCE", APART FROM THE MARK AS SHOWN.

CLASS 3—COSMETICS AND CLEANING PREPARATIONS

FOR FRAGRANCE REFILLS FOR NON-ELECTRIC AND ELECTRIC ROOM AND CAR FRAGRANCE DISPENSERS, SCENTED ROOM SPRAYS, SPRAY MIST FOR FRAGRANCING PILLOWS, ROOM FRAGRANCE GELS, CAR FRAGRANCE GELS, SCENTED FRAGRANCE BEADS, SCENTED FABRIC REFRESHER SPRAY, ROOM FRAGRANCE OILS, FRAGRANCE EMITTING WICKS FOR ROOM FRAGRANCE (U.S. CLS. 1, 4, 6, 50, 51 AND 52).

CLASS 4—LUBRICANTS AND FUELS

FOR CANDLES, SCENTED WAX FOR USE IN CANDLE WARMERS (U.S. CLS. 1, 6 AND 15).

**CLASS 11—ENVIRONMENTAL CONTROL AP-
PARATUS**

FOR ELECTRIC DISPENSER FOR ROOM AND CAR AIR FRESHENER (U.S. CLS. 13, 21, 23, 31 AND 34).

SN 77-559,435. MORSELS, L.P., AUSTIN, TX. FILED 8-29-2008.

CLASS 35—ADVERTISING AND BUSINESS

FOR RETAIL STORE SERVICES, MAIL ORDER RETAIL STORE SERVICES AND ONLINE RETAIL STORE SERVICES ALL IN THE FIELD OF HOME FRAGRANCE PRODUCTS AND ACCESSORIES (U.S. CLS. 100, 101 AND 102).

DAVID I, EXAMINING ATTORNEY



NO CLAIM IS MADE TO THE EXCLUSIVE RIGHT TO USE "FANCY AND STAPLE", APART FROM THE MARK AS SHOWN.

THE MARK CONSISTS OF "WALTON'S" IN STYLIZED FORM OVER THE STYLIZED WORDS "FANCY AND STAPLE" IN SMALLER LETTERS, IN TURN OVER THE STYLIZED WORDS "PERISHABLE, CHERISHABLE, FEISHABLE", ALL SET FORTH ON A GENERALLY RECTANGULAR BACKGROUND.

SN 77-559,340. MORSELS, L.P., AUSTIN, TX. FILED 8-29-2008.

CLASS 35—ADVERTISING AND BUSINESS

FOR RETAIL STORE SERVICES FEATURING FLOWERS, FLOWER ARRANGEMENTS, HOUSE PLANTS, SPECIALTY PLANTS, ANTIQUES, GIFT ITEMS, CANDLES, GIFT BAGS, BAKED GOODS, CHEESE, BOTTLED CONDIMENTS, AND COFFEE (U.S. CLS. 100, 101 AND 102).

CLASS 43—HOTEL AND RESTAURANT SERVICES

FOR DELICATESSEN, RESTAURANT AND CARRY-OUT RESTAURANT SERVICES (U.S. CLS. 100 AND 101).

CLASS 44—MEDICAL, BEAUTY AND AGRICULTURAL SERVICES

FOR FLOWER AND PLANT ARRANGEMENT AND DESIGN SERVICES FOR BUSINESSES, RESIDENCES, WEDDINGS AND EVENTS (U.S. CLS. 100 AND 101).

TRACY FLETCHER, EXAMINING ATTORNEY

WALTON'S FANCY AND STAPLE

THE MARK CONSISTS OF STANDARD CHARACTERS WITHOUT CLAIM TO ANY PARTICULAR FONT, STYLE, SIZE, OR COLOR.

NO CLAIM IS MADE TO THE EXCLUSIVE RIGHT TO USE "FANCY AND STAPLE", APART FROM THE MARK AS SHOWN.

CLASS 35—ADVERTISING AND BUSINESS

FOR RETAIL STORE SERVICES FEATURING FLOWERS, FLOWER ARRANGEMENTS, HOUSE PLANTS, SPECIALTY PLANTS, ANTIQUES, GIFT ITEMS, CANDLES, GIFT BAGS, BAKED GOODS, CHEESES, BOTTLED CONDIMENTS, AND COFFEE (U.S. CLS. 100, 101 AND 102).

CLASS 43—HOTEL AND RESTAURANT SERVICES

FOR DELICATESSEN, RESTAURANT AND CARRY-OUT RESTAURANT SERVICES (U.S. CLS. 100 AND 101).

CLASS 44—MEDICAL, BEAUTY AND AGRICULTURAL SERVICES

FOR FLOWER AND PLANT ARRANGEMENT AND DESIGN SERVICES FOR BUSINESSES, RESIDENCES, WEDDINGS AND EVENTS (U.S. CLS. 100 AND 101).

TRACY FLETCHER, EXAMINING ATTORNEY

SN 77-559,444. TELEVISA, S.A. DE C.V., COLONIA ZEDEC SANTA FE, MEXICO, FILED 8-29-2008.

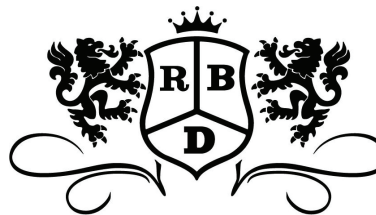

OWNER OF U.S. REG. NOS. 3,215,401, 3,215,468 AND 3,229,463.

THE MARK CONSISTS OF THE LETTERS "R", "B" AND "D" DRAWN WITHIN A DESIGN CONSISTING OF A SHIELD, TWO LION-LIKE FIGURES, A CROWN AND DECORATIVE FLOURISHES BENEATH THE MAIN DESIGN ELEMENT.

CLASS 3—COSMETICS AND CLEANING PREPARATIONS

FOR COSMETIC CREAMS, PERFUMES AND COSMETICS (U.S. CLS. 1, 4, 6, 50, 51 AND 52).

CLASS 16—PAPER GOODS AND PRINTED MATTER

FOR NOTEBOOKS, FOLDERS, BINDERS, RING BINDERS, PENCIL HOLDERS, PEN AND PENCIL CASES, SCRAPBOOKS, BLACKBOARDS, MARKERS, PENS, PENCILS, COLOR PENCILS, ERASERS, PENCIL SHARPENERS, UNGRADUATED RULERS, DRAWING RULERS AND DRAFTING RULERS, POSTERS, CALENDARS, COLLECTIBLE CARDS, STICKERS, TEMPORARY TATTOOS, DAILY PLANNERS, NOTEPADS, WRAPPING PAPER, ENVELOPES, PHOTO ALBUMS, APPOINTMENT BOOKS, DIARIES, PRINTED INVITATIONS, PAPER TABLECLOTHS, PAPER NAPKINS, PAPER BADGES, PLASTIC CANDY BAGS SOLD EMPTY, STICKER ALBUMS, MAGAZINE AND BOOKS FEATURING INFORMATION ON A MUSICAL GROUP (U.S. CLS. 2, 5, 22, 23, 29, 37, 38 AND 50).

CLASS 18—LEATHER GOODS

FOR BACKPACKS, BACKPACKS ON WHEELS, FASHION BAGS IN THE NATURE OF ALL-PURPOSE CARRYING BAGS, HANDBAGS, HAVERSACKS, WAIST BAGS, WALLETS, BILLFOLDS, PURSES (U.S. CLS. 1, 2, 3, 22 AND 41).

CLASS 20—FURNITURE AND ARTICLES NOT OTHERWISE CLASSIFIED

FOR DRINKING STRAWS (U.S. CLS. 2, 13, 22, 25, 32 AND 50).

CLASS 21—HOUSEWARES AND GLASS

FOR PAPER PLATES, PAPER CUPS (U.S. CLS. 2, 13, 23, 29, 30, 33, 40 AND 50).

CLASS 28—TOYS AND SPORTING GOODS

FOR PAPER PARTY HATS (U.S. CLS. 22, 23, 38 AND 50).
DAYNA BROWNE, EXAMINING ATTORNEY

SN 77-560,373. BUDDHIST ORTHO-CREED ASSOCIATION, DHARMA SEAL TEMPLE, ROSEMEAD, CA. FILED 9-2-2008.



NO CLAIM IS MADE TO THE EXCLUSIVE RIGHT TO USE THE CHINESE CHARACTER THAT MEANS "TEMPLE", APART FROM THE MARK AS SHOWN.

THE MARK CONSISTS OF A LOGO CONSISTING OF B.O.C.A. WRITTEN ABOVE AN ARC, A DRAWING OF DOVE UNDER THE ARC, AND 3 CHINESE CHARACTERS BELOW THE DOVE.

THE FOREIGN WORDING IN THE MARK TRANSLATES INTO ENGLISH AS DHARMA SEAL TEMPLE.

THE NON-LATIN CHARACTERS IN THE MARK TRANSLITERATE TO FA YIN SI AND THIS MEANS DHARMA SEAL TEMPLE IN ENGLISH.

CLASS 16—PAPER GOODS AND PRINTED MATTER

FOR RELIGIOUS BOOKS; RELIGIOUS CIRCULAR LETTERS (U.S. CLS. 2, 5, 22, 23, 29, 37, 38 AND 50).
FIRST USE 9-20-1977; IN COMMERCE 9-20-1977.

CLASS 45—PERSONAL AND LEGAL SERVICES

FOR CONDUCTING RELIGIOUS PRAYER SERVICES; MINISTERIAL SERVICES, NAMELY, HOLDING SPIRITUAL RETREATS TO ASSIST RELIGIOUS LEADERS, BOTH CLERGY AND LAY, TO DEVELOP AND ENHANCE THEIR SPIRITUAL LIVES; RELIGIOUS AND SPIRITUAL SERVICES, NAMELY, PROVIDING GATHERINGS AND RETREATS TO DEVELOP AND ENHANCE THE SPIRITUAL LIVES OF INDIVIDUALS (U.S. CLS. 100 AND 101).

FIRST USE 9-20-1977; IN COMMERCE 9-20-1977.
JILL PRATER, EXAMINING ATTORNEY

SN 77-560,390. KNORR-NÄHRMITTEL AKTIENGESELLSCHAFT, THAYNGEN CH-8240, SWITZERLAND, FILED 9-2-2008.

EVERY MEAL IS AN OPPORTUNITY

THE MARK CONSISTS OF STANDARD CHARACTERS WITHOUT CLAIM TO ANY PARTICULAR FONT, STYLE, SIZE, OR COLOR.

CLASS 29—MEATS AND PROCESSED FOODS

FOR MEAT, FISH, POULTRY AND GAME; MEAT EXTRACTS; PRESERVED, DRIED AND COOKED FRUITS AND VEGETABLES; JELLIES, JAMS, COMPOSITES; EGGS, MILK AND MILK PRODUCTS, NAMELY, MILK PRODUCTS EXCLUDING ICE CREAM, ICE MILK AND FROZEN YOGURT; EDIBLE OILS AND FATS (U.S. CL. 46).

CLASS 30—STAPLE FOODS

FOR COFFEE, TEA, COCOA, SUGAR, RICE, TAPIOCA, SAGO, ARTIFICIAL COFFEE; FLOUR, BREAD, ICES; HONEY, TREACLE; YEAST, BAKING-POWDER; SALT, MUSTARD; VINEGAR, SAUCES; CONDIMENTS, NAMELY, HERBS AND SEASONINGS, DIP SAUCES; SPICES; ICE (U.S. CL. 46).

MICHAEL ENGEL, EXAMINING ATTORNEY

SN 77-562,166. INNOVATIVE CARD SOLUTIONS, LLC, CINCINNATI, OH. FILED 9-4-2008.

IPAY

THE MARK CONSISTS OF STANDARD CHARACTERS WITHOUT CLAIM TO ANY PARTICULAR FONT, STYLE, SIZE, OR COLOR.

CLASS 9—ELECTRICAL AND SCIENTIFIC APPARATUS

FOR MAGNETICALLY CODED AND RELOADABLE PREPAID DEBIT CARDS (U.S. CLS. 21, 23, 26, 36 AND 38).

CLASS 35—ADVERTISING AND BUSINESS

FOR PROMOTING THE GOODS AND SERVICES OF OTHERS THROUGH THE DISTRIBUTION OF MAGNETICALLY CODED AND RELOADABLE PREPAID CARDS; AND ADMINISTRATION OF MAGNETICALLY CODED AND RELOADABLE PREPAID CARD DISCOUNT PROGRAMS THAT ENABLE PARTICIPANTS TO OBTAIN DISCOUNTS ON GOODS AND SERVICES (U.S. CLS. 100, 101 AND 102).

LEIGH LOWRY, EXAMINING ATTORNEY

CLASS 41—EDUCATION AND ENTERTAINMENT

FOR ENTERTAINMENT IN THE NATURE OF TELEVISION PROGRAMS, TELEVISION SEGMENTS, PODCASTS, AND WEBCASTS ABOUT ENTERTAINMENT, CELEBRITY NEWS AND GOSSIP, TELEVISION, MOVIES, MUSIC, INTERVIEWS, FASHION, THE INTERNET, INTERNET CONTENT, POP CULTURE, AND GENERAL INTEREST TOPICS; PRODUCTION, PRESENTATION AND DISTRIBUTION FOR OTHERS OF TELEVISION PROGRAMS, TELEVISION SEGMENTS, PODCASTS, AND WEBCASTS IN THE FIELDS OF ENTERTAINMENT, CELEBRITY NEWS AND GOSSIP, TELEVISION, MUSIC, THE INTERNET, NEWS, AND GENERAL INTEREST INFORMATION; PROVIDING TELEVISION PROGRAMS, TELEVISION SEGMENTS, PODCASTS, AND WEBCASTS VIA A GLOBAL COMPUTER NETWORK ABOUT ENTERTAINMENT, CELEBRITY NEWS AND GOSSIP, TELEVISION, MOVIES, MUSIC, INTERVIEWS, FASHION, THE INTERNET, INTERNET CONTENT, POP CULTURE, AND GENERAL INTEREST TOPICS; PROVIDING NEWS, INFORMATION, AND BLOGS RELATING TO ENTERTAINMENT, CELEBRITY NEWS AND GOSSIP, TELEVISION, MOVIES, MUSIC, THE INTERNET, AND GENERAL INTEREST TOPICS VIA A GLOBAL COMPUTER NETWORK AND THROUGH ONLINE DATABASES; ENTERTAINMENT SERVICES, NAMELY, TELEVISION PROGRAMS AND TELEVISION SEGMENTS BROADCAST OVER TELEVISION, CABLE, THE INTERNET, SATELLITE, MOBILE, WIRELESS, AUDIO, AND VIDEO MEDIA ABOUT ENTERTAINMENT, CELEBRITY NEWS AND GOSSIP, TELEVISION, MOVIES, MUSIC, INTERVIEWS, FASHION, THE INTERNET, INTERNET CONTENT, POP CULTURE, AND GENERAL INTEREST TOPICS; PROVIDING ONLINE NON-DOWNLOADABLE PUBLICATIONS IN THE NATURE OF BLOGS, ARTICLES, TIPS, AND OTHER ENTERTAINMENT CONTENT AND INFORMATION ABOUT ENTERTAINMENT, CELEBRITY NEWS AND GOSSIP, TELEVISION, MOVIES, MUSIC, INTERVIEWS, FASHION, THE INTERNET, INTERNET CONTENT, POP CULTURE, AND GENERAL INTEREST TOPICS (U.S. CLS. 100, 101 AND 107).

FRANK LATTUCA, EXAMINING ATTORNEY

SN 77-562,582. E! ENTERTAINMENT TELEVISION, INC., LOS ANGELES, CA. FILED 9-4-2008.

SN 77-564,744. STROKIN, LLC, CHASKA, MN. FILED 9-8-2008.

READ IT. WATCH IT. PASS IT
ON.

SADDLETRAMP

THE MARK CONSISTS OF STANDARD CHARACTERS WITHOUT CLAIM TO ANY PARTICULAR FONT, STYLE, SIZE, OR COLOR.

THE MARK CONSISTS OF STANDARD CHARACTERS WITHOUT CLAIM TO ANY PARTICULAR FONT, STYLE, SIZE, OR COLOR.

CLASS 38—COMMUNICATION

FOR TELEVISION, CABLE TELEVISION AND SATELLITE TELEVISION BROADCASTING SERVICES; BROADCASTING, DISTRIBUTION AND TRANSMISSION OF TELEVISION, CABLE, RADIO, DIGITAL, SATELLITE AND INTERNET PROGRAMS, SEGMENTS AND CONTENT; BROADCASTING, DISTRIBUTION AND TRANSMISSION OF PROGRAMS, SEGMENTS AND CONTENT FOR WIRELESS, CELLULAR AND MOBILE DEVICES; STREAMING OF AUDIO AND VIDEO CONTENT VIA THE INTERNET; TRANSMISSION OF PODCASTS FEATURING AUDIO AND VIDEO CONTENT; ELECTRONIC, WIRELESS AND WEB MESSAGING SERVICES (U.S. CLS. 100, 101 AND 104).

CLASS 12—VEHICLES

FOR SADDLE BAGS FOR MOTORCYCLES (U.S. CLS. 19, 21, 23, 31, 35 AND 44).

CLASS 18—LEATHER GOODS

FOR PURSES; DUFFEL BAGS; BACKPACKS; WALLETS; AND LUGGAGE (U.S. CLS. 1, 2, 3, 22 AND 41).

CLASS 25—CLOTHING

FOR BOOTS; SHOES; BELTS; MEN'S AND WOMEN'S WESTERN WEAR, NAMELY, SHIRTS AND JEANS; AND MEN'S AND WOMEN'S CLOTHING, NAMELY, LEATHER JACKETS, VESTS, PANTS, GLOVES AND CHAPS (U.S. CLS. 22 AND 39).

REBECCA EISINGER, EXAMINING ATTORNEY

SN 77-564,824. MOTT'S LLP, RYE BROOK, NY. FILED 9-8-2008.

SN 77-565,731. BRANDS UNLIMITED INTERNATIONAL, LLC, RIDGEFIELD, NJ. FILED 9-9-2008.

SHUT-EYE

THE MARK CONSISTS OF STANDARD CHARACTERS WITHOUT CLAIM TO ANY PARTICULAR FONT, STYLE, SIZE, OR COLOR.

CLASS 29—MEATS AND PROCESSED FOODS

FOR NON-CARBONATED BEVERAGES, NAMELY, DAIRY-BASED BEVERAGES (U.S. CL. 46).

CLASS 30—STAPLE FOODS

FOR NON-CARBONATED BEVERAGES, NAMELY, TEA (U.S. CL. 46).

CLASS 32—LIGHT BEVERAGES

FOR CARBONATED AND NON-CARBONATED BEVERAGES, NAMELY, FRUIT JUICE (U.S. CLS. 45, 46 AND 48).

MICHAEL GAAFAR, EXAMINING ATTORNEY

SN 77-565,435. COOK, ARNOLD J., DBA IRONWEAR, PITTSBURGH, PA. FILED 9-9-2008.

InVEST

THE MARK CONSISTS OF STANDARD CHARACTERS WITHOUT CLAIM TO ANY PARTICULAR FONT, STYLE, SIZE, OR COLOR.

CLASS 28—TOYS AND SPORTING GOODS

FOR EXERCISE WEIGHTS, NAMELY, WEIGHTED VESTS, WEIGHTED BELTS, HAND WEIGHTS, WRIST AND ANKLE WEIGHTS, SHOE AND LEG WEIGHTS USED TO IMPROVE A PERSON'S PHYSICAL HEALTH, STRENGTH, TONING, CONDITIONING, BALANCE, AND PROPRIOCEPTION (U.S. CLS. 22, 23, 38 AND 50).
FIRST USE 2-1-2004; IN COMMERCE 6-30-2008.

CLASS 41—EDUCATION AND ENTERTAINMENT

FOR PROVIDING INFORMATION, EXERCISES AND TRAINING METHODS TO INDIVIDUALS, AND THEIR TRAINERS TO HELP THEM IMPROVE THEIR PHYSICAL FITNESS, MUSCLE, CARDIOVASCULAR AND BONE STRENGTH, CONDITIONING, AND IMPROVEMENT IN THEIR DAILY LIVING AND THEIR LONGEVITY THROUGH THE USE OF WEIGHTED VESTS AND OTHER WEIGHT EQUIPMENT (U.S. CLS. 100, 101 AND 107).

FIRST USE 2-1-2004; IN COMMERCE 2-1-2004.
JULIE GUTTADAURO, EXAMINING ATTORNEY

BRANDS UNLIMITED

THE MARK CONSISTS OF STANDARD CHARACTERS WITHOUT CLAIM TO ANY PARTICULAR FONT, STYLE, SIZE, OR COLOR.

NO CLAIM IS MADE TO THE EXCLUSIVE RIGHT TO USE "BRANDS", APART FROM THE MARK AS SHOWN.

CLASS 9—ELECTRICAL AND SCIENTIFIC APPARATUS

FOR RADIOS, NAMELY, RADIOS AND RADIOS INCORPORATING CLOCKS, MP3 PLAYERS, USB HARDWARE, USB HUBS, AND USB-POWERED COMPUTER FANS (U.S. CLS. 21, 23, 26, 36 AND 38).

CLASS 11—ENVIRONMENTAL CONTROL APPARATUS

FOR LAMPS; ELECTRIC NIGHT LIGHTS (U.S. CLS. 13, 21, 23, 31 AND 34).

CLASS 14—JEWELRY

FOR CLOCKS (U.S. CLS. 2, 27, 28 AND 50).
MATTHEW KLINE, EXAMINING ATTORNEY

SN 77-565,787. FALCON GAS STORAGE COMPANY, INC., HOUSTON, TX. FILED 9-9-2008.



NO CLAIM IS MADE TO THE EXCLUSIVE RIGHT TO USE "GAS STORAGE", APART FROM THE MARK AS SHOWN.

THE MARK CONSISTS OF THE WORDS "FALCON GAS STORAGE" TO THE LEFT OF AN OUTLINE OF A FALCON.

CLASS 4—LUBRICANTS AND FUELS

FOR NATURAL GAS; NATURAL GAS LIQUIDS (U.S. CLS. 1, 6 AND 15).
FIRST USE 10-0-2000; IN COMMERCE 10-0-2000.

CLASS 39—TRANSPORTATION AND STORAGE

FOR STORAGE, DISTRIBUTION, AND TRANSPORTATION OF NATURAL GAS AND NATURAL GAS LIQUIDS (U.S. CLS. 100 AND 105).

FIRST USE 3-0-2001; IN COMMERCE 3-0-2001.
ALEX KEAM, EXAMINING ATTORNEY

SN 77-567,676. BANDED PRODUCTIONS, DBA THE FOWL LIFE, SPARKS, NV. FILED 9-11-2008.

THE FOWL LIFE

THE MARK CONSISTS OF STANDARD CHARACTERS WITHOUT CLAIM TO ANY PARTICULAR FONT, STYLE, SIZE, OR COLOR.

NO CLAIM IS MADE TO THE EXCLUSIVE RIGHT TO USE "FOWL", APART FROM THE MARK AS SHOWN.

CLASS 9—ELECTRICAL AND SCIENTIFIC APPARATUS

FOR RECORDED VIDEOS FEATURING OUTDOOR EVENTS, NAMELY, HUNTING WATERFOWL AND PREDATORS THROUGHOUT CANADA, MEXICO AND THE UNITED STATES, HOW-TO INSTRUCTIONS, AND THE LIFESTYLE ASSOCIATED WITH SAME (U.S. CLS. 21, 23, 26, 36 AND 38).

CLASS 41—EDUCATION AND ENTERTAINMENT

FOR ONGOING TELEVISION SHOW FEATURING OUTDOOR EVENTS, NAMELY, HUNTING WATERFOWL AND PREDATORS THROUGHOUT CANADA, MEXICO AND THE UNITED STATES, HOW-TO INSTRUCTIONS, AND THE LIFESTYLE ASSOCIATED WITH SAME (U.S. CLS. 100, 101 AND 107).

INGA ERVIN, EXAMINING ATTORNEY

SN 77-567,950. NATIONAL BUSINESS OFFICERS ASSOCIATION, INC., BOULDER, CO. FILED 9-11-2008.

Find solutions. Exchange
ideas.

THE MARK CONSISTS OF STANDARD CHARACTERS WITHOUT CLAIM TO ANY PARTICULAR FONT, STYLE, SIZE, OR COLOR.

CLASS 9—ELECTRICAL AND SCIENTIFIC APPARATUS

FOR DOWNLOADABLE RESEARCH REPORTS FEATURING INFORMATION AND NEWS ON TOPICS OF INTEREST TO INDEPENDENT SCHOOL BUSINESS OFFICERS; PRE-RECORDED COMPACT DISCS CONTAINING PROGRAM MATERIALS AND INFORMATION AND NEWS ON TOPICS OF INTEREST TO INDEPENDENT SCHOOL BUSINESS OFFICERS (U.S. CLS. 21, 23, 26, 36 AND 38).

CLASS 16—PAPER GOODS AND PRINTED MATTER

FOR NEWSLETTERS CONTAINING INFORMATION AND NEWS ON TOPICS OF INTEREST TO OF INDEPENDENT SCHOOL BUSINESS OFFICERS; RESEARCH REPORTS FEATURING INFORMATION AND NEWS ON TOPICS OF INTEREST OF INDEPENDENT SCHOOL BUSINESS OFFICERS (U.S. CLS. 2, 5, 22, 23, 29, 37, 38 AND 50).

CLASS 35—ADVERTISING AND BUSINESS

FOR ASSOCIATION SERVICES, NAMELY, PROMOTING THE INTERESTS OF INDEPENDENT SCHOOL BUSINESS OFFICERS; PROVIDING A WEB SITE OF INFORMATION IN THE FIELD OF INDEPENDENT SCHOOL OPERATION; PROVIDING WEB-BASED RESOURCES FOR INDEPENDENT SCHOOL BUSINESS OFFICERS, NAMELY, PROVIDING PROFESSIONAL DEVELOPMENT INFORMATION; DEVELOPMENT AND ADMINISTRATION OF GROUP PURCHASING PROGRAM; JOB LISTING SERVICE; CONSULTING SERVICES TO SCHOOLS AND SCHOOL BUSINESS OFFICERS IN THE AREAS OF INTERMEDIATE SANCTIONS, OPERATIONAL ISSUES, AND BUSINESS OFFICE ASSESSMENT; PROVIDING OTHERS WITH THE ABILITY TO CONDUCT AND REVIEW BUSINESS AND MARKET RESEARCH SURVEYS VIA E-MAIL; PROVIDING OTHERS WITH MARKET RESEARCH, BUSINESS RESEARCH INDEPENDENT SCHOOL MANAGEMENT INFORMATION (U.S. CLS. 100, 101 AND 102).

CLASS 41—EDUCATION AND ENTERTAINMENT

FOR ARRANGING AND CONDUCTING SEMINARS, SYMPOSIA AND RESIDENTIAL PROGRAMS IN THE FIELD OF INDEPENDENT SCHOOL MANAGEMENT; ORGANIZING AND CONDUCTING RECOGNITION AWARD PROGRAMS TO HONOR MEMBERS OF THE INDEPENDENT SCHOOL BUSINESS OFFICERS PROFESSION; PROVIDING NEWSLETTERS IN THE FIELD OF INDEPENDENT SCHOOL OPERATION AND MANAGEMENT VIA E-MAIL; WEBCASTS FEATURING INFORMATION AND NEWS IN THE FIELD OF INDEPENDENT SCHOOL OPERATION AND MANAGEMENT (U.S. CLS. 100, 101 AND 107).

LINDA MICKLEBURGH, EXAMINING ATTORNEY

SN 77-568,268. JACOBS CENTER FOR NEIGHBORHOOD INNOVATION, SAN DIEGO, CA. FILED 9-11-2008.

MARKET CREEK EVENTS &
VENUES

THE MARK CONSISTS OF STANDARD CHARACTERS WITHOUT CLAIM TO ANY PARTICULAR FONT, STYLE, SIZE, OR COLOR.

NO CLAIM IS MADE TO THE EXCLUSIVE RIGHT TO USE "EVENTS & VENUES", APART FROM THE MARK AS SHOWN.

CLASS 35—ADVERTISING AND BUSINESS

FOR RETAIL STORE SERVICES FEATURING BOOKS, FOOD, APPLIANCES AND COOKING SUPPLIES; ORGANIZING AND CONDUCTING BUSINESS CONFERENCES AND MEETINGS, PROMOTING PUBLIC INTEREST IN CULTURAL ARTS; PREPARING AUDIO-VISUAL PRESENTATIONS FOR USE IN ADVERTISING (U.S. CLS. 100, 101 AND 102).

FIRST USE 7-0-2008; IN COMMERCE 7-0-2008.

CLASS 41—EDUCATION AND ENTERTAINMENT

FOR DEVELOPING AND CONDUCTING EDUCATIONAL AND TRAINING PROGRAMS IN THE FIELDS OF BUSINESS, RETAILING, NUTRITION, COOKING, CAPACITY BUILDING FOR SMALL BUSINESS; ORGANIZING AND CONDUCTING EDUCATIONAL CONFERENCES IN THE FIELDS OF BUSINESS, RETAILING, NUTRITION, COOKING, CAPACITY BUILDING FOR SMALL BUSINESS; ORGANIZATION OF EXHIBITIONS FOR CULTURAL OR EDUCATIONAL PURPOSES; ORGANIZING COMMUNITY FESTIVALS FEATURING A VARIETY OF ACTIVITIES, NAMELY, SPORTING EVENTS, ART EXHIBITIONS, FLEA MARKETS, ETHNIC DANCES AND THE LIKE; ENTERTAINMENT IN THE NATURE OF VISUAL AND AUDIO PERFORMANCES (U.S. CLS. 100, 101 AND 107).

FIRST USE 7-0-2008; IN COMMERCE 7-0-2008.

CLASS 43—HOTEL AND RESTAURANT SERVICES

FOR PROVIDING CATERING SERVICES; FOOD PREPARATION SERVICES; PROVIDING TEMPORARY KITCHEN FACILITIES; RESTAURANTS (U.S. CLS. 100 AND 101).

FIRST USE 7-0-2008; IN COMMERCE 7-0-2008.
MARIA-VICTORIA SUAREZ, EXAMINING ATTORNEY

SN 77-569,780. CENTER FOR ECOLITERACY, BERKELEY, CA. FILED 9-15-2008.

SMART BY NATURE

THE MARK CONSISTS OF STANDARD CHARACTERS WITHOUT CLAIM TO ANY PARTICULAR FONT, STYLE, SIZE, OR COLOR.

CLASS 41—EDUCATION AND ENTERTAINMENT

FOR CONSULTATION IN THE FIELD OF K-12 EDUCATIONAL SYSTEMS, NAMELY, PROVIDING INFORMATION ON THE EDUCATION OF GRADES K-12; DEVELOPMENT AND DISSEMINATION OF EDUCATIONAL MATERIALS OF OTHERS IN THE FIELD OF SCHOOLING FOR SUSTAINABILITY; EDUCATION SERVICES, NAMELY, PROVIDING SEMINARS, CONFERENCES, AND WORKSHOPS IN THE FIELD OF SCHOOLING FOR SUSTAINABILITY; PROVIDING PROFESSIONAL DEVELOPMENT IN THE FIELD OF SCHOOLING FOR SUSTAINABILITY, NAMELY, CONDUCTING SEMINARS FOR TEACHERS IN HOW TO TEACH CHILDREN ABOUT SUSTAINABLE LIVING; EDUCATIONAL ASSESSMENT; EDUCATIONAL RESEARCH; EDUCATIONAL SERVICES, NAMELY, DEVELOPING CURRICULUM FOR OTHERS IN THE FIELD OF SCHOOLING FOR SUSTAINABILITY; EDUCATIONAL SERVICES, NAMELY, PROVIDING INCENTIVES TO SCHOOLS TO DEMONSTRATE EXCELLENCE IN THE FIELD OF SCHOOLING FOR SUSTAINABILITY; PROVIDING INFORMATION ON EDUCATION; PROVIDING INFORMATION AND NEWS IN THE FIELD OF TEACHING METHODOLOGY AND EDUCATION; ARRANGING AND CONDUCTING EDUCATIONAL CONFERENCES; CONDUCTING EDUCATIONAL EXHIBITIONS IN THE NATURE OF SCHOOLING FOR SUSTAINABILITY; PROVIDING AN INTERACTIVE WEBSITE FEATURING EDUCATION INFORMATION IN THE FIELD OF SCHOOLING FOR SUSTAINABILITY (U.S. CLS. 100, 101 AND 107).

CLASS 42—SCIENTIFIC AND COMPUTER SERVICES

FOR CONSULTATION IN THE FIELD OF K-12 EDUCATIONAL SYSTEMS, NAMELY, RESEARCH AND DEVELOPMENT OF TEACHING TECHNIQUES MOST SUITED TO GRADES K-12; HOSTING AN ON-LINE WEBSITE COMMUNITY IN THE FIELD OF SCHOOLING FOR SUSTAINABILITY (U.S. CLS. 100 AND 101).
ANGELA GAW, EXAMINING ATTORNEY

SN 77-570,233. BERKSHIRE CORPORATION, GREAT BARRINGTON, MA. FILED 9-15-2008.

VALUCLEAN

THE MARK CONSISTS OF STANDARD CHARACTERS WITHOUT CLAIM TO ANY PARTICULAR FONT, STYLE, SIZE, OR COLOR.

CLASS 16—PAPER GOODS AND PRINTED MATTER

FOR CELLULOSE WIPES FOR USE IN CONTROLLED ENVIRONMENTS IN THE NATURE OF LABORATORIES AND CLEAN ROOMS (U.S. CLS. 2, 5, 22, 23, 29, 37, 38 AND 50).

CLASS 21—HOUSEWARES AND GLASS

FOR NON-WOVEN POLYESTER FABRIC WIPES FOR USE IN CONTROLLED ENVIRONMENTS IN THE NATURE OF LABORATORIES AND CLEAN ROOMS (U.S. CLS. 2, 13, 23, 29, 30, 33, 40 AND 50).
PAUL CROWLEY, EXAMINING ATTORNEY

SN 77-570,306. MEDFILTERS, GREENSBORO, NC. FILED 9-15-2008.



NO CLAIM IS MADE TO THE EXCLUSIVE RIGHT TO USE "CLINICAL", APART FROM THE MARK AS SHOWN. THE MARK CONSISTS OF THE WORDS "CLINICAL CHOICE" SURROUNDED BY STYLIZED OVER SHAPE.

CLASS 10—MEDICAL APPARATUS

FOR SURGICAL AND MEDICAL APPARATUS AND INSTRUMENTS FOR USE IN GENERAL SURGERY (U.S. CLS. 26, 39 AND 44).

CLASS 21—HOUSEWARES AND GLASS

FOR BRUSHES USED FOR CLEANING MEDICAL INSTRUMENTS (U.S. CLS. 2, 13, 23, 29, 30, 33, 40 AND 50).

APRIL ROACH, EXAMINING ATTORNEY

SN 77-570,420. HOLIDAY RX, INC., MARINA DEL RAY, CA.
FILED 9-15-2008.

SN 77-570,945. OLDCASTLE PRECAST, INC., AUBURN, WA.
FILED 9-16-2008.

Terry Tyler

THE MARK CONSISTS OF STANDARD CHARACTERS WITHOUT CLAIM TO ANY PARTICULAR FONT, STYLE, SIZE, OR COLOR.

THE NAME(S), PORTRAIT(S), AND/OR SIGNATURE(S) SHOWN IN THE MARK IDENTIFIES "TERRY TYLER", WHOSE CONSENT(S) TO REGISTER IS SUBMITTED.

CLASS 10—MEDICAL APPARATUS

FOR CONDOMS (U.S. CLS. 26, 39 AND 44).

CLASS 25—CLOTHING

FOR CLOTHING, NAMELY, UNDERWEAR (U.S. CLS. 22 AND 39).

CLASS 41—EDUCATION AND ENTERTAINMENT

FOR FILM AND MUSIC PRODUCTION (U.S. CLS. 100, 101 AND 107).

MICHAEL GAAFAR, EXAMINING ATTORNEY

SN 77-570,908. ACCURATE TECHNOLOGIES COMPANY LIMITED, SAMUTPRAKARN, THAILAND, FILED 9-16-2008.



NO CLAIM IS MADE TO THE EXCLUSIVE RIGHT TO USE "INTERNATIONAL", APART FROM THE MARK AS SHOWN.

THE MARK CONSISTS OF GLOBE ON THE LEFT EDGE OF AN OUTLINE OF AN OVAL. THE WORD "INTERNATIONAL IMAGE" IS WITHIN THE OVAL. THE WORD "INTERNATIONAL" IS WRITTEN ALONG THE LEFT EDGE OF THE LETTER "I" IN "IMAGE".

CLASS 7—MACHINERY

FOR COMMERCIAL AND INDUSTRIAL LAUNDRY EQUIPMENT, NAMELY, WASHER EXTRACTORS, NAMELY, CLOTHES WASHING MACHINES, FLATWORK IRONERS, NAMELY, ELECTRIC CLOTHING PRESSING MACHINES, AND FLATWORK FOLDERS, NAMELY, CLOTHES FOLDING MACHINES (U.S. CLS. 13, 19, 21, 23, 31, 34 AND 35).

CLASS 11—ENVIRONMENTAL CONTROL APPARATUS

FOR CLOTHES DRYERS (U.S. CLS. 13, 21, 23, 31 AND 34).

KIM SAITO, EXAMINING ATTORNEY

CARSON

THE MARK CONSISTS OF STANDARD CHARACTERS WITHOUT CLAIM TO ANY PARTICULAR FONT, STYLE, SIZE, OR COLOR.

OWNER OF U.S. REG. NO. 2,752,368.
SEC. 2(F).

CLASS 6—METAL GOODS

FOR METAL DRAINAGE AND IRRIGATION PRODUCTS, NAMELY, GRATES AND COVERS; METAL VALVE BOXES AND ADAPTORS, NAMELY, METAL PIPE CONNECTORS AND FITTINGS; METAL METER BOXES (U.S. CLS. 2, 12, 13, 14, 23, 25 AND 50).

FIRST USE 7-0-2006; IN COMMERCE 7-0-2006.

CLASS 19—NON-METALLIC BUILDING MATERIALS

FOR NON-METAL DRAINAGE AND IRRIGATION PRODUCTS, NAMELY, GRATES, CAPS, COVERS, CATCH BASINS, DRAIN CHANNELS, ADAPTORS, NAMELY, NON-METAL PIPE CONNECTORS AND FITTINGS, CONNECTORS, SEWER AND DRAIN FITTINGS, AND BUSHINGS; NON-METAL VALVE BOXES AND ADAPTORS, NAMELY, NON-METAL PIPE CONNECTORS AND FITTINGS; NON-METAL METER BOXES; NON-METAL DUCT COMPONENTS, NAMELY, CONDUITS, CHANNELS, COVERS, ADAPTORS, NAMELY, NON-METAL PIPE CONNECTORS AND FITTINGS, TERMINATORS, AND CAPS; NON-METAL UTILITY, ELECTRICAL, COMMUNICATIONS, AND WATER VAULTS, BOXES, COVERS, ENCLOSURES, AND PEDESTALS; PLASTIC SUPPORT PADS FOR USE UNDER AIR CONDITIONING, POOL, SPA, AND TRANSFORMER EQUIPMENT; NON-METAL CABLE TROUGHS FOR ELECTRICAL AND COMMUNICATIONS CABLES (U.S. CLS. 1, 12, 33 AND 50).

FIRST USE 7-0-2006; IN COMMERCE 7-0-2006.
DORITT L. CARROLL, EXAMINING ATTORNEY

SN 77-571,705. HOW DOES YOUR GARDEN GROW? LLC, WILMINGTON, DE. FILED 9-17-2008.

THE G TEAM

THE MARK CONSISTS OF STANDARD CHARACTERS WITHOUT CLAIM TO ANY PARTICULAR FONT, STYLE, SIZE, OR COLOR.

CLASS 9—ELECTRICAL AND SCIENTIFIC APPARATUS

FOR PRERECORDED AUDIOTAPES, VIDEOTAPES, CD-ROMS AND DVDS FEATURING MUSICAL, ANIMATED, AND LIVE ACTION ENTERTAINMENT AND/OR EDUCATIONAL PROGRAMS REGARDING ENVIRONMENTALLY FRIENDLY GOODS, SERVICES AND LIFESTYLES; STILL IMAGES RECORDED ON COMPUTER MEDIA; INTERACTIVE VIDEO AND SOFTWARE GAMES (U.S. CLS. 21, 23, 26, 36 AND 38).

CLASS 16—PAPER GOODS AND PRINTED MATTER

FOR PUBLICATIONS, NAMELY, BOOKS, BOOKLETS, NEWSLETTERS, PAMPHLETS, AND MAGAZINES, FEATURING STORIES AND DEPICTIONS CONCERNING AND ARISING FROM MUSICAL, ANIMATED, AND LIVE ACTION ENTERTAINMENT AND/OR EDUCATIONAL PROGRAMS REGARDING ENVIRONMENTALLY FRIENDLY GOODS, SERVICES AND LIFESTYLES (U.S. CLS. 2, 5, 22, 23, 29, 37, 38 AND 50).

CLASS 25—CLOTHING

FOR CLOTHING, NAMELY, SHIRTS, TOPS, PANTS, JACKETS, HEADWEAR, AND FOOTWEAR (U.S. CLS. 22 AND 39).

CLASS 41—EDUCATION AND ENTERTAINMENT

FOR ENTERTAINMENT SERVICES IN THE NATURE OF ONGOING TELEVISION PROGRAMS IN THE FIELD OF ANIMATION AND LIVE ACTION SERIES EPISODES; ENTERTAINMENT SERVICES IN THE NATURE OF ONGOING TELEVISION CARTOONS; PROVIDING ONLINE COMPUTER GAMES; FILM PRODUCTION AND DISTRIBUTION (U.S. CLS. 100, 101 AND 107).

RON FAIRBANKS, EXAMINING ATTORNEY

CLASS 16—PAPER GOODS AND PRINTED MATTER

FOR PUBLICATIONS, NAMELY, BOOKS, BOOKLETS, NEWSLETTERS, PAMPHLETS, AND MAGAZINES, FEATURING STORIES AND DEPICTIONS CONCERNING AND ARISING FROM MUSICAL, ANIMATED, AND LIVE ACTION ENTERTAINMENT AND/OR EDUCATIONAL PROGRAMS REGARDING ENVIRONMENTALLY FRIENDLY GOODS, SERVICES AND LIFESTYLES (U.S. CLS. 2, 5, 22, 23, 29, 37, 38 AND 50).

CLASS 25—CLOTHING

FOR CLOTHING, NAMELY, SHIRTS, TOPS, PANTS, JACKETS, HEADWEAR, AND FOOTWEAR (U.S. CLS. 22 AND 39).

CLASS 41—EDUCATION AND ENTERTAINMENT

FOR ENTERTAINMENT SERVICES IN THE NATURE OF ONGOING TELEVISION PROGRAMS IN THE FIELD OF ANIMATION AND LIVE ACTION SERIES EPISODES; ENTERTAINMENT SERVICES IN THE NATURE OF ONGOING TELEVISION CARTOONS; PROVIDING ONLINE COMPUTER GAMES; FILM PRODUCTION AND DISTRIBUTION (U.S. CLS. 100, 101 AND 107).

RON FAIRBANKS, EXAMINING ATTORNEY

SN 77-571,706. HOW DOES YOUR GARDEN GROW? LLC, WILMINGTON, DE. FILED 9-17-2008.



THE COLOR(S) GREEN IS/ARE CLAIMED AS A FEATURE OF THE MARK.

THE MARK CONSISTS OF THE COLORS GREEN AND LIGHT GREEN, WITH THE COLOR GREEN APPEARING IN THE LARGE LETTER "G" AS WELL AS IN THE OUTLINE OF THE SUNBURST AND GLOBE/CONTINENTS, AND SHADES OF LIGHT GREEN APPEARING WITHIN THE STARBURST AND GLOBE/CONTINENTS DESIGNS.

CLASS 9—ELECTRICAL AND SCIENTIFIC APPARATUS

FOR PRERECORDED AUDIOTAPES, VIDEOTAPES, CD-ROMS AND DVDS FEATURING MUSICAL, ANIMATED, AND LIVE ACTION ENTERTAINMENT AND/OR EDUCATIONAL PROGRAMS REGARDING ENVIRONMENTALLY FRIENDLY GOODS, SERVICES AND LIFESTYLES; STILL IMAGES RECORDED ON COMPUTER MEDIA; INTERACTIVE VIDEO AND SOFTWARE GAMES (U.S. CLS. 21, 23, 26, 36 AND 38).

SN 77-571,708. HOW DOES YOUR GARDEN GROW? LLC, WILMINGTON, DE. FILED 9-17-2008.



THE COLOR(S) GREEN IS/ARE CLAIMED AS A FEATURE OF THE MARK.

THE MARK CONSISTS OF THE COLORS GREEN AND LIGHT GREEN, WITH THE COLOR GREEN APPEARING IN THE WORDING "THE G TEAM" AS WELL AS IN THE OUTLINE OF THE SUNBURST AND GLOBE/CONTINENTS, AND SHADES OF LIGHT GREEN APPEARING WITHIN THE STARBURST AND GLOBE/CONTINENTS DESIGNS.

CLASS 9—ELECTRICAL AND SCIENTIFIC APPARATUS

FOR PRERECORDED AUDIOTAPES, VIDEOTAPES, CD-ROMS AND DVDS FEATURING MUSICAL, ANIMATED, AND LIVE ACTION ENTERTAINMENT AND/OR EDUCATIONAL PROGRAMS REGARDING ENVIRONMENTALLY FRIENDLY GOODS, SERVICES AND LIFESTYLES; STILL IMAGES RECORDED ON COMPUTER MEDIA; INTERACTIVE VIDEO AND SOFTWARE GAMES (U.S. CLS. 21, 23, 26, 36 AND 38).

CLASS 16—PAPER GOODS AND PRINTED MATTER

FOR PUBLICATIONS, NAMELY, BOOKS, BOOKLETS, NEWSLETTERS, PAMPHLETS, AND MAGAZINES, FEATURING STORIES AND DEPICTIONS CONCERNING AND ARISING FROM MUSICAL, ANIMATED, AND LIVE ACTION ENTERTAINMENT AND/OR EDUCATIONAL PROGRAMS REGARDING ENVIRONMENTALLY FRIENDLY GOODS, SERVICES AND LIFESTYLES (U.S. CLS. 2, 5, 22, 23, 29, 37, 38 AND 50).

CLASS 25—CLOTHING

FOR CLOTHING, NAMELY, SHIRTS, TOPS, PANTS, JACKETS, HEADWEAR, AND FOOTWEAR (U.S. CLS. 22 AND 39).

CLASS 41—EDUCATION AND ENTERTAINMENT

FOR ENTERTAINMENT SERVICES IN THE NATURE OF ONGOING TELEVISION PROGRAMS IN THE FIELD OF ANIMATION AND LIVE ACTION SERIES EPISODES; ENTERTAINMENT SERVICES IN THE NATURE OF ONGOING TELEVISION CARTOONS; PROVIDING ONLINE COMPUTER GAMES; FILM PRODUCTION AND DISTRIBUTION (U.S. CLS. 100, 101 AND 107).
RON FAIRBANKS, EXAMINING ATTORNEY

CLASS 38—COMMUNICATION

FOR OUTCALL NOTIFICATION SERVICES (U.S. CLS. 100, 101 AND 104).
FIRST USE 5-0-2008; IN COMMERCE 5-0-2008.

CLASS 42—SCIENTIFIC AND COMPUTER SERVICES

FOR COMPUTER SERVICES, NAMELY, REMOTE AND ON-SITE MANAGEMENT OF ELECTRONIC MESSAGING SYSTEMS AND APPLICATIONS FOR OTHERS (U.S. CLS. 100 AND 101).
FIRST USE 5-0-2008; IN COMMERCE 5-0-2008.
AMY ALFIERI, EXAMINING ATTORNEY

SN 77-575,327. MOTT'S LLP, RYE BROOK, NY. FILED 9-22-2008.

SN 77-576,228. MILLENNIATA, INC., SPRINGVILLE, UT. FILED 9-23-2008.

SHUT EYE

THE MARK CONSISTS OF STANDARD CHARACTERS WITHOUT CLAIM TO ANY PARTICULAR FONT, STYLE, SIZE, OR COLOR.

CLASS 29—MEATS AND PROCESSED FOODS

FOR NON-CARBONATED BEVERAGES, NAMELY, DAIRY-BASED BEVERAGES (U.S. CL. 46).

CLASS 30—STAPLE FOODS

FOR NON-CARBONATED BEVERAGES, NAMELY, TEA (U.S. CL. 46).

CLASS 32—LIGHT BEVERAGES

FOR CARBONATED AND NON-CARBONATED BEVERAGES, NAMELY, FRUIT JUICE (U.S. CLS. 45, 46 AND 48).

MICHAEL GAAFAR, EXAMINING ATTORNEY

SN 77-576,070. CCC TECHNOLOGIES, INC., ELK GROVE VILLAGE, IL. FILED 9-22-2008.



The logo for ConvergeConnect features the word "Converge" in a bold, black, sans-serif font, followed by "Connect" in a blue, italicized, sans-serif font. A horizontal line is positioned above the "Connect" portion of the logo.

THE COLOR(S) BLACK AND BLUE IS/ARE CLAIMED AS A FEATURE OF THE MARK.
THE MARK CONSISTS OF THE WORD "CONVERGE" IN BLACK AND THE WORD "CONNECT" IN BLUE.

CLASS 35—ADVERTISING AND BUSINESS

FOR BUSINESS MANAGEMENT SERVICES RELATING TO MANAGING ELECTRONIC MESSAGING SYSTEMS AND APPLICATIONS FOR OTHERS (U.S. CLS. 100, 101 AND 102).

FIRST USE 5-0-2008; IN COMMERCE 5-0-2008.

M CLASS

THE MARK CONSISTS OF STANDARD CHARACTERS WITHOUT CLAIM TO ANY PARTICULAR FONT, STYLE, SIZE, OR COLOR.

CLASS 9—ELECTRICAL AND SCIENTIFIC APPARATUS

FOR COMPUTER HARDWARE AND COMPUTER PERIPHERAL DEVICES; BLANK MAGNETIC DATA CARRIERS; BLANK COMPUTER MAGNETIC AND OPTICAL DATA CARRIERS; BLANK OPTIC DATA CARRIERS; COMPUTER, DIGITAL AND OPTICAL DISC DRIVES AND READERS; APPARATUS, DEVICES AND BLANK DIGITAL STORAGE MEDIA AND DEVICES FOR RECORDING, TRANSMITTING, STORING, BACKING UP, ARCHIVING AND COPYING ELECTRONIC, COMPUTER AND DIGITAL DATA (U.S. CLS. 21, 23, 26, 36 AND 38).

CLASS 39—TRANSPORTATION AND STORAGE

FOR STORAGE SERVICES, NAMELY, ARCHIVING OF ELECTRONIC AND DIGITAL DATA (U.S. CLS. 100 AND 105).

CLASS 42—SCIENTIFIC AND COMPUTER SERVICES

FOR DESIGN AND DEVELOPMENT OF COMPUTER HARDWARE, SOFTWARE AND COMPUTER PERIPHERAL DEVICES FOR STORAGE, BACK-UP AND ARCHIVAL OF ELECTRONIC, COMPUTER AND DIGITAL DATA; ELECTRONIC AND DIGITAL DATA TRANSFER SERVICES FOR OTHERS, NAMELY, TRANSFERRING DATA FROM ONE COMPUTER FORMAT TO ANOTHER (U.S. CLS. 100 AND 101).

REBECCA EISINGER, EXAMINING ATTORNEY

SN 77-576,231. MILLENNIATA, INC., SPRINGVILLE, UT.
FILED 9-23-2008.

MILLENNIAL DISC

THE MARK CONSISTS OF STANDARD CHARACTERS WITHOUT CLAIM TO ANY PARTICULAR FONT, STYLE, SIZE, OR COLOR.

NO CLAIM IS MADE TO THE EXCLUSIVE RIGHT TO USE "DISC", APART FROM THE MARK AS SHOWN.

CLASS 9—ELECTRICAL AND SCIENTIFIC APPARATUS

FOR COMPUTER HARDWARE AND COMPUTER PERIPHERAL DEVICES; BLANK MAGNETIC DATA CARRIERS; BLANK COMPUTER MAGNETIC AND OPTICAL DATA CARRIERS; BLANK OPTIC DATA CARRIERS; COMPUTER, DIGITAL AND OPTICAL DISC DRIVES AND READERS; APPARATUS, DEVICES AND BLANK DIGITAL STORAGE MEDIA AND DEVICES FOR RECORDING, TRANSMITTING, STORING, BACKING UP, ARCHIVING AND COPYING ELECTRONIC, COMPUTER AND DIGITAL DATA (U.S. CLS. 21, 23, 26, 36 AND 38).

CLASS 39—TRANSPORTATION AND STORAGE

FOR STORAGE SERVICES, NAMELY, ARCHIVING OF ELECTRONIC AND DIGITAL DATA (U.S. CLS. 100 AND 105).

CLASS 42—SCIENTIFIC AND COMPUTER SERVICES

FOR DESIGN AND DEVELOPMENT OF COMPUTER HARDWARE, SOFTWARE AND COMPUTER PERIPHERAL DEVICES FOR STORAGE, BACK-UP AND ARCHIVAL OF ELECTRONIC, COMPUTER AND DIGITAL DATA; ELECTRONIC AND DIGITAL DATA TRANSFER SERVICES FOR OTHERS, NAMELY, TRANSFERRING DATA FROM ONE COMPUTER FORMAT TO ANOTHER (U.S. CLS. 100 AND 101).

REBECCA EISINGER, EXAMINING ATTORNEY

SN 77-576,235. MILLENNIATA, INC., SPRINGVILLE, UT.
FILED 9-23-2008.

MILLENNIAL DISC WRITER SYSTEM

THE MARK CONSISTS OF STANDARD CHARACTERS WITHOUT CLAIM TO ANY PARTICULAR FONT, STYLE, SIZE, OR COLOR.

NO CLAIM IS MADE TO THE EXCLUSIVE RIGHT TO USE "DISC WRITER SYSTEM", APART FROM THE MARK AS SHOWN.

CLASS 9—ELECTRICAL AND SCIENTIFIC APPARATUS

FOR COMPUTER HARDWARE AND COMPUTER PERIPHERAL DEVICES; BLANK MAGNETIC DATA CARRIERS; BLANK COMPUTER MAGNETIC AND OPTICAL DATA CARRIERS; BLANK OPTIC DATA CARRIERS; COMPUTER, DIGITAL AND OPTICAL DISC DRIVES AND READERS; APPARATUS, DEVICES AND BLANK DIGITAL STORAGE MEDIA AND DEVICES FOR RECORDING, TRANSMITTING, STORING, BACKING UP, ARCHIVING AND COPYING ELECTRONIC, COMPUTER AND DIGITAL DATA (U.S. CLS. 21, 23, 26, 36 AND 38).

CLASS 39—TRANSPORTATION AND STORAGE

FOR STORAGE SERVICES, NAMELY, ARCHIVING OF ELECTRONIC AND DIGITAL DATA (U.S. CLS. 100 AND 105).

CLASS 42—SCIENTIFIC AND COMPUTER SERVICES

FOR DESIGN AND DEVELOPMENT OF COMPUTER HARDWARE, SOFTWARE AND COMPUTER PERIPHERAL DEVICES FOR STORAGE, BACK-UP AND ARCHIVAL OF ELECTRONIC, COMPUTER AND DIGITAL DATA; ELECTRONIC AND DIGITAL DATA TRANSFER SERVICES FOR OTHERS, NAMELY, TRANSFERRING DATA FROM ONE COMPUTER FORMAT TO ANOTHER (U.S. CLS. 100 AND 101).

REBECCA EISINGER, EXAMINING ATTORNEY

SN 77-576,240. MILLENNIATA, INC., SPRINGVILLE, UT.
FILED 9-23-2008.

MILLENNIAL DRIVE

THE MARK CONSISTS OF STANDARD CHARACTERS WITHOUT CLAIM TO ANY PARTICULAR FONT, STYLE, SIZE, OR COLOR.

NO CLAIM IS MADE TO THE EXCLUSIVE RIGHT TO USE "DRIVE", APART FROM THE MARK AS SHOWN.

CLASS 9—ELECTRICAL AND SCIENTIFIC APPARATUS

FOR COMPUTER HARDWARE AND COMPUTER PERIPHERAL DEVICES; BLANK MAGNETIC DATA CARRIERS; BLANK COMPUTER MAGNETIC AND OPTICAL DATA CARRIERS; BLANK OPTIC DATA CARRIERS; COMPUTER, DIGITAL AND OPTICAL DISC DRIVES AND READERS; APPARATUS, DEVICES AND BLANK DIGITAL STORAGE MEDIA AND DEVICES FOR RECORDING, TRANSMITTING, STORING, BACKING UP, ARCHIVING AND COPYING ELECTRONIC, COMPUTER AND DIGITAL DATA (U.S. CLS. 21, 23, 26, 36 AND 38).

CLASS 39—TRANSPORTATION AND STORAGE

FOR STORAGE SERVICES, NAMELY, ARCHIVING OF ELECTRONIC AND DIGITAL DATA (U.S. CLS. 100 AND 105).

CLASS 42—SCIENTIFIC AND COMPUTER SERVICES

SN 77-576,257. MILLENNIATA, INC., SPRINGVILLE, UT. FILED 9-23-2008.

FOR DESIGN AND DEVELOPMENT OF COMPUTER HARDWARE, SOFTWARE AND COMPUTER PERIPHERAL DEVICES FOR STORAGE, BACK-UP AND ARCHIVAL OF ELECTRONIC, COMPUTER AND DIGITAL DATA; ELECTRONIC AND DIGITAL DATA TRANSFER SERVICES FOR OTHERS, NAMELY, TRANSFERRING DATA FROM ONE COMPUTER FORMAT TO ANOTHER (U.S. CLS. 100 AND 101).

REBECCA EISINGER, EXAMINING ATTORNEY



SN 77-576,244. MILLENNIATA, INC., SPRINGVILLE, UT. FILED 9-23-2008.

TIMELESS DATA ARCHIVING

MILLENNIAL WRITER

THE MARK CONSISTS OF STANDARD CHARACTERS WITHOUT CLAIM TO ANY PARTICULAR FONT, STYLE, SIZE, OR COLOR.

NO CLAIM IS MADE TO THE EXCLUSIVE RIGHT TO USE "WRITER", APART FROM THE MARK AS SHOWN.

THE MARK CONSISTS OF STANDARD CHARACTERS WITHOUT CLAIM TO ANY PARTICULAR FONT, STYLE, SIZE, OR COLOR.

NO CLAIM IS MADE TO THE EXCLUSIVE RIGHT TO USE "DATA ARCHIVING", APART FROM THE MARK AS SHOWN.

CLASS 9—ELECTRICAL AND SCIENTIFIC APPARATUS

FOR COMPUTER HARDWARE AND COMPUTER PERIPHERAL DEVICES; BLANK MAGNETIC DATA CARRIERS; BLANK COMPUTER MAGNETIC AND OPTICAL DATA CARRIERS; BLANK OPTIC DATA CARRIERS; COMPUTER, DIGITAL AND OPTICAL DISC DRIVES AND READERS; APPARATUS, DEVICES AND BLANK DIGITAL STORAGE MEDIA AND DEVICES FOR RECORDING, TRANSMITTING, STORING, BACKING UP, ARCHIVING AND COPYING ELECTRONIC, COMPUTER AND DIGITAL DATA (U.S. CLS. 21, 23, 26, 36 AND 38).

CLASS 9—ELECTRICAL AND SCIENTIFIC APPARATUS

FOR COMPUTER HARDWARE AND COMPUTER PERIPHERAL DEVICES; BLANK MAGNETIC DATA CARRIERS; BLANK COMPUTER MAGNETIC AND OPTICAL DATA CARRIERS; BLANK OPTIC DATA CARRIERS; COMPUTER, DIGITAL AND OPTICAL DISC DRIVES AND READERS; APPARATUS, DEVICES AND BLANK DIGITAL STORAGE MEDIA AND DEVICES FOR RECORDING, TRANSMITTING, STORING, BACKING UP, ARCHIVING AND COPYING ELECTRONIC, COMPUTER AND DIGITAL DATA (U.S. CLS. 21, 23, 26, 36 AND 38).

CLASS 39—TRANSPORTATION AND STORAGE

FOR STORAGE SERVICES, NAMELY, ARCHIVING OF ELECTRONIC AND DIGITAL DATA (U.S. CLS. 100 AND 105).

CLASS 39—TRANSPORTATION AND STORAGE

FOR STORAGE SERVICES, NAMELY, ARCHIVING OF ELECTRONIC AND DIGITAL DATA (U.S. CLS. 100 AND 105).

CLASS 42—SCIENTIFIC AND COMPUTER SERVICES

FOR DESIGN AND DEVELOPMENT OF COMPUTER HARDWARE, SOFTWARE AND COMPUTER PERIPHERAL DEVICES FOR STORAGE, BACK-UP AND ARCHIVAL OF ELECTRONIC, COMPUTER AND DIGITAL DATA; ELECTRONIC AND DIGITAL DATA TRANSFER SERVICES FOR OTHERS, NAMELY, TRANSFERRING DATA FROM ONE COMPUTER FORMAT TO ANOTHER (U.S. CLS. 100 AND 101).

REBECCA EISINGER, EXAMINING ATTORNEY

CLASS 42—SCIENTIFIC AND COMPUTER SERVICES

FOR DESIGN AND DEVELOPMENT OF COMPUTER HARDWARE, SOFTWARE AND COMPUTER PERIPHERAL DEVICES FOR STORAGE, BACK-UP AND ARCHIVAL OF ELECTRONIC, COMPUTER AND DIGITAL DATA; ELECTRONIC AND DIGITAL DATA TRANSFER SERVICES FOR OTHERS, NAMELY, TRANSFERRING DATA FROM ONE COMPUTER FORMAT TO ANOTHER (U.S. CLS. 100 AND 101).

REBECCA EISINGER, EXAMINING ATTORNEY

SN 77-576,549. BYRNE ELECTRICAL SPECIALISTS, INC., ROCKFORD, MI. FILED 9-23-2008.

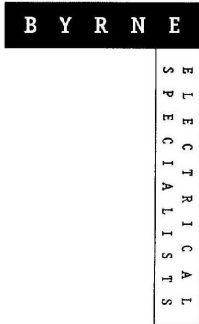

NO CLAIM IS MADE TO THE EXCLUSIVE RIGHT TO USE "ELECTRICAL SPECIALISTS", APART FROM THE MARK AS SHOWN.

THE MARK CONSISTS OF THE WORD "BYRNE" IN A RECTANGLE WHICH IS HORIZONTAL AND THE WORDS "ELECTRICAL SPECIALISTS" IN A RECTANGLE WHICH IS VERTICAL.

CLASS 9—ELECTRICAL AND SCIENTIFIC APPARATUS

FOR WIRING AND ELECTRICAL STRUCTURAL COMPONENTS, NAMELY, ELECTRICAL CONNECTORS, ELECTRIC WIRES, RECEPTACLES, NAMELY, ELECTRICAL RECEPTACLES, RACEWAYS, TERMINALS, NAMELY, ELECTRICAL TERMINALS, ELECTRICAL JUNCTION APPARATUS, NAMELY, POWER AND DATA ASSEMBLIES AND ELECTRICAL RACEWAY ASSEMBLIES AND PLUGS (U.S. CLS. 21, 23, 26, 36 AND 38).

CLASS 42—SCIENTIFIC AND COMPUTER SERVICES

FOR PRODUCT DEVELOPMENT AND PRODUCT DEVELOPMENT CONSULTATION IN THE FIELD OF WIRING AND ELECTRICAL STRUCTURAL COMPONENTS, NAMELY, ELECTRICAL CONNECTORS, CONDUCTIVE WIRING, RECEPTACLES, NAMELY, ELECTRICAL RECEPTACLES, RACEWAYS, TERMINALS, NAMELY, ELECTRICAL TERMINALS, ELECTRICAL JUNCTION APPARATUS, NAMELY, POWER AND DATA ASSEMBLIES AND ELECTRICAL RACEWAY ASSEMBLIES AND PLUGS ASSEMBLIES AND PLUGS (U.S. CLS. 100 AND 101).

ROBERT C. CLARK JR., EXAMINING ATTORNEY

SN 77-576,643. TENEREILLO, INC., CARLSBAD, CA. FILED 9-23-2008.

VIRTUAL RADAR

THE MARK CONSISTS OF STANDARD CHARACTERS WITHOUT CLAIM TO ANY PARTICULAR FONT, STYLE, SIZE, OR COLOR.

CLASS 9—ELECTRICAL AND SCIENTIFIC APPARATUS

FOR DOWNLOADABLE SOFTWARE FOR TRANSMISSION OF ALERTS REGARDING SPEED TRAPS, ROADWAY HAZARDS, AND OTHER ROADSIDE AND/OR NAVIGATIONAL CONDITIONS (U.S. CLS. 21, 23, 26, 36 AND 38).

FIRST USE 9-23-2008; IN COMMERCE 10-8-2008.

CLASS 38—COMMUNICATION

FOR WIRELESS COMMUNICATIONS SERVICES, NAMELY, TRANSMISSION OF ALERTS REGARDING SPEED TRAPS, ROADWAY HAZARDS, AND OTHER ROADSIDE AND/OR NAVIGATIONAL CONDITIONS (U.S. CLS. 100, 101 AND 104).

FIRST USE 9-23-2008; IN COMMERCE 9-23-2008. BRENDAN MCCAULEY, EXAMINING ATTORNEY

SN 77-577,342. DISTINCTIVE GRANITE & MARBLE, INC., HILTON HEAD ISLAND, SC. FILED 9-24-2008.

DISTINCTIVE GRANITE AND MARBLE

THE MARK CONSISTS OF STANDARD CHARACTERS WITHOUT CLAIM TO ANY PARTICULAR FONT, STYLE, SIZE, OR COLOR.

NO CLAIM IS MADE TO THE EXCLUSIVE RIGHT TO USE "GRANITE AND MARBLE", APART FROM THE MARK AS SHOWN.

CLASS 37—CONSTRUCTION AND REPAIR

FOR INSTALLATION OF GRANITE AND MARBLE STONE COUNTERTOPS, VANITIES, STAIRS, FLOORING, WALLS, AND FIREPLACES (U.S. CLS. 100, 103 AND 106).

FIRST USE 12-31-1994; IN COMMERCE 12-31-1994.

CLASS 40—MATERIAL TREATMENT

FOR CUSTOM FABRICATION OF STONE IN THE NATURE OF MARBLE AND GRANITE (U.S. CLS. 100, 103 AND 106).

FIRST USE 12-31-1994; IN COMMERCE 12-31-1994. JENNIFER MARTIN, EXAMINING ATTORNEY

SN 77-577,496. FOREMOST CORPORATION OF AMERICA, CALEDONIA, MI. FILED 9-24-2008.

FOREMOST PAYONLINE

THE MARK CONSISTS OF STANDARD CHARACTERS WITHOUT CLAIM TO ANY PARTICULAR FONT, STYLE, SIZE, OR COLOR.

NO CLAIM IS MADE TO THE EXCLUSIVE RIGHT TO USE "PAY ONLINE", APART FROM THE MARK AS SHOWN.

CLASS 36—INSURANCE AND FINANCIAL

FOR BILL PAYMENT SERVICES PROVIDED THROUGH A WEBSITE; ELECTRONIC PAYMENT PROCESSING SERVICES; ELECTRONIC PROCESSING AND TRANSMISSION OF BILL PAYMENT DATA; ON-LINE BUSINESS SERVICES, NAMELY, STATEMENT REVIEW AND BILL PAYMENT, ELECTRONIC PAYMENT, NAMELY ELECTRONIC PROCESSING AND TRANSMISSION OF BILL PAYMENT DATA AND STATEMENT REVIEW (U.S. CLS. 100, 101 AND 102).

FIRST USE 9-12-2007; IN COMMERCE 9-12-2007.

CLASS 45—PERSONAL AND LEGAL SERVICES

FOR PROVIDING AUTOMATED ON-LINE ALERT AND REMINDER SERVICES FOR THE PAYMENT OF BILLS (U.S. CLS. 100 AND 101).

FIRST USE 9-12-2007; IN COMMERCE 9-12-2007.
DAVID C. REIHNER, EXAMINING ATTORNEY

SN 77-577,823. JOSEPH K. LABONTE, PROVO, UT. FILED 9-24-2008.

IF IT AIN'T ABOUT...IT AIN'T AMERICA

THE MARK CONSISTS OF STANDARD CHARACTERS WITHOUT CLAIM TO ANY PARTICULAR FONT, STYLE, SIZE, OR COLOR.

CLASS 16—PAPER GOODS AND PRINTED MATTER

FOR PRINTED MATTER, NAMELY, BUMPER STICKERS, POSTERS, BOOKS IN THE FIELD OF POLITICS, HISTORY, PHILOSOPHY, LAW, SCIENCE, AGRICULTURE, EDUCATION, CHILDREN, WOMEN, ELDERS, ARTS, MATHEMATICS, MUSIC, ASTRONOMY, EVOLUTION AND NATIVE AMERICANS, NOTE PAPER; DECALS; APPOINTMENT BOOKS; BINDERS; BOOK COVERS; BOOK MARKERS; BOOKENDS; CALENDARS; CARTOON PRINTS; COMIC BOOKS; GIFT WRAP PAPER; GREETING CARDS; IRON-ON TRANSFERS; NOTEBOOKS; NOTEPADS; PAPER MATS; PAPER NAPKINS; AND RUBBER STAMPS (U.S. CLS. 2, 5, 22, 23, 29, 37, 38 AND 50).

CLASS 25—CLOTHING

FOR APPAREL, FOOTWEAR AND HEADGEAR, NAMELY, HATS AND CAPS; CLOTHING, NAMELY, SHIRTS, POLO SHIRTS, T-SHIRTS, SWEATSHIRTS; SWEATPANTS; JACKETS, COATS; PULLOVERS; VESTS; ARTICLES OF UNDERCLOTHING; SHORTS; SCARVES; SILK POCKET SQUARES; NECK-TIES; BRACES; SUSPENDERS; BELTS; SOCKS; LONG-SLEEVED SHIRTS AND LONG SLEEVED T-SHIRTS; SILK SCARVES; SILK SCARVES IN THE SHAPE OF SQUARES FOR WEARING OVER THE HEAD OR AROUND THE NECK; PANTS; FLEECE TOPS; THERMAL TOPS; JERSEYS; BASEBALL JERSEYS; HOCKEY JERSEYS; SWEATERS; TANK TOPS; WAISTCOATS; TROUSERS; GOLF SHIRTS; GOLF PANTS; GOLF SHOES; SWIM WEAR; BEACHWEAR; NIGHT GOWNS; PAJAMAS; DRESSING GOWNS; BATHROBES; BATHING CAPS; HEAD BANDS; SLIPPERS; BEACH SHOES; SANDALS (U.S. CLS. 22 AND 39).

KARANENDRA S. CHHINA, EXAMINING ATTORNEY

SN 77-578,257. LEMIEUX-BOKOR, JACQUELINE, BEVERLY FARMS, MA. FILED 9-24-2008.

Willow and Dove

THE MARK CONSISTS OF STANDARD CHARACTERS WITHOUT CLAIM TO ANY PARTICULAR FONT, STYLE, SIZE, OR COLOR.

CLASS 16—PAPER GOODS AND PRINTED MATTER

FOR MEMORIAL PRODUCTS FOR PRESERVATION OF MEMORIES CONCERNING A DECEASED INDIVIDUAL OR INDIVIDUALS, NAMELY, MEMORIAL CARD HOLDERS, PAPER MEMORY CARD BOXES, GUEST BOOKS, MEMORY BOOKS, PHOTO ALBUMS, PAPER KEEPSAKE BOXES, PAPER TISSUE BOXES, WRITING IMPLEMENT HOLDERS, WRITING IMPLEMENT HOLDERS, PAPER CARD BOXES, NOTE CARDS, COMPOSED OF TREE-FREE MATERIALS (U.S. CLS. 2, 5, 22, 23, 29, 37, 38 AND 50).

CLASS 20—FURNITURE AND ARTICLES NOT OTHERWISE CLASSIFIED

FOR MEMORIAL PRODUCTS FOR PRESERVATION OF MEMORIES CONCERNING A DECEASED INDIVIDUAL OR INDIVIDUALS, NAMELY, PICTURE FRAMES AND CREMATION REMAINS CONTAINERS, NAMELY, FUNERARY URNS (U.S. CLS. 2, 13, 22, 25, 32 AND 50).

MATTHEW KLINE, EXAMINING ATTORNEY

SN 77-578,967. ROTH, SUSAN J., WESTFIELD, NJ. FILED 9-25-2008.

Scent for the soul

THE MARK CONSISTS OF STANDARD CHARACTERS WITHOUT CLAIM TO ANY PARTICULAR FONT, STYLE, SIZE, OR COLOR.

NO CLAIM IS MADE TO THE EXCLUSIVE RIGHT TO USE "SCENT", APART FROM THE MARK AS SHOWN.

CLASS 3—COSMETICS AND CLEANING PREPARATIONS

FOR (BASED ON USE IN COMMERCE) EAU DE PARFUM/PERFUME, PERFUMED BODY LOTION, PERFUMED SOAP, PERFUMED BATH OIL, PERFUMED BATH GEL; (BASED ON INTENT TO USE) PERFUME AND FRAGRANCE FOR PERSONAL USE, NAMELY, PERFUMED BODY AND BEAUTY CARE PREPARATIONS IN THE NATURE OF AFTER-SHAVE GEL; AFTER-SHAVE LOTION; BATH GEL; BATH SOAPS IN LIQUID, SOLID OR GEL FORM; BODY CREAM, BODY OIL; COLOGNE, EAU DE COLOGNE; HAIR CARE PREPARATIONS; PERFUMED CREAMS, PERFUMED SOAP; AND OTHER PERFUMED PRODUCTS, NAMELY, DEODORANT FOR PERSONAL USE, ANTIPERSPIRANT AND SCENTED ROOM SPRAY (U.S. CLS. 1, 4, 6, 50, 51 AND 52).

FIRST USE 7-31-2008; IN COMMERCE 8-5-2008.

CLASS 4—LUBRICANTS AND FUELS

FOR (BASED ON USE IN COMMERCE) PERFUMED CANDLES (U.S. CLS. 1, 6 AND 15).
FIRST USE 7-31-2008; IN COMMERCE 8-5-2008.
LINDSEY RUBIN, EXAMINING ATTORNEY

SN 77-583,129. OPEN CONTACT, LTD., MINSK 220004, BELARUS, FILED 10-1-2008.

TryMyMind

THE MARK CONSISTS OF STANDARD CHARACTERS WITHOUT CLAIM TO ANY PARTICULAR FONT, STYLE, SIZE, OR COLOR.

SN 77-579,498. OSBOURNE, SHARON, NEW YORK, NY. FILED 9-26-2008.

BLACK CHRISTMAS

THE MARK CONSISTS OF STANDARD CHARACTERS WITHOUT CLAIM TO ANY PARTICULAR FONT, STYLE, SIZE, OR COLOR.

NO CLAIM IS MADE TO THE EXCLUSIVE RIGHT TO USE "CHRISTMAS", APART FROM THE MARK AS SHOWN.

CLASS 35—ADVERTISING AND BUSINESS

FOR ADVERTISING BY MAIL ORDER, PUBLICATION OF PUBLICITY TEXTS, DISSEMINATING OF ADVERTISING MATTER; ADVERTISING SERVICES; AND PUBLICITY CHRONICLE DISSEMINATION, NAMELY, DISTRIBUTION OF FLYERS, BROCHURES; BUSINESS MANAGEMENT (U.S. CLS. 100, 101 AND 102).

CLASS 38—COMMUNICATION

FOR COMMUNICATION BY COMPUTER TERMINALS, COMPUTER AIDED TRANSMISSION OF MESSAGES AND IMAGES (U.S. CLS. 100, 101 AND 104).

CLASS 42—SCIENTIFIC AND COMPUTER SERVICES

FOR INSTALLATION AND UPDATING OF COMPUTER SOFTWARE (U.S. CLS. 100 AND 101).
RUDY R. SINGLETON, EXAMINING ATTORNEY

CLASS 9—ELECTRICAL AND SCIENTIFIC APPARATUS

FOR SOUND RECORDINGS FEATURING MUSIC; VIDEO RECORDINGS FEATURING MUSIC; PRE-RECORDED CDS, AUDIO TAPES AND DVDS FEATURING MUSIC AND MUSIC ENTERTAINMENT; DOWNLOADABLE AUDIO RECORDINGS AND DOWNLOADABLE AUDIOVISUAL RECORDINGS FEATURING MUSIC VIA GLOBAL COMPUTER NETWORK AND WIRELESS DEVICES (U.S. CLS. 21, 23, 26, 36 AND 38).

SN 77-583,225. NODAL EXCHANGE, LLC, VIENNA, VA. FILED 10-1-2008.

THE NEXT GENERATION OF POWER TRADING

CLASS 25—CLOTHING

FOR CLOTHING, NAMELY, SHIRTS, T-SHIRTS, TANK TOPS, POLO SHIRTS, KNIT SHIRTS, JERSEYS, SPORTS SHIRTS, RUGBY SHIRTS, BLOUSES, CARDIGANS, SKIRTS, DRESSES, VESTS, JOGGING AND RUNNING SUITS, SWEATPANTS, SWEATSHIRTS, SWEAT SUITS, HOODED SWEATSHIRTS, SWEATERS, JACKETS, PULLOVERS, COATS, CLOAKS, CAPES, OVERCOATS, SUITS, TUXEDOS, PANTS, CAPRIS, SHORTS, JEANS, OVERALLS, JUMPERS, RAINWEAR, RAINCOATS, WIND RESISTANT COATS, PARKAS, SLEEPWEAR, LOUNGEWEAR, UNDERWEAR AND SWIMWEAR; FOOTWEAR; HEADWEAR, NAMELY, HATS, CAPS, BERETS, VISORS, HEADBANDS AND DO-RAGS; FASHION ACCESSORIES, NAMELY, BANDANAS, BELTS, SUSPENDERS, TIES, GLOVES, MITTENS, WRISTBANDS, SCARVES, SOCKS, HOSIERY, LEGGINGS, STOCKINGS, TIGHTS AND LEGWARMERS (U.S. CLS. 22 AND 39).

THE MARK CONSISTS OF STANDARD CHARACTERS WITHOUT CLAIM TO ANY PARTICULAR FONT, STYLE, SIZE, OR COLOR.

NO CLAIM IS MADE TO THE EXCLUSIVE RIGHT TO USE "POWER TRADING", APART FROM THE MARK AS SHOWN.

CLASS 36—INSURANCE AND FINANCIAL

FOR FINANCIAL EXCHANGE SERVICES (U.S. CLS. 100, 101 AND 102).
FIRST USE 11-27-2007; IN COMMERCE 11-27-2007.

CLASS 42—SCIENTIFIC AND COMPUTER SERVICES

FOR PROVIDING TEMPORARY USE OF NON-DOWNLOADABLE COMPUTER SOFTWARE VIA THE GLOBAL COMPUTER NETWORK FOR THE PURPOSE OF PROVIDING USERS WITH AN ONLINE ELECTRONIC TRADING SYSTEM FOR THE EXECUTION OF TRADES INVOLVING COMMODITY DERIVATIVE PRODUCTS AND RELATED FINANCIAL INSTRUMENTS (U.S. CLS. 100 AND 101).

FIRST USE 11-27-2007; IN COMMERCE 11-27-2007.
DEZMONA MIZELLE, EXAMINING ATTORNEY

CLASS 41—EDUCATION AND ENTERTAINMENT

FOR ENTERTAINMENT SERVICES IN THE NATURE OF ORGANIZING AND CONDUCTING MUSIC CONCERTS AND MUSIC FESTIVALS; LIVE PERFORMANCES FEATURING MUSIC; PRODUCTION OF THEATRICAL PERFORMANCES; PRODUCTION OF MOTION PICTURES (U.S. CLS. 100, 101 AND 107).
ANDREW RHIM, EXAMINING ATTORNEY

SN 77-583,622. MING CYCLE INDUSTRIAL CO., LTD.,
TAICHUNG HSIEN, TAIWAN, FILED 10-1-2008.



OWNER OF U.S. REG. NO. 2,463,862.
THE MARK CONSISTS OF "STRIDA" WITH THE DESIGN
OF A BAR EXTENDING ACROSS THE LETTERS "STR".

CLASS 18—LEATHER GOODS

FOR ATTACHE CASES, BACKPACKS, GARMENT
BAGS FOR TRAVEL, BRIEFCASES, HANDBAGS, POK-
ET WALLETS, SCHOOL BAGS, TEXTILE SHOPPING
BAGS, SUITCASE, TRAVELLING TRUNKS, VALISES
(U.S. CLS. 1, 2, 3, 22 AND 41).
FIRST USE 2-11-2004; IN COMMERCE 2-11-2004.

CLASS 25—CLOTHING

FOR BOOTS, CAPS FOR HEADWEAR; CLOTHING,
NAMELY, SHIRTS, SHORTS, PANTS, SWEATPANTS,
SWEATSHIRTS; CYCLISTS' CLOTHING, NAMELY, JER-
SEYS; HATS, CLOTHING JACKETS, CLOTHING JER-
SEYS, CLOTHING OF LEATHER, NAMELY, JACKETS;
OUTER CLOTHING, NAMELY, COATS; OVERALLS,
PANTS, SCARVES, SHIRTS, SHOULDER WRAPS,
SOCKS, SPORTS SHOES, TROUSERS, WAISTCOATS
(U.S. CLS. 22 AND 39).
FIRST USE 2-11-2004; IN COMMERCE 2-11-2004.
SANDRA MANIOS, EXAMINING ATTORNEY

SN 77-584,765. LARKIN INC., DBA ASIA COMPANY OR
KING'S GINSENG CO., SAN FRANCISCO, CA. FILED 10-
3-2008.



OWNER OF U.S. REG. NO. 3,174,017.
NO CLAIM IS MADE TO THE EXCLUSIVE RIGHT TO
USE "BRAND" AND THE NON-LATIN CHARACTERS
THAT MEAN "BRAND GINSENG", APART FROM THE
MARK AS SHOWN.
THE MARK CONSISTS OF A GINSENG ROOT ON THE

LEFT SIDE OF A STEAMING TEA CUP AND PLATE IN
THE CENTER OF ROUND EMBLEM. THIS GINSENG
ROOT AND TEA CUP AND PLATE ARE IN WHITE WHILE
THE BACKGROUND IS IN BLACK COLOR. "KINGIN-
SENG" IN CAPS SURROUNDS CENTER PICTURE FROM
THE TOP. KING'S BRAND GINSENG IN CHINESE CHAR-
ACTERS OUTLINES THE BOTTOM PORTION OF PICTURE
WITH A FIVE-PETAL FLOWER ON EACH SIDE. ALL
WORDS AND PICTURE ARE CAST INSIDE A ROUND,
CIRCLE EMBLEM.

THE NON-LATIN CHARACTER(S) IN THE MARK
TRANSLITERATE INTO HUANG PAI REN SHEN, AND
THIS MEANS KING'S BRAND GINSENG IN ENGLISH.

CLASS 5—PHARMACEUTICALS

FOR (BASED ON USE IN COMMERCE) HERB TEAS
FOR MEDICINAL PURPOSES; HERBAL TEAS FOR
MEDICINAL PURPOSES; MEDICINAL TEA (BASED ON
INTENT TO USE) ASTRINGENTS FOR MEDICINAL
PURPOSES; DIETARY SUPPLEMENTAL DRINKS; GIN-
SENG FOR MEDICINAL USE; MEDICINAL CREAMS
FOR SKIN CARE (U.S. CLS. 6, 18, 44, 46, 51 AND 52).
FIRST USE 2-20-1985; IN COMMERCE 2-20-1986.

CLASS 30—STAPLE FOODS

FOR (BASED ON USE IN COMMERCE) ROYAL JELLY
FOR FOOD PURPOSES (BASED ON INTENT TO USE)
CANDIES; CANDY; COCOA; COFFEE (U.S. CL. 46).
FIRST USE 2-20-1985; IN COMMERCE 2-20-1985.
H. M. FISHER, EXAMINING ATTORNEY

SN 77-585,170. HERITAGE CAPITAL CORPORATION, DAL-
LAS, TX. FILED 10-3-2008.

HERITAGE LIVE!

THE MARK CONSISTS OF STANDARD CHARACTERS
WITHOUT CLAIM TO ANY PARTICULAR FONT, STYLE,
SIZE, OR COLOR.

OWNER OF U.S. REG. NOS. 2,486,881, 2,746,296 AND
2,836,961.

NO CLAIM IS MADE TO THE EXCLUSIVE RIGHT TO
USE "LIVE", APART FROM THE MARK AS SHOWN.

CLASS 35—ADVERTISING AND BUSINESS

FOR INTERACTIVE AUCTION SERVICES VIA THE
INTERNET (U.S. CLS. 100, 101 AND 102).
FIRST USE 4-0-2007; IN COMMERCE 4-0-2007.

CLASS 38—COMMUNICATION

FOR STREAMING OF AUDIO AND VIDEO OF LIVE
AUCTION ITEMS VIA THE INTERNET BEFORE AND
DURING A LIVE AUCTION EVENT (U.S. CLS. 100, 101
AND 104).

FIRST USE 4-0-2007; IN COMMERCE 4-0-2007.
ROBIN CHOSID, EXAMINING ATTORNEY

SN 77-585,512. JHANE BARNES (DEL.) INC., WILMINGTON, DE. FILED 10-3-2008.

SN 77-587,150. DAY4 ENERGY INC., BURNABY, BC V3N 5G4, CANADA, FILED 10-7-2008.

BARNES STORM

THE MARK CONSISTS OF STANDARD CHARACTERS WITHOUT CLAIM TO ANY PARTICULAR FONT, STYLE, SIZE, OR COLOR.

CLASS 3—COSMETICS AND CLEANING PREPARATIONS

FOR PERFUME, TOILET WATER, COLOGNE, COSMETICS, NAMELY, MASCARA, EYE LINERS, EYE SHADOWS, EYE PENCILS, MAKE-UP POWDER, LIPSTICK; FACIAL AND BODY SOAPS; HAND AND BODY CREAMS AND LOTIONS; BATH SALTS; ESSENTIAL OILS FOR PERSONAL USE, HAIR SHampoos AND CONDITIONERS; NON-MEDICATED SKIN CREAMS, LOTIONS, AND OILS FOR COSMETIC PURPOSES (U.S. CLS. 1, 4, 6, 50, 51 AND 52).

CLASS 9—ELECTRICAL AND SCIENTIFIC APPARATUS

FOR EYEGLASSES, EYEGLASS CASES, SUNGLASSES, EYEGLASS FRAMES AND EYE SHADES (U.S. CLS. 21, 23, 26, 36 AND 38).

CLASS 18—LEATHER GOODS

FOR WALLETS, PURSES, CREDIT CARD CASES, BILLFOLDS, LEATHER KEY CASES, LUGGAGE, BRIEF CASES, AND ATTACHE CASES (U.S. CLS. 1, 2, 3, 22 AND 41).

CIMMERIAN COLEMAN, EXAMINING ATTORNEY

SN 77-586,953. WORKCIRCLE LIMITED, LONDON, UNITED KINGDOM, FILED 10-7-2008.

WORKCIRCLE

THE MARK CONSISTS OF STANDARD CHARACTERS WITHOUT CLAIM TO ANY PARTICULAR FONT, STYLE, SIZE, OR COLOR.

CLASS 35—ADVERTISING AND BUSINESS

FOR PROVIDING INFORMATION REGARDING EMPLOYMENT OPPORTUNITIES BY MEANS OF AN ONLINE AGGREGATOR SERVICE ON A GLOBAL COMPUTER NETWORK (U.S. CLS. 100, 101 AND 102).
FIRST USE 4-14-2009; IN COMMERCE 4-14-2009.

CLASS 42—SCIENTIFIC AND COMPUTER SERVICES

FOR PROVIDING A SEARCH ENGINE FOR OBTAINING INFORMATION REGARDING EMPLOYMENT OPPORTUNITIES (U.S. CLS. 100 AND 101).
FIRST USE 4-14-2009; IN COMMERCE 4-14-2009.
JOHN E. MICHOS, EXAMINING ATTORNEY

DAY4

THE MARK CONSISTS OF STANDARD CHARACTERS WITHOUT CLAIM TO ANY PARTICULAR FONT, STYLE, SIZE, OR COLOR.

CLASS 7—MACHINERY

FOR MANUFACTURING APPARATUS AND MACHINES FOR APPLYING ELECTROCONDUCTIVE, ANTI-REFLECTIVE COATING ON PHOTOVOLTAIC CELLS AND PHOTOVOLTAIC MODULES BY CHEMICAL VAPOR DEPOSITION FOR USE IN THE PRODUCTION OF PHOTOVOLTAIC CELLS AND PHOTOVOLTAIC MODULES; MANUFACTURING APPARATUS AND MACHINES FOR PRODUCING ELECTRODES FOR PHOTOVOLTAIC CELLS AND PHOTOVOLTAIC MODULES, NAMELY, MACHINES FOR METALLIC WIRE COATING WITH ALLOY, MACHINES FOR METALLIC WIRE IMBEDDING INTO POLYMERIC FILM WITH ADHESIVE LAYER, MACHINES FOR ELECTRODE POSITIONING ON THE PHOTOVOLTAIC CELLS, MACHINES FOR PHOTOVOLTAIC CELLS LAY-UP FOR PHOTOVOLTAIC MODULE MANUFACTURING (U.S. CLS. 13, 19, 21, 23, 31, 34 AND 35).

CLASS 9—ELECTRICAL AND SCIENTIFIC APPARATUS

FOR PHOTOVOLTAIC POWER GENERATION SYSTEMS COMPRISING OF PHOTOVOLTAIC CELLS AND PHOTOVOLTAIC SYSTEMS, COMPRISED OF PHOTOVOLTAIC MODULES, POWER INVERTERS, GRID-TIE SWITCHES, FIELD COMBINER BOXES, SAFETY CIRCUITS, MONITORING INSTRUMENTS, MOUNTING RACKS AND HARDWARE, ELECTRICAL WIRE AND CONDUIT, AND/OR SUN-TRACKING EQUIPMENT AND MOUNTS; ELECTRODES FOR PHOTOVOLTAIC CELLS AND PHOTOVOLTAIC MODULES; ACCESSORIES FOR PHOTOVOLTAIC CELLS AND PHOTOVOLTAIC MODULES, NAMELY, INVERTORS, CONVERTERS, ELECTRIC POWER METERS, TRANSFORMERS, COMPUTERS, COMPUTER PROGRAMS FOR USE IN PHOTOVOLTAIC POWER GENERATION SYSTEMS IN THE FIELD OF ELECTRIC POWER GENERATION; MEASURING AND TESTING INSTRUMENTS AND APPARATUS, NAMELY, PHOTOVOLTAIC CELLS AND PHOTOVOLTAIC MODULES FOR PERFORMANCE TESTING FOR EVALUATING THE POWER AND EFFECTIVITY OF PHOTOVOLTAIC CELLS AND PHOTOVOLTAIC MODULES, LIGHT SOURCES SIMULATING NATURAL AND CONCENTRATED SUN RADIATION (U.S. CLS. 21, 23, 26, 36 AND 38).

JILL PRATER, EXAMINING ATTORNEY

SN 77-588,236. JOSEPH SAYEGH, CORONA DEL MAR, CA. FILED 10-8-2008.

PHOENICIAN

THE MARK CONSISTS OF STANDARD CHARACTERS WITHOUT CLAIM TO ANY PARTICULAR FONT, STYLE, SIZE, OR COLOR.

CLASS 11—ENVIRONMENTAL CONTROL APPARATUS

FOR ORNAMENTAL FOUNTAINS, WATER FOUNTAINS (U.S. CLS. 13, 21, 23, 31 AND 34).

CLASS 19—NON-METALLIC BUILDING MATERIALS

FOR STONE FOR BUILDING AND CONSTRUCTION; MANTELS FOR FIREPLACES OF STONE; NON-METAL DOORS; NON-METAL TILES; SALVAGED NON-METAL ARCHITECTURAL COLUMNS; NON-METAL DECORATIVE MOLDINGS AND DECORATIVE TRIM FOR USE IN BUILDING CONSTRUCTION; NON-METAL CLADDING FOR CONSTRUCTION AND BUILDING; WORKS OF ART OF STONE, MARBLE, AND GRANITE; STATUES AND SCULPTURES OF STONE (U.S. CLS. 1, 12, 33 AND 50).

CLASS 21—HOUSEWARES AND GLASS

FOR WORKS OF ART OF EARTHENWARE, PORCELAIN, AND TERRA COTTA; HEADS AND BUSTS OF EARTHENWARE, PORCELAIN, AND TERRA COTTA; STATUES AND SCULPTURES OF EARTHENWARE, PORCELAIN, AND TERRA COTTA; URNS (U.S. CLS. 2, 13, 23, 29, 30, 33, 40 AND 50).

CLASS 35—ADVERTISING AND BUSINESS

FOR WHOLESALE AND RETAIL STORE SERVICES FEATURING STONE FOR BUILDING AND CONSTRUCTION; MANTELS FOR FIREPLACES; ORNAMENTAL FOUNTAINS AND WATER FOUNTAINS; NON-METAL DOORS; NON-METAL TILES; NON-METAL ARCHITECTURAL COLUMNS; NON-METAL DECORATIVE MOLDINGS AND DECORATIVE TRIM FOR USE IN BUILDING CONSTRUCTION; NON-METAL CLADDING FOR CONSTRUCTION AND BUILDING; WORKS OF ART OF STONE, MARBLE, AND GRANITE; WORKS OF ART OF EARTHENWARE, PORCELAIN, AND TERRA COTTA; HEADS AND BUSTS OF EARTHENWARE, PORCELAIN, AND TERRA COTTA; STATUES AND SCULPTURES OF EARTHENWARE, PORCELAIN, STONE, AND TERRA COTTA; URNS (U.S. CLS. 100, 101 AND 102).

VIVIAN MICZNIK FIRST, EXAMINING ATTORNEY

SN 77-588,663. MACROVISION SOLUTIONS CORPORATION, SANTA CLARA, CA. FILED 10-8-2008.

MEGA-DATA

THE MARK CONSISTS OF STANDARD CHARACTERS WITHOUT CLAIM TO ANY PARTICULAR FONT, STYLE, SIZE, OR COLOR.

CLASS 41—EDUCATION AND ENTERTAINMENT

FOR ENTERTAINMENT SERVICES, NAMELY, THE PROVISION OF INFORMATION IN THE FIELDS OF MUSIC, MOVIES AND GAMES VIA THE INTERNET (U.S. CLS. 100, 101 AND 107).

CLASS 42—SCIENTIFIC AND COMPUTER SERVICES

FOR COMPUTER SERVICES, NAMELY, HOSTING AND MAINTAINING AN ON-LINE WEB SITE FOR OTHERS FOR USE TO IDENTIFY DIGITAL OR PHYSICAL MEDIA IN THE FIELDS OF MUSIC, MOVIES AND GAMES (U.S. CLS. 100 AND 101).

ELLEN BURNS, EXAMINING ATTORNEY

SN 77-589,299. ANIMAL SUPPLIES INTERNATIONAL, INC., MODESTO, CA. FILED 10-9-2008.

BUSH BEAR

THE MARK CONSISTS OF STANDARD CHARACTERS WITHOUT CLAIM TO ANY PARTICULAR FONT, STYLE, SIZE, OR COLOR.

OWNER OF U.S. REG. NOS. 3,528,618 AND 3,528,619.

CLASS 9—ELECTRICAL AND SCIENTIFIC APPARATUS

FOR PROTECTIVE CLOTHING; PROTECTIVE HELMETS; PROTECTIVE GLOVES; PROTECTIVE JACKETS; PROTECTIVE EYEWEAR (U.S. CLS. 21, 23, 26, 36 AND 38).

CLASS 12—VEHICLES

FOR LAND VEHICLES; DIRT BIKES; MINI-BIKES; MOTORCYCLES; FARM AND RANCH UTILITY VEHICLES IN THE NATURE OF OFF-ROAD UTILITY VEHICLES (U.S. CLS. 19, 21, 23, 31, 35 AND 44).

MATTHEW PAPPAS, EXAMINING ATTORNEY

SN 77-589,402. JOSEPH SAYEGH, CORONA DEL MAR, CA. FILED 10-9-2008.

PHOENICIAN STONE

THE MARK CONSISTS OF STANDARD CHARACTERS WITHOUT CLAIM TO ANY PARTICULAR FONT, STYLE, SIZE, OR COLOR.

NO CLAIM IS MADE TO THE EXCLUSIVE RIGHT TO USE "STONE", APART FROM THE MARK AS SHOWN.

CLASS 11—ENVIRONMENTAL CONTROL APPARATUS

FOR ORNAMENTAL FOUNTAINS, WATER FOUNTAINS (U.S. CLS. 13, 21, 23, 31 AND 34).

CLASS 19—NON-METALLIC BUILDING MATERIALS

FOR STONE FOR BUILDING AND CONSTRUCTION; MANTELS FOR FIREPLACES OF STONE; NON-METAL DOORS; NON-METAL TILES; SALVAGED NON-METAL ARCHITECTURAL COLUMNS; NON-METAL DECORATIVE MOLDINGS AND DECORATIVE TRIM FOR USE IN BUILDING CONSTRUCTION; NON-METAL CLADDING FOR CONSTRUCTION AND BUILDING; WORKS OF ART OF STONE, MARBLE, AND GRANITE; STATUES AND SCULPTURES OF STONE (U.S. CLS. 1, 12, 33 AND 50).

CLASS 21—HOUSEWARES AND GLASS

FOR WORKS OF ART OF EARTHENWARE, PORCELAIN, AND TERRA COTTA; HEADS AND BUSTS OF EARTHENWARE, PORCELAIN, AND TERRA COTTA; STATUES AND SCULPTURES OF EARTHENWARE, PORCELAIN, AND TERRA COTTA; URNS (U.S. CLS. 2, 13, 23, 29, 30, 33, 40 AND 50).

CLASS 35—ADVERTISING AND BUSINESS

FOR WHOLESALE AND RETAIL STORE SERVICES FEATURING STONE FOR BUILDING AND CONSTRUCTION; MANTELS FOR FIREPLACES; ORNAMENTAL FOUNTAINS AND WATER FOUNTAINS; NON-METAL DOORS; NON-METAL TILES; NON-METAL ARCHITECTURAL COLUMNS; NON-METAL DECORATIVE MOLDINGS AND DECORATIVE TRIM FOR USE IN BUILDING CONSTRUCTION; NON-METAL CLADDING FOR CONSTRUCTION AND BUILDING; WORKS OF ART OF STONE, MARBLE, AND GRANITE; WORKS OF ART OF EARTHENWARE, PORCELAIN, AND TERRA COTTA; HEADS AND BUSTS OF EARTHENWARE, PORCELAIN, AND TERRA COTTA; STATUES AND SCULPTURES OF EARTHENWARE, PORCELAIN, STONE, AND TERRA COTTA; URNS (U.S. CLS. 100, 101 AND 102).

VIVIAN MICZNIK FIRST, EXAMINING ATTORNEY

SN 77-590,293. BRULIN & COMPANY, INC., INDIANAPOLIS, IN. FILED 10-10-2008.

TOPFOAM

THE MARK CONSISTS OF STANDARD CHARACTERS WITHOUT CLAIM TO ANY PARTICULAR FONT, STYLE, SIZE, OR COLOR.

CLASS 3—COSMETICS AND CLEANING PREPARATIONS

FOR HAND SOAPS NOT USED IN MEDICAL APPLICATIONS AS A SURGICAL DRESSING (U.S. CLS. 1, 4, 6, 50, 51 AND 52).

CLASS 5—PHARMACEUTICALS

FOR HAND-SANITIZING PREPARATIONS NOT USED IN MEDICAL APPLICATIONS AS A SURGICAL DRESSING (U.S. CLS. 6, 18, 44, 46, 51 AND 52).

MARC LEIPZIG, EXAMINING ATTORNEY

SN 77-590,627. STICS, INC., SAN DIEGO, CA. FILED 10-10-2008.

CHIPS

THE MARK CONSISTS OF STANDARD CHARACTERS WITHOUT CLAIM TO ANY PARTICULAR FONT, STYLE, SIZE, OR COLOR.

CLASS 9—ELECTRICAL AND SCIENTIFIC APPARATUS

FOR COMPUTER SOFTWARE, NAMELY, APPLICATIONS FOR USE IN STATISTICAL MODELING, ANALYSIS, AND FORECASTING APPLIED TO CUSTOMER BEHAVIOR, MARKETING ACTIVITIES AND PROFITABILITY ACROSS THE CASINO AND HOSPITALITY INDUSTRIES (U.S. CLS. 21, 23, 26, 36 AND 38).

CLASS 35—ADVERTISING AND BUSINESS

FOR BUSINESS CONSULTATION SERVICES, NAMELY, ANALYTICAL SERVICES FEATURING STATISTICAL MODELING, ANALYSIS, AND FORECASTING APPLIED TO CUSTOMER BEHAVIOR, MARKETING ACTIVITIES AND PROFITABILITY ACROSS THE CASINO AND HOSPITALITY INDUSTRIES (U.S. CLS. 100, 101 AND 102).

MARTHA FROMM, EXAMINING ATTORNEY

SN 77-592,643. INFRAWARE, INC., SEOUL, REPUBLIC OF KOREA, FILED 10-14-2008.

INFRAWARE

THE MARK CONSISTS OF STANDARD CHARACTERS WITHOUT CLAIM TO ANY PARTICULAR FONT, STYLE, SIZE, OR COLOR.

CLASS 9—ELECTRICAL AND SCIENTIFIC APPARATUS

FOR COMPUTER SOFTWARE FOR TELECOMMUNICATIONS, ELECTRONIC COMMUNICATIONS, DIGITAL RIGHTS MANAGEMENT (DRM), FACILITATING MULTIMEDIA MESSAGING SERVICES (MMS), INTERNET PROTOCOL TELEVISION (IPTV) SET TOP BOXES, AND MEDIA FILE PROCESSING (U.S. CLS. 21, 23, 26, 36 AND 38).

CLASS 42—SCIENTIFIC AND COMPUTER SERVICES

FOR COMPUTER SOFTWARE DEVELOPMENT (U.S. CLS. 100 AND 101).

CHERYL CLAYTON, EXAMINING ATTORNEY

SN 77-592,659. INFRAWARE, INC., SEOUL, REPUBLIC OF KOREA, FILED 10-14-2008.

SN 77-594,238. 360ED, INC., ORLANDO, FL. FILED 10-16-2008.



THE COLOR(S) GREEN AND GRAY IS/ARE CLAIMED AS A FEATURE OF THE MARK.

THE MARK CONSISTS OF A GREEN ORB NEXT TO THE WORD "INFRAWARE", WITH "INFRA" IN GREEN AND "WARE" IN GRAY.

CLASS 9—ELECTRICAL AND SCIENTIFIC APPARATUS

FOR COMPUTER SOFTWARE FOR TELECOMMUNICATIONS, ELECTRONIC COMMUNICATIONS, DIGITAL RIGHTS MANAGEMENT (DRM), FACILITATING MULTIMEDIA MESSAGING SERVICES (MMS), INTERNET PROTOCOL TELEVISION (IPTV) SET TOP BOXES, AND MEDIA FILE PROCESSING (U.S. CLS. 21, 23, 26, 36 AND 38).

CLASS 42—SCIENTIFIC AND COMPUTER SERVICES

FOR COMPUTER SOFTWARE DEVELOPMENT (U.S. CLS. 100 AND 101).

CHERYL CLAYTON, EXAMINING ATTORNEY

SN 77-593,027. JOHNSON-COTY, CRYSTAL, VALPARAISO, IN. FILED 10-15-2008.

CRYSTAL CLOSETS

THE MARK CONSISTS OF STANDARD CHARACTERS WITHOUT CLAIM TO ANY PARTICULAR FONT, STYLE, SIZE, OR COLOR.

NO CLAIM IS MADE TO THE EXCLUSIVE RIGHT TO USE "CLOSETS", APART FROM THE MARK AS SHOWN.

CLASS 37—CONSTRUCTION AND REPAIR

FOR INSTALLATION OF ORGANIZATIONAL SHELVES AND RACKS FOR CLOSETS (U.S. CLS. 100, 103 AND 106).

FIRST USE 8-5-2008; IN COMMERCE 8-5-2008.

CLASS 42—SCIENTIFIC AND COMPUTER SERVICES

FOR CLOSET ORGANIZATIONAL DESIGN (U.S. CLS. 100 AND 101).

FIRST USE 8-5-2008; IN COMMERCE 8-5-2008.

MARK RADEMACHER, EXAMINING ATTORNEY



NO CLAIM IS MADE TO THE EXCLUSIVE RIGHT TO USE "ED", APART FROM THE MARK AS SHOWN.

THE COLOR(S) GREY, BLACK, WHITE, BLUE, AND LIGHT BLUE IS/ARE CLAIMED AS A FEATURE OF THE MARK.

THE MARK CONSISTS OF A STYLIZED BLACK PAINTBRUSH STROKE ARCING FROM LEFT TO RIGHT, BECOMING DARKER AND MORE COMPLETE AS IT APPROACHES THE RIGHT-HAND SIDE OF THE LOGO. THE COMPOSITION OF THIS STROKE CHANGES AS IT WRAPS AROUND BELOW THE PRIMARY STROKE, CHANGING INTO A SERIES OF BLUE SQUARES THAT BEGIN AS DENSELY-PACKED, LARGE BLOCKS ON THE RIGHT-HAND SIDE OF THE LOGO AND PROCEEDING INTO SMALLER, GRAY-COLORED BLOCKS AS THEY APPROACH THE LEFT-HAND SIDE. THE OVERALL APPEARANCE OF THE LOGO IS AN INCOMPLETE SPHERE, WITH THE BLOCK-LIKE, BLUE-AND-GRAY SECTION LARGER THAN THE BLACK PAINTBRUSH STROKE SECTION ABOVE IT. BELOW THIS ICON IS THE WORD "360" IN LARGE, WIDE, GRAY LETTERS WITH A DARKER GRAY STROKE, FOLLOWED BY "ED" IN BLUE LETTERS IN A DIFFERENT FONT THAT APPEARS HANDWRITTEN.

CLASS 9—ELECTRICAL AND SCIENTIFIC APPARATUS

FOR ELECTRONIC GAME PROGRAMS; ELECTRONIC GAME SOFTWARE; INTERACTIVE GAME SOFTWARE; INTERACTIVE GAME PROGRAMS; VIDEO GAME SOFTWARE; VIDEO GAME PROGRAMS (U.S. CLS. 21, 23, 26, 36 AND 38).

CLASS 41—EDUCATION AND ENTERTAINMENT

FOR MULTIMEDIA EDUCATIONAL AND ENTERTAINMENT SERVICES, NAMELY, PROVIDING A WEBSITE FEATURING NEXT GENERATION INSTRUCTIONAL AND TEACHING MATERIALS IN VARIOUS FIELDS OF EDUCATIONAL INFORMATION FOR K-12 EDUCATION LEVELS; PROVIDING CONTINUING AND PROFESSIONAL EDUCATIONAL CONTENT IN THE FORM OF MULTIMEDIA ONLINE COURSES CONTAINING TEXT, VIDEO, AND AUDIO CONTENT WITH SOCIAL NETWORKING CAPABILITIES IN THE FIELDS OF ENGLISH, MATHEMATICS, HISTORY, SCIENCE, MUSIC, ART, LANGUAGE ARTS AND OTHER EDUCATIONAL TOPICS; ASSESSMENT AND EVALUATION OF THE CURRICULA AND EDUCATIONAL SERVICES OFFERED AND PROVIDED BY OTHERS AND CONSULTING SERVICES RELATED THERETO; PROVIDING ON-LINE INFORMATION RELATED TO GAME STRATEGIES AND PLAY STRATEGIES FOR VIDEO AND COMPUTER GAME SOFTWARE VIA A GLOBAL COMMUNICATION NETWORK (U.S. CLS. 100, 101 AND 107).

KATHRYN COWARD, EXAMINING ATTORNEY

SN 77-594,448. BONDDDESK GROUP LLC, MILL VALLEY, CA. FILED 10-16-2008.

BONDDDESK

THE MARK CONSISTS OF STANDARD CHARACTERS WITHOUT CLAIM TO ANY PARTICULAR FONT, STYLE, SIZE, OR COLOR.

CLASS 36—INSURANCE AND FINANCIAL

FOR SECURITIES TRADING AND INVESTING SERVICES FOR OTHERS VIA THE INTERNET; PROVIDING ONLINE FINANCIAL PORTFOLIO MANAGEMENT AND FINANCIAL VALUATION OF SECURITIES; PROVIDING FINANCIAL INFORMATION VIA AN ELECTRONIC DATA FEED REGARDING SECURITIES AND ANALYSIS OF SECURITIES TRANSACTIONS (U.S. CLS. 100, 101 AND 102).

FIRST USE 5-0-2002; IN COMMERCE 5-0-2002.

CLASS 42—SCIENTIFIC AND COMPUTER SERVICES

FOR PROVIDING TEMPORARY USE OF ON-LINE NON-DOWNLOADABLE SOFTWARE, NAMELY, A WEB-BASED ELECTRONIC PLATFORM TO FACILITATE THE TRADING OF SECURITIES AND PORTFOLIO MANAGEMENT AND VALUATION; DESIGNING AND IMPLEMENTING CUSTOMIZED ELECTRONIC SOFTWARE PLATFORMS FOR OTHERS TO FACILITATE THE TRADING OF SECURITIES (U.S. CLS. 100 AND 101).

FIRST USE 5-0-2002; IN COMMERCE 5-0-2002.
JOHN GARTNER, EXAMINING ATTORNEY

SN 77-596,017. FOGELSON, RANDALL, K. DBA GRANDMA ALICE PRODUCTS, BYRON, MN. FILED 10-20-2008.

Grandma Alice's



THE NAME(S), PORTRAIT(S), AND/OR SIGNATURE(S) SHOWN IN THE MARK DOES NOT IDENTIFY A PARTICULAR LIVING INDIVIDUAL.

THE MARK CONSISTS OF TEXT "GRANDMA ALICE'S" AND A PICTURE OF HER HEAD.

CLASS 29—MEATS AND PROCESSED FOODS

FOR BOTTLED COOKED MEAT; CANNED FRUITS AND VEGETABLES; CANNED OR BOTTLED FRUITS; CANNED OR BOTTLED VEGETABLES; CANNED VEGETABLES; CHEESE; CHEESE AND CRACKER COMBINATIONS; CHEESE FONDUE; CHEESE FOOD; CHEESE POWDER; CHEESE SPREADS; CHEESE SUBSTITUTES; PROCESSED CHEESE; CHOCOLATE MILK; CHOW MEIN; COMBINATION MEAL CONSISTING PRIMARILY OF A MEAT OR VEGETABLE-BASED ENTREE AND A SOUP OR SALAD FOR CONSUMPTION ON OR OFF THE PREMISES; COOKED FRUITS AND VEGETABLES; COTTAGE CHEESE; CREAM CHEESE; CUT FRUITS; CUT VEGETABLES; DAIRY PRODUCTS EXCLUDING ICE CREAM, ICE MILK AND FROZEN YOGURT; DAIRY-BASED SNACK FOODS EXCLUDING ICE CREAM, ICE MILK AND FROZEN YOGURT; DRIED EGGS; DRIED FLAKES OF LAYER FOR SPRINKLING ON RICE IN HOT WATER (OCHAZUKE-NORI); DRIED FRUIT AND VEGETABLES; DRIED VEGETABLES; DUCK EGGS; EGG NOG; EGG NOG MIXES; EGG PRODUCT; EGG SUBSTITUTE; EGG WHITES; EGG YOLKS; EGGS; FERMENTED VEGETABLES; FOOD ADDITIVES IN THE NATURE OF FAT ACIDS MADE FROM MEAT, FISH, FRUITS, VEGETABLES, EGGS, MILK AND EDIBLE OILS AND FATS; FOOD PACKAGE COMBINATIONS CONSISTING PRIMARILY OF CHEESE, MEAT AND/OR PROCESSED FRUIT; FORMED TEXTURED VEGETABLE PROTEIN FOR USE AS A MEAT EXTENDER OR MEAT SUBSTITUTE; FORMED TEXTURED VEGETABLE PROTEIN TO BE USED AS AN EXTENDER OR MEAT SUBSTITUTE; FRANKFURTERS; FRESH UNRIPENED CHEESES; FROZEN APPETIZERS CONSISTING PRIMARILY OF CHICKEN OR SEAFOOD; FROZEN EGGS; FROZEN FRUITS; FROZEN PRE-PACKAGED ENTREES CONSISTING PRIMARILY OF SEAFOOD; FROZEN VEGETABLES; FRUIT AND VEGETABLE SALADS; FRUIT SALADS AND VEGETABLE SALADS; FRUIT-BASED ORGANIC FOOD BARS, ALSO CONTAINING NUTS; HALF AND HALF; HAMBURGER; HEN EGGS; HOT DOGS; MARINATED MEAT; MEAT, FISH, FRUIT AND VEGETABLE JELLIES; MEAT, FISH, FRUIT AND VEGETABLE PRESERVES; MEAT, FROZEN; MEAT, FRUIT AND VEGETABLE JELLIES, JAMS; MEAT, FRUIT AND VEGETABLE JELLIES, JAMS, EGGS; MILK; MILK BASED BEVERAGES CONTAINING FRUIT JUICE; MILK BEVERAGES CONTAINING FRUITS; MILK BEVERAGES WITH HIGH MILK CONTENT; MILK CURD; MILK DRINKS CONTAINING FRUITS; MILK PRODUCTS EXCLUDING ICE CREAM, ICE MILK AND FROZEN YOGURT; MILK-BASED BEVERAGE CONTAINING COFFEE; MILK-BASED BEVERAGES CONTAINING MILK CONCENTRATES, VEGETABLE OIL AND ADDED NUTRIENTS; MOLD-RIPENED CHEESE; MOULD-RIPENED CHEESE; NON-DAIRY BASED MIX FOR MAKING WHIPPED ICINGS AND FILLINGS; NUT CHEESE, NAMELY, CHEESE-TYPE PRODUCT MADE FROM NUTS; SALAD OIL; PICKLED VEGETABLES; PRE-CUT VEGETABLE SALAD; PRE-PACKAGED DINNERS CONSISTING OF MEAT; PRESERVED FRUIT AND VEGETABLES; PRESERVED FRUITS AND VEGETABLES; PRESERVED VEGETABLES (IN OIL); PRESERVED, DRIED AND COOKED FRUIT AND VEGETABLES; PRESERVED, DRIED, COOKED AND GRILLED VEGETABLES; PROCESSED EGGS; PROCESSED GARLIC; PROCESSED GINSENG FOR USE AS A VEGETABLE; PROCESSED ORANGES; PROCESSED VEGETABLES; PROCESSED VEGETABLES AND FRUITS; QUAIL EGGS; REFRIGERATED FOOD PACKAGE COMBINATIONS CONSISTING PRIMARILY OF MEAT, CHEESE OR PROCESSED VEGETABLES FOR PURPOSES OF CREATING A SANDWICH; RIPENED CHEESE; RIPENED CHEESES; SANDWICH SPREAD, NAMELY, TURKEY; SHEEP CHEESE; SLICED FRUITS; SLICED VEGETABLES; SOFT CHEESE; SOFT WHITE CHEESE; SOFT-RIPENED CHEESE; STRAINED CHEESE; STRAINED SOFT WHITE CHEESES; STUFFED OLIVES WITH FETA CHEESE IN SUNFLOWER OIL; TEXTURED VEGETABLE PROTEIN BITS HAVING A BACON FLAVOR; TEXTURED VEGETABLE PROTEIN FOR USE AS A MEAT EXTENDER; TRUFFLE JUICE; UNFORMED TEXTURED VEGETABLE PROTEIN FOR USE AS A MEAT EXTENDER; VEGETABLE CHIPS; VEGETABLE JUICE FOR COOKING; VEGETABLE MOUSSE; VEGETABLE OILS; VEGETABLE OILS AND FATS; VEGETABLE PASTE; VEGETABLE PROTEIN BITS HAVING A BACON FLAVOR; VEGETABLE PUREE; VEGETABLE

SALADS; VEGETABLE-BASED CHOCOLATE FOOD BEVERAGES; VEGETABLE-BASED FOOD BEVERAGES; VEGETABLE-BASED MEAT SUBSTITUTES; VEGETABLE-BASED SNACK FOODS; VEGETABLE-BASED SPREADS; VEGETABLES, INSTANT FROZEN; VEGETABLES, NAMELY, FROZEN; WHITE CHEESE; PACKAGED ENTREES CONSISTING PRIMARILY OF MEAT, FISH, POULTRY OR VEGETABLES; PACKAGED MEALS CONSISTING PRIMARILY OF MEAT, FISH, POULTRY OR VEGETABLES; PACKAGED VEGETABLE-BASED ENTREES; VEGETABLE SOUFFLES (U.S. CL. 46).
FIRST USE 10-12-1994; IN COMMERCE 10-12-1994.

CLASS 30—STAPLE FOODS

FOR BAKERY DESSERTS; BAKERY GOODS; BAKERY PRODUCTS; BAKERY PRODUCTS, NAMELY, SWEET BAKERY GOODS; BISCUITS AND BREAD; BREAD; BREAD AND BUNS; BREAD AND PASTRY; BREAD CRUMB; BREAD CRUMBS; BREAD DOUGHS; BREAD MIXES; BREAD ROLLS; BREAD STICKS; BREAD WITH SOY BEAN; BRUSCHETTE-TOPPED BREAD; COFFEE BEVERAGES WITH MILK; COFFEE-BASED BEVERAGE CONTAINING MILK; EDIBLE ICES; FISH SANDWICHES; FLAVORED ICES; FOOD PACKAGE COMBINATIONS CONSISTING PRIMARILY OF BREAD, CRACKERS AND/OR COOKIES; FRANKFURTER SANDWICHES; FREEZABLE LIQUID FOR USE IN MAKING FROZEN CONFECTIONS; FRESH PIZZA; FROZEN APPETIZERS CONSISTING PRIMARILY OF CORNMEAL; FROZEN BREADS; FROZEN CONFECTIONERY; FROZEN CONFECTIONS; FROZEN CONFECTIONS, NAMELY, FREEZER POPS; FROZEN CUSTARDS; FROZEN DESSERT CONSISTING OF FRUIT AND CREAM OR CREAM SUBSTITUTES; FROZEN PIE CRUSTS; FROZEN SOY-BASED DESSERTS; FROZEN YOGHURT; FROZEN YOGURT; FROZEN YOGURT MIXES; FRUIT ICE; FRUIT ICE BAR; FRUIT ICES; HAMBURGER SANDWICHES; HOT DOG SANDWICHES; ICE; ICE BLOCKS; ICE CANDIES; ICE CREAM; ICE CREAM DRINKS; ICE CREAM FLOATS; ICE CREAM MIXES; ICE CREAM POWDER; ICE CREAM SANDWICHES; ICE CREAM SUBSTITUTE; ICE CREAMS; ICE CUBES; ICE FOR REFRESHMENT; ICE MILK; ICE MILK BARS; ICE-CREAM; ICE-CREAM CAKES; ICED CAKES; ICED COFFEE; ICED TEA; ICES AND ICE CREAMS; ICING; ICING MIXES; ITALIAN ICE; MILK CHOCOLATE; MIXES FOR BAKERY GOODS; MIXES FOR MAKING BREADING; PITA BREAD; PIZZA; PIZZA CRUST; PIZZA DOUGH; PIZZA SAUCE; PIZZAS; PROTEIN REDUCED AND GLUTEN FREE FLOUR AND BREAD; ROLLS; SANDWICHES; SANDWICHES, NAMELY, HAMBURGER; SHAVED ICE CONFECTIONS; SOY BURGER SANDWICHES; SOY-BASED ICE CREAM SUBSTITUTE; SPICES AND ICE; STUFFING MIXES CONTAINING BREAD; TURKEY BURGER SANDWICHES; UNLEAVENED BREAD IN THIN SHEETS; VEGGIE BURGER SANDWICHES; WATER ICE; WHOLEMEAL BREAD; PACKAGED ENTREES CONSISTING PRIMARILY OF PASTA OR RICE; PACKAGED MEALS CONSISTING PRIMARILY OF PASTA OR RICE (U.S. CL. 46).

FIRST USE 10-12-1994; IN COMMERCE 10-12-1994.

CLASS 32—LIGHT BEVERAGES

FOR BOTTLED ARTESIAN WATER; BOTTLED DRINKING WATER; BOTTLED WATER; COCONUT WATER; CONCENTRATED FRUIT JUICE; DISTILLED DRINKING WATER; DRINKING WATER; DRINKING WATER WITH VITAMINS; ESSENCES FOR THE PREPARATION OF MINERAL WATERS; FLAVORED BOTTLED WATER; FLAVORED WATERS; FLAVOURED MINERAL WATER; FLAVOURED WATERS; FROZEN FRUIT BEVERAGES; FROZEN FRUIT-BASED BEVERAGES; FRUIT DRINKS AND JUICES; FRUIT JUICE; FRUIT JUICE BASES; FRUIT JUICE CONCENTRATES; FRUIT JUICES; FRUIT JUICES AND FRUIT DRINKS; FRUITS DRINKS AND FRUIT JUICES; GLACIAL WATER; GRAPE JUICE BEVERAGES; JUICE BASE CONCENTRATES; LITHIA WATER; MAGNETICALLY TREATED WATER FOR HUMAN CONSUMPTION AND NOT FOR MEDICAL PURPOSES; MINERAL AND AERATED WATER; MINERAL AND AERATED WATERS; MINERAL AND CARBONATED WATERS; MINERAL WATER; MIXED FRUIT JUICE; NON-ALCOHOLIC BEV-

ERAGES CONTAINING FRUIT JUICES; NON-ALCOHOLIC FRUIT JUICE BEVERAGES; NON-CARBONATED, NON-ALCOHOLIC FROZEN FLAVORED BEVERAGES; ORANGE JUICE BEVERAGES; PINEAPPLE JUICE BEVERAGES; PURIFIED BOTTLED DRINKING WATER; QUININE WATER; SCENTED WATER FOR MAKING BEVERAGES; SELTZER WATER; SODA WATER; SPARKLING WATER; SPRING WATER; STILL WATER; STILL WATERS; TABLE WATER; TABLE WATERS; TOMATO JUICE; TOMATO JUICE BEVERAGES; VEGETABLE JUICE; VEGETABLE JUICES (U.S. CLS. 45, 46 AND 48).

FIRST USE 10-12-1994; IN COMMERCE 10-12-1994.

JACQUELINE A. LAVINE, EXAMINING ATTORNEY

SN 77-596,276. THE GERSON COMPANY, OLATHE, KS.
FILED 10-20-2008.

THE GG COLLECTION

THE MARK CONSISTS OF STANDARD CHARACTERS WITHOUT CLAIM TO ANY PARTICULAR FONT, STYLE, SIZE, OR COLOR.

NO CLAIM IS MADE TO THE EXCLUSIVE RIGHT TO USE "COLLECTION", APART FROM THE MARK AS SHOWN.

CLASS 11—ENVIRONMENTAL CONTROL APPARATUS

FOR CHAFING DISHES; ELECTRIC CANDLE SCONCES; PORTABLE BATTERY-OPERATED LIGHTS THAT CAN BE PLACED ON SURFACES WHERE OTHER LIGHT SOURCES ARE UNAVAILABLE (U.S. CLS. 13, 21, 23, 31 AND 34).

CLASS 21—HOUSEWARES AND GLASS

FOR SOAP DISPENSERS, LOTION DISPENSERS, SOAP DISHES, CERAMIC TISSUE BOX COVERS, COSMETIC BRUSH HOLDERS, WASTEBASKETS, TRASH CANS, TOOTHBRUSH HOLDERS; SERVING BOWLS, BUTTER DISHES, SUGAR BOWLS, CREAM PITCHERS, ICE BUCKETS, PUNCH BOWLS, BEVERAGE PITCHERS, CUPS, TEAPOTS, MUGS, SERVING TRAYS, SALT AND PEPPER SHAKERS, PLATES, CHARGER PLATES, SALAD BOWLS, PLATE STANDS, URNS; BEVERAGE SERVERS, NAMELY, PITCHERS; BREAD BOXES, PASTRY SERVING PLATES, TIERED SERVING DISHES, TEAPOT STANDS; BAKING DISH HOLDERS, NAMELY, TRIVETS; PIE DOMES, RELISH TRAYS, CERAMIC BAKING DISHES, CANISTERS FOR KITCHEN USE, CAKE PLATES, CAKE PEDESTALS, DESSERT PLATES, SOUP TUREENS, CHIP AND DIP SERVING PLATES, SOUP BOWLS, TABLE PLACE CARD HOLDERS NOT OF PRECIOUS METAL, CERAMIC BOXES FOR TEABAGS, BATHROOM VANITY TRAYS; NON-ELECTRIC CHANDELIERS; SERVINGWARE FOR SERVING FOOD, LAZY SUSANS, CANDLE HOLDERS (U.S. CLS. 2, 13, 23, 29, 30, 33, 40 AND 50).

LINDA LAVACHE, EXAMINING ATTORNEY

SN 77-596,737. SMB CAPITAL CORPORATION, ORLANDO, FL. FILED 10-21-2008.

EMPOWER SOFTWARE SOLUTIONS

THE MARK CONSISTS OF STANDARD CHARACTERS WITHOUT CLAIM TO ANY PARTICULAR FONT, STYLE, SIZE, OR COLOR.

NO CLAIM IS MADE TO THE EXCLUSIVE RIGHT TO USE "SOFTWARE SOLUTIONS" FOR INTERNATIONAL CLASS 9, APART FROM THE MARK AS SHOWN.

CLASS 9—ELECTRICAL AND SCIENTIFIC APPARATUS

FOR EMPLOYEE PAYROLL SOFTWARE FOR PAYROLL ADMINISTRATION AND PAYROLL TAX CALCULATION (U.S. CLS. 21, 23, 26, 36 AND 38).

CLASS 35—ADVERTISING AND BUSINESS

FOR PAYROLL AND HUMAN RESOURCE SERVICES, NAMELY, ADMINISTRATION OF PAYROLL FOR OTHERS, PAYROLL PREPARATION, AND PAYROLL PROCESSING SERVICES; HUMAN RESOURCE SERVICES, NAMELY, HUMAN RESOURCES MANAGEMENT (U.S. CLS. 100, 101 AND 102).

MARK SHINER, EXAMINING ATTORNEY

SN 77-598,605. COLONDRES, DOREEN, MIAMI, FL. FILED 10-22-2008.



THE MARK CONSISTS OF THE STYLIZED WORDING "LA COCINA NO MUERDE" WITH THE DESIGN OF AN OVEN MITT, WITH AN AMOEBA-LIKE SHAPE BEHIND ALL OTHER ELEMENTS OF THE MARK.

THE ENGLISH TRANSLATION OF "LA COCINA NO MUERDE" IN THE MARK IS THE KITCHEN DOESN'T BITE.

CLASS 38—COMMUNICATION

FOR BROADCASTING OF VIDEO AND AUDIO PROGRAMMING OVER THE INTERNET; BROADCASTING PROGRAMS VIA A GLOBAL COMPUTER NETWORK (U.S. CLS. 100, 101 AND 104).

FIRST USE 1-30-2008; IN COMMERCE 1-30-2008.

CLASS 41—EDUCATION AND ENTERTAINMENT

FOR ACADEMIC ENRICHMENT PROGRAMS IN THE FIELD(S) OF COOKING; CABLE TELEVISION PROGRAMMING; CONTINUING PUBLIC SERVICE PROGRAMS IN THE FIELD OF COOKING PRODUCED AND DISTRIBUTED OVER TELEVISION, SATELLITE, FILM, AUDIO, VIDEO, INTERNET, AND 3-D VIRTUAL REALITY MEDIA; DIRECTION OF MAKING RADIO OR TELEVISION PROGRAMS; DISTRIBUTION OF TELEVISION PROGRAMMING TO CABLE TELEVISION SYSTEMS; DISTRIBUTION OF TELEVISION PROGRAMS FOR OTHERS; EDUCATIONAL AND ENTERTAINMENT SERVICES, NAMELY, A CONTINUING PROGRAM ABOUT COOKING ACCESSIBLE BY RADIO, TELEVISION, SATELLITE, AUDIO, VIDEO AND COMPUTER NETWORKS; PRODUCTION OF CABLE TELEVISION PROGRAMS; PRODUCTION OF DVDS, VIDEOTAPES AND TELEVISION PROGRAMS FEATURING COOKING; PRODUCTION OF TELEVISION PROGRAMS; TELEVISION AND RADIO PROGRAMMING; TELEVISION PROGRAM SYNDICATION; TELEVISION PROGRAMMING; TELEVISION SCHEDULING (U.S. CLS. 100, 101 AND 107).

FIRST USE 1-30-2008; IN COMMERCE 1-30-2008.
JAY BESCH, EXAMINING ATTORNEY

SN 77-598,993. UNILEVER SUPPLY CHAIN, INC., CLINTON, CT. FILED 10-23-2008.



THE MARK CONSISTS OF A TRUCK DESIGN.

CLASS 30—STAPLE FOODS

FOR ICE CREAMS, WATER ICES, FROZEN CONFECTIONERY, FROZEN YOGURT, SHERBETS, SORBETS (U.S. CL. 46).

CLASS 43—HOTEL AND RESTAURANT SERVICES

FOR ICE CREAM SHOPS IN THE NATURE OF A RESTAURANT (U.S. CLS. 100 AND 101).

ANTHONY RINKER, EXAMINING ATTORNEY

SN 77-599,105. CENTENE CORPORATION, ST. LOUIS, MO. FILED 10-23-2008.



NO CLAIM IS MADE TO THE EXCLUSIVE RIGHT TO USE "INTEGRATED", APART FROM THE MARK AS SHOWN.

THE MARK CONSISTS OF THE WORD "INTEGRATED" WITH CIRCLE DESIGN.

CLASS 41—EDUCATION AND ENTERTAINMENT

FOR CONSULTING SERVICES IN THE FIELD OF SPECIAL EDUCATION FOR MENTAL HEALTH PATIENTS; CONDUCTING SPECIAL EDUCATION PROGRAMS IN THE FIELD OF EDUCATION FOR MENTAL HEALTH PATIENTS (U.S. CLS. 100, 101 AND 107).

FIRST USE 3-0-2009; IN COMMERCE 3-0-2009.

CLASS 44—MEDICAL, BEAUTY AND AGRICULTURAL SERVICES

FOR HEALTH CARE SERVICES IN THE FIELDS OF MENTAL HEALTH; CONSULTING SERVICES IN THE FIELD OF MENTAL HEALTH CARE (U.S. CLS. 100 AND 101).

FIRST USE 3-0-2009; IN COMMERCE 3-0-2009.
DAVID H. STINE, EXAMINING ATTORNEY

CLASS 20—FURNITURE AND ARTICLES NOT OTHERWISE CLASSIFIED

FOR DESKTOP STATUARY MADE OF PLASTIC OR WOOD; FIGURINES OF PLASTIC OR WOOD; NON-METAL TROPHIES; PICTURE AND PHOTOGRAPH FRAMES; PLAQUES OF PLASTIC OR WOOD; STATUETTES OF PLASTIC OR WOOD (U.S. CLS. 2, 13, 22, 25, 32 AND 50).

FIRST USE 1-1-1991; IN COMMERCE 1-1-1991.

CLASS 21—HOUSEWARES AND GLASS

FOR DESKTOP STATUARY MADE OF CRYSTAL; FIGURINES OF CRYSTAL; STATUETTES OF CRYSTAL (U.S. CLS. 2, 13, 23, 29, 30, 33, 40 AND 50).

FIRST USE 1-1-1991; IN COMMERCE 1-1-1991.
ERNEST SHOSHO, EXAMINING ATTORNEY

SN 77-600,428. ADMENTO SPECIALTIES, INC., DBA ADMENTO PROMOTIONS GROUP, NEW YORK, NY. FILED 10-24-2008.

SN 77-602,732. NISSAN JIDOSHA KABUSHIKI KAISHA, DBA NISSAN MOTOR CO., LTD., YOKOHAMA-SHI, JAPAN, FILED 10-29-2008.

admento

THE MARK CONSISTS OF STANDARD CHARACTERS WITHOUT CLAIM TO ANY PARTICULAR FONT, STYLE, SIZE, OR COLOR.

CLASS 20—FURNITURE AND ARTICLES NOT OTHERWISE CLASSIFIED

FOR DESKTOP STATUARY MADE OF PLASTIC OR WOOD; FIGURINES OF PLASTIC OR WOOD; NON-METAL TROPHIES; PICTURE AND PHOTOGRAPH FRAMES; STATUETTES OF PLASTIC OR WOOD (U.S. CLS. 2, 13, 22, 25, 32 AND 50).

FIRST USE 6-17-1987; IN COMMERCE 6-17-1987.

CLASS 21—HOUSEWARES AND GLASS

FOR DESKTOP STATUARY MADE OF CRYSTAL; FIGURINES OF CRYSTAL; STATUETTES OF CRYSTAL (U.S. CLS. 2, 13, 23, 29, 30, 33, 40 AND 50).

FIRST USE 1-1-1987; IN COMMERCE 1-1-1987.
ERNEST SHOSHO, EXAMINING ATTORNEY

SN 77-600,671. ADMENTO SPECIALTIES, INC., DBA ADMENTO PROMOTIONS GROUP, NEW YORK, NY. FILED 10-26-2008.

the art for the deal

THE MARK CONSISTS OF STANDARD CHARACTERS WITHOUT CLAIM TO ANY PARTICULAR FONT, STYLE, SIZE, OR COLOR.

GT
R

THE MARK CONSISTS OF STYLIZED LETTERS "G", "T", AND "R".

CLASS 6—METAL GOODS

FOR METAL KEY RINGS (U.S. CLS. 2, 12, 13, 14, 23, 25 AND 50).

CLASS 14—JEWELRY

FOR TIE TACKS, CUFF LINKS, LAPEL PINS, WATCHES, CLOCKS, WALL CLOCKS, KEY RINGS OF PRECIOUS METAL, ORNAMENTAL BADGES OF PRECIOUS METAL (U.S. CLS. 2, 27, 28 AND 50).

CLASS 16—PAPER GOODS AND PRINTED MATTER

FOR GRAPHIC ART REPRODUCTIONS, STICKERS, PENS, PENCILS, STANDS FOR PENS AND PENCILS, CALENDARS, STATIONERY-TYPE WRITING PORTFOLIOS, POSTERS, PHOTO ALBUMS, POCKET DIARIES (U.S. CLS. 2, 5, 22, 23, 29, 37, 38 AND 50).

CLASS 20—FURNITURE AND ARTICLES NOT OTHERWISE CLASSIFIED

FOR PHOTOGRAPH STANDS (U.S. CLS. 2, 13, 22, 25, 32 AND 50).

CLASS 24—FABRICS

FOR TOWELS, TEXTILE HANDKERCHIEFS (U.S. CLS. 42 AND 50).

CLASS 25—CLOTHING

FOR SHIRTS, T-SHIRTS, JACKETS, NECKTIES, MUFFLERS, CAPS, HATS, COATS, SWEATERS, POLO-SHIRTS, WORKING CLOTHING, NAMELY, PANTS, JACKETS, SHIRTS AND COATS, SCARVES (U.S. CLS. 22 AND 39).

CLASS 26—FANCY GOODS

FOR ORNAMENTAL NOVELTY BADGES (U.S. CLS. 37, 39, 40, 42 AND 50).
GEOFFREY FOSDICK, EXAMINING ATTORNEY

SN 77-603,531. FIVE GIRI INC., WESTLAKE VILLAGE, CA. FILED 10-29-2008.



OWNER OF U.S. REG. NO. 3,409,673.
THE MARK CONSISTS OF STYLIZED WORDING NEXT TO A THREE-ARMED HUB WHERE EACH ARM RADIATES FROM THE CENTER OF THE HUB AND EACH ARM HAS A TAPERED ARC EXTENDING FROM IT GIVING THE APPEARANCE OF MOTION.

CLASS 9—ELECTRICAL AND SCIENTIFIC APPARATUS

FOR PRE-RECORDED VIDEO TAPES FEATURING PHYSICAL FITNESS INSTRUCTION AND CD'S FEATURING MUSIC (U.S. CLS. 21, 23, 26, 36 AND 38).

CLASS 25—CLOTHING

FOR CLOTHING, NAMELY, SHIRTS, T-SHIRTS, LONG-SLEEVED SHIRTS, TANK TOPS, PANTS, SHORTS, HATS, SOCKS, WRISTBANDS AND GLOVES (U.S. CLS. 22 AND 39).
DOMINIC FATHY, EXAMINING ATTORNEY

SN 77-603,745. LEBANON TOURIST & CONVENTION COMMISSION, LEBANON, KY. FILED 10-30-2008.

HEART OF KENTUCKY

THE MARK CONSISTS OF STANDARD CHARACTERS WITHOUT CLAIM TO ANY PARTICULAR FONT, STYLE, SIZE, OR COLOR.

NO CLAIM IS MADE TO THE EXCLUSIVE RIGHT TO USE "KENTUCKY", APART FROM THE MARK AS SHOWN.

CLASS 16—PAPER GOODS AND PRINTED MATTER

FOR PAPER GOODS AND PRINTED MATTER, NAMELY, APPLICATIONS TO SPONSOR OR PARTICIPATE IN COMMUNITY EVENTS, POSTERS, BROCHURES, EVENT PROGRAMS AND FLYERS FEATURING INFORMATION ABOUT LEBANON, KENTUCKY AND SURROUNDING AREA, BUSINESS CARDS, LETTERHEAD PAPER AND ENVELOPES AND PRINT ADVERTISEMENTS PROMOTING LEBANON, KENTUCKY AND SURROUNDING AREA AS A TOURIST AND CONVENTION DESTINATION (U.S. CLS. 2, 5, 22, 23, 29, 37, 38 AND 50).

FIRST USE 8-1-2005; IN COMMERCE 8-1-2005.

CLASS 25—CLOTHING

FOR CLOTHING, NAMELY, T-SHIRTS PROMOTING LEBANON, KENTUCKY AND SURROUNDING AREA AS A TOURIST AND CONVENTION DESTINATION WHERE THE T-SHIRTS ARE ASSOCIATED WITH COMMUNITY EVENTS (U.S. CLS. 22 AND 39).

FIRST USE 8-1-2005; IN COMMERCE 8-1-2005.

CLASS 35—ADVERTISING AND BUSINESS

FOR ADVERTISING SERVICES, NAMELY, PROMOTING LEBANON, KENTUCKY AND SURROUNDING AREA AS A TOURIST AND CONVENTION DESTINATION THROUGH PRINT ADVERTISEMENTS, RADIO AND TELEVISION COMMERCIALS (U.S. CLS. 100, 101 AND 102).

FIRST USE 8-1-2005; IN COMMERCE 8-1-2005.

CLASS 41—EDUCATION AND ENTERTAINMENT

FOR EDUCATION AND ENTERTAINMENT SERVICES PROMOTING LEBANON, KENTUCKY AND SURROUNDING AREA AS A TOURIST AND CONVENTION DESTINATION, NAMELY, ORGANIZING AND CONDUCTING COMMUNITY SPORTING AND CULTURAL EVENTS, FAIRS AND SHOWS IN THE NATURE OF LIVE MUSICAL PERFORMANCES, ANTIQUE, ARTS AND CRAFTS EXHIBITS, MARTIAL ARTS WORKSHOPS, FARM HOME AND GARDEN EXHIBITS, ARTS EXHIBITS, YOUTH ASSEMBLIES, GOLF TOURNAMENTS, FOOTBALL TOURNAMENTS, SWIMMING TOURNAMENTS, BASKETBALL AND BASEBALL LEAGUES AND TOURNAMENTS, FISHING TOURNAMENTS, CORNHOLE TOURNAMENTS, FIREWORKS PERFORMANCES, AVIATION PERFORMANCES, FOOD EXHIBITS, LIVE HOLIDAY CELEBRATIONS AND LIVE HOLIDAY LIGHT PERFORMANCES (U.S. CLS. 100, 101 AND 107).

FIRST USE 8-1-2005; IN COMMERCE 8-1-2005.

KATHERINE CONNOLLY, EXAMINING ATTORNEY

SN 77-603,771. LEBANON TOURIST & CONVENTION COMMISSION, LEBANON, KY. FILED 10-30-2008.

FEEL THE BEAT

THE MARK CONSISTS OF STANDARD CHARACTERS WITHOUT CLAIM TO ANY PARTICULAR FONT, STYLE, SIZE, OR COLOR.

CLASS 16—PAPER GOODS AND PRINTED MATTER

FOR PAPER GOODS AND PRINTED MATTER, NAMELY, APPLICATIONS TO SPONSOR OR PARTICIPATE IN COMMUNITY EVENTS, POSTERS, BROCHURES, EVENT PROGRAMS AND FLYERS FEATURING INFORMATION ABOUT LEBANON, KENTUCKY AND SURROUNDING AREA, BUSINESS CARDS, LETTERHEAD PAPER AND ENVELOPES AND PRINT ADVERTISEMENTS PROMOTING LEBANON, KENTUCKY AND SURROUNDING AREA AS A TOURIST AND CONVENTION DESTINATION (U.S. CLS. 2, 5, 22, 23, 29, 37, 38 AND 50).

FIRST USE 8-1-2005; IN COMMERCE 8-1-2005.

CLASS 20—FURNITURE AND ARTICLES NOT OTHERWISE CLASSIFIED

FOR FURNITURE, NAMELY, CHAIRS PROMOTING LEBANON, KENTUCKY AND SURROUNDING AREA AS A TOURIST AND CONVENTION DESTINATION (U.S. CLS. 2, 13, 22, 25, 32 AND 50).

FIRST USE 8-1-2005; IN COMMERCE 8-1-2005.

CLASS 21—HOUSEWARES AND GLASS

FOR BEVERAGE CONTAINERS, NAMELY, COFFEE CUPS AND PLASTIC WATER BOTTLES SOLD EMPTY PROMOTING LEBANON, KENTUCKY AND SURROUNDING AREA AS A TOURIST AND CONVENTION DESTINATION WHERE THE COFFEE CUPS AND WATER BOTTLES ARE ASSOCIATED WITH COMMUNITY EVENTS (U.S. CLS. 2, 13, 23, 29, 30, 33, 40 AND 50).

FIRST USE 8-1-2005; IN COMMERCE 8-1-2005.

CLASS 25—CLOTHING

FOR CLOTHING, NAMELY, T-SHIRTS PROMOTING LEBANON, KENTUCKY AND SURROUNDING AREA AS A TOURIST AND CONVENTION DESTINATION WHERE THE T-SHIRTS ARE ASSOCIATED WITH COMMUNITY EVENTS (U.S. CLS. 22 AND 39).

FIRST USE 8-1-2005; IN COMMERCE 8-1-2005.

CLASS 35—ADVERTISING AND BUSINESS

FOR ADVERTISING SERVICES, NAMELY, PROMOTING LEBANON, KENTUCKY AND SURROUNDING AREA AS A TOURIST AND CONVENTION DESTINATION THROUGH PRINT ADVERTISEMENTS, RADIO AND TELEVISION COMMERCIALS (U.S. CLS. 100, 101 AND 102).

FIRST USE 8-1-2005; IN COMMERCE 8-1-2005.

CLASS 41—EDUCATION AND ENTERTAINMENT

FOR EDUCATION AND ENTERTAINMENT SERVICES PROMOTING LEBANON, KENTUCKY AND SURROUNDING AREA AS A TOURIST AND CONVENTION DESTINATION, NAMELY, ORGANIZING AND CONDUCTING COMMUNITY SPORTING AND CULTURAL EVENTS, FAIRS AND SHOWS IN THE NATURE OF LIVE MUSICAL PERFORMANCES, ANTIQUE, ARTS AND CRAFTS EXHIBITS, MARTIAL ARTS WORKSHOPS, FARM HOME AND GARDEN EXHIBITS, ARTS EXHIBITS, YOUTH ASSEMBLIES, GOLF TOURNAMENTS, FOOTBALL TOURNAMENTS, SWIMMING TOURNAMENTS, BASKETBALL AND BASEBALL LEAGUES AND TOURNAMENTS, FISHING TOURNAMENTS, COMHOLE TOURNAMENTS, FIREWORKS PERFORMANCES, AVIATION PERFORMANCES, FOOD EXHIBITS, LIVE HOLIDAY CELEBRATIONS AND LIVE HOLIDAY LIGHT PERFORMANCES (U.S. CLS. 100, 101 AND 107).

FIRST USE 8-1-2005; IN COMMERCE 8-1-2005.
KATHERINE CONNOLLY, EXAMINING ATTORNEY

SN 77-605,522. JENNY RAY, INC., DBA JENNY RAY, FLORENCE, AL. FILED 10-31-2008.

JENNY RAY

THE MARK CONSISTS OF STANDARD CHARACTERS WITHOUT CLAIM TO ANY PARTICULAR FONT, STYLE, SIZE, OR COLOR.

THE NAME SHOWN IN THE MARK IDENTIFIES "JENNY RAY" WHOSE CONSENT IS OF RECORD.

CLASS 9—ELECTRICAL AND SCIENTIFIC APPARATUS

FOR (BASED ON USE IN COMMERCE) AUDIO RECORDINGS FEATURING MUSIC; PRE-RECORDED CDS FEATURING MUSIC; SOUND RECORDINGS FEATURING MUSIC (BASED ON INTENT TO USE) AUDIO AND VIDEO RECORDINGS FEATURING MUSIC; DIGITAL MEDIA, NAMELY, PRE-RECORDED VIDEO CASSETTES, DIGITAL VIDEO DISCS, DIGITAL VERSATILE DISCS, DOWNLOADABLE AUDIO AND VIDEO RECORDINGS, DVDS, AND HIGH DEFINITION DIGITAL DISKS FEATURING MUSIC; DIGITAL MUSIC DOWNLOADABLE FROM THE INTERNET; DOWNLOADABLE MP3 FILES AND MP3 RECORDINGS FEATURING MUSIC; DOWNLOADABLE MUSICAL SOUND RECORDINGS; DOWNLOADABLE VIDEO RECORDINGS FEATURING MUSIC; PRE-RECORDED CDS, VIDEO TAPES, LASER DISKS AND DVDS FEATURING MUSIC; PRE-RECORDED DIGITAL MEDIA FEATURING MUSIC; PRE-RECORDED ELECTRONIC MEDIA MUSIC; VIDEO RECORDINGS FEATURING MUSIC (U.S. CLS. 21, 23, 26, 36 AND 38).

FIRST USE 10-7-2008; IN COMMERCE 10-7-2008.

CLASS 41—EDUCATION AND ENTERTAINMENT

FOR (BASED ON USE IN COMMERCE) ENTERTAINMENT SERVICES IN THE NATURE OF LIVE MUSICAL PERFORMANCES; PRESENTATION OF MUSICAL PERFORMANCE (BASED ON INTENT TO USE) ENTERTAINMENT IN THE NATURE OF VISUAL AND AUDIO PERFORMANCES, NAMELY, MUSICAL BAND, ROCK GROUP, GYMNASTIC, DANCE, AND BALLET PERFORMANCES; ENTERTAINMENT SERVICES, NAMELY, PROVIDING A WEB SITE FEATURING MUSICAL PERFORMANCES, MUSICAL VIDEOS, RELATED FILM CLIPS, PHOTOGRAPHS, AND OTHER MULTIMEDIA MATERIALS FEATURING MUSIC; ENTERTAINMENT, NAMELY, LIVE MUSIC CONCERTS (U.S. CLS. 100, 101 AND 107).

FIRST USE 10-17-2008; IN COMMERCE 10-17-2008.

MATTHEW PAPPAS, EXAMINING ATTORNEY

SN 77-605,799. GRAPHIC PACKAGING INTERNATIONAL, INC., MARIETTA, GA. FILED 11-3-2008.

NEXTWAVE PACKAGING

THE MARK CONSISTS OF STANDARD CHARACTERS WITHOUT CLAIM TO ANY PARTICULAR FONT, STYLE, SIZE, OR COLOR.

NO CLAIM IS MADE TO THE EXCLUSIVE RIGHT TO USE "PACKAGING", APART FROM THE MARK AS SHOWN.

CLASS 16—PAPER GOODS AND PRINTED MATTER

FOR PACKAGING MATERIALS, NAMELY, PAPERBOARD CARTONS, WRAPPING PAPER AND PLASTIC WRAP FOR PACKAGING FOR FOOD INTENDED FOR MICROWAVE OVENS (U.S. CLS. 2, 5, 22, 23, 29, 37, 38 AND 50).

CLASS 40—MATERIAL TREATMENT

FOR CUSTOM MANUFACTURE OF PACKAGING MATERIALS TO THE ORDER AND SPECIFICATIONS OF OTHERS (U.S. CLS. 100, 103 AND 106).

RON FAIRBANKS, EXAMINING ATTORNEY

CLASS 43—HOTEL AND RESTAURANT SERVICES

FOR CHILD CARE; JUVENILE CORRECTIONS SERVICES, NAMELY, PROVIDING RESIDENTIAL SERVICES FOR COURT-ORDERED CHILDREN AND TEENAGERS; CHILD WELFARE SERVICES, NAMELY, PROVIDING RESIDENTIAL HOMES AND HOUSING FOR AT-RISK CHILDREN, AT-RISK YOUTH, AND/OR MEDICALLY FRAGILE CHILDREN IN THE NATURE OF GROUP HOMES; RUNAWAY AND HOMELESS SHELTER FOR TEENS (U.S. CLS. 100 AND 101).

FIRST USE 11-4-2002; IN COMMERCE 11-4-2002.

SN 77-605,910. YOUTH VILLAGES, INC., MEMPHIS, TN.
FILED 11-3-2008.

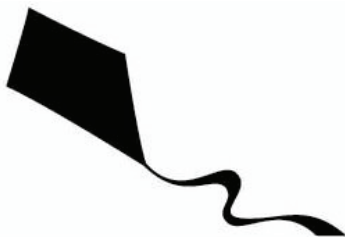

THE MARK CONSISTS OF A KITE LEANING TO THE LEFT WITH THE KITE TAIL POINTING RIGHT.

CLASS 41—EDUCATION AND ENTERTAINMENT

FOR EDUCATION SERVICES IN THE FORM OF PROVIDING ELEMENTARY THROUGH 12TH GRADE CLASSROOM INSTRUCTION AND TRAINING FOR CHILDREN, TEENAGERS, AND YOUNG ADULTS AGING OUT OF FOSTER CARE, ALL WITH SERIOUS BEHAVIORAL OR MENTAL HEALTH ISSUES, IN THE FIELDS OF MODIFYING BEHAVIOR, LEARNING SELF CONTROL, ESTABLISHING LIFE SKILLS, DEVELOPING AND IMPROVING SOCIAL SKILLS, AND PREPARING FOR CAREERS; MENTORING CHILDREN, TEENAGERS, AND YOUNG ADULTS WITH SERIOUS BEHAVIOR OR MENTAL HEALTH ISSUES IN THE FIELDS OF ACADEMIC PERFORMANCE, ESTABLISHING LIFE SKILLS, DEVELOPING AND IMPROVING SOCIAL SKILLS, MODIFYING BEHAVIOR, HOBBIES, BUILDING HEALTHY RELATIONSHIPS, AND DEVELOPING SUPPORT SYSTEMS; PROVIDING CAREER COUNSELING, LIFE SKILLS TRAINING, CAREER PLANNING IN THE NATURE OF VOCATIONAL GUIDANCE, AND CAREER TRAINING FOR TEENAGERS, YOUNG ADULTS, AND MEDICALLY FRAGILE CHILDREN, ALL AS THEY AGE OUT OF FOSTER CARE (U.S. CLS. 100, 101 AND 107).

FIRST USE 11-4-2002; IN COMMERCE 11-4-2002.

CLASS 44—MEDICAL, BEAUTY AND AGRICULTURAL SERVICES

FOR PSYCHOLOGICAL COUNSELING FOR CHILDREN AND TEENAGERS WITH SERIOUS BEHAVIORAL OR MENTAL HEALTH ISSUES; PSYCHOLOGICAL COUNSELING OF PARENTS AND FAMILIES IN AN EFFORT TO KEEP AT-RISK CHILDREN AND TEENAGERS AND/OR MEDICALLY FRAGILE CHILDREN IN THE HOME (U.S. CLS. 100 AND 101).

FIRST USE 11-4-2002; IN COMMERCE 11-4-2002.

CLASS 45—PERSONAL AND LEGAL SERVICES

FOR FOSTER CARE; ORGANIZING AND CONDUCTING SUPPORT GROUPS FOR CHILDREN AND TEENAGERS WITH SERIOUS BEHAVIORAL OR MENTAL HEALTH ISSUES IN THE FIELDS OF MODIFYING BEHAVIOR, LEARNING SELF CONTROL, DEVELOPING AND IMPROVING SOCIAL SKILLS, PROVIDING EMOTIONAL SUPPORT, AND COPING WITH MENTAL HEALTH ISSUES; ORGANIZING AND CONDUCTING SUPPORT GROUP SERVICES FOR FOSTER PARENTS TO HELP THEM DEAL WITH CHALLENGES RELATED TO CARING FOR FOSTER CHILDREN AND/OR MEDICALLY FRAGILE CHILDREN IN THE HOME IN AN EFFORT TO KEEP THE CHILDREN IN THE HOME; COUNSELING OF PARENTS AND FAMILIES IN THE FIELDS OF SOCIAL SKILLS DEVELOPMENT AND IMPROVEMENT, EMOTIONAL SUPPORT, BEHAVIORAL MODIFICATION, AND COPING WITH BEHAVIORAL OR MENTAL HEALTH ISSUES IN AN EFFORT TO KEEP THE CHILDREN IN THE HOME; PROVIDING EMOTIONAL COUNSELING AND EMOTIONAL SUPPORT SERVICES IN THE FIELDS OF MODIFYING BEHAVIOR, LEARNING SELF CONTROL, DEVELOPING AND IMPROVING SOCIAL SKILLS, PROVIDING EMOTIONAL SUPPORT, COPING WITH MENTAL HEALTH ISSUES, AND COPING WITH HEALTH AND MEDICAL ISSUES AND EMOTIONAL COUNSELING IN THE FORM OF BEHAVIORAL SUPPORT SERVICES FOR TROUBLED AND AT-RISK YOUTH AND THEIR BIRTH AND FOSTER FAMILIES IN AN EFFORT TO KEEP THE YOUTH AND CHILDREN IN THE HOME; ADOPTION SERVICES, NAMELY, ADOPTION AGENCIES, ADOPTION COUNSELING, AND ADOPTION PLACEMENT (U.S. CLS. 100 AND 101).

FIRST USE 11-4-2002; IN COMMERCE 11-4-2002.

ANDREA HACK, EXAMINING ATTORNEY

SN 77-605,954. YOUTH VILLAGES, INC., MEMPHIS, TN.
FILED 11-3-2008.



NO CLAIM IS MADE TO THE EXCLUSIVE RIGHT TO USE "YOUTH", APART FROM THE MARK AS SHOWN.

THE MARK CONSISTS OF THE WORDS "YOUTH VILLAGES" IN STYLIZED FONT WITH A KITE APPEARING ABOVE THE WORD "YOUTH".

CLASS 41—EDUCATION AND ENTERTAINMENT

FOR EDUCATION SERVICES IN THE FORM OF PROVIDING ELEMENTARY THROUGH 12TH GRADE CLASSROOM INSTRUCTION AND TRAINING FOR CHILDREN, TEENAGERS, AND YOUNG ADULTS AGING OUT OF FOSTER CARE, ALL WITH SERIOUS BEHAVIORAL OR MENTAL HEALTH ISSUES, IN THE FIELDS OF MODIFYING BEHAVIOR, LEARNING SELF CONTROL, ESTABLISHING LIFE SKILLS, DEVELOPING AND IMPROVING SOCIAL SKILLS, AND PREPARING FOR CAREERS; MENTORING CHILDREN, TEENAGERS, AND YOUNG ADULTS WITH SERIOUS BEHAVIOR OR MENTAL HEALTH ISSUES IN THE FIELDS OF ACADEMIC PERFORMANCE, ESTABLISHING LIFE SKILLS, DEVELOPING AND IMPROVING SOCIAL SKILLS, MODIFYING BEHAVIOR, HOBBIES, BUILDING HEALTHY RELATIONSHIPS, AND DEVELOPING SUPPORT SYSTEMS; PROVIDING CAREER COUNSELING, LIFE SKILLS TRAINING, CAREER PLANNING IN THE NATURE OF VOCATIONAL GUIDANCE, AND CAREER TRAINING FOR TEENAGERS, YOUNG ADULTS, AND MEDICALLY FRAGILE CHILDREN, ALL AS THEY AGE OUT OF FOSTER CARE (U.S. CLS. 100, 101 AND 107).

FIRST USE 11-4-2002; IN COMMERCE 11-4-2002.

CLASS 43—HOTEL AND RESTAURANT SERVICES

FOR CHILD CARE; JUVENILE CORRECTIONS SERVICES, NAMELY, PROVIDING RESIDENTIAL SERVICES FOR COURT-ORDERED CHILDREN AND TEENAGERS; CHILD WELFARE SERVICES, NAMELY, PROVIDING RESIDENTIAL HOMES AND HOUSING FOR AT-RISK CHILDREN, AT-RISK YOUTH, AND/OR MEDICALLY FRAGILE CHILDREN IN THE NATURE OF GROUP HOMES; RUNAWAY AND HOMELESS SHELTER FOR TEENS (U.S. CLS. 100 AND 101).

FIRST USE 11-4-2002; IN COMMERCE 11-4-2002.

CLASS 44—MEDICAL, BEAUTY AND AGRICULTURAL SERVICES

FOR PSYCHOLOGICAL COUNSELING FOR CHILDREN AND TEENAGERS WITH SERIOUS BEHAVIORAL OR MENTAL HEALTH ISSUES; PSYCHOLOGICAL COUNSELING OF PARENTS AND FAMILIES IN AN EFFORT TO KEEP AT-RISK CHILDREN AND TEENAGERS AND/OR MEDICALLY FRAGILE CHILDREN IN THE HOME (U.S. CLS. 100 AND 101).

FIRST USE 11-4-2002; IN COMMERCE 11-4-2002.

CLASS 45—PERSONAL AND LEGAL SERVICES

FOR FOSTER CARE; ORGANIZING AND CONDUCTING SUPPORT GROUPS FOR CHILDREN AND TEENAGERS WITH SERIOUS BEHAVIORAL OR MENTAL HEALTH ISSUES IN THE FIELDS OF MODIFYING BEHAVIOR, LEARNING SELF CONTROL, DEVELOPING AND IMPROVING SOCIAL SKILLS, PROVIDING EMOTIONAL SUPPORT, AND COPING WITH MENTAL HEALTH ISSUES; ORGANIZING AND CONDUCTING SUPPORT GROUP SERVICES FOR FOSTER PARENTS TO HELP THEM DEAL WITH CHALLENGES RELATED TO CARING FOR FOSTER CHILDREN AND/OR MEDICALLY FRAGILE CHILDREN IN THE HOME IN AN EFFORT TO KEEP THE CHILDREN IN THE HOME; COUNSELING OF PARENTS AND FAMILIES IN THE FIELDS OF SOCIAL SKILLS DEVELOPMENT AND IMPROVEMENT, EMOTIONAL SUPPORT, BEHAVIORAL MODIFICATION, AND COPING WITH BEHAVIORAL OR MENTAL HEALTH ISSUES IN AN EFFORT TO KEEP THE CHILDREN IN THE HOME; PROVIDING EMOTIONAL COUNSELING AND EMOTIONAL SUPPORT SERVICES IN THE FIELDS OF MODIFYING BEHAVIOR, LEARNING SELF CONTROL, DEVELOPING AND IMPROVING SOCIAL SKILLS, PROVIDING EMOTIONAL SUPPORT, COPING WITH MENTAL HEALTH ISSUES, AND COPING WITH HEALTH AND MEDICAL ISSUES AND EMOTIONAL COUNSELING IN THE FORM OF BEHAVIORAL SUPPORT SERVICES FOR TROUBLED AND AT-RISK YOUTH AND THEIR BIRTH AND FOSTER FAMILIES IN AN EFFORT TO KEEP THE YOUTH AND CHILDREN IN THE HOME; ADOPTION SERVICES, NAMELY, ADOPTION AGENCIES, ADOPTION COUNSELING, AND ADOPTION PLACEMENT (U.S. CLS. 100 AND 101).

FIRST USE 11-4-2002; IN COMMERCE 11-4-2002.

ANDREA HACK, EXAMINING ATTORNEY

SN 77-606,101. YOUTH VILLAGES, INC., MEMPHIS, TN.
FILED 11-3-2008.



NO CLAIM IS MADE TO THE EXCLUSIVE RIGHT TO USE "YOUTH", APART FROM THE MARK AS SHOWN.

THE MARK CONSISTS OF THE WORDS "YOUTH VILLAGES" IN STYLIZED FONT WITH THE WORD "YOUTH" APPEARING ON TOP OF THE WORD "VILLAGES" WITH A LINE BETWEEN THE TWO WORDS AND ALL OF THE AFOREMENTIONED UNDERNEATH THE IMAGE OF A KITE.

CLASS 41—EDUCATION AND ENTERTAINMENT

FOR EDUCATION SERVICES IN THE FORM OF PROVIDING ELEMENTARY THROUGH 12TH GRADE CLASSROOM INSTRUCTION AND TRAINING FOR CHILDREN, TEENAGERS, AND YOUNG ADULTS AGING OUT OF FOSTER CARE, ALL WITH SERIOUS BEHAVIORAL OR MENTAL HEALTH ISSUES, IN THE FIELDS OF MODIFYING BEHAVIOR, LEARNING SELF CONTROL, ESTABLISHING LIFE SKILLS, DEVELOPING AND IMPROVING SOCIAL SKILLS, AND PREPARING FOR CAREERS; MENTORING CHILDREN, TEENAGERS, AND YOUNG ADULTS WITH SERIOUS BEHAVIOR OR MENTAL HEALTH ISSUES IN THE FIELDS OF ACADEMIC PERFORMANCE, ESTABLISHING LIFE SKILLS, DEVELOPING AND IMPROVING SOCIAL SKILLS, MODIFYING BEHAVIOR, HOBBIES, BUILDING HEALTHY RELATIONSHIPS, AND DEVELOPING SUPPORT SYSTEMS; PROVIDING CAREER COUNSELING, LIFE SKILLS TRAINING, CAREER PLANNING IN THE NATURE OF VOCATIONAL GUIDANCE, AND CAREER TRAINING FOR TEENAGERS, YOUNG ADULTS, AND MEDICALLY FRAGILE CHILDREN, ALL AS THEY AGE OUT OF FOSTER CARE (U.S. CLS. 100, 101 AND 107).

FIRST USE 11-4-2002; IN COMMERCE 11-4-2002.

CLASS 43—HOTEL AND RESTAURANT SERVICES

FOR CHILD CARE; JUVENILE CORRECTIONS SERVICES, NAMELY, PROVIDING RESIDENTIAL SERVICES FOR COURT-ORDERED CHILDREN AND TEENAGERS; CHILD WELFARE SERVICES, NAMELY, PROVIDING RESIDENTIAL HOMES AND HOUSING FOR AT-RISK CHILDREN, AT-RISK YOUTH, AND/OR MEDICALLY FRAGILE CHILDREN IN THE NATURE OF GROUP HOMES; RUNAWAY AND HOMELESS SHELTER FOR TEENS (U.S. CLS. 100 AND 101).

FIRST USE 11-4-2002; IN COMMERCE 11-4-2002.

CLASS 44—MEDICAL, BEAUTY AND AGRICULTURAL SERVICES

FOR PSYCHOLOGICAL COUNSELING FOR CHILDREN AND TEENAGERS WITH SERIOUS BEHAVIORAL OR MENTAL HEALTH ISSUES; PSYCHOLOGICAL COUNSELING OF PARENTS AND FAMILIES IN AN EFFORT TO KEEP AT-RISK CHILDREN AND TEENAGERS AND/OR MEDICALLY FRAGILE CHILDREN IN THE HOME (U.S. CLS. 100 AND 101).

FIRST USE 11-4-2002; IN COMMERCE 11-4-2002.

CLASS 45—PERSONAL AND LEGAL SERVICES

FOR FOSTER CARE; ORGANIZING AND CONDUCTING SUPPORT GROUPS FOR CHILDREN AND TEENAGERS WITH SERIOUS BEHAVIORAL OR MENTAL HEALTH ISSUES IN THE FIELDS OF MODIFYING BEHAVIOR, LEARNING SELF CONTROL, DEVELOPING AND IMPROVING SOCIAL SKILLS, PROVIDING EMOTIONAL SUPPORT, AND COPING WITH MENTAL HEALTH ISSUES; ORGANIZING AND CONDUCTING SUPPORT GROUP SERVICES FOR FOSTER PARENTS TO HELP THEM DEAL WITH CHALLENGES RELATED TO CARING FOR FOSTER CHILDREN AND/OR MEDICALLY FRAGILE CHILDREN IN THE HOME IN AN EFFORT TO KEEP THE CHILDREN IN THE HOME; COUNSELING OF PARENTS AND FAMILIES IN THE FIELDS OF SOCIAL SKILLS DEVELOPMENT AND IMPROVEMENT, EMOTIONAL SUPPORT, BEHAVIORAL MODIFICATION, AND COPING WITH BEHAVIORAL OR MENTAL HEALTH ISSUES IN AN EFFORT TO KEEP THE CHILDREN IN THE HOME; PROVIDING EMOTIONAL COUNSELING AND EMOTIONAL SUPPORT SERVICES IN THE FIELDS OF MODIFYING

BEHAVIOR, LEARNING SELF CONTROL, DEVELOPING AND IMPROVING SOCIAL SKILLS, PROVIDING EMOTIONAL SUPPORT, COPING WITH MENTAL HEALTH ISSUES, AND COPING WITH HEALTH AND MEDICAL ISSUES AND EMOTIONAL COUNSELING IN THE FORM OF BEHAVIORAL SUPPORT SERVICES FOR TROUBLED AND AT-RISK YOUTH AND THEIR BIRTH AND FOSTER FAMILIES IN AN EFFORT TO KEEP THE YOUTH AND CHILDREN IN THE HOME; ADOPTION SERVICES, NAMELY, ADOPTION AGENCIES, ADOPTION COUNSELING, AND ADOPTION PLACEMENT (U.S. CLS. 100 AND 101).

FIRST USE 11-4-2002; IN COMMERCE 11-4-2002.

ANDREA HACK, EXAMINING ATTORNEY

SN 77-606.151. YOUTH VILLAGES, INC., MEMPHIS, TN.
FILED 11-3-2008.

YOUTH VILLAGES

THE MARK CONSISTS OF STANDARD CHARACTERS WITHOUT CLAIM TO ANY PARTICULAR FONT, STYLE, SIZE, OR COLOR.

NO CLAIM IS MADE TO THE EXCLUSIVE RIGHT TO USE "YOUTH", APART FROM THE MARK AS SHOWN.

CLASS 41—EDUCATION AND ENTERTAINMENT

FOR EDUCATION SERVICES IN THE FORM OF PROVIDING ELEMENTARY THROUGH 12TH GRADE CLASSROOM INSTRUCTION AND TRAINING FOR CHILDREN, TEENAGERS, AND YOUNG ADULTS AGING OUT OF FOSTER CARE, ALL WITH SERIOUS BEHAVIORAL OR MENTAL HEALTH ISSUES, IN THE FIELDS OF MODIFYING BEHAVIOR, LEARNING SELF CONTROL, ESTABLISHING LIFE SKILLS, DEVELOPING AND IMPROVING SOCIAL SKILLS, AND PREPARING FOR CAREERS; MENTORING CHILDREN, TEENAGERS, AND YOUNG ADULTS WITH SERIOUS BEHAVIOR OR MENTAL HEALTH ISSUES IN THE FIELDS OF ACADEMIC PERFORMANCE, ESTABLISHING LIFE SKILLS, DEVELOPING AND IMPROVING SOCIAL SKILLS, MODIFYING BEHAVIOR, HOBBIES, BUILDING HEALTHY RELATIONSHIPS, AND DEVELOPING SUPPORT SYSTEMS; PROVIDING CAREER COUNSELING, LIFE SKILLS TRAINING, CAREER PLANNING IN THE NATURE OF VOCATIONAL GUIDANCE, AND CAREER TRAINING FOR TEENAGERS, YOUNG ADULTS, AND MEDICALLY FRAGILE CHILDREN, ALL AS THEY AGE OUT OF FOSTER CARE (U.S. CLS. 100, 101 AND 107).

FIRST USE 2-1-1987; IN COMMERCE 2-1-1987.

CLASS 43—HOTEL AND RESTAURANT SERVICES

FOR CHILD CARE; JUVENILE CORRECTIONS SERVICES, NAMELY, PROVIDING RESIDENTIAL SERVICES FOR COURT-ORDERED CHILDREN AND TEENAGERS; CHILD WELFARE SERVICES, NAMELY, PROVIDING RESIDENTIAL HOMES AND HOUSING FOR AT-RISK CHILDREN, AT-RISK YOUTH, AND/OR MEDICALLY FRAGILE CHILDREN IN THE NATURE OF GROUP HOMES; RUNAWAY AND HOMELESS SHELTER FOR TEENS (U.S. CLS. 100 AND 101).

FIRST USE 2-1-1987; IN COMMERCE 2-1-1987.

CLASS 44—MEDICAL, BEAUTY AND AGRICULTURAL SERVICES

FOR PSYCHOLOGICAL COUNSELING FOR CHILDREN AND TEENAGERS WITH SERIOUS BEHAVIORAL OR MENTAL HEALTH ISSUES; PSYCHOLOGICAL COUNSELING OF PARENTS AND FAMILIES IN AN EFFORT TO KEEP AT-RISK CHILDREN AND TEENAGERS AND/OR MEDICALLY FRAGILE CHILDREN IN THE HOME (U.S. CLS. 100 AND 101).

FIRST USE 2-1-1987; IN COMMERCE 2-1-1987.

CLASS 45—PERSONAL AND LEGAL SERVICES

FOR FOSTER CARE; ORGANIZING AND CONDUCTING SUPPORT GROUPS FOR CHILDREN AND TEENAGERS WITH SERIOUS BEHAVIORAL OR MENTAL HEALTH ISSUES IN THE FIELDS OF MODIFYING BEHAVIOR, LEARNING SELF CONTROL, DEVELOPING AND IMPROVING SOCIAL SKILLS, PROVIDING EMOTIONAL SUPPORT, AND COPING WITH MENTAL HEALTH ISSUES; ORGANIZING AND CONDUCTING SUPPORT GROUP SERVICES FOR FOSTER PARENTS TO HELP THEM DEAL WITH CHALLENGES RELATED TO CARING FOR FOSTER CHILDREN AND/OR MEDICALLY FRAGILE CHILDREN IN THE HOME IN AN EFFORT TO KEEP THE CHILDREN IN THE HOME; COUNSELING OF PARENTS AND FAMILIES IN THE FIELDS OF SOCIAL SKILLS DEVELOPMENT AND IMPROVEMENT, EMOTIONAL SUPPORT, BEHAVIORAL MODIFICATION, AND COPING WITH BEHAVIORAL OR MENTAL HEALTH ISSUES IN AN EFFORT TO KEEP THE CHILDREN IN THE HOME; PROVIDING EMOTIONAL COUNSELING AND EMOTIONAL SUPPORT SERVICES IN THE FIELDS OF MODIFYING BEHAVIOR, LEARNING SELF CONTROL, DEVELOPING AND IMPROVING SOCIAL SKILLS, PROVIDING EMOTIONAL SUPPORT, COPING WITH MENTAL HEALTH ISSUES, AND COPING WITH HEALTH AND MEDICAL ISSUES AND EMOTIONAL COUNSELING IN THE FORM OF BEHAVIORAL SUPPORT SERVICES FOR TROUBLED AND AT-RISK YOUTH AND THEIR BIRTH AND FOSTER FAMILIES IN AN EFFORT TO KEEP THE YOUTH AND CHILDREN IN THE HOME; ADOPTION SERVICES, NAMELY, ADOPTION AGENCIES, ADOPTION COUNSELING, AND ADOPTION PLACEMENT (U.S. CLS. 100 AND 101).

FIRST USE 10-4-1990; IN COMMERCE 8-1-1997.
ANDREA HACK, EXAMINING ATTORNEY

SN 77-606,470. WESTERN RESEARCH 3000, INC, WESTLAKE VILLAGE, CA. FILED 11-4-2008.

NATURE'S HEALTHY WEIGHT LOSS SUPERFOOD

THE MARK CONSISTS OF STANDARD CHARACTERS WITHOUT CLAIM TO ANY PARTICULAR FONT, STYLE, SIZE, OR COLOR.

NO CLAIM IS MADE TO THE EXCLUSIVE RIGHT TO USE "HEALTHY WEIGHT LOSS SUPERFOOD", APART FROM THE MARK AS SHOWN.

CLASS 5—PHARMACEUTICALS

FOR DIETARY SUPPLEMENTS FOR ASSISTANCE WITH WEIGHT LOSS (U.S. CLS. 6, 18, 44, 46, 51 AND 52).

CLASS 29—MEATS AND PROCESSED FOODS

FOR FOOD PRODUCTS, NAMELY, DRIED FRUITS AND PROCESSED EDIBLE SEEDS (U.S. CL. 46).

CLASS 30—STAPLE FOODS

FOR FOOD PRODUCTS, NAMELY, COOKIES, GRANOLA BARS, GRANOLA AND CANDY (U.S. CL. 46).

CLASS 32—LIGHT BEVERAGES

FOR FRUIT JUICE (U.S. CLS. 45, 46 AND 48).
DAWN FELDMAN, EXAMINING ATTORNEY

SN 77-606,531. PEARSON EDUCATION, INC., UPPER SADDLE RIVER, NJ. FILED 11-4-2008.

DICK AND JANE

THE MARK CONSISTS OF STANDARD CHARACTERS WITHOUT CLAIM TO ANY PARTICULAR FONT, STYLE, SIZE, OR COLOR.

OWNER OF U.S. REG. NOS. 2,487,777, 3,110,817 AND OTHERS.

CLASS 16—PAPER GOODS AND PRINTED MATTER

FOR WRITING TABLETS; RECIPE BOOKS, PAPER SHOPPING BAGS, CHILDREN'S STORYBOOKS, PLASTIC SHOPPING BAGS; CHILDREN'S STORYBOOKS WITH STICKERS; AGENDAS; CHILDREN'S ACTIVITY BOOKS; TALKING CHILDREN'S BOOKS; BLANK JOURNAL BOOKS (U.S. CLS. 2, 5, 22, 23, 29, 37, 38 AND 50).

FIRST USE 7-31-2007; IN COMMERCE 7-31-2007.

CLASS 18—LEATHER GOODS

FOR TEXTILE SHOPPING BAGS (U.S. CLS. 1, 2, 3, 22 AND 41).

FIRST USE 5-31-2007; IN COMMERCE 5-31-2007.

CLASS 24—FABRICS

FOR BED SHEETS, COTTON FABRICS, KIT COMPRISED OF FABRICS FOR MAKING QUILTS (U.S. CLS. 42 AND 50).

FIRST USE 10-31-2006; IN COMMERCE 10-31-2006.

CLASS 28—TOYS AND SPORTING GOODS

FOR EDUCATIONAL CARD GAMES (U.S. CLS. 22, 23, 38 AND 50).

FIRST USE 7-31-2007; IN COMMERCE 7-31-2007.

FRANK LATTUCA, EXAMINING ATTORNEY

SN 77-608,146. 3FORM, INC., SALT LAKE CITY, UT. FILED 11-5-2008.

FULL CIRCLE

THE MARK CONSISTS OF STANDARD CHARACTERS WITHOUT CLAIM TO ANY PARTICULAR FONT, STYLE, SIZE, OR COLOR.

OWNER OF U.S. REG. NO. 3,523,488.

CLASS 17—RUBBER GOODS

FOR PLASTIC SHEETS AND PANELS FOR USE IN CONSTRUCTION AND GENERAL USE (U.S. CLS. 1, 5, 12, 13, 35 AND 50).

FIRST USE 9-11-2006; IN COMMERCE 9-11-2006.

CLASS 42—SCIENTIFIC AND COMPUTER SERVICES

FOR PROVIDING INFORMATION AND CONSULTATION SERVICES IN THE FIELD OF INTERIOR AND EXTERIOR DESIGN FOR RESIDENTIAL AND COMMERCIAL BUILDINGS BY MEANS OF A GLOBAL NETWORK (U.S. CLS. 100 AND 101).

FIRST USE 9-11-2006; IN COMMERCE 9-11-2006.
JENNY PARK, EXAMINING ATTORNEY

SN 77-609,064. LE CAY, INC., MORTON GOVE, IL. FILED 11-6-2008.

LE CAY

THE MARK CONSISTS OF STANDARD CHARACTERS WITHOUT CLAIM TO ANY PARTICULAR FONT, STYLE, SIZE, OR COLOR.

CLASS 29—MEATS AND PROCESSED FOODS

FOR JAMS, JELLIES (U.S. CL. 46).

CLASS 30—STAPLE FOODS

FOR SAUCES (U.S. CL. 46).
WON TEAK OH, EXAMINING ATTORNEY

SN 77-609,280. THE LIMU COMPANY, LLC, LAKE MARY, FL. FILED 11-6-2008.

Take A Sip On The Wild Side!

THE MARK CONSISTS OF STANDARD CHARACTERS WITHOUT CLAIM TO ANY PARTICULAR FONT, STYLE, SIZE, OR COLOR.

CLASS 5—PHARMACEUTICALS

FOR DIETARY AND NUTRITIONAL SUPPLEMENTS; DIETARY SUPPLEMENTAL DRINKS; LIQUID NUTRITIONAL SUPPLEMENT; NUTRITIONALLY FORTIFIED BEVERAGES (U.S. CLS. 6, 18, 44, 46, 51 AND 52).

CLASS 32—LIGHT BEVERAGES

FOR ENERGY DRINKS (U.S. CLS. 45, 46 AND 48).
TARAH HARDY, EXAMINING ATTORNEY

SN 77-610,066. THE LIMU COMPANY, LLC, LAKE MARY, FL. FILED 11-7-2008.

The Craze That Pays

THE MARK CONSISTS OF STANDARD CHARACTERS WITHOUT CLAIM TO ANY PARTICULAR FONT, STYLE, SIZE, OR COLOR.

CLASS 5—PHARMACEUTICALS

FOR DIETARY AND NUTRITIONAL SUPPLEMENTS; DIETARY SUPPLEMENTAL DRINKS; LIQUID NUTRITIONAL SUPPLEMENT; NUTRITIONALLY FORTIFIED BEVERAGES (U.S. CLS. 6, 18, 44, 46, 51 AND 52).

CLASS 32—LIGHT BEVERAGES

FOR ENERGY DRINKS (U.S. CLS. 45, 46 AND 48).

CLASS 35—ADVERTISING AND BUSINESS

FOR DISTRIBUTORSHIP SERVICES IN THE FIELD OF DIETARY AND NUTRITIONAL SUPPLEMENTS, DIETARY SUPPLEMENT DRINKS, NUTRITIONALLY FORTIFIED BEVERAGES, AND ENERGY DRINKS; MULTI-LEVEL MARKETING BUSINESS SERVICES; ON-LINE RETAIL STORE SERVICES FEATURING DIETARY AND NUTRITIONAL SUPPLEMENTS, DIETARY SUPPLEMENT DRINKS, NUTRITIONALLY FORTIFIED BEVERAGES, AND ENERGY DRINKS (U.S. CLS. 100, 101 AND 102).

TARAH HARDY, EXAMINING ATTORNEY

SN 77-610,666. GRAPHIC PACKAGING INTERNATIONAL, INC., MARIETTA, GA. FILED 11-10-2008.



The logo for NextWave Packaging features a stylized graphic of three waves above the text "NextWave" in a bold, sans-serif font, with "PACKAGING" in a smaller, all-caps font below it.

NO CLAIM IS MADE TO THE EXCLUSIVE RIGHT TO USE "PACKAGING", APART FROM THE MARK AS SHOWN.

THE MARK CONSISTS OF THREE WAVES ABOVE THE WORDS "NEXTWAVE PACKAGING".

CLASS 16—PAPER GOODS AND PRINTED MATTER

FOR PACKAGING MATERIALS, NAMELY, PAPERBOARD CARTONS, WRAPPING PAPER AND PLASTIC WRAP FOR PACKAGING FOR FOOD INTENDED FOR MICROWAVE OVENS (U.S. CLS. 2, 5, 22, 23, 29, 37, 38 AND 50).

CLASS 40—MATERIAL TREATMENT

FOR CUSTOM MANUFACTURE OF PACKAGING MATERIALS TO THE ORDER AND SPECIFICATIONS OF OTHERS (U.S. CLS. 100, 103 AND 106).
RON FAIRBANKS, EXAMINING ATTORNEY

SN 77-610,831. WINE.COM, INC., DBA WINE.COM, SAN FRANCISCO, CA. FILED 11-10-2008.

Wine.com Steward-Ship

THE MARK CONSISTS OF STANDARD CHARACTERS WITHOUT CLAIM TO ANY PARTICULAR FONT, STYLE, SIZE, OR COLOR.

NO CLAIM IS MADE TO THE EXCLUSIVE RIGHT TO USE "WINE.COM", APART FROM THE MARK AS SHOWN.

CLASS 35—ADVERTISING AND BUSINESS

FOR ADVERTISING SERVICES, NAMELY, PROMOTING THE FOOD AND WINE OF OTHERS (U.S. CLS. 100, 101 AND 102).
FIRST USE 10-1-2008; IN COMMERCE 11-1-2008.

CLASS 39—TRANSPORTATION AND STORAGE

FOR WINE CLUB SERVICES FEATURING PERIODIC SHIPMENTS OF WINE TO MEMBERS (U.S. CLS. 100 AND 105).
FIRST USE 10-1-2008; IN COMMERCE 11-1-2008.
KAREN BRACEY, EXAMINING ATTORNEY

SN 77-610,840. FRANK KAISER, INC., DBA TIRE TOWN, FREEPORT, NY. FILED 11-10-2008.

TIRE TOWN

THE MARK CONSISTS OF STANDARD CHARACTERS WITHOUT CLAIM TO ANY PARTICULAR FONT, STYLE, SIZE, OR COLOR.

NO CLAIM IS MADE TO THE EXCLUSIVE RIGHT TO USE "TIRE", APART FROM THE MARK AS SHOWN.

CLASS 35—ADVERTISING AND BUSINESS

FOR WHOLESALE DISTRIBUTORSHIP AND RETAIL STORE SERVICES FEATURING AUTO PARTS (U.S. CLS. 100, 101 AND 102).

CLASS 37—CONSTRUCTION AND REPAIR

FOR AUTOMOBILE MAINTENANCE AND REPAIR (U.S. CLS. 100, 103 AND 106).
INGRID C. EULIN, EXAMINING ATTORNEY

SN 77-611,081. AMERICA MARKETING, LLP., LONDON, ENGLAND, FILED 11-10-2008.



THE COLOR(S) BLUE AND GRAY IS/ARE CLAIMED AS A FEATURE OF THE MARK.

THE MARK CONSISTS OF THE WORDS "GRAND ISLAND" IN A STYLIZED FORMAT AND IN THE COLOR BLUE. "BVG", WHICH STANDS FOR BAY VIEW GRAND, IS WRITTEN UNDERNEATH THE WORDING IN GRAY SHOWN WITHIN A RECTANGLE OUTLINED IN GRAY.

CLASS 35—ADVERTISING AND BUSINESS

FOR ADVERTISING SERVICES (U.S. CLS. 100, 101 AND 102).

CLASS 36—INSURANCE AND FINANCIAL

FOR REAL ESTATE AFFAIRS, NAMELY, LEASING OF REAL ESTATE, BROKERAGE, CONSULTATION, AND ESCROW SERVICES (U.S. CLS. 100, 101 AND 102).

CLASS 37—CONSTRUCTION AND REPAIR

FOR BUILDING CONSTRUCTION SERVICES (U.S. CLS. 100, 103 AND 106).
JAY FLOWERS, EXAMINING ATTORNEY

SN 77-611,121. 1ST PRIMARY CARE, P.C., DBA IMMUNOE INTERNATIONAL IMMUNOLOGY CENTERS, CENTENNIAL, CO. FILED 11-10-2008.



NO CLAIM IS MADE TO THE EXCLUSIVE RIGHT TO USE "INTERNATIONAL IMMUNOLOGY CENTERS", APART FROM THE MARK AS SHOWN.

THE COLOR(S) PURPLE, ORANGE AND WHITE IS/ARE CLAIMED AS A FEATURE OF THE MARK.

THE MARK CONSISTS OF A LARGE, ORANGE, LOWER CASE LETTER "I" WITH A PURPLE, LOWER CASE LETTER "E" SWIRLED AROUND THE "I" FOLLOWED BY ORANGE TEXT "IMMUNOE" THEN A WHITE LOWER CASE LETTER "E" ENCIRCLED IN PURPLE. THE LINE BELOW CONTAINS THE WORD "INTERNATIONAL" IN ORANGE TEXT AND THE FINAL LINE CONTAINS THE WORDS "IMMUNOLOGY CENTERS" IN ORANGE TEXT.

CLASS 42—SCIENTIFIC AND COMPUTER SERVICES

FOR MEDICAL AND SCIENTIFIC RESEARCH IN THE FIELD OF IMMUNOLOGY (U.S. CLS. 100 AND 101).

CLASS 44—MEDICAL, BEAUTY AND AGRICULTURAL SERVICES

FOR MEDICAL SERVICES (U.S. CLS. 100 AND 101).
WENDY GOODMAN, EXAMINING ATTORNEY

SN 77-612,578. THE VIA GROUP LLC, PORTLAND, ME. FILED 11-12-2008.

VIVA CONTENT

THE MARK CONSISTS OF STANDARD CHARACTERS WITHOUT CLAIM TO ANY PARTICULAR FONT, STYLE, SIZE, OR COLOR.

NO CLAIM IS MADE TO THE EXCLUSIVE RIGHT TO USE "CONTENT", APART FROM THE MARK AS SHOWN.

CLASS 35—ADVERTISING AND BUSINESS

FOR ADVERTISING AND MARKETING SERVICES; COMMERCIAL ADMINISTRATION OF THE LICENSING OF THE GOODS AND SERVICES OF OTHERS; PROVIDING BUSINESS RESEARCH SERVICES, NAMELY, RESEARCHING ONLINE AUDIOVISUAL CONTENT (U.S. CLS. 100, 101 AND 102).

CLASS 45—PERSONAL AND LEGAL SERVICES

FOR LICENSING OF AUDIOVISUAL CONTENT FOR OTHERS (U.S. CLS. 100 AND 101).
JIM RINGLE, EXAMINING ATTORNEY

SN 77-613,371. INDUSTRIAPLEX, INC., ALPHARETTA, GA. FILED 11-13-2008.

BUSINESS DONE RIGHT

THE MARK CONSISTS OF STANDARD CHARACTERS WITHOUT CLAIM TO ANY PARTICULAR FONT, STYLE, SIZE, OR COLOR.

CLASS 35—ADVERTISING AND BUSINESS

FOR SUPPLY CHAIN MANAGEMENT SERVICES FOR OTHERS; BUSINESS MANAGEMENT SERVICES, NAMELY, MANAGING LOGISTICS, SUPPLY CHAIN SERVICES, MANAGEMENT OF OUTSOURCED PRODUCT AND EQUIPMENT MANUFACTURING, AND MANAGEMENT OF PRODUCT DISTRIBUTION PROCESSES FOR OTHERS; OUTSOURCING IN THE FIELD OF SUPPLY CHAIN MANAGEMENT; SOURCING OF INDUSTRIAL AND COMMERCIAL EQUIPMENT FOR OTHERS, NAMELY, SELECTION OF SUPPLIERS, NEGOTIATION AND PROCURING OF CONTRACTS FOR THE PURCHASE OF PRODUCTS, ORDER AND FULFILLMENT MANAGEMENT, MANAGING LOGISTICS, AND SUPPLY CHAIN SERVICES; BUSINESS CONSULTING SERVICES, NAMELY, PROVIDING BUSINESS PROCESS IMPROVEMENT AND RE-ENGINEERING SERVICES FOR OTHERS (U.S. CLS. 100, 101 AND 102).
FIRST USE 9-30-2007; IN COMMERCE 9-30-2007.

CLASS 37—CONSTRUCTION AND REPAIR

FOR INSTALLATION, MAINTENANCE, AND REPAIR OF EQUIPMENT FOR COMMERCIAL AND INDUSTRIAL FACILITIES OF OTHERS IN THE NATURE OF COMMERCIAL KITCHENS AND RETAIL STORE LOCATIONS, MACHINES USED IN PRODUCT HANDLING IN THE RETAIL AND FOOD SERVICES INDUSTRIES, AND FIXTURES USED IN PRODUCT STORAGE AND PRODUCT DISPLAY IN THE RETAIL AND FOOD SERVICES INDUSTRIES; BUILDING AND GROUNDS MAINTENANCE SERVICES, NAMELY, JANITORIAL SERVICES; HVAC CONTRACTOR SERVICES; ELECTRICAL CONTRACTOR SERVICES; PLUMBING; AND MECHANICAL CONTRACTOR SERVICES (U.S. CLS. 100, 103 AND 106).

FIRST USE 9-30-2007; IN COMMERCE 9-30-2007.
NICHOLAS COLEMAN, EXAMINING ATTORNEY

SN 77-613,421. NATIONAL COALITION FOR CANCER SURVIVORSHIP, SILVER SPRING, MD. FILED 11-13-2008.

GOT CANCER? GET A PLAN!

THE MARK CONSISTS OF STANDARD CHARACTERS WITHOUT CLAIM TO ANY PARTICULAR FONT, STYLE, SIZE, OR COLOR.

CLASS 16—PAPER GOODS AND PRINTED MATTER

FOR PUBLICATIONS, NAMELY, BROCHURES, BOOKLETS, AND TEACHING MATERIALS IN THE FIELD OF CANCER CARE PLANS (U.S. CLS. 2, 5, 22, 23, 29, 37, 38 AND 50).

CLASS 35—ADVERTISING AND BUSINESS

FOR PROMOTING PUBLIC AWARENESS OF THE NEED FOR DOCUMENTED CARE PLANS IN THE FIELD OF CANCER (U.S. CLS. 100, 101 AND 102).

CLASS 44—MEDICAL, BEAUTY AND AGRICULTURAL SERVICES

FOR PROVIDING INFORMATION IN THE FIELD OF CANCER CARE PLANS (U.S. CLS. 100 AND 101).
TAMARA FRAZIER, EXAMINING ATTORNEY

SN 77-614,184. TROY BARBOUR, CHINO HILLS, CA. FILED 11-13-2008.



OWNER OF U.S. REG. NOS. 3,461,128 AND 3,462,170. NO CLAIM IS MADE TO THE EXCLUSIVE RIGHT TO USE "DELUXE", APART FROM THE MARK AS SHOWN. THE MARK CONSISTS OF THE WORDS "DEVIL DELUXE 100% PURE EVIL" AND A PICTURE OF A TIRE AND TWO CHECKERED RACING FLAGS.

CLASS 25—CLOTHING

FOR CLOTHING, NAMELY, T-SHIRTS, BOWLING SHIRTS, WORK SHIRTS, TANK TOPS, JACKETS, AND HEADGEAR, NAMELY, HATS, CAPS, AND BEANIES (U.S. CLS. 22 AND 39).
FIRST USE 6-6-2006; IN COMMERCE 6-6-2006.

CLASS 35—ADVERTISING AND BUSINESS

FOR ON-LINE RETAIL STORE SERVICES FEATURING CLOTHING AND HEADGEAR (U.S. CLS. 100, 101 AND 102).
FIRST USE 6-6-2006; IN COMMERCE 6-6-2006.
BARBARA GAYNOR, EXAMINING ATTORNEY

SN 77-614,426. TEXAS A&M UNIVERSITY, COLLEGE STATION, TX. FILED 11-14-2008.

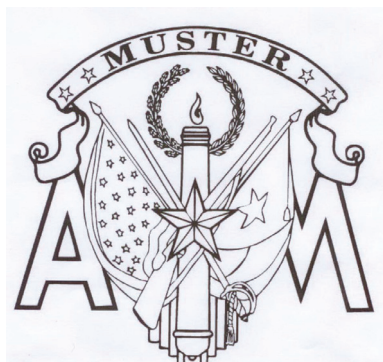

OWNER OF U.S. REG. NO. 1,965,066. THE MARK CONSISTS OF A BANNER WITH THE WORD "MUSTER" OVER A CREST SURROUNDED BY "A AND M".

CLASS 16—PAPER GOODS AND PRINTED MATTER

FOR STATIONERY, NOTE PADS, GREETING CARDS, EVENT PROGRAMS AND POSTERS (U.S. CLS. 2, 5, 22, 23, 29, 37, 38 AND 50).
FIRST USE 0-0-2004; IN COMMERCE 0-0-2004.

CLASS 25—CLOTHING

FOR SHIRTS, NAMELY, POLO SHIRTS AND T-SHIRTS (U.S. CLS. 22 AND 39).
FIRST USE 0-0-2004; IN COMMERCE 0-0-2004.

CLASS 41—EDUCATION AND ENTERTAINMENT

FOR ORGANIZING COMMUNITY CULTURAL EVENTS (U.S. CLS. 100, 101 AND 107).
FIRST USE 0-0-2004; IN COMMERCE 0-0-2004.
KATHRYN COWARD, EXAMINING ATTORNEY

SN 77-616,016. CSXT INTELLECTUAL PROPERTIES CORPORATION, JACKSONVILLE, FL. FILED 11-17-2008.

HOW TOMORROW MOVES

THE MARK CONSISTS OF STANDARD CHARACTERS WITHOUT CLAIM TO ANY PARTICULAR FONT, STYLE, SIZE, OR COLOR.

CLASS 35—ADVERTISING AND BUSINESS

FOR BUSINESS MANAGEMENT CONSULTING SERVICES IN THE FIELD OF FREIGHT TRANSPORTATION; CONSULTING SERVICES IN THE FIELDS OF TRANSPORTATION AND FREIGHT DISTRIBUTION AND STORAGE, NAMELY, CONSULTATION REGARDING THE IMPACT OF SELECTION OF FREIGHT TRANSPORTATION, STORAGE, MANUFACTURING AND DISTRIBUTION SITES ON THE EFFICIENCY OF FREIGHT LOGISTICS (U.S. CLS. 100, 101 AND 102).
FIRST USE 10-31-2007; IN COMMERCE 10-31-2007.

CLASS 39—TRANSPORTATION AND STORAGE

FOR TRANSPORTATION OF FREIGHT BY TRAIN AND TRUCK AND WAREHOUSE STORAGE OF FREIGHT (U.S. CLS. 100 AND 105).
FIRST USE 10-31-2007; IN COMMERCE 10-31-2007.
DANIEL BRODY, EXAMINING ATTORNEY

SN 77-616,022. CSXT INTELLECTUAL PROPERTIES CORPORATION, JACKSONVILLE, FL. FILED 11-17-2008.



THE MARK CONSISTS OF BRACKETS ON THE RIGHT AND LEFT WITH FOUR BLACK CIRCLES UNDER THE BRACKETS.

CLASS 35—ADVERTISING AND BUSINESS

FOR BUSINESS MANAGEMENT CONSULTING SERVICES IN THE FIELD OF FREIGHT TRANSPORTATION; CONSULTING SERVICES IN THE FIELDS OF TRANSPORTATION AND FREIGHT DISTRIBUTION AND STORAGE, NAMELY, CONSULTATION REGARDING THE IMPACT OF SELECTION OF FREIGHT TRANSPORTATION, STORAGE, MANUFACTURING AND DISTRIBUTION SITES ON THE EFFICIENCY OF FREIGHT LOGISTICS (U.S. CLS. 100, 101 AND 102).
FIRST USE 10-31-2007; IN COMMERCE 10-31-2007.

CLASS 39—TRANSPORTATION AND STORAGE

FOR TRANSPORTATION OF FREIGHT BY TRAIN AND TRUCK AND WAREHOUSE STORAGE OF FREIGHT (U.S. CLS. 100 AND 105).
FIRST USE 10-31-2007; IN COMMERCE 10-31-2007.
DANIEL BRODY, EXAMINING ATTORNEY

SN 77-616,484. PAULA DEEN ENTERPRISES, LLC, THUNDERBOLT, GA. FILED 11-18-2008.

PAULA DEEN

THE MARK CONSISTS OF STANDARD CHARACTERS WITHOUT CLAIM TO ANY PARTICULAR FONT, STYLE, SIZE, OR COLOR.

THE NAME(S), PORTRAIT(S), AND/OR SIGNATURE(S) SHOWN IN THE MARK IDENTIFIES "PAULA DEEN", WHOSE CONSENT(S) TO REGISTER IS MADE OF RECORD.

CLASS 4—LUBRICANTS AND FUELS

FOR SCENTED CANDLES (U.S. CLS. 1, 6 AND 15).
FIRST USE 3-0-2006; IN COMMERCE 3-0-2006.

CLASS 14—JEWELRY

FOR JEWELRY (U.S. CLS. 2, 27, 28 AND 50).
FIRST USE 10-0-2007; IN COMMERCE 10-0-2007.

CLASS 21—HOUSEWARES AND GLASS

FOR COOKWARE, NAMELY, POTS, PANS, SAUTEE PANS, DOUBLE BROILER PANS, SKILLETS, GRIDDLERS, BOWLS, SERVING BOWLS, SERVICE PLATTERS, PITCHERS, PLATES, AND CUPS (U.S. CLS. 2, 13, 23, 29, 30, 33, 40 AND 50).
FIRST USE 3-0-2008; IN COMMERCE 3-0-2008.

CLASS 24—FABRICS

FOR FABRIC TABLE RUNNERS; TEXTILE NAPKINS; TEXTILE TABLECLOTHS (U.S. CLS. 42 AND 50).
FIRST USE 3-0-2008; IN COMMERCE 3-0-2008.

CLASS 27—FLOOR COVERINGS

FOR RUGS (U.S. CLS. 19, 20, 37, 42 AND 50).
FIRST USE 1-0-2008; IN COMMERCE 1-0-2008.

CLASS 41—EDUCATION AND ENTERTAINMENT

FOR EDUCATIONAL SERVICES, NAMELY, PROVIDING CLASSES AND SEMINARS IN THE FIELDS OF COOKING (U.S. CLS. 100, 101 AND 107).
FIRST USE 5-0-2004; IN COMMERCE 5-0-2004.
ROBERT C. CLARK JR., EXAMINING ATTORNEY

SN 77-616,678. GOLDEN MILLS, LLC, CHATSWORTH, CA. FILED 11-18-2008.

GOLDEN MEMORY ECO GREEN

THE MARK CONSISTS OF STANDARD CHARACTERS WITHOUT CLAIM TO ANY PARTICULAR FONT, STYLE, SIZE, OR COLOR.

OWNER OF U.S. REG. NOS. 3,342,088, 3,363,787 AND OTHERS.

NO CLAIM IS MADE TO THE EXCLUSIVE RIGHT TO USE "GREEN", APART FROM THE MARK AS SHOWN.

CLASS 20—FURNITURE AND ARTICLES NOT OTHERWISE CLASSIFIED

FOR PILLOWS (U.S. CLS. 2, 13, 22, 25, 32 AND 50).

CLASS 24—FABRICS

FOR COMFORTERS (U.S. CLS. 42 AND 50).
MATTHEW PAPPAS, EXAMINING ATTORNEY

SN 77-617,823. CORPCOMM SOLUTIONS, LLC, ARLINGTON COUNTY, VA. FILED 11-19-2008.

SARSnSTRIPS

THE MARK CONSISTS OF STANDARD CHARACTERS WITHOUT CLAIM TO ANY PARTICULAR FONT, STYLE, SIZE, OR COLOR.

CLASS 9—ELECTRICAL AND SCIENTIFIC APPARATUS

FOR DIGITAL MEDIA, NAMELY, DOWNLOADABLE MULTIMEDIA FILES, IN THE FIELD OF FEDERAL AND STATE LAWS AND REGULATIONS GOVERNING ANTI-MONEY LAUNDERING AND RELATED FINANCIAL TRANSACTIONS, MONITORING AND REPORTING (U.S. CLS. 21, 23, 26, 36 AND 38).

CLASS 16—PAPER GOODS AND PRINTED MATTER

FOR CARTOON STRIPS IN THE FIELD OF FEDERAL AND STATE LAWS AND REGULATIONS GOVERNING ANTI-MONEY LAUNDERING AND RELATED FINANCIAL TRANSACTIONS, MONITORING AND REPORTING (U.S. CLS. 2, 5, 22, 23, 29, 37, 38 AND 50).

CLASS 41—EDUCATION AND ENTERTAINMENT

FOR PRODUCTION OF ANIMATED CARTOONS AND PUBLICATION OF CARTOON STRIPS, ALL IN THE FIELD OF FEDERAL AND STATE LAWS AND REGULATIONS GOVERNING ANTI-MONEY LAUNDERING AND RELATED FINANCIAL TRANSACTIONS, MONITORING AND REPORTING; ON-LINE PUBLICATIONS IN THE NATURE OF CARTOON STRIPS IN THE FIELD OF FEDERAL AND STATE LAWS AND REGULATIONS GOVERNING ANTI-MONEY LAUNDERING AND RELATED FINANCIAL TRANSACTIONS, MONITORING AND REPORTING (U.S. CLS. 100, 101 AND 107).

REBECCA EISINGER, EXAMINING ATTORNEY

SN 77-619,993. SWING FOR LIFE, MIDVALE, UT. FILED 11-21-2008.

SWING FOR LIFE

THE MARK CONSISTS OF STANDARD CHARACTERS WITHOUT CLAIM TO ANY PARTICULAR FONT, STYLE, SIZE, OR COLOR.

CLASS 35—ADVERTISING AND BUSINESS

FOR PROMOTING PUBLIC AWARENESS OF BREAST CANCER (U.S. CLS. 100, 101 AND 102).
FIRST USE 4-0-2007; IN COMMERCE 5-0-2008.

CLASS 36—INSURANCE AND FINANCIAL

FOR CHARITABLE FUNDRAISING SERVICES (U.S. CLS. 100, 101 AND 102).
FIRST USE 4-0-2007; IN COMMERCE 5-0-2008.
MARTHA FROMM, EXAMINING ATTORNEY

SN 77-618,351. KERR DRUG, INC., RALEIGH, NC. FILED 11-20-2008.

KERR HEALTH CARE SERVICES

THE MARK CONSISTS OF STANDARD CHARACTERS WITHOUT CLAIM TO ANY PARTICULAR FONT, STYLE, SIZE, OR COLOR.

OWNER OF U.S. REG. NO. 3,300,588.

NO CLAIM IS MADE TO THE EXCLUSIVE RIGHT TO USE "HEALTH CARE SERVICES", APART FROM THE MARK AS SHOWN.
SEC. 2(F).

CLASS 35—ADVERTISING AND BUSINESS

FOR PHARMACY SERVICES FOR OTHERS CONSISTING OF FULFILLMENT OF DRUG PRESCRIPTIONS FOR SPECIALIZED DISEASE MANAGEMENT; AND PHARMACY SERVICES, NAMELY, PRESCRIPTION DRUG FULFILLMENT SERVICES FOR RESIDENTS OF LONG-TERM NURSING CARE FACILITIES AND GROUP HOMES (U.S. CLS. 100, 101 AND 102).
FIRST USE 8-0-2002; IN COMMERCE 8-0-2002.

CLASS 40—MATERIAL TREATMENT

FOR CUSTOM COMPOUNDING OF SPECIALIZED PRESCRIPTION DRUGS FOR OTHERS (U.S. CLS. 100, 103 AND 106).
FIRST USE 8-0-2002; IN COMMERCE 8-0-2002.

CLASS 44—MEDICAL, BEAUTY AND AGRICULTURAL SERVICES

FOR MEDICATION THERAPY MANAGEMENT SERVICES FOR RESIDENTS OF LONG-TERM NURSING CARE FACILITIES AND GROUP HOMES (U.S. CLS. 100 AND 101).
FIRST USE 11-0-2001; IN COMMERCE 11-0-2001.
GRETTA YAO, EXAMINING ATTORNEY

SN 77-620,473. BARNES & NOBLE COLLEGE BOOKSELLERS, INC., BASKING RIDGE, NJ. FILED 11-24-2008.

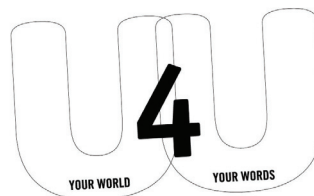

THE MARK CONSISTS OF TWO INTERSECTING LETTER "U" WITH AN OVERLAPPING NUMBER 4 WITH THE WORDS "YOUR WORLD" CONTAINED IN ONE LETTER "U" AND "YOUR WORDS" CONTAINED IN THE OTHER LETTER "U".

CLASS 9—ELECTRICAL AND SCIENTIFIC APPARATUS

FOR DOWNLOADABLE ELECTRONIC MAGAZINES AND NEWSLETTERS FEATURING ARTICLES AND INFORMATION ON STUDENT LIFE, STUDENT LIFESTYLE, COLLEGE AND UNIVERSITY CAMPUS LIFE AND THE CAMPUS BOOKSTORE AND COUPONS FOR PURCHASING OF BOOKS, MERCHANDISE AND SCHOOL RELATED ITEMS (U.S. CLS. 21, 23, 26, 36 AND 38).

CLASS 16—PAPER GOODS AND PRINTED MATTER

FOR PUBLICATIONS, NAMELY, MAGAZINES AND NEWSLETTERS FEATURING ARTICLES AND INFORMATION ON STUDENT LIFE, STUDENT LIFESTYLE, COLLEGE AND UNIVERSITY CAMPUS LIFE AND THE CAMPUS BOOKSTORE AND COUPONS FOR PURCHASING OF BOOKS, MERCHANDISE AND SCHOOL RELATED ITEMS (U.S. CLS. 2, 5, 22, 23, 29, 37, 38 AND 50).

CLASS 41—EDUCATION AND ENTERTAINMENT

FOR PROVIDING ONLINE NON-DOWNLOADABLE MAGAZINES AND NEWSLETTERS ON STUDENT LIFE, STUDENT LIFESTYLE, COLLEGE AND UNIVERSITY CAMPUS LIFE AND THE CAMPUS BOOKSTORE AND COUPONS FOR PURCHASING OF BOOKS, MERCHANDISE AND SCHOOL RELATED ITEMS; PROVIDING A WEB SITE FEATURING NON-DOWNLOADABLE MAGAZINES AND NEWSLETTERS ON STUDENT LIFE, STUDENT LIFESTYLE, COLLEGE AND UNIVERSITY CAMPUS LIFE AND THE CAMPUS BOOKSTORE AND COUPONS FOR PURCHASING OF BOOKS, MERCHANDISE AND SCHOOL RELATED ITEMS (U.S. CLS. 100, 101 AND 107).

JESSICA FATHY, EXAMINING ATTORNEY

SN 77-622,239. VALIO LTD., HELSINKI, FINLAND, FILED 11-26-2008.

REAL GOODNESS

THE MARK CONSISTS OF STANDARD CHARACTERS WITHOUT CLAIM TO ANY PARTICULAR FONT, STYLE, SIZE, OR COLOR.

CLASS 5—PHARMACEUTICALS

FOR DIETARY SUPPLEMENTS (U.S. CLS. 6, 18, 44, 46, 51 AND 52).

CLASS 29—MEATS AND PROCESSED FOODS

FOR MILK AND DAIRY PRODUCTS EXCLUDING ICE CREAM, ICE MILK AND FROZEN YOGURT (U.S. CL. 46).

CLASS 30—STAPLE FOODS

FOR ICE CREAM (U.S. CL. 46).
JAMES STEIN, EXAMINING ATTORNEY

SN 77-620,916. GRANT'S FINANCIAL PUBLISHING, INC., NEW YORK, NY. FILED 11-24-2008.

GRANT'S INTEREST RATE OBSERVER

THE MARK CONSISTS OF STANDARD CHARACTERS WITHOUT CLAIM TO ANY PARTICULAR FONT, STYLE, SIZE, OR COLOR.

OWNER OF U.S. REG. NO. 2,575,146.

NO CLAIM IS MADE TO THE EXCLUSIVE RIGHT TO USE "INTEREST RATE", APART FROM THE MARK AS SHOWN.

CLASS 9—ELECTRICAL AND SCIENTIFIC APPARATUS

FOR DOWNLOADABLE ELECTRONIC PUBLICATIONS IN THE NATURE OF FINANCIAL REPORTS AND BROCHURES IN THE FIELD OF FINANCE, NAMELY, PROVIDING ANALYSIS AND COMMENTARY ON WORLDWIDE FINANCIAL MARKETS, GLOBAL ECONOMICS AND ANALYSIS OF FINANCIAL TRENDS AND OPPORTUNITIES FOR INVESTORS, EDITORIAL COMMENTARY, AND ECONOMIC ANALYSIS AND PROVIDING FINANCIAL INFORMATION (U.S. CLS. 21, 23, 26, 36 AND 38).

FIRST USE 9-12-1997; IN COMMERCE 9-12-1997.

CLASS 16—PAPER GOODS AND PRINTED MATTER

FOR FINANCIAL PUBLICATIONS, NAMELY, FINANCIAL REPORTS AND BROCHURES PROVIDING ANALYSIS AND COMMENTARY ON WORLDWIDE FINANCIAL MARKETS, GLOBAL ECONOMICS AND ANALYSIS OF THE MOST IMPORTANT FINANCIAL TRENDS, ANOMALIES AND OPPORTUNITIES FOR INVESTORS, EDITORIAL COMMENTARY, AND ECONOMIC ANALYSIS AND PROVIDING FINANCIAL INFORMATION (U.S. CLS. 2, 5, 22, 23, 29, 37, 38 AND 50).

FIRST USE 11-7-1983; IN COMMERCE 11-7-1983.
JENNY PARK, EXAMINING ATTORNEY

SN 77-622,441. ALBEMARLE CORPORATION, BATON ROUGE, LA. FILED 11-26-2008.

ActivCat

THE MARK CONSISTS OF STANDARD CHARACTERS WITHOUT CLAIM TO ANY PARTICULAR FONT, STYLE, SIZE, OR COLOR.

CLASS 1—CHEMICALS

FOR CATALYSTS FOR USE IN THE MANUFACTURE OF PLASTICS, RUBBER, AND OLEFIN-BASED POLYMERS; OLEFIN-BASED POLYMERS, NAMELY, POLYETHYLENE AND POLYPROPYLENE BASED POLYMERS, AND PLASTIC MOLDING COMPOUNDS ALL FOR USE IN THE MANUFACTURE OF MOLDED PLASTIC ARTICLES, PLASTIC SHEETS AND FILMS (U.S. CLS. 1, 5, 6, 10, 26 AND 46).

CLASS 40—MATERIAL TREATMENT

FOR THE TREATMENT OF CHEMICAL MATERIALS FOR PRODUCTION AND OPTIMIZATION OF CATALYST SYSTEMS (U.S. CLS. 100, 103 AND 106).
LESLIE RICHARDS, EXAMINING ATTORNEY

SN 77-625,356. SHEAR WATER INVESTMENT CO., DBA HAWKEYE BREWING TECHNOLOGIES, LARKSPUR, CA. FILED 12-3-2008.

SN 77-626,492. A N D INTERNATIONAL LLC, NORTH MIAMI, FL. FILED 12-4-2008.

STEEP & RELEASE

THE MARK CONSISTS OF STANDARD CHARACTERS WITHOUT CLAIM TO ANY PARTICULAR FONT, STYLE, SIZE, OR COLOR.

CLASS 11—ENVIRONMENTAL CONTROL APPARATUS

FOR ELECTRIC COFFEE BREWING MACHINES (U.S. CLS. 13, 21, 23, 31 AND 34).

CLASS 30—STAPLE FOODS

FOR COFFEE (U.S. CL. 46).
HELENE LIWINSKI, EXAMINING ATTORNEY

SN 77-625,775. HELMER INC., NOBLESVILLE, IN. FILED 12-3-2008.

HELMER

THE MARK CONSISTS OF STANDARD CHARACTERS WITHOUT CLAIM TO ANY PARTICULAR FONT, STYLE, SIZE, OR COLOR.
SEC. 2(F).

CLASS 10—MEDICAL APPARATUS

FOR MEDICAL DEVICES AND APPARATUSES, NAMELY, PLATELET STORAGE INCUBATORS AND AGITATORS, CENTRIFUGES, CELL WASHERS AND PLASMA THAWING SYSTEMS COMPRISED OF AN ELECTRICALLY CONTROLLED HEATER, STAINLESS STEEL TANKS AND BASKETS AND A DRAIN; MEDICAL GOODS NAMELY, CRYOGENIC FREEZERS SPECIALLY ADAPTED FOR STORING BODILY FLUIDS (U.S. CLS. 26, 39 AND 44).
FIRST USE 0-0-1976; IN COMMERCE 0-0-1976.

CLASS 11—ENVIRONMENTAL CONTROL APPARATUS

FOR REFRIGERATORS AND FREEZERS FOR GENERAL MEDICAL USE (U.S. CLS. 13, 21, 23, 31 AND 34).
FIRST USE 0-0-1976; IN COMMERCE 0-0-1976.
JOHN SCHUYLER YARD, EXAMINING ATTORNEY

A N D INTERNATIONAL

THE MARK CONSISTS OF STANDARD CHARACTERS WITHOUT CLAIM TO ANY PARTICULAR FONT, STYLE, SIZE, OR COLOR.

NO CLAIM IS MADE TO THE EXCLUSIVE RIGHT TO USE "INTERNATIONAL", APART FROM THE MARK AS SHOWN.

CLASS 35—ADVERTISING AND BUSINESS

FOR REAL ESTATE ADVERTISING AND MARKETING SERVICES; PROVIDING INFORMATION IN THE NATURE OF REAL ESTATE ADVERTISING AND MARKETING INFORMATION FOR BROKERS, LANDLORDS, RENTERS AND SELLERS, AND DEVELOPERS OF HOMES, HOUSES, APARTMENTS, CONDOS, VILLAS, AND VACATION PROPERTIES VIA THE WORLD WIDE WEB (U.S. CLS. 100, 101 AND 102).

CLASS 36—INSURANCE AND FINANCIAL

FOR REAL ESTATE LISTING SERVICES FOR BROKERS, LANDLORDS, RENTERS AND SELLERS, AND DEVELOPERS OF HOMES, HOUSES, APARTMENTS, CONDO, VILLAS, AND VACATION PROPERTIES VIA THE WORLD WIDE WEB; PROVIDING INFORMATION RELATED TO VACATION TIMESHARES VIA ELECTRONIC COMMUNICATIONS NETWORKS (U.S. CLS. 100, 101 AND 102).

CLASS 39—TRANSPORTATION AND STORAGE

FOR PROVIDING INFORMATION RELATED TO VACATION TRAVEL, CRUISES AND VACATION PACKAGES VIA ELECTRONIC COMMUNICATIONS NETWORKS (U.S. CLS. 100 AND 105).

CLASS 43—HOTEL AND RESTAURANT SERVICES

FOR PROVIDING INFORMATION RELATED TO TEMPORARY ACCOMMODATIONS, NAMELY, HOTELS, CONDOS AND VILLAS VIA ELECTRONIC COMMUNICATIONS NETWORKS (U.S. CLS. 100 AND 101).
BONNIE LUKEN, EXAMINING ATTORNEY

SN 77-627,620. MEIJER, INC., GRAND RAPIDS, MI. FILED 12-5-2008.

Life in Motion

THE MARK CONSISTS OF STANDARD CHARACTERS WITHOUT CLAIM TO ANY PARTICULAR FONT, STYLE, SIZE, OR COLOR.

CLASS 9—ELECTRICAL AND SCIENTIFIC APPARATUS

FOR PRE-RECORDED DATA MEDIA, NAMELY, DVDS, FEATURING VIDEO, PHOTOS, TEXT, AND SOUND IN THE FIELD OF HOME MOVIES (U.S. CLS. 21, 23, 26, 36 AND 38).

FIRST USE 5-3-2008; IN COMMERCE 5-3-2008.

CLASS 41—EDUCATION AND ENTERTAINMENT

FOR PRODUCTION OF DVD'S FOR OTHERS, FEATURING VIDEO, PHOTOS, TEXT AND SOUND IN THE FIELD OF HOME MOVIES (U.S. CLS. 100, 101 AND 107).

FIRST USE 5-3-2008; IN COMMERCE 5-3-2008.

KATHERINE M. DUBRAY, EXAMINING ATTORNEY

SN 77-628,218. VALIO LTD., HELSINKI, FINLAND, FILED 12-8-2008.

DAIRY THAT DOES MORE

THE MARK CONSISTS OF STANDARD CHARACTERS WITHOUT CLAIM TO ANY PARTICULAR FONT, STYLE, SIZE, OR COLOR.

NO CLAIM IS MADE TO THE EXCLUSIVE RIGHT TO USE "DAIRY", APART FROM THE MARK AS SHOWN.

CLASS 5—PHARMACEUTICALS

FOR DIETARY SUPPLEMENTS (U.S. CLS. 6, 18, 44, 46, 51 AND 52).

CLASS 29—MEATS AND PROCESSED FOODS

FOR MILK AND DAIRY PRODUCTS EXCLUDING ICE CREAM, ICE MILK AND FROZEN YOGURT (U.S. CL. 46).

CLASS 30—STAPLE FOODS

FOR ICE CREAM (U.S. CL. 46).

JAMES STEIN, EXAMINING ATTORNEY

SN 77-628,369. OXYGEN BIOTHERAPEUTICS, INC., COSTA MESA, CA. FILED 12-8-2008.



NO CLAIM IS MADE TO THE EXCLUSIVE RIGHT TO USE "BIOTHERAPEUTICS", APART FROM THE MARK AS SHOWN.

THE MARK CONSISTS OF THE WORDS "OXYGEN BIOTHERAPEUTICS: EMPLOYING O2. PRESERVING LIFE." WITH CIRCLES DESIGN.

CLASS 1—CHEMICALS

FOR CHEMICAL COMPOUNDS USED TO MANUFACTURE PHARMACEUTICAL PREPARATIONS FOR THE TREATMENT OF TISSUE ISCHEMIA, BURNS, WOUNDS, TRAUMATIC BRAIN INJURY, LUNG DISORDERS, SICKLE CELL DISEASE, SKIN CONDITIONS, NAMELY, ACNE, AND HAIR CONDITIONS, NAMELY, DANDRUFF; CHEMICAL COMPOUNDS USED TO MANUFACTURE PHARMACEUTICAL PREPARATIONS FOR USE IN DERMATOLOGY AND COSMETOLOGY; CHEMICAL COMPOUNDS USED FOR OXYGEN TRANSPORT IN INDUSTRIAL PROCESSES (U.S. CLS. 1, 5, 6, 10, 26 AND 46).

CLASS 5—PHARMACEUTICALS

FOR PHARMACEUTICAL PREPARATIONS FOR THE TREATMENT OF TISSUE ISCHEMIA, BURNS, WOUNDS, TRAUMATIC BRAIN INJURY, LUNG DISORDERS, SICKLE CELL DISEASE, SKIN CONDITIONS, NAMELY, ACNE, AND HAIR CONDITIONS, NAMELY, DANDRUFF; PHARMACEUTICAL PREPARATIONS FOR USE IN DERMATOLOGY AND COSMETOLOGY (U.S. CLS. 6, 18, 44, 46, 51 AND 52).

MATTHEW KLINE, EXAMINING ATTORNEY

SN 77-629,649. RENAISSANCE LEARNING, INC., WISCONSIN RAPIDS, WI. FILED 12-9-2008.

SUCCESSFUL READER

THE MARK CONSISTS OF STANDARD CHARACTERS WITHOUT CLAIM TO ANY PARTICULAR FONT, STYLE, SIZE, OR COLOR.

NO CLAIM IS MADE TO THE EXCLUSIVE RIGHT TO USE "READER", APART FROM THE MARK AS SHOWN.

CLASS 9—ELECTRICAL AND SCIENTIFIC APPARATUS

FOR COMPUTER SOFTWARE, NAMELY, EDUCATIONAL SOFTWARE USED TO IMPROVE READING SKILLS FOR K-12 STUDENTS; DIGITAL AUDIO BOOKS DOWNLOADABLE FROM THE INTERNET OR PRE-LOADED ON MP3 PLAYERS (U.S. CLS. 21, 23, 26, 36 AND 38).

CLASS 16—PAPER GOODS AND PRINTED MATTER

FOR PRINTED EDUCATIONAL PUBLICATIONS, NAMELY, WORKBOOKS, TEXTBOOKS, WORKSHEETS AND MANUALS IN THE FIELD OF READING (U.S. CLS. 2, 5, 22, 23, 29, 37, 38 AND 50).

CLASS 41—EDUCATION AND ENTERTAINMENT

FOR EDUCATIONAL SERVICES, NAMELY, CONDUCTING CLASSES, WORKSHOPS AND SEMINARS IN THE FIELD OF READING FOR K-12 STUDENTS AND TEACHERS (U.S. CLS. 100, 101 AND 107).

KAREN BRACEY, EXAMINING ATTORNEY

SN 77-631,507. LUMINEX CORPORATION, AUSTIN, TX. FILED 12-11-2008.

MAGPIX

THE MARK CONSISTS OF STANDARD CHARACTERS WITHOUT CLAIM TO ANY PARTICULAR FONT, STYLE, SIZE, OR COLOR.

CLASS 1—CHEMICALS

FOR DIAGNOSTIC REAGENTS AND MICROSPHERES FOR SCIENTIFIC, CLINICAL OR RESEARCH USE FOR CONDUCTING MOLECULAR ANALYSIS FOR ENVIRONMENTAL, AGRICULTURAL, RESEARCH, DIAGNOSTIC, AND BIO-DEFENSE APPLICATIONS (U.S. CLS. 1, 5, 6, 10, 26 AND 46).

CLASS 5—PHARMACEUTICALS

FOR DIAGNOSTIC REAGENTS AND MICROSPHERES FOR MEDICAL USE FOR CONDUCTING MOLECULAR ANALYSIS FOR HEALTHCARE, RESEARCH, AND DIAGNOSTIC APPLICATIONS (U.S. CLS. 6, 18, 44, 46, 51 AND 52).

CLASS 9—ELECTRICAL AND SCIENTIFIC APPARATUS

FOR COMPUTER HARDWARE, COMPUTER SOFTWARE, AND LABORATORY INSTRUMENTS USING MICROSPHERES CONTAINING CHEMICAL REAGENTS, SOLD AS A UNIT, FOR CONDUCTING MOLECULAR ANALYSIS FOR HEALTHCARE, ENVIRONMENTAL, AGRICULTURAL, DIAGNOSTIC, BIO-DEFENSE, RESEARCH, AND OTHER APPLICATIONS (U.S. CLS. 21, 23, 26, 36 AND 38).
KAREN BRACEY, EXAMINING ATTORNEY

SN 77-631,815. KUSAKABE CO., LTD., TOKYO, JAPAN, FILED 12-12-2008.



OWNER OF JAPAN REG. NO. 4971501, DATED 7-21-2006, EXPIRES 7-21-2016.
THE MARK CONSISTS OF THE STYLIZED WORD "AQYLA".

CLASS 2—PAINTS

FOR COLORS IN THE NATURE OF WATERCOLOR PAINTS FOR DRAWING PICTURES; SLOW-CURING, QUICK-DRYING AQUEOUS PAINT USABLE IN COMBINATION WITH OIL-BASED PAINT (U.S. CLS. 6, 11 AND 16).

CLASS 16—PAPER GOODS AND PRINTED MATTER

FOR STATIONERY, SKETCH BOOKS, NOTEBOOKS; LOOSE LEAF PAPER; FELT PENS; DRAWING BRUSHES; SILK CANVAS FOR PAINTING; CANVAS FOR PAINTING; PASTEL CRAYONS; PAINT BRUSHES; PASTELS; PAINTING PALETTES; INK FOR WRITING INSTRUMENTS; INDIAN INKS (U.S. CLS. 2, 5, 22, 23, 29, 37, 38 AND 50).
ANDREA HACK, EXAMINING ATTORNEY

SN 77-631,901. SERIOUS MATERIALS, INC., SUNNYVALE, CA. FILED 12-12-2008.



THE MARK CONSISTS OF A STYLIZED LETTER "S" WITHIN A CIRCLE.

CLASS 2—PAINTS

FOR CONCRETE MOISTURE BARRIER COATING; ELASTOMERIC-BASED COATINGS FOR USE ON ROOFS, WALLS AND BUILDING FOUNDATIONS; WATER-BASED FIRE RETARDANT COATINGS FOR BUILDING CONSTRUCTION MATERIALS (U.S. CLS. 6, 11 AND 16).

CLASS 17—RUBBER GOODS

FOR SOUNDPROOFING MATERIALS FOR BUILDINGS (U.S. CLS. 1, 5, 12, 13, 35 AND 50).

CLASS 19—NON-METALLIC BUILDING MATERIALS

FOR BUILDING MATERIALS, NAMELY, WOOD, DECKING BOARDS; DRYWALL; NON-METAL WINDOWS; NON-METAL DOORS (U.S. CLS. 1, 12, 33 AND 50).

CLASS 35—ADVERTISING AND BUSINESS

FOR CONSULTING SERVICES IN THE AREA OF SUSTAINABLE BUSINESS SOLUTIONS (U.S. CLS. 100, 101 AND 102).
HOWARD SMIGA, EXAMINING ATTORNEY

SN 77-632,865. AVG TECHNOLOGIES CZ, S.R.O., BRNO, CZECH REPUBLIC, FILED 12-15-2008.

SN 77-633,482. TRAIN SIGNAL, INC., ROLLING MEADOWS, IL. FILED 12-15-2008.

AVG IDENTITY PROTECTION

THE MARK CONSISTS OF STANDARD CHARACTERS WITHOUT CLAIM TO ANY PARTICULAR FONT, STYLE, SIZE, OR COLOR.

OWNER OF U.S. REG. NO. 3,122,712.

NO CLAIM IS MADE TO THE EXCLUSIVE RIGHT TO USE "IDENTITY PROTECTION", APART FROM THE MARK AS SHOWN.

CLASS 9—ELECTRICAL AND SCIENTIFIC APPARATUS

FOR COMPUTER SOFTWARE AND PROGRAMS FOR SECURITY PROTECTION AND ANTI-VIRUS PROTECTION, IN THE FIELD OF COMPUTERS; ELECTRONIC, MAGNETIC AND OPTICAL MEDIA, NAMELY, CDS AND DVDS CONTAINING INFORMATION FOR SECURITY AND ANTI-VIRUS PROTECTION; DOWNLOADABLE ELECTRONIC MAGAZINES IN THE FIELD OF COMPUTERS; DOWNLOADABLE ELECTRONIC PUBLICATIONS, NAMELY, MAGAZINES IN THE FIELD OF SECURITY AND ANTI-VIRUS PROTECTION IN THE FIELD OF COMPUTERS; MULTI-MEDIA SOFTWARE RECORDED ON CD-ROMS FEATURING INFORMATION ON SECURITY AND ANTI-VIRUS PROTECTION; PERSONAL COMPUTERS AND PORTABLE PERSONAL COMPUTERS; COMPUTER PERIPHERALS (U.S. CLS. 21, 23, 26, 36 AND 38).

CLASS 16—PAPER GOODS AND PRINTED MATTER

FOR PRINTED PUBLICATIONS, NAMELY, COMPUTER MAGAZINES; PRINTED PERIODICALS ABOUT COMPUTER SECURITY SOFTWARE, AND ANTI-VIRUS PROTECTION; NON-PERIODICAL PRINTED MATTER, NAMELY, PRESS RELEASES ABOUT COMPUTER SECURITY SOFTWARE AND ANTI-VIRUS PROTECTION; PRINTED SOFTWARE INSTRUCTIONAL MANUALS ABOUT COMPUTER SECURITY SOFTWARE; PRINTED DIPLOMAS AND CERTIFICATES FROM PAPER BILLBOARDS MADE FROM PAPER OR PASTEBOARD; LEAFLETS ABOUT COMPUTER SECURITY SOFTWARE AND ANTI-VIRUS PROTECTION; POSTCARDS; PRINTED FORMS; PROMOTIONAL ITEMS FROM THE PRODUCTS, NAMELY, STICKERS (U.S. CLS. 2, 5, 22, 23, 29, 37, 38 AND 50).

CLASS 42—SCIENTIFIC AND COMPUTER SERVICES

FOR PRODUCT DEVELOPMENT, NAMELY, DEVELOPMENT OF SOFTWARE PROGRAMS FOR OTHERS; CONSULTANCY SERVICES IN THE FIELDS OF COMPUTER SOFTWARE AND HARDWARE, COMPUTER HARDWARE AND SOFTWARE INSTALLATIONS, UPDATING SOFTWARE, COMPUTER HARDWARE AND SOFTWARE LEASING, CONSULTANCY SERVICES IN THE FIELDS OF COPYING DATA, RENEWAL AND RESTORATION OF COMPUTER SOFTWARE, REGENERATION OF COMPUTER DATA AND SOFTWARE, AND COMPUTER SYSTEM ANALYSIS; CONSULTANCY SERVICES IN THE FIELDS OF TRANSFERRING DATA OR DOCUMENTS FROM PHYSICAL MEDIA TO ELECTRONIC MEDIA, CONVERSIONS OF COMPUTER DATA AND PROGRAMS, AND LEASING OF COMPUTERS; CONSULTANCY IN THE FIELD OF COMPUTER HARDWARE; MAINTENANCE OF COMPUTER SOFTWARE (U.S. CLS. 100 AND 101).

TRACY WHITTAKER-BROWN, EXAMINING ATTORNEY



TRAINSIGNAL
THE GLOBAL LEADER IN PROFESSIONAL COMPUTER TRAINING™

NO CLAIM IS MADE TO THE EXCLUSIVE RIGHT TO USE "COMPUTER TRAINING", APART FROM THE MARK AS SHOWN.

THE MARK CONSISTS OF A STYLIZED BULLET TRAIN, TO THE RIGHT, IN CAPITAL LETTERS, IS THE WORDING "TRAINSIGNAL," "TRAIN" IS IN BOLD. UNDERNEATH "TRAINSIGNAL" IS THE WORDING "THE GLOBAL LEADER IN PROFESSIONAL COMPUTER TRAINING" IN ALL CAPITAL LETTERS WITH A TRADEMARK SYMBOL.

SEC. 2(F) AS TO "THE GLOBAL LEADER IN PROFESSIONAL".

CLASS 9—ELECTRICAL AND SCIENTIFIC APPARATUS

FOR DIGITAL MEDIA, NAMELY, PRE-RECORDED DVDS FEATURING INSTRUCTION IN GENERAL COMPUTING, INFORMATION TECHNOLOGY, AND OFFICE SOFTWARE (U.S. CLS. 21, 23, 26, 36 AND 38).

FIRST USE 1-30-2003; IN COMMERCE 1-30-2003.

CLASS 41—EDUCATION AND ENTERTAINMENT

FOR ON-LINE JOURNALS, NAMELY, WEBSITES, BLOGS AND WEBCASTS FEATURING NEWS, CURRENT EVENTS, AND INSTRUCTION IN GENERAL COMPUTING, INFORMATION TECHNOLOGY, AND OFFICE SOFTWARE; EDUCATION SERVICES, NAMELY, PROVIDING SEMINARS IN THE FIELD OF GENERAL COMPUTING, INFORMATION, AND OFFICE SOFTWARE (U.S. CLS. 100, 101 AND 107).

FIRST USE 5-20-2005; IN COMMERCE 5-20-2005.

NAKIA HENRY, EXAMINING ATTORNEY

SN 77-635,321. NATIONAL MARROW DONOR PROGRAM, MINNEAPOLIS, MN. FILED 12-17-2008.

BE THE MATCH FOUNDATION

THE MARK CONSISTS OF STANDARD CHARACTERS WITHOUT CLAIM TO ANY PARTICULAR FONT, STYLE, SIZE, OR COLOR.

OWNER OF U.S. REG. NOS. 1,826,685 AND 1,969,048.

NO CLAIM IS MADE TO THE EXCLUSIVE RIGHT TO USE "FOUNDATION", APART FROM THE MARK AS SHOWN.

CLASS 35—ADVERTISING AND BUSINESS

FOR CHARITABLE SERVICES, NAMELY, ORGANIZING AND CONDUCTING VOLUNTEER PROGRAMS AND COMMUNITY SERVICE PROJECTS (U.S. CLS. 100, 101 AND 102).

CLASS 36—INSURANCE AND FINANCIAL

FOR FUNDRAISING SERVICES, NAMELY, ORGANIZING FUNDRAISERS TO RAISE FUNDS TO SUPPORT THE NATIONAL MARROW DONOR PROGRAM AND TO RAISE FUNDS TO SUPPORT THE MATCHING OF POTENTIAL DONORS OF BONE MARROW, PERIPHERAL BLOOD STEM CELLS OR CORD BLOOD WITH PATIENTS IN NEED OF A STEM CELL TRANSPLANT (U.S. CLS. 100, 101 AND 102).

LESLIE RICHARDS, EXAMINING ATTORNEY

CLASS 24—FABRICS

FOR BEACH TOWELS; BIG BATH TOWELS; BATH TOWELS; HAND TOWELS; WASH TOWELS; KITCHEN TOWELS; DISH TOWELS; FINGERTIP TOWELS; BLANKET SIZE TOWELS (U.S. CLS. 42 AND 50).

CLASS 27—FLOOR COVERINGS

FOR BATH MATS (U.S. CLS. 19, 20, 37, 42 AND 50).
RICHARD A. STRASER, EXAMINING ATTORNEY

SN 77-635,326. NATIONAL MARROW DONOR PROGRAM, MINNEAPOLIS, MN. FILED 12-17-2008.



OWNER OF U.S. REG. NOS. 1,826,685 AND 1,969,048.
NO CLAIM IS MADE TO THE EXCLUSIVE RIGHT TO USE "FOUNDATION", APART FROM THE MARK AS SHOWN.

THE MARK CONSISTS OF THE WORDS "BE THE MATCH FOUNDATION". FOUR CIRCLES WITH BLACK SHADING INCLUDED WITHIN EACH CIRCLE APPEARS AFTER THE WORD "BE".

CLASS 35—ADVERTISING AND BUSINESS

FOR CHARITABLE SERVICES, NAMELY, ORGANIZING AND CONDUCTING VOLUNTEER PROGRAMS AND COMMUNITY SERVICE PROJECTS (U.S. CLS. 100, 101 AND 102).

CLASS 36—INSURANCE AND FINANCIAL

FOR FUNDRAISING SERVICES, NAMELY, ORGANIZING FUNDRAISERS TO SUPPORT THE NATIONAL MARROW DONOR PROGRAM AND TO RAISE FUNDS TO SUPPORT THE MATCHING OF POTENTIAL DONORS OF BONE MARROW, PERIPHERAL BLOOD STEM CELLS OR CORD BLOOD WITH PATIENTS IN NEED OF A STEM CELL TRANSPLANT (U.S. CLS. 100, 101 AND 102).

LESLIE RICHARDS, EXAMINING ATTORNEY

SN 77-635,341. TAYLOR HOME FASHIONS LIMITED, KWUN TONG, KOWLOON, HONG KONG, FILED 12-17-2008.

SUPRASOFT

THE MARK CONSISTS OF STANDARD CHARACTERS WITHOUT CLAIM TO ANY PARTICULAR FONT, STYLE, SIZE, OR COLOR.

SN 77-636,244. GENERAL ELECTRIC COMPANY, SCHENECTADY, NY. FILED 12-18-2008.

INNOVATION YOU DON'T HAVE
TO WAIT FOR

THE MARK CONSISTS OF STANDARD CHARACTERS WITHOUT CLAIM TO ANY PARTICULAR FONT, STYLE, SIZE, OR COLOR.

CLASS 35—ADVERTISING AND BUSINESS

FOR BUSINESS REORGANIZATION SERVICES, NAMELY, PROVIDING BUSINESS CONSULTATION IN THE FIELD OF BUSINESS REORGANIZATIONS; BUSINESS MANAGEMENT SERVICES, NAMELY, VEHICLE FLEET MANAGEMENT SERVICES; BUSINESS ADMINISTRATION SERVICES, NAMELY, ADMINISTRATION OF BUSINESS PAYROLL FOR OTHERS; OPERATION AND BUSINESS MANAGEMENT OF POWER PLANTS; BUSINESS CONSULTANCY AND ADVISORY SERVICES AND PROVIDING BUSINESS INFORMATION FOR OTHERS RELATING TO ALL OF THE FOREGOING SERVICES; SUPPLY CHAIN MANAGEMENT AND CONSULTING SERVICES IN THE AREAS OF CHEMICAL PRODUCT AND SERVICE SOURCING AND PROCUREMENT, PRODUCT INVENTORY AND SUPPLY MANAGEMENT AND COST CONTAINMENT; CONSULTING, MARKETING, COST AND PRICING ANALYSIS RELATING TO ELECTROCHEMICAL LIQUID PURIFICATION UNITS FOR USE IN THE INDUSTRIAL SECTOR; ENERGY USAGE MANAGEMENT AND INFORMATION SERVICES; UTILITY BILL MANAGEMENT SERVICES; MANAGEMENT OF ENERGY CONSUMPTION BY ELECTRICAL APPLIANCES (U.S. CLS. 100, 101 AND 102).

CLASS 36—INSURANCE AND FINANCIAL

FOR ASSET BASED AND PRIVATE LABEL FINANCING SERVICES; FINANCIAL ANALYSIS AND CONSULTATION; CREDIT CARD FINANCIAL SERVICES; CREDIT CARD SERVICES, NAMELY, EXTENSION OF CREDIT TO OTHERS; FINANCIAL ASSET MANAGEMENT FOR OTHERS; ACQUISITION FINANCING SERVICES; COMMERCIAL FINANCING SERVICES; COMMERCIAL REAL ESTATE AGENCY SERVICES; MUTUAL FUND INVESTMENT; PRIVATE EQUITY AND DEBT INVESTMENT; CONSULTANCY, ADVISORY AND INFORMATION SERVICES RELATING TO ALL THE FOREGOING SERVICES, CREDIT AGENCY SERVICES IN THE FIELDS OF CONSUMER AND COMMERCIAL CREDIT, CREDIT CARD SERVICES, REAL ESTATE LOAN FINANCING SERVICES AND BANKING AND FINANCIAL SERVICES (U.S. CLS. 100, 101 AND 102).

CLASS 37—CONSTRUCTION AND REPAIR

FOR CONSULTING IN THE FIELD OF BUILDING CONSTRUCTION; CONSTRUCTION, INSTALLATION, REPAIR, REPLACEMENT, OVERHAUL AND MAINTENANCE OF POWER PLANTS, ENGINES, TURBINES, WIND TURBINES, MOTORS AND APPARATUS, EQUIPMENT AND INSTRUMENTS FOR THE GENERATION OF POWER AND ELECTRICITY AND THEIR COMPONENT PARTS, FITTINGS AND ACCESSORIES; INSTALLATION, MAINTENANCE AND REPAIR SERVICES FOR COMPRESSORS AND PUMPS, NAMELY, MACHINES, TURBO EXPANDERS, FUEL PUMPS AND FUEL DISTRIBUTION EQUIPMENT, CNG REFUELING EQUIPMENT, GAS TURBINES, STEAM TURBINES, AIR COOLED HEAT EXCHANGERS, STEAM CONDENSERS, HEAVY WALL REACTORS AND TUBULAR REACTORS; OIL AND GAS PIPELINE MAINTENANCE AND REPAIR SERVICES; OIL WELL CASING, TUBING AND DRILL PIPE INSTALLATION; RENTAL OF OIL AND GAS WELL DRILLING TOOLS; DIAGNOSTIC REPAIR AND MAINTENANCE SERVICES RENDERED IN THE REPAIR AND MAINTENANCE OF AIRCRAFT ENGINES, TURBINES, ELECTRICAL EQUIPMENT, MEDICAL EQUIPMENT, LOCOMOTIVES AND ACCESSORIES AND COMPONENT PARTS OF ALL THE FOREGOING; CONSTRUCTION EQUIPMENT LEASING; CHEMICAL CLEANING SERVICES FOR GLASS-LINED REACTOR VESSELS USED IN THE CHEMICAL AND PHARMACEUTICAL PROCESSING INDUSTRIES; MAINTENANCE SERVICES FOR HEAT TRANSFER SYSTEMS AND CONDENSERS; MAINTENANCE AND REPAIR SERVICES IN THE FIELD OF COMPUTERIZED COOLING SYSTEM EQUIPMENT; SERVICES RENDERED IN THE REPAIR AND MAINTENANCE OF MACHINERY, INSTRUMENTS, ELECTRICAL EQUIPMENT AND APPLIANCES; CONSULTING IN THE FIELD OF HOSPITAL CONSTRUCTION (U.S. CLS. 100, 103 AND 106).

CLASS 40—MATERIAL TREATMENT

FOR WATER AND WASTEWATER TREATMENT SERVICES, NAMELY, DESALINATION, PURIFICATION, CONDITIONING, IDENTIFYING AND CONTROLLING MICROBIOLOGICAL ORGANISMS, CLEANING OF ION EXCHANGE RESINS; MEMBRANE REGENERATION SERVICES; CHEMICAL TREATMENT SERVICES RELATING TO THE FEEDING OF TREATMENT CHEMICALS TO INDUSTRIAL WATER SYSTEMS; OIL AND GAS WELL TREATMENT SERVICES (U.S. CLS. 100, 103 AND 106).

CLASS 42—SCIENTIFIC AND COMPUTER SERVICES

FOR SERVICES RELATING TO WIND AND WIND POWER, NAMELY, PROFESSIONAL CONSULTING SERVICES AND ENGINEERING SERVICES; DESIGN FOR OTHERS IN THE FIELD OF WIND POWER; INDUSTRIAL DESIGN SERVICES; DESIGN OF POWER, WIND POWER AND ELECTRIC POWER GENERATING EQUIPMENT AND INSTALLATIONS; ENGINEERING SERVICES, TECHNICAL CONSULTATION AND RESEARCH SERVICES IN THE OIL AND GAS INDUSTRIES; OIL AND GAS EXPLORATION SERVICES; GEOPHYSICAL EXPLORATION FOR THE OIL AND GAS INDUSTRIES; ANALYSIS OF OIL AND GAS FIELDS; OIL AND GAS PROSPECTING, NAMELY, WELL LOGGING AND TESTING; OIL AND GAS WELL TESTING; OIL AND GAS PIPELINE INSPECTION; REMOTE MONITORING AND DIAGNOSTIC SERVICES FOR COMPRESSORS, PUMPS, TURBOEXPANDERS, FUEL PUMPS AND FUEL DISTRIBUTION EQUIPMENT, CNG REFUELING EQUIPMENT, GAS TURBINES, STEAM TURBINES, AIR COOLED HEAT EXCHANGERS, STEAM CONDENSERS, HEAVY WALL REACTORS AND TUBULAR REACTORS; INFORMATION TECHNOLOGY CONSULTATION SERVICES IN THE FIELD OF GLOBAL RAILROAD AND TRANSIT INDUSTRIES; COMPUTER EQUIPMENT LEASING; RESEARCH, CONSULTATION, AND ADVISORY SERVICES RELATING TO ENGINEERING, DESIGN AND DEVELOPMENT PROBLEMS ENCOUNTERED BY UTILITY, INDUSTRIAL, AND COMMERCIAL COMPANIES, GOVERNMENTS, AND INDIVIDUALS; COMPUTER PROGRAMMING SERVICES FOR OTHERS; COMPUTER SOFTWARE DESIGN AND ANALYSIS

SERVICES FOR OTHERS; COMPUTER CONSULTATION SERVICES; MAINTENANCE AND UPDATING OF COMPUTER SOFTWARE AND COMPUTER SYSTEMS FOR OTHERS; INSTALLATION OF COMPUTER SOFTWARE; COMPUTER SYSTEMS ANALYSIS AND DESIGN SERVICES FOR OTHERS; CONSULTANCY SERVICES RELATING TO CHEMICAL RESEARCH; CONSULTANCY SERVICES RELATING TO THE DISCOVERY AND EVALUATION OF DRUGS AND COMPOUNDS HAVING DIAGNOSTIC PROPERTIES; CONSULTANCY SERVICES RELATING TO METHODS FOR DIAGNOSIS USING LASER BASED OPTICAL SYSTEMS; HIGH THROUGH PUT SCREENING ASSAYS FOR DRUG DEVELOPMENT SERVICES; CUSTOMER SYNTHESIS, ANALYTICAL AND DIAGNOSTIC SERVICES; BIOTECHNOLOGICAL SERVICES; TECHNICAL SUPPORT SERVICES FOR FACTORY AUTOMATION SOFTWARE, NAMELY, PROVIDING MAINTENANCE OF COMPUTER SOFTWARE AND PROVIDING PERIODIC UPGRADES OF SOFTWARE; CUSTOM DESIGN OF SECURITY ACCESS SYSTEMS; DESIGN AND CONSULTING SERVICES IN CONNECTION WITH THE CONFIGURATION OF SYSTEMS USED IN APPLICATIONS SUPPORTING FIBER OPTIC TECHNOLOGY; TECHNICAL SUPPORT SERVICES, NAMELY, TROUBLESHOOTING OF PROBLEMS WITH COMPUTER HARDWARE, VIDEO AND ELECTRONIC COMMUNICATION HARDWARE, AND SOFTWARE; TECHNICAL CONSULTATION SERVICES FOR HARDWARE AND SOFTWARE USED IN CONNECTION WITH SECURITY AND ACCESS SYSTEMS; TECHNICAL CONSULTATION SERVICES FOR SURVEILLANCE CAMERAS; CUSTOM DESIGN SERVICES FOR OTHERS IN THE FIELDS OF SECURITY SYSTEMS, ACCESS SYSTEMS, AND TANGIBLE ASSET AND INVENTORY MONITORING SYSTEMS; LABORATORY AND TESTING SERVICES FOR FLUID SEPARATION AND MEMBRANE TESTING; ENGINEERING AND CONSULTING SERVICES IN THE FIELDS OF WATER TREATMENT, AQUEOUS SYSTEMS, COOLING WATER SYSTEMS, INDUSTRIAL BOILER WATER SYSTEMS, INDUSTRIAL WATER AND PROCESS SYSTEMS, INDUSTRIAL FUEL PROCESSING SYSTEM TREATMENT; ENGINEERING SERVICES AND TECHNICAL SUPPORT SERVICES RELATED TO THE DESIGN AND CONFIGURATION OF COMPUTER SOFTWARE AND HARDWARE SYSTEMS TO BE USED IN THE TREATMENT OF AQUEOUS SYSTEMS, PETROLEUM AND PETROCHEMICAL PROCESSING SYSTEMS; PROVIDING INFORMATION TO OTHERS, OVER A GLOBAL COMPUTER NETWORK, RELATING TO INDUSTRIAL WATER PURIFICATION SYSTEMS; ADVISORY SERVICES RELATED TO ALL THE AFORESAID; AUTOMATIC METER READING, DIAGNOSTIC SERVICES IN THE FIELD OF ELECTRICAL, WATER AND GAS METERS; REMOTE CONNECT/DISCONNECT OF ELECTRIC, WATER AND GAS METERS; REMOTE MONITORING AND MAINTENANCE SERVICES RENDERED IN THE REPAIR AND MAINTENANCE OF AIRCRAFT ENGINES, TURBINES, ELECTRICAL EQUIPMENT, MEDICAL EQUIPMENT, LOCOMOTIVES AND ACCESSORIES AND COMPONENT PARTS OF ALL THE FOREGOING (U.S. CLS. 100 AND 101).

CLASS 44—MEDICAL, BEAUTY AND AGRICULTURAL SERVICES

FOR CONSULTANCY SERVICES RELATING TO MEDICAL AND DIAGNOSTIC IMAGING; CONSULTANCY AND ADVISORY SERVICES RELATING TO DIAGNOSTIC, PROPHYLACTIC AND THERAPEUTIC PROPERTIES OF PHARMACEUTICALS; MEDICAL INFORMATION SERVICES; MEDICAL SERVICES, INCLUDING COMPREHENSIVE SERVICES IN THE MEDICAL FIELD RELATING TO IMPROVING AND MAINTAINING QUALITY OF PATIENT CARE, DIAGNOSIS AND TREATMENT THROUGHOUT A HOSPITAL; CONSULTANCY SERVICES IN THE MEDICAL AND HEALTHCARE FIELDS; MEDICAL SYSTEM LEASING (U.S. CLS. 100 AND 101).

PAUL F. GAST, EXAMINING ATTORNEY

SN 77-636,728. HLAVACS, JOHN, PORTLAND, OR. FILED 12-19-2008.

SN 77-637,096. SPORTS MEDIA ADVISORS, LLC, WASHINGTON, DC. FILED 12-19-2008.

LIGHTSPEED SOLDIERS

THE MARK CONSISTS OF STANDARD CHARACTERS WITHOUT CLAIM TO ANY PARTICULAR FONT, STYLE, SIZE, OR COLOR.

CLASS 41—EDUCATION AND ENTERTAINMENT

FOR TEACHING IN THE FIELD OF DESIGN AND ART; PERSONAL TRAINING SERVICES; PHOTOGRAPHY SERVICES; PRODUCTION OF VIDEOS (U.S. CLS. 100, 101 AND 107).

CLASS 42—SCIENTIFIC AND COMPUTER SERVICES

FOR INDUSTRIAL AND GRAPHIC DESIGN SERVICES; DESIGN OF GENERAL PRODUCTS FOR OTHERS; GRAPHIC ILLUSTRATION SERVICES FOR OTHERS (U.S. CLS. 100 AND 101).

NORA BUCHANAN WILL, EXAMINING ATTORNEY

SN 77-636,927. DOLLARS INSIDE FRANCHISING LLC, CAPE CORAL, FL. FILED 12-19-2008.



NO CLAIM IS MADE TO THE EXCLUSIVE RIGHT TO USE "DOLLARS", APART FROM THE MARK AS SHOWN.

THE MARK CONSISTS OF THE WORDS "DOLLARS INSIDE" WHEREIN THE "S" IN "INSIDE" IS REPRESENTED BY A DOLLAR SIGN, "\$" ALONG WITH A STYLIZED DRAWING OF AN OPENING BOOK.

CLASS 16—PAPER GOODS AND PRINTED MATTER

FOR ADVERTISING PAMPHLETS AND COUPON BOOKS WHICH PROMOTE THE GOODS AND SERVICES OF OTHERS (U.S. CLS. 2, 5, 22, 23, 29, 37, 38 AND 50).

CLASS 35—ADVERTISING AND BUSINESS

FOR FRANCHISE SERVICES, NAMELY, OFFERING BUSINESS MANAGEMENT ASSISTANCE IN THE ESTABLISHMENT AND OPERATION OF BUSINESS ENTITIES WHICH CREATE, MARKET AND DISTRIBUTE ADVERTISING PAMPHLETS AND COUPON BOOKS DESIGNED TO PROMOTE THE GOODS AND SERVICES OF OTHERS (U.S. CLS. 100, 101 AND 102).

WENDY GOODMAN, EXAMINING ATTORNEY

CELEBRITY SUPERSTARS

THE MARK CONSISTS OF STANDARD CHARACTERS WITHOUT CLAIM TO ANY PARTICULAR FONT, STYLE, SIZE, OR COLOR.

OWNER OF U.S. REG. NOS. 1,083,705 AND 1,244,560.

NO CLAIM IS MADE TO THE EXCLUSIVE RIGHT TO USE "CELEBRITY", APART FROM THE MARK AS SHOWN.

CLASS 25—CLOTHING

FOR SWIMWEAR, SHORTS, SHIRTS, T-SHIRTS, POLO SHIRTS, KNIT TOPS, JACKETS, COATS, PANTS, TANK TOPS, HATS, VISORS, AND SWEATSHIRTS (U.S. CLS. 22 AND 39).

CLASS 41—EDUCATION AND ENTERTAINMENT

FOR ENTERTAINMENT SERVICES, NAMELY, ORGANIZING, PRODUCING, AND CONDUCTING SPORTS CONTESTS AND EVENTS (U.S. CLS. 100, 101 AND 107).

JERI J. FICKES, EXAMINING ATTORNEY

SN 77-638,528. DREAM VIDEO INC, PLANO, TX. FILED 12-22-2008.



THE COLOR(S) RED, BLACK AND GREY IS/ARE CLAIMED AS A FEATURE OF THE MARK.

THE MARK CONSISTS OF A BLACK AND GREY OFFICE CHAIR. A RED, STYLIZED CAPITAL LETTER "L" IS FORMED FROM THE BACK AND SEAT OF THE CHAIR. THE LETTERS "OBBYINFO.NET", IN RED, ARE PLACED TO THE RIGHT OF THE CHAIR TO FORM THE WORD "LOBBYINFO.NET." THE COLOR WHITE CONSTITUTES BACKGROUND AND IS NOT PART OF THE MARK.

CLASS 9—ELECTRICAL AND SCIENTIFIC APPARATUS

FOR AUDIO AND VIDEO RECORDINGS FEATURING PHYSICIANS SPEAKING ABOUT SPECIFIC DISEASES, AILMENTS, TREATMENTS OR CONDITIONS (U.S. CLS. 21, 23, 26, 36 AND 38).

FIRST USE 6-30-2008; IN COMMERCE 7-28-2008.

CLASS 38—COMMUNICATION

FOR BROADCASTING OF VIDEO AND AUDIO PROGRAMMING OVER THE INTERNET (U.S. CLS. 100, 101 AND 104).

FIRST USE 6-30-2008; IN COMMERCE 7-28-2008.

NICHOLAS COLEMAN, EXAMINING ATTORNEY

SN 77-640,061. GUITAR CENTER, INC., WESTLAKE VIL-
LAGE, CA. FILED 12-25-2008.

VENUE

THE MARK CONSISTS OF STANDARD CHARACTERS
WITHOUT CLAIM TO ANY PARTICULAR FONT, STYLE,
SIZE, OR COLOR.

CLASS 9—ELECTRICAL AND SCIENTIFIC APPARATUS

FOR LIGHTING CONTROLLERS FOR SPECIAL EF-
FECTS LIGHTING AND THEATRICAL AND MUSICAL
PRODUCTION LIGHTING (U.S. CLS. 21, 23, 26, 36 AND
38).

FIRST USE 6-17-2008; IN COMMERCE 6-17-2008.

CLASS 11—ENVIRONMENTAL CONTROL AP- PARATUS

FOR LIGHTING DEVICES FOR THEATRICAL AND
MUSICAL PRODUCTIONS, NAMELY, EFFECTS LIGHT-
ING AND STAGE LIGHTING; FOG MACHINES; AND
LASER LIGHT PROJECTORS FOR THEATRICAL AND
MUSICAL PRODUCTIONS (U.S. CLS. 13, 21, 23, 31 AND
34).

FIRST USE 6-17-2008; IN COMMERCE 6-17-2008.
PATRICIA EVANKO, EXAMINING ATTORNEY

SN 77-640,337. KONA CONNECTION CORP., TORTOLA,
BR. VIRGIN ISLANDS, FILED 12-28-2008.

NOYU

THE MARK CONSISTS OF STANDARD CHARACTERS
WITHOUT CLAIM TO ANY PARTICULAR FONT, STYLE,
SIZE, OR COLOR.

OWNER OF U.S. REG. NOS. 3,509,300 AND 3,513,863.

CLASS 25—CLOTHING

FOR ATHLETIC APPAREL, NAMELY, SHIRTS,
PANTS, JACKETS, FOOTWEAR, HATS AND CAPS,
ATHLETIC UNIFORMS; INFANT AND TODDLER ONE
PIECE CLOTHING; WEARABLE GARMENTS AND
CLOTHING, NAMELY, SHIRTS (U.S. CLS. 22 AND 39).

FIRST USE 10-26-2007; IN COMMERCE 10-29-2007.

CLASS 32—LIGHT BEVERAGES

FOR FRUIT DRINKS AND FRUIT JUICES (U.S. CLS.
45, 46 AND 48).

FIRST USE 10-26-2007; IN COMMERCE 10-29-2007.
NICHOLAS ALTREE, EXAMINING ATTORNEY

SN 77-640,691. GUITAR CENTER, INC., WESTLAKE VIL-
LAGE, CA. FILED 12-29-2008.



THE MARK CONSISTS OF THE WORD "VENUE" IN
BLOCK PRINT WITH A STAR DRAWING PRECEDING
THE LETTER "V".

CLASS 9—ELECTRICAL AND SCIENTIFIC APPARATUS

FOR LIGHTING CONTROLLERS FOR SPECIAL EF-
FECTS LIGHTING AND THEATRICAL AND MUSICAL
PRODUCTION LIGHTING (U.S. CLS. 21, 23, 26, 36 AND
38).

FIRST USE 6-17-2008; IN COMMERCE 6-17-2008.

CLASS 11—ENVIRONMENTAL CONTROL AP- PARATUS

FOR LIGHTING DEVICES FOR THEATRICAL AND
MUSICAL PRODUCTIONS, NAMELY, EFFECTS LIGHT-
ING AND STAGE LIGHTING; FOG MACHINES; AND
LASER LIGHT PROJECTORS FOR THEATRICAL PRO-
DUCTIONS (U.S. CLS. 13, 21, 23, 31 AND 34).

FIRST USE 6-17-2008; IN COMMERCE 6-17-2008.
PATRICIA EVANKO, EXAMINING ATTORNEY

SN 77-640,707. BOKIER, INC., CHAPEL HILL, NC. FILED
12-29-2008.



THE MARK CONSISTS OF A HEART WITH THE WORD
"BIO" WRITTEN IN SCRIPT CONTAINED WITHIN.

CLASS 5—PHARMACEUTICALS

FOR PHARMACEUTICAL PREPARATIONS FOR THE
TREATMENT OF OBESITY, DIABETES, METABOLIC
SYNDROME, POLYCYSTIC OVARY SYNDROME
(PCOS), IMPAIRED GLUCOSE TOLERANCE (IGT), HY-
PERINSULINEMIA, NON-ALCOHOLIC FATTY LIVER
DISEASE, AND PRE-DIABETES (U.S. CLS. 6, 18, 44, 46,
51 AND 52).

CLASS 44—MEDICAL, BEAUTY AND AGRI- CULTURAL SERVICES

FOR MEDICAL SERVICES RELATED TO THE TREAT-
MENT OF OBESITY, DIABETES AND OTHER MEDICAL
CONDITIONS (U.S. CLS. 100 AND 101).

ANDREA HACK, EXAMINING ATTORNEY

SN 77-640,794. BIOKIER, INC., CHAPEL HILL, NC. FILED 12-29-2008.

SN 77-641,088. CON-WAL, INC., DBA SOUTHWESTERN SALES COMPANY, ROGERS, AR. FILED 12-30-2008.



THE MARK CONSISTS OF A HEART WITH THE WORD "BIO" WRITTEN IN SCRIPT CONTAINED WITHIN, AND BEFORE THE WORD "BIOKIER" IN A STYLIZED FONT.

CLASS 5—PHARMACEUTICALS

FOR PHARMACEUTICAL PREPARATIONS FOR THE TREATMENT OF OBESITY, DIABETES, METABOLIC SYNDROME, POLYCYSTIC OVARY SYNDROME (PCOS), IMPAIRED GLUCOSE TOLERANCE (IGT), HYPERINSULINEMIA, NON-ALCOHOLIC FATTY LIVER DISEASE, AND PRE-DIABETES (U.S. CLS. 6, 18, 44, 46, 51 AND 52).

CLASS 44—MEDICAL, BEAUTY AND AGRICULTURAL SERVICES

FOR MEDICAL SERVICES RELATED TO THE TREATMENT OF OBESITY, DIABETES AND OTHER MEDICAL CONDITIONS (U.S. CLS. 100 AND 101).
ANDREA HACK, EXAMINING ATTORNEY



THE MARK CONSISTS OF THE WORD "TARPARMOR" IN STYLIZED BLOCK LETTERS. THE "T" IS REPLACED BY A STYLIZED SWORD .

CLASS 12—VEHICLES

FOR FITTED COVERS FOR THE CARGO AREA OF VEHICLES IN THE NATURE OF TARPS (U.S. CLS. 19, 21, 23, 31, 35 AND 44).

CLASS 22—CORDAGE AND FIBERS

FOR TARPAULINS FOR USE AS LANDFILL COVERS, FABRIC STRUCTURES, SHADE AND WEATHER PROTECTION, AND EROSION CONTROL; UNFITTED COVERS FOR THE CARGO AREA OF VEHICLES IN THE NATURE OF TARPS; NON-METAL ATHLETIC FIELD COVER IN THE NATURE OF A TARPAULIN; UNFITTED FABRIC FURNITURE COVERS IN THE NATURE OF TARPAULINS; AWNINGS OF FABRIC IN THE NATURE OF A TARPAULIN (U.S. CLS. 1, 2, 7, 19, 22, 42 AND 50).
MARCIE MILONE, EXAMINING ATTORNEY

SN 77-641,084. CON-WAL, INC., DBA SOUTHWESTERN SALES COMPANY, ROGERS, AR. FILED 12-30-2008.

SN 77-641,314. MEIRITSU SEIKI CO., LTD., YOKOHAMA, JAPAN, FILED 12-30-2008.



THE MARK CONSISTS OF THE WORD "TARPARMOR" IN STYLIZED BLOCK LETTERS WITH A SWORD AND SHIELD DESIGN.

CLASS 12—VEHICLES

FOR FITTED COVERS FOR THE CARGO AREA OF VEHICLES IN THE NATURE OF TARPS (U.S. CLS. 19, 21, 23, 31, 35 AND 44).

CLASS 22—CORDAGE AND FIBERS

FOR TARPAULINS FOR USE AS LANDFILL COVERS, FABRIC STRUCTURES, SHADE AND WEATHER PROTECTION, AND EROSION CONTROL; UNFITTED COVERS FOR THE CARGO AREA OF VEHICLES IN THE NATURE OF TARPS; NON-METAL ATHLETIC FIELD COVER IN THE NATURE OF A TARPAULIN; UNFITTED FABRIC FURNITURE COVERS IN THE NATURE OF TARPAULINS; AWNINGS OF FABRIC IN THE NATURE OF A TARPAULIN (U.S. CLS. 1, 2, 7, 19, 22, 42 AND 50).
MARCIE MILONE, EXAMINING ATTORNEY



THE COLOR(S) GRAY IS/ARE CLAIMED AS A FEATURE OF THE MARK.
THE MARK CONSISTS OF STYLIZED LETTERING OF THE WORD MARK "MEIRITZ" IN THE COLOR GRAY.

CLASS 9—ELECTRICAL AND SCIENTIFIC APPARATUS

FOR VIBRATION ISOLATION SYSTEMS IN THE FIELDS OF SCIENCE AND TECHNOLOGY, NAMELY, EQUIPMENT THAT ISOLATES PRECISION MEASURING EQUIPMENT FROM VIBRATION (U.S. CLS. 21, 23, 26, 36 AND 38).

CLASS 42—SCIENTIFIC AND COMPUTER SERVICES

FOR THE CUSTOM DESIGN OF VIBRATION ISOLATION SYSTEMS FOR OTHERS (U.S. CLS. 100 AND 101).
RONALD AIKENS, EXAMINING ATTORNEY

SN 77-642,086. WILKINSON INDUSTRIES, INC., FORT CALHOUN, NE. FILED 12-31-2008.

SN 77-643,523. JONAS, STEVEN, EAST SETAUKET, NY. FILED 1-5-2009.

WILKINSON

THE MARK CONSISTS OF STANDARD CHARACTERS WITHOUT CLAIM TO ANY PARTICULAR FONT, STYLE, SIZE, OR COLOR.
SEC. 2(F).

CLASS 6—METAL GOODS

FOR METAL FOIL FOR USE IN FOOD SERVICE; METAL FOOD CONTAINERS FOR COMMERCIAL USE (U.S. CLS. 2, 12, 13, 14, 23, 25 AND 50).
FIRST USE 1-13-1955; IN COMMERCE 1-13-1955.

CLASS 20—FURNITURE AND ARTICLES NOT OTHERWISE CLASSIFIED

FOR PLASTIC FOOD CONTAINERS FOR COMMERCIAL USE (U.S. CLS. 2, 13, 22, 25, 32 AND 50).
FIRST USE 6-3-1988; IN COMMERCE 6-3-1988.
HOWARD B. LEVINE, EXAMINING ATTORNEY

SN 77-643,009. ROCKPORT RECREATION, CO. LLC, RANCHO SANTA FE, CA. FILED 1-4-2009.

BANDEX

THE MARK CONSISTS OF STANDARD CHARACTERS WITHOUT CLAIM TO ANY PARTICULAR FONT, STYLE, SIZE, OR COLOR.

CLASS 22—CORDAGE AND FIBERS

FOR HANGING NET FOR STORING SPORTS BALLS MADE OF FABRIC AND ELASTIC (U.S. CLS. 1, 2, 7, 19, 22, 42 AND 50).

CLASS 25—CLOTHING

FOR CLOTHING, NAMELY, T-SHIRTS, PANTS, SHORTS, SKORTS, SKIRTS, SHIRTS, DRESSES, TANK TOPS, PULLOVERS, SWEATSHIRTS, JACKETS, TRACKSUITS, SWIMSUITS, WORKOUT BIKINIS, BOXER SHORTS, BRAS, CAMISOLES, UNDERWEAR, SHOES, SOCKS, HATS, VISORS, HEADBANDS, WRISTBANDS, GLOVES, AND TIGHTS (U.S. CLS. 22 AND 39).
TAMARA FRAZIER, EXAMINING ATTORNEY

PACEWALKING

THE MARK CONSISTS OF STANDARD CHARACTERS WITHOUT CLAIM TO ANY PARTICULAR FONT, STYLE, SIZE, OR COLOR.

OWNER OF U.S. REG. NO. 1,510,185.

CLASS 16—PAPER GOODS AND PRINTED MATTER

FOR PRINTED MATERIALS IN THE NATURE OF BOOKS, PERIODICALS, NEWSLETTERS, SYNDICATED COLUMNS, MAGAZINE AND JOURNAL ARTICLES, BROCHURES, INFORMATIONAL CARDS IN THE FIELD OF WALKING FOR EXERCISE, HEALTH, WELLNESS, FITNESS, AND HEALTHY LIFESTYLE (U.S. CLS. 2, 5, 22, 23, 29, 37, 38 AND 50).

CLASS 35—ADVERTISING AND BUSINESS

FOR PROMOTING PUBLIC AWARENESS OF WALKING FOR EXERCISE, HEALTH, WELLNESS, FITNESS, AND HEALTHY LIFESTYLE (U.S. CLS. 100, 101 AND 102).

CLASS 41—EDUCATION AND ENTERTAINMENT

FOR EDUCATIONAL SERVICES, NAMELY, CONDUCTING CLASSES, CONFERENCES, AND SEMINARS IN THE FIELD OF WALKING FOR EXERCISE, HEALTH, WELLNESS, FITNESS, AND HEALTHY LIFESTYLE, AND DISTRIBUTION OF COURSE MATERIALS IN CONNECTION THEREWITH; PROVIDING ON-LINE PUBLICATIONS IN THE NATURE OF COLUMNS AND REPORTS IN THE FIELD OF WALKING FOR EXERCISE, HEALTH, WELLNESS AND HEALTHY LIFESTYLE (U.S. CLS. 100, 101 AND 107).

EUGENIA MARTIN, EXAMINING ATTORNEY

SN 77-643,794. BROWNELLS, INC., MONTEZUMA, IA. FILED 1-6-2009.



OWNER OF U.S. REG. NOS. 1,891,867, 1,895,766 AND 2,865,231.

THE MARK CONSISTS OF THE BLOCK LETTERS "HORIZONTAL FORMAT" UNDERLINED IN THE UPPER RIGHT, THE BLOCK LETTERS "UNIQUELY" IN THE MIDDLE RIGHT, THE BLOCK LETTERS "BROWNELLS" CENTERED ALONG THE BOTTOM, A RECTANGLE IN THE UPPER LEFT CORNER ALL WITHIN A RECTANGLE BLOCK.

CLASS 16—PAPER GOODS AND PRINTED MATTER

FOR GUNSMITH PUBLICATIONS, NAMELY, CATALOGS (U.S. CLS. 2, 5, 22, 23, 29, 37, 38 AND 50).
FIRST USE 4-9-2004; IN COMMERCE 4-9-2004.

CLASS 35—ADVERTISING AND BUSINESS

FOR ON-LINE RETAIL STORE SERVICES FEATURING GUNSMITHING AND KNIFE MAKING TOOLS AND SUPPLIES IN THE NATURE OF GUNSMITHING CHEMICALS AND COMPOSITIONS, NAMELY, METAL PLATING COMPOSITIONS, SOLDERING FLUX AND FLUXING FOR BULLET CASTING, SOLDERING CHEMICALS, ENGRAVING AND ETCHING CHEMICALS, GLUE FOR USE IN THE GUNSMITHING INDUSTRY, FILLER FOR GUN REPAIR, HAND TOOLS USED IN GUNSMITHING, NAMELY, PLIERS, HAMMERS, SCREWDRIVERS, VISES AND VISE JAWS, SCRAPERS, DRILLS, TAPS, DIES, REAMERS, MANUALLY OPERATED GRINDSTONES AND GRINDING WHEELS, SHARPENING STONES, PUNCHES, WRENCHES, CHISELS, CLAMPS, AND GUNSMITH PUBLICATIONS, NAMELY, CATALOGS, NEWLETTERS, BOOKS, MANUALS AND PAMPHLETS; MAIL ORDER AND ONLINE ORDERING SERVICES FEATURING GUNSMITHING AND KNIFE MAKING TOOLS AND SUPPLIES IN THE NATURE OF GUNSMITHING CHEMICALS AND COMPOSITIONS, NAMELY, METAL PLATING COMPOSITIONS, SOLDERING FLUX AND FLUXING FOR BULLET CASTING, SOLDERING CHEMICALS, ENGRAVING AND ETCHING CHEMICALS, GLUE FOR USE IN THE GUNSMITHING INDUSTRY, FILLER FOR GUN REPAIR, HAND TOOLS USED IN GUNSMITHING, NAMELY, PLIERS, HAMMERS, SCREWDRIVERS, VISES AND VISE JAWS, SCRAPERS, DRILLS, TAPS, DIES, REAMERS, MANUALLY OPERATED GRINDSTONES AND GRINDING WHEELS, SHARPENING STONES, PUNCHES, WRENCHES, CHISELS, CLAMPS, AND GUNSMITH PUBLICATIONS, NAMELY, CATALOGS, NEWLETTERS, BOOKS, MANUALS AND PAMPHLETS (U.S. CLS. 100, 101 AND 102).
FIRST USE 4-9-2004; IN COMMERCE 4-9-2004.
RONALD DELGIZZI, EXAMINING ATTORNEY

SN 77-644,131, EXCLAIM HOLDINGS, LLC, DALLAS, TX, FILED 1-6-2009.



THE MARK CONSISTS OF A STYLIZED EXCLAMATION POINT.

CLASS 16—PAPER GOODS AND PRINTED MATTER

FOR STATIONERY, NAMELY, WRITING PADS, NOTEPADS, AND BLANK JOURNALS; PAPER LABELS; STICKERS, INCLUDING BUMPER STICKERS (U.S. CLS. 2, 5, 22, 23, 29, 37, 38 AND 50).

CLASS 18—LEATHER GOODS

FOR HANDBAGS, SHOULDER BAGS, BEACH BAGS, CLUTCH BAGS, TOTE BAGS, AND ALL PURPOSE SPORTS BAGS; PLASTIC LUGGAGE LABELS (U.S. CLS. 1, 2, 3, 22 AND 41).

CLASS 25—CLOTHING

FOR MEN'S, WOMEN'S, AND CHILDREN'S APPAREL, NAMELY, TOPS, PANTS, SHORTS, JACKETS, HEADWEAR, AND DRESSES (U.S. CLS. 22 AND 39).
DAVID TOOLEY, EXAMINING ATTORNEY

SN 77-644,546, URWIND INC., MONTREAL, CANADA, FILED 1-7-2009.

urwind

THE MARK CONSISTS OF STANDARD CHARACTERS WITHOUT CLAIM TO ANY PARTICULAR FONT, STYLE, SIZE, OR COLOR.
PRIORITY CLAIMED UNDER SEC. 44(D) ON CANADA APPLICATION NO. 1423181, FILED 12-29-2008.

CLASS 7—MACHINERY

FOR WIND TURBINES (U.S. CLS. 13, 19, 21, 23, 31, 34 AND 35).

CLASS 37—CONSTRUCTION AND REPAIR

FOR INSTALLING WIND TURBINES (U.S. CLS. 100, 103 AND 106).
TINA BROWN, EXAMINING ATTORNEY

SN 77-644,920, FORMOLIGHT TECHNOLOGIES, INC., TAIPEI COUNTY 248, TAIWAN, FILED 1-7-2009.

FormoLight

THE MARK CONSISTS OF THE WORD "FORMOLIGHT" AND AN OVAL.

CLASS 9—ELECTRICAL AND SCIENTIFIC APPARATUS

FOR ELECTRONIC ADVERTISEMENT AND MESSAGING DISPLAY UNIT WITH MULTI-NETWORKING (TCP/IP) CAPABILITIES AND REMOTE CONNECTIVITY; COMPUTER-CONTROLLED ELECTRONIC ADVERTISEMENT BOARDS FEATURING LIGHT EMITTING DIODES (LEDS); ELECTRONIC TRANSIT INFORMATION SIGNS; MONOCHROMATIC OR CHROMATIC LIGHT EMITTING DIODE (LED) DISPLAYS; LIGHT EMITTING DIODE (LED) ELECTRONIC SCOREBOARD; VARIABLE INFORMATION LIGHT EMITTING DIODE (LED) DISPLAYS USED FOR ROAD; PASSENGER LIGHT EMITTING DIODE (LED) INFORMATION DISPLAYS ONBOARD TRACK VEHICLES; STATION, AIRPORT, AND FLIGHT INFORMATION LIGHT EMITTING DIODE (LED) DISPLAYS; LIGHT EMITTING DIODE (LED) DISPLAYS; LIQUID CRYSTAL DISPLAY (LCD) PANELS; LIQUID CRYSTAL DISPLAY (LCD) SCREEN WALL PANELS (U.S. CLS. 21, 23, 26, 36 AND 38).

FIRST USE 5-12-2004; IN COMMERCE 5-12-2004.

CLASS 37—CONSTRUCTION AND REPAIR

FOR INSTALLATION, MAINTENANCE, AND REPAIR OF ELECTRONIC BILLBOARDS, LIGHT EMITTING DIODE (LED) DISPLAY DEVICES, AND COMPUTER HARDWARE (U.S. CLS. 100, 103 AND 106).

FIRST USE 5-12-2004; IN COMMERCE 5-12-2004.

CLASS 42—SCIENTIFIC AND COMPUTER SERVICES

FOR PROGRAMMING, INSTALLATION, TESTING, MAINTENANCE, AND CONSULTING OF SOFTWARE IN THE FIELD OF LIGHT EMITTING DIODE (LED) DISPLAY SYSTEMS; TESTING OF ELECTRONIC BILLBOARDS, LIGHT EMITTING DIODE (LED) DISPLAY DEVICES AND COMPUTER HARDWARE (U.S. CLS. 100 AND 101).

FIRST USE 5-12-2004; IN COMMERCE 5-12-2004.
KHANH LE, EXAMINING ATTORNEY

SN 77-646,087. BOARD CORD, LLC, BOZEMAN, MT. FILED 1-8-2009.



THE MARK CONSISTS OF THE BETTERS "B" AND "C" IN STYLIZED FORMAT INSIDE OF A CIRCLE.

CLASS 25—CLOTHING

FOR SHIRTS; T-SHIRTS; HATS (U.S. CLS. 22 AND 39).

CLASS 28—TOYS AND SPORTING GOODS

FOR SNOWBOARD TETHER DEVICE COMPRISING A BASE THAT ADHERES TO A SNOWBOARD AND A RETRACTABLE MAGNETIC DOME THAT ATTACHES TO A PIECE OF STEEL IN THE FORM OF A POCKET TOKEN, CLOTHING CLIP OR FABRIC PATCH WHEN THE TETHER IS IN USE AND THAT ATTACHES TO THE BASE WHEN THE TETHER IS NOT IN USE; PARTS FOR USE IN CONNECTION WITH A SNOWBOARD TETHER DEVICE, NAMELY, POCKET TOKEN, CLOTHING CLIP AND FABRIC PATCH (U.S. CLS. 22, 23, 38 AND 50).

MARK T. MULLEN, EXAMINING ATTORNEY

SN 77-645,474. NATURES BALANCE CARE, LLC, ESTACADA, OR. FILED 1-8-2009.

NATURE'S BALANCE CARE

THE MARK CONSISTS OF STANDARD CHARACTERS WITHOUT CLAIM TO ANY PARTICULAR FONT, STYLE, SIZE, OR COLOR.

NO CLAIM IS MADE TO THE EXCLUSIVE RIGHT TO USE "CARE", APART FROM THE MARK AS SHOWN.

CLASS 3—COSMETICS AND CLEANING PREPARATIONS

FOR NON-MEDICATED SKIN CARE PREPARATIONS FOR ANIMALS AND HUMANS (U.S. CLS. 1, 4, 6, 50, 51 AND 52).

CLASS 5—PHARMACEUTICALS

FOR HERBAL ANTI-ITCH AND SORE SKIN OINTMENT FOR ANIMALS AND HUMANS (U.S. CLS. 6, 18, 44, 46, 51 AND 52).

HOWARD SMIGA, EXAMINING ATTORNEY

SN 77-646,489. MARK ANTHONY INTERNATIONAL SRL, WEST INDIES, BARBADOS, FILED 1-9-2009.

BARTENDER SECRETS

THE MARK CONSISTS OF STANDARD CHARACTERS WITHOUT CLAIM TO ANY PARTICULAR FONT, STYLE, SIZE, OR COLOR.

CLASS 32—LIGHT BEVERAGES

FOR ALCOHOLIC MALT-BASED BEVERAGES IN THE NATURE OF A PRE-MIXED COCKTAIL (U.S. CLS. 45, 46 AND 48).

CLASS 33—WINES AND SPIRITS

FOR ALCOHOLIC SPIRIT-BASED BEVERAGE IN THE NATURE OF A PRE-MIXED COCKTAIL (U.S. CLS. 47 AND 49).

JEFFREY LOOK, EXAMINING ATTORNEY

SN 77-647,574. INTUEOR CONSULTING INC., IRVINE, CA. FILED 1-12-2009.



THE COLOR(S) BLUE AND YELLOW IS/ARE CLAIMED AS A FEATURE OF THE MARK.

THE MARK CONSISTS OF DESIGN PLUS WORDS. A SQUARE FORMED BY CIRCLES OF VARYING SHADES. THE COLORED CIRCLES ARE ARRANGED TO FORM AN ARROW. THE WORD "INTUEOR" APPEARS TO THE RIGHT OF THE DESIGN ABOVE A SOLID LINE SEPARATOR IN STYLIZED FONT. THE WORDS "MAXIMIZING VALUE" APPEAR BELOW THE SOLID LINE SEPARATOR IN STYLIZED FONT. BLUE APPEARS ON THE CIRCLES FORMING AN ARROW AND THE LETTERING OF THE WORDS. YELLOW APPEARS ON THE REMAINING CIRCLES FORMING THE SQUARE.

CLASS 35—ADVERTISING AND BUSINESS

FOR PROVIDING BUSINESS CONSULTING SERVICES AND ADVICE IN THE AREAS OF STRATEGIC PLANNING, GOVERNANCE, BUSINESS PROCESS IMPROVEMENT, TECHNOLOGY AND PROJECT MANAGEMENT (U.S. CLS. 100, 101 AND 102).

FIRST USE 6-10-2005; IN COMMERCE 6-10-2005.

CLASS 42—SCIENTIFIC AND COMPUTER SERVICES

FOR ENGINEERING SERVICES FOR HIGHWAYS RAILROADS, AIRPORTS AND SEA PORTS (U.S. CLS. 100 AND 101).

FIRST USE 6-10-2005; IN COMMERCE 6-10-2005. SEAN CROWLEY, EXAMINING ATTORNEY

SN 77-647,970. KLK ENTERTAINMENT, INC., VAN NUYS, CA. FILED 1-13-2009.

Kagney Linn Karter

THE MARK CONSISTS OF STANDARD CHARACTERS WITHOUT CLAIM TO ANY PARTICULAR FONT, STYLE, SIZE, OR COLOR.

THE NAME(S), PORTRAIT(S), AND/OR SIGNATURE(S) SHOWN IN THE MARK IDENTIFIES "KAGNEY LINN CARTER", WHOSE CONSENT(S) TO REGISTER IS MADE OF RECORD.

CLASS 9—ELECTRICAL AND SCIENTIFIC APPARATUS

FOR DIGITAL MEDIA, NAMELY, PRE-RECORDED VIDEO CASSETTES, DIGITAL VIDEO DISCS, DIGITAL VERSATILE DISCS, DOWNLOADABLE AUDIO AND VIDEO RECORDINGS, DVDS, AND HIGH DEFINITION DIGITAL DISKS FEATURING ADULT ORIENTED INSTRUCTION AND ENTERTAINMENT (U.S. CLS. 21, 23, 26, 36 AND 38).

CLASS 41—EDUCATION AND ENTERTAINMENT

FOR ENTERTAINMENT IN THE NATURE OF LIVE PERFORMANCES BY AN ACTOR, DANCING PERFORMANCES AND MODELING FOR ADULT PERFORMANCES; ENTERTAINMENT SERVICES, NAMELY, PERSONAL APPEARANCES BY A STAR OF ADULT MOVIES; ENTERTAINMENT SERVICES, NAMELY, PROVIDING A WEB SITE FEATURING ADULT-THEMED PHOTOGRAPHS AND VIDEOS (U.S. CLS. 100, 101 AND 107).

KRISTIN DAHLING, EXAMINING ATTORNEY

SN 77-648,078. OPEN INVENTION NETWORK LLC, DURHAM, NC. FILED 1-13-2009.

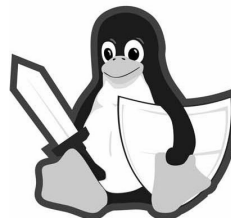

THE MARK CONSISTS OF A PENGUIN HOLDING A SWORD AND A SHIELD.

CLASS 35—ADVERTISING AND BUSINESS

FOR ADVISORY SERVICES IN THE FIELD OF MANAGING OPEN SOURCE SOFTWARE INTELLECTUAL PROPERTY; ACQUISITION OF INTELLECTUAL PROPERTY RIGHTS FOR OTHERS (U.S. CLS. 100, 101 AND 102).

CLASS 45—PERSONAL AND LEGAL SERVICES

FOR LEGAL SERVICES IN THE NATURE OF ACQUISITION AND ADVISORY OF OPEN SOURCE INTELLECTUAL PROPERTY RIGHTS; LICENSING OF OPEN SOURCE SOFTWARE INTELLECTUAL PROPERTY (U.S. CLS. 100 AND 101).

SAIMA MAKHDOOM, EXAMINING ATTORNEY

SN 77-648,222. CROCKER, HOWARD, GREENWICH, CT. FILED 1-13-2009.

POPSTATION

THE MARK CONSISTS OF STANDARD CHARACTERS WITHOUT CLAIM TO ANY PARTICULAR FONT, STYLE, SIZE, OR COLOR.

CLASS 9—ELECTRICAL AND SCIENTIFIC APPARATUS

FOR MUSICAL SOUND RECORDINGS, MUSICAL VIDEO RECORDINGS (U.S. CLS. 21, 23, 26, 36 AND 38).

CLASS 16—PAPER GOODS AND PRINTED MATTER

FOR ARTWORK, NAMELY, PHOTOGRAPHS AND POSTERS (U.S. CLS. 2, 5, 22, 23, 29, 37, 38 AND 50).

CLASS 25—CLOTHING

FOR APPAREL, NAMELY, SHIRTS, PANTS AND HATS (U.S. CLS. 22 AND 39).

CLASS 42—SCIENTIFIC AND COMPUTER SERVICES

FOR HOSTING ON-LINE WEB SITE FOR RATING A MUSICAL PERFORMANCE (U.S. CLS. 100 AND 101).
RONALD AIKENS, EXAMINING ATTORNEY

SN 77-649,349. CLARIZZA PIMENTEL, DBA COVENANT GREEN, GLENDALE, CA. FILED 1-14-2009.

SMALL CARBON FOOTPRINT

THE MARK CONSISTS OF STANDARD CHARACTERS WITHOUT CLAIM TO ANY PARTICULAR FONT, STYLE, SIZE, OR COLOR.

CLASS 18—LEATHER GOODS

FOR (BASED ON INTENT TO USE) ALL PURPOSE SPORT BAGS; ALL-PURPOSE ATHLETIC BAGS; ALL-PURPOSE CARRYING BAGS; ATHLETIC BAGS; BABY BACKPACKS; BABY CARRIERS WORN ON THE BODY; BABY CARRYING BAGS; BACK FRAMES FOR CARRYING CHILDREN; BACKPACKS, BOOK BAGS, SPORTS BAGS, BUM BAGS, WALLETS AND HANDBAGS; BAGS AND HOLDALLS FOR SPORTS CLOTHING; BAGS FOR CARRYING BABIES' ACCESSORIES; BAGS FOR SPORTS; BAGS FOR UMBRELLAS; BARREL BAGS; BEACH BAGS; BELT BAGS; BELT BAGS AND HIP BAGS; BOOK BAGS; BOSTON BAGS; BUM BAGS; CANTLE BAGS; CANVAS SHOPPING BAGS; CARRY-ALL BAGS; CARRY-ON BAGS; CHALK BAGS; CHARM BAGS (OMAMORI-IRE); CLUTCH BAGS; COSMETIC BAGS SOLD EMPTY; DIAPER BAGS; DRAWSTRING BAGS; DUFFEL BAGS; DUFFEL BAGS FOR TRAVEL; DUFFLE BAGS; FLEXIBLE BAGS FOR GARMENTS; GARMENT BAGS FOR TRAVEL; GENERAL PURPOSE BAGS FOR CARRYING YOGA EQUIPMENT; GENERAL PURPOSE BAGS FOR HOLDING DANCE EQUIPMENT; GYM BAGS; HIKING BAGS; INFANT CARRIERS WORN ON THE BODY; KEY BAGS; KIT BAGS; LEATHER AND IMITATION LEATHER BAGS; LEATHER BAGS AND WALLETS; LEATHER BAGS FOR MERCHANDISE PACKAGING; LEATHER BAGS, SUITCASES AND WALLETS; LEATHER SHOPPING BAGS; MAKE-UP BAGS SOLD EMPTY; MEN'S CLUTCH BAGS; MESH SHOPPING BAGS; MESSENGER BAGS; OVERNIGHT BAGS; POUCHES AND BAGS SOLD EMPTY FOR ATTACHMENT TO BACKPACKS; REUSABLE SHOPPING BAGS; ROLL BAGS; SADDLE BLANKETS; SCHOOL BAGS; SCHOOL BOOK BAGS; SHAVING BAGS SOLD EMPTY; SHOE BAGS FOR TRAVEL; SHOULDER BAGS; SLING BAGS; SLING BAGS FOR CARRYING INFANTS; SLINGS FOR CARRYING INFANTS; SMALL BAGS FOR MEN; SOUVENIR BAGS; SPORT BAGS; SPORTS BAGS; STRING BAGS FOR SHOPPING; SUIT BAGS; TEXTILE SHOPPING BAGS; TOILETRY BAGS SOLD

EMPTY; TOOL BAGS SOLD EMPTY; TOTE BAGS; TRAVEL BAGS; TRAVELING BAGS; TRAVELLING BAGS; UMBRELLAS FOR CHILDREN; WAIST BAGS; WASH BAGS FOR CARRYING TOILETRIES; WHEELED BAGS; WHEELED DUFFLE BAGS; WHEELED MESSENGER BAGS; WHEELED SHOPPING BAGS; WHEELED TOTE BAGS; WRIST MOUNTED CARRYALL BAGS; WRISTLET BAGS (U.S. CLS. 1, 2, 3, 22 AND 41).

CLASS 24—FABRICS

FOR (BASED ON INTENT TO USE) BATH TOWELS; BEACH TOWELS; BED BLANKETS; BLANKET THROWS; BLANKETS FOR OUTDOOR USE; CASHMERE BLANKETS; CHILDREN'S BLANKETS; CHILDREN'S TOWELS; CURTAINS AND TOWELS; FACE TOWELS; FACE TOWELS OF TEXTILES; GOLF TOWELS; HAND TOWELS; HAND TOWELS OF TEXTILE; HAND-TOWELS MADE OF TEXTILE FABRICS; HOODED TOWELS; JAPANESE COTTON TOWELS (TENUGUI); KITCHEN TOWELS; LARGE BATH TOWELS; PET BLANKETS; RECEIVING BLANKETS; SILK BED BLANKETS; SILK BLANKETS; TEA TOWELS; TERRY TOWELS; TOWEL SETS; TOWELLING COVERLETS; TOWELS; TOWELS; TOWELS THAT MAY BE WORN AS A DRESS OR SIMILAR GARMENT; WOOLLEN BLANKETS (U.S. CLS. 42 AND 50).

CLASS 25—CLOTHING

FOR (BASED ON USE IN COMMERCE) ANKLE SOCKS; ANKLETS; ATHLETIC APPAREL, NAMELY, SHIRTS, PANTS, JACKETS, FOOTWEAR, HATS AND CAPS, ATHLETIC UNIFORMS; BABY BIBS NOT OF PAPER; BABY BODYSUITS; BABY BOTTOMS; BABY BUNTING; BABY DOLL PYJAMAS; BABY TOPS; BALLOON PANTS; BASELAYER BOTTOMS; BASELAYER TOPS; BED JACKETS; BELTS; BELTS MADE OF LEATHER; BELTS OF TEXTILE; BOMBER JACKETS; BOTTOMS; CAPRI PANTS; CARGO PANTS; CHILDREN'S AND INFANTS' CLOTH BIBS; CHILDREN'S CLOTH EATING BIBS; CHILDREN'S HEADWEAR; COSTUMES FOR USE IN CHILDREN'S DRESS UP PLAY; CROP TOPS; DENIM JACKETS; DENIMS; DOWN JACKETS; DRESS SHIRTS; DRESSES; DRESSES MADE FROM SKINS; DRESSES THAT MAY ALSO BE USED AS TOWELS; DRESSING GOWNS; EVENING DRESSES; FABRIC BELTS; GOLF PANTS, SHIRTS AND SKIRTS; HALTER TOPS; HEAVY JACKETS; INFANT AND TODDLER ONE PIECE CLOTHING; INFANT CLOTH DIAPERS; INFANT DIAPER COVERS; INFANT SLEEPERS; INFANT WEAR; INFANTS' SHOES AND BOOTS; INFANTS' TROUSERS; JACKETS; JACKETS AND SOCKS; JAPANESE STYLE SOCKS (TABI COVERS); JAPANESE STYLE SOCKS (TABI); JOGGING PANTS; LEATHER BELTS; LEATHER JACKETS; LEATHER PANTS; LEOTARDS AND TIGHTS FOR WOMEN, MEN AND CHILDREN OF NYLON, COTTON OR OTHER TEXTILE FIBERS; LONG JACKETS; LOUNGE PANTS; MEN'S AND WOMEN'S JACKETS, COATS, TROUSERS, VESTS; MEN'S SOCKS; MOISTURE-WICKING SPORTS PANTS; MONEY BELTS; MUSCLE TOPS; NON-DISPOSABLE CLOTH TRAINING PANTS; ONE PIECE GARMENT FOR INFANTS AND TODDLERS; PADDED JACKETS; PADDING JACKETS; PAJAMA BOTTOMS; PANTS; PAPER SHOES USED WHEN GOING THROUGH METAL DETECTORS TO KEEP FEET AND SOCKS CLEAN; PETTI-PANTS; PLASTIC BABY BIBS; RAIN JACKETS; RAINPROOF JACKETS; REVERSIBLE JACKETS; RUGBY TOPS; SHORT-SLEEVED OR LONG-SLEEVED T-SHIRTS; SKIRTS AND DRESSES; SLEEVED OR SLEEVELESS JACKETS; SOCK SUSPENDERS; SOCKS; SOCKS AND STOCKINGS; SPORTS JACKETS; SPORTS PANTS; STRETCH PANTS; SUEDE JACKETS; SUSPENDER BELTS FOR MEN; SUSPENDER BELTS FOR WOMEN; SWEAT JACKETS; SWEAT PANTS; T-SHIRTS; TANK TOPS; TANK-TOPS; TAP PANTS; THERMAL SOCKS; TOP COATS; TOPS; TRACK JACKETS; TRACK PANTS; TRAVEL CLOTHING CONTAINED IN A PACKAGE COMPRISING REVERSIBLE JACKETS, PANTS, SKIRTS, TOPS AND A BELT OR SCARF; TUBE TOPS; WAIST BELTS; WATER SOCKS; WATERPROOF JACKETS AND PANTS; WOOLLEN SOCKS; WRAP BELTS FOR KIMONOS (DATEMAKI); YOGA PANTS (U.S. CLS. 22 AND 39).
FIRST USE 6-15-2008; IN COMMERCE 6-28-2008.
TRACY FLETCHER, EXAMINING ATTORNEY

SN 77-649,403. DESCH ANTRIEBSTECHNIK GMBH & CO. KG, ARNSBERG, FED REP GERMANY, FILED 1-14-2009.

SN 77-651,069. SPECTRUM SURGICAL INSTRUMENTS CORP., STOW, OH. FILED 1-16-2009.

Planox

THE MARK CONSISTS OF STANDARD CHARACTERS WITHOUT CLAIM TO ANY PARTICULAR FONT, STYLE, SIZE, OR COLOR.

OWNER OF FED REP GERMANY REG. NO. 777258, DATED 9-17-1963, EXPIRES 9-17-2013.

CLASS 7—MACHINERY

FOR COUPLINGS AND CLUTCHES FOR MACHINES; COUPLINGS AND CLUTCHES FOR MOTORS EXCEPT FOR LAND VEHICLES; MACHINE COUPLINGS EXCEPT FOR LAND VEHICLES; CLUTCHES FOR MACHINES; GEARS FOR MACHINES; BRAKES FOR MACHINES; AND PARTS FOR THE AFOREMENTIONED GOODS (U.S. CLS. 13, 19, 21, 23, 31, 34 AND 35).
FIRST USE 12-31-1963; IN COMMERCE 12-31-1978.

CLASS 12—VEHICLES

FOR COUPLINGS AND CLUTCHES FOR VEHICLES; CLUTCHES FOR LAND VEHICLES; GEARS FOR VEHICLES; BRAKES FOR VEHICLES; AND PARTS FOR THE AFOREMENTIONED GOODS (U.S. CLS. 19, 21, 23, 31, 35 AND 44).
FIRST USE 12-31-1963; IN COMMERCE 12-31-1978.
CURTIS FRENCH, EXAMINING ATTORNEY

SN 77-650,491. MCDANIEL, TIMOTHY, SAN JOSE, CA. FILED 1-15-2009.

Truebony Inc.

THE MARK CONSISTS OF STANDARD CHARACTERS WITHOUT CLAIM TO ANY PARTICULAR FONT, STYLE, SIZE, OR COLOR.

NO CLAIM IS MADE TO THE EXCLUSIVE RIGHT TO USE "INC.", APART FROM THE MARK AS SHOWN.

CLASS 25—CLOTHING

FOR HEADWEAR; JACKETS; SHIRTS (U.S. CLS. 22 AND 39).

CLASS 35—ADVERTISING AND BUSINESS

FOR PROMOTING THE PARTIES AND SPECIAL EVENTS OF OTHERS (U.S. CLS. 100, 101 AND 102).

CLASS 41—EDUCATION AND ENTERTAINMENT

FOR AUDIO RECORDING AND PRODUCTION; MULTIMEDIA ENTERTAINMENT SERVICES IN THE NATURE OF RECORDING, PRODUCTION AND POST-PRODUCTION SERVICES IN THE FIELDS OF MUSIC, VIDEO, AND FILMS; SPECIAL EVENT PLANNING (U.S. CLS. 100, 101 AND 107).
GRETNA YAO, EXAMINING ATTORNEY

INSTRUMENT PROCESSING ESSENTIALS

THE MARK CONSISTS OF STANDARD CHARACTERS WITHOUT CLAIM TO ANY PARTICULAR FONT, STYLE, SIZE, OR COLOR.

NO CLAIM IS MADE TO THE EXCLUSIVE RIGHT TO USE "INSTRUMENT", APART FROM THE MARK AS SHOWN.

CLASS 35—ADVERTISING AND BUSINESS

FOR MAIL ORDER CATALOG SERVICES FEATURING MEDICAL INSTRUMENTS, SURGICAL INSTRUMENTS, TOOLS FOR CLEANING MEDICAL AND SURGICAL INSTRUMENTS, SUPPLIES FOR CLEANING MEDICAL AND SURGICAL INSTRUMENTS, MEDICAL AND SURGICAL INSTRUMENT ACCESSORIES (U.S. CLS. 100, 101 AND 102).
FIRST USE 0-0-2004; IN COMMERCE 0-0-2004.

CLASS 37—CONSTRUCTION AND REPAIR

FOR REPAIR OF MEDICAL AND SURGICAL INSTRUMENTS (U.S. CLS. 100, 103 AND 106).
FIRST USE 0-0-2004; IN COMMERCE 0-0-2004.
CHRISTOPHER BUONGIORNO, EXAMINING ATTORNEY

SN 77-651,346. FLTI, DBA FAMILYLIFE, LITTLE ROCK, AR. FILED 1-16-2009.

WHAT GOD WANTS FOR CHRISTMAS

THE MARK CONSISTS OF STANDARD CHARACTERS WITHOUT CLAIM TO ANY PARTICULAR FONT, STYLE, SIZE, OR COLOR.

CLASS 9—ELECTRICAL AND SCIENTIFIC APPARATUS

FOR PRE-RECORDED AUDIO COMPACT DISCS FEATURING INFORMATION ON THE BIBLICAL ACCOUNT OF THE BIRTH OF JESUS AND INFORMATION AND RESOURCES FOR PLANNING PARTIES FEATURING THE BIBLICAL ACCOUNT OF THE BIRTH OF JESUS (U.S. CLS. 21, 23, 26, 36 AND 38).
FIRST USE 1-1-2005; IN COMMERCE 1-1-2005.

CLASS 16—PAPER GOODS AND PRINTED MATTER

FOR PARTY PLANNING KIT COMPRISING PRINTED PAPER INVITATIONS, PAPER PARTY FAVORS, COOKIE CUTTERS, AND PARTY PLANNING BOOKLET ALL IN A KEEPSAKE BOX SOLD AS A UNIT THEREWITH; PRINTED MATTER, NAMELY, BOOKS FEATURING THE BIBLICAL ACCOUNT OF THE BIRTH OF JESUS (U.S. CLS. 2, 5, 22, 23, 29, 37, 38 AND 50).
FIRST USE 1-1-2000; IN COMMERCE 1-1-2000.

CLASS 28—TOYS AND SPORTING GOODS

FOR EDUCATIONAL TOY KITS COMPRISING A RELIGIOUS MANGER SCENE, MOLDED TOY FIGURINES, GIFT BOXES, AND BOOK DESIGNED TO TEACH THE BIBLICAL ACCOUNT OF THE BIRTH OF JESUS SOLD AS A UNIT THEREWITH (U.S. CLS. 22, 23, 38 AND 50).

FIRST USE 1-1-2000; IN COMMERCE 1-1-2000.

CLASS 41—EDUCATION AND ENTERTAINMENT

FOR PROVIDING A WEBSITE FEATURING INFORMATION AND RESOURCES FOR PLANNING PARTIES FEATURING THE BIBLICAL ACCOUNT OF THE BIRTH OF JESUS (U.S. CLS. 100, 101 AND 107).

FIRST USE 4-22-2005; IN COMMERCE 4-22-2005.
HOWARD SMIGA, EXAMINING ATTORNEY

SN 77-651,928. BAYERISCHE MOTOREN WERKE AG, MUNICH, FED REP GERMANY, FILED 1-19-2009.

BMW Ultimate Service

THE MARK CONSISTS OF STANDARD CHARACTERS WITHOUT CLAIM TO ANY PARTICULAR FONT, STYLE, SIZE, OR COLOR.

OWNER OF U.S. REG. NOS. 1,240,182 AND 2,816,178.
NO CLAIM IS MADE TO THE EXCLUSIVE RIGHT TO USE "ULTIMATE SERVICE", APART FROM THE MARK AS SHOWN.

CLASS 36—INSURANCE AND FINANCIAL

FOR WARRANTY SERVICES, NAMELY, PROVIDING EXTENDED SERVICE CONTRACTS FOR MOTOR VEHICLES AND PROCESSING WARRANTY CLAIMS FOR MOTOR VEHICLES (U.S. CLS. 100, 101 AND 102).

FIRST USE 8-1-2006; IN COMMERCE 8-1-2006.

CLASS 37—CONSTRUCTION AND REPAIR

FOR REPAIR AND MAINTENANCE OF MOTOR VEHICLES; EMERGENCY ROADSIDE ASSISTANCE SERVICES, NAMELY, RESPONDING TO CALLS FOR ROADSIDE ASSISTANCE, FLAT TIRE CHANGING, EMERGENCY FUEL SUPPLYING, AND BATTERY JUMP STARTING (U.S. CLS. 100, 103 AND 106).

FIRST USE 8-1-2006; IN COMMERCE 8-1-2006.

CLASS 38—COMMUNICATION

FOR TELEMATIC SERVICES CONSISTING OF SOFTWARE, ELECTRONICS AND WIRELESS TELECOMMUNICATION SYSTEMS IN MOTOR VEHICLES, WHICH INTERACT WITH GLOBAL POSITIONING SATELLITES AND CUSTOMER SERVICE CENTERS, FOR PROVIDING THE DRIVER OF THE VEHICLE WITH SAFETY AND CONVENIENCE SERVICES, NAMELY, EMERGENCY ROADSIDE ASSISTANCE, STOLEN VEHICLE RECOVERY, REMOTE DOOR UNLOCK, AUTOMATIC COLLISION NOTIFICATION, OPERATOR-ASSISTED CALLS, CONCIERGE SERVICES, INFORMATION REGARDING DRIVING DIRECTIONS, TRAFFIC AND WEATHER CONDITIONS, AS WELL AS THE PROCESSING AND HANDLING OF VEHICLE REPAIR AND MAINTENANCE ORDERS (U.S. CLS. 100, 101 AND 104).

FIRST USE 8-1-2006; IN COMMERCE 8-1-2006.

CLASS 39—TRANSPORTATION AND STORAGE

FOR TRANSPORT OF PERSONS; EMERGENCY VEHICLE TOWING (U.S. CLS. 100 AND 105).

FIRST USE 8-1-2006; IN COMMERCE 8-1-2006.
LINDA MICKLEBURGH, EXAMINING ATTORNEY

SN 77-652,014. INTERSTATE BATTERY SYSTEM INTERNATIONAL, INC., DALLAS, TX. FILED 1-19-2009.

OUTRAGEOUSLY DEPENDABLE

THE MARK CONSISTS OF STANDARD CHARACTERS WITHOUT CLAIM TO ANY PARTICULAR FONT, STYLE, SIZE, OR COLOR.

CLASS 9—ELECTRICAL AND SCIENTIFIC APPARATUS

FOR BATTERIES (U.S. CLS. 21, 23, 26, 36 AND 38).

CLASS 35—ADVERTISING AND BUSINESS

FOR DISTRIBUTORSHIP SERVICES IN THE FIELD OF BATTERIES; RETAIL STORE SERVICES FEATURING BATTERIES (U.S. CLS. 100, 101 AND 102).

FIRST USE 12-15-2008; IN COMMERCE 12-15-2008.
DAVID ELTON, EXAMINING ATTORNEY

SN 77-652,949. 640 TENTH, LLC, DBA COWBOY STAR RESTAURANT AND BUTCHER SHOP, SAN DIEGO, CA. FILED 1-20-2009.

NO CLAIM IS MADE TO THE EXCLUSIVE RIGHT TO USE "RESTAURANT AND BUTCHER SHOP", APART FROM THE MARK AS SHOWN.

THE COLOR(S) BLUE AND LIGHT BLUE IS/ARE CLAIMED AS A FEATURE OF THE MARK.

THE MARK CONSISTS OF THE WORDING "COWBOY STAR" IN BLUE WITH LIGHT BLUE SHADOW ABOVE THE WORDING "RESTAURANT AND BUTCHER SHOP" IN BLUE.

CLASS 35—ADVERTISING AND BUSINESS

FOR BUTCHER SHOPS (U.S. CLS. 100, 101 AND 102).
FIRST USE 12-16-2006; IN COMMERCE 12-21-2006.

CLASS 43—HOTEL AND RESTAURANT SERVICES

FOR BAR AND RESTAURANT SERVICES (U.S. CLS. 100 AND 101).
FIRST USE 12-16-2006; IN COMMERCE 12-21-2006.
KIMBERLY FRYE, EXAMINING ATTORNEY

SN 77-653,886. OTHER MINDS, SAN FRANCISCO, CA. FILED 1-21-2009.

Other Minds

THE MARK CONSISTS OF STANDARD CHARACTERS WITHOUT CLAIM TO ANY PARTICULAR FONT, STYLE, SIZE, OR COLOR.

CLASS 9—ELECTRICAL AND SCIENTIFIC APPARATUS

FOR DOWNLOADABLE DIGITAL SOUND AND VIDEO RECORDINGS FEATURING MUSIC; CDS FEATURING MUSIC (U.S. CLS. 21, 23, 26, 36 AND 38). FIRST USE 1-29-1993; IN COMMERCE 1-29-1993.

CLASS 41—EDUCATION AND ENTERTAINMENT

FOR ENTERTAINMENT SERVICES, NAMELY, PROVIDING ONLINE NON-DOWNLOADABLE DIGITAL SOUND AND VIDEO RECORDINGS FEATURING MUSIC; ENTERTAINMENT SERVICES, NAMELY, PROVIDING ONLINE NON-DOWNLOADABLE DIGITAL SOUND AND VIDEO RECORDINGS FEATURING INTERVIEWS; ENTERTAINMENT IN THE NATURE OF LIVE MUSICAL CONCERTS AND PERFORMING ARTS PERFORMANCES; ARRANGING, CONDUCTING AND BOOKING MUSICAL CONCERTS AND PERFORMING ARTS PERFORMANCES; EDUCATIONAL SERVICES, NAMELY, WORKSHOPS AND CONFERENCES IN THE FIELD OF MUSICAL AND PERFORMING ARTS (U.S. CLS. 100, 101 AND 107). FIRST USE 1-29-1993; IN COMMERCE 1-29-1993. KRISTIN CARLSON, EXAMINING ATTORNEY

SN 77-654,368. HUMANA INC., LOUISVILLE, KY. FILED 1-22-2009.

WALK IT TEE TO GREEN

THE MARK CONSISTS OF STANDARD CHARACTERS WITHOUT CLAIM TO ANY PARTICULAR FONT, STYLE, SIZE, OR COLOR.

CLASS 41—EDUCATION AND ENTERTAINMENT

FOR ARRANGING AND CONDUCTING FITNESS PROGRAMS TO ENCOURAGE EXERCISE AND PHYSICAL ACTIVITY; ARRANGING AND CONDUCTING FITNESS PROGRAMS TO ENCOURAGE WALKING; ARRANGING AND CONDUCTING FITNESS PROGRAMS TO ENCOURAGE WALKING DURING GOLF OUTINGS AND GOLF TOURNAMENTS; PROVIDING GOLF FITNESS INSTRUCTION; PROVIDING INFORMATION ON EXERCISE AND WALKING (U.S. CLS. 100, 101 AND 107).

CLASS 44—MEDICAL, BEAUTY AND AGRICULTURAL SERVICES

FOR ARRANGING AND CONDUCTING HEALTH AND WELLNESS PROGRAMS TO ENCOURAGE EXERCISE AND PHYSICAL ACTIVITY; ARRANGING AND CONDUCTING HEALTH AND WELLNESS PROGRAMS TO ENCOURAGE WALKING FOR HEALTH IMPROVEMENT; ARRANGING AND CONDUCTING HEALTH AND WELLNESS PROGRAMS TO ENCOURAGE WALKING DURING GOLF OUTINGS AND GOLF TOURNAMENTS FOR HEALTH IMPROVEMENT (U.S. CLS. 100 AND 101). KIMBERLY FRYE, EXAMINING ATTORNEY

SN 77-654,427. TALENTMAVEN LLC, NEW YORK, NY. FILED 1-22-2009.

TalentMaven

THE MARK CONSISTS OF STANDARD CHARACTERS WITHOUT CLAIM TO ANY PARTICULAR FONT, STYLE, SIZE, OR COLOR.

CLASS 35—ADVERTISING AND BUSINESS

FOR OPERATION OF ON-LINE MARKETPLACES FOR SELLERS AND BUYERS OF GOODS AND/OR SERVICES (U.S. CLS. 100, 101 AND 102).

CLASS 42—SCIENTIFIC AND COMPUTER SERVICES

FOR HOSTING AN ON-LINE COMMUNITY WEB SITE WHICH ALLOWS USERS TO SHOWCASE THEIR INDIVIDUAL SKILLS AND EXPERTISE IN THE FIELDS OF MUSIC, ARTS, ATHLETICS, AND SPECIALIZED OCCUPATIONS AND INDUSTRIES AND THAT ALLOWS USERS TO DISCOVER, PROMOTE, SOLICIT AND RECRUIT PERSONS WITH SUCH SKILLS AND EXPERTISE (U.S. CLS. 100 AND 101). GRETCHEN ULRICH, EXAMINING ATTORNEY

SN 77-655,274. BLUE CANYON SOLUTIONS, LLC, LOUISVILLE, KY. FILED 1-23-2009.

BLUE CANYON

THE MARK CONSISTS OF STANDARD CHARACTERS WITHOUT CLAIM TO ANY PARTICULAR FONT, STYLE, SIZE, OR COLOR. OWNER OF U.S. REG. NOS. 3,569,828 AND 3,575,579.

CLASS 11—ENVIRONMENTAL CONTROL APPARATUS

FOR BASEMENT VENTILATION, RADON AND HARMFUL GAS MITIGATION, HUMIDITY REDUCTION, AND AIR QUALITY CONTROL SYSTEM COMPRISED OF AIR FLOW VENTILATION INFRASTRUCTURE, NAMELY, PIPING AND DAMPERS, AIR EXHAUST EQUIPMENT, ANTIMICROBIAL SPRAY TREATMENT, AND CLIMATE AND ENVIRONMENTAL MONITORING AND SUPPORT EQUIPMENT; CRAWLSPACE VENTILATION, RADON AND HARMFUL GAS MITIGATION, HUMIDITY REDUCTION, AND AIR QUALITY CONTROL SYSTEM COMPRISED OF AIR FLOW VENTILATION INFRASTRUCTURE, NAMELY, PIPING AND DAMPERS, AIR EXHAUST EQUIPMENT, ANTIMICROBIAL SPRAY TREATMENT, DEHUMIDIFIER, AND ENCAPSULATION SHEETING; CONSULTATION IN THE FIELD OF A BASEMENT VENTILATION, RADON AND HARMFUL GAS MITIGATION, HUMIDITY REDUCTION, AND AIR QUALITY CONTROL SYSTEM; CONSULTATION IN THE FIELD OF A CRAWLSPACE VENTILATION, RADON AND HARMFUL GAS MITIGATION, HUMIDITY REDUCTION, AND AIR QUALITY CONTROL SYSTEM (U.S. CLS. 13, 21, 23, 31 AND 34).

FIRST USE 2-15-2008; IN COMMERCE 2-15-2008.

CLASS 37—CONSTRUCTION AND REPAIR

FOR FOUNDATION, CHIMNEY, FOOTER, PORCH STOOP, SLAB FLOOR, AND WALL REPAIR SERVICES; CONSULTATION SERVICES IN THE FIELDS OF FOUNDATION, CHIMNEY, FOOTER, PORCH STOOP, SLAB FLOOR, AND WALL REPAIR; INSTALLATION AND MAINTENANCE IN THE FIELD OF A BASEMENT VENTILATION, RADON AND HARMFUL GAS MITIGATION, HUMIDITY REDUCTION, AND AIR QUALITY CONTROL SYSTEM; INSTALLATION AND MAINTENANCE IN THE FIELD OF A CRAWLSPACE VENTILATION, RADON AND HARMFUL GAS MITIGATION, HUMIDITY REDUCTION, AND AIR QUALITY CONTROL SYSTEM; REMODELING OF BASEMENTS; CONSULTATION IN THE FIELD OF BASEMENT REMODELING; CONSTRUCTION MANAGEMENT (U.S. CLS. 100, 103 AND 106).

FIRST USE 2-15-2008; IN COMMERCE 2-15-2008.
NAKIA HENRY, EXAMINING ATTORNEY

SN 77-655,317. BISSELL HOMECARE, INC., GRAND RAPIDS, MI. FILED 1-23-2009.

GROSS

THE MARK CONSISTS OF STANDARD CHARACTERS WITHOUT CLAIM TO ANY PARTICULAR FONT, STYLE, SIZE, OR COLOR.

CLASS 3—COSMETICS AND CLEANING PREPARATIONS

FOR HOUSEHOLD CLEANING PREPARATIONS FOR CARPETS, UPHOLSTERY, FLOORS, TEXTILES, HARD SURFACES, AUTOMOBILE INTERIORS AND PET BEDS; PET ODOR REMOVERS; STAIN REMOVERS; NON-ELECTRIC CLEANING APPLICATORS CONTAINING CLEANING PREPARATIONS (U.S. CLS. 1, 4, 6, 50, 51 AND 52).

CLASS 21—HOUSEWARES AND GLASS

FOR NON-ELECTRIC CLEANING APPLICATORS IN THE NATURE OF BRUSHES, SCRUBBERS, SPONGES, COMBS, AND COMBINATIONS THEREOF, AND A CLEANING DEVICE WITH SPRAY NOZZLES AND BRUSHES FOR APPLYING CLEANING PREPARATIONS TO CARPETS, AUTOMOBILE INTERIORS, RUGS AND/OR UPHOLSTERY (U.S. CLS. 2, 13, 23, 29, 30, 33, 40 AND 50).

SANI KHOURI, EXAMINING ATTORNEY

SN 77-655,352. BISSELL HOMECARE, INC., GRAND RAPIDS, MI. FILED 1-23-2009.

BLECH

THE MARK CONSISTS OF STANDARD CHARACTERS WITHOUT CLAIM TO ANY PARTICULAR FONT, STYLE, SIZE, OR COLOR.

CLASS 3—COSMETICS AND CLEANING PREPARATIONS

FOR HOUSEHOLD CLEANING PREPARATIONS FOR CARPETS, UPHOLSTERY, FLOORS, TEXTILES, HARD SURFACES, AUTOMOBILE INTERIORS AND PET BEDS; PET ODOR REMOVERS; STAIN REMOVERS; NON-ELECTRIC CLEANING APPLICATORS CONTAINING CLEANING PREPARATIONS (U.S. CLS. 1, 4, 6, 50, 51 AND 52).

CLASS 21—HOUSEWARES AND GLASS

FOR NON-ELECTRIC CLEANING APPLICATORS IN THE NATURE OF BRUSHES, SCRUBBERS, SPONGES, COMBS, AND COMBINATIONS THEREOF, AND A CLEANING DEVICE WITH SPRAY NOZZLES AND BRUSHES FOR APPLYING CLEANING PREPARATIONS TO CARPETS, AUTOMOBILE INTERIORS, RUGS AND/OR UPHOLSTERY (U.S. CLS. 2, 13, 23, 29, 30, 33, 40 AND 50).

SANI KHOURI, EXAMINING ATTORNEY

SN 77-655,542. BLUE CANYON SOLUTIONS, LLC, LOUISVILLE, KY. FILED 1-23-2009.

SN 77-655,579. BLUE CANYON SOLUTIONS, LLC, LOUISVILLE, KY. FILED 1-23-2009.



THE COLOR(S) BLUE AND WHITE IS/ARE CLAIMED AS A FEATURE OF THE MARK.

THE MARK CONSISTS OF A BLUE CIRCULAR DESIGN CONTAINING AN OVAL IN A LIGHTER SHADE OF BLUE AND A WHITE DESIGN ELEMENT EXTENDING FROM WITHIN THE OVAL TO THE OUTER BOUNDARY OF THE CIRCULAR DESIGN.

CLASS 11—ENVIRONMENTAL CONTROL APPARATUS

FOR BASEMENT VENTILATION, RADON AND HARMFUL GAS MITIGATION, HUMIDITY REDUCTION, AND AIR QUALITY CONTROL SYSTEM COMPRISED OF AIR FLOW VENTILATION INFRASTRUCTURE, NAMELY, PIPING AND DAMPERS, AIR EXHAUST EQUIPMENT, ANTIMICROBIAL SPRAY TREATMENT, AND CLIMATE AND ENVIRONMENTAL MONITORING AND SUPPORT EQUIPMENT; CRAWLSPACE VENTILATION, RADON AND HARMFUL GAS MITIGATION, HUMIDITY REDUCTION, AND AIR QUALITY CONTROL SYSTEM COMPRISED OF AIR FLOW VENTILATION INFRASTRUCTURE, NAMELY, PIPING AND DAMPERS, AIR EXHAUST EQUIPMENT, ANTIMICROBIAL SPRAY TREATMENT, DEHUMIDIFIER, AND ENCAPSULATION SHEETING; CONSULTATION IN THE FIELD OF A BASEMENT VENTILATION, RADON AND HARMFUL GAS MITIGATION, HUMIDITY REDUCTION, AND AIR QUALITY CONTROL SYSTEM; CONSULTATION IN THE FIELD OF A CRAWLSPACE VENTILATION, RADON AND HARMFUL GAS MITIGATION, HUMIDITY REDUCTION, AND AIR QUALITY CONTROL SYSTEM (U.S. CLS. 13, 21, 23, 31 AND 34).

FIRST USE 5-0-2008; IN COMMERCE 5-0-2008.

CLASS 37—CONSTRUCTION AND REPAIR

FOR FOUNDATION, CHIMNEY, FOOTER, PORCH STOOP, SLAB FLOOR, AND WALL REPAIR SERVICES; CONSULTATION SERVICES IN THE FIELDS OF FOUNDATION, CHIMNEY, FOOTER, PORCH STOOP, SLAB FLOOR, AND WALL REPAIR; INSTALLATION AND MAINTENANCE IN THE FIELD OF A BASEMENT VENTILATION, RADON AND HARMFUL GAS MITIGATION, HUMIDITY REDUCTION, AND AIR QUALITY CONTROL SYSTEM; INSTALLATION AND MAINTENANCE IN THE FIELD OF A CRAWLSPACE VENTILATION, RADON AND HARMFUL GAS MITIGATION, HUMIDITY REDUCTION, AND AIR QUALITY CONTROL SYSTEM; REMODELING OF BASEMENTS; CONSULTATION IN THE FIELD OF BASEMENT REMODELING; CONSTRUCTION MANAGEMENT (U.S. CLS. 100, 103 AND 106).

FIRST USE 5-0-2008; IN COMMERCE 5-0-2008.
NAKIA HENRY, EXAMINING ATTORNEY



THE MARK CONSISTS OF A CIRCULAR DESIGN CONTAINING AN OVAL AND A DESIGN ELEMENT EXTENDING FROM WITHIN THE OVAL TO THE OUTER BOUNDARY OF THE CIRCULAR DESIGN.

CLASS 11—ENVIRONMENTAL CONTROL APPARATUS

FOR BASEMENT VENTILATION, RADON AND HARMFUL GAS MITIGATION, HUMIDITY REDUCTION, AND AIR QUALITY CONTROL SYSTEM COMPRISED OF AIR FLOW VENTILATION INFRASTRUCTURE, NAMELY, PIPING AND DAMPERS, AIR EXHAUST EQUIPMENT, ANTIMICROBIAL SPRAY TREATMENT, AND CLIMATE AND ENVIRONMENTAL MONITORING AND SUPPORT EQUIPMENT; CRAWLSPACE VENTILATION, RADON AND HARMFUL GAS MITIGATION, HUMIDITY REDUCTION, AND AIR QUALITY CONTROL SYSTEM COMPRISED OF AIR FLOW VENTILATION INFRASTRUCTURE, NAMELY, PIPING AND DAMPERS, AIR EXHAUST EQUIPMENT, ANTIMICROBIAL SPRAY TREATMENT, DEHUMIDIFIER, AND ENCAPSULATION SHEETING; CONSULTATION IN THE FIELD OF A BASEMENT VENTILATION, RADON AND HARMFUL GAS MITIGATION, HUMIDITY REDUCTION, AND AIR QUALITY CONTROL SYSTEM; CONSULTATION IN THE FIELD OF A CRAWLSPACE VENTILATION, RADON AND HARMFUL GAS MITIGATION, HUMIDITY REDUCTION, AND AIR QUALITY CONTROL SYSTEM (U.S. CLS. 13, 21, 23, 31 AND 34).

FIRST USE 5-0-2008; IN COMMERCE 5-0-2008.

CLASS 37—CONSTRUCTION AND REPAIR

FOR FOUNDATION, CHIMNEY, FOOTER, PORCH STOOP, SLAB FLOOR, AND WALL REPAIR SERVICES; CONSULTATION SERVICES IN THE FIELDS OF FOUNDATION, CHIMNEY, FOOTER, PORCH STOOP, SLAB FLOOR, AND WALL REPAIR; INSTALLATION AND MAINTENANCE IN THE FIELD OF A BASEMENT VENTILATION, RADON AND HARMFUL GAS MITIGATION, HUMIDITY REDUCTION, AND AIR QUALITY CONTROL SYSTEM; INSTALLATION AND MAINTENANCE IN THE FIELD OF A CRAWLSPACE VENTILATION, RADON AND HARMFUL GAS MITIGATION, HUMIDITY REDUCTION, AND AIR QUALITY CONTROL SYSTEM; REMODELING OF BASEMENTS; CONSULTATION IN THE FIELD OF BASEMENT REMODELING; CONSTRUCTION MANAGEMENT (U.S. CLS. 100, 103 AND 106).

FIRST USE 5-0-2008; IN COMMERCE 5-0-2008.
NAKIA HENRY, EXAMINING ATTORNEY

SN 77-656,207. LAMAZE INTERNATIONAL, INC., WASHINGTON, DC. FILED 1-26-2009.

LAMAZE

THE MARK CONSISTS OF STANDARD CHARACTERS WITHOUT CLAIM TO ANY PARTICULAR FONT, STYLE, SIZE, OR COLOR.

OWNER OF U.S. REG. NOS. 1,349,474, 2,653,334 AND OTHERS.
SEC. 2(F).

CLASS 5—PHARMACEUTICALS

FOR VITAMINS, PREGNANCY TEST KITS, OVULATION TEST KITS (U.S. CLS. 6, 18, 44, 46, 51 AND 52).

CLASS 9—ELECTRICAL AND SCIENTIFIC APPARATUS

FOR CHILD SAFETY PRODUCTS, NAMELY, BABY MONITORS COMPRISED OF A TRANSMITTER AND A RECEIVER (U.S. CLS. 21, 23, 26, 36 AND 38).

CLASS 24—FABRICS

FOR BEDDING, NAMELY, SHEETS, BLANKETS, SHAMS, MATTRESS COVERS, DUST RUFFLES, AND QUILTS (U.S. CLS. 42 AND 50).

KAREN BRACEY, EXAMINING ATTORNEY

SN 77-656,281. MOON RIVER MARKETING, INC., ELKIN, NC. FILED 1-26-2009.



THE MARK CONSISTS OF A DEPICTION OF A CHILD ANGEL SITTING ON A CLOUD. THE ANGEL IS WEARING A BALL CAP AND A ROBE AND THE WORDS "LITTLE M" ARE POSITIONED BELOW THE CLOUD.

CLASS 9—ELECTRICAL AND SCIENTIFIC APPARATUS

FOR AUDIO RECORDINGS FEATURING STORIES FOCUSING ON A FICTIONAL CHARACTER AND OF A FAMILY-ORIENTED NATURE (U.S. CLS. 21, 23, 26, 36 AND 38).

CLASS 16—PAPER GOODS AND PRINTED MATTER

FOR PRINTED MATERIAL, NAMELY, CARTOON PRINTS, BUMPER STICKERS, GREETING CARDS, AND BOOKS FEATURING CARTOONS (U.S. CLS. 2, 5, 22, 23, 29, 37, 38 AND 50).

CLASS 25—CLOTHING

FOR APPAREL, NAMELY, HATS, SHIRTS, AND JACKETS (U.S. CLS. 22 AND 39).

GENE MACIOL, EXAMINING ATTORNEY

SN 77-656,282. NEMETH, ALLEN, LAKE IN THE HILLS, IL. FILED 1-26-2009.

SIZZLE STONE

THE MARK CONSISTS OF STANDARD CHARACTERS WITHOUT CLAIM TO ANY PARTICULAR FONT, STYLE, SIZE, OR COLOR.

NO CLAIM IS MADE TO THE EXCLUSIVE RIGHT TO USE "STONE", APART FROM THE MARK AS SHOWN.

CLASS 9—ELECTRICAL AND SCIENTIFIC APPARATUS

FOR PROMOTIONAL VIDEOS, NAMELY, VIDEO TAPES AND DVDS FEATURING USE OF CLAY OR CERAMIC SURFACES USED ON A BARBEQUE GRILL (U.S. CLS. 21, 23, 26, 36 AND 38).

CLASS 11—ENVIRONMENTAL CONTROL APPARATUS

FOR BARBEQUE COOKWARE, NAMELY, CLAY OR CERAMIC GRILLING SURFACES, NAMELY, CLAY OR CERAMIC SLABS TO BE USED ON BARBEQUE GRILLS (U.S. CLS. 13, 21, 23, 31 AND 34).

CLASS 16—PAPER GOODS AND PRINTED MATTER

FOR COOKBOOKS CONTAINING RECIPES; PRINTED RECIPE CARDS; PRINTED RECIPES SOLD AS A COMPONENT OF FOOD PACKAGING; RECIPE BOOKS (U.S. CLS. 2, 5, 22, 23, 29, 37, 38 AND 50).

LOURDES AYALA, EXAMINING ATTORNEY

SN 77-656,334. PARK, OTHILL, WEST WARWICK, RI. FILED 1-26-2009.

SMART GOLF SYSTEM

THE MARK CONSISTS OF STANDARD CHARACTERS WITHOUT CLAIM TO ANY PARTICULAR FONT, STYLE, SIZE, OR COLOR.

OWNER OF U.S. REG. NO. 3,564,607.

NO CLAIM IS MADE TO THE EXCLUSIVE RIGHT TO USE "GOLF SYSTEM", APART FROM THE MARK AS SHOWN.

CLASS 9—ELECTRICAL AND SCIENTIFIC APPARATUS

FOR DVDS FEATURING GOLF (U.S. CLS. 21, 23, 26, 36 AND 38).

CLASS 16—PAPER GOODS AND PRINTED MATTER

FOR BOOKS IN THE FIELD OF GOLF; CATALOGS IN THE FIELD OF GOLF; MANUALS IN THE FIELD OF GOLF CERTIFICATION; NEWSLETTERS IN THE FIELD OF GOLF (U.S. CLS. 2, 5, 22, 23, 29, 37, 38 AND 50).
DEZMONA MIZELLE, EXAMINING ATTORNEY

SN 77-656,676. GLIFFIK, LLC, HUNTINGTON BEACH, CA. FILED 1-26-2009.

GLIFFIK

THE MARK CONSISTS OF STANDARD CHARACTERS WITHOUT CLAIM TO ANY PARTICULAR FONT, STYLE, SIZE, OR COLOR.

CLASS 14—JEWELRY

FOR JEWELRY (U.S. CLS. 2, 27, 28 AND 50).

CLASS 25—CLOTHING

FOR WEARING APPAREL FOR MEN, WOMEN, YOUTH, CHILDREN, AND INFANTS, NAMELY, SHIRTS, SWEATSHIRTS, HATS, FOOTWEAR, PANTS, JACKETS, ATHLETIC UNIFORMS, UNDERWEAR, AND BABY SUITS (U.S. CLS. 22 AND 39).
NICHOLAS COLEMAN, EXAMINING ATTORNEY

SN 77-657,349. MARK PARISI, MELROSE, MA. FILED 1-27-2009.

off the mark

THE MARK CONSISTS OF STANDARD CHARACTERS WITHOUT CLAIM TO ANY PARTICULAR FONT, STYLE, SIZE, OR COLOR.

OWNER OF U.S. REG. NO. 2,280,770.

CLASS 16—PAPER GOODS AND PRINTED MATTER

FOR CALENDARS; COMIC BOOKS; COMIC STRIPS APPEARING IN NEWSPAPERS, MAGAZINES, BOOKS, AND OTHER PRINTED MATERIALS; COMIC STRIPS' COMIC FEATURES; GREETINGS CARDS AND POSTCARDS; NEWSPAPER COMIC STRIPS (U.S. CLS. 2, 5, 22, 23, 29, 37, 38 AND 50).

FIRST USE 9-1-1987; IN COMMERCE 9-1-1987.

CLASS 45—PERSONAL AND LEGAL SERVICES

FOR LICENSING COMIC STRIPS VIA THE INTERNET (U.S. CLS. 100 AND 101).

FIRST USE 9-1-1987; IN COMMERCE 9-1-1987.
STEPHEN AQUILA, EXAMINING ATTORNEY

SN 77-658,179. INNOVATION DIRECT LLC, CLEVELAND, OH. FILED 1-28-2009.

MICRO CAFE

THE MARK CONSISTS OF STANDARD CHARACTERS WITHOUT CLAIM TO ANY PARTICULAR FONT, STYLE, SIZE, OR COLOR.

CLASS 11—ENVIRONMENTAL CONTROL APPARATUS

FOR MICROWAVE COFFEE MAKER, MICROWAVE BEVERAGE MAKER (U.S. CLS. 13, 21, 23, 31 AND 34).

CLASS 21—HOUSEWARES AND GLASS

FOR NON-ELECTRIC COFFEE MAKER, NON-ELECTRIC BEVERAGE MAKER (U.S. CLS. 2, 13, 23, 29, 30, 33, 40 AND 50).

ZACHARY BELLO, EXAMINING ATTORNEY

SN 77-658,727. ANGLES BEAUTY CARE GROUP, DBA HAI ELITE, POWAY, CA. FILED 1-28-2009.

PureHeat

OWNER OF U.S. REG. NO. 3,592,794.
NO CLAIM IS MADE TO THE EXCLUSIVE RIGHT TO USE "HEAT", APART FROM THE MARK AS SHOWN.

THE COLOR(S) GREEN AND BLUE IS/ARE CLAIMED AS A FEATURE OF THE MARK.

THE MARK CONSISTS OF THE WORDS "PURE" AND "HEAT" SEPARATED BY A CIRCULAR DESIGN COMPOSED OF TWO LEAVES RESEMBLING A YIN YANG SYMBOL. THE BOTTOM LEAF IS SHADED SOLID AND IN AN UPWARD POSITION. THE TOP LEAF IS SHADED FEATURING A LEAF PATTERN AND IN A DOWNWARD POSITION. THE WORDS "PURE" AND "HEAT" AND THE BOTTOM LEAF ALL APPEAR IN THE COLOR BLUE. THE TOP LEAF APPEARS IN THE COLOR GREEN.

CLASS 9—ELECTRICAL AND SCIENTIFIC APPARATUS

FOR ELECTRIC AND BATTERY OPERATED HAIR CURLING IRONS; ELECTRIC AND BATTERY OPERATED HAIR STRAIGHTENING IRONS; ELECTRIC AND BATTERY OPERATED HAND-HELD HAIR STYLING IRONS; ELECTRIC AND BATTERY OPERATED FLAT IRONS; ELECTRIC AND BATTERY OPERATED HAND-HELD HOT AIR HAIR BRUSHES; AND ELECTRIC AND BATTERY OPERATED HAIR BRUSHES (U.S. CLS. 21, 23, 26, 36 AND 38).

FIRST USE 12-1-2008; IN COMMERCE 12-1-2008.

CLASS 11—ENVIRONMENTAL CONTROL APPARATUS

FOR HAND-HELD ELECTRIC AND BATTERY OPERATED HAIR DRYERS; DIFFUSERS FOR HAIR DRYERS; ELECTRIC AND BATTERY OPERATED PORTABLE STANDING HARD-HAT HAIR DRYERS (U.S. CLS. 13, 21, 23, 31 AND 34).

FIRST USE 12-1-2008; IN COMMERCE 12-1-2008.
ZHALEH DELANEY, EXAMINING ATTORNEY

SN 77-658,944. NATIONAL BOARD FOR CERTIFIED COUNSELORS, INC. (NBCC), GREENSBORO, NC. FILED 1-29-2009.



NO CLAIM IS MADE TO THE EXCLUSIVE RIGHT TO USE "MHF" AND "MENTAL HEALTH FACILITATOR", APART FROM THE MARK AS SHOWN.

THE COLOR(S) BLUE IS/ARE CLAIMED AS A FEATURE OF THE MARK.

THE MARK CONSISTS OF THE WORDS "MHF MENTAL HEALTH FACILITATOR," INCLUDING A DESIGN CONSISTING OF A WORLD GLOBE. THE LETTERS "MHF" AND THE WORD "FACILITATOR" ARE IN CAPITAL LETTERS. THE WORDS "MENTAL HEALTH" ARE LOWER CASE. THE LETTERS AND WORDS "MHF MENTAL HEALTH FACILITATOR," AND THE WORLD GLOBE DESIGN ARE BLUE.

CLASS 16—PAPER GOODS AND PRINTED MATTER

FOR PRINTED INSTRUCTIONAL, EDUCATIONAL, AND TEACHING MATERIALS IN THE FIELD OF MENTAL HEALTH FACILITATION AND INTERVENTION (U.S. CLS. 2, 5, 22, 23, 29, 37, 38 AND 50).

FIRST USE 9-28-2007; IN COMMERCE 3-14-2008.

CLASS 35—ADVERTISING AND BUSINESS

FOR MAINTAINING A REGISTRY OF INDIVIDUALS WHO HAVE COMPLETED THE MHF TRAINING PROGRAM, MHF TRAINERS, AND MHF MASTER TRAINERS (U.S. CLS. 100, 101 AND 102).

FIRST USE 9-28-2007; IN COMMERCE 3-14-2008.

CLASS 41—EDUCATION AND ENTERTAINMENT

FOR EDUCATIONAL SERVICES IN THE FIELD OF MENTAL HEALTH FACILITATION AND INTERVENTION, NAMELY, PROVIDING CLASSES, SEMINARS, AND WORKSHOPS; DEVELOPING CURRICULUM FOR OTHERS; AND, PROVIDING PROFESSIONAL EDUCATION, NAMELY, PROVIDING CLASSES, SEMINARS, AND WORKSHOPS IN THE FIELD OF MENTAL HEALTH FACILITATION AND INTERVENTION (U.S. CLS. 100, 101 AND 107).

FIRST USE 9-28-2007; IN COMMERCE 3-14-2008.
PAUL F. GAST, EXAMINING ATTORNEY

SN 77-659,060. HUMANA INC., LOUISVILLE, KY. FILED 1-29-2009.

WALK IT. WHO'S YOUR CADDY?

THE MARK CONSISTS OF STANDARD CHARACTERS WITHOUT CLAIM TO ANY PARTICULAR FONT, STYLE, SIZE, OR COLOR.

CLASS 41—EDUCATION AND ENTERTAINMENT

FOR ARRANGING AND CONDUCTING FITNESS PROGRAMS TO ENCOURAGE EXERCISE AND PHYSICAL ACTIVITY; ARRANGING AND CONDUCTING FITNESS PROGRAMS TO ENCOURAGE WALKING; ARRANGING AND CONDUCTING FITNESS PROGRAMS TO ENCOURAGE WALKING DURING GOLF OUTINGS AND GOLF TOURNAMENTS; PROVIDING GOLF FITNESS INSTRUCTION; PROVIDING INFORMATION ON EXERCISE AND WALKING (U.S. CLS. 100, 101 AND 107).

CLASS 44—MEDICAL, BEAUTY AND AGRICULTURAL SERVICES

FOR ARRANGING AND CONDUCTING HEALTH AND WELLNESS PROGRAMS TO ENCOURAGE EXERCISE AND PHYSICAL ACTIVITY; ARRANGING AND CONDUCTING HEALTH AND WELLNESS PROGRAMS TO ENCOURAGE WALKING FOR HEALTH IMPROVEMENT; ARRANGING AND CONDUCTING HEALTH AND WELLNESS PROGRAMS TO ENCOURAGE WALKING DURING GOLF OUTINGS AND GOLF TOURNAMENTS FOR HEALTH IMPROVEMENT (U.S. CLS. 100 AND 101).

KIMBERLY FRYE, EXAMINING ATTORNEY

SN 77-659,245. SOUTH FLORIDA WATER AND MOLD RESTORATION, INC., COOPER CITY, FL. FILED 1-29-2009.



NO CLAIM IS MADE TO THE EXCLUSIVE RIGHT TO USE "SOUTH FLORIDA WATER AND MOLD RESTORATION INC", APART FROM THE MARK AS SHOWN.

THE COLOR(S) ORANGE, PURPLE, GREEN, YELLOW, BLACK AND WHITE IS/ARE CLAIMED AS A FEATURE OF THE MARK.

THE MARK CONSISTS OF THE WORDING "SOUTH FLORIDA WATER AND MOLD RESTORATION, INC ONE CALL DOES IT ALL!". THE WORDING "SOUTH FLORIDA" APPEARS IN THE COLOR ORANGE, "WATER AND MOLD RESTORATION, INC" APPEARS IN THE COLOR PURPLE, "ONE CALL DOES IT ALL!" APPEARS IN THE COLOR GREEN. A TEETHY GREEN CHARACTER WITH BLACK AND WHITE EYES AND YELLOW TEETH APPEARS BENEATH THE WORDING "MOLD". AN ORANGE SWOOSH APPEARS TO THE LEFT OF ALL THE WORDING.

CLASS 37—CONSTRUCTION AND REPAIR

FOR WATER DAMAGE RESTORATION, GENERAL CONSTRUCTION (U.S. CLS. 100, 103 AND 106).

FIRST USE 12-1-2008; IN COMMERCE 12-1-2008.

CLASS 40—MATERIAL TREATMENT

SN 77-661,489. HUMANA INC., LOUISVILLE, KY. FILED 2-2-2009.

FOR MOLD REMEDIATION (U.S. CLS. 100, 103 AND 106).

FIRST USE 12-1-2008; IN COMMERCE 12-1-2008.
EMILY CHUO, EXAMINING ATTORNEY

KIMOBII INC.

THE MARK CONSISTS OF STANDARD CHARACTERS WITHOUT CLAIM TO ANY PARTICULAR FONT, STYLE, SIZE, OR COLOR.

NO CLAIM IS MADE TO THE EXCLUSIVE RIGHT TO USE "INC.", APART FROM THE MARK AS SHOWN.

CLASS 25—CLOTHING

FOR CAP VISORS; HATS; PANTS; SHORTS; SKIRTS; SOCKS; T-SHIRTS (U.S. CLS. 22 AND 39).

FIRST USE 8-21-2008; IN COMMERCE 8-21-2008.

CLASS 35—ADVERTISING AND BUSINESS

FOR ARRANGING AND CONDUCTING MARKETING PROMOTIONAL EVENTS FOR OTHERS (U.S. CLS. 100, 101 AND 102).

FIRST USE 8-21-2008; IN COMMERCE 8-21-2008.
WON TEAK OH, EXAMINING ATTORNEY

SN 77-661,417. MOLON LAVE, LLC, CHICAGO, IL. FILED 2-2-2009.

JAVA BREEZE

THE MARK CONSISTS OF STANDARD CHARACTERS WITHOUT CLAIM TO ANY PARTICULAR FONT, STYLE, SIZE, OR COLOR.

NO CLAIM IS MADE TO THE EXCLUSIVE RIGHT TO USE "JAVA" FOR INTERNATIONAL CLASS 030, APART FROM THE MARK AS SHOWN.

CLASS 30—STAPLE FOODS

FOR COFFEE; TEA (U.S. CL. 46).

CLASS 39—TRANSPORTATION AND STORAGEFOR DISTRIBUTION SERVICES, NAMELY, DELIVERY OF COFFEE AND TEA (U.S. CLS. 100 AND 105).
LAKEISHA LEWIS, EXAMINING ATTORNEY**PERFECT SERVICE**

THE MARK CONSISTS OF STANDARD CHARACTERS WITHOUT CLAIM TO ANY PARTICULAR FONT, STYLE, SIZE, OR COLOR.

NO CLAIM IS MADE TO THE EXCLUSIVE RIGHT TO USE "SERVICE", APART FROM THE MARK AS SHOWN.

CLASS 36—INSURANCE AND FINANCIAL

FOR PROVIDING INSURANCE SERVICES, NAMELY, INSURANCE ADMINISTRATION; PROVIDING HEALTHCARE AND LIFE INSURANCE SERVICES, NAMELY, UNDERWRITING OF HEALTHCARE AND LIFE INSURANCE; PROVIDING HEALTH INSURANCE ADMINISTRATION SERVICES; PROVIDING HEALTH INSURANCE BROKERAGE SERVICES; PROVIDING HEALTH INSURANCE UNDERWRITING SERVICES; PROVIDING TELEPHONE AND WRITTEN INFORMATION ABOUT HEALTH INSURANCE CLAIMS AND MEMBERS' HEALTH INSURANCE USE (U.S. CLS. 100, 101 AND 102).

CLASS 44—MEDICAL, BEAUTY AND AGRICULTURAL SERVICES

FOR HEALTHCARE SERVICES (U.S. CLS. 100 AND 101).

KIMBERLY FRYE, EXAMINING ATTORNEY

SN 77-661,549. BRIDGE, BRIANNE RENEE, DBA BRI BRIDGE, GLENDALE, AZ. FILED 2-2-2009.

BRI BRIDGE

THE MARK CONSISTS OF STANDARD CHARACTERS WITHOUT CLAIM TO ANY PARTICULAR FONT, STYLE, SIZE, OR COLOR.

THE NAME "BRI BRIDGE" IDENTIFIES A LIVING INDIVIDUAL WHOSE CONSENT IS OF RECORD.

CLASS 18—LEATHER GOODS

FOR FASHION HANDBAGS (U.S. CLS. 1, 2, 3, 22 AND 41).

FIRST USE 12-1-2007; IN COMMERCE 12-6-2007.

CLASS 25—CLOTHING

FOR DRESSES; HATS; JACKETS; PANTS; SCARVES; SHIRTS; SWIM WEAR (U.S. CLS. 22 AND 39).

FIRST USE 12-1-2007; IN COMMERCE 12-6-2007.

MARGERY A. TIERNEY, EXAMINING ATTORNEY

SN 77-661,793. BLUE DOG RV, INC., POST FALLS, ID. FILED 2-2-2009.

SN 77-661,898. MCDEVITT, DAVID P., IRVING, TX. FILED 2-3-2009.



NO CLAIM IS MADE TO THE EXCLUSIVE RIGHT TO USE "RV", APART FROM THE MARK AS SHOWN.

THE MARK CONSISTS OF WORDING AND DESIGNS. AT THE TOP OF THE MARK, THERE IS A STYLIZED SILHOUETTE OF A DOG RUNNING OR JUMPING. BELOW THAT, THE WORDS "BLUE DOG RV" APPEAR. BELOW THAT WORDING APPEARS THE WORDING "A CAMPER'S BEST FRIEND" IN SLIGHTLY SMALLER FONT.

CLASS 35—ADVERTISING AND BUSINESS

FOR DEALERSHIPS IN THE FIELD OF MOTOR VEHICLES, RECREATIONAL VEHICLES, CAMPERS, TRAILERS, MOTOR HOMES, AND PARTS AND ACCESSORIES THEREFOR (U.S. CLS. 100, 101 AND 102).

CLASS 37—CONSTRUCTION AND REPAIR

FOR VEHICLE REPAIR AND MAINTENANCE (U.S. CLS. 100, 103 AND 106).
CORY BOONE, EXAMINING ATTORNEY

SN 77-661,819. NOVICA UNITED, INC., LOS ANGELES, CA. FILED 2-2-2009.

NOVICA

THE MARK CONSISTS OF STANDARD CHARACTERS WITHOUT CLAIM TO ANY PARTICULAR FONT, STYLE, SIZE, OR COLOR.

CLASS 35—ADVERTISING AND BUSINESS

FOR DISSEMINATION OF ADVERTISING FOR OTHERS VIA AN ON-LINE COMMUNICATIONS NETWORK ON THE INTERNET; DISTRIBUTORSHIPS IN THE FIELD OF CRAFTS, ARTWORK AND PRODUCTS FROM COUNTRIES AROUND THE WORLD; ON-LINE RETAIL STORE SERVICES FEATURING CRAFTS, ARTWORK AND OTHER PRODUCTS FROM COUNTRIES AROUND THE WORLD (U.S. CLS. 100, 101 AND 102).
FIRST USE 4-17-1999; IN COMMERCE 4-17-1999.

CLASS 41—EDUCATION AND ENTERTAINMENT

FOR EDUCATIONAL SERVICES, NAMELY, PROVIDING ON-LINE EDUCATIONAL, ENTERTAINMENT AND CULTURAL INFORMATION RELATING TO CULTURES AND TRADITIONS OF PEOPLE IN COUNTRIES AROUND THE WORLD IN THE FIELDS OF DANCE, DRESS CRAFTS, ARTWORK AND ARTISAN PRODUCTS.; ENTERTAINMENT SERVICES, NAMELY, PROVIDING ON-LINE REVIEWS OF CRAFTS, ARTWORK AND PRODUCTS FROM COUNTRIES AROUND THE WORLD (U.S. CLS. 100, 101 AND 107).
FIRST USE 4-17-1999; IN COMMERCE 4-17-1999.
IRA J. GOODSID, EXAMINING ATTORNEY

Club Armour

THE MARK CONSISTS OF STANDARD CHARACTERS WITHOUT CLAIM TO ANY PARTICULAR FONT, STYLE, SIZE, OR COLOR.

NO CLAIM IS MADE TO THE EXCLUSIVE RIGHT TO USE "CLUB", APART FROM THE MARK AS SHOWN.

CLASS 24—FABRICS

FOR GOLF TOWELS (U.S. CLS. 42 AND 50).

CLASS 28—TOYS AND SPORTING GOODS

FOR COVERS FOR GOLF CLUBS; GOLF CLUB BAGS; GOLF CLUB COVERS; GOLF GLOVES; GOLF PUTTER COVERS; HEAD COVERS FOR GOLF CLUBS (U.S. CLS. 22, 23, 38 AND 50).

B. PARADEWELAI, EXAMINING ATTORNEY

SN 77-662,050. CLARK & FREEMAN CORP., NASHVILLE, TN. FILED 2-3-2009.

GRAN VIA

THE MARK CONSISTS OF STANDARD CHARACTERS WITHOUT CLAIM TO ANY PARTICULAR FONT, STYLE, SIZE, OR COLOR.

THE ENGLISH TRANSLATION OF "GRAN VIA" IN THE MARK IS GREAT WAY.

CLASS 18—LEATHER GOODS

FOR LEATHER GOODS, NAMELY, PURSES, PORTFOLIOS, BELTS AND WALLETS (U.S. CLS. 1, 2, 3, 22 AND 41).

CLASS 25—CLOTHING

FOR FOOTWEAR, NAMELY, SHOES, ATHLETIC SHOES AND BOOTS FOR MEN, WOMEN AND CHILDREN; CLOTHING, NAMELY, ATHLETIC UNIFORMS, BERMUDA SHORTS, BLOUSES, BODY SUITS, BOXER BRIEFS AND BOXER SHORTS; CAMP SHIRTS, CAPRI PANTS, GYM SHORTS, GYM SUITS, INFANT WEAR, JACKETS, JEANS, JOGGING SUITS, JUMP SUITS, PANTALOONS, PANTS, PANTSUITS, POLO SHIRTS, SHIRTS, SHORTS, SPORT SHIRTS, TENNIS WEAR, T-SHIRTS, AND WALKING SHORTS (U.S. CLS. 22 AND 39).
LEIGH CAROLINE CASE, EXAMINING ATTORNEY

SN 77-662,063. FOOD FOR THOUGHT L.L.C., FAIRAX, VA. FILED 2-3-2009.

SN 77-662,677. MARIA'S IDEAS, CHATHAM, NJ. FILED 2-3-2009.

udothedishes

THE MARK CONSISTS OF STANDARD CHARACTERS WITHOUT CLAIM TO ANY PARTICULAR FONT, STYLE, SIZE, OR COLOR.

CLASS 25—CLOTHING

FOR T-SHIRTS (U.S. CLS. 22 AND 39).

CLASS 45—PERSONAL AND LEGAL SERVICES

FOR ON-LINE SOCIAL NETWORKING SERVICES (U.S. CLS. 100 AND 101).
KAREN K. BUSH, EXAMINING ATTORNEY

SN 77-662,512. PIPELING, MELISSA, VENICE, CA. AND DR. DIDOMINICANTONIO, KIMBERLY, TORRANCE, CA. FILED 2-3-2009.

Guru Girls

THE MARK CONSISTS OF STANDARD CHARACTERS WITHOUT CLAIM TO ANY PARTICULAR FONT, STYLE, SIZE, OR COLOR.

CLASS 41—EDUCATION AND ENTERTAINMENT

FOR ON-LINE JOURNALS, NAMELY, BLOGS FEATURING HOLISTIC HEALTH (U.S. CLS. 100, 101 AND 107).

FIRST USE 11-25-2008; IN COMMERCE 11-25-2008.

CLASS 44—MEDICAL, BEAUTY AND AGRICULTURAL SERVICES

FOR PROVIDING A INTERACTIVE HOLISTIC WEB SITE FEATURING HEALTH INFORMATION AND PATIENT INITIATED, PATIENT AUTHORIZED, FEE-FOR-SERVICE, HOLISTIC APPROACH DISTANCE HEALING SESSIONS BASED ON THE PATIENT'S SPECIFIC SET OF SYMPTOMS, MEDICAL PROFILE AND MEDICAL RECORD ANALYSIS; AND PATIENT BENEFIT INFORMATION CONCERNING ORGANIC AND HOLISTIC PRODUCTS AND SERVICES; PROVIDING A WEB SITE FEATURING INFORMATION IN THE FIELD OF MENTAL HEALTH AND WELLNESS; PROVIDING A WEB SITE FEATURING INFORMATION ON HEALTH AND NUTRITION; PROVIDING A WEBSITE FEATURING INFORMATION CONCERNING ALTERNATIVE HEALTH AND HEALING; PROVIDING HEALTH INFORMATION (U.S. CLS. 100 AND 101).

FIRST USE 11-25-2008; IN COMMERCE 11-25-2008.
KATHLEEN LORENZO, EXAMINING ATTORNEY

Dorinha M.

THE MARK CONSISTS OF STANDARD CHARACTERS WITHOUT CLAIM TO ANY PARTICULAR FONT, STYLE, SIZE, OR COLOR.

THE NAME "DORINHA M." IDENTIFIES A LIVING INDIVIDUAL WHOSE CONSENT IS OF RECORD.

CLASS 16—PAPER GOODS AND PRINTED MATTER

FOR COOK BOOKS (U.S. CLS. 2, 5, 22, 23, 29, 37, 38 AND 50).

CLASS 35—ADVERTISING AND BUSINESS

FOR ON-LINE RETAIL STORE SERVICES FEATURING INTERIOR DESIGN ACCESSORIES, DECORATIVE PILLOWS, BLANKETS, DECORATIVE ACCESSORIES HAND MADE WITH FABRIC (U.S. CLS. 100, 101 AND 102).

BARBARA BROWN, EXAMINING ATTORNEY

SN 77-662,706. ONEOLA, INC., TORRANCE, CA. FILED 2-3-2009.

GLOBAL SHARING

THE MARK CONSISTS OF STANDARD CHARACTERS WITHOUT CLAIM TO ANY PARTICULAR FONT, STYLE, SIZE, OR COLOR.

NO CLAIM IS MADE TO THE EXCLUSIVE RIGHT TO USE "GLOBAL", APART FROM THE MARK AS SHOWN.

CLASS 38—COMMUNICATION

FOR PROVIDING MULTIPLE-USER ACCESS TO A GLOBAL COMPUTER INFORMATION NETWORK, NAMELY, PROVIDING AN OPEN LINKING NETWORK SYSTEM THAT LINKS HEALTHCARE SPECIALISTS TO HEALTHCARE SPECIALISTS, HEALTHCARE SPECIALISTS TO PATIENTS, AND PATIENTS TO PATIENTS (U.S. CLS. 100, 101 AND 104).

CLASS 44—MEDICAL, BEAUTY AND AGRICULTURAL SERVICES

FOR PROVIDING AN ON-LINE SEARCHABLE DATABASE FEATURING HEALTH-RELATED DATA (U.S. CLS. 100 AND 101).

G. MAYERSCHOFF, EXAMINING ATTORNEY

SN 77-662,857. V&V SUPREMO FOODS, INC., CHICAGO, IL.
FILED 2-4-2009.

SN 77-663,031. MOUNTAIN GOAT SOFTWARE, LLC, LA-
FAYETTE, CO. FILED 2-4-2009.

CON ZAMORA SE ENAMORA

THE MARK CONSISTS OF STANDARD CHARACTERS WITHOUT CLAIM TO ANY PARTICULAR FONT, STYLE, SIZE, OR COLOR.

OWNER OF U.S. REG. NO. 2,520,381.

THE ENGLISH TRANSLATION OF "CON ZAMORA SE ENAMORA" IN THE MARK IS WITH ZAMORA YOU'LL FALL IN LOVE.

CLASS 29—MEATS AND PROCESSED FOODS

FOR MEATS; DAIRY PRODUCTS, NAMELY, CHEESE, YOGURTS, BUTTERMILK AND SOUR CREAM; UN-FLAVORED AND UNSWEETENED GELATIN (U.S. CL. 46).

CLASS 30—STAPLE FOODS

FOR SOPES; FALVORED AND SWEETENED GELATIN (U.S. CL. 46).

KAREN BRACEY, EXAMINING ATTORNEY

SN 77-662,904. HYSTER SISTERS, INC., DENTON, TX.
FILED 2-4-2009.

HYSTERSISTERS

THE MARK CONSISTS OF STANDARD CHARACTERS WITHOUT CLAIM TO ANY PARTICULAR FONT, STYLE, SIZE, OR COLOR.

CLASS 16—PAPER GOODS AND PRINTED MATTER

FOR NON-FICTION BOOKS AND BOOKLETS IN THE FIELD OF HYSTERECTOMY SUPPORT AND RECOVERY (U.S. CLS. 2, 5, 22, 23, 29, 37, 38 AND 50).

FIRST USE 10-1-1998; IN COMMERCE 7-7-1999.

CLASS 35—ADVERTISING AND BUSINESS

FOR ON-LINE RETAIL STORE SERVICES FEATURING PRODUCTS FOR WOMEN'S HEALTH AND HYSTERECTOMY SUPPORT AND RECOVERY (U.S. CLS. 100, 101 AND 102).

FIRST USE 6-0-1999; IN COMMERCE 6-0-1999.

CLASS 44—MEDICAL, BEAUTY AND AGRICULTURAL SERVICES

FOR PROVIDING AN INTERNET-BASED DATABASE OF PATIENT MEDICAL INFORMATION WHERE PATIENTS CAN INQUIRE ABOUT MEDICAL ISSUES AND PROCEDURES FROM OTHER PATIENTS AND CAN RELAY INFORMATION ABOUT THEIR MEDICAL EXPERIENCES FOR HYSTERECTOMY SUPPORT, RECOVERY AND COMMUNITY (U.S. CLS. 100 AND 101).

FIRST USE 8-0-1998; IN COMMERCE 8-0-1998.

ZHALEH DELANEY, EXAMINING ATTORNEY

SUCCEEDING WITH SCRUM

THE MARK CONSISTS OF STANDARD CHARACTERS WITHOUT CLAIM TO ANY PARTICULAR FONT, STYLE, SIZE, OR COLOR.

OWNER OF U.S. REG. NO. 3,436,959.

CLASS 41—EDUCATION AND ENTERTAINMENT

FOR TRAINING, MENTORING, AND TUTORING SERVICES IN THE FIELDS OF PRODUCT DEVELOPMENT, PRODUCT DESIGN, PROJECT MANAGEMENT, PRODUCT DEVELOPMENT CONSULTATION, COMPUTER SOFTWARE DEVELOPMENT AND COMPUTER SOFTWARE DEVELOPMENT MANAGEMENT; EDUCATIONAL SERVICES, NAMELY, CONDUCTING CLASSES, PRESENTATIONS, SEMINARS, AND WORKSHOPS IN THE FIELDS OF PRODUCT DEVELOPMENT, PRODUCT DESIGN, PROJECT MANAGEMENT, PRODUCT DEVELOPMENT CONSULTATION, COMPUTER SOFTWARE DEVELOPMENT AND COMPUTER SOFTWARE DEVELOPMENT MANAGEMENT, AND DISTRIBUTION OF COURSE MATERIALS IN CONNECTION THEREWITH; PROVIDING ON-LINE PUBLICATIONS IN THE NATURE OF A SERIES OF ARTICLES IN THE FIELDS OF PRODUCT DEVELOPMENT, PRODUCT DESIGN, SOFTWARE PROJECT MANAGEMENT, PRODUCT DEVELOPMENT CONSULTATION, COMPUTER SOFTWARE DEVELOPMENT AND COMPUTER SOFTWARE DEVELOPMENT MANAGEMENT; PROVIDING ON-LINE BOOK PROFILES, REVIEWS AND A RESEARCH RESOURCE LIBRARY IN THE FIELDS OF PRODUCT DEVELOPMENT, PRODUCT DESIGN, SOFTWARE PROJECT MANAGEMENT, PRODUCT DEVELOPMENT CONSULTATION, COMPUTER SOFTWARE DEVELOPMENT AND COMPUTER SOFTWARE DEVELOPMENT MANAGEMENT (U.S. CLS. 100, 101 AND 107).

CLASS 42—SCIENTIFIC AND COMPUTER SERVICES

FOR PROVIDING INFORMATION IN THE FIELDS OF PRODUCT DEVELOPMENT, PRODUCT DESIGN, SOFTWARE PROJECT MANAGEMENT, PRODUCT DEVELOPMENT CONSULTATION, COMPUTER SOFTWARE DEVELOPMENT AND COMPUTER SOFTWARE DEVELOPMENT MANAGEMENT; ANALYSIS AND EVALUATION OF PROJECT AND PRODUCT DEVELOPMENT, DESIGN, AND MANAGEMENT PROCESSES UNDERTAKEN BY OTHERS, FOR PURPOSES OF CERTIFICATION; PROVIDING A WEB SITE FEATURING INFORMATION AND RESEARCH RESOURCE INFORMATION IN THE FIELDS OF PRODUCT DEVELOPMENT, PRODUCT DESIGN, SOFTWARE PROJECT MANAGEMENT, PRODUCT DEVELOPMENT CONSULTATION, COMPUTER SOFTWARE DEVELOPMENT AND COMPUTER SOFTWARE DEVELOPMENT MANAGEMENT (U.S. CLS. 100 AND 101).

BRIAN PINO, EXAMINING ATTORNEY

SN 77-663,366. VISI INCORPORATED, MINNEAPOLIS, MN.
FILED 2-4-2009.



OWNER OF U.S. REG. NOS. 2,224,424 AND 3,414,569.
THE MARK CONSISTS OF THE TERM "VISI" SUR-
ROUNDED BY A SLANTED OVAL.

CLASS 38—COMMUNICATION

FOR PROVIDING MULTIPLE USER ACCESS TO A
GLOBAL COMPUTER NETWORK; PROVIDING CO-LO-
CATION SERVICES FOR VOICE, VIDEO AND DATA
COMMUNICATIONS APPLICATIONS (U.S. CLS. 100, 101
AND 104).

FIRST USE 12-7-2005; IN COMMERCE 12-7-2005.

CLASS 42—SCIENTIFIC AND COMPUTER SERVICES

FOR WEB SITE HOSTING SERVICES; DISPLAYING
THE WEB SITES AND IMAGES OF OTHERS ON A
DEDICATED COMPUTER SERVER; E-MAIL SYSTEM
DESIGN AND IMPLEMENTATION FOR OTHERS; IN-
FORMATION TECHNOLOGY CONSULTATION (U.S.
CLS. 100 AND 101).

FIRST USE 12-7-2005; IN COMMERCE 12-7-2005.
JACLYN KIDWELL, EXAMINING ATTORNEY

SN 77-663,435. TLA ENTERTAINMENT GROUP, INC.,
PHILADELPHIA, PA. FILED 2-4-2009.

SIN BIN

THE MARK CONSISTS OF STANDARD CHARACTERS
WITHOUT CLAIM TO ANY PARTICULAR FONT, STYLE,
SIZE, OR COLOR.

CLASS 25—CLOTHING

FOR CLOTHING, NAMELY, SHIRTS, T-SHIRTS,
PANTS, SHORTS, JACKETS, COATS, SWEATERS,
SWEATSHIRTS, SWEATPANTS, SOCKS, HATS, UNDER-
WEAR, BRAS, AND LINGERIE (U.S. CLS. 22 AND 39).

CLASS 35—ADVERTISING AND BUSINESS

FOR COMPUTERIZED ON-LINE RETAIL STORE AND
ORDERING SERVICES IN THE FIELD OF ADULT
SEXUAL AIDS, NOVELTY ITEMS, CLOTHING, PRE-
RECORDED AUDIO TAPES, PRE-RECORDED VIDEO
TAPES, LASER DISCS, UNIVERSAL MINI DISCS, AND
DVDS FEATURING FILMS IN THE NATURE OF
ADULT FILMS (U.S. CLS. 100, 101 AND 102).

CLASS 41—EDUCATION AND ENTERTAIN- MENT

FOR ENTERTAINMENT SERVICES, NAMELY, PRO-
VIDING A WEB SITE FEATURING ENTERTAINMENT
INFORMATION AND ADULT-THEMED ENTERTAIN-
MENT INFORMATION, ADULT-THEMED VIDEOS, RE-
LATED FILM CLIPS, PHOTOGRAPHS, AND OTHER
MULTIMEDIA MATERIALS; ON-LINE JOURNALS,
NAMELY, BLOGS FEATURING ENTERTAINMENT IN-
FORMATION AND ADULT-THEMED ENTERTAIN-
MENT INFORMATION, ADULT-THEMED VIDEOS,
RELATED FILM CLIPS, PHOTOGRAPHS, AND OTHER
ADULT-THEMED MULTIMEDIA MATERIALS (U.S.
CLS. 100, 101 AND 107).

MICHAEL SOUDERS, EXAMINING ATTORNEY

SN 77-663,504. LOADRACK, LLC, ENCINITES, CA. FILED 2-
4-2009.

LoadRack

THE MARK CONSISTS OF STANDARD CHARACTERS
WITHOUT CLAIM TO ANY PARTICULAR FONT, STYLE,
SIZE, OR COLOR.

CLASS 35—ADVERTISING AND BUSINESS

FOR PROVIDING ELECTRONIC TRACKING OF
FREIGHT INFORMATION TO OTHERS; PROVIDING
TRACKING SERVICES AND INFORMATION CONCERNING
TRACKING OF ASSETS IN TRANSIT,
NAMELY, VEHICLES, TRAILERS, DRIVERS, CARGO
AND DELIVERY CONTAINERS; TRACKING, LOCATING
AND MONITORING OF VEHICLES, MARITIME
VESSELS AND AIRCRAFT SERVICES FOR COMMERCIAL
PURPOSES (U.S. CLS. 100, 101 AND 102).

CLASS 39—TRANSPORTATION AND STO- RAGE

FOR FREIGHT TRANSPORTATION BROKERAGE;
FREIGHT TRANSPORTATION CONSULTATION IN
THE FIELD OF FREIGHT TRANSPORTATION BY
TRUCK, RAIL, AIR AND OCEAN; SUPPLY CHAIN,
LOGISTICS AND REVERSE LOGISTICS SERVICES,
NAMELY, STORAGE, TRANSPORTATION AND DELIV-
ERY OF DOCUMENTS, PACKAGES, RAW MATERIALS,
AND OTHER FREIGHT FOR OTHERS BY AIR, RAIL,
SHIP OR TRUCK (U.S. CLS. 100 AND 105).

CLASS 42—SCIENTIFIC AND COMPUTER SERVICES

FOR COMPUTER SOFTWARE DEVELOPMENT IN
THE FIELD OF FREIGHT TRANSPORTATION BY
TRUCK, RAIL, AIR AND OCEAN (U.S. CLS. 100 AND
101).

ANDREW LEASER, EXAMINING ATTORNEY

SN 77-663,573. BARLIER, PIERRE J, LAFAYETTE, CA. FILED 2-4-2009.

SN 77-663,646. SIRSI CORPORATION, PROVO, UT. FILED 2-4-2009.

I was a plastic bottle

THE MARK CONSISTS OF STANDARD CHARACTERS WITHOUT CLAIM TO ANY PARTICULAR FONT, STYLE, SIZE, OR COLOR.

OWNER OF U.S. REG. NO. 3,517,869.

CLASS 16—PAPER GOODS AND PRINTED MATTER

FOR GROCERY BAGS; LUNCH BAGS; LUNCH BAGS MADE OF TEXTILE; PLASTIC OR PAPER BAGS FOR HOUSEHOLD USE; PLASTIC SHOPPING BAGS; TEXTILE GIFT BAGS FOR WINE; TEXTILE WINE GIFT BAGS (U.S. CLS. 2, 5, 22, 23, 29, 37, 38 AND 50).

CLASS 18—LEATHER GOODS

FOR SHOPPING BAGS WITH WHEELS ATTACHED; TEXTILE SHOPPING BAGS; TOTE BAGS; WINE BAGS WITH HANDLES FOR CARRYING OR HOLDING WINE (U.S. CLS. 1, 2, 3, 22 AND 41).

CLASS 21—HOUSEWARES AND GLASS

FOR THERMAL INSULATED BAGS FOR FOOD OR BEVERAGES (U.S. CLS. 2, 13, 23, 29, 30, 33, 40 AND 50).

CLASS 22—CORDAGE AND FIBERS

FOR SYNTHETIC FIBERS AND FILAMENTS FOR USE IN THE MANUFACTURE OF FABRICS, TEXTILES, YARNS, AND CARPETS; TEXTILE FIBERS (U.S. CLS. 1, 2, 7, 19, 22, 42 AND 50).

NAKIA HENRY, EXAMINING ATTORNEY

SN 77-663,616. MARTHA STEWART LIVING OMNIMEDIA, INC., NEW YORK, NY. FILED 2-4-2009.

THE HEALTHY ALTERNATIVE

THE MARK CONSISTS OF STANDARD CHARACTERS WITHOUT CLAIM TO ANY PARTICULAR FONT, STYLE, SIZE, OR COLOR.

CLASS 6—METAL GOODS

FOR ALUMINUM FOIL PAPER WITH PARCHMENT PAPER (U.S. CLS. 2, 12, 13, 14, 23, 25 AND 50).

CLASS 16—PAPER GOODS AND PRINTED MATTER

FOR PARCHMENT PAPER WITH ALUMINUM FOIL PAPER (U.S. CLS. 2, 5, 22, 23, 29, 37, 38 AND 50).

SUNG IN, EXAMINING ATTORNEY

SIRSIDYNIX ENTERPRISE

THE MARK CONSISTS OF STANDARD CHARACTERS WITHOUT CLAIM TO ANY PARTICULAR FONT, STYLE, SIZE, OR COLOR.

OWNER OF U.S. REG. NOS. 3,085,329, 3,558,677 AND OTHERS.

NO CLAIM IS MADE TO THE EXCLUSIVE RIGHT TO USE "ENTERPRISE", APART FROM THE MARK AS SHOWN.

CLASS 9—ELECTRICAL AND SCIENTIFIC APPARATUS

FOR COMPUTER SOFTWARE IN THE FIELD OF LIBRARY SCIENCE, NAMELY, COMPUTER SOFTWARE FOR USE IN AUTOMATED LIBRARY MANAGEMENT (U.S. CLS. 21, 23, 26, 36 AND 38).

FIRST USE 7-31-2008; IN COMMERCE 7-31-2008.

CLASS 42—SCIENTIFIC AND COMPUTER SERVICES

FOR APPLICATION SERVICE PROVIDER (ASP) FEATURING SOFTWARE IN THE FIELD OF LIBRARY SCIENCE FOR USE IN AUTOMATED LIBRARY MANAGEMENT (U.S. CLS. 100 AND 101).

FIRST USE 7-31-2008; IN COMMERCE 7-31-2008.

BARNEY CHARLON, EXAMINING ATTORNEY

SN 77-663,647. RD VISUAL DESIGN, INC., LAS VEGAS, NV. FILED 2-4-2009.

Another Day to Play

THE MARK CONSISTS OF STANDARD CHARACTERS WITHOUT CLAIM TO ANY PARTICULAR FONT, STYLE, SIZE, OR COLOR.

CLASS 18—LEATHER GOODS

FOR DOG APPAREL (U.S. CLS. 1, 2, 3, 22 AND 41).

CLASS 25—CLOTHING

FOR LONG-SLEEVED SHIRTS; SHORT-SLEEVED OR LONG-SLEEVED T-SHIRTS; T-SHIRTS (U.S. CLS. 22 AND 39).

DAVID YONTEF, EXAMINING ATTORNEY

SN 77-663,653. TIBESTI, LLC, LOS ANGELES, CA. FILED 2-4-2009.

IT PAYS TO BE SOCIAL

THE MARK CONSISTS OF STANDARD CHARACTERS WITHOUT CLAIM TO ANY PARTICULAR FONT, STYLE, SIZE, OR COLOR.

CLASS 35—ADVERTISING AND BUSINESS

FOR PROVIDING CONSUMER PRODUCT INFORMATION VIA THE INTERNET; OPERATING AN ON-LINE SHOPPING SITE IN THE FIELD OF A WIDE VARIETY OF CONSUMER PRODUCTS; ON-LINE BUSINESS NETWORKING SERVICES (U.S. CLS. 100, 101 AND 102).

CLASS 45—PERSONAL AND LEGAL SERVICES

FOR ON-LINE SOCIAL NETWORKING SERVICES (U.S. CLS. 100 AND 101).
DAVID YONTEF, EXAMINING ATTORNEY

SN 77-663,665. GEWERTZ, COBY, REDONDO BEACH, CA. FILED 2-4-2009.

Brat Fink

THE MARK CONSISTS OF STANDARD CHARACTERS WITHOUT CLAIM TO ANY PARTICULAR FONT, STYLE, SIZE, OR COLOR.

CLASS 16—PAPER GOODS AND PRINTED MATTER

FOR COLORING BOOKS (U.S. CLS. 2, 5, 22, 23, 29, 37, 38 AND 50).

CLASS 25—CLOTHING

FOR SWEAT SHIRTS; T-SHIRTS (U.S. CLS. 22 AND 39).
BARBARA BROWN, EXAMINING ATTORNEY

SN 77-663,794. HOMEGOODS, INC., FRAMINGHAM, MA. FILED 2-5-2009.

HG LOFT

THE MARK CONSISTS OF STANDARD CHARACTERS WITHOUT CLAIM TO ANY PARTICULAR FONT, STYLE, SIZE, OR COLOR.

OWNER OF U.S. REG. NOS. 3,242,059 AND 3,263,112.

CLASS 3—COSMETICS AND CLEANING PREPARATIONS

FOR BODY CARE PRODUCTS, NAMELY, SOAPS, BATH GEL, AND BATH OIL; BODY LOTION; BODY FRAGRANCES; POTPOURRI; SACHETS; SCENTED ROOM SPRAYS (U.S. CLS. 1, 4, 6, 50, 51 AND 52).

CLASS 8—HAND TOOLS

FOR HAND-OPERATED GARDEN TOOLS, NAMELY, TROWELS, SHOVELS, RAKES, CLIPPERS, SHEARS, CULTIVATORS, WEEDERS, AND TRANSPLANTERS; HOUSEHOLD KNIVES; FLATWARE; SPOONS (U.S. CLS. 23, 28 AND 44).

CLASS 11—ENVIRONMENTAL CONTROL APPARATUS

FOR LAMPS AND DECORATIVE LAMP SHADES; LANTERNS (U.S. CLS. 13, 21, 23, 31 AND 34).

CLASS 16—PAPER GOODS AND PRINTED MATTER

FOR DESK ACCESSORIES, NAMELY, DESK PADS, DESK BASKETS, DESK FILE TRAYS, AND PEN AND PENCIL HOLDERS; WALL CALENDARS; LAP DESKS; DECORATIVE POSTERS AND PAINTINGS; WALL ART, NAMELY REPRODUCED IMAGES OF PICTURES, PRINTED ART REPRODUCTIONS, CALLIGRAPHY, PAINTINGS, PHOTOGRAPHIC PRINTS, ART PRINTS, PICTORIAL PRINTS, PICTURES, AND MOUNTED AND UNMOUNTED POSTERS; COLLAGES; STATIONERY; BLANK JOURNALS (U.S. CLS. 2, 5, 22, 23, 29, 37, 38 AND 50).

CLASS 19—NON-METALLIC BUILDING MATERIALS

FOR CAST STONE GARDEN AND HOUSEHOLD ORNAMENTS (U.S. CLS. 1, 12, 33 AND 50).

CLASS 20—FURNITURE AND ARTICLES NOT OTHERWISE CLASSIFIED

FOR FURNITURE, NAMELY, DRESSERS, CHESTS OF DRAWERS, NIGHT STANDS, DESKS, COMPUTER DESKS, FILING CABINETS, TABLES, STOOLS, BARSTOOLS, AND OTTOMANS; PILLOWS AND DECORATIVE PILLOWS; HAMPERS; MIRRORS; WALL SHELVES; PICTURE AND PHOTOGRAPH FRAMES; GAZING GLOBES; OUTDOOR FURNITURE (U.S. CLS. 2, 13, 22, 25, 32 AND 50).

CLASS 21—HOUSEWARES AND GLASS

FOR BATHROOM ACCESSORIES, NAMELY, SOAP DISHES, TUMBLERS, TOOTHBRUSH HOLDERS, LIQUID SOAP DISPENSERS SOLD EMPTY, LOTION PUMP DISPENSERS, AND WASTE PAPER BASKETS; VASES; CANDLE HOLDERS; DECORATIVE ORNAMENTS AND FIGURINES MADE OF CERAMIC, CHINA, CRYSTAL, PORCELAIN, AND GLASS, NOT FOR USE ON CHRISTMAS TREES; BAR MOPS; DINNERWARE, DRINKWARE AND SERVEWARE, NAMELY, WATER GLASSES, DRINKING GLASSES, CHAMPAGNE FLUTES, MARTINI GLASSES, WINE GOBLETS, COCKTAIL GLASSES, TUMBLERS, DRINKING CUPS, SERVING TRAYS, SERVING SPOONS AND FORKS, PLATTERS, AND SOUP TUREENS; CANISTERS AND CANISTER SETS; COOKWARE, NAMELY, POTS AND PANS; HOUSEHOLD UTENSILS, NAMELY, BARBECUE FORKS AND TONGS, SPATULAS, FORKS AND SPOONS FOR FOOD PREPARATION, MIXING SPOONS, GARLIC PRESSES, CHEESE SPREADERS, VEGETABLE BRUSHES, STRAINERS, AND TURNERS, WOOD CHOPPING BLOCKS AND WOOD CHOPPING BOARDS FOR KITCHEN USE, ICE BUCKETS, KITCHEN LADLES, MEAL TRAYS, MUGS, NAPKIN HOLDERS, NAPKIN RINGS NOT OF PRECIOUS METAL, NON-ELECTRIC GRIDDLES, NON-ELECTRIC PRESSURE COOKERS,

NON-METAL PIGGYBANKS, OIL-FEEDING CANS, PEPPER GRINDERS, PIE SERVERS, PITCHERS, PLATES, PORTABLE BEVERAGE COOLERS, PORTABLE BEVERAGE DISPENSERS, PRESERVE GLASSES, ROLLING PINS, SALAD BOWLS, SALT AND PEPPER GRINDERS AND MILLS, SALT AND PEPPER SHAKERS, SALT CELLARS IN THE NATURE OF SHAKERS, SAUCEPANS, SAUCERS, SCOOPS, SHAVING BRUSH STANDS, SLOTTED SPOONS, SOAP BOXES, SOAP CONTAINERS, SOAP CONTAINERS AND HOLDERS, SOAP DISHES, SOAP DISPENSERS, SOAP HOLDERS, SPICE RACKS, SPONGE HOLDERS, MIXING SPOONS, STEAMER BASKETS, TEA BALLS NOT OF PRECIOUS METAL, TEA KETTLES, TEAPOTS NOT OF PRECIOUS METAL, THERMAL INSULATED CONTAINERS FOR FOOD OR BEVERAGES, TRASH CANS, TRIVETS, VASES, WASTE-PAPER BASKETS, WATERING CANS, WINE BOTTLE CRADLES, WINE BUCKETS; CUTTING BOARDS (U.S. CLS. 2, 13, 23, 29, 30, 33, 40 AND 50).

CLASS 24—FABRICS

FOR BEDDING, NAMELY, SHEETS, PILLOW CASES, SHEET SETS, PILLOW SHAMS, BED SKIRTS, QUILTS, COMFORTERS, BLANKETS, AND BLANKET THROWS; MATTRESS PADS AND MATTRESS COVERS; FABRIC WINDOW COVERINGS AND FABRIC WINDOW TREATMENTS, NAMELY CURTAINS, WINDOW VALANCES, AND SHEER WINDOW CURTAIN PANELS; BATH TOWELS, WASH CLOTHS, AND SHOWER CURTAINS; TABLE LINEN; KITCHEN LINENS; TEXTILE WALL HANGINGS (U.S. CLS. 42 AND 50).

CLASS 26—FANCY GOODS

FOR ARTIFICIAL FLOWERS AND FLOWER ARRANGEMENTS; ARTIFICIAL FLORAL WREATHS, SWAGS, AND GARLANDS (U.S. CLS. 37, 39, 40, 42 AND 50).

CLASS 27—FLOOR COVERINGS

FOR RUGS, AREA RUGS, BATH RUGS, AND BATH MATS; NON-TEXTILE WALL HANGINGS (U.S. CLS. 19, 20, 37, 42 AND 50).

CLASS 30—STAPLE FOODS

FOR SAUCES AND SALAD DRESSINGS (U.S. CL. 46).

CLASS 32—LIGHT BEVERAGES

FOR NON-ALCOHOLIC COCKTAIL MIXES (U.S. CLS. 45, 46 AND 48).

CLASS 33—WINES AND SPIRITS

FOR ALCOHOLIC COCKTAIL MIXES (U.S. CLS. 47 AND 49).
BRENDAN MCCAULEY, EXAMINING ATTORNEY

SN 77-663,797. THE 5 BROWNS, INC., HOLLADAY, UT.
FILED 2-5-2009.

THE 5 BROWNS

THE MARK CONSISTS OF STANDARD CHARACTERS WITHOUT CLAIM TO ANY PARTICULAR FONT, STYLE, SIZE, OR COLOR.

CLASS 9—ELECTRICAL AND SCIENTIFIC APPARATUS

FOR CDS AND CD-ROMS FEATURING PRE-RECORDED MUSIC AND RELATED VIDEOS (U.S. CLS. 21, 23, 26, 36 AND 38).

FIRST USE 12-1-2003; IN COMMERCE 12-1-2003.

CLASS 14—JEWELRY

FOR JEWELRY, JEWELRY BOXES AND PENDANTS (U.S. CLS. 2, 27, 28 AND 50).

FIRST USE 12-1-2003; IN COMMERCE 12-1-2003.

CLASS 25—CLOTHING

FOR SHIRTS, SHORT-SLEEVED T-SHIRTS, LONG-SLEEVED T-SHIRTS AND CAPS (U.S. CLS. 22 AND 39).

FIRST USE 12-1-2003; IN COMMERCE 12-1-2003.

CLASS 41—EDUCATION AND ENTERTAINMENT

FOR ENTERTAINMENT SERVICES IN THE NATURE OF LIVE MUSICAL PERFORMANCES; ENTERTAINMENT SERVICES, NAMELY, PROVIDING A WEBSITE FEATURING MUSICAL PERFORMANCES, MUSICAL VIDEOS, RELATED FILM CLIPS, PHOTOGRAPHS, AND OTHER MULTIMEDIA MATERIALS FEATURING A MUSICAL BAND (U.S. CLS. 100, 101 AND 107).

FIRST USE 12-1-2003; IN COMMERCE 12-1-2003.

JAMES GRIFFIN, EXAMINING ATTORNEY

SN 77-663,834. ING DIRECT BANCORP, WILMINGTON, DE.
FILED 2-5-2009.

TANGY TOWN

THE MARK CONSISTS OF STANDARD CHARACTERS WITHOUT CLAIM TO ANY PARTICULAR FONT, STYLE, SIZE, OR COLOR.

CLASS 36—INSURANCE AND FINANCIAL

FOR PROVIDING AN INTERACTIVE WEB SITE FEATURING INFORMATION FOR CHILDREN IN THE FIELD OF BANKING AND FINANCIAL SERVICES (U.S. CLS. 100, 101 AND 102).

CLASS 41—EDUCATION AND ENTERTAINMENT

FOR EDUCATIONAL SERVICES, NAMELY, PROVIDING A WEB SITE WITH GAMES AND LEARNING ACTIVITIES TO HELP CHILDREN UNDERSTAND MONEY MATTERS AND FINANCIAL MATTERS, EARNING, SAVINGS, BUDGETING AND INVESTING (U.S. CLS. 100, 101 AND 107).

LAKEISHA LEWIS, EXAMINING ATTORNEY

SN 77-663,840. ING DIRECT BANCORP, WILMINGTON, DE.
FILED 2-5-2009.

SN 77-663,874. FRANK BRUNCKHORST CO., L.L.C.,
BROOKLYN, NY. FILED 2-5-2009.

NAVEL CITY

DELI-TRICIOUS OPTIONS

THE MARK CONSISTS OF STANDARD CHARACTERS WITHOUT CLAIM TO ANY PARTICULAR FONT, STYLE, SIZE, OR COLOR.

THE MARK CONSISTS OF STANDARD CHARACTERS WITHOUT CLAIM TO ANY PARTICULAR FONT, STYLE, SIZE, OR COLOR.

CLASS 36—INSURANCE AND FINANCIAL

FOR PROVIDING AN INTERACTIVE WEB SITE FEATURING INFORMATION FOR CHILDREN IN THE FIELD OF BANKING AND FINANCIAL SERVICES (U.S. CLS. 100, 101 AND 102).

CLASS 16—PAPER GOODS AND PRINTED MATTER

FOR PRINTED RECIPE CARDS (U.S. CLS. 2, 5, 22, 23, 29, 37, 38 AND 50).

CLASS 41—EDUCATION AND ENTERTAINMENT

FOR EDUCATIONAL SERVICES, NAMELY, PROVIDING A WEB SITE WITH GAMES AND LEARNING ACTIVITIES TO HELP CHILDREN UNDERSTAND MONEY MATTERS AND FINANCIAL MATTERS, EARNING, SAVINGS, BUDGETING AND INVESTING (U.S. CLS. 100, 101 AND 107).
LAKEISHA LEWIS, EXAMINING ATTORNEY

CLASS 29—MEATS AND PROCESSED FOODS

FOR PROCESSED MEAT; CHEESE (U.S. CL. 46).

CLASS 44—MEDICAL, BEAUTY AND AGRICULTURAL SERVICES

FOR DIETARY AND NUTRITIONAL GUIDANCE (U.S. CLS. 100 AND 101).
PAUL CROWLEY, EXAMINING ATTORNEY

SN 77-663,843. ING DIRECT BANCORP, WILMINGTON, DE.
FILED 2-5-2009.

SN 77-663,932. CURWOOD, INC., OSHKOSH, WI. FILED 2-5-2009.

ORANGEOPOLIS

FORM-TITE

THE MARK CONSISTS OF STANDARD CHARACTERS WITHOUT CLAIM TO ANY PARTICULAR FONT, STYLE, SIZE, OR COLOR.

THE MARK CONSISTS OF STANDARD CHARACTERS WITHOUT CLAIM TO ANY PARTICULAR FONT, STYLE, SIZE, OR COLOR.

CLASS 36—INSURANCE AND FINANCIAL

FOR PROVIDING AN INTERACTIVE WEB SITE FEATURING INFORMATION FOR CHILDREN IN THE FIELD OF BANKING AND FINANCIAL SERVICES (U.S. CLS. 100, 101 AND 102).

CLASS 16—PAPER GOODS AND PRINTED MATTER

FOR SHRINKABLE ROLLSTOCK FOOD WRAPPING PLASTIC FILM NOT FOR COMMERCIAL OR INDUSTRIAL PURPOSES (U.S. CLS. 2, 5, 22, 23, 29, 37, 38 AND 50).
FIRST USE 10-27-2008; IN COMMERCE 10-27-2008.

CLASS 41—EDUCATION AND ENTERTAINMENT

FOR EDUCATIONAL SERVICES, NAMELY, PROVIDING A WEB SITE WITH GAMES AND LEARNING ACTIVITIES TO HELP CHILDREN UNDERSTAND MONEY MATTERS AND FINANCIAL MATTERS, EARNING, SAVINGS, BUDGETING AND INVESTING (U.S. CLS. 100, 101 AND 107).
LAKEISHA LEWIS, EXAMINING ATTORNEY

CLASS 17—RUBBER GOODS

FOR SHRINKABLE ROLLSTOCK PLASTIC FILM AS PACKAGING FOR FOOD (U.S. CLS. 1, 5, 12, 13, 35 AND 50).
FIRST USE 10-27-2008; IN COMMERCE 10-27-2008.
SIMON TENG, EXAMINING ATTORNEY

SN 77-664,041. HARMON, MARGARET, LONG VALLEY, NJ.
FILED 2-5-2009.

SN 77-664,187. MEDALS TO HONOR, INC., HUBERT, NC.
FILED 2-5-2009.

GARGEЕ THE READING FAIRY

THE MARK CONSISTS OF STANDARD CHARACTERS WITHOUT CLAIM TO ANY PARTICULAR FONT, STYLE, SIZE, OR COLOR.

NO CLAIM IS MADE TO THE EXCLUSIVE RIGHT TO USE "READING", APART FROM THE MARK AS SHOWN.

THE NAME "GARGEЕ" DOES NOT IDENTIFY A LIVING INDIVIDUAL.

CLASS 16—PAPER GOODS AND PRINTED MATTER

FOR EDUCATIONAL PUBLICATIONS, NAMELY, BOOKS, HAND-OUTS AND WORKBOOKS IN THE FIELDS OF READING (U.S. CLS. 2, 5, 22, 23, 29, 37, 38 AND 50).

CLASS 41—EDUCATION AND ENTERTAINMENT

FOR EDUCATIONAL SERVICES, NAMELY, PROVIDING CLASSES, SEMINARS, AND WORKSHOPS IN THE FIELDS OF READING (U.S. CLS. 100, 101 AND 107).

ELISSA GARBER KON, EXAMINING ATTORNEY

SN 77-664,066. LITCON GROUP, LLC, ALEXANDRIA, VA.
FILED 2-5-2009.

LITCON GROUP, LLC

THE MARK CONSISTS OF STANDARD CHARACTERS WITHOUT CLAIM TO ANY PARTICULAR FONT, STYLE, SIZE, OR COLOR.

NO CLAIM IS MADE TO THE EXCLUSIVE RIGHT TO USE "GROUP, LLC", APART FROM THE MARK AS SHOWN.

CLASS 36—INSURANCE AND FINANCIAL

FOR FINANCIAL CONSULTING SERVICES, NAMELY, EXPERT ANALYSIS IN FINANCE (U.S. CLS. 100, 101 AND 102).

FIRST USE 5-10-2007; IN COMMERCE 5-10-2007.

CLASS 45—PERSONAL AND LEGAL SERVICES

FOR LITIGATION SUPPORT SERVICES (U.S. CLS. 100 AND 101).

FIRST USE 5-10-2007; IN COMMERCE 5-10-2007.
JUSTINE D. PARKER, EXAMINING ATTORNEY

MEDALS TO HONOR

THE MARK CONSISTS OF STANDARD CHARACTERS WITHOUT CLAIM TO ANY PARTICULAR FONT, STYLE, SIZE, OR COLOR.

NO CLAIM IS MADE TO THE EXCLUSIVE RIGHT TO USE "MEDALS", APART FROM THE MARK AS SHOWN.

SEC. 2(F).

CLASS 14—JEWELRY

FOR COLLECTIBLE COINS; COMMEMORATIVE COINS; MEDALLIONS; MEDALS; MEDALS AND MEDALLIONS; NON-MONETARY COINS (U.S. CLS. 2, 27, 28 AND 50).

FIRST USE 7-1-1998; IN COMMERCE 8-1-1999.

CLASS 20—FURNITURE AND ARTICLES NOT OTHERWISE CLASSIFIED

FOR DISPLAY BOARDS; DISPLAY CASES; DISPLAY RACKS; DISPLAY STANDS; FURNITURE FOR DISPLAYING GOODS; FURNITURE, NAMELY, DISPLAY UNITS; METAL DISPLAY STANDS (U.S. CLS. 2, 13, 22, 25, 32 AND 50).

FIRST USE 7-1-1998; IN COMMERCE 8-1-1999.

CLASS 26—FANCY GOODS

FOR ORNAMENTAL RIBBONS MADE OF TEXTILES; PRIZE RIBBONS; RIBBONS (U.S. CLS. 37, 39, 40, 42 AND 50).

FIRST USE 7-1-1998; IN COMMERCE 8-1-1999.

CLASS 35—ADVERTISING AND BUSINESS

FOR ON-LINE RETAIL STORE SERVICES FEATURING MEDALS, MILITARY MEDALS, CUSTOM-MADE MEDALS, COINS, MILITARY COINS, COMMEMORATIVE COINS, CUSTOM-MADE COINS, MEDALLIONS, MILITARY MEDALLIONS, CUSTOM-MADE MEDALLIONS, STICKERS, PINS, KEY CHAINS, BADGES, MILITARY BADGES, CUSTOM-MADE BADGES, CUPS, RIBBONS, MILITARY RIBBONS, AWARD RIBBONS, CUSTOM-MADE RIBBONS, DISPLAY CASES, CUSTOM-MADE DISPLAY CASES, MOUNTING FOR MILITARY MEDALS, RIBBONS, AND AWARDS, CUSTOM-MADE MOUNTING FOR MILITARY MEDALS, RIBBONS AND AWARDS, MEMORABILIA HOLDERS, LOCKERBOXES, AND SWAGGER STICKS; RETAIL STORES FEATURING MEDALS, MILITARY MEDALS, CUSTOM-MADE MEDALS, COINS, MILITARY COINS, COMMEMORATIVE COINS, CUSTOM-MADE COINS, MEDALLIONS, MILITARY MEDALLIONS, CUSTOM-MADE MEDALLIONS, STICKERS, PINS, KEY CHAINS, BADGES, MILITARY BADGES, CUSTOM-MADE BADGES, CUPS, RIBBONS, MILITARY RIBBONS, AWARD RIBBONS, CUSTOM-MADE RIBBONS, DISPLAY CASES, CUSTOM-MADE DISPLAY CASES, MOUNTING FOR MILITARY MEDALS, RIBBONS, AND AWARDS, CUSTOM-MADE MOUNTING FOR MILITARY MEDALS, RIBBONS AND AWARDS, MEMORABILIA HOLDERS, LOCKERBOXES, AND SWAGGER STICKS; WHOLESALE AND RETAIL STORE SERVICES FEATURING MEDALS, MILITARY MEDALS, CUSTOM-MADE MEDALS, COINS, MILITARY COINS, COMMEMORATIVE COINS, CUSTOM-MADE COINS, MEDALLIONS, MILITARY MEDALLIONS, CUSTOM-MADE MEDALLIONS, STICKERS, PINS, KEY CHAINS, BADGES, MILITARY BADGES, CUSTOM-MADE BADGES, CUPS, RIBBONS, MILITARY RIBBONS, AWARD RIBBONS, CUSTOM-MADE RIBBONS, DISPLAY CASES, CUSTOM-MADE DISPLAY CASES, MOUNTING FOR MILITARY MEDALS, RIBBONS, AND AWARDS, CUSTOM-MADE MOUNTING

FOR MILITARY MEDALS, RIBBONS AND AWARDS, MEMORABILIA HOLDERS, LOCKERBOXES, AND SWAGGER STICKS; WHOLESALE STORES FEATURING MEDALS, MILITARY MEDALS, CUSTOM-MADE MEDALS, COINS, MILITARY COINS, COMMEMORATIVE COINS, CUSTOM-MADE COINS, MEDALLIONS, MILITARY MEDALLIONS, CUSTOM-MADE MEDALLIONS, STICKERS, PINS, KEY CHAINS, BADGES, MILITARY BADGES, CUSTOM-MADE BADGES, CUPS, RIBBONS, MILITARY RIBBONS, AWARD RIBBONS, CUSTOM-MADE RIBBONS, DISPLAY CASES, CUSTOM-MADE DISPLAY CASES, MOUNTING FOR MILITARY MEDALS, RIBBONS, AND AWARDS, CUSTOM-MADE MOUNTING FOR MILITARY MEDALS, RIBBONS AND AWARDS, MEMORABILIA HOLDERS, LOCKERBOXES, AND SWAGGER STICKS (U.S. CLS. 100, 101 AND 102).

FIRST USE 7-1-1998; IN COMMERCE 8-1-1999.
MATTHEW PAPPAS, EXAMINING ATTORNEY

SN 77-664,271. PIONEER ENGINEERING & ENVIRONMENTAL SERVICES, INC., CHICAGO, IL. FILED 2-5-2009.

PIONEER
ENGINEERING & ENVIRONMENTAL SERVICES, INC.

NO CLAIM IS MADE TO THE EXCLUSIVE RIGHT TO USE "ENGINEERING & ENVIRONMENTAL SERVICES, INC.", APART FROM THE MARK AS SHOWN.

THE MARK CONSISTS OF THE WORDING "PIONEER ENGINEERING & ENVIRONMENTAL SERVICES, INC." THE LETTER "O" IN "PIONEER" IS LARGER THAN THE OTHER LETTERS IN THE WORD, AND CONTAINS A TRIANGLE REPRESENTING A GEOLOGIC SYMBOL USED TO IDENTIFY THE PRESENCE OF THE WATER TABLE IN THE SUBSURFACE; BELOW THE TRIANGLE ARE HORIZONTAL LINES REPRESENTING WATER.

CLASS 40—MATERIAL TREATMENT

FOR ENVIRONMENTAL REMEDIATION SERVICES, NAMELY, SOIL, WASTE AND/OR WATER TREATMENT SERVICES (U.S. CLS. 100, 103 AND 106).

FIRST USE 0-0-2002, THE MARK WAS FIRST USED ANYWHERE IN A DIFFERENT FORM OTHER THAN THAT SOUGHT TO BE REGISTERED AT LEAST AS EARLY AS 00/00/1989.; IN COMMERCE 0-0-2002, THE MARK WAS FIRST USED IN COMMERCE IN A DIFFERENT FORM OTHER THAN THAT SOUGHT TO BE REGISTERED AT LEAST AS EARLY AS 00/00/1989..

CLASS 42—SCIENTIFIC AND COMPUTER SERVICES

FOR CONSULTING SERVICES IN THE FIELD OF ENVIRONMENTAL ASSESSMENT, COMPLIANCE AND PLANNING; ENGINEERING SERVICES FOR BUILDING AND PROPERTY CONDITION ASSESSMENT, FACILITY MANAGEMENT, REPAIR AND RESTORATION, BUILDING INSTRUMENTATION AND MONITORING, AND ENVIRONMENTAL CONSULTING; ENGINEERING SERVICES IN THE FIELD OF ENVIRONMENTAL COMPLIANCE; ENVIRONMENTAL TESTING AND INSPECTION SERVICES; CONSTRUCTION MATERIALS TESTING AND EVALUATION (U.S. CLS. 100 AND 101).

FIRST USE 0-0-2002, THE MARK WAS FIRST USED ANYWHERE IN A DIFFERENT FORM OTHER THAN THAT SOUGHT TO BE REGISTERED AT LEAST AS EARLY AS 00/00/1989.; IN COMMERCE 0-0-2002, THE MARK WAS FIRST USED IN COMMERCE IN A DIFFERENT FORM OTHER THAN THAT SOUGHT TO BE REGISTERED AT LEAST AS EARLY AS 00/00/1989..

ALICE SUE CARRUTHERS, EXAMINING ATTORNEY

SN 77-664,359. FARBERWARE LICENSING COMPANY LLC, NEEDHAM, MA. FILED 2-5-2009.

FARBERWARE

THE MARK CONSISTS OF STANDARD CHARACTERS WITHOUT CLAIM TO ANY PARTICULAR FONT, STYLE, SIZE, OR COLOR.

OWNER OF U.S. REG. NOS. 804,130, 806,655 AND 1,122,167.

CLASS 24—FABRICS

FOR KITCHEN TOWELS, POTHOLDERS, DISH-CLOTHS, OVEN MITTS, FABRIC PLACEMATS, AND KITCHEN CURTAINS (U.S. CLS. 42 AND 50).

FIRST USE 9-19-1996; IN COMMERCE 9-19-1996.

CLASS 25—CLOTHING

FOR APRONS (U.S. CLS. 22 AND 39).

FIRST USE 9-19-1996; IN COMMERCE 9-19-1996.
MICHELLE DUBOIS, EXAMINING ATTORNEY

SN 77-664,367. DELICIOUS ENTERTAINMENT, INC., NEW YORK, NY. FILED 2-5-2009.

EASY EXOTIC

THE MARK CONSISTS OF STANDARD CHARACTERS WITHOUT CLAIM TO ANY PARTICULAR FONT, STYLE, SIZE, OR COLOR.

OWNER OF U.S. REG. NOS. 3,036,729 AND 3,066,729.

CLASS 3—COSMETICS AND CLEANING PREPARATIONS

FOR BATH SALTS; BODY BUTTER; BODY SCRUB; EAU DE TOILETTE; INCENSE; PERFUME; SCENTED ROOM SPRAYS (U.S. CLS. 1, 4, 6, 50, 51 AND 52).

CLASS 4—LUBRICANTS AND FUELS

FOR CANDLES; SCENTED CANDLES (U.S. CLS. 1, 6 AND 15).

CLASS 8—HAND TOOLS

FOR CUTLERY; FLATWARE (U.S. CLS. 23, 28 AND 44).

CLASS 20—FURNITURE AND ARTICLES NOT OTHERWISE CLASSIFIED

FOR FURNITURE, MIRRORS, PICTURE FRAMES; PILLOWS; SCREENS; SHELVES; WINDOW BLINDS; WINDOW SHADES; WORKS OF ART OF WOOD, WAX, PLASTER OR PLASTIC (U.S. CLS. 2, 13, 22, 25, 32 AND 50).

CLASS 21—HOUSEWARES AND GLASS

FOR BEVERAGE GLASSWARE; BOWLS; CANDLE HOLDERS; DINNERWARE; FLOWER VASES AND BOWLS; NAPKIN HOLDERS; SALT AND PEPPER SHAKERS; SERVINGWARE FOR SERVING FOOD; TRIVETS; WORKS OF ART OF CHINA, CRYSTAL, EARTHENWARE, GLASS, PORCELAIN OR TERRA COTTA (U.S. CLS. 2, 13, 23, 29, 30, 33, 40 AND 50).

CLASS 24—FABRICS

FOR BED AND TABLE LINEN, WALL HANGINGS OF TEXTILE; CURTAINS; DRAPERIES; TABLE CLOTHS NOT OF PAPER; TEXTILE NAPKINS; TEXTILE PLACE MATS; THROWS (U.S. CLS. 42 AND 50).

CLASS 27—FLOOR COVERINGS

FOR CARPETS AND RUGS; NON-TEXTILE WALL HANGINGS; WALLCOVERINGS (U.S. CLS. 19, 20, 37, 42 AND 50).

CLASS 29—MEATS AND PROCESSED FOODS

FOR CANDIED NUTS; NUT-BASED SNACK FOODS, NAMELY, NUT CLUSTERS; NUT-BASED SNACK FOODS, NAMELY, NUT CRISPS; POTATO CHIPS; POTATO-BASED SNACK FOODS; PREPARED NUTS; PROCESSED NUTS; VEGETABLE-BASED SNACK FOODS (U.S. CL. 46).

CLASS 30—STAPLE FOODS

FOR CANDY; CEREAL-BASED SNACK FOODS; COOKIES; CRACKERS; FLOUR-BASED CHIPS; GRAIN-BASED CHIPS (U.S. CL. 46).
AARON BRODSKY, EXAMINING ATTORNEY

SN 77-664,378. EZ EVIDENCE, EBENSBURG, PA. FILED 2-5-2009.

EZ EVIDENCE

THE MARK CONSISTS OF STANDARD CHARACTERS WITHOUT CLAIM TO ANY PARTICULAR FONT, STYLE, SIZE, OR COLOR.

NO CLAIM IS MADE TO THE EXCLUSIVE RIGHT TO USE "EVIDENCE", APART FROM THE MARK AS SHOWN.

CLASS 41—EDUCATION AND ENTERTAINMENT

FOR EDUCATIONAL SERVICES, NAMELY, PROVIDING CONTINUING PROFESSIONAL EDUCATION IN THE FIELD OF PHYSICAL THERAPY (U.S. CLS. 100, 101 AND 107).

CLASS 44—MEDICAL, BEAUTY AND AGRICULTURAL SERVICES

FOR PROVIDING PHYSICAL THERAPY INFORMATION, NAMELY, INFORMATION ABOUT DISEASE, CONDITIONS, AND INDIVIDUAL CLINICAL GUIDELINES, TO PROVIDERS, PURCHASERS, AND USERS OF PHYSICAL THERAPY (U.S. CLS. 100 AND 101).
RUSS HERMAN, EXAMINING ATTORNEY

SN 77-664,395. FIBERLINK COMMUNICATIONS CORPORATION, BLUEBELL, PA. FILED 2-5-2009.

FAR360

THE MARK CONSISTS OF STANDARD CHARACTERS WITHOUT CLAIM TO ANY PARTICULAR FONT, STYLE, SIZE, OR COLOR.

CLASS 9—ELECTRICAL AND SCIENTIFIC APPARATUS

FOR COMPUTER SOFTWARE FOR PROVIDING MANAGED REMOTE ACCESS SERVICES, NAMELY, FOR PROVIDING SECURE, GENERAL PURPOSE CONNECTIVITY SO THAT A VARIETY OF COMPUTER SOFTWARE APPLICATIONS AND COMPUTER NETWORK-BASED SERVICES, FILE SHARING SERVICES, E-MAIL SERVICES, AND INTRANET SERVICES CAN BE SECURELY ACCESSED BY A USER CONNECTING REMOTELY TO THE ENTERPRISE LOCAL AREA NETWORK (LAN); DOWNLOADABLE SOFTWARE FOR PROVIDING MANAGED REMOTE ACCESS SERVICES, NAMELY, FOR PROVIDING SECURE, GENERAL PURPOSE CONNECTIVITY SO THAT COMPUTER APPLICATIONS AND COMPUTER NETWORK-BASED SERVICES, CAN BE SECURELY ACCESSED BY A USER CONNECTING REMOTELY TO THE ENTERPRISE LOCAL AREA NETWORK (LAN) AND FOR THE MANAGEMENT, ADMINISTRATION, MODIFICATION AND CONTROL OF THE REMOTE ACCESS; SOFTWARE FOR THE DETECTION, RECOGNITION AND USE OF WIFI, CELLULAR, MODEM, ETHERNET AND OTHER CONNECTION DEVICES AND SIGNALS; AND COMPUTER SOFTWARE FOR PROVIDING MANAGED REMOTE ACCESS SERVICES, NAMELY, FOR PROVIDING SECURE, GENERAL PURPOSE CONNECTIVITY SO THAT COMPUTER APPLICATIONS AND COMPUTER NETWORK-BASED SERVICES, CAN BE SECURELY ACCESSED BY A USER CONNECTING REMOTELY TO THE ENTERPRISE LAN AND FOR THE MANAGEMENT, ADMINISTRATION, MODIFICATION AND CONTROL OF THE REMOTE ACCESS (U.S. CLS. 21, 23, 26, 36 AND 38).

CLASS 35—ADVERTISING AND BUSINESS

FOR WHOLESALE ORDERING SERVICES IN THE FIELD OF TELECOMMUNICATIONS; WHOLESALING OF VARIOUS TYPES OF TELECOMMUNICATIONS SERVICES BY BUYING SUCH SERVICES FROM A SUPPLIER AND RESELLING THE SERVICES TO A USER (U.S. CLS. 100, 101 AND 102).

CLASS 38—COMMUNICATION

FOR TELECOMMUNICATIONS RESELLER SERVICES, NAMELY, PROVIDING LONG DISTANCE TELECOMMUNICATION SERVICES; PROVIDING MANAGED REMOTE ACCESS SERVICES, NAMELY, PROVIDING SECURE, GENERAL-PURPOSE CONNECTIVITY SO THAT COMPUTER SOFTWARE APPLICATIONS AND COMPUTER NETWORK-BASED SERVICES, FILE SHARING SERVICES, E-MAIL SERVICES, AND INTRANET SERVICES CAN BE SECURELY ACCESSED BY A USER CONNECTING REMOTELY TO THE ENTERPRISE LOCAL AREA NETWORK (LAN); VIRTUAL PRIVATE NETWORK SERVICES, NAMELY, PROVIDING REMOTE ACCESS TO LOCAL AREA NETWORKS (U.S. CLS. 100, 101 AND 104).

CLASS 42—SCIENTIFIC AND COMPUTER SERVICES

FOR APPLICATION SERVICE PROVIDER SERVICES, NAMELY, HOSTING COMPUTER APPLICATION SOFTWARE ON A COMPUTER SERVER FOR OTHERS FOR REMOTE ACCESS TO LOCAL AREA NETWORKS; PROVIDING A WEB-BASED SYSTEM AND ONLINE PORTAL FOR CUSTOMERS TO REMOTELY MANAGE, ADMINISTER, MODIFY AND CONTROL THEIR END USER COMPUTER DEVICES, DATA AND SOFTWARE APPLICATIONS (U.S. CLS. 100 AND 101).

JORDAN BAKER, EXAMINING ATTORNEY

SN 77-664,479. ELECTRONIC ARTS INC., REDWOOD CITY, CA. FILED 2-5-2009.

CHARM GIRLS CLUB

THE MARK CONSISTS OF STANDARD CHARACTERS WITHOUT CLAIM TO ANY PARTICULAR FONT, STYLE, SIZE, OR COLOR.

CLASS 9—ELECTRICAL AND SCIENTIFIC APPARATUS

FOR PRE-RECORDED AUDIO TAPES, VIDEO TAPES, AUDIO CASSETTES, VIDEO CASSETTES, CD-ROMS, DVDS, COMPACT DISCS, AND VIDEO DISCS, FEATURING ENTERTAINMENT RELATED TO FILMS, VIDEO, GAMES, ANIMATED CARTOONS AND MUSIC; RECORDED AND DOWNLOADABLE VIDEO AND AUDIO FILES FEATURING INFORMATION AND INSTRUCTIONS REGARDING COMPUTER AND VIDEO GAMES; COMPUTER GAME SOFTWARE; COMPUTER GAME SOFTWARE AND MANUALS SOLD AS A UNIT; COMPUTER VIDEO GAME SOFTWARE; COMPUTER VIDEO GAME SOFTWARE AND MANUALS SOLD AS A UNIT; INTERACTIVE VIDEO GAME PROGRAMS; INTERACTIVE COMPUTER GAME PROGRAMS; DOWNLOADABLE COMPUTER GAME SOFTWARE VIA A GLOBAL COMPUTER NETWORK AND WIRELESS DEVICES; COMPUTER GAME SOFTWARE FOR USE ON MOBILE AND CELLULAR PHONES, HANDHELD COMPUTERS, COMPUTERS, VIDEO GAME CONSOLES, BOTH HANDHELD AND FREE STANDING, AND OTHER WIRELESS DEVICES; DOWNLOADABLE INTERACTIVE ENTERTAINMENT SOFTWARE FOR PLAYING COMPUTER GAMES; DOWNLOADABLE INTERACTIVE ENTERTAINMENT SOFTWARE FOR PLAYING VIDEO GAMES (U.S. CLS. 21, 23, 26, 36 AND 38).

CLASS 41—EDUCATION AND ENTERTAINMENT

FOR ENTERTAINMENT SERVICES, NAMELY, PROVIDING NEWS AND INFORMATION REGARDING INTERACTIVE COMPUTER GAME SOFTWARE, INTERACTIVE VIDEO GAME SOFTWARE AND INTERACTIVE COMPUTER GAMES AND INTERACTIVE VIDEO GAMES, VIA ELECTRONIC, WIRELESS AND COMPUTER NETWORKS; PROVIDING NEWS AND INFORMATION IN THE FIELD OF ENTERTAINMENT RELATING TO MOTION PICTURE FILMS OVER AN ELECTRONIC NETWORK; ENTERTAINMENT SERVICES, NAMELY, PROVIDING ONLINE COMPUTER AND VIDEO GAMES ACCESSED AND PLAYED VIA ELECTRONIC, WIRELESS AND COMPUTER NETWORKS; ENTERTAINMENT SERVICES, NAMELY, PROVIDING COMPUTER AND VIDEO GAMES ACCESSED AND PLAYED VIA MOBILE AND CELLULAR PHONES AND OTHER WIRELESS DEVICES; ENTERTAINMENT SERVICES, NAMELY, PROVIDING COMPUTER GAMES, VIDEO GAMES, AND GAME SHOWS VIA TELEVISION, SATELLITE, AUDIO, AND VIDEO MEDIA; ENTERTAINMENT SERVICES, NAMELY, PROVIDING A WEB SITE FEATURING MUSICAL PERFORMANCES, MUSICAL VIDEOS, RELATED FILM CLIPS, PHOTOGRAPHS, AND OTHER MULTIMEDIA MATERIALS; ENTERTAINMENT SERVICES IN THE FIELD OF FILM AND TELEVISION, NAMELY, THE CREATION, PRODUCTION AND DISTRIBUTION OF FILMS, AND THE CREATION AND PRODUCTION OF VIDEOS, ANIMATION, AND COMPUTER GENERATED IMAGES; ENTERTAINMENT, NAMELY, A CONTINUING SHOW IN THE FIELD OF COMPUTER GAMES AND VIDEO GAMES DISTRIBUTED OVER ELECTRONIC MEDIA, NAMELY, GLOBAL AND LOCAL AREA COMPUTER NETWORKS; ENTERTAINMENT IN THE NATURE OF COMPETITIONS IN THE FIELD OF ENTERTAINMENT TRIVIA; FAN CLUB SERVICES; PRODUCTION AND DISTRIBUTION OF MOTION PICTURES; PROVIDING NEWS AND INFORMATION IN THE FIELD OF ENTERTAINMENT RELATING TO MOTION PICTURE FILMS VIA GLOBAL COMPUTER NETWORKS (U.S. CLS. 100, 101 AND 107).

KRISTIN CARLSON, EXAMINING ATTORNEY

SN 77-664,515. MIZUHO ORTHOPEDIC SYSTEMS, INC., SACRAMENTO, CA. FILED 2-5-2009.

BRINGING INNOVATION TO THE TABLE

THE MARK CONSISTS OF STANDARD CHARACTERS WITHOUT CLAIM TO ANY PARTICULAR FONT, STYLE, SIZE, OR COLOR.

CLASS 10—MEDICAL APPARATUS

FOR MEDICAL AND SURGICAL APPARATUS AND INSTRUMENTS, NAMELY, ORTHOPEDIC FIXATION DEVICES USED IN ORTHOPEDIC TRANSPLANT AND/OR IMPLANT SURGERY; MEDICAL APPARATUS AND INSTRUMENTS FOR USE IN ORTHOPEDIC SURGERY; ORTHOPEDIC SUPPORTS; SUPPORTS FOR HEADS, TORSOS, PELVISES, AND LEGS FOR MEDICAL USE; SURGICAL APPARATUS AND INSTRUMENTS FOR USE IN ORTHOPEDIC SURGERY (U.S. CLS. 26, 39 AND 44).

CLASS 41—EDUCATION AND ENTERTAINMENT

FOR MEDICAL TRAINING AND TEACHING (U.S. CLS. 100, 101 AND 107).

CORY BOONE, EXAMINING ATTORNEY

SN 77-664,563. THE LOVED DOG LLC, LOS ANGELES, CA. FILED 2-5-2009.

SN 77-664,638. CLAUDE CHRIQUI, DOUGLAS, GA. FILED 2-5-2009.



OWNER OF U.S. REG. NOS. 2,879,000, 3,436,033 AND OTHERS.

THE NAME "TAMAR GELLER" IDENTIFIES A LIVING INDIVIDUAL WHOSE CONSENT IS OF RECORD.

THE MARK CONSISTS OF A CROUCHING DOG WITH A RAISED TAIL AND THE WORDS "THE LOVED DOG BY TAMAR GELLER" UNDERNEATH.

CLASS 3—COSMETICS AND CLEANING PREPARATIONS

FOR DEODORIZERS FOR PETS; NON-MEDICATED GROOMING PREPARATIONS FOR PETS, NAMELY, SHAMPOO AND CONDITIONER (U.S. CLS. 1, 4, 6, 50, 51 AND 52).

CLASS 5—PHARMACEUTICALS

FOR INDOOR AND OUTDOOR REPELLENT SPRAYS FOR DOGS; DOG SPRAYS USED TO AID IN HOUSE-BREAKING DOGS; CARPET DEODORIZERS AND ROOM DEODORIZER COMPOSITIONS; NUTRITIONAL SUPPLEMENTS FOR PETS (U.S. CLS. 6, 18, 44, 46, 51 AND 52).

CLASS 8—HAND TOOLS

FOR GROOMING TOOLS AND APPARATUS FOR DOGS, NAMELY, NAIL CLIPPERS (U.S. CLS. 23, 28 AND 44).

CLASS 16—PAPER GOODS AND PRINTED MATTER

FOR PLASTIC BAGS FOR DISPOSING OF PET WASTES, MARKETED IN SMALL, PLASTIC CYLINDRICAL CONTAINERS; HOUSE TRAINING PRODUCTS FOR DOGS, NAMELY, BIODEGRADABLE PUPPY PADS (U.S. CLS. 2, 5, 22, 23, 29, 37, 38 AND 50).

CLASS 20—FURNITURE AND ARTICLES NOT OTHERWISE CLASSIFIED

FOR BEDS FOR HOUSEHOLD PETS; PET CRATES; PET CUSHIONS; CRATE COVERS FOR PETS; PICTURE FRAMES (U.S. CLS. 2, 13, 22, 25, 32 AND 50).

CLASS 21—HOUSEWARES AND GLASS

FOR BRUSHES FOR DOGS (U.S. CLS. 2, 13, 23, 29, 30, 33, 40 AND 50).

CLASS 28—TOYS AND SPORTING GOODS

FOR TOYS FOR DOGS (U.S. CLS. 22, 23, 38 AND 50).

CLASS 31—NATURAL AGRICULTURAL PRODUCTS

FOR DOG BISCUITS; DOG FOOD; DOG TREATS (U.S. CLS. 1 AND 46).
EMILY CARLSEN, EXAMINING ATTORNEY

PROFILO

THE MARK CONSISTS OF STANDARD CHARACTERS WITHOUT CLAIM TO ANY PARTICULAR FONT, STYLE, SIZE, OR COLOR.

CLASS 3—COSMETICS AND CLEANING PREPARATIONS

FOR COLOGNES, PERFUMES AND COSMETICS; COSMETICS IN GENERAL, INCLUDING PERFUMES; DISINFECTING PERFUMED SOAPS; EAU DE PERFUME; ESSENTIAL OILS AS PERFUME FOR LAUNDRY PURPOSES; LIQUID PERFUMES; OILS FOR PERFUMES AND SCENTS; PERFUME; PERFUME OILS; PERFUME OILS FOR THE MANUFACTURE OF COSMETIC PREPARATIONS; PERFUMED CREAMS; PERFUMED EXTRACTS FOR TISSUES AND PERFUMES; PERFUMED PASTE; PERFUMED POWDER; PERFUMED POWDERS; PERFUMED SOAP; PERFUMED SOAPS; PERFUMED TALCUM POWDER; PERFUMES; PERFUMES AND COLOGNES; PERFUMES AND TOILET WATERS; PERFUMES, AFTERSHAVES AND COLOGNES; PERFUMES, EAU DE COLOGNES AND AFTERSHAVES; PERFUMES, EAUX DE COLOGNE AND AFTERSHAVES; PERFUMING SACHETS; SHOE AND BOOT CREAM; SHOE AND BOOT POLISH; SHOE BLACK; SHOE CREAM; SHOE CREAMS AND POLISHES; SHOE POLISH; SHOE POLISH AND CREAMS; SHOE POLISH APPLICATORS CONTAINING SHOE POLISH (U.S. CLS. 1, 4, 6, 50, 51 AND 52).

CLASS 9—ELECTRICAL AND SCIENTIFIC APPARATUS

FOR ANTI-GLARE GLASSES; CASES FOR CHILDREN'S EYE GLASSES; CHILDREN'S EYE GLASSES; DIVING GLOVES; EYE GLASS CASES; EYE GLASS CORDS; EYE GLASSES; FIELD-GLASSES; FIRE RESISTANT GLOVES; FRAMES FOR GLASSES AND PINNEZ; FUSE CLIPS AND PANEL-MOUNTED FUSE HOLDERS FOR USE WITH ELECTRONIC GLASS AND CERAMIC FUSES; GLASS DRIERS FOR LABORATORY PURPOSES; GLASS GRADUATED SCALES; GLASS TUBES FOR SCIENTIFIC PURPOSES; GLOVES FOR PROTECTION AGAINST ACCIDENTS; MAGNIFYING GLASSES; MAGNIFYING GLASSES THAT FIT ON THE USER'S FACE IN THE MANNER OF EYEGLASSES; OPERA GLASSES; OPTICAL GLASSES; PLATES, GLASS SLIDES OR CHIPS HAVING MULTI-WELL ARRAYS THAT CAN BE USED IN CHEMICAL ANALYSIS, BIOLOGICAL ANALYSIS OR PATTERNING FOR SCIENTIFIC, LABORATORY OR MEDICAL RESEARCH USE; PROTECTIVE GLASSES; PROTECTIVE GLOVES FOR INDUSTRIAL USE; PROTECTIVE METAL GLOVES FOR MEAT CUTTING; PROTECTIVE WORK GLOVES; READING GLASSES; SKI GLASSES; SPECTACLE GLASSES; SPORTS GLASSES; SPORTS' GLASSES; SUN GLASSES; THEATRE GLASSES; VISUAL TRAINING AID, NAMELY, NON-PRESCRIPTION GLASSES USED FOR VISUAL TRAINING PURPOSES (U.S. CLS. 21, 23, 26, 36 AND 38).

CLASS 14—JEWELRY

FOR CASES FOR CLOCK AND WATCH-MAKING; CASES FOR WATCHES AND CLOCKS; CHRONOGRAPHS FOR USE AS WATCHES; CLOCK AND WATCH HANDS; CLOCKS AND WATCHES; CLOCKS AND WATCHES FOR PIGEON-FANCIERS; COMPLICATION WATCHES; DIALS FOR CLOCK-AND-WATCH-MAKING; DIVING WATCHES; DRESS WATCHES; JEWELLERY AND WATCHES; JEWELLERY, CLOCKS AND WATCHES; JEWELRY WATCHES; MECHANICAL AND AUTOMATIC WATCHES; PARTS FOR WATCHES; POCKET WATCHES; STOP WATCHES; WATCH AND CLOCK SPRINGS; WATCH BANDS (U.S. CLS. 2, 27, 28 AND 50).

CLASS 25—CLOTHING

FOR ANKLE SOCKS; ANKLETS; ANTI-PERSPIRANT SOCKS; ATHLETIC APPAREL, NAMELY, SHIRTS, PANTS, JACKETS, FOOTWEAR, HATS AND CAPS, ATHLETIC UNIFORMS; BALLOON PANTS; BATHING SUITS; BATHING SUITS FOR MEN; BODY SHIRTS; BODY SUITS; BOLO TIES; BOW TIES; BRIEFS; BUT-TON-FRONT ALOHA SHIRTS; CAMP SHIRTS; CAPRI PANTS; CARGO PANTS; CHEF'S HATS; CLOTHING FOR ATHLETIC USE, NAMELY, PADDED PANTS; CLOTHING FOR ATHLETIC USE, NAMELY, PADDED SHIRTS; DENIMS; DISPOSABLE UNDERWEAR; DRESS SHIRTS; DRESS SUITS; DRY SUITS; FLIGHT SUITS; FUR HATS; GOLF PANTS, SHIRTS AND SKIRTS; GOLF SHIRTS; GYM SUITS; HAT BANDS; HATS; HEADGEAR, NAMELY, HATS; HOODED SWEAT SHIRTS; JACKETS AND SOCKS; JAPANESE STYLE SOCKS (TABI COVERS); JAPANESE STYLE SOCKS (TABI); JOGGING PANTS; JOGGING SUITS; JUDO SUITS; KARATE SUITS; KNIT SHIRTS; KNITTED UNDERWEAR; LADIES' SUITS; LADIES' UNDERWEAR; LEATHER PANTS; LEISURE SUITS; LONG UNDERWEAR; LONG-SLEEVED SHIRTS; LOUNGE PANTS; MEN'S SOCKS; MEN'S SUITS; MEN'S SUITS, WOMEN'S SUITS; MIXED MARTIAL ARTS SUITS; MOISTURE-WICKING SPORTS PANTS; MOISTURE-WICKING SPORTS SHIRTS; NIGHT SHIRTS; NON-DISPOSABLE CLOTH TRAINING PANTS; NURSE PANTS; ONE-PIECE PLAY SUITS; OPEN-NECKED SHIRTS; PANTS; PAPER HATS FOR USE AS CLOTHING ITEMS; PAPER SHOES USED WHEN GOING THROUGH METAL DETECTORS TO KEEP FEET AND SOCKS CLEAN; PARTS OF CLOTHING, NAMELY, GUSSETS FOR TIGHTS, GUSSETS FOR STOCKINGS, GUSSETS FOR BATHING SUITS, GUSSETS FOR UNDERWEAR, GUSSETS FOR LEOTARDS AND GUSSETS FOR FOOTLETS; PARTY HATS; PERSPIRATION ABSORBENT UNDERWEAR CLOTHING; PETTI-PANTS; PIQUE SHIRTS; PLAY SUITS; POLO SHIRTS; RAIN SUITS; RUGBY SHIRTS; SCIENTIFIC AND TECHNOLOGICAL APPAREL, NAMELY, SHIRTS, PANTS, JACKETS, FOOTWEAR, HATS AND CAPS, UNIFORMS; SHIRT FRONTS; SHIRT YOKES; SHIRTS; SHIRTS FOR SUITS; SHORT-SLEEVED OR LONG-SLEEVED T-SHIRTS; SHORT-SLEEVED SHIRTS; SKI PANTS; SKI SUITS; SKI SUITS FOR COMPETITION; SKIRT SUITS; SLEEP SHIRTS; SMALL HATS; SNOW BOARDING SUITS; SNOW SUITS; SOCK SUSPENDERS; SOCKS; SOCKS AND STOCKINGS; SPORT SHIRTS; SPORTS SHIRTS; SPORTS SHIRTS WITH SHORT SLEEVES; SUIT COATS; SUITS; SUITS OF LEATHER; SWEAT SHIRTS; SWEAT SUITS; T-SHIRTS; TEE SHIRTS; THERMAL SOCKS; THERMAL UNDERWEAR; THONGS; TIES; TOBOGGAN HATS, PANTS AND CAPS; TRACK SUITS; TRAINING SUITS; TRIATHLON CLOTHING, NAMELY, TRIATHLON TIGHTS, TRIATHLON SHORTS, TRIATHLON SINGLET, TRIATHLON SHIRTS, TRIATHLON SUITS; UNDERWEAR; UNDERWEAR, NAMELY, BOY SHORTS; UNION SUITS; VESTED SUITS; WARM UP SUITS; WATER SOCKS; WEARABLE GARMENTS AND CLOTHING, NAMELY, SHIRTS; WET SUIT GLOVES; WET SUITS; WET SUITS FOR WATER-SKIING AND SUB-AQUA; WIND SHIRTS; WOMEN'S UNDERWEAR; WOOLLEN SOCKS; WOOLLY HATS; WOVEN OR KNITTED UNDERWEAR; YOGA SHIRTS; ZOOT SUITS (U.S. CLS. 22 AND 39).

INGRID C. EULIN, EXAMINING ATTORNEY

SN 77-664,752. SWEENEY HOLDINGS LLC, CELEBRATION, FL. FILED 2-6-2009.

Scwooshie

THE MARK CONSISTS OF STANDARD CHARACTERS WITHOUT CLAIM TO ANY PARTICULAR FONT, STYLE, SIZE, OR COLOR.

CLASS 18—LEATHER GOODS

FOR DIAPER BAGS (U.S. CLS. 1, 2, 3, 22 AND 41).

CLASS 20—FURNITURE AND ARTICLES NOT OTHERWISE CLASSIFIED

FOR BEDS, MATTRESSES, PILLOWS AND BOLSTERS; MATERNITY PILLOWS (U.S. CLS. 2, 13, 22, 25, 32 AND 50).

CLASS 24—FABRICS

FOR CHILDREN'S BLANKETS; CHILDREN'S TOWELS (U.S. CLS. 42 AND 50).

CLASS 25—CLOTHING

FOR CHILDREN'S AND INFANTS' CLOTH BIBS; INFANT AND TODDLER ONE PIECE CLOTHING (U.S. CLS. 22 AND 39).

JAMES GRIFFIN, EXAMINING ATTORNEY

SN 77-664,758. NISSAN JIDOSHA KABUSHIKI KAISHA, DBA NISSAN MOTOR CO., LTD., YOKOHAMA-SHI, JAPAN, FILED 2-6-2009.

SPEC V

THE MARK CONSISTS OF STANDARD CHARACTERS WITHOUT CLAIM TO ANY PARTICULAR FONT, STYLE, SIZE, OR COLOR.

CLASS 9—ELECTRICAL AND SCIENTIFIC APPARATUS

FOR COMPUTER GAME SOFTWARE, MOUSE PADS, COMPUTER STORAGE DEVICES, NAMELY, FLASH DRIVES, INTERACTIVE VIDEO GAME PROGRAMS, SUNGLASSES (U.S. CLS. 21, 23, 26, 36 AND 38).

CLASS 28—TOYS AND SPORTING GOODS

FOR TOYS AND PLAYTHINGS, NAMELY, MINIATURE DIE CAST VEHICLES, BATTERY OPERATED REMOTE CONTROL LAND VEHICLES; TOY PLASTIC MODEL HOBBY CRAFT KITS, SIT-IN AND RIDE-ON TOY VEHICLES, LIGHT AND SOUNDS TOYS IN THE NATURE OF MINIATURE CARS WITH LED LIGHTS, PLUSH TOYS, STUFFED TOYS, STAND ALONE VIDEO GAME MACHINES, COIN-OPERATED VIDEO GAMES; GOLF BAGS; GOLF BALLS; GOLF TEES (U.S. CLS. 22, 23, 38 AND 50).

APRIL HESIK, EXAMINING ATTORNEY

SN 77-664,793. FESTIVE PHOTO BOOTH, LLC, ST PETE BEACH, FL. FILED 2-6-2009.

FESTIVE PHOTO BOOTH

THE MARK CONSISTS OF STANDARD CHARACTERS WITHOUT CLAIM TO ANY PARTICULAR FONT, STYLE, SIZE, OR COLOR.

NO CLAIM IS MADE TO THE EXCLUSIVE RIGHT TO USE "PHOTO BOOTH", APART FROM THE MARK AS SHOWN.

CLASS 9—ELECTRICAL AND SCIENTIFIC APPARATUS

FOR PORTABLE INTERACTIVE PHOTOGRAPHY AND/OR VIDEOGRAPHY KIOSKS FOR CAPTURING, PRINTING AND UPLOADING DIGITAL IMAGES FOR FUTURE USE (U.S. CLS. 21, 23, 26, 36 AND 38).

CLASS 41—EDUCATION AND ENTERTAINMENT

FOR RENTAL OF PORTABLE PHOTOGRAPHY AND/OR VIDEOGRAPHY KIOSKS FOR TAKING OF PICTURES AND VIDEOS (U.S. CLS. 100, 101 AND 107).
CYNTHIA SLOAN, EXAMINING ATTORNEY

SN 77-664,954. THE BIG TWELVE CONFERENCE, INC., IRVING, TX. FILED 2-6-2009.

BIG 14

THE MARK CONSISTS OF STANDARD CHARACTERS WITHOUT CLAIM TO ANY PARTICULAR FONT, STYLE, SIZE, OR COLOR.

CLASS 25—CLOTHING

FOR APPAREL, NAMELY, T-SHIRTS, JERSEYS, SWEATSHIRTS, SHIRTS, CAPS, JACKETS, AND WIND RESISTANT SHIRTS, JACKETS AND PANTS (U.S. CLS. 22 AND 39).

CLASS 35—ADVERTISING AND BUSINESS

FOR ASSOCIATION SERVICES, NAMELY, SUPPORTING AND PROMOTING THE INTERESTS OF COLLEGES PARTICIPATING IN INTERCOLLEGIATE ATHLETIC PROGRAMS AND PROMOTING THE STANDARDS OF SCHOLARSHIP, SPORTSMANSHIP AND EQUITY INTERESTS OF COLLEGES; PROMOTING THE GOODS AND SERVICES OF OTHERS BY ARRANGING FOR SPONSORS TO AFFILIATE THEIR GOODS AND SERVICES WITH COLLEGE ATHLETIC COMPETITIONS AND CONTESTS; AND PROMOTING ATHLETIC COMPETITIONS AND CONTESTS (U.S. CLS. 100, 101 AND 102).

CLASS 41—EDUCATION AND ENTERTAINMENT

FOR ENTERTAINMENT SERVICES, NAMELY, ORGANIZING, PRESENTING AND COORDINATING ATHLETIC COMPETITIONS AND CONTESTS; PROVIDING NEWS, SCORES AND INFORMATION REGARDING SPORTING EVENTS VIA THE GLOBAL COMPUTER NETWORK (U.S. CLS. 100, 101 AND 107).
KATHERINE CHANG, EXAMINING ATTORNEY

SN 77-664,955. TRULIGHT SOLAR, LLC, NEW ORLEANS, LA. FILED 2-6-2009.

Trulight Solar

THE MARK CONSISTS OF STANDARD CHARACTERS WITHOUT CLAIM TO ANY PARTICULAR FONT, STYLE, SIZE, OR COLOR.

NO CLAIM IS MADE TO THE EXCLUSIVE RIGHT TO USE "SOLAR", APART FROM THE MARK AS SHOWN.

CLASS 37—CONSTRUCTION AND REPAIR

FOR INSTALLATION AND MAINTENANCE OF PHOTOVOLTAIC/SOLAR THERMAL HYBRID INSTALLATIONS; INSTALLATION AND MAINTENANCE OF SOLAR THERMAL INSTALLATIONS; REPAIR AND INSTALLATION SERVICES, NAMELY, THE INSTALLATION OF HEATING, COOLING AND ENVIRONMENTAL CONTROL SYSTEMS PRIMARILY USING SOLAR ENERGY, RENEWABLE ENERGY RESOURCES AND RAINWATER (U.S. CLS. 100, 103 AND 106).

CLASS 42—SCIENTIFIC AND COMPUTER SERVICES

FOR DESIGN OF SOLAR PHOTOVOLTAIC SYSTEMS; TECHNICAL PLANNING OF PHOTOVOLTAIC/SOLAR THERMAL HYBRID INSTALLATIONS; TECHNICAL PLANNING OF SOLAR THERMAL INSTALLATIONS (U.S. CLS. 100 AND 101).
KATHERINE CHANG, EXAMINING ATTORNEY

SN 77-664,959. RITANI LLC, NEW YORK, NY. FILED 2-6-2009.

**IF YOU'RE GONNA LEASH THE
BIG DOG YOU BETTER GIVE
HIM A NICE COLLAR**

THE MARK CONSISTS OF STANDARD CHARACTERS WITHOUT CLAIM TO ANY PARTICULAR FONT, STYLE, SIZE, OR COLOR.

CLASS 14—JEWELRY

FOR CUT DIAMONDS; DIAMOND JEWELRY; DIAMONDS; JEWELLERY; JEWELLERY AND IMITATION JEWELLERY; JEWELLERY AND PRECIOUS STONES; REAL AND IMITATION JEWELLERY; WATCHES, CLOCKS, JEWELLERY AND IMITATION JEWELLERY (U.S. CLS. 2, 27, 28 AND 50).

CLASS 35—ADVERTISING AND BUSINESS

FOR DISTRIBUTORSHIP SERVICES IN THE FIELD OF JEWELLERY, INCLUDING DIAMOND JEWELLERY, PRECIOUS STONES INCLUDING DIAMONDS AND SEMI-PRECIOUS STONES, HOROLOGICAL AND CHRONOMETRIC INSTRUMENTS, PRECIOUS METALS AND THEIR ALLOYS AND GOODS IN PRECIOUS METALS OR COATED THEREWITH; RETAIL STORE SERVICES FEATURING JEWELLERY, INCLUDING DIAMOND JEWELLERY, PRECIOUS STONES INCLUDING DIAMONDS AND SEMI-PRECIOUS STONES, HOROLOGICAL AND CHRONOMETRIC INSTRUMENTS, PRECIOUS METALS AND THEIR ALLOYS AND GOODS IN PRECIOUS METALS OR COATED THEREWITH; WHOLESALE ORDERING SERVICES IN THE FIELD OF JEWELLERY, INCLUDING DIAMOND JEWELLERY, PRECIOUS STONES INCLUDING DIAMONDS AND SEMI-PRECIOUS STONES, HOROLOGICAL AND CHRONOMETRIC INSTRUMENTS, PRECIOUS METALS AND THEIR ALLOYS AND GOODS IN PRECIOUS METALS OR COATED THEREWITH (U.S. CLS. 100, 101 AND 102).

KRISTIN CARLSON, EXAMINING ATTORNEY

SN 77-665,112. CREATION BY DESIGN LLC, TEANECK, NJ.
FILED 2-6-2009.

BIBLE STRIKE

THE MARK CONSISTS OF STANDARD CHARACTERS WITHOUT CLAIM TO ANY PARTICULAR FONT, STYLE, SIZE, OR COLOR.

NO CLAIM IS MADE TO THE EXCLUSIVE RIGHT TO USE "BIBLE", APART FROM THE MARK AS SHOWN.

CLASS 9—ELECTRICAL AND SCIENTIFIC APPARATUS

FOR VIDEO GAME SOFTWARE (U.S. CLS. 21, 23, 26, 36 AND 38).

CLASS 16—PAPER GOODS AND PRINTED MATTER

FOR EDUCATIONAL LEARNING CARDS FEATURING BIBLICAL THEMES AND EXPLANATORY TEXT; COMIC BOOKS; ILLUSTRATED BOOKS IN THE FIELD OF RELIGION; COLORING BOOKS (U.S. CLS. 2, 5, 22, 23, 29, 37, 38 AND 50).

TARAH HARDY, EXAMINING ATTORNEY

SN 77-665,128. HARGRAVE, HOLLY, MONTCLAIR, NJ.
FILED 2-6-2009.

ATHLETICGENIUS

THE MARK CONSISTS OF STANDARD CHARACTERS WITHOUT CLAIM TO ANY PARTICULAR FONT, STYLE, SIZE, OR COLOR.

CLASS 16—PAPER GOODS AND PRINTED MATTER

FOR EXERCISE BOOKS (U.S. CLS. 2, 5, 22, 23, 29, 37, 38 AND 50).

CLASS 41—EDUCATION AND ENTERTAINMENT

FOR PERSONAL TRAINING SERVICES, NAMELY, PHYSICAL FITNESS TRAINING (U.S. CLS. 100, 101 AND 107).

GINA FINK, EXAMINING ATTORNEY

SN 77-665,153. SUPERVALU INC., EDEN PRAIRIE, MN.
FILED 2-6-2009.

CRUNCH NATION

THE MARK CONSISTS OF STANDARD CHARACTERS WITHOUT CLAIM TO ANY PARTICULAR FONT, STYLE, SIZE, OR COLOR.

CLASS 29—MEATS AND PROCESSED FOODS

FOR POTATO CHIPS; PROCESSED NUTS; BEEF JERKY; TRAIL MIX CONSISTING PRIMARILY OF PROCESSED NUTS, DRIED FRUIT AND/OR RAISINS; CON QUESO DIP; SNACK DIPS; AND, CHEESE SPREADS (U.S. CL. 46).

CLASS 30—STAPLE FOODS

FOR TORTILLA CHIPS; CORN CHIPS; CORN-BASED SNACK FOODS, NAMELY, CHEESE PUFFS AND CRUNCHY CHEESE CURLS; PRETZELS; UNPOPPED POP-CORN; SNACK MIX CONSISTING PRIMARILY OF CRACKERS AND PRETZELS; SALSA; RICE CAKES; AND, CRACKERS (U.S. CL. 46).

MARK SHINER, EXAMINING ATTORNEY

SN 77-665,198. PH4 CORPORATION, BLOOMFIELD HILLS, MI. FILED 2-6-2009.

SUN CITY

THE MARK CONSISTS OF STANDARD CHARACTERS WITHOUT CLAIM TO ANY PARTICULAR FONT, STYLE, SIZE, OR COLOR.

OWNER OF U.S. REG. NOS. 768,006, 2,317,288 AND OTHERS.

CLASS 36—INSURANCE AND FINANCIAL

FOR REAL ESTATE AGENCY SERVICES (U.S. CLS. 100, 101 AND 102).

FIRST USE 1-1-1960; IN COMMERCE 1-1-1960.

CLASS 37—CONSTRUCTION AND REPAIR

FOR PLANNING AND CONSTRUCTION SERVICES, NAMELY, PLANNING, LAYING OUT AND CONSTRUCTION OF RESIDENTIAL AND COMMERCIAL COMMUNITIES (U.S. CLS. 100, 103 AND 106).
FIRST USE 1-1-1960; IN COMMERCE 1-1-1960.

CLASS 41—EDUCATION AND ENTERTAINMENT

FOR GOLF CLUB SERVICES; PROVIDING TENNIS COURT AND SWIMMING FACILITIES; PROVIDING FITNESS EXERCISE FACILITIES; RECREATIONAL SERVICES IN THE NATURE OF GOLF, SWIMMING, TENNIS, EXERCISE, CRAFTS, WALKING, CYCLING, FITNESS AND LAWN GAMES; PROVIDING RECREATIONAL FACILITIES (U.S. CLS. 100, 101 AND 107).
FIRST USE 1-1-1960; IN COMMERCE 1-1-1960.

REBECCA GILBERT, EXAMINING ATTORNEY

SN 77-665,254. YARDI SYSTEMS, INC., GOLETA, CA. FILED 2-6-2009.

RCASH

THE MARK CONSISTS OF STANDARD CHARACTERS WITHOUT CLAIM TO ANY PARTICULAR FONT, STYLE, SIZE, OR COLOR.

CLASS 35—ADVERTISING AND BUSINESS

FOR BUSINESS PROCESS OUTSOURCING SERVICES IN THE FIELD OF REAL ESTATE (U.S. CLS. 100, 101 AND 102).
FIRST USE 4-4-2006; IN COMMERCE 4-4-2006.

CLASS 42—SCIENTIFIC AND COMPUTER SERVICES

FOR PROVIDING ON-LINE NON-DOWNLOADABLE SOFTWARE FOR USE IN MANAGING REAL ESTATE (U.S. CLS. 100 AND 101).
FIRST USE 4-4-2006; IN COMMERCE 4-4-2006.
KIMBERLY PERRY, EXAMINING ATTORNEY

SN 77-665,323. D.M.J. INTERIORS, INC., ROCHESTER, MI. FILED 2-6-2009.

DMJ INTERIORS

THE MARK CONSISTS OF STANDARD CHARACTERS WITHOUT CLAIM TO ANY PARTICULAR FONT, STYLE, SIZE, OR COLOR.

NO CLAIM IS MADE TO THE EXCLUSIVE RIGHT TO USE "INTERIORS", APART FROM THE MARK AS SHOWN.

CLASS 35—ADVERTISING AND BUSINESS

FOR RETAIL STORE SERVICES FEATURING HOME FURNISHINGS (U.S. CLS. 100, 101 AND 102).
FIRST USE 7-31-1989; IN COMMERCE 7-31-1989.

CLASS 42—SCIENTIFIC AND COMPUTER SERVICES

FOR INTERIOR DESIGN SERVICES (U.S. CLS. 100 AND 101).
FIRST USE 7-31-1989; IN COMMERCE 7-31-1989.
JESSICA A. POWERS, EXAMINING ATTORNEY

SN 77-665,380. JM IP HOLDINGS LLC, WASHINGTON, DC. FILED 2-6-2009.

MORRISSEY 2

THE MARK CONSISTS OF STANDARD CHARACTERS WITHOUT CLAIM TO ANY PARTICULAR FONT, STYLE, SIZE, OR COLOR.

CLASS 41—EDUCATION AND ENTERTAINMENT

FOR NIGHT CLUB SERVICES; CABARET SERVICES (U.S. CLS. 100, 101 AND 107).

CLASS 43—HOTEL AND RESTAURANT SERVICES

FOR BAR AND RESTAURANT SERVICES; COCKTAIL LOUNGE SERVICES (U.S. CLS. 100 AND 101).
STEVEN R. FINE, EXAMINING ATTORNEY

SN 77-665,386. ADRIAN TRUJILLO, BURBANK, CA. FILED 2-6-2009.

KidKasa

THE MARK CONSISTS OF STANDARD CHARACTERS WITHOUT CLAIM TO ANY PARTICULAR FONT, STYLE, SIZE, OR COLOR.

CLASS 9—ELECTRICAL AND SCIENTIFIC APPARATUS

FOR MOTION PICTURE FILMS AND FILMS FOR TELEVISION FEATURING CHILDREN'S ENTERTAINMENT (U.S. CLS. 21, 23, 26, 36 AND 38).
FIRST USE 11-27-2006; IN COMMERCE 11-12-2008.

CLASS 41—EDUCATION AND ENTERTAINMENT

FOR ENTERTAINMENT IN THE NATURE OF VISUAL AND AUDIO PERFORMANCES, AND MUSICAL, VARIETY, NEWS AND COMEDY SHOWS (U.S. CLS. 100, 101 AND 107).
FIRST USE 11-27-2006; IN COMMERCE 11-12-2008.
KRISTIN DAHLING, EXAMINING ATTORNEY

SN 77-665,390. JM IP HOLDINGS LLC, WASHINGTON, DC.
FILED 2-6-2009.

SN 77-665,573. TERRAVANT WINE COMPANY, LLC,
BUELLTON, CA. FILED 2-6-2009.

M2

THE MARK CONSISTS OF STANDARD CHARACTERS WITHOUT CLAIM TO ANY PARTICULAR FONT, STYLE, SIZE, OR COLOR.

CLASS 41—EDUCATION AND ENTERTAINMENT

FOR NIGHT CLUB SERVICES; CABARET SERVICES (U.S. CLS. 100, 101 AND 107).
FIRST USE 1-23-2009; IN COMMERCE 1-23-2009.

CLASS 43—HOTEL AND RESTAURANT SERVICES

FOR BAR AND RESTAURANT SERVICES; COCKTAIL LOUNGE SERVICES (U.S. CLS. 100 AND 101).
FIRST USE 1-23-2009; IN COMMERCE 1-23-2009.
STEVEN R. FINE, EXAMINING ATTORNEY

SN 77-665,537. CONSULTING BY CHOICE LLC, DELRAY BEACH, FL. FILED 2-6-2009.



NO CLAIM IS MADE TO THE EXCLUSIVE RIGHT TO USE "MMA", APART FROM THE MARK AS SHOWN. THE STIPPLING IS A FEATURE OF THE MARK. THE MARK CONSISTS OF THE STYLIZED WORDS AND LETTERS "EAST WEST MMA".

CLASS 25—CLOTHING

FOR CLOTHING, NAMELY, MARTIAL ARTS UNIFORMS, SHORTS, JACKETS, SWEAT SHIRTS, RASH GUARDS, T-SHIRTS (U.S. CLS. 22 AND 39).
FIRST USE 1-1-2009; IN COMMERCE 1-1-2009.

CLASS 41—EDUCATION AND ENTERTAINMENT

FOR MARTIAL ARTS INSTRUCTION (U.S. CLS. 100, 101 AND 107).
FIRST USE 1-1-2009; IN COMMERCE 1-1-2009.
BRIAN CALLAGHAN, EXAMINING ATTORNEY

TERRAVANT

THE MARK CONSISTS OF STANDARD CHARACTERS WITHOUT CLAIM TO ANY PARTICULAR FONT, STYLE, SIZE, OR COLOR.

CLASS 39—TRANSPORTATION AND STORAGE

FOR WAREHOUSING SERVICES, NAMELY, STORAGE, DISTRIBUTION, PICK-UP, PACKING AND SHIPPING OF WINE; BOTTLING SERVICES (U.S. CLS. 100 AND 105).
FIRST USE 6-15-2007; IN COMMERCE 6-15-2007.

CLASS 40—MATERIAL TREATMENT

FOR WINERY SERVICES (U.S. CLS. 100, 103 AND 106).
FIRST USE 8-20-2008; IN COMMERCE 8-20-2008.
RUSS HERMAN, EXAMINING ATTORNEY

SN 77-665,583. ANDIS COMPANY, STURTEVANT, WI.
FILED 2-6-2009.

ANDIS

THE MARK CONSISTS OF STANDARD CHARACTERS WITHOUT CLAIM TO ANY PARTICULAR FONT, STYLE, SIZE, OR COLOR.

OWNER OF U.S. REG. NOS. 1,215,675, 3,336,225 AND OTHERS.

CLASS 8—HAND TOOLS

FOR BATTERY OPERATED ANIMAL GROOMING TOOL, NAMELY, HAIR TRIMMER (U.S. CLS. 23, 28 AND 44).
FIRST USE 11-25-2008; IN COMMERCE 11-25-2008.

CLASS 9—ELECTRICAL AND SCIENTIFIC APPARATUS

FOR ELECTRIC HAIR CURLING IRONS, ELECTRIC HAIR STYLING BRUSHES AND ELECTRIC HAIR CURLING IRONS HAVING A HAIR STYLING ATTACHMENT; ELECTRIC STRAIGHTENING IRONS (U.S. CLS. 21, 23, 26, 36 AND 38).
FIRST USE 10-3-1980; IN COMMERCE 10-3-1980.

CLASS 11—ENVIRONMENTAL CONTROL APPARATUS

FOR COMBINATION ELECTRIC HAIR DRYER AND STYLING BRUSH (U.S. CLS. 13, 21, 23, 31 AND 34).
FIRST USE 8-1-1977; IN COMMERCE 8-1-1977.
SOPHIA S. KIM, EXAMINING ATTORNEY

SN 77-665,599. APPLIED MINDS, INC., GLENDALE, CA.
FILED 2-6-2009.

Live Life, Share Private

THE MARK CONSISTS OF STANDARD CHARACTERS WITHOUT CLAIM TO ANY PARTICULAR FONT, STYLE, SIZE, OR COLOR.

CLASS 38—COMMUNICATION

FOR AUDIO AND VIDEO BROADCASTING SERVICES OVER THE INTERNET; BROADCASTING OF VIDEO AND AUDIO PROGRAMMING OVER THE INTERNET; BROADCASTING SERVICES AND PROVISION OF TELECOMMUNICATION ACCESS TO FILMS AND TELEVISION PROGRAMMES PROVIDED VIA A VIDEO-ON-DEMAND SERVICE; BROADCASTING SERVICES AND PROVISION OF TELECOMMUNICATION ACCESS TO VIDEO AND AUDIO CONTENT PROVIDED VIA A VIDEO-ON-DEMAND SERVICE VIA THE INTERNET; INTERACTIVE DELIVERY OF VIDEO OVER DIGITAL NETWORKS; STREAMING OF VIDEO MATERIAL ON THE INTERNET; TRANSMISSION OF INFORMATION THROUGH VIDEO COMMUNICATION SYSTEMS; TRANSMISSION OF SOUND, VIDEO AND INFORMATION; TRANSMISSION OF SOUND, VIDEO AND INFORMATION FROM WEB CAMS, VIDEO CAMERAS OR MOBILE PHONES, ALL FEATURING LIVE OR RECORDED MATERIALS; VIDEO BROADCASTING; VIDEO BROADCASTING SERVICES OVER THE INTERNET OR OTHER COMMUNICATIONS NETWORK FEATURING THE UPLOADED, POSTED AND TAGGED VIDEOS OF OTHERS; VIDEO BROADCASTING SERVICES OVER THE INTERNET OR OTHER COMMUNICATIONS NETWORK, NAMELY, SHOWING, DISPLAYING, AND ELECTRONICALLY TRANSMITTING VIDEO CLIPS; VIDEO BROADCASTING SERVICES VIA THE INTERNET; VIDEO CONFERENCING SERVICES; VIDEO BROADCASTING SERVICES; VIDEO STREAMING SERVICES VIA THE INTERNET, FEATURING INDEPENDENT FILMS AND MOVIES; VIDEO TELECONFERENCING; VIDEO TRANSMISSION OVER DIGITAL NETWORKS; VIDEO-ON-DEMAND TRANSMISSION SERVICES; VIDEO-ON-DEMAND TRANSMISSION SERVICES VIA THE INTERNET (U.S. CLS. 100, 101 AND 104).

CLASS 39—TRANSPORTATION AND STORAGE

FOR PROVIDING A WEB SITE FOR THE ELECTRONIC STORAGE OF DIGITAL PHOTOGRAPHS AND VIDEOS (U.S. CLS. 100 AND 105).

CLASS 42—SCIENTIFIC AND COMPUTER SERVICES

FOR COMPUTER SERVICES, NAMELY, DIGITAL FORMATTING AND COMPRESSION OF MUSIC AND IMAGES, NAMELY, PROCESSING OF DIGITAL MUSIC AND VIDEO IMAGES INTO DOWNLOADABLE PRODUCTS; COMPUTER SERVICES, NAMELY, HOSTING AN INTERACTIVE WEB SITE THAT ALLOWS FAMILIES TO RECORD AND DISPLAY FAMILY PROFILES, RELATIONSHIPS, INTERESTS, AUDIO AND VIDEO CONTENT; DIGITAL TRANSFER SERVICES FOR TRANSFERRING HOME VIDEOS AND FILM TO DVD AND THE INTERNET; PROCESSING OF VIDEO DATA, NAMELY, INTERPRETING VIDEO CONTENT AND IDENTIFYING SEGMENTS THAT CONTAIN PREDEFINED KEY EVENTS; PROVIDING A WEB SITE FEATURING TEMPORARY USE OF NON-DOWNLOADABLE SOFTWARE ALLOWING WEB SITE USERS TO UPLOAD ON-LINE VIDEOS FOR SHARING WITH OTHERS FOR ENTERTAINMENT PURPOSES; PROVIDING A WEB SITE FEATURING TEMPORARY USE OF NON-DOWNLOADABLE SOFTWARE ALLOWING WEB

SITE USERS TO UPLOAD, POST AND DISPLAY ON-LINE VIDEOS FOR SHARING WITH OTHERS FOR ENTERTAINMENT PURPOSES; PROVIDING A WEB SITE THAT GIVES COMPUTER USERS THE ABILITY TO UPLOAD AND SHARE USER-GENERATED VIDEOS, ESSAYS AND ARTICLES ON A WIDE VARIETY OF TOPICS AND SUBJECTS; PROVIDING A WEB SITE THAT GIVES COMPUTER USERS THE ABILITY TO UPLOAD, EXCHANGE AND SHARE PHOTOS, VIDEOS AND VIDEO LOGS; PROVIDING COMPUTER PROGRAMMING SERVICES TO CUSTOMERS THAT ENABLES THEM TO PROVIDE VIDEO AND AUDIO CONTENT ON THEIR WEB SITES (U.S. CLS. 100 AND 101).

APRIL HESIK, EXAMINING ATTORNEY

SN 77-665,631. ZERO MOTORCYCLES, INC., SCOTTS VALLEY, CA. FILED 2-6-2009.

Z-FORCE

THE MARK CONSISTS OF STANDARD CHARACTERS WITHOUT CLAIM TO ANY PARTICULAR FONT, STYLE, SIZE, OR COLOR.

CLASS 9—ELECTRICAL AND SCIENTIFIC APPARATUS

FOR BATTERIES FOR VEHICLES; BATTERY CABLES; BATTERY CHARGERS (U.S. CLS. 21, 23, 26, 36 AND 38).
FIRST USE 1-8-2009; IN COMMERCE 1-8-2009.

CLASS 12—VEHICLES

FOR ELECTRIC DRIVES FOR VEHICLES; GEARBOXES FOR LAND VEHICLES; LAND VEHICLE ENGINE REBUILD KITS, SOLD AS A UNIT; LAND VEHICLE PARTS, NAMELY, DRIVE BELTS; LAND VEHICLE PARTS, NAMELY, DRIVE GEARS; LAND VEHICLE PARTS, NAMELY, TRANSMISSIONS; LAND VEHICLE TRANSMISSION REBUILD KITS, SOLD AS A UNIT; LAND VEHICLE TRANSMISSIONS AND REPLACEMENT PARTS THEREOF; MOTORCYCLE ENGINES; MOTORS FOR LAND VEHICLES; STRUCTURAL PARTS FOR MOTORCYCLES; VEHICLE POWER TRAIN MECHANISM COMPRISED OF CLUTCH, TRANSMISSION, DRIVE SHAFT, AND DIFFERENTIAL (U.S. CLS. 19, 21, 23, 31, 35 AND 44).

FIRST USE 1-8-2009; IN COMMERCE 1-8-2009.
CHARLES L. JENKINS, EXAMINING ATTORNEY

SN 77-665,634. FLORE-FLOREA, JAVIER JULIAN, LLEIDA, SPAIN, FILED 2-6-2009.



THE NAME "BRUNO DIAZ" DOES NOT IDENTIFY A LIVING INDIVIDUAL.

THE COLOR(S) ORANGE, BLACK, BROWN AND WHITE IS/ARE CLAIMED AS A FEATURE OF THE MARK.

THE MARK CONSISTS OF THE SIDE OF A MAN'S HEAD WEARING A HAT AND SMOKING A CIGAR ABOVE A RECTANGLE INSIDE OF WHICH APPEAR THE WORDS "BRUNO DIAZ". THE COLOR BLACK APPEARS IN THE MAN'S HEAD, THE COLOR BROWN APPEARS IN THE WORDS "BRUNO DIAZ" AS WELL AS IN THE OUTER BORDER OF THE RECTANGLE. THE COLOR WHITE APPEARS INSIDE THE RECTANGLE AND THE COLOR ORANGE APPEARS IN THE BACKGROUND OF THE DESIGN.

CLASS 34—SMOKERS' ARTICLES

FOR ASHTRAYS; CIGAR AND CIGARETTE BOXES; CIGAR CASES; CIGAR CUTTERS; CIGAR HOLDERS; CIGAR HUMIDIFIERS; CIGAR LIGHTERS; CIGARETTE CASES; CIGARETTE FILTERS; CIGARETTE HOLDERS; CIGARETTE PAPER; CIGARETTE ROLLING MACHINES; CIGARETTES; CIGARS; HOLDERS FOR CIGARS AND CIGARETTES; HUMIDORS; LIGHTERS FOR SMOKERS; MATCH HOLDERS; MATCHES; POCKET-SIZE CIGARETTE ROLLING MACHINES; SMOKING PIPES; TOBACCO; TOBACCO FILTERS; TOBACCO GRINDERS; TOBACCO JARS; TOBACCO PIPE CLEANERS; TOBACCO POUCHES (U.S. CLS. 2, 8, 9 AND 17).

CLASS 35—ADVERTISING AND BUSINESS

FOR COMMERCIAL MANAGEMENT; IMPORT AND EXPORT AGENCIES; MANUFACTURER REPRESENTATIVES IN THE FIELD OF CIGARS, TOBACCO, MATCHES AND SMOKERS' ARTICLES; ON-LINE RETAIL STORE SERVICES FEATURING CIGARS, TOBACCO, MATCHES AND SMOKERS' ARTICLES; PROVIDING OFFICE FUNCTIONS; WHOLESALE AND RETAIL STORE SERVICES FEATURING CIGARS, TOBACCO, MATCHES AND SMOKERS' ARTICLES (U.S. CLS. 100, 101 AND 102).

LEIGH CAROLINE CASE, EXAMINING ATTORNEY

SN 77-665,641. CYNTHIA ADAMSON, BRADENTON, FL. FILED 2-7-2009.

NAUGHTY MAT

THE MARK CONSISTS OF STANDARD CHARACTERS WITHOUT CLAIM TO ANY PARTICULAR FONT, STYLE, SIZE, OR COLOR.

NO CLAIM IS MADE TO THE EXCLUSIVE RIGHT TO USE "MAT", APART FROM THE MARK AS SHOWN.

CLASS 20—FURNITURE AND ARTICLES NOT OTHERWISE CLASSIFIED

FOR SLEEPING MATS (U.S. CLS. 2, 13, 22, 25, 32 AND 50).

CLASS 27—FLOOR COVERINGS

FOR FLOOR MATS; FOAM MATS FOR USE ON PLAY AREA SURFACES; GYMNASIUM EXERCISE MATS; PERSONAL SITTING MATS; TEXTILE FLOOR MATS FOR USE IN THE HOME (U.S. CLS. 19, 20, 37, 42 AND 50).

CLASS 28—TOYS AND SPORTING GOODS

FOR PERSONAL EXERCISE MATS (U.S. CLS. 22, 23, 38 AND 50).

FRED MANDIR, EXAMINING ATTORNEY

SN 77-665,646. CENTRAL STATIONERY, INC., BUFFALO GROVE, IL. FILED 2-7-2009.

FROM EXPRESSIONS TO IMPRESSIONS

THE MARK CONSISTS OF STANDARD CHARACTERS WITHOUT CLAIM TO ANY PARTICULAR FONT, STYLE, SIZE, OR COLOR.

CLASS 16—PAPER GOODS AND PRINTED MATTER

FOR ADHESIVE NOTE PADS; ADHESIVE NOTE PAPER; ANNOUNCEMENT CARDS; BLANK NOTE CARDS; BUSINESS CARD PAPER; BUSINESS CARDS; CARDS BEARING UNIVERSAL GREETINGS; CHRISTMAS CARDS; CORRESPONDENCE CARDS; ENVELOPES FOR STATIONERY USE; GIFT CARDS; GREETING CARDS; GREETING CARDS HAVING A CHRISTIAN MESSAGE; GREETINGS CARDS AND POSTCARDS; HOLIDAY CARDS; INDEX CARDS; INVITATION CARDS; MOTIVATIONAL CARDS; NOTE CARDS; NOTE PADS; NOTE PAPERS; NOVELTY IDENTIFICATION CARDS; OCCASION CARDS; OFFICE PAPER STATIONERY; PAPER STATIONERY; PLACE CARDS; POST CARDS; POSTCARDS AND GREETING CARDS; PRINTED INVITATIONS; PRINTED RECIPE CARDS; SOCIAL NOTE CARDS; STATIONERY; STATIONERY WRITING PAPER AND ENVELOPES; STICKERS; VISITING CARDS; THANK YOU CARDS (U.S. CLS. 2, 5, 22, 23, 29, 37, 38 AND 50).

FIRST USE 1-1-2009; IN COMMERCE 1-1-2009.

CLASS 35—ADVERTISING AND BUSINESS

FOR ON-LINE RETAIL STORE SERVICES FEATURING ADHESIVE NOTE PADS; ADHESIVE NOTE PAPER; ANNOUNCEMENT CARDS; BLANK NOTE CARDS; BUSINESS CARD PAPER; BUSINESS CARDS; CARDS BEARING UNIVERSAL GREETINGS; CHRISTMAS CARDS; CORRESPONDENCE CARDS; ENVELOPES FOR STATIONERY USE; GIFT CARDS; GREETING CARDS; GREETING CARDS HAVING A CHRISTIAN MESSAGE; GREETINGS CARDS AND POSTCARDS; HOLIDAY CARDS; INDEX CARDS; INVITATION CARDS; MOTIVATIONAL CARDS; NOTE CARDS; NOTE PADS; NOTE PAPERS; NOVELTY IDENTIFICATION CARDS; OCCASION CARDS; OFFICE PAPER STATIONERY; PAPER STATIONERY; PLACE CARDS; POST CARDS; POSTCARDS AND GREETING CARDS; PRINTED INVITATIONS; PRINTED RECIPE CARDS; SOCIAL NOTE CARDS; STATIONERY; STATIONERY WRITING PAPER AND ENVELOPES; STICKERS; VISITING CARDS; PAPER AND PRINTED MATTER; THANK YOU CARDS (U.S. CLS. 100, 101 AND 102).

FIRST USE 1-1-2009; IN COMMERCE 1-1-2009.
ALICE SUE CARRUTHERS, EXAMINING ATTORNEY

SN 77-665,647. 1 THESS, LOS ANGELES, CA. FILED 2-7-2009.

Mighty Second

THE MARK CONSISTS OF STANDARD CHARACTERS WITHOUT CLAIM TO ANY PARTICULAR FONT, STYLE, SIZE, OR COLOR.

CLASS 16—PAPER GOODS AND PRINTED MATTER

FOR PROTECTIVE COVERS FOR BOOKS (U.S. CLS. 2, 5, 22, 23, 29, 37, 38 AND 50).

CLASS 28—TOYS AND SPORTING GOODS

FOR COLLECTABLE TOY FIGURES (U.S. CLS. 22, 23, 38 AND 50).
JENNIFER HETU, EXAMINING ATTORNEY

SN 77-665,653. 1 THESS, LOS ANGELES, CA. FILED 2-7-2009.

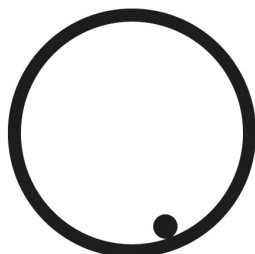

THE MARK CONSISTS OF CIRCLE WITH DOT.

CLASS 16—PAPER GOODS AND PRINTED MATTER

FOR PROTECTIVE COVERS FOR BOOKS (U.S. CLS. 2, 5, 22, 23, 29, 37, 38 AND 50).

CLASS 28—TOYS AND SPORTING GOODS

FOR COLLECTABLE TOY FIGURES (U.S. CLS. 22, 23, 38 AND 50).
JENNIFER HETU, EXAMINING ATTORNEY

SN 77-665,694. UNITED SOYBEAN BOARD, CHESTERFIELD, MO. FILED 2-7-2009.

BeanCast

THE MARK CONSISTS OF STANDARD CHARACTERS WITHOUT CLAIM TO ANY PARTICULAR FONT, STYLE, SIZE, OR COLOR.

CLASS 9—ELECTRICAL AND SCIENTIFIC APPARATUS

FOR DOWNLOADABLE PRERECORDED AUDIO PROGRAMS IN THE FIELD OF AGRICULTURE, NAMELY, SOYBEANS (U.S. CLS. 21, 23, 26, 36 AND 38).
FIRST USE 12-1-2008; IN COMMERCE 12-1-2008.

CLASS 38—COMMUNICATION

FOR DIGITAL MEDIA DISTRIBUTION SERVICES, NAMELY, STREAMING OF PRERECORDED AUDIO PROGRAMS IN THE FIELD OF AGRICULTURE, NAMELY, SOYBEANS, VIA THE INTERNET (U.S. CLS. 100, 101 AND 104).
FIRST USE 12-1-2008; IN COMMERCE 12-1-2008.

CLASS 44—MEDICAL, BEAUTY AND AGRICULTURAL SERVICES

FOR PROVIDING AGRICULTURAL INFORMATION IN THE FIELD OF SOYBEANS FOR THE SOYBEAN INDUSTRY (U.S. CLS. 100 AND 101).
FIRST USE 12-1-2008; IN COMMERCE 12-1-2008.
WILLIAM VERHOSEK, EXAMINING ATTORNEY

SN 77-665,719. KAITEN SUSHI FRANCHISING, INC., EDMONDS, WA. FILED 2-7-2009.

Kaiten Sushi

THE MARK CONSISTS OF STANDARD CHARACTERS WITHOUT CLAIM TO ANY PARTICULAR FONT, STYLE, SIZE, OR COLOR.

NO CLAIM IS MADE TO THE EXCLUSIVE RIGHT TO USE "SUSHI", APART FROM THE MARK AS SHOWN.
THE ENGLISH TRANSLATION OF "KAITEN" IN THE MARK IS "REVOLUTION".

CLASS 30—STAPLE FOODS

FOR SUSHI (U.S. CL. 46).

CLASS 43—HOTEL AND RESTAURANT SERVICES

FOR RESTAURANT SERVICES, NAMELY, PROVIDING OF FOOD AND BEVERAGES FOR CONSUMPTION ON AND OFF THE PREMISES (U.S. CLS. 100 AND 101).
MARK T. MULLEN, EXAMINING ATTORNEY

SN 77-665,731. GUERRERO, MARLON A, SAN FRANCISCO, CA. FILED 2-7-2009.

FashionRenew

THE MARK CONSISTS OF STANDARD CHARACTERS WITHOUT CLAIM TO ANY PARTICULAR FONT, STYLE, SIZE, OR COLOR.

CLASS 18—LEATHER GOODS

FOR PURSES; PURSES AND WALLETS; SMALL PURSES; WRIST MOUNTED PURSES (U.S. CLS. 1, 2, 3, 22 AND 41).

CLASS 25—CLOTHING

FOR ATHLETIC APPAREL, NAMELY, SHIRTS, PANTS, JACKETS, FOOTWEAR, HATS AND CAPS, ATHLETIC UNIFORMS; BODY SHIRTS; COATS; COATS MADE OF COTTON; COATS OF DENIM; DRESSING GOWNS; EVENING DRESSES; FUR COATS AND JACKETS; HATS; HEAVY COATS; JEANS; LEATHER COATS; LEATHER SHOES; LEISURE SHOES; LONG-SLEEVED SHIRTS; NIGHT SHIRTS; OPEN-NECKED SHIRTS; OVER COATS; PANTIES, SHORTS AND BRIEFS; PANTS; RAIN COATS; RUNNING SHOES; SHIRTS FOR SUITS; SHORTS; SKIRTS; SKIRTS AND DRESSES; SPORT SHIRTS; SPORTS SHIRTS WITH SHORT SLEEVES; SUIT COATS; SWEAT SHIRTS; T-SHIRTS; TENNIS SHOES; TRAINING SHOES; WEDDING DRESSES; WOMEN'S CEREMONIAL DRESSES; WOMEN'S SHOES; WORK SHOES AND BOOTS (U.S. CLS. 22 AND 39).
ROSELLE HERRERA, EXAMINING ATTORNEY

SN 77-665,809. EVOCATEUR LLC, WESTPORT, CT. FILED 2-8-2009.

Évocateur

THE MARK CONSISTS OF STANDARD CHARACTERS WITHOUT CLAIM TO ANY PARTICULAR FONT, STYLE, SIZE, OR COLOR.

THE ENGLISH TRANSLATION OF "ÉVOCATEUR" IN THE MARK IS EVOCATIVE.

CLASS 14—JEWELRY

FOR JEWELRY (U.S. CLS. 2, 27, 28 AND 50).
FIRST USE 2-2-2009; IN COMMERCE 2-2-2009.

CLASS 26—FANCY GOODS

FOR BELT BUCKLES (U.S. CLS. 37, 39, 40, 42 AND 50).
FIRST USE 2-2-2009; IN COMMERCE 2-2-2009.
JOHN GARTNER, EXAMINING ATTORNEY

SN 77-665,847. TALLEY INC., SANTA FE SPRINGS, CA. FILED 2-8-2009.

Talley
You connect the world. We
make it easy.

THE MARK CONSISTS OF STANDARD CHARACTERS WITHOUT CLAIM TO ANY PARTICULAR FONT, STYLE, SIZE, OR COLOR.

OWNER OF U.S. REG. NOS. 2,395,263, 3,227,285 AND 3,467,518.

CLASS 35—ADVERTISING AND BUSINESS

FOR DISTRIBUTORSHIP SERVICES IN THE FIELD OF WIRELESS COMMUNICATIONS EQUIPMENT (U.S. CLS. 100, 101 AND 102).
FIRST USE 1-12-2009; IN COMMERCE 1-12-2009.

CLASS 42—SCIENTIFIC AND COMPUTER SERVICES

FOR CONSULTING IN THE FIELD OF TELECOMMUNICATIONS TECHNOLOGY; TECHNICAL CONSULTATION IN THE FIELD OF REAL-TIME RECONFIGURABLE WIRELESS COMMUNICATION HANDSETS AND NETWORK EQUIPMENT FOR USE IN WIDEBAND COMMUNICATIONS (U.S. CLS. 100 AND 101).

FIRST USE 1-12-2009; IN COMMERCE 1-12-2009.
RONALD MCMORROW, EXAMINING ATTORNEY

SN 77-665,852. TALLEY INC., SANTA FE SPRINGS, CA. FILED 2-8-2009.

TALLEY
You Connect the World. We Make it Easy.

OWNER OF U.S. REG. NOS. 2,395,263, 3,227,285 AND 3,467,518.

THE COLOR(S) BLUE AND GREEN IS/ARE CLAIMED AS A FEATURE OF THE MARK.

THE MARK CONSISTS OF THE STYLIZED WORD "TALLEY" IN BLUE WITH EXCEPTION OF THE MIDDLE BAR OF THE "E" IN "TALLEY" WHICH IS IN GREEN; AND THE WORDS "YOU CONNECT THE WORLD. WE MAKE IT EASY." APPEARING IN MUCH SMALLER FONT AND IN THE COLOR BLUE DIRECTLY BELOW THE WORD "TALLEY".

CLASS 35—ADVERTISING AND BUSINESS

FOR DISTRIBUTORSHIP SERVICES IN THE FIELD OF WIRELESS COMMUNICATIONS EQUIPMENT (U.S. CLS. 100, 101 AND 102).

FIRST USE 1-12-2009; IN COMMERCE 1-12-2009.

CLASS 42—SCIENTIFIC AND COMPUTER SERVICES

FOR CONSULTING IN THE FIELD OF TELECOMMUNICATIONS TECHNOLOGY; TECHNICAL CONSULTATION IN THE FIELD OF REAL-TIME RECONFIGURABLE WIRELESS COMMUNICATION HANDSETS AND NETWORK EQUIPMENT FOR USE IN WIDEBAND COMMUNICATIONS (U.S. CLS. 100 AND 101).

FIRST USE 1-12-2009; IN COMMERCE 1-12-2009.
RONALD MCMORROW, EXAMINING ATTORNEY

SN 77-665,857. LEVESQUE, IAN ALDEN, DBA EPHEMERON INDUSTRIES, ELLINGTON, CT. FILED 2-8-2009.

Filevator

THE MARK CONSISTS OF STANDARD CHARACTERS WITHOUT CLAIM TO ANY PARTICULAR FONT, STYLE, SIZE, OR COLOR.

CLASS 9—ELECTRICAL AND SCIENTIFIC APPARATUS

FOR COMPUTER SOFTWARE FOR BACKING UP AND ARCHIVING ELECTRONIC DATA (U.S. CLS. 21, 23, 26, 36 AND 38).

CLASS 39—TRANSPORTATION AND STORAGE

FOR ELECTRONIC STORAGE OF DATA, INCLUDING REMOTE ONLINE BACKUP OF ELECTRONIC DATA; STORAGE SERVICES FOR ARCHIVING DATABASES, IMAGES AND OTHER ELECTRONIC DATA (U.S. CLS. 100 AND 105).

ESTHER A. BORSUK, EXAMINING ATTORNEY

SN 77-665,939. DIAGNOSTIC HYBRIDS, INC., ATHENS, OH. FILED 2-9-2009.

D3

THE MARK CONSISTS OF STANDARD CHARACTERS WITHOUT CLAIM TO ANY PARTICULAR FONT, STYLE, SIZE, OR COLOR.

OWNER OF U.S. REG. NO. 2,802,415.

CLASS 1—CHEMICALS

FOR DIAGNOSTIC PREPARATIONS FOR SCIENTIFIC AND RESEARCH USE; DIAGNOSTIC REAGENTS FOR USE IN IDENTIFYING VIRUSES FOR SCIENTIFIC AND RESEARCH USE; AND DIAGNOSTIC SCREENING KITS CONSISTING PRIMARILY OF DIAGNOSTIC REAGENTS FOR USE IN IDENTIFYING VIRUSES FOR SCIENTIFIC AND RESEARCH USE (U.S. CLS. 1, 5, 6, 10, 26 AND 46).

FIRST USE 1-2-2003; IN COMMERCE 1-2-2003.

CLASS 5—PHARMACEUTICALS

FOR DIAGNOSTIC PREPARATIONS FOR CLINICAL AND MEDICAL USE; DIAGNOSTIC REAGENTS FOR USE IN IDENTIFYING VIRUSES FOR CLINICAL AND MEDICAL USE; AND DIAGNOSTIC SCREENING KITS CONSISTING PRIMARILY OF DIAGNOSTIC REAGENTS FOR USE IN IDENTIFYING VIRUSES FOR CLINICAL AND MEDICAL USE (U.S. CLS. 6, 18, 44, 46, 51 AND 52).

FIRST USE 1-2-2003; IN COMMERCE 1-2-2003.
MATTHEW KLINE, EXAMINING ATTORNEY

SN 77-666,144. THE TREE HOUSE VENTURES, INC., CHELSEA, MI. FILED 2-9-2009.



THE MARK CONSISTS OF A TREE DISPOSED WITHIN A HOUSE.

CLASS 41—EDUCATION AND ENTERTAINMENT

FOR PROVIDING RECREATIONAL AREAS IN THE NATURE OF CHILDREN'S PLAY AREAS (U.S. CLS. 100, 101 AND 107).

FIRST USE 2-2-2009; IN COMMERCE 2-2-2009.

CLASS 43—HOTEL AND RESTAURANT SERVICES

FOR CAFE AND RESTAURANT SERVICES; COFFEE SHOPS (U.S. CLS. 100 AND 101).

FIRST USE 2-2-2009; IN COMMERCE 2-2-2009.
ZHALEH DELANEY, EXAMINING ATTORNEY

SN 77-666,204. MCLEAN, ROBERT H., FORT WORTH, TX. FILED 2-9-2009.

SN 77-666,399. TRANS-AMERICAN INSTITUTE OF PROFESSIONAL STUDIES, INC., KEARNEY, NE. FILED 2-9-2009.

DOODLEBUGS



THE MARK CONSISTS OF STANDARD CHARACTERS WITHOUT CLAIM TO ANY PARTICULAR FONT, STYLE, SIZE, OR COLOR.

CLASS 30—STAPLE FOODS

FOR ICE CREAM (U.S. CL. 46).

CLASS 43—HOTEL AND RESTAURANT SERVICES

FOR RESTAURANT SERVICES, NAMELY, PROVIDING FOOD AND DRINK (U.S. CLS. 100 AND 101).
STEPHANIE ALI, EXAMINING ATTORNEY

NO CLAIM IS MADE TO THE EXCLUSIVE RIGHT TO USE "INSTITUTE OF PROFESSIONAL STUDIES, INC." AND THE PICTORIAL REPRESENTATION OF THE UNITED STATES, APART FROM THE MARK AS SHOWN.

THE MARK CONSISTS OF AN OVAL HAVING LATITUDE AND LONGITUDE LINES AND AN OUTLINE OF THE CONTINENTAL UNITED STATES IN WHICH FOUR BOOKS ARE DISPOSED, THE PHRASE "TRANS-AMERICAN INSTITUTE" ALONG THE TOP PORTION OF THE OVAL AND THE PHRASE "OF PROFESSIONAL STUDIES, INC." ALONG THE BOTTOM PORTION OF THE OVAL.

CLASS 16—PAPER GOODS AND PRINTED MATTER

FOR PRINTED COURSE MATERIALS IN THE FIELD OF REAL ESTATE EDUCATION, NAMELY, BOOKS, WORKBOOKS, AND PAMPHLETS FOR INDIVIDUALS SEEKING REAL ESTATE APPRAISAL LICENSES, APPRAISERS, REAL ESTATE AGENTS AND FOR INDIVIDUALS CONDUCTING CONTINUING EDUCATION COURSES AND SEMINARS TO INDIVIDUALS SEEKING REAL ESTATE APPRAISAL LICENSES, APPRAISERS, AND REAL ESTATE AGENTS (U.S. CLS. 2, 5, 22, 23, 29, 37, 38 AND 50).

FIRST USE 12-31-2004; IN COMMERCE 12-31-2004.

CLASS 41—EDUCATION AND ENTERTAINMENT

FOR EDUCATIONAL SERVICES IN THE FIELD OF REAL ESTATE, NAMELY, PROVIDING PRE-LICENSE COURSES, SEMINARS AND WORKSHOPS TO INDIVIDUALS SEEKING REAL ESTATE APPRAISAL LICENSES; PROVIDING CONTINUING EDUCATION COURSES AND SEMINARS IN THE FIELD OF REAL ESTATE TO APPRAISERS AND REAL ESTATE AGENTS; PROVIDING CUSTOMIZED TRAINING PROGRAMS IN THE FIELD OF REAL ESTATE TO INDIVIDUAL APPRAISAL AND REAL ESTATE OFFICES (U.S. CLS. 100, 101 AND 107).

FIRST USE 12-31-2004; IN COMMERCE 12-31-2004.

JAMES LOVELACE, EXAMINING ATTORNEY

SN 77-666,207. CINCO VIDAS, INC., NEW YORK, NY. FILED 2-9-2009.



THE MARK CONSISTS OF THE WORD "CINCO" FOLLOWED BY FIVE CONNECTED LEAVES FOLLOWED BY THE WORD "VIDAS".

THE ENGLISH TRANSLATION OF "CINCO VIDAS" IS "FIVE LIVES".

CLASS 3—COSMETICS AND CLEANING PREPARATIONS

FOR COSMETICS; SOAPS FOR PERSONAL USE; HAIR LOTIONS; MAKE-UP; NON-MEDICATED SKIN CARE PREPARATIONS; COSMETIC PREPARATIONS FOR BODY CARE; HAIR, NAIL AND MAKE-UP PREPARATIONS (U.S. CLS. 1, 4, 6, 50, 51 AND 52).

CLASS 5—PHARMACEUTICALS

FOR HERBS, NAMELY, NUTRITIONAL SUPPLEMENTS, AND VITAMINS (U.S. CLS. 6, 18, 44, 46, 51 AND 52).

REBECCA POVARCHUK, EXAMINING ATTORNEY

SN 77-666,413. TRANS-AMERICAN INSTITUTE OF PROFESSIONAL STUDIES, INC., KEARNEY, NE. FILED 2-9-2009.

TRANS-AMERICAN INSTITUTE OF PROFESSIONAL STUDIES

THE MARK CONSISTS OF STANDARD CHARACTERS WITHOUT CLAIM TO ANY PARTICULAR FONT, STYLE, SIZE, OR COLOR.

NO CLAIM IS MADE TO THE EXCLUSIVE RIGHT TO USE "INSTITUTE OF PROFESSIONAL STUDIES", APART FROM THE MARK AS SHOWN.

CLASS 16—PAPER GOODS AND PRINTED MATTER

FOR PRINTED COURSE MATERIALS IN THE FIELD OF REAL ESTATE EDUCATION, NAMELY, BOOKS, WORKBOOKS, AND PAMPHLETS FOR INDIVIDUALS SEEKING REAL ESTATE APPRAISAL LICENSES, APPRAISERS, REAL ESTATE AGENTS AND FOR INDIVIDUALS CONDUCTING CONTINUING EDUCATION COURSES AND SEMINARS TO INDIVIDUALS SEEKING REAL ESTATE APPRAISAL LICENSES, APPRAISERS, AND REAL ESTATE AGENTS (U.S. CLS. 2, 5, 22, 23, 29, 37, 38 AND 50).

FIRST USE 12-31-2004; IN COMMERCE 12-31-2004.

CLASS 41—EDUCATION AND ENTERTAINMENT

FOR EDUCATIONAL SERVICES IN THE FIELD OF REAL ESTATE, NAMELY, PROVIDING PRE-LICENSE COURSES, SEMINARS AND WORKSHOPS TO INDIVIDUALS SEEKING REAL ESTATE APPRAISAL LICENSES; PROVIDING CONTINUING EDUCATION COURSES AND SEMINARS IN THE FIELD OF REAL ESTATE TO APPRAISERS AND REAL ESTATE AGENTS; PROVIDING CUSTOMIZED TRAINING PROGRAMS IN THE FIELD OF REAL ESTATE TO INDIVIDUAL APPRAISAL AND REAL ESTATE OFFICES (U.S. CLS. 100, 101 AND 107).

FIRST USE 12-31-2004; IN COMMERCE 12-31-2004.
JAMES LOVELACE, EXAMINING ATTORNEY

SN 77-666,419. TEDDER RECORDS, LLC, LOS ANGELES, CA. FILED 2-9-2009.

PATRIOT RECORDS

THE MARK CONSISTS OF STANDARD CHARACTERS WITHOUT CLAIM TO ANY PARTICULAR FONT, STYLE, SIZE, OR COLOR.

NO CLAIM IS MADE TO THE EXCLUSIVE RIGHT TO USE "RECORDS", APART FROM THE MARK AS SHOWN.

CLASS 9—ELECTRICAL AND SCIENTIFIC APPARATUS

FOR MUSICAL SOUND RECORDINGS; MUSICAL VIDEO RECORDINGS (U.S. CLS. 21, 23, 26, 36 AND 38).

CLASS 41—EDUCATION AND ENTERTAINMENT

FOR ENTERTAINMENT SERVICES, NAMELY, PROVIDING PRERECORDED MUSIC, INFORMATION IN THE FIELD OF MUSIC, AND COMMENTARY AND ARTICLES ABOUT MUSIC, ALL ON-LINE VIA A GLOBAL COMPUTER NETWORK; MULTIMEDIA ENTERTAINMENT SERVICES IN THE NATURE OF RECORDING, PRODUCTION AND POST-PRODUCTION SERVICES IN THE FIELDS OF MUSIC, VIDEO, AND FILMS; PRODUCTION OF SOUND AND MUSIC VIDEO RECORDINGS; PROVIDING AN INTERNET WEBSITE PORTAL FEATURING LINKS TO MUSICAL ARTIST WEBSITES AND MUSIC PERFORMANCE TICKET INFORMATION; PROVIDING AN INTERNET WEBSITE PORTAL IN THE FIELD OF MUSIC (U.S. CLS. 100, 101 AND 107).

CYNTHIA SLOAN, EXAMINING ATTORNEY

SN 77-666,514. TWO OLD HIPPIES, LLC, SPIRIT LAKE, IA. FILED 2-9-2009.

20H

THE MARK CONSISTS OF STANDARD CHARACTERS WITHOUT CLAIM TO ANY PARTICULAR FONT, STYLE, SIZE, OR COLOR.

CLASS 18—LEATHER GOODS

FOR BAGS, NAMELY, HANDBAGS, PURSES, AND SHOULDER BAGS; WALLETS (U.S. CLS. 1, 2, 3, 22 AND 41).

CLASS 25—CLOTHING

FOR CLOTHING, NAMELY, SHIRTS, TOPS, SWEATERS, SWEATPANTS, SWEATSHIRTS, TROUSERS, SHORTS, JACKETS, COATS, NECKTIES, SCARVES, HATS, CAPS, GLOVES, SKIRTS, DRESSES, PAJAMAS, ROBES, AND LOUNGEWEAR; OUTER SHIRTS, NAMELY, EVENING, DRESS, POLO AND SPORT SHIRTS; BEACH WEAR, NAMELY, SWIMWEAR, SWIM SUITS, BATHING TRUNKS, BEACH SHIRTS, BEACH COVER-UPS, AND BEACH SANDALS (U.S. CLS. 22 AND 39).

CLASS 35—ADVERTISING AND BUSINESS

FOR RETAIL AND ON-LINE STORE SERVICES FEATURING CLOTHING FOR MEN AND WOMEN, PERSONAL ACCESSORIES, AND MUSICAL INSTRUMENTS, NAMELY GUITARS, GUITAR PARTS, AND GUITAR ACCESSORIES (U.S. CLS. 100, 101 AND 102).

KEVIN DINALLO, EXAMINING ATTORNEY

SN 77-666,548. WEBTECH INSTITUTE, RIVERDALE, GA. FILED 2-9-2009.

WebTech Kids

THE MARK CONSISTS OF STANDARD CHARACTERS WITHOUT CLAIM TO ANY PARTICULAR FONT, STYLE, SIZE, OR COLOR.

NO CLAIM IS MADE TO THE EXCLUSIVE RIGHT TO USE "KIDS", APART FROM THE MARK AS SHOWN.

CLASS 9—ELECTRICAL AND SCIENTIFIC APPARATUS

FOR DOWNLOADABLE AUDIO FILES, MULTIMEDIA FILES, TEXT FILES, E-MAILS, WRITTEN DOCUMENTS INCLUDING GUIDES AND MANUALS, AUDIO MATERIAL, VIDEO MATERIAL AND GAMES FEATURING INFORMATION IN THE FORM OF A DOWNLOADABLE EDUCATIONAL/TRAINING PROGRAM IN THE FIELD OF COMPUTER BASED LEARNING PROGRAMS FOR SCHOOL AGED CHILDREN (U.S. CLS. 21, 23, 26, 36 AND 38).

FIRST USE 10-19-2007; IN COMMERCE 10-19-2007.

CLASS 16—PAPER GOODS AND PRINTED MATTER

FOR PRINTED TEACHING MATERIALS IN THE FIELD OF COMPUTER BASED WEBSITE CREATION CURRICULA DIRECTED AT E-LEARNING PROGRAMS FOR SCHOOL AGED CHILDREN (U.S. CLS. 2, 5, 22, 23, 29, 37, 38 AND 50).

FIRST USE 10-19-2007; IN COMMERCE 10-19-2007.

CLASS 41—EDUCATION AND ENTERTAINMENT

FOR EDUCATIONAL SERVICES, NAMELY, PROVIDING COURSES OF INSTRUCTION AT THE PRIMARY AND SECONDARY LEVEL DIRECTED AT A STUDENT'S MENTAL AND SOCIAL DEVELOPMENT AND DISTRIBUTING COURSE MATERIALS IN CONNECTION THEREWITH (U.S. CLS. 100, 101 AND 107).

FIRST USE 10-19-2007; IN COMMERCE 10-19-2007.

RICHARD WHITE, EXAMINING ATTORNEY

CLASS 35—ADVERTISING AND BUSINESS

FOR ADVERTISING AND PUBLICITY SERVICES, NAMELY, PROMOTING THE GOODS, SERVICES, BRAND IDENTITY AND COMMERCIAL INFORMATION AND NEWS OF THIRD PARTIES THROUGH PRINT, AUDIO, VIDEO, DIGITAL AND ON-LINE MEDIUM; BRAND CONCEPT AND BRAND DEVELOPMENT SERVICES FOR CORPORATE CLIENTS (U.S. CLS. 100, 101 AND 102).

CLASS 42—SCIENTIFIC AND COMPUTER SERVICES

FOR DESIGNING WEB SITES FOR ADVERTISING PURPOSES; GRAPHIC DESIGN (U.S. CLS. 100 AND 101).
DORITT L. CARROLL, EXAMINING ATTORNEY

SN 77-666,554. TOYON RESEARCH CORPORATION, GOLETA, CA. FILED 2-9-2009.

SN 77-666,731. RAB LIGHTING INC., NORTHVALE, NJ. FILED 2-9-2009.

SDN

THE MARK CONSISTS OF STANDARD CHARACTERS WITHOUT CLAIM TO ANY PARTICULAR FONT, STYLE, SIZE, OR COLOR.

CLASS 9—ELECTRICAL AND SCIENTIFIC APPARATUS

FOR DOWNLOADABLE COMPUTER SOFTWARE FOR USE IN GUIDANCE, NAVIGATION AND CONTROL SYSTEMS; COMPUTER HARDWARE AND SOFTWARE FOR USE IN GUIDANCE, NAVIGATION AND CONTROL SYSTEMS (U.S. CLS. 21, 23, 26, 36 AND 38).

CLASS 42—SCIENTIFIC AND COMPUTER SERVICES

FOR PROVIDING ON-LINE NON-DOWNLOADABLE SOFTWARE FOR USE IN GUIDANCE, NAVIGATION AND CONTROL SYSTEMS; SOFTWARE SERVICES IN THE NATURE OF DEVELOPING GUIDANCE, NAVIGATION AND CONTROL SYSTEMS (U.S. CLS. 100 AND 101).

FIRST USE 7-14-2005; IN COMMERCE 2-3-2009.

DEZMONA MIZELLE, EXAMINING ATTORNEY

RAB DESIGN

THE MARK CONSISTS OF STANDARD CHARACTERS WITHOUT CLAIM TO ANY PARTICULAR FONT, STYLE, SIZE, OR COLOR.

OWNER OF U.S. REG. NOS. 1,828,207, 3,476,075 AND OTHERS.

NO CLAIM IS MADE TO THE EXCLUSIVE RIGHT TO USE "DESIGN", APART FROM THE MARK AS SHOWN.

CLASS 6—METAL GOODS

FOR METAL POLES (U.S. CLS. 2, 12, 13, 14, 23, 25 AND 50).

CLASS 9—ELECTRICAL AND SCIENTIFIC APPARATUS

FOR APPARATUS AND INSTRUMENTS FOR CONVEYING, DISTRIBUTING, TRANSFORMING, STORING, REGULATING OR CONTROLLING ELECTRIC CURRENT; ELECTRIC OR ELECTRONIC SENSORS FOR DETECTING MOTION AND ELECTRIC OR ELECTRONIC SENSORS FOR DETECTING LIGHT (U.S. CLS. 21, 23, 26, 36 AND 38).

CLASS 11—ENVIRONMENTAL CONTROL APPARATUS

FOR LIGHTING FIXTURES; LIGHTING FIXTURES WITH MOTION DETECTION (U.S. CLS. 13, 21, 23, 31 AND 34).

MARIAM MAHMOUDI, EXAMINING ATTORNEY

SN 77-666,724. KELSEY ADVERTISING & DESIGN, LLC, LAGRANGE, GA. FILED 2-9-2009.

What's Next Now.

THE MARK CONSISTS OF STANDARD CHARACTERS WITHOUT CLAIM TO ANY PARTICULAR FONT, STYLE, SIZE, OR COLOR.

SN 77-666,826. HULTING, THOMAS JACK, DBA STATES-MAN ENTERPRISES, BLOOMINGTON, MN. FILED 2-9-2009.

SN 77-667,242. VOXELOGIX CORPORATION, SAN ANTONIO, TX. FILED 2-10-2009.

No More RINOs!

THE MARK CONSISTS OF STANDARD CHARACTERS WITHOUT CLAIM TO ANY PARTICULAR FONT, STYLE, SIZE, OR COLOR.

CLASS 16—PAPER GOODS AND PRINTED MATTER

FOR ADHESIVE-BACKED LETTERS AND NUMBERS FOR USE IN MAKING POSTERS; ADVERTISING SIGNS OF PAPER OR CARDBOARD; BUMPER STICKERS; PRINTED PAPER SIGNS; PRINTED PAPER SIGNS, NAMELY, TABLE TENTS; STICKERS; STICKERS AND DECALCOMANIAS (U.S. CLS. 2, 5, 22, 23, 29, 37, 38 AND 50).

CLASS 25—CLOTHING

FOR SHIRTS; SHORT-SLEEVED OR LONG-SLEEVED T-SHIRTS; SHORT-SLEEVED SHIRTS; T-SHIRTS; WEARABLE GARMENTS AND CLOTHING, NAMELY, SHIRTS (U.S. CLS. 22 AND 39).

CLASS 26—FANCY GOODS

FOR CAMPAIGN BUTTONS; NOVELTY BUTTONS (U.S. CLS. 37, 39, 40, 42 AND 50).
TRICIA SONNEBORN, EXAMINING ATTORNEY

SN 77-667,045. WE: WOMEN'S ENTERTAINMENT LLC, NEW YORK, NY. FILED 2-10-2009.

SIMPLY WEDDINGS

THE MARK CONSISTS OF STANDARD CHARACTERS WITHOUT CLAIM TO ANY PARTICULAR FONT, STYLE, SIZE, OR COLOR.

NO CLAIM IS MADE TO THE EXCLUSIVE RIGHT TO USE "WEDDINGS", APART FROM THE MARK AS SHOWN.

CLASS 38—COMMUNICATION

FOR BROADCAST SERVICES, NAMELY, BROADCASTING OF TELEVISION PROGRAMMING VIA TELEVISION, CABLE, SATELLITE, GLOBAL COMPUTER NETWORK, AUDIO AND VIDEO MEDIA, WIRELESS COMMUNICATIONS AND WIRED COMMUNICATIONS (U.S. CLS. 100, 101 AND 104).

CLASS 41—EDUCATION AND ENTERTAINMENT

FOR TELEVISION PROGRAMMING SERVICES (U.S. CLS. 100, 101 AND 107).
JENNY PARK, EXAMINING ATTORNEY

CTraum

THE MARK CONSISTS OF STANDARD CHARACTERS WITHOUT CLAIM TO ANY PARTICULAR FONT, STYLE, SIZE, OR COLOR.

CLASS 5—PHARMACEUTICALS

FOR BIOLOGICAL IMPLANTS, NAMELY, AVITAL PROCESSED HUMAN OR ANIMAL CONNECTIVE TISSUE; BONE FILLERS CONSISTING OF LIVING MATERIALS; HUMAN ALLOGRAFT BONE AND TISSUE; SURGICAL IMPLANTS COMPRISING LIVING TISSUE (U.S. CLS. 6, 18, 44, 46, 51 AND 52).

CLASS 10—MEDICAL APPARATUS

FOR ARTIFICIAL BONES FOR IMPLANTATION; DENTAL IMPLANTS; IMPLANTS CONSISTING OF ARTIFICIAL MATERIALS; MEDICAL AND SURGICAL APPARATUS AND INSTRUMENTS, NAMELY, DEVICES USED IN ORTHOPEDIC SURGERY TO POSITION SURGICAL INSTRUMENTS, IMPLANTS AND/OR PATIENTS' LIMBS; MEDICAL AND SURGICAL APPARATUS AND INSTRUMENTS, NAMELY, ORTHOPEDIC FIXATION DEVICE USED IN ORTHOPEDIC TRANSPLANT AND/OR IMPLANT SURGERY; MEDICAL DEVICES AND APPARATUS, NAMELY, SURGICAL IMPLANTS COMPRISED PRIMARILY OF ARTIFICIAL MATERIAL AND ALSO INCORPORATING PROCESSED ANIMAL TISSUE FOR USE IN PLASTIC RECONSTRUCTIVE SURGERY, AND REPAIR, REINFORCEMENT OR BUTTRESSING OF SOFT TISSUE, AND PARTS AND FITTINGS THEREFOR; MEDICAL, SURGICAL AND ORTHOPAEDIC IMPLANTS MADE OF ARTIFICIAL MATERIALS; PROSTHETIC AND FILLING MATERIALS, NAMELY, ARTIFICIAL MATERIALS FOR USE IN THE REPLACEMENT OF BONES; SURGICAL IMPLANTS COMPRISING ARTIFICIAL MATERIAL AND ASSOCIATED SURGICAL INSTRUMENT SETS (U.S. CLS. 26, 39 AND 44).

CLASS 40—MATERIAL TREATMENT

FOR DIGITAL ENHANCEMENT AND MANIPULATION OF RADIOLOGICAL DATA BY MEANS OF COMPUTERIZED SOFTWARE FOR USE IN THE FIELD OF DENTAL, MEDICAL, VETERINARY IMPLANTS (U.S. CLS. 100, 103 AND 106).

MARC LEIPZIG, EXAMINING ATTORNEY

SN 77-667,290. CHURCH & DWIGHT CO., INC., PRINCETON, NJ. FILED 2-10-2009.

ALLURA

THE MARK CONSISTS OF STANDARD CHARACTERS WITHOUT CLAIM TO ANY PARTICULAR FONT, STYLE, SIZE, OR COLOR.

OWNER OF U.S. REG. NO. 3,330,820.

CLASS 3—COSMETICS AND CLEANING PREPARATIONS

FOR WOOD FLOOR REFINISHING PREPARATIONS; WOOD FLOOR CLEANING PREPARATIONS, WOOD FLOOR CLEANING KITS CONSISTING OF WOOD FLOOR REFINISHING PREPARATIONS, WOOD FLOOR CLEANING PREPARATIONS, MOP, MOP HEAD, CLEANING AND REFINISHING PADS (U.S. CLS. 1, 4, 6, 50, 51 AND 52).

FIRST USE 3-31-2006; IN COMMERCE 3-31-2006.

CLASS 21—HOUSEWARES AND GLASS

FOR HOUSEHOLD CLEANING IMPLEMENTS, NAMELY, MOPS, MOP HEADS, CLEANING AND FLOOR REFINISHING PADS (U.S. CLS. 2, 13, 23, 29, 30, 33, 40 AND 50).

FIRST USE 3-31-2006; IN COMMERCE 3-31-2006.
VIVIAN MICZNIK FIRST, EXAMINING ATTORNEY

SN 77-667,303, WEBTECH INSTITUTE, RIVERDALE, GA.
FILED 2-10-2009.



NO CLAIM IS MADE TO THE EXCLUSIVE RIGHT TO USE "KIDS" AND "E-LEARNING PROGRAM", APART FROM THE MARK AS SHOWN.

THE MARK CONSISTS OF THE WORD "WEBTECH" IN LARGE STYLIZED LETTERS CENTERED AND DISPOSED IN AN ARCH OVER TWO CHILDREN IN FRONT OF A COMPUTER MONITOR. THE WORD "KIDS" IN SIMILAR STYLIZED LETTERS APPEARS TO THE RIGHT DISPOSED BENEATH THE "H" IN "TECH". A COMPUTER MOUSE IS DISPOSED TO THE LEFT UNDER THE "W" IN "WEB" AND IS CONNECTED TO THE WORD "KIDS" VIA THE MOUSE CORD. "E-LEARNING PROGRAM" IS DISPOSED UNDER THE MOUSE CORD.

CLASS 9—ELECTRICAL AND SCIENTIFIC APPARATUS

FOR DOWNLOADABLE AUDIO FILES, MULTIMEDIA FILES, TEXT FILES, E-MAILS, WRITTEN DOCUMENTS INCLUDING GUIDES AND MANUALS, AUDIO MATERIAL, VIDEO MATERIAL AND GAMES FEATURING INFORMATION IN THE FORM OF A DOWNLOADABLE EDUCATIONAL/TRAINING PROGRAM IN THE FIELD OF COMPUTER BASED LEARNING PROGRAMS FOR SCHOOL AGED CHILDREN FOSTERING PRINCIPLES IN BUSINESS, LEADERSHIP, EDUCATIONAL AS WELL AS CHARACTER-BUILDING INTO THEIR DAILY ACTIVITIES (U.S. CLS. 21, 23, 26, 36 AND 38).

FIRST USE 10-19-2007; IN COMMERCE 10-19-2007.

CLASS 16—PAPER GOODS AND PRINTED MATTER

FOR PRINTED TEACHING MATERIALS IN THE FIELD OF COMPUTER BASED WEBSITE CREATION CURRICULA DIRECTED AT E-LEARNING PROGRAMS FOR CHILDREN (U.S. CLS. 2, 5, 22, 23, 29, 37, 38 AND 50).

FIRST USE 10-19-2007; IN COMMERCE 10-19-2007.
RICHARD WHITE, EXAMINING ATTORNEY

SN 77-667,321, TLA ENTERTAINMENT GROUP, INC., PHILADELPHIA, PA. FILED 2-10-2009.

QFEST

THE MARK CONSISTS OF STANDARD CHARACTERS WITHOUT CLAIM TO ANY PARTICULAR FONT, STYLE, SIZE, OR COLOR.

CLASS 25—CLOTHING

FOR CLOTHING, NAMELY, SHIRTS, T-SHIRTS, PANTS, SHORTS, JACKETS, COATS, SWEATERS, SWEATSHIRTS, SWEATPANTS, SOCKS, HATS, UNDERWEAR, BRAS, AND LINGERIE (U.S. CLS. 22 AND 39).

CLASS 41—EDUCATION AND ENTERTAINMENT

FOR ENTERTAINMENT SERVICES, NAMELY, ORGANIZING AND CONDUCTING A SERIES OF FILM FESTIVALS (U.S. CLS. 100, 101 AND 107).

MICHAEL SOUDERS, EXAMINING ATTORNEY

SN 77-667,325, TLA ENTERTAINMENT GROUP, INC., PHILADELPHIA, PA. FILED 2-10-2009.

PHILADELPHIA QFEST

THE MARK CONSISTS OF STANDARD CHARACTERS WITHOUT CLAIM TO ANY PARTICULAR FONT, STYLE, SIZE, OR COLOR.

NO CLAIM IS MADE TO THE EXCLUSIVE RIGHT TO USE "PHILADELPHIA", APART FROM THE MARK AS SHOWN.

CLASS 25—CLOTHING

FOR CLOTHING, NAMELY, SHIRTS, T-SHIRTS, PANTS, SHORTS, JACKETS, COATS, SWEATERS, SWEATSHIRTS, SWEATPANTS, SOCKS, HATS, UNDERWEAR, BRAS, AND LINGERIE (U.S. CLS. 22 AND 39).

CLASS 41—EDUCATION AND ENTERTAINMENT

FOR ENTERTAINMENT SERVICES, NAMELY, ORGANIZING AND CONDUCTING A SERIES OF FILM FESTIVALS (U.S. CLS. 100, 101 AND 107).

MICHAEL SOUDERS, EXAMINING ATTORNEY

SN 77-667,373. FIRST 5 COMMISSION OF SAN DIEGO COUNTY, SAN DIEGO, CA. FILED 2-10-2009.

SN 77-667,596. UNITED WAY OF CENTRAL NEW MEXICO, ALBUQUERQUE, NM. FILED 2-10-2009.

IMPROVING THE LIVES OF CHILDREN AGES 0 THROUGH 5

THE MARK CONSISTS OF STANDARD CHARACTERS WITHOUT CLAIM TO ANY PARTICULAR FONT, STYLE, SIZE, OR COLOR.

CLASS 35—ADVERTISING AND BUSINESS

FOR PROMOTING PUBLIC AWARENESS OF CHILDREN'S HEALTH CARE, CHILDREN'S EDUCATION, AND CHILDREN'S OVERALL GROWTH AND DEVELOPMENT (U.S. CLS. 100, 101 AND 102).

FIRST USE 8-1-2008; IN COMMERCE 8-1-2008.

CLASS 41—EDUCATION AND ENTERTAINMENT

FOR EDUCATIONAL SERVICES, NAMELY, CONDUCTING PROGRAMS IN THE FIELD OF CHILDREN'S HEALTH CARE, CHILDREN'S EDUCATION, AND CHILDREN'S OVERALL GROWTH AND DEVELOPMENT (U.S. CLS. 100, 101 AND 107).

FIRST USE 8-1-2008; IN COMMERCE 8-1-2008.
AMY HELLA, EXAMINING ATTORNEY

SN 77-667,543. KOLCRAFT ENTERPRISES, INC., CHICAGO, IL. FILED 2-10-2009.

G-EDITION

THE MARK CONSISTS OF STANDARD CHARACTERS WITHOUT CLAIM TO ANY PARTICULAR FONT, STYLE, SIZE, OR COLOR.

CLASS 12—VEHICLES

FOR BABY STROLLERS; STROLLERS (U.S. CLS. 19, 21, 23, 31, 35 AND 44).

CLASS 18—LEATHER GOODS

FOR BABY CARRIERS WORN ON THE BODY; INFANT CARRIERS WORN ON THE BODY (U.S. CLS. 1, 2, 3, 22 AND 41).

COURTNEY MCCORMICK, EXAMINING ATTORNEY



THE MARK CONSISTS OF A CURSIVE LETTER "W".

CLASS 35—ADVERTISING AND BUSINESS

FOR CHARITABLE SERVICES, NAMELY, ORGANIZING AND CONDUCTING VOLUNTEER PROGRAMS AND COMMUNITY SERVICE PROJECTS; DEVELOPING AND COORDINATING VOLUNTEER PROJECTS FOR CHARITABLE ORGANIZATIONS (U.S. CLS. 100, 101 AND 102).

FIRST USE 9-30-2006; IN COMMERCE 9-30-2006.

CLASS 36—INSURANCE AND FINANCIAL

FOR CHARITABLE FUNDRAISING SERVICES; ELEMOSYNARY SERVICES IN THE FIELD OF MONETARY DONATIONS; PHILANTHROPIC SERVICES CONCERNING MONETARY DONATIONS (U.S. CLS. 100, 101 AND 102).

FIRST USE 9-30-2006; IN COMMERCE 9-30-2006.
DAVID H. STINE, EXAMINING ATTORNEY

SN 77-667,748. HEAP, STEVE, SALT LAKE CITY, UT. FILED 2-10-2009.

VUETONE

THE MARK CONSISTS OF STANDARD CHARACTERS WITHOUT CLAIM TO ANY PARTICULAR FONT, STYLE, SIZE, OR COLOR.

CLASS 35—ADVERTISING AND BUSINESS

FOR ADVERTISING SERVICES, NAMELY, CREATING CORPORATE LOGOS FOR OTHERS; BRANDING SERVICES, NAMELY, CONSULTING, DEVELOPMENT, MANAGEMENT AND MARKETING OF BRANDS FOR BUSINESSES (U.S. CLS. 100, 101 AND 102).

FIRST USE 7-0-2007; IN COMMERCE 7-0-2007.

CLASS 41—EDUCATION AND ENTERTAINMENT

FOR AUDIO AND VIDEO RECORDING SERVICES; MULTIMEDIA ENTERTAINMENT SERVICES IN THE NATURE OF RECORDING, PRODUCTION AND POST-PRODUCTION SERVICES IN THE FIELDS OF MUSIC, VIDEO, AND FILMS; PHOTOGRAPHY SERVICES (U.S. CLS. 100, 101 AND 107).
FIRST USE 7-0-2007; IN COMMERCE 7-0-2007.

CLASS 42—SCIENTIFIC AND COMPUTER SERVICES

FOR DESIGN OF HOME PAGES AND WEB SITES; GRAPHIC DESIGN SERVICES (U.S. CLS. 100 AND 101).
FIRST USE 7-0-2007; IN COMMERCE 7-0-2007.
GINA HAYES, EXAMINING ATTORNEY

SN 77-668,060. SEMPRA ENERGY, SAN DIEGO, CA. FILED 2-11-2009.



OWNER OF U.S. REG. NOS. 2,437,361, 3,411,029 AND OTHERS.

NO CLAIM IS MADE TO THE EXCLUSIVE RIGHT TO USE "COMPANY", APART FROM THE MARK AS SHOWN. THE MARK CONSISTS OF A CRESCENT AND DESIGN OF A HUMAN FIGURE HOLDING A FLAME NEXT TO THE WORDING "MOBILEGAS" ABOVE THE SMALLER WORDING "A SEMPRA COMPANY".

SN 77-667,980. TLA ENTERTAINMENT GROUP, INC., PHILADELPHIA, PA. FILED 2-11-2009.

CINEFEST

THE MARK CONSISTS OF STANDARD CHARACTERS WITHOUT CLAIM TO ANY PARTICULAR FONT, STYLE, SIZE, OR COLOR.

CLASS 25—CLOTHING

FOR CLOTHING, NAMELY, SHIRTS, T-SHIRTS, PANTS, SHORTS, JACKETS, COATS, SWEATERS, SWEATSHIRTS, SWEATPANTS, SOCKS, HATS, UNDERWEAR, BRAS, AND LINGERIE (U.S. CLS. 22 AND 39).

CLASS 41—EDUCATION AND ENTERTAINMENT

FOR ENTERTAINMENT SERVICES, NAMELY, ORGANIZING AND CONDUCTING A SERIES OF FILM FESTIVALS (U.S. CLS. 100, 101 AND 107).
MICHAEL SOUDERS, EXAMINING ATTORNEY

CLASS 39—TRANSPORTATION AND STORAGE

FOR PUBLIC UTILITY SERVICES; PUBLIC UTILITY SERVICES IN THE NATURE OF NATURAL GAS DISTRIBUTION; TRANSMISSION OF GAS THROUGH PIPELINES (U.S. CLS. 100 AND 105).

FIRST USE 1-6-2009, THE MARK WAS FIRST USED ANYWHERE IN A DIFFERENT FORM OTHER THAN THAT SOUGHT TO BE REGISTERED AT LEAST AS EARLY AS 00/00/1933.; IN COMMERCE 1-6-2009, THE MARK WAS FIRST USED IN COMMERCE IN A DIFFERENT FORM OTHER THAN THAT SOUGHT TO BE REGISTERED AT LEAST AS EARLY AS 00/00/1933..

CLASS 42—SCIENTIFIC AND COMPUTER SERVICES

FOR NATURAL GAS SERVICES, NAMELY, METERING (U.S. CLS. 100 AND 101).

FIRST USE 1-6-2009, THE MARK WAS FIRST USED ANYWHERE IN A DIFFERENT FORM OTHER THAN THAT SOUGHT TO BE REGISTERED AT LEAST AS EARLY AS 00/00/1933.; IN COMMERCE 1-6-2009, THE MARK WAS FIRST USED IN COMMERCE IN A DIFFERENT FORM OTHER THAN THAT SOUGHT TO BE REGISTERED AT LEAST AS EARLY AS 00/00/1933..

DAVID C. REIHNER, EXAMINING ATTORNEY

SN 77-668,502. THE SAUL ZAENTZ COMPANY, BERKELEY, CA. FILED 2-11-2009.

ARAGORN

THE MARK CONSISTS OF STANDARD CHARACTERS WITHOUT CLAIM TO ANY PARTICULAR FONT, STYLE, SIZE, OR COLOR.

CLASS 25—CLOTHING

FOR HALLOWEEN COSTUMES; COSTUMES FOR USE IN CHILDREN'S AND ADULT'S DRESS-UP PLAY CONSISTING PRIMARILY OF CLOAK, TUNIC, BELT AND BOOT TOPS; COSTUME ACCESSORY KITS CONSISTING PRIMARILY OF CLOAK, GLOVES, BELT AND TOY SWORD (U.S. CLS. 22 AND 39).

FIRST USE 10-25-2003; IN COMMERCE 8-24-2008.

CLASS 26—FANCY GOODS

FOR ORNAMENTAL CLOTH PATCHES (U.S. CLS. 37, 39, 40, 42 AND 50).

FIRST USE 5-17-2004; IN COMMERCE 8-24-2008.

CLASS 28—TOYS AND SPORTING GOODS

FOR TOY SWORD (U.S. CLS. 22, 23, 38 AND 50).

FIRST USE 10-2-2003; IN COMMERCE 8-3-2008.

LINDA POWELL, EXAMINING ATTORNEY

SN 77-669,400. TCBY SYSTEMS, LLC, SALT LAKE, UT. FILED 2-12-2009.



OWNER OF U.S. REG. NOS. 1,338,536, 3,388,311 AND OTHERS.

NO CLAIM IS MADE TO THE EXCLUSIVE RIGHT TO USE "TART" AND "TART YOGURT", APART FROM THE MARK AS SHOWN.

THE MARK CONSISTS OF AN OUTER AND INNER CIRCLE WITH WORDING BETWEEN BOTH CIRCLES AND A HART IN THE MIDDLE OF BOTH CIRCLES.

SN 77-668,982. TWINSTRATA, INC., AKA TWINSTRATA, NATICK, MA. FILED 2-12-2009.

TwinStrata

THE MARK CONSISTS OF STANDARD CHARACTERS WITHOUT CLAIM TO ANY PARTICULAR FONT, STYLE, SIZE, OR COLOR.

CLASS 9—ELECTRICAL AND SCIENTIFIC APPARATUS

FOR COMPUTER SOFTWARE AND HARDWARE FOR USE IN THE ONLINE STORAGE OF IMAGES, TEXT, DATA AND INFORMATION; COMPUTER SOFTWARE FOR USE IN THE ONLINE STORAGE OF IMAGES, TEXT, DATA AND INFORMATION; COMPUTER SOFTWARE FOR USE IN THE ONLINE STORAGE OF IMAGES, TEXT, DATA AND INFORMATION THAT MAY BE DOWNLOADED FROM A GLOBAL COMPUTER NETWORK; COMPUTER SOFTWARE PLATFORMS FOR USE IN THE ONLINE STORAGE OF IMAGES, TEXT, DATA AND INFORMATION; DATABASE MANAGEMENT SOFTWARE FOR USE IN THE ONLINE STORAGE OF IMAGES, TEXT, DATA AND INFORMATION; DOWNLOADABLE COMPUTER SOFTWARE FOR USE IN THE ONLINE STORAGE OF IMAGES, TEXT, DATA AND INFORMATION; FLOPPY DISCS FOR COMPUTERS FEATURING USE IN THE ONLINE STORAGE OF IMAGES, TEXT, DATA AND INFORMATION (U.S. CLS. 21, 23, 26, 36 AND 38).

CLASS 42—SCIENTIFIC AND COMPUTER SERVICES

FOR APPLICATION SERVICE PROVIDER (ASP) FEATURING SOFTWARE FOR USE IN THE ONLINE STORAGE OF IMAGES, TEXT, DATA AND INFORMATION; SOFTWARE AS A SERVICE (SAAS) SERVICES FEATURING THE ONLINE STORAGE OF IMAGES, TEXT, DATA AND INFORMATION; SOFTWARE AS A SERVICE (SAAS) SERVICES, NAMELY HOSTING SOFTWARE FOR USE BY OTHERS FOR USE IN THE ONLINE STORAGE OF IMAGES, TEXT, DATA AND INFORMATION (U.S. CLS. 100 AND 101).

JOHN DALIER, EXAMINING ATTORNEY

CLASS 25—CLOTHING

FOR T-SHIRTS (U.S. CLS. 22 AND 39).

CLASS 29—MEATS AND PROCESSED FOODS

FOR YOGURT (U.S. CL. 46).

CLASS 30—STAPLE FOODS

FOR FROZEN YOGURT (U.S. CL. 46).

SUSAN RICHARDS, EXAMINING ATTORNEY

SN 77-669,499. D'ADAMO, PETER JAMES, WILTON, CT. FILED 2-12-2009.

D'ADAMO PERSONALIZED NUTRITION

THE MARK CONSISTS OF STANDARD CHARACTERS WITHOUT CLAIM TO ANY PARTICULAR FONT, STYLE, SIZE, OR COLOR.

OWNER OF U.S. REG. NOS. 2,368,884, 2,663,668 AND 2,684,979.

NO CLAIM IS MADE TO THE EXCLUSIVE RIGHT TO USE "PERSONALIZED NUTRITION", APART FROM THE MARK AS SHOWN.

CLASS 5—PHARMACEUTICALS

FOR MINERAL SUPPLEMENTS; NUTRITIONAL SUPPLEMENTS; VITAMIN SUPPLEMENTS (U.S. CLS. 6, 18, 44, 46, 51 AND 52).

CLASS 35—ADVERTISING AND BUSINESS

FOR ON-LINE RETAIL STORE SERVICES FEATURING NUTRITIONAL SUPPLEMENTS, VITAMIN SUPPLEMENTS, MINERAL SUPPLEMENTS, TEA, PROTEIN POWDERS, FOOD BARS, SKIN CARE PRODUCTS, BOOKS, AUDIOBOOKS, AND BLOOD TYPING KITS (U.S. CLS. 100, 101 AND 102).

LAKEISHA LEWIS, EXAMINING ATTORNEY

COLORS OF ORANGE, LIGHT GREEN, DARK GREEN, TEAL AND BLUE, RESPECTIVELY, FROM TOP TO BOTTOM, WHICH PATTERN OF COLORED DOTS IS BROKEN UP BY DIAGONAL SEGMENTS RUNNING FROM THE TOP CENTER OF THE RECTANGLE TO BEYOND THE LEFT AND RIGHT EDGES OF THE RECTANGLE, FORMING RIGHT TRIANGLES ON EACH SIDE OF THE RECTANGLE, TO CREATE THE PROFILE OF A HOUSE, BELOW WHICH APPEAR THE LETTERS "AES" IN WHITE LOWERCASE CHARACTERS.

SN 77-669,569. TCBY SYSTEMS, LLC, SALT LAKE, UT. FILED 2-12-2009.



NO CLAIM IS MADE TO THE EXCLUSIVE RIGHT TO USE "TART", APART FROM THE MARK AS SHOWN. THE MARK CONSISTS OF THE WORD "I" WITH A HEART SYMBOL AND THE WORD "TART" WITH A LINE AROUND ENTIRE MARK MAKING A RECTANGULAR SHAPE.

CLASS 25—CLOTHING

FOR T-SHIRTS (U.S. CLS. 22 AND 39).

CLASS 29—MEATS AND PROCESSED FOODS

FOR YOGURT (U.S. CL. 46).

CLASS 30—STAPLE FOODS

FOR FROZEN YOGURT (U.S. CL. 46).
SUSAN RICHARDS, EXAMINING ATTORNEY

CLASS 9—ELECTRICAL AND SCIENTIFIC APPARATUS

FOR PHOTOVOLTAIC CELLS AND MODULES (U.S. CLS. 21, 23, 26, 36 AND 38).
FIRST USE 12-8-2008; IN COMMERCE 12-8-2008.

CLASS 11—ENVIRONMENTAL CONTROL APPARATUS

FOR SOLAR HEAT COLLECTION PANELS; SOLAR THERMAL AIR SYSTEMS FOR HEATING PURPOSES; SOLAR WATER HEATERS (U.S. CLS. 13, 21, 23, 31 AND 34).
FIRST USE 12-8-2008; IN COMMERCE 12-8-2008.

CLASS 35—ADVERTISING AND BUSINESS

FOR CONSULTATION IN THE FIELD OF ENERGY EFFICIENCY (U.S. CLS. 100, 101 AND 102).
FIRST USE 12-8-2008; IN COMMERCE 12-8-2008.

CLASS 37—CONSTRUCTION AND REPAIR

FOR INSTALLATION AND MAINTENANCE OF PHOTOVOLTAIC SYSTEMS; INSTALLATION AND MAINTENANCE OF SOLAR THERMAL SYSTEMS; INSTALLATION OF BUILDING INSULATION; INSTALLATION OF WINDOWS (U.S. CLS. 100, 103 AND 106).
FIRST USE 12-8-2008; IN COMMERCE 12-8-2008.
SKYE YOUNG, EXAMINING ATTORNEY

SN 77-669,962. AFFORDABLE ENERGY SOLUTIONS, INC., CLEARWATER, FL. FILED 2-13-2009.



THE COLOR(S) BLACK, WHITE, ORANGE, LIGHT GREEN, DARK GREEN, TEAL, AND BLUE IS/ARE CLAIMED AS A FEATURE OF THE MARK. THE MARK CONSISTS OF A BLACK RECTANGLE WITHIN WHICH APPEAR ROWS OF DOTS IN THE

SN 77-672,965. NETWORKS IN MOTION, INC., ALISO VIEJO, CA. FILED 2-18-2009.

TRAFFICBUILDER

THE MARK CONSISTS OF STANDARD CHARACTERS WITHOUT CLAIM TO ANY PARTICULAR FONT, STYLE, SIZE, OR COLOR.

CLASS 9—ELECTRICAL AND SCIENTIFIC APPARATUS

FOR COMPUTER HARDWARE AND COMPUTER SOFTWARE PROGRAMS THAT PROVIDE TRAFFIC AND TRAVELER INFORMATION SERVICES VIA WIRED AND WIRELESS TELECOMMUNICATIONS NETWORKS, INCLUDING THE INTERNET, CELLULAR PHONES, PDAS, PAGERS, TEXT MESSAGING DEVICES, AND HANDHELD AND IN-VEHICLE NAVIGATION SYSTEMS (U.S. CLS. 21, 23, 26, 36 AND 38).

CLASS 38—COMMUNICATION

FOR ELECTRONIC TRANSMISSION OF DATA REGARDING REAL-TIME TRAFFIC AND TRAVELER INFORMATION, ALERTS AND ADVISORIES INCLUDING PROJECTED ARRIVAL TIMES AND ALTERNATE ROUTES FOR TRAFFIC AVOIDANCE TO DRIVERS, PASSENGERS AND TRAVELERS VIA WIRELESS TELECOMMUNICATIONS NETWORKS, INCLUDING THE INTERNET, CELLULAR PHONES, PDAS, PAGERS, TEXT MESSAGING DEVICES, AND HANDHELD AND IN-VEHICLE NAVIGATION SYSTEMS (U.S. CLS. 100, 101 AND 104).

ANDREA K. NADELMAN, EXAMINING ATTORNEY

SN 77-673,450. CHURCH & DWIGHT CO., INC., PRINCETON, NJ. FILED 2-19-2009.



OWNER OF U.S. REG. NOS. 2,012,578, 3,134,437 AND OTHERS.

THE MARK CONSISTS OF WARRIOR HEAD FACING RIGHT.

CLASS 3—COSMETICS AND CLEANING PREPARATIONS

FOR MASSAGE OILS; NON-MEDICATED PRE-MOISTENED COSMETIC TOWELETTES FOR HYGIENIC USE; NON-MEDICATED PRE-MOISTENED COSMETIC WIPES FOR HYGIENIC USE (U.S. CLS. 1, 4, 6, 50, 51 AND 52).

CLASS 5—PHARMACEUTICALS

FOR WATER-BASED PERSONAL LUBRICANTS; SILICONE-BASED PERSONAL LUBRICANTS; VAGINAL MOISTURIZERS AND VAGINAL LUBRICANTS; GENITAL VASODILATORS IN THE FORM OF CREAMS, OILS, GEL, LOTIONS AND POTIONS FOR STIMULATING SEXUAL AROUSAL IN MALES AND FEMALES; DESENSITIZING OINTMENTS; MEDICATED PRE-MOISTENED TOWELETTES; MEDICATED PRE-MOISTENED WIPES; DISINFECTING PRE-MOISTENED TOWELETTES; DISINFECTING PRE-MOISTENED WIPES (U.S. CLS. 6, 18, 44, 46, 51 AND 52).

CLASS 10—MEDICAL APPARATUS

FOR CONSTRICTOR RINGS FOR MAINTAINING PENILE RIGIDITY; PENIS ENHANCEMENT RINGS (U.S. CLS. 26, 39 AND 44).

VIVIAN MICZNIK FIRST, EXAMINING ATTORNEY

SN 77-674,226. FRANK L. STILE M.D., PC, LAS VEGAS, NV. FILED 2-19-2009.

NUBIADERM

THE MARK CONSISTS OF STANDARD CHARACTERS WITHOUT CLAIM TO ANY PARTICULAR FONT, STYLE, SIZE, OR COLOR.

CLASS 3—COSMETICS AND CLEANING PREPARATIONS

FOR COSMETICS; NON-MEDICATED SKIN CARE PRODUCTS, NAMELY LOTIONS, MOISTURIZERS, CONDITIONERS, CLARIFIERS, CLEANSERS, OILS, EMOLLIENTS, PREPARATIONS, SOAPS, TONERS, AND CREAMS; NON-MEDICATED ACNE TREATMENT PREPARATIONS; EXFOLIANTS FOR SKIN; SOAPS, SHAMPOOS AND CONDITIONERS; SKIN LIGHTENERS; SKIN CARE PREPARATIONS, NAMELY, BODY POLISH AND CHEMICAL PEELS FOR SKIN; SKIN LIGHTENING AND WHITENING CREAMS AND PREPARATIONS (U.S. CLS. 1, 4, 6, 50, 51 AND 52).

CLASS 5—PHARMACEUTICALS

FOR MEDICATED SKIN CARE PREPARATIONS; MEDICINAL CREAMS FOR SKIN CARE; ACNE TREATMENT PREPARATIONS (U.S. CLS. 6, 18, 44, 46, 51 AND 52).

JAMES GRIFFIN, EXAMINING ATTORNEY

SN 77-675,096. SOCIAL GAMING NETWORK, INC., PALO ALTO, CA. FILED 2-20-2009.

SGN

THE MARK CONSISTS OF STANDARD CHARACTERS WITHOUT CLAIM TO ANY PARTICULAR FONT, STYLE, SIZE, OR COLOR.

CLASS 9—ELECTRICAL AND SCIENTIFIC APPARATUS

FOR COMPUTER GAME SOFTWARE (U.S. CLS. 21, 23, 26, 36 AND 38).
FIRST USE 10-0-2008; IN COMMERCE 10-0-2008.

CLASS 41—EDUCATION AND ENTERTAINMENT

FOR PROVIDING ONLINE COMPUTER GAMES (U.S. CLS. 100, 101 AND 107).
FIRST USE 10-0-2008; IN COMMERCE 10-0-2008.

CLASS 45—PERSONAL AND LEGAL SERVICES

FOR PROVIDING COMMUNICATION SERVICES, NAMELY, SOCIAL NETWORKING VIA THE INTERNET AND MOBILE COMMUNICATION DEVICES (U.S. CLS. 100 AND 101).

FIRST USE 10-0-2008; IN COMMERCE 10-0-2008.
MARK T. MULLEN, EXAMINING ATTORNEY

SN 77-675,689. ACURIAN INC., HORSHAM, PA. FILED 2-23-2009.

SN 77-676,780. CONAGRA FOODS RDM, INC., OMAHA, NE. FILED 2-24-2009.

ACURIAN RECRUITMENT MANAGER

THE MARK CONSISTS OF STANDARD CHARACTERS WITHOUT CLAIM TO ANY PARTICULAR FONT, STYLE, SIZE, OR COLOR.

OWNER OF U.S. REG. NOS. 2,566,246 AND 2,697,439.

NO CLAIM IS MADE TO THE EXCLUSIVE RIGHT TO USE "RECRUITMENT MANAGER", APART FROM THE MARK AS SHOWN.

CLASS 9—ELECTRICAL AND SCIENTIFIC APPARATUS

FOR SOFTWARE FOR PROVIDING A SECURE DATABASE OF INFORMATION RELATED TO PATIENT ENROLLMENT IN CLINICAL TRIALS, INCLUDING THE STATUS OF PATIENTS ENROLLMENT, A CALL CENTER OR ONLINE ACROSS TO CENTRALLY PRE-SCREEN PATIENTS THROUGH A RECRUITMENT CAMPAIGN, THE ABILITY TO TRACK ALL RECRUITMENT CAMPAIGNS AND APPOINTMENT SCHEDULING AND TRACK ALL PATIENTS FROM RESPONSE TO RANDOMIZATION PROVIDING QUANTITATIVE DATA ON HOW MANY PATIENTS ARE REFERRING, CONSENTING AND ENROLLING STUDIES AT ANY GIVEN TIME, AND INCLUDING COLLECTING AND ANALYZING DATA ON WHY PATIENTS ARE DISQUALIFYING AT THE PRE-SCREENING LEVEL TO HELP DETERMINE IF ADJUSTMENTS TO CRITERIA ARE NEEDED (U.S. CLS. 21, 23, 26, 36 AND 38).

CLASS 35—ADVERTISING AND BUSINESS

FOR PROVIDING AN ONLINE SECURE DATABASE OF RECRUITMENT INFORMATION FOR BUSINESS PURPOSES RELATED TO PATIENT ENROLLMENT IN CLINICAL TRIALS, INCLUDING THE STATUS OF PATIENTS ENROLLMENT, THE ABILITY TO TRACK ALL RECRUITMENT CAMPAIGNS AND APPOINTMENT SCHEDULING AND TRACK ALL PATIENTS FROM RESPONSE TO RANDOMIZING PROVIDING QUANTITATIVE DATA ON HOW MANY PATIENTS ARE REFERRING, CONSENTING AND ENROLLING STUDIES AT ANY GIVEN TIME, AND INCLUDING COLLECTING AND ANALYZING DATA ON WHY PATIENTS ARE DISQUALIFYING AT THE PRE-SCREENING LEVEL TO HELP DETERMINE IF ADJUSTMENTS TO CRITERIA ARE NEEDED; MANAGEMENT OF TELEPHONE CALL CENTERS FOR OTHERS (U.S. CLS. 100, 101 AND 102).

GRETTA YAO, EXAMINING ATTORNEY



THE MARK CONSISTS OF AN EXCLAMATION POINT.

CLASS 29—MEATS AND PROCESSED FOODS

FOR FROZEN, PREPARED OR PACKAGED MEALS CONSISTING PRIMARILY OF MEAT, SEAFOOD, POULTRY AND/OR VEGETABLES; SOUPS; FROZEN, PREPARED OR PACKAGED SIDE DISHES CONSISTING OF VEGETABLES OR FRUIT; YOGURT AND WHIPPING CREAM (U.S. CL. 46).

CLASS 30—STAPLE FOODS

FOR FROZEN, PREPARED OR PACKAGED MEALS CONSISTING PRIMARILY OF PASTA OR RICE; PIZZA; FROZEN NOVELTIES, NAMELY, ICE CREAM, ICE MILK, ICE CREAM BARS, ICE CREAM SANDWICHES; FROZEN YOGURT; BREAD; PASTA SAUCE; FLOUR; FROZEN, PREPARED OR PACKAGED SIDE DISHES CONSISTING OF PASTA, RICE OR GRAINS (U.S. CL. 46).

HEATHER BIDDULPH, EXAMINING ATTORNEY

SN 77-676,784. CONAGRA FOODS RDM, INC., OMAHA, NE. FILED 2-24-2009.



OWNER OF U.S. REG. NOS. 1,743,392, 1,967,461 AND OTHERS.

THE MARK CONSISTS OF THE WORD "HEALTHY" WITH AN EXCLAMATION POINT SERVING AS THE LETTER "L" ALONG WITH THE WORD "CHOICE" UNDERNEATH AND AN EXCLAMATION POINT TO THE RIGHT OF BOTH WORDS AND AN OVAL AS THE BACKGROUND.

CLASS 29—MEATS AND PROCESSED FOODS

FOR FROZEN, PREPARED OR PACKAGED MEALS CONSISTING PRIMARILY OF MEAT, SEAFOOD, POULTRY AND/OR VEGETABLES; SOUPS; FROZEN, PREPARED OR PACKAGED SIDE DISHES CONSISTING OF VEGETABLES OR FRUIT; YOGURT AND WHIPPING CREAM (U.S. CL. 46).

CLASS 30—STAPLE FOODS

FOR FROZEN, PREPARED OR PACKAGED MEALS CONSISTING PRIMARILY OF PASTA OR RICE; PIZZA; FROZEN NOVELTIES, NAMELY, ICE CREAM, ICE MILK, ICE CREAM BARS, ICE CREAM SANDWICHES; FROZEN YOGURT; BREAD; PASTA SAUCE; FLOUR; FROZEN, PREPARED OR PACKAGED SIDE DISHES CONSISTING OF PASTA, RICE OR GRAINS (U.S. CL. 46).

HEATHER BIDDULPH, EXAMINING ATTORNEY



SN 77-676,789. CONAGRA FOODS RDM, INC., OMAHA, NE. FILED 2-24-2009.



OWNER OF U.S. REG. NOS. 1,743,392, 1,967,461 AND OTHERS.

THE MARK CONSISTS OF THE WORD "HEA!THY" WITH AN EXCLAMATION POINT SERVING AS THE LETTER "L" ALONG WITH THE WORD "CHOICE" UNDERNEATH.

CLASS 29—MEATS AND PROCESSED FOODS

FOR FROZEN, PREPARED OR PACKAGED MEALS CONSISTING PRIMARILY OF MEAT, SEAFOOD, POULTRY AND/OR VEGETABLES; SOUPS; FROZEN, PREPARED OR PACKAGED SIDE DISHES CONSISTING OF VEGETABLES OR FRUIT; YOGURT AND WHIPPING CREAM (U.S. CL. 46).

CLASS 30—STAPLE FOODS

FOR FROZEN, PREPARED OR PACKAGED MEALS CONSISTING PRIMARILY OF PASTA OR RICE; PIZZA; FROZEN NOVELTIES, NAMELY, ICE CREAM, ICE MILK, ICE CREAM BARS, ICE CREAM SANDWICHES; FROZEN YOGURT; BREAD; PASTA SAUCE; FLOUR; FROZEN, PREPARED OR PACKAGED SIDE DISHES CONSISTING OF PASTA, RICE OR GRAINS (U.S. CL. 46).

HEATHER BIDDULPH, EXAMINING ATTORNEY



SN 77-676,795. CONAGRA FOODS RDM, INC., OMAHA, NE. FILED 2-24-2009.



OWNER OF U.S. REG. NOS. 1,743,392, 1,967,461 AND OTHERS.

THE MARK CONSISTS OF THE WORDS "HEA!THY CHOICE" WITH AN EXCLAMATION POINT SERVING AS THE LETTER "L".

CLASS 29—MEATS AND PROCESSED FOODS

FOR FROZEN, PREPARED OR PACKAGED MEALS CONSISTING PRIMARILY OF MEAT, SEAFOOD, POULTRY AND/OR VEGETABLES; SOUPS; FROZEN, PREPARED OR PACKAGED SIDE DISHES CONSISTING OF VEGETABLES OR FRUIT; YOGURT AND WHIPPING CREAM (U.S. CL. 46).

CLASS 30—STAPLE FOODS

FOR FROZEN, PREPARED OR PACKAGED MEALS CONSISTING PRIMARILY OF PASTA OR RICE; PIZZA; FROZEN NOVELTIES, NAMELY, ICE CREAM, ICE MILK, ICE CREAM BARS, ICE CREAM SANDWICHES; FROZEN YOGURT; BREAD; PASTA SAUCE; FLOUR; FROZEN, PREPARED OR PACKAGED SIDE DISHES CONSISTING OF PASTA, RICE OR GRAINS (U.S. CL. 46).

HEATHER BIDDULPH, EXAMINING ATTORNEY



SN 77-676,797. CONAGRA FOODS RDM, INC., OMAHA, NE. FILED 2-24-2009.

5 CHECKS TO HEALTHY LIVING

THE MARK CONSISTS OF STANDARD CHARACTERS WITHOUT CLAIM TO ANY PARTICULAR FONT, STYLE, SIZE, OR COLOR.

CLASS 29—MEATS AND PROCESSED FOODS

FOR FROZEN, PREPARED OR PACKAGED MEALS CONSISTING PRIMARILY OF MEAT, SEAFOOD, POULTRY AND/OR VEGETABLES; SOUPS; FROZEN, PREPARED OR PACKAGED SIDE DISHES CONSISTING OF VEGETABLES OR FRUIT; YOGURT AND WHIPPING CREAM (U.S. CL. 46).

CLASS 30—STAPLE FOODS

FOR FROZEN, PREPARED OR PACKAGED MEALS CONSISTING PRIMARILY OF PASTA OR RICE; PIZZA; FROZEN NOVELTIES, NAMELY, ICE CREAM, ICE MILK, ICE CREAM BARS, ICE CREAM SANDWICHES; FROZEN YOGURT; BREAD; PASTA SAUCE; FLOUR; FROZEN, PREPARED OR PACKAGED SIDE DISHES CONSISTING OF PASTA, RICE OR GRAINS (U.S. CL. 46).

HEATHER BIDDULPH, EXAMINING ATTORNEY



SN 77-676,897. PRODUCT PARTNERS, LLC, SANTA MONICA, CA. FILED 2-24-2009.

BRING IT!

THE MARK CONSISTS OF STANDARD CHARACTERS WITHOUT CLAIM TO ANY PARTICULAR FONT, STYLE, SIZE, OR COLOR.

CLASS 5—PHARMACEUTICALS

FOR MEAL REPLACEMENT BARS, NUTRITIONAL AND DIETARY SUPPLEMENTS (U.S. CLS. 6, 18, 44, 46, 51 AND 52).

CLASS 9—ELECTRICAL AND SCIENTIFIC APPARATUS

FOR PRE-RECORDED VIDEO TAPES, CASSETTES, DVDS, AND CDS, FEATURING EXERCISE, FITNESS AND DIETARY INFORMATION AND INSTRUCTION (U.S. CLS. 21, 23, 26, 36 AND 38).

JOHN GARTNER, EXAMINING ATTORNEY

CLASS 35—ADVERTISING AND BUSINESS

FOR INCREASING TRAFFIC FLOW TO WEBSITES ON THE INTERNET, NAMELY, PROMOTING THE GOODS AND SERVICES OF OTHERS BY PROVIDING AUTOMATED HYPERTEXT LINKS TO THE WEBSITES OF OTHERS USING OPTIMAL SEARCH TERMS AND SEARCH ENGINES; ONLINE AUCTION SERVICES VIA A GLOBAL COMPUTER NETWORK; PROVIDING AN ONLINE COMMERCIAL INFORMATION DIRECTORY ON THE INTERNET; BUSINESS APPRAISALS, NAMELY, PROVIDING APPRAISAL SERVICES RELATING TO THE PURCHASE AND SALE OF DOMAIN NAMES; DOMAIN MONETIZATION SERVICES FOR OTHERS; PAY PER CLICK ADVERTISING MANAGEMENT SERVICES, NAMELY, PROVIDING COMPUTER SERVICES WHICH ALLOWS FOR REVENUE GENERATED FROM CLICK-THROUGH ADVERTISING FOR FACILITATION OF THE STORAGE AND MONETIZATION OF DOMAIN NAME ADDRESSES; ADVERTISING SERVICES, NAMELY, CREATING CORPORATE AND BRAND IDENTITY FOR OTHERS (U.S. CLS. 100, 101 AND 102).

FIRST USE 12-1-2001; IN COMMERCE 12-1-2001.

SN 77-678,021. GODADDY.COM, SCOTTSDALE, AZ. FILED 2-25-2009.

CLASS 36—INSURANCE AND FINANCIAL

FOR FINANCIAL SPONSORSHIP OF ATHLETES AND ATHLETIC EVENTS; PHILANTHROPIC SERVICES RELATING TO MAKING CONTRIBUTIONS TO CHARITABLE AND COMMUNITY ORGANIZATIONS (U.S. CLS. 100, 101 AND 102).

FIRST USE 8-9-2006; IN COMMERCE 8-9-2006.

GO DADDY

THE MARK CONSISTS OF STANDARD CHARACTERS WITHOUT CLAIM TO ANY PARTICULAR FONT, STYLE, SIZE, OR COLOR.

OWNER OF U.S. REG. NOS. 2,558,989, 2,904,954 AND 2,945,200.

CLASS 9—ELECTRICAL AND SCIENTIFIC APPARATUS

FOR COMPUTER SEARCH ENGINE SOFTWARE FOR ENHANCING SEARCH ENGINE CAPABILITIES AND INCREASING INTERNET TRAFFIC TO WEB SITES; COMPUTER PROGRAMS, NAMELY, FOR DEVELOPING AND DISPLAYING AN INTERACTIVE ELECTRONIC STOREFRONT ON A GLOBAL NETWORK, FOR ADDING AND MANAGING A CATALOG OF PRODUCTS FOR SELLING ON A GLOBAL NETWORK, FOR PROCESSING PAYMENT CALCULATION AND COLLECTION OVER A GLOBAL NETWORK, AND FOR GENERATING REPORTS OF WEB SITE ACTIVITY FOR A DESIGNATED SITE ON A GLOBAL NETWORK; COMPUTER PROGRAMS TO ASSIST OTHERS IN MARKETING THEIR BUSINESSES THROUGH THE CREATION OF TARGETED EMAIL CAMPAIGNS (U.S. CLS. 21, 23, 26, 36 AND 38).

FIRST USE 3-20-2003; IN COMMERCE 3-20-2003.

CLASS 25—CLOTHING

FOR CLOTHING, NAMELY, MEN'S AND WOMEN'S T-SHIRTS, WOMEN'S TANK TOPS (U.S. CLS. 22 AND 39).

FIRST USE 2-28-2005; IN COMMERCE 2-28-2005.

CLASS 28—TOYS AND SPORTING GOODS

FOR SCALE MODEL CARS MADE OF DIE-CAST METAL (U.S. CLS. 22, 23, 38 AND 50).

FIRST USE 2-15-2008; IN COMMERCE 2-15-2008.

CLASS 39—TRANSPORTATION AND STORAGE

FOR PARKING DOMAIN NAMES FOR OTHERS, NAMELY, PROVIDING COMPUTER SERVERS FOR FACILITATION OF THE STORAGE OF DOMAIN NAME ADDRESSES; ELECTRONIC STORAGE OF FILES AND OTHER ELECTRONIC CONTENT ITEMS SELECTED BY USERS FOR LATER RETRIEVAL VIA THE INTERNET (U.S. CLS. 100 AND 105).

FIRST USE 10-28-2004; IN COMMERCE 10-28-2004.

CLASS 41—EDUCATION AND ENTERTAINMENT

FOR ENTERTAINMENT SERVICES, NAMELY, PROVIDING A WEB SITE FEATURING PHOTOGRAPHIC, AUDIO, VIDEO, AND PROSE PRESENTATIONS FEATURING CELEBRITY NEWS AND PROMOTIONAL MATERIAL; PROVIDING AN INTERNET NEWS PORTAL FEATURING LINKS TO NEWS STORIES AND ARTICLES IN THE FIELD OF CURRENT EVENTS (U.S. CLS. 100, 101 AND 107).

FIRST USE 11-2-2007; IN COMMERCE 11-2-2007.

CLASS 42—SCIENTIFIC AND COMPUTER SERVICES

FOR DESIGNING, DEVELOPING AND HOSTING WEB SITES FOR OTHERS ON A GLOBAL COMPUTER NETWORK; PROVIDING E-MAIL AND SPAM FILTERING SERVICES; BLOCKING POP-UP MESSAGES AND PROTECTING THE PRIVACY OF USERS DURING THE COURSE OF INTERACTING WITH A GLOBAL COMPUTER NETWORK; COMPUTER SERVICES, NAMELY, DATA ENCRYPTION SERVICE FOR DIGITAL COMMUNICATIONS FEATURING DIGITAL ENCRYPTION CERTIFICATES; TECHNICAL SUPPORT SERVICES, NAMELY, TROUBLESHOOTING OF COMPUTER HARDWARE AND SOFTWARE PROBLEMS FOR HARDWARE AND SOFTWARE USED IN ASSISTING WITH USER DIGITAL SIGNATURE CERTIFICATION AND WITH DATA ENCRYPTION; DESIGN SERVICES FOR OTHERS, NAMELY, DESIGN SERVICES IN THE NATURE OF GRAPHIC DESIGN IN THE FIELD OF LOGOS (U.S. CLS. 100 AND 101).

FIRST USE 3-17-2003; IN COMMERCE 3-17-2003.

CLASS 45—PERSONAL AND LEGAL SERVICES

FOR PROVIDING USER AUTHENTICATION SERVICE IN ELECTRONIC TRANSACTIONS AND COMMUNICATIONS ON A GLOBAL COMPUTER NETWORK; ONLINE SOCIAL NETWORKING SERVICES; GLOBAL COMPUTER SYSTEM DOMAIN NAME SEARCHING SERVICES; INFORMATION SERVICES CONCERNING AVAILABILITY OF DOMAIN NAMES; SERVICES PROVIDING INFORMATION INDICATING EXPIRED DOMAIN NAMES, SERVICES PROVIDING INFORMATION CONCERNING LISTINGS OF DOMAIN NAMES FOR SALE BY OTHERS; COMPUTER SERVICES, NAMELY, ASSISTING USERS IN REGISTERING PREVIOUSLY REGISTERED DOMAIN NAMES BY REGISTERING THE DOMAIN NAMES WHEN THE DOMAIN NAMES BECOME PUBLICLY AVAILABLE (U.S. CLS. 100 AND 101).

FIRST USE 3-8-2004; IN COMMERCE 3-8-2004.
SUNG IN, EXAMINING ATTORNEY

SN 77-681,485. D4D TECHNOLOGIES, LLC, RICHARDSON, TX. FILED 3-2-2009.

MEDUSA

THE MARK CONSISTS OF STANDARD CHARACTERS WITHOUT CLAIM TO ANY PARTICULAR FONT, STYLE, SIZE, OR COLOR.

CLASS 9—ELECTRICAL AND SCIENTIFIC APPARATUS

FOR COMPUTER SOFTWARE FOR USE IN DESIGNING DENTAL RESTORATIONS (U.S. CLS. 21, 23, 26, 36 AND 38).

SN 77-679,867. ARDEN CORPORATION, SOUTHFIELD, MI. FILED 2-27-2009.

CLASS 10—MEDICAL APPARATUS

FOR DENTAL IMAGING APPARATUS FOR USE IN DESIGNING DENTAL RESTORATIONS (U.S. CLS. 26, 39 AND 44).

ALLISON HOLTZ, EXAMINING ATTORNEY

GREENER PATH SOLUTIONS

THE MARK CONSISTS OF STANDARD CHARACTERS WITHOUT CLAIM TO ANY PARTICULAR FONT, STYLE, SIZE, OR COLOR.

NO CLAIM IS MADE TO THE EXCLUSIVE RIGHT TO USE "SOLUTIONS" FOR INTERNATIONAL CLASS 035, APART FROM THE MARK AS SHOWN.

SN 77-683,598. CHS INC., INVER GROVE HEIGHTS, MN. FILED 3-4-2009.

CLASS 11—ENVIRONMENTAL CONTROL APPARATUS

FOR WATER FOUNTAINS (U.S. CLS. 13, 21, 23, 31 AND 34).



OWNER OF U.S. REG. NOS. 1,070,076, 1,591,300 AND OTHERS.

THE MARK CONSISTS OF THE WORDS "CENEX ZIP TRIP" INSIDE A STYLIZED OVAL.

CLASS 18—LEATHER GOODS

FOR UMBRELLAS AND UMBRELLA BASES (U.S. CLS. 1, 2, 3, 22 AND 41).

CLASS 20—FURNITURE AND ARTICLES NOT OTHERWISE CLASSIFIED

FOR CUSHIONS AND FURNITURE (U.S. CLS. 2, 13, 22, 25, 32 AND 50).

CLASS 35—ADVERTISING AND BUSINESS

FOR RETAIL MOTOR VEHICLE FUEL SUPPLY SERVICES BY MEANS OF PUMP ISLAND CREDIT CARD READERS; RETAIL STORE SERVICES FEATURING CONVENIENCE STORE ITEMS AND GASOLINE AND DIESEL (U.S. CLS. 100, 101 AND 102).

CLASS 24—FABRICS

FOR COVERS FOR CUSHIONS, UNFITTED FABRIC FURNITURE COVERS (U.S. CLS. 42 AND 50).

CLASS 37—CONSTRUCTION AND REPAIR

FOR GASOLINE SERVICE STATION SERVICES IN THE NATURE OF AUTOMOBILE SERVICE STATION SERVICES (U.S. CLS. 100, 103 AND 106).

CLASS 35—ADVERTISING AND BUSINESS

FOR PROMOTING THE INTERESTS OF PEOPLE CONCERNED WITH ENVIRONMENTAL SUSTAINABILITY ISSUES (U.S. CLS. 100, 101 AND 102).
HAI-LY LAM, EXAMINING ATTORNEY

LINDA LAVACHE, EXAMINING ATTORNEY

SN 77-686,393. THE DOW CHEMICAL COMPANY, MIDLAND, MI. FILED 3-9-2009.

VIENTO

THE MARK CONSISTS OF STANDARD CHARACTERS WITHOUT CLAIM TO ANY PARTICULAR FONT, STYLE, SIZE, OR COLOR.
THE ENGLISH TRANSLATION OF "VIENTO" IS WIND.

CLASS 17—RUBBER GOODS

FOR ROOFING INSULATION FOR BUILDING AND CONSTRUCTION (U.S. CLS. 1, 5, 12, 13, 35 AND 50).

CLASS 19—NON-METALLIC BUILDING MATERIALS

FOR THERMOPLASTIC ROOFING MEMBRANES (U.S. CLS. 1, 12, 33 AND 50).
ANDREA K. NADELMAN, EXAMINING ATTORNEY

SN 77-687,282. THE DOW CHEMICAL COMPANY, MIDLAND, MI. FILED 3-10-2009.

TIEMPO

THE MARK CONSISTS OF STANDARD CHARACTERS WITHOUT CLAIM TO ANY PARTICULAR FONT, STYLE, SIZE, OR COLOR.
THE ENGLISH TRANSLATION OF "TIEMPO" IS TIME.

CLASS 17—RUBBER GOODS

FOR ROOFING INSULATION FOR BUILDING AND CONSTRUCTION (U.S. CLS. 1, 5, 12, 13, 35 AND 50).

CLASS 19—NON-METALLIC BUILDING MATERIALS

FOR THERMOPLASTIC ROOFING MEMBRANES (U.S. CLS. 1, 12, 33 AND 50).
ANDREA K. NADELMAN, EXAMINING ATTORNEY

SN 77-687,370. LAMPS PLUS, INC., CHATSWORTH, CA. FILED 3-10-2009.

CASA

THE MARK CONSISTS OF STANDARD CHARACTERS WITHOUT CLAIM TO ANY PARTICULAR FONT, STYLE, SIZE, OR COLOR.
OWNER OF U.S. REG. NO. 1,747,004.
THE ENGLISH TRANSLATION OF THE WORD "CASA" IN THE MARK IS HOUSE.

CLASS 9—ELECTRICAL AND SCIENTIFIC APPARATUS

FOR REMOTE CONTROL FOR ELECTRICAL LIGHTING APPARATUS (U.S. CLS. 21, 23, 26, 36 AND 38).
FIRST USE 9-30-1997; IN COMMERCE 9-30-1997.

CLASS 11—ENVIRONMENTAL CONTROL APPARATUS

FOR CEILING LIGHTS; CHANDELIERS (U.S. CLS. 13, 21, 23, 31 AND 34).
FIRST USE 9-30-1997; IN COMMERCE 9-30-1997.
ELISSA GARBER KON, EXAMINING ATTORNEY

SN 77-688,084. RAB LIGHTING INC., NORTHVALE, NJ. FILED 3-11-2009.

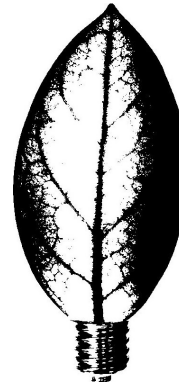

THE MARK CONSISTS OF A LEAF DESIGN WITH THE LOWER PORTION COMPRISED OF THE SCREW THREAD CONTACT PORTION OF A LIGHT BULB.

CLASS 9—ELECTRICAL AND SCIENTIFIC APPARATUS

FOR APPARATUS AND INSTRUMENTS FOR CONVEYING, DISTRIBUTING, TRANSFORMING, STORING, REGULATING OR CONTROLLING ELECTRIC CURRENT; ELECTRIC OR ELECTRONIC SENSORS FOR DETECTING MOTION AND ELECTRIC OR ELECTRONIC SENSORS FOR DETECTING LIGHT (U.S. CLS. 21, 23, 26, 36 AND 38).

CLASS 11—ENVIRONMENTAL CONTROL APPARATUS

FOR LIGHTING FIXTURES; LIGHTING FIXTURES WITH MOTION DETECTION (U.S. CLS. 13, 21, 23, 31 AND 34).
MARIAM MAHMOUDI, EXAMINING ATTORNEY

SN 77-692,213. INNEX, INC., CITY OF INDUSTRY, CA.
FILED 3-16-2009.

BREAKTHRU BRANDS

THE MARK CONSISTS OF STANDARD CHARACTERS WITHOUT CLAIM TO ANY PARTICULAR FONT, STYLE, SIZE, OR COLOR.

NO CLAIM IS MADE TO THE EXCLUSIVE RIGHT TO USE "BRANDS", APART FROM THE MARK AS SHOWN.

CLASS 9—ELECTRICAL AND SCIENTIFIC APPARATUS

FOR VIDEO GAME CONSOLES FOR USE WITH AN EXTERNAL DISPLAY SCREEN OR MONITOR, VIDEO GAME CONTROLLERS, ACCESSORIES FOR VIDEO GAME SYSTEMS, NAMELY, AC ADAPTERS, ELECTRIC CABLES, PROTECTIVE CASES, BATTERIES AND KITS COMPRISED OF CARTRIDGE CASES, EAR PHONES, PROTECTIVE CASES FOR HARDWARE, CLEANING CLOTH, CAR CHARGER; ELECTRIC CABLES FOR USE WITH AUDIO AND VIDEO COMPONENTS; FITTED PLASTIC FILMS KNOWN AS SKINS FOR COVERING AND PROVIDING A SCRATCH PROOF BARRIER OR PROTECTION FOR ELECTRONIC DEVICES, NAMELY, MP3 PLAYERS, CELLULAR TELEPHONES, VIDEO GAME CONSOLES, VIDEO GAME CONTROLLERS, LAPTOPS (U.S. CLS. 21, 23, 26, 36 AND 38).

CLASS 35—ADVERTISING AND BUSINESS

FOR WHOLESALE DISTRIBUTORSHIPS FEATURING VIDEO GAMES AND VIDEO GAME ACCESSORIES (U.S. CLS. 100, 101 AND 102).

CHRISTINE COOPER, EXAMINING ATTORNEY

SN 77-693,912. LIL' DRUG STORE PRODUCTS, INC., CEDAR RAPIDS, IA. FILED 3-18-2009.



OWNER OF U.S. REG. NOS. 1,296,316, 1,296,318 AND 1,934,934.

NO CLAIM IS MADE TO THE EXCLUSIVE RIGHT TO USE "DRUG STORE PRODUCTS", APART FROM THE MARK AS SHOWN.

THE MARK CONSISTS OF THE STYLIZED WORDING "LIL' DRUG STORE PRODUCTS".

CLASS 5—PHARMACEUTICALS

FOR NON-PRESCRIPTION DRUGS, NAMELY, ANALGESICS, PREPARATIONS FOR TREATING COLDS AND FLU, NASAL SPRAY PREPARATIONS, ANTA-CIDS, DIETARY AND NUTRITIONAL SUPPLEMENTS, AND SLEEP AIDS, NAMELY, SLEEPING PILLS AND TABLETS (U.S. CLS. 6, 18, 44, 46, 51 AND 52).

CLASS 35—ADVERTISING AND BUSINESS

FOR DISTRIBUTORSHIPS IN THE FIELD OF PHARMACEUTICALS, HEALTH PRODUCTS, BEAUTY CARE PRODUCTS, AUTOMOTIVE PRODUCTS, OFFICE SUPPLIES, BEVERAGES, ORTHOPEDIC BRACES AND SUPPORTS, ELECTRONICS, AND AIR FRESHENERS (U.S. CLS. 100, 101 AND 102).

MARC LEIPZIG, EXAMINING ATTORNEY

SN 77-696,168. A CLASSIC TIME WATCH COMPANY, INC., NEW YORK, NY. FILED 3-20-2009.

SELFISH

THE MARK CONSISTS OF STANDARD CHARACTERS WITHOUT CLAIM TO ANY PARTICULAR FONT, STYLE, SIZE, OR COLOR.

CLASS 9—ELECTRICAL AND SCIENTIFIC APPARATUS

FOR SUNGLASSES (U.S. CLS. 21, 23, 26, 36 AND 38).

CLASS 14—JEWELRY

FOR COSTUME JEWELRY (U.S. CLS. 2, 27, 28 AND 50).

CLASS 18—LEATHER GOODS

FOR HANDBAGS (U.S. CLS. 1, 2, 3, 22 AND 41).

GEORGE LORENZO, EXAMINING ATTORNEY

SN 77-696,829. FIBERLINK COMMUNICATIONS CORPORATION, BLUEBELL, PA. FILED 3-23-2009.

VISIBILITY360

THE MARK CONSISTS OF STANDARD CHARACTERS WITHOUT CLAIM TO ANY PARTICULAR FONT, STYLE, SIZE, OR COLOR.

CLASS 9—ELECTRICAL AND SCIENTIFIC APPARATUS

FOR DOWNLOADABLE SOFTWARE FOR USE FOR THE GENERATION OF REPORTS REGARDING THE STATUS OF COMPUTER LAPTOPS AND SOFTWARE APPLICATIONS RUNNING ON LAPTOPS CONNECTING REMOTELY TO LOCAL AREA NETWORKS (U.S. CLS. 21, 23, 26, 36 AND 38).

CLASS 42—SCIENTIFIC AND COMPUTER SERVICES

FOR APPLICATION SERVICE PROVIDER SERVICES, NAMELY, HOSTING COMPUTER APPLICATION SOFTWARE ON A COMPUTER SERVER FOR OTHERS FOR GENERATION OF REPORTS REGARDING THE STATUS OF COMPUTER LAPTOPS AND SOFTWARE APPLICATIONS RUNNING ON LAPTOPS CONNECTING REMOTELY TO LOCAL AREA NETWORKS (U.S. CLS. 100 AND 101).

JORDAN BAKER, EXAMINING ATTORNEY

SN 77-696,888. FIBERLINK COMMUNICATIONS CORPORATION, BLUEBELL, PA. FILED 3-23-2009.

CONTROL360

THE MARK CONSISTS OF STANDARD CHARACTERS WITHOUT CLAIM TO ANY PARTICULAR FONT, STYLE, SIZE, OR COLOR.

CLASS 9—ELECTRICAL AND SCIENTIFIC APPARATUS

FOR DOWNLOADABLE SOFTWARE FOR USE FOR THE GENERATION OF REPORTS REGARDING THE STATUS OF COMPUTER LAPTOPS AND SOFTWARE APPLICATIONS RUNNING ON LAPTOPS CONNECTING REMOTELY TO LOCAL AREA NETWORKS AND FOR CONTROLLING SECURE ACCESS TO THE LOCAL AREA NETWORKS (U.S. CLS. 21, 23, 26, 36 AND 38).

CLASS 42—SCIENTIFIC AND COMPUTER SERVICES

FOR APPLICATION SERVICE PROVIDER SERVICES, NAMELY, HOSTING COMPUTER APPLICATION SOFTWARE ON A COMPUTER SERVER FOR OTHERS FOR GENERATION OF REPORTS REGARDING THE STATUS OF COMPUTER LAPTOPS AND SOFTWARE APPLICATIONS RUNNING ON LAPTOPS CONNECTING REMOTELY TO LOCAL AREA NETWORKS AND FOR CONTROLLING SECURE ACCESS TO THE LOCAL AREA NETWORKS (U.S. CLS. 100 AND 101).

JORDAN BAKER, EXAMINING ATTORNEY

SN 77-696,895. FIBERLINK COMMUNICATIONS CORPORATION, BLUEBELL, PA. FILED 3-23-2009.

MOBILE360

THE MARK CONSISTS OF STANDARD CHARACTERS WITHOUT CLAIM TO ANY PARTICULAR FONT, STYLE, SIZE, OR COLOR.

CLASS 9—ELECTRICAL AND SCIENTIFIC APPARATUS

FOR DOWNLOADABLE SOFTWARE FOR USE FOR THE GENERATION OF REPORTS REGARDING THE STATUS OF COMPUTER LAPTOPS AND SOFTWARE APPLICATIONS RUNNING ON LAPTOPS CONNECTING REMOTELY TO LOCAL AREA NETWORKS AND FOR CONTROLLING SECURE ACCESS TO THE LOCAL AREA NETWORKS (U.S. CLS. 21, 23, 26, 36 AND 38).

CLASS 38—COMMUNICATION

FOR PROVIDING MANAGED REMOTE ACCESS SERVICES, NAMELY, PROVIDING SECURE, GENERAL-PURPOSE CONNECTIVITY SO THAT COMPUTER SOFTWARE APPLICATIONS AND COMPUTER NETWORK-BASED SERVICES, FILE SHARING SERVICES, E-MAIL SERVICES, AND INTRANET SERVICES CAN BE SECURELY ACCESSED BY A USER CONNECTING REMOTELY TO THE ENTERPRISE LOCAL AREA NETWORK (U.S. CLS. 100, 101 AND 104).

CLASS 42—SCIENTIFIC AND COMPUTER SERVICES

FOR APPLICATION SERVICE PROVIDER SERVICES, NAMELY, HOSTING COMPUTER APPLICATION SOFTWARE ON A COMPUTER SERVER FOR OTHERS FOR GENERATION OF REPORTS REGARDING THE STATUS OF COMPUTER LAPTOPS AND SOFTWARE APPLICATIONS RUNNING ON LAPTOPS CONNECTING REMOTELY TO LOCAL AREA NETWORKS AND FOR CONTROLLING SECURE ACCESS TO THE LOCAL AREA NETWORKS (U.S. CLS. 100 AND 101).

JORDAN BAKER, EXAMINING ATTORNEY

SN 77-697,053. LIL' DRUG STORE PRODUCTS, INC., CEDAR RAPIDS, IA. FILED 3-23-2009.



OWNER OF U.S. REG. NOS. 1,296,316, 1,296,318 AND 1,934,934.

NO CLAIM IS MADE TO THE EXCLUSIVE RIGHT TO USE "DRUG STORE", APART FROM THE MARK AS SHOWN.

THE COLOR(S) YELLOW AND BLACK IS/ARE CLAIMED AS A FEATURE OF THE MARK.

THE MARK CONSISTS OF THE STYLIZED WORDING "LIL' DRUG STORE" IN BLACK, WITH A YELLOW BACKGROUND, AND A DOUBLE-LINED BLACK BORDER. THE COLOR WHITE APPEARING IN THE MARK REPRESENTS BACKGROUND AREAS THAT ARE NOT PART OF THE MARK.

CLASS 5—PHARMACEUTICALS

FOR NON-PRESCRIPTION DRUG ITEMS, NAMELY, ANALGESICS, PREPARATIONS FOR TREATING COLDS AND FLU, NASAL SPRAY PREPARATIONS, ANTACIDS, DIETARY AND NUTRITIONAL SUPPLEMENTS, AND SLEEP AIDS, NAMELY, SLEEPING PILLS AND TABLETS (U.S. CLS. 6, 18, 44, 46, 51 AND 52).

CLASS 20—FURNITURE AND ARTICLES NOT OTHERWISE CLASSIFIED

FOR POINT OF PURCHASE DISPLAYS FOR VARIOUS NON-PRESCRIPTION DRUG ITEMS (U.S. CLS. 2, 13, 22, 25, 32 AND 50).

MARC LEIPZIG, EXAMINING ATTORNEY

SN 77-697,078. LIL' DRUG STORE PRODUCTS, INC., CEDAR RAPIDS, IA. FILED 3-23-2009.

SN 77-697,090. WYNDHAM TM CORP., LAS VEGAS, NV. FILED 3-23-2009.



OWNER OF U.S. REG. NOS. 1,597,467, 1,739,583 AND 1,964,049.

NO CLAIM IS MADE TO THE EXCLUSIVE RIGHT TO USE "AUTO STORE", APART FROM THE MARK AS SHOWN.

THE COLOR(S) YELLOW AND BLACK IS/ARE CLAIMED AS A FEATURE OF THE MARK.

THE MARK CONSISTS OF THE STYLIZED WORDING "LIL' AUTO STORE" IN BLACK, WITH A YELLOW BACKGROUND, AND A DOUBLE-LINED BLACK BORDER. THE COLOR WHITE APPEARING IN THE MARK REPRESENTS BACKGROUND AREAS THAT ARE NOT PART OF THE MARK.

CLASS 8—HAND TOOLS

FOR MANUALLY OPERATED HAND TOOLS FOR USE IN REPAIR AND SERVICING OF MOTOR VEHICLES, NAMELY, BATTERY POSTS CLEANING TOOLS, BATTERY TERMINAL LIFTERS, BRAKE CALIPER WRENCHES, CHISELS, DIES, DRIVERS, HAMMERS, HEX KEYS WRENCHES, JACK STANDS, LUG WRENCHES, OIL FILTER WRENCHES, PARTS RETRIEVERS FOR RETRIEVING SMALL STEEL PARTS, PLIERS, MANUAL PULLERS, PUNCHES, RATCHETS, RIVETERS, SAWS, SCREWDRIVERS, SNAP RING PLIERS, SNIPPERS, SOCKETS, SPARK PLUG SOCKETS, SPARK PLUG WRENCHES, TAPS, TORQUE WRENCHES, WIRE BRUSHES, WIRE CRIMPERS, AND WRENCHES (U.S. CLS. 23, 28 AND 44).

CLASS 9—ELECTRICAL AND SCIENTIFIC APPARATUS

FOR APPARATUS FOR REPAIR AND SERVICING OF MOTOR VEHICLES, NAMELY, ANTIFREEZE TESTERS, BATTERY BOLTS, BATTERY CABLES, BATTERY CHARGERS, BATTERY CHARGING POSTS AND BATTERY HOLD DOWNS, BEING BATTERY COMPONENT PARTS, BATTERY TERMINALS, BATTERY TESTERS, COMPASSES, FUSE HOLDERS, MEASURING TAPES, MILEAGE METERS, ELECTRIC, ELECTRICAL, POWER AND LIGHT SWITCHES, TAPPET GAUGES, TIRE PRESSURE GAUGES, TIRE PRESSURE TESTERS, WIRE CONTINUITY TESTERS (U.S. CLS. 21, 23, 26, 36 AND 38).

CLASS 11—ENVIRONMENTAL CONTROL APPARATUS

FOR AUTOMOTIVE LIGHT BULBS FOR TURN SIGNAL, BRAKE AND PARKING LIGHTS (U.S. CLS. 13, 21, 23, 31 AND 34).

CLASS 20—FURNITURE AND ARTICLES NOT OTHERWISE CLASSIFIED

FOR LICENSE PLATE FASTENER SCREWS AND BOLTS OF PLASTIC, PLASTIC GAS CAN SPOUTS, PLASTIC GAS CANS, SOLD EMPTY, POINT OF PURCHASE DISPLAYS FOR AUTOMOTIVE ITEMS (U.S. CLS. 2, 13, 22, 25, 32 AND 50).

MARC LEIPZIG, EXAMINING ATTORNEY

WYNDHAM REWARDS

THE MARK CONSISTS OF STANDARD CHARACTERS WITHOUT CLAIM TO ANY PARTICULAR FONT, STYLE, SIZE, OR COLOR.

OWNER OF U.S. REG. NOS. 3,485,726, 3,564,675 AND OTHERS.

NO CLAIM IS MADE TO THE EXCLUSIVE RIGHT TO USE "REWARDS", APART FROM THE MARK AS SHOWN.

CLASS 35—ADVERTISING AND BUSINESS

FOR PROMOTING THE GOODS AND SERVICES OF OTHERS THROUGH AN INCENTIVE AND DISCOUNT PROGRAM WHEREBY CREDIT CARD USERS ACCUMULATE POINTS BASED ON CREDIT CARD USAGE WHICH THEY CAN REDEEM FOR FREE AND DISCOUNTED GOODS AND SERVICES (U.S. CLS. 100, 101 AND 102).

FIRST USE 6-0-2008; IN COMMERCE 6-0-2008.

CLASS 36—INSURANCE AND FINANCIAL

FOR CREDIT CARD SERVICES (U.S. CLS. 100, 101 AND 102).

FIRST USE 6-0-2008; IN COMMERCE 6-0-2008.

MARK PILARO, EXAMINING ATTORNEY

SN 77-699,535. WARRIOR SPORTS, INC., WARREN, MI. FILED 3-26-2009.

PSYCO

THE MARK CONSISTS OF STANDARD CHARACTERS WITHOUT CLAIM TO ANY PARTICULAR FONT, STYLE, SIZE, OR COLOR.

OWNER OF U.S. REG. NO. 3,524,996.

CLASS 9—ELECTRICAL AND SCIENTIFIC APPARATUS

FOR PROTECTIVE HELMETS FOR SPORTS (U.S. CLS. 21, 23, 26, 36 AND 38).

CLASS 28—TOYS AND SPORTING GOODS

FOR ATHLETIC PROTECTIVE PADS FOR LACROSSE, NAMELY, SHOULDER PADS AND ARM PADS (U.S. CLS. 22, 23, 38 AND 50).

TEJBIR SINGH, EXAMINING ATTORNEY

SN 77-710,632. L'OREAL USA CREATIVE, INC., NEW YORK, NY. FILED 4-9-2009.

MATRIX IMAGINE ALL YOU CAN
BE

THE MARK CONSISTS OF STANDARD CHARACTERS WITHOUT CLAIM TO ANY PARTICULAR FONT, STYLE, SIZE, OR COLOR.

OWNER OF U.S. REG. NOS. 1,569,113, 2,226,310 AND 2,529,847.

CLASS 3—COSMETICS AND CLEANING PREPARATIONS

FOR HAIR CARE PRODUCTS, NAMELY, HAIR CARE PREPARATIONS, HAIR STYLING PREPARATIONS, HAIR COLORING PREPARATIONS AND NON-MEDICATED HAIR TREATMENT PREPARATIONS (U.S. CLS. 1, 4, 6, 50, 51 AND 52).

CLASS 16—PAPER GOODS AND PRINTED MATTER

FOR PRINTED MATTER AND PUBLICATIONS, NAMELY, BOOKS, MAGAZINES, EDUCATIONAL BROCHURES, PRINTED INFORMATION KITS COMPRISING TECHNICAL GUIDES AND WORKBOOKS CONCERNING HAIR CARE, HAIR STYLIST AND CLIENT INTERACTION, AND PRINTED INSTRUCTION MATERIALS DISTRIBUTED TO BEAUTY SALONS CONCERNING HAIR CARE (U.S. CLS. 2, 5, 22, 23, 29, 37, 38 AND 50).

JOHN HWANG, EXAMINING ATTORNEY

SN 77-714,673. MIDDLETOWN RANCHERIA OF POMO INDIANS OF CALIFORNIA, MIDDLETOWN, CA. FILED 4-15-2009.

TWIN PINE

THE MARK CONSISTS OF STANDARD CHARACTERS WITHOUT CLAIM TO ANY PARTICULAR FONT, STYLE, SIZE, OR COLOR.

CLASS 33—WINES AND SPIRITS

FOR ALCOHOLIC BEVERAGES EXCEPT BEERS (U.S. CLS. 47 AND 49).

CLASS 35—ADVERTISING AND BUSINESS

FOR RETAIL GIFT SHOPS; PROVIDING FACILITIES FOR THE USE OF OFFICE EQUIPMENT AND MACHINERY (U.S. CLS. 100, 101 AND 102).

CLASS 39—TRANSPORTATION AND STORAGE

FOR COORDINATING TRAVEL ARRANGEMENTS FOR INDIVIDUALS AND FOR GROUPS; TRAVEL INFORMATION SERVICES (U.S. CLS. 100 AND 105).

CLASS 41—EDUCATION AND ENTERTAINMENT

FOR CASINOS; ARRANGING AND CONDUCTING SPECIAL EVENTS (U.S. CLS. 100, 101 AND 107).

CLASS 43—HOTEL AND RESTAURANT SERVICES

FOR HOTEL SERVICES; BAR SERVICES; RESTAURANT SERVICES; PROVIDING OF FOOD AND DRINK; RESORT LODGING SERVICES; PROVIDING FACILITIES FOR CONCERTS, SPORTS, CONVENTIONS AND EXHIBITIONS; PROVIDING TEMPORARY TRAILER PARK FACILITIES; PROVIDING CAMPGROUND FACILITIES (U.S. CLS. 100 AND 101).

CLASS 44—MEDICAL, BEAUTY AND AGRICULTURAL SERVICES

FOR HEALTH SPA SERVICES FOR HEALTH AND WELLNESS OF THE BODY AND SPIRIT (U.S. CLS. 100 AND 101).

KATHY DE JONGE, EXAMINING ATTORNEY

SN 77-719,456. DEALERSPAN, LLC, BILLINGS, MT. FILED 4-22-2009.

DEALERSPAN

THE MARK CONSISTS OF STANDARD CHARACTERS WITHOUT CLAIM TO ANY PARTICULAR FONT, STYLE, SIZE, OR COLOR.

CLASS 35—ADVERTISING AND BUSINESS

FOR BUSINESS MANAGEMENT AND CONSULTING, NAMELY, WEB-BASED BUSINESS CONSULTING SERVICES FOR NEW AND USED AUTOMOBILE DEALERS AND THEIR CUSTOMERS, NAMELY, MANAGEMENT OF MARKETING AND ADVERTISING BUDGETS, DISTRIBUTION OF CUSTOMER LEADS, AND PROCUREMENT OF WEB DESIGNS THAT ARE TAILORED TO THE REQUIREMENTS OF CERTAIN FINANCE DEPARTMENTS (U.S. CLS. 100, 101 AND 102).

CLASS 36—INSURANCE AND FINANCIAL

FOR WEB-BASED FINANCIAL CONSULTING SERVICES FOR NEW AND USED AUTOMOBILE DEALERS AND THEIR CUSTOMERS, NAMELY, PROVISION OF CREDIT BUREAU INFORMATION; PROVISION OF AUTOMOBILE WHOLESALE AND RETAIL VALUATION INFORMATION (U.S. CLS. 100, 101 AND 102).

CLASS 41—EDUCATION AND ENTERTAINMENT

FOR TRAINING RELATED TO THE USE OF SOFTWARE FOR THE PREPARATION AND SUBMISSION OF FINANCE APPLICATIONS FOR THE PURCHASE OF NEW AND USED AUTOMOBILES (U.S. CLS. 100, 101 AND 107).

CLASS 42—SCIENTIFIC AND COMPUTER SERVICES

FOR APPLICATION SERVICE PROVIDER FEATURING SOFTWARE FOR THE PREPARATION AND SUBMISSION OF FINANCE APPLICATIONS FOR THE PURCHASE OF NEW AND USED AUTOMOBILES (U.S. CLS. 100 AND 101).

PAUL F. GAST, EXAMINING ATTORNEY

SN 77-976,996. COMMON GROUND HEALTH CLINIC, NEW ORLEANS, LA. FILED 4-17-2008.

SN 77-976,887. SAFECOR HEALTH, LLC, DBA SAFECOR HEALTH AND REGIONAL SERVICE CENTER, WOBURN, MA. FILED 5-27-2008.



The logo for SAFECOR HEALTH features the word "SAFECOR" in a bold, blue, sans-serif font. The letter "O" is replaced by a blue circle containing a white cross. Below "SAFECOR" is the word "HEALTH" in a smaller, blue, sans-serif font.

Solidarity Not Charity

NO CLAIM IS MADE TO THE EXCLUSIVE RIGHT TO USE "HEALTH", APART FROM THE MARK AS SHOWN.

THE COLOR(S) DARK BLUE, LIGHT BLUE, AND WHITE IS/ARE CLAIMED AS A FEATURE OF THE MARK.

THE MARK CONSISTS OF THE WORD "SAFECOR" IN DARK BLUE WITH THE "O" IN "SAFECOR" COMPLETELY FILLED IN WITH LIGHT BLUE. WITHIN THE LIGHT BLUE "O" FIVE DISTINCT AND UNCONNECTED WHITE SQUARES IN THE MIDDLE OF THE "O" FORM A PLUS SIGN. DIRECTLY UNDER "SAFECOR" IN THE IMAGE IS THE WORD "HEALTH" IN LIGHT BLUE.

CLASS 5—PHARMACEUTICALS

FOR HEALTHCARE SUPPLY KITS COMPRISED PRIMARILY OF PHARMACEUTICALS TO TREAT BLOOD CONDITIONS, SYRINGES FOR INJECTIONS, SMOKING CESSATION PATCHES, AND BANDAGES FOR SKIN WOUNDS; PHARMACEUTICALS USED AS GERMICIDES AND FOR THE TREATMENT OF HYPERTHYROIDISM (U.S. CLS. 6, 18, 44, 46, 51 AND 52).

FIRST USE 2-1-2009; IN COMMERCE 2-1-2009.

CLASS 35—ADVERTISING AND BUSINESS

FOR UNIT DOSE PACKAGING OF MEDICAL SUPPLIES AND PHARMACEUTICALS TO THE ORDER AND SPECIFICATION OF OTHERS; PACKAGING AND REPACKAGING OF PHARMACEUTICAL PRODUCTS TO THE ORDER AND SPECIFICATIONS OF OTHERS; PHARMACEUTICAL DISTRIBUTORSHIP SERVICES; INVENTORY CONTROL OF PHARMACEUTICALS AND HEALTH CARE PRODUCTS; PACKAGING LIQUID PHARMACEUTICALS TO THE ORDER AND SPECIFICATION OF OTHERS; PACKAGING EQUIPMENT TO THE ORDER AND SPECIFICATION OF HOSPITALS; ELECTRONIC CUSTOMER ORDERING SERVICES FOR UNIT DOSE PACKAGING, PHARMACEUTICALS, MEDICAL, SURGICAL AND LABORATORY SUPPLIES AND EQUIPMENT; COMPLETION OF HOSPITAL OPERATIONS SURVEYS IN THE NATURE OF CONDUCTING QUALITY ASSURANCE SURVEYS IN HOSPITALS TO DETERMINE SERVICE QUALITY; COMPUTERIZED DATABASE MANAGEMENT IN THE FIELD OF PHARMACEUTICAL LOT NUMBER AND EXPIRATION DATING; SALES VOLUME TRACKING FOR OTHERS; PACKAGING FOR PHARMACEUTICALS TO THE ORDER AND SPECIFICATION OF OTHERS AND BAR CODING SERVICES IN THE NATURE OF PLACING BAR CODES, FOR USE BY THIRD PARTIES, ON PACKAGING FOR PHARMACEUTICALS (U.S. CLS. 100, 101 AND 102).

FIRST USE 2-1-2009; IN COMMERCE 2-1-2009.
LAURIE MAYES, EXAMINING ATTORNEY

THE MARK CONSISTS OF STANDARD CHARACTERS WITHOUT CLAIM TO ANY PARTICULAR FONT, STYLE, SIZE, OR COLOR.

CLASS 16—PAPER GOODS AND PRINTED MATTER

FOR BROCHURES ABOUT HEALTH AND WELLNESS AND AVAILABILITY OF RESOURCES RELATED TO THE SAME; PAMPHLETS IN THE FIELD OF HEALTH AND WELLNESS AND AVAILABILITY OF RESOURCES RELATED TO THE SAME (U.S. CLS. 2, 5, 22, 23, 29, 37, 38 AND 50).

FIRST USE 9-9-2005; IN COMMERCE 9-9-2005.

CLASS 25—CLOTHING

FOR SHIRTS; SHORT-SLEEVED OR LONG-SLEEVED T-SHIRTS; T-SHIRTS; TEE SHIRTS (U.S. CLS. 22 AND 39).

FIRST USE 9-9-2005; IN COMMERCE 9-9-2005.

CLASS 41—EDUCATION AND ENTERTAINMENT

FOR EDUCATIONAL SERVICES, NAMELY, CONDUCTING WORKSHOPS, FAIRS, GROUP SEMINARS AND EVENTS IN THE NATURE OF CLASSES AND DEMONSTRATIONS, WHICH ARE OPEN TO THE COMMUNITY, CONCERNING HOLISTIC MEDICINE, NUTRITION, MEAL PREPARATION, LIFESTYLE CHOICES AND HERBALISM IN THE FIELD OF HEALTH AND WELLNESS EDUCATION; PUBLICATION OF BROCHURES (U.S. CLS. 100, 101 AND 107).

FIRST USE 9-9-2005; IN COMMERCE 9-9-2005.

CLASS 44—MEDICAL, BEAUTY AND AGRICULTURAL SERVICES

FOR ACUPUNCTURE; ACUPUNCTURE SERVICES; CHARITABLE SERVICES, NAMELY, PROVIDING DIABETIC PROVISIONS SUPPLIES TO THOSE IN NEED; CHARITABLE SERVICES, NAMELY, PROVIDING FIRST AID SUPPLIES TO THOSE IN NEED; CONSULTING SERVICES IN THE FIELD OF MENTAL HEALTH AND WELLNESS; COUNSELING SERVICES IN THE FIELDS OF HEALTH, NUTRITION AND LIFESTYLE WELLNESS; HEALTH CARE; HEALTH CARE SERVICES, NAMELY, DISEASE MANAGEMENT PROGRAMS; HEALTH CARE SERVICES, NAMELY, WELLNESS PROGRAMS; HEALTHCARE; MASSAGE; MASSAGE AND THERAPEUTIC SHIATSU MASSAGE; MASSAGES; MEDICAL AND PHARMACEUTICAL CONSULTATION; MEDICAL CLINICS; MEDICAL CONSULTATIONS; MEDICAL COUNSELING; MEDICAL INFORMATION; MENTAL HEALTH SERVICES; PROVIDING ASSISTANCE, FITNESS EVALUATION AND CONSULTATION TO INDIVIDUALS TO HELP THEM MAKE HEALTH, WELLNESS AND NUTRITIONAL CHANGES IN THEIR DAILY LIVING TO IMPROVE HEALTH; PROVIDING HEALTH INFORMATION; PROVIDING MEDICAL INFORMATION; PROVIDING MEDICAL INFORMATION, CONSULTANCY AND ADVISORY SERVICES; PROVIDING WELLNESS SERVICES, NAMELY, PERSONAL ASSESSMENTS, PERSONALIZED ROUTINES, MAINTENANCE SCHEDULES, AND COUNSELING; PSYCHIATRIC CONSULTATION; PSYCHOLOGICAL ASSESSMENT SERVICES; PSYCHOLOGICAL CONSULTATION; STRESS REDUCTION THERAPY; COUNSELING SERVICES IN THE FIELDS OF HEALTH, HERBALISM, AND LIFESTYLE WELLNESS (U.S. CLS. 100 AND 101).

FIRST USE 9-9-2005; IN COMMERCE 9-9-2005.

MARK RADEMACHER, EXAMINING ATTORNEY

SN 78-384,393. HARRYS OF LONDON LIMITED, LONDON W1B 5PQ, UNITED KINGDOM, FILED 3-15-2004.



OWNER OF ERPN CMNTY TM OFC REG. NO. 003906443, DATED 10-19-2005, EXPIRES 3-20-2014.

THE MARK CONSISTS OF A FANCIFUL DESIGN OF A HERON (BIRD).

CLASS 18—LEATHER GOODS

FOR LUGGAGE, BAGS, NAMELY, LEATHER TRAVEL BAGS, LEATHER SUIT CASES, LEATHER WASH BAGS, LEATHER HOLDALLS, LEATHER SUIT CARRIERS, LEATHER MESSENGER BAGS, LEATHER TOURING CASES, LEATHER BARREL HOLDALLS; UMBRELLAS; SMALL LEATHER GOODS, NAMELY, WALLETS, PURSES, CHANGE PURSES, BILLFOLDS, BODY POUCHES, FOLDING PURSES, LEATHER KEY-CASES, LEATHER KEY CHAINS; LEATHER ACCESSORIES, NAMELY, LEATHER BRIEFCASES, LEATHER DOCUMENT CASES, LEATHER BUSINESS CARD WALLETS, LEATHER NOTEPAD WALLETS, LEATHER CARD CASES, LEATHER PORTFOLIOS, LEATHER TRAVEL POUCHES, LEATHER ENVELOPE BAGS (U.S. CLS. 1, 2, 3, 22 AND 41).

CLASS 21—HOUSEWARES AND GLASS

FOR SHOE HORNS, SHOE TREES, SHOE STRETCHERS, SHOE CLEANING ACCESSORIES, NAMELY BRUSHES, SHOE SHINE CLOTHS, SHOE POLISHING MITTS, SHOE POLISH APPLICATORS NOT CONTAINING SHOE POLISH (U.S. CLS. 2, 13, 23, 29, 30, 33, 40 AND 50).

CLASS 25—CLOTHING

FOR MEN'S, WOMEN'S AND CHILDREN'S APPAREL AND ACCESSORIES, NAMELY, WOMEN'S FOOTWEAR, HATS, CAPS, BASEBALL CAPS, SHIRTS, POLO SHIRTS, TIES, BELTS, SCARVES, GLOVES, SOCKS, SWEATERS, UNDERWEAR (U.S. CLS. 22 AND 39).

SOPHIA S. KIM, EXAMINING ATTORNEY

SN 78-505,892. CANADIAN HOME PUBLISHERS, TORONTO, CANADA, FILED 10-26-2004.



PRIORITY CLAIMED UNDER SEC. 44(D) ON CANADA APPLICATION NO. 1224897, FILED 7-21-2004, REG. NO. TMA652151, DATED 11-2-2005, EXPIRES 11-5-2021.

OWNER OF U.S. REG. NO. 2,661,212.

THE COLOR(S) BLUE AND WHITE IS/ARE CLAIMED AS A FEATURE OF THE MARK.

THE COLOR(S) BLUE APPEARS IN THE RECTANGLE DESIGN OF THE MARK AND THE COLOR WHITE APPEARS IN THE TERM "H&H".

CLASS 4—LUBRICANTS AND FUELS

FOR CANDLES (U.S. CLS. 1, 6 AND 15).

CLASS 6—METAL GOODS

FOR METAL STEP LADDERS (U.S. CLS. 2, 12, 13, 14, 23, 25 AND 50).

CLASS 8—HAND TOOLS

FOR FLATWARE (U.S. CLS. 23, 28 AND 44).

CLASS 9—ELECTRICAL AND SCIENTIFIC APPARATUS

FOR ELECTRIC IRONS (U.S. CLS. 21, 23, 26, 36 AND 38).

CLASS 11—ENVIRONMENTAL CONTROL APPARATUS

FOR ELECTRIC LANTERNS; OIL LANTERNS (U.S. CLS. 13, 21, 23, 31 AND 34).

CLASS 16—PAPER GOODS AND PRINTED MATTER

FOR BULLETIN BOARDS; CORK BOARDS (U.S. CLS. 2, 5, 22, 23, 29, 37, 38 AND 50).

SN 78-534,796. B FREE WORLD LIMITED, SHENLEY, HERTFORDSHIRE, UNITED KINGDOM, FILED 12-17-2004.

CLASS 18—LEATHER GOODS

FOR UMBRELLAS (U.S. CLS. 1, 2, 3, 22 AND 41).

B FREE

CLASS 20—FURNITURE AND ARTICLES NOT OTHERWISE CLASSIFIED

FOR FURNITURE, BEDS, SOFAS, DINING TABLES; DECORATIVE PILLOWS; PICTURE FRAMES; OUT-DOOR FURNITURE AND ACCESSORIES, TABLES, CHAIRS, FOOTSTOOLS, LOUNGE CHAIRS, PILLOWS, CHAIR PADS; HAMPERS; NON-METAL HOOKS; MAGAZINE HOLDERS; CHAIRS AND CHAIRS FOR USE IN IRONING; NON-METAL STEP STOOLS (U.S. CLS. 2, 13, 22, 25, 32 AND 50).

THE MARK CONSISTS OF STANDARD CHARACTERS WITHOUT CLAIM TO ANY PARTICULAR FONT, STYLE, SIZE, OR COLOR.

PRIORITY CLAIMED UNDER SEC. 44(D) ON ERPN CMNTY TM OFC APPLICATION NO. 003877792, FILED 6-17-2004, REG. NO. 003877792, DATED 9-22-2005, EXPIRES 6-17-2014.

CLASS 21—HOUSEWARES AND GLASS

FOR BATH ACCESSORIES, NAMELY, SOAP DISPENSERS, TOOTHBRUSH HOLDERS, SOAP DISHES; DINNER PLATES, CUPS, SAUCERS, MUGS, DRINKING GLASSES, BEVERAGE GLASSWARE, BEVERAGE WARE; GLASS BEVERAGE WARE; BEVERAGE WARE, NAMELY, STEMWARE; TEAPOTS, NOT OF PRECIOUS METAL, CREAMERS, SERVING PLATTERS, BOWLS; IRONING BOARDS; CANDLE HOLDERS, NOT OF PRECIOUS METAL; VASES; LAUNDRY BASKETS OF WICKER, LAUNDRY HAMPERS; SERVING TRAYS, PITCHERS; BATHROOM HARDWARE, NAMELY, TOILET PAPER HOLDERS, TOWEL BARS, AND CUP HOLDERS; DISH DRYING RACKS, DRYING RACKS; WINE BOTTLE CRADLES, BOTTLE HOLDERS; WINE CUBES; CANVAS BINS FOR LAUNDRY (U.S. CLS. 2, 13, 23, 29, 30, 33, 40 AND 50).

CLASS 10—MEDICAL APPARATUS

FOR BABY BOTTLES; CUPS ADAPTED FOR FEEDING BABIES AND INFANTS; PARTS OF BABY BOTTLES AND CUPS ADAPTED FOR FEEDING BABIES AND INFANTS, NAMELY, NON-SPILL VALVES FOR CUPS AND BABY BOTTLES, SPOUTS FOR CUPS AND BABY BOTTLES, AND HANDLES FOR BABY BOTTLES (U.S. CLS. 26, 39 AND 44).

CLASS 21—HOUSEWARES AND GLASS

FOR FEEDING DISHES ADAPTED FOR USE BY BABIES AND INFANTS; BABY BOTTLE AND TEAT CLEANING BRUSHES (U.S. CLS. 2, 13, 23, 29, 30, 33, 40 AND 50).

LAURA HAMMEL, EXAMINING ATTORNEY

CLASS 22—CORDAGE AND FIBERS

FOR LAUNDRY BAGS AND LAUNDRY BAG SETS (U.S. CLS. 1, 2, 7, 19, 22, 42 AND 50).

SN 78-654,412. CANWEST LIMITED PARTNERSHIP, WINNIPEG, MANITOBA, CANADA, FILED 6-20-2005.

DOSE

CLASS 24—FABRICS

FOR SHOWER CURTAINS; TOWELS; BEDDING, BED SHEETS, BED SHEETS IN STAND ALONE COLORS, COMFORTERS, PILLOWCASES; COMFORTER COVERS; COMPLETE BEDDING SETS; DRAPERY; TEXTILE PLACE MATS, TEXTILE NAPKINS (U.S. CLS. 42 AND 50).

THE MARK CONSISTS OF STANDARD CHARACTERS WITHOUT CLAIM TO ANY PARTICULAR FONT, STYLE, SIZE, OR COLOR.

PRIORITY CLAIMED UNDER SEC. 44(D) ON CANADA APPLICATION NO. 1241384, FILED 12-20-2004, REG. NO. TMA736040, DATED 3-10-2009, EXPIRES 3-10-2024.

CLASS 27—FLOOR COVERINGS

FOR BATH MATS (U.S. CLS. 19, 20, 37, 42 AND 50). ERNEST SHOSHO, EXAMINING ATTORNEY

CLASS 9—ELECTRICAL AND SCIENTIFIC APPARATUS

FOR AUDIO AND VIDEO TAPES FEATURING ENTERTAINMENT, NAMELY, MOTION PICTURES, TELEVISION PROGRAMS, RADIO BROADCASTS AND PROGRAMS ABOUT COMEDY, DRAMA, HORROR, CELEBRITIES, CELEBRITY GOSSIP, CURRENT EVENTS, NAMELY, NEWS IN THE NATURE OF CURRENT EVENTS, MUSICAL PERFORMANCES AND RECORDINGS (U.S. CLS. 21, 23, 26, 36 AND 38).

CLASS 16—PAPER GOODS AND PRINTED MATTER

FOR PRINTED PUBLICATIONS, NAMELY, DAILY TABLOID NEWSPAPER AND MAGAZINE FEATURING INFORMATION AND NEWS ABOUT ENTERTAINMENT, NAMELY, MOTION PICTURES, TELEVISION PROGRAMS, RADIO BROADCASTS AND PROGRAMS, MUSICAL PERFORMANCES AND RECORDINGS, THEATER, DANCE, CELEBRITIES, CELEBRITY GOS-SIP, AND CURRENT EVENTS (U.S. CLS. 2, 5, 22, 23, 29, 37, 38 AND 50).

CLASS 35—ADVERTISING AND BUSINESS

FOR PROMOTING THE MUSIC CONCERTS AND COMMUNITY FESTIVALS AND CULTURAL EVENTS OF OTHERS (U.S. CLS. 100, 101 AND 102).

CLASS 38—COMMUNICATION

FOR BROADCASTING PROGRAMS VIA A GLOBAL COMPUTER NETWORK, BROADCASTING SERVICES AND PROVISION OF TELECOMMUNICATION ACCESS TO FILMS AND TV PROGRAMS PROVIDED VIA A VIDEO-ON-DEMAND SERVICE; RADIO BROADCAST-ING, TELEVISION BROADCASTING; WIRELESS BROADBAND COMMUNICATION SERVICES, WIRE-LESS COMMUNICATIONS SERVICES, NAMELY, WIRE-LESS ELECTRONIC TRANSMISSION OF VOICE SIGNALS, DATA, IMAGES AND INFORMATION; TELE-COMMUNICATIONS SERVICES, NAMELY, LOCAL AND LONG DISTANCE TRANSMISSION OF VOICE, DATA AND GRAPHICS BY MEANS OF CABLE AND SATELLITE TRANSMISSIONS; TELECOMMUNICA-TIONS SERVICES IN THE NATURE OF INTERNET TELEPHONY SERVICES, NAMELY, LOCAL AND LONG DISTANCE TRANSMISSION OF VOICE, DATA, AND GRAPHICS BY MEANS OF A GLOBAL COMPUTER NETWORK (U.S. CLS. 100, 101 AND 104).

**CLASS 41—EDUCATION AND ENTERTAIN-
MENT**

FOR PUBLICATION OF NEWSPAPERS IN PRINT, ON-LINE AND ELECTRONIC FORM; ENTERTAINMENT, NAMELY, LIVE MUSIC CONCERTS (U.S. CLS. 100, 101 AND 107).

PAUL CROWLEY, EXAMINING ATTORNEY

SN 78-703.389. THERMAL ENGINEERING INTERNA-TIONAL, INC., SANTA FE SPRINGS, CA. FILED 8-30-2005.

STRUTHERS WELLS

THE MARK CONSISTS OF STANDARD CHARACTERS WITHOUT CLAIM TO ANY PARTICULAR FONT, STYLE, SIZE, OR COLOR.

CLASS 7—MACHINERY

FOR CENTRIFUGES; PNEUMATIC PUMPS; SHAFTS FOR PUMPS; GAS COMPRESSORS; MACHINE PARTS, NAMELY, AIR AND GAS COOLERS; MOISTURE SE-PARATOR REHEATERS; MACHINE PARTS, NAMELY, CENTRIFUGAL COMPRESSOR INTERCOOLERS AND AFTERCOOLERS; MACHINE PARTS, NAMELY, EN-GINE INTERCOOLERS; AUTOMATED MANIPULATOR ARMS USED IN INDUSTRY FOR MANIPULATING PRESSURE VESSEL VALVES AND OPENING AND CLOSING PRESSURE VESSEL CLOSURES; SEMI-FAB-RICATED METAL MACHINE PARTS, NAMELY, DIE HEADS, DISHED ENDS, BOILER VESSELS AND FLANGES; MACHINE PARTS, NAMELY, PRESSURE VESSELS IN THE NATURE OF CONTAINERS DE-SIGNED TO HOLD GASES OR LIQUIDS AT A PRES-SURE DIFFERENT FROM THE AMBIENT PRESSURE (U.S. CLS. 13, 19, 21, 23, 31, 34 AND 35).

CLASS 9—ELECTRICAL AND SCIENTIFIC APPARATUS

FOR ELECTRIC CONTROLS FOR COMBUSTION CHAMBERS; THERMOSTATS; ELECTROLYTIC DE-VICES, NAMELY, CHLORINE AND CHLORATE AN-ODES AND CELLS AND COPPER START SHEET CATHODES (U.S. CLS. 21, 23, 26, 36 AND 38).

**CLASS 11—ENVIRONMENTAL CONTROL AP-
PARATUS**

FOR ELECTRIC HEATERS FOR COMMERCIAL USE; FEED WATER HEATERS; INDUSTRIAL BOILERS; ELECTRIC DIRECT FIRED PROCESS HEATERS FOR COMMERCIAL USE; GAS DIRECT FIRED PROCESS HEATERS FOR COMMERCIAL USE; THERMAL FLUID SYSTEMS, NAMELY, THERMAL FLUID HEATERS FOR HEAT TRANSFER OF LIQUIDS AND GASES; WASTE HEAT RECOVERY EQUIPMENT, NAMELY, INDUS-TRIAL BOILERS FOR HEAT RECOVERY; GAS AIR HEATERS; ELECTRIC AIR HEATERS; COMBUSTION CHAMBERS; PLUMBING FITTINGS, NAMELY, SCREW-ON PLUG CLOSURES; MULTI-WALL VESSELS IN THE NATURE OF HEAT EXCHANGERS THAT ARE NOT PARTS OF MACHINES; HEAT EXCHANGERS USED TO PREHEAT COMBUSTION AIR FOR FIRED PROCESS HEATERS, INDUSTRIAL BOILERS, AND CENTRAL STATION BOILERS; PROCESS EQUIPMENT, NAMELY, TANKS, ABSORPTION COLUMNS, DESORPTION COL-UMNS, EXTRACTION COLUMNS, REACTIFICATION COLUMNS, DISTILLATION COLUMNS, AND PIPING FOR USE IN BOILERS AND INDUSTRIAL HEATING SYSTEMS; ROTATING EQUIPMENT, NAMELY, AIR AND GAS BLOWERS FOR HEATERS; ONCE THROUGH STEAM GENERATORS; HEAT PUMPS (U.S. CLS. 13, 21, 23, 31 AND 34).

CLASS 40—MATERIAL TREATMENT

FOR METAL FABRICATION AND FINISHING SER-VICES; CONTRACT MANUFACTURING FOR OTHERS IN THE FIELD OF FEEDWATER HEATERS, STEAM SURFACE CONDENSERS AND POWER PLANT HEAT EXCHANGERS; CUSTOM CONSTRUCTION OF FEED-WATER HEATERS, STEAM SURFACE CONDENSERS AND POWER PLANT HEAT EXCHANGERS (U.S. CLS. 100, 103 AND 106).

CLASS 42—SCIENTIFIC AND COMPUTER SERVICES

FOR ENGINEERING; PROCESS DESIGN FOR OTHERS IN THE FIELD OF INDUSTRIAL HEATING AND COOLING; MECHANICAL ENGINEERING; FINITE-ELEMENT THERMAL AND STRESS ANALYSIS OF INDUSTRIAL BOILERS, PRESSURE VESSELS, FUEL DIRECT FIRED PROCESS HEATERS AND SHELL AND TUBE HEAT EXCHANGERS, ALL IN THE FIELD OF INDUSTRIAL HEATING AND COOLING EQUIPMENT; CHEMICAL REACTION ENGINEERING; DESIGN OF ELECTRICAL WIRING SYSTEMS FOR OTHERS; INSTRUMENTATION AND CONTROL SYSTEM ENGINEERING; FOUNDATION AND STRUCTURAL DESIGN FOR OTHERS IN THE FIELD OF INDUSTRIAL HEATING AND COOLING EQUIPMENT; SOFTWARE DEVELOPMENT; FIELD SERVICE ENGINEERING; FLUID PUMPING AND PIPING DESIGN FOR OTHERS; RESEARCH AND DEVELOPMENT OF FEEDWATER HEATERS, AND POWER PLANT HEAT EXCHANGERS (U.S. CLS. 100 AND 101).

KELLY BOULTON, EXAMINING ATTORNEY

CLASS 28—TOYS AND SPORTING GOODS

FOR GAMES, TOYS AND PLAYTHINGS ALL BASED ON A COMPUTER GAME WHICH SIMULATES WARS AND BATTLES, NAMELY, TOY COSTUMES COMPRISING TOY HELMETS, TOY BODY ARMOR AND TOY SWORDS AND TOY SHIELDS; GYMNASIAC APPARATUS AND SPORTING ARTICLES, NAMELY, TOY SWORDS AND TOY SHIELDS ALL BASED ON A COMPUTER GAME WHICH SIMULATES WARS AND BATTLES; HANDHELD UNITS FOR PLAYING ELECTRONIC GAMES, NAMELY, HAND-HELD ELECTRONIC GAMES WHICH SIMULATE WARS AND BATTLES; PLAY SETS COMPRISED OF TOY BUILDINGS, TOY FORTS, TOY WEAPONS, AND TOY ACTION FIGURES ALL BASED ON A COMPUTER GAME WHICH SIMULATES WARS AND BATTLES; PLAY CASES FOR PLAY ACCESSORIES BASED ON A COMPUTER GAME WHICH SIMULATES WARS AND BATTLES; TOY MODELS OF WAR SCENES COMPROMISING BATTLEFIELDS AND TOY FIGURINE SOLDIERS BASED ON A COMPUTER GAME WHICH SIMULATES WARS AND BATTLES; HANDHELD GAMES NAMELY, ELECTRONIC VIDEO GAMES WHICH SIMULATE WARS AND BATTLES (U.S. CLS. 22, 23, 38 AND 50).

CLASS 41—EDUCATION AND ENTERTAINMENT

FOR ENTERTAINMENT SERVICES, NAMELY, PROVIDING ON-LINE COMPUTER GAMES WHICH SIMULATE WARS AND BATTLES; INTERACTIVE MULTIMEDIA ENTERTAINMENT SOFTWARE PRODUCTION SERVICES ALL PERTAINING TO COMPUTER GAMING WHICH SIMULATES WARS AND BATTLES; EDUCATION AND ENTERTAINMENT SERVICES IN THE FORM OF CINEMATOGRAPHIC, TELEVISUAL, AND DIGITAL MOTION PICTURE FILM PRODUCTION FEATURING ENTERTAINMENT BASED ON A COMPUTER GAME WHICH SIMULATES WARS AND BATTLES; PRODUCTION OF RADIO AND TELEVISION PROGRAMS AND SHOWS, AND PROVISION OF INFORMATION ALL PERTAINING TO COMPUTER GAMING WHICH SIMULATES WARS AND BATTLES VIA COMPUTER NETWORKS, TELEVISION, CABLE TELEVISION AND OTHER ELECTRONIC MEANS; ENTERTAINMENT SERVICES, NAMELY, PROVIDING NON-DOWNLOADABLE ONLINE COMPUTER GAMES WHICH SIMULATE WARS AND BATTLES; AND PRODUCTION OF COMPUTER GAMES WHICH SIMULATE WARS AND BATTLES (U.S. CLS. 100, 101 AND 107).

KRISTIN DAHLING, EXAMINING ATTORNEY

SN 78-704,427. THE CREATIVE ASSEMBLY LIMITED, SOUTHWATER NR. HORSHAM, WEST SUSSEX, UNITED KINGDOM, FILED 8-31-2005.

SPARTAN: TOTAL WARRIOR

THE MARK CONSISTS OF STANDARD CHARACTERS WITHOUT CLAIM TO ANY PARTICULAR FONT, STYLE, SIZE, OR COLOR.

PRIORITY CLAIMED UNDER SEC. 44(D) ON UNITED KINGDOM APPLICATION NO. 004315842, FILED 3-1-2005, REG. NO. 004315842, DATED 3-29-2006, EXPIRES 3-1-2015.

CLASS 9—ELECTRICAL AND SCIENTIFIC APPARATUS

FOR ENTERTAINMENT COMPUTER SOFTWARE AND HARDWARE ALL FOR COMPUTER GAMING WHICH SIMULATES WARS AND BATTLES; ELECTRONIC GAMING APPARATUS, NAMELY, HAND HELD REMOTES AND PLAYER CONTROLS ALL FOR COMPUTER GAMING WHICH SIMULATES WARS AND BATTLES; INTERACTIVE COMPUTER SOFTWARE AND DATABASE SOFTWARE ALL FOR COMPUTER GAMING WHICH SIMULATES WARS AND BATTLES FOR USE VIA INTRANETS AND THE INTERNET; GAMING SOFTWARE ALL FOR COMPUTER GAMING WHICH SIMULATES WARS AND BATTLES (U.S. CLS. 21, 23, 26, 36 AND 38).

SN 78-705,641. EGALET A/S, KIRKE VÆRLØSE, DENMARK, FILED 9-1-2005.

PARVULET

THE MARK CONSISTS OF STANDARD CHARACTERS WITHOUT CLAIM TO ANY PARTICULAR FONT, STYLE, SIZE, OR COLOR.

PRIORITY CLAIMED UNDER SEC. 44(D) ON ERPN CMNTY TM OFC APPLICATION NO. 004320041, FILED 3-3-2005, REG. NO. 004320041, DATED 3-29-2006, EXPIRES 3-3-2015.

CLASS 5—PHARMACEUTICALS

FOR PHARMACEUTICAL AND VETERINARY PREPARATIONS FOR THE TREATMENT OF PAIN RELIEF AND PAIN MANAGEMENT, SHOCK, HEMORRHAGE AND BLEEDING, PRE- AND POST-OPERATIVE COMPLICATIONS IN THE NATURE OF HEMORRHAGE, BLEEDING, THROMBOSIS, EMBOLI, STROKE, APOPLEXY, LESIONS, RESPIRATORY AND CIRCULATORY CRISES AND DYSFUNCTIONS, COGNITIVE DYSFUNCTIONS, FIBROSIS, INFECTIONS, FEVER AND SEPSIS, AND TRAUMAS AND EMERGENCIES, NAMELY, FRACTURES, ABRASIONS, BURNS, PSYCHOLOGICAL AND IMMUNOLOGICAL SHOCK, POISONS AND POLLUTIONS, ANIMAL BITES OR STINGS, FEVER, RESPIRATORY AND CARDIOVASCULAR SHOCK, CRISES AND DYSFUNCTIONS, AND HEMORRHAGE, BLEEDING, THROMBOSIS, EMBOLI, STROKE, APOPLEXY, LESIONS AND COGNITIVE DYSFUNCTIONS, AND PHYSICAL AND PSYCHOLOGICAL SUBSTANCE DEPENDENCE, NAMELY, DRUG AND ALCOHOL DEPENDENCE, DRUG TOLERANCE, WITHDRAWAL SYMPTOMS, CONVULSIONS, ALZHEIMER DISEASE, DEMENTIAS, PARKINSON'S DISEASE, INSUFFICIENT SALIVA AND INABILITY TO SWALLOW, ALLERGY/IMMUNOLOGY DISORDERS, BURNS, DISEASES OF THE HEART AND BLOOD VESSELS, DENTAL AND GUM DISEASES, SKIN DISEASES, NUTRITIONAL AND DIETARY DISEASES, DISEASES OF THE ENDOCRINOLOGICAL SYSTEM AND PANCREATIC DISEASES, DIABETES, EPIDEMICAL DISEASES IN THE NATURE OF FLU, AIDS/HIV, ANTHRAX, PLAGUE, CHOLERA, BIOLOGICAL INFECTIONS, AND PRION EXPOSURE, DISEASES AND AFFLICTIONS OF THE GASTROENTEROLOGICAL SYSTEM, DISEASES OF THE BLOOD, INFECTIOUS DISEASES, NEUROLOGICAL DISEASES, NEPHROLOGICAL DISEASES, GENTOURINARY DISEASES AND AFFLICTIONS, PREMATURE LABOR, POISON EXPOSURE, CANCER, OPHTHALMOLOGICAL DISEASES, DISEASES AND AFFLICTIONS AFFECTING THE BONES, JOINTS, CARTILAGE MATERIAL AND MUSCLES, DISEASES AND AFFLICTIONS OF THE EAR, NOSE AND THROAT, DISEASES AND AFFLICTIONS ON THE PSYCHIATRIC FIELD, PULMONOLOGICAL DISEASES AND AFFLICTIONS, RHEUMATISM, UROLOGICAL DISEASES AND AFFLICTIONS, VETERINARY PREPARATIONS FOR THE TREATMENT OF BOVINE, SHEEP, HORSES, PIGS, POULTRY, OSTRICH, RODENTS, DOGS, CATS, CAMELS, DONKEYS, ELEPHANTS; CHEMICAL, BIOCHEMICAL, BIOLOGICAL AND BACTERIOLOGICAL RESEARCH AND ANALYSIS; PHARMACEUTICAL DRUG AND MEDICINE DEVELOPMENT SERVICES; DESIGN FOR OTHERS IN THE FIELD OF DRUGS AND MEDICINES; DEVELOPMENT OF PHARMACEUTICAL PREPARATIONS AND MEDICINES; PROFESSIONAL CONSULTANCY PERTAINING TO PHARMACOLOGY, NAMELY, BIOTECHNICAL AND BIOMEDICAL AND MEDICAL AND PHARMACEUTICAL SUBSTANCES, PREPARATIONS AND COMPOUNDS; PROFESSIONAL CONSULTANCY IN THE FIELD OF RESEARCH AND DEVELOPMENT OF MEDICINE AND THE DISPENSING OF PHARMACEUTICAL PREPARATIONS; PHARMACEUTICAL DRUG DEVELOPMENT SERVICES COMPRISED OF SCIENTIFIC, INDUSTRIAL, TECHNOLOGICAL, BIO TECHNICAL, PHARMACEUTICAL, BIOMEDICAL AND CLINICAL RESEARCH IN THE FIELD OF DRUGS AND DRUG CANDIDATES; MEDICAL AND SCIENTIFIC RESEARCH, NAMELY, CONDUCTING CLINICAL TRIALS OF NEW DRUG CANDIDATES; CONSULTATION IN THE FIELD OF SCIENTIFIC RESEARCH PERTAINING TO CHEMICAL, PHARMACEUTICAL AND MEDICAL GOODS; DESIGN FOR OTHERS IN THE FIELD OF MEDICAL PACKAGING AND EQUIPMENT; DEVELOPMENT OF PHARMACEUTICAL PREPARATIONS AND MEDICINES; CONSULTATION IN THE FIELD OF BIOTECHNOLOGICAL AND BIOMEDICAL SCIENTIFIC RESEARCH; BIOCHEMICAL AND MOLECULAR BIOLOGICAL ANALYSES; IN VITRO AND IN VIVO PRECLINICAL TESTS AND CLINICAL TESTS OF DRUG CANDIDATES AND POTENTIAL DRUGS; CONSULTANCY AND RESEARCH REGARDING PHARMACEUTICALS IN GEL-LIKE AND VISCOUS LIQUID DOSAGE FORMS; CONSULTANCY AND RESEARCH PERTAINING TO PHARMACOLOGY IN THE NATURE OF ALTERNATIVE DRUGS FOR THE YOUNG, ELDERLY AND THOSE WITH DIFFICULTIES SWALLOWING PILLS AND TABLETS; DEVELOPMENT OF IN VITRO AND IN VIVO PRECLINICAL TESTS OF DRUG CANDIDATES AND POTENTIAL DRUGS; BIOCHEMICAL AND MOLECULAR BIOLOGICAL ANALYSES; SCIENTIFIC, INDUSTRIAL, TECHNOLOGICAL AND BIOTECHNOLOGICAL ANALYSIS IN THE FIELD OF PHARMACEUTICAL AND VETERINARY DRUG AND MEDICINE ANALYSIS, ANALYSIS OF DRUG DELIVERY APPARATUS AND CONTAINERS, ANALY-

CLASS 10—MEDICAL APPARATUS

FOR SURGICAL, MEDICAL, DENTAL AND VETERINARY APPARATUS AND INSTRUMENTS, NAMELY, DRUG DELIVERY APPARATUS AND INSTRUMENTS IN THE FORM OF CONTAINERS FOR VARIOUS PHARMACEUTICALS, DRUGS, MEDICINES, COMPOUNDS AND SUBSTANCES IN THE FORM OF LIQUIDS, GELS, GRAINS, EMULSIONS, BLISTER PACKS AND SACHETS; SPOONS, CUPS AND SYRINGES FOR ADMINISTERING PHARMACEUTICAL SUBSTANCES AND MEDICINES; DRUG DELIVERY SYSTEMS (U.S. CLS. 26, 39 AND 44).

CLASS 40—MATERIAL TREATMENT

FOR TREATMENT OF MATERIALS, NAMELY, MILLING, MIXING, GRINDING, LIQUEFYING, PULVERIZING, MELTING AND EXTRUSION OF MEDICAL AND PHARMACEUTICAL SUBSTANCES, COMPOUNDS AND MATERIALS (U.S. CLS. 100, 103 AND 106).

CLASS 42—SCIENTIFIC AND COMPUTER SERVICES

FOR SCIENTIFIC RESEARCH; TECHNOLOGY CONSULTATION IN THE FIELD OF SCIENTIFIC RESEARCH; DESIGN FOR OTHERS IN THE FIELDS OF PAIN RELIEF AND PAIN MANAGEMENT, PHARMACEUTICAL DRUG AND MEDICINE DEVELOPMENT, DEVELOPMENT OF MEDICINES AND MEDICINE GOODS AND PACKAGING IN THE FIELDS OF TRAUMAS AND EMERGENCIES, ADDICTIONS, AGING, ALLERGY/IMMUNOLOGY, BURNS, DISEASES OF THE HEART AND BLOOD VESSELS, DENTAL AND GUM DISEASES, SKIN DISEASES, NUTRITIONAL AND DIETARY DISEASES, DISEASES OF THE ENDOCRINOLOGICAL SYSTEM AND PANCREATIC DISEASES, DIABETES, EPIDEMICAL DISEASES, DISEASES AND AFFLICTIONS OF THE GASTROENTEROLOGICAL SYSTEM, DISEASES OF THE BLOOD, INFECTIOUS DISEASES, NEUROLOGICAL DISEASES, NEPHROLOGICAL DISEASES, DISEASES IN THE OBSTETRICAL- AND GYNECOLOGICAL FIELD, OCCUPATIONAL DISEASES AND AFFLICTIONS, CANCER, OPHTHALMOLOGICAL DISEASES, DISEASES AND AFFLICTIONS AFFECTING THE BONES, JOINTS, CARTILAGE MATERIAL AND MUSCLES, DISEASES AND AFFLICTIONS OF THE EAR-NOSE AND THROAT, DISEASES AND AFFLICTIONS ON THE PSYCHIATRIC FIELD, PULMONOLOGICAL DISEASES AND AFFLICTIONS, RHEUMATISM, UROLOGICAL DISEASES AND AFFLICTIONS, VETERINARY PREPARATIONS FOR THE TREATMENT OF BOVINE, SHEEP, HORSES, PIGS, POULTRY, OSTRICH, RODENTS, DOGS, CATS, CAMELS, DONKEYS, ELEPHANTS; CHEMICAL, BIOCHEMICAL, BIOLOGICAL AND BACTERIOLOGICAL RESEARCH AND ANALYSIS; PHARMACEUTICAL DRUG AND MEDICINE DEVELOPMENT SERVICES; DESIGN FOR OTHERS IN THE FIELD OF DRUGS AND MEDICINES; DEVELOPMENT OF PHARMACEUTICAL PREPARATIONS AND MEDICINES; PROFESSIONAL CONSULTANCY PERTAINING TO PHARMACOLOGY, NAMELY, BIOTECHNICAL AND BIOMEDICAL AND MEDICAL AND PHARMACEUTICAL SUBSTANCES, PREPARATIONS AND COMPOUNDS; PROFESSIONAL CONSULTANCY IN THE FIELD OF RESEARCH AND DEVELOPMENT OF MEDICINE AND THE DISPENSING OF PHARMACEUTICAL PREPARATIONS; PHARMACEUTICAL DRUG DEVELOPMENT SERVICES COMPRISED OF SCIENTIFIC, INDUSTRIAL, TECHNOLOGICAL, BIO TECHNICAL, PHARMACEUTICAL, BIOMEDICAL AND CLINICAL RESEARCH IN THE FIELD OF DRUGS AND DRUG CANDIDATES; MEDICAL AND SCIENTIFIC RESEARCH, NAMELY, CONDUCTING CLINICAL TRIALS OF NEW DRUG CANDIDATES; CONSULTATION IN THE FIELD OF SCIENTIFIC RESEARCH PERTAINING TO CHEMICAL, PHARMACEUTICAL AND MEDICAL GOODS; DESIGN FOR OTHERS IN THE FIELD OF MEDICAL PACKAGING AND EQUIPMENT; DEVELOPMENT OF PHARMACEUTICAL PREPARATIONS AND MEDICINES; CONSULTATION IN THE FIELD OF BIOTECHNOLOGICAL AND BIOMEDICAL SCIENTIFIC RESEARCH; BIOCHEMICAL AND MOLECULAR BIOLOGICAL ANALYSES; IN VITRO AND IN VIVO PRECLINICAL TESTS AND CLINICAL TESTS OF DRUG CANDIDATES AND POTENTIAL DRUGS; CONSULTANCY AND RESEARCH REGARDING PHARMACEUTICALS IN GEL-LIKE AND VISCOUS LIQUID DOSAGE FORMS; CONSULTANCY AND RESEARCH PERTAINING TO PHARMACOLOGY IN THE NATURE OF ALTERNATIVE DRUGS FOR THE YOUNG, ELDERLY AND THOSE WITH DIFFICULTIES SWALLOWING PILLS AND TABLETS; DEVELOPMENT OF IN VITRO AND IN VIVO PRECLINICAL TESTS OF DRUG CANDIDATES AND POTENTIAL DRUGS; BIOCHEMICAL AND MOLECULAR BIOLOGICAL ANALYSES; SCIENTIFIC, INDUSTRIAL, TECHNOLOGICAL AND BIOTECHNOLOGICAL ANALYSIS IN THE FIELD OF PHARMACEUTICAL AND VETERINARY DRUG AND MEDICINE ANALYSIS, ANALYSIS OF DRUG DELIVERY APPARATUS AND CONTAINERS, ANALY-

SIS OF SYNTHETIC PEPTIDES FOR PHARMACEUTICAL PURPOSES, ANALYSIS OF PEPTIDE SUBSTRATES, ANALYSIS FOR THE PURPOSE OF DETECTING VARIOUS TOXINS, ANALYSIS OF DRUG CANDIDATES AND POTENTIAL DRUGS (U.S. CLS. 100 AND 101).
COLLEEN KEARNEY, EXAMINING ATTORNEY

SN 78-706,303. WESTERN REFINING COMPANY, L.P., EL PASO, TX. FILED 9-2-2005.



NO CLAIM IS MADE TO THE EXCLUSIVE RIGHT TO USE "REFINING", APART FROM THE MARK AS SHOWN. THE COLOR(S) BLACK, WHITE, YELLOW, AND GRAY IS/ARE CLAIMED AS A FEATURE OF THE MARK.

THE MARK CONSISTS OF THE WORD "WESTERN" IN BLACK LOCATED ABOVE THE WORD "REFINING" IN GRAY WITH THE LETTER "W" IN BLACK LETTERING. THE LETTER "W" INCLUDING A DROPLET HAVING THE COLORS YELLOW AND WHITE WITH YELLOW HASH MARKS. THE LETTER "W" IS LOCATED TO THE RIGHT OF THE WORDS "WESTERN" AND "REFINING".

CLASS 4—LUBRICANTS AND FUELS

FOR FUEL FROM CRUDE OIL (U.S. CLS. 1, 6 AND 15).
FIRST USE 8-29-2003; IN COMMERCE 8-29-2003.

CLASS 40—MATERIAL TREATMENT

FOR OIL REFINING SERVICES (U.S. CLS. 100, 103 AND 106).
FIRST USE 8-29-2003; IN COMMERCE 8-29-2003.
PAUL F. GAST, EXAMINING ATTORNEY

SN 78-719,460. PSIMEDICA LIMITED, WORCESTERSHIRE, ENGLAND, FILED 9-23-2005.

BRACHYSIL

THE MARK CONSISTS OF STANDARD CHARACTERS WITHOUT CLAIM TO ANY PARTICULAR FONT, STYLE, SIZE, OR COLOR.

OWNER OF ERPN CMNTY TM OFC REG. NO. 004641973, DATED 8-25-2006, EXPIRES 9-15-2015.

CLASS 5—PHARMACEUTICALS

FOR PHARMACEUTICAL AND MEDICAL PREPARATIONS FOR THE TREATMENT OF CANCER (U.S. CLS. 6, 18, 44, 46, 51 AND 52).

CLASS 10—MEDICAL APPARATUS

FOR DRUG DELIVERY SYSTEMS; IMPLANTS IN THE NATURE OF ARTIFICIAL SUBSTANCES, NAMELY, SILICON; MEDICAL PRODUCTS, NAMELY, INJECTABLE OR INTRAVENOUSLY DELIVERABLE FORMULATIONS OR SUSPENSIONS COMPRISING SILICON, BIOACTIVE SILICON, AND/OR RESORBABLE SILICON; PRODUCTS AND/OR SYSTEMS FOR THE TREATMENT OF CANCER, NAMELY, BIOPSY INSTRUMENTS, CANNULAE, CATHETERS, TROCARS, ENDOSCOPIC EQUIPMENT, INFUSION AND INJECTION DEVICES, INJECTION NEEDLES, INJECTION SYRINGES AND NEEDLE-BASED AND NEEDLE-FREE INJECTION SYSTEMS; RADIOTHERAPEUTIC PRODUCTS AND/OR SYSTEMS, NAMELY, CANNULAE, CATHETERS, TROCARS, ENDOSCOPIC EQUIPMENT, DRUG DELIVERY APPARATUS, INFUSION AND INJECTION DEVICES, INJECTION NEEDLES, INJECTION SYRINGES, AND NEEDLE-BASED AND NEEDLE-FREE INJECTION SYSTEMS, FOR THE INJECTION OF OR INTRAVENOUS ADMINISTRATION OF FORMULATIONS OR SUSPENSIONS FOR THE TREATMENT OF CANCER; CHEMOTHERAPEUTIC PRODUCTS AND/OR SYSTEMS, NAMELY, CANNULAE, CATHETERS, TROCARS, ENDOSCOPIC EQUIPMENT, DRUG DELIVERY APPARATUS, INFUSION AND INJECTION DEVICES, INJECTION NEEDLES, INJECTION SYRINGES, AND NEEDLE-BASED AND NEEDLE-FREE INJECTION SYSTEMS, FOR THE INJECTION OF OR INTRAVENOUS ADMINISTRATION OF FORMULATIONS OR SUSPENSIONS FOR THE TREATMENT OF CANCER; BRACHYTHERAPY PRODUCTS AND/OR SYSTEMS, FOR THE INJECTION OF OR INTRAVENOUS ADMINISTRATION OF FORMULATIONS OR SUSPENSIONS FOR THE TREATMENT OF CANCER, AND PARTS AND FITTINGS SOLD THEREWITH (U.S. CLS. 26, 39 AND 44).

CLASS 16—PAPER GOODS AND PRINTED MATTER

FOR PRINTED MATTER AND PRINTED PUBLICATIONS NAMELY, MANUALS, INSTRUCTIONAL AND TEACHING MATERIALS IN THE NATURE OF BOOKLETS, BOOKS, JOURNALS, LEAFLETS, NEWSLETTERS, PAMPHLETS, PRINTED COURSE MATERIALS, PRINTED INFORMATION GUIDES, PRINTED LESSONS, PRINTED TEACHING GUIDES, PRINTED TEACHING MATERIALS AND TEXTS RELATING TO CANCER OR TO THE TREATMENT OF CANCER; PAPER AND PAPER ARTICLES FEATURING THE SUBJECT OF CANCER OR THE TREATMENT OF CANCER, NAMELY, ADVERTISING SIGNS OF PAPER, BANNERS OF PAPER, CARRYING CASES OF PAPER, LETTER PAPER, NOTE PAPER, PRINTING PAPER, PAPER BADGES, PAPER BAGS AND SACKS, PAPER ENVELOPES, PAPER FOLDERS, PAPER FOR WRAPPING AND PACKAGING, PAPER LABELS, PAPER NAME BADGES, PAPER NAPKINS, PAPER NOTE BOOKS, PAPER REPORT COVERS, PAPER STATIONERY, PAPER TOWELS, POSTERS MADE OF PAPER, TISSUE PAPER AND WRITING PAPER (U.S. CLS. 2, 5, 22, 23, 29, 37, 38 AND 50).

JULIE GUTTADAURO, EXAMINING ATTORNEY

SN 78-772,694. HALICKI, DENICE SHAKARIAN, ENCINO, CA. FILED 12-13-2005.

SLICER

THE MARK CONSISTS OF STANDARD CHARACTERS WITHOUT CLAIM TO ANY PARTICULAR FONT, STYLE, SIZE, OR COLOR.

CLASS 9—ELECTRICAL AND SCIENTIFIC APPARATUS

FOR COMPUTER GAME CARTRIDGES AND COMPUTER SOFTWARE FOR OPERATING INTERACTIVE GAMES ON MULTIMEDIA DEVICES, VIDEO GAME MACHINES FOR USE WITH TELEVISIONS, PERSONAL COMPUTERS; COMPUTER GAME SOFTWARE AND MANUALS USED THEREWITH AND SOLD AS A UNIT, FOR USE OVER A GLOBAL COMPUTER NETWORK; PRERECORDED AUDIO AND VIDEOTAPES, DVD'S, UMD'S (UNIVERSAL MEDIA DISCS), LASER DISKS AND DIGITAL MEDIA, ALL FEATURING FILMS IN THE AUTOMOBILE, RACE CAR, ACTION, ADVENTURE, ANIMATION AND DRAMA GENRES; VIDEO GAME SOFTWARE; DOWNLOADABLE INTERACTIVE VIDEO RECORDINGS FEATURING VIDEO GAMES, AND VIDEOS IN THE AUTOMOBILE, RACE CAR, ACTION, ADVENTURE, ANIMATION AND DRAMA GENRES AND VIDEO GAMES FOR MOBILE DIGITAL MULTIMEDIA DEVICES AND MOBILE WIRELESS DEVICES; SPORTS HELMETS, GOGGLES FOR SPORTS, EYEGLASSES, SUN GLASS CASES, SPORTS EYEWEAR, EYEGLASS FRAMES, TIRE PRESSURE GAUGES DECORATIVE MAGNETS, MOUSE PADS, SLOT MACHINES, VENDING MACHINES, REFRIGERATOR AND DECORATIVE MAGNETS (U.S. CLS. 21, 23, 26, 36 AND 38).

CLASS 12—VEHICLES

FOR VEHICLES, NAMELY, AUTOMOBILES, ENGINES FOR AUTOMOBILES, STRUCTURAL PARTS FOR AUTOMOBILES, GO-CARTS, RACE CARS, MOTORCYCLES, AUTOMOTIVE PARTS, NAMELY, SEAT CUSHIONS AND HOODS, MOTORCYCLE PARTS, NAMELY, HANDLE BARS AND CLUTCH CABLES, BICYCLE PARTS, NAMELY, BRAKE SHOES AND DRIVE CHAIN, AUTOMOBILE EMBLEMS, TRAILER HITCH COVERS, AND STEERING WHEEL LOCKS; BADGES OF METAL FOR VEHICLE TRIM; PLASTIC LICENSE PLATE FRAMES (U.S. CLS. 19, 21, 23, 31, 35 AND 44).

CLASS 16—PAPER GOODS AND PRINTED MATTER

FOR SERIES OF FICTION BOOKS; NONFICTION BOOKS IN THE FIELD OF AUTOMOBILES AND ADVENTURE; CALENDARS, POSTERS, GREETING CARDS, COMIC BOOKS, STATIONERY (U.S. CLS. 2, 5, 22, 23, 29, 37, 38 AND 50).

CLASS 20—FURNITURE AND ARTICLES NOT OTHERWISE CLASSIFIED

FOR PLASTIC NOVELTY LICENSE PLATES, PICTURE FRAMES NOT OF PRECIOUS METAL, NONMETAL KEY CHAINS, EXECUTIVE NOVELTY, NAMELY, DESKTOP STATUARY MADE OF PLASTIC (U.S. CLS. 2, 13, 22, 25, 32 AND 50).

CLASS 25—CLOTHING

FOR CLOTHING, NAMELY, T-SHIRTS, SWEAT-SHIRTS, JACKETS, VESTS, TOPS, BOTTOMS, SHOES AND FOOTWEAR, BANDANAS, GLOVES, HEAD GEAR, NAMELY, CAPS, HATS, KNIT CAPS, AND NECKTIES (U.S. CLS. 22 AND 39).

CLASS 41—EDUCATION AND ENTERTAINMENT

FOR ENTERTAINMENT SERVICES, NAMELY, PROVIDING ONGOING TELEVISION AND RADIO PROGRAMS IN THE FIELDS OF AUTOMOBILES, ACTION, ADVENTURE, ANIMATION AND DRAMA; THE PRODUCTION AND DISTRIBUTION OF RADIO, TELEVISION AND ANIMATED TELEVISION SHOWS AND THEATRICAL MOTION PICTURES FOR OTHERS; ENTERTAINMENT SERVICES, NAMELY, CONDUCTING EXHIBITIONS OF AUTOMOBILES, CAR EVENTS AND CAR RACING EVENTS; ENTERTAINMENT SERVICES, NAMELY, PROVIDING A WEBSITE FEATURING AUTOMOBILE NEW AND TRIVIA ABOUT AUTOMO-

BILE RACING AND PERFORMANCE, ON-LINE COMPUTER GAMES, VIDEO GAMES, INTERACTIVE VIDEO GAMES; PUBLISHING ON-LINE MAGAZINES AND NEWSLETTERS IN THE FIELD OF AUTOMOBILES OVER THE INTERNET; PROVIDING AN ONLINE COMPUTER DATABASE IN THE FIELD OF AUTOMOBILE NEWS AND TRIVIA ABOUT AUTOMOBILE RACING AND PERFORMANCE; ENTERTAINMENT SERVICES BY MEANS OF MOTION PICTURES, NAMELY, MOTION PICTURE FILM PRODUCTION; FAN CLUB SERVICES; ANIMATED ENTERTAINMENT SERVICES, NAMELY, ANIMATION PRODUCTION SERVICES; AND ENTERTAINMENT SERVICES, NAMELY, PROVIDING ON-LINE COMPUTER GAMES (U.S. CLS. 100, 101 AND 107).

ODESSA BIBBINS, EXAMINING ATTORNEY

SN 78-804,270. SANTHERA PHARMACEUTICALS (SCHWEIZ) GMBH, CH-4410 LIESTAL, SWITZERLAND, FILED 2-1-2006.

DEDOXA

THE MARK CONSISTS OF STANDARD CHARACTERS WITHOUT CLAIM TO ANY PARTICULAR FONT, STYLE, SIZE, OR COLOR.

PRIORITY CLAIMED UNDER SEC. 44(D) ON ERPN CMNTY TM OFC APPLICATION NO. 004643755, FILED 9-21-2005, REG. NO. 004643755, DATED 3-16-2009, EXPIRES 3-16-2019.

CLASS 1—CHEMICALS

FOR CHEMICALS USED IN INDUSTRY AND SCIENCE (U.S. CLS. 1, 5, 6, 10, 26 AND 46).

CLASS 5—PHARMACEUTICALS

FOR PHARMACEUTICAL, VETERINARY AND SANITARY PREPARATIONS, NAMELY, CHEMICAL PRODUCTS FOR USE IN THE TREATMENT OF MUSCULAR DYSTROPHY, MUSCLE WASTING, ATROPHY, NEUROMUSCULAR DISEASES, CARDIOMYOPATHIES, ATAXIAS, OPTIC NERVE DEGRADATION, NEUROLOGICAL INDICATIONS AND MEMORY LOSS (U.S. CLS. 6, 18, 44, 46, 51 AND 52).

CLASS 42—SCIENTIFIC AND COMPUTER SERVICES

FOR COMPUTER PROGRAMMING FOR SCIENTIFIC AND INDUSTRIAL RESEARCH IN THE FIELDS OF CELL CULTURES, MUSCULAR DYSTROPHY, MUSCLE WASTING, ATROPHY, NEUROMUSCULAR DISEASES, CARDIOMYOPATHIES, ATAXIAS, OPTIC NERVE DEGRADATION, NEUROLOGICAL INDICATIONS AND MEMORY LOSS; SCIENTIFIC RESEARCH FOR CELLULAR TEST SYSTEMS THAT EVALUATE DRUGS AND ANTIBODIES; SCIENTIFIC RESEARCH FOR FINDING PHARMACOLOGICALLY ACTIVE COMPOUNDS AND ANIMAL MODELS FOR NEUROMUSCULAR DISEASES; SCIENTIFIC RESEARCH IN THE FIELDS OF MUSCULAR DYSTROPHY, MUSCLE WASTING, ATROPHY, NEUROMUSCULAR DISEASES, CARDIOMYOPATHIES, ATAXIAS, OPTIC NERVE DEGRADATION, NEUROLOGICAL INDICATIONS AND MEMORY LOSS (U.S. CLS. 100 AND 101).

ANDREA SAUNDERS, EXAMINING ATTORNEY

SN 78-828,906. ORBUS PHARMA, INC., MARKHAM, ONTARIO, CANADA, FILED 3-3-2006.

SN 78-834,400. TRI-SIS INC., LUNENBURG, ONTARIO, CANADA, FILED 3-10-2006.

RELEAF

ORBUS PHARMA

THE MARK CONSISTS OF STANDARD CHARACTERS WITHOUT CLAIM TO ANY PARTICULAR FONT, STYLE, SIZE, OR COLOR.

PRIORITY CLAIMED UNDER SEC. 44(D) ON CANADA APPLICATION NO. 1272343, FILED 9-6-2005, REG. NO. TMA724778, DATED 9-30-2008, EXPIRES 9-30-2023.

NO CLAIM IS MADE TO THE EXCLUSIVE RIGHT TO USE "PHARMA", APART FROM THE MARK AS SHOWN.

CLASS 1—CHEMICALS

FOR CHEMICAL, BIOLOGICAL AND DIAGNOSTIC REAGENTS FOR SCIENTIFIC AND RESEARCH USE; CHEMICALS ALL FOR USE IN THE MANUFACTURE OF PHARMACEUTICAL PREPARATIONS FOR HUMAN USE, NAMELY, DRUG PRECURSORS, EXCIPIENTS, DISPERSANTS, GRANULATING AGENTS, LUBRICANTS AND OPACIFIERS (U.S. CLS. 1, 5, 6, 10, 26 AND 46).

CLASS 5—PHARMACEUTICALS

FOR PHARMACEUTICAL PREPARATIONS FOR HUMAN USE, NAMELY, ANTI-EPILEPTICS, ANTIBIOTICS, ANTI-HYPERTENSIVES, ANTI-HYPERCHOLESTEROLEMIC, ANTI-HYPERLIPIDEMIAS, BETA-ADRENORECEPTOR ANTAGONISTS, ANTI-DEPRESSANTS, ANTIVIRALS, ANTI-PLATELETS, ADRENOCORTICALS, ANALGESICS, ANAPHYLACTICS, ANTI-ANGINALS, ANTI-ARTHRITICS, ANTI-INFLAMMATORIES, ANTIHISTAMINES, ANTIPSYCHOTICS, GASTROINTESTINAL PREPARATIONS, HORMONAL PREPARATIONS, RESPIRATORY PREPARATIONS, STEROID PREPARATIONS AND VACCINES; NUTRITIONAL SUPPLEMENTS; VITAMINS (U.S. CLS. 6, 18, 44, 46, 51 AND 52).

CLASS 40—MATERIAL TREATMENT

FOR MANUFACTURING OF PHARMACEUTICALS TO ORDER AND/OR SPECIFICATIONS OF OTHERS (U.S. CLS. 100, 103 AND 106).

CLASS 42—SCIENTIFIC AND COMPUTER SERVICES

FOR RESEARCH AND DEVELOPMENT SERVICES RELATING TO PHARMACEUTICAL PREPARATIONS FOR HUMAN USE; PHARMACEUTICAL DRUG DEVELOPMENT; PHARMACEUTICAL FORMULATION TESTING; PHARMACEUTICAL CLINICAL SERVICES, NAMELY, BASIC AND CLINICAL RESEARCH IN THE FIELD OF PHARMACEUTICALS (U.S. CLS. 100 AND 101).

MARIAM MAHMOUDI, EXAMINING ATTORNEY

THE MARK CONSISTS OF STANDARD CHARACTERS WITHOUT CLAIM TO ANY PARTICULAR FONT, STYLE, SIZE, OR COLOR.

PRIORITY CLAIMED UNDER SEC. 44(D) ON CANADA APPLICATION NO. 1273328, FILED 9-16-2005.

CLASS 5—PHARMACEUTICALS

FOR INCONTINENCE PRODUCTS, NAMELY, INCONTINENCE DIAPERS, ADULT DIAPERS, INCONTINENCE GARMENTS AND INCONTINENCE PADS; NURSING PADS (U.S. CLS. 6, 18, 44, 46, 51 AND 52).

CLASS 25—CLOTHING

FOR UNDERGARMENTS; UNDERWEAR; TEXTILE DIAPERS; NURSING BRAS; HEADGEAR, NAMELY, HATS, CAPS, HEADBANDS AND SWEATBANDS; ARMPIT SHIELDS; LININGS, NAMELY, FINISHED TEXTILE LININGS FOR GUSSETS AND OTHERWISE IN ARTICLES OF CLOTHING AND FOR SWIMWEAR, SPORTSWEAR, WORKWEAR, UNDERWEAR AND UNDERGARMENTS (U.S. CLS. 22 AND 39).

KATHY DE JONGE, EXAMINING ATTORNEY

SN 78-836,430. AGRANA BETEILIGUNGS-AKTIENGESELLSCHAFT, VIENNA, AUSTRIA, FILED 3-14-2006.



CLASS 3—COSMETICS AND CLEANING PREPARATIONS

FOR ETHEREAL AND ESSENTIAL OILS, VEGETABLE-BASED FLAVORINGS, ALL USED FOR FOOD FLAVORING (U.S. CLS. 1, 4, 6, 50, 51 AND 52).

CLASS 29—MEATS AND PROCESSED FOODS

FOR PRESERVED AND COOKED FRUITS AND VEGETABLES AND PREPARATIONS THEREOF FOR THE FOOD INDUSTRY, NAMELY, FOOD PRESERVES, JAMS, COMPOTES, STEWED VEGETABLES (U.S. CL. 46).

CLASS 30—STAPLE FOODS

FOR AROMA SUBSTANCES FOR BEVERAGES, OTHER THAN ESSENTIAL OILS FOR THE FOOD INDUSTRY, NAMELY, FLAVORINGS FOR BEVERAGES (U.S. CL. 46).

CLASS 31—NATURAL AGRICULTURAL PRODUCTS

FOR FRESH FRUITS AND VEGETABLES FOR THE FOOD INDUSTRY (U.S. CLS. 1 AND 46).

CLASS 32—LIGHT BEVERAGES

FOR FRUIT JUICES AND FRUIT DRINKS, FRUIT JUICE CONCENTRATES (U.S. CLS. 45, 46 AND 48).
FLORENTINA BLANDU, EXAMINING ATTORNEY

SN 78-864,598. DAIWA HOUSE INDUSTRY CO., LTD., OSAKA, JAPAN, FILED 4-19-2006.



OWNER OF JAPAN REG. NO. 4937188, DATED 3-17-2006, EXPIRES 3-17-2016.

THE COLOR(S) RED WITH DARK RED SHADING AND WHITE IS/ARE CLAIMED AS A FEATURE OF THE MARK.
THE MARK CONSISTS OF A TOROID IN RED WITH DARKER SHADES OF RED THROUGHOUT, WITH A WHITE CENTER.

SN 78-850,174. TACTICAL APPLICATIONS GROUP, JACKSONVILLE, NC. FILED 3-30-2006.

Spartan Assault Systems

THE MARK CONSISTS OF STANDARD CHARACTERS WITHOUT CLAIM TO ANY PARTICULAR FONT, STYLE, SIZE, OR COLOR.

NO CLAIM IS MADE TO THE EXCLUSIVE RIGHT TO USE "ASSAULT SYSTEMS", APART FROM THE MARK AS SHOWN.

CLASS 9—ELECTRICAL AND SCIENTIFIC APPARATUS

FOR VESTS FOR USE IN WEARING REMOVABLE BULLET PROOF PANELS (U.S. CLS. 21, 23, 26, 36 AND 38).

FIRST USE 2-1-2005; IN COMMERCE 2-1-2005.

CLASS 13—FIREARMS

FOR NYLON BALLISTIC CASES FOR USE IN CARRYING WEAPONS AND AMMUNITION (U.S. CLS. 2 AND 9).

FIRST USE 2-1-2005; IN COMMERCE 2-1-2005.

CLASS 18—LEATHER GOODS

FOR BACKPACKS, BAGS AND POUCHES WHICH CAN BE ATTACHED TO NYLON BALLISTIC OUTER CARRIERS (U.S. CLS. 1, 2, 3, 22 AND 41).

FIRST USE 2-1-2005; IN COMMERCE 2-1-2005.
MARGERY A. TIERNEY, EXAMINING ATTORNEY

CLASS 36—INSURANCE AND FINANCIAL

FOR BANKING SERVICES, NAMELY, ACCEPTANCE OF DEPOSITS; LOANING OF FUNDS AND DISCOUNTING BILLS; DOMESTIC CURRENCY EXCHANGE TRANSACTION SERVICES; SURETY OF DEBTS; GUARANTEED LOANS; SAFETY DEPOSIT BOX SERVICES, NAMELY, SAFEKEEPING OF SECURITIES, PRECIOUS METALS, AND OTHER ARTICLES; EXCHANGING OF MONEY; FUTURES EXCHANGE SERVICES; INSURANCE UNDERWRITING OF TRUST OF MONEY, SECURITIES, CREDITS, PERSONAL ESTATES, LAND OR FIXTURES THEREON, AND SURFACE RIGHTS OR LAND LEASING RIGHTS; FINANCIAL SERVICES, NAMELY, ASSISTING OTHERS WITH THE COMPLETION OF FINANCIAL TRANSACTIONS FOR STOCKS, BONDS, SECURITIES AND EQUITIES; FOREIGN CURRENCY EXCHANGE TRANSACTION SERVICES; ISSUING LETTERS OF CREDIT; PROVIDING INFORMATION RELATING TO HOUSING LOANS; INSTALLMENT LOANS; MANAGEMENT OF BUILDINGS; REAL ESTATE AGENCY AND BROKERAGE SERVICES FOR LEASING OF BUILDINGS, TRADING OF BUILDINGS, AND BUYING, SELLING AND LIKE KIND EXCHANGES OF BUILDINGS; LEASING OF BUILDINGS; APPRAISAL OF BUILDINGS OR LAND; REAL ESTATE MANAGEMENT; REAL ESTATE AGENCY AND BROKERAGE SERVICES FOR LEASING OF LAND, FOR BUYING AND SELLING OF LAND; LEASING OF LAND; PROVIDING INFORMATION RELATING TO THE LEASING, TRADING, BUYING AND SELLING OF BUILDINGS OR LAND (U.S. CLS. 100, 101 AND 102).

CLASS 37—CONSTRUCTION AND REPAIR

FOR BUILDING CONSTRUCTION SERVICES; CONSTRUCTION CONSULTATION; OPERATION, MAINTENANCE AND REPAIR OF BUILDING EQUIPMENT, INCLUDING HEATING, VENTILATING AND AIR CONDITIONING (HVAC) EQUIPMENT, ELECTRICAL EQUIPMENT SUCH AS CIRCUIT BREAKER BOXES, AND OTHER COMPONENTS OF LEASED PREMISES SUCH AS AUTOMATIC DOORS, AND SECURITY SYSTEMS (U.S. CLS. 100, 103 AND 106).

CLASS 43—HOTEL AND RESTAURANT SERVICES

FOR PROVIDING TEMPORARY ACCOMMODATION; MAKING RESERVATIONS AND BOOKING FOR TEMPORARY LODGING AT HOTELS, BOARDING HOUSES, AND THE LIKE; PROVISION OF FOODS AND BEVERAGES TO PATRONS OF HOTELS, BOARDING HOUSE, AND THE LIKE (U.S. CLS. 100 AND 101).

TINA L. SNAPP, EXAMINING ATTORNEY

SN 78-864,604. DAIWA HOUSE INDUSTRY CO., LTD., OSAKA, JAPAN, FILED 4-19-2006.

SN 78-865,327. GEN3 PARTNERS, INC., BOSTON, MA, FILED 4-19-2006.



Daiwa House

OWNER OF JAPAN REG. NO. 4994267, DATED 10-6-2006, EXPIRES 10-6-2016.

NO CLAIM IS MADE TO THE EXCLUSIVE RIGHT TO USE "HOUSE", APART FROM THE MARK AS SHOWN.

THE COLOR(S) RED WITH DARK RED SHADING, WHITE, AND BLACK IS/ARE CLAIMED AS A FEATURE OF THE MARK.

THE MARK CONSISTS OF TOROID IN RED WITH DARKER SHADES OF RED THROUGHOUT, WITH A WHITE CENTER, AND THE WORDS DAIWA HOUSE ARE IN BLACK.

THE ENGLISH TRANSLATION OF THE WORD "DAIWA" IN THE MARK IS "GRAND HARMONY".

CLASS 36—INSURANCE AND FINANCIAL

FOR BANKING SERVICES, NAMELY, ACCEPTANCE OF DEPOSITS; LOANING OF FUNDS AND DISCOUNTING BILLS; DOMESTIC CURRENCY EXCHANGE TRANSACTION SERVICES; SURETY OF DEBTS; GUARANTEED LOANS; INSURANCE UNDERWRITING OF TRUST OF MONEY, SECURITIES, CREDITS, PERSONAL ESTATES, LAND OR FIXTURES THEREON, AND SURFACE RIGHTS OR LAND LEASING RIGHTS; ISSUING LETTERS OF CREDIT; PROVIDING INFORMATION RELATING TO HOUSING LOANS; INSTALLMENT LOANS; MANAGEMENT OF BUILDINGS; REAL ESTATE AGENCY AND BROKERAGE SERVICES FOR LEASING OF BUILDINGS, TRADING OF BUILDINGS, AND BUYING, SELLING AND LIKE KIND EXCHANGES OF BUILDINGS; LEASING OF BUILDINGS; BUYING AND SELLING OF BUILDINGS; APPRAISAL OF BUILDINGS OR LAND; MANAGEMENT OF LAND; REAL ESTATE AGENCY AND BROKERAGE SERVICES FOR LEASING OF LAND, FOR BUYING AND SELLING OF LAND; LEASING OF LAND; BUYING AND SELLING OF LAND; PROVIDING INFORMATION RELATING TO THE LEASING, TRADING, BUYING AND SELLING OF BUILDINGS OR LAND (U.S. CLS. 100, 101 AND 102).

CLASS 37—CONSTRUCTION AND REPAIR

FOR BUILDING CONSTRUCTION SERVICES; CONSTRUCTION CONSULTATION; OPERATION, MAINTENANCE AND REPAIR OF BUILDING EQUIPMENT, INCLUDING HEATING, VENTILATING AND AIR CONDITIONING (HVAC) EQUIPMENT, ELECTRICAL EQUIPMENT SUCH AS CIRCUIT BREAKER BOXES, AND OTHER COMPONENTS OF LEASED PREMISES SUCH AS AUTOMATIC DOORS, AND SECURITY SYSTEMS (U.S. CLS. 100, 103 AND 106).

CLASS 43—HOTEL AND RESTAURANT SERVICES

FOR PROVIDING TEMPORARY ACCOMMODATION; MAKING RESERVATIONS AND BOOKING FOR TEMPORARY LODGING AT HOTELS, BOARDING HOUSES, AND THE LIKE; PROVISION OF FOODS AND BEVERAGES TO PATRONS OF HOTELS, BOARDING HOUSES, AND THE LIKE (U.S. CLS. 100 AND 101).

TINA L. SNAPP, EXAMINING ATTORNEY

MAIN PARAMETERS OF VALUE

THE MARK CONSISTS OF STANDARD CHARACTERS WITHOUT CLAIM TO ANY PARTICULAR FONT, STYLE, SIZE, OR COLOR.

CLASS 35—ADVERTISING AND BUSINESS

FOR ASSISTANCE, ADVISORY SERVICES, AND CONSULTANCY SERVICES REGARDING BUSINESS PLANNING, BUSINESS ANALYSIS, AND BUSINESS MANAGEMENT; BUSINESS CONSULTATION, ANALYSIS, AND MANAGEMENT REGARDING CUSTOMERS' PRODUCT AND SERVICE LINES (U.S. CLS. 100, 101 AND 102).

CLASS 41—EDUCATION AND ENTERTAINMENT

FOR EDUCATIONAL SERVICES, NAMELY, PROVIDING TRAINING AND WORKSHOPS IN THE FIELDS OF BUSINESS PLANNING, BUSINESS ANALYSIS, BUSINESS MANAGEMENT, AND PRODUCT AND SERVICE INNOVATION, RESEARCH AND DEVELOPMENT (U.S. CLS. 100, 101 AND 107).

CLASS 42—SCIENTIFIC AND COMPUTER SERVICES

FOR RESEARCH AND DEVELOPMENT SERVICES FOR NEW PRODUCTS AND TECHNOLOGY FOR OTHERS (U.S. CLS. 100 AND 101).

EUGENIA MARTIN, EXAMINING ATTORNEY

SN 78-899,344. IPIC ENTERTAINMENT, LLC., FT. LAUDERDALE, FL. FILED 6-2-2006.

IPIC

THE MARK CONSISTS OF STANDARD CHARACTERS WITHOUT CLAIM TO ANY PARTICULAR FONT, STYLE, SIZE, OR COLOR.

CLASS 41—EDUCATION AND ENTERTAINMENT

FOR ENTERTAINMENT SERVICES, NAMELY, MOVIE THEATERS AND BOWLING ALLEY SERVICES (U.S. CLS. 100, 101 AND 107).

CLASS 43—HOTEL AND RESTAURANT SERVICES

FOR RESTAURANT SERVICES (U.S. CLS. 100 AND 101).

DAYNA BROWNE, EXAMINING ATTORNEY

SN 78-906,885. PAYJR, FRISCO, TX. FILED 6-13-2006.

EARN SMART, SPEND SMART

THE MARK CONSISTS OF STANDARD CHARACTERS WITHOUT CLAIM TO ANY PARTICULAR FONT, STYLE, SIZE, OR COLOR.

CLASS 16—PAPER GOODS AND PRINTED MATTER

FOR PUBLICATIONS, NAMELY, BOOKS AND MAGAZINES ON GENERAL CHILDHOOD AND TEENAGE LIFESTYLES, AND CHORES, RESPONSIBILITY AND FINANCIAL EDUCATION FOR YOUNG PEOPLE (U.S. CLS. 2, 5, 22, 23, 29, 37, 38 AND 50).

CLASS 41—EDUCATION AND ENTERTAINMENT

FOR EDUCATIONAL PROGRAMS AND SERVICES, NAMELY, LIVE AND ONLINE CLASSES AND SEMINARS IN THE FIELD OF FINANCIAL EDUCATION FOR YOUNG PEOPLE ON MATTERS OF ENTREPRENEURSHIP, BUDGETING AND FINANCIAL RESPONSIBILITY (U.S. CLS. 100, 101 AND 107).

CLASS 42—SCIENTIFIC AND COMPUTER SERVICES

FOR PROVIDING TEMPORARY USE OF ONLINE NON-DOWNLOADABLE SOFTWARE USED TO TRACK CHORES AND ALLOWANCES OF YOUNG PEOPLE FOR THE PURPOSE OF TEACHING RESPONSIBILITY AND PROVIDING A FINANCIAL EDUCATION FOR USE BY YOUNG PEOPLE (U.S. CLS. 100 AND 101).
LINDA POWELL, EXAMINING ATTORNEY

SN 78-910,313. BROTHER INDUSTRIES, LTD., MIZUHO-KU, NAGOYA, JAPAN, FILED 6-16-2006.



OWNER OF JAPAN REG. NO. 5045472, DATED 5-11-2007, EXPIRES 5-11-2017.

THE COLOR(S) WHITE, BLUE, RED, ORANGE IS/ARE CLAIMED AS A FEATURE OF THE MARK.

THE MARK CONSISTS OF THE LETTERING "P&S" IS IN WHITE; THE BACKGROUND FOR THE LETTERING AND THE FIRST DOT ARE IN BLUE; THE MIDDLE DOT IS IN RED; AND THE RIGHT DOT IS IN ORANGE.

CLASS 2—PAINTS

FOR TONER FOR PRINTERS; TONER CARTRIDGES FOR PRINTERS; INK FOR PRINTERS, FACSIMILE MACHINES, COPYING MACHINES AND MULTIFUNCTION MACHINES, NAMELY, COMBINATION OF PRINTERS/FACSIMILE MACHINES/COPYING MACHINES/SCANNERS/VIDEO CAPTURES; AND FILLED INK CARTRIDGES FOR INK JET PRINTERS (U.S. CLS. 6, 11 AND 16).

CLASS 9—ELECTRICAL AND SCIENTIFIC APPARATUS

FOR PRINTERS; FACSIMILES; SCANNERS; COPYING MACHINES; MULTIFUNCTION MACHINES, NAMELY, COMBINATION OF PRINTERS/FACSIMILE MACHINES/COPYING MACHINES/SCANNERS/VIDEO CAPTURES, FOR USE IN COPYING, PRINTING, SCANNING, VIDEO CAPTURE AND/OR TRANSMITTING DOCUMENTS AND IMAGES; DRUM UNITS FOR PRINTERS; MOBILE PRINTERS; ELECTRONIC LABEL PRINTING MACHINES; ELECTRONIC PRE-INKED STAMP MAKING MACHINES; AND PARTS AND FITTINGS FOR ALL THE AFORESAID GOODS; OPERATING SOFTWARE FOR USE WITH THE ABOVE-MENTIONED PRODUCTS (U.S. CLS. 21, 23, 26, 36 AND 38).

BENJAMIN OKEKE, EXAMINING ATTORNEY

SN 78-920,980. COWBOY CHOPPERS, LLC, ELOY, AZ. FILED 6-30-2006.

COWBOY CHOPPERS

THE MARK CONSISTS OF STANDARD CHARACTERS WITHOUT CLAIM TO ANY PARTICULAR FONT, STYLE, SIZE, OR COLOR.

NO CLAIM IS MADE TO THE EXCLUSIVE RIGHT TO USE "COWBOY" AS TO CLASS 25 AND "CHOPPERS" AS TO CLASSES 12 AND 37, APART FROM THE MARK AS SHOWN.

CLASS 6—METAL GOODS

FOR METAL KEY CHAINS; METAL KEY FOBS; METAL KEY RINGS; METAL LICENSE PLATES (U.S. CLS. 2, 12, 13, 14, 23, 25 AND 50).

CLASS 12—VEHICLES

FOR LICENSE PLATE FRAMES; LICENSE PLATE HOLDERS; MOTORCYCLES; MOTORCYCLES AND STRUCTURAL PARTS THEREFOR; PARTS OF MOTORCYCLES, NAMELY, BRAKE PEDALS; PARTS OF MOTORCYCLES, NAMELY, HANDLE BAR GRIPS; PARTS OF MOTORCYCLES, NAMELY, HANDLE BARS; PARTS OF MOTORCYCLES, NAMELY, SHIFT LEVERS; STRUCTURAL PARTS FOR MOTORCYCLES (U.S. CLS. 19, 21, 23, 31, 35 AND 44).

CLASS 14—JEWELRY

FOR BRACELETS; CHARMS; JEWELRY; JEWELRY, NAMELY, CROSSES (U.S. CLS. 2, 27, 28 AND 50).

CLASS 16—PAPER GOODS AND PRINTED MATTER

FOR ADVERTISING PAMPHLETS; BLANK OR PARTIALLY PRINTED PAPER LABELS; BLANK OR PARTIALLY PRINTED POSTCARDS; DECALS; EMBROIDERY DESIGN PATTERNS; PAPER CARTONS FOR DELIVERING GOODS; PARTIALLY PRINTED FORMS; PRINTED PAPER LABELS; PRINTED PAPER SIGNS (U.S. CLS. 2, 5, 22, 23, 29, 37, 38 AND 50).

CLASS 18—LEATHER GOODS

FOR METAL HORSESHOES (U.S. CLS. 1, 2, 3, 22 AND 41).

CLASS 25—CLOTHING

FOR CAMP SHIRTS; CAPS; COATS FOR MEN AND WOMEN; COATS OF DENIM; CROP TOPS; DENIM JACKETS; DRESS SHIRTS; GOLF SHIRTS; HALTER TOPS; HEAVY JACKETS; INFANT AND TODDLER ONE PIECE CLOTHING; JACKETS; JERSEYS; KNIT SHIRTS; LEATHER BELTS; LEATHER COATS; LEATHER JACKETS; MUSCLE TOPS; NIGHT SHIRTS; POLO SHIRTS; RAIN COATS; RIDING COATS; SHORT-SLEEVED OR LONG-SLEEVED T-SHIRTS; SHORT-SLEEVED SHIRTS; SLEEP SHIRTS; SLEEVED OR SLEEVELESS JACKETS; SPORT SHIRTS; SPORTS JACKETS; SWEAT PANTS; SWEAT SHIRTS; SWEAT SHORTS; SWEAT SUITS; T-SHIRTS; TANK-TOPS; TOPS; WIND RESISTANT JACKETS (U.S. CLS. 22 AND 39).

CLASS 37—CONSTRUCTION AND REPAIR

FOR MOTORCYCLE CUSTOMIZATION SERVICES (U.S. CLS. 100, 103 AND 106).

MICHELE SWAIN, EXAMINING ATTORNEY

SN 78-945,428. INTERBRAND GROUP, LONDON, UNITED KINGDOM, FILED 8-4-2006.

INTERBRAND WOOD

THE MARK CONSISTS OF STANDARD CHARACTERS WITHOUT CLAIM TO ANY PARTICULAR FONT, STYLE, SIZE, OR COLOR.

OWNER OF U.S. REG. NOS. 1,570,384 AND 2,270,428.

CLASS 16—PAPER GOODS AND PRINTED MATTER

FOR BOOKS, BROCHURES, PRINTED INSTRUCTIONAL AND TEACHING MATERIALS IN THE FIELDS OF BRAND DEVELOPMENT, BRANDING AND BRAND MANAGEMENT; POSTERS (U.S. CLS. 2, 5, 22, 23, 29, 37, 38 AND 50).

FIRST USE 8-0-2001; IN COMMERCE 8-0-2001.

CLASS 35—ADVERTISING AND BUSINESS

FOR BUSINESS MARKETING CONSULTATION SERVICES; ADVERTISING AGENCY SERVICES; CONDUCTING BUSINESS AND MARKETING RESEARCH SURVEYS; SERVICES RELATING TO THE ANALYSIS, EVALUATION, CREATION AND BRAND ESTABLISHMENT OF TRADEMARKS, TRADE NAMES, LOGOS, CORPORATE IDENTITIES, AND DOMAIN NAMES; BUSINESS MANAGEMENT SERVICES IN THE FIELD OF BRAND NAMES, NAMELY, BRAND EVALUATION, BRAND POSITIONING, BRAND STRATEGY, AND CONSULTATION SERVICES RELATED THERETO; ADVERTISING AND PUBLICITY SERVICES, NAMELY, PROMOTING THE GOODS, SERVICES, BRAND IDENTITY AND COMMERCIAL INFORMATION AND NEWS OF THIRD PARTIES THROUGH PRINT, AUDIO, VIDEO, DIGITAL AND ON-LINE MEDIA; CONSULTATION AND DESIGN SERVICES FOR OTHERS IN THE FIELDS OF BRAND NAMES, LOGOS, AND CORPORATE IDENTITIES (U.S. CLS. 100, 101 AND 102).

FIRST USE 8-0-2001; IN COMMERCE 8-0-2001.

CLASS 41—EDUCATION AND ENTERTAINMENT

FOR PROVIDING NON-DOWNLOADABLE ELECTRONIC PUBLICATIONS, NAMELY, ARTICLES AND PRESS RELEASES, VIA A COMPUTER DATABASE OR THE INTERNET IN THE FIELD OF BRAND DEVELOPMENT, BRANDING AND BRAND MANAGEMENT; PROVIDING ONLINE JOURNALS, NAMELY, BLOGS FEATURING INFORMATION ABOUT BRANDING (U.S. CLS. 100, 101 AND 107).

FIRST USE 8-0-2001; IN COMMERCE 8-0-2001.

CLASS 42—SCIENTIFIC AND COMPUTER SERVICES

FOR CONSULTATION AND DESIGN SERVICES FOR OTHERS IN THE FIELDS PACKAGE DESIGN, GRAPHIC DESIGN OF BUSINESS STATIONERY AND PROMOTIONAL MATERIALS; DESIGN OF RETAIL SPACE, RETAIL KIOSKS AND INTERACTIVE MEDIA SPACE FOR OTHERS; PRODUCT RESEARCH AND DEVELOPMENT; DESIGN OF WEBSITES FOR OTHERS; TRADEMARK SEARCHING AND MONITORING; SERVICES RELATING TO THE PROTECTION, EXPLOITATION, ACQUISITION AND LICENSING OF INTELLECTUAL PROPERTY (U.S. CLS. 100 AND 101).

FIRST USE 8-0-2001; IN COMMERCE 8-0-2001.

FLORENTINA BLANDU, EXAMINING ATTORNEY

SN 78-967,762. REMINGTON DIRECT, LP, FORT WORTH, TX. FILED 9-6-2006.

CAN'T WEIGHT

THE MARK CONSISTS OF STANDARD CHARACTERS WITHOUT CLAIM TO ANY PARTICULAR FONT, STYLE, SIZE, OR COLOR.

CLASS 5—PHARMACEUTICALS

FOR VITAMINS, MINERAL SUPPLEMENTS, DIETARY SUPPLEMENTS, HERBAL SUPPLEMENTS; WEIGHT LOSS DIETARY SUPPLEMENTS; WEIGHT LOSS PRODUCTS, NAMELY, NUTRITIONALLY FORTIFIED WEIGHT LOSS BEVERAGES, WEIGHT LOSS BEVERAGE MIXES FOR USE AS DIETARY SUPPLEMENT, MEDICATED CANDY; CONFECTIONERY FOR NUTRITIONAL PURPOSES (U.S. CLS. 6, 18, 44, 46, 51 AND 52).

CLASS 29—MEATS AND PROCESSED FOODS

FOR WEIGHT LOSS PRODUCTS, NAMELY, PROTEIN BASED NUTRIENT-DENSE SNACK BARS AND FRUIT AND VEGETABLE BASED SNACK FOODS; CONFECTIONERY, NAMELY, FRUIT PEELS AND FRUIT LEATHERS (U.S. CL. 46).

CLASS 30—STAPLE FOODS

FOR CANDY; CONFECTIONARY, NAMELY, FRUIT JELLIES (U.S. CL. 46).

TOBY BULLOFF, EXAMINING ATTORNEY

SN 78-981,005. ANADARKO PETROLEUM CORPORATION,
HOUSTON, TX. FILED 4-26-2006.

SN 78-981,068. ANADARKO PETROLEUM CORPORATION,
HOUSTON, TX. FILED 4-26-2006.



OWNER OF ERPN CMNTY TM OFC REG. NO. 005002223,
DATED 10-11-2007, EXPIRES 3-21-2016.

OWNER OF U.S. REG. NO. 1,435,026.

NO CLAIM IS MADE TO THE EXCLUSIVE RIGHT TO
USE "NATURAL GAS COMPANY", APART FROM THE
MARK AS SHOWN.

THE MARK CONSISTS OF THE WORDING "ANADAR-
KO NATURAL GAS COMPANY", PRESENTED TOGETHER
WITH A STYLIZED REPRESENTATION OF AN OIL DER-
RICK.

SEC. 2(F) AS TO "ANADARKO" .

THE 2(F) IN PART CLAIM IS RESTRICTED TO CLASS(ES)

4

CLASS 4—LUBRICANTS AND FUELS

FOR LUBRICANTS AND FUELS, NAMELY, OIL,
NATURAL GAS AND LIQUID NATURAL GAS; AND
INDUSTRIAL OILS AND GREASES (U.S. CLS. 1, 6 AND
15).

CLASS 42—SCIENTIFIC AND COMPUTER SERVICES

FOR COMPUTER SERVICES, NAMELY, CREATING
INDEXES OF DATA AND INFORMATION REGARDING
WORK SITES AND OTHER RESOURCES IN THE
FIELDS OF ENERGY EXPLORATION AND PRODUC-
TION, WHEREIN SAID DATA AND INFORMATION IS
PROVIDED BY TECHNICALLY-ORIENTED PROFES-
SIONALS, NAMELY CHEMISTS, PHYSICISTS, ENGI-
NEERS AND COMPUTER SPECIALISTS; SCIENTIFIC
SERVICES IN THE FIELDS OF EXPLORATION AND
PRODUCTION, NAMELY, SCIENTIFIC RESEARCH
PROVIDED BY TECHNICALLY-ORIENTED PROFES-
SIONALS, NAMELY, CHEMISTS, PHYSICISTS, ENGI-
NEERS AND COMPUTER SPECIALISTS (U.S. CLS. 100
AND 101).

CLASS 45—PERSONAL AND LEGAL SERVICES

FOR LEGAL SERVICES IN THE FIELDS OF ENERGY
EXPLORATION AND PRODUCTION (U.S. CLS. 100 AND
101).

MICHAEL WIENER, EXAMINING ATTORNEY

PRIORITY CLAIMED UNDER SEC. 44(D) ON ERPN
CMNTY TM OFC APPLICATION NO. 004999637, FILED 3-
21-2006, REG. NO. 004999637, DATED 10-11-2007, EXPIRES 3-
21-2016.

OWNER OF U.S. REG. NO. 1,435,026.

NO CLAIM IS MADE TO THE EXCLUSIVE RIGHT TO
USE "E & P COMPANY LP", APART FROM THE MARK AS
SHOWN.

THE MARK CONSISTS OF THE WORDING "ANADAR-
KO E&P COMPANY LP", PRESENTED TOGETHER WITH A
STYLIZED REPRESENTATION OF AN OIL DERRICK.

SEC. 2(F) AS TO "ANADARKO".

CLASS 4—LUBRICANTS AND FUELS

FOR LUBRICANTS AND FUELS, NAMELY, OIL,
NATURAL GAS AND LIQUID NATURAL GAS; AND
INDUSTRIAL OILS AND GREASES (U.S. CLS. 1, 6 AND
15).

CLASS 42—SCIENTIFIC AND COMPUTER SERVICES

FOR COMPUTER SERVICES, NAMELY, THE COMPU-
TERIZED COMPILATION OF DATA AND INFORMA-
TION REGARDING WORK SITES AND OTHER
RESOURCES IN THE FIELDS OF ENERGY EXPLORA-
TION AND PRODUCTION, WHEREIN SAID DATA AND
INFORMATION IS COMPILED BY TECHNICALLY-OR-
IENTED PROFESSIONALS, NAMELY, GEOLOGISTS,
CHEMISTS, PHYSICISTS, GEOPHYSICISTS, ENGI-
NEERS AND COMPUTER SPECIALISTS; SCIENTIFIC
SERVICES IN THE FIELDS OF ENERGY EXPLORA-
TION AND PRODUCTION, NAMELY, SCIENTIFIC RE-
SEARCH IN THE FIELDS OF CHEMISTRY, PHYSICS,
ENGINEERING AND COMPUTER SCIENCE (U.S. CLS.
100 AND 101).

MICHAEL WIENER, EXAMINING ATTORNEY

SN 78-981,071. ANADARKO PETROLEUM CORPORATION, HOUSTON, TX. FILED 4-25-2006.



OWNER OF ERPN CMNTY TM OFC REG. NO. 005002241, DATED 10-11-2007, EXPIRES 3-21-2016.

OWNER OF U.S. REG. NO. 1,435,026.

NO CLAIM IS MADE TO THE EXCLUSIVE RIGHT TO USE "ENERGY SERVICES", APART FROM THE MARK AS SHOWN.

THE MARK CONSISTS OF THE WORDING "ANADARKO ENERGY SERVICES", PRESENTED TOGETHER WITH A STYLIZED REPRESENTATION OF AN OIL DERRICK.

SEC. 2(F) AS TO "ANADARKO".

CLASS 4—LUBRICANTS AND FUELS

FOR LUBRICANTS AND FUELS, NAMELY, OIL, NATURAL GAS AND LIQUID NATURAL GAS; AND INDUSTRIAL OILS AND GREASES (U.S. CLS. 1, 6 AND 15).

CLASS 42—SCIENTIFIC AND COMPUTER SERVICES

FOR COMPUTER SERVICES, NAMELY, THE COMPUTERIZED COMPILATION OF DATA AND INFORMATION REGARDING WORK SITES AND OTHER RESOURCES IN THE FIELDS OF ENERGY EXPLORATION AND PRODUCTION, WHEREIN SAID DATA AND INFORMATION IS COMPILED BY TECHNICALLY-ORIENTED PROFESSIONALS, NAMELY, GEOLOGISTS, CHEMISTS, PHYSICISTS, GEOPHYSICISTS, ENGINEERS AND COMPUTER SPECIALISTS; SCIENTIFIC SERVICES IN THE FIELDS OF ENERGY EXPLORATION AND PRODUCTION, NAMELY, SCIENTIFIC RESEARCH IN THE FIELDS OF CHEMISTRY, PHYSICS, ENGINEERING AND COMPUTER SCIENCE (U.S. CLS. 100 AND 101).

MICHAEL WIENER, EXAMINING ATTORNEY

SN 79-024,912. ZIMED (KENT) LIMITED, UNITED KINGDOM, FILED 12-16-2005.

DRUGPRINT

THE MARK CONSISTS OF STANDARD CHARACTERS WITHOUT CLAIM TO ANY PARTICULAR FONT, STYLE, SIZE, OR COLOR.

PRIORITY DATE OF 6-16-2005 IS CLAIMED.

OWNER OF INTERNATIONAL REGISTRATION 0887709 DATED 12-16-2005, EXPIRES 12-16-2015.

CLASS 5—PHARMACEUTICALS

FOR REAGENTS FOR USE IN PHARMACEUTICAL ASSAYS; DIAGNOSTIC REAGENTS FOR CLINICAL OR LABORATORY USE; CELLS AND LIVING TISSUES FOR PHARMACEUTICAL ASSAYS; CELLS AND LIVING TISSUES FOR USE IN TESTING THE TOXIC SIDE EFFECTS OF PHARMACEUTICALS; CELLS AND LIVING TISSUES FOR CLINICAL USE (U.S. CLS. 6, 18, 44, 46, 51 AND 52).

CLASS 9—ELECTRICAL AND SCIENTIFIC APPARATUS

FOR SCIENTIFIC APPARATUS AND INSTRUMENTS NAMELY, MICROELECTRODE ARRAY PLATES, MICROELECTRODE ARRAY AMPLIFIER STATIONS, DATA ACQUISITION CARDS, ANALOGUE TO DIGITAL CONVERSION HARDWARE REQUIRED TO TRANSFER ELECTRICAL SIGNALS FROM AN AMPLIFIER STATION TO THE ATTACHED COMPUTER, DRUG PERFUSION SYSTEMS COMPRISING A SERIES OF RESERVOIRS FOR LIQUID MEDIA AND DRUG SOLUTIONS, A PUMP OR SIMILAR DELIVERY SYSTEM TO CONTROL THE FLOW OF THE SOLUTIONS, ASSORTED TUBING AND A CELL CULTURE PLATE MANIFOLD, ASSAY KITS, AN ENVIRONMENTAL CONTROL SYSTEM COMPRISING OF TEMPERATURE CONTROL SYSTEM, HEATING PAD, HUMIDITY CONTROL AND AIR/CO₂ GAS SUPPLY AND INCORPORATED LABORATORY TROLLEYS, AND PARTS THEREFOR; COMPUTER SOFTWARE FOR CONTROLLING LABORATORY APPARATUS AND INSTRUMENTS, NAMELY, SOFTWARE FOR DRUG DISCOVERY AND SOFTWARE FOR USE IN SCHEDULING, TRACKING AND MONITORING AUTOMATED OPERATIONS OF LABORATORY APPARATUS IN THE FIELD OF DRUG DISCOVERY; DRUG TESTING SOFTWARE; SOFTWARE FOR USE IN SCREENING PHARMACEUTICAL, CHEMICAL AND DRUG COMPOUNDS INCLUDING NEW CHEMICAL ENTITIES; SOFTWARE FOR ANALYZING SCIENTIFIC DATA RELATING TO DRUGS AND NEW CHEMICAL ENTITIES; SOFTWARE FOR ANALYZING CHEMICAL AND BIOCHEMICAL DATA; COMPUTER SOFTWARE FOR PROVIDING AN ONLINE DATABASE IN THE FIELD OF PHARMACEUTICAL AND DRUG DISCOVERY, RESEARCH, SCREENING, TESTING AND DEVELOPMENT TO UPLOAD TRANSACTIONAL DATA, PROVIDE STATISTICAL ANALYSIS, AND PRODUCE NOTIFICATIONS AND REPORTS; COMPUTER PROGRAMS FOR USE IN DATABASE MANAGEMENT; ELECTRONIC DATABASES IN THE FIELDS OF PHARMACEUTICAL AND DRUG DISCOVERY, RESEARCH, SCREENING, TESTING AND DEVELOPMENT RECORDED ON COMPUTER MEDIA (U.S. CLS. 21, 23, 26, 36 AND 38).

CLASS 16—PAPER GOODS AND PRINTED MATTER

FOR PRINTED MATTER, NAMELY, NEWSLETTERS, ADVERTISING IN THE NATURE OF SIGNS AND BILLBOARDS OF PAPER OR CARDBOARD, POSTERS, PAMPHLETS, BROCHURES, PERIODICALS, MAGAZINES, AND PRINTED REPORTS, ALL FEATURING INFORMATION IN THE FIELDS OF SCIENCE, PHARMACEUTICALS, DRUG DEVELOPMENT AND RESEARCH; STATIONERY; PENS; PENCILS; DRAWING RULERS; UNGRADUATED RULERS; ERASERS (U.S. CLS. 2, 5, 22, 23, 29, 37, 38 AND 50).

CLASS 35—ADVERTISING AND BUSINESS

FOR COMPILATION OF SCIENTIFIC RESEARCH AND INFORMATION INTO COMPUTER DATABASES; COMPUTER DATABASE MANAGEMENT; INFORMATION AND ADVISORY SERVICES RELATING TO ALL THE AFORESAID SERVICES (U.S. CLS. 100, 101 AND 102).

CLASS 42—SCIENTIFIC AND COMPUTER SERVICES

FOR CHEMICAL ANALYSIS; SCIENTIFIC RESEARCH; RESEARCH SERVICES RELATING TO THE DEVELOPMENT AND TESTING OF PHARMACEUTICALS INCLUDING NEW CHEMICAL ENTITIES; SCIENTIFIC RESEARCH AND DEVELOPMENT SERVICES RELATING TO DRUG DISCOVERY, DRUG FORMULATION AND DRUG SAFETY PHARMACOLOGY; TECHNICAL DATA ANALYSIS SERVICES; SCIENTIFIC DATA ANALYSIS SERVICES; COMPUTER DATABASE CONSULTANCY AND DESIGN SERVICES; INFORMATION AND ADVISORY SERVICES RELATING TO ALL THE AFORESAID SERVICES (U.S. CLS. 100 AND 101).
HEATHER SAPP, EXAMINING ATTORNEY

SN 79-032,246. LPX GMBH, BASEL, SWITZERLAND, FILED 10-25-2006.

Listed Private Equity Index (LPX)

THE MARK CONSISTS OF STANDARD CHARACTERS WITHOUT CLAIM TO ANY PARTICULAR FONT, STYLE, SIZE, OR COLOR.

OWNER OF INTERNATIONAL REGISTRATION 0906851 DATED 10-25-2006, EXPIRES 10-25-2016.

OWNER OF U.S. REG. NO. 3,154,197.

NO CLAIM IS MADE TO THE EXCLUSIVE RIGHT TO USE "LISTED PRIVATE EQUITY INDEX", APART FROM THE MARK AS SHOWN.

CLASS 36—INSURANCE AND FINANCIAL

FOR COMPILING AND PROVIDING FINANCIAL DATA REGARDING SECURITIES AND INDEXES THEREFOR; ISSUING OF FINANCIAL INSTRUMENTS IN THE NATURE OF SECURITIES, OPTIONS, INDEX FUNDS; SERVICES IN RELATION TO MONETARY AND FINANCIAL TRANSACTIONS, NAMELY, MARKET MONITORING, ANALYSIS, INDEXING, AND PRICING OF STOCKS, BONDS, SECURITIES, COMMODITIES, FUTURES, DERIVATIVES OR OPTIONS; PROVIDING ONLINE COMPUTER DATABASES CONTAINING FINANCIAL INFORMATION AND INDEX FIGURES; PROVIDING FINANCIAL AND STOCK MARKET INFORMATION AND DATA, MESSAGES, AND IMAGES VIA THE GLOBAL COMPUTER NETWORK INCLUDING THE INTERNET; FINANCIAL ANALYSIS AND CONSULTATION (U.S. CLS. 100, 101 AND 102).

SN 79-029,988. PRIMETECH S.P.A., I-38013 FONDO (TRENTO), ITALY, FILED 8-7-2006.



OWNER OF INTERNATIONAL REGISTRATION 0901243 DATED 8-7-2006, EXPIRES 8-7-2016.

CLASS 7—MACHINERY

FOR MACHINES AND PARTS OF MACHINES AND MACHINE ACCESSORIES FOR FORESTRY AND AGRICULTURAL PURPOSES, NAMELY, PROFESSIONAL SHREDDERS USED FOR SURFACE PREPARATION AND IN-DEPTH FORESTRY AND AGRICULTURAL PURPOSES AND THE DISPOSAL OF WOODEN RESIDUES, SOIL STABILIZATION, DIRT ROADS AND SPECIALIZED HEAVY-DUTY MECHANICAL ATTACHMENTS FOR USE IN CONNECTION WITH MACHINES, NAMELY, HEAVY-DUTY MULCHERS, STUMP CUTTERS, FORESTRY TILLERS, STONE CRUSHERS, PASTURE MOWERS, SOIL STABILIZERS, EXCAVATORS, PRIME MOVERS, MULCHING HEADS, SKID STEER LOADERS, ORGANIC WASTER SHREDDERS AND PALLET SHREDDERS (U.S. CLS. 13, 19, 21, 23, 31, 34 AND 35).

CLASS 12—VEHICLES

FOR VEHICLES, NAMELY, TRACTORS AND ALL-TERRAIN, SELF-PROPELLED TRACT CARRIERS FOR USE IN AGRICULTURE AND FORESTRY, AND STRUCTURAL VEHICLE PARTS THEREFOR (U.S. CLS. 19, 21, 23, 31, 35 AND 44).

CLASS 42—SCIENTIFIC AND COMPUTER SERVICES

FOR TECHNICAL CONSULTANCY, NAMELY, RESEARCH IN THE FIELDS OF AGRICULTURE AND FORESTRY (U.S. CLS. 100 AND 101).

CLASS 44—MEDICAL, BEAUTY AND AGRICULTURAL SERVICES

FOR RENTAL OF AGRICULTURAL AND FORESTRY EQUIPMENT AND MACHINES (U.S. CLS. 100 AND 101).
DOMINIC J. FERRAIUOLO, EXAMINING ATTORNEY

CLASS 42—SCIENTIFIC AND COMPUTER SERVICES

FOR COMPUTER SOFTWARE DEVELOPMENT, NAMELY, WRITING AND UPDATING OF DATA PROCESSING PROGRAMS FOR OTHERS; DATABASE CONSULTING SERVICES WITH RESPECT TO DEVELOPING DATABASES CONTAINING STOCK MARKET INFORMATION AND INDEXES; CONSULTATION SERVICES IN THE FIELD OF COMPUTER SOFTWARE FOR USE IN THE FINANCIAL INDUSTRY AND STOCK EXCHANGE FIELD (U.S. CLS. 100 AND 101).
PATRICIA EVANKO, EXAMINING ATTORNEY

SN 79-041,996. VEE TWO PTY LTD, MALAGA, WA, AUSTRALIA, FILED 6-20-2007.



PRIORITY DATE OF 6-14-2007 IS CLAIMED.
OWNER OF INTERNATIONAL REGISTRATION 0933023 DATED 6-20-2007, EXPIRES 6-20-2017.

NO CLAIM IS MADE TO THE EXCLUSIVE RIGHT TO USE "VEE TWO", APART FROM THE MARK AS SHOWN.

CLASS 7—MACHINERY

FOR PARTS FOR LAND VEHICLE ENGINES, NAMELY, BEARING SLEEVES, CAMSHAFTS, CRANK SHAFTS, PISTONS, VALVES, CYLINDER HEADS, EXHAUST PIPES, CARBURETORS (U.S. CLS. 13, 19, 21, 23, 31, 34 AND 35).

CLASS 12—VEHICLES

FOR MOTORCYCLES; MOTORCYCLE ENGINES, GEARBOXES AND DRIVE TRAINS FOR MOTORCYCLES; PARTS AND ACCESSORIES FOR MOTORCYCLE ENGINES, GEARBOXES AND DRIVE TRAINS, NAMELY, CLUTCH LININGS, GEARS AND CNC (COMPUTER NUMERICAL CONTROL) MACHINED PARTS, NAMELY, CLUTCHES, CLUTCH SHIFT LEVERS, CLUTCH FRICTION PLATES, CLUTCH SPRINGS AND SPROCKETS, FOOT PEGS, AND DIP STICKS FOR MOTORCYCLES, GEARBOXES AND DRIVE TRAINS; WHEELS FOR MOTORCYCLES; AND WHEEL HUBS FOR MOTORCYCLES (U.S. CLS. 19, 21, 23, 31, 35 AND 44).

CLASS 37—CONSTRUCTION AND REPAIR

FOR REPAIR AND MAINTENANCE OF MOTORCYCLES, MOTORCYCLE ENGINES, GEARBOXES AND DRIVE TRAINS (U.S. CLS. 100, 103 AND 106).
DAVID TAYLOR, EXAMINING ATTORNEY

CLASS 16—PAPER GOODS AND PRINTED MATTER

FOR PRINTED MATTER, NAMELY, MAGAZINES, PERIODICALS, GUIDES, BOOKS, MEMO PADS IN THE FIELD OF BANKING, FINANCE, INSURANCE; INSTRUCTIONAL MANUALS IN THE FIELD OF BANKING, FINANCE, INSURANCE; PERIODICALS IN THE FIELD OF BANKING, FINANCE, INSURANCE; CHECKBOOKS, PRINTED BANK FORMS (U.S. CLS. 2, 5, 22, 23, 29, 37, 38 AND 50).

CLASS 35—ADVERTISING AND BUSINESS

FOR BUSINESS ADMINISTRATION; BUSINESS CONSULTING; BUSINESS INFORMATION OR INQUIRIES; ADMINISTRATIVE SERVICES FOR THE MANAGEMENT OF CUSTOMER ACCOUNTS; ACCOUNTING SERVICES; RESEARCHING BUSINESS INFORMATION IN COMPUTER DATABASES; BUSINESS MANAGEMENT ASSISTANCE FOR INDUSTRIAL AND COMMERCIAL COMPANIES; CONSULTANCY IN BUSINESS INFORMATION, INFORMATION COMPILATION; DRAFTING STATEMENTS OF ACCOUNTS (U.S. CLS. 100, 101 AND 102).

SN 79-043,276. NATIXIS, FRANCE, FILED 4-12-2007.



PRIORITY DATE OF 10-27-2006 IS CLAIMED.
OWNER OF INTERNATIONAL REGISTRATION 0936101 DATED 4-12-2007, EXPIRES 4-12-2017.

OWNER OF U.S. REG. NO. 2,339,552.
"THE COLOR(S) BLACK, RED AND BLUE IS/ARE CLAIMED AS A FEATURE OF THE MARK."

THE MARK CONSISTS OF THE WORDING "NATIXIS" IN BLACK, TO THE LEFT OF WHICH IS A DESIGN FORMED BY TWO OVERLAPPING DIAMOND SHAPES, WITH THE UPPER DIAMOND IN RED, THE LOWER IN BLUE AND THE OVERLAPPING PORTION IN BLACK."

CLASS 9—ELECTRICAL AND SCIENTIFIC APPARATUS

FOR MAGNETICALLY ENCODED CREDIT CARDS, DEBIT CARDS, MAGNETIC CARDS, CASH WITHDRAWAL CARDS, PAYMENT CARDS, ENCODED MEMORY CARDS; ENCODED CHIP CARDS FOR PAYMENT AND FINANCIAL OPERATIONS; SOFTWARE FOR ENCRYPTION, ALLOWING USERS TO PERFORM ELECTRONIC BUSINESS TRANSACTIONS VIA A GLOBAL COMPUTER NETWORK; ENCODED MEMORY OR CHIP LOYALTY CARDS FOR TRACKING USER PURCHASES; ENCODED MEMORY OR CHIP DISCOUNT CARDS FOR TRACKING USER PURCHASES AND AWARDED DISCOUNTS, STORED-VALUE SMART, CHIP CARD; MONEY COUNTING AND SORTING MACHINES; AUTOMATIC VENDING MACHINES; MECHANISMS FOR PREPAYMENT-OPERATED APPARATUS, NAMELY, ELECTRONIC MACHINES FOR READING ENCODED CARDS AND RECORDING FINANCIAL OPERATIONS; CASH REGISTERS, AUTOMATIC TELLER MACHINES, COUNTERFEIT COIN DETECTORS; READERS FOR MEMORY OR CHIP CARDS, MAGNETIC CARDS, PAYMENT CARDS, CREDIT CARDS, DEBIT CARDS, LOYALTY CARDS, DISCOUNT CARDS; SOFTWARE, NAMELY, SECURE PAYMENT SOFTWARE FOR INTERNET-TYPE COMPUTER COMMUNICATION NETWORKS (U.S. CLS. 21, 23, 26, 36 AND 38).

CLASS 36—INSURANCE AND FINANCIAL

FOR BANKING; FINANCIAL AFFAIRS, NAMELY, FINANCIAL CONSULTING, FINANCIAL MANAGEMENT, FINANCIAL PLANNING; MONETARY AFFAIRS, NAMELY, MONETARY EXCHANGE; REAL ESTATE AFFAIRS, NAMELY, REAL ESTATE APPRAISAL, REAL ESTATE INVESTMENT; ACTUARIAL SERVICES; FACTORING, NAMELY, FACTORING AGENCIES, CREDIT CARD FACTORING SERVICES; CREDIT AGENCIES; DEBT COLLECTION AGENCIES; FINANCIAL ANALYSIS; INSURANCE UNDERWRITING IN THE FIELD OF ALL TYPES OF INSURANCE; LIFE INSURANCE UNDERWRITING; INSURANCE CONSULTANCY; INVESTMENT, CONSULTING, MANAGEMENT IN PROVIDENT FUNDS; CREDIT CARD SERVICES; DEBIT CARD SERVICES; CREDIT GUARANTEES; FINANCIAL CONSULTING; REAL-ESTATE APPRAISAL SERVICES; REAL ESTATE BROKERAGE, REAL ESTATE MANAGEMENT; FINANCIAL MANAGEMENT, STOCK EXCHANGE QUOTATIONS; SECURITIES BROKERAGE; INSURANCE BROKERAGE; CREDIT BUREAU SERVICES; HIRE-PURCHASE FINANCING; SECURITY DEPOSITS; SECURITIES MANAGEMENT; ISSUING OF TRAVELLERS' CHECKS; ISSUING OF CREDIT CARDS, ISSUE OF LOYALTY CARDS FOR PAYMENT PURPOSES; SAVINGS, NAMELY, SAVINGS ACCOUNT SERVICES, SAVINGS BANK SERVICES; FINANCIAL EVALUATIONS OF INSURANCE, BANKING, AND REAL ESTATE; FINANCING SERVICES, NAMELY, MONEY LENDING, INVESTMENT COUNSELING, LEASE/PURCHASE FINANCING; FISCAL VALUATIONS, FIDUCIARY REPRESENTATIVE SERVICES; FUND ACCUMULATION, NAMELY, FUND SETTLING; FINANCIAL INFORMATION, NAMELY, FINANCIAL INFORMATION PROCESSING, FINANCIAL INFORMATION PROVIDED BY ELECTRONIC MEANS; INSURANCE INFORMATION, NAMELY, PROVIDING INFORMATION IN INSURANCE MATTERS; HOME BANKING; CAPITAL INVESTMENTS CONSULTATION AND SERVICE; CURRENCY EXCHANGE SERVICES; PROCESSING SERVICES FOR PAYMENT BY INSTALLMENTS; PROCESSING OF PAYMENT OF FUNDS; LOAN FINANCING; LOANS AGAINST SECURITY; FINANCIAL TRANSACTIONS, NAMELY, CREDIT CARD PAYMENT PROCESSING SERVICES, CHECK PROCESSING; ELECTRONIC FUNDS TRANSFER; CHECK VERIFICATION; FINANCIAL AND BANKING MANAGEMENT; ISSUING OF BANK CHEQUES, SAFE DEPOSIT SERVICES, FINANCIAL CLEARING OPERATIONS; FINANCIAL CONSULTING, MARINE INSURANCE, ACCIDENT INSURANCE, FIRE INSURANCE, HEALTH INSURANCE, RENTAL OF APARTMENTS, RENTAL OF OFFICES, RENT COLLECTION, PLEDGE LOANS, INSTALLMENT LOANS; MONEY LENDING; ONLINE BANKING, ALL THESE FINANCIAL AND MONETARY OPERATIONS POSSIBLY DONE VIA TELECOMMUNICATION NETWORKS AND COMPUTER COMMUNICATION NETWORKS (U.S. CLS. 100, 101 AND 102).

CLASS 38—COMMUNICATION

FOR TRANSMISSION OF FINANCIAL, MONETARY AND BANKING INFORMATION ACCESSIBLE BY ACCESS CODE (U.S. CLS. 100, 101 AND 104).

REBECCA POVARCHUK, EXAMINING ATTORNEY

SN 79-044,375. CITY INTERACTIVE; SPÓLKA Z OGRANICZONA ODPOWIEDZIALNOSCIA, POLAND, FILED 4-18-2007.

Brain College

THE MARK CONSISTS OF STANDARD CHARACTERS WITHOUT CLAIM TO ANY PARTICULAR FONT, STYLE, SIZE, OR COLOR.

OWNER OF INTERNATIONAL REGISTRATION 0938930 DATED 4-18-2007, EXPIRES 4-18-2017.

CLASS 9—ELECTRICAL AND SCIENTIFIC APPARATUS

FOR COMPUTER GAME SOFTWARE AND DOWNLOADABLE COMPUTER GAME SOFTWARE (U.S. CLS. 21, 23, 26, 36 AND 38).

CLASS 16—PAPER GOODS AND PRINTED MATTER

FOR STATIONERY, NAMELY, BALLPOINT PENS AND PENS; PRODUCTS FROM PAPER NOT INCLUDED IN OTHER CLASSES, NAMELY, POSTERS AND CALENDARS; MAGAZINES AND BOOKLETS IN THE FIELD OF COMPUTER GAMES; AND WRAPPING PAPER AND INSTRUCTION MANUALS FOR COMPUTER GAMES (U.S. CLS. 2, 5, 22, 23, 29, 37, 38 AND 50).

CLASS 25—CLOTHING

FOR CLOTHES, NAMELY, T-SHIRTS AND SWEAT SHIRTS; FOOTWEAR; HEADWEAR (U.S. CLS. 22 AND 39).

CLASS 41—EDUCATION AND ENTERTAINMENT

FOR AMUSEMENT SERVICES IN THE FIELD OF INTERACTIVE GAMES, ON-LINE THROUGH ELECTRONIC COMMUNICATION SYSTEMS AND THE GLOBAL COMPUTER NETWORK, NAMELY, ENTERTAINMENT SERVICES IN THE NATURE OF AN AMUSEMENT PARK SHOW; RENTAL OF AMUSEMENT MACHINES AND APPARATUS (U.S. CLS. 100, 101 AND 107).

ROBERT STRUCK, EXAMINING ATTORNEY

SN 79-045,651. OWLIENT, FRANCE, FILED 5-30-2007.



PRIORITY DATE OF 12-4-2006 IS CLAIMED.
OWNER OF INTERNATIONAL REGISTRATION 0942093 DATED 5-30-2007, EXPIRES 5-30-2017.

CLASS 28—TOYS AND SPORTING GOODS

FOR GAMES, NAMELY, AUTOMATIC AND COIN-OPERATED AMUSEMENT MACHINES, PARLOUR GAMES, ACTION SKILL GAMES, ARCADE GAMES, ARCADE-TYPE ELECTRONIC VIDEO GAMES; SHUTTLECOCKS; TOYS, NAMELY, ELECTRONIC LEARNING TOYS, ELECTRONIC ACTION TOYS (U.S. CLS. 22, 23, 38 AND 50).

CLASS 35—ADVERTISING AND BUSINESS

FOR ADVERTISING; DISSEMINATION OF ADVERTISING MATERIAL IN THE FORM OF LEAFLETS, PROSPECTUSES, PRINTED MATTER, AND SAMPLES; ORGANIZATION OF EXHIBITIONS FOR COMMERCIAL AND ADVERTISING PURPOSES; ONLINE ADVERTISING ON A COMPUTER NETWORK; RENTAL OF ACCESS TIME TO COMMUNICATION MEANS, NAMELY, INTERNET AND MOBILE PHONES, FOR ADVERTISING; PUBLICATION OF ADVERTISING TEXTS; RENTAL OF ADVERTISING SPACE; DISSEMINATION OF ADVERTISEMENTS; PUBLIC RELATIONS (U.S. CLS. 100, 101 AND 102).

CLASS 38—COMMUNICATION

FOR TELECOMMUNICATION SERVICES, NAMELY, TRANSMISSION OF VOICE, AUDIO, VISUAL IMAGES AND DATA BY TELECOMMUNICATIONS NETWORKS, WIRELESS COMMUNICATION NETWORKS, THE INTERNET, INFORMATION SERVICES NETWORKS, AND DATA NETWORKS; LOCAL AND LONG DISTANCE TRANSMISSION OF VOICE, DATA, AND GRAPHICS BY MEANS OF TELEPHONE, TELEGRAPHIC, CABLE, AND SATELLITE TRANSMISSIONS; BROADCASTING SERVICES AND PROVISION OF TELECOMMUNICATION ACCESS TO VIDEO AND AUDIO CONTENT PROVIDED VIA A VIDEO-ON-DEMAND SERVICE VIA THE INTERNET, NEWS AND INFORMATION AGENCIES, NAMELY, THE TRANSMISSION OF NEWS ITEMS TO NEWS REPORTING ORGANIZATIONS; TELECONFERENCING SERVICES; ELECTRONIC MAIL SERVICES (U.S. CLS. 100, 101 AND 104).

CLASS 41—EDUCATION AND ENTERTAINMENT

FOR EDUCATION SERVICES IN THE NATURE OF ELECTRONIC GAMES DISTRIBUTED TO MOBILE HANDSETS, WHICH MAY INCLUDE VIDEO, TEXT, PHOTOS, ILLUSTRATIONS OR HYPERTEXT; TRAINING IN THE FIELD OF GAMES AND ARCADE GAMES; ENTERTAINMENT IN THE FIELD OF GAMES AND ARCADE GAMES, NAMELY, PROVIDING ONLINE COMPUTER GAMES, AMUSEMENT ARCADES; SPORTING AND CULTURAL ACTIVITIES IN THE FIELD OF GAMES AND ARCADE GAMES, NAMELY, AMUSEMENT ARCADES; INFORMATION ON EDUCATIONAL AND ENTERTAINMENT EVENTS IN THE FIELD OF GAMES AND ARCADE GAMES; PROVIDING RECREATION FACILITIES; PUBLICATION OF BOOKS; ORGANIZATION OF COMPETITIONS IN THE FIELD OF GAMES AND ARCADE GAMES; ARRANGING AND CONDUCTING OF COLLOQUIUMS, CONFERENCES, AND CONVENTIONS IN THE FIELD OF GAMES AND ARCADE GAMES; ORGANIZATION OF EXHIBITIONS FOR CULTURAL AND EDUCATIONAL PURPOSES IN THE FIELD OF GAMES AND ARCADE GAMES; PROVIDING GAMES ONLINE ON A COMPUTER NETWORK; GAMBLING SERVICES; ELECTRONIC PUBLISHING OF BOOKS AND PERIODICALS ONLINE; DESKTOP PUBLISHING FOR OTHERS (U.S. CLS. 100, 101 AND 107).

CLASS 42—SCIENTIFIC AND COMPUTER SERVICES

FOR EVALUATIONS, ASSESSMENTS AND RESEARCH IN THE FIELDS OF GAMES AND ARCADE GAMES PROVIDED BY ENGINEERS; RESEARCH AND DEVELOPMENT OF NEW PRODUCTS FOR THIRD PARTIES; TECHNICAL PROJECT STUDIES IN THE FIELD OF GAMES AND ARCADE GAMES; DESIGN, DEVELOPMENT, INSTALLATION, MAINTENANCE, UPDATING, AND RENTAL OF SOFTWARE; COMPUTER PROGRAMMING; COMPUTER CONSULTING; DATA CONVERSION OF COMPUTER PROGRAMS AND DATA, NOT INCLUDING PHYSICAL CONVERSION; CONVERSION OF DOCUMENTS FROM A PHYSICAL TO AN ELECTRONIC MEDIUM (U.S. CLS. 100 AND 101).

EUGENIA MARTIN, EXAMINING ATTORNEY

CLASS 45—PERSONAL AND LEGAL SERVICES

FOR ISSUANCE OF MOTOR VEHICLE COMPETITION LICENSES FOR OTHERS (U.S. CLS. 100 AND 101).
EMILY CARLSEN, EXAMINING ATTORNEY

SN 79-048,091. CROWN CREATIVE CO., LTD., ADACHI-KU, TOKYO 120-0006, JAPAN, FILED 5-10-2007.

SN 79-046,823. FÉDÉRATION INTERNATIONALE DES VEHICULES ANCIENS; F.I.V.A., FRANCE, FILED 10-26-2007.

FIVA

PRIORITY DATE OF 5-11-2007 IS CLAIMED.
OWNER OF INTERNATIONAL REGISTRATION 0944999
DATED 10-26-2007, EXPIRES 10-26-2017.

CLASS 16—PAPER GOODS AND PRINTED MATTER

FOR PRINTED MATTER, NAMELY, PRINTED INSTRUCTIONAL AND TEACHING MATERIAL, PHOTOGRAPHS, TECHNICAL DATA SHEETS, MAGAZINES, NEWSLETTERS, HANDBOOKS, ADVICE SHEETS AND TECHNICAL INFORMATION LEAFLETS, ALL IN THE FIELD OF HISTORIC VEHICLES (U.S. CLS. 2, 5, 22, 23, 29, 37, 38 AND 50).

CLASS 25—CLOTHING

FOR CLOTHING, NAMELY, SHIRTS, SWEATSHIRTS, SWEATERS, FLEECE PULLOVERS, JACKETS, PANTS, COATS, NECKTIES, GLOVES AND SCARVES; FOOTWEAR, HEADGEAR, NAMELY, HATS AND CAPS (U.S. CLS. 22 AND 39).

CLASS 41—EDUCATION AND ENTERTAINMENT

FOR SPORTING AND CULTURAL ACTIVITIES, NAMELY, ARRANGING AND ORGANIZING SPORTING AND CULTURAL EVENTS RELATING TO HISTORIC VEHICLES; ORGANIZING CAR SHOWS AND AUTOMOBILE COMPETITIONS FOR ENTERTAINMENT, SPORTING AND CULTURAL PURPOSES; PROVIDING INFORMATION IN THE FIELD OF SPORTING EVENTS RELATING TO HISTORIC VEHICLES; EDUCATIONAL SERVICES, NAMELY, PROVIDING TRAINING IN THE FIELD OF HISTORIC VEHICLES; PROVIDING A NON-DOWNLOADABLE ELECTRONIC PUBLICATION, NAMELY, EDUCATIONAL AND INSTRUCTIONAL PAMPHLETS AND MANUALS IN THE FIELD OF HISTORIC VEHICLES; PUBLICATION OF ELECTRONIC BOOKS AND JOURNALS ON-LINE ON THE SUBJECT OF HISTORIC VEHICLES; NONE OF THE AFORESAID RELATING TO BASKETBALL (U.S. CLS. 100, 101 AND 107).



Rebeccabonbon

PRIORITY DATE OF 4-6-2007 IS CLAIMED.
OWNER OF INTERNATIONAL REGISTRATION 0948325
DATED 5-10-2007, EXPIRES 5-10-2017.

CLASS 3—COSMETICS AND CLEANING PREPARATIONS

FOR ADHESIVES FOR AFFIXING FALSE EYELASHES; STARCH FOR LAUNDRY PURPOSES; SEAWEED GELATINE FOR LAUNDRY USE (FUNORI); PAINT STRIPPING PREPARATIONS; SHOE CREAM; SHOE POLISH; POLISHING PREPARATIONS; SOAPS AND DETERGENTS; DENTIFRICES; COSMETICS AND NON-MEDICATED TOILETRIES; HAIR CARE KITS COMPRISING NON-MEDICATED HAIR CARE PREPARATIONS, NAMELY, SHAMPOO, CONDITIONER AND GEL; NON-MEDICATED SKIN CARE PREPARATIONS, NAMELY, CREAMS, LOTIONS, GELS, TONERS, CLEANERS AND PEELS; NON-MEDICATED SUN CARE PREPARATIONS; PET SHAMPOO NON-MEDICATED, NON-VETERINARY GROOMING PREPARATION; PERFUMERY; FRAGRANCES AND INCENSES; ESSENTIAL OILS; ABRASIVE PAPER; ABRASIVE CLOTH; POLISHING PAPER; POLISHING CLOTH; FALSE NAILS; FALSE EYELASHES; FITTED COSMETIC CREAM CASES, FITTED MAKE-UP CASES (U.S. CLS. 1, 4, 6, 50, 51 AND 52).

CLASS 6—METAL GOODS

FOR METAL KEYS FOR LOCKS; SWAGE BLOCKS; INDUSTRIAL PACKAGING CONTAINERS OF METAL, NOT INCLUDING METAL STOPPERS, LIDS AND CAPS; METAL STOPPERS FOR INDUSTRIAL PACKAGING CONTAINERS; METAL LIDS AND COVERS FOR INDUSTRIAL PACKAGING CONTAINERS; METAL NAMEPLATES AND DOOR NAMEPLATES; LETTER BOXES OF METAL; HAT-HANGING HOOKS OF METAL; MONEY BOXES OF METAL; WATER TANKS OF METAL FOR HOUSEHOLD PURPOSES; TOOL BOXES OF METAL; TOWEL DISPENSERS OF METAL; METAL JOINERY FITTINGS; METAL SAFES; UPRIGHT NON-LUMINOUS AND NON-MECHANICAL SIGNBOARDS OF METAL; TRANSPORTABLE GREENHOUSES OF METAL FOR HOUSEHOLD USE; FERRULES OF METAL FOR CANES AND WALKING-STICKS; SCULPTURES OF METAL (U.S. CLS. 2, 12, 13, 14, 23, 25 AND 50).

CLASS 9—ELECTRICAL AND SCIENTIFIC APPARATUS

FOR EAR PLUGS NOT FOR MEDICAL PURPOSES; OZONISERS; PHOTOCOPYING MACHINE; MANUALLY OPERATED CALCULATING MACHINES; TIME AND DATE STAMPING MACHINE; TIME CLOCKS BEING TIME RECORDING DEVICES; PUNCH CLOCKS; AUTOMATED BILLING MACHINES FOR PROCESSING ACCOUNTING INFORMATION; AUTOMATIC DISTRIBUTION MACHINES, NAMELY, VENDING MACHINES; COIN-OPERATED GATES FOR CAR PARKS OR PARKING LOTS; LIFE SAVING APPARATUS AND EQUIPMENT, NAMELY, LIFE BELTS, LIFE JACKETS, LIFE SAVING RAFTS AND FLOTATION VESTS; FIRE EXTINGUISHING APPARATUS; SPRINKLER SYSTEMS FOR FIRE PROTECTION; ANTI-THEFT WARNING APPARATUS, NAMELY, THEFT ALARMS; VEHICLE BREAKDOWN WARNING TRIANGLES; ARCADE VIDEO GAME MACHINES; PHOTOGRAPHIC MACHINES AND APPARATUS, NAMELY, CAMERAS, TRIPODS, SLIDE PROJECTORS AND SELF-TIMERS; OPTICAL APPARATUS AND INSTRUMENTS, NAMELY, BINOCULARS, TELESCOPES AND MICROSCOPES; MEASURING, TESTING OR SURVEYING MACHINES AND INSTRUMENTS, NAMELY, TEMPERATURE INDICATORS, BALANCES, TAPE MEASURES, JAPANESE STYLE BOXED-SHAPE VOLUME MEASURE, HYGROMETERS, TRIPODS AND MAGNETIC COMPASSES FOR SURVEYING; BATTERIES; DRY CELLS, SOLAR CELLS AND FUEL CELLS; ELECTRIC FLAT IRONS; HAIR-CURLERS, ELECTRICALLY HEATED; BUZZERS, ELECTRIC; TELECOMMUNICATIONS DEVICES, APPARATUS AND INSTRUMENTS, NAMELY, INTERCOMS, MOBILE PHONES, TELEPHONE SETS, FACSIMILE MACHINES, BROADCASTING MACHINES, NAMELY, TELEVISION AND RADIO RECEIVERS AND TRANSMITTERS, JUKE BOXES, DIGITAL CAMERAS, VIDEO CAMERAS, SOUND RECORDING INSTRUMENTS AND APPARATUS, WIRELESS COMMUNICATION DEVICE FEATURING VOICE, DATA AND IMAGE TRANSMISSION INCLUDING VOICE, TEXT AND PICTURE MESSAGING, A VIDEO AND STILL IMAGE CAMERA, ALSO FUNCTIONAL TO PURCHASE MUSIC, GAMES, VIDEO AND SOFTWARE APPLICATIONS OVER THE AIR FOR DOWNLOADING TO THE DEVICE; VIDEO FREQUENCY MACHINES AND APPARATUS, NAMELY, DIGITAL CAMERAS, VIDEO CAMERAS, DVD PLAYERS AND RECORDERS, VIDEO PLAYERS AND RECORDERS; PARTS AND ACCESSORIES FOR TELECOMMUNICATIONS DEVICES, APPARATUS AND INSTRUMENTS, NAMELY, CABINETS FOR LOUD-SPEAKERS, BLANK VIDEO TAPES, BLANK RECORDABLE DVDS, BLANK RECORD DISKS, BLANK DIGITAL STORAGE MEDIA, BLANK ELECTRONIC MEDIA, HEADPHONES, MICROPHONES, PHONOGRAPHIC RECORD CLEANING KITS COMPRISED PRIMARILY OF REPLACEMENT STYLUS NEEDLES AND ALSO INCLUDING CLEANING SOLUTIONS AND BRUSHES; MOBILE TELEPHONE ACCESSORIES, NAMELY, MOBILE TELEPHONE STRAPS, HEADSETS, MICROPHONES AND HEADPHONES; ELECTRONIC MACHINES APPARATUS AND THEIR PARTS, NAMELY, ELECTRONIC DESK CALCULATORS, COMPUTER MOUSE AND KEYBOARDS; APPARATUS AND INSTRUMENTS FOR CONDUCTING, SWITCHING, TRANSFORMING, ACCUMULATING, REGULATING OR CONTROLLING ELECTRICITY, NAMELY, ELECTRIC SWITCHES AND REMOTE CONTROLLERS FOR RADIOS, TELEVISIONS, STEREOS; COMPUTERS; PROGRAMS FOR COMPUTER OPERATING SYSTEMS; COMPUTER SOFTWARE FOR GAMES AND INTERACTIVE GAMES; COMPUTER SOFTWARE THAT IS DOWNLOADABLE AND ALLOWS THE USER ACCESS TO RING TONES, AUDIO FILES, MUSIC FILES, IMAGES, VIDEO IMAGES AND ELECTRONIC GAMES; MAGNETIC CORES; ELECTRODES; CIGAR LIGHTERS FOR AUTOMOBILES; GLOVES FOR PROTECTION AGAINST ACCIDENTS; DUST MASKS; GARMENTS FOR PROTECTION AGAINST FIRE; EYEGLASSES; DIVING GOGGLES AND SKI GOGGLES; SPECTACLES; PARTS AND ACCESSORIES FOR EYEGLASSES, GOGGLES, SPECTACLES, NAMELY, CONTAINERS, TEMPLES, PINCE-NEZ CORDS, CASES, FRAMES, AND CONTAINERS FOR CONTACT LENSES; CONSUMER VIDEO GAMES, NAMELY, CONSUMER GAME CONSOLES FOR USE WITH AN EXTERNAL DISPLAY SCREEN OR MONITOR, CONSUMER GAME JOY STICKS, VIDEO AND COMPUTER GAME PROGRAMS,

VIDEO AND COMPUTER GAME CARTRIDGES AND CASSETTES; ELECTRONIC CIRCUITS AND CD-ROM'S RECORDED WITH PROGRAMS FOR HAND-HELD GAMES WITH LIQUID CRYSTAL DISPLAYS; WEIGHT BELTS FOR SCUBA DIVING; DIVING SUITS; INFLATABLE SWIMMING FLOATS BEING PROTECTION AND SAFETY APPARATUS; PROTECTIVE HELMETS FOR SPORTS; AIR TANKS FOR SCUBA DIVING; SWIMMING FLUTTER BOARDS; REGULATORS FOR USE IN SCUBA DIVING; PHONOGRAPH RECORDS FEATURING MUSIC; SOUND RECORDED MAGNETIC CARDS, SHEETS AND TAPES; RECORDED COMPACT DISCS FEATURING SOUNDS, MUSIC, ANIMATION, IMAGES, VIDEO IMAGES, MOVIES, TELEVISION PROGRAMS AND INTERNET TELEVISION PROGRAMS; METRONOMES; ELECTRONIC CIRCUITS AND CD-ROMS RECORDED WITH AUTOMATIC PERFORMANCE PROGRAMS FOR ELECTRONIC MUSICAL INSTRUMENTS; SLIDE-RULES; EXPOSED CINEMATOGRAPHIC FILMS; EXPOSED SLIDE FILMS; SLIDE FILM MOUNTS; RECORDED VIDEO DISCS AND TAPES FEATURING SOUNDS, MUSIC, ANIMATION, IMAGES, VIDEO IMAGES, MOVIES; TELEVISION PROGRAMS; AND INTERNET TELEVISION PROGRAMS; DOWNLOADABLE ELECTRONIC PUBLICATIONS, NAMELY, BOOKS, MAGAZINES, NEWSLETTERS, MAPS AND COMICS FEATURING ANIMATION AND SUBJECTS OF GENERAL INTEREST, DOWNLOADABLE TEXT AND DATA FILES, MAGAZINES, BOOKS, NEWSPAPERS, MAPS, PICTURES AND DRAWINGS FEATURING IMAGES, MAPS, PICTURES, DRAWINGS, VIDEO IMAGES, AUDIO FILES, ANIMATION, SOUND FILES AND MUSIC FILES FEATURING FICTIONAL CHARACTERS AND SUBJECTS OF GENERAL INTEREST; DOWNLOADABLE ELECTRONIC PUBLICATIONS, NAMELY, BOOKS, MAGAZINES, NEWSLETTERS, AND COMICS FEATURING MUSIC, IMAGES, VIDEO IMAGES, SOUNDS, TEXT, ANIMATION AND INFORMATION RELATED TO FICTIONAL CHARACTERS AND SUBJECTS OF GENERAL INTEREST; DOWNLOADABLE ELECTRONIC PUBLICATIONS, NAMELY, BOOKS, MAGAZINES, NEWSLETTERS, AND COMICS FEATURING MUSIC, IMAGES, VIDEO IMAGES, SOUNDS, ANIMATION, TEXT, AND INFORMATION RELATED TO FICTIONAL CHARACTERS AND SUBJECTS OF GENERAL INTEREST, RECORDED ON ELECTRONIC MEDIA, NAMELY, ENCODED ELECTRONIC CIRCUITS, IC CARDS, MAGNETIC TAPES, MAGNETIC DISCS, OPTICAL DISCS, MAGNETIC OPTICAL DISCS, CD-ROMS AND DVDS RECORDED WITH MUSIC, SOUND, IMAGES, AND VIDEO IMAGES (U.S. CLS. 21, 23, 26, 36 AND 38).

CLASS 14—JEWELRY

FOR PRECIOUS METALS; KEY RINGS OF PRECIOUS METAL OR IMITATION PRECIOUS METAL OR SEMI-PRECIOUS METAL, BEING TRINKETS OR FOBS; JEWEL CASES OF PRECIOUS METAL; PRECIOUS METAL TROPHIES BEING PRIZE CUPS; ORNAMENTS OF PRECIOUS METAL, NAMELY, COMMEMORATIVE SHIELDS; PRECIOUS METAL OR IMITATION PRECIOUS METAL OR SEMI-PRECIOUS METAL PERSONAL ORNAMENTS; ORNAMENTS BEING JEWELRY; EARRINGS; INSIGNIAS OF PRECIOUS METAL; BADGES OF PRECIOUS METAL; BONNET PINS OF PRECIOUS METAL; TIE CLIPS; TIE PINS; NECKLACES; BRACELETS; PENDANTS; GEM BROOCHES; MEDALS; RINGS; MEDALLIONS; JEWELRY CHAINS; JEWELRY CHARMS; SILVER ORNAMENTS; JEWELRY; JEWELRY AMULETS; HAT ORNAMENTS OF PRECIOUS METAL; JEWELRY ORNAMENTS OF JET; JEWELRY OF YELLOW AMBER; PASTE JEWELRY BEING COSTUME JEWELRY; JEWELRY PINS; ORNAMENTAL PINS; TRINKETS BEING JEWELRY; CUFF LINKS; UNPROCESSED AND SEMI-PROCESSED PRECIOUS STONES AND THEIR IMITATIONS; SHOE ORNAMENTS OF PRECIOUS METAL; CLOCKS; WATCHES; PARTS OF CLOCKS AND WATCHES; ACCESSORIES OF CLOCKS AND WATCHES, NAMELY, WATCH STRAPS AND BANDS, CLOCK AND WATCH HANDS, DIALS FOR CLOCKS AND WATCHES; LUCKY CHARMS BEING JEWELRY (OMAMORI); GOLD THREAD JEWELRY, JET, UNWROUGHT OR SEMI-WROUGHT; PEARLS; PEARLS MADE OF AMBROID BEING PRESSED AMBER PEARLS; JEWELRY OF PRECIOUS METAL THREADS; PENDULUMS BEING PARTS OF CLOCKS AND WATCHES (U.S. CLS. 2, 27, 28 AND 50).

CLASS 16—PAPER GOODS AND PRINTED MATTER

FOR PASTES AND OTHER ADHESIVES FOR STATIONERY OR HOUSEHOLD PURPOSES; SEALING WAX; PRINTERS' REGLETS; PRINTING TYPE; ADDRESSING MACHINES; INKING RIBBONS; ELECTRIC STAPLERS FOR OFFICES; ENVELOPE SEALING MACHINES FOR OFFICES; DRAWING INSTRUMENTS; TYPEWRITERS; MIMEOGRAPHS; ROTARY DUPLICATORS; MARKING TEMPLATES; ELECTRIC PENCIL SHARPENERS; DECORATORS' PAINTBRUSHES; DISPOSABLE BABIES' DIAPER-PANTS OF PAPER; INDUSTRIAL PACKAGING CONTAINERS OF PAPER; FOOD WRAPPING PLASTIC FILM FOR HOUSEHOLD USE; GARBAGE BAGS OF PAPER FOR HOUSEHOLD USE; GARBAGE BAGS OF PLASTICS FOR HOUSEHOLD USE; PATTERNS FOR MAKING CLOTHES; TAILOR'S CHALK; BANNERS OF PAPER; FLAGS OF PAPER; HYGIENIC PAPER; TOWELS OF PAPER; TABLE NAPKINS OF PAPER; HAND TOWELS OF PAPER; HANDKERCHIEFS OF PAPER; BAGGAGE TAGS BEING PAPER IDENTIFICATION TAGS; TABLE CLOTHS OF PAPER; PAPER AND CARDBOARD; STATIONERY AND STUDY MATERIALS, NAMELY, SCHOOL DESK BASKETS FOR DESK ACCESSORIES, ARTS AND CRAFTS PAINT KITS AND STUDY GUIDES; PAINTERS' ARTICLES, NAMELY, CRAYONS, PAINTBRUSHES AND PALLETS FOR PAINTING; PRINTED MATTER, NAMELY, PICTURE POSTCARDS, POSTERS, SHEET MUSIC, CATALOGS, CALENDARS FEATURING ADVERTISEMENTS, COMICS, NOVELS, PRODUCTS AND/OR INFORMATION RELATED TO FICTIONAL CHARACTERS; MAGAZINES FEATURING ADVERTISEMENTS, COMICS, NOVELS, PRODUCTS AND/OR INFORMATION RELATED TO FICTIONAL CHARACTERS; BOOKS FEATURING ADVERTISEMENTS, COMICS, NOVELS, PRODUCTS AND/OR INFORMATION RELATED TO FICTIONAL CHARACTERS; NEWSPAPERS, GEOGRAPHIC MAPS, DIARIES, NEWSLETTERS FEATURING ADVERTISEMENTS, COMICS, NOVELS, PRODUCTS AND/OR INFORMATION RELATED TO FICTIONAL CHARACTERS; AND LEAFLETS FEATURING ADVERTISEMENTS, COMICS, NOVELS, PRODUCTS AND/OR INFORMATION RELATED TO FICTIONAL CHARACTERS; POSTCARDS; CATALOGUES FEATURING PRODUCTS AND INFORMATION RELATED TO FICTIONAL CHARACTERS; CALENDARS; MAGAZINES FEATURING ADVERTISEMENTS, COMICS, NOVELS, PRODUCTS AND INFORMATION RELATED TO FICTIONAL CHARACTERS; BOOKS FEATURING ADVERTISEMENTS, COMICS, NOVELS, PRODUCTS AND INFORMATION RELATED TO FICTIONAL CHARACTERS; NEWSPAPERS; PAMPHLETS FEATURING ADVERTISEMENTS, COMICS, NOVELS, PRODUCTS AND INFORMATION RELATED TO FICTIONAL CHARACTERS; POSTERS; PRINTED PERIODICALS FEATURING ADVERTISEMENTS, COMICS, NOVELS, PRODUCTS AND INFORMATION RELATED TO FICTIONAL CHARACTERS; HANDBOOKS FEATURING ADVERTISEMENTS, COMICS, NOVELS, PRODUCTS AND INFORMATION RELATED TO FICTIONAL CHARACTERS; PAINTINGS AND CALLIGRAPHIC WORKS; PHOTOGRAPHS; PHOTOGRAPH STANDS (U.S. CLS. 2, 5, 22, 23, 29, 37, 38 AND 50).

CLASS 18—LEATHER GOODS

FOR HANDBAG FRAMES; PURSE FRAMES; LEATHER ENVELOPES AND POUCHES FOR PACKAGING; CLOTHING FOR DOMESTIC PETS; COLLARS FOR ANIMALS; LEADS FOR PETS, NAMELY, DOG LEADS, AND LEATHER LEADS; BOOTS AND SHOES FOR DOGS AND CATS; BAGS, NAMELY, BACKPACKS, BOOK BAGS, SPORTS BAGS, BUM BAGS, WALLETS, HANDBAGS, SPORT BAGS, BELT BAGS, BOSTON BAGS, CARRY-ALL BAGS, SHOULDER BAGS, CHARM BAGS, SUITCASES, SCHOOL CHILDREN'S BACKPACKS, BEACH BAGS, FEED BAGS FOR ANIMALS, WINE BAGS WITH HANDLES FOR CARRYING OR HOLDING WINE, SHOE BAGS FOR TRAVEL, SUITCASES AND LEATHER CONTAINERS FOR PACKA-

GING, NAMELY, TRUNKS; POUCHES, NAMELY, KNITTED, KILTED, LEATHER, VINYL AND CANVAS POUCHES; POUCHES FOR HOLDING SCHOOL SUPPLIES; POUCHES FOR HOLDING KEYS; POUCHES FOR HOLDING PET ACCESSORIES; PURSES AND WALLETS; UNFITTED VANITY CASES; UMBRELLAS AND THEIR PARTS; WALKING STICKS; CANES; METAL PARTS OF CANES AND WALKING-STICKS; HANDLES OF CANES AND WALKING-STICKS; SADDLERY; LEATHER STRAPS; RAW HIDES; RAW SKINS; TANNED LEATHER; FUR; PURSES AND WALLETS OF PRECIOUS METAL (U.S. CLS. 1, 2, 3, 22 AND 41).

CLASS 21—HOUSEWARES AND GLASS

FOR TABLEWARE, NAMELY, DISPOSABLE TABLE PLATES, TABLE PLACE CARD HOLDERS NOT OF PRECIOUS METAL, CUPS, PLATES, BOWLS, MUGS, TEACUPS, SOUP BOWLS; COSMETIC AND TOILET UTENSILS, NAMELY, WASHING CLOTHS, COMBS, COMB CASES, POWDER COMPACTS, SOAP DISHES, NAIL BRUSHES, TOOTHBRUSHES NOT INCLUDING ELECTRIC TOOTHBRUSHES, HAIR BRUSHES, LIP BRUSHES, EYEBROW BRUSHES, HOLDERS FOR TOILET PAPER, TOILET BRUSHES, TOILET BRUSH HOLDERS, TOILET SPONGES, DISPENSERS FOR LIQUID SOAP, DISPENSERS FOR CLEANING AND DISINFECTING SOLUTIONS, PERFUME SPRAYERS SOLD EMPTY; FEEDING VESSELS FOR PETS; BRUSHES FOR PETS; BIRD CAGES; BIRD BATHS; CHAMBER POTS; TOILET PAPER HOLDERS; PIGGY BANKS, NOT OF METAL; STIRRERS FOR HOT BATHTUB WATER (YUKAKIBO); BATHROOM PAILS; DENTAL FLOSS; UNWORKED OR SEMI-WORKED GLASS NOT FOR BUILDING; MANGERS FOR ANIMALS BEING TROUGHS FOR LIVESTOCK; POULTRY RINGS; COOKING SKEWERS; TUB BRUSHES; METAL BRUSHES FOR CLEANING SHOES; BRUSHES FOR PIPES; SHIP-SCRUBBING BRUSHES; GLOVES FOR HOUSEHOLD PURPOSES; INDUSTRIAL PACKAGING CONTAINERS OF GLASS, NOT INCLUDING GLASS STOPPERS, LIDS AND COVERS; INDUSTRIAL PACKAGING CONTAINERS OF CERAMIC; GLASS STOPPERS FOR INDUSTRIAL PACKAGING CONTAINERS; GLASS COVERS AND LIDS FOR INDUSTRIAL PACKAGING CONTAINERS; NON-ELECTRIC COOKING POTS AND PANS; NON-ELECTRIC COFFEE-POTS; JAPANESE CAST IRON KETTLES, NON-ELECTRIC (TETSUBIN); NON-ELECTRIC KETTLES; PORTABLE NON-ELECTRIC COOLERS; RICE CHESTS; FOOD PRESERVING JARS OF GLASS; DRINKING FLASKS FOR TRAVELERS; VACUUM BOTTLES BEING FLASKS; ICE PAILS; NON-ELECTRIC WHISKS; COOKING STRAINERS; PEPPER POTS, SUGAR BOWLS; SALT SHAKERS; EGG CUPS; NAPKIN HOLDERS; NAPKIN RINGS; TRAYS; TOOTHPICK HOLDERS; COLANDERS; JAPANESE STYLE COOKED RICE SCOOPS (SHAMOJI); HAND-OPERATED COFFEE GRINDERS AND PEPPER MILLS; COOKING FUNNELS; JAPANESE STYLE WOODEN PESTLES (SURIKOGI); JAPANESE STYLE EARTHENWARE MORTARS (SURIBACHI); JAPANESE STYLE PERSONAL DINING TRAYS OR STANDS (ZEN); BOTTLE OPENERS; COOKING GRATERS; TART SCOOPS; PAN-MATS BEING TRIVETS; CHOPSTICKS; CHOPSTICK CASES; LADLES AND DIPERS FOR KITCHEN USE; COOKING SIEVES AND SIFTERS; CHOPPING BOARDS FOR KITCHEN USE; ROLLING PINS FOR COOKING PURPOSES; GRILLS BEING COOKING UTENSILS; TOOTHPICKS; LEMON SQUEEZERS BEING CITRUS JUICERS; NON-ELECTRIC WAFFLE IRONS; CLEANING TOOLS AND WASHING UTENSILS, NAMELY, CLOTHES PEGS, WASHING BRUSHES, WASH BASINS, DUSTING AND CLEANING CLOTHS, WASH-TUBS, SCRUBBING BRUSHES, DUST-PANS, BUCKETS, DUSTERS, BROOMS, MOPS, AND CLOTHES DRYING HANGERS; IRONING BOARDS; TAILOR'S SPRAYERS, NAMELY, SPRAYERS SOLD EMPTY USED FOR IRONING; IRONING BOARDS (KOTEDAI); CANDLE EXTINGUISHERS; CANDLE-STICKS; CINDER SIFTERS FOR HOUSEHOLD PURPOSES; COAL SCUTTLES; FLY SWATTERS; MOUSE TRAPS; FLOWER POTS; WATERING CANS; WATER TANKS AND ORNAMENTS FOR INDOOR AQUARIA; CLOTHES BRUSHES; BOXES OF METAL FOR DISPENSING PAPER TOWELS; BOOT JACKS; SOAP DISPENSERS; FLOWER VASES; FLOWER BOWLS; WIND CHIMES; PERFUME BURNERS; ELECTRIC TOOTHBRUSHES; SHOE BRUSHES; SHOE HORNS; SHOE SHINE CLOTHS; HANDY SHOE SHINERS, NAMELY,

SHOE SHINE CLOTHS; SHOE-TREES BEING STRETCHERS; PORTABLE COOKING KITS FOR OUTDOOR USE; PIG BRISTLES BEING HOG BRISTLES FOR BRUSHES; POWDER COMPACTS OF PRECIOUS METAL (U.S. CLS. 2, 13, 23, 29, 30, 33, 40 AND 50).

CLASS 24—FABRICS

FOR PERSONAL ARTICLES OF WOVEN TEXTILE NOT FOR WEAR, NAMELY, HAND TOWELS, TEXTILE HAND TOWELS, HANDKERCHIEFS, TEXTILE HANDKERCHIEFS, TOWELS, TEXTILE TOWELS; MOSQUITO NETS; BEDSHEETS; QUILTS; FITTED FUTON COVER NOT OF PAPER; UNFITTED FUTON COVER NOT OF PAPER; PILLOWCASES; BED BLANKETS, BLANKET THROWS, BLANKETS FOR OUT DOOR USE, CHILDREN'S BLANKETS, AND PET BLANKETS; SHOWER CURTAINS; TOILET SEAT COVERS OF TEXTILE; UNFITTED FABRIC CHAIR COVERS; WALL HANGINGS OF TEXTILE; CURTAINS, TABLE CLOTHS NOT OF PAPER; DRAPERIES BEING THICK DROP CURTAINS (U.S. CLS. 42 AND 50).

CLASS 25—CLOTHING

FOR NON-JAPANESE OUTER CLOTHES, NAMELY, BABY BODYSUITS, BABY BOTTOMS, BABY BUNTINGS, BABY DOLL PAJAMAS, BABY TOPS, BATHING SUITS, BATHING SUITS FOR MEN, BATHING SUITS FOR KIDS, BEACH COVER-UPS, BEACHWEAR, BATHROBES, TEXTILE BELTS, BLOUSES, BLOUSONS, BODY LINENS, BOMBER JACKETS, CAMISOLES, CAPRI PANTS, CHILDREN'S AND INFANTS' CLOTH BIBS, NECK TUBES, COATS, DRESS SHIRTS, DRESS SUITS, DRESSES, GOLF SHIRTS, GOLF TROUSERS, GYM SUITS, JACKETS, JEANS, JERSEYS, JOGGING OUTFITS, JUMPERS, JUMPSUITS, LEATHER JACKETS, LEG WARMERS, SUITS, NURSE DRESSES, ONE PIECE OUTFITS BEING ONE PIECE GARMENTS FOR INFANTS, CHILDREN AND ADULTS, PANTS, RAINCOATS, RAINWEAR, ROBES, ROMPERS, SHIRTS, SILK SCARVES, SKI SUITS, SNOW SUITS, SPORT JERSEYS, TANK TOPS, TIES, AND WIND COATS; COATS; SWEATERS AND CARDIGAN SWEATERS; SHIRTS, T-SHIRTS, SHIRTS, BLOUSES, POLO SHIRTS AND SWEAT SHIRTS; NIGHTWEAR; UNDERWEAR; SWIMWEAR; SWIMMING CAPS; APRONS FOR WEAR; COLLAR PROTECTORS FOR WEAR; SOCKS AND STOCKINGS; SHAWLS; SCARVES; GLOVES AND MITTENS; BABIES' DIAPERS OF TEXTILE; NECKTIES; NECKERCHIEFS; MUFFLERS; EAR MUFFS; HEADWEAR; CAPS; SUSPENDERS; WAISTBANDS; BELTS FOR CLOTHING; SHOES AND BOOTS OTHER THAN SHOE DOWELS, SHOE PEGS, SHOE HANDLES, HOBNAI LS AND SHOE PROTECTIVE METAL MEMBERS; JAPANESE STYLE SANDALS (ZORI); SPECIAL SPORTSWEAR, NAMELY, SHORTS, PANTS, JACKETS, COATS, VESTS AND BATHING SUITS; SPECIAL SPORTS FOOTWEAR OTHER THAN HORSE RIDING BOOTS (U.S. CLS. 22 AND 39).

CLASS 28—TOYS AND SPORTING GOODS

FOR WAX FOR SKIS; AMUSEMENT MACHINES AND APPARATUS FOR USE IN AMUSEMENT PARKS OTHER THAN ARCADE VIDEO GAME MACHINES, NAMELY, AMUSEMENT GAME MACHINES AND STAND ALONE VIDEO GAME MACHINES; TOYS FOR DOMESTIC PETS; TOYS, NAMELY, BABY MULTIPLE ACTIVITY TOYS, BATH TOYS, BATTERY OPERATED ACTION TOYS, BENDABLE TOYS, CLOCKWORK TOYS OF PLASTIC, COLLECTABLE TOY FIGURES, DOG TOYS, DRAWING TOYS, EDUCATIONAL TOYS FOR PURPOSES OF THE DEMONSTRATION OF ALTERNATIVE ENERGY SOURCES, ELECTRIC ACTION TOYS, FANTASY CHARACTER TOYS, INFANT TOYS, MUSICAL TOYS, PET TOYS, PLASTIC CHARACTER TOYS, PLUSH TOYS, POP UP TOYS, POSITIONABLE TOY FIGURES, PRINTING TOYS, PULL TOYS, PUSH TOYS, REMOTE CONTROL TOYS, NAMELY, CARS, TRUCKS, AIRPLANES, TRAINS AND BOATS, STUFFED ANIMAL TOYS, GIRLS DOLLS WITH CLOTHING; DOLLS; GO GAMES; JAPANESE PLAYING CARDS (UTAGARUTA); JAPANESE CHESS (SHOGI GAMES); DICE; JAPANESE DICE GAMES (SUGOROKU); DICE CUPS; CHESS GAMES; CHECKERS BEING CHECKER SETS; DOMINOES; PLAYING CARDS; JAPANESE PLAYING CARDS (HANAFUDA); MAH-JONG; AMUSEMENT GAME MA-

CHINES; BILLIARD EQUIPMENT; SPORTS EQUIPMENT, NAMELY, TENNIS RACKETS, BADMINTON RACKETS, TABLE TENNIS RACKETS, GOLF BAGS, GOLF CLUBS, GOLF BALLS, GOLF BALL MARKERS, GOLF GLOVES, GOLF CLUB COVERS, SKIS, SKI CASES, SWIM FINNS, SKATEBOARDS, SNOWBOARDS, SNOWBOARD CASES, SURFBOARDS, AND SURFBOARD CASES; FISHING TACKLE; ORNAMENTS FOR CHRISTMAS TREES, EXCEPT ILLUMINATION ARTICLES AND CONFECTIONERY; PARTY FAVORS IN THE NATURE OF SMALL TOYS AND BLOW-OUTS; SLOT MACHINES (U.S. CLS. 22, 23, 38 AND 50).

CLASS 30—STAPLE FOODS

FOR TEA; COFFEE AND COCOA; CONFECTIONERY, NAMELY, ICE CANDIES, ICE CREAM, WAFERS, CARAMELS, CANDIES, BONBONS, COOKIES, CRACKERS, CREAM PUFFS, TOFFEES, CHEWING GUMS, CHOCOLATE, DOUGHNUTS, CANDY DROPS, BISCUITS, FRUIT JELLIES, RUSKS AND BREADS; BREAD AND BUNS; SEASONINGS AND SPICES, NAMELY, WORCESTER SAUCE, MEAT GRAVIES, KETCHUP, SOY SAUCE, VINEGAR, VINEGAR MIXES, SEASONING SOY SAUCE (SOBA-TSUYU), SALAD DRESSINGS, WHITE SAUCE, MAYONNAISE AND SAUCES FOR BARBECUED MEAT; ICE CREAM MIXES; SHERBET MIXES; CEREAL PREPARATIONS, NAMELY, INSTANT NOODLES AND MACARONI; CONFECTIONERY, NAMELY, ALMOND PASTE; SANDWICHES; SUSHI; FRIED BALLS OF BATTER MIX WITH SMALL PIECES OF OCTOPUS CALLED "TAKOYAKI"; STEAMED BUNS STUFFED WITH MINCED MEAT CALLED "NIKUMANJUH"; HAMBURGER SANDWICHES; PIZZAS; BOX LUNCHES CONTAINING MAINLY COOKED RICE WITH THE ADDITION OF VEGETABLES AND MEAT; HOT DOG SANDWICHES; MEAT PIES; RAVIOLI; FERMENTING MALTED RICE CALLED "KOJI"; INSTANT CONFECTIONERY MIXES, NAMELY, FRUIT JELLY MIXES, DOUGHNUT MIXES, PUDDING MIXES AND PANCAKE MIXES; HUSKED RICE; HUSKED OATS; HUSKED BARLEY; FLOUR FOR FOOD; AND GLUTEN FOR FOOD (U.S. CL. 46).

DEBRA LEE, EXAMINING ATTORNEY

SN 79-048,582, ERLER-ZIMMER GMBH & CO. KG, FED REP GERMANY, FILED 11-13-2007.



PRIORITY DATE OF 7-6-2007 IS CLAIMED.
OWNER OF INTERNATIONAL REGISTRATION 0949750
DATED 11-13-2007, EXPIRES 11-13-2017.

CLASS 9—ELECTRICAL AND SCIENTIFIC APPARATUS

FOR SCIENTIFIC APPARATUS AND INSTRUMENTS AND TEACHING APPARATUS AND INSTRUMENTS, NAMELY, MEDICAL DIAGNOSTIC SIMULATORS FOR USE AS TEACHING AIDS FOR ARTHROSCOPY, COLONOSCOPY, ENDOSCOPY, LAPAROSCOPY, ANGIOPLASTY, INTRAMUSCULAR INJECTIONS, SURGERY, EMERGENCY MEDICAL TRAINING (EMT), FORENSIC SCIENCE, SUTURE PRACTICE, ULTRASOUND, X-RAY, ACUPUNCTURE, ALL USED FOR DEPICTING ANATOMICAL AND PATHOLOGICAL CONDITIONS AND PHYSIOLOGICAL, BIOLOGICAL, PHYSICAL, CHEMICAL, TOXICOLOGICAL AND PHARMACOLOGICAL PROCESSES; MEDICAL SIMULATION MODELS, NAMELY, RESUSCITATION MANNEQUINS; MEDICAL SIMULATORS BEING INSTRUCTIONAL AND TEACHING MATERIALS, NAMELY, MEDICAL TEACHING MANNEQUINS (U.S. CLS. 21, 23, 26, 36 AND 38).

CLASS 16—PAPER GOODS AND PRINTED MATTER

FOR PHOTOGRAPHS; GRAPHIC ART REPRESENTATIONS; INDEX CARDS; POSTERS; WALL CHARTS IN THE FIELD OF ANATOMY, PHARMACEUTICAL ADVERTISING; INSTRUCTIONAL AND TEACHING MATERIALS, EXCEPT APPARATUS, NAMELY, REPLICATIONS OF HUMAN AND ANIMAL SKELETONS, OR PARTS OF SKELETONS, AND REPLICATIONS OF HUMAN AND ANIMAL TORSOS AND ORGANS, OR PARTS OF TORSOS OR ORGANS FOR DEPICTING ANATOMICAL AND PATHOLOGICAL CONDITIONS AND PHYSIOLOGICAL, BIOLOGICAL, PHYSICAL, CHEMICAL, TOXICOLOGICAL AND PHARMACOLOGICAL PROCESSES; ANATOMICAL MODELS FOR INSTRUCTIONAL AND TEACHING PURPOSES (U.S. CLS. 2, 5, 22, 23, 29, 37, 38 AND 50).

CLASS 35—ADVERTISING AND BUSINESS

FOR WHOLESALE SERVICES AND RETAIL STORE SERVICES AND MAIL ORDER SERVICES FEATURING SCIENTIFIC APPARATUS AND INSTRUMENTS AND TEACHING APPARATUS AND INSTRUMENTS FOR DEPICTING ANATOMICAL AND PATHOLOGICAL CONDITIONS AND PHYSIOLOGICAL, BIOLOGICAL, PHYSICAL, CHEMICAL, TOXICOLOGICAL AND PHARMACOLOGICAL PROCESSES, ANATOMICAL MODELS BEING INSTRUCTIONAL AND TEACHING MATERIALS, PRINTED MATTER; PHOTOGRAPHS, GRAPHIC REPRESENTATIONS, INDEX CARDS, POSTERS, WALL-CHARTS, INSTRUCTIONAL AND TEACHING MATERIALS FOR DEPICTING ANATOMICAL AND PATHOLOGICAL CONDITIONS AND PHYSIOLOGICAL, BIOLOGICAL, PHYSICAL, CHEMICAL, TOXICOLOGICAL AND PHARMACOLOGICAL PROCESSES (EXCEPT APPARATUS), MEDICAL SIMULATION MODELS, MEDICAL SIMULATORS BEING INSTRUCTIONAL AND TEACHING MATERIALS; ADVERTISING FOR THIRD PARTIES (U.S. CLS. 100, 101 AND 102).

MARIAM MAHMOUDI, EXAMINING ATTORNEY

CLASS 35—ADVERTISING AND BUSINESS

FOR CONSULTANCY IN RELATION TO QUALITY MANAGEMENT AND STOCKPILE TRACKING, NAMELY, INVENTORY MANAGEMENT AND BUSINESS PROCESS RE-ENGINEERING SERVICES; PROFESSIONAL BUSINESS MANAGEMENT CONSULTANCY; PROJECT MANAGEMENT, NAMELY, BUSINESS MANAGEMENT CONSULTANCY AS WELL AS DEVELOPMENT OF PROCESSES FOR THE ANALYSIS AND THE IMPLEMENTATION OF STRATEGY PLANS AND MANAGEMENT PROJECTS; ASSISTANCE WITH BUSINESS MANAGEMENT AND PLANNING; BUSINESS AUDITING; COST PRICE ANALYSIS; BUSINESS MANAGEMENT ASSISTANCE; ECONOMIC FORECASTING; ALL THE FOREGOING IN RESPECT OF MINING AND BULK COMMODITIES INDUSTRIES (U.S. CLS. 100, 101 AND 102).

CLASS 36—INSURANCE AND FINANCIAL

FOR FINANCIAL ANALYSIS; FINANCIAL MODELING IN THE NATURE OF FINANCIAL FORECASTING; FINANCIAL CONSULTANCY AND EVALUATION; FINANCIAL INFORMATION; ALL THE FOREGOING IN RESPECT OF MINING AND BULK COMMODITIES INDUSTRIES (U.S. CLS. 100, 101 AND 102).

CLASS 42—SCIENTIFIC AND COMPUTER SERVICES

FOR CREATION OF BENCHMARK STANDARDS AND PERFORMANCE INDICATORS AND BENCHMARKING, NAMELY, QUALITY CONTROL FOR OTHERS; CONDUCTING TECHNICAL PROJECT FEASIBILITY STUDIES; TECHNICAL RESEARCH IN THE FIELD OF SUPPLY CHAIN MANAGEMENT; COMPUTER PROGRAMMING; COMPUTER SOFTWARE DESIGN; UPDATING OF COMPUTER SOFTWARE; ALL THE FOREGOING IN RESPECT OF MINING AND BULK COMMODITIES INDUSTRIES (U.S. CLS. 100 AND 101).

MATTHEW MCDOWELL, EXAMINING ATTORNEY

SN 79-048,959. OWLIENT, FRANCE, FILED 11-2-2007.

howrse

PRIORITY DATE OF 5-29-2007 IS CLAIMED.
OWNER OF INTERNATIONAL REGISTRATION 0950723
DATED 11-2-2007, EXPIRES 11-2-2017.

THE WORDING "HOWRSE" APPEARING IN THE MARK HAS NO MEANING IN A FOREIGN LANGUAGE.

CLASS 28—TOYS AND SPORTING GOODS

FOR GAMES, NAMELY, AUTOMATIC AND COIN-OPERATED AMUSEMENT MACHINES, PARLOUR GAMES, ACTION SKILL GAMES, ARCADE GAMES, ARCADE-TYPE ELECTRONIC VIDEO GAMES; SHUTTLECOCKS; TOYS, NAMELY, ELECTRONIC LEARNING TOYS, ELECTRONIC ACTION TOYS (U.S. CLS. 22, 23, 38 AND 50).

CLASS 35—ADVERTISING AND BUSINESS

FOR ADVERTISING; DISSEMINATION OF ADVERTISING MATERIAL IN THE FORM OF LEAFLETS, PROSPECTUSES, PRINTED MATTER, AND SAMPLES; ORGANIZATION OF EXHIBITIONS FOR COMMERCIAL AND ADVERTISING PURPOSES; ONLINE ADVERTISING ON A COMPUTER NETWORK; RENTAL OF ADVERTISING TIME ON ALL MEANS OF COMMUNICATION; PUBLICATION OF ADVERTISING TEXTS; RENTAL OF ADVERTISING SPACE; DISSEMINATION OF ADVERTISEMENTS; PUBLIC RELATIONS (U.S. CLS. 100, 101 AND 102).

SN 79-048,933. QMASTOR LIMITED, AUSTRALIA, FILED 12-14-2007.

QMASTOR

THE MARK CONSISTS OF STANDARD CHARACTERS WITHOUT CLAIM TO ANY PARTICULAR FONT, STYLE, SIZE, OR COLOR.

OWNER OF INTERNATIONAL REGISTRATION 0950672
DATED 12-14-2007, EXPIRES 12-14-2017.

THE WORDING "QMASTOR" APPEARING IN THE MARK HAS NO MEANING IN A FOREIGN LANGUAGE.

CLASS 9—ELECTRICAL AND SCIENTIFIC APPARATUS

FOR COMPUTER FIRMWARE, HARDWARE AND SOFTWARE TO FACILITATE BUSINESS CONSULTANCY AND FINANCIAL ANALYSIS BY PROVIDING SYNCHRONISATION ACROSS THE MINING SUPPLY CHAIN, TO TRACK TONNAGE, QUALITY AND VALUE IN THE MINING AND BULK COMMODITIES INDUSTRIES (U.S. CLS. 21, 23, 26, 36 AND 38).

CLASS 38—COMMUNICATION

FOR TELECOMMUNICATION SERVICES, NAMELY, ELECTRONIC TRANSMISSION OF VOICE, AUDIO, VISUAL IMAGES AND DATA BY TELECOMMUNICATIONS NETWORKS, WIRELESS COMMUNICATION NETWORKS, THE INTERNET, INFORMATION SERVICES NETWORKS, AND DATA NETWORKS; LOCAL AND LONG DISTANCE TRANSMISSION OF VOICE, DATA, AND GRAPHICS BY MEANS OF TELEPHONE, TELEGRAPHIC, CABLE, AND SATELLITE TRANSMISSIONS; VIDEO AND AUDIO BROADCASTING SERVICES AND PROVISION OF TELECOMMUNICATION ACCESS TO VIDEO AND AUDIO CONTENT PROVIDED VIA A VIDEO-ON-DEMAND SERVICE VIA THE INTERNET, NEWS AND INFORMATION AGENCIES, NAMELY, THE TRANSMISSION OF NEWS ITEMS TO NEWS REPORTING ORGANIZATIONS; TELECONFERENCING SERVICES; ELECTRONIC MAIL SERVICES (U.S. CLS. 100, 101 AND 104).

CLASS 41—EDUCATION AND ENTERTAINMENT

FOR ENTERTAINMENT SERVICES, NAMELY, PROVIDING ELECTRONIC ON-LINE COMPUTER GAMES FOR USE BY MOBILE HANDSETS FEATURING VIDEO, TEXT, PHOTOS, ILLUSTRATIONS AND HYPERTEXT; TRAINING IN THE FIELD OF GAMES AND ARCADE GAMES; ENTERTAINMENT IN THE FIELD OF GAMES AND ARCADE GAMES, NAMELY, PROVIDING ON-LINE COMPUTER GAMES, AMUSEMENT ARCADES; SPORTING AND CULTURAL ACTIVITIES IN THE FIELD OF GAMES AND ARCADE GAMES, NAMELY, AMUSEMENT ARCADES; INFORMATION ON EDUCATIONAL AND ENTERTAINMENT EVENTS IN THE FIELD OF GAMES AND ARCADE GAMES; PROVIDING RECREATION FACILITIES; PUBLICATION OF BOOKS; ORGANIZATION OF ENTERTAINMENT COMPETITIONS IN THE FIELD OF GAMES AND ARCADE GAMES; ARRANGING AND CONDUCTING OF EDUCATIONAL COLLOQUIUMS, CONFERENCES, AND CONVENTIONS IN THE FIELD OF GAMES AND ARCADE GAMES; ORGANIZATION OF EXHIBITIONS FOR CULTURAL AND EDUCATIONAL PURPOSES IN THE FIELD OF GAMES AND ARCADE GAMES; PROVIDING GAMES ONLINE ON A COMPUTER NETWORK; GAMBLING SERVICES; ELECTRONIC PUBLISHING OF BOOKS AND PERIODICALS ONLINE; DESKTOP PUBLISHING FOR OTHERS (U.S. CLS. 100, 101 AND 107).

Laura Hammel, Examining Attorney

CLASS 9—ELECTRICAL AND SCIENTIFIC APPARATUS

FOR AUDIO CASSETTE PLAYERS; AUDIO CASSETTE RECORDERS; DIGITAL AUDIO PLAYERS; MP3 PLAYERS; SOUND PLAYBACK MACHINES; VIDEO PLAYBACK APPARATUS; COMPUTER SOFTWARE FOR USE IN AUDIO PLAYBACK DEVICES, AUDIO BOOKS, DATABASE MANAGEMENT AND INFORMATION COMPILATION AND PRESENTATION; COMPUTER GAMES SOFTWARE; TALKING BOOKS, NAMELY, BOOKS FEATURING RELIGIOUS, SELF DEVELOPMENT AND IMPROVEMENT, SPIRITUAL, INSPIRATIONAL, MOTIVATIONAL AND EDUCATIONAL CONTENT RECORDED ON COMPUTER MEDIA, DIGITAL MEDIA, CASSETTES AND CDS; PRE-RECORDED CDS FEATURING RELIGIOUS, SELF DEVELOPMENT AND IMPROVEMENT, SPIRITUAL, INSPIRATIONAL AND EDUCATIONAL SPEECH AND GUIDANCE; PRE-RECORDED DVDS FEATURING RELIGIOUS, SELF DEVELOPMENT AND IMPROVEMENT, SPIRITUAL, INSPIRATIONAL AND EDUCATIONAL SPEECH AND GUIDANCE; AUDIO AND VIDEO RECORDINGS FEATURING MUSIC; DOWNLOADABLE AUDIO AND VIDEO RECORDINGS PRERECORDED DVDS FEATURING RELIGIOUS, SELF DEVELOPMENT AND IMPROVEMENT, SPIRITUAL, INSPIRATIONAL AND EDUCATIONAL SPEECH AND GUIDANCE AND MUSIC (U.S. CLS. 21, 23, 26, 36 AND 38).

CLASS 16—PAPER GOODS AND PRINTED MATTER

FOR PRINTED PUBLICATIONS, NAMELY, BOOKS, MAGAZINES, BOOKLETS, LEAFLETS, GUIDES, JOURNALS, PERIODICALS IN THE FIELD OF RELIGION, SELF DEVELOPMENT, SPIRITUALITY AND SELF AWARENESS AND CHRISTIANITY EDUCATION (U.S. CLS. 2, 5, 22, 23, 29, 37, 38 AND 50).

CLASS 41—EDUCATION AND ENTERTAINMENT

FOR EDUCATION SERVICES, NAMELY, PROVIDING CLASSES, SEMINARS, COURSES, WORKSHOPS, MENTORING, GUIDANCE AND ADVICE SESSIONS IN THE FIELD OF RELIGION, SELF DEVELOPMENT, SPIRITUALITY AND SELF AWARENESS AND CHRISTIANITY EDUCATION; RELIGIOUS EDUCATION, NAMELY, TUTORING IN PERSON AND OVER THE INTERNET OR OTHER TELECOMMUNICATIONS NETWORK; RELIGIOUS ENTERTAINMENT IN THE NATURE OF FESTIVALS AND GATHERINGS FEATURING A VARIETY OF ACTIVITIES, NAMELY, RELIGIOUS READINGS AND STORIES (U.S. CLS. 100, 101 AND 107).

Dominic Fathy, Examining Attorney

SN 79-049,028. FACT RADIO LIMITED, UNITED KINGDOM, FILED 7-10-2007.

SN 79-049,142. LUDORUM PLC, UNITED KINGDOM, FILED 10-24-2007.

TIMO



OWNER OF INTERNATIONAL REGISTRATION 0951374 DATED 10-24-2007, EXPIRES 10-24-2017.

THE COLOR(S) GREEN, GRAY, PURPLE, BLACK, WHITE, AND BLUE IS/ARE CLAIMED AS A FEATURE OF THE MARK.

THE COLOR GREEN APPEARS ON THE FRONT, SIDE, AND TOP OF THE TRAIN AND ON THE HORN ON TOP OF

PRIORITY DATE OF 1-11-2007 IS CLAIMED. OWNER OF INTERNATIONAL REGISTRATION 0950951 DATED 7-10-2007, EXPIRES 7-10-2017.

THE TRAIN; THE COLOR GRAY APPEARS ON THE FRONT, SIDE, AND TOP OF THE TRAIN, ON THE VENT ON THE SIDE OF THE TRAIN, ON THE PANEL AT THE BOTTOM OF THE TRAIN, ON THE WIPERS REPRESENTING THE TRAIN'S EYEBROWS, ON THE HORN ON THE TOP OF THE TRAIN, ON THE WHEELS, ON THE THREE RAISED PIECES ON THE TOP OF THE TRAIN, AND ON THE DOOR AND HANDLES ON THE SIDE OF THE TRAIN; THE COLOR PURPLE APPEARS ON THE BOTTOM SECTION OF THE TRAIN, ON THE STRIPE ON THE SIDE OF THE TRAIN, ON THE EYELIDS, AND ON THE RAISED PORTIONS ON THE FRONT OF THE TOP SECTION OF THE TRAIN; THE COLOR BLACK APPEARS ON THE EYES, ON THE WINDOWS, AND ON THE WHEELS; THE COLOR WHITE APPEARS ON THE EYES, AND IN THE GLARE ON THE HORNS; AND THE COLOR BLUE APPEARS IN THE EYES.

CLASS 9—ELECTRICAL AND SCIENTIFIC APPARATUS

FOR COMPACT DISCS FEATURING PRE-RECORDED TELEVISION PROGRAMS IN THE NATURE OF CHILDREN'S ENTERTAINMENT; MUSIC VIDEOS AND GAMES DOWNLOADABLE FROM THE INTERNET; COMPUTER GAME EQUIPMENT, NAMELY, COMPUTER GAME CONSOLES FOR USE WITH AN EXTERNAL DISPLAY SCREEN CONTAINING MEMORY DEVICES, NAMELY, DISCS; MOUSE PADS; MOBILE PHONE ACCESSORIES, NAMELY, STRAPS, COVERS AND CASES FOR MOBILE PHONES AND DEVICES FOR HANDS-FREE USE OF MOBILE PHONES; INTERACTIVE VIDEO GAME PROGRAMS; TELEVISIONS, VIDEO DISC, VIDEO TAPE AND CD PLAYERS; DOWNLOADABLE RING TONES VIA THE INTERNET AND WIRELESS DEVICES; COMPUTER SCREEN SAVER SOFTWARE; INTERACTIVE COMPUTER GAME PROGRAMS; INTERACTIVE VIRTUAL REALITY GAMES SOFTWARE; COMPUTER HARDWARE AND COMPUTER SOFTWARE PROGRAMS FOR THE INTEGRATION OF TEXT, AUDIO, GRAPHICS, STILL IMAGES AND MOVING PICTURES INTO AN INTERACTIVE DELIVERY FOR MULTI-MEDIA APPLICATIONS (U.S. CLS. 21, 23, 26, 36 AND 38).

CLASS 16—PAPER GOODS AND PRINTED MATTER

FOR BOOKS AND MAGAZINES IN THE FIELD OF CHILDREN'S ENTERTAINMENT, COMICS BOOKS AND STRIPS; STATIONERY; PENS (U.S. CLS. 2, 5, 22, 23, 29, 37, 38 AND 50).

CLASS 28—TOYS AND SPORTING GOODS

FOR GAMES, NAMELY, BOARD GAMES, CARD GAMES, ACTION SKILL GAMES; TOYS, NAMELY, MODEL TRAINS AND VEHICLES, ACCESSORIES FOR MODEL TRAINS AND VEHICLES, NAMELY, STORAGE CASES, TOY BRIDGES, TOY BUILDINGS, TOY CHARACTERS, TOY TRAIN TRACKS, TOY CROSSINGS, TOY TREES, TOY LOUDSPEAKERS; PLAY-SETS COMPRISING MODEL TRAIN VEHICLES AND ACCESSORIES, NAMELY, STORAGE CASES, TOY BRIDGES, TOY BUILDINGS, TOY CHARACTERS, TOY TRAIN TRACKS, TOY LOUDSPEAKERS, TOY CROSSINGS AND TOY TREES; BALLS FOR GAMES; TOY BUILDING BLOCKS; SOFT SCULPTURE TOYS, ROCKING TOYS IN THE NATURE OF ROCKING HORSES AND ROCKING TRAINS, RIDE-ON TOYS, RIDE-ON TOY TRAINS AND VEHICLES; SPINNING TOPS; SLIDES BEING PLAYGROUND EQUIPMENT; CLIMBING FRAMES BEING PLAYGROUND EQUIPMENT; AMUSEMENT PARK AND FAIRGROUND RIDES; SWINGS BEING PLAYGROUND EQUIPMENT; DOLLS; DOLLS CLOTHING; PLAY-TENTS; PUZZLES; PARTY FAVOURS IN THE NATURE OF SMALL TOYS; FELT PLAY SETS COMPRISING TRAIN TRACKS, CROSSINGS, MODEL TRAIN VEHICLES, MODEL CARS AND TRUCKS, BUILDINGS, TOWNS, AND COUNTRY-SIDE; FLIPPERS AND ARM BANDS IN THE NATURE OF ARM FLOATS FOR RECREATIONAL USE FOR SWIMMING; YO YOS; BATH TOYS; TOY SCOOTERS, ROLLER SKATES, INLINE ROLLER SKATES, SKATE BOARDS; CHILDREN'S TOY TROLLEYS; PULL-ALONG TOYS; TOYS ON WHEELS, NAMELY, TOY CARS AND TOY TRAINS; MUSICAL TOYS; SNOW GLOBES; BALLOONS; WIND-UP TOYS; SAND PITS BEING PLAYGROUND EQUIPMENT; CHRISTMAS TREE DECORATIONS; SELF CONTAINED COMPUTER GAME EQUIPMENT, NAMELY, HANDHELD UNITS FOR PLAYING VIDEO GAMES (U.S. CLS. 22, 23, 38 AND 50).

CLASS 41—EDUCATION AND ENTERTAINMENT

FOR EDUCATIONAL SERVICES, NAMELY, ARRANGING AND CONDUCTING WORKSHOPS FOR CHILDREN ON THE SUBJECT OF TRAINS AND RAILWAYS; ENTERTAINMENT SERVICES, NAMELY, ENTERTAINMENT IN THE NATURE OF ONGOING TELEVISION, RADIO, FILM AND ANIMATED FILM PROGRAMS IN THE FIELD OF CHILDREN'S ENTERTAINMENT FEATURING FICTIONAL TRAIN CHARACTERS; ENTERTAINMENT SERVICES, NAMELY, LIVE THEATRICAL EVENTS IN THE FIELD OF CHILDREN'S ENTERTAINMENT FEATURING FICTIONAL TRAIN CHARACTERS; THEME PARKS AND AMUSEMENT PARKS; ORGANISING COMMUNITY SPORTING AND CULTURAL EVENTS; PRODUCTION, DISTRIBUTION AND RENTAL OF TELEVISION AND RADIO PROGRAMS AND FILMS, ANIMATED FILMS; PRODUCTION AND RENTAL OF VIDEOS, DVDS, COMPUTER GAMES AND SOUND AND VISUAL RECORDING; PRODUCTION OF LIVE ENTERTAINMENT IN THE NATURE OF PLAYS, CONCERTS, MUSICALS, AMUSEMENT PARK SHOWS AND SHOWS IN THE FIELD OF CHILDREN'S ENTERTAINMENT FEATURING FICTIONAL TRAIN CHARACTERS; ENTERTAINMENT SERVICES, NAMELY, PROVIDING ON-LINE COMPUTER GAMES; ENTERTAINMENT SERVICES, NAMELY, PROVIDING NON-DOWNLOADABLE PRE-RECORDED MUSIC, GAMES AND VIDEOS VIA THE INTERNET, VIDEO ON DEMAND, ELECTRONIC STREAMING, WEB-CASTING, MOBILE PHONES AND/OR TELEVISION; ENTERTAINMENT SERVICES, NAMELY, PROVIDING PRE-RECORDED MUSIC VIA THE INTERNET; PROVIDING A COMPUTER GAME THAT MAY BE ACCESSED NETWORK WIDE BY NETWORK USERS; ENTERTAINMENT SERVICES FEATURING FICTIONAL CHARACTERS, NAMELY, ENTERTAINMENT IN THE NATURE OF TELEVISION, RADIO AND FILM PROGRAMS FEATURING PERFORMANCES BY FICTIONAL TRAIN CHARACTERS; MUSIC PUBLISHING SERVICES; PROVIDING OF ON-LINE NON-DOWNLOADABLE ELECTRONIC PUBLICATIONS IN THE NATURE OF ELECTRONIC BOOKS AND VIDEOS IN THE FIELD OF CHILDREN'S ENTERTAINMENT FEATURING TRAIN CHARACTERS; ENTERTAINMENT SERVICES, NAMELY, PROVIDING ON-LINE COMPUTER GAMES ON A COMPUTER DATABASE, THE INTERNET OR ANY OTHER COMMUNICA-

TIONS NETWORK INCLUDING WIRELESS, CABLE, SATELLITE, VIDEO ON DEMAND, ELECTRONIC STEAMING, WEB-CASTING, IP TV; CONSULTING SERVICES RELATED TO THE AFOREMENTIONED SERVICES (U.S. CLS. 100, 101 AND 107).

CLASS 45—PERSONAL AND LEGAL SERVICES

FOR LICENSING OF INTELLECTUAL PROPERTY IN THE NATURE OF TELEVISION PROGRAMS, CARTOON CHARACTERS AND MOTION PICTURE FILMS (U.S. CLS. 100 AND 101).

KRISTINA MORRIS, EXAMINING ATTORNEY

SN 79-049,149. KONINKLIJKE PHILIPS ELECTRONICS N.V., NETHERLANDS, FILED 11-5-2007.



PRIORITY DATE OF 5-9-2007 IS CLAIMED.
OWNER OF INTERNATIONAL REGISTRATION 0951396 DATED 11-5-2007, EXPIRES 11-5-2017.

THE COLOR(S) PALE GREEN AND MIDDLE GREEN IS/ARE CLAIMED AS A FEATURE OF THE MARK.

THE MARK CONSISTS OF THE COLORS PALE GREEN AND MIDDLE GREEN, WITH THE COLOR PALE GREEN AND MIDDLE GREEN APPEARING IN THE DESIGN OF THE LEAF AND THE COLOR MIDDLE GREEN APPEARING IN THE CIRCLE.

CLASS 8—HAND TOOLS

FOR CUTLERY; RAZORS, NAMELY, SHAVING BLADES, HAIR-CLIPPERS, CUTTING MEMBERS FOR SHAVING APPARATUS, AND ELECTRIC AND NON-ELECTRIC DEPILATION RAZORS (U.S. CLS. 23, 28 AND 44).

CLASS 9—ELECTRICAL AND SCIENTIFIC APPARATUS

FOR SCIENTIFIC APPARATUS, NAMELY, ELECTRON MICROSCOPES, PATHOLOGY MICROSCOPES, PATHOLOGY SCANNERS AND VIEWERS, CINEMATOGRAPHIC APPARATUS, NAMELY, HOME CINEMA SYSTEMS, OPTICAL APPARATUS, NAMELY, DVD RECORDERS, DVD PLAYERS, DVD HOME THEATER APPARATUS, NAMELY, DVD MACHINES; CONTROL APPARATUS, NAMELY, ELECTRICAL AND POWER CONTROLLERS FOR LIGHTING SYSTEMS FOR USE WITH SOFTWARE PROGRAMS FOR OPERATING AND CONTROLLING LIGHTING SYSTEMS; ELECTRONIC BALLASTS FOR LIGHTING PURPOSES; LIGHT EMITTING DIODES (LEDS), APPARATUS FOR RECORDING, TRANSMISSION OR REPRODUCTION OF SOUND OR IMAGES, TELEVISION SETS, FLAT TELEVISIONS, LCD AND PLASMA TELEVISIONS, MP3 AND MP4 PLAYERS, HIFI AUDIO SETS, NAMELY, AUDIO AMPLIFIERS AND SURROUND SOUND SPEAKERS, FLASH AUDIO PLAYERS, WEBCAMS, BATTERIES AND BATTERY CHARGERS; TELEPHONE SETS; DATA PROCESSING EQUIPMENT AND COMPUTERS (U.S. CLS. 21, 23, 26, 36 AND 38).

CLASS 10—MEDICAL APPARATUS

FOR SURGICAL, MEDICAL, DENTAL AND VETERINARY APPARATUS AND INSTRUMENTS, NAMELY, MRI SCANNERS, PATIENT MONITORS, NAMELY, MEDICAL MONITORS FOR CRITICAL CARE AND ANESTHESIA, FOR RECORDING AND ANALYZING SLEEP-RELATED DISORDERS, MEDICAL MONITORS, NAMELY, PATIENT MEDICAL MONITORS FOR RESPIRATORY MONITORING AND AIRFLOW MEASUREMENT, CARDIAC OUTPUT MONITORS, MONITORS FOR SURGICAL STIMULATION, ANALGESIA AND HYPNOTIC RELATED RESPONSES, ULTRASOUND TRANSDUCERS, DEFIBRILLATORS, MEDICAL AND CLINICAL APPARATUS USED IN DIGITAL RADIOGRAPHY AND TELEMETRY (U.S. CLS. 26, 39 AND 44).

CLASS 11—ENVIRONMENTAL CONTROL APPARATUS

FOR APPARATUS FOR LIGHTING, NAMELY, ELECTRIC LIGHTING FIXTURES, ELECTRIC LAMPS, FLUORESCENT LAMPS, LANDSCAPE LIGHTING INSTALLATIONS, STREET LIGHTS; LED STRING SYSTEMS FOR SIGNAGE, NAMELY, LIGHT ASSEMBLIES FOR STREET LIGHTS, SIGNS, AND COMMERCIAL LIGHTING, BAND LIGHTING AND ARCHITECTURAL APPLICATIONS, NAMELY, LIGHTING FIXTURES FOR USE IN ARCHITECTURAL ACCENT LIGHTING APPLICATIONS; LIGHT SOURCES USING LED TECHNOLOGY, NAMELY, LED LIGHT FIXTURES, LED LIGHTING FIXTURES FOR INDOOR AND OUTDOOR LIGHTING APPLICATIONS, LED LIGHT BULBS, HEATING APPARATUS, NAMELY, ELECTRIC HEATING FANS, ELECTRIC RADIATORS FOR HEATING BUILDINGS, TERRACE HEATERS; COOKING APPARATUS, NAMELY, ELECTRIC WATER KETTLES (U.S. CLS. 13, 21, 23, 31 AND 34).

CLASS 21—HOUSEWARES AND GLASS

FOR ELECTRIC TOOTHBRUSHES (U.S. CLS. 2, 13, 23, 29, 30, 33, 40 AND 50).

CLASS 42—SCIENTIFIC AND COMPUTER SERVICES

FOR SCIENTIFIC AND TECHNOLOGICAL SERVICES, NAMELY, CONSULTANCY IN THE FIELD OF SCIENTIFIC ENERGY-SAVING TECHNOLOGIES, DEVELOPMENT OF NEW TECHNOLOGIES FOR OTHERS IN THE FIELD OF ENERGY-SAVING AND ENVIRONMENTAL PROTECTION, AND RESEARCH AND DESIGN RELATING THERETO; INDUSTRIAL ANALYSIS AND RESEARCH SERVICES NAMELY, RESEARCH IN THE FIELD OF ENVIRONMENTAL PROTECTION; DESIGN AND DEVELOPMENT OF COMPUTER HARDWARE AND SOFTWARE (U.S. CLS. 100 AND 101).

YAT SYE, LEE, EXAMINING ATTORNEY

SN 79-049,430. THE MEDIA MERCHANTS TELEVISION; COMPANY LIMITED, LONDON, UNITED KINGDOM, FILED 5-24-2007.

LITTLE ART STORIES

THE MARK CONSISTS OF STANDARD CHARACTERS WITHOUT CLAIM TO ANY PARTICULAR FONT, STYLE, SIZE, OR COLOR.

PRIORITY DATE OF 11-25-2006 IS CLAIMED.

OWNER OF INTERNATIONAL REGISTRATION 0952195 DATED 5-24-2007, EXPIRES 5-24-2017.

NO CLAIM IS MADE TO THE EXCLUSIVE RIGHT TO USE "ART STORIES", APART FROM THE MARK AS SHOWN.

CLASS 9—ELECTRICAL AND SCIENTIFIC APPARATUS

FOR PRERECORDED VIDEO CASSETTES, AUDIO CASSETTES, CD'S, DVD'S AND OPTICAL AND MAGNETO-OPTICAL DISCS FEATURING MUSIC, TEXT DATA, STILL IMAGES AND MOTION PICTURES FOR CHILDREN'S ENTERTAINMENT; ELECTRONIC BOOKS FOR CHILDREN RECORDED ON COMPUTER MEDIA FEATURING CHILDREN'S STORIES, DVD PLAYERS, VIDEOCASSETTE PLAYERS, AUDIO CASSETTE PLAYERS, TELEVISIONS, PERSONAL STEREOS, MP3 PLAYERS, WALKIE-TALKIES, DECORATIVE MAGNETS, SPORT WHISTLES, CD CASES, CELL PHONES, CELL PHONE COVERS, VIDEO GAME CARTRIDGES AND COMPUTER SOFTWARE FEATURING EDUCATIONAL AND ENTERTAINMENT PROGRAMS FOR CHILDREN; SUNGLASSES, SPECTACLE FRAMES, BI-CYCLE HELMETS, DISPOSABLE CAMERAS (U.S. CLS. 21, 23, 26, 36 AND 38).

SN 79-049,693. MARKUS JOHANNES PRESTON, AUSTRALIA, FILED 11-13-2007.



PRIORITY DATE OF 9-27-2007 IS CLAIMED.
OWNER OF INTERNATIONAL REGISTRATION 0952860 DATED 11-13-2007, EXPIRES 11-13-2017.

THE COLOR(S) YELLOW AND BLACK IS/ARE CLAIMED AS A FEATURE OF THE MARK.

THE MARK CONSISTS OF THE COLOR BLACK APPEARING IN THE WORDING "PRESTON PERFORMANCE THROUGH INNOVATION" AND IN THE UNDERLINE AND OVERLINE IN THE MARK; THE COLOR YELLOW APPEARING IN THE RECTANGULAR BACKGROUND OF THE MARK.

CLASS 16—PAPER GOODS AND PRINTED MATTER

FOR CHILDREN'S BOOKS, COLORING BOOKS, CHILDREN'S ACTIVITY BOOKS, STICKERS, STICKER BOOKS, STICKER ALBUMS, BOARD BOOKS, BOOK-ENDS, PHOTO ALBUMS, PHOTO STORAGE BOXES, SCRAP BOOKS, CHILDREN'S MAGAZINES, FLASH CARDS, BOXED NOTE CARDS, STATIONERY, PAPER GIFT WRAP, PAPER GIFT BAGS, GIFT BOXES, PAPER GIFT TAGS, RIBBONS, GREETING CARDS, PARTY INVITATIONS, TREAT BAGS, NAMELY, PLASTIC BAGS FOR PARTY FAVORS, PAPER TABLE CLOTHS, PAPER NAPKINS, PAPER GARLANDS, PAPER DIARIES, PAPER ORGANIZERS FOR STATIONERY USE, ADDRESS BOOKS, NOTEBOOKS, DISPOSABLE DIAPERS, PAPER BOOKMARKS, CALENDARS, GREETING CARDS, PENCILS, PENCIL CASES, PENCIL SHARPENERS, RUBBER ERASERS, PENS, CRAYONS, MARKERS, PAINTING SETS, ART KITS COMPRISED OF DRAWING PAPER, CONSTRUCTION PAPER, PAINT, PENCILS, MARKERS, AND INSTRUCTION BOOKLETS IN THE FIELD OF ART; DRAWING PAPER, SKETCH PADS, CONSTRUCTION PAPER, EASELS, CHALK, RUBBER STAMP SETS, DRAWING RULERS, MODELING CLAY, TEMPORARY TATTOOS, BULLETIN BOARDS; DRY ERASE WRITING BOARDS (U.S. CLS. 2, 5, 22, 23, 29, 37, 38 AND 50).

CLASS 6—METAL GOODS

FOR BUILDING FRAMEWORKS OF METAL; METAL BUILDING BEAMS; GUTTERING OF METAL; GUTTERS OF METAL (U.S. CLS. 2, 12, 13, 14, 23, 25 AND 50).

CLASS 37—CONSTRUCTION AND REPAIR

FOR RENTAL OF APPARATUS FOR USE IN THE CONSTRUCTION OF BUILDINGS; RENTAL OF APPARATUS FOR USE IN THE CONSTRUCTION REPAIR OF BUILDINGS; RENTAL OF HAND AND POWER BUILDING TOOLS; BUILDING PLATFORM RENTAL; RENTAL OF BUILDING CONSTRUCTION PLATFORMS AND SCAFFOLDING (U.S. CLS. 100, 103 AND 106).

LAURA HAMMEL, EXAMINING ATTORNEY

CLASS 41—EDUCATION AND ENTERTAINMENT

FOR PRODUCTION OF A SERIES OF PROGRAMS FOR CHILDREN IN THE FIELD OF ART AND CRAFTS, FOR TELEVISION BROADCAST AND FOR LIVE AUDIENCES; ENTERTAINMENT SERVICES, NAMELY, PERSONAL APPEARANCES BY A COSTUMED CHARACTER; PROVISION OF ENTERTAINMENT FOR CHILDREN BY MEANS OF THE INTERNET, NAMELY, PROVIDING A WEBSITE FEATURING EDUCATIONAL GAMES IN THE FIELDS OF LANGUAGE, ALPHABET, NUMBERS, COLORS, SPATIAL RELATIONSHIPS, MANNERS, VOCABULARY, AND/OR MATH, AND INFORMATION ABOUT CHILDREN'S TELEVISION PROGRAMS; FAN CLUBS (U.S. CLS. 100, 101 AND 107).
WILLIAM ROSSMAN, EXAMINING ATTORNEY

SN 79-049,707. OPENSUGAR, F-38941 MEYLAN, FRANCE, FILED 12-17-2007.

ABPHONE

THE MARK CONSISTS OF STANDARD CHARACTERS WITHOUT CLAIM TO ANY PARTICULAR FONT, STYLE, SIZE, OR COLOR.

PRIORITY DATE OF 6-18-2007 IS CLAIMED.
OWNER OF INTERNATIONAL REGISTRATION 0952887 DATED 12-17-2007, EXPIRES 12-17-2017.

CLASS 9—ELECTRICAL AND SCIENTIFIC APPARATUS

FOR APPARATUS FOR RECORDING, TRANSMISSION, PROCESSING AND REPRODUCTION OF SOUND OR IMAGES, NAMELY, CELLULAR PHONES CONTAINING SOFTWARE AND COMPUTER SYSTEMS FOR RECORDING, TRANSMISSION, PROCESSING AND REPRODUCTION OF SOUND OR IMAGES; BLANK MAGNETIC RECORDING DISCS AND TAPES, ACOUSTIC AND OPTICAL DISCS; PRE-RECORDED MAGNETIC RECORDING DISCS AND TAPES, ACOUSTIC AND OPTICAL DISCS ALL FEATURING MUSIC PERFORMANCES, MUSIC VIDEOS, FILM CLIPS, SPORTS VIDEOS, DRAWINGS, PHOTOGRAPHS, AND COMPUTER GAMES; BLANK FLOPPY DISCS; PRE-RECORDED FLOPPY DISCS FEATURING MUSIC PERFORMANCES, MUSIC VIDEOS, FILM CLIPS, SPORTS VIDEOS, DRAWINGS, PHOTOGRAPHS, AND COMPUTER GAMES; AUTOMATIC VENDING MACHINES AND MECHANISMS FOR COIN-OPERATED APPARATUS; DATA PROCESSORS AND COMPUTERS; SOFTWARE FOR COMPUTER GAMES; COMPUTER SOFTWARE FEATURING MUSICAL SOUND RECORDINGS, MUSICAL VIDEO RECORDINGS AND GAMES, COMPUTER SOFTWARE FOR THE COLLECTION, EDITING, ORGANIZING, MODIFYING, BOOK MARKING, TRANSMISSION, STORAGE, SHARING AND TRANSMISSION OF DATA, INFORMATION, SOUNDS, IMAGES, VIDEO, AND GAMES, AND COMPUTER SOFTWARE FOR PROVIDING AN ON-LINE DATABASE OF DATA, INFORMATION, SOUNDS, IMAGES, VIDEO AND GAMES IN FIELDS OF GENERAL PUBLIC INTEREST; COMPUTER PERIPHERALS (U.S. CLS. 21, 23, 26, 36 AND 38).

CLASS 35—ADVERTISING AND BUSINESS

FOR ADVERTISING, BUSINESS MANAGEMENT; BUSINESS ADMINISTRATION; OFFICE FUNCTIONS; DISSEMINATION OF ADVERTISING MATERIAL, NAMELY, LEAFLETS, PROSPECTUSES, PRINTED MATTER, AND SAMPLES; NEWSPAPER SUBSCRIPTION SERVICES FOR THIRD PARTIES; COMPUTER FILE MANAGEMENT; ORGANIZATION OF EXHIBITIONS FOR COMMERCIAL OR ADVERTISING PURPOSES; ONLINE ADVERTISING ON A COMPUTER NETWORK; RENTAL OF ADVERTISING TIME ON ALL MEANS OF COMMUNICATION; PUBLICATION OF ADVERTISING TEXTS; RENTAL OF ADVERTISING SPACE; DISSEMINATION OF ADVERTISEMENTS; PUBLIC RELATIONS (U.S. CLS. 100, 101 AND 102).

CLASS 38—COMMUNICATION

FOR TELECOMMUNICATIONS SERVICES, NAMELY, PROVIDING TELECOMMUNICATIONS CONNECTIONS TO THE INTERNET OR ON-LINE DATABASES, TRANSMISSION AND RECEPTION VIA TELECOMMUNICATIONS OF DATA, INFORMATION, SOUNDS, IMAGES, VIDEO AND GAMES, AND ELECTRONIC EXCHANGE OF DATA, INFORMATION, SOUNDS, IMAGES, VIDEO AND GAMES STORED IN DATABASES ACCESSIBLE VIA TELECOMMUNICATIONS NETWORKS; INFORMATION ON TELECOMMUNICATIONS; COMMUNICATIONS VIA COMPUTER TERMINALS OR VIA FIBRE-OPTIC NETWORKS; RADIO OR TELEPHONE COMMUNICATION; MOBILE RADIO-TELEPHONY SERVICES; PROVISION OF ACCESS TO A GLOBAL COMPUTER NETWORK; TELECOMMUNICATIONS SERVICES, NAMELY, ELECTRONIC DISPLAY OF DATA, INFORMATION, SOUNDS, IMAGES, VIDEO AND GAMES ON CELLULAR PHONES; CONNECTION BY TELECOMMUNICATIONS TO A GLOBAL COMPUTER NETWORK; NEWS AGENCIES, NAMELY, TRANSMISSION OF NEWS ITEMS TO NEWS REPORTING ORGANIZATIONS; RENTAL OF TELECOMMUNICATION APPARATUS; RADIO OR TELEVISION BROADCASTING; TELECONFERENCING SERVICES; ELECTRONIC MAIL SERVICES; RENTAL OF ACCESS TIME TO GLOBAL COMPUTER NETWORKS (U.S. CLS. 100, 101 AND 104).

CLASS 41—EDUCATION AND ENTERTAINMENT

FOR ENTERTAINMENT SERVICES, NAMELY, PROVIDING ON-LINE DOWNLOADABLE AND STREAMING CONTENTS OF VIDEOS, IMAGES, AND SOUNDS FEATURING MUSIC PERFORMANCES, MUSIC VIDEOS, FILM CLIPS, SPORTS VIDEOS, DRAWINGS, PHOTOGRAPHS AND COMPUTER GAMES; ORGANIZING COMMUNITY SPORTING AND CULTURAL ACTIVITIES; INFORMATION ON EDUCATIONAL OR ENTERTAINMENT EVENTS; LEISURE SERVICES, NAMELY, PROVIDING INFORMATION, NEWS AND COMMENTARY IN THE FIELD OF RECREATION AND LEISURE ACTIVITIES; PUBLICATION OF BOOKS; LENDING LIBRARIES; VIDEO FILM PRODUCTION; RENTAL OF CINEMATOGRAPHIC FILMS; RENTAL OF SOUND RECORDINGS; VIDEOTAPE EDITING; PHOTOGRAPHY SERVICES; ORGANIZATION OF EXHIBITIONS FOR CULTURAL OR EDUCATIONAL PURPOSES; BOOKING OF SEATS FOR SHOWS; PROVIDING GAMES ONLINE ON A COMPUTER NETWORK; GAMBLING SERVICES; ELECTRONIC PUBLISHING OF BOOKS AND PERIODICALS ONLINE; DESKTOP PUBLISHING FOR OTHERS (U.S. CLS. 100, 101 AND 107).

CLASS 42—SCIENTIFIC AND COMPUTER SERVICES

FOR EVALUATIVE TESTING OF COMPUTER SOFTWARE, ASSESSMENTS AND RESEARCH IN THE FIELDS OF SCIENCE AND TECHNOLOGY PROVIDED BY ENGINEERS; DESIGN AND DEVELOPMENT OF COMPUTERS AND SOFTWARE; RESEARCH AND DEVELOPMENT OF NEW PRODUCTS FOR THIRD PARTIES; TECHNICAL PROJECT STUDIES IN THE FIELDS OF COLLECTION, EDITING, ORGANIZING, MODIFYING, BOOK MARKING, TRANSMISSION, STORAGE, SHARING AND TRANSMISSION OF DATA, INFORMATION, SOUNDS AND IMAGES, VIDEO AND GAMES; DESIGN, DEVELOPMENT, INSTALLATION, MAINTENANCE, UPDATING OR RENTAL OF SOFTWARE; COMPUTER PROGRAMMING; COMPUTER CONSULTING; NON-PHYSICAL DATA CONVERSION OF COMPUTER PROGRAMS AND DATA; CONVERSION OF DATA OR DOCUMENTS FROM PHYSICAL TO ELECTRONIC MEDIA; GRAPHIC ARTS DESIGN SERVICES (U.S. CLS. 100 AND 101).

JULIE WATSON, EXAMINING ATTORNEY

SN 79-049,907. BYCITY LIVING LTD., UNITED KINGDOM, FILED 11-2-2007.

URBANCODE

THE MARK CONSISTS OF STANDARD CHARACTERS WITHOUT CLAIM TO ANY PARTICULAR FONT, STYLE, SIZE, OR COLOR.

OWNER OF INTERNATIONAL REGISTRATION 0953343 DATED 11-2-2007, EXPIRES 11-2-2017.

CLASS 18—LEATHER GOODS

FOR HAND BAGS (U.S. CLS. 1, 2, 3, 22 AND 41).

CLASS 25—CLOTHING

FOR JACKETS, SKIRTS, TROUSERS, COATS, BELTS, SHOES (U.S. CLS. 22 AND 39).

SARA THOMAS, EXAMINING ATTORNEY

SN 79-050,153. BARCOS CO., LTD, JAPAN, FILED 10-15-2007.

SN 79-050,246. G-STAR INTERNATIONAL B.V., NETHERLANDS, FILED 12-19-2007.

ICO JEENE
イ コ ジ ー ニ

OWNER OF INTERNATIONAL REGISTRATION 0953919 DATED 10-15-2007, EXPIRES 10-15-2017.

THE WORDING "ICO JEENE" HAS NO MEANING IN ENGLISH.

THE JAPANESE CHARACTERS IN THE MARK TRANSLITERATE TO IKO ZIINI WHICH IS THE JAPANESE EQUIVALENT OF "ICO JEENE".

CLASS 14—JEWELRY

FOR PRECIOUS METALS; KEYRINGS OF PRECIOUS METAL IN THE NATURE OF TRINKETS AND KEY FOBS OF PRECIOUS METAL; PERSONAL ORNAMENTS, NAMELY, ORNAMENTS OF PRECIOUS METAL; CUFF LINKS; SEMI-PROCESSED PRECIOUS STONES AND THEIR IMITATIONS; CLOCKS AND WATCHES (U.S. CLS. 2, 27, 28 AND 50).

CLASS 18—LEATHER GOODS

FOR HANDBAG FRAMES; PURSE FRAMES; INDUSTRIAL PACKAGING CONTAINERS OF LEATHER; BAGS AND THE LIKE, NAMELY, HANDBAGS; POUCHES AND THE LIKE, NAMELY, POUCHES OF LEATHER; VANITY CASES NOT FITTED; UMBRELLAS AND THEIR PARTS; WALKING STICKS; CANES; METAL PARTS OF CANES AND WALKING-STICKS; HANDLES OF CANES AND WALKING-STICKS; SADDLERY; LEATHER STRAPS; RAWHIDES; RAW SKINS; TANNED LEATHER; FUR; PURSES AND WALLETS OF PRECIOUS METAL (U.S. CLS. 1, 2, 3, 22 AND 41).

CLASS 21—HOUSEWARES AND GLASS

FOR COSMETIC UTENSILS, NAMELY, COSMETIC BRUSHES, AND TOILET UTENSILS, NAMELY, TOILET BRUSHES; POWDER COMPACTS OF PRECIOUS METAL SOLD EMPTY; TABLEWARE, EXCLUDING KNIVES AND FORKS, OF PRECIOUS METAL, NAMELY, DECORATIVE PLATES (U.S. CLS. 2, 13, 23, 29, 30, 33, 40 AND 50).

CLASS 26—FANCY GOODS

FOR SEMI-FINISHED TAPES, NAMELY, ELASTIC TAPES; RIBBONS; ORNAMENTAL CLOTH PATCHES; BADGES FOR WEAR NOT OF PRECIOUS METAL, NAMELY, ORNAMENTAL NOVELTY BADGES NOT OF PRECIOUS METAL FOR WEAR; BUCKLES FOR CLOTHING; BROOCHES FOR CLOTHING; SPECIAL SASH CLIPS FOR OBI IN THE NATURE OF OBI-DOME; BONNET PINS NOT OF PRECIOUS METAL; ORNAMENTAL CLOTH STICKERS FOR FRONT OF JACKETS, NAMELY, ORNAMENTAL CLOTH PATCHES; BRASARDS; HAIR ORNAMENTS; BUTTONS AND THE LIKE, NAMELY, RIVET BUTTONS, PRESS BUTTONS (U.S. CLS. 37, 39, 40, 42 AND 50).

SARA THOMAS, EXAMINING ATTORNEY

G-STORE RAW

THE MARK CONSISTS OF STANDARD CHARACTERS WITHOUT CLAIM TO ANY PARTICULAR FONT, STYLE, SIZE, OR COLOR.

PRIORITY DATE OF 6-25-2007 IS CLAIMED.

OWNER OF INTERNATIONAL REGISTRATION 0954154 DATED 12-19-2007, EXPIRES 12-19-2017.

CLASS 18—LEATHER GOODS

FOR LEATHER AND IMITATIONS OF LEATHER, AND GOODS MADE OF THESE MATERIALS, NAMELY, LEATHER HANDBAGS, LEATHER KEY CASES, LEATHER WALLETS, LEATHER AND LEATHER BAGS; BAGS, NAMELY, HANDBAGS, PURSES, LEATHER SHOPPING BAGS, ALL PURPOSE ATHLETIC BAGS, BEACH BAGS, SHOULDER BAGS; RUCKSACKS AND WALLETS; TRUNKS, NAMELY, TRAVELING TRUNKS MADE OF LEATHER, LUGGAGE TRUNKS; TRAVELING BAGS; UMBRELLAS (U.S. CLS. 1, 2, 3, 22 AND 41).

CLASS 25—CLOTHING

FOR CLOTHING, NAMELY, SHIRTS, T-SHIRTS, SWEATERS, JACKETS, WARM-UP SUITS, SHORTS, JEANS, TROUSERS, BLOUSES, SKIRTS, VESTS, BELTS, BEACHWEAR, LOUNGEWEAR, SLEEPWEAR, UNDERGARMENTS, SOCKS; FOOTWEAR; HEADGEAR, NAMELY, HATS, BANDANNAS, CAPS, HEADSCARVES, SUN-VISORS (U.S. CLS. 22 AND 39).

CLASS 35—ADVERTISING AND BUSINESS

FOR ADVERTISING SERVICES, NAMELY, DISSEMINATION OF ADVERTISEMENTS FOR OTHERS (U.S. CLS. 100, 101 AND 102).

REBECCA SMITH, EXAMINING ATTORNEY

SN 79-050,530. AGU B.V., NETHERLANDS, FILED 7-6-2007.

AGU

THE MARK CONSISTS OF STANDARD CHARACTERS WITHOUT CLAIM TO ANY PARTICULAR FONT, STYLE, SIZE, OR COLOR.

PRIORITY DATE OF 3-16-2007 IS CLAIMED.

OWNER OF INTERNATIONAL REGISTRATION 0955093 DATED 7-6-2007, EXPIRES 7-6-2017.

OWNER OF U.S. REG. NO. 3,187,720.

CLASS 12—VEHICLES

FOR PARTS AND ACCESSORIES FOR BICYCLES, NAMELY, BICYCLE SADDLEBAGS, PANNIER BAGS FOR BICYCLES, BICYCLE BAGS TO BE ATTACHED TO THE STEERING WHEEL OF THE BICYCLE OR THE LUGGAGE CARRIER OF THE BICYCLE, COVERS AGAINST RAIN AND DIRT FOR BICYCLE SADDLEBAGS (U.S. CLS. 19, 21, 23, 31, 35 AND 44).

CLASS 18—LEATHER GOODS

FOR BAGS, NAMELY, SHOULDER BAGS, PURSES; RUCKSACKS; SPORTS BAGS, INCLUDED IN THIS CLASS; VALISES; BAG COVERS IN THE NATURE OF GARMENT BAGS FOR TRAVEL TO PROTECT GARMENTS AGAINST RAIN AND DIRT; PURSES, NOT OF PRECIOUS METALS; WALLETS, WALLETS FOR MONEY BELTS, TRAVEL BAGS FOR ROADMAPS, DRAWSTRING POUCHES, POUCHES OF LEATHER, WEARABLE STRAP-ON POUCHES, LEATHER SHOULDER STRAPS (U.S. CLS. 1, 2, 3, 22 AND 41).

CLASS 25—CLOTHING

FOR CLOTHING, NAMELY, SHIRTS, PANTS, COATS, JACKETS, SLEEVELESS JACKETS, WIND JACKETS; CLOTHING FOR SPORTS AND BICYCLING, NAMELY, SPORTS BRAS, SPORTS JERSEYS, SPORTS SHIRTS, CYCLISTS' JERSEYS, BICYCLE PANTS, CYCLE PANTS, CYCLE SHIRTS, BODYSUITS FOR CYCLING; UNDERCLOTHING, NAMELY, UNDERGARMENTS, UNDERWEAR, UNDERSHIRTS; RAINPROOF CLOTHING, NAMELY, RAIN TROUSERS, RAIN SLICKERS, RAINCOATS, RAINPROOF SUITS, RAINPROOF PANTS, RAINPROOF PONCHOS; BICYCLE GLOVES; SOCKS; FOOTWEAR, NAMELY, SPORT SHOES, CYCLE SHOES, BICYCLE SHOES, HIKING SHOES, GALOSHES, RAIN BOOTS; HEADGEAR, NAMELY, CAPS, RAIN HATS, HATS, BANDANAS; MONEY BELTS (U.S. CLS. 22 AND 39).

TAMARA FRAZIER, EXAMINING ATTORNEY

SN 79-051,066. SIGMA COACHAIR GROUP PTY LTD, AUSTRALIA, FILED 12-14-2007.

SIGMA COACHAIR

THE MARK CONSISTS OF STANDARD CHARACTERS WITHOUT CLAIM TO ANY PARTICULAR FONT, STYLE, SIZE, OR COLOR.

PRIORITY DATE OF 10-26-2007 IS CLAIMED.
OWNER OF INTERNATIONAL REGISTRATION 0956547 DATED 12-14-2007, EXPIRES 12-14-2017.
OWNER OF U.S. REG. NOS. 2,561,195, 2,685,214 AND OTHERS.

CLASS 11—ENVIRONMENTAL CONTROL APPARATUS

FOR HEATING, VENTILATION, AIR CONDITIONING, AIR FILTRATION, AND AIR PURIFICATION EQUIPMENT FOR ROAD, RAIL, AIR, AND WATER VEHICLES, AND PARTS, FITTINGS, AND ACCESSORIES THEREFOR, NAMELY, HVAC UNITS, REFRIGERATION AIR COOLING APPARATUS, EVAPORATIVE AIR COOLING APPARATUS, HUMIDIFIERS, DEHUMIDIFIERS, AIR PURIFICATIONS UNITS, AIR CLEANING UNITS, AND AIR HEATING SYSTEMS COMPRISING BOILERS, HEAT PUMPS, HEAT EXCHANGERS, FURNACES, THERMOSTATS, RADIATORS, RADIANT HEAT PANELS, REGISTERS, SOLAR PHOTOVOLTAIC PANELS, AND SOLAR THERMAL COLLECTORS (U.S. CLS. 13, 21, 23, 31 AND 34).

CLASS 37—CONSTRUCTION AND REPAIR

FOR INSTALLATION, REPAIR, AND MAINTENANCE OF AIR-CONDITIONING, FILTRATION, AND AIR PURIFICATION SYSTEMS (U.S. CLS. 100, 103 AND 106).
KRISTINA MORRIS, EXAMINING ATTORNEY

SN 79-051,460. STIFTUNG MYCLIMATE - THE CLIMATE PROTECTION; PARTNERSHIP, SWITZERLAND, FILED 2-25-2008.

myclimate

THE MARK CONSISTS OF STANDARD CHARACTERS WITHOUT CLAIM TO ANY PARTICULAR FONT, STYLE, SIZE, OR COLOR.

OWNER OF INTERNATIONAL REGISTRATION 0957628 DATED 2-25-2008, EXPIRES 2-25-2018.

CLASS 35—ADVERTISING AND BUSINESS

FOR ADVERTISING; BUSINESS MANAGEMENT; BUSINESS ADMINISTRATION; PROVIDING OFFICE FUNCTIONS (U.S. CLS. 100, 101 AND 102).

CLASS 41—EDUCATION AND ENTERTAINMENT

FOR EDUCATION, NAMELY, PROVIDING OF SEMINARS AND COURSE WORK IN THE FIELD OF SUSTAINABILITY AND CLIMATE CHANGE; PROVIDING OF BUSINESS TRAINING; ENTERTAINMENT IN THE NATURE OF EDUCATIONAL EXHIBITIONS; PROVIDING CULTURAL ACTIVITIES, NAMELY, EDUCATIONAL EXHIBITIONS (U.S. CLS. 100, 101 AND 107).

CLASS 42—SCIENTIFIC AND COMPUTER SERVICES

FOR SCIENTIFIC AND TECHNOLOGICAL RESEARCH SERVICES AND RESEARCH AND DESIGN RELATING THERETO IN THE FIELD OF SUSTAINABILITY AND CLIMATE CHANGE; LIFE CYCLE AND NATURAL RESOURCES ANALYSIS AND INDUSTRIAL RESEARCH SERVICES IN THE FIELD OF SUSTAINABILITY AND CLIMATE CHANGE; DESIGN AND DEVELOPMENT OF COMPUTER HARDWARE AND SOFTWARE (U.S. CLS. 100 AND 101).

RONALD DELGIZZI, EXAMINING ATTORNEY

SN 79-051,545. AERDATA B.V., LUCHTHAVEN SCHIPHOL, NETHERLANDS, FILED 1-16-2008.

AERDATA

THE MARK CONSISTS OF STANDARD CHARACTERS WITHOUT CLAIM TO ANY PARTICULAR FONT, STYLE, SIZE, OR COLOR.

PRIORITY DATE OF 7-19-2007 IS CLAIMED.
OWNER OF INTERNATIONAL REGISTRATION 0957805 DATED 1-16-2008, EXPIRES 1-16-2018.
THE WORDING "AERDATA" HAS NO MEANING IN A FOREIGN LANGUAGE.

CLASS 9—ELECTRICAL AND SCIENTIFIC APPARATUS

FOR SOFTWARE FOR THE MANAGEMENT OF AIRCRAFT LEASING (U.S. CLS. 21, 23, 26, 36 AND 38).

CLASS 35—ADVERTISING AND BUSINESS

FOR BUSINESS ADMINISTRATION IN RELATION TO THE LEASING OF AIRCRAFTS (U.S. CLS. 100, 101 AND 102).
NAKIA HENRY, EXAMINING ATTORNEY

SN 79-052,246. OBSHCHESTVO S OGRANICHENNOY; OT-
VETSTVENNOSTYOU "DKIS", RUSSIAN FED., FILED 1-
4-2008.

ISVAC

OWNER OF INTERNATIONAL REGISTRATION 0959721
DATED 1-4-2008, EXPIRES 1-4-2018.

CLASS 5—PHARMACEUTICALS

FOR PHARMACEUTICAL AND VETERINARY PREPARATIONS TO TREAT HEPATITIS C, CANCER AND OTHER DISEASES; SANITARY PREPARATIONS FOR MEDICAL PURPOSES; DIETETIC FOOD SUBSTANCES ADAPTED FOR MEDICAL USE; FOOD FOR BABIES; PLASTERS, MEDICAL DRESSINGS; MATERIALS FOR STOPPING TEETH; DENTAL IMPRESSION COMPOUNDS; ALL PURPOSE DISINFECTANTS; PREPARATIONS FOR DESTROYING VERMIN; FUNGICIDES, HERBICIDES; AMINO ACIDS FOR MEDICAL PURPOSES; ANTIBIOTICS; BIOCIDES; VACCINES; RADIOLOGICAL CONTRAST SUBSTANCES FOR MEDICAL PURPOSES; NUTRITIVE SUBSTANCES FOR MICROORGANISMS FOR MEDICAL USE; RADIOACTIVE SUBSTANCES FOR MEDICAL PURPOSES; ADDITIVES TO FODDER FOR MEDICAL PURPOSES; CAPSULES FOR MEDICINES SOLD EMPTY; CAPSULES FOR PHARMACEUTICAL PURPOSES SOLD EMPTY; CANDY FOR MEDICAL PURPOSES; CONFECTIONERY, MEDICATED; MEDICINAL ROOTS; CULTURES OF MICROORGANISMS FOR MEDICAL AND VETERINARY USE; MILK SUGAR LACTOSE FOR MANUFACTURING FOODSTUFF, LINIMENTS; DRUGS FOR MEDICAL PURPOSES, NAMELY, RECTAL SUPPOSITORY FOR INDUCTION OF SERUM INTERFERON IN PATIENT, SOLUTION FOR INJECTION FOR INDUCTION OF SERUM INTERFERON IN PATIENT, RECTAL SUPPOSITORY FOR TREATMENT OF HEPATITIS C AND OTHER INFECTIOUS DISEASES, SOLUTION FOR INJECTION FOR TREATMENT OF HEPATITIS C AND OTHER INFECTIOUS DISEASES, RECTAL SUPPOSITORY FOR TREATMENT OF CANCER, SOLUTION FOR INJECTION FOR TREATMENT OF CANCER, RECTAL SUPPOSITORY TO STIMULATE B-CELLS IN PATIENT, AND SOLUTION FOR INJECTION TO ENHANCE VACCINE RESPONSE IN PATIENT; MEDICINES FOR VETERINARY PURPOSES TO TREAT HEPATITIS C, CANCER AND OTHER DISEASES; SEROTHERAPEUTIC MEDICINES AND MEDICINES FOR HUMAN PURPOSES FOR THE TREATMENT OF HEPATITIS C; ALBUMINOUS MILK FOR MEDICAL PURPOSES; MILK OF ALMONDS FOR PHARMACEUTICAL PURPOSES; ROYAL JELLY FOR MEDICAL PURPOSES; MILK FERMENTS FOR PHARMACEUTICAL PURPOSES; DIETETIC BEVERAGES ADAPTED FOR MEDICAL PURPOSES; MALTED MILK BEVERAGES FOR MEDICAL PURPOSES; MEDICAL APPARATUS, NAMELY, INJECTION DEVICES FOR PHARMACEUTICALS; PILLS FOR PHARMACEUTICAL PURPOSES, NAMELY, FOR THE TREATMENT OF HEPATITIS C, CANCER AND OTHER INFECTIOUS DISEASES; BACTERIAL PREPARATIONS FOR MEDICAL AND VETERINARY USE; BACTERIOLOGICAL PREPARATIONS FOR MEDICAL AND VETERINARY USE; BALSAMIC PREPARATIONS FOR MEDICAL PURPOSES; ALBUMINOUS PREPARATIONS FOR MEDICAL PURPOSES; BIOLOGICAL PREPARATIONS FOR VETERINARY PURPOSES; BIOLOGICAL PREPARATIONS FOR MEDICAL PURPOSES; VITAMIN PREPARATIONS; DIAGNOSTIC PREPARATIONS FOR MEDICAL PURPOSES; MEDICAL THERAPEUTIC PREPARATIONS FOR THE BATH; PREPARATIONS FOR THE TREATMENT OF HEPATITIS; PREPARATIONS FOR THE TREATMENT OF AIDS; PREPARATIONS FOR THE DIAGNOSTICS OF HEPATITIS; PREPARATIONS FOR THE DIAGNOSTICS OF AIDS; MEDICATED BATH PREPARATIONS; PREPARATIONS OF TRACE ELEMENTS FOR HUMAN AND ANIMAL USE; ENZYME PREPARATIONS FOR VETERINARY AND MEDICAL PURPOSES; CHEMICO-PHARMACEUTICAL PREPARATIONS, NAMELY, CHEMICO-PHARMACEUTICAL PREPARATION TO INDUCE SER-

UM INTERFERON IN PATIENT, CHEMICO-PHARMACEUTICAL PREPARATION TO TREAT HEPATITIS C AND OTHER INFECTIOUS DISEASES, CHEMICO-PHARMACEUTICAL PREPARATION TO TREAT CANCER, CHEMICO-PHARMACEUTICAL PREPARATION TO STIMULATE B-CELLS IN PATIENT, CHEMICO-PHARMACEUTICAL PREPARATION TO ENHANCE VACCINE RESPONSE IN PATIENT; CHEMICAL PREPARATIONS FOR VETERINARY, MEDICAL AND PHARMACEUTICAL PURPOSES; ALBUMINOUS FOODSTUFFS FOR MEDICAL PURPOSES; DIETETIC FOODS ADAPTED FOR MEDICAL PURPOSES; ANAESTHETICS; ANTISEPTICS; ANALGESICS; PHARMACEUTICAL STYPTIC PREPARATIONS; PARASITICIDES; FEBRIFUGES; DEPURATIVES; PURGATIVES; ANTIPARASITIC PREPARATIONS; ADJUVANTS FOR MEDICAL PURPOSES; APPETITE SUPPRESSANTS FOR MEDICAL PURPOSES; MEDICAL PREPARATIONS FOR SLIMMING PURPOSES; CHEMICAL CONTRACEPTIVES; NERVINES; DIGESTIVES AID FOR PHARMACEUTICAL PURPOSES; MEDIA FOR BACTERIOLOGICAL CULTURES; STEROIDS; ANTI-AGING SERUMS; MEDICINAL HERBS; TRANQUILLIZERS; FERMENTS FOR VETERINARY, MEDICAL AND PHARMACEUTICAL PURPOSES; HERBS TEAS FOR MEDICINAL PURPOSES; METHYL ETHERS AND METHYL ESTERS FOR PHARMACEUTICAL PURPOSES; CELLULOSE ETHERS FOR PHARMACEUTICAL PURPOSES; RAT POISON; BACTERIAL POISONS (U.S. CLS. 6, 18, 44, 46, 51 AND 52).

CLASS 44—MEDICAL, BEAUTY AND AGRICULTURAL SERVICES

FOR MEDICAL SERVICES; NURSING HOMES; PHARMACY ADVICE; HOSPITALS; AROMATHERAPY SERVICES; MIDWIFE SERVICES; VETERINARY SERVICES; DENTISTRY; MEDICAL ASSISTANCE; RENTAL OF SANITATION FACILITIES; HEALTH CARE; HEALTH SPA SERVICES, NAMELY, COSMETIC BODY CARE SERVICES; MEDICAL SERVICES IN THE NATURE OF A OF A PSYCHOLOGICAL CONSULTATION; TELEMEDICINE SERVICES; PHARMACISTS' SERVICES TO MAKE UP PRESCRIPTIONS; NURSING, MEDICAL; PHYSICAL THERAPY; CHIROPRACTICS; PLASTIC SURGERY; MEDICAL SERVICES IN THE DOMAIN OF DIAGNOSING AND TREATMENT OF HEPATITIS; MEDICAL SERVICES IN THE DOMAIN OF DIAGNOSING AND TREATMENT OF AIDS (U.S. CLS. 100 AND 101).

MIDGE BUTLER, EXAMINING ATTORNEY

SN 79-052,841. MEDICIMAGE LIMITED, LONDON, UNITED KINGDOM, FILED 10-14-2007.

MEDICIMAGE

PRIORITY DATE OF 6-25-2007 IS CLAIMED.
OWNER OF INTERNATIONAL REGISTRATION 0961511
DATED 10-14-2007, EXPIRES 10-14-2017.
OWNER OF U.S. REG. NO. 3,514,542.

CLASS 9—ELECTRICAL AND SCIENTIFIC APPARATUS

FOR DOWNLOADABLE PODCASTS IN THE FIELD OF MEDICINE; DOWNLOADABLE STOCK VIDEO AND AUDIO MATERIALS IN THE FIELD OF MEDICINE, FOR USE IN MEDICAL TEACHING AND INSTRUCTION, AND IN ON-LINE AND PRINTED PROFESSIONAL PUBLICATIONS, HEALTHCARE AND LIFESTYLE MAGAZINES, ADVERTISING AND PUBLIC RELATIONS; AND DOWNLOADABLE PHOTOGRAPHIC IMAGES IN THE FIELD OF MEDICINE, FOR USE IN ON-LINE AND PRINTED PROFESSIONAL PUBLICATIONS, HEALTHCARE AND LIFESTYLE MAGAZINES, ADVERTISING AND PUBLIC RELATIONS (U.S. CLS. 21, 23, 26, 36 AND 38).

CLASS 41—EDUCATION AND ENTERTAINMENT

FOR PROVIDING A WEBSITE FEATURING NON-DOWNLOADABLE PHOTOGRAPHS AND AUDIO AND VIDEO RECORDINGS, IN THE FIELD OF MEDICINE, FOR USE IN MEDICAL TEACHING AND INSTRUCTION; PHOTOGRAPHY SERVICES; PRODUCTION OF AUDIO RECORDINGS AND AUDIO CLIPS; PRODUCTION OF VIDEO RECORDINGS AND VIDEO CLIPS; PODCASTING SERVICES (U.S. CLS. 100, 101 AND 107).

CLASS 45—PERSONAL AND LEGAL SERVICES

FOR COPYRIGHT LICENSING; LICENSING OF OTHERS TO USE AND REPRODUCE PHOTOGRAPHS, AUDIO AND VIDEO RECORDINGS, AUDIO CLIPS, VIDEO CLIPS AND OTHER SOUNDS OR STATIC OR MOVING IMAGES (U.S. CLS. 100 AND 101).
JESSICA FATHY, EXAMINING ATTORNEY

SN 79-053,021. NEMIROFF; INTELLECTUAL PROPERTY ESTABLISHMENT, LIECHTENSTEIN, FILED 2-28-2008.



PRIORITY DATE OF 9-14-2007 IS CLAIMED.
OWNER OF INTERNATIONAL REGISTRATION 0962003 DATED 2-28-2008, EXPIRES 2-28-2018.
OWNER OF U.S. REG. NOS. 3,242,612, 3,275,382 AND OTHERS.

NO CLAIM IS MADE TO THE EXCLUSIVE RIGHT TO USE "1872, DISTILLED AND BOTTLED BY, PREMIUM BRAND, CRANBERRY LIQUEUR, PRODUCED ACCORDING TO UNIQUE TECHNOLOGY FROM NATURAL CRANBERRY JUICE, IMPORTED, 21% ALC/VOL. (42 PROOF), 500 ML.", APART FROM THE MARK AS SHOWN.

THE COLOR(S) GOLD, RED, GREEN, DARK BROWN, BROWN, BLUE, BLACK AND WHITE IS/ARE CLAIMED AS A FEATURE OF THE MARK.

THE MARK CONSISTS OF THE COLORS GOLD, RED, GREEN, DARK BROWN, BROWN, BLUE, BLACK, AND WHITE, WITH THE COLOR GREEN APPEARING IN THE LEAVES, THE COLOR GOLD APPEARING IN THE VEINS OF THE LEAVES AND AROUND THE LEAVES, ON THE STEMS OF THE CRANBERRIES, ON THE THREE MEDALS, IN THE WRITING "NEMIROFF", ON THE TOP AND BOTTOM FRAME OF THE LABEL, THE WORDING "DISTILLED AND BOTTLED BY NEMIROFF", WHICH ARE WRITTEN IN GOLD AROUND THE CIRCLE ON THE TOP LEFT OF THE MARK, AND THE BACKGROUND COLOR OF THE CIRCLE ON THE TOP LEFT OF THE MARK. THE GOLD CIRCLE ON THE TOP LEFT OF THE MARK CONTAINS THE LETTER "N" IN A WINE GLASS WITH A CURVED LAUREL ON EACH SIDE OF THE GLASS AND THE YEAR "1872" BELOW THE GLASS, ALL OF WHICH APPEAR IN RED. THE COLOR RED APPEARS AS A BAND AROUND THE WHITE WORD "CRANBERRY", WITH THE BAND FADING FROM LIGHT RED TO DARK RED. THE COLOR RED ALSO APPEARS ABOVE THE GOLD STEM OF THE CRANBERRY IN TWO RED CURVED LINES. THE LEFT SIDE OF THE HORIZONTAL LINE ABOVE THE WORD "PRODUCED" IS ALSO RED AND FADES TO BLACK ON THE RIGHT SIDE. THE COLOR RED APPEARS

AS THE GENERAL BACKGROUND COLOR ON THE LEFT SIDE OF THE MARK AND THEN CHANGES INTO BROWN, THE WORDING "N 1872", "PREMIUM BRAND", "LIQUEUR", "PRODUCED ACCORDING TO UNIQUE TECHNOLOGY FROM NATURAL CRANBERRY JUICE", "IMPORTED", "21% ALC/VOL. (42 PROOF)", "500 ML" ARE WRITTEN IN DARK BROWN. A THIN BLUE LINE FRAMES THE ENTIRE MARK. THE COLOR OF THE CRANBERRIES IS RED AND EACH CRANBERRY HAS A SMALL GOLD CIRCLE NEAR THE BOTTOM OF THE CRANBERRY. THE OUTLINE OF THE WORD "NEMIROFF" IS BLACK AS WELL AS A SMALL PART OF THE RIGHT SIDE OF THE HORIZONTAL BAND NEAR THE TOP OF THE MARK WHICH "CRANBERRY" IS WRITTEN IN. THE WORD "CRANBERRY" IS WRITTEN IN WHITE.

CLASS 33—WINES AND SPIRITS

FOR ALCOHOLIC BEVERAGES, NAMELY, BITTERS (U.S. CLS. 47 AND 49).

CLASS 35—ADVERTISING AND BUSINESS

FOR ADVERTISING; BUSINESS MANAGEMENT; BUSINESS ADMINISTRATION; PROVIDING OFFICE FUNCTIONS; IMPORTATION AND EXPORTATION OF ALCOHOLIC BEVERAGES, RETAIL AND WHOLESALE STORE SERVICES FOR ALCOHOLIC BEVERAGES (U.S. CLS. 100, 101 AND 102).

ELLEN B. AWRICH, EXAMINING ATTORNEY

SN 79-053,414. MICROMOUNTAINS NETWORK E.V., FED REP GERMANY, FILED 5-15-2008.

Xpeering

THE MARK CONSISTS OF STANDARD CHARACTERS WITHOUT CLAIM TO ANY PARTICULAR FONT, STYLE, SIZE, OR COLOR.

PRIORITY DATE OF 1-21-2008 IS CLAIMED.
OWNER OF INTERNATIONAL REGISTRATION 0963161 DATED 5-15-2008, EXPIRES 5-15-2018.

THE WORDING "XPEERING" HAS NO MEANING IN A FOREIGN LANGUAGE.

CLASS 35—ADVERTISING AND BUSINESS

FOR ADVERTISING; BUSINESS MANAGEMENT SERVICES; BUSINESS ADMINISTRATION; PROVIDE OFFICE FUNCTIONS (U.S. CLS. 100, 101 AND 102).

CLASS 42—SCIENTIFIC AND COMPUTER SERVICES

FOR SCIENTIFIC AND TECHNOLOGICAL SERVICES AND RESEARCH AND DESIGN RELATING THERETO, NAMELY, SCIENTIFIC RESEARCH, DESIGN AND TESTING FOR NEW PRODUCT DEVELOPMENT; INDUSTRIAL ANALYSIS, NAMELY, CONSULTING SERVICES IN THE FIELD OF INDUSTRIAL DESIGN (U.S. CLS. 100 AND 101).

TINA BROWN, EXAMINING ATTORNEY

SN 79-053,611. CHIROFORM APS, DENMARK, FILED 6-26-2007.



PRIORITY DATE OF 4-3-2007 IS CLAIMED.
OWNER OF INTERNATIONAL REGISTRATION 0963673
DATED 6-26-2007, EXPIRES 6-26-2017.

CLASS 10—MEDICAL APPARATUS

FOR SURGICAL, MEDICAL AND ORTHOPAEDIC APPARATUS, INSTRUMENTS AND ARTICLES, NAMELY, APPARATUSES FOR ELECTRIC THERAPY, ULTRASOUND TREATMENT AND THERAPY, NERVE AND MUSCLE STIMULATING APPARATUS; PILLOWS AND MATTRESSES, NAMELY ANATOMICALLY SHAPED PILLOWS AND OTHER PILLOWS AND MATTRESSES AND TOP MATTRESSES FOR MEDICAL AND ERGONOMIC PURPOSES; SOPORIFIC PILLOWS FOR TREATMENT OF INSOMNIA; ORTHOPEDIC SUPPORTS, NAMELY, NECK CUSHIONS, LUMBAR CUSHIONS, LUMBAR PILLOWS, AND SITTING WEDGES; ELECTRIC HEATING CUSHIONS FOR MEDICAL PURPOSES; BEDS AND OTHER FURNITURE, NAMELY, DISSECTING, PATIENT EXAMINATION AND OPERATING TABLES, STRETCHERS AND WHEELED STRETCHERS, AND WALKING BARS AS WALKING AIDS, ALL FOR MEDICAL PURPOSES; ORTHOPAEDIC ARTICLES, NAMELY, SUPPORTIVE, ANATOMIC, ELASTIC, SURGICAL, AND ORTHOPAEDIC BANDAGES, PLASTER CAST BANDAGES, FOR ALL PARTS OF THE BODY AND JOINTS AND LIMBS; PELVIC BELTS, BACK SUPPORT BELTS, MEDICAL BRACES FOR TENNIS ELBOW, ORTHOPEDIC WRIST SUPPORT WITH OR WITHOUT STRAP; ORTHOPEDIC SPLINT AND THUMB BRACE; ORTHOPEDIC SUPPORTS AND BANDAGES, NAMELY, ELASTIC ELBOW SUPPORT, THIGH SUPPORT, KNEE SUPPORT, KNEE STRAP, AND ANKLE SUPPORT; CERVICAL COLLARS; ARCH SUPPORT FOR FOOTWEAR; AND ORTHOPEDIC CORRECTIVE SUPPORTS, NAMELY, INSOLES, HEEL WEDGES, AND HEEL SPUR WEDGES; ICE BAGS AND COLD AND HOT PACKS FOR MEDICAL PURPOSES; MASSAGE APPARATUS, BELTS FOR MEDICAL PURPOSES; NEEDLES, ELECTRODES, AND SIGNAL TRANSFER CABLES FOR ELECTRONIC MEDICAL DIAGNOSTIC AND TREATMENT UNITS, ALL FOR MEDICAL PURPOSES (U.S. CLS. 26, 39 AND 44).

CLASS 20—FURNITURE AND ARTICLES NOT OTHERWISE CLASSIFIED

FOR FURNITURE; BENCHES, CHAIRS, STOOLS, FOOTSTOOLS, PLANK BEDS, TABLES, SERVING TROLLEYS; FURNITURE PARTS FOR THE FOREGOING, NAMELY, HEAD-RESTS; PARTS OF FURNITURE FOR ALL THE ABOVE-MENTIONED GOODS, NAMELY, TABLE LEGS AND ARM RESTS; MATTRESSES (U.S. CLS. 2, 13, 22, 25, 32 AND 50).

CLASS 28—TOYS AND SPORTING GOODS

FOR GYMNAS TIC AND SPORTING ARTICLES, NAMELY, DUMBBELLS, BODY TRAINING APPARATUSES, STATIONARY EXERCISE BICYCLES, SPRINGBOARDS; WEIGHT LIFTING BELTS, APPLIANCES FOR GYMNAS TICS, NAMELY, GYMNAS TIC APPARATUS, EXERCISE EQUIPMENT, NAMELY, TEETERING BOARDS AND SEESAWS; WALKING STICKS (U.S. CLS. 22, 23, 38 AND 50).

CLASS 35—ADVERTISING AND BUSINESS

FOR PRESENTATION OF GOODS ON COMMUNICATION MEDIA, FOR RETAIL AND WHOLESALE PURPOSES; ON-LINE RETAIL STORE SERVICES FEATURING HOME MEDICAL EQUIPMENT AND FIRST AID PREPARATIONS AND PRODUCTS; ON-LINE RETAIL STORE SERVICES FEATURING HOSPITAL EQUIPMENT AND MEDICAL SUPPLIES FOR COMMERCIAL USE; THE BRINGING, TOGETHER, FOR THE BENEFIT OF OTHERS, OF A VARIETY OF GOODS EXCLUDING THE TRANSPORT THEREOF, ENABLING CUSTOMERS TO CONVENIENTLY VIEW AND PURCHASE THOSE GOODS, NAMELY, SURGICAL, MEDICAL AND ORTHOPAEDIC APPARATUS, INSTRUMENTS AND ARTICLES FOR HOME AND COMMERCIAL MEDICAL USE, INCLUDING APPARATUSES FOR ELECTRIC THERAPY, ULTRASOUND TREATMENT AND THERAPY, NERVE AND MUSCLE STIMULATING APPARATUS, PILLOWS AND MATTRESSES, NAMELY, ANATOMICALLY SHAPED PILLOWS AND OTHER PILLOWS AND MATTRESSES AND TOP MATTRESSES FOR MEDICAL AND ERGONOMIC PURPOSES, PILLOWS FOR INSOMNIA, NECK CUSHIONS, LUMBAR CUSHIONS, LUMBAR PILLOWS, SITTING WEDGES, TRAVEL PILLOWS, ELECTRIC HEATING CUSHIONS FOR MEDICAL PURPOSES, BEDS AND OTHER FURNITURE, INCLUDING TABLES, STRETCHERS AND WHEELED STRETCHERS, PLANK BEDS, WALKING BARS FOR MEDICAL PURPOSES, ORTHOPAEDIC ARTICLES, INCLUDING BANDAGES OF SUPPORTIVE, ANATOMIC, ELASTIC, SURGICAL, ORTHOPAEDIC AND/OR PLASTER KINDS FOR ALL PARTS OF THE BODY, JOINTS AND LIMBS, PELVIC BELTS, BACK SUPPORT BELTS, TENNIS ELBOW BRACES, WRIST SUPPORT WITH OR WITHOUT STRAP OR SPLINT, THUMB BRACE, ELASTIC ELBOW SUPPORT, THIGH SUPPORT, KNEE SUPPORT AND KNEE STRAP, ANKLE SUPPORT, NECK COLLARS, ARCH SUPPORT FOR FOOTWEAR AND OTHER INSOLES, HEEL WEDGES, HEEL SPUR WEDGES, ICE BAGS AND COLD AND HOT PACKS FOR MEDICAL PURPOSES, MASSAGE APPARATUS, BELTS FOR MEDICAL PURPOSES, NEEDLES, ELECTRODES AND CABLES, ALL FOR MEDICAL PURPOSES, FURNITURE, INCLUDING BENCHES, CHAIRS, STOOLS, FOOTSTOOLS, PLANK BEDS, TABLES, TROLLEYS, AND PARTS FOR THE SAME, INCLUDING HEAD-RESTS, MATTRESSES, GYMNAS TIC AND SUPPORT ARTICLES, INCLUDING DUMBBELLS, BODY TRAINING APPARATUSES, STATIONARY EXERCISE BICYCLES, SPRINGBOARDS, WEIGHT LIFTING BELTS, APPLIANCES FOR GYMNAS TICS, TEETERING BOARDS, SEESAWS, WALKING STICKS, ENABLING CUSTOMERS TO CONVENIENTLY VIEW AND PURCHASE THOSE GOODS (U.S. CLS. 100, 101 AND 102).

HANNO RITTNER, EXAMINING ATTORNEY

SN 79-053,718. A.P. EAGERS LIMITED, AUSTRALIA, FILED 1-31-2008.

Carzoos

THE MARK CONSISTS OF STANDARD CHARACTERS WITHOUT CLAIM TO ANY PARTICULAR FONT, STYLE, SIZE, OR COLOR.

PRIORITY DATE OF 12-24-2007 IS CLAIMED.
OWNER OF INTERNATIONAL REGISTRATION 0964006
DATED 1-31-2008, EXPIRES 1-31-2018.

CLASS 35—ADVERTISING AND BUSINESS

FOR WHOLESALE STORES, RETAIL STORES AND DISTRIBUTORSHIP SERVICES IN THE FIELD OF NEW AND USED MOTOR VEHICLES, MOTOR VEHICLE PARTS AND ACCESSORIES, ELECTRICAL COMPONENTS FOR MOTOR VEHICLES, MOTOR VEHICLE AFTERMARKET PRODUCTS, AND MOTOR VEHICLE RELATED MERCHANDISE; PROMOTION, ADVERTISING AND MARKETING SERVICES; BUSINESS MANAGEMENT SERVICES; ONLINE RETAIL STORE SERVICES FEATURING NEW AND USED MOTOR VEHICLES, MOTOR VEHICLE PARTS AND ACCESSORIES, ELECTRICAL COMPONENTS FOR MOTOR VEHICLES, MOTOR VEHICLE AFTERMARKET PRODUCTS, MOTOR VEHICLE RELATED MERCHANDISE; COMPUTERIZED DATABASE MANAGEMENT; COLLECTION OF DATA, NAMELY, DATA COMPILING SERVICES IN THE FIELD OF BUSINESS MANAGEMENT OF RETAIL AUTOMOTIVE DEALERSHIPS, COMPILING DATA ON NEW AND USED MOTOR VEHICLES FOR SALE, COMPILING DATA ON BUYERS AND SELLERS OF NEW AND USED MOTOR VEHICLES AND ACCESSORIES, COMPILING DATA ON AUTOMOTIVE MARKET STATISTICS AND PROVIDING CONSULTATION AND INFORMATION IN CONNECTION THEREWITH; COMPILATION OF COMMERCIAL INFORMATION, NAMELY, COMPILATION AND PROVISION OF TRADE AND BUSINESS PRICE STATISTICAL INFORMATION, COMPILATION AND SYSTEMIZATION OF INFORMATION IN COMPUTER DATABASES, COMPILATION OF STATISTICS FOR BUSINESS AND COMMERCIAL PURPOSES; PROMOTING THROUGH THE PREPARATION AND IMPLEMENTATION OF ADVERTISING AND MARKETING ACTIVITIES AND STRATEGIES AND PROVIDING REFERRALS REGARDING GOODS AND SERVICES OF OTHERS RELATED TO THE AUTOMOTIVE INDUSTRY; PROVISION OF ADVISORY, CONSULTANCY AND INFORMATION SERVICES IN RELATION TO THE AFOREMENTIONED SERVICES, NAMELY, BUSINESS CONSULTATION, ADVICE AND INFORMATION IN CONNECTION WITH WHOLESALE STORE, RETAIL STORE AND DISTRIBUTORSHIP SERVICES IN THE AUTOMOTIVE INDUSTRY, PROVIDING CONSULTATION, ADVISORY AND INFORMATION SERVICES REGARDING PROMOTION, MARKETING AND ADVERTISING SERVICES FOR THE AUTOMOTIVE INDUSTRY, BUSINESS MANAGEMENT CONSULTATION AND INFORMATION AND ADVISORY SERVICES IN CONNECTION THEREWITH, COMPUTERIZED DATABASE MANAGEMENT CONSULTATION AND INFORMATION AND ADVISORY SERVICES IN CONNECTION THEREWITH; PROVISION OF AFOREMENTIONED SERVICES AND INFORMATION IN RELATION TO SUCH SERVICES VIA A GLOBAL COMPUTER NETWORK, NAMELY, ONLINE WHOLESALE STORE, RETAIL STORE AND DISTRIBUTORSHIP SERVICES IN THE FIELD OF NEW AND USED MOTOR VEHICLES, MOTOR VEHICLE PARTS AND ACCESSORIES, ELECTRICAL COMPONENTS FOR MOTOR VEHICLES, MOTOR VEHICLE AFTERMARKET PRODUCTS, MOTOR VEHICLE RELATED MERCHANDISE, AND PROVISION OF INFORMATION PERTAINING THERETO, ONLINE PROMOTION, ADVERTISING AND MARKETING SERVICES AND PROVISION OF INFORMATION PERTAINING THERETO, ONLINE BUSINESS MANAGEMENT SERVICES AND INFORMATION PERTAINING THERETO, ONLINE COMPUTERIZED DATABASE MANAGEMENT, PROVIDING INFORMATION ABOUT AND MAKING REFERRALS REGARDING GOODS AND SERVICES IN THE AUTOMOTIVE INDUSTRY ONLINE (U.S. CLS. 100, 101 AND 102).

CLASS 36—INSURANCE AND FINANCIAL

FOR FINANCIAL SERVICES, NAMELY, ARRANGING, FACILITATING AND PROVIDING LOANS AND FINANCING IN RELATION TO MOTOR VEHICLES; INSURANCE SERVICES, NAMELY, ARRANGING, FACILITATING AND PROVIDING MOTOR VEHICLE INSURANCE; PROVISION OF WARRANTIES, NAMELY, ARRANGING, FACILITATING AND PROVIDING EXTENDED WARRANTIES ON MOTOR VEHICLES AND MOTOR VEHICLE PARTS AND ACCESSORIES; PROVISION OF ADVISORY, CONSULTANCY AND INFORMATION SERVICES IN RELATION TO THE AFOREMENTIONED SERVICES, NAMELY, FINANCIAL ADVICE AND CONSULTATION, PROVIDING FINANCIAL INFORMATION, INSURANCE ADVICE AND CONSULTATION, INSURANCE INFORMATION, PROVIDING INFORMATION ON EXTENDED WARRANTIES AND ADVICE AND CONSULTATION IN CONNECTION THERETO (U.S. CLS. 100, 101 AND 102).

CLASS 37—CONSTRUCTION AND REPAIR

FOR MOTOR VEHICLE MAINTENANCE AND REPAIR AND INSTALLATION OF MOTOR VEHICLE PARTS AND ACCESSORIES, ELECTRICAL COMPONENTS FOR MOTOR VEHICLES, STRUCTURAL PARTS FOR MOTOR VEHICLES AND MOTOR VEHICLE AFTER MARKET PRODUCTS; DETAILING SERVICES FOR MOTOR VEHICLES; PROVISION OF ADVISORY, CONSULTANCY AND INFORMATION SERVICES IN RELATION TO THE AFOREMENTIONED SERVICES, NAMELY, ADVICE, CONSULTATION AND INFORMATION REGARDING MOTOR VEHICLE MAINTENANCE, MOTOR VEHICLE REPAIR, INSTALLATION OF MOTOR VEHICLE PARTS AND ACCESSORIES, ELECTRICAL COMPONENTS FOR MOTOR VEHICLES, STRUCTURAL PARTS FOR MOTOR VEHICLES AND MOTOR VEHICLE AFTER MARKET PRODUCTS, AND DETAILING SERVICES FOR MOTOR VEHICLES; PROVISION OF AFOREMENTIONED SERVICES AND INFORMATION IN RELATION TO SUCH SERVICES VIA GLOBAL COMPUTER NETWORK, NAMELY, PROVIDING INFORMATION ON MOTOR VEHICLE MAINTENANCE, MOTOR VEHICLE REPAIR, INSTALLATION OF MOTOR VEHICLE PARTS AND ACCESSORIES, ELECTRICAL COMPONENTS FOR MOTOR VEHICLES, STRUCTURAL PARTS FOR MOTOR VEHICLES AND MOTOR VEHICLE AFTERMARKET PRODUCTS, AND DETAILING SERVICES FOR MOTOR VEHICLES VIA A GLOBAL COMPUTER NETWORK (U.S. CLS. 100, 103 AND 106).

CLASS 42—SCIENTIFIC AND COMPUTER SERVICES

FOR CERTIFICATION OF QUALITY OR STANDARDS OF MOTOR VEHICLES, NAMELY, TESTING, ANALYSIS AND EVALUATION OF MOTOR VEHICLES OF OTHERS FOR THE PURPOSE OF CERTIFICATION; INSPECTION AND TESTING OF MOTOR VEHICLES FOR ROAD WORTHINESS; ONLINE QUALITY ASSURANCE, NAMELY, PROVIDING QUALITY ASSURANCE SERVICES IN THE FIELD OF MOTOR VEHICLES THROUGH THE ONLINE REVIEW OF STANDARDS AND PRACTICES TO ASSURE COMPLIANCE WITH STATE AND FEDERAL LAWS AND REGULATIONS REGARDING MOTOR VEHICLE SAFETY STANDARDS; WEB HOSTING SERVICES, NAMELY, HOSTING OF COMPUTER WEBSITES, WEBPAGES, DATABASES, AND WEBLOGS OF OTHERS; WEB PORTAL SERVICES, NAMELY, DESIGNING AND HOSTING WEB SITES WHICH PROVIDE LINKS TO THE WEB SITES OF OTHERS; PROVISION OF ADVISORY, CONSULTANCY AND INFORMATION SERVICES IN RELATION TO THE AFOREMENTIONED SERVICES, NAMELY, CONSULTATION, ADVICE AND INFORMATION REGARDING

CERTIFICATION, QUALITY ASSURANCE, INSPECTION AND TESTING OF MOTOR VEHICLES, AND CONSULTATION, ADVICE AND INFORMATION PERTAINING TO WEBSITE DESIGN AND HOSTING; PROVISION OF AFOREMENTIONED SERVICES AND INFORMATION IN RELATION TO SUCH SERVICES VIA A GLOBAL COMPUTER NETWORK, NAMELY, PROVIDING ONLINE INFORMATION ON CERTIFICATION, QUALITY ASSURANCE OF MOTOR VEHICLES, INSPECTION AND TESTING OF MOTOR VEHICLES AND WEB HOSTING AND DESIGN SERVICES (U.S. CLS. 100 AND 101).

MARY CRAWFORD, EXAMINING ATTORNEY

SN 79-054,221. MNO BRANDS AB, SWEDEN, FILED 5-13-2008.

RED COLLAR PROJECT

OWNER OF INTERNATIONAL REGISTRATION 0965251 DATED 5-13-2008, EXPIRES 5-13-2018.

CLASS 14—JEWELRY

FOR PRECIOUS METALS AND THEIR ALLOYS; JEWELLERY; PRECIOUS STONES; WATCHES; CHRONOMETRIC INSTRUMENTS (U.S. CLS. 2, 27, 28 AND 50).

CLASS 18—LEATHER GOODS

FOR LEATHER AND IMITATIONS OF LEATHER; ANIMAL SKINS, HIDES; TRUNKS AND TRAVELLING BAGS; UMBRELLAS, PARASOLS AND WALKING STICKS; WHIPS, HARNESS AND SADDLERY (U.S. CLS. 1, 2, 3, 22 AND 41).

CLASS 25—CLOTHING

FOR FOOTWEAR (U.S. CLS. 22 AND 39).
DAVID HOFFMAN, EXAMINING ATTORNEY

SN 79-054,226. MNO BRANDS AB, SWEDEN, FILED 5-13-2008.

RULES BY MARY

OWNER OF INTERNATIONAL REGISTRATION 0965275 DATED 5-13-2008, EXPIRES 5-13-2018.

CLASS 14—JEWELRY

FOR PRECIOUS METALS AND THEIR ALLOYS; JEWELLERY; PRECIOUS STONES; WATCHES; CHRONOMETRIC INSTRUMENTS (U.S. CLS. 2, 27, 28 AND 50).

CLASS 18—LEATHER GOODS

FOR LEATHER AND IMITATIONS OF LEATHER; ANIMAL SKINS, HIDES; TRUNKS AND TRAVELLING BAGS; UMBRELLAS, PARASOLS AND WALKING STICKS; WHIPS, HARNESS AND SADDLERY (U.S. CLS. 1, 2, 3, 22 AND 41).

CLASS 25—CLOTHING

FOR FOOTWEAR (U.S. CLS. 22 AND 39).
DAVID HOFFMAN, EXAMINING ATTORNEY

SN 79-054,930. INGO HORAK, 20149 HAMBURG, FED REP GERMANY, FILED 12-4-2007.

DOCINSIDER

THE MARK CONSISTS OF STANDARD CHARACTERS WITHOUT CLAIM TO ANY PARTICULAR FONT, STYLE, SIZE, OR COLOR.

PRIORITY DATE OF 6-4-2007 IS CLAIMED.

OWNER OF INTERNATIONAL REGISTRATION 0967409 DATED 12-4-2007, EXPIRES 12-4-2017.

THE WORDING "DOCINSIDER" HAS NO MEANING IN ENGLISH.

CLASS 35—ADVERTISING AND BUSINESS

FOR ADVERTISING, IN PARTICULAR IN THE FIELD OF MEDICAL SERVICES; CONCEPTION AND EXECUTION OF MARKETING CAMPAIGNS IN THE FIELD OF HEALTH CARE, PUBLIC AUCTIONEERING OF MEDICAL SERVICES VIA THE INTERNET (U.S. CLS. 100, 101 AND 102).

CLASS 38—COMMUNICATION

FOR TELECOMMUNICATION, NAMELY, TELECOMMUNICATION ACCESS SERVICES; TELEPHONE SERVICES IN CONNECTION WITH MEDICAL SERVICES; NAMELY, TELEPHONE COMMUNICATION SERVICES IN THE NATURE OF PROVIDING TOLL-FREE MNE-MONIC TELEPHONE NUMBERS TO DOCTORS AND HOSPITALS; PROVIDING ACCESS TO AN ELECTRONIC CLASSIFIED DICTIONARY FOR DOCTORS AND MEDICAL SERVICES (U.S. CLS. 100, 101 AND 104).

CLASS 41—EDUCATION AND ENTERTAINMENT

FOR EDUCATION SERVICES, NAMELY, CLASSES, WORKSHOPS, PRESENTATIONS AND SEMINARS IN THE FIELD OF INTERNET SERVICES AND HEALTH-CARE; PROVIDING OF TRAINING IN THE FIELD OF INTERNET SERVICES AND HEALTH CARE SERVICES; ENTERTAINMENT IN THE NATURE OF ON-GOING TELEVISION PROGRAMS IN THE FIELD OF NEWS, TALK AND REPORTAGES; ORGANIZING COMMUNITY SPORTING AND CULTURE ACTIVITY (U.S. CLS. 100, 101 AND 107).

CLASS 42—SCIENTIFIC AND COMPUTER SERVICES

FOR INDUSTRIAL ANALYSIS AND RESEARCH SERVICES IN THE FIELD OF DOCTORS AND MEDICAL SERVICES AND INTERNET SERVICES; DESIGN AND DEVELOPMENT OF COMPUTER HARDWARE AND COMPUTER SOFTWARE; PROVIDING OF SEARCH ENGINES ON THE INTERNET FOR OBTAINING DATA ABOUT DOCTORS AND MEDICAL SERVICES (U.S. CLS. 100 AND 101).

PAUL MORENO, EXAMINING ATTORNEY

SN 79-055,137. MEVGAL S.A. -; DAIRY PRODUCT INDUSTRY; TRADING AS MEVGAL SA, GREECE, FILED 4-10-2008.



Milk. The essence of our life

PRIORITY DATE OF 3-24-2008 IS CLAIMED.
OWNER OF INTERNATIONAL REGISTRATION 0967871
DATED 4-10-2008, EXPIRES 4-10-2018.

OWNER OF U.S. REG. NO. 3,187,610.
NO CLAIM IS MADE TO THE EXCLUSIVE RIGHT TO USE "MILK", APART FROM THE MARK AS SHOWN.

THE COLOR(S) DARK BLUE, RED, AND WHITE IS/ARE CLAIMED AS A FEATURE OF THE MARK.

THE WORD "MEVGAL" IN WHITE CAPITAL, BOLD LETTERS, WITHIN A DARK BLUE OVAL FRAME; THE WORDS "MILK, THE ESSENCE OF OUR LIFE" IN RED LETTERS.

CLASS 29—MEATS AND PROCESSED FOODS

FOR MEAT, FISH, POULTRY AND GAME; MEAT EXTRACTS; PRESERVED, FROZEN, DRIED AND COOKED FRUITS AND VEGETABLES; JELLIES, JAMS, COMPOTES; EGGS, MILK AND MILK PRODUCTS; EDIBLE OILS AND FATS (U.S. CL. 46).

CLASS 30—STAPLE FOODS

FOR COFFEE, TEA, COCOA, SUGAR, RICE, TAPIOCA, SAGO, ARTIFICIAL COFFEE; FLOUR AND PROCESSED CEREALS, BREAD, PASTRY AND FROZEN CONFECTIONERY, FLAVORED ICES; HONEY, TREATLE; YEAST, BAKING-POWDER; SALT, MUSTARD; VINEGAR, SAUCES; SPICES; ICE (U.S. CL. 46).

CLASS 39—TRANSPORTATION AND STORAGE

FOR TRANSPORT OF GOODS; PACKAGING ARTICLES FOR TRANSPORTATION AND STORAGE OF GOODS; PROVIDING TRAVEL ARRANGEMENT SERVICES FOR OTHERS (U.S. CLS. 100 AND 105).
NAPOLEON SHARMA, EXAMINING ATTORNEY

SN 79-055,574. AFFIRIS FORSCHUNGS- UND ENTWICKLUNGS GMBH, A-1030 WIEN, AUSTRIA, FILED 2-25-2008.



THE MARK CONSISTS OF STANDARD CHARACTERS WITHOUT CLAIM TO ANY PARTICULAR FONT, STYLE, SIZE, OR COLOR.

PRIORITY DATE OF 8-31-2007 IS CLAIMED.
OWNER OF INTERNATIONAL REGISTRATION 0969068
DATED 2-25-2008, EXPIRES 2-25-2018.

THE WORDING "AFFITOMICS" HAS NO MEANING IN A FOREIGN LANGUAGE.

CLASS 5—PHARMACEUTICALS

FOR PHARMACEUTICAL AND VETERINARY PREPARATIONS, NAMELY, VACCINES FOR PRODUCTION ANIMALS AND DOMESTIC ANIMALS; CHEMICAL PREPARATIONS FOR PHARMACEUTICAL AND MEDICAL PURPOSES, NAMELY, FOR THE FORMULATION OF VACCINES; VACCINES; DIAGNOSTIC PREPARATIONS FOR MEDICAL PURPOSES; CHEMICAL REAGENTS FOR MEDICAL AND VETERINARY PURPOSES; CHEMICAL AND BIOLOGICAL PREPARATIONS FOR MEDICAL SCIENCE, NAMELY, FOR THE FORMULATION OF VACCINES (U.S. CLS. 6, 18, 44, 46, 51 AND 52).

CLASS 10—MEDICAL APPARATUS

FOR SURGICAL APPARATUS AND INSTRUMENTS FOR MEDICAL, DENTAL AND VETERINARY USE AND STRUCTURAL PARTS THEREOF; MEDICAL APPARATUS AND INSTRUMENTS USED IN LAB ANALYSIS AND FOR REMOVING PATHOLOGICAL MOLECULES FROM THE BLOOD, FOR USE IN THERAPY AND PROPHYLAXIS OF MEDICAL CONDITIONS, NAMELY, BLOOD FILTERS AND BLOOD COMPONENT SEPARATION APPARATUS; TESTING APPARATUS FOR MEDICAL USE, NAMELY, BLOOD TESTING APPARATUS (U.S. CLS. 26, 39 AND 44).

CLASS 42—SCIENTIFIC AND COMPUTER SERVICES

FOR DEVELOPMENT AND TEST OF CHEMICAL PRODUCTION METHODS FOR THE MANUFACTURING AND FORMULATION OF VACCINES; MEDICAL AND SCIENTIFIC RESEARCH IN THE FIELD OF CHEMICAL MEDICINE, PHARMACEUTICS AND BACTERIOLOGY (U.S. CLS. 100 AND 101).

CLASS 44—MEDICAL, BEAUTY AND AGRICULTURAL SERVICES

FOR PROVIDING PATIENTS WITH ALZHEIMER'S DISEASE AND ARTERIOSCLEROSIS AND OTHER CARDIO-VASCULAR DISEASES WITH CUSTOM TAILORED INFORMATION ABOUT THE RANGE OF POSSIBLE DIAGNOSES AND THERAPIES ASSOCIATED WITH A DEFINED SET OF SYMPTOMS (U.S. CLS. 100 AND 101).
WILLIAM ROSSMAN, EXAMINING ATTORNEY

SN 79-055,575. AFFIRIS FORSCHUNGS- UND ENTWICKLUNGS GMBH, A-1030 WIEN, AUSTRIA, FILED 2-25-2008.



THE MARK CONSISTS OF STANDARD CHARACTERS WITHOUT CLAIM TO ANY PARTICULAR FONT, STYLE, SIZE, OR COLOR.

PRIORITY DATE OF 8-31-2007 IS CLAIMED.
OWNER OF INTERNATIONAL REGISTRATION 0969069
DATED 2-25-2008, EXPIRES 2-25-2018.

THE WORDING "MIMOTOMICS" HAS NO MEANING IN A FOREIGN LANGUAGE

CLASS 5—PHARMACEUTICALS

FOR PHARMACEUTICAL AND VETERINARY PREPARATIONS, NAMELY, VACCINES FOR PRODUCTION ANIMALS AND DOMESTIC ANIMALS; CHEMICAL PREPARATIONS FOR PHARMACEUTICAL AND MEDICAL PURPOSES, NAMELY, FOR THE FORMULATION OF VACCINES; VACCINES; DIAGNOSTIC PREPARATIONS FOR MEDICAL PURPOSES; CHEMICAL REAGENTS FOR MEDICAL AND VETERINARY PURPOSES; CHEMICAL AND BIOLOGICAL PREPARATIONS FOR MEDICAL SCIENCE, NAMELY, FOR THE FORMULATION OF VACCINES (U.S. CLS. 6, 18, 44, 46, 51 AND 52).

CLASS 10—MEDICAL APPARATUS

FOR SURGICAL APPARATUS AND INSTRUMENTS FOR MEDICAL, DENTAL AND VETERINARY USE AND STRUCTURAL PARTS THEREOF; MEDICAL APPARATUS AND INSTRUMENTS USED IN LAB ANALYSIS AND FOR REMOVING PATHOLOGICAL MOLECULES FROM THE BLOOD, FOR USE IN THERAPY AND PROPHYLAXIS OF MEDICAL CONDITIONS, NAMELY, BLOOD FILTERS AND BLOOD COMPONENT SEPARATION APPARATUS; TESTING APPARATUS FOR MEDICAL USE, NAMELY, BLOOD TESTING APPARATUS (U.S. CLS. 26, 39 AND 44).

CLASS 42—SCIENTIFIC AND COMPUTER SERVICES

FOR DEVELOPMENT AND TEST OF CHEMICAL PRODUCTION METHODS FOR THE MANUFACTURING AND FORMULATION OF VACCINES; MEDICAL AND SCIENTIFIC RESEARCH IN THE FIELD OF CHEMICAL MEDICINE, PHARMACEUTICS AND BACTERIOLOGY (U.S. CLS. 100 AND 101).

CLASS 44—MEDICAL, BEAUTY AND AGRICULTURAL SERVICES

FOR PROVIDING PATIENTS WITH ALZHEIMER'S DISEASE AND ARTERIOSCLEROSIS AND OTHER CARDIO-VASCULAR DISEASES WITH CUSTOM TAILORED INFORMATION ABOUT THE RANGE OF POSSIBLE DIAGNOSES AND THERAPIES ASSOCIATED WITH A DEFINED SET OF SYMPTOMS (U.S. CLS. 100 AND 101).
WILLIAM ROSSMAN, EXAMINING ATTORNEY

SN 79-055,576. AFFIRIS FORSCHUNGS- UND ENTWICKLUNGS GMBH, A-1030 WIEN, AUSTRIA, FILED 2-25-2008.

AFFITOME

THE MARK CONSISTS OF STANDARD CHARACTERS WITHOUT CLAIM TO ANY PARTICULAR FONT, STYLE, SIZE, OR COLOR.

PRIORITY DATE OF 8-31-2007 IS CLAIMED.
OWNER OF INTERNATIONAL REGISTRATION 0969070 DATED 2-25-2008, EXPIRES 2-25-2018.

THE WORDING "AFFITOME" HAS NO MEANING IN A FOREIGN LANGUAGE

CLASS 5—PHARMACEUTICALS

FOR PHARMACEUTICAL AND VETERINARY PREPARATIONS, NAMELY, VACCINES FOR PRODUCTION ANIMALS AND DOMESTIC ANIMALS; CHEMICAL PREPARATIONS FOR PHARMACEUTICAL AND MEDICAL PURPOSES, NAMELY, FOR THE FORMULATION OF VACCINES; VACCINES; DIAGNOSTIC PREPARATIONS FOR MEDICAL PURPOSES; CHEMICAL REAGENTS FOR MEDICAL AND VETERINARY PURPOSES; CHEMICAL AND BIOLOGICAL PREPARATIONS FOR MEDICAL SCIENCE, NAMELY, FOR THE FORMULATION OF VACCINES (U.S. CLS. 6, 18, 44, 46, 51 AND 52).

CLASS 10—MEDICAL APPARATUS

FOR SURGICAL APPARATUS AND INSTRUMENTS FOR MEDICAL, DENTAL AND VETERINARY USE AND STRUCTURAL PARTS THEREOF; MEDICAL APPARATUS AND INSTRUMENTS USED IN LAB ANALYSIS AND FOR REMOVING PATHOLOGICAL MOLECULES FROM THE BLOOD, FOR USE IN THERAPY AND PROPHYLAXIS OF MEDICAL CONDITIONS, NAMELY, BLOOD FILTERS AND BLOOD COMPONENT SEPARATION APPARATUS; TESTING APPARATUS FOR MEDICAL USE, NAMELY, BLOOD TESTING APPARATUS (U.S. CLS. 26, 39 AND 44).

CLASS 42—SCIENTIFIC AND COMPUTER SERVICES

FOR DEVELOPMENT AND TEST OF CHEMICAL PRODUCTION METHODS FOR THE MANUFACTURING AND FORMULATION OF VACCINES; MEDICAL AND SCIENTIFIC RESEARCH IN THE FIELD OF CHEMICAL MEDICINE, PHARMACEUTICS AND BACTERIOLOGY (U.S. CLS. 100 AND 101).

CLASS 44—MEDICAL, BEAUTY AND AGRICULTURAL SERVICES

FOR PROVIDING PATIENTS WITH ALZHEIMER'S DISEASE AND ARTERIOSCLEROSIS AND OTHER CARDIO-VASCULAR DISEASES WITH CUSTOM TAILORED INFORMATION ABOUT THE RANGE OF POSSIBLE DIAGNOSES AND THERAPIES ASSOCIATED WITH A DEFINED SET OF SYMPTOMS (U.S. CLS. 100 AND 101).
WILLIAM ROSSMAN, EXAMINING ATTORNEY

SN 79-055,754. INDUCS AG, SWITZERLAND, FILED 3-28-2008.



PRIORITY DATE OF 10-12-2007 IS CLAIMED.
OWNER OF INTERNATIONAL REGISTRATION 0969442 DATED 3-28-2008, EXPIRES 3-28-2018.

CLASS 9—ELECTRICAL AND SCIENTIFIC APPARATUS

FOR ELECTRONIC APPARATUS AND INSTRUMENTS FOR THE REGULATION AND CONTROL OF INDUCTION COOKERS, INDUCTION ROASTERS AND INDUCTION FOOD WARMERS, AND STRUCTURAL PARTS THEREFOR, NAMELY, ELECTRONIC CONTROL UNITS, ELECTRONIC CONTROLLERS AND INDUCTION VOLTAGE REGULATORS; INDUCTION COILS FOR INDUCTION COOKERS, INDUCTION ROASTERS AND INDUCTION FOOD WARMERS, AND STRUCTURAL PARTS THEREFOR; ACCESSORIES FOR INDUCTION COOKERS, INDUCTION ROASTERS AND INDUCTION FOOD WARMERS, NAMELY, INDUCTION TEMPERATURE REGULATORS (U.S. CLS. 21, 23, 26, 36 AND 38).

CLASS 11—ENVIRONMENTAL CONTROL APPARATUS

FOR BUILT-IN AND TABLETOP INDUCTION COOKERS, BUILT-IN AND TABLETOP INDUCTION ROASTERS AND BUILT-IN AND TABLETOP INDUCTION FOOD WARMERS, AND COMPONENTS AND STRUCTURAL PARTS THEREFOR; INDUCTION COOKERS; PORTABLE INDUCTION COOKERS; INDUCTION GRILLS; INDUCTION GRIDDLES; INDUCTION FOOD WARMERS; INDUCTION DEEP FRYERS; INDUCTION COOKING STOVES; INDUCTION COOKING OVENS; INDUCTION KITCHEN RANGES; INDUCTION COOKING RANGES; INDUCTION HOBBS AND COOK TOPS FOR INDUCTION COOKING; GLASS AND CERAMIC PLATES SOLD AS PARTS OF INDUCTION STOVES; GLASS-CERAMIC HOBBS AND GLASS-CERAMIC TOPS FOR INDUCTION COOKING; ALL THE AFORESAID GOODS PARTICULARLY FOR USE IN INSTITUTIONAL KITCHENS AND GASTRONOMY (U.S. CLS. 13, 21, 23, 31 AND 34).

JENNIFER DIXON, EXAMINING ATTORNEY

SN 79-055,886. CONG TY CO PHAN TAP DOAN; KY NGHE GO TRUONG THANH; (TRUONG THANH FURNITURE CORPORATION), VIETNAM, FILED 5-29-2008.



OWNER OF INTERNATIONAL REGISTRATION 0969795 DATED 5-29-2008, EXPIRES 5-29-2018.

THE NAME(S), PORTRAIT(S), AND/OR SIGNATURE(S) SHOWN IN THE MARK IDENTIFIES A LIVING INDIVIDUAL, WHOSE CONSENT(S) TO REGISTER IS SUBMITTED.

THE COLOR(S) BLUE AND WHITE IS/ARE CLAIMED AS A FEATURE OF THE MARK.

THE MARK CONSISTS OF A FIGURE AND WORD ELEMENT, IN PARTICULAR THE WORD PART IS IN CAPITALS "TRUONG THANH" (TERMS HAVE NO MEANING) IN WHITE AND PLACED INSIDE THE FIGURE PART WHICH IS REPRESENTED AS A HORIZONTAL ELLIPSE IN BLUE AND BORDERED BY A WHITE HORIZONTAL ELLIPSE INSIDE THE BORDER.

SN 79-055,870. PEOPLE OWNED AB, SWEDEN, FILED 6-9-2008.

Wasted Space

THE MARK CONSISTS OF STANDARD CHARACTERS WITHOUT CLAIM TO ANY PARTICULAR FONT, STYLE, SIZE, OR COLOR.

PRIORITY DATE OF 12-9-2007 IS CLAIMED.

OWNER OF INTERNATIONAL REGISTRATION 0969761 DATED 6-9-2008, EXPIRES 6-9-2018.

CLASS 37—CONSTRUCTION AND REPAIR

FOR INSTALLATION OF BUILDING INSULATION, COMPUTER NETWORKS, COMPUTER SYSTEMS, DOORS AND WINDOWS, BURGLAR ALARMS, FIRE ALARMS, DETECTION AND SUPPRESSION SYSTEMS, AIR CONDITIONING APPARATUS, SOLAR THERMAL INSTALLATIONS, INSULATING MATERIALS, SECURITY SYSTEMS, TELEPHONE LINES, ELEVATORS, HEATING EQUIPMENT, ETHERNET AND WIRELESS NETWORKS, PLATE GLASS, HEATING, COOLING AND ENVIRONMENTAL CONTROL SYSTEMS, FIRE ESCAPES, SATELLITE DISHES, AND COMPUTER SOFTWARE (U.S. CLS. 100, 103 AND 106).

CLASS 38—COMMUNICATION

FOR TELECOMMUNICATION SERVICES, NAMELY, LOCAL AND LONG DISTANCE TRANSMISSION OF VOICE, DATA, GRAPHICS BY MEANS OF TELEPHONE, TELEGRAPHIC, CABLE, AND SATELLITE TRANSMISSIONS; TELECOMMUNICATION SERVICES, NAMELY, PROVIDING ACCESS TO PICTURES, VIDEO, ALARM STATUS, BUILDING PLANS AND OTHER BUILDING AND SECURITY INFORMATION AT A REMOTE STATION; TELECOMMUNICATION SERVICES, NAMELY, TRANSMISSION OF PODCASTS; TELECOMMUNICATION SERVICES, NAMELY, TRANSMISSION OF WEBCASTS; TELECOMMUNICATION SERVICES, NAMELY, LOCAL AND LONG DISTANCE TRANSMISSION OF VOICE, DATA, GRAPHICS AND VIDEO BY MEANS OF BROADBAND OPTICAL OR WIRELESS NETWORKS; TELECOMMUNICATION SERVICES, NAMELY, WIRELESS TELEPHONE SERVICES (U.S. CLS. 100, 101 AND 104).

JESSICA A. POWERS, EXAMINING ATTORNEY

CLASS 19—NON-METALLIC BUILDING MATERIALS

FOR PLANKS; JOINED PLANKS; PLYWOOD (U.S. CLS. 1, 12, 33 AND 50).

CLASS 20—FURNITURE AND ARTICLES NOT OTHERWISE CLASSIFIED

FOR WOODEN BEDS, WOODEN WARDROBES, WOODEN SHELVES, WOODEN STANDS, WOODEN TABLES AND CHAIRS, WOODEN PICTURE FRAMES AND OTHER WOODEN PRODUCTS, NAMELY, FURNITURE, CHOPPING BLOCKS, WOODEN CABINETS, WOODEN CRADLES, AND DOORS FOR FURNITURE (U.S. CLS. 2, 13, 22, 25, 32 AND 50).

DOMINIC J. FERRAIUOLO, EXAMINING ATTORNEY

SN 79-056,058. INSTA ELEKTRO GMBH, FED REP GERMANY, FILED 6-26-2008.



THE MARK CONSISTS OF STANDARD CHARACTERS WITHOUT CLAIM TO ANY PARTICULAR FONT, STYLE, SIZE, OR COLOR.

OWNER OF INTERNATIONAL REGISTRATION 0970149 DATED 6-26-2008, EXPIRES 6-26-2018.

THE WORDING "INSTA" HAS NO MEANING IN A FOREIGN LANGUAGE.

CLASS 9—ELECTRICAL AND SCIENTIFIC APPARATUS

FOR SCIENTIFIC, ELECTRIC, MEASURING, SIGNALING, CHECKING AND SUPERVISION, AND TEACHING APPARATUS AND INSTRUMENTS, NAMELY, HOME AND OFFICE AUTOMATION SYSTEMS COMPRISING WIRELESS AND WIRED CONTROLLERS, CONTROLLED DEVICES, AND SOFTWARE FOR LIGHTING, HVAC, SECURITY, SAFETY AND OTHER HOME AND OFFICE MONITORING AND CONTROL APPLICATIONS, ELECTRICAL CONTROLLERS (U.S. CLS. 21, 23, 26, 36 AND 38).

CLASS 11—ENVIRONMENTAL CONTROL APPARATUS

FOR APPARATUS FOR LIGHTING, NAMELY, ELECTRIC LIGHTING FIXTURES, FILTERS FOR LIGHTING, FLAT PANEL LIGHTING APPARATUS, LANDSCAPE LIGHTING INSTALLATIONS, LED (LIGHT EMITTING DIODE) LIGHTING FIXTURES, LIGHTING TUBES, OPTICAL LENS COVERS THAT IMPROVE LIGHT OUTPUT AND UNIFORMITY, AND PROTECTS THE LED SOLD AS A FEATURE OF AN LED LIGHTING SYSTEM, ELECTRIC AND ELECTRONIC LAMPS; LIGHT DIFFUSERS; GUARD DEVICES FOR LIGHTING, NAMELY, PROTECTIVE COVERS FOR LIGHTING DEVICES (U.S. CLS. 13, 21, 23, 31 AND 34).

CLASS 37—CONSTRUCTION AND REPAIR

FOR INSTALLATION, MAINTENANCE AND REPAIR OF ELECTRIC APPARATUS (U.S. CLS. 100, 103 AND 106).

TINA BROWN, EXAMINING ATTORNEY

SN 79-056,561. NEWSON GALE LIMITED, UNITED KINGDOM, FILED 7-3-2008.

Bond-Rite

THE MARK CONSISTS OF STANDARD CHARACTERS WITHOUT CLAIM TO ANY PARTICULAR FONT, STYLE, SIZE, OR COLOR.

OWNER OF INTERNATIONAL REGISTRATION 0971514 DATED 7-3-2008, EXPIRES 7-3-2018.

CLASS 9—ELECTRICAL AND SCIENTIFIC APPARATUS

FOR STATIC DISCHARGE GROUNDING SYSTEMS COMPRISED OF STATIC GROUNDING CLAMPS AND REMOTE MONITORS; STATIC DISCHARGE GROUNDING APPARATUS, NAMELY, STATIC GROUNDING CLAMPS; GROUNDING AND BONDING APPARATUS COMPRISED OF CLAMPS AND ELECTRIC WIRES; PARTS AND FITTINGS FOR ALL THE AFORESAIDMENTIONED GOODS (U.S. CLS. 21, 23, 26, 36 AND 38).

CLASS 35—ADVERTISING AND BUSINESS

FOR BUSINESS RESEARCH AND BUSINESS CONSULTATION SERVICES; BUSINESS INFORMATION SERVICES; ALL THE AFORESAID RELATING TO STATIC CONTROL SYSTEMS (U.S. CLS. 100, 101 AND 102).

CLASS 42—SCIENTIFIC AND COMPUTER SERVICES

FOR CONDUCTING OF SCIENTIFIC AND TECHNOLOGICAL RESEARCH IN THE FIELD OF STATIC CONTROL SYSTEMS; PROVISION OF SCIENTIFIC AND TECHNOLOGICAL CONSULTING SERVICES; INDUSTRIAL ANALYSIS AND RESEARCH SERVICES IN THE FIELD OF STATIC CONTROL SYSTEMS; ADVISORY SERVICES IN THE FIELD OF THE TECHNOLOGY OF STATIC CONTROL SYSTEMS (U.S. CLS. 100 AND 101).

FRED CARL, EXAMINING ATTORNEY

SN 79-056,674. KBA-GIORI SA, SWITZERLAND, FILED 6-30-2008.

PRIORITY DATE OF 2-28-2008 IS CLAIMED. OWNER OF INTERNATIONAL REGISTRATION 0971734 DATED 6-30-2008, EXPIRES 6-30-2018.

THE MARK CONSISTS OF THE WORD "INPRINT" WITH A STYLIZED DESIGN OF THE BOTTOM OF A PIECE OF PAPER BELOW THE WORD.

CLASS 7—MACHINERY

FOR MACHINES FOR CONTROLLING AND MONITORING THE MANUFACTURING PROCESS OF PAPER SECURITIES, NAMELY, BANK-NOTES (U.S. CLS. 13, 19, 21, 23, 31, 34 AND 35).

CLASS 9—ELECTRICAL AND SCIENTIFIC APPARATUS

FOR ELECTRIC AND ELECTRONIC APPARATUS FOR CONTROLLING AND MONITORING THE MANUFACTURING PROCESS OF PAPER SECURITIES, NAMELY, BANK-NOTES (U.S. CLS. 21, 23, 26, 36 AND 38).

PAUL MORENO, EXAMINING ATTORNEY

SN 79-056,692. ELEMATIC GROUP OY, FINLAND, FILED 6-2-2008.

PRIORITY DATE OF 5-14-2008 IS CLAIMED. OWNER OF INTERNATIONAL REGISTRATION 0971785 DATED 6-2-2008, EXPIRES 6-2-2018.

OWNER OF U.S. REG. NOS. 2,248,710 AND 2,477,165. THE MARK CONSISTS OF THE TERM "ELEMATIC" BELOW A SQUARE DESIGN.

CLASS 7—MACHINERY

FOR MACHINES AND SPECIALIZED EQUIPMENT FOR THE CONCRETE AND PRECAST CONCRETE INDUSTRY, NAMELY, CONCRETE MIXERS AND CONCRETE CONSTRUCTION MACHINE PARTS, NAMELY, CONVEYOR BUCKETS THEREFOR; CONCRETE CASTING MACHINES AND STRUCTURAL PARTS THEREFOR, NAMELY, SLIDE-CASTING EXTRUDERS; MACHINE PARTS, NAMELY, MOLDS FOR USE IN THE MANUFACTURE OF PRECAST CONCRETE ELEMENTS AND EXCLUSIVELY USED WITH ENGINEERED CONCRETE EQUIPMENT; METAL AND WOOD SAWING MACHINES AND DRILLING MACHINES FOR CONCRETE AND PRECAST CONCRETE ELEMENTS; CONCRETE CONSTRUCTION MACHINES; ASPHALT PAVING MACHINES; LIFTING EQUIPMENT, NAMELY, POWER-OPERATED LIFTING EQUIPMENT IN THE NATURE OF PIPE LAYERS, FORK LIFTS, TELEHANDLERS, LIFTS, CRANES, SKIP CONVEYORS AND BELT CONVEYORS; METAL PARTS AND FITTINGS FOR POWER-OPERATED LIFTING EQUIPMENT; AUTOMATIC AND PNEUMATIC MACHINES FOR ATTACHING LOOPS AND HOOKS TO FORM PARTS OF LIFTING CONNECTIONS; SPECIALIZED EQUIPMENT FOR SERVICING BEDS, MACHINES AND MACHINE PART MOLDS IN A PRECAST CONCRETE FACTORY, NAMELY, POWER-OPERATED CLEANING MACHINES USING BRUSHES AND POWER-OPERATED OILING MACHINES HAVING OIL TANKS AND LINES TO TRANSFER OIL TO NOZZLES; POWER-OPERATED AND AUTOMATIC MACHINES FOR MAKING RECESSES AND OPENINGS IN THE CONCRETE ELEMENTS; HEAT EXCHANGERS, PUMPS, BOILERS AND PIPES, ALL BEING PARTS OF MACHINES USED FOR HEAT-TREATMENT OF CONCRETE ELEMENTS; INDUSTRIAL ELECTROMECHANICAL MARKING MACHINES FOR MARKING CONCRETE ELEMENTS; HYDRAULIC PRETENSIONING MACHINES FOR PRESTRESSING CONCRETE ELEMENTS; CONCRETE VIBRATORS AND VIBRATING GRINDING MACHINES; POWER-OPERATED MACHINES FOR TILTING CONCRETE ELEMENTS; POWER-OPERATED AND AUTOMATIC MACHINES FOR ATTACHING METAL PLATES TO CONCRETE ELEMENTS; GRINDING, FLOATING CRANES AND POWER-OPERATED POLISHING MACHINES FOR SURFACE TREATMENT OF CONCRETE ELEMENTS; ROLLER CONVEYORS FOR ROLLING A PLASTIC COVER OVER CONCRETE ELEMENTS; INDUSTRIAL ROBOTS FOR POSITIONING MOLD WALLS; STRUCTURAL PARTS AND FITTINGS FOR ALL THE AFORESAID GOODS (U.S. CLS. 13, 19, 21, 23, 31, 34 AND 35).

CLASS 9—ELECTRICAL AND SCIENTIFIC APPARATUS

FOR COMPUTER SOFTWARE FOR PLANNING AND CONTROLLING PRODUCTION IN A CONCRETE FACTORY AND TRANSPORTATION, INVENTORY, WAREHOUSING, MATERIAL-HANDLING AND PACKAGING LOGISTICS (U.S. CLS. 21, 23, 26, 36 AND 38).

CLASS 19—NON-METALLIC BUILDING MATERIALS

FOR CONCRETE; PRECAST CONCRETE SLABS; REINFORCED AND PRE-STRESSED BUILDING CONSTRUCTION ELEMENTS, NAMELY, CONCRETE, CONCRETE PILLARS AND CONCRETE BEAMS; PRESTRESSED CONSTRUCTION ELEMENTS NOT MADE OF METAL, NAMELY, CONCRETE BLOCKS, CONCRETE BEAMS, CONCRETE COLUMNS, CONCRETE PANELS AND CONCRETE FLOORS; PROFILED AND FORMED CONCRETE ELEMENTS, NAMELY, BALCONY ENCLOSURES, STAIRS, TERRACE ENCLOSURES, VINEYARD POSTS, CONCRETE BLOCKS, CONCRETE BEAMS, CONCRETE COLUMNS, CONCRETE PANELS AND CONCRETE FLOORS; WALL

ELEMENTS, NAMELY, CONCRETE WALLS, INSULATED CONCRETE WALLS, DRYWALL AND WALL BOARDS; PLASTIC CONDUIT FOR DRAINAGE WHEN LAYING CONCRETE; CONCRETE BLOCKS AND CONCRETE SLABS FOR USE AS CONSTRUCTION ELEMENTS; PAVING BLOCKS; BOX ELEMENTS FOR CONSTRUCTION, NAMELY, LETTER BOXES OF MASONRY AND SECONDARY MOISTURE DRAINAGE SYSTEM CONSISTING OF NON-METAL TROUGHS AND COLLECTION BOXES; NOISE BARRIERS MADE OF CONCRETE; CONCRETE RAILROAD TIES (U.S. CLS. 1, 12, 33 AND 50).

CLASS 37—CONSTRUCTION AND REPAIR

FOR CONSTRUCTION OF INDUSTRIAL MANUFACTURING PLANTS, RESIDENTIAL BUILDINGS AND OFFICE BUILDINGS AND CONSTRUCTION SUPERVISION RELATED THERETO; SERVICING, INSTALLATION AND REPAIR OF SPECIALIZED MACHINES AND EQUIPMENT FOR THE CONSTRUCTION INDUSTRY (U.S. CLS. 100, 103 AND 106).

CLASS 42—SCIENTIFIC AND COMPUTER SERVICES

FOR TECHNICAL CONSULTATION IN THE FIELD OF BUILDING CONSTRUCTION; SCIENTIFIC RESEARCH; INDUSTRIAL RESEARCH AND DESIGN IN THE FIELD OF BUILDING CONSTRUCTION; DESIGN AND DEVELOPMENT OF COMPUTER SOFTWARE USED IN THE PRECAST CONCRETE INDUSTRY (U.S. CLS. 100 AND 101).

DAVID YONTEF, EXAMINING ATTORNEY

SN 79-056,693. ELEMATIC GROUP OY, FINLAND, FILED 6-2-2008.

ELEMATIC

THE MARK CONSISTS OF STANDARD CHARACTERS WITHOUT CLAIM TO ANY PARTICULAR FONT, STYLE, SIZE, OR COLOR.

PRIORITY DATE OF 5-14-2008 IS CLAIMED.
OWNER OF INTERNATIONAL REGISTRATION 0971786
DATED 6-2-2008, EXPIRES 6-2-2018.

OWNER OF U.S. REG. NOS. 2,248,710 AND 2,477,165.

CLASS 7—MACHINERY

FOR MACHINES AND SPECIALIZED EQUIPMENT FOR THE CONCRETE AND PRECAST CONCRETE INDUSTRY, NAMELY, CONCRETE MIXERS AND CONCRETE CONSTRUCTION MACHINE PARTS, NAMELY, CONVEYOR BUCKETS THEREFOR; CONCRETE CASTING MACHINES AND STRUCTURAL PARTS THEREFOR, NAMELY, SLIDE-CASTING EXTRUDERS; MACHINE PARTS, NAMELY, MOLDS FOR USE IN THE MANUFACTURE OF PRECAST CONCRETE ELEMENTS AND EXCLUSIVELY USED WITH ENGINEERED CONCRETE EQUIPMENT; METAL AND WOOD SAWING MACHINES AND DRILLING MACHINES FOR CONCRETE AND PRECAST CONCRETE ELEMENTS; CONCRETE CONSTRUCTION MACHINES; ASPHALT PAVING MACHINES; LIFTING EQUIPMENT, NAMELY, POWER-OPERATED LIFTING EQUIPMENT IN THE NATURE OF PIPE LAYERS, FORK LIFTS, TELEHANDLERS, LIFTS, CRANES, SKIP CONVEYORS AND BELT CONVEYORS; METAL PARTS AND FITTINGS FOR POWER-OPERATED LIFTING EQUIPMENT; AUTOMATIC AND PNEUMATIC MACHINES FOR ATTACHING LOOPS AND HOOKS TO FORM PARTS OF LIFTING CONNECTIONS; SPECIALIZED EQUIPMENT FOR SERVICING BEDS, MACHINES AND MACHINE PART MOLDS IN A PRECAST CONCRETE FACTORY, NAMELY, POWER-OPERATED CLEANING MACHINES USING BRUSHES AND POWER-OPERATED OILING MACHINES HAVING OIL TANKS AND LINES TO TRANSFER OIL TO NOZZLES; POWER-OPERATED AND AUTOMATIC MACHINES FOR MAKING RECESSES AND OPENINGS IN THE CONCRETE ELEMENTS; HEAT EXCHANGERS, PUMPS, BOILERS AND PIPES, ALL BEING PARTS OF MACHINES USED FOR HEAT-TREATMENT OF CONCRETE ELEMENTS; INDUSTRIAL ELECTROMECHANICAL MARKING MACHINES FOR MARKING CONCRETE ELEMENTS; HYDRAULIC PRETENSIONING MACHINES FOR PRESTRESSING CONCRETE ELEMENTS; CONCRETE VIBRATORS AND VIBRATING GRINDING MACHINES; POWER-OPERATED MACHINES FOR TILTING CONCRETE ELEMENTS; POWER-OPERATED AND AUTOMATIC MACHINES FOR ATTACHING METAL PLATES TO CONCRETE ELEMENTS; GRINDING, FLOATING CRANES AND POWER-OPERATED POLISHING MACHINES FOR SURFACE TREATMENT OF CONCRETE ELEMENTS; ROLLER CONVEYORS FOR ROLLING A PLASTIC COVER OVER CONCRETE ELEMENTS; INDUSTRIAL ROBOTS FOR POSITIONING MOLD WALLS; STRUCTURAL PARTS AND FITTINGS FOR ALL THE AFORESAID GOODS (U.S. CLS. 13, 19, 21, 23, 31, 34 AND 35).

CLASS 9—ELECTRICAL AND SCIENTIFIC APPARATUS

FOR COMPUTER SOFTWARE FOR PLANNING AND CONTROLLING PRODUCTION IN A CONCRETE FACTORY AND TRANSPORTATION, INVENTORY, WAREHOUSING, MATERIAL-HANDLING AND PACKAGING LOGISTICS (U.S. CLS. 21, 23, 26, 36 AND 38).

CLASS 19—NON-METALLIC BUILDING MATERIALS

FOR CONCRETE; PRECAST CONCRETE SLABS; REINFORCED AND PRE-STRESSED BUILDING CONSTRUCTION ELEMENTS, NAMELY, CONCRETE, CONCRETE PILLARS AND CONCRETE BEAMS; PRESTRESSED CONSTRUCTION ELEMENTS NOT MADE OF METAL, NAMELY, CONCRETE BLOCKS, CONCRETE BEAMS, CONCRETE COLUMNS, CONCRETE PANELS AND CONCRETE FLOORS; PROFILED AND FORMED CONCRETE ELEMENTS, NAMELY, BALCONY ENCLOSURES, STAIRS, TERRACE ENCLOSURES, VINEYARD POSTS, CONCRETE BLOCKS, CONCRETE BEAMS, CONCRETE COLUMNS, CONCRETE PANELS AND CONCRETE FLOORS; WALL

ELEMENTS, NAMELY, CONCRETE WALLS, INSULATED CONCRETE WALLS, DRYWALL AND WALL BOARDS; PLASTIC CONDUIT FOR DRAINAGE WHEN LAYING CONCRETE; CONCRETE BLOCKS AND CONCRETE SLABS FOR USE AS CONSTRUCTION ELEMENTS; PAVING BLOCKS; BOX ELEMENTS FOR CONSTRUCTION, NAMELY, LETTER BOXES OF MASONRY AND SECONDARY MOISTURE DRAINAGE SYSTEM CONSISTING OF NON-METAL TROUGHS AND COLLECTION BOXES; NOISE BARRIERS MADE OF CONCRETE; CONCRETE RAILROAD TIES (U.S. CLS. 1, 12, 33 AND 50).

CLASS 37—CONSTRUCTION AND REPAIR

FOR CONSTRUCTION OF INDUSTRIAL MANUFACTURING PLANTS, RESIDENTIAL BUILDINGS AND OFFICE BUILDINGS AND CONSTRUCTION SUPERVISION RELATED THERETO; SERVICING, INSTALLATION AND REPAIR OF SPECIALIZED MACHINES AND EQUIPMENT FOR THE CONSTRUCTION INDUSTRY (U.S. CLS. 100, 103 AND 106).

CLASS 42—SCIENTIFIC AND COMPUTER SERVICES

FOR TECHNICAL CONSULTATION IN THE FIELD OF BUILDING CONSTRUCTION; SCIENTIFIC RESEARCH; INDUSTRIAL RESEARCH AND DESIGN IN THE FIELD OF BUILDING CONSTRUCTION; DESIGN AND DEVELOPMENT OF COMPUTER SOFTWARE USED IN THE PRECAST CONCRETE INDUSTRY (U.S. CLS. 100 AND 101).

DAVID YONTEF, EXAMINING ATTORNEY

SN 79-056,748. ZF FRIEDRICHSHAFEN AG, FED REP GERMANY, FILED 11-8-2007.



PRIORITY DATE OF 8-3-2007 IS CLAIMED.
OWNER OF INTERNATIONAL REGISTRATION 0971939
DATED 11-8-2007, EXPIRES 11-8-2017.

OWNER OF U.S. REG. NOS. 1,161,631, 1,422,733 AND 2,780,982.

NO CLAIM IS MADE TO THE EXCLUSIVE RIGHT TO USE "PARTS", APART FROM THE MARK AS SHOWN.

THE MARK CONSISTS OF THE WORDING "ZF PARTS" IN A SHADED SQUARE WITH THE WORDING AT THE BOTTOM OF THE SQUARE.

CLASS 7—MACHINERY

FOR CONSTRUCTION MACHINERY, NAMELY, CRANES, MOBILE CRANES; MACHINE TOOLS, NAMELY, MACHINES FOR ROLLING, GRINDING, PLANING, SHAVING AND HOBBING GEARS; ENGINES NOT FOR LAND VEHICLES; CLUTCHES AND POWER TRANSMISSION DEVICES FOR MACHINES; TRANSMISSIONS, DRIVES AND CLUTCHES FOR MACHINES, ESPECIALLY FOR MACHINE TOOLS, HANDLING EQUIPMENT AND INDUSTRIAL ROBOTS; TRANSMISSIONS FOR INDUSTRIAL ROBOTS AND MACHINE TOOLS; PLANETARY TRANSMISSIONS FOR HYDROSTATIC AND ELECTRIC DRIVES; ELEVATOR TRANSMISSIONS, TRANSMISSIONS AND DRIVES FOR LIFTING DEVICES; HYDRAULIC PUMPS AND MOTORS, CLUTCHES, GEARS, VALVES AND BRAKES AS PARTS OF MACHINES, MACHINE TOOLS FOR THE PRODUCTION AND PROCESSING OF GEAR WHEELS; STRUCTURAL PARTS AND COMPONENTS OF THE AFOREMENTIONED PRODUCTS (U.S. CLS. 13, 19, 21, 23, 31, 34 AND 35).

CLASS 12—VEHICLES

FOR TRANSMISSIONS, MANUAL TRANSMISSIONS, SYNCHRONOUS AND POWERSHIFT TRANSMISSIONS, AUTOMATIC TRANSMISSIONS, CONTINUOUSLY VARIABLE AUTOMATIC TRANSMISSIONS, DUAL-CLUTCH TRANSMISSIONS, AND HYDRODYNAMIC AND HYDROSTATIC TRANSMISSIONS, ALL FOR LAND VEHICLES; TRANSFER CASES, AXLES, AXLE COMPONENTS FOR LAND VEHICLES, DIFFERENTIALS, CHASSIS COMPONENTS, TORQUE CONVERTERS, CLUTCHES, RETARDERS, BRAKES, SHIFT CLUTCHES AND CLUTCHES AND SYSTEMS COMPOSED OF THESE, AUXILIARY DRIVES, FINAL DRIVES, SHOCK ABSORBERS AND SHOCK-ABSORBER SPRINGS, STEERING TIE RODS, STABILIZERS, STABILIZER LINKS, STRUTS, WHEEL JOINTS, FOUR-POINT LINKS, A-ARMS, AXLE STRUTS, WHEEL JOINTS, ELECTRIC, ELECTRO-HYDRAULIC, HYDRAULIC AND MECHANICAL STEERING SYSTEMS COMPRISED OF STEERING ACTUATORS, STEERING WHEEL ACTUATORS, OPERATING CYLINDERS, CONTROL VALVES, STEERING PUMPS, OIL RESERVOIRS, PROSHAFTS, ANGLE DRIVES, BALL JOINTS AND STEERING COLUMNS, STEERING ACCESSORIES, NAMELY, UNIVERSAL JOINTS, ANGLE DRIVES, STEERING COLUMNS, STEERING PUMPS, OIL CONTAINERS, VALVES, POWER CYLINDERS FOR STEERING; WHEEL DRIVES, ELECTRIC DRIVES AND THEIR COMPONENTS; STRUCTURAL PARTS AND COMPONENTS OF THE AFOREMENTIONED PRODUCTS FOR VEHICLES (U.S. CLS. 19, 21, 23, 31, 35 AND 44).

MARILYN IZZI, EXAMINING ATTORNEY

SN 79-056,784. ERYTECH PHARMA, F-69008 LYON, FRANCE, FILED 7-8-2008.

ERYCAPS

THE MARK CONSISTS OF STANDARD CHARACTERS WITHOUT CLAIM TO ANY PARTICULAR FONT, STYLE, SIZE, OR COLOR.

OWNER OF INTERNATIONAL REGISTRATION 0972047 DATED 7-8-2008, EXPIRES 7-8-2018.

CLASS 5—PHARMACEUTICALS

FOR PHARMACEUTICAL PREPARATIONS FOR THE PREVENTION AND THE TREATMENT OF DISEASES IN THE FIELD OF HEMATOLOGY AND ONCOLOGY AND FOR THE PREVENTION AND THE TREATMENT OF METABOLIC DISEASES; CHEMICAL PREPARATIONS FOR MEDICAL USE; CHEMICAL PREPARATIONS FOR PHARMACEUTICAL USE, NAMELY, ERYTHROCYTES ENTRAPPING PREPARATIONS IN THE NATURE OF BIOLOGIC OR CHEMICAL DRUGS FOR MEDICAL TREATMENT OR DIAGNOSTIC (U.S. CLS. 6, 18, 44, 46, 51 AND 52).

CLASS 42—SCIENTIFIC AND COMPUTER SERVICES

FOR SCIENTIFIC RESEARCH FOR MEDICAL PURPOSES (U.S. CLS. 100 AND 101).

CLASS 44—MEDICAL, BEAUTY AND AGRICULTURAL SERVICES

FOR MEDICAL AND HEALTH SERVICES, NAMELY, HEALTH CARE SERVICES (U.S. CLS. 100 AND 101).
JOHN DALIER, EXAMINING ATTORNEY

SN 79-056,939. INTERFROTTA BAD-; UND HEIMTEXTILIEN GMBH, FED REP GERMANY, FILED 3-6-2008.

luz

THE MARK CONSISTS OF STANDARD CHARACTERS WITHOUT CLAIM TO ANY PARTICULAR FONT, STYLE, SIZE, OR COLOR.

OWNER OF INTERNATIONAL REGISTRATION 0972384 DATED 3-6-2008, EXPIRES 3-6-2018.
SEC. 2(F).

CLASS 24—FABRICS

FOR BEDCOVERS, COVERLETS, BED SHEETS, PILLOWCASES, DUVETS, MATTRESS COVERS, FURNITURE COVERS MADE OF TEXTILES, FITTED TOILET LID COVERS, TOWELS OF TEXTILE, BATH LINEN, SHOWER CURTAINS MADE OF TEXTILE MATERIAL, CURTAINS MADE OF TEXTILES FABRICS, ROLLER BLINDS MADE OF TEXTILE MATERIAL, TABLE-CLOTHS NOT OF PAPER, TEA CLOTHS, NAMELY, TEA TOWELS, TABLE LINEN NOT OF PAPER, PLACE MATS NOT OF PAPER, TEXTILE NAPKINS, FRIEZE, WOVEN FABRIC, JERSEY FABRICS FOR CLOTHING, FURNITURE CLOTH, NAMELY, UNFITTED FABRIC FURNITURE COVERS, DECORATIVE FABRIC FOR TEXTILE USE (U.S. CLS. 42 AND 50).

CLASS 25—CLOTHING

FOR PYJAMAS, NIGHTWEAR, DRESSING GOWNS, BEACH COVER-UPS, INFANT WEAR, SWIMSUITS, BATHING TRUNKS, BATHING CAPS, SANDALS FOR BATHING, SHOWER CAPS, BANDANAS (U.S. CLS. 22 AND 39).

CLASS 27—FLOOR COVERINGS

FOR BATH MATS OF COTTON AND POLYESTER, BEACH MATS, FLOOR MATS, FABRIC BATH MATS, PAPER BATH MATS, PERSONAL SITTING MATS, TEXTILE BATH MATS, LINOLEUM, CARPETS (U.S. CLS. 19, 20, 37, 42 AND 50).

PAUL MORENO, EXAMINING ATTORNEY

SN 79-057,207. DIAGNOSTICS FOR THE REAL WORLD LIMITED, UNITED STATES, FILED 12-21-2007.

SN 79-057,034. INFORM INSTITUT FÜR OPERATIONS; RESEARCH UND MANAGEMENT GMBH, FED REP GERMANY, FILED 2-14-2008.

SAMBA

SyncroLogistics

THE MARK CONSISTS OF STANDARD CHARACTERS WITHOUT CLAIM TO ANY PARTICULAR FONT, STYLE, SIZE, OR COLOR.

PRIORITY DATE OF 8-27-2007 IS CLAIMED.

OWNER OF INTERNATIONAL REGISTRATION 0972663 DATED 2-14-2008, EXPIRES 2-14-2018.

THE MARK CONSISTS OF STANDARD CHARACTERS WITHOUT CLAIM TO ANY PARTICULAR FONT, STYLE, SIZE, OR COLOR.

PRIORITY DATE OF 6-25-2007 IS CLAIMED.

OWNER OF INTERNATIONAL REGISTRATION 0972932 DATED 12-21-2007, EXPIRES 12-21-2017.

CLASS 9—ELECTRICAL AND SCIENTIFIC APPARATUS

FOR SOFTWARE FOR USE IN COMPANY RESOURCES OPTIMIZATION, AND BUSINESS PROCESS OPTIMIZATION; STORED SOFTWARE FOR USE IN COMPANY RESOURCES OPTIMIZATION, AND BUSINESS PROCESS OPTIMIZATION; COMPUTER OPERATING PROGRAMS FOR DATA PROCESSING EQUIPMENT STORED ON MACHINE READABLE DATA PROCESSING MEDIA; DATA PROCESSING EQUIPMENT AND COMPUTERS; APPARATUS AND DEVICES FOR DATA TRANSMISSION AS WELL AS EQUIPMENT CONSISTING COMPLETELY OR SUBSTANTIALLY THEREOF, NAMELY, WIRELESS POINT OF SERVICE DEVICES, WIRELESS TELEPHONES, WIRELESS TRANSCEIVER RADIOS, AND TELECOMMUNICATIONS TRANSMITTERS (U.S. CLS. 21, 23, 26, 36 AND 38).

CLASS 38—COMMUNICATION

FOR PROVISION OF ACCESS TO INFORMATION ON THE INTERNET, NAMELY, PROVIDING REMOTE INTERNET ACCESS, PROVISION OF PORTALS ON THE INTERNET, IN THE FIELD OF OPTIMIZATION OF SPECIAL PROCESSES AND METHODS, OF FUZZY LOGIC AND OTHER DECISION TECHNOLOGIES RESPECTIVELY, NAMELY, PROVIDING MULTIPLE USER ACCESS TO A GLOBAL COMPUTER INFORMATION NETWORK (U.S. CLS. 100, 101 AND 104).

CLASS 42—SCIENTIFIC AND COMPUTER SERVICES

FOR PROVISION OF SEARCH MACHINES FOR THE INTERNET IN THE FIELD OF OPTIMIZATION OF SPECIAL PROCESSES AND METHODS, FUZZY LOGIC AND OTHER DECISION TECHNOLOGIES, NAMELY, PROVIDING SEARCH ENGINES FOR OBTAINING DATA ON A GLOBAL COMPUTER NETWORK; DEVELOPMENT OF SOFTWARE; PREPARATION OF PROGRAMS FOR DATA PROCESSING, NAMELY, DEVELOPMENT OF DATA PROCESSING PROGRAMS FOR THIRD PARTIES; PREPARATION OF TECHNICAL PROFESSIONAL OPINIONS, TECHNICAL CONSULTANCY AND DRAFTING OF EXPERTS' REPORTS, ESPECIALLY IN THE FIELD OF DATA PROCESSING, NAMELY, COMPUTER SOFTWARE CONSULTANCY (U.S. CLS. 100 AND 101).

ROBERT STRUCK, EXAMINING ATTORNEY

CLASS 5—PHARMACEUTICALS

FOR DIAGNOSTIC PREPARATIONS FOR MEDICAL AND VETERINARY PURPOSES; CHEMICAL REAGENTS FOR MEDICAL AND VETERINARY PURPOSES; REAGENTS AND TEST STRIPS FOR USE IN DETECTING THE PRESENCE OF NUCLEIC ACID TARGETS, AND INDICATORS OF DISEASES, NAMELY, ENZYMES, ANTIGENS, ANTIBODIES AND NUCLEIC ACIDS FOR DETECTION OF INFECTIOUS DISEASE, CANCER, GENETIC DISEASE AND GENETIC DISORDER; MEDICAL DIAGNOSTIC TEST STRIPS FOR INFECTIOUS DISEASE, CANCER, GENETIC DISEASE AND GENETIC DISORDER, CHEMICAL REAGENTS AND SAMPLE COLLECTION SWABS FOR MEDICAL AND VETERINARY PURPOSES (U.S. CLS. 6, 18, 44, 46, 51 AND 52).

CLASS 10—MEDICAL APPARATUS

FOR MEDICAL AND VETERINARY APPARATUS AND INSTRUMENTS, NAMELY, URINE COLLECTORS IN THE NATURE OF FIRST-VOID OR MID-STREAM URINE SAMPLERS, BLOOD COLLECTORS IN THE NATURE OF APPARATUS FOR TAKING BLOOD AND APPARATUS FOR TESTING BLOOD, CONTAINERS FOR HOLDING REAGENTS AND TEST SAMPLES, FILTERS, CENTRIFUGE TUBES, MAGNETS AND PIPETTES, FOR USE IN DETECTING THE PRESENCE OF NUCLEIC ACID TARGETS AND OF INDICATORS OF DISEASES, NAMELY, ENZYMES, ANTIGENS, ANTIBODIES AND NUCLEIC ACIDS, FOR CLINICAL OR HOME USE; MEDICAL ELECTRIC HEATERS USED IN DETECTING THE PRESENCE OF NUCLEIC ACID TARGETS, AND OF INDICATORS OF DISEASES, SUCH INDICATORS INCLUDING ENZYMES, ANTIGENS, ANTIBODIES AND NUCLEIC ACIDS, FOR CLINICAL OR HOME USE (U.S. CLS. 26, 39 AND 44).

CLASS 42—SCIENTIFIC AND COMPUTER SERVICES

FOR SCIENTIFIC AND TECHNOLOGICAL SERVICES, NAMELY, DEVELOPMENT OF DIAGNOSTIC PREPARATIONS FOR MEDICAL AND VETERINARY DIAGNOSIS BY DETECTION OF NUCLEIC ACID TARGETS AND PROTEIN TARGETS, IN THE FIELD OF BIOTECHNOLOGY (U.S. CLS. 100 AND 101).

CLASS 44—MEDICAL, BEAUTY AND AGRICULTURAL SERVICES

FOR MEDICAL AND VETERINARY SERVICES (U.S. CLS. 100 AND 101).

HEATHER BIDDULPH, EXAMINING ATTORNEY

SN 79-057,295. TATTILE SRL, ITALY, FILED 2-20-2008.



PRIORITY DATE OF 1-23-2008 IS CLAIMED.
OWNER OF INTERNATIONAL REGISTRATION 0973143
DATED 2-20-2008, EXPIRES 2-20-2018.

THE MARK CONSISTS IN THE WORDING "TATTILE" IN COMBINATION WITH AN HEXAGONAL GEOMETRIC FIGURE WITH THE SIDES ALTERNATELY INTERRUPTED AND CONTAINING THREE SEPARATE TRIANGLES IN CORRESPONDENCE TO THE INTERRUPTIONS OF THE SIDES.

THE ENGLISH TRANSLATION OF "TATTILE" IN THE MARK IS "TACTILE".

CLASS 9—ELECTRICAL AND SCIENTIFIC APPARATUS

FOR ELECTRIC AND ELECTRONIC VIDEO SURVEILLANCE INSTALLATIONS; COMPUTER HARDWARE AND SOFTWARE SYSTEM FOR REMOTELY MONITORING ENVIRONMENTAL CONDITIONS; ELECTRONIC VIDEO SURVEILLANCE PRODUCTS, NAMELY, ELECTRONIC COMPONENTS FOR SECURITY SYSTEMS; COMPUTER HARDWARE, COMPUTER PERIPHERAL DEVICES, COMPUTER MEMORIES AND COMPUTER PROGRAMS FOR USE IN VIDEO SURVEILLANCE INSTALLATION; APPARATUS FOR RECORDING, TRANSMISSION, PROCESSING AND REPRODUCTION OF SOUNDS, IMAGES AND DATA; CAMCORDERS, VIDEO CAMERAS, OPTICAL LENSES, VIDEO SCREENS, TELEVISION SETS, TELECOMMUNICATIONS AND DATA NETWORKING HARDWARE, NAMELY, DEVICES FOR TRANSPORTING AND AGGREGATING VOICE, DATA, AND VIDEO COMMUNICATIONS ACROSS MULTIPLE NETWORK INFRASTRUCTURES AND COMMUNICATIONS PROTOCOLS; TELECOMMUNICATIONS HARDWARE AND SOFTWARE FOR MONITORING AND ALERTING REMOTE SENSOR STATUS VIA THE INTERNET; ELECTRIC APPARATUS AND INSTRUMENTS, NAMELY, ELECTRICAL SWITCHES, COMMUTATORS, AND POWER SUPPLY; ELECTRONIC AND OPTICAL COMMUNICATIONS INSTRUMENTS AND COMPONENTS, NAMELY, OPTICAL TRANSMITTERS, RECEIVERS, DATA LINKS, DIGITAL TRANSMITTERS; CABLES FOR ELECTRICAL AND OPTICAL SIGNAL TRANSMISSION SYSTEMS; SIGNALING APPARATUS AND INSTRUMENTS, NAMELY, SECURITY AND FIRE ALARMS; SENSORS FOR THE DETERMINATION OF TEMPERATURES, HUMIDITY, POSITIONS, PRESSURE, MOVEMENTS, SPEED, WEIGHT AND DISTANCES; ELECTRONIC POCKET TRANSLATORS; ELECTRONIC DEVICES FOR READING TRANSPONDER KEYS, NAMELY, OPTICAL CHARACTER READERS, BAR CODE AND MAGNETIC BAR CODE READERS, ELECTRIC CABLES AND OPTICAL FIBER AND WIRES (U.S. CLS. 21, 23, 26, 36 AND 38).

CLASS 37—CONSTRUCTION AND REPAIR

FOR INSTALLATION, REPAIR AND MAINTENANCE OF COMPUTERIZED APPARATUS, COMPUTER AND INFORMATION SYSTEMS, TELECOMMUNICATIONS APPARATUS (U.S. CLS. 100, 103 AND 106).

CLASS 38—COMMUNICATION

FOR TELECOMMUNICATIONS SERVICES, NAMELY, LOCAL AND LONG DISTANCE TRANSMISSION OF VOICE, IMAGES, DATA AND GRAPHICS BY MEANS OF TELEPHONE, CABLE AND SATELLITE TRANSMISSION (U.S. CLS. 100, 101 AND 104).

CLASS 42—SCIENTIFIC AND COMPUTER SERVICES

FOR CONSULTATION SERVICES IN THE FIELDS OF SELECTION, IMPLEMENTATION AND USE OF COMPUTER HARDWARE AND SOFTWARE SYSTEMS FOR OTHERS; COMPUTER SOFTWARE CONSULTANCY, NAMELY, CONSULTANCY IN THE FIELD OF COMPUTER SECURITY (U.S. CLS. 100 AND 101).
NAPOLEON SHARMA, EXAMINING ATTORNEY

SN 79-057,372. VOLKSWAGEN AKTIENGESELLSCHAFT, 38436 WOLFSBURG, FED REP GERMANY, FILED 4-21-2008.

VOLKSWAGEN - PEOPLE'S CAR

THE MARK CONSISTS OF STANDARD CHARACTERS WITHOUT CLAIM TO ANY PARTICULAR FONT, STYLE, SIZE, OR COLOR.

PRIORITY DATE OF 1-14-2008 IS CLAIMED.
OWNER OF INTERNATIONAL REGISTRATION 0973363
DATED 4-21-2008, EXPIRES 4-21-2018.
OWNER OF U.S. REG. NOS. 617,131, 1,378,042 AND OTHERS.

THE ENGLISH TRANSLATION OF THE GERMAN WORD "VOLKSWAGEN" IN THE MARK IS PEOPLE'S CAR.

CLASS 4—LUBRICANTS AND FUELS

FOR INDUSTRIAL GREASE AND OIL; INDUSTRIAL LUBRICANTS; PETROLEUM-BASED DUST SUPPRESSING COMPOSITIONS FOR USE ON UNPAVED ROADS; FUEL FOR MOTOR VEHICLES, NAMELY, ETHANOL, GAS, GASOLINE AND DIESEL, LIGHTING FUEL; CANDLES, WICKS FOR CANDLES (U.S. CLS. 1, 6 AND 15).

CLASS 7—MACHINERY

FOR METAL, WOOD, PLASTICS WORKING MACHINES, NAMELY, DRILL PRESSES, MACHINING CENTERS, CUFFING MACHINES, SPRAY GUNS FOR PAINTING, DEGREASERS FOR USE IN THE FIELD OF AUTOMOBILE DISMANTLING; MACHINES FOR PRODUCTION, REPAIR AND DISMANTLING OF LAND, AIR AND WATER VEHICLES, FOR THE CHEMICAL INDUSTRY, FOR AGRICULTURE, FOR MINING, FOR THE TEXTILE INDUSTRY, FOR THE FOOD INDUSTRY, FOR THE BEVERAGE INDUSTRY, FOR THE CONSTRUCTION INDUSTRY, FOR THE PACKAGING INDUSTRY, NAMELY, DIE-CUTTING MACHINES, MOLDING PRESSES, SCORING MACHINES, LAMINATING MACHINES, WATER JET CUTTING MACHINES, MILLING MACHINES, LONG FIBER INJECTION MACHINES; MACHINE TOOLS, NAMELY, ELECTRIC HAND HELD DRILLS; MOTORS, OTHER THAN FOR LAND VEHICLES; MOTOR PARTS FOR MOTORS OF ALL KIND, NAMELY, MOTOR STARTERS, MACHINE CYLINDERS, MACHINE CYLINDER HEADS, MACHINE PUMPS, CAMSHAFTS, PISTONS, FLY WHEELS, BEARINGS, VALVES, EXHAUSTS FOR ENGINES, INJECTORS FOR ENGINES, CARBURETORS FOR ENGINES, FILTERS FOR CLEANING COOLING AIR FOR ENGINES, GLOW PLUGS FOR DIESEL ENGINES, ENGINE BLOCKS, INTAKE AND EXHAUST MANIFOLDS, CYLINDERS; ELECTRIC MOTORS, NOT FOR LAND VEHICLES; PARTS FOR ELECTRIC MOTORS NOT FOR LAND VEHICLES SOLD AS AN INTEGRAL COMPONENT OF THE MOTORS, NAMELY, COILS; MACHINE COUPLINGS AND TRANSMISSIONS, EXCEPT FOR LAND VEHICLES; CLUTCHES FOR MACHINES; MACHINE COUPLINGS AND TRANSMISSIONS COMPONENTS EXCEPT FOR LAND VEHICLES; POWER-OPERATED JACKS; MOTORIZED LAWN MOWERS; AGRICULTURAL MACHINES, NAMELY, CULTIVATORS, HARVESTERS, DISK HARROWS, SEEDERS (U.S. CLS. 13, 19, 21, 23, 31, 34 AND 35).

CLASS 9—ELECTRICAL AND SCIENTIFIC APPARATUS

FOR SCIENTIFIC, NAUTICAL, SURVEYING, ELECTRIC, PHOTOGRAPHIC, CINEMATOGRAPHIC, OPTICAL, WEIGHING, MEASURING, SIGNALING, CHECKING (SUPERVISION), LIFE-SAVING AND TEACHING APPARATUS AND INSTRUMENTS, INCLUDED IN THIS CLASS, NAMELY, CONTACT LENSES, SPECTACLES, SPECTACLE CASES, BINOCULARS, MAGNIFYING GLASSES, SUNGLASSES, SIMULATORS FOR STEERING AND CONTROLLING VEHICLES, VOLTAGE REGULATORS FOR VEHICLES, VEHICLE BREAKDOWN WARNING TRIANGLES, VEHICLE BREAKDOWN WARNING LAMPS AND PARTS FOR VEHICLE BREAKDOWN WARNING LAMPS, NAMELY, FUSES; CIGAR LIGHTERS FOR AUTOMOBILES, ELECTRIC BATTERIES AND PARTS THEREOF IN THE NATURE OF CAPACITORS, ELECTRIC ACCUMULATORS AND PARTS THEREOF IN THE NATURE OF CAPACITORS, FUEL CELLS AND PARTS THEREOF IN THE NATURE OF CAPACITORS, CHARGERS FOR ELECTRIC BATTERIES, BURGLAR ALARMS, THIEF ALARMS, FIRE ALARMS, SMOKE ALARMS, GAS ALARMS, SPEED INDICATORS, GRADUATED RULERS, MEASURING APPARATUS AND MEASURING INSTRUMENTS FOR USE IN MOTOR VEHICLES, NAMELY, REVOLUTION COUNTERS; ELECTRONIC CONTROL MECHANISMS AND POWER AND VOLTAGE SUPPLY UNITS FOR VEHICLE HEADLIGHTS AND PARTS THEREOF IN THE NATURE OF ELECTRONIC CONTROL CIRCUITS, CONTROL MECHANISMS AND POWER AND VOLTAGE SUPPLY UNITS FOR VEHICLE LIGHTS AND PARTS THEREOF IN THE NATURE OF ELECTRONIC CONTROL CIRCUITS, ELECTRONIC CONTROLS FOR INTERNAL COMBUSTION ENGINES AND ELECTRIC MOTORS FOR LAND VEHICLES; LIFE SAVING APPARATUS AND EQUIPMENT, NAMELY, LIFE-SAVING RAFTS, FIRE ESCAPE LADDERS, SAFETY NETS, SAFETY TARPULINS, LIFE BELTS, LIFE BUOYS, LIFE JACKETS; ACID HYDROMETERS, FUSES, ELECTRIC RELAYS, LASERS NOT FOR MEDICAL PURPOSES, LASER POINTERS, SOLAR BATTERIES, COMPASSES, NAVIGATION APPARATUS FOR VEHICLES IN THE NATURE OF ON-BOARD COMPUTERS, SPIRIT LEVELS, BALANCING APPARATUS, NAMELY, TIRE BALANCING MACHINES FOR LAND VEHICLES; REMOTE CONTROLLING APPARATUS FOR RADIOS, TELEVISIONS AND STEREOs; APPARATUS AND INSTRUMENTS FOR CONDUCTING, SWITCHING, TRANSFORMING, ACCUMULATING, REGULATING AND CONTROLLING ELECTRICITY; APPARATUS FOR RECORDING, TRANSMISSION AND/OR REPRODUCTION OF SOUND AND IMAGES, AERIALS, RADIOS, TELEVISION APPARATUS FOR PROJECTION PURPOSES; TELEPHONE APPARATUS, VIDEO TELEPHONES, PROJECTION APPARATUS, NAMELY, TELEVISION APPARATUS FOR PROJECTION PURPOSES; CINEMATOGRAPHIC CAMERAS, CAMERAS, PHOTOCOPIERS; ELECTRONIC TRANSLATION APPARATUS, EXPOSED CAMERA FILMS; MAGNETIC, ELECTRONIC AND OPTICAL DATA CARRIERS EXCEPT UNEXPOSED FILMS, NAMELY, BLANK RECORDABLE CD-ROMS, BLANK COMPUTER HARD DISCS, BLANK SMART CARDS; RECORDING DISCS IN THE NATURE OF BLANK RECORDABLE CD-ROMS, BLANK RECORDABLE DVDS; ENCODED MAGNETIC CARDS, BLANK INTEGRATED CIRCUIT CARDS (SMART CARDS), MAGNETICALLY ENCODED TELEPHONE CALLING CARDS; AUTOMATIC VENDING MACHINES, MECHANISMS FOR COIN OPERATED APPARATUS; AUTOMATIC BANKING MACHINES; CASH REGISTERS, CALCULATORS, DATA PROCESSING APPARATUS, COMPUTERS, ELECTRONIC PERSONAL ORGANIZERS WITH CALENDARS, FACSIMILE APPARATUS, COMPUTER MONITORS, COMPUTER PERIPHERY DEVICES, POCKET CALCULATORS; RECORDED COMPUTER PROGRAMS AND SOFTWARE AND COLLECTED DATA IN THE FIELD OF AUTOMOBILES RECORDED ON DATA CARRIERS FOR USE IN DATA BASE MANAGEMENT; FIRE EXTINGUISHERS; AMUSEMENT APPARATUS ADAPTED FOR USE WITH EXTERNAL DISPLAY SCREEN OR MONITOR (U.S. CLS. 21, 23, 26, 36 AND 38).

CLASS 12—VEHICLES

FOR VEHICLES FOR LOCOMOTION BY LAND, AIR AND/OR WATER AND STRUCTURAL PARTS THEREOF, MOTORIZED LAND VEHICLES AND STRUCTURAL PARTS THEREOF, TRAILERS FOR LAND VEHICLES AND STRUCTURAL PARTS THEREOF, ENGINES FOR LAND VEHICLES, TIRES FOR VEHICLE WHEELS, RIMS FOR VEHICLE WHEELS, COMPLETE VEHICLE WHEELS AND STRUCTURAL PADS THEREOF FOR LAND VEHICLES, VEHICLE ALARM SYSTEMS, ANTI-THEFT DEVICES FOR VEHICLES, ANTI-THEFT DEVICES FOR MOTORIZED LAND VEHICLES (U.S. CLS. 19, 21, 23, 31, 35 AND 44).

CLASS 28—TOYS AND SPORTING GOODS

FOR PARLOR GAMES, BOARD GAMES, CARD GAMES, TOSS GAMES; SCALE MODEL VEHICLES, SCALE MODEL AUTOMOBILES AND TOY AUTOMOBILES; TOY VEHICLES FOR CHILDREN, SCOOTERS IN THE NATURE OF TOYS FOR CHILDREN; PLAYING CARDS, BALLS FOR GAMES, STUFFED TOY ANIMALS AND OTHER STUFFED TOYS; ELECTRONIC GAMES OTHER THAN THOSE ADAPTED FOR USE WITH TELEVISION RECEIVERS ONLY; COIN-OPERATED AUTOMATIC AMUSEMENT MACHINES; ORNAMENTS FOR CHRISTMAS TREES, EXCEPT ILLUMINATION ARTICLES AND CONFECTIONERY; KALEIDOSCOPIES (U.S. CLS. 22, 23, 38 AND 50).

CLASS 35—ADVERTISING AND BUSINESS

FOR RETAIL AND WHOLESALE STORE SERVICES CONCERNING MOTOR VEHICLES AND THEIR PARTS AND FITTINGS, RETAIL AND WHOLESALE STORE SERVICES FOR MAIL-ORDER BUSINESS CONCERNING MOTOR VEHICLES AND THEIR PARTS AND FITTINGS, RETAIL AND WHOLESALE STORE SERVICES VIA THE INTERNET CONCERNING MOTOR VEHICLES AND THEIR PARTS AND FITTINGS, RETAIL AND WHOLESALE STORE SERVICES VIA TELESHOPPING CONCERNING MOTOR VEHICLES AND THEIR PARTS AND FITTINGS; BRINGING TOGETHER, BUT NOT TRANSPORTING, A VARIETY OF MOTOR VEHICLES AND PARTS AND FITTINGS THEREFOR FOR THE BENEFIT OF OTHERS, THEREBY ENABLING CUSTOMERS TO VIEW AND PURCHASE THE GOODS IN A RETAIL OUTLET; NEGOTIATION OF CONTRACTS FOR THE BENEFIT OF OTHERS ABOUT SALE AND PURCHASE OF MOTOR VEHICLES AND THEIR PARTS AND/OR FITTINGS; PRESENTATION OF GOODS IN COMMUNICATIONS MEDIA FOR RETAIL PURPOSES; PRESENTATION OF AUCTIONS AND PUBLIC SALES ON THE INTERNET FOR RETAIL PURPOSES; COMMERCIAL INFORMATION AND ADVICE FOR CONSUMERS; ADMINISTRATIVE PROCESSING OF PURCHASE ORDERS; NEGOTIATION OF CONTRACTS FOR THE BENEFIT OF OTHERS ABOUT SALE AND PURCHASE OF GOODS; CONSULTANCY AND ASSISTANCE IN ORGANIZATION AND MANAGEMENT OF RETAIL AND BUSINESS COMPANIES; ADVERTISING; BUSINESS MANAGEMENT; BUSINESS ADMINISTRATION AND OFFICE WORK, NAMELY, PERSONNEL RECRUITMENT, PERSONNEL MANAGEMENT CONSULTANCY, BUSINESS MANAGEMENT CONSULTANCY, PUBLIC RELATIONS, ADVERTISING SERVICES OF A RADIO AND TELEVISION ADVERTISING AGENCY, ORGANIZATION OF TRADE FAIRS FOR COMMERCIAL OR ADVERTISING PURPOSES, COLLECTING AND ARRANGING OF RELEVANT PRESS ARTICLES, NAMELY, NEWS CLIPPING SERVICES (U.S. CLS. 100, 101 AND 102).

CLASS 36—INSURANCE AND FINANCIAL

FOR INSURANCE AGENCY SERVICES, HEALTH INSURANCE UNDERWRITING, INSURANCE BROKERAGE, ACCIDENT INSURANCE UNDERWRITING; FINANCIAL CONSULTING SERVICES, MONETARY STRATEGY CONSULTATION AND RESEARCH, ISSUANCE OF CREDIT CARDS, BANKING, LOAN FINANCING, INSTALLMENT LOANS, CREDIT BUREAUS, FINANCIAL CONSULTANCY, VEHICLE LEASE FINANCING, LEASING OF VEHICLES, SAVING BANKS, REAL ESTATE AGENCIES, APARTMENT HOUSE MANAGEMENT, REAL ESTATE MANAGEMENT, REAL ESTATE APPRAISAL, RENTAL OF OFFICES, RENTING OF FLATS, REAL ESTATE AGENCIES, REAL ESTATE SERVICES, NAMELY, RENTAL OF SHORT-TERM FURNISHED APARTMENTS; LEASING OF REAL ESTATES; INSURANCE BROKERAGE SERVICES; REAL ESTATE BROKERAGE SERVICES; SECURITIES BROKERAGE SERVICES; MORTGAGE BROKERAGE SERVICES; FINANCIAL APPRAISAL, NAMELY, THE PROVISION OF ESTIMATES FOR REPAIR COSTS (U.S. CLS. 100, 101 AND 102).

CLASS 37—CONSTRUCTION AND REPAIR

FOR RECONSTRUCTION, REPAIR, SERVICING, DISMANTLING, CLEANING, MAINTENANCE AND VARNISHING OF VEHICLES AND THEIR PARTS AND MOTORS AND THEIR PADS, VEHICLE REPAIR IN THE COURSE OF VEHICLE BREAKDOWN SERVICE; REFINEMENT AND TUNING OF AUTOMOBILES; CUSTOMIZATION OF AUTOMOBILES (U.S. CLS. 100, 103 AND 106).

CLASS 42—SCIENTIFIC AND COMPUTER SERVICES

FOR SCIENTIFIC AND TECHNOLOGICAL SERVICES AND RESEARCH AND DESIGN RELATING THERETO, NAMELY, RESEARCH SERVICES IN CONNECTION WITH THE DEVELOPMENT AND CONSTRUCTION AND PRODUCTION OF AUTOMOBILES; INDUSTRIAL ANALYSIS SERVICES IN THE AUTOMOBILE FIELD, INDUSTRIAL RESEARCH SERVICES IN THE AUTOMOBILE FIELD, INDUSTRIAL DEVELOPMENT SERVICES IN THE AUTOMOBILE FIELD; INDUSTRIAL DESIGN SERVICES; TECHNICAL CONSULTANCY IN THE AUTOMOBILE FIELD; COMPUTING CONSULTANCY; DESIGN AND DEVELOPMENT OF COMPUTER HARDWARE AND SOFTWARE; COMPUTER SOFTWARE CONSULTANCY (U.S. CLS. 100 AND 101).

STEPHEN AQUILA, EXAMINING ATTORNEY

CLASS 9—ELECTRICAL AND SCIENTIFIC APPARATUS

FOR DOWNLOADABLE COMPUTER PROGRAMS FOR USE IN DATABASE MANAGEMENT REGARDING ACQUISITION, ANALYSIS AND REPRESENTATION OF CUSTOMER DATA, OF BUYING BEHAVIOR, SHOPPING BEHAVIOR AND OF OTHER RELEVANT CUSTOMER BEHAVIOR DATA, AND PRE-RECORDED MAGNETIC AND OPTIC DATA CARRIERS FEATURING INFORMATION IN THE FIELD OF ACQUISITION, ANALYSIS AND REPRESENTATION OF CUSTOMER DATA, OF BUYING BEHAVIOR, SHOPPING BEHAVIOR AND OF OTHER RELEVANT CUSTOMER BEHAVIOR DATA, FOR THE PURPOSE OF CREW MANAGEMENT, IMPROVEMENT OF ADVERTISING STRATEGIES, IMPROVEMENT OF PRESENTATION OF GOODS, ENHANCEMENT AND IMPROVEMENT OF TRANSACTIONS (U.S. CLS. 21, 23, 26, 36 AND 38).

CLASS 38—COMMUNICATION

FOR PROVIDING MULTIPLE-USER ACCESS TO A GLOBAL COMPUTER INFORMATION NETWORK; ELECTRONIC MESSAGING SERVICES; COMPUTER AIDED TRANSMISSION OF IMAGES; RENTAL OF ACCESS TIME TO GLOBAL COMPUTER NETWORKS; PROVIDING ACCESS TO COMPUTER DATABASES; AFOREMENTIONED SERVICES, NAMELY, PROVIDING MULTIPLE-USER ACCESS TO A GLOBAL COMPUTER INFORMATION NETWORK, ELECTRONIC MESSAGING SERVICES, COMPUTER AIDED TRANSMISSION OF IMAGES, RENTAL OF ACCESS TIME TO GLOBAL COMPUTER NETWORKS, PROVIDING ACCESS TO COMPUTER DATABASES, IN THIS INTERNATIONAL CLASS EXCLUSIVELY IN THE FIELD OF ACQUISITION, ANALYSIS AND REPRESENTATION OF CUSTOMER DATA, OF BUYING BEHAVIOR, SHOPPING BEHAVIOR AND OF OTHER RELEVANT CUSTOMER BEHAVIOR DATA, FOR THE PURPOSE OF CREW MANAGEMENT, IMPROVEMENT OF ADVERTISING STRATEGIES, IMPROVEMENT OF PRESENTATION OF GOODS, ENHANCEMENT AND IMPROVEMENT OF TRANSACTIONS (U.S. CLS. 100, 101 AND 104).

CLASS 42—SCIENTIFIC AND COMPUTER SERVICES

FOR DESIGN, INSTALLATION, UPDATING AND MAINTENANCE OF COMPUTER SOFTWARE; SERVICES OF AN ELECTRONIC DATA PROCESSING (EDP) PROGRAMMER, NAMELY, COMPUTER PROGRAMMING; RENTAL OF COMPUTER SOFTWARE; PROVIDING AND RENTAL OF ELECTRONIC MEMORY SPACE ALSO KNOWN AS WEB SPACE ON THE INTERNET, NAMELY, WEBSITE HOSTING SERVICES; CONSULTING SERVICES IN THE FIELD OF DESIGN, SELECTION, IMPLEMENTATION AND USE OF COMPUTER HARDWARE AND COMPUTER SOFTWARE SYSTEMS FOR OTHERS; AFOREMENTIONED SERVICES, NAMELY, DESIGN, INSTALLATION, UPDATING AND MAINTENANCE OF COMPUTER SOFTWARE, SERVICES OF AN ELECTRONIC DATA PROCESSING (EDP) PROGRAMMER, NAMELY, COMPUTER PROGRAMMING, RENTAL OF COMPUTER SOFTWARE, PROVIDING AND RENTAL OF ELECTRONIC MEMORY SPACE ALSO KNOWN AS WEB SPACE ON THE INTERNET, NAMELY, WEBSITE HOSTING SERVICES, CONSULTING SERVICES IN THE FIELD OF DESIGN, SELECTION, IMPLEMENTATION AND USE OF COMPUTER HARDWARE AND COMPUTER SOFTWARE SYSTEMS FOR OTHERS WITHIN THIS INTERNATIONAL CLASS EXCLUSIVELY IN THE FIELD OF ACQUISITION, ANALYSIS AND REPRESENTATION OF CUSTOMER DATA, OF BUYING BEHAVIOR, SHOPPING BEHAVIOR AND OF OTHER RELEVANT CUSTOMER BEHAVIOR DATA, IN PARTICULAR FOR THE PURPOSE OF CREW MANAGEMENT, IMPROVEMENT OF ADVERTISING STRATEGIES, IMPROVEMENT OF PRESENTATION OF GOODS, ENHANCEMENT AND IMPROVEMENT OF TRANSACTIONS (U.S. CLS. 100 AND 101).

SN 79-057,417, VIS-À-PIX GMBH, FED REP GERMANY, FILED 3-25-2008.

PEOPLE SCOUT

THE MARK CONSISTS OF STANDARD CHARACTERS WITHOUT CLAIM TO ANY PARTICULAR FONT, STYLE, SIZE, OR COLOR.

PRIORITY DATE OF 10-10-2007 IS CLAIMED.

OWNER OF INTERNATIONAL REGISTRATION 0973506 DATED 3-25-2008, EXPIRES 3-25-2018.

NO CLAIM IS MADE TO THE EXCLUSIVE RIGHT TO USE "PEOPLE", APART FROM THE MARK AS SHOWN.

CLASS 45—PERSONAL AND LEGAL SERVICES

FOR ADMINISTRATION OF COPYRIGHTS, NAMELY, COPYRIGHT MANAGEMENT; ALLOCATION OF LICENSES FOR INTELLECTUAL PROPERTY RIGHTS, NAMELY, COPYRIGHT; AFOREMENTIONED SERVICES, NAMELY, ADMINISTRATION OF COPYRIGHTS, NAMELY, COPYRIGHT MANAGEMENT, ALLOCATION OF LICENSES FOR INTELLECTUAL PROPERTY RIGHTS, NAMELY, COPYRIGHT, WITHIN THIS INTERNATIONAL CLASS EXCLUSIVELY IN THE FIELD OF ACQUISITION, ANALYSIS AND REPRESENTATION OF CUSTOMER DATA, OF BUYING BEHAVIOR, SHOPPING BEHAVIOR AND OF OTHER RELEVANT CUSTOMER BEHAVIOR DATA, IN PARTICULAR FOR THE PURPOSE OF CREW MANAGEMENT, IMPROVEMENT OF ADVERTISING STRATEGIES, IMPROVEMENT OF PRESENTATION OF GOODS, ENHANCEMENT AND IMPROVEMENT OF TRANSACTIONS (U.S. CLS. 100 AND 101).

NAPOLEON SHARMA, EXAMINING ATTORNEY

SN 79-057,419. ADDITIONAL LIABILITY COMPANY; "THE INSTITUTE OF MODERN AGRARIAN; TECHNOLOGIES", UKRAINE, FILED 4-22-2008.

АГРОКЛЕВЕР
AGROCLEVER

OWNER OF INTERNATIONAL REGISTRATION 0973508 DATED 4-22-2008, EXPIRES 4-22-2018.

THE TRANSLITERATION OF THE NON-LATIN CHARACTERS IN THE MARK IS: AGROCLEVER.

CLASS 35—ADVERTISING AND BUSINESS

FOR ADVERTISING AND PUBLICITY SERVICES (U.S. CLS. 100, 101 AND 102).

CLASS 42—SCIENTIFIC AND COMPUTER SERVICES

FOR SCIENTIFIC AND TECHNOLOGICAL SERVICES IN THE FIELD OF AGRICULTURE AND RESEARCH AND DESIGN RELATING THERETO; DESIGN AND DEVELOPMENT OF COMPUTER HARDWARE AND SOFTWARE; SURVEYING; BIOLOGICAL RESEARCH; RESEARCH IN AGRICULTURAL, FORESTRY AND GARDENING; CHEMICAL RESEARCH; CHEMICAL ANALYSIS; CHEMISTRY AND BIOLOGICAL RESEARCH AND CONSULTING SERVICES IN AGRICULTURE, FORESTRY AND GARDENING; QUALITY CONTROL FOR OTHERS; COMPUTER PROGRAMMING; INSTALLATION OF COMPUTER SOFTWARE; DUPLICATION OF COMPUTER PROGRAMS; COMPUTER SYSTEM DESIGN; DATA CONVERSION OF COMPUTER PROGRAMS AND DATA, NOT PHYSICAL CONVERSION; CONVERSION OF DATA OR DOCUMENTS FROM PHYSICAL TO ELECTRONIC MEDIA; RENTAL OF COMPUTER SOFTWARE; COMPUTER SOFTWARE DESIGN; MAINTENANCE OF COMPUTER SOFTWARE; UPDATING OF COMPUTER SOFTWARE; CONSULTANCY IN THE FIELD OF COMPUTER HARDWARE; RECOVERY OF COMPUTER DATA; HOSTING COMPUTER SITES OF OTHERS ON A COMPUTER SERVER FOR A GLOBAL COMPUTER NETWORK; CREATING AND MAINTAINING WEB SITES FOR OTHERS; TECHNICAL PROJECT STUDIES IN THE FIELD OF AGRICULTURE (U.S. CLS. 100 AND 101).

DAVID HOFFMAN, EXAMINING ATTORNEY

SN 79-057,448. AREIM RUSSIA LIMITED, CYPRUS, FILED 1-10-2008.



PRIORITY DATE OF 11-19-2007 IS CLAIMED. OWNER OF INTERNATIONAL REGISTRATION 0973594 DATED 1-10-2008, EXPIRES 1-10-2018.

NO CLAIM IS MADE TO THE EXCLUSIVE RIGHT TO USE "REAL ESTATE INVESTMENT MANAGERS", APART FROM THE MARK AS SHOWN.

THE COLOR(S) RED AND GREY IS/ARE CLAIMED AS A FEATURE OF THE MARK.

THE COLOR RED FOR THE BACKGROUND OF THE APPLIED DESIGNATION AND LITTLE RECTANGLE INSIDE THE T-SHAPED DESIGN ELEMENT AND GREY FOR THE WORD DESIGNATIONS ACCENT AND REAL ESTATE INVESTMENT MANAGERS AND T-SHAPED DESIGN ELEMENT BETWEEN THEM.

THE APPLIED DESIGNATION IS A COMBINED MARK, CONSISTING OF A DOMINANT WORD ELEMENT "ACCENT" AND OTHER WORD ELEMENTS "REAL ESTATE INVESTMENT MANAGERS" AND T-SHAPED DESIGN ELEMENT; THE WORD ELEMENTS ARE IN GREY COLOR IN CAPITALIZED LETTERS OF DIFFERENT SIZE, ON THE RED BACKGROUND; THE WORD ELEMENTS "REAL ESTATE, INVESTMENT" AND "MANAGERS" ARE PLACED UNDER EACH OTHER; BETWEEN "ACCENT" AND OTHER WORD ELEMENTS IS A DESIGN ELEMENT IN GREY COLOR, VISUALLY PERCEIVED AS A CHIMNEY FLUE AND CONSISTING OF T-SHAPED FIGURE WITH A LITTLE RED RECTANGLE INSIDE IT. THE APPLIED DESIGNATION IS SEMANTICALLY NEUTRAL TO THE APPLIED GOODS AND SERVICES.

CLASS 16—PAPER GOODS AND PRINTED MATTER

FOR ADDRESS PLATES FOR ADDRESSING MACHINES; ADDRESS STAMPS; ADDRESSING MACHINES; ADHESIVE TAPE DISPENSERS; ADHESIVES, NAMELY, GLUE FOR STATIONERY OR HOUSEHOLD PURPOSES; ADVERTISEMENT BOARDS OF PAPER OR CARDBOARD; ALBUMS FOR PHOTOGRAPHS; ALMANACS; ANNOUNCEMENT CARDS; AQUARELLES; ARCHITECTS' MODELS; ATLASES; BAGS FOR MICROWAVE COOKING; GARBAGE BAGS OF PAPER OR OF PLASTICS; BALLS, NAMELY, TIPS, FOR BALL-POINT PENS; BIBS OF PAPER; LOOSE-LEAF BINDERS; BINDING STRIPS; BLACKBOARDS; BLOTTERS; BLUEPRINTS; BOOKBINDING MACHINES; BOOKBINDING CLOTH; BOOKBINDING CORDS; BOOKBINDING MATERIAL; BOOKBINDINGS; BOOKENDS; BOOKLETS IN THE FIELD OF REAL ESTATE AND FINANCE ACTIVITY; BOOKMARKERS; BOOKS IN THE FIELD OF REAL ESTATE AND FINANCE ACTIVITY; PAPER BOWS FOR GIFT WRAPS; BOXES FOR PENS; BOXES OF CARDBOARD OR PAPER; PLASTIC BUBBLE PACKS FOR WRAPPING OR PACKAGING; CABINETS FOR STATIONERY, NAMELY, DESKTOP STATIONERY CABINETS; CALENDARS; CANVAS FOR PAINTING; CARBON PAPER; CARDBOARD; CARDBOARD TUBES; CARDS, NAMELY, BUSINESS CARDS, GREETING CARDS; CASES FOR STAMPS; CATALOGUES IN THE FIELD OF REAL ESTATE AND FINANCE ACTIVITY; CHALK FOR LITHOGRAPHY; CHALK HOLDERS; MARKING CHALK; CHAPLETS; CHARCOAL PENCILS; CHART POINTERS, NON-ELECTRONIC; PRINTED CHARTS; CHECKBOOKS HOLDER; CLIPBOARDS; MONEY CLIPS; CLOTH FOR BOOKBINDING; COASTERS OF PAPER; PAPER FILTERS FOR COFFEE MAKERS; COMIC BOOKS; DRAWING COMPASSES; INK RIBBONS FOR COMPUTER PRINTERS; COPYING PAPER; BOOKBINDING CORDS; CORRECTING FLUIDS FOR TYPE; CORRECTING INK; COVERS OF PAPER FOR FLOWER POTS; BOOK COVERS; PAPER CUTTERS; DECALCOMANIAS; DIAGRAMS FOR BUILDING COMPUTER CIRCUITS; DOCUMENT FILES; DOCUMENT LAMINATORS FOR OFFICE USE; SCENTED PAPER DRAWER LINERS; DRAWING BOARDS; DRAWING INSTRUMENTS; DRAWING MATERIALS FOR BLACKBOARDS; DRAWING PADS; DRAWING PENS; DRAWING SQUARES; DRAWING T-SQUARES; ROTARY

DUPLICATORS; PAINTERS' EASELS; ELASTIC BANDS FOR OFFICES; ELECTROCARDIOGRAPH PAPER; ELECTROTYPES; EMBROIDERY DESIGN PATTERNS; ENGRAVING PLATES; ENVELOPE SEALING MACHINES, FOR OFFICES; ENVELOPES; BLACKBOARD ERASERS; ETCHING NEEDLES; ETCHINGS; FABRICS FOR BOOKBINDING; FACE TOWELS OF PAPER; PAPIER MACHE FIGURINES; FILTER PAPER; PAPER FOLDERS; FOLDERS; PRINTED FORMS; FOUNTAIN PENS; FRANKING MACHINES; FRENCH CURVES; PRINTERS' GALLEY RACKS; GEOGRAPHICAL MAPS; TERRESTRIAL GLOBES; GLUE FOR STATIONERY OR HOUSEHOLD PURPOSES; GRAINING COMBS; GRAPHIC PRINTS; GRAPHIC REPRESENTATIONS; GRAPHIC ART REPRODUCTIONS; HANDKERCHIEFS OF PAPER; PASSPORT HOLDERS; HYGIENIC PAPER; INDIAN INKS; INK STICKS; INK STONES, NAMELY, INK RESERVOIRS; INKING PADS; INKING RIBBONS; INK WELLS; PERFORATED CARDS FOR JACQUARD LOOMS; PAPER KNIVES; LEDGERS BOOKS; LETTER TRAYS; LITHOGRAPHIC WORKS OF ART; LITHOGRAPHS; PAPER MANIFOLDS; MODELLING CLAY; MOULDS FOR MODELLING CLAYS; MODELLING COMPOUNDS, NAMELY, MODELLING PASTE; MODELLING WAX, NOT FOR DENTAL PURPOSES; MOISTENERS FOR GUMMED SURFACES, NAMELY, MOISTENERS IN THE NATURE OF HAND HELD DEVICES FOR WETTING STAMPS, ENVELOPES AND GUMMED PAPER SURFACES; MOISTENERS BEING OFFICE REQUISITES; MUSICAL GREETING CARDS; NAPKINS OF PAPER FOR REMOVING MAKEUP; TABLE NAPKINS OF PAPER; NEWSLETTERS IN THE FIELD OF REAL ESTATE AND FINANCE ACTIVITY; NEWSPAPERS; PEN NIBS; PEN NIBS OF GOLD; NOTE BOOKS; OFFICE PERFORATORS; OFFICE REQUISITES, EXCEPT FURNITURE, NAMELY, PAPER EMBOSSERS; OLEOGRAPHS; PACKING PAPER; DESK PADS; WRITING PADS; PAINT BOXES; PAINTBRUSHES; PAINTERS' BRUSHES; PAINTINGS, FRAMED OR UNFRAMED; PALETTES FOR PAINTERS; PAMPHLETS IN THE FIELD OF REAL ESTATE AND FINANCE ACTIVITY; PAPER FOR RECORDING MACHINES; PAPER KNIVES BEING CUTTERS; PAPER RIBBONS; PAPER SHEETS FOR NOTE TAKING; PAPER SHREDDERS FOR OFFICE USE; WAXED PAPER, NAMELY, PARAFFINED PAPER; PAPERCLIPS; PAPERWEIGHTS; PAPIER MACHE; PARCHMENT PAPER; PASTEL CRAYONS; PASTES FOR STATIONERY OR HOUSEHOLD PURPOSES; PATTERNS FOR DRESSMAKING; PATTERNS FOR MAKING CLOTHES; PEN CASES; PEN CLIPS; PENCIL HOLDERS; PENCIL LEAD HOLDERS; PENCIL LEADS; ELECTRIC AND MECHANICAL PENCIL SHARPENERS; PENCILS; PENHOLDERS; PENS; PRINTED PERIODICALS IN THE FIELD OF REAL ESTATE AND FINANCE ACTIVITY; PHOTO-ENGRAVINGS; PHOTOGRAPH STANDS; PHOTOGRAPHS; PICTURES; PLACARDS OF PAPER OR CARDBOARD; PLACE MATS OF PAPER; PORTRAITS; POSTCARDS; POSTERS; PRINTED TIMETABLES; PRINTERS' BLANKETS, NOT OF TEXTILE; PRINTERS' REGLETS; PRINTING BLOCKS; PRINTING TYPE; PRINTS; PRINTED PUBLICATIONS IN THE FIELD OF REAL ESTATE AND FINANCE ACTIVITY; PUNCHES; ROSARIES; RUBBER ERASERS; DRAWING RULERS; SQUARE RULERS, NAMELY, DRAFTING RULERS; SCRAPBOOKS; SEALING STAMPS; SEALING WAX; SEALS BEING STAMPS, NAMELY, IMPRESSION STAMPS; SELF ADHESIVE TAPES FOR STATIONERY OR HOUSEHOLD PURPOSES; SLATE PENCILS; SONG BOOKS; STAMP PADS; STAMP STANDS; STANDS FOR PENS AND PENCILS; STAPLES FOR OFFICES; STAPLING PRESSES; STATIONERY; STEATITE, NAMELY, CHALK FOR TAILORS; STEEL PENS; STENCIL CASES; STENCIL PLATES; STENCILS; STICKERS; TABLE LINEN OF PAPER; TABLECLOTHS OF PAPER; TABLEMATS OF PAPER; TAGS FOR INDEX CARDS; TAILORS' CHALK; TEAR-OFF CALENDARS; THUMBTRACKS; TICKETS, NAMELY, PRICE TICKETS; TISSUES OF PAPER FOR REMOVING MAKEUP; TOILET PAPER; PAPER TOWELS; TRACING CLOTH, NAMELY, TRACING PAPER; TRACING NEEDLES FOR DRAWING PURPOSES; TRACING PAPER; TRANSFERS IN THE NATURE OF DECALCOMANIAS; PAPER TRANSPARENCIES; TYPEWRITER KEYS; TYPEWRITER RIBBONS; TYPEWRITERS, ELECTRIC OR NON-ELECTRIC; WATERCOLORS BEING PAINTINGS; ARTISTS' WATERCOLOUR SAUCERS; WATERCOLOURS; WOOD PULP PAPER; WRAPPERS BEING STATIONERY, NAMELY, COIN AND FOOD WRAPPERS; WRAPPING

PAPER; WRISTBANDS FOR THE RETENTION OF WRITING INSTRUMENTS; WRITING BRUSHES; WRITING CHALK; WRITING INSTRUMENTS; WRITING OR DRAWING BOOKS, NAMELY, SCHOOL WRITING BOOKS; WRITING PAPER; WRITING SLATES; WRITING TABLETS (U.S. CLS. 2, 5, 22, 23, 29, 37, 38 AND 50).

CLASS 35—ADVERTISING AND BUSINESS

FOR ACCOUNTING SERVICES; DRAWING UP OF STATEMENTS OF ACCOUNTS, NAMELY, FINANCIAL STATEMENT PREPARATION AND ANALYSIS FOR BUSINESSES; COMMERCIAL ADMINISTRATION OF THE LICENSING OF THE GOODS AND SERVICES OF OTHERS; ADMINISTRATIVE PROCESSING OF PURCHASE ORDERS; ADVERTISING SERVICES; ADVERTISING AGENCIES; ADVERTISING SERVICES BY MAIL ORDER, NAMELY, DIRECT MAIL ADVERTISING; UPDATING OF ADVERTISING MATERIAL; DISSEMINATION OF ADVERTISING MATTER; RENTAL OF ADVERTISING SPACE; COMMERCIAL INFORMATION AND ADVICE FOR CONSUMERS; COST PRICE ANALYSIS; TELEPHONE ANSWERING SERVICES FOR UNAVAILABLE SUBSCRIBERS; BUSINESS APPRAISALS; ARRANGING NEWSPAPER SUBSCRIPTIONS FOR OTHERS; ARRANGING SUBSCRIPTIONS TO TELECOMMUNICATION SERVICES FOR OTHERS; BUSINESS MANAGEMENT OF PERFORMING ARTISTS; BUSINESS MANAGEMENT ASSISTANCE; AUCTIONEERING; ACCOUNT AUDITING; BILL STICKING; BOOKKEEPING; PROFESSIONAL BUSINESS ADMINISTRATION CONSULTANCY; BUSINESS INFORMATION IN THE FIELD OF REAL ESTATE AND FINANCE ACTIVITY; BUSINESS INQUIRIES; BUSINESS INVESTIGATIONS; BUSINESS MANAGEMENT AND ORGANIZATION CONSULTANCY; BUSINESS MANAGEMENT CONSULTANCY; BUSINESS MANAGEMENT OF HOTELS FOR OTHERS; BUSINESS ORGANIZATION CONSULTANCY; BUSINESS RESEARCH; RELOCATION SERVICES FOR BUSINESSES; COMMERCIAL INFORMATION AGENCIES; COMMERCIAL AND INDUSTRIAL MANAGEMENT ASSISTANCE; PRESENTATION OF GOODS ON COMMUNICATION MEDIA, FOR RETAIL PURPOSES; PRICE COMPARISON SERVICES; COMPILATION OF INFORMATION INTO COMPUTER DATABASES; COMPILATION OF STATISTICS; SYSTEMIZATION OF INFORMATION INTO COMPUTER DATABASES; DEMONSTRATION OF PRODUCTS; DIRECT MAIL ADVERTISING; DISTRIBUTION OF SAMPLES FOR PUBLICITY PURPOSES; DOCUMENT REPRODUCTION; ECONOMIC FORECASTING; EFFICIENCY EXPERTS; EMPLOYMENT AGENCIES; EVALUATION OF STANDING TIMBER; EVALUATION OF WOOL; ORGANIZATION OF EXHIBITIONS FOR COMMERCIAL OR ADVERTISING PURPOSES; COMPUTERIZED FILE MANAGEMENT; IMPORT-EXPORT AGENCIES; INFORMATION SERVICES RELATING TO BUSINESS MATTERS; INVOICING; LAYOUT SERVICES FOR ADVERTISING PURPOSES; ADVISORY SERVICES FOR BUSINESS MANAGEMENT; PERSONNEL MANAGEMENT CONSULTATION; MARKETING RESEARCH SERVICES; CONDUCTING MARKETING STUDIES; MODELLING FOR ADVERTISING OR SALES PROMOTION; NEWS CLIPPING SERVICES; RENTAL OF OFFICE MACHINES AND EQUIPMENT; ONLINE ADVERTISING ON COMPUTER COMMUNICATION NETWORK; PUBLIC OPINION POLLING; ORGANIZATION OF TRADE FAIRS FOR COMMERCIAL OR ADVERTISING PURPOSES; OUTSOURCING SERVICES; PAYROLL PREPARATION; PERSONNEL RECRUITMENT; PHOTOCOPYING; WORD PROCESSING; PSYCHOLOGICAL TESTING FOR THE SELECTION OF PERSONNEL; PUBLIC RELATIONS; PUBLICATION OF PUBLICITY TEXTS; PUBLICITY CONSULTATION; PUBLICITY AGENTS; WRITING OF PUBLICITY TEXTS, NAMELY, COLUMNS; PUBLICITY MATERIAL RENTAL; WRITING OF PUBLICITY TEXTS; ADVERTISING SERVICES OF A RADIO AGENCY; PRODUCTION OF RADIO COMMERCIALS; RENTAL OF OFFICE EQUIPMENT, NAMELY, PHOTOCOPYING MACHINES; RENTAL OF VENDING MACHINES; BUSINESS RESEARCH; SALES PROMOTION FOR OTHERS PROVIDED THROUGH COMMUNICATION NETWORK; SECRETARIAL SERVICES; SPONSORSHIP SEARCH; TAX PREPARATION; TELEVISION ADVERTISING AGENCIES; PRODUCTION OF TELEVISION COMMERCIALS; MESSAGE TRANSCRIPTION; TYPING (U.S. CLS. 100, 101 AND 102).

CLASS 36—INSURANCE AND FINANCIAL

FOR ACCIDENT INSURANCE UNDERWRITING; CREDIT BUREAUX FOR APARTMENTS; ACTUARIAL SERVICES; FINANCIAL ANALYSES; ANTIQUE APPRAISAL; APARTMENT HOUSE MANAGEMENT; RENTING OF APARTMENTS; ART APPRAISAL; NUMISMATIC APPRAISAL; REAL ESTATE APPRAISAL; BAIL BONDING; BANKING; HOME BANKING; BUSINESS BROKERAGE; BUSINESS LIQUIDATION SERVICES; CAPITAL INVESTMENT SERVICES; CHARITABLE FUND RAISING; CHECK VERIFICATION; FINANCIAL CLEARING HOUSES; RENT COLLECTION; COLLECTION AGENCIES; FINANCIAL CONSULTANCY; INSURANCE CONSULTANCY; CREDIT BUREAUX; CREDIT CARD SERVICES; ISSUING CREDIT CARDS; CUSTOMS BROKERAGE; DEBIT CARD SERVICES; DEBT COLLECTION AGENCIES; SAFETY DEPOSIT BOX SERVICES; REAL ESTATE AGENCIES; REAL ESTATE MANAGEMENT; FINANCIAL EVALUATION FOR INSURANCE, BANKING AND REAL ESTATE PURPOSES; REPAIR COSTS EVALUATION; EXCHANGING MONEY; FACTORING AGENCIES; FIDUCIARY SERVICES, NAMELY, FIDUCIARY REPRESENTATIVE SERVICES; FINANCIAL INFORMATION PROCESSING; FINANCIAL MANAGEMENT; FINANCIAL SPONSORSHIP OF REAL ESTATE ACTIVITY; FINANCING SERVICES; FIRE INSURANCE UNDERWRITING; FISCAL ASSESSMENTS; FUND INVESTMENTS; ELECTRONIC FUNDS TRANSFER; FINANCIAL GUARANTEES; HEALTH INSURANCE UNDERWRITING; HIRE-PURCHASE FINANCING, NAMELY, BROKERAGE FOR HIRE-PURCHASE; INSURANCE INFORMATION; INSTALLMENT LOANS; INSURANCE BROKERAGE; INSURANCE UNDERWRITING IN THE FIELD OF REAL ESTATE AND CAPITAL INVESTMENT; CAPITAL INVESTMENT SERVICES; ISSUE OF TOKENS OF VALUE; TRAVEL AGENCY SERVICES, NAMELY, ISSUING OF TRAVELERS' CHECKS; LEASE-PURCHASE FINANCING; LEASING OF FARMS; LEASING OF REAL ESTATE; LIFE INSURANCE UNDERWRITING; LOANS FINANCING; MARINE INSURANCE UNDERWRITING; MORTGAGE BANKING; MUTUAL FUNDS INVESTMENT; PAWN BROKERAGE; INVESTMENT CONSULTANCY IN THE FIELD OF REAL ESTATE; BROKERAGE IN THE FIELD OF REAL ESTATE; RENTING OF OFFICES AND APARTMENTS; RENTING OF FLATS; RETIREMENT PAYMENT SERVICES, NAMELY, FINANCIAL PLANNING FOR RETIREMENT; SAFE DEPOSIT BOX SERVICES; SAVINGS BANKS; SECURITIES BROKERAGE; STOCK EXCHANGE PRICE QUOTATIONS; BROKERAGE IN THE FIELD OF STOCKS AND BONDS; TRUSTEESHIP REPRESENTATIVES; FISCAL VALUATIONS (U.S. CLS. 100, 101 AND 102).

CLASS 37—CONSTRUCTION AND REPAIR

FOR INSTALLATION AND REPAIR OF AIR CONDITIONING APPARATUS; ANTI-RUST TREATMENT FOR VEHICLES; ARTIFICIAL SNOW-MAKING SERVICES; ASPHALTING; BOILER CLEANING AND REPAIR; BRICKLAYING; BUILDING CONSTRUCTION SUPERVISION; BUILDING OF FAIR STALLS AND SHOPS; BUILDING SEALING AND CAULKING SERVICES; RENTAL OF BULLDOZERS; INSTALLATION AND MAINTENANCE OF BURGLAR AND/OR FIRE ALARMS; MAINTENANCE AND REPAIR OF BURNERS; CABINET MAKING; CAR WASHING; CHIMNEY SWEEPING; DIAPER CLEANING; DRY CLEANING; RENTAL OF FLOOR CLEANING MACHINES; CLEANING OF BUILDINGS EXTERIOR SURFACES; CLEANING OF BUILDINGS INTERIOR; VEHICLE CLEANING; CLOCK AND WATCH REPAIR; CLEANING OF CLOTHING; CLOTHING REPAIR; INSTALLATION, MAINTENANCE AND REPAIR OF COMPUTER HARDWARE; BUILDING CONSTRUCTION SERVICES; RENTAL OF CONSTRUCTION EQUIPMENT; INFORMATION CONCERNING RENTAL OF EQUIPMENT FOR CONSTRUCTIONS AND BUILDINGS; BUILDING DAMPROOFING; DEMOLITION OF BUILDINGS; DISINFECTING; INSTALLATION OF DOORS AND WINDOWS; DRILLING OF WELLS; ELEVATOR INSTALLATION AND REPAIR; RENTAL OF EARTH MOVING EQUIPMENT AND EXCAVATORS; VERMIN EXTERMINATING, OTHER THAN FOR AGRICULTURE; MINING EXTRACTION; HYDRO ELECTRIC FACTORY CONSTRUCTION; FILM PROJECTOR RE-

PAIR AND MAINTENANCE; FIRE ALARM INSTALLATION AND REPAIR; FURNACE INSTALLATION AND REPAIR; FURNITURE RESTORATION; VEHICLE GREASING; HEATING EQUIPMENT INSTALLATION AND REPAIR; INTERFERENCE SUPPRESSION IN ELECTRICAL APPARATUS; KNIFE SHARPENING; LAUNDERING; LEATHER CARE; LIFT INSTALLATION AND REPAIR; REPAIR OF SECURITY LOCKS, NAMELY, ELECTRONICALLY OPERATED SECURITY LOCKS; VEHICLE LUBRICATION; MACHINERY INSTALLATION; VEHICLE MAINTENANCE; MASONRY; MENDING OF CLOTHING; MINING EXTRACTION; MOTOR VEHICLE MAINTENANCE AND REPAIR; RESTORATION OF MUSICAL INSTRUMENTS; OFFICE MACHINES AND EQUIPMENT INSTALLATION, MAINTENANCE AND REPAIR; PAINTING, INTERIOR AND EXTERIOR; PAPER HANGING; ROAD PAVING; PHOTOGRAPHIC APPARATUS REPAIR; PIER BREAKWATER BUILDING, NAMELY, PIER BREAKWATER CONSTRUCTION; PIPELINE CONSTRUCTION AND MAINTENANCE; PLASTERING; PLUMBING; VEHICLE POLISHING; PRESSING OF CLOTHING; PUMICING; PUMP REPAIR; QUARRYING SERVICES; VERMIN EXTERMINATING IN A NATURE OF RAT EXTERMINATING; REBUILDING OF AUTOMOBILE ENGINES THAT HAVE BEEN WORN OR PARTIALLY DESTROYED; REBUILDING MACHINES THAT HAVE BEEN WORN OR PARTIALLY DESTROYED; REFILLING OF TONER CARTRIDGES; RENTAL OF CRANES BEING CONSTRUCTION EQUIPMENT, NAMELY, CRANE RENTAL AND LEASING FOR CONSTRUCTION PURPOSES; UNDERWATER REPAIR; RESTORATION OF WORKS OF ART; RE-TINNING; TIRE RETREADING; RIVETING; ROAD PAVING; ROOFING SERVICES; RUSTPROOFING; SAFE MAINTENANCE AND REPAIR; SCAFFOLDING ERECTION; VEHICLE SERVICE STATIONS, NAMELY, VEHICLE REFUELLING AND MAINTENANCE; SHIPBUILDING; SHOE REPAIR; STREET CLEANING; SWIMMING-POOL MAINTENANCE; TELEPHONE INSTALLATION AND REPAIR; UMBRELLA REPAIR; UNDERWATER BUILDING AND CONSTRUCTION; UPHOLSTERY REPAIR; VEHICLE REPAIR SERVICES; VEHICLE WASHING; WAREHOUSE CONSTRUCTION AND REPAIR; WASHING OF LINES; WINDOW CLEANING (U.S. CLS. 100, 103 AND 106).

CLASS 41—EDUCATION AND ENTERTAINMENT

FOR EDUCATION SERVICES, NAMELY, CLASSES, SEMINARS, WORKSHOPS IN THE FIELD OF REAL ESTATE AND FINANCE ACTIVITY; PROVIDING AMUSEMENT ARCADE SERVICES; AMUSEMENT PARKS; AMUSEMENTS, NAMELY, AMUSEMENT CENTERS; ANIMAL TRAINING; ARRANGING AND CONDUCTING OF CONCERTS; ARRANGING AND CONDUCTING OF EDUCATIONAL CONFERENCES; ARRANGING AND CONDUCTING OF SEMINARS IN THE FIELD OF REAL ESTATE AND FINANCE ACTIVITY; ARRANGING OF BEAUTY CONTESTS; BOARDING SCHOOLS; BOOKING OF SEATS FOR SHOWS; BOOKMOBILE SERVICES; PUBLICATION OF BOOKS; CALLIGRAPHY SERVICES; HOLIDAY CAMP SERVICES; SPORT CAMP SERVICES; PROVIDING CASINO FACILITIES; RENTAL OF CINE-FILMS; CINEMA THEATER PRESENTATIONS; CIRCUSES; CLUB SERVICES FOR PURPOSE OF ENTERTAINMENT OR EDUCATION, NAMELY, PROVIDING INSTRUCTION AND EQUIPMENT IN THE FIELD OF PHYSICAL EXERCISE; ORGANIZATION OF COMPETITIONS FOR PURPOSE OF EDUCATION OR ENTERTAINMENT, NAMELY, ORGANIZING SPORTING EVENTS, NAMELY, SWIMMING MEET, SOCCER COMPETITION, TRACK AND FIELD COMPETITION, WEIGHT LIFTING COMPETITION; ORGANIZATION OF SPORTS COMPETITIONS, NAMELY, SWIMMING MEET, SOCCER COMPETITION, SPORT FISHING COMPETITIONS; CORRESPONDENCE COURSES, NAMELY, EDUCATION IN THE FIELD OF REAL ESTATE AND FINANCE ACTIVITY RENDERED THROUGH CORRESPONDENCE COURSES; DIGITAL IMAGING SERVICES; DISCOTHEQUE SERVICES; RENTAL OF SKIN DIVING EQUIPMENT; DUBBING; EDUCATION INFORMATION; EDUCATIONAL EXAMINATION; ENTERTAINMENT INFORMATION; ORGANIZATION OF EXHIBITIONS FOR CULTURAL OR EDUCATIONAL PURPOSES; FILM PRODUCTION; PROVIDING GOLF FACILITIES; VOCATIONAL GUIDANCE; GYMNASIIC INSTRUCTION; HEALTH CLUB SERVICES, NAMELY,

PROVIDING INSTRUCTION AND EQUIPMENT IN THE FIELD OF PHYSICAL EXERCISE; SIGN LANGUAGE INTERPRETATION; LENDING LIBRARIES; MOBILE LIBRARY SERVICES; PRESENTATION OF LIVE PERFORMANCES BY A MUSICAL BAND; OPERATING LOTTERIES; MODELLING FOR ARTISTS; RENTAL OF MOTION PICTURES; RENTAL OF MOVIE PROJECTORS AND ACCESSORIES; MOVIE STUDIOS; MUSIC-HALLS; NEWS REPORTERS SERVICES; NIGHT CLUBS; NURSERY SCHOOLS; ORCHESTRA SERVICES; ORGANIZATION OF BALLS; ORGANIZATION OF FASHION SHOWS; PARTY PLANNING; PHOTOGRAPHIC REPORTING; PHOTOGRAPHY; PHYSICAL EDUCATION; PRACTICAL TRAINING IN THE FIELD OF REAL ESTATE AND FINANCE ACTIVITY; PRODUCTION OF RADIO AND TELEVISION PROGRAMMES; PRODUCTION OF SHOWS, NAMELY, ENTERTAINMENT, NAMELY, PRODUCTION OF TELEVISION SHOWS, PLAYS, OPERAS; VIDEOTAPE FILM PRODUCTION; PROVIDING SPORTS FACILITIES; PUBLICATION OF TEXTS; OTHER THAN PUBLICITY TEXTS; PUBLICATION OF NEWSLETTERS AND DOCUMENTATION IN THE FIELD OF INVESTMENT; RENTAL OF RADIO AND TELEVISION SETS; RADIO ENTERTAINMENT, NAMELY, RADIO ENTERTAINMENT PRODUCTION; RENTAL OF VIDEO CASSETTE RECORDERS; RECORDING STUDIO SERVICES; RENTAL OF AUDIO EQUIPMENT; RENTAL OF LIGHTING APPARATUS FOR THEATRICAL SETS OR TELEVISION STUDIOS; RENTAL OF SHOW SCENERY; RENTAL OF SOUND RECORDINGS; RENTAL OF SPORTS EQUIPMENT, EXCEPT VEHICLES; RENTAL OF STADIUM FACILITIES; RENTAL OF STAGE SCENERY; RENTAL OF TENNIS COURTS; RENTAL OF VIDEO CAMERAS; RENTAL OF VIDEOTAPES; SCRIPTWRITING SERVICES; TIMING OF SPORTS EVENTS; SUBTITLING; TEACHING IN THE FIELD OF REAL ESTATE AND FINANCE ACTIVITY; TELEVISION ENTERTAINMENT, NAMELY, ENTERTAINMENT IN THE NATURE OF TELEVISION NEWS SHOWS; WRITING OF TEXTS, OTHER THAN PUBLICITY TEXTS; ENTERTAINMENT IN THE NATURE OF THEATRE PRODUCTIONS; THEATRICAL TICKET AGENCY SERVICES FOR ENTERTAINMENT; TRANSLATION; VIDEOTAPING; ZOOLOGICAL GARDENS (U.S. CLS. 100, 101 AND 107).
 NAPOLEON SHARMA, EXAMINING ATTORNEY

CLASS 16—PAPER GOODS AND PRINTED MATTER

FOR ADDRESS PLATES FOR ADDRESSING MACHINES; ADDRESS STAMPS; ADDRESSING MACHINES; ADHESIVE TAPE DISPENSERS; ADHESIVES, NAMELY, GLUE FOR STATIONERY OR HOUSEHOLD PURPOSES; ADVERTISEMENT BOARDS OF PAPER OR CARDBOARD; ALBUMS FOR PHOTOGRAPHS; ALMANACS; ANNOUNCEMENT CARDS; AQUARELLES; ARCHITECTS' MODELS; ATLASES; BAGS FOR MICROWAVE COOKING; GARBAGE BAGS OF PAPER OR OF PLASTICS; BALLS, NAMELY, TIPS, FOR BALL-POINT PENS; BIBS OF PAPER; LOOSE-LEAF BINDERS; BINDING STRIPS; BLACKBOARDS; BLOTTERS; BLUE-PRINTS; BOOKBINDING MACHINES; BOOKBINDING CLOTH; BOOKBINDING CORDS; BOOKBINDING MATERIAL; BOOKBINDINGS; BOOKENDS; BOOKLETS IN THE FIELD OF REAL ESTATE AND FINANCE ACTIVITY; BOOKMARKERS; BOOKS IN THE FIELD OF REAL ESTATE AND FINANCE ACTIVITY; PAPER BOWS FOR GIFT WRAPS; BOXES FOR PENS; BOXES OF CARDBOARD OR PAPER; PLASTIC BUBBLE PACKS FOR WRAPPING OR PACKAGING; CABINETS FOR STATIONERY, NAMELY, DESKTOP STATIONERY CABINETS; CALENDARS; CANVAS FOR PAINTING; CARBON PAPER; CARDBOARD; CARDBOARD TUBES; CARDS, NAMELY, BUSINESS CARDS, GREETING CARDS; CASES FOR STAMPS; CATALOGUES IN THE FIELD OF REAL ESTATE AND FINANCE ACTIVITY; CHALK FOR LITHOGRAPHY; CHALK HOLDERS; MARKING CHALK; CHAPLETS; CHARCOAL PENCILS; CHART POINTERS, NON-ELECTRONIC; PRINTED CHARTS; CHECKBOOKS HOLDER; CLIPBOARDS; MONEY CLIPS; CLOTH FOR BOOKBINDING; COASTERS OF PAPER; PAPER FILTERS FOR COFFEE MAKERS; COMIC BOOKS; DRAWING COMPASSES; INK RIBBONS FOR COMPUTER PRINTERS; COPYING PAPER; BOOKBINDING CORDS; CORRECTING FLUIDS FOR TYPE; CORRECTING INK; COVERS OF PAPER FOR FLOWER POTS; BOOK COVERS; PAPER CUTTERS; DECALCOMANIAS; DIAGRAMS FOR BUILDING COMPUTER CIRCUITS; DOCUMENT FILES; DOCUMENT LAMINATORS FOR OFFICE USE; SCENTED PAPER DRAWER LINERS; DRAWING BOARDS; DRAWING INSTRUMENTS; DRAWING MATERIALS FOR BLACKBOARDS; DRAWING PADS; DRAWING PENS; DRAWING SQUARES; DRAWING T-SQUARES; ROTARY DUPLICATORS; PAINTERS' EASELS; ELASTIC BANDS FOR OFFICES; ELECTROCARDIOGRAPH PAPER; ELECTROTYPES; EMBROIDERY DESIGN PATTERNS; ENGRAVING PLATES; ENVELOPE SEALING MACHINES, FOR OFFICES; ENVELOPES; BLACKBOARD ERASERS; ETCHING NEEDLES; ETCHINGS; FABRICS FOR BOOKBINDING; FACE TOWELS OF PAPER; PAPIER MÂCHÉ FIGURINES; FILTER PAPER; PAPER FOLDERS; FOLDERS; PRINTED FORMS; FOUNTAIN PENS; FRANKING MACHINES; FRENCH CURVES; PRINTERS' GALLEY RACKS; GEOGRAPHICAL MAPS; TERRESTRIAL GLOBES; GLUE FOR STATIONERY OR HOUSEHOLD PURPOSES; GRAINING COMBS; GRAPHIC PRINTS; GRAPHIC REPRESENTATIONS; GRAPHIC ART REPRODUCTIONS; HANDKERCHIEFS OF PAPER; PASSPORT HOLDERS; HYGIENIC PAPER; INDIAN INKS; INK STICKS; INK STONES, NAMELY, INK RESERVOIRS; INKING PADS; INKING RIBBONS; INK WELLS; PERFORATED CARDS FOR JACQUARD LOOMS; PAPER KNIVES; LEDGERS BOOKS; LETTER TRAYS; LITHOGRAPHIC WORKS OF ART; LITHOGRAPHS; PAPER MANIFOLDS; MODELLING CLAY; MOULDS FOR MODELLING CLAYS; MODELLING COMPOUNDS, NAMELY, MODELLING PASTE; MODELLING WAX, NOT FOR DENTAL PURPOSES; MOISTENERS FOR GUMMED SURFACES, NAMELY, MOISTENERS IN THE NATURE OF HAND HELD DEVICES FOR WETTING STAMPS, ENVELOPES AND GUMMED PAPER SURFACES; MOISTENERS BEING OFFICE REQUISITES; MUSICAL GREETING CARDS; NAPKINS OF PAPER FOR REMOVING MAKEUP; TABLE NAPKINS OF PAPER; NEWSLETTERS IN THE FIELD OF REAL ESTATE AND FINANCE ACTIVITY; NEWSPAPERS; PEN NIBS; PEN NIBS OF GOLD; NOTE BOOKS; OFFICE PERFORATORS; OFFICE REQUISITES, EXCEPT FURNITURE, NAMELY, PAPER EMBOSSEES; OLEOGRAPHS; PACKING PAPER; DESK PADS; WRITING PADS; PAINT BOXES; PAINTBRUSHES; PAINTERS' BRUSHES; PAINTINGS, FRAMED OR UNFRAMED; PALETTES FOR PAINTERS; PAMPHLETS IN THE FIELD OF REAL ESTATE AND FINANCE ACTIVITY;

SN 79-057,449. AREIM RUSSIA LIMITED, CYPRUS, FILED 1-10-2008.

ACCENT  **REAL ESTATE INVESTMENT MANAGERS**

PRIORITY DATE OF 11-19-2007 IS CLAIMED.
 OWNER OF INTERNATIONAL REGISTRATION 0973595 DATED 1-10-2008, EXPIRES 1-10-2018.

NO CLAIM IS MADE TO THE EXCLUSIVE RIGHT TO USE "REAL ESTATE INVESTMENT MANAGERS", APART FROM THE MARK AS SHOWN.

THE COLOR(S) RED AND GREY IS/ARE CLAIMED AS A FEATURE OF THE MARK.

THE COLOR GREY FOR THE BACKGROUND OF THE APPLIED DESIGNATION AND LITTLE RECTANGLE INSIDE THE T-SHAPED DESIGN ELEMENT; RED FOR THE WORD DESIGNATIONS ACCENT AND REAL ESTATE INVESTMENT MANAGERS AND T-SHAPED DESIGN ELEMENT BETWEEN THEM.

THE APPLIED DESIGNATION IS A COMBINED MARK, CONSISTING OF A DOMINANT WORD ELEMENT "ACCENT" AND OTHER WORD ELEMENTS "REAL ESTATE INVESTMENT MANAGERS" AND T-SHAPED DESIGN ELEMENT; THE WORD ELEMENTS ARE IN RED COLOR IN CAPITALIZED LETTERS OF DIFFERENT SIZE, ON THE GREY BACKGROUND; THE WORD ELEMENTS "REAL ESTATE, INVESTMENT" AND "MANAGERS" ARE PLACED UNDER EACH OTHERS; BETWEEN "ACCENT" AND OTHER WORD ELEMENTS IS A DESIGN ELEMENT IN RED COLOR, VISUALLY PERCEIVED AS A CHIMNEY FLUE AND CONSISTING OF T-SHAPED FIGURE WITH A LITTLE GREY RECTANGLE INSIDE IT; THE APPLIED DESIGNATION IS SEMANTICALLY NEUTRAL TO THE APPLIED GOODS AND SERVICES.

PAPER FOR RECORDING MACHINES; PAPER KNIVES BEING CUTTERS; PAPER RIBBONS; PAPER SHEETS FOR NOTE TAKING; PAPER SHREDDERS FOR OFFICE USE; WAXED PAPER, NAMELY, PARAFFINED PAPER; PAPERCLIPS; PAPERWEIGHTS; PAPIER MACHE; PARCHMENT PAPER; PASTEL CRAYONS; PASTES FOR STATIONERY OR HOUSEHOLD PURPOSES; PATTERNS FOR DRESSMAKING; PATTERNS FOR MAKING CLOTHES; PEN CASES; PEN CLIPS; PENCIL HOLDERS; PENCIL LEAD HOLDERS; PENCIL LEADS; ELECTRIC AND MECHANICAL PENCIL SHARPENERS; PENCILS; PENHOLDERS; PENS; PRINTED PERIODICALS IN THE FIELD OF REAL ESTATE AND FINANCE ACTIVITY; PHOTO-ENGRAVINGS; PHOTOGRAPH STANDS; PHOTOGRAPHS; PICTURES; PLACARDS OF PAPER OR CARDBOARD; PLACE MATS OF PAPER; PORTRAITS; POSTCARDS; POSTERS; PRINTED TIMETABLES; PRINTERS' BLANKETS, NOT OF TEXTILE; PRINTERS' REGLETS; PRINTING BLOCKS; PRINTING TYPE; PRINTS; PRINTED PUBLICATIONS IN THE FIELD OF REAL ESTATE AND FINANCE ACTIVITY; PUNCHES; ROSARIES; RUBBER ERASERS; DRAWING RULERS; SQUARE RULERS, NAMELY, DRAFTING RULERS; SCRAPBOOKS; SEALING STAMPS; SEALING WAX; SEALS BEING STAMPS, NAMELY, IMPRESSION STAMPS; SELF ADHESIVE TAPES FOR STATIONERY OR HOUSEHOLD PURPOSES; SLATE PENCILS; SONG BOOKS; STAMP PADS; STAMP STANDS; STANDS FOR PENS AND PENCILS; STAPLES FOR OFFICES; STAPLING PRESSES; STATIONERY; STEATITE, NAMELY, CHALK FOR TAILORS; STEEL PENS; STENCIL CASES; STENCIL PLATES; STENCILS; STICKERS; TABLE LINEN OF PAPER; TABLECLOTHS OF PAPER; TABLEMATS OF PAPER; TAGS FOR INDEX CARDS; TAILORS' CHALK; TEAR-OFF CALENDARS; THUMBSTICKS; TICKETS, NAMELY, PRICE TICKETS; TISSUES OF PAPER FOR REMOVING MAKEUP; TOILET PAPER; PAPER TOWELS; TRACING CLOTH, NAMELY, TRACING PAPER; TRACING NEEDLES FOR DRAWING PURPOSES; TRACING PAPER; TRANSFERS IN THE NATURE OF DECALCOMANIAS; PAPER TRANSPARENCIES; TYPEWRITER KEYS; TYPEWRITER RIBBONS; TYPEWRITERS, ELECTRIC OR NON-ELECTRIC; WATERCOLORS BEING PAINTINGS; ARTISTS' WATERCOLOUR SAUCERS; WATERCOLOURS; WOOD PULP PAPER; WRAPPERS BEING STATIONERY, NAMELY, COIN AND FOOD WRAPPERS; WRAPPING PAPER; WRISTBANDS FOR THE RETENTION OF WRITING INSTRUMENTS; WRITING BRUSHES; WRITING CHALK; WRITING INSTRUMENTS; WRITING OR DRAWING BOOKS, NAMELY, SCHOOL WRITING BOOKS; WRITING PAPER; WRITING SLATES; WRITING TABLETS (U.S. CLS. 2, 5, 22, 23, 29, 37, 38 AND 50).

CLASS 35—ADVERTISING AND BUSINESS

FOR ACCOUNTING SERVICES; DRAWING UP OF STATEMENTS OF ACCOUNTS, NAMELY, FINANCIAL STATEMENT PREPARATION AND ANALYSIS FOR BUSINESSES; COMMERCIAL ADMINISTRATION OF THE LICENSING OF THE GOODS AND SERVICES OF OTHERS; ADMINISTRATIVE PROCESSING OF PURCHASE ORDERS; ADVERTISING SERVICES; ADVERTISING AGENCIES; ADVERTISING SERVICES BY MAIL ORDER, NAMELY, DIRECT MAIL ADVERTISING; UPDATING OF ADVERTISING MATERIAL; DISSEMINATION OF ADVERTISING MATTER; RENTAL OF ADVERTISING SPACE; COMMERCIAL INFORMATION AND ADVICE FOR CONSUMERS; COST PRICE ANALYSIS; TELEPHONE ANSWERING SERVICES FOR UNAVAILABLE SUBSCRIBERS; BUSINESS APPRAISALS; ARRANGING NEWSPAPER SUBSCRIPTIONS FOR OTHERS; ARRANGING SUBSCRIPTIONS TO TELECOMMUNICATION SERVICES FOR OTHERS; BUSINESS MANAGEMENT OF PERFORMING ARTISTS; BUSINESS MANAGEMENT ASSISTANCE; AUCTIONEERING; ACCOUNT AUDITING; BILL STICKING; BOOKKEEPING; PROFESSIONAL BUSINESS ADMINISTRATION CONSULTANCY; BUSINESS INFORMATION IN THE FIELD OF REAL ESTATE AND FINANCE ACTIVITY; BUSINESS INQUIRIES; BUSINESS INVESTIGATIONS; BUSINESS MANAGEMENT AND ORGANIZATION CONSULTANCY; BUSINESS MANAGEMENT CONSULTANCY; BUSINESS MANAGEMENT OF HOTELS FOR OTHERS; BUSINESS ORGANIZATION CONSULTANCY; BUSINESS RESEARCH; RELOCATION SERVICES FOR BUSINESSES; COMMERCIAL INFOR-

MATION AGENCIES; COMMERCIAL AND INDUSTRIAL MANAGEMENT ASSISTANCE; PRESENTATION OF GOODS ON COMMUNICATION MEDIA, FOR RETAIL PURPOSES; PRICE COMPARISON SERVICES; COMPILATION OF INFORMATION INTO COMPUTER DATABASES; COMPILATION OF STATISTICS; SYSTEMIZATION OF INFORMATION INTO COMPUTER DATABASES; DEMONSTRATION OF PRODUCTS; DIRECT MAIL ADVERTISING; DISTRIBUTION OF SAMPLES FOR PUBLICITY PURPOSES; DOCUMENT REPRODUCTION; ECONOMIC FORECASTING; EFFICIENCY EXPERTS; EMPLOYMENT AGENCIES; EVALUATION OF STANDING TIMBER; EVALUATION OF WOOL; ORGANIZATION OF EXHIBITIONS FOR COMMERCIAL OR ADVERTISING PURPOSES; COMPUTERIZED FILE MANAGEMENT; IMPORT-EXPORT AGENCIES; INFORMATION SERVICES RELATING TO BUSINESS MATTERS; INVOICING; LAYOUT SERVICES FOR ADVERTISING PURPOSES; ADVISORY SERVICES FOR BUSINESS MANAGEMENT; PERSONNEL MANAGEMENT CONSULTATION; MARKETING RESEARCH SERVICES; CONDUCTING MARKETING STUDIES; MODELLING FOR ADVERTISING OR SALES PROMOTION; NEWS CLIPPING SERVICES; RENTAL OF OFFICE MACHINES AND EQUIPMENT; ONLINE ADVERTISING ON COMPUTER COMMUNICATION NETWORK; PUBLIC OPINION POLLING; ORGANIZATION OF TRADE FAIRS FOR COMMERCIAL OR ADVERTISING PURPOSES; OUTSOURCING SERVICES; PAYROLL PREPARATION; PERSONNEL RECRUITMENT; PHOTOCOPYING; WORD PROCESSING; PSYCHOLOGICAL TESTING FOR THE SELECTION OF PERSONNEL; PUBLIC RELATIONS; PUBLICATION OF PUBLICITY TEXTS; PUBLICITY CONSULTATION; PUBLICITY AGENTS; WRITING OF PUBLICITY TEXTS, NAMELY, COLUMNS; PUBLICITY MATERIAL RENTAL; WRITING OF PUBLICITY TEXTS; ADVERTISING SERVICES OF A RADIO AGENCY; PRODUCTION OF RADIO COMMERCIALS; RENTAL OF OFFICE EQUIPMENT, NAMELY, PHOTOCOPYING MACHINES; RENTAL OF VENDING MACHINES; BUSINESS RESEARCH; SALES PROMOTION FOR OTHERS PROVIDED THROUGH COMMUNICATION NETWORK; SECRETARIAL SERVICES; SPONSORSHIP SEARCH; TAX PREPARATION; TELEVISION ADVERTISING AGENCIES; PRODUCTION OF TELEVISION COMMERCIALS; MESSAGE TRANSCRIPTION; TYPING (U.S. CLS. 100, 101 AND 102).

CLASS 36—INSURANCE AND FINANCIAL

FOR ACCIDENT INSURANCE UNDERWRITING; CREDIT BUREAUX FOR APARTMENTS; ACTUARIAL SERVICES; FINANCIAL ANALYSES; ANTIQUE APPRAISAL; APARTMENT HOUSE MANAGEMENT; RENTING OF APARTMENTS; ART APPRAISAL; NUMISMATIC APPRAISAL; REAL ESTATE APPRAISAL; BAIL BONDING; BANKING; HOME BANKING; BUSINESS BROKERAGE; BUSINESS LIQUIDATION SERVICES; CAPITAL INVESTMENT SERVICES; CHARITABLE FUND RAISING; CHECK VERIFICATION; FINANCIAL CLEARING HOUSES; RENT COLLECTION; COLLECTION AGENCIES; FINANCIAL CONSULTANCY; INSURANCE CONSULTANCY; CREDIT BUREAUX; CREDIT CARD SERVICES; ISSUING CREDIT CARDS; CUSTOMS BROKERAGE; DEBIT CARD SERVICES; DEBT COLLECTION AGENCIES; SAFETY DEPOSIT BOX SERVICES; REAL ESTATE AGENCIES; REAL ESTATE MANAGEMENT; FINANCIAL EVALUATION FOR INSURANCE, BANKING AND REAL ESTATE PURPOSES; REPAIR COSTS EVALUATION; EXCHANGING MONEY; FACTORING AGENCIES; FIDUCIARY SERVICES, NAMELY, FIDUCIARY REPRESENTATIVE SERVICES; FINANCIAL INFORMATION PROCESSING; FINANCIAL MANAGEMENT; FINANCIAL SPONSORSHIP OF REAL ESTATE ACTIVITY; FINANCING SERVICES; FIRE INSURANCE UNDERWRITING; FISCAL ASSESSMENTS; FUND INVESTMENTS; ELECTRONIC FUNDS TRANSFER; FINANCIAL GUARANTEES; HEALTH INSURANCE UNDERWRITING; HIRE-PURCHASE FINANCING, NAMELY, BROKERAGE FOR HIRE-PURCHASE; INSURANCE INFORMATION; INSTALLMENT LOANS; INSURANCE BROKERAGE; INSURANCE UNDERWRITING IN THE FIELD OF REAL ESTATE AND CAPITAL INVESTMENT; CAPITAL INVESTMENT SERVICES; ISSUE OF TOKENS OF VALUE; TRAVEL AGENCY SERVICES, NAMELY, ISSUING OF TRAVEL-

LEASERS' CHECKS; LEASE-PURCHASE FINANCING; LEASING OF FARMS; LEASING OF REAL ESTATE; LIFE INSURANCE UNDERWRITING; LOANS FINANCING; MARINE INSURANCE UNDERWRITING; MORTGAGE BANKING; MUTUAL FUNDS INVESTMENT; PAWN BROKERAGE; INVESTMENT CONSULTANCY IN THE FIELD OF REAL ESTATE; BROKERAGE IN THE FIELD OF REAL ESTATE; RENTING OF OFFICES AND APARTMENTS; RENTING OF FLATS; RETIREMENT PAYMENT SERVICES, NAMELY, FINANCIAL PLANNING FOR RETIREMENT; SAFE DEPOSIT BOX SERVICES; SAVINGS BANKS; SECURITIES BROKERAGE; STOCK EXCHANGE PRICE QUOTATIONS; BROKERAGE IN THE FIELD OF STOCKS AND BONDS; TRUSTEESHIP REPRESENTATIVES; FISCAL VALUATIONS (U.S. CLS. 100, 101 AND 102).

CLASS 37—CONSTRUCTION AND REPAIR

FOR INSTALLATION AND REPAIR OF AIR CONDITIONING APPARATUS; ANTI-RUST TREATMENT FOR VEHICLES; ARTIFICIAL SNOW-MAKING SERVICES; ASPHALTING; BOILER CLEANING AND REPAIR; BRICKLAYING; BUILDING CONSTRUCTION SUPERVISION; BUILDING OF FAIR STALLS AND SHOPS; BUILDING SEALING AND CAULKING SERVICES; RENTAL OF BULLDOZERS; INSTALLATION AND MAINTENANCE OF BURGLAR AND/OR FIRE ALARMS; MAINTENANCE AND REPAIR OF BURNERS; CABINET MAKING; CAR WASHING; CHIMNEY SWEEPING; DIAPER CLEANING; DRY CLEANING; RENTAL OF FLOOR CLEANING MACHINES; CLEANING OF BUILDINGS EXTERIOR SURFACES; CLEANING OF BUILDINGS INTERIOR; VEHICLE CLEANING; CLOCK AND WATCH REPAIR; CLEANING OF CLOTHING; CLOTHING REPAIR; INSTALLATION, MAINTENANCE AND REPAIR OF COMPUTER HARDWARE; BUILDING CONSTRUCTION SERVICES; RENTAL OF CONSTRUCTION EQUIPMENT; INFORMATION CONCERNING RENTAL OF EQUIPMENT FOR CONSTRUCTIONS AND BUILDINGS; BUILDING DAMPROOFING; DEMOLITION OF BUILDINGS; DISINFECTING; INSTALLATION OF DOORS AND WINDOWS; DRILLING OF WELLS; ELEVATOR INSTALLATION AND REPAIR; RENTAL OF EARTH MOVING EQUIPMENT AND EXCAVATORS; VERMIN EXTERMINATING, OTHER THAN FOR AGRICULTURE; MINING EXTRACTION; HYDRO ELECTRIC FACTORY CONSTRUCTION; FILM PROJECTOR REPAIR AND MAINTENANCE; FIRE ALARM INSTALLATION AND REPAIR; FURNACE INSTALLATION AND REPAIR; FURNITURE RESTORATION; VEHICLE GREASING; HEATING EQUIPMENT INSTALLATION AND REPAIR; INTERFERENCE SUPPRESSION IN ELECTRICAL APPARATUS; KNIFE SHARPENING; LAUNDERING; LEATHER CARE; LIFT INSTALLATION AND REPAIR; REPAIR OF SECURITY LOCKS, NAMELY, ELECTRONICALLY OPERATED SECURITY LOCKS; VEHICLE LUBRICATION; MACHINERY INSTALLATION; VEHICLE MAINTENANCE; MASONRY; MENDING OF CLOTHING; MINING EXTRACTION; MOTOR VEHICLE MAINTENANCE AND REPAIR; RESTORATION OF MUSICAL INSTRUMENTS; OFFICE MACHINES AND EQUIPMENT INSTALLATION, MAINTENANCE AND REPAIR; PAINTING, INTERIOR AND EXTERIOR; PAPER HANGING; ROAD PAVING; PHOTOGRAPHIC APPARATUS REPAIR; PIER BREAKWATER BUILDING, NAMELY, PIER BREAKWATER CONSTRUCTION; PIPELINE CONSTRUCTION AND MAINTENANCE; PLASTERING; PLUMBING; VEHICLE POLISHING; PRESSING OF CLOTHING; PUMICING; PUMP REPAIR; QUARRYING SERVICES; VERMIN EXTERMINATING IN A NATURE OF RAT EXTERMINATING; REBUILDING OF AUTOMOBILE ENGINES THAT HAVE BEEN WORN OR PARTIALLY DESTROYED; REBUILDING MACHINES THAT HAVE BEEN WORN OR PARTIALLY DESTROYED; REFILLING OF TONER CARTRIDGES; RENTAL OF CRANES BEING CONSTRUCTION EQUIPMENT, NAMELY, CRANE RENTAL AND LEASING FOR CONSTRUCTION PURPOSES; UNDERWATER REPAIR; RESTORATION OF WORKS OF ART; RE-TINNING; TIRE RETREADING; RIVETING; ROAD PAVING; ROOFING SERVICES; RUSTPROOFING; SAFE MAINTENANCE AND REPAIR; SCAFFOLDING ERECTION; VEHICLE SERVICE STATIONS, NAMELY, VEHICLE REFUELLING AND MAINTENANCE; SHIPBUILDING; SHOE REPAIR; STREET CLEANING; SWIMMING-POOL MAINTENANCE; TELE-

PHONE INSTALLATION AND REPAIR; UMBRELLA REPAIR; UNDERWATER BUILDING AND CONSTRUCTION; UPHOLSTERY REPAIR; VEHICLE REPAIR SERVICES; VEHICLE WASHING; WAREHOUSE CONSTRUCTION AND REPAIR; WASHING OF LINEN; WINDOW CLEANING (U.S. CLS. 100, 103 AND 106).

CLASS 41—EDUCATION AND ENTERTAINMENT

FOR EDUCATION SERVICES, NAMELY, CLASSES, SEMINARS, WORKSHOPS IN THE FIELD OF REAL ESTATE AND FINANCE ACTIVITY; PROVIDING AMUSEMENT ARCADE SERVICES; AMUSEMENT PARKS; AMUSEMENTS, NAMELY, AMUSEMENT CENTERS; ANIMAL TRAINING; ARRANGING AND CONDUCTING OF CONCERTS; ARRANGING AND CONDUCTING OF EDUCATIONAL CONFERENCES; ARRANGING AND CONDUCTING OF SEMINARS IN THE FIELD OF REAL ESTATE AND FINANCE ACTIVITY; ARRANGING OF BEAUTY CONTESTS; BOARDING SCHOOLS; BOOKING OF SEATS FOR SHOWS; BOOKMOBILE SERVICES; PUBLICATION OF BOOKS; CALLIGRAPHY SERVICES; HOLIDAY CAMP SERVICES; SPORT CAMP SERVICES; PROVIDING CASINO FACILITIES; RENTAL OF CINE-FILMS; CINEMA THEATER PRESENTATIONS; CIRCUSES; CLUB SERVICES FOR PURPOSE OF ENTERTAINMENT OR EDUCATION, NAMELY, PROVIDING INSTRUCTION AND EQUIPMENT IN THE FIELD OF PHYSICAL EXERCISE; ORGANIZATION OF COMPETITIONS FOR PURPOSE OF EDUCATION OR ENTERTAINMENT, NAMELY, ORGANIZING SPORTING EVENTS, NAMELY, SWIMMING MEET, SOCCER COMPETITION, TRACK AND FIELD COMPETITION, WEIGHT LIFTING COMPETITION; ORGANIZATION OF SPORTS COMPETITIONS, NAMELY, SWIMMING MEET, SOCCER COMPETITION, SPORT FISHING COMPETITIONS; CORRESPONDENCE COURSES, NAMELY, EDUCATION IN THE FIELD OF REAL ESTATE AND FINANCE ACTIVITY RENDERED THROUGH CORRESPONDENCE COURSES; DIGITAL IMAGING SERVICES; DISCOTHEQUE SERVICES; RENTAL OF SKIN DIVING EQUIPMENT; DUBBING; EDUCATION INFORMATION; EDUCATIONAL EXAMINATION; ENTERTAINMENT INFORMATION; ORGANIZATION OF EXHIBITIONS FOR CULTURAL OR EDUCATIONAL PURPOSES; FILM PRODUCTION; PROVIDING GOLF FACILITIES; VOCATIONAL GUIDANCE; GYMNASIUM INSTRUCTION; HEALTH CLUB SERVICES, NAMELY, PROVIDING INSTRUCTION AND EQUIPMENT IN THE FIELD OF PHYSICAL EXERCISE; SIGN LANGUAGE INTERPRETATION; LENDING LIBRARIES; MOBILE LIBRARY SERVICES; PRESENTATION OF LIVE PERFORMANCES BY A MUSICAL BAND; OPERATING LOTTERIES; MODELLING FOR ARTISTS; RENTAL OF MOTION PICTURES; RENTAL OF MOVIE PROJECTORS AND ACCESSORIES; MOVIE STUDIOS; MUSIC-HALLS; NEWS REPORTERS SERVICES; NIGHT CLUBS; NURSERY SCHOOLS; ORCHESTRA SERVICES; ORGANIZATION OF BALLS; ORGANIZATION OF FASHION SHOWS; PARTY PLANNING; PHOTOGRAPHIC REPORTING; PHOTOGRAPHY; PHYSICAL EDUCATION; PRACTICAL TRAINING IN THE FIELD OF REAL ESTATE AND FINANCE ACTIVITY; PRODUCTION OF RADIO AND TELEVISION PROGRAMMES; PRODUCTION OF SHOWS, NAMELY, ENTERTAINMENT, NAMELY, PRODUCTION OF TELEVISION SHOWS, PLAYS, OPERAS; VIDEOTAPE FILM PRODUCTION; PROVIDING SPORTS FACILITIES; PUBLICATION OF TEXTS; OTHER THAN PUBLICITY TEXTS; PUBLICATION OF NEWSLETTERS AND DOCUMENTATION IN THE FIELD OF INVESTMENT; RENTAL OF RADIO AND TELEVISION SETS; RADIO ENTERTAINMENT, NAMELY, RADIO ENTERTAINMENT PRODUCTION; RENTAL OF VIDEO CASSETTE RECORDERS; RECORDING STUDIO SERVICES; RENTAL OF AUDIO EQUIPMENT; RENTAL OF LIGHTING APPARATUS FOR THEATRICAL SETS OR TELEVISION STUDIOS; RENTAL OF SHOW SCENERY; RENTAL OF SOUND RECORDINGS; RENTAL OF SPORTS EQUIPMENT, EXCEPT VEHICLES; RENTAL OF STADIUM FACILITIES; RENTAL OF STAGE SCENERY; RENTAL OF TENNIS COURTS; RENTAL OF VIDEO CAMERAS; RENTAL OF VIDEOTAPES; SCRIPTWRITING SERVICES; TIMING OF SPORTS EVENTS; SUBTITLING; TEACHING IN THE FIELD OF REAL ESTATE AND FINANCE ACTIVITY; TELEVISION ENTERTAINMENT, NAMELY, ENTERTAINMENT IN THE NATURE OF

TELEVISION NEWS SHOWS; WRITING OF TEXTS, OTHER THAN PUBLICITY TEXTS; ENTERTAINMENT IN THE NATURE OF THEATRE PRODUCTIONS; THEATRICAL TICKET AGENCY SERVICES FOR ENTERTAINMENT; TRANSLATION; VIDEOTAPING; ZOOLOGICAL GARDENS (U.S. CLS. 100, 101 AND 107).
 NAPOLEON SHARMA, EXAMINING ATTORNEY

SN 79-057,667. HOFFMANN NEOPAC AG, SWITZERLAND,
 FILED 8-8-2008.

HOFFMANN NEOPAC

THE MARK CONSISTS OF STANDARD CHARACTERS WITHOUT CLAIM TO ANY PARTICULAR FONT, STYLE, SIZE, OR COLOR.

PRIORITY DATE OF 2-15-2008 IS CLAIMED.
 OWNER OF INTERNATIONAL REGISTRATION 0974086
 DATED 8-8-2008, EXPIRES 8-8-2018.

CLASS 6—METAL GOODS

FOR INDUSTRIAL METAL CONTAINERS FOR PACKAGING, AND METAL CLOSURES FOR CONTAINERS; INDUSTRIAL CONTAINERS FOR PACKAGING MADE PRIMARILY OF METAL, AND CLOSURES MADE PRIMARILY OF METAL FOR CONTAINERS (U.S. CLS. 2, 12, 13, 14, 23, 25 AND 50).

CLASS 20—FURNITURE AND ARTICLES NOT OTHERWISE CLASSIFIED

FOR PACKAGING CONTAINERS OF PLASTIC, NAMELY, PLASTIC TUBES MADE OF COMPOSITE PLASTIC AND LAMINATED TUBES; CONTAINERS FOR PACKAGING MADE OF PLASTIC AND MAINLY OF PLASTIC; CLOSURES MADE OF PLASTIC AND MAINLY OF PLASTIC FOR TUBES; AND PACKAGING MADE OF PLASTIC OR MAINLY OF PLASTIC, NAMELY, PLASTIC BINS AND TUBS (U.S. CLS. 2, 13, 22, 25, 32 AND 50).

HEATHER BIDDULPH, EXAMINING ATTORNEY

SN 79-057,862. EARLYBIRD VENTURE CAPITAL; GMBH &
 CO. KG, FED REP GERMANY, FILED 7-14-2008.

EARLYBIRD

OWNER OF INTERNATIONAL REGISTRATION 0697140
 DATED 7-13-1998, EXPIRES 7-13-2018.

OWNER OF U.S. REG. NO. 2,359,257.

CLASS 35—ADVERTISING AND BUSINESS

FOR BUSINESS MANAGEMENT, BUSINESS ADMINISTRATION, OFFICE FUNCTIONS, MANAGEMENT CONSULTING, BUSINESS OPERATION CONSULTING (U.S. CLS. 100, 101 AND 102).

CLASS 36—INSURANCE AND FINANCIAL

FOR MONETARY AFFAIRS, NAMELY, MONETARY STRATEGY CONSULTATION AND RESEARCH, PROVIDING OTHER WITH THE INFORMATION AND OPPORTUNITY TO MAKE MONETARY CONTRIBUTIONS TO CAPITAL FUNDS AND/OR VENTURE CAPITAL FUNDS; VENTURE CAPITAL SERVICES, NAMELY, PROVIDING FINANCING TO EMERGING AND START-UP COMPANIES, INVESTMENT MANAGEMENT SERVICES IN THE FIELD OF ACQUIRING EQUITY IN EMERGING AND START-UP COMPANIES, VENTURE CAPITAL FUNDING SERVICES TO EMERGING AND START-UP COMPANIES, VENTURE CAPITAL INVESTMENT CONSULTATION, MANAGEMENT OF A VENTURE CAPITAL FUND, ORGANIZING, ARRANGING AND CONDUCTING FUND RAISING PROGRAMS FOR ACQUIRING VENTURE CAPITAL; FINANCIAL SERVICES, NAMELY, EQUITY CAPITAL INVESTMENT, MANAGEMENT OF A CAPITAL INVESTMENT FUND, PROVIDING WORKING CAPITAL FINANCING BROKERAGE SERVICES, PROJECT FINANCING, FACILITATING AND ARRANGING FOR THE FINANCING OF COMPANIES, FUNDS INVESTMENT, INVESTMENT MANAGEMENT, INVESTMENT CONSULTATION, INVESTMENT OR FUNDS FOR OTHERS, FINANCIAL ANALYSIS, FINANCIAL RESEARCH AND INFORMATION SERVICES, FINANCIAL MANAGEMENT (U.S. CLS. 100, 101 AND 102).

JAMES GRIFFIN, EXAMINING ATTORNEY

SN 79-058,027. THE NOMAD COMPANY B.V., ZEVENAAR,
 NETHERLANDS, FILED 2-28-2008.

NOMAD

THE MARK CONSISTS OF STANDARD CHARACTERS WITHOUT CLAIM TO ANY PARTICULAR FONT, STYLE, SIZE, OR COLOR.

OWNER OF INTERNATIONAL REGISTRATION 0975088
 DATED 2-28-2008, EXPIRES 2-28-2018.

OWNER OF U.S. REG. NO. 1,543,541.

CLASS 18—LEATHER GOODS

FOR TRAVELLING TRUNKS; VALISES; BAGS, NAMELY, TRAVELLING BAGS; DUFFLE BAGS, RUCKSACKS; DAYPACKS; CASES ON WHEELS, NAMELY, TROLLEYS BAGS, WHEELED DUFFLE BAGS; WEEK-END BAGS, TOILETRY BAGS SOLD EMPTY; SHOULDER BAGS; HANDBAGS; HIP BAGS; NECK BAGS, NAMELY, ALL-PURPOSE CARRYING BAGS; BELT BAGS; BAGS FOR DOCUMENTS AND/OR SECURITIES, NAMELY, PASSPORTS WALLETS, DOCUMENT WALLETS; POCKET WALLETS; PURSES; WALKING STICKS (U.S. CLS. 1, 2, 3, 22 AND 41).

CLASS 20—FURNITURE AND ARTICLES NOT OTHERWISE CLASSIFIED

FOR SLEEPING BAGS; MATTRESSES; CARRY COTS; AIR PILLOWS; AIR CUSHIONS; AIR MATTRESSES FOR USE WHEN CAMPING; INFLATABLE MATTRESSES, INCLUDING SELF-INFLATING MATTRESSES, NAMELY, INFLATABLE MATTRESSES FOR USE WHEN CAMPING (U.S. CLS. 2, 13, 22, 25, 32 AND 50).

CLASS 22—CORDAGE AND FIBERS

FOR TENTS, AWNINGS, TARPAULINS, SACKS AND BAGS, NOT INCLUDED IN OTHER CLASSES, NAMELY, FITTED CASES AND COVERS FOR TENTS (U.S. CLS. 1, 2, 7, 19, 22, 42 AND 50).

CLASS 25—CLOTHING

FOR CLOTHING, NAMELY, OUTDOOR CLOTHING, NAMELY, JACKETS, PANTS, SKIRTS, SHIRTS, VESTS, PULLOVERS, SWEATERS, SHORTS, SKI CLOTHING, NAMELY, SKI JACKETS, SKI TROUSERS, SKI SWEATERS, MOUNTAINEERING BOOTS, CLIMBING BOOTS, HIKING SHOES, CAPS, HATS, GLOVES, SHAWLS AND SOCKS (U.S. CLS. 22 AND 39).

CLASS 35—ADVERTISING AND BUSINESS

FOR BUSINESS INTERMEDIARY AND ADVISORY SERVICES IN THE FIELD OF SELLING PRODUCTS VIA WHOLESALE CHANNELS AND RENDERING SERVICES; IMPORT AND EXPORT AGENCY SERVICES IN THE FIELD OF TRAVELING TRUNKS, VALISES, BAGS, NAMELY, TRAVELING BAGS, DUFFLE BAGS, RUCKSACKS, DAYPACKS, CASES ON WHEELS, NAMELY, TROLLEYS BAGS, WHEELED DUFFLE BAGS, BICYCLE BAGS, TOILETRY BAGS SOLD EMPTY, SHOULDER BAGS, HANDBAGS, HIP BAGS, NECK BAGS, NAMELY, NECKTIE WALLETS, BELT BAGS, BAGS FOR DOCUMENTS AND/OR SECURITIES, NAMELY, PASSPORTS WALLETS, DOCUMENT WALLETS, POCKET WALLETS, PURSES, WALKING STICKS, SLEEPING BAGS, MATTRESSES, CARRY COTS, AIR PILLOWS, AIR CUSHIONS, AIR MATTRESSES, INFLATABLE MATTRESSES, INCLUDING SELF-INFLATING MATTRESSES, TENTS, AWNINGS, TARPAULINS, SACKS AND BAGS, NOT INCLUDED IN OTHER CLASSES, NAMELY, CASES AND COVERS FOR TENTS CASES AND COVERS FOR TENTS, SLEEPING MATS, MATTRESSES, AIR MATTRESSES, AIR PILLOWS AND AIR CUSHIONS, CLOTHING, NAMELY, OUTDOOR CLOTHING, NAMELY, JACKETS, PANTS, SKITS, SHIRTS, VESTS, PULLOVERS, SWEATERS, SHORTS, SKI CLOTHING, NAMELY, SKI JACKETS, SKI TROUSERS, SKI SWEATERS, MOUNTAINEERING BOOTS, CLIMBING BOOTS, HIKING SHOES, CAPS, HATS, GLOVES, SHAWLS AND SOCKS, AFORESAID SERVICES ALSO PROVIDED VIA ELECTRONIC AND TELECOMMUNICATIONS MEANS (U.S. CLS. 100, 101 AND 102).

ROBERT STRUCK, EXAMINING ATTORNEY

CLASS 18—LEATHER GOODS

FOR LEATHER AND IMITATION OF LEATHER, TRUNKS AND SUITCASES, UMBRELLAS, BEACH UMBRELLAS, WALKING STICKS, HAVERSACK, BAGS, NAMELY, ATHLETIC BAGS, SPORTS AND TRAVELING BAGS, GARMENT BAGS FOR TRAVEL, SEA BAGS, NAMELY, DUFFEL BAGS, BACKPACKS, BRIEFCASES, PURSES, WALLETS, KEY CASES, SHOULDER BAGS, CARRY-ON BAGS, TOTE BAGS, HANDBAGS, LEATHER DOG LEASHES, SACHEL BAGS, COSMETIC CARRYING CASES SOLD EMPTY, WAIST BAGS (U.S. CLS. 1, 2, 3, 22 AND 41).

CLASS 25—CLOTHING

FOR CLOTHING ITEMS, NAMELY, SWEATERS, CARDIGANS, SLIPOVER, NAMELY, SLIPS, SUITS, TROUSERS, SHORTS, JUMPERS, RAINCOATS, SUITS AND DRESSES MADE OF LEATHER, STOCKINGS AND SOCKS, GARTER BELTS; OUTERWEAR, NAMELY, JACKETS, WIND-JACKETS, SKI TROUSERS, FUR COATS, OVERCOATS, JACKETS, SKIRTS, DRESSES, JACKETS, UNDERSHIRTS, T-SHIRT, SPORT T-SHIRTS, BLOUSES, SHIRT COLLARS, SHIRTS, FOULARDS, BEACHWEAR, SWIMSUITS, BIKINI, TRACKSUITS, UNDERWEAR, BRAS, BRASSIERE, CORSETS, SLIPS, BRIEFS AND BIKINI BRIEFS, VESTS, NIGHTGOWNS, NEGLIGEEES, PAJAMAS, GLOVES, SHAWLS, SCARVES, NECKTIES, BOWTIES, BELTS SUSPENDERS, HATS AND CAPS, SHOES, BOOTS, LACED BOOTS, LEATHER SHOES, RUBBER SHOES, RAIN SHOES, SPORT SHOES, NAMELY, CASUAL SHOES, RUNNING SHOES, SANDALS, SLIPPERS, SHOE SOLES, SHOE HEELS, MOULDED SOLES FOR SHOES (U.S. CLS. 22 AND 39).

PAUL MORENO, EXAMINING ATTORNEY

SN 79-058,062. FULLBOX SRL, ITALY, FILED 6-11-2008.

SN 79-058,126. AIR BERLIN PLC & CO.; LUFTVERKEHRS KG, 13627 BERLIN, FED REP GERMANY, FILED 6-9-2008.



PRIORITY DATE OF 5-30-2008 IS CLAIMED.
OWNER OF INTERNATIONAL REGISTRATION 0975232 DATED 6-11-2008, EXPIRES 6-11-2018.

THE COLOR(S) RED, BLACK IS/ARE CLAIMED AS A FEATURE OF THE MARK.

THE MARK CONSISTS OF THE WORD "REV" IN SPECIAL CHARACTERS, IN BLACK, INCLUDING A SMALL RED FIVE-POINTED STAR INTERPOSED AT THE BOTTOM OF THE LETTERS "R" AND "E".

THE WORDING "REV" HAS NO MEANING IN A FOREIGN LANGUAGE.

PRIORITY DATE OF 3-7-2008 IS CLAIMED.
OWNER OF INTERNATIONAL REGISTRATION 0975428 DATED 6-9-2008, EXPIRES 6-9-2018.

THE COLOR(S) RED AND WHITE IS/ARE CLAIMED AS A FEATURE OF THE MARK.

THE MARK CONSISTS OF THE WORDING "AIRBERLIN" IN RED ON A WHITE BACKGROUND.

SEC. 2(F).

CLASS 16—PAPER GOODS AND PRINTED MATTER

FOR PAPER, CARDBOARD AND GOODS MADE FROM THESE MATERIALS, NAMELY, BOXES, SIGNBOARDS, CONTAINERS, CARTONS, AND ADVERTISING SIGNS; PRINT PRODUCTS, NAMELY, MAGAZINES, BOOKS, PAMPHLETS, AND LEAFLETS ALL IN THE FIELD OF TRAVEL AND TRAVEL ACCOMMODATIONS; BOOKBINDING MATERIALS; PHOTOGRAPHS; WRITING MATERIALS, NAMELY, PENCILS, PENS AND MARKERS; GLUES FOR PAPER MATERIALS, NAMELY, GLUE FOR STATIONARY OR HOUSEHOLD PURPOSES; WRITING MATERIALS FOR HOUSEHOLD PURPOSES, NAMELY, PAPER, PENCILS, PENS AND MARKERS; MATERIALS FOR ARTISTS, NAMELY, PAINT BRUSHES, PENCILS, PENS, PASTELS AND CANVAS; TYPEWRITERS; OFFICE SUPPLIES NOT INCLUDING FURNITURE, NAMELY, BINDERS, ELASTIC BANDS, GLUE FOR THE OFFICE, STATIONARY, AND STAPLERS; EDUCATION SUPPLIES, NAMELY, WRITING INSTRUMENTS, PENS, PENCILS, MECHANICAL PENCILS, ERASERS, MARKERS, CRAYONS, HIGHLIGHTERS, FOLDERS, NOTEBOOKS, PAPER, PAPER CLIPS, PENCIL SHARPENERS, WRITING GRIPS, GLUE AND BOOK MARKS; PACKAGING MADE OF PLASTIC NOT INCLUDED IN OTHER CLASSES, NAMELY, PLASTIC BAGS AND BUBBLE PACKS; PRINTED LETTERS AND PRINT MACHINES, NAMELY, LABEL PRINTING MACHINES (U.S. CLS. 2, 5, 22, 23, 29, 37, 38 AND 50).

CLASS 39—TRANSPORTATION AND STORAGE

FOR TRANSPORTATION, PACKING AND STORAGE OF GOODS, ARRANGING OF TOURS (U.S. CLS. 100 AND 105).

CLASS 43—HOTEL AND RESTAURANT SERVICES

FOR PROVIDING TEMPORARY ACCOMMODATION AND CATERING FOR GUESTS; TRAVEL AGENCY SERVICES, NAMELY, PROVIDING THE ARRANGEMENT OF TEMPORARY ACCOMMODATION AND CATERING OF GUESTS; RESERVATION OF HOTEL ROOMS FOR TRAVELERS (U.S. CLS. 100 AND 101).
KATHERINE CONNOLLY, EXAMINING ATTORNEY

SN 79-058,256. PROTEINFABRIKKEN AS, NORWAY, FILED 6-25-2008.

IRONCORE NUTRITION

THE MARK CONSISTS OF STANDARD CHARACTERS WITHOUT CLAIM TO ANY PARTICULAR FONT, STYLE, SIZE, OR COLOR.

PRIORITY DATE OF 5-28-2008 IS CLAIMED.
OWNER OF INTERNATIONAL REGISTRATION 0975765 DATED 6-25-2008, EXPIRES 6-25-2018.

NO CLAIM IS MADE TO THE EXCLUSIVE RIGHT TO USE "NUTRITION", APART FROM THE MARK AS SHOWN.

CLASS 29—MEATS AND PROCESSED FOODS

FOR DIET, FOOD AND PROTEIN SUPPLEMENT PRODUCTS BASED ON ANIMAL NUTRIENTS, NAMELY, PROTEINS BEING FOODSTUFFS FOR HUMAN CONSUMPTION, PROTEIN BASED, NUTRIENT-DENSE SNACK BARS, PROTEIN FOR USE AS A FOOD ADDITIVE, PROTEIN POWDER FOR USE AS A FOOD ADDITIVE, WEIGHT MANAGEMENT POWDERS FOR USE AS A FOOD FILLERS, NAMELY, PROTEIN POWDERS FOR HUMAN CONSUMPTION FOR USE AS A FOOD ADDITIVE (U.S. CL. 46).

CLASS 32—LIGHT BEVERAGES

FOR AROMATIZED BEVERAGES BASED ON FRUIT, PROTEIN, CORDIAL, SUGAR AND OTHER FLUID NUTRIENTS, NAMELY, ENERGY DRINKS, PROTEIN DRINKS FOR USE AS A FOOD FILLERS AND NOT FOR USE AS A MEAL REPLACEMENT, CARBOHYDRATES DRINKS FOR USE AS A FOOD FILLERS, WHEY BEVERAGES, FRUIT BEVERAGES, SPORTS DRINKS, ISOTONIC DRINKS, AND FLAVORED BOTTLED WATER (U.S. CLS. 45, 46 AND 48).

CHRISTINE BLOMQUIST, EXAMINING ATTORNEY

SN 79-058,376. PURE TECHNOLOGY LIMITED; TRADING AS JAI KUDO, UNITED KINGDOM, FILED 4-22-2008.

JK LONDON

THE MARK CONSISTS OF STANDARD CHARACTERS WITHOUT CLAIM TO ANY PARTICULAR FONT, STYLE, SIZE, OR COLOR.

PRIORITY DATE OF 4-15-2008 IS CLAIMED.
OWNER OF INTERNATIONAL REGISTRATION 0976066 DATED 4-22-2008, EXPIRES 4-22-2018.

NO CLAIM IS MADE TO THE EXCLUSIVE RIGHT TO USE "LONDON", APART FROM THE MARK AS SHOWN.
THE NAME IN THE MARK DOES NOT IDENTIFY A LIVING INDIVIDUAL.

CLASS 9—ELECTRICAL AND SCIENTIFIC APPARATUS

FOR OPTICAL LENSES, OPTICAL FRAMES, SPECTACLES, CONTACT LENSES, AND SUNGLASSES; CONTAINERS FOR CONTACT LENSES; SPECTACLE AND SUNGLASSES' CASES; SPECTACLE AND SUNGLASSES' CHAINS AND CORDS; MAGNIFYING GLASSES, TELESCOPES, AND BINOCULARS; OPTICAL APPARATUS AND INSTRUMENTS, NAMELY, EQUIPMENT DESIGNED FOR CUTTING, DRILLING, MARKING, ENGRAVING, BUFFING, SHAPING, AND TINTING OPTICAL LENSES; CLEANING APPARATUS, NAMELY, EQUIPMENT DESIGNED FOR CLEANING, BUFFING, AND FINISHING OPTICAL LENSES AND OPTICAL FRAMES; PARTS AND FITTINGS, NAMELY, NOSE PADS, MOUNTINGS, SCREWS, PINS, AND HINGES FOR ALL THE AFORESAID GOODS, ALL INCLUDED IN THIS CLASS (U.S. CLS. 21, 23, 26, 36 AND 38).

CLASS 40—MATERIAL TREATMENT

FOR MANUFACTURING SERVICES RELATING TO LENSES, FRAMES, SPECTACLES, CONTACT LENSES AND SUNGLASSES (U.S. CLS. 100, 103 AND 106).

CLASS 44—MEDICAL, BEAUTY AND AGRICULTURAL SERVICES

FOR OPTICIAN SERVICES; ALL INCLUDED IN THIS CLASS (U.S. CLS. 100 AND 101).
MARILYN IZZI, EXAMINING ATTORNEY

SN 79-058,380. REDBUBBLE PTY LTD, FITZROY VIC 3065, AUSTRALIA, FILED 11-7-2007.

REDBUBBLE

PRIORITY DATE OF 5-11-2007 IS CLAIMED.
OWNER OF INTERNATIONAL REGISTRATION 0976072 DATED 11-7-2007, EXPIRES 11-7-2017.
THE WORDING "REDBUBBLE" HAS NO MEANING IN A FOREIGN LANGUAGE.

CLASS 16—PAPER GOODS AND PRINTED MATTER

FOR WORKS OF CREATIVE EXPRESSION, NAMELY, PHOTOGRAPHS, PAINTINGS, ART PRINTS, GRAPHIC AND PRINTED ART REPRODUCTIONS, LITHOGRAPHIC WORKS OF ART, CALENDARS, GREETING CARDS, ALBUMS, BOOKS FEATURING ART REPRODUCTIONS AND GRAPHIC PRINTS, BOOKMARKS, MAGAZINES FEATURING ART REPRODUCTIONS AND GRAPHIC PRINTS, PICTURES, PORTRAITS, POSTCARDS, POSTERS, STATIONERY, AND STICKERS (U.S. CLS. 2, 5, 22, 23, 29, 37, 38 AND 50).

CLASS 35—ADVERTISING AND BUSINESS

FOR ONLINE RETAIL STORE SERVICES FEATURING WORKS OF CREATIVE EXPRESSION, IN THE NATURE OF PHOTOGRAPHS, PRINTED APPAREL, MAGAZINES AND DIGITAL ARTS; ADVERTISING AND PROMOTIONAL SERVICES OF ART AND CREATIVE WORKS; CONSULTANCY IN THE FIELD OF ADVERTISING OF CREATIVE WORKS; ORGANIZING OF EXHIBITIONS FOR COMMERCIAL OR ADVERTISING PURPOSES RELATED TO WORKS OF CREATIVE EXPRESSION, INCLUDING, BUT NOT LIMITED TO, PHOTOGRAPHS, PRINTED APPAREL, MAGAZINES, AND DIGITAL ARTS; PUBLICITY SERVICES, NAMELY, PROMOTING AND MARKETING THE GOODS AND SERVICES OF OTHERS THROUGH ELECTRONIC COMMUNICATION MEANS AND VIA ONLINE DISTRIBUTION OF ADVERTISEMENTS AND COMMERCIAL ANNOUNCEMENTS (U.S. CLS. 100, 101 AND 102).
SUE LAWRENCE, EXAMINING ATTORNEY

SN 79-058,398. PROSPER INTELLIGENCE; INFORMATION-STECHNOLOGIE GMBH, AUSTRIA, FILED 6-18-2008.



PRIORITY DATE OF 12-18-2007 IS CLAIMED.
OWNER OF INTERNATIONAL REGISTRATION 0976107 DATED 6-18-2008, EXPIRES 6-18-2018.

NO CLAIM IS MADE TO THE EXCLUSIVE RIGHT TO USE "VIRTUALIZATION CONSOLIDATION ACADEMY", APART FROM THE MARK AS SHOWN.

THE COLOR(S) GRAY, LIGHT BLUE, BLUE, GREEN, YELLOW, BLACK AND WHITE IS/ARE CLAIMED AS A FEATURE OF THE MARK.

THE MARK CONSISTS OF THE COLORS GRAY, LIGHT BLUE, BLUE, GREEN, YELLOW, BLACK AND WHITE, WITH THE WORDS "VIRTUALIZATION CONSOLIDATION ACADEMY" APPEARING IN BLACK, THE LETTERS "VCA" APPEARING IN LIGHT BLUE, GREEN, YELLOW, AND BLUE OUTLINES, AND A GRAY DIAGONAL LINE APPEARING ON THE LEFT SIDE OF THE "V" IN "VCA" AND CONNECTING TO A GRAY LINE WHICH APPEARS UNDER "VCA" AND "ACADEMY", ALL AGAINST A WHITE BACKGROUND.

CLASS 9—ELECTRICAL AND SCIENTIFIC APPARATUS

FOR COMPUTER SOFTWARE FOR THE PURPOSE OF VIRTUALIZATION AND CONSOLIDATION OF SOFTWARE APPLIANCES, OPERATING SYSTEMS AND HARDWARE SYSTEMS (U.S. CLS. 21, 23, 26, 36 AND 38).

CLASS 41—EDUCATION AND ENTERTAINMENT

FOR COMPUTER EDUCATION TRAINING IN THE FIELD OF COMPUTER PROGRAMMING AND DATA PROCESSING ESPECIALLY IN CONNECTION WITH VIRTUALIZATION AND CONSOLIDATION SOLUTIONS FOR THE CONSOLIDATION OF THE IT ENVIRONMENT (U.S. CLS. 100, 101 AND 107).

CLASS 42—SCIENTIFIC AND COMPUTER SERVICES

FOR DESIGN AND DEVELOPMENT OF COMPUTER SOFTWARE AND COMPUTER HARDWARE; DEVELOPMENT OF PROGRAMS FOR DATA PROCESSING; COMPUTER SOFTWARE CONSULTANCY; COMPUTER SERVICES, NAMELY, CONSULTING SERVICES IN THE FIELD OF DESIGN, SELECTION, IMPLEMENTATION AND USE OF COMPUTER HARDWARE AND SOFTWARE SYSTEMS FOR OTHERS IN ORDER TO ACHIEVE A REDUCTION OF INFORMATION TECHNOLOGY EXPENSES AND SYSTEM SIMPLIFICATION; COMPUTER NETWORK DESIGN FOR OTHERS (U.S. CLS. 100 AND 101).
CHRISTINE BLOMQUIST, EXAMINING ATTORNEY

SN 79-058,420. EDITORIALE CAMPI S.R.L., ITALY, FILED 4-3-2008.

BARBANERA

THE MARK CONSISTS OF STANDARD CHARACTERS WITHOUT CLAIM TO ANY PARTICULAR FONT, STYLE, SIZE, OR COLOR.

OWNER OF INTERNATIONAL REGISTRATION 0766669 DATED 12-5-2000, EXPIRES 12-5-2010.

THE ENGLISH TRANSLATION OF "BARBANERA" IN THE MARK IS "BLACKBEARD".

CLASS 16—PAPER GOODS AND PRINTED MATTER

FOR PAPER, CARDBOARD AND GOODS MADE OF THESE MATERIALS, NOT INCLUDED IN OTHER CLASSES, NAMELY, PRINTED PAPER SIGNS, CARDBOARD BOXES; PRINTED MATTER, NAMELY, ALMANACS IN THE FIELD OF ASTROLOGY; NEWSPAPERS, PRINTED PERIODICALS IN THE FIELD OF FORTUNE TELLING, BOOKS IN THE FIELD OF ASTROLOGICAL CHARTS; BOOKBINDING MATERIAL; PHOTOGRAPHS; STATIONERY; ADHESIVES FOR STATIONERY OR HOUSEHOLD PURPOSES; MATERIALS FOR ARTISTS NAMELY, EASELS; PAINTBRUSHES; TYPEWRITERS AND OFFICE REQUISITES EXCEPT APPARATUS, NAMELY, STAPLERS; PLASTIC MATERIALS FOR PACKAGING NOT INCLUDED IN OTHER CLASSES, NAMELY, PLASTIC BAGS FOR PACKAGING; PLAYING CARDS; PRINTING TYPE; PRINTING BLOCKS (U.S. CLS. 2, 5, 22, 23, 29, 37, 38 AND 50).

CLASS 41—EDUCATION AND ENTERTAINMENT

FOR EDUCATION, ENTERTAINMENT AND INSTRUCTION SERVICES, NAMELY, PROVIDING SEMINARS, CLASSES, TUTORIALS IN THE FIELD OF ASTROLOGY, CARD-READING; PUBLICATION OF BOOKS, MAGAZINES, ALMANACS, JOURNALS ABOUT ASTROLOGICAL AND CARD-READING PREDICTIONS (U.S. CLS. 100, 101 AND 107).

CLASS 42—SCIENTIFIC AND COMPUTER SERVICES

FOR EDITORIAL SERVICES, NAMELY, PROVIDING TEMPORARY USE OF ONLINE NON-DOWNLOADABLE SOFTWARE FOR USE IN EDITING PRINTED PUBLICATIONS ABOUT ASTROLOGICAL PREDICTIONS AND CARD-READING PREDICTIONS, AND PROVIDING TEMPORARY USE OF ONLINE NON-DOWNLOADABLE SOFTWARE FOR USE IN EDITING PRINTED PUBLICATIONS FEATURING GENERAL INFORMATION ON HOROSCOPE CASTING (U.S. CLS. 100 AND 101).

MELISSA VALLILLO, EXAMINING ATTORNEY

SN 79-058,519. FM MARKETING GMBH, AUSTRIA, FILED 3-13-2008.

invitro

THE MARK CONSISTS OF STANDARD CHARACTERS WITHOUT CLAIM TO ANY PARTICULAR FONT, STYLE, SIZE, OR COLOR.

PRIORITY DATE OF 10-10-2007 IS CLAIMED.

OWNER OF INTERNATIONAL REGISTRATION 0976390 DATED 3-13-2008, EXPIRES 3-13-2018.

SN 79-058,426. BEIJING ORIENT SCIENCE & TECHNOLOGY; DEVELOPMENT CO., LTD., BEIJING, CHINA, FILED 2-2-2008.

E' GRID

OWNER OF INTERNATIONAL REGISTRATION 0863591 DATED 3-30-2005, EXPIRES 3-30-2015.

NO CLAIM IS MADE TO THE EXCLUSIVE RIGHT TO USE "GRID", APART FROM THE MARK AS SHOWN.

CLASS 19—NON-METALLIC BUILDING MATERIALS

FOR MATERIALS FOR MAKING AND COATING ROADS, NAMELY, POLYMER MESH; CONCRETE BUILDING MATERIALS, NAMELY, BLOCKS, BRICKS, POSTS, POLES, SLABS, PANELS; BITUMINOUS PRODUCTS FOR BUILDING, NAMELY, FIBREGLASS MESH, COATED WITH BITUMEN OR MODIFIED POLYMER; CONSTRUCTION ELEMENTS NOT MADE OF METAL, NAMELY, SHORES; CONSTRUCTION ELEMENTS NOT MADE OF METAL, NAMELY, BRACES; GEOTEXTILES, NAMELY, FABRICS FOR USE IN CIVIL ENGINEERING, TARPULIN, FABRIC AND SHEETING FOR NURSERY, GREENHOUSES AND LANDSCAPING (U.S. CLS. 1, 12, 33 AND 50).

CLASS 42—SCIENTIFIC AND COMPUTER SERVICES

FOR DESIGN AND ADVISORY SERVICES RELATING TO GEO-TECHNICAL AND HIGHWAY ENGINEERING; ENGINEERING DRAWINGS; MATERIAL TESTING; ARCHITECTURAL CONSULTATION; ENGINEERING; CONSTRUCTION DRAFTING (U.S. CLS. 100 AND 101).

LOURDES AYALA, EXAMINING ATTORNEY

CLASS 9—ELECTRICAL AND SCIENTIFIC APPARATUS

FOR REMOTE CONTROLS FOR COMPUTERS, RADIOS, TELEVISIONS, STEREOS AND DVD-PLAYERS; VIDEO GAME INTERACTIVE REMOTE CONTROL UNITS; KEYBOARDS, MULTIFUNCTION KEYBOARDS, COMPUTER KEYBOARDS, KEYBOARDS FOR MOBILE PHONE; TELEVISION DECODERS AND RECEIVERS, TELEVISION SETS; COMPUTER HARDWARE FOR TELECOMMUNICATIONS; VIDEO GAME MACHINES FOR USE WITH TELEVISIONS; COMMUNICATIONS SOFTWARE FOR CONNECTING COMPUTER NETWORK USERS, COMPUTER COMMUNICATIONS SOFTWARE TO ALLOW CUSTOMERS TO ACCESS BANK ACCOUNT INFORMATION AND TRANSACT BANK BUSINESS, COMPUTER E-COMMERCE SOFTWARE TO ALLOW USERS TO PERFORM ELECTRONIC BUSINESS TRANSACTIONS VIA A GLOBAL COMPUTER NETWORK, COMPUTER GAMES SOFTWARE, COMPUTER HARDWARE AND SOFTWARE USED FOR THE CONTROL OF VOICE CONTROLLED INFORMATION AND COMMUNICATION DEVICES, COMPUTER SOFTWARE FOR USE IN CONTROLLING AND IMPROVING AUDIO EQUIPMENT, SOUND QUALITY, VIDEO EQUIPMENT, IMAGE QUALITY AND HANDLING OF HOME ENTERTAINMENT APPARATUS IN THE FIELD OF HOME ENTERTAINMENT, VIDEO GAME SOFTWARE; COMPUTER SOFTWARE FOR ORGANIZING AND VIEWING DIGITAL IMAGES, MOVIES AND PHOTOGRAPHS (U.S. CLS. 21, 23, 26, 36 AND 38).

CLASS 38—COMMUNICATION

FOR COMMUNICATION VIA RADIO, TELEGRAPH, TELEPHONE AND TELEVISION TRANSMISSIONS; COMMUNICATION BY COMPUTER TERMINALS, COMMUNICATIONS BY MEANS OF MOBILE PHONES, COMMUNICATIONS BY TELEVISION FOR VIDEO CONFERENCES; COMMUNICATIONS SERVICES, NAMELY, TRANSMITTING STREAMED SOUND AND AUDIO VISUAL RECORDINGS VIA THE INTERNET AND VIA MULTINATIONAL TELECOMMUNICATION NETWORKS IN THE NATURE OF DATA COMMUNICATION NETWORKS, SATELLITE COMMUNICATION NETWORKS, BROADCASTING TELECOMMUNICATION NETWORKS, CABLE TELECOMMUNICATION NETWORKS, AND WIRELESS TELECOMMUNICATION NETWORKS; COMPUTER AIDED TRANSMISSION OF INFORMATION AND IMAGES; ELECTRONIC DATA INTERCHANGE, ELECTRONIC DATA TRANSMISSION; PAY-PER-VIEW TELEVISION TRANSMISSION SERVICES (U.S. CLS. 100, 101 AND 104).

CLASS 42—SCIENTIFIC AND COMPUTER SERVICES

FOR COMPUTER SOFTWARE CONSULTATION, COMPUTER SOFTWARE DEVELOPMENT, COMPUTER SOFTWARE DESIGN, COMPUTER PROGRAMMING, AND MAINTENANCE OF COMPUTER SOFTWARE, PROGRAMMING COMPUTER SOFTWARE FOR ORGANIZING AND VIEWING DIGITAL IMAGES, MOVIES AND PHOTOGRAPHS, DESIGN OF COMPUTER NETWORKS AND SOFTWARE FOR OTHERS FOR THE FIELD OF HOME ENTERTAINMENT, PERIODIC UPGRADING OF COMPUTER SOFTWARE FOR OTHERS; TECHNICAL SUPPORT SERVICES, NAMELY, CONSULTANCY RELATED TO COMPUTER HARDWARE AND SOFTWARE PROBLEMS; COMPUTER SOFTWARE DEVELOPMENT FOR ORGANIZING AND VIEWING DIGITAL IMAGES, MOVIES AND PHOTOGRAPHS (U.S. CLS. 100 AND 101).

LAURA HAMMEL, EXAMINING ATTORNEY

SN 79-058,571. EWALD HAIMERL, FED REP GERMANY, FILED 8-22-2008.

FIRE HERO

SN 79-058,568. GUANGZHOU PANYU WEIHUA; ELECTRICAL PRODUCTS LTD., CHINA, FILED 7-3-2008.



OWNER OF INTERNATIONAL REGISTRATION 0976483 DATED 7-3-2008, EXPIRES 7-3-2018.

THE MARK CONSISTS OF THE STYLIZED WORDING "VITER" WHEREIN THE LETTER "V" IS ENLARGED RELATIVE TO THE LETTERS "ITER"; A DIAGONAL LINE CONNECTED TO A HORIZONTAL LINE APPEARING ABOVE THE LETTERS "ITER" EMANATES FROM THE LETTER "V"; THERE IS A SHADED CIRCLE AFTER THE WORD "VITER".

CLASS 17—RUBBER GOODS

FOR PLASTIC IN THE FORM OF BARS, BLOCKS, PELLETS, RODS, SHEETS AND TUBES FOR USE IN MANUFACTURING (U.S. CLS. 1, 5, 12, 13, 35 AND 50).

CLASS 20—FURNITURE AND ARTICLES NOT OTHERWISE CLASSIFIED

FOR FURNITURE; SIDEBOARDS; CHAIRS; FURNITURE OF METAL; FURNITURE, NAMELY, DINNER WAGONS; CHESTS OF DRAWERS; CUSHIONS; SAW HORSES; PICTURE FRAMES (U.S. CLS. 2, 13, 22, 25, 32 AND 50).

MICHAEL TANNER, EXAMINING ATTORNEY

THE MARK CONSISTS OF STANDARD CHARACTERS WITHOUT CLAIM TO ANY PARTICULAR FONT, STYLE, SIZE, OR COLOR.

PRIORITY DATE OF 8-11-2008 IS CLAIMED.

OWNER OF INTERNATIONAL REGISTRATION 0976494 DATED 8-22-2008, EXPIRES 8-22-2018.

NO CLAIM IS MADE TO THE EXCLUSIVE RIGHT TO USE "FIRE" IN INTERNATIONAL CLASSES 9, 16 AND 28, APART FROM THE MARK AS SHOWN.

CLASS 9—ELECTRICAL AND SCIENTIFIC APPARATUS

FOR SAFETY FOOTWEAR, SAFETY BOOTS, PROTECTIVE AND SAFETY CLOTHING (U.S. CLS. 21, 23, 26, 36 AND 38).

CLASS 16—PAPER GOODS AND PRINTED MATTER

FOR PRINTED MATERIALS, NAMELY, TEXTBOOKS, SUMMARIES, BROCHURES, ALL RELATING TO FIRE AND SECURITY HAZARDS; BOOKBINDING MATERIALS; PHOTOGRAPHS; STATIONERY; ADHESIVES FOR STATIONERY OR HOUSEHOLD PURPOSES; PAINT BRUSHES; PRINTED INSTRUCTIONAL AND TEACHING MATERIAL IN THE FIELD OF FIRE AND SECURITY HAZARDS; PRINTERS' TYPE; PRINTING BLOCKS; POSTERS; NEWSPAPERS, PRINTED PERIODICALS IN THE FIELD OF FIRE AND SECURITY HAZARDS AND COMIC STRIPS (U.S. CLS. 2, 5, 22, 23, 29, 37, 38 AND 50).

CLASS 25—CLOTHING

FOR CLOTHING, NAMELY, SHIRTS, PANTS, COATS, SWEATERS; FOOTWEAR; HEADGEAR, NAMELY, HATS, CAPS (U.S. CLS. 22 AND 39).

CLASS 28—TOYS AND SPORTING GOODS

FOR DECORATIONS FOR CHRISTMAS TREES; TOY FIGURES (U.S. CLS. 22, 23, 38 AND 50).

MONIQUE MILLER, EXAMINING ATTORNEY

SN 79-058,609. COLOPLAST A/S, DENMARK, FILED 6-21-2008.

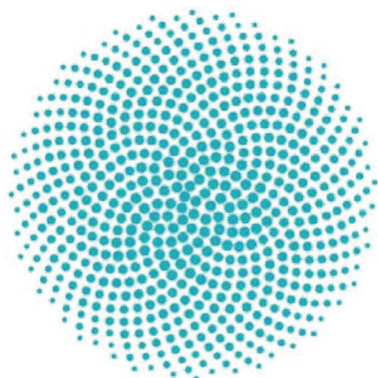

PRIORITY DATE OF 3-3-2008 IS CLAIMED.
OWNER OF INTERNATIONAL REGISTRATION 0976597
DATED 6-21-2008, EXPIRES 6-21-2018.

THE COLOR(S) TURQUOISE IS/ARE CLAIMED AS A
FEATURE OF THE MARK.

THE MARK CONSISTS OF THE COLOR TURQUOISE;
THE COLOR TURQUOISE APPEARS IN THE DOTS IN THE
SWIRL PATTERN THAT MAKE UP THE CIRCLE.

CLASS 3—COSMETICS AND CLEANING PREPARATIONS

FOR NON-MEDICATED PREPARATIONS FOR THE
CARE OF THE SKIN (U.S. CLS. 1, 4, 6, 50, 51 AND 52).

CLASS 5—PHARMACEUTICALS

FOR PHARMACEUTICAL PREPARATIONS FOR
WOUND TREATMENT; MEDICAL DRESSINGS, SURGI-
CAL DRESSINGS, WOUND DRESSINGS, SURGICAL
BANDAGES, MEDICAL ADHESIVE BANDAGES, BAN-
DAGES FOR SKIN WOUNDS; MEDICAL WOUND FILL-
ING MATERIALS IN THE FORM OF GEL, POWDER,
GRANULATES, PASTE OR ROPE, NAMELY, PHARMA-
CEUTICAL PREPARATIONS FOR WOUNDS; PLASTERS
FOR MEDICAL PURPOSES; ADHESIVE TAPE STRIPS
FOR MEDICAL PURPOSES, MEDICAL ADHESIVE BAN-
DAGES IN THE FORM OF STRIPS AND DISCS; MEDI-
CAL ADHESIVE BANDAGES CONTAINING
ANTIMICROBIAL TEXTILE MATERIALS; PREPARA-
TIONS FOR MEDICAL PURPOSES IN THE FORM OF
POWDERS, CREAMS, LOTIONS, AND PASTES,
NAMELY, BARRIER CREAMS FOR SOOTHING OF
DRY AND SORE SKIN PROTECTING AGAINST MA-
CERATION AND IRRITATED SKIN THAT COMES
FROM OSTOMY OR PERINEAL SKIN INJURIES; MEDI-
CATED LOTIONS FOR MOISTURIZATION OF SKIN
FOR DIABETIC FEET OR INCONTINENTS' DRY SKIN;
PASTES FOR FILLING CAVITIES AND LEVELING OUT
SKIN FOLDS AND WRINKLES TO PROVIDE A SECURE
SEAL AROUND A STOMA; PREPARATIONS IN THE
FORM OF CLEANSERS FOR OSTOMY OR PERINEAL
SKIN INJURIES; OSTOMY BAG DEODORANT IN POW-
DER FORM; PHARMACEUTICAL PREPARATIONS FOR
THE TREATMENT OF INCONTINENCE; PHARMA-
CEUTICAL PREPARATIONS FOR THE TREATMENT OF
THE URINARY TRACT SYSTEM; SANITARY URINE
ABSORBING TOWELS, URINE DRIP COLLECTORS,
NAMELY, AN ENVELOPE PLACED INSIDE UNDER-
WEAR TO ABSORB INCONTINENCE DRIPPING; UN-
DERWEAR FOR INCONTINENCE; TAMPONS FOR
HYGIENIC AND SURGICAL USE; PHARMACEUTICAL
PREPARATIONS AND SUBSTANCES FOR THE TREAT-
MENT OF SKIN DISORDERS; PHARMACEUTICAL
PREPARATIONS FOR THE TREATMENT OF OSTOMY
AND HERNIA CONDITIONS; MEDICATED PASTE FOR
LEVELING OUT SCARS AND SKIN FOLDS; DEODOR-
ANTS FOR MEDICAL PURPOSES FOR OSTOMY BAGS
AND CONTINENCE DEVICES (U.S. CLS. 6, 18, 44, 46, 51
AND 52).

CLASS 10—MEDICAL APPARATUS

FOR MEDICAL AND SURGICAL INSTRUMENTS FOR
USE IN THE TREATMENT OF OSTOMY, NAMELY,
OSTOMY BAGS, STRUCTURAL PARTS AND FITTINGS
FOR OSTOMY BAGS, NAMELY, MEDICAL TUBES,
MEDICAL ABDOMINAL BELTS, CLOSURE CLAMPS
FOR OSTOMY BAGS, MEDICAL VALVES, MEDICAL
ODOUR FILTERS FOR OSTOMY BAGS AND INCON-
TINENCE BAGS; MEDICAL PLUGS, NAMELY, PLUGS
INSERTED INTO AN OSTOMY IN ORDER TO EFFEC-
TIVELY BLOCK FECES, BUT CONTINUE TO ALLOW
FLATUS TO PASS THROUGH AN ODOUR ELIMINAT-
ING FILTER; MEDICAL CANNULAE; MEDICAL CA-
THETERS; ELASTIC BANDAGES; SUTURE
MATERIALS; BELTS FOR MEDICAL PURPOSES FOR
KEEPING IN PLACE BAGS AND CATHETERS; MEDI-
CAL AND SURGICAL APPARATUS AND INSTRU-
MENTS, NAMELY, ORTHOPEDIC SUPPORTS FOR THE
TREATMENT OF OSTOMY AND INCONTINENCE CON-
DITIONS, ORTHOPEDIC SUPPORTIVE BANDAGES,
SUPPORTIVE UNDERWEAR FOR MEDICAL PUR-
POSES; MEDICAL AND SURGICAL INSTRUMENTS
AND APPARATUS FOR USE IN THE TREATMENT OF
CONTINENCE, NAMELY, IRRIGATION APPLIANCES,
MEDICAL PROBES, CONDOMS FOR COLLECTION OF
URINE, URISHEATHS, FLEXIBLE HOSES, TUBES AND
TUBE JOINTS THEREFOR, URETHRAL STENTS, CAN-
NULAE FOR MEDICAL USE, BAGS, COLLECTORS AND
RECEPTACLES FOR THE COLLECTION OF EXCRE-
TIONS FROM THE HUMAN BODY, EXTERNAL AND
INDWELLING CATHETERS, SURGICAL AND MEDI-
CAL DEVICES IN THE FORM OF ELECTRONIC STI-
MULATING APPARATUS EITHER ATTACHED TO THE
BODY OR INSERTED INTO THE BODY TO STIMULATE
AND REHABILITATE THE MUSCLES CONTROLLING
THE FECAL AND URINARY FUNCTIONS FOR THE
REHABILITATION OF MUSCLES; MEDICAL AND SUR-
GICAL APPARATUS AND INSTRUMENTS FOR THE
TREATMENT OF WOUNDS, NAMELY, WOUND DRAI-
NAGE APPARATUS, WOUND SUCTION APPARATUS;
MEDICAL AND SURGICAL APPARATUS, NAMELY,
PENILE PROSTHESES, TESTICULAR PROSTHESES;
SURGICAL IMPLANTS FOR THE TREATMENT OF
INCONTINENCE, NAMELY, URETHRAL SLINGS; SUR-
GICAL IMPLANTS COMPRISING ARTIFICIAL MATERI-
AL; SURGICAL INSTRUMENTS FOR USE IN
URETHRAL IMPLANT SURGERY; SURGICAL INSTRU-
MENTS FOR USE IN UROLOGY SURGERY (U.S. CLS.
26, 39 AND 44).

CLASS 16—PAPER GOODS AND PRINTED MATTER

FOR MAGAZINES IN THE FIELD OF HEALTHCARE,
PRINTED MATTER IN THE NATURE OF PRESS RE-
LEASES, PRINTED GUIDES, PRINTED INSTRU-
CTIONAL MATERIAL AND PRINTED TEACHING
MATERIAL, ALL IN THE FIELD OF HEALTHCARE
(U.S. CLS. 2, 5, 22, 23, 29, 37, 38 AND 50).

CLASS 36—INSURANCE AND FINANCIAL

FOR FINANCIAL ADMINISTRATION OF CHARITA-
BLE FOUNDATIONS IN THE FIELD OF HEALTHCARE
(U.S. CLS. 100, 101 AND 102).

CLASS 41—EDUCATION AND ENTERTAINMENT

FOR EDUCATION SERVICES, NAMELY, PROVIDING
SEMINARS AND WORKSHOPS IN THE FIELD OF
HEALTHCARE; PROVIDING OF TRAINING IN THE
FIELD OF HEALTHCARE (U.S. CLS. 100, 101 AND 107).

CLASS 42—SCIENTIFIC AND COMPUTER SERVICES

FOR MEDICAL AND RESEARCH SERVICES IN THE
FIELD OF INCONTINENCE, OSTOMY AND WOUND
CARE, NAMELY, PROVIDING MEDICAL RESEARCH
AND CLINICAL MEDICAL TRIALS (U.S. CLS. 100 AND
101).

CLASS 44—MEDICAL, BEAUTY AND AGRICULTURAL SERVICES

FOR HEALTHCARE SERVICES; OPERATION OF MEDICAL CLINICS; PROVIDING OF MEDICAL INFORMATION IN RELATION TO HEALTHCARE (U.S. CLS. 100 AND 101).

MICHAEL TANNER, EXAMINING ATTORNEY

SN 79-058,745. SPORTSWEAR COMPANY - S.P.A.; (IN SIGLA SPW S.P.A.), BOLOGNA, ITALY, FILED 12-4-2007.

**C.P.
COMPANY**

OWNER OF INTERNATIONAL REGISTRATION 0928957 DATED 9-19-2006, EXPIRES 9-19-2016.

OWNER OF U.S. REG. NOS. 1,526,363, 3,508,981 AND OTHERS.

NO CLAIM IS MADE TO THE EXCLUSIVE RIGHT TO USE "COMPANY", APART FROM THE MARK AS SHOWN.

THE MARK CONSISTS OF THE WORDING "C.P. COMPANY" IN FANCY CHARACTERS AND PLACED ON TWO LINES, THE ABBREVIATION "C.P." BEING OF A LARGER SIZE AND PLACED ABOVE THE WORD "COMPANY".

SN 79-058,624. O.C.L.A.P. S.R.L., ITALY, FILED 7-8-2008.

PDD
Platform Dynamic Doors

PRIORITY DATE OF 5-9-2008 IS CLAIMED.

OWNER OF INTERNATIONAL REGISTRATION 0976638 DATED 7-8-2008, EXPIRES 7-8-2018.

NO CLAIM IS MADE TO THE EXCLUSIVE RIGHT TO USE "PLATFORM" AND "DOORS", APART FROM THE MARK AS SHOWN.

THE COLOR(S) ORANGE, BLACK AND WHITE IS/ARE CLAIMED AS A FEATURE OF THE MARK.

THE MARK CONSISTS OF THE WORDING "PDD" IN ORANGE WITH BLACK SHADOWING, AND THE WORDING "PLATFORM DYNAMIC DOORS" IN WHITE WITH BLACK OUTLINE APPEARING BELOW AND TO THE RIGHT OF THE WORDING "PDD".

CLASS 6—METAL GOODS

FOR FRAMES AND CARRYING STRUCTURES MADE OF METAL FOR SAFETY BARRIERS FOR THE PROTECTION AND CONTROL OF TRAVELERS' WAY TO RAILROAD AND BUS STATIONS AND TO THE ACCESS PLATFORMS OF VEHICLES OF THE PUBLIC TRANSPORT BOTH BY ROAD AND BY RAIL (U.S. CLS. 2, 12, 13, 14, 23, 25 AND 50).

CLASS 9—ELECTRICAL AND SCIENTIFIC APPARATUS

FOR ELECTRIC, ELECTRONIC AND ELECTROMECHANICAL DEVICES FOR FRAMES AND CARRYING STRUCTURES MADE OF METAL FOR SAFETY BARRIERS FOR THE SEPARATION BETWEEN THE TRAVELERS AND THE VEHICLES AND FOR THE PROTECTION AND CONTROL OF TRAVELERS' WAY TO RAILROAD AND BUS STATIONS AND TO THE ACCESS PLATFORMS OF VEHICLES OF THE PUBLIC TRANSPORT SECTOR BOTH BY ROAD AND BY RAILWAY (U.S. CLS. 21, 23, 26, 36 AND 38).

MARK PILARO, EXAMINING ATTORNEY

CLASS 3—COSMETICS AND CLEANING PREPARATIONS

FOR PERFUMES; TOILET WATER; PERSONAL DEODORANTS; ESSENTIAL OILS FOR PERSONAL USE; BODY LOTIONS; SHOWER GEL; BUBBLE BATH; BATH OILS; BATH PEARLS; SKIN SOAPS; SHAVING BALMS; SHAVING CREAM; AFTERSHAVE LOTIONS; COSMETIC PENCILS; FOUNDATION MAKE-UP; FACE POWDERS; TALCUM POWDER; ROUGES; LIPSTICKS; MASCARAS; SKIN CLEANSING CREAMS; SKIN CLEANSING LOTIONS; SUN SCREEN PREPARATION; NAIL POLISH; BEAUTY MASKS; FACIAL SCRUBS; FACE CREAMS; BODY CREAMS; HAIR SHAMPOOS; HAIR SPRAYS; HAIR LOTIONS; DENTIFRICES (U.S. CLS. 1, 4, 6, 50, 51 AND 52).

CLASS 9—ELECTRICAL AND SCIENTIFIC APPARATUS

FOR EYEGLASSES; SUNGLASSES; GOGGLES FOR SPORT; EYEGLASS CASES; RIMS FOR EYEGLASS LENSES, BEING PARTS OF EYEGLASS FRAMES; EYEGLASS LENSES; EYEGLASS FRAMES; EYEGLASS CHAINS; EYEGLASS CORDS; PINCE-NEZ; PINCE-NEZ CASES; PINCE-NEZ CHAINS; PINCE-NEZ CORDS (U.S. CLS. 21, 23, 26, 36 AND 38).

CLASS 14—JEWELRY

FOR BOXES OF PRECIOUS METAL; JEWEL CASES OF PRECIOUS METAL; ORNAMENTAL PINS; JEWELRY ARTICLES, NAMELY, BROOCHES, NECKLACES, BRACELETS, CHAINS, TIE CLIPS, RINGS, MEDALLIONS, EARRINGS, PENDANTS, DIADEMS, CUFF LINKS; WATCHES; CLOCKS; CHRONOMETERS; CLOCK CASES; WRISTWATCHES; ALARM CLOCKS; WATCH STRAPS; WATCH BANDS; WATCH CHAINS; WATCH CRYSTALS; WATCH GLASSES; WATCH SPRINGS (U.S. CLS. 2, 27, 28 AND 50).

CLASS 18—LEATHER GOODS

FOR HANDBAGS, LUGGAGE; SHOULDER BAGS; BEACH BAGS; CLUTCH BAGS; ALL PURPOSE SPORTS BAGS; ATTACHE CASES; SCHOOL BAGS; TOTE BAGS; TRAVELING BAGS; CASES OF LEATHER OR IMITATION LEATHER; BUSINESS CARD CASES, BEING BUSINESS NOTECASES, OF LEATHER OR IMITATION LEATHER; DOCUMENT BRIEFCASES OF LEATHER OR IMITATION LEATHER; COSMETIC CASES SOLD EMPTY; KEY CASES; KNAPSACKS; RUCKSACKS; BRIEFCASES; PURSES; WALLETS; TRAVELING TRUNKS; SUITCASES; UMBRELLAS; PARASOLS; WALKING STICKS (U.S. CLS. 1, 2, 3, 22 AND 41).

CLASS 25—CLOTHING

FOR PULLOVERS; GLOVES; CARDIGANS; JERSEYS; NECKWEAR; SWEATERS; SOCKS; STOCKINGS; TIGHTS; TROUSERS; LEGGINGS; SKIRTS; JACKETS; JERKINS; SHIRTS; VESTS; WAISTCOATS; JUMPERS; TRACK SUITS; BLOUSES; BLOUSONS; JEANS; SWEAT PANTS; GYM SUITS; KNICKERS; PANTS; SHORTS; T-SHIRTS; SWEAT-SHIRTS; SUITS AND DRESSES; OVERCOATS; COATS; ANORAKS; RAINCOATS; BELTS; SUSPENDERS; LOUNGEWEAR; UNDERWEAR; BEACHWEAR; SLEEPWEAR; FOOTWEAR; HEADWEAR; HOSIERY (U.S. CLS. 22 AND 39).

FRANK LATTUCA, EXAMINING ATTORNEY

SN 79-058,829. BIO-GATE AG, FED REP GERMANY, FILED 6-3-2008.

MicroSilver BG

THE MARK CONSISTS OF STANDARD CHARACTERS WITHOUT CLAIM TO ANY PARTICULAR FONT, STYLE, SIZE, OR COLOR.

OWNER OF INTERNATIONAL REGISTRATION 0977157 DATED 6-3-2008, EXPIRES 6-3-2018.

OWNER OF U.S. REG. NO. 2,855,953.

CLASS 3—COSMETICS AND CLEANING PREPARATIONS

FOR COSMETICS (U.S. CLS. 1, 4, 6, 50, 51 AND 52).

CLASS 14—JEWELRY

FOR PRECIOUS METALS AND THEIR ALLOYS (U.S. CLS. 2, 27, 28 AND 50).

DAVID HOFFMAN, EXAMINING ATTORNEY

SN 79-058,885. OTTO BIHLER HANDELS-BETEILIGUNGS-GMBH, FED REP GERMANY, FILED 10-10-2007.

BIHLER

PRIORITY DATE OF 4-10-2007 IS CLAIMED.

OWNER OF INTERNATIONAL REGISTRATION 0977330 DATED 10-10-2007, EXPIRES 10-10-2017.

SEC. 2(F).

CLASS 7—MACHINERY

FOR MACHINES AND MACHINE TOOLS, NAMELY, CUTTING MACHINES AND MECHANICAL PRESSES FOR METALWORKING AND METALWORKING MACHINE TOOLS; MACHINE PARTS, NAMELY, BEARING HOUSINGS; PUNCHING PRESSES AND BENDING MACHINES FOR METALWORKING; POWER-OPERATED TIRE MOUNTING MACHINES; WIRE COIL FEEDING MACHINES; METALWORKING MACHINE TOOLS FOR PROCESSING AND MOUNTING WIRES AND STRIPS; MOTORIZED WIRE COILING MACHINES; ELECTRIC WELDING MACHINES; INDUSTRIAL MACHINE PRESSES (U.S. CLS. 13, 19, 21, 23, 31, 34 AND 35).

CLASS 9—ELECTRICAL AND SCIENTIFIC APPARATUS

FOR LASERS NOT FOR MEDICAL USE FOR USE IN CONJUNCTION WITH CONSTRUCTION AND AUTOMATED MANUFACTURING; ELECTRONIC INTERFACE EQUIPMENT FOR USE WITH PUNCHING PRESSES AND WELDING MACHINES TO INPUT OR OUTPUT CNC, OR COMPUTER NUMERICAL CONTROL, DATA (U.S. CLS. 21, 23, 26, 36 AND 38).

CLASS 16—PAPER GOODS AND PRINTED MATTER

FOR CALENDARS, PRINTED TEACHING MATERIALS IN THE FIELD OF INDUSTRIAL ENGINEERING; ARCHITECTURE MODELS OF MACHINES AND APPARATUS (U.S. CLS. 2, 5, 22, 23, 29, 37, 38 AND 50).

CLASS 37—CONSTRUCTION AND REPAIR

FOR REPAIR OR MAINTENANCE OF MACHINES FOR INDUSTRIAL METALWORKING (U.S. CLS. 100, 103 AND 106).

CLASS 40—MATERIAL TREATMENT

FOR CUSTOM CONSTRUCTION OF POWER TOOLS AND INDUSTRIAL AUTOMATION MACHINES FOR OTHERS; PROTOTYPE FABRICATION OF NEW TOOLS AND MACHINES FOR OTHERS (U.S. CLS. 100, 103 AND 106).

CLASS 41—EDUCATION AND ENTERTAINMENT

FOR EDUCATIONAL SERVICES, NAMELY, CONDUCTING TRAINING COURSES, WORKSHOPS AND SEMINARS IN THE FIELD OF INDUSTRIAL AUTOMATION EQUIPMENT (U.S. CLS. 100, 101 AND 107).

CLASS 42—SCIENTIFIC AND COMPUTER SERVICES

FOR ENGINEERING; CONSULTING IN THE FIELD OF ENGINEERING FOR THE PURPOSE OF IMPROVING MANUFACTURING METHODS; MECHANICAL ENGINEERING; PRODUCT DEVELOPMENT FOR OTHERS IN THE FIELD OF INDUSTRIAL MANUFACTURING PLANTS AND MACHINES (U.S. CLS. 100 AND 101).

VERNA BETH RIRIE, EXAMINING ATTORNEY

SN 79-058,886. OTTO BIHLER HANDELS-BETEILIGUNGS-GMBH, FED REP GERMANY, FILED 10-10-2007.

BIHLER

THE MARK CONSISTS OF STANDARD CHARACTERS WITHOUT CLAIM TO ANY PARTICULAR FONT, STYLE, SIZE, OR COLOR.

PRIORITY DATE OF 4-10-2007 IS CLAIMED.

OWNER OF INTERNATIONAL REGISTRATION 0977331 DATED 10-10-2007, EXPIRES 10-10-2017.

SEC. 2(F).

CLASS 7—MACHINERY

FOR MACHINES AND MACHINE TOOLS, NAMELY, CUTTING MACHINES AND MECHANICAL PRESSES FOR METALWORKING AND METALWORKING MACHINE TOOLS; MACHINE PARTS, NAMELY, BEARING HOUSINGS; PUNCHING PRESSES AND BENDING MACHINES FOR METALWORKING; POWER-OPERATED TIRE MOUNTING MACHINES; WIRE COIL FEEDING MACHINES; METALWORKING MACHINE TOOLS FOR PROCESSING AND MOUNTING WIRES AND STRIPS; MOTORIZED WIRE COILING MACHINES; ELECTRIC WELDING MACHINES; INDUSTRIAL MACHINE PRESSES (U.S. CLS. 13, 19, 21, 23, 31, 34 AND 35).

CLASS 9—ELECTRICAL AND SCIENTIFIC APPARATUS

FOR LASERS NOT FOR MEDICAL USE FOR USE IN CONJUNCTION WITH CONSTRUCTION AND AUTOMATED MANUFACTURING; ELECTRONIC INTERFACE EQUIPMENT FOR USE WITH PUNCHING PRESSES AND WELDING MACHINES TO INPUT OR OUTPUT CNC, OR COMPUTER NUMERICAL CONTROL, DATA (U.S. CLS. 21, 23, 26, 36 AND 38).

CLASS 16—PAPER GOODS AND PRINTED MATTER

FOR CALENDARS, PRINTED TEACHING MATERIALS IN THE FIELD OF INDUSTRIAL ENGINEERING; ARCHITECTURE MODELS OF MACHINES AND APPARATUS (U.S. CLS. 2, 5, 22, 23, 29, 37, 38 AND 50).

CLASS 37—CONSTRUCTION AND REPAIR

FOR REPAIR OR MAINTENANCE OF MACHINES FOR INDUSTRIAL METALWORKING (U.S. CLS. 100, 103 AND 106).

CLASS 40—MATERIAL TREATMENT

FOR CUSTOM CONSTRUCTION OF POWER TOOLS AND INDUSTRIAL AUTOMATION MACHINES FOR OTHERS; PROTOTYPE FABRICATION OF NEW TOOLS AND MACHINES FOR OTHERS (U.S. CLS. 100, 103 AND 106).

CLASS 41—EDUCATION AND ENTERTAINMENT

FOR EDUCATIONAL SERVICES, NAMELY, CONDUCTING TRAINING COURSES, WORKSHOPS AND SEMINARS IN THE FIELD OF INDUSTRIAL AUTOMATION EQUIPMENT (U.S. CLS. 100, 101 AND 107).

CLASS 42—SCIENTIFIC AND COMPUTER SERVICES

FOR ENGINEERING; CONSULTING IN THE FIELD OF ENGINEERING FOR THE PURPOSE OF IMPROVING MANUFACTURING METHODS; MECHANICAL ENGINEERING; PRODUCT DEVELOPMENT FOR OTHERS IN THE FIELD OF INDUSTRIAL MANUFACTURING PLANTS AND MACHINES (U.S. CLS. 100 AND 101).

VERNA BETH RIRIE, EXAMINING ATTORNEY

SN 79-058,995. IETEC ORTHOPÄDISCHE EINLAGEN GMBH PRODUKTIONS KG, FED REP GERMANY, FILED 5-20-2008.



OWNER OF INTERNATIONAL REGISTRATION 0977641 DATED 5-20-2008, EXPIRES 5-20-2018.

THE MARK CONSISTS OF THE STYLIZED WORDING "MOVE CONTROL" TO THE LEFT OF THE OUTLINE OF THE REAR VIEW OF A FOOT AND ANKLE SHOWN INSIDE A CIRCLE WITH ARROWS POINTING IN VARIOUS DIRECTIONS AND A DOTTED LINE BELOW THE BOTTOM OF THE FOOT.

CLASS 9—ELECTRICAL AND SCIENTIFIC APPARATUS

FOR ELECTRONIC MEASURING DEVICES FOR OBTAINING DIGITAL DATA ON THE BODY, NAMELY, DATA CONCERNING THE LOWER LEG AND FOOT, FOR USE IN THE PRODUCTION OF FOOTWEAR; COMPUTER SOFTWARE FOR DETERMINING AND ANALYZING DIGITAL DATA ON THE BODY FOR USE IN THE PRODUCTION OF FOOTWEAR (U.S. CLS. 21, 23, 26, 36 AND 38).

CLASS 10—MEDICAL APPARATUS

FOR ORTHOPEDIC FOOTWEAR, ORTHOTICS FOR THE LOWER LEG AND FOOT, ARTIFICIAL JOINTS AND LIMBS (U.S. CLS. 26, 39 AND 44).

CLASS 25—CLOTHING

FOR INSOLES (U.S. CLS. 22 AND 39).

CLASS 42—SCIENTIFIC AND COMPUTER SERVICES

FOR SCIENTIFIC RESEARCH AND ANALYSIS OF DIGITAL DATA ON THE BODY FOR USE IN THE PRODUCTION OF FOOTWEAR (U.S. CLS. 100 AND 101).
DAVID HOFFMAN, EXAMINING ATTORNEY

SN 79-059,226. BIGPOINT GMBH, FED REP GERMANY, FILED 7-10-2008.

Actionleague

THE MARK CONSISTS OF STANDARD CHARACTERS WITHOUT CLAIM TO ANY PARTICULAR FONT, STYLE, SIZE, OR COLOR.

OWNER OF INTERNATIONAL REGISTRATION 0978240 DATED 7-10-2008, EXPIRES 7-10-2018.

CLASS 9—ELECTRICAL AND SCIENTIFIC APPARATUS

FOR COMPUTERS; RECORDED COMPUTER PROGRAMS FOR COMPUTER GAMES; DOWNLOADABLE COMPUTER PROGRAMS AND SOFTWARE FOR COMPUTER GAMES; COMPUTER GAME PROGRAMS FOR COMPUTER, VIDEO, ONLINE AND BROWSER GAMES; ELECTRONIC GAME PROGRAMS FOR MOBILE TELEPHONES (U.S. CLS. 21, 23, 26, 36 AND 38).

CLASS 28—TOYS AND SPORTING GOODS

FOR GAMES, NAMELY, HAND HELD UNITS FOR PLAYING ELECTRONIC GAMES FOR USE WITH COMPUTER, VIDEO, ONLINE AND BROWSER GAMES, NONE BEING FOR USE WITH TELEVISION RECEIVERS, NAMELY, MULTI PLAY ONLINE GAMES, SPORTS GAMES, ACTION SKILL GAMES (U.S. CLS. 22, 23, 38 AND 50).

CLASS 38—COMMUNICATION

FOR PROVIDING ACCESS TO INFORMATION VIA THE INTERNET; PROVIDING ACCESS TO PLATFORMS AND PORTALS VIA THE INTERNET; TRANSMISSION OF INFORMATION BY ELECTRONIC MEANS; ELECTRONIC TRANSMISSION OF MESSAGES AND IMAGES VIA COMPUTER NETWORKS (U.S. CLS. 100, 101 AND 104).

CLASS 41—EDUCATION AND ENTERTAINMENT

FOR CONDUCTING ONLINE COMPUTER GAMES; ENTERTAINMENT, IN THE FORM OF ONLINE COMPUTER GAMES, ONLINE VIDEO COMPUTER GAMES, ONLINE COMPUTER GAMES AND ONLINE BROWSER COMPUTER GAMES AND ONLINE COMPUTER GAMES FOR MOBILE TELEPHONES AS WELL AS PROVIDING INFORMATION, PORTALS AND PLATFORMS ABOUT ONLINE COMPUTER GAMES VIA THE INTERNET; PROVIDING ONLINE COMPUTER GAMES SERVICES, NAMELY, PROVIDING INFORMATION ONLINE RELATING TO COMPUTER GAMES AND COMPUTER ENHANCEMENTS FOR GAMES, CONSULTATION SERVICES IN THE FIELD OF PROVIDING ONLINE COMPUTER GAMES ON COMPUTER NETWORKS (U.S. CLS. 100, 101 AND 107).

ALLISON SCHRODY, EXAMINING ATTORNEY

CLASS 9—ELECTRICAL AND SCIENTIFIC APPARATUS

FOR SCIENTIFIC, NAUTICAL, SURVEYING, ELECTRIC, ELECTRONIC, OPTO-ELECTRONIC, PHOTOGRAPHIC, CINEMATOGRAPHIC, OPTICAL, WEIGHING, MEASURING, SIGNALING, CHECKING AND SUPERVISION APPARATUS AND INSTRUMENTS, NAMELY, OPTICAL DETECTORS IN THE NATURE OF OPTICAL CHARACTER READERS AND OPTICAL SCANNERS, OPTICAL LENSES FOR SCANNING OR READING CHARACTERS IN A TELEFAXING OR COPYING APPARATUS; PHOTOGRAPHIC, CINEMATOGRAPHIC AND PROJECTION OBJECTIVES, NAMELY, COMBINATIONS OF PHOTOGRAPHIC LENSES FOR USE WITH CAMERAS, ENLARGERS AND PROJECTORS; LIGHT METERS, OPTICAL REFLECTORS, CONDENSERS, DIAPHRAGMS FOR CAMERAS, OPTICAL POWER SPLITTERS, DIGITAL SIGNAL PROCESSORS; PROJECTOR LAMPS AND FLASH LAMPS FOR CAMERAS; APPARATUS FOR RECORDING, TRANSMISSION OR REPRODUCTION OF SOUND AND IMAGES; BLANK MAGNETIC DATA CARRIERS; DATA PROCESSING EQUIPMENT, NAMELY, COMPUTERS, COMPUTER INTERFACE BOARDS, OPTICAL COMPUTER INPUTS, NAMELY, INTERFACES; PRINTED CIRCUIT CARDS FOR INTERFACING COMPUTERS AND OPTICAL CHARACTER RECOGNITION DEVICES, NAMELY, INTERFACES; PHOTOGRAPHIC AND CINEMATOGRAPHIC PROJECTION OBJECTIVES; OPTICAL GLASS, OPTICAL FIBERS, OPTICAL FILTERS (U.S. CLS. 21, 23, 26, 36 AND 38).

CLASS 42—SCIENTIFIC AND COMPUTER SERVICES

FOR SCIENTIFIC RESEARCH AND DEVELOPMENT; TECHNOLOGY CONSULTATION, RESEARCH AND DESIGN RELATING TO OPTICAL TECHNOLOGY; INDUSTRIAL ANALYSIS AND RESEARCH SERVICES; DESIGN AND DEVELOPMENT OF COMPUTER HARDWARE AND SOFTWARE; ALL THE AFOREMENTIONED SERVICES IN THE FIELD OF OPTICS (U.S. CLS. 100 AND 101).

ERNEST SHOSHO, EXAMINING ATTORNEY

SN 79-059,252. JOS. SCHNEIDER OPTISCHE WERKE GMBH, FED REP GERMANY, FILED 7-29-2008.

SN 79-059,304. GSMC LIMITED, ATLANTA, GA. FILED 9-2-2008.

catch the light



THE MARK CONSISTS OF STANDARD CHARACTERS WITHOUT CLAIM TO ANY PARTICULAR FONT, STYLE, SIZE, OR COLOR.

PRIORITY DATE OF 6-19-2008 IS CLAIMED.
OWNER OF INTERNATIONAL REGISTRATION 0978306 DATED 7-29-2008, EXPIRES 7-29-2018.

PRIORITY DATE OF 8-21-2008 IS CLAIMED.
OWNER OF INTERNATIONAL REGISTRATION 0978426 DATED 9-2-2008, EXPIRES 9-2-2018.

THE MARK CONSISTS OF TWO STYLIZED BIRDS IN FLIGHT.

CLASS 9—ELECTRICAL AND SCIENTIFIC APPARATUS

FOR APPARATUS, INSTRUMENTS AND DEVICES FOR USE IN PROVIDING MOBILE COMMUNICATIONS, NAMELY, TELEPHONES, PAGERS, PERSONAL DIGITAL ASSISTANTS, RADIOS, PORTABLE AND HANDHELD DIGITAL ELECTRONIC DEVICES FOR RECORDING, ORGANIZING, TRANSMITTING, MANIPULATING, AND REVIEWING TEXT, DATA, IMAGE, AND AUDIO FILES, MOBILE DATA RECEIVERS, HEADSETS FOR TELEPHONES, DEVICES FOR HANDS-FREE USE OF MOBILE PHONES, USB (UNIVERSAL SERIAL BUS) HARDWARE, FLASH MEMORY CARD, COMPUTER PERIPHERALS, HARDWARE AND SOFTWARE FOR USE IN COMMUNICATIONS NETWORKS, NAMELY, INTERNET PROTOCOL AND TELECOMMUNICATIONS NETWORK TRANSMITTERS, RECEIVERS, CONVERTERS AND ROUTERS WHICH ALLOW THE USER TO SEND VOICE, DATA, PICTURES, MUSIC AND VIDEO OVER WIRELESS NETWORKS; APPARATUS, INSTRUMENTS AND DEVICES FOR PROVIDING ACCESS TO THE INTERNET, NAMELY, TELEPHONES, PERSONAL DIGITAL ASSISTANTS, PORTABLE AND HANDHELD DIGITAL ELECTRONIC DEVICES FOR RECORDING, ORGANIZING, TRANSMITTING, MANIPULATING, AND REVIEWING TEXT, DATA, IMAGE, AND AUDIO FILES, MOBILE DATA RECEIVERS, USB (UNIVERSAL SERIAL BUS) HARDWARE, COMPUTER PERIPHERALS; COMPUTERS; COMPUTER HARDWARE; COMPUTER CHIPS; MOBILE TELEPHONES; CAMERAS; GLOBAL POSITIONING SYSTEMS (U.S. CLS. 21, 23, 26, 36 AND 38).

CLASS 38—COMMUNICATION

FOR TELECOMMUNICATIONS SERVICES, NAMELY, TRANSMISSION OF VOICE, DATA, GRAPHICS, IMAGES, AUDIO AND VIDEO AND ACCESS TO THE INTERNET BY MEANS OF WIRELESS BROADBAND COMMUNICATION NETWORKS; WIRELESS BROADBAND COMMUNICATIONS SERVICES; PROVIDING TELECOMMUNICATIONS CONNECTIONS TO THE INTERNET; PROVIDING TELECOMMUNICATIONS CONNECTIONS TO MOBILE TELECOMMUNICATIONS NETWORKS; INTERNET PORTAL SERVICES, NAMELY, PROVIDING ACCESS TO THE INTERNET; PROVIDING USER ACCESS SERVICES TO THE INTERNET (U.S. CLS. 100, 101 AND 104).

WILLIAM VERHOSEK, EXAMINING ATTORNEY

SN 79-059,452. PROBIOGEN AG, FED REP GERMANY, FILED 7-18-2008.



PRIORITY DATE OF 1-21-2008 IS CLAIMED. OWNER OF INTERNATIONAL REGISTRATION 0978718 DATED 7-18-2008, EXPIRES 7-18-2018.

NO CLAIM IS MADE TO THE EXCLUSIVE RIGHT TO USE "LINES", APART FROM THE MARK AS SHOWN.

THE COLOR(S) ORANGE AND GREY IS/ARE CLAIMED AS A FEATURE OF THE MARK.

THE MARK CONSISTS OF THE LITERAL ELEMENT "AGE1.CELL LINES". THE LETTER "G" IS HIGHLY STYLIZED. THE COLOR ORANGE APPEARS IN THE STYLIZED LETTER "G" AND THE COLOR GREY APPEARS IN THE REMAINING LETTERS AND PERIODS IN THE MARK. THE LETTERS "AGE1." APPEAR IN LARGER FONT SIZE THAN THE WORDS "CELL LINES".

CLASS 5—PHARMACEUTICALS

FOR BIOLOGICAL PREPARATIONS FOR DIAGNOSTIC, PHARMACEUTICAL, MEDICAL AND VETERINARY PURPOSES, NAMELY, PREPARATIONS DEVELOPED FROM BIOLOGICAL CELLS; BIOLOGICAL PREPARATIONS FOR MEDICAL AND VETERINARY PURPOSES, NAMELY, CELL CULTURES, CELL LINES IN THE NATURE OF DESIGNER CELL LINES, AND CELL SUBSTRATES FOR PHARMACEUTICAL, MEDICAL AND VETERINARY PURPOSES, NAMELY, FOR MANUFACTURING VACCINES, PROTEINS, AND OTHER PHARMACEUTICAL ACTIVE SUBSTANCES; VACCINES, ANTIBODIES AND PROTEINS FOR DIAGNOSTIC, PHARMACEUTICAL, MEDICAL AND VETERINARY PURPOSES, NAMELY, ACTIVE PHARMACEUTICAL INGREDIENTS FOR THE THERAPEUTICAL, PREVENTIVE AND IN VITRO DIAGNOSTIC USE (U.S. CLS. 6, 18, 44, 46, 51 AND 52).

CLASS 42—SCIENTIFIC AND COMPUTER SERVICES

FOR SCIENTIFIC AND INDUSTRIAL BIOLOGICAL RESEARCH AND DEVELOPMENT, NAMELY, MANUFACTURE OF PROTEINS AND VACCINES WITH THE AID OF BIOLOGICAL CELLS, INCLUDING CELL LINE DESIGN; MEDICAL LABORATORY SERVICES, NAMELY, MANUFACTURE OF PROTEINS AND VACCINES WITH THE AID OF BIOLOGICAL CELLS AND CELL LINE DESIGN (U.S. CLS. 100 AND 101).

CLASS 45—PERSONAL AND LEGAL SERVICES

FOR LICENSING OF INTELLECTUAL PROPERTY (U.S. CLS. 100 AND 101).
PAUL MORENO, EXAMINING ATTORNEY

SN 79-059,851. JUSHI GROUP CO., LTD., CHINA, FILED 7-4-2008.



巨石 JU SHI

OWNER OF INTERNATIONAL REGISTRATION 0979588 DATED 7-4-2008, EXPIRES 7-4-2018.

THE MARK CONSISTS OF A BLACK RECTANGLE WITH A LETTER "J" AND "S" IN TEXT AND STYLED FORMAT SHOWING THE ABBREVIATED NAME OF THE COMPANY. UNDER THE RECTANGLE, IT IS THE COMPANY NAME IN CHINESE "JU SHI" AND ENGLISH "JU SHI".

THE NON-LATIN CHARACTERS IN THE MARK TRANSLITERATE TO "JUSHI", AND THIS MEANS HUGE ROCK IN ENGLISH.

CLASS 17—RUBBER GOODS

FOR VULCANIZED FIBER; CARBON FIBERS, OTHER THAN FOR TEXTILE USE; PLASTIC FIBERS, NOT FOR USE IN TEXTILES; ASBESTOS FIBERS; FIBERGLASS HEAT PRESERVATION BOARD AND PIPE FOR INSULATION PURPOSES; INSULATING FELT FOR USE IN ELECTRONIC INDUSTRY, CONSTRUCTION INDUSTRY; INSULATING FABRICS; FIBERGLASS FOR INSULATION OF BUILDINGS; FIBERGLASS FABRICS, FOR INSULATION OF BUILDINGS; SEALING THREAD FOR INSULATION OF BUILDINGS (U.S. CLS. 1, 5, 12, 13, 35 AND 50).

CLASS 21—HOUSEWARES AND GLASS

FOR CHINA ORNAMENTS; DRINKING VESSELS; SPRINKLING DEVICES, NAMELY, SALT AND PEPPER SHAKERS; LAMP-GLASS BRUSHES; TOOTHBRUSHES; TOOTHPICKS; COSMETIC UTENSILS, NAMELY, BRUSHES; THERMALLY INSULATED CONTAINERS FOR FOOD; CLEANING TOWELS, NAMELY, CLOTHS; VITREOUS SILICA FIBERS FOR GENERAL INDUSTRIAL AND FURTHER MANUFACTURING USE, NOT FOR TEXTILE USE; FIBERGLASS OTHER THAN FOR INSULATION OR TEXTILE USE; FIBERGLASS THREAD, NOT FOR INSULATION OR TEXTILE USE; FEEDING TROUGHES FOR ANIMALS; INSECT TRAPS (U.S. CLS. 2, 13, 23, 29, 30, 33, 40 AND 50).

CLASS 22—CORDAGE AND FIBERS

FOR RAW LINEN; SAILS; SACKS OF TEXTILE, FOR PACKAGING; FIBROUS GASKETS FOR SHIPS, NAMELY, FABRIC FOR HOLDING A STOWED SAIL IN PLACE; RAW FIBROUS TEXTILE; COCONUT FIBER; COTTON TOW; VITREOUS SILICA FIBERS FOR TEXTILE USE; RAMIE FIBRE; TEXTILE FIBRES; TEXTILE FIBERS; CARBON FIBERS FOR TEXTILE USE; PLASTIC FIBERS FOR TEXTILE USE; GLASS FIBERS FOR TEXTILE USE (U.S. CLS. 1, 2, 7, 19, 22, 42 AND 50).

CLASS 23—YARNS AND THREADS

FOR YARN; SPUN COTTON; SPUN WOOL; SPUN SILK; RAYON YARN AND THREAD; THREAD; COIR THREAD AND YARN; FIBERGLASS THREAD FOR TEXTILE USE; WOOLEN THREAD AND YARN; CASHMERE THREAD AND YARN (U.S. CL. 43).

CLASS 24—FABRICS

FOR FABRIC FOR TEXTILE USE; CLOTH TEXTILE FOR USE IN MANUFACTURE OF FABRIC, GLASS FABRIC AND FELT; ADHESIVE FABRIC FOR APPLICATION BY HEAT; GLASS-CLOTH TOWELS; FIBERGLASS FABRICS, FOR TEXTILE USE; FELT; TOWEL QUILT; FITTED TOILET LID COVERS (U.S. CLS. 42 AND 50).

DAVID HOFFMAN, EXAMINING ATTORNEY

SN 79-060,020. EINSTEIN PROGETTI E PRODOTTI S.P.A., I-40017 SAN GIOVANNI IN PERSICETO, ITALY, FILED 4-17-2008.

SEXY WOMAN

THE MARK CONSISTS OF STANDARD CHARACTERS WITHOUT CLAIM TO ANY PARTICULAR FONT, STYLE, SIZE, OR COLOR.

PRIORITY DATE OF 3-26-2008 IS CLAIMED.
OWNER OF INTERNATIONAL REGISTRATION 0979998 DATED 4-17-2008, EXPIRES 4-17-2018.

OWNER OF U.S. REG. NO. 3,389,110.
NO CLAIM IS MADE TO THE EXCLUSIVE RIGHT TO USE "WOMAN", APART FROM THE MARK AS SHOWN.

CLASS 18—LEATHER GOODS

FOR GOODS MADE OF LEATHER OR OF IMITATIONS OF LEATHER, NAMELY, BOXES OF LEATHER OR OF LEATHERBOARD, ENVELOPES OF LEATHER; TRUNKS, VALISES, TRAVELLING BAGS, TRAVELLING BAG SETS, GARMENT BAGS FOR TRAVEL, VANITY CASES SOLD EMPTY, RUCKSACKS, HANDBAGS, BEACH BAGS, SHOPPING BAGS OF LEATHER, SHOULDER BAGS, ATTACHE CASES, BRIEFCASES, POUCHES OF LEATHER, FINE LEATHER GOODS, NAMELY, POCKET WALLETS, PURSES, KEY CASES, NAME CARD CASES, CREDIT CARD CASES, BUSINESS CARD CASES; UMBRELLAS, PARASOLS, SUNSHADES BEING PARASOLS, CANES, WALKING STICK SEATS (U.S. CLS. 1, 2, 3, 22 AND 41).

CLASS 25—CLOTHING

FOR CLOTHING AND UNDERWEAR, NAMELY, SWEATERS, SHIRTS, CORSETS, SUITS, WAISTCOATS, WATERPROOF CLOTHING, NAMELY, JACKETS, COATS, SKIRTS, COATS, TROUSERS, PULLOVERS, DRESSES, JACKETS BEING CLOTHING, SHAWLS, SCARVES, SASHES FOR WEAR, NECKTIES, TIES, BRACES, NAMELY, SUSPENDERS, GLOVES BEING CLOTHING, BELTS FOR CLOTHING, STOCKINGS, TIGHTS, SOCKS, BATHING SUITS, BATH ROBES; FOOTWEAR; HEADGEAR, NAMELY, HATS, CAPS FOR WEAR (U.S. CLS. 22 AND 39).

CARYN GLASSER, EXAMINING ATTORNEY

SN 79-060,182. WIL JOOSTEN, NETHERLANDS, FILED 4-1-2008.



PRIORITY DATE OF 2-29-2008 IS CLAIMED.
OWNER OF INTERNATIONAL REGISTRATION 0980378 DATED 4-1-2008, EXPIRES 4-1-2018.

NO CLAIM IS MADE TO THE EXCLUSIVE RIGHT TO USE "GT CAR CENTER", APART FROM THE MARK AS SHOWN.

THE COLOR(S) GREEN, WHITE AND GRAY IS/ARE CLAIMED AS A FEATURE OF THE MARK.

THE MARK CONSISTS OF THE GREEN LETTERS "GTCC" WITH "GT CAR CENTER" APPEARING JUST ABOVE IT, ALSO IN GREEN LETTERING, ALL SET ON A WHITE BACKGROUND. THIS WORDING IS INSIDE A GREEN OVAL BORDER WHICH HAS A WHITE BORDER SURROUNDING IT AND A THIN GRAY LINE BORDER ENCLOSING THE ENTIRE DESIGN.

CLASS 35—ADVERTISING AND BUSINESS

FOR ADVERTISING SERVICES IN THE FIELD OF NEW AND SECONDHAND CARS BY FACILITATING COMMUNICATION BETWEEN INDIVIDUALS AND RETAILERS; BUSINESS MEDIATION AND CONSULTANCY FOR COMPANIES ENGAGED IN THE TRADE OF CARS AND/OR CAR PARTS, THE MAINTENANCE AND REPAIR OF CARS AND THE RENTAL OF CARS; BUSINESS MEDIATION OF AGREEMENTS REGARDING THE SALE AND PURCHASE OF NEW AND SECOND-HAND CARS AND CAR PARTS AND THE ACQUISITION OF SERVICES VIA A GLOBAL COMPUTER NETWORK; ON-LINE RETAIL STORE SERVICES FEATURING MOTOR PARTS AND CAR PARTS; NEGOTIATION AND SETTLEMENT OF COMMERCIAL TRANSACTIONS FOR OTHERS; PROVIDING CONSUMER INFORMATION RELATING TO THE PURCHASE AND SALE OF CARS (U.S. CLS. 100, 101 AND 102).

CLASS 37—CONSTRUCTION AND REPAIR

FOR GARAGE SERVICES, NAMELY, MAINTENANCE AND REPAIR OF CARS; INSTALLATION AND MOUNTING OF CAR PARTS AND CAR ACCESSORIES (U.S. CLS. 100, 103 AND 106).

CLASS 39—TRANSPORTATION AND STORAGE

FOR TRANSPORT, STORAGE, PACKAGING AND DELIVERY OF PARTS FOR AUTOMOBILES; INFORMATION IN THE FIELD OF WAREHOUSING AND TRANSPORT (U.S. CLS. 100 AND 105).

CLASS 41—EDUCATION AND ENTERTAINMENT

FOR CONDUCTING WORKSHOPS IN THE FIELD OF NEW AND SECOND-HAND CARS, CAR PARTS AND CAR REPAIR; ARRANGING AND CONDUCTING TRAINING COURSES SPECIFICALLY DESIGNED FOR MECHANICS AND SALES PEOPLE IN THE FIELD OF NEW AND SECOND-HAND CARS, CAR PARTS AND CAR REPAIR; PUBLICATION OF MANUALS FOR USE IN EDUCATIONAL COURSES AND TRAINING (U.S. CLS. 100, 101 AND 107).

WENDY GOODMAN, EXAMINING ATTORNEY

SN 79-060,376. PASSPACK S.R.L., MERCATO SARACENO (FC), ITALY, FILED 8-8-2008.

Passpack 

PRIORITY DATE OF 5-16-2008 IS CLAIMED. OWNER OF INTERNATIONAL REGISTRATION 0980782 DATED 8-8-2008, EXPIRES 8-8-2018.

THE MARK CONSISTS OF THE WORD "PASSPACK" WRITTEN IN PARTICULAR CHARACTER; TO THE RIGHT OF THIS WORD THERE IS THE STYLIZED IMAGE OF AN HALF-OPENED CUBE ON THE TOP AND TURNED TO THE RIGHT.

CLASS 9—ELECTRICAL AND SCIENTIFIC APPARATUS

FOR INFORMATION APPARATUS FOR DATA PROCESSING, NAMELY, DATA PROCESSORS; SOFTWARE FOR DATA PROCESSING; APPARATUS, INSTRUMENT AND MEANS FOR RECORDING, REPRODUCING, TRANSFERRING, FILING, PROCESSING, HANDLING, TRANSMITTING, BROADCASTING AND CALL BACK PUBLICATIONS, TEXTS, SIGNALS, SOFTWARE, INFORMATION, DATA, CODES, SOUND AND IMAGES, NAMELY, COMPUTERS, APPARATUS FOR RECORDING, TRANSMITTING AND REPRODUCING SOUNDS, IMAGES AND DATA, HARDWARE AND SOFTWARE FOR MANAGING DATABASES (U.S. CLS. 21, 23, 26, 36 AND 38).

CLASS 42—SCIENTIFIC AND COMPUTER SERVICES

FOR HARDWARE AND SOFTWARE DESIGN AND DEVELOPMENT (U.S. CLS. 100 AND 101).

TRACY FLETCHER, EXAMINING ATTORNEY

SN 79-060,626. LIDL STIFTUNG & CO. KG, FED REP GERMANY, FILED 6-3-2008.

aquapur

THE MARK CONSISTS OF STANDARD CHARACTERS WITHOUT CLAIM TO ANY PARTICULAR FONT, STYLE, SIZE, OR COLOR.

OWNER OF INTERNATIONAL REGISTRATION 0693752 DATED 2-26-1998, EXPIRES 2-26-2018.

CLASS 10—MEDICAL APPARATUS

FOR GLOVES FOR BODY CARE, NAMELY, GLOVES FOR MASSAGING (U.S. CLS. 26, 39 AND 44).

CLASS 21—HOUSEWARES AND GLASS

FOR CLEANING CLOTHS, PARTICULARLY CLOTHS FOR CLEANING WINDOWS, FLOOR CLOTHS, TEA TOWELS, HOUSEHOLD CLEANING CLOTHS; PAN CLEANING CLOTHS MADE WITH COATED FABRIC; HOUSEHOLD GLOVES FOR GENERAL USE MADE WITH SYNTHETIC FIBRES WHICH WORK WITHOUT ADDED CLEANING PRODUCTS; GLOVES FOR DUSTING, GLOVES FOR POLISHING; CLEANING CLOTHS MADE WITH SYNTHETIC FIBRES WHICH WORK WITHOUT ADDED CLEANING PRODUCTS (U.S. CLS. 2, 13, 23, 29, 30, 33, 40 AND 50).

CLASS 24—FABRICS

FOR GLOVES FOR BODY CARE, NAMELY, WASH CLOTHS (U.S. CLS. 42 AND 50).

DAVID HOFFMAN, EXAMINING ATTORNEY

SN 79-060,731. ING. MILOSLAV TUTTER, CZ-109 00 PRAHA 10, CZECH REPUBLIC, FILED 8-21-2008.

CZA

OWNER OF INTERNATIONAL REGISTRATION 0981648 DATED 8-21-2008, EXPIRES 8-21-2018.

THE MARK CONSISTS OF THE WORDING "CZA" IN STYLIZED FONT.

CLASS 37—CONSTRUCTION AND REPAIR

FOR UPKEEP AND REPAIR OF AIRCRAFT EQUIPMENT (U.S. CLS. 100, 103 AND 106).

CLASS 39—TRANSPORTATION AND STORAGE

FOR AIR TRANSPORT (U.S. CLS. 100 AND 105).

TINA BROWN, EXAMINING ATTORNEY

SN 79-060,735. LIDL STIFTUNG & CO. KG, FED REP GERMANY, FILED 10-9-2008.

FAIRGLOBE

THE MARK CONSISTS OF STANDARD CHARACTERS WITHOUT CLAIM TO ANY PARTICULAR FONT, STYLE, SIZE, OR COLOR.

PRIORITY DATE OF 5-8-2008 IS CLAIMED.

OWNER OF INTERNATIONAL REGISTRATION 0981653 DATED 10-9-2008, EXPIRES 10-9-2018.

OWNER OF U.S. REG. NO. 3,324,992.

CLASS 18—LEATHER GOODS

FOR TEXTILE SHOPPING BAGS (U.S. CLS. 1, 2, 3, 22 AND 41).

CLASS 20—FURNITURE AND ARTICLES NOT OTHERWISE CLASSIFIED

FOR BEDDING, NAMELY, BEDS, BED FRAMES, HEADBOARDS, BED RESTS, MATTRESSES AND BOLSTERS; PILLOWS (U.S. CLS. 2, 13, 22, 25, 32 AND 50).

CLASS 24—FABRICS

FOR TEXTILE FABRICS FOR THE MANUFACTURE OF CLOTHING, NAMELY, CHENILLE FABRIC, CASHMERE FABRIC, COTTON FABRIC, COTTON-BASED MIXED FABRICS, CHEVIOT FABRIC, JEANS FABRIC, JERSEY MATERIAL, LINEN, LINGERIE FABRIC, KNITTED FABRIC, POLYESTER FABRIC, NYLON FABRIC, RAYON FABRIC, SILK FABRICS, SILK-BASED MIXED FABRICS, TEXTILE FABRICS FOR HOME AND COMMERCIAL INTERIORS, AND TEXTILE GOODS, NAMELY, WALL HANGINGS OF TEXTILE, MATTRESS PADS, FABRIC TABLE RUNNERS, FABRIC VALANCES; FABRICS FOR TEXTILE USE, COTTON FABRICS FOR TEXTILE USE; CURTAINS; HOUSEHOLD LINEN, TABLE AND BED LINEN, TABLE CLOTHS NOT OF PAPER AND BED COVERS, BED BLANKETS, EXCEPT WOOL BLANKETS, TEXTILE TABLE MATS, TOWELS OF TEXTILE, NAPKINS OF TEXTILE; HOUSEHOLD TEXTILES, NAMELY, QUILTS, TEXTILE SERVIETTES, TEXTILE PLACE MATS, HOUSEHOLD LINEN, SLEEPING BAGS; COVERS FOR CUSHIONS (U.S. CLS. 42 AND 50).

CLASS 25—CLOTHING

FOR CLOTHING, NAMELY, WOVEN AND KNITTED CLOTHING, NAMELY, SHIRTS, JACKETS, SLACKS, PANTS, SHORTS, SKIRTS, SWEATERS, MITTENS, SCARVES, DRESSES, JOGGING SUITS, YOGA PANTS, EXERCISE SHORTS, UNDERWEAR, GLOVES, FOOTWEAR, TEXTILE FOOTWEAR, HEADGEAR, NAMELY, HATS AND CAPS (U.S. CLS. 22 AND 39).

CLASS 29—MEATS AND PROCESSED FOODS

FOR MEAT, FISH, POULTRY AND GAME, INCLUDING THE AFORESAID GOODS FROZEN; MEAT PRODUCTS, NAMELY, MEAT AND SAUSAGE, MEAT PRESERVES, SAUSAGE PRESERVES, SMALL SAUSAGE PRESERVES, MEAT JELLIES; MEAT PASTE, MEAT JUICES, SAUSAGES, SMALL SAUSAGES, BLOOD SAUSAGES, RING BOLOGNA, BRAUNSCHWEIGER, SMOKED SAUSAGE, BRATWURST, POLISH SAUSAGE, ITALIAN SAUSAGE, SUMMER SAUSAGE, BOLOGNA AND SMOKED BEEF, FRANKFURTERS, HAMBURGER MEAT, HOT DOGS, MEAT-BASED MOUSSE, MEAT-BASED SPREADS, HAM, BACON, SALAMI, MORTADELLA, BACON RINDS, ROAST BEEF, BEEF PATTIES, PATE AND CHARCUTERIE; MEAT EXTRACTS; SHELLFISH FOR HUMAN CONSUMPTION; PRESERVED, DRIED AND COOKED FRUITS AND VEGETABLES, INCLUDING THE AFORESAID GOODS IN SWEET AND/OR SOUR PICKLED SAUCES; JELLIES; JAMS, MARMALADES; EGGS, MILK AND MILK PRODUCTS INCLUDED IN THIS CLASS EXCLUDING ICE CREAM, ICE MILK AND FROZEN YOGURT, MIXED MILK-BASED BEVERAGES, NAMELY, MILK BEVERAGES WITH HIGH MILK CONTENT; MEAT, SAUSAGE, FISH, FRUIT AND VEGETABLE PRESERVES; PROCESSED NUTS; EDIBLE OILS AND FATS; PREPARED MEALS AND FROZEN FOODSTUFFS INCLUDED IN THIS CLASS, NAMELY, FROZEN, PREPARED AND PACKAGED MEALS CONSISTING PRIMARILY OF MEAT, FISH, POULTRY OR VEGETABLES; FROZEN VEGETABLES, FROZEN FRUIT, INSTANT POTATOES, INSTANT SOUP AND STEW; DIETETIC SUBSTANCES AND FOODSTUFFS, NOT ADAPTED FOR MEDICAL USE, INCLUDED IN THIS CLASS, NAMELY, FRUIT BASED SNACK FOOD AND DRIED FRUITS (U.S. CL. 46).

CLASS 30—STAPLE FOODS

FOR COFFEE, TEA, COCOA, SUGAR, RICE, TAPIOCA, SAGO, ARTIFICIAL COFFEE; COFFEE, TEA, COCOA OR CHOCOLATE-BASED DRINKS, NAMELY, TEA-BASED BEVERAGES WITH FRUIT FLAVORING; CAPPUCCINO COFFEES; COFFEE, COCOA AND CHOCOLATE PREPARATIONS, NAMELY, MIXES IN THE NATURE OF CONCENTRATES, SYRUPS OR POWDERS USED IN THE PREPARATION OF ALCOHOLIC OR NON-ALCOHOLIC DRINKS; FLOUR AND PREPARATIONS MADE FROM CEREALS, NAMELY, PROCESSED CEREALS AND MUESLI; PASTA; BREAD, PASTRY AND CONFECTIONERY, NAMELY, CAKES, WAFFLES, BISCUITS, CAKES, TARTS; CONFECTIONERY, CHOCOLATE AND CHOCOLATE GOODS, NAMELY, GRATED CHOCOLATE, CHOCOLATE TOPPING, SHEETS, GRANULES AND FLAKES, CHOCOLATE BARS, CHOCOLATE TRUFFLES, CHOCOLATE CHIPS, CHOCOLATE EGGS, CHOCOLATE CANDY, PRALINES, CARAMEL TOPPING, MARZIPAN, ALMOND CAKE, ALMOND CANDY, ROASTED ALMONDS COATED IN CHOCOLATE, CRYSTALLIZED SUGAR PIECES, SWEETMEATS, CARAMELS, PASTILLES, CANDY AND SWEETS, TOFFEE, PEANUT BRITTLE, FRUIT JELLIES, GUM SWEETS, SHAVED ICE CONFECTIONS, ICE CREAM, ICE CREAM CAKES, BLANCMANGES, ITALIAN ICE, EDIBLE ICES; HONEY, TREACLE; YEAST, BAKING POWDER, STARCH FOR FOOD; SALT; MUSTARD; MAYONNAISE, KETCHUP; VINEGAR, SAUCES, SALAD DRESSINGS; SPICES; PREPARED MEALS AND FROZEN FOODSTUFFS, NAMELY, FROZEN, PREPARED AND PACKAGED MEALS CONSISTING PRIMARILY OF PASTA OR RICE; DIETETIC SUBSTANCES AND FOODSTUFFS, NOT ADAPTED FOR MEDICAL USE, NAMELY, PUFFED RICE (U.S. CL. 46).

CLASS 31—NATURAL AGRICULTURAL PRODUCTS

FOR FRESH FRUITS AND VEGETABLES; NUTS, NAMELY, FRESH, RAW AND UNPROCESSED NUTS; SEEDS, NAMELY, PLANT SEEDS, UNPROCESSED EDIBLE SEEDS, SEEDS FOR FLOWERS, SEEDS FOR FRUIT AND VEGETABLES; NATURAL LIVE PLANTS AND FLOWERS; DRIED PLANTS; ANIMAL FEED AND ADDITIVES FOR ANIMAL FEED, NAMELY, NON-MEDICATED ADDITIVES FOR ANIMAL FEED, NUTRITIONAL ADDITIVES FOR ANIMAL FOODSTUFFS, NOT FOR MEDICAL PURPOSES; MALT FOR BREWING AND DISTILLING; BEDDING FOR ANIMALS, NAMELY, CHOPPED STRAW, LOOSE HEMP AND WOOD SHAVINGS (U.S. CLS. 1 AND 46).

CLASS 32—LIGHT BEVERAGES

FOR BEERS; MINERAL AND AERATED WATERS AND OTHER NON-ALCOHOLIC DRINKS, NAMELY, CARBONATED WATER AND CARBONATED NON-ALCOHOLIC BEVERAGES; FRUIT DRINKS, FRUIT CORDIALS AND FRUIT JUICES; SYRUPS FOR MAKING BEVERAGES AND OTHER PREPARATIONS, NAMELY, SYRUPS, CONCENTRATES, POWDERS AND FRUIT EXTRACTS FOR MAKING NON-ALCOHOLIC BEVERAGES AND SOFT DRINKS (U.S. CLS. 45, 46 AND 48).

CLASS 33—WINES AND SPIRITS

FOR ALCOHOLIC BEVERAGES, EXCEPT BEERS, NAMELY, WINE, SPIRITS AND LIQUEURS, AND ALCOHOLIC MIXED MILK BEVERAGES, COCKTAILS AND APERITIFS WITH A SPIRIT OR WINE BASE; BEVERAGES CONTAINING WINE IN THE NATURE OF WINE COOLERS; ALCOHOLIC PREPARATIONS FOR MAKING BEVERAGES, NAMELY, ALCOHOLIC COCKTAIL MIXES, ALCOHOLIC BITTERS (U.S. CLS. 47 AND 49).

DOMINIC FATHY, EXAMINING ATTORNEY

SN 79-060,869. MEPHISTO S.A.; (SOCIÉTÉ ANONYME À DIRECTOIRE ET; CONSEIL DE SURVEILLANCE), FRANCE, FILED 9-26-2008.

SN 79-061,385. BATTIONI PAGANI POMPE S.P.A., ITALY, FILED 9-1-2008.

SOFT-AIR

BATTIONI PAGANI

THE MARK CONSISTS OF STANDARD CHARACTERS WITHOUT CLAIM TO ANY PARTICULAR FONT, STYLE, SIZE, OR COLOR.

PRIORITY DATE OF 4-4-2008 IS CLAIMED.

OWNER OF INTERNATIONAL REGISTRATION 0982061 DATED 9-26-2008, EXPIRES 9-26-2018.

CLASS 25—CLOTHING

FOR FOOTWEAR, SHOES, ESPECIALLY CHILDREN'S SHOES, EXERCISE SHOES, WALKING AND HIKING SHOES, SPORTS SHOES, COMFORT FOOTWEAR, TOWN SHOES, SANDALS, CASUAL FOOTWEAR (U.S. CLS. 22 AND 39).

CLASS 35—ADVERTISING AND BUSINESS

FOR WHOLESALE AND RETAIL STORE SERVICES FEATURING FOOTWEAR (U.S. CLS. 100, 101 AND 102). TINA KUAN, EXAMINING ATTORNEY

SN 79-061,384. BATTIONI PAGANI POMPE S.P.A., ITALY, FILED 9-1-2008.

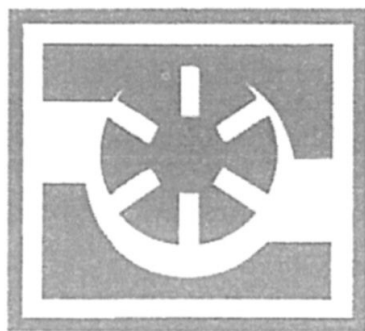

PRIORITY DATE OF 7-29-2008 IS CLAIMED. OWNER OF INTERNATIONAL REGISTRATION 0983227 DATED 9-1-2008, EXPIRES 9-1-2018.

THE MARK COMPRISES A LOGO INCLUDING A CIRCULAR SHAPE PROVIDED WITH RADIAL EXPANSIONS AND INSERTED IN A SQUARE FRAME.

CLASS 7—MACHINERY

FOR PUMPS, NAMELY, VACUUM PUMPS AND COMPRESSOR PUMPS; PUMPS AS PARTS OF MACHINES OR MOTORS; AND HYDRAULIC MOTORS (U.S. CLS. 13, 19, 21, 23, 31, 34 AND 35).

CLASS 37—CONSTRUCTION AND REPAIR

FOR MAINTENANCE, INSTALLATION AND REPAIR SERVICES FOR PUMPS USED IN MACHINES, AS PARTS OF MACHINES OR OF MOTORS, AND HYDRAULIC MOTORS (U.S. CLS. 100, 103 AND 106). RON FAIRBANKS, EXAMINING ATTORNEY

THE MARK CONSISTS OF STANDARD CHARACTERS WITHOUT CLAIM TO ANY PARTICULAR FONT, STYLE, SIZE, OR COLOR.

PRIORITY DATE OF 7-29-2008 IS CLAIMED.

OWNER OF INTERNATIONAL REGISTRATION 0983228 DATED 9-1-2008, EXPIRES 9-1-2018.

"BATTIONI PAGANI" DOES NOT IDENTIFY A LIVING INDIVIDUAL.

CLASS 7—MACHINERY

FOR PUMPS, NAMELY, VACUUM PUMPS AND COMPRESSOR PUMPS; PUMPS AS PARTS OF MACHINES OR MOTORS; AND HYDRAULIC MOTORS (U.S. CLS. 13, 19, 21, 23, 31, 34 AND 35).

CLASS 37—CONSTRUCTION AND REPAIR

FOR MAINTENANCE, INSTALLATION AND REPAIR SERVICES FOR PUMPS USED IN MACHINES, AS PARTS OF MACHINES OR OF MOTORS, AND HYDRAULIC MOTORS (U.S. CLS. 100, 103 AND 106). RON FAIRBANKS, EXAMINING ATTORNEY

SN 79-061,462. BRIDGESTONE CORPORATION, JAPAN, FILED 6-10-2008.

CAIS(Contact Area Information Sensing)

PRIORITY DATE OF 4-30-2008 IS CLAIMED. OWNER OF INTERNATIONAL REGISTRATION 0983435 DATED 6-10-2008, EXPIRES 6-10-2018.

NO CLAIM IS MADE TO THE EXCLUSIVE RIGHT TO USE "CONTRACT AREA INFORMATION SENSING", APART FROM THE MARK AS SHOWN.

CLASS 9—ELECTRICAL AND SCIENTIFIC APPARATUS

FOR VIBRATION ACCELEROMETERS; STRAIN SENSORS; MEASURING OR TESTING MACHINES AND INSTRUMENTS, NAMELY, APPARATUS FOR CENTRALLY MONITORING DRIVING CONDITIONS BY COMPUTER THROUGH DETECTING OSCILLATING WAVES FROM TIRES AND STRAIN STATE OF TIRES BOTH OF WHICH ARE CAUSED WHILE THE VEHICLE IS MOVING (U.S. CLS. 21, 23, 26, 36 AND 38).

CLASS 12—VEHICLES

FOR VEHICLE TIRES, NAMELY, TIRES FOR PASSENGER CARS, TIRES FOR TRUCKS, TIRES FOR BUSES, TIRES FOR RACING CARS, TIRES FOR AUTOMOBILES (U.S. CLS. 19, 21, 23, 31, 35 AND 44). TRACY FLETCHER, EXAMINING ATTORNEY

SN 79-061,970. GNOSIS S.P.A., ITALY, FILED 7-18-2008.

SN 79-062,068. ALPASLAN SELÇUK, KÜÇÜKÇEKMECE-ISTANBUL, TURKEY, FILED 7-30-2008.



PRIORITY DATE OF 5-30-2008 IS CLAIMED.
OWNER OF INTERNATIONAL REGISTRATION 0984658
DATED 7-18-2008, EXPIRES 7-18-2018.

NO CLAIM IS MADE TO THE EXCLUSIVE RIGHT TO
USE "NATURAL NATTOKINASE", APART FROM THE
MARK AS SHOWN.

THE COLOR(S) RED AND WHITE IS/ARE CLAIMED AS
A FEATURE OF THE MARK.

FIGURATIVE TRADEMARK CONSISTING OF THE
WORDING "BIO" AND "KYN" IN SPECIAL CHARACTERS;
THE FIRST WORD "BIO", WHICH IS IN LOWERCASE
LETTERS, IS IN RED; ON THE RIGHT OF THE MARK,
THE SECOND WORD "KYN", WHICH IS IN WHITE
CAPITAL LETTERS, APPEARS INSIDE A RED SPHERE,
WHICH HAS TONES AND SHADING TO MAKE IT APPEAR
THREE-DIMENSIONAL; THE WORDING "NATURAL NAT-
TOKINASE" APPEARS INSIDE THE SPHERE IN SMALLER,
WHITE CAPITAL LETTERS, UNDER THE WORDING
"KYN".

CLASS 1—CHEMICALS

FOR CHEMICAL ADDITIVES FOR USE IN THE
MANUFACTURE OF FOOD SUPPLEMENTS, NUTRI-
TIONALLY FORTIFIED BEVERAGES AND NUTRI-
TIONAL SUPPLEMENTS (U.S. CLS. 1, 5, 6, 10, 26 AND
46).

CLASS 5—PHARMACEUTICALS

FOR NUTRITIONAL SUPPLEMENTS; DIETARY SUP-
PLEMENTS; BEVERAGES ADAPTED FOR MEDICINAL
PURPOSES; DIETETIC BEVERAGES ADAPTED FOR
MEDICINAL PURPOSES; DIETETIC SUBSTANCES,
NAMELY, FOOD AND BEVERAGES ADAPTED FOR
MEDICINAL PURPOSES; NUTRITIONALLY FORTI-
FIED BEVERAGES; DIETARY FOOD SUPPLEMENTS;
DIETARY SUPPLEMENT DRINKS; FOOD SUPPLE-
MENTS FOR DIETETIC USE; MEAL REPLACEMENT
AND DIETARY SUPPLEMENT DRINK MIXES; NUTRA-
CEUTICALS FOR USE AS A DIETARY SUPPLEMENT
(U.S. CLS. 6, 18, 44, 46, 51 AND 52).

ANGELA M. MICHELI, EXAMINING ATTORNEY



OWNER OF INTERNATIONAL REGISTRATION 0984918
DATED 7-30-2008, EXPIRES 7-30-2018.

THE MARK CONSISTS OF THE WORDING "DDI HAAN-
GAR" CONTAINED WITHIN A SHAPE THAT IS OVAL ON
THE TOP AND RECTANGULAR ON THE BOTTOM, ALL
CONTAINED WITHIN A SQUARE CARRIER.

THE WORDING "DDI HAAN-GAR" HAS NO MEANING
IN A FOREIGN LANGUAGE.

CLASS 25—CLOTHING

FOR APRONS, ATHLETIC UNIFORMS, BATH SLIP-
PERS, BATHING CAPS, BATHING SUITS, BATHING
TRUNKS, BATHROBES, BEACH COVER-UPS, BEACH-
WEAR, BELTS, BERETS, BIKINIS, BLAZERS, BLOUSES,
BOOTS, BOW TIES, BRAS, BRASSIERES, CAMISOLES,
CAPES, CAPS, CARDIGANS, CHEMISES, COATS, COR-
SETS, DRESSES, DRESSING GOWNS, EAR MUFFS,
FOOTWEAR, GARTERS, GLOVES, GOWNS, GYM
SHORTS, GYM SUITS, HALTER TOPS, HATS, HEAD-
BANDS, HEADWEAR, HOUSECOATS, INFANT WEAR,
JACKETS, JEANS, JERSEYS, JOGGING SUITS, JUM-
PERS, LINGERIE, LOUNGEWEAR, MITTENS, MUFFS,
NECKTIES, NECKWEAR, NIGHT DRESSES, NIGHT
GOWNS, NIGHTWEAR, OVER COATS, OVERALLS,
PAJAMAS, PANTIES, PANTS, PARKAS, POLO SHIRTS,
PULLOVERS, RAINCOATS, RAINWEAR, ROBES, SAND-
DALS, SCARVES, SCHOOL UNIFORMS, SHAWLS,
SHIRTS, SHOES, SHORTS, SKIRTS, SLEEPWEAR, SLIP-
PERS, SLIPS, SOCKS, SPORT COATS, SUITS, SUSPEN-
DERS, SWEAT PANTS, SWEAT SHIRTS, SWEAT SUITS,
SWEATBANDS, SWEATERS, SWIM WEAR, TANK-TOPS,
TENNIS WEAR, TIGHTS, TRACKSUITS, TRENCH
COATS, T-SHIRTS, UNDERGARMENTS, UNDERPANTS,
UNDERSHIRTS, UNDERWEAR, VESTS, WAISTCOATS,
WRISTBANDS (U.S. CLS. 22 AND 39).

CLASS 35—ADVERTISING AND BUSINESS

FOR BUSINESS CONSULTING SERVICE FOR ESTAB-
LISHMENT, ORGANISATION, MANAGEMENT OF
SHOPPING CENTRES, SHOPS, MARKETS; CONSULT-
ING SERVICE FOR RETAIL MANAGEMENT OF SHOP-
PING CENTRES, SHOPS, MARKETS; IMPORT-EXPORT
AGENCY SERVICES; THE BRINGING TOGETHER, FOR
THE BENEFIT OF OTHERS, OF A VARIETY OF GOODS,
ENABLING CUSTOMERS TO CONVENIENTLY VIEW
AND PURCHASE THOSE GOODS IN THE FIELD OF
TEXTILES AND TEXTILE PRODUCTS, GARMENTS,
CLOTHING AND ACCESSORIES, FOOTWEAR, HEAD-
WEAR, LEATHER GOODS, OUTDOOR AND SPORTS
WEAR; ON-LINE RETAIL STORE SERVICES, MAIL
ORDER CATALOG SERVICES, AND RETAIL STORE
SERVICES FEATURING TEXTILES AND TEXTILE PRO-
DUCTS, GARMENTS, CLOTHING AND ACCESSORIES,
FOOTWEAR, HEADWEAR, LEATHER GOODS, OUT-
DOOR AND SPORTS WEAR; ON-LINE RETAIL STORE
SERVICES, MAIL ORDER CATALOG SERVICES, AND
RETAIL STORE SERVICES FEATURING A WIDE VARI-
ETY OF CONSUMER GOODS OF OTHERS; RETAIL
VARIETY STORES (U.S. CLS. 100, 101 AND 102).

FRED CARL, EXAMINING ATTORNEY

SN 79-062,807. ZHI FEI WU, CHINA, FILED 10-30-2008.

SN 79-062,899. KNORR-NÄHRMITTEL AKTIENGESELLSCHAFT, SWITZERLAND, FILED 10-21-2008.

PASTA PRIMO

THE MARK CONSISTS OF STANDARD CHARACTERS WITHOUT CLAIM TO ANY PARTICULAR FONT, STYLE, SIZE, OR COLOR.

PRIORITY DATE OF 9-5-2008 IS CLAIMED.

OWNER OF INTERNATIONAL REGISTRATION 0986798 DATED 10-30-2008, EXPIRES 10-30-2018.

NO CLAIM IS MADE TO THE EXCLUSIVE RIGHT TO USE "PASTA", APART FROM THE MARK AS SHOWN.

CLASS 20—FURNITURE AND ARTICLES NOT OTHERWISE CLASSIFIED

FOR PACKAGING CONTAINERS OF PLASTIC (U.S. CLS. 2, 13, 22, 25, 32 AND 50).

CLASS 21—HOUSEWARES AND GLASS

FOR NON-ELECTRIC COOKING UTENSILS, NAMELY, NON-ELECTRIC AUTOCLAVES AND NON-ELECTRIC PRESSURE COOKERS; KITCHEN UTENSILS, NAMELY, SPATULAS (U.S. CLS. 2, 13, 23, 29, 30, 33, 40 AND 50).

ROBERT C. CLARK JR., EXAMINING ATTORNEY



SN 79-062,863. COGNIS IP MANAGEMENT GMBH, FED REP GERMANY, FILED 10-28-2008.

ETERNISKIN

THE MARK CONSISTS OF STANDARD CHARACTERS WITHOUT CLAIM TO ANY PARTICULAR FONT, STYLE, SIZE, OR COLOR.

PRIORITY DATE OF 7-8-2008 IS CLAIMED.

OWNER OF INTERNATIONAL REGISTRATION 0986907 DATED 10-28-2008, EXPIRES 10-28-2018.

CLASS 1—CHEMICALS

FOR CHEMICAL PREPARATIONS IN THE NATURE OF EXTRACTS OF NATURAL, VEGETAL, MARINE, SYNTHETIC OR BIOTECHNOLOGICAL ORIGIN, INTENDED FOR THE FURTHER MANUFACTURE OF COSMETIC PRODUCTS AND SANITARY PREPARATIONS FOR COSMETIC BODY, HAIR AND FACE CARE (U.S. CLS. 1, 5, 6, 10, 26 AND 46).

CLASS 3—COSMETICS AND CLEANING PREPARATIONS

FOR COSMETIC PREPARATIONS FOR SKIN AND BODY CARE, NAMELY, SKIN EMULSIONS, GELS AND LOTIONS, SKIN CREAMS, BODY LOTIONS, AND DEPILATORIES; HAIR CARE PRODUCTS, NAMELY, SHAMPOOS, HAIR EMULSIONS, HAIR LOTIONS, HAIR TREATMENT FOAMS, AND HAIR SETTING GELS; COSMETICS, NAMELY, MAKE-UP PREPARATIONS, MAKE-UP POWDERS, COLORING CREAMS FOR COSMETIC PURPOSES, BLUSHERS, LIPSTICK, MASCARA, EYE PENCILS, EYE SHADOWS, AND MAKE-UP REMOVING PREPARATIONS; TANNING CREAMS AND LOTIONS; NAIL CARE PREPARATIONS; PERFUMES; ESSENTIAL OILS FOR PERSONAL USE; OILS FOR COSMETIC PURPOSES (U.S. CLS. 1, 4, 6, 50, 51 AND 52).

COLLEEN DOMBROW, EXAMINING ATTORNEY

PRIORITY DATE OF 9-9-2008 IS CLAIMED.

OWNER OF INTERNATIONAL REGISTRATION 0987003 DATED 10-21-2008, EXPIRES 10-21-2018.

OWNER OF U.S. REG. NO. 685,624.

THE COLOR(S) WHITE, YELLOW, RED, LIGHT GREEN AND DARK GREEN IS/ARE CLAIMED AS A FEATURE OF THE MARK.

THE MARK CONSISTS OF THE COLOR(S) YELLOW, RED, LIGHT GREEN AND DARK GREEN AND WHITE, WITH THE COLOR RED APPEARING IN THE WORDING "KNORR", THE COLOR YELLOW APPEARING IN THE UPPER, INTERIOR CURVED BAND AND THE LOWER, EXTERIOR CURVED BAND, THE COLORS LIGHT GREEN AND DARK GREEN APPEARING IN THE UPPER, EXTERIOR CURVED BAND AND THE LOWER INTERIOR CURVED BAND, WHERE THE LIGHT GREEN APPEARS IN THE BOTTOM HALF OF THE LEAF DESIGN AND THE DARK GREEN APPEARS IN THE TOP HALF OF THE LEAF DESIGN, AND THE COLOR WHITE APPEARING IN THE BACKGROUND.

CLASS 29—MEATS AND PROCESSED FOODS

FOR MEAT, FISH, POULTRY AND GAME; MEAT EXTRACTS; PRESERVED, FROZEN, DRIED AND COOKED FRUITS AND VEGETABLES; JELLIES, JAMS, COMPOTES; EGGS; EDIBLE OILS AND FATS (U.S. CL. 46).

CLASS 30—STAPLE FOODS

FOR COFFEE, TEA, COCOA, SUGAR, RICE, TAPIOCA, SAGO, ARTIFICIAL COFFEE; FLOURS, BREAD, PASTRY; EDIBLE ICES; HONEY, TREACLE; YEAST, BAKING-POWDER; SALT, MUSTARD; VINEGAR, SAUCES, CONDIMENTS, NAMELY, SPICES; ICE FOR REFRESHMENT (U.S. CL. 46).

CLASS 32—LIGHT BEVERAGES

FOR BEERS; MINERAL AND AERATED WATERS; FRUIT DRINKS AND FRUIT JUICES; SYRUPS FOR MAKING BEVERAGES AND OTHER PREPARATIONS FOR MAKING BEVERAGES, NAMELY, FRUIT AND VEGETABLE DRINKS (U.S. CLS. 45, 46 AND 48).

MARY MUNSON, EXAMINING ATTORNEY

SN 79-062,921. VOLKSWAGEN AKTIENGESELLSCHAFT, FED REP GERMANY, FILED 7-18-2008.

SN 79-062,967. STATOILHYDRO ASA, NORWAY, FILED 8-5-2008.



OWNER OF INTERNATIONAL REGISTRATION 0714792 DATED 5-6-1999, EXPIRES 5-6-2009.

NO CLAIM IS MADE TO THE EXCLUSIVE RIGHT TO USE "PROMOTION", APART FROM THE MARK AS SHOWN.

THE COLOR(S) ORANGE, BLACK, WHITE, BLUE, YELLOW IS/ARE CLAIMED AS A FEATURE OF THE MARK.

THE MARK CONSISTS OF AN ORANGE AND WHITE RECTANGLE ON TOP OF WHICH IS A BLACK RECTANGLE. WITHIN THE BLACK RECTANGLE IS THE WORD "MOTION" IN WHITE IN A STYLIZED FONT ALONG WITH VARIOUS ABSTRACT SHAPES IN BLUE AND YELLOW. BENEATH THE BLACK RECTANGLE IS THE WORD "PROMOTION" WITH "PRO" IN BLACK AND "MOTION" IN ORANGE WITH A BLUE LINE UNDERNEATH THE TERM.

CLASS 35—ADVERTISING AND BUSINESS

FOR ADVERTISING; BUSINESS MANAGEMENT; BUSINESS ADMINISTRATION AND OFFICE WORK; PERSONNEL RECRUITMENT, PERSONNEL MANAGEMENT CONSULTANCY, BUSINESS MANAGEMENT CONSULTANCY, PUBLIC RELATIONS, ORGANIZATION OF TRADE FAIRS FOR COMMERCIAL OR ADVERTISING PURPOSES (U.S. CLS. 100, 101 AND 102).

CLASS 36—INSURANCE AND FINANCIAL

FOR INSURANCE, NAMELY, HEALTH INSURANCE UNDERWRITING, INSURANCE BROKERAGE, ACCIDENT INSURANCE UNDERWRITING; FINANCIAL AFFAIRS, NAMELY, FINANCIAL ADVICE AND CONSULTANCY SERVICES; MONETARY AFFAIRS, NAMELY, ISSUANCE OF CREDIT CARDS, BANKING, LOAN FINANCING, INSTALLMENT LOANS, CREDIT BUREAUS, FINANCIAL CONSULTANCY, HIRE-PURCHASE FINANCING, SAVING BANKS, PARTIAL INSTALLMENT LOANS; REAL ESTATE AFFAIRS, NAMELY, APARTMENT HOUSE MANAGEMENT, REAL ESTATE MANAGEMENT, REAL ESTATE APPRAISAL, REAL ESTATE RENTAL SERVICES FEATURING RENTAL OF OFFICES AND RENTING OF FLATS, REAL ESTATE AGENCIES, ACCOMMODATION BUREAU SERVICES FEATURING RENTAL OF APARTMENTS, LEASING OF REAL ESTATE (U.S. CLS. 100, 101 AND 102).

CLASS 42—SCIENTIFIC AND COMPUTER SERVICES

FOR PROVIDING OF FOOD AND DRINK; LEGAL SERVICES; SCIENTIFIC RESEARCH AND INDUSTRIAL RESEARCH IN THE FIELD OF AUTOMOBILES; COMPUTER PROGRAMMING; CONSULTANCY IN THE FIELD OF COMPUTER HARDWARE, RENTAL OF COMPUTER SOFTWARE, COMPUTER RENTAL, TECHNICAL PROJECT STUDIES, NAMELY, TECHNICAL RESEARCH IN THE FIELD OF AUTOMOBILES; MECHANICAL AND TECHNICAL RESEARCH IN THE FIELDS OF AUTOMOBILES (U.S. CLS. 100 AND 101).
ERNEST SHOSHO, EXAMINING ATTORNEY

iEVO

PRIORITY DATE OF 6-2-2008 IS CLAIMED.
OWNER OF INTERNATIONAL REGISTRATION 0987134 DATED 8-5-2008, EXPIRES 8-5-2018.

CLASS 1—CHEMICALS

FOR CHEMICALS FOR INDUSTRIAL AND SCIENTIFIC PURPOSES; FIRE EXTINGUISHING COMPOSITIONS; HYDROGEN (U.S. CLS. 1, 5, 6, 10, 26 AND 46).

CLASS 3—COSMETICS AND CLEANING PREPARATIONS

FOR CLEANING PREPARATIONS, AUTOMOBILE CLEANERS; CLEANING, POLISHING AND SCOURING PREPARATIONS; SOAPS FOR HOUSEHOLD USE (U.S. CLS. 1, 4, 6, 50, 51 AND 52).

CLASS 4—LUBRICANTS AND FUELS

FOR OILS AND GREASES FOR INDUSTRIAL PURPOSES; AUTOMOTIVE AND INDUSTRIAL LUBRICANTS; ENGINE FUELS AND LIGHTING FUELS; FUEL PELLETS; FUEL OIL; FUEL GAS; CANDLES AND WICKS FOR CANDLES (U.S. CLS. 1, 6 AND 15).

CLASS 29—MEATS AND PROCESSED FOODS

FOR MEAT, FISH, POULTRY AND GAME; MEAT EXTRACTS; PRESERVED, FROZEN, DRIED AND COOKED FRUITS AND VEGETABLES; JELLIES, JAMS, COMPOTES; EGGS, MILK AND MILK PRODUCTS EXCLUDING ICE CREAM, ICE MILK AND FROZEN YOGURT; EDIBLE OILS AND FATS, AND ALSO READY-MADE MEALS CONSISTING PRIMARILY OF MEAT, FISH, POULTRY OR VEGETABLES; EDIBLE OILS AND FATS, NAMELY, VEGETABLE OILS AND PALM OIL (U.S. CL. 46).

CLASS 30—STAPLE FOODS

FOR COFFEE, TEA, COCOA, SUGAR, RICE, TAPIOCA, SAGO, ARTIFICIAL COFFEE; FLOUR, BREAD, PASTRY; FLAVOURED ICES, ICE (U.S. CL. 46).

CLASS 31—NATURAL AGRICULTURAL PRODUCTS

FOR AGRICULTURAL, HORTICULTURAL AND FORESTRY PRODUCTS AND GRAINS, NAMELY SUGAR CANE, FRESH MAIZE, FRESH CORN, UNPROCESSED SOY BEANS, RAPESEED BEING SOWING SEEDS, NATURAL PLANTS AND LIVE TREES, NAMELY, JATROPHA, MAHUA, MUSTARD, FLAX, SUNFLOWER, HEMP, FIELD PENNYCRESS AND ALGAE (U.S. CLS. 1 AND 46).

CLASS 36—INSURANCE AND FINANCIAL

FOR ELECTRONIC PAYMENT, NAMELY, ELECTRONIC PROCESSING AND TRANSMISSION OF PAYMENTS FOR PURCHASE OF CARBON DIOXIDE (CO2) EMISSIONS QUOTAS (U.S. CLS. 100, 101 AND 102).

CLASS 37—CONSTRUCTION AND REPAIR

FOR MAINTENANCE AND REPAIR OF VEHICLES; CAR WASH (U.S. CLS. 100, 103 AND 106).

CLASS 42—SCIENTIFIC AND COMPUTER SERVICES

FOR SCIENTIFIC AND TECHNOLOGICAL SERVICES, NAMELY, CARBON DIOXIDE (CO₂) EMISSION CALCULATION AND RESEARCH AND DESIGN RELATING TO TRANSPORTATION FUELS; DESIGN AND DEVELOPMENT OF COMPUTER HARDWARE AND SOFTWARE (U.S. CLS. 100 AND 101).

CLASS 43—HOTEL AND RESTAURANT SERVICES

FOR SERVICES FOR PROVIDING FOOD AND DRINK (U.S. CLS. 100 AND 101).
LAKEISHA LEWIS, EXAMINING ATTORNEY

SN 79-063,909. PEAK PERFORMANCE PRODUCTION AB, SWEDEN, FILED 12-3-2008.

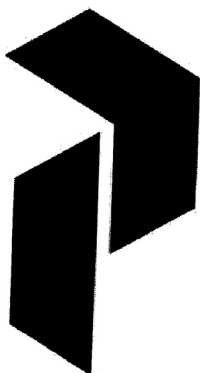

PRIORITY DATE OF 7-3-2008 IS CLAIMED.
OWNER OF INTERNATIONAL REGISTRATION 0989616 DATED 12-3-2008, EXPIRES 12-3-2018.

THE MARK CONSISTS OF ONE VERTICALLY ALIGNED QUADRILATERAL AND TWO QUADRILATERALS JOINED ON AN ANGLE TO FORM A STYLIZED LETTER "p".

CLASS 3—COSMETICS AND CLEANING PREPARATIONS

FOR PERFUMES, BODY LOTIONS, PERSONAL DEODORANTS, AND TOILET SOAPS, AND HAIR SHAMPOOS, AFTERSHAVE LOTIONS (U.S. CLS. 1, 4, 6, 50, 51 AND 52).

CLASS 9—ELECTRICAL AND SCIENTIFIC APPARATUS

FOR SPECTACLES, SUNGLASSES AND SPECTACLE CASES, SPECTACLE FRAMES (U.S. CLS. 21, 23, 26, 36 AND 38).

CLASS 18—LEATHER GOODS

FOR RUCKSACKS, VALISES, WALLETS, HANDBAGS, SUITCASES, TRAVELLING BAGS (U.S. CLS. 1, 2, 3, 22 AND 41).

CLASS 25—CLOTHING

FOR MEN'S AND WOMEN'S JEANS, PANTS, SHORTS, SHIRTS, T-SHIRTS, SWEATSHIRTS, SWEATERS, BELTS, COATS, JACKETS, BLAZERS, COVER-ALLS, OVER-ALLS, VESTS, SHOES, TIES, SOCKS, SCARVES, SWIMWEAR, BOOTS, UNDERWEAR, SHIRT JACKETS, POLO SHIRTS, AND WOMEN'S SKIRTS, DRESSES, BLOUSES, SHAWLS, KNIT TOPS, AND STOCKINGS; SPORTS CLOTHING, NAMELY, FOOTWEAR, SHORTS, PANTS, SHIRTS, SKIRTS, JEANS, JERSEYS, POLO SHIRTS, SWEATPANTS, SWEATSUITS, SWEATSHIRTS, JACKETS, CAPS AND HEADBANDS (U.S. CLS. 22 AND 39).

JULIE GUTTADAURO, EXAMINING ATTORNEY

SN 79-064,067. HILDEGARD BRAUKMANN KOSMETIK; GMBH & CO. KG, FED REP GERMANY, FILED 12-2-2008.

HILDEGARD BRAUKMANN

PRIORITY DATE OF 7-3-2008 IS CLAIMED.
OWNER OF INTERNATIONAL REGISTRATION 0989882 DATED 12-2-2008, EXPIRES 12-2-2018.

OWNER OF U.S. REG. NO. 3,055,709.

THE NAME "HILDEGARD BRAUKMANN" DOES NOT IDENTIFY A LIVING INDIVIDUAL.

THE COLOR(S) BLACK AND WHITE IS/ARE CLAIMED AS A FEATURE OF THE MARK.

THE MARK CONSISTS OF THE WORDING "HILDEGARD" IN A BLACK STYLIZED FONT IMMEDIATELY ABOVE THE WORDING "BRAUKMANN" IN THE SAME BLACK STYLIZED FONT, ALL ON A WHITE BACKGROUND.

CLASS 3—COSMETICS AND CLEANING PREPARATIONS

FOR SOAPS, NAMELY, HAND SOAPS, LIQUID SOAPS FOR HANDS, FACE AND BODY; PERFUMERY; ESSENTIAL OILS FOR PERSONAL USE; ARTICLES FOR BODY AND BEAUTY-CARE, NAMELY, BODY CREAMS, BODY EMULSIONS, BODY MASKS, BODY MILKS, BODY SPRAYS, SKIN LOTIONS, BEAUTY MASKS; HAIRCARE PREPARATIONS; HAIR LOTIONS; SUN-TANNING AND SUN-SCREENING PREPARATIONS; COSMETICS; DENTIFRICES (U.S. CLS. 1, 4, 6, 50, 51 AND 52).

CLASS 44—MEDICAL, BEAUTY AND AGRICULTURAL SERVICES

FOR BEAUTY SALONS; HAIRDRESSING SALONS (U.S. CLS. 100 AND 101).

SONYA STEPHENS, EXAMINING ATTORNEY

SN 79-064,377. KYBUN AG, ROGGWIL, SWITZERLAND, FILED 11-13-2008.

KYBOOT

THE MARK CONSISTS OF STANDARD CHARACTERS WITHOUT CLAIM TO ANY PARTICULAR FONT, STYLE, SIZE, OR COLOR.

PRIORITY DATE OF 5-29-2008 IS CLAIMED.

OWNER OF INTERNATIONAL REGISTRATION 0990793 DATED 11-13-2008, EXPIRES 11-13-2018.

CLASS 10—MEDICAL APPARATUS

FOR ORTHOPAEDIC ARTICLES FOR PHYSICAL AND PHYSIOTHERAPEUTIC EXERCISES, NAMELY, ORTHOPAEDIC FOOTWEAR AND MEDICAL WEARING APPAREL IN THE NATURE OF SHOES WITH ORTHOPAEDIC SOLES; MEDICAL WEARING APPAREL, NAMELY, FOOTWEAR FOR USE WITH MEDICAL THERAPEUTIC METHODS, MEDICAL REHABILITATION METHODS AND MEDICAL TRAINING METHODS (U.S. CLS. 26, 39 AND 44).

CLASS 25—CLOTHING

FOR APPAREL, NAMELY, COATS, RAINCOATS, BELTS, WAISTCOAT, BLOUSES AND PULLOVERS, JACKETS, TROUSERS, SKIRTS, DRESSES, SUITS, SHIRTS AND CHEMISES, T-SHIRTS, SWEATERS, UNDERWEAR, SOCKS AND STOCKINGS, GLOVES, TIES, SCARVES, HATS AND CAPS, BOOTS, SHOES AND SLIPPERS, FASHION WEAR, NAMELY, HATS, COATS, SUITS, SLACKS, RAINCOATS, SCARVES, HOSIERY, SHORTS, SWIMSUITS, GLOVES, JACKETS, CARCOATS, DRESSES, SKIRTS, SWEATERS, NIGHTGOWNS, ROBES, SHIRTS AND BLOUSES, FOOTWEAR, SHOES, SPORTS SHOES, SOCKS (U.S. CLS. 22 AND 39).

CLASS 44—MEDICAL, BEAUTY AND AGRICULTURAL SERVICES

FOR PHYSICAL THERAPY SERVICES, MEDICAL SERVICES, THERAPEUTIC REHABILITATION SERVICES, NAMELY, PHYSICAL REHABILITATION SERVICES RELATED TO THE LOCOMOTORY SYSTEM (U.S. CLS. 100 AND 101).

CARYN GLASSER, EXAMINING ATTORNEY

CLASS 9—ELECTRICAL AND SCIENTIFIC APPARATUS

FOR WEIGHING APPARATUS AND SCALES, NAMELY, ELECTRONIC RETAIL SCALES AND INDUSTRIAL SCALES; WEIGHING APPARATUS FOR WEIGHT AND PRICE MARKING OF GOODS, NAMELY, SCALES MECHANICALLY COUPLED WITH PRINTERS; CASH REGISTERS IN COMBINATION WITH WEIGHING APPARATUS, CODE READER SCANNERS AND DATA PROCESSING EQUIPMENT AND STRUCTURAL PARTS OF THE AFORESAID GOODS; DATA PROCESSING EQUIPMENT AND DATA INPUT AND OUTPUT APPARATUS, TOGETHER WITH RETAIL SCALES AND INDUSTRIAL SCALES, CASH REGISTERS, PRICE MARKING APPARATUS AND STRUCTURAL PARTS OF THE AFORESAID GOODS; COMPUTER PROGRAMS FOR THE OPERATION OF PACKAGING SYSTEMS, MARKING SYSTEMS, WEIGHING SYSTEMS, PRINTING SYSTEMS, LABELING SYSTEMS, SCALE AND PRINTING SYSTEMS, CASH REGISTER SYSTEMS AND SYSTEMS COMPRISED OF SCALES AND DATA PROCESSING EQUIPMENT AND DATA INPUT AND OUTPUT APPARATUS; COMPUTER PRINTERS FOR DATA PROCESSING EQUIPMENT FOR PRINTING LABELS AND COUPONS (U.S. CLS. 21, 23, 26, 36 AND 38).

CLASS 16—PAPER GOODS AND PRINTED MATTER

FOR SELF ADHESIVE LABELS AND COUPONS OF PAPER, CARDBOARD OR PLASTIC, LABEL ROLLS AND TILL ROLLS OF PAPER AND PLASTIC FOR THE MARKING OF GOODS, INKING RIBBONS, PLASTIC MATERIALS FOR PACKAGING, NAMELY, PLASTIC BUBBLE PACKS FOR PACKAGING, PLASTIC BAGS FOR PACKAGING (U.S. CLS. 2, 5, 22, 23, 29, 37, 38 AND 50).

JULIE WATSON, EXAMINING ATTORNEY

SN 79-064,854. BIZERBA GMBH & CO. KG, FED REP GERMANY, FILED 12-5-2008.



PRIORITY DATE OF 6-10-2008 IS CLAIMED.

OWNER OF INTERNATIONAL REGISTRATION 0992006 DATED 12-5-2008, EXPIRES 12-5-2018.

NO CLAIM IS MADE TO THE EXCLUSIVE RIGHT TO USE "RETAIL", APART FROM THE MARK AS SHOWN.

THE MARK CONSISTS OF A DESIGN ELEMENT MADE UP OF A SQUARE WITH A CIRCLE IN ITS LOWER RIGHT CORNER AND THE WORD "RETAIL" IN STYLIZED FONT TO THE RIGHT OF THE DESIGN ELEMENT.

CLASS 7—MACHINERY

FOR MACHINES FOR THE TREATMENT AND PROCESSING OF FOODSTUFFS, NAMELY, PACKAGING MACHINES FOR PACKAGING AND WHERE NECESSARY FOR MARKING OF GOODS, IN COMBINATION WITH MACHINE WEIGHING, PRINTING, LABELLING AND PACKAGE HANDLING DEVICES; AUTOMATIC INDUSTRIAL LABELLING MACHINES FOR APPLYING LABELS TO PACKAGED PRODUCTS; PRINTING MACHINES FOR PRINTING LABELS AND COUPONS (U.S. CLS. 13, 19, 21, 23, 31, 34 AND 35).

SN 79-065,326. DAVINCI EDITRICE SRL, I-06131 PERUGIA, ITALY, FILED 9-24-2008.



OWNER OF INTERNATIONAL REGISTRATION 0993317 DATED 9-24-2008, EXPIRES 9-24-2018.

THE MARK CONSISTS OF THE WORD "BANG!".

CLASS 16—PAPER GOODS AND PRINTED MATTER

FOR PAPER, CARDBOARD AND GOODS MADE FROM THESE MATERIALS, NOT INCLUDED IN OTHER CLASSES, NAMELY, GAME BOXES IN THE NATURE OF CARDBOARD BOXES FOR USE IN STORING GAMES, PLASTIC BAGS FOR PACKAGING, POSTERS, LEAFLETS ABOUT GAMES, CATALOGUES FEATURING BOARD GAMES, CARD GAMES, DICE GAMES AND TABLETOP GAMES; PRINTED MATTER, NAMELY, BOOKS AND BROCHURES ABOUT GAMES (U.S. CLS. 2, 5, 22, 23, 29, 37, 38 AND 50).

CLASS 28—TOYS AND SPORTING GOODS

FOR GAMES AND PLAYTHINGS, NAMELY, FAMILY PARLOR GAMES, BOARD GAMES, CARD GAMES, TABLETOP GAMES, DICE GAMES, TILE GAMES IN THE NATURE OF BOARD GAMES FEATURING CARDBOARD TILES WITH CLUES OR ILLUSTRATIONS (U.S. CLS. 22, 23, 38 AND 50).

MELISSA VALLILLO, EXAMINING ATTORNEY

SN 79-065,477. ALPRO GMBH, FED REP GERMANY, FILED 10-13-2008.

SN 79-065,499. ELISAVET CHRISTIDOU, FRANKFURT, FED REP GERMANY, FILED 12-16-2008.

ALPRO

THE MARK CONSISTS OF STANDARD CHARACTERS WITHOUT CLAIM TO ANY PARTICULAR FONT, STYLE, SIZE, OR COLOR.

OWNER OF INTERNATIONAL REGISTRATION 0993755 DATED 10-13-2008, EXPIRES 10-13-2018.

OWNER OF U.S. REG. NOS. 1,732,573 AND 2,174,339.

CLASS 9—ELECTRICAL AND SCIENTIFIC APPARATUS

FOR SHOES FOR INDUSTRIAL USE AND FOR PROTECTION AGAINST ACCIDENTS AND FIRES, NAMELY, PROTECTIVE SHOES AND SAFETY SHOES AND COMPONENT AND REPLACEMENT PARTS THEREOF; SAFETY EQUIPMENT, NAMELY, CUSHIONS FOR KNEELING; AND KNEE PADS FOR WORKERS (U.S. CLS. 21, 23, 26, 36 AND 38).

CLASS 20—FURNITURE AND ARTICLES NOT OTHERWISE CLASSIFIED

FOR CUSHIONS FOR KNEELING (U.S. CLS. 2, 13, 22, 25, 32 AND 50).

CLASS 25—CLOTHING

FOR FOOTWEAR AND PARTS THEREFOR, NAMELY, SPORTS FOOTWEAR AND CASUAL FOOTWEAR, IN PARTICULAR SPORTS SHOES AND CASUAL SHOES, COMFORTABLE SHOES, HEALTH SHOES, WORK SHOES; BOOTS, LOW SHOES, SHOES, SANDALS, CHILDREN'S SANDALS, GYMNASIAC SANDALS, OPEN-TOED SANDALS, BACKLESS SLIPPERS, SLIPPERS, SANDALS WITH HEEL STRAPS AND CLOGS, AND SHOES WITH ANATOMICALLY SHAPED DEEP FOOT BEDS; GOODS FOR PRIMARILY NON-ORTHOPEDIC PURPOSES, NAMELY, FOOT PADS AND SHOE INSERTS, INSERTS TO PROTECT THE PRESSURE-SENSITIVE POINTS OF THE FOOT, FOOTRESTS, FITTED PARTS, HEEL CUPS, WEDGES, PADS, INSOLES, HEELS, SOLES, PARTS OF SHOE BOTTOMS, FOOT BEDS AND SHAPED SOLES AND PARTS THEREFOR, IN THE NATURE OF SHAPED SOLES AND FOOT BEDS IN THE FORM OF SOLID PLASTIC INSERTS WITH FOOT BEDS OR ANATOMICALLY SHAPED DEEP FOOT BEDS, IN PARTICULAR OF NATURAL CORK, THERMAL CORK, PLASTIC, LATEX OR FOAMED PLASTIC MATERIALS, INCLUDING OF ELASTIC COMPOUNDS OF CORK-LATEX OR PLASTIC-CORK MIXTURES; PARTS FOR SHOE UPPERS, CLOTHING FOR SPORT AND LEISURE PURPOSES, NAMELY, SPORT SHIRTS, SPORTS PANTS, SPORTS UNIFORMS, T-SHIRTS, PANTS; HEADGEAR, NAMELY, HATS AND CAPS (U.S. CLS. 22 AND 39).

ERNEST SHOSHO, EXAMINING ATTORNEY



OWNER OF INTERNATIONAL REGISTRATION 0993843 DATED 12-16-2008, EXPIRES 12-16-2018.

CLASS 29—MEATS AND PROCESSED FOODS

FOR MILK AND MILK PRODUCTS EXCLUDING ICE CREAM, ICE MILK AND FROZEN YOGURT (U.S. CL. 46).

CLASS 30—STAPLE FOODS

FOR TEA, COCOA (U.S. CL. 46).

CLASS 32—LIGHT BEVERAGES

FOR MINERAL AND AERATED WATERS; FRUIT DRINKS AND FRUIT JUICES; OTHER NON-ALCOHOLIC DRINKS, NAMELY, ENERGY DRINKS AND VEGETABLE JUICES (U.S. CLS. 45, 46 AND 48).

TINA KUAN, EXAMINING ATTORNEY

SN 79-065,750. WILD HIBISCUS FLOWER COMPANY PTY LTD, AUSTRALIA, FILED 12-10-2008.

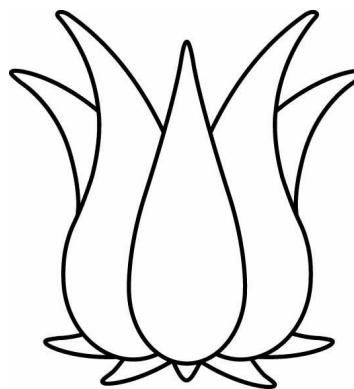

PRIORITY DATE OF 6-17-2008 IS CLAIMED. OWNER OF INTERNATIONAL REGISTRATION 0994557 DATED 12-10-2008, EXPIRES 12-10-2018.

THE MARK CONSISTS OF A STYLIZED HIBISCUS FLOWER.

CLASS 29—MEATS AND PROCESSED FOODS

FOR PRESERVED FRUITS; DRIED FRUIT; COOKED FRUITS IN THE NATURE OF MARMALADES; PROCESSED EDIBLE FLOWERS AND LEAVES, BEING DRIED, COOKED AND PRESERVED; JELLIES; JAMS; COMPOTES (U.S. CL. 46).

CLASS 32—LIGHT BEVERAGES

FOR NON-ALCOHOLIC BEVERAGES, NAMELY, CARBONATED BEVERAGES, FRUIT JUICE, AND FRUIT JUICE BASED BEVERAGE; FRUIT DRINKS; FRUIT JUICE CONCENTRATES; SYRUPS FOR BEVERAGES; FRUIT JUICE NECTAR BEVERAGES AND FRUIT JUICE NECTAR FOR MAKING BEVERAGES; NON ALCOHOLIC COCKTAILS; NON ALCOHOLIC COCKTAIL BASES (U.S. CLS. 45, 46 AND 48).

CLASS 33—WINES AND SPIRITS

FOR ALCOHOLIC BEVERAGES, NAMELY, DISTILLED SPIRITS AND WINE EXCLUDING BEER; ALCOHOLIC BEVERAGES CONTAINING FRUIT; ALCOHOLIC FRUIT EXTRACTS; PREPARED ALCOHOLIC COCKTAILS (U.S. CLS. 47 AND 49).
JACLYN KIDWELL, EXAMINING ATTORNEY

CLASS 24—FABRICS

FOR BEDS BLANKETS, BED LINEN, HOUSEHOLD LINEN, NOT OF PAPER; BATH AND TOILET LINEN, NAMELY, TOWELS; WASHING MITTS (U.S. CLS. 42 AND 50).

CLASS 35—ADVERTISING AND BUSINESS

FOR RETAIL STORE SERVICES FEATURING LADIES' UNDERWEAR AND LADIES' LINGERIE ARTICLES; PERFUMES, TOILET WATER AND COSMETICS, HOUSEHOLD AND BATH LINEN; BUSINESS CONSULTING SERVICES FOR CREATING AND OPERATING RETAIL OUTLETS AND PURCHASING CO-OPERATIVES FOR RETAIL SALES AND ADVERTISING; SALES PROMOTION SERVICES FOR THIRD PARTIES; ADVERTISING SERVICES, BUSINESS MANAGEMENT, BUSINESS ADMINISTRATION; ONLINE ADVERTISING ON A COMPUTER NETWORK; DISSEMINATION OF ADVERTISING MATERIAL IN THE NATURE OF TRACTS, PROSPECTUSES, FREE NEWSPAPERS AND SAMPLES, ARRANGING NEWSPAPER SUBSCRIPTION FOR OTHERS; BUSINESS INFORMATION AND INQUIRIES; ORGANIZATION OF EVENTS AND EXHIBITIONS FOR COMMERCIAL OR ADVERTISING PURPOSES; ADVERTISING MANAGEMENT CONSULTANCY; RENTAL OF ADVERTISING SPACE; ADVERTISING SERVICES OF A RADIO AND TELEVISION ADVERTISING AGENCY, PROMOTIONAL SPONSORSHIP, NAMELY, PROMOTING THE GOODS AND SERVICES OF OTHERS BY RADIO, TELEVISION, FLYERS, BROCHURES, LEAFLETS, SAMPLES, AND ON A GLOBAL COMPUTER NETWORK (U.S. CLS. 100, 101 AND 102).

SN 79-975,063. CHANTELLE (SOCIÉTÉ ANONYME), FRANCE, FILED 8-1-2007.

Chantelle Paris

PRIORITY DATE OF 2-7-2007 IS CLAIMED.
OWNER OF INTERNATIONAL REGISTRATION 0934290 DATED 8-1-2007, EXPIRES 8-1-2017.
OWNER OF U.S. REG. NO. 1,636,190.
NO CLAIM IS MADE TO THE EXCLUSIVE RIGHT TO USE PARIS, APART FROM THE MARK AS SHOWN.

CLASS 44—MEDICAL, BEAUTY AND AGRICULTURAL SERVICES

FOR SANITARY AND BEAUTY CARE SERVICES FOR HUMAN BEINGS, NAMELY, BEAUTY PARLOURS AND BEAUTY SALONS; COSMETIC CARE SERVICES, NAMELY, COSMETIC BODY CARE SERVICES IN THE NATURE OF HEALTH SPAS AND BEAUTY SALONS; CONSULTING IN THE FIELD OF BEAUTY AND HYGIENE CARE; RELAXATION, MASSAGE AND SPA SERVICES, NAMELY, HEALTH SPA SERVICES FOR HEALTH AND WELLNESS OF THE MIND, BODY AND SPIRIT (U.S. CLS. 100 AND 101).
DAVID HOFFMAN, EXAMINING ATTORNEY

* * * * *

SECTION 2.— INTERNATIONAL CLASSIFICATION

The short titles associated below with the international class numbers are terms designed merely for quick identification and are not an official part of the international classification. The full names of international classes are given in section 6.1 of the trademark rules of practice.

The designation "U.S. Cl." appearing in this section refers to the U.S. class in effect prior to Sep. 1, 1973 rather than the international class which applies to applications filed on or after that date. For adoption of international classification see notice in the OFFICIAL GAZETTE of Jun. 26, 1973 (911 O.G. TM 210).

Application in one class

CLASS 1—CHEMICALS

SN 76-692,540. INNOVATIVE POLYMER SOLUTIONS, INC., VALRICO, FL. FILED 9-2-2008.

Knit-Tech 9112

THE MARK CONSISTS OF STANDARD CHARACTERS WITHOUT CLAIM TO ANY PARTICULAR FONT, STYLE, SIZE, OR COLOR.

FOR CHEMICALS FOR RUBBER AND PLASTICS PROCESSING APPLICATIONS (U.S. CLS. 1, 5, 6, 10, 26 AND 46).

FIRST USE 1-1-2007; IN COMMERCE 6-1-2007.
MARK SPARACINO, EXAMINING ATTORNEY

SN 76-695,660. COWSMO, INC., COCHRANE, WI. FILED 2-9-2009.

COWSMO

THE MARK CONSISTS OF STANDARD CHARACTERS WITHOUT CLAIM TO ANY PARTICULAR FONT, STYLE, SIZE, OR COLOR.

FOR COMPOST, COMPOST FERTILIZER, AND POTTING COMPOST (U.S. CLS. 1, 5, 6, 10, 26 AND 46).

FIRST USE 3-20-2002; IN COMMERCE 3-20-2002.
ALEX KEAM, EXAMINING ATTORNEY

CLASS 1—(Continued).

SN 77-519,419. HERBALSCIENCE GROUP, LLC, NAPLES, FL. FILED 7-10-2008.

SLEEPWELL

THE MARK CONSISTS OF STANDARD CHARACTERS WITHOUT CLAIM TO ANY PARTICULAR FONT, STYLE, SIZE, OR COLOR.

FOR BOTANICAL EXTRACTS, NAMELY, PLANT EXTRACTS FOR MEDICAL OR PHARMACEUTICAL PURPOSES; PLANT EXTRACTS FOR MEDICAL AND NUTRITIONAL PURPOSES; PLANT EXTRACTS FOR MEDICAL AND PHARMACEUTICAL PURPOSE; PLANT EXTRACTS FOR MEDICAL AND NUTRACEUTICAL PURPOSES; BOTANICAL EXTRACTS FOR USE IN THE MANUFACTURE OF NUTRACEUTICALS; BOTANICAL EXTRACTS FOR USE IN THE MANUFACTURE OF PHARMACEUTICAL PREPARATIONS, NAMELY, CREAMS, AND TOPICAL ANALGESICS AND ANESTHETICS, TABLETS, CAPSULES, PILLS, TINCTURE, SUPPOSITORIES AND AMPULE FOR INJECTION; BOTANICAL EXTRACTS FOR USE IN THE MANUFACTURE OF NUTRACEUTICALS AND PHARMACEUTICALS; BOTANICAL EXTRACTS FOR USE IN THE MANUFACTURE OF NUTRACEUTICALS AND PHARMACEUTICALS; ALL NATURAL CHEMICAL ADDITIVES MADE FROM EXTRACTS AND ACTIVE PRINCIPLES EXTRACTED FROM MEDICINAL PLANTS FOR USE IN THE MANUFACTURE OF NUTRACEUTICALS AND PHARMACEUTICALS; ALL NATURAL CHEMICAL ADDITIVES MADE FROM EXTRACTS AND ACTIVE PRINCIPLES EXTRACTED FROM MEDICINAL PLANTS FOR USE IN THE PHARMACEUTICAL INDUSTRY, NAMELY, CHEMICAL AGENTS MADE FROM BOTANICAL EXTRACTS AND AN ASSOCIATION OF CHEMICAL EXTRACTS FOR USE IN THE MANUFACTURE OF PHARMACEUTICAL OR NUTRACEUTICAL PRODUCTS; BOTANICAL EXTRACTS USED IN THE MANUFACTURE OF PREPARATIONS, NAMELY, LOTIONS, CREAMS, AND TOPICAL ANALGESICS AND ANESTHETICS, TABLETS, CAPSULES, PILLS, LOZENGES, INHALERS, TINCTURE, SUPPOSITORIES AND AMPULE FOR INJECTION; BOTANICAL EXTRACTS USED IN THE MANUFACTURE OF PHARMACEUTICAL PREPARATIONS, NAMELY, LOTIONS, CREAMS, AND TOPICAL ANALGESICS AND ANESTHETICS, TABLETS, CAPSULES, PILLS, TINCTURE, SUPPOSITORIES AND AMPULE FOR INJECTION; ALL NATURAL CHEMICAL NUTRITIONAL ADDITIVES FOR USE IN THE MANUFACTURE OF FOODS AND DIETARY SUPPLEMENTS FOR HUMAN CONSUMPTION FOR MEDICAL OR NON-MEDICAL PURPOSES; ALL NATURAL CHEMICAL ADDITIVES MADE FROM BOTANICALS AND BOTANICAL BLENDS, HERBALS AND HERBAL BLENDS, BOTANICAL EXTRACTS AND BOTANICAL EXTRACT BLENDS, FLAVOR EXTRACTS AND FLAVOR EXTRACT BLENDS, ALGAL EXTRACTS AND ALGAL EXTRACT

CLASS 1—(Continued).

BLENDS, ALL FOR USE IN THE MANUFACTURE OF NUTRITIONAL SUPPLEMENTS AND VITAMINS; ALL NATURAL CHEMICAL ADDITIVES MADE FROM HERBAL EXTRACTS AND HERBAL BLENDS FOR USE IN THE MANUFACTURE OF FUNCTIONAL FOODS OR BEVERAGES; ALL NATURAL CHEMICAL ADDITIVES MADE FROM HERBAL EXTRACTS AND HERBAL BLENDS FOR USE IN MEDICINAL FOODS OR BEVERAGES; BOTANICAL EXTRACTS AND BLENDS FOR USE IN THE MANUFACTURE OF FUNCTIONAL FOODS AND BEVERAGES; BOTANICAL EXTRACTS AND BLENDS FOR USE IN THE MANUFACTURE OF MEDICINAL FOODS AND BEVERAGES; DESIGNER EXTRACTS, NAMELY, ALL NATURAL CHEMICAL ADDITIVES MADE FROM HERBAL EXTRACTS FOR USE IN MAKING MEDICAL, VETERINARY AND PHARMACEUTICAL PREPARATIONS; BOTANICAL EXTRACTS AND BLENDS, NAMELY, HERBAL AND ALGAL INGREDIENTS FOR USE IN MAKING COSMETICS; BOTANICAL EXTRACTS AND BLENDS, NAMELY, ALGAL INGREDIENTS FOR MEDICAL OR PHARMACEUTICAL PURPOSES; BOTANICAL AND HERBAL EXTRACTS FOR USE IN MAKING MEDICAL, VETERINARY AND PHARMACEUTICAL PREPARATIONS; DESIGNER BOTANICAL AND HERBAL EXTRACTS, NAMELY, PLANT, HERBAL AND BOTANICAL EXTRACTS FOR USE IN MAKING MEDICAL, VETERINARY AND PHARMACEUTICAL PREPARATIONS (U.S. CLS. 1, 5, 6, 10, 26 AND 46).
LOURDES AYALA, EXAMINING ATTORNEY

SN 77-530,294. UNIVERSAL COOPERATIVES, INC., EAGAN, MN. FILED 7-24-2008.

AIRLINK

THE MARK CONSISTS OF STANDARD CHARACTERS WITHOUT CLAIM TO ANY PARTICULAR FONT, STYLE, SIZE, OR COLOR.

FOR AGRICULTURAL ADJUVANTS FOR USE WITH HERBICIDES, INSECTICIDES, AND PESTICIDES (U.S. CLS. 1, 5, 6, 10, 26 AND 46).

KIMBERLY PERRY, EXAMINING ATTORNEY

SN 77-530,317. UNIVERSAL COOPERATIVES, INC., EAGAN, MN. FILED 7-24-2008.

EXCLAIM

THE MARK CONSISTS OF STANDARD CHARACTERS WITHOUT CLAIM TO ANY PARTICULAR FONT, STYLE, SIZE, OR COLOR.

FOR AGRICULTURAL ADJUVANTS FOR USE WITH HERBICIDES, INSECTICIDES, AND PESTICIDES (U.S. CLS. 1, 5, 6, 10, 26 AND 46).

KIMBERLY PERRY, EXAMINING ATTORNEY

CLASS 1—(Continued).

SN 77-530,335. UNIVERSAL COOPERATIVES, INC., EAGAN, MN. FILED 7-24-2008.

ASTOUND

THE MARK CONSISTS OF STANDARD CHARACTERS WITHOUT CLAIM TO ANY PARTICULAR FONT, STYLE, SIZE, OR COLOR.

FOR AGRICULTURAL ADJUVANTS FOR USE WITH HERBICIDES, INSECTICIDES, AND PESTICIDES (U.S. CLS. 1, 5, 6, 10, 26 AND 46).

KIMBERLY PERRY, EXAMINING ATTORNEY

SN 77-539,822. TRANCERT MARKETING INC., POINT ROBERTS, WA. FILED 8-5-2008.



INTERCHARGER
Improving Engine Performance

NO CLAIM IS MADE TO THE EXCLUSIVE RIGHT TO USE "IMPROVING ENGINE PERFORMANCE", APART FROM THE MARK AS SHOWN.

THE COLOR(S) GOLD, BLUE AND GRAY IS/ARE CLAIMED AS A FEATURE OF THE MARK.

THE MARK CONSISTS OF THE WORD "INTER" IN GOLD AND STYLIZED FONT WITH A CAPITAL "I" AND SMALL CAPITAL "NTER" FOLLOWED BY A SPACE AND THEN THE WORD "CHARGER" IN GOLD AND STYLIZED FONT WITH A CAPITAL "C" AND SMALL CAPITAL "HARGER." THE SPACE BETWEEN THE WORDS "INTER" AND "CHARGER" CONTAINS A BLUE LIGHTNING BOLT HITTING THE SURFACE WITH A GRAY SMALL OVAL UNDERNEATH THE BLUE LIGHTNING BOLT. THE BLUE LIGHTNING BOLT HAS A GRAY SHADOW. THE BOTTOM PORTION OF THE MARK HAS THE WORDING "IMPROVING ENGINE PERFORMANCE" IN BLUE.

FOR FLUID CRACKING CATALYSTS (U.S. CLS. 1, 5, 6, 10, 26 AND 46).

FIRST USE 9-1-2007; IN COMMERCE 9-1-2007.

JULIE WATSON, EXAMINING ATTORNEY

CLASS 1—(Continued).

SN 77-552,490. RGL SALES AND MARKETING, INC., NOBLESVILLE, IN. FILED 8-21-2008.



NO CLAIM IS MADE TO THE EXCLUSIVE RIGHT TO USE "CLEAN", APART FROM THE MARK AS SHOWN.

THE MARK CONSISTS OF "CLEAN PLAST" OVER A STYLIZED DRAWING OF THE INSIDE OF A SCORED TUBE.

FOR READY-TO-USE CHEMICAL PURGING COMPOUND IN PELLET FORM FOR USE IN CYLINDERS OF INJECTION MACHINES, EXTRUDERS AND INTERNAL PARTS OF MOLDS OR DIES FOR THERMOPLASTICS PROCESSORS WITHIN A SHORT TIME (U.S. CLS. 1, 5, 6, 10, 26 AND 46).

FIRST USE 2-1-2008; IN COMMERCE 2-1-2008.
ESTHER A. BORSUK, EXAMINING ATTORNEY

SN 77-559,001. MONOBIND, INC., LAKE FOREST, CA. FILED 8-29-2008.

Combi-Cal

THE MARK CONSISTS OF STANDARD CHARACTERS WITHOUT CLAIM TO ANY PARTICULAR FONT, STYLE, SIZE, OR COLOR.

FOR A SET OF REAGENTS COMBINING MULTIPLE ANALYTES IN A SINGLE HUMAN-SERUM MATRIX AT VARIOUS CONCENTRATIONS AS A CALIBRATOR SET TO MEASURE THOSE UNIQUE ANALYTES IN HUMAN SERUM OR PLASMA FROM PATIENT SAMPLES AS PART OF A MEDICAL DEVICE PRODUCT (U.S. CLS. 1, 5, 6, 10, 26 AND 46).

FIRST USE 7-20-2005; IN COMMERCE 7-20-2005.
SUSAN STIGLITZ, EXAMINING ATTORNEY

SN 77-583,453. PELICAN WORLDWIDE, INC., HOUSTON, TX. FILED 10-1-2008.

MAXXIMUS

THE MARK CONSISTS OF STANDARD CHARACTERS WITHOUT CLAIM TO ANY PARTICULAR FONT, STYLE, SIZE, OR COLOR.

FOR BLENDED POWDERED POLYMERS, NAMELY, POLYTETRAFLUOROETHYLENE FOR USE IN THE MANUFACTURE OF INDUSTRIAL PRODUCTS, CONSUMER AND HOUSEHOLD PRODUCTS, COATINGS AND PLASTICS (U.S. CLS. 1, 5, 6, 10, 26 AND 46).

FIRST USE 7-23-2008; IN COMMERCE 7-23-2008.
WILLIAM ROSSMAN, EXAMINING ATTORNEY

CLASS 1—(Continued).

SN 77-606,305. BPSI HOLDINGS, LLC., WILMINGTON, DE. FILED 11-3-2008.

SURESPHERES

THE MARK CONSISTS OF STANDARD CHARACTERS WITHOUT CLAIM TO ANY PARTICULAR FONT, STYLE, SIZE, OR COLOR.

FOR PHARMACEUTICAL EXCIPIENTS IN THE FORM OF SPHERES OR PELLETS FOR USE IN THE MANUFACTURE OF DRUGS (U.S. CLS. 1, 5, 6, 10, 26 AND 46).

GENE MACIOL, EXAMINING ATTORNEY

SN 77-616,746. ASSOCIATED MATERIALS, LLC, DBA AL-SIDE, CUYAHOGA FALLS, OH. FILED 11-18-2008.

CHROMATRUE

THE MARK CONSISTS OF STANDARD CHARACTERS WITHOUT CLAIM TO ANY PARTICULAR FONT, STYLE, SIZE, OR COLOR.

FOR CHEMICAL ADDITIVE USED IN THE MANUFACTURE OF VINYL SIDING (U.S. CLS. 1, 5, 6, 10, 26 AND 46).

ANDREA K. NADELMAN, EXAMINING ATTORNEY

SN 77-626,414. HERCULES INCORPORATED, WILMINGTON, DE. FILED 12-4-2008.

PHLEX

THE MARK CONSISTS OF STANDARD CHARACTERS WITHOUT CLAIM TO ANY PARTICULAR FONT, STYLE, SIZE, OR COLOR.

FOR NEUTRALIZING CHEMICAL AGENTS USED IN THE MANUFACTURE OF COATINGS, NAMELY, PAINTS (U.S. CLS. 1, 5, 6, 10, 26 AND 46).

SUSAN STIGLITZ, EXAMINING ATTORNEY

CLASS 1—(Continued).

SN 77-630,592. MULTI-CHEM GROUP, L.L.C., SAN ANGELO, TX. FILED 12-10-2008.

MULTI-SWEET

THE MARK CONSISTS OF STANDARD CHARACTERS WITHOUT CLAIM TO ANY PARTICULAR FONT, STYLE, SIZE, OR COLOR.

FOR CHEMICALS FOR USE IN THE FIELD OF OIL EXPLORATION AND PRODUCTION (U.S. CLS. 1, 5, 6, 10, 26 AND 46).

SKYE YOUNG, EXAMINING ATTORNEY

SN 77-646,586. CHEMPORT, INC., DBA CHEMPORT, INC., EL PASO, TX. FILED 1-9-2009.

PACKHARD

THE MARK CONSISTS OF STANDARD CHARACTERS WITHOUT CLAIM TO ANY PARTICULAR FONT, STYLE, SIZE, OR COLOR.

FOR FERTILIZERS FOR AGRICULTURAL USE (U.S. CLS. 1, 5, 6, 10, 26 AND 46).

CHRISTOPHER BUONGIORNO, EXAMINING ATTORNEY

SN 77-647,121. SLK, INC., SNOHOMISH, WA. FILED 1-10-2009.

ICE RESIN

THE MARK CONSISTS OF STANDARD CHARACTERS WITHOUT CLAIM TO ANY PARTICULAR FONT, STYLE, SIZE, OR COLOR.

NO CLAIM IS MADE TO THE EXCLUSIVE RIGHT TO USE "RESIN", APART FROM THE MARK AS SHOWN.

FOR EPOXY RESINS (U.S. CLS. 1, 5, 6, 10, 26 AND 46). FIRST USE 1-22-2008; IN COMMERCE 6-1-2008.

COLLEEN KEARNEY, EXAMINING ATTORNEY

CLASS 1—(Continued).

SN 77-652,939. STEVENS INDUSTRIES, INC., TEUTOPOLIS, IL. FILED 1-20-2009.

STEVENSWOOD

THE MARK CONSISTS OF STANDARD CHARACTERS WITHOUT CLAIM TO ANY PARTICULAR FONT, STYLE, SIZE, OR COLOR.

FOR MELAMINE (U.S. CLS. 1, 5, 6, 10, 26 AND 46).

FIRST USE 8-0-2004; IN COMMERCE 8-0-2004.

KIMBERLY FRYE, EXAMINING ATTORNEY

SN 77-658,303. ALLIEDPATH, INC., SAN DIEGO, CA. FILED 1-28-2009.



AlliedPath

THE COLOR(S) GREEN, BLUE, GREY, AND BLACK IS/ ARE CLAIMED AS A FEATURE OF THE MARK.

THE MARK CONSISTS OF AN ELLIPSE OUTLINED IN BLACK WITH THE INTERIOR COLORED IN GREEN ON THE TOP, BLUE ON THE BOTTOM, AND SHADING FROM ONE TO THE OTHER IN THE MIDDLE. THE BLACK LETTERS "AP" ARE INSIDE THE ELLIPSE IN BOSNIA WIDE NORMAL FONT. A GREY LINE EXTENDS FROM JUST TO THE LEFT OF THE "A" TO THE OUTSIDE OF THE ELLIPSE, WITH THE LINE FADING FROM DARK GREY ON THE RIGHT TO LIGHT GREY ON THE LEFT. THE BLACK WORDING "ALLIEDPATH" IN FRANKLIN GOTHIC #2 FONT IS BELOW THE ELLIPSE.

FOR DIAGNOSTIC KITS CONSISTING PRIMARILY OF MONOCLONAL ANTIBODIES, BUFFERS, AND REAGENTS TO MONITOR TOXICITY OF DRUGS; DIAGNOSTIC PREPARATIONS FOR SCIENTIFIC OR RESEARCH USE; DIAGNOSTIC PREPARATIONS FOR CLINICAL OR MEDICAL LABORATORY USE; DIAGNOSTIC REAGENTS FOR CLINICAL OR MEDICAL LABORATORY USE (U.S. CLS. 1, 5, 6, 10, 26 AND 46).

STEPHEN AQUILA, EXAMINING ATTORNEY

CLASS 1—(Continued).

SN 77-659,940. NO-TILL FARMS, INC., KALISPELL, MT. FILED 1-30-2009.

BinBuster XP

THE MARK CONSISTS OF STANDARD CHARACTERS WITHOUT CLAIM TO ANY PARTICULAR FONT, STYLE, SIZE, OR COLOR.

FOR FOOD SUPPLEMENTS FOR AGRICULTURAL PRODUCTS AND OTHER PLANTS; PREPARATIONS FOR FORTIFYING PLANTS (U.S. CLS. 1, 5, 6, 10, 26 AND 46).

DAVID C. REIHNER, EXAMINING ATTORNEY

CLASS 1—(Continued).

SN 77-663,186. THE DOW CHEMICAL COMPANY, MIDLAND, MI. FILED 2-4-2009.

FUELTANE

THE MARK CONSISTS OF STANDARD CHARACTERS WITHOUT CLAIM TO ANY PARTICULAR FONT, STYLE, SIZE, OR COLOR.

FOR CHEMICAL ADDITIVES FOR DIESEL FUEL TREATMENT, NAMELY, NITROPROPANE AND NITROETHANE (U.S. CLS. 1, 5, 6, 10, 26 AND 46).

ANDREA K. NADELMAN, EXAMINING ATTORNEY

SN 77-661,216. JOHN L. DOSTAL, DBA DOSTAL ENTERPRISES, L.L.C., CARROLL, IA. FILED 2-2-2009.

FC 2000

THE MARK CONSISTS OF STANDARD CHARACTERS WITHOUT CLAIM TO ANY PARTICULAR FONT, STYLE, SIZE, OR COLOR.

FOR CHEMICAL DRYING PREPARATIONS FOR THE ABSORPTION AND DRYING OF LIQUIDS INCLUDING OIL, GASOLINE, LIQUID CHEMICALS, HERBICIDES, PESTICIDES, GREASE, BLOOD AND ACIDS (U.S. CLS. 1, 5, 6, 10, 26 AND 46).

FIRST USE 0-0-2000; IN COMMERCE 0-0-2000.
DAVON HATCHETT, EXAMINING ATTORNEY

SN 77-663,895. COMAX MANUFACTURING CORPORATION, MELVILLE, NY. FILED 2-5-2009.

VANI-MAX

THE MARK CONSISTS OF STANDARD CHARACTERS WITHOUT CLAIM TO ANY PARTICULAR FONT, STYLE, SIZE, OR COLOR.

FOR CHEMICALS FOR USE IN THE MANUFACTURE OF FLAVORS (U.S. CLS. 1, 5, 6, 10, 26 AND 46).

YAT SYE, LEE, EXAMINING ATTORNEY

SN 77-662,833. DELO INDUSTRIAL ADHESIVES LLC, MELVILLE, NY. FILED 2-4-2009.

DELOMONOPOX

THE MARK CONSISTS OF STANDARD CHARACTERS WITHOUT CLAIM TO ANY PARTICULAR FONT, STYLE, SIZE, OR COLOR.

FOR ADHESIVES FOR INDUSTRIAL USE (U.S. CLS. 1, 5, 6, 10, 26 AND 46).

SHAILA SETTLES, EXAMINING ATTORNEY

SN 77-664,015. ALLIEDPATH, INC., SAN DIEGO, CA. FILED 2-5-2009.

Delivering Tomorrow's Results Today!

THE COLOR(S) GREEN IS/ARE CLAIMED AS A FEATURE OF THE MARK.

THE MARK CONSISTS OF THE WORDS, "DELIVERING TOMORROW'S RESULTS TODAY" ITALICIZED, IN GREEN AND IN ARIEL FONT.

FOR DIAGNOSTIC REAGENTS FOR CLINICAL OR MEDICAL LABORATORY USE (U.S. CLS. 1, 5, 6, 10, 26 AND 46).

STEPHEN AQUILA, EXAMINING ATTORNEY

CLASS 1—(Continued).

SN 77-666,670. KABUSHIKI KAISHA KOBE SEIKO SHO, TA KOBE STEEL, LTD., KOBE-SHI, HYOGO, JAPAN, FILED 2-9-2009.

TRUSTARC

THE MARK CONSISTS OF STANDARD CHARACTERS WITHOUT CLAIM TO ANY PARTICULAR FONT, STYLE, SIZE, OR COLOR.

FOR METAL WELDING FLUX; CHEMICALS FOR WELDING (U.S. CLS. 1, 5, 6, 10, 26 AND 46).

FIRST USE 7-8-2008; IN COMMERCE 7-8-2008.

BARNEY CHARLON, EXAMINING ATTORNEY

SN 77-666,849. ENVIROTECH SERVICES, INC., GREELEY, CO. FILED 2-9-2009.

DURABLEND

THE MARK CONSISTS OF STANDARD CHARACTERS WITHOUT CLAIM TO ANY PARTICULAR FONT, STYLE, SIZE, OR COLOR.

FOR CHEMICAL PREPARATIONS AND COMPOSITIONS, NAMELY, A DUST CONTROL/STABILIZATION LIQUID FOR USE ON ROADS, PARKING LOTS, PARKS, FEEDLOTS, NURSERIES, ORCHARDS, AIRFIELDS, HELICOPTER PADS, CONSTRUCTION AREAS, QUARRIES AND MINES (U.S. CLS. 1, 5, 6, 10, 26 AND 46).

ROBERT C. CLARK JR., EXAMINING ATTORNEY

CLASS 1—(Continued).

SN 78-945,956. NOVORR, JAMES B., WOODLAND HILLS, CA. FILED 8-6-2006.



NO CLAIM IS MADE TO THE EXCLUSIVE RIGHT TO USE "PERFORMANCE BOOSTER", APART FROM THE MARK AS SHOWN.

THE COLOR(S) GREEN, BLUE, BLACK, YELLOW, ORANGE, DARKER ORANGE AND WHITE IS/ARE CLAIMED AS A FEATURE OF THE MARK.

THE MARK CONSISTS OF A STYLIZED GREEN CIRCLE, SURROUNDED BY A BLUE ARROW, A GREEN ARROW, AND A WHITE ARROW WITH A BLACK CROSS IN THE CENTER OF THE GREEN CIRCLE THAT HAS "GO 15" PRINTED ACROSS THE MIDDLE OF THE CROSS IN SHADES RANGING FROM YELLOW TO ORANGE TO DARKER ORANGE, FOLLOWED BY "PERFORMANCE BOOSTER" IN WHITE.

FOR CHEMICAL MOTOR OIL ADDITIVES FOR ENHANCING THE PERFORMANCE OF LUBRICATING OILS IN ENGINES BY CONDITIONING THE METALS IN ENGINES (U.S. CLS. 1, 5, 6, 10, 26 AND 46).

FIRST USE 8-15-2005; IN COMMERCE 8-15-2005.

SKYE YOUNG, EXAMINING ATTORNEY

SN 79-052,925. COGNIS FRANCE, SAINT MARTORY F-31360, FRANCE, FILED 3-13-2008.

Vit-A-Like

THE MARK CONSISTS OF STANDARD CHARACTERS WITHOUT CLAIM TO ANY PARTICULAR FONT, STYLE, SIZE, OR COLOR.

OWNER OF INTERNATIONAL REGISTRATION 0961735 DATED 3-13-2008, EXPIRES 3-13-2018.

FOR ACTIVE PRINCIPLES OBTAINED FROM NATURAL, VEGETABLE, BIOTECHNOLOGICAL EXTRACTS FOR USE IN THE MANUFACTURE OF COSMETIC AND PERSONAL HYGIENE GOODS, NAMELY, PLANT EXTRACTS, NAMELY, BOTANICAL EXTRACTS, USED IN THE MANUFACTURE OF COSMETIC AND PERSONAL HYGIENE GOODS (U.S. CLS. 1, 5, 6, 10, 26 AND 46).

LEIGH LOWRY, EXAMINING ATTORNEY

CLASS 1—(Continued).

SN 79-056,573. ZEBRA HOLDINGS PTY LTD, AUSTRALIA,
FILED 7-7-2008.



OWNER OF INTERNATIONAL REGISTRATION 0971534
DATED 7-7-2008, EXPIRES 7-7-2018.

NO CLAIM IS MADE TO THE EXCLUSIVE RIGHT TO
USE "YIELD INCREASING MICROBES", APART FROM
THE MARK AS SHOWN.

THE MARK CONSISTS OF A PARTIALLY SHADED
DIAMOND CONTAINING THE UNDERLINED WORDING
"TWINN" IN THE MIDDLE, A DESIGN OF A PLANT IN A
CIRCLE ABOVE THE WORDING AND ROOTS GROWING
BELOW THE WORDING, AND THE WORDING "YIELD
INCREASING MICROBES" UNDER THE BOTTOM RIGHT
SIDE OF THE DIAMOND.

FOR CHEMICALS FOR USE IN AGRICULTURE;
BIOLOGICAL PREPARATIONS FOR AGRICULTURE,
NAMELY, ENZYMES AND MICROORGANISMS TO
ENHANCE PLANT GROWTH AND IMPROVE SOIL
CONDITION; CHEMICAL AND BIOLOGICAL PRE-
PARATIONS FOR APPLICATION TO CROPS AND
PLANTS, NAMELY, PREPARATIONS FOR ENCOURA-
GING AND ENHANCING PLANT GROWTH; AGRICUL-
TURAL PREPARATIONS CONTAINING MICRO-
ORGANISMS, NAMELY, ORGANIC AND NATURAL
FERTILIZER; PREPARATIONS FOR ENHANCING
PLANT GROWTH AND NITROGEN FIXATION; SOIL
IMPROVEMENT PREPARATIONS; FERTILIZER PRE-
PARATIONS; AND TREATMENTS FOR SOILS AND
PLANTS, NAMELY, SOIL CONDITIONING PREPARA-
TIONS (U.S. CLS. 1, 5, 6, 10, 26 AND 46).

TOBY BULLOFF, EXAMINING ATTORNEY

CLASS 2—PAINTS

SN 77-154,373. INTERNATIONAL BARRIER TECHNOLOGY
INC., WATKINS, MN. FILED 4-11-2007.

BLAZEGUARD

THE MARK CONSISTS OF STANDARD CHARACTERS
WITHOUT CLAIM TO ANY PARTICULAR FONT, STYLE,
SIZE, OR COLOR.

OWNER OF U.S. REG. NO. 1,693,014.
FOR FIRE RETARDANT PAINT (U.S. CLS. 6, 11 AND
16).

FIRST USE 3-15-2007; IN COMMERCE 3-15-2007.
ZHALEH DELANEY, EXAMINING ATTORNEY

CLASS 2—(Continued).

SN 77-570,589. PPG INDUSTRIES OHIO, INC., CLEVELAND,
OH. FILED 9-16-2008.

HOBAS

THE MARK CONSISTS OF STANDARD CHARACTERS
WITHOUT CLAIM TO ANY PARTICULAR FONT, STYLE,
SIZE, OR COLOR.

FOR COATING COMPOSITIONS IN THE NATURE OF
PAINTS, VARNISHES AND PRINTING INKS FOR
PACKAGING APPLICATIONS; PAINT THINNERS (U.S.
CLS. 6, 11 AND 16).

JIM RINGLE, EXAMINING ATTORNEY

SN 77-593,782. AKZO NOBEL COATINGS INTERNATIONAL
B.V., ARNHEM, NETHERLANDS, FILED 10-16-2008.

GELSHIELD

THE MARK CONSISTS OF STANDARD CHARACTERS
WITHOUT CLAIM TO ANY PARTICULAR FONT, STYLE,
SIZE, OR COLOR.

FOR EXTERIOR AND INTERIOR SURFACE PROTEC-
TIVE COATINGS FOR USE IN MARINE APPLICATIONS
FOR COATING FIBERGLASS SURFACES (U.S. CLS. 6,
11 AND 16).

KATHERINE E. HALMEN, EXAMINING ATTORNEY

SN 77-646,537. BEAVER CLOTH CUTTING MACHINES,
INC., DBA BEAVER LUMINESCERS, NEWTON, MA.
FILED 1-9-2009.



NO CLAIM IS MADE TO THE EXCLUSIVE RIGHT TO
USE "U.V. ENERGIZED LIGHT-EMITTING ORGANIC
COMPOUNDS", APART FROM THE MARK AS SHOWN.

THE COLOR(S) BLACK, WHITE, MAGENTA, VIOLET,
BLUE, GREEN, YELLOW, GOLD, ORANGE, AND RED IS/
ARE CLAIMED AS A FEATURE OF THE MARK.

THE MARK CONSISTS OF THE TERMS "BEAVER
LUMINESCERS" IN BLACK. BELOW THAT IN A SMALLER
BLACK FONT ARE THE TERMS "U.V. ENERGIZED
LIGHT-EMITTING ORGANIC COMPOUNDS". A MULTI-
COLORED BAND IS BENEATH THE TERMS WITH THE
COLORS BLUE, FADING INTO GREEN, FADING INTO
YELLOW, FADING INTO GOLD, FADING INTO ORANGE,
FADING INTO RED, FROM LEFT TO RIGHT. ABOVE THE

CLASS 2—(Continued).

TERMS IS A BLACK RECTANGLE. A RIGHT-ANGLE ARROW BEGINS OUTSIDE THE RECTANGLE, ANGLES AT THE BORDER OF THE RECTANGLE, AND ENDS UP POINTING UPWARD IN THE UPPER RIGHT CORNER OF THE RECTANGLE. THE BASE OF THE ARROW IS IN THE COLOR MAGENTA, FADING INTO VIOLET, FADING INTO BLUE, FADING INTO GREEN, FADING INTO YELLOW, FADING INTO GOLD, FADING INTO ORANGE, AND MOVING IN THE UPWARD POINT. THE BACKGROUND IS WHITE.

FOR CLEAR AND PIGMENTED COATINGS USED IN THE NATURE OF PAINT; COLOR PIGMENTS; ORGANIC PIGMENTS; PIGMENTS; PRINTING INKS, COATINGS, PIGMENTS AND DISPERSIONS FOR USE IN THE GRAPHIC ARTS INDUSTRY; PRINTING INKS, COATINGS, PIGMENTS AND DISPERSIONS FOR USE ON CARTONS AND PACKAGING (U.S. CLS. 6, 11 AND 16).

FIRST USE 1-1-1999; IN COMMERCE 1-1-1999.

MICHAEL KEATING, EXAMINING ATTORNEY

SN 78-635,302. ADICOLOR S.R.L., TRIGINTO DI MEDIGLIA (PROVINCE OF MILANO, ITALY, FILED 5-23-2005).

ADICOLOR

THE MARK CONSISTS OF STANDARD CHARACTERS WITHOUT CLAIM TO ANY PARTICULAR FONT, STYLE, SIZE, OR COLOR.

PRIORITY CLAIMED UNDER SEC. 44(D) ON ITALY APPLICATION NO. MI2004C01173, FILED 11-26-2004.

OWNER OF ITALY REG. NO. 1090938, DATED 1-30-2008, EXPIRES 11-24-2014.

FOR PAINTS, COLOURS, NAMELY, PERMANENT COLOR REFINISH FOR LEATHER AND VINYL, VARNISHES, LACQUERS; COLORANTS FOR USE IN THE MANUFACTURE OF PAINT; MORDANT DYES (U.S. CLS. 6, 11 AND 16).

MARK RADEMACHER, EXAMINING ATTORNEY

CLASS 3—COSMETICS AND CLEANING PREPARATIONS

SN 77-066,024. ADVANCED BEAUTY SYSTEMS, INC., DALLAS, TX. FILED 12-17-2006.

SCENTSABILITY

THE MARK CONSISTS OF STANDARD CHARACTERS WITHOUT CLAIM TO ANY PARTICULAR FONT, STYLE, SIZE, OR COLOR.

FOR SHOWER GELS, BODY LOTION, BODY CREAM, BODY MIST, PERFUME AND COLOGNE (U.S. CLS. 1, 4, 6, 50, 51 AND 52).

DAWN FELDMAN, EXAMINING ATTORNEY

CLASS 3—(Continued).

SN 77-281,787. RECKITT BENCKISER N.V., HOOFDDORP, NETHERLANDS, FILED 9-18-2007.

DIAMOND STANDARD

THE MARK CONSISTS OF STANDARD CHARACTERS WITHOUT CLAIM TO ANY PARTICULAR FONT, STYLE, SIZE, OR COLOR.

PRIORITY CLAIMED UNDER SEC. 44(D) ON ERPNTY TM OFC APPLICATION NO. 006005078, FILED 6-15-2007, REG. NO. 006005078, DATED 5-15-2008, EXPIRES 6-15-2017.

OWNER OF U.S. REG. NO. 2,702,614.

FOR DISHWASHING DETERGENTS; COMBINATION CLEANERS, FRESHENERS AND DEODORIZERS FOR MACHINE DISHWASHERS; RINSE AGENTS FOR MACHINE DISHWASHERS; DECALCIFYING AND DESCALING PREPARATIONS FOR DOMESTIC USE; SALTS FOR USE IN MACHINE DISHWASHERS, NAMELY, DISHWASHER ADDITIVES FOR PREVENTING LIMESCALE ACCUMULATION ON THE DISHWASHER AND ON GLASSES AND DISHES, AND FOR INCREASING THE CLEANING POWER OF DISHWASHING DETERGENT (U.S. CLS. 1, 4, 6, 50, 51 AND 52).

YAT SYE, LEE, EXAMINING ATTORNEY

SN 77-367,569. NAERHEIM, TOR, BEND, OR. FILED 1-9-2008.

Elements Naturals

THE MARK CONSISTS OF STANDARD CHARACTERS WITHOUT CLAIM TO ANY PARTICULAR FONT, STYLE, SIZE, OR COLOR.

NO CLAIM IS MADE TO THE EXCLUSIVE RIGHT TO USE "NATURALS", APART FROM THE MARK AS SHOWN. FOR BABY WIPES (U.S. CLS. 1, 4, 6, 50, 51 AND 52).

AMY HELLA, EXAMINING ATTORNEY

SN 77-427,142. STRANGE INVISIBLE PERFUMES, LLC, BEVERLY HILLS, CA. FILED 3-20-2008.

DAUGHTERS OF CHAOS

THE MARK CONSISTS OF STANDARD CHARACTERS WITHOUT CLAIM TO ANY PARTICULAR FONT, STYLE, SIZE, OR COLOR.

FOR NATURAL PERFUMES; NATURAL FRAGRANCES; NATURAL COSMETICS; NATURAL NON-MEDICATED SKIN CARE PREPARATIONS; NATURAL BODY AND BEAUTY CARE COSMETICS; NATURAL HAIR CARE PREPARATIONS (U.S. CLS. 1, 4, 6, 50, 51 AND 52).

TRACY WHITTAKER-BROWN, EXAMINING ATTORNEY

CLASS 3—(Continued).

SN 77-427,701. MAKAI SPORT, LLC, MALIBU, CA. FILED 3-20-2008.



NO CLAIM IS MADE TO THE EXCLUSIVE RIGHT TO USE "SKIN", APART FROM THE MARK AS SHOWN.

THE MARK CONSISTS OF THE STYLIZED WORDS "NIU ISLAND SKIN". THE DOT IN THE LETTER "I" IS REPLACED BY PALM TREE LEAVES.

FOR EXFOLIATING SALT SCRUBS, EXFOLIATING SUGAR SCRUBS, SKIN LOTIONS AND BODY LOTIONS, BATH SALTS, BODY WASH, EXFOLIATING BODY WASH, PERFUMES IN THE NATURE OF ESSENCE OILS, MOISTURIZING COCONUT OIL AND SOAPS (U.S. CLS. 1, 4, 6, 50, 51 AND 52).

FIRST USE 9-14-2007; IN COMMERCE 9-14-2007.
NORA BUCHANAN WILL, EXAMINING ATTORNEY

SN 77-428,206. OJON CORPORATION, NEW YORK, NY. FILED 3-21-2008.

WILDCRAFTED BEAUTY

THE MARK CONSISTS OF STANDARD CHARACTERS WITHOUT CLAIM TO ANY PARTICULAR FONT, STYLE, SIZE, OR COLOR.

FOR HAIR CARE PREPARATIONS; NON-MEDICATED SKIN CARE PREPARATIONS; BODY AND BEAUTY CARE COSMETICS; COSMETICS (U.S. CLS. 1, 4, 6, 50, 51 AND 52).

BARNEY CHARLON, EXAMINING ATTORNEY

SN 77-443,250. DOBER CHEMICAL CORPORATION, WOODRIDGE, IL. FILED 4-8-2008.

E-MAX

THE MARK CONSISTS OF STANDARD CHARACTERS WITHOUT CLAIM TO ANY PARTICULAR FONT, STYLE, SIZE, OR COLOR.

FOR INDUSTRIAL AND COMMERCIAL LAUNDRY PRODUCTS, NAMELY, LAUNDRY DETERGENTS, AND COMBINATION LAUNDRY PRODUCTS, NAMELY, LAUNDRY DETERGENTS COMBINED WITH WATER CONDITIONERS AND ALKALINE BUILDERS (U.S. CLS. 1, 4, 6, 50, 51 AND 52).

ROBIN CHOSID, EXAMINING ATTORNEY

CLASS 3—(Continued).

SN 77-445,543. MIRA, LLC, CAPISTRANO BEACH, CA. FILED 4-10-2008.

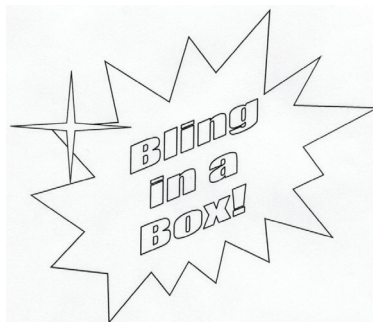

THE MARK CONSISTS OF THE TEXT "BLING IN A BOX!" INSIDE A STAR PATTERN.

FOR KIT FOR CLEANING JEWELRY COMPRISING A CONTAINER OF CLEANING PREPARATION FOR CLEANING JEWELRY AND A CLEANING BASKET (U.S. CLS. 1, 4, 6, 50, 51 AND 52).

DEIRDRE ROBERTSON, EXAMINING ATTORNEY

SN 77-455,832. COTY US LLC, NEW YORK, NY. FILED 4-23-2008.

SALLY HANSEN NATURAL BEAUTY

THE MARK CONSISTS OF STANDARD CHARACTERS WITHOUT CLAIM TO ANY PARTICULAR FONT, STYLE, SIZE, OR COLOR.

OWNER OF U.S. REG. NOS. 688,093, 3,437,459 AND OTHERS.

NO CLAIM IS MADE TO THE EXCLUSIVE RIGHT TO USE "NATURAL BEAUTY", APART FROM THE MARK AS SHOWN.

THE NAME(S), PORTRAIT(S), AND/OR SIGNATURE(S) SHOWN IN THE MARK DOES NOT IDENTIFY A PARTICULAR LIVING INDIVIDUAL.

FOR COSMETICS; EYE MAKE-UP; MAKE-UP; MAKE-UP FOR THE FACE AND BODY; MAKE-UP FOUNDATIONS; LIP BALM; LIP GLOSS; LIP LINER; NAIL CARE PREPARATIONS; NAIL POLISH; NAIL POLISH REMOVER (U.S. CLS. 1, 4, 6, 50, 51 AND 52).

FIRST USE 1-1-2008; IN COMMERCE 1-1-2008.

ALEX KEAM, EXAMINING ATTORNEY

CLASS 3—(Continued).

SN 77-455,884. COTY US LLC, NEW YORK, NY. FILED 4-23-2008.



OWNER OF U.S. REG. NOS. 688,093, 3,437,459 AND OTHERS.

NO CLAIM IS MADE TO THE EXCLUSIVE RIGHT TO USE "NATURAL BEAUTY", APART FROM THE MARK AS SHOWN.

THE NAME(S), PORTRAIT(S), AND/OR SIGNATURE(S) SHOWN IN THE MARK DOES NOT IDENTIFY A PARTICULAR LIVING INDIVIDUAL.

THE COLOR(S) BLACK, WHITE AND GREEN IS/ARE CLAIMED AS A FEATURE OF THE MARK.

THE MARK CONSISTS OF THE COLOR BLACK IN THE WORDS "SALLY HANSEN NATURAL BEAUTY", THE COLOR GREEN IN THE LEAF DESIGN, AND THE COLOR WHITE IN THE MIDDLE OF THE LEAF DESIGN.

FOR COSMETICS; EYE MAKE-UP; MAKE-UP; MAKE-UP FOR THE FACE AND BODY; MAKE-UP FOUNDATIONS; LIP BALM; LIP GLOSS; LIP LINER; NAIL CARE PREPARATIONS; NAIL POLISH; NAIL POLISH REMOVER (U.S. CLS. 1, 4, 6, 50, 51 AND 52).

FIRST USE 1-1-2008; IN COMMERCE 1-1-2008.

ALEX KEAM, EXAMINING ATTORNEY

CLASS 3—(Continued).

SN 77-497,978. LOVE RENAISSANCE (U.S.A.), INC., HONOLULU, HI. FILED 6-12-2008.

XTRUE

THE MARK CONSISTS OF STANDARD CHARACTERS WITHOUT CLAIM TO ANY PARTICULAR FONT, STYLE, SIZE, OR COLOR.

FOR COSMETIC SOAPS; COSMETICS; PERFUMES; COSMETIC SOAPS; COSMETICS; PERFUMES (U.S. CLS. 1, 4, 6, 50, 51 AND 52).

MARK RADEMACHER, EXAMINING ATTORNEY

SN 77-472,741. NEW KINGDOM, INC., DBA SUE DEVITT STUDIO, NEW YORK, NY. FILED 5-13-2008.

BEAUTY AND THE BEACH

THE MARK CONSISTS OF STANDARD CHARACTERS WITHOUT CLAIM TO ANY PARTICULAR FONT, STYLE, SIZE, OR COLOR.

FOR COSMETICS, COLOR COSMETICS, NON-MEDICATED SUN CARE PREPARATIONS, MASSAGE OILS (U.S. CLS. 1, 4, 6, 50, 51 AND 52).

DAVID HOFFMAN, EXAMINING ATTORNEY

SN 77-505,357. JOHNSON & JOHNSON, NEW BRUNSWICK, NJ. FILED 6-23-2008.

FOREVER FRESH

SN 77-485,192. NEW KINGDOM, INC., DBA SUE DEVITT STUDIO, NEW YORK, NY. FILED 5-28-2008.

BEAUTY AND THE BUSH

THE MARK CONSISTS OF STANDARD CHARACTERS WITHOUT CLAIM TO ANY PARTICULAR FONT, STYLE, SIZE, OR COLOR.

FOR COSMETICS, COLOR COSMETICS, NON-MEDICATED SUN CARE PREPARATIONS, MASSAGE OILS (U.S. CLS. 1, 4, 6, 50, 51 AND 52).

DAVID HOFFMAN, EXAMINING ATTORNEY

THE MARK CONSISTS OF STANDARD CHARACTERS WITHOUT CLAIM TO ANY PARTICULAR FONT, STYLE, SIZE, OR COLOR.

FOR TOILETRIES, NAMELY, BODY WASH, SKIN CLEANSERS, BODY LOTION, BODY MOISTURIZERS AND SKIN CREAM (U.S. CLS. 1, 4, 6, 50, 51 AND 52).

FIRST USE 3-0-2009; IN COMMERCE 3-0-2009.

ERNEST SHOSHO, EXAMINING ATTORNEY

CLASS 3—(Continued).

SN 77-508,822. AMERICAN BUSINESS FORMS, INC., GLENWOOD, MN. FILED 6-26-2008.



NO CLAIM IS MADE TO THE EXCLUSIVE RIGHT TO USE "GREATER PROTECTION" AND "REDUCED COST", APART FROM THE MARK AS SHOWN.

THE MARK CONSISTS OF A SHIELD WITH AN EAGLE IN THE CENTER SURROUNDED BY A CIRCLE OF STARS AND TWO ARROWS, ONE POINTING UP AT THE TOP OF THE SHIELD, AND ONE POINTING DOWN AT THE BOTTOM OF THE SHIELD.

FOR CLEANING PREPARATIONS FOR CLEANING, DISINFECTING, PROTECTING AND SANITIZING MAN-MADE, NATURAL AND TREATED SURFACES (U.S. CLS. 1, 4, 6, 50, 51 AND 52).

FIRST USE 2-1-2008; IN COMMERCE 3-1-2008.

REGINA DRUMMOND, EXAMINING ATTORNEY

SN 77-509,666. MADAEN NATURAL PRODUCTS, DBA ONE WITH NATURE, BEACHWOOD, OH. FILED 6-27-2008.



THE COLOR(S) THE COLORS BLACK, WHITE, YELLOW/GOLD, AND BLUE ARE CLAIMED AS A FEATURE OF THE MARK IS/ARE CLAIMED AS A FEATURE OF THE MARK.

THE MARK CONSISTS OF THE WORDS "ONE WITH NATURE" IN WHITE WITH A BLACK BACKGROUND, YELLOW/GOLD AND BLACK SUN ABOVE THE WORDS "ONE WITH NATURE", AND BLUE WAVES BELOW THE WORDS "ONE WITH NATURE".

FOR BAR SOAP; BATH SOAPS; BATH SOAPS IN LIQUID, SOLID OR GEL FORM; BEAUTY LOTIONS; BODY AND BEAUTY CARE COSMETICS; HAND SOAPS (U.S. CLS. 1, 4, 6, 50, 51 AND 52).

FIRST USE 10-1-2005; IN COMMERCE 10-1-2005.

STEVEN JACKSON, EXAMINING ATTORNEY

CLASS 3—(Continued).

SN 77-510,808. KRESS & OWEN CO., INC., AVONDALE ESTATES, GA. FILED 6-29-2008.

GLYCO- THYMOLINE

THE MARK CONSISTS OF STANDARD CHARACTERS WITHOUT CLAIM TO ANY PARTICULAR FONT, STYLE, SIZE, OR COLOR.

FOR NON-MEDICATED MOUTHWASH AND GARGLE, NAMELY, ALKALINE DEODORIZING AND NON-IRRITATING SOLUTION FOR APPLICATION TO SKIN AND MUCOUS MEMBRANES AND FOR ORAL HYGIENE (U.S. CLS. 1, 4, 6, 50, 51 AND 52).

FIRST USE 12-1-1891; IN COMMERCE 12-1-1891.

CURTIS FRENCH, EXAMINING ATTORNEY

SN 77-514,437. INTERNATIONAL PRODUCTS GROUP, LLC, SANDY, UT. FILED 7-3-2008.

GREEN SOUL

THE MARK CONSISTS OF STANDARD CHARACTERS WITHOUT CLAIM TO ANY PARTICULAR FONT, STYLE, SIZE, OR COLOR.

FOR HAIR CARE PREPARATIONS, NAMELY, SHAMPOO AND CONDITIONER; BATH SOAP, SHOWER GEL, FACIAL AND BODY LOTION, NON-MEDICATED LIP BALM, BODY SCRUBS, AND FACIAL MASKS (U.S. CLS. 1, 4, 6, 50, 51 AND 52).

SHAUNIA CARLYLE, EXAMINING ATTORNEY

SN 77-521,491. BATH & BODY WORKS BRAND MANAGEMENT, INC., REYNOLDSBURG, OH. FILED 7-14-2008.

SIGNATURE KIDS

THE MARK CONSISTS OF STANDARD CHARACTERS WITHOUT CLAIM TO ANY PARTICULAR FONT, STYLE, SIZE, OR COLOR.

NO CLAIM IS MADE TO THE EXCLUSIVE RIGHT TO USE "KIDS", APART FROM THE MARK AS SHOWN.

FOR PERSONAL CARE PRODUCTS, NAMELY, BATH FOAM; BODY LOTION; SHIMMER BODY SPLASH; LIP BALM; HAND SOAP; SHOWER GEL; BUBBLE BATH; SHAMPOO; CONDITIONER; LIP GLOSS; PRE-MOISTENED COSMETIC FRAGRANT WIPES; HAIR DETANGLE SPRAY; HAND CLEANSING GEL (U.S. CLS. 1, 4, 6, 50, 51 AND 52).

DAVID I, EXAMINING ATTORNEY

CLASS 3—(Continued).

SN 77-521,510. BATH & BODY WORKS BRAND MANAGEMENT, INC., REYNOLDSBURG, OH. FILED 7-14-2008.

SIGNATURE **kids**

NO CLAIM IS MADE TO THE EXCLUSIVE RIGHT TO USE "KIDS", APART FROM THE MARK AS SHOWN.

THE MARK CONSISTS OF THE WORDS "SIGNATURE" AND "KIDS".

FOR PERSONAL CARE PRODUCTS, NAMELY, BATH FOAM; BODY LOTION; SHIMMER BODY SPLASH; LIP BALM; HAND SOAP; SHOWER GEL; BUBBLE BATH; SHAMPOO; CONDITIONER; LIP GLOSS; PRE-MOISTENED COSMETIC FRAGRANT WIPES; HAIR DETANGLE SPRAY; HAND CLEANSING GEL (U.S. CLS. 1, 4, 6, 50, 51 AND 52).

DAVID I, EXAMINING ATTORNEY

SN 77-533,192. ELEMI PTY LTD, WEST END, AUSTRALIA, FILED 7-28-2008.

LYCOflex

THE MARK CONSISTS OF STANDARD CHARACTERS WITHOUT CLAIM TO ANY PARTICULAR FONT, STYLE, SIZE, OR COLOR.

OWNER OF AUSTRALIA REG. NO. 1249720, DATED 7-3-2008, EXPIRES 7-3-2018.

FOR DEPILATORY CREAMS; DEPILATORY PREPARATIONS; DEPILATORY PREPARATIONS AND SUBSTANCES; DEPILATORY WAX; PARAFFIN WAX FOR COSMETIC PURPOSES; WAX FOR REMOVING BODY HAIR (U.S. CLS. 1, 4, 6, 50, 51 AND 52).

PATRICIA EVANKO, EXAMINING ATTORNEY

SN 77-540,498. PRODUCT QUEST MANUFACTURING, INC., HOLLY HILL, FL. FILED 8-6-2008.

SunPlex
broad spectrum uva-uvb

NO CLAIM IS MADE TO THE EXCLUSIVE RIGHT TO USE "BROAD SPECTRUM UVA-UVB", APART FROM THE MARK AS SHOWN.

THE COLOR(S) NAVY BLUE, BLACK, AND YELLOW IS/ARE CLAIMED AS A FEATURE OF THE MARK.

THE MARK CONSISTS OF THE WORDING "SUNPLEX" IN NAVY BLUE LETTERING ABOVE THE WORDING "BROAD SPECTRUM UVA-UVB" IN BLACK LETTERING. BENEATH ALL THE LETTERING ARE TWO CURVED LINES, THE UPPER LINE IS BLACK AND THE LOWER LINE IS YELLOW. THERE IS A YELLOW SPHERE ON THE RIGHT SIDE OF THE CURVED LINES.

FOR SUNSCREEN, NOT INCLUDING PREPARATIONS, SOLUTIONS, SPRAYS, LOTIONS, OR LIQUIDS USED FOR THE PURPOSE OF ARTIFICIAL TANNING (U.S. CLS. 1, 4, 6, 50, 51 AND 52).

WENDY GOODMAN, EXAMINING ATTORNEY

CLASS 3—(Continued).

SN 77-544,550. L'OREAL, PARIS, FRANCE, FILED 8-12-2008.

L'OREAL PROFESSIONNEL PARIS

THE MARK CONSISTS OF STANDARD CHARACTERS WITHOUT CLAIM TO ANY PARTICULAR FONT, STYLE, SIZE, OR COLOR.

OWNER OF U.S. REG. NOS. 661,746, 3,081,932 AND 3,281,234.

NO CLAIM IS MADE TO THE EXCLUSIVE RIGHT TO USE "PROFESSIONNEL" AND "PARIS", APART FROM THE MARK AS SHOWN.

THE ENGLISH TRANSLATION OF THE WORD "PROFESSIONNEL" IN THE MARK IS PROFESSIONAL.

FOR HAIR CARE PREPARATIONS; HAIR STYLING PREPARATIONS; HAIR TREATMENT PREPARATIONS; HAIR COLOURING AND DECOLORANT PREPARATIONS (U.S. CLS. 1, 4, 6, 50, 51 AND 52).

FIRST USE 0-0-1999; IN COMMERCE 0-0-1999.

ELISSA GARBER KON, EXAMINING ATTORNEY

SN 77-557,336. BATH & BODY WORKS BRAND MANAGEMENT, INC., REYNOLDSBURG, OH. FILED 8-27-2008.

TRUE BLUE NAKED

THE MARK CONSISTS OF STANDARD CHARACTERS WITHOUT CLAIM TO ANY PARTICULAR FONT, STYLE, SIZE, OR COLOR.

OWNER OF U.S. REG. NO. 2,739,051.

FOR PERSONAL CARE PRODUCTS, NAMELY, ANTI-BACTERIAL SKIN SOAPS, BATH BEADS, BATH CRYSTALS, BATH FOAMS, BATH GELS, BATH LOTION, BATH MILKS, BATH OILS FOR COSMETIC PURPOSES, BATH PEARLS, BATH SALTS, BATH SOAPS IN LIQUID, SOLID OR GEL FORM, BATHING LOTIONS, BODY CREAM SOAP, BODY CREAMS, BODY EMULSIONS, BODY LOTIONS, BODY MASKS, BODY MILKS, BODY MOISTURIZING MOUSSE, BODY OILS, BODY SCRUB, BODY SPRAY USED AS A PERSONAL DEODORANT AND AS FRAGRANCE, BODY SPRAYS, NAMELY, WATER IN ATOMIZED CONTAINERS USED TO PRODUCE A COOLING EFFECT, BODY WASHES, BUBBLE BATH, COLOGNE, COLOGNE WATER, CREAMS FOR CELLULITE REDUCTION, CREAM TO OIL BODY LOTION, DEPILATORIES, DEPILATORY CREAMS, EAU DE PARFUM, EAU DE TOILETTE, ESSENTIAL OILS FOR PERSONAL USE, FIRMLING BODY LOTION, HAIR SHAMPOO, HAIR CONDITIONERS, HAND CREAMS, HAND LOTIONS, HAND SOAPS, LIP BALM, LIP GLOSS, LIQUID BATH SOAPS, LIQUID SOAP, LIQUID SOAPS FOR HANDS, FACE AND BODY, LOTIONS FOR CELLULITE REDUCTION, LOTIONS FOR FACE AND BODY CARE, MOISTURIZING CREAMS, MOISTURIZING MILKS, PERFUME, PERFUME OILS, PRE-SHAVE CREAMS, SCENTED BODY SPRAY, SHAVING BALM, SHAVING CREAMS, SHAVING FOAMS, SHAVING GELS, SHAVING LOTIONS, SHAVING MOUSSE, SHAVING PREPARATIONS, SHAVING SOAP, SHOWER AND BATH FOAM, SHOWER AND BATH GEL, SHOWER CREAMS, AND SHOWER GELS (U.S. CLS. 1, 4, 6, 50, 51 AND 52).

DAVID I, EXAMINING ATTORNEY

CLASS 3—(Continued).

SN 77-574,001. MAX MARA INTERNATIONAL S.A., L-2449 LUXEMBOURG, LUXEMBOURG, FILED 9-19-2008.

MAX & CO.

THE MARK CONSISTS OF STANDARD CHARACTERS WITHOUT CLAIM TO ANY PARTICULAR FONT, STYLE, SIZE, OR COLOR.

OWNER OF U.S. REG. NO. 2,211,314.
NO CLAIM IS MADE TO THE EXCLUSIVE RIGHT TO USE "CO.", APART FROM THE MARK AS SHOWN.
FOR PERFUMES (U.S. CLS. 1, 4, 6, 50, 51 AND 52).
WILLIAM P. SHANAHAN, EXAMINING ATTORNEY

SN 77-577,075. CLEANING SYSTEMS, INC., DE PERE, WI. FILED 9-23-2008.

InterGreen

THE MARK CONSISTS OF STANDARD CHARACTERS WITHOUT CLAIM TO ANY PARTICULAR FONT, STYLE, SIZE, OR COLOR.

FOR ALKALINE DETERGENT USED IN COMMERCIAL TRUCK AND LARGE VEHICLE WASHES (U.S. CLS. 1, 4, 6, 50, 51 AND 52).
FIRST USE 8-29-2003; IN COMMERCE 8-29-2003.
MATTHEW KLINE, EXAMINING ATTORNEY

SN 77-585,965. GARCOA, INC., CALABASAS, CA. FILED 10-6-2008.

PURE NANOLOGY

THE MARK CONSISTS OF STANDARD CHARACTERS WITHOUT CLAIM TO ANY PARTICULAR FONT, STYLE, SIZE, OR COLOR.

FOR BODY WASHES; HAIR SHAMPOOS AND CONDITIONERS; HAIR STYLING PREPARATIONS; LOTIONS FOR FACE AND BODY CARE (U.S. CLS. 1, 4, 6, 50, 51 AND 52).
FIRST USE 7-25-2008; IN COMMERCE 7-25-2008.
MELISSA VALLILLO, EXAMINING ATTORNEY

CLASS 3—(Continued).

SN 77-590,892. DEN-MAT HOLDINGS, LLC, SANTA MARIA, CA. FILED 10-11-2008.

LUMIBRIGHT

THE MARK CONSISTS OF STANDARD CHARACTERS WITHOUT CLAIM TO ANY PARTICULAR FONT, STYLE, SIZE, OR COLOR.

FOR TEETH WHITENING KITS (U.S. CLS. 1, 4, 6, 50, 51 AND 52).
JOHN DWYER, EXAMINING ATTORNEY

SN 77-599,542. THIRD MAN, INC., NEW YORK, NY. FILED 10-23-2008.

EAU MONUMENTALE

THE MARK CONSISTS OF STANDARD CHARACTERS WITHOUT CLAIM TO ANY PARTICULAR FONT, STYLE, SIZE, OR COLOR.

THE ENGLISH TRANSLATION OF THE WORD "MONUMENTALE" IN THE MARK IS MONUMENTAL.
FOR AFTERSHAVE; BATHING LOTIONS; BEAUTY LOTIONS; BODY LOTIONS; COLOGNE; COSMETIC PREPARATIONS FOR BODY CARE; COSMETIC SOAPS; COSMETICS AND COSMETIC PREPARATIONS; EAU DE TOILETTE AND EAU DE COLOGNE; FRAGRANCES FOR PERSONAL USE; NON-MEDICATED TOILETRIES; PERFUMES; POTPOURRI; ROOM FRAGRANCES; SKIN AND BODY TOPICAL LOTIONS, CREAMS AND OILS FOR COSMETIC USE; TOILET WATER (U.S. CLS. 1, 4, 6, 50, 51 AND 52).
ERNEST SHOSHO, EXAMINING ATTORNEY

SN 77-604,509. JLO HOLDING COMPANY, LLC, SANTA MONICA, CA. FILED 10-30-2008.

MY GLOW

THE MARK CONSISTS OF STANDARD CHARACTERS WITHOUT CLAIM TO ANY PARTICULAR FONT, STYLE, SIZE, OR COLOR.

FOR SOAPS, FRAGRANCES, NAMELY, EAU DE TOILETTE, ESSENTIAL OILS, BODY CREAMS, BODY LOTIONS, AND BODY WASHES (U.S. CLS. 1, 4, 6, 50, 51 AND 52).
ANNE MADDEN, EXAMINING ATTORNEY

CLASS 3—(Continued).

SN 77-612,338. GUTHY-RENKER LLC, PALM DESERT, CA. FILED 11-11-2008.

MAKEUP THAT MATTERS

THE MARK CONSISTS OF STANDARD CHARACTERS WITHOUT CLAIM TO ANY PARTICULAR FONT, STYLE, SIZE, OR COLOR.

NO CLAIM IS MADE TO THE EXCLUSIVE RIGHT TO USE "MAKEUP", APART FROM THE MARK AS SHOWN.

FOR SKIN AND BODY CARE PREPARATIONS, NAMELY, SKIN CLEANSERS, SKIN MOISTURIZERS, SKIN LOTIONS, SKIN SOAPS, SUN SCREEN PREPARATIONS, COSMETICS, NON-MEDICATED HAIR CARE PREPARATIONS, NAIL CARE PREPARATIONS, NON-MEDICATED SKIN CARE PREPARATIONS, COLOGNES, PERFUMES AND TOOTH WHITENING PREPARATIONS (U.S. CLS. 1, 4, 6, 50, 51 AND 52).

MORGAN WYNNE, EXAMINING ATTORNEY

CLASS 3—(Continued).

SN 77-625,494. CE LICENSING, LLC, LOS ANGELES, CA. FILED 12-3-2008.

Carmen Electra

SN 77-613,864. REVLON CONSUMER PRODUCTS CORPORATION, NEW YORK, NY. FILED 11-13-2008.

ALMAY ONE COAT VOLUME CONTROL

THE MARK CONSISTS OF STANDARD CHARACTERS WITHOUT CLAIM TO ANY PARTICULAR FONT, STYLE, SIZE, OR COLOR.

OWNER OF U.S. REG. NOS. 980,494, 2,601,794 AND 3,072,210.

NO CLAIM IS MADE TO THE EXCLUSIVE RIGHT TO USE "ONE COAT", APART FROM THE MARK AS SHOWN.

FOR COSMETICS; MAKE-UP (U.S. CLS. 1, 4, 6, 50, 51 AND 52).

ZACHARY BELLO, EXAMINING ATTORNEY

THE MARK CONSISTS OF STANDARD CHARACTERS WITHOUT CLAIM TO ANY PARTICULAR FONT, STYLE, SIZE, OR COLOR.

THE NAME SHOWN IN THE MARK IDENTIFIES A LIVING INDIVIDUAL, WHOSE CONSENT IS OF RECORD.

FOR FRAGRANCE AND COSMETIC PRODUCTS, NAMELY, FACE CREAM; BODY CREAM; NON-MEDICATED ANTI-WRINKLE CREAM; NON-MEDICATED SKIN RENEWAL CREAM; EYE CREAM; BODY LOTION; BODY OIL; NON-MEDICATED LIP BALM; SKIN BALANCING LOTION; OIL CONTROL SKIN LOTION; SKIN FIRING PREPARATION; SKIN BLEMISH PREPARATION; FACIAL TONER; BODY TONER; FACIAL CLEANSER; BODY CLEANSER; FACIAL EXFOLIATING PREPARATION; BODY EXFOLIATING PREPARATION; BODY AND HAIR SHAMPOO AND CONDITIONER-IN-ONE; EYE MAKEUP REMOVER; FACIAL MAKEUP REMOVER; FACE MASQUE; BODY MASQUE; SKIN REFRESHING LOTION, CREAM AND GEL; HAIR SHAMPOO; HAIR CONDITIONER; HAIR SPRAY; HAIR MOUSSE; HAIR GEL; HAIR HUMECTANT; NON-MEDICATED REVITALIZING CREAM; BODY SUNSCREEN; FACIAL SUNSCREEN; NON-MEDICATED LIP SUN-CARE PREPARATION; SELF-TANNING CREAMS; AFTER SUN SOOTHING MOISTURIZING LOTIONS, CREAMS AND GELS; FOUNDATION MAKEUP; LIP-STICK; LIPGLOSS; EYELINER; EYESHADOW; MAS-CARA; SKIN-TONE CORRECTOR CREAM; FACE POWDER; BODY POWDER; BRONZER; SKIN CONCEALER; EYEBROW PENCILS; COSMETIC PENCILS; BLUSHER; NAIL ENAMEL; NAIL ENAMEL TOP COAT; NAIL ENAMEL BASE COAT; QUICK DRY TOP COAT FOR NAILS; NAIL CONDITIONERS; NAIL STRENGTHENERS; NAIL POLISH REMOVER; RIDGEFILLER FOR NAILS; CUTICLE MOISTURIZING CREAM; CUTICLE REMOVING PREPARATIONS; NAIL WHITENING PENCILS AND PREPARATIONS; EAU DE PERFUME; EAU DE TOILETTE; PERFUME; COLOGNE; FRAGRANCED BODY LOTION; FRAGRANCED BODY CREAM; BATH POWDER; BATH OIL; SKIN CLEANSING LOTION; SKIN CLEANSING GEL; FACIAL AND BODY OIL SPRAY; SOAP; SHAVING FOAM; PRE-SHAVE PREPARATIONS; AFTER SHAVE LOTIONS AND GELS; AFTER SHAVE BALM; ANTI-PERSPIRANT/DEODORANT; POTPOURRI; MASSAGE OIL; ESSENTIAL OILS FOR PERSONAL USE (U.S. CLS. 1, 4, 6, 50, 51 AND 52).

REBECCA SMITH, EXAMINING ATTORNEY

SN 77-620,453. NYCOMED US INC., MELVILLE, NY. FILED 11-24-2008.

SULPHO-LAC

THE MARK CONSISTS OF STANDARD CHARACTERS WITHOUT CLAIM TO ANY PARTICULAR FONT, STYLE, SIZE, OR COLOR.

SEC. 2(F).

FOR MEDICATED SOAP TO BE USED IN THE TREATMENT OF SKIN IRRITATIONS, ACNE, SEBORRHEA, ACNE ROSEACTA, AND ALLIED DERMATOSES (U.S. CLS. 1, 4, 6, 50, 51 AND 52).

FIRST USE 12-0-2000; IN COMMERCE 12-0-2000.

AMEEN IMAM, EXAMINING ATTORNEY

CLASS 3—(Continued).

SN 77-625,783. YIWEN & DAVID, LLC, RENO, NV. FILED 12-3-2008.



OWNER OF U.S. REG. NO. 3,217,446.
THE MARK CONSISTS OF A STYLIZED "Y" WHICH IS THE FIRST LETTER OF THE SIGNATURE OF THE COMPANY'S FOUNDER.
FOR ANTI-AGING CREAMS; ANTI-AGING MOISTURIZER; ANTI-AGING TONER; BEAUTY MASKS; BODY MASKS; COSMETIC CREAMS; HAIR SHAMPOOS AND CONDITIONERS; LIP BALM; LOTIONS FOR FACE AND BODY CARE (U.S. CLS. 1, 4, 6, 50, 51 AND 52).
FIRST USE 5-31-2005; IN COMMERCE 5-31-2005.
JILL PRATER, EXAMINING ATTORNEY

SN 77-631,243. AUSTRALIAN GOLD, LLC, INDIANAPOLIS, IN. FILED 12-11-2008.

ETERNAL TWILIGHT

THE MARK CONSISTS OF STANDARD CHARACTERS WITHOUT CLAIM TO ANY PARTICULAR FONT, STYLE, SIZE, OR COLOR.
OWNER OF U.S. REG. NO. 3,018,609.
FOR SKIN CARE PREPARATIONS, NAMELY, NON-MEDICATED INDOOR TANNING PREPARATIONS DISTRIBUTED AND MARKETED FOR SALE AND USE IN INDOOR TANNING SALONS (U.S. CLS. 1, 4, 6, 50, 51 AND 52).
TRACY WHITTAKER-BROWN, EXAMINING ATTORNEY

CLASS 3—(Continued).

SN 77-632,663. UNCLE FUNKY'S DAUGHTER, INC., HOUSTON, TX. FILED 12-14-2008.

Curly Magic

THE MARK CONSISTS OF STANDARD CHARACTERS WITHOUT CLAIM TO ANY PARTICULAR FONT, STYLE, SIZE, OR COLOR.
NO CLAIM IS MADE TO THE EXCLUSIVE RIGHT TO USE "CURLY", APART FROM THE MARK AS SHOWN.
FOR HAIR CARE CREAMS; HAIR CARE KITS COMPRISING NON-MEDICATED HAIR CARE PREPARATIONS, NAMELY, GELS, SHAMPOOS, CONDITIONERS, MOISTURIZERS AND SPRAYS; HAIR CARE LOTIONS; HAIR CARE PREPARATIONS; HAIR CARE PREPARATIONS CONSISTING OF ORGANIC COCONUT VIRGIN OIL AND COCONUT VIRGIN OIL; HAIR CREAMS; HAIR GEL; HAIR LOTIONS; HAIR NOURISHERS; HAIR OILS; HAIR PRODUCTS, NAMELY, THICKENING CONTROL CREAMS; HAIR SHAMPOOS AND CONDITIONERS; HAIR SPRAYS AND HAIR GELS; HAIR STYLING FIXATIVE IN THE NATURE OF HAIR WAX; HAIR STYLING GEL; HAIR STYLING PREPARATIONS; HAIR STYLING SPRAY; HAIR TONICS; HAIR WAVING LOTION; HAIR WAVING PREPARATIONS; HAIR WAX; MOUSSE FOR HAIR; PREPARATIONS FOR SETTING HAIR; STYLING CLAY FOR HAIR; STYLING FOAM FOR HAIR; STYLING PASTE FOR HAIR (U.S. CLS. 1, 4, 6, 50, 51 AND 52).
FIRST USE 2-2-2001; IN COMMERCE 12-3-2001.
LINDA ESTRADA, EXAMINING ATTORNEY

SN 77-636,164. HADARY, DAVID J., DBA GREEN STRIPE CLEANING PRODUCTS, ALEXANDRIA, VA. FILED 12-18-2008.

BAY SAFE

THE MARK CONSISTS OF STANDARD CHARACTERS WITHOUT CLAIM TO ANY PARTICULAR FONT, STYLE, SIZE, OR COLOR.
FOR ALL PURPOSE CLEANING PREPARATIONS; CLEANING, WASHING AND POLISHING PREPARATIONS (U.S. CLS. 1, 4, 6, 50, 51 AND 52).
SHAILA SETTLES, EXAMINING ATTORNEY

CLASS 3—(Continued).

SN 77-639,204. ENESSE, INC. DBA PETAPOTTY; SKYBARK, LOS ANGELES, CA. FILED 12-23-2008.

smellulator

THE MARK CONSISTS OF STANDARD CHARACTERS WITHOUT CLAIM TO ANY PARTICULAR FONT, STYLE, SIZE, OR COLOR.

FOR BIOTECHNOLOGICAL CLEANING SOLUTION FOR ELIMINATING ODORS, BREAKING DOWN ORGANICS, AND REMOVING STAINS (U.S. CLS. 1, 4, 6, 50, 51 AND 52).

FIRST USE 11-15-2002; IN COMMERCE 1-1-2005.
CURTIS FRENCH, EXAMINING ATTORNEY

SN 77-643,041. SWEETYET DEVELOPMENT LIMITED, WANCHAI, HONG KONG, FILED 1-5-2009.

ASEPSO

THE MARK CONSISTS OF STANDARD CHARACTERS WITHOUT CLAIM TO ANY PARTICULAR FONT, STYLE, SIZE, OR COLOR.

OWNER OF U.S. REG. NO. 3,532,226.

FOR SOAPS, NAMELY, DETERGENT SOAPS, MEDICATED SOAPS, LIQUID SOAPS, DISINFECTANT SOAPS; NON-MEDICATED BATH AND SHOWER PREPARATIONS, NAMELY, BATH FOAM AND SHOWER GELS; TALCUM POWDER; LIQUID HAND AND BODY WASH; SHAMPOO; HAIR CONDITIONER; WET TISSUES, NAMELY, NON-MEDICATED TISSUES IMPREGNATED WITH A SKIN CLEANSER, TISSUES IMPREGNATED WITH NON-MEDICATED SKIN CARE PREPARATIONS FOR PERSONAL USE, TISSUES IMPREGNATED WITH PERFUMED PREPARATIONS, TISSUES IMPREGNATED WITH TOILET PREPARATIONS AND PREPARATIONS FOR CLEANING FOR HOUSEHOLD PURPOSES; PERFUMERY; ESSENTIAL OILS; COSMETICS; FACIAL WASH; FACIAL MASK; NON-MEDICATED SKIN CARE PREPARATIONS, NAMELY, CREAMS AND LOTIONS; HAIR CARE PREPARATIONS; HAIR GEL AND OTHER HAIRSTYLING PRODUCTS, NAMELY, HAIR COLOR, HAIR COLOR REMOVER, HAIRSTYLING FOAM, HAIR SPRAY, HAIR MASSAGE OIL; SKIN CARE PREPARATIONS, NAMELY, BODY POLISH, SKIN CLEANSERS, SKIN EMOLLIENTS, SKIN TONERS; SPOT REMOVER; SHAVING FOAM AND SHAVING GEL; AFTERSHAVE; ANTI-PERSPIRANTS; DETERGENTS FOR HOUSEHOLD USE; DENTIFRICES; BLEACHING PREPARATIONS AND OTHER SUBSTANCES ALL FOR LAUNDRY USE; CLEANING, POLISHING, SCOURING AND ABRASIVE PREPARATIONS; DISINFECTANT SOAPS; DEODORANTS FOR PERSONAL USE; EAU DE COLOGNE; EAU DE TOILETTE (U.S. CLS. 1, 4, 6, 50, 51 AND 52).

NAKIA HENRY, EXAMINING ATTORNEY

CLASS 3—(Continued).

SN 77-648,101. MAPALO, CORDELLIA, WOODLAND, CA. AND CAROTHERS, DON, WOODLAND, CA. FILED 1-13-2009.

WINDSHIELD-BUDDIES

THE MARK CONSISTS OF STANDARD CHARACTERS WITHOUT CLAIM TO ANY PARTICULAR FONT, STYLE, SIZE, OR COLOR.

FOR ALL PURPOSE CLEANING PREPARATIONS (U.S. CLS. 1, 4, 6, 50, 51 AND 52).

DOMINIC J. FERRAIUOLO, EXAMINING ATTORNEY

SN 77-651,959. HERMES INTERNATIONAL, PARIS, FRANCE, FILED 1-19-2009.



VANILLE GALANTE

HERMES

PRIORITY CLAIMED UNDER SEC. 44(D) ON FRANCE APPLICATION NO. 083589913, FILED 7-22-2008, REG. NO. 083589913, DATED 7-22-2008, EXPIRES 7-22-2018.

OWNER OF U.S. REG. NOS. 930,149, 3,055,813 AND OTHERS.

NO CLAIM IS MADE TO THE EXCLUSIVE RIGHT TO USE "COLLECTION" AND "VANILLE", APART FROM THE MARK AS SHOWN.

THE MARK CONSISTS OF THE LETTER "H" SURROUNDED BY TWO CONCENTRIC CIRCLES WHICH CONTAIN THE WORDS "HERMESSE COLLECTION" WITH DOTS SEPARATING THEM. BELOW THIS DESIGN, WRITTEN VERTICALLY IS THE WORDING "VANILLE GALANTE" AND HORIZONTALLY BELOW THEM THE WORD "HERMES".

THE ENGLISH TRANSLATION OF "VANILLE GALANTE" IN THE MARK IS FLIRTATIOUS VANILLA.

FOR PERFUMES, TOILET WATER, PERFUME WATER, ESSENTIAL OILS FOR PERSONAL USE, COSMETICS, HAIR LOTIONS, BODY LOTIONS, SOAPS, DENTIFRICES, DEODORANTS FOR PERSONAL USE, SHOWER GEL, SHAMPOOS, BEAUTY CREAM FOR THE BODY (U.S. CLS. 1, 4, 6, 50, 51 AND 52).

LINDA MICKLEBURGH, EXAMINING ATTORNEY

CLASS 3—(Continued).

SN 77-653,679. GRAYSON O. COMPANY, KANNAPOLIS, NC. FILED 1-21-2009.

HEATSMART SERUM

THE MARK CONSISTS OF STANDARD CHARACTERS WITHOUT CLAIM TO ANY PARTICULAR FONT, STYLE, SIZE, OR COLOR.

OWNER OF U.S. REG. NO. 3,172,182.

NO CLAIM IS MADE TO THE EXCLUSIVE RIGHT TO USE "SERUM", APART FROM THE MARK AS SHOWN.

FOR HAIR CARE PRODUCTS, NAMELY, SHAMPOOS, CONDITIONERS, LEAVE-IN CONDITIONERS, ORGANIC CLEANERS FOR HAIR, STYLING FOAM, STYLING GEL, STYLING LOTION, STYLING CREMES, CUTTING LOTION, HAIR SPRAYS, TREATMENTS FOR HAIR COLOR AND PERMANENT WAVE SOLUTIONS (U.S. CLS. 1, 4, 6, 50, 51 AND 52).

SUE LAWRENCE, EXAMINING ATTORNEY

SN 77-654,704. SOCIETE CLINICAL SKINCARE, LLC, AKA SOCIETE MEDICAL SKINCARE, POWDER SPRINGS, GA. FILED 1-22-2009.

Société

THE MARK CONSISTS OF STANDARD CHARACTERS WITHOUT CLAIM TO ANY PARTICULAR FONT, STYLE, SIZE, OR COLOR.

THE ENGLISH TRANSLATION OF "SOCIÉTÉ" IN THE MARK IS SOCIETY.

FOR COSMETIC CREAMS FOR SKIN CARE; COSMETIC PREPARATIONS FOR SKIN RENEWAL; EXFOLIANTS FOR SKIN; LOTIONS FOR SKIN; NON-MEDICATED SKIN CARE PREPARATIONS, NAMELY, CREAMS, LOTIONS, GELS, TONERS, CLEANERS AND PEELS; SKIN AND BODY TOPICAL LOTIONS, CREAMS AND OILS FOR COSMETIC USE; SKIN CARE PREPARATIONS, NAMELY, CHEMICAL PEELS FOR SKIN; SKIN CARE PREPARATIONS, NAMELY, BODY BALM; SKIN CARE PRODUCTS, NAMELY, NON-MEDICATED SKIN SERUM; SKIN CLEANSERS; SKIN CREAM; SKIN LIGHTENING CREAMS; SKIN MASKS; SKIN MOISTURIZER; SKIN MOISTURIZER MASKS; SKIN TONERS; WRINKLE REMOVING SKIN CARE PREPARATIONS (U.S. CLS. 1, 4, 6, 50, 51 AND 52).

FIRST USE 8-1-2008; IN COMMERCE 1-15-2009.

KAREN K. BUSH, EXAMINING ATTORNEY

CLASS 3—(Continued).

SN 77-660,028. DABUR INDIA LIMITED, NEW DELHI, INDIA, FILED 1-30-2009.

DABUR AMLA

THE MARK CONSISTS OF STANDARD CHARACTERS WITHOUT CLAIM TO ANY PARTICULAR FONT, STYLE, SIZE, OR COLOR.

OWNER OF U.S. REG. NOS. 1,890,384, 2,628,528 AND 3,529,735.

NO CLAIM IS MADE TO THE EXCLUSIVE RIGHT TO USE "AMLA", APART FROM THE MARK AS SHOWN.

FOR HAIR OIL (U.S. CLS. 1, 4, 6, 50, 51 AND 52).

FIRST USE 2-6-2000; IN COMMERCE 12-31-2003.

KELLY CHOE, EXAMINING ATTORNEY

SN 77-660,170. GIOVANNI COSMETICS, INC., COMPTON, CA. FILED 1-30-2009.

STREET CHIC

THE MARK CONSISTS OF STANDARD CHARACTERS WITHOUT CLAIM TO ANY PARTICULAR FONT, STYLE, SIZE, OR COLOR.

FOR NON-MEDICATED HAIR CARE PREPARATIONS; HAIR CARE PRODUCTS, NAMELY, SHAMPOOS, HAIR RINSES, HAIR CONDITIONERS, HAIR THICKENERS, HAIR GLOSSERS, HAIR LOTIONS, HAIR SPRAYS, STYLING LOTIONS AND GELS, NON-MEDICATED BEAUTY AND HAIR SERUMS, POMADES, HAIR RESTRUCTURERS; HAIR SHINE, HAIR MOUSSE, HAIR VOLUMIZING SPRAYS, HAIR STYLING CREAMS, FIXATIVES IN THE NATURE OF HAIR WAX, HAIR PASTE AND HAIR CREAM; HAIR STRENGTHENING GELS; NON-MEDICATED HAIR TREATMENT PREPARATIONS; BODY LOTIONS; BODY SCRUBS; BODY WASHES; BAR SOAPS; PRE-MOISTENED COSMETIC TOWELETES; SKIN CARE PRODUCTS, NAMELY, MOISTURIZING, EXFOLIATING, TONING AND REJUVENATING CREAMS AND LOTIONS; BODY BATHS, FACIAL AND BODY SOAPS, FACIAL TONERS, FACIAL CREAMS, FACIAL LOTIONS AND FACIAL MASKS; DEODORANTS; PERFUMES; LIP BALMS (U.S. CLS. 1, 4, 6, 50, 51 AND 52).

LESLEY LAMOTHE, EXAMINING ATTORNEY

CLASS 3—(Continued).

SN 77-661,104. PENSELS LTD., EAST NORTHPORT, NY.
FILED 2-2-2009.

Doctors' Intimate Formula for Personal Care

THE MARK CONSISTS OF STANDARD CHARACTERS WITHOUT CLAIM TO ANY PARTICULAR FONT, STYLE, SIZE, OR COLOR.

NO CLAIM IS MADE TO THE EXCLUSIVE RIGHT TO USE "DOCTORS'" AND "FORMULA FOR PERSONAL CARE", APART FROM THE MARK AS SHOWN.

FOR BODY AND BEAUTY CARE COSMETICS; COSMETIC CREAMS FOR SKIN CARE; COSMETIC PREPARATIONS; COSMETIC PREPARATIONS FOR EYE LASHES; COSMETIC PREPARATIONS FOR SKIN RENEWAL; COSMETIC PRODUCTS IN THE FORM OF AEROSOLS FOR SKINCARE; COSMETICS AND MAKE-UP; COSMETICS, NAMELY, LIP REPAIRERS; ESSENTIAL OILS FOR PERSONAL USE; FACE CREAMS FOR COSMETIC USE; FOAM CLEANSERS FOR PERSONAL USE; LOTIONS FOR COSMETIC PURPOSES; NUTRITIONAL OILS FOR COSMETIC PURPOSES; OILS FOR COSMETIC PURPOSES; RETINOL CREAM FOR COSMETIC PURPOSES; SHEA BUTTER FOR COSMETIC PURPOSES; SKIN AND BODY TOPICAL LOTIONS, CREAMS AND OILS FOR COSMETIC USE; SOAPS FOR PERSONAL USE (U.S. CLS. 1, 4, 6, 50, 51 AND 52).
BARBARA RUTLAND, EXAMINING ATTORNEY

SN 77-662,307. PRODUCT MANAGEMENT GROUP LLC,
PHOENIX, AZ. FILED 2-3-2009.

WHAT DIRT?

THE MARK CONSISTS OF STANDARD CHARACTERS WITHOUT CLAIM TO ANY PARTICULAR FONT, STYLE, SIZE, OR COLOR.

FOR ALL-PURPOSE CLEANERS (U.S. CLS. 1, 4, 6, 50, 51 AND 52).

SOPHIA S. KIM, EXAMINING ATTORNEY

CLASS 3—(Continued).

SN 77-662,793. FIT*SKIN LLC, LOS ANGELES, CA. FILED 2-3-2009.

Your Face. Naturally Fit.

THE MARK CONSISTS OF STANDARD CHARACTERS WITHOUT CLAIM TO ANY PARTICULAR FONT, STYLE, SIZE, OR COLOR.

FOR ANTI-AGING CREAMS; ANTI-WRINKLE CREAMS; BODY CREAMS; COSMETIC CREAMS; DISPOSABLE WIPES IMPREGNATED WITH CLEANSING CHEMICALS OR COMPOUNDS FOR USE ON THE FACE OR TO CLEAN ITEMS THAT WILL TOUCH THE FACE; DISPOSABLE WIPES IMPREGNATED WITH CLEANSING COMPOUNDS FOR USE ON THE FACE; FACE CREAMS; FACIAL CLEANSERS; FACIAL CREAMS; FACIAL LOTION; FACIAL MAKE-UP; FACIAL SCRUBS; FACIAL WASHES; LOTIONS FOR SKIN; PRE-MOISTENED COSMETIC WIPES; SKIN CREAMS; SUNSCREEN CREAMS; WRINKLE-MINIMIZING COSMETIC PREPARATIONS FOR TOPICAL FACIAL USE (U.S. CLS. 1, 4, 6, 50, 51 AND 52).

ELLEN PERKINS, EXAMINING ATTORNEY

SN 77-663,162. PHYSICIANS FORMULA, INC., AZUSA, CA.
FILED 2-4-2009.

HOW GREEN IS YOUR SKINCARE?

THE MARK CONSISTS OF STANDARD CHARACTERS WITHOUT CLAIM TO ANY PARTICULAR FONT, STYLE, SIZE, OR COLOR.

OWNER OF U.S. REG. NO. 3,544,638.

FOR SKIN CARE PRODUCTS, NAMELY, NON-MEDICATED SKIN CARE PREPARATIONS (U.S. CLS. 1, 4, 6, 50, 51 AND 52).

COLLEEN DOMBROW, EXAMINING ATTORNEY

SN 77-663,406. MANA PRODUCTS, INC., LONG ISLAND CITY, NY. FILED 2-4-2009.

ACCELERASE

THE MARK CONSISTS OF STANDARD CHARACTERS WITHOUT CLAIM TO ANY PARTICULAR FONT, STYLE, SIZE, OR COLOR.

FOR COSMETICS (U.S. CLS. 1, 4, 6, 50, 51 AND 52).

LINDSEY RUBIN, EXAMINING ATTORNEY

CLASS 3—(Continued).

SN 77-663,765. MICHAEL WADDELL, LLC, FORTSON, GA. FILED 2-5-2009.

MICHAEL WADDELL

THE MARK CONSISTS OF STANDARD CHARACTERS WITHOUT CLAIM TO ANY PARTICULAR FONT, STYLE, SIZE, OR COLOR.

FOR BATH AND BODY PRODUCTS, NAMELY, BODY DEODORANTS; SHAMPOOS (U.S. CLS. 1, 4, 6, 50, 51 AND 52).

JACQUELINE A. LAVINE, EXAMINING ATTORNEY



SN 77-663,771. PRL USA HOLDINGS, INC., WILMINGTON, DE. FILED 2-5-2009.

PERFECT GLAMOUR MASCARA

THE MARK CONSISTS OF STANDARD CHARACTERS WITHOUT CLAIM TO ANY PARTICULAR FONT, STYLE, SIZE, OR COLOR.

NO CLAIM IS MADE TO THE EXCLUSIVE RIGHT TO USE "MASCARA", APART FROM THE MARK AS SHOWN.

FOR MASCARA (U.S. CLS. 1, 4, 6, 50, 51 AND 52). FRED CARL, EXAMINING ATTORNEY



SN 77-664,114. AUSTRALIAN GOLD LLC, INDIANAPOLIS, IN. FILED 2-5-2009.

LEGALLY DARK

THE MARK CONSISTS OF STANDARD CHARACTERS WITHOUT CLAIM TO ANY PARTICULAR FONT, STYLE, SIZE, OR COLOR.

FOR NON-MEDICATED INDOOR AND OUTDOOR SKIN TANNING PREPARATIONS (U.S. CLS. 1, 4, 6, 50, 51 AND 52).

WARREN L. OLANDRIA, EXAMINING ATTORNEY

CLASS 3—(Continued).

SN 77-664,160. BOECKHOLT, JOSEPH A., PRAIRIE VILLAGE, KS. FILED 2-5-2009.

THE COLOR(S) GREEN IS/ARE CLAIMED AS A FEATURE OF THE MARK.

THE MARK CONSISTS OF A UNIQUE HIGHLY CONDENSED SAN-SERIF FONT WITH STRONG VERTICAL LINEAR ELEMENTS. ENTIRE MARK IS REPRODUCED IN GREEN.

FOR PERFUMES AND COLOGNES (U.S. CLS. 1, 4, 6, 50, 51 AND 52). JEFFREY LOOK, EXAMINING ATTORNEY



SN 77-664,182. AUSTRALIAN GOLD LLC, INDIANAPOLIS, IN. FILED 2-5-2009.

HOT GREEN TEASE

THE MARK CONSISTS OF STANDARD CHARACTERS WITHOUT CLAIM TO ANY PARTICULAR FONT, STYLE, SIZE, OR COLOR.

FOR NON-MEDICATED INDOOR AND OUTDOOR SKIN TANNING PREPARATIONS (U.S. CLS. 1, 4, 6, 50, 51 AND 52).

WARREN L. OLANDRIA, EXAMINING ATTORNEY



SN 77-664,379. MANA PRODUCTS, INC., LONG ISLAND CITY, NY. FILED 2-5-2009.

DAILY ACID ATTACK

THE MARK CONSISTS OF STANDARD CHARACTERS WITHOUT CLAIM TO ANY PARTICULAR FONT, STYLE, SIZE, OR COLOR.

NO CLAIM IS MADE TO THE EXCLUSIVE RIGHT TO USE "DAILY" AND "ACID", APART FROM THE MARK AS SHOWN.

FOR COSMETICS; NON-MEDICATED SKIN CARE PREPARATIONS; NON-MEDICATED TOILETRIES (U.S. CLS. 1, 4, 6, 50, 51 AND 52).

LINDSEY RUBIN, EXAMINING ATTORNEY

CLASS 3—(Continued).

SN 77-664,708. WEINZIMMER, RUSS, MILFORD, NH. FILED 2-6-2009.

SeatSeptic

THE MARK CONSISTS OF STANDARD CHARACTERS WITHOUT CLAIM TO ANY PARTICULAR FONT, STYLE, SIZE, OR COLOR.

FOR DISPOSABLE WIPES IMPREGNATED WITH CLEANSING COMPOUNDS FOR USE ON TOILET SEATS (U.S. CLS. 1, 4, 6, 50, 51 AND 52).

HANNO RITTRER, EXAMINING ATTORNEY

CLASS 3—(Continued).

SN 77-665,107. PBJ DEVELOPMENT, INC., BEAR, DE. FILED 2-6-2009.

PEROXIUM

THE MARK CONSISTS OF STANDARD CHARACTERS WITHOUT CLAIM TO ANY PARTICULAR FONT, STYLE, SIZE, OR COLOR.

FOR PREPARATIONS FOR THE CARE OF MOUTH AND TEETH, NAMELY, BLEACHING PREPARATIONS FOR COSMETIC PURPOSES (U.S. CLS. 1, 4, 6, 50, 51 AND 52).

MATTHEW PAPPAS, EXAMINING ATTORNEY

SN 77-664,989. CHB ENTERPRISES, WATERLOO, IA. FILED 2-6-2009.

GolfScents

THE MARK CONSISTS OF STANDARD CHARACTERS WITHOUT CLAIM TO ANY PARTICULAR FONT, STYLE, SIZE, OR COLOR.

FOR AROMATHERAPY INHALER SOLD FILLED WITH AROMATHERAPY ESSENTIAL OILS (U.S. CLS. 1, 4, 6, 50, 51 AND 52).

JESSICA A. POWERS, EXAMINING ATTORNEY

SN 77-665,110. GAME DAY IOWA, L.L.C., CORALVILLE, IA. FILED 2-6-2009.

REVOLT

THE MARK CONSISTS OF STANDARD CHARACTERS WITHOUT CLAIM TO ANY PARTICULAR FONT, STYLE, SIZE, OR COLOR.

FOR SHAVING PREPARATIONS (U.S. CLS. 1, 4, 6, 50, 51 AND 52).

FIRST USE 5-16-2006; IN COMMERCE 5-16-2006.

GEORGE LORENZO, EXAMINING ATTORNEY

SN 77-665,064. NU VISION GROUP LLC, NEW YORK, NY. FILED 2-6-2009.

PRETTYINPINK

THE MARK CONSISTS OF STANDARD CHARACTERS WITHOUT CLAIM TO ANY PARTICULAR FONT, STYLE, SIZE, OR COLOR.

FOR COLOGNE; FRAGRANCES; PERFUMES (U.S. CLS. 1, 4, 6, 50, 51 AND 52).

FIRST USE 6-0-2006; IN COMMERCE 6-0-2006.

GEOFFREY FOSDICK, EXAMINING ATTORNEY

SN 77-665,157. DEREK ANDREW INC., BELLEVUE, WA. FILED 2-6-2009.

TWISTED HEART

THE MARK CONSISTS OF STANDARD CHARACTERS WITHOUT CLAIM TO ANY PARTICULAR FONT, STYLE, SIZE, OR COLOR.

OWNER OF U.S. REG. NOS. 2,930,606 AND 3,600,195. FOR PERFUMERY, COSMETICS, HAIR LOTIONS AND OILS, BATH LOTIONS AND OILS, AND SOAPS FOR PERSONAL USE (U.S. CLS. 1, 4, 6, 50, 51 AND 52).

MICHAEL WEBSTER, EXAMINING ATTORNEY

CLASS 3—(Continued).

SN 77-665,161. DEREK ANDREW INC., BELLEVUE, WA. FILED 2-6-2009.



OWNER OF U.S. REG. NOS. 3,202,995, 3,610,341 AND 3,610,342.
 THE MARK CONSISTS OF HEART, WINGS, CROWN.
 FOR PERFUMERY, COSMETICS, HAIR LOTIONS AND OILS, BATH LOTIONS AND OILS, AND SOAPS FOR PERSONAL USE (U.S. CLS. 1, 4, 6, 50, 51 AND 52).
 MICHAEL WEBSTER, EXAMINING ATTORNEY

CLASS 3—(Continued).

SN 77-665,582. DYNAMIC SPECTRAL OUTPUT, COLUMBIA, SC. FILED 2-6-2009.

dreadhq

THE MARK CONSISTS OF STANDARD CHARACTERS WITHOUT CLAIM TO ANY PARTICULAR FONT, STYLE, SIZE, OR COLOR.
 FOR HAIR CARE PRODUCTS, NAMELY, SHAMPOOS, CREAMS, WAXES, BUTTERS, GELS AND SPRAYS FOR DREADLOCKS (U.S. CLS. 1, 4, 6, 50, 51 AND 52).
 MARK PILARO, EXAMINING ATTORNEY

SN 77-665,445. AMDL, INC., TUSTIN, CA. FILED 2-6-2009.

ELLEUXE

THE MARK CONSISTS OF STANDARD CHARACTERS WITHOUT CLAIM TO ANY PARTICULAR FONT, STYLE, SIZE, OR COLOR.
 FOR ANTI-AGING MOISTURIZER; ANTI-AGING TONER; EYE LOTIONS; FACE CREAMS; FACIAL CLEANSERS; SKIN CLEANSERS; SKIN CREAMS; SKIN MOISTURIZER; WRINKLE REMOVING SKIN CARE PREPARATIONS; WRINKLE RESISTANT CREAM; WRINKLE-MINIMIZING COSMETIC PREPARATIONS FOR TOPICAL FACIAL USE (U.S. CLS. 1, 4, 6, 50, 51 AND 52).
 MICHELLE DUBOIS, EXAMINING ATTORNEY

SN 77-665,815. LE MON, GARY, GREEN VALLEY, AZ. FILED 2-8-2009.

Denta Sure

THE MARK CONSISTS OF STANDARD CHARACTERS WITHOUT CLAIM TO ANY PARTICULAR FONT, STYLE, SIZE, OR COLOR.
 FOR TOOTH WHITENING PREPARATIONS (U.S. CLS. 1, 4, 6, 50, 51 AND 52).
 FIRST USE 6-1-2008; IN COMMERCE 6-1-2008.
 AMY HELLA, EXAMINING ATTORNEY

SN 77-665,513. MARCIA DAVIS HOLDINGS, LLC, WASHINGTON, DC. FILED 2-6-2009.

Jamaican Miracle

THE MARK CONSISTS OF STANDARD CHARACTERS WITHOUT CLAIM TO ANY PARTICULAR FONT, STYLE, SIZE, OR COLOR.
 NO CLAIM IS MADE TO THE EXCLUSIVE RIGHT TO USE "JAMAICAN", APART FROM THE MARK AS SHOWN.
 FOR HAIR CARE PREPARATIONS (U.S. CLS. 1, 4, 6, 50, 51 AND 52).
 JOHN E. MICHOS, EXAMINING ATTORNEY

SN 77-666,040. AUSTRALIAN GOLD LLC, INDIANAPOLIS, IN. FILED 2-9-2009.

FIG-GET ME NOT

THE MARK CONSISTS OF STANDARD CHARACTERS WITHOUT CLAIM TO ANY PARTICULAR FONT, STYLE, SIZE, OR COLOR.
 FOR NON-MEDICATED INDOOR AND OUTDOOR SKIN TANNING PREPARATIONS (U.S. CLS. 1, 4, 6, 50, 51 AND 52).
 WARREN L. OLANDRIA, EXAMINING ATTORNEY

CLASS 3—(Continued).

SN 77-666,047. PHILOSOPHY, INC., PHOENIX, AZ. FILED 2-9-2009.

THE SORORITY HOUSE

THE MARK CONSISTS OF STANDARD CHARACTERS WITHOUT CLAIM TO ANY PARTICULAR FONT, STYLE, SIZE, OR COLOR.

FOR BABY LOTION; BABY POWDER; BABY SHAMPOO; BAR SOAP; BODY POWDER; BODY SCRUB; COSMETIC FACIAL BLOTting PAPERS; COSMETIC PADS; COSMETIC PENCILS; COSMETIC PREPARATIONS FOR THE CARE OF MOUTH AND TEETH; COSMETICS; DEPILATORIES; FACIAL CLEANSERS; FACIAL SCRUBS; FRAGRANCES; HAIR CARE PREPARATIONS; NAIL CARE PREPARATIONS; NON-MEDICATED BATH PREPARATIONS; NON-MEDICATED LIP CARE PREPARATIONS; NON-MEDICATED SKIN CARE PREPARATIONS; NON-MEDICATED SUN CARE PREPARATIONS; NON-MEDICATED TOILETRIES; PERSONAL DEODORANTS; SCENTED ROOM SPRAYS; SHAVING PREPARATIONS; SHOWER AND BATH GEL (U.S. CLS. 1, 4, 6, 50, 51 AND 52).

KEVON CHISOLM, EXAMINING ATTORNEY

SN 77-666,139. MIXAROMA INC., NORTH MIAMI BEACH, FL. FILED 2-9-2009.

COCOADDICT

THE MARK CONSISTS OF STANDARD CHARACTERS WITHOUT CLAIM TO ANY PARTICULAR FONT, STYLE, SIZE, OR COLOR.

FOR SKIN AND BODY TOPICAL LOTIONS, CREAMS AND OILS FOR COSMETIC USE (U.S. CLS. 1, 4, 6, 50, 51 AND 52).

GIANCARLO CASTRO, EXAMINING ATTORNEY

SN 77-666,142. POSERGY LLC, KIMBERLY, ID. FILED 2-9-2009.

Posergy

THE MARK CONSISTS OF STANDARD CHARACTERS WITHOUT CLAIM TO ANY PARTICULAR FONT, STYLE, SIZE, OR COLOR.

FOR BABY LOTION; BABY OILS; BABY POWDER; BABY SHAMPOO; BODY CREAMS; BODY LOTIONS; BODY SCRUB; ESSENTIAL OILS; FACIAL MASKS; FACIAL WASHES; HAIR CONDITIONERS; MAKE-UP; SHAMPOOS; SKIN CLEANSERS; SKIN MOISTURIZER; SKIN TONERS (U.S. CLS. 1, 4, 6, 50, 51 AND 52).

FIRST USE 6-10-2008; IN COMMERCE 7-20-2008.
GIANCARLO CASTRO, EXAMINING ATTORNEY

CLASS 3—(Continued).

SN 77-666,293. PHILOSOPHY, INC., PHOENIX, AZ. FILED 2-9-2009.

HOLIDAY HOSTESS

THE MARK CONSISTS OF STANDARD CHARACTERS WITHOUT CLAIM TO ANY PARTICULAR FONT, STYLE, SIZE, OR COLOR.

FOR BABY LOTION; BABY POWDER; BABY SHAMPOO; BAR SOAP; BODY POWDER; BODY SCRUB; COSMETIC FACIAL BLOTting PAPERS; COSMETIC PADS; COSMETIC PENCILS; COSMETIC PREPARATIONS FOR THE CARE OF MOUTH AND TEETH; COSMETICS; DEPILATORIES; FACIAL CLEANSERS; FACIAL SCRUBS; FRAGRANCES; HAIR CARE PREPARATIONS; NAIL CARE PREPARATIONS; NON-MEDICATED BATH PREPARATIONS; NON-MEDICATED LIP CARE PREPARATIONS; NON-MEDICATED SKIN CARE PREPARATIONS; NON-MEDICATED SUN CARE PREPARATIONS; NON-MEDICATED TOILETRIES; PERSONAL DEODORANTS; SCENTED ROOM SPRAYS; SHAVING PREPARATIONS; SHOWER AND BATH GEL (U.S. CLS. 1, 4, 6, 50, 51 AND 52).

KEVON CHISOLM, EXAMINING ATTORNEY

SN 77-666,353. PHILOSOPHY, INC., PHOENIX, AZ. FILED 2-9-2009.

THE SPICE RACK

THE MARK CONSISTS OF STANDARD CHARACTERS WITHOUT CLAIM TO ANY PARTICULAR FONT, STYLE, SIZE, OR COLOR.

FOR BABY LOTION; BABY POWDER; BABY SHAMPOO; BAR SOAP; BODY POWDER; BODY SCRUB; COSMETIC FACIAL BLOTting PAPERS; COSMETIC PADS; COSMETIC PENCILS; COSMETIC PREPARATIONS FOR THE CARE OF MOUTH AND TEETH; COSMETICS; DEPILATORIES; FACIAL CLEANSERS; FACIAL SCRUBS; FRAGRANCES; HAIR CARE PREPARATIONS; NAIL CARE PREPARATIONS; NON-MEDICATED BATH PREPARATIONS; NON-MEDICATED LIP CARE PREPARATIONS; NON-MEDICATED SKIN CARE PREPARATIONS; NON-MEDICATED SUN CARE PREPARATIONS; NON-MEDICATED TOILETRIES; PERSONAL DEODORANTS; SCENTED ROOM SPRAYS; SHAVING PREPARATIONS; SHOWER AND BATH GEL (U.S. CLS. 1, 4, 6, 50, 51 AND 52).

KEVON CHISOLM, EXAMINING ATTORNEY

CLASS 3—(Continued).

SN 77-666,538. JAFRA COSMETICS INTERNATIONAL, INC., WESTLAKE VILLAGE, CA. FILED 2-9-2009.

HARSHALA

THE MARK CONSISTS OF STANDARD CHARACTERS WITHOUT CLAIM TO ANY PARTICULAR FONT, STYLE, SIZE, OR COLOR.

FOR BODY CARE PRODUCTS, NAMELY, BODY GEL; BODY LOTION; BODY LOTION WITH GLITTER; BODY OIL; HAND CREAM; BODY SCRUB; HAIR AND BODY SHAMPOO; SHOWER GEL; PERSONAL DEODORANT; ANTI-PERSPIRANT; EAU DE TOILETTE; EAU DE COLOGNE; PERFUME; COLOGNE; SOLID PARFUM; FRAGRANCES; SKIN AND BODY SOAP; DUSTING POWDER; BODY WASH; AND BODY FRAGRANCE FOR PERSONAL USE (U.S. CLS. 1, 4, 6, 50, 51 AND 52).
KEVIN DINALLO, EXAMINING ATTORNEY

SN 77-666,674. ROLL INTERNATIONAL CORPORATION, LOS ANGELES, CA. FILED 2-10-2009.

BYRON & TRACEY

THE MARK CONSISTS OF STANDARD CHARACTERS WITHOUT CLAIM TO ANY PARTICULAR FONT, STYLE, SIZE, OR COLOR.

FOR COSMETICS AND COSMETIC PREPARATIONS (U.S. CLS. 1, 4, 6, 50, 51 AND 52).
GEORGE LORENZO, EXAMINING ATTORNEY

SN 77-667,160. DONNELLAN, SUSAN, EAGLE, ID. FILED 2-10-2009.

BODYVERDE

THE MARK CONSISTS OF STANDARD CHARACTERS WITHOUT CLAIM TO ANY PARTICULAR FONT, STYLE, SIZE, OR COLOR.

FOR PERSONAL CARE PRODUCTS, NAMELY, CREAMS AND LOTIONS FOR THE FACE, BODY AND SKIN, BODY POWDER AND ESSENTIAL OILS (U.S. CLS. 1, 4, 6, 50, 51 AND 52).
KATHERINE CHANG, EXAMINING ATTORNEY

CLASS 3—(Continued).

SN 77-667,501. 3B INTERNATIONAL, LLC, CARLSTADT, NJ. FILED 2-10-2009.

LOVE IN THE CITY

THE MARK CONSISTS OF STANDARD CHARACTERS WITHOUT CLAIM TO ANY PARTICULAR FONT, STYLE, SIZE, OR COLOR.

FOR FRAGRANCES AND PERFUMERY (U.S. CLS. 1, 4, 6, 50, 51 AND 52).
HEATHER SAPP, EXAMINING ATTORNEY

SN 77-674,428. UNILEVER SUPPLY CHAIN, INC., CLINTON, CT. FILED 2-20-2009.

WHIPPED SOUFFLÉ

THE MARK CONSISTS OF STANDARD CHARACTERS WITHOUT CLAIM TO ANY PARTICULAR FONT, STYLE, SIZE, OR COLOR.

FOR BODY WASH (U.S. CLS. 1, 4, 6, 50, 51 AND 52).
SANI KHOURI, EXAMINING ATTORNEY

SN 77-681,598. MANA PRODUCTS, INC., LONG ISLAND CITY, NY. FILED 3-2-2009.

SLEEP LAB

THE MARK CONSISTS OF STANDARD CHARACTERS WITHOUT CLAIM TO ANY PARTICULAR FONT, STYLE, SIZE, OR COLOR.

NO CLAIM IS MADE TO THE EXCLUSIVE RIGHT TO USE "LAB", APART FROM THE MARK AS SHOWN.
FOR COSMETICS; NON-MEDICATED SKIN CARE PREPARATIONS (U.S. CLS. 1, 4, 6, 50, 51 AND 52).
LINDSEY RUBIN, EXAMINING ATTORNEY

CLASS 3—(Continued).

SN 77-683,190. JAFRA COSMETICS INTERNATIONAL, INC., WESTLAKE VILLAGE, CA. FILED 3-4-2009.

VARSHA

THE MARK CONSISTS OF STANDARD CHARACTERS WITHOUT CLAIM TO ANY PARTICULAR FONT, STYLE, SIZE, OR COLOR.

FOR BODY CARE PRODUCTS, NAMELY, BODY GEL; BODY LOTION; BODY LOTION WITH GLITTER; BODY OIL; HAND CREAM; BODY SCRUB; HAIR AND BODY SHAMPOO; SHOWER GEL; PERSONAL DEODORANT; ANTI-PERSPIRANT; EAU DE TOILETTE; EAU DE COLOGNE; PERFUME; COLOGNE; SOLID PARFUM; FRAGRANCES; SKIN AND BODY SOAP; DUSTING POWDER; BODY WASH; AND BODY FRAGRANCE FOR PERSONAL USE (U.S. CLS. 1, 4, 6, 50, 51 AND 52).
KEVIN DINALLO, EXAMINING ATTORNEY

SN 77-695,881. MANA PRODUCTS, INC., LONG ISLAND CITY, NY. FILED 3-20-2009.

**REMD THE SCIENCE OF
HEALTHY SKIN**

THE MARK CONSISTS OF STANDARD CHARACTERS WITHOUT CLAIM TO ANY PARTICULAR FONT, STYLE, SIZE, OR COLOR.

NO CLAIM IS MADE TO THE EXCLUSIVE RIGHT TO USE "HEALTHY SKIN", APART FROM THE MARK AS SHOWN.

FOR COSMETICS; NON-MEDICATED SKIN CARE PREPARATIONS (U.S. CLS. 1, 4, 6, 50, 51 AND 52).
LINDSEY RUBIN, EXAMINING ATTORNEY

SN 77-696,079. MANA PRODUCTS, INC., LONG ISLAND CITY, NY. FILED 3-20-2009.

DERMACOVER

THE MARK CONSISTS OF STANDARD CHARACTERS WITHOUT CLAIM TO ANY PARTICULAR FONT, STYLE, SIZE, OR COLOR.

FOR COSMETICS (U.S. CLS. 1, 4, 6, 50, 51 AND 52).
FIRST USE 6-0-2004; IN COMMERCE 6-0-2004.
LINDSEY RUBIN, EXAMINING ATTORNEY

CLASS 3—(Continued).

SN 77-698,577. MANA PRODUCTS, INC., LONG ISLAND CITY, NY. FILED 3-25-2009.

OCEAN BEACH

THE MARK CONSISTS OF STANDARD CHARACTERS WITHOUT CLAIM TO ANY PARTICULAR FONT, STYLE, SIZE, OR COLOR.

FOR LIP BALM; LIP GLOSS (U.S. CLS. 1, 4, 6, 50, 51 AND 52).
LINDSEY RUBIN, EXAMINING ATTORNEY

SN 77-700,942. MANA PRODUCTS, INC., LONG ISLAND CITY, NY. FILED 3-27-2009.

STATE OF MIND

THE MARK CONSISTS OF STANDARD CHARACTERS WITHOUT CLAIM TO ANY PARTICULAR FONT, STYLE, SIZE, OR COLOR.

OWNER OF U.S. REG. NO. 2,699,059.
FOR COSMETIC PREPARATIONS FOR BODY CARE; COSMETICS; FRAGRANCES FOR PERSONAL USE; HAIR CARE PREPARATIONS; NON-MEDICATED SKIN CARE PREPARATIONS (U.S. CLS. 1, 4, 6, 50, 51 AND 52).
LINDSEY RUBIN, EXAMINING ATTORNEY

SN 78-719,845. KATHERINE T. ANDERSON, WESTLAKE VILLAGE, CA. FILED 9-23-2005.

MALIBU SECRET BODY BUTTER

THE MARK CONSISTS OF STANDARD CHARACTERS WITHOUT CLAIM TO ANY PARTICULAR FONT, STYLE, SIZE, OR COLOR.

NO CLAIM IS MADE TO THE EXCLUSIVE RIGHT TO USE "MALIBU" AND "BODY BUTTER", APART FROM THE MARK AS SHOWN.

FOR BODY CREAM (U.S. CLS. 1, 4, 6, 50, 51 AND 52).
FIRST USE 9-19-2005; IN COMMERCE 9-19-2005.
LESLIE RICHARDS, EXAMINING ATTORNEY

CLASS 3—(Continued).

SN 79-028,117. PRIMO EMPORIO S.N.C.; DI GIOVANNI PROVITERA & C., ITALY, FILED 2-10-2006.



OWNER OF INTERNATIONAL REGISTRATION 0896520 DATED 2-10-2006, EXPIRES 2-10-2016.

NO CLAIM IS MADE TO THE EXCLUSIVE RIGHT TO USE "EMPORIO", APART FROM THE MARK AS SHOWN.

THE MARK CONSISTS OF TWO OVERLAPPING PITCH-FORKS.

THE FOREIGN WORDING IN THE MARK TRANSLATES INTO ENGLISH AS FIRST EMPORIUM.

FOR PERFUMERY, NAMELY, PERFUMES AND EAU DE TOILETTE, ESSENTIAL OILS FOR BODY, COSMETICS, HAND SOAPS (U.S. CLS. 1, 4, 6, 50, 51 AND 52). EDWARD FENNESSY, EXAMINING ATTORNEY

CLASS 3—(Continued).

SN 79-059,243. BEST WORLD INTERNATIONAL LIMITED, SINGAPORE 498789, SINGAPORE, FILED 9-5-2008.



PRIORITY DATE OF 5-22-2008 IS CLAIMED. OWNER OF INTERNATIONAL REGISTRATION 0978271 DATED 9-5-2008, EXPIRES 9-5-2018.

THE COLOR(S) BLUE AND GREEN IS/ARE CLAIMED AS A FEATURE OF THE MARK.

THE MARK CONSISTS OF THE WORD "MIRAGLO" IN A STYLIZED FONT TO THE LEFT OF A CIRCLE DESIGN MADE UP OF GREEN DOTS FORMING A CIRCULAR PERIMETER THAT CONTAINS FIVE SMALLER CIRCLES MADE OF GREEN DOT WITHIN THE PERIMETER CIRCLE. THE COLOR BLUE APPEARS IN THE LETTERS "GLO" AND THE REMAINDER OF THE MARK IN GREEN.

FOR EXFOLIANTS FOR THE CARE AND CLEANSING OF THE SKIN (U.S. CLS. 1, 4, 6, 50, 51 AND 52).

TRACY WHITTAKER-BROWN, EXAMINING ATTORNEY

SN 79-058,938. STUDIO 46 S.R.L., ITALY, FILED 7-22-2008.



OWNER OF INTERNATIONAL REGISTRATION 0977467 DATED 7-22-2008, EXPIRES 7-22-2018.

THE MARK CONSISTS OF THE WORDING "KEARR" VERTICALLY IN FANCY CHARACTERS, ON THE RIGHT SIDE OF WHICH THERE IS A BAND.

FOR PERFUMES, TOILET WATER, PERSONAL DEODORANTS, INCENSES, ESSENTIAL OILS FOR PERSONAL USE, EMERY, SHOE CREAM, BODY LOTIONS, AFTERSHAVE LOTIONS, SHAVING BALMS, SHAVING CREAM, SHOWER GEL, BUBBLE BATH, BATH PEARLS, SKIN SOAPS, EYE SHADOWS, COSMETIC PENCILS, FOUNDATION MAKE-UP, FACE POWDERS, TALCUM POWDER, ROUGES, LIPSTICKS, MASCARAS, SKIN CLEANSING CREAMS, SKIN CLEANSING LOTIONS, SUN SCREEN PREPARATION, NAIL POLISH, BEAUTY MASKS, FACIAL SCRUBS, FACE CREAMS, BODY CREAMS; COSMETIC CREAMS AND GELS ALL FOR WEIGHT REDUCTION OR SLIMMING PURPOSES; COSMETIC CREAMS AND GELS ALL FOR THE PREVENTION, REDUCTION AND ELIMINATION OF CELLULITE; HAIR SHAMPOOS, SHAMPOOS FOR PETS, HAIR SPRAYS, HAIR LOTIONS, HAIR DYE, HAIR RINSES, HAIR LIGHTENERS, HAIR CONDITIONERS, HAIR MOISTURIZERS, HAIR STYLING FOAM AND GELS, DENTIFRICES (U.S. CLS. 1, 4, 6, 50, 51 AND 52). MICHAEL TANNER, EXAMINING ATTORNEY

SN 79-059,693. EDO S.R.L., ITALY, FILED 6-25-2008.



OWNER OF INTERNATIONAL REGISTRATION 0979290 DATED 6-25-2008, EXPIRES 6-25-2018.

NO CLAIM IS MADE TO THE EXCLUSIVE RIGHT TO USE "LIMPO", APART FROM THE MARK AS SHOWN.

THE COLOR(S) BLUE AND GREEN IS/ARE CLAIMED AS A FEATURE OF THE MARK.

THE VERBAL ELEMENT "LIMPO" IN BLUE AND THE FIGURATIVE ELEMENT THAT CONSISTS OF THE BUTTERFLY IN GREEN.

THE MARK CONSISTS OF THE TERM "LIMPO" IN BLUE AND THE FIGURATIVE ELEMENT THAT CONSISTS OF THE BUTTERFLY IN BLUE WITH THE LOWER WING PORTION IN GREEN.

THE ENGLISH TRANSLATION OF "LIMPO" IN THE MARK IS "CLEAN".

FOR CLEANING, POLISHING AND SCOURING PREPARATIONS (U.S. CLS. 1, 4, 6, 50, 51 AND 52). RON FAIRBANKS, EXAMINING ATTORNEY

CLASS 3—(Continued).

SN 79-060,782. COTY DEUTSCHLAND GMBH, FED REP GERMANY, FILED 9-18-2008.

RIMMEL MOISTURE REPAIR

THE MARK CONSISTS OF STANDARD CHARACTERS WITHOUT CLAIM TO ANY PARTICULAR FONT, STYLE, SIZE, OR COLOR.

PRIORITY DATE OF 3-28-2008 IS CLAIMED. OWNER OF INTERNATIONAL REGISTRATION 0981804 DATED 9-18-2008, EXPIRES 9-18-2018.

NO CLAIM IS MADE TO THE EXCLUSIVE RIGHT TO USE "MOISTURE REPAIR", APART FROM THE MARK AS SHOWN.

FOR SOAPS, PERFUMERY; ESSENTIAL OILS; COSMETICS; COSMETIC HAIR LOTIONS (U.S. CLS. 1, 4, 6, 50, 51 AND 52).

DAVID TAYLOR, EXAMINING ATTORNEY

SN 79-066,486. LUMENE OY, FINLAND, FILED 2-4-2009.

BEAUTIFULLY TRUE

THE MARK CONSISTS OF STANDARD CHARACTERS WITHOUT CLAIM TO ANY PARTICULAR FONT, STYLE, SIZE, OR COLOR.

PRIORITY DATE OF 12-22-2008 IS CLAIMED. OWNER OF INTERNATIONAL REGISTRATION 0996671 DATED 2-4-2009, EXPIRES 2-4-2019.

FOR COSMETICS, NAMELY, BODY CARE, FACE CARE AND HAND CARE PRODUCTS IN THE FORM OF NOURISHING, CONDITIONING AND MOISTURIZING LIQUIDS FOR FACE AND BODY CARE, CREAMS, MASKS, AMPOULES CONTAINING NOURISHING, CONDITIONING AND MOISTURIZING LIQUIDS FOR FACE AND BODY CARE; NOURISHING, CONDITIONING AND MOISTURIZING GELS AND EMULSIONS FOR FACE AND BODY CARE; FACIAL MAKEUP, FOUNDATIONS, SKIN CLEANSING LOTIONS, CLEANING, SOOTHING AND REFRESHING TONICS FOR FACE CARE, NON-MEDICATED ACNE PREPARATIONS, LIPSTICK, LIP GLOSSES, LIP LINER, NAIL POLISH, MASCARA, EYELINER, EYE SHADOW, EYE MAKE-UP REMOVER, FACE POWDER, FACE CREAMS, ROUGES, NAIL POLISH REMOVER; NAIL CARE PREPARATIONS, SUN PROTECTION PREPARATIONS; BODY SOAPS, BODY SHAMPOOS, ESSENTIAL OILS FOR PERSONAL USE; SHAVING PREPARATIONS (U.S. CLS. 1, 4, 6, 50, 51 AND 52).

BRENDAN REGAN, EXAMINING ATTORNEY

CLASS 4—LUBRICANTS AND FUELS

SN 77-584,566. AMSOIL INC., SUPERIOR, WI. FILED 10-2-2008.

SLIP LOCK

THE MARK CONSISTS OF STANDARD CHARACTERS WITHOUT CLAIM TO ANY PARTICULAR FONT, STYLE, SIZE, OR COLOR.

FOR AUTOMOTIVE LUBRICANT ADDITIVES, NAMELY, DIFFERENTIAL ADDITIVES (U.S. CLS. 1, 6 AND 15).

FIRST USE 6-12-2003; IN COMMERCE 6-12-2003. MATTHEW EINSTEIN, EXAMINING ATTORNEY

SN 77-663,223. SEMPRA ENERGY, SAN DIEGO, CA. FILED 2-4-2009.



OWNER OF U.S. REG. NOS. 2,437,361, 3,411,029 AND OTHERS.

NO CLAIM IS MADE TO THE EXCLUSIVE RIGHT TO USE "ENERGY", APART FROM THE MARK AS SHOWN.

THE MARK CONSISTS OF A CRESCENT AND A DESIGN OF A HUMAN FIGURE HOLDING A FLAME NEXT TO THE WORDS "SEMPRA ENERGY" AND ABOVE THE WORDS "FOR EVERY DAY LIFE".

FOR LIQUEFIED NATURAL GAS (U.S. CLS. 1, 6 AND 15).

DAVID C. REIHNER, EXAMINING ATTORNEY

SN 77-664,601. ZAVAKOS, VICKY, LAKE ZURICH, IL. FILED 2-5-2009.

BASA ZEE

THE MARK CONSISTS OF STANDARD CHARACTERS WITHOUT CLAIM TO ANY PARTICULAR FONT, STYLE, SIZE, OR COLOR.

FOR CANDLES (U.S. CLS. 1, 6 AND 15). IRA J. GOODSaid, EXAMINING ATTORNEY

CLASS 4—(Continued).

SN 77-665,444. HARRIS, NICK ALLEN, DBA ANGELIC AROMAS, TULSA, OK. AND HARRIS, LARRY NICK, DBA ANGELIC AROMAS, PARK HILL, OK. FILED 2-6-2009.



THE MARK CONSISTS OF THE WORDS, "ANGELIC AROMAS", IN STYLIZED FORM, WITH THE FANCIFUL DESIGN OF AN ANGEL'S WING ATTACHED TO THE CAPITAL LETTER "A" IN BOTH WORDS, ALL WITHIN THE DESIGN OF TWO CONCENTRIC, SHADED OVALS. FOR SCENTED CANDLES (U.S. CLS. 1, 6 AND 15). BARBARA A. GOLD, EXAMINING ATTORNEY

CLASS 4—(Continued).

SN 77-666,175. MVP GROUP INTERNATIONAL, INC., CHARLESTON, SC. FILED 2-9-2009.



THE MARK CONSISTS OF STYLIZED LETTERS "U" AND "C" WITHIN A CIRCLE. FOR CANDLES (U.S. CLS. 1, 6 AND 15). REBECCA POVARCHUK, EXAMINING ATTORNEY

SN 77-666,069. SEMPRA ENERGY, SAN DIEGO, CA. FILED 2-9-2009.



OWNER OF U.S. REG. NOS. 2,437,361, 3,411,029 AND OTHERS. NO CLAIM IS MADE TO THE EXCLUSIVE RIGHT TO USE "ENERGY", APART FROM THE MARK AS SHOWN. THE MARK CONSISTS OF A CRESCENT DESIGN OF A HUMAN FIGURE HOLDING A FLAME NEXT TO THE WORDS "SEMPRA ENERGY". FOR LIQUEFIED NATURAL GAS (U.S. CLS. 1, 6 AND 15). DAVID C. REIHNER, EXAMINING ATTORNEY

SN 77-666,186. CARPENTER, ROBERT, METAMORA, MI. FILED 2-9-2009.

Great American Candle

THE MARK CONSISTS OF STANDARD CHARACTERS WITHOUT CLAIM TO ANY PARTICULAR FONT, STYLE, SIZE, OR COLOR. NO CLAIM IS MADE TO THE EXCLUSIVE RIGHT TO USE "CANDLE", APART FROM THE MARK AS SHOWN. FOR CANDLES (U.S. CLS. 1, 6 AND 15). FIRST USE 11-26-2008; IN COMMERCE 1-22-2009. PAUL F. GAST, EXAMINING ATTORNEY

SN 77-666,081. SEMPRA ENERGY, SAN DIEGO, CA. FILED 2-9-2009.



OWNER OF U.S. REG. NOS. 2,437,361, 3,411,029 AND OTHERS. THE MARK CONSISTS OF A CRESCENT AND DESIGN OF A HUMAN FIGURE HOLDING A FLAME NEXT TO THE WORD "SEMPRA". FOR LIQUEFIED NATURAL GAS (U.S. CLS. 1, 6 AND 15). DAVID C. REIHNER, EXAMINING ATTORNEY

SN 77-666,268. BP P.L.C., LONDON SW1Y 4PD, UNITED KINGDOM, FILED 2-9-2009.



OWNER OF U.S. REG. NOS. 928,078, 1,854,364 AND OTHERS. NO CLAIM IS MADE TO THE EXCLUSIVE RIGHT TO USE "DIESEL", APART FROM THE MARK AS SHOWN. THE MARK CONSISTS OF "BP" DIESEL. FOR DIESEL FUEL (U.S. CLS. 1, 6 AND 15). EMILY CHUO, EXAMINING ATTORNEY

CLASS 4—(Continued).

SN 77-671,662. MVP GROUP INTERNATIONAL, INC.,
CHARLESTON, SC. FILED 2-17-2009.

CLASS 5—PHARMACEUTICALS

SN 76-690,023. WEDGEWOOD VILLAGE PHARMACY, INC.,
SWEDESBORO, NJ. FILED 5-27-2008.

SWEET INDULGENCE

THE MARK CONSISTS OF STANDARD CHARACTERS
WITHOUT CLAIM TO ANY PARTICULAR FONT, STYLE,
SIZE, OR COLOR.

FOR CANDLES (U.S. CLS. 1, 6 AND 15).
REBECCA POVARCHUK, EXAMINING ATTORNEY

 The logo for "Twist-a-Dose" features the brand name in a bold, italicized, sans-serif font. The letters "S" and "T" in "Twist" are partially enclosed by a curved line that loops around them. A similar curved line is positioned above the "I" in "Dose", suggesting a continuous shape that might represent a pill or a specific packaging element.

SN 78-836,757. RENEWAFUEL, LLC, ROSEMOUNT, MN.
FILED 3-14-2006.

RENEWAFUEL

THE MARK CONSISTS OF STANDARD CHARACTERS
WITHOUT CLAIM TO ANY PARTICULAR FONT, STYLE,
SIZE, OR COLOR.

FOR RENEWABLE BIOMASS-BASED SOLID FUELS
FOR USE IN INDUSTRIAL AND INSTITUTIONAL
SOLID-FUEL BOILERS AND PROCESS HEATERS; RENEWABLE
COMPOSITE BIOMASS SOLID FUEL PELLETS FOR USE IN
INDUSTRIAL AND INSTITUTIONAL SOLID-FUEL BOILERS
AND PROCESS HEATERS; RENEWABLE BIOMASS
FEEDSTOCK IN THE NATURE OF PELLETS OF
COMPRESSED FIBER MANUFACTURED FROM A PLANT
CROP TO BE USED AS FUEL IN INDUSTRIAL AND
INSTITUTIONAL SOLID-FUEL BOILERS AND PROCESS
HEATERS (U.S. CLS. 1, 6 AND 15).
MICHAEL TANNER, EXAMINING ATTORNEY

THE MARK CONSISTS OF THE WORDING "TWIST-A-
DOSE" WITH CURVED LINES SURROUNDING THE LET-
TERS "ST" AND A PORTION OF THE CURVED LINES
FORMING THE LETTER "I".

FOR VETERINARY PHARMACEUTICAL PREPARA-
TIONS FOR DOGS AND CATS AND OTHER HOUSE-
HOLD DOMESTIC ANIMALS FOR THE TREATMENT
OF HYPERTENSION, KIDNEY DISEASE, CHRONIC
RENAL FAILURE, ALLERGIES, BACTERIAL INFEC-
TIONS, DISORDERS OF THE GASTROINTESTINAL
TRACT, DIGESTIVE DISORDERS, ULCERS, GASTRO-
INTESTINAL TRACT MOTILITY DISORDERS, NAU-
SEA, VOMITING, HYPERTHYROIDISM, TYPE II
DIABETES, ADDISON'S DISEASE, ARTHRITIS, AUTO-
IMMUNE DISEASES, SEPARATION ANXIETY, ANXI-
ETY, PHOBIAS, OBSESSIVE COMPULSIVE DISORDERS,
URINE SPRAYING AND URINATING OUTSIDE LIT-
TER BOX, HEART CONDITIONS, HEART DISEASE,
ENLARGED HEARTS, HEART FAILURE AND CON-
GESTIVE HEART FAILURE; VETERINARY PHARMA-
CEUTICAL PREPARATIONS FOR DOGS AND CATS,
NAMELY, ANTI-DEPRESSANTS, ANTI-INFLAMMA-
TORY MEDICATIONS, MUSCLE RELAXANTS,
BRONCHODILATORS, AND PAIN RELIEVERS; VETERI-
NARY PHARMACEUTICAL PREPARATIONS FOR
HORSES FOR THE TREATMENT OF FOR THE TREAT-
MENT OF DISORDERS OF THE GASTROINTESTINAL
TRACT, BACTERIAL INFECTONS, GASTROINTESTINAL
MOTILITY DISORDERS, NAUSEA AND VOMIT-
ING; VETERINARY PHARMACEUTICAL
PREPARATIONS FOR HORSES, NAMELY, MUSCLE
RELAXANTS AND ANTI-INFLAMMATORY MEDICA-
TIONS; ALL OF THE FOREGOING SOLD IN A CON-
TAINER/DISPENSER WHICH SERVES AS PACKAGING
FOR GOODS AND FURTHER ALLOWS INDIVIDUAL
DOSES TO BE ADMINISTERED TO ANIMALS (U.S. CLS.
6, 18, 44, 46, 51 AND 52).

FIRST USE 9-17-2007; IN COMMERCE 9-17-2007.
JOHN SCHUYLER YARD, EXAMINING ATTORNEY

CLASS 5—(Continued).

SN 76-690,024. WEDGEWOOD VILLAGE PHARMACY, INC., SWEDESBORO, NJ. FILED 5-27-2008.

GOURMEDS

THE MARK CONSISTS OF STANDARD CHARACTERS WITHOUT CLAIM TO ANY PARTICULAR FONT, STYLE, SIZE, OR COLOR.

FOR VETERINARY PHARMACEUTICAL PREPARATIONS FOR DOGS, CATS AND OTHER HOUSEHOLD DOMESTIC ANIMALS FOR THE TREATMENT OF HYPERTENSION, DISORDERS OF THE GASTROINTESTINAL TRACT, OBSESSIVE COMPULSIVE DISORDERS AND SEPARATION ANXIETY, URINARY INCONTINENCE IN SPAYED FEMALES, HYPERTHYROIDISM, PROTOZOAL AND ANAEROBIC BACTERIAL INFECTIONS AND PITUITARY DEPENDANT HYPERADRENOCORTICISM; VETERINARY PHARMACEUTICAL PREPARATIONS FOR DOGS, CATS AND OTHER HOUSEHOLD DOMESTIC ANIMALS, NAMELY, TRANQUILIZERS, SEDATIVES AND ANTI-ANXIETY MEDICATIONS, GENERAL PURPOSE ANTIBIOTICS, MUSCLE RELAXANTS AND ANTI-INFLAMMATORY MEDICATIONS; VETERINARY PHARMACEUTICAL PREPARATIONS FOR HORSES FOR THE TREATMENT OF DISORDERS OF THE GASTROINTESTINAL TRACT, PROTOZOAL AND ANAEROBIC BACTERIAL INFECTIONS, AND PITUITARY DEPENDANT HYPERADRENOCORTICISM; VETERINARY PHARMACEUTICAL PREPARATIONS FOR HORSES, NAMELY, TRANQUILIZERS, SEDATIVES AND ANTI-ANXIETY MEDICATIONS, GENERAL PURPOSE ANTIBIOTICS, MUSCLE RELAXANTS AND ANTI-INFLAMMATORY MEDICATIONS (U.S. CLS. 6, 18, 44, 46, 51 AND 52).

FIRST USE 1-17-2007; IN COMMERCE 1-17-2007.
JOHN SCHUYLER YARD, EXAMINING ATTORNEY

CLASS 5—(Continued).

SN 76-690,028. WEDGEWOOD VILLAGE PHARMACY, INC., SWEDESBORO, NJ. FILED 5-27-2008.

TWIST-A-DOSE

THE MARK CONSISTS OF STANDARD CHARACTERS WITHOUT CLAIM TO ANY PARTICULAR FONT, STYLE, SIZE, OR COLOR.

FOR VETERINARY PHARMACEUTICAL PREPARATIONS FOR DOGS AND CATS AND OTHER HOUSEHOLD DOMESTIC ANIMALS FOR THE TREATMENT OF HYPERTENSION, KIDNEY DISEASE, CHRONIC RENAL FAILURE, ALLERGIES, BACTERIAL INFECTIONS, DISORDERS OF THE GASTROINTESTINAL TRACT, DIGESTIVE DISORDERS, ULCERS, GASTROINTESTINAL TRACT MOTILITY DISORDERS, NAUSEA, VOMITING, HYPERTHYROIDISM, TYPE II DIABETES, ADDISON'S DISEASE, ARTHRITIS, AUTOIMMUNE DISEASES, SEPARATION ANXIETY, ANXIETY, PHOBIAS, OBSESSIVE COMPULSIVE DISORDERS, URINE SPRAYING AND URINATING OUTSIDE LITTER BOX, HEART CONDITIONS, HEART DISEASE, ENLARGED HEARTS, HEART FAILURE AND CONGESTIVE HEART FAILURE; VETERINARY PHARMACEUTICAL PREPARATIONS FOR DOGS AND CATS, NAMELY, ANTI-DEPRESSANTS, ANTI-INFLAMMATORY MEDICATIONS, MUSCLE RELAXANTS, BRONCHODILATORS, AND PAIN RELIEVERS; VETERINARY PHARMACEUTICAL PREPARATIONS FOR HORSES FOR THE TREATMENT OF FOR THE TREATMENT OF DISORDERS OF THE GASTROINTESTINAL TRACT, BACTERIAL INFECTIONS, GASTROINTESTINAL MOTILITY DISORDERS, NAUSEA AND VOMITING; VETERINARY PHARMACEUTICAL PREPARATIONS FOR HORSES, NAMELY, MUSCLE RELAXANTS AND ANTI-INFLAMMATORY MEDICATIONS; ALL OF THE FOREGOING SOLD IN A CONTAINER/DISPENSER WHICH SERVES AS PACKAGING FOR GOODS AND FURTHER ALLOWS INDIVIDUAL DOSES TO BE ADMINISTERED TO ANIMALS (U.S. CLS. 6, 18, 44, 46, 51 AND 52).

FIRST USE 9-17-2007; IN COMMERCE 9-17-2007.
JOHN SCHUYLER YARD, EXAMINING ATTORNEY

SN 76-690,654. FERRANTE, RALPH M., UPPER GRANDVIEW, NY. FILED 6-19-2008.

BIIDS

THE MARK CONSISTS OF STANDARD CHARACTERS WITHOUT CLAIM TO ANY PARTICULAR FONT, STYLE, SIZE, OR COLOR.

FOR DIETARY SUPPLEMENTS, NUTRITIONAL SUPPLEMENTS AND VITAMIN SUPPLEMENTS (U.S. CLS. 6, 18, 44, 46, 51 AND 52).

LOURDES AYALA, EXAMINING ATTORNEY

CLASS 5—(Continued).

SN 77-059,662. INTERHEALTH BIOSCIENCES PTY LTD, BURLEIGH, QUEENSLAND, AUSTRALIA, FILED 12-7-2006.



PRIORITY CLAIMED UNDER SEC. 44(D) ON AUSTRALIA APPLICATION NO. 1138176, FILED 9-29-2006, REG. NO. 1138176, DATED 9-29-2006, EXPIRES 9-29-2016.

THE MARK CONSISTS OF "IBA" AND 3 LEAF DEVICE. FOR NUTRACEUTICALS FOR USE AS A DIETARY SUPPLEMENT; PHARMACEUTICAL AND NUTRACEUTICAL PRODUCTS FOR THE TREATMENT OF OSTEO ARTHRITIS, JOINT PAIN, AND FOR PROSTATE FUNCTION; TOPICAL MEDICAMENTS FOR THE TREATMENT OF OSTEO ARTHRITIS AND JOINT PAIN; HERBAL REMEDIES, NAMELY, HERBAL TEAS FOR MEDICAL PURPOSES; MEDICAL HERBS IN DRIED OR PRESERVED FORM; ALL OF THE AFOREMENTIONED GOODS FOR HUMANS (U.S. CLS. 6, 18, 44, 46, 51 AND 52).

ANNE FARRELL, EXAMINING ATTORNEY

SN 77-155,960. ALLMAX NUTRITION INC., ONTARIO, CANADA, FILED 4-13-2007.

ISOFLEX

THE MARK CONSISTS OF STANDARD CHARACTERS WITHOUT CLAIM TO ANY PARTICULAR FONT, STYLE, SIZE, OR COLOR.

OWNER OF CANADA REG. NO. 1338708, DATED 12-8-2008, EXPIRES 12-8-2023.

FOR PROTEIN POWDERED DRINK MIX, PROTEIN BARS, AND PROTEIN DRINKS USED AS MEAL REPLACEMENTS (U.S. CLS. 6, 18, 44, 46, 51 AND 52).

SANDRA MANIOS, EXAMINING ATTORNEY

SN 77-318,709. AJINOMOTO AMINOSCIENCE LLC, RALEIGH, NC. FILED 11-1-2007.

CORYNEX

THE MARK CONSISTS OF STANDARD CHARACTERS WITHOUT CLAIM TO ANY PARTICULAR FONT, STYLE, SIZE, OR COLOR.

FOR NUTRITIONAL SUPPLEMENTS (U.S. CLS. 6, 18, 44, 46, 51 AND 52).

LINDA M. KING, EXAMINING ATTORNEY

CLASS 5—(Continued).

SN 77-392,630. NUTRAGENESIS, LLC, BRATTLEBORO, VT. FILED 2-8-2008.

SENDARA

THE MARK CONSISTS OF STANDARD CHARACTERS WITHOUT CLAIM TO ANY PARTICULAR FONT, STYLE, SIZE, OR COLOR.

THE MARK "SENDARA" HAS NO MEANING IN A FOREIGN LANGUAGE.

FOR BOTANICAL-BASED NUTRITIONAL FUNCTIONAL ADDITIVES FOR USE IN DIETARY SUPPLEMENTS, FOODS AND BEVERAGES FOR THE PURPOSE OF SKIN HEALTH, INFLAMMATORY RESPONSE, ANTI-OXIDANT ACTIVITY, STRESS REDUCTION AND MOOD ENHANCEMENT (U.S. CLS. 6, 18, 44, 46, 51 AND 52).

ALLISON HOLTZ, EXAMINING ATTORNEY

SN 77-416,209. LRC PRODUCTS LIMITED, LONDON, ENGLAND, FILED 3-7-2008.

QUIVER

THE MARK CONSISTS OF STANDARD CHARACTERS WITHOUT CLAIM TO ANY PARTICULAR FONT, STYLE, SIZE, OR COLOR.

FOR WATER-BASED PERSONAL LUBRICANTS; HYGIENIC PREPARATIONS, NAMELY, HYGIENIC LUBRICANTS IN THE FORM OF LIQUIDS AND GELS FOR USE IN THE AREA OF THE VAGINA, ANUS AND PENIS; WATER-BASED PERSONAL LUBRICANT FOR FREEZING (U.S. CLS. 6, 18, 44, 46, 51 AND 52).

BILL DAWE, EXAMINING ATTORNEY

SN 77-489,953. ANUTRA FARMS ACQUISITION, INC., ORLANDO, FL. FILED 6-3-2008.

NATURE'S HEALTHIEST WHOLE FOOD

THE MARK CONSISTS OF STANDARD CHARACTERS WITHOUT CLAIM TO ANY PARTICULAR FONT, STYLE, SIZE, OR COLOR.

FOR DIETARY AND NUTRITIONAL SUPPLEMENTS (U.S. CLS. 6, 18, 44, 46, 51 AND 52).

KARANENDRA S. CHHINA, EXAMINING ATTORNEY

CLASS 5—(Continued).

SN 77-497,371. HISAMITSU PHARMACEUTICAL CO., INC., TOSU-SHI, SAGA, JAPAN, FILED 6-12-2008.

COMFORT STRETCH TECHNOLOGY

THE MARK CONSISTS OF STANDARD CHARACTERS WITHOUT CLAIM TO ANY PARTICULAR FONT, STYLE, SIZE, OR COLOR.

NO CLAIM IS MADE TO THE EXCLUSIVE RIGHT TO USE "STRETCH TECHNOLOGY", APART FROM THE MARK AS SHOWN.

FOR MEDICATED TRANSDERMAL PATCHES FOR THE TEMPORARY RELIEF OF ACHES AND PAINS OF MUSCLES AND JOINTS ASSOCIATED WITH ARTHRITIS, SIMPLE BACKACHES, STRAINS, BRUISES AND SPRAINS (U.S. CLS. 6, 18, 44, 46, 51 AND 52).

WENDY GOODMAN, EXAMINING ATTORNEY

SN 77-497,381. HISAMITSU PHARMACEUTICAL CO., INC., TOSU-SHI, SAGA, JAPAN, FILED 6-12-2008.

COMFORT STRETCH

THE MARK CONSISTS OF STANDARD CHARACTERS WITHOUT CLAIM TO ANY PARTICULAR FONT, STYLE, SIZE, OR COLOR.

NO CLAIM IS MADE TO THE EXCLUSIVE RIGHT TO USE "STRETCH", APART FROM THE MARK AS SHOWN.

FOR MEDICATED TRANSDERMAL PATCHES FOR THE TEMPORARY RELIEF OF ACHES AND PAINS OF MUSCLES AND JOINTS ASSOCIATED WITH ARTHRITIS, SIMPLE BACKACHES, STRAINS, BRUISES AND SPRAINS (U.S. CLS. 6, 18, 44, 46, 51 AND 52).

FIRST USE 9-0-2008; IN COMMERCE 9-0-2008.
WENDY GOODMAN, EXAMINING ATTORNEY

CLASS 5—(Continued).

SN 77-516,769. N.V. NUTRICIA, ZOETERMEER, NETHERLANDS, FILED 7-8-2008.

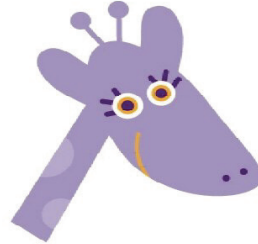

PRIORITY CLAIMED UNDER SEC. 44(D) ON BENELUX APPLICATION NO. 1151787, FILED 1-24-2008, REG. NO. 0838569, DATED 2-19-2008, EXPIRES 2-19-2018.

THE COLOR(S) ORANGE, PURPLE AND WHITE IS/ARE CLAIMED AS A FEATURE OF THE MARK.

THE MARK CONSISTS OF A REPRESENTATION OF A HEAD OF A GIRAFFE IN PURPLE WITH LIGHTER SHADES OF PURPLE ON THE NECK, ORANGE, WHITE AND DARKER PURPLE EYES, ORANGE MOUTH AND DARKER PURPLE NOSE.

FOR DIETETIC FOODS ADAPTED FOR MEDICAL USE; FORTIFYING FOOD FOR MEDICAL USE, NAMELY, FOOD FOR BABIES, INFANTS, CHILDREN, ADULTS, ELDERLY PEOPLE, PEOPLE WITH MEDICAL CONDITIONS, PEOPLE WITH DISEASES AND INVALIDS; NUTRITIONAL DIETARY SUPPLEMENTS FOR MEDICAL USE (U.S. CLS. 6, 18, 44, 46, 51 AND 52).

KIMBERLY PERRY, EXAMINING ATTORNEY

SN 77-520,237. SEQUELLA, INC., ROCKVILLE, MD. FILED 7-11-2008.

B-SMART

THE MARK CONSISTS OF STANDARD CHARACTERS WITHOUT CLAIM TO ANY PARTICULAR FONT, STYLE, SIZE, OR COLOR.

FOR MEDICAL DIAGNOSTIC TEST KIT FOR DIAGNOSIS OF INFECTIOUS DISEASES AND FOR EVALUATING DRUG SUSCEPTIBILITY THERETO CONSISTING PRIMARILY OF NUCLEIC ACID SEQUENCES, BUFFERS AND REAGENTS (U.S. CLS. 6, 18, 44, 46, 51 AND 52).

DANIEL CAPSHAW, EXAMINING ATTORNEY

CLASS 5—(Continued).

SN 77-523,410. OPTIMER PHARMACEUTICALS, SAN DIEGO, CA. FILED 7-16-2008.

PRUVEL

THE MARK CONSISTS OF STANDARD CHARACTERS WITHOUT CLAIM TO ANY PARTICULAR FONT, STYLE, SIZE, OR COLOR.

THE WORDING "PRUVEL" HAS NO MEANING IN A FOREIGN LANGUAGE.

FOR MEDICINES FOR HUMAN PURPOSES, NAMELY, ANTI-INFECTIVE DRUGS (U.S. CLS. 6, 18, 44, 46, 51 AND 52).

BARNEY CHARLON, EXAMINING ATTORNEY

CLASS 5—(Continued).

SN 77-547,220. PACIFIC PHARMACEUTICALS LIMITED, AUCKLAND, NEW ZEALAND, FILED 8-14-2008.

HEADWAY

THE MARK CONSISTS OF STANDARD CHARACTERS WITHOUT CLAIM TO ANY PARTICULAR FONT, STYLE, SIZE, OR COLOR.

FOR PHARMACEUTICAL PREPARATIONS, NAMELY, PREPARATIONS FOR PROMOTING HAIR GROWTH AND/OR REDUCING HAIR LOSS (U.S. CLS. 6, 18, 44, 46, 51 AND 52).

FIRST USE 12-7-2003; IN COMMERCE 12-7-2003.

ERNEST SHOSHO, EXAMINING ATTORNEY

SN 77-536,796. MONSANTO TECHNOLOGY LLC, SAINT LOUIS, MO. FILED 8-1-2008.

ACCELERON

THE MARK CONSISTS OF STANDARD CHARACTERS WITHOUT CLAIM TO ANY PARTICULAR FONT, STYLE, SIZE, OR COLOR.

FOR CHEMICAL PREPARATIONS FOR THE TREATMENT OF SEEDS, NAMELY, FUNGICIDES, INSECTICIDES AND NEMATOCIDES (U.S. CLS. 6, 18, 44, 46, 51 AND 52).

MAYUR VAGHANI, EXAMINING ATTORNEY

SN 77-547,284. OVOS NATURAL HEALTH INC., LAVAL, QC, CANADA, FILED 8-14-2008.

VIVIMIND

THE MARK CONSISTS OF STANDARD CHARACTERS WITHOUT CLAIM TO ANY PARTICULAR FONT, STYLE, SIZE, OR COLOR.

PRIORITY CLAIMED UNDER SEC. 44(D) ON CANADA APPLICATION NO. 1384574, FILED 2-22-2008.

FOR DIETARY AND NUTRITIONAL SUPPLEMENTS, NAMELY, VITAMIN, HERBAL AND MINERAL SUPPLEMENTS IN POWDER, CAPSULE, TABLET AND LIQUID FORM; DIETARY SUPPLEMENTS, NAMELY, AMINO ACIDS, FIBRE, PROBIOTICS, ENZYME, PROTEIN SUPPLEMENTS IN POWDER, CAPSULE, TABLET, AND LIQUID FORM (U.S. CLS. 6, 18, 44, 46, 51 AND 52).

ELIZABETH KAJUBI, EXAMINING ATTORNEY

SN 77-540,407. Z-MEDICA CORPORATION, WALLINGFORD, CT. FILED 8-6-2008.

QUIKCLOT EMERGENCY DRESSING

THE MARK CONSISTS OF STANDARD CHARACTERS WITHOUT CLAIM TO ANY PARTICULAR FONT, STYLE, SIZE, OR COLOR.

OWNER OF U.S. REG. NOS. 2,798,757, 3,406,191 AND OTHERS.

NO CLAIM IS MADE TO THE EXCLUSIVE RIGHT TO USE "EMERGENCY DRESSING", APART FROM THE MARK AS SHOWN.

FOR CHEMICALS THAT AID IN THE COAGULATION OF BLOOD FOR HUMAN MEDICINAL USE (U.S. CLS. 6, 18, 44, 46, 51 AND 52).

KELLEY WELLS, EXAMINING ATTORNEY

SN 77-552,747. MONSANTO TECHNOLOGY LLC, SAINT LOUIS, MO. FILED 8-21-2008.



THE MARK CONSISTS OF THE WORD "ACCELERON" IN CAPITAL LETTERS BETWEEN TWO BROKEN PARALLEL LINES WITH A LEAF DESIGN ABOVE THE "L" AND A DIAMOND DESIGN BELOW THE "L" IN THE WORD "ACCELERON".

FOR CHEMICAL PREPARATIONS FOR THE TREATMENT OF SEEDS, NAMELY, FUNGICIDES, INSECTICIDES, AND NEMATOCIDES (U.S. CLS. 6, 18, 44, 46, 51 AND 52).

MAYUR VAGHANI, EXAMINING ATTORNEY

CLASS 5—(Continued).

SN 77-553,909. HERO AG, LENZBURG, SWITZERLAND, FILED 8-22-2008.

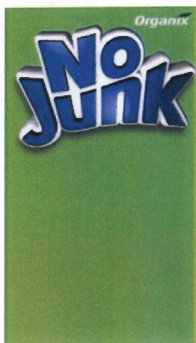

NO CLAIM IS MADE TO THE EXCLUSIVE RIGHT TO USE "ORGANIX", APART FROM THE MARK AS SHOWN. THE COLOR(S) GREEN, BLUE, WHITE, GREY AND BLACK IS/ARE CLAIMED AS A FEATURE OF THE MARK. THE MARK CONSISTS OF THE COLOR GREEN WHICH APPEARS IN THE BACKGROUND; THE COLOR BLUE WHICH APPEARS IN THE WORDING "NO JUNK"; THE COLOR WHITE WHICH APPEARS IN THE OUTLINE OF THE WORDING "NO JUNK" AND IN THE WORDING "ORGANIX"; THE COLOR GREY WHICH APPEARS IN THE SHADOWING AROUND THE WORDING "NO JUNK"; AND THE COLOR BLACK WHICH APPEARS IN THE DESIGN OVER THE LETTERS "IX" IN THE WORDING "ORGANIX". FOR BABY AND INFANT FOODS, DRINKS FOR BABIES AND INFANTS, NAMELY, NUTRITIONALLY FORTIFIED BEVERAGES, ALL ORGANIC (U.S. CLS. 6, 18, 44, 46, 51 AND 52).
ALEX KEAM, EXAMINING ATTORNEY

SN 77-596,949. TRINITY LABORATORIES, INC., SAN ANTONIO, TX. FILED 10-21-2008.

PALOXIN

THE MARK CONSISTS OF STANDARD CHARACTERS WITHOUT CLAIM TO ANY PARTICULAR FONT, STYLE, SIZE, OR COLOR. FOR PHARMACEUTICAL PREPARATIONS IN THE NATURE OF A TOPICAL GEL FOR THE TREATMENT OF PAIN (U.S. CLS. 6, 18, 44, 46, 51 AND 52).
LESLIE RICHARDS, EXAMINING ATTORNEY

CLASS 5—(Continued).

SN 77-597,926. WYETH, MADISON, NJ. FILED 10-22-2008.

**NEVER LET YOUR LIPS GO
NAKED**

THE MARK CONSISTS OF STANDARD CHARACTERS WITHOUT CLAIM TO ANY PARTICULAR FONT, STYLE, SIZE, OR COLOR. FOR MEDICATED LIP BALM (U.S. CLS. 6, 18, 44, 46, 51 AND 52).
KELLY CHOE, EXAMINING ATTORNEY

SN 77-606,889. BAYER HEALTHCARE LLC, PITTSBURGH, PA. FILED 11-4-2008.

CAMPHO-PHENIQUE

THE MARK CONSISTS OF STANDARD CHARACTERS WITHOUT CLAIM TO ANY PARTICULAR FONT, STYLE, SIZE, OR COLOR. OWNER OF U.S. REG. NOS. 1,251,488 AND 1,510,656. FOR ANTISEPTIC PREPARATIONS; PREPARATION FOR THE RELIEF OF PAIN (U.S. CLS. 6, 18, 44, 46, 51 AND 52).
FIRST USE 2-29-1884; IN COMMERCE 2-29-1884.
REBECCA POVARCHUK, EXAMINING ATTORNEY

SN 77-618,256. AMGEN INC., THOUSAND OAKS, CA. FILED 11-20-2008.

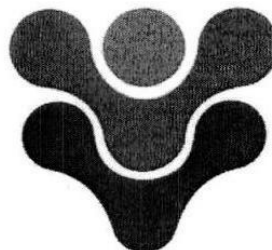

THE MARK CONSISTS OF A STYLIZED MOLECULAR STRUCTURE. FOR PHARMACEUTICAL PREPARATIONS FOR THE TREATMENT OF BONE DISEASE (U.S. CLS. 6, 18, 44, 46, 51 AND 52).
AMY ALFIERI, EXAMINING ATTORNEY

CLASS 5—(Continued).

SN 77-619,461. TOPICA PHARMACEUTICALS, INC., PALO ALTO, CA. FILED 11-21-2008.

SOLUTIONS BEYOND THE SURFACE

THE MARK CONSISTS OF STANDARD CHARACTERS WITHOUT CLAIM TO ANY PARTICULAR FONT, STYLE, SIZE, OR COLOR.

FOR DERMATOLOGICAL PHARMACEUTICAL PRODUCTS; ANTI-FUNGAL PREPARATIONS FOR MEDICAL USE (U.S. CLS. 6, 18, 44, 46, 51 AND 52).
TINA BROWN, EXAMINING ATTORNEY

SN 77-621,037. AMES, PHILIP, NORTH HOLLYWOOD, CA. FILED 11-24-2008.

CONTACT CLEANSE

THE MARK CONSISTS OF STANDARD CHARACTERS WITHOUT CLAIM TO ANY PARTICULAR FONT, STYLE, SIZE, OR COLOR.

NO CLAIM IS MADE TO THE EXCLUSIVE RIGHT TO USE "CLEANSE", APART FROM THE MARK AS SHOWN.
FOR HAND SANITIZING ANTI-BACTERIAL LOTIONS, GELS AND FOAMS (U.S. CLS. 6, 18, 44, 46, 51 AND 52).
JENNY PARK, EXAMINING ATTORNEY

CLASS 5—(Continued).

SN 77-625,467. AMERICAN CHINESE NATURAL HERBS, INC., GARLAND, TX. FILED 12-3-2008.



OWNER OF U.S. REG. NO. 2,715,546.
NO CLAIM IS MADE TO THE EXCLUSIVE RIGHT TO USE "NATURAL HERBS" AND "HEALTH FOOD", APART FROM THE MARK AS SHOWN.

THE MARK CONSISTS OF TWO CONCENTRIC CIRCLES, THE OUTER ONE BEING A THICK CIRCLE, THE INNER ONE BEING A THIN CIRCLE; THE WORDS "AMERICAN CHINESE NATURAL HERBS HEALTH FOOD" TYPED AROUND THE INSIDE THE SMALLER CIRCLE; THE CENTER OF THE DESIGN HAVING A FLOWER SHAPE WITH THE CHINESE SYMBOL FOR THE WORD DUONG INSIDE IT.

THE CHINESE CHARACTERS IN THE MARK TRANSLITERATE TO DUONG, AND THIS HAS THE MEANING ONLY OF A SURNAME IN ENGLISH.

SEC. 2(F) AS TO "AMERICAN CHINESE".
FOR HERBAL SUPPLEMENTS (U.S. CLS. 6, 18, 44, 46, 51 AND 52).

FIRST USE 6-1-1992; IN COMMERCE 6-1-1992.
ELLEN B. AWRICH, EXAMINING ATTORNEY

SN 77-630,504. INDOOR AIR PROFESSIONALS, INC., LANCASTER, NY. FILED 12-10-2008.

KANBERRA GEL

THE MARK CONSISTS OF STANDARD CHARACTERS WITHOUT CLAIM TO ANY PARTICULAR FONT, STYLE, SIZE, OR COLOR.

NO CLAIM IS MADE TO THE EXCLUSIVE RIGHT TO USE "GEL", APART FROM THE MARK AS SHOWN.
FOR AIR DEODERIZER AND AIR PURIFYING PREPARATIONS (U.S. CLS. 6, 18, 44, 46, 51 AND 52).
FIRST USE 4-1-2008; IN COMMERCE 4-1-2008.
ALICE BENMAMAN, EXAMINING ATTORNEY

CLASS 5—(Continued).

SN 77-636,235. GENERAL ELECTRIC COMPANY, SCHE-
NECTADY, NY. FILED 12-18-2008.

INNOVATION YOU DON'T HAVE
TO WAIT FOR

THE MARK CONSISTS OF STANDARD CHARACTERS
WITHOUT CLAIM TO ANY PARTICULAR FONT, STYLE,
SIZE, OR COLOR.

FOR PHARMACEUTICAL PREPARATIONS FOR USE
IN MEDICAL DIAGNOSIS OF DISEASES AND CONDI-
TIONS IN HUMANS; VETERINARY PHARMACEUTI-
CAL PREPARATIONS FOR USE IN VETERINARY
DIAGNOSIS OF DISEASES AND CONDITIONS IN ANI-
MALS; PHARMACEUTICAL AND VETERINARY SUB-
STANCES FOR MEDICAL PURPOSES; DIAGNOSTIC
REAGENTS AND PREPARATIONS FOR MEDICAL PUR-
POSES; DIAGNOSTIC SUBSTANCES FOR MEDICAL
PURPOSES; CONTRAST MEDIA FOR MEDICAL IMA-
GING; DIAGNOSTIC SCANNING AGENTS FOR IN
VIVO USE; DIAGNOSTIC IMAGING AGENTS FOR
MAGNETIC RESONANCE IMAGING; RADIOPHARMA-
CEUTICAL PRODUCTS FOR CLINICAL, MEDICAL,
SCIENTIFIC AND RESEARCH USE; RADIOPHARMA-
CEUTICAL SOURCES AND STANDARDS FOR USE IN
NUCLEAR MEDICINE; RADIOACTIVE PHARMACEU-
TICAL PREPARATIONS AND NON-RADIOACTIVE RE-
AGENTS FOR PRODUCING
RADIOPHARMACEUTICALS FOR IN VIVO DIAGNOS-
TIC OR THERAPEUTIC USE; GASES AND GAS MIX-
TURES FOR MEDICAL IMAGING; PRE-FILLED VIALS
CONTAINING MEDICAL DIAGNOSTIC REAGENTS;
PRE-FILLED CYLINDERS CONTAINING GASES AND
GAS MIXTURES FOR MEDICAL USE (U.S. CLS. 6, 18, 44,
46, 51 AND 52).

PAUL F. GAST, EXAMINING ATTORNEY

SN 77-637,587. ASB SPORTS NUTRITION, DBA ALLSTAR-
BODY SPORTS NUTRITION, MIAMI, FL. FILED 12-22-
2008.



NO CLAIM IS MADE TO THE EXCLUSIVE RIGHT TO
USE "BIO-ENGINEERED PERFORMANCE" AND "SPORTS
NUTRITION", APART FROM THE MARK AS SHOWN.

THE MARK CONSISTS OF THE LETTERS "ASB" ON
SWIRL DESIGNS, WHICH CONTAIN ZIG-ZAG LINES. THE
TERM "BIO-ENGINEERED PERFORMANCE" IS ABOVE
THE SWIRL DESIGNS AND A RECTANGULAR BOX
APPEARS ON THE BOTTOM OF THE SWIRL DESIGNS
CONTAINING THE TERM "SPORTS NUTRITION."

FOR DIETARY AND NUTRITIONAL SUPPLEMENTS
(U.S. CLS. 6, 18, 44, 46, 51 AND 52).

FIRST USE 12-15-2008; IN COMMERCE 12-15-2008.

TARA PATE, EXAMINING ATTORNEY

CLASS 5—(Continued).

SN 77-640,788. WELLNESS RESOURCES, INC., MINNEAPO-
LIS, MN. FILED 12-29-2008.

SLEEP HELPER

THE MARK CONSISTS OF STANDARD CHARACTERS
WITHOUT CLAIM TO ANY PARTICULAR FONT, STYLE,
SIZE, OR COLOR.

NO CLAIM IS MADE TO THE EXCLUSIVE RIGHT TO
USE "SLEEP", APART FROM THE MARK AS SHOWN.

FOR DIETARY AND NUTRITIONAL SUPPLEMENTS
(U.S. CLS. 6, 18, 44, 46, 51 AND 52).

FIRST USE 10-15-2008; IN COMMERCE 10-15-2008.

ANNE MADDEN, EXAMINING ATTORNEY

SN 77-641,595. GEORGE XU, FLUSHING, NY. FILED 12-30-
2008.

ArthroHeal

THE MARK CONSISTS OF STANDARD CHARACTERS
WITHOUT CLAIM TO ANY PARTICULAR FONT, STYLE,
SIZE, OR COLOR.

FOR MEDICINAL HERBAL EXTRACTS FOR MEDI-
CAL PURPOSES (U.S. CLS. 6, 18, 44, 46, 51 AND 52).

FIRST USE 5-1-2008; IN COMMERCE 5-1-2008.

BRENDAN REGAN, EXAMINING ATTORNEY

SN 77-645,203. ABBOTT LABORATORIES, ABBOTT PARK,
IL. FILED 1-7-2009.

STRONGBABIES SYSTEM

THE MARK CONSISTS OF STANDARD CHARACTERS
WITHOUT CLAIM TO ANY PARTICULAR FONT, STYLE,
SIZE, OR COLOR.

OWNER OF U.S. REG. NO. 3,420,209.

FOR INFANT FORMULA, ELECTROLYTE SOLU-
TIONS, AND NUTRITIONAL SUPPLEMENTS (U.S. CLS.
6, 18, 44, 46, 51 AND 52).

DANNEAN HETZEL, EXAMINING ATTORNEY

CLASS 5—(Continued).

SN 77-656,340. WHITE, WAYNE, SANTA CLAUS, IN. FILED 1-26-2009.

THE PENIS DIAPER

THE MARK CONSISTS OF STANDARD CHARACTERS WITHOUT CLAIM TO ANY PARTICULAR FONT, STYLE, SIZE, OR COLOR.

NO CLAIM IS MADE TO THE EXCLUSIVE RIGHT TO USE "DIAPER", APART FROM THE MARK AS SHOWN.

FOR INCONTINENCE GARMENTS (U.S. CLS. 6, 18, 44, 46, 51 AND 52).

DEZMONA MIZELLE, EXAMINING ATTORNEY

SN 77-657,142. HOFFMANN-LA ROCHE INC., NUTLEY, NJ. FILED 1-27-2009.

EVALRIVE

THE MARK CONSISTS OF STANDARD CHARACTERS WITHOUT CLAIM TO ANY PARTICULAR FONT, STYLE, SIZE, OR COLOR.

FOR PHARMACEUTICAL ONCOLOGY PREPARATION, NAMELY, PHARMACEUTICAL PRODUCTS FOR THE PREVENTION OR TREATMENT OF CANCER (U.S. CLS. 6, 18, 44, 46, 51 AND 52).

SAIMA MAKHDOOM, EXAMINING ATTORNEY

SN 77-657,433. SOUTHERN GROUP ENTERPRISES, LLC, MIAMI, FL. FILED 1-27-2009.

**DETOX^{PM}
ULTIMATE**

NO CLAIM IS MADE TO THE EXCLUSIVE RIGHT TO USE "DETOX PM", APART FROM THE MARK AS SHOWN. FOR DIETARY AND NUTRITIONAL SUPPLEMENTS (U.S. CLS. 6, 18, 44, 46, 51 AND 52).

FIRST USE 12-31-2003; IN COMMERCE 12-31-2003.
GRETTA YAO, EXAMINING ATTORNEY

CLASS 5—(Continued).

SN 77-657,451. SOUTHERN GROUP ENTERPRISES, LLC, MIAMI, FL. FILED 1-27-2009.

**EXPEDRINE
MAX**

OWNER OF U.S. REG. NO. 3,230,320.
FOR DIETARY AND NUTRITIONAL SUPPLEMENTS (U.S. CLS. 6, 18, 44, 46, 51 AND 52).
FIRST USE 12-31-2003; IN COMMERCE 12-31-2003.
GRETTA YAO, EXAMINING ATTORNEY

SN 77-657,472. SOUTHERN GROUP ENTERPRISES, LLC, MIAMI, FL. FILED 1-27-2009.

**MAX
DETOX^{PM}**

NO CLAIM IS MADE TO THE EXCLUSIVE RIGHT TO USE "DETOX PM", APART FROM THE MARK AS SHOWN. FOR DIETARY AND NUTRITIONAL SUPPLEMENTS (U.S. CLS. 6, 18, 44, 46, 51 AND 52).
FIRST USE 12-31-2003; IN COMMERCE 12-31-2003.
GRETTA YAO, EXAMINING ATTORNEY

SN 77-658,072. OTB HOLDINGS, HOUSTON, TX. FILED S.R. 1-28-2009; AM. P.R. 4-27-2009.

Thermophedra

THE MARK CONSISTS OF STANDARD CHARACTERS WITHOUT CLAIM TO ANY PARTICULAR FONT, STYLE, SIZE, OR COLOR.

FOR DIETARY AND NUTRITIONAL SUPPLEMENTS (U.S. CLS. 6, 18, 44, 46, 51 AND 52).

FIRST USE 1-1-2000; IN COMMERCE 6-1-2005.
KATHERINE CHANG, EXAMINING ATTORNEY

CLASS 5—(Continued).

SN 77-658,530. SWEET WHEAT, INC., CLEARWATER, FL. FILED 1-28-2009.

SWEET KID

THE MARK CONSISTS OF STANDARD CHARACTERS WITHOUT CLAIM TO ANY PARTICULAR FONT, STYLE, SIZE, OR COLOR.

NO CLAIM IS MADE TO THE EXCLUSIVE RIGHT TO USE "KID", APART FROM THE MARK AS SHOWN. FOR NUTRITIONAL SUPPLEMENTS (U.S. CLS. 6, 18, 44, 46, 51 AND 52).

FIRST USE 7-31-2000; IN COMMERCE 7-31-2000. FRED CARL, EXAMINING ATTORNEY

CLASS 5—(Continued).

SN 77-659,522. USP LABS, LLC, DALLAS, TX. FILED 1-29-2009.

SUPERCISSUS RX

THE MARK CONSISTS OF STANDARD CHARACTERS WITHOUT CLAIM TO ANY PARTICULAR FONT, STYLE, SIZE, OR COLOR.

NO CLAIM IS MADE TO THE EXCLUSIVE RIGHT TO USE "RX", APART FROM THE MARK AS SHOWN. FOR DIETARY SUPPLEMENTS (U.S. CLS. 6, 18, 44, 46, 51 AND 52).

FIRST USE 12-15-2006; IN COMMERCE 12-15-2006. SUNG IN, EXAMINING ATTORNEY

SN 77-659,019. ME4KIDZ LLC, PHOENIX, AZ. FILED 1-29-2009.

Diaper Bag Buddy

THE MARK CONSISTS OF STANDARD CHARACTERS WITHOUT CLAIM TO ANY PARTICULAR FONT, STYLE, SIZE, OR COLOR.

NO CLAIM IS MADE TO THE EXCLUSIVE RIGHT TO USE "DIAPER BAG", APART FROM THE MARK AS SHOWN.

FOR FIRST AID KITS (U.S. CLS. 6, 18, 44, 46, 51 AND 52).

FIRST USE 11-1-2008; IN COMMERCE 11-1-2008. LINDA ESTRADA, EXAMINING ATTORNEY

SN 77-659,874. D'ADAMO, PETER JAMES, WILTON, CT. FILED 1-30-2009.

**PERSONALIZED NUTRITION
DESIGNED BY DR. PETER
D'ADAMO**

THE MARK CONSISTS OF STANDARD CHARACTERS WITHOUT CLAIM TO ANY PARTICULAR FONT, STYLE, SIZE, OR COLOR.

OWNER OF U.S. REG. NO. 2,368,884.

NO CLAIM IS MADE TO THE EXCLUSIVE RIGHT TO USE "PERSONALIZED NUTRITION DESIGNED BY", APART FROM THE MARK AS SHOWN.

FOR MINERAL SUPPLEMENTS; NUTRITIONAL SUPPLEMENTS; VITAMIN SUPPLEMENTS (U.S. CLS. 6, 18, 44, 46, 51 AND 52).

LAKEISHA LEWIS, EXAMINING ATTORNEY

SN 77-659,070. BIOMED EST., LIECHTENSTEIN, LIECHTENSTEIN, FILED 1-29-2009.

PENTAGUM

THE MARK CONSISTS OF STANDARD CHARACTERS WITHOUT CLAIM TO ANY PARTICULAR FONT, STYLE, SIZE, OR COLOR.

FOR DENTAL IMPRESSION MATERIALS (U.S. CLS. 6, 18, 44, 46, 51 AND 52).

AMY KERTGATE, EXAMINING ATTORNEY

SN 77-660,071. MACHOVINA, KIM, INDIAN ROCKS BEACH, FL. FILED 1-30-2009.

REAL ROOTS USA

THE MARK CONSISTS OF STANDARD CHARACTERS WITHOUT CLAIM TO ANY PARTICULAR FONT, STYLE, SIZE, OR COLOR.

NO CLAIM IS MADE TO THE EXCLUSIVE RIGHT TO USE "USA", APART FROM THE MARK AS SHOWN.

FOR AIR DEODORIZER; AIR FRESHENERS (U.S. CLS. 6, 18, 44, 46, 51 AND 52).

MARTHA FROMM, EXAMINING ATTORNEY

CLASS 5—(Continued).

SN 77-660,734. HOLMS ENTERPRISES INC, LAS VEGAS, NV.
FILED 1-30-2009.

SlimBiotics

THE MARK CONSISTS OF STANDARD CHARACTERS WITHOUT CLAIM TO ANY PARTICULAR FONT, STYLE, SIZE, OR COLOR.

FOR DIET PILLS (U.S. CLS. 6, 18, 44, 46, 51 AND 52).
FIRST USE 9-25-2008; IN COMMERCE 9-25-2008.
JOHN E. MICHOS, EXAMINING ATTORNEY

CLASS 5—(Continued).

SN 77-661,634. FOSTER AND SMITH, INC., RHINELANDER, WI. FILED 2-2-2009.

CRAN HEALTH

THE MARK CONSISTS OF STANDARD CHARACTERS WITHOUT CLAIM TO ANY PARTICULAR FONT, STYLE, SIZE, OR COLOR.

NO CLAIM IS MADE TO THE EXCLUSIVE RIGHT TO USE "HEALTH", APART FROM THE MARK AS SHOWN.
FOR DIETARY SUPPLEMENT FOR ANIMALS (U.S. CLS. 6, 18, 44, 46, 51 AND 52).
ERIN FALK, EXAMINING ATTORNEY

SN 77-661,464. PURE SCIENCE INTERNATIONAL, INC., MISSION VIEJO, CA. FILED 2-2-2009.

SUGARMDRX

THE MARK CONSISTS OF STANDARD CHARACTERS WITHOUT CLAIM TO ANY PARTICULAR FONT, STYLE, SIZE, OR COLOR.

FOR DIETARY SUPPLEMENTS (U.S. CLS. 6, 18, 44, 46, 51 AND 52).
KATHERINE M. DUBRAY, EXAMINING ATTORNEY

SN 77-662,378. CTI SCIENCE, INC., LEXINGTON, KY. FILED 2-3-2009.

OSR#1

THE MARK CONSISTS OF STANDARD CHARACTERS WITHOUT CLAIM TO ANY PARTICULAR FONT, STYLE, SIZE, OR COLOR.

FOR FOOD SUPPLEMENTS, NAMELY, ANTI-OXIDANTS (U.S. CLS. 6, 18, 44, 46, 51 AND 52).
GIANCARLO CASTRO, EXAMINING ATTORNEY

SN 77-661,466. PURE SCIENCE INTERNATIONAL, INC., MISSION VIEJO, CA. FILED 2-2-2009.

PRESSURMDRX

THE MARK CONSISTS OF STANDARD CHARACTERS WITHOUT CLAIM TO ANY PARTICULAR FONT, STYLE, SIZE, OR COLOR.

FOR DIETARY SUPPLEMENTS (U.S. CLS. 6, 18, 44, 46, 51 AND 52).
KATHERINE M. DUBRAY, EXAMINING ATTORNEY

SN 77-662,650. VITANICA LLC, TUALATIN, OR. FILED 2-3-2009.

OSTEOBLEND

THE MARK CONSISTS OF STANDARD CHARACTERS WITHOUT CLAIM TO ANY PARTICULAR FONT, STYLE, SIZE, OR COLOR.

FOR DIETARY SUPPLEMENTS (U.S. CLS. 6, 18, 44, 46, 51 AND 52).
FIRST USE 9-1-1999; IN COMMERCE 9-1-1999.
DAVID TOOLEY, EXAMINING ATTORNEY

CLASS 5—(Continued).

SN 77-662,825. REJUVEN8 LABORATORIES, INC., MISSISSAUGA, CANADA, FILED 2-4-2009.

CLASS 5—(Continued).

SN 77-663,835. CHEMI NUTRA, LLC, WHITE BEAR LAKE, MN. FILED 2-5-2009.

Weedphyter

THE MARK CONSISTS OF STANDARD CHARACTERS WITHOUT CLAIM TO ANY PARTICULAR FONT, STYLE, SIZE, OR COLOR.

FOR BIOCIDES, GERMICIDES, BACTERICIDES, VIRUCIDES, FUNGICIDES, INSECTICIDES, PESTICIDES AND HERBICIDES; FUNGICIDES AND HERBICIDES; HERBICIDES; HERBICIDES FOR AGRICULTURAL USE; HERBICIDES FOR DOMESTIC USE; HERBICIDES, INSECTICIDES, PESTICIDES AND FUNGICIDES FOR HOME, GARDEN AND LAWN USE AND FOR PROFESSIONAL USE (U.S. CLS. 6, 18, 44, 46, 51 AND 52).

FIRST USE 12-12-2008; IN COMMERCE 1-18-2009.
WON TEAK OH, EXAMINING ATTORNEY

ADHERE

THE MARK CONSISTS OF STANDARD CHARACTERS WITHOUT CLAIM TO ANY PARTICULAR FONT, STYLE, SIZE, OR COLOR.

FOR NUTRITIONAL SUPPLEMENTS (U.S. CLS. 6, 18, 44, 46, 51 AND 52).

JAMES STEIN, EXAMINING ATTORNEY

SN 77-662,941. FOSTER AND SMITH, INC., RHINELANDER, WI. FILED 2-4-2009.

ULTRA-CALM

THE MARK CONSISTS OF STANDARD CHARACTERS WITHOUT CLAIM TO ANY PARTICULAR FONT, STYLE, SIZE, OR COLOR.

OWNER OF U.S. REG. NO. 2,741,614.
FOR VETERINARY PREPARATIONS, NAMELY, ANTI-STRESS TABLET FOR PETS (U.S. CLS. 6, 18, 44, 46, 51 AND 52).

ERIN FALK, EXAMINING ATTORNEY

SN 77-663,837. CHEMI NUTRA, LLC, WHITE BEAR LAKE, MN. FILED 2-5-2009.

SN 77-663,036. ANTALL, KIRPAL SINGH, WEST VALLEY, UT. FILED 2-4-2009.

SUCCEED

AMTIYOGA

THE MARK CONSISTS OF STANDARD CHARACTERS WITHOUT CLAIM TO ANY PARTICULAR FONT, STYLE, SIZE, OR COLOR.

FOR DIETARY AND NUTRITIONAL SUPPLEMENTS; DIETARY SUPPLEMENTS; NATURAL HERBAL SUPPLEMENTS; NUTRITIONAL SUPPLEMENTS (U.S. CLS. 6, 18, 44, 46, 51 AND 52).

FONG HSU, EXAMINING ATTORNEY

THE MARK CONSISTS OF STANDARD CHARACTERS WITHOUT CLAIM TO ANY PARTICULAR FONT, STYLE, SIZE, OR COLOR.

FOR NUTRITIONAL SUPPLEMENTS FOR HUMAN CONSUMPTION (U.S. CLS. 6, 18, 44, 46, 51 AND 52).

JAMES STEIN, EXAMINING ATTORNEY

CLASS 5—(Continued).

SN 77-663,993. WLNS, LLC, DBA WELLWORLD SCIENCE, LAS VEGAS, NV. FILED 2-5-2009.



THE MARK CONSISTS OF AN ABSTRACT BIRD DESIGN AND A CIRCLE.

FOR APPETITE SUPPRESSANTS; DIETARY AND NUTRITIONAL SUPPLEMENTS; DIETARY AND NUTRITIONALLY FORTIFIED FOOD PRODUCTS ADAPTED FOR MEDICAL USE; DIETARY BEVERAGE SUPPLEMENTS FOR HUMAN CONSUMPTION IN LIQUID AND DRY MIX FORM FOR THERAPEUTIC PURPOSES; DIETARY FOOD SUPPLEMENTS; DIETARY SUPPLEMENTS; DIETARY SUPPLEMENTS FOR ANIMALS; DIETARY SUPPLEMENTS FOR HUMAN CONSUMPTION; DIETARY SUPPLEMENTS FOR PETS; FOOD SUPPLEMENTS, NAMELY, ANTI-OXIDANTS; HERBAL SUPPLEMENTS; LIQUID NUTRITIONAL SUPPLEMENT; NUTRACEUTICALS FOR USE AS A DIETARY SUPPLEMENT; NUTRITIONAL ADDITIVES FOR MEDICAL PURPOSES FOR USE IN FOODS AND DIETARY SUPPLEMENTS FOR HUMAN CONSUMPTION; NUTRITIONAL SUPPLEMENTS; THERAPEUTIC AGENTS FOR WEIGHT CONTROL AND APPETITE SUPPRESSION; VITAMIN AND MINERAL SUPPLEMENTS (U.S. CLS. 6, 18, 44, 46, 51 AND 52).

COLLEEN DOMBROW, EXAMINING ATTORNEY

SN 77-664,040. DECAS BOTANICAL SYNERGIES, CARVER, MA. FILED 2-5-2009.

CYSTICRAN

THE MARK CONSISTS OF STANDARD CHARACTERS WITHOUT CLAIM TO ANY PARTICULAR FONT, STYLE, SIZE, OR COLOR.

FOR NUTRACEUTICALS FOR USE AS A DIETARY SUPPLEMENT (U.S. CLS. 6, 18, 44, 46, 51 AND 52).

TRACY FLETCHER, EXAMINING ATTORNEY

CLASS 5—(Continued).

SN 77-664,335. MEZOTRACE CORPORATION, WINNEMUCCA, NV. FILED 2-5-2009.

VITA-MUDD

THE MARK CONSISTS OF STANDARD CHARACTERS WITHOUT CLAIM TO ANY PARTICULAR FONT, STYLE, SIZE, OR COLOR.

FOR MINERAL BLOCK FOR HORSES (U.S. CLS. 6, 18, 44, 46, 51 AND 52).

RUSS HERMAN, EXAMINING ATTORNEY

SN 77-664,452. VISEN MEDICAL, INC., BEDFORD, MA. FILED 2-5-2009.

MMPSENSE

THE MARK CONSISTS OF STANDARD CHARACTERS WITHOUT CLAIM TO ANY PARTICULAR FONT, STYLE, SIZE, OR COLOR.

FOR BIOMEDICAL REAGENTS IN THE NATURE OF CONTRAST MEDIA FOR IN VIVO IMAGING OF MOLECULAR AND MORPHOLOGIC TARGETS AND PROCESSES IN ANIMALS (U.S. CLS. 6, 18, 44, 46, 51 AND 52).

FIRST USE 12-14-2005; IN COMMERCE 12-14-2005.

ALICE BENMAMAN, EXAMINING ATTORNEY

SN 77-664,863. THOMAS, BENJAMIN J., THOUSAND OAKS, CA. FILED 2-6-2009.

UNDEFEATED

THE MARK CONSISTS OF STANDARD CHARACTERS WITHOUT CLAIM TO ANY PARTICULAR FONT, STYLE, SIZE, OR COLOR.

FOR DIETARY AND NUTRITIONAL SUPPLEMENTS; MEAL REPLACEMENT AND DIETARY SUPPLEMENT DRINK MIXES (U.S. CLS. 6, 18, 44, 46, 51 AND 52).

FIRST USE 10-26-2006; IN COMMERCE 10-26-2006.

JIM RINGLE, EXAMINING ATTORNEY

CLASS 5—(Continued).

SN 77-665,219. LIL' DRUG STORE PRODUCTS, INC., CEDAR RAPIDS, IA. FILED 2-6-2009.

REPHRESH CLEAN BALANCE

THE MARK CONSISTS OF STANDARD CHARACTERS WITHOUT CLAIM TO ANY PARTICULAR FONT, STYLE, SIZE, OR COLOR.

OWNER OF U.S. REG. NOS. 2,757,069, 2,757,071 AND 3,591,790.

NO CLAIM IS MADE TO THE EXCLUSIVE RIGHT TO USE "CLEAN", APART FROM THE MARK AS SHOWN.

FOR DOUCHES (U.S. CLS. 6, 18, 44, 46, 51 AND 52).

FIRST USE 5-31-2008; IN COMMERCE 5-31-2008.

MARC LEIPZIG, EXAMINING ATTORNEY

SN 77-665,661. WARD, CHARLES R., HOMER, AK. FILED 2-7-2009.

Retibol

THE MARK CONSISTS OF STANDARD CHARACTERS WITHOUT CLAIM TO ANY PARTICULAR FONT, STYLE, SIZE, OR COLOR.

FOR DIETARY AND NUTRITIONAL SUPPLEMENTS (U.S. CLS. 6, 18, 44, 46, 51 AND 52).

MARK SHINER, EXAMINING ATTORNEY

SN 77-665,747. LOVEY, EDWARD, BEDFORD HTS, OH. FILED 2-7-2009.

doctor next door

THE MARK CONSISTS OF STANDARD CHARACTERS WITHOUT CLAIM TO ANY PARTICULAR FONT, STYLE, SIZE, OR COLOR.

FOR ANIMAL FEED ADDITIVE FOR USE AS A NUTRITIONAL SUPPLEMENT FOR MEDICAL PURPOSES; ANIMAL FEED SUPPLEMENTS; BEE POLLEN FOR USE AS A DIETARY FOOD SUPPLEMENT; CALCIUM MONTMORILLONITE CLAY FOR THERAPEUTIC PURPOSES USED TO ENHANCE THE PRODUCTION OF ENZYMES IN LIVING BEINGS OR AS A MINERAL SUPPLEMENT; CALCIUM SUPPLEMENTS; DIETARY AND NUTRITIONAL SUPPLEMENTS; DIETARY BEVERAGE SUPPLEMENTS FOR HUMAN CONSUMPTION IN LIQUID AND DRY MIX FORM FOR THERAPEUTIC PURPOSES; DIETARY FOOD SUPPLEMENTS; DIETARY PET SUPPLEMENTS IN THE FORM OF PET TREATS; DIETARY SUPPLEMENTAL DRINKS; DIETARY SUPPLEMENTS; DIETARY SUPPLEMENTS FOR ANIMALS; DIETARY SUPPLEMENTS FOR CONTROLLING CHOLESTEROL; DIETARY SUPPLEMENTS FOR HUMAN CONSUMPTION; DIETARY SUPPLEMENTS FOR PETS; DIETARY SUPPLEMENTS FOR PETS IN THE NATURE OF A POWDERED DRINK MIX; FOOD SUPPLEMENTS;

CLASS 5—(Continued).

FOOD SUPPLEMENTS, NAMELY, ANTI-OXIDANTS; GROUND FLAXSEED FIBER FOR USE AS A DIETARY SUPPLEMENT; HERBAL SUPPLEMENTS; HOMEOPATHIC SUPPLEMENTS; LECITHIN FOR USE AS A DIETARY SUPPLEMENT; LIQUID NUTRITIONAL SUPPLEMENT; MEAL REPLACEMENT AND DIETARY SUPPLEMENT DRINK MIXES; MINERAL FOOD SUPPLEMENTS; MINERAL NUTRITIONAL SUPPLEMENTS; MINERAL SUPPLEMENTS; MIXED VITAMIN PREPARATIONS; MULTI-VITAMIN PREPARATIONS; NATURAL HERBAL SUPPLEMENTS; NATURAL SUPPLEMENTS FOR TREATING CANDIDA; NATURAL SUPPLEMENTS FOR TREATING DEPRESSION AND ANXIETY; NATURAL SUPPLEMENTS FOR TREATING ERECTILE DYSFUNCTION; NON-MEDICATED ADDITIVES FOR ANIMAL FEED FOR USE AS NUTRITIONAL SUPPLEMENTS; NUTRACEUTICALS FOR USE AS A DIETARY SUPPLEMENT; NUTRITIONAL ADDITIVES FOR MEDICAL PURPOSES FOR USE IN FOODS AND DIETARY SUPPLEMENTS FOR HUMAN CONSUMPTION; NUTRITIONAL SUPPLEMENT IN THE NATURE OF A NUTRIENT-DENSE, PROTEIN-BASED DRINK MIX; NUTRITIONAL SUPPLEMENTS; NUTRITIONAL SUPPLEMENTS IN LOTION FORM SOLD AS A COMPONENT OF NUTRITIONAL SKIN CARE PRODUCTS; POWDERED FRUIT-FLAVORED DIETARY SUPPLEMENT DRINK MIX; POWDERED NUTRITIONAL SUPPLEMENT DRINK MIX; PROTEIN SUPPLEMENTS; SOY PROTEIN FOR USE AS A NUTRITIONAL SUPPLEMENT IN VARIOUS POWDERED AND READY-TO-DRINK BEVERAGES; VITAMIN AND MINERAL FORMED AND PACKAGED AS BARS; VITAMIN AND MINERAL PREPARATIONS FOR MEDICAL USE; VITAMIN AND MINERAL PREPARATIONS FOR USE AS INGREDIENTS IN THE FOOD AND PHARMACEUTICAL INDUSTRY; VITAMIN AND MINERAL SUPPLEMENTS; VITAMIN B PREPARATIONS; VITAMIN C PREPARATIONS; VITAMIN D PREPARATIONS; VITAMIN DROPS; VITAMIN ENRICHED BREAD FOR THERAPEUTIC PURPOSES; VITAMIN ENRICHED WATER; VITAMIN FORTIFIED BEVERAGES; VITAMIN OILS FOR HUMAN CONSUMPTION; VITAMIN PREPARATIONS; VITAMIN SUPPLEMENT IN TABLET FORM FOR USE IN MAKING AN EFFERVESCENT BEVERAGE WHEN ADDED TO WATER; VITAMIN SUPPLEMENTS; VITAMIN TABLETS; VITAMINS; VITAMINS AND DIETARY FOOD SUPPLEMENTS FOR ANIMALS; VITAMINS AND VITAMIN PREPARATIONS; VITAMINS FOR PETS; WHEAT FOR USE AS A DIETARY SUPPLEMENT; ZINC SUPPLEMENT LOZENGES (U.S. CLS. 6, 18, 44, 46, 51 AND 52).

FIRST USE 1-1-2004; IN COMMERCE 12-1-2004.

NAKWAMA ANKRAH, EXAMINING ATTORNEY

SN 77-666,179. CITRA ANTICOAGULANTS, INC., BRAINTREE, MA. FILED 2-9-2009.

noClot-400

THE MARK CONSISTS OF STANDARD CHARACTERS WITHOUT CLAIM TO ANY PARTICULAR FONT, STYLE, SIZE, OR COLOR.

SEC. 2(F).

FOR PHARMACEUTICAL PREPARATIONS, NAMELY, ANTICOAGULANTS (U.S. CLS. 6, 18, 44, 46, 51 AND 52).

FIRST USE 1-1-2007; IN COMMERCE 1-1-2007.

REBECCA POVARCHUK, EXAMINING ATTORNEY

CLASS 5—(Continued).

SN 77-666,678. DR. SMOOTHIE BRANDS, FULLERTON, CA. FILED 2-9-2009.

Fresh Face

THE MARK CONSISTS OF STANDARD CHARACTERS WITHOUT CLAIM TO ANY PARTICULAR FONT, STYLE, SIZE, OR COLOR.

FOR DIETARY AND NUTRITIONAL SUPPLEMENTS; DIETARY BEVERAGE SUPPLEMENTS FOR HUMAN CONSUMPTION IN LIQUID AND DRY MIX FORM FOR THERAPEUTIC PURPOSES; DIETARY FOOD SUPPLEMENTS; DIETARY SUPPLEMENTS; DIETARY SUPPLEMENTS FOR HUMAN CONSUMPTION; NUTRACEUTICALS FOR USE AS A DIETARY SUPPLEMENT; NUTRITIONAL SUPPLEMENTS (U.S. CLS. 6, 18, 44, 46, 51 AND 52).

FIRST USE 12-8-2008; IN COMMERCE 12-8-2008.
ZACHARY BELLO, EXAMINING ATTORNEY

SN 77-666,741. PINERICH INVESTMENTS, LTD., AKA OFFSHORE INCORPORATIONS LTD., ROAD TOWN, TORTOLA, BR. VIRGIN ISLANDS, FILED 2-9-2009.

CRILA

THE MARK CONSISTS OF STANDARD CHARACTERS WITHOUT CLAIM TO ANY PARTICULAR FONT, STYLE, SIZE, OR COLOR.

FOR DIETARY SUPPLEMENT CONSISTING OF PHARMACEUTICAL PLANT EXTRACT FORMULATION FOR PROSTATE AND UTERINE HEALTH (U.S. CLS. 6, 18, 44, 46, 51 AND 52).

KHANH LE, EXAMINING ATTORNEY

SN 77-666,843. HEALTH E KIDZ, INC., IRVINE, CA. FILED 2-9-2009.

Healthekidz

THE MARK CONSISTS OF STANDARD CHARACTERS WITHOUT CLAIM TO ANY PARTICULAR FONT, STYLE, SIZE, OR COLOR.

FOR NUTRITIONALLY FORTIFIED BEVERAGES; VITAMIN FORTIFIED BEVERAGES (U.S. CLS. 6, 18, 44, 46, 51 AND 52).

ROBERT C. CLARK JR., EXAMINING ATTORNEY

CLASS 5—(Continued).

SN 77-667,295. REALIFE RESOURCES, INC, SALT LAKE CITY, UT. FILED 2-10-2009.

EZPAK

THE MARK CONSISTS OF STANDARD CHARACTERS WITHOUT CLAIM TO ANY PARTICULAR FONT, STYLE, SIZE, OR COLOR.

FOR NUTRACEUTICALS FOR USE AS A DIETARY SUPPLEMENT (U.S. CLS. 6, 18, 44, 46, 51 AND 52).
ELLEN B. AWRICH, EXAMINING ATTORNEY

SN 77-667,512. NUTRITIONAL HEALTH INSTITUTE LABORATORIES, TALLAHASSEE, FL. FILED 2-10-2009.

EXTRA SLIM

THE MARK CONSISTS OF STANDARD CHARACTERS WITHOUT CLAIM TO ANY PARTICULAR FONT, STYLE, SIZE, OR COLOR.

FOR DIETARY SUPPLEMENTS (U.S. CLS. 6, 18, 44, 46, 51 AND 52).
ALICIA COLLINS, EXAMINING ATTORNEY

SN 77-667,528. SAVIND, INC., URBANA, IL. FILED 2-10-2009.

INTENSE

THE MARK CONSISTS OF STANDARD CHARACTERS WITHOUT CLAIM TO ANY PARTICULAR FONT, STYLE, SIZE, OR COLOR.

FOR NUTRITIONAL SUPPLEMENTS (U.S. CLS. 6, 18, 44, 46, 51 AND 52).
FIRST USE 1-29-2009; IN COMMERCE 2-9-2009.

MARLENE BELL, EXAMINING ATTORNEY

CLASS 5—(Continued).

SN 77-668,913. I PLAY, INC., ASHEVILLE, NC. FILED 2-12-2009.



THE MARK CONSISTS OF A STYLIZED SLEEPING SPROUT NESTLED IN AND PARTIALLY SURROUNDED BY THE TWO HALVES OF A POD RESTING ON TWO SMALL FAUX FEET.

FOR BREAST-NURSING PADS; MEDICATED PRE-MOISTENED WIPES; AND SANITIZING WIPES (U.S. CLS. 6, 18, 44, 46, 51 AND 52).

AISHA SALEM, EXAMINING ATTORNEY

CLASS 5—(Continued).

SN 77-671,835. SMITHKLINE BEECHAM CORPORATION, PHILADELPHIA, PA. FILED 2-17-2009.

TINY TUMS

THE MARK CONSISTS OF STANDARD CHARACTERS WITHOUT CLAIM TO ANY PARTICULAR FONT, STYLE, SIZE, OR COLOR.

OWNER OF U.S. REG. NOS. 268,593, 2,076,469 AND OTHERS.

NO CLAIM IS MADE TO THE EXCLUSIVE RIGHT TO USE "TINY", APART FROM THE MARK AS SHOWN.

FOR ANTACIDS AND CALCIUM SUPPLEMENTS (U.S. CLS. 6, 18, 44, 46, 51 AND 52).

GEOFFREY FOSDICK, EXAMINING ATTORNEY

SN 77-671,639. JOHNSON & JOHNSON, NEW BRUNSWICK, NJ. FILED 2-17-2009.

EVARREST

THE MARK CONSISTS OF STANDARD CHARACTERS WITHOUT CLAIM TO ANY PARTICULAR FONT, STYLE, SIZE, OR COLOR.

FOR BIO-ABSORBABLE HEMOSTAT (U.S. CLS. 6, 18, 44, 46, 51 AND 52).

DAVID COLLIER, EXAMINING ATTORNEY

SN 77-681,076. BOEHRINGER INGELHEIM PHARMACEUTICALS, INC., RIDGEFIELD, CT. FILED 3-2-2009.

ZANTAC EFFERDOSE

THE MARK CONSISTS OF STANDARD CHARACTERS WITHOUT CLAIM TO ANY PARTICULAR FONT, STYLE, SIZE, OR COLOR.

OWNER OF U.S. REG. NOS. 1,220,525, 3,565,518 AND OTHERS.

FOR PHARMACEUTICAL PREPARATIONS FOR THE TREATMENT AND/OR ALLEVIATION OF ULCERS AND GASTROINTESTINAL DISORDERS (U.S. CLS. 6, 18, 44, 46, 51 AND 52).

PRISCILLA MILTON, EXAMINING ATTORNEY

SN 77-671,641. JOHNSON & JOHNSON, NEW BRUNSWICK, NJ. FILED 2-17-2009.

CYTADEL

THE MARK CONSISTS OF STANDARD CHARACTERS WITHOUT CLAIM TO ANY PARTICULAR FONT, STYLE, SIZE, OR COLOR.

FOR BIO-ABSORBABLE HEMOSTAT (U.S. CLS. 6, 18, 44, 46, 51 AND 52).

DAVID COLLIER, EXAMINING ATTORNEY

SN 77-686,130. BODYWELL NUTRITION LLC, SUNRISE, FL. FILED 3-9-2009.

Top Secret

THE MARK CONSISTS OF STANDARD CHARACTERS WITHOUT CLAIM TO ANY PARTICULAR FONT, STYLE, SIZE, OR COLOR.

FOR DIET PILLS (U.S. CLS. 6, 18, 44, 46, 51 AND 52).

SIMON TENG, EXAMINING ATTORNEY

CLASS 5—(Continued).

SN 77-690,141. GALDERMA S.A., CHAM, SWITZERLAND,
FILED 3-13-2009.

TALIXANE

THE MARK CONSISTS OF STANDARD CHARACTERS
WITHOUT CLAIM TO ANY PARTICULAR FONT, STYLE,
SIZE, OR COLOR.

FOR PHARMACEUTICAL PREPARATIONS AND SUB-
STANCES FOR THE TREATMENT OF DERMATOLOGI-
CAL DISORDERS (U.S. CLS. 6, 18, 44, 46, 51 AND 52).
STEVEN R. FINE, EXAMINING ATTORNEY

SN 77-690,990. NANA PATRICIA MCPEAK, EL DORADO
HILLS, CA. FILED 3-13-2009.

NanaCea 24/7

THE MARK CONSISTS OF STANDARD CHARACTERS
WITHOUT CLAIM TO ANY PARTICULAR FONT, STYLE,
SIZE, OR COLOR.

NO CLAIM IS MADE TO THE EXCLUSIVE RIGHT TO
USE "24/7", APART FROM THE MARK AS SHOWN.

FOR DIETARY DRINK MIX FOR USE AS A MEAL
REPLACEMENT (U.S. CLS. 6, 18, 44, 46, 51 AND 52).

FIRST USE 10-1-2008; IN COMMERCE 10-1-2008.
DAVID H. STINE, EXAMINING ATTORNEY

SN 77-692,175. NANA PATRICIA MCPEAK, EL DORADO
HILLS, CA. FILED 3-16-2009.

NanaCea NanaFlex

THE MARK CONSISTS OF STANDARD CHARACTERS
WITHOUT CLAIM TO ANY PARTICULAR FONT, STYLE,
SIZE, OR COLOR.

FOR DIETARY AND NUTRITIONAL SUPPLEMENTS
(U.S. CLS. 6, 18, 44, 46, 51 AND 52).

FIRST USE 10-1-2008; IN COMMERCE 10-1-2008.
DAVID H. STINE, EXAMINING ATTORNEY

CLASS 5—(Continued).

SN 77-695,885. DR. SMOOTHIE BRANDS, FULLERTON, CA.
FILED 3-20-2009.

Smoothieceuticals

THE MARK CONSISTS OF STANDARD CHARACTERS
WITHOUT CLAIM TO ANY PARTICULAR FONT, STYLE,
SIZE, OR COLOR.

FOR DIETARY AND NUTRITIONAL SUPPLEMENTS
(U.S. CLS. 6, 18, 44, 46, 51 AND 52).

FIRST USE 1-19-2009; IN COMMERCE 1-19-2009.
ZACHARY BELLO, EXAMINING ATTORNEY

SN 78-474,688. WESTERN HOLDINGS, LLC, CASPER, WY.
FILED 8-27-2004.

XANTRIL

THE MARK CONSISTS OF STANDARD CHARACTERS
WITHOUT CLAIM TO ANY PARTICULAR FONT, STYLE,
SIZE, OR COLOR.

FOR DIETARY SUPPLEMENTS (U.S. CLS. 6, 18, 44, 46,
51 AND 52).

RONALD DELGIZZI, EXAMINING ATTORNEY

SN 78-700,661. NATURAVIT INC., MIAMI, FL. FILED 8-25-
2005.

IPANEMA SLIM

THE MARK CONSISTS OF STANDARD CHARACTERS
WITHOUT CLAIM TO ANY PARTICULAR FONT, STYLE,
SIZE, OR COLOR.

FOR DIETARY SUPPLEMENT (U.S. CLS. 6, 18, 44, 46,
51 AND 52).

DAWN FELDMAN, EXAMINING ATTORNEY

CLASS 5—(Continued).

SN 78-730,388. JOHNSON & JOHNSON, NEW BRUNSWICK, NJ. FILED 10-11-2005.

BERRY BLAST

THE MARK CONSISTS OF STANDARD CHARACTERS WITHOUT CLAIM TO ANY PARTICULAR FONT, STYLE, SIZE, OR COLOR.

NO CLAIM IS MADE TO THE EXCLUSIVE RIGHT TO USE "BERRY", APART FROM THE MARK AS SHOWN.

FOR SANITIZING PREPARATIONS, NAMELY, HAND SANITIZERS HAVING ANTI-MICROBIAL AND ANTI-BACTERIAL PROPERTIES; GERMICIDES (U.S. CLS. 6, 18, 44, 46, 51 AND 52).

AISHA CLARKE, EXAMINING ATTORNEY

SN 78-857,888. INOVIOBIOLOGIC INC., CALGARY, ALBERTA, FILED 4-10-2006.

RICHBERRY6000

THE MARK CONSISTS OF STANDARD CHARACTERS WITHOUT CLAIM TO ANY PARTICULAR FONT, STYLE, SIZE, OR COLOR.

PRIORITY CLAIMED UNDER SEC. 44(D) ON CANADA APPLICATION NO. 1297263, FILED 4-10-2006, REG. NO. TMA724721, DATED 9-29-2008, EXPIRES 9-29-2023.

FOR DIETARY AND NUTRITIONAL SUPPLEMENTS; HERBAL SUPPLEMENTS (U.S. CLS. 6, 18, 44, 46, 51 AND 52).

DAYNA BROWNE, EXAMINING ATTORNEY

SN 78-959,041. INOVIOBIOLOGIC INC., CALGARY, ALBERTA, FILED 8-23-2006.

BLACKBERRYRICH

THE MARK CONSISTS OF STANDARD CHARACTERS WITHOUT CLAIM TO ANY PARTICULAR FONT, STYLE, SIZE, OR COLOR.

PRIORITY CLAIMED UNDER SEC. 44(D) ON CANADA APPLICATION NO. 1314140, FILED 8-23-2006, REG. NO. TMA713987, DATED 5-9-2008, EXPIRES 5-6-2023.

FOR DIETARY AND NUTRITIONAL SUPPLEMENTS; DIETARY FOOD SUPPLEMENTS (U.S. CLS. 6, 18, 44, 46, 51 AND 52).

DAYNA BROWNE, EXAMINING ATTORNEY

CLASS 5—(Continued).

SN 79-035,544. ASTELLAS PHARMA INC., JAPAN, FILED 1-22-2007.

VYPOTEX

PRIORITY DATE OF 8-8-2006 IS CLAIMED. OWNER OF INTERNATIONAL REGISTRATION 0916415 DATED 1-22-2007, EXPIRES 1-22-2017.

FOR PHARMACEUTICAL PREPARATIONS AND SUBSTANCES, NAMELY, AGENTS AFFECTING CENTRAL NERVOUS SYSTEM, AGENTS AFFECTING PERIPHERAL NERVOUS SYSTEM, AGENTS AFFECTING SENSORY ORGANS, ANTIALLERGENIC AGENTS, CARDIOVASCULAR AGENTS, AGENTS AFFECTING RESPIRATORY ORGANS, AGENTS AFFECTING DIGESTIVE ORGANS FOR HUMAN, HORMONES FOR MEDICAL PURPOSES, UROGENITAL OR ANAL TREATMENT AGENTS, DERMATOLOGICAL PREPARATIONS, IMMUNOTHERAPEUTIC AGENTS AFFECTING TRANSPLANT, VITAMIN PREPARATIONS FOR HUMANS, METABOLIC AGENTS, TUMOR SUPPRESSING AGENTS, ANTICANCER AGENTS AFFECTING KIDNEY DISEASES, VACCINES FOR THE TREATMENT OF INFECTIOUS DISEASES AGENTS AFFECTING INFECTIOUS DISEASES, DIAGNOSTIC PREPARATIONS FOR TESTING URINE, OCCULT BLOOD OF FECES AND BLOOD DISEASES, AGENTS AFFECTING INFLAMMATION, NIGHTTIME SLEEP AID, ANTHELMINTICS FOR HUMANS, GERMICIDES FOR HUMANS; ANTIBIOTIC PREPARATIONS FOR HUMAN USE (U.S. CLS. 6, 18, 44, 46, 51 AND 52).

SUE LAWRENCE, EXAMINING ATTORNEY

SN 79-035,545. ASTELLAS PHARMA INC., JAPAN, FILED 1-22-2007.

VIBATIV

PRIORITY DATE OF 8-8-2006 IS CLAIMED. OWNER OF INTERNATIONAL REGISTRATION 0916416 DATED 1-22-2007, EXPIRES 1-22-2017.

FOR PHARMACEUTICAL PREPARATIONS AND SUBSTANCES, NAMELY, AGENTS AFFECTING CENTRAL NERVOUS SYSTEM, AGENTS AFFECTING PERIPHERAL NERVOUS SYSTEM, AGENTS AFFECTING SENSORY ORGANS, ANTIALLERGENIC AGENTS, CARDIOVASCULAR AGENTS, AGENTS AFFECTING RESPIRATORY ORGANS, AGENTS AFFECTING DIGESTIVE ORGANS FOR HUMAN, HORMONES FOR MEDICAL PURPOSES, UROGENITAL OR ANAL TREATMENT AGENTS, DERMATOLOGICAL PREPARATIONS, IMMUNOTHERAPEUTIC AGENTS AFFECTING TRANSPLANT, VITAMIN PREPARATIONS FOR HUMANS, METABOLIC AGENTS, TUMOR SUPPRESSING AGENTS, ANTICANCER AGENTS AFFECTING KIDNEY DISEASES, VACCINES FOR THE TREATMENT OF INFECTIOUS DISEASES AGENTS AFFECTING INFECTIOUS DISEASES, DIAGNOSTIC PREPARATIONS FOR TESTING URINE, OCCULT BLOOD OF FECES AND BLOOD DISEASES, AGENTS AFFECTING INFLAMMATION, NIGHTTIME SLEEP AID, ANTHELMINTICS FOR HUMANS, GERMICIDES FOR HUMANS; ANTIBIOTIC PREPARATIONS FOR HUMAN USE (U.S. CLS. 6, 18, 44, 46, 51 AND 52).

SUE LAWRENCE, EXAMINING ATTORNEY

CLASS 5—(Continued).

SN 79-036,130. SANTEN PHARMACEUTICAL CO., LTD., JAPAN, FILED 1-24-2007.

A CLEAR VISION FOR LIFE

PRIORITY DATE OF 1-8-2007 IS CLAIMED.
OWNER OF INTERNATIONAL REGISTRATION 0917778 DATED 1-24-2007, EXPIRES 1-24-2017.

FOR PHARMACEUTICAL PREPARATIONS FOR THE SENSORY ORGANS FOR THE TREATMENT OF EYE DISEASES AND CONDITIONS (U.S. CLS. 6, 18, 44, 46, 51 AND 52).

DANIEL BRODY, EXAMINING ATTORNEY

SN 79-059,720. BIOTECH PHARMACEUTICALS PTY LTD, AUSTRALIA, FILED 6-12-2008.



PRIORITY DATE OF 12-12-2007 IS CLAIMED.
OWNER OF INTERNATIONAL REGISTRATION 0979362 DATED 6-12-2008, EXPIRES 6-12-2018.

THE MARK CONSISTS OF THE TERM "SLIMMM" IN A STYLISED FORMAT.

FOR PHARMACEUTICAL PREPARATIONS AND SUBSTANCES, NAMELY, SUBSTANCES AND PREPARATIONS FOR HUMAN CONSUMPTION WHICH ASSIST WITH THE PROCESS OF WEIGHT LOSS; FOODS AND BEVERAGES INCLUDED IN THIS CLASS, NAMELY, FOODS AND BEVERAGES FOR HUMAN CONSUMPTION WHICH ASSIST IN THE PROCESS OF WEIGHT LOSS (U.S. CLS. 6, 18, 44, 46, 51 AND 52).

FRANK LATTUCA, EXAMINING ATTORNEY

SN 79-065,269. NOVARTIS AG, SWITZERLAND, FILED 1-22-2009.



OWNER OF INTERNATIONAL REGISTRATION 0993156 DATED 1-22-2009, EXPIRES 1-22-2019.

THE MARK CONSISTS OF A STYLIZED BIRD.
FOR PHARMACEUTICAL PREPARATIONS FOR TREATING RESPIRATORY DISEASES AND ASTHMA (U.S. CLS. 6, 18, 44, 46, 51 AND 52).

DANIEL CAPSHAW, EXAMINING ATTORNEY

CLASS 6—METAL GOODS

SN 77-508,914. HI-SHEAR CORPORATION, TORRANCE, CA, FILED 6-26-2008.

HI-KOTE

THE MARK CONSISTS OF STANDARD CHARACTERS WITHOUT CLAIM TO ANY PARTICULAR FONT, STYLE, SIZE, OR COLOR.

FOR PROTECTIVE CORROSION RESISTANT COATING SOLD AS AN INTEGRAL COMPONENT OF FINISHED METAL FASTENERS, NAMELY, RIVETS, BOLTS AND NUTS, AND FINISHED THREADED METAL FASTENERS (U.S. CLS. 2, 12, 13, 14, 23, 25 AND 50).

FIRST USE 0-0-1968; IN COMMERCE 0-0-1968.

MARLENE BELL, EXAMINING ATTORNEY

SN 77-553,226. LBC ACQUISITIONS, LLC, ANNISTON, AL, FILED 8-22-2008.

LEE FREE

THE MARK CONSISTS OF STANDARD CHARACTERS WITHOUT CLAIM TO ANY PARTICULAR FONT, STYLE, SIZE, OR COLOR.

FOR METAL PIPE FITTINGS (U.S. CLS. 2, 12, 13, 14, 23, 25 AND 50).

FIRST USE 6-2-2008; IN COMMERCE 6-2-2008.

TRACY WHITTAKER-BROWN, EXAMINING ATTORNEY

SN 77-558,899. MARKS USA I, LLC, AMITYVILLE, NY, FILED 8-29-2008.



NO CLAIM IS MADE TO THE EXCLUSIVE RIGHT TO USE "USA", APART FROM THE MARK AS SHOWN.

THE MARK CONSISTS OF THE LETTER "M" IN A CIRCLE FOLLOWED BY THE NAMES "MARKS" AND "USA".

FOR METAL LOCK SETS AND PARTS THEREOF, NAMELY, LOCKS, LOCK CYLINDERS, AND KEYS (U.S. CLS. 2, 12, 13, 14, 23, 25 AND 50).

MORGAN WYNNE, EXAMINING ATTORNEY

CLASS 6—(Continued).

SN 77-595,073. SEASTAR HOLDING, INC., NEWPORT BEACH, CA. FILED 10-17-2008.

QUANTAS

THE MARK CONSISTS OF STANDARD CHARACTERS WITHOUT CLAIM TO ANY PARTICULAR FONT, STYLE, SIZE, OR COLOR.
THE WORDING "QUANTAS" HAS NO MEANING IN A FOREIGN LANGUAGE.
FOR BOAT ANCHORS (U.S. CLS. 2, 12, 13, 14, 23, 25 AND 50).
COLLEEN DOMBROW, EXAMINING ATTORNEY



SN 77-614,071. CLIPSY, LLC, SAN FRANCISCO, CA. FILED 11-13-2008.

HOOK UP

THE MARK CONSISTS OF STANDARD CHARACTERS WITHOUT CLAIM TO ANY PARTICULAR FONT, STYLE, SIZE, OR COLOR.
FOR METAL DECORATIVE CLIPS FOR SUSPENDING PERSONAL OBJECTS FROM VARIOUS SURFACES (U.S. CLS. 2, 12, 13, 14, 23, 25 AND 50).
SUE LAWRENCE, EXAMINING ATTORNEY



SN 77-632,039. SEASTAR HOLDING, INC., NEWPORT BEACH, CA. FILED 12-12-2008.

SEASPEAR

THE MARK CONSISTS OF STANDARD CHARACTERS WITHOUT CLAIM TO ANY PARTICULAR FONT, STYLE, SIZE, OR COLOR.
FOR BOAT ANCHORS (U.S. CLS. 2, 12, 13, 14, 23, 25 AND 50).
SEAN CROWLEY, EXAMINING ATTORNEY

CLASS 6—(Continued).

SN 77-632,043. SEASTAR HOLDING, INC., NEWPORT BEACH, CA. FILED 12-12-2008.

PLOWSTAR

THE MARK CONSISTS OF STANDARD CHARACTERS WITHOUT CLAIM TO ANY PARTICULAR FONT, STYLE, SIZE, OR COLOR.
FOR BOAT ANCHORS (U.S. CLS. 2, 12, 13, 14, 23, 25 AND 50).
SEAN CROWLEY, EXAMINING ATTORNEY



SN 77-646,265. YKK CORPORATION OF AMERICA, MARIETTA, GA. FILED 1-9-2009.

SPLINETECH

THE MARK CONSISTS OF STANDARD CHARACTERS WITHOUT CLAIM TO ANY PARTICULAR FONT, STYLE, SIZE, OR COLOR.
FOR ARCHITECTURAL PRODUCTS PRIMARILY MADE OF METAL, NAMELY, CURTAIN WALL GLAZING SYSTEMS CONSISTING OF CURTAIN WALL STRUCTURAL SUPPORTS, FRAMING, MULLIONS, FASTENERS, JAMBS, SPLICES, GLAZING BLOCKS, GASKETS, AND HARDWARE (U.S. CLS. 2, 12, 13, 14, 23, 25 AND 50).
FIRST USE 10-30-2006; IN COMMERCE 10-30-2006.
SARA THOMAS, EXAMINING ATTORNEY



SN 77-661,789. DOCHOR ENGINEERING, INC., SANTA ANA, CA. FILED 2-2-2009.

Clog-Eater

THE MARK CONSISTS OF STANDARD CHARACTERS WITHOUT CLAIM TO ANY PARTICULAR FONT, STYLE, SIZE, OR COLOR.
FOR METAL FITTING ATTACHMENT FOR PLUMBING USE, NAMELY, A DEVICE FOR LINKING A HOSE WITH A DRAIN SO THAT PRESSURIZED FLUID CAN BE USED TO CLEAR DRAINPIPES OF BLOCKAGES AND DEBRIS (U.S. CLS. 2, 12, 13, 14, 23, 25 AND 50).
CORY BOONE, EXAMINING ATTORNEY

CLASS 6—(Continued).

SN 77-662,024. RIGIDIZED METALS CORPORATION, BUFFALO, NY. FILED 2-3-2009.

FoodPack Systems

THE MARK CONSISTS OF STANDARD CHARACTERS WITHOUT CLAIM TO ANY PARTICULAR FONT, STYLE, SIZE, OR COLOR.

NO CLAIM IS MADE TO THE EXCLUSIVE RIGHT TO USE "SYSTEMS", APART FROM THE MARK AS SHOWN.

FOR METAL CONTAINERS FOR THE STORAGE AND TRANSPORTATION OF GOODS (U.S. CLS. 2, 12, 13, 14, 23, 25 AND 50).

ELIZABETH HUGHITT, EXAMINING ATTORNEY

SN 77-663,333. HYDROSWING, INC., COTTONWOOD, MN. FILED 2-4-2009.

LID Light Industrial Doors

THE MARK CONSISTS OF STANDARD CHARACTERS WITHOUT CLAIM TO ANY PARTICULAR FONT, STYLE, SIZE, OR COLOR.

NO CLAIM IS MADE TO THE EXCLUSIVE RIGHT TO USE "LIGHT INDUSTRIAL DOORS", APART FROM THE MARK AS SHOWN.

FOR METAL HYDRAULICALLY - OPERATED OVERHEAD DOORS (U.S. CLS. 2, 12, 13, 14, 23, 25 AND 50).

SIMON TENG, EXAMINING ATTORNEY

SN 77-664,247. ROTALOC INT'L, LLC, LITTLETON, CO. FILED 2-5-2009.

ROTALOC

THE MARK CONSISTS OF STANDARD CHARACTERS WITHOUT CLAIM TO ANY PARTICULAR FONT, STYLE, SIZE, OR COLOR.

FOR METAL BONDING FASTENERS FOR MOUNTING AND DEMOUNTING OF CEILING AND WALL PANELS; METAL FASTENERS, NAMELY, METAL BONDING FASTENERS, NAMELY, LARGE-PERFORATED-FLANGED NUTS, BOLTS AND COLLARS OF VARIOUS THREAD SIZES AND LENGTHS; METAL FASTENING ANCHORS; METAL THREADED FASTENERS (U.S. CLS. 2, 12, 13, 14, 23, 25 AND 50).

FIRST USE 10-24-1999; IN COMMERCE 10-24-1999.

MATTHEW PAPPAS, EXAMINING ATTORNEY

CLASS 6—(Continued).

SN 77-666,308. HYDROSWING, INC., COTTONWOOD, MN. FILED 2-9-2009.



OWNER OF U.S. REG. NOS. 2,332,441 AND 3,334,252. NO CLAIM IS MADE TO THE EXCLUSIVE RIGHT TO USE "LIGHT INDUSTRIAL DOORS", APART FROM THE MARK AS SHOWN.

THE COLOR(S) BLACK, BLUE AND GRAY IS/ARE CLAIMED AS A FEATURE OF THE MARK.

THE MARK CONSISTS OF THE WORD "LID" (THE "L" IS CAPITALIZED IN BLACK, THE "I" IS LOWERCASE IN BLUE AND THE "D" IS CAPITALIZED IN GRAY). UNDERNEATH "LID" ARE THE WORDS "LIGHT INDUSTRIAL DOORS BY" ALL IN GRAY. UNDERNEATH "LIGHT INDUSTRIAL DOORS BY" IS THE WORD "HYDROSWING" ALL IN CAPS BUT IN A SMALLER FONT THAN THE CAPS FOR "L" AND "D", THE LETTERS "HYDRO" ARE IN BLACK AND THE LETTER "SWING" ARE IN BLUE. BEFORE THE WORD "HYDROSWING" ARE THREE GRAY BARS FANNING OUT FROM THE "H".

FOR METAL HYDRAULICALLY - OPERATED OVERHEAD DOORS (U.S. CLS. 2, 12, 13, 14, 23, 25 AND 50).

SIMON TENG, EXAMINING ATTORNEY

SN 77-666,473. JOHN MANEELY COMPANY, BEACHWOOD, OH. FILED 2-9-2009.

ECO-POLE

THE MARK CONSISTS OF STANDARD CHARACTERS WITHOUT CLAIM TO ANY PARTICULAR FONT, STYLE, SIZE, OR COLOR.

FOR STEEL TUBE (U.S. CLS. 2, 12, 13, 14, 23, 25 AND 50).

FLORENTINA BLANDU, EXAMINING ATTORNEY

SN 77-668,454. SAUL ZAENTZ COMPANY, THE, BERKELEY, CA. FILED 2-11-2009.

ARAGORN

THE MARK CONSISTS OF STANDARD CHARACTERS WITHOUT CLAIM TO ANY PARTICULAR FONT, STYLE, SIZE, OR COLOR.

FOR METAL KEY CHAIN (U.S. CLS. 2, 12, 13, 14, 23, 25 AND 50).

FIRST USE 11-21-2002; IN COMMERCE 2-13-2008.

LINDA POWELL, EXAMINING ATTORNEY

CLASS 6—(Continued).

SN 78-741,786. NUCOR CORPORATION, INC., CHARLOTTE, NC. FILED 10-27-2005.

FOCUS

THE MARK CONSISTS OF STANDARD CHARACTERS WITHOUT CLAIM TO ANY PARTICULAR FONT, STYLE, SIZE, OR COLOR.

FOR COMPONENTS AND SYSTEMS FOR METAL BUILDINGS, NAMELY, METAL FLASHING, METAL TRIM, METAL CLADDING, METAL BUILDING FRAMES, AND METAL ROOFS (U.S. CLS. 2, 12, 13, 14, 23, 25 AND 50).

CYNTHIA SLOAN, EXAMINING ATTORNEY

SN 79-046,504. LINSINGER MASCHINENBAU GMBH, AUSTRIA, FILED 5-30-2007.

LIN

THE MARK CONSISTS OF STANDARD CHARACTERS WITHOUT CLAIM TO ANY PARTICULAR FONT, STYLE, SIZE, OR COLOR.

OWNER OF INTERNATIONAL REGISTRATION 0944187 DATED 5-30-2007, EXPIRES 5-30-2017.

THE WORDING "LIN" HAS NO MEANING IN A FOREIGN LANGUAGE.

FOR COMMON METALS AND THEIR ALLOYS FOR FURTHER MANUFACTURING; TRANSPORTABLE BUILDINGS OF METAL; MATERIALS OF METAL FOR RAILWAY TRACKS, NAMELY, RAILS, FASTENING DEVICES, NAMELY, NUTS, BOLTS, SCREWS, AND THREADED FASTENERS; NON ELECTRICAL CABLES WIRES OF COMMON METAL; IRON MONGERY AND SMALL ITEMS OF METAL HARDWARE, NAMELY, NAMELY, PULLEYS, SPRINGS, NUTS AND WASHERS AND STRUCTURAL AND REPLACEMENT PARTS FOR THE AFOREMENTIONED GOODS; PIPES AND TUBES OF METAL; GOODS OF COMMON METAL AS FAR AS INCLUDED IN THIS CLASS, NAMELY, METAL PIPE CONNECTORS, METAL PIPE MUFFS, AND FASTENING DEVICES, NAMELY, NUTS, BOLTS, SCREWS, AND THREADED FASTENERS (U.S. CLS. 2, 12, 13, 14, 23, 25 AND 50).

SETH A. RAPPAPORT, EXAMINING ATTORNEY

CLASS 6—(Continued).

SN 79-064,943. JOHN GJERDE AS, NORWAY, FILED 8-27-2008.



PRIORITY DATE OF 6-2-2008 IS CLAIMED. OWNER OF INTERNATIONAL REGISTRATION 0992219 DATED 8-27-2008, EXPIRES 8-27-2018.

THE NAME "JOHN GJERDE" DOES NOT IDENTIFY A LIVING INDIVIDUAL.

THE MARK CONSISTS OF THE WORDING "JOHN GJERDE" AND A DESIGN OF A SQUARE ENCASING FOUR GEOMETRIC SHAPES FORMING THE HIGHLY STYLIZED LETTER "G".

FOR VALVES OF METAL NOT BEING PARTS OF MACHINES, NAMELY, VALVES FOR SHIPS, VESSELS AND FLOATING INSTALLATIONS; AIR VENTILATION VALVES, NAMELY, METAL AIR VENTILATION VALVES NOT BEING PARTS OF MACHINES FOR ALLOWING TANKS TO BREATHE DURING FILLING, DRAINING, VOLUME DISPLACEMENT AND VOLUME VARIATIONS CAUSED BY THERMAL CHANGES AND FOR PREVENTING INGRESS OF SEAWATER ON SERVICE TANKS CARRYING BALLAST, FUEL OIL, LUBRICATED OIL AND/OR DRINKING WATER; VALVES OF COMMON METAL NOT BEING PARTS OF MACHINES (U.S. CLS. 2, 12, 13, 14, 23, 25 AND 50).

LAURA HAMMEL, EXAMINING ATTORNEY

CLASS 7—MACHINERY

SN 76-682,293. SOUTHARD, ROBERT C., HOUSTON, TX. FILED 9-25-2007.

SOUTHARD-DRIL

THE MARK CONSISTS OF STANDARD CHARACTERS WITHOUT CLAIM TO ANY PARTICULAR FONT, STYLE, SIZE, OR COLOR.

SEC. 2(F).

FOR DRILLING APPARATUS, NAMELY, EARTH BORING DEVICES FOR DRILLING BORE HOLES; DRILL BITS USED TO DRILL THROUGH SUBTERRANEAN ZONES INCLUDING HYDROCARBON RESERVOIRS; DRILLING SYSTEMS COMPRISING TUBULAR MEMBERS AND A DRILL BIT; DRILLING SYSTEMS FOR DRILLING SUBTERRANEAN ZONES COMPRISING AN INNER BIT AND AN OUTER BIT (U.S. CLS. 13, 19, 21, 23, 31, 34 AND 35).

FIRST USE 9-26-2007; IN COMMERCE 9-26-2007.

ANNE MADDEN, EXAMINING ATTORNEY

CLASS 7—(Continued).

SN 76-685,763. FORDIA GROUP INC., SAINT-LAURENT, QUEBEC, CANADA, FILED 1-14-2008.



PRIORITY CLAIMED UNDER SEC. 44(D) ON CANADA APPLICATION NO. 1,357,057, FILED 7-25-2007, REG. NO. TMA723181, DATED 9-8-2008, EXPIRES 9-8-2023.

THE GREY TONES IN THE DRAWING ARE TO SHOW SHADING NOT COLOR.

FOR HYDRAULIC DRILLING TOOLS, NAMELY, DRILL RIGS (U.S. CLS. 13, 19, 21, 23, 31, 34 AND 35).
JAMES LOVELACE, EXAMINING ATTORNEY

SN 76-694,270. BOWMAN TOOL COMPANY, EAST BERLIN, PA. FILED 11-17-2008.

DOMINATOR

THE MARK CONSISTS OF STANDARD CHARACTERS WITHOUT CLAIM TO ANY PARTICULAR FONT, STYLE, SIZE, OR COLOR.

FOR CUTTING MACHINE MOVABLE IN UNDERGROUND CONDUITS (U.S. CLS. 13, 19, 21, 23, 31, 34 AND 35).

FIRST USE 3-13-2008; IN COMMERCE 3-13-2008.
PAUL E. FAHRENKOPF, EXAMINING ATTORNEY

SN 77-212,401. CLAYMORE FIELD SERVICES, STETTLER, CANADA, FILED 6-21-2007.

WIREDRYER

THE MARK CONSISTS OF STANDARD CHARACTERS WITHOUT CLAIM TO ANY PARTICULAR FONT, STYLE, SIZE, OR COLOR.

PRIORITY CLAIMED UNDER SEC. 44(D) ON CANADA APPLICATION NO. 1329369, FILED 12-21-2006, REG. NO. TMA703067, DATED 12-13-2007, EXPIRES 12-13-2022.

FOR DEVICES FOR SEPARATING OIL AND SAND, NAMELY, OIL SEPARATORS (U.S. CLS. 13, 19, 21, 23, 31, 34 AND 35).

MATTHEW MCDOWELL, EXAMINING ATTORNEY

CLASS 7—(Continued).

SN 77-324,731. AMERICAN HANDLING SYSTEMS, INC., DBA POSITECH CORPORATION, LAURENS, IA. FILED 11-8-2007.

The word "Positech" is written in a very bold, italicized, sans-serif font. The letters are thick and closely spaced, with a slight slant to the right.

THE MARK CONSISTS OF "POSITECH" IN STYLIZED TEXT.

FOR INDUSTRIAL MATERIAL HANDLING EQUIPMENT, MAINLY LIFT ASSIST DEVICES IN THE NATURE OF ELECTRIC OR PNEUMATIC BALANCERS FOR POSITIONING INDUSTRIAL WORK LOADS (U.S. CLS. 13, 19, 21, 23, 31, 34 AND 35).

FIRST USE 4-25-1997; IN COMMERCE 4-25-1997.
H. M. FISHER, EXAMINING ATTORNEY

SN 77-335,757. EQUIPEMENTS COMACT INC./COMACT EQUIPMENT INC., CANTON TREMBLAY(QUEBEC, CANADA, FILED 11-21-2007.

CETEC

THE MARK CONSISTS OF STANDARD CHARACTERS WITHOUT CLAIM TO ANY PARTICULAR FONT, STYLE, SIZE, OR COLOR.

PRIORITY CLAIMED UNDER SEC. 44(D) ON CANADA APPLICATION NO. 1348193, FILED 5-22-2007, REG. NO. TMA715686, DATED 6-3-2008, EXPIRES 6-3-2023.

FOR INDUSTRIAL BANDSAW TO CUT LOG OR TIMBER USED IN THE LUMBER AND THE SAWMILL INDUSTRY (U.S. CLS. 13, 19, 21, 23, 31, 34 AND 35).

KHANH LE, EXAMINING ATTORNEY

SN 77-355,327. CU-BIC SPACE, LLC, SAGINAW, TX. FILED 12-19-2007.

Q-LOC

THE MARK CONSISTS OF STANDARD CHARACTERS WITHOUT CLAIM TO ANY PARTICULAR FONT, STYLE, SIZE, OR COLOR.

FOR LATCHING MECHANISMS FOR STATIONARY POWER-OPERATED LIFTING PLATFORMS, ALL IN THE NATURE OF METAL LATCHING PARTS FOR STATIONARY POWER-OPERATED LIFTING PLATFORMS USED FOR STORAGE-RELATED PURPOSES (U.S. CLS. 13, 19, 21, 23, 31, 34 AND 35).

MAUREEN DALL, EXAMINING ATTORNEY

CLASS 7—(Continued).

SN 77-396,237. KLEENOIL USA, INC., SHREVEPORT, LA. FILED 2-13-2008.

MAKE GREEN THE NEW COLOR
OF YOUR BOTTOM LINE

THE MARK CONSISTS OF STANDARD CHARACTERS WITHOUT CLAIM TO ANY PARTICULAR FONT, STYLE, SIZE, OR COLOR.

NO CLAIM IS MADE TO THE EXCLUSIVE RIGHT TO USE "GREEN", APART FROM THE MARK AS SHOWN.

FOR ON-BOARD OIL RECYCLING, RESTORATION AND RECLAMATION SYSTEM COMPRISED OF A FILTER HOUSING WITH A FILTER MEDIUM USED TO FILTER LUBRICATING OILS (U.S. CLS. 13, 19, 21, 23, 31, 34 AND 35).

NAPOLEON SHARMA, EXAMINING ATTORNEY

SN 77-449,421. PUMPTEC INC., ANOKA, MN. FILED 4-16-2008.

ABSOLUTE PROPORTIONING

THE MARK CONSISTS OF STANDARD CHARACTERS WITHOUT CLAIM TO ANY PARTICULAR FONT, STYLE, SIZE, OR COLOR.

NO CLAIM IS MADE TO THE EXCLUSIVE RIGHT TO USE "PROPORTIONING", APART FROM THE MARK AS SHOWN.

FOR METERING SYSTEMS AND COMPONENTS THEREOF, NAMELY, PUMPS, STORAGE TANKS, PIPELINES AND NOZZLES FOR METERING OUT TWO OR MORE INPUT FLUIDS FOR DOMESTIC, COMMERCIAL, AND INDUSTRIAL APPLICATIONS (U.S. CLS. 13, 19, 21, 23, 31, 34 AND 35).

CIMMERIAN COLEMAN, EXAMINING ATTORNEY

CLASS 7—(Continued).

SN 77-504,499. AUTOMATED MAILING SYSTEMS CORP., DALLAS, TX. FILED 6-20-2008.

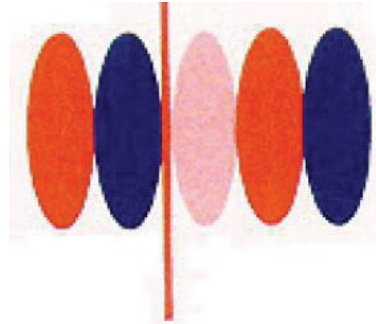

OWNER OF U.S. REG. NO. 2,198,895.
THE COLOR(S) RED, LIGHT RED AND BLUE IS/ARE CLAIMED AS A FEATURE OF THE MARK.

THE MARK CONSISTS OF FIVE OVALS WITH A HORIZONTAL LINE. BETWEEN THE TWO OVALS ON THE RIGHT AND THE THREE OVALS ON THE LEFT IS A LONG VERTICAL RED LINE. THE COLOR OF THE OVALS FROM LEFT TO RIGHT ARE RED, BLUE, LIGHT RED, RED AND BLUE.

FOR CORRESPONDENCE AND PACKAGE PROCESSING EQUIPMENT, NAMELY, MACHINES FOR LABELING, SORTING, IMPRINTING, FOLDING, STACKING, INSERTING, INDEXING, ADDRESSING, WRAPPING, SEALING AND OPENING MAIL PACKAGING (U.S. CLS. 13, 19, 21, 23, 31, 34 AND 35).

FIRST USE 0-0-1957; IN COMMERCE 0-0-1957.

CHRISTINA SOBRAL, EXAMINING ATTORNEY

SN 77-512,389. LONGYEAR TM, INC., SOUTH JORDAN, UT. FILED 7-1-2008.

STOPEMASTER

THE MARK CONSISTS OF STANDARD CHARACTERS WITHOUT CLAIM TO ANY PARTICULAR FONT, STYLE, SIZE, OR COLOR.

FOR DRILLING RIGS (U.S. CLS. 13, 19, 21, 23, 31, 34 AND 35).

SUSAN STIGLITZ, EXAMINING ATTORNEY

CLASS 7—(Continued).

SN 77-516,461. KARMAN RUBBER COMPANY, AKRON, OH. FILED 7-8-2008.

VIBRO INSULATORS

THE MARK CONSISTS OF STANDARD CHARACTERS WITHOUT CLAIM TO ANY PARTICULAR FONT, STYLE, SIZE, OR COLOR.

OWNER OF U.S. REG. NO. 2,831,753.

NO CLAIM IS MADE TO THE EXCLUSIVE RIGHT TO USE "INSULATORS", APART FROM THE MARK AS SHOWN.

SEC. 2(F).

FOR MACHINERY MOUNTINGS OR SUPPORTS FABRICATED OF RUBBER AND METAL (U.S. CLS. 13, 19, 21, 23, 31, 34 AND 35).

FIRST USE 1-1-1985; IN COMMERCE 1-1-1985.

STEVEN R. FOSTER, EXAMINING ATTORNEY

SN 77-534,904. REAY, GAVIN. LONDON SW151DQ, UNITED KINGDOM, FILED 7-30-2008.

STIRR A REVOLUTION IN YOUR PAN

THE MARK CONSISTS OF STANDARD CHARACTERS WITHOUT CLAIM TO ANY PARTICULAR FONT, STYLE, SIZE, OR COLOR.

FOR KITCHEN MACHINES FOR FOOD PREPARATION, NAMELY, ELECTRIC MIXERS (U.S. CLS. 13, 19, 21, 23, 31, 34 AND 35).

EDWARD FENNESSY, EXAMINING ATTORNEY

SN 77-535,862. IRWIN INDUSTRIAL TOOL COMPANY, ATLANTA, GA. FILED 7-31-2008.

SNAP-BACK

THE MARK CONSISTS OF STANDARD CHARACTERS WITHOUT CLAIM TO ANY PARTICULAR FONT, STYLE, SIZE, OR COLOR.

FOR HOLE SAW BLADES FOR POWER TOOLS, AND ARBORS FOR HOLE SAW BLADES FOR POWER TOOLS (U.S. CLS. 13, 19, 21, 23, 31, 34 AND 35).

LESLIE RICHARDS, EXAMINING ATTORNEY

CLASS 7—(Continued).

SN 77-539,564. THE BLACK & DECKER CORPORATION, TOWSON, MD. FILED 8-5-2008.



NO CLAIM IS MADE TO THE EXCLUSIVE RIGHT TO USE "ZERO EMISSIONS", APART FROM THE MARK AS SHOWN.

THE MARK CONSISTS OF A SLIGHTLY CURVED REPRESENTATION OF A WINDOW INSIDE A SQUARE BACKGROUND IN WHICH THE WINDOW CONTAINS THE LITERAL ELEMENT "ZERO EMISSIONS IN YOUR YARD" AGAINST A LAWN VIEW WITH CLOUDS ABOVE AND GRASS BELOW.

FOR BATTERY POWERED LAWN AND GARDEN TOOLS, NAMELY, STRING TRIMMERS, HEDGE TRIMMERS, BLOWERS AND VACUUMS FOR LAWN DEBRIS, CULTIVATORS, CHAIN SAWS, AND MOWERS (U.S. CLS. 13, 19, 21, 23, 31, 34 AND 35).

JULIE WATSON, EXAMINING ATTORNEY

SN 77-563,736. EMCO MAIER CORPORATION, COLUMBUS, OH. FILED 9-5-2008.



THE MARK CONSISTS OF THE LETTER "V" IN A CIRCLE.

FOR MACHINE TOOLS CONTROLLED NUMERICALLY VIA COMPUTER, NAMELY, LATHES AND MILLING, BORING, DRILLING AND TAPPING MACHINES (U.S. CLS. 13, 19, 21, 23, 31, 34 AND 35).

FIRST USE 7-15-2008; IN COMMERCE 1-13-2009.

TRACY FLETCHER, EXAMINING ATTORNEY

CLASS 7—(Continued).

SN 77-580,031. LONGYEAR TM, INC., SOUTH JORDAN, UT. FILED 9-26-2008.

CLASS 7—(Continued).

SN 77-594,211. PSK INC., GYEONGGI-DO, REPUBLIC OF KOREA, FILED 10-16-2008.

DELTATOOLS

FUTAS

THE MARK CONSISTS OF STANDARD CHARACTERS WITHOUT CLAIM TO ANY PARTICULAR FONT, STYLE, SIZE, OR COLOR.

FOR POWER OPERATED EARTH DRILLING TOOLS AND EQUIPMENT AND PARTS THEREFOR, NAMELY, CASINGS AND EARTH DRILLING MACHINES AND PARTS THEREFOR; EARTH DRILLING GROUTING TOOLS AND EQUIPMENT AND PARTS THEREFOR, NAMELY, GROUTING MACHINES AND PARTS THEREFOR FOR USE IN THE FIELD OF EARTH DRILLING (U.S. CLS. 13, 19, 21, 23, 31, 34 AND 35).
HOWARD SMIGA, EXAMINING ATTORNEY

THE MARK CONSISTS OF STANDARD CHARACTERS WITHOUT CLAIM TO ANY PARTICULAR FONT, STYLE, SIZE, OR COLOR.

PRIORITY CLAIMED UNDER SEC. 44(D) ON REPUBLIC OF KOREA APPLICATION NO. 40-2008-0022, FILED 5-8-2008.

OWNER OF REPUBLIC OF KOREA REG. NO. 40-0782045, DATED 3-9-2009, EXPIRES 3-9-2019.

"FUTAS" HAS NO MEANING IN A FOREIGN LANGUAGE.

FOR MACHINES FOR TREATING SEMICONDUCTOR WAFERS; ETCHING MACHINES USED FOR TREATING SEMICONDUCTOR WAFERS; ASHING MACHINES USED FOR TREATING SEMICONDUCTOR WAFERS; AND CLEANING MACHINES USED FOR TREATING SEMICONDUCTOR WAFERS (U.S. CLS. 13, 19, 21, 23, 31, 34 AND 35).

DAVID MILLER, EXAMINING ATTORNEY

SN 77-588,537. PENTAIR FILTRATION, INC., SHEBOYGAN, WI. FILED 10-8-2008.

SN 77-627,509. SANDIA PLASTICS, INC., HUNTINGTON BEACH, CA. FILED 12-5-2008.

DRIFLEX

ALL HEPA ALL THE TIME

THE MARK CONSISTS OF STANDARD CHARACTERS WITHOUT CLAIM TO ANY PARTICULAR FONT, STYLE, SIZE, OR COLOR.

FOR SEPARATION AND FILTRATION SYSTEMS COMPRISED PRIMARILY OF PUMPS, MOTORS, SEPARATION MEMBRANES AND FILTERS FOR REMOVING ENTRAINED WATER, GASES AND PARTICLES FROM MACHINE LUBRICANTS AND HYDRAULIC FLUIDS (U.S. CLS. 13, 19, 21, 23, 31, 34 AND 35).
RONALD MCMORROW, EXAMINING ATTORNEY

THE MARK CONSISTS OF STANDARD CHARACTERS WITHOUT CLAIM TO ANY PARTICULAR FONT, STYLE, SIZE, OR COLOR.

FOR CLEANING EQUIPMENT, NAMELY, VACUUM CLEANERS (U.S. CLS. 13, 19, 21, 23, 31, 34 AND 35).
RICHARD WHITE, EXAMINING ATTORNEY

CLASS 7—(Continued).

SN 77-636,249. GENERAL ELECTRIC COMPANY, SCHE-
NECTADY, NY. FILED 12-18-2008.

INNOVATION YOU DON'T HAVE
TO WAIT FOR

THE MARK CONSISTS OF STANDARD CHARACTERS
WITHOUT CLAIM TO ANY PARTICULAR FONT, STYLE,
SIZE, OR COLOR.

FOR ENGINES USING ALTERNATIVE FUELS,
NAMELY, GAS, COAL, MINE GAS, BIOGAS CREATED
DURING THE FERMENTATION OF AGRICULTURAL
WASTE, SEWAGE GAS AND INDUSTRIAL WASTE GAS;
APPARATUS, EQUIPMENT AND INSTRUMENTS FOR
THE GENERATION OF POWER, NAMELY, ELECTRIC
GENERATORS AND WIND POWERED ELECTRICITY
GENERATORS; TURBINES; TURBINES FOR POWER
GENERATION; WIND TURBINES FOR POWER GEN-
ERATION; WIND TURBINES IN ASSOCIATION WITH
WIND FARMS, TURBINE GENERATING INSTALLA-
TIONS, NAMELY, POWER GENERATING INSTALLA-
TIONS; ENGINES FOR THE GENERATION OF
ELECTRICITY; AND PARTS AND FITTINGS FOR ALL
THE AFORESAID; SOLAR-POWERED ELECTRICITY
GENERATORS; HYDROELECTRIC POWER GENERA-
TORS; COMPLETE LINE OF MATERIALS, APPLI-
ANCES, MACHINERY, COMPONENTS, PARTS,
SYSTEMS AND PLANTS FOR THE GENERATION,
TRANSFORMATION, CONVERSION, TRANSMISSION,
DISTRIBUTION, CONTROL AND UTILIZATION OF
ELECTRICITY; DYNAMO ELECTRIC MACHINES, IN-
DUCTION DEVICES, ELECTRIC TRANSLATING DE-
VICES, ELECTRIC REGULATING AND
CONTROLLING DEVICES, ELECTRIC LAMPS, ELEC-
TRIC MEASURING INSTRUMENTS, ELECTRIC PRO-
TECTIVE DEVICES, SWITCHBOARDS, SWITCHBOARD
APPLIANCES, WIRING DEVICES, AND SUPPLIES;
ELECTRIC MOTORS OF ALL KINDS, STEAM AND
GAS TURBINES AND PARTS THEREOF, ELECTRIC
GENERATORS AND THEIR PARTS, AIRCRAFT EN-
GINES, COMPRESSORS; WASHING MACHINES, LAUN-
DRY CENTERS, NAMELY, A CLOTHES WASHER
COMBINED WITH A CLOTHES DRYER, DISH-
WASHERS, GARBAGE DISPOSERS AND COMPAC-
TORS; PUMPS, NAMELY, CENTRIFUGAL PUMPS,
DIAPHRAGM PUMPS, BELLOWS PUMPS AND PRO-
CESS AND TRANSFER PUMPS; FLUID CONTROL
DEVICES, NAMELY, VALVES, FLOW METERS, PRES-
SURE SWITCHES, SEQUENCE TIMERS, REGULATORS,
LEVELERS, EJECTORS, AND ELECTRICAL CONTROLS
AND SWITCHES; FLUID SEPARATION CARTRIDGES
AND PARTS THEREFORE, INCLUDING SEMI-PERME-
ABLE MEMBRANES; FILTER CARTRIDGES FOR VAR-
IOUS INDUSTRIAL MACHINES FOR FILTRATION
APPLICATIONS INCLUDING THE FILTRATION OF
COATING SOLUTIONS FOR THE MANUFACTURE OF
MAGNETIC TAPE AND THE FILTRATION OF PETRO-
CHEMICALS, PORTABLE WATER, BEER IN THE
BREWING INDUSTRY, AND OTHER SPECIALTY CHE-
MICALS, MACHINES FOR THE FEEDING AND APPLI-
CATION OF CHEMICALS FOR INDUSTRIAL USE;
AXIAL AND CENTRIFUGAL COMPRESSORS; RECI-
PROCATING COMPRESSORS; SCREW AND VANE
COMPRESSORS; ROTARY, VACUUM, ELECTRIC, SUB-
MERSIBLE AND CENTRIFUGAL PUMPS; TURBO EX-
PANDERS, NAMELY, AIR AND ELECTRIC
COMPRESSORS; CNG REFUELING MACHINES FOR
LAND VEHICLES AND INDUSTRIAL EQUIPMENT
AND ACCESSORIES AND PARTS FOR ALL THE FORE-
GOING, NAMELY, PUMPS, VALVES, FUEL FILTERS,
FILTER CASINGS, DISTRIBUTOR ROTORS, BLADES,
BEARINGS AND MECHANICAL SEALS; STEAM CON-
DENSERS; BOAT ENGINES; TURBOCHARGERS FOR
ENGINES; FUEL INJECTORS; ELECTRIC MIXERS;
ELECTRIC KNIVES; ELECTRIC CAN OPENERS, VA-
CUUM CLEANERS (U.S. CLS. 13, 19, 21, 23, 31, 34 AND
35).

PAUL F. GAST, EXAMINING ATTORNEY

CLASS 7—(Continued).

SN 77-636,531. MUSTANG VACUUM SYSTEMS, LLC, SAR-
ASOTA, FL. FILED 12-19-2008.

Mustang Solar

THE MARK CONSISTS OF STANDARD CHARACTERS
WITHOUT CLAIM TO ANY PARTICULAR FONT, STYLE,
SIZE, OR COLOR.

NO CLAIM IS MADE TO THE EXCLUSIVE RIGHT TO
USE "SOLAR", APART FROM THE MARK AS SHOWN.

FOR MACHINERY, NAMELY, FOR APPLICATION OF
UNIFORM THIN-FILM COATING PROCESS FOR
PHOTOVOLTAIC/SOLAR CELL MANUFACTURING
(U.S. CLS. 13, 19, 21, 23, 31, 34 AND 35).

FIRST USE 1-1-2008; IN COMMERCE 1-1-2008.

JACQUELINE A. LAVINE, EXAMINING ATTORNEY

SN 77-639,647. DELAWARE CAPITAL FORMATION, INC.,
WILMINGTON, DE. FILED 12-24-2008.

SIDEWINDER

THE MARK CONSISTS OF STANDARD CHARACTERS
WITHOUT CLAIM TO ANY PARTICULAR FONT, STYLE,
SIZE, OR COLOR.

FOR NON-METAL ROD CENTRALIZING GUIDE FOR
USE IN SUBTERRANEAN OIL AND GAS WELLS,
WHEREBY THE GUIDE ATTACHES TO A CYLINDRI-
CAL ROD BEFORE THE ROD IS PLACED WITHIN A
WELL BORE AND PREVENTS THE ROD FROM MOV-
ING SIDEWAYS OR WOBBLING WITHIN THE WELL
BORE (U.S. CLS. 13, 19, 21, 23, 31, 34 AND 35).

FIRST USE 11-12-2007; IN COMMERCE 11-12-2007.

NICHOLAS COLEMAN, EXAMINING ATTORNEY

CLASS 7—(Continued).

SN 77-644,615. HOUSTON HYDRAULIC SALES AND SERVICE, INC., HOUSTON, TX. FILED 1-7-2009.

HYDRABARIC

THE MARK CONSISTS OF STANDARD CHARACTERS WITHOUT CLAIM TO ANY PARTICULAR FONT, STYLE, SIZE, OR COLOR.

FOR INDUSTRIAL TOOLS AND MACHINE PARTS AND COMPONENTS FOR PRESSURE AND FORCE PRODUCTION, NAMELY, ELECTRIC TENSIONER PUMPS; INDUSTRIAL SYSTEMS AND TOOLS USED PRIMARILY IN THE POWER GENERATION INDUSTRY, NAMELY, HYDRAULIC TENSIONING AND TORQUING TOOLS, HYDRAULIC RAM AND PUMP COMBINATION SETS AND POWER UNITS; HYDRAULIC AND PNEUMATIC PUMPS, RAMS, CYLINDERS, VALVES AND VALVE ACTUATORS; HYDRAULIC AND PNEUMATIC POWER UNITS (U.S. CLS. 13, 19, 21, 23, 31, 34 AND 35).

FIRST USE 4-1-2008; IN COMMERCE 4-1-2008.
RAUL CORDOVA, EXAMINING ATTORNEY

CLASS 7—(Continued).

SN 77-656,598. MARTIN ENGINEERING COMPANY, NEPONSET, IL. FILED 1-26-2009.

EVO

THE MARK CONSISTS OF STANDARD CHARACTERS WITHOUT CLAIM TO ANY PARTICULAR FONT, STYLE, SIZE, OR COLOR.

FOR BULK MATERIAL TRANSFER SYSTEMS, COMPRISED OF CONVEYOR BELT SYSTEMS, VIBRATION INDUCERS, AERATORS, UNLOADERS, TRANSFER CHUTES, AND PARTS AND ACCESSORIES THEREFOR (U.S. CLS. 13, 19, 21, 23, 31, 34 AND 35).

PAUL MORENO, EXAMINING ATTORNEY

SN 77-651,657. RONES, SEAN, SAN DIEGO, CA. FILED 1-16-2009.

H2Oflo

THE MARK CONSISTS OF STANDARD CHARACTERS WITHOUT CLAIM TO ANY PARTICULAR FONT, STYLE, SIZE, OR COLOR.

FOR STEAM CLEANING MACHINES (U.S. CLS. 13, 19, 21, 23, 31, 34 AND 35).

FIRST USE 11-1-2008; IN COMMERCE 11-1-2008.
LESLEY LAMOTHE, EXAMINING ATTORNEY

SN 77-657,410. BILLY GOAT INDUSTRIES, INC., LEE'S SUMMIT, MO. FILED 1-27-2009.



SN 77-652,934. SHOP VAC CORPORATION, WILLIAMSPORT, PA. FILED 1-20-2009.

MINI PRO

THE MARK CONSISTS OF STANDARD CHARACTERS WITHOUT CLAIM TO ANY PARTICULAR FONT, STYLE, SIZE, OR COLOR.

NO CLAIM IS MADE TO THE EXCLUSIVE RIGHT TO USE "MINI", APART FROM THE MARK AS SHOWN.

FOR VACUUM CLEANERS (U.S. CLS. 13, 19, 21, 23, 31, 34 AND 35).

ELIZABETH KAJUBI, EXAMINING ATTORNEY

OWNER OF U.S. REG. NO. 2,332,293.
THE MARK CONSISTS OF GOAT HEAD SUPERIMPOSED OVER A SOLID CIRCLE.

FOR LAWN AND GARDEN MACHINERY, NAMELY, POWER BLOWERS, VACUUMS AND LOADERS FOR USE WITH ORGANIC AND MAN-MADE DEBRIS; GRASS MOWERS, BRUSH CUTTERS AND LAWN RENOVATION EQUIPMENT, NAMELY, POWER RAKES, OVERSEEDERS, AERATORS, AND SOD CUTTERS AND ATTACHMENTS THEREOF (U.S. CLS. 13, 19, 21, 23, 31, 34 AND 35).

FIRST USE 3-31-1966; IN COMMERCE 3-31-1966.
BRIAN CALLAGHAN, EXAMINING ATTORNEY

CLASS 7—(Continued).

SN 77-657,411. BILLY GOAT INDUSTRIES, INC., LEE'S SUMMIT, MO. FILED 1-27-2009.

BILLY GOAT

THE MARK CONSISTS OF STANDARD CHARACTERS WITHOUT CLAIM TO ANY PARTICULAR FONT, STYLE, SIZE, OR COLOR.

OWNER OF U.S. REG. NO. 2,423,201.
FOR LAWN AND GARDEN MACHINERY, NAMELY, POWER BLOWERS, VACUUMS AND LOADERS FOR USE WITH ORGANIC AND MAN-MADE DEBRIS; GRASS MOWERS, BRUSH CUTTERS AND LAWN RENOVATION EQUIPMENT, NAMELY, POWER RAKES, OVERSEEDERS, AERATORS, AND SOD CUTTERS AND ATTACHMENTS THEREOF (U.S. CLS. 13, 19, 21, 23, 31, 34 AND 35).

FIRST USE 3-31-1966; IN COMMERCE 3-31-1966.
BRIAN CALLAGHAN, EXAMINING ATTORNEY

CLASS 7—(Continued).

SN 77-662,477. WESTCO MANUFACTURING, L.L.C., DALLAS, TX. FILED 2-3-2009.

WESTCO

THE MARK CONSISTS OF STANDARD CHARACTERS WITHOUT CLAIM TO ANY PARTICULAR FONT, STYLE, SIZE, OR COLOR.

FOR MACHINES AND MACHINE TOOLS USED IN WELL SERVICING AND PIPE HANDLING, NAMELY, ROD TONGS, PIPE TONGS, TUBING TONGS, TUBING SPIDERS, HYDRAULIC CASING TONGS, ELECTRO-HYDRAULIC POWER GENERATORS, DIESEL HYDRAULIC POWER GENERATORS (U.S. CLS. 13, 19, 21, 23, 31, 34 AND 35).

FIRST USE 4-1-1999; IN COMMERCE 4-1-1999.
GIANCARLO CASTRO, EXAMINING ATTORNEY

SN 77-662,521. TOOL-FLO MANUFACTURING INC., HOUSTON, TX. FILED 2-3-2009.

BANTAM

THE MARK CONSISTS OF STANDARD CHARACTERS WITHOUT CLAIM TO ANY PARTICULAR FONT, STYLE, SIZE, OR COLOR.

FOR CUTTING TOOLS, NAMELY, BORING BARS (U.S. CLS. 13, 19, 21, 23, 31, 34 AND 35).

FIRST USE 12-1-2008; IN COMMERCE 12-1-2008.
DEZMONA MIZELLE, EXAMINING ATTORNEY

SN 77-660,828. TANGARIE ALTERNATIVE POWER LLC, HILLSBOROUGH, NJ. FILED 1-31-2009.

**GALE
Green Alternative Lasting
Energy**

THE MARK CONSISTS OF STANDARD CHARACTERS WITHOUT CLAIM TO ANY PARTICULAR FONT, STYLE, SIZE, OR COLOR.

NO CLAIM IS MADE TO THE EXCLUSIVE RIGHT TO USE "GREEN ALTERNATIVE" AND "ENERGY", APART FROM THE MARK AS SHOWN.

FOR AIR TURBINES; GENERATORS FOR WIND TURBINES; HYDRAULIC TURBINES; PARTS OF WIND TURBINE MOTORS, NAMELY, COMPACT DRIVE SYSTEMS; PROPELLERS FOR WIND-POWERED ELECTRICITY GENERATORS; TURBINES; TURBINES OTHER THAN FOR LAND VEHICLES; VERTICAL TURBINE PUMPS; WIND TURBINES; WIND-POWERED ELECTRICITY GENERATORS (U.S. CLS. 13, 19, 21, 23, 31, 34 AND 35).

ERIN FALK, EXAMINING ATTORNEY

SN 77-663,270. EMHART GLASS S.A., CHAM CH-6330, SWITZERLAND, FILED 2-4-2009.

SIS

THE MARK CONSISTS OF STANDARD CHARACTERS WITHOUT CLAIM TO ANY PARTICULAR FONT, STYLE, SIZE, OR COLOR.

FOR GLASS FORMING EQUIPMENT, NAMELY, GLASS FEEDERS, GLASS FORMING MACHINES, GLASS INSPECTION MACHINES, AND ELECTRICAL CONTROL SYSTEMS SOLD AS A COMPONENT PART OF THE LISTED GLASS FORMING EQUIPMENT (U.S. CLS. 13, 19, 21, 23, 31, 34 AND 35).

TOBY BULLOFF, EXAMINING ATTORNEY

CLASS 7—(Continued).

SN 77-664,240. FLUID MANAGEMENT, INC., WHEELING, IL. FILED 2-5-2009.

ACCUTINTER

THE MARK CONSISTS OF STANDARD CHARACTERS WITHOUT CLAIM TO ANY PARTICULAR FONT, STYLE, SIZE, OR COLOR.

OWNER OF U.S. REG. NO. 1,500,985.
FOR COMPUTER CONTROLLED FLUID DISPENSING MACHINES FOR INDUSTRIAL, COMMERCIAL AND DOMESTIC USE (U.S. CLS. 13, 19, 21, 23, 31, 34 AND 35).
FIRST USE 2-28-1980; IN COMMERCE 2-28-1980.
MATTHEW PAPPAS, EXAMINING ATTORNEY

CLASS 7—(Continued).

SN 77-666,260. WIDGETEER, INC., OAKWOOD HILLS, IL. FILED 2-9-2009.

VAC-IT

THE MARK CONSISTS OF STANDARD CHARACTERS WITHOUT CLAIM TO ANY PARTICULAR FONT, STYLE, SIZE, OR COLOR.

OWNER OF U.S. REG. NO. 3,596,304.
FOR VACUUM SEAL SYSTEM COMPRISING A VACUUM PUMP AND RE-USABLE ONE-WAY AIR VALVE SNAPS FOR EXTRACTING AIR FROM AND SEALING PLASTIC BAGS (U.S. CLS. 13, 19, 21, 23, 31, 34 AND 35).
FIRST USE 3-16-2008; IN COMMERCE 3-16-2008.
CYNTHIA SLOAN, EXAMINING ATTORNEY

SN 77-664,823. BEACH FILTER PRODUCTS, INC., GLEN ROCK, PA. FILED 2-6-2009.

FLUIDGUARD

THE MARK CONSISTS OF STANDARD CHARACTERS WITHOUT CLAIM TO ANY PARTICULAR FONT, STYLE, SIZE, OR COLOR.

FOR OIL FILTERS (U.S. CLS. 13, 19, 21, 23, 31, 34 AND 35).
RICHARD A. STRASER, EXAMINING ATTORNEY

SN 77-667,047. AEROWERKS, INC., MISSISSAUGA, CANADA, FILED 2-10-2009.

SPACEMISER

THE MARK CONSISTS OF STANDARD CHARACTERS WITHOUT CLAIM TO ANY PARTICULAR FONT, STYLE, SIZE, OR COLOR.

FOR CONVEYOR LINES; CONVEYORS (U.S. CLS. 13, 19, 21, 23, 31, 34 AND 35).
ELI HELLMAN, EXAMINING ATTORNEY

SN 77-665,405. MCNEILLY, ROBERT LAWRENCE, COURTENAY BC, CANADA, FILED 2-6-2009.

Snobob

THE MARK CONSISTS OF STANDARD CHARACTERS WITHOUT CLAIM TO ANY PARTICULAR FONT, STYLE, SIZE, OR COLOR.

OWNER OF CANADA REG. NO. TMA575230, DATED 2-6-2003, EXPIRES 12-12-2015.
FOR SNOW REMOVAL MACHINE (U.S. CLS. 13, 19, 21, 23, 31, 34 AND 35).
JOHN HWANG, EXAMINING ATTORNEY

SN 77-674,455. GRANQUARTZ HOLDINGS, LLC, TUCKER, GA. FILED 2-20-2009.

MAGNUM

THE MARK CONSISTS OF STANDARD CHARACTERS WITHOUT CLAIM TO ANY PARTICULAR FONT, STYLE, SIZE, OR COLOR.

FOR VACUUM CLEANERS FOR INDUSTRIAL PURPOSES (U.S. CLS. 13, 19, 21, 23, 31, 34 AND 35).
FIRST USE 5-0-2006; IN COMMERCE 5-0-2006.
VERNA BETH RIRIE, EXAMINING ATTORNEY

CLASS 7—(Continued).

SN 77-684,757. EMHART GLASS S.A., CHAM, SWITZERLAND, FILED 3-5-2009.

NIS

THE MARK CONSISTS OF STANDARD CHARACTERS WITHOUT CLAIM TO ANY PARTICULAR FONT, STYLE, SIZE, OR COLOR.

FOR GLASS FORMING EQUIPMENT, NAMELY, GLASS FEEDERS, GLASS FORMING MACHINES, GLASS INSPECTION MACHINES, AND ELECTRICAL CONTROL SYSTEMS SOLD AS A COMPONENT PART OF THE LISTED GLASS FORMING EQUIPMENT (U.S. CLS. 13, 19, 21, 23, 31, 34 AND 35).

TOBY BULLOFF, EXAMINING ATTORNEY

SN 79-056,411. STAUBLI INTERNATIONAL AG, SWITZERLAND, FILED 6-16-2008.



PRIORITY DATE OF 12-20-2007 IS CLAIMED. OWNER OF INTERNATIONAL REGISTRATION 0971097 DATED 6-16-2008, EXPIRES 6-16-2018.

THE MARK CONSISTS OF THE TERM "STERICLEAN" APPEARING IN STYLIZED FONT BETWEEN TWO BRACKETS.

FOR INDUSTRIAL ROBOTS AND STRUCTURAL PARTS THEREFOR (U.S. CLS. 13, 19, 21, 23, 31, 34 AND 35).

KATHERINE E. HALMEN, EXAMINING ATTORNEY

SN 79-057,309. FORBO FINANCIAL SERVICES AG, SWITZERLAND, FILED 5-29-2008.

PROPIPE

THE MARK CONSISTS OF STANDARD CHARACTERS WITHOUT CLAIM TO ANY PARTICULAR FONT, STYLE, SIZE, OR COLOR.

PRIORITY DATE OF 11-30-2007 IS CLAIMED. OWNER OF INTERNATIONAL REGISTRATION 0973178 DATED 5-29-2008, EXPIRES 5-29-2018.

FOR CONVEYOR BELTS AND BAND CONVEYORS FOR THE TRANSPORT OF ALL KINDS OF GOODS; BELTS FOR MACHINES, NAMELY, FEEDER BELTS FOR BOARD AND PANEL PROCESSING AND HAUL-OFF BELTS FOR HAUL-OFF UNITS; MACHINES FOR THE PROCESSING AND TREATMENT OF PLASTICS; ALL THE AFOREMENTIONED GOODS WHICH ARE NOT IN CONNECTION WITH PIPE MANUFACTURE (U.S. CLS. 13, 19, 21, 23, 31, 34 AND 35).

CHRISIE B. KING, EXAMINING ATTORNEY

CLASS 7—(Continued).

SN 79-058,944. SOILMEC S.P.A., I-47023 CESENA (FO), ITALY, FILED 2-13-2008.

CTjet

THE MARK CONSISTS OF STANDARD CHARACTERS WITHOUT CLAIM TO ANY PARTICULAR FONT, STYLE, SIZE, OR COLOR.

PRIORITY DATE OF 12-10-2007 IS CLAIMED.

OWNER OF INTERNATIONAL REGISTRATION 0977484 DATED 2-13-2008, EXPIRES 2-13-2018.

FOR DRILLING MACHINES USED TO MAKE BORES, WALLS, DIAPHRAGMS AND TRENCHES IN THE SOIL; MACHINES FOR SEPARATING EXCAVATED TARGET MATERIALS IN THE NATURE OF MIXING SOIL FROM MIXTURES OF MATERIALS CONTAINING FLUIDS (U.S. CLS. 13, 19, 21, 23, 31, 34 AND 35).

CHRISTINE BLOMQUIST, EXAMINING ATTORNEY

SN 79-065,153. HEBEI ASIAN SAGE INDUSTRY CO., LTD., CHINA, FILED 8-28-2008.

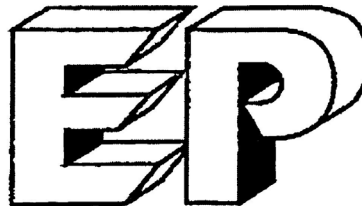

OWNER OF INTERNATIONAL REGISTRATION 0992844 DATED 8-28-2008, EXPIRES 8-28-2018.

FOR PAPERMAKING MACHINES; BOARD MACHINE FOR THE WINDING OF PAPER; PAPER REELING MACHINE; MACHINES PARTS FOR PAPERMAKING MACHINES, NAMELY, KNIVES AND BOARDS (U.S. CLS. 13, 19, 21, 23, 31, 34 AND 35).

ERNEST SHOSHO, EXAMINING ATTORNEY

CLASS 8—HAND TOOLS

SN 76-689,023. COBRA DIAMOND TOOL & SUPPLY, LLC, CHICAGO, IL. FILED 4-25-2008.



NO CLAIM IS MADE TO THE EXCLUSIVE RIGHT TO USE "DIAMOND TOOL & SUPPLY LLC", APART FROM THE MARK AS SHOWN.

FOR HAND OPERATED CONCRETE CUTTING TOOLS, NAMELY, SAWS, DRILLS, BITS FOR HAND-OPERATED DRILLS AND SAWS FOR HAND OPERATED SAWS (U.S. CLS. 23, 28 AND 44).

FIRST USE 3-1-2008; IN COMMERCE 3-1-2008.
HEATHER BIDDULPH, EXAMINING ATTORNEY

CLASS 8—(Continued).

COLOR IS NOT CLAIMED AS A FEATURE OF THE MARK. PARTICULAR MATERIALS USED IN THE MANUFACTURE OF THE KNIFE HANDLE ARE NOT CLAIMED AS A FEATURE OF THE MARK. THE OVERALL CONTOUR OF THE KNIFE HANDLE IS NOT CLAIMED AS A FEATURE OF THE MARK. THE BLADE IS NOT CLAIMED AS A FEATURE OF THE MARK. THE BROKEN LINES ARE USED TO REPRESENT THE KNIFE IN RELATION TO THE CLAIMED DESIGN AND ARE NOT A PART OF THE MARK.

SEC. 2(F).
FOR CUTLERY, NAMELY, CARVING KNIVES, SLICING KNIVES, CHEF KNIVES, PARING KNIVES, STEAK KNIVES, CLEAVERS, BONING KNIVES, FILLET KNIVES, AND BREAD SLICING KNIVES (U.S. CLS. 23, 28 AND 44).

FIRST USE 11-30-2002; IN COMMERCE 11-30-2002.
EDWARD FENNESSY, EXAMINING ATTORNEY

SN 77-483,063. H&P INDUSTRIAL LTD, HONG KONG, CHINA, FILED 5-24-2008.



THE MARK CONSISTS OF SPOON (UTENSIL IMAGE) WITH THE WORD "UTENSELECT" UNDER THE SPOON.
FOR CUTLERY, NAMELY, FORKS, SPOONS, KNIVES, AND SPORKS (U.S. CLS. 23, 28 AND 44).
KATHLEEN M. VANSTON, EXAMINING ATTORNEY

SN 77-373,909. HELLMAN, PAUL L., DBA GUNTER WILHELM CUTLERY, TENAFLY, NJ. FILED 1-17-2008.

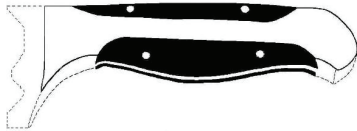

THE MARK CONSISTS OF THREE CONTRASTING SHAPES. THE UPPER SHAPE HAS A VERY SMALL CURVATURE ALONG THE UPPER HORIZONTAL PLANE AND THE LOWER PORTION OF THE UPPER SHAPE HAS ITS ENDS CURVED UPWARD GIVING THE APPEARANCE OF A PROFILE VIEW OF A SIMPLE BOAT OR CANOE; THE MIDDLE SHAPE (TANG PORTION OF THE HANDLE) SEPARATES THE UPPER AND LOWER SHAPES AS A RESULT OF ITS CONTRASTING COLOR, WITH THE LOWER LEFT SIDE OF THE SHAPE CURVING DOWNWARD AT THE HEEL PORTION OF THE KNIFE, AND THE RIGHT SIDE OF THE MIDDLE SHAPE PROTRUDING BEYOND THE UPPER AND LOWER SHAPES AND FORMING A HOOKED CURVATURE GIVING THE APPEARANCE OF AN ICONIC BIRD SHAPE LAYING ON ITS SIDE; THE LOWER SHAPE HAS THE ENDS OF ITS UPPER PORTION CURVED DOWNWARD AND ITS LOWER HORIZONTAL PORTION BEING A WAVE CURVATURE WITH THE MIDDLE SECTION OF THE LOWER PORTION REPRESENTING THE TROUGH OF THE WAVE, GIVING THE LOWER SHAPE THE APPEARANCE OF A SIMPLE UNADORNED PROFILE VIEW OF A BIRD. THE DARK BAND ALONG THE LOWER SECTION OF THE HANDLE SHOWS WHERE THE LOWER SECTION OF THE STYLIZED BIRD DESIGN FROM THE BACK-SIDE OF THE KNIFE HANDLE APPEARS ON THE INNER CONTOUR OF THE HANDLE.

SN 77-528,137. BUCK KNIVES, INC., POST FALLS, ID. FILED 7-22-2008.

X-TRACT ESSENTIAL

THE MARK CONSISTS OF STANDARD CHARACTERS WITHOUT CLAIM TO ANY PARTICULAR FONT, STYLE, SIZE, OR COLOR.
FOR FOLDING KNIVES; MULTI-FUNCTION HAND TOOLS COMPRISED OF SCREWDRIVERS, KNIVES, AND SCISSORS; POCKET KNIVES (U.S. CLS. 23, 28 AND 44).
FIRST USE 7-1-2008; IN COMMERCE 7-1-2008.
JOHN DALIER, EXAMINING ATTORNEY

CLASS 8—(Continued).

SN 77-562,761. ALLIANCE SPORTS GROUP, L.P., GRAND PRAIRIE, TX. FILED 9-4-2008.

TURTLE

THE MARK CONSISTS OF STANDARD CHARACTERS WITHOUT CLAIM TO ANY PARTICULAR FONT, STYLE, SIZE, OR COLOR.

FOR MULTIFUNCTION HAND TOOLS PRIMARILY FOR USE IN HUNTING AND FISHING COMPRISED SOLELY OF PLIERS, WIRE CUTTERS, WIRE STRIPPER, KNIFE, SCREWDRIVERS AND CARABINERS (U.S. CLS. 23, 28 AND 44).

FIRST USE 9-3-2008; IN COMMERCE 9-3-2008.
PAUL CROWLEY, EXAMINING ATTORNEY

CLASS 8—(Continued).

SN 77-663,537. LORENSON, PAT, O'FALLON, MO. FILED 2-4-2009.

SAV-A-CLIMB

THE MARK CONSISTS OF STANDARD CHARACTERS WITHOUT CLAIM TO ANY PARTICULAR FONT, STYLE, SIZE, OR COLOR.

FOR HANDTOOLS, NAMELY, CUTTERS FOR CUTTING ELECTRICAL LINES AND POWER LINES (U.S. CLS. 23, 28 AND 44).

MICHAEL WEBSTER, EXAMINING ATTORNEY

SN 77-614,441. DERBY WORX INC., MILLSTADT, IL. AND WARP SPEED DERBY INC., HARRISBURG, NC. FILED 11-14-2008.

RAILRIDER

THE MARK CONSISTS OF STANDARD CHARACTERS WITHOUT CLAIM TO ANY PARTICULAR FONT, STYLE, SIZE, OR COLOR.

FOR HAND TOOLS, NAMELY, DIES, CLAMPS, AND CAMBER ADJUSTING TOOLS FOR MODEL CAR AXLES IN MODEL CAR RACING (U.S. CLS. 23, 28 AND 44).

JOHN SCHUYLER YARD, EXAMINING ATTORNEY

SN 77-666,751. SPARK LABS, TAMPA, FL. FILED 2-9-2009.

MAGBOLT VERSATILITY KNIFE

THE MARK CONSISTS OF STANDARD CHARACTERS WITHOUT CLAIM TO ANY PARTICULAR FONT, STYLE, SIZE, OR COLOR.

NO CLAIM IS MADE TO THE EXCLUSIVE RIGHT TO USE "KNIFE", APART FROM THE MARK AS SHOWN.

FOR BLADES FOR UTILITY KNIVES; KNIVES; UTILITY KNIVES (U.S. CLS. 23, 28 AND 44).

BARBARA GAYNOR, EXAMINING ATTORNEY

SN 77-661,583. TUSCAN LEVELING, INC., FAIRFIELD, IA. FILED 2-2-2009.

Tuscan Leveling System

THE MARK CONSISTS OF STANDARD CHARACTERS WITHOUT CLAIM TO ANY PARTICULAR FONT, STYLE, SIZE, OR COLOR.

NO CLAIM IS MADE TO THE EXCLUSIVE RIGHT TO USE "LEVELING SYSTEM", APART FROM THE MARK AS SHOWN.

FOR HAND TOOLS, NAMELY, A FLATTENING DEVICE WITH A TOP AND BOTTOM PLATE CONNECTED BY A SHAFT, FOR LEVELING TILE, MARBLE, CERAMIC, ONYX AND GRANITE (U.S. CLS. 23, 28 AND 44).

ANDREW RHIM, EXAMINING ATTORNEY

SN 77-667,030. ORION PHOTO INDUSTRIES, INC., PRESCOTT, AZ. FILED 2-10-2009.

NameStar

THE MARK CONSISTS OF STANDARD CHARACTERS WITHOUT CLAIM TO ANY PARTICULAR FONT, STYLE, SIZE, OR COLOR.

FOR SPOON, FORK, AND UTILITY KNIVES (U.S. CLS. 23, 28 AND 44).

JOHN DALIER, EXAMINING ATTORNEY

CLASS 8—(Continued).

SN 77-668,951. I PLAY, INC., ASHEVILLE, NC. FILED 2-12-2009.



THE MARK CONSISTS OF A STYLIZED SLEEPING SPROUT NESTLED IN AND PARTIALLY SURROUNDED BY THE TWO HALVES OF A POD RESTING ON TWO SMALL FAUX FEET.
FOR BIODEGRADABLE CUTLERY; BIODEGRADABLE CUTLERY, NAMELY, FORKS AND SPOONS; AND CUTLERY (U.S. CLS. 23, 28 AND 44).
AISHA SALEM, EXAMINING ATTORNEY

SN 77-690,392. ANDIS COMPANY, STURTEVANT, WI. FILED 3-13-2009.

SHOW EDGE

THE MARK CONSISTS OF STANDARD CHARACTERS WITHOUT CLAIM TO ANY PARTICULAR FONT, STYLE, SIZE, OR COLOR.
NO CLAIM IS MADE TO THE EXCLUSIVE RIGHT TO USE "EDGE", APART FROM THE MARK AS SHOWN.
FOR BLADES FOR ELECTRIC HAIR CLIPPERS (U.S. CLS. 23, 28 AND 44).
SOPHIA S. KIM, EXAMINING ATTORNEY

CLASS 9—ELECTRICAL AND SCIENTIFIC APPARATUS

SN 76-675,388. EPCSOLUTIONS, INC., GREAT FALLS, VA. FILED 4-11-2007.

AOIP

THE MARK CONSISTS OF STANDARD CHARACTERS WITHOUT CLAIM TO ANY PARTICULAR FONT, STYLE, SIZE, OR COLOR.
FOR COMPUTER NETWORK SYSTEMS COMPRISED OF COMPUTER HARDWARE AND SOFTWARE FOR CREATING RADIO FREQUENCY IDENTIFICATION TAGS FOR GOODS AND TRACKING THOSE SAME GOODS IN TRANSIT (U.S. CLS. 21, 23, 26, 36 AND 38).
KATHLEEN M. VANSTON, EXAMINING ATTORNEY

SN 76-676,188. JOBY, INC., SAN FRANCISCO, CA. FILED 4-30-2007.

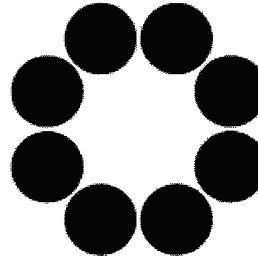

FOR PHOTOGRAPHY AND VIDEOGRAPHY ACCESSORIES, NAMELY, A FLEXIBLE TRIPOD FOR USE WITH CAMERAS, CAMERA FLASHES, AND OTHER PHOTOGRAPHY AND VIDEOGRAPHY EQUIPMENT (U.S. CLS. 21, 23, 26, 36 AND 38).
RENEE SERVANCE, EXAMINING ATTORNEY

SN 76-682,927. BUCKEYE VACUUM CLEANER SUPPLY COMPANY, SMYRNA, GA. FILED 10-15-2007.

EZT
EZ TOOLS

NO CLAIM IS MADE TO THE EXCLUSIVE RIGHT TO USE "TOOLS", APART FROM THE MARK AS SHOWN.
FOR UPRIGHT AND CANISTER VACUUM CLEANERS AND ACCESSORIES AND PARTS THEREFOR, NAMELY, VACUUM CLEANER HOSES AND BUSH ATTACHMENTS (U.S. CLS. 21, 23, 26, 36 AND 38).
FIRST USE 9-25-2007; IN COMMERCE 9-25-2007.
JESSICA A. POWERS, EXAMINING ATTORNEY

CLASS 9—(Continued).

SN 76-684,385. INTELLIGENCE, INC., SANTA CLARA, CA. FILED 11-28-2007.

INTELLISEARCH

THE MARK CONSISTS OF STANDARD CHARACTERS WITHOUT CLAIM TO ANY PARTICULAR FONT, STYLE, SIZE, OR COLOR.

FOR COMPUTER HARDWARE AND SOFTWARE APPLICATIONS FOR DATA MANAGEMENT AND DATA ORGANIZATION FOR USE WITH COMPUTER NETWORKS (U.S. CLS. 21, 23, 26, 36 AND 38).

DAVID C. REIHNER, EXAMINING ATTORNEY

CLASS 9—(Continued).

SN 76-691,821. SOFT COMPUTER CONSULTANTS, INC., CLEARWATER, FL. FILED 8-4-2008.

SOFTLAB

THE MARK CONSISTS OF STANDARD CHARACTERS WITHOUT CLAIM TO ANY PARTICULAR FONT, STYLE, SIZE, OR COLOR.

FOR COMPUTER SOFTWARE PROGRAMS USED FOR WORKFLOW EFFICIENCY AND PRODUCTION IN A LABORATORY, HOSPITAL CLINIC OR ALLIED HEALTH ENVIRONMENT (U.S. CLS. 21, 23, 26, 36 AND 38).

FIRST USE 6-1-1990; IN COMMERCE 6-1-1990.
SUE LAWRENCE, EXAMINING ATTORNEY

SN 76-690,352. TELESTREAM, INC., NEVADA CITY, CA. FILED 6-6-2008.

SPLIT-AND-STITCH

THE MARK CONSISTS OF STANDARD CHARACTERS WITHOUT CLAIM TO ANY PARTICULAR FONT, STYLE, SIZE, OR COLOR.

FOR COMPUTER SOFTWARE THAT DIVIDES DIGITAL VIDEO AND AUDIO FILES INTO SMALL SEGMENTS, DISTRIBUTES THEM ACROSS MULTIPLE PROCESSORS, AND THEN REASSEMBLES THEM INTO ONE COMPLETE FILE TO SPEED THE FORMAT CONVERSION PROCESS (U.S. CLS. 21, 23, 26, 36 AND 38).

FIRST USE 9-0-2006; IN COMMERCE 11-30-2006.
CHARLES L. JENKINS, EXAMINING ATTORNEY

SN 76-694,048. PRECISION TIME, BOLIVIA, NC. FILED 11-5-2008.



OWNER OF U.S. REG. NO. 2,695,341.
SEC. 2(F) AS TO "PRECISION TIME".

FOR ELECTRONIC TIMING SYSTEMS USED IN SPORTING EVENTS TO AUTOMATICALLY START AND STOP GAME CLOCKS COMPOSED OF A BASE STATION CONTROLLER WHICH IS INTERFACED WITH SPORT VENUE TIME-KEEPING EQUIPMENT, BELT-PACK TRANSMITTERS WORN BY OFFICIALS TO REMOTELY START AND STOP GAME CLOCKS AND OMNI-DIRECTIONAL MICROPHONES TUNED TO A SPECIFIC WHISTLE FREQUENCY WHICH ENABLE OFFICIALS TO INSTANTLY STOP THE GAME CLOCK AT THE SOUND OF THE GAME WHISTLE (U.S. CLS. 21, 23, 26, 36 AND 38).

FIRST USE 9-0-1995; IN COMMERCE 9-0-1995.
JOHN DWYER, EXAMINING ATTORNEY

SN 76-690,811. 1017299 ONTARIO LIMITED, DBA KAPTION AUDIO, CONCORD, ONTARIO, CANADA, FILED 6-23-2008.

KAPTION AUDIO

THE MARK CONSISTS OF STANDARD CHARACTERS WITHOUT CLAIM TO ANY PARTICULAR FONT, STYLE, SIZE, OR COLOR.

NO CLAIM IS MADE TO THE EXCLUSIVE RIGHT TO USE "AUDIO", APART FROM THE MARK AS SHOWN.

FOR LOUDSPEAKERS, AMPLIFIERS, AND ELECTRONIC AUDIO CABLE (U.S. CLS. 21, 23, 26, 36 AND 38).

FIRST USE 8-0-1988; IN COMMERCE 9-24-2002.
ANTHONY RINKER, EXAMINING ATTORNEY

SN 76-695,636. GRENIER, DAVID R., ROGUE RIVER, OR. FILED 2-6-2009.

NIGHT SPOTTER

THE MARK CONSISTS OF STANDARD CHARACTERS WITHOUT CLAIM TO ANY PARTICULAR FONT, STYLE, SIZE, OR COLOR.

FOR VEHICLE SAFETY EQUIPMENT IN THE NATURE OF TIRE TREAD WEAR INDICATORS, NAMELY, TIRE TREAD WEAR MONITORS (U.S. CLS. 21, 23, 26, 36 AND 38).

DOUGLAS LEE, EXAMINING ATTORNEY

CLASS 9—(Continued).

SN 76-695,641. KOBASHIKAWA, GARY K., HONOLULU, HI. FILED 2-6-2009.

YOU ARE SOMEBODY

FOR SUNGLASSES AND MAGNIFYING GLASSES (U.S. CLS. 21, 23, 26, 36 AND 38).
ALICIA COLLINS, EXAMINING ATTORNEY

SN 76-695,715. LONE STAR INDUSTRIAL CORPORATION OF TEXAS, INC., EL PASO, TX. FILED 2-10-2009.



NO CLAIM IS MADE TO THE EXCLUSIVE RIGHT TO USE "LONE STAR INDUSTRIAL", APART FROM THE MARK AS SHOWN.

THE STIPPLING IS A FEATURE OF THE MARK. THE MARK CONSISTS IN PART OF A STAR WITH FOUR LINES.

FOR PROBES FOR TESTING ELECTRICAL CONNECTIONS (U.S. CLS. 21, 23, 26, 36 AND 38).
FIRST USE 0-0-1987; IN COMMERCE 0-0-1987.
ALEX KEAM, EXAMINING ATTORNEY

SN 77-001,978. VOLO, LLC, BLOOMFIELD HILLS, MI. FILED 9-19-2006.

YUBE

THE MARK CONSISTS OF STANDARD CHARACTERS WITHOUT CLAIM TO ANY PARTICULAR FONT, STYLE, SIZE, OR COLOR.

FOR VIRTUAL REALITY SIMULATORS FOR BIKING CONSISTING OF COMPUTER HARDWARE, VIRTUAL REALITY COMPUTER SOFTWARE, AND VIEWING APPARATUSES, NAMELY, VIDEO SCREENS AND GLASSES INCORPORATING VIDEO SCREENS IN THE LENSES (U.S. CLS. 21, 23, 26, 36 AND 38).
REBECCA POVARCHUK, EXAMINING ATTORNEY

CLASS 9—(Continued).

SN 77-065,099. DATA ACCESS, PARIS, FRANCE, FILED 12-15-2006.

AST

THE MARK CONSISTS OF STANDARD CHARACTERS WITHOUT CLAIM TO ANY PARTICULAR FONT, STYLE, SIZE, OR COLOR.

PRIORITY CLAIMED UNDER SEC. 44(D) ON FRANCE APPLICATION NO. 63435203, FILED 6-16-2006, REG. NO. 063435203, DATED 1-5-2007, EXPIRES 6-16-2016.

FOR COMPUTER CAMERAS; COMPUTER HARDWARE; COMPUTER KEYBOARDS; COMPUTER MONITORS; COMPUTER MOUSE; COMPUTER NETWORK HUBS, SWITCHES AND ROUTERS; COMPUTER PERIPHERALS; COMPUTER PRINTERS; DESKTOP COMPUTERS; DIGITAL CAMERAS; DIGITAL CELLULAR PHONES; DIGITAL PHONES; FAX DEVICES; GLOBAL POSITIONING SYSTEM (GPS) CONSISTING OF COMPUTERS, COMPUTER SOFTWARE, TRANSMITTERS, RECEIVERS, AND NETWORK INTERFACE DEVICES; HANDHELD COMPUTERS; HARD DISCS FOR COMPUTERS; LAPTOP COMPUTERS; NOTEBOOK COMPUTERS; TELEVISION ANTENNAS; TELEVISION DECODER; TELEVISION MONITORS; TELEVISION RECEIVERS; WIRELESS COMPUTER PERIPHERALS (U.S. CLS. 21, 23, 26, 36 AND 38).

CAROLINE WOOD, EXAMINING ATTORNEY

SN 77-068,638. FURUKAWA ELECTRIC NORTH AMERICA, INC., NORCROSS, GA. FILED 12-20-2006.

SLIM LINE

THE MARK CONSISTS OF STANDARD CHARACTERS WITHOUT CLAIM TO ANY PARTICULAR FONT, STYLE, SIZE, OR COLOR.

FOR EQUIPMENT AND INSTRUMENTS FOR GUIDING, SWITCHING, TRANSFORMATION, ACCUMULATION, REGULATION OR CONTROL OF LIGHT SIGNALS, IN THE FORM OF OPTICAL FIBER AND DATA CABLES FOR COMMUNICATION PURPOSES, OPTICAL FIBER CABLES, DATA CABLES, TELECOMMUNICATION CABLES, AND CONNECTORS, NAMELY, LC, SC, ST2 AND ST2 PLUS CONNECTORS FOR USE IN CONNECTION WITH OPTICAL TELECOMMUNICATION EQUIPMENT (U.S. CLS. 21, 23, 26, 36 AND 38).
GIANCARLO CASTRO, EXAMINING ATTORNEY

CLASS 9—(Continued).

SN 77-088,085. HIRSCHMANN AUTOMATION AND CONTROL GMBH, NECKARTENZLINGEN, FED REP GERMANY, FILED 1-22-2007.



OWNER OF FED REP GERMANY REG. NO. 30614411, DATED 8-23-2006, EXPIRES 3-3-2016.

NO CLAIM IS MADE TO THE EXCLUSIVE RIGHT TO USE "NETWORKS", APART FROM THE MARK AS SHOWN.

THE COLOR(S) RED, GREY, AND BLACK IS/ARE CLAIMED AS A FEATURE OF THE MARK.

THE MARK CONSISTS OF THE WORDS "UNITED NETWORK X" WITH THE "X" TWICE THE HEIGHT OF THE OTHER LETTERS AND A SPHERE DESIGN. THE WORD "UNITED" AND THE TERM "NETWORK" ARE BLACK. THE LETTER "X" IS RED. THE SPHERE IS GREY AND IS SURROUNDED BY AN OPEN RING WITH AN OVERLAPPING ARCUATE SEGMENT. THE ARCUATE SEGMENT IS BLACK WITH GREY ON THE UPPER BACK PORTIONS. THE SPHERE INCLUDES AN ELLIPSE OR OVAL IN THE UPPER PORTION. THE COLOR WHITE APPEARS AS BACKGROUND AND IS NOT CLAIMED AS A FEATURE OF THE MARK.

FOR DATA PROCESSING EQUIPMENT FOR COMPUTER NETWORK INTERCONNECTION, NAMELY, COMPUTERS, SWITCHES, IN THE NATURE OF LAYER 2 SWITCHES AND LAYER 3 SWITCHES, BACKBONE SWITCHES AND CORE SWITCHES, ROUTERS AND WAN ROUTERS, CONVERTERS SUCH AS FIELDBUS FIBROPTIC INTERFACES, GATEWAYS FOR DATA CONVERSION SUCH AS SERIAL-TO-SERIAL, ETHERNET-TO-SERIAL OR ETHERNET-TO-FIELDBUS OR OTHER DATA CONVERSIONS; COMPUTER HARDWARE, NAMELY, MODEMS FOR USE IN WIRED OR WIRELESS TELEPHONES IN ACCORDANCE WITH THE STANDARDS PSTN, ISDN, GSM OR OTHER STANDARDS; COMPUTER HARDWARE SECURITY DEVICES FOR DATA TRANSMISSION, NAMELY, ROUTERS AND FIREWALLS AND COMPUTER SOFTWARE FOR OPERATION OF THESE GOODS; COMPUTER HARDWARE DEVICES FOR DATA TRANSMISSION WITH WIRELESS OR WIRED COMPUTER NETWORKS, NAMELY, ACCESS POINTS, ANTENNAS, CABLES, PLUG-IN CONNECTORS, CABLES WITH INTEGRATED FITTINGS, DISTRIBUTORS, NAMELY, SPLITTERS SUCH AS T SPLITTERS OR Y SPLITTERS; BULKHEADS FOR CABLES, IN PARTICULAR PLUG-IN BULKHEAD RECEPTACLES, SWITCH/CONTROL CABINETS, NAMELY, 19" RACK SYSTEMS, DATA COMMUNICATIONS CABINETS, CLIMATE CONTROL UNITS FOR CONTROLLING TEMPERATURE AND HUMIDITY FOR SWITCH CONTROL CABINETS; SPLITTERS FOR PATCH CABLES, CONNECTION BOXES FOR DATA WIRING; ELECTRICAL EQUIPMENT, NAMELY, OUTLET BOXES FOR DATA CABLES; DEVICES FOR TELEPHONY AND DATA TRANSMISSION OVER THE INTERNET FOR VOICE OVER IP OR VIDEO OVER IP, NAMELY, TELEPHONES, CAMERAS, ENCODERS, DECODERS, MONITORS, KEYBOARDS, SWITCHES, MULTIPLEXERS, RECORDERS, SOFTWARE FOR OPERATING THE ABOVE MENTIONED DEVICES; ELECTRICAL EQUIPMENT, NAMELY, SURGE PROTECTORS; COMPUTER SOFTWARE SOLD AS AN ACCESSORY WITH THE FORGOING EQUIPMENT, NAMELY, COMPUTER SOFTWARE FOR THE PURPOSE OF ANALYZING AND MANAGING THE OPERATION OF COMPUTER NETWORKS AND COMPUTER NETWORK INFRASTRUCTURE (U.S. CLS. 21, 23, 26, 36 AND 38).

BONNIE LUKEN, EXAMINING ATTORNEY

CLASS 9—(Continued).

SN 77-161,781. QUANTUM SIMULATIONS, INC., MURRYSVILLE, PA. FILED 4-20-2007.

QUANTUM TUTORS

THE MARK CONSISTS OF STANDARD CHARACTERS WITHOUT CLAIM TO ANY PARTICULAR FONT, STYLE, SIZE, OR COLOR.

OWNER OF U.S. REG. NOS. 3,168,200, 3,210,726 AND OTHERS.

NO CLAIM IS MADE TO THE EXCLUSIVE RIGHT TO USE "TUTORS", APART FROM THE MARK AS SHOWN.

FOR DOWNLOADABLE COMPUTER SOFTWARE, NAMELY, EDUCATIONAL SOFTWARE ACCESSIBLE SOLELY FROM THE INTERNET FOR USE ON A COMPUTER FOR TUTORING STUDENTS IN THE FIELDS OF SCIENCE AND MATHEMATICS; DOWNLOADABLE COMPUTER SOFTWARE, NAMELY, EDUCATIONAL SOFTWARE ACCESSIBLE SOLELY FROM THE INTERNET FOR USE ON A COMPUTER FOR TUTORING STUDENTS IN THE FIELDS OF BUSINESS AND ACCOUNTING (U.S. CLS. 21, 23, 26, 36 AND 38).

FIRST USE 2-7-2002; IN COMMERCE 2-7-2002.

EMILY CHUO, EXAMINING ATTORNEY

SN 77-182,799. ADVANCEDLO SYSTEMS INC., VANCOUVER, BC, CANADA, FILED 5-16-2007.

udpXG

THE MARK CONSISTS OF STANDARD CHARACTERS WITHOUT CLAIM TO ANY PARTICULAR FONT, STYLE, SIZE, OR COLOR.

FOR COMPUTER SOFTWARE AND HARDWARE FOR ACCELERATING ETHERNET COMMUNICATION PROTOCOLS IN EMBEDDED SYSTEMS BY OFFLOADING POCKET PROCESSING (U.S. CLS. 21, 23, 26, 36 AND 38).

ROBERT C. CLARK JR., EXAMINING ATTORNEY

SN 77-182,845. ADVANCEDLO SYSTEMS INC., VANCOUVER, B.C., CANADA, FILED 5-16-2007.

streamXG

THE MARK CONSISTS OF STANDARD CHARACTERS WITHOUT CLAIM TO ANY PARTICULAR FONT, STYLE, SIZE, OR COLOR.

FOR COMPUTER SOFTWARE AND HARDWARE FOR STREAMING DATA BETWEEN INPUT/OUTPUT DEVICES AND ETHERNET DEVICES IN EMBEDDED SYSTEMS BY OFFLOADING POCKET PROCESSING (U.S. CLS. 21, 23, 26, 36 AND 38).

ROBERT C. CLARK JR., EXAMINING ATTORNEY

CLASS 9—(Continued).

SN 77-197,577. VALHALLA ENTERPRISES, INC., FT. LAUDERDALE, FL. FILED 6-5-2007.



NO CLAIM IS MADE TO THE EXCLUSIVE RIGHT TO USE "COMPANY", APART FROM THE MARK AS SHOWN. THE COLOR(S) THE APPLICANT CLAIMS COLOR AS A FEATURE OF THE MARK, NAMELY, RED, TURQUOISE IS/ARE CLAIMED AS A FEATURE OF THE MARK. THE MARK CONSISTS OF THE WORDS "OCEANVIEW A VEI COMPANY", WHEREIN "OCEAN" IS IN TURQUOISE; "VEI" IS IN BLACK; AND "VIEW", "A", AND "COMPANY" ARE IN RED. THE TWO SLANTED CIRCULAR DESIGNS ARE RED AND ARE UNDERNEATH THE WORDS "OCEAN" AND "VEI".
 FOR CAMERAS (U.S. CLS. 21, 23, 26, 36 AND 38).
 FIRST USE 4-25-2007; IN COMMERCE 4-25-2007.
 ALICIA COLLINS, EXAMINING ATTORNEY

SN 77-201,383. THREE W NETWORKS LTD., NASSAU, NEW PROVIDENCE, BAHAMAS, FILED 6-8-2007.

ARES

THE MARK CONSISTS OF STANDARD CHARACTERS WITHOUT CLAIM TO ANY PARTICULAR FONT, STYLE, SIZE, OR COLOR.
 FOR COMPUTER SOFTWARE FOR USE IN COMMUNICATING AMONG COMPUTERS, RETRIEVING AND SHARING DATA AND FILES AMONG COMPUTERS AND SEARCHING THE INTERNET (U.S. CLS. 21, 23, 26, 36 AND 38).
 FIRST USE 10-19-2005; IN COMMERCE 12-20-2007.
 SUSAN RICHARDS, EXAMINING ATTORNEY

SN 77-202,619. RESNET, BOXBOROUGH, MA. FILED 6-11-2007.

FIELDPRO

THE MARK CONSISTS OF STANDARD CHARACTERS WITHOUT CLAIM TO ANY PARTICULAR FONT, STYLE, SIZE, OR COLOR.
 FOR SOFTWARE FOR COMPLETE FIELD-ORIENTED MULTI-WELL ENGINEERING, STORING ALL WELL-AND PROJECT- RAW AND PROCESSED DATA AND APPLYING ANALYSIS MODULES FOR OPTIMIZATION WITH CALCULATION OF OVERALL PRODUCTION ECONOMICS (U.S. CLS. 21, 23, 26, 36 AND 38).
 FIRST USE 1-1-2001; IN COMMERCE 1-1-2001.
 JESSICA A. POWERS, EXAMINING ATTORNEY

CLASS 9—(Continued).

SN 77-204,850. FINANCIAL MODELING SPECIALISTS, INC., VIENNA, VA. FILED 6-13-2007.

Sentinel Visualizer

THE MARK CONSISTS OF STANDARD CHARACTERS WITHOUT CLAIM TO ANY PARTICULAR FONT, STYLE, SIZE, OR COLOR.
 OWNER OF U.S. REG. NO. 3,019,767.
 FOR COMPUTER SOFTWARE FOR IMPORTING, CATEGORIZING, STORING, RETRIEVING, DISPLAYING, ANALYZING AND MANAGING DATA RELATED TO ENTITIES AND RELATIONSHIPS, METADATA, AND OTHER RELATED ELECTRONIC INFORMATION FOR THE PURPOSE OF DETERMINING AND CONTROLLING PHYSICAL AND FINANCIAL THREAT MANAGEMENT TO ORGANIZATIONS AND OTHER ENTITIES, ALL FOR USE IN THE FIELD OF HOMELAND SECURITY AND LAW ENFORCEMENT (U.S. CLS. 21, 23, 26, 36 AND 38).
 FIRST USE 5-14-2007; IN COMMERCE 5-14-2007.
 SHANNON TWOHIG, EXAMINING ATTORNEY

SN 77-216,182. LUXIUM LIGHTING & TECHNOLOGY CO., LTD., SEONGNAM-CITY, REPUBLIC OF KOREA, FILED 6-26-2007.

LUXEED

THE MARK CONSISTS OF STANDARD CHARACTERS WITHOUT CLAIM TO ANY PARTICULAR FONT, STYLE, SIZE, OR COLOR.
 PRIORITY CLAIMED UNDER SEC. 44(D) ON REPUBLIC OF KOREA APPLICATION NO. 40-2007-0002, FILED 1-16-2007, REG. NO. 0728725, DATED 11-20-2007, EXPIRES 11-20-2017.
 "LUXEED" HAS NO MEANING IN A FOREIGN LANGUAGE.
 FOR COMPUTER KEYBOARDS; KEYBOARDS FOR MOBILE PHONES; MULTIFUNCTION KEYBOARDS (U.S. CLS. 21, 23, 26, 36 AND 38).
 MATTHEW PAPPAS, EXAMINING ATTORNEY

SN 77-221,423. AMERICAN INSULATED WIRE CORPORATION, MANSFIELD, MA. FILED 7-3-2007.

AMERICAN MUSTANG

THE MARK CONSISTS OF STANDARD CHARACTERS WITHOUT CLAIM TO ANY PARTICULAR FONT, STYLE, SIZE, OR COLOR.
 FOR PORTABLE POWER CABLES AND ELECTRICAL CORDS (U.S. CLS. 21, 23, 26, 36 AND 38).
 FIRST USE 10-0-1986; IN COMMERCE 10-0-1986.
 DORITT L. CARROLL, EXAMINING ATTORNEY

CLASS 9—(Continued).

SN 77-221,440. AMERICAN INSULATED WIRE CORPORATION, MANSFIELD, MA. FILED 7-3-2007.



THE MARK CONSISTS OF THE WORDING "AMERICAN MUSTANG" WITH STAR AS PART OF THE "A".
FOR PORTABLE POWER CABLES AND ELECTRICAL CORDS (U.S. CLS. 21, 23, 26, 36 AND 38).
FIRST USE 5-0-1998; IN COMMERCE 5-0-1998.
DORITT L. CARROLL, EXAMINING ATTORNEY

SN 77-225,202. SUNDANCE ENTERPRISES, INC., SUNDANCE, UT. FILED 7-9-2007.

SUNDANCE FARMS

THE MARK CONSISTS OF STANDARD CHARACTERS WITHOUT CLAIM TO ANY PARTICULAR FONT, STYLE, SIZE, OR COLOR.
OWNER OF U.S. REG. NOS. 1,431,477, 3,083,106 AND OTHERS.

FOR MUSICAL SOUND RECORDINGS; PRE-RECORDED CDS, DVDS, AUDIO AND VIDEO TAPES FEATURING MUSIC AND MUSIC VIDEOS; AUDIO AND VIDEO RECORDINGS FEATURING DRAMA, COMEDY, DOCUMENTARY, ADVENTURE, ROMANCE, SPORTS, MUSIC, SUSPENSE, ANIMATED, FAMILY AND CHILDREN'S SUBJECTS; PRE-RECORDED CDS, DVDS, AUDIO AND VIDEO TAPES FEATURING DRAMA, COMEDY, DOCUMENTARY, ADVENTURE, ROMANCE, SPORTS, MUSIC, SUSPENSE, ANIMATED, FAMILY AND CHILDREN'S SUBJECTS; COMPUTER GAME CARTRIDGES, CASSETTES, DISCS, PROGRAMS, SOFTWARE AND TAPES; VIDEO GAME CARTRIDGES, DISCS, AND SOFTWARE; PRE-RECORDED CDS, DVDS, AUDIO AND VIDEO TAPES FEATURING EXERCISE INSTRUCTION, YOGA INSTRUCTION, AND PILATES INSTRUCTION; DIGITAL PHOTO FRAMES FOR DISPLAYING PHOTOS, VIDEO CLIPS AND MUSIC; DIGITAL CAMERAS; DOWNLOADABLE RING TONES, MUSIC, ELECTRONIC GAMES, SHORT FILMS AND SHOWS, MP3 FILES, MP3 RECORDINGS, ONLINE DISCUSSION BOARDS, WEB CASTS, POD CASTS FEATUR-

CLASS 9—(Continued).

ING MUSIC, AUDIO BOOKS AND NEWS BROADCASTS, ALL VIA A GLOBAL COMPUTER NETWORK AND WIRELESS DEVICES; ELECTRIC IRONS, ELECTRIC HAIR IRONS, ELECTRONIC AND MAGNETIC ID CARDS FOR USE IN CONNECTION WITH PAYMENT FOR SERVICES; GLOBAL POSITIONING DEVICES AND SYSTEMS, NAMELY, PROTECTIVE CARRYING CASES SPECIALLY ADAPTED FOR GLOBAL POSITIONING SYSTEM (GPS) APPARATUS; LOUDSPEAKERS, MP3 PLAYERS, ELECTRONIC PUBLICATIONS, NAMELY, MAGAZINES, NEWSLETTERS AND BOOKS, ALL IN THE FIELDS OF LIFESTYLE ISSUES, HEALTHY AND NATURAL LIVING, THE OUTDOORS, FOOD, HOME AND GARDEN, CURRENT AFFAIRS, LITERATURE, THEATER, MUSIC, FILM, FILMMAKING, ENTERTAINMENT, MOVIES, ART, AND WRITING, ALL RECORDED ON COMPUTER MEDIA; RADIOS; SCUBA EQUIPMENT, NAMELY, DIVING MASKS, GOGGLES, SNORKELS, WEIGHT BELTS, AIR TANKS, REGULATORS, BUOYANCY COMPENSATOR JACKETS (U.S. CLS. 21, 23, 26, 36 AND 38).

MARK RADEMACHER, EXAMINING ATTORNEY

SN 77-232,169. KAUZLARIC, CLAYTON A., BOTHELL, WA. FILED 7-18-2007.

Rock God

THE MARK CONSISTS OF STANDARD CHARACTERS WITHOUT CLAIM TO ANY PARTICULAR FONT, STYLE, SIZE, OR COLOR.

FOR COMPUTER GAME SOFTWARE (U.S. CLS. 21, 23, 26, 36 AND 38).
DANNEAN HETZEL, EXAMINING ATTORNEY

SN 77-235,249. PINKBERRY, INC., LOS ANGELES, CA. FILED 7-20-2007.

pinkberry

THE MARK CONSISTS OF STANDARD CHARACTERS WITHOUT CLAIM TO ANY PARTICULAR FONT, STYLE, SIZE, OR COLOR.

FOR PRE-RECORDED CDS, DVDS, AND DOWNLOADABLE DIGITAL AUDIO AND VIDEO FILES FEATURING MUSIC AND MUSIC VIDEOS (U.S. CLS. 21, 23, 26, 36 AND 38).

MARCIE MILONE, EXAMINING ATTORNEY

CLASS 9—(Continued).

SN 77-235,255. PINKBERRY, INC., LOS ANGELES, CA.
FILED 7-20-2007.



THE COLOR(S) LIME GREEN AND PINK IS/ARE CLAIMED AS A FEATURE OF THE MARK.

THE MARK CONSISTS OF THE WORD "PINKBERRY" IN LIME GREEN LETTERING WITH A SWIRL TO THE LEFT OF THE WORD "PINKBERRY". THE SWIRL IS PINK, BENEATH A LIME GREEN STYLIZED LEAF.

FOR PRE-RECORDED CDS, DVDS, AND DOWNLOADABLE DIGITAL AUDIO AND VIDEO FILES FEATURING MUSIC AND MUSIC VIDEOS (U.S. CLS. 21, 23, 26, 36 AND 38).

MARCIE MILONE, EXAMINING ATTORNEY

CLASS 9—(Continued).

SN 77-320,726. DIGI TIME CAPSULE, LLC, CHAPEL HILL, NC. FILED 11-3-2007.

DIGI TIME CAPSULE

FOR COMPUTER SOFTWARE INTENDED FOR ONE SINGLE USER FOR THE PURPOSE OF ENTERTAINMENT IN CAPTURING JOURNEYS IN ONE'S LIFE THROUGH PRE-WRITTEN QUESTIONS WITH THE ABILITY TO UPLOAD ONE'S OWN MEDIA FILES IN VARIOUS FORMS OF DIGITAL PHOTOS, AUDIO MESSAGES, AND MUSIC AND GIVING THE USER THE ABILITY TO TURN ALL OF THE MEDIA PREVIOUSLY UPLOADED INTO A SINGLE-SELF PLAYING MOVIE FILE (U.S. CLS. 21, 23, 26, 36 AND 38).

FIRST USE 9-1-2007; IN COMMERCE 9-1-2007.
DOMINIC FATHY, EXAMINING ATTORNEY

SN 77-235,562. BOUNDLESS NETWORK, INC., AUSTIN, TX.
FILED 7-22-2007.

BRANDFORGE

THE MARK CONSISTS OF STANDARD CHARACTERS WITHOUT CLAIM TO ANY PARTICULAR FONT, STYLE, SIZE, OR COLOR.

FOR SOFTWARE FOR COMMUNICATING PURCHASE OPPORTUNITIES, ORDER STATUS, AND OTHER INFORMATION RELATED TO BRANDED ASSETS (U.S. CLS. 21, 23, 26, 36 AND 38).

FIRST USE 9-30-2006; IN COMMERCE 9-30-2006.
HOWARD SMIGA, EXAMINING ATTORNEY

SN 77-321,447. FAGER, JAN G., VASTERAS, SWEDEN,
FILED 11-5-2007.

POSEYE

THE MARK CONSISTS OF STANDARD CHARACTERS WITHOUT CLAIM TO ANY PARTICULAR FONT, STYLE, SIZE, OR COLOR.

OWNER OF ERPN CMNTY TM OFC REG. NO. 001136688, DATED 4-17-2007, RENEWED AS REG. NO. 001136688, DATED 4-14-2009, EXPIRES 4-13-2019.

THE WORD "POSEYE" HAS NO MEANING IN A FOREIGN LANGUAGE.

FOR APPARATUS FOR MEASURING, INDICATING, AND CHECKING THE POSITION AND ORIENTATION OF ROBOTS, VEHICLES, CONVEYORS, CAMERAS, DISPLAYS AND DETECTORS TO ASSIST IN THE CONTROL OF ROBOTS, VEHICLES, CONVEYORS, CAMERAS, DISPLAYS AND DETECTORS, NAMELY, COMPUTERS, COMPUTER OPERATING PROGRAMS, TIMING SENSORS, ELECTRIC REGULATING APPARATUS FOR REGULATING POSITIONS AND ORIENTATIONS, DETECTORS AND INDICATORS, COMPUTER MONITORS, VIDEO DISPLAYS, OPTICAL CHARACTER READERS, CAMERAS, CINEMATOGRAPHIC CAMERAS, REMOTE CONTROL APPARATUS, X-RAY EQUIPMENT, SCANNERS, OPTICAL LENSES, JOYSTICKS, CONTROL PANELS, AND SIGHT EQUIPMENT; BLANK MAGNETIC COMPUTER TAPES AND OPTICAL DISCS; BLANK MAGNETIC DATA CARRIERS; COMPUTER PROGRAMS FOR USE IN CONTROLLING THE FUNCTION AND ACTIVITIES OF ROBOTS, VEHICLES, CONVEYORS, CAMERAS, DISPLAYS AND DETECTORS; LABORATORY ROBOTS AND PERSONAL AND HOBBY USE ROBOTS (U.S. CLS. 21, 23, 26, 36 AND 38).

LINDA E. BLOHM, EXAMINING ATTORNEY

SN 77-287,264. FOTONATION INC., BURLINGAME, CA.
FILED 9-24-2007.

FASTTRACK

THE MARK CONSISTS OF STANDARD CHARACTERS WITHOUT CLAIM TO ANY PARTICULAR FONT, STYLE, SIZE, OR COLOR.

FOR COMPUTER SOFTWARE FOR USE IN DIGITAL PHOTOGRAPHY AND VIDEO, DOCUMENT IMAGING, AND IMAGE MANIPULATION (U.S. CLS. 21, 23, 26, 36 AND 38).

AISHA CLARKE, EXAMINING ATTORNEY

CLASS 9—(Continued).

SN 77-323,285. HOWARD HOGAN, DBA SUN RESORTS TANNING SALON, TOPEKA, KS. FILED 11-7-2007.

PODZ

THE MARK CONSISTS OF STANDARD CHARACTERS WITHOUT CLAIM TO ANY PARTICULAR FONT, STYLE, SIZE, OR COLOR.

FOR EYE PIECES FOR PROTECTION AGAINST ULTRAVIOLET RAYS FOR USE WITH INDOOR AND OUTDOOR SUN TANNING BOOTHS (U.S. CLS. 21, 23, 26, 36 AND 38).

MAYUR VAGHANI, EXAMINING ATTORNEY

SN 77-332,024. ENLIVEN MARKETING TECHNOLOGIES CORPORATION, NEW YORK, NY. FILED 11-16-2007.

ENLIVEN MARKETING TECHNOLOGIES

THE MARK CONSISTS OF STANDARD CHARACTERS WITHOUT CLAIM TO ANY PARTICULAR FONT, STYLE, SIZE, OR COLOR.

OWNER OF U.S. REG. NOS. 2,232,558 AND 2,497,451.

NO CLAIM IS MADE TO THE EXCLUSIVE RIGHT TO USE "MARKETING TECHNOLOGIES", APART FROM THE MARK AS SHOWN.

FOR COMPUTER SOFTWARE FOR USE IN CREATING, DELIVERING AND REPORTING ON ONLINE ADVERTISEMENTS, RICH MEDIA ADVERTISEMENTS AND ADVERTISING CAMPAIGNS; COMPUTER SOFTWARE FOR USE IN MEDIA PLANNING ASSISTANCE, ADVERTISING CAMPAIGN CREATION AND DELIVERY, CONTENT CREATION AND DATA REPORTING USED TO EVALUATE AND MONITOR ADVERTISING CAMPAIGN PERFORMANCE; COMPUTER SOFTWARE FOR CREATING, DISPLAYING AND PUBLISHING 3D MODELS, ANIMATIONS, 3D ANIMATIONS AND INTERFACES, OBJECT AND SPEECH PAIRING ANIMATIONS, 2D IMAGES, AND STREAMING VIDEO; COMPUTER SOFTWARE FOR DELIVERING CUSTOM, RELEVANT AND PERSONALIZED CONTENT; COMPUTER SOFTWARE FOR USE IN CREATING, DELIVERING, INSTALLING, DISPLAYING, PUBLISHING AND MANAGING WIDGETS; COMPUTER SOFTWARE FOR USE IN CREATING, DISPLAYING AND PUBLISHING DIGITAL CONTENT; COMPUTER SOFTWARE FOR USE IN CREATING DISPLAYING AND PUBLISHING ANIMATIONS; COMPUTER SOFTWARE FOR USE IN CREATING, DISPLAYING AND PUBLISHING A COLLECTION OF PHOTOGRAPHS AND DRAWINGS, 2D MODELS, 3D MODELS, ANIMATIONS, IMAGES, VIDEO AND OTHER MULTIMEDIA ASSETS; COMPUTER SOFTWARE FOR COMPRESSING OR UNCOMPRESSING FILES; COMPUTER SOFTWARE FOR EDITING IMAGES ONLINE; COMPUTER SOFTWARE FOR USE IN DISPLAYING, ROTATING, TRACKING AND REPORTING ON ADVERTISING APPEARING IN COMPUTER GAMES (U.S. CLS. 21, 23, 26, 36 AND 38).

CURTIS FRENCH, EXAMINING ATTORNEY

CLASS 9—(Continued).

SN 77-350,112. AMERICAN INSULATED WIRE CORPORATION, MANSFIELD, MA. FILED 12-12-2007.

★ AMERICAN MUSTANG

FOR PORTABLE POWER CABLES AND ELECTRICAL CORDS (U.S. CLS. 21, 23, 26, 36 AND 38).

KATHY DE JONGE, EXAMINING ATTORNEY

SN 77-352,444. SYNERGETICS INCORPORATED, FORT COLLINS, CO. FILED 12-14-2007.



THE COLOR(S) BLUE, GRAY, WHITE AND RED IS/ARE CLAIMED AS A FEATURE OF THE MARK.

THE MARK CONSISTS OF A ROUND BLUE DESIGN WITH GRAY STARS ENCIRCLING A BLUE, GRAY, WHITE AND RED CD DESIGN AGAINST AN OVERALL GRAY BACKGROUND. THE BLUE AND GRAY "I" AND "O" NUMBERS RADIATE FROM THE CD DESIGN. THE WORDING "IMD" IS IN WHITE COLOR.

FOR COMPUTER SOFTWARE FOR CREATING SEARCHABLE DATABASES AND DATA COMPRESSION SOFTWARE IN THE FIELD OF LOGISTICS MANAGEMENT (U.S. CLS. 21, 23, 26, 36 AND 38).

FIRST USE 12-4-2007; IN COMMERCE 12-4-2007.

DAWN HAN, EXAMINING ATTORNEY

CLASS 9—(Continued).

SN 77-352,742. ICS TRIPLEX TECHNOLOGY LIMITED, MALDON, UNITED KINGDOM, FILED 12-14-2007.

TRUSTED

THE MARK CONSISTS OF STANDARD CHARACTERS WITHOUT CLAIM TO ANY PARTICULAR FONT, STYLE, SIZE, OR COLOR.

OWNER OF U.S. REG. NO. 2,202,366.
SEC. 2(F).

FOR INDUSTRIAL PROCESS CONTROL AND MONITORING APPARATUS AND INSTRUMENTS, NAMELY, AUTOMATIC, MANUAL AND COMPUTER COMPATIBLE ELECTRONIC PROCESS CONTROLLERS AND MONITORS; SAFETY, FIRE AND GAS MONITORING APPARATUS, NAMELY, MONITORS FOR MONITORING STATUS OF ELECTRICAL HYDRAULIC OR PNEUMATIC EQUIPMENT, SMOKE, FIRE OR FLAME TOGETHER WITH CONTROLLERS TO CONTROL AN ALARM OR EXTINGUISANT RELEASE; ALARM SYSTEMS COMPRISED OF MONITORS FOR MONITORING AUTOMATIC, MANUAL AND COMPUTER COMPATIBLE ELECTRONIC PROCESS CONTROLLERS OR STATUS OF ELECTRICAL HYDRAULIC OR PNEUMATIC EQUIPMENT, SMOKE, FIRE OR FLAME AND ALARM INDICATORS FOR INDICATING WHEN OPERATIONAL PARAMETERS ARE EXCEEDED; EMERGENCY SHUTDOWN SYSTEMS COMPRISED OF MONITORS FOR MONITORING AUTOMATIC, MANUAL AND COMPUTER COMPATIBLE ELECTRONIC PROCESS CONTROLLERS AND STATUS OF ELECTRICAL HYDRAULIC OR PNEUMATIC EQUIPMENT, SMOKE, FIRE OR FLAME AND ALARM INDICATORS FOR INDICATING WHEN OPERATIONAL PARAMETERS ARE EXCEEDED, AND CONTROLLERS FOR SHUTTING DOWN PROCESSES AND EQUIPMENT WHEN OPERATIONAL PARAMETERS ARE EXCEEDED; DISPLAY APPARATUS, NAMELY, COMPUTER HARDWARE AND SOFTWARE FOR DISPLAY OF STATUS OF INDUSTRIAL PROCESS CONTROL AND MONITORING APPARATUS AND INSTRUMENTS, NAMELY, AUTOMATIC, MANUAL AND COMPUTER COMPATIBLE ELECTRONIC PROCESS CONTROLLERS AND MONITORS; COMPUTER HARDWARE AND SOFTWARE FOR DISPLAY OF STATUS OF SAFETY, FIRE AND GAS MONITORING APPARATUS, NAMELY, MONITORS FOR MONITORING STATUS OF ELECTRICAL HYDRAULIC OR PNEUMATIC EQUIPMENT, SMOKE, FIRE OR FLAME TOGETHER WITH CONTROLLERS TO CONTROL AN ALARM OR EXTINGUISANT RELEASE; COMPUTER SOFTWARE USED TO OPERATE INDUSTRIAL PROCESS CONTROL AND MONITORING APPARATUS AND INSTRUMENTS, NAMELY, AUTOMATIC, MANUAL AND COMPUTER COMPATIBLE ELECTRONIC PROCESS CONTROLLERS AND MONITORS; COMPUTER SOFTWARE USED TO OPERATE ALARM SYSTEMS COMPRISED OF MONITORS FOR MONITORING STATUS OF ELECTRICAL HYDRAULIC OR PNEUMATIC EQUIPMENT, SMOKE, FIRE OR FLAME AND ALARM INDICATORS FOR INDICATING WHEN OPERATIONAL PARAMETERS ARE EXCEEDED; COMPUTER SOFTWARE USED TO OPERATE EMERGENCY SHUTDOWN SYSTEMS COMPRISED OF MONITORS FOR MONITORING STATUS OF ELECTRICAL HYDRAULIC OR PNEUMATIC EQUIPMENT, SMOKE, FIRE OR FLAME AND ALARM INDICATORS FOR INDICATING WHEN OPERATIONAL PARAMETERS ARE EXCEEDED, AND CONTROLLERS FOR SHUTTING DOWN PROCESSES AND EQUIPMENT WHEN OPERATIONAL PARAMETERS ARE EXCEEDED; PARTS FOR ALL THE AFORESAID GOODS, NAMELY, ELECTRONIC PROCESS CONTROLLERS, MONITORS IN THE NATURE OF SAFETY, FIRE AND GAS MONITORS THAT MONITOR THE STATUS OF ELECTRICAL HYDRAULIC OR PNEUMATIC EQUIPMENT, SMOKE, FIRE OR FLAME; ALARM SYSTEMS COMPRISING MONITORS FOR MONITORING AUTOMATIC, MANUAL AND COMPUTER COMPATIBLE ELECTRONIC PROCESS CONTROLLERS OR STA-

CLASS 9—(Continued).

TUS OF ELECTRICAL HYDRAULIC OR PNEUMATIC EQUIPMENT, SMOKE, FIRE OR FLAME; ALARM INDICATORS THAT INDICATE WHEN OPERATIONAL PARAMETERS ARE EXCEEDED; DISPLAY APPARATUS IN THE NATURE OF COMPUTER HARDWARE AND SOFTWARE FOR DISPLAY OF STATUS OF INDUSTRIAL PROCESS CONTROL AND MONITORING APPARATUS AND INSTRUMENTS, NAMELY, AUTOMATIC, MANUAL AND COMPUTER COMPATIBLE ELECTRONIC PROCESS CONTROLLERS AND MONITORS; COMPUTER HARDWARE AND COMPUTER SOFTWARE FOR DATABASE MANAGEMENT, DISPLAY OF STATUS OF INDUSTRIAL PROCESS CONTROL AND MONITORING APPARATUS AND INSTRUMENTS, OPERATION OF EMERGENCY SHUTDOWN SYSTEMS, MONITORING AND EMERGENCY SHUTDOWN PURPOSES, ALL IN THE FIELD OF INDUSTRIAL PROCESS CONTROL AND MONITORING (U.S. CLS. 21, 23, 26, 36 AND 38).

FIRST USE 6-19-1995; IN COMMERCE 6-19-1995.
KRISTINA MORRIS, EXAMINING ATTORNEY

SN 77-363,742. MONSTER CABLE PRODUCTS, INC., BRISBANE, CA. FILED 1-3-2008.

BLACKOUT

THE MARK CONSISTS OF STANDARD CHARACTERS WITHOUT CLAIM TO ANY PARTICULAR FONT, STYLE, SIZE, OR COLOR.

FOR ELECTRICAL, ELECTROMAGNETIC AND AUDIO AND VIDEO SIGNAL TRANSMITTING, AMPLIFYING, RECEIVING AND CONVERTING DEVICES, NAMELY, CABLES, WIRES, CONNECTORS, AND ELECTRICAL POWER CONTROL AND SIGNAL CONDITIONING DEVICES FOR USE WITH ELECTRICAL, ELECTRONIC, AND COMPUTER DEVICES; NETWORKABLE DATA STORAGE, ARCHIVAL, AND RETRIEVAL DEVICES, NAMELY, COMPUTER HARDWARE AND SOFTWARE FOR THE COLLECTION, ORGANIZING, STORAGE, ARCHIVING, RETRIEVING, AND TRANSMISSION OF DATA ; AND CONTROL PROTOCOL SOFTWARE FEATURING INTEROPERABILITY STANDARDS, AND COMPUTER HARDWARE AND ELECTRICAL CONTROLLERS, FOR CENTRALIZED HOME CONTROL, NAMELY, FOR CONTROLLING RESIDENTIAL LIGHTING, COMMUNICATIONS SYSTEMS, CLIMATE SYSTEMS, SECURITY SYSTEMS, AND AUDIO AND VIDEO DEVICES (U.S. CLS. 21, 23, 26, 36 AND 38).
ANDREW RHIM, EXAMINING ATTORNEY

CLASS 9—(Continued).

SN 77-376,047. ACTIVISION PUBLISHING, INC., SANTA MONICA, CA. FILED 1-19-2008.

GUITAR HERO ON TOUR

THE MARK CONSISTS OF STANDARD CHARACTERS WITHOUT CLAIM TO ANY PARTICULAR FONT, STYLE, SIZE, OR COLOR.

OWNER OF U.S. REG. NOS. 3,002,745 AND 3,299,080. NO CLAIM IS MADE TO THE EXCLUSIVE RIGHT TO USE "GUITAR", APART FROM THE MARK AS SHOWN.

FOR COMPUTER GAME SOFTWARE AND RELATED INSTRUCTION MANUAL SOLD TOGETHER AS A UNIT; INTERACTIVE VIDEO GAME PROGRAMS; COMPUTER GAME CARTRIDGES; COMPUTER GAME DISCS; DOWNLOADABLE COMPUTER GAME SOFTWARE; VIDEO GAME CONTROLLERS; INTERACTIVE VIDEO GAME COMPRISED OF A CARTRIDGE OR DVD SOLD AS A UNIT WITH A VIDEO GAME CONTROLLER (U.S. CLS. 21, 23, 26, 36 AND 38).

TINA KUAN, EXAMINING ATTORNEY

SN 77-393,670. UTAG LTD, WATERLOOVILLE, UNITED KINGDOM, FILED 2-11-2008.



PRIORITY CLAIMED UNDER SEC. 44(D) ON ERP N CMNTY TM OFC APPLICATION NO. 006599252, FILED 1-22-2008, REG. NO. 006599252, DATED 10-23-2008, EXPIRES 1-22-2018.

FOR ELECTRONIC DEVICES, NAMELY, MEMORY MEDIA, FOR THE STORAGE, RECORDING AND TRANSMISSION OF MEDICAL INFORMATION; COMPUTER HARDWARE FOR THE STORAGE, RECORDING AND TRANSMISSION OF MEDICAL RECORDS, DATA AND INFORMATION (U.S. CLS. 21, 23, 26, 36 AND 38).

GRETTA YAO, EXAMINING ATTORNEY

CLASS 9—(Continued).

SN 77-394,447. CONTROLLED ENTRY DISTRIBUTORS, INC., SALT LAKE CITY, UT. FILED 2-12-2008.



NO CLAIM IS MADE TO THE EXCLUSIVE RIGHT TO USE "HOME ALERT", APART FROM THE MARK AS SHOWN.

THE MARK CONSISTS OF THE LETTERS "EZ" SURROUNDED BY A SUBSTANTIALLY OVAL DESIGN, ALONG WITH THE WORDS "HOME ALERT".

FOR HOME SECURITY AND MONITORING SYSTEMS, NAMELY, TRANSMITTERS AND RECEIVERS (U.S. CLS. 21, 23, 26, 36 AND 38).

DOMINIC J. FERRAIUOLO, EXAMINING ATTORNEY

SN 77-394,449. CONTROLLED ENTRY DISTRIBUTORS, INC., SALT LAKE CITY, UT. FILED 2-12-2008.

EZ HOME ALERT

THE MARK CONSISTS OF STANDARD CHARACTERS WITHOUT CLAIM TO ANY PARTICULAR FONT, STYLE, SIZE, OR COLOR.

NO CLAIM IS MADE TO THE EXCLUSIVE RIGHT TO USE "HOME ALERT", APART FROM THE MARK AS SHOWN.

FOR HOME SECURITY AND MONITORING SYSTEMS, NAMELY, TRANSMITTERS AND RECEIVERS (U.S. CLS. 21, 23, 26, 36 AND 38).

DOMINIC J. FERRAIUOLO, EXAMINING ATTORNEY

SN 77-396,976. SAMSUNG ELECTRONICS CO., LTD., SUWON-SI, GYEONGGI-DO, REPUBLIC OF KOREA, FILED 2-14-2008.

MULTIXPRESS

THE MARK CONSISTS OF STANDARD CHARACTERS WITHOUT CLAIM TO ANY PARTICULAR FONT, STYLE, SIZE, OR COLOR.

PRIORITY CLAIMED UNDER SEC. 44(D) ON REPUBLIC OF KOREA APPLICATION NO. 2008-0005705, FILED 2-5-2008, REG. NO. 0777105, DATED 1-23-2009, EXPIRES 1-23-2019.

FOR COMPUTER PRINTERS; ELECTRONIC PHOTOCOPIERS; PHOTO-COPYING MACHINES; FACSIMILE APPARATUS; PORTABLE TELECOMMUNICATION INSTANT MESSAGING DEVICE; TELEPHONES; TELEVISION RECEIVERS; CAMCORDERS; MP3 PLAYERS; DVD PLAYERS; COMPUTERS; PERSONAL DIGITAL ASSISTANTS; FACSIMILE MACHINES (U.S. CLS. 21, 23, 26, 36 AND 38).

RONALD DELGIZZI, EXAMINING ATTORNEY

CLASS 9—(Continued).

SN 77-453,946. GENERAL DYNAMICS C4 SYSTEMS, INC., SCOTTSDALE, AZ. FILED 4-21-2008.

CoAction

THE MARK CONSISTS OF STANDARD CHARACTERS WITHOUT CLAIM TO ANY PARTICULAR FONT, STYLE, SIZE, OR COLOR.

FOR COMPUTER SOFTWARE CONSISTING OF COMPUTER DATABASE MANAGEMENT SOFTWARE AND COMPUTER SOFTWARE INSTALLED ON BOTH COMPUTERS AND COMPUTER SERVERS FOR CREATING A VIRTUAL MAP-BASED VISUALIZATION FOR EACH USER OF ON-SCENE CONDITIONS USED TO CAPTURE, TRACK AND SHARE IMPORTANT UP TO THE MINUTE INFORMATION AND DATA IN A VISUAL FORM ALLOWING SHARED SITUATIONAL AWARENESS AMONG USERS (U.S. CLS. 21, 23, 26, 36 AND 38).
 BONNIE LUKEN, EXAMINING ATTORNEY

SN 77-455,740. AN, BUM GUYN, DBA KOTRONIX USA, INC., SAN PABLO, CA. FILED S.R. 4-23-2008; AM. P.R. 3-20-2009.



THE COLOR(S) BLACK, RED AND WHITE IS/ARE CLAIMED AS A FEATURE OF THE MARK.

THE MARK CONSISTS OF THE WORDS "KBOX" THE COLOR OF THE WORDS ARE BLACK, THE BACKGROUND COLOR OF THE WORD "K" IS RED AND BACKGROUND COLOR OF THE WORD "BOX" ARE CONSIST OF WHITE.

FOR SATELLITE RECEIVERS (U.S. CLS. 21, 23, 26, 36 AND 38).

FIRST USE 4-15-2008; IN COMMERCE 4-15-2008.
 ALICE BENMAMAN, EXAMINING ATTORNEY

SN 77-456,052. B.E. MEYERS & COMPANY, INC., DBA MEYERS, REDMOND, WA. FILED S.R. 4-23-2008; AM. P.R. 4-24-2009.

MiniPoint

THE MARK CONSISTS OF STANDARD CHARACTERS WITHOUT CLAIM TO ANY PARTICULAR FONT, STYLE, SIZE, OR COLOR.

FOR LASER OBJECT DETECTORS FOR USE ON VEHICLES; LASER POINTERS; LASER POINTING DEVICE FOR USE WITH FIREARMS; LASERS NOT FOR MEDICAL USE (U.S. CLS. 21, 23, 26, 36 AND 38).

FIRST USE 4-1-2008; IN COMMERCE 4-1-2008.
 DAYNA BROWNE, EXAMINING ATTORNEY

CLASS 9—(Continued).

SN 77-456,276. MITSUBISHI CABLE INDUSTRIES, LTD., CHIYODA-KU, TOKYO, JAPAN, FILED 4-23-2008.

TOUGHBEND

THE MARK CONSISTS OF STANDARD CHARACTERS WITHOUT CLAIM TO ANY PARTICULAR FONT, STYLE, SIZE, OR COLOR.

OWNER OF JAPAN REG. NO. 5,123,340, DATED 3-28-2008, EXPIRES 3-28-2018.

FOR OPTICAL FIBERS; ELECTRIC WIRES AND CABLES; OPTICAL AMPLIFIERS; OPTICAL APPARATUS AND INSTRUMENTS, NAMELY, BLANK OPTICAL DISCS, BLANK RECORDABLE OPTICAL DISCS, FILTERS FOR OPTICAL DEVICES, OPTICAL CABLES, OPTICAL DISK DRIVES, EYEGLASSES, SUNGLASSES, OPTICAL LENSES, OPTICAL FRAMES, LIGHT SOURCES FOR OPTICAL FIBER SENSING SYSTEMS, GYROSCOPES, HIGH PRECISION OPTICAL MEASUREMENT SYSTEMS AND CROSS-SECTIONAL IMAGING SYSTEMS; OPTICAL FIBER ENDOSCOPES FOR NON-MEDICAL USE; AND TELECOMMUNICATION DEVICES AND APPARATUS, NAMELY, TELEPHONES, CELL PHONES, TELECOMMUNICATION TOWERS, TELECOMMUNICATION SWITCHES AND EXCHANGERS, TELECOMMUNICATION CABLES (U.S. CLS. 21, 23, 26, 36 AND 38).

HOWARD SMIGA, EXAMINING ATTORNEY

SN 77-457,066. B.E. MEYERS & COMPANY, INC., DBA MEYERS LASERS, REDMOND, WA. FILED S.R. 4-24-2008; AM. P.R. 4-24-2009.

UltraPoint

THE MARK CONSISTS OF STANDARD CHARACTERS WITHOUT CLAIM TO ANY PARTICULAR FONT, STYLE, SIZE, OR COLOR.

FOR LASER OBJECT DETECTORS FOR USE ON VEHICLES; LASER POINTERS; LASER POINTING DEVICE FOR USE WITH FIREARMS; LASER RANGEFINDERS; LASERS NOT FOR MEDICAL USE (U.S. CLS. 21, 23, 26, 36 AND 38).

FIRST USE 4-1-2008; IN COMMERCE 4-1-2008.
 CHRISTINE BLOMQUIST, EXAMINING ATTORNEY

CLASS 9—(Continued).

SN 77-463,219. CHURCH UNIVERSAL AND TRIUMPHANT, INC., GARDINER, MT. FILED 5-1-2008.

SUMMIT UNIVERSITY PRESS

THE MARK CONSISTS OF STANDARD CHARACTERS WITHOUT CLAIM TO ANY PARTICULAR FONT, STYLE, SIZE, OR COLOR.

OWNER OF U.S. REG. NOS. 1,075,919 AND 1,076,660.

NO CLAIM IS MADE TO THE EXCLUSIVE RIGHT TO USE "UNIVERSITY PRESS", APART FROM THE MARK AS SHOWN.

FOR PRERECORDED CD-ROMS, AUDIOTAPES, VIDEOTAPES AND DVDS FEATURING ELECTRONIC BOOKS, AUDIO BOOKS, TEXT, NARRATION, MUSICAL AND DRAMATIC PERFORMANCES, MOTION AND NON-MOTION PICTURE FILM AND DIGITAL IMAGES, AND THE SPOKEN WORD, ALL IN THE FIELDS OF RELIGION, PHILOSOPHY AND SPIRITUALITY; DOWNLOADABLE ELECTRONIC PUBLICATIONS, NAMELY, ELECTRONIC BOOKS, AUDIO BOOKS, TEXT, NARRATION, MUSICAL AND DRAMATIC PERFORMANCES, MOTION AND NON-MOTION PICTURE FILM AND DIGITAL IMAGES, AND RECORDINGS OF THE SPOKEN WORD, ALL IN THE FIELDS OF RELIGION, PHILOSOPHY AND SPIRITUALITY (U.S. CLS. 21, 23, 26, 36 AND 38).

YAT SYE, LEE, EXAMINING ATTORNEY

CLASS 9—(Continued).

SN 77-468,490. KABUSHIKI KAISHA MORPHO, DBA MORPHO, INC., TOKYO, JAPAN, FILED 5-7-2008.

FRAMESOLID

THE MARK CONSISTS OF STANDARD CHARACTERS WITHOUT CLAIM TO ANY PARTICULAR FONT, STYLE, SIZE, OR COLOR.

PRIORITY CLAIMED UNDER SEC. 44(D) ON JAPAN APPLICATION NO. 2008-34922, FILED 5-7-2008, REG. NO. 5183963, DATED 11-28-2008, EXPIRES 11-28-2018.

FOR COMPUTER PROGRAMS AND SOFTWARE FOR IMAGE PROCESSING; COMPUTER PROGRAMS AND SOFTWARE FOR IMAGE PROCESSING USED FOR MOBILE PHONES (U.S. CLS. 21, 23, 26, 36 AND 38).

ROBIN MITTLER, EXAMINING ATTORNEY

SN 77-468,497. ALASKA NATIVE TRIBAL HEALTH CONSORTIUM, ANCHORAGE, AK. FILED 5-7-2008.

tConsult

THE MARK CONSISTS OF STANDARD CHARACTERS WITHOUT CLAIM TO ANY PARTICULAR FONT, STYLE, SIZE, OR COLOR.

FOR SOFTWARE FOR CAPTURING, PROCESSING, STORING, AND FORWARDING DATA GENERATED BY MEDICAL DIAGNOSTIC EQUIPMENT, NAMELY, IMAGE MANAGEMENT SOFTWARE THAT ACQUIRES DATA FROM MEDICAL DIAGNOSTIC EQUIPMENT, PROCESSES, STORES, AND TRANSMITS SUCH DATA, AND DISPLAYS SUCH DATA ON COMPUTER MONITORS; WEB INTERFACE SOFTWARE FOR CAPTURING DATA AND DISPLAYING MEDICAL IMAGES AND DATA, FOR CREATING AND DISPLAYING CASE FILES IN CONNECTION WITH THE DELIVERY OF MEDICAL AND HEALTH-RELATED SERVICES VIA TELECOMMUNICATIONS TECHNOLOGIES; COMMUNICATIONS SOFTWARE FOR ALLOWING SERVERS TO SHARE DATA RELATING TO THE DELIVERY OF MEDICAL AND HEALTH-RELATED SERVICES VIA TELECOMMUNICATIONS TECHNOLOGIES; SOFTWARE FOR MONITORING AND REPORTING ON THE STATUS OF COMPUTER HARDWARE AND SOFTWARE USED IN CONNECTION WITH THE DELIVERY OF MEDICAL AND HEALTH-RELATED SERVICES VIA TELECOMMUNICATIONS TECHNOLOGIES; SOFTWARE FOR THE AUTOMATIC AND SECURE DISTRIBUTION OF UPDATES TO SOFTWARE APPLICATIONS, NAMELY, A COMPUTER APPLICATION THAT COMMUNICATES SECURELY WITH A SERVER APPLICATION TO COORDINATE THE TRANSFER OF OTHER SOFTWARE APPLICATIONS AND ASSOCIATED DATA FILES FROM THE SERVER TO THE CLIENT AS A MECHANISM TO REMOTELY UPDATE SOFTWARE ON THE CLIENT (U.S. CLS. 21, 23, 26, 36 AND 38).

SAIMA MAKHDOOM, EXAMINING ATTORNEY

SN 77-465,810. TW STORAGE INC., DBA INDEX ENGINES, RUMSON, NJ. FILED 5-5-2008.

Power Over Information

THE MARK CONSISTS OF STANDARD CHARACTERS WITHOUT CLAIM TO ANY PARTICULAR FONT, STYLE, SIZE, OR COLOR.

FOR COMPUTER SOFTWARE FOR THE COLLECTION, EDITING, ORGANIZING, MODIFYING, BOOK MARKING, TRANSMISSION, STORAGE AND SHARING OF DATA AND INFORMATION; COMPUTER PROGRAMS FOR SEARCHING THE CONTENTS OF COMPUTERS AND COMPUTER NETWORKS BY REMOTE CONTROL; COMPUTER SEARCH ENGINE SOFTWARE (U.S. CLS. 21, 23, 26, 36 AND 38).

FIRST USE 4-1-2008; IN COMMERCE 5-1-2008.

KAREN K. BUSH, EXAMINING ATTORNEY

CLASS 9—(Continued).

SN 77-471,683. GENERAL MEDIA COMMUNICATIONS, INC., BOCA RATON, FL. FILED 5-12-2008.

PENTHOUSE FORUM

THE MARK CONSISTS OF STANDARD CHARACTERS WITHOUT CLAIM TO ANY PARTICULAR FONT, STYLE, SIZE, OR COLOR.

OWNER OF U.S. REG. NOS. 880,922 AND 1,292,185. FOR PRE-RECORDED DIGITAL MEDIA FEATURING ADULT ENTERTAINMENT (U.S. CLS. 21, 23, 26, 36 AND 38).

FIRST USE 10-2-2007; IN COMMERCE 10-2-2007. MIDGE BUTLER, EXAMINING ATTORNEY

SN 77-481,102. OPTIBRAND LTD., LLC, FORT COLLINS, CO. FILED 5-22-2008.

CLEARVIEW

THE MARK CONSISTS OF STANDARD CHARACTERS WITHOUT CLAIM TO ANY PARTICULAR FONT, STYLE, SIZE, OR COLOR.

FOR MEDICAL AND VETERINARY SOFTWARE FOR VIEWING MEDICAL OR VETERINARY VIDEO IMAGES, CAPTURING STILL IMAGES AND PERFORMING ID VERIFICATION (U.S. CLS. 21, 23, 26, 36 AND 38). SONYA STEPHENS, EXAMINING ATTORNEY

SN 77-485,980. A51 DOO, NOVI SAD, SERBIA, FILED 5-29-2008.

ACTIVECOLLAB

THE MARK CONSISTS OF STANDARD CHARACTERS WITHOUT CLAIM TO ANY PARTICULAR FONT, STYLE, SIZE, OR COLOR.

FOR DOWNLOADABLE WEB BASED PROJECT MANAGEMENT AND COLLABORATION SOFTWARE (U.S. CLS. 21, 23, 26, 36 AND 38).

FIRST USE 6-0-2006; IN COMMERCE 6-0-2006. JILL PRATER, EXAMINING ATTORNEY

CLASS 9—(Continued).

SN 77-487,981. THE MCGRAW-HILL COMPANIES, INC., NEW YORK, NY. FILED 5-31-2008.

**District Leader's Podcast:
Leading today for success
tomorrow**

THE MARK CONSISTS OF STANDARD CHARACTERS WITHOUT CLAIM TO ANY PARTICULAR FONT, STYLE, SIZE, OR COLOR.

NO CLAIM IS MADE TO THE EXCLUSIVE RIGHT TO USE "PODCAST", APART FROM THE MARK AS SHOWN. FOR DOWNLOADABLE PODCASTS IN THE FIELD OF EDUCATION (U.S. CLS. 21, 23, 26, 36 AND 38).

FIRST USE 3-1-2007; IN COMMERCE 10-22-2007. HOWARD SMIGA, EXAMINING ATTORNEY

SN 77-493,453. URBACH, JULIAN M., SHERMAN OAKS, CA. FILED 6-6-2008.

OTOY

THE MARK CONSISTS OF STANDARD CHARACTERS WITHOUT CLAIM TO ANY PARTICULAR FONT, STYLE, SIZE, OR COLOR.

FOR COMPUTER SOFTWARE FOR USE IN THE FIELD OF COMPUTER GENERATED IMAGERY FOR USE IN ENTERTAINMENT, INCLUDING COMPUTER GENERATED GRAPHICS, AND INTERACTIVE COMPUTER GRAPHICS APPLICATIONS; COMPUTER GAME SOFTWARE (U.S. CLS. 21, 23, 26, 36 AND 38).

FIRST USE 10-0-2002; IN COMMERCE 10-0-2002. AMOS T. MATTHEWS, JR., EXAMINING ATTORNEY

SN 77-495,245. CIBER, INC., GREENWOOD VILLAGE, CO. FILED 6-10-2008.

CIBERLAW ELITE

THE MARK CONSISTS OF STANDARD CHARACTERS WITHOUT CLAIM TO ANY PARTICULAR FONT, STYLE, SIZE, OR COLOR.

NO CLAIM IS MADE TO THE EXCLUSIVE RIGHT TO USE "CYBERLAW", APART FROM THE MARK AS SHOWN.

FOR COMPUTER SOFTWARE FOR USE IN INTEGRATING, CONFIGURING, PROCESSING, REPORTING AND TRACING OF LEGAL CASE ACTIVITY AND DOCUMENTS (U.S. CLS. 21, 23, 26, 36 AND 38).

CAROLYN CATALDO, EXAMINING ATTORNEY

CLASS 9—(Continued).

SN 77-495,259. CIBER, INC., GREENWOOD VILLAGE, CO. FILED 6-10-2008.

CIBERLAW ELITE EXPRESS

THE MARK CONSISTS OF STANDARD CHARACTERS WITHOUT CLAIM TO ANY PARTICULAR FONT, STYLE, SIZE, OR COLOR.

NO CLAIM IS MADE TO THE EXCLUSIVE RIGHT TO USE "CYBERLAW" AND "EXPRESS", APART FROM THE MARK AS SHOWN.

FOR COMPUTER SOFTWARE FOR USE IN INTEGRATING, CONFIGURING, PROCESSING, REPORTING AND TRACING OF LEGAL CASE ACTIVITY AND DOCUMENTS (U.S. CLS. 21, 23, 26, 36 AND 38).

CAROLYN CATALDO, EXAMINING ATTORNEY

SN 77-501,021. EDWARDS, BILL, TAMPA, FL. FILED 6-17-2008.

GUITAR LAB

THE MARK CONSISTS OF STANDARD CHARACTERS WITHOUT CLAIM TO ANY PARTICULAR FONT, STYLE, SIZE, OR COLOR.

NO CLAIM IS MADE TO THE EXCLUSIVE RIGHT TO USE "GUITAR", APART FROM THE MARK AS SHOWN.

FOR EDUCATIONAL SOFTWARE, AUDIO RECORDINGS AND VIDEO RECORDINGS, INCLUDING DOWNLOADABLE AUDIO AND VIDEO RECORDINGS, ALL FEATURING MUSICAL INSTRUCTION, INTERACTIVE MULTIMEDIA COMPUTER GAME PROGRAM (U.S. CLS. 21, 23, 26, 36 AND 38).

MARGARET POWER, EXAMINING ATTORNEY

SN 77-501,451. RESTAURANT INNOVATIONS LTD, HATFIELD, UNITED KINGDOM, FILED 6-18-2008.

iServe

THE MARK CONSISTS OF STANDARD CHARACTERS WITHOUT CLAIM TO ANY PARTICULAR FONT, STYLE, SIZE, OR COLOR.

FOR COMPUTER SOFTWARE FOR CONTROLLING SELF-SERVICE TERMINALS; CUSTOMER SELF SERVICE ELECTRONIC CHECKOUT STATION FOR POINT OF SALE; POINT-OF-SALE TERMINALS; WIRELESS POS (POINT OF SERVICE) DEVICES (U.S. CLS. 21, 23, 26, 36 AND 38).

FIRST USE 9-1-2007; IN COMMERCE 9-1-2007.

KRISTIN CARLSON, EXAMINING ATTORNEY

CLASS 9—(Continued).

SN 77-501,677. VISIPLEX, INC., VERNON HILLS, IL. FILED 6-18-2008.

ALERTWAVE

THE MARK CONSISTS OF STANDARD CHARACTERS WITHOUT CLAIM TO ANY PARTICULAR FONT, STYLE, SIZE, OR COLOR.

FOR PUBLIC ADDRESS SYSTEMS FOR BROADCASTING VOICE AND TEXT MESSAGES; MASS NOTIFICATION SYSTEMS COMPRISED OF SPEAKERS, SIGNBOARDS, STROBES, SIRENS, PAGERS, LIGHTS, TELEPHONES, CELL PHONES AND COMPUTERS FOR ALERTING AND INSTRUCTING INDIVIDUALS DURING EMERGENCY AND/OR DISASTER SITUATIONS (U.S. CLS. 21, 23, 26, 36 AND 38).

FIRST USE 4-17-2006; IN COMMERCE 4-17-2006.

HOWARD FRIEDMAN, EXAMINING ATTORNEY

SN 77-505,456. HITACHI GLOBAL STORAGE TECHNOLOGIES NETHERLANDS B.V., AMSTERDAM, NETHERLANDS, FILED 6-23-2008.

LIFESTUDIO

THE MARK CONSISTS OF STANDARD CHARACTERS WITHOUT CLAIM TO ANY PARTICULAR FONT, STYLE, SIZE, OR COLOR.

FOR HARD DISK DRIVES AND PORTABLE HARD DISK DRIVES AND INSTRUCTION MANUALS SOLD AS A UNIT; COMPUTER SOFTWARE FOR BIOS (BASIC INPUT/OUTPUT SYSTEM) AND NETWORK SECURITY AND INSTRUCTION MANUALS SOLD AS A UNIT (U.S. CLS. 21, 23, 26, 36 AND 38).

HEATHER BIDDULPH, EXAMINING ATTORNEY

SN 77-505,641. TRILITHIC, INC., INDIANAPOLIS, IN. FILED 6-23-2008.

XFTP SAT-2150

THE MARK CONSISTS OF STANDARD CHARACTERS WITHOUT CLAIM TO ANY PARTICULAR FONT, STYLE, SIZE, OR COLOR.

FOR SATELLITE SIGNAL LEVEL METERS (U.S. CLS. 21, 23, 26, 36 AND 38).

FIRST USE 10-10-2007; IN COMMERCE 10-10-2007.

ANTHONY RINKER, EXAMINING ATTORNEY

CLASS 9—(Continued).

SN 77-508,172. GANNON TECHNOLOGIES GROUP, LLC, ALEXANDRIA, VA. FILED 6-25-2008.

CLASS 9—(Continued).

SN 77-508,188. GANNON TECHNOLOGIES GROUP, LLC, ALEXANDRIA, VA. FILED 6-25-2008.

GANNON TECHNOLOGIES GROUP

FLEX-TRACKER

THE MARK CONSISTS OF STANDARD CHARACTERS WITHOUT CLAIM TO ANY PARTICULAR FONT, STYLE, SIZE, OR COLOR.

NO CLAIM IS MADE TO THE EXCLUSIVE RIGHT TO USE "TECHNOLOGIES GROUP", APART FROM THE MARK AS SHOWN.

SEC. 2(F).

FOR BIOMETRIC IDENTIFICATION SOFTWARE; BIOMETRIC SECURITY SOFTWARE; COMPUTER SOFTWARE FOR ELECTRONIC IDENTITY VERIFICATION; COMPUTER SOFTWARE, NAMELY, SOFTWARE FOR CAPTURING, BIOMETRIC DATA; COMPUTER SOFTWARE, NAMELY, SOFTWARE FOR VERIFYING BIOMETRIC DATA; COMPUTER SOFTWARE, NAMELY, SOFTWARE FOR AUTHENTICATING BIOMETRIC DATA; COMPUTER SOFTWARE FOR STORAGE OF BIOMETRIC DATA; COMPUTER SOFTWARE FOR WORD SEARCHES; COMPUTER SOFTWARE FOR MAKING MACHINE GENERATED DOCUMENTS SEARCHABLE; COMPUTER SOFTWARE FOR MAKING HANDWRITTEN DOCUMENTS SEARCHABLE; COMPUTER SOFTWARE FOR DISCERNING OBJECTS IN PHOTOGRAPHIC IMAGES; COMPUTER SOFTWARE FOR DATA CAPTURING; COMPUTER SOFTWARE FOR TRIAGING HANDWRITTEN DOCUMENTS; COMPUTER SOFTWARE FOR CAPTURING SIGNATURES; COMPUTER SOFTWARE FOR SIGNATURE RECOGNITION; COMPUTER SOFTWARE FOR SIGNATURE VERIFICATION; COMPUTER SOFTWARE FOR SIGNATURE AUTHENTICATION; COMPUTER SOFTWARE FOR COLLECTING DATA IN GRAPH FORM; COMPUTER SOFTWARE FOR VERIFYING DATA IN GRAPH FORM; COMPUTER SOFTWARE FOR AUTHENTICATING DATA IN GRAPH FORM; COMPUTER SOFTWARE FOR COLLECTING, VERIFYING AND AUTHENTICATING DATA IN GRAPH FORM, NAMELY, SOUND AND RADIATION; COMPUTER SOFTWARE FOR COLLECTING DATA IN GRAPH FORM AND USING THAT INFORMATION FOR VERIFICATION OR RECOGNITION PURPOSES; COMPUTER SOFTWARE FOR USE IN DOCUMENT AND DATA STORAGE, RETRIEVAL, VIEWING AND SEARCHING; COMPUTER SOFTWARE FOR ELECTRONIC IDENTIFICATION USING OPTICAL CHARACTER RECOGNITION FOR USE IN THE FIELD OF BIOMETRICS; COMPUTER SOFTWARE FOR OPTICAL CHARACTER RECOGNITION; COMPUTER SOFTWARE FOR IDENTIFICATION AUTHENTICATION FOR USE WITH BIOMETRIC DEVICES; COMPUTER SOFTWARE FOR IDENTIFICATION VERIFICATION FOR USE WITH BIOMETRIC DEVICES (U.S. CLS. 21, 23, 26, 36 AND 38).

FIRST USE 8-30-2003; IN COMMERCE 8-30-2003. CHRISTINE COOPER, EXAMINING ATTORNEY

THE MARK CONSISTS OF STANDARD CHARACTERS WITHOUT CLAIM TO ANY PARTICULAR FONT, STYLE, SIZE, OR COLOR.

FOR BIOMETRIC IDENTIFICATION SOFTWARE; BIOMETRIC SECURITY SOFTWARE; COMPUTER SOFTWARE FOR ELECTRONIC IDENTITY VERIFICATION; COMPUTER SOFTWARE, NAMELY, SOFTWARE FOR CAPTURING BIOMETRIC DATA; COMPUTER SOFTWARE, NAMELY, SOFTWARE FOR VERIFYING BIOMETRIC DATA; COMPUTER SOFTWARE, NAMELY, SOFTWARE FOR AUTHENTICATING BIOMETRIC DATA; COMPUTER SOFTWARE FOR STORAGE OF BIOMETRIC DATA; COMPUTER SOFTWARE FOR WORD SEARCHES; COMPUTER SOFTWARE FOR MAKING MACHINE GENERATED DOCUMENTS SEARCHABLE; COMPUTER SOFTWARE FOR MAKING HANDWRITTEN DOCUMENTS SEARCHABLE; COMPUTER SOFTWARE FOR DISCERNING OBJECTS IN PHOTOGRAPHIC IMAGES; COMPUTER SOFTWARE FOR DATA CAPTURING; COMPUTER SOFTWARE FOR TRIAGING HANDWRITTEN DOCUMENTS; COMPUTER SOFTWARE FOR CAPTURING SIGNATURES; COMPUTER SOFTWARE FOR SIGNATURE RECOGNITION; COMPUTER SOFTWARE FOR SIGNATURE VERIFICATION; COMPUTER SOFTWARE FOR SIGNATURE AUTHENTICATION; COMPUTER SOFTWARE FOR COLLECTING DATA IN GRAPH FORM; COMPUTER SOFTWARE FOR VERIFYING DATA IN GRAPH FORM; COMPUTER SOFTWARE FOR AUTHENTICATING DATA IN GRAPH FORM; COMPUTER SOFTWARE FOR COLLECTING, VERIFYING AND AUTHENTICATING DATA IN GRAPH FORM, NAMELY, SOUND AND RADIATION; COMPUTER SOFTWARE FOR COLLECTING DATA IN GRAPH FORM AND USING THAT INFORMATION FOR VERIFICATION OR RECOGNITION PURPOSES; COMPUTER SOFTWARE FOR USE IN DOCUMENT AND DATA STORAGE, RETRIEVAL, VIEWING AND SEARCHING; COMPUTER SOFTWARE FOR ELECTRONIC IDENTIFICATION USING OPTICAL CHARACTER RECOGNITION FOR USE IN THE FIELD OF BIOMETRICS; COMPUTER SOFTWARE FOR OPTICAL CHARACTER RECOGNITION; COMPUTER SOFTWARE FOR IDENTIFICATION AUTHENTICATION FOR USE WITH BIOMETRIC DEVICES; COMPUTER SOFTWARE FOR IDENTIFICATION VERIFICATION FOR USE WITH BIOMETRIC DEVICES (U.S. CLS. 21, 23, 26, 36 AND 38).

CHRISTINE COOPER, EXAMINING ATTORNEY

CLASS 9—(Continued).

SN 77-508,195. GANNON TECHNOLOGIES GROUP, LLC, ALEXANDRIA, VA. FILED 6-25-2008.

CLASS 9—(Continued).

SN 77-508,201. GANNON TECHNOLOGIES GROUP, LLC, ALEXANDRIA, VA. FILED 6-25-2008.

FLEX-MINER**THE EXAMINER**

THE MARK CONSISTS OF STANDARD CHARACTERS WITHOUT CLAIM TO ANY PARTICULAR FONT, STYLE, SIZE, OR COLOR.

FOR BIOMETRIC IDENTIFICATION SOFTWARE; BIOMETRIC SECURITY SOFTWARE; COMPUTER SOFTWARE FOR ELECTRONIC IDENTITY VERIFICATION; COMPUTER SOFTWARE, NAMELY, SOFTWARE FOR CAPTURING BIOMETRIC DATA; COMPUTER SOFTWARE, NAMELY, SOFTWARE FOR VERIFYING BIOMETRIC DATA; COMPUTER SOFTWARE, NAMELY, SOFTWARE FOR AUTHENTICATING BIOMETRIC DATA; COMPUTER SOFTWARE FOR STORAGE OF BIOMETRIC DATA; COMPUTER SOFTWARE FOR WORD SEARCHES; COMPUTER SOFTWARE FOR MAKING MACHINE GENERATED DOCUMENTS SEARCHABLE; COMPUTER SOFTWARE FOR MAKING HANDWRITTEN DOCUMENTS SEARCHABLE; COMPUTER SOFTWARE FOR DISCERNING OBJECTS IN PHOTOGRAPHIC IMAGES; COMPUTER SOFTWARE FOR DATA CAPTURING; COMPUTER SOFTWARE FOR TRIAGING HANDWRITTEN DOCUMENTS; COMPUTER SOFTWARE FOR CAPTURING SIGNATURES; COMPUTER SOFTWARE FOR SIGNATURE RECOGNITION; COMPUTER SOFTWARE FOR SIGNATURE VERIFICATION; COMPUTER SOFTWARE FOR SIGNATURE AUTHENTICATION; COMPUTER SOFTWARE FOR COLLECTING DATA IN GRAPH FORM; COMPUTER SOFTWARE FOR VERIFYING DATA IN GRAPH FORM; COMPUTER SOFTWARE FOR AUTHENTICATING DATA IN GRAPH FORM; COMPUTER SOFTWARE FOR COLLECTING, VERIFYING AND AUTHENTICATING DATA IN GRAPH FORM, NAMELY, SOUND AND RADIATION; COMPUTER SOFTWARE FOR COLLECTING DATA IN GRAPH FORM AND USING THAT INFORMATION FOR VERIFICATION OR RECOGNITION PURPOSES; COMPUTER SOFTWARE FOR USE IN DOCUMENT AND DATA STORAGE, RETRIEVAL, VIEWING AND SEARCHING; COMPUTER SOFTWARE FOR ELECTRONIC IDENTIFICATION USING OPTICAL CHARACTER RECOGNITION FOR USE IN THE FIELD OF BIOMETRICS; COMPUTER SOFTWARE FOR OPTICAL CHARACTER RECOGNITION; COMPUTER SOFTWARE FOR IDENTIFICATION AUTHENTICATION FOR USE WITH BIOMETRIC DEVICES; COMPUTER SOFTWARE FOR IDENTIFICATION VERIFICATION FOR USE WITH BIOMETRIC DEVICES (U.S. CLS. 21, 23, 26, 36 AND 38).

CHRISTINE COOPER, EXAMINING ATTORNEY

THE MARK CONSISTS OF STANDARD CHARACTERS WITHOUT CLAIM TO ANY PARTICULAR FONT, STYLE, SIZE, OR COLOR.

FOR BIOMETRIC IDENTIFICATION SOFTWARE; BIOMETRIC SECURITY SOFTWARE; COMPUTER SOFTWARE FOR ELECTRONIC IDENTITY VERIFICATION; COMPUTER SOFTWARE, NAMELY, SOFTWARE FOR CAPTURING BIOMETRIC DATA; COMPUTER SOFTWARE, NAMELY, SOFTWARE FOR VERIFYING BIOMETRIC DATA; COMPUTER SOFTWARE, NAMELY, SOFTWARE FOR AUTHENTICATING BIOMETRIC DATA; COMPUTER SOFTWARE FOR STORAGE OF BIOMETRIC DATA; COMPUTER SOFTWARE FOR WORD SEARCHES; COMPUTER SOFTWARE FOR MAKING MACHINE GENERATED DOCUMENTS SEARCHABLE; COMPUTER SOFTWARE FOR MAKING HANDWRITTEN DOCUMENTS SEARCHABLE; COMPUTER SOFTWARE FOR DISCERNING OBJECTS IN PHOTOGRAPHIC IMAGES; COMPUTER SOFTWARE FOR DATA CAPTURING; COMPUTER SOFTWARE FOR TRIAGING HANDWRITTEN DOCUMENTS; COMPUTER SOFTWARE FOR CAPTURING SIGNATURES; COMPUTER SOFTWARE FOR SIGNATURE RECOGNITION; COMPUTER SOFTWARE FOR SIGNATURE VERIFICATION; COMPUTER SOFTWARE FOR SIGNATURE AUTHENTICATION; COMPUTER SOFTWARE FOR COLLECTING DATA IN GRAPH FORM; COMPUTER SOFTWARE FOR VERIFYING DATA IN GRAPH FORM; COMPUTER SOFTWARE FOR AUTHENTICATING DATA IN GRAPH FORM; COMPUTER SOFTWARE FOR COLLECTING, VERIFYING AND AUTHENTICATING DATA IN GRAPH FORM, NAMELY, SOUND AND RADIATION; COMPUTER SOFTWARE FOR COLLECTING DATA IN GRAPH FORM AND USING THAT INFORMATION FOR VERIFICATION OR RECOGNITION PURPOSES; COMPUTER SOFTWARE FOR USE IN DOCUMENT AND DATA STORAGE, RETRIEVAL, VIEWING AND SEARCHING; COMPUTER SOFTWARE FOR ELECTRONIC IDENTIFICATION USING OPTICAL CHARACTER RECOGNITION FOR USE IN THE FIELD OF BIOMETRICS; COMPUTER SOFTWARE FOR OPTICAL CHARACTER RECOGNITION; COMPUTER SOFTWARE FOR IDENTIFICATION AUTHENTICATION FOR USE WITH BIOMETRIC DEVICES; COMPUTER SOFTWARE FOR IDENTIFICATION VERIFICATION FOR USE WITH BIOMETRIC DEVICES (U.S. CLS. 21, 23, 26, 36 AND 38).

CHRISTINE COOPER, EXAMINING ATTORNEY

CLASS 9—(Continued).

SN 77-510,541. MESSNER, WILLIAM G., FOREST PARK, IL. FILED 6-27-2008.

PonyPak

THE MARK CONSISTS OF STANDARD CHARACTERS WITHOUT CLAIM TO ANY PARTICULAR FONT, STYLE, SIZE, OR COLOR.

FOR HARNESES AND BAGS INCORPORATING CLIPPING ASSEMBLIES SPECIALLY ADAPTED FOR CARRYING, HOLDING AND SECURING AIR BOTTLES AND OTHER UNDERWATER DIVING ACCESSORIES USED BY UNDERWATER DIVERS (U.S. CLS. 21, 23, 26, 36 AND 38).

HELENE LIWINSKI, EXAMINING ATTORNEY

CLASS 9—(Continued).

SN 77-513,960. DAN MILLMAN, SAN RAFAEL, CA. AND JOY MILLMAN, SAN RAFAEL, CA. FILED 7-2-2008.

PEACEFUL WARRIOR

THE MARK CONSISTS OF STANDARD CHARACTERS WITHOUT CLAIM TO ANY PARTICULAR FONT, STYLE, SIZE, OR COLOR.

OWNER OF U.S. REG. NOS. 1,563,134 AND 1,566,431. FOR SOUND RECORDINGS FEATURING PROGRAMMING ON PERSONAL DEVELOPMENT OF THE BODY, MIND AND SPIRIT; VIDEO RECORDINGS FEATURING PROGRAMMING ON PERSONAL DEVELOPMENT OF THE BODY, MIND AND SPIRIT (U.S. CLS. 21, 23, 26, 36 AND 38).

FIRST USE 11-30-1986; IN COMMERCE 11-30-1986. BILL DAWE, EXAMINING ATTORNEY

SN 77-511,731. INTERCARD, INC., ST. LOUIS, MO. FILED 6-30-2008.

i-Reader

THE MARK CONSISTS OF STANDARD CHARACTERS WITHOUT CLAIM TO ANY PARTICULAR FONT, STYLE, SIZE, OR COLOR.

FOR MAGNETIC CARD READERS, NAMELY, MAGNETIC ENCODED CARD READERS HAVING ONE OR MORE INTERACTIVE DISPLAYS WHICH DISPLAY AN IMAGE OF INTEREST TO THE USER WHEN A CARD IS SWIPED (U.S. CLS. 21, 23, 26, 36 AND 38).

FIRST USE 11-21-2007; IN COMMERCE 11-21-2007. G. MAYERSCHOFF, EXAMINING ATTORNEY

SN 77-514,355. CONNECTICUT ELECTRIC, INC., ANDERSON, IN. FILED 7-3-2008.

THE POWER TO BRING PEOPLE AND PLACES TOGETHER

THE MARK CONSISTS OF STANDARD CHARACTERS WITHOUT CLAIM TO ANY PARTICULAR FONT, STYLE, SIZE, OR COLOR.

FOR CONVERTERS; ELECTRICAL AC/DC DISTRIBUTION PANELS; AND ELECTRICAL LINE SWITCHES AND GENERATOR SWITCHES (U.S. CLS. 21, 23, 26, 36 AND 38).

FIRST USE 2-29-2004; IN COMMERCE 2-29-2004. EMILY CARLSEN, EXAMINING ATTORNEY

SN 77-512,143. INFOVISTA SA, LES ULIS, FRANCE, FILED 7-1-2008.

INFOVISTA

THE MARK CONSISTS OF STANDARD CHARACTERS WITHOUT CLAIM TO ANY PARTICULAR FONT, STYLE, SIZE, OR COLOR.

OWNER OF U.S. REG. NOS. 2,120,954, 2,583,376 AND 2,907,923.

FOR COMPUTER SOFTWARE FOR USE IN MONITORING AND REPORTING ON PERFORMANCE, QUALITY AND USAGE OF SERVICES OF NETWORKS, APPLICATIONS (U.S. CLS. 21, 23, 26, 36 AND 38).

FIRST USE 4-5-1996; IN COMMERCE 7-25-1996. ALICE BENMAMAN, EXAMINING ATTORNEY

SN 77-515,969. AXIS TECHNOLOGY, LLC, BOSTON, MA. FILED 7-7-2008.

DMSUITE

THE MARK CONSISTS OF STANDARD CHARACTERS WITHOUT CLAIM TO ANY PARTICULAR FONT, STYLE, SIZE, OR COLOR.

FOR COMPUTER SOFTWARE THAT COVERTS COMPUTER PROGRAM DATA OR INFORMATION; COMPUTER SOFTWARE THAT TRANSFORMS DATA FROM ONE FORM TO ANOTHER FORM, NAMELY, TO PROTECT, CONCEAL, OR SECURE DATA IN THE ORIGINAL FORM FROM DISCLOSURE; COMPUTER SOFTWARE THAT CONVERTS SENSITIVE OR SECRET DATA TO ANOTHER FORM TO ALLOW DISSEMINATION OF THE CONVERTED DATA WITHOUT REVEALING THE ORIGINAL SENSITIVE OR SECRET DATA (U.S. CLS. 21, 23, 26, 36 AND 38).

FIRST USE 8-25-2006; IN COMMERCE 8-25-2006. WON TEAK OH, EXAMINING ATTORNEY

CLASS 9—(Continued).

SN 77-516,653. ACM ADVANCED CURRENCY MARKETS SA, GENEVA, SWITZERLAND, FILED 7-8-2008.



THE COLOR(S) RED AND BLACK IS/ARE CLAIMED AS A FEATURE OF THE MARK.

THE MARK CONSISTS OF A BLACK BULL WITH A RED EYE

FOR COMPUTER SOFTWARE IN THE FIELD OF FINANCIAL INFORMATION, INVESTMENT, AND TRADING PRIMARILY RELATED TO CURRENCY AND PRECIOUS METALS TRADING, NAMELY, ELECTRONIC TRADING SOFTWARE, PORTFOLIO MANAGEMENT SOFTWARE, FINANCIAL ANALYTICAL SOFTWARE, FINANCIAL RISK MODELING SOFTWARE, AND SOFTWARE FOR PROVIDING ELECTRONIC CONNECTIVITY TO FINANCIAL EXCHANGES AND MARKETS (U.S. CLS. 21, 23, 26, 36 AND 38).
KIMBERLY FRYE, EXAMINING ATTORNEY

SN 77-516,891. ACM ADVANCED CURRENCY MARKETS SA, GENEVA, SWITZERLAND, FILED 7-8-2008.

WYCIWYG

THE MARK CONSISTS OF STANDARD CHARACTERS WITHOUT CLAIM TO ANY PARTICULAR FONT, STYLE, SIZE, OR COLOR.

FOR COMPUTER SOFTWARE IN THE FIELD OF FINANCIAL INFORMATION, INVESTMENT, AND TRADING PRIMARILY RELATED TO CURRENCY AND PRECIOUS METALS TRADING, NAMELY, ELECTRONIC TRADING SOFTWARE, PORTFOLIO MANAGEMENT SOFTWARE, FINANCIAL ANALYTICAL SOFTWARE, FINANCIAL RISK MODELING SOFTWARE, AND SOFTWARE FOR PROVIDING ELECTRONIC CONNECTIVITY TO FINANCIAL EXCHANGES AND MARKETS (U.S. CLS. 21, 23, 26, 36 AND 38).
KIMBERLY FRYE, EXAMINING ATTORNEY

CLASS 9—(Continued).

SN 77-521,039. FUTURE HEALTH, INC., CARROLL, IA. FILED 7-14-2008.

DC²

FOR COMPUTER SOFTWARE PROVIDING AN INTERNAL SYSTEM FOR DOCUMENTATION OF A PATIENT'S HEALTH CARE OFFICE VISIT/ENCOUNTER SPECIFICALLY WITH A DOCTOR OF CHIROPRACTIC (U.S. CLS. 21, 23, 26, 36 AND 38).

FIRST USE 3-2-2006; IN COMMERCE 3-2-2006.
STEVEN JACKSON, EXAMINING ATTORNEY

SN 77-521,064. FUTURE HEALTH, INC., CARROLL, IA. FILED 7-14-2008.

PT²

FOR COMPUTER SOFTWARE PROVIDING AN INTERNAL SYSTEM FOR DOCUMENTATION OF A PATIENT'S HEALTH CARE OFFICE VISIT/ENCOUNTER SPECIFICALLY WITH A PHYSICAL THERAPY HEALTH CARE PROVIDER (U.S. CLS. 21, 23, 26, 36 AND 38).

FIRST USE 5-23-2008; IN COMMERCE 5-23-2008.
STEVEN JACKSON, EXAMINING ATTORNEY

SN 77-521,075. FUTURE HEALTH, INC., CARROLL, IA. FILED 7-14-2008.

MD²

FOR COMPUTER SOFTWARE PROVIDING AN INTERNAL SYSTEM FOR DOCUMENTATION OF A PATIENT'S HEALTH CARE OFFICE VISIT/ENCOUNTER SPECIFICALLY WITH MEDICAL DOCTORS OR OSTEOPATHIC DOCTORS (U.S. CLS. 21, 23, 26, 36 AND 38).

FIRST USE 5-23-2008; IN COMMERCE 5-23-2008.
STEVEN JACKSON, EXAMINING ATTORNEY

CLASS 9—(Continued).

SN 77-521,170. FUTURE HEALTH, INC., CARROLL, IA. FILED 7-14-2008.

CLINIC OF THE FUTURE

THE MARK CONSISTS OF STANDARD CHARACTERS WITHOUT CLAIM TO ANY PARTICULAR FONT, STYLE, SIZE, OR COLOR.

NO CLAIM IS MADE TO THE EXCLUSIVE RIGHT TO USE "CLINIC", APART FROM THE MARK AS SHOWN.

FOR COMPUTER SOFTWARE FOR USE IN INTERNAL OPERATIONS OF HEALTH CARE PRACTICES OR PROVIDERS (U.S. CLS. 21, 23, 26, 36 AND 38).

FIRST USE 3-2-2006; IN COMMERCE 3-2-2006.
STEVEN JACKSON, EXAMINING ATTORNEY

CLASS 9—(Continued).

SN 77-522,403. SARCASM, INC., SHELBY TOWNSHIP, MI. FILED 7-15-2008.



THE MARK CONSISTS OF A CIRCULAR SPIRAL DESIGN ENDING WITH A SHADED CIRCLE IN THE INTERIOR OF THE SPIRAL.

FOR GRAPHICS AND FONT SOFTWARE (U.S. CLS. 21, 23, 26, 36 AND 38).

ELLEN B. AWRICH, EXAMINING ATTORNEY

SN 77-521,248. FUTURE HEALTH, INC., CARROLL, IA. FILED 7-14-2008.

FUSION TECHNOLOGY

THE MARK CONSISTS OF STANDARD CHARACTERS WITHOUT CLAIM TO ANY PARTICULAR FONT, STYLE, SIZE, OR COLOR.

NO CLAIM IS MADE TO THE EXCLUSIVE RIGHT TO USE "TECHNOLOGY", APART FROM THE MARK AS SHOWN.

FOR INTEGRATED SUITE OF HEALTHCARE PROVIDER PRACTICE SOFTWARE (U.S. CLS. 21, 23, 26, 36 AND 38).

FIRST USE 9-10-2007; IN COMMERCE 9-10-2007.
STEVEN JACKSON, EXAMINING ATTORNEY

SN 77-523,129. THE TEMPLE OF THE PRESENCE, INC., TUCSON, AZ. FILED 7-16-2008.

ACROPOLIS SOPHIA BOOKS & WORKS

SN 77-521,259. FUTURE HEALTH, INC., CARROLL, IA. FILED 7-14-2008.

TRUE EHR

THE MARK CONSISTS OF STANDARD CHARACTERS WITHOUT CLAIM TO ANY PARTICULAR FONT, STYLE, SIZE, OR COLOR.

NO CLAIM IS MADE TO THE EXCLUSIVE RIGHT TO USE "EHR", APART FROM THE MARK AS SHOWN.

FOR ELECTRONIC DOCUMENT STORAGE SOFTWARE (U.S. CLS. 21, 23, 26, 36 AND 38).

FIRST USE 9-10-2007; IN COMMERCE 9-10-2007.
STEVEN JACKSON, EXAMINING ATTORNEY

THE MARK CONSISTS OF STANDARD CHARACTERS WITHOUT CLAIM TO ANY PARTICULAR FONT, STYLE, SIZE, OR COLOR.

OWNER OF U.S. REG. NO. 3,019,984.

NO CLAIM IS MADE TO THE EXCLUSIVE RIGHT TO USE "BOOKS & WORKS", APART FROM THE MARK AS SHOWN.

THE ENGLISH TRANSLATION OF THE GREEK WORDING "ACROPOLIS SOPHIA" IN THE MARK IS CITADEL OF WISDOM.

FOR AUDIO RECORDINGS FEATURING TEACHINGS IN THE FIELDS OF RELIGION, PHILOSOPHY, AND SPIRITUALITY; VIDEO RECORDINGS FEATURING TEACHINGS IN THE FIELDS OF RELIGION, PHILOSOPHY, AND SPIRITUALITY (U.S. CLS. 21, 23, 26, 36 AND 38).

BERYL GARDNER, EXAMINING ATTORNEY

CLASS 9—(Continued).

SN 77-523,130. THE TEMPLE OF THE PRESENCE, INC., TUCSON, AZ. FILED 7-16-2008.

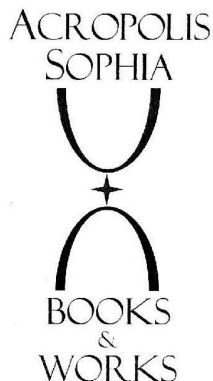

OWNER OF U.S. REG. NO. 3,019,984.

NO CLAIM IS MADE TO THE EXCLUSIVE RIGHT TO USE "BOOKS & WORKS", APART FROM THE MARK AS SHOWN.

THE MARK CONSISTS OF AN UPWARD AND DOWNWARD-CURVING ARCH AND A FOUR-POINTED DIAMOND, BETWEEN THE WORDING "ACROPOLIS SOPHIA BOOKS & WORKS".

THE ENGLISH TRANSLATION OF THE GREEK WORDING "ACROPOLIS SOPHIA" IN THE MARK IS CITADEL OF WISDOM.

FOR AUDIO RECORDINGS FEATURING TEACHINGS IN THE FIELDS OF RELIGION, PHILOSOPHY, AND SPIRITUALITY; VIDEO RECORDINGS FEATURING TEACHINGS IN THE FIELDS OF RELIGION, PHILOSOPHY, AND SPIRITUALITY (U.S. CLS. 21, 23, 26, 36 AND 38).

BERYL GARDNER, EXAMINING ATTORNEY

SN 77-523,158. RESEARCH DATA NET, INC., SAN ANTONIO, TX. FILED 7-16-2008.



NO CLAIM IS MADE TO THE EXCLUSIVE RIGHT TO USE "RESEARCH DATA NET.COM", APART FROM THE MARK AS SHOWN.

THE COLOR(S) GREEN, BLUE, ORANGE, AND YELLOW IS/ARE CLAIMED AS A FEATURE OF THE MARK.

THE MARK CONSISTS OF THE TERM "RESEARCH" APPEARING IN THE COLOR BLUE, THE TERM "DATA" APPEARING IN THE COLOR ORANGE, AND THE TERMS "NET" AND "COM" APPEARING IN THE COLOR GREEN. A BUTTERFLY WITH A BLUE BODY AND YELLOW AND ORANGE WINGS IS POSITIONED OVER THE TERM "DATA" AND A BLUE BUTTERFLY NET IS POSITIONED TO SEPARATE THE TERMS "NET" AND "COM". THERE IS A PARTIAL OVAL SWIRL APPEARING IN THE COLORS BLUE, GREEN, AND ORANGE WHICH EXTENDS FROM THE BUTTERFLY NET TO THE BUTTERFLY.

FOR COMPUTER SOFTWARE FOR THE COLLECTION, EDITING, ORGANIZING, MODIFYING, BOOK MARKING, TRANSMISSION, STORAGE AND SHARING OF DATA AND INFORMATION (U.S. CLS. 21, 23, 26, 36 AND 38).

COURTNEY MCCORMICK, EXAMINING ATTORNEY

CLASS 9—(Continued).

SN 77-523,933. ARRIS GROUP, INC., SUWANEE, GA. FILED 7-16-2008.

OPTICAL EDGE

THE MARK CONSISTS OF STANDARD CHARACTERS WITHOUT CLAIM TO ANY PARTICULAR FONT, STYLE, SIZE, OR COLOR.

NO CLAIM IS MADE TO THE EXCLUSIVE RIGHT TO USE "OPTICAL", APART FROM THE MARK AS SHOWN.

FOR TELECOMMUNICATION EQUIPMENT, NAMELY, DEVICES FOR TRANSPORTING AND AGGREGATING VOICE, DATA, AND VIDEO COMMUNICATIONS ACROSS MULTIPLE NETWORK INFRASTRUCTURES AND COMMUNICATION PROTOCOLS; ELECTRONIC EQUIPMENT, NAMELY, TRANSMITTER FOR TRANSMITTING RADIO-FREQUENCY SIGNALS OVER A COMMUNICATION NETWORK, AND RECEIVER FOR RECEIVING RADIO-FREQUENCY SIGNALS OVER A COMMUNICATION NETWORK (U.S. CLS. 21, 23, 26, 36 AND 38).

DEIRDRE ROBERTSON, EXAMINING ATTORNEY

SN 77-524,070. IGT, RENO, NV. FILED 7-16-2008.

WU XING SEVENS

THE MARK CONSISTS OF STANDARD CHARACTERS WITHOUT CLAIM TO ANY PARTICULAR FONT, STYLE, SIZE, OR COLOR.

OWNER OF U.S. REG. NO. 3,459,485.

NO CLAIM IS MADE TO THE EXCLUSIVE RIGHT TO USE "SEVENS", APART FROM THE MARK AS SHOWN.

THE ENGLISH TRANSLATION OF "WU XING" IN THE MARK IS "FIVE ELEMENTS."

FOR GAMING MACHINES, NAMELY, DEVICES WHICH ACCEPT A WAGER (U.S. CLS. 21, 23, 26, 36 AND 38).

MICHAEL KEATING, EXAMINING ATTORNEY

CLASS 9—(Continued).

SN 77-524,077. BEYOND ACCESS, INC., ROLLING HILLS ESTATES, CA. FILED 7-16-2008.



THE COLOR(S) YELLOW, ORANGE AND BROWN IS/ ARE CLAIMED AS A FEATURE OF THE MARK.

THE MARK CONSISTS OF EIGHT FIVE-POINT STARS; THE STARS APPEAR IN THE COLORS YELLOW AND ORANGE WITH BROWN SHADING TO REFLECT THREE-DIMENSIONAL CHARACTERISTICS.

FOR COMPUTERS, LAPTOP COMPUTERS; COMPUTER PERIPHERALS; OPERATING SOFTWARE FOR COMPUTERS AND PERIPHERALS; SOFTWARE FOR USE IN AUTOMATED MAINTENANCE OF COMPUTERS AND PERIPHERALS, MEDIA DOCKS FOR COMPUTERS AND PERIPHERALS; CHARGING STATIONS FOR COMPUTERS AND PERIPHERALS; COMPUTER HARDWARE AND SOFTWARE FOR MONITORING AND MAINTAINING SECURITY FOR COMPUTER USAGE, NETWORKING, AND INTERNET USE (U.S. CLS. 21, 23, 26, 36 AND 38).

JORDAN BAKER, EXAMINING ATTORNEY

CLASS 9—(Continued).

SN 77-524,537. THERMALOGIC CORPORATION, HUDSON, MA. FILED 7-17-2008.

MASTER SERIES

THE MARK CONSISTS OF STANDARD CHARACTERS WITHOUT CLAIM TO ANY PARTICULAR FONT, STYLE, SIZE, OR COLOR.

NO CLAIM IS MADE TO THE EXCLUSIVE RIGHT TO USE "SERIES", APART FROM THE MARK AS SHOWN.

FOR ELECTRONIC CONTROLS FOR THE REGULATION OF TEMPERATURE, HUMIDITY, AND CLIMATE-CONTROL PROCESSES (U.S. CLS. 21, 23, 26, 36 AND 38). FIRST USE 11-0-2005; IN COMMERCE 11-0-2005.

DAVID MILLER, EXAMINING ATTORNEY

SN 77-524,772. QWELL TECHNOLOGIES, LLC, LOS ANGELES, CA. FILED 7-17-2008.

QWELL

THE MARK CONSISTS OF STANDARD CHARACTERS WITHOUT CLAIM TO ANY PARTICULAR FONT, STYLE, SIZE, OR COLOR.

FOR COMPUTER APPLICATION SOFTWARE FOR MOBILE PHONES; DIGITAL TELEPHONE PLATFORMS AND SOFTWARE; MOBILE PHONES; TELEPHONES (U.S. CLS. 21, 23, 26, 36 AND 38).

RICHARD A. STRASER, EXAMINING ATTORNEY

SN 77-524,094. TM COMPUTER CONSULTING, INC., TERREBONNE, OR. FILED 7-16-2008.



THE MARK CONSISTS OF A STYLIZED MORTAR AND PESTLE CONTAINED WITHIN AN OVAL RING.

FOR COMPUTER SOFTWARE FOR CONTROLLING AND MANAGING MEDICATIONS AND MEDICAL INFORMATION; MEDICAL SOFTWARE FOR CONTROLLING AND MANIPULATING MEDICATIONS AND PATIENT INFORMATION (U.S. CLS. 21, 23, 26, 36 AND 38).

FIRST USE 4-15-2000; IN COMMERCE 4-15-2000.
LAURIE MAYES, EXAMINING ATTORNEY

SN 77-524,850. VISIBLE ASSETS, INC., MISSISSAUGA, CANADA, FILED 7-17-2008.

Dot-Tool

THE MARK CONSISTS OF STANDARD CHARACTERS WITHOUT CLAIM TO ANY PARTICULAR FONT, STYLE, SIZE, OR COLOR.

FOR RADIO RECEIVERS, RADIO TRANSMITTERS, RADIO RECEIVERS FOR MONITORING LOCATION OF TOOLS; RADIO TRANSMITTERS FOR MONITORING LOCATION OF TOOLS (U.S. CLS. 21, 23, 26, 36 AND 38).

DORITT L. CARROLL, EXAMINING ATTORNEY

CLASS 9—(Continued).

SN 77-525,096. MORE MEDIA DIRECT, INC., MIAMI BEACH, FL. FILED 7-17-2008.

KNUCKLEBUSTERS

THE MARK CONSISTS OF STANDARD CHARACTERS WITHOUT CLAIM TO ANY PARTICULAR FONT, STYLE, SIZE, OR COLOR.

FOR DIGITAL MEDIA, NAMELY, DVDS FEATURING SPORTING EVENTS (U.S. CLS. 21, 23, 26, 36 AND 38).
BARBARA GAYNOR, EXAMINING ATTORNEY

SN 77-525,105. PANASONIC CORPORATION OF NORTH AMERICA, SECAUCUS, NJ. FILED 7-17-2008.

THE NEW VISUAL ERA

THE MARK CONSISTS OF STANDARD CHARACTERS WITHOUT CLAIM TO ANY PARTICULAR FONT, STYLE, SIZE, OR COLOR.

FOR FLAT PANEL DISPLAYS, NAMELY, TELEVISIONS (U.S. CLS. 21, 23, 26, 36 AND 38).
BILL DAWE, EXAMINING ATTORNEY

SN 77-526,566. JORDAN, JR., FREDRICK L, DBA DYNAMIC SOUND ENCLOSURES, SPRING HILL, FL. FILED 7-19-2008.



THE MARK CONSISTS OF LABEL OF BLACK BACKGROUND, DEPICTING THE COMPANY LOGO "D.S.E.". FOR AUDIO SPEAKER ENCLOSURES (U.S. CLS. 21, 23, 26, 36 AND 38).

FIRST USE 1-1-2008; IN COMMERCE 1-1-2008.
ANNE E. GUSTASON, EXAMINING ATTORNEY

CLASS 9—(Continued).

SN 77-526,638. SMARTERGO, INC., MORRIS PLAINS, NJ. FILED 7-19-2008.

SMART ERGO

THE MARK CONSISTS OF STANDARD CHARACTERS WITHOUT CLAIM TO ANY PARTICULAR FONT, STYLE, SIZE, OR COLOR.

NO CLAIM IS MADE TO THE EXCLUSIVE RIGHT TO USE "SMART", APART FROM THE MARK AS SHOWN.

THE ENGLISH TRANSLATION OF THE WORD "ERGO" IN THE MARK IS THEREFORE OR HENCE.

FOR COMPUTER SOFTWARE USED IN EVALUATING AND REMEDYING IMPROPER COMPUTER USAGE ERGONOMIC CONDITIONS (U.S. CLS. 21, 23, 26, 36 AND 38).

RICHARD A. STRASER, EXAMINING ATTORNEY

SN 77-526,639. SMARTERGO, INC., MORRIS PLAINS, NJ. FILED 7-19-2008.

ERGO SUITE

THE MARK CONSISTS OF STANDARD CHARACTERS WITHOUT CLAIM TO ANY PARTICULAR FONT, STYLE, SIZE, OR COLOR.

NO CLAIM IS MADE TO THE EXCLUSIVE RIGHT TO USE "SUITE", APART FROM THE MARK AS SHOWN.

THE ENGLISH TRANSLATION OF THE WORD ERGO IN THE MARK IS "THEREFORE OR HENCE".

FOR COMPUTER SOFTWARE USED IN EVALUATING AND REMEDYING IMPROPER COMPUTER USAGE ERGONOMIC CONDITIONS (U.S. CLS. 21, 23, 26, 36 AND 38).

RICHARD A. STRASER, EXAMINING ATTORNEY

CLASS 9—(Continued).

SN 77-527,891. RIVERSIDE MANUFACTURING COMPANY, MOULTRIE, GA. FILED 7-22-2008.



NO CLAIM IS MADE TO THE EXCLUSIVE RIGHT TO USE "FR", APART FROM THE MARK AS SHOWN.

THE MARK CONSISTS OF THE DESIGN OF A SHIELD WITH THE LETTERS "FR" SEPARATED BY A LIGHTNING BOLT.

FOR CLOTHING FOR PROTECTION AGAINST FIRE; CLOTHING FOR PROTECTION AGAINST FIRE, NAMELY, WOVEN SHIRTS, SHORT SLEEVE AND LONG SLEEVE, KNIT SHIRTS, SHORT SLEEVE AND LONG SLEEVE, TROUSERS, JEANS, COVERALLS, T-SHIRTS, SWEATSHIRTS AND OUTERWEAR (U.S. CLS. 21, 23, 26, 36 AND 38).

FIRST USE 1-0-2007; IN COMMERCE 1-0-2007.
BARBARA BROWN, EXAMINING ATTORNEY

SN 77-530,015. SUN EDISON LLC, BELTSVILLE, MD. FILED 7-23-2008.



OWNER OF U.S. REG. NOS. 3,407,196 AND 3,426,602.
NO CLAIM IS MADE TO THE EXCLUSIVE RIGHT TO USE "ENERGY & ENVIRONMENTAL DATA SYSTEM", APART FROM THE MARK AS SHOWN.

THE MARK CONSISTS OF THE WORDS "SUNEDISON ENERGY & ENVIRONMENTAL DATA SYSTEM SEEDS" IN A RECTANGLE.

FOR COMPUTER HARDWARE AND SOFTWARE SYSTEM USED FOR COLLECTING AND MONITORING ENERGY USAGE INFORMATION AND MANAGING ENERGY USAGE (U.S. CLS. 21, 23, 26, 36 AND 38).

ELISSA GARBER KON, EXAMINING ATTORNEY

CLASS 9—(Continued).

SN 77-530,405. ARAI HELMET AMERICAS, INC., DAYTONA, FL. FILED 7-24-2008.

SIGNET

THE MARK CONSISTS OF STANDARD CHARACTERS WITHOUT CLAIM TO ANY PARTICULAR FONT, STYLE, SIZE, OR COLOR.

FOR SAFETY HELMETS AND MOTORCYCLE HELMETS (U.S. CLS. 21, 23, 26, 36 AND 38).
DAVID TAYLOR, EXAMINING ATTORNEY

SN 77-532,575. TSI, INC., SHOREVIEW, MN. FILED 7-28-2008.

AEROTRAK

THE MARK CONSISTS OF STANDARD CHARACTERS WITHOUT CLAIM TO ANY PARTICULAR FONT, STYLE, SIZE, OR COLOR.

FOR HANDHELD OPTICAL PARTICLE COUNTER AND PORTABLE OPTICAL PARTICLE COUNTER FOR THE PURPOSE OF MEASURING AIR QUALITY (U.S. CLS. 21, 23, 26, 36 AND 38).

FIRST USE 4-25-2006; IN COMMERCE 4-25-2006.
MEGHAN REINHART, EXAMINING ATTORNEY

SN 77-532,977. SYNAPSE WIRELESS, INC., HUNTSVILLE, AL. FILED 7-28-2008.

EagleEye

THE MARK CONSISTS OF STANDARD CHARACTERS WITHOUT CLAIM TO ANY PARTICULAR FONT, STYLE, SIZE, OR COLOR.

FOR ELECTRONIC POSITIONING APPARATUSES AND INSTRUMENTS IN THE NATURE OF LOCAL POSITIONING SYSTEMS FOR TRACKING OBJECTS AND PERSONNEL; TRACKING DEVICES, NAMELY, COMPUTER HARDWARE AND SOFTWARE USING TRILATERATION ALGORITHMS FOR DETERMINING NODE LOCATION WITHIN A LOCAL POSITIONING SYSTEM; AND WIRELESS COMMUNICATION DEVICES, NAMELY, COMPUTER HARDWARE AND SOFTWARE FOR WIRELESSLY COMMUNICATING BETWEEN NODES OF A LOCAL POSITIONING SYSTEM (U.S. CLS. 21, 23, 26, 36 AND 38).

ALLISON HOLTZ, EXAMINING ATTORNEY

CLASS 9—(Continued).

SN 77-533,046. LUCID DESIGN GROUP, INC., OAKLAND, CA. FILED 7-28-2008.

Your car has a dashboard.
Why not your building?

THE MARK CONSISTS OF STANDARD CHARACTERS WITHOUT CLAIM TO ANY PARTICULAR FONT, STYLE, SIZE, OR COLOR.

FOR COMPUTER SOFTWARE FOR MONITORING AND DISPLAYING RESOURCE USAGE AND ENVIRONMENTAL PERFORMANCE OF BUILDINGS AND BUILDING SYSTEMS OR TECHNOLOGIES IN REAL TIME ON WEBSITES, KIOSK DISPLAYS AND WEB-ENABLED DEVICES (U.S. CLS. 21, 23, 26, 36 AND 38).
FIRST USE 1-1-2006; IN COMMERCE 3-1-2006.

DAVID I, EXAMINING ATTORNEY

SN 77-533,893. BIG FISH GAMES, INC., SEATTLE, WA. FILED 7-29-2008.

RAVENHEARST

THE MARK CONSISTS OF STANDARD CHARACTERS WITHOUT CLAIM TO ANY PARTICULAR FONT, STYLE, SIZE, OR COLOR.

OWNER OF U.S. REG. NO. 3,419,177.

FOR DOWNLOADABLE INTERACTIVE COMPUTER, VIDEO, AND ELECTRONIC GAME SOFTWARE; COMPUTER GAME SOFTWARE; AUDIO AND VIDEO RECORDINGS IN THE FIELDS OF ONLINE, COMPUTER AND VIDEO GAMES AND ENTERTAINMENT; DOWNLOADABLE COMPUTER GAME SOFTWARE AND ELECTRONIC GAME SOFTWARE FOR USE ON ELECTRONIC AND WIRELESS COMMUNICATION DEVICES; COMPUTER AND ELECTRONIC GAME PROGRAMS; CD ROM DISCS FEATURING ENTERTAINMENT CONTENT IN THE NATURE OF GAMES, GAME HINTS, GAME FACTS, MUSIC AND STORIES; DOWNLOADABLE ELECTRONIC PUBLICATIONS IN THE NATURE OF ELECTRONIC STRATEGY AND INSTRUCTIONAL GUIDES FOR ONLINE, COMPUTER AND VIDEO GAMES; DOWNLOADABLE MULTIMEDIA FILE CONTAINING ARTWORK, TEXT, AUDIO, VIDEO, GAMES, AND INTERNET WEB LINKS RELATING TO ONLINE, COMPUTER AND VIDEO GAMES AND ENTERTAINMENT (U.S. CLS. 21, 23, 26, 36 AND 38).
FIRST USE 12-14-2006; IN COMMERCE 12-14-2006.

COURTNEY MCCORMICK, EXAMINING ATTORNEY

CLASS 9—(Continued).

SN 77-538,693. THREE AMIGOS, LLC, EL CAJON, CA. FILED 8-4-2008.



THE MARK CONSISTS OF THE WORDING "CURRENTAUDIO" AND A STYLIZED AUDIO SPEAKER DESIGN COMPRISING OF A DOT INSIDE OF A GENERALLY TRIANGULAR SHAPE IN A CIRCLE.

FOR AUDIO AMPLIFIERS; AUDIO CASSETTE AND CD PLAYERS; AUDIO PROCESSING EQUIPMENT, NAMELY, LIMITERS AND COMPRESSORS; AUDIO SPEAKER ENCLOSURES; AUDIO SPEAKERS; CABINETS FOR LOUDSPEAKERS; CLIMATE CONTROL SYSTEMS CONSISTING OF DIGITAL THERMOSTATS, AIR CONDITIONING, HEATING, VENTILATION AND DRYING CONTROL DEVICES; COMPUTER HARDWARE AND SOFTWARE SYSTEM FOR REMOTELY MONITORING ENVIRONMENTAL CONDITIONS AND CONTROLLING DEVICES WITHIN A BUILDING, FACILITY, GROUNDS, OR DESIGNATED SPATIAL AREA; COMPUTER SOFTWARE FOR MANIPULATING DIGITAL AUDIO INFORMATION FOR USE IN AUDIO MEDIA APPLICATIONS; COMPUTER SOFTWARE FOR USE IN THE ENCRYPTION AND DECRYPTION OF DIGITAL FILES, INCLUDING AUDIO, VIDEO, TEXT, BINARY, STILL IMAGES, GRAPHICS AND MULTIMEDIA FILES; COMPUTER SOFTWARE TO CONTROL AND IMPROVE COMPUTER AND AUDIO EQUIPMENT SOUND QUALITY; CONICAL ATTACHMENT TO AN AUDIO SPEAKER FOR DIFFUSING AND DISTRIBUTING SOUND AS IT IS TRANSMITTED FROM THE SPEAKER; CONSUMER ELECTRONIC PRODUCTS, NAMELY, AUDIO AMPLIFIERS, AUDIO SPEAKERS, AUDIO RECEIVERS, ELECTRICAL AUDIO AND SPEAKER CABLES AND CONNECTORS, HOME THEATER SYSTEMS, AUDIO DECODERS, VIDEO DECODERS, SPEAKERS, POWER CONVERSION DEVICES, POWER CONVERTERS, AND POWER INVERTERS; DIGITAL AUDIO PLAYERS; DIGITAL AUDIO TAPE PLAYERS; DISTRIBUTION AMPLIFIERS FOR AUDIO AND VIDEO SIGNALS; ELECTRIC AUDIO PLAYBACK UNITS; ELECTRIC LIGHT DIMMERS; ELECTRIC LIGHT SWITCHES; ELECTRONIC PRODUCTS FOR THE GENERATION, MEASUREMENT, AND ANALYSIS OF AUDIO SIGNALS, NAMELY, AUDIO ANALYZERS; ELECTRONIC SCALERS FOR AUDIO AND VIDEO SIGNALS; ELECTRONIC SWITCHERS FOR AUDIO AND VIDEO SIGNALS; LOUD SPEAKER SYSTEMS; LOUD SPEAKERS; LOUDSPEAKER CABINETS; LOUDSPEAKER SYSTEMS; LOUDSPEAKERS; LOUDSPEAKERS WITH BUILT IN AMPLIFIERS; LOUDSPEAKERS, HEADPHONES, MICROPHONES AND CD PLAYERS; MATRIX SWITCHERS FOR AUDIO AND VIDEO SIGNALS; POWER AMPLIFIERS; PRE-AMPLIFIERS; PUBLIC ADDRESS (PA) AND SOUND SYSTEM ACCESSORIES, NAMELY, MICROPHONE STANDS, SPEAKER STANDS, MICROPHONE CABLES, SPEAKER CABLES, SPEAKER BOXES AND SOUND MIXERS; RACKS FOR AMPLIFIERS; RACKS FOR LOUDSPEAKERS; SOUND AMPLIFIERS; SOUND MIXERS WITH INTEGRATED AMPLIFIERS; SPEAKER ENCLOSURES; STEREO AMPLIFIERS; TRANSMITTERS AND RECEIVERS FOR AUDIO AND VIDEO SIGNALS FOR TRANSMISSION OVER TWISTED PAIR CABLES (U.S. CLS. 21, 23, 26, 36 AND 38).

FIRST USE 6-1-2008; IN COMMERCE 6-1-2008.
HANNO RITTNER, EXAMINING ATTORNEY

CLASS 9—(Continued).

SN 77-548,178. BARRETT PRODUCTIONS, INC., MISSOULA, MT. FILED 8-15-2008.

UNTOUCHED AMERICA

THE MARK CONSISTS OF STANDARD CHARACTERS WITHOUT CLAIM TO ANY PARTICULAR FONT, STYLE, SIZE, OR COLOR.

NO CLAIM IS MADE TO THE EXCLUSIVE RIGHT TO USE "AMERICA", APART FROM THE MARK AS SHOWN. FOR PRE-RECORDED VIDEO TAPES AND DVDS FEATURING A SERIES OF PROGRAMS ON NATURAL AND PROTECTED LANDS, ENVIRONMENTAL CONSERVATION, AND OUTDOOR ACTIVITIES (U.S. CLS. 21, 23, 26, 36 AND 38).

MIDGE BUTLER, EXAMINING ATTORNEY

CLASS 9—(Continued).

SN 77-551,651. COOPER TECHNOLOGIES COMPANY, HOUSTON, TX. FILED 8-20-2008.

TRON

THE MARK CONSISTS OF STANDARD CHARACTERS WITHOUT CLAIM TO ANY PARTICULAR FONT, STYLE, SIZE, OR COLOR.

FOR ELECTRIC FUSES, IN-LINE FUSE HOLDERS, FUSE CLIP CLAMPS (U.S. CLS. 21, 23, 26, 36 AND 38).

FIRST USE 5-19-1958; IN COMMERCE 5-19-1958. ANTHONY RINKER, EXAMINING ATTORNEY

SN 77-552,084. CENTER FOR ECOLITERACY, BERKELEY, CA. FILED 8-20-2008.

CENTER FOR ECOLITERACY

THE MARK CONSISTS OF STANDARD CHARACTERS WITHOUT CLAIM TO ANY PARTICULAR FONT, STYLE, SIZE, OR COLOR.

NO CLAIM IS MADE TO THE EXCLUSIVE RIGHT TO USE "ECOLITERACY", APART FROM THE MARK AS SHOWN.

FOR DOWNLOADABLE AUDIO MATERIAL, VIDEO MATERIAL, MULTIMEDIA FILES, TEXT FILES AND WRITTEN DOCUMENTS, ALL OF THE FOREGOING IN THE FIELD OF EDUCATION FOR SUSTAINABLE LIVING (U.S. CLS. 21, 23, 26, 36 AND 38).

ANGELA GAW, EXAMINING ATTORNEY

SN 77-555,259. DAYMEN PHOTO MARKETING LP, MARKHAM, ONTARIO, CANADA, FILED 8-25-2008.

IMPULSE

THE MARK CONSISTS OF STANDARD CHARACTERS WITHOUT CLAIM TO ANY PARTICULAR FONT, STYLE, SIZE, OR COLOR.

FOR BAGS, HARD AND SOFT COVERED CASES, BACKPACKS WITH ROLLING WHEELS, BACKPACKS WITHOUT ROLLING WHEELS, BELT PACKS, POCKETS AND POUCHES, ALL DESIGNED FOR CARRYING PHOTOGRAPHIC EQUIPMENT AND PHOTOGRAPHIC ACCESSORIES, NAMELY, LENSES, FILM, FLASHES, TRIPODS, CABLES, CORDS AND BATTERIES; WAIST HARNESSES AND SHOULDER HARNESSES DESIGNED FOR USE WITH THE FOREGOING GOODS (U.S. CLS. 21, 23, 26, 36 AND 38).

ANNE MADDEN, EXAMINING ATTORNEY

SN 77-548,717. MIC ELECTRONICS LIMITED, HYDERABAD, INDIA, FILED 8-16-2008.

MIC Electronics

THE MARK CONSISTS OF STANDARD CHARACTERS WITHOUT CLAIM TO ANY PARTICULAR FONT, STYLE, SIZE, OR COLOR.

NO CLAIM IS MADE TO THE EXCLUSIVE RIGHT TO USE "ELECTRONICS", APART FROM THE MARK AS SHOWN.

FOR ELECTRONIC ADVERTISEMENT AND MESSAGING DISPLAY UNIT WITH MULTI-NETWORKING (TCP/IP) CAPABILITIES AND REMOTE CONNECTIVITY; ELECTRONIC SCOREBOARDS; FLAT PANEL DISPLAY SCREENS; HOME AND OFFICE AUTOMATION SYSTEMS COMPRISING WIRELESS AND WIRED CONTROLLERS, CONTROLLED DEVICES, AND SOFTWARE FOR LIGHTING, HVAC, SECURITY, SAFETY AND OTHER HOME AND OFFICE MONITORING AND CONTROL APPLICATIONS; LIGHT EMITTING DIODE (LED)DISPLAYS; LIGHTING CONTROL PANELS; LIGHTING CONTROL SOFTWARE FOR USE IN COMMERCIAL AND INDUSTRIAL FACILITIES; TELECOMMUNICATIONS AND DATA NETWORKING HARDWARE, NAMELY, DEVICES FOR TRANSPORTING AND AGGREGATING VOICE, DATA, AND VIDEO COMMUNICATIONS ACROSS MULTIPLE NETWORK INFRASTRUCTURES AND COMMUNICATIONS PROTOCOLS; VIDEO SCREENS (U.S. CLS. 21, 23, 26, 36 AND 38).

FIRST USE 5-17-1988; IN COMMERCE 5-17-1988. JESSICA A. POWERS, EXAMINING ATTORNEY

CLASS 9—(Continued).

SN 77-561,356. ICX RADIATION GMBH, SOLINGEN, FED REP GERMANY, FILED 9-3-2008.

identiSPEC

THE MARK CONSISTS OF STANDARD CHARACTERS WITHOUT CLAIM TO ANY PARTICULAR FONT, STYLE, SIZE, OR COLOR.

PRIORITY CLAIMED UNDER SEC. 44(D) ON ERPN CMNTY TM OFC APPLICATION NO. 006728596, FILED 3-5-2008, REG. NO. 006728596, DATED 2-6-2009, EXPIRES 3-5-2018.

FOR DEVICES FOR THE MEASUREMENT OF IONIZING AND RADIOACTIVE RADIATION, INCLUDING X-RAYS, GAMMA-RADIATION, BETA RADIATION, AND NEUTRONS (U.S. CLS. 21, 23, 26, 36 AND 38).

ALICE BENMAMAN, EXAMINING ATTORNEY

SN 77-563,045. INTRALOT SA, ATHENS, GREECE, FILED 9-5-2008.

PHOTON

THE MARK CONSISTS OF STANDARD CHARACTERS WITHOUT CLAIM TO ANY PARTICULAR FONT, STYLE, SIZE, OR COLOR.

FOR ELECTRONIC TERMINALS FOR AN ELECTRONIC LOTTERY SYSTEM, WHICH VALIDATES LOTTERY TICKETS, AND COMPUTER SOFTWARE FOR THE VALIDATION OF LOTTERY TICKETS, SOLD AS A UNIT; TERMINALS FOR ENTERTAINING, NAMELY, VIDEO LOTTERY TERMINALS, GAMING MACHINES FEATURING LOTTERY GAMES, WITH AND WITHOUT VIDEO INPUT, AND COMPUTER GAME SOFTWARE FOR THE AFOREMENTIONED VIDEO LOTTERY TERMINALS AND GAMING MACHINES FEATURING LOTTERY GAMES, SOLD AS A UNIT; TERMINALS FOR GAMES OF CHANCE, NAMELY, GAMING MACHINES FEATURING KENO CARD GAMES, GAMING MACHINES FEATURING BINGO GAMES, GAMING MACHINES, NAMELY, DEVICES THAT ACCEPT A WAGER, AND COMPUTER GAME SOFTWARE FOR THE AFOREMENTIONED GAMING MACHINES, SOLD AS A UNIT; CASH REGISTERS (U.S. CLS. 21, 23, 26, 36 AND 38).

MARY MUNSON, EXAMINING ATTORNEY

CLASS 9—(Continued).

SN 77-563,128. MANTIS PRODUCTS LLC, AKA MANTIS PRODUCTS OR MANTIS WIRELESS, WEST BLOOMFIELD, MI. FILED 9-5-2008.



NO CLAIM IS MADE TO THE EXCLUSIVE RIGHT TO USE "WIRELESS PRODUCTS", APART FROM THE MARK AS SHOWN.

THE COLOR(S) GREEN, BLACK AND WHITE IS/ARE CLAIMED AS A FEATURE OF THE MARK.

THE MARK CONSISTS OF THE STYLIZED WORD "MANTIS" OVER THE STYLIZED WORDING "WIRELESS PRODUCTS", WHICH IS CENTERED ON AN OBLONG BACKGROUND. THE DESIGN OF A HEAD OF A PRAYING MANTIS IS TO THE UPPER LEFT OF THE "M" IN "MANTIS", AND THE DESIGN OF THE LEGS OF A PRAYING MANTIS EXTEND TO THE LEFT OF THE "M" IN "MANTIS". THE COLOR BLACK APPEARS IN THE BACKGROUND OF THE EYES OF THE PRAYING MANTIS AND IN THE WORDING "MANTIS" IN THE MARK. THE COLOR GREEN APPEARS IN THE PRAYING MANTIS'S ANTENNAS, HEAD, AND LEGS, AND IN THE OBLONG-SHAPED BACKGROUND BEHIND THE WORDING "WIRELESS PRODUCTS" IN THE MARK. THE COLOR WHITE APPEARS IN THE EYEBALLS OF THE PRAYING MANTIS AND IN THE WORDING "WIRELESS PRODUCTS" IN THE MARK. THE REMAINDER OF THE WHITE IN THE DRAWING REPRESENTS BACKGROUND AREAS AND IS NOT PART OF THE MARK.

FOR COMMUNICATIONS HEADSETS FOR USE WITH COMMUNICATION RADIOS, INTERCOM SYSTEMS, OR OTHER COMMUNICATIONS NETWORK TRANSCIVERS; HANDS FREE KITS FOR PHONES (U.S. CLS. 21, 23, 26, 36 AND 38).

MAUREEN DALL, EXAMINING ATTORNEY

SN 77-567,016. ELIZABETH WILLIS, LLC, NEW YORK, NY. FILED 9-10-2008.



THE NAME(S), PORTRAIT(S), AND/OR SIGNATURE(S) SHOWN IN THE MARK IDENTIFIES "ELIZABETH WILLIS", WHOSE CONSENT(S) TO REGISTER IS MADE OF RECORD.

THE MARK CONSISTS OF THE SILHOUETTE OF A WOMAN'S FACE, IN PROFILE, FACING RIGHT, AND THE WORDS "ELIZABETH WILLIS" IN A STYLIZED FONT, APPEARING WITH FLORAL DECORATIONS ON BOTH THE LEFT AND RIGHT SIDES OF THE WORDS.

FOR MUSICAL SOUND RECORDINGS (U.S. CLS. 21, 23, 26, 36 AND 38).

FIRST USE 3-14-2008; IN COMMERCE 3-14-2008.

MEGHAN REINHART, EXAMINING ATTORNEY

CLASS 9—(Continued).

SN 77-567,464. KNOWLES, BEYONCE, BEVERLY HILLS, CA.
FILED 9-11-2008.

SASHA FIERCE

THE MARK CONSISTS OF STANDARD CHARACTERS WITHOUT CLAIM TO ANY PARTICULAR FONT, STYLE, SIZE, OR COLOR.

THE NAME(S), PORTRAIT(S), AND/OR SIGNATURE(S) SHOWN IN THE MARK DOES NOT IDENTIFY A PARTICULAR LIVING INDIVIDUAL.

FOR DVDS, CDS, AUDIO CASSETTES FEATURING MUSIC, MUSICAL PERFORMANCES, DRAMATIC PERFORMANCES; VIDEO GAME SOFTWARE, CARTRIDGES AND DISCS (U.S. CLS. 21, 23, 26, 36 AND 38).
SHANNON TWOHIG, EXAMINING ATTORNEY

SN 77-567,725. OSP GLOBAL LLC, DBA CONTROLCASE LLC, MCLEAN, VA. FILED 9-11-2008.

Compliance Signatures

THE MARK CONSISTS OF STANDARD CHARACTERS WITHOUT CLAIM TO ANY PARTICULAR FONT, STYLE, SIZE, OR COLOR.

NO CLAIM IS MADE TO THE EXCLUSIVE RIGHT TO USE "COMPLIANCE", APART FROM THE MARK AS SHOWN.

FOR COMPUTER SOFTWARE AND HARDWARE FOR COMPLIANCE AND REGULATORY MANAGEMENT; COMPUTER SOFTWARE FOR THE COLLECTION, EDITING, ORGANIZING, MODIFYING, BOOK MARKING, TRANSMISSION, STORAGE AND SHARING OF DATA AND INFORMATION; COMPUTER SOFTWARE FOR COMPLIANCE AND REGULATORY MANAGEMENT (U.S. CLS. 21, 23, 26, 36 AND 38).

FIRST USE 1-21-2007; IN COMMERCE 1-21-2007.

WILLIAM P. SHANAHAN, EXAMINING ATTORNEY

SN 77-569,312. MEDIDOX CORPORATION, TIBURON, CA.
FILED 9-12-2008.

MediDox

THE MARK CONSISTS OF STANDARD CHARACTERS WITHOUT CLAIM TO ANY PARTICULAR FONT, STYLE, SIZE, OR COLOR.

FOR COMPUTER SOFTWARE FOR MANAGING HEALTH CARE PATIENT RECORDS (U.S. CLS. 21, 23, 26, 36 AND 38).

FIRST USE 9-14-2002; IN COMMERCE 9-14-2002.

ERIN FALK, EXAMINING ATTORNEY

CLASS 9—(Continued).

SN 77-569,315. MEDIDOX CORPORATION, TIBURON, CA.
FILED 9-12-2008.

RadiDox

THE MARK CONSISTS OF STANDARD CHARACTERS WITHOUT CLAIM TO ANY PARTICULAR FONT, STYLE, SIZE, OR COLOR.

FOR COMPUTER SOFTWARE FOR MANAGING HEALTH CARE RADIOLOGY REPORTS (U.S. CLS. 21, 23, 26, 36 AND 38).

FIRST USE 11-16-2004; IN COMMERCE 11-16-2004.

ERIN FALK, EXAMINING ATTORNEY

SN 77-569,776. CENTER FOR ECOLITERACY, BERKELEY, CA. FILED 9-15-2008.

SMART BY NATURE

THE MARK CONSISTS OF STANDARD CHARACTERS WITHOUT CLAIM TO ANY PARTICULAR FONT, STYLE, SIZE, OR COLOR.

FOR DOWNLOADABLE AUDIO MATERIAL, VIDEO MATERIAL, MULTIMEDIA FILES, TEXT FILES AND WRITTEN DOCUMENTS RELATED TO SCHOOLING FOR SUSTAINABILITY (U.S. CLS. 21, 23, 26, 36 AND 38).

ANGELA GAW, EXAMINING ATTORNEY

SN 77-573,602. C3 PROTECTION, LLC, PINEHURST, TX.
FILED 9-18-2008.



NO CLAIM IS MADE TO THE EXCLUSIVE RIGHT TO USE "PROTECTION INTEGRATED SYSTEMS", APART FROM THE MARK AS SHOWN.

THE COLOR(S) BLUE, GREEN, BLACK AND GRAY IS/ARE CLAIMED AS A FEATURE OF THE MARK.

THE MARK CONSISTS OF THE COLOR BLUE APPEARING ON THE LETTER "C" AND TERM "PROTECTION", THE COLOR GREEN APPEARS ON THE NUMBER "3", THE COLOR BLACK APPEARS ON THE TERMS "INTEGRATED SYSTEMS" AND THE COLOR GRAY APPEARS ON THE "C" AND "3" REPRESENTING REFLECTED LIGHT.

FOR ACCESS CONTROL AND ALARM MONITORING SYSTEMS (U.S. CLS. 21, 23, 26, 36 AND 38).

FIRST USE 6-16-2008; IN COMMERCE 6-16-2008.

KATHRYN COWARD, EXAMINING ATTORNEY

CLASS 9—(Continued).

SN 77-575,346. DAIKIN INDUSTRIES, LTD., OSAKA, JAPAN,
FILED 9-22-2008.



THE COLOR(S) BLUE, WHITE, AND BLACK IS/ARE CLAIMED AS A FEATURE OF THE MARK.

THE MARK CONSISTS OF THE WORDING "BIO-THETA" IN BLACK INSIDE A BLUE RECTANGULAR BOX WITH A WHITE DIAGONAL AND HORIZONTAL STRIPE.

FOR SCIENTIFIC APPARATUS FOR DETECTION AND INSPECTION OF MICROBE AND BACTERIA; SCIENTIFIC APPARATUS FOR DETECTION AND INSPECTION OF MICROBE AND BACTERIA IN FOOD (U.S. CLS. 21, 23, 26, 36 AND 38).

ANDREA SAUNDERS, EXAMINING ATTORNEY

SN 77-575,368. DAIKIN INDUSTRIES, LTD., OSAKA, JAPAN,
FILED 9-22-2008.

DAIKIN DOX

THE MARK CONSISTS OF STANDARD CHARACTERS WITHOUT CLAIM TO ANY PARTICULAR FONT, STYLE, SIZE, OR COLOR.

OWNER OF U.S. REG. NOS. 972,356, 2,434,591 AND OTHERS.

FOR SCIENTIFIC APPARATUS FOR DETECTION AND INSPECTION OF MICROBE AND BACTERIA; SCIENTIFIC APPARATUS FOR DETECTION AND INSPECTION OF MICROBE AND BACTERIA IN FOOD (U.S. CLS. 21, 23, 26, 36 AND 38).

ANDREA SAUNDERS, EXAMINING ATTORNEY

SN 77-575,376. DAIKIN INDUSTRIES, LTD., OSAKA, JAPAN,
FILED 9-22-2008.

Bio-Theta

THE MARK CONSISTS OF STANDARD CHARACTERS WITHOUT CLAIM TO ANY PARTICULAR FONT, STYLE, SIZE, OR COLOR.

FOR SCIENTIFIC APPARATUS FOR DETECTION AND INSPECTION OF MICROBE AND BACTERIA; SCIENTIFIC APPARATUS FOR DETECTION AND INSPECTION OF MICROBE AND BACTERIA IN FOOD (U.S. CLS. 21, 23, 26, 36 AND 38).

ANDREA SAUNDERS, EXAMINING ATTORNEY

CLASS 9—(Continued).

SN 77-575,423. DAIKIN INDUSTRIES, LTD., OSAKA, JAPAN,
FILED 9-22-2008.

Bio-Theta DOX

THE MARK CONSISTS OF STANDARD CHARACTERS WITHOUT CLAIM TO ANY PARTICULAR FONT, STYLE, SIZE, OR COLOR.

FOR SCIENTIFIC APPARATUS FOR DETECTION AND INSPECTION OF MICROBE AND BACTERIA; SCIENTIFIC APPARATUS FOR DETECTION AND INSPECTION OF MICROBE AND BACTERIA IN FOOD (U.S. CLS. 21, 23, 26, 36 AND 38).

ANDREA SAUNDERS, EXAMINING ATTORNEY

SN 77-577,979. BLACK ICE SOFTWARE, LLC., NASHUA,
NH. FILED 9-24-2008.

Print2XPS

THE MARK CONSISTS OF STANDARD CHARACTERS WITHOUT CLAIM TO ANY PARTICULAR FONT, STYLE, SIZE, OR COLOR.

FOR COMPUTER SOFTWARE FOR DOCUMENT CONVERSION TO XML PAPER SPECIFICATION THAT MAY BE DOWNLOADED FROM A GLOBAL COMPUTER NETWORK (U.S. CLS. 21, 23, 26, 36 AND 38).

FIRST USE 9-1-2008; IN COMMERCE 9-1-2008.

JILL PRATER, EXAMINING ATTORNEY

SN 77-578,332. ROBOSOFT TECHNOLOGIES PRIVATE LIMITED, KARNATAKA, INDIA, FILED 9-25-2008.



NO CLAIM IS MADE TO THE EXCLUSIVE RIGHT TO USE "99 GAMES", APART FROM THE MARK AS SHOWN.

THE COLOR(S) PINK, YELLOW AND GREEN IS/ARE CLAIMED AS A FEATURE OF THE MARK.

THE MARK CONSISTS OF THE NUMBER "99" THAT IS YELLOW, WITHIN A STYLIZED DROP OF LIQUID THAT IS PINK, TO THE LEFT OF THE WORD "GAMES", THAT IS GREEN.

FOR COMPUTER GAME SOFTWARE (U.S. CLS. 21, 23, 26, 36 AND 38).

VIVIAN MICZNIK FIRST, EXAMINING ATTORNEY

CLASS 9—(Continued).

SN 77-578,845. BLACK ICE SOFTWARE, LLC, FORMERLY BLACK ICE SOFTWARE, LLC, NASHUA, NH. FILED 9-25-2008.

CLASS 9—(Continued).

SN 77-582,273. TUTHILL CORPORATION, BURR RIDGE, IL. FILED 9-30-2008.

FileMorph

FPP METERS

THE MARK CONSISTS OF STANDARD CHARACTERS WITHOUT CLAIM TO ANY PARTICULAR FONT, STYLE, SIZE, OR COLOR.

FOR COMPUTER SOFTWARE FOR DOCUMENT CONVERSION OF ANY PRINTABLE FILE TO AN IMAGE OR PDF DOCUMENT THAT MAY BE DOWN-LOADED FROM A GLOBAL COMPUTER NETWORK (U.S. CLS. 21, 23, 26, 36 AND 38).

FIRST USE 11-1-2007; IN COMMERCE 11-1-2007.
AMY ALFIERI, EXAMINING ATTORNEY

THE MARK CONSISTS OF STANDARD CHARACTERS WITHOUT CLAIM TO ANY PARTICULAR FONT, STYLE, SIZE, OR COLOR.

NO CLAIM IS MADE TO THE EXCLUSIVE RIGHT TO USE "METERS", APART FROM THE MARK AS SHOWN.

FOR FLOW METERS TO CALCULATE LIQUID FLOW AND DISPLAY RESULTS (U.S. CLS. 21, 23, 26, 36 AND 38).

FIRST USE 1-1-1987; IN COMMERCE 1-1-1987.
LINDSEY RUBIN, EXAMINING ATTORNEY

SN 77-578,914. TECSIS GMBH, OFFENBACH, FED REP GERMANY, FILED 9-25-2008.

SN 77-584,171. NODCONCEPT, LLC, LOS GATOS, CA. FILED 10-2-2008.

DELTA METRICS

NODCONCEPT

THE MARK CONSISTS OF STANDARD CHARACTERS WITHOUT CLAIM TO ANY PARTICULAR FONT, STYLE, SIZE, OR COLOR.

PRIORITY CLAIMED UNDER SEC. 44(D) ON FED REP GERMANY APPLICATION NO. 302008019666, FILED 3-26-2008, REG. NO. 302008019666, DATED 10-7-2008, EXPIRES 3-31-2018.

NO CLAIM IS MADE TO THE EXCLUSIVE RIGHT TO USE "METRICS", APART FROM THE MARK AS SHOWN.

FOR MECHANICAL AND ELECTRICAL PRESSURE MEASURING APPARATUSES, NAMELY, PRESSURE GAUGES, PRESSURE TRANSDUCERS, PRESSURE SENSORS; FORCE MEASURING APPARATUS, NAMELY, DYNAMOMETERS, LOAD CELLS, CANTILEVER BEAMS; TORQUE TRANSDUCERS; ACCELEROMETERS, ACCELERATION SENSORS; THERMOMETERS, TEMPERATURE SENSORS, TEMPERATURE SWITCHES, TEMPERATURE INDICATORS, TEMPERATURE TRANSMITTERS, AND STRUCTURAL PARTS THEREFOR (U.S. CLS. 21, 23, 26, 36 AND 38).

CARYN GLASSER, EXAMINING ATTORNEY

THE MARK CONSISTS OF STANDARD CHARACTERS WITHOUT CLAIM TO ANY PARTICULAR FONT, STYLE, SIZE, OR COLOR.

FOR VIDEO AND COMPUTER GAME SOFTWARE FOR USE WITH MOBILE PHONES AND WIRELESS DEVICES; COMPUTER SOFTWARE FOR USE IN OPERATING MOBILE PHONES AND WIRELESS DEVICES; COMPUTER SOFTWARE TO ENABLE THE TRANSMISSION OF TEXT MESSAGES, INFORMATION, PHOTOS AND DATA; COMPUTER SOFTWARE TO ENABLE THE STORING, ORGANIZING AND EDITING OF DATA AND IMAGES; COMPUTER SOFTWARE FOR USE IN RETRIEVING AND STORING TRAVEL AND ENTERTAINMENT INFORMATION; COMPUTER SOFTWARE FOR USE IN RECORDING, TRACKING, ANALYZING AND MANAGING TIME ALLOCATED TO ONE OR MORE ACTIVITIES; COMPUTER SOFTWARE FOR USE IN PROVIDING POLLS AMONG USERS OF MOBILE PHONES AND WIRELESS DEVICES (U.S. CLS. 21, 23, 26, 36 AND 38).

JENNY PARK, EXAMINING ATTORNEY

CLASS 9—(Continued).

SN 77-585,681. NAVJACK CO. LTD, TAIPEI COUNTY 2344, TAIWAN, FILED 10-4-2008.



THE COLOR(S) BLACK AND GREEN IS/ARE CLAIMED AS A FEATURE OF THE MARK.

THE MARK CONSISTS OF THE WORD "NAVJACK" WITH THE "C" IN STYLIZED FORM AND IN THE COLOR GREEN AND WITH ALL OTHER LETTERS IN BLACK.

FOR COMPUTER SOFTWARE THAT CONSISTS OF AN ANIMATED PENGUIN USED TO NAVIGATE THROUGH COMPUTER SCREENS, COMPUTER SOFTWARE AND COMPUTER LANGUAGES FOR PROVIDING ELECTRONIC MULTIMEDIA DATA PUBLISHING SYSTEMS AND FOR THE OPERATION OF COMPUTER NETWORKS INTENDED FOR THE PUBLICATION OF CONTENTS ON FIXED AND MOBILE RADIOTELEPHONE GLOBAL COMMUNICATION NETWORK, THE INTERNET, OR PRIVATE ACCESS COMMUNICATION NETWORKS, INTRANETS; COMPUTER INTERFACES, NAMELY, FOR PROVIDING ACCESS TO MULTIMEDIA DATA BANKS; COMPUTER DATABASE SERVERS; COMPUTER SOFTWARE FOR APPLICATIONS IN THE FIELD OF COMPUTER NETWORKS, MANAGEMENT OF COMPUTER SYSTEMS AND THE DESIGN OF SOFTWARE; COMPUTER PROGRAMS, COMPUTER SOFTWARE AND SOFTWARE PACKAGES FOR USE IN REMOTELY CONNECTING COMPUTERS AND COMPUTER NETWORKS; COMPUTER PROGRAMS FOR USE IN REMOTELY SEARCHING THE CONTENTS OF COMPUTER DATABASE SERVERS AND COMPUTER NETWORKS; NAVIGATION SOFTWARE, NAMELY, SOFTWARE ENABLING USERS TO NAVIGATE THROUGH COMPUTER NETWORKS FROM FIXED AND MOBILE RADIOTELEPHONE GLOBAL COMMUNICATION NETWORKS, THE INTERNET OR PRIVATE ACCESS COMMUNICATIONS NETWORKS, INTRANETS (U.S. CLS. 21, 23, 26, 36 AND 38).

MICHAEL ENGEL, EXAMINING ATTORNEY

SN 77-588,922. AIRKAST, INC., CUPERTINO, CA. FILED 10-8-2008.

EXTENDING THE MOBILE BOUNDARY

THE MARK CONSISTS OF STANDARD CHARACTERS WITHOUT CLAIM TO ANY PARTICULAR FONT, STYLE, SIZE, OR COLOR.

FOR SOFTWARE FOR MOBILE PHONES AND MOBILE DEVICES USED FOR STREAMING, UPLOADING AND DOWNLOADING MUSIC FROM INTERNET RADIO, SHOWS FROM INTERNET TV, SHOWS AND VIDEO CLIPS FROM INTERNET WEBSITES AND ADVERTISEMENTS FROM INTERNET AD SERVING FIRMS (U.S. CLS. 21, 23, 26, 36 AND 38).

FIRST USE 8-28-2008; IN COMMERCE 8-28-2008.

TEJBIR SINGH, EXAMINING ATTORNEY

CLASS 9—(Continued).

SN 77-590,527. ALLIANT TECHSYSTEMS INC., MINNEAPOLIS, MN. FILED 10-10-2008.



NO CLAIM IS MADE TO THE EXCLUSIVE RIGHT TO USE "OPTICS", APART FROM THE MARK AS SHOWN.

THE COLOR(S) BLACK, BROWN AND TAN IS/ARE CLAIMED AS A FEATURE OF THE MARK.

THE MARK CONSISTS OF THE STYLIZED DEPICTION OF THE "NITREX OPTICS" MARK AND ANTLER DESIGN, WHERE THE LETTERS "NI" IN "NITREX", THE WORD "OPTICS", AND THE SHADOWING OF THE WORDING "NITREX OPTICS" AND ANTLER DESIGN ARE IN THE COLOR BLACK, AND WHERE THE LETTERS "TREX" IN "NITREX", THE DOT ABOVE THE LETTER "I" IN "NITREX", AND THE ANTLER DESIGN ARE IN THE COLORS BROWN AND TAN.

FOR FIREARM OPTICS ACCESSORIES FOR GUN AND RIFLE SCOPES, NAMELY, ANTI-FOG CLEANING CLOTHES, LENS CLEANING PEN, AND LENS DISPLAY PROTECTOR TO PROVIDE SHADE FROM SUNLIGHT (U.S. CLS. 21, 23, 26, 36 AND 38).

ANTHONY RINKER, EXAMINING ATTORNEY

SN 77-590,705. STANDARD CABLE USA, INC., RANCHO SANTA MARGARITA, CA. FILED 10-10-2008.

EVO-FLEX

THE MARK CONSISTS OF STANDARD CHARACTERS WITHOUT CLAIM TO ANY PARTICULAR FONT, STYLE, SIZE, OR COLOR.

FOR ELECTRICAL CONDUCTORS AND ELECTRICAL COMPONENTS, NAMELY, ELECTRICAL WIRES AND CABLES AND CONNECTORS; ELECTRICAL WIRES AND CABLES FOR POWER, SIGNAL AND DATA TRANSFER (U.S. CLS. 21, 23, 26, 36 AND 38).

FIRST USE 6-0-2008; IN COMMERCE 6-0-2008.

BARBARA GAYNOR, EXAMINING ATTORNEY

CLASS 9—(Continued).

SN 77-590,712. STANDARD CABLE USA, INC., RANCHO SANTA MARGARITA, CA. FILED 10-10-2008.

ARC-FLEX

THE MARK CONSISTS OF STANDARD CHARACTERS WITHOUT CLAIM TO ANY PARTICULAR FONT, STYLE, SIZE, OR COLOR.

FOR ELECTRICAL CONDUCTORS AND COMPONENTS, NAMELY, ELECTRICAL WIRES AND CABLES AND CONNECTORS; ELECTRICAL WIRES AND CABLES FOR ELECTRICAL APPLIANCE WIRING; APPLIANCE WIRING MATERIALS IN THE NATURE OF ELECTRICAL WIRES AND CONNECTORS USED IN THE INTERNAL WIRING OF ELECTRICAL APPLIANCES AND MACHINES (U.S. CLS. 21, 23, 26, 36 AND 38).

FIRST USE 8-0-2003; IN COMMERCE 8-0-2003.
BARBARA GAYNOR, EXAMINING ATTORNEY

CLASS 9—(Continued).

SN 77-590,721. STANDARD CABLE USA, INC., RANCHO SANTA MARGARITA, CA. FILED 10-10-2008.

MEDI-TOUGH

THE MARK CONSISTS OF STANDARD CHARACTERS WITHOUT CLAIM TO ANY PARTICULAR FONT, STYLE, SIZE, OR COLOR.

FOR ELECTRICAL CONDUCTORS AND ELECTRICAL COMPONENTS, NAMELY, ELECTRICAL WIRES AND CABLES AND CONNECTORS; ELECTRICAL WIRES AND CABLES FOR MEDICAL APPLIANCES AND HOSPITAL BEDS; RETRACTABLE COILED ELECTRICAL CABLES; ELECTRICAL CONNECTORS FOR POWER CONNECTION; ELECTRICAL CONNECTORS FOR SIGNAL AND DATA TRANSFER (U.S. CLS. 21, 23, 26, 36 AND 38).

FIRST USE 1-0-2007; IN COMMERCE 1-0-2007.
BARBARA GAYNOR, EXAMINING ATTORNEY

SN 77-592,462. RMI CORPORATION, CUPERTINO, CA. FILED 10-14-2008.

XLP

THE MARK CONSISTS OF STANDARD CHARACTERS WITHOUT CLAIM TO ANY PARTICULAR FONT, STYLE, SIZE, OR COLOR.

FOR INTEGRATED CIRCUITS; SEMICONDUCTORS; SYSTEM-ON-CHIP MICROPROCESSORS; COMPUTER HARDWARE AND SOFTWARE FOR CONNECTING GLOBAL COMPUTER NETWORKS; TELECOMMUNICATIONS EQUIPMENT AND SYSTEMS HARDWARE, NAMELY, ENTERPRISE, TELECOMMUNICATIONS AND NETWORKING MICROPROCESSORS, NETWORKING SWITCHES, ROUTERS, MICROPROCESSOR DEVELOPMENT BOARDS, DIGITAL LINE CARDS AND INTERFACE CIRCUITS; COMPUTER SOFTWARE FOR NETWORKING, ENTERPRISE AND TELECOMMUNICATIONS EQUIPMENT AND SYSTEMS, NAMELY, FOR FACILITATING THE OPERATION OF TELECOMMUNICATIONS AND NETWORKING MICROPROCESSORS, NETWORKING SWITCHES, ROUTERS, MICROPROCESSOR DEVELOPMENT BOARDS, DIGITAL LINE CARDS AND INTERFACE CIRCUITS; AND SOFTWARE PROGRAMMABLE SEMICONDUCTORS THAT ENABLE BROADBAND COMMUNICATIONS, ACCESS AND NETWORKING APPLICATIONS FOR PROCESSING VOICE, VIDEO AND DATA (U.S. CLS. 21, 23, 26, 36 AND 38).

G. MAYERSCHOFF, EXAMINING ATTORNEY

SN 77-590,714. STANDARD CABLE USA, INC., RANCHO SANTA MARGARITA, CA. FILED 10-10-2008.

AQUA-FLEX

THE MARK CONSISTS OF STANDARD CHARACTERS WITHOUT CLAIM TO ANY PARTICULAR FONT, STYLE, SIZE, OR COLOR.

FOR ELECTRICAL CONDUCTORS AND ELECTRICAL COMPONENTS, NAMELY, ELECTRICAL WIRES AND CABLES AND CONNECTORS; ELECTRICAL WIRES AND CABLES AND CONNECTORS FOR UNDERWATER USE, ELECTRICAL WIRES AND CABLES AND CONNECTORS FOR USE IN WET ENVIRONMENTS, ELECTRICAL WIRES AND CABLES AND CONNECTORS FOR SWIMMING POOL AND SWIMMING POOL CONTROL PANEL APPLICATIONS (U.S. CLS. 21, 23, 26, 36 AND 38).

BARBARA GAYNOR, EXAMINING ATTORNEY

CLASS 9—(Continued).

SN 77-593,633. 4C ENTITY, LLC, MORGAN HILL, CA. FILED 10-15-2008.



THE COLOR(S) LIGHT GREEN, DARK GREEN AND WHITE IS/ARE CLAIMED AS A FEATURE OF THE MARK.
THE MARK CONSISTS OF THE STYLIZED LETTERS "CPXM" IN THE COLOR DARK GREEN, WITH A BORDER DESIGN SURROUNDING THE LETTERS IN THE COLORS LIGHT GREEN AND WHITE.

FOR BLANK RECORDABLE DVDS AND OPTICAL DISCS, BLANK DIGITAL STORAGE MEDIA, BLANK ELECTRONIC STORAGE MEDIA, FLASH MEMORY CARD, DATA STORAGE MEDIA, NAMELY, INTEGRATED CIRCUIT MEMORY CARDS, SOLID STATE MEMORY CARTRIDGE SOLD BLANK OR CARRYING DATA-COMPRESSION SOFTWARE, DVD RECORDING APPARATUS, DVD VIDEO AND AUDIO PLAYERS, DVD BURNERS, PORTABLE MEDIA PLAYERS, MP3 PLAYERS, MINIDISC PLAYERS, CELL PHONES, HAND-HELD COMPUTERS, PORTABLE AND HAND-HELD DIGITAL ELECTRONIC DEVICES FOR RECORDING, ORGANIZING, TRANSMITTING, MANIPULATING AND REVIEWING DIGITAL FILES, INCLUDING AUDIO, VIDEO, TEXT, BINARY, STILL IMAGES, GRAPHICS AND MULTIMEDIA FILES, AUDIO AND VIDEO DISC PLAYERS, NAVIGATION APPARATUS AND OTHER DIGITAL ELECTRONIC DEVICES FOR RECORDING, ORGANIZING, TRANSMITTING, MANIPULATING AND REVIEWING AUDIO, DATA AND VIDEO FOR VEHICLES IN THE NATURE OF ON-BOARD COMPUTERS, COMPUTERS, COMPUTER PERIPHERAL EQUIPMENT, COMPUTER PERIPHERAL DEVICES, COMPUTER PERIPHERAL APPARATUS, COMPUTER PERIPHERALS, COMPUTER SERVERS, NETWORK ACCESS SERVER OPERATING SOFTWARE, NETWORK ACCESS SERVER HARDWARE, COMPUTER SOFTWARE FOR DECRYPTING AND ENCRYPTING DATA FOR USE IN MULTIMEDIA APPLICATIONS, ENCRYPTION TECHNOLOGIES, SECURITY, COPY PROTECTION AND DIGITAL RIGHTS MANAGEMENT, COMPUTER SOFTWARE FOR DECRYPTING AND ENCRYPTING DATA FOR USE IN THE SAFEGUARDING OF DIGITAL FILES, INCLUDING AUDIO, VIDEO, TEXT, BINARY, STILL IMAGES, GRAPHICS AND MULTIMEDIA FILES, COMPUTER SOFTWARE FOR USE IN THE ENCRYPTION AND DECRYPTION OF DIGITAL FILES, INCLUDING AUDIO, VIDEO, TEXT, BINARY, STILL IMAGES, GRAPHICS AND MULTIMEDIA FILES, DIGITAL CAMERAS AND CAMCORDERS, MANUALS PROVIDED TOGETHER WITH EACH OF THE FOREGOING GOODS (U.S. CLS. 21, 23, 26, 36 AND 38).

KELLY CHOE, EXAMINING ATTORNEY

CLASS 9—(Continued).

SN 77-598,991. REDHORSE SYSTEMS, INC., WILMINGTON, DE. FILED 10-23-2008.

RedHorse CRM

THE MARK CONSISTS OF STANDARD CHARACTERS WITHOUT CLAIM TO ANY PARTICULAR FONT, STYLE, SIZE, OR COLOR.

NO CLAIM IS MADE TO THE EXCLUSIVE RIGHT TO USE "CRM", APART FROM THE MARK AS SHOWN.

FOR COMPUTER SOFTWARE FOR USE IN CUSTOMER RELATIONSHIP MANAGEMENT (CRM) (U.S. CLS. 21, 23, 26, 36 AND 38).

FIRST USE 6-1-2008; IN COMMERCE 6-1-2008.

MICHAEL ENGEL, EXAMINING ATTORNEY

SN 77-599,188. QUADRAMED CORPORATION, RESTON, VA. FILED 10-23-2008.

VACC

THE MARK CONSISTS OF STANDARD CHARACTERS WITHOUT CLAIM TO ANY PARTICULAR FONT, STYLE, SIZE, OR COLOR.

FOR COMPUTER SOFTWARE FOR PATIENT RECORD MANAGEMENT, INFORMATION MANAGEMENT, BILLING, AND INSURANCE CLAIM CODING FOR THE HEALTHCARE INDUSTRY; COMPUTER SOFTWARE FOR HEALTHCARE INFORMATION VERIFICATION THAT ENABLES USERS TO COMPLY WITH HEALTHCARE REGULATIONS AND LAWS (U.S. CLS. 21, 23, 26, 36 AND 38).

FIRST USE 10-0-2004; IN COMMERCE 10-0-2004.

MARLENE BELL, EXAMINING ATTORNEY

SN 77-600,558. RESEARCH DATA NET, INC., SAN ANTONIO, TX. FILED 10-25-2008.

NET D@TA PAD

THE MARK CONSISTS OF STANDARD CHARACTERS WITHOUT CLAIM TO ANY PARTICULAR FONT, STYLE, SIZE, OR COLOR.

NO CLAIM IS MADE TO THE EXCLUSIVE RIGHT TO USE "NET DATA", APART FROM THE MARK AS SHOWN.

FOR COMPUTER SOFTWARE FOR THE COLLECTION, EDITING, ORGANIZING, MODIFYING, BOOK MARKING, TRANSMISSION, STORAGE AND SHARING OF DATA AND INFORMATION (U.S. CLS. 21, 23, 26, 36 AND 38).

DAVID I, EXAMINING ATTORNEY

CLASS 9—(Continued).

SN 77-601,211. FUJIFILM U.S.A., INC., VALHALLA, NY. FILED 10-27-2008.

SPRAY

THE MARK CONSISTS OF STANDARD CHARACTERS WITHOUT CLAIM TO ANY PARTICULAR FONT, STYLE, SIZE, OR COLOR.
FOR WATERPROOF DIGITAL CAMERAS FOR CONSUMER USE (U.S. CLS. 21, 23, 26, 36 AND 38).
MARK SHINER, EXAMINING ATTORNEY

SN 77-602,585. MEDKEN LLC, CHICAGO, IL. FILED 10-28-2008.

MEDKEN

THE MARK CONSISTS OF STANDARD CHARACTERS WITHOUT CLAIM TO ANY PARTICULAR FONT, STYLE, SIZE, OR COLOR.
FOR COMPUTER SOFTWARE AND HARDWARE FOR ANALYZING, INTERPRETING AND ANNOTATING MEDICAL IMAGES; COMPUTER SOFTWARE AND HARDWARE FOR REPORTING DIAGNOSES OF MEDICAL IMAGE ANALYSIS; AND COMPUTER SOFTWARE AND HARDWARE FOR KNOWLEDGE SHARING OF MEDICAL IMAGE ANALYSIS (U.S. CLS. 21, 23, 26, 36 AND 38).
MARK SPARACINO, EXAMINING ATTORNEY

SN 77-602,953. HYPERTHERM, INC., HANOVER, NH. FILED 10-29-2008.

ARCGLIDE

THE MARK CONSISTS OF STANDARD CHARACTERS WITHOUT CLAIM TO ANY PARTICULAR FONT, STYLE, SIZE, OR COLOR.
FOR ELECTRONIC, ELECTRIC, OR COMPUTER-BASED CONTROLLERS AND SENSORS FOR MANUFACTURING EQUIPMENT; ELECTRONIC, ELECTRIC, OR COMPUTER-BASED CONTROLLERS AND SENSORS FOR CUTTING SYSTEMS, NAMELY TORCH HEIGHT CONTROLLERS; AND PLASMA ARC TORCH HEIGHT CONTROLLERS FOR CONTROLLING THE HEIGHT OF A PLASMA ARC TORCH RELATIVE TO A METAL WORKPIECE, COMPRISED OF CONTROL CIRCUITRY, INTERFACE CIRCUITRY, OPERATING SOFTWARE, REMOTELY CONTROLLED PENDANT, AND ELECTRICAL INTERFACE CABLES (U.S. CLS. 21, 23, 26, 36 AND 38).
LINDSEY RUBIN, EXAMINING ATTORNEY

CLASS 9—(Continued).

SN 77-605,068. POLYCOM, INC., PLEASANTON, CA. FILED 10-31-2008.

HDX

THE MARK CONSISTS OF STANDARD CHARACTERS WITHOUT CLAIM TO ANY PARTICULAR FONT, STYLE, SIZE, OR COLOR.
FOR COMMUNICATIONS SERVERS; COMPUTER SOFTWARE AND HARDWARE FOR VOICE AND VIDEO CONFERENCING (U.S. CLS. 21, 23, 26, 36 AND 38).
FIRST USE 10-31-2006; IN COMMERCE 12-31-2006.
JOHN DWYER, EXAMINING ATTORNEY

SN 77-605,911. CAVALERA, RICHARD, PHOENIX, AZ. FILED 11-3-2008.

INCITE

THE MARK CONSISTS OF STANDARD CHARACTERS WITHOUT CLAIM TO ANY PARTICULAR FONT, STYLE, SIZE, OR COLOR.
FOR SERIES OF MUSICAL SOUND RECORDINGS (U.S. CLS. 21, 23, 26, 36 AND 38).
FIRST USE 5-14-2005; IN COMMERCE 5-14-2005.
MICHAEL KEATING, EXAMINING ATTORNEY

SN 77-609,634. EYE RESPONSE TECHNOLOGIES, CHARLOTTESVILLE, VA. FILED 11-7-2008.

LIFEMATE

THE MARK CONSISTS OF STANDARD CHARACTERS WITHOUT CLAIM TO ANY PARTICULAR FONT, STYLE, SIZE, OR COLOR.
FOR COMPUTER SOFTWARE AND HARDWARE FOR ASSISTING INDIVIDUALS WITH DISABILITIES TO COMMUNICATE WITH PEOPLE AROUND THEM, ACCESS A COMPUTER AND TO CONTROL THEIR HOME AND OFFICE ENVIRONMENTAL CONDITIONS, INCLUDING LIGHTING, HVAC, SECURITY AND OTHER HOME AND OFFICE MONITORING AND CONTROL APPLICATIONS, ALL OF THE FOREGOING BY PROVIDING A VARIETY OF ACCESS METHODS, NAMELY, EYE CONTROL, HEAD CONTROL, SCANNING AND DIRECT SELECTION (U.S. CLS. 21, 23, 26, 36 AND 38).
ELIZABETH HUGHITT, EXAMINING ATTORNEY

CLASS 9—(Continued).

SN 77-609,638. EYE RESPONSE TECHNOLOGIES, CHARLOTTEVILLE, VA. FILED 11-7-2008.

ENVIROMATE

THE MARK CONSISTS OF STANDARD CHARACTERS WITHOUT CLAIM TO ANY PARTICULAR FONT, STYLE, SIZE, OR COLOR.

FOR COMPUTER SOFTWARE FOR ASSISTING INDIVIDUALS WITH DISABILITIES TO CONTROL THEIR HOME AND OFFICE ENVIRONMENTAL CONDITIONS, INCLUDING LIGHTING, HVAC, SECURITY AND OTHER HOME AND OFFICE MONITORING AND CONTROL APPLICATIONS (U.S. CLS. 21, 23, 26, 36 AND 38).
ELIZABETH HUGHITT, EXAMINING ATTORNEY

SN 77-618,286. ARUZE CORP., TOKYO, JAPAN, FILED 11-20-2008.



THE MARK CONSISTS OF A CIRCULAR DOUBLE RING WITH AN ANGLED BANNER ACROSS THE CENTER CONTAINING THE WORDS "BIG CHALLENGE".

FOR SLOT MACHINES AND REPLACEMENT PARTS THEREFOR; VIDEO SLOT MACHINES AND REPLACEMENT PARTS THEREFOR; GAMING MACHINES AND REPLACEMENT PARTS THEREFOR; GAMING MACHINES WITH LIQUID CRYSTAL DISPLAYS AND REPLACEMENT PARTS THEREFOR; MECHANICAL REEL TYPE SLOT MACHINES WITH LIQUID CRYSTAL DISPLAYS AND REPLACEMENT PARTS THEREFOR; MEDIA STORAGE COMPUTER SOFTWARE FOR ELECTRONIC CIRCUITS, OPTICAL DISKS, MAGNETIC TAPES, MAGNETIC DISKS, MAGNETIC CARDS, OPTICAL-MAGNETIC DISKS, CD-ROMS, ROM-CARTRIDGES AND DVDS, NAMELY, COMPUTER SOFTWARE FOR CONTROLLING SLOT MACHINES AND GAME MACHINES; COMPUTER GAME SOFTWARE FOR GAME MACHINES AND SLOT MACHINES (U.S. CLS. 21, 23, 26, 36 AND 38).
GINA HAYES, EXAMINING ATTORNEY

CLASS 9—(Continued).

SN 77-623,212. EMUZE, LLC, OAKLAND, NJ. FILED 11-28-2008.



THE COLOR(S) RED, WHITE, AND BLACK IS/ARE CLAIMED AS A FEATURE OF THE MARK.

THE MARK CONSISTS OF THE COLORS RED, WHITE, AND BLACK, WITH THE COLOR RED APPEARING IN THE WORDING "EMUZE", THE COLOR WHITE APPEARING IN THE "E" AND IN A CIRCLE AROUND THE "E", AND THE COLOR BLACK APPEARING WITHIN THE "E" AND IN TWO CIRCLE SURROUNDING THE "E".

FOR DOWNLOADABLE MP3 FILES, MP3 RECORDINGS, ON-LINE DISCUSSION BOARDS, WEBCASTS AND PODCASTS FEATURING MUSIC, AUDIO BOOKS AND NEWS BROADCASTS (U.S. CLS. 21, 23, 26, 36 AND 38).

LAURA HAMMEL, EXAMINING ATTORNEY

SN 77-628,229. DCM SOLUTIONS, INC., DBA DCM SYSTEMS, INC., HINGHAM, MA. FILED 12-8-2008.

RetenGine

THE MARK CONSISTS OF STANDARD CHARACTERS WITHOUT CLAIM TO ANY PARTICULAR FONT, STYLE, SIZE, OR COLOR.

FOR COMPUTER SOFTWARE FOR THE CLASSIFICATION OF DATA AND INFORMATION TO SUPPORT RETENTION MANAGEMENT, LEGAL HOLD MANAGEMENT, INFORMATION SECURITY CLASSIFICATION AND INTELLECTUAL PROPERTY MANAGEMENT IN THE ENTERPRISE ENVIRONMENT (U.S. CLS. 21, 23, 26, 36 AND 38).

FIRST USE 8-1-2008; IN COMMERCE 9-11-2008.

SUSAN STIGLITZ, EXAMINING ATTORNEY

CLASS 9—(Continued).

SN 77-628,301. AMANO USA HOLDINGS, INC., FORMERLY AMANO INTERNATIONAL USA, INC. AND AMANO USA, INC., ROSELAND, NJ. FILED 12-8-2008.

TS-3000i

THE MARK CONSISTS OF STANDARD CHARACTERS WITHOUT CLAIM TO ANY PARTICULAR FONT, STYLE, SIZE, OR COLOR.

FOR CENTRAL PROCESSING UNIT CLOCKS THAT AUTOMATICALLY SYNCHS WEB CLOCKS TO PROVIDE END USERS WITH VALIDATED TIME AND REPORTING CAPABILITIES; AND CLOCKS THAT CAN BE USED TO VALIDATE TIME AND REPORTING ON THE GLOBAL COMPUTER NETWORK (U.S. CLS. 21, 23, 26, 36 AND 38).

INGRID C. EULIN, EXAMINING ATTORNEY

CLASS 9—(Continued).

SN 77-631,842. KABUSHIKI KAISHA SEGA, DBA SEGA CORPORATION, OHTA-KU, TOKYO, JAPAN, FILED 12-12-2008.



OWNER OF JAPAN REG. NO. 4457004, DATED 3-2-2001, EXPIRES 3-2-2011.

OWNER OF U.S. REG. NOS. 2,194,026, 2,676,040 AND 3,123,980.

NO CLAIM IS MADE TO THE EXCLUSIVE RIGHT TO USE "VIRTUAL" AND "TANGRAM", APART FROM THE MARK AS SHOWN.

THE MARK CONSISTS OF THE STYLIZED WORDS "CYBER TROOPERS," AND BELOW THAT JAPANESE CHARACTERS THAT TRANSLITERATE TO "DENNO SENKI VIRTUAL ON," AND BELOW THAT THE STYLIZED WORDS "VIRTUAL ON," AND BELOW THAT THE STYLIZED WORDS "ORATORIO TANGRAM," ALL SUPERIMPOSED ON A CIRCULAR DESIGN WITH TWO SIDE HANDLES.

THE FOREIGN WORDING "DENNO SENKI" IN THE MARK TRANSLATES INTO ENGLISH AS "CYBER TROOPERS."

THE NON-LATIN CHARACTERS IN THE MARK TRANSLITERATE INTO "DENNO SENKI VIRTUAL ON"

FOR VIDEO GAME SOFTWARE; COMPUTER GAME PROGRAMS (U.S. CLS. 21, 23, 26, 36 AND 38).

MICHAEL LITZAU, EXAMINING ATTORNEY

SN 77-630,746. APPLIED PRECISION, INC., ISSAQUAH, WA. FILED 12-10-2008.

DeltaVision|OMX

OWNER OF U.S. REG. NOS. 1,951,203 AND 2,827,172. THE MARK CONSISTS OF STYLIZED LETTERS AND A LINE BETWEEN "DELTAVISION AND OMX".

FOR ELECTRICAL AND SCIENTIFIC APPARATUS, NAMELY, OPTICAL IMAGING APPARATUS AND MICROSCOPES, ALL FOR BIOLOGICAL RESEARCH (U.S. CLS. 21, 23, 26, 36 AND 38).

NICHOLAS ALTREE, EXAMINING ATTORNEY

SN 77-634,711. JBN, LLC, HANOVER, PA. FILED 12-17-2008.

VIDEO ROCKS

THE MARK CONSISTS OF STANDARD CHARACTERS WITHOUT CLAIM TO ANY PARTICULAR FONT, STYLE, SIZE, OR COLOR.

NO CLAIM IS MADE TO THE EXCLUSIVE RIGHT TO USE "VIDEO", APART FROM THE MARK AS SHOWN.

FOR PRE-RECORDED AUDIOVISUAL WORKS, NAMELY, INSTRUCTIONAL HOW-TO VIDEOS ON A VARIETY OF TOPICS SUPPLIED IN DIGITAL FORMAT (U.S. CLS. 21, 23, 26, 36 AND 38).

MARY ROSSMAN, EXAMINING ATTORNEY

CLASS 9—(Continued).

SN 77-634,733. ASTRO CORPORATION, TAIPEI, TAIWAN, FILED 12-17-2008.

BABYLON CASH

THE MARK CONSISTS OF STANDARD CHARACTERS WITHOUT CLAIM TO ANY PARTICULAR FONT, STYLE, SIZE, OR COLOR.

NO CLAIM IS MADE TO THE EXCLUSIVE RIGHT TO USE "CASH", APART FROM THE MARK AS SHOWN.

FOR MACHINES FOR PLAYING GAMES OF CHANCE; GAMBLING MACHINES; PLAYER-OPERATED ELECTRONIC CONTROLLERS FOR ELECTRONIC VIDEO GAME MACHINES; VIDEO GAME SOFTWARE; VIDEO GAME PROGRAMS RECORDED ON CASSETTE TAPES; COMPUTER GAME PROGRAMS RECORDED ON DISCS; VIDEO GAME CARTRIDGES; VIDEO GAME MACHINES FOR USE WITH TELEVISIONS; VIDEO GAME MACHINES FOR USE WITH COMPUTERS; COMPUTER INTERFACE BOARDS; CIRCUIT BOARDS (U.S. CLS. 21, 23, 26, 36 AND 38).

FIRST USE 10-1-2008; IN COMMERCE 10-1-2008.
ESTHER BELENKER, EXAMINING ATTORNEY

SN 77-637,915. THINK TANK PHOTO, INC., SANTA ROSA, CA. FILED 12-22-2008.

STREETWALKER

THE MARK CONSISTS OF STANDARD CHARACTERS WITHOUT CLAIM TO ANY PARTICULAR FONT, STYLE, SIZE, OR COLOR.

FOR BACKPACKS SPECIFICALLY ADAPTED FOR CARRYING PHOTOGRAPHIC, CINEMATOGRAPHIC AND VIDEOGRAPHIC EQUIPMENT; BACKPACKS SPECIFICALLY ADAPTED FOR CARRYING COMPUTER EQUIPMENT AND ACCESSORIES; BACKPACKS SPECIFICALLY ADAPTED FOR CARRYING AUDIO AND VISUAL ELECTRONIC EQUIPMENT, NAMELY, MP3 PLAYERS, CD PLAYERS, DVD PLAYERS, HD DVD PLAYERS, PERSONAL DIGITAL ASSISTANTS, OPTICAL AND MAGNETO-OPTICAL DISC PLAYERS, CELLULAR TELEPHONES, AND ACCESSORIES FOR THE FOREGOING AUDIO AND VISUAL ELECTRONIC EQUIPMENT (U.S. CLS. 21, 23, 26, 36 AND 38).

FIRST USE 12-5-2008; IN COMMERCE 12-5-2008.
MELISSA VALLILLO, EXAMINING ATTORNEY

CLASS 9—(Continued).

SN 77-640,708. KIRBY MORGAN DIVE SYSTEMS, INC., SANTA BARBARA, CA. FILED 12-29-2008.

27

THE MARK CONSISTS OF STANDARD CHARACTERS WITHOUT CLAIM TO ANY PARTICULAR FONT, STYLE, SIZE, OR COLOR.

SEC. 2(F).
FOR DIVING HELMETS (U.S. CLS. 21, 23, 26, 36 AND 38).

FIRST USE 12-16-1991; IN COMMERCE 12-16-1991.
RONALD DELGIZZI, EXAMINING ATTORNEY

SN 77-640,931. HELIXIS, INC., CARLSBAD, CA. FILED 12-29-2008.

PIXO

THE MARK CONSISTS OF STANDARD CHARACTERS WITHOUT CLAIM TO ANY PARTICULAR FONT, STYLE, SIZE, OR COLOR.

FOR REAL TIME LABORATORY INSTRUMENTS FOR PERFORMING POLYMERASE CHAIN REACTION (PCR) ANALYSIS FOR SCIENCE AND MEDICAL RESEARCH USE; ASSOCIATED COMPUTER SOFTWARE FOR USE IN POLYMERASE CHAIN REACTION (PCR) ANALYSIS; LABORATORY ACCESSORIES FOR USE IN POLYMERASE CHAIN REACTION (PCR), NAMELY, CENTRIFUGES, SAMPLE PREPARATION INSTRUMENTS, PLATES, PLATES SEALER, PLATE SEALING TOOLS, DOCK TO ENABLE PLATE LOADING, TUBES, VIALS AND CAPS, AND LIDS AND SEALS FOR LABORATORY VESSELS, EVALUATION KITS CONSISTING OF PLATES AND REAGENTS (U.S. CLS. 21, 23, 26, 36 AND 38).

FONG HSU, EXAMINING ATTORNEY

SN 77-641,053. ZHU, JIAXIANG, GUANGDONG PROVINCE, CHINA, FILED 12-30-2008.

PROTECTWELL

OWNER OF CHINA REG. NO. 3856351, DATED 1-14-2006, EXPIRES 1-13-2016.

THE MARK CONSISTS OF THE WORD "PROTECTWELL" IS AN INVENTED WORD AND HAS NO MEANING OR SIGNIFICANCE IN THE RELEVANT TRADE OR IN ANY LANGUAGES.

FOR BURGLAR ALARMS, FIRE ALARMS, SMOKE DETECTORS; WARNING DEVICES, NAMELY, BELLS; SOUND ALARMS; PUSH BUTTONS FOR ELECTRIC DOOR BELLS; TELEPHONES, AND LOUDSPEAKERS (U.S. CLS. 21, 23, 26, 36 AND 38).

RICHARD A. STRASER, EXAMINING ATTORNEY

CLASS 9—(Continued).

SN 77-641,433. COMAU, INC., SOUTHFIELD, MI. FILED 12-30-2008.

RECOGNISENSE

THE MARK CONSISTS OF STANDARD CHARACTERS WITHOUT CLAIM TO ANY PARTICULAR FONT, STYLE, SIZE, OR COLOR.

FOR ROBOTIC GUIDANCE SYSTEMS COMPRISED PRIMARILY OF COMPUTER HARDWARE AND SOFTWARE FOR USE IN MONITORING AND CONTROLLING INDUSTRIAL ROBOTS AND ELECTRONIC CONTROL SYSTEMS FOR INDUSTRIAL ROBOTS (U.S. CLS. 21, 23, 26, 36 AND 38).

JAY BESCH, EXAMINING ATTORNEY

SN 77-642,465. PMVISIONWARE, INCORPORATED, JACKSONVILLE, FL. FILED 1-1-2009.

PM PEPTALK

THE MARK CONSISTS OF STANDARD CHARACTERS WITHOUT CLAIM TO ANY PARTICULAR FONT, STYLE, SIZE, OR COLOR.

NO CLAIM IS MADE TO THE EXCLUSIVE RIGHT TO USE "PM", APART FROM THE MARK AS SHOWN.

FOR DIGITAL MEDIA, NAMELY, PRE-RECORDED VIDEO CASSETTES, DIGITAL VIDEO DISCS, DIGITAL VERSATILE DISCS, DOWNLOADABLE AUDIO AND VIDEO RECORDINGS, DVDS, AND HIGH DEFINITION DIGITAL DISKS FEATURING AUDIO LECTURES IN THE FIELD OF PROJECT MANAGEMENT; DIGITAL MEDIA, NAMELY, CDS, DVDS, DOWNLOADABLE AUDIO FILES FEATURING AUDIO LECTURES IN THE FIELD OF PROJECT MANAGEMENT; DOWNLOADABLE AUDIO FILES, MULTIMEDIA FILES, TEXT FILES, E-MAILS, WRITTEN DOCUMENTS, AUDIO MATERIAL, VIDEO MATERIAL AND GAMES FEATURING INFORMATION IN THE FORM OF DOWNLOADABLE SHORT EDUCATIONAL/TRAINING COMMUNICATIONS IN THE FIELD OF HUMAN RESOURCE DEVELOPMENT FOR THE PROMOTION OF EMPLOYEE RETENTION, CAREER GROWTH AND INCREASED PRODUCTIVITY FOR EMPLOYEES AND EMPLOYERS; DOWNLOADABLE ELECTRONIC NEWSLETTERS IN THE FIELD OF PROJECT MANAGEMENT; DOWNLOADABLE MP3 FILES AND MP3 RECORDINGS FEATURING AUDIO LECTURES IN THE FIELD OF PROJECT MANAGEMENT; DOWNLOADABLE MP3 FILES, MP3 RECORDINGS, ON-LINE DISCUSSION BOARDS, WEBCASTS AND PODCASTS FEATURING MUSIC, AUDIO BOOKS AND NEWS BROADCASTS; DOWNLOADABLE MULTIMEDIA FILE CONTAINING ARTWORK, TEXT, AUDIO, VIDEO, GAMES, AND INTERNET WEB LINKS RELATING TO PROJECT MANAGEMENT; DOWNLOADABLE PODCASTS IN THE FIELD OF PROJECT MANAGEMENT; DOWNLOADABLE VIDEO RECORDINGS FEATURING LECTURES IN THE FIELD OF PROJECT MANAGEMENT; DOWNLOADABLE WEBCASTS IN THE FIELD OF PROJECT MANAGEMENT; DOWNLOADABLE AUDIO AND VIDEO, NAMELY, AUDIO LECTURES, IN THE FIELD OF PROJECT MANAGEMENT VIA THE INTERNET AND WIRELESS DEVICES (U.S. CLS. 21, 23, 26, 36 AND 38).

CORY BOONE, EXAMINING ATTORNEY

CLASS 9—(Continued).

SN 77-642,999. ADLER, PHILIP F, DBA ACCUNOTES, LLC, JACKSONVILLE, FL. FILED 1-4-2009.

AccuNotes

THE MARK CONSISTS OF STANDARD CHARACTERS WITHOUT CLAIM TO ANY PARTICULAR FONT, STYLE, SIZE, OR COLOR.

FOR COMPUTER SOFTWARE FOR CONTROLLING AND MANAGING PATIENT MEDICAL INFORMATION (U.S. CLS. 21, 23, 26, 36 AND 38).

JENNY PARK, EXAMINING ATTORNEY

SN 77-643,022. LIVE FOR YOUR KIDS!, MAPLE VALLEY, WA. FILED 1-5-2009.

Live For Your Kids!

THE MARK CONSISTS OF STANDARD CHARACTERS WITHOUT CLAIM TO ANY PARTICULAR FONT, STYLE, SIZE, OR COLOR.

FOR CHILDREN'S EDUCATIONAL SOFTWARE (U.S. CLS. 21, 23, 26, 36 AND 38).

FIRST USE 12-9-2008; IN COMMERCE 12-9-2008.

JOHN KELLY, EXAMINING ATTORNEY

SN 77-643,662. I.M.P.A.C. INC., SALEM, OR. FILED 1-5-2009.

Pro-Efficiency

THE MARK CONSISTS OF STANDARD CHARACTERS WITHOUT CLAIM TO ANY PARTICULAR FONT, STYLE, SIZE, OR COLOR.

FOR DIGITAL TRAINING MATERIALS, NAMELY, DVD'S FEATURING CHIROPRACTIC TECHNIQUES (U.S. CLS. 21, 23, 26, 36 AND 38).

ERIN FALK, EXAMINING ATTORNEY

CLASS 9—(Continued).

SN 77-644,855. RYAN PETERS LLC, LEWES, DE. FILED 1-7-2009.

DECALGIRL

THE MARK CONSISTS OF STANDARD CHARACTERS WITHOUT CLAIM TO ANY PARTICULAR FONT, STYLE, SIZE, OR COLOR.

FOR FITTED PLASTIC ORNAMENTAL FILMS KNOWN AS SKINS FOR COVERING AND PROVIDING A SCRATCH PROOF BARRIER OR PROTECTION FOR ELECTRONIC DEVICES, NAMELY, MP3 PLAYERS, MOBILE TELEPHONES, SMART TELEPHONES, DIGITAL CAMERAS, GLOBAL POSITIONING SYSTEMS, PERSONAL DIGITAL ASSISTANTS, LAPTOPS AND COMPUTERS (U.S. CLS. 21, 23, 26, 36 AND 38).

FIRST USE 4-0-2003; IN COMMERCE 4-0-2003.
DAWN HAN, EXAMINING ATTORNEY

CLASS 9—(Continued).

SN 77-645,492. NEWTECH ELECTRONICS INDUSTRIES, INC., MIAMI, FL. FILED 1-8-2009.

CRAIG

THE MARK CONSISTS OF STANDARD CHARACTERS WITHOUT CLAIM TO ANY PARTICULAR FONT, STYLE, SIZE, OR COLOR.

OWNER OF U.S. REG. NO. 1,115,990.

FOR COMPUTERS; PORTABLE MUSIC AND VIDEO PLAYER DOCKING STATIONS; RADIOS; AUDIO SPEAKERS; MP3 PLAYERS; TRANSMITTERS OF ELECTRONIC SIGNALS; DVD PLAYERS; DIGITAL PHOTO FRAMES FOR DISPLAYING DIGITAL PICTURES, VIDEO CLIPS AND MUSIC; AUDIO AMPLIFIERS; AUDIO RECEIVERS; ELECTRICAL AUDIO AND SPEAKER CABLES AND CONNECTORS; HEAD PHONES; HOME THEATER SYSTEMS COMPRISING DVD AND CD PLAYERS, AUDIO AMPLIFIERS, AUDIO SPEAKERS AND REMOTE CONTROLLERS; KARAOKE PLAYERS; AUDIO CASSETTE AND CD PLAYERS (U.S. CLS. 21, 23, 26, 36 AND 38).

JILL PRATER, EXAMINING ATTORNEY

SN 77-644,867. RYAN PETERS LLC, LEWES, DE. FILED 1-7-2009.

SN 77-648,661. THINK TANK PHOTO, INC., SANTA ROSA, CA. FILED 1-13-2009.

**SHAPE SHIFTER**

THE MARK CONSISTS OF STANDARD CHARACTERS WITHOUT CLAIM TO ANY PARTICULAR FONT, STYLE, SIZE, OR COLOR.

FOR BACKPACKS SPECIFICALLY ADAPTED FOR CARRYING PHOTOGRAPHIC, CINEMATOGRAPHIC AND VIDEOGRAPHIC EQUIPMENT; BACKPACKS SPECIFICALLY ADAPTED FOR CARRYING COMPUTER EQUIPMENT AND ACCESSORIES; BACKPACKS SPECIFICALLY ADAPTED FOR CARRYING AUDIO AND VISUAL ELECTRONIC EQUIPMENT, NAMELY, MP3 PLAYERS, CD PLAYERS, DVD PLAYERS, HD DVD PLAYERS, PERSONAL DIGITAL ASSISTANTS, OPTICAL AND MAGNETO-OPTICAL DISC PLAYERS, CELLULAR TELEPHONES, AND ACCESSORIES FOR THE FOREGOING AUDIO AND VISUAL ELECTRONIC EQUIPMENT (U.S. CLS. 21, 23, 26, 36 AND 38).

FIRST USE 10-15-2008; IN COMMERCE 12-4-2008.
MELISSA VALLILLO, EXAMINING ATTORNEY

THE MARK CONSISTS OF A FANCIFUL FEMALE SHAPE WITHIN A SQUARE.

FOR FITTED PLASTIC ORNAMENTAL FILMS KNOWN AS SKINS FOR COVERING AND PROVIDING A SCRATCH PROOF BARRIER OR PROTECTION FOR ELECTRONIC DEVICES, NAMELY, MP3 PLAYERS, MOBILE TELEPHONES, SMART TELEPHONES, DIGITAL CAMERAS, GLOBAL POSITIONING SYSTEMS, PERSONAL DIGITAL ASSISTANTS, LAPTOPS AND COMPUTERS (U.S. CLS. 21, 23, 26, 36 AND 38).

FIRST USE 4-0-2003; IN COMMERCE 4-0-2003.
DAWN HAN, EXAMINING ATTORNEY

CLASS 9—(Continued).

SN 77-651,025. DENTSPLY INTERNATIONAL INC., YORK, PA. FILED 1-16-2009.

VISTADENT

THE MARK CONSISTS OF STANDARD CHARACTERS WITHOUT CLAIM TO ANY PARTICULAR FONT, STYLE, SIZE, OR COLOR.

FOR COMPUTER SOFTWARE FOR IMPORTING AND DISPLAYING IMAGES ON A COMPUTER SCREEN IN THE FIELD OF ORTHODONTIC IMAGING AND FOR PROVIDING PATIENT EDUCATION USING SUCH IMAGES (U.S. CLS. 21, 23, 26, 36 AND 38).

FIRST USE 6-24-1997; IN COMMERCE 6-24-1997.
 BONNIE LUKEN, EXAMINING ATTORNEY

SN 77-652,090. DENTSPLY INTERNATIONAL INC., YORK, PA. FILED 1-19-2009.

TRURXPERT

THE MARK CONSISTS OF STANDARD CHARACTERS WITHOUT CLAIM TO ANY PARTICULAR FONT, STYLE, SIZE, OR COLOR.

FOR COMPUTER SOFTWARE FOR THE PURPOSE OF DEVELOPING AND DISPLAYING AN EDUCATIONAL TUTORIAL TO DENTAL PROFESSIONALS AND PATIENTS IN THE FIELD OF DENTISTRY (U.S. CLS. 21, 23, 26, 36 AND 38).

BONNIE LUKEN, EXAMINING ATTORNEY

SN 77-652,696. DAWN PATROL, LLC, NEW CASTLE, NH. FILED S.R. 1-20-2009; AM. P.R. 4-17-2009.

P.A.L.

THE MARK CONSISTS OF STANDARD CHARACTERS WITHOUT CLAIM TO ANY PARTICULAR FONT, STYLE, SIZE, OR COLOR.

FOR COMPUTER PROGRAMS FOR USING THE INTERNET AND THE WORLD WIDE WEB, NAMELY, FOR AGGREGATING AND COLLECTING DATA OF SPECIFIC INTERESTS TO THE USER, AND FOR ISSUING PERIODIC ALERTS TO COMPUTER USERS THAT DATA OF SPECIFIC INTEREST TO THE USER, COLLECTED FROM THE INTERNET, HAS BEEN UPDATED (U.S. CLS. 21, 23, 26, 36 AND 38).

FIRST USE 3-5-2008; IN COMMERCE 1-20-2009.
 ESTHER BELENKER, EXAMINING ATTORNEY

CLASS 9—(Continued).

SN 77-656,952. PIRACLE, INC., MURRAY, UT. FILED 1-26-2009.



OWNER OF U.S. REG. NOS. 2,735,368, 3,416,364 AND 3,536,896.

NO CLAIM IS MADE TO THE EXCLUSIVE RIGHT TO USE "RAPID REMIT", APART FROM THE MARK AS SHOWN.

THE MARK CONSISTS OF THE WORDS "PIRACLE RAPID REMIT" WITH A ROUND CIRCLE TO THE LEFT OF THE WORDS WITH A DESIGN INSIDE THE CIRCLE.

FOR COMPUTER SOFTWARE WHICH ENABLES THE SECURE MOVEMENT OF FINANCIAL AND PAYMENT OF DATA FROM ONE LOCATION TO ANOTHER, AND WHICH CREATES, RECORDS, SHARES AND TRANSMITS PAYMENTS AND PAYMENT INFORMATION (U.S. CLS. 21, 23, 26, 36 AND 38).

FIRST USE 7-10-2007; IN COMMERCE 7-10-2007.
 LINDA MICKLEBURGH, EXAMINING ATTORNEY

SN 77-657,274. SHAMIR INSIGHT, INC., SAN DIEGO, CA. FILED 1-27-2009.

AUTOGRAPH ATTITUDE

THE MARK CONSISTS OF STANDARD CHARACTERS WITHOUT CLAIM TO ANY PARTICULAR FONT, STYLE, SIZE, OR COLOR.

OWNER OF U.S. REG. NOS. 2,899,853 AND 3,373,744. FOR EYEGGLASS LENSES (U.S. CLS. 21, 23, 26, 36 AND 38).

FIRST USE 11-1-2008; IN COMMERCE 11-1-2008.
 DANNEAN HETZEL, EXAMINING ATTORNEY

SN 77-657,283. SHAMIR INSIGHT, INC., SAN DIEGO, CA. FILED 1-27-2009.

AUTOGRAPH II

THE MARK CONSISTS OF STANDARD CHARACTERS WITHOUT CLAIM TO ANY PARTICULAR FONT, STYLE, SIZE, OR COLOR.

OWNER OF U.S. REG. NOS. 2,899,853 AND 3,373,744. FOR EYEGGLASS LENSES (U.S. CLS. 21, 23, 26, 36 AND 38).

FIRST USE 11-1-2008; IN COMMERCE 11-1-2008.
 DANNEAN HETZEL, EXAMINING ATTORNEY

CLASS 9—(Continued).

SN 77-657,287. SHAMIR INSIGHT, INC., SAN DIEGO, CA. FILED 1-27-2009.

AUTOGRAPH SINGLE VISION

THE MARK CONSISTS OF STANDARD CHARACTERS WITHOUT CLAIM TO ANY PARTICULAR FONT, STYLE, SIZE, OR COLOR.

OWNER OF U.S. REG. NOS. 2,899,853 AND 3,373,744.

NO CLAIM IS MADE TO THE EXCLUSIVE RIGHT TO USE "SINGLE VISION", APART FROM THE MARK AS SHOWN.

FOR EYEGLASS LENSES (U.S. CLS. 21, 23, 26, 36 AND 38).

FIRST USE 11-1-2008; IN COMMERCE 11-1-2008.
DANNEAN HETZEL, EXAMINING ATTORNEY

SN 77-657,480. STENOCAST, INC., SAN DIEGO, CA. FILED 1-27-2009.

StenoCast Edge

THE MARK CONSISTS OF STANDARD CHARACTERS WITHOUT CLAIM TO ANY PARTICULAR FONT, STYLE, SIZE, OR COLOR.

OWNER OF U.S. REG. NO. 3,417,455.

FOR ELECTRONIC TRANSMITTERS AND RECEIVERS FOR STENOGRAPHERS' STENO NOTES AND STORAGE OF STENOGRAPHERS' DIGITAL STENO NOTE FILES AND AUDIO RECORDING FILES (U.S. CLS. 21, 23, 26, 36 AND 38).

FIRST USE 1-10-2009; IN COMMERCE 1-10-2009.
TINA BROWN, EXAMINING ATTORNEY

SN 77-657,723. FAABORG, ROGER F, DBA RFF ELECTRONICS, LOVELAND, CO. FILED 1-27-2009.

RFFlow

THE MARK CONSISTS OF STANDARD CHARACTERS WITHOUT CLAIM TO ANY PARTICULAR FONT, STYLE, SIZE, OR COLOR.

FOR COMPUTER GRAPHICS SOFTWARE (U.S. CLS. 21, 23, 26, 36 AND 38).

FIRST USE 3-1-1989; IN COMMERCE 3-1-1989.

PAUL E. FAHRENKOPF, EXAMINING ATTORNEY

CLASS 9—(Continued).

SN 77-658,564. ELI WILNER, NEW YORK, NY. FILED 1-28-2009.

FAMOUS FRAMES

THE MARK CONSISTS OF STANDARD CHARACTERS WITHOUT CLAIM TO ANY PARTICULAR FONT, STYLE, SIZE, OR COLOR.

NO CLAIM IS MADE TO THE EXCLUSIVE RIGHT TO USE "FRAMES", APART FROM THE MARK AS SHOWN.

FOR DECORATIVE MAGNETS; DIGITAL PHOTO FRAMES FOR DISPLAYING DIGITAL PICTURES, VIDEO CLIPS AND MUSIC (U.S. CLS. 21, 23, 26, 36 AND 38).

SHAUNIA CARLYLE, EXAMINING ATTORNEY

SN 77-658,650. ROSENTHAL COLLINS GROUP, LLC, CHICAGO, IL. FILED 1-28-2009.

RCG Onyx WebTrader

THE MARK CONSISTS OF STANDARD CHARACTERS WITHOUT CLAIM TO ANY PARTICULAR FONT, STYLE, SIZE, OR COLOR.

OWNER OF U.S. REG. NOS. 3,055,122, 3,094,103 AND 3,246,007.

NO CLAIM IS MADE TO THE EXCLUSIVE RIGHT TO USE "WEBTRADER", APART FROM THE MARK AS SHOWN.

FOR COMPUTER SOFTWARE, NAMELY, DOWNLOADABLE COMPUTER SOFTWARE FOR ELECTRONIC TRADING OVER A GLOBAL COMPUTER NETWORK (U.S. CLS. 21, 23, 26, 36 AND 38).

FIRST USE 1-1-2009; IN COMMERCE 1-1-2009.

RONALD MCMORROW, EXAMINING ATTORNEY

SN 77-659,119. ACTIVE INTERNET MARKETING, TRAVERSE CITY, MI. FILED 1-29-2009.

AIMcrm

THE MARK CONSISTS OF STANDARD CHARACTERS WITHOUT CLAIM TO ANY PARTICULAR FONT, STYLE, SIZE, OR COLOR.

FOR COMPUTER SOFTWARE FOR MANAGING SALES, MARKETING AND CUSTOMER SERVICE, NAMELY, COMPUTER SOFTWARE FOR USE IN CUSTOMER RELATIONSHIP MANAGEMENT (CRM) (U.S. CLS. 21, 23, 26, 36 AND 38).

FIRST USE 5-2-2007; IN COMMERCE 5-2-2007.

AISHA SALEM, EXAMINING ATTORNEY

CLASS 9—(Continued).

SN 77-659,175. LABARRON EDWARDS, DBA INDOVIZUALZ, CERRITOS, CA. FILED 1-29-2009.

CLASS 9—(Continued).

SN 77-659,838. ALAWAR ENTERTAINMENT, INC, ALEXANDRIA, VA. FILED 1-30-2009.

INDOVIZUALZ

Natalie Brooks

THE MARK CONSISTS OF STANDARD CHARACTERS WITHOUT CLAIM TO ANY PARTICULAR FONT, STYLE, SIZE, OR COLOR.

FOR PRE-RECORDED MUSICAL CDS; DOWNLOADABLE MUSIC VIA THE INTERNET AND WIRELESS DEVICES (U.S. CLS. 21, 23, 26, 36 AND 38).
HENRY S. ZAK, EXAMINING ATTORNEY

THE MARK CONSISTS OF STANDARD CHARACTERS WITHOUT CLAIM TO ANY PARTICULAR FONT, STYLE, SIZE, OR COLOR.

THE NAME(S), PORTRAIT(S), AND/OR SIGNATURE(S) SHOWN IN THE MARK DOES NOT IDENTIFY A PARTICULAR LIVING INDIVIDUAL.

FOR COMPUTER GAME SOFTWARE; DOWNLOADABLE COMPUTER SOFTWARE FOR USE AS AN ENTERTAINMENT MULTIMEDIA GAME VIA THE INTERNET AND WIRELESS DEVICES; ELECTRONIC GAME SOFTWARE (U.S. CLS. 21, 23, 26, 36 AND 38).
FIRST USE 12-29-2007; IN COMMERCE 12-29-2007.

JESSICA FATHY, EXAMINING ATTORNEY

SN 77-659,600. TERMINAL REALITY, INC., LEWISVILLE, TX. FILED 1-29-2009.

SN 77-660,614. PUNCH ENTERTAINMENT, INC., PALO ALTO, CA. FILED 1-30-2009.



REIGN OF SWORDS

NO CLAIM IS MADE TO THE EXCLUSIVE RIGHT TO USE "ENGINE", APART FROM THE MARK AS SHOWN.

THE MARK CONSISTS OF THE WORDS "INFERNAL ENGINE" BELOW A STYLIZED FLAME DESIGN.

FOR COMPUTER SOFTWARE IN THE FIELD OF COMPUTER VIDEO GAMES AND COMPUTER GRAPHICS (U.S. CLS. 21, 23, 26, 36 AND 38).
HEATHER SAPP, EXAMINING ATTORNEY

THE MARK CONSISTS OF STANDARD CHARACTERS WITHOUT CLAIM TO ANY PARTICULAR FONT, STYLE, SIZE, OR COLOR.

FOR DOWNLOADABLE ELECTRONIC GAME SOFTWARE FOR USE ON COMPUTERIZED PLATFORMS, NAMELY, MOBILE PHONES, HAND HELD COMPUTERS, PERSONAL DIGITAL ASSISTANTS, PORTABLE MEDIA PLAYERS, LAPTOP COMPUTERS AND DESKTOP COMPUTERS (U.S. CLS. 21, 23, 26, 36 AND 38).
FIRST USE 5-1-2008; IN COMMERCE 5-1-2008.

SETH A. RAPPAPORT, EXAMINING ATTORNEY

CLASS 9—(Continued).

SN 77-660,620. NEIRA ALVEAR, JOSÉ MARÍA, MADRID, SPAIN, FILED 1-30-2009.



THE COLOR(S) PINK, YELLOW AND BLUE IS/ARE CLAIMED AS A FEATURE OF THE MARK.

THE MARK CONSISTS OF "DINAMIX" IN STYLIZED LETTERS. THE LETTER "D" APPEARS SOMEWHAT SLANTED TOWARDS THE RIGHT SIDE OVER A PINK SQUARE THAT IS POSITIONED SIDWAYS. TWO YELLOW DOTS APPEAR TO THE UPPER LEFT SIDE OF THE LETTER "D". "INAMIX" APPEARS IN BLUE COLORS. THE COLOR WHITE IS NOT CLAIMED. IT MERELY SERVES TO SHOW THE BACKGROUND.

THE WORDING DINAMIX HAS NO MEANING IN A FOREIGN LANGUAGE.

FOR COMPUTER SOFTWARE FOR GENERATING MOVING IMAGES FROM STILL PHOTOGRAPHS (U.S. CLS. 21, 23, 26, 36 AND 38).

FIRST USE 12-31-2001; IN COMMERCE 1-31-2008.

TARA PATE, EXAMINING ATTORNEY

CLASS 9—(Continued).

SN 77-660,786. SILICONIX INCORPORATED, SANTA CLARA, CA. FILED 1-31-2009.

TURBOFET

THE MARK CONSISTS OF STANDARD CHARACTERS WITHOUT CLAIM TO ANY PARTICULAR FONT, STYLE, SIZE, OR COLOR.

FOR SEMICONDUCTOR DEVICES (U.S. CLS. 21, 23, 26, 36 AND 38).

LESLIE RICHARDS, EXAMINING ATTORNEY

SN 77-660,628. PUNCH ENTERTAINMENT, INC., PALO ALTO, CA. FILED 1-30-2009.



THE STIPPLING IS FOR SHADING PURPOSES ONLY. FOR DOWNLOADABLE ELECTRONIC GAME SOFTWARE FOR USE ON COMPUTERIZED PLATFORMS, NAMELY, MOBILE PHONES, HAND HELD COMPUTERS, PERSONAL DIGITAL ASSISTANTS, PORTABLE MEDIA PLAYERS, LAPTOP COMPUTERS AND DESKTOP COMPUTERS (U.S. CLS. 21, 23, 26, 36 AND 38).

FIRST USE 5-1-2008; IN COMMERCE 5-1-2008.

SETH A. RAPPAPORT, EXAMINING ATTORNEY

SN 77-660,898. FULCHER, LEONARD, GLENDALE, AZ. FILED 2-1-2009.

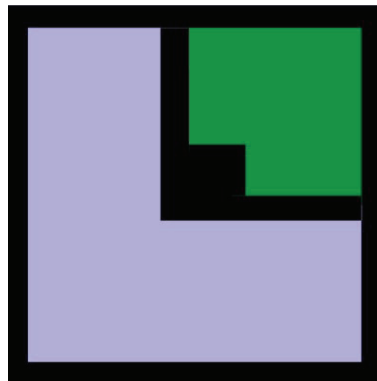

SN 77-660,660. SCIENCE AND TECHNOLOGY INTERNATIONAL, INC., HONOLULU, HI. FILED 1-30-2009.

STI

THE MARK CONSISTS OF STANDARD CHARACTERS WITHOUT CLAIM TO ANY PARTICULAR FONT, STYLE, SIZE, OR COLOR.

FOR IMAGING SOFTWARE THAT ANALYZES DATA; RADIATION-MEASURING INSTRUMENTS WHICH RECORD, TRANSMIT OR REPRODUCE IMAGES OF MATERIALS (U.S. CLS. 21, 23, 26, 36 AND 38).

IRA J. GOODSAD, EXAMINING ATTORNEY

THE COLOR(S) BLUE, GREEN, BLACK IS/ARE CLAIMED AS A FEATURE OF THE MARK.

THE MARK CONSISTS OF THREE OVERLAPPING SQUARES WITH THICK BLACK BORDERS. THE LARGEST COLORED IN BLUE, THE SECOND LARGEST POSITIONED IN THE LARGEST SQUARES UPPER RIGHT CORNER COLORED IN GREEN, AND THE SMALLEST SQUARE POSITIONED IN THE SECOND LARGEST'S LOWER LEFT CORNER COLORED IN BLACK.

FOR DATA COMPRESSION SOFTWARE (U.S. CLS. 21, 23, 26, 36 AND 38).

FIRST USE 1-15-2009; IN COMMERCE 1-15-2009.

KAREN SEVERSON, EXAMINING ATTORNEY

CLASS 9—(Continued).

SN 77-661,064. WARD ASHMAN, MOUNTAIN VIEW, CA. FILED 2-2-2009.

NINE DOORS

THE MARK CONSISTS OF STANDARD CHARACTERS WITHOUT CLAIM TO ANY PARTICULAR FONT, STYLE, SIZE, OR COLOR.

FOR DVDS FEATURING EDUCATIONAL AND TRAINING MATERIALS IN THE FIELDS OF CORPORATE CULTURAL DEVELOPMENT AND SELF AWARENESS (U.S. CLS. 21, 23, 26, 36 AND 38).

FIRST USE 8-28-2007; IN COMMERCE 8-28-2007.
KIM MONINGHOFF, EXAMINING ATTORNEY

CLASS 9—(Continued).

SN 77-661,530. RETAIL ROYALTY COMPANY, LAS VEGAS, NV. FILED 2-2-2009.

77KIDS

THE MARK CONSISTS OF STANDARD CHARACTERS WITHOUT CLAIM TO ANY PARTICULAR FONT, STYLE, SIZE, OR COLOR.

OWNER OF U.S. REG. NOS. 2,548,073, 2,601,845 AND 3,376,629.

FOR SUNGLASSES (U.S. CLS. 21, 23, 26, 36 AND 38).
FIRST USE 1-28-2009; IN COMMERCE 1-28-2009.
WARREN L. OLANDRIA, EXAMINING ATTORNEY

SN 77-661,316. GLOBAL LEAK DETECTION USA, INC., HUNTINGTON BEACH, CA. FILED 2-2-2009.

SMOKE WIZARD

THE MARK CONSISTS OF STANDARD CHARACTERS WITHOUT CLAIM TO ANY PARTICULAR FONT, STYLE, SIZE, OR COLOR.

NO CLAIM IS MADE TO THE EXCLUSIVE RIGHT TO USE "SMOKE", APART FROM THE MARK AS SHOWN.

FOR ELECTRICAL APPARATUS FOR TESTING A CLOSED FLUID SYSTEM OF A MOTOR VEHICLE FOR LEAKS BY MEANS OF GENERATING AND INTRODUCING A VAPOR TO THE SYSTEM TO BE TESTED (U.S. CLS. 21, 23, 26, 36 AND 38).

FIRST USE 1-19-2009; IN COMMERCE 1-19-2009.
AMY HELLA, EXAMINING ATTORNEY

SN 77-662,079. B LABS LTD., CAMBRIDGE, UNITED KINGDOM, FILED 2-3-2009.

CODEZERO

THE MARK CONSISTS OF STANDARD CHARACTERS WITHOUT CLAIM TO ANY PARTICULAR FONT, STYLE, SIZE, OR COLOR.

FOR COMPUTER SOFTWARE, NAMELY, OPERATING SYSTEM SOFTWARE FOR WIRELESS COMMUNICATIONS, EMBEDDED COMPUTERS AND INFORMATION DEVICES, NAMELY, CELLULAR TELEPHONES, PERSONAL DIGITAL ASSISTANTS, ELECTRONIC PERSONAL ORGANIZERS, SET-TOP BOXES, EMBEDDED COMPUTER PLATFORMS; COMPUTER SOFTWARE USED IN THE DESIGN, DEVELOPMENT, MODELING, SIMULATION, COMPILATION, DEBUGGING, VERIFICATION, CONSTRUCTION AND INTERFACING OF OPERATING SYSTEM SOFTWARE FOR EMBEDDED COMPUTERS, WIRELESS COMMUNICATIONS AND INFORMATION DEVICES, NAMELY, CELLULAR TELEPHONES, PERSONAL DIGITAL ASSISTANTS, ELECTRONIC PERSONAL ORGANIZERS, SET-TOP BOXES; COMPUTER SOFTWARE, NAMELY, HYPERVISOR SOFTWARE FOR VIRTUALISATION AND VIRTUALISED EXECUTION OF OPERATING SYSTEMS; COMPUTER OPERATING SYSTEMS SOFTWARE, NAMELY, SOFTWARE CONTROLLING THE OPERATION OF A COMPUTER AND THE EXECUTION OF PROGRAMS; COMPUTER SOFTWARE WHICH FACILITATES THE CREATION AND EXECUTION OF VISUAL PROGRAMS, NAMELY, EXECUTION OF GRAPHICAL USER INTERFACES; SOFTWARE DEVELOPMENT SOFTWARE, NAMELY, COMPUTER SOFTWARE DE-

SN 77-661,334. ENERGY GREEN CONSULTANT, LLC, FRISCO, TX. FILED 2-2-2009.

MedStripe

THE MARK CONSISTS OF STANDARD CHARACTERS WITHOUT CLAIM TO ANY PARTICULAR FONT, STYLE, SIZE, OR COLOR.

FOR MAGNETICALLY ENCODED IDENTITY CARDS (U.S. CLS. 21, 23, 26, 36 AND 38).

MORGAN WYNNE, EXAMINING ATTORNEY

CLASS 9—(Continued).

VELOPMENT TOOLS; NETWORKING SOFTWARE, NAMELY, SOFTWARE FOR CONNECTING COMPUTER NETWORKS, FOR DISTRIBUTED COMPUTING ON LOCAL AREA NETWORKS, AND FOR USE IN THE TRANSFER OF INFORMATION BETWEEN COMPUTERS; WEB BROWSERS; COMPUTER SOFTWARE FOR USE IN THE TRANSFER OF INFORMATION AND THE CONDUCT OF COMMERCIAL TRANSACTIONS ACROSS LOCAL, NATIONAL AND WORLDWIDE INFORMATION NETWORKS; MULTIMEDIA SOFTWARE, NAMELY, COMPUTER SOFTWARE TO ENHANCE THE AUDIO-VISUAL CAPABILITIES OF MULTIMEDIA APPLICATIONS, NAMELY, FOR THE INTEGRATION OF TEXT, AUDIO, GRAPHICS, STILL IMAGES AND MOVING PICTURES; AND INSTRUCTIONAL BOOKS AND GUIDES SOLD AS A UNIT WITH THE SOFTWARE REFERRED TO ABOVE; DOWNLOADABLE ELECTRONIC PUBLICATIONS, NAMELY, EDUCATIONAL BOOK GUIDES AND MANUALS FEATURING EMBEDDED SOFTWARE, COMPUTER PROGRAMMING, AND OPERATING SYSTEMS (U.S. CLS. 21, 23, 26, 36 AND 38).

PAM WILLIS, EXAMINING ATTORNEY

SN 77-662,176. THE POWERWISE GROUP, INC., BOCA RATON, FL. FILED 2-3-2009.

ECOWISE

THE MARK CONSISTS OF STANDARD CHARACTERS WITHOUT CLAIM TO ANY PARTICULAR FONT, STYLE, SIZE, OR COLOR.

FOR ENERGY SAVING ELECTRONIC INDUCTION MOTOR CONTROLLERS (U.S. CLS. 21, 23, 26, 36 AND 38).

CAROLINE WOOD, EXAMINING ATTORNEY

SN 77-662,240. CHANT INTERNATIONAL, LLC, LA CANADA, CA. FILED 2-3-2009.

TURTLE SHADES

THE MARK CONSISTS OF STANDARD CHARACTERS WITHOUT CLAIM TO ANY PARTICULAR FONT, STYLE, SIZE, OR COLOR.

OWNER OF U.S. REG. NOS. 2,604,400 AND 2,682,916.

NO CLAIM IS MADE TO THE EXCLUSIVE RIGHT TO USE "SHADES", APART FROM THE MARK AS SHOWN.

FOR EYE GLASSES; READING EYEGLASSES; READING GLASSES; SPECTACLE GLASSES; SPORTS GLASSES; SPORTS' GLASSES; SUN GLASSES (U.S. CLS. 21, 23, 26, 36 AND 38).

FIRST USE 9-11-2003; IN COMMERCE 9-11-2003.

ERIN FALK, EXAMINING ATTORNEY

CLASS 9—(Continued).

SN 77-662,921. AMERICAN ASSOCIATION OF CHRISTIAN COUNSELORS, INC., FOREST, VA. FILED 2-4-2009.

AACC

THE MARK CONSISTS OF STANDARD CHARACTERS WITHOUT CLAIM TO ANY PARTICULAR FONT, STYLE, SIZE, OR COLOR.

OWNER OF U.S. REG. NOS. 2,204,692 AND 2,219,851.

FOR PRERECORDED CDS AND DVDS FEATURING SPEECHES, PRESENTATIONS, INTERVIEWS, WORKSHOPS AND SEMINARS PRESENTED BY CHRISTIAN COUNSELORS (U.S. CLS. 21, 23, 26, 36 AND 38).

FIRST USE 10-31-2003; IN COMMERCE 10-31-2003.

HEATHER BIDDULPH, EXAMINING ATTORNEY

SN 77-663,028. STENOGRAPH L.L.C., MOUNT PROSPECT, IL. FILED 2-4-2009.

CASE CATALYST

THE MARK CONSISTS OF STANDARD CHARACTERS WITHOUT CLAIM TO ANY PARTICULAR FONT, STYLE, SIZE, OR COLOR.

FOR COMMUNICATION SOFTWARE FOR PROVIDING ACCESS TO THE INTERNET; COMPUTER HARDWARE AND COMPUTER SOFTWARE PROGRAMS FOR THE INTEGRATION OF TEXT, AUDIO, GRAPHICS, STILL IMAGES AND MOVING PICTURES INTO AN INTERACTIVE DELIVERY FOR MULTIMEDIA APPLICATIONS; COMPUTER HARDWARE AND SOFTWARE FOR SETTING UP AND CONFIGURING LOCAL AREA NETWORKS; COMPUTER HARDWARE AND SOFTWARE USED FOR THE CONTROL OF VOICE CONTROLLED INFORMATION AND COMMUNICATION DEVICES; COMPUTER SOFTWARE AND COMPUTER HARDWARE FOR USE IN LANGUAGE LOCALIZATION, BY MEANS OF LANGUAGE TRANSLATION, SUBTITLING, DUBBING, CLOSED CAPTIONING AND TELETXT FOR FEATURE FILMS, TELEVISION PROGRAMS, VIDEOS AND DIGITAL MEDIA IN GENERAL; COMPUTER SOFTWARE FOR ACCESSING INFORMATION DIRECTORIES THAT MAY BE DOWNLOADED FROM THE GLOBAL COMPUTER NETWORK; COMPUTER SOFTWARE FOR APPLICATION AND DATABASE INTEGRATION; COMPUTER SOFTWARE FOR CREAT-

CLASS 9—(Continued).

ING SEARCHABLE DATABASES OF INFORMATION AND DATA; COMPUTER SOFTWARE FOR ORGANIZING AND VIEWING DIGITAL IMAGES AND PHOTOGRAPHS; COMPUTER SOFTWARE FOR THE COLLECTION, EDITING, ORGANIZING, MODIFYING, BOOK MARKING, TRANSMISSION, STORAGE AND SHARING OF DATA AND INFORMATION; COMPUTER SOFTWARE FOR USE IN THE ENCRYPTION AND DECRYPTION OF DIGITAL FILES, INCLUDING AUDIO, VIDEO, TEXT, BINARY, STILL IMAGES, GRAPHICS AND MULTIMEDIA FILES; COMPUTER SOFTWARE FOR WIRELESS CONTENT DELIVERY; COMPUTER SOFTWARE FOR VOICE AND STENO TRANSCRIPTION; ELECTRONIC SOFTWARE UPDATES, NAMELY, DOWNLOADABLE COMPUTER SOFTWARE AND ASSOCIATED DATA FILES FOR UPDATING COMPUTER SOFTWARE IN THE FIELDS OF VOICE AND STENO TRANSCRIPTION, PROVIDED VIA COMPUTER AND COMMUNICATION NETWORKS; SOFTWARE FOR PROCESSING IMAGES, GRAPHICS AND TEXT (U.S. CLS. 21, 23, 26, 36 AND 38).

FIRST USE 4-12-1996; IN COMMERCE 6-12-1997.
LINDA POWELL, EXAMINING ATTORNEY

CLASS 9—(Continued).

SN 77-663,072. RSSREADY, LLC, BOULDER, CO. FILED 2-4-2009.



THE COLOR(S) RED, GRAY, AND BLACK IS/ARE CLAIMED AS A FEATURE OF THE MARK.

THE MARK CONSISTS OF THE WORD "MAVEN" IN RED WITH THE WORD "MAP" IN BLACK. THERE ARE SIX GRAY ARROWS AND FOUR RED ARROWS AROUND THE LETTER "A" WHICH FORM THE DESIGN OF COMPASS POINTS.

FOR COMPUTER SEARCH ENGINE SOFTWARE THAT FACILITATES THE RESEARCH AND IDENTIFICATION OF INFLUENTIAL PEOPLE AND GROUPS WITHIN SOCIAL NETWORKS, BLOGS, ONLINE COMMUNITIES AND WEBSITES USING KEY WORDS, ALL TO GENERATE MARKETING AND BUSINESS INTELLIGENCE REPORTS (U.S. CLS. 21, 23, 26, 36 AND 38).
IRA J. GOODSaid, EXAMINING ATTORNEY

SN 77-663,065. MIZRAHI, EDDIE, BROOKLYN, NY. FILED 2-4-2009.

SN 77-663,076. RSSREADY, LLC, BOULDER, CO. FILED 2-4-2009.

ICONNECT

Maven Map

THE MARK CONSISTS OF STANDARD CHARACTERS WITHOUT CLAIM TO ANY PARTICULAR FONT, STYLE, SIZE, OR COLOR.

FOR KEYBOARDS THAT INCLUDE A MOUNTING DEVICE FOR AN MP3 PLAYER (U.S. CLS. 21, 23, 26, 36 AND 38).

DAVID I, EXAMINING ATTORNEY

THE MARK CONSISTS OF STANDARD CHARACTERS WITHOUT CLAIM TO ANY PARTICULAR FONT, STYLE, SIZE, OR COLOR.

FOR COMPUTER SEARCH ENGINE SOFTWARE THAT FACILITATES THE RESEARCH AND IDENTIFICATION OF INFLUENTIAL PEOPLE AND GROUPS WITHIN SOCIAL NETWORKS, BLOGS, ONLINE COMMUNITIES AND WEBSITES USING KEY WORDS, ALL TO GENERATE MARKETING AND BUSINESS INTELLIGENCE REPORTS (U.S. CLS. 21, 23, 26, 36 AND 38).

IRA J. GOODSaid, EXAMINING ATTORNEY

CLASS 9—(Continued).

SN 77-663,131. CALLAGHAN, TIMOTHY P, DBA FAIR-CHILD MUSIC PRODUCTIONS, TRAVERSE CTIY, MI. FILED 2-4-2009.

Thumusic

THE MARK CONSISTS OF STANDARD CHARACTERS WITHOUT CLAIM TO ANY PARTICULAR FONT, STYLE, SIZE, OR COLOR.

FOR COMPUTER STORAGE DEVICES, NAMELY, FLASH DRIVES (U.S. CLS. 21, 23, 26, 36 AND 38).
ROSELLE HERRERA, EXAMINING ATTORNEY

SN 77-663,237. FARRIS, MICHEAL CHRISTOPHER, RED OAK, TX. FILED 2-4-2009.

MIL-QUAD

THE MARK CONSISTS OF STANDARD CHARACTERS WITHOUT CLAIM TO ANY PARTICULAR FONT, STYLE, SIZE, OR COLOR.

FOR BINOCULARS; GUN SCOPES; RIFLE SCOPES; RIFLESCOPES; SPOTTING SCOPES (U.S. CLS. 21, 23, 26, 36 AND 38).
NATALIE POLZER, EXAMINING ATTORNEY

SN 77-663,286. FARRIS, MICHEAL CHRISTOPHER, RED OAK, TX. FILED 2-4-2009.

QUAD-DROP

THE MARK CONSISTS OF STANDARD CHARACTERS WITHOUT CLAIM TO ANY PARTICULAR FONT, STYLE, SIZE, OR COLOR.

FOR BINOCULARS; GUN SCOPES; RIFLE SCOPES; RIFLESCOPES; SPOTTING SCOPES (U.S. CLS. 21, 23, 26, 36 AND 38).
NATALIE POLZER, EXAMINING ATTORNEY

CLASS 9—(Continued).

SN 77-663,488. LOADRACK, LLC, ENCINITES, CA. FILED 2-4-2009.

LoadRack

THE MARK CONSISTS OF STANDARD CHARACTERS WITHOUT CLAIM TO ANY PARTICULAR FONT, STYLE, SIZE, OR COLOR.

FOR AUTOMATED SYSTEMS, NAMELY, SOFTWARE, HARDWARE AND COMMUNICATIONS DEVICES FOR PLANNING, SCHEDULING, CONTROLLING, MONITORING AND PROVIDING INFORMATION ON TRANSPORTATION ASSETS AND PARTS THEREOF; COMPUTER E-COMMERCE SOFTWARE TO ALLOW USERS TO PERFORM ELECTRONIC BUSINESS TRANSACTIONS VIA A GLOBAL COMPUTER NETWORK; ENVIRONMENTAL MONITORING SYSTEM COMPRISED OF METERS AND SENSORS THAT MEASURE PRESSURE, HUMIDITY, TEMPERATURE AND INCLUDES ALARM AND REPORTING FUNCTIONS; SENSORS FOR THE DETERMINATION OF TEMPERATURES, POSITIONS AND DISTANCES; TEMPERATURE CONTROLLERS FOR MONITORING AND ADJUSTING TEMPERATURE OF TRAILERS AND CARGO THEREOF; TEMPERATURE INDICATORS; TEMPERATURE SENSORS; TEMPERATURE TRANSMITTERS; TRANSPONDER LOCATION SYSTEM; VEHICLE LOCATOR AND RECOVERY DEVICE PROGRAMMED TO USE GLOBAL POSITIONING SYSTEMS (GPS) AND CELLULAR TELECOMMUNICATIONS (U.S. CLS. 21, 23, 26, 36 AND 38).

ANDREW LEASER, EXAMINING ATTORNEY

SN 77-663,529. DESTRON FEARING CORPORATION, SOUTH SAINT PAUL, MN. FILED 2-4-2009.

E2.TAG

THE MARK CONSISTS OF STANDARD CHARACTERS WITHOUT CLAIM TO ANY PARTICULAR FONT, STYLE, SIZE, OR COLOR.

OWNER OF U.S. REG. NOS. 2,566,303 AND 3,537,810.
FOR ELECTRONIC ENCODED IDENTIFICATION TAGS FOR USE WITH LIVESTOCK (U.S. CLS. 21, 23, 26, 36 AND 38).
MICHAEL WEBSTER, EXAMINING ATTORNEY

CLASS 9—(Continued).

SN 77-663,599. BARZ ADVENTURES INC, AUSTIN, TX. FILED 2-4-2009.



THE MARK CONSISTS OF A GLOBE OF THE WORLD, THE WORDS "RANGER" AND "QUEST" SEPARATED BY A STYLIZED QUESTION MARK CONSISTING OF A DASHED LINE FOR THE UPPER PART OF THE QUESTION MARK AND AN "X" FOR THE PERIOD OF THE QUESTION MARK.

FOR ELECTRONIC GAME SOFTWARE FOR HAND-HELD ELECTRONIC DEVICES (U.S. CLS. 21, 23, 26, 36 AND 38).

FIRST USE 4-14-2008; IN COMMERCE 5-23-2008. ELIZABETH KAJUBI, EXAMINING ATTORNEY

CLASS 9—(Continued).

SN 77-663,823. MICHAEL WADDELL, LLC, FORTSON, GA. FILED 2-5-2009.

MICHAEL WADDELL

THE MARK CONSISTS OF STANDARD CHARACTERS WITHOUT CLAIM TO ANY PARTICULAR FONT, STYLE, SIZE, OR COLOR.

FOR OPTICAL APPARATUSES AND INSTRUMENTS, NAMELY, RANGE FINDERS, BINOCULARS, FIREARM SCOPES, SPOTTING SCOPES; ELECTRONIC DEVICES FOR ANIMAL TRACKING FOR CONNECTING TO THE GLOBAL POSITIONING SYSTEM (GPS); PRERECORDED COMPACT DISCS, DIGITAL VIDEO DISCS, VIDEO CASSETTES, VIDEO HOME SYSTEM CASSETTES, AND DOWNLOADABLE MEDIA IN THE NATURE OF AUDIO AND VIDEO RECORDINGS FEATURING CONTENT IN THE FIELD OF HUNTING; CHRONOGRAPHS, NAMELY, SPECIALIZED TIME RECORDING APPARATUSES (U.S. CLS. 21, 23, 26, 36 AND 38).

JACQUELINE A. LAVINE, EXAMINING ATTORNEY

SN 77-663,852. BETHESDA SOFTWARES LLC, ROCKVILLE, MD. FILED 2-5-2009.

FALLOUT

THE MARK CONSISTS OF STANDARD CHARACTERS WITHOUT CLAIM TO ANY PARTICULAR FONT, STYLE, SIZE, OR COLOR.

OWNER OF U.S. REG. NO. 2,181,084. FOR MOTION PICTURE FILMS ABOUT A POST-NUCLEAR APOCALYPTIC WORLD (U.S. CLS. 21, 23, 26, 36 AND 38).

MARK T. MULLEN, EXAMINING ATTORNEY

SN 77-663,651. SIRSI CORPORATION, PROVO, UT. FILED 2-4-2009.

DIRECTORS STATION

THE MARK CONSISTS OF STANDARD CHARACTERS WITHOUT CLAIM TO ANY PARTICULAR FONT, STYLE, SIZE, OR COLOR.

OWNER OF U.S. REG. NOS. 2,948,022, 3,558,677 AND OTHERS.

FOR COMPUTER SOFTWARE IN THE FIELD OF LIBRARY SCIENCE, NAMELY, COMPUTER SOFTWARE FOR USE IN AUTOMATED LIBRARY MANAGEMENT (U.S. CLS. 21, 23, 26, 36 AND 38).

FIRST USE 3-31-2004; IN COMMERCE 3-31-2004. BARNEY CHARLON, EXAMINING ATTORNEY

SN 77-663,890. JAVELIN SEMICONDUCTOR, INC., AUSTIN, TX. FILED 2-5-2009.



NO CLAIM IS MADE TO THE EXCLUSIVE RIGHT TO USE "SEMICONDUCTOR", APART FROM THE MARK AS SHOWN.

THE MARK CONSISTS OF THE WORDS "JAVELIN" ABOVE THE WORD "SEMICONDUCTOR". THE LEFT SIDE OF THE LETTER "V" IN THE WORD "JAVELIN" IS EXAGGERATED TO LOOK LIKE A JAVELIN.

FOR INTEGRATED CIRCUITS (U.S. CLS. 21, 23, 26, 36 AND 38).

DAVID MURRAY, EXAMINING ATTORNEY

CLASS 9—(Continued).

SN 77-663,897. RECHARGE POWER LLC, GATES MILLS, OH. FILED 2-5-2009.

RECHARGE POWER

THE MARK CONSISTS OF STANDARD CHARACTERS WITHOUT CLAIM TO ANY PARTICULAR FONT, STYLE, SIZE, OR COLOR.

NO CLAIM IS MADE TO THE EXCLUSIVE RIGHT TO USE "POWER", APART FROM THE MARK AS SHOWN.

FOR BATTERY CABLES; BATTERY CHARGE DEVICES; BATTERY CHARGERS; CHARGING APPLIANCES FOR RECHARGEABLE EQUIPMENT; ELECTRIC CHARGING CABLES (U.S. CLS. 21, 23, 26, 36 AND 38).

JORDAN BAKER, EXAMINING ATTORNEY

CLASS 9—(Continued).

SN 77-663,954. NEWBOLD CORPORATION, ROCKY MOUNT, VA. FILED 2-5-2009.

KioskWorks

THE MARK CONSISTS OF STANDARD CHARACTERS WITHOUT CLAIM TO ANY PARTICULAR FONT, STYLE, SIZE, OR COLOR.

OWNER OF U.S. REG. NOS. 2,678,979 AND 3,178,430.
FOR COMPUTER SOFTWARE FOR CONTROLLING AND MANAGING PATIENT MEDICAL INFORMATION; COMPUTER SOFTWARE FOR CONTROLLING SELF-SERVICE TERMINALS (U.S. CLS. 21, 23, 26, 36 AND 38).

ANN E. SAPPENFIELD, EXAMINING ATTORNEY

SN 77-663,943. DANGEROUS MUSIC, INC., EDMESTON, NY. FILED 2-5-2009.

MASTERING CREATIVITY

THE MARK CONSISTS OF STANDARD CHARACTERS WITHOUT CLAIM TO ANY PARTICULAR FONT, STYLE, SIZE, OR COLOR.

FOR AUDIO AMPLIFIERS; AUDIO CIRCUIT BOARDS; AUDIO MIXERS; AUDIO PROCESSING EQUIPMENT, NAMELY, LIMITERS AND COMPRESSORS (U.S. CLS. 21, 23, 26, 36 AND 38).

LINDA LAVACHE, EXAMINING ATTORNEY

SN 77-663,985. NAJMABADI, CYRUS, NEW YORK, NY. FILED 2-5-2009.

PocketFlix

THE MARK CONSISTS OF STANDARD CHARACTERS WITHOUT CLAIM TO ANY PARTICULAR FONT, STYLE, SIZE, OR COLOR.

FOR COMPUTER APPLICATION SOFTWARE FOR MOBILE PHONES (U.S. CLS. 21, 23, 26, 36 AND 38).

FIRST USE 6-1-2008; IN COMMERCE 6-1-2008.

SUSAN LESLIE DUBOIS, EXAMINING ATTORNEY

SN 77-663,953. RECHARGE POWER LLC, GATES MILLS, OH. FILED 2-5-2009.

RechargePower 

NO CLAIM IS MADE TO THE EXCLUSIVE RIGHT TO USE "POWER", APART FROM THE MARK AS SHOWN.

THE MARK CONSISTS OF THE WORDING "RECHARGE POWER" WITH THE FIRST "R" STYLIZED TO INCLUDE AN ELECTRICAL CABLE DESIGN.

FOR BATTERY CABLES; BATTERY CHARGERS; CHARGERS FOR ELECTRIC BATTERIES; ELECTRIC CHARGING CABLES (U.S. CLS. 21, 23, 26, 36 AND 38).

JORDAN BAKER, EXAMINING ATTORNEY

SN 77-664,132. MICHAELS, DRAYTON DAVINA GLAMP-PIRE, AKA GLAMP-PIRE, RED BANK, NJ. FILED 2-5-2009.

Glampire

THE MARK CONSISTS OF STANDARD CHARACTERS WITHOUT CLAIM TO ANY PARTICULAR FONT, STYLE, SIZE, OR COLOR.

FOR SERIES OF MUSICAL SOUND AND VIDEO RECORDINGS FEATURING MUSIC (U.S. CLS. 21, 23, 26, 36 AND 38).

FIRST USE 5-1-1996; IN COMMERCE 5-1-1996.

MICHAEL WIENER, EXAMINING ATTORNEY

CLASS 9—(Continued).

SN 77-664,192. TRIPWIRE, INC., PORTLAND, OR. FILED 2-5-2009.

VWIRE

THE MARK CONSISTS OF STANDARD CHARACTERS WITHOUT CLAIM TO ANY PARTICULAR FONT, STYLE, SIZE, OR COLOR.

FOR COMPUTER SOFTWARE FOR FILE SYSTEM OPTIMIZATION; COMPUTER NETWORK OPTIMIZATION, SYSTEM OPTIMIZATION, APPLICATION OPTIMIZATION, FILE OPTIMIZATION, AND DATA OPTIMIZATION SOFTWARE; COMPUTER SOFTWARE FOR THE MANAGEMENT AND MONITORING OF COMPUTER NETWORK CONFIGURATIONS, SYSTEMS, APPLICATIONS, FILES, AND DATA; COMPUTER SOFTWARE FOR THE DETECTION, ANALYSIS, REPORTING, AND RESTORATION OF CHANGES TO COMPUTER NETWORK CONFIGURATION, SYSTEMS, APPLICATIONS, FILES, AND DATA; COMPUTER SOFTWARE FOR COMPUTER NETWORK VIRTUAL INFRASTRUCTURE MANAGEMENT, NAMELY, THE DETECTION, ANALYSIS, AND REPORTING OF CHANGES IN CONFIGURATION PROPERTIES, CONFIGURATION CHANGES, CRITICAL EVENTS, AND PERFORMANCE DATA (U.S. CLS. 21, 23, 26, 36 AND 38).
AARON BRODSKY, EXAMINING ATTORNEY

SN 77-664,553. CAVERN, SAN DIEGO, CA. FILED 2-5-2009.

Cavern

THE MARK CONSISTS OF STANDARD CHARACTERS WITHOUT CLAIM TO ANY PARTICULAR FONT, STYLE, SIZE, OR COLOR.

FOR CONSUMER ELECTRONICS, NAMELY, HEADPHONES (U.S. CLS. 21, 23, 26, 36 AND 38).
TARAH HARDY, EXAMINING ATTORNEY

SN 77-664,561. MERRY, JOHN, EL DORADO HILLS, CA. FILED 2-5-2009.

Pigskinkids.com

THE MARK CONSISTS OF STANDARD CHARACTERS WITHOUT CLAIM TO ANY PARTICULAR FONT, STYLE, SIZE, OR COLOR.

FOR DIGITAL MATERIALS, NAMELY, CDS, DVDS, DOWNLOADABLE AUDIO AND PRE-RECORDED VIDEO FILES FEATURING TEACHING FUNDAMENTALS AND TECHNIQUES OF YOUTH FOOTBALL TO BOYS FROM 6 TO 18 (U.S. CLS. 21, 23, 26, 36 AND 38).
EMILY CARLSEN, EXAMINING ATTORNEY

CLASS 9—(Continued).

SN 77-664,609. SPARK LABS, TAMPA, FL. FILED 2-5-2009.

TOUR WRIST

THE MARK CONSISTS OF STANDARD CHARACTERS WITHOUT CLAIM TO ANY PARTICULAR FONT, STYLE, SIZE, OR COLOR.

FOR COMPUTER APPLICATION SOFTWARE FOR MOBILE PHONES (U.S. CLS. 21, 23, 26, 36 AND 38).
BARBARA GAYNOR, EXAMINING ATTORNEY

SN 77-664,748. ARKADIUM, INC., NEW YORK, NY. FILED 2-6-2009.

ARKADIUM AGORA SERVER

THE MARK CONSISTS OF STANDARD CHARACTERS WITHOUT CLAIM TO ANY PARTICULAR FONT, STYLE, SIZE, OR COLOR.

OWNER OF U.S. REG. NOS. 2,963,255 AND 3,466,666.
NO CLAIM IS MADE TO THE EXCLUSIVE RIGHT TO USE "SERVER", APART FROM THE MARK AS SHOWN.
FOR COMPUTER SOFTWARE PLATFORM FOR A MULTI-USER SOCKET SERVER DESIGNED TO FACILITATE THE TRANSFER OF INFORMATION BETWEEN MULTIPLAYER INTERNET GAMES AND SOCIAL NETWORKS (U.S. CLS. 21, 23, 26, 36 AND 38).
JAMES LOVELACE, EXAMINING ATTORNEY

SN 77-664,876. DEJIMA TECH BV, ARNHEM, NETHERLANDS, FILED 2-6-2009.

TWISTAR

THE MARK CONSISTS OF STANDARD CHARACTERS WITHOUT CLAIM TO ANY PARTICULAR FONT, STYLE, SIZE, OR COLOR.

FOR OPTICAL COMPENSATION FILMS FOR USE AS AN OPTICAL COMPENSATION COMPONENT OF LIQUID CRYSTAL DISPLAYS, THE OPTICAL COMPENSATION FILMS NOT FOR USE WITH LASERS (U.S. CLS. 21, 23, 26, 36 AND 38).
JIM RINGLE, EXAMINING ATTORNEY

CLASS 9—(Continued).

SN 77-664,939. LOISEAU, GAVIN, SPRING VALLEY, NY.
FILED S.R. 2-6-2009; AM. P.R. 4-27-2009.

DIE RICH RECORDS

THE MARK CONSISTS OF STANDARD CHARACTERS WITHOUT CLAIM TO ANY PARTICULAR FONT, STYLE, SIZE, OR COLOR.

NO CLAIM IS MADE TO THE EXCLUSIVE RIGHT TO USE "RECORDS", APART FROM THE MARK AS SHOWN. FOR MUSICAL SOUND RECORDINGS (U.S. CLS. 21, 23, 26, 36 AND 38).

FIRST USE 7-27-2008; IN COMMERCE 7-27-2008.
JAY FLOWERS, EXAMINING ATTORNEY

SN 77-665,102. WILLIAMS, SAMUEL, K, JUNCTION CITY, OR. FILED 2-6-2009.



THE COLOR(S) RED, BLACK, WHITE IS/ARE CLAIMED AS A FEATURE OF THE MARK.

THE MARK CONSISTS OF TWO WHITE HANDS WITH BLACK OUTLINE SHUFFLING A RED DECK OF CARDS WITH A RED DOT ABOVE THE DECK OF CARDS AND THE WORD "DEAL" IN RED BELOW THE HANDS, WITH THE CARDS AND DOT REPRESENTING THE LETTER "I", ALL WITHIN THE DESIGN OF A BLACK SQUARE WITH ROUNDED CORNERS.

FOR ELECTRONIC GAME SOFTWARE FOR CELLULAR TELEPHONES (U.S. CLS. 21, 23, 26, 36 AND 38).
MARK PILARO, EXAMINING ATTORNEY

SN 77-665,160. DEREK ANDREW INC., BELLEVUE, WA.
FILED 2-6-2009.

TWISTED HEART

THE MARK CONSISTS OF STANDARD CHARACTERS WITHOUT CLAIM TO ANY PARTICULAR FONT, STYLE, SIZE, OR COLOR.

OWNER OF U.S. REG. NOS. 2,930,606 AND 3,600,195.
FOR SUNGLASSES (U.S. CLS. 21, 23, 26, 36 AND 38).
MICHAEL WEBSTER, EXAMINING ATTORNEY

CLASS 9—(Continued).

SN 77-665,164. DEREK ANDREW INC., BELLEVUE, WA.
FILED 2-6-2009.



OWNER OF U.S. REG. NOS. 3,202,995, 3,610,341 AND 3,610,342.

THE MARK CONSISTS OF HEART, WINGS, CROWN. FOR SUNGLASSES (U.S. CLS. 21, 23, 26, 36 AND 38).
MICHAEL WEBSTER, EXAMINING ATTORNEY

SN 77-665,166. WALDEN, NARADA MICHAEL, DBA TARPAN STUDIOS, SAN RAFAEL, CA. FILED 2-6-2009.

Rhinestone Kitties & The Furry Dog

THE MARK CONSISTS OF STANDARD CHARACTERS WITHOUT CLAIM TO ANY PARTICULAR FONT, STYLE, SIZE, OR COLOR.

FOR AUDIO TAPES FEATURING MUSIC; CHILDREN'S EDUCATIONAL MUSIC CDS AND DVDS; CHILDREN'S VIDEO TAPES (U.S. CLS. 21, 23, 26, 36 AND 38).

MICHAEL WEBSTER, EXAMINING ATTORNEY

SN 77-665,194. ALTAIR ENGINEERING, INC., TROY, MI.
FILED 2-6-2009.

HYPERWELD

THE MARK CONSISTS OF STANDARD CHARACTERS WITHOUT CLAIM TO ANY PARTICULAR FONT, STYLE, SIZE, OR COLOR.

FOR COMPUTER SOFTWARE FOR USE IN WELDING SIMULATION (U.S. CLS. 21, 23, 26, 36 AND 38).
JORDAN BAKER, EXAMINING ATTORNEY

CLASS 9—(Continued).

SN 77-665,209. ALTAIR ENGINEERING, INC., TROY, MI. FILED 2-6-2009.

CLASS 9—(Continued).

SN 77-665,459. LOADRACK, LLC, ENCINITES, CA. FILED 2-6-2009.

HYPERMOLD

THE MARK CONSISTS OF STANDARD CHARACTERS WITHOUT CLAIM TO ANY PARTICULAR FONT, STYLE, SIZE, OR COLOR.

FOR COMPUTER SOFTWARE, NAMELY, A FINITE ELEMENT PRE- AND POST- PROCESSOR THAT SUPPORTS INJECTION MOLDING SOLVERS (U.S. CLS. 21, 23, 26, 36 AND 38).

JORDAN BAKER, EXAMINING ATTORNEY



THE MARK CONSISTS OF STYLIZED WORD, "LOADRACK.COM" WITH AN ARROW ON THE BOTTOM ON "LOAD".

FOR AUTOMATED SYSTEMS, NAMELY, SOFTWARE, HARDWARE AND COMMUNICATIONS DEVICES FOR PLANNING, SCHEDULING, CONTROLLING, MONITORING AND PROVIDING INFORMATION ON TRANSPORTATION ASSETS AND PARTS THEREOF; COMPUTER E-COMMERCE SOFTWARE TO ALLOW USERS TO PERFORM ELECTRONIC BUSINESS TRANSACTIONS VIA A GLOBAL COMPUTER NETWORK; ENVIRONMENTAL MONITORING SYSTEM COMPRISED OF METERS AND SENSORS THAT MEASURE PRESSURE, HUMIDITY, TEMPERATURE AND INCLUDES ALARM AND REPORTING FUNCTIONS; SENSORS FOR THE DETERMINATION OF TEMPERATURES, POSITIONS AND DISTANCES; TEMPERATURE CONTROLLERS FOR MONITORING AND ADJUSTING TEMPERATURE OF TRAILERS AND CARGO THEREOF; TEMPERATURE INDICATORS; TEMPERATURE SENSORS; TEMPERATURE TRANSMITTERS; TRANSPONDER LOCATION SYSTEM; VEHICLE LOCATOR AND RECOVERY DEVICE PROGRAMMED TO USE GLOBAL POSITIONING SYSTEMS (GPS) AND CELLULAR TELECOMMUNICATIONS (U.S. CLS. 21, 23, 26, 36 AND 38).

ANDREW LEASER, EXAMINING ATTORNEY

SN 77-665,228. SHELBY G. TACKETT, GARLAND, TX. FILED 2-6-2009.

24/7 MailWatch

THE MARK CONSISTS OF STANDARD CHARACTERS WITHOUT CLAIM TO ANY PARTICULAR FONT, STYLE, SIZE, OR COLOR.

NO CLAIM IS MADE TO THE EXCLUSIVE RIGHT TO USE "24/7", APART FROM THE MARK AS SHOWN.

FOR MAGNETIC OBJECT DETECTOR USED IN CONJUNCTION WITH A MAILBOX TO VISUALLY DETERMINE WHEN MAIL HAS BEEN PLACED IN THE MAILBOX (U.S. CLS. 21, 23, 26, 36 AND 38).

FIRST USE 2-5-2009; IN COMMERCE 2-5-2009. JESSICA A. POWERS, EXAMINING ATTORNEY

SN 77-665,502. PORTABLE ZOO, SANTA CLARA, CA. FILED 2-6-2009.

LETTER BUG

THE MARK CONSISTS OF STANDARD CHARACTERS WITHOUT CLAIM TO ANY PARTICULAR FONT, STYLE, SIZE, OR COLOR.

FOR DIGITAL MEDIA, NAMELY, DOWNLOADABLE VIDEO GAMES FEATURING WORD PUZZLES (U.S. CLS. 21, 23, 26, 36 AND 38).

ELI HELLMAN, EXAMINING ATTORNEY

CLASS 9—(Continued).

SN 77-665,507. PLAYMESH, INC., MOUNTAIN VIEW, CA. FILED 2-6-2009.

PlayMesh

THE MARK CONSISTS OF STANDARD CHARACTERS WITHOUT CLAIM TO ANY PARTICULAR FONT, STYLE, SIZE, OR COLOR.

FOR DOWNLOADABLE ELECTRONIC GAME SOFTWARE FOR CELLULAR TELEPHONES VIA THE INTERNET AND WIRELESS DEVICES (U.S. CLS. 21, 23, 26, 36 AND 38).

FIRST USE 1-23-2009; IN COMMERCE 1-23-2009.
WENDY JUN, EXAMINING ATTORNEY

SN 77-665,515. CODELATHE LLC, PLANO, TX. FILED 2-6-2009.

TONIDO

THE MARK CONSISTS OF STANDARD CHARACTERS WITHOUT CLAIM TO ANY PARTICULAR FONT, STYLE, SIZE, OR COLOR.

FOR COMPUTER SOFTWARE FOR COMMUNICATION AND COLLABORATION THAT MAY BE DOWNLOADED FROM A GLOBAL COMPUTER NETWORK (U.S. CLS. 21, 23, 26, 36 AND 38).

FIRST USE 1-31-2009; IN COMMERCE 1-31-2009.
JOHN E. MICHOS, EXAMINING ATTORNEY

SN 77-665,748. COSTAN, VICTOR M, BUCHAREST, ROMANIA, FILED 2-7-2009.

Zergling.Net

THE MARK CONSISTS OF STANDARD CHARACTERS WITHOUT CLAIM TO ANY PARTICULAR FONT, STYLE, SIZE, OR COLOR.

FOR COMPUTER APPLICATION SOFTWARE FOR MOBILE PHONES; COMPUTER SOFTWARE THAT PROVIDES WEB-BASED ACCESS TO APPLICATIONS AND SERVICES THROUGH A WEB OPERATING SYSTEM OR PORTAL INTERFACE; COMPUTER SOFTWARE, NAMELY, SOFTWARE DEVELOPMENT TOOLS FOR THE CREATION OF MOBILE INTERNET APPLICATIONS AND CLIENT INTERFACES; WEB SITE DEVELOPMENT SOFTWARE (U.S. CLS. 21, 23, 26, 36 AND 38).

STEVEN R. FOSTER, EXAMINING ATTORNEY

CLASS 9—(Continued).

SN 77-665,797. MUNDUE LLC, ACTON, MA. FILED 2-8-2009.

INFACT

THE MARK CONSISTS OF STANDARD CHARACTERS WITHOUT CLAIM TO ANY PARTICULAR FONT, STYLE, SIZE, OR COLOR.

FOR COMPUTER GAME PROGRAMS; COMPUTER GAME SOFTWARE; COMPUTER PROGRAMS FOR PRE-RECORDED GAMES; COMPUTER PROGRAMS FOR VIDEO AND COMPUTER GAMES; DOWNLOADABLE GRAPHICS FOR MOBILE PHONES; DOWNLOADABLE MULTIMEDIA FILE CONTAINING ARTWORK, TEXT, AUDIO, VIDEO, GAMES, AND INTERNET WEB LINKS RELATING TO ELECTRONIC GAMES; DOWNLOADABLE ELECTRONIC GAMES VIA THE INTERNET AND WIRELESS DEVICES; ELECTRONIC GAME PROGRAMS; ELECTRONIC GAME SOFTWARE; ELECTRONIC GAME SOFTWARE FOR CELLULAR TELEPHONES; ELECTRONIC GAME SOFTWARE FOR HANDHELD ELECTRONIC DEVICES; ELECTRONIC GAME SOFTWARE FOR WIRELESS DEVICES; GAME SOFTWARE; HIGH PERFORMANCE COMPUTER HARDWARE WITH SPECIALIZED FEATURES FOR ENHANCED GAME PLAYING ABILITY; INTERACTIVE MULTIMEDIA COMPUTER GAME PROGRAM; INTERACTIVE VIDEO GAME PROGRAM, NAMELY, A VIDEO CRAPS GAME; INTERACTIVE VIDEO GAME PROGRAMS; INTERACTIVE VIDEO GAMES OF VIRTUAL REALITY COMPRISED OF COMPUTER HARDWARE AND SOFTWARE; VIDEO GAME INTERACTIVE HAND HELD REMOTE CONTROLS FOR PLAYING ELECTRONIC GAMES; VIDEO GAME SOFTWARE; VIRTUAL REALITY GAME SOFTWARE (U.S. CLS. 21, 23, 26, 36 AND 38).

FIRST USE 12-19-2008; IN COMMERCE 12-19-2008.
REBECCA GILBERT, EXAMINING ATTORNEY

SN 77-665,907. CONNECTIV SOLUTIONS, INC., BETHESDA, MD. FILED 2-8-2009.

NETCLARUS

THE MARK CONSISTS OF STANDARD CHARACTERS WITHOUT CLAIM TO ANY PARTICULAR FONT, STYLE, SIZE, OR COLOR.

FOR COMPUTER SOFTWARE FOR CREATING SEARCHABLE DATABASES OF INFORMATION AND DATA; COMPUTER SOFTWARE THAT PROVIDES WEB-BASED ACCESS TO APPLICATIONS AND SERVICES THROUGH A WEB OPERATING SYSTEM OR PORTAL INTERFACE (U.S. CLS. 21, 23, 26, 36 AND 38).

JANICE KIM, EXAMINING ATTORNEY

CLASS 9—(Continued).

SN 77-666,027. NEWTOY, INC., MCKINNEY, TX. FILED 2-9-2009.

NEWTOY

THE MARK CONSISTS OF STANDARD CHARACTERS WITHOUT CLAIM TO ANY PARTICULAR FONT, STYLE, SIZE, OR COLOR.

FOR GAME SOFTWARE (U.S. CLS. 21, 23, 26, 36 AND 38).

FIRST USE 11-6-2008; IN COMMERCE 11-6-2008.
STEPHANIE ALI, EXAMINING ATTORNEY

CLASS 9—(Continued).

SN 77-666,241. RIVERBED TECHNOLOGY, INC., SAN FRANCISCO, CA. FILED 2-9-2009.

CASCADE

THE MARK CONSISTS OF STANDARD CHARACTERS WITHOUT CLAIM TO ANY PARTICULAR FONT, STYLE, SIZE, OR COLOR.

FOR COMPUTER SOFTWARE USED TO MONITOR AND MANAGE THE PERFORMANCE AND SECURITY OF COMPUTER APPLICATIONS, SERVERS, NETWORK DEVICES, DATA STORAGE AND COMMUNICATIONS PROTOCOLS USED IN WIDE AREA, LOCAL AREA, OR GLOBAL NETWORKS; COMPUTER SOFTWARE, AND EMBEDDED SERVER SOFTWARE SOLD AS AN INTEGRAL COMPONENT OF COMPUTER HARDWARE, USED TO MONITOR AND MANAGE THE PERFORMANCE AND/OR SECURITY OF WIDE AREA, LOCAL AREA, OR GLOBAL NETWORKS; EMBEDDED SERVER SOFTWARE SOLD AS AN INTEGRAL COMPONENT OF COMPUTER HARDWARE USED TO MONITOR AND MANAGE THE PERFORMANCE AND SECURITY OF COMPUTER APPLICATIONS, SERVERS, NETWORK DEVICES, DATA STORAGE AND COMMUNICATIONS PROTOCOLS USED IN WIDE AREA, LOCAL AREA, OR GLOBAL NETWORKS; COMPUTER SOFTWARE, AND EMBEDDED SERVER SOFTWARE SOLD AS AN INTEGRAL COMPONENT OF COMPUTER HARDWARE, USED TO MONITOR AND MANAGE THE PERFORMANCE AND/OR SECURITY OF WIDE AREA, LOCAL AREA, OR GLOBAL NETWORKS (U.S. CLS. 21, 23, 26, 36 AND 38).

JILL C. ALT, EXAMINING ATTORNEY

SN 77-666,239. RIVERBED TECHNOLOGY, INC., SAN FRANCISCO, CA. FILED 2-9-2009.

RIVERBED CASCADE

THE MARK CONSISTS OF STANDARD CHARACTERS WITHOUT CLAIM TO ANY PARTICULAR FONT, STYLE, SIZE, OR COLOR.

FOR COMPUTER SOFTWARE USED TO MONITOR AND MANAGE THE PERFORMANCE AND SECURITY OF COMPUTER APPLICATIONS, SERVERS, NETWORK DEVICES, DATA STORAGE AND COMMUNICATIONS PROTOCOLS USED IN WIDE AREA, LOCAL AREA, OR GLOBAL NETWORKS; COMPUTER SOFTWARE, AND EMBEDDED SERVER SOFTWARE SOLD AS AN INTEGRAL COMPONENT OF COMPUTER HARDWARE, USED TO MONITOR AND MANAGE THE PERFORMANCE AND/OR SECURITY OF WIDE AREA, LOCAL AREA, OR GLOBAL NETWORKS; EMBEDDED SERVER SOFTWARE SOLD AS AN INTEGRAL COMPONENT OF COMPUTER HARDWARE USED TO MONITOR AND MANAGE THE PERFORMANCE AND SECURITY OF COMPUTER APPLICATIONS, SERVERS, NETWORK DEVICES, DATA STORAGE AND COMMUNICATIONS PROTOCOLS USED IN WIDE AREA, LOCAL AREA, OR GLOBAL NETWORKS; COMPUTER SOFTWARE, AND EMBEDDED SERVER SOFTWARE SOLD AS AN INTEGRAL COMPONENT OF COMPUTER HARDWARE, USED TO MONITOR AND MANAGE THE PERFORMANCE AND/OR SECURITY OF WIDE AREA, LOCAL AREA, OR GLOBAL NETWORKS (U.S. CLS. 21, 23, 26, 36 AND 38).

JILL C. ALT, EXAMINING ATTORNEY

SN 77-666,342. INTERNATIONAL PETROLEUM PRODUCTS AND ADDITIVE COMPANY, INC., DUBLIN, CA. FILED 2-9-2009.

QUICKBLEND

THE MARK CONSISTS OF STANDARD CHARACTERS WITHOUT CLAIM TO ANY PARTICULAR FONT, STYLE, SIZE, OR COLOR.

FOR COMPUTER SOFTWARE FOR PREDICTING FLUID PROPERTIES (U.S. CLS. 21, 23, 26, 36 AND 38).

FIRST USE 10-31-2008; IN COMMERCE 1-17-2009.
CYNTHIA TRIPI, EXAMINING ATTORNEY

CLASS 9—(Continued).

SN 77-666,521. FIBERLITE CENTRIFUGE LLC, SANTA CLARA, CA. FILED 2-9-2009.

FIBERLITE

THE MARK CONSISTS OF STANDARD CHARACTERS WITHOUT CLAIM TO ANY PARTICULAR FONT, STYLE, SIZE, OR COLOR.

FOR LABORATORY APPARATUS, NAMELY, CENTRIFUGE ROTORS FOR LIQUID SAMPLE SEPARATIONS (U.S. CLS. 21, 23, 26, 36 AND 38).

FIRST USE 12-0-1996; IN COMMERCE 12-0-1996.

JULIE WATSON, EXAMINING ATTORNEY

SN 77-666,582. KVH INDUSTRIES, INC., MIDDLETOWN, RI. FILED 2-9-2009.

TRI-AMERICAS

THE MARK CONSISTS OF STANDARD CHARACTERS WITHOUT CLAIM TO ANY PARTICULAR FONT, STYLE, SIZE, OR COLOR.

FOR LOW-NOISE BLOCK CONVERTERS (LNB) FOR USE IN SATELLITE COMMUNICATIONS (U.S. CLS. 21, 23, 26, 36 AND 38).

TOBY BULLOFF, EXAMINING ATTORNEY

SN 77-666,812. CLEVER INNOVATIONS, INC., SARATOGA SPRINGS, NY. FILED 2-9-2009.

ADEO

THE MARK CONSISTS OF STANDARD CHARACTERS WITHOUT CLAIM TO ANY PARTICULAR FONT, STYLE, SIZE, OR COLOR.

FOR ELECTRONIC IN STORE SIGNS WITH VIDEO DISPLAYS AND AUDIO USED TO ADVERTISE AND PROMOTE THE PRODUCTS AND SERVICES OF OTHERS (U.S. CLS. 21, 23, 26, 36 AND 38).

DEIRDRE ROBERTSON, EXAMINING ATTORNEY

CLASS 9—(Continued).

SN 77-666,820. ROBERTS RETROVALVE, INC, BELLEVUE, WA. FILED 2-9-2009.

RetroValve

THE MARK CONSISTS OF STANDARD CHARACTERS WITHOUT CLAIM TO ANY PARTICULAR FONT, STYLE, SIZE, OR COLOR.

FOR VACUUM TUBE REPLACEMENT DEVICES, NAMELY, SOLID-STATE VACUUM TUBE EMULATORS (U.S. CLS. 21, 23, 26, 36 AND 38).

DEIRDRE ROBERTSON, EXAMINING ATTORNEY

SN 77-667,491. GENESIS COMPUTER CONSULTANTS, INC., TAPPAN, NY. FILED 2-10-2009.

GENESISNY

THE MARK CONSISTS OF STANDARD CHARACTERS WITHOUT CLAIM TO ANY PARTICULAR FONT, STYLE, SIZE, OR COLOR.

FOR COMPUTER SOFTWARE, NAMELY, COMPUTER SOFTWARE FOR THE ANALYSIS AND MANAGEMENT OF REAL ESTATE-RELATED INFORMATION AND DATA (U.S. CLS. 21, 23, 26, 36 AND 38).

FIRST USE 2-9-2009; IN COMMERCE 2-9-2009.

DAVID MURRAY, EXAMINING ATTORNEY

CLASS 9—(Continued).

SN 77-667,636. RIVERBED TECHNOLOGY, INC., SAN FRANCISCO, CA. FILED 2-10-2009.

RIVERBED CASCADE

THE MARK CONSISTS OF STANDARD CHARACTERS WITHOUT CLAIM TO ANY PARTICULAR FONT, STYLE, SIZE, OR COLOR.

FOR COMPUTER SOFTWARE USED TO MONITOR AND MANAGE THE PERFORMANCE OF COMPUTER APPLICATIONS, SERVERS, NETWORK DEVICES, DATA STORAGE AND COMMUNICATIONS PROTOCOLS USED IN WIDE AREA, LOCAL AREA, OR GLOBAL NETWORKS; COMPUTER SOFTWARE USED TO MONITOR AND MANAGE THE PERFORMANCE OF WIDE AREA, LOCAL AREA, OR GLOBAL NETWORKS; EMBEDDED SERVER SOFTWARE SOLD AS AN INTEGRAL COMPONENT OF COMPUTER HARDWARE USED TO MONITOR AND MANAGE THE PERFORMANCE OF COMPUTER APPLICATIONS, SERVERS, NETWORK DEVICES, DATA STORAGE AND COMMUNICATIONS PROTOCOLS USED IN WIDE AREA, LOCAL AREA, OR GLOBAL NETWORKS; EMBEDDED SERVER SOFTWARE SOLD AS AN INTEGRAL COMPONENT OF COMPUTER HARDWARE USED TO MONITOR AND MANAGE THE PERFORMANCE OF WIDE AREA, LOCAL AREA, OR GLOBAL NETWORKS (U.S. CLS. 21, 23, 26, 36 AND 38).

JILL C. ALT, EXAMINING ATTORNEY

CLASS 9—(Continued).

SN 77-667,775. VIZIONCORE, INC., BUFFALO GROVE, IL. FILED 2-10-2009.

VAUTOMATOR

THE MARK CONSISTS OF STANDARD CHARACTERS WITHOUT CLAIM TO ANY PARTICULAR FONT, STYLE, SIZE, OR COLOR.

FOR COMPUTER SOFTWARE FOR USE IN OPTIMIZING PRODUCTIVITY, MANAGING OTHER HARDWARE, SOFTWARE AND ELECTRONIC DEVICES AND ESTABLISHING POLICIES TO MAXIMIZE THE EFFICIENT USE OF COMPUTER SYSTEMS (U.S. CLS. 21, 23, 26, 36 AND 38).

JIM RINGLE, EXAMINING ATTORNEY

SN 77-667,784. VIZIONCORE, INC., BUFFALO GROVE, IL. FILED 2-10-2009.

VCONVERTER

THE MARK CONSISTS OF STANDARD CHARACTERS WITHOUT CLAIM TO ANY PARTICULAR FONT, STYLE, SIZE, OR COLOR.

FOR COMPUTER SOFTWARE FOR USE IN TRANSFER OF COMPUTER DATA, APPLICATIONS AND OPERATING SYSTEMS AND FOR CREATING AND DISPLAYING IMAGES OF A COMPUTER ENVIRONMENT (U.S. CLS. 21, 23, 26, 36 AND 38).

JIM RINGLE, EXAMINING ATTORNEY

SN 77-667,650. RIVERBED TECHNOLOGY, INC., SAN FRANCISCO, CA. FILED 2-10-2009.

CASCADE

THE MARK CONSISTS OF STANDARD CHARACTERS WITHOUT CLAIM TO ANY PARTICULAR FONT, STYLE, SIZE, OR COLOR.

FOR COMPUTER SOFTWARE USED TO MONITOR AND MANAGE THE PERFORMANCE OF COMPUTER APPLICATIONS, SERVERS, NETWORK DEVICES, DATA STORAGE AND COMMUNICATIONS PROTOCOLS USED IN WIDE AREA, LOCAL AREA, OR GLOBAL NETWORKS; COMPUTER SOFTWARE USED TO MONITOR AND MANAGE THE PERFORMANCE OF WIDE AREA, LOCAL AREA, OR GLOBAL NETWORKS; EMBEDDED SERVER SOFTWARE SOLD AS AN INTEGRAL COMPONENT OF COMPUTER HARDWARE USED TO MONITOR AND MANAGE THE PERFORMANCE OF COMPUTER APPLICATIONS, SERVERS, NETWORK DEVICES, DATA STORAGE AND COMMUNICATIONS PROTOCOLS USED IN WIDE AREA, LOCAL AREA, OR GLOBAL NETWORKS; EMBEDDED SERVER SOFTWARE SOLD AS AN INTEGRAL COMPONENT OF COMPUTER HARDWARE USED TO MONITOR AND MANAGE THE PERFORMANCE OF WIDE AREA, LOCAL AREA, OR GLOBAL NETWORKS (U.S. CLS. 21, 23, 26, 36 AND 38).

JILL C. ALT, EXAMINING ATTORNEY

SN 77-667,786. VIZIONCORE, INC., BUFFALO GROVE, IL. FILED 2-10-2009.

VMIGRATOR

THE MARK CONSISTS OF STANDARD CHARACTERS WITHOUT CLAIM TO ANY PARTICULAR FONT, STYLE, SIZE, OR COLOR.

FOR COMPUTER SOFTWARE FOR USE IN PORTING COMPUTER DATA, APPLICATIONS, AND OPERATING SYSTEMS (U.S. CLS. 21, 23, 26, 36 AND 38).

JIM RINGLE, EXAMINING ATTORNEY

CLASS 9—(Continued).

SN 77-667,791. VIZIONCORE, INC., BUFFALO GROVE, IL.
FILED 2-10-2009.

VECOSHELL

THE MARK CONSISTS OF STANDARD CHARACTERS WITHOUT CLAIM TO ANY PARTICULAR FONT, STYLE, SIZE, OR COLOR.

FOR COMPUTER SOFTWARE FOR USE IN FACILITATING THE MANAGEMENT AND ADMINISTRATION OF VIRTUAL SYSTEMS (U.S. CLS. 21, 23, 26, 36 AND 38).

JIM RINGLE, EXAMINING ATTORNEY

SN 77-669,223. ECHOSTAR TECHNOLOGIES L.L.C., ENGLEWOOD, CO. FILED 2-12-2009.

THE COLOR(S) RED AND BLACK IS/ARE CLAIMED AS A FEATURE OF THE MARK.

THE MARK CONSISTS OF THE WORD "ECHOSTAR" IN A STYLIZED FORMAT, WITH THE COLOR OF THE MARK TRANSITIONING FROM RED AT THE TOP TO BLACK AT THE BOTTOM.

FOR COMMUNICATIONS EQUIPMENT, NAMELY, DIGITAL VIDEO RECORDERS, AUDIO-VIDEO RECEIVERS, SIGNAL FREQUENCY RECEIVERS AND ANTENNAE FOR RECEIVING SIGNAL FREQUENCIES; COMMUNICATIONS SOFTWARE, NAMELY, SYSTEM APPLICATION AND OPERATING SOFTWARE FOR RESIDENTIAL AND COMMERCIAL TELEVISION RECEIVER SYSTEMS AND PLACE SHIFTING DEVICES; SATELLITE TRANSMITTERS AND RECEIVERS; SATELLITE AERIALS; SATELLITE DISHES; SOFTWARE REFLECTING THE ON-SCREEN LISTING OF AVAILABLE PROGRAMMING; MICRO-PROCESSOR BASED PLASTIC CARDS; LOW NOISE CONVERTERS, DECODERS AND ELECTRONIC ENCRYPTION EQUIPMENT; TELEPHONE EXTENSION CIRCUITRY; DEVICES FOR TRANSMISSION OF DATA OVER POWER LINES; UNIVERSAL REMOTE CONTROLS FOR HOME ELECTRONIC DEVICES, NAMELY TELEVISIONS, VCRS, DVD PLAYERS, STEREO RECEIVERS, AND STEREO AMPLIFIERS; RECEIVERS FOR RECEIVING AUDIO, VIDEO AND DATA SIGNALS DISTRIBUTED VIA SATELLITE; SATELLITE TELEVISION RECEIVERS; CABLE TELEVISION RECEIVERS; TERRESTRIAL TELEVISION RECEIVERS; INTERNET TELEVISION RECEIVERS; PROGRAMMABLE DIGITAL TELEVISION RECORDERS; TELEVISIONS AND DISPLAYS; PLACE SHIFTING DEVICES; PORTABLE MEDIA PLAYERS; HOME AUDIO AND VIDEO SERVERS; DIGITAL MEDIA ADAPTERS; VIDEO PROCESSORS; VIDEO TRANSMITTERS; MOBILE PHONES; PERSONAL DIGITAL ASSISTANTS (PDA); DIGITAL CAMERAS; NETWORKED SECURITY CAMERAS; STORAGE DEVICES FOR STORING AUDIO, VIDEO, IMAGE AND DATA INFORMATION; ELECTRONIC APPARATUS AND DEVICES FOR CONTROLLING ACCESS TO PAY-TELEVISION SERVICES; COMMUNICATIONS SOFTWARE, NAMELY, NETWORKING SOFTWARE FOR AUDIO, VIDEO AND DATA DISTRIBUTION SYSTEMS; SOFTWARE TO ENABLE UPLOADING, POSTING, SHOWING, MODIFYING, DISPLAYING, TAGGING, BLOGGING, SHARING OR OTHERWISE PROVIDING ELECTRONIC MEDIA AND INFORMATION OVER THE INTERNET OR OTHER COMMUNICATION NETWORKS; COMPUTER

CLASS 9—(Continued).

HARDWARE AND SOFTWARE FOR CONTROLLING THE OPERATION OF AUDIO AND VIDEO DEVICES AND FOR VIEWING, SEARCHING AND PLAYING AUDIO, VIDEO, TELEVISION, MOVIES, PHOTOGRAPHS AND OTHER DIGITAL IMAGES; PORTABLE AND HANDHELD DIGITAL ELECTRONIC DEVICES, NAMELY, MOBILE TELEPHONES, PERSONAL DIGITAL ASSISTANTS, PORTABLE MEDIA PLAYERS AND LAPTOP COMPUTERS FOR RECORDING, ORGANIZING, TRANSMITTING, RECEIVING, MANIPULATING, PLAYING AND REVIEWING TEXT, DATA, IMAGE, AUDIO, AND VIDEO FILES; COMPUTER SOFTWARE FOR USE IN ORGANIZING, TRANSMITTING, RECEIVING, MANIPULATING, PLAYING AND REVIEWING TEXT, DATA, IMAGE, AUDIO, AND VIDEO FILES; DISTRIBUTION SYSTEMS FOR TRANSMITTING AUDIO, VIDEO AND DATA SIGNALS FROM A RECEIVER TO PRESENTATION CLIENT DEVICES; COMPUTER HARDWARE AND SOFTWARE FOR STREAMING AUDIO, VIDEO, IMAGE AND DATA INFORMATION TO A VARIETY OF CLIENT DEVICES, NAMELY, TELEVISIONS, PERSONAL COMPUTERS, MOBILE PHONES, PERSONAL DIGITAL ASSISTANTS (PDA) AND STAND-ALONE HARDWARE DECODERS; PARTS AND FITTINGS OF THE AFOREMENTIONED GOODS; OPERATOR MAINTENANCE AND INSTRUCTIONAL MANUALS DISTRIBUTED THEREWITH (U.S. CLS. 21, 23, 26, 36 AND 38).

JOHN WILKE, EXAMINING ATTORNEY

SN 77-669,869. GUARDSMAN SCIENTIFIC, INC., PARK CITY, UT. FILED 2-13-2009.

EGAM U C SOLUTION

THE MARK CONSISTS OF STANDARD CHARACTERS WITHOUT CLAIM TO ANY PARTICULAR FONT, STYLE, SIZE, OR COLOR.

NO CLAIM IS MADE TO THE EXCLUSIVE RIGHT TO USE "SOLUTION", APART FROM THE MARK AS SHOWN. FOR COMPUTER SOFTWARE FOR USE IN CONNECTION WITH ULTRASOUND DEVICES THAT ANALYZES DATA AND SUGGESTS CLINICAL MANAGEMENT TO HEALTHCARE PROVIDERS (U.S. CLS. 21, 23, 26, 36 AND 38).

JESSICA A. POWERS, EXAMINING ATTORNEY

SN 77-669,875. GUARDSMAN SCIENTIFIC, INC., PARK CITY, UT. FILED 2-13-2009.

EGHEM U C SOLUTION

THE MARK CONSISTS OF STANDARD CHARACTERS WITHOUT CLAIM TO ANY PARTICULAR FONT, STYLE, SIZE, OR COLOR.

NO CLAIM IS MADE TO THE EXCLUSIVE RIGHT TO USE "SOLUTION", APART FROM THE MARK AS SHOWN. FOR COMPUTER SOFTWARE FOR USE IN CONNECTION WITH ULTRASOUND DEVICES THAT ANALYZES DATA AND SUGGESTS CLINICAL MANAGEMENT TO HEALTHCARE PROVIDERS (U.S. CLS. 21, 23, 26, 36 AND 38).

JESSICA A. POWERS, EXAMINING ATTORNEY

CLASS 9—(Continued).

SN 77-670,121. LEUPOLD & STEVENS, INC., BEAVERTON, OR. FILED 2-13-2009.

KENAI

THE MARK CONSISTS OF STANDARD CHARACTERS WITHOUT CLAIM TO ANY PARTICULAR FONT, STYLE, SIZE, OR COLOR.

FOR SPOTTING SCOPES (U.S. CLS. 21, 23, 26, 36 AND 38).

DAWN FELDMAN, EXAMINING ATTORNEY

SN 77-670,333. ROSENTHAL COLLINS GROUP, LLC, CHICAGO, IL. FILED 2-13-2009.

RCG ONYX WEB

THE MARK CONSISTS OF STANDARD CHARACTERS WITHOUT CLAIM TO ANY PARTICULAR FONT, STYLE, SIZE, OR COLOR.

OWNER OF U.S. REG. NOS. 3,055,122, 3,094,103 AND 3,246,007.

NO CLAIM IS MADE TO THE EXCLUSIVE RIGHT TO USE "WEB", APART FROM THE MARK AS SHOWN.

FOR COMPUTER SOFTWARE, NAMELY, DOWNLOADABLE COMPUTER SOFTWARE FOR ELECTRONIC TRADING OVER A GLOBAL COMPUTER NETWORK (U.S. CLS. 21, 23, 26, 36 AND 38).

FIRST USE 2-1-2009; IN COMMERCE 2-1-2009.
RONALD MCMORROW, EXAMINING ATTORNEY

SN 77-675,669. HONEYWELL INTERNATIONAL INC., MORRISTOWN, NJ. FILED 2-23-2009.

LOBBYWORKS

THE MARK CONSISTS OF STANDARD CHARACTERS WITHOUT CLAIM TO ANY PARTICULAR FONT, STYLE, SIZE, OR COLOR.

FOR ELECTRONIC VISITOR MANAGEMENT SOFTWARE WHICH CREATES IDENTIFICATION BADGES, RECORDS ENTRY AND EXIT OF VISITORS, EMPLOYEES AND PACKAGES, SPECIFIES WHETHER VISITORS REQUIRE ESCORT, RECORDS WHO PICKS UP PACKAGES, IDENTIFIES WHO IS ALLOWED ACCESS TO A BUILDING; ELECTRONIC VISITOR MANAGEMENT SYSTEM COMPRISING A COMPUTER, SCANNER, CAMERA, PRINTER AND SOFTWARE WHICH CREATES IDENTIFICATION BADGES, RECORDS ENTRY AND EXIT OF VISITORS, EMPLOYEES AND PACKAGES, SPECIFIES WHETHER VISITORS REQUIRE ESCORT, RECORDS WHO PICKS UP PACKAGES, AND IDENTIFIES WHO IS ALLOWED ACCESS TO A BUILDING (U.S. CLS. 21, 23, 26, 36 AND 38).

FIRST USE 6-30-2004; IN COMMERCE 6-30-2004.
KRISTIN DAHLING, EXAMINING ATTORNEY

CLASS 9—(Continued).

SN 77-677,210. HOMER TLC, INC., WILMINGTON, DE. FILED 2-24-2009.

Home Depot Link

THE MARK CONSISTS OF STANDARD CHARACTERS WITHOUT CLAIM TO ANY PARTICULAR FONT, STYLE, SIZE, OR COLOR.

NO CLAIM IS MADE TO THE EXCLUSIVE RIGHT TO USE "LINK", APART FROM THE MARK AS SHOWN.

FOR COMPUTER SOFTWARE THAT PROVIDES WEB-BASED ACCESS TO APPLICATIONS AND SERVICES THROUGH A WEB OPERATING SYSTEM AND PORTAL INTERFACE (U.S. CLS. 21, 23, 26, 36 AND 38).

DAVID MURRAY, EXAMINING ATTORNEY

SN 77-681,325. THE POWERWISE GROUP, INC., BOCA RATON, FL. FILED 3-2-2009.



MOTORWISE

THE MARK CONSISTS OF THE LITERAL ELEMENT AND A FANCIFUL LIGHTNING BOLT DESIGN ELEMENT WITHIN A FANCIFUL LEAF DESIGN ELEMENT, BOTH ELEMENTS WITHIN A FANCIFUL COGWHEEL DESIGN ELEMENT WHERE SUCH FANCIFUL DESIGN ELEMENTS ARE ABOVE THE LITERAL ELEMENT, "MOTORWISE".

FOR ELECTRONIC CONTROLLERS AND MICRO-PROCESSOR-BASED HARDWARE SYSTEMS USED TO REDUCE POWER CONSUMPTION (U.S. CLS. 21, 23, 26, 36 AND 38).

CAROLINE WOOD, EXAMINING ATTORNEY

CLASS 9—(Continued).

SN 77-681,358. THE POWERWISE GROUP, INC., BOCA RATON, FL. FILED 3-2-2009.



THE MARK CONSISTS OF A FANCIFUL LIGHTNING BOLT DESIGN ELEMENT WITHIN A FANCIFUL LEAF DESIGN ELEMENT, BOTH ELEMENTS WITHIN A FANCIFUL LIGHT BULB DESIGN ELEMENT WHERE SUCH FANCIFUL DESIGN ELEMENTS ARE ABOVE THE LITERAL ELEMENT, "ECOWISE".

FOR ELECTRONIC CONTROLLERS AND MICRO-PROCESSOR-BASED HARDWARE SYSTEMS USED TO REDUCE POWER CONSUMPTION (U.S. CLS. 21, 23, 26, 36 AND 38).

CAROLINE WOOD, EXAMINING ATTORNEY

SN 77-681,370. THE POWERWISE GROUP, INC., BOCA RATON, FL. FILED 3-2-2009.



NO CLAIM IS MADE TO THE EXCLUSIVE RIGHT TO USE "GROUP", APART FROM THE MARK AS SHOWN.

THE MARK CONSISTS OF THE LITERAL ELEMENT AND A FANCIFUL LIGHTNING BOLT DESIGN ELEMENT WITHIN A FANCIFUL LEAF DESIGN ELEMENT WHERE SUCH FANCIFUL DESIGN ELEMENTS ARE ABOVE THE LITERAL ELEMENT, "THE TECHNO WISE GROUP".

FOR ELECTRONIC CONTROLLERS AND MICRO-PROCESSOR-BASED HARDWARE SYSTEMS USED TO REDUCE POWER CONSUMPTION (U.S. CLS. 21, 23, 26, 36 AND 38).

CAROLINE WOOD, EXAMINING ATTORNEY

CLASS 9—(Continued).

SN 77-681,376. THE POWERWISE GROUP, INC., BOCA RATON, FL. FILED 3-2-2009.

TECHNOWISE

THE MARK CONSISTS OF STANDARD CHARACTERS WITHOUT CLAIM TO ANY PARTICULAR FONT, STYLE, SIZE, OR COLOR.

FOR ELECTRONIC CONTROLLERS AND MICRO-PROCESSOR-BASED HARDWARE SYSTEMS USED TO REDUCE POWER CONSUMPTION (U.S. CLS. 21, 23, 26, 36 AND 38).

CAROLINE WOOD, EXAMINING ATTORNEY

SN 77-681,383. THE POWERWISE GROUP, INC., BOCA RATON, FL. FILED 3-2-2009.



THE MARK CONSISTS OF A FANCIFUL LIGHTNING BOLT DESIGN ELEMENT WITHIN A FANCIFUL LEAF DESIGN ELEMENT.

FOR ELECTRONIC CONTROLLERS AND MICRO-PROCESSOR-BASED HARDWARE SYSTEMS USED TO REDUCE POWER CONSUMPTION (U.S. CLS. 21, 23, 26, 36 AND 38).

CAROLINE WOOD, EXAMINING ATTORNEY

SN 77-685,184. SUNWIZE TECHNOLOGIES, INC., SAN JOSE, CA. FILED 3-6-2009.

**Reliable People :::
Reliable Products :::
Reliable Power!**

THE MARK CONSISTS OF STANDARD CHARACTERS WITHOUT CLAIM TO ANY PARTICULAR FONT, STYLE, SIZE, OR COLOR.

FOR PHOTOVOLTAIC DEVICES AND MODULES CONSISTING OF AND INTEGRATING SOLAR CELLS AND INTERCONNECTED SOLAR CELLS FOR INCORPORATION IN POWER SYSTEMS AND PRODUCTS REQUIRING PHOTOVOLTAIC VOLTAGE/WATTAGE POWER (U.S. CLS. 21, 23, 26, 36 AND 38).

FIRST USE 8-30-2004; IN COMMERCE 2-12-2009.
JOHN WILKE, EXAMINING ATTORNEY

CLASS 9—(Continued).

SN 77-685,587. PLANTRONICS, INC., SANTA CRUZ, CA. FILED 3-6-2009.

BE SAVI IN THE OFFICE

THE MARK CONSISTS OF STANDARD CHARACTERS WITHOUT CLAIM TO ANY PARTICULAR FONT, STYLE, SIZE, OR COLOR.

FOR TELECOMMUNICATIONS DEVICES, NAMELY, HEADSETS FOR USE WITH CELLULAR PHONES, COMPUTERS, TELEPHONES AND TELEPHONE COMMUNICATIONS SYSTEMS (U.S. CLS. 21, 23, 26, 36 AND 38).

JEAN IM, EXAMINING ATTORNEY

SN 77-685,628. PLANTRONICS, INC., SANTA CRUZ, CA. FILED 3-6-2009.

THE VOICE OF UNIFIED COMMUNICATIONS

THE MARK CONSISTS OF STANDARD CHARACTERS WITHOUT CLAIM TO ANY PARTICULAR FONT, STYLE, SIZE, OR COLOR.

OWNER OF U.S. REG. NO. 3,145,623. NO CLAIM IS MADE TO THE EXCLUSIVE RIGHT TO USE "UNIFIED COMMUNICATIONS", APART FROM THE MARK AS SHOWN.

FOR SPEAKER PHONES; TELEPHONE COMMUNICATIONS HANDSETS; HEADSETS FOR USE WITH MOBILE PHONES, TELEPHONES, VOIP PHONES AND COMPUTERS (U.S. CLS. 21, 23, 26, 36 AND 38).

JEAN IM, EXAMINING ATTORNEY

SN 77-688,898. INTEK AMERICA, INC., RANCHO DOMINGUEZ, CA. FILED 3-11-2009.



THE COLOR(S) GREEN IS/ARE CLAIMED AS A FEATURE OF THE MARK.

THE MARK CONSISTS OF A CAPITAL "S" FOLLOWED BY LOWER CASE "EED" WITH ALL LETTERS IN GREEN. THE SECOND "E" ENDS IN A POWER PLUG.

FOR AUTOMATIC OR MANUALLY CONTROLLED POWER STRIPS OR CONNECTORS THAT SHUTOFF STANDBY POWER IN HOME AND OFFICE APPLIANCES OR EQUIPMENT (U.S. CLS. 21, 23, 26, 36 AND 38).

DOMINICK J. SALEMI, EXAMINING ATTORNEY

CLASS 9—(Continued).

SN 77-691,409. HONEYWELL INTERNATIONAL INC., MORRISTOWN, NJ. FILED 3-16-2009.

ECONOSWITCH

THE MARK CONSISTS OF STANDARD CHARACTERS WITHOUT CLAIM TO ANY PARTICULAR FONT, STYLE, SIZE, OR COLOR.

FOR ELECTRONIC TIMER SWITCHES (U.S. CLS. 21, 23, 26, 36 AND 38).

KRISTIN DAHLING, EXAMINING ATTORNEY

SN 77-691,564. ANDIS COMPANY, STURTEVANT, WI. FILED 3-16-2009.

ECO CURL

THE MARK CONSISTS OF STANDARD CHARACTERS WITHOUT CLAIM TO ANY PARTICULAR FONT, STYLE, SIZE, OR COLOR.

NO CLAIM IS MADE TO THE EXCLUSIVE RIGHT TO USE "CURL", APART FROM THE MARK AS SHOWN.

FOR ELECTRIC HAIR CURLING IRONS (U.S. CLS. 21, 23, 26, 36 AND 38).

SOPHIA S. KIM, EXAMINING ATTORNEY

SN 77-691,568. ANDIS COMPANY, STURTEVANT, WI. FILED 3-16-2009.

ECO STRAIGHTEN

THE MARK CONSISTS OF STANDARD CHARACTERS WITHOUT CLAIM TO ANY PARTICULAR FONT, STYLE, SIZE, OR COLOR.

NO CLAIM IS MADE TO THE EXCLUSIVE RIGHT TO USE "STRAIGHTEN", APART FROM THE MARK AS SHOWN.

FOR ELECTRIC HAIR STRAIGHTENING IRONS (U.S. CLS. 21, 23, 26, 36 AND 38).

SOPHIA S. KIM, EXAMINING ATTORNEY

CLASS 9—(Continued).

SN 77-699,526. WARRIOR SPORTS, INC., WARREN, MI.
FILED 3-26-2009.

VK2

THE MARK CONSISTS OF STANDARD CHARACTERS WITHOUT CLAIM TO ANY PARTICULAR FONT, STYLE, SIZE, OR COLOR.
FOR PROTECTIVE HELMETS FOR SPORTS (U.S. CLS. 21, 23, 26, 36 AND 38).
TEJBIR SINGH, EXAMINING ATTORNEY

SN 77-699,530. WARRIOR SPORTS, INC., WARREN, MI.
FILED 3-26-2009.

VENTILATOR

THE MARK CONSISTS OF STANDARD CHARACTERS WITHOUT CLAIM TO ANY PARTICULAR FONT, STYLE, SIZE, OR COLOR.
OWNER OF U.S. REG. NOS. 2,687,510, 2,863,349 AND 3,088,401.
FOR PROTECTIVE HELMETS FOR SPORTS (U.S. CLS. 21, 23, 26, 36 AND 38).
TEJBIR SINGH, EXAMINING ATTORNEY

SN 77-714,401. PRODUCT PARTNERS LLC, SANTA MONICA, CA. FILED 4-15-2009.

OWNER OF U.S. REG. NOS. 2,843,063, 3,444,723 AND OTHERS.
THE MARK CONSISTS OF "P90X" IN BLOCK LETTERS.
FOR PRE-RECORDED VIDEO TAPES, CASSETTES, DVDS AND CDS FEATURING EXERCISE, FITNESS AND DIETARY INFORMATION AND INSTRUCTION (U.S. CLS. 21, 23, 26, 36 AND 38).
FIRST USE 7-21-2003; IN COMMERCE 7-21-2003.
JOHN GARTNER, EXAMINING ATTORNEY

CLASS 9—(Continued).

SN 77-718,537. VIZIONCORE, INC., BUFFALO GROVE, IL.
FILED 4-21-2009.

VRANGER

THE MARK CONSISTS OF STANDARD CHARACTERS WITHOUT CLAIM TO ANY PARTICULAR FONT, STYLE, SIZE, OR COLOR.
FOR COMPUTER SOFTWARE FOR USE IN SERVER, DATA, FILE AND DATABASE BACKUP, RECOVERY, AND REPLICATION (U.S. CLS. 21, 23, 26, 36 AND 38).
JIM RINGLE, EXAMINING ATTORNEY

SN 77-976,981. SUNBELT U.S.A., INC., LA VERNE, CA.
FILED 11-7-2008.

GONE FISHING

THE MARK CONSISTS OF STANDARD CHARACTERS WITHOUT CLAIM TO ANY PARTICULAR FONT, STYLE, SIZE, OR COLOR.
FOR SUNGLASSES, SUNGLASS CASES AND SUNGLASS RETAINERS (U.S. CLS. 21, 23, 26, 36 AND 38).
FIRST USE 9-10-2008; IN COMMERCE 9-10-2008.
CHRISTINE COOPER, EXAMINING ATTORNEY

SN 78-283,048. RENEWED VISION, LLC, ALPHARETTA, GA.
FILED 8-5-2003.



THE COLOR(S) BLUE, ORANGE, BLACK AND WHITE IS/ARE CLAIMED AS A FEATURE OF THE MARK.
THE MARK CONSISTS OF THE WORD "PROPRESENTER" SUPERIMPOSED OVER TWO QUADRILATERALS. THE WORDING APPEARS IN BLACK OUTLINED IN WHITE. THE COLOR ORANGE APPEARS IN THE OBSCURED QUADRILATERAL CONTAINING "PRO" AND THE COLOR BLUE APPEARS IN THE QUADRILATERAL CONTAINING THE WORD "PRESENTER".
FOR DOWNLOADABLE COMPUTER SOFTWARE USED FOR PRESENTING TEXT, GRAPHICS, VIDEO, AND SOUND IN LIVE OR RECORDED VIDEO PRESENTATIONS (U.S. CLS. 21, 23, 26, 36 AND 38).
FIRST USE 7-1-1999; IN COMMERCE 7-1-1999.
JASON TURNER, EXAMINING ATTORNEY

CLASS 9—(Continued).

SN 78-580,875. AXESSTEL, INC., SAN DIEGO, CA. FILED 3-4-2005.

AXESSTEL

THE MARK CONSISTS OF STANDARD CHARACTERS WITHOUT CLAIM TO ANY PARTICULAR FONT, STYLE, SIZE, OR COLOR.

FOR TELECOMMUNICATION DEVICES, NAMELY, WIRELESS TELEPHONES (U.S. CLS. 21, 23, 26, 36 AND 38).

RUSS HERMAN, EXAMINING ATTORNEY

SN 78-690,624. THADANI, MOHAN J., MISSISSAUGA, CANADA, FILED 8-11-2005.

SOLARIS

FOR WEIGHING EQUIPMENT, NAMELY, BALANCES AND SCALES (U.S. CLS. 21, 23, 26, 36 AND 38).
SARA THOMAS, EXAMINING ATTORNEY

SN 78-757,907. SONY KABUSHIKI KAISHA ALSO TRADING AS SONY CORPORATION, TA SONY CORPORATION, TOKYO, JAPAN, FILED 11-21-2005.

VSPEC

OWNER OF JAPAN REG. NO. 4967352, DATED 7-7-2006, EXPIRES 7-7-2016.

THE MARK CONSISTS OF THE WORD VSPEC APPEARING TO COME OUT OF A STYLIZATION OF A LCD PANEL.

FOR LCD PANELS (U.S. CLS. 21, 23, 26, 36 AND 38).
MELVIN AXILBUND, EXAMINING ATTORNEY

CLASS 9—(Continued).

SN 78-868,914. HICKS, JERRY S., SAN ANTONIO, TX. AND HICKS, ESTHER W., SAN ANTONIO, TX. FILED 4-25-2006.

LAW OF DELIBERATE CREATION

THE MARK CONSISTS OF STANDARD CHARACTERS WITHOUT CLAIM TO ANY PARTICULAR FONT, STYLE, SIZE, OR COLOR.

FOR PRERECORDED CDS, CASSETTES, VIDEOS AND DVDS IN THE FIELD OF INSPIRATION AND SELF ESTEEM (U.S. CLS. 21, 23, 26, 36 AND 38).

FIRST USE 12-31-1988; IN COMMERCE 12-31-1988.
JOHN GARTNER, EXAMINING ATTORNEY

SN 78-974,187. AZTEK NETWORKS, INC., BOULDER, CO. FILED 9-14-2006.

aztek 
NETWORKS

NO CLAIM IS MADE TO THE EXCLUSIVE RIGHT TO USE "NETWORKS", APART FROM THE MARK AS SHOWN.

FOR COMPUTER HARDWARE AND SOFTWARE FOR ENABLING VOICE OVER INTERNET PROTOCOL (VOIP), IP MULTIMEDIA SUBSYSTEM (IMS) AND EMERGENCY CALL SERVICES IN THE FIELD OF TELECOMMUNICATIONS; AUTOMATIC SWITCHING DEVICES FOR TELECOMMUNICATIONS (U.S. CLS. 21, 23, 26, 36 AND 38).

PAUL E. FAHRENKOPF, EXAMINING ATTORNEY

SN 79-013,297. LAUDA DR. R. WOBSEY GMBH & CO. KG, 97922 LAUDA-KÖNIGSHOFEN, FED REP GERMANY, FILED 10-28-2004.

LAUDA

PRIORITY DATE OF 5-11-2004 IS CLAIMED.
OWNER OF INTERNATIONAL REGISTRATION 0856574 DATED 10-28-2004, EXPIRES 10-28-2014.

OWNER OF U.S. REG. NO. 1,684,311.
LAUDA IS THE FIRST WORD OF "LAUDA-KDNIGSHOFEN", THE NAME OF A TOWN IN GERMANY.

SEC. 2(F).
FOR THERMOSTATS, NAMELY, HEATING THERMOSTATS, COOLING THERMOSTATS AND WATER BATHS, FOR USE IN LABORATORIES; PROCESS THERMOSTATS; AND MEASURING INSTRUMENTS FOR PHYSICAL VALUES, NAMELY, THERMOMETERS, DIGITAL THERMOMETERS, VISCOSITY MEASURING INSTRUMENTS AND TENSIMETERS (U.S. CLS. 21, 23, 26, 36 AND 38).

FOR THERMOSTATS, NAMELY, HEATING THERMOSTATS, COOLING THERMOSTATS AND WATER BATHS, FOR USE IN LABORATORIES; PROCESS THERMOSTATS; AND MEASURING INSTRUMENTS FOR PHYSICAL VALUES, NAMELY, THERMOMETERS, DIGITAL THERMOMETERS, VISCOSITY MEASURING INSTRUMENTS AND TENSIMETERS (U.S. CLS. 21, 23, 26, 36 AND 38).
SANJEEV VOHRA, EXAMINING ATTORNEY

CLASS 9—(Continued).

SN 79-042,206. INTERFACE CORPORATION, JAPAN, FILED 6-25-2007.

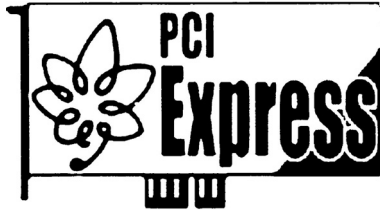

OWNER OF INTERNATIONAL REGISTRATION 0933512 DATED 6-25-2007, EXPIRES 6-25-2017.

OWNER OF U.S. REG. NOS. 2,507,463 AND 3,021,720.

NO CLAIM IS MADE TO THE EXCLUSIVE RIGHT TO USE "PCI EXPRESS", APART FROM THE MARK AS SHOWN.

FOR ELECTRONIC MACHINES, APPARATUS AND THEIR PARTS COMPLIANT WITH SPECIFICATION FOR EXTENDING THE INTERNAL CIRCUITRY BUS THAT TRANSMITS DATA FROM ONE PART OF A COMPUTER TO ANOTHER BY INSERTING CIRCUIT BOARDS, NAMELY, COMPUTERS AND COMPUTER HARDWARE; AND COMPUTER SOFTWARE THAT IS COMPLIANT WITH THE SPECIFICATION FOR EXTENDING THE INTERNAL CIRCUITRY BUS THAT TRANSMITS DATA FROM ONE PART OF A COMPUTER TO ANOTHER BY INSERTING CIRCUIT BOARDS FOR USE AS A SPREADSHEET (U.S. CLS. 21, 23, 26, 36 AND 38).

AMY HELLA, EXAMINING ATTORNEY

SN 79-044,925. TELECOM ITALIA SPA, ITALY, FILED 2-16-2007.

TIM

THE MARK CONSISTS OF STANDARD CHARACTERS WITHOUT CLAIM TO ANY PARTICULAR FONT, STYLE, SIZE, OR COLOR.

OWNER OF INTERNATIONAL REGISTRATION 0882640 DATED 8-5-2005, EXPIRES 8-5-2015.

OWNER OF U.S. REG. NO. 2,710,413.

FOR SCIENTIFIC, NAUTICAL, SURVEYING, PHOTOGRAPHIC, CINEMATOGRAPHIC, OPTICAL, WEIGHING, MEASURING, SIGNALLING, CHECKING SUPERVISION, LIFE-SAVING AND TEACHING APPARATUS AND INSTRUMENTS ALL FOR USE WITH TELECOMMUNICATIONS, NAMELY, CELLULAR PHONES, PERSONAL DIGITAL ASSISTANTS, PORTABLE WIRELESS VOICE AND DATA TRANSMISSION DEVICES, NAMELY, MOBILE PHONES, PAGERS, WIRELESS E-MAIL AND MESSAGING DEVICES, NAMELY, ELECTRONIC HANDHELD UNITS FOR THE WIRELESS RECEIPT AND/OR TRANSMISSION OF DATA THAT ENABLE THE USER TO KEEP TRACK OF OR MANAGE PERSONAL INFORMATION; PERSONAL COMMUNICATION DEVICES AND INSTRUMENTS, NAMELY, PERSONAL DIGITAL ASSISTANTS WITH RADIO MODULES FOR MOBILE PHONE NETWORKS, MOBILE PHONES WITH SUPPORT FOR SOFTWARE APPLICATIONS, MOBILE PHONES WITH DIGITAL MESSAGING CAPABILITIES; VIDEO DEVICES, NAMELY, ANALOGUE AND DIGITAL TRANSMISSION DEVICES FOR TRANSMITTING STILL PICTURES AND MOTION PICTURES VIA WIRELESS OR WIRED MEANS, NAMELY, TELECOMMUNICATION TERMINALS IN THE NATURE OF TELEPHONE AND COMPUTER TERMINALS, FAX MACHINES, PC

CLASS 9—(Continued).

PHONES, ANTENNAS; DEVICES FOR RECORDINGS, NAMELY, ANALOGUE AND DIGITAL VIDEO-RECORDERS, COMPUTER HARD DISK RECORDERS, LIVE STREAMING AND RECORDING DEVICES FOR TRANSMISSION AND FOR REPLAY OF SOUND, DATA AND/OR IMAGE OVER MOBILE DIGITAL DATA NETWORKS, NAMELY, AUDIO TAPE RECORDERS, ANALOG AND DIGITAL SOUND RECORDERS, OPTICAL AND MAGNETIC RECORDING DEVICES FOR COMPUTERS, NAMELY, COMPACT DISC RECORDERS, OPTICAL DRIVES, BLANK HARD DRIVES AND TAPE DRIVES, VIDEO AND AUDIO RECORDERS, DATA RECORDING DEVICES, NAMELY, ELECTRONIC MEMORIES; DATA PROCESSING DEVICES, NAMELY, INTELLIGENT PORTABLE DEVICES FOR MOBILE COMMUNICATION NETWORKS, NAMELY, APPARATUS FOR RECORDING, TRANSMISSION, PROCESSING AND REPRODUCTION OF SOUND, IMAGES OR DATA AND PORTABLE COMPUTING DEVICES, NAMELY, COMPUTER MEMORIES AND COMPUTER DISC DRIVES, COMPUTER PERIPHERALS FOR WIRELESS NETWORKING AND TELECOMMUNICATION AND COMPUTERS; INTEGRATED CIRCUITS FOR COMPUTERS, PARTICULARLY FOR DATA TRANSMISSION; COMPUTER PROGRAMS FOR ON AND OFFLINE GEOGRAPHICAL MAPPING OF ROADS, RAILWAYS, RUNWAYS, BUSINESS INFORMATION DATABASE SOFTWARE PROVIDING MULTI-USER ACCESS TO A GLOBAL COMPUTER INFORMATION NETWORK FOR THE TRANSFER AND DISSEMINATION OF A WIDE RANGE OF INFORMATION AND NETWORK IN THE FIELD OF BUSINESS, STORED ON MAGNETIC DATA CARRIERS; TELEPHONES, CELLULAR TELEPHONES, NAMELY, MOBILE TELEPHONES WITH DATA EXCHANGE MEANS FOR THE INTERNET; MODEMS; DEVICES FOR BROADBAND FIXED LINES, NAMELY, SWITCHES, COUPLERS, DIALERS, FOR DATA TRANSMISSION; APPARATUS FOR RECORDING, TRANSMISSION OR REPRODUCTION OF SOUND OR IMAGES, NAMELY, TELETYPEWRITERS, AUTOMATIC TELEGRAPH APPARATUS, PHOTOTELEGRAPHY APPARATUS, MANUAL TELEGRAPH APPARATUS, TRUNK EXCHANGE APPARATUS, FACSIMILE MACHINES, FREQUENCY-CARRIER APPARATUS, NAMELY, AUDIO FREQUENCY TRANSMISSION APPARATUS, CABLE-TYPE FREQUENCY-CARRIER APPARATUS, POWER-LINE-TYPE FREQUENCY-CARRIER APPARATUS, OPEN-WIRE-TYPE FREQUENCY-CARRIER APPARATUS, CARRIER-FREQUENCY REPEATERS, AND COMPUTER PERIPHERALS, BROADCASTING APPARATUS, NAMELY, TELEVISION RECEIVERS, TELEVISION TRANSMITTERS, RADIO RECEIVERS, RADIO TRANSMITTERS, RADIO COMMUNICATION APPARATUS, NAMELY, PORTABLE RADIO COMMUNICATION APPARATUS, AERONAUTICAL RADIO COMMUNICATION APPARATUS, MULTI-CHANNEL RADIO COMMUNICATION APPARATUS FOR FIXED STATIONS, SINGLE-CHANNEL RADIO COMMUNICATION APPARATUS FOR FIXED STATIONS, VEHICULAR RADIO COMMUNICATION APPARATUS, MARINE RADIO COMMUNICATION APPARATUS, RADIO APPLICATION APPARATUS, NAMELY, RADIO BEACON APPARATUS, RADIO DIRECTION FINDERS, RADAR APPARATUS, AUDIO FREQUENCY APPARATUS, NAMELY, PUBLIC-ADDRESS SYSTEMS, JUKE BOXES, TAPE RECORDERS, ELECTRIC PHONOGRAPHS, RECORD PLAYERS, APPARATUS FOR RECORDING SOUND, NAMELY, DIGITAL-VERSATILE-DISC RECORDERS, HARD-DISC-DRIVE RECORDERS, VIDEO FREQUENCY APPARATUS, NAMELY, VIDEO-CAMERAS, VIDEODISC PLAYERS, VIDEOTAPE RECORDERS; TELEPHONE APPARATUS INCLUDING MOBILE RADIO TELEPHONES AND CELLULAR TELEPHONES; BLANK MAGNETIC DATA CARRIERS, BLANK RECORDING OPTICAL DISCS; AUTOMATIC VENDING MACHINES AND MECHANISMS FOR COIN-OPERATED APPARATUS; CASH REGISTERS, CALCULATING MACHINES, DATA PROCESSING EQUIPMENT; MAGNETIC CARDS (U.S. CLS. 21, 23, 26, 36 AND 38).

SARA THOMAS, EXAMINING ATTORNEY

CLASS 9—(Continued).

SN 79-051,987. GA MODEFINE S.A., SWITZERLAND, FILED 9-19-2007.

GIORGIO ARMANI

OWNER OF INTERNATIONAL REGISTRATION 0502877 DATED 5-1-1986, EXPIRES 5-1-2016.

OWNER OF U.S. REG. NOS. 1,546,115, 3,204,214 AND OTHERS.

THE NAME "GIORGIO ARMANI" IDENTIFIES A LIVING INDIVIDUAL WHOSE CONSENT IS OF RECORD.

FOR SCIENTIFIC, NAUTICAL, SURVEYING, PHOTOGRAPHIC, CINEMATOGRAPHIC, OPTICAL, WEIGHING, MEASURING, SIGNALING, MONITORING, EMERGENCY AND TEACHING APPARATUS AND INSTRUMENTS, NAMELY, SPECTACLES, EYEGLASSES, SUNGLASSES, SPORT GLASSES, SPORTS GOGGLES, PINCE-NEZ, CASES FOR EYEGLASSES AND SUNGLASSES, CHAINS FOR EYEGLASSES AND SUNGLASSES, FRAMES FOR EYEGLASSES AND SUNGLASSES, LENSES FOR EYEGLASSES AND SUNGLASSES; PROTECTIVE HELMETS; PHOTOGRAPHIC CAMERAS, OPTICAL FILTERS, CINEMATOGRAPHIC CAMERAS, VIDEO CAMERAS, COMPACT DISC PLAYERS; COMPACT DISC BURNERS; DVD PLAYERS, DIGITAL AUDIO AND VIDEO RECORDERS; DVD BURNERS; AUDIO TAPE RECORDERS AND VIDEO RECORDERS; TELEVISIONS; CELLULAR PHONES, MOBILE PHONES, VIDEO PHONES, TELEPHONES, TELEPHONE ANSWERING MACHINES; COMPUTERS; PERSONAL DIGITAL ASSISTANTS; APPARATUS FOR MAGNETIC RECORDING, TRANSMISSION AND REPRODUCTION OF SOUND AND IMAGES; BLANK MAGNETIC RECORDING MEDIA IN THE NATURE OF CD-ROMS, RECORDABLE DVD, AUDIO AND VIDEO TAPES; BLANK PHONOGRAPH RECORDS; PRE-RECORDED COMPACT DISCS, AUDIO CASSETTES, PHONOGRAPH RECORDS, VIDEOTAPE AND DIGITAL VIDEO DISCS, ALL FEATURING MUSIC AND FASHION; AUTOMATIC VENDING MACHINES AND MECHANISMS FOR COIN-OPERATED APPARATUS; CASH REGISTERS, CALCULATING MACHINES AND DATA PROCESSING EQUIPMENT; FIRE EXTINGUISHERS (U.S. CLS. 21, 23, 26, 36 AND 38).

LEIGH LOWRY, EXAMINING ATTORNEY

CLASS 9—(Continued).

TEST KEYS AS ELECTRONIC AND ELECTRIC MEASURING SENSORS/CALIPERS, CABLE-CONTROL PATH SENSORS; ELECTRONIC SENSORS FOR GAUGING THICKNESS OF METALS IN THE AREA OF AUTOMOTIVE ENGINEERING, AND INDUSTRIAL APPLICATIONS; MEASURING APPARATUS, NAMELY, RESISTANCE STRAIN GAUGES FOR MEASURING STRESS-STRAIN CURVES, AND WEIGHING CELLS AS PART OF WEIGHING EQUIPMENT, NAMELY, SCALES AND BALANCES; DIGITAL TORQUE GAUGES; DIGITAL VOLTMETERS, AMPLIFIERS, LIQUID CRYSTAL DIGITAL DISPLAYS, MOTION COMPENSATORS, ELECTRONIC CABLE ASSEMBLIES, INCLUDED IN THIS CLASS, FOR USE WITH ELECTRONIC WEIGHING APPARATUS AND SCANNERS, NAMELY, LASER SCANNERS; ELECTRICAL EQUIPMENT FOR NON-DESTRUCTIVE MATERIAL TESTING, NAMELY, ULTRASOUND TESTING EQUIPMENT, NAMELY, ULTRASOUND MICROSCOPES, ULTRASOUND TOMOGRAPHS AS ULTRASONIC EQUIPMENT USED TO TEST OR INSPECT DAMAGE TO MATERIALS USED IN AUTOMOTIVE AND INDUSTRIAL APPLICATIONS; ELECTRIC AND ELECTRONIC EQUIPMENT FOR SOUND EMISSION ANALYSIS, NAMELY, SOUND RECORDING APPARATUS; OPTICAL SENSORS IN THE NATURE OF LIGHT BARRIERS, NAMELY, PHOTOELECTRIC BARRIERS, ELECTRIC AND SENSOR BARRIERS AS PHOTOELECTRIC, ELECTRONIC AND SENSOR GUARDS AND LIGHT CURTAINS; ELECTRONIC SENSORS FOR DETECTING ELECTROMAGNETIC WAVES AND VIBRATIONS; APPARATUS FOR QUALITATIVE AND QUANTITATIVE IMAGE ANALYSIS AND IMAGE PROCESSING, NAMELY, APPARATUS AND COMPUTER HARDWARE FOR RECORDING, TRANSMISSION, PROCESSING AND REPRODUCTION OF SOUND, IMAGES OR DATA; ELECTRIC SPOT WELDING APPARATUS, NAMELY, WELDING TORCHES FOR ATTACHING GAUGES; COMPUTER HARDWARE AND COMPUTER SOFTWARE FOR USE AS COMPUTER APPLICATION SOFTWARE FOR THE FAST CREATION OF INDUSTRIAL APPLICATIONS AND VISUAL PROGRAMMING, NAMELY, IN THE AREAS OF DATA ACQUISITION AND CONTROL, AUTOMATION, QUALITY CONTROL, IMAGE PROCESSING, RESEARCH AND DEVELOPMENT, EDUCATION (U.S. CLS. 21, 23, 26, 36 AND 38).

WILLIAM ROSSMAN, EXAMINING ATTORNEY

ç

SN 79-055,370. MICRO-EPSILON-MESSTECHNIK GMBH & CO. KG, FED REP GERMANY, FILED 1-22-2008.

MICROEPSILON

OWNER OF INTERNATIONAL REGISTRATION 0968431 DATED 1-22-2008, EXPIRES 1-22-2018.

OWNER OF U.S. REG. NO. 1,164,425.

FOR ELECTRONIC AND ELECTRIC SENSORS INCLUDED IN THIS CLASS, NAMELY, PATH-MEASURING SENSORS FOR NON-CONTACT PATH-MEASURING, SENSORS FOR DISPLACEMENT, DISTANCE AND POSITION, NAMELY, CAPACITIVE DISPLACEMENT AND POSITION SENSORS, EDDY CURRENT/INDUCTIVE SENSORS FOR DISPLACEMENT AND POSITION, LINEAR INDUCTIVE LVDT SENSORS, LASER SENSORS FOR DISPLACEMENT AND POSITION, CONFOCAL CHROMATIC SENSORS FOR DISPLACEMENT AND POSITION, LASER DISTANCE SENSORS FOR EXTRA LONG RANGES, DRAW-WIRE DISPLACEMENT SENSORS, 2D/3D SENSORS FOR POSITION, PROFILE AND DIMENSION, NAMELY, HIGH RESOLUTION OPTICAL MICROMETERS, 2D/3D LASER PROFILE SENSORS, INFRARED SENSORS FOR TEMPERATURE MEASUREMENT, NAMELY, TEMPERATURE SENSORS WITH LASER AIMING, TEMPERATURE SENSORS WITH INTEGRATED CONTROLLERS, UNIVERSAL TEMPERATURE SENSORS, HANDHELD PYROMETERS WITH LASER SIGHTING, SPEED AND LENGTH SENSORS,

CLASS 9—(Continued).

SN 79-057,381. EVOC INTELLIGENT TECHNOLOGY CO., LTD., CHINA, FILED 5-5-2008.



OWNER OF INTERNATIONAL REGISTRATION 0973382 DATED 5-5-2008, EXPIRES 5-5-2018.

THE MARK CONSISTS OF THE WORD "EVOC" IN BLACK AND A DESIGN OF A HALF RISING SUN IN BLACK, ALL ON A WHITE BACKGROUND.

FOR COMPUTERS; DATA PROCESSORS; MICROPROCESSORS; JOINTS USED FOR COMPUTER, NAMELY, ELECTRICAL CONNECTORS, CONNECTION CABLES; COMPUTER PERIPHERAL DEVICES; RECORDED COMPUTER SOFTWARE FOR USE IN DATA PROCESSING, FOR USE AS A SPREADSHEET; COMPUTER PROGRAMS MONITORS, NAMELY, COMPUTER SOFTWARE FOR USE IN MONITORING FACTORY MANUFACTURING PROCESSES; OPTICAL DISCS, NAMELY, BLANK OPTICAL DISCS, OPTICAL DISCS FEATURING COMPUTER SOFTWARE FOR USE IN DATA PROCESSING; CENTRAL PROCESSING UNITS; HYDROMETRY APPARATUS, NAMELY, HYDROMETERS; QUERY DEVICES USED FOR DATA PROCESSING, NAMELY, COMPUTER HARDWARE; ELECTRONIC DISPLAYS, NAMELY, ELECTRIC LUMINESCENT DISPLAY PANELS; PRESSURE GAUGES; AUTOMATIC DEVICES FOR POWER STATION, NAMELY, POWER-LINE TRANSMISSION MACHINES AND APPARATUS (U.S. CLS. 21, 23, 26, 36 AND 38).
MARY CRAWFORD, EXAMINING ATTORNEY

SN 79-058,844. BAZE TECHNOLOGY AS, NORWAY, FILED 7-3-2008.

BAZE

THE MARK CONSISTS OF STANDARD CHARACTERS WITHOUT CLAIM TO ANY PARTICULAR FONT, STYLE, SIZE, OR COLOR.

PRIORITY DATE OF 1-3-2008 IS CLAIMED.
OWNER OF INTERNATIONAL REGISTRATION 0977185 DATED 7-3-2008, EXPIRES 7-3-2018.

FOR COMPUTER SOFTWARE FOR PROVIDING REAL-TIME, INTEGRATED BUSINESS MANAGEMENT INTELLIGENCE BY COMBINING INFORMATION FROM VARIOUS DATABASES AND PRESENTING IT IN AN EASY-TO-UNDERSTAND USER INTERFACE (U.S. CLS. 21, 23, 26, 36 AND 38).

JACLYN KIDWELL, EXAMINING ATTORNEY

CLASS 9—(Continued).

SN 79-059,027. TE GROUP N.V., BELGIUM, FILED 5-20-2008.

ISO2CAR

THE MARK CONSISTS OF STANDARD CHARACTERS WITHOUT CLAIM TO ANY PARTICULAR FONT, STYLE, SIZE, OR COLOR.

PRIORITY DATE OF 4-29-2008 IS CLAIMED.

OWNER OF INTERNATIONAL REGISTRATION 0977754 DATED 5-20-2008, EXPIRES 5-20-2018.

FOR CELLULAR AND WIRELESS ACCESSORIES, NAMELY, CAR BATTERY CHARGERS, HOME BATTERY CHARGERS, PORTABLE HANDS FREE HEADSETS FOR USE WITH PHONES, HANDS FREE CAR KITS FOR USE WITH PHONES, WIRELESS PHONE HOLDERS IN THE NATURE OF EASES, SPECIALTY HOLSTERS FOR CARRYING WIRELESS PHONES, WIRELESS PHONE CARRYING CASES, ANTENNAE, BATTERIES, DATA CONNECTION CABLES AND VOICE DATA CONNECTION CABLES (U.S. CLS. 21, 23, 26, 36 AND 38).

MARIAM MAHMOUDI, EXAMINING ATTORNEY

SN 79-061,440. XI'AN STATE IMPORT & EXPORT CORP., YANTA DISTRICT; XI'AN; SHAANXI, CHINA, FILED 8-29-2008.

SHV

OWNER OF INTERNATIONAL REGISTRATION 0983375 DATED 8-29-2008, EXPIRES 8-29-2018.

FOR PRINTED CIRCUITS; CAPACITORS; OPTICAL FIBERS; ELECTRICAL INDUCTORS (U.S. CLS. 21, 23, 26, 36 AND 38).

ELI HELLMAN, EXAMINING ATTORNEY

SN 79-063,176. HEALTHSTATS INTERNATIONAL PTE LTD, SINGAPORE, FILED 10-15-2008.

A-PULSE CASP

PRIORITY DATE OF 4-18-2008 IS CLAIMED.

OWNER OF INTERNATIONAL REGISTRATION 0987718 DATED 10-15-2008, EXPIRES 10-15-2018.

NO CLAIM IS MADE TO THE EXCLUSIVE RIGHT TO USE "CASP", APART FROM THE MARK AS SHOWN.

THE MARK CONSISTS OF THE STYLIZED WORDING "A-PULSE CASP" WHERE THE LETTER "A" IN "A-PULSE" IS REPRESENTED IN CHEVRON.

FOR APPLICATION SOFTWARE FOR ASSISTING IN THE EVALUATION AND DISPLAY OF BLOOD PRESSURE PULSE WAVES, AND FOR BLOOD PRESSURE MEASURING AND ANALYSIS; COMPUTER SOFTWARE FOR ASSISTING IN EVALUATION AND DISPLAY OF BLOOD PRESSURE PULSE WAVES (U.S. CLS. 21, 23, 26, 36 AND 38).

KELLEY WELLS, EXAMINING ATTORNEY

CLASS 9—(Continued).

SN 79-064,723. PREDIGGO SA, SWITZERLAND, FILED 12-12-2008.

prediggo

PRIORITY DATE OF 8-12-2008 IS CLAIMED.
 OWNER OF INTERNATIONAL REGISTRATION 0991734
 DATED 12-12-2008, EXPIRES 12-12-2018.
 FOR COMPUTER SOFTWARE FOR MAKING TARGETED
 RECOMMENDATIONS TO A USER ON A GLOBAL
 COMPUTER NETWORK (U.S. CLS. 21, 23, 26,
 36 AND 38).
 HEATHER SAPP, EXAMINING ATTORNEY

SN 79-066,497. VARTA MICROBATTERY GMBH, FED REP
 GERMANY, FILED 2-4-2009.



PRIORITY DATE OF 8-5-2008 IS CLAIMED.
 OWNER OF INTERNATIONAL REGISTRATION 0996708
 DATED 2-4-2009, EXPIRES 2-4-2019.
 FOR BATTERIES, ACCUMULATORS, GALVANIC
 CELLS, ELECTRIC PRIMARY AND SECONDARY
 CELLS, MICROBATTERIES, STARTER BATTERIES,
 EQUIPMENT BATTERIES, LITHIUM BATTERIES,
 LITHIUM ACCUMULATORS, ZINC AIR BATTERIES,
 NICKEL-METAL HYDRIDE BATTERIES; FUEL ELE-
 MENTS AND FUEL CELLS; GAS GENERATING CELLS,
 IN PARTICULAR CELLS FOR GENERATING OXYGEN
 AND HYDROGEN; EQUIPMENT AND APPARATUS
 FOR CHARGING, TESTING, MAINTAINING AND
 MONITORING THE AFORESAID GOODS; RECTIFIERS,
 SWITCHING EQUIPMENT, SWITCHES AND CAPACITY
 METERS FOR ALL THE AFORESAID GOODS (U.S. CLS.
 21, 23, 26, 36 AND 38).
 MATTHEW KLINE, EXAMINING ATTORNEY

CLASS 10—MEDICAL APPARATUS

SN 76-694,873. ERGOMEDICA LIMITED, LONDON NW4
 ILL, UNITED KINGDOM, FILED S.R. 12-17-2008; AM. P.R.
 12-17-2008.

MEDMAT

THE MARK CONSISTS OF STANDARD CHARACTERS
 WITHOUT CLAIM TO ANY PARTICULAR FONT, STYLE,
 SIZE, OR COLOR.
 FOR ABSORBENT MATS THAT PROVIDE STERILE
 SETTINGS FOR SURGICAL AND NON-SURGICAL
 MEDICAL PROCEDURES SUCH AS CHANGING
 WOUND DRESSINGS AND CHANGING CATHETERS
 FOR USE IN PREVENTING CONTAMINATION; ABSOR-
 BENT MATS WITH INTEGRATED WASTE BAGS THAT
 PROVIDE STERILE SETTINGS FOR SURGICAL AND
 NON-SURGICAL MEDICAL PROCEDURES SUCH AS
 CHANGING WOUND DRESSINGS AND CHANGING
 CATHETERS FOR USE IN PREVENTING CONTAMINA-
 TION (U.S. CLS. 26, 39 AND 44).
 MARY ROSSMAN, EXAMINING ATTORNEY

SN 76-695,688. EB BRANDS HOLDINGS, INC., YONKERS,
 NY. FILED 2-9-2009.

META

THE MARK CONSISTS OF STANDARD CHARACTERS
 WITHOUT CLAIM TO ANY PARTICULAR FONT, STYLE,
 SIZE, OR COLOR.
 FOR HEART RATE MONITOR TO BE WORN DURING
 EXERCISE (U.S. CLS. 26, 39 AND 44).
 DEZMONA MIZELLE, EXAMINING ATTORNEY

SN 77-399,608. LABORATOIRE NATUREL PARIS, LLC,
 RENO, NV. FILED 2-18-2008.

WRINKLEPEN

THE MARK CONSISTS OF STANDARD CHARACTERS
 WITHOUT CLAIM TO ANY PARTICULAR FONT, STYLE,
 SIZE, OR COLOR.
 FOR SKIN TREATMENT DEVICES, NAMELY, A
 HAND-HELD ELECTRONIC DEVICE FOR APPLYING
 VITAMIN C TO THE SKIN FOR THE TREATMENT OF
 SKIN CONDITIONS; AND A HAND-HELD APPLICATOR
 DEVICE CONSISTING OF TWO ELEMENTS SOLD
 TOGETHER, SUCH ELEMENTS BEING AN ABSORBENT
 ELEMENT FOR APPLYING VITAMIN C TO THE SKIN
 FOR THE TREATMENT OF SKIN CONDITIONS AND
 AN ABRASIVE ELEMENT FOR EXFOLIATING THE
 SKIN (U.S. CLS. 26, 39 AND 44).
 MARK PILARO, EXAMINING ATTORNEY

CLASS 10—(Continued).

SN 77-485,394. APPLIED MEDICAL RESOURCES CORPORATION, RANCHO SANTA MARGARITA, CA. FILED 5-28-2008.

INZII

THE MARK CONSISTS OF STANDARD CHARACTERS WITHOUT CLAIM TO ANY PARTICULAR FONT, STYLE, SIZE, OR COLOR.

FOR MEDICAL AND SURGICAL DEVICES, NAMELY, SPECIMEN RETRIEVAL BAG FOR ENDOSCOPIC SURGERY (U.S. CLS. 26, 39 AND 44).

BRIAN PINO, EXAMINING ATTORNEY

SN 77-503,721. PERLSTEIN, ELIZABETH, HUNTINGTON, NY. FILED 6-20-2008.

JETT STEP

THE MARK CONSISTS OF STANDARD CHARACTERS WITHOUT CLAIM TO ANY PARTICULAR FONT, STYLE, SIZE, OR COLOR.

NO CLAIM IS MADE TO THE EXCLUSIVE RIGHT TO USE "STEP", APART FROM THE MARK AS SHOWN.

FOR FOOT REST FOR MEDICAL OR THERAPEUTIC PURPOSES, NAMELY, A FOOT REST FOR ADAPTING TO A FOUR-LEGGED CHAIR TO PROVIDE OR ASSIST A SPECIAL-NEEDS CHILD OR OTHER INDIVIDUAL THAT SITS IN THE FOUR-LEGGED CHAIR WITH SUPPORT FOR THEIR FEET WITHOUT THE SPECIAL-NEEDS CHILD OR OTHER INDIVIDUAL BEING ABLE TO KICK THE FOOT REST AWAY FROM THE FOUR-LEGGED CHAIR SO AS TO IMPROVE OF THE POSTURE AND ATTENTION SPAN OF THE SPECIAL-NEEDS CHILD OR OTHER INDIVIDUAL. THAT MIGHT OTHERWISE BE CAUSED OR AGGRAVATED BY THE FEET OF THE SPECIAL-NEEDS CHILD OR OTHER INDIVIDUAL BEING UNSUPPORTED (U.S. CLS. 26, 39 AND 44).

JOHN SCHUYLER YARD, EXAMINING ATTORNEY

CLASS 10—(Continued).

SN 77-505,273. TAEYEONMEDICAL CO. LTD., INCHEON, REPUBLIC OF KOREA, FILED 6-23-2008.



NO CLAIM IS MADE TO THE EXCLUSIVE RIGHT TO USE "MEDICAL CO., LTD" OR THE NON-LATIN CHARACTERS THAT MEAN "MEDICAL CO., LTD", APART FROM THE MARK AS SHOWN.

THE COLOR(S) WHITE, GREEN AND BLACK IS/ARE CLAIMED AS A FEATURE OF THE MARK.

THE MARK CONSISTS OF A GREEN OVAL WITH A WHITE UPSIDE-DOWN TRIANGLE DESIGN WITHIN TO THE LEFT OF THE WORDS "JOO TAE YEON MEDICAL" IN BLACK KOREAN CHARACTERS ABOVE THE WORDS "TAEYEON MEDICAL CO., LTD." IN BLACK.

THE NON-LATIN CHARACTERS IN THE MARK TRANSLITERATE TO "JOO TAE YEON MEDICAL." AND THIS MEANS "TAEYEON MEDICAL CO., LTD" IN ENGLISH.

FOR MEDICAL APPARATUS AND INSTRUMENTS FOR USE IN ORTHOPEDIC SURGERY (U.S. CLS. 26, 39 AND 44).

DAVID TOOLEY, EXAMINING ATTORNEY

SN 77-511,529. STRYKER CORPORATION, KALAMAZOO, MI. FILED 6-30-2008.

COR-FX

THE MARK CONSISTS OF STANDARD CHARACTERS WITHOUT CLAIM TO ANY PARTICULAR FONT, STYLE, SIZE, OR COLOR.

FOR MEDICAL/SURGICAL INSTRUMENTS FOR THE TREATMENT OF BONE FRACTURES, CANNULAE FOR ESTABLISHING FLOW PATHS FOR INJECTING CEMENT INTO BONE, AND REPLACEMENT PARTS FOR THE FOREGOING GOODS (U.S. CLS. 26, 39 AND 44).

EMILY CARLSEN, EXAMINING ATTORNEY

CLASS 10—(Continued).

SN 77-512,350. W & W CUSTOM CASE COMPANY, INC., HICKORY, NC. FILED 7-1-2008.

US P.O.D. BOX

THE MARK CONSISTS OF STANDARD CHARACTERS WITHOUT CLAIM TO ANY PARTICULAR FONT, STYLE, SIZE, OR COLOR.

NO CLAIM IS MADE TO THE EXCLUSIVE RIGHT TO USE "US" OR "BOX", APART FROM THE MARK AS SHOWN.

FOR CASES FITTED FOR MEDICAL INSTRUMENTS AND/OR FOR USE BY DOCTORS; SURGICAL APPARATUS AND INSTRUMENTS FOR MEDICAL, DENTAL OR VETERINARY USE (U.S. CLS. 26, 39 AND 44).

FIRST USE 11-1-2006; IN COMMERCE 11-1-2006.
MATTHEW MCDOWELL, EXAMINING ATTORNEY

SN 77-512,401. W & W CUSTOM CASE COMPANY, INC., HICKORY, NC. FILED 7-1-2008.

POD BOX

THE MARK CONSISTS OF STANDARD CHARACTERS WITHOUT CLAIM TO ANY PARTICULAR FONT, STYLE, SIZE, OR COLOR.

NO CLAIM IS MADE TO THE EXCLUSIVE RIGHT TO USE "BOX", APART FROM THE MARK AS SHOWN.

FOR CASES FITTED FOR MEDICAL INSTRUMENTS AND/OR FOR USE BY DOCTORS; SURGICAL APPARATUS AND INSTRUMENTS FOR MEDICAL, DENTAL OR VETERINARY USE (U.S. CLS. 26, 39 AND 44).

MATTHEW MCDOWELL, EXAMINING ATTORNEY

SN 77-518,517. MARTINNI BEAUTY, INC., PINOLE, CA. FILED 7-9-2008.

SUPER FRECATOR

THE MARK CONSISTS OF STANDARD CHARACTERS WITHOUT CLAIM TO ANY PARTICULAR FONT, STYLE, SIZE, OR COLOR.

FOR ELECTRICALLY-POWERED APPARATUS FOR TREATING SKIN BY APPLYING ELECTRICAL CURRENT (U.S. CLS. 26, 39 AND 44).

FIRST USE 5-24-2007; IN COMMERCE 5-24-2007.
JENNIFER DIXON, EXAMINING ATTORNEY

CLASS 10—(Continued).

SN 77-523,552. LANX, INC., BROOMFIELD, CO. FILED 7-16-2008.



NO CLAIM IS MADE TO THE EXCLUSIVE RIGHT TO USE "EXTREME ANGLE TURRET SCREW", APART FROM THE MARK AS SHOWN.

FOR BONE SCREWS, NAMELY, SPINAL FIXATION PEDICLE SCREWS (U.S. CLS. 26, 39 AND 44).

DANNEAN HETZEL, EXAMINING ATTORNEY

SN 77-524,937. LUMINETX CORPORATION, MEMPHIS, TN. FILED 7-17-2008.

**10 OUT OF 10 PATIENTS
PREFER LESS PAIN**

THE MARK CONSISTS OF STANDARD CHARACTERS WITHOUT CLAIM TO ANY PARTICULAR FONT, STYLE, SIZE, OR COLOR.

FOR VEIN IMAGING APPARATUS FOR MEDICAL USE (U.S. CLS. 26, 39 AND 44).

TRACY FLETCHER, EXAMINING ATTORNEY

SN 77-525,684. LUMINETX CORPORATION, MEMPHIS, TN. FILED 7-18-2008.

THERE'S A BETTER WAY

THE MARK CONSISTS OF STANDARD CHARACTERS WITHOUT CLAIM TO ANY PARTICULAR FONT, STYLE, SIZE, OR COLOR.

FOR VEIN IMAGING APPARATUS FOR MEDICAL USE (U.S. CLS. 26, 39 AND 44).

TRACY FLETCHER, EXAMINING ATTORNEY

CLASS 10—(Continued).

SN 77-526,338. LANX, INC., BROOMFIELD, CO. FILED 7-18-2008.

Silverton-D

THE MARK CONSISTS OF STANDARD CHARACTERS WITHOUT CLAIM TO ANY PARTICULAR FONT, STYLE, SIZE, OR COLOR.

FOR SURGICAL IMPLANTS AND INSTRUMENTS FOR USE IN ORTHOPEDIC SURGERY, NAMELY, SPINAL DEFORMITY FIXATION SYSTEM COMPRISED PRIMARILY OF RODS, ROD CONNECTORS, SCREWS, AND HOOKS (U.S. CLS. 26, 39 AND 44).

DANNEAN HETZEL, EXAMINING ATTORNEY

SN 77-561,102. VASCULAR SOLUTIONS, INC., MINNEAPOLIS, MN. FILED 9-3-2008.

Hunter Biopsy Marker

THE MARK CONSISTS OF STANDARD CHARACTERS WITHOUT CLAIM TO ANY PARTICULAR FONT, STYLE, SIZE, OR COLOR.

NO CLAIM IS MADE TO THE EXCLUSIVE RIGHT TO USE "BIOPSY MARKER", APART FROM THE MARK AS SHOWN.

FOR A MEDICAL DEVICE USED IN OPEN SURGICAL OR PERCUTANEOUS ORGAN BIOPSY PROCEDURES TO MARK THE BIOPSY SITE FOR SUBSEQUENT INTERVENTION OR DIAGNOSTIC PROCEDURES (U.S. CLS. 26, 39 AND 44).

LEIGH CAROLINE CASE, EXAMINING ATTORNEY

SN 77-561,428. NANOTHERAPEUTICS, INC., ALACHUA, FL. FILED 9-3-2008.

NANOFUSE

THE MARK CONSISTS OF STANDARD CHARACTERS WITHOUT CLAIM TO ANY PARTICULAR FONT, STYLE, SIZE, OR COLOR.

FOR AUGMENTED DEMINERALIZED BONE MATRIX AND BIOACTIVE GLASS PRODUCTS, NAMELY, A PASTE PRIMARILY COMPOSED OF BIOACTIVE GLASS TO FILL BONE VOIDS TO HELP BONE RECONSTRUCTION FOR USE IN ORTHOPEDIC SURGERY (U.S. CLS. 26, 39 AND 44).

DOMINIC J. FERRAIUOLO, EXAMINING ATTORNEY

CLASS 10—(Continued).

SN 77-574,252. DENATOR AB, GÖTEBORG, SWEDEN, FILED 9-19-2008.

MAINTAINOR

THE MARK CONSISTS OF STANDARD CHARACTERS WITHOUT CLAIM TO ANY PARTICULAR FONT, STYLE, SIZE, OR COLOR.

FOR CARDS FOR PLACEMENT OF BIOLOGICAL SAMPLES FOR USE IN THE MEDICAL FIELD (U.S. CLS. 26, 39 AND 44).

MATTHEW KLINE, EXAMINING ATTORNEY

SN 77-582,228. AMERICAN WEST MEDICAL COMPANY, LLC, LENEXA, KS. FILED 9-30-2008.

CONTOUR

THE MARK CONSISTS OF STANDARD CHARACTERS WITHOUT CLAIM TO ANY PARTICULAR FONT, STYLE, SIZE, OR COLOR.

FOR POST SURGICAL COMPRESSION GARMENTS FOR PROMOTING HEALING AND SHAPING OF THE BODY (U.S. CLS. 26, 39 AND 44).

FIRST USE 9-3-1993; IN COMMERCE 9-3-1993.

ELIZABETH HUGHITT, EXAMINING ATTORNEY

SN 77-588,045. HEMA METRICS, LLC, KAYSVILLE, UT. FILED 10-8-2008.

CRITSCAN

THE MARK CONSISTS OF STANDARD CHARACTERS WITHOUT CLAIM TO ANY PARTICULAR FONT, STYLE, SIZE, OR COLOR.

FOR MEDICAL DIAGNOSTIC EQUIPMENT, NAMELY, BLOOD HEMATOCRIT MONITORING DEVICES (U.S. CLS. 26, 39 AND 44).

JOHN DWYER, EXAMINING ATTORNEY

CLASS 10—(Continued).

SN 77-593,924. ACCELERATED CARE PLUS CORP., RENO, NV. FILED 10-16-2008.

OMNIPRO

THE MARK CONSISTS OF STANDARD CHARACTERS WITHOUT CLAIM TO ANY PARTICULAR FONT, STYLE, SIZE, OR COLOR.

FOR ORTHOTICS FOR WRISTS, HANDS, ELBOWS, SHOULDERS, KNEES, ANKLES AND FEET (U.S. CLS. 26, 39 AND 44).

KELLY MCCOY, EXAMINING ATTORNEY

SN 77-605,235. ARROW INTERNATIONAL INVESTMENT CORP., WILMINGTON, DE. FILED 10-31-2008.

STIMUPOD

THE MARK CONSISTS OF STANDARD CHARACTERS WITHOUT CLAIM TO ANY PARTICULAR FONT, STYLE, SIZE, OR COLOR.

FOR NERVE STIMULATOR APPARATUS FOR ANESTHETIC USE (U.S. CLS. 26, 39 AND 44).

STEVEN PEREZ, EXAMINING ATTORNEY

SN 77-615,759. ARBEL MEDICAL LTD., YOKNEAM, ISRAEL, FILED 11-17-2008.

MED ICE

THE MARK CONSISTS OF STANDARD CHARACTERS WITHOUT CLAIM TO ANY PARTICULAR FONT, STYLE, SIZE, OR COLOR.

NO CLAIM IS MADE TO THE EXCLUSIVE RIGHT TO USE "MED", APART FROM THE MARK AS SHOWN.

FOR MEDICAL DEVICES FOR PERFORMING CRYOTHERAPY AND ESTHETIC TREATMENT, NAMELY, PROBES, NEEDLES, CATHETERS, APPLICATORS, SPRAYERS, BALLOONS, AND AEROSOLIZING DEVICES (U.S. CLS. 26, 39 AND 44).

MICHELLE DUBOIS, EXAMINING ATTORNEY

CLASS 10—(Continued).

SN 77-626,587. LRC PRODUCTS LIMITED, LONDON, UNITED KINGDOM, FILED 12-4-2008.

PLEASURE CURVE

THE MARK CONSISTS OF STANDARD CHARACTERS WITHOUT CLAIM TO ANY PARTICULAR FONT, STYLE, SIZE, OR COLOR.

OWNER OF U.S. REG. NOS. 3,131,822, 3,509,278 AND OTHERS.

NO CLAIM IS MADE TO THE EXCLUSIVE RIGHT TO USE "CURVE", APART FROM THE MARK AS SHOWN.

FOR CONDOMS: CONTRACEPTIVES MADE OF NATURAL OR SYNTHETIC RUBBER OR LIKE MATERIALS FOR HYGIENIC OR PROPHYLACTIC PURPOSES (U.S. CLS. 26, 39 AND 44).

FIRST USE 5-1-2008; IN COMMERCE 5-1-2008.

MICHELLE DUBOIS, EXAMINING ATTORNEY

SN 77-627,126. CODAN HOLDING GMBH, LENSahn, FED REP GERMANY, FILED 12-5-2008.

I.V. STAR

THE MARK CONSISTS OF STANDARD CHARACTERS WITHOUT CLAIM TO ANY PARTICULAR FONT, STYLE, SIZE, OR COLOR.

NO CLAIM IS MADE TO THE EXCLUSIVE RIGHT TO USE "I.V.", APART FROM THE MARK AS SHOWN.

FOR FILTERS FOR FILTERING SOLUTIONS AND MEDICINE DURING INFUSION THERAPY (U.S. CLS. 26, 39 AND 44).

SUSAN LESLIE DUBOIS, EXAMINING ATTORNEY

SN 77-632,207. BLACKSTONE MEDICAL, INC., SPRINGFIELD, MA. FILED 12-12-2008.

FIREBIRD

THE MARK CONSISTS OF STANDARD CHARACTERS WITHOUT CLAIM TO ANY PARTICULAR FONT, STYLE, SIZE, OR COLOR.

FOR MEDICAL DEVICES, NAMELY, SPINAL FIXATION DEVICES CONSISTING OF A THORACOLUMBAR PEDICLE SCREW SYSTEM COMPRISED OF SPINAL IMPLANTS COMPRISED OF ARTIFICIAL MATERIALS, SURGICAL INSTRUMENTS AND APPARATUS FOR USE IN ORTHOPEDIC AND SPINAL SURGERY, BONE SCREW CONNECTORS, RODS USED TO CONNECT BONE SCREWS, BONE SCREWS, AND REMOVABLE BONE SCREW HEADS (U.S. CLS. 26, 39 AND 44).

ANDREA BUTLER, EXAMINING ATTORNEY

CLASS 10—(Continued).

SN 77-636,871. GENERAL ELECTRIC COMPANY, SCHE-
NECTADY, NY. FILED 12-19-2008.

INNOVATION YOU DON'T HAVE
TO WAIT FOR

THE MARK CONSISTS OF STANDARD CHARACTERS WITHOUT CLAIM TO ANY PARTICULAR FONT, STYLE, SIZE, OR COLOR.

FOR TEST KITS FOR CLINICAL MEDICAL USE CONTAINING TEST TUBES, TEST PLATES AND INDICATOR CHARTS FOR EVALUATING TEST RESULTS; MEDICAL APPARATUS AND ACCESSORIES SYSTEMS FOR THE DISPENSING OF MEASURED UNIT DOSES OF PHARMACEUTICAL PREPARATIONS; VIALS; CANNULAS; SYRINGES; INJECTORS; CARTRIDGES; PRE-FILLED VIALS CONTAINING MEDICAL DIAGNOSTIC REAGENTS; PRE-FILLED CARTRIDGES CONTAINING CHEMICAL SOLUTIONS FOR MEDICAL USE; PRE-FILLED CYLINDERS CONTAINING GASES AND GAS MIXTURES FOR MEDICAL USE; INFUSION PUMPS FOR INTRAVENOUS ADMINISTRATION OF FLUIDS; NEEDLES FOR MEDICAL PURPOSES; IMPLANTABLE RADIATION THERAPY DEVICES CONSISTING OF ENCAPSULATED RADIOISOTOPE BRACHYTHERAPY SOURCES; RADIATION THERAPY DELIVERY SYSTEM CONSISTING OF RADIOACTIVE SEEDS AND A BIOABSORBABLE CARRIER ASSEMBLY; CARDIAC OUTPUT MONITORS; HEAT AND MOISTURE EXCHANGERS; BACTERIA FILTERS; GAS ANALYZERS FOR MEDICAL PURPOSES; ANESTHESIA RECORD KEEPING AND DATA MANAGEMENT SYSTEMS AND PATIENT MONITOR SYSTEMS, NAMELY, GAS MONITORS; PULSE OXIMETERS, MULTIPARAMETER MONITORS, ECG MONITORS, INVASIVE AND NON-INVASIVE BLOOD PRESSURE MONITORS, NEUROMUSCULAR TRANSMISSION MONITORS, METABOLIC MONITORS AND SPIROMETERS FOR ANESTHESIA, INTENSIVE CARE AND DIAGNOSTIC APPLICATIONS; ANESTHESIA MACHINES AND VENTILATORS; INTENSIVE CARE AND ANESTHESIA ACCESSORIES FOR SINGLE PATIENT USE, NAMELY, GAS SAMPLING LINES, AIRWAY ADAPTERS, BREATHING CIRCUITS, SPIROMETRY SENSORS AND TUBES, TUBES, WATER TRAPS, PULSE OXIMETRY SENSORS, NON-INVASIVE BLOOD PRESSURE CUFFS, FLUSHING SETS, ANESTHESIA MASKS, CARBON DIOXIDE ABSORBERS, TEMPERATURE PROBES AND NEBULIZERS; CENTRAL NERVOUS SYSTEM MONITORS; GASTROINTESTINAL TONOMETERS; GRADIENT COILS, NAMELY, MAGNETIC GRADIENT COILS USED IN MAGNETIC RESONANCE IMAGING; MEDICAL DIAGNOSTIC DEVICES, NAMELY, BONE DENSITOMETERS; FETAL MONITORING APPARATUS, NAMELY, FETAL PULSE AND VITAL SIGNS MONITORS; PATIENT MONITORING APPARATUS, NAMELY, HEART AND VITAL SIGNS MONITORS; MEDICAL IMAGING SYSTEMS, NAMELY, ULTRASOUNDS, MEDICAL DIAGNOSTIC IMAGING MACHINES, IMAGING DEVICES FOR SCREENING AND DIAGNOSTIC APPLICATIONS FOR USE IN PLANNING INTERVENTION AND SURGERY, AND PARTS THEREOF AND ATTACHMENTS THERE-TO; MEDICAL DIAGNOSTIC APPARATUS FOR DISPLAYING DIAGNOSTIC IMAGES, NAMELY, SPOT FILM APPARATUS, X-RAY IMAGE INTENSIFIERS, X-RAY FLUOROSCOPES, MOBILE X-RAY UNITS, RADIOGRAPHIC FILM VIEWERS, COMPUTERIZED TOMOGRAPHY SCANNERS, NUCLEAR RESONANCE SCANNERS, ULTRA SOUND SCANNERS, MAGNETIC RESONANCE SCANNERS, POSITRON EMISSION TOMOGRAPHY (PET) SCANNERS; AND PARTS THEREOF AND ATTACHMENTS THERETO INCLUDING TABLES AND PADS; DISPOSABLE CARTRIDGE FOR HOLDING AND TRANSFERRING ENCAPSULATED RADIOISOTOPE BRACHYTHERAPY SOURCES FOR USE IN TREATING PROSTATE AND OTHER CANCERS (U.S. CLS. 26, 39 AND 44).

PAUL F. GAST, EXAMINING ATTORNEY

CLASS 10—(Continued).

SN 77-637,294. METTLER ELECTRONICS CORP., ANAHEIM, CA. FILED 12-19-2008.



NO CLAIM IS MADE TO THE EXCLUSIVE RIGHT TO USE "WHEEL", APART FROM THE MARK AS SHOWN.

THE MARK CONSISTS OF THE STYLIZED TEXT "M WHEEL" INSIDE A CIRCLE AND DOTS ON THE OUTSIDE. FOR ELECTRONIC COMPONENTS, NAMELY, MEDICAL DEVICE CONTROL FOR USE IN PHYSICAL THERAPY IN THE NATURE OF ELECTROMEDICAL REHABILITATIVE AND PAIN MANAGEMENT PRODUCTS FOR CLINICAL AND HOME USE, NAMELY, ELECTRICAL NERVE AND MUSCLE STIMULATORS; ULTRASONIC STIMULATORS AND LASER THERAPY STIMULATORS (U.S. CLS. 26, 39 AND 44).

ANN E. SAPPENFIELD, EXAMINING ATTORNEY

SN 77-645,758. I PLAY, INC., ASHEVILLE, NC. FILED 1-8-2009.

GREEN SPROUTS

THE MARK CONSISTS OF STANDARD CHARACTERS WITHOUT CLAIM TO ANY PARTICULAR FONT, STYLE, SIZE, OR COLOR.

OWNER OF U.S. REG. NO. 3,441,687.

NO CLAIM IS MADE TO THE EXCLUSIVE RIGHT TO USE "GREEN", APART FROM THE MARK AS SHOWN.

FOR BABY BOTTLE ACCESSORIES, NAMELY, BABY BOTTLE NIPPLE HOLE ENLARGER; BABY BOTTLE NIPPLES; BABY BOTTLES; CUPS ADAPTED FOR FEEDING BABIES AND CHILDREN; COMPONENT PARTS OF BABY BOTTLES, NAMELY, DETACHABLE HANDLES; INFANT TEETHERS; NIPPLES FOR BABY BOTTLES; PACIFIER CLIPS; PACIFIERS FOR BABIES; TEETHING RINGS; AND TEETHING RINGS INCORPORATING BABY RATTLES (U.S. CLS. 26, 39 AND 44).

FIRST USE 6-13-2008; IN COMMERCE 6-13-2008.

AISHA SALEM, EXAMINING ATTORNEY

CLASS 10—(Continued).

SN 77-649,411. COLOPLAST A/S, HUMLEBAEK, DENMARK,
FILED 1-14-2009.

TREVE

THE MARK CONSISTS OF STANDARD CHARACTERS
WITHOUT CLAIM TO ANY PARTICULAR FONT, STYLE,
SIZE, OR COLOR.

THE WORDING "TREVE" HAS NO MEANING IN A
FOREIGN LANGUAGE.

FOR MEDICAL DEVICES, NAMELY, ARTIFICIAL
SUBURETHRAL SLING AND INSERTION TOOL FOR
THE SURGICAL TREATMENT OF URINARY INCON-
TINENCE (U.S. CLS. 26, 39 AND 44).

ANNE MADDEN, EXAMINING ATTORNEY

SN 77-653,234. HOLOGIC, INC., BEDFORD, MA. FILED 1-21-
2009.

THS

THE MARK CONSISTS OF STANDARD CHARACTERS
WITHOUT CLAIM TO ANY PARTICULAR FONT, STYLE,
SIZE, OR COLOR.

FOR HYSTEROSCOPIC VIDEO SYSTEM COMPRISED
OF A HYSTEROSCOPE AND ASSOCIATED SHEATH, A
COMPACT LED LIGHT SOURCE, A CAMERA HEAD,
AND AN LED MONITOR WITH AN INTEGRATED
CAMERA CONTROL UNIT ALL HOUSED IN A LIGHT-
WEIGHT CARRYING CASE (U.S. CLS. 26, 39 AND 44).

MATTHEW MCDOWELL, EXAMINING ATTORNEY

SN 77-658,570. NORTH AMERICAN RESCUE, INCORPO-
RATED, GREER, SC. FILED 1-28-2009.

HPMK

THE MARK CONSISTS OF STANDARD CHARACTERS
WITHOUT CLAIM TO ANY PARTICULAR FONT, STYLE,
SIZE, OR COLOR.

FOR EMERGENCY MEDICAL EQUIPMENT,
NAMELY, BLANKETS WITH HEATING ELEMENTS
(U.S. CLS. 26, 39 AND 44).

FIRST USE 10-28-2005; IN COMMERCE 10-28-2005.

KIM SAITO, EXAMINING ATTORNEY

CLASS 10—(Continued).

SN 77-660,847. CARTER, VANDETTE, YORKTOWN
HEIGHTS, NY. FILED 1-31-2009.

EKOscope

THE MARK CONSISTS OF STANDARD CHARACTERS
WITHOUT CLAIM TO ANY PARTICULAR FONT, STYLE,
SIZE, OR COLOR.

FOR MEDICAL ULTRASOUND APPARATUS (U.S.
CLS. 26, 39 AND 44).

JENNIFER HETU, EXAMINING ATTORNEY

SN 77-662,073. MCCLARD, ANITA, WESTMORELAND, TN.
FILED 2-3-2009.

Info Scubs

THE MARK CONSISTS OF STANDARD CHARACTERS
WITHOUT CLAIM TO ANY PARTICULAR FONT, STYLE,
SIZE, OR COLOR.

FOR SURGICAL SCRUB SUITS (U.S. CLS. 26, 39 AND
44).

PAM WILLIS, EXAMINING ATTORNEY

SN 77-662,347. EYEONICS, INC., ALISO VIEJO, CA. FILED 2-
3-2009.

CRYSTALENS HD

THE MARK CONSISTS OF STANDARD CHARACTERS
WITHOUT CLAIM TO ANY PARTICULAR FONT, STYLE,
SIZE, OR COLOR.

OWNER OF U.S. REG. NOS. 2,521,196, 3,117,571 AND
3,160,844.

NO CLAIM IS MADE TO THE EXCLUSIVE RIGHT TO
USE "HD", APART FROM THE MARK AS SHOWN.

FOR INTRAOCULAR LENSES (U.S. CLS. 26, 39 AND
44).

MARGARET POWER, EXAMINING ATTORNEY

CLASS 10—(Continued).

SN 77-662,483. WOLF, JOHN, LOCKPORT, NY. FILED 2-3-2009.

PyraMED

THE MARK CONSISTS OF STANDARD CHARACTERS WITHOUT CLAIM TO ANY PARTICULAR FONT, STYLE, SIZE, OR COLOR.

FOR URINE SPECIMEN COLLECTION APPARATUS FOR MEDICAL PURPOSES (U.S. CLS. 26, 39 AND 44). FIRST USE 7-30-2008; IN COMMERCE 9-22-2008. WARREN L. OLANDRIA, EXAMINING ATTORNEY

SN 77-662,592. SPINAL SIMPLICITY, LLC, OVERLAND PARK, KS. FILED 2-3-2009.

SCARAB

THE MARK CONSISTS OF STANDARD CHARACTERS WITHOUT CLAIM TO ANY PARTICULAR FONT, STYLE, SIZE, OR COLOR.

FOR MEDICAL AND SURGICAL APPARATUS AND INSTRUMENTS, NAMELY, ORTHOPEDIC FIXATION DEVICE USED IN ORTHOPEDIC TRANSPLANT AND/OR IMPLANT SURGERY (U.S. CLS. 26, 39 AND 44). RAUL CORDOVA, EXAMINING ATTORNEY

SN 77-662,741. MICROVENTION, INC., ALISO VIEJO, CA. FILED 2-3-2009.

HYDROFILL

THE MARK CONSISTS OF STANDARD CHARACTERS WITHOUT CLAIM TO ANY PARTICULAR FONT, STYLE, SIZE, OR COLOR.

FOR MEDICAL DEVICES, NAMELY, EMBOLIC IMPLANTS (U.S. CLS. 26, 39 AND 44). BRIAN PINO, EXAMINING ATTORNEY

CLASS 10—(Continued).

SN 77-662,837. LUDECKER, ROBERT SCOTT, MOUNT SINAI, NY. FILED 2-4-2009.



THE COLOR(S) GREEN AND BLACK IS/ARE CLAIMED AS A FEATURE OF THE MARK.

THE MARK CONSISTS OF THE WORD "NOVA" APPEARING IN GREEN FOLLOWED BY THE WORD "SURGICAL" APPEARING IN BLACK WITH AN ABSTRACT BLACK LINE DESIGN DIRECTLY ABOVE THE WORDING.

FOR BONE IMPLANTS COMPOSED OF ARTIFICIAL MATERIALS; MEDICAL AND SURGICAL APPARATUS AND INSTRUMENTS, NAMELY, ORTHOPEDIC FIXATION DEVICE USED IN ORTHOPEDIC TRANSPLANT AND/OR IMPLANT SURGERY; SPINAL IMPLANTS COMPOSED OF ARTIFICIAL MATERIAL; SURGICAL IMPLANTS COMPRISING ARTIFICIAL MATERIAL AND ASSOCIATED SURGICAL INSTRUMENT SETS (U.S. CLS. 26, 39 AND 44).

ASMAT KHAN, EXAMINING ATTORNEY

SN 77-662,974. WELCH ALLYN PROTOCOL, INC., BEAVERTON, OR. FILED 2-4-2009.

PROPAQ

THE MARK CONSISTS OF STANDARD CHARACTERS WITHOUT CLAIM TO ANY PARTICULAR FONT, STYLE, SIZE, OR COLOR.

OWNER OF U.S. REG. NO. 1,523,389. FOR VITAL SIGNS MONITORS (U.S. CLS. 26, 39 AND 44).

FIRST USE 2-28-1988; IN COMMERCE 2-28-1988. KIM MONINGHOFF, EXAMINING ATTORNEY

SN 77-663,042. ERBE ELEKTROMEDIZIN GMBH, 72072 TÜBINGEN, FED REP GERMANY, FILED 2-4-2009.

FIAPC

THE MARK CONSISTS OF STANDARD CHARACTERS WITHOUT CLAIM TO ANY PARTICULAR FONT, STYLE, SIZE, OR COLOR.

FOR SURGICAL INSTRUMENTS FOR USE IN ARGON PLASMA COAGULATION (U.S. CLS. 26, 39 AND 44). BRIAN PINO, EXAMINING ATTORNEY

CLASS 10—(Continued).

SN 77-663,384. HOSPIRA, INC., LAKE FOREST, IL. FILED 2-4-2009.

LIFESHIELD

THE MARK CONSISTS OF STANDARD CHARACTERS WITHOUT CLAIM TO ANY PARTICULAR FONT, STYLE, SIZE, OR COLOR.

OWNER OF U.S. REG. NO. 1,676,340.
FOR MEDICAL PRODUCTS AND DEVICES WHICH HELP PREVENT THE SPREAD OF INFECTION, NAMELY, PUMP SETS FOR PARENTERAL FEEDING, PARENTERAL FEEDING TUBES, CONNECTORS, VALVES AND NEEDLE SHEATHS (U.S. CLS. 26, 39 AND 44).

FIRST USE 12-21-1990; IN COMMERCE 12-21-1990.
HENRY S. ZAK, EXAMINING ATTORNEY

CLASS 10—(Continued).

SN 77-664,343. RESET MEDICAL, INC., BALTIMORE, MD. FILED 2-5-2009.

FREEZE DISEASE. RESET LIFE.

SN 77-664,062. EBI, LLC, PARSIPPANY, NJ. FILED 2-5-2009.

SCOUT

THE MARK CONSISTS OF STANDARD CHARACTERS WITHOUT CLAIM TO ANY PARTICULAR FONT, STYLE, SIZE, OR COLOR.

FOR ORTHOPEDIC FOOTWEAR FOR USE IN CONNECTION WITH BONE FRACTURES (U.S. CLS. 26, 39 AND 44).

BRENDAN REGAN, EXAMINING ATTORNEY

SN 77-664,158. PROCEREX DENTAL LAB LLC, GLENDALE, AZ. FILED 2-5-2009.

P³ ZIRCONIA

NO CLAIM IS MADE TO THE EXCLUSIVE RIGHT TO USE "ZIRCONIA", APART FROM THE MARK AS SHOWN. THE MARK CONSISTS OF THE LETTER "P" WITH A NUMBER "3" SUPERSCRIPED AND THE WORD "ZIRCONIA".

FOR DENTAL CAPS; DENTAL CROWNS; DENTAL FIXTURES, NAMELY, PREFABRICATED PARTS FOR CROWNS; BRIDGES AND PONTICS; DENTAL IMPLANTS (U.S. CLS. 26, 39 AND 44).

FIRST USE 12-9-2008; IN COMMERCE 12-9-2008.
CYNTHIA SLOAN, EXAMINING ATTORNEY

THE MARK CONSISTS OF STANDARD CHARACTERS WITHOUT CLAIM TO ANY PARTICULAR FONT, STYLE, SIZE, OR COLOR.

FOR CRYOSURGICAL APPARATUS FOR USE IN PERFORMING ABLATIVE SURGERY; MEDICAL DEVICES, NAMELY, CRYOTHERAPY AND CRYOSURGICAL DEVICES, NAMELY, SURGICAL AND TREATMENT PROBES, CATHETERS, ENDOSCOPES, AND CONTROL SYSTEMS FOR SAID CRYOTHERAPY AND CRYOSURGICAL DEVICES, NAMELY, APPARATUS FOR CONTROLLING THE FLOW OF CRYOGENS, BLEEDER AND PRESSURE REDUCTION VALVES FOR MAINTAINING PRESSURE IN CRYOTHERAPY AND CRYOSURGICAL DEVICES AND DELIVERY SYSTEMS, RIGID AND FLEXIBLE MEDICAL ENDOSCOPES, CATHETERS, LUMEN BLOCKING BALLOONS AND SHIELDS FOR GASTRIC BLOCKING, NASOGASTRIC TUBES, SUCTION DEVICES FOR CRYOGENS REMOVAL AND ENDOSCOPY CAMERAS; CRYOSURGICAL TOOLS OR UNITS USED TO DESTROY TISSUE DURING SURGICAL PROCEDURES; NAMELY, CATHETERS FOR THE INTRODUCTION OF A CRYOGEN TO A TARGET TISSUE; THERAPY AND SURGICAL DELIVERY SYSTEMS AND COMPONENTS THEREOF FOR DELIVERING CRYOGENS TO A PATIENT, NAMELY, SURGICAL AND TREATMENT PROBES, CATHETERS AND ENDOSCOPES; CRYOSURGICAL AND CRYOTHERAPY DEVICE CONTROL SYSTEMS, NAMELY, APPARATUS FOR CONTROLLING THE FLOW OF CRYOGENS, BLEEDER AND PRESSURE REDUCTION VALVES FOR MAINTAINING PRESSURE IN CRYOTHERAPY AND CRYOSURGICAL DEVICES AND DELIVERY SYSTEMS, RIGID AND FLEXIBLE MEDICAL ENDOSCOPES, CATHETERS, LUMEN BLOCKING BALLOONS AND SHIELDS FOR GASTRIC BLOCKING, NASOGASTRIC TUBES, SUCTION DEVICES FOR CRYOGENS REMOVAL AND ENDOSCOPY CAMERAS; THERAPY AND SURGICAL DELIVERY SYSTEMS AND COMPONENTS THEREOF, NAMELY, APPARATUS FOR CONTROLLING THE FLOW OF CRYOGENS, BLEEDER AND PRESSURE REDUCTION VALVES FOR MAINTAINING PRESSURE IN THE CRYOTHERAPY AND CRYOSURGICAL DEVICES AND DELIVERY SYSTEMS, RIGID AND FLEXIBLE MEDICAL ENDOSCOPES, CATHETERS, LUMEN BLOCKING BALLOONS AND SHIELDS FOR GASTRIC BLOCKING, NASOGASTRIC TUBES, SUCTION DEVICES FOR CRYOGENS REMOVAL AND ENDOSCOPY CAMERAS (U.S. CLS. 26, 39 AND 44).

MICHELLE DUBOIS, EXAMINING ATTORNEY

CLASS 10—(Continued).

SN 77-664,531. HOME AIDE DIAGNOSTICS, INC., DBA HOME AIDE DIAGNOSTICS, INC., DEERFIELD BEACH, FL. FILED 2-5-2009.

Heart Check

THE MARK CONSISTS OF STANDARD CHARACTERS WITHOUT CLAIM TO ANY PARTICULAR FONT, STYLE, SIZE, OR COLOR.

FOR BLOOD PRESSURE MEASURING APPARATUS; BLOOD PRESSURE MONITORS (U.S. CLS. 26, 39 AND 44).

FIRST USE 3-10-2006; IN COMMERCE 5-15-2006.
AMY HELLA, EXAMINING ATTORNEY

SN 77-664,538. HOME AIDE DIAGNOSTICS, INC., DBA HOME AIDE DIAGNOSTICS, INC., DEERFIELD BEACH, FL. FILED 2-5-2009.

Health Sense

THE MARK CONSISTS OF STANDARD CHARACTERS WITHOUT CLAIM TO ANY PARTICULAR FONT, STYLE, SIZE, OR COLOR.

NO CLAIM IS MADE TO THE EXCLUSIVE RIGHT TO USE "HEALTH", APART FROM THE MARK AS SHOWN.

FOR BLOOD PRESSURE MEASURING APPARATUS; BLOOD PRESSURE MONITORS (U.S. CLS. 26, 39 AND 44).

FIRST USE 10-12-2006; IN COMMERCE 1-15-2007.
AMY HELLA, EXAMINING ATTORNEY

SN 77-664,691. SAUERS, CAROL, MARIETTA, GA. AND SAUERS, ROBERT, MARIETTA, GA. FILED 2-5-2009.

DIAMOND ELITE

THE MARK CONSISTS OF STANDARD CHARACTERS WITHOUT CLAIM TO ANY PARTICULAR FONT, STYLE, SIZE, OR COLOR.

FOR WHIRLPOOLS FOR USE IN HOSPITALS OR FOR THERAPEUTIC USE (U.S. CLS. 26, 39 AND 44).

KAREN K. BUSH, EXAMINING ATTORNEY

CLASS 10—(Continued).

SN 77-664,976. GUARDSMAN SCIENTIFIC, INC., PARK CITY, UT. FILED 2-6-2009.

EGAM U C SYSTEM

THE MARK CONSISTS OF STANDARD CHARACTERS WITHOUT CLAIM TO ANY PARTICULAR FONT, STYLE, SIZE, OR COLOR.

NO CLAIM IS MADE TO THE EXCLUSIVE RIGHT TO USE "SYSTEM", APART FROM THE MARK AS SHOWN.

FOR MEDICAL DEVICE, NAMELY, AN ULTRASOUND-BASED DEVICE THAT ALLOWS PHYSICIANS AND OTHER MEDICAL PROFESSIONALS TO MONITOR THE HEART (U.S. CLS. 26, 39 AND 44).

JESSICA A. POWERS, EXAMINING ATTORNEY

SN 77-664,978. GUARDSMAN SCIENTIFIC, INC., PARK CITY, UT. FILED 2-6-2009.

EGAM U C SOLUTION

THE MARK CONSISTS OF STANDARD CHARACTERS WITHOUT CLAIM TO ANY PARTICULAR FONT, STYLE, SIZE, OR COLOR.

NO CLAIM IS MADE TO THE EXCLUSIVE RIGHT TO USE "SOLUTION", APART FROM THE MARK AS SHOWN.

FOR MEDICAL DEVICE, NAMELY, AN ULTRASOUND-BASED DEVICE THAT ALLOWS PHYSICIANS AND OTHER MEDICAL PROFESSIONALS TO MONITOR THE HEART (U.S. CLS. 26, 39 AND 44).

JESSICA A. POWERS, EXAMINING ATTORNEY

SN 77-664,981. GUARDSMAN SCIENTIFIC, INC., PARK CITY, UT. FILED 2-6-2009.

EGHEM U C SYSTEM

THE MARK CONSISTS OF STANDARD CHARACTERS WITHOUT CLAIM TO ANY PARTICULAR FONT, STYLE, SIZE, OR COLOR.

NO CLAIM IS MADE TO THE EXCLUSIVE RIGHT TO USE "SYSTEM", APART FROM THE MARK AS SHOWN.

FOR MEDICAL DEVICE, NAMELY, AN ULTRASOUND-BASED DEVICE THAT ALLOWS PHYSICIANS AND OTHER MEDICAL PROFESSIONALS TO MONITOR THE HEART (U.S. CLS. 26, 39 AND 44).

JESSICA A. POWERS, EXAMINING ATTORNEY

CLASS 10—(Continued).

SN 77-664,982. GUARDSMAN SCIENTIFIC, INC., PARK CITY, UT. FILED 2-6-2009.

EGHEM U C SOLUTION

THE MARK CONSISTS OF STANDARD CHARACTERS WITHOUT CLAIM TO ANY PARTICULAR FONT, STYLE, SIZE, OR COLOR.

NO CLAIM IS MADE TO THE EXCLUSIVE RIGHT TO USE "SOLUTION", APART FROM THE MARK AS SHOWN. FOR MEDICAL DEVICE, NAMELY, AN ULTRASOUND-BASED DEVICE THAT ALLOWS PHYSICIANS AND OTHER MEDICAL PROFESSIONALS TO MONITOR THE HEART (U.S. CLS. 26, 39 AND 44).
JESSICA A. POWERS, EXAMINING ATTORNEY

CLASS 10—(Continued).

SN 77-666,941. PROCEREX DENTAL LAB LLC, GLENDALE, AZ. FILED 2-10-2009.



NO CLAIM IS MADE TO THE EXCLUSIVE RIGHT TO USE "ZIRCONIA", APART FROM THE MARK AS SHOWN.

THE MARK CONSISTS OF A SHIELD WITH THE WORDS "PROCEREX" ON TOP, THE LETTER "P" WITH A NUMBER "3" SUPERSCRIPIT IN THE MIDDLE OF THE SHIELD AND THE WORD "ZIRCONIA" IN THE BOTTOM OF THE SHIELD.

FOR DENTAL CAPS; DENTAL CROWNS; DENTAL FIXTURES, NAMELY, PREFABRICATED PARTS FOR CROWNS, BRIDGES AND PONTICS; DENTAL IMPLANTS (U.S. CLS. 26, 39 AND 44).

FIRST USE 12-9-2008; IN COMMERCE 12-9-2008.
CYNTHIA SLOAN, EXAMINING ATTORNEY

SN 77-667,034. HOSPIRA, INC., LAKE FOREST, IL. FILED 2-10-2009.

PLUM

THE MARK CONSISTS OF STANDARD CHARACTERS WITHOUT CLAIM TO ANY PARTICULAR FONT, STYLE, SIZE, OR COLOR.

FOR MEDICAL DEVICE, NAMELY, AN INFUSION PUMP AND MEDICAL TUBE SETS FOR DRUG AND NUTRITIONAL DELIVERY (U.S. CLS. 26, 39 AND 44).

FIRST USE 1-24-1989; IN COMMERCE 1-24-1989.
HENRY S. ZAK, EXAMINING ATTORNEY

SN 77-664,987. GUARDSMAN SCIENTIFIC, INC., PARK CITY, UT. FILED 2-6-2009.

IF YOU DON'T LOOK, YOU DON'T KNOW

THE MARK CONSISTS OF STANDARD CHARACTERS WITHOUT CLAIM TO ANY PARTICULAR FONT, STYLE, SIZE, OR COLOR.

FOR MEDICAL DEVICE, NAMELY, AN ULTRASOUND-BASED DEVICE THAT ALLOWS PHYSICIANS AND OTHER MEDICAL PROFESSIONALS TO MONITOR THE HEART (U.S. CLS. 26, 39 AND 44).
JESSICA A. POWERS, EXAMINING ATTORNEY

SN 77-667,040. ORION PHOTO INDUSTRIES, INC., PRESCOTT, AZ. FILED 2-10-2009.

NameStar

THE MARK CONSISTS OF STANDARD CHARACTERS WITHOUT CLAIM TO ANY PARTICULAR FONT, STYLE, SIZE, OR COLOR.

FOR PACIFIERS (U.S. CLS. 26, 39 AND 44).
JOHN DALIER, EXAMINING ATTORNEY

CLASS 10—(Continued).

SN 77-667,115. MIDMARK CORPORATION, VERSAILLES, OH. FILED 2-10-2009.

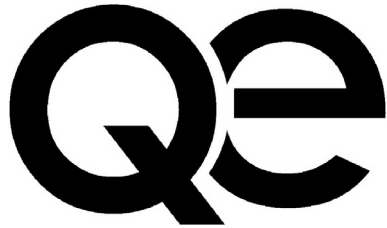

THE MARK CONSISTS OF THE STYLIZED LETTERS "Q" AND "E".
FOR MEDICAL EXAMINATION TABLES (U.S. CLS. 26, 39 AND 44).
LAURIE MAYES, EXAMINING ATTORNEY

CLASS 10—(Continued).

SN 77-668,964. I PLAY. INC., ASHEVILLE, NC. FILED 2-12-2009.



THE MARK CONSISTS OF A STYLIZED SLEEPING SPROUT NESTLED IN AND PARTIALLY SURROUNDED BY THE TWO HALVES OF A POD RESTING ON TWO SMALL FAUX FEET.
FOR BABY BOTTLE ACCESSORIES, NAMELY, BABY BOTTLE NIPPLE HOLE ENLARGER; BABY BOTTLE NIPPLES; BABY BOTTLES; CUPS ADAPTED FOR FEEDING BABIES AND CHILDREN; COMPONENT PARTS OF BABY BOTTLES, NAMELY, DETACHABLE HANDLES; INFANT TEETHERS; NIPPLES FOR BABY BOTTLES; PACIFIER CLIPS; PACIFIERS FOR BABIES; TEETHING RINGS; AND TEETHING RINGS INCORPORATING BABY RATTLES (U.S. CLS. 26, 39 AND 44).
AISHA SALEM, EXAMINING ATTORNEY

SN 77-667,204. VOXELOGIX CORPORATION, SAN ANTONIO, TX. FILED 2-10-2009.

FirstSmile

THE MARK CONSISTS OF STANDARD CHARACTERS WITHOUT CLAIM TO ANY PARTICULAR FONT, STYLE, SIZE, OR COLOR.
FOR DENTAL FIXTURES, NAMELY, PREFABRICATED PARTS FOR CROWNS, BRIDGES AND PON-TICS; DENTAL IMPLANTS; DENTAL PROSTHESES (U.S. CLS. 26, 39 AND 44).
MARC LEIPZIG, EXAMINING ATTORNEY

SN 77-669,293. I PLAY. INC., ASHEVILLE, NC. FILED 2-12-2009.



OWNER OF U.S. REG. NO. 3,441,687.
NO CLAIM IS MADE TO THE EXCLUSIVE RIGHT TO USE "GREEN", APART FROM THE MARK AS SHOWN.
THE MARK CONSISTS OF A DESIGN OF A STYLIZED SLEEPING SPROUT NESTLED IN AND PARTIALLY SURROUNDED BY THE TWO HALVES OF A POD RESTING ON TWO SMALL FAUX FEET, TO THE LEFT OF THE WORDS "GREEN SPROUTS."
FOR BABY BOTTLE ACCESSORIES, NAMELY, BABY BOTTLE NIPPLE HOLE ENLARGER; BABY BOTTLE NIPPLES; BABY BOTTLES; CUPS ADAPTED FOR FEEDING BABIES AND CHILDREN; COMPONENT PARTS OF BABY BOTTLES, NAMELY, DETACHABLE HANDLES; INFANT TEETHERS; NIPPLES FOR BABY BOTTLES; PACIFIER CLIPS; PACIFIERS FOR BABIES; TEETHING RINGS; AND TEETHING RINGS INCORPORATING BABY RATTLES (U.S. CLS. 26, 39 AND 44).
AISHA SALEM, EXAMINING ATTORNEY

CLASS 10—(Continued).

SN 77-673,248. ENDOCARE, INC., IRVINE, CA. FILED 2-18-2009.

DIRECT ACCESS

THE MARK CONSISTS OF THE WORDING "DIRECT ACCESS" WITH THE WORD "DIRECT" EXTENDING THROUGH BROKEN LETTERS "AC", THE FIRST TWO LETTERS OF "ACCESS", AND THE DESIGN OF AN ICE-BALL WITHIN THE FIRST "C" OF "ACCESS".

FOR MEDICAL DEVICES AND INSTRUMENTS FOR USE IN CRYOSURGICAL PROCEDURES, NAMELY, CRYOSURGICAL APPARATUS FOR USE IN PERFORMING ABLATIVE SURGERY; CRYOSURGICAL PROBES; TEMPERATURE PROBES FOR MEDICAL USE; URETHRAL WARMING CATHETER; CRYOSURGICAL PROBE INSERTION GRID (U.S. CLS. 26, 39 AND 44).

FIRST USE 4-23-2003; IN COMMERCE 4-25-2003.
IRA J. GOODSAD, EXAMINING ATTORNEY

SN 77-689,720. HOME AIDE DIAGNOSTICS, INC., DEERFIELD BEACH, FL. FILED 3-12-2009.

Ultra Neb

THE MARK CONSISTS OF STANDARD CHARACTERS WITHOUT CLAIM TO ANY PARTICULAR FONT, STYLE, SIZE, OR COLOR.

NO CLAIM IS MADE TO THE EXCLUSIVE RIGHT TO USE "NEB", APART FROM THE MARK AS SHOWN.

FOR NEBULIZER FOR ADMINISTERING MEDICATION IN THE FORM OF A MIST INHALED INTO THE LUNGS, FOR TREATMENT OF RESPIRATORY DISEASES; NEBULIZERS FOR RESPIRATION THERAPY (U.S. CLS. 26, 39 AND 44).

AMY HELLA, EXAMINING ATTORNEY

SN 77-689,826. HOME AIDE DIAGNOSTICS, INC., DEERFIELD BEACH, FL. FILED 3-12-2009.

True Neb

THE MARK CONSISTS OF STANDARD CHARACTERS WITHOUT CLAIM TO ANY PARTICULAR FONT, STYLE, SIZE, OR COLOR.

NO CLAIM IS MADE TO THE EXCLUSIVE RIGHT TO USE "NEB", APART FROM THE MARK AS SHOWN.

FOR NEBULIZER FOR ADMINISTERING MEDICATION IN THE FORM OF A MIST INHALED INTO THE LUNGS, FOR TREATMENT OF RESPIRATORY DISEASES; NEBULIZERS FOR RESPIRATION THERAPY (U.S. CLS. 26, 39 AND 44).

AMY HELLA, EXAMINING ATTORNEY

CLASS 10—(Continued).

SN 78-641,372. NEUROCOMP SYSTEMS, INC., IRVINE, CA. FILED 6-1-2005.

Pulsar 64+

THE MARK CONSISTS OF STANDARD CHARACTERS WITHOUT CLAIM TO ANY PARTICULAR FONT, STYLE, SIZE, OR COLOR.

FOR MEDICAL MONITORING DEVICE, NAMELY, AN ELECTROENCEPHALOGRAPH FOR TRANSDUCTION AND PROCESSING OF BRAIN ELECTRICAL VOLTAGE POTENTIALS, NAMELY, THE ELECTROENCEPHALOGRAPH (EEG) (U.S. CLS. 26, 39 AND 44).

SUNG IN, EXAMINING ATTORNEY

SN 78-741,700. SPECIALTY APPLIANCE WORKS, INC., CUMMING, GA. FILED 10-27-2005.

MiniScope

THE MARK CONSISTS OF STANDARD CHARACTERS WITHOUT CLAIM TO ANY PARTICULAR FONT, STYLE, SIZE, OR COLOR.

FOR ORTHODONTIC APPLIANCE, NAMELY, A ROD AND TUBE TELESCOPING MECHANISM FOR USE IN HERBST ORTHODONTIC DEVICE (U.S. CLS. 26, 39 AND 44).

FIRST USE 4-29-2005; IN COMMERCE 4-29-2005.

KATHRYN COWARD, EXAMINING ATTORNEY

SN 78-972,914. RESMED LIMITED, BELLA VISTA, NSW, AUSTRALIA, FILED 9-12-2006.

QUATTRO

THE MARK CONSISTS OF STANDARD CHARACTERS WITHOUT CLAIM TO ANY PARTICULAR FONT, STYLE, SIZE, OR COLOR.

PRIORITY CLAIMED UNDER SEC. 44(D) ON AUSTRALIA APPLICATION NO. 1103877, FILED 3-14-2006, REG. NO. 1103877, DATED 3-14-2006, EXPIRES 3-14-2016.

THE FOREIGN WORDING IN THE MARK TRANSLATES INTO ENGLISH AS FOUR.

FOR MEDICAL INSTRUMENTS, NAMELY, PATIENT INTERFACE PRODUCTS, NAMELY, NASAL MASKS, FULL FACE MASKS, NASAL PRONGS, NASAL CANNULAE, NASAL PILLOWS, NASAL SEALS AND PARTS AND ACCESSORIES THEREFOR, ALL FOR USE WITH MEDICAL EQUIPMENT FOR TREATING SLEEP DISORDERED BREATHING (U.S. CLS. 26, 39 AND 44).

ANDREA BUTLER, EXAMINING ATTORNEY

CLASS 10—(Continued).

SN 79-049,184. GYNAECOLOGIQ B.V., NETHERLANDS, FILED 12-14-2007.

GIS

THE MARK CONSISTS OF STANDARD CHARACTERS WITHOUT CLAIM TO ANY PARTICULAR FONT, STYLE, SIZE, OR COLOR.

PRIORITY DATE OF 7-5-2007 IS CLAIMED.

OWNER OF INTERNATIONAL REGISTRATION 0951504 DATED 12-14-2007, EXPIRES 12-14-2017.

THE WORDING "GIS" APPEARING IN THE MARK HAS NO MEANING IN A FOREIGN LANGUAGE.

FOR SURGICAL AND MEDICAL APPARATUS AND INSTRUMENTS, NAMELY, CATHETERS, GEL INJECTORS, TUBES, POUCHES IN THE FIELD OF GYNECOLOGY (U.S. CLS. 26, 39 AND 44).

MATTHEW MCDOWELL, EXAMINING ATTORNEY

SN 79-055,540. TOSHIBA; MEDICAL SYSTEMS CORPORATION, TOCHIGI 324-8550, JAPAN, FILED 6-4-2008.

UltraExtend

THE MARK CONSISTS OF STANDARD CHARACTERS WITHOUT CLAIM TO ANY PARTICULAR FONT, STYLE, SIZE, OR COLOR.

PRIORITY DATE OF 5-14-2008 IS CLAIMED.

OWNER OF INTERNATIONAL REGISTRATION 0968964 DATED 6-4-2008, EXPIRES 6-4-2018.

FOR PICTURE ARCHIVING AND COMMUNICATION SYSTEM (PACS) FOR ULTRASONIC IMAGING DIAGNOSTIC APPARATUS FOR MEDICAL USE COMPRISED OF ULTRASONIC DIAGNOSTIC IMAGING APPARATUS, COMPUTER HARDWARE, AND COMPUTER SOFTWARE FOR USE IN CAPTURING, RECEIVING, STORING, ANALYZING, ORGANIZING, AND TRANSMITTING MEDICAL IMAGES (U.S. CLS. 26, 39 AND 44).

ELI HELLMAN, EXAMINING ATTORNEY

SN 79-064,977. ADOLESCO AB, SE-111 47 STOCKHOLM, SWEDEN, FILED 9-25-2008.

CARDIOTOM

THE MARK CONSISTS OF STANDARD CHARACTERS WITHOUT CLAIM TO ANY PARTICULAR FONT, STYLE, SIZE, OR COLOR.

OWNER OF INTERNATIONAL REGISTRATION 0992334 DATED 9-25-2008, EXPIRES 9-25-2018.

THE WORDING "CARDIOTOM" HAS NO MEANING IN ENGLISH.

FOR GAMMA CAMERA APPARATUS, AND PARTS AND FITTINGS THEREFOR, INTENDED FOR MEDICAL DIAGNOSIS, RADIOGRAPHIC TREATMENT AND OTHER MEDICAL LABORATORY AND CLINICAL USE (U.S. CLS. 26, 39 AND 44).

PAUL MORENO, EXAMINING ATTORNEY

CLASS 10—(Continued).

SN 79-065,288. BERNHARD FÖRSTER GMBH, FED REP GERMANY, FILED 10-23-2008.

BioLingual

THE MARK CONSISTS OF STANDARD CHARACTERS WITHOUT CLAIM TO ANY PARTICULAR FONT, STYLE, SIZE, OR COLOR.

PRIORITY DATE OF 6-5-2008 IS CLAIMED.

OWNER OF INTERNATIONAL REGISTRATION 0993192 DATED 10-23-2008, EXPIRES 10-23-2018.

FOR SURGICAL APPARATUS AND INSTRUMENTS; SURGICAL IMPLANTS COMPRISING ARTIFICIAL MATERIALS; PRODUCTS FOR USE IN JAW-ORTHOPEDICS AND ORTHODONTIA IN THE FORM OF APPARATUS AND ALSO METALLIC COMPONENTS, CERAMIC COMPONENTS AND OF COMPONENTS MADE OF PLASTIC, IN PARTICULAR WIRES, PREFORMED WIRES, ARCH WIRES, BRACKETS, BUCCAL TUBES, BANDS AND MOLAR BANDS WITH AND WITHOUT PARTS WELDED THERETO, SPRINGS, SCREWS HAVING A SPRING-LOADED PISTON, EXPANSION SCREWS AND DENTAL SCREWS; ARTIFICIAL TEETH; DENTAL PROSTHESIS; ORTHODONTIC APPLIANCES; PINS FOR ARTIFICIAL TEETH; ROOT CANAL PINS; JAW SURGICAL IMPLANTS COMPRISING ARTIFICIAL MATERIALS, IN PARTICULAR SCREW IMPLANTS AND ABUTMENTS FOR IMPLANTS; FOILS AND PLATES MADE OF PLASTIC FOR DENTAL PURPOSES; ORTHODONTIC, PROSTHETIC AND SURGICAL DENTAL INSTRUMENTS FOR MANIPULATING, ATTACHING, DETACHING, ADJUSTING AND/OR OPENING THE AFORESAID GOODS; REPLACEMENT PARTS FOR THE AFORESAID GOODS (U.S. CLS. 26, 39 AND 44).

JOHN SCHUYLER YARD, EXAMINING ATTORNEY

CLASS 11—ENVIRONMENTAL CONTROL APPARATUS

SN 76-695,340. KING TECHNOLOGY, INC., HOPKINS, MN, FILED 1-16-2009.

SPA FROG DIGITAL

THE MARK CONSISTS OF STANDARD CHARACTERS WITHOUT CLAIM TO ANY PARTICULAR FONT, STYLE, SIZE, OR COLOR.

OWNER OF U.S. REG. NOS. 2,298,963, 2,443,833 AND 2,508,507.

NO CLAIM IS MADE TO THE EXCLUSIVE RIGHT TO USE "SPA" AND "DIGITAL", APART FROM THE MARK AS SHOWN.

FOR EQUIPMENT FOR DISPENSING WATER PURIFICATION MATERIALS, NAMELY, CONTROLLER FOR DISPENSING WATER PURIFICATION MATERIALS FOR SWIMMING POOLS, SPAS, HOT TUBS, WHIRLPOOLS, AND OTHER RECREATIONAL BODIES OF WATER (U.S. CLS. 13, 21, 23, 31 AND 34).

BARBARA BROWN, EXAMINING ATTORNEY

CLASS 11—(Continued).

SN 76-695,470. SKYDON CORP., WALNUT, CA. FILED 1-28-2009.

THINK ALKALINE

THE MARK CONSISTS OF STANDARD CHARACTERS WITHOUT CLAIM TO ANY PARTICULAR FONT, STYLE, SIZE, OR COLOR.

NO CLAIM IS MADE TO THE EXCLUSIVE RIGHT TO USE "ALKALINE", APART FROM THE MARK AS SHOWN.

FOR WATER IONIZERS FOR HOUSEHOLD AND COMMERCIAL PURPOSES; WATER FILTERING UNITS FOR DOMESTIC, COMMERCIAL AND INDUSTRIAL USE; WATER CONDITIONING UNITS FOR DOMESTIC, COMMERCIAL AND INDUSTRIAL USE; WATER FILTERS; WATER PURIFICATION UNITS; ELECTROLYTIC WATER GENERATORS FOR ELECTRICALLY DECOMPOSING WATER TO GENERATE ELECTROLYTIC WATER; ELECTROLYTIC WATER GENERATOR FOR ELECTRICALLY DECOMPOSING WATER TO GENERATE ELECTROLYTIC WATER FOR SANITIZATION, CLEANING AND SKIN TONING (U.S. CLS. 13, 21, 23, 31 AND 34).

FIRST USE 1-0-2007; IN COMMERCE 1-0-2007.
BRIAN PINO, EXAMINING ATTORNEY



SN 77-366,557. METSO POWER OY, 33101 TAMPERE, FINLAND, FILED 1-8-2008.

CYMIC

THE MARK CONSISTS OF STANDARD CHARACTERS WITHOUT CLAIM TO ANY PARTICULAR FONT, STYLE, SIZE, OR COLOR.

OWNER OF FINLAND REG. NO. 125314, DATED 2-22-1993, EXPIRES 2-22-2013.

FOR BOILERS FOR INDUSTRIAL USE (U.S. CLS. 13, 21, 23, 31 AND 34).

NELSON SNYDER, EXAMINING ATTORNEY



SN 77-374,037. GONZALEZ-QUEVEDO, DANIEL, MIAMI, FL. AND HALLMAN, HAL, MIAMI, FL. FILED 1-17-2008.

READY HOT

THE MARK CONSISTS OF STANDARD CHARACTERS WITHOUT CLAIM TO ANY PARTICULAR FONT, STYLE, SIZE, OR COLOR.

FOR ELECTRIC TANK LESS WATER HEATER (U.S. CLS. 13, 21, 23, 31 AND 34).

ELISSA GARBER KON, EXAMINING ATTORNEY

CLASS 11—(Continued).

SN 77-469,285. LIGHTWEIGHT SAFETY, LTD., CHICAGO, IL. FILED 5-8-2008.

LIGHTWEIGHTS

THE MARK CONSISTS OF STANDARD CHARACTERS WITHOUT CLAIM TO ANY PARTICULAR FONT, STYLE, SIZE, OR COLOR.

FOR BICYCLE REFLECTORS; LIGHT REFLECTORS; REFLECTORS FOR CLOTHING (U.S. CLS. 13, 21, 23, 31 AND 34).

FIRST USE 4-0-2005; IN COMMERCE 9-6-2005.
TINA L. SNAPP, EXAMINING ATTORNEY



SN 77-503,066. EVERPURE, LLC, HANOVER PARK, IL. FILED 6-19-2008.

ENJOY THE TASTE, WITHOUT THE WASTE

THE MARK CONSISTS OF STANDARD CHARACTERS WITHOUT CLAIM TO ANY PARTICULAR FONT, STYLE, SIZE, OR COLOR.

FOR DRINKING WATER TREATMENT AND DISPENSING SYSTEM COMPRISED OF A REFRIGERATED WATER DISPENSING UNIT AND A PRE-DISPENSING WATER FILTER FOR PROVIDING AMBIENT STILL, CHILLED STILL AND CHILLED SPARKLING WATER (U.S. CLS. 13, 21, 23, 31 AND 34).

ELLEN PERKINS, EXAMINING ATTORNEY



SN 77-512,465. ROBURN COMPANY LTD., SHIN CHUNG CITY, TAIWAN, FILED 7-1-2008.

ROBURN

THE MARK CONSISTS OF STANDARD CHARACTERS WITHOUT CLAIM TO ANY PARTICULAR FONT, STYLE, SIZE, OR COLOR.

OWNER OF U.S. REG. NO. 3,356,794.
FOR ACETYLENE BURNERS, ACETYLENE GENERATORS, SOLDERING LAMPS, GAS TORCHES, NAMELY, BUTANE TORCHES FOR COOKING, AND BUTANE GAS BURNERS FOR COMMERCIAL AND DOMESTIC USE (U.S. CLS. 13, 21, 23, 31 AND 34).

YAT SYE, LEE, EXAMINING ATTORNEY

CLASS 11—(Continued).

SN 77-543,401. ORC MANUFACTURING CO., LTD., TOKYO, JAPAN, FILED 8-11-2008.

OCL

THE MARK CONSISTS OF STANDARD CHARACTERS WITHOUT CLAIM TO ANY PARTICULAR FONT, STYLE, SIZE, OR COLOR.

PRIORITY CLAIMED UNDER SEC. 44(D) ON JAPAN APPLICATION NO. 2008-049230, FILED 6-20-2008, REG. NO. 5194430, DATED 1-9-2009, EXPIRES 1-9-2019.

FOR LAMPS USED IN MACHINES FOR MANUFACTURING PRINTED CIRCUIT BOARDS (U.S. CLS. 13, 21, 23, 31 AND 34).

ROBERT LAVACHE, EXAMINING ATTORNEY

CLASS 11—(Continued).

SN 77-548,716. MIC ELECTRONICS LIMITED, HYDERABAD, INDIA, FILED 8-16-2008.

MIC Electronics

THE MARK CONSISTS OF STANDARD CHARACTERS WITHOUT CLAIM TO ANY PARTICULAR FONT, STYLE, SIZE, OR COLOR.

NO CLAIM IS MADE TO THE EXCLUSIVE RIGHT TO USE "ELECTRONICS", APART FROM THE MARK AS SHOWN.

FOR ELECTRIC LIGHTING FIXTURES; ELECTRIC TORCHES FOR LIGHTING; LED (LIGHT EMITTING DIODES) LIGHTING FIXTURES FOR USE IN DISPLAY, COMMERCIAL, INDUSTRIAL, RESIDENTIAL, AND ARCHITECTURAL ACCENT LIGHTING APPLICATIONS; LIGHTING FIXTURES; SOLAR LIGHT FIXTURES, NAMELY, INDOOR AND OUTDOOR SOLAR POWERED LIGHTING UNITS AND FIXTURES (U.S. CLS. 13, 21, 23, 31 AND 34).

FIRST USE 10-30-2006; IN COMMERCE 10-30-2006.

JESSICA A. POWERS, EXAMINING ATTORNEY

SN 77-551,891. HONEYWELL INTERNATIONAL INC., MORRISTOWN, NJ. FILED 8-20-2008.

TRUEUV

THE MARK CONSISTS OF STANDARD CHARACTERS WITHOUT CLAIM TO ANY PARTICULAR FONT, STYLE, SIZE, OR COLOR.

FOR AIR PURIFICATION UNITS; AIR AND SURFACE PURIFICATION EQUIPMENT, NAMELY, UV BULBS (U.S. CLS. 13, 21, 23, 31 AND 34).

FIRST USE 2-27-2008; IN COMMERCE 2-27-2008.

DAVID TAYLOR, EXAMINING ATTORNEY

SN 77-547,471. SOLARONE SOLUTIONS, INC., FRAMINGHAM, MA. FILED 8-14-2008.

THE MARK CONSISTS OF THE WORD "SO" FOLLOWED BY A SPECIAL SUNBURST (*) FOLLOWED BY THE WORD "BRIGHT".

SEC. 2(F).

FOR ELECTRIC LIGHTING FIXTURES, NAMELY, POWER FAILURE BACKUP SAFETY LIGHTING; LED (LIGHT EMITTING DIODE) LIGHTING FIXTURES; LED (LIGHT EMITTING DIODES) LIGHTING FIXTURES FOR USE IN DISPLAY, COMMERCIAL, INDUSTRIAL, RESIDENTIAL, AND ARCHITECTURAL ACCENT LIGHTING APPLICATIONS; LED AND HID LIGHT FIXTURES; LED LIGHT ASSEMBLIES FOR STREET LIGHTS, SIGNS, COMMERCIAL LIGHTING, AUTOMOBILES, BUILDINGS, AND OTHER ARCHITECTURAL USES; LED LIGHT BULBS; LED LIGHTING FIXTURES FOR INDOOR AND OUTDOOR LIGHTING APPLICATIONS; LIGHTING FIXTURES; LIGHTING FIXTURES FOR USE IN PARKING LOTS AND WALKWAYS; SOLAR LIGHT FIXTURES, NAMELY, INDOOR AND OUTDOOR SOLAR POWERED LIGHTING UNITS AND FIXTURES (U.S. CLS. 13, 21, 23, 31 AND 34).

FIRST USE 1-19-2007; IN COMMERCE 1-19-2007.

ALLISON SCHRODY, EXAMINING ATTORNEY

SN 77-556,178. A2BE CARBON CAPTURE, LLC, BOULDER, CO. FILED 8-26-2008.

CC&R MACHINE

THE MARK CONSISTS OF STANDARD CHARACTERS WITHOUT CLAIM TO ANY PARTICULAR FONT, STYLE, SIZE, OR COLOR.

NO CLAIM IS MADE TO THE EXCLUSIVE RIGHT TO USE "MACHINE", APART FROM THE MARK AS SHOWN.

FOR CLOSED SYSTEM PHOTO-BIOREACTOR FOR USE IN THE TREATMENT OF CO₂ (U.S. CLS. 13, 21, 23, 31 AND 34).

DAVID HOFFMAN, EXAMINING ATTORNEY

CLASS 11—(Continued).

SN 77-575,531. THE ORNAMENTAL DIFFUSER COMPANY L.L.C., ROCHESTER, NH. FILED 9-22-2008.

Decaroma

THE MARK CONSISTS OF STANDARD CHARACTERS WITHOUT CLAIM TO ANY PARTICULAR FONT, STYLE, SIZE, OR COLOR.

FOR ELECTRIC DIFFUSERS FOR DIFFUSING ESSENTIAL OILS TO PROVIDE AROMATIC FRAGRANCE (U.S. CLS. 13, 21, 23, 31 AND 34).

EDWARD FENNESSY, EXAMINING ATTORNEY

SN 77-580,006. HANTECH CORPORATION, CHINO, CA. FILED 9-26-2008.



NO CLAIM IS MADE TO THE EXCLUSIVE RIGHT TO USE "ULTRAVIOLET", APART FROM THE MARK AS SHOWN.

THE MARK CONSISTS OF A HALF CIRCLE LINE WITH A STAR OVER THE "I" IN "POLARIS".

FOR DISINFECTING ULTRAVIOLET LAMPS HOUSED IN A CONTAINER OR COVER FOR DISINFECTING OBJECTS PLACED THEREIN, AND FEATURING A STAINLESS STEEL CYLINDRICAL CHAMBER AND AN ELECTRICAL BALLAST (U.S. CLS. 13, 21, 23, 31 AND 34).

FIRST USE 5-30-2008; IN COMMERCE 5-30-2008.
DORITT L. CARROLL, EXAMINING ATTORNEY

SN 77-592,161. FERGUSON ENTERPRISES, INC., NEWPORT NEWS, VA. FILED 10-14-2008.



THE COLOR(S) PURPLE AND WHITE IS/ARE CLAIMED AS A FEATURE OF THE MARK.

THE MARK CONSISTS OF THE STYLIZED WORD "LIGHTTEK" IN WHITE ON A PURPLE FIELD WITH A STYLIZED PURPLE TRIANGLE PARTIALLY COVERING THE WORD. A PURPLE REFLECTION OF THE STYLIZED WORD "LIGHTTEK" ALSO APPEARS IN THE MARK BELOW THE SHOWING OF THE STYLIZED WORD "LIGHTTEK" IN WHITE.

FOR INTERIOR AND EXTERIOR ELECTRIC LIGHTING FIXTURES, CEILING FANS AND LIGHT BULBS (U.S. CLS. 13, 21, 23, 31 AND 34).

FIRST USE 8-7-2008; IN COMMERCE 8-7-2008.
FRED MANDIR, EXAMINING ATTORNEY

CLASS 11—(Continued).

SN 77-602,829. PACKWAYS INDUSTRIES LIMITED, KWUN TONG, KOWLOON, HONG KONG, FILED 10-29-2008.

RIGHT WHITE

THE MARK CONSISTS OF STANDARD CHARACTERS WITHOUT CLAIM TO ANY PARTICULAR FONT, STYLE, SIZE, OR COLOR.

NO CLAIM IS MADE TO THE EXCLUSIVE RIGHT TO USE "WHITE", APART FROM THE MARK AS SHOWN.

FOR LIGHTING APPARATUS, NAMELY, BOOK LIGHTS, CEILING LIGHTS, TABLE LIGHTS, WALL LIGHTS, DIVING LIGHTS, ELECTRIC LIGHT BULBS, LED LIGHT BULBS, VEHICLE LIGHTS AND LIGHTS FOR USE IN ILLUMINATING SIGNS AND DISPLAYS; PORTABLE LIGHTING APPARATUS, NAMELY, FLASHLIGHTS; DECORATIVE LIGHTS; INCANDESCENT MINI BULBS; LED (LIGHT EMITTING DIODE) LIGHTING DEVICES, NAMELY, LED AND HID LIGHT FIXTURES; CHRISTMAS LIGHTING PRODUCTS, NAMELY, ELECTRIC LIGHTS FOR CHRISTMAS TREES, ELECTRIC HOLIDAY LIGHTS; PARTS AND FITTINGS FOR THE AFOREMENTIONED LIGHTS, LIGHT BULBS, FLASHLIGHTS, AND LIGHT FIXTURES (U.S. CLS. 13, 21, 23, 31 AND 34).

YAT SYE, LEE, EXAMINING ATTORNEY

SN 77-621,058. GLOBE UNION (BERMUDA) TRADING LTD., HAMILTON, BERMUDA, FILED 11-24-2008.

RIVERDALE

THE MARK CONSISTS OF STANDARD CHARACTERS WITHOUT CLAIM TO ANY PARTICULAR FONT, STYLE, SIZE, OR COLOR.

FOR FAUCETS; TUB AND SHOWER FITTINGS, NAMELY, SHOWER HEADS, TUB SPOUTS AND HANDLES, AND ROMAN TUB FILLERS (U.S. CLS. 13, 21, 23, 31 AND 34).

MATTHEW EINSTEIN, EXAMINING ATTORNEY

SN 77-630,948. FRANZ KALDEWEI GMBH & CO. KG, AHLEN, FED REP GERMANY, FILED 12-11-2008.

BASSINO

THE MARK CONSISTS OF STANDARD CHARACTERS WITHOUT CLAIM TO ANY PARTICULAR FONT, STYLE, SIZE, OR COLOR.

PRIORITY CLAIMED UNDER SEC. 44(D) ON FED REP GERMANY APPLICATION NO. 302008073306, FILED 11-21-2008, REG. NO. 302008073306, DATED 2-3-2009, EXPIRES 11-30-2018.

FOR BATHTUBS AND SHOWER TRAYS (U.S. CLS. 13, 21, 23, 31 AND 34).

GRETTA YAO, EXAMINING ATTORNEY

CLASS 11—(Continued).

SN 77-631,905. QVC, INC., WEST CHESTER, PA. FILED 12-12-2008.

HOME REFLECTIONS

THE MARK CONSISTS OF STANDARD CHARACTERS WITHOUT CLAIM TO ANY PARTICULAR FONT, STYLE, SIZE, OR COLOR.

NO CLAIM IS MADE TO THE EXCLUSIVE RIGHT TO USE "HOME", APART FROM THE MARK AS SHOWN.

FOR BATTERY OPERATED CANDLES (U.S. CLS. 13, 21, 23, 31 AND 34).

KATHLEEN M. VANSTON, EXAMINING ATTORNEY

SN 77-638,859. VICTORY ENERGY OPERATIONS, L.L.C., COLLINSVILLE, OK. FILED 12-23-2008.



NO CLAIM IS MADE TO THE EXCLUSIVE RIGHT TO USE "SERIES", APART FROM THE MARK AS SHOWN.

THE MARK CONSISTS OF THE WORDS "SOLARGEN SERIES" IN COMBINATION WITH A DESIGN COMPOSED OF CURVED LINES.

FOR INDUSTRIAL BOILERS (U.S. CLS. 13, 21, 23, 31 AND 34).

REGINA DRUMMOND, EXAMINING ATTORNEY

SN 77-653,103. FLEMINGS OF COHASSET INC. DBA FLEMINGS LIGHTING, COHASSET, MA. FILED 1-21-2009.

fleming's lighting
bringing solutions to light

THE MARK CONSISTS OF STANDARD CHARACTERS WITHOUT CLAIM TO ANY PARTICULAR FONT, STYLE, SIZE, OR COLOR.

NO CLAIM IS MADE TO THE EXCLUSIVE RIGHT TO USE "LIGHTING", APART FROM THE MARK AS SHOWN.

FOR LED (LIGHT EMITTING DIODES) LIGHTING FIXTURES FOR USE IN DISPLAY, COMMERCIAL, INDUSTRIAL, RESIDENTIAL, AND ARCHITECTURAL ACCENT LIGHTING APPLICATIONS (U.S. CLS. 13, 21, 23, 31 AND 34).

HEATHER SAPP, EXAMINING ATTORNEY

CLASS 11—(Continued).

SN 77-660,990. ELUTRASEP, INC., BALL GROUND, GA. FILED 2-2-2009.

Cryptonite

THE COLOR(S) BLUE AND GRAY IS/ARE CLAIMED AS A FEATURE OF THE MARK.

THE MARK CONSISTS OF A PRODUCT NAME WRITTEN IN TWO SEPARATE COLORS. THE FIRST SIX LETTERS ARE IN A LIGHT GRAY COLOR WITH THE LAST THREE LETTERS IN A LIGHT BLUE.

FOR FILTERS MADE OF FIBER FOR WATER FILTRATION (U.S. CLS. 13, 21, 23, 31 AND 34).

FIRST USE 5-7-2007; IN COMMERCE 5-7-2007.
 LESLEY LAMOTHE, EXAMINING ATTORNEY

SN 77-662,962. PF WATERWORKS LP, HOUSTON, TX. FILED 2-4-2009.

PERMAFLOW

THE MARK CONSISTS OF STANDARD CHARACTERS WITHOUT CLAIM TO ANY PARTICULAR FONT, STYLE, SIZE, OR COLOR.

FOR PLUMBING FITTINGS, NAMELY, TRAPS (U.S. CLS. 13, 21, 23, 31 AND 34).

FIRST USE 1-1-2008; IN COMMERCE 1-1-2008.

WILLIAM VERHOSEK, EXAMINING ATTORNEY

SN 77-663,980. EAGLE EYES TRAFFIC INDUSTRIAL CO., LTD., YUNG KANG CITY, TAIWAN, FILED 2-5-2009.

Starline

THE MARK CONSISTS OF STANDARD CHARACTERS WITHOUT CLAIM TO ANY PARTICULAR FONT, STYLE, SIZE, OR COLOR.

FOR ELECTRIC LIGHT BULBS; FITTINGS FOR ELECTRIC LAMPS, NAMELY, LAMP CASINGS AND LAMPSHADE HOLDERS; AND LIGHTS FOR VEHICLES, NAMELY, HEADLIGHTS, REAR LAMPS, DIRECTIONAL LIGHTS, SIDEMARKER LAMPS, FOG LIGHTS, CORNER LAMPS, BRAKE LAMPS AND AUXILIARY BRAKE LAMPS (U.S. CLS. 13, 21, 23, 31 AND 34).

KATHERINE M. DUBRAY, EXAMINING ATTORNEY

CLASS 11—(Continued).

SN 77-664,088. ADVANCED AGRI-DIRECT (USA) INC., YORK, NE. FILED 2-5-2009.

COOLHOG

THE MARK CONSISTS OF STANDARD CHARACTERS WITHOUT CLAIM TO ANY PARTICULAR FONT, STYLE, SIZE, OR COLOR.
 FOR MISTING SYSTEMS FOR OUTDOOR COOLING (U.S. CLS. 13, 21, 23, 31 AND 34).
 FIRST USE 5-22-2006; IN COMMERCE 5-22-2006.
 CURTIS FRENCH, EXAMINING ATTORNEY

SN 77-664,526. EVO, INC., BEAVERTON, OR. FILED 2-5-2009.

evo

THE MARK CONSISTS OF STANDARD CHARACTERS WITHOUT CLAIM TO ANY PARTICULAR FONT, STYLE, SIZE, OR COLOR.
 OWNER OF U.S. REG. NO. 3,308,969.
 FOR BARBECUE GRILLS, OUTDOOR AND INDOOR GAS AND ELECTRIC COOKING GRILLS AND OVENS (U.S. CLS. 13, 21, 23, 31 AND 34).
 FIRST USE 10-27-2000; IN COMMERCE 10-27-2000.
 CORY BOONE, EXAMINING ATTORNEY

SN 77-665,593. SMARTWATER, INC., SEATTLE, WA. FILED 2-6-2009.

SMARTSHOWER

THE MARK CONSISTS OF STANDARD CHARACTERS WITHOUT CLAIM TO ANY PARTICULAR FONT, STYLE, SIZE, OR COLOR.
 FOR SHOWER HEAD AND SHOWER RETROFIT, DESIGNED TO CONSERVE WATER USAGE, AND SHOWER HEAD SPRAYER (U.S. CLS. 13, 21, 23, 31 AND 34).
 KELLEY WELLS, EXAMINING ATTORNEY

CLASS 11—(Continued).

SN 77-665,846. GOOCH, PHILIP LEE, PFLUGERVILLE, TX. FILED 2-8-2009.

LiquidLux

THE MARK CONSISTS OF STANDARD CHARACTERS WITHOUT CLAIM TO ANY PARTICULAR FONT, STYLE, SIZE, OR COLOR.
 FOR LED (LIGHT EMITTING DIODE) LIGHTING FIXTURES; LED (LIGHT EMITTING DIODES) LIGHTING FIXTURES FOR USE IN DISPLAY, COMMERCIAL, INDUSTRIAL, RESIDENTIAL, AND ARCHITECTURAL ACCENT LIGHTING APPLICATIONS; LED LIGHT BULBS (U.S. CLS. 13, 21, 23, 31 AND 34).
 RONALD MCMORROW, EXAMINING ATTORNEY

SN 77-668,980. I PLAY, INC., ASHEVILLE, NC. FILED 2-12-2009.



THE MARK CONSISTS OF A STYLIZED SLEEPING SPROUT NESTLED IN AND PARTIALLY SURROUNDED BY THE TWO HALVES OF A POD RESTING ON TWO SMALL FAUX FEET.
 FOR ELECTRIC FOOD STEAMER (U.S. CLS. 13, 21, 23, 31 AND 34).
 AISHA SALEM, EXAMINING ATTORNEY

SN 77-671,457. HENNY PENNY CORPORATION, EATON, OH. FILED 2-16-2009.

EVOLUTION ELITE

THE MARK CONSISTS OF THE STYLIZED WORDING "EVOLUTION ELITE" WHERE "ELITE" IS TO THE LOWER RIGHT OF "EVOLUTION". THE FIRST LETTER "O" IN "EVOLUTION" HAS A GRADIENT ORB IN THE CENTER. A LINE EXTENDS UNDER THE WORD "EVOLUTION" UNTIL IT MEETS THE FIRST LETTER "E" IN "ELITE".
 FOR COMMERCIAL FOODSERVICE EQUIPMENT, NAMELY, ELECTRIC AND GAS FOOD FRYERS (U.S. CLS. 13, 21, 23, 31 AND 34).
 KIM SAITO, EXAMINING ATTORNEY

CLASS 11—(Continued).

SN 77-687,657. THE COCA-COLA COMPANY, ATLANTA, GA. FILED 3-10-2009.

FLEX FRESH

THE MARK CONSISTS OF STANDARD CHARACTERS WITHOUT CLAIM TO ANY PARTICULAR FONT, STYLE, SIZE, OR COLOR.
FOR ELECTRIC MACHINE FOR BREWING AND DISPENSING TEA (U.S. CLS. 13, 21, 23, 31 AND 34).
REBECCA SMITH, EXAMINING ATTORNEY

SN 77-690,387. ANDIS COMPANY, STURTEVANT, WI. FILED 3-13-2009.

COMFORT DRY

THE MARK CONSISTS OF STANDARD CHARACTERS WITHOUT CLAIM TO ANY PARTICULAR FONT, STYLE, SIZE, OR COLOR.
NO CLAIM IS MADE TO THE EXCLUSIVE RIGHT TO USE "DRY", APART FROM THE MARK AS SHOWN.
FOR ELECTRIC HAIR DRYERS FOR ANIMALS (U.S. CLS. 13, 21, 23, 31 AND 34).
FIRST USE 2-19-2009; IN COMMERCE 2-19-2009.
SOPHIA S. KIM, EXAMINING ATTORNEY

SN 77-696,036. ANDIS COMPANY, STURTEVANT, WI. FILED 3-20-2009.

SPEED DRY

THE MARK CONSISTS OF STANDARD CHARACTERS WITHOUT CLAIM TO ANY PARTICULAR FONT, STYLE, SIZE, OR COLOR.
NO CLAIM IS MADE TO THE EXCLUSIVE RIGHT TO USE "DRY", APART FROM THE MARK AS SHOWN.
FOR HAND-HELD ELECTRIC HAIR DRYERS (U.S. CLS. 13, 21, 23, 31 AND 34).
SOPHIA S. KIM, EXAMINING ATTORNEY

CLASS 11—(Continued).

SN 78-426,783. AS IP HOLDCO, LLC, BOSTON, MA. FILED 5-28-2004.

ZEN

THE MARK CONSISTS OF STANDARD CHARACTERS WITHOUT CLAIM TO ANY PARTICULAR FONT, STYLE, SIZE, OR COLOR.
FOR SINKS (U.S. CLS. 13, 21, 23, 31 AND 34).
FIRST USE 8-2-2000; IN COMMERCE 8-2-2000.
RICHARD WHITE, EXAMINING ATTORNEY

SN 79-064,533. PROPIT AB, SWEDEN, FILED 6-2-2008.

PROFIT

THE MARK CONSISTS OF STANDARD CHARACTERS WITHOUT CLAIM TO ANY PARTICULAR FONT, STYLE, SIZE, OR COLOR.
PRIORITY DATE OF 5-16-2008 IS CLAIMED.
OWNER OF INTERNATIONAL REGISTRATION 0991182 DATED 6-2-2008, EXPIRES 6-2-2018.
THE WORDING "PROFIT" HAS NO MEANING IN A FOREIGN LANGUAGE.
FOR WIND POWER PLANTS AND STRUCTURAL PARTS AND COMPONENTS THEREFOR (U.S. CLS. 13, 21, 23, 31 AND 34).
ALLISON SCHRODY, EXAMINING ATTORNEY

SN 79-065,456. OSRAM; GESELLSCHAFT MIT BESCHRÄNKTER HAFTUNG, AKA OSRAM GMBH, FED REP GERMANY, FILED 12-12-2008.

LEDstixx

THE MARK CONSISTS OF STANDARD CHARACTERS WITHOUT CLAIM TO ANY PARTICULAR FONT, STYLE, SIZE, OR COLOR.
OWNER OF INTERNATIONAL REGISTRATION 0993690 DATED 12-12-2008, EXPIRES 12-12-2018.
FOR LIGHTING APPARATUS, NAMELY, ELECTRIC LAMPS AND LUMINAIRES, AND COMPONENT PARTS OF THE AFOREMENTIONED GOODS (U.S. CLS. 13, 21, 23, 31 AND 34).
DANIEL CAPSHAW, EXAMINING ATTORNEY

CLASS 12—VEHICLES

SN 77-263,593. CARDONE INDUSTRIES, INC., PHILADELPHIA, PA. FILED 8-24-2007.

S3 SUPERIOR STEERING SOLUTIONS

THE MARK CONSISTS OF STANDARD CHARACTERS WITHOUT CLAIM TO ANY PARTICULAR FONT, STYLE, SIZE, OR COLOR.

NO CLAIM IS MADE TO THE EXCLUSIVE RIGHT TO USE "SUPERIOR STEERING SOLUTIONS", APART FROM THE MARK AS SHOWN.

FOR POWER STEERING, POWER STEERING PUMPS, POWER STEERING FILTERS, STEERING GEARS, CONTROL VALVES, POWER CYLINDERS AND RACK AND PINION STEERING UNITS FOR MOTOR VEHICLES (U.S. CLS. 19, 21, 23, 31, 35 AND 44).

ZACHARY BELLO, EXAMINING ATTORNEY

SN 77-392,198. AIRNIMAL EUROPE LIMITED, LONGSTANTON, UNITED KINGDOM, FILED 2-8-2008.

AIRNIMAL

THE MARK CONSISTS OF STANDARD CHARACTERS WITHOUT CLAIM TO ANY PARTICULAR FONT, STYLE, SIZE, OR COLOR.

OWNER OF UNITED KINGDOM REG. NO. 2442536, DATED 12-29-2006, EXPIRES 12-29-2016.

FOR ACCESSORIES FOR BICYCLES, NAMELY, BELLS, PUMPS, BAG RACKS, LUGGAGE IN THE NATURE OF PANNIER BAGS, SADDLEBAGS AND HANDLEBAR BAGS FOR BICYCLES, BAGS FOR PROTECTING BICYCLES AND BAGS FOR CARRYING BICYCLES; COMPONENTS FOR BICYCLES, NAMELY, FRAMES, FORKS HEADSETS WHICH PROVIDE A ROTABLE INTERFACE BETWEEN THE BICYCLE FORK AND THE BICYCLE FRAME, HANDLEBARS, HANDLEBAR STEMS, HANDLEBAR GRIPS, BRAKES, BRAKE LEVERS, BRAKE CABLES, BRAKE CALIPERS, BRAKE BLOCKS, GEARS, GEAR LEVERS, GEAR CABLES, SEAT POSTS, SEAT CLAMPS, SADDLES, BOTTOM BRACKETS, CHAIN SETS, CHAIN RINGS, CHAINS, CRANKS, PEDALS, WHEELS, HUBS, SPOKES, RIMS, TIRES, INNER TUBES, MUDGUARDS AND STANDS (U.S. CLS. 19, 21, 23, 31, 35 AND 44).

APRIL ROACH, EXAMINING ATTORNEY

CLASS 12—(Continued).

SN 77-475,948. JOHNNYPAG.COM, INC., DBA JOHNNY PAG MOTORCYCLES, IRVINE, CA. FILED 5-15-2008.



NO CLAIM IS MADE TO THE EXCLUSIVE RIGHT TO USE "MOTORCYCLES", APART FROM THE MARK AS SHOWN.

THE NAME(S), PORTRAIT(S), AND/OR SIGNATURE(S) SHOWN IN THE MARK IDENTIFIES "JOHNNY R. PAGNI- NI", WHOSE CONSENT(S) TO REGISTER IS SUBMITTED.

THE MARK CONSISTS OF THE STYLIZED TEXT "JOHN- NY PAG MOTORCYCLES", ABOVE THE TEXT IS AN OUTLINE OF A MOTORCYCLE. THE BACK TIRE OF THE MOTORCYCLE IS LOCATED TO THE RIGHT OF THE TEXT.

FOR MOTORCYCLES ; MOTORCYCLES AND STRUC- TURAL PARTS THEREFOR (U.S. CLS. 19, 21, 23, 31, 35 AND 44).

FIRST USE 6-1-2006; IN COMMERCE 6-1-2006. ROBIN MITTLER, EXAMINING ATTORNEY

SN 77-485,029. ECOMOTORS, INC., TROY, MI. FILED 5-28-2008.

ECOMOTORS INTERNATIONAL

THE MARK CONSISTS OF STANDARD CHARACTERS WITHOUT CLAIM TO ANY PARTICULAR FONT, STYLE, SIZE, OR COLOR.

NO CLAIM IS MADE TO THE EXCLUSIVE RIGHT TO USE "INTERNATIONAL", APART FROM THE MARK AS SHOWN.

FOR LAND VEHICLES AND STRUCTURAL PARTS THEREFORE; LAND VEHICLES, NAMELY, AUTOMO- BILES, TRUCKS, MOTORCYCLES; ENGINES FOR LAND VEHICLES; PARTS AND COMPONENTS FOR LAND VEHICLES, NAMELY, AXLES, DRIVE GEARS, AND TRANSMISSIONS; LAND VEHICLE POWER TRAIN SYSTEMS COMPRISED OF ENGINES, DRIVE- SHAFTS, AXLES, AND TRANSMISSIONS (U.S. CLS. 19, 21, 23, 31, 35 AND 44).

MARILYN IZZI, EXAMINING ATTORNEY

CLASS 12—(Continued).

SN 77-508,868. CIRRUS DESIGN CORPORATION, DULUTH, MN. FILED 6-26-2008.

Cirrus Vision

THE MARK CONSISTS OF STANDARD CHARACTERS WITHOUT CLAIM TO ANY PARTICULAR FONT, STYLE, SIZE, OR COLOR.

OWNER OF U.S. REG. NO. 1,907,261.
FOR AIRPLANES AND STRUCTURAL PARTS THEREFOR (U.S. CLS. 19, 21, 23, 31, 35 AND 44).
VERNA BETH RIRIE, EXAMINING ATTORNEY

SN 77-515,696. RAWLINGS SPORTING GOODS COMPANY, INC., TULLAHOMA, TN. FILED 7-7-2008.

APPLIED PRODUCTS

THE MARK CONSISTS OF STANDARD CHARACTERS WITHOUT CLAIM TO ANY PARTICULAR FONT, STYLE, SIZE, OR COLOR.

NO CLAIM IS MADE TO THE EXCLUSIVE RIGHT TO USE "PRODUCTS", APART FROM THE MARK AS SHOWN.
FOR BICYCLE AND BICYCLE COMPONENTS AND PARTS, NAMELY, FRAME TUBES, FRAMES, HANDLEBARS, SEAT POSTS, STEEL TUBES, PEDALS, SHOCK ABSORBER TUBES, BRAKES AND WHEELS (U.S. CLS. 19, 21, 23, 31, 35 AND 44).

NAAKWAMA ANKRAH, EXAMINING ATTORNEY

SN 77-525,616. YACHT TEN, INC., FORT LAUDERDALE, FL. FILED 7-18-2008.

MEGAFEND

THE MARK CONSISTS OF STANDARD CHARACTERS WITHOUT CLAIM TO ANY PARTICULAR FONT, STYLE, SIZE, OR COLOR.

FOR SPECIALTY MOORING PRODUCTS, NAMELY, BOAT FENDERS, PARTS FOR BOAT FENDERS, NAMELY, FENDER HOOKS, PNEUMATIC AIR FILLED BOAT FENDERS, SOLID CORE BOAT FENDERS AND REMOVABLE CHAFE GEAR, NAMELY, BOAT CHAFE GUARDS (U.S. CLS. 19, 21, 23, 31, 35 AND 44).

FIRST USE 11-1-1992; IN COMMERCE 11-1-1992.
MARGARET POWER, EXAMINING ATTORNEY

CLASS 12—(Continued).

SN 77-526,088. GROS, EUGENE W., WHITE CITY, OR. FILED 7-18-2008.

Pavati Marine

THE MARK CONSISTS OF STANDARD CHARACTERS WITHOUT CLAIM TO ANY PARTICULAR FONT, STYLE, SIZE, OR COLOR.

NO CLAIM IS MADE TO THE EXCLUSIVE RIGHT TO USE "MARINE", APART FROM THE MARK AS SHOWN.

THE ENGLISH TRANSLATION OF THE WORD "PAVATI" IN THE MARK IS CLEAR WATER.

FOR ALUMINUM BOATS (U.S. CLS. 19, 21, 23, 31, 35 AND 44).

FIRST USE 7-1-2008; IN COMMERCE 7-1-2008.

BRENDAN MCCAULEY, EXAMINING ATTORNEY

SN 77-526,098. DAIMLER AG, 70327 STUTTGART, FED REP GERMANY, FILED 7-18-2008.

BLUECHARGE

THE MARK CONSISTS OF STANDARD CHARACTERS WITHOUT CLAIM TO ANY PARTICULAR FONT, STYLE, SIZE, OR COLOR.

PRIORITY CLAIMED UNDER SEC. 44(D) ON FED REP GERMANY APPLICATION NO. 302008010733, FILED 2-20-2008, REG. NO. 302008010733, DATED 7-9-2008, EXPIRES 2-28-2018.

OWNER OF U.S. REG. NOS. 2,685,201 AND 3,224,057.
FOR MOTOR VEHICLES AND THEIR STRUCTURAL PARTS (U.S. CLS. 19, 21, 23, 31, 35 AND 44).
BARBARA RUTLAND, EXAMINING ATTORNEY

SN 77-526,215. GROS, EUGENE W., WHITE CITY, OR. FILED 7-18-2008.

Nightcrawler Boats

THE MARK CONSISTS OF STANDARD CHARACTERS WITHOUT CLAIM TO ANY PARTICULAR FONT, STYLE, SIZE, OR COLOR.

NO CLAIM IS MADE TO THE EXCLUSIVE RIGHT TO USE "BOATS", APART FROM THE MARK AS SHOWN.

FOR ALUMINUM BOATS (U.S. CLS. 19, 21, 23, 31, 35 AND 44).

FIRST USE 7-1-2008; IN COMMERCE 7-1-2008.

BRENDAN MCCAULEY, EXAMINING ATTORNEY

CLASS 12—(Continued).

SN 77-526,253. GROS, EUGENE W., WHITE CITY, OR. FILED 7-18-2008.

Our Bottoms are Tighter

THE MARK CONSISTS OF STANDARD CHARACTERS WITHOUT CLAIM TO ANY PARTICULAR FONT, STYLE, SIZE, OR COLOR.

FOR ALUMINUM BOATS (U.S. CLS. 19, 21, 23, 31, 35 AND 44).

FIRST USE 7-1-2008; IN COMMERCE 7-1-2008.

BRENDAN MCCAULEY, EXAMINING ATTORNEY

CLASS 12—(Continued).

SN 77-547,990. AIXAM MEGA, AIX LES BAINS, FRANCE, FILED 8-15-2008.



SN 77-530,821. STROKIN, LLC, CHASKA, MN. FILED 7-24-2008.

I-PED

THE MARK CONSISTS OF STANDARD CHARACTERS WITHOUT CLAIM TO ANY PARTICULAR FONT, STYLE, SIZE, OR COLOR.

FOR BICYCLES AND BICYCLE ACCESSORIES, NAMELY, BICYCLE BELLS, BICYCLE RACKS FOR VEHICLES, AND BICYCLE WATER-BOTTLE CAGES (U.S. CLS. 19, 21, 23, 31, 35 AND 44).

REBECCA EISINGER, EXAMINING ATTORNEY

PRIORITY CLAIMED UNDER SEC. 44(D) ON FRANCE APPLICATION NO. 083559980, FILED 3-3-2008, REG. NO. 083559980, DATED 3-3-2008, EXPIRES 3-3-2018.

NO CLAIM IS MADE TO THE EXCLUSIVE RIGHT TO USE "ECOLOGIC", APART FROM THE MARK AS SHOWN. THE COLOR(S) DARK GREY, GREY, WHITE AND GREEN IS/ARE CLAIMED AS A FEATURE OF THE MARK.

THE MARK CONSISTS OF THE WORD "MEGA" OUTLINED IN DARK GREY, AND FILLED IN WITH GREY THAT GRADUALLY LIGHTENS TO WHITE. BELOW "MEGA" APPEARS THE WORD "ECOLOGIC" WITHIN "ECO IN GREY AND "LOGIC" IN GREEN. A GREEN BRANCH IS DISPLAYED FORMING AN ARC UNDER THE LETTERS "ME" AND CONTINUING BETWEEN THE LETTERS "E" AND "G" AND DISPLAYING THREE GREEN LEAVES AT THE TOP OF THE DESIGN.

FOR VEHICLES, NAMELY, AUTOMOBILES, CARS, TRUCKS, MOTORCYCLES AND QUADRICYCLES (U.S. CLS. 19, 21, 23, 31, 35 AND 44).

RENEE SERVANCE, EXAMINING ATTORNEY

SN 77-531,459. MILES ELECTRIC VEHICLES, INC., SANTA MONICA, CA. FILED 7-25-2008.

UNPLUG AND PLAY

THE MARK CONSISTS OF STANDARD CHARACTERS WITHOUT CLAIM TO ANY PARTICULAR FONT, STYLE, SIZE, OR COLOR.

FOR AUTOMOBILES AND STRUCTURAL PARTS THEREFOR; ELECTRIC AUTOMOBILES AND STRUCTURAL PARTS THEREFOR; BATTERY ELECTRIC AUTOMOBILES AND STRUCTURAL PARTS THEREFOR; EXTENDED RANGE ELECTRIC AUTOMOBILES AND STRUCTURAL PARTS THEREFOR; RECHARGEABLE ELECTRIC AUTOMOBILES AND STRUCTURAL PARTS THEREFOR (U.S. CLS. 19, 21, 23, 31, 35 AND 44).

CAROLYN CATALDO, EXAMINING ATTORNEY

SN 77-555,630. JK TYRE & INDUSTRIES LIMITED, WEST BENGAL, INDIA, FILED 8-26-2008.



THE MARK CONSISTS OF A ROUND CIRCLE WITH THE WORD "VIKRANT" NEXT TO IT.

THE WORDING "VIKRANT" HAS NO MEANING IN A FOREIGN LANGUAGE.

FOR TIRES, INNER TUBES FOR VEHICLE TIRES AND TREADS USED TO RETREAD VEHICLE TIRES (U.S. CLS. 19, 21, 23, 31, 35 AND 44).

JAMES LOVELACE, EXAMINING ATTORNEY

CLASS 12—(Continued).

SN 77-564,122. BEIJING CAPITAL TYRE CO., LTD., BEIJING, CHINA, FILED 9-7-2008.



BCT 首创轮胎
BEIJING CAPITAL TIRE

NO CLAIM IS MADE TO THE EXCLUSIVE RIGHT TO USE "BEIJING", "TIRE" AND THE NON-LATIN CHARACTERS THAT MEAN WHEELS TIRES, APART FROM THE MARK AS SHOWN.

THE MARK CONSISTS OF THE WORDS "BCT BEIJING CAPITAL TIRE" IN A STYLIZED FORM AND FOUR CHINESE CHARACTERS.

THE NON-LATIN CHARACTER(S) IN THE MARK TRANSLITERATE INTO SHOU CHUANG LUN TAI, AND THIS MEANS CAPITAL CREATE WHEELS TIRES IN ENGLISH.

FOR TIRES, TIRES FOR LAND VEHICLES, TIRES OF TWO WHEELED MOTOR VEHICLES AND BICYCLES, TIRE LINERS, INNER TUBES FOR VEHICLES (U.S. CLS. 19, 21, 23, 31, 35 AND 44).

RONALD AIKENS, EXAMINING ATTORNEY

CLASS 12—(Continued).

SN 77-616,233. ZERO MOTORCYCLES, INC., SCOTTS VALLEY, CA. FILED 11-17-2008.



ZERO X

THE MARK CONSISTS OF STANDARD CHARACTERS WITHOUT CLAIM TO ANY PARTICULAR FONT, STYLE, SIZE, OR COLOR.

FOR ELECTRIC MOTORCYCLES; MOTORCYCLES AND STRUCTURAL PARTS THEREFOR; MOTORCYCLES FOR MOTOCROSS (U.S. CLS. 19, 21, 23, 31, 35 AND 44).

REBECCA POVARCHUK, EXAMINING ATTORNEY

SN 77-580,036. LIBERTY AEROSPACE, INC., MELBOURNE, FL. FILED 9-26-2008.



XL2

FOR AIRPLANES (U.S. CLS. 19, 21, 23, 31, 35 AND 44). FIRST USE 10-6-2000; IN COMMERCE 10-6-2000.
KATHERINE M. DUBRAY, EXAMINING ATTORNEY

SN 77-618,660. GIANT MANUFACTURING CO., LTD., TACHIA, TAICHUNG HSIEN, TAIWAN, FILED 11-20-2008.



MOMENTUM

THE MARK CONSISTS OF STANDARD CHARACTERS WITHOUT CLAIM TO ANY PARTICULAR FONT, STYLE, SIZE, OR COLOR.

FOR BICYCLES, COLLAPSIBLE BICYCLES, ELECTRIC BICYCLES AND ELECTRIC COLLAPSIBLE BICYCLES, AND STRUCTURAL PARTS THEREOF; PARTS FOR BICYCLES, NAMELY, FRAMES, HANDLEBARS, HANDLEBAR STEMS, DERAILLEURS, GEARS, SADDLES, SADDLE COVERS, SADDLE BAGS, SEAT POSTS, SEAT TUBES, PEDALS, CRANKS, TIRES, WHEELS, INNER TUBES, SPOKES, PUMPS, FORKS, CARGO AND LUGGAGE CARRIERS, BICYCLE MUDGUARDS, CHAINS, CHAIN-GUARDS, WHEEL HUBS, BRAKES, HANDLE BAR CONTROL LEVERS, SHIFT LEVERS, TOE STRAPS AND CLIPS, LUGGAGE RACKS ADAPTED FOR BICYCLES, BICYCLE BELLS, BICYCLE STOP STANDS, REARVIEW MIRRORS, TIRE PATCHES, BABY CARRIAGES, BICYCLE CANTEN RACKS, ADHESIVE RUBBER PATCHES FOR REPAIRING TUBES OR TIRES, TIRE INFLATORS, TIRE RETREADING CAPS, TREAD USED TO RETREAD TIRES, BICYCLE HOLDERS FOR VEHICLES, BAGS ADAPTED FOR BICYCLES, BICYCLE HANDLE-BAR GRIP COVERS, TRAILERS, BASKETS ADAPTED FOR BICYCLES, BICYCLE PROTECTIVE WHEELS, WHEEL COVER, BICYCLE SHOCK ABSORBERS, AND OTHER ACCESSORIES FOR BICYCLES, NAMELY, WATER BOTTLE CAGES (U.S. CLS. 19, 21, 23, 31, 35 AND 44).

SANDRA MANIOS, EXAMINING ATTORNEY

SN 77-582,333. DAIMLER AG, STUTTGART, FED REP GERMANY, FILED 9-30-2008.



INSPIRATION

THE MARK CONSISTS OF STANDARD CHARACTERS WITHOUT CLAIM TO ANY PARTICULAR FONT, STYLE, SIZE, OR COLOR.

OWNER OF FED REP GERMANY REG. NO. 2091828, DATED 2-13-1995, EXPIRES 2-28-2014.

FOR AUTOMOBILES AND THEIR STRUCTURAL PARTS (U.S. CLS. 19, 21, 23, 31, 35 AND 44).

ALEXANDER L. POWERS, EXAMINING ATTORNEY

CLASS 12—(Continued).

SN 77-638,883. MAIMIN, ISRAEL, DBA BAK INDUSTRIES, SAN FERNANDO, CA. AND MAIMIN, JULIAN, DBA BAK INDUSTRIES, SAN FERNANDO, CA. FILED 12-23-2008.

Bak Industries

THE MARK CONSISTS OF STANDARD CHARACTERS WITHOUT CLAIM TO ANY PARTICULAR FONT, STYLE, SIZE, OR COLOR.

NO CLAIM IS MADE TO THE EXCLUSIVE RIGHT TO USE "INDUSTRIES", APART FROM THE MARK AS SHOWN.

SEC. 2(F).

FOR ACCESSORIES FOR CARS AND TRUCKS, NAMELY, FITTED BED LINERS; PROTECTIVE PADS FOR TRUCK BEDS; FITTED TRUCK BED COVERS; LIGHTED AND NON-LIGHTED TRUCK BED RAILS; AUTOMOTIVE AND TRUCK PARTS, NAMELY, REPLACEMENT GRILLS AND GRILL COVERS; LIGHTED AND NON-LIGHTED RUNNING BOARDS FOR LAND VEHICLES; VEHICLE DOOR PROTECTORS, NAMELY, RUBBER AND PLASTIC DOOR SILL PROTECTORS; TRUCK ACCESSORIES, NAMELY, TAILGATE LINERS WITH ORGANIZING COMPARTMENTS AND PADDED TAILGATE LINERS; CARGO CLEATS FOR TRUCK BEDS; AND TRUCK CAB PROTECTORS IN THE NATURE OF PLASTIC GUARDS TO PROTECT AGAINST SCRATCHES FROM CARGO (U.S. CLS. 19, 21, 23, 31, 35 AND 44).

FIRST USE 1-3-1997; IN COMMERCE 1-3-1997.
MARTHA FROMM, EXAMINING ATTORNEY

SN 77-638,928. MAIMIN, ISRAEL, DBA BAK INDUSTRIES, SAN FERNANDO, CA. AND MAIMIN, JULIAN, DBA BAK INDUSTRIES, SAN FERNANDO, CA. FILED 12-23-2008.



THE COLOR(S) RED, SILVER, BLACK AND WHITE IS/ ARE CLAIMED AS A FEATURE OF THE MARK.

THE MARK CONSISTS OF A STYLIZED "B" IN AN OVAL CARRIER NEXT TO THE WORD "BAK" INSIDE A RECTANGLE CARRIER. THE COLOR RED APPEARS ON THE OVAL CARRIER, THE COLOR SILVER APPEARS ON THE STYLIZED "B", THE COLOR BLACK APPEARS ON THE RECTANGULAR CARRIER AND THE COLOR WHITE APPEARS IN THE WORD "BAK".

FOR ACCESSORIES FOR CARS AND TRUCKS, NAMELY, FITTED BED LINERS; PROTECTIVE PADS FOR TRUCK BEDS; FITTED TRUCK BED COVERS; LIGHTED AND NON-LIGHTED TRUCK BED RAILS; AUTOMOTIVE AND TRUCK PARTS, NAMELY, REPLACEMENT GRILLS AND GRILL COVERS; LIGHTED AND NON-LIGHTED RUNNING BOARDS FOR LAND VEHICLES; VEHICLE DOOR PROTECTORS, NAMELY, RUBBER AND PLASTIC DOOR SILL PROTECTORS; TRUCK ACCESSORIES, NAMELY, TAILGATE LINERS WITH ORGANIZING COMPARTMENTS AND PADDED TAILGATE LINERS; CARGO CLEATS FOR TRUCK BEDS; AND TRUCK CAB PROTECTORS IN THE NATURE OF PLASTIC GUARDS TO PROTECT AGAINST SCRATCHES FROM CARGO (U.S. CLS. 19, 21, 23, 31, 35 AND 44).

FIRST USE 1-3-1997; IN COMMERCE 1-3-1997.
MARTHA FROMM, EXAMINING ATTORNEY

CLASS 12—(Continued).

SN 77-643,322. A-FAB, LLC, LINCOLN, NE. FILED 1-5-2009.



NO CLAIM IS MADE TO THE EXCLUSIVE RIGHT TO USE "US" AND "BRAKE", APART FROM THE MARK AS SHOWN.

THE MARK CONSISTS OF STYLIZED LETTERING FOR "US BRAKE". THE TERM, "US" IS SURROUNDED BY A CURVED RECTANGLE.

FOR BRAKING SYSTEMS FOR VEHICLES AND PARTS THEREOF (U.S. CLS. 19, 21, 23, 31, 35 AND 44).

FIRST USE 0-0-2003; IN COMMERCE 0-0-2003.
HOWARD SMIGA, EXAMINING ATTORNEY

SN 77-662,867. CLASSIC EXPORTS, PASCHIM VIHAR, DELHI, INDIA, FILED 2-4-2009.

C2K

THE MARK CONSISTS OF STANDARD CHARACTERS WITHOUT CLAIM TO ANY PARTICULAR FONT, STYLE, SIZE, OR COLOR.

FOR STEERING AND SUSPENSION SYSTEMS AND PARTS FOR STEERING AND SUSPENSION SYSTEMS FOR VEHICLES, NAMELY, UPPER BALL JOINTS, LOWER BALL JOINTS, BALL JOINTS WITH CONTROL ARMS, BUSHING KITS, INNER TIE ROD ENDS, OUTER TIE ROD ENDS, SLEEVES, IDLER ARMS, CENTER LINKS, STABILIZER KITS, INNER SOCKETS AND PITMAN ARMS (U.S. CLS. 19, 21, 23, 31, 35 AND 44).

GINA FINK, EXAMINING ATTORNEY

SN 77-662,963. BASSAM ABDALLAH, PARIS, FRANCE, FILED 2-4-2009.

M11

THE MARK CONSISTS OF STANDARD CHARACTERS WITHOUT CLAIM TO ANY PARTICULAR FONT, STYLE, SIZE, OR COLOR.

FOR AUTOMOBILES AND STRUCTURAL PARTS AND FITTINGS THEREOF (U.S. CLS. 19, 21, 23, 31, 35 AND 44).

WILLIAM VERHOSEK, EXAMINING ATTORNEY

CLASS 12—(Continued).

SN 77-663,737. BRAVE NEW WHEEL INC., FORT COLLINS, CO. FILED 2-5-2009.

ONE MORE BIKE

THE MARK CONSISTS OF STANDARD CHARACTERS WITHOUT CLAIM TO ANY PARTICULAR FONT, STYLE, SIZE, OR COLOR.

NO CLAIM IS MADE TO THE EXCLUSIVE RIGHT TO USE "BIKE", APART FROM THE MARK AS SHOWN.

FOR AIR PUMPS OF TWO-WHEELED MOTOR VEHICLES OR BICYCLES; BASKETS ADAPTED FOR BICYCLES; BICYCLE BELLS; BICYCLE BRAKES; BICYCLE CHAINS; BICYCLE FRAMES; BICYCLE FRAMES AND BICYCLE HANDLEBAR GRIPS; BICYCLE GEARS; BICYCLE GRIP TAPE; BICYCLE HANDLEBAR GRIPS; BICYCLE HORNS; BICYCLE KICKSTANDS; BICYCLE PARTS, NAMELY, BRAKE SHOES; BICYCLE PARTS, NAMELY, CHANGE-SPEED GEARS; BICYCLE PARTS, NAMELY, DISK WHEELS; BICYCLE PARTS, NAMELY, DRIVE CHAINS; BICYCLE PARTS, NAMELY, DRIVE TRAINS; BICYCLE PARTS, NAMELY, FORK CROWN COVERS; BICYCLE PARTS, NAMELY, FORKS; BICYCLE PARTS, NAMELY, FRONT FORK JOINTS; BICYCLE PARTS, NAMELY, GEAR WHEELS; BICYCLE PARTS, NAMELY, HANDLE BAR ENDS; BICYCLE PARTS, NAMELY, HANDLE BAR STEMS; BICYCLE PARTS, NAMELY, SPROCKETS; BICYCLE PARTS, NAMELY, TUBES AND CONNECTORS FOR BICYCLE FRAMES; BICYCLE PEDALS; BICYCLE PUMPS; BICYCLE RACKS FOR VEHICLES; BICYCLE SADDLE COVERS; BICYCLE SADDLES; BICYCLE SEAT POSTS; BICYCLE STANDS; BICYCLE TRAILERS (RIYAKAH); BICYCLE WATER BOTTLE CAGES; BICYCLE WHEELS; BICYCLES; FITTED BICYCLE COVERS; FRAMES FOR BICYCLES; FRAMES, FOR LUGGAGE CARRIERS, FOR BICYCLES; FRONT AND REAR BICYCLE RACK PACKS; HANDLEBARS; INNER TUBES; INNER TUBES FOR BICYCLES; MUDGUARDS; PANNIER BAGS FOR BICYCLES; RACING BICYCLES; RACKS FOR VEHICLES FOR BICYCLES; RIMS FOR BICYCLE WHEELS; ROAD RACING BICYCLES; SADDLE COVERS FOR BICYCLES; SADDLES FOR BICYCLES; SAFETY PADS FOR BICYCLES; SPOKES FOR BICYCLE WHEELS; STRUCTURAL PARTS OF BICYCLES; SUSPENSION SYSTEMS FOR BICYCLES; TANDEM BICYCLES; TIRE INFLATORS; TIRES; TIRES FOR CHILDRENS' BICYCLES; TOURING BICYCLES; WATER BOTTLE CAGES FOR BICYCLES; WATER BOTTLE HOLDERS FOR BICYCLES; WHEEL HUBS; WHEEL HUBS FOR BICYCLES; WHEEL RIMS; WHEELS FOR BICYCLES, CYCLES (U.S. CLS. 19, 21, 23, 31, 35 AND 44).

EMILY CHUO, EXAMINING ATTORNEY

CLASS 12—(Continued).

SN 77-664,984. FOX FACTORY, INC., WATSONVILLE, CA. FILED 2-6-2009.



OWNER OF U.S. REG. NOS. 2,321,069 AND 2,321,107.
THE MARK CONSISTS OF THE WORD "FOX" WITH A WHITE-TIPPED FOX TAIL EXTENDED THROUGH THE CENTER OF THE LETTER "O" IN THE WORD "FOX" PLACED WITHIN A WIDE-BANDED CIRCLE.

FOR VEHICLE PARTS, NAMELY, SHOCK ABSORBERS; BICYCLE PARTS, NAMELY, SHOCK ABSORBERS (U.S. CLS. 19, 21, 23, 31, 35 AND 44).

FIRST USE 12-31-2005; IN COMMERCE 12-31-2005.
KAREN K. BUSH, EXAMINING ATTORNEY

SN 77-665,063. STRATEGIC IMPORT SUPPLY, LLC, MINNETONKA, MN. FILED 2-6-2009.

AG PRO

THE MARK CONSISTS OF STANDARD CHARACTERS WITHOUT CLAIM TO ANY PARTICULAR FONT, STYLE, SIZE, OR COLOR.

NO CLAIM IS MADE TO THE EXCLUSIVE RIGHT TO USE "AG", APART FROM THE MARK AS SHOWN.

FOR TIRES FOR LAND VEHICLES (U.S. CLS. 19, 21, 23, 31, 35 AND 44).

GEOFFREY FOSDICK, EXAMINING ATTORNEY

SN 77-665,108. CONFEDERATE MOTOR COMPANY, INC., MANDEVILLE, LA. FILED 2-6-2009.

The Art of Rebellion

THE MARK CONSISTS OF STANDARD CHARACTERS WITHOUT CLAIM TO ANY PARTICULAR FONT, STYLE, SIZE, OR COLOR.

FOR MOTORCYCLES AND STRUCTURAL PARTS THEREFOR (U.S. CLS. 19, 21, 23, 31, 35 AND 44).

FIRST USE 1-1-1999; IN COMMERCE 1-1-1999.
MATTHEW PAPPAS, EXAMINING ATTORNEY

CLASS 12—(Continued).

SN 77-665,628. ZERO MOTORCYCLES, INC., SCOTTS VALLEY, CA. FILED 2-6-2009.

ZERO SS

THE MARK CONSISTS OF STANDARD CHARACTERS WITHOUT CLAIM TO ANY PARTICULAR FONT, STYLE, SIZE, OR COLOR.

FOR ELECTRIC MOTORCYCLES; MOTORCYCLES AND STRUCTURAL PARTS THEREFOR (U.S. CLS. 19, 21, 23, 31, 35 AND 44).

CHARLES L. JENKINS, EXAMINING ATTORNEY

CLASS 12—(Continued).

SN 77-666,129. TIRE DEAL, INC, GERMANTOWN, TN. FILED 2-9-2009.

NEPTUNE

THE MARK CONSISTS OF STANDARD CHARACTERS WITHOUT CLAIM TO ANY PARTICULAR FONT, STYLE, SIZE, OR COLOR.

FOR TIRES; TIRES; TIRES FOR LAND VEHICLES (U.S. CLS. 19, 21, 23, 31, 35 AND 44).

FIRST USE 8-1-2007; IN COMMERCE 2-1-2008.

VIVIAN MICZNIK FIRST, EXAMINING ATTORNEY

SN 77-665,629. ZERO MOTORCYCLES, INC., SCOTTS VALLEY, CA. FILED 2-6-2009.

ZERO S

THE MARK CONSISTS OF STANDARD CHARACTERS WITHOUT CLAIM TO ANY PARTICULAR FONT, STYLE, SIZE, OR COLOR.

FOR ELECTRIC MOTORCYCLES; MOTORCYCLES AND STRUCTURAL PARTS THEREFOR (U.S. CLS. 19, 21, 23, 31, 35 AND 44).

FIRST USE 8-8-2008; IN COMMERCE 8-8-2008.

CHARLES L. JENKINS, EXAMINING ATTORNEY

SN 77-669,016. I PLAY, INC., ASHEVILLE, NC. FILED 2-12-2009.

SN 77-665,669. INCOLBESTOS S.A., BOGOTÁ, D.C., COLOMBIA, FILED 2-7-2009.



NO CLAIM IS MADE TO THE EXCLUSIVE RIGHT TO USE "BRAKE BLOCKS", APART FROM THE MARK AS SHOWN.

THE COLOR(S) RED, BLACK AND GREY IS/ARE CLAIMED AS A FEATURE OF THE MARK.

THE MARK CONSISTS OF THE WORD "XTRONG" IN STYLIZED LETTERS AND THE WORDS "BRAKE BLOCKS" IN MUCH SMALLER LETTERS POSITIONED BELOW THE LETTERS N AND G OF THE WORD "XTRONG". THE COLOR RED APPEARS IN THE LETTER "X". THE COLOR GREY APPEARS IN THE LETTERS "TRONG". THE COLOR BLACK APPEARS IN THE WORDS "BRAKE BLOCKS" AS WELL AS IN THE OUTER BORDER OF THE WORD "XTRONG".

FOR BRAKE BLOCKS FOR LAND VEHICLES (U.S. CLS. 19, 21, 23, 31, 35 AND 44).

MARK SHINER, EXAMINING ATTORNEY



THE MARK CONSISTS OF A STYLIZED SLEEPING SPROUT NESTLED IN AND PARTIALLY SURROUNDED BY THE TWO HALVES OF A POD RESTING ON TWO SMALL FAUX FEET.

FOR FITTED COVERS FOR SHOPPING CARTS (U.S. CLS. 19, 21, 23, 31, 35 AND 44).

AISHA SALEM, EXAMINING ATTORNEY

CLASS 12—(Continued).

SN 77-672,400. SHIMANO INC., SAKAI CITY, JAPAN, FILED 2-17-2009.

KORYAK

THE MARK CONSISTS OF STANDARD CHARACTERS WITHOUT CLAIM TO ANY PARTICULAR FONT, STYLE, SIZE, OR COLOR.

FOR ELECTRIC BICYCLES, BICYCLES, AND THEIR PARTS AND FITTINGS, NAMELY, HUBS, INTERNAL GEAR HUBS, BICYCLE DYNAMOS HUBS, HUB QUICK RELEASE LEVERS, HUB QUICK RELEASE DEVICES, GEAR RELEASE LEVERS, GEAR SHIFT LEVERS, FRONT DERAILLEURS, REAR DERAILLEURS, CHAIN GUIDES, FREEWHEELS, SPROCKETS, PULLEYS, CHAINS, CHAIN DEFLECTORS, SHIFT CABLES, CRANKS, CRANK SETS, CHAIN WHEELS, PEDALS, TOE CLIPS, BRAKE LEVERS, FRONT BRAKES, REAR BRAKES, BRAKE CABLES, BRAKE SHOES, RIMS, WHEELS, SPOKES, SPOKE CLIPS, BOTTOM BRACKETS, SEAT PILLARS, SEAT PILLAR QUICK RELEASES, HEAD PARTS FOR FRAME-FORK ASSEMBLY, SUSPENSIONS, HANDLEBARS, HANDLEBAR STEMS, GRIPS FOR HANDLEBARS, BAR ENDS, SEAT POSTS, SADDLES, DERAILLEURS CONTROLLED BY COMPUTER, WHEEL BAGS FOR BICYCLES, GEAR POSITION INDICATORS FOR BICYCLES (U.S. CLS. 19, 21, 23, 31, 35 AND 44).

KYLE PEETE, EXAMINING ATTORNEY

SN 77-673,018. HOMER TLC, INC., WILMINGTON, DE. FILED 2-18-2009.

EVERBILT

THE MARK CONSISTS OF STANDARD CHARACTERS WITHOUT CLAIM TO ANY PARTICULAR FONT, STYLE, SIZE, OR COLOR.

FOR MECHANICS' CREEPERS (U.S. CLS. 19, 21, 23, 31, 35 AND 44).

DAVID MURRAY, EXAMINING ATTORNEY

CLASS 12—(Continued).

SN 77-681,082. NISSAN JIDOSHA KABUSHIKI KAISHA, DBA NISSAN MOTOR CO., LTD., YOKOHAMA-SHI, JAPAN, FILED 3-2-2009.

MIXIM

THE MARK CONSISTS OF STANDARD CHARACTERS WITHOUT CLAIM TO ANY PARTICULAR FONT, STYLE, SIZE, OR COLOR.

FOR MOTOR VEHICLES, NAMELY, AUTOMOBILES, TRUCKS, VANS, SPORT UTILITY VEHICLES, CROSS-OVER UTILITY VEHICLES, AND STRUCTURAL PARTS THEREFOR; ELECTRIC VEHICLES, NAMELY, AUTOMOBILES (U.S. CLS. 19, 21, 23, 31, 35 AND 44).

APRIL HESIK, EXAMINING ATTORNEY

SN 77-684,929. MICHAEL WADDELL, LLC, FORTSON, GA. FILED 3-6-2009.

MICHAEL WADDELL

THE MARK CONSISTS OF STANDARD CHARACTERS WITHOUT CLAIM TO ANY PARTICULAR FONT, STYLE, SIZE, OR COLOR.

FOR ALL TERRAIN VEHICLE AFTERMARKET REPLACEMENT PARTS AND ACCESSORIES, NAMELY, MUD FLAPS, FENDERS, STEERING WHEEL COVERS, WHEEL COVERS, SEAT COVERS, FITTED AND SEMI-FITTED VEHICLE COVERS, HUB CAPS, HUB CAP COVERS, PANNIER BAGS, AND SEAT CUSHIONS (U.S. CLS. 19, 21, 23, 31, 35 AND 44).

JACQUELINE A. LAVINE, EXAMINING ATTORNEY

CLASS 13—FIREARMS

SN 77-662,968. INGRAM ENTERPRISES, INC., SPRINGFIELD, MO. FILED 2-4-2009.

RAPID RAMPAGE

THE MARK CONSISTS OF STANDARD CHARACTERS WITHOUT CLAIM TO ANY PARTICULAR FONT, STYLE, SIZE, OR COLOR.

FOR FIREWORKS IN SHELL FORMS (U.S. CLS. 2 AND 9).

GEORGE LORENZO, EXAMINING ATTORNEY

CLASS 13—(Continued).

SN 77-674,626. INGRAM ENTERPRISES, INC., SPRINGFIELD, MO. FILED 2-20-2009.

MIND GAMES

THE MARK CONSISTS OF STANDARD CHARACTERS WITHOUT CLAIM TO ANY PARTICULAR FONT, STYLE, SIZE, OR COLOR.

FOR FIREWORKS IN SHELL FORMS (U.S. CLS. 2 AND 9).

FIRST USE 4-9-2008; IN COMMERCE 4-9-2008.

GEORGE LORENZO, EXAMINING ATTORNEY

CLASS 14—JEWELRY

SN 77-450,750. SANCHEZ, BLANCA A., PEMBROKE PINES, FL. FILED 4-17-2008.

Bela Chic

THE MARK CONSISTS OF STANDARD CHARACTERS WITHOUT CLAIM TO ANY PARTICULAR FONT, STYLE, SIZE, OR COLOR.

NO CLAIM IS MADE TO THE EXCLUSIVE RIGHT TO USE "CHIC", APART FROM THE MARK AS SHOWN.

FOR BRACELETS; COSTUME JEWELRY; GEMSTONE JEWELRY; JEWELRY; JEWELRY AND IMITATION JEWELRY; JEWELRY CHAINS; JEWELRY FOR THE HEAD; JEWELRY IN THE NATURE OF ARMBANDS; JEWELRY, NAMELY, CROSSES; PET JEWELRY; PLASTIC BRACELETS IN THE NATURE OF JEWELRY; RINGS; RINGS BEING JEWELRY (U.S. CLS. 2, 27, 28 AND 50).

FIRST USE 11-1-2004; IN COMMERCE 11-1-2004.

WILLIAM BRECKENFELD, EXAMINING ATTORNEY

SN 77-490,640. NAFTALI KUGEL, BROOKLYN NY, NY. FILED 6-4-2008.

Clocs

THE MARK CONSISTS OF STANDARD CHARACTERS WITHOUT CLAIM TO ANY PARTICULAR FONT, STYLE, SIZE, OR COLOR.

FOR STRAPS AND BANDS FOR WATCHES, AND WATCHES (U.S. CLS. 2, 27, 28 AND 50).

DANIEL CAPSHAW, EXAMINING ATTORNEY

CLASS 14—(Continued).

SN 77-521,703. EILUX INTERNATIONAL, INC., ROAD TOWN, TORTOLA, BR.VIRGIN ISLANDS, FILED 7-14-2008.



The logo for EILUX EUROPE features the word "EILUX" in a bold, sans-serif font with a horizontal line underneath it. Below the line, the word "EUROPE" is written in a smaller, spaced-out, sans-serif font.

PRIORITY CLAIMED UNDER SEC. 44(D) ON HONG KONG APPLICATION NO. 301083456, FILED 4-1-2008, REG. NO. 301083456, DATED 4-1-2008, EXPIRES 4-1-2018. OWNER OF U.S. REG. NO. 2,901,634.

NO CLAIM IS MADE TO THE EXCLUSIVE RIGHT TO USE "EUROPE", APART FROM THE MARK AS SHOWN. THE MARK CONSISTS OF STYLIZED TEXT OF "EILUX EUROPE" WITH THE TERM "EILUX" PLACED ABOVE THE TERM "EUROPE".

THE WORDING "EILUX" HAS NO MEANING IN A FOREIGN LANGUAGE

FOR WATCH WINDERS AND PARTS THEREOF; AND WATCH BOXES (U.S. CLS. 2, 27, 28 AND 50).

FIRST USE 4-15-2007; IN COMMERCE 3-13-2008.

WILLIAM ROSSMAN, EXAMINING ATTORNEY

SN 77-526,236. ACCENT ARTISTRY, L.L.C., SANDY, UT. FILED 7-18-2008.

PERSISTENCE OF VISION

THE MARK CONSISTS OF STANDARD CHARACTERS WITHOUT CLAIM TO ANY PARTICULAR FONT, STYLE, SIZE, OR COLOR.

FOR JEWELRY; ORNAMENTS OF PRECIOUS METAL (U.S. CLS. 2, 27, 28 AND 50).

RONALD MCMORROW, EXAMINING ATTORNEY

SN 77-529,531. SENO JEWELRY LLC, NEW YORK, NY. FILED 7-23-2008.

IPPOLITINI

THE MARK CONSISTS OF STANDARD CHARACTERS WITHOUT CLAIM TO ANY PARTICULAR FONT, STYLE, SIZE, OR COLOR.

OWNER OF U.S. REG. NO. 2,829,602.

THE WORDING "IPPOLITINI" HAS NO MEANING IN A FOREIGN LANGUAGE.

FOR JEWELRY (U.S. CLS. 2, 27, 28 AND 50).

FIRST USE 3-0-2006; IN COMMERCE 3-0-2008.

HELENE LIWINSKI, EXAMINING ATTORNEY

CLASS 14—(Continued).

SN 77-550,494. TURTLE POND PUBLICATIONS LLC, NEW YORK, NY. FILED 8-19-2008.

Mivumbi



THE MARK CONSISTS OF THE WORD "MIVUMBI" WITH A FOUR PART MISCELLANEOUS DESIGN.

THE WORDING "MIVUMBI" HAS NO MEANING IN A FOREIGN LANGUAGE.

FOR JEWELRY AND CHARM BRACELETS (U.S. CLS. 2, 27, 28 AND 50).

KAREN K. BUSH, EXAMINING ATTORNEY

CLASS 14—(Continued).

SN 77-551,118. MOHAMMED KHAN JEWELLERS PRIVATE LIMITED, HYDERABAD, INDIA, FILED 8-20-2008.

MOHAMMED KHAN

THE MARK CONSISTS OF STANDARD CHARACTERS WITHOUT CLAIM TO ANY PARTICULAR FONT, STYLE, SIZE, OR COLOR.

THE NAME "MOHAMMED KHAN" DOES NOT IDENTIFY A LIVING INDIVIDUAL.

FOR CUT DIAMONDS; DIAMOND; DIAMOND JEWELLERY; DIAMONDS; GOLD; GOLD, UNWORKED OR SEMI-WORKED; JEWELLERY AND IMITATION JEWELLERY; JEWELLERY AND PRECIOUS STONES; JEWELLERY CHAINS; JEWELLERY PLATED WITH PRECIOUS METALS; JEWELLERY, CLOCKS AND WATCHES; NECKLACES; PEARLS; PLATINUM; PLATINUM ALLOY INGOTS; PRECIOUS METALS AND THEIR ALLOYS, NAMELY, GOLD, SILVER, PLATINUM AND STUDDED JEWELLERY; SILVER; SILVER ALLOY INGOTS; SINTERED DIAMONDS; SYNTHETIC DIAMONDS (U.S. CLS. 2, 27, 28 AND 50).

FIRST USE 10-23-1991; IN COMMERCE 11-14-1991.

EDWARD NELSON, EXAMINING ATTORNEY

SN 77-550,540. TURTLE POND PUBLICATIONS LLC, NEW YORK, NY. FILED 8-19-2008.

Tumaini



THE MARK CONSISTS OF THE WORD "TUMAINI" WITH A STYLIZED FLOWER DESIGN.

THE ENGLISH TRANSLATION OF THE WORD "TUMAINI" IS HOPE OR BELIEF.

FOR JEWELRY AND CHARM BRACELETS (U.S. CLS. 2, 27, 28 AND 50).

KAREN K. BUSH, EXAMINING ATTORNEY

SN 77-572,354. TKS, BASTOGNE, BELGIUM, FILED 9-17-2008.

ice
SWISS

NO CLAIM IS MADE TO THE EXCLUSIVE RIGHT TO USE "SWISS", APART FROM THE MARK AS SHOWN.

THE MARK CONSISTS OF THE WORDS "ICE SWISS" IN WHICH THE WORD "ICE" IS WRITTEN ABOVE AND IN LARGER LETTER THAN "SWISS" AND THERE IS A LINE BETWEEN THE TWO WORDS.

FOR WATCHES AND CLOCKS WHICH ARE OF SWISS ORIGIN AS DEFINED BY THE SWISS ORDINANCE GOVERNING THE USE OF THE APPELLATION "SWITZERLAND" OR "SWISS" FOR WATCHES (U.S. CLS. 2, 27, 28 AND 50).

JOHN SCHUYLER YARD, EXAMINING ATTORNEY

CLASS 14—(Continued).

SN 77-578,868. COOK, MARIA BOTELHO, AKA KENDRA GRACE, LAGUNA BEACH, CA. FILED 9-25-2008.



THE MARK CONSISTS OF CIRCLE ENCLOSED GEOMETRIC DESIGN INCLUDING A HEXAGONAL STAR. FOR JEWELRY (U.S. CLS. 2, 27, 28 AND 50). FIRST USE 4-15-1988; IN COMMERCE 2-5-1989. SANDRA MANIOS, EXAMINING ATTORNEY

CLASS 14—(Continued).

SN 77-591,460. LAX, SAMUEL, DBA SALA-GROUP, MISSION HILLS, CA. FILED 10-13-2008.

SALA

THE MARK CONSISTS OF STANDARD CHARACTERS WITHOUT CLAIM TO ANY PARTICULAR FONT, STYLE, SIZE, OR COLOR. FOR JEWELRY; WATCHES (U.S. CLS. 2, 27, 28 AND 50). FIRST USE 12-31-1967; IN COMMERCE 12-31-1967. TRACY WHITTAKER-BROWN, EXAMINING ATTORNEY

SN 77-601,210. FMTM DISTRIBUTION LTD., IM1 2LR DOUGLAS, ISLE OF MAN, FILED 10-27-2008.

FRANCK MULLER NUANCE

SN 77-583,287. ONE MEANING, NEW YORK, NY. FILED 10-1-2008.

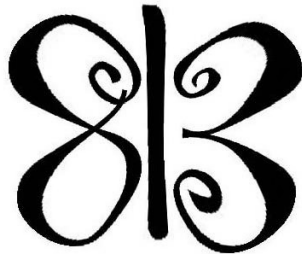

ONEMEANING

THE MARK CONSISTS OF THE WORDS "ONE MEANING" TOGETHER WITH A BUTTERFLY DESIGN. THE BUTTERFLY DESIGN IS COMPRISED OF THE NUMBER 813, WHICH FORMS THE WINGS AND BODY OF THE BUTTERFLY.

FOR BRACELETS; CHARMS; IDENTIFICATION BRACELETS; JEWELRY; JEWELRY AND IMITATION JEWELRY; JEWELRY FOR ATTACHMENT TO CLOTHING; JEWELRY WATCHES; LEATHER JEWELRY AND ACCESSORY BOXES; PET JEWELRY; RINGS (U.S. CLS. 2, 27, 28 AND 50). JEAN IM, EXAMINING ATTORNEY

THE MARK CONSISTS OF STANDARD CHARACTERS WITHOUT CLAIM TO ANY PARTICULAR FONT, STYLE, SIZE, OR COLOR.

PRIORITY CLAIMED UNDER SEC. 44(D) ON SWITZERLAND APPLICATION NO. 57118/2008, FILED 6-5-2008, REG. NO. 577229, DATED 10-1-2008, EXPIRES 6-5-2018.

OWNER OF U.S. REG. NOS. 1,945,105, 2,737,587 AND 2,977,213.

FOR HOROLOGICAL AND CHRONOMETRIC INSTRUMENTS, NAMELY, CLOCKS, WATCHES, WRISTWATCHES, TABLE CLOCKS AND CHRONOMETERS (U.S. CLS. 2, 27, 28 AND 50).

FRANK LATTUCA, EXAMINING ATTORNEY

SN 77-625,511. CE LICENSING, LLC, LOS ANGELES, CA. FILED 12-3-2008.

Carmen Electra

THE MARK CONSISTS OF STANDARD CHARACTERS WITHOUT CLAIM TO ANY PARTICULAR FONT, STYLE, SIZE, OR COLOR.

THE NAME SHOWN IN THE MARK IDENTIFIES A LIVING INDIVIDUAL, WHOSE CONSENT IS OF RECORD.

FOR CLOCKS; JEWEL CASES OF PRECIOUS METAL; JEWELRY; WATCHBANDS; WATCHES (U.S. CLS. 2, 27, 28 AND 50).

REBECCA SMITH, EXAMINING ATTORNEY

CLASS 14—(Continued).

SN 77-653,143. JEWELS FOR GOD, INC., DBA JEWELS FOR GOD, INC., LOCUST GROVE, VA. FILED 1-21-2009.

Jewels 4 God

THE MARK CONSISTS OF STANDARD CHARACTERS WITHOUT CLAIM TO ANY PARTICULAR FONT, STYLE, SIZE, OR COLOR.

NO CLAIM IS MADE TO THE EXCLUSIVE RIGHT TO USE "JEWELS", APART FROM THE MARK AS SHOWN.

FOR JEWELRY (U.S. CLS. 2, 27, 28 AND 50).

FIRST USE 5-1-2007; IN COMMERCE 5-1-2007.

NAKIA HENRY, EXAMINING ATTORNEY

CLASS 14—(Continued).

SN 77-662,748. MARTIN, CANDIS M, DAWSONVILLE, GA. FILED 2-3-2009.

Maternalert

THE MARK CONSISTS OF STANDARD CHARACTERS WITHOUT CLAIM TO ANY PARTICULAR FONT, STYLE, SIZE, OR COLOR.

FOR IDENTIFICATION BRACELETS; RUBBER OR SILICON WRISTBANDS IN THE NATURE OF A BRACELET (U.S. CLS. 2, 27, 28 AND 50).

MICHELE SWAIN, EXAMINING ATTORNEY

SN 77-660,017. ASHI DIAMONDS, LLC, NEW YORK, NY. FILED 1-30-2009.

BABY BRIDALS

THE MARK CONSISTS OF STANDARD CHARACTERS WITHOUT CLAIM TO ANY PARTICULAR FONT, STYLE, SIZE, OR COLOR.

NO CLAIM IS MADE TO THE EXCLUSIVE RIGHT TO USE "BRIDALS", APART FROM THE MARK AS SHOWN.

FOR DIAMOND JEWELRY; PRECIOUS STONES (U.S. CLS. 2, 27, 28 AND 50).

FIRST USE 6-15-2008; IN COMMERCE 1-15-2009.

APRIL HESIK, EXAMINING ATTORNEY

SN 77-662,949. THE SAUL ZAENTZ COMPANY, BERKELEY, CA. FILED 2-4-2009.

ARWEN

THE MARK CONSISTS OF STANDARD CHARACTERS WITHOUT CLAIM TO ANY PARTICULAR FONT, STYLE, SIZE, OR COLOR.

OWNER OF U.S. REG. NOS. 3,274,479, 3,507,968 AND OTHERS.

FOR BRACELETS; BROOCHES; RINGS; RINGS BEING JEWELRY (U.S. CLS. 2, 27, 28 AND 50).

FIRST USE 1-14-2009; IN COMMERCE 1-14-2009.

LINDA POWELL, EXAMINING ATTORNEY

SN 77-662,123. BERNARD SCHUMACHER, BISMARCK, ND. FILED 2-3-2009.

GRAND

THE MARK CONSISTS OF STANDARD CHARACTERS WITHOUT CLAIM TO ANY PARTICULAR FONT, STYLE, SIZE, OR COLOR.

FOR DIAMOND JEWELRY (U.S. CLS. 2, 27, 28 AND 50).

EMILY CARLSEN, EXAMINING ATTORNEY

SN 77-664,254. GATENBY, CAMILLE M., SAN JOSE, CA. FILED 2-5-2009.

Bling It On

THE MARK CONSISTS OF STANDARD CHARACTERS WITHOUT CLAIM TO ANY PARTICULAR FONT, STYLE, SIZE, OR COLOR.

FOR JEWELRY (U.S. CLS. 2, 27, 28 AND 50).

FIRST USE 5-1-2007; IN COMMERCE 5-1-2007.

MATTHEW PAPPAS, EXAMINING ATTORNEY

CLASS 14—(Continued).

SN 77-664,753. FATHOM WATCH COMPANY, LLC, PITTSBURGH, PA. FILED 2-6-2009.

Deeper by Design

THE MARK CONSISTS OF STANDARD CHARACTERS WITHOUT CLAIM TO ANY PARTICULAR FONT, STYLE, SIZE, OR COLOR.
FOR WATCH CASES; WATCH FACES; WATCH PARTS; WATCHES (U.S. CLS. 2, 27, 28 AND 50).
JAMES LOVELACE, EXAMINING ATTORNEY

CLASS 14—(Continued).

SN 77-665,483. INGBERG, CHERYL LYNN, DBA CHERYL LYNN, VERGAS, MN. FILED 2-6-2009.

THE MARK CONSISTS OF "CHERYL LYNN" WRITTEN IN STYLIZED LETTERS.
FOR HANDMADE AND MANUFACTURED JEWELRY MADE OF STERLING SILVER, GOLD, PRECIOUS METALS, COPPER, BRASS, BRONZE, BASE METAL, GEMSTONES, PRECIOUS STONES, SEMI-PRECIOUS STONES, AND PEARLS, NAMELY, PENDANTS, EARRINGS, BRACELETS, BROOCHES, RINGS, CHARMS, CHAINS, PINS, JEWELRY PINS FOR USE ON HATS, JEWELRY FOR THE ATTACHMENT TO CLOTHING, JEWELRY IN THE NATURE OF ARMBANDS, JEWELRY WATCHES, LAPEL PINS, ANKLE BRACELETS, JEWELRY CROSSES, IDENTIFICATION BRACELETS, BEADS FOR THE USE OF MANUFACTURE IN JEWELRY, JEWELRY FINDINGS, COSTUME JEWELRY, PET JEWELRY AND JEWELRY BOXES (U.S. CLS. 2, 27, 28 AND 50).
FIRST USE 7-19-1988; IN COMMERCE 7-19-1988.
BRENDAN MCCAULEY, EXAMINING ATTORNEY

SN 77-664,835. LOUIS CREATIONS INC., NEW YORK, NY. FILED 2-6-2009.

LCI

THE MARK CONSISTS OF STANDARD CHARACTERS WITHOUT CLAIM TO ANY PARTICULAR FONT, STYLE, SIZE, OR COLOR.
FOR BRACELETS; DIAMOND JEWELRY; GEMSTONE JEWELRY; JEWELRY; JEWELRY, NAMELY, STONE PENDANTS; RINGS (U.S. CLS. 2, 27, 28 AND 50).
MATTHEW PAPPAS, EXAMINING ATTORNEY

SN 77-665,613. BAER, JACQUELINE E, ST GEORGE, UT. FILED 2-6-2009.

SN 77-664,973. ALPHIN, KENNETH W., NASHVILLE, TN. FILED 2-6-2009.

LOVE EVERYBODY

THE MARK CONSISTS OF STANDARD CHARACTERS WITHOUT CLAIM TO ANY PARTICULAR FONT, STYLE, SIZE, OR COLOR.
OWNER OF U.S. REG. NOS. 3,289,587 AND 3,292,464.
FOR JEWELRY (U.S. CLS. 2, 27, 28 AND 50).
TARAH HARDY, EXAMINING ATTORNEY

THE MARK CONSISTS OF THE TERM "PERMAPIERCE" WITH THE STRAIGHT LINE OF THE LETTER "P"'S STYLIZED TO DEPICT PIERCING STUDS.
FOR BODY JEWELRY; JEWELRY (U.S. CLS. 2, 27, 28 AND 50).
ANDREA K. NADELMAN, EXAMINING ATTORNEY

CLASS 14—(Continued).

SN 77-665,649. COLUMBIA GEM HOUSE, INC., VANCOUVER, WA. FILED 2-7-2009.

FAIR TRADE GEMS

THE MARK CONSISTS OF STANDARD CHARACTERS WITHOUT CLAIM TO ANY PARTICULAR FONT, STYLE, SIZE, OR COLOR.

OWNER OF U.S. REG. NO. 3,539,053.
NO CLAIM IS MADE TO THE EXCLUSIVE RIGHT TO USE "GEMS", APART FROM THE MARK AS SHOWN.
SEC. 2(F).
FOR GEMSTONES AND JEWELRY (U.S. CLS. 2, 27, 28 AND 50).
FIRST USE 1-30-2004; IN COMMERCE 1-30-2004.
FRED MANDIR, EXAMINING ATTORNEY

SN 77-665,810. DAWN MICHELE RUSSELL, BELLOWS FALLS, VT. FILED 2-8-2009.

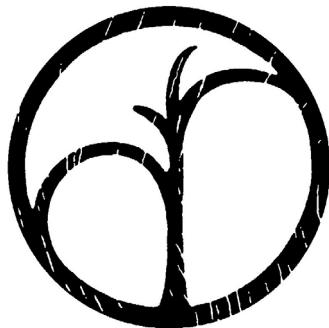

THE MARK CONSISTS OF A CIRCLE ENCLOSING THE LOWERCASE INITIALS D AND R. THE TWO LOWERCASE INITIALS MERGE AT THE CENTER TO CREATE A SYMBOL THAT RESEMBLES A GROWING PLANT.
FOR JEWELRY (U.S. CLS. 2, 27, 28 AND 50).
FIRST USE 12-1-2007; IN COMMERCE 12-1-2007.
JOHN GARTNER, EXAMINING ATTORNEY

SN 77-665,819. CHELSEA GOSSETT, MEMPHIS, TN. FILED 2-8-2009.

**COUNT ME HEALTHY GOLF
GODDESS**

THE MARK CONSISTS OF STANDARD CHARACTERS WITHOUT CLAIM TO ANY PARTICULAR FONT, STYLE, SIZE, OR COLOR.
FOR BRACELETS (U.S. CLS. 2, 27, 28 AND 50).
JAY BESCH, EXAMINING ATTORNEY

CLASS 14—(Continued).

SN 77-665,821. GOSSETT, CHELSEA, MEMPHIS, TN. FILED 2-8-2009.

**COUNT ME HEALTHY HAPPY AND
BLESSED**

THE MARK CONSISTS OF STANDARD CHARACTERS WITHOUT CLAIM TO ANY PARTICULAR FONT, STYLE, SIZE, OR COLOR.
FOR BRACELETS (U.S. CLS. 2, 27, 28 AND 50).
JAY BESCH, EXAMINING ATTORNEY

SN 77-665,928. REINERT, KATY, HUTCHINSON, MN. FILED 2-9-2009.

TRULY COWGIRL

THE MARK CONSISTS OF STANDARD CHARACTERS WITHOUT CLAIM TO ANY PARTICULAR FONT, STYLE, SIZE, OR COLOR.
FOR JEWELRY (U.S. CLS. 2, 27, 28 AND 50).
FIRST USE 9-8-2008; IN COMMERCE 9-8-2008.
SETH A. RAPPAPORT, EXAMINING ATTORNEY

SN 77-666,198. GOLDART INTERNATIONAL INC., GARDEN CITY, NY. FILED 2-9-2009.

Cachinn

THE MARK CONSISTS OF STANDARD CHARACTERS WITHOUT CLAIM TO ANY PARTICULAR FONT, STYLE, SIZE, OR COLOR.
THE ENGLISH TRANSLATION OF "CACHINN" IN THE MARK IS "LAUGH".
FOR JEWELRY MADE IN WHOLE OR SIGNIFICANT PART OF GOLD AND SILVER, NAMELY, RINGS, BRACELETS, CHARMS, PENDANTS, NECKLACES, EARRINGS, WATCHES, CHAINS, PINS; WATCHES AND TIME MEASURING DEVICES, NAMELY, CLOCKS (U.S. CLS. 2, 27, 28 AND 50).
STEPHANIE ALI, EXAMINING ATTORNEY

CLASS 14—(Continued).

SN 77-666,313. GOLDART INTERNATIONAL INC., GARDEN CITY, NY. FILED 2-9-2009.

Caecil

THE MARK CONSISTS OF STANDARD CHARACTERS WITHOUT CLAIM TO ANY PARTICULAR FONT, STYLE, SIZE, OR COLOR.

THE WORDING "CAECIL" HAS NO MEANING IN A FOREIGN LANGUAGE.

FOR JEWELRY MADE IN WHOLE OR SIGNIFICANT PART OF GOLD AND SILVER, NAMELY, RINGS, BRACELETS, CHARMS, PENDANTS, NECKLACES, EARRINGS, WATCHES, CHAINS, PINS; WATCHES AND TIME MEASURING DEVICES, NAMELY, CLOCKS (U.S. CLS. 2, 27, 28 AND 50).

PATRICIA EVANKO, EXAMINING ATTORNEY



SN 77-666,389. LYDIAN MINT, LLC, ANN ARBOR, MI. FILED 2-9-2009.



THE MARK CONSISTS OF THE LETTER "L" CENTERED AND OVERLAID ON TOP OF THE LETTER "M".

FOR BULLION COINS (U.S. CLS. 2, 27, 28 AND 50).

FIRST USE 12-0-2008; IN COMMERCE 12-0-2008.

CAROLYN CATALDO, EXAMINING ATTORNEY



SN 77-666,760. A CLASSIC TIME WATCH COMPANY, INC., NEW YORK, NY. FILED 2-9-2009.

SELFISH

THE MARK CONSISTS OF STANDARD CHARACTERS WITHOUT CLAIM TO ANY PARTICULAR FONT, STYLE, SIZE, OR COLOR.

FOR WATCHES (U.S. CLS. 2, 27, 28 AND 50).

GEORGE LORENZO, EXAMINING ATTORNEY

CLASS 14—(Continued).

SN 77-666,894. FATHOM WATCH COMPANY, LLC, PITTSBURGH, PA. FILED 2-10-2009.

Different by Design

THE MARK CONSISTS OF STANDARD CHARACTERS WITHOUT CLAIM TO ANY PARTICULAR FONT, STYLE, SIZE, OR COLOR.

FOR DIALS FOR CLOCK-AND-WATCH-MAKING; WATCH CASES; WATCH MOVEMENTS; WATCHES (U.S. CLS. 2, 27, 28 AND 50).

JAMES LOVELACE, EXAMINING ATTORNEY



SN 77-673,028. JOSTENS, INC., MINNEAPOLIS, MN. FILED 2-18-2009.

AMBER ELITE

THE MARK CONSISTS OF STANDARD CHARACTERS WITHOUT CLAIM TO ANY PARTICULAR FONT, STYLE, SIZE, OR COLOR.

OWNER OF U.S. REG. NO. 3,200,283.

NO CLAIM IS MADE TO THE EXCLUSIVE RIGHT TO USE "AMBER", APART FROM THE MARK AS SHOWN.

FOR JEWELRY (U.S. CLS. 2, 27, 28 AND 50).

LESLEY LAMOTHE, EXAMINING ATTORNEY



SN 77-673,467. ALPHIN, KENNETH W., NASHVILLE, TN. FILED 2-19-2009.

love everybody



OWNER OF U.S. REG. NOS. 3,289,587 AND 3,292,464.

THE MARK CONSISTS OF THE STYLIZED WORD LOVE CENTERED ABOVE THE STYLIZED WORD EVERYBODY, CENTERED ABOVE THE DESIGN OF A STYLIZED HEART.

FOR JEWELRY (U.S. CLS. 2, 27, 28 AND 50).

TARAH HARDY, EXAMINING ATTORNEY

CLASS 14—(Continued).

SN 78-930,336. LOS ANGELES POLICE REVOLVER AND ATHLETIC CLUB, LOS ANGELES, CA. FILED 7-15-2006.

LAPD

THE MARK CONSISTS OF STANDARD CHARACTERS WITHOUT CLAIM TO ANY PARTICULAR FONT, STYLE, SIZE, OR COLOR.

OWNER OF U.S. REG. NOS. 3,038,631 AND 3,047,180.
FOR JEWELRY, CLOCKS, WATCHES, BELT BUCKLES OF PRECIOUS METAL (U.S. CLS. 2, 27, 28 AND 50).
THEODORE MCBRIDE, EXAMINING ATTORNEY

CLASS 15—(Continued).

SN 77-658,639. CANNONBALL MUSICAL INSTRUMENTS, L.L.C., SANDY, UT. FILED 1-28-2009.

VINTAGE REBORN

THE MARK CONSISTS OF STANDARD CHARACTERS WITHOUT CLAIM TO ANY PARTICULAR FONT, STYLE, SIZE, OR COLOR.

NO CLAIM IS MADE TO THE EXCLUSIVE RIGHT TO USE "VINTAGE", APART FROM THE MARK AS SHOWN.
FOR SAXOPHONES (U.S. CLS. 2, 21 AND 36).
FIRST USE 12-31-2008; IN COMMERCE 12-31-2008.
RONALD MCMORROW, EXAMINING ATTORNEY

SN 79-049,977. ANASTASSIOS LIOPIARIS, FED REP GERMANY, FILED 9-13-2007.



CRISTALUNA
art in acrylic jewelry

PRIORITY DATE OF 3-14-2007 IS CLAIMED.
OWNER OF INTERNATIONAL REGISTRATION 0953520 DATED 9-13-2007, EXPIRES 9-13-2017.

NO CLAIM IS MADE TO THE EXCLUSIVE RIGHT TO USE "ART IN ACRYLIC JEWELRY", APART FROM THE MARK AS SHOWN.

THE COLOR(S) BLUE AND GRAY IS/ARE CLAIMED AS A FEATURE OF THE MARK.

THE COLOR BLUE APPEARS IN THE TEXT OF THE WORDING "CRISTALUNA", WHILE THE COLOR GRAY APPEARS IN THE TEXT OF THE WORDING "ART IN ACRYLIC JEWELRY".

THE WORDING "CRISTALUNA" HAS NO MEANING OTHER THAN TRADEMARK SIGNIFICANCE.

FOR PRECIOUS METALS; PRECIOUS METAL ALLOYS; JEWELRY, JEWELRY ORNAMENTS, PRECIOUS STONES; CLOCKS, CHRONOMETRIC INSTRUMENTS (U.S. CLS. 2, 27, 28 AND 50).

ELI HELLMAN, EXAMINING ATTORNEY

CLASS 16—PAPER GOODS AND PRINTED MATTER

SN 76-687,047. LABEL DADDY, LLC, TARZANA, CA. FILED 2-25-2008.



Label Daddy

THE COLOR(S) BLACK, GREEN, BLUE AND WHITE IS/ARE CLAIMED AS A FEATURE OF THE MARK.

THE MARK CONSISTS OF THE WORDS "LABEL DADDY" IN GREEN WITH BLUE SHADOWING. THERE ARE WHITE STARS INSIDE THE "L" IN "LABEL" AND THE FIRST "D" IN "DADDY". ON TOP OF THE WORD "LABEL" IS A RECLINING BLACK STICK FIGURE.

FOR LABELS AND STICKERS (U.S. CLS. 2, 5, 22, 23, 29, 37, 38 AND 50).

FIRST USE 10-1-2007; IN COMMERCE 10-1-2007.
EUGENIA MARTIN, EXAMINING ATTORNEY

CLASS 15—MUSICAL INSTRUMENTS

SN 76-695,635. EHELL, BARBARA A., KENNEWICK, WA. FILED 2-6-2009.

MEMORIES

THE MARK CONSISTS OF STANDARD CHARACTERS WITHOUT CLAIM TO ANY PARTICULAR FONT, STYLE, SIZE, OR COLOR.

FOR MUSICAL BOX FEATURING STORAGE SPACE FOR MEMORABILIA FROM A LOVED ONE WHO HAS PASSED AWAY (U.S. CLS. 2, 21 AND 36).

DOUGLAS LEE, EXAMINING ATTORNEY

SN 76-695,593. CREATIVE ESSENTIALS, LLC, DBA LAP DESK, ARLINGTON, TX. FILED 2-3-2009.

LAP SHIELD

THE MARK CONSISTS OF STANDARD CHARACTERS WITHOUT CLAIM TO ANY PARTICULAR FONT, STYLE, SIZE, OR COLOR.

NO CLAIM IS MADE TO THE EXCLUSIVE RIGHT TO USE "LAP", APART FROM THE MARK AS SHOWN.

FOR LAP DESKS (U.S. CLS. 2, 5, 22, 23, 29, 37, 38 AND 50).

RAUL CORDOVA, EXAMINING ATTORNEY

CLASS 16—(Continued).

SN 76-695,595. CREATIVE ESSENTIALS, LLC, DBA LAP DESK, ARLINGTON, TX. FILED 2-4-2009.

COOL SURF

THE MARK CONSISTS OF STANDARD CHARACTERS WITHOUT CLAIM TO ANY PARTICULAR FONT, STYLE, SIZE, OR COLOR.

FOR LAP DESKS (U.S. CLS. 2, 5, 22, 23, 29, 37, 38 AND 50).

RAUL CORDOVA, EXAMINING ATTORNEY

SN 77-096,993. TOKYOPOP INC., LOS ANGELES, CA. FILED 2-1-2007.

DRAMA CON

THE MARK CONSISTS OF STANDARD CHARACTERS WITHOUT CLAIM TO ANY PARTICULAR FONT, STYLE, SIZE, OR COLOR.

FOR ADDRESS BOOKS; ANNIVERSARY BOOKS; AUTOGRAPH BOOKS; BOOK COVERS; BOOK-COVER PAPER; CHILDREN'S BOOKS; CHILDREN'S INTERACTIVE EDUCATIONAL BOOKS; COFFEE TABLE BOOKS FEATURING COMEDY AND ROMANCE; COLORING BOOKS; COMIC BOOKS; MEMORY BOOKS; NOTE BOOKS; PICTURE BOOKS; ROLE PLAYING GAME EQUIPMENT IN THE NATURE OF GAME BOOK MANUALS; SERIES OF FICTION BOOKS; SKETCH BOOKS; STORY BOOKS; TALKING CHILDREN'S BOOKS (U.S. CLS. 2, 5, 22, 23, 29, 37, 38 AND 50).

FIRST USE 5-1-2005; IN COMMERCE 10-1-2005.

JEAN IM, EXAMINING ATTORNEY

SN 77-236,590. SOKA GAKKAI INTERNATIONAL - USA, SANTA MONICA, CA. FILED 7-23-2007.

Esperanza

THE MARK CONSISTS OF STANDARD CHARACTERS WITHOUT CLAIM TO ANY PARTICULAR FONT, STYLE, SIZE, OR COLOR.

THE FOREIGN WORDING IN THE MARK TRANSLATES INTO ENGLISH AS HOPE.

FOR SPANISH LANGUAGE MAGAZINES IN THE FIELD OF BUDDHISM (U.S. CLS. 2, 5, 22, 23, 29, 37, 38 AND 50).

FIRST USE 4-30-2006; IN COMMERCE 4-30-2006.

SONYA STEPHENS, EXAMINING ATTORNEY

CLASS 16—(Continued).

SN 77-253,359. THE MODERN GROUP, LTD., BEAUMONT, TX. FILED 8-13-2007.

GO GALVANIZED

THE MARK CONSISTS OF STANDARD CHARACTERS WITHOUT CLAIM TO ANY PARTICULAR FONT, STYLE, SIZE, OR COLOR.

NO CLAIM IS MADE TO THE EXCLUSIVE RIGHT TO USE "GALVANIZED", APART FROM THE MARK AS SHOWN.

FOR PRINTED PRODUCTS, NAMELY, PRODUCT GUIDES FEATURING AGRICULTURAL MACHINES, NAMELY, MOWERS, HYDRAULIC SKID MOWERS, AND HAY EQUIPMENT, AGRICULTURAL MACHINERY AND ATTACHMENTS THEREFORE, NAMELY, ROTARY MOWERS, BOX SCRAPERS, AND THREE POINT ATTACHMENTS, AND TRACTOR TOWED AGRICULTURAL IMPLEMENTS, NAMELY, MOWERS; PRINTED VISUALS IN THE NATURE OF PROMOTIONAL MATERIALS FEATURING AGRICULTURAL MACHINES, AGRICULTURAL MACHINERY AND ATTACHMENTS THEREFORE, AND TRACTOR TOWED AGRICULTURAL IMPLEMENTS (U.S. CLS. 2, 5, 22, 23, 29, 37, 38 AND 50).

FIRST USE 9-30-2006; IN COMMERCE 9-30-2006.

KATHERINE CHANG, EXAMINING ATTORNEY

SN 77-318,768. WOODSTOCK VENTURES, L.C., NEW YORK, NY. FILED 11-1-2007.

WOODSTOCK

THE MARK CONSISTS OF STANDARD CHARACTERS WITHOUT CLAIM TO ANY PARTICULAR FONT, STYLE, SIZE, OR COLOR.

FOR STATIONERY, PAPER BAGS, FICTION AND SERIES OF NON-FICTION BOOKS IN THE FIELD OF MUSIC AND ENTERTAINMENT; GENERAL INTEREST MAGAZINES, MAGAZINES IN THE FIELD OF MUSIC AND ENTERTAINMENT; CALENDARS, GREETING CARDS, POSTERS, PHOTOGRAPHIC PRINTS, PENS AND PENCILS, MARKERS, CHALK, HIGHLIGHTERS; DESK ACCESSORIES, NAMELY, DESKTOP ORGANIZERS, CALENDAR REFILLS; CALENDARS; DESK PADS; DESKTOP FILE HOLDERS; MAGAZINE STORAGE BOXES; INDEX CARDS AND INDEX CARD HOLDERS; BLOTTERS; PEN AND PENCIL HOLDERS; PRINTED MATTER, NAMELY, BOOKLETS, NEWSLETTERS AND GAZETTES IN THE FIELD OF MUSIC AND ENTERTAINMENT; COMICS GIFT CARDS, COUPONS; PAPER PRODUCTS, NAMELY, POSTCARDS, WRAPPING PAPER; STATIONERY PRODUCTS, NAMELY, STATIONERY PAPER, ENVELOPES, NOTE PADS; PARTY GOODS, NAMELY, PAPER NAPKINS, PAPER PARTY FAVORS AND PAPER PARTY DECORATIONS; BOARD MOUNTED WALL ART PRINTS; STICKERS (U.S. CLS. 2, 5, 22, 23, 29, 37, 38 AND 50).

CHRIS WELLS, EXAMINING ATTORNEY

CLASS 16—(Continued).

SN 77-330,595. OAG WORLDWIDE LIMITED, BEDFORDSHIRE LU5 4HB, UNITED KINGDOM, FILED 11-15-2007.

OAG POCKET FLIGHT GUIDE

THE MARK CONSISTS OF STANDARD CHARACTERS WITHOUT CLAIM TO ANY PARTICULAR FONT, STYLE, SIZE, OR COLOR.

OWNER OF U.S. REG. NOS. 2,788,280, 2,960,136 AND OTHERS.

NO CLAIM IS MADE TO THE EXCLUSIVE RIGHT TO USE "GUIDE", APART FROM THE MARK AS SHOWN.

SEC. 2(F) AS TO "POCKET FLIGHT GUIDE".

FOR PERIODIC BOOKLETS IN THE FIELD OF AIRLINE SCHEDULE INFORMATION FOR USE OF CUSTOMERS AND TRAVEL AGENTS (U.S. CLS. 2, 5, 22, 23, 29, 37, 38 AND 50).

FIRST USE 1-31-2008; IN COMMERCE 1-31-2008.

NATALIE POLZER, EXAMINING ATTORNEY

SN 77-353,596. STEVE FENDER, SAN ANTONIO, TX. FILED 12-17-2007.



THE COLOR(S) RED, BLUE, AND WHITE IS/ARE CLAIMED AS A FEATURE OF THE MARK.

THE COLOR RED APPEARS IN THE WORDING "VOTE THE BIBLE" AND IN THE CHECK MARK DESIGN; THE COLOR BLUE APPEARS IN THE RECTANGULAR DESIGN AND THE COLOR WHITE APPEARS AS THE OUTLINE OF THE SQUARE CONTAINING THE CHECKMARK.

FOR ADVERTISING BOARDS OF PAPER OR CARDBOARD; ADVERTISING PAMPHLETS; ADVERTISING SIGNS OF PAPER OR CARDBOARD; BROCHURES ABOUT VOTING / CHRISTIANITY; INFORMATIONAL FLYERS FEATURING VOTING / CHRISTIANITY; INFORMATIONAL SHEETS ABOUT VOTING / CHRISTIANITY; LEAFLETS ABOUT VOTING / CHRISTIANITY; BUMPER STICKERS (U.S. CLS. 2, 5, 22, 23, 29, 37, 38 AND 50).

FIRST USE 11-1-2003; IN COMMERCE 11-1-2003.

PAM WILLIS, EXAMINING ATTORNEY

SN 77-363,553. NUTRITION TEACHING TOOLS, LLC, BOCA RATON, FL. FILED 1-3-2008.

ACTION TRACT

THE MARK CONSISTS OF STANDARD CHARACTERS WITHOUT CLAIM TO ANY PARTICULAR FONT, STYLE, SIZE, OR COLOR.

NO CLAIM IS MADE TO THE EXCLUSIVE RIGHT TO USE "TRACT", APART FROM THE MARK AS SHOWN.

FOR TEACHING APPARATUS AND MEDICAL MODEL, NAMELY, ANATOMICAL MODELS FOR SCIENTIFIC, INSTRUCTIONAL AND EDUCATIONAL PURPOSES (U.S. CLS. 2, 5, 22, 23, 29, 37, 38 AND 50).

FIRST USE 8-20-2008; IN COMMERCE 8-20-2008.

HEATHER BIDDULPH, EXAMINING ATTORNEY

CLASS 16—(Continued).

SN 77-368,051. KENT, GREG, PHOENIX, AZ. FILED 1-9-2008.

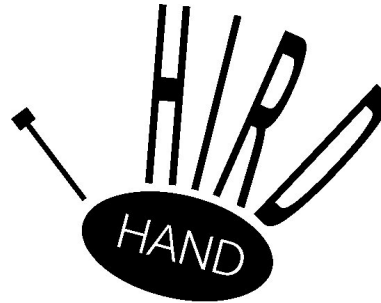

THE MARK CONSISTS OF AN ABSTRACTION OF A HUMAN HAND. THE WORD "T HIRD" REPRESENT THE FINGERS. THE WORD "HAND" IS WRITTEN IN AN OVAL THAT REPRESENTS THE PALM.

FOR ROLL-UP CARRIER SPECIALLY ADAPTED TO HOLD BLUEPRINTS, PLATS AND OTHER LARGE DOCUMENTS (U.S. CLS. 2, 5, 22, 23, 29, 37, 38 AND 50).

FIRST USE 1-1-1995; IN COMMERCE 1-23-1995.

BARBARA RUTLAND, EXAMINING ATTORNEY

SN 77-370,998. VAN NOSTRAND, WILLARD RANDOLPH, III, TUCSON, AZ. FILED 1-14-2008.

THE COLOR(S) RED, ORANGE, GREEN, BLUE, PURPLE, AND BROWN IS/ARE CLAIMED AS A FEATURE OF THE MARK.

THE MARK CONSISTS OF A RED "K", AN ORANGE "I", A GREEN "N", A BLUE "D", A PURPLE "E", A BROWN "R", AND A GREEN "GARDEN".

FOR PUBLICATIONS, NAMELY, BROCHURES, BOOKLETS, AND TEACHING MATERIALS IN THE FIELD OF GARDENING EDUCATION (U.S. CLS. 2, 5, 22, 23, 29, 37, 38 AND 50).

JENNIFER MARTIN, EXAMINING ATTORNEY

SN 77-383,177. CORTEC CORPORATION, ST. PAUL, MN. FILED 1-29-2008.

CORRTAINER

THE MARK CONSISTS OF STANDARD CHARACTERS WITHOUT CLAIM TO ANY PARTICULAR FONT, STYLE, SIZE, OR COLOR.

FOR CORRUGATED CARDBOARD BOXES COATED WITH CORROSION INHIBITORS USED FOR SHIPMENT AND STORAGE OF METALLIC OBJECTS SUBJECT TO CORROSION (U.S. CLS. 2, 5, 22, 23, 29, 37, 38 AND 50).

BONNIE LUKEN, EXAMINING ATTORNEY

CLASS 16—(Continued).

SN 77-392,512. GREENSPUN MEDIA GROUP, LLC, HENDERSON, NV. AND VEGAS.COM, LLC, HENDERSON, NV. FILED 2-8-2008.



NO CLAIM IS MADE TO THE EXCLUSIVE RIGHT TO USE "VEGAS", APART FROM THE MARK AS SHOWN.

THE MARK CONSISTS OF THE WORD "VEGAS" INSIDE AN ARROW AND "2 GO" INSIDE A CIRCLE UNDER THE TIP OF THE ARROW.

FOR GENERAL FEATURE MAGAZINES; MAGAZINES FEATURING CURRENT EVENTS, ENTERTAINMENT INFORMATION, AND DINING GUIDES (U.S. CLS. 2, 5, 22, 23, 29, 37, 38 AND 50).

FIRST USE 1-6-2008; IN COMMERCE 1-6-2008.
MATTHEW KLINE, EXAMINING ATTORNEY

CLASS 16—(Continued).

PENCIL BOXES; PENS; PENCILS; MARKERS; PEN AND PENCIL SETS; ERASERS; DRAFTING AND DRAWING RULERS; PENCIL SHARPENERS; BOOKENDS; BOOK COVERS AND HOLDERS; CHECKBOOK COVERS; COIN AND PHOTOGRAPH ALBUMS; PHOTOGRAPHIC, PICTURE OR ART MOUNTS; PHOTOGRAPHIC PRINTS; PHOTOGRAPHS; LITHOGRAPHS; DECORATIVE PAPER CENTERPIECES AND PENCIL-TOP ORNAMENTS; PICTURE BOOKS; PAPERWEIGHTS; PAPER CLIP AND SIGN HOLDERS; PRINTED PAPER SIGNS; CLIP BOARDS; PAPER PARTY FAVORS; PAPER EMBLEMS; PRINTED EMBLEMS; PAPER IDENTIFICATION TAGS; PAPER NAME BADGES; PAPER HANDKERCHIEFS; TOUR BOOKS; CONCERT SOUVENIR PROGRAMS; SONG BOOKS; SHEET MUSIC BOOKS; BOOKS, MAGAZINES, LEAFLETS, FOLIOS, JOURNALS, NEWSLETTERS, BOOKLETS, PAMPHLETS AND BROCHURES, ALL OF THE AFORESAID FEATURING MUSIC, ENTERTAINMENT, ARTS, FASHION, LIFESTYLES, CULTURE, POLITICS AND EDUCATION (U.S. CLS. 2, 5, 22, 23, 29, 37, 38 AND 50).

LINDA ESTRADA, EXAMINING ATTORNEY

SN 77-493,686. GARTNER STUDIOS, INC., STILLWATER, MN. FILED 6-8-2008.

Sweet!

SN 77-463,554. GOLDSBORO, STEPHEN D., ST. LOUIS, MO. FILED 5-1-2008.

YOUNG STEFF

THE MARK CONSISTS OF STANDARD CHARACTERS WITHOUT CLAIM TO ANY PARTICULAR FONT, STYLE, SIZE, OR COLOR.

THE NAME "YOUNG STEFF" IDENTIFIES A LIVING INDIVIDUAL WHOSE CONSENT IS OF RECORD

FOR POSTERS; CALENDARS; TEMPORARY TATTOOS; STICKERS; DECALS; IRON-ON OR PLASTIC TRANSFERS; BUMPER STICKERS; BLANK CARDS; GIFT AND GREETING CARDS; MOTIVATIONAL CARDS; OCCASION AND NOTE CARDS; TRADING CARDS; POSTCARDS; SCRAPBOOKS; STICKER BOOKS; STATIONERY; NOTE PADS; PAPER NOTE TABLETS; WRITING TABLETS; NOTE BOOKS; FOLDERS; BOOKMARKS; PAPER PENNANTS; BINDERS; WRITING PAPER; ENVELOPES; ADDRESS AND APPOINTMENT BOOKS; DESK PADS; PAPER TAGS; PASSPORT HOLDERS; DESK TOP AND PERSONAL ORGANIZERS; ORGANIZERS FOR STATIONERY USE; STATIONERY-TYPE PORTFOLIOS; PAPER FLAGS; MOUNTS FOR STAMPS; RUBBER STAMPS; STAMP ALBUMS; STAMP PAD INKS; STAMP PADS; SLEEVES FOR HOLDING AND PROTECTING STAMPS; PAPER BANNERS; HOLDERS FOR DESK ACCESSORIES; LETTER OPENERS, RACKS AND TRAYS; PEN AND PENCIL CUPS;

THE MARK CONSISTS OF STANDARD CHARACTERS WITHOUT CLAIM TO ANY PARTICULAR FONT, STYLE, SIZE, OR COLOR.

FOR PAPER PRODUCTS, NAMELY, PREDESIGNED CARDSTOCK FOR CUSTOM IMPRINTING, ENVELOPES, INVITATIONS, STATIONERY, ADHESIVE LABELS AND SEALS, NOTEPADS, CALENDARS, PAPER PARTY PRODUCTS, NAMELY, BAGS, DECORATIONS, AND FAVORS, ADDRESS BOOKS, PAPER, SCRAPBOOK ALBUMS, CHIPBOARD, CARDSTOCK, PAPER SHEETS FOR NOTE TAKING, CRAFT, VELLUM, TEXTURED, DRAWING, DYED, CARDSTOCK BACKGROUND PAPERS, BACKGROUND PAPER FOR CHIPBOARD SCRAPBOOKS, WHEREIN CHIPBOARD SCRAPBOOKS ARE SCRAPBOOKS THAT HAVE PAGES MADE OF THICK PAGES OF SHAPED CARDBOARD, AND PRINTED PAPERS FOR USE IN CREATING PHOTO ALBUMS AND SCRAPBOOKS ALBUMS, PAPER DIE CUTS IN VARIOUS SHAPES, PAPER STICKERS; PHOTO AND SCRAPBOOK ALBUM THEME KITS CONSISTING, NAMELY, CRAFT PAPER, VELLUM PAPER, TEXTURED PAPER, DRAWING PAPER, BORDER TRIM IN THE NATURE OF CRAFT PAPER, VELLUM PAPER, TEXTURED PAPER, FELT PAPER, DRAWING PAPER, PAPER DIE CUTS IN VARIOUS SHAPES, SIZES AND COLORS FOR USE IN THE ARTS AND CRAFTS INDUSTRY; PAPER STICKERS, PAPER CUT OUTS IN THE NATURE OF STENCILS, PRINTED PAPER, DRAWING RULERS, PAPER HOLE PUNCHES, EMBOSSED STAMPS, PAPER EMBOSSERS AND SCISSORS ALL SOLD AS A UNIT; PRINTED DESIGN PAPER SHEETS IN THE NATURE OF CRAFT PAPER, VELLUM PAPER, TEXTURED PAPER, DRAWING PAPER, DECORATIVE PAPER BORDERS IN THE NATURE OF MATS; PHOTO MOUNTING CORNERS, STATIONERY-TYPE PORTFOLIOS AND PAPER CLOSURES OF PORTFOLIOS, PRE-EMBOSSSED PICTURES, FRAMING PAPER MATS, MEMORY BOOKS, PAPER GIFT BAGS, PRE-DECORATED PAPER GIFT BOXES, PAPER RIBBONS (U.S. CLS. 2, 5, 22, 23, 29, 37, 38 AND 50).

PRISCILLA MILTON, EXAMINING ATTORNEY

CLASS 16—(Continued).

SN 77-504,745. BETTER OFFICE PRODUCTS, CANOGA PARK, CA. FILED 6-20-2008.

BOP ART

THE MARK CONSISTS OF STANDARD CHARACTERS WITHOUT CLAIM TO ANY PARTICULAR FONT, STYLE, SIZE, OR COLOR.

NO CLAIM IS MADE TO THE EXCLUSIVE RIGHT TO USE "ART", APART FROM THE MARK AS SHOWN.

FOR EXPANDABLE FILES, REUSABLE ENVELOPES, TELEPHONE NUMBER/ADDRESS BOOKS, BLANK WRITING JOURNALS, NOTE PAD HOLDERS, NOTE PADS, NOTEBOOKS, DOCUMENT PORTFOLIOS, STATIONERY-TYPE PORTFOLIOS, REPORT COVERS, BINDERS, INDEX DIVIDERS, INDEX CARD CASES, CARRYING CASES FOR WRITING INSTRUMENTS, CARRYING BOXES FOR WRITING INSTRUMENTS, CARRYING POUCHES FOR WRITING INSTRUMENTS, DOCUMENT CARRY-ALLS, NAMELY, DOCUMENT PORTFOLIOS, FILE FOLDERS, SINGLE-POCKET DOCUMENT FOLDERS, MULTIPLE-POCKET DOCUMENT FOLDERS, BINDER POCKETS, STICKERS, LABELS, NAMELY, ADDRESS, ADHESIVE, BAR CODE, NAME TAG, BLANK OR PARTIALLY PRINTED, PAPER, PRINTED NOVELTY WINE, PRINTED PAPER, AND SHIPPING LABELS, CALENDARS, BLANK OR PARTIALLY PRINTED NOVELTY STATIONERY, WRITING INSTRUMENTS, CHALK, CRAYONS, DECORATIONS FOR WRITING INSTRUMENTS, DECORATIVE ORNAMENTS FOR TOPS OF WRITING INSTRUMENTS, EDUCATIONAL PUBLICATIONS, NAMELY, EDUCATIONAL LEARNING CARDS, FLASH CARDS, ACTIVITY CARDS, ACTIVITY BOOKS, AND POSTERS, STORY BOOKS, PUZZLE BOOKS, ALL IN THE FIELD OF CHILDREN'S ACTIVITIES, COLORING BOOKS, POSTERS, ARTS AND CRAFTS PAINT KITS, ARTS AND CRAFTS CLAY KITS, ART PRINTS AND REPRODUCTIONS, GRAPHIC ART REPRODUCTIONS, PRINTED ART REPRODUCTIONS, POSTERS, WRITING GRIPS, BOOKMARKS, BOOK MARKERS, PLASTIC GIFT BAGS, PLASTIC PROMOTIONAL BAGS, AND PLASTIC MERCHANDISE BAGS (U.S. CLS. 2, 5, 22, 23, 29, 37, 38 AND 50).

FIRST USE 4-7-2008; IN COMMERCE 4-7-2008.
ALICE BENMAMAN, EXAMINING ATTORNEY

CLASS 16—(Continued).

SN 77-504,746. BETTER OFFICE PRODUCTS, CANOGA PARK, CA. FILED 6-20-2008.

BOP GREEN

THE MARK CONSISTS OF STANDARD CHARACTERS WITHOUT CLAIM TO ANY PARTICULAR FONT, STYLE, SIZE, OR COLOR.

NO CLAIM IS MADE TO THE EXCLUSIVE RIGHT TO USE "GREEN", APART FROM THE MARK AS SHOWN.

FOR EXPANDABLE FILES, REUSABLE ENVELOPES, TELEPHONE NUMBER/ADDRESS BOOKS, BLANK WRITING JOURNALS, NOTE PAD HOLDERS, NOTE PADS, NOTEBOOKS, DOCUMENT PORTFOLIOS, STATIONERY-TYPE PORTFOLIOS, REPORT COVERS, BINDERS, INDEX DIVIDERS, INDEX CARD CASES, CARRYING CASES FOR WRITING INSTRUMENTS, CARRYING BOXES FOR WRITING INSTRUMENTS, CARRYING POUCHES FOR WRITING INSTRUMENTS, DOCUMENT CARRY-ALLS, NAMELY, DOCUMENT PORTFOLIOS, FILE FOLDERS, SINGLE-POCKET DOCUMENT FOLDERS, MULTIPLE-POCKET DOCUMENT FOLDERS, BINDER POCKETS, STICKERS, LABELS, NAMELY, ADDRESS, ADHESIVE, BAR CODE, NAME TAG, BLANK OR PARTIALLY PRINTED, PAPER, PRINTED NOVELTY WINE, PRINTED PAPER, AND SHIPPING LABELS, CALENDARS, BLANK OR PARTIALLY PRINTED NOVELTY STATIONERY, WRITING INSTRUMENTS, CHALK, CRAYONS, DECORATIONS FOR WRITING INSTRUMENTS, DECORATIVE ORNAMENTS FOR TOPS OF WRITING INSTRUMENTS, EDUCATIONAL PUBLICATIONS, NAMELY, EDUCATIONAL LEARNING CARDS, FLASH CARDS, ACTIVITY CARDS, ACTIVITY BOOKS, AND POSTERS, STORY BOOKS, PUZZLE BOOKS, ALL IN THE FIELD OF CHILDREN'S ACTIVITIES, COLORING BOOKS, POSTERS, ARTS AND CRAFTS PAINT KITS, ARTS AND CRAFTS CLAY KITS, ART PRINTS AND REPRODUCTIONS, GRAPHIC ART REPRODUCTIONS, PRINTED ART REPRODUCTIONS, POSTERS, WRITING GRIPS, BOOKMARKS, BOOK MARKERS, PLASTIC GIFT BAGS, PLASTIC PROMOTIONAL BAGS, AND PLASTIC MERCHANDISE BAGS (U.S. CLS. 2, 5, 22, 23, 29, 37, 38 AND 50).

FIRST USE 4-7-2008; IN COMMERCE 4-7-2008.
ALICE BENMAMAN, EXAMINING ATTORNEY

SN 77-510,892. HEART STAR PRESS, LLC, FREDERICKSBURG, VA. FILED 6-30-2008.

AMERICAN HERO BOOKS

THE MARK CONSISTS OF STANDARD CHARACTERS WITHOUT CLAIM TO ANY PARTICULAR FONT, STYLE, SIZE, OR COLOR.

NO CLAIM IS MADE TO THE EXCLUSIVE RIGHT TO USE "BOOKS", APART FROM THE MARK AS SHOWN.

FOR SERIES OF CHILDREN'S BOOKS FEATURING PEOPLE IN VARIOUS CAREERS (U.S. CLS. 2, 5, 22, 23, 29, 37, 38 AND 50).

MARY MUNSON, EXAMINING ATTORNEY

CLASS 16—(Continued).

SN 77-511,502. HASKELL, GLORIA THOMPSON, CHAPEL HILL, NC. AND HASKELL, GREGORY EDWARD, CHAPEL HILL, NC. FILED 6-30-2008.

Green Hill Kids



NO CLAIM IS MADE TO THE EXCLUSIVE RIGHT TO USE "KIDS", APART FROM THE MARK AS SHOWN.

THE COLOR(S) GREEN AND CREAM IS/ARE CLAIMED AS A FEATURE OF THE MARK.

THE MARK CONSISTS OF THE GREEN WORDING "GREEN HILL KIDS" AND THE DESIGN OF A CREAM COLORED CIRCLE OUTLINED WITH TWO CONCENTRIC GREEN CIRCLES. IN THE CREAM CIRCLE ARE THREE FLOWERS. EACH FLOWER IS COMPRISED OF A GREEN CIRCLE WITH A GREEN RING AROUND IT, A GREEN STALK, AND A GREEN LEAF WITH CREAM-COLORED VEINS. INSIDE THE GREEN CIRCLE OF EACH FLOWER IS A CREAM COLORED LETTER. THE FIRST FLOWER HAS THE LETTER "G", THE SECOND FLOWER HAS THE LETTER "H", AND THE THIRD FLOWER HAS THE LETTER "K".

FOR BUSINESS CARDS; OFFICE STATIONERY; CARDBOARD TRADE SHOW DISPLAY UNITS FOR MERCHANDISING PRODUCTS; BUSINESS ENVELOPES, CARDBOARD PACKAGING; PAPER STICKERS TO ACT AS LABELS; CARDBOARD TAGS AND PAPER TAGS TO GO ON STRING TO BE PLACED AROUND OBJECTS (U.S. CLS. 2, 5, 22, 23, 29, 37, 38 AND 50).
MARGARET POWER, EXAMINING ATTORNEY

SN 77-512,176. WASHINGTON MAGAZINE, INC., WASHINGTON, DC. FILED 7-1-2008.

WASHINGTONIAN BRIDE & GROOM

THE MARK CONSISTS OF STANDARD CHARACTERS WITHOUT CLAIM TO ANY PARTICULAR FONT, STYLE, SIZE, OR COLOR.

OWNER OF U.S. REG. NOS. 1,109,998, 1,462,294 AND 1,989,979.

NO CLAIM IS MADE TO THE EXCLUSIVE RIGHT TO USE "BRIDE & GROOM", APART FROM THE MARK AS SHOWN.

FOR MAGAZINES FEATURING WEDDINGS (U.S. CLS. 2, 5, 22, 23, 29, 37, 38 AND 50).
JAMES LOVELACE, EXAMINING ATTORNEY

CLASS 16—(Continued).

SN 77-518,727. LATINA MEDIA VENTURES, NEW YORK, NY. FILED 7-10-2008.

LATINA

OWNER OF U.S. REG. NOS. 2,521,637, 2,804,076 AND 2,839,474.

THE MARK CONSISTS OF THE WORDING "LATINA" IN STYLIZED FONT.

SEC. 2(F).
FOR MAGAZINES WITH ARTICLES AND COMMENTARY CONCERNING FASHION, BEAUTY, CELEBRITIES, HEALTH ISSUES, PARENTING, FOOD AND RELATIONSHIPS (U.S. CLS. 2, 5, 22, 23, 29, 37, 38 AND 50).

FIRST USE 2-19-2008; IN COMMERCE 2-19-2008.
ROBERT STRUCK, EXAMINING ATTORNEY

SN 77-520,514. AMERICAN COPAK CORPORATION, CHATSWORTH, CA. FILED 7-11-2008.

SURROUNDSHAPE

THE MARK CONSISTS OF STANDARD CHARACTERS WITHOUT CLAIM TO ANY PARTICULAR FONT, STYLE, SIZE, OR COLOR.

FOR PLASTIC, LAMINATE OR POLYPROPYLENE FOIL BAGS FOR CONSUMER, COMMERCIAL AND INDUSTRIAL PACKAGING AND PACKING (U.S. CLS. 2, 5, 22, 23, 29, 37, 38 AND 50).

NATALIE POLZER, EXAMINING ATTORNEY

SN 77-522,361. IMS PUBLISHING, INC., FORT LAUDERDALE, FL. FILED 7-15-2008.

YACHTS INTERNATIONAL

THE MARK CONSISTS OF STANDARD CHARACTERS WITHOUT CLAIM TO ANY PARTICULAR FONT, STYLE, SIZE, OR COLOR.

SEC. 2(F).
FOR PRINTED PERIODICALS IN THE FIELDS OF BOATING, WATER SPORTS, RECREATION, TRAVEL, AND MARINE ACTIVITIES (U.S. CLS. 2, 5, 22, 23, 29, 37, 38 AND 50).

FIRST USE 6-0-1997; IN COMMERCE 6-0-1997.
CHRIS WELLS, EXAMINING ATTORNEY

CLASS 16—(Continued).

SN 77-523,131. THE TEMPLE OF THE PRESENCE, INC., TUCSON, AZ. FILED 7-16-2008.

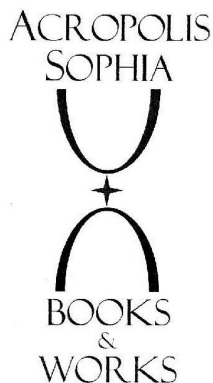

OWNER OF U.S. REG. NO. 3,019,984.
NO CLAIM IS MADE TO THE EXCLUSIVE RIGHT TO USE "BOOKS & WORKS", APART FROM THE MARK AS SHOWN.

THE MARK CONSISTS OF AN UPWARD AND DOWNWARD-CURVING ARCH AND A FOUR-POINTED DIAMOND, BETWEEN THE WORDING "ACROPOLIS SOPHIA BOOKS & WORKS".

THE ENGLISH TRANSLATION OF THE GREEK WORDING "ACROPOLIS SOPHIA" IN THE MARK IS CITADEL OF WISDOM.

FOR BOOKS IN THE FIELD OF RELIGION, PHILOSOPHY, AND SPIRITUALITY (U.S. CLS. 2, 5, 22, 23, 29, 37, 38 AND 50).

FIRST USE 2-0-2003; IN COMMERCE 2-0-2003.
BERYL GARDNER, EXAMINING ATTORNEY

SN 77-523,132. THE TEMPLE OF THE PRESENCE, INC., TUCSON, AZ. FILED 7-16-2008.

ACROPOLIS SOPHIA BOOKS &
WORKS

THE MARK CONSISTS OF STANDARD CHARACTERS WITHOUT CLAIM TO ANY PARTICULAR FONT, STYLE, SIZE, OR COLOR.

OWNER OF U.S. REG. NO. 3,019,984.
NO CLAIM IS MADE TO THE EXCLUSIVE RIGHT TO USE BOOKS & WORKS, APART FROM THE MARK AS SHOWN.

THE ENGLISH TRANSLATION OF THE GREEK WORDING "ACROPOLIS SOPHIA" IN THE MARK IS CITADEL OF WISDOM.

FOR BOOKS IN THE FIELD OF RELIGION, PHILOSOPHY, AND SPIRITUALITY (U.S. CLS. 2, 5, 22, 23, 29, 37, 38 AND 50).

FIRST USE 2-0-2003; IN COMMERCE 2-0-2003.
BERYL GARDNER, EXAMINING ATTORNEY

CLASS 16—(Continued).

SN 77-542,873. SIMPLE NETWORK, INC., EDISON, NJ. FILED 8-8-2008.

MOTHER INDIA

THE MARK CONSISTS OF STANDARD CHARACTERS WITHOUT CLAIM TO ANY PARTICULAR FONT, STYLE, SIZE, OR COLOR.

OWNER OF U.S. REG. NO. 3,605,097.

NO CLAIM IS MADE TO THE EXCLUSIVE RIGHT TO USE "INDIA", APART FROM THE MARK AS SHOWN.

FOR PREPAID NON-MAGNETICALLY ENCODED TELEPHONE CARDS (U.S. CLS. 2, 5, 22, 23, 29, 37, 38 AND 50).

FIRST USE 8-1-2000; IN COMMERCE 8-1-2000.

JOHN E. MICHOS, EXAMINING ATTORNEY

SN 77-546,256. RADIOLOGY BUSINESS MANAGEMENT ASSOCIATION, FAIRFAX, VA. FILED 8-13-2008.

RBMA BULLETIN

THE MARK CONSISTS OF STANDARD CHARACTERS WITHOUT CLAIM TO ANY PARTICULAR FONT, STYLE, SIZE, OR COLOR.

NO CLAIM IS MADE TO THE EXCLUSIVE RIGHT TO USE "BULLETIN", APART FROM THE MARK AS SHOWN.

FOR TRADE JOURNALS IN THE FIELD OF THE RADIOLOGY BUSINESS; BULLETINS CONCERNING THE RADIOLOGY BUSINESS; PRINTED PUBLICATIONS, NAMELY, BOOKS AND SERIES OF ARTICLES IN THE FIELD OF RADIOLOGY BUSINESS MANAGEMENT; MAGAZINES FEATURING THE RADIOLOGY BUSINESS (U.S. CLS. 2, 5, 22, 23, 29, 37, 38 AND 50).

FIRST USE 12-31-1973; IN COMMERCE 12-31-1973.

KEVON CHISOLM, EXAMINING ATTORNEY

SN 77-547,823. SOCIETE BIC, CLICHY, FRANCE, FILED 8-15-2008.

ECOLUTIONS

THE MARK CONSISTS OF STANDARD CHARACTERS WITHOUT CLAIM TO ANY PARTICULAR FONT, STYLE, SIZE, OR COLOR.

FOR REPOSITIONABLE ADHESIVE NOTE PAPER, NOTE PADS, NOTEBOOKS; CORRECTION FLUID FOR DOCUMENTS; CORRECTION PENS FOR TYPE AND INK AND CORRECTING TAPE DISPENSERS SOLD AS A UNIT (U.S. CLS. 2, 5, 22, 23, 29, 37, 38 AND 50).

BARNEY CHARLON, EXAMINING ATTORNEY

CLASS 16—(Continued).

SN 77-550,503. TURTLE POND PUBLICATIONS LLC, NEW YORK, NY. FILED 8-19-2008.

Mivumbi



THE MARK CONSISTS OF THE WORD "MIVUMBI" WITH A FOUR PART MISCELLANEOUS DESIGN.

THE WORDING "MIVUMBI" HAS NO MEANING IN A FOREIGN LANGUAGE.

FOR PUBLICATIONS, NAMELY, CHILDREN'S BOOKS, MAGAZINES AND PRINTED PERIODICALS FEATURING CHILDREN'S ACTIVITIES AND STORIES (U.S. CLS. 2, 5, 22, 23, 29, 37, 38 AND 50).

KAREN K. BUSH, EXAMINING ATTORNEY

SN 77-550,550. TURTLE POND PUBLICATIONS LLC, NEW YORK, NY. FILED 8-19-2008.

Tumaini



THE MARK CONSISTS OF THE WORD "TUMAINI" WITH A STYLIZED FLOWER DESIGN.

THE ENGLISH TRANSLATION OF THE WORD "TUMAINI" IS HOPE OR BELIEF.

FOR PUBLICATIONS, NAMELY, CHILDREN'S BOOKS, MAGAZINES AND PRINTED PERIODICALS FEATURING CHILDREN'S ACTIVITIES AND STORIES (U.S. CLS. 2, 5, 22, 23, 29, 37, 38 AND 50).

KAREN K. BUSH, EXAMINING ATTORNEY

CLASS 16—(Continued).

SN 77-552,086. CENTER FOR ECOLITERACY, BERKELEY, CA. FILED 8-20-2008.

CENTER FOR ECOLITERACY

THE MARK CONSISTS OF STANDARD CHARACTERS WITHOUT CLAIM TO ANY PARTICULAR FONT, STYLE, SIZE, OR COLOR.

NO CLAIM IS MADE TO THE EXCLUSIVE RIGHT TO USE "ECOLITERACY", APART FROM THE MARK AS SHOWN.

FOR EDUCATIONAL PUBLICATIONS, NAMELY, BOOKS, HAND-OUTS, GUIDES, PAMPHLETS, WORKBOOKS, ALL OF THE FOREGOING IN THE FIELD OF EDUCATION FOR SUSTAINABLE LIVING (U.S. CLS. 2, 5, 22, 23, 29, 37, 38 AND 50).

FIRST USE 6-1-1995; IN COMMERCE 6-1-1995.
ANGELA GAW, EXAMINING ATTORNEY

SN 77-561,397. PUNTA BRAVA, LLC, AUSTIN, TX. FILED 9-3-2008.

PUNTA BRAVA

THE MARK CONSISTS OF STANDARD CHARACTERS WITHOUT CLAIM TO ANY PARTICULAR FONT, STYLE, SIZE, OR COLOR.

THE FOREIGN WORDING IN THE MARK TRANSLATES INTO ENGLISH AS "BRAVE END".

FOR PRINTED GOODS, NAMELY, LETTERHEAD PAPER, STATIONERY, BUSINESS CARDS, ENVELOPES, PHOTOGRAPHS, STAMPS, NAMELY, ADDRESS STAMPS, COMMEMORATIVE STAMP SHEETS, DATE STAMPS, IMPRESSION STAMPS, INK STAMPS, AND RUBBER STAMPS, NEWSLETTERS, MAGAZINES, BROCHURES, PAMPHLETS, BOOKS, MAPS, POSTCARDS, IN THE FIELDS OF REAL ESTATE AND TRAVEL (U.S. CLS. 2, 5, 22, 23, 29, 37, 38 AND 50).

STEVEN JACKSON, EXAMINING ATTORNEY

SN 77-575,463. FOTOBET, INC., ASTORIA, NY. FILED 9-22-2008.

Fotobet

THE MARK CONSISTS OF STANDARD CHARACTERS WITHOUT CLAIM TO ANY PARTICULAR FONT, STYLE, SIZE, OR COLOR.

FOR PHOTOGRAPHIC PRINTS; PHOTOGRAPHS; UNMOUNTED AND MOUNTED PHOTOGRAPHS (U.S. CLS. 2, 5, 22, 23, 29, 37, 38 AND 50).

KEVIN CORWIN, EXAMINING ATTORNEY

CLASS 16—(Continued).

SN 77-591,218. SIGNAL PUBLISHERS, VIERA, FL. FILED 10-13-2008.



NO CLAIM IS MADE TO THE EXCLUSIVE RIGHT TO USE "LA REVISTA LATINOAMERICANA", APART FROM THE MARK AS SHOWN.

THE ENGLISH TRANSLATION OF "LA REVISTA LATINOAMERICANA" IN THE MARK IS "THE LATIN AMERICAN MAGAZINE".

FOR MAGAZINE FEATURING OPINION, ANALYSIS AND INVESTIGATION IN ECONOMICAL, POLITICAL, AND SOCIAL ISSUES (U.S. CLS. 2, 5, 22, 23, 29, 37, 38 AND 50).

KATHERINE CONNOLLY, EXAMINING ATTORNEY

SN 77-592,209. FITZELL, SUSAN, MANCHESTER, NH. FILED 10-14-2008.

Fitzell Acceleration Center

THE MARK CONSISTS OF STANDARD CHARACTERS WITHOUT CLAIM TO ANY PARTICULAR FONT, STYLE, SIZE, OR COLOR.

FOR EDUCATIONAL PUBLICATIONS, NAMELY, EDUCATIONAL LEARNING CARDS, FLASH CARDS, ACTIVITY CARDS, WORKBOOKS, TEXTBOOKS, ACTIVITY BOOKS, STORY BOOKS, PUZZLE BOOKS, PRINTED PUZZLES, TEACHER GUIDES, MANUALS, POSTERS AND EDUCATIONAL BOOKLETS IN THE FIELD OF DIFFERENTIATED INSTRUCTION AND SPECIAL EDUCATION (U.S. CLS. 2, 5, 22, 23, 29, 37, 38 AND 50).

FIRST USE 9-0-2008; IN COMMERCE 9-0-2008.
RENEE SERVANCE, EXAMINING ATTORNEY

CLASS 16—(Continued).

SN 77-594,267. HISPANIC MARKETING, INC., GREENVILLE, SC. FILED 10-16-2008.



NO CLAIM IS MADE TO THE EXCLUSIVE RIGHT TO USE "HISPANA" AND "PERIÓDICO", APART FROM THE MARK AS SHOWN.

THE COLOR(S) LIGHT GREEN, GREEN, OLIVE, RED, WHITE AND BLACK IS/ARE CLAIMED AS A FEATURE OF THE MARK.

THE MARK CONSISTS OF THE WORDING "LA NACIÓN" IN LIGHT GREEN AND GREEN WITH BLACK HIGHLIGHTING. THE WORD "HISPANA" IS RED. THE WORDING "EL PERIÓDICO QUE LLEGA A NUESTRA GENTE" IS WHITE. THE UPPER AND LOWER HORIZONTAL BAR IS OLIVE. THE MARK APPEARS ON A TRANSPARENT BACKGROUND.

THE FOREIGN WORDING IN THE MARK TRANSLATES INTO ENGLISH AS THE HISPANIC NATION AND THE NEWSPAPER THAT REACHES OUR PEOPLE.

FOR WEEKLY HISPANIC NEWSPAPER FEATURING NEWS, FEATURE STORIES AND ARTICLES ON IMMIGRATION, HEALTH AND WELLNESS, ENTERTAINMENT, SPORTS, ECONOMY, POLITICS, GLOBAL, NATIONAL AND LOCAL COMMUNITY ISSUES (U.S. CLS. 2, 5, 22, 23, 29, 37, 38 AND 50).

DAVID MILLER, EXAMINING ATTORNEY

SN 77-604,237. CRAYOLA PROPERTIES, INC., EASTON, PA. FILED 10-30-2008.

ASPARAGUS

THE MARK CONSISTS OF STANDARD CHARACTERS WITHOUT CLAIM TO ANY PARTICULAR FONT, STYLE, SIZE, OR COLOR.

FOR CRAYONS (U.S. CLS. 2, 5, 22, 23, 29, 37, 38 AND 50).

FIRST USE 12-31-1993; IN COMMERCE 12-31-1993.
ALEXANDER L. POWERS, EXAMINING ATTORNEY

CLASS 16—(Continued).

SN 77-614,334. BENITEZ, ALBERTO, MIAMI, FL. FILED 11-14-2008.

Mundo Organik'O

THE MARK CONSISTS OF STANDARD CHARACTERS WITHOUT CLAIM TO ANY PARTICULAR FONT, STYLE, SIZE, OR COLOR.

THE ENGLISH TRANSLATION OF "MUNDO ORGANIK'O" IN THE MARK IS WORLD ORGANIC.

FOR MAGAZINE SECTIONS IN THE FIELD OF NEW TECHNOLOGIES AND PRODUCTS INVOLVING ENVIRONMENTAL ELEMENTS, OPTIMIZATION OF ENERGY USE, USE OF BIODEGRADABLES, RECYCLABLES AND NATURAL FOODS AND PRESENTING VIEWS ON THE MANAGEMENT OF ALTERNATIVE ENERGIES AND THE DEVELOPMENT OF NEW PRODUCTS; MAGAZINE SUPPLEMENTS TO NEWSPAPERS IN THE FIELD OF NEW TECHNOLOGIES AND PRODUCTS INVOLVING ENVIRONMENTAL ELEMENTS, OPTIMIZATION OF ENERGY USE, USE OF BIODEGRADABLES, RECYCLABLES AND NATURAL FOODS AND PRESENTING VIEWS ON THE MANAGEMENT OF ALTERNATIVE ENERGIES AND THE DEVELOPMENT OF NEW PRODUCTS (U.S. CLS. 2, 5, 22, 23, 29, 37, 38 AND 50).

PAUL MORENO, EXAMINING ATTORNEY

SN 77-619,023. JUDITH A. ZERAFA, ENGLEWOOD, CO. FILED 11-20-2008.

JUDY ZERAFA'S SEVEN KEYS TO SUCCESS LIFE PROGRAM

THE MARK CONSISTS OF STANDARD CHARACTERS WITHOUT CLAIM TO ANY PARTICULAR FONT, STYLE, SIZE, OR COLOR.

THE NAME "JUDY ZERAFA" IDENTIFIES A LIVING INDIVIDUAL WHOSE CONSENT IS OF RECORD.

FOR BOOKS, WORKBOOKS, GUIDE BOOKS, ACTIVITY CARDS AND FLASH CARDS IN THE FIELDS OF SELF-HELP AND PERSONAL ACHIEVEMENT (U.S. CLS. 2, 5, 22, 23, 29, 37, 38 AND 50).

ARETHA SOMERVILLE, EXAMINING ATTORNEY

CLASS 16—(Continued).

SN 77-619,614. NEOCORP MEDIA INC., COLLEGE POINT, NY. FILED 11-21-2008.

NEO Magazine

THE MARK CONSISTS OF STANDARD CHARACTERS WITHOUT CLAIM TO ANY PARTICULAR FONT, STYLE, SIZE, OR COLOR.

NO CLAIM IS MADE TO THE EXCLUSIVE RIGHT TO USE "MAGAZINE", APART FROM THE MARK AS SHOWN. FOR GENERAL FEATURE MAGAZINES (U.S. CLS. 2, 5, 22, 23, 29, 37, 38 AND 50).

FIRST USE 9-1-2005; IN COMMERCE 10-3-2005.

NAPOLEON SHARMA, EXAMINING ATTORNEY

SN 77-620,887. LINDENWOOD FEMALE COLLEGE, ST. CHARLES, MO. FILED 11-24-2008.

THE CONFLUENCE

THE MARK CONSISTS OF STANDARD CHARACTERS WITHOUT CLAIM TO ANY PARTICULAR FONT, STYLE, SIZE, OR COLOR.

FOR JOURNALS FEATURING SCHOLARLY ARTICLES IN THE FIELDS OF HISTORY, ART, PUBLIC POLICY, SCIENCE, SOCIAL SCIENCES, ARCHITECTURE, AND LITERATURE (U.S. CLS. 2, 5, 22, 23, 29, 37, 38 AND 50).

PRISCILLA MILTON, EXAMINING ATTORNEY

SN 77-627,096. BUTLER, TRACY, SAINT CHARLES, MO. FILED 12-5-2008.

Lackadaisy

THE MARK CONSISTS OF STANDARD CHARACTERS WITHOUT CLAIM TO ANY PARTICULAR FONT, STYLE, SIZE, OR COLOR.

FOR COMIC BOOKS; COMIC STRIPS APPEARING IN BOOKS AND ON THE INTERNET.; COMIC STRIPS' COMIC FEATURES (U.S. CLS. 2, 5, 22, 23, 29, 37, 38 AND 50).

FIRST USE 7-1-2006; IN COMMERCE 7-1-2006.

DEZMONA MIZELLE, EXAMINING ATTORNEY

CLASS 16—(Continued).

SN 77-629,862. TEASDALE JAMES A. CABLE, WI. FILED 12-9-2008.

I WASN'T MADE IN CHINA,
WHY IS EVERYTHING I BUY?

THE MARK CONSISTS OF STANDARD CHARACTERS WITHOUT CLAIM TO ANY PARTICULAR FONT, STYLE, SIZE, OR COLOR.

FOR BUMPER STICKERS (U.S. CLS. 2, 5, 22, 23, 29, 37, 38 AND 50).

MICHAEL LITZAU, EXAMINING ATTORNEY

SN 77-639,093. ESTATE OF JEAN-MICHEL BASQUIAT C/O CINQUE AND CINQUE, P.C., NEW YORK, NY. FILED 12-23-2008.

BASQUIAT

THE MARK CONSISTS OF STANDARD CHARACTERS WITHOUT CLAIM TO ANY PARTICULAR FONT, STYLE, SIZE, OR COLOR.

THE NAME SHOWN IN THE MARK DOES NOT IDENTIFY A PARTICULAR LIVING INDIVIDUAL.

SEC. 2(F).

FOR PAINTINGS; POSTERS; ART PRINTS; PRINTED ART REPRODUCTIONS; PAPER MERCHANDISE BAGS (U.S. CLS. 2, 5, 22, 23, 29, 37, 38 AND 50).

FIRST USE 0-0-1984; IN COMMERCE 0-0-1984.

PAUL E. FAHRENKOPF, EXAMINING ATTORNEY

SN 77-641,978. ATLAS PAPER MILLS, LLC, MIAMI, FL. FILED 12-31-2008.

GREEN HERITAGE

THE MARK CONSISTS OF STANDARD CHARACTERS WITHOUT CLAIM TO ANY PARTICULAR FONT, STYLE, SIZE, OR COLOR.

NO CLAIM IS MADE TO THE EXCLUSIVE RIGHT TO USE "GREEN", APART FROM THE MARK AS SHOWN.

FOR FACIAL TISSUES; BATHROOM TISSUE; PAPER TOWELS; PAPER NAPKINS (U.S. CLS. 2, 5, 22, 23, 29, 37, 38 AND 50).

LEIGH CAROLINE CASE, EXAMINING ATTORNEY

CLASS 16—(Continued).

SN 77-641,986. ATLAS PAPER MILLS, LLC, MIAMI, FL. FILED 12-31-2008.

BORN GREEN

THE MARK CONSISTS OF STANDARD CHARACTERS WITHOUT CLAIM TO ANY PARTICULAR FONT, STYLE, SIZE, OR COLOR.

NO CLAIM IS MADE TO THE EXCLUSIVE RIGHT TO USE "GREEN", APART FROM THE MARK AS SHOWN.

FOR FACIAL TISSUES; BATHROOM TISSUE; PAPER TOWELS; PAPER NAPKINS (U.S. CLS. 2, 5, 22, 23, 29, 37, 38 AND 50).

LEIGH CAROLINE CASE, EXAMINING ATTORNEY

SN 77-644,221. CPP INTERNATIONAL, LLC, CHARLOTTE, NC. FILED 1-6-2009.



NO CLAIM IS MADE TO THE EXCLUSIVE RIGHT TO USE "DIVISION OF" AND "PAD", APART FROM THE MARK AS SHOWN.

THE MARK CONSISTS OF THE WORDS "NOTE2SELF! DIVISION OF CAROLINA PAD" SUPERIMPOSED ON A DARK RECTANGULAR SHAPED BACKGROUND PLACED AT AN ANGLE.

SEC. 2(F) AS TO "CAROLINA PAD".

FOR ADDRESS BOOKS, ADHESIVE NOTE PAPER, APPOINTMENT BOOKS, ART PADS, BALL POINT PENS, BINDERS, BLANK JOURNALS, BLANK NOTE CARDS, CALENDARS, CONSTRUCTION PAPER, DAILY PLANNERS, DESK CALENDARS, DESK PADS, DRAWING PADS, DRY ERASE BOARDS, ENVELOPES, FILE CARDS, FILE FOLDERS, FOAM FRAMING MAT BOARDS, FOLDERS, HIGHLIGHTER PENS, INDEX CARDS, INK PENS, NOTEBOOK DIVIDERS, NOTEBOOKS, PADFOLIOS, PEN AND PENCIL CASES, PENCILS, POCKET CALENDARS, POSTER BOARD, RULED PAPER AND STATIONERY (U.S. CLS. 2, 5, 22, 23, 29, 37, 38 AND 50).

JEFFREY LOOK, EXAMINING ATTORNEY

CLASS 16—(Continued).

SN 77-645,811. ADAMSON, SARAH, NAPERVILLE, IL.
FILED 1-8-2009.

SARAH'S BACKSTAGE PASS

THE MARK CONSISTS OF STANDARD CHARACTERS WITHOUT CLAIM TO ANY PARTICULAR FONT, STYLE, SIZE, OR COLOR.

FOR PUBLICATIONS, NAMELY, ARTICLES, CIRCULARS, COLUMNS, MAGAZINES, NEWSLETTERS, AND PAMPHLETS IN THE FIELDS OF ENTERTAINMENT, MOVIES, ACTING, PERFORMING, PERFORMING ARTS, FILM CRITICISM, ENTERTAINMENT NEWS, FILM AND TELEVISION PRODUCTION, DIRECTING, FILM AND TELEVISION LOCATIONS, INTERVIEWS, FILM RELEASE DATES, BOX OFFICE INFORMATION, DVD RELEASE DATES AND CRITICISM, RED CARPET EVENTS, AND FILM PREMIERES, EXPRESSLY EXCLUDING PROVIDING ENTERTAINMENT INFORMATION AND PUBLICATIONS TO ENTERTAINMENT PROFESSIONALS (U.S. CLS. 2, 5, 22, 23, 29, 37, 38 AND 50).

FIRST USE 11-1-2007; IN COMMERCE 11-1-2007.
DAVID ELTON, EXAMINING ATTORNEY

SN 77-647,116. LAUFMAN, ALAN K., FLOWER MOUND, TX. FILED 1-10-2009.

SEX WHISPERING

THE MARK CONSISTS OF STANDARD CHARACTERS WITHOUT CLAIM TO ANY PARTICULAR FONT, STYLE, SIZE, OR COLOR.

NO CLAIM IS MADE TO THE EXCLUSIVE RIGHT TO USE "SEX", APART FROM THE MARK AS SHOWN.

THE WORDING "SEX WHISPERING" HAS NO MEANING OTHER THAN TRADEMARK SIGNIFICANCE.

FOR PRINTED MATTER, NAMELY, NEWSLETTERS, BROCHURES, BOOKS AND PERIODICALS CONCERNING TOPICS OF SEXUALITY, SEXUAL RELATIONSHIP COUNSELING AND SEX EDUCATION INCLUDING BEST PRACTICES, BIRTH CONTROL, SEXUALLY TRANSMITTED INFECTIONS, HEALTHY VERSUS UNHEALTHY RELATIONSHIPS, SEXUAL RESPONSE, MEDICAL AND SCIENTIFIC LITERATURE REVIEWS, SCHOLARLY COMMENTARY, EDUCATIONAL PROGRAM REPORTS, AND MEDIA REVIEWS, NAMELY, REVIEWS OF BOOKS, VIDEOS AND INTERNET RESOURCES (U.S. CLS. 2, 5, 22, 23, 29, 37, 38 AND 50).

FONG HSU, EXAMINING ATTORNEY

CLASS 16—(Continued).

SN 77-651,682. RIVETING NOTES, LLC, CHARLESTON, WV.
FILED 1-17-2009.

RIVETING NOTES LLC

THE MARK CONSISTS OF STANDARD CHARACTERS WITHOUT CLAIM TO ANY PARTICULAR FONT, STYLE, SIZE, OR COLOR.

NO CLAIM IS MADE TO THE EXCLUSIVE RIGHT TO USE "NOTES LLC", APART FROM THE MARK AS SHOWN. FOR GREETING CARDS (U.S. CLS. 2, 5, 22, 23, 29, 37, 38 AND 50).

FIRST USE 4-9-2009; IN COMMERCE 4-9-2009.
MAUREEN DALL, EXAMINING ATTORNEY

SN 77-652,357. QUALITY DESIGN (CI) LIMITED, ALDERNEY, GUERNSEY, FILED 1-20-2009.



THE COLOR(S) RED, BLACK, GREEN, YELLOW, GRAY AND WHITE IS/ARE CLAIMED AS A FEATURE OF THE MARK.

THE MARK CONSISTS OF BLACK SHIELD CENTRE WITH WHITE DESIGNS. RED LIONS WEARING YELLOW CROWNS ARE STANDING ON EITHER SIDE OF THE SHIELD WHICH IS SURMOUNTED WITH A GRAY, GREEN, YELLOW AND BLACK HELM WITH A WHITE SCRIPT BEARING THE WORDS "QUAERE VERUM" IN BLACK BELOW THE SHIELD.

THE ENGLISH TRANSLATION OF "QUAERE VERUM" IN THE MARK IS SEEK THE TRUTH.

FOR PAPER AND CARDBOARD; PAPER BOARD; PAPER BOARDS; PAPER STATIONERY (U.S. CLS. 2, 5, 22, 23, 29, 37, 38 AND 50).

JANICE KIM, EXAMINING ATTORNEY

CLASS 16—(Continued).

SN 77-653,772. BENJAMIN, ANDRÉ, LOS ANGELES, CA. FILED 1-21-2009.

ANDRE 3000

THE MARK CONSISTS OF STANDARD CHARACTERS WITHOUT CLAIM TO ANY PARTICULAR FONT, STYLE, SIZE, OR COLOR.

FOR POSTERS; STICKERS; BUMPERSTICKERS; DECALS; CALENDARS; POSTER BOOKS; CONCERT SOUVENIR PROGRAMS; PHOTOGRAPHS; POSTCARDS; NOTEBOOKS; BOOK COVERS; BINDERS; BOOK MARKS; MEMO PADS; PENS; PENCILS; PEN AND PENCIL CASES; PENCIL SHARPENERS; STATIONERY; WRITING PAPER; DIARIES; ADDRESS BOOKS; APPOINTMENT BOOKS; HOLIDAY CARDS; COLORING BOOKS; CHILDREN'S ACTIVITY BOOKS; PHOTO ALBUMS; GIFT WRAPPING PAPER; PAPER PARTY DECORATIONS; PAPER NAPKINS; TEMPORARY TATTOOS; NOTE CARDS; PICTURE POSTCARDS; GREETING CARDS; MUSICAL GREETING CARDS; PRINTED GREETING CARDS WITH ELECTRONIC INFORMATION STORED THEREIN; GIFT CARDS; OCCASION CARDS; SOCIAL NOTE CARDS; MOTIVATIONAL CARDS; CARDS BEARING UNIVERSAL GREETINGS; BLANK CARDS; BLANK NOTE CARDS; PLACE CARDS; BLANK AND PARTIALLY PRINTED GREETING CARDS; RECORD CARDS; SCORE CARDS; CARDBOARD OR PAPER PICTURE MOUNTS; TRADING CARDS; SCRAPBOOKS; NOTE PADS; PAPER NOTE TABLETS; WRITING TABLETS; FOLDERS; FILE FOLDERS; STATIONERY FOLDERS; PAPER PENNANTS; ENVELOPES; DESK PADS AND PAPER TAGS; PASSPORT HOLDERS; PERSONAL ORGANIZERS; DESK TOP ORGANIZERS; ORGANIZERS FOR STATIONERY USE AND STATIONERY-TYPE PORTFOLIOS; PAPER FLAGS; RUBBER STAMPS; PAPER BANNERS; LETTER OPENERS; MARKERS; STICK MARKERS; BOOK ENDS; BOOK COVERS; CHECKBOOK COVERS; BOOK HOLDERS; PHOTOGRAPHIC PRINTS; LITHOGRAPHS; DECORATIVE PAPER CENTERPIECES; DECORATIVE PENCIL-TOP ORNAMENTS; PICTURE BOOKS; PAPER AND CARDBOARD PICTURE MOUNTS; GLOBES; PAPERWEIGHTS; PAPER SIGN HOLDERS; PRINTED PAPER SIGNS; AND CLIP BOARDS (U.S. CLS. 2, 5, 22, 23, 29, 37, 38 AND 50).

CURTIS FRENCH, EXAMINING ATTORNEY

CLASS 16—(Continued).

SN 77-654,527. TURNER, WILLIAM W, DBA ADVANCED LAMINATING, INC, EAST BRIDGEWATER, MA. FILED 1-22-2009.



NO CLAIM IS MADE TO THE EXCLUSIVE RIGHT TO USE THE DESIGN OF THE RECYCLING SYMBOL, "PLANETSAFE PLANNERS" AND "100% BIODEGRADABLE", APART FROM THE MARK AS SHOWN.

THE COLOR(S) WHITE AND GREEN IS/ARE CLAIMED AS A FEATURE OF THE MARK.

THE MARK CONSISTS OF A GREEN OUTER CIRCLE WITH THREE GREEN ARROWS, A PLANET IMAGE WITH WHITE CONTINENTS AND ISLANDS AND GREEN OCEANS, AND THE WORDS "PLANETSAFE PLANNERS" AND "100% BIODEGRADABLE" DISPLAYED IN GREEN, WITH THE REMAINDER OF THE INTERIOR OF THE CIRCLE BEING WHITE.

FOR WALL CALENDARS (U.S. CLS. 2, 5, 22, 23, 29, 37, 38 AND 50).

FIRST USE 12-1-2008; IN COMMERCE 12-1-2008.

STEVEN R. FOSTER, EXAMINING ATTORNEY

SN 77-655,853. HALLISY, JULIA A., SAN FRANCISCO, CA. FILED 1-23-2009.

THE EMPOWERED PATIENT

THE MARK CONSISTS OF STANDARD CHARACTERS WITHOUT CLAIM TO ANY PARTICULAR FONT, STYLE, SIZE, OR COLOR.

NO CLAIM IS MADE TO THE EXCLUSIVE RIGHT TO USE "PATIENT", APART FROM THE MARK AS SHOWN.

FOR MANUALS IN THE FIELD OF PATIENT SAFETY AND HOSPITAL SAFETY (U.S. CLS. 2, 5, 22, 23, 29, 37, 38 AND 50).

FIRST USE 5-31-2008; IN COMMERCE 5-31-2008.

DOMINICK J. SALEMI, EXAMINING ATTORNEY

CLASS 16—(Continued).

SN 77-658,182. MBKP INTERNATIONAL LLC, ALBUQUERQUE, NM. FILED 1-28-2009.

STACK

THE MARK CONSISTS OF STANDARD CHARACTERS WITHOUT CLAIM TO ANY PARTICULAR FONT, STYLE, SIZE, OR COLOR.

FOR GUILLOTINE PAPER CUTTER (U.S. CLS. 2, 5, 22, 23, 29, 37, 38 AND 50).

FIRST USE 11-10-2006; IN COMMERCE 11-10-2006.
ZACHARY BELLO, EXAMINING ATTORNEY

SN 77-658,502. GILBERT, JACK, DEL MAR, CA. FILED 1-28-2009.



NO CLAIM IS MADE TO THE EXCLUSIVE RIGHT TO USE "FABLES", APART FROM THE MARK AS SHOWN.

THE NAME(S), PORTRAIT(S), AND/OR SIGNATURE(S) SHOWN IN THE MARK IDENTIFIES JACK GILBERT, WHOSE CONSENT(S) TO REGISTER IS MADE OF RECORD.

THE MARK CONSISTS OF THE PHRASE "GILBERT'S FABLES" IN STYLIZED FORMAT. THE DESIGN CONSISTS OF THREE ABSTRACT CURVED LINES ARISING FROM AND OFF TO THE LEFT OF THE TERM "GILBERT'S" AND THREE ABSTRACT CURVED LINES TO THE RIGHT OF THE TERM "FABLES". THE MARK IS PRESENTED WITHOUT CLAIM TO ANY PARTICULAR COLOR.

FOR BOOKS IN THE FIELD OF ILLUSTRATED FABLES (U.S. CLS. 2, 5, 22, 23, 29, 37, 38 AND 50).
MARTHA FROMM, EXAMINING ATTORNEY

SN 77-659,495. XK. INC., NEW YORK, NY. FILED 1-29-2009.

New York Wen Yi

THE MARK CONSISTS OF STANDARD CHARACTERS WITHOUT CLAIM TO ANY PARTICULAR FONT, STYLE, SIZE, OR COLOR.

NO CLAIM IS MADE TO THE EXCLUSIVE RIGHT TO USE "NEW YORK", APART FROM THE MARK AS SHOWN.

THE ENGLISH TRANSLATION OF "WEN YI" IN THE MARK IS LITERATURE AND ART.

FOR MAGAZINES FEATURING SHORT STORIES IN CHINESE (U.S. CLS. 2, 5, 22, 23, 29, 37, 38 AND 50).

KATHY DE JONGE, EXAMINING ATTORNEY

CLASS 16—(Continued).

SN 77-661,730. TIMOTHY WILLIAM HENRY, MIRA LOMA, CA. FILED 2-2-2009.

design studio pro

THE MARK CONSISTS OF STANDARD CHARACTERS WITHOUT CLAIM TO ANY PARTICULAR FONT, STYLE, SIZE, OR COLOR.

NO CLAIM IS MADE TO THE EXCLUSIVE RIGHT TO USE "DESIGN STUDIO", APART FROM THE MARK AS SHOWN.

FOR ARTS AND CRAFT CLAY KITS (U.S. CLS. 2, 5, 22, 23, 29, 37, 38 AND 50).

ANDREA K. NADELMAN, EXAMINING ATTORNEY

SN 77-662,233. WARSAW ORTHOPEDIC, INC., WARSAW, IN. FILED 2-3-2009.

MAST

THE MARK CONSISTS OF STANDARD CHARACTERS WITHOUT CLAIM TO ANY PARTICULAR FONT, STYLE, SIZE, OR COLOR.

FOR PRINTED MATERIALS, NAMELY, COURSE MATERIAL, INFORMATIONAL BROCHURES AND PAMPHLETS IN THE FIELD OF SPINAL AND ORTHOPEDIC SURGICAL TECHNIQUES (U.S. CLS. 2, 5, 22, 23, 29, 37, 38 AND 50).

ANNE MADDEN, EXAMINING ATTORNEY

SN 77-662,604. LITTLE NUTTHINGS, LLC, FAIRFAX, VA. AND SHARKEY, MOIRA E., DBA LITTLE NUTTHINGS, FAIRFAX, VA. FILED 2-3-2009.

THE COLOR(S) LIGHT TEAL IS/ARE CLAIMED AS A FEATURE OF THE MARK.

THE MARK CONSISTS OF "LITTLE NUTTHING'S" IN A LARGE FONT, BELOW IN A SMALLER FONT APPEARS "GIFTS MADE FROM REAL NUTS...FOR REAL NUTS." ALL THE WORDING APPEARS IN LIGHT TEAL.

FOR CALENDARS; GREETINGS CARDS AND POSTCARDS; NOTE CARDS (U.S. CLS. 2, 5, 22, 23, 29, 37, 38 AND 50).

FIRST USE 12-7-2007; IN COMMERCE 10-9-2008.

ELIZABETH KAJUBI, EXAMINING ATTORNEY

CLASS 16—(Continued).

SN 77-662,617. LONGVIEW FIBRE PAPER AND PACKAGING, INC., LONGVIEW, WA. FILED 2-3-2009.

FIBRESHIELD

THE MARK CONSISTS OF STANDARD CHARACTERS WITHOUT CLAIM TO ANY PARTICULAR FONT, STYLE, SIZE, OR COLOR.

FOR SEMI-EXTENDIBLE HIGH PERFORMANCE MULTI WALLED PAPER (U.S. CLS. 2, 5, 22, 23, 29, 37, 38 AND 50).

FIRST USE 4-10-2009; IN COMMERCE 4-10-2009.
RAUL CORDOVA, EXAMINING ATTORNEY

SN 77-662,819. CHINESEMALL.COM INC., KIRKLAND, WA. FILED 2-4-2009.

Making Chinese Easier

THE MARK CONSISTS OF STANDARD CHARACTERS WITHOUT CLAIM TO ANY PARTICULAR FONT, STYLE, SIZE, OR COLOR.

FOR A SERIES OF BOOKS AND WRITTEN ARTICLES IN THE FIELD OF LEARNING CHINESE LANGUAGE AND CULTURE (U.S. CLS. 2, 5, 22, 23, 29, 37, 38 AND 50).
SANDRA MANIOS, EXAMINING ATTORNEY

SN 77-662,967. BAUER, STEFANIE, SANTA MONICA, CA. FILED 2-4-2009.

ONE EYED GIRLS

THE MARK CONSISTS OF STANDARD CHARACTERS WITHOUT CLAIM TO ANY PARTICULAR FONT, STYLE, SIZE, OR COLOR.

FOR GIFT WRAPPING PAPER, NOTE PAPER, PAPER GIFT TAGS, PAPER BOXES, PAPER GIFT BAGS, PAPER HANG TAGS, PAPER NAPKINS, PAPER PARTY DECORATIONS, PAPER TABLECLOTHS, PAPER NOTEBOOKS, PAPER WINE GIFT BAGS, STATIONERY, WRITING PAPER AND ENVELOPES, POSTERS MADE OF PAPER, ART PRINTS, CALENDARS, GREETING CARDS AND POSTCARDS, PAPER BOOK COVERS, FLIP BOOKS, APPOINTMENT BOOKS, COMIC BOOKS, STORY BOOKS, COMIC STRIPS (U.S. CLS. 2, 5, 22, 23, 29, 37, 38 AND 50).

WILLIAM VERHOSEK, EXAMINING ATTORNEY

CLASS 16—(Continued).

SN 77-663,281. KELLER, SOPHIE, LOS ANGELES, CA. FILED 2-4-2009.

How Happy is

THE MARK CONSISTS OF STANDARD CHARACTERS WITHOUT CLAIM TO ANY PARTICULAR FONT, STYLE, SIZE, OR COLOR.

FOR A SERIES OF BOOKS AND WRITTEN ARTICLES IN THE FIELD OF NON FICTION SELF HELP, SELF IMPROVEMENT, SOCIAL COMMENTARY, SPIRITUALITY, HEALTH, FOOD, DIET, COOKING, HOME, GARDEN, OFFICE, RELIGION, POLITICS, INTER PERSONAL RELATIONSHIPS, PARENTING, FAMILY, BUSINESS, MONEY, SCHOOL, HOME IMPROVEMENT, CAREER ADVICE, ENVIRONMENTAL AWARENESS, PREGNANCY, BIRTH, YOUNG ADULT, CHILDREN, TEENS, PETS, MECHANICS, SPORT (U.S. CLS. 2, 5, 22, 23, 29, 37, 38 AND 50).

CHARLES L. JENKINS, EXAMINING ATTORNEY

SN 77-663,908. AOLONGXING OF NY INC, DBA PLASTIC BAG SALES, BROOKLYN, NY. FILED 2-5-2009.



THE MARK CONSISTS OF A DESIGN COMPRISED OF TWO THICK DIAGONAL LINES AND A FOUR POINT STAR ENCLOSED WITHIN A CIRCLE.

FOR GARBAGE BAGS OF PLASTIC (U.S. CLS. 2, 5, 22, 23, 29, 37, 38 AND 50).

FIRST USE 6-1-2006; IN COMMERCE 6-1-2006.
PAUL CROWLEY, EXAMINING ATTORNEY

CLASS 16—(Continued).

SN 77-664,049. NICOBOKS, HOUSTON, TX. FILED 2-5-2009.

Nicobooks

THE MARK CONSISTS OF STANDARD CHARACTERS WITHOUT CLAIM TO ANY PARTICULAR FONT, STYLE, SIZE, OR COLOR.

FOR BLANK CARDS; CALENDARS; MEMORY BOOKS; POSTERS; PRINTS (U.S. CLS. 2, 5, 22, 23, 29, 37, 38 AND 50).

CHRIS WELLS, EXAMINING ATTORNEY

CLASS 16—(Continued).

SN 77-664,578. BOXER, LESTER, BEVERLY HILLS, CA. FILED 2-5-2009.

FROM MY HEART 2 YOU

THE MARK CONSISTS OF STANDARD CHARACTERS WITHOUT CLAIM TO ANY PARTICULAR FONT, STYLE, SIZE, OR COLOR.

FOR GIFT BOXES WITH PRERECORDED MUSIC AND RECORDABLE PERSONALIZED MESSAGE (U.S. CLS. 2, 5, 22, 23, 29, 37, 38 AND 50).

AARON BRODSKY, EXAMINING ATTORNEY

SN 77-664,207. CHARTPAK, INC., MELVILLE, NY. FILED 2-5-2009.

L. & C. HARDTMUTH

THE MARK CONSISTS OF STANDARD CHARACTERS WITHOUT CLAIM TO ANY PARTICULAR FONT, STYLE, SIZE, OR COLOR.

OWNER OF U.S. REG. NOS. 504,631, 3,151,716 AND 3,159,431.

FOR FINE WRITING INSTRUMENTS, PENCILS AND PENCIL LEADS (U.S. CLS. 2, 5, 22, 23, 29, 37, 38 AND 50).

MATTHEW PAPPAS, EXAMINING ATTORNEY

SN 77-664,585. CREATIVE IMPULSE ENTERTAINMENT, INC., NEW YORK, NY. FILED 2-5-2009.

JUSTICE FOR HIRE

THE MARK CONSISTS OF STANDARD CHARACTERS WITHOUT CLAIM TO ANY PARTICULAR FONT, STYLE, SIZE, OR COLOR.

FOR BLANK CARDS; COMIC BOOKS; GRAPHIC NOVELS; POSTERS (U.S. CLS. 2, 5, 22, 23, 29, 37, 38 AND 50).

FIRST USE 8-1-2003; IN COMMERCE 9-1-2004.

TIMOTHY FINNEGAN, EXAMINING ATTORNEY

SN 77-664,501. STRIDE INC., ALBUQUERQUE, NM. FILED 2-5-2009.

Money Detector

THE MARK CONSISTS OF STANDARD CHARACTERS WITHOUT CLAIM TO ANY PARTICULAR FONT, STYLE, SIZE, OR COLOR.

FOR FELT MARKING PENS (U.S. CLS. 2, 5, 22, 23, 29, 37, 38 AND 50).

GRETCHEN ULRICH, EXAMINING ATTORNEY

SN 77-664,868. IBASIS, INC., BURLINGTON, MA. FILED 2-6-2009.

Marathon

THE MARK CONSISTS OF STANDARD CHARACTERS WITHOUT CLAIM TO ANY PARTICULAR FONT, STYLE, SIZE, OR COLOR.

FOR PRE-PAID TELEPHONE CALLING CARDS, NOT MAGNETICALLY ENCODED; TELEPHONE CALLING CARDS, NOT MAGNETICALLY ENCODED (U.S. CLS. 2, 5, 22, 23, 29, 37, 38 AND 50).

LOURDES AYALA, EXAMINING ATTORNEY

CLASS 16—(Continued).

SN 77-664,902. DIONNE, GARY C, AMHERST, NH. FILED 2-6-2009.

Mr. K'notHead

THE MARK CONSISTS OF STANDARD CHARACTERS WITHOUT CLAIM TO ANY PARTICULAR FONT, STYLE, SIZE, OR COLOR.

FOR CHILDREN'S BOOKS (U.S. CLS. 2, 5, 22, 23, 29, 37, 38 AND 50).

MARY BOAGNI, EXAMINING ATTORNEY

SN 77-664,936. ORCHIDS PAPER PRODUCTS COMPANY, PRYOR, OK. FILED 2-6-2009.

BIG MOPPER

THE MARK CONSISTS OF STANDARD CHARACTERS WITHOUT CLAIM TO ANY PARTICULAR FONT, STYLE, SIZE, OR COLOR.

FOR PAPER TOWELS (U.S. CLS. 2, 5, 22, 23, 29, 37, 38 AND 50).

FIRST USE 4-23-1998; IN COMMERCE 4-23-1998.
MIDGE BUTLER, EXAMINING ATTORNEY

SN 77-664,967. ONCE OPENED, LLC, COXSACKIE, NY. FILED 2-6-2009.



THE MARK CONSISTS OF AN IMAGE OF A SILOUETTE OF A WOMAN HOLDING A WATCH IN HER HAND INSIDE AN OVAL SHAPED DESIGN. TO THE RIGHT OF THE IMAGE IS THE STYLIZED WORDS "ONCE OPENED". OUTSIDE OF THE OVAL IS A CLOUD-LIKE DESIGN.

FOR EXPIRATION LABELING KIT FOR PRODUCTS THAT BEGIN THEIR LIFE SPAN ONCE THEY ARE OPENED - CONSISTS OF, MARKERS, SELF LAMINATED LABELS, GUIDE, AND PENS SOLD AS A UNIT (U.S. CLS. 2, 5, 22, 23, 29, 37, 38 AND 50).

PATRICIA EVANKO, EXAMINING ATTORNEY

CLASS 16—(Continued).

SN 77-665,097. CREATION BY DESIGN LLC, TEANECK, NJ. FILED 2-6-2009.

MY BIBLE CARDS

THE MARK CONSISTS OF STANDARD CHARACTERS WITHOUT CLAIM TO ANY PARTICULAR FONT, STYLE, SIZE, OR COLOR.

NO CLAIM IS MADE TO THE EXCLUSIVE RIGHT TO USE "BIBLE CARDS", APART FROM THE MARK AS SHOWN.

FOR EDUCATIONAL LEARNING CARDS FEATURING BIBLICAL THEMES AND EXPLANATORY TEXT (U.S. CLS. 2, 5, 22, 23, 29, 37, 38 AND 50).

TARAH HARDY, EXAMINING ATTORNEY

SN 77-665,465. TRUEBERRY BOOKS INC., SANTA MONICA, CA. FILED 2-6-2009.

Trueberry Books

THE MARK CONSISTS OF STANDARD CHARACTERS WITHOUT CLAIM TO ANY PARTICULAR FONT, STYLE, SIZE, OR COLOR.

NO CLAIM IS MADE TO THE EXCLUSIVE RIGHT TO USE "BOOKS", APART FROM THE MARK AS SHOWN.

FOR CHILDREN'S BOOKS (U.S. CLS. 2, 5, 22, 23, 29, 37, 38 AND 50).

NORA BUCHANAN WILL, EXAMINING ATTORNEY

SN 77-665,565. GRAND A. INTERNATIONAL CO., INC., S. EL MONTE, CA. FILED 2-6-2009.

RIPTIE

THE MARK CONSISTS OF STANDARD CHARACTERS WITHOUT CLAIM TO ANY PARTICULAR FONT, STYLE, SIZE, OR COLOR.

FOR GARBAGE BAGS OF PLASTIC; GARBAGE BAGS OF PLASTICS; GENERAL PURPOSE PLASTIC BAGS; PLASTIC GARBAGE BAGS; PLASTIC TRASH BAGS; TRASH BAGS; TRASH CAN LINERS (U.S. CLS. 2, 5, 22, 23, 29, 37, 38 AND 50).

NATALIE POLZER, EXAMINING ATTORNEY

CLASS 16—(Continued).

SN 77-665,680. WENDY P RAATZ, DBA WENDY RAATZ, WENATCHEE, WA. FILED 2-7-2009.

CalendarArt

THE MARK CONSISTS OF STANDARD CHARACTERS WITHOUT CLAIM TO ANY PARTICULAR FONT, STYLE, SIZE, OR COLOR.

FOR CALENDAR DESK PADS; CALENDAR REFILLS; CALENDAR-FINISHED PAPER; CALENDARS; CALENDARS AND DIARIES; DESK CALENDARS; MOUNTED POSTERS; NOTE CARDS THAT UNFOLD TO ACT AS WORKSHEETS FOR DAILY/MONTHLY PLANNERS, ORGANIZERS, CALENDARS, TO DO LISTS THAT REFOLD TO MAKE A CREDIT CARD SIZED ITEM THAT FITS NEATLY IN YOUR WALLET OR POCKET; POCKET CALENDARS; POSTERS; POSTERS MADE OF PAPER; PRINTED CALENDARS; TEAR-OFF CALENDARS; UNMOUNTED POSTERS; WALL CALENDARS (U.S. CLS. 2, 5, 22, 23, 29, 37, 38 AND 50).

NAAKWAMA ANKRAH, EXAMINING ATTORNEY

SN 77-666,212. CHUCK THE YUCK, PORTLAND, OR. FILED 2-9-2009.

chuck *
the **yuck**

THE MARK CONSISTS OF THE STYLIZED WORDS "CHUCK THE YUCK". THE WORD "CHUCK" APPEARS ON THE TOP LINE. TO THE RIGHT OF THE WORD "CHUCK" IS AN IMAGE OF A ABSTRACT DESIGN OF A SIX POINTED STAR. THE WORDS "THE YUCK" APPEAR ON THE BOTTOM LINE.

FOR MOTION SICKNESS BAGS MADE OUT OF PAPER (U.S. CLS. 2, 5, 22, 23, 29, 37, 38 AND 50).

FIRST USE 1-2-2008; IN COMMERCE 12-18-2008.
AMEETA JORDAN, EXAMINING ATTORNEY

SN 77-666,363. IBASIS, INC., BURLINGTON, MA. FILED 2-9-2009.

URGE

THE MARK CONSISTS OF STANDARD CHARACTERS WITHOUT CLAIM TO ANY PARTICULAR FONT, STYLE, SIZE, OR COLOR.

FOR PRE-PAID TELEPHONE CALLING CARDS, NOT MAGNETICALLY ENCODED; TELEPHONE CALLING CARDS, NOT MAGNETICALLY ENCODED (U.S. CLS. 2, 5, 22, 23, 29, 37, 38 AND 50).

LOURDES AYALA, EXAMINING ATTORNEY

CLASS 16—(Continued).

SN 77-666,652. ANGEL DE LA JUSTICIA, INC., WOODLAND HILLS, CA. FILED 2-9-2009.

Angel de la Justicia

THE MARK CONSISTS OF STANDARD CHARACTERS WITHOUT CLAIM TO ANY PARTICULAR FONT, STYLE, SIZE, OR COLOR.

NO CLAIM IS MADE TO THE EXCLUSIVE RIGHT TO USE "DE LA JUSTICIA", APART FROM THE MARK AS SHOWN.

THE ENGLISH TRANSLATION OF THE WORD "DE LA JUSTICIA" IN THE MARK IS OF JUSTICE, EQUALITY, OR FAIRNESS.

FOR BOOKS IN THE FIELD OF NONFICTION; SELF-HELP; LAW (U.S. CLS. 2, 5, 22, 23, 29, 37, 38 AND 50).

RICHARD A. STRASER, EXAMINING ATTORNEY

SN 77-666,787. WILKERSON, DAVID, NEW YORK, NY. FILED 2-9-2009.

DAVID WILKERSON PUBLICATIONS

THE MARK CONSISTS OF STANDARD CHARACTERS WITHOUT CLAIM TO ANY PARTICULAR FONT, STYLE, SIZE, OR COLOR.

NO CLAIM IS MADE TO THE EXCLUSIVE RIGHT TO USE "PUBLICATIONS", APART FROM THE MARK AS SHOWN.

THE NAME(S), PORTRAIT(S), AND/OR SIGNATURE(S) SHOWN IN THE MARK IDENTIFIES "DAVID WILKERSON", AN INDIVIDUAL, WHOSE CONSENT(S) TO REGISTER IS MADE OF RECORD.

FOR RELIGIOUS BOOKS (U.S. CLS. 2, 5, 22, 23, 29, 37, 38 AND 50).

FIRST USE 0-0-2005; IN COMMERCE 0-0-2005.

MICHAEL WEBSTER, EXAMINING ATTORNEY

SN 77-667,122. AMERICAN SNOWSPORTS EDUCATION ASSOCIATION, INC. - EDUCATION FOUNDATION, LAKEWOOD, CO. FILED 2-10-2009.

32 DEGREES THE JOURNAL OF PROFESSIONAL SNOWSPORTS INSTRUCTION

THE MARK CONSISTS OF STANDARD CHARACTERS WITHOUT CLAIM TO ANY PARTICULAR FONT, STYLE, SIZE, OR COLOR.

NO CLAIM IS MADE TO THE EXCLUSIVE RIGHT TO USE "THE JOURNAL OF PROFESSIONAL SNOWSPORTS INSTRUCTION", APART FROM THE MARK AS SHOWN.

FOR PERIODICAL MAGAZINES FOR INSTRUCTORS IN THE FIELD OF SNOWSPORTS (U.S. CLS. 2, 5, 22, 23, 29, 37, 38 AND 50).

FIRST USE 9-29-2008; IN COMMERCE 9-29-2008.

JAY FLOWERS, EXAMINING ATTORNEY

CLASS 16—(Continued).

SN 77-668,990. I PLAY, INC., ASHEVILLE, NC. FILED 2-12-2009.



THE MARK CONSISTS OF A STYLIZED SLEEPING SPROUT NESTLED IN AND PARTIALLY SURROUNDED BY THE TWO HALVES OF A POD RESTING ON TWO SMALL FAUX FEET.

FOR BABY BOOKS; DISPOSABLE SWIM PANTS FOR CHILDREN AND INFANTS; DISPOSABLE WIPES NOT IMPREGNATED WITH CHEMICALS OR COMPOUNDS; AND PAPER HANDTOWELS (U.S. CLS. 2, 5, 22, 23, 29, 37, 38 AND 50).

AISHA SALEM, EXAMINING ATTORNEY

SN 77-673,812. HARRAH'S LICENSE COMPANY, LLC, LAS VEGAS, NV. FILED 2-19-2009.

World Series of Poker

THE MARK CONSISTS OF STANDARD CHARACTERS WITHOUT CLAIM TO ANY PARTICULAR FONT, STYLE, SIZE, OR COLOR.

OWNER OF U.S. REG. NOS. 1,025,395, 3,537,943 AND OTHERS.

NO CLAIM IS MADE TO THE EXCLUSIVE RIGHT TO USE "POKER", APART FROM THE MARK AS SHOWN.

FOR BOOKS FEATURING INFORMATION, NEWS, AND ENTERTAINMENT RELATED TO GAMING AND THE GAME OF POKER; MAGAZINES FEATURING INFORMATION, NEWS, AND ENTERTAINMENT RELATED TO GAMING AND THE GAME OF POKER (U.S. CLS. 2, 5, 22, 23, 29, 37, 38 AND 50).

DAVID COLLIER, EXAMINING ATTORNEY

CLASS 16—(Continued).

SN 77-677,733. HARRAH'S LICENSE COMPANY, LLC, LAS VEGAS, NV. FILED 2-25-2009.

World Series of Poker

THE MARK CONSISTS OF STANDARD CHARACTERS WITHOUT CLAIM TO ANY PARTICULAR FONT, STYLE, SIZE, OR COLOR.

OWNER OF U.S. REG. NOS. 1,025,395, 3,537,943 AND OTHERS.

NO CLAIM IS MADE TO THE EXCLUSIVE RIGHT TO USE "POKER", APART FROM THE MARK AS SHOWN.

FOR EVENT PROGRAMS (U.S. CLS. 2, 5, 22, 23, 29, 37, 38 AND 50).

FIRST USE 5-10-1986; IN COMMERCE 5-10-1986.

DAVID COLLIER, EXAMINING ATTORNEY

SN 77-693,383. MEIJER, INC., GRAND RAPIDS, MI. FILED 3-18-2009.

Fresh Perspective

THE MARK CONSISTS OF STANDARD CHARACTERS WITHOUT CLAIM TO ANY PARTICULAR FONT, STYLE, SIZE, OR COLOR.

NO CLAIM IS MADE TO THE EXCLUSIVE RIGHT TO USE "FRESH", APART FROM THE MARK AS SHOWN.

FOR MAGAZINES IN THE FIELD OF RETAIL GROCERY STORE SERVICES (U.S. CLS. 2, 5, 22, 23, 29, 37, 38 AND 50).

FIRST USE 2-8-2009; IN COMMERCE 2-8-2009.

SALLY SHIH, EXAMINING ATTORNEY

SN 77-696,111. LONGVIEW FIBRE PAPER AND PACKAGING, INC., LONGVIEW, WA. FILED 3-20-2009.

FIBRE TRAN

THE MARK CONSISTS OF STANDARD CHARACTERS WITHOUT CLAIM TO ANY PARTICULAR FONT, STYLE, SIZE, OR COLOR.

NO CLAIM IS MADE TO THE EXCLUSIVE RIGHT TO USE "FIBRE", APART FROM THE MARK AS SHOWN.

FOR CORRUGATED CONTAINERS (U.S. CLS. 2, 5, 22, 23, 29, 37, 38 AND 50).

RAUL CORDOVA, EXAMINING ATTORNEY

CLASS 16—(Continued).

SN 78-672,778. OCTOPUS PUBLISHING GROUP LIMITED, LONDON, UNITED KINGDOM, FILED 7-18-2005.

BOUNTY

THE MARK CONSISTS OF STANDARD CHARACTERS WITHOUT CLAIM TO ANY PARTICULAR FONT, STYLE, SIZE, OR COLOR.

OWNER OF UNITED KINGDOM REG. NO. 2307468, DATED 9-17-2004, EXPIRES 8-7-2012.

FOR PRINTED PUBLICATIONS, NAMELY, BOOKS, PERIODICALS AND JOURNALS IN THE FIELDS OF STYLE, FASHION, MUSIC, DANCE, FILM, FOOD AND DRINK, ARTS, CRAFTS, INTERIORS, NATURAL HISTORY, PET CARE, HISTORY, HEALTH, SEX, NEW AGE FASHION AND PSYCHOLOGY, BEAUTY, SPORTS, GARDEN, DESIGN, ANTIQUES, LIVING, ASTRONOMY, ARCHITECTURE, CHILDREN, MAPPING/CARTOGRAPHY, AND DO-IT-YOURSELF HOME IMPROVEMENT AND DECORATING; PHOTOGRAPHS; POSTERS; CALENDARS; BUT NOT INCLUDING ANY OF THE AFORESAID GOODS FOR, OR ADAPTED FOR, EDUCATIONAL PURPOSES ABOUT YOUNG FAMILIES, PRE-NATAL AND POST-NATAL MOTHERS, YOUNG MOTHERS AND YOUNG CHILDREN (U.S. CLS. 2, 5, 22, 23, 29, 37, 38 AND 50).

DAVID COLLIER, EXAMINING ATTORNEY

SN 78-930,337. LOS ANGELES POLICE REVOLVER AND ATHLETIC CLUB, LOS ANGELES, CA, FILED 7-15-2006.

LAPD

THE MARK CONSISTS OF STANDARD CHARACTERS WITHOUT CLAIM TO ANY PARTICULAR FONT, STYLE, SIZE, OR COLOR.

OWNER OF U.S. REG. NOS. 3,038,631 AND 3,047,180.

FOR PAPER AND PRINTED GOODS, NAMELY, BOOKS IN THE FIELD OF LAW ENFORCEMENT, COOKBOOKS, MAGAZINES IN THE FIELD OF LAW ENFORCEMENT, PRINTED PERIODICALS IN THE FIELD OF LAW ENFORCEMENT, PRINTED INSTRUCTIONAL AND TEACHING MATERIALS IN THE FIELD OF LAW ENFORCEMENT, STATIONERY, DESK AND OFFICE ACCESSORIES, NAMELY, LETTER OPENERS, DESK TRAYS, PENCIL AND PEN HOLDERS, BUSINESS CARD HOLDERS, PAPERWEIGHTS; STICKERS, DECALS AND POSTERS (U.S. CLS. 2, 5, 22, 23, 29, 37, 38 AND 50).

THEODORE MCBRIDE, EXAMINING ATTORNEY

CLASS 16—(Continued).

SN 79-062,341. ZEBRA CO., LTD., JAPAN, FILED 8-7-2008.

SHARBO

OWNER OF INTERNATIONAL REGISTRATION 0985526 DATED 8-7-2008, EXPIRES 8-7-2018.

OWNER OF U.S. REG. NO. 1,193,984.

THE MARK CONSISTS OF THE WORDING "SHARBO" WITH A CIRCULAR ARROW FORMING THE LETTER "O".

FOR FELT WRITING PENS, MECHANICAL PENCILS, FELT MARKING PENS, PEN NIBS, PENHOLDERS, BALL-POINT PENS, CORRECTING FLUID FOR TYPE AND DOCUMENTS (U.S. CLS. 2, 5, 22, 23, 29, 37, 38 AND 50).

MARIAM MAHMOUDI, EXAMINING ATTORNEY

CLASS 17—RUBBER GOODS

SN 76-692,262. JASON INCORPORATED, RICHMOND, VA, FILED 8-20-2008.

COOLBALANCE

THE MARK CONSISTS OF STANDARD CHARACTERS WITHOUT CLAIM TO ANY PARTICULAR FONT, STYLE, SIZE, OR COLOR.

FOR INSULATING, SEALING, BARRIER AND SHIELDING BRUSHES, PRIMARILY NON-METALLIC (U.S. CLS. 1, 5, 12, 13, 35 AND 50).

FIRST USE 5-12-2008; IN COMMERCE 6-6-2008.

DOMINIC FATHY, EXAMINING ATTORNEY

SN 77-016,928. SPC RESOURCES, INC., HARTSVILLE, SC, FILED 10-9-2006.

SMARTSEAL

THE MARK CONSISTS OF STANDARD CHARACTERS WITHOUT CLAIM TO ANY PARTICULAR FONT, STYLE, SIZE, OR COLOR.

FOR FLEXIBLE LAMINATE COMPOSITE FILMS COMPRISED PRIMARILY OF PLASTIC FOR USE IN THE PACKAGING OF FOOD PRODUCTS, HOUSEHOLD PRODUCTS AND PERSONAL CARE PRODUCTS (U.S. CLS. 1, 5, 12, 13, 35 AND 50).

FIRST USE 6-30-2005; IN COMMERCE 6-30-2005.

JOHN KELLY, EXAMINING ATTORNEY

CLASS 17—(Continued).

SN 77-412,218. INTEGRA COMPANIES, INC., DEVENS, MA.
FILED 3-4-2008.

ColorGrip

THE MARK CONSISTS OF STANDARD CHARACTERS WITHOUT CLAIM TO ANY PARTICULAR FONT, STYLE, SIZE, OR COLOR.

FOR PIPE GASKETS (U.S. CLS. 1, 5, 12, 13, 35 AND 50).
FIRST USE 9-19-2005; IN COMMERCE 9-19-2005.
BARNEY CHARLON, EXAMINING ATTORNEY

CLASS 17—(Continued).

SN 77-525,964. ARANAR GLASS TECH, LLC, WEST PALM BEACH, FL. FILED 7-18-2008.

POLYSURE

THE MARK CONSISTS OF STANDARD CHARACTERS WITHOUT CLAIM TO ANY PARTICULAR FONT, STYLE, SIZE, OR COLOR.

FOR SPRAY ON POLYERMIC FOAM MATERIAL FOR STORM PROTECTION OF WINDOWS (U.S. CLS. 1, 5, 12, 13, 35 AND 50).
PAUL CROWLEY, EXAMINING ATTORNEY

SN 77-508,281. POPPACK LLC, SAN FRANCISCO, CA. FILED 6-25-2008.

AIR LEVER

THE MARK CONSISTS OF STANDARD CHARACTERS WITHOUT CLAIM TO ANY PARTICULAR FONT, STYLE, SIZE, OR COLOR.

FOR NON-METAL SEALS FOR USE IN OPENING A PACKAGE BY MEANS OF POPPING ONE OR MORE BUBBLES EMBEDDED IN OR NEAR THE SEAL. SOLD AS AN INTEGRAL COMPONENT OF FLEXIBLE FILM PACKAGING FOR FOOD AND NON-FOOD COMMERCIAL USE; PLASTIC PACKAGING HAVING A PRESSURE SENSITIVE OPENING DEVICE USED FOR CONSUMER FOOD PACKAGING AND FOR INDUSTRIAL AND COMMERCIAL NON-FOOD PACKAGING (U.S. CLS. 1, 5, 12, 13, 35 AND 50).

MARTHA SANTOMARTINO, EXAMINING ATTORNEY

SN 77-587,450. LAROCHE, SOPHIE L., CLEARWATER, FL. FILED 10-7-2008.

FoamShield

THE MARK CONSISTS OF STANDARD CHARACTERS WITHOUT CLAIM TO ANY PARTICULAR FONT, STYLE, SIZE, OR COLOR.

FOR INSULATING MATERIALS, NAMELY, POLYURETHANE FOAM AND POLYETHYLENE FOAM; LOW-DENSITY POLYURETHANE PACKAGING FOAM (U.S. CLS. 1, 5, 12, 13, 35 AND 50).

FIRST USE 2-1-2007; IN COMMERCE 2-1-2007.
SIMON TENG, EXAMINING ATTORNEY

SN 77-510,482. PROTEQ COATINGS LLC, AUSTIN, TX. FILED 6-27-2008.

CeramaKote

THE MARK CONSISTS OF STANDARD CHARACTERS WITHOUT CLAIM TO ANY PARTICULAR FONT, STYLE, SIZE, OR COLOR.

FOR INSULATING PAINTS FOR USE IN EXTERIOR, HOUSE AND INTERIOR APPLICATIONS (U.S. CLS. 1, 5, 12, 13, 35 AND 50).

FIRST USE 5-14-2008; IN COMMERCE 5-14-2008.
BARBARA BROWN, EXAMINING ATTORNEY

SN 77-588,308. ECOMEDIA, INC., EDGERTON, WI. FILED 10-8-2008.



WHERE SCIENCE MEETS NATURE

THE MARK CONSISTS OF TWO STYLIZED LEAVES AND THE STYLIZED TEXT "ECO MEDIA" WITH THE "WHERE SCIENCE MEETS NATURE" TEXT WRITTEN BELOW.

FOR A POLYETHYLENE BASED FILM EXTRUDED IN A LOW-DENSITY CO-POLYMER FORM THAT IS BOTH RECYCLABLE AND BIODEGRADABLE PRODUCED FOR PRINTING BACKLIGHT DISPLAYS, BANNERS, POINT OF PURCHASE DISPLAYS, INDOOR SIGNAGE, POSTERS, YARD SIGNS AND VEHICLE GRAPHICS (U.S. CLS. 1, 5, 12, 13, 35 AND 50).

FIRST USE 5-1-2008; IN COMMERCE 6-27-2008.
G. MAYERSCHOFF, EXAMINING ATTORNEY

CLASS 17—(Continued).

SN 77-589,119. INTERNATIONAL INSULATION SUPPLIERS PTY LTD, SYDNEY MARKETS, NSW, AUSTRALIA, FILED 10-9-2008.

iMat

THE MARK CONSISTS OF STANDARD CHARACTERS WITHOUT CLAIM TO ANY PARTICULAR FONT, STYLE, SIZE, OR COLOR.

OWNER OF AUSTRALIA REG. NO. 1219498, DATED 1-16-2008, EXPIRES 1-16-2018.

FOR INSULATING MATERIALS, INCLUDING POLYIMIDE FOAM (U.S. CLS. 1, 5, 12, 13, 35 AND 50).

STEPHEN AQUILA, EXAMINING ATTORNEY

SN 77-642,504. FORMOSA RAINTEX CO., LTD., TAICHUNG, TAIWAN, FILED 1-2-2009.

RAINTEX

THE MARK CONSISTS OF STANDARD CHARACTERS WITHOUT CLAIM TO ANY PARTICULAR FONT, STYLE, SIZE, OR COLOR.

FOR POLYURETHANE FILM FOR USE IN PAPER LAMINATION, POLYURETHANE FILM FOR USE IN CLOTH LAMINATION, PACKING FILM USED AS AN INDUSTRIAL OR COMMERCIAL PACKING MATERIAL, FILM USED AS AN INDUSTRIAL OR COMMERCIAL PACKING, PLASTIC FILM THAT IS TINTED AND LAMINATED FOR USE IN AUTOMOBILE WINDOWS, CELLULOSE ACETATE FILM USED IN THE MANUFACTURE OF PRESSURE SENSITIVE ADHESIVE TAPE, CELLULOSE ACETATE FILM USED IN THE MANUFACTURE OF PHOTOGRAPHIC OR MAGNETIC SOUND RECORDINGS, ADHESIVE TAPE FOR INDUSTRIAL OR COMMERCIAL PACKING USE, ADHESIVE TAPE FOR INDUSTRIAL AND COMMERCIAL USE, EXPANDED POLYTETRAFLUOROETHYLENE (EPTFE) MEMBRANE IN FILM FORM FOR USE IN PAPER LAMINATION, EXPANDED POLYTETRAFLUOROETHYLENE (EPTFE) MEMBRANE IN FILM FORM FOR USE IN CLOTH LAMINATION (U.S. CLS. 1, 5, 12, 13, 35 AND 50).

FIRST USE 11-1-2008; IN COMMERCE 11-1-2008.
ZHALEH DELANEY, EXAMINING ATTORNEY

CLASS 17—(Continued).

SN 77-657,557. XORB, L.L.C., BOWLING GREEN, OH. FILED 1-27-2009.

CELLPRO

THE MARK CONSISTS OF STANDARD CHARACTERS WITHOUT CLAIM TO ANY PARTICULAR FONT, STYLE, SIZE, OR COLOR.

FOR ABSORBENT PRODUCTS, NAMELY, ABSORBENT PADS, ABSORBENT ROLLS, ABSORBENT PILLOWS, ABSORBENT SOCKS, AND ABSORBENT TABS, ALL CONTAINING CELLULOSE-BASED COMPOSITIONS, FOR ABSORBING AQUEOUS MATERIALS (U.S. CLS. 1, 5, 12, 13, 35 AND 50).

FIRST USE 12-27-2006; IN COMMERCE 12-27-2006.
SETH A. RAPPAPORT, EXAMINING ATTORNEY

SN 77-660,978. PERO VEGETABLE COMPANY, LLC, DELRAY BEACH, FL. AND PERO FRESH FOODS, LLC, DELRAY BEACH, FL. FILED 2-2-2009.

THE MARK CONSISTS OF "FRESHWRAP" IN STYLIZED FORM WITH A CIRCULAR DESIGN CONSISTING OF THREE CRESCENT SHAPED SWIRLS AROUND AN ELLIPTICAL SHAPE HAVING ONE HALF IN DARKER SHADE THAN THE OTHER.

FOR PLASTIC FILMS USED AS PACKAGING FOR FOOD (U.S. CLS. 1, 5, 12, 13, 35 AND 50).
JULIE WATSON, EXAMINING ATTORNEY

SN 77-664,938. TRANSCO INC., CHICAGO, IL. FILED 2-6-2009.

HEATAINER

THE MARK CONSISTS OF STANDARD CHARACTERS WITHOUT CLAIM TO ANY PARTICULAR FONT, STYLE, SIZE, OR COLOR.

FOR NON-METAL BLANKET INSULATION USED TO ENCASE VESSELS, GENERATORS, TURBINES, ENGINES, PUMPS, REACTORS, TOP HEADS, BOTTOM HEADS, FANS, BLOWERS, FLANGES, VALVES, EXHAUSTS, COMPRESSORS, EXCHANGERS, HEADERS, TANKS, DRYERS, HOPPERS, PIPES, T-JOINTS, AND ELBOWS, IN POWER GENERATING STATIONS, STEAM AND GAS TURBINES, NUCLEAR FACILITIES, AND HEAT RETENTION APPLICATIONS (U.S. CLS. 1, 5, 12, 13, 35 AND 50).

LOURDES AYALA, EXAMINING ATTORNEY

CLASS 17—(Continued).

SN 77-664,944. TRANSCO INC., CHICAGO, IL. FILED 2-6-2009.

RAPIDRAP

THE MARK CONSISTS OF STANDARD CHARACTERS WITHOUT CLAIM TO ANY PARTICULAR FONT, STYLE, SIZE, OR COLOR.

FOR NON-METAL BLANKET INSULATION USED TO ENCASE VESSELS, GENERATORS, TURBINES, ENGINES, PUMPS, REACTORS, TOP HEADS, BOTTOM HEADS, FANS, BLOWERS, FLANGES, VALVES, EXHAUSTS, COMPRESSORS, EXCHANGERS, HEADERS, TANKS, DRYERS, HOPPERS, PIPES, T-JOINTS, AND ELBOWS, IN POWER GENERATING STATIONS, STEAM AND GAS TURBINES, NUCLEAR FACILITIES, AND HEAT RETENTION APPLICATIONS (U.S. CLS. 1, 5, 12, 13, 35 AND 50).

LOURDES AYALA, EXAMINING ATTORNEY

SN 77-666,021. NITTO DENKO CORPORATION, IBARAKI-SHI, OSAKA, JAPAN, FILED 2-9-2009.

SURFTACK

THE MARK CONSISTS OF STANDARD CHARACTERS WITHOUT CLAIM TO ANY PARTICULAR FONT, STYLE, SIZE, OR COLOR.

FOR PROTECTION FILMS FOR AUTOMOBILES, ADHESIVE PROTECTION FILMS FOR AUTOMOBILES, ANTI-CHIPPING FILM, SHEETS OR TAPES MADE OF PLASITC (U.S. CLS. 1, 5, 12, 13, 35 AND 50).

ZACHARY BELLO, EXAMINING ATTORNEY

SN 79-062,607. SHENZHEN KINGBOARD INVESTMENT CO., LTD., SHENZHEN CITY, GUANGDONG PROVINCE, CHINA, FILED 11-26-2008.

KB

OWNER OF INTERNATIONAL REGISTRATION 0986259 DATED 11-26-2008, EXPIRES 11-26-2018.

FOR GLASS EPOXY COPPER CLAD LAMINATES COMPRISED PRIMARILY OF EPOXY RESIN AND GLASS FABRIC; PAPER PHENOLIC COPPER CLAD LAMINATES COMPRISED PRIMARILY OF PHENOLIC RESIN AND BLEACHED KRAFT PAPER; THE FOREGOING LAMINATES FOR USE IN THE MANUFACTURE OF INSULATION; INSULATING MATERIALS, NAMELY, INSULATION FOR AIRCRAFT, BUILDING INSULATION, INSULATION FOR AIR CONDITIONERS (U.S. CLS. 1, 5, 12, 13, 35 AND 50).

ELI HELLMAN, EXAMINING ATTORNEY

CLASS 18—LEATHER GOODS

SN 77-012,347. LUXURY GOODS INTERNATIONAL (LGI) SA, 6814 CADEMPINO, SWITZERLAND, FILED 10-3-2006.

DOWNTOWN

THE MARK CONSISTS OF STANDARD CHARACTERS WITHOUT CLAIM TO ANY PARTICULAR FONT, STYLE, SIZE, OR COLOR.

FOR ANIMAL SKINS, LEATHER AND IMITATION OF LEATHER GOODS, NAMELY, KEY CASES IN LEATHER, HANDBAGS, LUGGAGE, WALLETS, PURSES, BRIEFCASES, SCHOOL BAGS, BEACH BAGS, TRAVEL BAGS, SUITCASES, ANIMAL HIDES, TRUNKS AND TRAVELING BAGS, PURSE CLASPS, RUCKSACKS, SHOPPING BAGS, VANITY CASES SOLD EMPTY, PARASOLS, WALKING STICKS, CANES, METAL PARTS OF CANES, TOILETRY BAGS SOLD EMPTY, TRAVELING CASES, TRAVELING SETS, NAMELY, SETS OF MATCHING LUGGAGE; ATTACHE CASES, HARNESS FOR ANIMALS; WHIPS; SADDLERY (U.S. CLS. 1, 2, 3, 22 AND 41).

JOHN WILKE, EXAMINING ATTORNEY

SN 77-318,777. WOODSTOCK VENTURES, L.C., NEW YORK, NY. FILED 11-1-2007.

WOODSTOCK

THE MARK CONSISTS OF STANDARD CHARACTERS WITHOUT CLAIM TO ANY PARTICULAR FONT, STYLE, SIZE, OR COLOR.

FOR PURSES, ALL-PURPOSE CARRYING BAGS, UMBRELLAS; LEATHER GOODS, NAMELY, LUGGAGE, LUGGAGE STRAPS, TRAVEL BAGS, GARMENT BAGS AND SHOE BAGS FOR TRAVEL, BRIEFCASE, BRIEFCASE-TYPE PORTFOLIOS, ATTACHE CASES; POCKETBOOKS, LEATHER EVENING BAGS, CLUTCHES, TOTE BAGS, ATHLETIC BAGS, DUFFEL BAGS, BEACHBAGS, DIAPER BAGS, COSMETIC BAGS SOLD EMPTY, TOILETRY CASES SOLD EMPTY, SCHOOL BAGS, KNAPSACKS, WAIST PACKS, WALLETS, BILLFOLDS, BUSINESS CARD CASES, CREDIT CARD CASES, LEATHER KEY CASES, LEATHER KEY CHAINS, IMITATION LEATHER KEY CHAINS, CHANGE PURSES (U.S. CLS. 1, 2, 3, 22 AND 41).

CHRIS WELLS, EXAMINING ATTORNEY

CLASS 18—(Continued).

SN 77-352,216. K & A PRODUCTS, SCOTTSDALE, AZ. FILED 12-14-2007.

KA LINE

THE MARK CONSISTS OF STANDARD CHARACTERS WITHOUT CLAIM TO ANY PARTICULAR FONT, STYLE, SIZE, OR COLOR.

NO CLAIM IS MADE TO THE EXCLUSIVE RIGHT TO USE "LINE", APART FROM THE MARK AS SHOWN.

FOR LEATHER AND IMITATIONS OF LEATHER; GOODS MADE OF LEATHER AND IMITATIONS OF LEATHER, NAMELY, HANDBAGS, LEATHER CASES, LEATHER STRAPS, LEATHER FOR FURNITURE; ANIMAL SKINS; HIDES; TRUNKS AND TRAVELING BAGS; UMBRELLAS, PARASOLS AND WALKING STICKS; WHIPS, HARNESSSES AND SADDLERY (U.S. CLS. 1, 2, 3, 22 AND 41).

JAY BESCH, EXAMINING ATTORNEY

SN 77-363,615. HUBBS, CHARLIE, DALTON, GA. FILED 1-3-2008.

SIL-CUSH

THE MARK CONSISTS OF STANDARD CHARACTERS WITHOUT CLAIM TO ANY PARTICULAR FONT, STYLE, SIZE, OR COLOR.

FOR SADDLE PADS AND SADDLE COMPONENTS, NAMELY, SADDLE BLANKETS, SADDLE COVERS AND SADDLE BAGS (U.S. CLS. 1, 2, 3, 22 AND 41).

BRENDAN REGAN, EXAMINING ATTORNEY

SN 77-423,467. EBERHARD GOBEL GMBH & CO., ULM/DONAU, FED REP GERMANY, FILED 3-17-2008.

birdiepal
windflex

OWNER OF U.S. REG. NO. 2,286,401.
THE MARK CONSISTS OF THE WORDS "BIRDIEPAL" AND "WINDFLEX" IN LOWER CASE LETTERS. ABOVE THE WORDS IS AN ARC WHICH IS GRADUALLY THINNER FROM THE LEFT SIDE TO THE CENTER AND GRADUALLY THICKER FROM THE CENTER TO THE RIGHT SIDE.

FOR UMBRELLAS (U.S. CLS. 1, 2, 3, 22 AND 41).
FIRST USE 8-10-2004; IN COMMERCE 6-6-2005.
H. M. FISHER, EXAMINING ATTORNEY

CLASS 18—(Continued).

SN 77-524,963. CDS-IP, S.A., COUVIN, BELGIUM, FILED 7-17-2008.

DONNAY

THE MARK CONSISTS OF STANDARD CHARACTERS WITHOUT CLAIM TO ANY PARTICULAR FONT, STYLE, SIZE, OR COLOR.

OWNER OF ERPN CMNTY TM OFC REG. NO. 004077897, DATED 1-12-2006, EXPIRES 10-18-2014.

OWNER OF U.S. REG. NOS. 1,477,692, 2,963,914 AND 3,204,944.

SEC. 2(F).

FOR CAMPING BAGS, TRAVEL BAGS, BEACH BAGS, HANDBAGS, BUM BAGS, TOTE BAGS, NET BAGS FOR SHOPPING, RUCKSACKS, SCHOOL BAGS, SATCHELS, SLING BAGS, TRAVELLING TRUNKS, LUGGAGE, STRAPS FOR LUGGAGE, WHEELED SHOPPING BAGS, SPORTS BAGS, COSMETIC BAGS SOLD EMPTY, DUFFEL BAGS, SHOULDER BAGS, CARRY BAGS, TOILETRY BAGS SOLD EMPTY, BACKPACKS, BRIEFCASES, TIE CASES, CARD CASES, NAMELY, BUSINESS CARD CASES, CREDIT CARD CASES, HAVERSACKS, KEY CASES, ATTACHÉ CASES, POCKET WALLETS, PURSES, UMBRELLAS, PARASOLS, VANITY CASES NOT FITTED (U.S. CLS. 1, 2, 3, 22 AND 41).

EDWARD FENNESSY, EXAMINING ATTORNEY

SN 77-530,336. JOEY WEAR LLC, SAN LEANDRO, CA. FILED 7-24-2008.



NO CLAIM IS MADE TO THE EXCLUSIVE RIGHT TO USE "WEAR", APART FROM THE MARK AS SHOWN.

THE STIPPLING IS FOR SHADING PURPOSES ONLY.

THE MARK CONSISTS OF THE OUTLINED STYLIZED TEXT "JOEY" WRITTEN IN THICK LETTERS WITH A HOLLOW CENTER. THE WORD "WEAR" IS WRITTEN IN TAHOMA STYLE FONT, UNDERNEATH THE WORD "JOEY", ON TOP OF THE WORD "JOEY" IS AN ANIMATED PICTURE OF A KANGAROO WITH A JOEY INSIDE HER POUCH, FACING HER MOTHER KANGAROO.

FOR BABY CARRIERS WORN ON THE BODY (U.S. CLS. 1, 2, 3, 22 AND 41).

KIMBERLY PERRY, EXAMINING ATTORNEY

CLASS 18—(Continued).

SN 77-544,996. REVSON, JENNIFER, RALEIGH, NC. FILED 8-12-2008.

SPEED WITH STYLE

THE MARK CONSISTS OF STANDARD CHARACTERS WITHOUT CLAIM TO ANY PARTICULAR FONT, STYLE, SIZE, OR COLOR.

FOR LUGGAGE; SUITCASES, CARRYALL BAGS, DUFFLE BAGS, SUIT BAGS, DRESS BAGS, TOTE BAGS, BACKPACKS, KNAPSACKS, BRIEFCASES, ATTACHE CASES, SPORTS HELMET BAGS, SPORTS GEAR BAGS, SPORTS SHOE BAGS, SHOE BAGS, SPORTS ACCESSORY BAGS, TROPHY BAGS, BOOK BAGS, JEWELRY BAGS, AND COSMETIC BAGS SOLD EMPTY (U.S. CLS. 1, 2, 3, 22 AND 41).

MARGERY A. TIERNEY, EXAMINING ATTORNEY

SN 77-562,529. HOLLY JORDAN, ST PAUL, MN. AND DAWN SIVANICH, BROOKLYN PARK, MN. FILED 9-4-2008.



THE COLOR(S) BLACK, GREEN IS/ARE CLAIMED AS A FEATURE OF THE MARK.

THE MARK CONSISTS OF THE COLOR(S) BLACK APPEARS IN THE WORDING "ESSE EVERYDAY SOLUTIONS FOR SAVING THE EARTH" AND THE OUTLINE OF THE LEAF DESIGN; THE COLOR GREEN APPEARS IN THE LEAF DESIGN IS/ARE CLAIMED AS A FEATURE OF THE MARK. THE MARK CONSISTS OF THE STYLIZED WORDING "ESSE EVERYDAY SOLUTIONS FOR SAVING THE EARTH" AND THE DESIGN OF A LEAF.

FOR CANVAS SHOPPING BAGS; MESH SHOPPING BAGS (U.S. CLS. 1, 2, 3, 22 AND 41).

HOWARD B. LEVINE, EXAMINING ATTORNEY

CLASS 18—(Continued).

SN 77-572,798. MINER, ANTHONY, BEVERLY HILLS, CA. FILED 9-18-2008.

Bonsai Sheroes

THE MARK CONSISTS OF STANDARD CHARACTERS WITHOUT CLAIM TO ANY PARTICULAR FONT, STYLE, SIZE, OR COLOR.

FOR BABY BACKPACKS; BACKPACKS; BOOK BAGS; SPORTS BAGS; BUM BAGS; WALLETS AND HAND-BAGS; FANNY PACKS; POUCHES AND BAGS SOLD EMPTY FOR ATTACHMENT TO BACKPACKS; SCHOOL CHILDREN'S BACKPACKS; SMALL BACKPACKS; SPORTS PACKS; WAIST PACKS (U.S. CLS. 1, 2, 3, 22 AND 41).

JEFF DEFORD, EXAMINING ATTORNEY

SN 77-574,689. CHEN, ALLEN, DIAMOND BAR, CA. FILED 9-19-2008.

UTOPIE

THE MARK CONSISTS OF STANDARD CHARACTERS WITHOUT CLAIM TO ANY PARTICULAR FONT, STYLE, SIZE, OR COLOR.

THE ENGLISH TRANSLATION OF THE WORD "UTOPIE" IN THE MARK IS UTOPIA.

FOR LUGGAGE; SUITCASES; HARD SIDE CARRYING CASE, NAMELY, CASES HAVING ALUMINUM, PLASTIC, NYLON, OR POLYESTER SIDES; VALISES; BRIEFCASES; CARRYING CASE HAVING ON THE INSIDE WALLS A LAYER OF SOFT RUBBER OR POLYMER FOAM; COSMETIC AND TOILETRY CASES SOLD EMPTY; BEAUTY SUPPLY CASES SOLD EMPTY (U.S. CLS. 1, 2, 3, 22 AND 41).

FIRST USE 1-20-1999; IN COMMERCE 1-20-1999.

HOWARD SMIGA, EXAMINING ATTORNEY

SN 77-577,136. GREEN CHIC BAG COMPANY, DBA GREEN CHIC BAG COMPANY, VANCOUVER, WA. FILED 9-23-2008.



NO CLAIM IS MADE TO THE EXCLUSIVE RIGHT TO USE "GREEN AND BAG CO.", APART FROM THE MARK AS SHOWN.

THE COLOR(S) BLACK, WHITE, GREEN, BROWN IS/ARE CLAIMED AS A FEATURE OF THE MARK.

THE MARK CONSISTS OF THE DESIGN OF A TREE APPEARING BETWEEN THE WORDING "GREEN" AND "CHIC". THE WORDING "BAG CO." APPEARS UNDERNEATH AND THE WORDING "WWW.GREENCHICBAG-

CLASS 18—(Continued).

CO.COM" APPEARS UNDERNEATH THE WORDING "BAG CO." ALL OF THESE APPEAR INSIDE OF THE DESIGN OF AN OVAL WHICH IS INSIDE THE DESIGN OF A RECTANGLE. THE COLOR BLACK APPEARS IN THE WORDING "GREEN CHIC BAG CO." "WWW.GREENCHICBAGCO.COM" AND THE DESIGN OF THE RECTANGLE BACKGROUND. THE COLOR WHITE APPEARS IN THE DESIGN OF AN OVAL. THE COLOR GREEN APPEARS IN THE DESIGN OF THE TREE LEAVES AND THE OUTLINE OF THE OVAL AND THE COLOR BROWN APPEARS IN THE DESIGN OF THE TREE TRUNK AND BRANCHES.

FOR CANVAS SHOPPING BAGS (U.S. CLS. 1, 2, 3, 22 AND 41).

FIRST USE 8-11-2008; IN COMMERCE 8-11-2008.
AMY C. KEAN, EXAMINING ATTORNEY

SN 77-601,717. HILDEBRAND, REBECCA, A. DBA SAVERS OF THE ENVIRONMENT, ATHENS, AL. FILED 10-28-2008.

SAVERS OF THE ENVIRONMENT S.O.T.E

THE MARK CONSISTS OF STANDARD CHARACTERS WITHOUT CLAIM TO ANY PARTICULAR FONT, STYLE, SIZE, OR COLOR.

FOR TOTE BAGS (U.S. CLS. 1, 2, 3, 22 AND 41).
MARGARET POWER, EXAMINING ATTORNEY

SN 77-610,417. ERIC HARRIS PAVONY, BROOKLYN, NY. FILED 11-8-2008.

YES WE CANVAS

THE MARK CONSISTS OF STANDARD CHARACTERS WITHOUT CLAIM TO ANY PARTICULAR FONT, STYLE, SIZE, OR COLOR.

FOR CANVAS SHOPPING BAGS (U.S. CLS. 1, 2, 3, 22 AND 41).

FIRST USE 11-7-2008; IN COMMERCE 11-7-2008.
TINA KUAN, EXAMINING ATTORNEY

SN 77-610,756. FOX CREEK LEATHER, INDEPENDENCE, VA. FILED 11-10-2008.

FCL

THE MARK CONSISTS OF STANDARD CHARACTERS WITHOUT CLAIM TO ANY PARTICULAR FONT, STYLE, SIZE, OR COLOR.

FOR SADDLEBAGS (U.S. CLS. 1, 2, 3, 22 AND 41).
FIRST USE 1-1-2007; IN COMMERCE 1-1-2007.
ODESSA BIBBINS, EXAMINING ATTORNEY

CLASS 18—(Continued).

SN 77-619,302. GARRETT LEATHER CORPORATION, BUFFALO, NY. FILED 11-21-2008.

GARRETT DISTRESSED

THE MARK CONSISTS OF STANDARD CHARACTERS WITHOUT CLAIM TO ANY PARTICULAR FONT, STYLE, SIZE, OR COLOR.

NO CLAIM IS MADE TO THE EXCLUSIVE RIGHT TO USE "DISTRESSED", APART FROM THE MARK AS SHOWN.

FOR LEATHER (U.S. CLS. 1, 2, 3, 22 AND 41).
FIRST USE 1-2-1998; IN COMMERCE 1-2-1998.
JENNY PARK, EXAMINING ATTORNEY

SN 77-619,306. GARRETT LEATHER CORPORATION, BUFFALO, NY. FILED 11-21-2008.

GARRETT WOVENS

THE MARK CONSISTS OF STANDARD CHARACTERS WITHOUT CLAIM TO ANY PARTICULAR FONT, STYLE, SIZE, OR COLOR.

NO CLAIM IS MADE TO THE EXCLUSIVE RIGHT TO USE "WOVENS", APART FROM THE MARK AS SHOWN.

FOR LEATHER (U.S. CLS. 1, 2, 3, 22 AND 41).
FIRST USE 1-2-1999; IN COMMERCE 1-2-1999.
JENNY PARK, EXAMINING ATTORNEY

SN 77-619,308. GARRETT LEATHER CORPORATION, BUFFALO, NY. FILED 11-21-2008.

GARRETT TUBULAR WOVENS

THE MARK CONSISTS OF STANDARD CHARACTERS WITHOUT CLAIM TO ANY PARTICULAR FONT, STYLE, SIZE, OR COLOR.

NO CLAIM IS MADE TO THE EXCLUSIVE RIGHT TO USE "TUBULAR WOVENS", APART FROM THE MARK AS SHOWN.

FOR LEATHER (U.S. CLS. 1, 2, 3, 22 AND 41).
FIRST USE 1-2-2002; IN COMMERCE 1-2-2002.
JENNY PARK, EXAMINING ATTORNEY

CLASS 18—(Continued).

SN 77-623,660. HALPERN, BARBARA, VAN NUYS, CA. AND DORFMAN, VIOLA, VAN NUYS, CA. AND CYMAN, MIRIAM, VAN NUYS, CA. FILED 12-1-2008.

LINGERIE VALET

THE MARK CONSISTS OF STANDARD CHARACTERS WITHOUT CLAIM TO ANY PARTICULAR FONT, STYLE, SIZE, OR COLOR.

NO CLAIM IS MADE TO THE EXCLUSIVE RIGHT TO USE "LINGERIE", APART FROM THE MARK AS SHOWN.

FOR FABRIC ORGANIZERS, NAMELY, TRAVEL BAGS FOR HOLDING LINGERIE AND CLOTHING WHICH CAN THEN BE PACKED IN LARGER PIECES OF LUGGAGE (U.S. CLS. 1, 2, 3, 22 AND 41).

MONIQUE MILLER, EXAMINING ATTORNEY

CLASS 18—(Continued).

SN 77-653,241. HBI BRANDED APPAREL ENTERPRISES, LLC, WINSTON-SALEM, NC. FILED 1-21-2009.

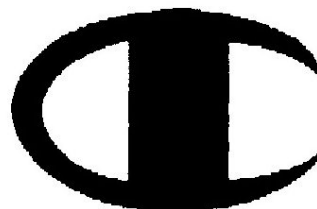

OWNER OF U.S. REG. NOS. 1,127,251, 3,345,050 AND OTHERS.

FOR ATHLETIC BAGS; BACKPACKS; SCHOOL BAGS; TRAVEL BAGS (U.S. CLS. 1, 2, 3, 22 AND 41).

FIRST USE 1-1-2000; IN COMMERCE 1-1-2000.

KARANENDRA S. CHHINA, EXAMINING ATTORNEY

SN 77-625,529. CE LICENSING, LLC, LOS ANGELES, CA. FILED 12-3-2008.

Carmen Electra

THE MARK CONSISTS OF STANDARD CHARACTERS WITHOUT CLAIM TO ANY PARTICULAR FONT, STYLE, SIZE, OR COLOR.

THE NAME SHOWN IN THE MARK IDENTIFIES A LIVING INDIVIDUAL, WHOSE CONSENT IS OF RECORD.

FOR ATHLETIC BAGS; BACKPACKS; BEACH BAGS; BILLFOLDS; BOOK BAGS; BRIEFCASES; BUSINESS CARD CASES; CARRY-ALL BAGS; CARRY-ON BAGS; CARRYALLS; CHANGE PURSES; CLOTHING FOR ANIMALS; COIN PURSES; COLLARS FOR PETS; COSMETIC BAGS SOLD EMPTY; COSMETIC CASES SOLD EMPTY; CREDIT CARD CASES; DUFFEL BAGS; FANNY PACKS; FASHION HANDBAGS; FLIGHT BAGS; GYM BAGS; HANDBAGS; JEWELRY ORGANIZERS FOR TRAVEL; KEY CASES; LEASHES FOR ANIMALS; LUGGAGE; MAKE-UP BAGS SOLD EMPTY; POCKETBOOKS; PURSES; SHOULDER BAGS; SLING BAGS; SPORT BAGS; TOTE BAGS; TRAVEL BAGS; UMBRELLAS; WAIST PACKS; WALLETS (U.S. CLS. 1, 2, 3, 22 AND 41).

REBECCA SMITH, EXAMINING ATTORNEY

SN 77-657,674. REBECCA RAY DESIGNS, LLC, CHAGRIN FALLS, OH. FILED 1-27-2009.

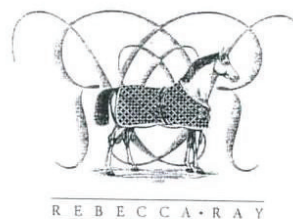

THE NAME "REBECCA RAY" DOES NOT IDENTIFY A LIVING INDIVIDUAL.

THE MARK CONSISTS OF A RIGHT SIDE VIEW OF A HORSE WITH A BACKGROUND CONSISTING OF A SCRIPTED LETTER "R" FACING RIGHT INTERTWINED WITH A SCRIPTED LETTER "R" FACING LEFT. SHADING IMMEDIATELY BELOW THE HORSE REPRESENTS THE GROUND. FURTHER BELOW THE HORSE IS THE TEXT "REBECCA RAY", WHEREIN THE TWO WORDS ARE SEPARATED BY A DOT. THE TEXT "REBECCA RAY" IS BORDERED BY A SOLID LINE ABOVE AND BELOW THE TEXT.

FOR HANDBAGS (U.S. CLS. 1, 2, 3, 22 AND 41).

BRENDAN MCCAULEY, EXAMINING ATTORNEY

CLASS 18—(Continued).

SN 77-663,736. BO & DEEMO LLC, LAS VEGAS, NV. FILED 2-5-2009.

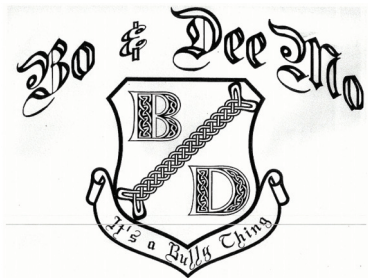

THE MARK CONSISTS OF THE STYLIZED WORDING "BO & DEEMO" APPEARING ABOVE A COAT OF ARMS. A ROPE DESIGN AND THE LETTERS "B" AND "D" APPEAR WITHIN THE COAT OF ARMS. A BANNER CONTAINING THE WORDING "IT'S A BULLY THING" APPEARS BENEATH THE COAT OF ARMS.

FOR DOG CLOTHING (U.S. CLS. 1, 2, 3, 22 AND 41).
EMILY CHUO, EXAMINING ATTORNEY

SN 77-664,003. MICHAEL WADDELL, LLC, FORTSON, GA. FILED 2-5-2009.

MICHAEL WADDELL

THE MARK CONSISTS OF STANDARD CHARACTERS WITHOUT CLAIM TO ANY PARTICULAR FONT, STYLE, SIZE, OR COLOR.

FOR DUFFLE BAGS, WAIST BAGS, BACK PACKS (U.S. CLS. 1, 2, 3, 22 AND 41).
JACQUELINE A. LAVINE, EXAMINING ATTORNEY

SN 77-665,013. VO, AMANDA, ORLANDO, FL. FILED 2-6-2009.

Zooligans

THE MARK CONSISTS OF STANDARD CHARACTERS WITHOUT CLAIM TO ANY PARTICULAR FONT, STYLE, SIZE, OR COLOR.

FOR BABY BACKPACKS; BACK PACKS; BACKPACKS; BOOK BAGS, SPORTS BAGS, BUM BAGS, WALLETS AND HANDBAGS; SCHOOLCHILDREN'S BACKPACKS; SMALL BACKPACKS; SPORTS PACKS (U.S. CLS. 1, 2, 3, 22 AND 41).

LOURDES AYALA, EXAMINING ATTORNEY

CLASS 18—(Continued).

SN 77-665,268. STEPHANIE JOHNSON HOLDINGS, LLC, LOS ANGELES, CA. FILED 2-6-2009.

STEPHANIE JOHNSON

THE MARK CONSISTS OF STANDARD CHARACTERS WITHOUT CLAIM TO ANY PARTICULAR FONT, STYLE, SIZE, OR COLOR.

OWNER OF U.S. REG. NOS. 2,713,259 AND 2,966,069.
FOR ALL-PURPOSE CARRYING BAGS; COSMETIC BAGS SOLD EMPTY; COSMETIC CARRYING CASES SOLD EMPTY; HANDBAGS; JEWELRY ORGANIZERS FOR TRAVEL; LUGGAGE; LUGGAGE TAGS; PURSES; TOILETRY BAGS SOLD EMPTY; TOILETRY CASES SOLD EMPTY; TOTE BAGS; TRAVEL BAGS; WALLETS (U.S. CLS. 1, 2, 3, 22 AND 41).

FIRST USE 6-0-1997; IN COMMERCE 6-0-1997.
KIMBERLY PERRY, EXAMINING ATTORNEY

SN 77-665,425. TUMI, INC., SOUTH PLAINFIELD, NJ. FILED 2-6-2009.

JUST IN CASE

THE MARK CONSISTS OF STANDARD CHARACTERS WITHOUT CLAIM TO ANY PARTICULAR FONT, STYLE, SIZE, OR COLOR.

FOR CARRY ON LUGGAGE, TOTE BAGS, HANDBAGS, CLUTCHES, TOILETRY CASES SOLD EMPTY, MAKE-UP BAGS SOLD EMPTY, TRAVEL KITS SOLD EMPTY, SHOULDER BAGS, BACKPACKS, BOOK BAGS, WAIST PACKS, POCKET WALLETS, SCHOOL BAGS, AND ALL PURPOSE SPORTS BAGS (U.S. CLS. 1, 2, 3, 22 AND 41).

FIRST USE 10-1-2006; IN COMMERCE 10-1-2006.
EDWARD NELSON, EXAMINING ATTORNEY

SN 77-665,597. DIAZ, FRANCES, TORRANCE, CA. FILED 2-6-2009.

D'Bags

THE MARK CONSISTS OF STANDARD CHARACTERS WITHOUT CLAIM TO ANY PARTICULAR FONT, STYLE, SIZE, OR COLOR.

FOR TOTE BAGS (U.S. CLS. 1, 2, 3, 22 AND 41).
MARC LEIPZIG, EXAMINING ATTORNEY

CLASS 18—(Continued).

SN 77-666,722. TEN THIRTEEN, INC., BEVERLY HILLS, CA. FILED 2-9-2009.

CopterCop

THE MARK CONSISTS OF STANDARD CHARACTERS WITHOUT CLAIM TO ANY PARTICULAR FONT, STYLE, SIZE, OR COLOR.

FOR BACKPACKS, SUITCASES, BRIEFCASES, TRAVELING BAGS, HANDBAGS, WALLETS, PURSES, KEY CASES, CALLING CARD CASES, AND COSMETIC CASES SOLD EMPTY, ALL MADE OF LEATHER OR IMITATION LEATHER; LUGGAGE TRUNKS; UMBRELLAS, AND LEATHER OR IMITATION LEATHER TRAVEL BAGS (U.S. CLS. 1, 2, 3, 22 AND 41).

LINDA LAVACHE, EXAMINING ATTORNEY

SN 77-669,000. I PLAY, INC., ASHEVILLE, NC. FILED 2-12-2009.



THE MARK CONSISTS OF A STYLIZED SLEEPING SPROUT NESTLED IN AND PARTIALLY SURROUNDED BY THE TWO HALVES OF A POD RESTING ON TWO SMALL FAUX FEET.

FOR TRAVEL CASES (U.S. CLS. 1, 2, 3, 22 AND 41).
AISHA SALEM, EXAMINING ATTORNEY

CLASS 18—(Continued).

SN 78-930,339. LOS ANGELES POLICE REVOLVER AND ATHLETIC CLUB, LOS ANGELES, CA. FILED 7-15-2006.

LAPD

THE MARK CONSISTS OF STANDARD CHARACTERS WITHOUT CLAIM TO ANY PARTICULAR FONT, STYLE, SIZE, OR COLOR.

OWNER OF U.S. REG. NOS. 3,038,631 AND 3,047,180.
FOR BAGS, NAMELY, ATHLETIC BAGS, DIAPER BAGS, SCHOOLBOOK BAGS, TRAVEL BAGS; LUGGAGE, PURSES, UMBRELLAS, BACKPACKS, KNAPSACKS, WALLETS, POCKETBOOKS, MESSENGER BAGS, BRIEFCASES, HAND BAGS, DOCK KITS, NAMELY, BAGS FOR PERSONAL CARE PRODUCTS (U.S. CLS. 1, 2, 3, 22 AND 41).

THEODORE MCBRIDE, EXAMINING ATTORNEY

CLASS 19—NON-METALLIC BUILDING MATERIALS

SN 76-682,952. NIEHOFF, THOMAS H., NORTH BABYLON, NY. FILED 10-15-2007.

FALLS OF HONOR

THE MARK CONSISTS OF STANDARD CHARACTERS WITHOUT CLAIM TO ANY PARTICULAR FONT, STYLE, SIZE, OR COLOR.

FOR MONUMENTS OF STONE (U.S. CLS. 1, 12, 33 AND 50).

FIRST USE 11-1-2007; IN COMMERCE 12-1-2007.
TEJBIR SINGH, EXAMINING ATTORNEY

SN 77-240,460. FABRICUSHION LTD., MARKHAM, CANADA, FILED 7-27-2007.

QUIETMAXX

THE MARK CONSISTS OF STANDARD CHARACTERS WITHOUT CLAIM TO ANY PARTICULAR FONT, STYLE, SIZE, OR COLOR.

OWNER OF CANADA REG. NO. 1356708, DATED 8-21-2008, EXPIRES 8-21-2023.

FOR RESIDENTIAL AND COMMERCIAL UNDERLAYMENT FOR HARDWOOD AND LAMINATE FLOORING (U.S. CLS. 1, 12, 33 AND 50).

FIRST USE 1-30-2008; IN COMMERCE 1-30-2008.
ZACHARY BELLO, EXAMINING ATTORNEY

CLASS 19—(Continued).

SN 77-442,344. CRANE BUILDING PRODUCTS LLC, COLUMBUS, OH. FILED 4-8-2008.

EXTERIOR PORTFOLIO BY CRANE

THE MARK CONSISTS OF STANDARD CHARACTERS WITHOUT CLAIM TO ANY PARTICULAR FONT, STYLE, SIZE, OR COLOR.

NO CLAIM IS MADE TO THE EXCLUSIVE RIGHT TO USE "EXTERIOR PORTFOLIO", APART FROM THE MARK AS SHOWN.

FOR NON-METALLIC BUILDING MATERIALS, NAMELY, COMPOSITE INSULATED VINYL SIDING WALL SYSTEM COMPRISING VINYL SIDING; NON-METAL CLADDING FOR CONSTRUCTION AND BUILDING; NON-METAL ROOFING (U.S. CLS. 1, 12, 33 AND 50).

LINDA LAVACHE, EXAMINING ATTORNEY

SN 77-492,405. LES CHANTIERS DE CHIBOUGAMAU LTÉE, DORVAL, CANADA, FILED 6-5-2008.

NORDIC OPEN-I

THE MARK CONSISTS OF STANDARD CHARACTERS WITHOUT CLAIM TO ANY PARTICULAR FONT, STYLE, SIZE, OR COLOR.

PRIORITY CLAIMED UNDER SEC. 44(D) ON CANADA APPLICATION NO. 1375614, FILED 12-11-2007, REG. NO. TMA733983, DATED 2-5-2009, EXPIRES 2-5-2024.

FOR PREFABRICATED WOOD I-JOISTS (U.S. CLS. 1, 12, 33 AND 50).

BARBARA BROWN, EXAMINING ATTORNEY

SN 77-503,147. LF, LLC, WILMINGTON, DE. FILED 6-19-2008.

TOP CHOICE

THE MARK CONSISTS OF STANDARD CHARACTERS WITHOUT CLAIM TO ANY PARTICULAR FONT, STYLE, SIZE, OR COLOR.

FOR BUILDING MATERIALS FOR CONSTRUCTION, NAMELY, EDGE GLUED PANELS, BOARDS AND SLATS CONSTRUCTED FROM WOOD (U.S. CLS. 1, 12, 33 AND 50).

ROBERT C. CLARK JR., EXAMINING ATTORNEY

CLASS 19—(Continued).

SN 77-510,296. UNITED WAY OF AMERICA, ALEXANDRIA, VA. FILED 6-27-2008.

LIVE UNITED

THE MARK CONSISTS OF STANDARD CHARACTERS WITHOUT CLAIM TO ANY PARTICULAR FONT, STYLE, SIZE, OR COLOR.

FOR NON-METAL WALL-MOUNTED PANEL UNITS FOR EXHIBITIONS, DISPLAYS AND PARTITIONING (U.S. CLS. 1, 12, 33 AND 50).

ANGELA GAW, EXAMINING ATTORNEY

SN 77-516,635. LEISURE CONCEPTS, INC., SPOKANE, WA. FILED 7-8-2008.

MOTO PAD

THE MARK CONSISTS OF STANDARD CHARACTERS WITHOUT CLAIM TO ANY PARTICULAR FONT, STYLE, SIZE, OR COLOR.

NO CLAIM IS MADE TO THE EXCLUSIVE RIGHT TO USE "PAD", APART FROM THE MARK AS SHOWN.

FOR MODULAR PLASTIC DECKING TO SERVE AS A GROUND COVER (U.S. CLS. 1, 12, 33 AND 50).

JAY BESCH, EXAMINING ATTORNEY

SN 77-562,855. PACIFIC WOOD PRESERVING OF BAKERSFIELD, INC., BAKERSFIELD, CA. FILED 9-4-2008.



THE PACIFIC WOOD PRESERVING COMPANIES

OWNER OF U.S. REG. NO. 2,590,736. NO CLAIM IS MADE TO THE EXCLUSIVE RIGHT TO USE "COMPANIES", APART FROM THE MARK AS SHOWN.

THE MARK CONSISTS OF THERE IS A TREE EMBEDDED IN THE "P" OF "PWP". THE WORDS "THE PACIFIC WOOD PRESERVING COMPANIES" ARE TO THE RIGHT OF THE "PWP".

SEC. 2(F) AS TO "PACIFIC WOOD PRESERVING". FOR CHEMICALLY TREATED WOOD, NAMELY, WOOD BEAMS, WOOD BOARDS, WOOD JOISTS, WOOD POLES, WOOD POSTS, WOOD RAFTERS, WOOD SIDING, WOODEN BEAMS, WOODEN POLES FOR ELECTRIC POWER LINES, AND WOODEN RAILINGS, ALL FOR AQUATIC USES; CHEMICALLY TREATED WOOD, NAMELY, WOOD BEAMS, WOOD BOARDS, WOOD JOISTS, WOOD RAFTERS, WOOD SIDING, WOOD TILE FLOORS AND FLOORING, WOOD TRIM, WOODEN BEAMS, WOODEN FLOORING, WOODEN AILINGS, AND WOODEN WAINSCOTING, ALL OF THE ABOVE CONTAINING A FIRE RETARDANT CHEMICAL; PRESERVED WOOD (U.S. CLS. 1, 12, 33 AND 50).

FIRST USE 7-31-2001; IN COMMERCE 7-31-2001.

RONALD AIKENS, EXAMINING ATTORNEY

CLASS 19—(Continued).

SN 77-600,223. PAULDING, RAYMOND, PALM CITY, FL. FILED 10-24-2008.

POOLCAST

THE MARK CONSISTS OF STANDARD CHARACTERS WITHOUT CLAIM TO ANY PARTICULAR FONT, STYLE, SIZE, OR COLOR.

FOR MONOLITHIC PRECAST CONCRETE STRUCTURE, NAMELY, THE HOUSING FOR A THERAPEUTIC AND RECREATIONAL SPA (U.S. CLS. 1, 12, 33 AND 50).

GINA HAYES, EXAMINING ATTORNEY

SN 77-600,496. ALASKA STRUCTURES, INC., ANCHORAGE, AK. FILED 10-24-2008.



THE COLOR(S) YELLOW AND BLUE IS/ARE CLAIMED AS A FEATURE OF THE MARK.

THE MARK CONSISTS OF AN ARROW-LIKE OBJECT POINTING TO THE RIGHT WHOSE BODY IS YELLOW, WITH THE YELLOW BEING SOMEWHAT FADED ON THE LEFT SIDE OF THE BODY OF THE ARROW AND GRADUALLY BECOMING MORE OPAQUE FROM LEFT TO RIGHT, AND WHOSE POINT CONSISTS OF A THICK BLUE LINE SHAPED LIKE AN ARROW SYMBOL OR A "GREATER THAN" SYMBOL, I.E., >, POINTING TO THE RIGHT. TO THE RIGHT OF THE ARROW SYMBOL ARE LIGHTER BLUE LETTERS SPELLING "KAIREON", WITH THE BLUE BEING SOMEWHAT FADED ON THE LEFT SIDE OF THE WORD "KAIREON" GRADUALLY BECOMING MORE OPAQUE FROM LEFT TO RIGHT.

THE WORDING KAIREON HAS NO MEANING IN A FOREIGN LANGUAGE.

FOR MOBILE AND PORTABLE NON-METAL BUILDINGS FOR BUSINESS CONTINUITY, CONSISTING OF ONE OR MORE MOBILE, FABRIC-COVERED STRUCTURES CONTAINING A MOBILE HEATING, VENTILATION AND AIR CONDITIONING UNIT, A MOBILE ELECTRIC POWER GENERATOR, ELECTRICAL DISTRIBUTION HARDWARE AND WIRING, LIGHTING UNITS, AND FURNITURE, SOLD AS A UNIT CONFIGURED SO AS TO CREATE AN ENVIRONMENT IN WHICH CIVILIAN BUSINESSES OR GOVERNMENT ORGANIZATIONS CAN CONTINUE TO OPERATE AFTER THEIR OWN PREMISES HAVE BEEN DAMAGED OR DESTROYED (U.S. CLS. 1, 12, 33 AND 50).

BILL DAWE, EXAMINING ATTORNEY

CLASS 19—(Continued).

SN 77-600,499. ALASKA STRUCTURES, INC., ANCHORAGE, AK. FILED 10-24-2008.



THE MARK CONSISTS OF AN ARROW-LIKE OBJECT POINTING TO THE RIGHT WITH A POINT THAT CONSISTS OF A THICK, CONTRASTINGLY DARKER LINE SHAPED LIKE AN ARROW SYMBOL OR A "GREATER THAN" SYMBOL, I.E., > POINTING TO THE RIGHT. TO THE RIGHT OF THE ARROW ARE LETTERS SPELLING THE WORD "KAIREON".

THE WORDING "KAIREON" HAS NO MEANING IN A FOREIGN LANGUAGE.

FOR MOBILE AND PORTABLE NON-METAL BUILDINGS FOR BUSINESS CONTINUITY, CONSISTING OF ONE OR MORE MOBILE, FABRIC-COVERED STRUCTURES CONTAINING A MOBILE HEATING, VENTILATION AND AIR CONDITIONING UNIT, A MOBILE ELECTRIC POWER GENERATOR, ELECTRICAL DISTRIBUTION HARDWARE AND WIRING, LIGHTING UNITS, AND FURNITURE, SOLD AS A UNIT CONFIGURED SO AS TO CREATE AN ENVIRONMENT IN WHICH CIVILIAN BUSINESSES OR GOVERNMENT ORGANIZATIONS CAN CONTINUE TO OPERATE AFTER THEIR OWN PREMISES HAVE BEEN DAMAGED OR DESTROYED (U.S. CLS. 1, 12, 33 AND 50).

BILL DAWE, EXAMINING ATTORNEY

SN 77-609,654. OLDCASTLE PRECAST, INC., AUBURN, WA. FILED 11-7-2008.

STORM CAPTURE

THE MARK CONSISTS OF STANDARD CHARACTERS WITHOUT CLAIM TO ANY PARTICULAR FONT, STYLE, SIZE, OR COLOR.

NO CLAIM IS MADE TO THE EXCLUSIVE RIGHT TO USE "STORM", APART FROM THE MARK AS SHOWN.

FOR PRECAST CONCRETE MODULAR UNDERGROUND STORM WATER SYSTEM COMPRISED PRIMARILY OF CONCRETE SLABS AND PILLARS (U.S. CLS. 1, 12, 33 AND 50).

DORITT L. CARROLL, EXAMINING ATTORNEY

CLASS 19—(Continued).

SN 77-611,011. LEXINGTON MANUFACTURING, INC., MINNEAPOLIS, MN. FILED 11-10-2008.

CLASS 19—(Continued).

SN 77-630,194. BECKSTEAD, KENNETH M., OCEANSIDE, CA. FILED 12-10-2008.

Response CME

THE MARK CONSISTS OF STANDARD CHARACTERS WITHOUT CLAIM TO ANY PARTICULAR FONT, STYLE, SIZE, OR COLOR.

FOR WINDOW AND DOOR FRAMING COMPRISED OF SOLID OR VENEERED COMBUSTIBLE NON-METAL WINDOW AND DOOR FRAMES THAT IN CASE OF FIRE, WILL LEAVE BEHIND A NON-COMBUSTIBLE ATTACHMENT TO HOLD THE WINDOW AND DOOR IN PLACE (U.S. CLS. 1, 12, 33 AND 50).

COLLEEN DOMBROW, EXAMINING ATTORNEY

SN 77-615,163. BILT, LLC, SAN FRANCISCO, CA. FILED 11-14-2008.

BIG PICTURE

THE MARK CONSISTS OF STANDARD CHARACTERS WITHOUT CLAIM TO ANY PARTICULAR FONT, STYLE, SIZE, OR COLOR.

FOR NON-STRUCTURAL BUILDING MATERIALS, NAMELY, STONE, CEMENTITIOUS, RESIN, GLASS, GRANITE, MARBLE ENGINEERED COMPOSITE SLABS, PANELS, AND TILES USED IN DECORATIVE SURFACE APPLICATIONS FOR COUNTERTOPS, INTERIOR AND EXTERIOR WALL SURFACES AND PANELS, AND FLOORING (U.S. CLS. 1, 12, 33 AND 50).

SHARON MEIER, EXAMINING ATTORNEY

SN 77-625,985. GALLAGHER, JOSEPH, HAMPTON, VA. FILED 12-3-2008.

The Cross of Love Trellis Indoor/Outdoor

THE MARK CONSISTS OF STANDARD CHARACTERS WITHOUT CLAIM TO ANY PARTICULAR FONT, STYLE, SIZE, OR COLOR.

NO CLAIM IS MADE TO THE EXCLUSIVE RIGHT TO USE "TRELLIS INDOOR/OUTDOOR", APART FROM THE MARK AS SHOWN.

FOR NON-METAL TRELLISES (U.S. CLS. 1, 12, 33 AND 50).

SOPHIA S. KIM, EXAMINING ATTORNEY

GUTTER CRITTERS

THE MARK CONSISTS OF STANDARD CHARACTERS WITHOUT CLAIM TO ANY PARTICULAR FONT, STYLE, SIZE, OR COLOR.

NO CLAIM IS MADE TO THE EXCLUSIVE RIGHT TO USE "GUTTER", APART FROM THE MARK AS SHOWN.

FOR A NON-METAL GUTTER COVER FOR OBSTRUCTING OR DIRECTING THE FLOW OF WATER (U.S. CLS. 1, 12, 33 AND 50).

FIRST USE 10-10-2008; IN COMMERCE 10-10-2008.
MICHAEL WEBSTER, EXAMINING ATTORNEY

SN 77-632,311. SUPERIOR LAMINATE FLOORS, LLC, CEDAR CITY, UT. FILED 12-12-2008.

HEIDEMANN FLOORING

THE MARK CONSISTS OF STANDARD CHARACTERS WITHOUT CLAIM TO ANY PARTICULAR FONT, STYLE, SIZE, OR COLOR.

NO CLAIM IS MADE TO THE EXCLUSIVE RIGHT TO USE "FLOORING", APART FROM THE MARK AS SHOWN. SEC. 2(F).

FOR LAMINATE FLOORING (U.S. CLS. 1, 12, 33 AND 50).

FIRST USE 2-1-2001; IN COMMERCE 2-1-2001.
MATTHEW KLINE, EXAMINING ATTORNEY

CLASS 19—(Continued).

SN 77-634,245. APPALACHIAN ANTIQUE HARDWOODS LLC, WAYNESVILLE, NC. FILED 12-16-2008.



NO CLAIM IS MADE TO THE EXCLUSIVE RIGHT TO USE "ANTIQUÉ HARDWOODS, LLC", APART FROM THE MARK AS SHOWN.

THE COLOR(S) BLACK, WHITE AND ORANGE IS/ARE CLAIMED AS A FEATURE OF THE MARK.

THE MARK CONSISTS OF A HORIZONTAL OVAL HAVING A BLACK BORDER. THE OVAL IS BISECTED HORIZONTALLY IN EQUAL HALVES WITH THE UPPER HALF IN WHITE THE LOWER HALF IN BLACK. THE UPPER OVAL PORTION CONTAINS "APPALACHIAN" IN BLACK AND AN ORANGE MAPLE LEAF. "ANTIQUÉ HARDWOODS, LLC" APPEARS IN WHITE IN THE LOWER HALF OF THE OVAL.

SEC. 2(F) AS TO "APPALACHIAN ANTIQUÉ HARDWOODS, LLC".

FOR WOOD BUILDING MATERIALS, NAMELY, NEW AND RECYCLED FLOORING, BEAMS, TIMBERS, VENEERS, SIDING, RAILINGS AND LOGS (U.S. CLS. 1, 12, 33 AND 50).

FIRST USE 10-0-2003; IN COMMERCE 10-0-2003.
REBECCA POVARCHUK, EXAMINING ATTORNEY

SN 77-644,284. TENSATOR GROUP LIMITED, MILTON KEYNES, UNITED KINGDOM, FILED 1-6-2009.

TENSACLEAR

THE MARK CONSISTS OF STANDARD CHARACTERS WITHOUT CLAIM TO ANY PARTICULAR FONT, STYLE, SIZE, OR COLOR.

OWNER OF U.S. REG. NOS. 1,438,074, 2,707,211 AND OTHERS.

FOR PORTABLE NON-METAL BARRIERS FOR PEDESTRIAN TRAFFIC CONTROL (U.S. CLS. 1, 12, 33 AND 50).

FIRST USE 2-1-2001; IN COMMERCE 2-1-2001.
NICHOLAS ALTREE, EXAMINING ATTORNEY

CLASS 19—(Continued).

SN 77-651,936. DEMARCO, DAVID, AUSTIN, TX. FILED 1-19-2009.

WHITE = GREEN

THE MARK CONSISTS OF STANDARD CHARACTERS WITHOUT CLAIM TO ANY PARTICULAR FONT, STYLE, SIZE, OR COLOR.

FOR ROOFING MEMBRANES (U.S. CLS. 1, 12, 33 AND 50).

FIRST USE 7-10-2007; IN COMMERCE 7-15-2007.
TOBY BULLOFF, EXAMINING ATTORNEY

SN 77-652,875. COLD SPRING GRANITE COMPANY, COLD SPRING, MN. FILED 1-20-2009.

LAKE PLACID BLUE

THE MARK CONSISTS OF STANDARD CHARACTERS WITHOUT CLAIM TO ANY PARTICULAR FONT, STYLE, SIZE, OR COLOR.

NO CLAIM IS MADE TO THE EXCLUSIVE RIGHT TO USE "BLUE", APART FROM THE MARK AS SHOWN.

FOR GRANITE, CUT STONE, DIMENSIONAL STONE, SLABS OF GRANITE, AND MONUMENTAL STONE (U.S. CLS. 1, 12, 33 AND 50).

FIRST USE 11-11-1985; IN COMMERCE 11-11-1985.
CIMMERIAN COLEMAN, EXAMINING ATTORNEY

SN 77-659,483. OCEANIA USA, INC., HARRIS COUNTY, HOUSTON, TX. FILED 1-29-2009.



NO CLAIM IS MADE TO THE EXCLUSIVE RIGHT TO USE "SHUTTERS", APART FROM THE MARK AS SHOWN.

THE MARK CONSISTS OF THE WORDS "OCEANIA SHUTTERS", PLUS A LOGO DESIGN.

FOR NONMETAL SHUTTERS FOR WINDOWS, AND STRUCTURAL AND COMPONENT PARTS THEREFOR (U.S. CLS. 1, 12, 33 AND 50).

FIRST USE 6-1-2007; IN COMMERCE 6-1-2007.
CAROLYN CATALDO, EXAMINING ATTORNEY

CLASS 19—(Continued).

SN 77-662,680. JOHN AND ARIEL MOSELEY LLC, EL GRANADA, CA. FILED 2-3-2009.

CLASS 19—(Continued).

SN 77-679,739. MATHEWS BROTHERS COMPANY, BELFAST, ME. FILED 2-27-2009.

Coolstone

THE MARK CONSISTS OF STANDARD CHARACTERS WITHOUT CLAIM TO ANY PARTICULAR FONT, STYLE, SIZE, OR COLOR.

FOR LANDSCAPE PAVERS; RETAINING WALLS CONSISTING OF CONCRETE, WOOD, AND CLAY (U.S. CLS. 1, 12, 33 AND 50).

MAYUR VAGHANI, EXAMINING ATTORNEY



SN 77-662,862. BLUELINX SERVICES INC., ATLANTA, GA. FILED 2-4-2009.

PROLINE

THE MARK CONSISTS OF STANDARD CHARACTERS WITHOUT CLAIM TO ANY PARTICULAR FONT, STYLE, SIZE, OR COLOR.

FOR BUILDING MATERIALS, NAMELY, PLYWOOD SUB-FLOOR UNDERLAYMENT BOARDS (U.S. CLS. 1, 12, 33 AND 50).

GINA FINK, EXAMINING ATTORNEY



SN 77-663,955. JAC HOLDINGS, LTD., UPPER MONTCLAIR, NJ. FILED 2-5-2009.

BLOCK 'N ROLL

THE MARK CONSISTS OF STANDARD CHARACTERS WITHOUT CLAIM TO ANY PARTICULAR FONT, STYLE, SIZE, OR COLOR.

FOR NON-METAL ROLLER CURTAIN DOORS DESIGNED SPECIFICALLY FOR SALT AND SAND STORAGE BUILDINGS (U.S. CLS. 1, 12, 33 AND 50).

FIRST USE 5-16-2000; IN COMMERCE 10-23-2000.
SUSAN LESLIE DUBOIS, EXAMINING ATTORNEY

Stimulus 'E'

THE MARK CONSISTS OF STANDARD CHARACTERS WITHOUT CLAIM TO ANY PARTICULAR FONT, STYLE, SIZE, OR COLOR.

NO CLAIM IS MADE TO THE EXCLUSIVE RIGHT TO USE "E", APART FROM THE MARK AS SHOWN.

FOR BUILDING GLASS; COMMON SHEET GLASS; GLASS PANELS FOR BUILDING CONSTRUCTION PURPOSES; GLASS PANES; INSULATED GLASS; LAMINATED FLAT GLASS; MODIFIED SHEET GLASS; SAFETY GLASS FOR BUILDING PURPOSES; WINDOW GLASS (U.S. CLS. 1, 12, 33 AND 50).

MARTHA FROMM, EXAMINING ATTORNEY

CLASS 19—(Continued).

SN 79-058.646. GRUPPO CERAMICHE GRESMALT S.P.A., ITALY, FILED 6-10-2008.



OWNER OF INTERNATIONAL REGISTRATION 0976698 DATED 6-10-2008, EXPIRES 6-10-2018.

THE COLOR(S) WHITE AND GREEN IS/ARE CLAIMED AS A FEATURE OF THE MARK.

THE WORDING SINTESI IN WHITE; LIGHT GREEN BACKGROUND; LIGHT GREEN FIGURE OF A BIRD'S HEAD WITH SHADOW IN WHITE.

THE MARK IS CONSTITUTED BY THE WORDING "SINTESI" DEPICTED ON A LIGHT GREEN BACKGROUND AND ASSOCIATED WITH A STYLIZED FIGURE OF A BIRD'S HEAD WITH SHADOW IN NEGATIVE.

THE ENGLISH TRANSLATION OF THE FOREIGN WORD(S) IN THE MARK IS: SYNTHESIS.

FOR STONES; GRANITE; MARBLE; ARTIFICIAL STONE; BUILDING STONE; TILE FLOORINGS, NOT OF METAL; GLASS BUILDING MOSAICS FOR USE IN BUILDING CONSTRUCTION; BUILDING MATERIALS, NAMELY COATINGS OF ASPHALT FOR ROOFING; FLOOR TILES, NOT OF METAL; PAVING SLABS, NOT OF METAL; PAVING BLOCKS, NOT OF METAL; WALL TILES, NOT OF METAL; WAINSCOTING, NOT OF METAL; FLOOR PANELS, NOT OF METAL; MOSAIC TILES, NOT OF METAL; BUILDING PANELS NOT OF METAL; FURRRINGS OF WOOD; WOOD PANELLING; WOODEN FLOORING; PARQUET FLOOR BOARDS; CONCRETE; SANDSTONE FOR BUILDING; CLINKER STONE; GRAVEL; SAND; CALCAREOUS STONE; BRICKS, NAMELY, MADE OF EARTH; POTTERS' CLAY; ALABASTER; CONCRETE BUILDING ELEMENTS, NAMELY, CEMENT SLABS; CERAMIC TILES; ASBESTOS CEMENT TILES; BRICKS; REFRACTORY CONSTRUCTION MATERIAL, NAMELY, FIRE BRICK AND FIRE TILES; SLABS NOT OF METAL; ROOFING TILES, NOT OF METAL; ROOFING SHINGLES, NOT OF METAL; ROOF COVERINGS, NOT OF METAL; CEILING TILES, NOT OF METAL; PLASTIC BOARD FOR CONSTRUCTION; CLADDING, NOT OF METAL, FOR BUILDING CONSTRUCTION; REINFORCING MATERIALS, NOT OF METAL, FOR BUILDING; WALL CLADDINGS, NOT OF METAL, FOR BUILDING; WALL LININGS, NOT OF METAL, FOR BUILDING; PARQUET FLOORING; PRE-FABRICATED BUILDINGS, NOT OF METAL; SAFETY GLASS FOR BUILDING PURPOSES; INSULATING GLASS FOR BUILDING PURPOSES; BUILDING GLASS; ALABASTER GLASS FOR BUILDING PURPOSES; NON-METAL BUILDING TILES; CERAMIC TILES FOR BUILDING (U.S. CLS. 1, 12, 33 AND 50).

FRANK LATTUCA, EXAMINING ATTORNEY

CLASS 19—(Continued).

SN 79-975.072. SHENZHEN TRONY SCIENCE & TECHNOLOGY; DEVELOPMENT CO. LTD, CHINA, FILED 3-31-2008.



OWNER OF INTERNATIONAL REGISTRATION 0967966 DATED 3-31-2008, EXPIRES 3-31-2018.

THE MARK CONSISTS OF THE WORD "TRONY" IN WHICH THE LETTER "O" IS A STYLIZED REPRESENTATION OF THE SUN RADIATING RAYS OF LIGHT. THE RAYS OF LIGHT ALSO APPEAR ON THE OTHER LETTERS IN THE WORD "TRONY".

FOR AMORPHOUS SILICON SOLAR CELL MATERIAL FOR ELECTRICAL ENERGY GENERATION FOR USE IN BUILDINGS, NAMELY, ROOFING, NOT OF METAL, INCORPORATING AMORPHOUS SILICON PHOTOVOLTAIC POWER MODULES, PAVEMENT INCORPORATING AMORPHOUS SILICON SOLAR CELL MATERIAL FOR ELECTRICAL ENERGY GENERATION; NON-METAL ROOF PANELS FOR MOUNTING AMORPHOUS SILICON SOLAR PANELS; ROAD NOISE BARRIERS NOT OF METAL INCORPORATING AMORPHOUS SILICON PHOTOVOLTAIC POWER MODULES, SEALED INSULATING CRYSTALLINE SILICON BUILDING GLASS INCORPORATING AMORPHOUS SILICON PHOTOVOLTAIC POWER MODULES, SOLAR PHOTOVOLTAIC LAMINATED BUILDING GLASS INCORPORATING AMORPHOUS SILICON PHOTOVOLTAIC POWER MODULES, NON-METAL SOLAR PHOTOVOLTAIC CURTAIN WALLS INCORPORATING AMORPHOUS SILICON PHOTOVOLTAIC POWER MODULES; SOLAR CELL MATERIAL FOR ELECTRICAL ENERGY GENERATION FOR USE IN BUILDINGS, ROOFING, NOT OF METAL, INCORPORATING PHOTOVOLTAIC POWER MODULES, PAVEMENT INCORPORATING SOLAR CELL MATERIAL FOR ELECTRICAL ENERGY GENERATION, NON-METAL ROOF PANELS FOR MOUNTING SOLAR PANELS; ROAD NOISE BARRIERS NOT OF METAL INCORPORATING PHOTOVOLTAIC POWER MODULES, SEALED INSULATING CRYSTALLINE SILICON BUILDING GLASS INCORPORATING PHOTOVOLTAIC POWER MODULES, SOLAR PHOTOVOLTAIC LAMINATED BUILDING GLASS INCORPORATING PHOTOVOLTAIC POWER MODULES, SOLAR PHOTOVOLTAIC CURTAIN WALLS INCORPORATING PHOTOVOLTAIC POWER MODULES; DYE-SENSITIZED SOLAR CELL MATERIAL FOR ELECTRICAL ENERGY GENERATION FOR USE IN BUILDINGS, NAMELY, ROOFING, NOT OF METAL, INCORPORATING DYE-SENSITIZED PHOTOVOLTAIC POWER MODULES; PAVEMENT INCORPORATING DYE-SENSITIZED SOLAR CELL MATERIAL FOR ELECTRICAL ENERGY GENERATION; BUILDING GLASS INCORPORATING SILICON SOLAR CELL MATERIAL FOR ELECTRICAL ENERGY GENERATION; SAFETY GLASS FOR BUILDING PURPOSES INCORPORATING SILICON SOLAR CELL MATERIAL FOR ELECTRICAL ENERGY GENERATION; FILM PLATED GLASS, NAMELY, LAMINATED FLAT GLASS FOR BUILDING PURPOSES INCORPORATING SILICON SOLAR CELL MATERIAL FOR ELECTRICAL ENERGY GENERATION; NON-METAL WINDOWS INCORPORATING SILICON PHOTOVOLTAIC POWER MODULES (U.S. CLS. 1, 12, 33 AND 50).

MICHAEL TANNER, EXAMINING ATTORNEY

CLASS 20—FURNITURE AND ARTICLES NOT OTHERWISE CLASSIFIED

SN 76-694,456. ASHLEY FURNITURE INDUSTRIES, INC., ARCADIA, WI. FILED 11-24-2008.



OWNER OF U.S. REG. NOS. 1,600,879, 3,342,492 AND OTHERS.

THE MARK CONSISTS OF A STYLED LETTER "A" FOLLOWED BY THE WORDING "ASHLEY-SLEEP" BELOW A HIGHLY STYLIZED STICK FIGURE OF AN INDIVIDUAL LAYING DOWN.

FOR MATTRESSES (U.S. CLS. 2, 13, 22, 25, 32 AND 50).
RAUL CORDOVA, EXAMINING ATTORNEY

SN 77-339,502. NEMSCHOFF CHAIRS, INC., SHEBOYGAN, WI. FILED 11-28-2007.

ABC

THE MARK CONSISTS OF STANDARD CHARACTERS WITHOUT CLAIM TO ANY PARTICULAR FONT, STYLE, SIZE, OR COLOR.

FOR CHAIRS USED FOR NON-MEDICAL PURPOSES IN THE HEALTHCARE INDUSTRY (U.S. CLS. 2, 13, 22, 25, 32 AND 50).

JANICE L. MCMORROW, EXAMINING ATTORNEY

SN 77-436,845. THE BLACK & DECKER CORPORATION, TOWSON, MD. FILED 4-1-2008.

OWNER OF U.S. REG. NOS. 1,456,143, 3,240,370 AND OTHERS.

FOR NON-METAL STORAGE CABINETS (U.S. CLS. 2, 13, 22, 25, 32 AND 50).

FIRST USE 1-23-2008; IN COMMERCE 1-23-2008.
JAMES LOVELACE, EXAMINING ATTORNEY

CLASS 20—(Continued).

SN 77-439,674. TOFASCO OF AMERICA, INC., LA VERNE, CA. FILED 4-3-2008.

Maccabee

THE MARK CONSISTS OF STANDARD CHARACTERS WITHOUT CLAIM TO ANY PARTICULAR FONT, STYLE, SIZE, OR COLOR.

SEC. 2(F).
FOR FURNITURE, NAMELY, INDOOR AND OUTDOOR FURNITURE AND CHILDREN'S FURNITURE (U.S. CLS. 2, 13, 22, 25, 32 AND 50).

FIRST USE 6-11-1993; IN COMMERCE 6-11-1993.
RAMONA ORTIGA, EXAMINING ATTORNEY

SN 77-529,162. RANZAU, KARYN E., LOUISVILLE, KY. FILED 7-23-2008.

BRILLIANT BOWMAKER

THE MARK CONSISTS OF STANDARD CHARACTERS WITHOUT CLAIM TO ANY PARTICULAR FONT, STYLE, SIZE, OR COLOR.

NO CLAIM IS MADE TO THE EXCLUSIVE RIGHT TO USE "BOWMAKER", APART FROM THE MARK AS SHOWN.

FOR PLASTIC TEMPLATES FOR FOLDING HAIR BOWS (U.S. CLS. 2, 13, 22, 25, 32 AND 50).

PAUL MORENO, EXAMINING ATTORNEY

SN 77-531,287. INTERNATIONAL OFFICE PRODUCTS CO-OPERATIVE, GREER, SC. FILED 7-25-2008.

MULTISORT

THE MARK CONSISTS OF STANDARD CHARACTERS WITHOUT CLAIM TO ANY PARTICULAR FONT, STYLE, SIZE, OR COLOR.

OWNER OF U.S. REG. NO. 2,427,684.

SEC. 2(F).
FOR FURNITURE, NAMELY, TABLES, CABINETS, NON-METAL SORTER BINS, MAIL CARTS, METAL SORTING RACKS FOR SORTING DOCUMENTS AND/OR MAIL, METAL FRAME FURNITURE WORK STATIONS, AND WOOD FRAME FURNITURE WORK STATIONS (U.S. CLS. 2, 13, 22, 25, 32 AND 50).

FIRST USE 2-1-1995; IN COMMERCE 2-1-1995.
RONALD DELGIZZI, EXAMINING ATTORNEY

CLASS 20—(Continued).

SN 77-539,038. DUCDUC LLC, NEW YORK, NY. FILED 8-5-2008.

MASON GRAY

THE MARK CONSISTS OF STANDARD CHARACTERS WITHOUT CLAIM TO ANY PARTICULAR FONT, STYLE, SIZE, OR COLOR.

THE NAME(S), PORTRAIT(S), AND/OR SIGNATURE(S) SHOWN IN THE MARK DOES NOT IDENTIFY A PARTICULAR LIVING INDIVIDUAL.

FOR FURNITURE, PILLOWS, NON-METAL HANDLES FOR CABINETS, DOORS AND DRAWERS; DRAWERS; DOORS FOR FURNITURE; WOOD AND PLASTIC KNOBS FOR CABINETS, DOORS AND DRAWERS; DRAWER PULLS OF PLASTIC OR WOOD, CORK, REED, CANE, WICKER, HORN, BONE, IVORY, WHALEBONE, SHELL, AMBER, MOTHER-OF-PEARL, MEERSCHAUM AND SUBSTITUTES FOR ALL THESE MATERIALS (U.S. CLS. 2, 13, 22, 25, 32 AND 50).

KRISTIN DAHLING, EXAMINING ATTORNEY

SN 77-585,610. SHEN'S GALLERY & IMPORTS, INC., SANTA CRUZ, CA. FILED 10-3-2008.

SHEN'S GALLERY

THE MARK CONSISTS OF STANDARD CHARACTERS WITHOUT CLAIM TO ANY PARTICULAR FONT, STYLE, SIZE, OR COLOR.

NO CLAIM IS MADE TO THE EXCLUSIVE RIGHT TO USE "GALLERY", APART FROM THE MARK AS SHOWN. SEC. 2(F) AS TO "SHEN".

FOR ARMOIRES; BED FRAMES; BEDS; BENCHES; BOOK STANDS; BOOKCASES; BOOKSHELVES; CABINETS; CHAIRS; DECORATIVE WINDOW FINIALS; DOORS FOR FURNITURE; FURNITURE; NON-METAL CHESTS; SIDEBOARDS; STOOLS; TABLES; TELEVISION STANDS (U.S. CLS. 2, 13, 22, 25, 32 AND 50).

FIRST USE 0-0-1990; IN COMMERCE 0-0-1992.

JASON TURNER, EXAMINING ATTORNEY

CLASS 20—(Continued).

SN 77-594,337. KINGSDOWN, INC., MEBANE, NC. FILED 10-16-2008.

SCIENTIFIC MEASUREMENT AND RESPONSE TECHNOLOGY

THE MARK CONSISTS OF STANDARD CHARACTERS WITHOUT CLAIM TO ANY PARTICULAR FONT, STYLE, SIZE, OR COLOR.

NO CLAIM IS MADE TO THE EXCLUSIVE RIGHT TO USE "SCIENTIFIC" AND "TECHNOLOGY", APART FROM THE MARK AS SHOWN.

FOR MATTRESSES AND BOX SPRINGS (U.S. CLS. 2, 13, 22, 25, 32 AND 50).

FIRST USE 10-20-2008; IN COMMERCE 11-20-2008.

DANIEL CAPSHAW, EXAMINING ATTORNEY

SN 77-623,613. HNI TECHNOLOGIES INC., MUSCATINE, IA. FILED 12-1-2008.

SILEA

THE MARK CONSISTS OF STANDARD CHARACTERS WITHOUT CLAIM TO ANY PARTICULAR FONT, STYLE, SIZE, OR COLOR.

THE WORDING "SILEA" HAS NO MEANING IN A FOREIGN LANGUAGE.

FOR FURNITURE; OFFICE FURNITURE; OFFICE FURNITURE SYSTEMS COMPRISED PRIMARILY OF MOVABLE AND FREE-STANDING OFFICE FURNITURE PARTITIONS, DESKS, TABLES, DRAWERS, CABINETS, OFFICE FURNITURE PARTITIONS WITH SURFACE FINISH OPTIONS ALLOWING FOR USE OF SAME AS MARKING BOARDS, TACK BOARDS, AND PAPER MANAGEMENT TOOL BOARDS, STORAGE RACKS, FILING CABINETS, AND SHELVING; OFFICE WORKSTATIONS HAVING MULTI-USE WORK SURFACES FOR USE IN A WIDE VARIETY OF FIELDS (U.S. CLS. 2, 13, 22, 25, 32 AND 50).

MARLENE BELL, EXAMINING ATTORNEY

SN 77-642,032. NFS GLOBAL, L.L.C., MARCUS, IA. FILED 12-31-2008.



OWNER OF U.S. REG. NO. 3,201,328.
NO CLAIM IS MADE TO THE EXCLUSIVE RIGHT TO USE "BOX", APART FROM THE MARK AS SHOWN.

THE MARK CONSISTS OF THE WORDS "THE NESTING BOX" WITH A PIGLET PEEKING OUT OF A BOX.

FOR NON-METAL HOG FARROWING BOX (U.S. CLS. 2, 13, 22, 25, 32 AND 50).

FIRST USE 4-0-2004; IN COMMERCE 4-0-2004.

GINA HAYES, EXAMINING ATTORNEY

CLASS 20—(Continued).

SN 77-647,144. JERRY LISTER CUSTOM UPHOLSTERY INC., DBA DEL MOTORIZED SOLUTIONS, BENSALEM, PA. FILED 1-10-2009.

Innovation in Shading Systems

THE MARK CONSISTS OF STANDARD CHARACTERS WITHOUT CLAIM TO ANY PARTICULAR FONT, STYLE, SIZE, OR COLOR.

NO CLAIM IS MADE TO THE EXCLUSIVE RIGHT TO USE "SHADING SYSTEMS", APART FROM THE MARK AS SHOWN.

FOR WINDOW BLINDS; WINDOW SHADES (U.S. CLS. 2, 13, 22, 25, 32 AND 50).

RAMONA ORTIGA, EXAMINING ATTORNEY

CLASS 20—(Continued).

SN 77-655,555. KINGSDOWN, INC., MEBANE, NC. FILED 1-23-2009.

BODY NATURAL

THE MARK CONSISTS OF STANDARD CHARACTERS WITHOUT CLAIM TO ANY PARTICULAR FONT, STYLE, SIZE, OR COLOR.

OWNER OF U.S. REG. NOS. 1,654,338, 2,990,187 AND OTHERS.

FOR MATTRESSES AND BOX SPRINGS (U.S. CLS. 2, 13, 22, 25, 32 AND 50).

ARETHA SOMERVILLE, EXAMINING ATTORNEY

SN 77-653,197. HANGER MEDIA GROUP LLC, BAYSIDE, NY. FILED 1-21-2009.

The Closet Billboard

THE MARK CONSISTS OF STANDARD CHARACTERS WITHOUT CLAIM TO ANY PARTICULAR FONT, STYLE, SIZE, OR COLOR.

NO CLAIM IS MADE TO THE EXCLUSIVE RIGHT TO USE "CLOSET", APART FROM THE MARK AS SHOWN.

FOR HANGERS FOR CLOTHES (U.S. CLS. 2, 13, 22, 25, 32 AND 50).

SHARON MEIER, EXAMINING ATTORNEY

SN 77-658,681. ELI WILNER, NEW YORK, NY. FILED 1-28-2009.

FAMOUS FRAMES

THE MARK CONSISTS OF STANDARD CHARACTERS WITHOUT CLAIM TO ANY PARTICULAR FONT, STYLE, SIZE, OR COLOR.

NO CLAIM IS MADE TO THE EXCLUSIVE RIGHT TO USE "FRAMES", APART FROM THE MARK AS SHOWN.

FOR PICTURE AND PHOTOGRAPH FRAMES (U.S. CLS. 2, 13, 22, 25, 32 AND 50).

SHAUNIA CARLYLE, EXAMINING ATTORNEY

SN 77-654,131. ALLIED BUYING CORPORATION, LOMBARD, IL. FILED 1-22-2009.

CENTAUR

THE MARK CONSISTS OF STANDARD CHARACTERS WITHOUT CLAIM TO ANY PARTICULAR FONT, STYLE, SIZE, OR COLOR.

OWNER OF U.S. REG. NO. 3,584,467.

FOR CHAIRS; FURNITURE; FURNITURE PARTS; FURNITURE PARTS, NAMELY, TABLE BASES; SEATING FURNITURE; TABLE TOPS (U.S. CLS. 2, 13, 22, 25, 32 AND 50).

GENE MACIOL, EXAMINING ATTORNEY

SN 77-660,513. SITWELL, LLC, CERRITOS, CA. FILED 1-30-2009.

CREATE-A-MESH CHAIR

THE MARK CONSISTS OF STANDARD CHARACTERS WITHOUT CLAIM TO ANY PARTICULAR FONT, STYLE, SIZE, OR COLOR.

NO CLAIM IS MADE TO THE EXCLUSIVE RIGHT TO USE "MESH CHAIR", APART FROM THE MARK AS SHOWN.

FOR CHAIRS (U.S. CLS. 2, 13, 22, 25, 32 AND 50).

LINDA ESTRADA, EXAMINING ATTORNEY

CLASS 20—(Continued).

SN 77-661,160. ENNOVATE, INC, SUFFERN, NY. FILED 2-2-2009.

SANDHAND

THE MARK CONSISTS OF STANDARD CHARACTERS WITHOUT CLAIM TO ANY PARTICULAR FONT, STYLE, SIZE, OR COLOR.
 FOR TABLES FOR USE AT THE BEACH WITH BUILT-IN CANOPY (U.S. CLS. 2, 13, 22, 25, 32 AND 50).
 ALYSSA STEEL, EXAMINING ATTORNEY

SN 77-662,136. BURNS, JAMES E, LIGHTHOUSE POINT, FL. FILED 2-3-2009.

BAG-MATE

THE MARK CONSISTS OF STANDARD CHARACTERS WITHOUT CLAIM TO ANY PARTICULAR FONT, STYLE, SIZE, OR COLOR.
 FOR PLASTIC HANDLES FOR SHOPPING BAGS (U.S. CLS. 2, 13, 22, 25, 32 AND 50).
 TEJBIR SINGH, EXAMINING ATTORNEY

CLASS 20—(Continued).

SN 77-664,251. KAO, TZU-MIN, BETHESDA, MD. FILED 2-5-2009.



THE MARK CONSISTS OF A CHINESE-STYLE BRUSH DRAWING OF A PANDA SITTING IN FRONT OF A SMALL BAMBOO PLANT AND SAID DRAWING ALSO RESEMBLES THE CHINESE CALLIGRAPHY OF THE CHARACTER MEANING FORTUNE.

FOR CAST STONE HOUSEHOLD AND GARDEN FURNITURE; DECORATIONS OF PLASTIC FOR FOOD-STUFFS; DECORATIVE BEAD CURTAINS; DECORATIVE DECOYS MADE OF PLASTIC; DECORATIVE WINDOW FINIALS; GIFT PACKAGE DECORATIONS MADE OF PLASTIC; NON-ADHESIVE PLASTIC PARTY TAPE FOR DECORATING; NON-METAL FIXTURES COMPRISING HOOKS, SUPPORT ARMS, AND SHELVING FOR HANGING GENERAL HOUSEHOLD GOODS; OUTDOOR HOLIDAY DECORATIONS MADE OF CLEAR OR TRANSLUCENT PVC OR POLYPROPYLENE DIE CUT FORMS HAVING HOLIDAY THEMED SHAPES AND ICONS; PICTURE FRAMES WITH PLUSH DECORATIVE OUTER SURFACE; PLASTIC DECORATIVE MOUNTING HARDWARE USED IN THE ASSEMBLING AND SECURING OF CHRISTMAS DECORATIONS, NAMELY, HOOKS, STAKES, SUPPORTS AND TREE CLIPS; SOFT SCULPTURE WALL DECORATIONS (U.S. CLS. 2, 13, 22, 25, 32 AND 50).

MATTHEW PAPPAS, EXAMINING ATTORNEY

SN 77-664,417. ORTHO MATTRESS INC., LA MIRADA, CA. FILED 2-5-2009.

LFC Luxury Foam Core

THE MARK CONSISTS OF STANDARD CHARACTERS WITHOUT CLAIM TO ANY PARTICULAR FONT, STYLE, SIZE, OR COLOR.

NO CLAIM IS MADE TO THE EXCLUSIVE RIGHT TO USE "LUXURY FOAM CORE", APART FROM THE MARK AS SHOWN.

FOR BED FRAMES; BEDROOM FURNITURE; BEDS; BEDS, MATTRESSES, PILLOWS AND BOLSTERS; BED-SPRINGS; BOX SPRINGS; MATTRESS CUSHIONS; MATTRESS FOUNDATIONS; MATTRESS TOPPERS; MATTRESSES; MATTRESSES AND PILLOWS (U.S. CLS. 2, 13, 22, 25, 32 AND 50).

KRISTIN DAHLING, EXAMINING ATTORNEY

CLASS 20—(Continued).

SN 77-664,727. ADAMSON, CYNTHIA, M, BRADENTON, FL. FILED 2-6-2009.

NAUGHTY CHAIR

THE MARK CONSISTS OF STANDARD CHARACTERS WITHOUT CLAIM TO ANY PARTICULAR FONT, STYLE, SIZE, OR COLOR.

NO CLAIM IS MADE TO THE EXCLUSIVE RIGHT TO USE "CHAIR", APART FROM THE MARK AS SHOWN.

FOR CHAIR CUSHIONS; CHAIR MATS IN THE NATURE OF A PILLOW OR SEAT LINER; CHAIR PADS; CHAIRS (U.S. CLS. 2, 13, 22, 25, 32 AND 50).

MARK T. MULLEN, EXAMINING ATTORNEY

CLASS 20—(Continued).

SN 77-668,487. SAUL ZAENTZ COMPANY, THE, BERKELEY, CA. FILED 2-11-2009.

ARAGORN

THE MARK CONSISTS OF STANDARD CHARACTERS WITHOUT CLAIM TO ANY PARTICULAR FONT, STYLE, SIZE, OR COLOR.

FOR HAND-HELD MIRRORS; ORNAMENTS MADE OF RESIN (U.S. CLS. 2, 13, 22, 25, 32 AND 50).

FIRST USE 12-13-2004; IN COMMERCE 8-3-2008.

LINDA POWELL, EXAMINING ATTORNEY

SN 77-666,475. CASE SYSTEMS, INC., MIDLAND, MI. FILED 2-9-2009.

CASELINER

THE MARK CONSISTS OF STANDARD CHARACTERS WITHOUT CLAIM TO ANY PARTICULAR FONT, STYLE, SIZE, OR COLOR.

FOR POLYURETHANE/POLYUREA ELASTOMER-COATED SHELF FOR USE ON CABINETS, WORKSTATIONS OR FURNITURE (U.S. CLS. 2, 13, 22, 25, 32 AND 50).

FIRST USE 2-29-2008; IN COMMERCE 2-29-2008.

FLORENTINA BLANDU, EXAMINING ATTORNEY

SN 77-677,023. KOLCRAFT ENTERPRISES, INC., CHICAGO, IL. FILED 2-24-2009.

OMNI-PEDIC

THE MARK CONSISTS OF STANDARD CHARACTERS WITHOUT CLAIM TO ANY PARTICULAR FONT, STYLE, SIZE, OR COLOR.

FOR CRIB MATTRESSES (U.S. CLS. 2, 13, 22, 25, 32 AND 50).

FIRST USE 2-28-1993; IN COMMERCE 2-28-1993.

COURTNEY MCCORMICK, EXAMINING ATTORNEY

SN 77-668,438. SAUL ZAENTZ COMPANY, THE, BERKELEY, CA. FILED 2-11-2009.

LOTR

THE MARK CONSISTS OF STANDARD CHARACTERS WITHOUT CLAIM TO ANY PARTICULAR FONT, STYLE, SIZE, OR COLOR.

FOR DIORAMAS OF POLYSTONE FEATURING FIGURINES FROM FILMS (U.S. CLS. 2, 13, 22, 25, 32 AND 50).

FIRST USE 11-30-2007; IN COMMERCE 8-24-2008.

LINDA POWELL, EXAMINING ATTORNEY

SN 78-561,771. HEB GROCERY COMPANY, L.P., SAN ANTONIO, TX. FILED 2-7-2005.

TEXAS BACKYARD

THE MARK CONSISTS OF STANDARD CHARACTERS WITHOUT CLAIM TO ANY PARTICULAR FONT, STYLE, SIZE, OR COLOR.

NO CLAIM IS MADE TO THE EXCLUSIVE RIGHT TO USE "TEXAS", APART FROM THE MARK AS SHOWN.

FOR LAWN FURNITURE; OUTDOOR FURNITURE; WIND CHIMES (U.S. CLS. 2, 13, 22, 25, 32 AND 50).

DAVID TAYLOR, EXAMINING ATTORNEY

CLASS 20—(Continued).

SN 79-060,009. ZHEJIANG XIANJU HUALI; ART & CRAFT FACTORY, 317300 ZHEJIANG, CHINA, FILED 7-25-2008.



OWNER OF INTERNATIONAL REGISTRATION 0979977 DATED 7-25-2008, EXPIRES 7-25-2018.

THE MARK CONSISTS OF TWO LETTERS "H" AND "L" IN A STYLIZED FONT WITH THE "L" IN WHITE LAPS ON THE "H" IN BLACK, THREE CHINESE CHARACTERS AND THE TRANSLITERATION OF THESE CHINESE CHARACTERS "WEI LAO DA".

THE ENGLISH TRANSLATION OF "WEI LAO DA" IS SAJOR, OLD, BIG.

THE TRANSLITERATION OF THE NON-LATIN CHARACTERS IN THE MARK IS "WEI LAO DA".

FOR FURNITURE; WORKS OF ART OF BAMBOO AND WOOD; WORKS OF ART AND SCULPTURES OF CLAY; CRAFTWORKS OF CLAY, NAMELY, POLYMER CLAY FIGURINES (U.S. CLS. 2, 13, 22, 25, 32 AND 50).

MARIAM MAHMOUDI, EXAMINING ATTORNEY

SN 79-066,981. JESSE S.P.A., ITALY, FILED 1-29-2009.



PRIORITY DATE OF 12-18-2008 IS CLAIMED. OWNER OF INTERNATIONAL REGISTRATION 0997959 DATED 1-29-2009, EXPIRES 1-29-2019.

FOR ARMOIRES, CHAIRS, TABLES, SMALL TABLES, MIRRORS, BEDS, BEDROOM FURNITURE, ARM-CHAIRS, SOFAS, BATHROOM FURNITURE, BOOK-SHELVES, DESKS, KITCHEN FURNITURE, LIVING ROOM FURNITURE (U.S. CLS. 2, 13, 22, 25, 32 AND 50).

JAMES A. RAUEN, EXAMINING ATTORNEY

CLASS 21—HOUSEWARES AND GLASS

SN 76-695,637. STRICKLAND, DEBORAH, BAIRD, TX. FILED 2-6-2009.

USE IT AND LOSE IT

THE MARK CONSISTS OF STANDARD CHARACTERS WITHOUT CLAIM TO ANY PARTICULAR FONT, STYLE, SIZE, OR COLOR.

FOR DENTAL FLOSS DISPENSER FEATURING A STORAGE CONTAINER FOR THE USED DENTAL FLOSS (U.S. CLS. 2, 13, 23, 29, 30, 33, 40 AND 50).

DOUGLAS LEE, EXAMINING ATTORNEY

SN 77-156,230. ERNIE BALL, INC., SAN LUIS OBISPO, CA. FILED 4-13-2007.

WONDER WIPES

THE MARK CONSISTS OF STANDARD CHARACTERS WITHOUT CLAIM TO ANY PARTICULAR FONT, STYLE, SIZE, OR COLOR.

NO CLAIM IS MADE TO THE EXCLUSIVE RIGHT TO USE "WIPES", APART FROM THE MARK AS SHOWN.

FOR PRE-MOISTENED TOWELETTES FOR CLEANING, PROTECTING, POLISHING, AND CONDITIONING MUSICAL INSTRUMENTS, NONE FOR USE WITH HOUSEHOLD OR AUTOMOTIVE GOODS OR FOR USE ON THE BODY OR FACE (U.S. CLS. 2, 13, 23, 29, 30, 33, 40 AND 50).

FIRST USE 1-17-2007; IN COMMERCE 1-17-2007.

ANNE E. GUSTASON, EXAMINING ATTORNEY

SN 77-156,238. ERNIE BALL, INC., SAN LUIS OBISPO, CA. FILED 4-13-2007.



NO CLAIM IS MADE TO THE EXCLUSIVE RIGHT TO USE "WIPES", APART FROM THE MARK AS SHOWN.

THE MARK CONSISTS OF THE WORDS "WONDER" AND "WIPES" STACKED VERTICALLY AND SHARING THE SAME LARGE LETTER "W" FOR THE FIRST LETTER OF EACH WORD.

FOR PRE-MOISTENED TOWELETTES FOR CLEANING, PROTECTING, POLISHING, AND CONDITIONING MUSICAL INSTRUMENTS, NONE FOR USE WITH HOUSEHOLD OR AUTOMOTIVE GOODS OR FOR USE ON THE BODY OR FACE (U.S. CLS. 2, 13, 23, 29, 30, 33, 40 AND 50).

FIRST USE 1-17-2007; IN COMMERCE 1-17-2007.

ANNE E. GUSTASON, EXAMINING ATTORNEY

CLASS 21—(Continued).

SN 77-332,940. DATCO INTERNATIONAL, INC., BIRMINGHAM, MI. FILED 11-19-2007.

Diamond WipeTech

THE MARK CONSISTS OF THE WORDS "DIAMOND" AND "WIPETECH" WITH A CAPITAL "T" ON "TECH". FOR POLISHING CLOTHS (U.S. CLS. 2, 13, 23, 29, 30, 33, 40 AND 50).
MATTHEW MCDOWELL, EXAMINING ATTORNEY

SN 77-363,484. PARTYLITE WORLDWIDE, INC., PLYMOUTH, MA. FILED 1-3-2008.

ICED CRYSTAL

THE MARK CONSISTS OF STANDARD CHARACTERS WITHOUT CLAIM TO ANY PARTICULAR FONT, STYLE, SIZE, OR COLOR.
NO CLAIM IS MADE TO THE EXCLUSIVE RIGHT TO USE "CRYSTAL", APART FROM THE MARK AS SHOWN.
SEC. 2(F).
FOR CANDLE HOLDERS (U.S. CLS. 2, 13, 23, 29, 30, 33, 40 AND 50).
FIRST USE 12-31-1987; IN COMMERCE 12-31-1987.
LOURDES AYALA, EXAMINING ATTORNEY

SN 77-384,940. KEVIN F. LOHMEIER, ROSCOE, IL. FILED 1-31-2008.

FORM-A-FUNNEL

THE MARK CONSISTS OF STANDARD CHARACTERS WITHOUT CLAIM TO ANY PARTICULAR FONT, STYLE, SIZE, OR COLOR.
FOR CHANNELING AND CONTAINMENT TOOL AND APPARATUS, NAMELY, FUNNELS COMPRISING RUBBER-ENCASED LEAD FOIL AND LEAD SHEET USED FOR LIQUID AND ARTICLE DIVERSION, FLOW AND DIRECTIONAL CONTROL, AND TRAPPING AND CONTAINMENT PURPOSES (U.S. CLS. 2, 13, 23, 29, 30, 33, 40 AND 50).
ERIN FALK, EXAMINING ATTORNEY

CLASS 21—(Continued).

SN 77-456,548. SILVERMAN, ADAM, LOS ANGELES, CA. FILED 4-24-2008.

ATWATER POTTERY

THE MARK CONSISTS OF STANDARD CHARACTERS WITHOUT CLAIM TO ANY PARTICULAR FONT, STYLE, SIZE, OR COLOR.
NO CLAIM IS MADE TO THE EXCLUSIVE RIGHT TO USE "POTTERY", APART FROM THE MARK AS SHOWN.
SEC. 2(F).
FOR CERAMIC SCULPTURES, VASES, VESSELS, BOWLS, PLATES AND POTS; COFFEE CUPS, TEA CUPS AND MUGS (U.S. CLS. 2, 13, 23, 29, 30, 33, 40 AND 50).
FIRST USE 10-9-2002; IN COMMERCE 10-9-2002.
JAMES LOVELACE, EXAMINING ATTORNEY

SN 77-486,110. B4UGOGA-GA LP, NEW YORK, NY. FILED 5-29-2008.



THE NAME IN THE MARK IDENTIFIES A LIVING INDIVIDUAL WHOSE CONSENT IS OF RECORD.
THE MARK CONSISTS OF A STYLIZED UMBRELLA WITH THE WORDS "NANNY JO", WITH THE LETTER "J" AS THE HANDLE OF THE UMBRELLA.
FOR TABLEWARE, NAMELY, PLATES, BOWLS AND DRINKING VESSELS (U.S. CLS. 2, 13, 23, 29, 30, 33, 40 AND 50).
WILLIAM VERHOSEK, EXAMINING ATTORNEY

CLASS 21—(Continued).

SN 77-486,700. TABLETOPS UNLIMITED, INC., CARSON, CA. FILED 5-29-2008.

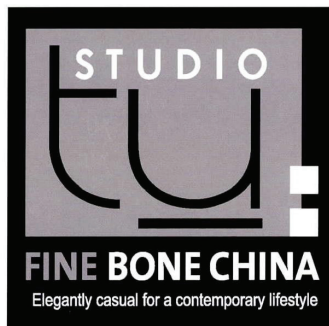

NO CLAIM IS MADE TO THE EXCLUSIVE RIGHT TO USE "FINE BONE CHINA", APART FROM THE MARK AS SHOWN.

FOR PLATES, MUGS, CUPS, SAUCERS (U.S. CLS. 2, 13, 23, 29, 30, 33, 40 AND 50).

FIRST USE 4-0-2007; IN COMMERCE 4-0-2007.
ANNE MADDEN, EXAMINING ATTORNEY

SN 77-520,647. STOCKDALE, JAMES, STOCKTON, CA. FILED 7-11-2008.

DUDE

THE MARK CONSISTS OF STANDARD CHARACTERS WITHOUT CLAIM TO ANY PARTICULAR FONT, STYLE, SIZE, OR COLOR.

FOR FIGURES OF GLASS, NAMELY, INSCRIPTED NOVELTY ITEMS FROM SOLID GLASS OR FLATTENED GLASS SOLIDS BEARING WORDS OR PHRASES (U.S. CLS. 2, 13, 23, 29, 30, 33, 40 AND 50).

ALICE BENMAMAN, EXAMINING ATTORNEY

SN 77-539,407. BATH & BODY WORKS BRAND MANAGEMENT, INC., REYNOLDSBURG, OH. FILED 8-5-2008.

LUMISHIELD

THE MARK CONSISTS OF STANDARD CHARACTERS WITHOUT CLAIM TO ANY PARTICULAR FONT, STYLE, SIZE, OR COLOR.

FOR ALUMINUM HEAT DEFLECTIVE INSERT FOR CERAMIC CANDLE HOLDERS AND LIDS, NAMELY, AN INSERT INCORPORATED INTO A CERAMIC CANDLE LID, WHICH DEFLECTS THE HEAT PRODUCED FROM THE CANDLE FLAME, MAINTAINING A SAFE TEMPERATURE FOR THE OUTSIDE OF THE LID (U.S. CLS. 2, 13, 23, 29, 30, 33, 40 AND 50).

DAVID I, EXAMINING ATTORNEY

CLASS 21—(Continued).

SN 77-559,664. TRUE VALUE COMPANY, CHICAGO, IL. FILED 8-31-2008.



OWNER OF U.S. REG. NOS. 2,523,311, 3,376,542 AND OTHERS.

NO CLAIM IS MADE TO THE EXCLUSIVE RIGHT TO USE "GRILL", APART FROM THE MARK AS SHOWN.

THE MARK CONSISTS OF THE WORDS "GRILL" AND "ZONE" APPEARING ON AN OVAL BACKGROUND WITH A FLAME DESIGN IN BETWEEN.

FOR BARBECUE ACCESSORIES, NAMELY, COOKING SKEWERS, BASTING BRUSHES, WIRE GRILL BRUSHES, TURNERS, GRILL SCRUBBING BRUSHES, GRILL CLEANING BRUSHES AND GRILL SCRAPERS, SPATULAS, DISPOSABLE GRILL TOPPERS, STAINLESS STEEL GRILL TOPPERS, PORCELAIN TOPPERS, PORCELAIN WOK TOPPERS, PVC GRILL COVERS, STAINLESS STEEL GRILL BASKETS, STAINLESS STEEL FISH BASKETS, REPLACEMENT GRILL BRUSH HEADS, EXPANDABLE PORCELAIN GRID GRATES, EXPANDABLE CHROME GRID GRATES, BARBECUE SMOKER BOXES; NONELECTRIC WOKS; CHIMNEY STYLE CHARCOAL STARTERS, NAMELY, COAL SCUTTLES (U.S. CLS. 2, 13, 23, 29, 30, 33, 40 AND 50).

FIRST USE 9-0-2008; IN COMMERCE 9-0-2008.
MIDGE BUTLER, EXAMINING ATTORNEY

SN 77-561,401. PUNTA BRAVA, LLC, AUSTIN, TX. FILED 9-3-2008.

PUNTA BRAVA

THE MARK CONSISTS OF STANDARD CHARACTERS WITHOUT CLAIM TO ANY PARTICULAR FONT, STYLE, SIZE, OR COLOR.

THE ENGLISH TRANSLATION OF THE WORD "PUNTA BRAVA" IN THE MARK IS "BRAVE END".

FOR CONTAINERS FOR HOUSEHOLD OR KITCHEN USE: BOWLS; PLATES; HOUSEHOLD UTENSILS, NAMELY, KITCHEN TONGS AND SERVING TONGS, CHOP STICKS; BEVERAGE GLASSWARE; DRINK WARE, NAMELY, WINE GLASSES, MUGS, SHOT GLASSES, BRANDY SNIFFERS, GOBLET, AND MARGARITA GLASSES (U.S. CLS. 2, 13, 23, 29, 30, 33, 40 AND 50).

STEVEN JACKSON, EXAMINING ATTORNEY

CLASS 21—(Continued).

SN 77-566,634. APX ALARM SECURITY SOLUTIONS, INC., PROVO, UT. FILED 9-10-2008.

CLASS 21—(Continued).

SN 77-631,388. GLASSHOUSE, LLC., CHICAGO, IL. FILED 12-11-2008.

APX ALARM

KLAASP

THE MARK CONSISTS OF STANDARD CHARACTERS WITHOUT CLAIM TO ANY PARTICULAR FONT, STYLE, SIZE, OR COLOR.

FOR BEVERAGEWARE DISTRIBUTED PRIMARILY TO CONSUMERS OF INTRUSION, FIRE AND TROUBLE ALERT SYSTEMS IN CONNECTION WITH THE PROMOTION OF INTRUSION, FIRE AND TROUBLE ALERT SYSTEMS (U.S. CLS. 2, 13, 23, 29, 30, 33, 40 AND 50).

KAREN K. BUSH, EXAMINING ATTORNEY

THE MARK CONSISTS OF STANDARD CHARACTERS WITHOUT CLAIM TO ANY PARTICULAR FONT, STYLE, SIZE, OR COLOR.

THE WORDING "KLAASP" HAS NO MEANING IN A FOREIGN LANGUAGE.

FOR KITCHEN UTENSIL, NAMELY, A DEVICE FOR ENCLOSING STEMWARE AND GLASSWARE FOR USE IN PROTECTING STEMWARE AND GLASSWARE WHILE CLEANING (U.S. CLS. 2, 13, 23, 29, 30, 33, 40 AND 50).

HEATHER BIDDULPH, EXAMINING ATTORNEY

SN 77-619,982. ATLANTA PACIFIC INDUSTRIES LLC, DBA CULMETA, SAN JOSE, CA. FILED 11-21-2008.

SN 77-640,914. FERNCO, INC., DAVISON, MI. FILED 12-29-2008.



THE COLOR(S) GREEN AND PURPLE IS/ARE CLAIMED AS A FEATURE OF THE MARK.

THE MARK CONSISTS OF A GREEN BAMBOO LEAF INSIDE A PURPLE RECTANGLE AND THE WORD "CULMETA" WHICH IS IN PURPLE.

THE WORDING "CULMETA" HAS NO MEANING IN A FOREIGN LANGUAGE.

FOR CHOPPING BOARDS FOR KITCHEN USE; CONTAINERS FOR HOUSEHOLD OR KITCHEN USE NOT OF PRECIOUS METAL (U.S. CLS. 2, 13, 23, 29, 30, 33, 40 AND 50).

FIRST USE 1-15-2008; IN COMMERCE 8-1-2008.
EDWARD NELSON, EXAMINING ATTORNEY



OWNER OF U.S. REG. NO. 3,076,367.

NO CLAIM IS MADE TO THE EXCLUSIVE RIGHT TO USE "NO DIG PIPE REPAIR SYSTEM", APART FROM THE MARK AS SHOWN.

THE COLOR(S) BLUE, BLACK AND GREY IS/ARE CLAIMED AS A FEATURE OF THE MARK.

THE MARK CONSISTS OF A GREY RECTANGLE BEHIND AND TO THE LEFT OF A BLACK BROKEN PIPE, WHICH TOGETHER FORMS THE LETTER "P". THE LETTERING "IPE PATCH" NEXT TO THE DESIGN ELEMENT APPEARS IN BLUE. THE WORDS "NO DIG PIPE REPAIR SYSTEM" APPEARS BELOW IN BLACK.

FOR SEWER PIPE REPAIR KITS COMPRISING A FIBERGLASS MAT, AN ADHESIVE CONSISTING OF A RESIN AND A HARDENER, A PLASTIC PROTECTIVE SLEEVE THAT ACTS AS AN INFLATABLE BALLOON OR BLADDER, ELECTRICIAN'S TAPE, A PLASTIC WORK SURFACE, A SPREADING SPATULA, DISPOSABLE GLOVES, AND BINDING WIRE ALL SOLD AS A UNIT (U.S. CLS. 2, 13, 23, 29, 30, 33, 40 AND 50).

FIRST USE 10-31-2004; IN COMMERCE 10-31-2004.
ELLEN PERKINS, EXAMINING ATTORNEY

CLASS 21—(Continued).

SN 77-641,067. FERNCO, INC., DAVISON, MI. FILED 12-30-2008.



THE COLOR(S) GREEN, GREY, BLACK AND WHITE IS/ ARE CLAIMED AS A FEATURE OF THE MARK.

THE MARK CONSISTS OF AN OPEN PIPE IN THE COLOR GREY WITH A GREEN CENTER. THE WORDING "SOURCE ONE ENVIRONMENTAL" APPEARS ON THE EDGE OF THE PIPE, WITH THE WORDS "SOURCE ONE" ARCHING OVER THE TOP PORTION OF THE PIPE AND THE TERM "ENVIRONMENTAL" ON THE BOTTOM ARC OF THE PIPE. IN BETWEEN THE WORDING APPEARS A GRAY DESIGN WITH A GREEN DOT ON EITHER SIDE OF THE PIPE AND THE DESIGN IS OUTLINED IN GREEN. THE TERMS "SOURCE" AND "ENVIRONMENTAL" APPEAR IN BLACK AND OUTLINED IN WHITE AND THE WORD "ONE" APPEARS IN GREEN AND IS OUTLINED IN WHITE. THE CENTER OF THE PIPE IS GREEN WITH A BLACK AT THE EDGE AND THE NUMBER "1" APPEARS IN THE CENTER IN GREY AND OUTLINED IN GREEN.

FOR SEWER PIPE REPAIR KITS COMPRISING A FIBERGLASS MAT, AN ADHESIVE CONSISTING OF A RESIN AND A HARDENER, A PLASTIC PROTECTIVE SLEEVE THAT ACTS AS AN INFLATABLE BALLOON OR BLADDER, ELECTRICIAN'S TAPE, A PLASTIC WORK SURFACE, A SPREADING SPATULA, DISPOSABLE GLOVES, AND NYLON ZIP TIES ALL SOLD AS A UNIT (U.S. CLS. 2, 13, 23, 29, 30, 33, 40 AND 50).

ELLEN PERKINS, EXAMINING ATTORNEY

SN 77-645,797. I PLAY, INC., ASHEVILLE, NC. FILED 1-8-2009.

GREEN SPROUTS

THE MARK CONSISTS OF STANDARD CHARACTERS WITHOUT CLAIM TO ANY PARTICULAR FONT, STYLE, SIZE, OR COLOR.

OWNER OF U.S. REG. NO. 3,441,687.

NO CLAIM IS MADE TO THE EXCLUSIVE RIGHT TO USE "GREEN", APART FROM THE MARK AS SHOWN.

FOR BABY FOOD JAR HOLDERS TO PREVENT BABY FOOD JARS FROM TIPPING OVER; BOTTLES, SOLD EMPTY; DISHES AND PLATES; HOUSEHOLD CONTAINERS FOR FOODS; HOUSEHOLD UTENSILS, NAMELY, SPATULAS; ICE CUBE MOLDS; INSULATING SLEEVE HOLDERS FOR BEVERAGE CANS; NEOPRENE ZIPPERED BOTTLE HOLDERS; PLASTIC WATER BOTTLES SOLD EMPTY; SPORTS BOTTLES SOLD EMPTY; AND TRAINING CUPS FOR BABIES AND CHILDREN (U.S. CLS. 2, 13, 23, 29, 30, 33, 40 AND 50).

FIRST USE 6-13-2008; IN COMMERCE 6-13-2008.

AISHA SALEM, EXAMINING ATTORNEY

CLASS 21—(Continued).

SN 77-646,248. MASTERCHEM INDUSTRIES LLC, IMPERIAL, MO. FILED 1-9-2009.

NO RUNS, NO DRIPS, NO MESS

THE MARK CONSISTS OF STANDARD CHARACTERS WITHOUT CLAIM TO ANY PARTICULAR FONT, STYLE, SIZE, OR COLOR.

FOR PAINT CONTAINER SPOUT, NAMELY, POURABLE SPOUTS (U.S. CLS. 2, 13, 23, 29, 30, 33, 40 AND 50).

JOHN DWYER, EXAMINING ATTORNEY

SN 77-646,767. SATORI HOLDINGS, LLC, DBA WATERBOX, PARK CITY, UT. FILED 1-9-2009.

WATERBOX

THE MARK CONSISTS OF STANDARD CHARACTERS WITHOUT CLAIM TO ANY PARTICULAR FONT, STYLE, SIZE, OR COLOR.

FOR BOTTLES, SOLD EMPTY (U.S. CLS. 2, 13, 23, 29, 30, 33, 40 AND 50).

FIRST USE 11-1-2008; IN COMMERCE 12-1-2008.

JACQUELINE A. LAVINE, EXAMINING ATTORNEY

SN 77-647,628. COST PLUS MANAGEMENT SERVICES, INC., OAKLAND, CA. FILED 1-12-2009.

WORLD GRILL

THE MARK CONSISTS OF STANDARD CHARACTERS WITHOUT CLAIM TO ANY PARTICULAR FONT, STYLE, SIZE, OR COLOR.

NO CLAIM IS MADE TO THE EXCLUSIVE RIGHT TO USE "GRILL", APART FROM THE MARK AS SHOWN.

FOR UTENSILS FOR BARBECUES, NAMELY, FORKS, TONGS AND TURNERS; BARBECUE COOKING ACCESSORIES, NAMELY, RACK, BASKETS AND SKILLETS; FOOD DOMES; COOKING SKEWERS; WOOD COOKING PLANKS FOR USE IN GRILLING; ENAMEL DINNERWARE (U.S. CLS. 2, 13, 23, 29, 30, 33, 40 AND 50).

JASON BLAIR, EXAMINING ATTORNEY

CLASS 21—(Continued).

SN 77-651,745. DERVIN, BERNARD M., BEND, OR. FILED S.R. 1-17-2009; AM. P.R. 4-13-2009.

TIGHTWAD

THE MARK CONSISTS OF STANDARD CHARACTERS WITHOUT CLAIM TO ANY PARTICULAR FONT, STYLE, SIZE, OR COLOR.
FOR TOILET ROLL HOLDERS (U.S. CLS. 2, 13, 23, 29, 30, 33, 40 AND 50).
JENNIFER MARTIN, EXAMINING ATTORNEY

CLASS 21—(Continued).

SN 77-662,916. THE SAUL ZAENTZ COMPANY, BERKELEY, CA. FILED 2-4-2009.

MINES OF MORIA

THE MARK CONSISTS OF STANDARD CHARACTERS WITHOUT CLAIM TO ANY PARTICULAR FONT, STYLE, SIZE, OR COLOR.
FOR GOBLETS (U.S. CLS. 2, 13, 23, 29, 30, 33, 40 AND 50).
FIRST USE 1-14-2009; IN COMMERCE 1-14-2009.
LINDA POWELL, EXAMINING ATTORNEY

SN 77-652,213. JEROBOAM, L.L.C., CARSON CITY, NV. FILED 1-19-2009.



THE MARK CONSISTS OF A CIRCLE AROUND AN IMAGE OF A DOCTOR TO THE LEFT OF THE TERM "WINE DOCTOR".
FOR VACUUM PUMPS FOR WINE BOTTLES; BOTTLE OPENERS (U.S. CLS. 2, 13, 23, 29, 30, 33, 40 AND 50).
ELLEN PERKINS, EXAMINING ATTORNEY

SN 77-663,018. SAUL ZAENTZ COMPANY, THE, BERKELEY, CA. FILED 2-4-2009.

SARUMAN

THE MARK CONSISTS OF STANDARD CHARACTERS WITHOUT CLAIM TO ANY PARTICULAR FONT, STYLE, SIZE, OR COLOR.
OWNER OF U.S. REG. NOS. 2,944,700, 3,549,311 AND OTHERS.
FOR CANDLE HOLDERS (U.S. CLS. 2, 13, 23, 29, 30, 33, 40 AND 50).
FIRST USE 1-14-2009; IN COMMERCE 1-14-2009.
LINDA POWELL, EXAMINING ATTORNEY

SN 77-660,041. YOU CANN & CO., LLC, RIDGEFIELD, CT. FILED 1-30-2009.

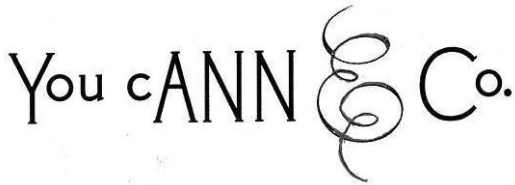

NO CLAIM IS MADE TO THE EXCLUSIVE RIGHT TO USE "CO.", APART FROM THE MARK AS SHOWN.
THE MARK CONSISTS OF "YOU CANN & CO." WITH DESIGN STYLIZED IN THE DEPICTION OF THE AMPERSAND SYMBOL AND IN THE RAISED PLACEMENT OF LOWER CASE LETTERING.
FOR DINNERWARE, NAMELY, CONSUMER DINING PLATE (U.S. CLS. 2, 13, 23, 29, 30, 33, 40 AND 50).
AARON BRODSKY, EXAMINING ATTORNEY

SN 77-663,960. ADVANCED AGRI-DIRECT (USA) INC., YORK, NE. FILED 2-5-2009.

COWCRETE

THE MARK CONSISTS OF STANDARD CHARACTERS WITHOUT CLAIM TO ANY PARTICULAR FONT, STYLE, SIZE, OR COLOR.
FOR CATTLE TROUGHS (U.S. CLS. 2, 13, 23, 29, 30, 33, 40 AND 50).
FIRST USE 5-22-2006; IN COMMERCE 5-22-2006.
CURTIS FRENCH, EXAMINING ATTORNEY

CLASS 21—(Continued).

SN 77-664,077. NOFLY CONE INC., PORTLAND, OR. FILED 2-5-2009.

NO FLY CONE

THE MARK CONSISTS OF STANDARD CHARACTERS WITHOUT CLAIM TO ANY PARTICULAR FONT, STYLE, SIZE, OR COLOR.
FOR INSECT TRAPS (U.S. CLS. 2, 13, 23, 29, 30, 33, 40 AND 50).

FIRST USE 8-10-2008; IN COMMERCE 8-10-2008.
GIANCARLO CASTRO, EXAMINING ATTORNEY

CLASS 21—(Continued).

SN 77-669,036. I PLAY, INC., ASHEVILLE, NC. FILED 2-12-2009.

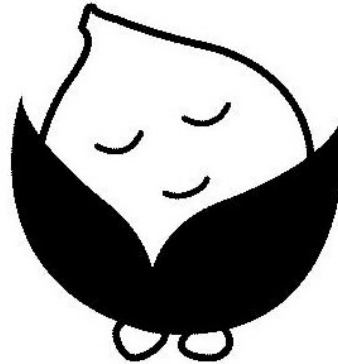

THE MARK CONSISTS OF A STYLIZED SLEEPING SPROUT NESTLED IN AND PARTIALLY SURROUNDED BY THE TWO HALVES OF A POD RESTING ON TWO SMALL FAUX FEET.

FOR BABY FOOD JAR HOLDERS TO PREVENT BABY FOOD JARS FROM TIPPING OVER; BOTTLES, SOLD EMPTY; DISHES AND PLATES; HOUSEHOLD CONTAINERS FOR FOODS; HOUSEHOLD UTENSILS, NAMELY, SPATULAS; ICE CUBE MOLDS; INSULATING SLEEVE HOLDERS FOR BEVERAGE CANS; NEOPRENE ZIPPERED BOTTLE HOLDERS; PLASTIC WATER BOTTLES SOLD EMPTY; SPORTS BOTTLES SOLD EMPTY; AND TRAINING CUPS FOR BABIES AND CHILDREN (U.S. CLS. 2, 13, 23, 29, 30, 33, 40 AND 50).

AISHA SALEM, EXAMINING ATTORNEY

SN 77-666,341. AP&G CO., INC., BROOKLYN, NY. FILED 2-9-2009.

SureSnap

THE MARK CONSISTS OF STANDARD CHARACTERS WITHOUT CLAIM TO ANY PARTICULAR FONT, STYLE, SIZE, OR COLOR.

FOR RODENT TRAPS, NAMELY, MOUSE TRAPS AND RAT TRAPS (U.S. CLS. 2, 13, 23, 29, 30, 33, 40 AND 50).

CYNTHIA TRIPI, EXAMINING ATTORNEY

SN 77-681,735. DIXIE CONSUMER PRODUCTS LLC, ATLANTA, GA. FILED 3-2-2009.



THE MARK CONSISTS OF A FIGURE OF A PERSON IN MOTION CARRYING A TRAY WITH ONE HAND ABOVE WHICH THE WORDS "GET CARRIED AWAY" APPEARS.

FOR BOWLS; CUPS; PLATES (U.S. CLS. 2, 13, 23, 29, 30, 33, 40 AND 50).

MARY CRAWFORD, EXAMINING ATTORNEY

CLASS 21—(Continued).

SN 77-689,624. AP&G CO., INC., BROOKLYN, NY. FILED 3-12-2009.

MULTI-TRAP

THE MARK CONSISTS OF STANDARD CHARACTERS WITHOUT CLAIM TO ANY PARTICULAR FONT, STYLE, SIZE, OR COLOR.

OWNER OF U.S. REG. NO. 3,074,022.
FOR RODENT TRAPS, NAMELY, MOUSE TRAPS AND RAT TRAPS (U.S. CLS. 2, 13, 23, 29, 30, 33, 40 AND 50).
CYNTHIA TRIPI, EXAMINING ATTORNEY

CLASS 21—(Continued).

SN 77-696,163. EMHART GLASS S.A., CHAM, SWITZERLAND, FILED 3-20-2009.

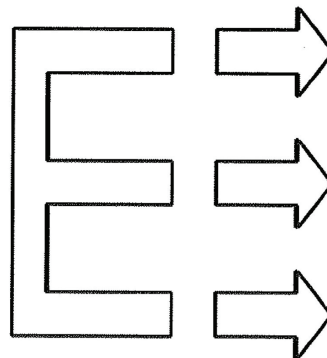

SN 77-690,189. AP&G CO., INC., BROOKLYN, NY. FILED 3-13-2009.

Lo-Pro

THE MARK CONSISTS OF STANDARD CHARACTERS WITHOUT CLAIM TO ANY PARTICULAR FONT, STYLE, SIZE, OR COLOR.

FOR RODENT TRAPS, NAMELY, MOUSE TRAPS AND RAT TRAPS (U.S. CLS. 2, 13, 23, 29, 30, 33, 40 AND 50).
CYNTHIA TRIPI, EXAMINING ATTORNEY

THE MARK CONSISTS OF A STYLIZED CAPITAL LETTER "E" WITH THREE OUTLINED ARROW DESIGNS DIRECTLY TO THE RIGHT OF EACH LINE OF THE LETTER "E".

FOR GLASS CONTAINERS FOR HOLDING LIQUIDS AND SOLIDS (U.S. CLS. 2, 13, 23, 29, 30, 33, 40 AND 50).
TOBY BULLOFF, EXAMINING ATTORNEY

SN 78-930,341. LOS ANGELES POLICE REVOLVER AND ATHLETIC CLUB, LOS ANGELES, CA. FILED 7-15-2006.

LAPD

SN 77-693,544. AP&G CO., INC., BROOKLYN, NY. FILED 3-18-2009.

Catch-a-Max

THE MARK CONSISTS OF STANDARD CHARACTERS WITHOUT CLAIM TO ANY PARTICULAR FONT, STYLE, SIZE, OR COLOR.

FOR RODENT TRAPS, NAMELY, MOUSE TRAPS AND RAT TRAPS (U.S. CLS. 2, 13, 23, 29, 30, 33, 40 AND 50).
CYNTHIA TRIPI, EXAMINING ATTORNEY

THE MARK CONSISTS OF STANDARD CHARACTERS WITHOUT CLAIM TO ANY PARTICULAR FONT, STYLE, SIZE, OR COLOR.

OWNER OF U.S. REG. NOS. 3,038,631 AND 3,047,180.
FOR DINNERWARE, BEVERAGE GLASSWARE; EARTHENWARE, CERAMIC AND GLASS CUPS, MUGS, AND PLATES, KITCHEN UTENSILS, NAMELY, FORKS, SPOONS AND KNIVES; COFFEE MUGS, CANDLE-HOLDERS, HOUSEHOLD PRODUCTS, NAMELY, CERAMIC SCULPTURES, VASES, VESSELS, BOWLS, PLATES AND POTS; INSULATED VACUUM BOTTLES, ICE BUCKETS, NON-METAL PIGGY BANKS, PET FEEDING DISHES, PORTABLE COOLERS, SOUVENIR PLATES (U.S. CLS. 2, 13, 23, 29, 30, 33, 40 AND 50).

THEODORE MCBRIDE, EXAMINING ATTORNEY

CLASS 22—CORDAGE AND FIBERS

SN 77-318,790. WOODSTOCK VENTURES, L.C., NEW YORK, NY. FILED 11-1-2007.

WOODSTOCK

THE MARK CONSISTS OF STANDARD CHARACTERS WITHOUT CLAIM TO ANY PARTICULAR FONT, STYLE, SIZE, OR COLOR.

FOR TENTS; CAMPING EQUIPMENT, NAMELY, TABLES, PORTABLE COOLERS NOT MADE OF HARD PLASTIC; CANVAS PRODUCTS, NAMELY, CANVAS STORAGE BAGS FOR CAMPING, CANVAS TARPAULINS, CANVAS CANOPIES (U.S. CLS. 1, 2, 7, 19, 22, 42 AND 50).

CHRIS WELLS, EXAMINING ATTORNEY

SN 77-620,194. ALTITUDE STRATEGIES, LLC, DBA I-SAILS, PARK CITY, UT. FILED 11-22-2008.

i-Sails

THE MARK CONSISTS OF STANDARD CHARACTERS WITHOUT CLAIM TO ANY PARTICULAR FONT, STYLE, SIZE, OR COLOR.

FOR MARINE SAILS AND SAIL HANDLING SYSTEMS COMPRISING LINES AND FITTINGS SOLD AS A UNIT; SAILS (U.S. CLS. 1, 2, 7, 19, 22, 42 AND 50).

FIRST USE 6-1-2007; IN COMMERCE 6-1-2007.
JAMES STEIN, EXAMINING ATTORNEY

CLASS 23—YARNS AND THREADS

SN 79-057,500. AMANN OXLEY THREADS LIMITED, ASHTON-UNDER-LYNE OL7 OPJ, UNITED KINGDOM, FILED 7-11-2008.

OXCEL

THE MARK CONSISTS OF STANDARD CHARACTERS WITHOUT CLAIM TO ANY PARTICULAR FONT, STYLE, SIZE, OR COLOR.

OWNER OF INTERNATIONAL REGISTRATION 0973749 DATED 7-11-2008, EXPIRES 7-11-2018.

THE WORDING "OXCEL" HAS NO MEANING IN A FOREIGN LANGUAGE.

FOR YARNS AND THREADS ALL INCLUDED IN THIS CLASS (U.S. CL. 43).

BILL DAWE, EXAMINING ATTORNEY

CLASS 24—FABRICS

SN 77-318,797. WOODSTOCK VENTURES, L.C., NEW YORK, NY. FILED 11-1-2007.

WOODSTOCK

THE MARK CONSISTS OF STANDARD CHARACTERS WITHOUT CLAIM TO ANY PARTICULAR FONT, STYLE, SIZE, OR COLOR.

FOR BEDDING, NAMELY, SHEETS, BLANKETS, COMFORTERS, BEDSKIRTS, PILLOWCASES, SHAMS, DUVET COVERS, AFGHANS, THROW BLANKETS; TOWELS, BEACH TOWELS, PLASTIC TABLE COVERS AND CLOTHS NOT OF PAPER, HOUSEHOLD LINENS; DOMESTICS, NAMELY, RUGS, FLOOR MATS, BATHROOM MATS, WELCOME MATS; TEXTILE GOODS, NAMELY, SHOWER CURTAINS, CURTAINS, TAPETRIES OF TEXTILE, TEXTILE FABRICS, TEXTILE NAPKINS; PICNIC BLANKETS; NON-TEXTILE WALL HANGINGS AND TEXTILE WALL HANGINGS (U.S. CLS. 42 AND 50).

CHRIS WELLS, EXAMINING ATTORNEY

SN 77-476,730. NEW KINGDOM, INC., DBA SUE DEVITT STUDIO, NEW YORK, NY. FILED 5-16-2008.

BEAUTY AND THE BEACH

THE MARK CONSISTS OF STANDARD CHARACTERS WITHOUT CLAIM TO ANY PARTICULAR FONT, STYLE, SIZE, OR COLOR.

FOR TOWELS (U.S. CLS. 42 AND 50).

DAVID HOFFMAN, EXAMINING ATTORNEY

SN 77-489,785. TURNER ENTERTAINMENT NETWORKS ASIA, INC., ATLANTA, GA. FILED 6-3-2008.

TUZKI

THE MARK CONSISTS OF STANDARD CHARACTERS WITHOUT CLAIM TO ANY PARTICULAR FONT, STYLE, SIZE, OR COLOR.

THE WORDING "TUZKI" HAS NO MEANING IN A FOREIGN LANGUAGE.

FOR TOWELS; BED, KITCHEN AND TABLE LINENS (U.S. CLS. 42 AND 50).

TINA L. SNAPP, EXAMINING ATTORNEY

CLASS 24—(Continued).

SN 77-504,303. COOTIE COVER CORPORATION, AVEN-
TURA, FL. FILED 6-20-2008.

KEHEI TRAVELER

THE MARK CONSISTS OF STANDARD CHARACTERS WITHOUT CLAIM TO ANY PARTICULAR FONT, STYLE, SIZE, OR COLOR.

NO CLAIM IS MADE TO THE EXCLUSIVE RIGHT TO USE "TRAVELER", APART FROM THE MARK AS SHOWN.

FOR UNFITTED FURNITURE COVERS NOT OF PAPER, NAMELY, ARM, SEAT, AND TRAY COVERS FOR PUBLIC SEATING ENVIRONMENTS (U.S. CLS. 42 AND 50).

MICHAEL LITZAU, EXAMINING ATTORNEY

SN 77-513,505. PARK B. SMITH, INC., NEW YORK, NY.
FILED 7-2-2008.



The logo for "eco-ordinates" features the word in a lowercase, sans-serif font. The letter "i" in "ordinates" has a small leaf-like shape above its dot.

OWNER OF U.S. REG. NOS. 2,752,730 AND 3,298,430.

THE MARK CONSISTS OF OF THE WORDING "ECO-ORDINATES", IN STYLIZED LETTERING WITH A STYLIZED DESIGN OF A LEAF REPRESENTING THE DOT OVER THE LETTER "I".

FOR AFGHANS; BED SHEETS; BEDSHEETS; BLANKET THROWS; COMFORTERS; COVERLETS; CURTAIN TIE-BACKS; DUST RUFFLES; DUVET COVERS; FABRIC WINDOW COVERINGS AND TREATMENTS, NAMELY, DRAPERIES, CURTAINS, FABRIC VALANCES, AND CURTAIN PANELS; KITCHEN TOWELS; OVEN MITTS; PILLOW COVERS; POT HOLDERS; SHAMS; SHOWER CURTAINS; TABLE LINEN, NAMELY, PLACEMETS MADE OF FABRIC AND NAPKINS MADE OF FABRIC; UNFITTED FABRIC FURNITURE COVERS (U.S. CLS. 42 AND 50).

FIRST USE 7-12-2006; IN COMMERCE 7-12-2006.
PAUL CROWLEY, EXAMINING ATTORNEY

SN 77-525,449. INSTYLE CONTRACT TEXTILES PTY LTD,
MASCOR, AUSTRALIA, FILED 7-17-2008.

LIFE Textiles

THE MARK CONSISTS OF STANDARD CHARACTERS WITHOUT CLAIM TO ANY PARTICULAR FONT, STYLE, SIZE, OR COLOR.

OWNER OF AUSTRALIA REG. NO. 952654, DATED 5-6-2003, EXPIRES 5-6-2013.

NO CLAIM IS MADE TO THE EXCLUSIVE RIGHT TO USE "TEXTILES", APART FROM THE MARK AS SHOWN.

FOR TEXTILE AND TEXTILE GOODS, NAMELY, WOOL FABRIC, UPHOLSTERY FABRICS, AND FABRICS FOR THE MANUFACTURE OF SCREEN, WORKSTATION AND PANEL FABRICS (U.S. CLS. 42 AND 50).

SEAN CROWLEY, EXAMINING ATTORNEY

CLASS 24—(Continued).

SN 77-539,045. DUCDUC LLC, NEW YORK, NY. FILED 8-5-2008.

MASON GRAY

THE MARK CONSISTS OF STANDARD CHARACTERS WITHOUT CLAIM TO ANY PARTICULAR FONT, STYLE, SIZE, OR COLOR.

THE NAME(S), PORTRAIT(S), AND/OR SIGNATURE(S) SHOWN IN THE MARK DOES NOT IDENTIFY A PARTICULAR LIVING INDIVIDUAL.

FOR CRIB AND BED SHEETS, CRIB AND BED BLANKETS, PILLOW CASES, PILLOW SHAMS, QUILTS, CRIB BUMPERS, COMFORTERS, MATTRESS SHAMS, MATTRESS COVERS, DIAPER CHANGING PADS NOT MADE OF PAPER, AND TOWELS (U.S. CLS. 42 AND 50).
KRISTIN DAHLING, EXAMINING ATTORNEY

SN 77-561,404. PUNTA BRAVA, LLC, AUSTIN, TX. FILED 9-3-2008.

PUNTA BRAVA

THE MARK CONSISTS OF STANDARD CHARACTERS WITHOUT CLAIM TO ANY PARTICULAR FONT, STYLE, SIZE, OR COLOR.

THE ENGLISH TRANSLATION OF THE WORD "PUNTA BRAVA" IN THE MARK IS "BRAVE END".

FOR TEXTILES, NAMELY, BED SHEETS, DUVETS, PILLOW CASES, THROWS, BED BLANKETS, BLANKETS FOR OUTDOOR USE, TOWELS, WASHCLOTHS, TABLE CLOTHS NOT OF PAPER, OVEN MITTS, AND GOLF TOWELS; PLASTIC TABLE COVERS (U.S. CLS. 42 AND 50).

STEVEN JACKSON, EXAMINING ATTORNEY

SN 77-620,586. HUMMER, LYNN, MARIETTA, GA. AND
SERRROELS, PATRICIA, MARIETTA, GA. FILED 11-24-2008.

Wrapped In Prayers

THE MARK CONSISTS OF STANDARD CHARACTERS WITHOUT CLAIM TO ANY PARTICULAR FONT, STYLE, SIZE, OR COLOR.

NO CLAIM IS MADE TO THE EXCLUSIVE RIGHT TO USE "PRAYERS", APART FROM THE MARK AS SHOWN.

FOR PRAYER QUILTS DESIGNED SO PEOPLE CAN WRITE THEIR PRAYERS AND CARES PRIMARILY FOR THOSE GOING THROUGH CHEMOTHERAPY AND RADIATION TREATMENT FOR CANCER (U.S. CLS. 42 AND 50).

ELIZABETH HUGHITT, EXAMINING ATTORNEY

CLASS 24—(Continued).

SN 77-663,850. THREADTEX, INC., NEW YORK, NY. FILED 2-5-2009.

SILEX

THE MARK CONSISTS OF STANDARD CHARACTERS WITHOUT CLAIM TO ANY PARTICULAR FONT, STYLE, SIZE, OR COLOR.

OWNER OF U.S. REG. NO. 1,499,618.
FOR COTTON FABRICS FOR GARMENTS (U.S. CLS. 42 AND 50).
JOHN WILKE, EXAMINING ATTORNEY

SN 77-669,046. I PLAY, INC., ASHEVILLE, NC. FILED 2-12-2009.



THE MARK CONSISTS OF A STYLIZED SLEEPING SPROUT NESTLED IN AND PARTIALLY SURROUNDED BY THE TWO HALVES OF A POD RESTING ON TWO SMALL FAUX FEET.

FOR BATH MITTS; BURP CLOTHS; CHILDREN'S BLANKETS; AND WASHCLOTHS (U.S. CLS. 42 AND 50).
AISHA SALEM, EXAMINING ATTORNEY

SN 77-692,441. WYNDHAM TM CORP., LAS VEGAS, NV. FILED 3-17-2009.

WYNREST

THE MARK CONSISTS OF STANDARD CHARACTERS WITHOUT CLAIM TO ANY PARTICULAR FONT, STYLE, SIZE, OR COLOR.

FOR BED LINENS; BED SHEETS; PILLOW CASES (U.S. CLS. 42 AND 50).
MARK PILARO, EXAMINING ATTORNEY

CLASS 24—(Continued).

SN 77-692,443. WYNDHAM TM CORP., LAS VEGAS, NV. FILED 3-17-2009.

WYNDRY

THE MARK CONSISTS OF STANDARD CHARACTERS WITHOUT CLAIM TO ANY PARTICULAR FONT, STYLE, SIZE, OR COLOR.

FOR TOWELS; BATH LINENS (U.S. CLS. 42 AND 50).
MARK PILARO, EXAMINING ATTORNEY

SN 79-058,681. LANIFICIO MARCOLANA S.R.L., I-59100 PRATO, ITALY, FILED 7-4-2008.



OWNER OF INTERNATIONAL REGISTRATION 0976791 DATED 7-4-2008, EXPIRES 7-4-2018.

NO CLAIM IS MADE TO THE EXCLUSIVE RIGHT TO USE "LANIFICIO", APART FROM THE MARK AS SHOWN.

THE MARK CONSISTS OF THE WORD "MARCOLANA" INSIDE A RECTANGLE, AND BELOW IS THE WORD "LANIFICIO" INSIDE ANOTHER RECTANGLE.

THE ENGLISH TRANSLATION OF "LANIFICIO" IN THE MARK IS WOOL SPINNING MILL. THE WORD "MARCOLANA" HAS NO MEANING IN A FOREIGN LANGUAGE.

FOR TEXTILES, NAMELY, FABRICS FOR TEXTILE USE, CASHMERE FABRIC, WOOL BASE MIXED FABRICS, SILK FABRICS, MESH-WOVEN FABRICS, NATURAL AND SYNTHETIC FABRICS AND TEXTILES, NAMELY, COTTON, SILK, POLYESTER AND NYLON FABRICS, FLAX FABRICS AND TEXTILE FABRICS FOR THE MANUFACTURE OF CLOTHING (U.S. CLS. 42 AND 50).

MARY MUNSON, EXAMINING ATTORNEY

CLASS 25—CLOTHING

SN 76-690,479. JOZETTE PTY LTD., POTTS POINT NSW 2011, AUSTRALIA, FILED 6-11-2008.

JOZETTE HAZZOURI

THE MARK CONSISTS OF STANDARD CHARACTERS WITHOUT CLAIM TO ANY PARTICULAR FONT, STYLE, SIZE, OR COLOR.

THE NAME "JOZETTE HAZZOURI" IDENTIFIES A LIVING INDIVIDUAL WHOSE CONSENT IS OF RECORD.

FOR WOMEN'S BLOUSES, SHIRTS, SKIRTS, DRESSES, PANTS, EVENING DRESSES, EVENING GOWNS, FUR COATS, JACKETS, OVERCOATS, SHRUGS, LINGERIE, SWIMWEAR, BEACH COVERUPS, SHOES, SWEAT SUITS, SWEAT SHIRTS, SWEAT PANTS, T-SHIRTS, JOGGING OUTFITS, AND CLOTHING FOR WEAR IN THE PRACTICE AND PERFORMANCE OF DANCE, NAMELY, LEOTARDS, AND TIGHTS (U.S. CLS. 22 AND 39).

ANDREW RHIM, EXAMINING ATTORNEY

CLASS 25—(Continued).

SN 76-691,626. JAH INNOVATIONS INC., ZEBULON, GA.
FILED 7-28-2008.

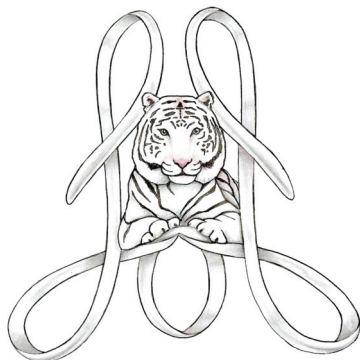

THE COLOR(S) GREY, BLACK AND PINK IS/ARE CLAIMED AS A FEATURE OF THE MARK.

THE MARK CONSISTS OF A TIGER OUTLINED IN BLACK WITH BLACK STRIPES AND GREY DETAILING AND A PINK NOSE, THE TIGER IS SITTING ON A RIBBON THAT WRAPS AROUND THE TIGER AND IS OUTLINED IN BLACK AND DETAILED IN GREY.

FOR CLOTHING, NAMELY, JEANS, PANTS, SHIRTS, HEADGEAR, NAMELY, HATS AND CAPS; AND T-SHIRTS (U.S. CLS. 22 AND 39).

CHRISTINA SOBRAL, EXAMINING ATTORNEY

SN 76-694,754. BRADY, GLEN DALE., ROCHESTER, NY.
FILED 12-11-2008.



FOR CLOTHING, NAMELY, T-SHIRT; HEADGEAR, NAMELY, BASEBALL CAPS AND FOOTWEAR (U.S. CLS. 22 AND 39).

FIRST USE 10-23-2008; IN COMMERCE 12-6-2008.
MATTHEW EINSTEIN, EXAMINING ATTORNEY

SN 76-695,557. BETLEWICZ, FRANKIE, BROOKLYN, NY.
FILED 2-2-2009.



THE LITERAL ELEMENT OF THE MARK CONSISTS OF "QK". THE MARK CONSISTS OF THE LETTER "K" INSIDE THE LETTER "Q.A" SHADOW APPEARS UNDERNEATH FORMING THE LETTERS "Q" AND "K".

FOR CLOTHING, NAMELY, T-SHIRTS, SWEAT-SHIRTS, HATS, PANTS, SNEAKERS, BANDANAS, COATS AND UNDERGARMENTS (U.S. CLS. 22 AND 39).

ZACHARY BELLO, EXAMINING ATTORNEY

CLASS 25—(Continued).

SN 76-695,558. SIO, CARLOS RENE TSE, BROOKLYN, NY.
FILED 2-2-2009.

ROYAL CREW

THE MARK CONSISTS OF STANDARD CHARACTERS WITHOUT CLAIM TO ANY PARTICULAR FONT, STYLE, SIZE, OR COLOR.

FOR CLOTHING, NAMELY, JEANS, PANTS, POLO SHIRTS, T-SHIRTS, SHIRTS, SLEEVES, JACKETS, BELTS AND SHOES (U.S. CLS. 22 AND 39).

ZACHARY BELLO, EXAMINING ATTORNEY

SN 76-695,628. MILLENIA CONCEPTS INC., CHICAGO, IL.
FILED 2-6-2009.



THE MARK CONSISTS OF STANDARD CHARACTERS WITHOUT CLAIM TO ANY PARTICULAR FONT, STYLE, SIZE, OR COLOR.

OWNER OF U.S. REG. NO. 2,002,041.

FOR MEN'S DRESS SHIRTS AND SPORT SHIRTS, COATS AND JACKETS IN CLOTH AND LEATHER, PANTS, SWEATERS, POLO SHIRTS, T-SHIRTS, JEANS (U.S. CLS. 22 AND 39).

MICHAEL KEATING, EXAMINING ATTORNEY

SN 77-016,125. GLY, INC., LOS ANGELES, CA. FILED 10-6-2006.

FLYING MONKEY

THE MARK CONSISTS OF STANDARD CHARACTERS WITHOUT CLAIM TO ANY PARTICULAR FONT, STYLE, SIZE, OR COLOR.

FOR CLOTHING, NAMELY, DENIM JEANS, PANTS, SHORTS, JACKETS, SHIRTS, SKIRTS, CAPRIS (U.S. CLS. 22 AND 39).

FIRST USE 6-0-2005; IN COMMERCE 6-0-2005.

DAVID I, EXAMINING ATTORNEY

CLASS 25—(Continued).

SN 77-024,996. NICK PRICE COLLECTION, L.L.C., ABERDEEN, NC. FILED 10-19-2006.

COOL-LUXE

THE MARK CONSISTS OF STANDARD CHARACTERS WITHOUT CLAIM TO ANY PARTICULAR FONT, STYLE, SIZE, OR COLOR.

THE ENGLISH TRANSLATION OF "COOL-LUXE" IS LUXURY.

FOR FABRIC SOLD AS AN INTEGRAL COMPONENT OF SHIRTS (U.S. CLS. 22 AND 39).

FIRST USE 7-15-2006; IN COMMERCE 7-15-2006.
DAVID H. STINE, EXAMINING ATTORNEY

SN 77-043,082. INDEKA IMPORTS LTD., OAKVILLE, CANADA, FILED 11-13-2006.

SANTANA CANADA

THE MARK CONSISTS OF STANDARD CHARACTERS WITHOUT CLAIM TO ANY PARTICULAR FONT, STYLE, SIZE, OR COLOR.

PRIORITY CLAIMED UNDER SEC. 44(D) ON CANADA APPLICATION NO. 1322338, FILED 10-31-2006, REG. NO. TMA734411, DATED 2-13-2009, EXPIRES 2-13-2024.

OWNER OF U.S. REG. NOS. 1,061,270 AND 1,992,324.

NO CLAIM IS MADE TO THE EXCLUSIVE RIGHT TO USE "CANADA", APART FROM THE MARK AS SHOWN.

FOR (BASED ON USE IN COMMERCE)(BASED ON 44(E)) BOOTS; (BASED ON 44(E)) (BASED ON INTENT TO USE) SHOES, SLIPPERS, SANDALS (U.S. CLS. 22 AND 39).

FIRST USE 10-18-2006; IN COMMERCE 10-18-2006.
SONYA STEPHENS, EXAMINING ATTORNEY

SN 77-094,860. LIVE NATION WORLDWIDE, INC., BEVERLY HILLS, CA. FILED 1-30-2007.

THE FILLMORE

THE MARK CONSISTS OF STANDARD CHARACTERS WITHOUT CLAIM TO ANY PARTICULAR FONT, STYLE, SIZE, OR COLOR.

OWNER OF U.S. REG. NOS. 2,523,868, 3,049,045 AND 3,175,606.

FOR T-SHIRTS, UNIFORMS, JACKETS, AND HATS (U.S. CLS. 22 AND 39).

FIRST USE 12-31-1986; IN COMMERCE 12-31-1986.
TRICIA SONNEBORN, EXAMINING ATTORNEY

CLASS 25—(Continued).

SN 77-094,871. LIVE NATION WORLDWIDE, INC., BEVERLY HILLS, CA. FILED 1-30-2007.

THE FILLMORE

THE MARK CONSISTS OF STANDARD CHARACTERS WITHOUT CLAIM TO ANY PARTICULAR FONT, STYLE, SIZE, OR COLOR.

OWNER OF U.S. REG. NOS. 2,523,868, 3,049,045 AND 3,175,606.

FOR MEN'S, WOMEN'S AND CHILDREN'S CLOTHING AND FASHION ACCESSORIES, NAMELY, SHIRTS, RUGBY SHIRTS, POLO SHIRTS, JERSEYS, TANK TOPS, SWEATSHIRTS, NECKWEAR, BANDANAS, SWEAT PANTS, HEADWEAR, CAPS, VISORS, HEADBANDS, WRISTBANDS (U.S. CLS. 22 AND 39).

TRICIA SONNEBORN, EXAMINING ATTORNEY

SN 77-177,921. OFFICIAL BUGLE BOY, LLC, COLUMBUS, OH. FILED 5-10-2007.

752

THE MARK CONSISTS OF STANDARD CHARACTERS WITHOUT CLAIM TO ANY PARTICULAR FONT, STYLE, SIZE, OR COLOR.

FOR CLOTHING, NAMELY, JEANS AND SHORTS (U.S. CLS. 22 AND 39).

MARLENE BELL, EXAMINING ATTORNEY

SN 77-201,897. DOLCE VITA INTIMATES LLC, NEW YORK, NY. FILED 6-8-2007.

DESERT ROSE

THE MARK CONSISTS OF STANDARD CHARACTERS WITHOUT CLAIM TO ANY PARTICULAR FONT, STYLE, SIZE, OR COLOR.

FOR BRAS; PANTIES; SLEEPWEAR; CAMISOLES; LOUNGEWEAR (U.S. CLS. 22 AND 39).

BARBARA RUTLAND, EXAMINING ATTORNEY

CLASS 25—(Continued).

SN 77-210,160. MCDONALD SAREP, MELISSA, NORCO, CA.
FILED 6-19-2007.

CLASS 25—(Continued).

SN 77-355,438. SMILING SYDNEY, SEASIDE, CA. FILED 12-
19-2007.

CIR

THE MARK CONSISTS OF STANDARD CHARACTERS
WITHOUT CLAIM TO ANY PARTICULAR FONT, STYLE,
SIZE, OR COLOR.

FOR SHORT-SLEEVED OR LONG-SLEEVED T-SHIRTS
(U.S. CLS. 22 AND 39).

DEZMONA MIZELLE, EXAMINING ATTORNEY

SN 77-274,488. RACK ROOM SHOES OF VIRGINIA, LLC,
CHARLOTTE, NC. FILED 9-7-2007.



OWNER OF U.S. REG. NO. 1,826,362.
THE NAME SHOWN IN THE MARK DOES NOT IDENTIFY
A PARTICULAR LIVING INDIVIDUAL.

THE MARK CONSISTS OF THE WORD "BORELLI" WITH
UPPER CASE FIRST LETTER "B" AND LAST LETTER "I"
WITH ALL OTHER LETTERS LOWER CASE.

SEC. 2(F).

FOR SHOES (U.S. CLS. 22 AND 39).

DEZMONA MIZELLE, EXAMINING ATTORNEY

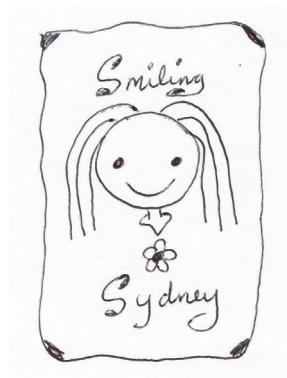

SN 77-338,108. NOT-NOT, INC., TEMPLE TERRACE, FL.
FILED 11-27-2007.

NETI-NETI

THE MARK CONSISTS OF STANDARD CHARACTERS
WITHOUT CLAIM TO ANY PARTICULAR FONT, STYLE,
SIZE, OR COLOR.

THE ENGLISH TRANSLATION OF "NETI-NETI" IN THE
MARK IS "NOT THIS NOT THIS".

FOR CLOTHING, NAMELY, HATS, SHIRTS, UNDER-
WEAR, SOCKS AND TIES (U.S. CLS. 22 AND 39).

DAVID I, EXAMINING ATTORNEY

THE MARK CONSISTS OF A LITTLE GIRL'S ROUND
SMILING FACE/HEAD WITH LONG HAIR OFF THE TOP
OF HER HEAD. NECK AND COLLAR ARE ATTACHED
WITH A FLOWER CENTERED UNDER HER HEAD.
ABOVE THE HEAD IS THE WORD "SMILING" AND
BELOW HEAD AND FLOWER IN CURSIVE IS THE WORD
"SYDNEY".

FOR INFANT TO JUNIORS CLOTHING, NAMELY,
INFANT AND TODDLER ONE PIECE CLOTHING AND
SHIRTS (U.S. CLS. 22 AND 39).

FIRST USE 5-10-2004; IN COMMERCE 11-1-2006.

ANDREA SAUNDERS, EXAMINING ATTORNEY

CLASS 25—(Continued).

SN 77-361,712. BLACKHEART HOLDINGS, INC., BRONX, NY. FILED 12-31-2007.

Jaelus Black the Stone Wear Gear & Ghetto Girl Gear Collection

THE MARK CONSISTS OF STANDARD CHARACTERS WITHOUT CLAIM TO ANY PARTICULAR FONT, STYLE, SIZE, OR COLOR.

NO CLAIM IS MADE TO THE EXCLUSIVE RIGHT TO USE "STONE WEAR GEAR" AND "GEAR COLLECTION", APART FROM THE MARK AS SHOWN.

THE NAME "JAEUS BLACK" IDENTIFIES A LIVING INDIVIDUAL WHOSE CONSENT IS OF RECORD.

FOR CLOTHING FOR MEN, WOMEN AND CHILDREN, NAMELY, COATS, RAINCOATS, ANORAKS, PARKAS, BLAZERS, JACKETS, CARDIGANS, BOLEROS, SPORT COATS, WIND RESISTANT JACKETS, SUITS, VESTS, DRESSES, EVENING GOWNS, JUMPERS, SKIRTS, PANTS, SLACKS, TROUSERS, JEANS, DUNGAREES, JUMP SUITS, OVERALLS, COVERALLS, GYM SUITS, JOGGING SUITS, SWEAT PANTS, THERMAL UNDERWEAR, SHORTS, SKORTS, ROMPERS, SHORTS, SHIRTS, SWEATERS, JERSEYS, BLOUSES, TUNICS, SWEATSHIRTS, T-SHIRTS, HALTER TOPS, TANK TOPS, BODYSUITS, UNITARDS, CAMISOLES, CHEMISES, UNDERSHIRTS, SLIPS, FOUNDATION GARMENTS, BODYSHAPERS, BRASSIERES, BUSTIERS, BRIEFS, BOXER SHORTS, UNDERPANTS, PANTIES, LINGERIE, LOUNGEWEAR, NIGHTGOWNS, NIGHT SHIRTS, NEGLIGEEES, ROBES, PAJAMAS, HOSE, PANTYHOSE, TIGHTS, KNEE HIGHS, LEGGINGS, SOCKS, HEAD WEAR, HATS, CAPS, HOODS, HEAD BANDS, NECKTIES, BOW TIES, POCKET SQUARES, SCARVES, SHAWLS, NECKERCHIEFS, GLOVES, MITTENS, BELTS, SASHES, CUMMERBUNDS, SHOES, FOOTWEAR, BOOTS, ATHLETIC SHOES, ATHLETIC FOOTWEAR, GALOSHES, SWIMWEAR, BATHING SUITS, BATHING TRUNKS, BEACHWEAR, BEACH COVERUPS, SARONGS, SKI WEAR, SKI SUITS, SKI PANTS, SKI GLOVES, THERMAL SOCKS, INFANT WEAR, BOOTIES, PLAYSUITS (U.S. CLS. 22 AND 39).

EDWARD FENNESSY, EXAMINING ATTORNEY

SN 77-447,584. HEALY, CATHERINE A., DBA CAT HATS, SANTA MONICA, CA. FILED 4-14-2008.

Cat Hats

THE MARK CONSISTS OF STANDARD CHARACTERS WITHOUT CLAIM TO ANY PARTICULAR FONT, STYLE, SIZE, OR COLOR.

NO CLAIM IS MADE TO THE EXCLUSIVE RIGHT TO USE "HATS", APART FROM THE MARK AS SHOWN.

FOR FUR HATS; HATS (U.S. CLS. 22 AND 39).
FIRST USE 11-21-2007; IN COMMERCE 11-21-2007.
TOBY BULLOFF, EXAMINING ATTORNEY

CLASS 25—(Continued).

SN 77-451,364. COMMON GROUND HEALTH CLINIC, NEW ORLEANS, LA. FILED 4-17-2008.

Solidarity Not Charity

THE MARK CONSISTS OF STANDARD CHARACTERS WITHOUT CLAIM TO ANY PARTICULAR FONT, STYLE, SIZE, OR COLOR.

FOR GOLF SHIRTS; KNIT SHIRTS; LONG-SLEEVED SHIRTS; POLO SHIRTS; SWEAT SHIRTS (U.S. CLS. 22 AND 39).

MARK RADEMACHER, EXAMINING ATTORNEY

SN 77-459,228. MITTELSTADT, CHARLES D., ROSWELL, GA. FILED 4-28-2008.

13 1/2

THE MARK CONSISTS OF STANDARD CHARACTERS WITHOUT CLAIM TO ANY PARTICULAR FONT, STYLE, SIZE, OR COLOR.

FOR CHEF'S HATS; FUR HATS; HAT BANDS; HATS; HEADGEAR, NAMELY, BASEBALL CAPS, FLAT BILL CAPS; PAPER HATS FOR USE AS CLOTHING ITEMS; SEDGE HATS (SUGE-GASA); SMALL HATS; TOBOGGAN HATS, PANTS AND CAPS; WOOLLY HATS (U.S. CLS. 22 AND 39).

KAPIL BHANOT, EXAMINING ATTORNEY

SN 77-466,376. LEFT COAST DENIM, EL PASO, TX. FILED 5-5-2008.

IGGY & PEACHES

THE MARK CONSISTS OF STANDARD CHARACTERS WITHOUT CLAIM TO ANY PARTICULAR FONT, STYLE, SIZE, OR COLOR.

FOR DENIMS; JEANS (U.S. CLS. 22 AND 39).
AISHA CLARKE, EXAMINING ATTORNEY

CLASS 25—(Continued).

SN 77-477,903. KATY FRANCES SOSBE, LONDON, UNITED KINGDOM, FILED 5-19-2008.

High & Waisted

THE MARK CONSISTS OF STANDARD CHARACTERS WITHOUT CLAIM TO ANY PARTICULAR FONT, STYLE, SIZE, OR COLOR.

PRIORITY CLAIMED UNDER SEC. 44(D) ON UNITED KINGDOM APPLICATION NO. REF200751271, FILED 11-20-2007, REG. NO. 2472790, DATED 11-20-2007, EXPIRES 11-20-2017.

FOR BLOUSES; CARDIGANS; COATS; DENIM JACKETS; DRESS SHIRTS; DRESSES; EVENING DRESSES; HEAD SCARVES; JACKETS; JEANS; KNIT SHIRTS; LADIES' UNDERWEAR; LONG JACKETS; LONG SLEEVED VESTS; SCARVES; SHIRTS; SHORT TROUSERS; SLEEVED OR SLEEVELESS JACKETS; SLEEVELESS JERSEYS; SWEATERS; T-SHIRTS; TANK TOPS; TEE SHIRTS; TOPS; TROUSERS; UNDERWEAR; VESTS; WOMEN'S UNDERWEAR (U.S. CLS. 22 AND 39).
JENNIFER VASQUEZ, EXAMINING ATTORNEY

SN 77-495,183. UNION APPAREL INTERNATIONAL LIMITED, KOWLOON, HONG KONG, FILED 6-10-2008.



THE MARK CONSISTS OF THE ENGLISH WORDS "INDIGO FARM" IN ALL CAPITAL LETTERS, A CHINESE WORD TRANSLITERATED AS "LAN" AND TRANSLATED AS "BLUE" IS ON TOP OF THE WORD "INDIGO" AND A CHINESE WORD TRANSLITERATED AS "LONG" AND TRANSLATED AS "DRAGON" IS ON TOP OF THE WORD "FARM".

THE NON-LATIN CHARACTER(S) IN THE MARK TRANSLITERATES INTO LAN LONG, AND THIS MEANS BLUE DRAGON IN ENGLISH.

FOR CLOTHING, NAMELY, BUSINESS SUITS, WET SUITS, SPORTS SUITS, NAMELY, TRAINING SUITS, BATHING SUITS; EVENING DRESSES, EVENING SUITS AND CASUAL WEAR, NAMELY, JERSEY; FOOTWEAR; HEADWEAR; ARTICLES OF OUTER CLOTHING, NAMELY, TOP COATS, PARKAS, RAINCOATS; BLOUSES; POLO SHIRTS; T-SHIRTS; DRESSES; PAJAMAS; KNITWEAR, NAMELY, KNITTED SHIRTS, KNITTED CAPS, KNITTED SKIRTS, KNITTED JACKETS, KNITTED SCARVES, KNITTED SWEATERS, KNITTED T-SHIRTS, KNITTED TROUSERS, KNITTED CARDIGANS AND KNITTED SOCKS; SHIRTS; TROUSERS; SUITS; JACKETS; UNDERCLOTHING; HOSIERY; TRACKSUITS; TIES; SCARVES; CARDIGANS; BLAZERS; SWEATERS; JEANS; WIND-RESISTANT JACKETS; ANORAKS; PANTS; SHOES; SHORTS (U.S. CLS. 22 AND 39).
MICHAEL WIENER, EXAMINING ATTORNEY

CLASS 25—(Continued).

SN 77-499,968. PONI, CATHI, DBA UPTOWN MAMA, REDDING, CA. FILED 6-16-2008.

Uptown Mama

THE MARK CONSISTS OF STANDARD CHARACTERS WITHOUT CLAIM TO ANY PARTICULAR FONT, STYLE, SIZE, OR COLOR.

FOR WOMEN'S CLOTHING, NAMELY, T-SHIRTS, TANK TOPS, SCARVES, COATS, HEADWEAR, SKIRTS, DRESSES, AND SKORTS, CHILDREN'S CLOTHING, NAMELY, T-SHIRTS, COATS, HEADWEAR, SKIRTS, DRESSES, SHOES, AND SHORTS, INFANT CLOTHING, NAMELY, ONE PIECE GARMENTS, CLOTH BIBS, HEADWEAR, SHOES, AND LAYETTES (U.S. CLS. 22 AND 39).

FIRST USE 4-20-2008; IN COMMERCE 5-31-2008.
DORITT L. CARROLL, EXAMINING ATTORNEY

SN 77-503,504. G-III LEATHER FASHIONS, INC., NEW YORK, NY. FILED 6-19-2008.

INDUSTRIAL COTTON GARAGE

THE MARK CONSISTS OF STANDARD CHARACTERS WITHOUT CLAIM TO ANY PARTICULAR FONT, STYLE, SIZE, OR COLOR.

NO CLAIM IS MADE TO THE EXCLUSIVE RIGHT TO USE "INDUSTRIAL COTTON", APART FROM THE MARK AS SHOWN.

FOR CLOTHING ALL MADE IN WHOLE OR IN SUBSTANTIAL PART OF COTTON, NAMELY, BOTTOMS, SLACKS, PANTS, JEANS, CAPRIS, SHORTS, SKIRTS, AND JACKETS (U.S. CLS. 22 AND 39).

JULIE GUTTADAURO, EXAMINING ATTORNEY

SN 77-505,692. TURTLE POND PUBLICATIONS LLC, NEW YORK, NY. FILED 6-23-2008.

KABIRIZI

THE MARK CONSISTS OF STANDARD CHARACTERS WITHOUT CLAIM TO ANY PARTICULAR FONT, STYLE, SIZE, OR COLOR.

THE WORDING "KABIRIZI" HAS NO MEANING IN A FOREIGN LANGUAGE.

FOR CLOTHING, NAMELY, T-SHIRTS, PANTS, SWIM SUITS, OVER COATS, PAJAMAS, TIES, SOCKS, AND SLIPPERS; AND HATS, CAPS (U.S. CLS. 22 AND 39).

ANGELA GAW, EXAMINING ATTORNEY

CLASS 25—(Continued).

SN 77-510,586. CHRISTOPHER CODDINGTON, WHITTIER, CA. FILED 6-28-2008.

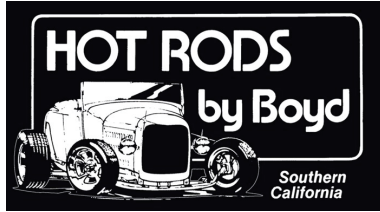

NO CLAIM IS MADE TO THE EXCLUSIVE RIGHT TO USE "SOUTHERN CALIFORNIA", APART FROM THE MARK AS SHOWN.

THE MARK CONSISTS OF STYLIZED BLOCK LETTERING "HOT RODS BY BOYD" INSIDE A ROUND-EDGED RECTANGLE WITH A CLASSIC CAR IN THE LOWER LEFT CORNER, ALL OF THE FOREGOING BEING IN A LARGER RECTANGLE WITH "SOUTHERN CALIFORNIA" IN THE LOWER RIGHT CORNER.

FOR ATHLETIC APPAREL, NAMELY, SHIRTS, PANTS, JACKETS, FOOTWEAR, HATS AND CAPS, ATHLETIC UNIFORMS (U.S. CLS. 22 AND 39).
BRENDAN REGAN, EXAMINING ATTORNEY

SN 77-510,832. TMLS SERVICES LIMITED, LONDON, UNITED KINGDOM, FILED 6-30-2008.



OWNER OF ERPN CMNTY TM OFC REG. NO. 003569514, DATED 6-16-2005, EXPIRES 12-3-2013.

NO CLAIM IS MADE TO THE EXCLUSIVE RIGHT TO USE "STUDIO", APART FROM THE MARK AS SHOWN.

THE MARK CONSISTS OF THE WORDS "STUDIO TMLS" IN A STYLIZED FONT IN A RECTANGULAR BOX.

FOR ARTICLES OF CLOTHING, NAMELY, SKIRTS, SHIRTS, SHORTS, SWEAT PANTS, JACKETS, PANTS, FOOTWEAR AND HEADGEAR, NAMELY, HATS, CAPS AND BEANIES (U.S. CLS. 22 AND 39).

JANICE KIM, EXAMINING ATTORNEY

SN 77-512,103. BACKWOODS EQUIPMENT COMPANY, AUSTIN, TX. FILED 7-1-2008.



OWNER OF U.S. REG. NO. 3,572,493.
THE MARK CONSISTS OF A PINECONE DESIGN.
FOR SHIRTS, T-SHIRTS; PANTS; COATS; VESTS; JACKETS; SLEEPWEAR (U.S. CLS. 22 AND 39).
FIRST USE 5-31-2008; IN COMMERCE 5-31-2008.
SAMUEL E. SHARPER JR., EXAMINING ATTORNEY

CLASS 25—(Continued).

SN 77-514,164. YAMUNA INTERNATIONAL, GAUTAM BUDH NAGAR, UTTAR PRADESH, INDIA, FILED 7-3-2008.

COOL LINE

THE MARK CONSISTS OF STANDARD CHARACTERS WITHOUT CLAIM TO ANY PARTICULAR FONT, STYLE, SIZE, OR COLOR.

NO CLAIM IS MADE TO THE EXCLUSIVE RIGHT TO USE "LINE", APART FROM THE MARK AS SHOWN.

FOR HORSE RIDING CLOTHING AND APPAREL, NAMELY, PANTS, SHIRTS, JACKETS, VESTS, SOCKS, CHAPS, BREECHES, JODHPURS AND POLO T-SHIRTS (U.S. CLS. 22 AND 39).

FIRST USE 5-1-2008; IN COMMERCE 5-1-2008.

REGINA DRUMMOND, EXAMINING ATTORNEY

SN 77-516,570. HYPERBOLE, INC., MIDDLE VILLAGE, NY. FILED 7-8-2008.

BLANCHO

THE MARK CONSISTS OF STANDARD CHARACTERS WITHOUT CLAIM TO ANY PARTICULAR FONT, STYLE, SIZE, OR COLOR.

THE WORDING "BLANCHO" HAS NO MEANING IN A FOREIGN LANGUAGE.

FOR PONCHOS (U.S. CLS. 22 AND 39).

TINA KUAN, EXAMINING ATTORNEY

CLASS 25—(Continued).

SN 77-518,047. ARGON TECHNOLOGIES, INC., OGDEN, UT. FILED 7-9-2008.

CLASS 25—(Continued).

SN 77-519,433. MAGIC MOLEHILL PRODUCTIONS INC., SACRAMENTO, CA. FILED 7-10-2008.



NO CLAIM IS MADE TO THE EXCLUSIVE RIGHT TO USE "DOG", APART FROM THE MARK AS SHOWN.

THE COLOR(S) RED AND BLUE IS/ARE CLAIMED AS A FEATURE OF THE MARK.

THE MARK CONSISTS OF THE WORD "GREATEST" IN RED WITH TWO RED STARS ON BOTH SIDES OF THE WORD, THE WORDS "AMERICAN DOG "IN DOG WE TRUST"" IN BLUE, AND THE DOG LEAPING THROUGH THE LETTER "O" IN THE WORD "DOG" IS RED.

FOR MEN'S, WOMEN'S, CHILDREN'S AND INFANT CLOTHING, NAMELY, APRONS; SHIRTS, PANTS, TROUSERS; FOOTWEAR, A-SHIRTS; BABY BIBS NOT OF PAPER; BEACHWEAR; SHORTS; BRIEFS; SHIRTS; CAPELETS; CLOTH BIB'S; PLASTIC BIB'S; HEADWEAR; ARM WARMERS; WRAP AROUNDS; OUTERWEAR FOR MEN, WOMEN, CHILDREN, AND INFANTS, NAMELY, COATS, COLLAR PROTECTORS; COLLARS; JACKETS; DICKIES; EAR MUFFS; EAR WARMERS; EAR BANDS; HALLOWEEN COSTUMES AND MASKS SOLD IN CONNECTION THEREWITH; HALTER TOPS; HEAD SCARVES; DIAPERS; INFANT DIAPER COVERS; JERSEYS; KERCHIEFS; UNDERWEAR; SKIRTS; MITTENS; MUSCLE TOPS; NECKWEAR; GLOVES; PAPER SHOES USED WHEN GOING THROUGH METAL DETECTORS TO KEEP FEET AND SOCKS CLEAN; RAINWEAR; ROBES; SCRUBS NOT FOR MEDICAL USE; SHAWLS; SLEEPWEAR; SUSPENDER BELTS; SUSPENDERS; SWEATSHIRTS; SWEATPANTS; SWEATERS; TOGAS; WRIST BANDS (U.S. CLS. 22 AND 39).

RENEE SERVANCE, EXAMINING ATTORNEY

SN 77-520,481. DIAXIS, LLC, EL SEGUNDO, CA. FILED 7-11-2008.

DROORS

THE MARK CONSISTS OF A CIRCLE WITH A MOUNTAIN AND "KLYMIT".

FOR CLOTHING, NAMELY, JACKETS, PANTS, BOOTS, GLOVES, MITTENS, LINERS, VESTS, HATS, BEANIES, EAR WARMERS/HEADBANDS, SUITS, SHIRTS, SWEATERS, SOCKS, SHOES, BOOTS, UNIFORMS, UNDERWEAR, WET SUITS, FISHING WADERS, SKI BIBS, SWIMWEAR (U.S. CLS. 22 AND 39).

KIMBERLY PERRY, EXAMINING ATTORNEY

THE MARK CONSISTS OF STANDARD CHARACTERS WITHOUT CLAIM TO ANY PARTICULAR FONT, STYLE, SIZE, OR COLOR.

OWNER OF U.S. REG. NOS. 1,795,090 AND 2,662,530. FOR T-SHIRTS, SHIRTS, TANK TOPS, SWEATSHIRTS, PANTS, SHORTS, JEANS, CAPS, HATS, BEANIES, FOOTWEAR (U.S. CLS. 22 AND 39).

HENRY S. ZAK, EXAMINING ATTORNEY

CLASS 25—(Continued).

SN 77-521,798. ASPEN SKIING COMPANY, ASPEN, CO.
FILED 7-14-2008.

RESIDENCES AT THE LITTLE
NELL

THE MARK CONSISTS OF STANDARD CHARACTERS
WITHOUT CLAIM TO ANY PARTICULAR FONT, STYLE,
SIZE, OR COLOR.

OWNER OF U.S. REG. NOS. 2,475,788, 3,289,145 AND
OTHERS.

FOR CLOTHING, NAMELY, SHIRTS, T-SHIRTS,
TANK TOPS, SWEAT SHIRTS, JACKETS, FLEECE JACK-
ETS, AND HATS (U.S. CLS. 22 AND 39).

MICHAEL KEATING, EXAMINING ATTORNEY

SN 77-524,255. INGRAM, JOSEPHINE TOURNIER, SANTA
BARBARA, CA. FILED 7-16-2008.

ecozuzu

THE MARK CONSISTS OF STANDARD CHARACTERS
WITHOUT CLAIM TO ANY PARTICULAR FONT, STYLE,
SIZE, OR COLOR.

FOR (BASED ON USE IN COMMERCE) HATS;
HOODED SWEAT SHIRTS; LONG-SLEEVED SHIRTS; T-
SHIRTS(BASED ON INTENT TO USE) ANKLE SOCKS;
ANKLETS; APRONS; BABY TOPS; BEANIES; BOXER
BRIEFS; BOXER SHORTS; BRAS; BRIEFS; CAPS; DRESS
SHIRTS; HEAD SCARVES; INFANT AND TODDLER
ONE PIECE CLOTHING; JACKETS; JERSEYS; LADIES'
UNDERWEAR; LONG UNDERWEAR; LOUNGE PANTS;
MEN'S AND WOMEN'S JACKETS, COATS, TROUSERS,
VESTS; MEN'S SOCKS; NIGHT SHIRTS; OPEN-NECKED
SHIRTS; POLO SHIRTS; SCARVES; SHIRTS; SHORT-
SLEEVED OR LONG-SLEEVED T-SHIRTS; SHORT-
SLEEVED SHIRTS; SHOULDER WRAPS; SILK
SCARVES; SKIRTS AND DRESSES; SLEEVED OR SLEE-
VELESS JACKETS; SNOWBOARD PANTS; SOCKS;
SWEAT JACKETS; SWEAT PANTS; SWEAT SHIRTS;
TANK TOPS; TEE SHIRTS; THERMAL UNDERWEAR;
TIES; TRACK JACKETS; UNDERWEAR; UNDERWEAR,
NAMELY, BOY SHORTS; WOMEN'S UNDERWEAR;
YOGA PANTS; YOGA SHIRTS (U.S. CLS. 22 AND 39).

FIRST USE 12-1-2007; IN COMMERCE 12-14-2007.

JIM RINGLE, EXAMINING ATTORNEY

CLASS 25—(Continued).

SN 77-524,286. HEALY, CATHERINE A., DBA CAT HATS,
SANTA MONICA, CA. FILED 7-17-2008.



NO CLAIM IS MADE TO THE EXCLUSIVE RIGHT TO
USE "HATS", APART FROM THE MARK AS SHOWN.

THE MARK CONSISTS OF THE DESIGN OF A CAT
FACE, WITH THE EARS FORMED BY THE PHRASE "CAT
HATS".

FOR FUR HATS; HATS (U.S. CLS. 22 AND 39).

FIRST USE 1-1-2008; IN COMMERCE 1-1-2008.

CHRISTINE BLOMQUIST, EXAMINING ATTORNEY

SN 77-526,727. SOUND MIND ENTERPRISES, INC., LA-
PEER, MI. FILED 7-20-2008.

Speak Kind Words

THE MARK CONSISTS OF STANDARD CHARACTERS
WITHOUT CLAIM TO ANY PARTICULAR FONT, STYLE,
SIZE, OR COLOR.

THE NAME(S), PORTRAIT(S), AND/OR SIGNATURE(S)
SHOWN IN THE MARK DOES NOT IDENTIFY A PARTI-
CULAR LIVING INDIVIDUAL.

FOR SHIRTS (U.S. CLS. 22 AND 39).

FIRST USE 9-22-2007; IN COMMERCE 9-22-2007.

JILL C. ALT, EXAMINING ATTORNEY

CLASS 25—(Continued).

SN 77-529,817. MAJESTIC INDUSTRIES(CANADA)LTD, MONTREAL, CANADA, FILED 7-23-2008.

M
pour la Femme

NO CLAIM IS MADE TO THE EXCLUSIVE RIGHT TO USE "POUR LA FEMME", APART FROM THE MARK AS SHOWN.

THE ENGLISH TRANSLATION OF "POUR LA FEMME" IN THE MARK IS FOR THE WOMAN.

FOR WOMEN'S CLOTHING, NAMELY, COORDINATED TOPS AND BOTTOMS, NAMELY, JACKETS, PANTS, CAPRI PANTS, SHIRTS, TOPS, SWEATERS; WOMEN'S ACTIVWEAR, NAMELY, SWEAT PANTS, SWEAT SHIRTS, TRACK AND JOGGING SUITS; WOMEN'S LOUNGEWEAR, NAMELY, ROBES, BATH-ROBES, WRAPS, LOUNGE PANTS, LOUNGE SHORTS; LOCKER ROOM KILTS, NAMELY, WRAP-AROUND TOWELS; WOMEN'S SLEEPWEAR, NAMELY, PAJAMAS, SHORTY PAJAMAS, NIGHT SHIRTS, NIGHTIES; WOMEN'S UNDERWEAR, NAMELY, CAMISOLES, KNIT AND WOVEN PANTIES, SHORTS (U.S. CLS. 22 AND 39).

ELLEN BURNS, EXAMINING ATTORNEY

SN 77-530,347. KRYSTAL BALL PRODUCTIONS, INC., GLENDALE, CA. FILED 7-24-2008.

FERGALICIOUS BY FERGIE

THE MARK CONSISTS OF STANDARD CHARACTERS WITHOUT CLAIM TO ANY PARTICULAR FONT, STYLE, SIZE, OR COLOR.

THE NAME "STACY FERGUSON" AKA "FERGIE" IDENTIFIES A LIVING INDIVIDUAL WHOSE CONSENT IS OF RECORD.

FOR FOOTWEAR (U.S. CLS. 22 AND 39).
MARC LEIPZIG, EXAMINING ATTORNEY

CLASS 25—(Continued).

SN 77-530,421. SANCHEZ, BENJAMIN GUTIERREZ, FONTANA, CA. FILED 7-24-2008.

People of the Sun

THE MARK CONSISTS OF STANDARD CHARACTERS WITHOUT CLAIM TO ANY PARTICULAR FONT, STYLE, SIZE, OR COLOR.

FOR CLOTHING, NAMELY, T-SHIRTS, SWEATSHIRTS, THERMAL LONG SLEEVE T-SHIRTS, THERMAL UNDERWEAR, PANTS, SHOES, HOODED SWEATSHIRTS, DRESSES, UNDERWEAR, SWIMWEAR, BELTS; OUTERWEAR IN THE NATURE OF COATS, NYLON JACKETS, DENIM JACKETS, RAINCOATS, WIND RESISTANT JACKETS, TRACK JACKETS, SWEATERS; WORKWEAR IN THE NATURE OF WORK SHIRTS, WORK PANTS, COVERALLS, OVERALLS, JACKETS, WORK SHOES, HATS AND BELTS (U.S. CLS. 22 AND 39).

FIRST USE 5-10-2008; IN COMMERCE 5-10-2008.
JORDAN BAKER, EXAMINING ATTORNEY

SN 77-534,916. AMERICAN SPORTING GOODS CORPORATION, ALISO VIEJO, CA. FILED 7-30-2008.

AMERICAN SPORTING GOODS CORP.

THE MARK CONSISTS OF STANDARD CHARACTERS WITHOUT CLAIM TO ANY PARTICULAR FONT, STYLE, SIZE, OR COLOR.

NO CLAIM IS MADE TO THE EXCLUSIVE RIGHT TO USE "SPORTING GOODS CORP.", APART FROM THE MARK AS SHOWN.

SEC. 2(F).

FOR CLOTHING, NAMELY, SHIRTS, T-SHIRTS, TANK TOPS, JACKETS, SWEATSHIRTS, SWEATERS, PANTS, SHORTS, SWEATPANTS, TOPS, BOTTOMS, ATHLETIC BRAS, SOCKS, HEADWEAR; ATHLETIC APPAREL, NAMELY, YOGA WEAR, JOGGING SUITS, EXERCISE OUTFITS, WARM-UP SUITS, SHIRTS, T-SHIRTS, TANK TOPS, JACKETS, SWEATSHIRTS, SWEATERS, PANTS, SHORTS, SWEATPANTS, TOPS, BOTTOMS, ATHLETIC BRAS, SOCKS, HEADWEAR; FOOTWEAR; ATHLETIC FOOTWEAR; SNEAKERS (U.S. CLS. 22 AND 39).

FIRST USE 12-31-1983; IN COMMERCE 12-31-1983.
EMILY CHUO, EXAMINING ATTORNEY

CLASS 25—(Continued).

SN 77-535,128. CASHMERE HOUSE, INC., SANTA ANA, CA. FILED 7-30-2008.

TSESAY

THE MARK CONSISTS OF STANDARD CHARACTERS WITHOUT CLAIM TO ANY PARTICULAR FONT, STYLE, SIZE, OR COLOR.

OWNER OF U.S. REG. NOS. 2,160,418, 3,357,442 AND OTHERS.

FOR MEN'S AND CHILDREN'S CLOTHING, NAMELY, HEADWEAR, FOOTWEAR, HOSIERY, SHIRTS, T-SHIRTS, SWEATSHIRTS, SWEATPANTS, LEGGINGS, BLOUSES, JACKETS, COATS, BLAZERS, PANTS, SKIRTS, SUITS, SHORTS, SCARVES, BATHROBES, NIGHTGOWNS, PAJAMAS; WOMEN'S CLOTHING, NAMELY, BATHROBES, NIGHTGOWNS, LINGERIE, PAJAMAS (U.S. CLS. 22 AND 39).
JAY FLOWERS, EXAMINING ATTORNEY

CLASS 25—(Continued).

SN 77-537,921. MR. CHUNG HWA TAI, NEW YORK, NY. FILED 8-4-2008.

ANNE CARSON

THE MARK CONSISTS OF STANDARD CHARACTERS WITHOUT CLAIM TO ANY PARTICULAR FONT, STYLE, SIZE, OR COLOR.

THE NAME "ANNE CARSON" DOES NOT IDENTIFY A LIVING INDIVIDUAL.

FOR WOMEN'S GARMENTS AND SPORTSWEAR, NAMELY, DRESSES, BLOUSES, SKIRTS AND JACKETS; MEN'S SPORTSWEAR NAMELY, SHIRTS, JACKETS AND PANTS (U.S. CLS. 22 AND 39).

FIRST USE 9-30-1993; IN COMMERCE 9-30-1993.
AMY ALFIERI, EXAMINING ATTORNEY

SN 77-543,028. ISVERA, ASPEN, CO. FILED 8-8-2008.

ISVERA

THE MARK CONSISTS OF STANDARD CHARACTERS WITHOUT CLAIM TO ANY PARTICULAR FONT, STYLE, SIZE, OR COLOR.

FOR BOXER BRIEFS; SHORT-SLEEVED OR LONG-SLEEVED T-SHIRTS (U.S. CLS. 22 AND 39).

DAWN FELDMAN, EXAMINING ATTORNEY

SN 77-543,830. MAIDENFORM, INC., ISELIN, NJ. FILED 8-11-2008.

FAT FREE

THE MARK CONSISTS OF STANDARD CHARACTERS WITHOUT CLAIM TO ANY PARTICULAR FONT, STYLE, SIZE, OR COLOR.

FOR FOUNDATION GARMENTS; WOMEN'S UNDERGARMENTS; LINGERIE; WOMEN'S INTIMATE APPAREL, NAMELY, BRASSIERES, PANTIES, UNDERWEAR, BRIEFS, CAMISOLES, SHAPEWEAR, NAMELY, CONTROL BRIEFS, BOY SHORTS, THIGH SLIMMERS, PANT LINERS, BODY BRIEFERS, WAISTNIPPERS, SLIPS, UNITARDS, BODYSUITS AND BODY SHAPERS (U.S. CLS. 22 AND 39).

JAY FLOWERS, EXAMINING ATTORNEY

SN 77-537,880. UNITED STATES POLO ASSOCIATION, LEXINGTON, KY. FILED 8-4-2008.

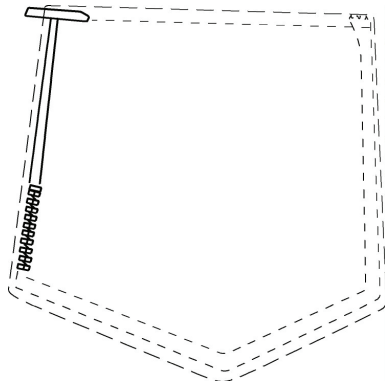

THE MARK CONSISTS OF THE DESIGN OF A POLO Mallet. THE DOTTED LINES INDICATE THE PLACEMENT OF THE MARK ON THE GOODS AND ARE NOT CLAIMED AS A FEATURE OF THE MARK.

FOR PANTS (U.S. CLS. 22 AND 39).
CHRISTINE BLOMQUIST, EXAMINING ATTORNEY

CLASS 25—(Continued).

SN 77-548,693. PRESCOTT, KIMBERLY I., MALIBU, CA. FILED 8-15-2008.

Cowneck Bibs

THE MARK CONSISTS OF STANDARD CHARACTERS WITHOUT CLAIM TO ANY PARTICULAR FONT, STYLE, SIZE, OR COLOR.

NO CLAIM IS MADE TO THE EXCLUSIVE RIGHT TO USE "BIBS", APART FROM THE MARK AS SHOWN.

FOR CHILDREN'S AND INFANTS' CLOTH BIBS; CHILDREN'S CLOTH EATING BIBS; CLOTH BIBS (U.S. CLS. 22 AND 39).

KAREN K. BUSH, EXAMINING ATTORNEY



SN 77-550,510. TURTLE POND PUBLICATIONS LLC, NEW YORK, NY. FILED 8-19-2008.

Mivumbi



THE MARK CONSISTS OF THE WORD "MIVUMBI" WITH A FOUR PART MISCELLANEOUS DESIGN.

THE WORDING "MIVUMBI" HAS NO MEANING IN A FOREIGN LANGUAGE.

FOR CLOTHING, NAMELY, T-SHIRTS, SHIRTS, PANTS, SWIMSUITS, OVER COATS, PAJAMAS, TIES, SOCKS, AND SLIPPERS; FOOTWEAR; AND HATS, CAPS (U.S. CLS. 22 AND 39).

KAREN K. BUSH, EXAMINING ATTORNEY

CLASS 25—(Continued).

SN 77-550,554. TURTLE POND PUBLICATIONS LLC, NEW YORK, NY. FILED 8-19-2008.

Tumaini



THE MARK CONSISTS OF THE WORD "TUMAINI" WITH A STYLIZED FLOWER DESIGN.

THE ENGLISH TRANSLATION OF THE WORD "TUMAINI" IS HOPE OR BELIEF.

FOR CLOTHING, NAMELY, T-SHIRTS, SHIRTS, PANTS, SWIM SUITS, OVER COATS, PAJAMAS, TIES, SOCKS, AND SLIPPERS; FOOTWEAR; AND HATS, CAPS (U.S. CLS. 22 AND 39).

KAREN K. BUSH, EXAMINING ATTORNEY



SN 77-551,064. WHEATBREAD LLC, ATLANTA, GA. FILED 8-19-2008.

Wheatbread

THE MARK CONSISTS OF STANDARD CHARACTERS WITHOUT CLAIM TO ANY PARTICULAR FONT, STYLE, SIZE, OR COLOR.

FOR CLOTHING, NAMELY, T-SHIRTS, TANK TOPS, PANTS, SHORTS, SKIRTS, BUTTON DOWN SHIRTS, POLO SHIRTS, JEANS, KNIT SHIRTS, CARDIGANS, SWEATERS, WOVEN KNIT TIES, JACKETS, COATS, SHOES, SOCKS, UNDERGARMENTS, BRAS, PANTIES, UNDERWEAR, BOXER SHORTS, SWEAT SUITS, ATHLETIC FOOTWEAR, SCARVES, HOODED SWEAT SHIRTS, GLOVES, TURTLENECKS, HEADWEAR, HATS, OUTERWEAR IN THE NATURE OF COATS AND JACKETS, AND CAPS (U.S. CLS. 22 AND 39).

FIRST USE 9-12-1998; IN COMMERCE 10-2-2002.

LAURIE MAYES, EXAMINING ATTORNEY

CLASS 25—(Continued).

SN 77-551,735. PEPE JEANS LONDON LLC, NEW YORK, NY.
FILED 8-20-2008.

ROYAL RIVET

THE MARK CONSISTS OF STANDARD CHARACTERS WITHOUT CLAIM TO ANY PARTICULAR FONT, STYLE, SIZE, OR COLOR.

NO CLAIM IS MADE TO THE EXCLUSIVE RIGHT TO USE "RIVET", APART FROM THE MARK AS SHOWN.

FOR CLOTHING, NAMELY, JEANS, SKIRTS, BLOUSES, PANTS, PULL OVER SWEATERS, DRESSES, SWEATERS, JACKETS, SHIRTS, SWEAT SHIRTS, CAPS, AND T-SHIRTS (U.S. CLS. 22 AND 39).

KELLY BOULTON, EXAMINING ATTORNEY

SN 77-552,276. NINHO PEQUENO LLC, DBA FAROFA NATION, MIAMI, FL. FILED 8-21-2008.

FAROFA**NATION**

THE MARK CONSISTS OF AN IMAGE OF A CIRCLE WITH STARS DEPICTING THE EYES AND A PLUS SIGN AS THE MOUTH AND NOSE. THE STYLIZED WORD "FAROFA" IS ABOVE THE CIRCLE. THE STYLIZED WORD "NATION" IS BELOW THE CIRCLE.

FOR JACKETS; PANTS; SHIRTS; SHOES (U.S. CLS. 22 AND 39).

FIRST USE 10-1-2007; IN COMMERCE 10-1-2007.
JENNY PARK, EXAMINING ATTORNEY

CLASS 25—(Continued).

SN 77-553,345. ASPEN SKIING COMPANY, ASPEN, CO.
FILED 8-22-2008.



OWNER OF U.S. REG. NOS. 2,628,176 AND 3,485,374.
THE COLOR(S) BURGUNDY AND WHITE IS/ARE CLAIMED AS A FEATURE OF THE MARK.

THE MARK CONSISTS OF THE WORD "AJAX" DISPLAYED ABOVE THE SMALLER "TAVERN" BOTH IN WHITE AND SURROUNDED BY A BURGUNDY DIAMOND SHAPE.

FOR CLOTHING, NAMELY, SHIRTS, T-SHIRTS, TANK TOPS, SWEAT SHIRTS, JACKETS, FLEECE JACKETS, AND HATS (U.S. CLS. 22 AND 39).

MICHAEL KEATING, EXAMINING ATTORNEY

SN 77-558,002. RANDALL STEVEN CORPORATION, DBA RANDALL STEVEN CORPORATION, KIRKLAND, WA.
FILED 8-28-2008.

Atattooed

THE MARK CONSISTS OF STANDARD CHARACTERS WITHOUT CLAIM TO ANY PARTICULAR FONT, STYLE, SIZE, OR COLOR.

FOR WEARABLE GARMENTS AND CLOTHING, NAMELY, SHIRTS (U.S. CLS. 22 AND 39).

GISELLE AGOSTO, EXAMINING ATTORNEY

SN 77-558,184. TUFTS UNIVERSITY, MEDFORD, MA.
FILED 8-28-2008.

FLETCHER

THE MARK CONSISTS OF STANDARD CHARACTERS WITHOUT CLAIM TO ANY PARTICULAR FONT, STYLE, SIZE, OR COLOR.

OWNER OF U.S. REG. NOS. 2,723,290, 2,763,323 AND 2,770,760.

SEC. 2(F).

FOR CLOTHING, NAMELY, TEE SHIRTS, SWEATSHIRTS, JACKETS, PANTS, CAPS, AND HATS (U.S. CLS. 22 AND 39).

FIRST USE 4-1-2004; IN COMMERCE 4-1-2004.
DAWN HAN, EXAMINING ATTORNEY

CLASS 25—(Continued).

SN 77-561,407. PUNTA BRAVA, LLC, AUSTIN, TX. FILED 9-3-2008.

PUNTA BRAVA

THE MARK CONSISTS OF STANDARD CHARACTERS WITHOUT CLAIM TO ANY PARTICULAR FONT, STYLE, SIZE, OR COLOR.

THE ENGLISH TRANSLATION OF THE WORD "PUNTA BRAVA" IN THE MARK IS "BRAVE END".

FOR CLOTHING GOODS, NAMELY, SHIRTS, SWEATERS, TANK TOPS, SCARVES, PANTS, TRUNKS, BOARD SHORTS, BOXERS, BRIEFS, BOXER-BRIEFS, ROBES, GLOVES, SHAWLS, BLOUSES, SKIRTS, JUMP SUITS, DRESSES, BLAZERS, SUITS, TIES, BOW TIES, TURTLENECKS, COATS, WIND RESISTANT JACKETS, VESTS, JACKETS, SOCKS, BIKINIS, SWIMSUITS, BOOTIES, SWEAT BANDS, BICYCLING GLOVES; BANDANAS; FOOTWEAR; HEADWEAR (U.S. CLS. 22 AND 39).

STEVEN JACKSON, EXAMINING ATTORNEY

CLASS 25—(Continued).

SN 77-566,742. GRUPO ANDREA, S.A. DE C.V., LEON GTO, MEXICO, FILED 9-10-2008.

ferrato 

OWNER OF U.S. REG. NO. 3,459,496.

THE COLOR(S) ORANGE AND BLACK IS/ARE CLAIMED AS A FEATURE OF THE MARK.

THE MARK CONSISTS OF THE COLORS ORANGE AND BLACK, WITH THE COLOR ORANGE APPEARING IN AN INCOMPLETE CIRCLE IN WHICH THE TERM "LIFE" APPEARS; AND THE COLOR BLACK APPEARS IN THE WORDING "FERRATO", WHICH APPEARS TO THE LEFT OF THE CIRCLE, AND IN THE TERM "LIFE"; THE BACKGROUND OF THE MARK IS TRANSPARENT.

THE FOREIGN WORDING IN THE MARK TRANSLATES INTO ENGLISH AS IRONSHOD, WELL READ OR WELL INFORMED.

FOR CLOTHING, NAMELY, T-SHIRTS, SHIRTS AND HATS; AND FOOTWEAR (U.S. CLS. 22 AND 39).

BILL DAWE, EXAMINING ATTORNEY

SN 77-563,955. STUDVILLE CLOTHING, INC., DECATUR, GA. FILED 9-6-2008.

STUDVILLE

THE MARK CONSISTS OF STANDARD CHARACTERS WITHOUT CLAIM TO ANY PARTICULAR FONT, STYLE, SIZE, OR COLOR.

FOR ATHLETIC APPAREL, NAMELY, SHIRTS, PANTS, JACKETS, FOOTWEAR, HATS AND CAPS, ATHLETIC UNIFORMS; HATS; HEADGEAR, NAMELY, HATS, CAPS, HEADBANDS, BANDANAS, VISORS.; HOODS; JACKETS; JEANS; JERSEYS; RAINPROOF JACKETS; SHORT SETS; SNEAKERS; SWEAT JACKETS; TIES; TOPS; TRACK JACKETS; WEARABLE GARMENTS AND CLOTHING, NAMELY, SHIRTS; WIND RESISTANT JACKETS; WRAPS (U.S. CLS. 22 AND 39).

FIRST USE 5-5-2005; IN COMMERCE 5-5-2005.

JENNIFER MARTIN, EXAMINING ATTORNEY

SN 77-566,935. ROUSSO APPAREL GROUP, INC., NEW YORK, NY. FILED 9-10-2008.

PURE. SIMPLE. NATURAL.

THE MARK CONSISTS OF STANDARD CHARACTERS WITHOUT CLAIM TO ANY PARTICULAR FONT, STYLE, SIZE, OR COLOR.

FOR MEN'S, WOMEN'S AND CHILDREN'S CLOTHING, NAMELY, JACKETS, PANTS, TOPS, SHORTS, T-SHIRTS, SHIRTS AND SKIRTS (U.S. CLS. 22 AND 39).

FIRST USE 10-24-2006; IN COMMERCE 10-24-2006.

ERIN FALK, EXAMINING ATTORNEY

CLASS 25—(Continued).

SN 77-574,625. HCI DIRECT, INC., BENSALEM, PA. FILED 9-19-2008.

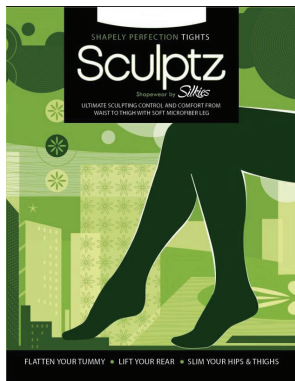

OWNER OF U.S. REG. NOS. 1,503,070, 3,048,001 AND OTHERS.

NO CLAIM IS MADE TO THE EXCLUSIVE RIGHT TO USE "TIGHTS" AND "SHAPEWEAR" AND "MICROFIBER LEG", APART FROM THE MARK AS SHOWN.

THE COLOR(S) BLACK, WHITE AND VARIOUS SHADES OF GREEN IS/ARE CLAIMED AS A FEATURE OF THE MARK.

THE MARK CONSISTS OF AN OVERALL RECTANGULAR DESIGN WITH A BLACK RECTANGLE APPEARING AT THE TOP OF THE DESIGN. THE WORDS "SHAPELY PERFECTION" APPEAR IN GREEN WITH THE WORD "TIGHTS" APPEARING IN WHITE, IN A LARGER FONT THE WORD "SCULPTZ" APPEARS IN WHITE WITH GREEN OUTLINING. THE WORDS "SHAPEWEAR BY" APPEAR IN GREEN WITH THE WORD "SILKIES" IN WHITE IN A CURSIVE LIKE APPEARANCE. THE WORDS "ULTIMATE SCULPTING CONTROL AND COMFORT FROM WAIST TO THIGH WITH SOFT MICROFIBER LEG" APPEAR IN WHITE LETTERING AT THE BOTTOM OF THE UPPER BLACK RECTANGLE. APPEARING ON THE RIGHT ARE HUMAN LEGS APPEARING IN AN ALMOST SITTING POSITION IN DARK GREEN. APPEARING ON THE BOTTOM LEFT OF THE DESIGN IS A CITYSCAPE DESIGN SHOWING BUILDINGS OF VARIOUS HEIGHTS IN VARIOUS SHADES OF GREEN. APPEARING THROUGHOUT THE OVERALL DESIGN ARE VARIOUS GEOMETRICAL SHAPES SUCH AS CIRCLES, A FIVE POINTED STAR, FLORAL DESIGNS, FLORAL DESIGNS INSIDE CIRCLES AND OTHER MISCELLANEOUS DESIGNS IN VARIOUS SHADES OF GREEN. AT THE BOTTOM OF THE DESIGN THERE IS A BLACK RECTANGLE WITH THE FOLLOWING WORDS APPEARING IN WHITE "FLATTEN YOUR TUMMY" (GREEN DOT) "LIFT YOUR REAR" (GREEN DOT) "SLIM YOUR HIPS & THIGHS". THE CURVED RECTANGLE IN WHITE THAT APPEARS AT THE TOP OF THE MARK REPRESENTS A TRANSPARENT AREA AND IS NOT PART OF THE MARK.

FOR WEARING APPAREL, NAMELY, TIGHTS COMPOSED IN WHOLE OR SUBSTANTIALLY IN PART OF MICROFIBER AND MICRO FILAMENT (U.S. CLS. 22 AND 39).

SUSAN STIGLITZ, EXAMINING ATTORNEY

CLASS 25—(Continued).

SN 77-575,977. CDS-IP, S.A., SAINTES, BELGIUM, FILED 9-22-2008.



OWNER OF ERPN CMNTY TM OFC REG. NO. 004457958, DATED 7-11-2006, EXPIRES 5-26-2015.

THE MARK CONSISTS OF THE STYLIZED LITERAL ELEMENT "D".

FOR GOLF CLOTHING, NAMELY, WATERPROOF AND WEATHERPROOF CLOTHING, NAMELY, CA-GOULES, JACKETS, ANORAKS AND PULLOVERS, TROUSERS, SHIRTS AND T-SHIRTS, SOCKS; HEADGEAR, NAMELY, CAPS, HATS AND HEADBANDS; CLOTHING FOR RACKET SPORTS, NAMELY, SHORTS, SHIRTS, T-SHIRTS, SWEATERS, PULLOVERS, JACKETS, DRESSES, SKIRTS, SOCKS; COURT SHOES, NAMELY, TENNIS, SQUASH, BADMINTON AND TABLE TENNIS SHOES; TRAINERS, NAMELY, SNEAKERS (U.S. CLS. 22 AND 39).

EDWARD FENNESSY, EXAMINING ATTORNEY

SN 77-578,891. VAEI PROJECT, LLC, ENCINO, CA. FILED 9-25-2008.

BLACK LABORATORIES

THE MARK CONSISTS OF STANDARD CHARACTERS WITHOUT CLAIM TO ANY PARTICULAR FONT, STYLE, SIZE, OR COLOR.

NO CLAIM IS MADE TO THE EXCLUSIVE RIGHT TO USE "BLACK", APART FROM THE MARK AS SHOWN.

FOR CLOTHING FOR MEN, WOMEN AND CHILDREN, NAMELY, COATS, JACKETS, TROUSERS, T-SHIRTS, PANTS, SWEATSHIRTS, SHIRTS, UNDERWEAR, DRESSES AND SKIRTS; AND FOOTWEAR FOR MEN, WOMEN AND CHILDREN (U.S. CLS. 22 AND 39).

AMEEN IMAM, EXAMINING ATTORNEY

CLASS 25—(Continued).

SN 77-579,836. ONE MEANING, NEW YORK, NY. FILED 9-26-2008.



THE MARK CONSISTS OF THE WORDS "ONE MEANING" TOGETHER WITH A BUTTERFLY DESIGN. THE BUTTERFLY DESIGN IS COMPRISED OF THE NUMBER "813", WHICH FORMS THE WINGS AND BODY OF THE BUTTERFLY.

FOR BOTTOMS; SHIRTS; T-SHIRTS; TEE SHIRTS; TOPS; WEARABLE GARMENTS AND CLOTHING, NAMELY, SHIRTS (U.S. CLS. 22 AND 39).

CURTIS FRENCH, EXAMINING ATTORNEY

CLASS 25—(Continued).

SN 77-598,553. CHYNNA DOLLS, LLC, FULLERTON, CA. FILED 10-22-2008.



THE COLOR(S) PINK IS/ARE CLAIMED AS A FEATURE OF THE MARK.

THE MARK CONSISTS OF A PINK ABSTRACT SYMBOL FOR THE LETTERS "C" AND "D", WHICH IS ALSO AN ABSTRACT REPRESENTATION OF THE CONTOURS TO THE BACKSIDE OF A BODY.

FOR BIKINIS; COATS FOR MEN AND WOMEN; SWIMWEAR; WOMEN'S CEREMONIAL DRESSES; WOMEN'S UNDERWEAR (U.S. CLS. 22 AND 39).

FIRST USE 1-31-2001; IN COMMERCE 1-31-2001.

PAUL E. FAHRENKOPF, EXAMINING ATTORNEY

SN 77-598,173. WEINBRENNER SHOE COMPANY, INC., MERRILL, WI. FILED 10-22-2008.



OWNER OF U.S. REG. NO. 678,929.
NO CLAIM IS MADE TO THE EXCLUSIVE RIGHT TO USE "TRADEMARK" AND "SINCE 1892", APART FROM THE MARK AS SHOWN.

THE MARK CONSISTS OF THE WORDS "TRADE MARK" ON THE TOP LINE WITH A WHEEL AND WINGS STYLE DESIGN BETWEEN "TRADE" AND "MARK", DIRECTLY UNDERNEATH APPEARS THE WORD "THOROGOOD" UNDERLINED BY THE TAIL OF THE "D" PORTION OF THE MARK, AND ON THE THIRD LINE THE WORDS AND NUMBERS "SINCE 1892"; ALL APPEAR ON TOP OF A TRIANGULAR SHAPED OUTLINE.

FOR FOOTWEAR (U.S. CLS. 22 AND 39).
FIRST USE 12-31-1892; IN COMMERCE 12-31-1892.
GIANCARLO CASTRO, EXAMINING ATTORNEY

SN 77-599,381. LOCKLEAR, JEREMY, WASILLA, AK. FILED 10-23-2008.

Adrenaline Junkeez

THE MARK CONSISTS OF STANDARD CHARACTERS WITHOUT CLAIM TO ANY PARTICULAR FONT, STYLE, SIZE, OR COLOR.

FOR CLOTHING, NAMELY, SHIRTS, SWEATERS, HOODED SWEATSHIRTS, PANTS, HATS, BEANIES, JACKETS, AND UNDERGARMENTS (U.S. CLS. 22 AND 39).

MICHAEL KEATING, EXAMINING ATTORNEY

CLASS 25—(Continued).

SN 77-610,153. DA BUBS, INC., DBA SHAYKEY, ROSLINDALE, MA. FILED 11-7-2008.



THE MARK CONSISTS OF "SHAYKEY". FOR ATHLETIC APPAREL, NAMELY, SHIRTS, PANTS, JACKETS, FOOTWEAR, HATS AND CAPS, ATHLETIC UNIFORMS; BASEBALL CAPS; HOODED SWEAT SHIRTS; SHIRTS (U.S. CLS. 22 AND 39). FIRST USE 11-14-2008; IN COMMERCE 11-14-2008. HOWARD SMIGA, EXAMINING ATTORNEY

SN 77-617,043. DR. BROWN DESIGNS, LLC, NEWPORT BEACH, CA. FILED 11-18-2008.

PROPRIO

THE MARK CONSISTS OF STANDARD CHARACTERS WITHOUT CLAIM TO ANY PARTICULAR FONT, STYLE, SIZE, OR COLOR.

THE ENGLISH TRANSLATION OF "PROPRIO" IN THE MARK IS ONE'S OWN.

FOR CLOTHING, NAMELY, SHIRTS, PANTS AND SHORTS; SOCKS; SKI WEAR; WOMEN'S BRAS AND LINGERIE; WETSUITS (U.S. CLS. 22 AND 39). JAY FLOWERS, EXAMINING ATTORNEY

SN 77-625,540. CE LICENSING, LLC, LOS ANGELES, CA. FILED 12-3-2008.

Carmen Electra

THE MARK CONSISTS OF STANDARD CHARACTERS WITHOUT CLAIM TO ANY PARTICULAR FONT, STYLE, SIZE, OR COLOR.

THE NAME SHOWN IN THE MARK IDENTIFIES A LIVING INDIVIDUAL, WHOSE CONSENT IS OF RECORD.

FOR CLOTHING, NAMELY, BELTS; BOOTS; BOTTOMS; CAPS; COATS; DRESSES; FOOTWEAR; GLOVES; GOWNS; HATS; HEAD BANDS; HEADWEAR; JACKETS; JEANS; JOGGING SUITS; LINGERIE; LOUNGEWEAR; NECKWEAR; NIGHTSHIRTS; PANTS; ROBES; SCARVES; SHIRTS; SHORTS; SLEEPWEAR; SOCKS; STOCKINGS; SWEAT PANTS; SWEAT SHIRTS; SWEAT SUITS; SWEATERS; SWIM WEAR; TOPS; TROUSERS; T-SHIRTS; UNDERWEAR; VESTS; VISORS; WARM-UP SUITS; WRAPS (U.S. CLS. 22 AND 39). REBECCA SMITH, EXAMINING ATTORNEY

CLASS 25—(Continued).

SN 77-628,587. AMERICAN EXCHANGE APPAREL GROUP, CORP, NEW YORK, NY. FILED 12-8-2008.

Joey Couture

THE MARK CONSISTS OF STANDARD CHARACTERS WITHOUT CLAIM TO ANY PARTICULAR FONT, STYLE, SIZE, OR COLOR.

NO CLAIM IS MADE TO THE EXCLUSIVE RIGHT TO USE "COUTURE", APART FROM THE MARK AS SHOWN. THE NAME "JOEY COUTURE" IDENTIFIES A LIVING INDIVIDUAL WHOSE CONSENT IS OF RECORD.

FOR MEN, WOMEN AND CHILDREN CLOTHING, NAMELY, SUITS, DRESSES, SKIRTS, COATS, DRESS SHIRTS, SHIRTS, T-SHIRTS, POLO SHIRTS, SWEAT SHIRTS, PANTS, PANT SUITS, SWEAT PANTS, CAPS, HATS, SHOES, SOCKS, BATHING SUITS, UNDERWEAR, BELTS, HOODS, JERSEYS, SHORT SETS, VESTS, TIES, GYM SUITS, SWEAT SHORTS, KNIT SHORTS (U.S. CLS. 22 AND 39).

FIRST USE 1-2-2005; IN COMMERCE 1-2-2005. FONG HSU, EXAMINING ATTORNEY

SN 77-632,791. HARVEY BALL SMILE LIMITED, SHINAGAWA-KU TOKYO, JAPAN, FILED 12-14-2008.



THE MARK CONSISTS OF A SMILEY FACE DEPICTING TWO VERTICAL SHADED OVALS REPRESENTING EYES, EACH WITH AN UNSHADED CIRCLE AT THE TOP, AND A SHADED AND UNSHADED SMILE BELOW, WITH SHORT LINES DEPICTING CORNERS OF THE SMILE.

FOR CAPS; COATS; FOOTWEAR; GLOVES; HATS; NECKTIES; PAJAMAS; PANTS; SCARVES; SHIRTS; SHORTS; SKIRTS; SOCKS AND STOCKINGS; SWEATERS; SWIMSUITS; T-SHIRTS; TROUSERS; UNDERWEAR (U.S. CLS. 22 AND 39).

ODESSA BIBBINS, EXAMINING ATTORNEY

CLASS 25—(Continued).

SN 77-632,793. HARVEY BALL SMILE LIMITED, SHINAGAWA-KU TOKYO, JAPAN, FILED 12-14-2008.



THE MARK CONSISTS OF SMILEY FACE DEPICTING TWO VERTICAL PARTIALLY UNSHADED AND SHADED OVALS REPRESENTING EYES, A SHADED VERTICAL OVAL REPRESENTING A NOSE, AND A SHADED AND UNSHADED SMILE WITH CORNERS.

FOR CAPS; COATS; FOOTWEAR; GLOVES; HATS; NECKTIES; PAJAMAS; PANTS; SCARVES; SHIRTS; SHORTS; SKIRTS; SOCKS AND STOCKINGS; SWEATERS; SWIMSUITS; T-SHIRTS; TROUSERS; UNDERWEAR (U.S. CLS. 22 AND 39).

ODESSA BIBBINS, EXAMINING ATTORNEY

CLASS 25—(Continued).

SN 77-632,797. HARVEY BALL SMILE LIMITED, SHINAGAWA-KU TOKYO, JAPAN, FILED 12-14-2008.



THE MARK CONSISTS OF A SMILEY FACE WITH SHADED SUNGLASSES WITHOUT HANDLES, IN AN UNSHADED FRAME, WITH A SMILE BELOW.

FOR CAPS; COATS; FOOTWEAR; GLOVES; HATS; NECKTIES; PAJAMAS; PANTS; SCARVES; SHIRTS; SHORTS; SKIRTS; SOCKS AND STOCKINGS; SWEATERS; SWIMSUITS; T-SHIRTS; TROUSERS; UNDERWEAR (U.S. CLS. 22 AND 39).

ODESSA BIBBINS, EXAMINING ATTORNEY

SN 77-632,795. HARVEY BALL SMILE LIMITED, SHINAGAWA-KU TOKYO, JAPAN, FILED 12-14-2008.



THE MARK CONSISTS OF A SMILEY FACE DEPICTING THE LENS PORTION OF SUNGLASSES THAT ARE PARTIALLY SHADED AND UNSHADED, WITH A SMILE WITH CORNERS AND A LIP BELOW.

FOR CAPS; COATS; FOOTWEAR; GLOVES; HATS; NECKTIES; PAJAMAS; PANTS; SCARVES; SHIRTS; SHORTS; SKIRTS; SOCKS AND STOCKINGS; SWEATERS; SWIMSUITS; T-SHIRTS; TROUSERS; UNDERWEAR (U.S. CLS. 22 AND 39).

ODESSA BIBBINS, EXAMINING ATTORNEY

SN 77-633,670. MULDER, RICHARD J., SANTA ANA, CA. FILED 12-16-2008.

**HEEL
BRUISE**

COLOR IS NOT CLAIMED AS A FEATURE OF THE MARK. THE MARK CONSISTS OF THE WORDS "HEEL BRUISE".

FOR ATHLETIC APPAREL, NAMELY, SHIRTS, PANTS, JACKETS, FOOTWEAR, HATS AND CAPS, ATHLETIC UNIFORMS; DRESS SHIRTS; HOODED SWEAT SHIRTS; KNIT SHIRTS; LONG-SLEEVED SHIRTS; POLO SHIRTS; SOCKS; SWEATERS; SWIMWEAR; UNDERWEAR (U.S. CLS. 22 AND 39).

FIRST USE 10-21-2008; IN COMMERCE 12-1-2008.

KATHY DE JONGE, EXAMINING ATTORNEY

CLASS 25—(Continued).

SN 77-634,669. HARVEY BALL SMILE LIMITED, SHINAGAWA-KU TOKYO, JAPAN, FILED 12-17-2008.



OWNER OF U.S. REG. NO. 3,242,722.
THE MARK CONSISTS OF A SMILEY FACE COMPRISED OF TWO VERTICAL SHADED OVALS REPRESENTING EYES AND A SHADED CURVED LINE WITH CORNERS, REPRESENTING A MOUTH.

FOR CAPS; COATS; FOOTWEAR; GLOVES; HATS; NECKTIES; PAJAMAS; PANTS; SCARVES; SHIRTS; SHORTS; SKIRTS; SOCKS AND STOCKINGS; SWEATERS; SWIMSUITS; T-SHIRTS; TROUSERS; UNDERWEAR (U.S. CLS. 22 AND 39).

ODESSA BIBBINS, EXAMINING ATTORNEY

SN 77-636,388. RHOADES, CHRISTOPHER, NORTH HOLLYWOOD, CA. FILED 12-18-2008.

ILOCOS NORTE CLOTHING

THE MARK CONSISTS OF STANDARD CHARACTERS WITHOUT CLAIM TO ANY PARTICULAR FONT, STYLE, SIZE, OR COLOR.

NO CLAIM IS MADE TO THE EXCLUSIVE RIGHT TO USE "CLOTHING", APART FROM THE MARK AS SHOWN. THE ENGLISH TRANSLATION OF THE WORD "NORTE" IN THE MARK IS NORTH.

FOR HATS; JACKETS; PANTS; SHIRTS; SHORTS (U.S. CLS. 22 AND 39).

CHRIS WELLS, EXAMINING ATTORNEY

CLASS 25—(Continued).

SN 77-638,959. WALLER, RON, CHESTER, VA. FILED 12-23-2008.



THE MARK CONSISTS OF THE STYLIZED TEXT "TWIN-HEAD" WITH TWO IDENTICAL TWIN FACES. THE FACES HAVE SHARP TEETH, EYES, AND EARS.

FOR CLOTHING, NAMELY, SHIRTS, SWEAT SUITS, JACKETS, HATS, BEANIES, POLO SHIRTS, T-SHIRTS, WARM UP SUITS, SHORTS (U.S. CLS. 22 AND 39).

ALEX KEAM, EXAMINING ATTORNEY

SN 77-644,792. DONELLA LLOYD, LLC, BURLINGAME, CA. FILED 1-7-2009.

True Essence, True Power

THE MARK CONSISTS OF STANDARD CHARACTERS WITHOUT CLAIM TO ANY PARTICULAR FONT, STYLE, SIZE, OR COLOR.

FOR SWEATERS, CARDIGANS, T-SHIRTS, TOPS, SHIRTS, BLOUSES, JACKETS, SHORTS, PANTS, JEANS, SHORTS, SLACKS, DRESSES, SKIRTS, SWEATSHIRTS, SWEATPANTS, HOODED SWEATSHIRTS, SWIMWEAR, BELTS FOR CLOTHING, SASHES, SCARVES, SHOULDER WRAPS, HOSIERY, HATS, AND SHOES (U.S. CLS. 22 AND 39).

HOWARD B. LEVINE, EXAMINING ATTORNEY

CLASS 25—(Continued).

SN 77-645,308. MAXFIELD, CLAYTON W., CHICAGO, IL. FILED 1-7-2009.

NEW BLOOD

THE MARK CONSISTS OF STANDARD CHARACTERS WITHOUT CLAIM TO ANY PARTICULAR FONT, STYLE, SIZE, OR COLOR.

FOR CLOTHING, NAMELY, SHIRTS, PANTS, SHORTS, UNDERWEAR, SOCKS, SCARVES, HEADWEAR, FOOTWEAR, DRESSES, TANK TOPS, SKIRTS, BLOUSES, SWEATSHIRTS, T-SHIRTS, SLEEPWEAR, SWIMWEAR, BELTS FOR CLOTHING, BOXER SHORTS, GLOVES, SWEAT BANDS; OUTERWEAR, NAMELY, JACKETS, CAPES, CLOAKS, COATS AND PULLOVERS (U.S. CLS. 22 AND 39).

TAMARA FRAZIER, EXAMINING ATTORNEY

CLASS 25—(Continued).

SN 77-648,345. YATES, JAMIE R., TALLMADGE, OH. FILED 1-13-2009.



THE MARK CONSISTS OF THE STYLIZED DESIGN OF A PIECE OF CANDY CONTAINING THE STYLIZED WORD "DULCE".

THE ENGLISH TRANSLATION OF "DULCE" IN THE MARK IS SWEET.

FOR CLOTHING, NAMELY, T-SHIRTS, PANTS, SHIRTS, TANK TOPS, SWEATSHIRTS, SWEATPANTS, HEADWEAR, NAMELY, HATS AND CAPS, AND ROBES (U.S. CLS. 22 AND 39).

FIRST USE 12-12-2008; IN COMMERCE 1-1-2009. JEFFERY COWARD, EXAMINING ATTORNEY

SN 77-648,369. YATES, JAMIE R., TALLMADGE, OH. FILED 1-13-2009.

A Que Te Gusta

THE MARK CONSISTS OF STANDARD CHARACTERS WITHOUT CLAIM TO ANY PARTICULAR FONT, STYLE, SIZE, OR COLOR.

THE ENGLISH TRANSLATION OF "A QUE TE GUSTA" IN THE MARK IS TO WHAT DO YOU WANT.

FOR CLOTHING, NAMELY, T-SHIRTS, PANTS, SHIRTS, TANK TOPS, SWEATSHIRTS, SWEATPANTS, HEADWEAR, NAMELY, HATS AND CAPS, AND ROBES (U.S. CLS. 22 AND 39).

FIRST USE 12-12-2008; IN COMMERCE 1-1-2009. JEFFERY COWARD, EXAMINING ATTORNEY

SN 77-647,246. MAXFIELD, CLAYTON W., CHICAGO, IL. FILED 1-11-2009.

NEW BLOOD FIGHT GEAR

THE MARK CONSISTS OF STANDARD CHARACTERS WITHOUT CLAIM TO ANY PARTICULAR FONT, STYLE, SIZE, OR COLOR.

NO CLAIM IS MADE TO THE EXCLUSIVE RIGHT TO USE "FIGHT GEAR", APART FROM THE MARK AS SHOWN.

FOR CLOTHING, NAMELY, SHIRTS, PANTS, SHORTS, UNDERWEAR, SOCKS, SCARVES, HEADWEAR, FOOTWEAR, DRESSES, TANK TOPS, SKIRTS, BLOUSES, SWEATSHIRTS, T-SHIRTS, SLEEPWEAR, SWIMWEAR, BELTS FOR CLOTHING, BOXER SHORTS, GLOVES, SWEAT BANDS; OUTERWEAR, NAMELY, JACKETS, CAPES, CLOAKS, COATS AND PULLOVERS (U.S. CLS. 22 AND 39).

TAMARA FRAZIER, EXAMINING ATTORNEY

SN 77-649,539. THE NORTH FACE APPAREL CORP, WILMINGTON, DE. FILED 1-14-2009.



THE MARK CONSISTS OF THREE CURVED BANDS. FOR FOOTWEAR (U.S. CLS. 22 AND 39). DAVON HATCHETT, EXAMINING ATTORNEY

CLASS 25—(Continued).

SN 77-649,860. METAFOR ENTERPRISES, MERRIFIELD, VA. FILED 1-14-2009.



OWNER OF U.S. REG. NO. 3,522,055.
 THE MARK CONSISTS OF RECTANGLE DESIGN SURROUNDING THE WORDINGS "METAFÖR MASTERING OUR EXIXTENCE." THE LETTER "O" IN "METAFÖR" HAS A LATIN DIERESIS OVER THE TOP, THE LETTER "R" IS BACKWARDS. THE WORDING "METAFÖR" IS MIRRORRED OVER THE TOP OF "MASTERING OUR EXIXTENCE."

FOR A-SHIRTS; ATHLETIC APPAREL, NAMELY, SHIRTS, PANTS, JACKETS, FOOTWEAR, HATS AND CAPS, ATHLETIC UNIFORMS; BELTS; CAPRI PANTS; CAPS; CARGO PANTS; DENIM JACKETS; DENIMS; DRESS SHIRTS; GOLF PANTS, SHIRTS AND SKIRTS; GOLF SHIRTS; HATS; HOODED SWEAT SHIRTS; HOODS; JEANS; JERSEYS; LEATHER BELTS; LONG-SLEEVED SHIRTS; PANTS; PIQUE SHIRTS; POLO SHIRTS; SHIRTS; SHORT SETS; SHORT-SLEEVED OR LONG-SLEEVED T-SHIRTS; SHORTS; SWEAT PANTS; SWEAT SHIRTS; SWEAT SHORTS; T-SHIRTS; TOPS; WIND SHIRTS (U.S. CLS. 22 AND 39).

FIRST USE 4-29-2008; IN COMMERCE 7-2-2008.
 DAWN HAN, EXAMINING ATTORNEY

CLASS 25—(Continued).

SN 77-654,814. BEDENBAUGH, AARON C, BRISTOL, CT. FILED 1-22-2009.

the 1 tee

THE MARK CONSISTS OF STANDARD CHARACTERS WITHOUT CLAIM TO ANY PARTICULAR FONT, STYLE, SIZE, OR COLOR.

NO CLAIM IS MADE TO THE EXCLUSIVE RIGHT TO USE "TEE", APART FROM THE MARK AS SHOWN.

FOR WEARABLE GARMENTS AND CLOTHING, NAMELY, SHIRTS (U.S. CLS. 22 AND 39).

FIRST USE 1-1-2009; IN COMMERCE 1-1-2009.
 ERIN FALK, EXAMINING ATTORNEY

SN 77-653,787. BENJAMIN, ANDRÉ, LOS ANGELES, CA. FILED 1-21-2009.

ANDRE 3000



THE MARK CONSISTS OF STANDARD CHARACTERS WITHOUT CLAIM TO ANY PARTICULAR FONT, STYLE, SIZE, OR COLOR.

FOR CLOTHING, NAMELY, TOPS, BOTTOMS, HEADWEAR, FOOTWEAR, SLEEPWEAR, UNDERWEAR, UNDERGARMENTS, BEACH WEAR, SWIM WEAR, JUMPERS, SWEATERS, PULLOVERS, SINGLETS, WRISTBANDS, BELTS (U.S. CLS. 22 AND 39).

CURTIS FRENCH, EXAMINING ATTORNEY

THE MARK CONSISTS OF THE STYLIZED LETTERS "P" AND "R" OVER A LAUREL WREATH WITH A STAR SYMBOL DISPLAYED IN THE LETTER "R".

FOR FOOTWEAR (U.S. CLS. 22 AND 39).
 FIRST USE 5-31-2006; IN COMMERCE 5-31-2006.
 RONALD AIKENS, EXAMINING ATTORNEY

CLASS 25—(Continued).

SN 77-656,158. HARVEY BALL SMILE LIMITED, SHINAGAWA-KU TOKYO, JAPAN, FILED 1-26-2009.



OWNER OF U.S. REG. NOS. 3,242,722, 3,502,405 AND 3,502,982.

THE MARK CONSISTS OF A CIRCULAR FACE WITH ELONGATED OVALS FOR EYES AND A CURVED LINE WITH ROUNDED ENDS THAT CURVE UPWARD TO FORM A SYMMETRICAL SMILE, SURROUNDED BY A SIMPLE CIRCLE, ALL LINES OF WHICH HAVE THE SAME WIDTH.

FOR CAPS; COATS; FOOTWEAR; GLOVES; HATS; NECKTIES; PAJAMAS; PANTS; SCARVES; SHIRTS; SHORTS; SKIRTS; SOCKS AND STOCKINGS; SWEATERS; SWIMSUITS; T-SHIRTS; TROUSERS; UNDERWEAR (U.S. CLS. 22 AND 39).

EDWARD FENNESSY, EXAMINING ATTORNEY

CLASS 25—(Continued).

SN 77-656,167. HARVEY BALL SMILE LIMITED, SHINAGAWA-KU TOKYO, JAPAN, FILED 1-26-2009.



OWNER OF U.S. REG. NOS. 3,242,722, 3,502,405 AND 3,502,982.

THE MARK CONSISTS OF A CIRCULAR FACE WITH KIDNEY BEAN SHAPED EYES WITH INDENTATIONS ON THE LEFT SIDE OF BOTH, BELOW THE LEFT EYE IS AN OVAL SHAPED TEARDROP, BELOW WHICH APPEARS A SYMMETRICAL SMILE IN A SINGLE THICK LINE WHICH HAS PERPENDICULAR END LINES, ALL SURROUNDED BY A SIMPLE CIRCLE.

FOR CAPS; COATS; FOOTWEAR; GLOVES; HATS; NECKTIES; PAJAMAS; PANTS; SCARVES; SHIRTS; SHORTS; SKIRTS; SOCKS AND STOCKINGS; SWEATERS; SWIMSUITS; T-SHIRTS; TROUSERS; UNDERWEAR (U.S. CLS. 22 AND 39).

EDWARD FENNESSY, EXAMINING ATTORNEY

SN 77-656,159. HARVEY BALL SMILE LIMITED, SHINAGAWA-KU TOKYO, JAPAN, FILED 1-26-2009.

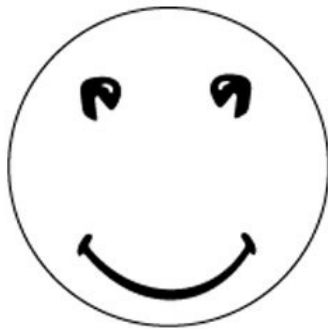

OWNER OF U.S. REG. NOS. 3,242,722, 3,502,405 AND 3,502,982.

THE MARK CONSISTS OF A CIRCULAR FACE WITH ROUNDED V-SHAPED EYES INVERTED TO POINT TOWARD THE NOSE AREA, WITH PERPENDICULAR END LINES WHICH CURVE UPWARD TO FORM A SYMMETRICAL SMILE, SURROUNDED BY A SIMPLE CIRCLE.

FOR CAPS; COATS; FOOTWEAR; GLOVES; HATS; NECKTIES; PAJAMAS; PANTS; SCARVES; SHIRTS; SHORTS; SKIRTS; SOCKS AND STOCKINGS; SWEATERS; SWIMSUITS; T-SHIRTS; TROUSERS; UNDERWEAR (U.S. CLS. 22 AND 39).

EDWARD FENNESSY, EXAMINING ATTORNEY

SN 77-656,168. HARVEY BALL SMILE LIMITED, SHINAGAWA-KU TOKYO, JAPAN, FILED 1-26-2009.



OWNER OF U.S. REG. NOS. 3,242,722, 3,502,405 AND 3,502,982.

THE MARK CONSISTS OF A CIRCULAR FACE WITH A THICK UPPERCASE LETTER "S" FOR A RIGHT EYE AND THICK UPPERCASE LETTER "F" FOR THE LEFT EYE, BELOW WHICH APPEARS AN ASYMMETRICAL SMILE WITH PERPENDICULAR END LINES AND A TONGUE THAT PROTRUDES UPWARD TOWARD THE SPACE BETWEEN THE EYES, ALL SURROUNDED BY A SIMPLE CIRCLE.

FOR CAPS; COATS; FOOTWEAR; GLOVES; HATS; NECKTIES; PAJAMAS; PANTS; SCARVES; SHIRTS; SHORTS; SKIRTS; SOCKS AND STOCKINGS; SWEATERS; SWIMSUITS; T-SHIRTS; TROUSERS; UNDERWEAR (U.S. CLS. 22 AND 39).

EDWARD FENNESSY, EXAMINING ATTORNEY

CLASS 25—(Continued).

SN 77-656,170. HARVEY BALL SMILE LIMITED, SHINAGAWA-KU TOKYO, JAPAN, FILED 1-26-2009.



OWNER OF U.S. REG. NO. 3,242,722.
 THE MARK CONSISTS OF A DISTORTED SMILEY FACE WITH AN ASYMMETRICAL "X" FORMING THE RIGHT AND LEFT EYE AND AN ASYMMETRICAL SMILE WITH THREE LINES EXTENDING BELOW THE SMILE.
 FOR CAPS; COATS; FOOTWEAR; GLOVES; HATS; NECKTIES; PAJAMAS; PANTS; SCARVES; SHIRTS; SHORTS; SKIRTS; SOCKS AND STOCKINGS; SWEATERS; SWIMSUITS; T-SHIRTS; TROUSERS; UNDERWEAR (U.S. CLS. 22 AND 39).
 B. PARADEWELAI, EXAMINING ATTORNEY

CLASS 25—(Continued).

SN 77-656,172. HARVEY BALL SMILE LIMITED, SHINAGAWA-KU TOKYO, JAPAN, FILED 1-26-2009.



OWNER OF U.S. REG. NO. 3,242,722.
 THE MARK CONSISTS OF A SMILEY FACE WITH A TONGUE AND A STAR FOR A LEFT EYE AND RIGHT EYE.
 FOR CAPS; COATS; FOOTWEAR; GLOVES; HATS; NECKTIES; PAJAMAS; PANTS; SCARVES; SHIRTS; SHORTS; SKIRTS; SOCKS AND STOCKINGS; SWEATERS; SWIMSUITS; T-SHIRTS; TROUSERS; UNDERWEAR (U.S. CLS. 22 AND 39).
 B. PARADEWELAI, EXAMINING ATTORNEY

SN 77-656,171. HARVEY BALL SMILE LIMITED, SHINAGAWA-KU TOKYO, JAPAN, FILED 1-26-2009.

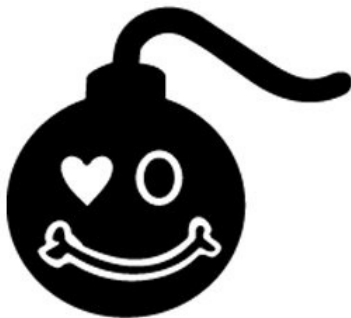

OWNER OF U.S. REG. NO. 3,242,722.
 THE MARK CONSISTS OF A SMILEY FACE IN THE SHAPE OF A BOMB WITH A HEART FOR A LEFT EYE AND ELONGATED OVAL FOR A RIGHT EYE.
 FOR CAPS; COATS; FOOTWEAR; GLOVES; HATS; NECKTIES; PAJAMAS; PANTS; SCARVES; SHIRTS; SHORTS; SKIRTS; SOCKS AND STOCKINGS; SWEATERS; SWIMSUITS; T-SHIRTS; TROUSERS; UNDERWEAR (U.S. CLS. 22 AND 39).
 B. PARADEWELAI, EXAMINING ATTORNEY

SN 77-656,173. HARVEY BALL SMILE LIMITED, SHINAGAWA-KU TOKYO, JAPAN, FILED 1-26-2009.



OWNER OF U.S. REG. NO. 3,242,722.
 THE MARK CONSISTS OF AN OPEN MOUTH SMILEY FACE WITH OVAL SHAPED EYES.
 FOR CAPS; COATS; FOOTWEAR; GLOVES; HATS; NECKTIES; PAJAMAS; PANTS; SCARVES; SHIRTS; SHORTS; SKIRTS; SOCKS AND STOCKINGS; SWEATERS; SWIMSUITS; T-SHIRTS; TROUSERS; UNDERWEAR (U.S. CLS. 22 AND 39).
 B. PARADEWELAI, EXAMINING ATTORNEY

CLASS 25—(Continued).

SN 77-656,175. HARVEY BALL SMILE LIMITED, SHINAGAWA-KU TOKYO, JAPAN, FILED 1-26-2009.



OWNER OF U.S. REG. NO. 3,242,722.
THE MARK CONSISTS OF A GRINNING SMILEY FACE WITH A HEART FOR A LEFT EYE AND RIGHT EYE.
FOR CAPS; COATS; FOOTWEAR; GLOVES; HATS; NECKTIES; PAJAMAS; PANTS; SCARVES; SHIRTS; SHORTS; SKIRTS; SOCKS AND STOCKINGS; SWEATERS; SWIMSUITS; T-SHIRTS; TROUSERS; UNDERWEAR (U.S. CLS. 22 AND 39).
B. PARADEWELAI, EXAMINING ATTORNEY

CLASS 25—(Continued).

SN 77-656,178. HARVEY BALL SMILE LIMITED, SHINAGAWA-KU TOKYO, JAPAN, FILED 1-26-2009.



OWNER OF U.S. REG. NO. 3,242,722.
THE MARK CONSISTS OF A SMILEY FACE WITH HEART SHAPED GLASSES.
FOR CAPS; COATS; FOOTWEAR; GLOVES; HATS; NECKTIES; PAJAMAS; PANTS; SCARVES; SHIRTS; SHORTS; SKIRTS; SOCKS AND STOCKINGS; SWEATERS; SWIMSUITS; T-SHIRTS; TROUSERS; UNDERWEAR (U.S. CLS. 22 AND 39).
B. PARADEWELAI, EXAMINING ATTORNEY

SN 77-656,176. HARVEY BALL SMILE LIMITED, SHINAGAWA-KU TOKYO, JAPAN, FILED 1-26-2009.



OWNER OF U.S. REG. NO. 3,242,722.
THE MARK CONSISTS OF A SMILEY FACE WITH ELONGATED OVAL SHAPED EYES AND A TONGUE.
FOR CAPS; COATS; FOOTWEAR; GLOVES; HATS; NECKTIES; PAJAMAS; PANTS; SCARVES; SHIRTS; SHORTS; SKIRTS; SOCKS AND STOCKINGS; SWEATERS; SWIMSUITS; T-SHIRTS; TROUSERS; UNDERWEAR (U.S. CLS. 22 AND 39).
B. PARADEWELAI, EXAMINING ATTORNEY

SN 77-657,003. HARVEY BALL SMILE LIMITED, SHINAGAWA-KU TOKYO, JAPAN, FILED 1-26-2009.



OWNER OF U.S. REG. NOS. 3,242,722, 3,502,405 AND 3,502,982.
THE MARK CONSISTS OF A CIRCULAR FACE WITH AN ELONGATED OVAL FOR A RIGHT EYE, WITH THREE ASYMMETRICAL EYELASHES, AND WITH A SYMMETRICAL HEART FOR A LEFT EYE, BELOW WHICH APPEARS A ASYMMETRICAL SMILE WITH FIVE LINES EXTENDING BELOW THE SMILE, ALL SURROUNDED BY A SIMPLE CIRCLE.
FOR CAPS; COATS; FOOTWEAR; GLOVES; HATS; NECKTIES; PAJAMAS; PANTS; SCARVES; SHIRTS; SHORTS; SKIRTS; SOCKS AND STOCKINGS; SWEATERS; SWIMSUITS; T-SHIRTS; TROUSERS; UNDERWEAR (U.S. CLS. 22 AND 39).
EDWARD FENNESSY, EXAMINING ATTORNEY

CLASS 25—(Continued).

SN 77-657,043. HARVEY BALL SMILE LIMITED, SHINAGAWA-KU TOKYO, JAPAN, FILED 1-26-2009.



OWNER OF U.S. REG. NO. 3,242,722.
THE MARK CONSISTS OF A GRINNING SMILEY FACE WITH ROUND SHAPED EYES.
FOR CAPS; COATS; FOOTWEAR; GLOVES; HATS; NECKTIES; PAJAMAS; PANTS; SCARVES; SHIRTS; SHORTS; SKIRTS; SOCKS AND STOCKINGS; SWEATERS; SWIMSUITS; T-SHIRTS; TROUSERS; UNDERWEAR (U.S. CLS. 22 AND 39).
B. PARADEWELAI, EXAMINING ATTORNEY

SN 77-657,050. OSBORNE, HOWARD, HICKORY, NC. FILED 1-26-2009.



NO CLAIM IS MADE TO THE EXCLUSIVE RIGHT TO USE "PLAYWEAR", APART FROM THE MARK AS SHOWN.
THE MARK CONSISTS OF THE STYLIZED TEXT "HLO PLAYWEAR" WITH A SMILEY FACE BELOW.
FOR BEACHWEAR; INFANT AND TODDLER ONE PIECE CLOTHING; JACKETS; PANTS; SHIRTS; SHOES; SHORTS; SOCKS; SWEAT SHIRTS; UNDERGARMENTS; WRISTBANDS (U.S. CLS. 22 AND 39).
FIRST USE 3-1-2008; IN COMMERCE 3-15-2008.
JESSICA FATHY, EXAMINING ATTORNEY

CLASS 25—(Continued).

SN 77-657,953. STRAVINSKY, TARA C, DBA TYESBYTARA, DENVER, CO. FILED 1-27-2009.

Get Tyed

THE MARK CONSISTS OF STANDARD CHARACTERS WITHOUT CLAIM TO ANY PARTICULAR FONT, STYLE, SIZE, OR COLOR.
FOR NECKTIES, BOW TIES AND WRIST CUFFS (U.S. CLS. 22 AND 39).
FIRST USE 10-1-2008; IN COMMERCE 10-1-2008.
MARK SPARACINO, EXAMINING ATTORNEY

SN 77-657,999. KAPOI, KEA, WAILUKU, HI. FILED 1-28-2009.



THE MARK CONSISTS OF THE LETTER "C" WITH INVERTED LETTER "C" THAT ARE INTERLOCKED.
FOR ATHLETIC APPAREL, NAMELY, SHIRTS, PANTS, JACKETS, FOOTWEAR, HATS AND CAPS, ATHLETIC UNIFORMS; BEANIES; BOARD SHORTS; CARGO PANTS; CLOTHING FOR WEAR IN WRESTLING GAMES; DENIMS; FLEECE SHORTS; FOOTWEAR NOT FOR SPORTS; GYM SHORTS; HEADWEAR; LEATHER BELTS; PANTIES, SHORTS AND BRIEFS; PANTS; SHIRT YOKES; SHIRTS; SHORT-SLEEVED OR LONG-SLEEVED T-SHIRTS; SHORT-SLEEVED SHIRTS; SHORTS; SKIRTS AND DRESSES; SNOW PANTS; SNOWBOARD PANTS; SPORT SHIRTS; SPORTS PANTS; SPORTS SHIRTS; SPORTS SHIRTS WITH SHORT SLEEVES; SWEAT SHIRTS; SWEAT SHORTS; T-SHIRTS; TEE SHIRTS; TRACK PANTS; TRAVEL CLOTHING CONTAINED IN A PACKAGE COMPRISING REVERSIBLE JACKETS, PANTS, SKIRTS, TOPS AND A BELT OR SCARF; UNDERWEAR, NAMELY, BOY SHORTS; WALKING SHORTS; WEARABLE GARMENTS AND CLOTHING, NAMELY, SHIRTS; WIND PANTS (U.S. CLS. 22 AND 39).
RAUL CORDOVA, EXAMINING ATTORNEY

CLASS 25—(Continued).

SN 77-658,086. KADOUCH,VERONIQUE, GOLDEN BEACH, FL. FILED 1-28-2009.

CLASS 25—(Continued).

SN 77-659,499. BEAUTIFUL BUTTERFLY LLC, ROSEVILLE, CA. FILED 1-29-2009.



Revela Tu ADN

THE MARK CONSISTS OF STANDARD CHARACTERS WITHOUT CLAIM TO ANY PARTICULAR FONT, STYLE, SIZE, OR COLOR.

THE ENGLISH TRANSLATION OF "REVELA TU ADN" IS "REVEAL YOUR DNA".

FOR BEACH WEAR, NAMELY, BATHING SUITS; CLOTHING, NAMELY, BLOUSES, SHORTS, DRESSES, JACKETS, JEANS, KNIT SHIRTS, KNIT TOPS, SKIRTS, SWEAT SHIRTS, SWIM WEAR, TANK TOPS, JOGGING OUTFITS, CAPS, SHORT SLEEVED OR LONG SLEEVED T-SHIRTS, JERSEYS, DENIM JACKETS, PANTS, SHIRTS, SURF WEAR, GYM SUITS, BEACH SHOES (U.S. CLS. 22 AND 39).

MARTHA FROMM, EXAMINING ATTORNEY

NO CLAIM IS MADE TO THE EXCLUSIVE RIGHT TO USE "LLC", APART FROM THE MARK AS SHOWN.

THE COLOR(S) FUCHSIA, LIGHT PINK, WHITE, ORANGE, YELLOW, GREEN AND BLUE IS/ARE CLAIMED AS A FEATURE OF THE MARK.

THE MARK CONSISTS OF THE WORDING "BEAUTIFUL BUTTERFLY" IN FUCHSIA AND "LLC" IN BLUE. BETWEEN "BEAUTIFUL" AND "BUTTERFLY", THERE IS A BLUE OVAL WITH LIGHT PINK AND WHITE VERTICAL STRIPES INSIDE. THERE IS A BUTTERFLY ALSO INSIDE THE OVAL WITH A BLUE BODY AND ANTENNAE, WINGS CONTAINING FUCHSIA AT THE TOP, THEN ORANGE IN THE MIDDLE, A BIT OF BLUE, THEN YELLOW, AND GREEN AT THE BOTTOM, AND OUTLINED IN BLUE.

FOR ATHLETIC APPAREL, NAMELY, SHIRTS, PANTS, JACKETS, FOOTWEAR, HATS AND CAPS, ATHLETIC UNIFORMS; BODY SHIRTS; BOXING SHOES; BUTTON-FRONT ALOHA SHIRTS; CAMP SHIRTS; CANVAS SHOES; CHEF'S HATS; CLEATS FOR ATTACHMENT TO SPORTS SHOES; CLOTHING FOR ATHLETIC USE, NAMELY, PADDED SHIRTS; CYCLING SHOES; DANCE SHOES; DECK-SHOES; DRESS SHIRTS; DRIVERS; FITTED SHOE OR BOOT COVERING TO PROTECT THE SHOES OR BOOT FROM WATER OR OTHER DAMAGE; FOOTBALL SHOES; FUR HATS; GOLF PANTS, SHIRTS AND SKIRTS; GOLF SHIRTS; GOLF SHOES; GYMNASTIC SHOES; HANDBALL SHOES; HAT BANDS; HATS; HEEL PIECES FOR SHOES; HOCKEY SHOES; HOODED SWEAT SHIRTS; INFANTS' SHOES AND BOOTS; INSOLES; KNIT SHIRTS; LEATHER SHOES; LEISURE SHOES; LONG-SLEEVED SHIRTS; MOISTURE-WICKING SPORTS SHIRTS; NIGHT SHIRTS; OPEN-NECKED SHIRTS; PIQUE SHIRTS; POLO SHIRTS; RUGBY SHIRTS (U.S. CLS. 22 AND 39).

TOBY BULLOFF, EXAMINING ATTORNEY

CLASS 25—(Continued).

SN 77-659,872. KOLBO, AMOS, BISMARCK, ND. FILED 1-30-2009.

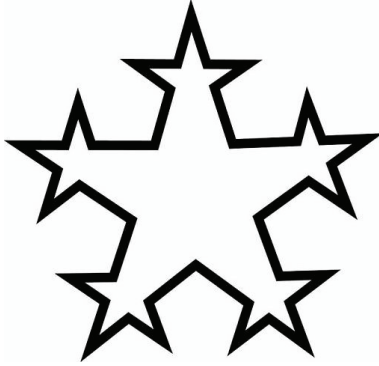

THE MARK CONSISTS OF THE OUTLINE OF A FIVE POINTED STAR WITH THREE ADDITIONAL POINTS ON EACH POINT.

FOR SHIRTS; PANTS; JEANS; HATS; CAPS; GLOVES; JACKETS; WINTER JACKETS; SNOW PANTS; SCARVES; BANDANAS; SHOES; SOCKS; BOARDSHORTS; BELTS (U.S. CLS. 22 AND 39).

FIRST USE 3-1-1998; IN COMMERCE 3-1-1998.
G. MAYERSCHOFF, EXAMINING ATTORNEY

SN 77-661,198. MITCHELL, GERALD B., LAWRENCEVILLE, GA. FILED 2-2-2009.



THE MARK CONSISTS OF THE WORD "MY" AND STYLIZED LETTERS "ODC".

FOR ATHLETIC APPAREL, NAMELY, SHIRTS, PANTS, JACKETS, FOOTWEAR, HATS AND CAPS, ATHLETIC UNIFORMS (U.S. CLS. 22 AND 39).

DAVID YONTEF, EXAMINING ATTORNEY

CLASS 25—(Continued).

SN 77-661,719. SEFARAD GROUP LLC, NEW YORK, NY. FILED 2-2-2009.

SPENGLISH

THE MARK CONSISTS OF STANDARD CHARACTERS WITHOUT CLAIM TO ANY PARTICULAR FONT, STYLE, SIZE, OR COLOR.

FOR MEN'S SHIRTS, WOMEN'S TOPS, HATS FOR MEN AND WOMEN (U.S. CLS. 22 AND 39).

SANDRA MANIOS, EXAMINING ATTORNEY

SN 77-662,069. LIEGEY, CATHARINE, NEW YORK, NY. FILED 2-3-2009.

Twig & Feather

THE MARK CONSISTS OF STANDARD CHARACTERS WITHOUT CLAIM TO ANY PARTICULAR FONT, STYLE, SIZE, OR COLOR.

FOR SHAPEWEAR, NAMELY, GIRDLES AND BRAS (U.S. CLS. 22 AND 39).

KAREN K. BUSH, EXAMINING ATTORNEY

SN 77-662,214. 241 SPORTS HOLDINGS INTERNATIONAL, LLC, NEWHALL, CA. FILED 2-3-2009.

SHOTMASTER

THE MARK CONSISTS OF STANDARD CHARACTERS WITHOUT CLAIM TO ANY PARTICULAR FONT, STYLE, SIZE, OR COLOR.

FOR ATHLETIC SHOES; BASEBALL CAPS; BASKETBALL SNEAKERS; BRIEFS; COATS; GOLF CAPS; GYM SHORTS; HATS; HEADBANDS; HIKING BOOTS; JACKETS; JERSEYS; POLO SHIRTS; RUNNING SHOES; SHOES; SHORTS; SKULL CAPS; SLEEVELESS JERSEYS; SOCKS; SPORTS BRAS; SWEAT PANTS; SWEAT SHIRTS; T-SHIRTS; TENNIS SHOES; TRUNKS; UNDERWEAR; WRISTBANDS (U.S. CLS. 22 AND 39).

MARTHA FROMM, EXAMINING ATTORNEY

CLASS 25—(Continued).

SN 77-662,827. EQ & I, LOS ANGELES, CA. FILED 2-4-2009.

BODY POLICY

THE MARK CONSISTS OF STANDARD CHARACTERS WITHOUT CLAIM TO ANY PARTICULAR FONT, STYLE, SIZE, OR COLOR.

FOR CLOTHING, NAMELY, SHIRTS, T-SHIRTS, DRESSES, SKIRTS, PANTS, JACKETS, BLAZERS, COATS, SHORTS, SWEATERS, UNDERWEAR, AND STOCKINGS (U.S. CLS. 22 AND 39).

ROBIN MITTLER, EXAMINING ATTORNEY

SN 77-662,912. DIBA IMPORTS, L.P., EARTH CITY, MO. FILED 2-4-2009.

diba lol

OWNER OF U.S. REG. NOS. 1,701,917, 2,624,043 AND OTHERS.

THE MARK CONSISTS OF A SMALL SCRIPT FONT OF "DIBA LOL" WITH A FACE IN THE LETTER "O" OF "LOL". FOR FOOTWEAR (U.S. CLS. 22 AND 39).

JACLYN KIDWELL, EXAMINING ATTORNEY

SN 77-662,942. FIELD, PATRICIA, NEW YORK, NY. FILED 2-4-2009.

DESTINATION STYLE

THE MARK CONSISTS OF STANDARD CHARACTERS WITHOUT CLAIM TO ANY PARTICULAR FONT, STYLE, SIZE, OR COLOR.

NO CLAIM IS MADE TO THE EXCLUSIVE RIGHT TO USE "STYLE", APART FROM THE MARK AS SHOWN.

FOR CLOTHING, NAMELY, SHIRTS, PANTS, UNDERWEAR, BRAS, JACKETS, SHORTS, TANK TOPS, SWEAT SHIRTS, SWEAT PANTS, SKIRT, SOCKS AND FOOTWEAR (U.S. CLS. 22 AND 39).

FIRST USE 9-25-2008; IN COMMERCE 9-25-2008.

SANJEEV VOHRA, EXAMINING ATTORNEY

CLASS 25—(Continued).

SN 77-663,001. CHENAULT CLOTHING INC., LOS ANGELES, CA. FILED 2-4-2009.

CHENAULT

THE MARK CONSISTS OF STANDARD CHARACTERS WITHOUT CLAIM TO ANY PARTICULAR FONT, STYLE, SIZE, OR COLOR.

SEC. 2(F).

FOR CLOTHING, NAMELY, BLAZERS; BLOUSES; BLOUSONS; BOLEROS; BOTTOMS; CAMISOLES; CAMP SHIRTS; CAPRI PANTS; CAPRIS; CARDIGANS; CARGO PANTS; COATS; COATS MADE OF COTTON; COATS OF DENIM; COVERALLS; CROP TOPS; DENIM JACKETS; DENIMS; DRESSES; DUSTERS; JACKETS; JEANS; JUMPERS; JUMPSUITS; LADIES' SUITS; LONG JACKETS; LONG SLEEVED VESTS; MEN AND WOMEN JACKETS, COATS, TROUSERS, VESTS; MINISKIRTS; MOCK TURTLE-NECK SWEATERS; PANTS; PANTSUITS; PEDAL PUSHERS; PULLOVERS; SARONGS; SHAWLS AND STOLE; SHIFTS; SHIRTS; SHIRTS FOR SUITS; SHORT SETS; SHORT TROUSERS; SHORT-SLEEVED OR LONG-SLEEVED T-SHIRTS; SHORT-SLEEVED SHIRTS; SHORTALLS; SHORTS; SHRUGS; SLEEVED OR SLEEVELESS JACKETS; SLEEVELESS JERSEYS; SMOCKS; SMOKING JACKETS; SWEAT PANTS; SWEAT SHIRTS; SWEAT SUITS; SWEATERS; TANK TOPS; TANKINIS; TEDDIES; TROUSERS; TUNICS; TURTLENECK SWEATERS; TURTLENECKS; V-NECK SWEATERS; VESTS; WALKING SHORTS; YOGA PANTS; YOGA SHIRTS (U.S. CLS. 22 AND 39).

FIRST USE 1-15-2002; IN COMMERCE 6-30-2002.

SANJEEV VOHRA, EXAMINING ATTORNEY

SN 77-663,285. DAWSON, ANDREW C., OXFORD, MI. FILED 2-4-2009.

TIGHT TIGHT

THE MARK CONSISTS OF STANDARD CHARACTERS WITHOUT CLAIM TO ANY PARTICULAR FONT, STYLE, SIZE, OR COLOR.

FOR ATHLETIC APPAREL, NAMELY, SHIRTS, PANTS, JACKETS, FOOTWEAR, HATS AND CAPS, ATHLETIC UNIFORMS (U.S. CLS. 22 AND 39).

JEFFERY COWARD, EXAMINING ATTORNEY

CLASS 25—(Continued).

SN 77-663,381. MOSLEY-SMITH, TARA, CHICAGO, IL. FILED 2-4-2009.



NO CLAIM IS MADE TO THE EXCLUSIVE RIGHT TO USE "DESIGNING", APART FROM THE MARK AS SHOWN.

THE MARK CONSISTS OF THE OUTLINE OF A STYLIZED LETTER "D" SLANTED TO THE RIGHT ABOVE THE OUTLINE OF A STYLIZED LETTER "D" SLANTED TO THE LEFT. IN BOLD, ITALIC PRINT ON TOP OF THE UPPER LETTER "D" IS "DESIGNING". IN BOLD PRINT ON TOP OF THE LOWER LETTER "D" IS "DIFFERENT". IN THE MIDDLE IS A LARGE, BOLD PRINT NUMBER "2". IN SMALLER PRINT IS THE OUTLINE OF THE SYMBOL "&" THAT IS VISIBLE ON TOP OF THE LETTERS AND NUMBERS. NEXT TO THE SYMBOL IS THE WORD "BEYOND" IN BOLD, ITALIC PRINT.

FOR (BASED ON USE IN COMMERCE) CLOTHING, NAMELY, SHIRTS, T-SHIRTS, TUNICS, DRESS SHIRTS, HALTER TOPS, PONCHOS, STRAPLESS TOPS, SWEATERS, SHRUGS, CAPES, JACKETS, COATS, VESTS, BLAZERS, WRAPS, PULLOVERS, SNOW SUITS, CAPRI PANTS, DRESSES, GOWNS, SKIRTS, SCARVES, BELTS, TIES, NECKERCHIEFS; INFANT AND TODDLER CLOTHING, NAMELY, JACKETS, COATS, DRESSES, TOPS, PANTS.; (BASED ON INTENT TO USE) CLOTHING, NAMELY, TANK TOPS, SHORTS, PANTS, JEANS, SLACKS, TROUSERS, CARGO PANTS, OVERALLS, COVERALLS, JUMPERS, JUMPSUITS, HATS, GLOVES, MITTENS, SUSPENDERS, JOGGING SUITS, TRACK SUITS, SHORTS, SWIM WEAR, BOXERS, CORSETS, BUSTIERS, LEGWARMERS, SHOES, SANDALS, BOOTS, SNEAKERS, FOOTWEAR, FLIPFLOPS, SLIPPERS, GYM-SHOES, KNEE HIGHS, LEGWARMERS, BUSTIERS, CORSETS, LOUNGEWEAR, ROBES, VISORS, CAPS, BERETS (U.S. CLS. 22 AND 39).

FIRST USE 1-19-2009; IN COMMERCE 1-19-2009.
AMOS T. MATTHEWS, JR., EXAMINING ATTORNEY

CLASS 25—(Continued).

SN 77-663,498. RING OF FIRE, LLC, DBA KOLD TURKEY, LOS ANGELES, CA. FILED 2-4-2009.

Kold Turkey

THE MARK CONSISTS OF STANDARD CHARACTERS WITHOUT CLAIM TO ANY PARTICULAR FONT, STYLE, SIZE, OR COLOR.

FOR ATHLETIC SHOES; BEANIES; BLAZERS; CANVAS SHOES; CAPS; CARGO PANTS; DENIMS; DRESS SHIRTS; FLEECE PULLOVERS; HOODED SWEAT SHIRTS; HOODS; JACKETS; KNIT SHIRTS; LEATHER BELTS; LEATHER SHOES; LONG-SLEEVED SHIRTS; PIQUE SHIRTS; POLO SHIRTS; SHOES; SHORTS; SWEATERS; T-SHIRTS (U.S. CLS. 22 AND 39).

FIRST USE 1-11-2008; IN COMMERCE 1-11-2008.
ANDREW LEASER, EXAMINING ATTORNEY

SN 77-663,576. GARNER, LARRY, PALATKA, FL. FILED 2-4-2009.

onakwest

THE MARK CONSISTS OF STANDARD CHARACTERS WITHOUT CLAIM TO ANY PARTICULAR FONT, STYLE, SIZE, OR COLOR.

FOR HATS; SWEAT SHIRTS; T-SHIRTS (U.S. CLS. 22 AND 39).

NAKIA HENRY, EXAMINING ATTORNEY

SN 77-663,764. BEASLEY, STACEY W., CHESAPEAKE, VA. FILED 2-5-2009.

MYAPPARREL

THE MARK CONSISTS OF STANDARD CHARACTERS WITHOUT CLAIM TO ANY PARTICULAR FONT, STYLE, SIZE, OR COLOR.

FOR FABRIC SOLD AS AN INTEGRAL COMPONENT OF FINISHED CLOTHING ITEMS, NAMELY, T-SHIRTS, JERSEYS, JACKETS, SWEATERS, HATS (U.S. CLS. 22 AND 39).

JAMES STEIN, EXAMINING ATTORNEY

CLASS 25—(Continued).

SN 77-663,784. GOLDFIELD, KRISTINA, ODESSA, FL.
FILED 2-5-2009.

puretoes

THE MARK CONSISTS OF STANDARD CHARACTERS
WITHOUT CLAIM TO ANY PARTICULAR FONT, STYLE,
SIZE, OR COLOR.
FOR ATHLETIC FOOTWEAR (U.S. CLS. 22 AND 39).
RICHARD WHITE, EXAMINING ATTORNEY

SN 77-663,856. ALPHA SKY ASSOCIATES LTD., SINGA-
PORE, SINGAPORE, FILED 2-5-2009.

schubar

THE MARK CONSISTS OF STANDARD CHARACTERS
WITHOUT CLAIM TO ANY PARTICULAR FONT, STYLE,
SIZE, OR COLOR.

FOR CLOTHING FOR MEN, WOMEN, CHILDREN
AND INFANTS, NAMELY, BELTS, CAPS, TIES, TOPS;
READY MADE GARMENTS, NAMELY, SHIRTS, T-
SHIRTS, SWEATERS, JERSEYS, PULLOVERS, CARDI-
GANS, JUMPERS, JACKETS, VESTS, COATS, SUITS,
DRESSES, SKIRTS, BLOUSES, PANTS, JEANS; KNIT-
WEAR, NAMELY, KNIT SHIRTS, KNITTED CAPS,
KNITTED GLOVES; ATHLETIC APPAREL, NAMELY,
SHIRTS, PANTS, JACKETS, FOOTWEAR, HATS AND
CAPS, ATHLETIC UNIFORMS; GENTLEMEN'S, LA-
DIES' AND CHILDREN'S FOOTWEAR INCLUDING
SHOES, BOOTS, LEATHER SHOES, RUBBER SHOES,
VINYL SHOES, SPORTS SHOES, BEACH SHOES, SAN-
DALS AND SLIPPERS; SHOES FOR LEISUREWEAR;
SHOES OTHER THAN PROTECTIVE OR ORTHOPAEDIC
(U.S. CLS. 22 AND 39).
JAMES STEIN, EXAMINING ATTORNEY

SN 77-663,872. LUCKY BRAND DUNGAREES, INC., VER-
NON, CA. FILED 2-5-2009.

Generation L

THE MARK CONSISTS OF STANDARD CHARACTERS
WITHOUT CLAIM TO ANY PARTICULAR FONT, STYLE,
SIZE, OR COLOR.
FOR JEANS; SHIRTS; T-SHIRTS (U.S. CLS. 22 AND 39).
TRACY FLETCHER, EXAMINING ATTORNEY

CLASS 25—(Continued).

SN 77-663,911. DONOVAN E. WEBSTER, BAKERSFIELD,
CA. FILED 2-5-2009.

DO U MOTIVATIONAL WEAR

THE MARK CONSISTS OF STANDARD CHARACTERS
WITHOUT CLAIM TO ANY PARTICULAR FONT, STYLE,
SIZE, OR COLOR.

NO CLAIM IS MADE TO THE EXCLUSIVE RIGHT TO
USE "WEAR", APART FROM THE MARK AS SHOWN.
FOR HATS; SHORTS; SWEAT PANTS; SWEAT SHIRTS;
SWEAT SUITS; T-SHIRTS (U.S. CLS. 22 AND 39).
DEIRDRE ROBERTSON, EXAMINING ATTORNEY

SN 77-663,931. ROWELL, ALLEN, DBA SERVING LOVE,
INC., BROOKLYN, NY. FILED 2-5-2009.

Authennis

THE MARK CONSISTS OF STANDARD CHARACTERS
WITHOUT CLAIM TO ANY PARTICULAR FONT, STYLE,
SIZE, OR COLOR.

FOR ATHLETIC APPAREL, NAMELY, SHIRTS,
PANTS, JACKETS, FOOTWEAR, HATS AND CAPS,
ATHLETIC UNIFORMS (U.S. CLS. 22 AND 39).
SIMON TENG, EXAMINING ATTORNEY

SN 77-664,059. ALEX KARAYAN, LA CANADA, CA. FILED
2-5-2009.

ELMCOMPANY

THE MARK CONSISTS OF STANDARD CHARACTERS
WITHOUT CLAIM TO ANY PARTICULAR FONT, STYLE,
SIZE, OR COLOR.

FOR HEADWEAR, HATS, CAPS, BEANIES, SUN VI-
SORS, NECKWEAR, BANDANAS, SCARVES; SHIRTS, T-
SHIRTS, SWEATSHIRTS, SWEATERS, JACKETS, COATS
(U.S. CLS. 22 AND 39).
FIRST USE 12-31-2002; IN COMMERCE 12-31-2002.
BRENDAN REGAN, EXAMINING ATTORNEY

CLASS 25—(Continued).

SN 77-664,274. LAND N' SEA, NEW YORK, NY. FILED 2-5-2009.

FIT SENSATIONS

THE MARK CONSISTS OF STANDARD CHARACTERS WITHOUT CLAIM TO ANY PARTICULAR FONT, STYLE, SIZE, OR COLOR.

FOR BLOUSES; JACKETS; PANTS; SKIRTS AND DRESSES; SWEATERS (U.S. CLS. 22 AND 39).
COURTNEY MCCORMICK, EXAMINING ATTORNEY

SN 77-664,381. SEARS BRANDS, LLC, HOFFMAN ESTATES, IL. FILED 2-5-2009.

COUNTRY BOOTS

THE MARK CONSISTS OF STANDARD CHARACTERS WITHOUT CLAIM TO ANY PARTICULAR FONT, STYLE, SIZE, OR COLOR.

NO CLAIM IS MADE TO THE EXCLUSIVE RIGHT TO USE "BOOTS", APART FROM THE MARK AS SHOWN.

FOR FOOTWEAR (U.S. CLS. 22 AND 39).
GRETTA YAO, EXAMINING ATTORNEY

SN 77-664,429. GRUCCIO, WILLIAM M., VINELAND, NJ. FILED 2-5-2009.



NO CLAIM IS MADE TO THE EXCLUSIVE RIGHT TO USE "CLOTHING", APART FROM THE MARK AS SHOWN.

THE MARK CONSISTS OF THE WORD "LIMIT" SUPERIMPOSED OVER A MOUNTAIN RANGE WITH THE MOUNTAINS FORMING THE "M" IN "LIMIT" AND THE WORD "CLOTHING" BELOW THE MOUNTAINS.

FOR CAPS; HATS; JACKETS; PANTS; SHIRTS; SHORTS; SOCKS; T-SHIRTS (U.S. CLS. 22 AND 39).
ZACHARY BELLO, EXAMINING ATTORNEY

CLASS 25—(Continued).

SN 77-664,458. SEARS BRANDS, LLC, HOFFMAN ESTATES, IL. FILED 2-5-2009.

COBBIES

THE MARK CONSISTS OF STANDARD CHARACTERS WITHOUT CLAIM TO ANY PARTICULAR FONT, STYLE, SIZE, OR COLOR.

OWNER OF U.S. REG. NOS. 151,287 AND 1,168,509.
FOR FOOTWEAR (U.S. CLS. 22 AND 39).
GRETTA YAO, EXAMINING ATTORNEY

SN 77-664,477. THOMPSON, TED A., WOODINVILLE, WA. FILED 2-5-2009.

ONE LESS

THE MARK CONSISTS OF STANDARD CHARACTERS WITHOUT CLAIM TO ANY PARTICULAR FONT, STYLE, SIZE, OR COLOR.

FOR CLOTHING, NAMELY, SWEATSHIRTS; HOODED TOPS; T-SHIRTS; LONG SLEEVE SHIRTS; SHORT SLEEVE SHIRTS; TANK TOPS; POLO SHIRTS; BLAZERS; SPORT COATS; PANTS; JEANS; SKIRTS; SUITS; OVERALLS; DRESSES; VESTS; PARKAS; BIKINIS; OVERCOATS; ROBES; BELTS; BATHROBES; BASEBALL CAPS; STOCKING HATS; SHOES; BOOTS; SNEAKERS; BEACH SHOES (U.S. CLS. 22 AND 39).
REBECCA POVARCHUK, EXAMINING ATTORNEY

SN 77-664,586. CREATIVE IMPULSE ENTERTAINMENT, INC., NEW YORK, NY. FILED 2-5-2009.

JUSTICE FOR HIRE

THE MARK CONSISTS OF STANDARD CHARACTERS WITHOUT CLAIM TO ANY PARTICULAR FONT, STYLE, SIZE, OR COLOR.

FOR ATHLETIC APPAREL, NAMELY, SHIRTS, PANTS, JACKETS, FOOTWEAR, HATS AND CAPS, ATHLETIC UNIFORMS; COATS; FOOTWEAR; PANTS; SHIRTS; SOCKS; UNDERWEAR (U.S. CLS. 22 AND 39).
FIRST USE 8-1-2003; IN COMMERCE 9-1-2004.

TIMOTHY FINNEGAN, EXAMINING ATTORNEY

CLASS 25—(Continued).

SN 77-664,695. NORTH N' SOUTH, INC., NORTHBROOK, IL.
FILED 2-5-2009.

CLASS 25—(Continued).

SN 77-664,787. INGRASSIA, THOMAS, SADDLE RIVER, NJ.
FILED 2-6-2009.

RECOVERCAP



THE MARK CONSISTS OF STANDARD CHARACTERS WITHOUT CLAIM TO ANY PARTICULAR FONT, STYLE, SIZE, OR COLOR.
FOR HEADWEAR (U.S. CLS. 22 AND 39).
JORDAN BAKER, EXAMINING ATTORNEY

THE MARK CONSISTS OF THE NUMBERS "6012" SURROUNDED BY AN OVAL SHAPED CARRIER.
FOR MEN'S AND WOMEN'S CLOTHING, NAMELY, LONG SLEEVED AND SHORT SLEEVED SHIRTS, TANK TOPS, SWEATPANTS, TRACK JACKETS, WIND RESISTANT JACKETS, HOODED SWEATSHIRTS AND ZIPPERED HOODED SWEATSHIRTS; SHOES, NAMELY, SNEAKERS (U.S. CLS. 22 AND 39).
JULIE WATSON, EXAMINING ATTORNEY

SN 77-664,717. ZHEJIANG TONGYUN KNITTING CO., LTD., ZHUJI CITY, ZHEJIANG, CHINA, FILED 2-6-2009.

SN 77-664,794. INGRASSIA, THOMAS, SADDLE RIVER, NJ.
FILED 2-6-2009.



SIXTY-TWELVE

THE MARK CONSISTS OF A STYLIZED ABBREVIATION OF "TONG YUN" WITH WORD "TONGYUN".
THE WORDING "TONGYUN" HAS NO MEANING IN A FOREIGN LANGUAGE.
FOR CAPS; HOSIERY; JACKETS; KNIT SHIRTS; LAYETTES; NECKTIES; OVERALLS; SCARVES; SHIRTS; SHOES; SKIRTS; SOCKS AND STOCKINGS; STOCKINGS; T-SHIRTS; TROUSERS; UNDERWEAR; WAIST BELTS; WATERPROOF JACKETS AND PANTS (U.S. CLS. 22 AND 39).
FIRST USE 10-5-2005; IN COMMERCE 2-1-2007.
DORITT L. CARROLL, EXAMINING ATTORNEY

THE MARK CONSISTS OF STANDARD CHARACTERS WITHOUT CLAIM TO ANY PARTICULAR FONT, STYLE, SIZE, OR COLOR.
FOR MEN'S AND WOMEN'S CLOTHING, NAMELY, LONG SLEEVED AND SHORT SLEEVED SHIRTS, TANK TOPS, SWEATPANTS, TRACK JACKETS, WIND RESISTANT JACKETS, HOODED SWEATSHIRTS AND ZIPPERED HOODED SWEATSHIRTS; SHOES, NAMELY, SNEAKERS (U.S. CLS. 22 AND 39).
JULIE WATSON, EXAMINING ATTORNEY

CLASS 25—(Continued).

SN 77-664,873. LADI JAI FASHIONS, INC, TULSA, OK. FILED 2-6-2009.

WunderFhunk

THE MARK CONSISTS OF STANDARD CHARACTERS WITHOUT CLAIM TO ANY PARTICULAR FONT, STYLE, SIZE, OR COLOR.

FOR CLOTHING, NAMELY, T-SHIRTS, LONG SLEEVED SHIRTS, KNIT CAPS, BANDANAS, BOXERS, PANTIES, SWEAT SHIRTS, SWEAT PANTS, TANK TOPS, CAMISOLES, JACKETS, SCARVES, HATS, HEAD BANDS, PAJAMAS AND SLEEPWEAR (U.S. CLS. 22 AND 39).

DEZMONA MIZELLE, EXAMINING ATTORNEY

SN 77-664,883. LOFTISS, BRETT, EDMOND, OK. FILED 2-6-2009.



THE MARK CONSISTS OF THE STYLIZED TEXT "DUST BOWL TOUGH".

FOR CAPS; HATS; JACKETS; SWEAT SHIRTS; T-SHIRTS; TANK TOPS (U.S. CLS. 22 AND 39).

FIRST USE 6-2-2008; IN COMMERCE 6-14-2008.
DAVON HATCHETT, EXAMINING ATTORNEY

SN 77-664,948. SEARS BRANDS, LLC, HOFFMAN ESTATES, IL. FILED 2-6-2009.



NO CLAIM IS MADE TO THE EXCLUSIVE RIGHT TO USE "BOOTS", APART FROM THE MARK AS SHOWN.

THE MARK CONSISTS OF THE WORDS "COUNTRY BOOTS" UNDERNEATH A STYLIZED MOUNTAIN DESIGN.

FOR FOOTWEAR (U.S. CLS. 22 AND 39).
GRETTA YAO, EXAMINING ATTORNEY

CLASS 25—(Continued).

SN 77-664,957. BRAVADO INTERNATIONAL GROUP MERCHANDISING SERVICES, INC., NEW YORK, NY. FILED 2-6-2009.

TRANSMISSION

THE MARK CONSISTS OF STANDARD CHARACTERS WITHOUT CLAIM TO ANY PARTICULAR FONT, STYLE, SIZE, OR COLOR.

FOR T-SHIRTS, SHIRTS, SWEATSHIRTS, SWEAT-PANTS, SHORTS, HATS, CAPS, TIES, SOCKS, JACKETS, TANK TOPS, PANTS, SWEATERS AND VESTS (U.S. CLS. 22 AND 39).

MIDGE BUTLER, EXAMINING ATTORNEY

SN 77-665,027. STEWART, ANTHONY W., INDIANAPOLIS, IN. FILED 2-6-2009.

HEROES DRIVE US

THE MARK CONSISTS OF STANDARD CHARACTERS WITHOUT CLAIM TO ANY PARTICULAR FONT, STYLE, SIZE, OR COLOR.

FOR HATS; SHIRTS; SWEAT SHIRTS (U.S. CLS. 22 AND 39).

WON TEAK OH, EXAMINING ATTORNEY

SN 77-665,068. THE NOBODY-SOMEBODY COLLECTION, L.L.C., AKA NOBODY-SOMEBODY COLLECTION, SUWANEE, GA. FILED 2-6-2009.



THE MARK CONSISTS OF A CARTOON HEAD RESTING ON TWO SHOES.

FOR TEE SHIRTS AND TANK TOPS (U.S. CLS. 22 AND 39).

GEOFFREY FOSDICK, EXAMINING ATTORNEY

CLASS 25—(Continued).

SN 77-665,079. JASON IAN BERTRAM, SAN DIEGO, CA. FILED 2-6-2009.

RIDE RHINO

THE MARK CONSISTS OF STANDARD CHARACTERS WITHOUT CLAIM TO ANY PARTICULAR FONT, STYLE, SIZE, OR COLOR.

FOR CLOTHING FOR ATHLETIC USE, NAMELY, PADDED ELBOW COMPRESSION SLEEVES; CLOTHING, NAMELY, ARM WARMERS; CLOTHING, NAMELY, BASE LAYERS; CLOTHING, NAMELY, FOLK COSTUMES; CLOTHING, NAMELY, HAND-WARMERS; CLOTHING, NAMELY, KHAKIS; CLOTHING, NAMELY, KNEE WARMERS; CLOTHING, NAMELY, NECK TUBES; CLOTHING, NAMELY, THOBES; CLOTHING, NAMELY, WRAP-AROUNDS; HEAD WEAR; HEADGEAR, NAMELY, HATS, BEANIES, BANDANAS, SUN VISORS, BERETS, HOODS, AND TURBANS; HOODS; JERSEYS; LEATHER BELTS; MANTLES; MUFFLERS; PARTS OF CLOTHING, NAMELY, GUSSETS FOR TIGHTS, GUSSETS FOR STOCKINGS, GUSSETS FOR BATHING SUITS, GUSSETS FOR UNDERWEAR, GUSSETS FOR LEOTARDS AND GUSSETS FOR FOOTLETS; PARTS OF CLOTHING, NAMELY, UNDERARM GUSSETS; PARTY HATS; SHOULDER WRAPS; SKI WEAR; SURF WEAR; SWADDLING CLOTHES; SWIM WEAR; SWIM WEAR FOR GENTLEMEN AND LADIES; TENNIS WEAR; TIES; TOPS; TRAVEL CLOTHING CONTAINED IN A PACKAGE COMPRISING REVERSIBLE JACKETS, PANTS, SKIRTS, TOPS AND A BELT OR SCARF; TRIATHLON CLOTHING, NAMELY, TRIATHLON TIGHTS, TRIATHLON SHORTS, TRIATHLON SINGLET, TRIATHLON SHIRTS, TRIATHLON SUITS; UNDERARM CLOTHING SHIELDS; WEARABLE GARMENTS AND CLOTHING, NAMELY, SHIRTS (U.S. CLS. 22 AND 39).

LEIGH CAROLINE CASE, EXAMINING ATTORNEY

SN 77-665,134. PARISI FRANCHISE SYSTEMS, INC., WYCKOFF, NJ. FILED 2-6-2009.

SPEED KILLS

THE MARK CONSISTS OF STANDARD CHARACTERS WITHOUT CLAIM TO ANY PARTICULAR FONT, STYLE, SIZE, OR COLOR.

FOR BASEBALL CAPS; SHIRTS; SWEAT PANTS; SWEAT SHIRTS (U.S. CLS. 22 AND 39).

DAVID MURRAY, EXAMINING ATTORNEY

CLASS 25—(Continued).

SN 77-665,135. JASON IAN BERTRAM, SAN DIEGO, CA. FILED 2-6-2009.



THE MARK CONSISTS OF THE WORD 'RIDE' ON TOP OF A SPORTING VEHICLE, AND THE WORD 'RHINO' DIRECTLY BELOW THE VEHICLE.

FOR ATHLETIC APPAREL, NAMELY, SHIRTS, PANTS, JACKETS, FOOTWEAR, HATS AND CAPS, ATHLETIC UNIFORMS; ATHLETIC FOOTWEAR; BEACH FOOTWEAR; BELTS; BIBS NOT OF CLOTH OR PAPER; CAPS; CHILDREN'S AND INFANTS' CLOTH BIBS; CHILDREN'S CLOTH EATING BIBS; CLOTH BIBS; CLOTH BIBS FOR ADULT DINERS; CLOTHING FOR ATHLETIC USE, NAMELY, PADDED ELBOW COMPRESSION SLEEVES; CLOTHING FOR ATHLETIC USE, NAMELY, PADDED PANTS; CLOTHING FOR ATHLETIC USE, NAMELY, PADDED SHIRTS; CLOTHING FOR ATHLETIC USE, NAMELY, PADDED SHORTS; CLOTHING, NAMELY, ARM WARMERS; CLOTHING, NAMELY, BASE LAYERS; CLOTHING, NAMELY, FOLK COSTUMES; CLOTHING, NAMELY, HAND-WARMERS; CLOTHING, NAMELY, KHAKIS; CLOTHING, NAMELY, KNEE WARMERS; CLOTHING, NAMELY, NECK TUBES; CLOTHING, NAMELY, THOBES; CLOTHING, NAMELY, WRAP-AROUNDS; COATS FOR MEN AND WOMEN; EMBOSSED SOLES AND HEELS OF RUBBER OR OF PLASTIC MATERIALS; FOOTBALL BOOTS AND STUDS THEREFOR; FOOTWEAR; FOOTWEAR FOR MEN; FOOTWEAR FOR MEN AND WOMEN; FOOTWEAR FOR TRACK AND FIELD ATHLETICS; FOOTWEAR FOR WOMEN; FOOTWEAR MADE OF WOOD; FOOTWEAR NOT FOR SPORTS; FOOTWEAR, NAMELY, PUMPS; FOOTWEAR, NAMELY, RUBBERS; FOOTWEAR, NAMELY, WORK BOOTS; GOLF PANTS, SHIRTS AND SKIRTS; HALLOWEEN COSTUMES AND MASKS SOLD IN CONNECTION THEREWITH; HEADGEAR, NAMELY, HATS, BEANIES, BANDANAS, SUN VISORS, BERETS, HOODS, AND TURBANS, HOODS; INFANTS' SHOES AND BOOTS; JACKETS AND SOCKS; JERSEYS; LEATHER BELTS; LEOTARDS AND TIGHTS FOR WOMEN, MEN AND CHILDREN OF NYLON, COTTON OR OTHER TEXTILE FIBERS; MANTLES; MASQUERADE COSTUMES AND MASKS SOLD IN CONNECTION THEREWITH; MEN'S AND WOMEN'S JACKETS, COATS, TROUSERS, VESTS; ONE PIECE GARMENT FOR INFANTS AND TODDLERS; PANTIES, SHORTS AND BRIEFS; PAPER HATS FOR USE AS CLOTHING ITEMS; PAPER SHOES USED WHEN GOING THROUGH METAL DETECTORS TO KEEP FEET AND SOCKS CLEAN; PARTS OF CLOTHING, NAMELY, GUSSETS FOR TIGHTS, GUSSETS FOR STOCKINGS, GUSSETS FOR BATHING SUITS, GUSSETS FOR UNDERWEAR, GUSSETS FOR LEOTARDS AND GUSSETS FOR FOOTLETS; PARTS OF CLOTHING, NAMELY, UNDERARM GUSSETS; PARTY HATS; PERSPIRATION ABSORBENT UNDERWEAR CLOTHING; PROTECTIVE METAL MEMBERS FOR SHOES AND BOOTS; PUMPS; SCIENTIFIC AND TECHNOLOGICAL APPAREL, NAMELY, SHIRTS, PANTS, JACKETS, FOOTWEAR, HATS AND CAPS, UNIFORMS; SHORT SETS; SKI AND SNOWBOARD SHOES AND PARTS THEREOF; SKIRTS AND DRESSES; SOCKS AND STOCKINGS; SOLES FOR FOOTWEAR; SPORTS JERSEYS AND BREECHES FOR

CLASS 25—(Continued).

SPORTS; SWIM WEAR FOR GENTLEMEN AND LADIES; THONGS; TIES; TIPS FOR FOOTWEAR; TOPS; TRACK AND FIELD SHOES; TRAVEL CLOTHING CONTAINED IN A PACKAGE COMPRISING REVERSIBLE JACKETS, PANTS, SKIRTS, TOPS AND A BELT OR SCARF; TRIATHLON CLOTHING, NAMELY, TRIATHLON TIGHTS, TRIATHLON SHORTS, TRIATHLON SINGLET, TRIATHLON SHIRTS, TRIATHLON SUITS; UNDERARM CLOTHING SHIELDS; WATERPROOF JACKETS AND PANTS; WEARABLE GARMENTS AND CLOTHING, NAMELY, SHIRTS; WET SUITS FOR WATER-SKIING AND SUB-AQUA (U.S. CLS. 22 AND 39).
LEIGH CAROLINE CASE, EXAMINING ATTORNEY

SN 77-665,454. STUART DAVIS BRAND, LLC, AKA SDB, LONGMONT, CO. FILED 2-6-2009.

FASHION FOR THE SPIRITUALLY HIP AND PHILOSOPHICALLY SEXY

THE MARK CONSISTS OF STANDARD CHARACTERS WITHOUT CLAIM TO ANY PARTICULAR FONT, STYLE, SIZE, OR COLOR.

NO CLAIM IS MADE TO THE EXCLUSIVE RIGHT TO USE "FASHION", APART FROM THE MARK AS SHOWN.
FOR FOOTWEAR; COATS; HATS; HEADWEAR; JACKETS; PANTS; SHIRTS; SHORTS; SWIMWEAR; UNDERGARMENTS; UNDERWEAR (U.S. CLS. 22 AND 39).
BARBARA A. GOLD, EXAMINING ATTORNEY

SN 77-665,511. BUNKHOUSE TRADING CO. INC., PRESCOTT, AZ. FILED 2-6-2009.

Kactus Kuties

THE MARK CONSISTS OF STANDARD CHARACTERS WITHOUT CLAIM TO ANY PARTICULAR FONT, STYLE, SIZE, OR COLOR.

FOR BELTS; CAPS; SWEAT PANTS; SWEAT SHIRTS; T-SHIRTS; TANK TOPS (U.S. CLS. 22 AND 39).
JOHN E. MICHOS, EXAMINING ATTORNEY

SN 77-665,595. CHAMBERLIN, JAMES, TUCSON, AZ. FILED 2-6-2009.

LOOK N BACK

THE MARK CONSISTS OF STANDARD CHARACTERS WITHOUT CLAIM TO ANY PARTICULAR FONT, STYLE, SIZE, OR COLOR.

FOR HATS; JACKETS; PANTS; SHIRTS; SHORTS (U.S. CLS. 22 AND 39).
MICHAEL SOUDERS, EXAMINING ATTORNEY

CLASS 25—(Continued).

SN 77-665,651. LUCKY SPROUT, LLC, DBA LUCKY SPROUT, WILMINGTON, OH. FILED 2-7-2009.



THE COLOR(S) WHITE AND ORANGE IS/ARE CLAIMED AS A FEATURE OF THE MARK.

THE COLOR WHITE APPEARS IN THE WORDING "LUCKY SPROUT". THE COLOR ORANGE APPEARS IN THE SQUARE DESIGN ELEMENT.

FOR BODY SHIRTS (U.S. CLS. 22 AND 39).
JENNIFER HETU, EXAMINING ATTORNEY

SN 77-665,698. WALFORD-BERGEL, KIMBERLEY, EUREKA, CA. FILED 2-7-2009.

Domestic Deva

THE MARK CONSISTS OF STANDARD CHARACTERS WITHOUT CLAIM TO ANY PARTICULAR FONT, STYLE, SIZE, OR COLOR.

FOR CLOTHING, NAMELY, T-SHIRTS, SWEATSHIRTS, JACKETS, HATS, CAPS, NIGHTGOWNS, SLIPPERS, GLOVES (U.S. CLS. 22 AND 39).

WILLIAM VERHOSEK, EXAMINING ATTORNEY

SN 77-665,735. GROUP 5 INVESTMENTS, LLC., APPLE VALLEY, CA. FILED 2-7-2009.

Made Of Cookies

THE MARK CONSISTS OF STANDARD CHARACTERS WITHOUT CLAIM TO ANY PARTICULAR FONT, STYLE, SIZE, OR COLOR.

FOR CAPS; CHILDREN'S AND INFANTS' CLOTH BIBS; HOODS; INFANT AND TODDLER ONE PIECE CLOTHING; SWADDLING CLOTHES; TOPS; WEARABLE GARMENTS AND CLOTHING, NAMELY, SHIRTS (U.S. CLS. 22 AND 39).

FIRST USE 1-31-2009; IN COMMERCE 1-31-2009.
KATHY DE JONGE, EXAMINING ATTORNEY

CLASS 25—(Continued).

SN 77-665,745. MAHROUG, ERWIN, POORTUGAAL, NETHERLANDS, FILED 2-7-2009.

STREET SCIENTISTS

THE MARK CONSISTS OF STANDARD CHARACTERS WITHOUT CLAIM TO ANY PARTICULAR FONT, STYLE, SIZE, OR COLOR.

FOR ATHLETIC APPAREL, NAMELY, SHIRTS, PANTS, JACKETS, FOOTWEAR, HATS AND CAPS, ATHLETIC UNIFORMS; ATHLETIC SHOES; BASEBALL CAPS; CAPS; DANCE SHOES; DENIM JACKETS; HEADGEAR, NAMELY, SPIN CAPS, CAPS AND HATS; JACKETS; JACKETS AND SOCKS; JEANS; MEN'S AND WOMEN'S JACKETS, COATS, TROUSERS, VESTS; PANTS; RUNNING SHOES; SHIRTS; SHOES; SHORT-SLEEVED OR LONG-SLEEVED T-SHIRTS; SHORT-SLEEVED SHIRTS; SWEAT PANTS; SWEAT SHIRTS; T-SHIRTS; TEE SHIRTS (U.S. CLS. 22 AND 39).
CYNTHIA SLOAN, EXAMINING ATTORNEY

SN 77-665,948. DAN POST BOOT COMPANY, MT. GILEAD, NC. FILED 2-9-2009.

EL DORADO

THE MARK CONSISTS OF STANDARD CHARACTERS WITHOUT CLAIM TO ANY PARTICULAR FONT, STYLE, SIZE, OR COLOR.

THE ENGLISH TRANSLATION OF THE WORD "EL DORADO" IN THE MARK IS THE GOLDEN ONE.
FOR MEN'S, WOMEN'S AND CHILDREN'S COWBOY BOOTS (U.S. CLS. 22 AND 39).
ESTHER A. BORSUK, EXAMINING ATTORNEY

SN 77-666,157. PHILLIPS, KALEB, MODESTO, CA. FILED 2-9-2009.



THE MARK CONSISTS OF A STYLIZED HEART SHAPED DESIGN.
FOR JACKETS; PANTS; SHIRTS; SHOES (U.S. CLS. 22 AND 39).
RUSS HERMAN, EXAMINING ATTORNEY

CLASS 25—(Continued).

SN 77-666,282. BODEGA LLC, BOSTON, MA. FILED 2-9-2009.

bodega

THE MARK CONSISTS OF STANDARD CHARACTERS WITHOUT CLAIM TO ANY PARTICULAR FONT, STYLE, SIZE, OR COLOR.

FOR ATHLETIC SHOES; LEATHER SHOES; LEISURE SHOES; RUNNING SHOES; SOCCER SHOES; TENNIS SHOES; TRACK AND FIELD SHOES; TRAINING SHOES; WOMEN'S SHOES; WORK SHOES AND BOOTS (U.S. CLS. 22 AND 39).

FIRST USE 5-15-2006; IN COMMERCE 5-15-2006.
ROSELLE HERRERA, EXAMINING ATTORNEY

SN 77-666,505. GRANICK LLC, MEDINA, WA. FILED 2-9-2009.

NALA

THE MARK CONSISTS OF STANDARD CHARACTERS WITHOUT CLAIM TO ANY PARTICULAR FONT, STYLE, SIZE, OR COLOR.

FOR CLOTHING IN THE NATURE OF ACTIVE WEAR AND FITNESS WEAR, NAMELY, SHIRTS, SHORTS, PANTS, SCARVES, SKIRTS, CAPRI PANTS AND LOUNGE WEAR (U.S. CLS. 22 AND 39).
JESSICA A. POWERS, EXAMINING ATTORNEY

SN 77-666,579. THE BRAINY BABY COMPANY, LLC, SUWANEE, GA. FILED 2-9-2009.

SNUGGLE & GROW

THE MARK CONSISTS OF STANDARD CHARACTERS WITHOUT CLAIM TO ANY PARTICULAR FONT, STYLE, SIZE, OR COLOR.

FOR INFANT'S AND CHILDREN'S CLOTHING, NAMELY, BIBS, HATS, TOPS, T-SHIRTS, PANTS, SHOES, UNDERWEAR, DRESSES, SHIRTS, SOCKS, BATHING SUITS, SLEEPWEAR, JUMPERS, AND OUTERWEAR, NAMELY, JACKETS, COATS AND SWEATERS (U.S. CLS. 22 AND 39).
ALYSSA STEEL, EXAMINING ATTORNEY

CLASS 25—(Continued).

SN 77-666,657. NIA TECHNIQUE INC., PORTLAND, OR.
FILED 2-9-2009.

NIAWEAR

THE MARK CONSISTS OF STANDARD CHARACTERS WITHOUT CLAIM TO ANY PARTICULAR FONT, STYLE, SIZE, OR COLOR.

FOR CLOTHING, NAMELY, HATS, SWEAT SHIRTS, SWEAT PANTS, T-SHIRTS, PANTS, TOPS, NECKTIES, BELTS, JACKETS, HEADBANDS, SKIRTS, AND BATHROBES (U.S. CLS. 22 AND 39).

FIRST USE 1-1-1998; IN COMMERCE 1-1-1998.

LAURA KOVALSKY, EXAMINING ATTORNEY

CLASS 25—(Continued).

SN 77-666,734. AHMED KOTOB, ANAHEIM HILLS, CA.
FILED 2-9-2009.

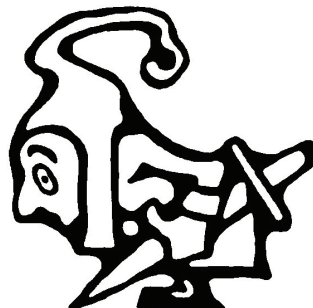

THE MARK CONSISTS OF A STYLIZED JESTER IN PROFILE VIEW, HOLDING A SWORD IN HIS LEFT HAND AND WEARING A CURLED HAT.

FOR WOMEN'S AND MEN'S CLOTHING, NAMELY, SUITS, VESTS, JACKETS, COATS, SHIRTS, SHOES AND DRESSES (U.S. CLS. 22 AND 39).

FIRST USE 2-19-2002; IN COMMERCE 2-19-2002.

GEORGE LORENZO, EXAMINING ATTORNEY

SN 77-666,744. MGM MIRAGE, LAS VEGAS, NV. FILED 2-9-2009.

SKYLOFTS

THE MARK CONSISTS OF STANDARD CHARACTERS WITHOUT CLAIM TO ANY PARTICULAR FONT, STYLE, SIZE, OR COLOR.

FOR CLOTHING, NAMELY, T-SHIRTS, SHIRTS, TANK TOPS, COLLARED GOLF SHIRTS, SWEATERS, JACKETS, JOGGING SUITS, SWEAT SHIRTS, SWEAT PANTS, SHORT PANTS, SWIM WEAR, DRESS SHIRTS, SKIRTS, JEANS, PANTS, ROBES, SLEEPWEAR, ROMPERS, SCARVES, BLOUSES, DRESS PANTS, CAPS, HATS AND BANDANNAS; HEADWEAR; SHOES, SOCKS, SLIPPERS (U.S. CLS. 22 AND 39).

GINA HAYES, EXAMINING ATTORNEY

SN 77-666,766. THE HIP HOSTESS, WASHINGTON, MI.
FILED 2-9-2009.

THE HIP HOSTESS

SN 77-666,712. MOTLEY, KEVIN T., DANVILLE, VA. FILED 2-9-2009.

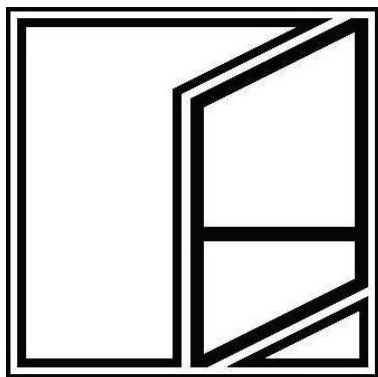

THE MARK CONSISTS OF THREE GEOMETRIC SHAPES WITHIN A SQUARE. THE GEOMETRIC SHAPES REPRESENT AN ABSTRACT LETTER "C" AND AN EXCLAMATION POINT.

FOR HATS; JACKETS; SHIRTS; SWEAT SHIRTS (U.S. CLS. 22 AND 39).

EMILY CARLSEN, EXAMINING ATTORNEY

THE MARK CONSISTS OF STANDARD CHARACTERS WITHOUT CLAIM TO ANY PARTICULAR FONT, STYLE, SIZE, OR COLOR.

FOR APRONS (U.S. CLS. 22 AND 39).

FIRST USE 4-1-2008; IN COMMERCE 4-1-2008.

MELVIN AXILBUND, EXAMINING ATTORNEY

CLASS 25—(Continued).

SN 77-667,142. KEYS, PHILLIP, LA CROSSE, WI. FILED 2-10-2009.



THE MARK CONSISTS OF A STYLIZED KEY HOLE. FOR BELTS; HATS; PANTS; SHIRTS (U.S. CLS. 22 AND 39).
FIRST USE 1-1-2009; IN COMMERCE 1-6-2009.
DAVID C. REIHNER, EXAMINING ATTORNEY

SN 77-667,563. CHARLIE WEINBERGER, LOS ANGELES, CA. FILED 2-10-2009.

MEDICALI

THE MARK CONSISTS OF STANDARD CHARACTERS WITHOUT CLAIM TO ANY PARTICULAR FONT, STYLE, SIZE, OR COLOR.
FOR T-SHIRTS, CAPS (U.S. CLS. 22 AND 39).
FIRST USE 8-31-2007; IN COMMERCE 8-31-2007.
DANNEAN HETZEL, EXAMINING ATTORNEY

SN 77-667,820. AC29 APPAREL, INC, SANTA FE SPRINGS, CA. FILED 2-10-2009.

ATOMIC DOLL

THE MARK CONSISTS OF STANDARD CHARACTERS WITHOUT CLAIM TO ANY PARTICULAR FONT, STYLE, SIZE, OR COLOR.
FOR BODY SHIRTS; JACKETS; PANTS; SHIRTS (U.S. CLS. 22 AND 39).
FIRST USE 2-1-2009; IN COMMERCE 2-1-2009.
JOHN DALIER, EXAMINING ATTORNEY

CLASS 25—(Continued).

SN 77-667,919. GAME DAY IOWA, L.L.C., CORALVILLE, IA. FILED 2-11-2009.

CYCLOWNS

THE MARK CONSISTS OF STANDARD CHARACTERS WITHOUT CLAIM TO ANY PARTICULAR FONT, STYLE, SIZE, OR COLOR.

FOR CLOTHING, NAMELY, T-SHIRTS, SWEATSHIRTS, SKIRTS, KNIT SHIRTS, BLOUSES, SWEATERS, TANK TOPS, JERSEYS, VESTS, CAPS, HATS, BELTS, PANTS, SHORTS, GLOVES, MITTENS, TIES, SUSPENDERS, SCARVES, SOCKS, PONCHOS, JACKETS, COATS, KNITTED COATS AND SWEATERS, BANDANNAS, JOGGING AND WARM-UP SUITS, ATHLETIC JERSEYS, HEAD WEAR AND PAINTERS' CAPS; CHILDREN'S AND INFANT CLOTHING, NAMELY, INFANT AND CHILDREN'S SHIRTS, SHORTS, PANTS, JACKETS, BABY CLOTH BIBS, AND INFANT FOOTWEAR; SLEEPWEAR, NAMELY, NIGHTSHIRTS, PAJAMAS AND BABY BUNTING; AND FOOTWEAR, NAMELY, SHOES, SANDALS AND SNEAKERS (U.S. CLS. 22 AND 39).
GEORGE LORENZO, EXAMINING ATTORNEY

SN 77-668,815. MGM MIRAGE, LAS VEGAS, NV. FILED 2-11-2009.



SKYLOFTS

THE MARK CONSISTS OF A VERTICAL RECTANGLE WITH TWO VERTICAL AND TWO HORIZONTAL LINES THAT MEET INSIDE THE RECTANGLE FORMING TWO 90 DEGREE ANGLES AND THE WORD "SKYLOFTS" BELOW THE RECTANGLE.

FOR CLOTHING, NAMELY, T-SHIRTS, SHIRTS, TANK TOPS, COLLARED GOLF SHIRTS, SWEATERS, JACKETS, JOGGING SUITS, SWEAT SHIRTS, SWEAT PANTS, SHORT PANTS, SWIM WEAR, DRESS SHIRTS, SKIRTS, JEANS, PANTS, ROBES, SLEEPWEAR, ROMPERS, SCARVES, BLOUSES, DRESS PANTS, CAPS, HATS AND BANDANNAS; HEADWEAR; SHOES, SOCKS, SLIPPERS (U.S. CLS. 22 AND 39).
GINA HAYES, EXAMINING ATTORNEY

CLASS 25—(Continued).

SN 77-669,104. I PLAY, INC., ASHEVILLE, NC. FILED 2-12-2009.



THE MARK CONSISTS OF A STYLIZED SLEEPING SPROUT NESTLED IN AND PARTIALLY SURROUNDED BY THE TWO HALVES OF A POD RESTING ON TWO SMALL FAUX FEET.

FOR BABY BIBS NOT OF PAPER; BABY BUNTING; CAPS; CHILDREN'S AND INFANTS' CLOTH BIBS; CHILDREN'S CLOTH EATING BIBS; CHILDREN'S HEADWEAR; CLOTH BIBS; CLOTH DIAPERS; COATS; HEADWEAR; INFANT AND TODDLER ONE PIECE CLOTHING; INFANT CLOTH DIAPERS; INFANT DIAPER COVERS; INFANT SLEEPERS; INFANTS' SHOES AND BOOTS; INFANTS' TROUSERS; INFANTWEAR; JERSEYS; PAJAMAS; PLAY SUITS; SLEEPING GARMENTS; SLEEPWEAR; AND TOPS (U.S. CLS. 22 AND 39).
AISHA SALEM, EXAMINING ATTORNEY

SN 77-671,862. LAND N' SEA, NEW YORK, NY. FILED 2-17-2009.

SLIMMING SENSATIONS

THE MARK CONSISTS OF STANDARD CHARACTERS WITHOUT CLAIM TO ANY PARTICULAR FONT, STYLE, SIZE, OR COLOR.

NO CLAIM IS MADE TO THE EXCLUSIVE RIGHT TO USE "SLIMMING", APART FROM THE MARK AS SHOWN. FOR BLOUSES; JACKETS; PANTS; SKIRTS AND DRESSES; SWEATERS (U.S. CLS. 22 AND 39).

COURTNEY MCCORMICK, EXAMINING ATTORNEY

CLASS 25—(Continued).

SN 77-672,783. ELVIS PRESLEY ENTERPRISES, INC., MEMPHIS, TN. FILED 2-18-2009.

SHAKE, RATTLE & ROLL

THE MARK CONSISTS OF STANDARD CHARACTERS WITHOUT CLAIM TO ANY PARTICULAR FONT, STYLE, SIZE, OR COLOR.

OWNER OF U.S. REG. NO. 3,288,976.

FOR CLOTHING, NAMELY, SHIRTS, T-SHIRTS, SWEATSHIRTS, CAPS, SHORTS AND PANTS (U.S. CLS. 22 AND 39).

MARK SPARACINO, EXAMINING ATTORNEY

SN 77-672,788. ELVIS PRESLEY ENTERPRISES, INC., MEMPHIS, TN. FILED 2-18-2009.

JAILHOUSE ROCK

THE MARK CONSISTS OF STANDARD CHARACTERS WITHOUT CLAIM TO ANY PARTICULAR FONT, STYLE, SIZE, OR COLOR.

OWNER OF U.S. REG. NOS. 2,471,334, 3,238,136 AND OTHERS.

FOR CLOTHING, NAMELY, SHIRTS, T-SHIRTS, SWEATSHIRTS, CAPS, SHORTS AND PANTS (U.S. CLS. 22 AND 39).

MARK SPARACINO, EXAMINING ATTORNEY

SN 77-672,796. ELVIS PRESLEY ENTERPRISES, INC., MEMPHIS, TN. FILED 2-18-2009.

BURNING LOVE

THE MARK CONSISTS OF STANDARD CHARACTERS WITHOUT CLAIM TO ANY PARTICULAR FONT, STYLE, SIZE, OR COLOR.

OWNER OF U.S. REG. NOS. 2,469,342 AND 3,073,616.

FOR CLOTHING, NAMELY, SHIRTS, T-SHIRTS, SWEATSHIRTS, CAPS, SHORTS AND PANTS (U.S. CLS. 22 AND 39).

MARK SPARACINO, EXAMINING ATTORNEY

CLASS 25—(Continued).

SN 77-672,803. ELVIS PRESLEY ENTERPRISES, INC., MEMPHIS, TN. FILED 2-18-2009.

SUSPICIOUS MINDS

THE MARK CONSISTS OF STANDARD CHARACTERS WITHOUT CLAIM TO ANY PARTICULAR FONT, STYLE, SIZE, OR COLOR.

FOR CLOTHING, NAMELY, SHIRTS, T-SHIRTS, SWEATSHIRTS, CAPS, SHORTS AND PANTS (U.S. CLS. 22 AND 39).

MARK SPARACINO, EXAMINING ATTORNEY

CLASS 25—(Continued).

SN 77-685,705. BRAVADO INTERNATIONAL GROUP MERCHANDISING SERVICES, INC., NEW YORK, NY. FILED 3-6-2009.

ELECTRIC CIRCUS

THE MARK CONSISTS OF STANDARD CHARACTERS WITHOUT CLAIM TO ANY PARTICULAR FONT, STYLE, SIZE, OR COLOR.

FOR T-SHIRTS, SHIRTS, SWEATSHIRTS, SWEAT-PANTS, SHORTS, HATS, CAPS, TIES, SOCKS, JACKETS, TANK TOPS, PANTS, SWEATERS AND VESTS (U.S. CLS. 22 AND 39).

MIDGE BUTLER, EXAMINING ATTORNEY

SN 77-680,424. PEDIPED INFANT FOOTWEAR, LLC, HENDERSON, NV. FILED 2-27-2009.

PEDIPED

THE MARK CONSISTS OF STANDARD CHARACTERS WITHOUT CLAIM TO ANY PARTICULAR FONT, STYLE, SIZE, OR COLOR.

OWNER OF U.S. REG. NOS. 3,271,174 AND 3,528,745. FOR FOOTWEAR (U.S. CLS. 22 AND 39).

FIRST USE 1-31-2006; IN COMMERCE 1-31-2006. HEATHER BIDDULPH, EXAMINING ATTORNEY

SN 77-685,743. BRAVADO INTERNATIONAL GROUP MERCHANDISING SERVICES, INC., NEW YORK, NY. FILED 3-6-2009.

2 FAST 2 LIVE

THE MARK CONSISTS OF STANDARD CHARACTERS WITHOUT CLAIM TO ANY PARTICULAR FONT, STYLE, SIZE, OR COLOR.

FOR T-SHIRTS, SHIRTS, SWEATSHIRTS, SWEAT-PANTS, SHORTS, HATS, CAPS, TIES, SOCKS, JACKETS, TANK TOPS, PANTS, SWEATERS AND VESTS (U.S. CLS. 22 AND 39).

MIDGE BUTLER, EXAMINING ATTORNEY

SN 77-684,933. MICHAEL WADDELL, LLC, FORTSON, GA. FILED 3-6-2009.

MICHAEL WADDELL

THE MARK CONSISTS OF STANDARD CHARACTERS WITHOUT CLAIM TO ANY PARTICULAR FONT, STYLE, SIZE, OR COLOR.

FOR GLOVES, HATS, BOOTS, HEADGEAR IN THE NATURE OF FACE MASKS TO KEEP THE FACE WARM DURING OUTDOOR ACTIVITIES, JACKETS, SHIRTS, PANTS, SWEATSHIRTS, VESTS, PARKAS, RAINWEAR (U.S. CLS. 22 AND 39).

JACQUELINE A. LAVINE, EXAMINING ATTORNEY

SN 77-689,619. SIMMONS, DOMINIQUE T., DBA RESILINE CLOTHING, KILLEEN, TX. FILED 3-12-2009.

Resiline Clothing

THE MARK CONSISTS OF STANDARD CHARACTERS WITHOUT CLAIM TO ANY PARTICULAR FONT, STYLE, SIZE, OR COLOR.

NO CLAIM IS MADE TO THE EXCLUSIVE RIGHT TO USE "CLOTHING", APART FROM THE MARK AS SHOWN. THE WORDING "RESILINE" HAS NO MEANING IN A FOREIGN LANGUAGE.

FOR WEARABLE GARMENTS AND CLOTHING, NAMELY, SHIRTS (U.S. CLS. 22 AND 39).

ANDREW LEASER, EXAMINING ATTORNEY

CLASS 25—(Continued).

SN 78-777,852. VAUGHN, TIFFANY, BENTONVILLE, AR. FILED 12-21-2005.



NO CLAIM IS MADE TO THE EXCLUSIVE RIGHT TO USE "DESIGNS", APART FROM THE MARK AS SHOWN. FOR CHILDREN'S CLOTHING, NAMELY, HATS, GOWNS, DIAPER COVERS AND CLOTH BIBS (U.S. CLS. 22 AND 39).
KAPIL BHANOT, EXAMINING ATTORNEY

SN 78-831,757. BOSTON RED SOX BASEBALL CLUB LIMITED PARTNERSHIP, BOSTON, MA. FILED 3-7-2006.

BOSTON PURITANS

THE MARK CONSISTS OF STANDARD CHARACTERS WITHOUT CLAIM TO ANY PARTICULAR FONT, STYLE, SIZE, OR COLOR.
OWNER OF U.S. REG. NOS. 1,578,939 AND 1,736,679.
NO CLAIM IS MADE TO THE EXCLUSIVE RIGHT TO USE "BOSTON", APART FROM THE MARK AS SHOWN.
FOR CLOTHING, NAMELY, CAPS, HATS, SHIRTS, T-SHIRTS, BASEBALL UNIFORMS, JERSEYS AND JACKETS ALL RELATING TO A HISTORIC BASEBALL TEAM (U.S. CLS. 22 AND 39).
DAVID C. REIHNER, EXAMINING ATTORNEY

SN 78-844,695. FRANCO HARRIS, PITTSBURGH, PA. FILED 3-23-2006.

WE WIN BACK-TO-BACK

THE MARK CONSISTS OF STANDARD CHARACTERS WITHOUT CLAIM TO ANY PARTICULAR FONT, STYLE, SIZE, OR COLOR.
FOR WEARING APPAREL, NAMELY, T-SHIRTS, CAPS AND HATS, JACKETS, SWEATSHIRTS AND SWEATPANTS, JERSEYS AND SOCKS (U.S. CLS. 22 AND 39).
LAURIE KAUFMAN, EXAMINING ATTORNEY

CLASS 25—(Continued).

SN 78-879,745. SUBLIMATION FACTORY, INC., LOS ANGELES, CA. FILED 5-9-2006.



THE MARK CONSISTS OF THE STYLIZED TEXT "OKTOPUS" WITH THE LETTER "K" APPEARING BACKWARDS.
FOR MEN'S AND WOMEN'S CLOTHING, NAMELY, JEANS, PANTS, SHIRTS, SHORTS, SWEATERS, SWEATSHIRTS, SKIRTS, DRESSES AND TANKTOPS (U.S. CLS. 22 AND 39).
LYDIA BELZER, EXAMINING ATTORNEY

SN 79-036,660. NAHRO OKTAY, FED REP GERMANY, FILED 10-13-2006.



PRIORITY DATE OF 4-13-2006 IS CLAIMED.
OWNER OF INTERNATIONAL REGISTRATION 0919302 DATED 10-13-2006, EXPIRES 10-13-2016.
FOR CLOTHING, NAMELY, JUMPERS, SHIRTS, SUSPENDERS, GIRDLES, LEATHER BELTS, JACKETS, JERSEYS, TOPS, BOTTOMS, UNDERWEAR, DRESS SUITS, LAYETTES, BATHING SUITS, BATHING TRUNKS, BATHING ROBES, FROCKS, GLOVES, NECKTIES, PULLOVERS, COATS, COMBINATIONS, PYJAMAS, SKIRTS AND DRESSES, SOCKS, TROUSERS, T-SHIRTS, SWEATERS, UNIFORMS, SINGLET, COLLAR PROTECTORS, VESTS, SHORTS; FOOTWEAR, NAMELY, ATHLETIC FOOTWEAR, THONGS, FLIP FLOPS, RUBBERS, PUMPS, BOOTS, SOLES FOR FOOTWEAR, BEACH FOOTWEAR, SLIPPERS; HEADGEAR, NAMELY, CAPS, HATS (U.S. CLS. 22 AND 39).
DAVID HOFFMAN, EXAMINING ATTORNEY

CLASS 25—(Continued).

CLASS 25—(Continued).

SN 79-056,752. KAWASHITA JUNZO, JAPAN, FILED 2-21-2008.

SN 79-053,396. SHENZHENSHI CHUANGER GARMENT CORPORATION, CHINA, FILED 5-5-2008.

レグコート

Leg coat

あしがっぱ
足合羽

PRIORITY DATE OF 11-28-2007 IS CLAIMED.
OWNER OF INTERNATIONAL REGISTRATION 0971947
DATED 2-21-2008, EXPIRES 2-21-2018.

NO CLAIM IS MADE TO THE EXCLUSIVE RIGHT TO
USE "COAT" OR THE NON-LATIN CHARACTERS THAT
MEAN "COAT", APART FROM THE MARK AS SHOWN.

THE ENGLISH TRANSLATION OF THE FOREIGN
WORD(S) IN THE MARK IS COATS OF LEG.

THE TRANSLITERATION OF THE NON-LATIN CHARACTERS
IN THE MARK IS LEG COAT, ASHIGAPPA, ASHIGAPPA.

FOR RAINCOATS MADE OF RUBBER; RAINCOATS
MADE OF VINYL; RAINCOATS; RAIN JACKET; RAIN
WEAR; RAIN SHOES; COAT MADE OF WOOL; WIND
COATS; SPORTS OVER UNIFORMS; COATS MADE OF
CASHMERE; RAINCOATS MADE OF GABARDINE;
GRAND COATS; CAPE COATS; COATS, EXCLUDING
LIVERY FOR JUDGE AND PROFESSORS; FINISHED
TEXTILE LINER FOR COATS; RAINCOATS MADE OF
RUBBER-COATED WATERPROOF CLOTH; RAIN-
COATS FOR GOLF SHORT COATS; SPORTS COATS;
DUFFEL COATS; TUNIC COATS; TOPPER COATS;
TRENCH COATS; HALF COATS; HOUSE COATS;
BEACH COATS; FROCK COATS; BLAZERS; PETTI-
COATS; CUTAWAY COATS; COATS WITH LINER;
LEATHER COATS; LONG COATS; COATS FOR BEACH;
COATS FOR CHILDREN; JACKET VEST COATS WITH
ITS BODY SLING BEING DETACHABLE; COATS WEAR-
ABLE OVER WET SUITS, ESPECIALLY WHEN ONE
GETS OUT OF THE WATER; JUMPER-TYPE OUTER
WEAR, NAMELY, COATS; COAT-TYPE OUTER WEAR,
NAMELY, JACKETS; COATS FOR WOMEN CARRYING
BABIES ON HER BACKS; HALF-LENGTH COAT;
LEATHER CLOTHES, NAMELY, JACKETS, PANTS,
SKIRTS; LEATHER COATS; COATS FOR PROTECTION
AGAINST THE COLD; FUR COATS; OVERCOATS
MADE OF FUR; COATS IN JAPANESE DRESS; COATS
FOR JAPANESE DRESS; SUIT COATS; BOOTS MADE OF
RUBBER; BOOTS MADE OF PLASTIC; WADERS;
BOOTS; CLOTHES FOR FISHING, NAMELY, BOOTS,
COATS; FINISHED TEXTILE LINERS FOR BOOTS FOR
FISHING; RUBBER FISHING BOOTS; WATERPROOF-
ING BOOTS FOR FISHING; STRING BOOTS (U.S. CLS.
22 AND 39).

OWNER OF INTERNATIONAL REGISTRATION 0963071
DATED 5-5-2008, EXPIRES 5-5-2018.

FOR BOOTS, SUITS, PULLOVERS, COATS, COLLAR
PROTECTORS, BODICES, CAMISOLES, SKIRTS, HALF-
BOOTS, VESTS, SHIRTS, OVERCOATS, JACKETS,
TROUSERS, FROCKS, SANDALS, BREECHES (U.S.
CLS. 22 AND 39).

HELENE LIWINSKI, EXAMINING ATTORNEY

REBECCA POVARCHUK, EXAMINING ATTORNEY

CLASS 25—(Continued).

SN 79-056,753. KAWASHITA JUNZO, JAPAN, FILED 2-21-2008.

アームコート

Arm coat

てがっぱ
手合羽

PRIORITY DATE OF 11-28-2007 IS CLAIMED.
OWNER OF INTERNATIONAL REGISTRATION 0971948
DATED 2-21-2008, EXPIRES 2-21-2018.

NO CLAIM IS MADE TO THE EXCLUSIVE RIGHT TO USE "COAT" OR THE NON-LATIN CHARACTERS THAT MEAN "COAT", APART FROM THE MARK AS SHOWN.

THE ENGLISH TRANSLATION OF THE FOREIGN WORD(S) IN THE MARK IS COATS OF ARM.

THE TRANSLITERATION OF THE NON-LATIN CHARACTERS IN THE MARK IS ARM COAT, TEGAPPA, TEGAPPA.

FOR RAINCOATS MADE OF RUBBER; RAINCOATS MADE OF VINYL; RAINCOATS; RAIN JACKET; RAIN WEAR; RAIN SHOES; COAT MADE OF WOOL; WIND COATS; SPORTS OVER UNIFORMS; COATS MADE OF CASHMERE; RAINCOATS MADE OF GABARDINE; GRAND COATS; CAPE COATS; COATS EXCLUDING LIVERY FOR JUDGE AND PROFESSORS; FINISHED TEXTILE LINER FOR COATS; RAINCOATS MADE OF RUBBER-COATED WATERPROOF CLOTH; RAINCOATS FOR GOLF; SHORT COATS; SPORTS COATS; DUFFEL COATS; TUNIC COATS; TOPPER COATS; TRENCH COATS; HALF COATS; HOUSE COATS; BEACH COATS; FROCK COATS; BLAZERS; PETTICOATS; CUTAWAY COATS; COATS WITH LINER; LEATHER COATS; LONG COATS; COATS FOR BEACH; COATS FOR CHILDREN; JACKET VEST COATS WITH ITS BODY SLING BEING DETACHABLE; COATS WEARABLE OVER WET SUITS, ESPECIALLY WHEN ONE GETS OUT OF THE WATER; JUMPER-TYPE OUTER WEAR, NAMELY, COATS; COAT-TYPE OUTER WEAR, NAMELY, JACKETS; COATS FOR WOMEN CARRYING BABIES ON HER BACKS; HALF-LENGTH COAT; LEATHER CLOTHES, NAMELY, JACKETS, PANTS, SKIRTS; LEATHER COATS; COATS FOR PROTECTION AGAINST THE COLD; FUR COATS; OVERCOATS MADE OF FUR; COATS IN JAPANESE DRESS; COATS FOR JAPANESE DRESS; SUIT COATS; BOOTS MADE OF RUBBER; BOOTS MADE OF PLASTIC; WADERS; BOOTS; CLOTHES FOR FISHING, NAMELY, BOOTS, COATS; FINISHED TEXTILE LINERS FOR BOOTS FOR FISHING; RUBBER FISHING BOOTS; WATERPROOFING BOOTS FOR FISHING; STRING BOOTS (U.S. CLS. 22 AND 39).

REBECCA POVARCHUK, EXAMINING ATTORNEY

CLASS 25—(Continued).

SN 79-058,554. SORBINO JEANS; DI SORBINO CIRO & C. S.A.S., ITALY, FILED 7-21-2008.

HAMAKI-HO

PRIORITY DATE OF 5-26-2008 IS CLAIMED.
OWNER OF INTERNATIONAL REGISTRATION 0976459
DATED 7-21-2008, EXPIRES 7-21-2018.

THE TRADEMARK CONSISTS OF THE INVENTED WORDS "HAMAKI-HO" IN STANDARD LETTERS.

THE WORDING HAMAKI-HO HAS NO MEANING IN A FOREIGN LANGUAGE.

FOR CLOTHING, NAMELY, BELTS, SHIRTS AND T-SHIRTS, SOCKS, PANTIES AND UNDERPANTS, SLACKS, TROUSERS, JEANS, OVERALLS, SKIRTS AND SHORT SKIRTS, BLOUSES, VESTS, CARDIGANS, COATS, SCARVES, GLOVES AND DRESSING GOWNS, PANTS, JACKETS, SWEATERS; CLOTHING MADE OF IMITATION LEATHER, NAMELY, PANTS AND JACKETS; CLOTHING MADE OF ANIMAL SKIN OR HIDES, NAMELY, PANTS AND JACKETS; KNITWEAR, NAMELY, SWEATERS; SASHES; FOOTWEAR; HEADGEAR, NAMELY, HATS AND CLOTHING CAPS (U.S. CLS. 22 AND 39).

CHRISTINA SOBRAL, EXAMINING ATTORNEY

SN 79-062,880. ZHANG YING, BEIJING, CHINA, FILED 12-1-2008.

ALL BERTTI

OWNER OF INTERNATIONAL REGISTRATION 0986954
DATED 12-1-2008, EXPIRES 12-1-2018.

THE NAME(S), PORTRAIT(S), AND/OR SIGNATURE(S) SHOWN IN THE MARK DOES NOT IDENTIFY A PARTICULAR LIVING INDIVIDUAL.

THE WORDING "ALL BERTTI" HAS NO MEANING IN A FOREIGN LANGUAGE.

FOR SHOES; BOOTS; CLIMBING SHOES WITH METAL NAILS; CLOTHING, NAMELY, JACKETS; LAYETTES; HATS; HOSIERY; NECKTIES; GIRDLES; WEDDING GOWNS (U.S. CLS. 22 AND 39).

DOMINIC FATHY, EXAMINING ATTORNEY

CLASS 25—(Continued).

SN 79-063,124. FEIYUE, FRANCE, FILED 11-28-2008.



PRIORITY DATE OF 6-18-2008 IS CLAIMED.
OWNER OF INTERNATIONAL REGISTRATION 0987572 DATED 11-28-2008, EXPIRES 11-28-2018.

THE MARK CONSISTS OF THE WORDING "FLYING FORWARD" REPRESENTED IN STYLIZED FONT APPEARING IN THE CENTER OF A DESIGN FEATURING TWO SHADED CONCENTRIC CIRCLES.

FOR CLOTHING, NAMELY, T-SHIRTS, SHIRTS, POLO SHIRTS, SWEATERS, PANTS, JOGGING SUITS, JACKETS, COATS, CARDIGAN, DRESSES; FOOTWEAR; HEADGEAR, NAMELY, HATS, CAPS, BERETS; LEATHER OR IMITATION LEATHER CLOTHING, NAMELY, PANTS, JACKETS, COATS, BELTS, SKIRTS; BELTS; FUR CLOTHING, NAMELY, FUR COATS, FUR JACKETS AND FUR HATS; GLOVES; SCARVES; TIES; HOSIERY; SOCKS; SLIPPERS; SPORTS SHOES; BEACH SHOES; SKI BOOTS; UNDERWEAR; TEXTILE NAPPIES (U.S. CLS. 22 AND 39).

WARREN L. OLANDRIA, EXAMINING ATTORNEY

SN 79-063,891. JACOB ROHNER AG, SWITZERLAND, FILED 12-3-2008.



PRIORITY DATE OF 6-5-2008 IS CLAIMED.
OWNER OF INTERNATIONAL REGISTRATION 0989566 DATED 12-3-2008, EXPIRES 12-3-2018.

OWNER OF U.S. REG. NO. 2,227,684.
THE MARK CONSISTS OF A SHADED RECTANGULAR BACKGROUND CONTAINING THE WORDING "ROHNER" AND "NEXT" IN STYLIZED LETTERING AND SEPARATED BY A VERTICAL LINE.

FOR CLOTHING, NAMELY, SOCKS (U.S. CLS. 22 AND 39).

JULIE GUTTADAURO, EXAMINING ATTORNEY

CLASS 25—(Continued).

SN 79-065,953. MY PLAZA PTY LTD, AUSTRALIA, FILED 2-6-2009.

WHOOGA

THE MARK CONSISTS OF STANDARD CHARACTERS WITHOUT CLAIM TO ANY PARTICULAR FONT, STYLE, SIZE, OR COLOR.

PRIORITY DATE OF 12-23-2008 IS CLAIMED.
OWNER OF INTERNATIONAL REGISTRATION 0995083 DATED 2-6-2009, EXPIRES 2-6-2019.

FOR FOOTWEAR, NAMELY, SHEEP SKIN BOOTS (U.S. CLS. 22 AND 39).

DANIEL CAPSHAW, EXAMINING ATTORNEY

CLASS 26—FANCY GOODS

SN 76-694,630. STALLINS, CAROLINE, MIDDLETOWN, RI. FILED 12-3-2008.

SNUG-EASE

THE MARK CONSISTS OF STANDARD CHARACTERS WITHOUT CLAIM TO ANY PARTICULAR FONT, STYLE, SIZE, OR COLOR.

FOR CLAMPS FOR SIZING CLOTHING, COMPRISED OF PLASTIC, NAMELY, FOR GATHERING THE WAISTBAND OR OTHER AREA OF CLOTHING TO MAKE IT FIT MORE SNUGLY WITHOUT ALTERATION (U.S. CLS. 37, 39, 40, 42 AND 50).

ESTHER BELENKER, EXAMINING ATTORNEY

SN 77-526,214. CLARENCE HALL, CONYERS, GA. FILED 7-18-2008.

PRAISE BUTTON

THE MARK CONSISTS OF STANDARD CHARACTERS WITHOUT CLAIM TO ANY PARTICULAR FONT, STYLE, SIZE, OR COLOR.

NO CLAIM IS MADE TO THE EXCLUSIVE RIGHT TO USE "BUTTON", APART FROM THE MARK AS SHOWN.

FOR NOVELTY BUTTONS; ORNAMENTAL NOVELTY BUTTONS; NOVELTY BUTTONS CONTAINING ELECTRONIC, MECHANICAL OR OTHER MEANS TO PRODUCE VOICES, SOUNDS, OR MUSIC (U.S. CLS. 37, 39, 40, 42 AND 50).

CHRIS WELLS, EXAMINING ATTORNEY

CLASS 26—(Continued).

SN 77-532,686. CLARENCE HALL, CONYERS, GA. FILED 7-28-2008.

PRAYER BUTTON

THE MARK CONSISTS OF STANDARD CHARACTERS WITHOUT CLAIM TO ANY PARTICULAR FONT, STYLE, SIZE, OR COLOR.

NO CLAIM IS MADE TO THE EXCLUSIVE RIGHT TO USE "BUTTON", APART FROM THE MARK AS SHOWN.

FOR NOVELTY BUTTONS; ORNAMENTAL NOVELTY BUTTONS; NOVELTY BUTTONS CONTAINING ELECTRONIC, MECHANICAL OR OTHER MEANS TO PRODUCE VOICES, SOUNDS, OR MUSIC (U.S. CLS. 37, 39, 40, 42 AND 50).

CHRIS WELLS, EXAMINING ATTORNEY

SN 77-624,511. SAUERS, BRIAN D., MARS, PA. FILED 12-2-2008.



NO CLAIM IS MADE TO THE EXCLUSIVE RIGHT TO USE "BEARD", APART FROM THE MARK AS SHOWN.

THE MARK CONSISTS OF THE DESIGN OF A BEARDED FACE HAVING FOUR BLACKENED TEETH, A SCAR, AND A BLACK MARK UNDER ONE EYE, WITH THE WORDS "THE OFFICIAL" ABOVE THE FACE, AND THE WORDS "PLAYOFF BEARD" BELOW THE FACE, AND A RECTILINEAR OBJECT TO THE LEFT OF THE FACE.

FOR FALSE BEARDS (U.S. CLS. 37, 39, 40, 42 AND 50).
DAVID ELTON, EXAMINING ATTORNEY

CLASS 26—(Continued).

SN 77-664,512. ARANA, PATRICIA KYLE, LOS ANGELES, CA. FILED 2-5-2009.

N*Jeanious

THE COLOR(S) FUCHSIA, GREEN, BLUE IS/ARE CLAIMED AS A FEATURE OF THE MARK.

THE MARK CONSISTS OF THE LETTER "N" STYLIZED, FOLLOWED BY AN ASTERISK, FOLLOWED BY THE WORDING "JEANIOUS", ALL OF WHICH CREATE A PLAY ON THE SPELLING OF THE WORD INGENIOUS. THE LETTERS "N" AND "IOUS" ARE FUCHSIA, THE ASTERISK IS GREEN, AND THE LETTERS "JEAN" ARE BLUE.

FOR CLOTHING TAPE STRIPS USED WITH DENIM JEANS THAT TEMPORARILY ALTERS THE HEM OF THE GARMENT (U.S. CLS. 37, 39, 40, 42 AND 50).

CORY BOONE, EXAMINING ATTORNEY

CLASS 27—FLOOR COVERINGS

SN 77-318,802. WOODSTOCK VENTURES, L.C., NEW YORK, NY. FILED 11-1-2007.

WOODSTOCK

THE MARK CONSISTS OF STANDARD CHARACTERS WITHOUT CLAIM TO ANY PARTICULAR FONT, STYLE, SIZE, OR COLOR.

FOR RUGS, BATH MATS, FLOOR MATS, DOOR MATS, FLOOR COVERINGS; WALL COVERINGS, NAMELY, WALL PAPER, CLOTH WALL COVERINGS; TAPESTRY-STYLE WALL HANGINGS, NOT OF TEXTILE; WALL HANGS, NAMELY, NON-TEXTILE AND TEXTILE WALL HANGINGS (U.S. CLS. 19, 20, 37, 42 AND 50).

CHRIS WELLS, EXAMINING ATTORNEY

SN 77-539,054. DUCDUC LLC, NEW YORK, NY. FILED 8-5-2008.

MASON GRAY

THE MARK CONSISTS OF STANDARD CHARACTERS WITHOUT CLAIM TO ANY PARTICULAR FONT, STYLE, SIZE, OR COLOR.

THE NAME(S), PORTRAIT(S), AND/OR SIGNATURE(S) SHOWN IN THE MARK DOES NOT IDENTIFY A PARTICULAR LIVING INDIVIDUAL.

FOR WALLPAPER (U.S. CLS. 19, 20, 37, 42 AND 50).
KRISTIN DAHLING, EXAMINING ATTORNEY

CLASS 27—(Continued).

SN 77-625,767. ATG SPORTS INDUSTRIES, INC., ANDOVER, KS. FILED 12-3-2008.

FlexFiber Grass

THE MARK CONSISTS OF STANDARD CHARACTERS WITHOUT CLAIM TO ANY PARTICULAR FONT, STYLE, SIZE, OR COLOR.

NO CLAIM IS MADE TO THE EXCLUSIVE RIGHT TO USE "GRASS", APART FROM THE MARK AS SHOWN.

FOR ARTIFICIAL TURF (U.S. CLS. 19, 20, 37, 42 AND 50).

FIRST USE 1-1-2008; IN COMMERCE 1-1-2008.
MICHAEL SOUDERS, EXAMINING ATTORNEY

SN 77-665,796. M7 CORPORATION, DBA METROGRASS, VERBANK, NY. FILED 2-8-2009.

MetroGrass

THE MARK CONSISTS OF STANDARD CHARACTERS WITHOUT CLAIM TO ANY PARTICULAR FONT, STYLE, SIZE, OR COLOR.

FOR ARTIFICIAL TURF (U.S. CLS. 19, 20, 37, 42 AND 50).

JENNIFER MARTIN, EXAMINING ATTORNEY

SN 79-061,710. PONGRASS GROUP OPERATIONS PTY LIMITED, AUSTRALIA, FILED 9-3-2008.

TAPISTER

THE MARK CONSISTS OF STANDARD CHARACTERS WITHOUT CLAIM TO ANY PARTICULAR FONT, STYLE, SIZE, OR COLOR.

OWNER OF INTERNATIONAL REGISTRATION 0893665 DATED 7-26-2006. EXPIRES 7-26-2016.

OWNER OF U.S. REG. NO. 3,335,422.

FOR CARPETS, RUGS, TAPESTRY-STYLE WALL HANGINGS, NOT OF TEXTILE (U.S. CLS. 19, 20, 37, 42 AND 50).

LINDSEY RUBIN, EXAMINING ATTORNEY

CLASS 28—TOYS AND SPORTING GOODS

SN 76-678,430. OBITSU PLASTIC MANUFACTURING CO., LTD., KATSUSHIKA-KU, TOKYO, JAPAN, FILED 6-19-2007.

OBITSUBODY

THE MARK CONSISTS OF "OBITSUBODY" IN A STYLIZED FONT.

FOR DOLLS, NAMELY, HEADLESS DOLLS, DOLLS WITH HEADS, JAPANESE TRADITIONAL DOLLS, GIRLS' FESTIVAL DOLLS, BOYS' FESTIVAL DOLLS; PARTS OF DOLLS, NAMELY, BODIES, BONES, HEADS, NECKS, TRUNKS, CHESTS, ABDOMENS, GROINS, ARMS, HANDS, FINGERS, LEGS, FEET, TOES, EYES, EYELASHES, HAIR AND WIGS, POSABLE ACTION DOLLS THAT ALLOW FOR EACH PART OR PORTION OF THE TRUNK TO BE ATTACHED AND DETACHED AND EACH JOINT TO BE MOVED SMOOTHLY; MARIONETTE PUPPETS; TOY DOLL FIGURES; ACTION TOY DOLL FIGURES; DOLL CLOTHING; DOLL UNDERWEAR; DOLL FOOTWEAR AND SHOES; DOLL HOSIERY AND SOCKS; DOLL EYEGLASSES, DOLL ACCESSORIES; DOLL FURNITURE; DOLL CARS; TOY FIGURES OF ANIMALS, BIRDS, FISH, SHELLS, INSECTS, WORMS, DINOSAURS, AND PLANTS; TOYS, NAMELY, INFLATABLE TOYS, TOY MODEL CARS, STUFFED TOYS, AND TOY BUILDING BLOCKS (U.S. CLS. 22, 23, 38 AND 50).

RONALD MCMORROW, EXAMINING ATTORNEY

SN 76-695,563. COMMONWEALTH TOY & NOVELTY CO., INC, NEW YORK, NY. FILED 2-2-2009.

Lots A Lots A Leggggggs

THE MARK CONSISTS OF STANDARD CHARACTERS WITHOUT CLAIM TO ANY PARTICULAR FONT, STYLE, SIZE, OR COLOR.

FOR PLUSH STUFFED TOYS (U.S. CLS. 22, 23, 38 AND 50).

FIRST USE 11-1-1983; IN COMMERCE 11-1-1983.
REBECCA SMITH, EXAMINING ATTORNEY

SN 76-695,644. POOF-SLINKY, INC., PLYMOUTH, MI. FILED 2-6-2009.

FRONTIER LOGS

THE MARK CONSISTS OF STANDARD CHARACTERS WITHOUT CLAIM TO ANY PARTICULAR FONT, STYLE, SIZE, OR COLOR.

NO CLAIM IS MADE TO THE EXCLUSIVE RIGHT TO USE "LOGS", APART FROM THE MARK AS SHOWN.

FOR TOY CONSTRUCTION SETS (U.S. CLS. 22, 23, 38 AND 50).

FIRST USE 6-30-1987; IN COMMERCE 6-30-1987.
LINDA LAVACHE, EXAMINING ATTORNEY

CLASS 28—(Continued).

SN 76-695,649. POOF-SLINKY, INC., PLYMOUTH, MI.
FILED 2-6-2009.

FIDDLESTIX

THE MARK CONSISTS OF STANDARD CHARACTERS
WITHOUT CLAIM TO ANY PARTICULAR FONT, STYLE,
SIZE, OR COLOR.

OWNER OF U.S. REG. NO. 1,922,195.
FOR TOY CONSTRUCTION SETS OF INTERCON-
NECTABLE COMPONENTS (U.S. CLS. 22, 23, 38 AND 50).
FIRST USE 6-30-1994; IN COMMERCE 6-30-1994.
LINDA LAVACHE, EXAMINING ATTORNEY

SN 76-695,650. POOF-SLINKY, INC., PLYMOUTH, MI.
FILED 2-6-2009.

AMAZE-N-MARBLES

THE MARK CONSISTS OF STANDARD CHARACTERS
WITHOUT CLAIM TO ANY PARTICULAR FONT, STYLE,
SIZE, OR COLOR.

FOR TOYS, GAMES AND PLAYTHINGS, NAMELY,
INTER-ARRANGEABLE BLOCKS FOR MARBLE ROLL-
ING (U.S. CLS. 22, 23, 38 AND 50).
FIRST USE 6-30-1997; IN COMMERCE 6-30-1997.
LINDA LAVACHE, EXAMINING ATTORNEY

SN 77-211,126. EASTON SPORTS, INC., VAN NUYS, CA.
FILED 6-20-2007.

SURGE

THE MARK CONSISTS OF STANDARD CHARACTERS
WITHOUT CLAIM TO ANY PARTICULAR FONT, STYLE,
SIZE, OR COLOR.

FOR BASEBALL, SOFTBALL AND YOUTH BATS (U.S.
CLS. 22, 23, 38 AND 50).
CHARLES L. JENKINS, EXAMINING ATTORNEY

CLASS 28—(Continued).

SN 77-319,109. NICKENT GOLF, INC., CITY OF INDUSTRY,
CA. FILED 11-1-2007.

EVOLVER

THE MARK CONSISTS OF STANDARD CHARACTERS
WITHOUT CLAIM TO ANY PARTICULAR FONT, STYLE,
SIZE, OR COLOR.

FOR GOLF CLUBS (U.S. CLS. 22, 23, 38 AND 50).
ROBERT C. CLARK JR., EXAMINING ATTORNEY

SN 77-326,283. JULIAN ERIC CHRISTIAN MORLEY, LON-
DON, UNITED KINGDOM, FILED 11-9-2007.

TRUVIS

THE MARK CONSISTS OF STANDARD CHARACTERS
WITHOUT CLAIM TO ANY PARTICULAR FONT, STYLE,
SIZE, OR COLOR.

PRIORITY CLAIMED UNDER SEC. 44(D) ON ERP
CMNTY TM OFC APPLICATION NO. 005914346, FILED 5-
17-2007, REG. NO. 005914346, DATED 9-17-2008, EXPIRES 5-
17-2017.

FOR GOLF BALLS, GOLF GLOVES, GOLF CLUBS,
GOLF CLUB HEAD COVERS, GOLF BALL MARKERS,
GOLF TEES, GOLF CLUB BAGS; STANDS FOR GOLF
BAGS, GOLF CLUB GRIPS, GOLF BALL PITCH MARK
REPAIR TOOLS; PARTS AND FITTINGS FOR THE
AFORESAID GOODS (U.S. CLS. 22, 23, 38 AND 50).
GIANCARLO CASTRO, EXAMINING ATTORNEY

CLASS 28—(Continued).

SN 77-330,726. MAO, INC., BILOXI, MS. FILED 11-15-2007.



NO CLAIM IS MADE TO THE EXCLUSIVE RIGHT TO USE "HOLD 'EM", APART FROM THE MARK AS SHOWN.

THE MARK CONSISTS OF DEPICTS THE STYLIZED WORDS "LONGHORN HOLD 'EM" IN CONJUNCTION WITH THE BACKSIDE VIEW OF A STEER WEARING A HAT AND HOLDING A PAIR OF PLAYING CARDS SEATED ON A CHAIR COMPOSED IN PART WITH THE TEXAS FLAG, THE FOREGOING IMAGE BORDERED ON THE BOTTOM WITH A FREE FLOATING LONGHORN RACK. A STAR SYMBOL IS USED TO REPRESENT THE SINGLE APOSTROPHE MARK.

FOR AMUSEMENT GAME MACHINES; CARD GAMES; EQUIPMENT SOLD AS A UNIT FOR PLAYING CARD GAMES; GAMING TABLES (U.S. CLS. 22, 23, 38 AND 50).

FIRST USE 1-1-2006; IN COMMERCE 1-1-2006.
DORITT L. CARROLL, EXAMINING ATTORNEY

SN 77-392,200. JAKKS PACIFIC, INC., MALIBU, CA. FILED 2-8-2008.

DREAM FOUNTAIN

THE MARK CONSISTS OF STANDARD CHARACTERS WITHOUT CLAIM TO ANY PARTICULAR FONT, STYLE, SIZE, OR COLOR.

OWNER OF U.S. REG. NO. 2,202,179.

NO CLAIM IS MADE TO THE EXCLUSIVE RIGHT TO USE "FOUNTAIN", APART FROM THE MARK AS SHOWN.

FOR TOYS, GAMES AND PLAYTHINGS, NAMELY, CHILDREN'S PLAY COSMETICS, TOY COSMETIC MAKING KITS, TOY TOILETRY SETS, TOY MAKEUP KITS FOR CHILDREN, TOY PERFUME KITS FOR CHILDREN, TOY PERFUME MAKING KITS FOR CHILDREN (U.S. CLS. 22, 23, 38 AND 50).

MAUREEN DALL, EXAMINING ATTORNEY

CLASS 28—(Continued).

SN 77-395,073. SPIN MASTER LTD., TORONTO ONTARIO, CANADA, FILED 2-12-2008.

KID KLEEN

THE MARK CONSISTS OF STANDARD CHARACTERS WITHOUT CLAIM TO ANY PARTICULAR FONT, STYLE, SIZE, OR COLOR.

PRIORITY CLAIMED UNDER SEC. 44(D) ON CANADA APPLICATION NO. 1372834, FILED 11-20-2007, REG. NO. TMA735547, DATED 3-3-2009, EXPIRES 3-3-2024.

NO CLAIM IS MADE TO THE EXCLUSIVE RIGHT TO USE "CLEAN", APART FROM THE MARK AS SHOWN.

FOR BATH TOYS, MOLDABLE TOY SOAPS AND TOY BUBBLE MAKERS (U.S. CLS. 22, 23, 38 AND 50).

AMY HELLA, EXAMINING ATTORNEY

SN 77-395,680. DEREK D'ANDREA, REGINA, SASKATCHEWAN, CANADA, FILED 2-13-2008.

Fightguard

THE MARK CONSISTS OF STANDARD CHARACTERS WITHOUT CLAIM TO ANY PARTICULAR FONT, STYLE, SIZE, OR COLOR.

PRIORITY CLAIMED UNDER SEC. 44(D) ON CANADA APPLICATION NO. 1380871, FILED 1-28-2008, REG. NO. TMA737805, DATED 4-9-2009, EXPIRES 4-9-2024.

FOR ATHLETIC EQUIPMENT, NAMELY, MOUTH GUARDS (U.S. CLS. 22, 23, 38 AND 50).

JENNIFER VASQUEZ, EXAMINING ATTORNEY

SN 77-425,609. TODD A BOLLING, LAUREL, MD. FILED 3-18-2008.

CORE SIZER

THE MARK CONSISTS OF STANDARD CHARACTERS WITHOUT CLAIM TO ANY PARTICULAR FONT, STYLE, SIZE, OR COLOR.

NO CLAIM IS MADE TO THE EXCLUSIVE RIGHT TO USE "CORE", APART FROM THE MARK AS SHOWN.

FOR EXERCISE BALL APPARATUS, NAMELY, AN EXERCISE BALL ANCHORED ON A PEDESTAL HAVING PULL HANDLES COUPLED TO RESISTANCE MEANS ALLOWING FOR A FULL UPPER BODY WORKOUT (U.S. CLS. 22, 23, 38 AND 50).

ANNE FARRELL, EXAMINING ATTORNEY

CLASS 28—(Continued).

SN 77-443,410. STRATEGIC PARTNERS, INC., CHATSWORTH, CA. FILED 4-8-2008.

Hospital Critterz

THE MARK CONSISTS OF STANDARD CHARACTERS WITHOUT CLAIM TO ANY PARTICULAR FONT, STYLE, SIZE, OR COLOR.

NO CLAIM IS MADE TO THE EXCLUSIVE RIGHT TO USE "CRITTERS", APART FROM THE MARK AS SHOWN.

FOR MOLDED TOY FIGURES; PLUSH TOYS; RUBBER CHARACTER TOYS; SOFT SCULPTURE PLUSH TOYS; SOFT SCULPTURE TOYS; SQUEEZABLE SQUEAKING TOYS; SQUEEZE TOYS; STUFFED AND PLUSH TOYS; STUFFED TOY ANIMALS; STUFFED TOYS; TOY ANIMALS; TOY ANIMALS AND ACCESSORIES THEREFOR; TOY FIGURES (U.S. CLS. 22, 23, 38 AND 50).

DEZMONA MIZELLE, EXAMINING ATTORNEY

CLASS 28—(Continued).

SN 77-484,186. KID GALAXY, INC, MANCHESTER, NH. FILED 5-27-2008.

Bendos

THE MARK CONSISTS OF STANDARD CHARACTERS WITHOUT CLAIM TO ANY PARTICULAR FONT, STYLE, SIZE, OR COLOR.

FOR PLASTIC COATED WIRE FRAME TOY PLAY FIGURES (U.S. CLS. 22, 23, 38 AND 50).

MICHAEL TANNER, EXAMINING ATTORNEY

SN 77-486,488. THE REUBEN B. KLAMER LIVING TRUST, KLAMER, REUBEN B., TRUSTEE, SAN DIEGO, CA. FILED 5-29-2008.

WALL WORLD

THE MARK CONSISTS OF STANDARD CHARACTERS WITHOUT CLAIM TO ANY PARTICULAR FONT, STYLE, SIZE, OR COLOR.

NO CLAIM IS MADE TO THE EXCLUSIVE RIGHT TO USE "WALL", APART FROM THE MARK AS SHOWN.

FOR PLAYTHINGS, NAMELY, WALL-MOUNTED DECORATIVE PLAYSETS FOR DISPLAYING TOYS AND PLAYING WITH TOYS (U.S. CLS. 22, 23, 38 AND 50).

DAVID COLLIER, EXAMINING ATTORNEY

SN 77-468,786. KOMKIN, ANDREY V, BARNAUL, RUSSIAN FED., FILED 5-8-2008.

КАШТАН
 CHESTNUT

OWNER OF RUSSIAN FED. REG. NO. 225277, DATED 10-21-2002, EXPIRES 10-26-2009.

OWNER OF U.S. REG. NOS. 3,467,205 AND 3,479,577.

THE MARK CONSISTS OF A WORD IN CYRILLIC CHARACTERS WHICH TRANSLITERATES TO KASHTAN AND TRANSLATES TO "CHESTNUT". THE WORD IS TYPED IN A SPECIAL STYLE FONT. THERE IS A HORIZONTAL LINE UNDER THAT WORD. UNDER THE LINE THERE IS AN ENGLISH WORD "CHESTNUT".

THE FOREIGN WORDING IN THE MARK TRANSLATES INTO ENGLISH AS CHESTNUT.

THE NON-LATIN CHARACTER(S) IN THE MARK TRANSLITERATE INTO KASHTAN, AND THIS MEANS CHESTNUT IN ENGLISH.

FOR EXERCISE BALLS FOR DEVELOPMENT OF FINE MOTORS SKILLS; REHABILITATION EXERCISE BALLS COVERED WITH POINTED TIPS; STRESS RELIEF BALLS FOR HAND EXERCISE (U.S. CLS. 22, 23, 38 AND 50).

EMILY CARLSEN, EXAMINING ATTORNEY

SN 77-489,373. SNAP A DECK, INC., MIAMI, FL. FILED 6-3-2008.

SNAP A DECK

THE MARK CONSISTS OF STANDARD CHARACTERS WITHOUT CLAIM TO ANY PARTICULAR FONT, STYLE, SIZE, OR COLOR.

NO CLAIM IS MADE TO THE EXCLUSIVE RIGHT TO USE "DECK", APART FROM THE MARK AS SHOWN.

FOR A FLOOR COVERING PRODUCT, CONSISTING OF WOOD FLOORING PLANKS, WOODEN FRAMES AND PLASTIC CONNECTORS FOR CONSTRUCTING DECKS AND FLOORS (U.S. CLS. 22, 23, 38 AND 50).

FIRST USE 4-15-2008; IN COMMERCE 4-15-2008.

BONNIE LUKEN, EXAMINING ATTORNEY

CLASS 28—(Continued).

SN 77-492,691. CUMULUS STUDIOS, LLC, NEW YORK, NY.
FILED 6-6-2008.

CUMULUS STUDIOS

THE MARK CONSISTS OF STANDARD CHARACTERS WITHOUT CLAIM TO ANY PARTICULAR FONT, STYLE, SIZE, OR COLOR.

NO CLAIM IS MADE TO THE EXCLUSIVE RIGHT TO USE "STUDIOS", APART FROM THE MARK AS SHOWN.

FOR GAME TABLES, NAMELY, PING-PONG TABLES; OUTDOOR PLAY EQUIPMENT, NAMELY, CLUB-HOUSES, SWING SETS, JUNGLE GYM SETS, CLIMBING UNITS AND WALLS, SLIDES, AND SANDBOXES; POOL AND BEACH TOYS, NAMELY, PLASTIC SHOVELS, PLASTIC PAILS, PLASTIC WATERING CANS, PLASTIC SHAPES, PLASTIC SIEVES, SAND CASTLE BUILDING SETS COMPRISED OF MOLDS, TOY BOATS, AND INFLATABLE TOYS; SWIMMING AIDS, NAMELY, SWIM FLOATS FOR RECREATIONAL USE, INFLATABLE FLOATATION DEVICES, PLAY SWIMMING POOLS, AND SWIM SEATS; SURFBOARDS (U.S. CLS. 22, 23, 38 AND 50).

REGINA DRUMMOND, EXAMINING ATTORNEY

SN 77-498,803. ABRAMS GENTILE ENTERTAINMENT, INC., NEW YORK, NY. FILED 6-13-2008.

RED FALCON

THE MARK CONSISTS OF STANDARD CHARACTERS WITHOUT CLAIM TO ANY PARTICULAR FONT, STYLE, SIZE, OR COLOR.

FOR TOYS, NAMELY, TOY ACTION FIGURES, TOY ROBOTS CONVERTIBLE INTO OTHER VISUAL TOY FORMS (U.S. CLS. 22, 23, 38 AND 50).

DORITT L. CARROLL, EXAMINING ATTORNEY

SN 77-501,995. DOUGLAS J. FLOOD, NEWMARKET, CANADA, FILED 6-18-2008.

SARGENT

THE MARK CONSISTS OF STANDARD CHARACTERS WITHOUT CLAIM TO ANY PARTICULAR FONT, STYLE, SIZE, OR COLOR.

PRIORITY CLAIMED UNDER SEC. 44(D) ON CANADA APPLICATION NO. 1399339, FILED 6-12-2008.

FOR BASEBALL EQUIPMENT, NAMELY, BATS (U.S. CLS. 22, 23, 38 AND 50).

WILLIAM BRECKENFELD, EXAMINING ATTORNEY

CLASS 28—(Continued).

SN 77-513,993. BIG W PRODUCTIONS, INC., ENCINO, CA.
FILED 7-2-2008.

FACECHIPZ

THE MARK CONSISTS OF STANDARD CHARACTERS WITHOUT CLAIM TO ANY PARTICULAR FONT, STYLE, SIZE, OR COLOR.

FOR TOYS AND GAMES, NAMELY, COLLECTABLE GAME TOKENS FOR USE IN CONNECTION WITH AN ONLINE GAME PLATFORM (U.S. CLS. 22, 23, 38 AND 50).

TINA KUAN, EXAMINING ATTORNEY

SN 77-518,806. FRANDSON, JUSTIN, CORONA DEL MAR, CA. FILED 7-10-2008.

Wog

THE MARK CONSISTS OF THE STYLIZED WORD "WOG".

THE WORDING "WOG" HAS NO MEANING IN A FOREIGN LANGUAGE.

FOR GAMES, NAMELY, MULTIPLE HIGH-DENSITY FOAM BLOCKS THAT USERS TOSS AND CATCH IN A TIMED SEQUENCE USED TO ENHANCE AMBIDEXTERITY, CONCENTRATION AND COORDINATION (U.S. CLS. 22, 23, 38 AND 50).

BILL DAWE, EXAMINING ATTORNEY

SN 77-520,997. VORTEX, INC., AUSTIN, TX. FILED 7-14-2008.

THE TEXAS CHAINSAW MASSACRE

THE MARK CONSISTS OF STANDARD CHARACTERS WITHOUT CLAIM TO ANY PARTICULAR FONT, STYLE, SIZE, OR COLOR.

NO CLAIM IS MADE TO THE EXCLUSIVE RIGHT TO USE "TEXAS", APART FROM THE MARK AS SHOWN.

FOR ACTION FIGURES AND ACCESSORIES THEREFOR; CASES FOR ACTION FIGURES; PLAYING CARD CASES; PLAYING CARDS; PUZZLES; ROLE PLAYING GAMES; TOY FIGURES; TOY TRAINS AND PARTS AND ACCESSORIES THEREFOR; TOY VEHICLES AND ACCESSORIES THEREFOR (U.S. CLS. 22, 23, 38 AND 50).

ROBERT C. CLARK JR., EXAMINING ATTORNEY

CLASS 28—(Continued).

SN 77-522,104. WARRIOR SPORTS, INC., WARREN, MI. FILED 7-15-2008.

WARRIOR DIAMOND

THE MARK CONSISTS OF STANDARD CHARACTERS WITHOUT CLAIM TO ANY PARTICULAR FONT, STYLE, SIZE, OR COLOR.

FOR LACROSSE STICK HANDLES (U.S. CLS. 22, 23, 38 AND 50).

FIRST USE 8-0-2004; IN COMMERCE 8-0-2004.

ANNE E. GUSTASON, EXAMINING ATTORNEY

SN 77-523,814. FREMANTLEMEDIA NORTH AMERICA, INC., BURBANK, CA. FILED 7-16-2008.

I'VE GOT YOUR NUMBER

THE MARK CONSISTS OF STANDARD CHARACTERS WITHOUT CLAIM TO ANY PARTICULAR FONT, STYLE, SIZE, OR COLOR.

FOR TARGET GAMES, BOARD GAMES, CARD GAMES, KITES, TOY ACTION FIGURES, DISC-TYPE TOSS TOYS, ARCHERY BOWS AND ARROWS, BALLS OF ALL KINDS, DOLLS, DOLL PLAYSETS, PLUSH TOYS, TOY VEHICLES, TOY CARS, TOY TRUCKS, TOY BUCKET AND SHOVEL SETS, ROLLER SKATES, TOY MODEL HOBBYCRAFT KITS, TOY ROCKETS, TOY GUNS, TOY HOLSTERS, MUSICAL TOYS, JIGSAW PUZZLES, BADMINTON SETS, BUBBLE MAKING WANDS AND SOLUTION SETS, TOY FIGURINES, TOY BANKS, PUPPETS, TOY BALLOONS, YO-YOS, SKATEBOARDS, TOY SCOOTERS, FACE MASKS, STAND ALONE VIDEO GAME MACHINES, LCD GAME MACHINES, HAND HELD UNIT FOR PLAYING ELECTRONIC GAMES, BUT SPECIFICALLY EXCLUDING DICE GAMES AND COMPUTER SOFTWARE GAMES; LOTTERY TICKETS AND SCRATCH CARDS FOR PLAYING LOTTERY GAMES; COIN-OPERATED VIDEO GAMES; ARCADE GAMES (U.S. CLS. 22, 23, 38 AND 50).

MARTHA FROMM, EXAMINING ATTORNEY

SN 77-525,883. BAD ASS INTERNATIONAL TACKLE, SEMINOLE, FL. FILED 7-18-2008.

Bad Ass International Tackle

THE MARK CONSISTS OF STANDARD CHARACTERS WITHOUT CLAIM TO ANY PARTICULAR FONT, STYLE, SIZE, OR COLOR.

NO CLAIM IS MADE TO THE EXCLUSIVE RIGHT TO USE "INTERNATIONAL TACKLE", APART FROM THE MARK AS SHOWN.

FOR FISHING TACKLE; PACKAGED FREEZE-DRIED FISHING BAIT (U.S. CLS. 22, 23, 38 AND 50).

JILL PRATER, EXAMINING ATTORNEY

CLASS 28—(Continued).

SN 77-532,302. I LOVE MY PLANET TOYS, INC., NEW CITY, NY. FILED 7-27-2008.



NO CLAIM IS MADE TO THE EXCLUSIVE RIGHT TO USE "TOYS", APART FROM THE MARK AS SHOWN.

THE COLOR(S) BLUE, RED, GREEN, BROWN IS/ARE CLAIMED AS A FEATURE OF THE MARK.

THE MARK CONSISTS OF THE WORDING "I MY PLANET TOYS" WITH A STYLIZED RED HEART DESIGN BETWEEN THE TERMS "I" AND "MY". THE WORDS "I" AND "MY" ARE BLUE. THE TERM "PLANET" IS GREEN, AND THE TERM "TOYS" IS BROWN.

FOR (BASED ON USE IN COMMERCE) EDUCATIONAL TOY FOR THE PURPOSE OF THE DEMONSTRATION OF ALTERNATIVE ENERGY SOURCES; FANTASY CHARACTER TOYS; MUSIC BOX TOYS; MUSICAL TOYS; PLUSH TOYS; POP UP TOYS; POSITIONABLE PRINTED TOY FIGURES FOR USE IN PUZZLES; POSITIONABLE TOY FIGURES; PULL TOYS; PUSH TOYS; RIDE-ON TOYS; SOFT SCULPTURE PLUSH TOYS; SOFT SCULPTURE TOYS; STUFFED AND PLUSH TOYS; STUFFED TOY ANIMALS; STUFFED TOYS; TOY ANIMALS; TOY ANIMALS AND ACCESSORIES THEREFOR; TOY BUILDINGS AND ACCESSORIES THEREFOR; TOY FIGURES; TOY MOBILES; TOY MUSIC BOXES; TOY XYLOPHONES (BASED ON INTENT TO USE) BENDABLE TOYS; CHILDREN'S MULTIPLE ACTIVITY TOYS; CRIB TOYS; INFANT DEVELOPMENT TOYS; INFANT TOYS; PLAY MATS CONTAINING INFANT TOYS (U.S. CLS. 22, 23, 38 AND 50).

FIRST USE 6-18-2008; IN COMMERCE 6-18-2008.

NELSON SNYDER, EXAMINING ATTORNEY

SN 77-543,717. INTERACTIVE TOY CONCEPTS, LTD., TORONTO, ONTARIO, CANADA, FILED 8-11-2008.

Feel What's Real

THE MARK CONSISTS OF STANDARD CHARACTERS WITHOUT CLAIM TO ANY PARTICULAR FONT, STYLE, SIZE, OR COLOR.

FOR RADIO-CONTROLLED AND BATTERY-OPERATED TOY AIRPLANES, GLIDERS, BLIMPS, HELICOPTERS, AIRCRAFT, AND GROUND VEHICLES (U.S. CLS. 22, 23, 38 AND 50).

ELLEN PERKINS, EXAMINING ATTORNEY

CLASS 28—(Continued).

SN 77-550,521. TURTLE POND PUBLICATIONS LLC, NEW YORK, NY. FILED 8-19-2008.

Mivumbi



THE MARK CONSISTS OF THE WORD "MIVUMBI" WITH A FOUR PART MISCELLANEOUS DESIGN. THE WORDING "MIVUMBI" HAS NO MEANING IN A FOREIGN LANGUAGE. FOR PLUSH TOYS (U.S. CLS. 22, 23, 38 AND 50). KAREN K. BUSH, EXAMINING ATTORNEY

SN 77-550,565. TURTLE POND PUBLICATIONS LLC, NEW YORK, NY. FILED 8-19-2008.

Tumaini



THE MARK CONSISTS OF THE WORD "TUMAINI" WITH A STYLIZED FLOWER DESIGN. THE ENGLISH TRANSLATION OF THE WORD "TUMAINI" IS HOPE OR BELIEF FOR PLUSH TOYS (U.S. CLS. 22, 23, 38 AND 50). KAREN K. BUSH, EXAMINING ATTORNEY

CLASS 28—(Continued).

SN 77-556,098. SRI KABUSHIKI KAISHA, TA SRI SPORTS LIMITED, KOBE-SHI, HYOGO, JAPAN, FILED 8-26-2008.

SRIXON LADY

THE MARK CONSISTS OF STANDARD CHARACTERS WITHOUT CLAIM TO ANY PARTICULAR FONT, STYLE, SIZE, OR COLOR. OWNER OF U.S. REG. NOS. 2,900,232 AND 2,993,532. NO CLAIM IS MADE TO THE EXCLUSIVE RIGHT TO USE "LADY", APART FROM THE MARK AS SHOWN. THE WORDING "SRIXON" HAS NO MEANING IN A FOREIGN LANGUAGE. FOR GOLF BALLS (U.S. CLS. 22, 23, 38 AND 50). HENRY S. ZAK, EXAMINING ATTORNEY

SN 77-561,286. ACELERANT INCORPORATED, DBA STINGRAY TACKLE COMPANY, VIRGINIA BEACH, VA. FILED 9-3-2008.

INDIGO BAY

THE MARK CONSISTS OF STANDARD CHARACTERS WITHOUT CLAIM TO ANY PARTICULAR FONT, STYLE, SIZE, OR COLOR. FOR FISHING RODS (U.S. CLS. 22, 23, 38 AND 50). FIRST USE 6-1-2008; IN COMMERCE 6-1-2008. BARNEY CHARLON, EXAMINING ATTORNEY

CLASS 28—(Continued).

SN 77-575,993. CDS-IP, S.A., SAINTES, BELGIUM, FILED 9-22-2008.



OWNER OF ERPN CMNTY TM OFC REG. NO. 004457958, DATED 7-11-2006, EXPIRES 5-26-2015.

THE MARK CONSISTS OF THE STYLIZED LITERAL ELEMENT "D".

FOR GOLF CLUBS; GOLF BALLS; GOLF GLOVES; GOLF BAGS; TROLLEY BAGS FOR GOLF EQUIPMENT; GOLF TEES; GOLF HEAD COVERS; TENNIS RACKETS; SQUASH RACKETS; BADMINTON RACKETS; TABLE TENNIS BATS; TENNIS BALLS; SQUASH BALLS; SHUTTLECOCKS; TABLE TENNIS BALLS; BAGS FOR CARRYING TENNIS RACKETS; BAGS FOR CARRYING SQUASH RACKETS; BAGS FOR CARRYING BADMINTON RACKETS; BAGS FOR CARRYING TABLE TENNIS BATS; REPLACEMENT GRIPS FOR TENNIS RACKETS AND GOLF CLUBS; TENNIS RACKET HEAD COVERS; VIBRATION DAMPENERS, NAMELY, FOR TENNIS RACKETS (U.S. CLS. 22, 23, 38 AND 50).

EDWARD FENNESSY, EXAMINING ATTORNEY

SN 77-598,535. WILLIAMS, JAMES CASEY, PALOS VERDES, CA. FILED 10-22-2008.

SICK SKATEBOARDS

THE MARK CONSISTS OF STANDARD CHARACTERS WITHOUT CLAIM TO ANY PARTICULAR FONT, STYLE, SIZE, OR COLOR.

NO CLAIM IS MADE TO THE EXCLUSIVE RIGHT TO USE "SKATEBOARDS", APART FROM THE MARK AS SHOWN.

FOR SKATEBOARD DECKS; SKATEBOARD TRUCKS; SKATEBOARD WHEELS; SKATEBOARDS (U.S. CLS. 22, 23, 38 AND 50).

JACLYN KIDWELL, EXAMINING ATTORNEY

CLASS 28—(Continued).

SN 77-606,417. BANACH, AARON C., DBA VALUE GOLF, GIRARD, PA. FILED 11-3-2008.

Value Golf

THE MARK CONSISTS OF STANDARD CHARACTERS WITHOUT CLAIM TO ANY PARTICULAR FONT, STYLE, SIZE, OR COLOR.

NO CLAIM IS MADE TO THE EXCLUSIVE RIGHT TO USE "GOLF", APART FROM THE MARK AS SHOWN.

FOR FITTED HEAD COVERS FOR GOLF CLUBS; GOLF BALLS; GOLF CLUB BAGS; GOLF CLUB COVERS; GOLF CLUB GRIPS; GOLF CLUB HEADS; GOLF CLUB SHAFTS; GOLF CLUBS; GOLF IRONS; GOLF PUTTER COVERS; GOLF PUTTERS; HEAD COVERS FOR GOLF CLUBS (U.S. CLS. 22, 23, 38 AND 50).

FIRST USE 9-1-2001; IN COMMERCE 9-1-2001.

GENE MACIOL, EXAMINING ATTORNEY

SN 77-612,885. INTERNATIONAL PLAYTHINGS, INC., PAR-SIPPANY, NJ. FILED 11-12-2008.

SCRUB-A-DUB DOGGIE

THE MARK CONSISTS OF STANDARD CHARACTERS WITHOUT CLAIM TO ANY PARTICULAR FONT, STYLE, SIZE, OR COLOR.

NO CLAIM IS MADE TO THE EXCLUSIVE RIGHT TO USE "DOGGIE", APART FROM THE MARK AS SHOWN.

FOR BATH TOYS (U.S. CLS. 22, 23, 38 AND 50).

MARIA-VICTORIA SUAREZ, EXAMINING ATTORNEY

SN 77-634,479. RATNER, BRETT, LOS ANGELES, CA. FILED 12-16-2008.

HILHAVEN LODGE

THE MARK CONSISTS OF STANDARD CHARACTERS WITHOUT CLAIM TO ANY PARTICULAR FONT, STYLE, SIZE, OR COLOR.

FOR CROQUET SET, BOCCE BALLS, DART BOARDS, DARTS, POOL BALLS, POOL CUES, BACKGAMMON GAMES, PLAYING CARDS, POKER CHIPS, CHESS SET, DOMINOS, TABLE TENNIS PADDLES, TABLE TENNIS BALLS, GOLF CLUBS, GOLF CLUB COVERS, GOLF BALLS, GOLF TEES, BAGS SPECIFICALLY ADAPTED FOR SPORTS EQUIPMENT, GOLF CLUB PROTECTORS, NAMELY, CLUB HEAD COVERS, GOLF MARKERS AND GOLF GLOVES (U.S. CLS. 22, 23, 38 AND 50).

EUGENIA MARTIN, EXAMINING ATTORNEY

CLASS 28—(Continued).

SN 77-647,139. HAGUE, MATTHEW J, DBA FAN JETS USA, OSCEOLA, IN. FILED 1-10-2009.

JETAPULT

THE MARK CONSISTS OF STANDARD CHARACTERS WITHOUT CLAIM TO ANY PARTICULAR FONT, STYLE, SIZE, OR COLOR.
FOR RADIO CONTROLLED MODEL VEHICLE LAUNCHER (U.S. CLS. 22, 23, 38 AND 50).
FIRST USE 12-13-2008; IN COMMERCE 12-13-2008.
HOWARD SMIGA, EXAMINING ATTORNEY

SN 77-649,320. PEREZ, JOSE RIGOBERTO, YONKERS, NY. FILED 1-14-2009.

Rigonball

THE MARK CONSISTS OF STANDARD CHARACTERS WITHOUT CLAIM TO ANY PARTICULAR FONT, STYLE, SIZE, OR COLOR.
FOR BALLS FOR SPORTS (U.S. CLS. 22, 23, 38 AND 50).
DAVID TOOLEY, EXAMINING ATTORNEY

SN 77-654,773. MATTEL, INC., EL SEGUNDO, CA. FILED 1-22-2009.

HI-TAIL HAULER

THE MARK CONSISTS OF STANDARD CHARACTERS WITHOUT CLAIM TO ANY PARTICULAR FONT, STYLE, SIZE, OR COLOR.

OWNER OF U.S. REG. NO. 3,258,079.
NO CLAIM IS MADE TO THE EXCLUSIVE RIGHT TO USE "HAULER", APART FROM THE MARK AS SHOWN.
FOR TOYS, GAMES AND PLAYTHINGS, NAMELY, TOY VEHICLES AND ACCESSORIES THEREFOR (U.S. CLS. 22, 23, 38 AND 50).
AMY KERTGATE, EXAMINING ATTORNEY

CLASS 28—(Continued).

SN 77-661,338. ZOBMONDO!! ENTERTAINMENT LLC, LOS ANGELES, CA. FILED 2-2-2009.

Spin Meister

THE MARK CONSISTS OF STANDARD CHARACTERS WITHOUT CLAIM TO ANY PARTICULAR FONT, STYLE, SIZE, OR COLOR.
FOR BOARD GAMES; CARD GAMES; PARTY GAMES (U.S. CLS. 22, 23, 38 AND 50).
ELLEN BURNS, EXAMINING ATTORNEY

SN 77-662,672. RIZZO, PATRICIA, SAN CLEMENTE, CA. FILED 2-3-2009.



THE STIPPLING IS FOR SHADING PURPOSES ONLY.
THE MARK CONSISTS OF THE STYLIZED TEXT "STIK CHECK" AND A LACROSSE PLAYER IN THE SHAPE OF THE "K" IN THE TEXT "STIK". THE LACROSSE PLAYER IS SHOOTING A BALL TOWARDS THE GOAL. EMANATING FROM THE LETTER "I" IN THE TEXT "STIK" IS A CURVED BAND THAT EXTENDS OUT FROM LEFT TO RIGHT. ON THE BACKGROUND OF THE TEXT "CHECK" THERE IS A GOAL GRAPHIC NET. THE SIDE POSTS OF THE GOAL ARE FORMED BY THE LETTERS "H" AND "K" IN THE TEXT "CHECK".

FOR STORAGE RACKS FOR ATHLETIC EQUIPMENT (U.S. CLS. 22, 23, 38 AND 50).
FIRST USE 1-5-2009; IN COMMERCE 1-5-2009.
BRIAN CALLAGHAN, EXAMINING ATTORNEY

CLASS 28—(Continued).

SN 77-663,910. MVL RIGHTS LLC, MANHATTAN BEACH, CA. FILED 2-5-2009.

IRON MAN

THE MARK CONSISTS OF STANDARD CHARACTERS WITHOUT CLAIM TO ANY PARTICULAR FONT, STYLE, SIZE, OR COLOR.

OWNER OF U.S. REG. NOS. 893,304, 1,355,280 AND 2,442,890.

FOR ARCADE GAMES; BALLOONS; BALLS FOR GAMES; BATTERY OPERATED ACTION TOYS; BOARD GAMES; BOBBLE HEAD DOLLS; CARD GAMES; CHRISTMAS TREE ORNAMENTS AND DECORATIONS; COIN-OPERATED VIDEO GAMES; COLLECTABLE TOY FIGURES; DOLL ACCESSORIES; DOLLS; ELBOW GUARDS FOR ATHLETIC USE; FLYING DISCS; INFLATABLE BOP BAGS; INFLATABLE SWIMMING POOLS; INFLATABLE TOYS; JIGSAW PUZZLES; KITES; KNEE GUARDS FOR ATHLETIC USE; MECHANICAL ACTION TOYS; PINBALL GAMES; PINBALL-TYPE GAMES; PLAY SETS FOR ACTION FIGURES; PLAYING CARDS; PLAYSETS FOR MAKE-BELIEVE PLAY BATTLE AND ADVENTURE ACTIVITIES; PLUSH TOYS; RADIO CONTROLLED TOY VEHICLES; ROLE PLAYING GAMES; ROLLER SKATES; RUBBER BALLS; SKATEBOARDS; SNOW SLEDS FOR RECREATIONAL USE; SOFT SCULPTURE TOYS; SWIM BOARDS FOR RECREATIONAL USE; TARGET GAMES; TOY ACTION FIGURES AND ACCESSORIES THEREFOR; TOY MODEL HOBBY-CRAFT KITS; TOY VEHICLES AND ACCESSORIES THEREFOR; TOY WEAPONS; WATER SQUIRTING TOYS; YO-YOS (U.S. CLS. 22, 23, 38 AND 50).

FIRST USE 9-7-1978; IN COMMERCE 9-7-1978.

ANNE E. GUSTASON, EXAMINING ATTORNEY

SN 77-664,018. WINNING MOVES INC., DANVERS, MA. FILED 2-5-2009.

25 RANDOM THINGS ABOUT ME

THE MARK CONSISTS OF STANDARD CHARACTERS WITHOUT CLAIM TO ANY PARTICULAR FONT, STYLE, SIZE, OR COLOR.

FOR BOARD GAMES; CARD GAMES; DICE GAMES (U.S. CLS. 22, 23, 38 AND 50).

RAUL CORDOVA, EXAMINING ATTORNEY

CLASS 28—(Continued).

SN 77-664,113. JAKKS PACIFIC, INC., MALIBU, CA. FILED 2-5-2009.

GX SKATE

THE MARK CONSISTS OF STANDARD CHARACTERS WITHOUT CLAIM TO ANY PARTICULAR FONT, STYLE, SIZE, OR COLOR.

NO CLAIM IS MADE TO THE EXCLUSIVE RIGHT TO USE "SKATE", APART FROM THE MARK AS SHOWN.

FOR TOYS, GAMES AND PLAYTHINGS, NAMELY, SPINNING TOYS AND ACCESSORIES THEREFOR; PLAYSETS FOR SPINNING TOYS, TOY VEHICLES AND ACCESSORIES THEREFOR; PLAYSETS FOR TOY VEHICLES (U.S. CLS. 22, 23, 38 AND 50).

RICHARD A. STRASER, EXAMINING ATTORNEY

SN 77-664,486. TRISAR, INC., ORANGE, CA. FILED 2-5-2009.

YA OTTA PIÑATA

THE MARK CONSISTS OF STANDARD CHARACTERS WITHOUT CLAIM TO ANY PARTICULAR FONT, STYLE, SIZE, OR COLOR.

NO CLAIM IS MADE TO THE EXCLUSIVE RIGHT TO USE "PIÑATA", APART FROM THE MARK AS SHOWN.

FOR PINATAS AND ACCESSORIES, NAMELY, BATS AND BLINDFOLDS (U.S. CLS. 22, 23, 38 AND 50).

FIRST USE 12-31-1988; IN COMMERCE 12-31-1988.

CYNTHIA SLOAN, EXAMINING ATTORNEY

SN 77-665,061. KABUSHIKI KAISHA MIKI, DBA MIKI CO., LTD., GUNMA-KEN 370-2321, JAPAN, FILED 2-6-2009.

DUAL FORCE

THE MARK CONSISTS OF STANDARD CHARACTERS WITHOUT CLAIM TO ANY PARTICULAR FONT, STYLE, SIZE, OR COLOR.

FOR POOL CUES AND BILLIARD GAME PLAYING EQUIPMENT (U.S. CLS. 22, 23, 38 AND 50).

FIRST USE 9-12-2008; IN COMMERCE 1-10-2009.

GEOFFREY FOSDICK, EXAMINING ATTORNEY

CLASS 28—(Continued).

SN 77-665,560. SKI-EZE PRODUCTS INTERNATIONAL INC., BRIDGEPORT, CT. FILED 2-6-2009.

Ski Hugger

THE MARK CONSISTS OF STANDARD CHARACTERS WITHOUT CLAIM TO ANY PARTICULAR FONT, STYLE, SIZE, OR COLOR.

NO CLAIM IS MADE TO THE EXCLUSIVE RIGHT TO USE "SKI", APART FROM THE MARK AS SHOWN.

FOR PADDED SKI HOLDER AND CARRIERS, NAMELY, PADDED BAGS FOR HOLDING AND CARRYING SKIS (U.S. CLS. 22, 23, 38 AND 50).

TRACY WHITTAKER-BROWN, EXAMINING ATTORNEY

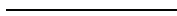

SN 77-665,706. SKIRTS UNLIMITED, INC., KINSALE, VA. FILED 2-7-2009.

Living Image

THE MARK CONSISTS OF STANDARD CHARACTERS WITHOUT CLAIM TO ANY PARTICULAR FONT, STYLE, SIZE, OR COLOR.

FOR FISHING SKIRTS (U.S. CLS. 22, 23, 38 AND 50).

FIRST USE 6-1-2008; IN COMMERCE 6-1-2008.

GRETTA YAO, EXAMINING ATTORNEY



SN 77-666,006. ATLAS O, LLC., HILLSIDE, NJ. FILED 2-9-2009.

ANGEL TRAIN

THE MARK CONSISTS OF STANDARD CHARACTERS WITHOUT CLAIM TO ANY PARTICULAR FONT, STYLE, SIZE, OR COLOR.

NO CLAIM IS MADE TO THE EXCLUSIVE RIGHT TO USE "TRAIN", APART FROM THE MARK AS SHOWN.

FOR TOY MODEL TRAIN SETS; TOY TRAINS AND PARTS AND ACCESSORIES THEREFOR (U.S. CLS. 22, 23, 38 AND 50).

TARAH HARDY, EXAMINING ATTORNEY

CLASS 28—(Continued).

SN 77-666,154. MATTEL, INC., EL SEGUNDO, CA. FILED 2-9-2009.

HEK-TOR KUR

THE MARK CONSISTS OF STANDARD CHARACTERS WITHOUT CLAIM TO ANY PARTICULAR FONT, STYLE, SIZE, OR COLOR.

FOR TOYS, GAMES AND PLAYTHINGS, NAMELY, TOY ACTION FIGURES AND ACCESSORIES THEREFOR (U.S. CLS. 22, 23, 38 AND 50).

REBECCA POVARCHUK, EXAMINING ATTORNEY



SN 77-666,334. NORTHLAND FISHING TACKLE, INC., BEMIDJI, MN. FILED 2-9-2009.

GILL GETTER

THE MARK CONSISTS OF STANDARD CHARACTERS WITHOUT CLAIM TO ANY PARTICULAR FONT, STYLE, SIZE, OR COLOR.

FOR FISHING TACKLE (U.S. CLS. 22, 23, 38 AND 50).

FIRST USE 7-0-2008; IN COMMERCE 7-0-2008.

JAY FLOWERS, EXAMINING ATTORNEY



SN 77-666,393. WARRIOR SPORTS, INC., DBA BRINE, WARREN, MI. FILED 2-9-2009.



THE COLOR(S) LIGHT BLUE AND DARK BLUE IS/ARE CLAIMED AS A FEATURE OF THE MARK.

THE MARK CONSISTS OF A TRIANGULAR DESIGN MADE UP OF THREE DARK AND LIGHT BLUE SWOOSHES.

FOR VOLLEYBALLS (U.S. CLS. 22, 23, 38 AND 50).

TEJBIR SINGH, EXAMINING ATTORNEY

CLASS 28—(Continued).

SN 77-666,400. WARRIOR SPORTS, INC., DBA BRINE, WARREN, MI. FILED 2-9-2009.

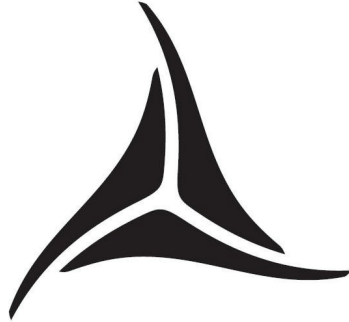

THE MARK CONSISTS OF A TRIANGULAR DESIGN MADE UP OF THREE SWOOSHES.
FOR VOLLEYBALLS (U.S. CLS. 22, 23, 38 AND 50).
TEJBIR SINGH, EXAMINING ATTORNEY

SN 77-666,456. NORTHLAND FISHING TACKLE, INC., BEMIDJI, MN. FILED 2-9-2009.

TRICK-STICK

THE MARK CONSISTS OF STANDARD CHARACTERS WITHOUT CLAIM TO ANY PARTICULAR FONT, STYLE, SIZE, OR COLOR.
OWNER OF U.S. REG. NOS. 1,487,643 AND 3,225,796.
FOR FISHING TACKLE (U.S. CLS. 22, 23, 38 AND 50).
FIRST USE 7-0-2007; IN COMMERCE 7-0-2007.
JAY FLOWERS, EXAMINING ATTORNEY

SN 77-666,618. NORTHLAND FISHING TACKLE, INC., BEMIDJI, MN. FILED 2-9-2009.

SLURP!

THE MARK CONSISTS OF STANDARD CHARACTERS WITHOUT CLAIM TO ANY PARTICULAR FONT, STYLE, SIZE, OR COLOR.
OWNER OF U.S. REG. NO. 3,417,023.
FOR FISHING TACKLE (U.S. CLS. 22, 23, 38 AND 50).
FIRST USE 7-0-2008; IN COMMERCE 7-0-2008.
JAY FLOWERS, EXAMINING ATTORNEY

CLASS 28—(Continued).

SN 77-666,710. BEACH TENNIS USA, LLC, NEW YORK, NY. FILED 2-9-2009.



OWNER OF U.S. REG. NOS. 3,245,602, 3,352,967 AND 3,612,781.

NO CLAIM IS MADE TO THE EXCLUSIVE RIGHT TO USE "BEACH TENNIS USA", APART FROM THE MARK AS SHOWN.

THE MARK CONSISTS OF AN OVAL WITH A SILHOUETTE OF A PERSON HITTING A BALL WITH A RACKET INSIDE AND THE LITERAL ELEMENT "BEACH TENNIS USA" BELOW.

FOR SPORTS EQUIPMENT, NAMELY, BEACH TENNIS PADDLES (U.S. CLS. 22, 23, 38 AND 50).
EMILY CARLSEN, EXAMINING ATTORNEY

SN 77-667,276. JOSEPH A. KLINGELE, PLANO, TX. FILED 2-10-2009.

Sir Launchalot

THE MARK CONSISTS OF STANDARD CHARACTERS WITHOUT CLAIM TO ANY PARTICULAR FONT, STYLE, SIZE, OR COLOR.

FOR GOLF CLUBS (U.S. CLS. 22, 23, 38 AND 50).
TRICIA SONNEBORN, EXAMINING ATTORNEY

SN 77-667,642. MATTEL, INC., EL SEGUNDO, CA. FILED 2-10-2009.

TOOLIGAN

THE MARK CONSISTS OF STANDARD CHARACTERS WITHOUT CLAIM TO ANY PARTICULAR FONT, STYLE, SIZE, OR COLOR.

FOR TOYS, GAMES AND PLAYTHINGS, NAMELY, TOY VEHICLES AND ACCESSORIES THEREFOR (U.S. CLS. 22, 23, 38 AND 50).

REBECCA POVARCHUK, EXAMINING ATTORNEY

CLASS 28—(Continued).

SN 77-667,819. THE MAYA GROUP, INC., GARDEN GROVE, CA. FILED 2-10-2009.

MAXTECH TOYS

THE MARK CONSISTS OF STANDARD CHARACTERS WITHOUT CLAIM TO ANY PARTICULAR FONT, STYLE, SIZE, OR COLOR.

NO CLAIM IS MADE TO THE EXCLUSIVE RIGHT TO USE "TOYS", APART FROM THE MARK AS SHOWN.

FOR TOYS, GAMES AND PLAYTHINGS, NAMELY, NON-ELECTRONIC TOY VEHICLES, RADIO CONTROL CARS, REMOTE CONTROL CARS, BOATS AND AIRPLANES, DIE CAST TOY VEHICLES, AND SCALE MODEL VEHICLES AND AIRPLANES (U.S. CLS. 22, 23, 38 AND 50).

JOHN DALIER, EXAMINING ATTORNEY

CLASS 28—(Continued).

SN 77-669,128. WINNING MOVES INC., DANVERS, MA. FILED 2-12-2009.

TAKE A CHANCE

THE MARK CONSISTS OF STANDARD CHARACTERS WITHOUT CLAIM TO ANY PARTICULAR FONT, STYLE, SIZE, OR COLOR.

FOR BOARD GAMES; CARD GAMES; DICE GAMES (U.S. CLS. 22, 23, 38 AND 50).

RAUL CORDOVA, EXAMINING ATTORNEY

SN 77-669,302. MATTEL, INC., EL SEGUNDO, CA. FILED 2-12-2009.

PLAY 'N WIGGLE

THE MARK CONSISTS OF STANDARD CHARACTERS WITHOUT CLAIM TO ANY PARTICULAR FONT, STYLE, SIZE, OR COLOR.

FOR TOYS, GAMES AND PLAYTHINGS, NAMELY, DOLLS, DOLL CLOTHING AND DOLL ACCESSORIES, PLUSH TOYS AND ACCESSORIES THEREFOR (U.S. CLS. 22, 23, 38 AND 50).

REBECCA POVARCHUK, EXAMINING ATTORNEY

SN 77-669,303. MATTEL, INC., EL SEGUNDO, CA. FILED 2-12-2009.

PEEK AND WIGGLE

THE MARK CONSISTS OF STANDARD CHARACTERS WITHOUT CLAIM TO ANY PARTICULAR FONT, STYLE, SIZE, OR COLOR.

FOR TOYS, GAMES AND PLAYTHINGS, NAMELY, DOLLS, DOLL CLOTHING AND DOLL ACCESSORIES, PLUSH TOYS AND ACCESSORIES THEREFOR (U.S. CLS. 22, 23, 38 AND 50).

REBECCA POVARCHUK, EXAMINING ATTORNEY

SN 77-669,094. I PLAY, INC., ASHEVILLE, NC. FILED 2-12-2009.



THE MARK CONSISTS OF A STYLIZED SLEEPING SPROUT NESTLED IN AND PARTIALLY SURROUNDED BY THE TWO HALVES OF A POD RESTING ON TWO SMALL FAUX FEET.

FOR BABY MULTIPLE ACTIVITY TOYS; BABY RATTLES; BABY RATTLES INCORPORATING TEETHING RINGS; BATH TOYS; DOLLS; INFANT DEVELOPMENT TOYS; INFANT TOYS; PLAY BALLS AND PLAY BALLOONS; STACKING TOYS; AND STUFFED AND PLUSH TOYS (U.S. CLS. 22, 23, 38 AND 50).

AISHA SALEM, EXAMINING ATTORNEY

CLASS 28—(Continued).

SN 77-671,803. MATTEL, INC., EL SEGUNDO, CA. FILED 2-17-2009.

SIR HOOTS A LOT

THE MARK CONSISTS OF STANDARD CHARACTERS WITHOUT CLAIM TO ANY PARTICULAR FONT, STYLE, SIZE, OR COLOR.

FOR TOYS, GAMES AND PLAYTHINGS, NAMELY, TOY FIGURES AND ACCESSORIES THEREFOR (U.S. CLS. 22, 23, 38 AND 50).

REBECCA POVARCHUK, EXAMINING ATTORNEY

SN 77-672,254. MATTEL, INC., EL SEGUNDO, CA. FILED 2-17-2009.

ARAMINA

THE MARK CONSISTS OF STANDARD CHARACTERS WITHOUT CLAIM TO ANY PARTICULAR FONT, STYLE, SIZE, OR COLOR.

FOR TOYS, GAMES AND PLAYTHINGS, NAMELY, DOLLS, DOLL CLOTHING AND DOLL ACCESSORIES (U.S. CLS. 22, 23, 38 AND 50).

REBECCA POVARCHUK, EXAMINING ATTORNEY

CLASS 28—(Continued).

SN 77-675,851. UNITED STATES VOLLEYBALL ASSOCIATION, COLORADO SPRINGS, CO. FILED 2-23-2009.



USA Volleyball

OWNER OF U.S. REG. NOS. 2,144,649, 3,087,363 AND OTHERS.

NO CLAIM IS MADE TO THE EXCLUSIVE RIGHT TO USE "VOLLEYBALL", APART FROM THE MARK AS SHOWN.

THE COLOR(S) RED, WHITE, AND BLUE IS/ARE CLAIMED AS A FEATURE OF THE MARK.

THE MARK CONSISTS OF THE WORDING "USA VOLLEYBALL" BELOW A VOLLEYBALL DESIGN. THE VOLLEYBALL IS SPLIT INTO THIRDS AND IS COLORED TO RESEMBLE AN AMERICAN FLAG. THE TOP LEFT THIRD OF THE BALL CONTAINS NUMEROUS WHITE STARS ON A BLUE FIELD. THE RIGHT AND BOTTOM THIRDS OF THE BALL EACH CONTAIN THREE STRIPES OF RED, WHITE, RED. THE WORD "USA" IS IN RED, WHILE THE WORD "VOLLEYBALL" IS IN BLUE.

SEC. 2(F) "USA VOLLEYBALL".

FOR VOLLEYBALLS; TOY VOLLEYBALLS; VOLLEYBALL NETS; TOY VOLLEYBALL NETS; VOLLEYBALL NET SUPPORT SYSTEMS; TOY VOLLEYBALL NET SUPPORT SYSTEMS; VOLLEYBALL NET SUPPORT PADDING; KNEE PADS FOR ATHLETIC USE (U.S. CLS. 22, 23, 38 AND 50).

CORY BOONE, EXAMINING ATTORNEY

SN 77-684,983. MICHAEL WADDELL, LLC, FORTSON, GA. FILED 3-6-2009.

MICHAEL WADDELL

THE MARK CONSISTS OF STANDARD CHARACTERS WITHOUT CLAIM TO ANY PARTICULAR FONT, STYLE, SIZE, OR COLOR.

FOR HUNTING GAME CALLS, NAMELY, MOUTH CALLS, BOX CALLS, ELECTRONIC CALLS, GRUNT CALLS; IMPLEMENTS FOR ARCHERY, NAMELY, BOWS, SIGHTS, RESTS, RELEASES, STABILIZERS, CASES, ARROWS, BROAD HEADS, ARROW WRAPS, ARROW FLETCHING DEVICES, STRINGS; HUNTING DECOYS AND ACCESSORIES THEREFOR, NAMELY, NON-MOTORIZED DECOY BODIES; HUNTING BLINDS; HUNTING STANDS; HUNTING SLING SHOTS; HUNTER'S SCENT CAMOUFLAGE, NAMELY, HUMAN ODOR COVER SCENTS FOR USE IN HUNTING (U.S. CLS. 22, 23, 38 AND 50).

JACQUELINE A. LAVINE, EXAMINING ATTORNEY

CLASS 28—(Continued).

SN 77-686,934. LICHODZIEJEWSKI, MICHAEL J., CHICAGO, IL. FILED 3-10-2009.

GIGGLETRON

THE MARK CONSISTS OF STANDARD CHARACTERS WITHOUT CLAIM TO ANY PARTICULAR FONT, STYLE, SIZE, OR COLOR.

FOR TOYS, NAMELY, ELECTRONIC ACTION TOYS, ELECTRONIC LEARNING TOYS, CHILDREN'S ELECTRONIC OR NON-ELECTRONIC TOYS, NAMELY, CHILDREN'S MULTIPLE ACTIVITY TOYS, CHILDREN'S MULTIPLE ACTIVITY TOYS SOLD AS A UNIT WITH PRINTED BOOKS, ELECTRONIC ACTION TOYS, BOARD GAMES, PRESCHOOL TOYS, NAMELY, ROLE PLAYING GAMES, HANDS-ON LEARNING TOYS, NAMELY, PUZZLES AND BUILDING BLOCKS, CHARACTER AND NON-CHARACTER BASED MULTIPLE ACTIVITY PLAY SETS FOR ACTION FIGURES, ELECTRONIC AND NON-ELECTRONIC CREATIVE TOYS, NAMELY, DRAWING TOYS, MUSICAL TOYS, HANDHELD UNITS FOR PLAYING ELECTRONIC GAMES, INFANT TOYS, PLUSH TOYS (U.S. CLS. 22, 23, 38 AND 50).

JESSICA A. POWERS, EXAMINING ATTORNEY

SN 77-688,011. WINNING MOVES INC., DANVERS, MA. FILED 3-11-2009.

JACK AND THE BEANSTALK

THE MARK CONSISTS OF STANDARD CHARACTERS WITHOUT CLAIM TO ANY PARTICULAR FONT, STYLE, SIZE, OR COLOR.

FOR BOARD GAMES; CARD GAMES (U.S. CLS. 22, 23, 38 AND 50).

RAUL CORDOVA, EXAMINING ATTORNEY

SN 77-694,513. WARRIOR SPORTS, INC., DBA BRINE, WARREN, MI. FILED 3-19-2009.

SHAKEDOWN

THE MARK CONSISTS OF STANDARD CHARACTERS WITHOUT CLAIM TO ANY PARTICULAR FONT, STYLE, SIZE, OR COLOR.

FOR ATHLETIC PROTECTIVE PADS FOR USE IN LACROSSE, NAMELY, GLOVES, ARM GUARDS AND SHOULDER PADS (U.S. CLS. 22, 23, 38 AND 50).

TEJBIR SINGH, EXAMINING ATTORNEY

CLASS 28—(Continued).

SN 77-694,517. WARRIOR SPORTS, INC., DBA BRINE, WARREN, MI. FILED 3-19-2009.



OWNER OF U.S. REG. NOS. 2,717,961, 2,900,729 AND 2,913,583.

THE MARK CONSISTS OF A STYLIZED LETTER "X". FOR LACROSSE STICK HEADS (U.S. CLS. 22, 23, 38 AND 50).

TEJBIR SINGH, EXAMINING ATTORNEY

SN 77-694,522. WARRIOR SPORTS, INC., DBA BRINE, WARREN, MI. FILED 3-19-2009.

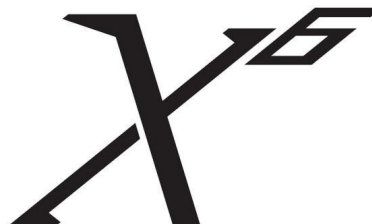

OWNER OF U.S. REG. NOS. 2,717,961, 2,900,729 AND 2,913,583.

THE MARK CONSISTS OF A STYLIZED LETTER "X" WITH A SUPERScript "6".

FOR LACROSSE STICK HEADS (U.S. CLS. 22, 23, 38 AND 50).

TEJBIR SINGH, EXAMINING ATTORNEY

SN 77-696,708. WARRIOR SPORTS, INC., WARREN, MI. FILED 3-23-2009.

TruOffset

THE MARK CONSISTS OF STANDARD CHARACTERS WITHOUT CLAIM TO ANY PARTICULAR FONT, STYLE, SIZE, OR COLOR.

OWNER OF U.S. REG. NO. 2,473,265. FOR LACROSSE STICK HANDLES; LACROSSE STICK HEADS; LACROSSE STICKS (U.S. CLS. 22, 23, 38 AND 50).

TEJBIR SINGH, EXAMINING ATTORNEY

CLASS 28—(Continued).

SN 77-698,552. BITE TECH, INC., MINNEAPOLIS, MN.
FILED 3-25-2009.

WEDGE

THE MARK CONSISTS OF STANDARD CHARACTERS WITHOUT CLAIM TO ANY PARTICULAR FONT, STYLE, SIZE, OR COLOR.

FOR MOUTH GUARDS FOR ATHLETIC USE (U.S. CLS. 22, 23, 38 AND 50).

DAVID YONTEF, EXAMINING ATTORNEY

SN 77-698,753. BITE TECH, INC., MINNEAPOLIS, MN.
FILED 3-25-2009.

ZONE

THE MARK CONSISTS OF STANDARD CHARACTERS WITHOUT CLAIM TO ANY PARTICULAR FONT, STYLE, SIZE, OR COLOR.

FOR MOUTH GUARDS FOR ATHLETIC USE (U.S. CLS. 22, 23, 38 AND 50).

DAVID YONTEF, EXAMINING ATTORNEY

SN 78-664,713. SPIN MASTER LTD., TORONTO, ONTARIO,
CANADA, FILED 7-6-2005.

ACRO-JET

THE MARK CONSISTS OF STANDARD CHARACTERS WITHOUT CLAIM TO ANY PARTICULAR FONT, STYLE, SIZE, OR COLOR.

PRIORITY CLAIMED UNDER SEC. 44(D) ON CANADA APPLICATION NO. 1,255,712, FILED 4-28-2005, REG. NO. TMA736,412, DATED 3-17-2009, EXPIRES 3-17-2024.

FOR TOY AIRPLANES. (U.S. CLS. 22, 23, 38 AND 50).
CHARLES L. JENKINS, EXAMINING ATTORNEY

CLASS 28—(Continued).

SN 79-061,843. QITELE GROUP LTD., CHINA, FILED 8-12-2008.



OWNER OF INTERNATIONAL REGISTRATION 0984341 DATED 8-12-2008, EXPIRES 8-12-2018.

THE MARK CONSISTS OF THE TERM "QITELE" TO THE LEFT OF THREE CHINESE CHARACTERS. THE WORDING AND CHARACTERS ARE SURROUNDED BY AN OVAL CARRIER DESIGN.

THE NON-LATIN CHARACTERS IN THE MARK TRANSLITERATE TO "QI TE LE" AND THIS MEANS "PECULIAR" "ESPECIALLY" AND "HAPPY" RESPECTIVELY IN ENGLISH.

FOR SWINGS; ROCKING HORSES; PLAYGROUND EQUIPMENT, NAMELY, SLIDES; TOY BUILDING BLOCKS; AND TOYS, NAMELY, CHILDREN'S MULTIPLE ACTIVITY TOYS, ELECTRONIC ACTION TOYS, ELECTRONIC TOY VEHICLES (U.S. CLS. 22, 23, 38 AND 50).

JEFFERY COWARD, EXAMINING ATTORNEY

SN 79-067,003. BANDAI S.A., FRANCE, FILED 12-8-2008.

KeyTweens

THE MARK CONSISTS OF STANDARD CHARACTERS WITHOUT CLAIM TO ANY PARTICULAR FONT, STYLE, SIZE, OR COLOR.

PRIORITY DATE OF 9-23-2008 IS CLAIMED.

OWNER OF INTERNATIONAL REGISTRATION 0998015 DATED 12-8-2008, EXPIRES 12-8-2018.

FOR PLAYTHINGS, NAMELY, PUPPET SHOWS IN THE NATURE OF KITS COMPRISED OF PUPPETS AND THEATERS AND PUPPET THEATERS; PLUSH TOYS, NAMELY, PLUSH ANIMALS AND PLUSH DOLLS; DOLLS FOR PLAYING AND ACCESSORIES THEREFOR (U.S. CLS. 22, 23, 38 AND 50).

JEFFREY LOOK, EXAMINING ATTORNEY

CLASS 29—MEATS AND PROCESSED FOODS

SN 76-620,390. BADGER BAY MUSSEL FARMS LIMITED, NEWFOUNDLAND A0J 1V0, CANADA, FILED 11-10-2004.



NO CLAIM IS MADE TO THE EXCLUSIVE RIGHT TO USE "100% NATURAL NEWFOUNDLAND ROPE CULTURED MUSSELS", APART FROM THE MARK AS SHOWN.
FOR CULTURED MUSSELS, NOT LIVE (U.S. CL. 46).
DAWN HAN, EXAMINING ATTORNEY

CLASS 29—(Continued).

SN 77-125,786. EBRO PULEVA, S.A., MADRID, SPAIN, FILED 3-8-2007.



OWNER OF SPAIN REG. NO. 2126032, DATED 3-22-1999, RENEWED AS REG. NO. 2122032, DATED 4-9-2008, EXPIRES 11-13-2017.
THE COLOR(S) BLUE, GREEN AND WHITE IS/ARE CLAIMED AS A FEATURE OF THE MARK.
THE MARK CONSISTS OF A RECTANGLE, THE TOP PART OF WHICH IS BLUE AND HAS THE NAME "PULEVA" WRITTEN IN WHITE, THE BOTTOM PART OF WHICH IS GREEN, AND BETWEEN THE TWO PARTS IS A WHITE RIBBON.
FOR MILK; MILK PRODUCTS EXCLUDING ICE CREAM, ICE MILK AND FROZEN YOGURT (U.S. CL. 46).
ESTHER BELENKER, EXAMINING ATTORNEY

SN 77-282,071. PREMIER GROUP, LLC, PLEASANT HILL, CA. FILED 9-18-2007.

SN 76-695,530. VERSATILE OIL COMPANY, INC., LITCHFIELD, CT. FILED 2-2-2009.

VOIL

THE MARK CONSISTS OF STANDARD CHARACTERS WITHOUT CLAIM TO ANY PARTICULAR FONT, STYLE, SIZE, OR COLOR.
FOR FLAVORED OIL FOR COOKING AND CONSUMPTION (U.S. CL. 46).
ALEX KEAM, EXAMINING ATTORNEY

N.Y. Minute Deli

THE MARK CONSISTS OF STANDARD CHARACTERS WITHOUT CLAIM TO ANY PARTICULAR FONT, STYLE, SIZE, OR COLOR.
NO CLAIM IS MADE TO THE EXCLUSIVE RIGHT TO USE "DELI", APART FROM THE MARK AS SHOWN.
FOR REFRIGERATED FOOD PACKAGE COMBINATIONS CONSISTING PRIMARILY OF MEAT, CHEESE OR PROCESSED VEGETABLES FOR PURPOSES OF CREATING A SANDWICH; FOOD PACKAGE COMBINATIONS CONSISTING PRIMARILY OF CHEESE, MEAT AND/OR PROCESSED FRUIT; LUNCHEON MEATS; MEAT; PROCESSED MEAT; SEASONED MEAT, SEAFOOD, FISH, POULTRY, OR VEGETABLES; CUT VEGETABLES; MEAT-BASED SNACK FOODS; FRUIT-BASED SNACK FOOD; VEGETABLE-BASED SNACK FOODS; FROZEN, PREPARED AND PACKAGED MEALS CONSISTING PRIMARILY OF MEAT, FISH, POULTRY OR VEGETABLES; FROZEN, PREPARED AND PACKAGED VEGETABLE-BASED ENTREES; PREPACKAGED DINNERS CONSISTING OF MEAT, SEAFOOD OR POULTRY SERVED WITH PASTA, RICE AND VEGETABLES (U.S. CL. 46).
ADA HAN, EXAMINING ATTORNEY

CLASS 29—(Continued).

SN 77-337,756. THE TRUSTEES OF THE JOY OF COOKING TRUST, VONORE, TN. FILED 11-27-2007.

DISCOVER THE JOY

THE MARK CONSISTS OF STANDARD CHARACTERS WITHOUT CLAIM TO ANY PARTICULAR FONT, STYLE, SIZE, OR COLOR.

FOR FROZEN APPETIZERS CONSISTING PRIMARILY OF MEAT, POULTRY OR SEAFOOD; PREPARED AND PACKAGED APPETIZERS, NAMELY, CHEESE AND CRABMEAT; FROZEN, PREPARED AND PACKAGED ENTREES CONSISTING PRIMARILY OF MEAT, POULTRY, SEAFOOD, FRUIT OR VEGETABLES (U.S. CL. 46).

SONYA STEPHENS, EXAMINING ATTORNEY

SN 77-337,777. THE TRUSTEES OF THE JOY OF COOKING TRUST, VONORE, TN. FILED 11-27-2007.

THE BEST RECIPES START WITH THE BEST INGREDIENTS

THE MARK CONSISTS OF STANDARD CHARACTERS WITHOUT CLAIM TO ANY PARTICULAR FONT, STYLE, SIZE, OR COLOR.

FOR FROZEN APPETIZERS CONSISTING PRIMARILY OF MEAT, POULTRY OR SEAFOOD; PREPARED AND PACKAGED APPETIZERS, NAMELY, CHEESE AND CRABMEAT; FROZEN, PREPARED AND PACKAGED ENTREES CONSISTING PRIMARILY OF MEAT, POULTRY, SEAFOOD, FRUIT OR VEGETABLES (U.S. CL. 46).

SONYA STEPHENS, EXAMINING ATTORNEY

SN 77-379,787. MCCAIN FOODS USA, INC., LISLE, IL. FILED 1-24-2008.

INFERNO

THE MARK CONSISTS OF STANDARD CHARACTERS WITHOUT CLAIM TO ANY PARTICULAR FONT, STYLE, SIZE, OR COLOR.

FOR FROZEN PROCESSED POTATOES (U.S. CL. 46).
RENEE SERVANCE, EXAMINING ATTORNEY

CLASS 29—(Continued).

SN 77-517,274. SLOVACEK FOODS, LP, DBA DBA SLOVACEK SAUSAGE CO. DBA SLOVACEK SAUSAGE, SNOOK, TX. FILED 7-8-2008.



NO CLAIM IS MADE TO THE EXCLUSIVE RIGHT TO USE "SAUSAGE", APART FROM THE MARK AS SHOWN. FOR BACON; BEEF; CHEESE; HAM; JERKY; PORK; SAUSAGES; TURKEY (U.S. CL. 46).
FIRST USE 7-8-2004; IN COMMERCE 7-8-2004.
JUDITH HELFMAN, EXAMINING ATTORNEY

SN 77-520,161. ALDERFER, INC., HARLEYSVILLE, PA. FILED 7-11-2008.



THE COLOR(S) YELLOW, GOLD, BROWN, WHITE IS/ ARE CLAIMED AS A FEATURE OF THE MARK.

THE MARK CONSISTS OF THE WORDING "SALFORD HILLS" AND THE DESIGN OF A FIELD WITH GRAINS OF WHEAT, CLOUDS, TREES, AND ROLLING HILLS, ALL INSIDE A RECTANGULAR BORDER. THE COLOR YELLOW IS IN THE SKY, FIELD, ROLLING HILLS, AND GRAINS OF WHEAT. THE COLOR GOLD IS IN THE FIELD, ROLLING HILLS, GRAINS OF WHEAT, AND RECTANGULAR BORDER. THE COLOR BROWN IS IN THE TREES, ROLLING HILLS, GRAINS OF WHEAT, AND OUTLINING OF THE WORDING "SALFORD HILLS". THE COLOR WHITE IS IN THE WORDING "SALFORD HILLS" AND IN THE CLOUDS.

FOR PROCESSED MEAT, NAMELY, PORK, TURKEY (U.S. CL. 46).
MARGARET POWER, EXAMINING ATTORNEY

CLASS 29—(Continued).

SN 77-523,156. FUJIAN FUDING HAIYOU AQUATIC FOOD PRODUCTS CO., LTD, FUJIAN PROVINCE., CHINA, FILED 7-16-2008.



OWNER OF CHINA REG. NO. 1498291, DATED 12-28-2000, EXPIRES 12-27-2010.

THE MARK CONSISTS OF 2 FISHES, "JIUYANG" AND CHINESE CHARACTERS IN A CIRCLE.

THE FOREIGN WORDING IN THE MARK TRANSLATES INTO ENGLISH AS NINE OCEAN.

THE NON-LATIN CHARACTER(S) IN THE MARK TRANSLITERATE INTO "JIU YANG", AND THIS MEANS NINE OCEAN IN ENGLISH.

FOR PROCESSED ANCHOVY; FISH FILLET; FISH NOT LIVE; SHRIMP NOT LIVE; OYSTERS NOT LIVE; FOOD PRODUCTS MADE FROM FISH, NAMELY, FISH SAUSAGE, FISH CAKE; SQUID NOT LIVE; DRIED SHRIMP (U.S. CL. 46).

CHRISTINA SOBRAL, EXAMINING ATTORNEY

SN 77-524,667. TRAXI ADVISORS, LLC, EDISON, NJ. FILED 7-17-2008.

VEG-A-MAJIGS

THE MARK CONSISTS OF STANDARD CHARACTERS WITHOUT CLAIM TO ANY PARTICULAR FONT, STYLE, SIZE, OR COLOR.

THE WORDING "MAJIGS" HAS NO MEANING IN A FOREIGN LANGUAGE.

FOR VEGETABLE-BASED SNACK BARS; FRUIT-BASED ORGANIC FOOD BARS CONTAINING ONE OR MORE OF THE FOLLOWING: FRUITS, DRIED FRUITS, FRUIT JUICE, GRAINS, VEGETABLES, NUTS, SEEDS, AND CHOCOLATE; PROCESSED FRUIT AND NUT BASED FOOD BARS; VEGETABLE-BASED CHOCOLATE FOOD BEVERAGES; AND VEGETABLE-BASED FOOD BEVERAGES (U.S. CL. 46).

ERIN FALK, EXAMINING ATTORNEY

CLASS 29—(Continued).

SN 77-525,960. POPPEN, CHAD, PHOENIX, AZ. FILED 7-18-2008.

GRILLMARK STEAKS

THE MARK CONSISTS OF STANDARD CHARACTERS WITHOUT CLAIM TO ANY PARTICULAR FONT, STYLE, SIZE, OR COLOR.

NO CLAIM IS MADE TO THE EXCLUSIVE RIGHT TO USE "STEAKS", APART FROM THE MARK AS SHOWN. FOR MEAT, NAMELY, STEAKS AND UNCOOKED HAMBURGER PATTIES (U.S. CL. 46).

FIRST USE 10-11-2007; IN COMMERCE 10-11-2007.

ERIN FALK, EXAMINING ATTORNEY

SN 77-529,062. TRAXI ADVISORS, LLC, EDISON, NJ. FILED 7-23-2008.

FRUIT-A-MAJIGS

THE MARK CONSISTS OF STANDARD CHARACTERS WITHOUT CLAIM TO ANY PARTICULAR FONT, STYLE, SIZE, OR COLOR.

THE WORDING "MAJIGS" HAS NO MEANING IN A FOREIGN LANGUAGE.

FOR VEGETABLE-BASED SNACK BARS; FRUIT-BASED ORGANIC FOOD BARS ALSO CONTAINING ON OR MORE OF THE FOLLOWING: FRUITS, DRIED FRUITS, FRUIT JUICE, GRAINS, VEGETABLES, NUTS, SEEDS AND CHOCOLATE; PROCESSED FRUIT AND NUT BASED FOOD BARS; VEGETABLE-BASED CHOCOLATE FOOD BEVERAGES; AND VEGETABLE-BASED FOOD BEVERAGES (U.S. CL. 46).

ERIN FALK, EXAMINING ATTORNEY

SN 77-532,352. LESSLIE, JAMES, HOWARD BEACH, NY. FILED 7-28-2008.

PRIME-TIME

THE MARK CONSISTS OF STANDARD CHARACTERS WITHOUT CLAIM TO ANY PARTICULAR FONT, STYLE, SIZE, OR COLOR.

FOR MEAT-BASED SNACK FOODS (U.S. CL. 46).

FIRST USE 6-10-1995; IN COMMERCE 6-10-1995.

KOURTNEE HODGES, EXAMINING ATTORNEY

CLASS 29—(Continued).

SN 77-585,254. CAVENDISH FARMS CORPORATION, DIEPPE, NEW BRUNSWICK, CANADA, FILED 10-3-2008.

CAVENDISH FARMS FROM THE FARM

THE MARK CONSISTS OF STANDARD CHARACTERS WITHOUT CLAIM TO ANY PARTICULAR FONT, STYLE, SIZE, OR COLOR.

OWNER OF U.S. REG. NOS. 1,235,374, 3,014,906 AND OTHERS.

FOR FROZEN FRENCH FRIES AND OTHER FROZEN POTATO PRODUCTS, NAMELY, POTATO PATTIES, POTATO NUGGETS, POTATO CROWNS, POTATO LOGS AND HASH BROWNS (U.S. CL. 46).

PRISCILLA MILTON, EXAMINING ATTORNEY

SN 77-588,412. CHATEAU MIRAVAL, CORRENS, FRANCE, FILED 10-8-2008.

CHATEAU MIRAVAL

THE MARK CONSISTS OF STANDARD CHARACTERS WITHOUT CLAIM TO ANY PARTICULAR FONT, STYLE, SIZE, OR COLOR.

NO CLAIM IS MADE TO THE EXCLUSIVE RIGHT TO USE "CHATEAU", APART FROM THE MARK AS SHOWN.

THE ENGLISH TRANSLATION OF "CHATEAU MIRAVAL" IN THE MARK IS HOUSE OF MIRAVAL.

FOR OLIVE OIL (U.S. CL. 46).

FIRST USE 4-11-2004; IN COMMERCE 4-11-2004.

ALEXANDER L. POWERS, EXAMINING ATTORNEY

CLASS 29—(Continued).

SN 77-593,385. HASUNJUNG GENERAL FOOD CO., LTD., GYEONGGI-DO, REPUBLIC OF KOREA, FILED 10-15-2008.



OWNER OF REPUBLIC OF KOREA REG. NO. 733396, DATED 1-7-2008, EXPIRES 1-7-2018.

OWNER OF U.S. REG. NOS. 2,150,776, 2,164,792 AND 2,997,239.

THE COLOR(S) RED, BROWN, ORANGE, WHITE, GREEN IS/ARE CLAIMED AS A FEATURE OF THE MARK.

THE MARK CONSISTS OF WHITE KOREAN CHARACTERS CONTAINED IN PART IN THREE INTERSECTING BOXES. THE FIRST BOX IS ORANGE, THE SECOND BOX IS RED AND THE THIRD BOX IS GREEN. THE SECOND BOX HAS AT THE TOP THE STYLIZED REPRESENTATION OF CHOP STICKS IN BROWN. ABOVE THE ORANGE BOX, ADDITIONAL KOREAN CHARACTERS APPEAR IN RED.

THE NON-LATIN CHARACTERS IN THE MARK TRANSLITERATE TO NAERIMSONMAT AND HASUNJUNG IN THE MARK IS "TASTE PASSED DOWN THROUGH GENERATIONS" AND WITH A SINCERE HEART AND A CLEAR CONSCIENCE, WE SHALL DO OUT BEST TO MAKE THIS A BETTER WORKD.

FOR PICKLED RADISHES, PICKLED CUCUMBERS, PICKLED VEGETABLES IN SOY SAUCE OR SOYBEAN PASTE, PICKLED SHALLOTS, PROCESSED GARLIC, USED AS A VEGETABLE, NOT SEASONING, PICKLED GARLIC STEMS IN RED PEPPER SAUCE, SEASONED DRIED RADISH SLICES, SEASONED SESAME LEAVES AND SOY-BOILED BURDOCKS (U.S. CL. 46).

JULIE WATSON, EXAMINING ATTORNEY

SN 77-598,323. PHIL'S BBQ, INC., SAN DIEGO, CA. FILED 10-22-2008.

CHICK-LESS

THE MARK CONSISTS OF STANDARD CHARACTERS WITHOUT CLAIM TO ANY PARTICULAR FONT, STYLE, SIZE, OR COLOR.

FOR MEAT; PREPARED ENTREES CONSISTING PRIMARILY OF MEAT, FISH, POULTRY OR VEGETABLES (U.S. CL. 46).

FIRST USE 2-21-1998; IN COMMERCE 2-21-1998.

JAY BESCH, EXAMINING ATTORNEY

CLASS 29—(Continued).

SN 77-598,632. SAN SHU GONG FOOD CO., LTD., TAIPEI COUNTY, TAIWAN, FILED 10-23-2008.



THE COLOR(S) PURPLE, PINK, GREY, YELLOW AND WHITE IS/ARE CLAIMED AS A FEATURE OF THE MARK. THE MARK CONSISTS OF AN OVAL BEAN DESIGN WITH CHINESE CHARACTERS AT THE TOP AND LOWER HALF OF THE OVAL. A FLOWER DESIGN IS NEXT TO THE CHINESE CHARACTER AT THE TOP. THE OVAL BEAN DESIGN IS YELLOW WITH GRAY SHADING ON THE RIGHT SIDE. THE TOP CHINESE CHARACTER IS PURPLE, THE FLOWER IS PINK. THE LOWER CHINESE CHARACTERS ARE GRAY.

THE NON-LATIN CHARACTERS IN THE MARK TRANSLITERATE TO HUA NO LIAN YU AND THIS MEANS LOVE WORDS OF FLOWERS IN ENGLISH.

FOR JELLIES FOR FOOD; POWDER PREPARATIONS FOR MAKING JELLIES FOR FOOD; JELLY MADE FROM DEVIL'S TONGUE ROOT; PROCESSED PLUMS; PRESERVED FRUITS AND PINEAPPLES; FRUIT AND VEGETABLE CHIPS; PROCESSED ORANGE PEELS; RAISINS; DRIED OR GLAZED FRUITS AND VEGETABLES (U.S. CL. 46).

FIRST USE 1-18-2002; IN COMMERCE 6-28-2006.
IRA J. GOODSAD, EXAMINING ATTORNEY

SN 77-612,776. HAIN PURE FOOD CO., INC., MELVILLE, NY. FILED 11-12-2008.

HAIN PURE FOODS

THE MARK CONSISTS OF STANDARD CHARACTERS WITHOUT CLAIM TO ANY PARTICULAR FONT, STYLE, SIZE, OR COLOR.

OWNER OF U.S. REG. NOS. 811,803, 2,634,522 AND OTHERS.

NO CLAIM IS MADE TO THE EXCLUSIVE RIGHT TO USE "PURE FOODS", APART FROM THE MARK AS SHOWN.

FOR COOKING OILS; SUNFLOWER OIL; SESAME OIL; WALNUT OIL; PEANUT OIL; OLIVE OIL; SAFFLOWER OIL; AND CANOLA OIL (U.S. CL. 46).

FIRST USE 4-30-1993; IN COMMERCE 4-30-1993.
MATTHEW MCDOWELL, EXAMINING ATTORNEY

CLASS 29—(Continued).

SN 77-617,319. ISLE OF MAN MILK MARKETING ASSOCIATION LIMITED, FORMERLY ISLE OF MAN MILK MARKETING ASSOCIATION, CRONKBOURNE, ISLE OF MAN, FILED 11-19-2008.

DRUIDALE

THE MARK CONSISTS OF STANDARD CHARACTERS WITHOUT CLAIM TO ANY PARTICULAR FONT, STYLE, SIZE, OR COLOR.

OWNER OF UNITED KINGDOM REG. NO. 2445387, DATED 3-7-2008, EXPIRES 2-1-2017.

FOR (BASED ON INTENT TO USE) CHEESE(BASED ON 44(E)) CHEESE (U.S. CL. 46).
NAKIA HENRY, EXAMINING ATTORNEY

SN 77-649,659. CRISPY GREEN, INC., FAIRFIELD, NJ. FILED 1-14-2009.

FRUITZIO

THE MARK CONSISTS OF STANDARD CHARACTERS WITHOUT CLAIM TO ANY PARTICULAR FONT, STYLE, SIZE, OR COLOR.

FOR FRUIT-BASED SNACK FOODS (U.S. CL. 46).
WILLIAM BRECKENFELD, EXAMINING ATTORNEY

SN 77-657,872. EL PRIMO FOODS, INC., MONTEREY PARK, CA. FILED 1-27-2009.

FRITZ'S FRIED PICKLES

THE MARK CONSISTS OF STANDARD CHARACTERS WITHOUT CLAIM TO ANY PARTICULAR FONT, STYLE, SIZE, OR COLOR.

NO CLAIM IS MADE TO THE EXCLUSIVE RIGHT TO USE "FRIED PICKLES", APART FROM THE MARK AS SHOWN.

THE NAME(S), PORTRAIT(S), AND/OR SIGNATURE(S) SHOWN IN THE MARK DOES NOT IDENTIFY A PARTICULAR LIVING INDIVIDUAL.

FOR VEGETARIAN FROZEN APPETIZERS, NAMELY, FRIED PICKLES (U.S. CL. 46).
MICHAEL ENGEL, EXAMINING ATTORNEY

CLASS 29—(Continued).

SN 77-661,214. LENNY'S REAL BEEF COMPANY, LLC, CHICAGO, IL. FILED 2-2-2009.

LENNY'S

THE MARK CONSISTS OF STANDARD CHARACTERS WITHOUT CLAIM TO ANY PARTICULAR FONT, STYLE, SIZE, OR COLOR.

FOR MEAT (U.S. CL. 46).

DAVON HATCHETT, EXAMINING ATTORNEY

SN 77-661,957. HOLY COW LLC, IRVING, TX. FILED 2-3-2009.



NO CLAIM IS MADE TO THE EXCLUSIVE RIGHT TO USE "NUT", APART FROM THE MARK AS SHOWN.

THE NAME "LORD NUT LIVINGSTON" DOES NOT IDENTIFY A LIVING INDIVIDUAL.

THE MARK CONSISTS OF THE BUST OF A MAN WITH A HANDLE-BAR MUSTACHE IN 19TH CENTURY DRESS SURROUNDED BY THE WORDS "LORD NUT LIVINGSTON" AND THE WORDS "PARDON MY FLAVOR" ON A SCROLL BELOW THE NECK OF THE MAN.

FOR SNACK MIXES CONSISTING PRIMARILY OF PROCESSED NUTS, SEEDS, DRIED FRUIT AND ALSO INCLUDING CHOCOLATE (U.S. CL. 46).

ANGELA GAW, EXAMINING ATTORNEY

SN 77-663,664. 24 HOUR FITNESS USA, INC., SAN RAMON, CA. FILED 2-4-2009.

FIT4SOY

THE MARK CONSISTS OF STANDARD CHARACTERS WITHOUT CLAIM TO ANY PARTICULAR FONT, STYLE, SIZE, OR COLOR.

FOR SOY BASED SNACK FOOD; SOY BASED FOOD BARS (U.S. CL. 46).

FIRST USE 12-15-2008; IN COMMERCE 12-15-2008.

BARBARA BROWN, EXAMINING ATTORNEY

CLASS 29—(Continued).

SN 77-664,570. STATE FAIR MINI-DONUTS, INC., MINNETONKA, MN. FILED 2-5-2009.



OWNER OF U.S. REG. NO. 1,474,358.

THE COLOR(S) RED, WHITE, BLUE, AND BLACK IS/ARE CLAIMED AS A FEATURE OF THE MARK.

THE MARK CONSISTS OF THE WORDS "STATE FAIR" IN RED OVER A BLUE BACKGROUND. THE WORDS "STATE FAIR" ARE OUTLINED IN WHITE. THE SHAPE OF A CIRCUS TENT IS DISPOSED ABOVE THE LETTERS "T" AND "E" IN THE WORD "STATE" AND THE LETTER "F" IN THE WORD "FAIR". THE TENT IS SHOWN IN THE COLORS RED AND WHITE UPON A BLUE BACKGROUND. TWO RED BANNERS ARE LOCATED ATOP THE PEAKS OF THE TENT. A BLACK BORDER SURROUNDS THE BLUE BACKGROUND. THE TWO RED BANNERS EXTEND OUTSIDE THE BLACK BORDER.

FOR CHEESE, NAMELY, CHEESE CURDS (U.S. CL. 46).

FIRST USE 2-4-2009; IN COMMERCE 2-4-2009.

COLLEEN DOMBROW, EXAMINING ATTORNEY

SN 77-664,865. STONE, MICHAEL, PULASKI, NY. FILED 2-6-2009.

STONEY BONES

THE MARK CONSISTS OF STANDARD CHARACTERS WITHOUT CLAIM TO ANY PARTICULAR FONT, STYLE, SIZE, OR COLOR.

FOR FOOD PACKAGE COMBINATIONS CONSISTING PRIMARILY OF PEPPERONI AND/OR CHEESE (U.S. CL. 46).

JIM RINGLE, EXAMINING ATTORNEY

SN 77-665,213. ON-COR FROZEN FOODS, LLC, NORTH-BROOK, IL. FILED 2-6-2009.

EASY EATIN'

THE MARK CONSISTS OF STANDARD CHARACTERS WITHOUT CLAIM TO ANY PARTICULAR FONT, STYLE, SIZE, OR COLOR.

OWNER OF U.S. REG. NO. 2,221,846.

FOR COOKED AND FROZEN READY TO HEAT AND SERVE PREPACKAGED MEAT AND POULTRY (U.S. CL. 46).

FIRST USE 12-31-1997; IN COMMERCE 12-31-1997.

ROSELLE HERRERA, EXAMINING ATTORNEY

CLASS 29—(Continued).

SN 77-666,064. PLANET SMOOTHIE, LLC, ATLANTA, GA. FILED 2-9-2009.

PLANET SOUP

THE MARK CONSISTS OF STANDARD CHARACTERS WITHOUT CLAIM TO ANY PARTICULAR FONT, STYLE, SIZE, OR COLOR.

OWNER OF U.S. REG. NOS. 2,360,991, 2,469,892 AND 2,560,830.

NO CLAIM IS MADE TO THE EXCLUSIVE RIGHT TO USE "SOUP", APART FROM THE MARK AS SHOWN.

FOR SOUPS (U.S. CL. 46).
HENRY S. ZAK, EXAMINING ATTORNEY

CLASS 29—(Continued).

SN 79-059,866. LIDL STIFTUNG & CO. KG, FED REP GERMANY, FILED 6-3-2008.

proViact

THE MARK CONSISTS OF STANDARD CHARACTERS WITHOUT CLAIM TO ANY PARTICULAR FONT, STYLE, SIZE, OR COLOR.

PRIORITY DATE OF 12-4-2007 IS CLAIMED.

OWNER OF INTERNATIONAL REGISTRATION 0979623 DATED 6-3-2008, EXPIRES 6-3-2018.

OWNER OF U.S. REG. NO. 3,128,628.

FOR MILK AND MILK PRODUCTS, NAMELY, BUTTER, CHEESE, FRESH MILK, PASTEURIZED MILK, UHT MILK, CREAM, YOGHURT, SOUR MILK QUARK, MILK POWDER FOR NUTRITIONAL PURPOSES, DESSERTS MADE OF YOGHURT, SOUR MILK QUARK CURD, AND CREAM; CHEESE AND CHEESE PRODUCTS, NAMELY, CHEESE, CHEESE SPREADS, CHEESE FOOD, CHEESE FONDUE, CHEESE AND CRACKER COMBINATIONS CONSISTING PRIMARILY OF CHEESE, CREAM CHEESE, COTTAGE CHEESE, CHEESE POWDER, CHEESE SUBSTITUTES, GOUDA CHEESE, EDAM CHEESE, CHEDDAR CHEESE, SOFT CHEESE, STRAINED CHEESE, WHITE CHEESE, AND PROCESSED CHEESE (U.S. CL. 46).

DAVID HOFFMAN, EXAMINING ATTORNEY

SN 79-058,767. FUJIAN MINZHONG ORGANIC FOOD; CO., LTD., CHINA, FILED 7-11-2008.



OWNER OF INTERNATIONAL REGISTRATION 0977019 DATED 7-11-2008, EXPIRES 7-11-2018.

THE MARK CONSISTS OF THE ASIAN CHARACTERS FOR THE WORDS "MIN" AND "ZHONG" ON EITHER SIDE OF A STYLIZED MOUNTAIN LANDSCAPE WITH A WAVY LINE REPRESENTING A RIVER DISPLAYED ACROSS THE LANDSCAPE.

THE ENGLISH TRANSLATION OF THE FOREIGN WORD(S) IN THE MARK IS MIN MEANS MIN IN ENGLISH, ZHONG MEANS IN IN ENGLISH; THE TWO CHINESE CHARACTERS MINZHONG COMBINING TOGETHER HAVE NO MEANING IN ENGLISH.

THE TANSLITERATION OF THE NON-LATIN CHARACTERS IN THE MARK IS: MINZHONG.

FOR GHERKINS; LENTILS, PRESERVED; DRIED TURNIP; DRIED EDIBLE SEAWEED; DRIED CABBAGE; RAISINS; DRY BAMBOO SHOOT; KELP POWDER (U.S. CL. 46).

RENEE SERVANCE, EXAMINING ATTORNEY

CLASS 30—STAPLE FOODS

SN 76-674,268. PROSPERITY RESOURCES INT'L., INC., IRVINGTON, NJ, FILED 3-19-2007.



NO CLAIM IS MADE TO THE EXCLUSIVE RIGHT TO USE THE NON-LATIN CHARACTERS THAT MEAN "OYSTER FLAVORED SAUCE", APART FROM THE MARK AS SHOWN.

THE MARK CONSISTS OF A CURVED RECTANGLE CONTAINING TWO CONCENTRIC OVALS. A DRAGON AND A GRIFFON ARE LOCATED INSIDE THE INTERIOR OVAL. THE OVAL ALSO CONTAINS FLOWERS. THE TOP OF THE EXTERIOR OVAL CONTAINS ASIAN CHARACTERS THAT ARE PRONOUNCED "HUP HING LOONG" AND WHICH HAS NO ENGLISH TRANSLATION. THE BOTTOM OF THE EXTERIOR OVAL CONTAINS THE

CLASS 30—(Continued).

WORDING "HUP HUNG LOONG", WHICH HAS NO ENGLISH TRANSLATION. TO THE LEFT OF THE OVALS ARE ASIAN CHARACTERS THAT ARE PRONOUNCED "HO MEL CHENG" AND TRANSLATE TO "OYSTER FLAVORED SAUCE". TO THE RIGHT OF THE OVALS ARE ASIAN CHARACTERS THAT ARE PRONOUNCED "TUM LUNG FUNG" AND TRANSLATE TO "GOLDEN DRAGON". A THIN BAND RUNS ALONG THE LENGTH OF THE RECTANGLE CLOSE TO THE TOP, AND A SIMILAR BAND IS LOCATED CLOSE TO THE BOTTOM.

THE WORDING "HUP HING LOONG" HAS NO MEANING IN A FOREIGN LANGUAGE.

THE NON-LATIN CHARACTERS IN THE MARK TRANSLITERATE TO HUP HING LOONG, AND THIS HAS NO MEANING IN A FOREIGN LANGUAGE, AND TO "HO MEI CHENG" AND "TUM LUNG FUNG" AND THIS MEANS "OYSTER FLAVORED SAUCE" AND "GOLDEN DRAGON" IN ENGLISH.

FOR OYSTER SAUCE (U.S. CL. 46).

FIRST USE 11-1-2006; IN COMMERCE 11-1-2006.

ROBIN MITTLER, EXAMINING ATTORNEY

SN 76-677,448. TRESPLAIN INVESTMENTS LIMITED, TSING YI, NT, HONG KONG, FILED 5-29-2007.



OWNER OF U.S. REG. NO. 2,437,765.

NO CLAIM IS MADE TO THE EXCLUSIVE RIGHT TO USE "BRAND", "PREMIUM THAI HOMALI RICE", "NET WT. 20LB (9.07KG)", "GAO JASMINE THUAN CHUNG CAO CAP THAI LAN," THE NON-LATIN CHARACTERS THAT MEAN "BRAND", "JASMINE," "PREMIUM THAI JASMINE RICE," AND "NET WT. 20LB (9.07KG)", APART FROM THE MARK AS SHOWN.

THE ENGLISH TRANSLATION OF THE WORD "HOMALI" "GAO" AND "THUAN CHUNG GAO CAP THAI LAN" IN THE MARK IS "JASMINE" FOR THE WORD "HOMALI," AND "PREMIUM THAI JASMINE RICE" FOR THE SENTENCE "GAO JASMINE THUAN CHUNG GAO CAP THAI LAN".

THE NON-LATIN CHARACTERS AT THE TOP AND MIDDLE OF THE MARK TRANSLITERATE TO "JIN-XIANG-PAL" AND "DING-SHANG-TAI-QUO-MO-LI-XIANG-MI," AND THIS MEANS "GOLDEN ELEPHANT BRAND" AND "PREMIUM THAI JASMINE RICE" IN ENGLISH. THE NON-LATIN CHARACTERS AT THE BOTTOM OF THE MARK TRANSLITERATE TO "JING ZHONG", "PANG", AND "GONG JIN", AND THIS MEANS "NET WEIGHT", "POUND", AND "KILOGRAM" IN ENGLISH.

FOR PREMIUM THAI JASMINE RICE (U.S. CL. 46).

FIRST USE 1-3-2005; IN COMMERCE 1-3-2005.

AMEETA JORDAN, EXAMINING ATTORNEY

CLASS 30—(Continued).

SN 76-690,752. MIXON, MYRON A., UNADILLA, GA. FILED 6-23-2008.

JACK'S OLD SOUTH

THE MARK CONSISTS OF STANDARD CHARACTERS WITHOUT CLAIM TO ANY PARTICULAR FONT, STYLE, SIZE, OR COLOR.

THE TERM "JACK'S" DOES NOT IDENTIFY A LIVING INDIVIDUAL.

FOR BARBECUE SAUCES AND MEAT RUBS (U.S. CL. 46).

FIRST USE 3-31-2001; IN COMMERCE 3-31-2001.

JOHN DWYER, EXAMINING ATTORNEY

SN 76-691,005. ALCORN STATE UNIVERSITY, ALCORN STATE, MS. FILED 7-1-2008.



OWNER OF U.S. REG. NOS. 3,113,561 AND 3,376,841. NO CLAIM IS MADE TO THE EXCLUSIVE RIGHT TO USE "HOT SAUCE NATURAL", APART FROM THE MARK AS SHOWN.

THE MARK CONSISTS OF A DESIGN OF A UNIVERSITY BUILDING ON THE LEFT OVER THE LETTERS "ASU", NEXT TO THE WORDING "ALCORN HOT SAUCE NATURAL", BOTH OVER A DESIGN OF SIX PEPPERS, ALL OF WHICH ARE CONTAINED IN SEPARATE QUADRILATERALS.

FOR CONDIMENTS, NAMELY, PEPPER SAUCE; CHILI SAUCE; HOT SAUCE; SAUCES AND SEASONINGS (U.S. CL. 46).

FIRST USE 9-6-2007; IN COMMERCE 9-6-2007.

FRED CARL, EXAMINING ATTORNEY

SN 76-694,964. FEWELL, DEBORAH T., WASHINGTON, DC. AND FIELDS, ROY T., WASHINGTON, DC. AND FIELDS, GWENDOLYN L., WASHINGTON, DC. FILED 12-23-2008.

"My Daddy's Herbs"

THE MARK CONSISTS OF STANDARD CHARACTERS WITHOUT CLAIM TO ANY PARTICULAR FONT, STYLE, SIZE, OR COLOR.

NO CLAIM IS MADE TO THE EXCLUSIVE RIGHT TO USE "HERBS", APART FROM THE MARK AS SHOWN.

FOR SPICES AND PROCESSED HERBS TO BE SOLD IN RETAIL FOOD TYPE MARKETS (U.S. CL. 46).

MARIAM MAHMOUDI, EXAMINING ATTORNEY

CLASS 30—(Continued).

SN 76-695,664. HOWARD, ANDRE' ALEXANDER, SR., COMPTON, CA. FILED 2-9-2009.

"COREBURGER"

THE MARK CONSISTS OF STANDARD CHARACTERS WITHOUT CLAIM TO ANY PARTICULAR FONT, STYLE, SIZE, OR COLOR.

FOR HAMBURGER SANDWICH (U.S. CL. 46).
ALEX KEAM, EXAMINING ATTORNEY

SN 77-335,842. MILES, LOREN, LOS ANGELES, CA. FILED 11-22-2007.

Save The Cupcakes!

THE MARK CONSISTS OF STANDARD CHARACTERS WITHOUT CLAIM TO ANY PARTICULAR FONT, STYLE, SIZE, OR COLOR.

NO CLAIM IS MADE TO THE EXCLUSIVE RIGHT TO USE "CUPCAKES", APART FROM THE MARK AS SHOWN. FOR NATURAL SWEETENER (U.S. CL. 46).
FIRST USE 3-2-2007; IN COMMERCE 4-2-2007.
JOHN DALIER, EXAMINING ATTORNEY

SN 77-342,403. LAPPERT'S, INC., HANAPEPE, HI. FILED 12-3-2007.

KAUAI PIE

THE MARK CONSISTS OF STANDARD CHARACTERS WITHOUT CLAIM TO ANY PARTICULAR FONT, STYLE, SIZE, OR COLOR.

CONCURRENT USE INFORMATION. GOODS: ICE CREAM AND COFFEE GEOGRAPHIC AREA: THE STATE OF HAWAII MODE OF USE: ON THE GOODS
SEC. 2(F).
FOR ICE CREAM AND COFFEE (U.S. CL. 46).
FIRST USE 1-1-1987; IN COMMERCE 1-1-1987.
RONALD AIKENS, EXAMINING ATTORNEY

CLASS 30—(Continued).

SN 77-347,610. SPECIALTY ROAST COFFEE COMPANY LLC, BELLEVUE, WA. FILED 12-9-2007.

Sell Some Good

THE MARK CONSISTS OF STANDARD CHARACTERS WITHOUT CLAIM TO ANY PARTICULAR FONT, STYLE, SIZE, OR COLOR.

FOR COFFEE (U.S. CL. 46).
SUSAN STIGLITZ, EXAMINING ATTORNEY

SN 77-386,871. CLOUD TOP, AKA CLOUD TOP LLC, AKA CLOUD TOP YOGURT, PASADENA, CA. FILED 2-1-2008.

CLOUD TOP

THE MARK CONSISTS OF STANDARD CHARACTERS WITHOUT CLAIM TO ANY PARTICULAR FONT, STYLE, SIZE, OR COLOR.

FOR FROZEN YOGURT AND FROZEN YOGURT BASED DESSERTS (U.S. CL. 46).
NATALIE POLZER, EXAMINING ATTORNEY

SN 77-409,814. EQUAL EXCHANGE, INC., WEST BRIDGE-WATER, MA. FILED 2-29-2008.

GREEN MAGIC TEA

THE MARK CONSISTS OF STANDARD CHARACTERS WITHOUT CLAIM TO ANY PARTICULAR FONT, STYLE, SIZE, OR COLOR.

NO CLAIM IS MADE TO THE EXCLUSIVE RIGHT TO USE "GREEN" AND "TEA", APART FROM THE MARK AS SHOWN.
FOR TEA (U.S. CL. 46).
FIRST USE 7-11-2006; IN COMMERCE 7-11-2006.
DAWN FELDMAN, EXAMINING ATTORNEY

CLASS 30—(Continued).

SN 77-431,230. OLÉ MEXICAN FOODS, INC., NORCROSS, GA. FILED 3-25-2008.



THE COLOR(S) GREEN, WHITE AND RED IS/ARE CLAIMED AS A FEATURE OF THE MARK.

THE MARK CONSISTS OF THREE HORIZONTAL BANDS OF GREEN, WHITE, AND RED; THE TOP BAND APPEARS IN THE COLOR GREEN, THE MIDDLE BAND IS WHITE, AND THE BOTTOM BAND APPEARS IN THE COLOR RED.

FOR TORTILLA CHIPS; TORTILLAS; TOSTADAS (U.S. CL. 46).

RICHARD WHITE, EXAMINING ATTORNEY

SN 77-493,043. NUTRASWEET PROPERTY HOLDINGS, INC., CHICAGO, IL. FILED 6-6-2008.

NUTRASWEET PINK

THE MARK CONSISTS OF STANDARD CHARACTERS WITHOUT CLAIM TO ANY PARTICULAR FONT, STYLE, SIZE, OR COLOR.

OWNER OF U.S. REG. NOS. 1,262,746 AND 1,336,188.

NO CLAIM IS MADE TO THE EXCLUSIVE RIGHT TO USE "PINK", APART FROM THE MARK AS SHOWN.

FOR SUGAR SUBSTITUTES; SUGAR SUBSTITUTES, NAMELY, COMBINATIONS OF NATURAL AND ARTIFICIAL SWEETENERS CONSISTING PRINCIPALLY OF NATURAL SWEETENERS BY WEIGHT (U.S. CL. 46).

FIRST USE 6-6-2008; IN COMMERCE 6-6-2008.

MARTHA FROMM, EXAMINING ATTORNEY

SN 77-505,697. TURTLE POND PUBLICATIONS LLC, NEW YORK, NY. FILED 6-23-2008.

KABIRIZI

THE MARK CONSISTS OF STANDARD CHARACTERS WITHOUT CLAIM TO ANY PARTICULAR FONT, STYLE, SIZE, OR COLOR.

THE WORDING "KABIRIZI" HAS NO MEANING IN A FOREIGN LANGUAGE.

FOR FOOD, NAMELY, COOKIES, CANDY, CEREAL IN THE NATURE OF BREAKFAST CEREAL, ICE CREAM, CHEWING GUM AND CAKES (U.S. CL. 46).

ANGELA GAW, EXAMINING ATTORNEY

CLASS 30—(Continued).

SN 77-520,199. AGORA, INC., DAWSONVILLE, GA. FILED 7-11-2008.

TORTILLA CRUNCH

THE MARK CONSISTS OF STANDARD CHARACTERS WITHOUT CLAIM TO ANY PARTICULAR FONT, STYLE, SIZE, OR COLOR.

NO CLAIM IS MADE TO THE EXCLUSIVE RIGHT TO USE "TORTILLA", APART FROM THE MARK AS SHOWN.

FOR MIXES FOR MAKING BREADING; BREAD CRUMB; BREAD CRUMBS; SEASONED COATING FOR MEAT, FISH, POULTRY, CHEESE, VEGETABLES, FRUIT; SEASONED COATING MIXTURES FOR FOODS; BREADCRUMBS; DRY SEASONING MIXES FOR FOOD BATTER; MIXES FOR MAKING BATTERS; MIXES FOR MAKING BATTER FOR HUSHPUDDIES; MIXES FOR MAKING BATTERS FOR FRIED FOODS; SEASONING MIXES; SEASONED TORTILLA CRUMBS FOR USE AS A PIZZA TOPPING; TOPPING FOR PREPARED FOODS, NAMELY, SEASONED TORTILLA CRUMBS FOR USE AS A TOPPING FOR PIZZA, CASSEROLES, AND POT PIES (U.S. CL. 46).

KATHY DE JONGE, EXAMINING ATTORNEY

SN 77-521,373. TK MANAGEMENT, LLC, YOUNTVILLE, CA. FILED 7-14-2008.

BOUCHON

THE MARK CONSISTS OF STANDARD CHARACTERS WITHOUT CLAIM TO ANY PARTICULAR FONT, STYLE, SIZE, OR COLOR.

OWNER OF U.S. REG. NO. 2,559,236.

THE ENGLISH TRANSLATION OF THE WORD "BOUCHON" IN THE MARK IS "PLUG", "CORK" OR "STOPPER".

FOR CHOCOLATES; COFFEE; SANDWICHES; COOKIE MIXES; BAKERY PRODUCTS; COOKIES; BAGUETTES; BREADS; BAKERY DESSERTS; TARTS; MUFFINS; PASTRIES; BRIOCHES; CROISSANTS; QUICHES (U.S. CL. 46).

DAVID YONTEF, EXAMINING ATTORNEY

SN 77-528,164. ALDI INC., BATAVIA, IL. FILED 7-22-2008.

APPLE ROUNDS

THE MARK CONSISTS OF STANDARD CHARACTERS WITHOUT CLAIM TO ANY PARTICULAR FONT, STYLE, SIZE, OR COLOR.

OWNER OF U.S. REG. NO. 1,446,679.

NO CLAIM IS MADE TO THE EXCLUSIVE RIGHT TO USE "APPLE", APART FROM THE MARK AS SHOWN.

FOR BREAKFAST CEREALS; APPLE AND CINNAMON FLAVORED PROCESSED CEREAL (U.S. CL. 46).

PAUL CROWLEY, EXAMINING ATTORNEY

CLASS 30—(Continued).

SN 77-529,358. JIM'S SOFT PRETZEL BAKERY, LLC, IVY-LAND, PA. FILED 7-23-2008.

PHILADELPHIA PRETZEL EXPRESS

THE MARK CONSISTS OF STANDARD CHARACTERS WITHOUT CLAIM TO ANY PARTICULAR FONT, STYLE, SIZE, OR COLOR.

NO CLAIM IS MADE TO THE EXCLUSIVE RIGHT TO USE "PHILADELPHIA PRETZEL", APART FROM THE MARK AS SHOWN.

FOR PRETZELS (U.S. CL. 46).
CAROLYN CATALDO, EXAMINING ATTORNEY

CLASS 30—(Continued).

SN 77-542,203. SARA LEE CORPORATION, DOWNERS GROVE, IL. FILED 8-8-2008.

ALFARO'S MICRO-BAKERY

THE MARK CONSISTS OF STANDARD CHARACTERS WITHOUT CLAIM TO ANY PARTICULAR FONT, STYLE, SIZE, OR COLOR.

NO CLAIM IS MADE TO THE EXCLUSIVE RIGHT TO USE "MICRO-BAKERY", APART FROM THE MARK AS SHOWN.

SEC. 2(F).
FOR BAKERY GOODS (U.S. CL. 46).
FIRST USE 0-0-1990; IN COMMERCE 0-0-1990.
JOHN DALIER, EXAMINING ATTORNEY

SN 77-531,179. BIOPOLYMER ENGINEERING, INC., DBA BIOTHERA, EAGAN, MN. FILED 7-25-2008.

WELLTEA

THE MARK CONSISTS OF STANDARD CHARACTERS WITHOUT CLAIM TO ANY PARTICULAR FONT, STYLE, SIZE, OR COLOR.

FOR FUNCTIONAL BEVERAGES, NAMELY, BEVERAGES MADE OF TEA (U.S. CL. 46).

AMEETA JORDAN, EXAMINING ATTORNEY

SN 77-549,025. MANNA ORGANICS LLC, LISLE, IL. FILED 8-18-2008.

MANNA ORGANICS

SN 77-542,117. FUJIAN CEREALS OILS & FOODSTUFFS (M.Y.) CO., LTD., FUJIAN PROVINCE, CHINA, FILED 8-8-2008.

**桐口
TUNG KOW**

THE WORDING "TUNG KOW" HAS NO MEANING IN A FOREIGN LANGUAGE.

THE NON-LATIN CHARACTERS IN THE MARK TRANSLITERATE TO "TUNG KOW", AND THIS HAS NO MEANING IN A FOREIGN LANGUAGE.

FOR RICE VERMICELLI STICKS; CHINESE NOODLES; INSTANT NOODLES; PRODUCTS MADE FROM RICE, NAMELY, RICE-BASED SNACK FOODS, RICE STARCH FLOUR, RICE CAKES; NOODLES; SPAGHETTI; CHINESE VERMICELLI; RICE CAKE (U.S. CL. 46).

FIRST USE 6-8-1975; IN COMMERCE 6-8-1975.
HOWARD B. LEVINE, EXAMINING ATTORNEY

THE MARK CONSISTS OF STANDARD CHARACTERS WITHOUT CLAIM TO ANY PARTICULAR FONT, STYLE, SIZE, OR COLOR.

OWNER OF U.S. REG. NO. 2,066,142.
NO CLAIM IS MADE TO THE EXCLUSIVE RIGHT TO USE "ORGANICS", APART FROM THE MARK AS SHOWN.

FOR ORGANIC BAKED GOODS, NAMELY, BREADS, ROLLS, MUFFINS, AND TORTILLAS (U.S. CL. 46).
KATHERINE CONNOLLY, EXAMINING ATTORNEY

CLASS 30—(Continued).

SN 77-556,064. DANKUNI FOOD PRODUCTS PVT. LTD., WEST BENGAL, INDIA, FILED 8-26-2008.



THE COLOR(S) RED, WHITE AND GRAY/SILVER IS/ARE CLAIMED AS A FEATURE OF THE MARK.

THE MARK CONSISTS OF THE WORDING "12 MONTHS" IN WHITE LETTERING LOCATED ON A RED DIAGONAL DESIGN. A SQUARE DESIGN WITH ALTERNATING GRAY/SILVER AND WHITE HORIZONTAL LINES APPEARS BEHIND THE RED DIAGONAL.

FOR COFFEE; TEA; COCOA; SUGAR; RICE; TAPIOCA; SAGO; ARTIFICIAL COFFEE; FLOUR; PREPARATIONS MADE FROM CEREALS, NAMELY, CEREAL BASED SNACK FOODS; BREAD; PASTRY; FROZEN CONFECTIONERY; ICES; HONEY; TREACLE; YEAST; BAKING POWDER; SALT; MUSTARD; VINEGAR; SAUCES; CONDIMENTS, NAMELY, CHUTNEYS AND PEPPER SAUCE; SPICES, NAMELY, RAW SPICES, POWDER SPICES, MIX SPICES AND ALL OTHER SPICES; ICE (U.S. CL. 46).

NATALIE POLZER, EXAMINING ATTORNEY

CLASS 30—(Continued).

SN 77-574,901. KLIKA, GEORGE PETER, KAPAAU, HI. FILED 9-19-2008.

Shangri-La Tea

THE MARK CONSISTS OF STANDARD CHARACTERS WITHOUT CLAIM TO ANY PARTICULAR FONT, STYLE, SIZE, OR COLOR.

NO CLAIM IS MADE TO THE EXCLUSIVE RIGHT TO USE "TEA", APART FROM THE MARK AS SHOWN.

FOR BEVERAGES MADE OF TEA; COFFEE AND TEA; DISPOSABLE CUPS WITH A TEA-FILLED POUCH ULTRASONICALLY WELDED TO ONE SIDE OF THE BOTTOM OF THE CUP, WHICH ALLOWS THE NATURAL FIBER POUCH TO FLOAT NEAR THE BOTTOM; FLAVOURINGS OF TEA; FRUIT TEAS; GREEN TEA; HERB TEA; HERBAL FOOD BEVERAGES; HERBAL INFUSIONS; HERBAL TEA; ICED TEA; INSTANT TEA; JAPANESE GREEN TEA; LIME TEA; MIXES IN THE NATURE OF CONCENTRATES, SYRUPS OR POWDERS USED IN THE PREPARATION OF TEA BASED BEVERAGES; OOLONG TEA (U.S. CL. 46).

JENNY PARK, EXAMINING ATTORNEY

SN 77-581,348. HERSHEY CHOCOLATE & CONFECTIONERY CORPORATION, WHEAT RIDGE, CO. FILED 9-29-2008.

SN 77-574,072. TRAXI ADVISORS, LLC, EDISON, NJ. FILED 9-19-2008.

FRUIT-A-MAJIGS

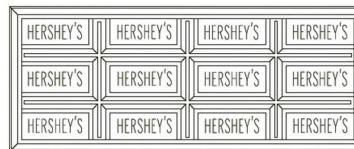

THE MARK CONSISTS OF STANDARD CHARACTERS WITHOUT CLAIM TO ANY PARTICULAR FONT, STYLE, SIZE, OR COLOR.

THE WORDING "MAJIGS" HAS NO MEANING IN A FOREIGN LANGUAGE.

FOR CANDY (U.S. CL. 46).

FIRST USE 3-10-2008; IN COMMERCE 3-10-2008.

ERIN FALK, EXAMINING ATTORNEY

OWNER OF U.S. REG. NOS. 54,041, 863,592 AND 1,367,943.

THE MARK CONSISTS OF TWELVE (12) EQUALLY-SIZED RECESSED RECTANGULAR PANELS ARRANGED IN A FOUR PANEL BY THREE PANEL FORMAT WITH EACH PANEL HAVING ITS OWN RAISED BORDER WITHIN A LARGE RECTANGLE WITH LETTERS SPELLING "HERSHEY'S" IN EACH RECESSED PANEL.

SEC. 2(F).

FOR CANDY (U.S. CL. 46).

FIRST USE 12-31-1968; IN COMMERCE 12-31-1968.

ROBERT C. CLARK JR., EXAMINING ATTORNEY

CLASS 30—(Continued).

SN 77-598,596. HEIDI AND ARTHUR INC., VALLEY COT-
TAGE, NY. FILED 10-22-2008.



OWNER OF U.S. REG. NO. 3,495,167.
NO CLAIM IS MADE TO THE EXCLUSIVE RIGHT TO
USE "CHOCOLATIERS", APART FROM THE MARK AS
SHOWN.

THE MARK CONSISTS OF ONE LARGE DUCK STAND-
ING NEXT TO A SMALL DUCK BOTH OF WHICH ARE
STANDING OVER THE WORDS "HEIDI & ARTHUR
CHOCOLATIERS".

FOR CHOCOLATE; CHOCOLATE AND CHOCO-
LATES; CHOCOLATE BARS; CHOCOLATE CANDIES;
CHOCOLATE CHIPS; CHOCOLATE TRUFFLES; CHO-
COLATES AND CHOCOLATE BASED READY TO EAT
CANDIES AND SNACKS (U.S. CL. 46).

FIRST USE 1-5-2007; IN COMMERCE 1-5-2007.
BILL DAWE, EXAMINING ATTORNEY

SN 77-610,096. GREEN MOUNTAIN COFFEE ROASTERS,
INC., WATERBURY, VT. FILED 11-7-2008.

THE PERFECT PEACH

THE MARK CONSISTS OF STANDARD CHARACTERS
WITHOUT CLAIM TO ANY PARTICULAR FONT, STYLE,
SIZE, OR COLOR.

NO CLAIM IS MADE TO THE EXCLUSIVE RIGHT TO
USE "PEACH", APART FROM THE MARK AS SHOWN.

FOR COFFEE (U.S. CL. 46).
STEVEN JACKSON, EXAMINING ATTORNEY

CLASS 30—(Continued).

SN 77-612,783. HAIN PURE FOOD CO., INC., MELVILLE,
NY. FILED 11-12-2008.

HAIN PURE FOODS

THE MARK CONSISTS OF STANDARD CHARACTERS
WITHOUT CLAIM TO ANY PARTICULAR FONT, STYLE,
SIZE, OR COLOR.

OWNER OF U.S. REG. NOS. 811,803, 2,634,522 AND
OTHERS.

NO CLAIM IS MADE TO THE EXCLUSIVE RIGHT TO
USE "PURE FOODS", APART FROM THE MARK AS
SHOWN.

FOR BAKING POWDER; CRACKERS; RICE CAKES;
DRY GRAVY MIX; VINEGAR; SEA SALT; SUGARS;
MAYONNAISE; GRAHAM CRACKERS; POPPED POP-
CORN BASED SNACK FOOD; AND COOKIES (U.S. CL.
46).

FIRST USE 4-30-1993; IN COMMERCE 4-30-1993.
MATTHEW MCDOWELL, EXAMINING ATTORNEY

SN 77-618,727. CADBURY IRELAND LTD., COOLOCK,
DUBLIN 5, IRELAND, FILED 11-20-2008.

ADVANCED MOISTURE ACTION

THE MARK CONSISTS OF STANDARD CHARACTERS
WITHOUT CLAIM TO ANY PARTICULAR FONT, STYLE,
SIZE, OR COLOR.

OWNER OF U.S. REG. NO. 3,222,535.
NO CLAIM IS MADE TO THE EXCLUSIVE RIGHT TO
USE "MOISTURE", APART FROM THE MARK AS SHOWN.

FOR NON-MEDICATED LOZENGES AND THROAT
DROPS (U.S. CL. 46).

ERIN FALK, EXAMINING ATTORNEY

SN 77-620,828. INULINA Y MIEL DE AGAVE SA DE CV,
CAPILLA DE GUADALUPE, MEXICO, FILED 11-24-2008.

DON JULIO

THE MARK CONSISTS OF STANDARD CHARACTERS
WITHOUT CLAIM TO ANY PARTICULAR FONT, STYLE,
SIZE, OR COLOR.

THE NAME(S), PORTRAIT(S), AND/OR SIGNATURE(S)
SHOWN IN THE MARK DOES NOT IDENTIFY A PARTI-
CULAR LIVING INDIVIDUAL.

THE FOREIGN WORDING IN THE MARK TRANSLATES
INTO ENGLISH AS MISTER JULIO.

FOR HONEY; HONEY SUBSTITUTES; PANCAKE
SYRUP; TABLE SYRUP; TOPPING SYRUP (U.S. CL. 46).
MARGERY A. TIERNEY, EXAMINING ATTORNEY

CLASS 30—(Continued).

SN 77-626,178. U.S. MILLS, LLC, NEEDHAM, MA. FILED 12-4-2008.

EREWHON STRAWBERRY CRISP

THE MARK CONSISTS OF STANDARD CHARACTERS WITHOUT CLAIM TO ANY PARTICULAR FONT, STYLE, SIZE, OR COLOR.

OWNER OF U.S. REG. NOS. 969,721, 1,701,981 AND OTHERS.

NO CLAIM IS MADE TO THE EXCLUSIVE RIGHT TO USE "STRAWBERRY CRISP", APART FROM THE MARK AS SHOWN.

FOR BREAKFAST CEREAL (U.S. CL. 46).
FIRST USE 4-8-2009; IN COMMERCE 4-8-2009.
LINDA LAVACHE, EXAMINING ATTORNEY

SN 77-628,416. VLP TRADES LLC, MIDLOTHIAN, VA. FILED 12-8-2008.

VILLA VICENZA CAFFE

THE MARK CONSISTS OF STANDARD CHARACTERS WITHOUT CLAIM TO ANY PARTICULAR FONT, STYLE, SIZE, OR COLOR.

NO CLAIM IS MADE TO THE EXCLUSIVE RIGHT TO USE "CAFFE", APART FROM THE MARK AS SHOWN.

THE ENGLISH TRANSLATION OF "CAFFE" IN THE MARK IS COFFEE.

SEC. 2(F).

FOR GREEN COFFEE BEANS; ROASTED COFFEE BEANS; FLAVORED COFFEE BEANS (U.S. CL. 46).
SUSAN LESLIE DUBOIS, EXAMINING ATTORNEY

SN 77-638,641. KUROHIME MEDICAL HERB TEA CO., LTD., NAGANO 389-1305, JAPAN, FILED 12-23-2008.

ENMEI-CHA

THE MARK CONSISTS OF STANDARD CHARACTERS WITHOUT CLAIM TO ANY PARTICULAR FONT, STYLE, SIZE, OR COLOR.

THE WORDING "ENMEI-CHA" HAS NO MEANING IN A FOREIGN LANGUAGE.

FOR BLENDED HERB TEA, HERB TEA, NUTRITIONAL TEA, HEALTH TEA, ALL FOR NON-MEDICAL USE (U.S. CL. 46).

DAVON HATCHETT, EXAMINING ATTORNEY

CLASS 30—(Continued).

SN 77-642,239. NUTIVA, INC., SEBASTOPOL, CA. FILED 12-31-2008.

MAYOMEGA-3 6 9

THE MARK CONSISTS OF STANDARD CHARACTERS WITHOUT CLAIM TO ANY PARTICULAR FONT, STYLE, SIZE, OR COLOR.

FOR SALAD DRESSING THAT MAY ALSO BE USED AS A BREAD SPREAD OR SANDWICH SPREAD, NAMELY, A MAYONNAISE SUBSTITUTE (U.S. CL. 46).
JENNIFER DIXON, EXAMINING ATTORNEY

SN 77-645,569. ELIZABETH MALLEK, WESTON, FL. FILED 1-8-2009.

BethMarie Chocolates

THE MARK CONSISTS OF STANDARD CHARACTERS WITHOUT CLAIM TO ANY PARTICULAR FONT, STYLE, SIZE, OR COLOR.

NO CLAIM IS MADE TO THE EXCLUSIVE RIGHT TO USE "CHOCOLATES", APART FROM THE MARK AS SHOWN.

FOR CHOCOLATE CANDIES, CHOCOLATE AND CHOCOLATES, CHOCOLATE COVERED NUTS, CHOCOLATE COVERED FRUIT, CHOCOLATE COVERED RAISINS, CHOCOLATE COVERED ROASTED COFFEE BEANS, CHOCOLATE TRUFFLES, CHOCOLATE AND CHOCOLATE BASED READY TO EAT CANDIES AND SNACKS, CANDY, CANDY WITH COCOA, CANDY WITH CARAMEL, TOFFEES AND COOKIES (U.S. CL. 46).
SUSAN LESLIE DUBOIS, EXAMINING ATTORNEY

SN 77-647,429. THE J.M. SMUCKER COMPANY, ORRVILLE, OH. FILED 1-12-2009.



OWNER OF U.S. REG. NOS. 974,661, 2,233,007 AND OTHERS.

NO CLAIM IS MADE TO THE EXCLUSIVE RIGHT TO USE "SINCE 1883", APART FROM THE MARK AS SHOWN. THE MARK CONSISTS OF A FLOWER.

FOR FLOUR AND CORNMEAL MIX (U.S. CL. 46).
FIRST USE 9-22-1997; IN COMMERCE 9-22-1997.
SOPHIA S. KIM, EXAMINING ATTORNEY

CLASS 30—(Continued).

SN 77-649,005. TWANG PARTNERS, LTD, SAN ANTONIO, TX. FILED 1-14-2009.

CLASS 30—(Continued).

SN 77-652,136. ARCUS, LLC, EARLVILLE, MD. FILED 1-19-2009.

ADD ZING TO ANYTHING!

THE MARK CONSISTS OF STANDARD CHARACTERS WITHOUT CLAIM TO ANY PARTICULAR FONT, STYLE, SIZE, OR COLOR.
FOR FLAVORED SALT (U.S. CL. 46).
FIRST USE 1-1-2007; IN COMMERCE 1-1-2007.
KAREN SEVERSON, EXAMINING ATTORNEY

ROCKFISH JOHNNIES SPICY SAUCE

THE MARK CONSISTS OF STANDARD CHARACTERS WITHOUT CLAIM TO ANY PARTICULAR FONT, STYLE, SIZE, OR COLOR.
NO CLAIM IS MADE TO THE EXCLUSIVE RIGHT TO USE "SPICY SAUCE", APART FROM THE MARK AS SHOWN.
THE NAME "ROCKFISH JOHNNIES" DOES NOT IDENTIFY A LIVING INDIVIDUAL.
FOR CONDIMENTS, NAMELY, SAUCES (U.S. CL. 46).
ANGELA M. MICHELI, EXAMINING ATTORNEY

SN 77-649,098. MALT-O-MEAL COMPANY, MINNEAPOLIS, MN. FILED 1-14-2009.

OAT FIT

THE MARK CONSISTS OF STANDARD CHARACTERS WITHOUT CLAIM TO ANY PARTICULAR FONT, STYLE, SIZE, OR COLOR.
NO CLAIM IS MADE TO THE EXCLUSIVE RIGHT TO USE "OAT", APART FROM THE MARK AS SHOWN.
FOR BREAKFAST CEREAL (U.S. CL. 46).
GRETTA YAO, EXAMINING ATTORNEY

SN 77-652,872. CANDIES TOLTECA, FRESNO, CA. FILED 1-20-2009.

SN 77-649,371. LANGE, CRAIG, VICTORVILLE, CA. FILED 1-14-2009.

BINER BAR



THE MARK CONSISTS OF STANDARD CHARACTERS WITHOUT CLAIM TO ANY PARTICULAR FONT, STYLE, SIZE, OR COLOR.
NO CLAIM IS MADE TO THE EXCLUSIVE RIGHT TO USE "BAR", APART FROM THE MARK AS SHOWN.
FOR FOOD, SNACK AND ENERGY BARS, NAMELY, GRANOLA-BASED SNACK BARS, CEREAL BASED ENERGY BARS AND GRAIN BASED FOOD BARS ALSO CONTAINING SOY, DRIED FRUITS, CHOCOLATE, AND NUTS (U.S. CL. 46).
SEAN CROWLEY, EXAMINING ATTORNEY

OWNER OF U.S. REG. NO. 3,546,684.
THE MARK CONSISTS OF A CARTOON BABOON LOOKING OUT FROM BEHIND DIAGONALLY ACROSS IT. THE WORD "BABOON" WRITTEN DIAGONALLY ACROSS IT.
FOR CANDY; MEXICAN CANDY (U.S. CL. 46).
FIRST USE 2-24-2004; IN COMMERCE 2-24-2004.
GENE MACIOL, EXAMINING ATTORNEY

CLASS 30—(Continued).

SN 77-661,352. MI KYONG CHOI, DBA STEVEN'S USA CORP., ALBERTSON, NY. FILED 2-2-2009.



NO CLAIM IS MADE TO THE EXCLUSIVE RIGHT TO USE "NEW YORK" OR "NEW YORK HOT DOG", APART FROM THE MARK AS SHOWN.

THE COLOR(S) DARK GREEN, LIGHT GREEN, WHITE, BLACK, RED, AND YELLOW IS/ARE CLAIMED AS A FEATURE OF THE MARK.

THE MARK CONSISTS OF A CIRCLE SHAPE WITH AN OUTER GREEN LINE, A MIDDLE WHITE LINE, AND AN INNER BAND OF LIGHT GREEN. ON THE INNER BAND THE WORDING "NEW YORK HOT DOG" APPEARS IN BLACK. THE INTERIOR OF THE CIRCLE IS WHITE BEHIND A GREEN AND WHITE CHECKERED AREA. OVER THE CIRCLE THE WORDING "NEW YORK" IS IN RED WITH BLACK OUTLINING, AND THERE IS A RED HOT DOG WITH A YELLOW BUN AND YELLOW SAUCE, ALL OUTLINED IN BLACK.

FOR HOT DOG SANDWICHES (U.S. CL. 46).
FIRST USE 8-7-2008; IN COMMERCE 8-7-2008.
REBECCA POVARCHUK, EXAMINING ATTORNEY

SN 77-661,416. GENERAL BISCUITS BELGIE, B-2200 HERENTALS, BELGIUM, FILED 2-2-2009.

TUC

THE MARK CONSISTS OF STANDARD CHARACTERS WITHOUT CLAIM TO ANY PARTICULAR FONT, STYLE, SIZE, OR COLOR.

OWNER OF U.S. REG. NOS. 2,947,308 AND 3,167,059.
FOR CRACKERS (U.S. CL. 46).
LAKEISHA LEWIS, EXAMINING ATTORNEY

CLASS 30—(Continued).

SN 77-661,524. TWANG PARTNERS, LTD, SAN ANTONIO, TX. FILED 2-2-2009.

IT'S NOT GONNA LICK ITSELF

THE MARK CONSISTS OF STANDARD CHARACTERS WITHOUT CLAIM TO ANY PARTICULAR FONT, STYLE, SIZE, OR COLOR.

FOR FLAVORED SALT; FLAVORED SUGAR; FOOD SEASONINGS; SALT-BASED SPICES INTENDED FOR USE WITH BEER (U.S. CL. 46).

KAREN SEVERSON, EXAMINING ATTORNEY

SN 77-661,945. PET INCORPORATED, MINNEAPOLIS, MN. FILED 2-3-2009.

TORTILLA STUFFERS

THE MARK CONSISTS OF STANDARD CHARACTERS WITHOUT CLAIM TO ANY PARTICULAR FONT, STYLE, SIZE, OR COLOR.

NO CLAIM IS MADE TO THE EXCLUSIVE RIGHT TO USE "TORTILLA", APART FROM THE MARK AS SHOWN.

FOR PACKAGED MEAL STARTER KITS CONSISTING PRIMARILY OF RICE, WITH MEAT OR POULTRY, AND VEGETABLES (U.S. CL. 46).

EMILY CHUO, EXAMINING ATTORNEY

SN 77-662,117. DEVITIS, ROBERT, AKRON, OH. FILED 2-3-2009.

Life Begins at Coffee!

THE MARK CONSISTS OF STANDARD CHARACTERS WITHOUT CLAIM TO ANY PARTICULAR FONT, STYLE, SIZE, OR COLOR.

FOR COFFEE; COFFEE BEANS (U.S. CL. 46).
HEATHER SAPP, EXAMINING ATTORNEY

CLASS 30—(Continued).

SN 77-662,886. FASENMYER, JODY CHRISTINE, LAUREL, MD. FILED 2-4-2009.

The Good Sin

THE MARK CONSISTS OF STANDARD CHARACTERS WITHOUT CLAIM TO ANY PARTICULAR FONT, STYLE, SIZE, OR COLOR.
FOR BAKERY PRODUCTS (U.S. CL. 46).
DEZMONA MIZELLE, EXAMINING ATTORNEY

CLASS 30—(Continued).

SN 77-663,938. SENSATIONAL FOUR, INC., ELGIN, IL. FILED 2-5-2009.

SPRINKLE MAGIC COLLECTION

THE MARK CONSISTS OF STANDARD CHARACTERS WITHOUT CLAIM TO ANY PARTICULAR FONT, STYLE, SIZE, OR COLOR.
NO CLAIM IS MADE TO THE EXCLUSIVE RIGHT TO USE "SPRINKLE" AND "COLLECTION", APART FROM THE MARK AS SHOWN.
FOR CANDY DECORATIONS FOR CAKES; CANDY SPRINKLES; EDIBLE DECORATIONS FOR CAKES; EDIBLE ICES (U.S. CL. 46).
FIRST USE 1-29-2009; IN COMMERCE 1-29-2009.
TOBY BULLOFF, EXAMINING ATTORNEY

SN 77-663,818. SNOWIZARD, INC., FORMERLY SNOWIZARD EXTRACTS, INC. AND SNOWIZARD HOLDINGS, INC., NEW ORLEANS, LA. FILED 2-5-2009.

SNOWIZARD

THE MARK CONSISTS OF STANDARD CHARACTERS WITHOUT CLAIM TO ANY PARTICULAR FONT, STYLE, SIZE, OR COLOR.
OWNER OF U.S. REG. NO. 2,544,216.
FOR FOOD FLAVORINGS (U.S. CL. 46).
FIRST USE 1-1-1945; IN COMMERCE 1-1-1945.
DEZMONA MIZELLE, EXAMINING ATTORNEY

SN 77-664,304. ENJOY LIFE NATURAL BRANDS, LLC, FORMERLY ENJOY LIFE FOODS, SCHILLER PARK, IL. FILED 2-5-2009.

PERKY'S CRUNCHY RICE

THE MARK CONSISTS OF STANDARD CHARACTERS WITHOUT CLAIM TO ANY PARTICULAR FONT, STYLE, SIZE, OR COLOR.
OWNER OF U.S. REG. NOS. 2,831,464 AND 3,078,174.
NO CLAIM IS MADE TO THE EXCLUSIVE RIGHT TO USE "CRUNCHY RICE", APART FROM THE MARK AS SHOWN.
FOR BREAKFAST CEREALS (U.S. CL. 46).
SUE LAWRENCE, EXAMINING ATTORNEY

SN 77-663,861. SNOWIZARD, INC., FORMERLY SNOWIZARD EXTRACTS, INC. AND SNOWIZARD HOLDINGS, INC., NEW ORLEANS, LA. FILED 2-5-2009.

SNOLITE

THE MARK CONSISTS OF STANDARD CHARACTERS WITHOUT CLAIM TO ANY PARTICULAR FONT, STYLE, SIZE, OR COLOR.
FOR UNFLAVORED, UNSWEETENED SYRUP MIXES (U.S. CL. 46).
FIRST USE 11-1-1994; IN COMMERCE 11-1-1994.
DEZMONA MIZELLE, EXAMINING ATTORNEY

SN 77-664,324. ENJOY LIFE NATURAL BRANDS, LLC, FORMERLY ENJOY LIFE FOODS, SCHILLER PARK, IL. FILED 2-5-2009.

PERKY'S CRUNCHY FLAX

THE MARK CONSISTS OF STANDARD CHARACTERS WITHOUT CLAIM TO ANY PARTICULAR FONT, STYLE, SIZE, OR COLOR.
OWNER OF U.S. REG. NOS. 2,831,464 AND 3,078,174.
NO CLAIM IS MADE TO THE EXCLUSIVE RIGHT TO USE "CRUNCHY FLAX", APART FROM THE MARK AS SHOWN.
FOR BREAKFAST CEREALS (U.S. CL. 46).
SUE LAWRENCE, EXAMINING ATTORNEY

CLASS 30—(Continued).

SN 77-664,442. SNOWIZARD, INC., FORMERLY SNOWIZARD EXTRACTS, INC. AND SNOWIZARD HOLDINGS, INC., NEW ORLEANS, LA. FILED 2-5-2009.

SNOFREE

THE MARK CONSISTS OF STANDARD CHARACTERS WITHOUT CLAIM TO ANY PARTICULAR FONT, STYLE, SIZE, OR COLOR.

OWNER OF U.S. REG. NO. 3,580,057.
FOR UNFLAVORED, UNSWEETENED SYRUP MIXES (U.S. CL. 46).
FIRST USE 11-1-1994; IN COMMERCE 11-1-1994.
DEZMONA MIZELLE, EXAMINING ATTORNEY

SN 77-664,844. MALT-O-MEAL COMPANY, MINNEAPOLIS, MN. FILED 2-6-2009.

BETTER OATS...AND A BETTER WORLD

THE MARK CONSISTS OF STANDARD CHARACTERS WITHOUT CLAIM TO ANY PARTICULAR FONT, STYLE, SIZE, OR COLOR.

FOR BREAKFAST CEREAL (U.S. CL. 46).
GRETTA YAO, EXAMINING ATTORNEY

SN 77-664,846. MALT-O-MEAL COMPANY, MINNEAPOLIS, MN. FILED 2-6-2009.

BETTER OATS...FOR ALL

THE MARK CONSISTS OF STANDARD CHARACTERS WITHOUT CLAIM TO ANY PARTICULAR FONT, STYLE, SIZE, OR COLOR.

FOR BREAKFAST CEREAL (U.S. CL. 46).
GRETTA YAO, EXAMINING ATTORNEY

CLASS 30—(Continued).

SN 77-665,085. MALT-O-MEAL COMPANY, MINNEAPOLIS, MN. FILED 2-6-2009.

YOUR FAMILY DESERVES BETTER OATS

THE MARK CONSISTS OF STANDARD CHARACTERS WITHOUT CLAIM TO ANY PARTICULAR FONT, STYLE, SIZE, OR COLOR.

FOR BREAKFAST CEREAL (U.S. CL. 46).
GRETTA YAO, EXAMINING ATTORNEY

SN 77-665,406. TAMPA'S TEAM, LLC, TAMPA, FL. FILED 2-6-2009.

Buddy Brew Coffee

THE MARK CONSISTS OF STANDARD CHARACTERS WITHOUT CLAIM TO ANY PARTICULAR FONT, STYLE, SIZE, OR COLOR.

NO CLAIM IS MADE TO THE EXCLUSIVE RIGHT TO USE "BREW COFFEE", APART FROM THE MARK AS SHOWN.

FOR BEVERAGES MADE OF COFFEE; COFFEE; COFFEE; COFFEE BASED BEVERAGES; COFFEE BEANS; COFFEE BEVERAGES WITH MILK; COFFEE-BASED BEVERAGES; GREEN COFFEE; GROUND COFFEE BEANS; PREPARED COFFEE AND COFFEE-BASED BEVERAGES; ROASTED COFFEE BEANS; UNROASTED COFFEE (U.S. CL. 46).
JOHN HWANG, EXAMINING ATTORNEY

SN 77-667,749. BOARDHOUSE SANDWICHES, INC., LAS VEGAS, NV. FILED 2-10-2009.

THE WOODY

THE MARK CONSISTS OF STANDARD CHARACTERS WITHOUT CLAIM TO ANY PARTICULAR FONT, STYLE, SIZE, OR COLOR.

FOR SANDWICHES (U.S. CL. 46).
GINA HAYES, EXAMINING ATTORNEY

CLASS 30—(Continued).

SN 77-678,326. KRAFT FOODS GLOBAL BRANDS LLC, NORTHFIELD, IL. FILED 2-25-2009.



THE MARK CONSISTS OF THE DESIGN OF A MAN LICKING A COOKIE WITHIN A RECTANGULAR BORDER, WITH THE LETTERING "DSRL" ALSO WITHIN THE LOWER RIGHT CORNER OF THE RECTANGULAR BORDER.

FOR COOKIES (U.S. CL. 46).
FIRST USE 1-1-2008; IN COMMERCE 1-1-2008.
RUDY R. SINGLETON, EXAMINING ATTORNEY

SN 77-686,127. PROMARK BRANDS INC., MERIDIAN, ID. FILED 3-9-2009.

**CHEF-MADE QUALITY.
READY-MADE PROFIT.**

THE MARK CONSISTS OF STANDARD CHARACTERS WITHOUT CLAIM TO ANY PARTICULAR FONT, STYLE, SIZE, OR COLOR.

FOR CHEESECAKES; CAKES; BROWNIES; DESSERT BARS, NAMELY, FRUIT BARS, CARAMEL BARS, CHOCOLATE BARS, COCONUT-BASED BARS, CHOCOLATE CHIP BARS, CHOCOLATE PEANUT BUTTER BARS, AND CHEESECAKE BARS; PIES; DESSERT PUDDINGS; DESSERT MOUSSE; TORTES (U.S. CL. 46).

FIRST USE 8-30-2006; IN COMMERCE 8-30-2006.
CURTIS FRENCH, EXAMINING ATTORNEY

SN 79-052,908. JOINT-STOCK COMPANY "KRASNYJ OCYABR", RUSSIAN FED., FILED 3-4-2008.

ИСКУШЕНИЕ

OWNER OF INTERNATIONAL REGISTRATION 0961691 DATED 3-4-2008, EXPIRES 3-4-2018.

THE ENGLISH TRANSLATION OF THE FOREIGN WORD(S) IN THE MARK IS: TEMPTATION.

THE TRANSLITERATION OF THE NON-LATIN CHARACTERS IN THE MARK IS: ISKUSHENIYE.

FOR CONFECTIONERY, NAMELY, BONBONS, CANDY BARS, CHOCOLATE BARS, CHOCOLATE CANDIES, CHOCOLATE TRUFFLES, FILLED CHOCOLATE, MILK CHOCOLATE, TOFFEE, COOKIES, SPICE-CAKES, RUSKS, HALVAH, FRUIT JELLIES, FONDANTS, PASTILLES, MARSHMALLOWS, CANDIED ROASTED NUTS AND ALMONDS (U.S. CL. 46).

BARNEY CHARLON, EXAMINING ATTORNEY

CLASS 30—(Continued).

SN 79-058,920. LIDL STIFTUNG & CO. KG, FED REP GERMANY, FILED 8-13-2008.

Opey

THE MARK CONSISTS OF STANDARD CHARACTERS WITHOUT CLAIM TO ANY PARTICULAR FONT, STYLE, SIZE, OR COLOR.

PRIORITY DATE OF 3-5-2008 IS CLAIMED.
OWNER OF INTERNATIONAL REGISTRATION 0977399 DATED 8-13-2008, EXPIRES 8-13-2018.

THE WORDING "OPEY" HAS NO MEANING IN A FOREIGN LANGUAGE.

FOR BREAD, PASTRY AND CONFECTIONERY, NAMELY, BREAD AND BAKERY PRODUCTS, GINGERBREAD, FROZEN CONFECTIONERY, CONFECTIONERY BAKING CHIPS; COOKIES INCLUDING WITH CHOCOLATE, BISCUITS, CAKES, CHOCOLATE, CHOCOLATE GOODS, NAMELY, CHOCOLATE CANDIES, CHOCOLATE CHIPS, CHOCOLATE COVERED FRUIT, CHOCOLATE COVERED NUTS, CHOCOLATE COVERED RAISINS, CHOCOLATE COVERED ROASTED COFFEE BEANS, CHOCOLATE FONDUE, CHOCOLATE FOOD BEVERAGES NOT BEING DAIRY-BASED OR VEGETABLE BASED, CHOCOLATE MOUSSE, CHOCOLATE PASTES, CHOCOLATE POWDER, CHOCOLATE SYRUP, CHOCOLATE TOPPING, CHOCOLATE TRUFFLES, CHOCOLATES AND CHOCOLATE BASED READY TO EAT CANDIES AND SNACKS, CHOCOLATE-BASED FILLINGS FOR CAKES AND PIES, CHOCOLATE-BASED READY-TO-EAT FOOD BARS, CHOCOLATE COVERED POTATO CHIPS, FILLED CHOCOLATE, MILK CHOCOLATE, SPREAD CONTAINING CHOCOLATE AND NUTS; CHOCOLATE GOODS, NAMELY, CHOCOLATE EGGS AND CHOCOLATE BARS, PRALINES; SUGAR CONFECTIONERY, NAMELY, CRYSTAL SUGAR PIECES, SWEETMEATS, CARAMELS, PASTILLES, CANDY, GUMMI BEARS, AND TOFFEES; INCLUDING ALL THE AFORESAID GOODS USING SUGAR SUBSTITUTES (U.S. CL. 46).

WILLIAM ROSSMAN, EXAMINING ATTORNEY

SN 79-059,828. LIDL STIFTUNG & CO. KG, FED REP GERMANY, FILED 10-2-2008.

SIR EDWARD TEA

OWNER OF INTERNATIONAL REGISTRATION 0955167 DATED 2-19-2008, EXPIRES 2-19-2018.

OWNER OF U.S. REG. NO. 2,614,885.
NO CLAIM IS MADE TO THE EXCLUSIVE RIGHT TO USE "TEA", APART FROM THE MARK AS SHOWN.

FOR TEA, HERBAL TEA, NOT FOR MEDICAL PURPOSES, FRUIT TEA, TEA BEVERAGES (U.S. CL. 46).

DAVID HOFFMAN, EXAMINING ATTORNEY

CLASS 30—(Continued).

SN 79-060,643. LIDL STIFTUNG & CO. KG, FED REP GERMANY, FILED 10-16-2008.



PRIORITY DATE OF 5-6-2008 IS CLAIMED.
OWNER OF INTERNATIONAL REGISTRATION 0977195 DATED 8-18-2008, EXPIRES 8-18-2018.

OWNER OF U.S. REG. NO. 3,485,260.
THE COLOR(S) WHITE, BLUE, YELLOW, RED IS/ARE CLAIMED AS A FEATURE OF THE MARK.

THE MARK CONSISTS OF A RED RECTANGLE WITH TWO CURVED SIDE; THE RECTANGLE IS OUTLINED FROM THE OUTSIDE BY THE COLORS, WHITE, BLUE AND WHITE; THE INTERIOR OF THE RECTANGLE IS RED AND CONTAINS THE WORDING "CHOCO SOFTIES" IN THE COLOR BLUE HAVING A WHITE OUTLINE; THE WORDING IS UNDERLINED BY A YELLOW WAVY BAR; A WHITE BIRD OUTLINED IN BLUE IS LOCATED ABOVE THE WORD "CHOCO" AND EXTENDS OUT OF THE RECTANGLE.

FOR MARSHMALLOWS COATED WITH CHOCOLATE (U.S. CL. 46).
DOMINIC FATHY, EXAMINING ATTORNEY

CLASS 31—(Continued).

SN 77-507,588. BLAIN SUPPLY, INC., JANESVILLE, WI. FILED 6-25-2008.

Purrfect Hearts

THE MARK CONSISTS OF STANDARD CHARACTERS WITHOUT CLAIM TO ANY PARTICULAR FONT, STYLE, SIZE, OR COLOR.

FOR PET TREATS (U.S. CLS. 1 AND 46).
NAKIA HENRY, EXAMINING ATTORNEY

SN 77-523,945. OVERDEVEST NURSERIES, L.P., BRIDGETON, NJ. FILED 7-16-2008.

STEPPING TOWARDS A GREENER TOMORROW

THE MARK CONSISTS OF STANDARD CHARACTERS WITHOUT CLAIM TO ANY PARTICULAR FONT, STYLE, SIZE, OR COLOR.

FOR LIVE PLANTS (U.S. CLS. 1 AND 46).
FIRST USE 7-1-2008; IN COMMERCE 7-1-2008.
DANIEL BRODY, EXAMINING ATTORNEY

CLASS 31—NATURAL AGRICULTURAL PRODUCTS

SN 77-470,900. ULTRA WILDFLOWERS, GARY, IN. FILED 5-9-2008.

Ultra Wildflowers

THE MARK CONSISTS OF STANDARD CHARACTERS WITHOUT CLAIM TO ANY PARTICULAR FONT, STYLE, SIZE, OR COLOR.

NO CLAIM IS MADE TO THE EXCLUSIVE RIGHT TO USE "WILDFLOWERS", APART FROM THE MARK AS SHOWN.

FOR FLOWER SEEDS (U.S. CLS. 1 AND 46).
MARLENE BELL, EXAMINING ATTORNEY

SN 77-542,862. NATURA PET PRODUCTS, INC., DAVIS, CA. FILED 8-8-2008.

evidence based nutrition

THE MARK CONSISTS OF STANDARD CHARACTERS WITHOUT CLAIM TO ANY PARTICULAR FONT, STYLE, SIZE, OR COLOR.

NO CLAIM IS MADE TO THE EXCLUSIVE RIGHT TO USE "NUTRITION", APART FROM THE MARK AS SHOWN.

FOR PET FOOD (U.S. CLS. 1 AND 46).
DOMINIC J. FERRAIUOLO, EXAMINING ATTORNEY

CLASS 31—(Continued).

SN 77-606,905. PET FOOD EXPRESS, LTD., SAN LEANDRO, CA. FILED 11-4-2008.

ORGANIC N' SAFE

THE MARK CONSISTS OF STANDARD CHARACTERS WITHOUT CLAIM TO ANY PARTICULAR FONT, STYLE, SIZE, OR COLOR.

SEC. 2(F).

FOR ORGANIC PET LITTER (U.S. CLS. 1 AND 46).

FIRST USE 1-1-1992; IN COMMERCE 1-1-1992.

AMY ALFIERI, EXAMINING ATTORNEY

CLASS 31—(Continued).

SN 77-662,128. PENDULUM NURSERY AND SALES LLC, REDMOND, OR. FILED 2-3-2009.

PACIFIC BRILLIANCE

THE MARK CONSISTS OF STANDARD CHARACTERS WITHOUT CLAIM TO ANY PARTICULAR FONT, STYLE, SIZE, OR COLOR.

FOR LIVE TREES (U.S. CLS. 1 AND 46).

JEAN IM, EXAMINING ATTORNEY

SN 77-632,026. PERO FRESH FOODS, LLC, DELRAY BEACH, FL. AND PERO VEGETABLE COMPANY, LLC, DELRAY BEACH, FL. FILED 12-12-2008.

JUICE IT PERO FRESH

THE MARK CONSISTS OF STANDARD CHARACTERS WITHOUT CLAIM TO ANY PARTICULAR FONT, STYLE, SIZE, OR COLOR.

NO CLAIM IS MADE TO THE EXCLUSIVE RIGHT TO USE "FRESH", APART FROM THE MARK AS SHOWN.

THE WORDING "PERO" HAS NO MEANING IN A FOREIGN LANGUAGE.

FOR FRESH FRUIT AND VEGETABLES (U.S. CLS. 1 AND 46).

DAVID C. REIHNER, EXAMINING ATTORNEY

SN 77-662,443. ORGANIC ALLIANCE, INC., SAN ANTONIO, TX. FILED 2-3-2009.

AvocadoMan

THE MARK CONSISTS OF STANDARD CHARACTERS WITHOUT CLAIM TO ANY PARTICULAR FONT, STYLE, SIZE, OR COLOR.

FOR FRESH AVOCADOS (U.S. CLS. 1 AND 46).

JOHN GARTNER, EXAMINING ATTORNEY

SN 77-660,047. TIMCO WORLDWIDE, INC., DAVIS, CA. FILED 1-30-2009.

MELON UP! CLASSIC

THE MARK CONSISTS OF STANDARD CHARACTERS WITHOUT CLAIM TO ANY PARTICULAR FONT, STYLE, SIZE, OR COLOR.

OWNER OF U.S. REG. NO. 2,774,364.

NO CLAIM IS MADE TO THE EXCLUSIVE RIGHT TO USE "MELON", APART FROM THE MARK AS SHOWN.

FOR FRUITS, NAMELY, FRESH WATERMELON (U.S. CLS. 1 AND 46).

BRENDAN REGAN, EXAMINING ATTORNEY

SN 77-664,678. FLORISTS' TRANSWORLD DELIVERY, INC., DOWNERS GROVE, IL. FILED 2-5-2009.

SAY IT YOUR WAY

THE MARK CONSISTS OF STANDARD CHARACTERS WITHOUT CLAIM TO ANY PARTICULAR FONT, STYLE, SIZE, OR COLOR.

FOR FLOWERS, INCLUDING LIVE CUT FLORAL ARRANGEMENTS ACCOMPANIED BY PRERECORDED PERSONAL MESSAGES (U.S. CLS. 1 AND 46).

FIRST USE 1-29-2009; IN COMMERCE 1-29-2009.

MARK PILARO, EXAMINING ATTORNEY

CLASS 31—(Continued).

SN 77-665,310. WAGNER'S, LLC, PURCHASE, NY. FILED 2-6-2009.

ADVANCED BIRDING

THE MARK CONSISTS OF STANDARD CHARACTERS WITHOUT CLAIM TO ANY PARTICULAR FONT, STYLE, SIZE, OR COLOR.

NO CLAIM IS MADE TO THE EXCLUSIVE RIGHT TO USE "BIRDING", APART FROM THE MARK AS SHOWN. FOR BIRD FOOD; BIRD SEED (U.S. CLS. 1 AND 46). ZACHARY BELLO, EXAMINING ATTORNEY

SN 77-688,475. SOD SOLUTIONS, INC., MT. PLEASANT, SC. FILED 3-11-2009.



NO CLAIM IS MADE TO THE EXCLUSIVE RIGHT TO USE "BLUEGRASS", "HEAT TOLERANT" AND "LESS MOWING", APART FROM THE MARK AS SHOWN.

THE MARK CONSISTS OF THE WORD "BELLA" IN ARCHED BOLD AND SHADED PRINT WITH THE WORD "BLUEGRASS" BENEATH, AND THE WORDS "HEAT TOLERANT" AND "LESS MOWING" SEPARATED BY A CENTERED PERIOD STYLE BULLET AND ABOVE THE WORDS "HEAT TOLERANT" AND "LESS MOWING" APPEAR TWO SHOOTING STYLE ARROWS AND FIVE STARS BETWEEN THE TWO ARROWS.

FOR NATURAL TURF, NAMELY, GRASS AND GRASS PLUGS; SOD AND NON-ARTIFICIAL TURF (U.S. CLS. 1 AND 46).

FIRST USE 12-15-2007; IN COMMERCE 12-15-2007. CAROLYN CATALDO, EXAMINING ATTORNEY

SN 77-696,035. NATURAL BALANCE PET FOODS, INC., PACOIMA, CA. FILED 3-20-2009.

THE FOOD FOR A LIFETIME

THE MARK CONSISTS OF STANDARD CHARACTERS WITHOUT CLAIM TO ANY PARTICULAR FONT, STYLE, SIZE, OR COLOR.

FOR DOG FOOD AND CAT FOOD (U.S. CLS. 1 AND 46).

KRISTIN CARLSON, EXAMINING ATTORNEY

CLASS 31—(Continued).

SN 79-057,871. H & N INTERNATIONAL GMBH, CUXHAVEN, FED REP GERMANY, FILED 4-15-2008.



OWNER OF INTERNATIONAL REGISTRATION 0792484 DATED 8-6-2002, EXPIRES 8-6-2012.

NO CLAIM IS MADE TO THE EXCLUSIVE RIGHT TO USE "INTERNATIONAL", APART FROM THE MARK AS SHOWN.

THE COLOR(S) BLACK, BLUE AND RED IS/ARE CLAIMED AS A FEATURE OF THE MARK.

THE MARK CONSISTS OF THE COLORS BLACK, BLUE AND RED, THE COLOR BLUE APPEARS THE WORDING "H" AND "N", THE COLOR RED APPEARS IN THE WORDING "&" AND THE COLOR BLACK APPEARS IN THE WORDING "INTERNATIONAL", AND IN THE OUTLINING OF THE MARK.

FOR MALE AND FEMALE EGG LAYER BREEDING STOCK, PULLETS, AND CHICKS; EGGS FOR HATCHING AND INCUBATION (U.S. CLS. 1 AND 46).

SEAN CROWLEY, EXAMINING ATTORNEY

CLASS 32—LIGHT BEVERAGES

SN 77-215,937. RACoon ESTATE PTY LTD, RESERVOIR, VICTORIA, AUSTRALIA, FILED 6-26-2007.

BROK

THE MARK CONSISTS OF STANDARD CHARACTERS WITHOUT CLAIM TO ANY PARTICULAR FONT, STYLE, SIZE, OR COLOR.

PRIORITY CLAIMED UNDER SEC. 44(D) ON AUSTRALIA APPLICATION NO. 1182311, FILED 6-14-2007, REG. NO. 1182311, DATED 6-14-2007, EXPIRES 6-14-2017.

THE ENGLISH TRANSLATION OF THE MARK IS PIECE, CHUNK, SLING, HERNIA, AND PELLET.

FOR BEERS; MINERAL AND AERATED WATERS AND OTHER NON-ALCOHOLIC DRINKS, NAMELY, SOFT DRINKS; FRUIT DRINKS AND FRUIT JUICES; SYRUPS FOR MAKING BEVERAGES (U.S. CLS. 45, 46 AND 48).

SUSAN RICHARDS, EXAMINING ATTORNEY

CLASS 32—(Continued).

SN 77-242,645. OBIOHA, ANTHONY, SPRINGDALE, MD. FILED 7-31-2007.



NO CLAIM IS MADE TO THE EXCLUSIVE RIGHT TO USE "ENERGY DRINK", APART FROM THE MARK AS SHOWN.

THE COLOR(S) BLACK, WHITE, BLUE AND GREY IS/ ARE CLAIMED AS A FEATURE OF THE MARK.

THE MARK CONSISTS OF THE WORDS "BLUE", "STORM", AND "ENERGY DRINK" WHICH ARE WRITTEN IN CAPS AND STYLIZED IN WHITE COLOR WITH GRAY. THE WORDING "BLUE STORM" ALSO IS OUTLINED IN BLACK AND BLUE ON A BLACK BACKGROUND. THE ENTIRE MARK SITS ON TOP OF DESIGNS IN BLUE AND GREY.

FOR ENERGY DRINK (U.S. CLS. 45, 46 AND 48).
NAKIA HENRY, EXAMINING ATTORNEY

CLASS 32—(Continued).

SN 77-473,927. ABDIJ AFFLIGEM, AFFLIGEM, BELGIUM, FILED 5-14-2008.



OWNER OF ERPN CMNTY TM OFC REG. NO. 6446587, DATED 10-17-2008, EXPIRES 11-16-2017.

OWNER OF U.S. REG. NO. 2,539,871.

NO CLAIM IS MADE TO THE EXCLUSIVE RIGHT TO USE "ABBAYE" AND "ABDIJ" AND "ANNO 1074", APART FROM THE MARK AS SHOWN.

THE MARK CONSISTS OF THE WORD "AFFLIGEM" IN LARGE BLACK LETTERS IN STYLIZED PRINT WITH GRAYSCALE SHADOWING IN EACH LETTER. THE WORDS "ABBAYE - ABDIJ" ARE WRITTEN IN UPPER-CASE LETTERS ABOVE "AFFLIGEM" AND THE WORDS "ANNO 1074" IS WRITTEN IN SMALL LETTERS TO THE LOWER RIGHT OF THE WORD "AFFLIGEM". A SHIELD DESIGN IS PRESENT BELOW THE WORD "AFFLIGEM" IN WHICH IS A SMALLER SHIELD DESIGN SHOWING A SWORD DESIGN. BELOW THE SMALLER SHIELD DESIGN THE NAME "PP BENEDICTIJNEN" IS WRITTEN IN SCRIPT.

THE ENGLISH TRANSLATION OF "AFFLIGEM ABBAYE-ABDIJ 1074 PP BENEDICTIJNEN" IN THE MARK IS AFFLIGEM ABBEY-ABBAY SINCE THE YEAR 1074 PP BENEDICTINES.

FOR BEERS, ALES (U.S. CLS. 45, 46 AND 48).
CHRISTINA SOBRAL, EXAMINING ATTORNEY

SN 77-383,853. SUPER BAKERY, INCORPORATED, PITTSBURGH, PA. FILED 1-30-2008.

RAIDERADE

THE MARK CONSISTS OF STANDARD CHARACTERS WITHOUT CLAIM TO ANY PARTICULAR FONT, STYLE, SIZE, OR COLOR.

FOR SPORTS DRINKS (U.S. CLS. 45, 46 AND 48).
MICHAEL WIENER, EXAMINING ATTORNEY

SN 77-517,891. COTT BEVERAGES INC., TAMPA, FL. FILED 7-9-2008.

LOOPY LIMON

THE MARK CONSISTS OF STANDARD CHARACTERS WITHOUT CLAIM TO ANY PARTICULAR FONT, STYLE, SIZE, OR COLOR.

FOR SOFT DRINKS (U.S. CLS. 45, 46 AND 48).
JAMES LOVELACE, EXAMINING ATTORNEY

CLASS 32—(Continued).

SN 77-518,560. BALTIKA BREWERIES, SAINT-PETERSBURG, RUSSIAN FED., FILED 7-10-2008.



OWNER OF U.S. REG. NOS. 2,760,850, 3,292,967 AND OTHERS.

THE COLOR(S) YELLOW, GOLD, RED, BLACK AND WHITE IS/ARE CLAIMED AS A FEATURE OF THE MARK.

THE RECTANGULAR BACKGROUND IS GOLD, THE CENTRAL OVAL IS YELLOW, THE BANNER IS BLACK OUTLINED IN GOLD AND WHITE TRIM, THE THREE WAVY LINES AND WORD "BALTIKA" AND THE NUMBER "5" ARE WHITE. THE CROWN IS GOLD WITH A RED CENTER, THE GRAIN IS GOLD, THE CIRCLE IS WHITE AND HAVING A RED CENTER WITH WHITE WAVY LINES INSIDE, AND THE BANNERS EXTENDING FROM THE CIRCLE ARE WHITE AND THE STRING AT THE BOTTOM IS GOLD.

THE WORDING "BALTIKA" HAS NO MEANING IN A FOREIGN LANGUAGE.

FOR BEER; NON-ALCOHOLIC BEER (U.S. CLS. 45, 46 AND 48).

FIRST USE 7-25-2007; IN COMMERCE 7-25-2007.
JOHN WILKE, EXAMINING ATTORNEY

CLASS 32—(Continued).

NEXT RING IS GREEN, THE INNER OVAL IS WHITE, THE BANNER IS GREEN OUTLINED IN WHITE AND YELLOW, THE THREE WAVY LINES AND THE WORD "BALTIKA" ARE WHITE OUTLINED IN GREEN, THE NUMBER "1" IS GREEN SHADED WITH BLACK AND WHITE, THE CROWN IS GREEN WITH A RED AND WHITE CENTER, THE GRAIN IS YELLOW, THE CIRCLE IS WHITE AND HAVING A RED CENTER WITH WHITE WAVY LINES INSIDE, AND THE BANNERS EXTENDING FROM THE CIRCLE ARE WHITE.

THE WORDING BALTIKA HAS NO MEANING IN A FOREIGN LANGUAGE.

FOR BEER; NON-ALCOHOLIC BEER (U.S. CLS. 45, 46 AND 48).

FIRST USE 3-6-2007; IN COMMERCE 3-6-2007.
JOHN WILKE, EXAMINING ATTORNEY

SN 77-523,139. BALTIKA BREWERIES, SAINT-PETERSBURG, RUSSIAN FED., FILED 7-16-2008.



OWNER OF U.S. REG. NOS. 2,760,850, 3,292,967 AND OTHERS.

THE COLOR(S) GOLD, RED, GREEN, GRAY, BLUE, YELLOW AND WHITE IS/ARE CLAIMED AS A FEATURE OF THE MARK.

THE RECTANGULAR BACKGROUND IS GRAY, THE CENTRAL OVAL IS GREEN, THE BANNER IS BLUE OUTLINED IN GOLD AND WHITE TRIM, THE THREE WAVY LINES AND WORD "BALTIKA" AND THE NUMBER 6 ARE WHITE, THE CROWN IS GOLD WITH A RED CENTER, THE GRAIN IS GOLD, THE CIRCLE IS WHITE AND HAVING A RED CENTER WITH WHITE WAVY LINES INSIDE, AND THE BANNERS EXTENDING FROM THE CIRCLE ARE WHITE, THE STRING AT THE BOTTOM IS YELLOW.

THE WORDING "BALTIKA" HAS NO MEANING IN A FOREIGN LANGUAGE.

FOR BEER; NON-ALCOHOLIC BEER (U.S. CLS. 45, 46 AND 48).

FIRST USE 10-30-2007; IN COMMERCE 10-30-2007.
JOHN WILKE, EXAMINING ATTORNEY

SN 77-518,561. BALTIKA BREWERIES, SAINT-PETERSBURG, RUSSIAN FED., FILED 7-10-2008.



OWNER OF U.S. REG. NOS. 2,760,850, 3,292,967 AND OTHERS.

THE COLOR(S) BLUE, YELLOW, GREEN, RED, BLACK AND WHITE IS/ARE CLAIMED AS A FEATURE OF THE MARK.

THE OUTSIDE RING OF THE OVAL IS WHITE, THE NEXT RING IS YELLOW, THE NEXT RING IS BLUE, THE

CLASS 32—(Continued).

SN 77-523,145. BALTIKA BREWERIES, SAINT-PETERSBURG, RUSSIAN FED., FILED 7-16-2008.

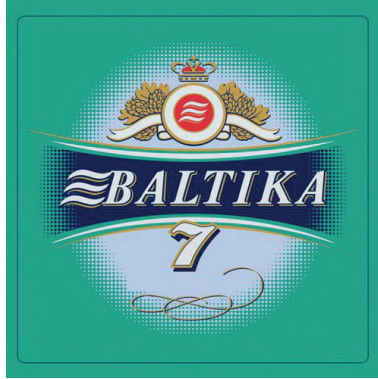

OWNER OF U.S. REG. NOS. 2,760,850, 3,292,967 AND OTHERS.

THE COLOR(S) TURQUOISE, GOLD, RED, BLUE, YELLOW AND WHITE IS/ARE CLAIMED AS A FEATURE OF THE MARK.

THE RECTANGULAR BACKGROUND IS TURQUOISE, THE CENTRAL OVAL IS WHITE, THE BANNER IS BLUE OUTLINED IN TURQUOISE, WHITE AND GOLD TRIM, THE THREE WAVY LINES AND WORD "BALTIKA" AND THE NUMBER 7 ARE WHITE SHADED IN YELLOW. THE CROWN IS GOLD WITH A RED CENTER, THE GRAIN IS GOLD, THE CIRCLE IS WHITE AND HAVING A RED CENTER WITH WHITE WAVY LINES INSIDE, AND THE BANNERS EXTENDING FROM THE CIRCLE ARE WHITE AND THE STRING AT THE BOTTOM IS GOLD.

THE WORDING "BALTIKA" HAS NO MEANING IN A FOREIGN LANGUAGE.

FOR BEER; NON-ALCOHOLIC BEER (U.S. CLS. 45, 46 AND 48).

FIRST USE 4-30-2007; IN COMMERCE 4-30-2007.
JOHN WILKE, EXAMINING ATTORNEY

CLASS 32—(Continued).

CENTRAL OVAL IS WHITE, THE BANNER IS YELLOW OUTLINED IN BROWN, WHITE AND GOLD TRIM, THE THREE WAVY LINES AND WORD "BALTIKA" ARE BLUE, THE NUMBER 8 IS WHITE SHADED IN BLUE AND YELLOW. THE CROWN IS GOLD WITH A RED CENTER, THE GRAIN IS GOLD, THE CIRCLE IS WHITE AND HAVING A RED CENTER WITH WHITE WAVY LINES INSIDE, AND THE BANNERS EXTENDING FROM THE CIRCLE ARE WHITE AND THE RIBBON AT THE BOTTOM IS GOLD.

THE WORDING "BALTIKA" HAS NO MEANING IN A FOREIGN LANGUAGE.

FOR BEER; NON-ALCOHOLIC BEER (U.S. CLS. 45, 46 AND 48).

FIRST USE 10-30-2007; IN COMMERCE 10-30-2007.
JOHN WILKE, EXAMINING ATTORNEY

SN 77-523,147. BALTIKA BREWERIES, SAINT-PETERSBURG, RUSSIAN FED., FILED 7-16-2008.



SN 77-523,146. BALTIKA BREWERIES, SAINT-PETERSBURG, RUSSIAN FED., FILED 7-16-2008.



OWNER OF U.S. REG. NOS. 2,760,850, 3,292,967 AND OTHERS.

THE COLOR(S) YELLOW, BROWN, GOLD, RED, BLUE AND WHITE IS/ARE CLAIMED AS A FEATURE OF THE MARK.

THE RECTANGULAR BACKGROUND IS BROWN, THE

OWNER OF U.S. REG. NOS. 2,760,850, 3,292,967 AND OTHERS.

THE COLOR(S) BLUE, YELLOW, RED, GREEN, PINK AND WHITE IS/ARE CLAIMED AS A FEATURE OF THE MARK.

THE TOP OF THE MARK IS BLUE, THE LINE BELOW IS GREEN, THE LINE BELOW THAT IS YELLOW, THE LINE BELOW THAT IS BLUE, THE LINE BELOW THAT IS WHITE, THE LINE BELOW THAT IS BLUE, THE NEXT SECTION IS BLUE WITH WHITE SWATCHES ON EITHER SIDE, THE LINE BELOW THAT IS BLUE, THE LINE BELOW THAT IS WHITE, THE LINE BELOW THAT IS BLUE, THE LINE BELOW THAT IS YELLOW, THE LINE BELOW THAT IS GREEN. THE BOTTOM SECTION IS BLUE, THE BANNER IS DARK BLUE IN THE CENTER FADING TO LIGHT BLUE ON THE ENDS AND OUTLINED IN BLUE AND WHITE, THE THREE WAVY LINES AND THE WORD "BALTIKA" ARE PINK OUTLINED IN WHITE, THE FINE LINE AROUND THE EDGE IS PINK.

THE WORDING "BALTIKA" HAS NO MEANING IN A FOREIGN LANGUAGE.

THE NON-LATIN CHARACTERS IN THE MARK TRANSLITERATE INTO "BALTIKA", AND THIS HAS NO MEANING IN ENGLISH.

FOR BEER; NON-ALCOHOLIC BEER (U.S. CLS. 45, 46 AND 48).

FIRST USE 4-15-2008; IN COMMERCE 4-15-2008.
JOHN WILKE, EXAMINING ATTORNEY

CLASS 32—(Continued).

SN 77-523,153. BALTIKA BREWERIES, SAINT-PETERSBURG, RUSSIAN FED., FILED 7-16-2008.



OWNER OF U.S. REG. NOS. 2,760,850, 3,168,942 AND OTHERS.

NO CLAIM IS MADE TO THE EXCLUSIVE RIGHT TO USE THE FOREIGN CHARACTERS WHICH TRANSLATE TO "BREWING COMPANY" AND "FOUNDED IN 1990", APART FROM THE MARK AS SHOWN.

THE COLOR(S) BLUE, YELLOW, RED, GRAY, PINK, BLACK AND WHITE IS/ARE CLAIMED AS A FEATURE OF THE MARK.

THE BACKGROUND IS YELLOW WITH A WHITE BORDER, THE WORD "COOLER" IS BLUE OUTLINED IN WHITE AND BLACK, THE CROWN, GRAIN, BANNERS, CIRCULAR RINGS AND WORDING "BALTIKA BREWING COMPANY" WITHIN THE CIRCLES ARE LIGHT GRAY, THE CENTRAL CIRCLE IS RED WITH THE THREE WHITE WAVY LINES UNDERLINED IN PINK.

THE WORDING "BALTIKA" HAS NO MEANING IN A FOREIGN LANGUAGE.

THE NON-LATIN CHARACTERS IN THE MARK TRANSLATE IN ENGLISH TO "BALTIKA BREWING COMPANY, FOUNDED IN 1990."

FOR BEER; NON-ALCOHOLIC BEER (U.S. CLS. 45, 46 AND 48).

FIRST USE 12-21-2006; IN COMMERCE 12-25-2006.
JOHN WILKE, EXAMINING ATTORNEY

CLASS 32—(Continued).

BANNER IS BLUE OUTLINED IN WHITE, THE THREE WAVY LINES AND THE WORD "BALTIKA" ARE PINK, THE CROWN IS BLUE WITH A RED CENTER, THE GRAIN IS YELLOW AND BROWN, THE CIRCLE IS PINK HAVING A RED CENTER WITH PINK WAVY LINES INSIDE, AND THE BANNERS EXTENDING FROM THE CIRCLE ARE PINK, THE NUMBER 7 IS BLUE ON A PINK CIRCLE WITH A BLUE AND WHITE BORDER, THE FINE LINES AROUND THE EDGES AND THE DOTTED LINES ARE PINK.

THE WORDING "BALTIKA" HAS NO MEANING IN A FOREIGN LANGUAGE.

FOR BEER; NON-ALCOHOLIC BEER (U.S. CLS. 45, 46 AND 48).

FIRST USE 4-15-2008; IN COMMERCE 4-15-2008.
JOHN WILKE, EXAMINING ATTORNEY

SN 77-524,303. BALTIKA BREWERIES, SAINT-PETERSBURG, RUSSIAN FED., FILED 7-17-2008.



SN 77-523,164. BALTIKA BREWERIES, SAINT-PETERSBURG, RUSSIAN FED., FILED 7-16-2008.



OWNER OF U.S. REG. NOS. 2,760,850, 3,292,967 AND OTHERS.

THE COLOR(S) BLUE, YELLOW, RED, BROWN, PINK AND WHITE IS/ARE CLAIMED AS A FEATURE OF THE MARK.

THE TOP OF THE MARK IS BLUE, THE LINE BELOW IS YELLOW, THE LINE BELOW THAT IS BLUE, THE LINE BELOW THAT IS PINK, THE LINE BELOW THAT IS BLUE, THE LINE BELOW THAT IS WHITE, THE NEXT SECTION IS BLUE WITH WHITE SWATCHES ON EITHER SIDE AND AT THE BOTTOM, THE LINE BELOW THAT IS WHITE, THE LINE BELOW THAT IS BLUE, THE LINE BELOW THAT IS YELLOW, THE BOTTOM SECTION IS BLUE, THE

OWNER OF U.S. REG. NOS. 2,760,850, 3,292,967 AND OTHERS.

THE COLOR(S) YELLOW, GOLD, RED, PINK, BLACK AND WHITE IS/ARE CLAIMED AS A FEATURE OF THE MARK.

THE OUTSIDE RING OF THE OVAL IS YELLOW, THE NEXT RING IS BLACK, THE NEXT RING IS RED, THE INNER OVAL IS RED AND BLACK, THE BANNER IS RED OUTLINED IN BLACK AND YELLOW, THE THREE WAVY LINES AND THE WORD "BALTIKA" ARE PINK OUTLINED IN YELLOW, THE NUMBER 4 IS PINK SHADED WITH BLACK, THE CROWN IS GOLD WITH A RED CENTER, THE GRAIN IS YELLOW, THE CIRCLE IS PINK HAVING A RED CENTER WITH PINK WAVY LINES INSIDE, AND THE BANNERS EXTENDING FROM THE CIRCLE AND THE RIBBON AT THE BOTTOM ARE PINK.

THE NON-LATIN CHARACTERS IN THE MARK TRANSLITERATE TO "BALTIKA" AND THIS HAS NO MEANING IN A FOREIGN LANGUAGE.

FOR BEER; NON-ALCOHOLIC BEER (U.S. CLS. 45, 46 AND 48).

FIRST USE 7-31-2007; IN COMMERCE 7-31-2007.
JOHN WILKE, EXAMINING ATTORNEY

CLASS 32—(Continued).

SN 77-524,304. BALTIKA BREWERIES, SAINT-PETERSBURG, RUSSIAN FED., FILED 7-17-2008.



OWNER OF U.S. REG. NOS. 2,760,850, 3,292,967 AND OTHERS.

THE COLOR(S) YELLOW, GOLD, RED, PINK, GREEN, BLACK AND WHITE IS/ARE CLAIMED AS A FEATURE OF THE MARK.

THE OUTSIDE RING OF THE OVAL IS YELLOW, THE NEXT RING IS BLACK, THE NEXT RING IS GREEN, THE INNER OVAL IS GREEN AND BLACK, THE BANNER IS GREEN OUTLINED IN BLACK AND YELLOW, THE THREE WAVY LINES AND THE WORD "BALTIKA" ARE PINK OUTLINED IN YELLOW, THE NUMBER 2 IS PINK SHADED WITH BLACK, THE CROWN IS GOLD WITH A RED CENTER, THE GRAIN IS YELLOW, THE CIRCLE IS PINK HAVING A RED CENTER WITH PINK WAVY LINES INSIDE, AND THE BANNERS EXTENDING FROM THE CIRCLE AND THE RIBBON AT THE BOTTOM ARE PINK.

THE WORDING "BALTIKA" HAS NO MEANING IN A FOREIGN LANGUAGE.

FOR BEER; NON-ALCOHOLIC BEER (U.S. CLS. 45, 46 AND 48).

FIRST USE 7-19-2007; IN COMMERCE 7-19-2007.
JOHN WILKE, EXAMINING ATTORNEY

CLASS 32—(Continued).

SIDE, THE LINE BELOW THAT IS RED, THE LINE BELOW THAT IS WHITE, THE LINE BELOW THAT IS PINK, THE LINE BELOW THAT IS YELLOW, THE BOTTOM SECTION IS PINK, THE BANNER IS PINK IN THE CENTER AND WHITE ON THE ENDS AND OUTLINED IN BLUE, THE THREE WAVY LINES AND THE WORD "BALTIKA" ARE BLUE, THE CROWN IS YELLOW WITH A RED CENTER, THE GRAIN IS YELLOW AND BROWN, THE CIRCLE IS PINK HAVING A RED CENTER WITH PINK WAVY LINES INSIDE.

THE WORDING "BALTIKA" HAS NO MEANING IN A FOREIGN LANGUAGE.

FOR BEER; NON-ALCOHOLIC BEER (U.S. CLS. 45, 46 AND 48).

FIRST USE 5-31-2008; IN COMMERCE 5-31-2008.
JOHN WILKE, EXAMINING ATTORNEY

SN 77-530,911. AMERILAB TECHNOLOGIES, INC., PLYMOUTH, MN. FILED 7-24-2008.

GUAVA RUSH

THE MARK CONSISTS OF STANDARD CHARACTERS WITHOUT CLAIM TO ANY PARTICULAR FONT, STYLE, SIZE, OR COLOR.

NO CLAIM IS MADE TO THE EXCLUSIVE RIGHT TO USE "GUAVA", APART FROM THE MARK AS SHOWN.

FOR ENERGY DRINK (U.S. CLS. 45, 46 AND 48).
EMILY CARLSEN, EXAMINING ATTORNEY

SN 77-524,305. BALTIKA BREWERIES, SAINT-PETERSBURG, RUSSIAN FED., FILED 7-17-2008.



OWNER OF U.S. REG. NOS. 2,760,850, 3,292,967 AND OTHERS.

THE COLOR(S) BLUE, GRAY, YELLOW, RED, BROWN, PINK AND WHITE IS/ARE CLAIMED AS A FEATURE OF THE MARK.

THE TOP OF THE MARK IS PINK, THE LINE BELOW IS YELLOW, THE LINE BELOW THAT IS PINK, THE LINE BELOW THAT IS WHITE, THE LINE BELOW THAT IS PINK, THE LINE BELOW THAT IS WHITE, THE NEXT SECTION IS GRAY WITH PINK SWATCHES ON EITHER

SN 77-533,983. MANZEN, LLC, LAS VEGAS, NV. FILED 7-29-2008.

18 DUMMY

THE MARK CONSISTS OF STANDARD CHARACTERS WITHOUT CLAIM TO ANY PARTICULAR FONT, STYLE, SIZE, OR COLOR.

FOR ENERGY DRINKS; FRUIT DRINKS; FRUIT JUICES; NON-ALCOHOLIC BEVERAGES, NAMELY, CARBONATED BEVERAGES; PREPARATIONS FOR MAKING BEVERAGES, NAMELY, CARBONATED BEVERAGES, ENERGY DRINKS, FRUIT DRINKS, SOFT DRINKS, SPORTS DRINKS AND SMOOTHIES; SMOOTHIES; SOFT DRINKS; SPORTS DRINKS (U.S. CLS. 45, 46 AND 48).

Laurie Mayes, Examining Attorney

CLASS 32—(Continued).

SN 77-534,512. HERSHEY CHOCOLATE & CONFECTIONERY CORPORATION, WHEAT RIDGE, CO. FILED 7-30-2008.

TROPICAL TREMOR

THE MARK CONSISTS OF STANDARD CHARACTERS WITHOUT CLAIM TO ANY PARTICULAR FONT, STYLE, SIZE, OR COLOR.

OWNER OF U.S. REG. NO. 2,553,393.
FOR PUNCH; SOFT DRINKS, NAMELY, NON-CARBONATED SOFT DRINKS (U.S. CLS. 45, 46 AND 48).
FIRST USE 6-16-2008; IN COMMERCE 6-16-2008.
NICHOLAS COLEMAN, EXAMINING ATTORNEY

SN 77-537,861. VITAMIN PETS, LLC, NEW YORK, NY. FILED 8-4-2008.

VITAMIN K9

THE MARK CONSISTS OF STANDARD CHARACTERS WITHOUT CLAIM TO ANY PARTICULAR FONT, STYLE, SIZE, OR COLOR.

NO CLAIM IS MADE TO THE EXCLUSIVE RIGHT TO USE "VITAMIN", APART FROM THE MARK AS SHOWN.
FOR DRINKING WATER FOR PETS (U.S. CLS. 45, 46 AND 48).
HANNO RITTRER, EXAMINING ATTORNEY

SN 77-542,027. RED HEAD, INC., NOVATO, CA. FILED 8-7-2008.

1013 SINGLE CANE

THE MARK CONSISTS OF STANDARD CHARACTERS WITHOUT CLAIM TO ANY PARTICULAR FONT, STYLE, SIZE, OR COLOR.

NO CLAIM IS MADE TO THE EXCLUSIVE RIGHT TO USE "SINGLE CANE", APART FROM THE MARK AS SHOWN.
FOR NON-ALCOHOLIC COCKTAIL MIXES (U.S. CLS. 45, 46 AND 48).
ELLEN PERKINS, EXAMINING ATTORNEY

CLASS 32—(Continued).

SN 77-554,274. EVO BEVERAGE AND DISTRIBUTION, LLC, DRAPER, UT. FILED 8-23-2008.

LIQUID EVOLUTION

THE MARK CONSISTS OF STANDARD CHARACTERS WITHOUT CLAIM TO ANY PARTICULAR FONT, STYLE, SIZE, OR COLOR.

NO CLAIM IS MADE TO THE EXCLUSIVE RIGHT TO USE "LIQUID", APART FROM THE MARK AS SHOWN.
FOR SPORTS DRINKS; ENERGY DRINKS; ISOTONIC DRINKS; SOFT DRINKS; FRUIT FLAVORED DRINKS; BOTTLED WATER; DRINKING WATER; ENERGY DRINKS IN SHOT FORM; LIQUID ENERGY DRINKS IN SHOT FORM; POWDERS USED IN THE PREPARATION OF SPORTS DRINKS, ENERGY DRINKS, ISOTONIC DRINKS, SOFT DRINKS AND/OR FRUIT FLAVORED DRINKS; PREPARATIONS FOR MAKING BEVERAGES, NAMELY, SPORTS DRINKS, ENERGY DRINKS, ISOTONIC DRINKS, SOFT DRINKS AND/OR FRUIT FLAVORED DRINKS (U.S. CLS. 45, 46 AND 48).
LINDA ESTRADA, EXAMINING ATTORNEY

SN 77-556,630. HERO/WHITEWAVE, LLC, BROOMFIELD, CO. FILED 8-27-2008.

**SIP.
CHEW.
SIP.
CHEW.
SIP.
CHEW.**

THE MARK CONSISTS OF THE WORDS "SIP. CHEW. SIP. CHEW. SIP. CHEW." VERTICALLY DISPLAYED.
FOR FRUIT JUICES, NON-ALCOHOLIC FRUIT JUICE BEVERAGES, FRUIT NECTARS (U.S. CLS. 45, 46 AND 48).
ALICE BENMAMAN, EXAMINING ATTORNEY

CLASS 32—(Continued).

SN 77-556,641. HERO/WHITEWAVE, LLC, BROOMFIELD, CO. FILED 8-27-2008.

ENJOY YOUR FRUIT IN A WHOLE NEW WAY

THE MARK CONSISTS OF STANDARD CHARACTERS WITHOUT CLAIM TO ANY PARTICULAR FONT, STYLE, SIZE, OR COLOR.

FOR FRUIT JUICES, NON-ALCOHOLIC FRUIT JUICE BEVERAGES, FRUIT NECTARS (U.S. CLS. 45, 46 AND 48).

ALICE BENMAMAN, EXAMINING ATTORNEY

SN 77-572,829. JAQUEZ, RAMON E., BRENTWOOD, NY. FILED 9-18-2008.



OWNER OF U.S. REG. NOS. 3,170,459, 3,315,068 AND OTHERS.

NO CLAIM IS MADE TO THE EXCLUSIVE RIGHT TO USE "ENERGY" OR "MULTIVITAMIN DRINK", APART FROM THE MARK AS SHOWN.

THE COLOR(S) BLUE, GOLD, GRAY, RED, AND WHITE IS/ARE CLAIMED AS A FEATURE OF THE MARK.

THE MARK CONSISTS OF THE STYLIZED LETTER "R" AND STYLIZED WORDS "ENERGY" AND "MULTIVITAMIN DRINK". THE LETTER "R" IS IN RED WITH GOLD SHADING SURROUNDING THE RED COLOR. THE WORD "ENERGY" IS WHITE WITH GRAY INTERIOR SHADING AND BLUE OUTSIDE SHADING. THE WORDS "MULTIVITAMIN DRINK" ARE IN GOLD.

FOR DRINKING WATER WITH VITAMINS (U.S. CLS. 45, 46 AND 48).

FIRST USE 9-1-2008; IN COMMERCE 9-1-2008.
BRIAN PINO, EXAMINING ATTORNEY

SN 77-585,716. GRECH, NIGEL M., FRESNO, CA. FILED 10-4-2008.

VUMA

THE MARK CONSISTS OF STANDARD CHARACTERS WITHOUT CLAIM TO ANY PARTICULAR FONT, STYLE, SIZE, OR COLOR.

FOR NON ALCOHOLIC BEVERAGES, NAMELY, FRUIT JUICES (U.S. CLS. 45, 46 AND 48).

AMEEN IMAM, EXAMINING ATTORNEY

CLASS 32—(Continued).

SN 77-585,719. GRECH, NIGEL M., FRESNO, CA. FILED 10-4-2008.

VUMA JUICES

THE MARK CONSISTS OF STANDARD CHARACTERS WITHOUT CLAIM TO ANY PARTICULAR FONT, STYLE, SIZE, OR COLOR.

NO CLAIM IS MADE TO THE EXCLUSIVE RIGHT TO USE "JUICES", APART FROM THE MARK AS SHOWN.

FOR NON ALCOHOLIC BEVERAGES, NAMELY, FRUIT JUICES (U.S. CLS. 45, 46 AND 48).

AMEEN IMAM, EXAMINING ATTORNEY

SN 77-585,720. GRECH, NIGEL M., FRESNO, CA. FILED 10-4-2008.

VUMA NATURALS

THE MARK CONSISTS OF STANDARD CHARACTERS WITHOUT CLAIM TO ANY PARTICULAR FONT, STYLE, SIZE, OR COLOR.

NO CLAIM IS MADE TO THE EXCLUSIVE RIGHT TO USE "NATURALS", APART FROM THE MARK AS SHOWN.

FOR NON ALCOHOLIC BEVERAGES, NAMELY, FRUIT JUICES (U.S. CLS. 45, 46 AND 48).

AMEEN IMAM, EXAMINING ATTORNEY

SN 77-609,145. CYTOSPORT, INC., BENICIA, CA. FILED 11-6-2008.

MUSCLE ENERGY

THE MARK CONSISTS OF STANDARD CHARACTERS WITHOUT CLAIM TO ANY PARTICULAR FONT, STYLE, SIZE, OR COLOR.

NO CLAIM IS MADE TO THE EXCLUSIVE RIGHT TO USE "ENERGY", APART FROM THE MARK AS SHOWN.

FOR ENERGY DRINKS (U.S. CLS. 45, 46 AND 48).

ZACHARY BELLO, EXAMINING ATTORNEY

CLASS 32—(Continued).

SN 77-619,870. CIRCLE K STORES INC., CHARLOTTE, NC.
FILED 11-21-2008.

GIMME A G

THE MARK CONSISTS OF STANDARD CHARACTERS
WITHOUT CLAIM TO ANY PARTICULAR FONT, STYLE,
SIZE, OR COLOR.

FOR ENERGY DRINKS (U.S. CLS. 45, 46 AND 48).
MARK SPARACINO, EXAMINING ATTORNEY

CLASS 32—(Continued).

SN 77-662,866. 638 BREWING COMPANY INC., DBA FOOT-
HILLS BREWING, WINSTON SALEM, NC. FILED 2-4-
2009.

SEXUAL CHOCOLATE

THE MARK CONSISTS OF STANDARD CHARACTERS
WITHOUT CLAIM TO ANY PARTICULAR FONT, STYLE,
SIZE, OR COLOR.

NO CLAIM IS MADE TO THE EXCLUSIVE RIGHT TO
USE "CHOCOLATE", APART FROM THE MARK AS
SHOWN.

FOR BEER, ALE, LAGER, STOUT AND PORTER,
SPECIFICALLY A CHOCOLATE FLAVORED STOUT
(U.S. CLS. 45, 46 AND 48).

FIRST USE 2-12-2007; IN COMMERCE 2-12-2007.
GINA FINK, EXAMINING ATTORNEY

SN 77-663,277. WALKER, THOMAS, GRAND RAPIDS, MI.
FILED 2-4-2009.

SN 77-662,588. AMERICAN INSTANTS, INC., FLANDERS,
NJ. FILED 2-3-2009.

LOTTERY SODA

THE MARK CONSISTS OF STANDARD CHARACTERS
WITHOUT CLAIM TO ANY PARTICULAR FONT, STYLE,
SIZE, OR COLOR.

NO CLAIM IS MADE TO THE EXCLUSIVE RIGHT TO
USE "SODA", APART FROM THE MARK AS SHOWN.

FOR NON-ALCOHOLIC BEVERAGES, NAMELY, CAR-
BONATED BEVERAGES (U.S. CLS. 45, 46 AND 48).

JEFFERY COWARD, EXAMINING ATTORNEY

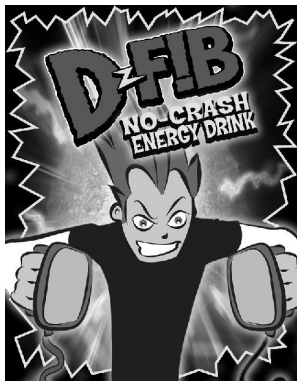

OWNER OF U.S. REG. NO. 3,606,765.
NO CLAIM IS MADE TO THE EXCLUSIVE RIGHT TO
USE "ENERGY DRINK", APART FROM THE MARK AS
SHOWN.

THE MARK CONSISTS OF THE LITERAL ELEMENTS "D-
FIB NO-CRASH ENERGY DRINK" IN STYLIZED LETTER-
ING WITH THE ASSOCIATED DESIGN A BOY HOLDING
CRASH PADDLES, WITH A LIGHTNING EFFECT BEHIND
HIS IMAGE, AND A ZIG-ZAG LINE ALONG THE BORDER
OF THE MARK.

FOR NON-ALCOHOLIC BEVERAGES, NAMELY, EN-
ERGY DRINKS AND SPORTS DRINKS (U.S. CLS. 45, 46
AND 48).

JUDITH HELFMAN, EXAMINING ATTORNEY

SN 77-663,575. HIJINKS ENERGY, LLC, NEWPORT BEACH,
CA. FILED 2-4-2009.

HIJINKS

THE MARK CONSISTS OF STANDARD CHARACTERS
WITHOUT CLAIM TO ANY PARTICULAR FONT, STYLE,
SIZE, OR COLOR.

FOR ENERGY DRINKS (U.S. CLS. 45, 46 AND 48).
NAKIA HENRY, EXAMINING ATTORNEY

CLASS 32—(Continued).

SN 77-665,477. MOHAMMAD A. MAZED, YORBA LINDA, CA. FILED 2-6-2009.



THE COLOR(S) GREEN, PURPLE AND ORANGE IS/ARE CLAIMED AS A FEATURE OF THE MARK.

THE MARK CONSISTS OF A SMALL ORANGE CIRCLE AT THE BOTTOM THAT OVERLAPS A MEDIUM-SIZED PURPLE CIRCLE THAT APPEARS TO ITS LEFT AND ABOVE AND A LARGE GREEN CIRCLE THAT APPEARS TO ITS RIGHT AND ABOVE, WITH THE PURPLE CIRCLE ALSO OVERLAPPING THE LARGE GREEN CIRCLE TO ITS RIGHT.

FOR FRUIT JUICE (U.S. CLS. 45, 46 AND 48).
KRISTIN CARLSON, EXAMINING ATTORNEY

SN 77-665,516. PAPPAS, STEVE, SANTA YNEZ, CA. FILED 2-6-2009.

AMBITION

THE MARK CONSISTS OF STANDARD CHARACTERS WITHOUT CLAIM TO ANY PARTICULAR FONT, STYLE, SIZE, OR COLOR.

FOR NON-ALCOHOLIC BEVERAGES, NAMELY, BOTTLED DRINKING WATER, SOFT DRINKS; POWDERS, SYRUPS AND CONCENTRATES USED FOR MAKING SOFT DRINKS (U.S. CLS. 45, 46 AND 48).

FIRST USE 1-10-2009; IN COMMERCE 1-10-2009.
JOHN E. MICHOS, EXAMINING ATTORNEY

SN 77-665,762. BAYWOOD INTERNATIONAL, INC., SCOTTSDALE, AZ. FILED 2-7-2009.

TURN IT OVER

THE MARK CONSISTS OF STANDARD CHARACTERS WITHOUT CLAIM TO ANY PARTICULAR FONT, STYLE, SIZE, OR COLOR.

FOR NON-ALCOHOLIC BEVERAGES, NAMELY, CARBONATED SOFT DRINKS, FRUIT JUICES, SMOOTHIES, DRINKING WATER, FRUIT DRINKS, ENERGY DRINKS, SPORTS AND ENERGY DRINKS (U.S. CLS. 45, 46 AND 48).

AMY ALFIERI, EXAMINING ATTORNEY

CLASS 32—(Continued).

SN 77-667,119. EARTHSODA LLC, MEQUON, WI. FILED 2-10-2009.

CUJUICE

THE MARK CONSISTS OF STANDARD CHARACTERS WITHOUT CLAIM TO ANY PARTICULAR FONT, STYLE, SIZE, OR COLOR.

FOR NON-ALCOHOLIC BEVERAGES CONTAINING FRUIT AND/OR VEGETABLE JUICES (U.S. CLS. 45, 46 AND 48).

JENNY PARK, EXAMINING ATTORNEY

SN 77-672,811. USALOE, INC., CARLSBAD, CA. FILED 2-18-2009.

AloeBoost

THE MARK CONSISTS OF STANDARD CHARACTERS WITHOUT CLAIM TO ANY PARTICULAR FONT, STYLE, SIZE, OR COLOR.

FOR ENERGY DRINKS (U.S. CLS. 45, 46 AND 48).

FIRST USE 12-30-2008; IN COMMERCE 12-30-2008.

CHRIS WELLS, EXAMINING ATTORNEY

SN 77-684,882. THE COCA-COLA COMPANY, ATLANTA, GA. FILED 3-5-2009.

MORE FANTA, LESS SERIOUS

THE MARK CONSISTS OF STANDARD CHARACTERS WITHOUT CLAIM TO ANY PARTICULAR FONT, STYLE, SIZE, OR COLOR.

OWNER OF U.S. REG. NOS. 513,565, 616,935 AND 3,011,381.

FOR BEVERAGES, NAMELY, DRINKING WATERS, FLAVORED WATERS, MINERAL AND AERATED WATERS; AND OTHER NON-ALCOHOLIC BEVERAGES, NAMELY, SOFT DRINKS, FRUIT DRINKS AND JUICES; SYRUPS, CONCENTRATES AND POWDERS FOR MAKING BEVERAGES, NAMELY, FLAVORED WATERS, MINERAL AND AERATED WATERS, SOFT DRINKS, FRUIT DRINKS AND JUICES (U.S. CLS. 45, 46 AND 48).

REBECCA SMITH, EXAMINING ATTORNEY

CLASS 32—(Continued).

SN 77-695,443. THE COCA-COLA COMPANY, ATLANTA, GA. FILED 3-20-2009.

ORANGE LAVABURST

THE MARK CONSISTS OF STANDARD CHARACTERS WITHOUT CLAIM TO ANY PARTICULAR FONT, STYLE, SIZE, OR COLOR.

NO CLAIM IS MADE TO THE EXCLUSIVE RIGHT TO USE "ORANGE", APART FROM THE MARK AS SHOWN.

FOR NON-ALCOHOLIC BEVERAGES, NAMELY, FRUIT DRINKS, AND SYRUPS AND CONCENTRATES FOR MAKING SAMES (U.S. CLS. 45, 46 AND 48).

FIRST USE 11-20-2000; IN COMMERCE 11-20-2000.
REBECCA SMITH, EXAMINING ATTORNEY

SN 79-065,612. BROUWERIJ BOCKOR, NAAMLOZE VEN-NOOTSCHAP, BELGIUM, FILED 1-30-2009.

OMER

THE MARK CONSISTS OF STANDARD CHARACTERS WITHOUT CLAIM TO ANY PARTICULAR FONT, STYLE, SIZE, OR COLOR.

PRIORITY DATE OF 8-19-2008 IS CLAIMED. OWNER OF INTERNATIONAL REGISTRATION 0994148 DATED 1-30-2009, EXPIRES 1-30-2019.

FOR BEERS (U.S. CLS. 45, 46 AND 48).
KYLE PEETE, EXAMINING ATTORNEY

CLASS 33—WINES AND SPIRITS

SN 77-074,636. SPIRITS OF SERENDIPITY IMPORTS, LLC, SAN FRANCISCO, CA. FILED 1-2-2007.

BUBBLY LUCK

THE MARK CONSISTS OF STANDARD CHARACTERS WITHOUT CLAIM TO ANY PARTICULAR FONT, STYLE, SIZE, OR COLOR.

NO CLAIM IS MADE TO THE EXCLUSIVE RIGHT TO USE "BUBBLY", APART FROM THE MARK AS SHOWN.

FOR SPARKLING WINE (U.S. CLS. 47 AND 49).
ZHALEH DELANEY, EXAMINING ATTORNEY

CLASS 33—(Continued).

SN 77-117,756. ENDEAVOUR VINEYARDS PTY LTD., VICTORIA, AUSTRALIA, FILED 2-27-2007.

TINDERBOX

THE MARK CONSISTS OF STANDARD CHARACTERS WITHOUT CLAIM TO ANY PARTICULAR FONT, STYLE, SIZE, OR COLOR.

OWNER OF AUSTRALIA REG. NO. 1163750, DATED 2-27-2007, EXPIRES 2-27-2017.

FOR ALCOHOLIC BEVERAGES, NAMELY, WINES AND SPIRITS (U.S. CLS. 47 AND 49).
WENDY GOODMAN, EXAMINING ATTORNEY

SN 77-261,578. SLG PRODUCTIONS, INC., NEW YORK, NY. FILED 8-22-2007.



NO CLAIM IS MADE TO THE EXCLUSIVE RIGHT TO USE "SAKE" AND THE NON-LATIN CHARACTERS WHICH TRANSLITERATE TO "ICHIBAN SAKE" WHICH MEANS "BEST SAKE" OR "NUMBER ONE" SAKE IN ENGLISH, APART FROM THE MARK AS SHOWN.

THE MARK CONSISTS OF JAPANESE LETTERING/"SAMURAI LOVE SAKE"/CROSS, CIRCLE AND ARROW LOGO WITH JAPANESE LETTERS IN CIRCLE/"A DRINK TO PLEASURE".

THE NON-LATIN CHARACTER(S) IN THE MARK TRANSLITERATES INTO "ICHIBAN SAKE" AND "AI", AND THIS MEANS "BEST SAKE" OR "NUMBER ONE SAKE" AND "LOVE" IN ENGLISH.

FOR SAKE (U.S. CLS. 47 AND 49).
ALICIA COLLINS, EXAMINING ATTORNEY

CLASS 33—(Continued).

SN 77-420,742. PLAYA HOLDING CORPORATION, NEW YORK, NY. FILED 3-13-2008.

MIL DRAGONES

THE MARK CONSISTS OF STANDARD CHARACTERS WITHOUT CLAIM TO ANY PARTICULAR FONT, STYLE, SIZE, OR COLOR.

OWNER OF MEXICO REG. NO. 1034183, DATED 4-8-2008, EXPIRES 4-8-2018.

THE FOREIGN WORDING IN THE MARK TRANSLATES INTO ENGLISH AS THOUSAND DRAGONS.

FOR DISTILLED SPIRITS, INCLUDING TEQUILA (U.S. CLS. 47 AND 49).

CARRIE GENOVESE, EXAMINING ATTORNEY

CLASS 33—(Continued).

SN 77-513,290. DIAGEO NORTH AMERICA, INC., NORWALK, CT. FILED 7-2-2008.

FINEST CUT

THE MARK CONSISTS OF STANDARD CHARACTERS WITHOUT CLAIM TO ANY PARTICULAR FONT, STYLE, SIZE, OR COLOR.

FOR ALCOHOLIC BEVERAGES EXCEPT BEERS (U.S. CLS. 47 AND 49).

TRACY WHITTAKER-BROWN, EXAMINING ATTORNEY

SN 77-502,100. VINECOL S.A., BUENOS AIRES, ARGENTINA, FILED 6-18-2008.

MEDANOS

THE MARK CONSISTS OF STYLIZED TEXT OF THE WORDING "MEDANOS".

THE ENGLISH TRANSLATION OF THE WORD "MEDANOS" IN THE MARK IS "DUNES."

FOR ALCOHOLIC BEVERAGES EXCEPT BEERS; WINE (U.S. CLS. 47 AND 49).

RAMONA ORTIGA, EXAMINING ATTORNEY

SN 77-521,315. CHATAM INTERNATIONAL INCORPORATED, WILMINGTON, DE. FILED 7-14-2008.

EPICUREAN

THE MARK CONSISTS OF STANDARD CHARACTERS WITHOUT CLAIM TO ANY PARTICULAR FONT, STYLE, SIZE, OR COLOR.

FOR DISTILLED SPIRITS (U.S. CLS. 47 AND 49).

ROBERT C. CLARK JR., EXAMINING ATTORNEY

SN 77-510,926. R & A BAILEY & CO, DUBLIN 12, IRELAND, FILED 6-30-2008.

PALOSANTO

THE MARK CONSISTS OF STANDARD CHARACTERS WITHOUT CLAIM TO ANY PARTICULAR FONT, STYLE, SIZE, OR COLOR.

PRIORITY CLAIMED UNDER SEC. 44(D) ON ERPN CMNTY TM OFC APPLICATION NO. 006561914, FILED 1-8-2008, REG. NO. 006561914, DATED 12-18-2008, EXPIRES 1-8-2018.

THE ENGLISH TRANSLATION OF "PALOSANTO" IN THE MARK IS "HOLY WOOD".

FOR ALCOHOLIC BEVERAGES EXCEPT BEERS (U.S. CLS. 47 AND 49).

STEVEN R. FINE, EXAMINING ATTORNEY

SN 77-533,010. RED HEAD, INC., NOVATO, CA. FILED 7-28-2008.

1013 SINGLE CANE

THE MARK CONSISTS OF STANDARD CHARACTERS WITHOUT CLAIM TO ANY PARTICULAR FONT, STYLE, SIZE, OR COLOR.

NO CLAIM IS MADE TO THE EXCLUSIVE RIGHT TO USE "SINGLE CANE", APART FROM THE MARK AS SHOWN.

FOR ALCOHOLIC COCKTAIL MIXES; RUM (U.S. CLS. 47 AND 49).

ELLEN PERKINS, EXAMINING ATTORNEY

CLASS 33—(Continued).

SN 77-539,516. WEDDINGTON, BERNARD, BALTIMORE, MD. AND PARKER, RICHARD, BALTIMORE, MD. AND GILMORE, ERIC D., JR., BALTIMORE, MD. FILED 8-5-2008.

Adult Ice

THE MARK CONSISTS OF STANDARD CHARACTERS WITHOUT CLAIM TO ANY PARTICULAR FONT, STYLE, SIZE, OR COLOR.

NO CLAIM IS MADE TO THE EXCLUSIVE RIGHT TO USE "ICE", APART FROM THE MARK AS SHOWN.

FOR ALCOHOLIC BEVERAGES, NAMELY, FROZEN PREPARED ALCOHOLIC COCKTAILS (U.S. CLS. 47 AND 49).

FIRST USE 5-3-2008; IN COMMERCE 5-3-2008.

RENEE MCCRAY, EXAMINING ATTORNEY

SN 77-547,808. VENHO, TOM, P. DBA MALIBU BRAND CONCEPTS, PLAYA DEL REY, CA. FILED 8-15-2008.

The Blue Swan Organic brand

THE MARK CONSISTS OF STANDARD CHARACTERS WITHOUT CLAIM TO ANY PARTICULAR FONT, STYLE, SIZE, OR COLOR.

NO CLAIM IS MADE TO THE EXCLUSIVE RIGHT TO USE "ORGANIC BRAND", APART FROM THE MARK AS SHOWN.

FOR ALCOHOLIC APERITIF BITTERS; ALCOHOLIC BEVERAGE PRODUCED FROM A BREWED MALT BASE WITH NATURAL FLAVORS; ALCOHOLIC BEVERAGES EXCEPT BEERS; ALCOHOLIC BEVERAGES OF FRUIT; ALCOHOLIC BEVERAGES, NAMELY, VODKA; ALCOHOLIC BITTERS; ALCOHOLIC COCKTAIL MIXES; ALCOHOLIC COCKTAILS CONTAINING MILK; ALCOHOLIC COFFEE-BASED BEVERAGE; ALCOHOLIC EGG NOG; ALCOHOLIC ENERGY DRINKS; ALCOHOLIC ESSENCES; ALCOHOLIC EXTRACTS; ALCOHOLIC FRUIT COCKTAIL DRINKS; ALCOHOLIC FRUIT EXTRACTS; ALCOHOLIC MALT COOLERS; ALCOHOLIC PUNCH; ALCOHOLIC TEA-BASED BEVERAGE; APERITIFS WITH A DISTILLED ALCOHOLIC LIQUOR BASE; FLAVORED BREWED MALT BEVERAGE; LIQUOR AND LIQUEUR BEVERAGES, NAMELY, CORDIALS; PREPARED ALCOHOLIC COCKTAIL; RUM; SPIRITS; ALL OF THE FOREGOING BEING ORGANIC (U.S. CLS. 47 AND 49).

TASNEEM HUSSAIN, EXAMINING ATTORNEY

CLASS 33—(Continued).

SN 77-560,715. AVERILL CREEK VINEYARD LTD., DUNCAN, B.C., CANADA, FILED 9-2-2008.



THE COLOR(S) LIGHT BLUE, BLUE, DARK BLUE, RED, WHITE AND BLACK IS/ARE CLAIMED AS A FEATURE OF THE MARK.

THE MARK CONSISTS OF A RECTANGULAR DESIGN OF SCENERY COMPRISED OF A BODY OF WATER, A SILHOUETTE OF A MOUNTAIN AND VARIOUS SHAPES PROTRUDING FROM THE WATER, AND A SKY. A GRADIENT OF FROM LIGHT BLUE AT THE TOP TO RED COMPRISES THE SKY. A GRADIENT OF DARK BLUE TO BLUE COMPRISES THE SILHOUETTE OF A MOUNTAIN. THE COLORS BLUE AND LIGHT BLUE MAKE UP THE DESIGN OF THE BODY OF WATER. THE COLOR BLACK APPEARS IN THE VARIOUS SHAPES PROTRUDING FROM THE BODY OF WATER. THE COLOR WHITE APPEARS IN A BAND AT THE TOP OF THE DESIGN AND IN A BAND AT THE BOTTOM OF THE DESIGN.

FOR WINES (U.S. CLS. 47 AND 49).

JAY BESCH, EXAMINING ATTORNEY

SN 77-565,707. JACKSON WINE ESTATES INTERNATIONAL, LTD., LOUGHLINSTOWN, IRELAND, FILED 9-9-2008.

ARCENO

THE MARK CONSISTS OF STANDARD CHARACTERS WITHOUT CLAIM TO ANY PARTICULAR FONT, STYLE, SIZE, OR COLOR.

FOR WINES (U.S. CLS. 47 AND 49).

FIRST USE 5-21-2001; IN COMMERCE 5-21-2001.

STEVEN JACKSON, EXAMINING ATTORNEY

CLASS 33—(Continued).

SN 77-605,862. R&G SCHATZ FARM INC, DBA PELTIER STATION, LOCKEFORD, CA. FILED 11-3-2008.



THE COLOR(S) BLACK, WHITE, GRAY AND RED IS/ ARE CLAIMED AS A FEATURE OF THE MARK.

THE MARK CONSISTS OF THE COLORS BLACK, WHITE, GRAY AND RED, WITH THE COLOR BLACK APPEARING IN THE BACKGROUND, THE COLOR WHITE APPEARS IN THE WORDING "USB". THE COLOR RED APPEARS IN THE WORDING "PELTIER STATION". THE COLOR GRAY APPEARS IN THE IMAGE OF A VINE AND "USB" SYMBOL, WHICH ARE COMPRISED OF WRITTEN BINARY 1'S AND 0'S.

FOR PORT WINES; RED WINE; TABLE WINES; WINES AND FORTIFIED WINES (U.S. CLS. 47 AND 49).
FIRST USE 9-1-2008; IN COMMERCE 9-1-2008.
JENNIFER VASQUEZ, EXAMINING ATTORNEY

SN 77-617,766. LAGINA, MARTIN G., TRAVERSE CITY, MI. FILED 11-19-2008.

ARCUS VINETUM

THE MARK CONSISTS OF STANDARD CHARACTERS WITHOUT CLAIM TO ANY PARTICULAR FONT, STYLE, SIZE, OR COLOR.

NO CLAIM IS MADE TO THE EXCLUSIVE RIGHT TO USE "VINETUM", APART FROM THE MARK AS SHOWN.

THE ENGLISH TRANSLATION OF "ARCUS VINETUM" IN THE MARK IS ARCHED VINEYARD OR ARCH VINEYARD.

FOR WINE (U.S. CLS. 47 AND 49).
SUSAN STIGLITZ, EXAMINING ATTORNEY

CLASS 33—(Continued).

SN 77-619,333. BACARDI & COMPANY LIMITED, VADUZ FL-9490, LIECHTENSTEIN, FILED 11-21-2008.

CORZO SILVER SMOOTH

THE MARK CONSISTS OF STANDARD CHARACTERS WITHOUT CLAIM TO ANY PARTICULAR FONT, STYLE, SIZE, OR COLOR.

OWNER OF U.S. REG. NOS. 2,977,332, 3,107,812 AND 3,303,427.

NO CLAIM IS MADE TO THE EXCLUSIVE RIGHT TO USE "SILVER", APART FROM THE MARK AS SHOWN.

THE ENGLISH TRANSLATION OF "CORZO" IN THE MARK IS ROE DEER.

FOR TEQUILA-BASED PREPARED ALCOHOLIC COCKTAIL (U.S. CLS. 47 AND 49).

MATTHEW EINSTEIN, EXAMINING ATTORNEY

SN 77-624,721. BOUCHARD AINE & FILS "B.A.F.", 21200 BEAUNE, FRANCE, FILED 12-2-2008.

BOUCHARD AÎNÉ & FILS

THE MARK CONSISTS OF STANDARD CHARACTERS WITHOUT CLAIM TO ANY PARTICULAR FONT, STYLE, SIZE, OR COLOR.

OWNER OF U.S. REG. NO. 2,437,995.

THE FOREIGN WORDING IN THE MARK TRANSLATES INTO ENGLISH AS SENIOR & SONS.

SEC. 2(F).

FOR WINES (U.S. CLS. 47 AND 49).

FIRST USE 8-5-1998; IN COMMERCE 1-1-1999.

RENEE MCCRAY, EXAMINING ATTORNEY

SN 77-631,057. TECHCOIRE, INC., FOLSOM, CA. FILED 12-11-2008.

OPPORTUNITY RESERVE

THE MARK CONSISTS OF STANDARD CHARACTERS WITHOUT CLAIM TO ANY PARTICULAR FONT, STYLE, SIZE, OR COLOR.

NO CLAIM IS MADE TO THE EXCLUSIVE RIGHT TO USE "RESERVE", APART FROM THE MARK AS SHOWN.

FOR WINE (U.S. CLS. 47 AND 49).

FIRST USE 4-1-2007; IN COMMERCE 4-1-2007.

MARC LEIPZIG, EXAMINING ATTORNEY

CLASS 33—(Continued).

SN 77-639,978. HALL, ROBERT C., PLACERVILLE, CA.
FILED 12-24-2008.

FLYING ZIN

THE MARK CONSISTS OF STANDARD CHARACTERS
WITHOUT CLAIM TO ANY PARTICULAR FONT, STYLE,
SIZE, OR COLOR.

NO CLAIM IS MADE TO THE EXCLUSIVE RIGHT TO
USE "ZIN", APART FROM THE MARK AS SHOWN.

FOR GRAPE WINE; RED WINE; RED WINES; TABLE
WINES; WINE; WINES (U.S. CLS. 47 AND 49).

FIRST USE 10-21-2008; IN COMMERCE 10-21-2008.
GRETTA YAO, EXAMINING ATTORNEY

SN 77-642,513. TOAST CHAMPAGNE, LLC, HENDERSON,
NV. FILED 1-2-2009.

Beau Joie

THE MARK CONSISTS OF STANDARD CHARACTERS
WITHOUT CLAIM TO ANY PARTICULAR FONT, STYLE,
SIZE, OR COLOR.

THE ENGLISH TRANSLATION OF "BEAU JOIE" IS
BEAUTIFUL JOY.

FOR CHAMPAGNE; FRUIT WINE; NATURAL SPARK-
LING WINES; PREPARED WINE COCKTAILS; SPARK-
LING WINES; WINE; WINE COOLERS; WINE PUNCHES;
WINES; WINES AND SPARKLING WINES (U.S. CLS. 47
AND 49).

RENEE SERVANCE, EXAMINING ATTORNEY

SN 77-652,221. IGLOO'S FROZEN DRINKS, FT. WORTH, TX.
FILED 1-19-2009.

THUNDERITA

THE MARK CONSISTS OF STANDARD CHARACTERS
WITHOUT CLAIM TO ANY PARTICULAR FONT, STYLE,
SIZE, OR COLOR.

OWNER OF U.S. REG. NOS. 2,944,639, 2,952,863 AND
3,435,406.

FOR FROZEN AND NON-FROZEN ALCOHOLIC
COCKTAILS (U.S. CLS. 47 AND 49).

REBECCA POVARCHUK, EXAMINING ATTORNEY

CLASS 33—(Continued).

SN 77-652,244. IGLOO'S FROZEN DRINKS, FT. WORTH, TX.
FILED 1-19-2009.

CRYOGENIC COCKTAILS

THE MARK CONSISTS OF STANDARD CHARACTERS
WITHOUT CLAIM TO ANY PARTICULAR FONT, STYLE,
SIZE, OR COLOR.

NO CLAIM IS MADE TO THE EXCLUSIVE RIGHT TO
USE "COCKTAILS", APART FROM THE MARK AS
SHOWN.

FOR FROZEN ALCOHOLIC COCKTAILS (U.S. CLS. 47
AND 49).

REBECCA POVARCHUK, EXAMINING ATTORNEY

SN 77-657,220. ASTROLABE WINES LIMITED, GROVE-
TOWN, BLENHEIM, NEW ZEALAND, FILED 1-27-2009.

ASTROLABE

THE MARK CONSISTS OF STANDARD CHARACTERS
WITHOUT CLAIM TO ANY PARTICULAR FONT, STYLE,
SIZE, OR COLOR.

OWNER OF NEW ZEALAND REG. NO. 700649, DATED 3-
9-2004, EXPIRES 8-29-2013.

FOR WINE (U.S. CLS. 47 AND 49).

MARK SPARACINO, EXAMINING ATTORNEY

SN 77-657,225. ASTROLABE WINES LIMITED, GROVE-
TOWN, BLENHEIM, NEW ZEALAND, FILED 1-27-2009.

DURVILLEA

THE MARK CONSISTS OF STANDARD CHARACTERS
WITHOUT CLAIM TO ANY PARTICULAR FONT, STYLE,
SIZE, OR COLOR.

FOR WINE (U.S. CLS. 47 AND 49).

MARK SPARACINO, EXAMINING ATTORNEY

CLASS 33—(Continued).

SN 77-663,123. CIA TEQUILERA DE JALISCO SA DE CV, VILLA HIDALGO, MEXICO, FILED 2-4-2009.

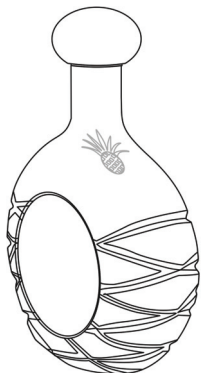

THE MARK CONSISTS OF A THREE-DIMENSIONAL SHAPE BOTTLE.
FOR TEQUILA (U.S. CLS. 47 AND 49).
SETH A. RAPPAPORT, EXAMINING ATTORNEY

SN 77-663,518. STOLLER VINEYARDS, INC., DUNDEE, OR. FILED 2-4-2009.



THE MARK CONSISTS OF A STYLIZED DEPICTION OF A TURKEY.
FOR WINE (U.S. CLS. 47 AND 49).
FIRST USE 8-0-2002; IN COMMERCE 8-0-2002.
NAKIA HENRY, EXAMINING ATTORNEY

SN 77-663,937. VINARIUM INTERNATIONAL IMPORTS, LLC, ATLANTIC CITY, NJ. FILED 2-5-2009.

VIAMONDO

THE MARK CONSISTS OF STANDARD CHARACTERS WITHOUT CLAIM TO ANY PARTICULAR FONT, STYLE, SIZE, OR COLOR.
THE ENGLISH TRANSLATION OF "VIA" IS "STREET" AND THE ENGLISH TRANSLATION OF "MONDO" IS "WORLD."
FOR WINE (U.S. CLS. 47 AND 49).
LINDA LAVACHE, EXAMINING ATTORNEY

CLASS 33—(Continued).

SN 77-664,046. AARON JACKSON, DBA AARON WINES, CAYUCOS, CA. FILED 2-5-2009.

Go Big or go home.

THE MARK CONSISTS OF STANDARD CHARACTERS WITHOUT CLAIM TO ANY PARTICULAR FONT, STYLE, SIZE, OR COLOR.
FOR WINE (U.S. CLS. 47 AND 49).
FIRST USE 9-15-2005; IN COMMERCE 2-10-2006.
CHRIS WELLS, EXAMINING ATTORNEY

SN 77-664,084. FREY FAMILY ENTERPRISES, LLC, MCMINNVILLE, OR. FILED 2-5-2009.

TRISAE

THE MARK CONSISTS OF STANDARD CHARACTERS WITHOUT CLAIM TO ANY PARTICULAR FONT, STYLE, SIZE, OR COLOR.
FOR WINE (U.S. CLS. 47 AND 49).
WON TEAK OH, EXAMINING ATTORNEY

SN 77-664,493. CONSTANT, FREDERIC W., CALISTOGA, CA. FILED 2-5-2009.

CONSTANT

THE MARK CONSISTS OF STANDARD CHARACTERS WITHOUT CLAIM TO ANY PARTICULAR FONT, STYLE, SIZE, OR COLOR.
FOR WINES (U.S. CLS. 47 AND 49).
FIRST USE 4-24-2001; IN COMMERCE 4-24-2001.
BONNIE LUKEN, EXAMINING ATTORNEY

CLASS 33—(Continued).

SN 77-664,924. PLAYA HOLDING CORPORATION, NEW YORK, NY. FILED 2-6-2009.



THE COLOR(S) BROWN, WHITE AND BLUE IS/ARE CLAIMED AS A FEATURE OF THE MARK.

THE MARK CONSISTS OF A STYLIZED BROWN STAR ABOVE A BROWN DESIGN OF AN EAGLE HOLDING A SNAKE WITH ITS BEAK AND TALON, ALL OF THIS ON TOP OF A BLUE CIRCLE WITH BROWN INTERIOR AND EXTERIOR BORDERS, WITHIN WHICH APPEARS THE WORDING "CASA DRAGONES" AND A WHITE INTERIOR CIRCLE CONTAINING THE BROWN, LINED NUMBER "16".

THE ENGLISH TRANSLATION OF CASA DRAGONES IN THE MARK IS "HOUSE OF DRAGONS".

FOR DISTILLED SPIRITS, INCLUDING TEQUILA (U.S. CLS. 47 AND 49).

MIDGE BUTLER, EXAMINING ATTORNEY

CLASS 33—(Continued).

SN 77-666,208. CODORNIU NAPA, INC., NAPA, CA. FILED 2-9-2009.

BLACKTAIL DEER VINEYARD

THE MARK CONSISTS OF STANDARD CHARACTERS WITHOUT CLAIM TO ANY PARTICULAR FONT, STYLE, SIZE, OR COLOR.

NO CLAIM IS MADE TO THE EXCLUSIVE RIGHT TO USE "VINEYARD", APART FROM THE MARK AS SHOWN. FOR WINES (U.S. CLS. 47 AND 49).

REBECCA POVARCHUK, EXAMINING ATTORNEY

SN 77-666,344. DINCO CORP, SAN JUAN, PUERTO RICO, FILED 2-9-2009.

Quintrala

THE MARK CONSISTS OF STANDARD CHARACTERS WITHOUT CLAIM TO ANY PARTICULAR FONT, STYLE, SIZE, OR COLOR.

FOR GRAPE WINE (U.S. CLS. 47 AND 49). FIRST USE 7-29-2008; IN COMMERCE 9-18-2008. PATRICIA EVANKO, EXAMINING ATTORNEY

SN 77-665,021. ECKS MARKETING, INC., MIAMI, FL. FILED 2-6-2009.

CURVATURE

THE MARK CONSISTS OF STANDARD CHARACTERS WITHOUT CLAIM TO ANY PARTICULAR FONT, STYLE, SIZE, OR COLOR.

FOR RED WINE; RED WINES; WHITE WINE; WINE; WINES (U.S. CLS. 47 AND 49).

WON TEAK OH, EXAMINING ATTORNEY

SN 77-666,754. ADASTRA WINES, INC., DBA ADASTRA, ED'S RED, NAPA, CA. FILED 2-9-2009.

Ed's Red

THE MARK CONSISTS OF STANDARD CHARACTERS WITHOUT CLAIM TO ANY PARTICULAR FONT, STYLE, SIZE, OR COLOR.

NO CLAIM IS MADE TO THE EXCLUSIVE RIGHT TO USE "RED", APART FROM THE MARK AS SHOWN. FOR RED WINE; RED WINES; WINE (U.S. CLS. 47 AND 49).

FIRST USE 4-19-2008; IN COMMERCE 4-19-2008. GINA HAYES, EXAMINING ATTORNEY

CLASS 33—(Continued).

SN 77-667,637. PONAK, INC., KANSAS CITY, MO. FILED 2-10-2009.

PONAK'S WICKED ATTITUDE

THE MARK CONSISTS OF STANDARD CHARACTERS WITHOUT CLAIM TO ANY PARTICULAR FONT, STYLE, SIZE, OR COLOR.

FOR ALCOHOLIC COCKTAIL MIXES (U.S. CLS. 47 AND 49).

NATALIE POLZER, EXAMINING ATTORNEY



SN 77-667,639. PONAK, INC., KANSAS CITY, MO. FILED 2-10-2009.

PONAK'S FAMOUS ATTITUDE

THE MARK CONSISTS OF STANDARD CHARACTERS WITHOUT CLAIM TO ANY PARTICULAR FONT, STYLE, SIZE, OR COLOR.

FOR ALCOHOLIC COCKTAIL MIXES (U.S. CLS. 47 AND 49).

NATALIE POLZER, EXAMINING ATTORNEY



SN 77-670,233. NORTHERN UNITED BREWING COMPANY, LLC, ANN ARBOR, MI. FILED 2-13-2009.

BONAFIDE

THE MARK CONSISTS OF STANDARD CHARACTERS WITHOUT CLAIM TO ANY PARTICULAR FONT, STYLE, SIZE, OR COLOR.

FOR WINE (U.S. CLS. 47 AND 49).

RENEE MCCRAY, EXAMINING ATTORNEY

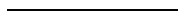

SN 77-670,235. NORTHERN UNITED BREWING COMPANY, LLC, ANN ARBOR, MI. FILED 2-13-2009.

CIVILIZED

THE MARK CONSISTS OF STANDARD CHARACTERS WITHOUT CLAIM TO ANY PARTICULAR FONT, STYLE, SIZE, OR COLOR.

FOR DISTILLED SPIRITS (U.S. CLS. 47 AND 49).

RENEE MCCRAY, EXAMINING ATTORNEY

CLASS 33—(Continued).

SN 77-695,664. PLAYA HOLDING CORPORATION, NEW YORK, NY. FILED 3-20-2009.



THE COLOR(S) GOLD, WHITE AND BLUE IS/ARE CLAIMED AS A FEATURE OF THE MARK.

THE MARK CONSISTS OF A STYLIZED GOLD STAR ABOVE A GOLD DESIGN OF AN EAGLE HOLDING AN AGAVE PLANT WITH ITS TALON, ALL OF THIS ON TOP OF A BLUE CIRCLE WITH GOLD INTERIOR AND EXTERIOR BORDERS, WITHIN WHICH APPEARS THE WORDING "CASA DRAGONES" AND A WHITE INTERIOR CIRCLE CONTAINING THE GOLD, LINED NUMBER "16".

THE ENGLISH TRANSLATION OF CASA DRAGONES IN THE MARK IS HOUSE OF DRAGONS.

FOR DISTILLED SPIRITS, INCLUDING TEQUILA (U.S. CLS. 47 AND 49).

MIDGE BUTLER, EXAMINING ATTORNEY



SN 78-764,318. GLOBAL WINES LLC, DANIA BEACH, FL. FILED 12-1-2005.

CARLOS SANTAMARIA

THE MARK CONSISTS OF STANDARD CHARACTERS WITHOUT CLAIM TO ANY PARTICULAR FONT, STYLE, SIZE, OR COLOR.

THE NAME "CARLOS SANTAMARIA" IDENTIFIES A LIVING INDIVIDUAL WHOSE CONSENT IS OF RECORD. FOR WINES (U.S. CLS. 47 AND 49).

AISHA SALEM, EXAMINING ATTORNEY

CLASS 33—(Continued).

SN 78-793,629. PASTERNAK WINE IMPORTS, HARRISON, NY. FILED 1-18-2006.

PASTERNAK

THE MARK CONSISTS OF STANDARD CHARACTERS WITHOUT CLAIM TO ANY PARTICULAR FONT, STYLE, SIZE, OR COLOR.

SEC. 2(F).
FOR WINE, LIQUOR AND DISTILLED SPIRITS, EXCLUDING VODKA (U.S. CLS. 47 AND 49).
FIRST USE 0-0-1988; IN COMMERCE 0-0-1988.
KATHERINE M. DUBRAY, EXAMINING ATTORNEY

SN 79-050,451. LOSADA VINOS DE FINCA, S.A., SPAIN, FILED 1-8-2008.

LOSADA

PRIORITY DATE OF 12-17-2007 IS CLAIMED.
OWNER OF INTERNATIONAL REGISTRATION 0954869 DATED 1-8-2008, EXPIRES 1-8-2018.
THE WORDING "LOSADA" HAS NO MEANING IN A FOREIGN LANGUAGE.
FOR WINES (U.S. CLS. 47 AND 49).
LYDIA BELZER, EXAMINING ATTORNEY

SN 79-050,452. LOSADA VINOS DE FINCA, S.A., SPAIN, FILED 1-8-2008.

ALTOS DE LOSADA

PRIORITY DATE OF 12-17-2007 IS CLAIMED.
OWNER OF INTERNATIONAL REGISTRATION 0954870 DATED 1-8-2008, EXPIRES 1-8-2018.
THE FOREIGN WORDING IN THE MARK TRANSLATES INTO ENGLISH AS "THE HEIGHTS", AND THUS THE MARK WOULD BE TRANSLATED AS "THE HEIGHTS OF LOSADA".
FOR WINES (U.S. CLS. 47 AND 49).
LYDIA BELZER, EXAMINING ATTORNEY

SN 79-055,638. PERNOD RICARD NEW ZEALAND LIMITED, NEW ZEALAND, FILED 4-11-2008.

GABRIEL'S GULLY

THE MARK CONSISTS OF STANDARD CHARACTERS WITHOUT CLAIM TO ANY PARTICULAR FONT, STYLE, SIZE, OR COLOR.
OWNER OF INTERNATIONAL REGISTRATION 0948892 DATED 11-21-2007, EXPIRES 11-21-2017.
FOR WINE (U.S. CLS. 47 AND 49).
PAUL MORENO, EXAMINING ATTORNEY

CLASS 33—(Continued).

SN 79-057,122. MIONETTO S.P.A., ITALY, FILED 7-18-2008.

LEGATURA

OWNER OF INTERNATIONAL REGISTRATION 0646111 DATED 10-27-1995, EXPIRES 10-27-2015.
THE ENGLISH TRANSLATION OF "LEGATURA" IN THE MARK IS "TIE, BINDING".
FOR WINES (U.S. CLS. 47 AND 49).
CARYN GLASSER, EXAMINING ATTORNEY

SN 79-057,610. MACDONALD & MUIR LIMITED, UNITED KINGDOM, FILED 7-17-2008.

NECTAR D'ÒR

THE MARK CONSISTS OF STANDARD CHARACTERS WITHOUT CLAIM TO ANY PARTICULAR FONT, STYLE, SIZE, OR COLOR.
OWNER OF INTERNATIONAL REGISTRATION 0973892 DATED 7-17-2008, EXPIRES 7-17-2018.
THE ENGLISH TRANSLATION OF "NECTAR D'ÒR" IN THE MARK IS GOLD NECTAR.
FOR WHISKY AND SPIRITS (U.S. CLS. 47 AND 49).
KAREN K. BUSH, EXAMINING ATTORNEY

SN 79-057,759. TESO LA MONJA, S.L., SPAIN, FILED 5-5-2008.

ALMIREZ

OWNER OF INTERNATIONAL REGISTRATION 0974368 DATED 5-5-2008, EXPIRES 5-5-2018.
THE ENGLISH TRANSLATION OF ALMIREZ IN THE MARK IS MORTAR.
FOR ALCOHOLIC BEVERAGES IN PARTICULAR WINE AND LIQUEURS, NAMELY, VODKA, RUM, WHISKY, BRANDY AND GIN (U.S. CLS. 47 AND 49).
SEAN CROWLEY, EXAMINING ATTORNEY

CLASS 33—(Continued).

SN 79-058,750. IL MOSNEL DI EMANUELA; BARBOGLIO E FIGI SOCIETA'; AGRICOLA SEMPLICE, ITALY, FILED 11-6-2007.



OWNER OF INTERNATIONAL REGISTRATION 0946163 DATED 11-6-2007, EXPIRES 11-6-2017.

THE MARK CONSISTS OF THE WORDING "IL MOSNEL" IN STYLIZED FONT, ABOVE WHICH THERE IS A PROFILED CIRCULAR DESIGN INTERRUPTED IN ITS LOWER PORTION BY A SQUARE CONTAINING FOUR TRIANGLES AND, IN ITS UPPER PORTION, BY FANCY ESCUTCHEON ABOVE WHICH THERE IS A STYLIZED CROWN, ALL CONTAINING THE ILLUSTRATION OF STYLIZED OPEN GATEWAY FEATURING TWO STATUES IN THE FORM OF HUMAN FIGURES, AND POSITIONED BEHIND WHICH THERE IS A STYLIZED BUILDING.

THE WORDING "MOSNEL" HAS NO MEANING IN A FOREIGN LANGUAGE.

FOR WINES, STILL WINES, SEMI-SPARKLING WINES, SPARKLING WINES, FRUIT WINE, GRAPE WINE, SWEET WINES, STRAWBERRY WINES, TABLE WINES, COOKING WINES, PORT WINES, WINE PUNCHES, APERITIF WINES, APERITIFS WITH A WINE BASE, WINE-BASED AROMATIC BEVERAGES, PREPARED WINE COCKTAILS, ALCOHOLIC APERITIF BITTERS, PREPARED ALCOHOLIC COCKTAILS, ALCOHOLIC APERITIFS, GRAPPA, VERMOUTH, ALCOHOLIC BITTERS, COGNAC, VODKA, BRANDY, WHISKEY, DISTILLED SPIRITS, LIQUEURS, DISTILLED LIQUORS (U.S. CLS. 47 AND 49).

CHRISTINE BLOMQUIST, EXAMINING ATTORNEY

SN 79-059,337. MACDONALD & MUIR LIMITED, UNITED KINGDOM, FILED 7-17-2008.

QUINTA RUBAN

THE MARK CONSISTS OF STANDARD CHARACTERS WITHOUT CLAIM TO ANY PARTICULAR FONT, STYLE, SIZE, OR COLOR.

OWNER OF INTERNATIONAL REGISTRATION 0978533 DATED 7-17-2008, EXPIRES 7-17-2018.

THE ENGLISH TRANSLATION OF "QUINTA RUBAN" IN THE MARK IS RUBY ESTATE.

FOR ALCOHOLIC BEVERAGES EXCEPT BEERS (U.S. CLS. 47 AND 49).

KAREN K. BUSH, EXAMINING ATTORNEY

CLASS 33—(Continued).

SN 79-060,706. MIGUEL TORRES S.A., SPAIN, FILED 8-11-2008.

AGUAMARINA

THE MARK CONSISTS OF STANDARD CHARACTERS WITHOUT CLAIM TO ANY PARTICULAR FONT, STYLE, SIZE, OR COLOR.

OWNER OF INTERNATIONAL REGISTRATION 0981561 DATED 8-11-2008, EXPIRES 8-11-2018.

THE ENGLISH TRANSLATION OF THE FOREIGN WORD IN THE MARK IS AQUAMARINE.

FOR WINES (U.S. CLS. 47 AND 49).

CHRISTINE BLOMQUIST, EXAMINING ATTORNEY

SN 79-061,574. CHATEAU PAVIE; SOCIETE CIVILE AGRICOLE, FRANCE, FILED 9-24-2008.

LA ROSÉE DE PAVIE

THE MARK CONSISTS OF STANDARD CHARACTERS WITHOUT CLAIM TO ANY PARTICULAR FONT, STYLE, SIZE, OR COLOR.

OWNER OF INTERNATIONAL REGISTRATION 0983722 DATED 9-24-2008, EXPIRES 9-24-2018.

OWNER OF U.S. REG. NOS. 1,615,975, 2,024,815 AND 3,158,926.

THE ENGLISH TRANSLATION OF "LA ROSEE DE PAVIE" IN THE MARK IS "THE DEW OF PAVIE".

FOR WINE (U.S. CLS. 47 AND 49).

LYDIA BELZER, EXAMINING ATTORNEY

CLASS 34—SMOKERS' ARTICLES

SN 76-631,041. C.A.T. TOBACCO CORPORATION, MIAMI, FL. FILED 2-16-2005.

CARLOS TORAÑO RESERVA SELECTA

THE MARK CONSISTS OF STANDARD CHARACTERS WITHOUT CLAIM TO ANY PARTICULAR FONT, STYLE, SIZE, OR COLOR.

OWNER OF U.S. REG. NOS. 2,064,589, 2,618,954 AND 3,587,147.

NO CLAIM IS MADE TO THE EXCLUSIVE RIGHT TO USE "RESERVA", APART FROM THE MARK AS SHOWN.

THE NAME "CARLOS TORANO" IDENTIFIES A LIVING INDIVIDUAL WHOSE CONSENT IS OF RECORD.

THE ENGLISH TRANSLATION OF "RESERVA SELECTA" IS "SELECT RESERVE".

SEC. 2(F) AS TO "RESERVA SELECTA".

FOR HANDMADE CIGARS (U.S. CLS. 2, 8, 9 AND 17).

FIRST USE 10-0-1999; IN COMMERCE 10-0-1999.

PRISCILLA MILTON, EXAMINING ATTORNEY

CLASS 34—(Continued).

SN 77-514,402. HANA IMPORTS, INC., MIAMI, FL. AND HANA IMPORTS, INC., MIAMI, FL. FILED 7-3-2008.



NO CLAIM IS MADE TO THE EXCLUSIVE RIGHT TO USE THE WORDS "BAHIA" AND "HAND MADE IN NICARAGUA", APART FROM THE MARK AS SHOWN.

THE NAME(S), PORTRAIT(S), AND/OR SIGNATURE(S) SHOWN IN THE MARK IDENTIFIES "TONY BORHANI", WHOSE CONSENT(S) TO REGISTER IS MADE OF RECORD.

THE COLOR(S) BLUE AND SILVER IS/ARE CLAIMED AS A FEATURE OF THE MARK.

THE MARK CONSISTS OF THE WORDS "BAHIA BLU" ITALICIZED IN SILVER AND THE WORD "BAHIA" IS OVER A SILVER LINE. THE WORDS "TONY BORHANI HAND MADE IN NICARAGUA" ARE IN CAPITAL LETTERS. THE BACKGROUND IS BLUE.

FOR CIGARS (U.S. CLS. 2, 8, 9 AND 17).

FIRST USE 7-1-2003; IN COMMERCE 7-1-2003.

JILL C. ALT, EXAMINING ATTORNEY

SN 77-586,652. INHALE, INC., EL CAJON, CA. FILED 10-6-2008.

REAPER

THE MARK CONSISTS OF STANDARD CHARACTERS WITHOUT CLAIM TO ANY PARTICULAR FONT, STYLE, SIZE, OR COLOR.

FOR HOOKAHS; HOOKAH BASES; HOOKAH PIPES; HOOKAH HOSES; HOOKAH ACCESSORIES, NAMELY, MOUTHPIECE, PLATE, BOWL, AND CERAMIC BOWL (U.S. CLS. 2, 8, 9 AND 17).

FIRST USE 3-3-2007; IN COMMERCE 2-1-2008.

ESTHER A. BORSUK, EXAMINING ATTORNEY

SN 77-592,345. MAX ROHR, INC., WILMINGTON, DE. FILED 10-14-2008.

FIREFOX

THE MARK CONSISTS OF STANDARD CHARACTERS WITHOUT CLAIM TO ANY PARTICULAR FONT, STYLE, SIZE, OR COLOR.

FOR CIGARS, LITTLE CIGARS, ROLL-YOUR-OWN TOBACCO, PIPE TOBACCO, SMOKELESS TOBACCO, AND RELATED ACCESSORIES, NAMELY, ASHTRAYS, CIGAR BOXES, CIGAR CUTTERS, CIGAR CASES AND LIGHTERS FOR SMOKERS (U.S. CLS. 2, 8, 9 AND 17).

THOMAS MANOR, EXAMINING ATTORNEY

CLASS 34—(Continued).

SN 77-607,458. MAX ROHR, INC., WILMINGTON, DE. FILED 11-5-2008.

HUMI-STIK

THE MARK CONSISTS OF STANDARD CHARACTERS WITHOUT CLAIM TO ANY PARTICULAR FONT, STYLE, SIZE, OR COLOR.

OWNER OF U.S. REG. NO. 3,547,614.

FOR CIGAR HUMIDIFIERS (U.S. CLS. 2, 8, 9 AND 17).

THOMAS MANOR, EXAMINING ATTORNEY

SN 77-663,841. NATIONAL TOBACCO COMPANY, L.P., LOUISVILLE, KY. FILED 2-5-2009.

RED CAP

THE MARK CONSISTS OF STANDARD CHARACTERS WITHOUT CLAIM TO ANY PARTICULAR FONT, STYLE, SIZE, OR COLOR.

FOR TOBACCO, NAMELY, PIPE TOBACCO (U.S. CLS. 2, 8, 9 AND 17).

JOHN WILKE, EXAMINING ATTORNEY

SN 77-665,074. CIGARBOYZ LLC, AUSTIN, TX. FILED 2-6-2009.



NO CLAIM IS MADE TO THE EXCLUSIVE RIGHT TO USE "CIGARS", APART FROM THE MARK AS SHOWN.

THE MARK CONSISTS OF THE WORDING "CIGARBOYZ.COM" ON TOP OF A CROWN THE LETTERS "CB CIGARZ" UNDERNEATH THE CROWN.

FOR CIGAR BANDS; CIGAR BOXES; CIGARS (U.S. CLS. 2, 8, 9 AND 17).

DAVID MURRAY, EXAMINING ATTORNEY

CLASS 34—(Continued).

SN 77-665,527. GOD OF FIRE, INC., COMMERCE, CA. FILED 2-6-2009.

ANGELENOS

THE MARK CONSISTS OF STANDARD CHARACTERS WITHOUT CLAIM TO ANY PARTICULAR FONT, STYLE, SIZE, OR COLOR.

FOR CIGARS, CIGARETTE AND CIGAR LIGHTERS, HUMIDORS, CIGAR CASES AND ASHTRAYS (U.S. CLS. 2, 8, 9 AND 17).

SIMON TENG, EXAMINING ATTORNEY

SERVICE MARKS

CLASS 35—ADVERTISING AND BUSINESS

SN 76-693,186. C&J INVESTMENTS INC., IRVING, TX. FILED 9-29-2008.

ORANGECUP

THE MARK CONSISTS OF STANDARD CHARACTERS WITHOUT CLAIM TO ANY PARTICULAR FONT, STYLE, SIZE, OR COLOR.

FOR RETAIL STORE SERVICES FEATURING, CLOTHING, AUDIO RECORDINGS, VIDEO RECORDINGS, BOOKS, CALENDARS, POSTERS, AND GREETING CARDS; THE FOREGOING GOODS COMPRISED OF MATERIALS THAT LESSENER ADVERSE EFFECTS ON THE ENVIRONMENT, AND PROMOTE ENVIRONMENTAL AWARENESS, AND REVITALIZATION OF MIND AND BODY; PROMOTING PUBLIC AWARENESS OF THE BENEFITS OF RECYCLING OR RE-USE OF POST-CONSUMER MATERIALS, NAMELY, PAPER NAPKINS, PAPER BAGS, PLASTIC WARE, AND RECYCLING BINS (U.S. CLS. 100, 101 AND 102).

ELI HELLMAN, EXAMINING ATTORNEY

CLASS 35—(Continued).

SN 76-694,118. UNITED TRANSPORTATION UNION, CLEVELAND, OH. FILED 11-7-2008.

THE VOICE OF TRANSPORTATION LABOR

THE MARK CONSISTS OF STANDARD CHARACTERS WITHOUT CLAIM TO ANY PARTICULAR FONT, STYLE, SIZE, OR COLOR.

NO CLAIM IS MADE TO THE EXCLUSIVE RIGHT TO USE "TRANSPORTATION LABOR", APART FROM THE MARK AS SHOWN.

FOR PROVIDING A WEBSITE FEATURING LABOR UNION INFORMATION (U.S. CLS. 100, 101 AND 102).

FIRST USE 10-1-1997; IN COMMERCE 10-1-1997.

MICHELE SWAIN, EXAMINING ATTORNEY

SN 76-694,817. PINCKNEY, MICHAEL, PENSACOLA, FL. FILED 12-15-2008.

AVIAVIEW

THE MARK CONSISTS OF STANDARD CHARACTERS WITHOUT CLAIM TO ANY PARTICULAR FONT, STYLE, SIZE, OR COLOR.

FOR ONLINE ADVERTISING AND MARKETING OF AIRCRAFT; PROMOTING THE GOODS AND SERVICES OF OTHERS THROUGH THE VISUAL DISPLAY OF AIRCRAFT AND AVIATION RELATED PRODUCTS AND SERVICES VIA THE GLOBAL COMPUTER NETWORK (U.S. CLS. 100, 101 AND 102).

FIRST USE 6-23-2006; IN COMMERCE 6-23-2006.

MICHELE SWAIN, EXAMINING ATTORNEY

SN 76-695,090. AXIS NEXUS LLC, DBA PAK KHALIS FOODS, TACOMA, WA. FILED 12-31-2008.



NO CLAIM IS MADE TO THE EXCLUSIVE RIGHT TO USE "FOODS", APART FROM THE MARK AS SHOWN.

THE FOREIGN WORDING IN THE MARK TRANSLATES INTO ENGLISH AS "PURE CLEAN".

FOR WHOLESALE FOOD DISTRIBUTORSHIP SERVICES (U.S. CLS. 100, 101 AND 102).

FIRST USE 2-1-1998; IN COMMERCE 4-25-2007.

DAVON HATCHETT, EXAMINING ATTORNEY

CLASS 35—(Continued).

SN 76-695,633. HOME & GARDEN PARTY, LTD., MARSHALL, TX. FILED 2-6-2009.

CELEBRATING HOME

THE MARK CONSISTS OF STANDARD CHARACTERS WITHOUT CLAIM TO ANY PARTICULAR FONT, STYLE, SIZE, OR COLOR.

FOR BUSINESS INFORMATION, ADVICE AND CONSULTATION IN THE FIELDS OF DIRECT SALE ORGANIZATION, PLANNING AND ESTABLISHMENT AND FOR OPERATION OF A BUSINESS SPECIALIZING IN THE SALES OF HOUSEWARE AND GIFTS; RETAIL SERVICES BY DIRECT SOLICITATION BY SALES AGENTS IN THE FIELD OF HOUSEWARE AND GIFTABLES; RETAIL SHOP-AT-HOME SERVICES BY DIRECT SOLICITATION BY SALES AGENTS IN THE FIELD OF HOUSEWARE AND GIFTABLES; RETAIL SHOP-AT-HOME PARTY IN THE FIELD OF HOUSEWARE AND GIFTABLES (U.S. CLS. 100, 101 AND 102).
DOUGLAS LEE, EXAMINING ATTORNEY

SN 76-695,668. CENTRAL STATES MANUFACTURING, INC., LOWELL, AR. FILED 2-9-2009.

RIGHT, ON TIME, EVERY TIME.

THE MARK CONSISTS OF STANDARD CHARACTERS WITHOUT CLAIM TO ANY PARTICULAR FONT, STYLE, SIZE, OR COLOR.

FOR DISTRIBUTORSHIPS IN THE FIELD OF METAL BUILDING COMPONENTS, NAMELY, METAL ROOFING PANELS, METAL SIDING PANELS, AND TRIM FOR METAL BUILDINGS (U.S. CLS. 100, 101 AND 102).
FIRST USE 6-17-2005; IN COMMERCE 6-17-2005.
ALEX KEAM, EXAMINING ATTORNEY

SN 76-695,677. M.I.S.S. SPORTSWEAR, INC., NEW YORK, NY. FILED 2-9-2009.

IT'S THE FIT!

THE MARK CONSISTS OF STANDARD CHARACTERS WITHOUT CLAIM TO ANY PARTICULAR FONT, STYLE, SIZE, OR COLOR.

FOR WHOLESALE DISTRIBUTORSHIP OF CLOTHING (U.S. CLS. 100, 101 AND 102).
FIRST USE 9-0-2007; IN COMMERCE 9-0-2007.
ALEX KEAM, EXAMINING ATTORNEY

CLASS 35—(Continued).

SN 77-058,510. LAS VEGAS CONVENTION AND VISITORS AUTHORITY, LAS VEGAS, NV. FILED 12-6-2006.

WHAT HAPPENS HERE, STAYS HERE.

THE MARK CONSISTS OF STANDARD CHARACTERS WITHOUT CLAIM TO ANY PARTICULAR FONT, STYLE, SIZE, OR COLOR.

FOR PROMOTING THE LAS VEGAS, NEVADA AREA AS A DESTINATION FOR LEISURE AND BUSINESS TRAVELERS (U.S. CLS. 100, 101 AND 102).
FIRST USE 12-0-2002; IN COMMERCE 12-0-2002.
SAIMA MAKHDOOM, EXAMINING ATTORNEY

SN 77-100,125. ADBRITE, INC., SAN FRANCISCO, CA. FILED 2-6-2007.

BRITEPIC

THE MARK CONSISTS OF STANDARD CHARACTERS WITHOUT CLAIM TO ANY PARTICULAR FONT, STYLE, SIZE, OR COLOR.

FOR ADVERTISING AGENCIES, NAMELY, PROMOTING THE GOODS AND SERVICES OF OTHERS; RENTAL OF ADVERTISING SPACE ON WEBSITES (U.S. CLS. 100, 101 AND 102).
TOBY BULLOFF, EXAMINING ATTORNEY

SN 77-116,042. 4273672 CANADA INC., MONT-ROYAL, QUEBEC, CANADA, FILED 2-26-2007.

CAVA SPILIADIS

THE MARK CONSISTS OF STANDARD CHARACTERS WITHOUT CLAIM TO ANY PARTICULAR FONT, STYLE, SIZE, OR COLOR.

PRIORITY CLAIMED UNDER SEC. 44(D) ON CANADA APPLICATION NO. 1,336,333, FILED 2-21-2007, REG. NO. TMA730523, DATED 12-9-2008, EXPIRES 12-9-2023.

OWNER OF CANADA REG. NO. TMA730523, DATED 12-9-2008, EXPIRES 12-9-2023.

NO CLAIM IS MADE TO THE EXCLUSIVE RIGHT TO USE "CAVA", APART FROM THE MARK AS SHOWN.

FOR IMPORT OF WINE, NAMELY, WHOLESALE DISTRIBUTORSHIP, FEATURING WINE (U.S. CLS. 100, 101 AND 102).

PRISCILLA MILTON, EXAMINING ATTORNEY

CLASS 35—(Continued).

SN 77-176,492. DYNAMEX INC., DALLAS, TX. FILED 5-9-2007.



PRIORITY CLAIMED UNDER SEC. 44(D) ON CANADA APPLICATION NO. 1343245, FILED 4-13-2007, REG. NO. 706815, DATED 2-7-2008, EXPIRES 2-7-2023.

OWNER OF U.S. REG. NOS. 2,106,226 AND 2,862,153. THE MARK CONSISTS OF THE WORDS "DXFRANCHISE" WITH THE WORDS "POWERED BY DYNAMEX" DIRECTLY UNDERNEATH. THERE IS A SWOOSH CURVE DIRECTLY UNDERNEATH THE WORDS.

FOR FRANCHISE SERVICES, NAMELY, OFFERING TECHNICAL AND BUSINESS MANAGEMENT ASSISTANCE IN THE ESTABLISHMENT AND OPERATION OF COURIER SERVICES (U.S. CLS. 100, 101 AND 102). ELISSA GARBER KON, EXAMINING ATTORNEY

SN 77-236,838. CARDINAL HEALTH TECHNOLOGIES, LLC, LAS VEGAS, NV. FILED 7-24-2007.

CARDINALASSIST

THE MARK CONSISTS OF STANDARD CHARACTERS WITHOUT CLAIM TO ANY PARTICULAR FONT, STYLE, SIZE, OR COLOR.

OWNER OF U.S. REG. NO. 2,383,686. FOR BUSINESS SERVICES FOR OTHERS IN THE HEALTH CARE FIELD, NAMELY, COMPUTERIZED ON-LINE ORDERING TO REPLENISH DRUGS FOR PHARMACIES AND MEDICATION DISPENSING MACHINES; COMPUTERIZED DATABASE MANAGEMENT IN THE FIELD OF PHARMACEUTICAL LOT NUMBER AND EXPIRATION DATING; SALES VOLUME TRACKING; AND DISTRIBUTORSHIP SERVICES FEATURING PREPACKAGED PHARMACEUTICALS AND SUPPLIES (U.S. CLS. 100, 101 AND 102).

FIRST USE 12-15-1997; IN COMMERCE 12-15-1997. HEATHER THOMPSON, EXAMINING ATTORNEY

CLASS 35—(Continued).

SN 77-271,731. ADVANTAGE BRANDS, LTD., AVON, MN. FILED 9-5-2007.



THE COLOR(S) RED AND WHITE IS/ARE CLAIMED AS A FEATURE OF THE MARK.

THE MARK CONSISTS OF THE RED WORDING "SETTING THE PACE" WITH A WHITE OUTLINE AROUND THE WORDING, ALL ON A RED RECTANGULAR BACKGROUND. THE REMAINDER OF THE WHITE IN THE DRAWING REPRESENTS TRANSPARENT AREAS AND IS NOT PART OF THE MARK.

FOR RETAIL GASOLINE SUPPLY SERVICES; RETAIL STORE SERVICES FEATURING CONVENIENCE STORE ITEMS AND GASOLINE (U.S. CLS. 100, 101 AND 102).

FIRST USE 5-1-2007; IN COMMERCE 5-1-2007. MAUREEN DALL, EXAMINING ATTORNEY

SN 77-311,195. TRIPP & ASSOCIATES, INC., PLYMOUTH, MN. FILED 10-23-2007.

Defenders of Freedom

THE MARK CONSISTS OF STANDARD CHARACTERS WITHOUT CLAIM TO ANY PARTICULAR FONT, STYLE, SIZE, OR COLOR.

FOR PROMOTING THE PUBLIC AWARENESS OF THE NEED FOR SAFE FIREARM USE THROUGH FUND RAISING PROMOTIONS (U.S. CLS. 100, 101 AND 102).

WARREN L. OLANDRIA, EXAMINING ATTORNEY

SN 77-317,331. REDCATS, ROUBAIX, FRANCE, FILED 10-30-2007.

VIE PRIVEE

THE MARK CONSISTS OF STANDARD CHARACTERS WITHOUT CLAIM TO ANY PARTICULAR FONT, STYLE, SIZE, OR COLOR.

OWNER OF FRANCE REG. NO. 98743715, DATED 7-27-1998, RENEWED AS REG. NO. 98743715, DATED 5-27-2008, EXPIRES 5-27-2018.

OWNER OF U.S. REG. NO. 2,574,900. THE ENGLISH TRANSLATION OF THE WORD "VIE PRIVEE" IN THE MARK IS PRIVATE LIFE.

FOR PUBLICITY AGENCIES, COMMERCIAL MANAGEMENT ASSISTANCE; LABOR EXCHANGES; SAMPLE DISTRIBUTION; BUSINESS CONSULTING; ARRANGING FOR SUBSCRIPTIONS FOR THE PUBLICATIONS OF OTHERS; BOOKKEEPING; DOCUMENT REPRODUCTION; PERSONNEL PLACEMENT AND RECRUITMENT; COMPUTERIZED DATABASE MANAGEMENT (U.S. CLS. 100, 101 AND 102).

CHRISTINA SOBRAL, EXAMINING ATTORNEY

CLASS 35—(Continued).

SN 77-322,387. ICF INCORPORATED, LLC, FAIRFAX, VA. FILED 11-6-2007.

ICF INTERNATIONAL'S ASPIRE

THE MARK CONSISTS OF STANDARD CHARACTERS WITHOUT CLAIM TO ANY PARTICULAR FONT, STYLE, SIZE, OR COLOR.

OWNER OF U.S. REG. NOS. 2,806,834 AND 2,845,154.

NO CLAIM IS MADE TO THE EXCLUSIVE RIGHT TO USE "INTERNATIONAL'S", APART FROM THE MARK AS SHOWN.

FOR BUSINESS MANAGEMENT CONSULTING SERVICES IN THE FIELDS OF ENERGY, ENVIRONMENT, TRANSPORTATION, ECONOMIC AND COMMUNITY DEVELOPMENT, AND ENERGY MANAGEMENT AS WELL AS IN THE AREAS OF INFORMATION MANAGEMENT, STRATEGIC COMMUNICATIONS AND CHANGE MANAGEMENT CONCERNING A SYSTEMATIC, INTEGRATED APPROACH TO ALL DIMENSIONS OF AN ORGANIZATION, INCLUDING MISSION, BUSINESS PROCESS, CAPITAL INVESTMENT AND ORGANIZATION CULTURE (U.S. CLS. 100, 101 AND 102).

SOPHIA S. KIM, EXAMINING ATTORNEY

SN 77-327,239. DIGITAL TRUST, INC., JACKSONVILLE BEACH, FL. FILED 11-12-2007.

MARKETINGEXPERIMENTS

THE MARK CONSISTS OF STANDARD CHARACTERS WITHOUT CLAIM TO ANY PARTICULAR FONT, STYLE, SIZE, OR COLOR.

SEC. 2(F).

FOR MARKET RESEARCH CONDUCTED AND MADE AVAILABLE ONLINE THROUGH A WEBSITE (U.S. CLS. 100, 101 AND 102).

FIRST USE 0-0-1999; IN COMMERCE 0-0-1999.

PRISCILLA MILTON, EXAMINING ATTORNEY

SN 77-330,543. PREP PROFILE SYSTEMS, INC., BEND, OR. FILED 11-15-2007.

PREP

THE MARK CONSISTS OF STANDARD CHARACTERS WITHOUT CLAIM TO ANY PARTICULAR FONT, STYLE, SIZE, OR COLOR.

FOR BUSINESS MANAGEMENT CONSULTATION SERVICES, NAMELY, PROVIDING BUSINESS MANAGEMENT INFORMATION IN THE FIELDS OF PERSONALITY ASSESSMENT, CAREER ASSESSMENT, HUMAN PERFORMANCE, JOB PROFILING AND MATCHING, AND LEADERSHIP TRAINING AND DEVELOPMENT (U.S. CLS. 100, 101 AND 102).

SONYA STEPHENS, EXAMINING ATTORNEY

CLASS 35—(Continued).

SN 77-332,026. ENLIVEN MARKETING TECHNOLOGIES CORPORATION, NEW YORK, NY. FILED 11-16-2007.

ENLIVEN MARKETING TECHNOLOGIES

THE MARK CONSISTS OF STANDARD CHARACTERS WITHOUT CLAIM TO ANY PARTICULAR FONT, STYLE, SIZE, OR COLOR.

OWNER OF U.S. REG. NOS. 2,232,558 AND 2,497,451.

NO CLAIM IS MADE TO THE EXCLUSIVE RIGHT TO USE "MARKETING TECHNOLOGIES", APART FROM THE MARK AS SHOWN.

FOR BUSINESS CONSULTING SERVICES; MARKETING AND PROMOTIONAL SERVICES; ADVERTISING SERVICES; ONLINE ADVERTISING SERVICES; ADVERTISING AGENCY SERVICES; WEB-BASED MARKET ANALYSIS AND RESEARCH SERVICES; COMMERCIAL INFORMATION IN THE FIELD OF ONLINE ADVERTISING, RICH MEDIA, MEDIA PLANNING, SEARCH ENGINE MARKETING, SOFTWARE TOOLS, ONLINE SEARCHING, CREATION OF WIDGETS, AND 2D AND 3D IMAGERY; MARKETING CONSULTING SERVICES; WEB MARKETING CONSULTING SERVICES; ADVERTISING CONSULTING SERVICES (U.S. CLS. 100, 101 AND 102).

CURTIS FRENCH, EXAMINING ATTORNEY

SN 77-339,497. REMEMBRANCE RIDE INC., OSCEOLA, IN. FILED 11-28-2007.

Remembrance Ride

THE MARK CONSISTS OF STANDARD CHARACTERS WITHOUT CLAIM TO ANY PARTICULAR FONT, STYLE, SIZE, OR COLOR.

SEC. 2(F).

FOR CHARITABLE SERVICES, NAMELY, ORGANIZING AND CONDUCTING VOLUNTEER PROGRAMS AIMED AT INCREASING SUPPORT AND MORALE OF FAMILIES OF DECEASED WAR VETERANS, WAR VETERANS, CURRENT MEMBERS AND FUTURE MEMBERS OF THE U.S. MILITARY (U.S. CLS. 100, 101 AND 102).

FIRST USE 6-1-2001; IN COMMERCE 6-1-2001.

JANICE L. MCMORROW, EXAMINING ATTORNEY

CLASS 35—(Continued).

SN 77-340,525. MOTHER'S NUTRITIONAL CENTER, INC., SANTA FE SPRINGS, CA. FILED 11-29-2007.

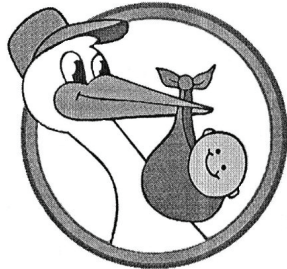

THE MARK CONSISTS OF AN IMAGE OF A STORK AND A BABY.
FOR RETAIL GROCERY STORES (U.S. CLS. 100, 101 AND 102).
BONNIE LUKEN, EXAMINING ATTORNEY

CLASS 35—(Continued).

SN 77-434,981. SMILEY MILEY, INC., LOS ANGELES, CA. FILED 3-28-2008.

MILEY

SN 77-382,183. HACHETTE FILIPACCHI MEDIA U.S., INC., NEW YORK, NY. FILED 1-28-2008.

TOTAL SHELTER NETWORK

THE MARK CONSISTS OF STANDARD CHARACTERS WITHOUT CLAIM TO ANY PARTICULAR FONT, STYLE, SIZE, OR COLOR.
NO CLAIM IS MADE TO THE EXCLUSIVE RIGHT TO USE "SHELTER NETWORK", APART FROM THE MARK AS SHOWN.
FOR BUSINESS MARKETING AND ADVERTISING SERVICES, NAMELY, PROVIDING MARKETING AND ADVERTISING SERVICES TO HOME DESIGN AND DECORATION WEBSITES (U.S. CLS. 100, 101 AND 102).
WILLIAM VERHOSEK, EXAMINING ATTORNEY

THE MARK CONSISTS OF STANDARD CHARACTERS WITHOUT CLAIM TO ANY PARTICULAR FONT, STYLE, SIZE, OR COLOR.
THE NAME(S), PORTRAIT(S), AND/OR SIGNATURE(S) SHOWN IN THE MARK IDENTIFIES DESTINY HOPE CYUS AKA MILEY RAY CYRUS, WHOSE CONSENT(S) TO REGISTER IS SUBMITTED.

SN 77-383,658. FARIENT ADVISORS, LLC, SAN MARINO, CA. FILED 1-29-2008.

FOR ON-LINE RETAIL STORE SERVICES FEATURING CLOTHING, TOYS AND GAMES, ELECTRONIC MEDIA FEATURING PRE-RECORDED CONTENT RELATING TO ENTERTAINMENT AND MUSIC, PAPER GOODS, NAMELY, PLATES, NAPKINS, CUPS, BANNERS, SIGNS, PARTY HATS, WRAPPING PAPER, PRINTED MATTER, NAMELY, NOTEBOOKS, CALENDARS, DIARIES, PLANNERS, GREETINGS CARDS, SOUVENIR BOOKS, AUTOGRAPH BOOKS, APPOINTMENT BOOKS, COLORING BOOKS, STATIONARY, ADDRESS BOOKS, PRINTED INVITATIONS, STATIONARY, NEWSLETTERS FEATURING INFORMATION ON MUSICAL EVENTS, CONCERTS, APPEARANCES, FASHION, MUSIC AND ENTERTAINMENT, SHOW PROGRAMS, POSTERS, PAPER BANNERS, PAPER PENNANTS, BOOK COVERS, DECALS, STICKERS, PAPER EMBLEMS, ALBUMS, NAMELY, STICKER ALBUMS, SCRAPBOOK ALBUMS AND PHOTOGRAPH ALBUMS, NON-METAL MERCHANDISE, NAMELY, JEWELRY, STATUTES, FIGURINES, PICTURE FRAMES, NON-METAL MONEY CLIPS, WRITING IMPLEMENTS, WRITING INK AND STAMPING INK, MUGS AND OTHER HOUSEHOLD ITEMS; ON-LINE RETAIL STORE SERVICES FEATURING DOWNLOADABLE PRE-RECORDED MUSIC AND VIDEOS AND AUDIOS FEATURING MUSICAL ENTERTAINMENT (U.S. CLS. 100, 101 AND 102).
HENRY S. ZAK, EXAMINING ATTORNEY

EXECUTIVE TOP SHEET

THE MARK CONSISTS OF STANDARD CHARACTERS WITHOUT CLAIM TO ANY PARTICULAR FONT, STYLE, SIZE, OR COLOR.
NO CLAIM IS MADE TO THE EXCLUSIVE RIGHT TO USE "EXECUTIVE", APART FROM THE MARK AS SHOWN.
FOR DATA SERVICES INVOLVING EXECUTIVE COMPENSATION, NAMELY, DATA COMPILING AND ANALYZING RELATING TO EXECUTIVE PERFORMANCE AND EXECUTIVE COMPENSATION (U.S. CLS. 100, 101 AND 102).
CHRISTINE BLOMQUIST, EXAMINING ATTORNEY

CLASS 35—(Continued).

SN 77-445,765. THE PROFIT VISE, PAWLING, NY. FILED 4-11-2008.



Finding New Profits. Fixing Profit Leaks.

NO CLAIM IS MADE TO THE EXCLUSIVE RIGHT TO USE "PROFIT", APART FROM THE MARK AS SHOWN.

THE MARK CONSISTS OF THE STYLIZED WORDS "THE PROFIT VISE FINDING NEW PROFITS. FIXING PROFIT LEAKS.". A THIN LINE UNDER THE WORD "PROFIT VISE". ABOVE THE STYLIZED WORDS IS AN IMAGE OF A VISELIKE FIGURE HOLDING UP AN ARROW. THE ARROW REPRESENTS RISING PROFITS. FIVE STARS ARCH OVER THE VISELIKE FIGURE. THE SILHOUETTE OF A CITY SKYLINE APPEARS AT THE BASE OF THE VISELIKE FIGURE.

FOR BUSINESS CONSULTATION (U.S. CLS. 100, 101 AND 102).

FIRST USE 6-10-2008; IN COMMERCE 6-10-2008.
ROBERT STRUCK, EXAMINING ATTORNEY

SN 77-445,781. REGIONALBEST.COM, LLC, BALA CY-NWYD, PA. FILED 4-11-2008.

LOCAL FOODS THAT MAKE AMERICA GREAT

THE MARK CONSISTS OF STANDARD CHARACTERS WITHOUT CLAIM TO ANY PARTICULAR FONT, STYLE, SIZE, OR COLOR.

FOR ON-LINE RETAIL STORE SERVICES FEATURING FOOD (U.S. CLS. 100, 101 AND 102).

JAMES STEIN, EXAMINING ATTORNEY

CLASS 35—(Continued).

SN 77-451,701. HONG, CHANG, WILMETTE, IL. FILED 4-18-2008.

hairsisters.com

THE MARK CONSISTS OF STANDARD CHARACTERS WITHOUT CLAIM TO ANY PARTICULAR FONT, STYLE, SIZE, OR COLOR.

FOR ONLINE RETAIL STORE SERVICES FEATURING HUMAN AND SYNTHETIC HAIR IN WIGS, BRAIDS, EXTENSIONS, WEAVES, PONYTAILS, BEAUTY AIDS, AND ACCESSORIES (U.S. CLS. 100, 101 AND 102).

FIRST USE 10-1-2004; IN COMMERCE 10-1-2004.
JULIE GUTTADAURO, EXAMINING ATTORNEY

SN 77-463,737. REGULATORY AND TAX CONSULTANTS, LLC, SUWANEE, GA. FILED 5-1-2008.



NO CLAIM IS MADE TO THE EXCLUSIVE RIGHT TO USE "REGULATORY AND TAX CONSULTANTS, LLC", "LLC" AND "FORENSIC TAX TEAM", APART FROM THE MARK AS SHOWN.

THE STIPPLING IS FOR SHADING PURPOSES ONLY.

THE COLOR(S) GOLD, RED, BLACK, BLUE, GREY, WHITE, PINK, BROWN AND CREAM IS/ARE CLAIMED AS A FEATURE OF THE MARK.

THE MARK CONSISTS OF A POLICE SHIELD CARRIER DESIGN OF THE COLORS GOLD, GREY, WHITE AND BLACK CONTAINING THE STYLIZED WORDING "REGULATORY AND TAX CONSULTANTS, LLC". "RTC LLC" AND "FORENSIC TAX TEAM", AS WELL AS DESIGNS OF TWO MEN, A WOMAN AND A DOG. THE WORDING "REGULATORY AND TAX CONSULTANTS, LLC" IS BLUE WITH A WHITE OUTLINE AND APPEARS AT THE TOP OF THE SHIELD CARRIER DESIGN WHILE "FORENSIC TAX TEAM" APPEARS AT THE BOTTOM. THE LEFTMOST MAN IS WEARING A BLACK SUIT WITH WHITE PINSTRIPE, A WHITE SHIRT, AND A RED TIE, AND IS HOLDING A PAD OF PAPER OF WHITE, GREY AND BLACK IN HIS RIGHT HAND AND A MAGNIFYING GLASS OF BLUE, BLACK AND WHITE IN HIS LEFT HAND. THE MAN'S FACE AND HANDS ARE BROWN, THE HAIR IS BLACK, AND THE PERSON'S EYES ARE BROWN, BLACK AND WHITE. A WOMAN WEARING GREY, BLACK AND WHITE GLASSES, WHITE SHIRT, RED SWEATER AND A BLACK SUIT WITH WHITE PINSTRIPE APPEARS IN THE MIDDLE OF THE SHIELD CARRIER DESIGN HOLDING A SMALL GREY BOX WITH A BLACK OUTLINE IN HER RIGHT HAND. THE WOMAN'S FACE AND HANDS ARE CREAM, HER FINGERNAILS AND LIPS ARE PINK, AND THE EYES ARE BLUE, WHITE AND BLACK. THE WOMAN'S HAIR IS LIGHT BROWN AND GOLD. THE MAN ON THE RIGHT IS WEARING GREY, WHITE AND BLACK

CLASS 35—(Continued).

GLASSES, A WHITE SHIRT, RED TIE AND BLACK SUIT WITH WHITE PINSTRIPES. THE RIGHTMOST MAN IS ALSO WEARING A GREY AND BLACK COMMUNICATIONS EARPIECE IN HIS RIGHT EAR, AND IS HOLDING A GREY, BLUE AND BLACK CELL PHONE IN HIS LEFT HAND. THE RIGHTMOST MAN'S FACE AND HANDS ARE LIGHT BROWN, HIS HAIR IS BLACK AND HIS OPEN MOUTH IS WHITE. A BLACK, WHITE AND GREY SIBERIAN HUSKY DOG WEARING GREY, BLACK AND WHITE GLASSES AND A GOLD, GREY AND WHITE SHIELD-SHAPED TAG BEARING THE BLACK LETTERING "RTC, LLC" APPEARS AT THE BOTTOM OF THE SHIELD CARRIER DESIGN. THE DOG'S MOUTH IS PINK, AND THE DOG'S EYES ARE BLUE, WHITE AND BLACK. BLACK IS USED TO OUTLINE THE FEATURES OF THE PERSONS AND DOG.

FOR TELECOMMUNICATIONS REGULATORY TAX REPORTING; TAX CONSULTATION (U.S. CLS. 100, 101 AND 102).

FIRST USE 2-0-2008; IN COMMERCE 2-0-2008.
NELSON SNYDER, EXAMINING ATTORNEY

SN 77-472,079. HOTELS.COM, LP, DALLAS, TX. FILED 5-12-2008.

welcomerewards

THE COLOR(S) REDDISH-ORANGE AND BLUISH-GREY IS/ARE CLAIMED AS A FEATURE OF THE MARK.

THE MARK CONSISTS OF THE COMPOUND WORD "WELCOMEREWARDS" WITH THE LITERAL ELEMENT "WELCOME" APPEARING IN THE COLOR REDDISH-ORANGE AND THE LITERAL ELEMENT "REWARDS" APPEARING IN THE COLOR BLUISH-GREY.

FOR CONDUCTING INCENTIVE AWARD PROGRAMS TO PROMOTE THE SALE OF ACCOMMODATIONS, HOTEL AND MOTEL ROOMS; CONSUMER LOYALTY SERVICES FOR COMMERCIAL, PROMOTIONAL, AND ADVERTISING PURPOSES, NAMELY, ADMINISTRATION OF FREQUENT TRAVELER PROGRAM; CUSTOMER LOYALTY SERVICES AND CUSTOMER CLUB SERVICES, FOR COMMERCIAL, PROMOTIONAL AND/OR ADVERTISING PURPOSES (U.S. CLS. 100, 101 AND 102).

BILL DAWE, EXAMINING ATTORNEY

CLASS 35—(Continued).

SN 77-483,858. SV PROGRAM MANAGEMENT INC., PEARL RIVER, NY. FILED 5-27-2008.



NO CLAIM IS MADE TO THE EXCLUSIVE RIGHT TO USE "SIGNATURE VALIDATION PROGRAM", APART FROM THE MARK AS SHOWN.

THE COLOR(S) NAVY BLUE, RED AND WHITE IS/ARE CLAIMED AS A FEATURE OF THE MARK.

THE MARK CONSISTS OF THE TERMS "SVP" AND "SIGNATURE VALIDATION PROGRAM" IN NAVY BLUE, NEXT TO A SERIES OF RECEDING RED SQUARES WITH WHITE INTERIORS.

FOR ELECTRONIC AND MANUAL SIGNATURE VERIFICATION AND AUTHENTICATION SERVICES FOR NON-SECURITIES RELATED COMMERCIAL TRANSACTIONS (U.S. CLS. 100, 101 AND 102).

ANN E. SAPPENFIELD, EXAMINING ATTORNEY

SN 77-484,177. EURPAC SERVICE INCORPORATED, NORWALK, CT. FILED 5-27-2008.

A2M
DISTRIBUTION

NO CLAIM IS MADE TO THE EXCLUSIVE RIGHT TO USE "DISTRIBUTION", APART FROM THE MARK AS SHOWN.

THE MARK CONSISTS OF THE LETTERS "AM" WITH A NUMBER "2" SUPERIMPOSED OVER THE LETTERS, ALL ABOVE THE WORD "DISTRIBUTION".

FOR DISTRIBUTORSHIPS AND WHOLESALE DISTRIBUTORSHIPS IN THE FIELD OF MUSIC ON BEHALF OF MUSIC ARTISTS, ALL FEATURING PRE-RECORDED AUDIO AND AUDIOVISUAL WORKS AND RELATED AUDIO-VISUAL MERCHANDISE, BUT EXCLUDING THOSE FEATURING ADULT ENTERTAINMENT (U.S. CLS. 100, 101 AND 102).

FIRST USE 7-0-2005; IN COMMERCE 8-0-2005.

MAUREEN DALL, EXAMINING ATTORNEY

CLASS 35—(Continued).

SN 77-494,667. R/GA MEDIA GROUP, INC., NEW YORK, NY. FILED 6-9-2008.

THE AGENCY FOR THE DIGITAL
AGE

THE MARK CONSISTS OF STANDARD CHARACTERS WITHOUT CLAIM TO ANY PARTICULAR FONT, STYLE, SIZE, OR COLOR.

NO CLAIM IS MADE TO THE EXCLUSIVE RIGHT TO USE "AGENCY", APART FROM THE MARK AS SHOWN.

FOR ADVERTISING AGENCY SERVICES; ADVERTISING AND MARKETING SERVICES; MEDIA PLANNING AND BUYING SERVICES, NAMELY, ADVISING CLIENTS ON THE MEDIA OUTLETS ON WHICH TO PURCHASE ADVERTISING SPACE AND TIME; INTERNET AND ONLINE ADVERTISING AND MARKETING SERVICES; DESIGN AND CREATION OF INTERACTIVE AND DIGITAL ADVERTISEMENTS AND MARKETING MATERIALS FOR OTHERS (U.S. CLS. 100, 101 AND 102).

FIRST USE 10-20-2006; IN COMMERCE 10-20-2006.

WILLIAM BRECKENFELD, EXAMINING ATTORNEY

SN 77-497,692. WEISMAN, WILLIAM E., MINNEAPOLIS, MN. FILED 6-12-2008.

Philanthromarketing

THE MARK CONSISTS OF STANDARD CHARACTERS WITHOUT CLAIM TO ANY PARTICULAR FONT, STYLE, SIZE, OR COLOR.

FOR BUSINESS MARKETING CONSULTING SERVICES; BUSINESS MARKETING SERVICES; COOPERATIVE ADVERTISING AND MARKETING; MARKETING CONSULTATION IN THE FIELD OF PHILANTHROPY AND CHARITABLE GIVING; MARKETING SERVICES IN THE FIELD OF PLANNED-GIVING FOR NON-PROFIT AND CHARITABLE ORGANIZATIONS (U.S. CLS. 100, 101 AND 102).

JANICE L. MCMORROW, EXAMINING ATTORNEY

SN 77-502,003. SCARLET MODA EUROPA, S.A. DE C.V., NAUCALPAN DE JUAREZ, MEXICO, FILED 6-18-2008.

MARINGO

THE MARK CONSISTS OF STANDARD CHARACTERS WITHOUT CLAIM TO ANY PARTICULAR FONT, STYLE, SIZE, OR COLOR.

OWNER OF MEXICO REG. NO. 880,422, DATED 5-29-2005, EXPIRES 3-15-2015.

FOR ADVERTISING AND ADVERTISEMENT SERVICES; BUSINESS MANAGEMENT; BUSINESS ADMINISTRATION; PERFORMING OFFICE FUNCTIONS (U.S. CLS. 100, 101 AND 102).

WILLIAM BRECKENFELD, EXAMINING ATTORNEY

CLASS 35—(Continued).

SN 77-504,048. CLARENDON CAPITAL CORPORATION, ATLANTA, GA. FILED 6-20-2008.

The Leader in Outdoor
Advertising

THE MARK CONSISTS OF STANDARD CHARACTERS WITHOUT CLAIM TO ANY PARTICULAR FONT, STYLE, SIZE, OR COLOR.

NO CLAIM IS MADE TO THE EXCLUSIVE RIGHT TO USE "OUTDOOR ADVERTISING", APART FROM THE MARK AS SHOWN.

FOR ELECTRONIC BILLBOARD ADVERTISING; OUT-OF-HOME ADVERTISING SERVICES, NAMELY, RENTAL OF ADVERTISING SPACE, AND PREPARING AND PLACING ADVERTISEMENTS FOR OTHERS; PREPARING AND PLACING OUTDOOR ADVERTISEMENTS FOR OTHERS; RENTAL OF ADVERTISING SPACE; RENTAL OF SIGNS FOR ADVERTISING PURPOSES (U.S. CLS. 100, 101 AND 102).

FIRST USE 2-23-2009; IN COMMERCE 2-23-2009.

REGINA DRUMMOND, EXAMINING ATTORNEY

SN 77-505,740. SEAN MURPHY RISK CONSULTING, LTD., NEW YORK, NY. FILED 6-23-2008.

WILLOW ROAD

THE MARK CONSISTS OF STANDARD CHARACTERS WITHOUT CLAIM TO ANY PARTICULAR FONT, STYLE, SIZE, OR COLOR.

FOR BUSINESS CONSULTING SERVICES, NAMELY, RISK CONSULTING SERVICES AND BUSINESS CONTINUITY MANAGEMENT AND ADVISORY SERVICES (U.S. CLS. 100, 101 AND 102).

BARBARA BROWN, EXAMINING ATTORNEY

SN 77-506,264. GOODMART, LLC, NEW YORK, NY. FILED 6-24-2008.

GOODMART

THE MARK CONSISTS OF STANDARD CHARACTERS WITHOUT CLAIM TO ANY PARTICULAR FONT, STYLE, SIZE, OR COLOR.

SEC. 2(F).

FOR ON-LINE RETAIL STORE SERVICES AND RETAIL OUTLETS FEATURING LIGHTING EQUIPMENT, TOOLS, ELECTRICAL SUPPLIES, HEATING AND COOLING SUPPLIES, DATA COMMUNICATION SUPPLIES, TEST AND MEASUREMENT EQUIPMENT, SAFETY EQUIPMENT AND APPAREL INCLUDING HEADWEAR AND GLOVES (U.S. CLS. 100, 101 AND 102).

FIRST USE 3-1-2001; IN COMMERCE 3-1-2001.

RUDY R. SINGLETON, EXAMINING ATTORNEY

CLASS 35—(Continued).

SN 77-506,947. YU, KUN WON, DALLAS, TX. FILED 6-24-2008.



THE MARK CONSISTS OF A MAN DRESSED IN A MARIACHI UNIFORM AND A SOMBERO. HIS BELT HAS A LARGE OVAL BUCKLE WITH A CAPITAL "T" EMBLAZONED ON IT. HIS FEET ARE TOGETHER AT THE HEELS. HIS ARMS ARE UP IN THE AIR, HE IS SMILING, AND LOOKING DOWN.

FOR RETAIL AND WHOLESALE STORES FEATURING GROCERIES, LIQUOR, TOBACCO, HARDWARE, ELECTRONICS, APPLIANCES; WHOLESALE DISTRIBUTORSHIPS FEATURING GROCERIES, LIQUOR, AND TOBACCO (U.S. CLS. 100, 101 AND 102).

FIRST USE 1-29-1995; IN COMMERCE 12-15-2007.
RONALD AIKENS, EXAMINING ATTORNEY

SN 77-506,972. YU, KUN WON, DALLAS, TX. FILED 6-24-2008.

TERRY'S EL MARIACHI

THE MARK CONSISTS OF STANDARD CHARACTERS WITHOUT CLAIM TO ANY PARTICULAR FONT, STYLE, SIZE, OR COLOR.

FOR RETAIL AND WHOLESALE STORES FEATURING GROCERIES, LIQUOR, TOBACCO, HARDWARE, ELECTRONICS, APPLIANCES; WHOLESALE DISTRIBUTORSHIPS FEATURING GROCERIES, LIQUOR AND TOBACCO (U.S. CLS. 100, 101 AND 102).

FIRST USE 12-15-2007; IN COMMERCE 12-15-2007.
RONALD AIKENS, EXAMINING ATTORNEY

CLASS 35—(Continued).

SN 77-506,973. YU, KUN WON, DALLAS, TX. FILED 6-24-2008.

TERRY'S

THE MARK CONSISTS OF STANDARD CHARACTERS WITHOUT CLAIM TO ANY PARTICULAR FONT, STYLE, SIZE, OR COLOR.

FOR RETAIL AND WHOLESALE STORES FEATURING GROCERIES, LIQUOR, TOBACCO, HARDWARE, ELECTRONICS, APPLIANCES; WHOLESALE DISTRIBUTORSHIPS FEATURING GROCERIES, LIQUOR, AND TOBACCO (U.S. CLS. 100, 101 AND 102).

FIRST USE 1-29-1995; IN COMMERCE 12-15-2007.
RONALD AIKENS, EXAMINING ATTORNEY

SN 77-507,341. LOCAWEB LTDA., VILA NOVA CONCEICAO, BRAZIL, FILED 6-25-2008.



THE COLOR(S) WHITE, RED AND BLACK IS/ARE CLAIMED AS A FEATURE OF THE MARK.

THE MARK CONSISTS OF THE WORD "LOCAWEB" IN WHITE LETTERS SURROUNDED BY A RED BORDER, WITH BOTH THE WHITE AND RED PORTIONS OF THE MARK OUTLINED IN BLACK OVER THE WORDS "KEEP IT SIMPLE", WHERE THE WORDS "KEEP" AND "SIMPLE" ARE IN BLACK LETTERS AND THE WORD "IT" IS IN RED LETTERS.

FOR RENTAL OF ADVERTISING SPACE; COMPILATION OF INFORMATION INTO COMPUTER DATABASES; COMPUTERIZED FILE MANAGEMENT; ONLINE ADVERTISING ON A COMPUTER NETWORK; SYSTEMIZATION OF INFORMATION INTO COMPUTER DATABASES (U.S. CLS. 100, 101 AND 102).

MATTHEW EINSTEIN, EXAMINING ATTORNEY

SN 77-507,870. AMERICAN CHIROPRACTIC ASSOCIATION, ARLINGTON, VA. FILED 6-25-2008.

CMCP

THE MARK CONSISTS OF STANDARD CHARACTERS WITHOUT CLAIM TO ANY PARTICULAR FONT, STYLE, SIZE, OR COLOR.

FOR ASSOCIATION SERVICES, NAMELY, PROMOTING THE INTERESTS OF CHIROPRACTORS; MANAGEMENT AND BUSINESS CONSULTING SERVICES IN THE FIELD OF CHIROPRACTIC EDUCATION AND THE CHIROPRACTIC PROFESSION; CONSULTING SERVICES IN BUSINESS ORGANIZATION AND MANAGEMENT (U.S. CLS. 100, 101 AND 102).

FIRST USE 9-0-2004; IN COMMERCE 9-0-2004.
ALICE BENMAMAN, EXAMINING ATTORNEY

CLASS 35—(Continued).

SN 77-508,600. DOODLECAKES, INC., KENNESAW, GA. FILED 6-26-2008.

DOODLECAKES BAKERY

THE MARK CONSISTS OF STANDARD CHARACTERS WITHOUT CLAIM TO ANY PARTICULAR FONT, STYLE, SIZE, OR COLOR.

OWNER OF U.S. REG. NO. 3,306,334.

NO CLAIM IS MADE TO THE EXCLUSIVE RIGHT TO USE "BAKERY", APART FROM THE MARK AS SHOWN.

FOR RETAIL STORE AND ONLINE RETAIL STORE SERVICES FEATURING BAKED GOODS, NAMELY, CAKES, CUPCAKES, PASTRIES, AND OTHER BAKED GOODS (U.S. CLS. 100, 101 AND 102).

MARK SHINER, EXAMINING ATTORNEY

SN 77-509,032. QFORMA, INC., SANTA FE, NM. FILED 6-26-2008.

IQFIELDFORCE

THE MARK CONSISTS OF STANDARD CHARACTERS WITHOUT CLAIM TO ANY PARTICULAR FONT, STYLE, SIZE, OR COLOR.

FOR BUSINESS CONSULTING, PRODUCT SALES FORECASTING, AND MARKETING SERVICES FOR THE HEALTHCARE INDUSTRY (U.S. CLS. 100, 101 AND 102).

RENEE SERVANCE, EXAMINING ATTORNEY

SN 77-509,056. QFORMA, INC., SANTA FE, NM. FILED 6-26-2008.

IQTRAX

THE MARK CONSISTS OF STANDARD CHARACTERS WITHOUT CLAIM TO ANY PARTICULAR FONT, STYLE, SIZE, OR COLOR.

FOR BUSINESS CONSULTING, SALES ANALYSIS, AND MARKETING SERVICES FOR THE HEALTHCARE INDUSTRY (U.S. CLS. 100, 101 AND 102).

RENEE SERVANCE, EXAMINING ATTORNEY

CLASS 35—(Continued).

SN 77-509,090. BRIDGES TO COMMUNITY, INC., OSSING, NY. FILED 6-26-2008.



THE MARK CONSISTS OF THE TEXT "BRIDGES TO COMMUNITY" AND A CURVED LINE ABOVE THE TEXT.

FOR BUSINESS ADMINISTRATION IN THE FIELD OF EDUCATIONAL, CULTURAL, HUMANITARIAN, ECONOMIC DEVELOPMENT, HEALTHCARE AND PEACE-BUILDING PROGRAMS; ORGANIZING AND CONDUCTING VOLUNTEER PROGRAMS AND COMMUNITY SERVICE PROJECTS; PROMOTING PUBLIC AWARENESS OF THE NEED FOR EDUCATIONAL, CULTURAL, HUMANITARIAN, ECONOMIC, HEALTHCARE AND PEACE-BUILDING DEVELOPMENT IN WORLD-WIDE COMMUNITIES (U.S. CLS. 100, 101 AND 102).

FIRST USE 10-5-1993; IN COMMERCE 10-5-1993.
LAURA HAMMEL, EXAMINING ATTORNEY

SN 77-509,099. BRIDGES TO COMMUNITY, INC., OSSING, NY. FILED 6-26-2008.

BRIDGES TO COMMUNITY

THE MARK CONSISTS OF STANDARD CHARACTERS WITHOUT CLAIM TO ANY PARTICULAR FONT, STYLE, SIZE, OR COLOR.

FOR BUSINESS ADMINISTRATION IN THE FIELD OF EDUCATIONAL, CULTURAL, HUMANITARIAN, ECONOMIC DEVELOPMENT, HEALTHCARE AND PEACE-BUILDING PROGRAMS; ORGANIZING AND CONDUCTING VOLUNTEER PROGRAMS AND COMMUNITY SERVICE PROJECTS; PROMOTING PUBLIC AWARENESS OF THE NEED FOR EDUCATIONAL, CULTURAL, HUMANITARIAN, ECONOMIC, HEALTHCARE AND PEACE-BUILDING DEVELOPMENT IN WORLD-WIDE COMMUNITIES (U.S. CLS. 100, 101 AND 102).

FIRST USE 10-5-1993; IN COMMERCE 10-5-1993.
LAURA HAMMEL, EXAMINING ATTORNEY

CLASS 35—(Continued).

SN 77-510,378. LENS.COM, LAS VEGAS, NV. FILED 6-27-2008.

CONTACTS AMERICA

THE MARK CONSISTS OF STANDARD CHARACTERS WITHOUT CLAIM TO ANY PARTICULAR FONT, STYLE, SIZE, OR COLOR.

NO CLAIM IS MADE TO THE EXCLUSIVE RIGHT TO USE "CONTACTS", APART FROM THE MARK AS SHOWN. SEC. 2(F).

FOR MAIL ORDER AND TELEPHONE ORDER-TAKING SERVICES IN THE FIELD OF CONTACT LENSES AND RELATED PRODUCTS, NAMELY, READING GLASSES; COMPUTERIZED ON-LINE RETAIL STORE SERVICES FEATURING CONTACT LENSES AND RELATED PRODUCTS, NAMELY, READING GLASSES (U.S. CLS. 100, 101 AND 102).

FIRST USE 1-17-1999; IN COMMERCE 1-17-1999. RONALD DELGIZZI, EXAMINING ATTORNEY

CLASS 35—(Continued).

SN 77-512,667. THE BRIDGE BREAST NETWORK, DALLAS, TX. FILED 7-1-2008.



THE MARK CONSISTS OF A SINGLE RIBBON WITH LOOPS FORMING THE OUTLINE OF A BRIDGE. FOR MEDICAL REFERRALS (U.S. CLS. 100, 101 AND 102).

FIRST USE 1-31-2006; IN COMMERCE 1-31-2006. ALEX KEAM, EXAMINING ATTORNEY

SN 77-513,169. DIAGEO NORTH AMERICA, INC., NORWALK, CT. FILED 7-2-2008.

SN 77-512,099. BACKWOODS EQUIPMENT COMPANY, AUSTIN, TX. FILED 7-1-2008.



OWNER OF U.S. REG. NO. 3,572,493. THE MARK CONSISTS OF A PINECONE DESIGN. FOR RETAIL CLOTHING AND SPORTING GOODS STORE SERVICES (U.S. CLS. 100, 101 AND 102). FIRST USE 5-31-2007; IN COMMERCE 5-31-2007. SAMUEL E. SHARPER JR., EXAMINING ATTORNEY



NO CLAIM IS MADE TO THE EXCLUSIVE RIGHT TO USE "COCKTAILS", APART FROM THE MARK AS SHOWN.

THE MARK CONSISTS OF THE WORDS "SIMPLY COCKTAILS 3 WAYS TO MIX IN SOMETHING NEW, POUR IT, STIR IT AND SHAKE IT" PRESENTED IN A STYLIZED FONT, WITH A DESIGN. THE DESIGN FEATURES A CLUSTER OF 4 COCKTAILS AT THE TOP LEFT OF THE MARK, WITH LIQUID BEING Poured INTO AND SPLASHING UP OUT OF ONE OF THE GLASSES. THE DESIGN ALSO FEATURES 3 DESIGNS CONTAINED WITHIN CIRCLES THAT ARE CONNECTED BY A RECTANGULAR CARRIER CONTAINING "POUR IT", "STIR IT" AND "SHAKE IT". THE DESIGN IN THE CIRCLES ARE, FROM LEFT TO RIGHT: 1) LIQUID BEING Poured OUT OF A BOTTLE INTO A GLASS WITH ICE CUBES, 2) A GLASS CONTAINING ICE CUBES AND 3) A SPOON, AND A COCKTAIL SHAKER.

FOR BUSINESS CONSULTING SERVICES IN THE FIELD OF RETAIL MERCHANDISING DISPLAYS FOR ALCOHOLIC BEVERAGES, NON-ALCOHOLIC MIXERS, COCKTAIL INGREDIENTS, AND GARNISHES (U.S. CLS. 100, 101 AND 102).

TRACY WHITTAKER-BROWN, EXAMINING ATTORNEY

CLASS 35—(Continued).

SN 77-513,204. R STUDIO, LLC, BROOKLYN, NY. FILED 7-2-2008.

MODULART

THE MARK CONSISTS OF STANDARD CHARACTERS WITHOUT CLAIM TO ANY PARTICULAR FONT, STYLE, SIZE, OR COLOR.

FOR ART GALLERY; RETAIL STORE SERVICES FEATURING ART (U.S. CLS. 100, 101 AND 102).
THEODORE MCBRIDE, EXAMINING ATTORNEY

SN 77-513,406. GRAPHIC SURGERY LLC, ST. LOUIS, MO. FILED 7-2-2008.

WELVIE SURGERY ANALYTICS

THE MARK CONSISTS OF STANDARD CHARACTERS WITHOUT CLAIM TO ANY PARTICULAR FONT, STYLE, SIZE, OR COLOR.

NO CLAIM IS MADE TO THE EXCLUSIVE RIGHT TO USE "SURGERY ANALYTICS", APART FROM THE MARK AS SHOWN.

FOR HEALTH CARE UTILIZATION AND REVIEW SERVICES, NAMELY, AGGREGATION, MEASUREMENT, ANALYSIS AND COMPARISON OF SURGICAL UTILIZATION AND COSTS FROM MULTIPLE SOURCES INCLUDING PHYSICIANS, HOSPITALS AND CLINICS, PHARMACEUTICAL AND PRESCRIPTION PROVIDERS, AND DEVICE AND EQUIPMENT SUPPLIERS (U.S. CLS. 100, 101 AND 102).

WILLIAM BRECKENFELD, EXAMINING ATTORNEY

CLASS 35—(Continued).

SN 77-515,905. DOREL E-COMMERCE INC., WRIGHT CITY, MO. FILED 7-7-2008.



THE MARK CONSISTS OF THE COLORS BLACK AND LIGHT GREEN, WITH THE COLOR BLACK APPEARING THE WORDING "KIBICRICKET" AND IN THE DESIGN AS OUTLINING FOR THE CRICKET. THE COLOR LIGHT GREEN APPEARS IN THE WORDING ".COM" AND IN THE DESIGN AS SHADING FOR THE BODY OF THE CRICKET AND AS SHADING FOR THE DOTS APPEARING IN AN ARC ABOVE THE WORDING AND DESIGN OF A CRICKET.

FOR THE BRINGING TOGETHER, FOR THE BENEFIT OF OTHERS, OF A VARIETY OF GOODS AND SERVICES, ENABLING CUSTOMERS TO CONVENIENTLY VIEW AND PURCHASE THOSE GOODS AND SERVICES FROM AN INTERNET WEBSITE PARTICULARLY SPECIALIZING IN THE MARKETING AND SALE OF GOODS AND SERVICES OF OTHERS (U.S. CLS. 100, 101 AND 102).

FIRST USE 4-24-2008; IN COMMERCE 4-24-2008.
BRIAN CALLAGHAN, EXAMINING ATTORNEY

SN 77-516,064. DAVIS AND DAVIS CPAS, PC, SOUTHFIELD, MI. FILED 7-7-2008.

Dental Office Playbook

THE MARK CONSISTS OF STANDARD CHARACTERS WITHOUT CLAIM TO ANY PARTICULAR FONT, STYLE, SIZE, OR COLOR.

NO CLAIM IS MADE TO THE EXCLUSIVE RIGHT TO USE "DENTAL OFFICE", APART FROM THE MARK AS SHOWN.

FOR ADVICE IN THE FIELD OF BUSINESS MANAGEMENT AND MARKETING; ADVICE RELATING TO THE ORGANISATION AND MANAGEMENT OF BUSINESS; ADVISORY SERVICES RELATING TO BUSINESS MANAGEMENT AND BUSINESS OPERATIONS; ANALYZING AND COMPILING DATA FOR MEASURING THE PERFORMANCE OF FINANCIAL MARKETS; ASSISTANCE, ADVISORY SERVICES AND CONSULTANCY WITH REGARD TO BUSINESS PLANNING, BUSINESS ANALYSIS, BUSINESS MANAGEMENT, AND BUSINESS ORGANIZATION; BUSINESS ADMINISTRATION AND MANAGEMENT; BUSINESS CONSULTING, MANAGEMENT, PLANNING AND SUPERVISION; BUSINESS MANAGEMENT CONSULTANCY AS WELL AS DEVELOPMENT OF PROCESSES FOR THE ANALYSIS AND THE IMPLEMENTATION OF STRATEGY PLANS AND MANAGEMENT PROJECTS; CONSULTING SERVICES IN THE FIELD OF DENTAL PRACTICE MANAGEMENT; CONSULTING SERVICES, NAMELY, EXPERT ANALYSIS AND MANAGEMENT CONSULTING IN ECONOMICS AND ACCOUNTING; DENTAL PRACTICE MANAGEMENT FOR OTHERS (U.S. CLS. 100, 101 AND 102).

JILL C. ALT, EXAMINING ATTORNEY

CLASS 35—(Continued).

SN 77-516,087. DAVIS AND DAVIS CPAS, PC, SOUTHFIELD, MI. FILED 7-7-2008.

Dental Playbook

THE MARK CONSISTS OF STANDARD CHARACTERS WITHOUT CLAIM TO ANY PARTICULAR FONT, STYLE, SIZE, OR COLOR.

NO CLAIM IS MADE TO THE EXCLUSIVE RIGHT TO USE "DENTAL", APART FROM THE MARK AS SHOWN.

FOR ADVICE IN THE FIELD OF BUSINESS MANAGEMENT AND MARKETING; ADVICE RELATING TO THE ORGANISATION AND MANAGEMENT OF BUSINESS; ADVISORY SERVICES RELATING TO BUSINESS MANAGEMENT AND BUSINESS OPERATIONS; ANALYZING AND COMPILING DATA FOR MEASURING THE PERFORMANCE OF FINANCIAL MARKETS; ARRANGING OF MANAGED CARE CONTRACTUAL SERVICES IN THE FIELDS OF DIAGNOSTIC IMAGING, HOME HEALTH CARE, DURABLE MEDICAL EQUIPMENT, SPECIALTY PHARMACY, AND DIAGNOSTIC LAB SERVICES; BUSINESS CONSULTING, MANAGEMENT, PLANNING AND SUPERVISION; BUSINESS INFORMATION MANAGEMENT; BUSINESS MANAGEMENT AND ADVICE; BUSINESS MANAGEMENT CONSULTANCY AS WELL AS DEVELOPMENT OF PROCESSES FOR THE ANALYSIS AND THE IMPLEMENTATION OF STRATEGY PLANS AND MANAGEMENT PROJECTS; BUSINESS MANAGEMENT CONSULTANCY SERVICES; BUSINESS MANAGEMENT CONSULTING; BUSINESS MANAGEMENT CONSULTING AND ADVISORY SERVICES; COMPANY MANAGEMENT, INCLUDING CONSULTANCY IN DEMOGRAPHIC MATTERS; CONSULTING SERVICES IN BUSINESS LEADERSHIP DEVELOPMENT AND BUSINESS MANAGEMENT; CONSULTING SERVICES IN BUSINESS ORGANIZATION AND MANAGEMENT; CONSULTING SERVICES IN THE FIELD OF DENTAL PRACTICE MANAGEMENT; DENTAL PRACTICE MANAGEMENT FOR OTHERS; FINANCIAL RECORDS MANAGEMENT; FINANCIAL STATEMENT PREPARATION AND ANALYSIS FOR BUSINESSES (U.S. CLS. 100, 101 AND 102).

JILL C. ALT, EXAMINING ATTORNEY

SN 77-516,517. ANIMAL LEGAL DEFENSE FUND, COTATI, CA. FILED 7-8-2008.

ANIMAL BILL OF RIGHTS

THE MARK CONSISTS OF STANDARD CHARACTERS WITHOUT CLAIM TO ANY PARTICULAR FONT, STYLE, SIZE, OR COLOR.

NO CLAIM IS MADE TO THE EXCLUSIVE RIGHT TO USE "ANIMAL", APART FROM THE MARK AS SHOWN.

FOR PROMOTING PUBLIC AWARENESS OF ANIMAL RIGHTS PROTECTION AND ANIMAL WELFARE (U.S. CLS. 100, 101 AND 102).

FIRST USE 3-1-1985; IN COMMERCE 3-1-1985.

MATTHEW EINSTEIN, EXAMINING ATTORNEY

CLASS 35—(Continued).

SN 77-516,926. PLANNING MATTERS INC., CHARLOTTE, NC. FILED 7-8-2008.

RELATIVE INSIGHTS

THE MARK CONSISTS OF STANDARD CHARACTERS WITHOUT CLAIM TO ANY PARTICULAR FONT, STYLE, SIZE, OR COLOR.

FOR PROMOTION AND MARKETING SERVICES FOR EDUCATIONAL PRODUCTS AND SERVICES, NAMELY, THE WEB-BASED COURSEWARE, WEB CONFERENCES, WEB CASTS, WEB SEMINARS, LIVE AND TELEVISED SEMINARS AND WORKSHOPS OF OTHERS AND RETAIL STORE SERVICES FEATURING EDUCATIONAL PRODUCTS, NAMELY, DOWNLOADABLE AUDIO AND VIDEO FILES FEATURING WEB-BASED COURSEWARE, WEB CONFERENCES, WEB CASTS, WEB SEMINARS, PRERECORDED AND TELEVISED SEMINARS AND WORKSHOPS, AND WRITTEN DOCUMENTS AND PRINTABLE MATERIALS IN CONNECTION THEREWITH (U.S. CLS. 100, 101 AND 102).

JASON TURNER, EXAMINING ATTORNEY

SN 77-517,517. KING'S SEAFOOD DISTRIBUTION, LLC, COSTA MESA, CA. FILED 7-8-2008.



OWNER OF U.S. REG. NOS. 2,335,541 AND 2,431,937.
NO CLAIM IS MADE TO THE EXCLUSIVE RIGHT TO USE "SEAFOOD DISTRIBUTION CO.", APART FROM THE MARK AS SHOWN.

THE MARK CONSISTS OF "KING'S" ABOVE THE WORD "SEAFOOD" WHICH ARE BOTH ABOVE THE WORDS "DISTRIBUTION CO.".

FOR WHOLESALE FOOD DISTRIBUTORSHIP SERVICES IN THE FIELD OF FRESH FISH AND SEAFOOD TO RESTAURANTS (U.S. CLS. 100, 101 AND 102).

FIRST USE 10-0-1998; IN COMMERCE 10-0-1998.

TARA PATE, EXAMINING ATTORNEY

CLASS 35—(Continued).

SN 77-518,740. LATINA MEDIA VENTURES, NEW YORK, NY. FILED 7-10-2008.

the
SHOPS^{at}
Latina

OWNER OF U.S. REG. NOS. 2,521,637, 2,804,076 AND 2,839,474.

NO CLAIM IS MADE TO THE EXCLUSIVE RIGHT TO USE "SHOPS", APART FROM THE MARK AS SHOWN.

THE MARK CONSISTS OF THE WORDING "THE SHOPS AT LATINA" IN STYLIZED FONT.

FOR ONLINE RETAIL STORE SERVICES FEATURING CONSUMER GOODS; ADVERTISING SERVICES, NAMELY, PROVIDING SPACE ON WEB SITES FOR ADVERTISING THE GOODS AND SERVICES OF OTHERS (U.S. CLS. 100, 101 AND 102).

FIRST USE 11-23-2007; IN COMMERCE 11-23-2007.
ROBERT STRUCK, EXAMINING ATTORNEY

SN 77-519,253. CARROLL, CHARLES, DBA C. EDWARD CARROLL-BURL, SMYRNA, GA. FILED 7-10-2008.

SHOP AROUND HERE!

THE MARK CONSISTS OF STANDARD CHARACTERS WITHOUT CLAIM TO ANY PARTICULAR FONT, STYLE, SIZE, OR COLOR.

FOR ADVERTISING AGENCIES; ADVERTISING AGENCIES PROVIDING THE STRATEGY, DESIGN AND EXECUTION OF PROGRAMS TO PROMOTE BUSINESSES IN THE FOOD AND FOODSERVICE INDUSTRIES; ADVERTISING AGENCIES, NAMELY, PROMOTING THE GOODS AND SERVICES OF OTHERS; ADVERTISING AGENCY SPECIALIZING IN THE DESIGN AND EXECUTION OF WORD OF MOUTH, VIRAL, BUZZ AND EXPERIENTIAL MARKETING PROGRAMS; ADVERTISING AND ADVERTISEMENT SERVICES; ADVERTISING AND BUSINESS ADVICE RELATING TO TELEMATICS' SERVICES; ADVERTISING AND BUSINESS MANAGEMENT CONSULTANCY; ADVERTISING AND BUSINESS SERVICES, NAMELY, SECURING AIRTIME ON ALL FORMS OF MEDIA COMMUNICATIONS STATIONS, SYSTEMS, NETWORKS, AND SERVICES FOR THE PURPOSE OF PROMOTING THE GOODS AND SERVICES OF OTHERS; ADVERTISING AND COMMERCIAL INFORMATION SERVICES, VIA THE INTERNET; ADVERTISING AND MARKETING; ADVERTISING AND PROMOTION SERVICES AND RELATED CONSULTING; ADVERTISING AND PROMOTIONAL SERVICES; ADVERTISING AND PUBLICITY SERVICES; ADVERTISING AND PUBLICITY SERVICES, NAMELY, PROMOTING THE GOODS, SERVICES, BRAND IDENTITY AND COMMERCIAL INFORMATION AND NEWS OF THIRD PARTIES THROUGH PRINT, AUDIO, VIDEO, DIGITAL AND ON-LINE MEDIUM; ADVERTISING BUSINESS ESPECIALLY IN THE FIELD OF TELEMATIC AND TELEPHONE NETWORKS; ADVERTISING BY TRANSMISSION OF ON-LINE PUBLICITY FOR THIRD PARTIES THROUGH ELECTRONIC COMMUNICATIONS NETWORKS; ADVERTISING CONSULTATION; ADVERTISING FLYER DISTRIBUTION; ADVERTISING PARTICULARLY SERVICES FOR THE PROMOTION OF GOODS; ADVERTISING RELATING TO PHARMACEUTICAL PRODUCTS AND IN-VIVO IMAGING PRODUCTS; ADVERTISING SERVICES; ADVERTISING SERVICES FOR PROMOTING THE BROKERAGE OF STOCKS AND OTHER SECURITIES; ADVERTISING SERVICES OF A RADIO AND TELEVISION ADVERTISING AGENCY; ADVERTISING SERVICES RELATING TO SANDWICHES; ADVERTISING

CLASS 35—(Continued).

SERVICES, FOR THIRD PARTIES, IN CONNECTION WITH THE COMMERCIALIZATION AND SALE OF PERFUMERY AND COSMETIC ARTICLES, PRODUCTS FOR HOUSEHOLD PURPOSES, OPTICAL PRODUCTS, CLOCKS AND TIMEPIECES, JEWELLERY, FURNISHING ARTICLES; ADVERTISING SERVICES, NAMELY, COST-PER-ACTION ON-LINE ADVERTISING; ADVERTISING SERVICES, NAMELY, CREATING CORPORATE AND BRAND IDENTITY FOR OTHERS; ADVERTISING SERVICES, NAMELY, CREATING CORPORATE LOGOS FOR OTHERS; ADVERTISING SERVICES, NAMELY, PRODUCTION OF SPECIAL EFFECTS INCLUDING MODEL-MAKING SERVICES, COMPUTER-GENERATED IMAGERY AND COMPUTER-GENERATED GRAPHICS FOR THE PRODUCTION OF COMMERCIALS; ADVERTISING SERVICES, NAMELY, PROMOTING AND MARKETING THE GOODS AND SERVICES OF OTHERS IN THE FIELD OF UPSCALE CHOICES SUCH AS CULTURAL EVENTS, RESTAURANTS, SHOPPING, AND TRAVEL VIA PRINT AND ELECTRONIC MEDIA; ADVERTISING SERVICES, NAMELY, PROMOTING AND MARKETING THE GOODS AND SERVICES OF OTHERS THROUGH ALL PUBLIC COMMUNICATION MEANS; ADVERTISING SERVICES, NAMELY, PROMOTING PROPERTIES FOR SALE BY OWNER VIA THE INTERNET; ADVERTISING SERVICES, NAMELY, PROMOTING THE FOOD AND WINE OF OTHERS; ADVERTISING SERVICES, NAMELY, PROMOTING THE GIFT CARDS OF OTHERS; ADVERTISING SERVICES, NAMELY, PROMOTING THE SANDWICHES OF OTHERS; ADVERTISING SERVICES, NAMELY, PROVIDING ADVERTISING SPACE IN A PERIODICAL; ADVERTISING SERVICES, PUBLIC RELATIONS AND MARKETING SERVICES, NAMELY, PROMOTING AND MARKETING THE GOODS AND SERVICES OF OTHERS THROUGH ALL PUBLIC COMMUNICATION MEANS; ADVERTISING THROUGH ALL PUBLIC COMMUNICATION MEANS; ADVERTISING VIA ELECTRONIC MEDIA AND SPECIFICALLY THE INTERNET; ADVERTISING, INCLUDING PROMOTION OF PRODUCTS AND SERVICES OF THIRD PARTIES THROUGH SPONSORING ARRANGEMENTS AND LICENSE AGREEMENTS RELATING TO INTERNATIONAL SPORTS' EVENTS; ADVERTISING, INCLUDING PROMOTION RELATING TO THE SALE OF ARTICLES AND SERVICES FOR THIRD PARTIES BY THE TRANSMISSION OF ADVERTISING MATERIAL AND THE DISSEMINATION OF ADVERTISING MESSAGES ON COMPUTER NETWORKS; ADVERTISING, MARKETING AND PROMOTION SERVICES; ADVERTISING, MARKETING AND PROMOTIONAL SERVICES FOR AUTOMOTIVE DEALERSHIPS; ADVERTISING, MARKETING AND PROMOTIONAL SERVICES FOR THE DONATION OF HUMAN BLOOD THAT EXACTLY MATCHES THE BLOOD TYPE OF INDIVIDUALS NEEDING TRANSFUSIONS; ADVERTISING, MARKETING AND PROMOTIONAL SERVICES RELATED TO ALL INDUSTRIES FOR THE PURPOSE OF FACILITATING NETWORKING AND SOCIALIZING OPPORTUNITIES FOR BUSINESS PURPOSES; ADVERTISING, PROMOTION AND MARKETING SERVICES IN THE NATURE OF E-MAIL BLAST CAMPAIGNS FOR OTHERS; AGENCIES FOR ADVERTISING TIME AND SPACE; ARRANGING AND CONDUCTING OF FAIRS AND EXHIBITIONS FOR BUSINESS AND ADVERTISING PURPOSES; BUSINESS MANAGEMENT AND CONSULTING SERVICES FOR THE HEALTH CARE INDUSTRY, NAMELY, CUSTOMER SERVICE, ACCOUNTING SERVICES, AND WEB-BASED ADVERTISING AND MARKETING SERVICES; CINEMA ADVERTISING; COMPILATION OF ADVERTISEMENTS FOR USE AS WEB PAGES ON THE INTERNET; CONSUMER LOYALTY SERVICES FOR COMMERCIAL, PROMOTIONAL, AND/OR ADVERTISING PURPOSES, NAMELY, ADMINISTRATION OF FREQUENT FLYER PROGRAM THAT ALLOWS MEMBERS TO REDEEM MILES FOR POINTS OR AWARDS OFFERED BY OTHER LOYALTY PROGRAMS; COOPERATIVE ADVERTISING AND MARKETING; COOPERATIVE ADVERTISING AND MARKETING SERVICES BY WAY OF SOLICITATION, CUSTOMER SERVICE AND PROVIDING MARKETING INFORMATION VIA WEB SITES ON A GLOBAL COMPUTER NETWORK; CREATING AND UPDATING ADVERTISING MATERIAL; CREATION OF MARKETING TOOLS DESIGNED TO INCREASE A CLIENT COMPANY'S KNOWLEDGE OF CUSTOMER NEEDS, AND ITS COMPETITORS' PRO-

CLASS 35—(Continued).

DUCTS AND SERVICES, PRICING, ADVERTISING STRATEGY AND SALES STRATEGY; CUSTOMER LOYALTY SERVICES AND CUSTOMER CLUB SERVICES, FOR COMMERCIAL, PROMOTIONAL AND/OR ADVERTISING PURPOSES; DESIGN OF ADVERTISING FLYERS FOR OTHERS; DESIGN OF ADVERTISING MATERIALS FOR OTHERS; DESIGN OF INTERNET ADVERTISING; DEVELOPMENT, OPERATION AND ADMINISTRATION OF DIGITAL SIGNAGE SYSTEMS AND DIGITAL ADVERTISING SYSTEMS FOR OTHERS, NAMELY, PROVIDING ADVERTISING SPACE BY ELECTRONIC MEANS AND GLOBAL COMPUTER INFORMATION NETWORKS; DIRECT MAIL ADVERTISING; DIRECT MARKETING ADVERTISING FOR OTHERS; DISPLAYING ADVERTISEMENTS FOR OTHERS; DISSEMINATION OF ADVERTISEMENTS; DISSEMINATION OF ADVERTISEMENTS AND OF ADVERTISING MATERIAL; DISSEMINATION OF ADVERTISING FOR OTHERS VIA AN ON-LINE COMMUNICATIONS NETWORK ON THE INTERNET; DISSEMINATION OF ADVERTISING FOR OTHERS VIA THE INTERNET; DISSEMINATION OF ADVERTISING MATERIAL; DISSEMINATION OF ADVERTISING MATTER; DISSEMINATION OF ADVERTISING, SCHEDULING AND MANAGING OF TRAINING COURSES AND PROGRAMS FOR OTHERS VIA A GLOBAL COMPUTER NETWORK; DISTRIBUTION AND DISSEMINATION OF ADVERTISING MATERIALS; DISTRIBUTION OF ADVERTISEMENTS AND COMMERCIAL ANNOUNCEMENTS; DISTRIBUTION OF ADVERTISING MAIL AND OF ADVERTISING SUPPLEMENTS ATTACHED TO REGULAR EDITIONS; DISTRIBUTION OF PRODUCTS FOR ADVERTISING PURPOSES; ELECTRONIC BILLBOARD ADVERTISING; ELECTRONIC COMMERCE SERVICES, NAMELY, PROVIDING INFORMATION ABOUT PRODUCTS VIA TELECOMMUNICATION NETWORKS FOR ADVERTISING AND SALES PURPOSES; ENTERTAINMENT MARKETING SERVICES, NAMELY, MARKETING, PROMOTION AND ADVERTISING FOR INDEPENDENT RECORDING ARTISTS; INTERNET ADVERTISING SERVICES; ISSUING AND UPDATING OF ADVERTISING TEXTS; LAYOUT SERVICES FOR ADVERTISING PURPOSES; MARKETING AND ADVERTISING SERVICES FOR AUTOMOBILE DEALERSHIPS; MARKETING, PROMOTIONAL AND ADVERTISING SERVICES PROVIDED BY MOBILE TELEPHONE CONNECTIONS; MEDIA BUYING ADVICE, NAMELY, ADVISING THE CLIENT HOW MUCH MEDIA TIME, AND AT WHAT TIMES THE CLIENT SHOULD BE PURCHASING ADVERTISING; MEDIA PLANNING, NAMELY, ADVISING THE CLIENT ON THE CORRECT TIMES AND STATIONS TO ADVERTISE BASED ON MEDIA ANALYSIS OF THE MARKET FOR THAT MEDIA; MEDIA PRODUCTION LOCATION SCOUTING SERVICES FOR ADVERTISING PURPOSES; MEDIATION OF ADVERTISING; MODELING FOR ADVERTISING OR SALES PROMOTION; MODELING SERVICES FOR ADVERTISING OR SALES PROMOTION; MUSIC SELECTION SERVICES FOR USE IN ADVERTISING; ON-LINE ADVERTISING AND MARKETING SERVICES; ON-LINE ADVERTISING ON COMPUTER COMMUNICATION NETWORKS; ORGANISATION AND HOLDING OF FAIRS FOR COMMERCIAL OR ADVERTISING PURPOSES; ORGANISING EXHIBITIONS FOR COMMERCIAL OR ADVERTISING PURPOSES; ORGANIZING EXHIBITIONS FOR COMMERCIAL OR ADVERTISING PURPOSES; OUT-OF-HOME ADVERTISING SERVICES, NAMELY, RENTAL OF ADVERTISING SPACE, AND PREPARING AND PLACING ADVERTISEMENTS FOR OTHERS; PLACING ADVERTISEMENTS FOR OTHERS; PLANNING AND CONDUCTING OF TRADE FAIRS, EXHIBITIONS AND PRESENTATIONS FOR ECONOMIC OR ADVERTISING PURPOSES; PREPARATION AND REALIZATION OF MEDIA AND ADVERTISING PLANS AND CONCEPTS; PREPARATION OF CUSTOM ADVERTISEMENTS FOR OTHERS; PREPARATION OF CUSTOM OR NON-CUSTOM ADVERTISING FOR BUSINESSES FOR DISSEMINATION VIA THE WEB, CD OR DVD FOR OPTIONAL UPLOAD OR DOWNLOAD TO A COMPUTER; PREPARING ADVERTISEMENTS FOR OTHERS; PREPARING AND PLACING ADVERTISEMENTS FOR OTHERS; PREPARING AND PLACING OF ADVERTISEMENTS; PREPARING AND PLACING OUTDOOR ADVERTISEMENTS FOR OTHERS; PREPARING AUDIOVISUAL PRESENTATIONS FOR USE IN ADVERTISING; PREPARING SPEECHES AND ORAL PRESENTATIONS FOR OTHERS

CLASS 35—(Continued).

FOR USE IN ADVERTISING; PROCESSING TELEPHONE INQUIRIES REGARDING ADVERTISED GOODS AND SERVICES; PROMOTING THE GOODS AND SERVICES OF OTHERS BY DISTRIBUTING ADVERTISING MATERIALS THROUGH A VARIETY OF METHODS; PROMOTING THE GOODS AND SERVICES OF OTHERS BY PREPARING AND PLACING ADVERTISEMENTS IN AN ELECTRONIC MAGAZINE ACCESSED THROUGH A GLOBAL COMPUTER NETWORK; PROMOTING, ADVERTISING AND MARKETING OF THE ON-LINE WEB SITES OF OTHERS; PROMOTION, ADVERTISING AND MARKETING OF ON-LINE WEB SITES; PROVIDING A SEARCHABLE ONLINE ADVERTISING GUIDE FEATURING THE GOODS AND SERVICES OF OTHER ON-LINE VENDORS ON THE INTERNET; PROVIDING A WEB SITE AT WHICH FITNESS PROFESSIONALS AND FACILITIES CAN POST PROMOTIONAL PROFILES AND RESPOND TO ADVERTISEMENTS FOR THEIR SERVICES; PROVIDING A WEB SITE THAT ENABLES USERS TO POST ITEMS FOR SALE THROUGH ONLINE CLASSIFIED ADVERTISEMENTS; PROVIDING A WEB SITE WHICH FEATURES ADVERTISEMENTS FOR THE GOODS AND SERVICES OF OTHERS ON A GLOBAL COMPUTER NETWORK; PROVIDING ADVERTISING SERVICES USING 3D AND ANIMATION DESIGNS; PROVIDING ADVERTISING, MARKETING AND PROMOTIONAL SERVICES FOR THE PHARMACEUTICAL AND MEDICAL INDUSTRY; PROVIDING ADVERTISING, MARKETING AND PROMOTIONAL SERVICES FOR THE PHARMACEUTICAL AND MEDICAL PRODUCTS OF OTHERS; PROVIDING AND RENTAL OF ADVERTISING SPACE ON THE INTERNET; PROVIDING SPACE AT A WEB SITE FOR THE ADVERTISEMENT OF THE GOODS AND SERVICES OF OTHERS; PROVIDING TELEVISION ADVERTISING FOR OTHERS; PROVISION OF ADVERTISING SPACE BY ELECTRONIC MEANS AND GLOBAL INFORMATION NETWORKS; PROVISION OF SPACE ON WEBSITES FOR ADVERTISING GOODS AND SERVICES; PUBLISHING OF ADVERTISING TEXTS; REAL ESTATE ADVERTISING SERVICES; RECRUITMENT ADVERTISEMENT SERVICES, NAMELY, POSTING OF CLINICAL TRIAL NOTICES FOR THE PURPOSE OF RECRUITING PATIENTS FOR PARTICIPATION IN CLINICAL TRIALS FOR THE TESTING OF DRUGS; RENTAL OF ADVERTISEMENT SPACE AND ADVERTISING MATERIAL; RENTAL OF ADVERTISING SPACE; RENTAL OF ADVERTISING SPACE ON WEB SITES; RENTAL OF SIGNS FOR ADVERTISING PURPOSES; RENTING OF ADVERTISING SPACES; SERVICES TO DETERMINE THE AUDIENCE AFFECTED BY ADVERTISEMENTS; TELEVISION ADVERTISING AGENCIES (U.S. CLS. 100, 101 AND 102).

FIRST USE 1-7-2002; IN COMMERCE 12-1-2006.
STEVEN JACKSON, EXAMINING ATTORNEY

SN 77-520,380. VISUAL HEALTH TOOLS, LLC, TUCSON, AZ.
FILED 7-11-2008.

BASIC COLOR SCORE

THE MARK CONSISTS OF STANDARD CHARACTERS WITHOUT CLAIM TO ANY PARTICULAR FONT, STYLE, SIZE, OR COLOR.

FOR PROVIDING ASSISTANCE, FITNESS EVALUATION AND CONSULTATION TO CORPORATE CLIENTS TO HELP THEIR EMPLOYEES MAKE HEALTH, WELLNESS AND NUTRITIONAL CHANGES IN THEIR DAILY LIVING TO INCREASE PRODUCTIVITY AND LOWER HEALTH CARE COSTS (U.S. CLS. 100, 101 AND 102).

FIRST USE 11-9-2006; IN COMMERCE 5-1-2008.
KAPIL BHANOT, EXAMINING ATTORNEY

CLASS 35—(Continued).

SN 77-521,855. VENERABLE PARTNERS, LLC, CHICAGO, IL. FILED 7-14-2008.

VENERABLE REGISTRY

THE MARK CONSISTS OF STANDARD CHARACTERS WITHOUT CLAIM TO ANY PARTICULAR FONT, STYLE, SIZE, OR COLOR.

OWNER OF U.S. REG. NO. 2,898,229.

NO CLAIM IS MADE TO THE EXCLUSIVE RIGHT TO USE "REGISTRY", APART FROM THE MARK AS SHOWN.

FOR PROVIDING A DATABASE IN THE FIELD OF EXECUTIVE SEARCH, BOARD OF DIRECTOR RECRUITING AND EXECUTIVE BENCHMARKING ASSESSMENTS (U.S. CLS. 100, 101 AND 102).

FIRST USE 6-14-2004; IN COMMERCE 6-14-2004.

KATHERINE CHANG, EXAMINING ATTORNEY

SN 77-521,957. FACEBOOK, INC., PALO ALTO, CA. FILED 7-14-2008.

FB

THE MARK CONSISTS OF STANDARD CHARACTERS WITHOUT CLAIM TO ANY PARTICULAR FONT, STYLE, SIZE, OR COLOR.

FOR PROVIDING A WEB SITE THAT ENABLES USERS TO POST ITEMS FOR SALE THROUGH ON-LINE CLASSIFIED ADVERTISEMENTS; PROMOTING THE GOODS AND SERVICES OF OTHERS OVER THE INTERNET (U.S. CLS. 100, 101 AND 102).

MICHAEL SOUDERS, EXAMINING ATTORNEY

SN 77-523,057. ESCALONA, FRANK P, WOODINVILLE, WA. FILED 7-15-2008.

WESSEL, DUVAL & Co.

NO CLAIM IS MADE TO THE EXCLUSIVE RIGHT TO USE "& CO.", APART FROM THE MARK AS SHOWN.

THE MARK CONSISTS OF THE WORDING "WESSEL, DUVAL & CO."

FOR EXPORT AND IMPORT AGENCIES (U.S. CLS. 100, 101 AND 102).

FIRST USE 1-1-2005; IN COMMERCE 3-30-2008.

KIMBERLY PERRY, EXAMINING ATTORNEY

CLASS 35—(Continued).

SN 77-523,801. AMERICAN COPAK CORPORATION, CHATSWORTH, CA. FILED 7-16-2008.

SURROUNDSHAPE

THE MARK CONSISTS OF STANDARD CHARACTERS WITHOUT CLAIM TO ANY PARTICULAR FONT, STYLE, SIZE, OR COLOR.

FOR PACKAGING FOOD STUFFS, BEVERAGES, COSMETICS, CREAMS, LIQUID PRODUCTS, GEL AND CREAM PRODUCTS, AND POWDERED PRODUCTS TO THE ORDER AND SPECIFICATION OF OTHERS; MERCHANDISE PACKAGING OF PACKAGING FOOD STUFFS, BEVERAGES, COSMETICS, CREAMS, LIQUID PRODUCTS, GEL AND CREAM PRODUCTS, AND POWDERED PRODUCTS TO THE ORDER AND SPECIFICATION OF OTHERS (U.S. CLS. 100, 101 AND 102).

FIRST USE 4-14-2009; IN COMMERCE 4-14-2009.

NATALIE POLZER, EXAMINING ATTORNEY

SN 77-523,841. GAMELOGIC, INC., WALTHAM, MA. FILED 7-16-2008.

EZSTAKES

THE MARK CONSISTS OF STANDARD CHARACTERS WITHOUT CLAIM TO ANY PARTICULAR FONT, STYLE, SIZE, OR COLOR.

FOR ADVERTISING AND PROMOTIONAL SERVICES FOR OTHERS IN THE NATURE OF DISSEMINATION OF ADVERTISEMENTS AND PROMOTIONS VIA THE INTERNET; SALES PROMOTION AND ADMINISTRATION OF CUSTOMER SALES INCENTIVE AND LOYALTY PROGRAMS FOR THE GOODS AND SERVICES OF OTHERS; ON-LINE GAMES AND CONTESTS AND INCENTIVE AWARD PROGRAMS TO PROMOTE THE SALE OF PRODUCTS AND SERVICES OF OTHERS (U.S. CLS. 100, 101 AND 102).

CARYN GLASSER, EXAMINING ATTORNEY

SN 77-524,030. ARTHUR ROBINS, O'DRISCOLL, KELLEY LTD., EAST MOLESEY, UNITED KINGDOM, FILED 7-16-2008.

MAX THE FLYING SAUSAGE DOG

THE MARK CONSISTS OF STANDARD CHARACTERS WITHOUT CLAIM TO ANY PARTICULAR FONT, STYLE, SIZE, OR COLOR.

FOR ON-LINE RETAIL STORE SERVICES FEATURING CALENDARS, STICKERS, GREETING CARDS, COFFEE MUGS, BOARD GAMES AND TOYS (U.S. CLS. 100, 101 AND 102).

ALEX KEAM, EXAMINING ATTORNEY

CLASS 35—(Continued).

SN 77-524,110. TRADERCOM USA INC., MIAMI, FL. FILED 7-16-2008.

traetelo.com

THE MARK CONSISTS OF STANDARD CHARACTERS WITHOUT CLAIM TO ANY PARTICULAR FONT, STYLE, SIZE, OR COLOR.

FOR ONLINE RETAIL STORE FEATURING SPORTS GEAR, CLOTHING, CONSUMER ELECTRONICS PRODUCTS, TOYS, EYEGLASSES, WATCHES, AND SHOES (U.S. CLS. 100, 101 AND 102).

FIRST USE 12-2-2006; IN COMMERCE 12-2-2006.
ALEX KEAM, EXAMINING ATTORNEY

CLASS 35—(Continued).

ON THE CORRECT TIMES AND STATIONS TO ADVERTISE BASED ON MEDIA ANALYSIS OF THE MARKET FOR THAT MEDIA; ON-LINE ADVERTISING AND MARKETING SERVICES; ON-LINE ADVERTISING ON COMPUTER COMMUNICATION NETWORKS; PROMOTING, ADVERTISING AND MARKETING OF THE ON-LINE WEB SITES OF OTHERS; PROMOTION, ADVERTISING AND MARKETING OF ON-LINE WEB SITES; PROVIDING A SEARCHABLE ONLINE ADVERTISING GUIDE FEATURING THE GOODS AND SERVICES OF OTHER ON-LINE VENDORS ON THE INTERNET; PROVIDING A WEB SITE THAT ENABLES USERS TO POST ITEMS FOR SALE THROUGH ON-LINE CLASSIFIED ADVERTISEMENTS; PROVIDING A WEB SITE WHICH FEATURES ADVERTISEMENTS FOR THE GOODS AND SERVICES OF OTHERS ON A GLOBAL COMPUTER NETWORK; PROVIDING AND RENTAL OF ADVERTISING SPACE ON THE INTERNET; PROVISION OF SPACE ON WEBSITES FOR ADVERTISING GOODS AND SERVICES; RENTAL OF ADVERTISING SPACE ON WEB SITES (U.S. CLS. 100, 101 AND 102).

ALEX KEAM, EXAMINING ATTORNEY

SN 77-525,538. RICCARDO VIERI, MONTESPERTOLI, ITALY, FILED 7-18-2008.

TEXTENGER

THE MARK CONSISTS OF STANDARD CHARACTERS WITHOUT CLAIM TO ANY PARTICULAR FONT, STYLE, SIZE, OR COLOR.

FOR ADVERTISING AND BUSINESS SERVICES, NAMELY, SECURING AIRTIME ON ALL FORMS OF MEDIA COMMUNICATIONS STATIONS, SYSTEMS, NETWORKS, AND SERVICES FOR THE PURPOSE OF PROMOTING THE GOODS AND SE SERVICES OF OTHERS; ADVERTISING AND PUBLICITY SERVICES, NAMELY, PROMOTING THE GOODS, SERVICES, BRAND IDENTITY AND COMMERCIAL INFORMATION AND NEWS OF THIRD PARTIES THROUGH PRINT, AUDIO, VIDEO, DIGITAL AND ON-LINE MEDIUM; ADVERTISING BY TRANSMISSION OF ON-LINE PUBLICITY FOR THIRD PARTIES THROUGH ELECTRONIC COMMUNICATIONS NETWORKS; ADVERTISING SERVICES, NAMELY, COST-PER-ACTION ON-LINE ADVERTISING; ADVERTISING, INCLUDING PROMOTION RELATING TO THE SALE OF ARTICLES AND SERVICES FOR THIRD PARTIES BY THE TRANSMISSION OF ADVERTISING MATERIAL AND THE DISSEMINATION OF ADVERTISING MESSAGES ON COMPUTER NETWORKS; COMPILATION OF ADVERTISEMENTS FOR USE AS WEB PAGES ON THE INTERNET; COOPERATIVE ADVERTISING AND MARKETING SERVICES BY WAY OF SOLICITATION, CUSTOMER SERVICE AND PROVIDING MARKETING INFORMATION VIA WEB SITES ON A GLOBAL COMPUTER NETWORK; DISSEMINATION OF ADVERTISING FOR OTHERS VIA AN ON-LINE COMMUNICATIONS NETWORK ON THE INTERNET; MEDIA PLANNING, NAMELY, ADVISING THE CLIENT

SN 77-526,436. THE BROOKLYN BROTHERS LLC, NEW YORK, NY. FILED 7-18-2008.

THE BROOKLYN BROTHERS

THE MARK CONSISTS OF STANDARD CHARACTERS WITHOUT CLAIM TO ANY PARTICULAR FONT, STYLE, SIZE, OR COLOR.

NO CLAIM IS MADE TO THE EXCLUSIVE RIGHT TO USE "BROOKLYN", APART FROM THE MARK AS SHOWN.

FOR ADVERTISING AGENCIES; ADVERTISING CONSULTATION; ADVERTISING AND MARKETING SERVICES; CREATING CORPORATE AND BRAND IDENTITY FOR OTHERS (U.S. CLS. 100, 101 AND 102).

FIRST USE 6-30-2001; IN COMMERCE 3-31-2003.
TEJBIR SINGH, EXAMINING ATTORNEY

CLASS 35—(Continued).

SN 77-527,640. AUTOMATIC TRANSMISSION REBUILDERS ASSOCIATION, OXNARD, CA. FILED 7-21-2008.

POWERTRAIN EXPO

THE MARK CONSISTS OF STANDARD CHARACTERS WITHOUT CLAIM TO ANY PARTICULAR FONT, STYLE, SIZE, OR COLOR.

OWNER OF U.S. REG. NO. 2,128,263.

NO CLAIM IS MADE TO THE EXCLUSIVE RIGHT TO USE "EXPO", APART FROM THE MARK AS SHOWN.

SEC. 2(F).

FOR ORGANIZING, ARRANGING, CONDUCTING AND PRODUCING TRADE SHOWS, BUSINESS CONFERENCES AND EXHIBITIONS IN THE FIELD OF AUTOMOTIVE TRANSMISSION AND REPAIR SERVICES; ASSOCIATION SERVICES, NAMELY, PROMOTING THE INTERESTS OF AUTOMOTIVE REPAIR SERVICE PROVIDERS AND MEMBERS OF THE TRANSMISSION REBUILDING INDUSTRY; BUSINESS CONSULTATION AND MANAGEMENT SERVICES IN THE FIELD OF AUTOMOTIVE TRANSMISSION REPAIR AND MAINTENANCE; AND CONDUCTING BUSINESS AND MARKETING RESEARCH STUDIES AND SURVEYS IN THE FIELD OF AUTOMOTIVE TRANSMISSION REPAIR AND MAINTENANCE (U.S. CLS. 100, 101 AND 102).

FIRST USE 7-15-2004; IN COMMERCE 7-15-2004.

LINDA MICKLEBURGH, EXAMINING ATTORNEY

CLASS 35—(Continued).

SN 77-533,402. WARSCHAWSKI PUBLIC RELATIONS, INC., BALTIMORE, MD. FILED 7-29-2008.



warschawski

THE COLOR(S) WHITE, BLACK AND YELLOW, IS/ARE CLAIMED AS A FEATURE OF THE MARK.

THE MARK CONSISTS OF A "W" IN WHITE INSIDE A SHADED YELLOW SQUARE, ABOVE THE NAME "WARSCHAWSKI", IN BLACK.

FOR MARKETING AND BRANDING SERVICES, NAMELY, PERFORMING CONSUMER INSIGHT AND BRAND STRATEGY OF COMPANY LOGOS; ADVERTISING AND ADVERTISEMENT SERVICES FEATURING CREATIVE DESIGN OF ADVERTISING AND PROMOTIONAL MATERIALS FOR OTHERS; DESIGN OF ADVERTISING FOR ELECTRONIC MEDIA AND THE INTERNET; PUBLIC RELATIONS; PROVIDING INFORMATION PERTAINING TO INVESTORS WHO QUALIFY TO PURCHASE CERTAIN TYPES OF SECURITIES; PROVIDING BUSINESS MANAGEMENT INFORMATION IN CONNECTION WITH CONSULTING AND ADVISORY SERVICES IN THE FIELD OF STRATEGIC PLANNING (U.S. CLS. 100, 101 AND 102).

FIRST USE 6-30-2008; IN COMMERCE 6-30-2008.

BARBARA A. GOLD, EXAMINING ATTORNEY

SN 77-536,091. AMERICAN PUBLIC POWER ASSOCIATION, WASHINGTON, DC. FILED 7-31-2008.



**CAREERS
In Public Power**

NO CLAIM IS MADE TO THE EXCLUSIVE RIGHT TO USE "CAREERS IN PUBLIC POWER", APART FROM THE MARK AS SHOWN.

THE MARK CONSISTS OF A DESIGN OF ELECTRIC WIRES LINKED TO A CITY IN THE RIGHT HAND OF A FLEXED ARM ABOVE THE WORDS "CAREERS IN PUBLIC POWER".

FOR PROVIDING JOB SEEKERS INFORMATION REGARDING EMPLOYMENT OPPORTUNITIES IN THE FIELD OF PUBLICALLY OWNED ELECTRICITY GENERATION FACILITIES (U.S. CLS. 100, 101 AND 102).

MARC LEIPZIG, EXAMINING ATTORNEY

SN 77-527,646. SAN FRANCISCO SOCIETY FOR THE PREVENTION OF CRUELTY TO ANIMALS, SAN FRANCISCO, CA. FILED 7-21-2008.

ECO-DOG

THE MARK CONSISTS OF STANDARD CHARACTERS WITHOUT CLAIM TO ANY PARTICULAR FONT, STYLE, SIZE, OR COLOR.

FOR COMPUTER SERVICES, NAMELY, PROVIDING A WEBSITE FEATURING CONSUMER INFORMATION, ADVICE AND TIPS IN THE FIELD OF PETS RELATING TO PET PRODUCTS, PET TREATS AND PET TOYS (U.S. CLS. 100, 101 AND 102).

ELISSA GARBER KON, EXAMINING ATTORNEY

CLASS 35—(Continued).

SN 77-536,103. ALICE & KERI INC, DBA MILKIN' MAMAS, SEAL BEACH, CA. FILED 7-31-2008.

Milkin' Mamas

THE MARK CONSISTS OF STANDARD CHARACTERS WITHOUT CLAIM TO ANY PARTICULAR FONT, STYLE, SIZE, OR COLOR.

FOR PROMOTING PUBLIC AWARENESS OF THE NEED FOR HUMAN BREAST MILK DONATION (U.S. CLS. 100, 101 AND 102).

FIRST USE 7-0-2006; IN COMMERCE 6-28-2007.
JUSTINE D. PARKER, EXAMINING ATTORNEY

CLASS 35—(Continued).

SN 77-536,971. C.S.I. INTERNATIONAL, INC., NIAGARA FALLS, NY. FILED 8-1-2008.



NO CLAIM IS MADE TO THE EXCLUSIVE RIGHT TO USE "RECOGNITION", APART FROM THE MARK AS SHOWN.

THE COLOR(S) PURPLE AND BLACK IS/ARE CLAIMED AS A FEATURE OF THE MARK.

THE MARK CONSISTS OF THE STYLIZED WORD "SPOT" IN BLACK LETTERS WITH THE "O" IN THE WORD "SPOT" SHOWN AS A SOLID DARK PURPLE CIRCLE WITH THE WORD "RECOGNITION" IN BLACK LETTERS UNDERNEATH THE "P" IN THE WORD "SPOT".

FOR ONLINE RETAIL STORE SERVICES FEATURING CUSTOMIZED EMPLOYEE RECOGNITION GIFTS, NAMELY, MILESTONE AWARDS (U.S. CLS. 100, 101 AND 102).

FIRST USE 3-1-2008; IN COMMERCE 3-1-2008.
DEIRDRE ROBERTSON, EXAMINING ATTORNEY

SN 77-536,380. INFORMATIVE DESIGN GROUP, INC., DBA THE HISTORY FACTORY, CHANTILLY, VA. FILED 7-31-2008.



SN 77-540,841. TWENTIETH CENTURY FOX FILM CORPORATION, LOS ANGELES, CA. FILED 8-6-2008.

UTARGET.FOX

THE MARK CONSISTS OF THE LETTERS "BCR" TO THE RIGHT OF A LOGO COMPRISED OF AN ARROW PASSING FROM LEFT TO RIGHT THROUGH THE CENTER OF THREE SQUARE SHAPED BLOCKS SHADED TO CREATE DIMENSION.

FOR BUSINESS RESEARCH SERVICES, BUSINESS CONSULTING SERVICES, BUSINESS MANAGEMENT CONSULTING, CONDUCTING BUSINESS RESEARCH, CONDUCTING HISTORICAL BUSINESS RESEARCH, BUSINESS RECORDS MANAGEMENT SERVICES, ARCHIVAL RECORDS MANAGEMENT SERVICES IN THE NATURE OF DOCUMENT INDEXING FOR OTHERS, CONDUCTING BUSINESS AND MARKET RESEARCH SURVEYS, NON-QUANTITATIVE MARKET RESEARCH SERVICES, STRATEGIC BUSINESS PLANNING SERVICES, FIELD MARKET RESEARCH, AND ASSISTANCE IN MANAGEMENT OF BUSINESS ACTIVITIES IN TIMES OF CRISIS (U.S. CLS. 100, 101 AND 102).

FIRST USE 6-2-2007; IN COMMERCE 6-2-2007.
VERNA BETH RIRIE, EXAMINING ATTORNEY

THE MARK CONSISTS OF STANDARD CHARACTERS WITHOUT CLAIM TO ANY PARTICULAR FONT, STYLE, SIZE, OR COLOR.

OWNER OF U.S. REG. NO. 3,463,741.
FOR ADVERTISING, PROMOTION AND MARKETING SERVICES (U.S. CLS. 100, 101 AND 102).

BARBARA RUTLAND, EXAMINING ATTORNEY

CLASS 35—(Continued).

SN 77-540,914. LA JOLLA FOUNDATION, INC., LA JOLLA, CA. FILED 8-6-2008.

LA JOLLA FOUNDATION

THE MARK CONSISTS OF STANDARD CHARACTERS WITHOUT CLAIM TO ANY PARTICULAR FONT, STYLE, SIZE, OR COLOR.

NO CLAIM IS MADE TO THE EXCLUSIVE RIGHT TO USE "FOUNDATION", APART FROM THE MARK AS SHOWN.

SEC. 2(F).

FOR BUSINESS SERVICES, NAMELY, ASSISTING OTHERS IN THE ESTABLISHMENT OF CHARITABLE ORGANIZATIONS; CHARITABLE SERVICES, NAMELY, ORGANIZING AND CONDUCTING VOLUNTEER PROGRAMS AND COMMUNITY SERVICE PROJECTS; CHARITABLE SERVICES, NAMELY, ORGANIZING YOUTH GROUPS TO UNDERTAKE PROJECTS TO BENEFIT THE NEEDY AND THE COMMUNITY TO ENCOURAGE LEADERSHIP, CHARACTER, COMPASSION, AND GOOD CITIZENSHIP; CHARITABLE SERVICES, NAMELY, PROMOTING ENVIRONMENTAL AWARENESS TO CHILDREN; DEVELOPING AND COORDINATING VOLUNTEER PROJECTS FOR CHARITABLE ORGANIZATIONS (U.S. CLS. 100, 101 AND 102).

FIRST USE 6-1-1999; IN COMMERCE 6-1-1999.

JAMES GRIFFIN, EXAMINING ATTORNEY

SN 77-541,512. BLUE DIAMOND VENTURE, LLC, LAS VEGAS, NV. FILED 8-7-2008.

EXPOCITY

THE MARK CONSISTS OF STANDARD CHARACTERS WITHOUT CLAIM TO ANY PARTICULAR FONT, STYLE, SIZE, OR COLOR.

FOR ARRANGING, ORGANIZING, AND CONDUCTING TRADE EXHIBITIONS, TRADE CONVENTIONS, AND TRADE SHOWS IN THE FIELD OF ACCOUNTING, ADVERTISING AND MARKETING, AEROSPACE AND AVIATION, AGRICULTURE, AIR CONDITIONING, HEATING AND REFRIGERATION, AMUSEMENT, APPAREL, ARCHITECTURE, ART AND ANTIQUES, ASSOCIATIONS, AUDIO-VISUAL, AUDITORIUMS AND FACILITIES, AUTOMOTIVE AND TRUCKING, BANKING, BEAUTY AND HAIR CARE, BOATS AND SHIPS, BUILDING AND CONSTRUCTION, BUSINESS, CERAMICS AND GLASS, CHEMICAL, CHINA AND GLASSWARE, COMMUNICATIONS, COMPUTERS AND SOFTWARE, DENTAL, EDUCATION, ELECTRICAL AND ELECTRONICS, ENERGY, ENGINEERING, FINANCIAL AND LEGAL, FIRE AND FIRE PROTECTION, FISHING, FLORICULTURE AND HORTICULTURE, FOOD AND BEVERAGE, FOOD PROCESSING AND DISTRIBUTION, FOREST PRODUCTS, FUNERAL INDUSTRY, GIFTS AND GIFTWARE, GOVERNMENT, HARDWARE, HOME ECONOMICS, HOME FURNISHINGS AND INTERIOR DESIGN, HOTELS, HOSPITALITY AND RESORTS, HOUSEWARES, HOUSING, INDUSTRIAL, INSURANCE, JEWELRY AND WATCHES, LANDSCAPE AND GARDEN SUPPLIES, LAUNDRY AND DRY CLEANING, LEATHER GOODS AND LUGGAGE, LIBRARIES, LIGHTING, MANUFACTURED HOUSING, MANUFACTURING, MEDICAL AND HEALTH CARE, METALWORKING, MILITARY, MINING, MOTORCYCLES, MUSIC, NURSING, OCEAN

CLASS 35—(Continued).

SCIENCE AND EQUIPMENT, OFFICE EQUIPMENT, PACKAGING, PAINT, PAPER AND CARDBOARD, PETROLEUM, OIL AND GAS, PHARMACEUTICALS, PHOTOGRAPHIC, PHYSICAL DISTRIBUTION AND SHIPPING, PLANT ENGINEERING AND OPERATIONS, PLASTICS, POLICE, POLLUTION CONTROL, POWER TRANSMISSION, PRINTING, PUBLISHING, RADIO, TV, CABLE AND BROADCAST, RAILROADS, REAL ESTATE, RECREATIONAL VEHICLES, RECRUITMENT, RELIGIOUS, RENTAL AND LEASING, EQUIPMENT, RESTAURANTS AND FOOD SERVICE, ROBOTICS AND AUTOMATION, SAFETY, SANITATION AND WASTE MANAGEMENT, SCIENCE, SECURITY, SPORTING GOODS AND RECREATION, STORES AND STORE FITTINGS, TELECOMMUNICATIONS, TELEPHONES, TEXTILES, TOYS, HOBBIES AND CRAFTS, TRANSPORTATION, TRAVEL INDUSTRY, VETERINARY, WATER, WELDING, WIRE, WOMEN'S ISSUES, WOODWORKING; ADVERTISING SERVICES, NAMELY, PROMOTING THE GOODS AND SERVICES OF OTHERS AT EXHIBITION AND SHOWROOM FACILITIES THROUGH THE DISPLAY AND EXHIBITION OF GOODS AND MANUFACTURERS AND THROUGH THE DISTRIBUTION OF PRINTED, AUDIO AND AUDIO VISUAL PROMOTIONAL MATERIALS IN THE FIELDS OF ACCOUNTING, ADVERTISING AND MARKETING, AEROSPACE AND AVIATION, AGRICULTURE, AIR CONDITIONING, HEATING AND REFRIGERATION, AMUSEMENT, APPAREL, ARCHITECTURE, ART AND ANTIQUES, ASSOCIATIONS, AUDIO-VISUAL, AUDITORIUMS AND FACILITIES, AUTOMOTIVE AND TRUCKING, BANKING, BEAUTY AND HAIR CARE, BOATS AND SHIPS, BUILDING AND CONSTRUCTION, BUSINESS, CERAMICS AND GLASS, CHEMICAL, CHINA AND GLASSWARE, COMMUNICATIONS, COMPUTERS AND SOFTWARE, DENTAL, EDUCATION, ELECTRICAL AND ELECTRONICS, ENERGY, ENGINEERING, FINANCIAL AND LEGAL, FIRE AND FIRE PROTECTION, FISHING, FLORICULTURE AND HORTICULTURE, FOOD AND BEVERAGE, FOOD PROCESSING AND DISTRIBUTION, FOREST PRODUCTS, FUNERAL INDUSTRY, GIFTS AND GIFTWARE, GOVERNMENT, HARDWARE, HOME ECONOMICS, HOME FURNISHINGS AND INTERIOR DESIGN, HOTELS, HOSPITALITY AND RESORTS, HOUSEWARES, HOUSING, INDUSTRIAL, INSURANCE, JEWELRY AND WATCHES, LANDSCAPE AND GARDEN SUPPLIES, LAUNDRY AND DRY CLEANING, LEATHER GOODS AND LUGGAGE, LIBRARIES, LIGHTING, MANUFACTURED HOUSING, MANUFACTURING, MEDICAL AND HEALTH CARE, METALWORKING, MILITARY, MINING, MOTORCYCLES, MUSIC, NURSING, OCEAN SCIENCE AND EQUIPMENT, OFFICE EQUIPMENT, PACKAGING, PAINT, PAPER AND CARDBOARD, PETROLEUM, OIL AND GAS, PHARMACEUTICALS, PHOTOGRAPHIC, PHYSICAL DISTRIBUTION AND SHIPPING, PLANT ENGINEERING AND OPERATIONS, PLASTICS, POLICE, POLLUTION CONTROL, POWER TRANSMISSION, PRINTING, PUBLISHING, RADIO, TV, CABLE AND BROADCAST, RAILROADS, REAL ESTATE, RECREATIONAL VEHICLES, RECRUITMENT, RELIGIOUS, RENTAL AND LEASING, EQUIPMENT, RESTAURANTS AND FOOD SERVICE, ROBOTICS AND AUTOMATION, SAFETY, SANITATION AND WASTE MANAGEMENT, SCIENCE, SECURITY, SPORTING GOODS AND RECREATION, STORES AND STORE FITTINGS, TELECOMMUNICATIONS, TELEPHONES, TEXTILES, TOYS, HOBBIES AND CRAFTS, TRANSPORTATION, TRAVEL INDUSTRY, VETERINARY, WATER, WELDING, WIRE, WOMEN'S ISSUES, WOODWORKING, WHO DISPLAY WARES AT OUR EXHIBITION AND SHOWROOM FACILITIES THROUGH THE DISTRIBUTION OF PRINTED AND AUDIO PROMOTIONAL MATERIAL; ARRANGING AND CONDUCTING OF FAIRS AND EXHIBITIONS FOR BUSINESS AND ADVERTISING PURPOSES (U.S. CLS. 100, 101 AND 102).

CHRISTINA SOBRAL, EXAMINING ATTORNEY

CLASS 35—(Continued).

SN 77-547,924. LEADERSHIP HABITUDE, IRVINE, CA. FILED 8-15-2008.

THE PEOPLE PROBLEM SOLVER

THE MARK CONSISTS OF STANDARD CHARACTERS WITHOUT CLAIM TO ANY PARTICULAR FONT, STYLE, SIZE, OR COLOR.

FOR HUMAN RESOURCES CONSULTATION (U.S. CLS. 100, 101 AND 102).

FIRST USE 5-1-2008; IN COMMERCE 7-19-2008.
BILL DAWE, EXAMINING ATTORNEY

SN 77-548,421. SHAW'S SUPERMARKETS, INC., WEST BRIDGEWATER, MA. FILED 8-15-2008.

Shaw's

THE MARK CONSISTS OF STANDARD CHARACTERS WITHOUT CLAIM TO ANY PARTICULAR FONT, STYLE, SIZE, OR COLOR.

OWNER OF U.S. REG. NOS. 1,187,005, 2,638,924 AND OTHERS.

SEC. 2(F).
FOR RETAIL PHARMACY SERVICES (U.S. CLS. 100, 101 AND 102).

FIRST USE 5-31-2007; IN COMMERCE 5-31-2007.
DAWN HAN, EXAMINING ATTORNEY

SN 77-548,543. CERCIS CONSULTING, LLC, GASTON, OR. FILED 8-15-2008.

CERCIS CONSULTING

THE MARK CONSISTS OF STANDARD CHARACTERS WITHOUT CLAIM TO ANY PARTICULAR FONT, STYLE, SIZE, OR COLOR.

NO CLAIM IS MADE TO THE EXCLUSIVE RIGHT TO USE "CONSULTING", APART FROM THE MARK AS SHOWN.

FOR BUSINESS CONSULTING SERVICES IN THE FIELD OF PROJECT MANAGEMENT AND PROCESS-RELATED ISSUES (U.S. CLS. 100, 101 AND 102).

FIRST USE 3-1-2008; IN COMMERCE 7-1-2008.
JACQUELINE A. LAVINE, EXAMINING ATTORNEY

CLASS 35—(Continued).

SN 77-549,316. NEWLANDS, GUILHERME FRANCONI, PARKLAND, FL. FILED 8-18-2008.



THE COLOR(S) BLUE, GREEN, BLACK, AND GRAY IS/ ARE CLAIMED AS A FEATURE OF THE MARK.

THE MARK CONSISTS OF A RECTANGLE DESIGN IN COLORS BLUE, AT THE TOP, BLENDING INTO GREEN AT THE BOTTOM, BROKEN IN THE MIDDLE BY A LIGHTNING BOLT DESIGN IN COLOR BLACK, TO THE RIGHT OF WHICH IS THE WORDING "HANGOVERHERE.COM" IN THE COLOR GRAY, WITH THE ENTIRE MARK INSIDE A BLACK RECTANGLE.

FOR PROVIDING A WEB SITE THAT ENABLES USERS TO POST ITEMS FOR SALE THROUGH ON-LINE CLASSIFIED ADVERTISEMENTS (U.S. CLS. 100, 101 AND 102).

JOHN GARTNER, EXAMINING ATTORNEY

SN 77-550,290. MYPPOINTS.COM, INC., SAN FRANCISCO, CA. FILED 8-19-2008.



OWNER OF U.S. REG. NOS. 2,119,246, 2,371,125 AND 2,788,641.

THE MARK CONSISTS OF THE WORDING "MYPPOINTS" TO THE RIGHT OF A GROUPING OF THREE SMALL RIGHT DIAGONAL ANGLED TRIANGLES WHICH FORM A LARGER RIGHT DIAGONAL ANGLED TRIANGLE.

FOR PROMOTING THE GOODS AND SERVICES OF OTHERS THROUGH THE ADMINISTRATION OF AN ON-LINE BUSINESS PROGRAM AND AWARD PROGRAM WHICH REWARDS USERS FOR VISITING THE WEB SITES OF OTHERS ON GLOBAL COMPUTER NETWORKS AND THE INTERNET; PROMOTING THE GOODS AND SERVICES OF OTHERS THROUGH ELECTRONIC DIRECT MAIL ADVERTISING OFFERING INCENTIVES TO LOYALTY CUSTOMERS (U.S. CLS. 100, 101 AND 102).

FIRST USE 8-16-2007; IN COMMERCE 8-16-2007.
KAREN SEVERSON, EXAMINING ATTORNEY

CLASS 35—(Continued).

SN 77-556,518. LIVE GREEN INC., SAN FRANCISCO, CA. FILED 8-27-2008.

VIV

THE MARK CONSISTS OF STANDARD CHARACTERS WITHOUT CLAIM TO ANY PARTICULAR FONT, STYLE, SIZE, OR COLOR.

FOR A LOYALTY PROGRAM DESIGNED TO HELP THIRD PARTY MERCHANTS ENGAGE THEIR CONSUMERS THROUGH THE USE OF LOYALTY CARDS AND OTHER FORM FACTORS, INCLUDING STICKERS AND KEY FOBs, TO COLLECT INFORMATION ABOUT CONSUMER TRANSACTIONS; PROVIDING A WEBSITE FEATURING ONLINE REGISTRATION SERVICES FOR ENTRY IN A CUSTOMER LOYALTY PROGRAM AND PROVIDING CONSUMER AND RETAILER INFORMATION FOR MEMBERS OF A LOYALTY PROGRAM DESIGNED TO HELP THIRD PARTY MERCHANTS ENGAGE THEIR CONSUMERS; PROVIDING AN ON-LINE DATABASE THAT PROVIDES INFORMATION ABOUT RETAIL TRANSACTIONS FOR MEMBERS OF A LOYALTY PROGRAM (U.S. CLS. 100, 101 AND 102).

BRIAN CALLAGHAN, EXAMINING ATTORNEY

SN 77-556,676. ROSLAND CAPITAL LLC, SANTA MONICA, CA. FILED 8-27-2008.

ROS LAND

THE MARK CONSISTS OF STANDARD CHARACTERS WITHOUT CLAIM TO ANY PARTICULAR FONT, STYLE, SIZE, OR COLOR.

THE MARK "ROS LAND" HAS NO MEANING IN A FOREIGN LANGUAGE.

FOR RETAIL STORE SERVICES FEATURING PRECIOUS METAL INGOTS AND NUMISMATIC COINS; ON-LINE RETAIL STORE SERVICES FEATURING PRECIOUS METAL INGOTS AND NUMISMATIC COINS; RETAIL CATALOG ORDERING SERVICES VIA TELEPHONE FEATURING PRECIOUS METAL INGOTS AND NUMISMATIC COINS (U.S. CLS. 100, 101 AND 102).

NELSON SNYDER, EXAMINING ATTORNEY

CLASS 35—(Continued).

SN 77-556,679. ROSLAND CAPITAL LLC, SANTA MONICA, CA. FILED 8-27-2008.

ROSLAND CAPITAL

THE MARK CONSISTS OF STANDARD CHARACTERS WITHOUT CLAIM TO ANY PARTICULAR FONT, STYLE, SIZE, OR COLOR.

NO CLAIM IS MADE TO THE EXCLUSIVE RIGHT TO USE "CAPITAL", APART FROM THE MARK AS SHOWN.

THE WORDING "ROSLAND" HAS NO MEANING IN A FOREIGN LANGUAGE.

FOR RETAIL STORE SERVICES FEATURING PRECIOUS METAL INGOTS AND NUMISMATIC COINS; ON-LINE RETAIL STORE SERVICES FEATURING PRECIOUS METAL INGOTS AND NUMISMATIC COINS; RETAIL CATALOG ORDERING SERVICES VIA TELEPHONE FEATURING PRECIOUS METAL INGOTS AND NUMISMATIC COINS (U.S. CLS. 100, 101 AND 102).

NELSON SNYDER, EXAMINING ATTORNEY

SN 77-556,681. ROSLAND CAPITAL LLC, SANTA MONICA, CA. FILED 8-27-2008.



**Rosland
Capital**

NO CLAIM IS MADE TO THE EXCLUSIVE RIGHT TO USE "CAPITAL", APART FROM THE MARK AS SHOWN.

THE MARK CONSISTS OF THE WORDING "ROSLAND CAPITAL" AND A CIRCULAR DESIGN TO THE LEFT OF THE WORDING CONSISTING OF A REPRESENTATION OF THE EARTH. THE WORD "ROSLAND" APPEARS TO THE UPPER RIGHT OF THE DESIGN AND THE WORD "CAPITAL" APPEARS UNDER THE WORD "ROSLAND".

THE WORDING "ROSLAND" HAS NO MEANING IN A FOREIGN LANGUAGE.

FOR RETAIL STORE SERVICES FEATURING PRECIOUS METAL INGOTS AND NUMISMATIC COINS; ON-LINE RETAIL STORE SERVICES FEATURING PRECIOUS METAL INGOTS AND NUMISMATIC COINS; RETAIL CATALOG ORDERING SERVICES VIA TELEPHONE FEATURING PRECIOUS METAL INGOTS AND NUMISMATIC COINS (U.S. CLS. 100, 101 AND 102).

NELSON SNYDER, EXAMINING ATTORNEY

CLASS 35—(Continued).

SN 77-556,688. ROSLAND CAPITAL LLC, SANTA MONICA, CA. FILED 8-27-2008.



NO CLAIM IS MADE TO THE EXCLUSIVE RIGHT TO USE "CAPITAL", APART FROM THE MARK AS SHOWN.

THE COLOR(S) RED, BLACK, BLUE, YELLOW AND WHITE IS/ARE CLAIMED AS A FEATURE OF THE MARK.

THE MARK CONSISTS OF THE WORDING "ROSLAND CAPITAL" TO THE RIGHT OF A CIRCULAR DESIGN. THE DESIGN APPEARS TO THE LEFT OF THE WORDING AND CONSISTS OF A REPRESENTATION OF THE EARTH WITH BLUE AREAS FORMING OCEANS, AND YELLOW AND WHITE SHAPES FORMING CONTINENTS. THE WORD "ROSLAND" APPEARS TO THE UPPER RIGHT OF THE DESIGN AND IS IN RED. THE WORD "CAPITAL" APPEARS UNDER THE WORD "ROSLAND" AND IS IN BLACK.

THE TERM "ROSLAND" HAS NO MEANING IN A FOREIGN LANGUAGE.

FOR RETAIL STORE SERVICES FEATURING PRECIOUS METAL INGOTS AND NUMISMATIC COINS; ON-LINE RETAIL STORE SERVICES FEATURING PRECIOUS METAL INGOTS AND NUMISMATIC COINS; RETAIL CATALOG ORDERING SERVICES VIA TELEPHONE FEATURING PRECIOUS METAL INGOTS AND NUMISMATIC COINS (U.S. CLS. 100, 101 AND 102).

NELSON SNYDER, EXAMINING ATTORNEY

SN 77-557,606. WEST, RONDA, PIPERTON, TN. FILED 8-28-2008.

The South is Sexy

THE MARK CONSISTS OF STANDARD CHARACTERS WITHOUT CLAIM TO ANY PARTICULAR FONT, STYLE, SIZE, OR COLOR.

FOR CHAMBER OF COMMERCE SERVICES, NAMELY, PROMOTING BUSINESS AND TOURISM IN THE SOUTHERN UNITED STATES (U.S. CLS. 100, 101 AND 102).

FIRST USE 3-10-2007; IN COMMERCE 3-10-2007.
MEGHAN REINHART, EXAMINING ATTORNEY

CLASS 35—(Continued).

SN 77-557,951. ARBROWN-US, LLC, SEWICKLEY, PA. FILED 8-28-2008.



THE MARK CONSISTS OF A BOX DIVIDED INTO FOUR SMALLER BOXES. TO THE RIGHT THE STYLIZED TEXT "AR BROWN-US".

FOR DISTRIBUTORSHIPS IN THE FIELD OF LABORATORY AND SCIENCE PRODUCTS INCLUDING INSTRUMENTS, REAGENTS AND CHEMICALS (U.S. CLS. 100, 101 AND 102).

FIRST USE 7-1-2008; IN COMMERCE 7-1-2008.
FRANK LATTUCA, EXAMINING ATTORNEY

SN 77-558,645. ANDERSON, TODD R., BARBOURVILLE, KY. FILED 8-29-2008.

HUMAN CAPITAL OPTIMIZATION (HCO)

THE MARK CONSISTS OF STANDARD CHARACTERS WITHOUT CLAIM TO ANY PARTICULAR FONT, STYLE, SIZE, OR COLOR.

NO CLAIM IS MADE TO THE EXCLUSIVE RIGHT TO USE "HUMAN CAPITAL OPTIMIZATION", APART FROM THE MARK AS SHOWN.

FOR BUSINESS CONSULTING SERVICES IN THE FIELD OF MAXIMIZING PERSONS' ABILITIES AND CONTRIBUTIONS TO GROUPS (U.S. CLS. 100, 101 AND 102).

JOHN KELLY, EXAMINING ATTORNEY

SN 77-560,196. MILE HIGH BABIES LLC, WILMINGTON, DE. FILED 9-2-2008.



NO CLAIM IS MADE TO THE EXCLUSIVE RIGHT TO USE "BABIES" AND "BABY ESSENTIALS", APART FROM THE MARK AS SHOWN.

THE COLOR(S) BLUE, GREEN, BROWN, BEIGE, ORANGE, RED, WHITE, BLACK AND GRAY IS/ARE CLAIMED AS A FEATURE OF THE MARK.

THE MARK CONSISTS OF A BABY WITH BEIGE SKIN, RED AND GRAY MOUTH, ORANGE CHEEKS AND HAIR, ALL OUTLINED IN BLACK, WITH BLUE AND BROWN GOGGLES AND WEARING A BROWN HAT AND SCARF, FLYING A VINTAGE TOY PLANE IN RED, ALL OUT-

CLASS 35—(Continued).

LINED IN BLACK, WITH GRAY TRIM, TWO RED, WHITE AND GRAY BULLS EYE DESIGNS, A GRAY STEERING DEVICE, BLACK WHEELS WITH GRAY SHADING CONNECTED TO GRAY AND BLACK BARS, AND A WHIRLING PROPELLER IN WHITE, GRAY AND BLACK, SUPERIMPOSED OVER A GLOBE WHERE THE LAND MASSES ARE IN LIGHT GREEN WITH DARK GREEN SHADING AND THE WATER IS IN TEAL GREEN. THE GLOBE HAS A GRAY BORDER SURROUNDED BY A WIDER DARK GRAY BORDER CONTAINING THE WORDING "BABY ESSENTIALS" IN GRAY. A CURVING DARK GRAY BANNER IS SUPERIMPOSED ON THE GLOBE DESIGN AND CONTAINS THE WORDING "MILE HIGH BABIES" IN WHITE, OUTLINED IN BLUE, THEN OUTLINED IN WHITE.

FOR VENDING MACHINE SERVICES FEATURING DIAPERS, WIPES, FORMULA, MILK, WATER, JUICE, HEALTH KIT, CLOTHES, SUNSCREEN, SUNGLASSES, BABY MEDICATIONS, TOYS, BOOKS, DVDS, DVD PLAYER, BABY CARRIERS WORN ON THE BODY, BABY FEEDING SEAT, CHILDREN'S FLIGHT HARNESS, BABY FOOD, TODDLER SNACKS, FEEDING SUPPLIES, NAMELY, SPOONS AND FORKS, AND SWIM DIAPERS FOR TRAVELING PARENTS AND CHILDREN (U.S. CLS. 100, 101 AND 102).

TARA PATE, EXAMINING ATTORNEY

SN 77-560,730. PRESCOTT, TRINITY, FORT COLLINS, CO. FILED 9-2-2008.



NO CLAIM IS MADE TO THE EXCLUSIVE RIGHT TO USE "LOCAL SEARCH PLACEMENT SYSTEM FEATURING A BUSINESS & SHOPPING NETWORK", APART FROM THE MARK AS SHOWN.

THE STIPPLING IS FOR SHADING PURPOSES ONLY. THE MARK CONSISTS OF A GEOMETRIC FIGURE FORMING THE LETTERS "SL" APPEARING WITHIN A CIRCLE DESIGN. A DESIGN OF A RING APPEARS AROUND THE CIRCLE. THE STYLIZED WORDING "SURFLOCAL.NET LOCAL SEARCH PLACEMENT SYSTEM FEATURING A BUSINESS & SHOPPING NETWORK" APPEARS UNDERNEATH THE DESIGN.

FOR ADVERTISING AND COMMERCIAL INFORMATION SERVICES, VIA THE INTERNET (U.S. CLS. 100, 101 AND 102).

FIRST USE 6-10-2008; IN COMMERCE 6-10-2008. CIMMERIAN COLEMAN, EXAMINING ATTORNEY

CLASS 35—(Continued).

SN 77-561,411. PUNTA BRAVA, LLC, AUSTIN, TX. FILED 9-3-2008.

PUNTA BRAVA

THE MARK CONSISTS OF STANDARD CHARACTERS WITHOUT CLAIM TO ANY PARTICULAR FONT, STYLE, SIZE, OR COLOR.

THE FOREIGN WORDING IN THE MARK TRANSLATES INTO ENGLISH AS "BRAVE END".

FOR ADVERTISING AND MARKETING SERVICES IN THE FIELDS OF REAL ESTATE AND TRAVEL; BUSINESS MANAGEMENT AND ADMINISTRATION SERVICES IN THE FIELDS OF HOTELS, RESTAURANTS, AND GOLF COURSES; PROVIDING FACILITIES FOR BUSINESS MEETINGS; RETAIL STORE SERVICES FEATURING CLOTHING GOODS, SPORTING GOODS, GOLF ACCESSORIES, TOILETRIES, HAIR CARE, BODY CARE AND SKIN CARE PRODUCTS; ONLINE RETAIL STORE SERVICES FEATURING CLOTHING GOODS, SPORTING GOODS, GOLF ACCESSORIES; CHARITABLE SERVICES, NAMELY, EDUCATIONAL ACTIVITIES, PROMOTING ACADEMIC AND ATHLETIC SCHOLARSHIP PROGRAMS AND PROMOTING PUBLIC AWARENESS OF ECOLOGICAL PROGRAMS (U.S. CLS. 100, 101 AND 102).

SAMUEL E. SHARPER JR., EXAMINING ATTORNEY

SN 77-563,415. BLUE DIAMOND VENTURE, LLC, LAS VEGAS, NV. FILED 9-5-2008.

EXPO CITY

THE MARK CONSISTS OF STANDARD CHARACTERS WITHOUT CLAIM TO ANY PARTICULAR FONT, STYLE, SIZE, OR COLOR.

NO CLAIM IS MADE TO THE EXCLUSIVE RIGHT TO USE "EXPO", APART FROM THE MARK AS SHOWN.

FOR ARRANGING, ORGANIZING, AND CONDUCTING TRADE EXHIBITIONS, TRADE CONVENTIONS, AND TRADE SHOWS IN THE FIELD OF ACCOUNTING, ADVERTISING AND MARKETING, AEROSPACE AND AVIATION, AGRICULTURE, AIR CONDITIONING, HEATING AND REFRIGERATION, AMUSEMENT, APPAREL, ARCHITECTURE, ART AND ANTIQUES, ASSOCIATIONS, AUDIO-VISUAL, AUDITORIUMS AND FACILITIES, AUTOMOTIVE AND TRUCKING, BANKING, BEAUTY AND HAIR CARE, BOATS AND SHIPS, BUILDING AND CONSTRUCTION, BUSINESS, CERAMICS AND GLASS, CHEMICAL, CHINA AND GLASSWARE, COMMUNICATIONS, COMPUTERS AND SOFTWARE, DENTAL, EDUCATION, ELECTRICAL AND ELECTRONICS, ENERGY, ENGINEERING, FINANCIAL AND LEGAL, FIRE AND FIRE PROTECTION, FISHING, FLORICULTURE AND HORTICULTURE, FOOD AND BEVERAGE, FOOD PROCESSING AND DISTRIBUTION, FOREST PRODUCTS, FUNERAL INDUSTRY, GIFTS AND GIFTWARE, GOVERNMENT, HARDWARE, HOME ECONOMICS, HOME FURNISHINGS AND INTERIOR DESIGN, HOTELS, HOSPITALITY AND RESORTS, HOUSEWARES, HOUSING, INDUSTRIAL, INSURANCE, JEWELRY AND WATCHES, LANDSCAPE AND GARDEN SUPPLIES, LAUNDRY AND DRY CLEANING, LEATHER GOODS AND LUGGAGE, LIBRARIES, LIGHTING, MANUFACTURED HOUSING, MANUFACTURING, MEDICAL AND HEALTH CARE, METALWORKING, MILITARY,

CLASS 35—(Continued).

MINING, MOTORCYCLES, MUSIC, NURSING, OCEAN SCIENCE AND EQUIPMENT, OFFICE EQUIPMENT, PACKAGING, PAINT, PAPER AND CARDBOARD, PETROLEUM, OIL AND GAS, PHARMACEUTICALS, PHOTOGRAPHIC, PHYSICAL DISTRIBUTION AND SHIPPING, PLANT ENGINEERING AND OPERATIONS, PLASTICS, POLICE, POLLUTION CONTROL, POWER TRANSMISSION, PRINTING, PUBLISHING, RADIO, TV, CABLE AND BROADCAST, RAILROADS, REAL ESTATE, RECREATIONAL VEHICLES, RECRUITMENT, RELIGIOUS, RENTAL AND LEASING, EQUIPMENT, RESTAURANTS AND FOOD SERVICE, ROBOTICS AND AUTOMATION, SAFETY, SANITATION AND WASTE MANAGEMENT, SCIENCE, SECURITY, SPORTING GOODS AND RECREATION, STORES AND STORE FITTINGS, TELECOMMUNICATIONS, TELEPHONES, TEXTILES, TOYS, HOBBIES AND CRAFTS, TRANSPORTATION, TRAVEL INDUSTRY, VETERINARY, WATER, WELDING, WIRE, WOMEN'S ISSUES, WOODWORKING; ADVERTISING SERVICES, NAMELY, PROMOTING THE GOODS AND SERVICES OF OTHERS AT EXHIBITION AND SHOWROOM FACILITIES THROUGH THE DISPLAY AND EXHIBITION OF GOODS AND MANUFACTURERS AND THROUGH THE DISTRIBUTION OF PRINTED AND AUDIO AND AUDIO-VISUAL PROMOTIONAL MATERIALS IN THE FIELDS OF ACCOUNTING, ADVERTISING AND MARKETING, AEROSPACE AND AVIATION, AGRICULTURE, AIR CONDITIONING, HEATING AND REFRIGERATION, AMUSEMENT, APPAREL, ARCHITECTURE, ART AND ANTIQUES, ASSOCIATIONS, AUDIO-VISUAL, AUDITORIUMS AND FACILITIES, AUTOMOTIVE AND TRUCKING, BANKING, BEAUTY AND HAIR CARE, BOATS AND SHIPS, BUILDING AND CONSTRUCTION, BUSINESS, CERAMICS AND GLASS, CHEMICAL, CHINA AND GLASSWARE, COMMUNICATIONS, COMPUTERS AND SOFTWARE, DENTAL, EDUCATION, ELECTRICAL AND ELECTRONICS, ENERGY, ENGINEERING, FINANCIAL AND LEGAL, FIRE AND FIRE PROTECTION, FISHING, FLORICULTURE AND HORTICULTURE, FOOD AND BEVERAGE, FOOD PROCESSING AND DISTRIBUTION, FOREST PRODUCTS, FUNERAL INDUSTRY, GIFTS AND GIFTWARE, GOVERNMENT, HARDWARE, HOME ECONOMICS, HOME FURNISHINGS AND INTERIOR DESIGN, HOTELS, HOSPITALITY AND RESORTS, HOUSEWARES, HOUSING, INDUSTRIAL, INSURANCE, JEWELRY AND WATCHES, LANDSCAPE AND GARDEN SUPPLIES, LAUNDRY AND DRY CLEANING, LEATHER GOODS AND LUGGAGE, LIBRARIES, LIGHTING, MANUFACTURED HOUSING, MANUFACTURING, MEDICAL AND HEALTH CARE, METALWORKING, MILITARY, MINING, MOTORCYCLES, MUSIC, NURSING, OCEAN SCIENCE AND EQUIPMENT, OFFICE EQUIPMENT, PACKAGING, PAINT, PAPER AND CARDBOARD, PETROLEUM, OIL AND GAS, PHARMACEUTICALS, PHOTOGRAPHIC, PHYSICAL DISTRIBUTION AND SHIPPING, PLANT ENGINEERING AND OPERATIONS, PLASTICS, POLICE, POLLUTION CONTROL, POWER TRANSMISSION, PRINTING, PUBLISHING, RADIO, TV, CABLE AND BROADCAST, RAILROADS, REAL ESTATE, RECREATIONAL VEHICLES, RECRUITMENT, RELIGIOUS, RENTAL AND LEASING, EQUIPMENT, RESTAURANTS AND FOOD SERVICE, ROBOTICS AND AUTOMATION, SAFETY, SANITATION AND WASTE MANAGEMENT, SCIENCE, SECURITY, SPORTING GOODS AND RECREATION, STORES AND STORE FITTINGS, TELECOMMUNICATIONS, TELEPHONES, TEXTILES, TOYS, HOBBIES AND CRAFTS, TRANSPORTATION, TRAVEL INDUSTRY, VETERINARY, WATER, WELDING, WIRE, WOMEN'S ISSUES, WOODWORKING; ARRANGING AND CONDUCTING OF FAIRS AND EXHIBITIONS FOR BUSINESS AND ADVERTISING PURPOSES (U.S. CLS. 100, 101 AND 102).

CHRISTINA SOBRAL, EXAMINING ATTORNEY

CLASS 35—(Continued).

SN 77-564,254. BOSSMAN ENTERTAINMENT, INC., MIAMI, FL. FILED 9-8-2008.



NO CLAIM IS MADE TO THE EXCLUSIVE RIGHT TO USE "ENTERTAINMENT INC.", APART FROM THE MARK AS SHOWN.

THE MARK CONSISTS OF THE WORDS "BOSSMAN" WITH THE DESIGN OF A MICROPHONE AND A HAT ON TOP OF THE LETTERS "BM" ABOVE THE WORDING "ENTERTAINMENT INC.", ALL INSIDE A CIRCLE.

FOR PROMOTING MUSIC OF OTHERS, PROMOTING CONCERTS FOR OTHERS, PROMOTING CLUBS OF OTHERS (U.S. CLS. 100, 101 AND 102).

FIRST USE 5-0-2005; IN COMMERCE 5-0-2005.
LINDA E. BLOHM, EXAMINING ATTORNEY

SN 77-564,449. STAMBLER, SARAH, NEW YORK, NY. FILED 9-8-2008.

E-TACTICS

THE MARK CONSISTS OF STANDARD CHARACTERS WITHOUT CLAIM TO ANY PARTICULAR FONT, STYLE, SIZE, OR COLOR.

OWNER OF U.S. REG. NO. 2,616,079.
SEC. 2(F).

FOR ADVERTISING SERVICES, NAMELY, THE DISSEMINATION OF ADVERTISING MATERIAL FOR OTHERS VIA A WORLDWIDE COMPUTER NETWORK, CREATING ADVERTISING MATERIAL FOR OTHERS, PROMOTING THE GOODS AND SERVICES OF OTHERS BY CREATING PROMOTIONAL MATERIAL AND DISSEMINATION OF MARKETING MATERIAL VIA A WORLDWIDE COMPUTER NETWORK, BUSINESS MARKETING CONSULTING, BUSINESS SERVICES, NAMELY, PAY PER CLICK ADVERTISING SERVICES, ON LINE ADVERTISING AND MARKETING SERVICES; ADVERTISING AND BUSINESS MARKETING SERVICES, NAMELY, DEVELOPING STRATEGIES FOR PLACEMENT OF LINKS AND CONVERSION OF CONTACTS INTO SALES, E-COMMERCE DEVELOPMENT SERVICES, NAMELY, BUSINESS MARKETING AND STRATEGY SERVICES TO INCREASE E-COMMERCE FOR CLIENTS, WEB MARKET ANALYSIS SERVICES, NAMELY, BUSINESS ANALYSIS OF CONVERSIONS OF CONTACTS TO ACTUAL SALES (U.S. CLS. 100, 101 AND 102).

FIRST USE 3-0-1998; IN COMMERCE 3-0-1998.
MATTHEW KLINE, EXAMINING ATTORNEY

CLASS 35—(Continued).

SN 77-566,186. PAMPERED BRIDE CHICAGO, CHICAGO, ILL. FILED S.R. 9-9-2008; AM. P.R. 9-9-2008.

Pampered Bride

THE MARK CONSISTS OF STANDARD CHARACTERS WITHOUT CLAIM TO ANY PARTICULAR FONT, STYLE, SIZE, OR COLOR.

NO CLAIM IS MADE TO THE EXCLUSIVE RIGHT TO USE "BRIDE", APART FROM THE MARK AS SHOWN.

FOR PROMOTING, ARRANGING, PLANNING AND CONDUCTING TRADE SHOWS AND EXHIBITIONS IN THE FIELD OF WEDDING, BRIDAL AND HONEYMOON GOODS AND BRIDAL AND HONEYMOON RELATED SERVICES; PROMOTING THE SALE OF GOODS AND SERVICES OF OTHERS USING SPECIAL SHOWINGS AND PREVIEWS OF WEDDING APPAREL AND ACCESSORIES IN THE FIELD OF WEDDING APPAREL AND ACCESSORIES, AND THROUGH NEWSPAPER, BILLBOARD, DIRECT MAIL AND OTHER ADVERTISING MEDIA; ADVERTISING AND DIRECTORY SERVICES, NAMELY, PROMOTING THE SERVICES OF OTHERS BY PROVIDING A WEB PAGE FEATURING LINKS TO THE WEBSITES OF OTHERS; PROMOTING THE WEDDING APPAREL AND ACCESSORIES SERVICES, AND HONEYMOON TRAVEL SERVICES OF OTHERS BY MEANS OF A WEBSITE (U.S. CLS. 100, 101 AND 102).

FIRST USE 7-1-2008; IN COMMERCE 7-1-2008.
EMILY CARLSEN, EXAMINING ATTORNEY

SN 77-570,115. GOODCENTS CONCEPTS, INC., ATLANTA, GA. FILED 9-15-2008.



OWNER OF U.S. REG. NOS. 2,267,718, 2,347,535 AND 2,373,362.

THE COLOR(S) GREEN AND BLACK IS/ARE CLAIMED AS A FEATURE OF THE MARK.

THE MARK CONSISTS OF A STYLIZED ROOF IN WHICH THE UPPER PORTION IS THE COLOR GREEN AND THE LOWER PORTION IS THE COLOR BLACK, ALL

CLASS 35—(Continued).

OF WHICH IS OVER THE WORD "GOODCENTS" IN WHICH THE "C" IS COMPRISED OF THE CENT SYMBOL, AND THE ENTIRE WORD IS SURROUNDED BY A GREEN OUTLINE, THE LETTERS "GOOD" ARE THE COLOR GREEN, AND THE LETTERS "CENTS" ARE THE COLOR BLACK. THE WHITE AREA INSIDE THE BORDER THAT SURROUNDS THE WORD "GOODCENTS" AND THE WHITE AREAS INSIDE THE LETTERS "OOD" AND "E" ARE TRANSPARENT AREAS AND ARE NOT PART OF THE MARK.

FOR ENERGY EFFICIENCY AND ENERGY MANAGEMENT SERVICES FOR UTILITY COMPANIES AND CONSULTING SERVICES RELATED THERETO, INCLUDING DESIGNING, IMPLEMENTING, AND MANAGING PROGRAMS IN THE FIELDS OF ENERGY EFFICIENCY, PEAK LOAD MANAGEMENT, DEMAND RESPONSE, AND ADVANCED METERING INFRASTRUCTURE; PROVIDING MARKETING PROGRAMS IN THE FIELDS OF ENERGY EFFICIENCY AND ENERGY MANAGEMENT; AND EVALUATING THE IMPLEMENTED ENERGY EFFICIENCY AND ENERGY MANAGEMENT PROGRAMS (U.S. CLS. 100, 101 AND 102).

FIRST USE 9-11-2008; IN COMMERCE 9-11-2008.
WILLIAM BRECKENFELD, EXAMINING ATTORNEY

SN 77-574,110. PORTABLES UNLIMITED, LLC, NANUET, NY. FILED 9-19-2008.

WIRELESS CHAMPS

THE MARK CONSISTS OF STANDARD CHARACTERS WITHOUT CLAIM TO ANY PARTICULAR FONT, STYLE, SIZE, OR COLOR.

NO CLAIM IS MADE TO THE EXCLUSIVE RIGHT TO USE "WIRELESS", APART FROM THE MARK AS SHOWN.

FOR WHOLESALE AND RETAIL STORE SERVICES AND DISTRIBUTORSHIP SERVICES IN THE FIELD OF WIRELESS PRODUCTS, NAMELY, PERSONAL DIGITAL ASSISTANTS, WIRELESS HANDHELD MULTIMEDIA DEVICES, WIRELESS TELEPHONES AND WIRELESS PHONE ACCESSORIES, NAMELY, CHARGERS, BATTERIES, MEMORY CARDS, HEADSETS, DATA CABLES, ANTENNAS, CELLULAR PHONE CASES, ADAPTORS; RETAIL STORE SERVICES FEATURING WIRELESS TELECOMMUNICATIONS SERVICE PLANS AND WIRELESS TELECOMMUNICATIONS SERVICE ACTIVATION (U.S. CLS. 100, 101 AND 102).

KIM SAITO, EXAMINING ATTORNEY

CLASS 35—(Continued).

SN 77-576,220. REVONET, INC., NEW CANAAN, CT. FILED 9-23-2008.

CLASS 35—(Continued).

SN 77-581,277. COX ENTERPRISES, INC., ATLANTA, GA. FILED 9-29-2008.

METRICVIEW

THE MARK CONSISTS OF STANDARD CHARACTERS WITHOUT CLAIM TO ANY PARTICULAR FONT, STYLE, SIZE, OR COLOR.

FOR BUSINESS AND MARKET RESEARCH, MARKET RESEARCH SERVICES AND MARKET STUDIES, BUSINESS AND MARKET RESEARCH SERVICES, NAMELY, GATHERING, ANALYZING BUSINESS AND MARKET DATA AND PREPARING BUSINESS AND MARKET REPORTS; MARKET STRATEGY DEVELOPMENT (U.S. CLS. 100, 101 AND 102).

FIRST USE 7-30-1999; IN COMMERCE 7-30-1999. MARGARET POWER, EXAMINING ATTORNEY

AJC MEDIA SOLUTIONS

THE MARK CONSISTS OF STANDARD CHARACTERS WITHOUT CLAIM TO ANY PARTICULAR FONT, STYLE, SIZE, OR COLOR.

OWNER OF U.S. REG. NOS. 2,350,258, 3,441,167 AND OTHERS.

NO CLAIM IS MADE TO THE EXCLUSIVE RIGHT TO USE "MEDIA SOLUTIONS", APART FROM THE MARK AS SHOWN.

FOR ADVERTISING SERVICES, NAMELY, ARRANGING AND PLACING ADVERTISEMENTS FOR THE GOODS AND SERVICES OF OTHERS IN PRINT AND ONLINE MEDIA (U.S. CLS. 100, 101 AND 102).

FIRST USE 2-2-2009; IN COMMERCE 2-2-2009. BARBARA RUTLAND, EXAMINING ATTORNEY

SN 77-583,305. ONE MEANING, NEW YORK, NY. FILED 10-1-2008.

SN 77-581,103. SHIELD CALIFORNIA HEALTH CARE CENTERS, INC., VALENCIA, CA. FILED 9-29-2008.



OWNER OF U.S. REG. NOS. 1,811,309, 1,852,717 AND 2,746,826.

NO CLAIM IS MADE TO THE EXCLUSIVE RIGHT TO USE "HEALTHCARE", APART FROM THE MARK AS SHOWN.

THE MARK CONSISTS OF A DESIGN OF AN UPSIDE DOWN TRIANGLE WITH THE UPPER RIGHT CORNER TURNED BACK AND HAVING HORIZONTAL LINES THROUGH THE EXPOSED CORNER. THE WORDING "SHIELD HEALTHCARE" APPEARS IN STYLIZED FONT TO THE RIGHT OF THE DESIGN.

FOR MAIL ORDER MEDICAL AND HEALTH SUPPLY SERVICES (U.S. CLS. 100, 101 AND 102).

FIRST USE 11-1-1991; IN COMMERCE 11-1-1991. CIMMERIAN COLEMAN, EXAMINING ATTORNEY

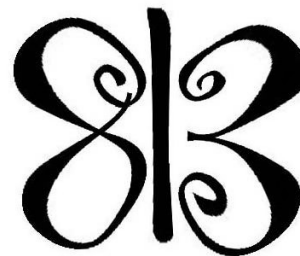

ONEMEANING

THE MARK CONSISTS OF THE WORDS "ONE MEANING" TOGETHER WITH A BUTTERFLY DESIGN. THE BUTTERFLY DESIGN IS COMPRISED OF THE NUMBER "813", WHICH FORMS THE WINGS AND BODY OF THE BUTTERFLY.

FOR PROMOTIONAL SERVICES, NAMELY, PROMOTING THE CHARITIES OF OTHERS (U.S. CLS. 100, 101 AND 102).

CURTIS FRENCH, EXAMINING ATTORNEY

CLASS 35—(Continued).

SN 77-587,534. NRC BROADCASTING MOUNTAIN GROUP, LLC, DENVER, CO. FILED 10-7-2008.

SIGN LANGUAGE A MARKETING
COMPANY

THE MARK CONSISTS OF STANDARD CHARACTERS WITHOUT CLAIM TO ANY PARTICULAR FONT, STYLE, SIZE, OR COLOR.

NO CLAIM IS MADE TO THE EXCLUSIVE RIGHT TO USE "A MARKETING COMPANY", APART FROM THE MARK AS SHOWN.

FOR ADVERTISING AND ADVERTISEMENT SERVICES; ADVERTISING AND PROMOTIONAL SERVICES; ADVERTISING SERVICES; DESIGN OF ADVERTISING MATERIALS FOR OTHERS; DISSEMINATION OF ADVERTISING MATERIAL; PROMOTING THE GOODS AND SERVICES OF OTHERS BY DISTRIBUTING ADVERTISING MATERIALS THROUGH A VARIETY OF METHODS; SPECIALTY MERCHANDISING SERVICES, NAMELY, PROMOTING THE GOODS AND SERVICES OF OTHERS THROUGH THE DISTRIBUTION OF CUSTOMIZED ADVERTISING MATERIALS, NAMELY, BANNERS, T-SHIRTS, POSTERS AND DECALS (U.S. CLS. 100, 101 AND 102).

FIRST USE 9-5-2008; IN COMMERCE 9-5-2008.

HENRY S. ZAK, EXAMINING ATTORNEY

SN 77-589,017. HEATH SR., ROBERT L., KOKOMO, IN. FILED 10-9-2008.

I DON'T THINK SO

THE MARK CONSISTS OF STANDARD CHARACTERS WITHOUT CLAIM TO ANY PARTICULAR FONT, STYLE, SIZE, OR COLOR.

FOR PROVIDING A WEBSITE FEATURING CONSUMER INFORMATION IN THE FIELD OF CONSUMER ADVOCACY (U.S. CLS. 100, 101 AND 102).

FIRST USE 1-1-2003; IN COMMERCE 1-1-2003.

DOMINIC FATHY, EXAMINING ATTORNEY

CLASS 35—(Continued).

SN 77-592,233. BROADPATH, INC., TUCSON, AZ. FILED 10-14-2008.

BROADPATH

THE MARK CONSISTS OF STANDARD CHARACTERS WITHOUT CLAIM TO ANY PARTICULAR FONT, STYLE, SIZE, OR COLOR.

FOR EMPLOYMENT STAFFING SERVICES, NAMELY, FILLING THE TEMPORARY AND PERMANENT STAFFING NEEDS OF BUSINESSES IN THE FIELDS OF HEALTHCARE AND INSURANCE; BUSINESS OPERATIONS CONSULTING SERVICES IN THE FIELDS OF HEALTHCARE AND INSURANCE; OPERATIONS OUTSOURCING SERVICES IN THE FIELDS OF HEALTHCARE AND INSURANCE (U.S. CLS. 100, 101 AND 102).

FIRST USE 8-18-2008; IN COMMERCE 9-1-2008.

JULIE WATSON, EXAMINING ATTORNEY

SN 77-594,618. GRODIN, CARL, SANTA BARBARA, CA. FILED 10-16-2008.

Elevated Advertising

THE MARK CONSISTS OF STANDARD CHARACTERS WITHOUT CLAIM TO ANY PARTICULAR FONT, STYLE, SIZE, OR COLOR.

NO CLAIM IS MADE TO THE EXCLUSIVE RIGHT TO USE "ADVERTISING", APART FROM THE MARK AS SHOWN.

FOR ADVERTISING SERVICES, NAMELY, THE APPLICATION OF ADVERTISEMENTS ON INTERIOR AND EXTERIOR ELEVATOR DOOR PANELS IN COMMERCIAL AND RESIDENTIAL FACILITIES (U.S. CLS. 100, 101 AND 102).

FIRST USE 6-26-2008; IN COMMERCE 6-26-2008.

WILLIAM P. SHANAHAN, EXAMINING ATTORNEY

CLASS 35—(Continued).

SN 77-600,203. CARBAJALES, LEONARDO NALES, COCONUT GROVE, FL. AND PIDAL, RODRIGO GUTIERREZ, COCONUT GROVE, FL. FILED 10-24-2008.



NAUTIKOS

OWNER OF MEXICO REG. NO. 788370, DATED 4-9-2002, EXPIRES 4-9-2012.

NO CLAIM IS MADE TO THE EXCLUSIVE RIGHT TO USE "NAUTIKOS", APART FROM THE MARK AS SHOWN.

THE MARK CONSISTS OF "NAUTIKOS" IN STYLIZED LETTERING WITH A WAVE EXTENDING FROM THE END OF THE LETTER "K" BACK TO THE LETTER "T" WITH A WAVE ATOP OF THE WAVE.

THE ENGLISH TRANSLATION OF "NAUTIKOS" IN THE MARK IS NAUTICAL.

FOR RETAIL SPORTING GOODS STORES FEATURING NEW AND USED YACHTS (U.S. CLS. 100, 101 AND 102).

FIRST USE 12-13-2001; IN COMMERCE 4-9-2002. CARRIE GENOVESE, EXAMINING ATTORNEY

SN 77-600,632. TRIFECTATICKETS LLC, DBA BUBBA'S GOT TICKETS, ASHLAND, OH. FILED 10-25-2008.

Bubbas Got Tickets

THE MARK CONSISTS OF STANDARD CHARACTERS WITHOUT CLAIM TO ANY PARTICULAR FONT, STYLE, SIZE, OR COLOR.

NO CLAIM IS MADE TO THE EXCLUSIVE RIGHT TO USE "TICKETS", APART FROM THE MARK AS SHOWN.

FOR OPERATING ONLINE MARKETPLACES FEATURING TICKETS FOR SPORTING EVENTS, MUSICAL CONCERTS, AND OTHER ENTERTAINMENT EVENTS (U.S. CLS. 100, 101 AND 102).

FIRST USE 9-25-2008; IN COMMERCE 9-25-2008. JIM RINGLE, EXAMINING ATTORNEY

CLASS 35—(Continued).

SN 77-601,664. STICS, INC., SAN DIEGO, CA. FILED 10-27-2008.

CACHE-In

THE MARK CONSISTS OF STANDARD CHARACTERS WITHOUT CLAIM TO ANY PARTICULAR FONT, STYLE, SIZE, OR COLOR.

FOR BUSINESS CONSULTING SERVICES IN THE FIELD OF CUSTOMER BEHAVIOR FOR THE CASINO, HOSPITALITY AND ENTERTAINMENT INDUSTRIES; AND ANALYTICAL SERVICES, NAMELY, STATISTICAL ANALYSIS OF ANONYMIZED BEHAVIORAL AND DEMOGRAPHIC DATA FOR THE PURPOSE OF UNDERSTANDING AND PREDICTING CUSTOMER BEHAVIOR, MARKETING ACTIVITIES AND PROFITABILITY ACROSS THE CASINO, HOSPITALITY AND ENTERTAINMENT INDUSTRIES (U.S. CLS. 100, 101 AND 102).

MARTHA FROMM, EXAMINING ATTORNEY

SN 77-601,825. HOFFMAN, LLC, APPLETON, WI. FILED 10-28-2008.

**TOTAL PROJECT MANAGEMENT:
IT'S THE PROCESS**

THE MARK CONSISTS OF STANDARD CHARACTERS WITHOUT CLAIM TO ANY PARTICULAR FONT, STYLE, SIZE, OR COLOR.

OWNER OF U.S. REG. NOS. 2,201,277 AND 3,241,873. NO CLAIM IS MADE TO THE EXCLUSIVE RIGHT TO USE "TOTAL PROJECT MANAGEMENT", APART FROM THE MARK AS SHOWN.

FOR PROCUREMENT SERVICES, NAMELY, PURCHASING CONSTRUCTION MATERIALS AND EQUIPMENT FOR OTHERS (U.S. CLS. 100, 101 AND 102).

FIRST USE 2-1-1997; IN COMMERCE 2-1-1997. WON TEAK OH, EXAMINING ATTORNEY

SN 77-603,308. VANELLA, MARI ANNE, AKA MARI ANNE VANELLA, SAN JOSE, CA. FILED 10-29-2008.

Telesales 2.0

THE MARK CONSISTS OF STANDARD CHARACTERS WITHOUT CLAIM TO ANY PARTICULAR FONT, STYLE, SIZE, OR COLOR.

NO CLAIM IS MADE TO THE EXCLUSIVE RIGHT TO USE "TELESALES", APART FROM THE MARK AS SHOWN.

FOR TELEMARKETING (U.S. CLS. 100, 101 AND 102). FIRST USE 10-1-2008; IN COMMERCE 10-1-2008.

PATRICIA EVANKO, EXAMINING ATTORNEY

CLASS 35—(Continued).

SN 77-607,751. PHARMAKON LONG TERM CARE PHARMACY, INC., INDIANAPOLIS, IN. FILED 11-5-2008.



NO CLAIM IS MADE TO THE EXCLUSIVE RIGHT TO USE "RX" AND "LONG TERM CARE PHARMACY", APART FROM THE MARK AS SHOWN.

THE MARK CONSISTS OF THE STYLIZED TEXT "RX" INSIDE A CIRCLE. TO THE RIGHT THE STYLIZED TEXT "PHARMAKON LONG TERM CARE PHARMACY, INC." APPEARS.

FOR INSTITUTIONAL RETAIL PHARMACY SERVICES (U.S. CLS. 100, 101 AND 102).

FIRST USE 11-11-2007; IN COMMERCE 11-11-2007.
SAIMA MAKHDOOM, EXAMINING ATTORNEY

CLASS 35—(Continued).

SN 77-610,667. PHARMERICA CORPORATION, LOUISVILLE, KY. FILED 11-10-2008.

COMPUTRAN

THE MARK CONSISTS OF STANDARD CHARACTERS WITHOUT CLAIM TO ANY PARTICULAR FONT, STYLE, SIZE, OR COLOR.

OWNER OF U.S. REG. NO. 1,162,141.

FOR BUSINESS SERVICES IN THE FIELDS OF HEALTH CARE AND NURSING CARE, NAMELY, BUSINESS RECORDS MANAGEMENT AND PREPARING BUSINESS REPORTS (U.S. CLS. 100, 101 AND 102).
FIRST USE 8-17-1978; IN COMMERCE 8-17-1978.

THEODORE MCBRIDE, EXAMINING ATTORNEY

SN 77-609,287. INTERNATIONAL ASSOCIATION FOR COLON HYDROTHERAPY, SAN ANTONIO, TX. FILED 11-6-2008.



NO CLAIM IS MADE TO THE EXCLUSIVE RIGHT TO USE "INTERNATIONAL ASSOCIATION COLON HYDROTHERAPY", APART FROM THE MARK AS SHOWN.

THE STIPPLING IS FOR SHADING PURPOSES ONLY.

THE MARK CONSISTS OF AN IMAGE OF A GLOBE WITH THE STYLIZED LETTER AND WORD "I-ACT" ACROSS THE MIDDLE. THE STYLIZED WORDS "INTERNATIONAL ASSOCIATION COLON HYDROTHERAPY" AROUND THE OUTSIDE OF THE GLOBE.

FOR ASSOCIATION SERVICES, NAMELY, PROMOTING THE INTERESTS OF COLON HYDROTHERAPY (U.S. CLS. 100, 101 AND 102).

FIRST USE 10-15-1995; IN COMMERCE 10-15-1995.
KHANH LE, EXAMINING ATTORNEY

SN 77-610,916. CITY IMAGE LLC, LANCASTER, PA. FILED 11-10-2008.



THE COLOR(S) BLACK, RED AND WHITE IS/ARE CLAIMED AS A FEATURE OF THE MARK.

THE MARK CONSISTS OF THE TWO WORDS "CITY IMAGE" IN A STYLIZED FONT WITH THE WORD "CITY" CANTED ABOVE AND ON THE LEFT-HAND SIDE OF THE WORD "IMAGE" WITH A CITY LANDSCAPE DESIGN IN THE BACKGROUND. SMALL JAGGED MARKINGS APPEAR AS HOLES INSIDE THE LETTERS "I", "M", "A" AND "E" IN THE WORD "IMAGE." THE TOP OF THE WORD "CITY" APPEARS IN BLACK INCREMENTALLY TRANSITIONING TO RED AT THE BOTTOM. THE TOP PORTION OF THE WORD "IMAGE" APPEARS IN RED INCREMENTALLY TRANSITIONING TO WHITE AT THE BOTTOM. THE CITY LANDSCAPE DESIGN APPEARS IN BLACK AT THE TOP INCREMENTALLY TRANSITIONING THROUGH RED TO WHITE AT THE BOTTOM. THE COLOR WHITE ALSO APPEARS OUTLINING THE LETTERS IN THE WORDING "CITY IMAGE" AND OUTLINING THE SMALL JAGGED MARKINGS.

FOR RETAIL STORE SERVICES FEATURING CLOTHING, HATS AND FOOTWEAR (U.S. CLS. 100, 101 AND 102).

FIRST USE 3-31-2004; IN COMMERCE 3-31-2004.
NATALIE POLZER, EXAMINING ATTORNEY

CLASS 35—(Continued).

SN 77-611,060. LAUNCH, LLC, DBA LAUNCH SOMETHING, SPARTANBURG, SC. FILED 11-10-2008.

LAUNCH SOMETHING

THE MARK CONSISTS OF STANDARD CHARACTERS WITHOUT CLAIM TO ANY PARTICULAR FONT, STYLE, SIZE, OR COLOR.

FOR ADVERTISING SERVICES, NAMELY, PROMOTING THE GOODS AND SERVICES OF OTHERS, THROUGH PRINT, AUDIO, VIDEO AND ON-LINE MEDIA, PROMOTION OF SPECIAL EVENTS AND UTILIZATION OF PROMOTIONAL PRODUCTS AND INCENTIVES; BUSINESS MARKETING SERVICES, NAMELY, CONSULTATION IN THE AREAS OF MARKET RESEARCH, MARKETING STRATEGY, MARKETING TOOLS, SALES DEVELOPMENT, BRAND IDENTITY, DEVELOPMENT AND PROTECTION, AND DESIGN AND PRODUCTION OF PROMOTIONAL MATERIALS; AND PUBLIC RELATION SERVICES (U.S. CLS. 100, 101 AND 102).

FIRST USE 11-10-2008; IN COMMERCE 11-10-2008.
KIMBERLY PERRY, EXAMINING ATTORNEY

SN 77-611,109. LAUNCH, LLC, DBA LAUNCH SOMETHING, SPARTANBURG, SC. FILED 11-10-2008.

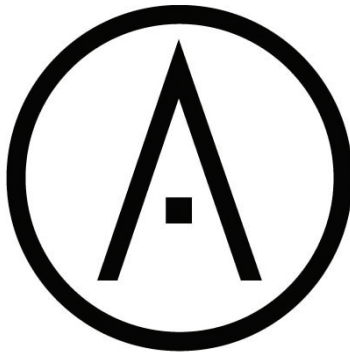

THE MARK CONSISTS OF A STYLIZED LETTER "A" INSIDE A CIRCLE.

FOR ADVERTISING SERVICES, NAMELY, PROMOTING THE GOODS AND SERVICES OF OTHERS, THROUGH PRINT, AUDIO, VIDEO AND ON-LINE MEDIA, PROMOTION OF SPECIAL EVENTS AND UTILIZATION OF PROMOTIONAL PRODUCTS AND INCENTIVES; BUSINESS MARKETING SERVICES, NAMELY, CONSULTATION IN THE AREAS OF MARKET RESEARCH, MARKETING STRATEGY, MARKETING TOOLS, SALES DEVELOPMENT, BRAND IDENTITY, DEVELOPMENT AND PROTECTION, AND DESIGN AND PRODUCTION OF PROMOTIONAL MATERIALS; AND PUBLIC RELATION SERVICES (U.S. CLS. 100, 101 AND 102).

FIRST USE 7-1-2005; IN COMMERCE 7-1-2005.
KIMBERLY PERRY, EXAMINING ATTORNEY

CLASS 35—(Continued).

SN 77-611,132. LAUNCH, LLC, DBA LAUNCH SOMETHING, SPARTANBURG, SC. FILED 11-10-2008.

**STRATEGIZE. EXECUTE.
IGNITE.**

THE MARK CONSISTS OF STANDARD CHARACTERS WITHOUT CLAIM TO ANY PARTICULAR FONT, STYLE, SIZE, OR COLOR.

FOR ADVERTISING SERVICES, NAMELY, PROMOTING THE GOODS AND SERVICES OF OTHERS, THROUGH PRINT, AUDIO, VIDEO AND ON-LINE MEDIA, PROMOTION OF SPECIAL EVENTS AND UTILIZATION OF PROMOTIONAL PRODUCTS AND INCENTIVES; BUSINESS MARKETING SERVICES, NAMELY, CONSULTATION IN THE AREAS OF MARKET RESEARCH, MARKETING STRATEGY, MARKETING TOOLS, SALES DEVELOPMENT, BRAND IDENTITY, DEVELOPMENT AND PROTECTION, AND DESIGN AND PRODUCTION OF PROMOTIONAL MATERIALS; AND PUBLIC RELATION SERVICES (U.S. CLS. 100, 101 AND 102).

FIRST USE 11-10-2008; IN COMMERCE 11-10-2008.
KIMBERLY PERRY, EXAMINING ATTORNEY

SN 77-611,470. SAMENMAIS CORPORATION, OKLAHOMA CITY, OK. FILED 11-10-2008.



NO CLAIM IS MADE TO THE EXCLUSIVE RIGHT TO USE "A DIVISION OF" AND "CORPORATION", APART FROM THE MARK AS SHOWN.

THE MARK CONSISTS OF THREE MONKEYS VERTICALLY ALIGNED WITH THE STYLIZED TEXT "SEE-HEAR-SPEAK.COM A DIVISION OF THE SAMENMAIS CORPORATION" ALSO VERTICALLY ALIGNED.

FOR PROVIDING A WEB SITE FEATURING CUSTOMER SATISFACTION SURVEYS AND EMPLOYEE ASSESSMENTS REGARDING WORK PLACE SATISFACTION (U.S. CLS. 100, 101 AND 102).

FIRST USE 3-1-2008; IN COMMERCE 3-1-2008.
DAVID ELTON, EXAMINING ATTORNEY

CLASS 35—(Continued).

SN 77-611,484. JUST POP IN, INDIANAPOLIS, IN. FILED 11-10-2008.

Two Too Good!

THE MARK CONSISTS OF STANDARD CHARACTERS WITHOUT CLAIM TO ANY PARTICULAR FONT, STYLE, SIZE, OR COLOR.

FOR RETAIL STORE SERVICES FEATURING POPCORN AND ON-LINE RETAIL STORE SERVICES FEATURING POPCORN (U.S. CLS. 100, 101 AND 102).

FIRST USE 10-19-2003; IN COMMERCE 10-19-2003.
MARY MUNSON, EXAMINING ATTORNEY

SN 77-611,651. PENNWELL CORPORATION, TULSA, OK. FILED 11-11-2008.



NO CLAIM IS MADE TO THE EXCLUSIVE RIGHT TO USE "OIL SANDS HEAVY OIL TECHNOLOGIES", APART FROM THE MARK AS SHOWN.

FOR ARRANGING AND CONDUCTING BUSINESS CONFERENCES AND EXHIBITIONS IN THE FIELD OF OIL SANDS AND HEAVY OIL TECHNOLOGIES (U.S. CLS. 100, 101 AND 102).

FIRST USE 12-1-2006; IN COMMERCE 12-1-2006.
MARK SPARACINO, EXAMINING ATTORNEY

SN 77-612,791. PENNWELL CORPORATION, TULSA, OK. FILED 11-12-2008.



NO CLAIM IS MADE TO THE EXCLUSIVE RIGHT TO USE "POWER GRID EUROPE", APART FROM THE MARK AS SHOWN.

THE MARK CONSISTS OF THE WORDS "POWERGRID EUROPE" WITH THE WORD "EUROPE" AND A GEOMETRIC DESIGN UNDERNEATH THE WORD "POWERGRID".

FOR ARRANGING AND CONDUCTING BUSINESS CONFERENCES AND EXHIBITIONS RELATING TO THE POWER TRANSMISSION AND DISTRIBUTION INDUSTRY IN EUROPE (U.S. CLS. 100, 101 AND 102).

FIRST USE 7-1-2006; IN COMMERCE 7-1-2006.
MARK SPARACINO, EXAMINING ATTORNEY

CLASS 35—(Continued).

SN 77-621,111. MASKED MAGICIAN ENTERPRISES, LAS VEGAS, NV. FILED 11-24-2008.

MASKED MAGICIAN ACADEMY OF MYSTICAL ARTS

THE MARK CONSISTS OF STANDARD CHARACTERS WITHOUT CLAIM TO ANY PARTICULAR FONT, STYLE, SIZE, OR COLOR.

NO CLAIM IS MADE TO THE EXCLUSIVE RIGHT TO USE "MYSTICAL ARTS", APART FROM THE MARK AS SHOWN.

FOR PROVIDING AN ONLINE DIRECTORY INFORMATION SERVICE FEATURING A LISTING OF BUSINESSES THAT OFFER MAGIC ILLUSIONS AND MAGIC TRICKS, SOCIAL NETWORKING, PHOTO SHARING, AND TRANSMISSION OF PHOTOGRAPHIC IMAGES;

PROVIDING AN ON-LINE SEARCHABLE DATABASE FEATURING CLASSIFIED AD LISTINGS; PROMOTING THE GOODS AND SERVICES OF OTHERS OVER THE INTERNET; PROVIDING ADVERTISING SPACE VIA THE GLOBAL COMPUTER NETWORK; PROVIDING ON-LINE COMPUTER DATABASES AND ON-LINE SEARCHABLE DATABASES IN THE FIELD OF CLASSIFIED AD LISTING; ONLINE RETAIL STORE SERVICES FEATURING A WIDE VARIETY OF CONSUMER GOODS OF OTHERS (U.S. CLS. 100, 101 AND 102).

MICHAEL SOUDERS, EXAMINING ATTORNEY

SN 77-621,941. NATIONAL SUNROOM ASSOCIATION, CLEVELAND, OH. FILED 11-25-2008.



NO CLAIM IS MADE TO THE EXCLUSIVE RIGHT TO USE "ASSOCIATION", APART FROM THE MARK AS SHOWN.

THE COLOR(S) BLUE, YELLOW, AND WHITE IS/ARE CLAIMED AS A FEATURE OF THE MARK.

THE MARK CONSISTS OF A YELLOW AND WHITE SUN DESIGN TO THE LEFT OF THE BLUE WORDING "NATIONAL SUNROOM ASSOCIATION".

SEC. 2(F).

FOR ASSOCIATION SERVICES, NAMELY, PROMOTING THE INTERESTS OF MANUFACTURERS OF SUNROOMS, PATIO ROOMS, AND SOLARIUMS (U.S. CLS. 100, 101 AND 102).

FIRST USE 7-0-1997; IN COMMERCE 7-0-1997.
KEVIN CORWIN, EXAMINING ATTORNEY

CLASS 35—(Continued).

SN 77-625,451. TOYOTA JIDOSHA KABUSHIKI KAISHA, TA
TOYOTA MOTOR CORPORATION, TOYOTA-SHI, JA-
PAN, FILED 12-3-2008.



NO CLAIM IS MADE TO THE EXCLUSIVE RIGHT TO USE "CERTIFIED USED HYBRIDS", APART FROM THE MARK AS SHOWN.

THE COLOR(S) BLUE, GREEN, BLACK AND WHITE IS/ARE CLAIMED AS A FEATURE OF THE MARK.

THE MARK CONSISTS OF A LARGE BLACK OVAL WITH A BLACK HORIZONTAL BAR IN THE MIDDLE. WITHIN THE OVAL, THE WORDS "TOYOTA", "CERTIFIED USED HYBRIDS" AND THE STYLIZED "T" MARK SURROUNDED BY AN OVAL ARE ALL IN WHITE. THE UPPER AND LOWER SEGMENTS DEFINED BY THE ARCS AND STRAIGHT BAR HAVE THE COLORS WHITE, LIGHT BLUE, DARKER BLUE, DARKER GREEN, AND LIGHT GREEN WITHIN THE BOUNDARIES FLOWING DIAGONALLY. THE HORIZONTAL LINES ABOVE AND BELOW THE WORD "CERTIFIED" ARE IN WHITE.

FOR DEALERSHIP SERVICES IN THE FIELD OF USED VEHICLES (U.S. CLS. 100, 101 AND 102).
MICHAEL WEBSTER, EXAMINING ATTORNEY

SN 77-627,629. CATALINA MARKETING CORPORATION,
ST. PETERSBURG, FL. FILED 12-5-2008.

PIVOTAL POINT CONSUMER

THE MARK CONSISTS OF STANDARD CHARACTERS WITHOUT CLAIM TO ANY PARTICULAR FONT, STYLE, SIZE, OR COLOR.

NO CLAIM IS MADE TO THE EXCLUSIVE RIGHT TO USE "CONSUMER", APART FROM THE MARK AS SHOWN.

FOR ADVERTISING AND BUSINESS SERVICES, NAMELY, PROVIDING CONSUMER INSIGHT AND BRAND MARKETING STRATEGY TO CONSUMER PACKAGED GOODS MANUFACTURERS AND OTHERS, PROVIDING BUSINESS CONSULTATION FOR THE UNDERSTANDING AND PREDICTING OF CONSUMERS, MARKET TRENDS AND ACTIONS, AND CONDUCTING CONSUMER TRACKING BEHAVIOR RESEARCH AND CONSUMER TREND ANALYSIS (U.S. CLS. 100, 101 AND 102).

ALLISON SCHRODY, EXAMINING ATTORNEY

CLASS 35—(Continued).

SN 77-629,252. WOODFIN HEATING, INC., DBA US FLEET
UNIVERSAL, GARNER, NC. FILED 12-9-2008.



OWNER OF U.S. REG. NOS. 3,566,800 AND 3,566,801.
NO CLAIM IS MADE TO THE EXCLUSIVE RIGHT TO USE "U.S. FLEET" AND "FLEET FUEL MANAGEMENT", APART FROM THE MARK AS SHOWN.

THE COLOR(S) BLUE, RED, AND WHITE IS/ARE CLAIMED AS A FEATURE OF THE MARK.

THE WORDING "U.S." AND "FLEET FUEL MANAGEMENT" APPEARS IN BLUE. THE WORDING "FLEET" APPEARS IN RED, AND THE WORDING "WATCHCARD" APPEARS IN WHITE AGAINST A RED RECTANGULAR BORDER, THE DOG IS WHITE AND BLUE AND THE TRIANGLE MADE OF WHITE AND BLUE STRIPES. THE REMAINING WHITE IN THE MARK IS INTENDED AS BACKGROUND ONLY AND NOT INTENDED AS A FEATURE OF THE MARK.

FOR RETAIL STORE SERVICES FEATURING FUELS (U.S. CLS. 100, 101 AND 102).

FIRST USE 12-31-2003; IN COMMERCE 12-31-2003.

MICHAEL LITZAU, EXAMINING ATTORNEY

SN 77-630,402. AMERICAN EXPRESS MARKETING & DE-
VELOPMENT CORP., NEW YORK, NY. FILED 12-10-2008.

THRIFTY SCHOLARSHIP

THE MARK CONSISTS OF STANDARD CHARACTERS WITHOUT CLAIM TO ANY PARTICULAR FONT, STYLE, SIZE, OR COLOR.

FOR PROMOTING THE USE OF CHARGE CARD AND CREDIT CARD ACCOUNTS THROUGH THE ADMINISTRATION OF INCENTIVE AWARD PROGRAMS IN ORDER TO ATTRACT MORE BUSINESS TO MERCHANTS (U.S. CLS. 100, 101 AND 102).

INGA ERVIN, EXAMINING ATTORNEY

SN 77-630,413. AMERICAN EXPRESS MARKETING & DE-
VELOPMENT CORP., NEW YORK, NY. FILED 12-10-2008.

STAR-SPANGLED SPEND

THE MARK CONSISTS OF STANDARD CHARACTERS WITHOUT CLAIM TO ANY PARTICULAR FONT, STYLE, SIZE, OR COLOR.

NO CLAIM IS MADE TO THE EXCLUSIVE RIGHT TO USE "SPEND", APART FROM THE MARK AS SHOWN.

FOR PROMOTING THE USE OF CHARGE CARD AND CREDIT CARD ACCOUNTS THROUGH THE ADMINISTRATION OF INCENTIVE AWARD PROGRAMS IN ORDER TO ATTRACT MORE BUSINESS TO MERCHANTS (U.S. CLS. 100, 101 AND 102).

INGA ERVIN, EXAMINING ATTORNEY

CLASS 35—(Continued).

SN 77-632,499. BRAD LUNDAHL, SALT LAKE CITY, UT. FILED 12-12-2008.

Lucky Salesman

THE MARK CONSISTS OF STANDARD CHARACTERS WITHOUT CLAIM TO ANY PARTICULAR FONT, STYLE, SIZE, OR COLOR.

NO CLAIM IS MADE TO THE EXCLUSIVE RIGHT TO USE SALESMAN, APART FROM THE MARK AS SHOWN. FOR BUSINESS CONSULTATION (U.S. CLS. 100, 101 AND 102).

FLORENTINA BLANDU, EXAMINING ATTORNEY

CLASS 35—(Continued).

SN 77-633,918. WIDE OPEN, CAMDEN, NJ. FILED 12-16-2008.



NO CLAIM IS MADE TO THE EXCLUSIVE RIGHT TO USE "MC" AND "EST 1985" AND "SOUTH JERSEY", APART FROM THE MARK AS SHOWN.

THE STIPPLING IS FOR SHADING PURPOSES ONLY.

THE MARK CONSISTS OF THE STYLIZED WORDS "WIDE OPEN M.C. STREET OR DIRT SOUTH JERSEY EST 1985". IN BETWEEN THE STYLIZED WORDS IS AN IMAGE OF A MOTORCYCLE WITH A RIDER ON IT GOING DOWN A BLACKTOP ROAD AND A OFF ROAD QUAD WITH A RIDER ON IT RIDING OVER A DIRT HILL.

FOR ASSOCIATION SERVICES, NAMELY, PROMOTING THE INTERESTS OF MOTORCYCLE RIDERS (U.S. CLS. 100, 101 AND 102).

MARIA-VICTORIA SUÁREZ, EXAMINING ATTORNEY

SN 77-633,523. DOGS BOLLOCKS 5, LLC, DBA DOGS BOLLOCKS, SAN MARINO, CA. FILED 12-15-2008.



THE COLOR(S) BLACK AND RED IS/ARE CLAIMED AS A FEATURE OF THE MARK.

THE MARK CONSISTS OF THE LOWERCASE LETTERS "D" AND "B" WITH THE NUMBER "5" DANGLING FROM THE "B". THE WORDS "DOGS BULLOCKS" IN SMALLER FONT ABOVE AND TO THE RIGHT. THE COLOR BLACK APPEARS IN THE WORDING "DOGS BOLLOCKS" AND IN THE LETTERS "DB" AND THE COLOR RED APPEARS IN THE NUMBER "5".

FOR MARKETING CONSULTING SERVICES; BUSINESS ADVICE AND ANALYSIS OF CUSTOMER HABITS AND NEEDS; ANALYZING AND COMPILING DATA FOR MEASURING THE PERFORMANCE OF MARKETING EFFORTS; PROVIDING BUSINESS MARKETING INFORMATION; STATISTICAL EVALUATION OF MARKETING DATA; BRAND IMAGERY CONSULTING SERVICES; ANALYZING AND COMPILING DATA FOR MEASURING THE PERFORMANCE OF BRAND NAMES AND IMAGES; DATA PROCESSING SERVICES IN THE FIELD OF BUSINESS INFORMATION, STATISTICS AND INDICES; STATISTICAL EVALUATIONS OF DATA RELATING TO BRAND IMAGE (U.S. CLS. 100, 101 AND 102).

FIRST USE 10-1-2008; IN COMMERCE 10-1-2008. PAM WILLIS, EXAMINING ATTORNEY

SN 77-635,686. HM WALLACE, INC., LITHIA SPRINGS, GA. FILED 12-18-2008.



NO CLAIM IS MADE TO THE EXCLUSIVE RIGHT TO USE "NATIONAL BUILDER SUPPLY", APART FROM THE MARK AS SHOWN.

THE MARK CONSISTS OF THE WORDS "NATIONAL-BUILDERSUPPLY" CENTERED OVER WHICH IS A STYLIZED LOGO IN THE FORM OF A DIAMOND ENCOMPASSING A STYLIZED LETTER "N".

FOR ONLINE RETAIL STORE SERVICES IN THE FIELDS OF KITCHEN HARDWARE, BATH HARDWARE, LIGHTING, APPLIANCES AND HARDWARE (U.S. CLS. 100, 101 AND 102).

FIRST USE 7-11-2007; IN COMMERCE 10-18-2008. JENNIFER VASQUEZ, EXAMINING ATTORNEY

CLASS 35—(Continued).

SN 77-636,812. INSCAPE SOFTWARE HOLDING, INC.,
MONTREAL, QC, CANADA, FILED 12-19-2008.

ISCOPIA

THE MARK CONSISTS OF STANDARD CHARACTERS WITHOUT CLAIM TO ANY PARTICULAR FONT, STYLE, SIZE, OR COLOR.

THE WORDING "ISCOPIA" HAS NO MEANING IN A FOREIGN LANGUAGE.

FOR PROVIDING AN INTERACTIVE WEBSITE, INTERNET WEBSITE CONSOLE OR INTERNET WEBSITE PORTAL IN THE FIELD OF ASSESSMENT FOR EMPLOYMENT RECRUITING, CAREER DEVELOPMENT AND CAREER ADVANCEMENT (U.S. CLS. 100, 101 AND 102).

SANDRA MANIOS, EXAMINING ATTORNEY

SN 77-637,037. INSCAPE SOFTWARE HOLDING, INC.,
MONTREAL, QC, CANADA, FILED 12-19-2008.

ISCOPIA SOFTWARE

THE MARK CONSISTS OF STANDARD CHARACTERS WITHOUT CLAIM TO ANY PARTICULAR FONT, STYLE, SIZE, OR COLOR.

NO CLAIM IS MADE TO THE EXCLUSIVE RIGHT TO USE "SOFTWARE", APART FROM THE MARK AS SHOWN.

THE WORDING "ISCOPIA" HAS NO MEANING IN A FOREIGN LANGUAGE.

FOR PROVIDING AN INTERACTIVE WEBSITE, INTERNET WEBSITE CONSOLE OR INTERNET WEBSITE PORTAL IN THE FIELD OF ASSESSMENT FOR EMPLOYMENT RECRUITING, CAREER DEVELOPMENT AND CAREER ADVANCEMENT (U.S. CLS. 100, 101 AND 102).

SANDRA MANIOS, EXAMINING ATTORNEY

SN 77-637,089. INSCAPE SOFTWARE HOLDING, INC.,
MONTREAL, QC, CANADA, FILED 12-19-2008.

ISCOPIA MARKET

THE MARK CONSISTS OF STANDARD CHARACTERS WITHOUT CLAIM TO ANY PARTICULAR FONT, STYLE, SIZE, OR COLOR.

NO CLAIM IS MADE TO THE EXCLUSIVE RIGHT TO USE "MARKET", APART FROM THE MARK AS SHOWN.

FOR PROVIDING AN INTERACTIVE WEBSITE, INTERNET WEBSITE CONSOLE OR INTERNET WEBSITE PORTAL IN THE FIELD OF ASSESSMENT FOR EMPLOYMENT RECRUITING, CAREER DEVELOPMENT AND CAREER ADVANCEMENT (U.S. CLS. 100, 101 AND 102).

SANDRA MANIOS, EXAMINING ATTORNEY

CLASS 35—(Continued).

SN 77-637,320. BARRETT, THOMAS A, READING, MA.
FILED 12-19-2008.

SiteSee

THE MARK CONSISTS OF STANDARD CHARACTERS WITHOUT CLAIM TO ANY PARTICULAR FONT, STYLE, SIZE, OR COLOR.

FOR ADVERTISING AND DIRECTORY SERVICES, NAMELY, PROMOTING THE SERVICES OF OTHERS BY PROVIDING A WEB PAGE FEATURING LINKS TO THE WEBSITES OF OTHERS; ON-LINE BUSINESS DIRECTORIES FEATURING LOCALIZED CONTENT, NAMELY, BUSINESS ADDRESS AND CONTACT INFORMATION, HOTELS, RESTAURANTS, TOURIST ATTRACTIONS; PROVIDING AN ON-LINE DIRECTORY INFORMATION SERVICE FEATURING INFORMATION REGARDING MEMBERS OF TRADE ASSOCIATIONS AND NON-PROFIT ORGANIZATIONS; PROVIDING ON-LINE DIRECTORY INFORMATION SERVICES ALSO FEATURING HYPERLINKS TO OTHER WEB SITES (U.S. CLS. 100, 101 AND 102).

FIRST USE 8-5-2008; IN COMMERCE 11-10-2008.
SHAUNIA CARLYLE, EXAMINING ATTORNEY

SN 77-640,944. NATIONAL COUNCIL OF YOUNG ISRAEL,
NEW YORK, NY. FILED 12-29-2008.



NO CLAIM IS MADE TO THE EXCLUSIVE RIGHT TO USE "ISRAEL", THE NON-LATIN CHARACTERS IN THE MARK THAT MEAN "ISRAEL" AND THE REPRESENTATION OF THE STAR OF DAVID, APART FROM THE MARK AS SHOWN.

THE MARK CONSISTS OF A JEWISH STAR IN THE MIDDLE OF THE TRIANGLE LOGO WITH THE TEN COMMANDMENTS REPRESENTED BY TWO HEBREW LETTERS INSIDE THE JEWISH STAR.

THE ENGLISH TRANSLATION OF "YUD" AND "TZA-DIK" IN THE MARK IS YOUNG ISRAEL.

THE NON-LATIN CHARACTERS IN THE MARK TRANSLITERATE TO "YUD" AND "TZADIK," AND THIS MEANS "YOUNG ISRAEL" IN ENGLISH.

FOR ASSOCIATION SERVICES, NAMELY, PROMOTING THE INTERESTS OF TRADITIONAL JUDAISM BY ORGANIZING SPIRITUAL, CULTURAL, SOCIAL AND COMMUNAL PROGRAMS AND ACTIVITIES (U.S. CLS. 100, 101 AND 102).

FIRST USE 4-30-2006; IN COMMERCE 4-30-2006.
CHARLES L. JENKINS, EXAMINING ATTORNEY

CLASS 35—(Continued).

SN 77-641,553. INTERNET SPORTS TRAVEL INC., PALO ALTO, CA. FILED 12-30-2008.



NO CLAIM IS MADE TO THE EXCLUSIVE RIGHT TO USE "SOCCER CAMPS INTERNATIONAL", APART FROM THE MARK AS SHOWN.

THE MARK CONSISTS OF A SOCCER BALL WITH INTEGRATED OUTLINES OF NORTH AMERICA AND EUROPE CONTINENTS. THE WORDS "SOCCER CAMPS INTERNATIONAL" APPEAR AROUND THE DESIGN.

FOR PROMOTING SOCCER CAMPS, CLINICS AND SCHOOLS SOCCER COMPETITIONS AND/OR EVENTS OF OTHERS; PROVIDING REGISTRATION SERVICES FOR OTHERS, NAMELY, REGISTRATION SERVICES FOR SOCCER CAMPS, CLINICS AND SCHOOLS OF OTHERS (U.S. CLS. 100, 101 AND 102).

FIRST USE 9-1-2008; IN COMMERCE 9-1-2008.
LESLIE RICHARDS, EXAMINING ATTORNEY

SN 77-645,914. SHOW OF SUPPORT MILITARY HUNT, INC., MIDLAND, TX. FILED 1-8-2009.



OWNER OF U.S. REG. NO. 3,491,133.

NO CLAIM IS MADE TO THE EXCLUSIVE RIGHT TO USE "HUNT", APART FROM THE MARK AS SHOWN.

THE COLOR(S) RED, WHITE, AND BLUE IS/ARE CLAIMED AS A FEATURE OF THE MARK.

THE MARK CONSISTS OF A THICK, BLUE, CIRCULAR BORDER. THE WORDS "SHOW OF SUPPORT" ARE WITHIN THE UPPER HALF OF THE CIRCULAR BORDER IN BOLD WHITE LETTERING. THE WORDS "MILITARY HUNT" ARE WITHIN THE LOWER HALF OF THE CIRCULAR BORDER IN NON-BOLD WHITE LETTERING. INSIDE THE CIRCULAR BORDER IS A FIVE-POINTED RED STAR WHOSE POINTS TOUCH THE INSIDE OF THE CIRCULAR

CLASS 35—(Continued).

BORDER. THERE IS ONE BLUE RIFLE STANDING ON ITS STOCK WITH THE TRIGGER FACING OUTWARDS TO THE LEFT OF THE CIRCULAR BORDER AND A SECOND BLUE RIFLE SIMILARLY STATIONED TO THE RIGHT OF THE CIRCULAR BORDER WITH BOTH RIFLES TOUCHING THE OUTSIDE OF THE BORDER. THE WORDS "HUNT FOR HEROES" APPEAR IMMEDIATELY BELOW THE THICK, BLUE, CIRCULAR BORDER, BETWEEN THE STOCK BUTTS OF THE RIFLES AND ARE IN THE COLOR RED. THE BACKGROUND IS WHITE.

FOR CHARITABLE SERVICES, NAMELY, ORGANIZING AND CONDUCTING VOLUNTEER PROGRAMS AND COMMUNITY SERVICE PROJECTS AIMED AT INCREASING SUPPORT AND MORALE OF MEMBERS OF THE U.S. MILITARY (U.S. CLS. 100, 101 AND 102).

FIRST USE 7-1-2007; IN COMMERCE 7-1-2007.
BARBARA RUTLAND, EXAMINING ATTORNEY

SN 77-647,808. EQUITY AGENDAS LLC, DALLAS, TX. FILED 1-12-2009.



NO CLAIM IS MADE TO THE EXCLUSIVE RIGHT TO USE "DRIVERS", APART FROM THE MARK AS SHOWN.

THE COLOR(S) GREEN, LIGHT GREEN, BLACK, LIGHT ORANGE IS/ARE CLAIMED AS A FEATURE OF THE MARK.

THE MARK CONSISTS OF SEMICIRCLE GREEN CAR BODY INCLOSING A 5 POINT LIGHT ORANGE STAR. THE 5 POINT LIGHT ORANGE STAR ENCOMPASSES APPROXIMATELY THE MAJORITY OF THE INTERIOR SPACE OF THE SEMICIRCLE GREEN CAR BODY. A SMALL BLACK LINE EXTENDS AT APPROXIMATELY 45 DEGREES ON THE RIGHT SIDE OF THE EXTERIOR OF THE SEMICIRCLE GREEN CAR BODY. THE SMALL BLACK LINE ANTENNA GRADUALLY DECREASES IN WIDTH FROM BASE TO TIP. THE TIP OF THE SMALL BLACK LINE ANTENNA IS COMPOSED OF A SMALL SLANTED NARROW OVAL. TWO SMALL LIGHT GREEN CIRCLE TIRES OVERLAP AND ARE IN FRONT OF THE SEMICIRCLE GREEN CAR BODY. ONE SMALL LIGHT GREEN CIRCLE TIRE IS PLACE AT OPPOSITE BOTTOM ENDS OF THE SEMICIRCLE GREEN CAR BODY. EACH LIGHT GREEN CIRCLE TIRE IS COMPOSED OF TWO BLACK ARROWS LYING ON THE OUTER CIRCUMFERENCE OF THE LIGHT GREEN CIRCLE TIRE. THE ARROW TIPS POINT IN A COUNTERCLOCKWISE DIRECTION. EACH ARROW BODY INCREASES IN THICKNESS AROUND THE CIRCUMFERENCE OF AN INDIVIDUAL LIGHT GREEN CIRCLE TIRE FROM ARROW END TO ARROW TIP IN A COUNTERCLOCKWISE DIRECTION. THERE IS A GAP IN WHICH AN INDIVIDUAL LIGHT GREEN CIRCLE TIRE IS NOT COVERED BY ANY PORTION OF THE ARROW WHERE ONE ARROW TIP ENDS AND ANOTHER ARROW BODY BEGINS. THE WORD "STAR DRIVERS" IN BLACK

CLASS 35—(Continued).

IS UNDERNEATH AND RUNS THE LENGTH FROM THE BEGINNING OF THE LEFT SMALL LIGHT GREEN TIRE TO THE END OF THE RIGHT SMALL LIGHT GREEN TIRE. THE TEXT "STAR DRIVERS" IS IMMEDIATELY FOLLOWED BY THREE HORIZONTAL LINES. THE LINES ARE SPACED APART APPROXIMATELY ALMOST THE HEIGHT OF THE LOWERCASE LETTERS IN "DRIVERS". THE TOP LINE IS PLACE FURTHER RIGHT THAN THE MIDDLE LINE AND THE MIDDLE LINE IS PLACE FURTHER RIGHT THAN THE BOTTOM LINE.

FOR ONLINE RETAIL STORE SERVICES FEATURING FUEL EFFICIENCY PRODUCTS; RETAIL STORE SERVICES IN THE FIELD OF FUEL EFFICIENCY PRODUCTS FEATURING A BONUS INCENTIVE PROGRAM FOR CUSTOMERS; ADMINISTRATION OF A PROGRAM FOR ENABLING PARTICIPANTS TO OBTAIN DISCOUNTS ON FUEL EFFICIENCY PRODUCTS AND RECEIVE IMPROVED SERVICES; PROVIDING SUPPORT IN THE NATURE OF BUSINESS CONSULTATION IN THE FIELD OF FUEL EFFICIENCY TO ADVISE DESIGNATED VEHICLE OPERATORS ON HOW TO REDUCE HARMFUL EMISSIONS AND CONSUME LESS FUEL; MEMBERSHIP CLUB SERVICES PROVIDING DISCOUNTS TO MEMBERS WHO ARE DESIGNATED VEHICLE OPERATORS PARTICIPATING IN A PROGRAM TO REDUCE HARMFUL EMISSIONS AND CONSUME LESS FUEL (U.S. CLS. 100, 101 AND 102).

FIRST USE 1-8-2009; IN COMMERCE 1-8-2009.
EMILY CHUO, EXAMINING ATTORNEY

CLASS 35—(Continued).

SN 77-648,843. VARNER, TERRY, STE. GENEVIEVE, MO. FILED 1-13-2009.



NO CLAIM IS MADE TO THE EXCLUSIVE RIGHT TO USE "AUTO DEALERS VIDEOS", APART FROM THE MARK AS SHOWN.

THE STIPPLING IS FOR SHADING PURPOSES ONLY. THE MARK CONSISTS OF A FORWARD ARROW INSIDE A CAR. THE ARROW AND THE CAR ARE INSIDE A CIRCLE. TO THE RIGHT THERE IS THE STYLIZED TEXT "AUTO DEALERS VIDEOS".

FOR PROVIDING A WEBSITE FEATURING LISTINGS OF NEW AND USED AUTOMOBILES FROM AUTOMOBILE DEALERS (U.S. CLS. 100, 101 AND 102).
FIRST USE 6-1-2008; IN COMMERCE 6-16-2008.
BARBARA BROWN, EXAMINING ATTORNEY

SN 77-649,140. GLOBAL TRADESOURCE, LTD., DBA GLOBAL TRADESOURCE, LTD., CHICAGO, IL. FILED 1-14-2009.

SN 77-648,763. OXSTEIN DESIGN LABS, LLC, LOS ANGELES, CA. FILED 1-13-2009.



NO CLAIM IS MADE TO THE EXCLUSIVE RIGHT TO USE "EXPERT", APART FROM THE MARK AS SHOWN.

THE COLOR(S) ORANGE, WHITE, BLACK, BLUE, GREEN, RED AND YELLOW IS/ARE CLAIMED AS A FEATURE OF THE MARK.

THE MARK CONSISTS OF THE WORDING "WOMEN ENTREPRENEURS GROW GLOBAL" IN ORANGE AND THE WORDING "WEGG EXPERT" IN WHITE ON A BLACK BACKGROUND, TO THE RIGHT OF WHICH APPEARS A WOMAN'S FACE IN BLUE WITH GREEN AND WHITE EYES, BLACK EYEBROWS, UPON WHICH IS OVERLAID AN IMAGE OF A MAP IN ORANGE, YELLOW AND GREEN.

FOR MARKET RESEARCH; KNOWLEDGE SHARING, NAMELY, BUSINESS MANAGEMENT AND MARKETING CONSULTING IN THE FIELD OF INTERNATIONAL COMMERCE; INTERNATIONAL BUSINESS CONSULTING IN THE FIELD OF BUSINESS ORGANIZATION AND MANAGEMENT BY WOMEN (U.S. CLS. 100, 101 AND 102).

FIRST USE 1-8-2008; IN COMMERCE 11-7-2008.
EDWARD FENNESSY, EXAMINING ATTORNEY

Klout

THE MARK CONSISTS OF STANDARD CHARACTERS WITHOUT CLAIM TO ANY PARTICULAR FONT, STYLE, SIZE, OR COLOR.

FOR BUSINESS MONITORING SERVICES, NAMELY, TRACKING WEB SITES OF OTHERS TO PROVIDE A RATING SERVICE WHICH RATES INDIVIDUAL USERS ONLINE ACTIVITY IN ORDER TO GAUGE THEIR INFLUENCE FOR ADVERTISING AND MARKETING PURPOSES (U.S. CLS. 100, 101 AND 102).

FONG HSU, EXAMINING ATTORNEY

CLASS 35—(Continued).

SN 77-649,186. HOME ENERGY TEAM LLC, MCLEAN, VA.
FILED 1-14-2009.



NO CLAIM IS MADE TO THE EXCLUSIVE RIGHT TO USE "HOME ENERGY TEAM", APART FROM THE MARK AS SHOWN.

THE MARK CONSISTS OF A SHAPE OF AN OUTLINED HOUSE, WITH A LEAF IN THE CENTER, TO THE LEFT THE WORDS "HOME ENERGY TEAM".

FOR ENERGY AUDITING (U.S. CLS. 100, 101 AND 102).

FIRST USE 10-0-2008; IN COMMERCE 10-0-2008.
BARBARA RUTLAND, EXAMINING ATTORNEY

SN 77-650,044. CLOW, DAVID, SOUTH PASADENA, CA.
FILED 1-15-2009.

From The Chair

THE MARK CONSISTS OF STANDARD CHARACTERS WITHOUT CLAIM TO ANY PARTICULAR FONT, STYLE, SIZE, OR COLOR.

FOR CONSULTING SERVICES IN THE FIELD OF MARKETING PROVIDED TO HEALTH AND MEDICAL PROFESSIONALS INCLUDING BUT NOT LIMITED TO DENTISTS, DENTAL STUDENTS, HYGIENISTS AND DENTAL SCHOOLS (U.S. CLS. 100, 101 AND 102).

SHARON MEIER, EXAMINING ATTORNEY

SN 77-650,637. BUSINESS NOVA CONSULTING, AKA BIZ-NOVA CONSULTING, PHOENIX, AZ. FILED 1-15-2009.

E-Merkatus

THE MARK CONSISTS OF STANDARD CHARACTERS WITHOUT CLAIM TO ANY PARTICULAR FONT, STYLE, SIZE, OR COLOR.

THE ENGLISH TRANSLATION OF THE LATIN TERM "MERKATUS" CONTAINED IN THE MARK IS TRADE.

FOR ON-LINE MARKETPLACES FOR SELLERS OF GOODS AND/OR SERVICES (U.S. CLS. 100, 101 AND 102).

RAUL CORDOVA, EXAMINING ATTORNEY

CLASS 35—(Continued).

SN 77-652,274. CROWD SCIENCE, INC., MOUNTAIN VIEW, CA. FILED 1-19-2009.



THE COLOR(S) ORANGE, WHITE, AND BLACK IS/ARE CLAIMED AS A FEATURE OF THE MARK.

THE MARK CONSISTS OF THREE ADJOINING, DIFFERENT-SIZED OVALS WITH ORANGE MARGINS AND WHITE INTERIORS, WITH THE WORDS "CROWD SCIENCE" TO THE RIGHT IN BLACK.

FOR MARKET RESEARCH SERVICES, NAMELY, AUTOMATICALLY SURVEYING WEBSITE VISITORS FOR DEMOGRAPHIC AND OPINION INFORMATION IN ORDER TO ANALYZE AND REPORT SURVEY RESULTS TO WEBSITE OWNER; MARKET RESEARCH SERVICES, NAMELY, AUTOMATICALLY SELECTING AND INVITING WEBSITE VISITORS TO PARTICIPATE IN THIRD-PARTY MARKET AND OPINION RESEARCH (U.S. CLS. 100, 101 AND 102).

FIRST USE 6-1-2008; IN COMMERCE 12-1-2008.
ANNE E. GUSTASON, EXAMINING ATTORNEY

SN 77-652,625. DARWIN, JOHN, DALLAS, TX. FILED 1-20-2009.



NO CLAIM IS MADE TO THE EXCLUSIVE RIGHT TO USE "WORKERS SUPPLY", APART FROM THE MARK AS SHOWN.

THE MARK CONSISTS OF TWO CIRCLES WITH THE STYLIZED TEXT "WORKERS SUPPLY" ON THE OUTER CIRCLE AND A DESIGN OF A WORKER WEARING A HAT IN THE INNER CIRCLE.

FOR RETAIL STORE AND ON-LINE RETAIL STORE SERVICES FEATURING WORK CLOTHING AND SAFETY FOOTWEAR (U.S. CLS. 100, 101 AND 102).

PAM WILLIS, EXAMINING ATTORNEY

CLASS 35—(Continued).

SN 77-654,202. VON STODDARD, GERALD R., PORTLAND, ME. FILED 1-22-2009.

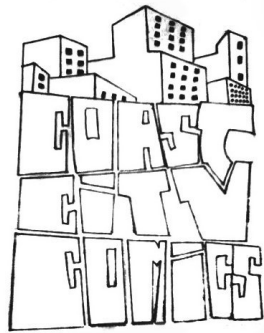

NO CLAIM IS MADE TO THE EXCLUSIVE RIGHT TO USE "COMICS", APART FROM THE MARK AS SHOWN.

THE MARK CONSISTS OF THE WORDING "COAST CITY COMICS" IN LARGE OUTLINED BLOCK LETTERS, ONE WORD ON TOP OF THE OTHER, WITH A CITYSCAPE ABOVE THE WORDING AND TWO ELONGATED QUADRILATERALS BELOW IT.

FOR ON-LINE RETAIL STORE SERVICES FEATURING COMIC BOOKS AND COMIC BOOK COLLECTIBLES; RETAIL STORE SERVICES FEATURING COMIC BOOKS AND COMIC BOOK COLLECTIBLES (U.S. CLS. 100, 101 AND 102).

ALICE SUE CARRUTHERS, EXAMINING ATTORNEY

SN 77-654,666. HINGE INCORPORATED, RESTON, VA. FILED 1-22-2009.

HINGE

THE MARK CONSISTS OF STANDARD CHARACTERS WITHOUT CLAIM TO ANY PARTICULAR FONT, STYLE, SIZE, OR COLOR.

FOR MARKETING AND ADVERTISING SERVICES, NAMELY, BRAND DEVELOPMENT, CONSUMER MARKETING RESEARCH, DEVELOPMENT, DESIGN AND CREATION OF MARKETING STRATEGIES, WEBSITE AND ELECTRONIC MARKETING, MARKETING PLANNING AND IMPLEMENTATION, AND ADVERTISING AND MARKETING CONSULTING (U.S. CLS. 100, 101 AND 102).

FIRST USE 9-16-2002; IN COMMERCE 9-16-2002. MICHELLE DUBOIS, EXAMINING ATTORNEY

CLASS 35—(Continued).

SN 77-654,819. GO BOOZERS, HOUSTON, TX. FILED 1-22-2009.

Boozers

THE MARK CONSISTS OF STANDARD CHARACTERS WITHOUT CLAIM TO ANY PARTICULAR FONT, STYLE, SIZE, OR COLOR.

FOR RETAIL DELICATESSEN SERVICES; RETAIL STORE AND ON-LINE RETAIL STORE SERVICES FEATURING LIQUOR, WINE, TOBACCO (U.S. CLS. 100, 101 AND 102).

ERIN FALK, EXAMINING ATTORNEY

SN 77-655,670. BOOMVANG CREATIVE GROUP, LLC, PHOENIX, AZ. FILED 1-23-2009.

BOOMVANG

THE MARK CONSISTS OF STANDARD CHARACTERS WITHOUT CLAIM TO ANY PARTICULAR FONT, STYLE, SIZE, OR COLOR.

FOR CUSTOM WRITING OF TEXTS FOR ADVERTISING, PUBLIC RELATIONS AND MARKETING THROUGH ALL TYPES OF PRINT AND DIGITAL MEDIA (U.S. CLS. 100, 101 AND 102).

RAMONA ORTIGA, EXAMINING ATTORNEY

SN 77-655,683. CEQUEL COMMUNICATIONS, LLC, DBA SUDDENLINK COMMUNICATIONS, ST. LOUIS, MO. FILED 1-23-2009.

VIPPERKS

THE MARK CONSISTS OF STANDARD CHARACTERS WITHOUT CLAIM TO ANY PARTICULAR FONT, STYLE, SIZE, OR COLOR.

FOR ARRANGING AND CONDUCTING INCENTIVE REWARD PROGRAMS FOR CUSTOMERS TO PROMOTE THE SALE OF TELECOMMUNICATIONS SERVICES, NAMELY, CABLE TELEVISION TRANSMISSION, HIGH SPEED INTERNET ACCESS, AND TELEPHONE SERVICES (U.S. CLS. 100, 101 AND 102).

COURTNEY MCCORMICK, EXAMINING ATTORNEY

CLASS 35—(Continued).

SN 77-657,777. PUROSYSTEMS, INC., TAMARAC, FL. FILED 1-27-2009.

PUROCLEAN: THE REAL
RECESSION PROOF FRANCHISE

THE MARK CONSISTS OF STANDARD CHARACTERS WITHOUT CLAIM TO ANY PARTICULAR FONT, STYLE, SIZE, OR COLOR.

OWNER OF U.S. REG. NOS. 1,689,761, 3,561,929 AND OTHERS.

NO CLAIM IS MADE TO THE EXCLUSIVE RIGHT TO USE "FRANCHISE", APART FROM THE MARK AS SHOWN.

FOR FRANCHISE SERVICES, NAMELY, OFFERING TECHNICAL ASSISTANCE IN THE ESTABLISHMENT AND/OR OPERATION OF PROPERTY DAMAGE RESTORATION SERVICES, DISASTER RECOVERY SERVICES IN THE NATURE OF BUILDING CLEANUP AND REPAIR AND COMMERCIAL AND RESIDENTIAL BUILDING CLEANING SERVICES (U.S. CLS. 100, 101 AND 102).

ELLEN BURNS, EXAMINING ATTORNEY

CLASS 35—(Continued).

SN 77-657,980. THE STEPHEN PAUL COMPANY, SAN ANTONIO, TX. FILED 1-28-2009.



THE COLOR(S) GREEN, BLUE, RED, ORANGE, YELLOW, AND PURPLE IS/ARE CLAIMED AS A FEATURE OF THE MARK.

THE MARK CONSISTS OF THREE (3) WORDS "IGNITE YOUR PASSION". THE WORDS "IGNITE" AND "YOUR" ARE ABOVE THE WORD "PASSION". THE TEXT COLORS ARE GREEN ("IGNITE"), GREEN ("YOUR"), AND BLUE ("PASSION"). THERE IS A FLAME ENCIRCLED BY 4 SEMI-CIRCLE BANDS. THE COLORS OF THE BANDS FROM TOP TO BOTTOM ARE BLUE, PURPLE, YELLOW, AND GREEN. THE FLAME ITSELF IS RED AT THE BOTTOM AND HAS A GRADIENT TO ORANGE AT THE TOP. THE FLAME IS LOCATED TO THE LEFT OF THE TEXT.

FOR ELECTRONIC COMMERCE SERVICES, NAMELY, PROVIDING INFORMATION ABOUT PRODUCTS VIA TELECOMMUNICATION NETWORKS FOR ADVERTISING AND SALES PURPOSES, EXCLUDING THE FIELD OF WATERCRAFT AND WATER ACTIVITIES (U.S. CLS. 100, 101 AND 102).

FIRST USE 1-25-2009; IN COMMERCE 1-25-2009.
MELVIN AXILBUND, EXAMINING ATTORNEY

SN 77-657,945. DR. ARLENE KAISER, MILPITAS, CA. FILED 1-27-2009.

NATIONAL TWO DIFFERENT
COLORED SHOES DAY

THE MARK CONSISTS OF STANDARD CHARACTERS WITHOUT CLAIM TO ANY PARTICULAR FONT, STYLE, SIZE, OR COLOR.

NO CLAIM IS MADE TO THE EXCLUSIVE RIGHT TO USE "NATIONAL" AND "DAY", APART FROM THE MARK AS SHOWN.

FOR PROMOTING PUBLIC AWARENESS OF THE UNIQUENESS AND DIVERSITY OF HUMANITY THROUGH A NATIONAL ANNUAL DAY EVENT (U.S. CLS. 100, 101 AND 102).

FIRST USE 1-14-2009; IN COMMERCE 1-14-2009.
AMY KERTGATE, EXAMINING ATTORNEY

SN 77-658,238. ADVANCE NBOD INC., BROOKLYN, NY. FILED 1-28-2009.



NBOD A Project Developing Company

NO CLAIM IS MADE TO THE EXCLUSIVE RIGHT TO USE "A PROJECT DEVELOPING COMPANY", APART FROM THE MARK AS SHOWN.

THE MARK CONSISTS OF THE CAPITAL LETTER "A" ON A SHADED SQUARE ABOVE THE WORDING "NBOD A PROJECT DEVELOPING COMPANY".

FOR BUSINESS MANAGEMENT CONSULTING WITH RELATION TO STRATEGY, MARKETING AND RETAIL AND WHOLESALE SALES MATTERS (U.S. CLS. 100, 101 AND 102).

AISHA SALEM, EXAMINING ATTORNEY

CLASS 35—(Continued).

SN 77-658,346. CHIP 1 EXCHANGE USA, INC., DBA CHIP 1 EXCHANGE, RANCHO SANTA MARAGRITA, CA. FILED 1-28-2009.



NO CLAIM IS MADE TO THE EXCLUSIVE RIGHT TO USE "CHIP" AND "EXCHANGE", APART FROM THE MARK AS SHOWN.

THE COLOR(S) GREEN AND GRAY IS/ARE CLAIMED AS A FEATURE OF THE MARK.

THE MARK CONSISTS OF A STAR WITH EIGHT POINTS AND THE WORDS "CHIP ONE" CENTERED IN STYLIZED FONT BELOW THE STAR, THE WORD "EXCHANGE" IN UPPERCASE CENTERED BELOW THE WORDS "CHIP ONE". THE COLOR GREEN APPEARS ON THE UPPER, LOWER AND RIGHT SIDE POINTS OF THE STAR AND THE WORD "CHIP". THE COLOR GRAY APPEARS ON THE LEFT SIDE POINTS OF THE STAR, THE WORD "ONE" AND "EXCHANGE".

FOR WHOLESALE DISTRIBUTORSHIPS FEATURING ELECTRONIC COMPONENTS (U.S. CLS. 100, 101 AND 102).

FIRST USE 4-18-2007; IN COMMERCE 4-18-2007.
TINA BROWN, EXAMINING ATTORNEY

SN 77-658,933. POLITICS4ALL.COM CORPORATION, MONTGOMERY, AL. FILED 1-29-2009.



OWNER OF U.S. REG. NO. 3,606,970.
NO CLAIM IS MADE TO THE EXCLUSIVE RIGHT TO USE "POLITICS", APART FROM THE MARK AS SHOWN.

THE MARK CONSISTS OF A CIRCULAR BALL WITH THE TOP AND BOTTOM PORTIONS OF THE BALL SHADED AND A LINE THROUGH THE CENTER OF THE BALL IN WHITE WITH THE NUMBER "4" CENTERED, WITH A DASH ON EACH SIDE OF THE NUMBER "4", AND THE WORD, "POLITICS", TO THE LEFT OF THE BALL AND THE WORD, "ALL", TO THE RIGHT OF THE BALL.

FOR PROVIDING A COMMUNITY-DRIVEN WEBSITE FOR THE PUBLIC, NAMELY, A WEBSITE FEATURING INFORMATION ON POLITICAL CANDIDATES AND ISSUES, POLITICAL CAMPAIGNS, SPECIAL INTEREST ORGANIZATIONS, AND ONLINE POLLING FOR VOTERS, POLITICAL CANDIDATES, SPECIAL INTEREST GROUPS AND LOBBYISTS ON A COMPUTER SERVER VIA A GLOBAL COMPUTER NETWORK; PROVIDING NEWS AND OTHER INFORMATION IN THE FIELD OF POLITICS, NAMELY, INFORMATION ON POLITICAL CANDIDATES AND ISSUES, POLITICAL CAMPAIGNS, SPECIAL INTEREST ORGANIZATIONS, AND ONLINE POLLING VIA A GLOBAL COMPUTER NETWORK (U.S. CLS. 100, 101 AND 102).

FIRST USE 9-9-2008; IN COMMERCE 9-9-2008.
JORDAN BAKER, EXAMINING ATTORNEY

CLASS 35—(Continued).

SN 77-659,342. BURROUGHS, TONY, PAGOSA SPRINGS, CO. FILED 1-29-2009.

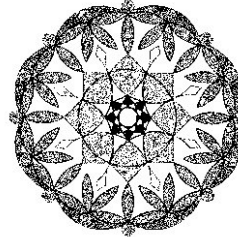

THE STIPLING IS FOR SHADING PURPOSES ONLY.

THE MARK CONSISTS OF A CIRCULAR LOGO CONTAINING AN OUTER RING MADE UP OF 16 STICK-LIKE FIGURES ALTERNATING, ONE WITH TWO LEGS AND THE NEXT WITH ONE LEG. THEIR ARMS ARE CONNECTED TO FORM THE OUTER CIRCLE OF THE LOGO. INSIDE THIS RING ARE TWO BOXES OVERLAYED ON EACH OTHER FORMING AN EIGHT POINTED DESIGN. INSIDE OF THAT IS A CIRCLE WITH AN EIGHT POINTED STAR. AND INSIDE THE STAR IS ANOTHER RING WITH SMALL EIGHT DIAMONDS IN IT. THERE IS A SMALL DOT IN THE EXACT CENTER OF THE LOGO.

FOR ON-LINE RETAIL STORE SERVICES FEATURING BOOKS, DVDS, POSTERS, CLOTHING, GREETING CARDS, DECALS, AND JEWELRY (U.S. CLS. 100, 101 AND 102).

FIRST USE 1-1-2001; IN COMMERCE 1-1-2001.
COURTNEY MCCORMICK, EXAMINING ATTORNEY

SN 77-659,355. ENTERGY CORPORATION, NEW ORLEANS, LA. FILED 1-29-2009.

ENTERGY ANSWERS

THE MARK CONSISTS OF STANDARD CHARACTERS WITHOUT CLAIM TO ANY PARTICULAR FONT, STYLE, SIZE, OR COLOR.

OWNER OF U.S. REG. NOS. 2,387,356, 3,287,484 AND 3,289,605.

FOR EDUCATIONAL SERVICES, NAMELY, PROVIDING ON-LINE INFORMATION IN THE FIELD OF ENERGY CONSERVATION, ENERGY USAGE, AND ENERGY EFFICIENCY (U.S. CLS. 100, 101 AND 102).

APRIL HESIK, EXAMINING ATTORNEY

CLASS 35—(Continued).

SN 77-659,835. JUST DIAL PRIVATE LIMITED, MUMBAI, INDIA, FILED 1-30-2009.

Justdial.com

THE COLOR(S) DARK GREY, LIGHT GREY AND WHITE IS/ARE CLAIMED AS A FEATURE OF THE MARK.

THE MARK CONSISTS OF THE WORD "JUSTDIAL.COM" IN WHICH THE "JUST" IS IN DARK GREY, AND "DIAL" AND ".COM" ARE IN LIGHT GREY. THE MARK IS IN WHITE BACKGROUND. THE COLORS DARK GREY, LIGHT GREY AND WHITE ARE CLAIMED AS A FEATURE OF THE MARK.

FOR ADVERTISING AND DIRECTORY SERVICES, NAMELY, PROMOTING THE SERVICES OF OTHERS BY PROVIDING A WEB PAGE FEATURING LINKS TO THE WEBSITES OF OTHERS; ADVERTISING AND PUBLICITY SERVICES, NAMELY, PROMOTING THE GOODS, SERVICES, BRAND IDENTITY AND COMMERCIAL INFORMATION AND NEWS OF THIRD PARTIES THROUGH PRINT, AUDIO, VIDEO, DIGITAL AND ON-LINE MEDIUM; COMMERCIAL INFORMATION AND DIRECTORY AGENCY; PROVIDING AN ON-LINE COMMERCIAL INFORMATION DIRECTORY ON THE INTERNET; TELEPHONE DIRECTORY ASSISTANCE SERVICES; TELEPHONE DIRECTORY INFORMATION (U.S. CLS. 100, 101 AND 102).

JOHN SCHUYLER YARD, EXAMINING ATTORNEY

CLASS 35—(Continued).

SN 77-660,024. VAUGHT, INC., DBA NIGHT WATCH, BECKLEY, WV. FILED 1-30-2009.

Night Watch

THE MARK CONSISTS OF STANDARD CHARACTERS WITHOUT CLAIM TO ANY PARTICULAR FONT, STYLE, SIZE, OR COLOR.

NO CLAIM IS MADE TO THE EXCLUSIVE RIGHT TO USE "NIGHT", APART FROM THE MARK AS SHOWN.

FOR EMPLOYMENT STAFFING IN THE FIELD OF PHARMACY (U.S. CLS. 100, 101 AND 102).

FIRST USE 11-7-2006; IN COMMERCE 11-7-2006.

SARA THOMAS, EXAMINING ATTORNEY

SN 77-659,867. D'ADAMO, PETER JAMES, WILTON, CT. FILED 1-30-2009.

PERSONALIZED NUTRITION
DESIGNED BY DR. PETER
D'ADAMO

THE MARK CONSISTS OF STANDARD CHARACTERS WITHOUT CLAIM TO ANY PARTICULAR FONT, STYLE, SIZE, OR COLOR.

OWNER OF U.S. REG. NO. 2,368,884.

NO CLAIM IS MADE TO THE EXCLUSIVE RIGHT TO USE "PERSONALIZED NUTRITION DESIGNED BY", APART FROM THE MARK AS SHOWN.

FOR ON-LINE RETAIL STORE SERVICES FEATURING NUTRITIONAL SUPPLEMENTS, VITAMIN SUPPLEMENTS, MINERAL SUPPLEMENTS, TEA, PROTEIN POWDERS, FOOD BARS, SKIN CARE PRODUCTS, BOOKS, AUDIOBOOKS, AND BLOOD TYPING KITS (U.S. CLS. 100, 101 AND 102).

FIRST USE 3-0-2008; IN COMMERCE 3-0-2008.

LAKEISHA LEWIS, EXAMINING ATTORNEY

SN 77-660,166. MEL FOSTER CO. INC. OF IOWA, DAVENPORT, IA. FILED 1-30-2009.

Making It Happen

THE MARK CONSISTS OF STANDARD CHARACTERS WITHOUT CLAIM TO ANY PARTICULAR FONT, STYLE, SIZE, OR COLOR.

FOR REAL ESTATE ADVERTISING SERVICES (U.S. CLS. 100, 101 AND 102).

FIRST USE 6-13-2003; IN COMMERCE 6-13-2003.

AMY KERTGATE, EXAMINING ATTORNEY

CLASS 35—(Continued).

SN 77-660,274. SIERRA TRADING POST, INC., CHEYENNE, WY. FILED 1-30-2009.

ADVENTURE EDGE

THE MARK CONSISTS OF STANDARD CHARACTERS WITHOUT CLAIM TO ANY PARTICULAR FONT, STYLE, SIZE, OR COLOR.

OWNER OF U.S. REG. NO. 2,501,065.

FOR COMPUTERIZED ON-LINE SHOPPING AND ORDERING SERVICES, AND CATALOG MAIL ORDER, TELEPHONE ORDER AND FAX ORDER SERVICES, FEATURING MEN'S, WOMEN'S, AND CHILDREN'S CLOTHING, OUTERWEAR, FOOTWEAR, ATHLETIC AND SPORTING WEAR, SLEEPWEAR, HEADWEAR, PURSES, HANDBAGS, BELTS, SUNGLASSES, SPORTS GOGGLES, WATCHES, LUGGAGE, HAND BAGS, GYM BAGS, SHOULDER BAGS, BACKPACKS, DAY PACKS, FANNY PACKS AND RUCKSACKS, DUFFEL BAGS, SLEEPING BAGS, TENTS, PORTABLE CHAIRS, SNOWSHOES, CRAMPONS, ICE AXES, FLASHLIGHTS, CAMERAS, BINOCULARS, PORTABLE OUTDOOR ELECTRONICS, CAMPING EQUIPMENT, SKI EQUIPMENT, SNOWBOARDING EQUIPMENT, SLEDDING EQUIPMENT, SPORTING GOODS, MOUNTAINEERING EQUIPMENT, CLIMBING EQUIPMENT, FISHING EQUIPMENT, HIKING EQUIPMENT, HUNTING EQUIPMENT, BICYCLING EQUIPMENT, AND WATER SPORTS EQUIPMENT FOR USE IN SCUBA DIVING, WATER SKIING, SURFING, AND SWIMMING, AND ACCESSORIES FOR THE FOREGOING GOODS (U.S. CLS. 100, 101 AND 102).

LINDA MICKLEBURGH, EXAMINING ATTORNEY

SN 77-660,447. SIERRA TRADING POST, INC., CHEYENNE, WY. FILED 1-30-2009.

GREAT DEALS. GREAT BRANDS.

THE MARK CONSISTS OF STANDARD CHARACTERS WITHOUT CLAIM TO ANY PARTICULAR FONT, STYLE, SIZE, OR COLOR.

FOR CATALOG MAIL ORDER, TELEPHONE ORDER AND FAX ORDER SERVICES, AND COMPUTERIZED ON-LINE SHOPPING AND ORDERING SERVICES, ALL FEATURING MEN'S, WOMEN'S, AND CHILDREN'S CLOTHING, OUTERWEAR, FOOTWEAR, SHOES, BOOTS, SANDALS, SLIPPERS, SOCKS, ATHLETIC AND SPORTING WEAR, SLEEPWEAR, LEATHER CLOTHING, HAIR ORNAMENTS, HEADWEAR, PURSES, HANDBAGS, LEATHER HANDBAGS, BELTS, SUNGLASSES, WATCHES, LUGGAGE, LEATHER LUGGAGE, GYM BAGS, SHOULDER BAGS, BACKPACKS, DAY PACKS, FANNY PACKS AND RUCKSACKS, DUFFEL BAGS, BEAN BAGS, GARMENT BAGS FOR STORAGE, ALL PURPOSE SPORTS BAGS, SLEEPING BAGS, TENTS, PORTABLE CHAIRS, SNOWSHOES, CRAMPONS, ICE AXES, FLASHLIGHTS, CAMERAS, BINOCULARS, RADIO TELEPHONES, RADIO TRANSMITTERS, PORTABLE OUTDOOR ELECTRONICS, SPORTING GOODS, WATER SPORTS EQUIPMENT FOR USE IN SCUBA DIVING, WATER SKIING, SURFING AND SWIMMING, EQUIPMENT, CLOTHING AND ACCESSORIES FOR HUNTING, FISHING, HIKING, WALKING, CLIMBING, CAMPING, SKIING, SNOWBOARDING, SLEDDING, MOUNTAINEERING AND BICYCLING, BICYCLES, WALKING CANES AND STICKS, LINENS, BED LINENS, BED BLANKETS, BED SHEETS, BED

CLASS 35—(Continued).

SPREADS, MATTRESSES, MATTRESS COVERS, TOWELS, HOME FURNISHINGS, OUTDOOR CLOTHING, GARDENING EQUIPMENT, PRODUCTS FOR THE HOME, HOME OFFICE, GARAGE, LAWN, GARDEN, POOL AND SPA, PERSONAL GIFTS, NAMELY, MONEY HOLDERS, TIMEPIECES, JEWELRY, COSTUME JEWELRY, CHRISTMAS ORNAMENTS AND DECORATIONS, GROOMING PRODUCTS, ELECTRONICS AND ACCESSORIES, GAMES, TOYS, PET PRODUCTS, GENERAL CONSUMER HOME GOODS, TRAVEL GEAR, OFFICE ACCESSORIES, COOKING UTENSILS AND ACCESSORIES, OUTDOOR AND SPORT GEAR AND EQUIPMENT, EYEGLASSES, SPORTS EYEWEAR, PROTECTIVE EYEWEAR, SUNGLASS CASES, DIVING GOGGLES, SWIMMING GOGGLES, SCUBA GOGGLES, SKI GOGGLES, SNOW GOGGLES, HUNTING GOGGLES, SHOOTING SAFETY GOGGLES, SAFETY GOGGLES, SPORT GOGGLES, EYEWEAR ACCESSORIES, NAMELY, CASES, NECK CORDS, STRAPS, SUNGLASS LENSES, AND ACCESSORIES FOR THE FOREGOING GOODS (U.S. CLS. 100, 101 AND 102).

LINDA MICKLEBURGH, EXAMINING ATTORNEY

SN 77-660,462. SIERRA TRADING POST, INC., CHEYENNE, WY. FILED 1-30-2009.

SIERRA TRADING POST

THE MARK CONSISTS OF STANDARD CHARACTERS WITHOUT CLAIM TO ANY PARTICULAR FONT, STYLE, SIZE, OR COLOR.

OWNER OF U.S. REG. NOS. 2,289,952, 2,518,373 AND OTHERS.

FOR CATALOG MAIL ORDER, TELEPHONE ORDER AND FAX ORDER SERVICES, AND COMPUTERIZED ON-LINE SHOPPING AND ORDERING SERVICES, ALL FEATURING MEN'S, WOMEN'S, AND CHILDREN'S OUTERWEAR, SOCKS, SHOES, SANDALS, BOOTS, SLIPPERS, ATHLETIC AND SPORTING WEAR, SLEEPWEAR, BELTS, LUGGAGE, DAY PACKS, FANNY PACKS AND RUCKSACKS, DUFFEL BAGS, SLEEPING BAGS, TENTS, PORTABLE CHAIRS, SNOWSHOES, CRAMPONS, ICE AXES, FLASHLIGHTS, CAMERAS, BINOCULARS, CLOTHING AND ACCESSORIES FOR HUNTING, FISHING, HIKING, WALKING, CLIMBING, CAMPING, SKIING, SNOWBOARDING, SLEDDING, MOUNTAINEERING AND BICYCLING, WALKING CANES AND STICKS, LINENS, TOWELS, OUTDOOR CLOTHING, GARDENING EQUIPMENT, PRODUCTS FOR THE HOME, HOME OFFICE, GARAGE, LAWN, GARDEN, POOL AND SPA, PERSONAL GIFTS, NAMELY, MONEY HOLDERS, TIME PIECES, JEWELRY, CHRISTMAS ORNAMENTS AND DECORATIONS, GROOMING PRODUCTS, ELECTRONICS AND ACCESSORIES, GAMES, TOYS, PET PRODUCTS, GENERAL CONSUMER HOME GOODS, TRAVEL GEAR, OFFICE ACCESSORIES, COOKING UTENSILS AND ACCESSORIES, OUTDOOR AND SPORT GEAR AND EQUIPMENT, SPORTS EYEWEAR, PROTECTIVE EYEWEAR, SUNGLASS CASES, DIVING GOGGLES, SNOW GOGGLES, HUNTING GOGGLES, SHOOTING SAFETY GOGGLES, SAFETY GOGGLES, EYEWEAR ACCESSORIES, NAMELY, CASES, NECK CORDS, STRAPS, SUNGLASS LENSES, AND ACCESSORIES FOR THE FOREGOING GOODS (U.S. CLS. 100, 101 AND 102).

LINDA MICKLEBURGH, EXAMINING ATTORNEY

CLASS 35—(Continued).

SN 77-660,576. OPUS III-VII CORPORATION, OMAHA, NE.
FILED 1-30-2009.

RxCareAssurance
POWERED BY OPUS

THE MARK CONSISTS OF THE STYLIZED WORDING "RXCAREASSURANCE" ABOVE THE WORDING "POWERED BY OPUS". THE "X" IS "RX" FORMS A CHECK MARK.

FOR BUSINESS MANAGEMENT, BUSINESS CONSULTING, MARKETING, ADVERTISING AND PROMOTIONAL SERVICES FOR THE PHARMACY INDUSTRY; BUSINESS CONSULTING SERVICES IN THE FIELD OF MEDICATION MANAGEMENT BY CARE FACILITIES; PROCUREMENT, NAMELY, PURCHASING PHARMACY SUPPLIES FOR OTHERS (U.S. CLS. 100, 101 AND 102).

MICHAEL SOUDERS, EXAMINING ATTORNEY

CLASS 35—(Continued).

SN 77-661,254. ANDERSON HENDRIX, HOMEWOOD, IL.
FILED 2-2-2009.

Anderson Hendrix

THE MARK CONSISTS OF STANDARD CHARACTERS WITHOUT CLAIM TO ANY PARTICULAR FONT, STYLE, SIZE, OR COLOR.

THE NAME SHOWN IN THE MARK DOES NOT IDENTIFY A PARTICULAR LIVING INDIVIDUAL.

FOR PROVIDING BUSINESS CONSULTATION SERVICES IN ORDER TO ASSIST BUSINESSES IN REALIZING THEIR FULL POTENTIAL, NAMELY, PROVIDING ASSISTANCE, ADVISORY SERVICES AND CONSULTANCY WITH REGARD TO BUSINESS PLANNING, BUSINESS ANALYSIS, BUSINESS MANAGEMENT AND BUSINESS ORGANIZATION; ADVERTISING AND MARKETING; BUSINESS STRATEGY CONSULTING; BUSINESS MANAGEMENT CONSULTING WITH RELATION TO STRATEGY, FINANCING, MARKETING, PRODUCTION, PERSONNEL AND SALE MATTERS FOR COMPANIES INVOLVED WITH CONSUMER PRODUCTS, INDUSTRIAL PRODUCTS, FINANCIAL SERVICES, ENTERTAINMENT, TECHNOLOGY, RETAIL, MEDIA, ENERGY, REAL ESTATE, INDUSTRIAL PRODUCTS, HARD AND SOFT GOODS MANUFACTURING, ELECTRONICS, TRAVEL, TRANSPORTATION, LIFE SCIENCE, INSURANCE, APPAREL AND TEXTILES (U.S. CLS. 100, 101 AND 102).

FIRST USE 1-1-2004; IN COMMERCE 1-1-2004.

MARTHA FROMM, EXAMINING ATTORNEY

SN 77-661,023. JAYEN, INC., VICTORIA, TX. FILED 2-2-2009.

FASTOP

THE MARK CONSISTS OF STANDARD CHARACTERS WITHOUT CLAIM TO ANY PARTICULAR FONT, STYLE, SIZE, OR COLOR.

FOR RETAIL STORE SERVICES FEATURING CONVENIENCE STORE ITEMS AND GASOLINE (U.S. CLS. 100, 101 AND 102).

FIRST USE 7-1-1983; IN COMMERCE 7-1-1983.

WON TEAK OH, EXAMINING ATTORNEY

SN 77-661,311. HOME IMPROVEMENTS 4 LESS, ONTARIO, CA. FILED 2-2-2009.



NO CLAIM IS MADE TO THE EXCLUSIVE RIGHT TO USE "HOME IMPROVEMENTS FOR LESS", APART FROM THE MARK AS SHOWN.

THE COLOR(S) BLUE, GREEN AND WHITE IS/ARE CLAIMED AS A FEATURE OF THE MARK.

THE MARK CONSISTS OF A PARTIAL BLUE OUTLINE OF A STICK HOUSE WITH THE WORDS HOME IMPROVEMENTS IN GREEN AND 4 LESS IN BLUE COMING OUT OF THE HOUSE. BELOW THESE WORDS IS A BLUE RECTANGLE CONTAINING THE WHITE WORDS YOUR PROJECT YOUR PRICE WITH A WHITE DOT BETWEEN THE WORDS PROJECT AND YOUR.

FOR ADVERTISING AND MARKETING SERVICES, NAMELY, PROMOTING THE GOODS AND SERVICES OF OTHERS (U.S. CLS. 100, 101 AND 102).

FIRST USE 10-22-2008; IN COMMERCE 1-20-2009.

ALLISON HOLTZ, EXAMINING ATTORNEY

CLASS 35—(Continued).

SN 77-661,409. LOVINGER, MARK, RIVERSIDE, CA. AND LOVINGER, ROBERTA, RIVERSIDE, CA. FILED 2-2-2009.

DISCOUNT HYDROPONICS

THE MARK CONSISTS OF STANDARD CHARACTERS WITHOUT CLAIM TO ANY PARTICULAR FONT, STYLE, SIZE, OR COLOR.

NO CLAIM IS MADE TO THE EXCLUSIVE RIGHT TO USE "DISCOUNT", APART FROM THE MARK AS SHOWN. SEC. 2(F).

FOR RETAIL AGRICULTURAL STORE SERVICES FEATURING HYDROPONIC AND ORGANIC EQUIPMENT AND SUPPLIES (U.S. CLS. 100, 101 AND 102).

FIRST USE 10-1-1999; IN COMMERCE 10-1-1999.
LAKEISHA LEWIS, EXAMINING ATTORNEY

CLASS 35—(Continued).

SN 77-661,751. RELOADER MOTORCYCLE PARTS WAREHOUSE, PHILADELPHIA, PA. FILED 2-2-2009.

Reloader

THE MARK CONSISTS OF STANDARD CHARACTERS WITHOUT CLAIM TO ANY PARTICULAR FONT, STYLE, SIZE, OR COLOR.

FOR RETAIL STORE AND ON-LINE RETAIL STORE SERVICES FEATURING NEW AND USED MOTORCYCLE PARTS, MOTORCYCLE RELATED APPAREL, MOTORCYCLE ACCESSORIES, AND MOTOR VEHICLE NOVELTIES (U.S. CLS. 100, 101 AND 102).

FIRST USE 8-22-2007; IN COMMERCE 8-22-2007.
LESLIE RICHARDS, EXAMINING ATTORNEY

SN 77-661,540. THE CHOCOLATERIE, INC., AKA THE CHOCOLATERIE LUXURY CHOCOLATES, CUMMING, GA. FILED 2-2-2009.



NO CLAIM IS MADE TO THE EXCLUSIVE RIGHT TO USE "THE CHOCOLATERIE", APART FROM THE MARK AS SHOWN.

THE MARK CONSISTS OF THE LETTER "C" IN THE CENTER OF A MEDALLION WITH 14 CURVED BARS SWIRLING FROM THE CENTER OUTWARD. THE OUTER EDGE OF THE MEDALLION SHAPE HAS 14 SCALLOPS, ONE FOR EACH CURVED BAR SWIRLING FROM THE CENTER OF THE MARK. BELOW THE MARK IS THE PHRASE "THE CHOCOLATERIE".

THE ENGLISH TRANSLATION OF "CHOCOLATERIE" IN THE MARK IS CHOCOLATE MAKER.

FOR RETAIL STORE SERVICES FEATURING CHOCOLATES AND CHOCOLATE FOOD PRODUCTS; MAIL ORDER SERVICES FEATURING CHOCOLATES AND CHOCOLATE FOOD PRODUCTS; ON-LINE RETAIL STORE SERVICES FEATURING CHOCOLATES AND CHOCOLATE FOOD PRODUCTS (U.S. CLS. 100, 101 AND 102).

FIRST USE 3-12-2007; IN COMMERCE 3-12-2007.
MARGERY A. TIERNEY, EXAMINING ATTORNEY

SN 77-661,892. THE ATILIO GROUP, LLC, RACINE, WI. FILED 2-3-2009.



OWNER OF U.S. REG. NOS. 3,596,156 AND 3,596,157.

THE MARK CONSISTS OF THE WORDS "SIMPLY FASTER" NEXT TO A STYLIZED "TAG" WHEREIN THE "A" LOOKS SIMILAR TO AN INVERTED "V", WITH A SMALL TRIANGLE BENEATH THE "A".

FOR PROVIDING OFFICE SUPPORT STAFF SERVICES IN THE CONSTRUCTION INDUSTRY, NAMELY, PROCESSING OF BIDS, SUBCONTRACTS, CHANGE ORDERS, PROJECT CLOSING AND COMPLETION DOCUMENTATION, PAYROLL, BILLING AND PAYMENTS, LIEN WAIVERS, AND INSURANCE PROCUREMENT IN CONSTRUCTION PROJECTS; BUSINESS INFORMATION AND ACCOUNTING ADVISORY SERVICES (U.S. CLS. 100, 101 AND 102).

B. PARADEWELAI, EXAMINING ATTORNEY

CLASS 35—(Continued).

SN 77-662,064. NATIONAL ASSOCIATION OF CONSTRUCTION AUDITORS, LLC, MIDLOTHIAN, VA. FILED 2-3-2009.



NO CLAIM IS MADE TO THE EXCLUSIVE RIGHT TO USE "NATIONAL ASSOCIATION OF CONSTRUCTION AUDITORS", APART FROM THE MARK AS SHOWN. THE STIPPLING IS FOR SHADING PURPOSES ONLY. THE MARK CONSISTS OF THE TEXT "NACA" WITH A CRANE ORIGINATING OUT OF THE "N", WITH BACKGROUND OF A CITY SKYLINE AND LARGE SUN, AND THE WORDS "NATIONAL ASSOCIATION OF CONSTRUCTION AUDITORS". FOR ASSOCIATION SERVICES, NAMELY, PROMOTING THE INTERESTS OF CONSTRUCTION AUDITORS (U.S. CLS. 100, 101 AND 102). KAREN K. BUSH, EXAMINING ATTORNEY

CLASS 35—(Continued).

SN 77-662,311. BBA AVIATION, PLC, LONDON, UNITED KINGDOM, FILED 2-3-2009.



THE COLOR(S) RED AND BLUE IS/ARE CLAIMED AS A FEATURE OF THE MARK. THE MARK CONSISTS OF THE WORD "ZIPP" IN STYLIZED FONT INSIDE THE IMAGE OF AN AIRPLANE, ALL IN BLUE. THE WORDS "ZERO INCIDENT PHILOSOPHY + PROCESS" APPEAR IN STYLIZED FONT BELOW THE AIRPLANE, ALL IN RED WITH THE EXCEPTION OF THE SYMBOL "+", WHICH IS IN BLUE. FOR BUSINESS ADMINISTRATION AND ADVERTISING AND PROMOTION SERVICES OF A GLOBAL SAFETY CAMPAIGN IN THE FIELD OF AVIATION; DEVELOPING PROMOTIONAL CAMPAIGNS FOR BUSINESS (U.S. CLS. 100, 101 AND 102). SOPHIA S. KIM, EXAMINING ATTORNEY

SN 77-662,215. WALMAN OPTICAL, MINNEAPOLIS, MN. FILED 2-3-2009.

PROLENS HD

THE MARK CONSISTS OF STANDARD CHARACTERS WITHOUT CLAIM TO ANY PARTICULAR FONT, STYLE, SIZE, OR COLOR. NO CLAIM IS MADE TO THE EXCLUSIVE RIGHT TO USE "HD", APART FROM THE MARK AS SHOWN. FOR DISTRIBUTORSHIP SERVICES IN THE FIELD OF OPTICAL LENSES, OPTICAL LENS TREATMENTS, OPTICAL LENS PREPARATIONS, AND OPTICAL LENS COATINGS (U.S. CLS. 100, 101 AND 102). MARTHA FROMM, EXAMINING ATTORNEY

SN 77-662,331. SOCIAL SERVICE COORDINATORS, INC., MIAMI LAKES, FL. FILED 2-3-2009.

MEDICARE PATHWAYS

THE MARK CONSISTS OF STANDARD CHARACTERS WITHOUT CLAIM TO ANY PARTICULAR FONT, STYLE, SIZE, OR COLOR. NO CLAIM IS MADE TO THE EXCLUSIVE RIGHT TO USE "MEDICARE", APART FROM THE MARK AS SHOWN. FOR BUSINESS MANAGEMENT AND CONSULTATION IN THE FIELD OF HEALTHCARE BENEFITS (U.S. CLS. 100, 101 AND 102). MICHELE SWAIN, EXAMINING ATTORNEY

CLASS 35—(Continued).

SN 77-662,359. FLORES, ARTHUR R, DBA GOINGGREEN, LAVON, TX. FILED S.R. 2-3-2009; AM. P.R. 4-21-2009.



NO CLAIM IS MADE TO THE EXCLUSIVE RIGHT TO USE "GREEN", APART FROM THE MARK AS SHOWN.
 THE COLOR(S) BLACK, GREEN AND WHITE IS/ARE CLAIMED AS A FEATURE OF THE MARK.
 THE MARK CONSISTS OF THE WORDS "GOING GREEN" IN WHITE LETTERS WITHIN A GREEN RECTANGLE OUTLINED IN BLACK. AFFIXED ABOVE THE WORDING IS A TREE WITH BLACK TRUNK AND BRANCHES, AND LEAVES IN GREEN AND WHITE, ALL AGAINST A GREEN, RECTANGULAR BACKGROUND.
 FOR ENERGY AUDITING (U.S. CLS. 100, 101 AND 102).
 FIRST USE 2-3-2009; IN COMMERCE 2-3-2009.
 IRA J. GOODSaid, EXAMINING ATTORNEY

SN 77-662,360. SOCIAL SERVICE COORDINATORS, INC., MIAMI LAKES, FL. FILED 2-3-2009.

SOCIAL SERVICE CHECKUP

THE MARK CONSISTS OF STANDARD CHARACTERS WITHOUT CLAIM TO ANY PARTICULAR FONT, STYLE, SIZE, OR COLOR.
 NO CLAIM IS MADE TO THE EXCLUSIVE RIGHT TO USE "SOCIAL SERVICE", APART FROM THE MARK AS SHOWN.
 FOR BUSINESS MANAGEMENT AND CONSULTATION IN THE FIELD OF BENEFITS ELIGIBILITY (U.S. CLS. 100, 101 AND 102).
 FIRST USE 11-30-2005; IN COMMERCE 11-30-2005.
 MICHELE SWAIN, EXAMINING ATTORNEY

SN 77-662,363. BIOSILO FOODS, INC., LA JOLLA, CA. FILED 2-3-2009.

BIOSILO FOODS

THE MARK CONSISTS OF STANDARD CHARACTERS WITHOUT CLAIM TO ANY PARTICULAR FONT, STYLE, SIZE, OR COLOR.
 NO CLAIM IS MADE TO THE EXCLUSIVE RIGHT TO USE "FOODS", APART FROM THE MARK AS SHOWN.
 FOR WHOLESALE FOOD DISTRIBUTORSHIP SERVICES (U.S. CLS. 100, 101 AND 102).
 FIRST USE 3-1-2008; IN COMMERCE 3-3-2008.
 LINDA LAVACHE, EXAMINING ATTORNEY

CLASS 35—(Continued).

SN 77-662,397. HENRY BERKOWITZ, NORWALK, CT. FILED 2-3-2009.

STRATEGIC STUMBLING

THE MARK CONSISTS OF STANDARD CHARACTERS WITHOUT CLAIM TO ANY PARTICULAR FONT, STYLE, SIZE, OR COLOR.
 FOR BUSINESS CONSULTATION (U.S. CLS. 100, 101 AND 102).
 RENEE MCCRAY, EXAMINING ATTORNEY

SN 77-662,721. BUTLER, LES, SMYRNA, TN. FILED 2-3-2009.

Family Music Group

THE MARK CONSISTS OF STANDARD CHARACTERS WITHOUT CLAIM TO ANY PARTICULAR FONT, STYLE, SIZE, OR COLOR.
 NO CLAIM IS MADE TO THE EXCLUSIVE RIGHT TO USE "MUSIC GROUP", APART FROM THE MARK AS SHOWN.
 FOR ENTERTAINMENT MARKETING SERVICES, NAMELY, MARKETING, PROMOTION AND ADVERTISING FOR INDEPENDENT RECORDING ARTISTS (U.S. CLS. 100, 101 AND 102).
 FIRST USE 1-1-1997; IN COMMERCE 1-1-1997.
 NATALIE POLZER, EXAMINING ATTORNEY

SN 77-662,768. NATIONAL UNION OF HEALTHCARE WORKERS, OAKLAND, CA. FILED 2-3-2009.



NO CLAIM IS MADE TO THE EXCLUSIVE RIGHT TO USE "NATIONAL UNION OF HEALTHCARE WORKERS", APART FROM THE MARK AS SHOWN.
 THE COLOR(S) RED, WHITE, BLACK IS/ARE CLAIMED AS A FEATURE OF THE MARK.
 THE MARK CONSISTS OF THE STYLIZED LETTERS "N", "U", "H" AND "W" IN WHITE WITH EACH LETTER IN A SEPARATE RED BOX AND "NATIONAL UNION OF HEALTHCARE WORKERS" IN BLACK TEXT UNDERNEATH.
 FOR LABOR UNIONS (U.S. CLS. 100, 101 AND 102).
 FIRST USE 2-2-2009; IN COMMERCE 2-2-2009.
 ALEX KEAM, EXAMINING ATTORNEY

CLASS 35—(Continued).

SN 77-662,775. EJ TOYS AND GIFTS, LLC, CULVER CITY, CA. FILED 2-3-2009.

EJ

THE MARK CONSISTS OF STANDARD CHARACTERS WITHOUT CLAIM TO ANY PARTICULAR FONT, STYLE, SIZE, OR COLOR.

FOR WHOLESALE DISTRIBUTORSHIP SERVICES IN THE FIELD OF TOYS, GAMES, PLAYTHINGS, AND GIFTS (U.S. CLS. 100, 101 AND 102).

FIRST USE 0-0-1989; IN COMMERCE 0-0-1989.
ALEX KEAM, EXAMINING ATTORNEY

SN 77-662,903. THE RESOURCING SOLUTIONS GROUP, INC., CHARLOTTE, NC. FILED 2-4-2009.



THE COLOR(S) LIGHT AND DARK GREEN IS/ARE CLAIMED AS A FEATURE OF THE MARK.

THE MARK CONSISTS OF A TWO-COLOR DRAWING OF A HORSE IN LIGHT AND DARK GREEN THE WORD "PRONTO" IN LIGHT GREEN THE WORD "PAYROLL" IN DARK GREEN.

FOR ADMINISTRATION OF BUSINESS PAYROLL FOR OTHERS (U.S. CLS. 100, 101 AND 102).
SHAILA SETTLES, EXAMINING ATTORNEY

SN 77-662,939. SOLVATE.COM, INC., WASHINGTON DE-POT, CT. FILED 2-4-2009.

SOLVATE

THE MARK CONSISTS OF STANDARD CHARACTERS WITHOUT CLAIM TO ANY PARTICULAR FONT, STYLE, SIZE, OR COLOR.

FOR PROVIDING A WEBSITE FEATURING BUSINESS SOLUTIONS TO CLIENTS BY OFFERING BUSINESS ADVICE AND INFORMATION AND ASSOCIATED BUSINESS ADMINISTRATIVE SUPPORT SERVICES (U.S. CLS. 100, 101 AND 102).

FIRST USE 1-5-2009; IN COMMERCE 1-5-2009.
FRED MANDIR, EXAMINING ATTORNEY

CLASS 35—(Continued).

SN 77-663,051. NEBRASKA BOOK COMPANY, INC., LINCOLN, NE. FILED 2-4-2009.

CampusHub

THE MARK CONSISTS OF STANDARD CHARACTERS WITHOUT CLAIM TO ANY PARTICULAR FONT, STYLE, SIZE, OR COLOR.

OWNER OF U.S. REG. NO. 2,867,029.
FOR VALUE-ADDED RESELLER SERVICES, NAMELY, DISTRIBUTORSHIP SERVICES IN THE FIELD OF COMPUTER SOFTWARE LICENSES FOR THE BOOKSTORE INDUSTRY; ASSISTING BOOKSTORES TO PROMOTE THE SALE OF BOOKSTORE MERCHANDISE THROUGH WEB SITES MAINTAINED EITHER BY OR FOR THE BENEFIT OF THE BOOKSTORES, NAMELY, BUSINESS CONSULTING SERVICES (U.S. CLS. 100, 101 AND 102).

FIRST USE 3-0-2000; IN COMMERCE 3-0-2000.
ESTHER BELENKER, EXAMINING ATTORNEY

SN 77-663,053. BATTERIES PLUS, LLC, HARTLAND, WI. FILED 2-4-2009.

LightBulbsPlus+

OWNER OF U.S. REG. NOS. 2,725,695 AND 3,322,549.
THE COLOR(S) GREEN AND ORANGE IS/ARE CLAIMED AS A FEATURE OF THE MARK.

THE MARK CONSISTS OF THE WORD "LIGHTBULBS" IN GREEN, THE WORD "PLUS" IN ORANGE WITH A GREEN AND ORANGE PLUS SYMBOL IN THE SHAPE OF A PERSON.

FOR FRANCHISING, NAMELY, OFFERING TECHNICAL ASSISTANCE IN THE ESTABLISHMENT AND/OR OPERATION OF RETAIL STORES FEATURING LIGHT BULBS; RETAIL STORE SERVICES FEATURING LIGHT BULBS (U.S. CLS. 100, 101 AND 102).
DAVID ELTON, EXAMINING ATTORNEY

SN 77-663,145. BATTERIES PLUS, LLC, HARTLAND, WI. FILED 2-4-2009.

BulbsPlus+

OWNER OF U.S. REG. NOS. 2,725,695 AND 3,322,549.
THE COLOR(S) GREEN AND ORANGE IS/ARE CLAIMED AS A FEATURE OF THE MARK.

THE MARK CONSISTS OF THE WORD "BULBS" IN GREEN, THE WORD "PLUS" IN ORANGE WITH A GREEN AND ORANGE PLUS SYMBOL IN THE SHAPE OF A PERSON.

FOR FRANCHISING, NAMELY, OFFERING TECHNICAL ASSISTANCE IN THE ESTABLISHMENT AND/OR OPERATION OF RETAIL STORES FEATURING LIGHT BULBS; RETAIL STORE SERVICES FEATURING LIGHT BULBS (U.S. CLS. 100, 101 AND 102).
DAVID ELTON, EXAMINING ATTORNEY

CLASS 35—(Continued).

SN 77-663,165. DEUTCH, RONI LYNN, NORTH HIGHLANDS, CA. FILED 2-4-2009.

NOT YOUR TYPICAL BEAN COUNTER

THE MARK CONSISTS OF STANDARD CHARACTERS WITHOUT CLAIM TO ANY PARTICULAR FONT, STYLE, SIZE, OR COLOR.

FOR INCOME TAX CONSULTATION; INCOME TAX PREPARATION; TAX ADVISORY SERVICES; TAX CONSULTATION; TAX FILING SERVICES; TAX PREPARATION (U.S. CLS. 100, 101 AND 102).

FIRST USE 1-28-2009; IN COMMERCE 1-28-2009.
ANNE MADDEN, EXAMINING ATTORNEY

SN 77-663,189. 100 WATT MEDIA, INC., ROLLING HILLS ESTATES, CA. FILED 2-4-2009.

BELOWRP

THE MARK CONSISTS OF STANDARD CHARACTERS WITHOUT CLAIM TO ANY PARTICULAR FONT, STYLE, SIZE, OR COLOR.

FOR PROMOTING THE GOODS AND SERVICES OF MANUFACTURERS BY PROVIDING A WEBSITE FEATURING PRODUCT INFORMATION, DISCOUNT INFORMATION, PRICING INFORMATION, AND PURCHASE INFORMATION (U.S. CLS. 100, 101 AND 102).

DANNEAN HETZEL, EXAMINING ATTORNEY

SN 77-663,216. DEUTCH, RONI LYNN, NORTH HIGHLANDS, CA. FILED 2-4-2009.

WE DO TAXES RIGHT!

THE MARK CONSISTS OF STANDARD CHARACTERS WITHOUT CLAIM TO ANY PARTICULAR FONT, STYLE, SIZE, OR COLOR.

FOR INCOME TAX CONSULTATION; INCOME TAX PREPARATION; TAX ADVISORY SERVICES; TAX CONSULTATION; TAX FILING SERVICES; TAX PREPARATION (U.S. CLS. 100, 101 AND 102).

FIRST USE 3-1-2008; IN COMMERCE 3-1-2008.
ANNE MADDEN, EXAMINING ATTORNEY

CLASS 35—(Continued).

SN 77-663,339. SPORTGENIC, INC., FORMERLY ACTIVE ATHLETE, INC., SAN FRANCISCO, CA. FILED 2-4-2009.



THE MARK CONSISTS OF A STYLIZED LETTER "V" WITH A DOT IN THE MIDDLE, WHICH IS SUPERIMPOSED IN FRONT OF THE SHAPE OF A RECTANGLE.

FOR ADVERTISING AND PUBLICITY SERVICES, NAMELY, PROMOTING THE GOODS, SERVICES, BRAND IDENTITY AND COMMERCIAL INFORMATION AND NEWS OF THIRD PARTIES THROUGH PRINT, AUDIO, VIDEO, DIGITAL AND ON-LINE MEDIUM; ADVERTISING SERVICES, PUBLIC RELATIONS AND MARKETING SERVICES, NAMELY, PROMOTING AND MARKETING THE GOODS AND SERVICES OF OTHERS THROUGH ALL PUBLIC COMMUNICATION MEANS; ADVERTISING THROUGH ALL PUBLIC COMMUNICATION MEANS; DISSEMINATION OF ADVERTISING FOR OTHERS VIA THE INTERNET; INTERNET ADVERTISING SERVICES; ON-LINE ADVERTISING AND MARKETING SERVICES; PROMOTING, ADVERTISING AND MARKETING OF THE ON-LINE WEB SITES OF OTHERS; PROMOTION, ADVERTISING AND MARKETING OF ON-LINE WEB SITES; PROVISION OF SPACE ON WEBSITES FOR ADVERTISING GOODS AND SERVICES (U.S. CLS. 100, 101 AND 102).

FIRST USE 2-5-2009; IN COMMERCE 2-5-2009.
VERNA BETH RIRIE, EXAMINING ATTORNEY

SN 77-663,497. ATHLETICVILLE, INC, HOLLYWOOD, FL. FILED 2-4-2009.



NO CLAIM IS MADE TO THE EXCLUSIVE RIGHT TO USE ".COM", APART FROM THE MARK AS SHOWN.

THE COLOR(S) RED, ORANGE AND BLACK IS/ARE CLAIMED AS A FEATURE OF THE MARK.

THE MARK CONSISTS OF A STYLIZED "AV" WITH A CURVY, RETRO RED "A" WITHOUT THE CROSS LINE COMBINED WITH A CURVY, RETRO ORANGE "V", ALL TO THE LEFT OF THE STYLIZED WORDING "ATHLETICVILLE" IN BLACK, WHICH APPEARS ABOVE THE SMALLER WORDING "COM" ALSO IN BLACK.

FOR ADVERTISING AND MARKETING SERVICES, NAMELY, PROMOTING THE GOODS AND SERVICES OF OTHERS (U.S. CLS. 100, 101 AND 102).

ANDREW LEASER, EXAMINING ATTORNEY

CLASS 35—(Continued).

SN 77-663,548. GOSAVE, INC., LOS ANGELES, CA. FILED 2-4-2009.



THE STIPLING IS FOR SHADING PURPOSES ONLY. THE MARK CONSISTS OF THE STYLIZED TEXT "GOSAVE!".
 FOR PROMOTING THE GOODS AND SERVICES OF OTHERS BY PROVIDING A COMMUNITY-DRIVEN WEB SITE FEATURING USER-SUBMITTED CONTENT IN THE NATURE OF COUPONS, REBATES, PRICE-COMPARISON INFORMATION, PRODUCT REVIEWS, LINKS TO THE RETAIL WEB SITES OF OTHERS, AND DISCOUNT INFORMATION (U.S. CLS. 100, 101 AND 102).
 FIRST USE 8-1-2008; IN COMMERCE 1-1-2009.
 AMY HELLA, EXAMINING ATTORNEY

SN 77-663,564. OPC FOUNDATION, SCOTTSDALE, AZ. FILED 2-4-2009.

OPC FOUNDATION

THE MARK CONSISTS OF STANDARD CHARACTERS WITHOUT CLAIM TO ANY PARTICULAR FONT, STYLE, SIZE, OR COLOR.
 OWNER OF U.S. REG. NOS. 3,212,596, 3,212,598 AND 3,224,299.
 NO CLAIM IS MADE TO THE EXCLUSIVE RIGHT TO USE "FOUNDATION", APART FROM THE MARK AS SHOWN.
 FOR ASSOCIATION SERVICES, NAMELY, PROMOTING THE INTERESTS OF PROVIDERS OF CONTROL SYSTEMS AND INSTRUMENTATION AND THE CREATION AND MAINTENANCE OF OPEN SPECIFICATIONS FOR STANDARDIZATION OF DEVICES USED IN CONTROL SYSTEMS (U.S. CLS. 100, 101 AND 102).
 FIRST USE 1-31-1996; IN COMMERCE 1-31-1996.
 DORITT L. CARROLL, EXAMINING ATTORNEY

CLASS 35—(Continued).

SN 77-663,570. OPC FOUNDATION, SCOTTSDALE, AZ. FILED 2-4-2009.



OWNER OF U.S. REG. NOS. 3,212,596, 3,212,598 AND 3,224,299.
 NO CLAIM IS MADE TO THE EXCLUSIVE RIGHT TO USE "FOUNDATION", APART FROM THE MARK AS SHOWN.
 THE MARK CONSISTS OF THE LETTERS "OPC" WITH SIX HORIZONTAL LINES INTERSECTING WITH THE LETTER "O" AND DIAMOND-SHAPED DESIGNS LAID OVER THE HORIZONTAL LINES AND THE LETTER "O", ALL APPEARING ABOVE THE WORDING "FOUNDATION".
 FOR ASSOCIATION SERVICES, NAMELY, PROMOTING THE INTERESTS OF PROVIDERS OF CONTROL SYSTEMS AND INSTRUMENTATION AND THE CREATION AND MAINTENANCE OF OPEN SPECIFICATIONS FOR STANDARDIZATION OF DEVICES USED IN CONTROL SYSTEMS (U.S. CLS. 100, 101 AND 102).
 FIRST USE 1-31-1996; IN COMMERCE 1-31-1996.
 DORITT L. CARROLL, EXAMINING ATTORNEY

SN 77-663,612. PHARMAKON LONG TERM CARE PHARMACY, INC., CARMEL, IN. FILED 2-4-2009.



THE MARK CONSISTS OF THE STYLIZED WORDS "MEDICATIONS FOR LIFE." TO THE RIGHT OF THE STYLIZED WORDS IS AN IMAGE OF THREE STICK FIGURES WITH AN ARC OF THE TOP.
 FOR RETAIL PHARMACY SERVICES (U.S. CLS. 100, 101 AND 102).
 FIRST USE 8-1-2008; IN COMMERCE 8-1-2008.
 LINDA POWELL, EXAMINING ATTORNEY

SN 77-663,621. PHILIPP KRUGER, NEW YORK, NY. FILED 2-4-2009.

THE WORLD IS YOUR LAB

THE MARK CONSISTS OF STANDARD CHARACTERS WITHOUT CLAIM TO ANY PARTICULAR FONT, STYLE, SIZE, OR COLOR.
 FOR OUTSOURCING IN THE FIELD OF SCIENTIFIC RESEARCH (U.S. CLS. 100, 101 AND 102).
 SUNG IN, EXAMINING ATTORNEY

CLASS 35—(Continued).

SN 77-663,662. VUKAN, NIKOLAJE, GLENDALE, NY. FILED 2-4-2009.

CLASS 35—(Continued).

SN 77-663,880. PLIANT MARKETING GROUP, INC., BRONXVILLE, NY. FILED 2-5-2009.

THE EQUESTRIAN CORNER

I WANT THAT!

THE MARK CONSISTS OF STANDARD CHARACTERS WITHOUT CLAIM TO ANY PARTICULAR FONT, STYLE, SIZE, OR COLOR.

FOR ON-LINE AUCTION SERVICES; RETAIL STORE AND ON-LINE RETAIL STORE SERVICES FEATURING COLLECTIBLES (U.S. CLS. 100, 101 AND 102).
BARBARA BROWN, EXAMINING ATTORNEY

THE MARK CONSISTS OF STANDARD CHARACTERS WITHOUT CLAIM TO ANY PARTICULAR FONT, STYLE, SIZE, OR COLOR.

NO CLAIM IS MADE TO THE EXCLUSIVE RIGHT TO USE "EQUESTRIAN", APART FROM THE MARK AS SHOWN.

FOR ON-LINE RETAIL CLOTHING STORE; ONLINE RETAIL STORE SERVICES FEATURING TACK, NAMELY, RIDING SADDLES, PADS FOR HORSE SADDLES, PADS FOR HORSE LEGS, BRIDLES, REINS, LEADS, BITS, STIRRUP LEATHERS, GIRTH STRAPS, LUNGE LINES, HALTERS, HORSE BLANKETS, EXERCISE SHEETS FOR HORSES, DRESS SHEETS FOR HORSES, HORSE COOLING BLANKETS, HORSE FLY SHEETS, HORSE BISCUITS, WHIPS, HORSE BITS, CROPS, DIETARY SUPPLEMENTS FOR HORSES, GREASES AND PETROLEUM JELLY FOR VETERINARY PURPOSES, DOG BLANKETS, DOG LEASHES, DOG COLLARS, JEWELRY, PRE-RECORDED CDS, VIDEO TAPES, LASER DISKS AND DVDS FEATURING HORSES, PLUSH TOYS, HANDBAGS, TOTE BAGS, PURSES, BELTS, WALLETS, SCARVES, TRAVEL BAGS, CASES, PILLOWS, NAPKIN RINGS (U.S. CLS. 100, 101 AND 102).

FIRST USE 12-1-2006; IN COMMERCE 12-1-2006.
ELLEN B. AWRICH, EXAMINING ATTORNEY

SN 77-663,860. THE TJX COMPANIES, INC., FRAMINGHAM, MA. FILED 2-5-2009.

SN 77-663,891. SPINENET LLC, WINTER PARK, FL. FILED 2-5-2009.

VALUE BEYOND COMPARE



THE MARK CONSISTS OF STANDARD CHARACTERS WITHOUT CLAIM TO ANY PARTICULAR FONT, STYLE, SIZE, OR COLOR.

FOR RETAIL DEPARTMENT STORE SERVICES (U.S. CLS. 100, 101 AND 102).
FIRST USE 3-1-2009; IN COMMERCE 3-1-2009.
CYNTHIA SLOAN, EXAMINING ATTORNEY

THE MARK CONSISTS OF A CURVE BOLD LINE; THE WORD "SPINE" IN STYLIZED LOWER CASE, UNDERNEATH THE CURVE BOLD LINE; THE WORD "NET" NEXT TO THE WORD "SPINE" IN BLOCK PRINT UPPER CASE, UNDERNEATH THE CURVE BOLD LINE.

FOR RESELLER SERVICES, NAMELY, DISTRIBUTORSHIP SERVICES IN THE FIELD OF MEDICAL DEVICES AND INSTRUMENTS FOR THE SPINAL COLUMN (U.S. CLS. 100, 101 AND 102).
FRED MANDIR, EXAMINING ATTORNEY

CLASS 35—(Continued).

SN 77-663,995. NETWORK COMMUNICATIONS, INC., LAWRENCEVILLE, GA. FILED 2-5-2009.

IPAK

THE MARK CONSISTS OF STANDARD CHARACTERS WITHOUT CLAIM TO ANY PARTICULAR FONT, STYLE, SIZE, OR COLOR.

FOR ADVERTISING SERVICES, NAMELY, PROMOTING APARTMENTS FOR RENT BY OTHERS (U.S. CLS. 100, 101 AND 102).

KELLEY WELLS, EXAMINING ATTORNEY

SN 77-664,061. ZOOMPOP, LLC, SEATTLE, WA. FILED 2-5-2009.

ZoomPop

THE MARK CONSISTS OF STANDARD CHARACTERS WITHOUT CLAIM TO ANY PARTICULAR FONT, STYLE, SIZE, OR COLOR.

FOR BUSINESS CONSULTING SERVICES, IN THE FIELDS OF ADVERTISING, MARKETING, BRANDING, STRATEGY, DESIGN, EVENTS, MERCHANDISING, PROMOTIONS AND COMMUNICATIONS (U.S. CLS. 100, 101 AND 102).

ELISSA GARBER KON, EXAMINING ATTORNEY

SN 77-664,205. TPN HOLDINGS, LLC, DBA FILELATER, LA JOLLA, CA. FILED 2-5-2009.

FileLater

THE MARK CONSISTS OF STANDARD CHARACTERS WITHOUT CLAIM TO ANY PARTICULAR FONT, STYLE, SIZE, OR COLOR.

FOR TAX FILING SERVICES (U.S. CLS. 100, 101 AND 102).

FIRST USE 1-17-2008; IN COMMERCE 3-0-2008.
MAYUR VAGHANI, EXAMINING ATTORNEY

CLASS 35—(Continued).

SN 77-664,330. THE COCA-COLA COMPANY, ATLANTA, GA. FILED 2-5-2009.



THE MARK CONSISTS OF A PLUS SYMBOL WITHIN A STAR WITHIN A CIRCLE.

FOR ONLINE CONSUMER LOYALTY INCENTIVE PROGRAM FOR COMMERCIAL, PROMOTIONAL AND/OR ADVERTISING PURPOSES WHEREBY PARTICIPANTS ACCUMULATE VALUE FROM PURCHASES WHICH CAN BE REDEEMED FOR MERCHANDISE, DISCOUNT OR CASH PRIZES (U.S. CLS. 100, 101 AND 102).

REBECCA SMITH, EXAMINING ATTORNEY

SN 77-664,421. PICTURELINE, SALT LAKE CITY, UT. FILED 2-5-2009.

pictureline

THE MARK CONSISTS OF STANDARD CHARACTERS WITHOUT CLAIM TO ANY PARTICULAR FONT, STYLE, SIZE, OR COLOR.

FOR RETAIL STORE AND ON-LINE RETAIL STORE SERVICES FEATURING SUPPLIES AND EQUIPMENT FOR DIGITAL IMAGING AND PHOTOGRAPHY (U.S. CLS. 100, 101 AND 102).

FIRST USE 6-10-1989; IN COMMERCE 6-10-1989.
ZACHARY BELLO, EXAMINING ATTORNEY

SN 77-664,460. INTEK AMERICA, INC., RANCHO DOMINGUEZ, CA. FILED 2-5-2009.

GOECOLIFE

THE MARK CONSISTS OF STANDARD CHARACTERS WITHOUT CLAIM TO ANY PARTICULAR FONT, STYLE, SIZE, OR COLOR.

FOR PROVIDING CUSTOMER SERVICE, NAMELY, PROVIDING CUSTOMER SERVICE VIA TELEPHONE AND EMAIL IN THE FIELD OF ECO-FRIENDLY PRODUCTS; PROCESSING PRODUCT WARRANTY REGISTRATION DOCUMENTS IN THE FIELD OF ECO-FRIENDLY PRODUCTS (U.S. CLS. 100, 101 AND 102).

DOMINICK J. SALEMI, EXAMINING ATTORNEY

CLASS 35—(Continued).

SN 77-664,467. RAM OIL, LTD., LLP, SAN ANTONIO, TX. FILED 2-5-2009.

RAM

THE MARK CONSISTS OF STANDARD CHARACTERS WITHOUT CLAIM TO ANY PARTICULAR FONT, STYLE, SIZE, OR COLOR.

FOR RETAIL STORE SERVICES FEATURING CONVENIENCE STORE ITEMS (U.S. CLS. 100, 101 AND 102).
KELLY CHOE, EXAMINING ATTORNEY

CLASS 35—(Continued).

SN 77-664,690. LAGUZZA, ANNE L. LONG BEACH, CA. FILED S.R. 2-5-2009; AM. P.R. 4-27-2009.

The Works

THE MARK CONSISTS OF STANDARD CHARACTERS WITHOUT CLAIM TO ANY PARTICULAR FONT, STYLE, SIZE, OR COLOR.

FOR ACQUISITION AND MERGER CONSULTATION; ASSISTANCE, ADVISORY SERVICES AND CONSULTANCY WITH REGARD TO BUSINESS PLANNING, BUSINESS ANALYSIS, BUSINESS MANAGEMENT, AND BUSINESS ORGANIZATION; BUSINESS ACQUISITION AND MERGER CONSULTATION; BUSINESS ADMINISTRATION CONSULTANCY; BUSINESS ADVISORY SERVICES, CONSULTANCY AND INFORMATION; BUSINESS CONSULTATION; BUSINESS CONSULTATION IN THE FIELD OF LEADERSHIP DEVELOPMENT; BUSINESS CONSULTATION SERVICES; BUSINESS CONSULTING AND BUSINESS INFORMATION FOR ENTERPRISES; BUSINESS CONSULTING SERVICES IN THE FIELD OF ORGANIZATIONAL CHANGE MANAGEMENT; BUSINESS CONSULTING SERVICES, NAMELY, PROVIDING ASSISTANCE IN DEVELOPMENT OF BUSINESS STRATEGIES AND CREATIVE IDEATION; BUSINESS CONSULTING, INQUIRIES OR INFORMATION; BUSINESS CONSULTING, MANAGEMENT, PLANNING AND SUPERVISION; BUSINESS MANAGEMENT AND CONSULTATION; BUSINESS MANAGEMENT AND CONSULTATION IN THE FIELD OF ORGANIZATIONAL DEVELOPMENT; BUSINESS MANAGEMENT CONSULTANCY AND ADVISORY SERVICES; BUSINESS MANAGEMENT CONSULTANCY AS WELL AS DEVELOPMENT OF PROCESSES FOR THE ANALYSIS AND THE IMPLEMENTATION OF STRATEGY PLANS AND MANAGEMENT PROJECTS; BUSINESS MANAGEMENT CONSULTANCY SERVICES; BUSINESS MANAGEMENT CONSULTATION; BUSINESS MANAGEMENT CONSULTATION AND SERVICES, NAMELY, MANAGING AND ADMINISTERING NON-CORE FUNCTIONS, NAMELY, MAILING AND SHIPPING, RECORDS MANAGEMENT, INFORMATION SERVICES, ADMINISTRATION, PAYROLL AND ACCOUNTING, AND TELEMARKETING SERVICES; BUSINESS MANAGEMENT CONSULTATION IN THE FIELD OF EXECUTIVE AND LEADERSHIP DEVELOPMENT; BUSINESS MANAGEMENT CONSULTING; BUSINESS MANAGEMENT CONSULTING AND ADVISORY SERVICES; BUSINESS MANAGEMENT CONSULTING IN THE FIELD OF TEAM DEVELOPMENT; BUSINESS MERGER CONSULTATION; BUSINESS ORGANISATION AND MANAGEMENT CONSULTING SERVICES; BUSINESS ORGANISATION CONSULTING; BUSINESS ORGANIZATION AND MANAGEMENT CONSULTING; BUSINESS ORGANIZATION AND OPERATION CONSULTANCY; BUSINESS ORGANIZATION CONSULTING; BUSINESS ORGANIZATIONAL CONSULTATION; BUSINESS RESEARCH CONSULTATION; BUSINESS RISK MANAGEMENT CONSULTATION; CONSULTANCY OF PERSONNEL RECRUITMENT; CONSULTANCY SERVICES REGARDING BUSINESS STRATEGIES; CONSULTING SERVICES IN BUSINESS LEADERSHIP DEVELOPMENT AND BUSINESS MANAGEMENT; CONSULTING SERVICES IN BUSINESS ORGANIZATION AND MANAGEMENT; CONSULTING SERVICES IN THE FIELD OF HUMAN RESOURCES DEVELOPMENT, NAMELY, FOR THE PROMOTION OF EMPLOYEE RETENTION, CAREER GROWTH, AND INCREASED PRODUCTIVITY FOR EMPLOYEES AND EMPLOYERS; CONSULTING SERVICES IN THE FIELD OF HUMAN RESOURCES DEVELOPMENT, NAMELY, UTILIZING TECHNOLOGY FOR THE PROMOTION OF EMPLOYEE RETENTION, CAREER GROWTH AND INCREASED PRODUCTIVITY FOR EMPLOYEES AND EMPLOYERS; EMPLOYMENT RECRUITING CONSULTATION; HUMAN RESOURCES CONSULTATION;

SN 77-664,530. VIPE INC., PALO ALTO, CA. FILED 2-5-2009.

Vipe

THE MARK CONSISTS OF STANDARD CHARACTERS WITHOUT CLAIM TO ANY PARTICULAR FONT, STYLE, SIZE, OR COLOR.

FOR PROMOTING THE GOODS AND SERVICES OF OTHERS BY PROVIDING A WEB SITE FEATURING THE BUSINESS INFORMATION OF OTHERS IN THE FORM OF VIDEO PRESENTATIONS (U.S. CLS. 100, 101 AND 102).

FIRST USE 5-8-2006; IN COMMERCE 11-1-2006.
DAVID C. REIHNER, EXAMINING ATTORNEY

SN 77-664,590. PROXIMAL SECURITY, LLC, HENDERSON, NV. FILED 2-5-2009.

PROXIMAL SECURITY

THE MARK CONSISTS OF STANDARD CHARACTERS WITHOUT CLAIM TO ANY PARTICULAR FONT, STYLE, SIZE, OR COLOR.

FOR GOODS IMPORT-EXPORT AGENCIES (U.S. CLS. 100, 101 AND 102).
TIMOTHY FINNEGAN, EXAMINING ATTORNEY

CLASS 35—(Continued).

MANAGEMENT AND BUSINESS CONSULTING SERVICES IN THE FIELD OF TRAINING AND RECRUITMENT; MANAGEMENT AND BUSINESS CONSULTING SERVICES IN THE FIELD OF HUMAN RESOURCES; PERSONNEL CONSULTANCY; PERSONNEL MANAGEMENT CONSULTATION; PROFESSIONAL BUSINESS CONSULTING; PROVIDING BUSINESS MANAGEMENT INFORMATION IN CONNECTION WITH CONSULTING AND ADVISORY SERVICES IN THE FIELD OF STRATEGIC PLANNING; PROVIDING ORGANIZATIONAL DEVELOPMENT CONSULTING SERVICES (U.S. CLS. 100, 101 AND 102).

FIRST USE 1-1-2001; IN COMMERCE 1-1-2001.
KAREN K. BUSH, EXAMINING ATTORNEY

UNITED INVENTORS
ASSOCIATION

SN 77-664,697. UNITED INVENTORS ASSOCIATION OF THE UNITED STATES OF AMERICA, AKA UNITED INVENTORS ASSOCIATION, HENRIETTA, NY. FILED 2-5-2009.

THE MARK CONSISTS OF STANDARD CHARACTERS WITHOUT CLAIM TO ANY PARTICULAR FONT, STYLE, SIZE, OR COLOR.

NO CLAIM IS MADE TO THE EXCLUSIVE RIGHT TO USE "INVENTORS ASSOCIATION", APART FROM THE MARK AS SHOWN.

FOR ASSOCIATION SERVICES, NAMELY, PROMOTING THE INTERESTS OF INDIVIDUAL INVENTORS AND INVENTOR ASSOCIATIONS AND SERVICE PROVIDERS (U.S. CLS. 100, 101 AND 102).

FIRST USE 11-16-1990; IN COMMERCE 11-16-1990.
KIMBERLY FRYE, EXAMINING ATTORNEY

SN 77-664,792. FLORIDA ASSOCIATION OF SINKHOLE STABILIZATION SPECIALISTS, INC., TAMPA, FL. FILED 2-6-2009.

FAS3

THE MARK CONSISTS OF STANDARD CHARACTERS WITHOUT CLAIM TO ANY PARTICULAR FONT, STYLE, SIZE, OR COLOR.

FOR ASSOCIATION SERVICES, NAMELY, PROMOTING THE INTERESTS OF ENGINEERS, GEOLOGIST, AND CONTRACTORS PERFORMING SINKHOLE REMEDIATION WORK (U.S. CLS. 100, 101 AND 102).

FIRST USE 11-3-2006; IN COMMERCE 1-1-2008.
MATTHEW PAPPAS, EXAMINING ATTORNEY

CLASS 35—(Continued).

SN 77-665,042. UNITED INVENTORS ASSOCIATION OF THE UNITED STATES OF AMERICA, AKA UNITED INVENTORS ASSOCIATION, HENRIETTA, NY. FILED 2-6-2009.



NO CLAIM IS MADE TO THE EXCLUSIVE RIGHT TO USE "INVENTORS ASSOCIATION", APART FROM THE MARK AS SHOWN.

THE COLOR(S) BLUE AND BLACK IS/ARE CLAIMED AS A FEATURE OF THE MARK.

THE MARK CONSISTS OF THE WORDING "UNITED INVENTORS ASSOCIATION" IN BLACK, UNDERNEATH THE STYLIZED LETTERS "UIA". THE LETTERS "U" AND "A" ARE BLACK. THE LETTER "I" IS BLUE WITH A BLACK STARBURST DESIGN ABOVE IT.

FOR ASSOCIATION SERVICES, NAMELY, PROMOTING THE INTERESTS OF INDIVIDUAL INVENTORS AND INVENTOR ASSOCIATIONS AND SERVICE PROVIDERS (U.S. CLS. 100, 101 AND 102).

FIRST USE 7-31-2006; IN COMMERCE 7-31-2006.
KIMBERLY FRYE, EXAMINING ATTORNEY

SN 77-665,056. CENTER FOR APPLICATIONS OF PSYCHOLOGICAL TYPE, INC., GAINESVILLE, FL. FILED 2-6-2009.

GREAT TEAMS AREN'T JUST
THROWN TOGETHER

THE MARK CONSISTS OF STANDARD CHARACTERS WITHOUT CLAIM TO ANY PARTICULAR FONT, STYLE, SIZE, OR COLOR.

OWNER OF U.S. REG. NO. 3,609,680.

FOR ONLINE RETAIL STORE SERVICES FEATURING PSYCHOLOGICAL TESTS IN THE FIELDS OF GROUP DYNAMICS, TEAM BUILDING, DEVELOPING INDIVIDUAL SKILLS AND BEHAVIORS TO IMPROVE TEAM PERFORMANCE AND PRODUCTIVITY, LEADERSHIP DEVELOPMENT AND ORGANIZATIONAL DEVELOPMENT (U.S. CLS. 100, 101 AND 102).

FIRST USE 12-22-2008; IN COMMERCE 12-22-2008.
MICHAEL SOUDERS, EXAMINING ATTORNEY

CLASS 35—(Continued).

SN 77-665,080. CONNEXTIONS, INC., ORLANDO, FL. FILED 2-6-2009.

MARS

THE MARK CONSISTS OF STANDARD CHARACTERS WITHOUT CLAIM TO ANY PARTICULAR FONT, STYLE, SIZE, OR COLOR.

FOR BUSINESS CONSULTING SERVICES, NAMELY, ASSISTING HEALTH INSURANCE PROVIDERS TO OBTAIN, RETAIN, AND SERVICE HEALTH PLAN MEMBERS THROUGH THE USE OF TECHNOLOGY SERVICES AND PRODUCTS (U.S. CLS. 100, 101 AND 102).

JORDAN BAKER, EXAMINING ATTORNEY

CLASS 35—(Continued).

SN 77-665,181. FAT & SASSY, INC., CHARLOTTE, NC. FILED 2-6-2009.

Fat & Sassy

THE MARK CONSISTS OF STANDARD CHARACTERS WITHOUT CLAIM TO ANY PARTICULAR FONT, STYLE, SIZE, OR COLOR.

FOR WHOLESALE ORDERING SERVICES IN THE FIELDS OF PRINTED GOODS, TRAVEL BAGS, AND CLOTHING FOR ADULTS AND CHILDREN (U.S. CLS. 100, 101 AND 102).

ESTHER A. BORSUK, EXAMINING ATTORNEY

SN 77-665,331. EAGLE MATERIALS IP LLC, DALLAS, TX. FILED 2-6-2009.

RIO GRANDE

SN 77-665,104. CENTER FOR APPLICATIONS OF PSYCHOLOGICAL TYPE, INC., GAINESVILLE, FL. FILED 2-6-2009.



OWNER OF U.S. REG. NO. 3,609,696.
THE MARK CONSISTS OF A COMPOSITE DRAWING OF AN ANIMAL, COMPOSED OF PARTS FROM A GIRAFFE, A CRANE, A CHICKEN, A PIG AND HUMAN LEGS WEARING HIGH-HEELED SHOES.

FOR ONLINE RETAIL STORE SERVICES FEATURING PSYCHOLOGICAL TESTS IN THE FIELDS OF GROUP DYNAMICS, TEAM BUILDING, DEVELOPING INDIVIDUAL SKILLS AND BEHAVIORS TO IMPROVE TEAM PERFORMANCE AND PRODUCTIVITY, LEADERSHIP DEVELOPMENT AND ORGANIZATIONAL DEVELOPMENT (U.S. CLS. 100, 101 AND 102).

FIRST USE 12-22-2008; IN COMMERCE 12-22-2008.
MICHAEL SOUDERS, EXAMINING ATTORNEY

THE MARK CONSISTS OF STANDARD CHARACTERS WITHOUT CLAIM TO ANY PARTICULAR FONT, STYLE, SIZE, OR COLOR.

SEC. 2(F).

FOR WHOLESALE DISTRIBUTORSHIPS FEATURING DRYWALL AND DRYWALL SUPPLIES (U.S. CLS. 100, 101 AND 102).

FIRST USE 5-1-1986; IN COMMERCE 5-1-1986.

TINA KUAN, EXAMINING ATTORNEY

SN 77-665,524. PARAGON TEXTILES, DBA HUNGRY BOOKWORM, LOS ANGELES, CA. FILED 2-6-2009.



THE STIPPLING IS FOR SHADING PURPOSES ONLY.
THE MARK CONSISTS OF A WORM HOLDING A STACK OF BOOKS AND SITTING ON A CHAIR. TO THE RIGHT THERE IS THE STYLIZED TEXT "HUNGRY BOOKWORM".
FOR ON-LINE RETAIL STORE SERVICES FEATURING NEW AND USED BOOKS (U.S. CLS. 100, 101 AND 102).

FIRST USE 2-1-2007; IN COMMERCE 7-1-2007.
TRACY FLETCHER, EXAMINING ATTORNEY

CLASS 35—(Continued).

SN 77-665,637. AXEL GOTHE, NEW YORK, NY. FILED 2-6-2009.

DROMEDIA inc.

NO CLAIM IS MADE TO THE EXCLUSIVE RIGHT TO USE "INC.", APART FROM THE MARK AS SHOWN.

THE MARK CONSISTS OF THE WORDING "DROMEDIA, INC.", CONTAINING THE IMAGE OF THE EARTH WITHIN THE LETTER "O".

FOR ADVERTISING AND PUBLICITY SERVICES, NAMELY, PROMOTING THE GOODS, SERVICES, BRAND IDENTITY AND COMMERCIAL INFORMATION AND NEWS OF THIRD PARTIES THROUGH PRINT, AUDIO, VIDEO, DIGITAL AND ON-LINE MEDIUM; PROVIDING ADVERTISING, MARKETING AND PROMOTIONAL SERVICES, NAMELY, DEVELOPMENT OF ADVERTISING CAMPAIGNS FOR TELEVISION, PRINT, INTERNET MEDIA AND CD-ROM (U.S. CLS. 100, 101 AND 102).

PATRICIA EVANKO, EXAMINING ATTORNEY

SN 77-665,700. MOTORPOOL, LLC, BIRMINGHAM, AL. FILED 2-7-2009.

MOTORPOOL

THE MARK CONSISTS OF STANDARD CHARACTERS WITHOUT CLAIM TO ANY PARTICULAR FONT, STYLE, SIZE, OR COLOR.

FOR PROVIDING AN ONLINE DIRECTORY INFORMATION SERVICE FEATURING INFORMATION REGARDING CLASSIFIEDS, VIRTUAL COMMUNITY, SOCIAL NETWORKING, AND INFORMATION OF INTEREST TO AUTOMOBILE COLLECTORS AND ENTHUSIASTS, NAMELY, INFORMATION REGARDING AUTOMOBILE COLLECTING, VINTAGE AUTOMOBILES, CLASSIC AUTOMOBILES, COLLECTOR AUTOMOBILES, AUTOMOBILE SHOWS, AUTOMOBILE RESTORATION, ROAD TRIPS, AND AUTOMOBILE CLUBS (U.S. CLS. 100, 101 AND 102).

FIRST USE 1-15-2009; IN COMMERCE 1-15-2009.
CYNTHIA SLOAN, EXAMINING ATTORNEY

CLASS 35—(Continued).

SN 77-665,741. TRIBAL PETS, INC., PHILADELPHIA, PA. FILED 2-7-2009.

TRIBAL PETS

THE MARK CONSISTS OF STANDARD CHARACTERS WITHOUT CLAIM TO ANY PARTICULAR FONT, STYLE, SIZE, OR COLOR.

NO CLAIM IS MADE TO THE EXCLUSIVE RIGHT TO USE "PETS", APART FROM THE MARK AS SHOWN.

FOR RETAIL PET STORES (U.S. CLS. 100, 101 AND 102).

HANNO RITTNER, EXAMINING ATTORNEY

SN 77-665,782. NATHAN, RESNICK, CHEVY CHASE, MD. FILED 2-7-2009.

Opportunia

THE MARK CONSISTS OF STANDARD CHARACTERS WITHOUT CLAIM TO ANY PARTICULAR FONT, STYLE, SIZE, OR COLOR.

THE WORDING "OPPORTUNIA" HAS NO MEANING IN A FOREIGN LANGUAGE.

FOR ARRANGING AND CONDUCTING ONLINE AUCTIONS FOR CHARITABLE FUND RAISING PURPOSES; ARRANGING AND CONDUCTION OF AUCTION SALES; ON-LINE RETAIL STORE SERVICES FEATURING AUCTIONS; ORGANIZING AND CONDUCTING CHARITY AUCTIONS FOR CHARITABLE FUND RAISING PURPOSES (U.S. CLS. 100, 101 AND 102).

CYNTHIA SLOAN, EXAMINING ATTORNEY

SN 77-665,949. SOCIAL MEDIA ADVERTISING CONSORTIUM, BOSTON, MA. FILED 2-9-2009.

SMAC

THE MARK CONSISTS OF STANDARD CHARACTERS WITHOUT CLAIM TO ANY PARTICULAR FONT, STYLE, SIZE, OR COLOR.

FOR ADVERTISING SERVICES, NAMELY, STUDYING AND REPORTING ON MEASUREMENTS FOR THE EFFECTIVENESS OF ONLINE SOCIAL ENGAGEMENT AS IT RELATES TO ADVERTISING CAMPAIGNS, INCLUDING ADVERTISING INTEGRATION, ADVERTISING RESEARCH FINDINGS, AND REPORTING METHODOLOGIES FOR MEASURING SUCCESSFUL ADVERTISING RESULTS FROM SOCIAL MEDIA ENGAGEMENTS (U.S. CLS. 100, 101 AND 102).

MIDGE BUTLER, EXAMINING ATTORNEY

CLASS 35—(Continued).

SN 77-666,225. WEB PRODUCTS, INC., KANSAS CITY, MO. FILED 2-9-2009.

WEB PRODUCTS

THE MARK CONSISTS OF STANDARD CHARACTERS WITHOUT CLAIM TO ANY PARTICULAR FONT, STYLE, SIZE, OR COLOR.

OWNER OF U.S. REG. NOS. 1,662,389, 3,322,227 AND OTHERS.

NO CLAIM IS MADE TO THE EXCLUSIVE RIGHT TO USE "PRODUCTS", APART FROM THE MARK AS SHOWN. SEC. 2(F) AS TO "WEB".

FOR PROVIDING COMPUTERIZED ON-LINE RETAIL STORE SERVICES FEATURING HEATING, VENTILATION AND AIR CONDITIONING PRODUCTS (U.S. CLS. 100, 101 AND 102).

FIRST USE 5-5-2006; IN COMMERCE 5-5-2006.
ALICE SUE CARRUTHERS, EXAMINING ATTORNEY

SN 77-666,405. J. C. PENNEY CORPORATION, INC., PLANO, TX. FILED 2-9-2009.

BOTANICAL SENSE

THE MARK CONSISTS OF STANDARD CHARACTERS WITHOUT CLAIM TO ANY PARTICULAR FONT, STYLE, SIZE, OR COLOR.

FOR RETAIL DEPARTMENT STORE SERVICES, RETAIL MAIL ORDER CATALOG SERVICES, AND COMPUTERIZED ONLINE RETAIL DEPARTMENT STORE SERVICES IN THE FIELDS OF COSMETICS, JEWELRY, LUGGAGE, HANDBAGS, FURNITURE, PICTURE FRAMES, LAMPS, DINNERWARE, GLASSWARE, WEARING APPAREL AND FOOTWEAR FOR MEN, WOMEN, AND CHILDREN, BEDDING, WINDOW COVERINGS AND WINDOW HARDWARE, TOWELS, TABLE LINENS, RUGS, EXERCISE EQUIPMENT, PET ACCESSORIES, DECORATIVE HOME FURNISHINGS ITEMS, SMALL ELECTRIC APPLIANCES (U.S. CLS. 100, 101 AND 102).

JULIE WATSON, EXAMINING ATTORNEY

SN 77-666,430. SOURPUSS CLOTHING LLC, GLOUCESTER CITY, NJ. FILED 2-9-2009.



THE MARK CONSISTS OF A SKULL AND CROSSBONES WITH THE WORD "SOURPUSS" APPEARING TO THE RIGHT IN ALL CAPITAL LETTER AND IN STYLIZED FORMAT.

FOR RETAIL STORE SERVICES FEATURING CLOTHING, MUGS, BAGS, SWITCHPLATES AND BELTS (U.S. CLS. 100, 101 AND 102).

FIRST USE 1-1-2001; IN COMMERCE 1-1-2001.
GEORGE LORENZO, EXAMINING ATTORNEY

CLASS 35—(Continued).

SN 77-666,511. THE WOODMANSEE GROUP, LLC, COLUMBUS, OH. FILED 2-9-2009.



THE COLOR(S) RED AND WHITE IS/ARE CLAIMED AS A FEATURE OF THE MARK.

THE MARK CONSISTS OF A RED RECTANGULAR BOX WITH A WHITE BACKGROUND SURROUNDING THE STYLIZED RED CAPITAL LETTERS "TWG".

FOR EXECUTIVE RECRUITING SERVICES; EXECUTIVE SEARCH AND PLACEMENT SERVICES (U.S. CLS. 100, 101 AND 102).

FIRST USE 1-1-2006; IN COMMERCE 3-29-2006.
TINA BROWN, EXAMINING ATTORNEY

SN 77-666,616. SAPIENZA, JOSEPH L., REDONDO BEACH, CA. FILED 2-9-2009.

**evolution of online
business**

THE MARK CONSISTS OF STANDARD CHARACTERS WITHOUT CLAIM TO ANY PARTICULAR FONT, STYLE, SIZE, OR COLOR.

FOR ADVERTISING AND COMMERCIAL INFORMATION SERVICES, VIA THE INTERNET; ON-LINE ADVERTISING AND MARKETING SERVICES (U.S. CLS. 100, 101 AND 102).

WILLIAM P. SHANAHAN, EXAMINING ATTORNEY

SN 77-666,639. HILL, JOSHUA, KANSAS CITY, MO. FILED 2-9-2009.

BIG EAGLE

THE MARK CONSISTS OF STANDARD CHARACTERS WITHOUT CLAIM TO ANY PARTICULAR FONT, STYLE, SIZE, OR COLOR.

FOR TEMPORARY EMPLOYMENT STAFFING SERVICES (U.S. CLS. 100, 101 AND 102).

REBECCA GILBERT, EXAMINING ATTORNEY

CLASS 35—(Continued).

SN 77-666,687. SIMON, DAVID K., NEW YORK, NY. FILED 2-9-2009.



THE COLOR(S) BLUE IS/ARE CLAIMED AS A FEATURE OF THE MARK.

THE MARK CONSISTS OF A BLUE SWIRL DESIGN. FOR PROCUREMENT, NAMELY, PURCHASING CARPET AND FLOORING FOR OTHERS; WHOLESALE ORDERING SERVICES IN THE FIELD OF CARPET AND FLOORING (U.S. CLS. 100, 101 AND 102).

FIRST USE 1-31-2001; IN COMMERCE 1-31-2001.
NATALIE POLZER, EXAMINING ATTORNEY

SN 77-666,748. MGM MIRAGE, LAS VEGAS, NV. FILED 2-9-2009.

SKYLOFTS

THE MARK CONSISTS OF STANDARD CHARACTERS WITHOUT CLAIM TO ANY PARTICULAR FONT, STYLE, SIZE, OR COLOR.

FOR RETAIL STORE SERVICES FEATURING A WIDE VARIETY OF CONSUMER GOODS OF OTHERS; PROVIDING FACILITIES FOR BUSINESS MEETINGS; ART GALLERIES; RETAIL STORE SERVICES FEATURING ARTWORKS; CUSTOMER INCENTIVE AWARD PROGRAM, NAMELY, A CASINO CUSTOMER LOYALTY PROGRAM THAT PROVIDES CASINO BENEFITS TO REWARD REPEAT CUSTOMERS, FOR COMMERCIAL, PROMOTIONAL AND ADVERTISING PURPOSES (U.S. CLS. 100, 101 AND 102).

GINA HAYES, EXAMINING ATTORNEY

CLASS 35—(Continued).

SN 77-666,757. SAMOUN INC, NEW YORK, NY. FILED 2-9-2009.

Diamondicious

THE MARK CONSISTS OF STANDARD CHARACTERS WITHOUT CLAIM TO ANY PARTICULAR FONT, STYLE, SIZE, OR COLOR.

FOR ON-LINE RETAIL STORE SERVICES FEATURING JEWELRY, CLOTHING AND FASHION ACCESSORIES (U.S. CLS. 100, 101 AND 102).

GINA HAYES, EXAMINING ATTORNEY

SN 77-666,773. DAVID HINKEL, DBA DAVID HINKEL, ESCONDIDO, CA. FILED 2-9-2009.

Blue Abyss Photo

THE MARK CONSISTS OF STANDARD CHARACTERS WITHOUT CLAIM TO ANY PARTICULAR FONT, STYLE, SIZE, OR COLOR.

NO CLAIM IS MADE TO THE EXCLUSIVE RIGHT TO USE "PHOTO", APART FROM THE MARK AS SHOWN.

FOR RETAIL STORE AND ON-LINE RETAIL STORE SERVICES FEATURING UNDERWATER PHOTOGRAPHIC EQUIPMENT, ACCESSORIES AND RELATED SERVICES (U.S. CLS. 100, 101 AND 102).

FIRST USE 10-1-2008; IN COMMERCE 10-1-2008.
ANDREA BUTLER, EXAMINING ATTORNEY

SN 77-666,809. CLEVER INNOVATIONS, INC., SARATOGA SPRINGS, NY. FILED 2-9-2009.

ADEO

THE MARK CONSISTS OF STANDARD CHARACTERS WITHOUT CLAIM TO ANY PARTICULAR FONT, STYLE, SIZE, OR COLOR.

FOR MARKETING AND PROMOTIONAL AGENCY SERVICES, NAMELY, PROMOTING THE GOODS AND SERVICES OF OTHERS THROUGH THE DISTRIBUTION OF PRINTED, AUDIO AND VIDEO PROMOTIONAL MATERIALS AND BY PROVIDING ADVICE TO OTHERS IN PREPARING AND PLACING ADVERTISING FOR THEIR PRODUCTS AND/OR SERVICES AND IN THE RENTING OF ADVERTISING SPACE FOR THEIR PRODUCT(S) AND/OR SERVICES (U.S. CLS. 100, 101 AND 102).

DEIRDRE ROBERTSON, EXAMINING ATTORNEY

CLASS 35—(Continued).

SN 77-666,816. GREENBERG QUALITATIVE RESEARCH, INC., EMERYVILLE, CA. FILED 2-9-2009.

HUMANQUANT

THE MARK CONSISTS OF STANDARD CHARACTERS WITHOUT CLAIM TO ANY PARTICULAR FONT, STYLE, SIZE, OR COLOR.
FOR MARKET RESEARCH SERVICES (U.S. CLS. 100, 101 AND 102).
DEIRDRE ROBERTSON, EXAMINING ATTORNEY

CLASS 35—(Continued).

SN 77-667,240. LEADERSHIP WORKS, LLC, HONOLULU, HI. FILED 2-10-2009.

HIVIVE

THE MARK CONSISTS OF STANDARD CHARACTERS WITHOUT CLAIM TO ANY PARTICULAR FONT, STYLE, SIZE, OR COLOR.
FOR ON-LINE RETAIL STORE SERVICES FEATURING BOOKS, CDS, DVDS, EDUCATIONAL KITS, AND EDUCATIONAL MATERIALS RELATING TO LEADERSHIP DEVELOPMENT AND TRAINING, AND APPAREL (U.S. CLS. 100, 101 AND 102).
REBECCA GILBERT, EXAMINING ATTORNEY

SN 77-667,089. MCCALL, KEITH, LAGUNA NIGUEL, CA. FILED 2-10-2009.

IT'S NOT RUST, IT'S HAWAIIAN CHROME!

THE MARK CONSISTS OF STANDARD CHARACTERS WITHOUT CLAIM TO ANY PARTICULAR FONT, STYLE, SIZE, OR COLOR.
FOR RETAIL STORE SERVICES FEATURING CLOTHING AND HATS (U.S. CLS. 100, 101 AND 102).
JAY FLOWERS, EXAMINING ATTORNEY

SN 77-667,502. SIMON, DAVID K., NEW YORK, NY. FILED 2-10-2009.

SN 77-667,208. WILKERSON, DAVID, NEW YORK, NY. FILED 2-10-2009.

DAVID WILKERSON PUBLICATIONS

THE MARK CONSISTS OF STANDARD CHARACTERS WITHOUT CLAIM TO ANY PARTICULAR FONT, STYLE, SIZE, OR COLOR.
NO CLAIM IS MADE TO THE EXCLUSIVE RIGHT TO USE "PUBLICATIONS", APART FROM THE MARK AS SHOWN.
THE NAME(S), PORTRAIT(S), AND/OR SIGNATURE(S) SHOWN IN THE MARK IDENTIFIES DAVID WILKERSON, AN INDIVIDUAL, WHOSE CONSENT(S) TO REGISTER IS MADE OF RECORD.
FOR ONLINE RETAIL STORE SERVICES FEATURING DVDS, AUDIO CDS, AUDIO CASSETTES, VIDEO CASSETTES AND BOOKS (U.S. CLS. 100, 101 AND 102).
FIRST USE 2-0-2007; IN COMMERCE 2-0-2007.
MICHAEL WEBSTER, EXAMINING ATTORNEY



THE MARK CONSISTS OF A SWIRL DESIGN WITH THE WORDS "BCEXCHANGE."
FOR PROCUREMENT, NAMELY, PURCHASING CARPET AND FLOORING FOR OTHERS; WHOLESALE ORDERING SERVICES IN THE FIELD OF CARPET AND FLOORING (U.S. CLS. 100, 101 AND 102).
FIRST USE 8-31-2006; IN COMMERCE 8-31-2006.
NATALIE POLZER, EXAMINING ATTORNEY

CLASS 35—(Continued).

SN 77-667,755. GENUINE CREATIVE, INC., RICHMOND, VA. FILED 2-10-2009.

Genuine Creative

THE MARK CONSISTS OF STANDARD CHARACTERS WITHOUT CLAIM TO ANY PARTICULAR FONT, STYLE, SIZE, OR COLOR.

FOR ADVERTISING AND MARKETING; ADVERTISING SERVICES, NAMELY, PROMOTING AND MARKETING THE GOODS AND SERVICES OF OTHERS THROUGH ALL PUBLIC COMMUNICATION MEANS; BUSINESS CONSULTATION AND MANAGEMENT REGARDING MARKETING ACTIVITIES AND LAUNCHING OF NEW PRODUCTS; BUSINESS MANAGEMENT CONSULTING WITH RELATION TO STRATEGY, MARKETING, SALES, OPERATION, PRODUCT DESIGN PARTICULARLY SPECIALIZING IN THE USE OF ANALYTIC AND STATISTIC MODELS FOR THE UNDERSTANDING AND PREDICTING OF CONSUMERS, BUSINESSES, AND MARKET TRENDS AND ACTIONS; BUSINESS MARKETING AND DIRECT MAIL CONSULTING SERVICES; BUSINESS MARKETING CONSULTING SERVICES; CONDUCTING MARKETING STUDIES; CREATION OF MARKETING TOOLS DESIGNED TO INCREASE A CLIENT COMPANY'S KNOWLEDGE OF CUSTOMER NEEDS, AND ITS COMPETITORS' PRODUCTS AND SERVICES, PRICING, ADVERTISING STRATEGY AND SALES STRATEGY; DEVELOPMENT OF MARKETING STRATEGIES AND CONCEPTS; MARKETING CONSULTING; MARKETING PLAN DEVELOPMENT; SOCIAL MEDIA STRATEGY AND MARKETING CONSULTANCY FOCUSING ON HELPING CLIENTS CREATE AND EXTEND THEIR PRODUCT AND BRAND STRATEGIES BY BUILDING VIRALLY ENGAGING MARKETING SOLUTIONS (U.S. CLS. 100, 101 AND 102).

FIRST USE 10-17-2007; IN COMMERCE 5-17-2008.
JULIE WATSON, EXAMINING ATTORNEY

SN 77-668,004. AMERICAREERS, LLC, EAST LANSING, MI. FILED 2-11-2009.

AMERICAREERS

THE MARK CONSISTS OF STANDARD CHARACTERS WITHOUT CLAIM TO ANY PARTICULAR FONT, STYLE, SIZE, OR COLOR.

FOR PROVIDING AN ON-LINE SEARCHABLE DATABASE FEATURING EMPLOYMENT OPPORTUNITIES (U.S. CLS. 100, 101 AND 102).

FIRST USE 12-10-2004; IN COMMERCE 12-10-2004.
HEATHER SAPP, EXAMINING ATTORNEY

CLASS 35—(Continued).

SN 77-668,035. WEBMOBLINK, MIAMI, FL. FILED 2-11-2009.



NO CLAIM IS MADE TO THE EXCLUSIVE RIGHT TO USE "WEB AND MOBILE ADVERTISING", APART FROM THE MARK AS SHOWN.

THE COLOR(S) BLUE AND ORANGE IS/ARE CLAIMED AS A FEATURE OF THE MARK.

THE MARK CONSISTS OF THE WORD "WEB" IN BLUE, THE WORD "MOB" IS IN ORANGE, THE WORD "LINK" IS IN BLUE, UNDERNEATH THE PHRASE; "WEB AND MOBILE ADVERTISING" IN ORANGE, AND THE 3 SAILS ON THE RIGHT HANDSIDE OF THE LOGO ARE: THE TOP ONE IS IN BLUE, THE MIDDLE ONE IN ORANGE AND THE BOTTOM ONE IN BLUE.

FOR DISSEMINATION OF ADVERTISING OF OTHERS VIA ONLINE WEBSITES AND APPLICATIONS; ONLINE ADVERTISING FOR OTHERS, EXPRESSLY, PROVIDING ADVERTISING SPACE ON ONLINE WEBSITES AND APPLICATIONS; DISSEMINATION OF ADVERTISING FOR OTHERS VIA MOBILE WEBSITE, DEVICES AND APPLICATIONS; ONLINE ADVERTISING FOR OTHERS, EXPRESSLY PROVIDING ADVERTISING SPACE ON MOBILE WEBSITES, APPLICATIONS, AND DEVICES; PRODUCTION OF ADVERTISING MATTER FOR ONLINE AND MOBILE SITES (U.S. CLS. 100, 101 AND 102).

DEIRDRE ROBERTSON, EXAMINING ATTORNEY

SN 77-668,818. MGM MIRAGE, LAS VEGAS, NV. FILED 2-11-2009.



SKYLOFTS

THE MARK CONSISTS OF A VERTICAL RECTANGLE WITH TWO VERTICAL AND TWO HORIZONTAL LINES THAT MEET INSIDE THE RECTANGLE FORMING TWO 90 DEGREE ANGLES AND THE WORD "SKYLOFTS" BELOW THE RECTANGLE.

FOR RETAIL STORE SERVICES FEATURING A WIDE VARIETY OF CONSUMER GOODS OF OTHERS; PROVIDING FACILITIES FOR BUSINESS MEETINGS; ART GALLERIES; RETAIL STORE SERVICES FEATURING ARTWORKS; CUSTOMER INCENTIVE AWARD PROGRAM, NAMELY, A CASINO CUSTOMER LOYALTY PROGRAM THAT PROVIDES CASINO BENEFITS TO REWARD REPEAT CUSTOMERS, FOR COMMERCIAL, PROMOTIONAL AND ADVERTISING PURPOSES (U.S. CLS. 100, 101 AND 102).

GINA HAYES, EXAMINING ATTORNEY

CLASS 35—(Continued).

SN 77-674,147. LIPPINCOTT, LLC, NARBERTH, PA. FILED 2-19-2009.

IT'S TIME TO BREAK UP WITH
HIS JEWELRY, TOO.

THE MARK CONSISTS OF STANDARD CHARACTERS WITHOUT CLAIM TO ANY PARTICULAR FONT, STYLE, SIZE, OR COLOR.

FOR PROCUREMENT SERVICES FOR OTHERS, NAMELY, PURCHASING PRECIOUS METALS, PRECIOUS STONES, JEWELS, JEWELRY, WATCHES AND LUXURY GOODS (U.S. CLS. 100, 101 AND 102).
GRETCHEN ULRICH, EXAMINING ATTORNEY

SN 77-674,284. VISA INTERNATIONAL SERVICE ASSOCIATION, FOSTER CITY, CA. FILED 2-19-2009.

GO MODE

THE MARK CONSISTS OF STANDARD CHARACTERS WITHOUT CLAIM TO ANY PARTICULAR FONT, STYLE, SIZE, OR COLOR.

FOR ON-LINE ADVERTISING AND MARKETING SERVICES; PROMOTION RELATING TO THE SALE OF GOODS AND SERVICES FOR THIRD PARTIES BY THE TRANSMISSION OF ADVERTISING MATERIAL AND THE DISSEMINATION OF ADVERTISING MESSAGES ON COMPUTER NETWORKS; PROMOTING ACTIVATION AND USAGE OF PAYMENT CARDS FOR FINANCIAL INSTITUTIONS; PROMOTION OF FINANCIAL SERVICES AND FINANCIAL OFFERS ON BEHALF OF THIRD PARTIES; PROMOTING THE SALE OF GOODS AND SERVICES OF OTHERS BY MEANS OF VALUE ADDED OFFERS AND INCENTIVES GENERATED IN CONNECTION WITH THE USE OF PAYMENT CARDS (U.S. CLS. 100, 101 AND 102).
ESTHER A. BORSUK, EXAMINING ATTORNEY

CLASS 35—(Continued).

SN 77-674,318. BONILLA, ANTHONY, DBA NY FIGHTER, ASTORIA, NY. FILED 2-19-2009.

NY FIGHTER

THE MARK CONSISTS OF STANDARD CHARACTERS WITHOUT CLAIM TO ANY PARTICULAR FONT, STYLE, SIZE, OR COLOR.

NO CLAIM IS MADE TO THE EXCLUSIVE RIGHT TO USE "NY", APART FROM THE MARK AS SHOWN.

FOR GENERAL BUSINESS MERCHANDISING SERVICES, NAMELY, MARKETING; INVENTORYING MERCHANDISE; MERCHANDISE PACKAGING; PRODUCT MERCHANDISING; RETAIL DISCOUNT STORE SERVICES IN THE FIELD OF CLOTHING; SPECIALTY MERCHANDISING SERVICES, NAMELY, PROMOTING THE GOODS AND SERVICES OF OTHERS THROUGH THE DISTRIBUTION OF CUSTOMIZED ADVERTISING MATERIALS, NAMELY, CLOTHING (U.S. CLS. 100, 101 AND 102).

G. MAYERSCHOFF, EXAMINING ATTORNEY

SN 77-675,137. PAYLESS SHOESOURCE WORLDWIDE, INC., TOPEKA, KS. FILED 2-20-2009.

PROTECT YOUR MOST VALUABLE
ASSETS - YOUR EMPLOYEES.

THE MARK CONSISTS OF STANDARD CHARACTERS WITHOUT CLAIM TO ANY PARTICULAR FONT, STYLE, SIZE, OR COLOR.

FOR RETAIL SHOE STORE SERVICES; COMPUTERIZED ON-LINE RETAIL STORE SERVICES IN THE FIELD OF FOOTWEAR, ACCESSIBLE VIA GLOBAL COMPUTER NETWORKS (U.S. CLS. 100, 101 AND 102).
LINDA MICKLEBURGH, EXAMINING ATTORNEY

SN 77-675,141. PAYLESS SHOESOURCE WORLDWIDE, INC., TOPEKA, KS. FILED 2-20-2009.

DESIGNED TO PROTECT YOUR
MOST VALUABLE ASSETS -
YOUR EMPLOYEES.

THE MARK CONSISTS OF STANDARD CHARACTERS WITHOUT CLAIM TO ANY PARTICULAR FONT, STYLE, SIZE, OR COLOR.

FOR RETAIL SHOE STORE SERVICES; COMPUTERIZED ON-LINE RETAIL STORE SERVICES IN THE FIELD OF FOOTWEAR, ACCESSIBLE VIA GLOBAL COMPUTER NETWORKS (U.S. CLS. 100, 101 AND 102).
LINDA MICKLEBURGH, EXAMINING ATTORNEY

CLASS 35—(Continued).

SN 77-676,513. PHARMAVITE LLC, MISSION HILLS, CA.
FILED 2-23-2009.

WHEN YOU SLEEP WELL, YOU
LIVE WELL

THE MARK CONSISTS OF STANDARD CHARACTERS
WITHOUT CLAIM TO ANY PARTICULAR FONT, STYLE,
SIZE, OR COLOR.

FOR ON-LINE WHOLESALE AND RETAIL STORE
SERVICES FEATURING VITAMINS, MINERALS AND
DIETARY SUPPLEMENTS (U.S. CLS. 100, 101 AND 102).
JAMES LOVELACE, EXAMINING ATTORNEY

SN 77-679,076. COMMERCIAL PRO, INC., LONGMEADOW,
MA. FILED 2-26-2009.

1-800-MYTVCASE

THE MARK CONSISTS OF STANDARD CHARACTERS
WITHOUT CLAIM TO ANY PARTICULAR FONT, STYLE,
SIZE, OR COLOR.

FOR ADVERTISING AND MARKETING; ADVERTIS-
ING AND MARKETING SERVICES, NAMELY, PRO-
MOTING THE GOODS AND SERVICES OF OTHERS
(U.S. CLS. 100, 101 AND 102).

FIRST USE 11-22-2005; IN COMMERCE 11-22-2005.
VIVIAN MICZNIK FIRST, EXAMINING ATTORNEY

SN 77-679,099. COMMERCIAL PRO, INC., LONGMEADOW,
MA. FILED 2-26-2009.

MYTVCASE

THE MARK CONSISTS OF STANDARD CHARACTERS
WITHOUT CLAIM TO ANY PARTICULAR FONT, STYLE,
SIZE, OR COLOR.

FOR ADVERTISING AND MARKETING; ADVERTIS-
ING AND MARKETING SERVICES, NAMELY, PRO-
MOTING THE GOODS AND SERVICES OF OTHERS
(U.S. CLS. 100, 101 AND 102).

FIRST USE 11-22-2005; IN COMMERCE 11-22-2005.
VIVIAN MICZNIK FIRST, EXAMINING ATTORNEY

CLASS 35—(Continued).

SN 77-681,375. HOMER TLC, INC., WILMINGTON, DE.
FILED 3-2-2009.



OWNER OF U.S. REG. NO. 3,407,242.
THE COLOR(S) ORANGE, GREEN AND WHITE IS/ARE
CLAIMED AS A FEATURE OF THE MARK.

THE MARK CONSISTS OF A HOUSE AND TREE DESIGN
WITHIN A BLOCK FIGURE WITH THE WORDS "ECO
OPTIONS" IN A BLOCK FIGURE BELOW THE HOUSE AND
TREE DESIGN. THE COLOR ORANGE APPEARS IN THE
BLOCK AT THE BOTTOM OF THE MARK THAT CON-
TAINS THE WORDING "ECO OPTIONS" AND IN THE
DOOR OF THE HOUSE DESIGN. THE COLOR GREEN
APPEARS AS BACKGROUND TO THE TREE AND HOUSE
DESIGN. THE COLOR WHITE APPEARS IN THE TREE
AND HOUSE DESIGN AND THE ARCHED WHITE LINE.

FOR ON-LINE RETAIL STORE SERVICES FEATUR-
ING ENVIRONMENTALLY FRIENDLY HOME IMP-
ROVEMENT PRODUCTS; RETAIL STORES
FEATURING ENVIRONMENTALLY FRIENDLY HOME
IMPROVEMENT PRODUCTS (U.S. CLS. 100, 101 AND
102).

DAVID MURRAY, EXAMINING ATTORNEY

CLASS 35—(Continued).

SN 77-681,613. GREATER LAFAYETTE CHAMBER OF COMMERCE, INC., LAFAYETTE, LA. FILED 3-2-2009.



NO CLAIM IS MADE TO THE EXCLUSIVE RIGHT TO USE "49" AND "ENERGY CORRIDOR", APART FROM THE MARK AS SHOWN.

THE COLOR(S) GREEN AND WHITE IS/ARE CLAIMED AS A FEATURE OF THE MARK.

THE MARK CONSISTS OF THE NUMBER "49" INSIDE A REPLICA OF AN INTERSTATE HIGHWAY SIGN, WITH TWO CURVED LINES REPRESENTING A HIGHWAY EXTENDING FROM THE UPPER RIGHT SIDE OF THE SIGN AND CURVING BELOW THE NUMBER TO THE UPPER LEFT SIDE OF THE SIGN; THE WORDING "AMERICA'S ENERGY CORRIDOR" APPEARS BELOW THE DESIGN. THE WORDING AND DESIGN ARE WHITE ON A GREEN RECTANGULAR BACKGROUND.

FOR PROMOTING POLITICAL AND PUBLIC AWARENESS OF THE UPGRADING OF U.S. HIGHWAY 90 FROM LAFAYETTE, LOUISIANA TO NEW ORLEANS, LOUISIANA TO INTERSTATE HIGHWAY STANDARDS (U.S. CLS. 100, 101 AND 102).

FIRST USE 2-19-2009; IN COMMERCE 2-19-2009.
ALICE SUE CARRUTHERS, EXAMINING ATTORNEY

SN 77-683,912. HOMER TLC, INC., WILMINGTON, DE. FILED 3-5-2009.

HAZ MAS, AHORRANDO.

THE MARK CONSISTS OF STANDARD CHARACTERS WITHOUT CLAIM TO ANY PARTICULAR FONT, STYLE, SIZE, OR COLOR.

THE ENGLISH TRANSLATION OF "HAZ MAS, AHORRANDO" IN THE MARK IS "MORE SAVING. MORE DOING."

FOR RETAIL STORE SERVICES, ELECTRONIC RETAIL STORE SERVICES AND MAIL ORDER CATALOG SERVICES, FEATURING HOUSEHOLD HARDWARE PRODUCTS, INDOOR AND OUTDOOR HOME ACCESSORIES, SPORTING GOODS, HOME IMPROVEMENT PRODUCTS, AND HOUSEWARES (U.S. CLS. 100, 101 AND 102).

DAVID MURRAY, EXAMINING ATTORNEY

CLASS 35—(Continued).

SN 77-683,945. SUPERVALU INC., EDEN PRAIRIE, MN. FILED 3-5-2009.

YOUR WEEKLY LIST FOR LESS

THE MARK CONSISTS OF STANDARD CHARACTERS WITHOUT CLAIM TO ANY PARTICULAR FONT, STYLE, SIZE, OR COLOR.

FOR RETAIL GROCERY STORE SERVICES (U.S. CLS. 100, 101 AND 102).

FIRST USE 3-5-2009; IN COMMERCE 3-5-2009.
MARK SHINER, EXAMINING ATTORNEY

SN 77-687,032. THE TJX COMPANIES, INC., FRAMINGHAM, MA. FILED 3-10-2009.

SERIOUSLY SHOPPORTUNISTIC

THE MARK CONSISTS OF STANDARD CHARACTERS WITHOUT CLAIM TO ANY PARTICULAR FONT, STYLE, SIZE, OR COLOR.

FOR RETAIL DEPARTMENT STORE SERVICES (U.S. CLS. 100, 101 AND 102).

CYNTHIA SLOAN, EXAMINING ATTORNEY

SN 77-687,967. SENN-DELANEY LEADERSHIP CONSULTING GROUP, LLC, LONG BEACH, CA. FILED 3-11-2009.

Thriving Conversations

THE MARK CONSISTS OF STANDARD CHARACTERS WITHOUT CLAIM TO ANY PARTICULAR FONT, STYLE, SIZE, OR COLOR.

FOR BUSINESS CONSULTATION SERVICES, NAMELY, BUSINESS CONSULTATION IN THE FIELD OF ORGANIZATIONAL CULTURE CHANGE THAT INCLUDES IDENTIFYING CULTURAL PROBLEMS, DESIGNING NEW CULTURAL PRINCIPLES, AND CREATING IMPLEMENTATION PLANS FOR BUSINESS ORGANIZATIONS (U.S. CLS. 100, 101 AND 102).

AMY HELLA, EXAMINING ATTORNEY

CLASS 35—(Continued).

SN 77-690,369. PARAGON TEXTILES INC., DBA HUNGRY BOOKWORM, LOS ANGELES, CA. FILED 3-13-2009.

Hungry Bookworm

THE MARK CONSISTS OF STANDARD CHARACTERS WITHOUT CLAIM TO ANY PARTICULAR FONT, STYLE, SIZE, OR COLOR.

FOR ON-LINE RETAIL STORE SERVICES FEATURING NEW AND USED BOOKS (U.S. CLS. 100, 101 AND 102).

FIRST USE 2-1-2007; IN COMMERCE 7-1-2007.
TRACY FLETCHER, EXAMINING ATTORNEY

SN 77-690,544. JOHNSON DIVERSEY, INC., STURTEVANT, WI. FILED 3-13-2009.

CONNEXION

THE MARK CONSISTS OF STANDARD CHARACTERS WITHOUT CLAIM TO ANY PARTICULAR FONT, STYLE, SIZE, OR COLOR.

FOR PROVIDING A WEB-BASED ORDERING SERVICE THAT ENABLES CLEANING OPERATIONS TO MANAGE THE PURCHASING OF JANITORIAL CLEANING AND SANITATION SUPPLIES (U.S. CLS. 100, 101 AND 102).

FIRST USE 8-31-2007; IN COMMERCE 8-31-2007.
VIVIAN MICZNIK FIRST, EXAMINING ATTORNEY

SN 77-700,549. SUPERVALU INC., EDEN PRAIRIE, MN. FILED 3-27-2009.

SAVINGS YOU'LL LOVE ARE JUST AROUND THE CORNER

THE MARK CONSISTS OF STANDARD CHARACTERS WITHOUT CLAIM TO ANY PARTICULAR FONT, STYLE, SIZE, OR COLOR.

OWNER OF U.S. REG. NO. 3,573,874.
FOR RETAIL GROCERY STORE SERVICES (U.S. CLS. 100, 101 AND 102).

FIRST USE 2-9-2009; IN COMMERCE 2-9-2009.
MARK SHINER, EXAMINING ATTORNEY

CLASS 35—(Continued).

SN 77-700,556. SUPERVALU INC., EDEN PRAIRIE, MN. FILED 3-27-2009.

TASTY SAVINGS ARE JUST AROUND THE CORNER

THE MARK CONSISTS OF STANDARD CHARACTERS WITHOUT CLAIM TO ANY PARTICULAR FONT, STYLE, SIZE, OR COLOR.

OWNER OF U.S. REG. NO. 3,573,874.
FOR RETAIL GROCERY STORE SERVICES (U.S. CLS. 100, 101 AND 102).
FIRST USE 3-3-2009; IN COMMERCE 3-3-2009.
MARK SHINER, EXAMINING ATTORNEY

SN 77-713,370. THE TJX COMPANIES, INC., FRAMINGHAM, MA. FILED 4-14-2009.

IT PAYS TO BE SHOPPORTUNISTIC

THE MARK CONSISTS OF STANDARD CHARACTERS WITHOUT CLAIM TO ANY PARTICULAR FONT, STYLE, SIZE, OR COLOR.

FOR RETAIL DEPARTMENT STORE SERVICES (U.S. CLS. 100, 101 AND 102).
CYNTHIA SLOAN, EXAMINING ATTORNEY

SN 77-976,950. MAISTI, S.L., SALOU (TARRAGONA), SPAIN, FILED 8-6-2007.



THE MARK CONSISTS OF A "POUND SIGN" OVER WHOSE UPPER HORIZONTAL LINE APPEAR THE WORDS "DESIGNHOTELSCOLLECTION#".

FOR ADVERTISING AND ADVERTISEMENT SERVICES; BUSINESS MANAGEMENT; BUSINESS ADMINISTRATION AND OFFICE WORK (U.S. CLS. 100, 101 AND 102).

SARA THOMAS, EXAMINING ATTORNEY

CLASS 35—(Continued).

SN 78-581,787. PALLADIUM GROUP, INC., LINCOLN, MA.
FILED 3-7-2005.

PALLADIUM

THE MARK CONSISTS OF STANDARD CHARACTERS WITHOUT CLAIM TO ANY PARTICULAR FONT, STYLE, SIZE, OR COLOR.

OWNER OF U.S. REG. NO. 3,605,038.

FOR CONSULTING SERVICES IN THE FIELD OF BUSINESS ORGANIZATION, STRATEGY AND MANAGEMENT, EXCLUDING CONSULTING IN THE FIELD OF TEMPORARY OR INTERIM BUSINESS MANAGEMENT; VALUE-ADDED RESELLER SERVICES, NAMELY, DISTRIBUTORSHIP SERVICES IN THE FIELD OF BUSINESS INTELLIGENCE AND DATABASE COMPUTER SOFTWARE FOR THE FINANCIAL SERVICES AND RETAIL INDUSTRIES (U.S. CLS. 100, 101 AND 102).

FIRST USE 4-5-2005; IN COMMERCE 4-5-2005.

ELISSA GARBER KON, EXAMINING ATTORNEY

SN 78-659,782. JENNIFER ANN VICKERS, SANTA MONICA, CA. FILED 6-28-2005.

Magnetic Cosmetics

THE MARK CONSISTS OF STANDARD CHARACTERS WITHOUT CLAIM TO ANY PARTICULAR FONT, STYLE, SIZE, OR COLOR.

NO CLAIM IS MADE TO THE EXCLUSIVE RIGHT TO USE "COSMETICS", APART FROM THE MARK AS SHOWN.

FOR COSMETIC PRODUCT DEMONSTRATION SERVICES (U.S. CLS. 100, 101 AND 102).

EDWARD NELSON, EXAMINING ATTORNEY

CLASS 35—(Continued).

SN 78-671,285. BRYDELS JR., JOHN, BATON ROUGE, LA.
FILED 7-15-2005.

HEART AND SOUL

THE MARK CONSISTS OF STANDARD CHARACTERS WITHOUT CLAIM TO ANY PARTICULAR FONT, STYLE, SIZE, OR COLOR.

FOR COMPUTERIZED ON-LINE AND MAIL ORDER RETAIL SERVICES IN THE FIELD OF AFRICAN AMERICAN GOODS, NAMELY, COOKBOOKS AND RECIPES. (U.S. CLS. 100, 101 AND 102).

MARY BOAGNI, EXAMINING ATTORNEY

SN 79-058,418. GFK AG, FED REP GERMANY, FILED 7-17-2008.

AD*VANTAGE

OWNER OF INTERNATIONAL REGISTRATION 0640959 DATED 6-30-1995, EXPIRES 6-30-2015.

FOR CONDUCTING MARKETING STUDIES, BUSINESS RESEARCH, NAMELY, ADVERTISING RESEARCH, COMMUNICATION RESEARCH (U.S. CLS. 100, 101 AND 102).

ANNE E. GUSTASON, EXAMINING ATTORNEY

SN 79-063,215. TURHAN SAHINKAYA, YILDIRIM BURSA, TURKEY, FILED 10-24-2008.

**TURHAN ŞAHINKAYA
"EVERYBODY IS KING AND QUEEN HERE"**

OWNER OF INTERNATIONAL REGISTRATION 0987809 DATED 10-24-2008, EXPIRES 10-24-2018.

OWNER OF U.S. REG. NO. 3,591,489.

THE NAME SHOWN IN THE MARK IDENTIFIES "TURHAN SAHINKAYA" WHOSE CONSENT IS OF RECORD.

FOR ADVERTISEMENT AGENCY SERVICES, NAMELY, PROMOTING THE GOODS AND SERVICES OF OTHERS; ADVERTISEMENT OFFICE SERVICES, NAMELY, PROMOTING THE GOODS AND SERVICES OF OTHERS; BUSINESS MANAGEMENT; BUSINESS ADMINISTRATION; PROVIDING OFFICE FUNCTIONS; PUBLIC RELATIONS; IMPORT AND EXPORT AGENCIES; BUSINESS MANAGEMENT OF PERFORMING ARTISTS; EXPERT EVALUATIONS RELATING TO INDUSTRIAL AND COMMERCIAL GOODS; AUCTIONEERING; RETAIL SALE SERVICES, NAMELY, BRINGING TOGETHER, FOR THE BENEFIT OF OTHERS, A WIDE VARIETY OF GOODS ENABLING CUSTOMERS TO VIEW AND PURCHASE THOSE GOODS; RETAIL SALE SERVICES, NAMELY, BRINGING TOGETHER A WIDE VARIETY OF GOODS ENABLING CUSTOMERS TO VIEW AND PURCHASE THOSE GOODS FEATURING FOOD AND GROCERIES, NUTRITIONAL SUPPLEMENTS, CLEANING AND HYGIENIC PRODUCTS, BODY CARE PRODUCTS AND OILS, COSMETICS, PERFUMERY, TEXTILE PRODUCTS, CLOTHING AND ACCESSORIES, KITCHEN UTENSILS, BATH AND HOUSEHOLD PRODUCTS, APPLIANCES AND FURNITURE (U.S. CLS. 100, 101 AND 102).

ELIZABETH KAJUBI, EXAMINING ATTORNEY

CLASS 35—(Continued).

SN 79-064,690. FÉDÉRATION EUROPÉENNE DU VERRE; D'EMBALLAGE, ASSOCIATION INTERNATIONALE; SANS BUT LUCRATIF, BELGIUM, FILED 12-16-2008.

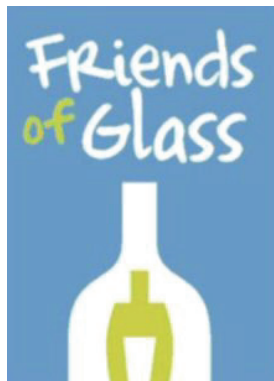

PRIORITY DATE OF 11-14-2008 IS CLAIMED.
OWNER OF INTERNATIONAL REGISTRATION 0991647 DATED 12-16-2008, EXPIRES 12-16-2018.

THE COLOR(S) BLUE, GREEN, AND WHITE IS/ARE CLAIMED AS A FEATURE OF THE MARK.

THE MARK CONSISTS OF THE WORDING "FRIENDS" IN WHITE, "OF" IN GREEN, AND "GLASS" IN WHITE, WITH THREE NESTING BOTTLES AND GLASSES IN GREEN AND WHITE AGAINST A BLUE BACKGROUND.

FOR ADVERTISING; RENTAL OF ADVERTISING SPACE; BUSINESS MANAGEMENT ASSISTANCE; BUSINESS INFORMATION AND INQUIRIES; BUSINESS MANAGEMENT AND ORGANIZATION CONSULTANCY; BUSINESS INFORMATION AGENCIES; BUSINESS INFORMATION AND ADVICE TO CONSUMERS; COMPILATION OF STATISTICS; DOCUMENT REPRODUCTION; ECONOMIC FORECASTING; MARKET RESEARCH; MARKET STUDIES; ORGANIZATION OF TRADE FAIRS TO ADVERTISE AND PROMOTE COMMODITY EXCHANGES FOR COMMERCIAL OR ADVERTISING PURPOSES; PUBLIC RELATIONS; ALL THESE SERVICES PROVIDED FOR THE GLASS INDUSTRY (U.S. CLS. 100, 101 AND 102).

KRISTIN DAHLING, EXAMINING ATTORNEY

CLASS 36—INSURANCE AND FINANCIAL

SN 76-312,888. AMERICAN HEALTH FIRST, INC., HOUSTON, TX. FILED 9-17-2001.

AMERICAN HEALTH FIRST

NO CLAIM IS MADE TO THE EXCLUSIVE RIGHT TO USE "AMERICAN HEALTH", APART FROM THE MARK AS SHOWN.

FOR PROVIDING FINANCIAL SERVICES TO HOSPITALS, NAMELY, RECOVERING UNCOMPENSATED MEDICAL COSTS; PROVIDING FINANCIAL ELIGIBILITY CONSULTING SERVICES TO HOSPITALS; SECURING PAYMENTS OF MEDICAL AND HOSPITAL COSTS THROUGH PRIVATE AND/OR GOVERNMENT SOURCES FOR PATIENTS WITH NO INSURANCE WHO ARE FINANCIALLY INCAPABLE OF INDEPENDENTLY PAYING FOR HOSPITAL/DOCTOR EXPENSES (U.S. CLS. 100, 101 AND 102).

CAROLYN CATALDO, EXAMINING ATTORNEY

CLASS 36—(Continued).

SN 76-651,693. SOVEREIGN MILITARY HOSPITALLER ORDER OF SAINT JOHN OF JERUSALEM OF RHODES AND OF MALTA, ROME, ITALY, FILED 12-9-2005.

KNIGHTS OF ST. JOHN OF JERUSALEM

THE MARK CONSISTS OF STANDARD CHARACTERS WITHOUT CLAIM TO ANY PARTICULAR FONT, STYLE, SIZE, OR COLOR.

OWNER OF U.S. REG. NOS. 2,783,933, 2,915,824 AND 3,056,803.

NO CLAIM IS MADE TO THE EXCLUSIVE RIGHT TO USE "KNIGHTS", APART FROM THE MARK AS SHOWN, FOR CHARITABLE SERVICES, NAMELY, FUNDRAISING FOR AND PROVIDING GRANTS TO DOMESTIC AND INTERNATIONAL HUMANITARIAN, HOSPITALER, MEDICAL, RELIGIOUS, AND DIPLOMATIC CAUSES (U.S. CLS. 100, 101 AND 102).

FIRST USE 1-1-1113; IN COMMERCE 12-7-2005.

PRISCILLA MILTON, EXAMINING ATTORNEY

SN 76-689,640. TRANSUNION RENTAL SCREENING SOLUTIONS, INC., ENGLEWOOD, CO. FILED 5-14-2008.

SMARTMOVE

THE MARK CONSISTS OF STANDARD CHARACTERS WITHOUT CLAIM TO ANY PARTICULAR FONT, STYLE, SIZE, OR COLOR.

FOR PROVIDING CREDIT SCREENING OF POTENTIAL RENTERS TO RENTAL PROPERTY OWNERS (U.S. CLS. 100, 101 AND 102).

JORDAN BAKER, EXAMINING ATTORNEY

SN 76-694,669. COLUMBIAN MUTUAL LIFE INSURANCE COMPANY, BINGHAMTON, NY. FILED 12-5-2008.

CARING SOLUTIONS

FOR LIFE INSURANCE UNDERWRITING SERVICES (U.S. CLS. 100, 101 AND 102).

FIRST USE 12-1-2008; IN COMMERCE 12-1-2008.

DAVID C. REIHNER, EXAMINING ATTORNEY

CLASS 36—(Continued).

SN 77-080,002. F.N.B. CORPORATION, HERMITAGE, PA.
FILED 1-10-2007.

F.N.B. INVESTMENT ADVISORS

THE MARK CONSISTS OF STANDARD CHARACTERS WITHOUT CLAIM TO ANY PARTICULAR FONT, STYLE, SIZE, OR COLOR.

OWNER OF U.S. REG. NOS. 2,685,150, 2,690,885 AND 3,246,078.

NO CLAIM IS MADE TO THE EXCLUSIVE RIGHT TO USE "INVESTMENT ADVISORS", APART FROM THE MARK AS SHOWN.

FOR INVESTMENT MANAGEMENT AND ASSETS MANAGEMENT AND CONSULTATION; ADMINISTRATION AND MANAGEMENT OF, INDIVIDUAL RETIREMENT ACCOUNTS, SELF EMPLOYED QUALIFIED RETIREMENT PLANS, 401(K) PLANS AND OTHER TYPE QUALIFIED AND NON-QUALIFIED RETIREMENT PLANS AND MONEY MARKET ACCOUNT SERVICES; MUTUAL FUNDS SERVICES, NAMELY, ESTABLISHMENT OF MUTUAL FUNDS FOR OTHERS AND BROKERAGE, INVESTMENT AND DISTRIBUTION; TRUST SERVICES, NAMELY, INVESTMENT AND TRUST COMPANY SERVICES; FIDUCIARY REPRESENTATIVE SERVICES AND TRUST ADMINISTRATION; FINANCIAL ANALYSIS AND CONSULTATION; FINANCIAL CLEARING HOUSES; FINANCIAL SERVICES IN THE NATURE OF AN INVESTMENT SECURITY; FINANCIAL INFORMATION IN THE NATURE OF RATES OF EXCHANGE, FINANCIAL EXCHANGE, FINANCIAL FORECASTING AND FINANCIAL GUARANTEE AND SURETY; FINANCIAL INFORMATION PROVIDED BY ELECTRONIC MEANS; FINANCIAL MANAGEMENT; FINANCIAL PLANNING; FINANCIAL PORTFOLIO MANAGEMENT; FINANCIAL RESEARCH; FINANCIAL VALUATION OF PERSONAL PROPERTY AND REAL ESTATE; FINANCING SERVICES; INVESTMENT SERVICES, NAMELY, INVESTMENT BROKERAGE; CAPITAL INVESTMENT CONSULTATION AND ADVICE; FUND INVESTMENT CONSULTATION; INVESTMENT CONSULTATION; FINANCIAL INVESTMENT IN THE FIELD OF SECURITIES; FUNDS INVESTMENT; MUTUAL FUNDS INVESTMENT; REAL ESTATE INVESTMENT; COMMODITY INVESTMENT ADVICE; INVESTMENT ADVICE; INVESTMENT BROKERAGE; INVESTMENT CLUBS; CAPITAL INVESTMENT CONSULTATION; INVESTMENT MANAGEMENT; MAINTAINING ESCROW ACCOUNTS FOR INVESTMENTS; INVESTMENT OF FUNDS FOR OTHERS; INVESTMENT OF FUNDS, MUTUAL FUNDS AND REAL ESTATE; INVESTMENT OF TRUST FUNDS FOR OTHERS; INVESTMENT AND FINANCIAL INVESTMENT IN THE FIELD OF REAL ESTATE AND SECURITIES; FINANCIAL INFORMATION SERVICES FOR ALL OF THE FOREGOING PROVIDED VIA A GLOBAL COMPUTER NETWORK; FINANCIAL SERVICES, NAMELY, BANKING SERVICES, PROVIDED BY TELEPHONE (U.S. CLS. 100, 101 AND 102).

FIRST USE 1-0-2002; IN COMMERCE 1-0-2002.

RONALD DELGIZZI, EXAMINING ATTORNEY

CLASS 36—(Continued).

SN 77-194,801. THE AUCTION HOUSE INC, SAN FRANCISCO, CA. FILED 5-31-2007.



THE MARK CONSISTS OF A HOUSE ON A HILL WITH THE WORDS "THE AUCTION HOUSE" UNDERNEATH. UNDER THAT, THE WORDS "CHANGING THE WAY AMERICA SELLS REAL ESTATE!"

FOR REAL ESTATE BROKERAGE (U.S. CLS. 100, 101 AND 102).

REGINA DRUMMOND, EXAMINING ATTORNEY

SN 77-220,305. TAHOE UNITED MANAGEMENT, INC., LAS VEGAS, NV. FILED 7-2-2007.

CAPTAIN BRAD

THE MARK CONSISTS OF STANDARD CHARACTERS WITHOUT CLAIM TO ANY PARTICULAR FONT, STYLE, SIZE, OR COLOR.

FOR REAL ESTATE BROKERAGE SERVICES; ACQUISITION SERVICES FOR REAL ESTATE INVESTORS; MORTGAGE INFORMATION SERVICES; MODELING AND ANALYSIS OF MORTGAGOR BEHAVIOR FOR OTHERS; PURCHASE AND SALE OF RESIDENTIAL, COMMERCIAL AND NON-RESIDENTIAL MORTGAGES FOR OTHERS; PURCHASE AND SALE OF RESIDENTIAL, COMMERCIAL AND NON-RESIDENTIAL REAL ESTATE, NAMELY, REAL ESTATE ACQUISITION, REAL ESTATE AGENCIES SERVICES AND REAL ESTATE BROKERAGE; AND CONSULTING SERVICES IN THE FIELD OF REAL ESTATE MANAGEMENT, REAL ESTATE FINANCING, REAL ESTATE INVESTMENT, MORTGAGE LENDING AND IN PREVENTING REAL ESTATE FORECLOSURE (U.S. CLS. 100, 101 AND 102).

FIRST USE 2-0-2008; IN COMMERCE 2-0-2008.

FRANK LATTUCA, EXAMINING ATTORNEY

SN 77-301,255. RON LAWNER'S CATALYST LLC, BOSTON, MA. FILED 10-11-2007.

PURPLE DOG TAG

THE MARK CONSISTS OF STANDARD CHARACTERS WITHOUT CLAIM TO ANY PARTICULAR FONT, STYLE, SIZE, OR COLOR.

NO CLAIM IS MADE TO THE EXCLUSIVE RIGHT TO USE "DOG TAG", APART FROM THE MARK AS SHOWN.

FOR CHARITABLE SERVICES, NAMELY, FUNDRAISING, ACCEPTING AND ADMINISTERING CHARITABLE CONTRIBUTIONS TO ORGANIZATIONS THAT SERVE AND SUPPORT WOUNDED MILITARY PERSONNEL (U.S. CLS. 100, 101 AND 102).

BERYL GARDNER, EXAMINING ATTORNEY

CLASS 36—(Continued).

SN 77-320,003. FASHION OUTLETS OF SANTA FE, LLC, CORAL GABLES, FL. FILED 11-2-2007.

FASHION OUTLETS OF SANTA FE

THE MARK CONSISTS OF STANDARD CHARACTERS WITHOUT CLAIM TO ANY PARTICULAR FONT, STYLE, SIZE, OR COLOR.

NO CLAIM IS MADE TO THE EXCLUSIVE RIGHT TO USE "OUTLETS", APART FROM THE MARK AS SHOWN. SEC. 2(F).

FOR SHOPPING CENTER SERVICES, NAMELY, RENTAL OF SHOPPING CENTER SPACE (U.S. CLS. 100, 101 AND 102).

FIRST USE 10-0-2007; IN COMMERCE 10-0-2007.

PAM WILLIS, EXAMINING ATTORNEY

SN 77-358,054. KEEFE & ASSOCIATES, INC., SAN JOSE, CA. FILED 12-21-2007.

CONTINUUM WEALTH MANAGEMENT

THE MARK CONSISTS OF STANDARD CHARACTERS WITHOUT CLAIM TO ANY PARTICULAR FONT, STYLE, SIZE, OR COLOR.

NO CLAIM IS MADE TO THE EXCLUSIVE RIGHT TO USE "WEALTH MANAGEMENT", APART FROM THE MARK AS SHOWN.

FOR FINANCIAL PLANNING SERVICES, NAMELY, WEALTH MANAGEMENT SERVICES THAT PROVIDE PRIVATE CLIENTS WITH A HOLISTIC AND INTEGRATED LIFETIME PICTURE OF THEIR EXISTING AND PROJECTED ASSETS, LIABILITIES, INCOME AND EXPENSES, AND DEVELOP AND IMPLEMENT INVESTMENT STRATEGIES BASED ON PERIODIC REVIEWS THAT ENABLE CLIENTS TO REVIEW AND CHANGE THEIR STRATEGIES AS THEY TRACK THEIR PROGRESS TOWARD ACHIEVING THEIR GOALS (U.S. CLS. 100, 101 AND 102).

FIRST USE 9-15-2006; IN COMMERCE 9-15-2006.

DOMINICK J. SALEMI, EXAMINING ATTORNEY

CLASS 36—(Continued).

SN 77-358,089. PADRES L.P., SAN DIEGO, CA. FILED 12-21-2007.

PADRES

THE MARK CONSISTS OF STANDARD CHARACTERS WITHOUT CLAIM TO ANY PARTICULAR FONT, STYLE, SIZE, OR COLOR.

OWNER OF U.S. REG. NOS. 1,158,446, 3,136,500 AND OTHERS.

FOR FINANCIAL SERVICES, NAMELY, CHARITABLE FUNDRAISING SERVICES, FINANCIAL CONSULTING SERVICES, FINANCIAL ADVISORY SERVICES, FINANCIAL ANALYSIS SERVICES, FINANCIAL INFORMATION SERVICES, FINANCIAL PLANNING SERVICES, FINANCIAL RESEARCH SERVICES, FINANCIAL MANAGEMENT SERVICES, MONEY LENDING SERVICES, FINANCIAL SPONSORSHIP OF SPORTING EVENTS, BANKING SERVICES, FINANCING SERVICES, SAVINGS PROGRAMS FOR YOUTHS, MORTGAGE SERVICES; INVESTMENT SERVICES, NAMELY, PROVIDING INVESTMENT ANALYSIS, DEVELOPMENT, ACQUISITION, CONSULTATION, PLANNING, MANAGEMENT, ADVISORY, BROKERAGE, BANKING AND RESEARCH SERVICES WITH RESPECT TO STOCKS, MUTUAL FUNDS, SECURITIES, BONDS, COMMODITIES, REAL ESTATE AND OTHER INSTRUMENTS OF INVESTMENT; CREDIT CARD SERVICES (U.S. CLS. 100, 101 AND 102).

JUSTINE D. PARKER, EXAMINING ATTORNEY

SN 77-358,395. DENNY HECKER'S AUTOMOTIVE GROUP, INC., MINNEAPOLIS, MN. FILED 12-21-2007.

GOOD PEOPLE HELPING GOOD
PEOPLE

THE MARK CONSISTS OF STANDARD CHARACTERS WITHOUT CLAIM TO ANY PARTICULAR FONT, STYLE, SIZE, OR COLOR.

OWNER OF U.S. REG. NOS. 3,453,067 AND 3,453,068.

FOR INSURANCE BROKERAGE; FINANCING RELATING TO AUTOMOBILES (U.S. CLS. 100, 101 AND 102).

FIRST USE 7-0-1999; IN COMMERCE 7-0-1999.

LAURA HAMMEL, EXAMINING ATTORNEY

CLASS 36—(Continued).

SN 77-363,004. ALTIN FUND, ROCHESTER, MI. FILED 1-2-2008.

CLASS 36—(Continued).

SN 77-373,291. LINCOLN INVESTMENT PLANNING, INC., WYNCOTE, PA. FILED 1-16-2008.

EMBRACE THE OPPORTUNITY

ALTIN FUND

THE MARK CONSISTS OF STANDARD CHARACTERS WITHOUT CLAIM TO ANY PARTICULAR FONT, STYLE, SIZE, OR COLOR.

NO CLAIM IS MADE TO THE EXCLUSIVE RIGHT TO USE "FUND", APART FROM THE MARK AS SHOWN.

THE WORDING "ALTIN" HAS NO MEANING IN A FOREIGN LANGUAGE.

FOR ADVICE RELATING TO INVESTMENTS; CAPITAL INVESTMENT CONSULTATION; COMMODITY INVESTMENT ADVICE; EQUITY CAPITAL INVESTMENT; FINANCIAL AND INVESTMENT SERVICES, NAMELY, MANAGEMENT AND BROKERAGE IN THE FIELDS OF STOCKS, BONDS, OPTIONS, COMMODITIES, FUTURES AND OTHER SECURITIES, AND THE INVESTMENT OF FUNDS OF OTHERS; FINANCIAL PLANNING AND INVESTMENT ADVISORY SERVICES; FINANCIAL SERVICES IN THE NATURE OF AN INVESTMENT SECURITY; FINANCIAL SERVICES, NAMELY, A TOTAL PORTFOLIO OFFERING FOR HIGH NET WORTH CLIENTS CONSISTING OF BOTH SEPARATE ACCOUNTS AND MUTUAL FUNDS FOR EQUITY AND FIXED INCOME INVESTMENTS; FINANCIAL SERVICES, NAMELY, INVESTMENT FUND TRANSFER AND TRANSACTION SERVICES; FUND INVESTMENT CONSULTATION; FUNDS INVESTMENT; HEDGE FUND INVESTMENT SERVICES; INVESTMENT ADVICE; INVESTMENT ADVISORY SERVICES; INVESTMENT BANKING SERVICES; INVESTMENT BROKERAGE; INVESTMENT CONSULTATION; INVESTMENT MANAGEMENT; INVESTMENT MANAGEMENT OF AND DISTRIBUTION OF ANNUITIES; INVESTMENT MANAGEMENT OF AND DISTRIBUTION OF VARIABLE ANNUITIES; INVESTMENT MANAGEMENT SERVICES IN THE FIELD OF ACQUIRING JOINT VENTURES; INVESTMENT OF FUNDS FOR OTHERS; INVESTMENT SERVICES, NAMELY, ASSET ACQUISITION, CONSULTATION, DEVELOPMENT AND MANAGEMENT SERVICES; LEVERAGED BUY OUTS AND INVESTMENTS IN FINANCIALLY DISTRESSED OR UNDERPERFORMING COMPANIES; MANAGEMENT OF A CAPITAL INVESTMENT FUND; MUTUAL FUND INVESTMENT; PRIVATE EQUITY FUND INVESTMENT SERVICES; PROVIDING INFORMATION AND ADVICE IN THE FIELD OF FINANCE, FINANCIAL INVESTMENTS, FINANCIAL VALUATIONS, AND THE FINANCIAL ASPECTS OF RETIREMENT; PUBLIC EQUITY INVESTMENT MANAGEMENT; REAL ESTATE INVESTMENT; REAL ESTATE INVESTMENT SERVICES IN THE NATURE OF PURCHASING AND SELLING OF REAL ESTATE FOR OTHERS; SECURITIES TRADING AND INVESTING SERVICES FOR OTHERS VIA THE INTERNET; INVESTMENT BY ELECTRONIC MEANS (U.S. CLS. 100, 101 AND 102).

MAUREEN DALL, EXAMINING ATTORNEY

THE MARK CONSISTS OF STANDARD CHARACTERS WITHOUT CLAIM TO ANY PARTICULAR FONT, STYLE, SIZE, OR COLOR.

FOR FINANCIAL AND INVESTMENT SERVICES FOR RETIREMENT AND RETIREMENT PLANNING, NAMELY, INVESTMENT BROKERAGE, MUTUAL FUND BROKERAGE, INSURANCE BROKERAGE SERVICES, INVESTMENT ADVISORY SERVICES, MUTUAL FUND INVESTMENT, ISSUANCE AND ADMINISTRATION OF ANNUITIES, FINANCIAL PLANNING AND INVESTMENT CONSULTATION (U.S. CLS. 100, 101 AND 102).

ELI HELLMAN, EXAMINING ATTORNEY

SN 77-373,304. LINCOLN INVESTMENT PLANNING, INC., WYNCOTE, PA. FILED 1-16-2008.

EMBRACE THE FUTURE

THE MARK CONSISTS OF STANDARD CHARACTERS WITHOUT CLAIM TO ANY PARTICULAR FONT, STYLE, SIZE, OR COLOR.

FOR FINANCIAL AND INVESTMENT SERVICES FOR RETIREMENT AND RETIREMENT PLANNING, NAMELY, INVESTMENT BROKERAGE, MUTUAL FUND BROKERAGE, INSURANCE BROKERAGE SERVICES, INVESTMENT ADVISORY SERVICES, MUTUAL FUND INVESTMENT, ISSUANCE AND ADMINISTRATION OF ANNUITIES, FINANCIAL PLANNING AND INVESTMENT CONSULTATION (U.S. CLS. 100, 101 AND 102).

ELI HELLMAN, EXAMINING ATTORNEY

CLASS 36—(Continued).

SN 77-381,175. ASCOT UNDERWRITING LTD., LONDON, UNITED KINGDOM, FILED 1-25-2008.

ASCOT RENEWCO

THE MARK CONSISTS OF STANDARD CHARACTERS WITHOUT CLAIM TO ANY PARTICULAR FONT, STYLE, SIZE, OR COLOR.

PRIORITY CLAIMED UNDER SEC. 44(D) ON ERPN CMNTY TM OFC APPLICATION NO. 6174569, FILED 7-27-2007, REG. NO. 00617569, DATED 6-16-2008, EXPIRES 7-27-2017.

FOR INSURANCE SERVICES, NAMELY, WRITING PROPERTY AND CASUALTY INSURANCE; REINSURANCE UNDERWRITING SERVICES; ARRANGING OF INSURANCE, NAMELY, UNDERWRITING INSURANCE IN THE FIELDS OF PROPERTY, ENERGY PRODUCTION AND DISTRIBUTION, CARGO TRANSIT, BUSINESS INTERRUPTION AND DESTRUCTION, MARINE HULL AND LIABILITY, EXCESS LOSS, SPECIE AND FINE ART, AND ACCIDENT AND HEALTH; INSURANCE CONSULTANCY, INSURANCE UNDERWRITING CONSULTANCY; ESTIMATES FOR INSURANCE UNDERWRITING PURPOSES, NAMELY, PROVIDING APPRAISALS IN THE FIELDS OF PROPERTY, ENERGY PRODUCTION AND DISTRIBUTION, CARGO TRANSIT, BUSINESS INTERRUPTION AND DESTRUCTION, MARINE HULL AND LIABILITY, EXCESS LOSS, SPECIE AND FINE ART, AND ACCIDENT AND HEALTH; INSURANCE AND REINSURANCE UNDERWRITING AND BROKERAGE SERVICES; BROKERAGE SERVICES FOR RENEWABLE ENERGY; INFORMATION AND ADVISORY SERVICES RELATING TO INSURANCE UNDERWRITING AND BROKERAGE SERVICES (U.S. CLS. 100, 101 AND 102).

GENE MACIOL, EXAMINING ATTORNEY

SN 77-390,368. DISCLOSURE INSIGHT, INC., PLYMOUTH, MN. FILED 2-6-2008.

D.I. EVERYTHING

THE MARK CONSISTS OF STANDARD CHARACTERS WITHOUT CLAIM TO ANY PARTICULAR FONT, STYLE, SIZE, OR COLOR.

FOR PROVIDING BUNDLED FINANCIAL INFORMATION AND INVESTMENT INFORMATION SERVICES REGARDING SEC FILINGS AND RELATED FINANCIAL INVESTMENTS VIA REPORTS, NEWSLETTERS, E-MAIL ALERTS, VOICE MAIL, COMPANY LISTING INFORMATION, CONFERENCE CALLS, ANALYST CONTACT, AND IN-PERSON MEETINGS (U.S. CLS. 100, 101 AND 102).

FIRST USE 4-7-2008; IN COMMERCE 4-7-2008.

CIMMERIAN COLEMAN, EXAMINING ATTORNEY

CLASS 36—(Continued).

SN 77-471,564. MONEY MANAGEMENT SERVICES INC., BIRMINGHAM, AL. FILED 5-12-2008.

**MORE THAN JUST A WEALTH
MANAGEMENT FIRM**

THE MARK CONSISTS OF STANDARD CHARACTERS WITHOUT CLAIM TO ANY PARTICULAR FONT, STYLE, SIZE, OR COLOR.

NO CLAIM IS MADE TO THE EXCLUSIVE RIGHT TO USE "WEALTH MANAGEMENT FIRM", APART FROM THE MARK AS SHOWN.

FOR INVESTMENT ADVISORY SERVICES (U.S. CLS. 100, 101 AND 102).

FIRST USE 2-6-2008; IN COMMERCE 2-6-2008.

FRANK LATTUCA, EXAMINING ATTORNEY

SN 77-488,375. AIDS RESEARCH CONSORTIUM OF ATLANTA, INC., ATLANTA, GA. FILED 6-2-2008.

Uncork a Cure

THE MARK CONSISTS OF STANDARD CHARACTERS WITHOUT CLAIM TO ANY PARTICULAR FONT, STYLE, SIZE, OR COLOR.

SEC. 2(F).

FOR CHARITABLE FUNDRAISING SERVICES (U.S. CLS. 100, 101 AND 102).

FIRST USE 4-0-1992; IN COMMERCE 4-0-1992.

MARILYN IZZI, EXAMINING ATTORNEY

SN 77-511,837. VERIS WEALTH PARTNERS LLC, NEW YORK, NY. FILED 6-30-2008.

**VALUES. WEALTH.
SUSTAINABILITY.**

THE MARK CONSISTS OF STANDARD CHARACTERS WITHOUT CLAIM TO ANY PARTICULAR FONT, STYLE, SIZE, OR COLOR.

FOR FINANCIAL MANAGEMENT; FINANCIAL PORTFOLIO MANAGEMENT; INVESTMENT MANAGEMENT; MANAGEMENT OF PORTFOLIOS COMPRISING SECURITIES; INVESTMENT ADVICE; INVESTMENT CONSULTATION; FINANCIAL INVESTMENT IN THE FIELD OF SECURITIES AND MUTUAL FUNDS; ESTATE PLANNING; FINANCIAL PLANNING; FINANCIAL PLANNING CONSULTATION; ADVICE RELATING TO INVESTMENTS; FUND INVESTMENT CONSULTATION; FINANCIAL CONSULTATION; FINANCIAL ANALYSIS AND CONSULTATION; MUTUAL FUND INVESTMENT; INSURANCE CONSULTATION (U.S. CLS. 100, 101 AND 102).

FIRST USE 7-1-2007; IN COMMERCE 7-1-2007.

EDWARD NELSON, EXAMINING ATTORNEY

CLASS 36—(Continued).

SN 77-513,164. CHILD HEALTH RESEARCH INSTITUTE, ROCKVILLE, MD. FILED 7-2-2008.

Cure Kids USA

THE MARK CONSISTS OF STANDARD CHARACTERS WITHOUT CLAIM TO ANY PARTICULAR FONT, STYLE, SIZE, OR COLOR.

NO CLAIM IS MADE TO THE EXCLUSIVE RIGHT TO USE "KIDS USA", APART FROM THE MARK AS SHOWN.

FOR CHARITABLE FUNDRAISING IN SUPPORT OF FUNDING RESEARCH ON CHILDHOOD DISEASES (U.S. CLS. 100, 101 AND 102).

FIRST USE 4-28-2008; IN COMMERCE 4-28-2008.
TASNEEM HUSSAIN, EXAMINING ATTORNEY

SN 77-513,483. CHILD HEALTH RESEARCH INSTITUTE, DBA CURE KIDS USA, ROCKVILLE, MD. FILED 7-2-2008.

Cure Kids

THE MARK CONSISTS OF STANDARD CHARACTERS WITHOUT CLAIM TO ANY PARTICULAR FONT, STYLE, SIZE, OR COLOR.

NO CLAIM IS MADE TO THE EXCLUSIVE RIGHT TO USE "KIDS", APART FROM THE MARK AS SHOWN.

FOR CHARITABLE FUNDRAISING IN SUPPORT OF FUNDING RESEARCH ON CHILDHOOD DISEASES (U.S. CLS. 100, 101 AND 102).

TASNEEM HUSSAIN, EXAMINING ATTORNEY

SN 77-517,162. BUSINESS BANQUE INCORPORATED, LA-FAYETTE, LA. FILED 7-8-2008.

Business Express

THE MARK CONSISTS OF STANDARD CHARACTERS WITHOUT CLAIM TO ANY PARTICULAR FONT, STYLE, SIZE, OR COLOR.

OWNER OF U.S. REG. NO. 1,513,829.

NO CLAIM IS MADE TO THE EXCLUSIVE RIGHT TO USE "BUSINESS", APART FROM THE MARK AS SHOWN.

FOR FINANCIAL EXCHANGE AND BARTER SERVICES FOR OTHERS, KNOWN AS MUTUAL CREDIT ALLIANCES, WHEREBY MEMBER BANKS AND/OR OTHER FINANCIAL INSTITUTIONS USE AN ASSET-BASED ALTERNATIVE CURRENCY SUCH AS, A COMMUNITY CURRENCY, COMPLIMENTARY CURRENCY OR OTHER NON-US OFFICIAL CURRENCY TO ALLOW THEIR CUSTOMERS TO PAY EACH OTHER FOR PURCHASES THROUGH THE EXCHANGE OF THIS CURRENCY OR BARTERING OF GOODS AND SERVICES (U.S. CLS. 100, 101 AND 102).

MARIAM MAHMOUDI, EXAMINING ATTORNEY

CLASS 36—(Continued).

SN 77-518,479. STARWOOD HOTELS & RESORTS WORLD-WIDE, INC., WHITE PLAINS, NY. FILED 7-9-2008.



OWNER OF U.S. REG. NOS. 3,544,727 AND 3,555,294.
THE MARK CONSISTS OF THE TERM "ALOFT" IN STYLIZED FORM WITH THE "A" APPEARING WITHIN A QUADRILATERAL.

FOR REAL ESTATE SERVICES, NAMELY, BROKERAGE, LEASING AND MANAGEMENT FOR OTHERS OF RESIDENTIAL OR VACATION TIME-SHARE CONDOMINIUMS; LEASING OF APARTMENTS, NAMELY, RESIDENTIAL OR VACATION TIME-SHARE CONDOMINIUMS; ALL THE FOREGOING CONDOMINIUMS LOCATED WITHIN THE SAME DEVELOPMENT SITE AS ALOFT BRANDED HOTELS OR ALOFT BRANDED HOTEL, MOTEL, OR RESORT DEVELOPMENTS (U.S. CLS. 100, 101 AND 102).

JENNIFER MARTIN, EXAMINING ATTORNEY

SN 77-518,481. STARWOOD HOTELS & RESORTS WORLD-WIDE, INC., WHITE PLAINS, NY. FILED 7-9-2008.



OWNER OF U.S. REG. NOS. 2,294,753, 3,544,727 AND 3,555,294.

NO CLAIM IS MADE TO THE EXCLUSIVE RIGHT TO USE "HOTELS", APART FROM THE MARK AS SHOWN.

THE MARK CONSISTS OF THE TERM "ALOFT" IN STYLIZED FORM WITH THE "A" APPEARING WITHIN A QUADRILATERAL WITH THE WORDS "A VISION OF W HOTELS" BELOW.

FOR REAL ESTATE SERVICES, NAMELY, BROKERAGE, LEASING AND MANAGEMENT FOR OTHERS OF RESIDENTIAL OR VACATION TIME-SHARE CONDOMINIUMS; LEASING OF APARTMENTS, NAMELY, RESIDENTIAL OR VACATION TIME-SHARE CONDOMINIUMS; ALL THE FOREGOING CONDOMINIUMS LOCATED WITHIN THE SAME DEVELOPMENT SITE AS ALOFT BRANDED HOTELS OR ALOFT BRANDED HOTEL, MOTEL, OR RESORT DEVELOPMENTS (U.S. CLS. 100, 101 AND 102).

JENNIFER MARTIN, EXAMINING ATTORNEY

CLASS 36—(Continued).

SN 77-518,484. STARWOOD HOTELS & RESORTS WORLD-WIDE, INC., WHITE PLAINS, NY. FILED 7-9-2008.



OWNER OF U.S. REG. NOS. 2,294,753, 3,544,727 AND 3,555,294.

NO CLAIM IS MADE TO THE EXCLUSIVE RIGHT TO USE "HOTELS", APART FROM THE MARK AS SHOWN.

THE MARK CONSISTS OF THE TERM "ALOFT" IN STYLIZED FORM WITH THE "A" APPEARING WITHIN A QUADRILATERAL AND THE WORDS "W HOTELS" BE-NEATH.

FOR REAL ESTATE SERVICES, NAMELY, BROKER-AGE, LEASING AND MANAGEMENT FOR OTHERS OF RESIDENTIAL OR VACATION TIME-SHARE CONDO-MINIUMS; LEASING OF APARTMENTS, NAMELY, RESIDENTIAL OR VACATION TIME-SHARE CONDO-MINIUMS; ALL THE FOREGOING CONDOMINIUMS LOCATED WITHIN THE SAME DEVELOPMENT SITE AS ALOFT BRANDED HOTELS OR ALOFT BRANDED HOTEL, MOTEL, OR RESORT DEVELOPMENTS (U.S. CLS. 100, 101 AND 102).

JENNIFER MARTIN, EXAMINING ATTORNEY

SN 77-518,954. PAYMENT PROCESSING, INC., NEWARK, CA. FILED 7-10-2008.

PAYPROS

THE MARK CONSISTS OF STANDARD CHARACTERS WITHOUT CLAIM TO ANY PARTICULAR FONT, STYLE, SIZE, OR COLOR.

FOR PROVIDING ELECTRONIC PROCESSING OF CREDIT CARD TRANSACTIONS AND ELECTRONIC PAYMENTS VIA A GLOBAL COMPUTER NETWORK (U.S. CLS. 100, 101 AND 102).

ANDREA K. NADELMAN, EXAMINING ATTORNEY

SN 77-526,174. BIG BEAR COOL CABINS, INC., BIG BEAR LAKE, CA. FILED 7-18-2008.

COOL CABINS

THE MARK CONSISTS OF STANDARD CHARACTERS WITHOUT CLAIM TO ANY PARTICULAR FONT, STYLE, SIZE, OR COLOR.

NO CLAIM IS MADE TO THE EXCLUSIVE RIGHT TO USE "CABINS", APART FROM THE MARK AS SHOWN.

FOR RENTAL OF VACATION PROPERTIES (U.S. CLS. 100, 101 AND 102).

FIRST USE 1-0-2003; IN COMMERCE 1-0-2003.
STEVEN JACKSON, EXAMINING ATTORNEY

CLASS 36—(Continued).

SN 77-528,581. THE RITZ-CARLTON HOTEL COMPANY, L.L.C., BETHESDA, MD. FILED 7-22-2008.

MEANINGFUL MEETINGS

THE MARK CONSISTS OF STANDARD CHARACTERS WITHOUT CLAIM TO ANY PARTICULAR FONT, STYLE, SIZE, OR COLOR.

NO CLAIM IS MADE TO THE EXCLUSIVE RIGHT TO USE "MEETINGS", APART FROM THE MARK AS SHOWN.

FOR CHARITABLE FUND RAISING SERVICES; PRO-VIDING FINANCIAL SUPPORT TO CHARITABLE, FAM-ILY SERVICES AND HEALTH-RELATED ORGANIZATIONS (U.S. CLS. 100, 101 AND 102).

FIRST USE 9-27-2007; IN COMMERCE 9-27-2007.
ROBERT LAVACHE, EXAMINING ATTORNEY

SN 77-530,062. THE DEPARTMENT OF FORECLOSURE ADVISORS, LLC, MIAMI, FL. FILED 7-24-2008.



NO CLAIM IS MADE TO THE EXCLUSIVE RIGHT TO USE "DEPARTMENT OF FORECLOSURE ADVISORS", APART FROM THE MARK AS SHOWN.

THE MARK CONSISTS OF A SEAL WITH THE IMAGE OF A HOUSE AND THE IMAGE OF THE STATE OF FLORIDA, WITH THE TERMS "THE DEPARTMENT OF FORECLO-SURE ADVISORS".

FOR FINANCIAL ADVISORY AND CONSULTANCY SERVICES; MORTGAGE FORECLOSURE MITIGATION AND LOAN DEFAULT MITIGATION SERVICES, NAMELY, ACQUISITION AND LEASE-BACK OF REAL ESTATE; REAL ESTATE SERVICES TO STOP FORECLO-SURE, NAMELY, MORTGAGE DEBT MANAGEMENT (U.S. CLS. 100, 101 AND 102).

FIRST USE 7-1-2008; IN COMMERCE 7-1-2008.
ESTHER A. BORSUK, EXAMINING ATTORNEY

CLASS 36—(Continued).

SN 77-533,714. BIZEQUITY CORP., SPRING HOUSE, PA. FILED 7-29-2008.

BIZEQUITY.COM

THE MARK CONSISTS OF STANDARD CHARACTERS WITHOUT CLAIM TO ANY PARTICULAR FONT, STYLE, SIZE, OR COLOR.

FOR BUSINESS VALUATION SERVICES (U.S. CLS. 100, 101 AND 102).

FIRST USE 9-8-2008; IN COMMERCE 9-8-2008.
RICHARD A. STRASER, EXAMINING ATTORNEY



SN 77-533,724. BIZEQUITY CORP., SPRING HOUSE, PA. FILED 7-29-2008.

BIZEQUITY

THE MARK CONSISTS OF STANDARD CHARACTERS WITHOUT CLAIM TO ANY PARTICULAR FONT, STYLE, SIZE, OR COLOR.

FOR BUSINESS VALUATION SERVICES (U.S. CLS. 100, 101 AND 102).

FIRST USE 9-8-2008; IN COMMERCE 9-8-2008.
RICHARD A. STRASER, EXAMINING ATTORNEY



SN 77-537,688. OPTOMETRY GIVING SIGHT, GOLDEN, CO. FILED 8-2-2008.

Optometry's Opportunity

THE MARK CONSISTS OF STANDARD CHARACTERS WITHOUT CLAIM TO ANY PARTICULAR FONT, STYLE, SIZE, OR COLOR.

NO CLAIM IS MADE TO THE EXCLUSIVE RIGHT TO USE "OPTOMETRY'S", APART FROM THE MARK AS SHOWN.

FOR CHARITABLE FUNDRAISING SERVICES (U.S. CLS. 100, 101 AND 102).

DAWN FELDMAN, EXAMINING ATTORNEY

CLASS 36—(Continued).

SN 77-537,908. GUARD INSURANCE GROUP, INC., WILKES-BARRE, PA. FILED 8-4-2008.

EASTGUARD INSURANCE COMPANY

THE MARK CONSISTS OF STANDARD CHARACTERS WITHOUT CLAIM TO ANY PARTICULAR FONT, STYLE, SIZE, OR COLOR.

OWNER OF U.S. REG. NO. 1,995,504.

NO CLAIM IS MADE TO THE EXCLUSIVE RIGHT TO USE "INSURANCE COMPANY", APART FROM THE MARK AS SHOWN.

FOR INSURANCE SERVICES, NAMELY, THE UNDERWRITING OF WORKERS' COMPENSATION, PROPERTY AND CASUALTY INSURANCE, INCLUDING COMMERCIAL AUTO, BUSINESS OWNERS' POLICIES AND UMBRELLA COVERAGE (U.S. CLS. 100, 101 AND 102).

FIRST USE 7-1-1995; IN COMMERCE 7-1-1995.
ALEX KEAM, EXAMINING ATTORNEY



SN 77-539,489. 1ST REVERSE FINANCIAL SERVICES, LLC, WESTMONT, IL. FILED 8-5-2008.

THE COLOR(S) BLUE AND BLACK IS/ARE CLAIMED AS A FEATURE OF THE MARK.

THE MARK CONSISTS OF A CURSIVE RENDERING OF THE WORD "REVMAE" WHEREIN THE VERTICAL PORTION OF THE CAPITAL "R" IS FORMED BY A BLUE NUMBER "1" AND THE BALANCE OF THE WORD IS RENDERED IN BLACK.

FOR MORTGAGE BANKING SERVICES, NAMELY, ORIGINATION, ACQUISITION, SERVICING, SECURITIZATION AND BROKERAGE OF MORTGAGE LOANS (U.S. CLS. 100, 101 AND 102).

FIRST USE 1-30-2004; IN COMMERCE 1-30-2004.
KATHERINE M. DUBRAY, EXAMINING ATTORNEY

CLASS 36—(Continued).

SN 77-541,540. BLUE DIAMOND VENTURE, LLC, LAS VEGAS, NV. FILED 8-7-2008.

CLASS 36—(Continued).

SN 77-545,120. BANKERS LIFE AND CASUALTY COMPANY, CHICAGO, IL. FILED 8-12-2008.

EXPOCITY

THE MARK CONSISTS OF STANDARD CHARACTERS WITHOUT CLAIM TO ANY PARTICULAR FONT, STYLE, SIZE, OR COLOR.

FOR LEASING TRADE AND SHOWROOM EXHIBITION SPACE TO MANUFACTURERS OF GOODS IN THE FIELDS OF ACCOUNTING, ADVERTISING AND MARKETING, AEROSPACE AND AVIATION, AGRICULTURE, AIR CONDITIONING, HEATING AND REFRIGERATION, AMUSEMENT, APPAREL, ARCHITECTURE, ART AND ANTIQUES, ASSOCIATIONS, AUDIO-VISUAL, AUDITORIUMS AND FACILITIES, AUTOMOTIVE AND TRUCKING, BANKING, BEAUTY AND HAIR CARE, BOATS AND SHIPS, BUILDING AND CONSTRUCTION, BUSINESS, CERAMICS AND GLASS, CHEMICAL, CHINA AND GLASSWARE, COMMUNICATIONS, COMPUTERS AND SOFTWARE, DENTAL, EDUCATION, ELECTRICAL AND ELECTRONICS, ENERGY, ENGINEERING, FINANCIAL AND LEGAL, FIRE AND FIRE PROTECTION, FISHING, FLORICULTURE AND HORTICULTURE, FOOD AND BEVERAGE, FOOD PROCESSING AND DISTRIBUTION, FOREST PRODUCTS, FUNERAL INDUSTRY, GIFTS AND GIFTWARE, GOVERNMENT, HARDWARE, HOME ECONOMICS, HOME FURNISHINGS AND INTERIOR DESIGN, HOTELS, HOSPITALITY AND RESORTS, HOUSEWARES, HOUSING, INDUSTRIAL, INSURANCE, JEWELRY AND WATCHES, LANDSCAPE AND GARDEN SUPPLIES, LAUNDRY AND DRY CLEANING, LEATHER GOODS AND LUGGAGE, LIBRARIES, LIGHTING, MANUFACTURED HOUSING, MANUFACTURING, MEDICAL AND HEALTH CARE, METALWORKING, MILITARY, MINING, MOTORCYCLES, MUSIC, NURSING, OCEAN SCIENCE AND EQUIPMENT, OFFICE EQUIPMENT, PACKAGING, PAINT, PAPER AND CARDBOARD, PETROLEUM, OIL AND GAS, PHARMACEUTICALS, PHOTOGRAPHIC, PHYSICAL DISTRIBUTION AND SHIPPING, PLANT ENGINEERING AND OPERATIONS, PLASTICS, POLICE, POLLUTION CONTROL, POWER TRANSMISSION, PRINTING, PUBLISHING, RADIO, TV, CABLE AND BROADCAST, RAILROADS, REAL ESTATE, RECREATIONAL VEHICLES, RECRUITMENT, RELIGIOUS, RENTAL AND LEASING, EQUIPMENT, RESTAURANTS AND FOOD SERVICE, ROBOTICS AND AUTOMATION, SAFETY, SANITATION AND WASTE MANAGEMENT, SCIENCE, SECURITY, SPORTING GOODS AND RECREATION, STORES AND STORE FITTINGS, TELECOMMUNICATIONS, TELEPHONES, TEXTILES, TOYS, HOBBIES AND CRAFTS, TRANSPORTATION, TRAVEL INDUSTRY, VETERINARY, WATER, WELDING, WIRE, WOMEN'S ISSUES, WOODWORKING; REAL ESTATE SERVICES, NAMELY, PROVIDING AND OPERATING MARKETPLACES AND TRADE SHOWROOMS FOR SELLERS OF GOODS AND/OR SERVICES; SHOPPING MALL SERVICES, NAMELY, LEASING OF SHOPPING MALL SPACE (U.S. CLS. 100, 101 AND 102).

CHRISTINA SOBRAL, EXAMINING ATTORNEY

GrowthPoint

THE MARK CONSISTS OF STANDARD CHARACTERS WITHOUT CLAIM TO ANY PARTICULAR FONT, STYLE, SIZE, OR COLOR.

FOR UNDERWRITING AND ADMINISTRATION OF INDEXED EQUITY ANNUITY PRODUCTS (U.S. CLS. 100, 101 AND 102).

DAWN FELDMAN, EXAMINING ATTORNEY

SN 77-548,644. WASHINGTON MUTUAL, INC., SEATTLE, WA. FILED 8-15-2008.



OWNER OF U.S. REG. NOS. 2,368,337, 2,919,255 AND OTHERS.

THE MARK CONSISTS OF A STYLIZED "W".
FOR CREDIT CARD AND DEBIT CARD SERVICES; CREDIT RATING SERVICES; CREDIT REPORTING SERVICES; PROVIDING INFORMATION ON PRIVACY PROTECTION PRODUCTS AND SERVICES, NAMELY, PROVIDING CONSULTING SERVICES AND INFORMATION ON OBTAINING AND MONITORING CONSUMER CREDIT INFORMATION, CREDIT CARD INFORMATION AND CREDIT RATINGS, PROTECTING CREDIT RATINGS, REGISTERING AND CANCELING CREDIT CARDS AND DEBIT CARDS AND RESTORING AND ANALYZING CREDIT (U.S. CLS. 100, 101 AND 102).

DAYNA BROWNE, EXAMINING ATTORNEY

CLASS 36—(Continued).

SN 77-548,646. WASHINGTON MUTUAL, INC., SEATTLE, WA. FILED 8-15-2008.



WaMu

OWNER OF U.S. REG. NOS. 2,368,337, 2,919,255 AND OTHERS.

THE MARK CONSISTS OF A STYLIZED "W" IN A SQUARE PRECEDING THE TEXT "WAMU".

FOR CREDIT CARD AND DEBIT CARD SERVICES; CREDIT RATING SERVICES; CREDIT REPORTING SERVICES; PROVIDING INFORMATION ON PRIVACY PROTECTION PRODUCTS AND SERVICES, NAMELY, PROVIDING CONSULTING SERVICES AND INFORMATION ON OBTAINING AND MONITORING CONSUMER CREDIT INFORMATION, CREDIT CARD INFORMATION AND CREDIT RATINGS, PROTECTING CREDIT RATINGS, REGISTERING AND CANCELING CREDIT CARDS AND DEBIT CARDS AND RESTORING AND ANALYZING CREDIT (U.S. CLS. 100, 101 AND 102).

DAYNA BROWNE, EXAMINING ATTORNEY

SN 77-548,653. WASHINGTON MUTUAL, INC., SEATTLE, WA. FILED 8-15-2008.

WAMU

THE MARK CONSISTS OF STANDARD CHARACTERS WITHOUT CLAIM TO ANY PARTICULAR FONT, STYLE, SIZE, OR COLOR.

OWNER OF U.S. REG. NOS. 2,315,782, 3,532,722 AND OTHERS.

FOR BANKING SERVICES; MORTGAGE AND HOME EQUITY LENDING SERVICES; CREDIT RATING SERVICES; CREDIT REPORTING SERVICES; PROVIDING INFORMATION ON PRIVACY PROTECTION PRODUCTS AND SERVICES, NAMELY, PROVIDING CONSULTING SERVICES AND INFORMATION ON OBTAINING AND MONITORING CONSUMER CREDIT INFORMATION, CREDIT CARD INFORMATION AND CREDIT RATINGS, PROTECTING CREDIT RATINGS, REGISTERING AND CANCELING CREDIT CARDS AND DEBIT CARDS AND RESTORING AND ANALYZING CREDIT; AUTOMATED TELLER MACHINE SERVICES; SAVINGS, CHECKING AND CERTIFICATE OF DEPOSIT ACCOUNT SERVICES; CASH CARD SERVICES; STORED VALUE CARD SERVICES; DEPOSIT CARD SERVICES; ELECTRONIC PAYMENT SERVICES, NAMELY, ELECTRONIC PROCESSING AND TRANSMISSION OF BILL PAYMENT DATA; HOME EQUITY LENDING SERVICES; EQUIPMENT FINANCING SERVICES; MORTGAGE BANKING SERVICES; FINANCIAL PORTFOLIO MANAGEMENT AND ANALYSIS SERVICES; MUTUAL FUND CONSULTATION, BROKERAGE, DISTRIBUTION AND INVESTMENT SERVICES; ESTABLISHING AND ADMINISTERING MUTUAL FUNDS FOR OTHERS; INVESTMENT, MANAGEMENT AND DISTRIBUTION OF FIXED AND VARIABLE ANNUITIES; RETIREMENT ACCOUNT MANAGEMENT AND DISTRIBUTION; INSURANCE BROKERAGE AND AGENCIES IN THE FIELDS OF MORTGAGE, LONG TERM HEALTH, MEDICAL, DENTAL, VISION, PET, AND ACCIDENTAL DISMEMBERMENT; INSURANCE UNDERWRITING AND BROKERAGE IN THE FIELD OF HOME WARRANTIES; CHARITABLE FINANCIAL SPONSORSHIP OF NON-PROFIT COMMUNITY, CULTURAL, THEATRICAL, ARTISTIC, MUSICAL, EDUCA-

CLASS 36—(Continued).

TIONAL AND SPORTING EVENTS AND PROGRAMS; PROVIDING CHARITABLE GRANTS TO EDUCATIONAL INSTITUTIONS, STUDENTS AND COMMUNITY ORGANIZATIONS; PROVIDING EDUCATIONAL SCHOLARSHIPS; CHARITABLE FINANCIAL SPONSORSHIP OF NON-PROFIT COMMUNITY EVENTS; ORGANIZING FINANCIAL SPONSORSHIP OF FUNDRAISING EVENTS TO RAISE MONEY FOR RECOGNITION OF EDUCATORS, ARRANGING FINANCIAL SPONSORSHIP OF FUNDRAISING EVENTS TO RAISE MONEY FOR RECOGNITION OF EDUCATORS, AND PROVIDING FINANCIAL SPONSORSHIP OF FUNDRAISING EVENTS TO RAISE MONEY FOR RECOGNITION OF EDUCATORS; ARRANGING FOR OTHERS TO PROVIDE FINANCIAL SPONSORSHIP OF FUNDRAISING EVENTS IN THE FIELD OF EDUCATION AND TEACHING; PROVIDING FINANCIAL SPONSORSHIP OF FUNDRAISING EVENTS IN THE FIELD OF EDUCATION AND TEACHING; ORGANIZING AND CONDUCTING FUNDRAISING EVENTS TO RAISE MONEY FOR RECOGNITION OF EDUCATORS; CHARITABLE FUND RAISING FOR FUNDRAISING EVENTS; PROVIDING INFORMATION RELATED TO ALL OF THE FOREGOING SERVICES AND ASSOCIATED ACCOUNTS VIA THE INTERNET (U.S. CLS. 100, 101 AND 102).

DAYNA BROWNE, EXAMINING ATTORNEY

SN 77-551,449. THE WILMINGTON MLS, WILMINGTON, NC. FILED 8-20-2008.



NO CLAIM IS MADE TO THE EXCLUSIVE RIGHT TO USE "WILMINGTONMLS.COM", APART FROM THE MARK AS SHOWN.

THE MARK CONSISTS OF A SERIES OF BUILDINGS WITH THE STYLIZED TEXT "THEWILMINGTONMLS.COM" BELOW.

FOR REAL ESTATE MULTIPLE LISTING SERVICES (U.S. CLS. 100, 101 AND 102).

FIRST USE 12-31-1986; IN COMMERCE 12-31-1986.

MARK T. MULLEN, EXAMINING ATTORNEY

SN 77-554,889. PENNIES IN ACTION FOUNDATION, ASTON, PA. FILED 8-25-2008.

PENNIES IN ACTION

THE MARK CONSISTS OF STANDARD CHARACTERS WITHOUT CLAIM TO ANY PARTICULAR FONT, STYLE, SIZE, OR COLOR.

NO CLAIM IS MADE TO THE EXCLUSIVE RIGHT TO USE "PENNIES", APART FROM THE MARK AS SHOWN.

FOR CHARITABLE FUND RAISING (U.S. CLS. 100, 101 AND 102).

FIRST USE 12-0-2007; IN COMMERCE 2-17-2008.

PRISCILLA MILTON, EXAMINING ATTORNEY

CLASS 36—(Continued).

SN 77-559,957. MICHIGAN RETAILERS SERVICES, INC., DBA RETAILERS PROCESSING NETWORK, LANSING, MI. FILED 9-2-2008.



NO CLAIM IS MADE TO THE EXCLUSIVE RIGHT TO USE "RETAILERS PROCESSING NETWORK", APART FROM THE MARK AS SHOWN.

THE MARK CONSISTS OF THE LITERAL ELEMENT "RETAILERS PROCESSING NETWORK" ADJACENT A STYLIZED BLOCK DESIGN.

FOR CREDIT CARD TRANSACTION PROCESSING SERVICES (U.S. CLS. 100, 101 AND 102).

FIRST USE 9-23-2008; IN COMMERCE 9-23-2008.
JILL PRATER, EXAMINING ATTORNEY

SN 77-560,878. MILLER, MANDY M., DBA ROVING WOOL-LENS LLC, VERONA, WI. FILED 9-2-2008.

PETS FOR THE PLANET

THE MARK CONSISTS OF STANDARD CHARACTERS WITHOUT CLAIM TO ANY PARTICULAR FONT, STYLE, SIZE, OR COLOR.

NO CLAIM IS MADE TO THE EXCLUSIVE RIGHT TO USE "PETS", APART FROM THE MARK AS SHOWN.

FOR CHARITABLE FUND RAISING (U.S. CLS. 100, 101 AND 102).

FIRST USE 8-15-2008; IN COMMERCE 8-23-2008.
KATHLEEN LORENZO, EXAMINING ATTORNEY

SN 77-561,961. EMERGING GLOBAL ADVISORS, LLC, RIDGEWOOD, NJ. FILED 9-4-2008.

EGA EMERGING GLOBAL SHARES

THE MARK CONSISTS OF STANDARD CHARACTERS WITHOUT CLAIM TO ANY PARTICULAR FONT, STYLE, SIZE, OR COLOR.

NO CLAIM IS MADE TO THE EXCLUSIVE RIGHT TO USE "GLOBAL SHARES", APART FROM THE MARK AS SHOWN.

FOR FINANCIAL SERVICES, NAMELY, CONSULTATION IN THE FIELD OF INVESTMENT IN EXCHANGE TRADED FUNDS (U.S. CLS. 100, 101 AND 102).

STEVEN R. FINE, EXAMINING ATTORNEY

CLASS 36—(Continued).

SN 77-562,350. TEABULL ASSET TIMER LTD., BURNABY, CANADA, FILED 9-4-2008.

UR WEALTHY

THE MARK CONSISTS OF STANDARD CHARACTERS WITHOUT CLAIM TO ANY PARTICULAR FONT, STYLE, SIZE, OR COLOR.

NO CLAIM IS MADE TO THE EXCLUSIVE RIGHT TO USE "WEALTHY", APART FROM THE MARK AS SHOWN.

FOR FINANCIAL SERVICES, NAMELY, PROVIDING INFORMATION VIA A WEBSITE FEATURING INFORMATION IN THE FIELD OF FINANCIAL STOCK QUOTES, BOND QUOTES, CURRENCY QUOTES, INTEREST RATE QUOTES; FINANCIAL SERVICES, NAMELY, PROVIDING INFORMATION VIA A WEBSITE FEATURING INFORMATION ABOUT PUBLICLY TRADED COMPANIES, FINANCIAL NEWS RELEASES AND FINANCIAL ARTICLES, PROVIDING FINANCIAL INFORMATION TO HELP THE USER DETERMINE WHETHER OR NOT A PARTICULAR INVESTMENT MEETS THEIR INVESTING CRITERIA (U.S. CLS. 100, 101 AND 102).

FIRST USE 9-3-2008; IN COMMERCE 9-3-2008.
NAPOLEON SHARMA, EXAMINING ATTORNEY

SN 77-563,439. BLUE DIAMOND VENTURE, LLC, LAS VEGAS, NV. FILED 9-5-2008.

EXPO CITY

THE MARK CONSISTS OF STANDARD CHARACTERS WITHOUT CLAIM TO ANY PARTICULAR FONT, STYLE, SIZE, OR COLOR.

NO CLAIM IS MADE TO THE EXCLUSIVE RIGHT TO USE "EXPO", APART FROM THE MARK AS SHOWN.

FOR LEASING TRADE AND SHOWROOM EXHIBITION SPACE TO MANUFACTURERS OF GOODS IN THE FIELDS OF ACCOUNTING, ADVERTISING AND MARKETING, AEROSPACE AND AVIATION, AGRICULTURE, AIR CONDITIONING, HEATING AND REFRIGERATION, AMUSEMENT, APPAREL, ARCHITECTURE, ART AND ANTIQUES, ASSOCIATIONS, AUDIO-VISUAL, AUDITORIUMS AND FACILITIES, AUTOMOTIVE AND TRUCKING, BANKING, BEAUTY AND HAIR CARE, BOATS AND SHIPS, BUILDING AND CONSTRUCTION, BUSINESS, CERAMICS AND GLASS, CHEMICAL, CHINA AND GLASSWARE, COMMUNICATIONS, COMPUTERS AND SOFTWARE, DENTAL, EDUCATION, ELECTRICAL AND ELECTRONICS, ENERGY, ENGINEERING, FINANCIAL AND LEGAL, FIRE AND FIRE PROTECTION, FISHING, FLORICULTURE AND HORTICULTURE, FOOD AND BEVERAGE, FOOD PROCESSING AND DISTRIBUTION, FOREST PRODUCTS, FUNERAL INDUSTRY, GIFTS AND GIFTWARE, GOVERNMENT, HARDWARE, HOME ECONOMICS, HOME FURNISHINGS AND INTERIOR DESIGN, HOTELS, HOSPITALITY AND RESORTS, HOUSEWARES, HOUSING, INDUSTRIAL, INSURANCE, JEWELRY AND WATCHES, LANDSCAPE AND GARDEN SUPPLIES, LAUNDRY AND DRY CLEANING, LEATHER GOODS AND LUGGAGE, LIBRARIES, LIGHTING, MANUFACTURED HOUSING, MANUFACTURING, MEDICAL AND HEALTH CARE, METALWORKING, MILITARY, MINING, MOTORCYCLES, MUSIC, NURSING, OCEAN SCIENCE AND EQUIPMENT, OFFICE EQUIPMENT, PACKAGING, PAINT,

CLASS 36—(Continued).

PAPER AND CARDBOARD, PETROLEUM, OIL AND GAS, PHARMACEUTICALS, PHOTOGRAPHIC, PHYSICAL DISTRIBUTION AND SHIPPING, PLANT ENGINEERING AND OPERATIONS, PLASTICS, POLICE, POLLUTION CONTROL, POWER TRANSMISSION, PRINTING, PUBLISHING, RADIO, TV, CABLE AND BROADCAST, RAILROADS, REAL ESTATE, RECREATIONAL VEHICLES, RECRUITMENT, RELIGIOUS, RENTAL AND LEASING, EQUIPMENT, RESTAURANTS AND FOOD SERVICE, ROBOTICS AND AUTOMATION, SAFETY, SANITATION AND WASTE MANAGEMENT, SCIENCE, SECURITY, SPORTING GOODS AND RECREATION, STORES AND STORE FITTINGS, TELECOMMUNICATIONS, TELEPHONES, TEXTILES, TOYS, HOBBIES AND CRAFTS, TRANSPORTATION, TRAVEL INDUSTRY, VETERINARY, WATER, WELDING, WIRE, WOMEN'S ISSUES, WOODWORKING; REAL ESTATE SERVICES, NAMELY, PROVIDING AND OPERATING MARKETPLACES AND TRADE SHOWROOMS FOR SELLERS OF GOODS AND/OR SERVICES; SHOPPING MALL SERVICES, NAMELY, LEASING OF SHOPPING MALL SPACE (U.S. CLS. 100, 101 AND 102).

CHRISTINA SOBRAL, EXAMINING ATTORNEY

CLASS 36—(Continued).

SN 77-563,966. BLUE LEAF CLAIMS, INC., SUFFIELD, CT. FILED 9-6-2008.



NO CLAIM IS MADE TO THE EXCLUSIVE RIGHT TO USE "CLAIMS", APART FROM THE MARK AS SHOWN. THE COLOR(S) BLUE AND BROWN IS/ARE CLAIMED AS A FEATURE OF THE MARK.

THE MARK CONSISTS OF THE WORD "BLUELEAF" IN BLUE WITH THE LAST LETTER "F" FORMING A LEAF UPWARD TO THE RIGHT, WITH THE CENTER OF THE LEAF AS A BROWN STEM UPWARD TO THE RIGHT, AND WITH THE WORD "CLAIMS" AT THE BOTTOM RIGHT OF THE LOGO IN BROWN AND IN ALL CAPITAL LETTERS.

FOR CLAIMS ADJUSTMENT IN THE FIELD OF INSURANCE; CLAIMS ADMINISTRATION IN THE FIELD OF WORKERS' COMPENSATION; INSURANCE CLAIMS ADMINISTRATION; INSURANCE CLAIMS PROCESSING (U.S. CLS. 100, 101 AND 102).

FIRST USE 8-14-2007; IN COMMERCE 8-14-2007. STEPHEN AQUILA, EXAMINING ATTORNEY

SN 77-563,663. BLUE LEAF CLAIMS, INC., SUFFIELD, CT. FILED 9-5-2008.



NO CLAIM IS MADE TO THE EXCLUSIVE RIGHT TO USE "A VIRTUAL CLAIM COMPANY" AND "CLAIMS", APART FROM THE MARK AS SHOWN.

THE COLOR(S) BROWN, BLUE, AND WHITE IS/ARE CLAIMED AS A FEATURE OF THE MARK.

THE MARK CONSISTS OF THE WORDS "A VIRTUAL CLAIM COMPANY" (ALL CAPITAL LETTERS) ACROSS THE TOP IN BROWN, WITH THE WORD "BLUELEAF" IN BLUE WITH THE LAST LETTER "F" FORMING A LEAF UPWARD TO THE RIGHT, WITH THE CENTER OF THE LEAF AS A BROWN STEM UPWARD TO THE RIGHT, AND WITH THE WORD "CLAIMS" AT THE BOTTOM RIGHT OF THE LOGO IN BROWN WITH ALL CAPITAL LETTERS, ALL OF WHICH APPEARS ON A WHITE BACKGROUND.

FOR CLAIMS ADJUSTMENT IN THE FIELD OF INSURANCE; CLAIMS ADMINISTRATION IN THE FIELD OF WORKERS' COMPENSATION; INSURANCE CLAIMS ADMINISTRATION; INSURANCE CLAIMS PROCESSING (U.S. CLS. 100, 101 AND 102).

STEPHEN AQUILA, EXAMINING ATTORNEY

SN 77-564,622. BLUE LEAF CLAIMS, INC., SUFFIELD, CT. FILED 9-8-2008.

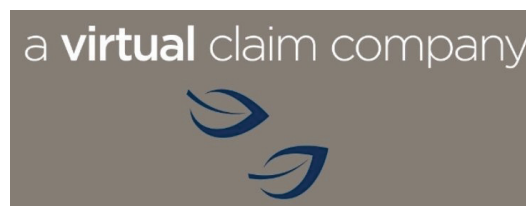

NO CLAIM IS MADE TO THE EXCLUSIVE RIGHT TO USE "A VIRTUAL CLAIM COMPANY", APART FROM THE MARK AS SHOWN.

THE COLOR(S) WHITE, BLUE, GRAY IS/ARE CLAIMED AS A FEATURE OF THE MARK.

THE MARK CONSISTS OF A LOGO WITH THE WORDS "A VIRTUAL CLAIM COMPANY" IN WHITE AT THE TOP, ON A GRAY BACKGROUND. THE WORD "VIRTUAL" IN IN BOLD FACED PRINT. THERE ARE TWO BLUE LEAVES AT THE BOTTOM, JUST BELOW THE WORD "CLAIM". THERE IS A BLUE STEM WHICH THINS OUT AS IT MEETS THE CENTER TOP OF EACH LEAF. THE LEAVES ARE AGAINST THE GRAY BACKGROUND, AS WELL.

FOR CLAIMS ADJUSTMENT IN THE FIELD OF INSURANCE; CLAIMS ADMINISTRATION IN THE FIELD OF WORKERS' COMPENSATION; INSURANCE CLAIMS ADMINISTRATION; INSURANCE CLAIMS PROCESSING (U.S. CLS. 100, 101 AND 102).

STEPHEN AQUILA, EXAMINING ATTORNEY

CLASS 36—(Continued).

SN 77-566,381. GUPTA, SANDEEP, DBA DR. SANDEEP GUPTA, SALMIYA, KUWAIT, FILED 9-10-2008.

Quantum Stride

THE MARK CONSISTS OF STANDARD CHARACTERS WITHOUT CLAIM TO ANY PARTICULAR FONT, STYLE, SIZE, OR COLOR.

FOR ADVICE RELATING TO INVESTMENTS; HEDGE FUND INVESTMENT SERVICES; INVESTMENT ADVISORY SERVICES (U.S. CLS. 100, 101 AND 102).
ROBIN CHOSID, EXAMINING ATTORNEY

SN 77-567,864. CORPORACION OCCIDENTE, S.A., BBX 361.1122, GUATEMALA, FILED 9-11-2008.

OCCIDENTE

THE MARK CONSISTS OF STANDARD CHARACTERS WITHOUT CLAIM TO ANY PARTICULAR FONT, STYLE, SIZE, OR COLOR.

THE ENGLISH TRANSLATION OF THE WORD "OCCIDENTE" IN THE MARK IS "OCCIDENT".

FOR BANKING; BANKING SERVICES; BROKERAGE IN THE FIELD OF INSURANCE AND STOCK; CREDIT CARD SERVICES; ELECTRONIC TRANSFERS OF MONEY; FINANCIAL MANAGEMENT; FINANCING AND LOAN SERVICES; HOME EQUITY LOANS; ISSUING OF LETTERS OF CREDIT; LOAN FINANCING; MONEY TRANSFER; MORTGAGE BANKING; PROVIDING LOANS SECURED BY COMMERCIAL PAPER (U.S. CLS. 100, 101 AND 102).

FIRST USE 1-2-1999; IN COMMERCE 1-2-1999.
MICHELE SWAIN, EXAMINING ATTORNEY

SN 77-580,861. ARAG INSURANCE COMPANY, DES MOINES, IA. FILED 9-29-2008.

CAREGIVERASSIST

THE MARK CONSISTS OF STANDARD CHARACTERS WITHOUT CLAIM TO ANY PARTICULAR FONT, STYLE, SIZE, OR COLOR.

FOR ADMINISTRATION OF BENEFIT PLANS, NAMELY, ADMINISTRATION OF INSURED AND NON-INSURED PROFESSIONAL SERVICE PLANS THAT PROVIDE DISCOUNTED LEGAL SERVICES, LEGAL ADVICE, FINANCIAL PLANNING ADVICE, TAX ADVICE, AND THAT PROVIDE ASSISTANCE IN ACCESSING FEDERAL AND STATE SOCIAL SERVICES (U.S. CLS. 100, 101 AND 102).

RENEE SERVANCE, EXAMINING ATTORNEY

CLASS 36—(Continued).

SN 77-581,369. SIKICH CORPORATE FINANCE, LLC, AURORA, IL. FILED 9-29-2008.

MAXIMIZE POTENTIAL, MINIMIZE RISK.

THE MARK CONSISTS OF STANDARD CHARACTERS WITHOUT CLAIM TO ANY PARTICULAR FONT, STYLE, SIZE, OR COLOR.

FOR INVESTMENT BANKING SERVICES (U.S. CLS. 100, 101 AND 102).

FIRST USE 6-24-2008; IN COMMERCE 6-24-2008.
SUSAN STIGLITZ, EXAMINING ATTORNEY

SN 77-582,637. ARABIAN GULF HOLDINGS LLC, NEW YORK, NY. FILED 9-30-2008.

Fund Dubai

THE MARK CONSISTS OF STANDARD CHARACTERS WITHOUT CLAIM TO ANY PARTICULAR FONT, STYLE, SIZE, OR COLOR.

NO CLAIM IS MADE TO THE EXCLUSIVE RIGHT TO USE "FUND", APART FROM THE MARK AS SHOWN.

SEC. 2(F).

FOR ADVICE RELATING TO INVESTMENTS; CAPITAL INVESTMENT CONSULTATION; CAPITAL INVESTMENT SERVICES; COMMODITY INVESTMENT ADVICE; EQUITY CAPITAL INVESTMENT; FINANCIAL AND INVESTMENT SERVICES, NAMELY, MANAGEMENT AND BROKERAGE IN THE FIELDS OF STOCKS, BONDS, OPTIONS, COMMODITIES, FUTURES AND OTHER SECURITIES, AND THE INVESTMENT OF FUNDS OF OTHERS; FINANCIAL PLANNING AND INVESTMENT ADVISORY SERVICES; FINANCIAL SERVICES IN THE NATURE OF AN INVESTMENT SECURITY (U.S. CLS. 100, 101 AND 102).

FIRST USE 1-1-2001; IN COMMERCE 5-11-2001.
KELLY BOULTON, EXAMINING ATTORNEY

SN 77-588,478. HERMAN, JOSH, BEVERLY HILLS, CA. FILED 10-8-2008.

JOSH HERMAN BAIL BONDS

THE MARK CONSISTS OF STANDARD CHARACTERS WITHOUT CLAIM TO ANY PARTICULAR FONT, STYLE, SIZE, OR COLOR.

NO CLAIM IS MADE TO THE EXCLUSIVE RIGHT TO USE "BAIL BONDS", APART FROM THE MARK AS SHOWN.

THE NAME "JOSH HERMAN" IDENTIFIES A LIVING INDIVIDUAL WHOSE CONSENT IS OF RECORD.

FOR BAIL BONDING (U.S. CLS. 100, 101 AND 102).
FIRST USE 7-13-1990; IN COMMERCE 7-13-1990.
KAREN K. BUSH, EXAMINING ATTORNEY

CLASS 36—(Continued).

SN 77-588,492. FIRST NIAGARA FINANCIAL GROUP, INC., LOCKPORT, NY. FILED 10-8-2008.

FIRST NIAGARA

THE MARK CONSISTS OF STANDARD CHARACTERS WITHOUT CLAIM TO ANY PARTICULAR FONT, STYLE, SIZE, OR COLOR.

NO CLAIM IS MADE TO THE EXCLUSIVE RIGHT TO USE "NIAGARA", APART FROM THE MARK AS SHOWN. FOR BANKING SERVICES (U.S. CLS. 100, 101 AND 102).

FIRST USE 1-10-2000; IN COMMERCE 1-10-2000.
KAREN K. BUSH, EXAMINING ATTORNEY

SN 77-590,178. RAYMOND JAMES FINANCIAL, INC., ST. PETERSBURG, FL. FILED 10-10-2008.

RAYMOND JAMES SERVICE 1ST

THE MARK CONSISTS OF STANDARD CHARACTERS WITHOUT CLAIM TO ANY PARTICULAR FONT, STYLE, SIZE, OR COLOR.

OWNER OF U.S. REG. NOS. 2,179,629, 2,759,100 AND OTHERS.

NO CLAIM IS MADE TO THE EXCLUSIVE RIGHT TO USE "SERVICE", APART FROM THE MARK AS SHOWN.

THE NAME "RAYMOND JAMES" SHOWN IN THE MARK DOES NOT IDENTIFY A PARTICULAR LIVING INDIVIDUAL.

FOR FINANCIAL PLANNING SERVICES; INSURANCE SERVICES, NAMELY, INSURANCE UNDERWRITING SERVICES IN THE FIELDS OF LIFE, HEALTH, ACCIDENT, FIRE, AND CASUALTY INSURANCE EXCLUDING THE PROCESSING OF AUTOMOBILE CLAIMS, AND INSURANCE BROKERAGE SERVICES IN THE FIELDS OF LIFE, HEALTH, ACCIDENT, FIRE, AND CASUALTY INSURANCE (U.S. CLS. 100, 101 AND 102).

ANDREW LEASER, EXAMINING ATTORNEY

SN 77-591,099. MMM HOLDINGS, INC., SAN JUAN, PUERTO RICO, FILED 10-13-2008.



NO CLAIM IS MADE TO THE EXCLUSIVE RIGHT TO USE "INFO MED", APART FROM THE MARK AS SHOWN.

THE COLOR(S) RED AND TEAL IS/ARE CLAIMED AS A FEATURE OF THE MARK.

THE MARK CONSISTS OF THE WORD "INFO" APPEARS

CLASS 36—(Continued).

ON TOP AND THE WORD "MED" ON THE BOTTOM, BOTH ARE A TEAL COLOR AND THEY ARE SURROUNDED STARTING ON THE LEFT SIDE BY THE TOP PART OF A STETHOSCOPE AND A CORD RUNS ALONG THE WORD "MED" STARTING ON THE TOP OF THE "M" AND FINISHING AT THE END OF THE WORD "MED", AT THE END OF THE CORD THERE IS A PHONE HANDSET. THE STETHOSCOPE, THE CORD AND THE HANDSET ARE ALL IN A RED COLOR. INSIDE THE LETTER "D" IS A TEAL COLOR PYRAMID WITH A RAY OF LIGHT CROSSING THROUGH THE PYRAMID THAT WIDENS ALONG THE WAY, UNDERNEATH THE PYRAMID THREE STYLIZED "M" IN TEAL COLOR.

FOR PROVIDING INFORMATION IN INSURANCE MATTERS, NAMELY, AUTOMATIC SERVICE WITH INFORMATION REGARDING MEDICAL INSURANCE AFFILIATED, RECLAMATIONS REPORT, PAYMENTS, VERIFICATION RECLAMATION STATUS, AND PAYMENTS WORK DONE BY THE INSURANCE COMPANY, INCLUDING A HISTORY OF THE SAME (U.S. CLS. 100, 101 AND 102).

AARON BRODSKY, EXAMINING ATTORNEY

SN 77-592,623. ARKANSAS VALLEY BANCSHARES, INC., DBA ARKANSAS VALLEY STATE BANK, BROKEN ARROW, OK. FILED 10-14-2008.



THE COLOR(S) BLUE, WHITE AND GRAY IS/ARE CLAIMED AS A FEATURE OF THE MARK.

THE MARK CONSISTS OF 4 BLUE CIRCLES THAT TOUCH OR INTERCONNECT WITH A SMALLER CONCENTRIC WHITE LINE CIRCLE WITHIN EACH OF THE 4 BLUE CIRCLES THAT ALSO TOUCH OR INTERCONNECT; ALL ADJACENT TO THE GRAY LETTERS "AVB".

FOR BANKING SERVICES (U.S. CLS. 100, 101 AND 102).

RONALD MCMORROW, EXAMINING ATTORNEY

CLASS 36—(Continued).

SN 77-597,633. MORTGAGE SOLUTIONS, LLC, BRIDGETON, MO. FILED 10-22-2008.



NO CLAIM IS MADE TO THE EXCLUSIVE RIGHT TO USE "CU" AND "MORTGAGE", APART FROM THE MARK AS SHOWN.

THE COLOR(S) MAROON AND GREY IS/ARE CLAIMED AS A FEATURE OF THE MARK.

THE MARK CONSISTS OF THE WORDS "CU MORTGAGE Q" IN MAROON; THERE IS A GREY DOT SEPARATING THE LETTERS "CU" AND "MORTGAGE"; THE LETTER "Q" IS ENCASED IN A GREY SQUARE; THE WORD "MORTGAGE" HAS TWO GREY LINES ABOVE IT TO LOOK LIKE A ROOF OF A HOUSE.

THE WORDING "Q" HAS NO MEANING IN A FOREIGN LANGUAGE.

FOR MORTGAGE BANKING SERVICES, NAMELY, ORIGINATION, ACQUISITION, SERVICING, SECURITIZATION AND BROKERAGE OF MORTGAGE LOANS (U.S. CLS. 100, 101 AND 102).

FIRST USE 9-12-2008; IN COMMERCE 9-12-2008.

NAAKWAMA ANKRAH, EXAMINING ATTORNEY

SN 77-604,400. MASCOT CAPITAL MANAGEMENT LLC, TAMPA, FL. FILED 10-30-2008.

Mascot Capital Management

THE MARK CONSISTS OF STANDARD CHARACTERS WITHOUT CLAIM TO ANY PARTICULAR FONT, STYLE, SIZE, OR COLOR.

NO CLAIM IS MADE TO THE EXCLUSIVE RIGHT TO USE "CAPITAL MANAGEMENT", APART FROM THE MARK AS SHOWN.

FOR INVESTMENT MANAGEMENT AND FUNDS INVESTMENT SERVICES (U.S. CLS. 100, 101 AND 102).

ODESSA BIBBINS, EXAMINING ATTORNEY

SN 77-606,387. THE DOCTORS COMPANY, NAPA, CA. FILED 11-3-2008.

DEFEND PROTECT REWARD

THE MARK CONSISTS OF STANDARD CHARACTERS WITHOUT CLAIM TO ANY PARTICULAR FONT, STYLE, SIZE, OR COLOR.

FOR INSURANCE UNDERWRITING IN THE FIELD OF PROFESSIONAL LIABILITY (U.S. CLS. 100, 101 AND 102).

FIRST USE 5-0-2007; IN COMMERCE 5-0-2007.

ALYSSA STEEL, EXAMINING ATTORNEY

CLASS 36—(Continued).

SN 77-612,044. EOX HOLDINGS LLC, NEW YORK, NY. FILED 11-11-2008.

EOXLIVE

THE MARK CONSISTS OF STANDARD CHARACTERS WITHOUT CLAIM TO ANY PARTICULAR FONT, STYLE, SIZE, OR COLOR.

FOR COMMODITY BROKERAGE (U.S. CLS. 100, 101 AND 102).

FIRST USE 1-27-2009; IN COMMERCE 1-27-2009.

JEFFERY COWARD, EXAMINING ATTORNEY

SN 77-621,486. BRIDGE MEADOWS, PORTLAND, OR. FILED 11-25-2008.

BRIDGE MEADOWS

THE MARK CONSISTS OF STANDARD CHARACTERS WITHOUT CLAIM TO ANY PARTICULAR FONT, STYLE, SIZE, OR COLOR.

FOR REAL ESTATE MANAGEMENT; REAL ESTATE MANAGEMENT SERVICES, NAMELY, MANAGING COMMON AREA FACILITIES AND DEVELOPMENT AMENITIES FOR FAMILIES AND ELDERS (U.S. CLS. 100, 101 AND 102).

KIM MONINGHOFF, EXAMINING ATTORNEY

SN 77-621,567. ITG SOFTWARE SOLUTIONS, INC., CULVER CITY, CA. FILED 11-25-2008.

PLEXUS PLAN SPONSOR

THE MARK CONSISTS OF STANDARD CHARACTERS WITHOUT CLAIM TO ANY PARTICULAR FONT, STYLE, SIZE, OR COLOR.

NO CLAIM IS MADE TO THE EXCLUSIVE RIGHT TO USE "PLAN SPONSOR", APART FROM THE MARK AS SHOWN.

FOR FINANCIAL INVESTMENT AND FINANCIAL MANAGEMENT CONSULTING SERVICES (U.S. CLS. 100, 101 AND 102).

FIRST USE 3-16-2007; IN COMMERCE 3-16-2007.

JACQUELINE A. LAVINE, EXAMINING ATTORNEY

CLASS 36—(Continued).

SN 77-623,054. GRATEFUL AMERICAN COIN, INC., ODESSA, FL. FILED 11-28-2008.

Grateful American Coin

THE MARK CONSISTS OF STANDARD CHARACTERS WITHOUT CLAIM TO ANY PARTICULAR FONT, STYLE, SIZE, OR COLOR.

NO CLAIM IS MADE TO THE EXCLUSIVE RIGHT TO USE "AMERICAN COIN", APART FROM THE MARK AS SHOWN.

FOR CHARITABLE FUND RAISING SERVICES, NAMELY, BY PROVIDING INDIVIDUALS WITH THE INFORMATION AND OPPORTUNITY TO MAKE MONETARY DONATIONS TO THEIR FAVORITE CHARITY (U.S. CLS. 100, 101 AND 102).

FIRST USE 12-1-2007; IN COMMERCE 12-1-2007.
DOUGLAS LEE, EXAMINING ATTORNEY

CLASS 36—(Continued).

SN 77-629,104. SIMON PROPERTY GROUP, L.P., INDIANAPOLIS, IN. FILED 12-9-2008.

LAKELINE

THE MARK CONSISTS OF STANDARD CHARACTERS WITHOUT CLAIM TO ANY PARTICULAR FONT, STYLE, SIZE, OR COLOR.

FOR SHOPPING CENTER SERVICES, NAMELY, LEASING OF SHOPPING MALL SPACE (U.S. CLS. 100, 101 AND 102).

FIRST USE 3-1-1985; IN COMMERCE 3-1-1985.
DAVID TAYLOR, EXAMINING ATTORNEY

SN 77-646,784. BROKER BRAIN, LLC, LAS VEGAS, NV. FILED 1-9-2009.



NO CLAIM IS MADE TO THE EXCLUSIVE RIGHT TO USE "BROKER", APART FROM THE MARK AS SHOWN.

THE MARK CONSISTS OF THE WORDS "BROKER BRAIN" UNDER A HOME'S ROOF AND TO THE RIGHT SIDE OF ONE OF THE HOME'S OUTER WALLS; A PICTURE OF A BRAIN IN THE ATTIC; AND A SOLID LINE UNDER THE HOME AND WORDS.

FOR REAL ESTATE SERVICES, NAMELY, PROVIDING A WEB-BASED PROPERTY ASSET MANAGEMENT SYSTEM FOR REAL ESTATE BROKER AND AGENTS, WITH AN EMPHASIS FOR FORECLOSURE SPECIALISTS (U.S. CLS. 100, 101 AND 102).

FIRST USE 10-17-2008; IN COMMERCE 11-2-2008.
ANNE MADDEN, EXAMINING ATTORNEY

SN 77-627,305. UNITED CEREBRAL PALSY ASSOCIATION OF GREATER CHICAGO, CHICAGO, IL. FILED 12-5-2008.



OWNER OF U.S. REG. NOS. 2,195,074, 2,254,174 AND OTHERS.

NO CLAIM IS MADE TO THE EXCLUSIVE RIGHT TO USE "CHEFS TASTING PARTY", APART FROM THE MARK AS SHOWN.

THE MARK CONSISTS OF A STYLIZED CHEF TO THE RIGHT OF THE STYLIZED WORDING "GREAT CHEFS TASTING PARTY".

FOR CHARITABLE FUND RAISING (U.S. CLS. 100, 101 AND 102).

FIRST USE 4-1-2005; IN COMMERCE 4-1-2005.
KELLY BOULTON, EXAMINING ATTORNEY

SN 77-648,809. REVE PACIFIC, NEWPORT BEACH, CA. FILED 1-13-2009.



THE MARK CONSISTS OF THE STYLIZED TEXT "REVÉ PACIFIC".

THE ENGLISH TRANSLATION OF "REVÉ" IN THE MARK IS "DREAMED".

FOR LEASING OF REAL ESTATE; REAL ESTATE BROKERAGE; REAL ESTATE CONSULTATION (U.S. CLS. 100, 101 AND 102).

FIRST USE 9-1-2008; IN COMMERCE 9-1-2008.
CHRISTINE COOPER, EXAMINING ATTORNEY

CLASS 36—(Continued).

SN 77-648,948. CLARK & WAMBERG, LLC, DBA INTEGRATED HEALTHCARE STRATEGIES, MINNEAPOLIS, MN. FILED 1-14-2009.

IH STRATEGIES

THE MARK CONSISTS OF STANDARD CHARACTERS WITHOUT CLAIM TO ANY PARTICULAR FONT, STYLE, SIZE, OR COLOR.

NO CLAIM IS MADE TO THE EXCLUSIVE RIGHT TO USE "STRATEGIES", APART FROM THE MARK AS SHOWN.

FOR FINANCIAL ADVISORY SERVICES IN THE FIELDS OF ORGANIZATION AND ADMINISTRATION OF EXECUTIVE HEALTH CARE PLANS (U.S. CLS. 100, 101 AND 102).

CHRISTOPHER BUONGIORNO, EXAMINING ATTORNEY

SN 77-650,110. MILTOS KAMBOURIDES, ATHENS, GREECE, FILED 1-15-2009.

DEMILIA

THE MARK CONSISTS OF STANDARD CHARACTERS WITHOUT CLAIM TO ANY PARTICULAR FONT, STYLE, SIZE, OR COLOR.

THE WORDING "DEMILIA" HAS NO MEANING IN A FOREIGN LANGUAGE.

FOR ADVISORY SERVICES RELATING TO CREDIT AND DEBIT CONTROL, INVESTMENT, GRANTS AND FINANCING OF LOANS; FINANCIAL ADVISORY AND CONSULTANCY SERVICES; FINANCIAL ADVISORY AND CONSULTANCY SERVICES RELATING TO MICRO CREDITS, MICRO FINANCE AND ENERGY PRODUCTS; FINANCIAL INFORMATION AND ADVISORY SERVICES; FINANCIAL PLANNING AND INVESTMENT ADVISORY SERVICES; INVESTMENT ADVISORY SERVICES (U.S. CLS. 100, 101 AND 102).

LAURA KOVALSKY, EXAMINING ATTORNEY

CLASS 36—(Continued).

SN 77-652,391. COVIDIEN AG, NEUHAUSEN AM RHEINFALL, SWITZERLAND, FILED 1-20-2009.

COVIDIEN VENTURES

THE MARK CONSISTS OF STANDARD CHARACTERS WITHOUT CLAIM TO ANY PARTICULAR FONT, STYLE, SIZE, OR COLOR.

PRIORITY CLAIMED UNDER SEC. 44(D) ON SWITZERLAND APPLICATION NO. 60345/2008, FILED 8-21-2008, REG. NO. 575901, DATED 8-27-2008, EXPIRES 8-27-2018.

OWNER OF U.S. REG. NOS. 3,361,986, 3,524,947 AND OTHERS.

NO CLAIM IS MADE TO THE EXCLUSIVE RIGHT TO USE "VENTURES", APART FROM THE MARK AS SHOWN.

FOR FINANCIAL SERVICES, NAMELY, PROVIDING CAPITAL TO COMPANIES IN THE HEALTHCARE FIELD (U.S. CLS. 100, 101 AND 102).

FIRST USE 8-19-2008; IN COMMERCE 8-19-2008.

GRETTA YAO, EXAMINING ATTORNEY

SN 77-652,521. NATIONAL ASSOCIATION OF PROFESSIONAL PET SITTERS, INC., MT. LAUREL, NJ. FILED 1-20-2009.



OWNER OF U.S. REG. NO. 3,575,458.

NO CLAIM IS MADE TO THE EXCLUSIVE RIGHT TO USE "IN SUPPORT OF NATIONAL ANIMAL SHELTER WEEK", APART FROM THE MARK AS SHOWN.

THE COLOR(S) GREEN, YELLOW, BLACK, AND WHITE IS/ARE CLAIMED AS A FEATURE OF THE MARK.

THE MARK CONSISTS OF THE WORDS "PRESENTS 4 PETS" IN GREEN SUPERIMPOSED OVER A BLACK DOG AND CAT BEHIND A GIFT WHICH CONTAINS AN IMAGE OF A GREEN DOG AND CAT AND WHICH FEATURES A YELLOW BOW. UNDERNEATH THE IMAGE OF THE CAT AND DOG IN THE GIFT IS THE WORDING "NAPPS NATIONAL ASSOCIATION OF PROFESSIONAL PET SITTERS", WITH THE WORD "OF" APPEARING VERTICALLY RATHER THAN HORIZONTALLY. THE WORDING "IN SUPPORT OF NATIONAL ANIMAL SHELTER APPRECIATION WEEK" APPEARS IN BLACK BENEATH THE ENTIRE MARK. A PORTION OF THE WRAPPED GIFT IS IN THE COLOR WHITE.

SEC. 2(F) AS TO "NATIONAL ASSOCIATION OF PROFESSIONAL PET SITTERS".

FOR CHARITABLE COLLECTION DRIVE SERVICES TO RAISE DONATIONS OF MONEY FOR SUPPORTING ANIMAL SHELTERS (U.S. CLS. 100, 101 AND 102).

FIRST USE 4-0-2006; IN COMMERCE 4-0-2006.

RICHARD A. STRASER, EXAMINING ATTORNEY

CLASS 36—(Continued).

SN 77-653,572. CARDVEST LLC, WESTWOOD, MA. FILED 1-21-2009.

SOCIAL SAVINGS NETWORK

THE MARK CONSISTS OF STANDARD CHARACTERS WITHOUT CLAIM TO ANY PARTICULAR FONT, STYLE, SIZE, OR COLOR.

NO CLAIM IS MADE TO THE EXCLUSIVE RIGHT TO USE "NETWORK", APART FROM THE MARK AS SHOWN.

FOR FINANCIAL SERVICES, NAMELY, PROVIDING CREDIT CARD, DEBIT CARD, BANK CARD, PRE-PAID CARD AND CHARGE CARD SERVICES (U.S. CLS. 100, 101 AND 102).

REGINA DRUMMOND, EXAMINING ATTORNEY

SN 77-654,590. C. V. STARR & CO., INC., NEW YORK, NY. FILED 1-22-2009.

STARR EXCESS

THE MARK CONSISTS OF STANDARD CHARACTERS WITHOUT CLAIM TO ANY PARTICULAR FONT, STYLE, SIZE, OR COLOR.

OWNER OF U.S. REG. NOS. 2,877,409, 3,587,775 AND OTHERS.

NO CLAIM IS MADE TO THE EXCLUSIVE RIGHT TO USE "EXCESS", APART FROM THE MARK AS SHOWN.

FOR PROPERTY AND CASUALTY INSURANCE UNDERWRITING AND AGENCY SERVICES; INSURANCE UNDERWRITING IN THE FIELD OF LIFE, ACCIDENT AND HEALTH (U.S. CLS. 100, 101 AND 102).

MICHAEL SOUDERS, EXAMINING ATTORNEY

SN 77-655,622. BANK OF AMERICA CORPORATION, CHARLOTTE, NC. FILED 1-23-2009.

FLAT FEE MORTGAGE PLUS

THE MARK CONSISTS OF STANDARD CHARACTERS WITHOUT CLAIM TO ANY PARTICULAR FONT, STYLE, SIZE, OR COLOR.

NO CLAIM IS MADE TO THE EXCLUSIVE RIGHT TO USE "FLAT FEE MORTGAGE", APART FROM THE MARK AS SHOWN.

FOR BANKING AND RELATED FINANCIAL SERVICES (U.S. CLS. 100, 101 AND 102).

JANICE L. MCMORROW, EXAMINING ATTORNEY

CLASS 36—(Continued).

SN 77-656,291. REN, LLC, DALLAS, TX. FILED 1-26-2009.

CONNECTED NET LEASE

THE MARK CONSISTS OF STANDARD CHARACTERS WITHOUT CLAIM TO ANY PARTICULAR FONT, STYLE, SIZE, OR COLOR.

NO CLAIM IS MADE TO THE EXCLUSIVE RIGHT TO USE "NET LEASE", APART FROM THE MARK AS SHOWN.

FOR REAL ESTATE BROKERAGE (U.S. CLS. 100, 101 AND 102).

FIRST USE 9-9-2008; IN COMMERCE 9-9-2008.

ROBERT STRUCK, EXAMINING ATTORNEY

SN 77-656,939. SCHARFMAN, JASON, JERSEY CITY, NJ. FILED 1-26-2009.

CORGENTUM

THE MARK CONSISTS OF STANDARD CHARACTERS WITHOUT CLAIM TO ANY PARTICULAR FONT, STYLE, SIZE, OR COLOR.

THE TRANSLATION OF "CORGENTUM" APPEARING IN THE MARK HAS NO MEANING IN A FOREIGN LANGUAGE.

FOR FINANCIAL CONSULTING SERVICES (U.S. CLS. 100, 101 AND 102).

LINDA MICKLEBURGH, EXAMINING ATTORNEY

CLASS 36—(Continued).

SN 77-658,536. BUSINESS OWNERS CHARTER INC., CHICAGO, IL. FILED 1-28-2009.

pert number

THE MARK CONSISTS OF STANDARD CHARACTERS WITHOUT CLAIM TO ANY PARTICULAR FONT, STYLE, SIZE, OR COLOR.

NO CLAIM IS MADE TO THE EXCLUSIVE RIGHT TO USE "NUMBER", APART FROM THE MARK AS SHOWN.

FOR BROKERAGE SERVICES FOR STOCKS AND BONDS; BUSINESS, STOCK OPTION AND PENSION VALUATION SERVICES; FIDUCIARY SERVICES, NAMELY, FIDUCIARY REPRESENTATIVE SERVICES; FINANCIAL ADVICE; FINANCIAL ADVICE AND CONSULTANCY SERVICES; FINANCIAL ADVISORY AND CONSULTANCY SERVICES; FINANCIAL ANALYSES; FINANCIAL ANALYSIS AND CONSULTATION; FINANCIAL AND INVESTMENT SERVICES, NAMELY, MANAGEMENT AND BROKERAGE IN THE FIELDS OF STOCKS, BONDS, OPTIONS, COMMODITIES, FUTURES AND OTHER SECURITIES, AND THE INVESTMENT OF FUNDS OF OTHERS; FINANCIAL CONSULTANCY; FINANCIAL CONSULTATION; FINANCIAL CONSULTING; FINANCIAL FORECASTING; FINANCIAL INFORMATION AND EVALUATIONS; FINANCIAL PLANNING; FINANCIAL PLANNING CONSULTATION; FINANCIAL PLANNING FOR RETIREMENT (U.S. CLS. 100, 101 AND 102).

FIRST USE 1-28-2009; IN COMMERCE 1-28-2009.
FRED CARL, EXAMINING ATTORNEY

CLASS 36—(Continued).

SN 77-658,971. LUIS A. MOLINA, HOUSTON, TX. FILED 1-29-2009.

SCALAR FUND MANAGEMENT

THE MARK CONSISTS OF STANDARD CHARACTERS WITHOUT CLAIM TO ANY PARTICULAR FONT, STYLE, SIZE, OR COLOR.

NO CLAIM IS MADE TO THE EXCLUSIVE RIGHT TO USE "FUND MANAGEMENT", APART FROM THE MARK AS SHOWN.

FOR INVESTMENT OF FUNDS FOR OTHERS (U.S. CLS. 100, 101 AND 102).

JESSICA A. POWERS, EXAMINING ATTORNEY

SN 77-658,761. CANTO, GLYNIS, GREAT FALLS, VA. FILED 1-28-2009.

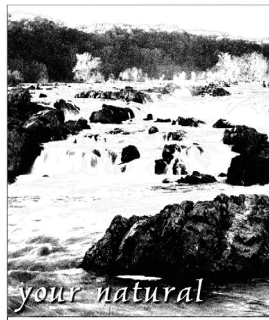

CONNECTION

THE MARK CONSISTS OF THE STYLIZED TEXT "YOUR NATURAL CONNECTION" WITH A PICTURE OF A WATERFALL IN THE BACKGROUND.

FOR LEASING OF REAL ESTATE; PROVIDING REAL ESTATE LISTINGS AND REAL ESTATE INFORMATION VIA THE INTERNET; REAL ESTATE CONSULTATION; REAL ESTATE LISTING (U.S. CLS. 100, 101 AND 102).

FIRST USE 3-1-2004; IN COMMERCE 4-1-2004.
BONNIE LUKEN, EXAMINING ATTORNEY

SN 77-660,121. BANK OF AMERICA CORPORATION, CHARLOTTE, NC. FILED 1-30-2009.

SIMPLEEQUITY

THE MARK CONSISTS OF STANDARD CHARACTERS WITHOUT CLAIM TO ANY PARTICULAR FONT, STYLE, SIZE, OR COLOR.

FOR REVERSE MORTGAGE LENDING SERVICES (U.S. CLS. 100, 101 AND 102).

FIRST USE 12-15-2006; IN COMMERCE 12-15-2006.
JANICE L. MCMORROW, EXAMINING ATTORNEY

CLASS 36—(Continued).

SN 77-660,684. MECHANICS BANK, RICHMOND, CA.
FILED 1-30-2009.

CLASS 36—(Continued).

SN 77-661,107. GIVE ON THE GO, LLC, MIAMI BEACH, FL.
FILED 2-2-2009.

**MECHANICS BANK**

NO CLAIM IS MADE TO THE EXCLUSIVE RIGHT TO USE "MOBILE DONATIONS", APART FROM THE MARK AS SHOWN.

THE MARK CONSISTS OF THE WORDS "GIVE ON THE GO", WITH A CELLULAR PHONE SYMBOL USED TO DEPICT THE LETTER "I" IN THE WORD "GIVE". A CIRCULAR DESIGN SURROUNDS THE WORD "GO". THE WORDS "MOBILE DONATIONS" APPEAR UNDERNEATH THE WORDS "GIVE ON THE GO".

FOR CHARITABLE FUND RAISING SERVICES, NAMELY, BY PROVIDING INDIVIDUALS WITH THE INFORMATION AND OPPORTUNITY TO MAKE MONETARY DONATIONS TO THEIR FAVORITE CHARITY (U.S. CLS. 100, 101 AND 102).

FIRST USE 1-29-2009; IN COMMERCE 1-29-2009.

CHARLES L. JENKINS, EXAMINING ATTORNEY

THE MARK CONSISTS OF STANDARD CHARACTERS WITHOUT CLAIM TO ANY PARTICULAR FONT, STYLE, SIZE, OR COLOR.

OWNER OF U.S. REG. NO. 2,303,476.

NO CLAIM IS MADE TO THE EXCLUSIVE RIGHT TO USE "BANK", APART FROM THE MARK AS SHOWN.

FOR BANKING SERVICES; FINANCING SERVICES; ON-LINE BANKING SERVICES; WEALTH MANAGEMENT SERVICES, NAMELY, FINANCIAL MANAGEMENT AND ESTATE PLANNING; ADMINISTRATION OF EMPLOYEE WELFARE BENEFIT PLANS; BROKERAGE OF SHARES AND OTHER SECURITIES; CHECKING ACCOUNT SERVICES; CREDIT AND LOAN SERVICES; FINANCING AND LOAN SERVICES; CREDIT AND DEBIT CARD SERVICES; FINANCIAL PLANNING; INVESTMENT ADVISORY SERVICES; INVESTMENT MANAGEMENT; TRUST SERVICES, NAMELY, INVESTMENT AND TRUST COMPANY SERVICES; CASH MANAGEMENT; AND ESCROW SERVICES, NAMELY, REAL ESTATE ESCROW SERVICES, MAINTAINING ESCROW ACCOUNTS FOR INVESTMENTS, AND MAINTAINING MORTGAGE ESCROW ACCOUNTS (U.S. CLS. 100, 101 AND 102).

FIRST USE 2-0-2008, THE MARK WAS FIRST USED ANYWHERE IN A DIFFERENT FORM OTHER THAN THAT SOUGHT TO BE REGISTERED AT LEAST AS EARLY AS 00/00/1907.; IN COMMERCE 4-0-2008, THE MARK WAS FIRST USED IN COMMERCE IN A DIFFERENT FORM OTHER THAN THAT SOUGHT TO BE REGISTERED AT LEAST AS EARLY AS 00/00/1907..

KIM MONINGHOFF, EXAMINING ATTORNEY

SN 77-661,203. VAVREK, DENNIS J., SAN DIEGO, CA.
FILED 2-2-2009.

DYADPLEX

THE MARK CONSISTS OF STANDARD CHARACTERS WITHOUT CLAIM TO ANY PARTICULAR FONT, STYLE, SIZE, OR COLOR.

FOR FINANCING AND LOAN SERVICES IN THE FIELD OF DYADIC-RESIDENCY COMMON-INTEREST DWELLING-UNITS; FINANCIAL SERVICES, NAMELY, ISSUANCE, MANAGEMENT AND TRADING OF SECURITIES BACKED BY LOAN PORTFOLIOS SECURED BY DYADIC-RESIDENCY COMMON-INTEREST DWELLING-UNITS WHICH ARE SUBSEQUENTLY MANAGED TO INSURE THE INTEGRITY OF THE SECURITIES (U.S. CLS. 100, 101 AND 102).

DAVID YONTEF, EXAMINING ATTORNEY

CLASS 36—(Continued).

SN 77-662,237. TRANSAMERICA CORPORATION, CEDAR RAPIDS, IA. FILED 2-3-2009.

TRANSAMERICA SELECT

THE MARK CONSISTS OF STANDARD CHARACTERS WITHOUT CLAIM TO ANY PARTICULAR FONT, STYLE, SIZE, OR COLOR.

OWNER OF U.S. REG. NOS. 718,353, 718,358 AND 831,626. FOR ANNUITY UNDERWRITING SERVICES (U.S. CLS. 100, 101 AND 102).

FIRST USE 11-0-2008; IN COMMERCE 11-0-2008.
ERIN FALK, EXAMINING ATTORNEY

CLASS 36—(Continued).

SN 77-662,874. MIDLAND NATIONAL LIFE INSURANCE COMPANY, SIOUX FALLS, SD. FILED 2-4-2009.

LEGACY GUARANTEED

THE MARK CONSISTS OF STANDARD CHARACTERS WITHOUT CLAIM TO ANY PARTICULAR FONT, STYLE, SIZE, OR COLOR.

OWNER OF U.S. REG. NOS. 2,589,561 AND 2,814,300. FOR LIFE INSURANCE UNDERWRITING SERVICES (U.S. CLS. 100, 101 AND 102).

BRIDGETT SMITH, EXAMINING ATTORNEY

SN 77-662,618. INTELLECTUAL PROPERTY EXCHANGE INTERNATIONAL, INC., CHICAGO, IL. FILED 2-3-2009.



NO CLAIM IS MADE TO THE EXCLUSIVE RIGHT TO USE "INTERNATIONAL", APART FROM THE MARK AS SHOWN.

THE COLOR(S) LIGHT BLUE, ROYAL BLUE, AND DARK BLUE IS/ARE CLAIMED AS A FEATURE OF THE MARK.

THE MARK CONSISTS OF THE WORDING "IPX INTERNATIONAL"; "IPX" IS INSIDE A CIRCLE, WITH "INTERNATIONAL" DIVIDING AND EXTENDING OUTSIDE THE CIRCLE. THE CIRCLE IS LIGHT BLUE, "IPX" IS ROYAL BLUE, AND "INTERNATIONAL" IS DARK BLUE.

FOR CONDUCTING AN EXCHANGE FOR TRADING SECURITIES, LICENSES AND CONTRACTS AND RELATED EXCHANGE SERVICES, NAMELY, PROVIDING FINANCIAL INFORMATION, COMPILING AND DISSEMINATING QUOTES, ORDERS, EXECUTIONS, INDEX VALUES; PROVIDING ON-LINE FINANCIAL INFORMATION VIA A GLOBAL COMPUTER NETWORK; ELECTRONIC PROCESSING OF ORDERS FOR PURCHASE AND SALE OF SECURITIES, LICENSES AND CONTRACTS (U.S. CLS. 100, 101 AND 102).

ALICE SUE CARRUTHERS, EXAMINING ATTORNEY

SN 77-663,070. ELM RESOURCES, OAKLAND, CA. FILED 2-4-2009.



OWNER OF U.S. REG. NOS. 2,044,381, 3,609,702 AND OTHERS.

NO CLAIM IS MADE TO THE EXCLUSIVE RIGHT TO USE "RESOURCES", APART FROM THE MARK AS SHOWN.

THE MARK CONSISTS OF THE WORDS "ELM RESOURCES" IN STYLIZED FONT, SHOWN TO THE LEFT OF A LEAFLESS TREE IN A RECTANGLE.

FOR PROVIDING INFORMATION IN THE FIELD OF STUDENT LOANS VIA ELECTRONIC NETWORKS AND THE INTERNET (U.S. CLS. 100, 101 AND 102).

FIRST USE 5-31-2007; IN COMMERCE 5-31-2007.
ESTHER BELENKER, EXAMINING ATTORNEY

SN 77-663,513. GENEQUITY MORTGAGE, INC., IRVING, TX. FILED 2-4-2009.



OWNER OF U.S. REG. NO. 3,509,181.

NO CLAIM IS MADE TO THE EXCLUSIVE RIGHT TO USE "MORTGAGE", APART FROM THE MARK AS SHOWN.

THE MARK CONSISTS OF TWO INTERLOCKING DIAMONDS AND THE WORDING "GENEQUITY MORTGAGE".

FOR FINANCIAL SERVICES, NAMELY, MORTGAGE PLANNING; MORTGAGE BROKERAGE; MORTGAGE LENDING; MORTGAGE PROCUREMENT FOR OTHERS (U.S. CLS. 100, 101 AND 102).

FIRST USE 10-6-2006; IN COMMERCE 1-2-2008.
YAT SYE, LEE, EXAMINING ATTORNEY

SN 77-662,807. RACE RAISER, INC., LONG BEACH, CA. FILED 2-4-2009.

The logo for Race Raiser features the word "RACERAISER" in a bold, black, sans-serif font. The letters are slightly shadowed, giving them a 3D appearance as if they are floating above a reflective surface.

THE COLOR(S) BLUE AND BLACK IS/ARE CLAIMED AS A FEATURE OF THE MARK.

THE MARK CONSISTS OF BLUE TEXT "RACE" ALONGSIDE BLACK TEXT "RAISE" SUCH THAT THE MARK STATES "RACERAISE" IN BLUE AND BLACK. SOME FADED, REFLECTIVE TEXT IS ALSO INCLUDED BE NEATH THE LETTERS.

FOR CHARITABLE FUNDRAISING SERVICES (U.S. CLS. 100, 101 AND 102).

PAUL E. FAHRENKOPF, EXAMINING ATTORNEY

CLASS 36—(Continued).

SN 77-663,586. CU ANYTIME, LLC, ALBUQUERQUE, NM. FILED 2-4-2009.



OWNER OF U.S. REG. NOS. 1,369,436, 2,238,526 AND 3,062,474.

THE MARK CONSISTS OF A SQUARE WITH "CU" PRINTED IN LARGE ITALICS AND WITH "ANYTIME" PRINTED IN SMALLER ITALICS BELOW "CU", AND WITH TWELVE SMALLER SQUARES TO THE RIGHT OF THE LARGER SQUARE, ARRANGED IN FOUR ROWS OF THREE COLUMNS.

FOR AUTOMATED TELLER MACHINE SERVICES; CREDIT UNION SERVICES; ON-LINE BANKING SERVICES (U.S. CLS. 100, 101 AND 102).

FIRST USE 3-1-1997; IN COMMERCE 3-1-1997.
MARK PILARO, EXAMINING ATTORNEY

SN 77-663,917. ALLIANZ SE, MUNCHEN, FED REP GERMANY, FILED 2-5-2009.

ALLIANZ ENDURANCE

THE MARK CONSISTS OF STANDARD CHARACTERS WITHOUT CLAIM TO ANY PARTICULAR FONT, STYLE, SIZE, OR COLOR.

OWNER OF U.S. REG. NOS. 2,256,628, 3,471,387 AND OTHERS.

THE ENGLISH TRANSLATION OF "ALLIANZ" IN THE MARK IS "ALLIANCE".

FOR ANNUITY SERVICES, NAMELY, ACCOUNT AND INVESTMENT ADMINISTRATION; ANNUITY UNDERWRITING; INVESTMENT MANAGEMENT OF AND DISTRIBUTION OF ANNUITIES; ISSUANCE AND ADMINISTRATION OF ANNUITIES (U.S. CLS. 100, 101 AND 102).

ANNE E. GUSTASON, EXAMINING ATTORNEY

CLASS 36—(Continued).

SN 77-664,227. SRS REAL ESTATE PARTNERS, INC., A-DISON, TX. FILED 2-5-2009.

SRS REAL ESTATE PARTNERS

THE MARK CONSISTS OF STANDARD CHARACTERS WITHOUT CLAIM TO ANY PARTICULAR FONT, STYLE, SIZE, OR COLOR.

NO CLAIM IS MADE TO THE EXCLUSIVE RIGHT TO USE "REAL ESTATE PARTNERS", APART FROM THE MARK AS SHOWN.

FOR REAL ESTATE BROKERAGE (U.S. CLS. 100, 101 AND 102).

FIRST USE 1-22-2009; IN COMMERCE 1-22-2009.
MATTHEW PAPPAS, EXAMINING ATTORNEY

SN 77-664,669. CONFIE SEGUROS, INC., NEW YORK, NY. FILED 2-5-2009.

DEDICADOS A SU FUTURO

THE MARK CONSISTS OF STANDARD CHARACTERS WITHOUT CLAIM TO ANY PARTICULAR FONT, STYLE, SIZE, OR COLOR.

THE ENGLISH TRANSLATION OF DEDICADOS A SU FUTURO IN THE MARK IS DEDICATED TO YOUR FUTURE.

FOR INSURANCE AGENCIES; INSURANCE BROKERAGE (U.S. CLS. 100, 101 AND 102).

FIRST USE 5-1-2006; IN COMMERCE 5-1-2006.
RICHARD A. STRASER, EXAMINING ATTORNEY

SN 77-664,903. BUTTERFLIES FROM HEAVEN FOUNDATION INC., DAVIE, FL. FILED 2-6-2009.



OWNER OF U.S. REG. NO. 3,453,502.

NO CLAIM IS MADE TO THE EXCLUSIVE RIGHT TO USE "FOUNDATION, INC.", APART FROM THE MARK AS SHOWN.

THE COLOR(S) BLUE AND YELLOW IS/ARE CLAIMED AS A FEATURE OF THE MARK.

THE MARK CONSISTS OF THE OUTLINE OF A BUTTERFLY IN DARK BLUE, ONE WING OF WHICH FORMS A CAPITAL "B", FOLLOWED BY THE LETTERS "UTTERFLIES FROM HEAVEN FOUNDATION, INC." IN LIGHT BLUE, WITH A YELLOW HALO OVER THE "N" OF "HEAVEN".

FOR CHARITABLE FUND RAISING (U.S. CLS. 100, 101 AND 102).

FIRST USE 2-0-2007; IN COMMERCE 5-1-2007.
MARY BOAGNI, EXAMINING ATTORNEY

CLASS 36—(Continued).

SN 77-665,150. MICHIGAN STATE UNIVERSITY FEDERAL CREDIT UNION, EAST LANSING, MI. FILED 2-6-2009.

Green on the Go

THE MARK CONSISTS OF STANDARD CHARACTERS WITHOUT CLAIM TO ANY PARTICULAR FONT, STYLE, SIZE, OR COLOR.

FOR CREDIT UNION SERVICES PROVIDED BY MOBILE TELEPHONE CONNECTIONS (U.S. CLS. 100, 101 AND 102).

FIRST USE 3-18-2009; IN COMMERCE 3-18-2009.
JOHN WILKE, EXAMINING ATTORNEY

CLASS 36—(Continued).

SN 77-665,570. COMPASS DESIGN & DEVELOPMENT, UPPER MARLBORO, MD. FILED 2-6-2009.

WEAR YOUR HEART

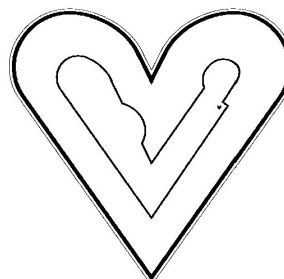

ON YOUR SLEEVE.

THE MARK CONSISTS OF A SYMMETRICAL HEART SHAPE DESIGN. INSIDE THE HEART APPEARS AN ARM BENT AT THE ELBOW WITH A HEART BUTTON ON THE SLEEVE. THE WORDING "WEAR YOUR HEART" APPEARS ABOVE THE DESIGN AND "ON YOUR SLEEVE" APPEARS BELOW THE DESIGN.

FOR CHARITABLE FUND RAISING (U.S. CLS. 100, 101 AND 102).

KATHERINE CONNOLLY, EXAMINING ATTORNEY

SN 77-665,610. FLETCHER ASSET MANAGEMENT, INC., NEW YORK, NY. FILED 2-6-2009.

RICHCOURT

THE MARK CONSISTS OF STANDARD CHARACTERS WITHOUT CLAIM TO ANY PARTICULAR FONT, STYLE, SIZE, OR COLOR.

FOR HEDGE FUND INVESTMENT SERVICES (U.S. CLS. 100, 101 AND 102).

FIRST USE 0-0-1992; IN COMMERCE 0-0-1992.
MAYUR VAGHANI, EXAMINING ATTORNEY

SN 77-665,542. MY CHILD'S MONEY, ENGLEWOOD, CO. FILED 2-6-2009.

MY CHILD'S MONEY

THE MARK CONSISTS OF STANDARD CHARACTERS WITHOUT CLAIM TO ANY PARTICULAR FONT, STYLE, SIZE, OR COLOR.

FOR FINANCIAL PLANNING AND INVESTMENT ADVISORY SERVICES; PROVIDING A WEBSITE FEATURING INFORMATION FOR FAMILIES TO EDUCATE CHILDREN IN FINANCIAL MATTERS; FINANCIAL SERVICES, NAMELY, PROVIDING A WEBSITE WHERE USERS CAN PURCHASE FINANCIAL PRODUCTS AND SERVICES (U.S. CLS. 100, 101 AND 102).

ALICE SUE CARRUTHERS, EXAMINING ATTORNEY

SN 77-665,612. FLETCHER ASSET MANAGEMENT, INC., NEW YORK, NY. FILED 2-6-2009.

NEW WAVE ASSET MANAGEMENT

THE MARK CONSISTS OF STANDARD CHARACTERS WITHOUT CLAIM TO ANY PARTICULAR FONT, STYLE, SIZE, OR COLOR.

NO CLAIM IS MADE TO THE EXCLUSIVE RIGHT TO USE "ASSET MANAGEMENT", APART FROM THE MARK AS SHOWN.

FOR FUNDS INVESTMENT (U.S. CLS. 100, 101 AND 102).

FIRST USE 5-31-2008; IN COMMERCE 5-31-2008.
MAYUR VAGHANI, EXAMINING ATTORNEY

CLASS 36—(Continued).

SN 77-665,622. VISA INTERNATIONAL SERVICE ASSOCIATION, FOSTER CITY, CA. FILED 2-6-2009.

GO CASHLESS

THE MARK CONSISTS OF STANDARD CHARACTERS WITHOUT CLAIM TO ANY PARTICULAR FONT, STYLE, SIZE, OR COLOR.

FOR BROAD BASED FINANCIAL SERVICES, NAMELY, BANKING SERVICES, CREDIT CARD SERVICES, DEBIT CARD SERVICES, CHARGE CARD SERVICES, PRE-PAID CARD SERVICES OFFERED THROUGH CARDS WITH STORED VALUE, BILL PAYMENT AND PRESENTMENT SERVICES, CASH DISBURSEMENT, CASH REPLACEMENT RENDERED BY CREDIT CARD AND DEBIT CARDS, ELECTRONIC CASH TRANSACTIONS; AUTOMATED TELLER MACHINE SERVICES, NAMELY, PROVIDING DEPOSITS, WITHDRAWALS AND FINANCIAL INFORMATION; POINT OF SALE AND POINT OF TRANSACTION SERVICES, TRANSACTION AUTHORIZATION AND SETTLEMENT SERVICES, ELECTRONIC FUNDS TRANSFER, ELECTRONIC PAYMENT PROCESSING SERVICES, CREDIT CARD AND DEBIT CARD VERIFICATION, PAYMENT TRANSACTION AUTHENTICATION AND VERIFICATION SERVICES; CHECK VERIFICATION SERVICES; FACILITATING PERSON-TO-PERSON PAYMENT SERVICES THROUGH ELECTRONIC MEANS VIA A GLOBAL COMPUTER NETWORK; PROVISION OF DEBIT AND CREDIT SERVICES BY MEANS OF RADIO FREQUENCY IDENTIFICATION DEVICES; VALUE EXCHANGE SERVICES, NAMELY, SECURE ELECTRONIC CASH TRANSACTIONS OVER COMPUTER NETWORKS TO FACILITATE ELECTRONIC COMMERCE; PROCESSING OF FINANCIAL TRANSACTIONS ONLINE VIA A GLOBAL COMPUTER NETWORK OR VIA TELECOMMUNICATION, MOBILE OR WIRELESS DEVICES; ELECTRONIC CASH SERVICES, NAMELY, CURRENCY EXCHANGE OVER A GLOBAL ELECTRONIC NETWORK; PROVIDING FINANCIAL INFORMATION, NAMELY, CREDIT AND DEBIT CARD DATA AND REPORTS; FINANCIAL SPONSORSHIP OF SPORTS COMPETITIONS, EVENTS, ACTIVITIES, AND GAMES; FINANCIAL SPONSORSHIP OF ATHLETES AND TEAMS PARTICIPATING IN ATHLETIC COMPETITIONS (U.S. CLS. 100, 101 AND 102).

ESTHER A. BORSUK, EXAMINING ATTORNEY

SN 77-665,941. NOCTUA PARTNERS, LLC., BRICKELL AVENUE, FL. FILED 2-9-2009.

NOCTUA PARTNERS

THE MARK CONSISTS OF STANDARD CHARACTERS WITHOUT CLAIM TO ANY PARTICULAR FONT, STYLE, SIZE, OR COLOR.

NO CLAIM IS MADE TO THE EXCLUSIVE RIGHT TO USE "PARTNERS", APART FROM THE MARK AS SHOWN.

FOR FINANCIAL ADVISORY AND CONSULTANCY SERVICES; FINANCIAL SERVICES, NAMELY, INVESTMENT ADVICE, INVESTMENT MANAGEMENT, INVESTMENT CONSULTATION AND INVESTMENT OF FUNDS FOR OTHERS, INCLUDING PRIVATE AND PUBLIC EQUITY AND DEBT INVESTMENT SERVICES (U.S. CLS. 100, 101 AND 102).

ESTHER A. BORSUK, EXAMINING ATTORNEY

CLASS 36—(Continued).

SN 77-666,431. EQUOTE, INC., SAN DIEGO, CA. FILED 2-9-2009.

EQUOTE

THE MARK CONSISTS OF STANDARD CHARACTERS WITHOUT CLAIM TO ANY PARTICULAR FONT, STYLE, SIZE, OR COLOR.

OWNER OF U.S. REG. NO. 3,487,361.

SEC. 2(F).

FOR INSURANCE BROKERAGE AND AGENCY SERVICES, NAMELY, PROVIDING GENERAL INSURANCE, PROPERTY AND CASUALTY INSURANCE, AND DISABILITY INSURANCE (U.S. CLS. 100, 101 AND 102).

FIRST USE 2-1-2000; IN COMMERCE 2-1-2000.

REBECCA GILBERT, EXAMINING ATTORNEY

SN 77-667,312. NATIONAL DEALERS WARRANTY, INC., ST. PETERS, MO. FILED 2-10-2009.

stoprepairbills.com

THE MARK CONSISTS OF STANDARD CHARACTERS WITHOUT CLAIM TO ANY PARTICULAR FONT, STYLE, SIZE, OR COLOR.

FOR INSURANCE SERVICES, NAMELY, PROVIDING VEHICLE SERVICE CONTRACTS WHICH COVER MOTOR VEHICLE MAINTENANCE AND REPAIR SERVICES (U.S. CLS. 100, 101 AND 102).

SIMON TENG, EXAMINING ATTORNEY

SN 77-667,727. DANA-FARBER CANCER INSTITUTE, INC., BOSTON, MA. FILED 2-10-2009.

RALLY AGAINST CANCER

THE MARK CONSISTS OF STANDARD CHARACTERS WITHOUT CLAIM TO ANY PARTICULAR FONT, STYLE, SIZE, OR COLOR.

FOR CHARITABLE FUND RAISING SERVICES, NAMELY, ORGANIZING AND SPONSORING ROAD RACES TO RAISE MONEY FOR CANCER TREATMENT CENTER OPERATIONS, CANCER RESEARCH AND CANCER AWARENESS (U.S. CLS. 100, 101 AND 102).

FIRST USE 4-5-2006; IN COMMERCE 4-5-2006.

CHRISTINA SOBRAL, EXAMINING ATTORNEY

CLASS 36—(Continued).

SN 77-667,732. MCLEAN, ANDREW, PALM SPRINGS, CA. FILED 2-10-2009.

GREENDAQ

THE MARK CONSISTS OF THE STYLIZED TEXT "GREENDAQ".

FOR ONLINE WEBSITE PROVIDING INFORMATION IN THE FIELDS OF COMMODITIES EXCHANGE AND FINANCIAL INVESTMENT (U.S. CLS. 100, 101 AND 102). FIRST USE 6-1-2008; IN COMMERCE 8-1-2008. ESTHER A. BORSUK, EXAMINING ATTORNEY

SN 77-667,733. DANA-FARBER CANCER INSTITUTE, INC., BOSTON, MA. FILED 2-10-2009.

GET ON THE RIGHT COURSE TO
FIGHT CANCER

THE MARK CONSISTS OF STANDARD CHARACTERS WITHOUT CLAIM TO ANY PARTICULAR FONT, STYLE, SIZE, OR COLOR.

FOR CHARITABLE FUND RAISING SERVICES, NAMELY, ORGANIZING AND SPONSORING GOLF TOURNAMENTS TO RAISE MONEY FOR CANCER TREATMENT CENTER OPERATIONS, CANCER RESEARCH AND CANCER AWARENESS (U.S. CLS. 100, 101 AND 102).

FIRST USE 5-4-2005; IN COMMERCE 5-4-2005. CHRISTINA SOBRAL, EXAMINING ATTORNEY

SN 77-668,726. DANA-FARBER CANCER INSTITUTE, INC., BOSTON, MA. FILED 2-11-2009.

IT TAKES MORE THAN COURAGE
TO BEAT CANCER

THE MARK CONSISTS OF STANDARD CHARACTERS WITHOUT CLAIM TO ANY PARTICULAR FONT, STYLE, SIZE, OR COLOR.

FOR CHARITABLE FUNDRAISING SERVICES, NAMELY, FUNDRAISING FOR PROMOTION OF PUBLIC EDUCATION AND AWARENESS OF BIOMEDICAL SCIENCES RESEARCH, PARTICULARLY WITH REGARD TO THE PREVENTION, DETECTION, DIAGNOSIS AND TREATMENT OF CANCER, AND FOR THE FURNISHING OF MEDICAL ASSISTANCE FOR THE PREVENTION, DETECTION, DIAGNOSIS AND TREATMENT OF CANCER (U.S. CLS. 100, 101 AND 102).

FIRST USE 5-1-1997; IN COMMERCE 5-1-1997. CHRISTINA SOBRAL, EXAMINING ATTORNEY

CLASS 36—(Continued).

SN 77-669,567. PH4 CORPORATION, BLOOMFIELD HILLS, MI. FILED 2-12-2009.

DEL WEBB

THE MARK CONSISTS OF STANDARD CHARACTERS WITHOUT CLAIM TO ANY PARTICULAR FONT, STYLE, SIZE, OR COLOR.

OWNER OF U.S. REG. NOS. 2,345,498, 2,680,564 AND 2,877,276.

THE NAME(S), PORTRAIT(S), AND/OR SIGNATURE(S) SHOWN IN THE MARK DOES NOT IDENTIFY A PARTICULAR LIVING INDIVIDUAL.

FOR REAL ESTATE AGENCY SERVICES (U.S. CLS. 100, 101 AND 102).

FIRST USE 1-1-1960; IN COMMERCE 1-1-1960. REBECCA GILBERT, EXAMINING ATTORNEY

SN 77-673,221. SRS REAL ESTATE PARTNERS, INC., ADISON, TX. FILED 2-18-2009.

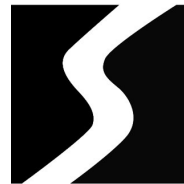

SRS

Real Estate Partners

NO CLAIM IS MADE TO THE EXCLUSIVE RIGHT TO USE "REAL ESTATE PARTNERS", APART FROM THE MARK AS SHOWN.

THE MARK CONSISTS OF A STYLIZED LETTER "S" FOLLOWED BY THE LITERAL ELEMENT "SRS REAL ESTATE PARTNERS."

FOR REAL ESTATE BROKERAGE (U.S. CLS. 100, 101 AND 102).

FIRST USE 1-22-2009; IN COMMERCE 1-22-2009. MATTHEW PAPPAS, EXAMINING ATTORNEY

SN 77-674,799. CITIZENS FINANCIAL GROUP, INC., PROVIDENCE, RI. FILED 2-20-2009.

CITIZENS BANK HOMEBUYER
SAVINGS

THE MARK CONSISTS OF STANDARD CHARACTERS WITHOUT CLAIM TO ANY PARTICULAR FONT, STYLE, SIZE, OR COLOR.

OWNER OF U.S. REG. NOS. 2,482,203, 2,668,486 AND OTHERS.

NO CLAIM IS MADE TO THE EXCLUSIVE RIGHT TO USE "BANK HOMEBUYER SAVINGS", APART FROM THE MARK AS SHOWN.

FOR BANKING SERVICES, NAMELY, AN INCENTIVIZED SAVINGS ACCOUNT TO ASSIST PROSPECTIVE HOMEOWNERS IN SAVING FOR A DOWN PAYMENT ON A HOME (U.S. CLS. 100, 101 AND 102).

COURTNEY MCCORMICK, EXAMINING ATTORNEY

CLASS 36—(Continued).

SN 77-674,811. CITIZENS FINANCIAL GROUP, INC., PROVIDENCE, RI. FILED 2-20-2009.

CITIZENS BANK HOME BUYER
SAVINGS

THE MARK CONSISTS OF STANDARD CHARACTERS WITHOUT CLAIM TO ANY PARTICULAR FONT, STYLE, SIZE, OR COLOR.

OWNER OF U.S. REG. NOS. 2,482,203, 2,668,486 AND OTHERS.

NO CLAIM IS MADE TO THE EXCLUSIVE RIGHT TO USE "BANK HOME BUYER SAVINGS", APART FROM THE MARK AS SHOWN.

FOR BANKING SERVICES, NAMELY, AN INCENTIVIZED SAVINGS ACCOUNT TO ASSIST PROSPECTIVE HOMEOWNERS IN SAVING FOR A DOWN PAYMENT ON A HOME (U.S. CLS. 100, 101 AND 102).

COURTNEY MCCORMICK, EXAMINING ATTORNEY

CLASS 36—(Continued).

SN 77-675,733. WELLS FARGO & COMPANY, MINNEAPOLIS, MN. FILED 2-23-2009.

WELLS FARGO ADVISORS
FINANCIAL NETWORK

THE MARK CONSISTS OF STANDARD CHARACTERS WITHOUT CLAIM TO ANY PARTICULAR FONT, STYLE, SIZE, OR COLOR.

OWNER OF U.S. REG. NOS. 3,114,074, 3,521,517 AND OTHERS.

NO CLAIM IS MADE TO THE EXCLUSIVE RIGHT TO USE "ADVISORS FINANCIAL NETWORK", APART FROM THE MARK AS SHOWN.

FOR FINANCIAL AND INVESTMENT SERVICES, NAMELY, BROKERAGE SERVICES IN THE FIELDS OF STOCKS, BONDS, OPTIONS, MUTUAL FUNDS, COMMODITIES, FUTURES, AND OTHER SECURITIES; PROPRIETARY TRADING SERVICES, NAMELY, FUND INVESTMENT SERVICES FEATURING THE TRADING OF AN ACCOUNT HOLDER'S SECURITIES ACCORDING TO PREVIOUSLY ESTABLISHED CRITERIA IN ORDER TO MAINTAIN A PREDETERMINED LEVEL OF PAYMENTS TO THE ACCOUNT HOLDER; INVESTMENT BANKING SERVICES; SECURITIES BROKERAGE; EQUITY CAPITAL INVESTMENT SERVICES; PRIVATE PLACEMENTS OF HEDGE FUNDS, PRIVATE EQUITY FUNDS, SECURITIES AND DERIVATIVES FOR OTHERS; INVESTMENT OF FUNDS FOR OTHERS; SECURITIES TRADING AND INVESTING SERVICES FOR OTHERS VIA THE INTERNET; INVESTMENT ADVISORY SERVICES; INVESTMENT CONSULTATION SERVICES; INVESTMENT MANAGEMENT SERVICES; PROVIDING INFORMATION AND ADVICE IN THE FIELD OF FINANCE, FINANCIAL INVESTMENTS, FINANCIAL VALUATIONS, AND THE FINANCIAL ASPECTS OF RETIREMENT THROUGH A GLOBAL COMPUTER NETWORK; FINANCIAL PLANNING; CASH MANAGEMENT ACCOUNT SERVICES; PROVIDING FINANCIAL PORTFOLIO MANAGEMENT SERVICES; PROVIDING AN INTERACTIVE ONLINE COMPUTER DATABASE IN THE FIELD OF FINANCIAL PORTFOLIO MANAGEMENT, FINANCIAL DECISION MAKING, INVESTMENT RESEARCH, MONITORING INVESTMENT VALUE AND PERFORMANCE OF INVESTMENTS, ANALYZING INVESTMENT PERFORMANCE, EVALUATING ASSET ALLOCATION, RISK TOLERANCE, FINANCIAL ALTERNATIVE PLANS, AND INVESTMENT TIME FRAMES (U.S. CLS. 100, 101 AND 102).

THOMAS MANOR, EXAMINING ATTORNEY

SN 77-675,730. WELLS FARGO & COMPANY, MINNEAPOLIS, MN. FILED 2-23-2009.

WELLS FARGO ADVISORS

THE MARK CONSISTS OF STANDARD CHARACTERS WITHOUT CLAIM TO ANY PARTICULAR FONT, STYLE, SIZE, OR COLOR.

OWNER OF U.S. REG. NOS. 3,114,074, 3,521,517 AND OTHERS.

NO CLAIM IS MADE TO THE EXCLUSIVE RIGHT TO USE "ADVISORS", APART FROM THE MARK AS SHOWN.

FOR FINANCIAL AND INVESTMENT SERVICES, NAMELY, BROKERAGE SERVICES IN THE FIELDS OF STOCKS, BONDS, OPTIONS, MUTUAL FUNDS, COMMODITIES, FUTURES, AND OTHER SECURITIES; PROPRIETARY TRADING SERVICES, NAMELY, FUND INVESTMENT SERVICES FEATURING THE TRADING OF AN ACCOUNT HOLDER'S SECURITIES ACCORDING TO PREVIOUSLY ESTABLISHED CRITERIA IN ORDER TO MAINTAIN A PREDETERMINED LEVEL OF PAYMENTS TO THE ACCOUNT HOLDER; INVESTMENT BANKING SERVICES; SECURITIES BROKERAGE; EQUITY CAPITAL INVESTMENT SERVICES; PRIVATE PLACEMENTS OF HEDGE FUNDS, PRIVATE EQUITY FUNDS, SECURITIES AND DERIVATIVES FOR OTHERS; INVESTMENT OF FUNDS FOR OTHERS; SECURITIES TRADING AND INVESTING SERVICES FOR OTHERS VIA THE INTERNET; INVESTMENT ADVISORY SERVICES; INVESTMENT CONSULTATION SERVICES; INVESTMENT MANAGEMENT SERVICES; PROVIDING INFORMATION AND ADVICE IN THE FIELD OF FINANCE, FINANCIAL INVESTMENTS, FINANCIAL VALUATIONS, AND THE FINANCIAL ASPECTS OF RETIREMENT THROUGH A GLOBAL COMPUTER NETWORK; FINANCIAL PLANNING; CASH MANAGEMENT ACCOUNT SERVICES; PROVIDING FINANCIAL PORTFOLIO MANAGEMENT SERVICES; PROVIDING AN INTERACTIVE ONLINE COMPUTER DATABASE IN THE FIELD OF FINANCIAL PORTFOLIO MANAGEMENT, FINANCIAL DECISION MAKING, INVESTMENT RESEARCH, MONITORING INVESTMENT VALUE AND PERFORMANCE OF INVESTMENTS, ANALYZING INVESTMENT PERFORMANCE, EVALUATING ASSET ALLOCATION, RISK TOLERANCE, FINANCIAL ALTERNATIVE PLANS, AND INVESTMENT TIME FRAMES (U.S. CLS. 100, 101 AND 102).

THOMAS MANOR, EXAMINING ATTORNEY

CLASS 36—(Continued).

SN 77-680,276. C. V. STARR & CO., INC., NEW YORK, NY.
FILED 2-27-2009.

**STARR SPECIALTY LINES
INSURANCE AGENCY, LLC**

THE MARK CONSISTS OF STANDARD CHARACTERS WITHOUT CLAIM TO ANY PARTICULAR FONT, STYLE, SIZE, OR COLOR.

OWNER OF U.S. REG. NOS. 2,877,409, 3,587,775 AND OTHERS.

NO CLAIM IS MADE TO THE EXCLUSIVE RIGHT TO USE "SPECIALTY LINES INSURANCE AGENCY, LLC", APART FROM THE MARK AS SHOWN.

FOR PROPERTY, CASUALTY AND EXCESS INSURANCE UNDERWRITING AND AGENCY SERVICES (U.S. CLS. 100, 101 AND 102).

MICHAEL SOUDERS, EXAMINING ATTORNEY

SN 77-680,362. C. V. STARR & CO., INC., NEW YORK, NY.
FILED 2-27-2009.

STARLINK

THE MARK CONSISTS OF STANDARD CHARACTERS WITHOUT CLAIM TO ANY PARTICULAR FONT, STYLE, SIZE, OR COLOR.

OWNER OF U.S. REG. NOS. 2,877,409, 3,587,775 AND OTHERS.

FOR AVIATION INSURANCE UNDERWRITING AND AGENCY SERVICES (U.S. CLS. 100, 101 AND 102).

MICHAEL SOUDERS, EXAMINING ATTORNEY

SN 77-680,501. C. V. STARR & CO., INC., NEW YORK, NY.
FILED 2-27-2009.



OWNER OF U.S. REG. NOS. 2,877,409, 3,587,775 AND OTHERS.

NO CLAIM IS MADE TO THE EXCLUSIVE RIGHT TO USE "SPECIALTY LINES INSURANCE AGENCY, LLC", APART FROM THE MARK AS SHOWN.

THE MARK CONSISTS OF THE WORDS "STARR SPECIALTY LINES INSURANCE AGENCY, LLC" ON THE RIGHT SIDE OF A STAR WITHIN A SHADED BOX.

FOR PROPERTY, CASUALTY AND EXCESS INSURANCE UNDERWRITING AND AGENCY SERVICES (U.S. CLS. 100, 101 AND 102).

MICHAEL SOUDERS, EXAMINING ATTORNEY

CLASS 36—(Continued).

SN 77-682,929. TRANSAMERICA CORPORATION, CEDAR RAPIDS, IA. FILED 3-4-2009.

TRANSABILITY

THE MARK CONSISTS OF STANDARD CHARACTERS WITHOUT CLAIM TO ANY PARTICULAR FONT, STYLE, SIZE, OR COLOR.

OWNER OF U.S. REG. NOS. 718,353, 831,626 AND OTHERS.

FOR FINANCIAL PLANNING AND INVESTMENT ADVISORY SERVICES; PROVIDING INFORMATION AND ADVICE TO FINANCIAL PLANNERS AND LIFE INSURANCE PROFESSIONALS WITH CLIENTS WHO HAVE CHILDREN OR RELATIVES WITH SPECIAL NEEDS (U.S. CLS. 100, 101 AND 102).

ERIN FALK, EXAMINING ATTORNEY

SN 77-692,112. TEAM UNDERWIRES, STERLING, IL. FILED 3-16-2009.



THE COLOR(S) PINK, RED, AND BLACK IS/ARE CLAIMED AS A FEATURE OF THE MARK.

THE MARK CONSISTS OF THE TEXT "TEAM UNDERWIRES" IN BLACK, "PROUD TO WEAR PINK!" IN RED, CENTERED ABOVE TWO CURVED LINES IN BLACK WITH A SMALL PINK RIBBON INTERSECTING ONE CURVED LINE.

FOR CHARITABLE FUND RAISING SERVICES, NAMELY, RAISING MONEY FOR COMMUNITY BREAST CANCER HEALTHCARE AND AWARENESS SERVICES (U.S. CLS. 100, 101 AND 102).

DAVID C. REIHNER, EXAMINING ATTORNEY

CLASS 36—(Continued).

SN 77-697,360. NATIONWIDE MUTUAL INSURANCE COMPANY, COLUMBUS, OH. FILED 3-23-2009.

ESTA DE TU LADO

THE MARK CONSISTS OF STANDARD CHARACTERS WITHOUT CLAIM TO ANY PARTICULAR FONT, STYLE, SIZE, OR COLOR.

OWNER OF U.S. REG. NOS. 1,793,850, 3,038,893 AND 3,302,256.

THE ENGLISH TRANSLATION OF "ESTA DE TU LADO" IN THE MARK IS IS ON YOUR SIDE.

FOR INSURANCE SERVICES, NAMELY, UNDERWRITING AND CLAIMS ADMINISTRATION OF PROPERTY AND CASUALTY INSURANCE (U.S. CLS. 100, 101 AND 102).

FIRST USE 2-3-2006; IN COMMERCE 2-3-2006.
CHRISTINA SOBRAL, EXAMINING ATTORNEY

CLASS 36—(Continued).

SN 78-663,529. CLARITY BENEFIT CONSULTING, LLC, ATLANTA, GA. FILED 7-5-2005.

Clarity

THE MARK CONSISTS OF STANDARD CHARACTERS WITHOUT CLAIM TO ANY PARTICULAR FONT, STYLE, SIZE, OR COLOR.

FOR CONSULTING SERVICES, NAMELY, EMPLOYEE BENEFIT CONSULTING SERVICES (U.S. CLS. 100, 101 AND 102).

FIRST USE 4-1-2005; IN COMMERCE 4-1-2005.
DANIEL CAPSHAW, EXAMINING ATTORNEY

SN 77-714,466. RICHARD R. BLAKE, JR., WASHINGTON, DC. FILED 4-15-2009.

Duncaster Investments

THE MARK CONSISTS OF STANDARD CHARACTERS WITHOUT CLAIM TO ANY PARTICULAR FONT, STYLE, SIZE, OR COLOR.

NO CLAIM IS MADE TO THE EXCLUSIVE RIGHT TO USE "INVESTMENTS", APART FROM THE MARK AS SHOWN.

FOR FINANCIAL INVESTMENT IN THE FIELD OF VENTURE CAPITAL INVESTMENTS IN NEW INFORMATION AND COMMUNICATIONS TECHNOLOGY FIRMS (U.S. CLS. 100, 101 AND 102).

FIRST USE 2-11-2000; IN COMMERCE 2-11-2000.
EMILY CARLSEN, EXAMINING ATTORNEY

SN 78-168,607. FIRST NIAGARA FINANCIAL GROUP, INC., LOCKPORT, NY. FILED 9-27-2002.

FIRST NIAGARA

PRIORITY CLAIMED UNDER SEC. 44(D) ON CANADA APPLICATION NO. 1135809, FILED 3-28-2002.

FOR INSURANCE AGENCY SERVICES (U.S. CLS. 100, 101 AND 102).

FIRST USE 0-0-1984; IN COMMERCE 0-0-1984.
MARIA-VICTORIA SUAREZ, EXAMINING ATTORNEY

SN 78-868,851. ANADARKO PETROLEUM CORPORATION, HOUSTON, TX. FILED 4-25-2006.



OWNER OF ERPN CMNTY TM OFC REG. NO. 005002241, DATED 10-11-2007, EXPIRES 3-21-2016.

OWNER OF U.S. REG. NO. 1,435,026.

NO CLAIM IS MADE TO THE EXCLUSIVE RIGHT TO USE "ENERGY SERVICES", APART FROM THE MARK AS SHOWN.

THE MARK CONSISTS OF THE WORDING "ANADARKO ENERGY SERVICES", PRESENTED TOGETHER WITH A STYLIZED REPRESENTATION OF AN OIL DERRICK.

SEC. 2(F) AS TO "ANADARKO".

FOR FINANCIAL SERVICES RENDERED IN RELATION TO ESCROW CONTRACTS, NAMELY, MAINTAINING ESCROW ACCOUNTS FOR INVESTMENTS IN THE FIELDS OF ENERGY EXPLORATION AND PRODUCTION; SERVICES OF AN INVESTMENT TRUST, NAMELY, INVESTMENT TRUST COMPANY SERVICES IN THE FIELDS OF ENERGY EXPLORATION AND PRODUCTION; SERVICES RENDERED IN CONNECTION WITH THE ISSUANCE, RECEIPT AND TRANSFER OF LINES OF CREDIT IN THE FIELDS OF ENERGY EXPLORATION AND PRODUCTION, NAMELY, CREDIT PROCESSING SERVICES (U.S. CLS. 100, 101 AND 102).

MICHAEL WIENER, EXAMINING ATTORNEY

CLASS 36—(Continued).

SN 78-870,295. ANADARKO PETROLEUM CORPORATION, HOUSTON, TX. FILED 4-26-2006.



PRIORITY CLAIMED UNDER SEC. 44(D) ON ERPNCMNTY TM OFC APPLICATION NO. 004999637, FILED 3-21-2006, REG. NO. 004999637, DATED 10-11-2007, EXPIRES 3-21-2016.

OWNER OF U.S. REG. NO. 1,435,026.

NO CLAIM IS MADE TO THE EXCLUSIVE RIGHT TO USE "E & P COMPANY LP", APART FROM THE MARK AS SHOWN.

THE MARK CONSISTS OF THE WORDING "ANADARKO E&P COMPANY LP", PRESENTED TOGETHER WITH A STYLIZED REPRESENTATION OF AN OIL DERRICK.

SEC. 2(F) AS TO "ANADARKO".

FOR FINANCIAL SERVICES RENDERED IN RELATION TO ESCROW CONTRACTS, NAMELY, MAINTAINING ESCROW ACCOUNTS FOR INVESTMENTS IN THE FIELDS OF ENERGY EXPLORATION AND PRODUCTION; SERVICES OF AN INVESTMENT TRUST, NAMELY, INVESTMENT TRUST COMPANY SERVICES IN THE FIELDS OF ENERGY EXPLORATION AND PRODUCTION; SERVICES RENDERED IN CONNECTION WITH THE ISSUANCE, RECEIPT AND TRANSFER OF LINES OF CREDIT IN THE FIELDS OF ENERGY EXPLORATION AND PRODUCTION, NAMELY, CREDIT PROCESSING SERVICES (U.S. CLS. 100, 101 AND 102).

MICHAEL WIENER, EXAMINING ATTORNEY

SN 78-883,455. RBS LYNK INCORPORATED, ATLANTA, GA. FILED 5-15-2006.

CASHPORT

THE MARK CONSISTS OF STANDARD CHARACTERS WITHOUT CLAIM TO ANY PARTICULAR FONT, STYLE, SIZE, OR COLOR.

FOR CREDIT CARD AND DEBIT CARD SERVICES (U.S. CLS. 100, 101 AND 102).

KEVIN CORWIN, EXAMINING ATTORNEY

CLASS 37—CONSTRUCTION AND REPAIR

SN 76-677,504. MD HOMES, LLC, MILLERSVILLE, MD. FILED 5-29-2007.



NO CLAIM IS MADE TO THE EXCLUSIVE RIGHT TO USE "HOMES", APART FROM THE MARK AS SHOWN.

THE MARK APPEARS IN STANDARD FONT CHARACTERS WITH THE LETTERS "PCS" APPEARING SOMEWHAT LARGER THAN "HOMES", AND THE LETTERS "PCS" BEING CROWNED WITH A TRIANGLE ROOF.

FOR CUSTOM CONSTRUCTION OF HOMES (U.S. CLS. 100, 103 AND 106).

FIRST USE 0-0-1990; IN COMMERCE 0-0-1990.

NAPOLEON SHARMA, EXAMINING ATTORNEY

SN 77-201,398. WALNUT STREET LESSEE, LP, DALLAS, TX. FILED 6-8-2007.

THE RADIAN

THE MARK CONSISTS OF STANDARD CHARACTERS WITHOUT CLAIM TO ANY PARTICULAR FONT, STYLE, SIZE, OR COLOR.

FOR DEVELOPMENT OF MIXED-USE AND MULTIFAMILY RESIDENTIAL COMMUNITIES AND DEVELOPMENTS, NAMELY, PLANNING, LAYOUT AND CONSTRUCTION OF MIXED-USE RESIDENTIAL COMPLEXES CONTAINING VARIOUS COMBINATIONS OF RETAIL, OFFICE, RESTAURANT AND MULTIFAMILY RESIDENTIAL FACILITIES (U.S. CLS. 100, 103 AND 106).

SUSAN RICHARDS, EXAMINING ATTORNEY

CLASS 37—(Continued).

SN 77-207,306. OFFIX LC, HAYMARKET, VA. FILED 6-15-2007.

SERVICE SMART

THE MARK CONSISTS OF STANDARD CHARACTERS WITHOUT CLAIM TO ANY PARTICULAR FONT, STYLE, SIZE, OR COLOR.

NO CLAIM IS MADE TO THE EXCLUSIVE RIGHT TO USE "SERVICE", APART FROM THE MARK AS SHOWN.

FOR INSTALLATION, MAINTENANCE, AND REPAIR OF OFFICE EQUIPMENT, NAMELY, COMPUTER HARDWARE, DIGITAL COLOR COPIERS, PHOTOCOPIERS, COMBINATION PHOTOCOPIERS, COPIERS, PRINTERS, AND FACSIMILE MACHINES THAT OFFER COPYING, PRINTING, FAXING AND SCAN TO EMAIL CAPABILITIES, PHOTOGRAPHIC IMAGING EQUIPMENT, SCANNERS, COMPUTERS, OFFLINE FINISHING EQUIPMENT, MONITORS, DOCUMENT STORAGE AND RETRIEVAL SYSTEMS, DOCUMENT MANAGEMENT SYSTEMS, NETWORK SYSTEM HARDWARE AND SOFTWARE, AND NETWORK SUPPORT SOFTWARE (U.S. CLS. 100, 103 AND 106).

FIRST USE 12-1-2006; IN COMMERCE 12-1-2006.
THOMAS MANOR, EXAMINING ATTORNEY

SN 77-229,252. TEMO, INC., CLINTON TOWNSHIP, MI. FILED 7-13-2007.



NO CLAIM IS MADE TO THE EXCLUSIVE RIGHT TO USE "D.I.Y. DO IT YOURSELF", APART FROM THE MARK AS SHOWN.

THE MARK CONSISTS OF THE WORDS "D.I.Y. DO IT YOURSELF PLUS" WITHIN THE OUTLINE OF A FRAMED HOUSING STRUCTURE WITH A GRAPHICAL DEPICTION OF A CONSTRUCTION WORKER.

FOR INSTALLATION OF DOORS AND WINDOWS; INSTALLATION OF BUILDING INSULATION; INSTALLATION OF BASEMENT WATERPROOFING PRODUCTS; CONSTRUCTION, RENOVATION, REMODELING, REPAIR AND CONSTRUCTION IMPROVEMENTS OF RESIDENTIAL, COMMERCIAL, AND INDUSTRIAL BUILDINGS, SUNROOMS, AND BASEMENTS (U.S. CLS. 100, 103 AND 106).

TARA PATE, EXAMINING ATTORNEY

CLASS 37—(Continued).

SN 77-428,028. MILLER & LONG CO., INC., BETHESDA, MD. FILED 3-21-2008.

OUR REPUTATION IS BUILDING

THE MARK CONSISTS OF STANDARD CHARACTERS WITHOUT CLAIM TO ANY PARTICULAR FONT, STYLE, SIZE, OR COLOR.

FOR BUILDING CONSTRUCTION SERVICES (U.S. CLS. 100, 103 AND 106).

FIRST USE 3-25-2003; IN COMMERCE 3-25-2003.
MICHAEL TANNER, EXAMINING ATTORNEY

SN 77-520,186. NTRD INC., MAMMOTH LAKES, CA. FILED 7-11-2008.



THE MARK CONSISTS OF A GENERALLY DIAMOND SHAPED ROAD SIGN WITH A DEPICTION OF AN OCCUPIED MOTOR VEHICLE BEING SPRAYED BY A SHOWER-HEAD FRAMED BY A BORDER.

FOR VEHICLE, WATERCRAFT, AND AIRCRAFT CLEANING, WASHING, AND DETAILING SERVICES (U.S. CLS. 100, 103 AND 106).

JOHN DALIER, EXAMINING ATTORNEY

SN 77-522,223. DRH HOLDINGS (AUSTRALIA) LTD., COOK ISLANDS, AUSTRALIA, FILED 7-15-2008.

DAVID REID HOMES

THE MARK CONSISTS OF STANDARD CHARACTERS WITHOUT CLAIM TO ANY PARTICULAR FONT, STYLE, SIZE, OR COLOR.

OWNER OF AUSTRALIA REG. NO. 1026671, DATED 10-25-2004, EXPIRES 10-25-2014.

NO CLAIM IS MADE TO THE EXCLUSIVE RIGHT TO USE "HOMES", APART FROM THE MARK AS SHOWN.

THE NAME "DAVID REID" IDENTIFIES A LIVING INDIVIDUAL WHOSE CONSENT IS OF RECORD.

FOR BUILDING CONSTRUCTION, CONSTRUCTION PLANNING, REAL ESTATE DEVELOPMENT AND ERECTION OF RESIDENTIAL DWELLINGS (U.S. CLS. 100, 103 AND 106).

HANNO RITTNER, EXAMINING ATTORNEY

CLASS 37—(Continued).

SN 77-535,820. LINCOLN COMMERCIAL CONSTRUCTION LLC, PORTLAND, OR. FILED 7-31-2008.



NO CLAIM IS MADE TO THE EXCLUSIVE RIGHT TO USE "COMMERCIAL CONSTRUCTION", APART FROM THE MARK AS SHOWN.

THE COLOR(S) GOLD, BLACK, AND WHITE IS/ARE CLAIMED AS A FEATURE OF THE MARK.

THE MARK CONSISTS OF A WHITE WITH BLACK SHADOWING LETTER "L" DEPICTED IN THREE DIMENSIONS OVER A GOLD RECTANGLE WITH A GOLD ARC TO THE LEFT AND CONTINUING PARTIALLY TO THE RIGHT, ALL ABOVE THE BLACK WORDS "LINCOLN COMMERCIAL CONSTRUCTION".

FOR BUILDING CONSTRUCTION, REMODELING AND REPAIR (U.S. CLS. 100, 103 AND 106).

FIRST USE 5-22-2008; IN COMMERCE 5-22-2008.
CHRISTINA SOBRAL, EXAMINING ATTORNEY

CLASS 37—(Continued).

SN 77-540,953. CROCKER GROUP CORP., SANTA BARBARA, CA. FILED 8-6-2008.



SN 77-540,250. THOMAS FLINT LANDSCAPE DESIGN & DEVELOPMENT LLC, RAMSEY, NJ. FILED 8-6-2008.



NO CLAIM IS MADE TO THE EXCLUSIVE RIGHT TO USE "LANDSCAPE DESIGN AND DEVELOPMENT", APART FROM THE MARK AS SHOWN.

THE NAME SHOWN IN THE MARK IDENTIFIES "THOMAS FLINT" WHOSE CONSENT IS OF RECORD.

THE MARK CONSISTS OF THE STYLIZED TEXT "THOMAS" AND "FLINT" WITH A MAN HOLDING A SHOVEL STANDING ON SHADOWED EARTH IN BETWEEN. BELOW THEM IS THE STYLIZED TEXT "LANDSCAPE DESIGN & DEVELOPMENT".

FOR CUSTOM CONSTRUCTION OF OUTDOOR STRUCTURES IN THE NATURE OF STONEMASONRY, RETAINING WALLS, PATIOS AND WALKWAYS (U.S. CLS. 100, 103 AND 106).

FIRST USE 5-0-2004; IN COMMERCE 5-0-2004.
LINDA MICKLEBURGH, EXAMINING ATTORNEY

NO CLAIM IS MADE TO THE EXCLUSIVE RIGHT TO USE "COOL", APART FROM THE MARK AS SHOWN.

THE MARK CONSISTS OF A BEAR ON A BLOCK OF ICE THAT APPEARS TO BE MELTING WITH THE WORDS "THINK COOL" ON THE BLOCK OF ICE.

FOR AIR CONDITIONING CONTRACTOR SERVICES; AIR DUCT CLEANING SERVICES; BOILER CLEANING AND REPAIR; BURNER MAINTENANCE OR REPAIR; FURNACE INSTALLATION AND REPAIR; HEATING CONTRACTOR SERVICES; HEATING EQUIPMENT INSTALLATION AND REPAIR; INSTALLATION AND REPAIR OF AIR CONDITIONING APPARATUS; INSTALLATION OF REFRIGERATION SYSTEMS, AIR CONDITIONING SYSTEMS, AND HEATING APPLICATIONS, NAMELY, GAS FURNACES, ELECTRIC HEAT PUMPS, ELECTRIC STRIP HEATERS, AND BOILERS; INSTALLATION, MAINTENANCE AND REPAIR OF REFRIGERATION SYSTEMS, AIR CONDITIONING SYSTEMS, AND HEATING APPLICATIONS, NAMELY, GAS FURNACES, ELECTRIC HEAT PUMPS, ELECTRIC STRIP HEATERS, AND BOILERS; INSTALLATION, REPAIR AND MAINTENANCE OF HEATING EQUIPMENT; MAINTENANCE AND REPAIR OF HEATING INSTALLATIONS; REPAIR AND INSTALLATION SERVICES, NAMELY, THE INSTALLATION OF HEATING, COOLING AND ENVIRONMENTAL CONTROL SYSTEMS PRIMARILY USING SOLAR ENERGY, RENEWABLE ENERGY RESOURCES AND RAINWATER; REPAIR OR MAINTENANCE OF AIR-CONDITIONING APPARATUS (U.S. CLS. 100, 103 AND 106).

FIRST USE 12-10-2002; IN COMMERCE 12-10-2002.
NAPOLEON SHARMA, EXAMINING ATTORNEY

CLASS 37—(Continued).

SN 77-562,957. FP IPROPERTIES LLC, BLUE SPRINGS, MO. FILED 9-5-2008.

REO RESQ

THE MARK CONSISTS OF STANDARD CHARACTERS WITHOUT CLAIM TO ANY PARTICULAR FONT, STYLE, SIZE, OR COLOR.

NO CLAIM IS MADE TO THE EXCLUSIVE RIGHT TO USE "REO", APART FROM THE MARK AS SHOWN.

FOR REAL ESTATE MAINTENANCE SERVICES, NAMELY, WEATHERPROOFING, PROPERTY SECURING, NAMELY, BOARDING UP OF WINDOWS AND INSTALLING OF LOCKS, WINTERIZATION AND PROPERTY PRESERVATION WORK; BUILDING REPAIR AND MAINTENANCE SERVICES, HANDYMAN SERVICES, NAMELY, BUILDING REPAIR AND MAINTENANCE, CARPENTRY SERVICES, AND MASONRY SERVICES, PROPERTY PRESERVATION SERVICES, NAMELY, BUILDING WEATHERPROOFING, SNOW REMOVAL, DEBRIS REMOVAL, NAMELY, TRASH COLLECTION, JANITORIAL SERVICES, BUILDING DEMOLITION, SET UP AND REPAIR OF LOCKS, BOARDING OF BUILDINGS, SWIMMING POOL MAINTENANCE, NAMELY, SWIMMING POOL COVERING AND SECURING, ROOF TARPING, MAID SERVICE, PRESSURE WASHING, CARPET CLEANING AND EMERGENCY MAINTENANCE, NAMELY, REPAIR OF HAZARDOUS CONDITIONS (U.S. CLS. 100, 103 AND 106).

PRISCILLA MILTON, EXAMINING ATTORNEY

SN 77-563,474. BLUE DIAMOND VENTURE, LLC, LAS VEGAS, NV. FILED 9-5-2008.

EXPO CITY

THE MARK CONSISTS OF STANDARD CHARACTERS WITHOUT CLAIM TO ANY PARTICULAR FONT, STYLE, SIZE, OR COLOR.

NO CLAIM IS MADE TO THE EXCLUSIVE RIGHT TO USE "EXPO", APART FROM THE MARK AS SHOWN.

FOR REAL ESTATE DEVELOPMENT, NAMELY, SITE SELECTION, CONSTRUCTION PLANNING, CONSTRUCTION MANAGEMENT AND SUPERVISION, AND CONSTRUCTION SERVICES, NAMELY, PLANNING, LAYING OUT AND CONSTRUCTION OF TRADE SHOWROOM, CONFERENCE, EXHIBITION AND MEETING FACILITIES (U.S. CLS. 100, 103 AND 106).

CHRISTINA SOBRAL, EXAMINING ATTORNEY

CLASS 37—(Continued).

SN 77-575,069. VERHOFF, JOHN PAUL, CAPE CORAL, FL. FILED 9-21-2008.

iplumber

THE MARK CONSISTS OF STANDARD CHARACTERS WITHOUT CLAIM TO ANY PARTICULAR FONT, STYLE, SIZE, OR COLOR.

FOR PLUMBING; PLUMBING AND GAS AND WATER INSTALLATION; PLUMBING CONTRACTOR SERVICES; PLUMBING SERVICES (U.S. CLS. 100, 103 AND 106).

FIRST USE 9-19-2008; IN COMMERCE 9-19-2008.
DAVID ELTON, EXAMINING ATTORNEY

SN 77-595,642. BAY HILL AUTO DETAIL, INC., DBA BAY HILL AUTO DETAIL, ORLANDO, FL. FILED 10-18-2008.



NO CLAIM IS MADE TO THE EXCLUSIVE RIGHT TO USE "BAY HILL AUTO DETAIL", APART FROM THE MARK AS SHOWN.

THE MARK CONSISTS OF THE WORDS "BAY HILL AUTO DETAIL" AND A FLAG AND FLAG POLE DESIGN. FOR AUTOMOBILE CLEANING AND CAR WASHING (U.S. CLS. 100, 103 AND 106).

FIRST USE 8-22-2007; IN COMMERCE 8-22-2007.
DOUGLAS LEE, EXAMINING ATTORNEY

SN 77-598,602. PAPAGIANNIS, RENA M., DBA CINDERELLA'S DAY JOB, SANTA FE, NM. FILED 10-22-2008.

Cinderella's Day Job

THE COLOR(S) PINK IS/ARE CLAIMED AS A FEATURE OF THE MARK.

THE MARK CONSISTS OF STYLIZED LETTERING "CINDERELLA'S DAY JOB" IN THE COLOR PINK. FOR CLEANING RESIDENTIAL AND COMMERCIAL BUILDINGS (U.S. CLS. 100, 103 AND 106).

FIRST USE 9-1-2004; IN COMMERCE 9-1-2004.
JAY BESCH, EXAMINING ATTORNEY

CLASS 37—(Continued).

SN 77-631,374. SIKES, KEVIN, SEATTLE, WA. FILED 12-11-2008.

Green Revolution

THE MARK CONSISTS OF STANDARD CHARACTERS WITHOUT CLAIM TO ANY PARTICULAR FONT, STYLE, SIZE, OR COLOR.

NO CLAIM IS MADE TO THE EXCLUSIVE RIGHT TO USE "GREEN", APART FROM THE MARK AS SHOWN. FOR ENERGY EFFICIENT REMODELING OF HOMES AND BUILDINGS (U.S. CLS. 100, 103 AND 106). FIRST USE 3-31-2006; IN COMMERCE 3-31-2006. MARK SHINER, EXAMINING ATTORNEY

SN 77-634,159. E. OSBORNE SMITH, INC., NEW YORK, NY. FILED 12-16-2008.

**E. OSBORNE SMITH
DEVELOPMENT CORP**

THE MARK CONSISTS OF STANDARD CHARACTERS WITHOUT CLAIM TO ANY PARTICULAR FONT, STYLE, SIZE, OR COLOR.

NO CLAIM IS MADE TO THE EXCLUSIVE RIGHT TO USE "DEVELOPMENT CORP", APART FROM THE MARK AS SHOWN.

THE NAME(S), PORTRAIT(S), AND/OR SIGNATURE(S) SHOWN IN THE MARK DOES NOT IDENTIFY A PARTICULAR LIVING INDIVIDUAL.

FOR REAL ESTATE DEVELOPMENT (U.S. CLS. 100, 103 AND 106).

FIRST USE 0-0-1997, THE MARK WAS FIRST USED ANYWHERE IN A DIFFERENT FORM OTHER THAN THAT SOUGHT TO BE REGISTERED ON 00/00/1933; IN COMMERCE 0-0-1997, THE MARK WAS FIRST USED IN COMMERCE IN A DIFFERENT FORM OTHER THAN THAT SOUGHT TO BE REGISTERED ON 00/00/1933. CHERYL CLAYTON, EXAMINING ATTORNEY

CLASS 37—(Continued).

SN 77-637,218. GREEN LADY CLEANING, LLC., DOWNERS GROVE, IL. FILED 12-19-2008.



NO CLAIM IS MADE TO THE EXCLUSIVE RIGHT TO USE "GREEN" AND "CLEANING", APART FROM THE MARK AS SHOWN.

THE STIPPLING IS FOR SHADING PURPOSES ONLY. THE MARK CONSISTS OF THE STYLIZED WORDS "GREEN LADY C.L.E.A.N.I.N.G". IN BETWEEN THE WORDS "GREEN" AND "LADY" IS AN IMAGE OF A PLANT SPROUTING OUT OF A VACUUM.

FOR CLEANING OF INDUSTRIAL PREMISES; CLEANING OF RESIDENTIAL HOUSES (U.S. CLS. 100, 103 AND 106). DEZMONA MIZELLE, EXAMINING ATTORNEY

SN 77-644,872. SERVICEMASTER BRANDS L.L.C., BURLINGTON, VT. FILED 1-7-2009.



NO CLAIM IS MADE TO THE EXCLUSIVE RIGHT TO USE "HEALTHCARE ENVIRONMENTAL SERVICES PROVIDER", APART FROM THE MARK AS SHOWN.

THE MARK CONSISTS OF A CAPITAL LETTER "H" WITH THE CROSS MEMBER OF "H" EXTENDING THROUGH THE LEFT SIDE OF THE LETTER, WITH THE WORDS "HEALTHCARE ENVIRONMENTAL SERVICES PROVIDER" ADJACENT TO THE RIGHT SIDE OF THE SYLIZED LETTER "H".

FOR COMMERCIAL BUILDING CLEANING SERVICES; JANITORIAL SERVICES; WINDOW, CARPET, FLOOR AND FURNITURE CLEANING SERVICES (U.S. CLS. 100, 103 AND 106).

FIRST USE 7-22-2008; IN COMMERCE 7-22-2008. MATTHEW KLINE, EXAMINING ATTORNEY

CLASS 37—(Continued).

SN 77-645,672. LUCKENBAUGH, INC., DBA ANDY'S AUTOMOTIVE SERVICE:ANDREW LUCKENBAUGH, RED LION, PA. FILED 1-8-2009.



NO CLAIM IS MADE TO THE EXCLUSIVE RIGHT TO USE "AUTOMOTIVE SERVICE WE SERVICE IMPORT & DOMESTIC VEHICLES", APART FROM THE MARK AS SHOWN.

THE COLOR(S) BLACK, WHITE, GRAY AND RED IS/ARE CLAIMED AS A FEATURE OF THE MARK.

THE MARK CONSISTS OF A BLACK OUTLINE OF A VEHICLE WITH THE FRONT AND BACK WINDOWS OUTLINED IN BLACK. "ANDY'S" APPEARS IN RED CURSIVE BLOCK LETTERING STRAIGHT AND BELOW THE WINDOWS. BELOW THE WORD "ANDY'S" ARE SIMPLE STANDARD BLACK LETTERS WITH THE WORDS "AUTOMOTIVE SERVICE" WITH A SHORT THIN RED LINE JUST BEFORE THE WORD "AUTOMOTIVE", AND A SHORT THIN RED LINE IMMEDIATELY AFTER THE WORD "SERVICE". ON THE NEXT LINE, JUST BELOW, ARE SMALLER BLACK LETTERS WHICH SAY, "WE SERVICE IMPORT & DOMESTIC VEHICLES". TO THE FAR LEFT ON THE NEXT LINE ARE THE WORDS "BE SAFE" IN RED CAPITAL LETTERS, FOLLOWED JUST BELOW THE "AFE" IN "SAFE" IS THE SENTENCE "FEEL GOOD ABOUT YOUR CAR." IN BLACK CURSIVE LETTERS DIAGONALLY ACROSS THE BOTTOM OF THE INSIDE ON THE CAR, UNDERLINED WITH A RED LINE THAT IS THICK IN THE BEGINNING AND THINS OUT TOWARDS THE END OF THE SENTENCE. BELOW THE VEHICLE IS A GRAYISH SHADOW OF THE BOTTOM OF THE VEHICLE.

FOR REPAIR AND MAINTENANCE OF VEHICLES (U.S. CLS. 100, 103 AND 106).

FIRST USE 8-7-2008; IN COMMERCE 8-7-2008.
ESTHER BELENKER, EXAMINING ATTORNEY

SN 77-647,316. ACHTWO, LLC, ORANGE, TX. FILED 1-12-2009.

ACHTWO

THE MARK CONSISTS OF STANDARD CHARACTERS WITHOUT CLAIM TO ANY PARTICULAR FONT, STYLE, SIZE, OR COLOR.

THE WORDING "ACHTWO" HAS NO MEANING IN A FOREIGN LANGUAGE.

FOR SWIMMING POOL MAINTENANCE (U.S. CLS. 100, 103 AND 106).

FIRST USE 1-29-2008; IN COMMERCE 1-29-2008.
SEAN CROWLEY, EXAMINING ATTORNEY

CLASS 37—(Continued).

SN 77-653,502. PRO-AIR SERVICES, INC., DECATUR, AL. FILED 1-21-2009.

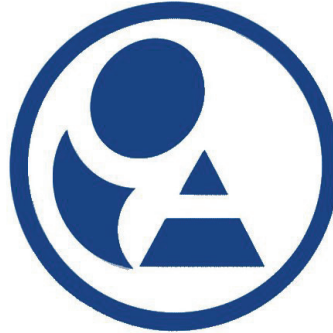

THE COLOR(S) BLUE AND WHITE IS/ARE CLAIMED AS A FEATURE OF THE MARK.

THE MARK CONSISTS OF THE ARTISTIC RENDERING OF THE BLUE LETTERS "P" AND "A" INSIDE A CIRCLE OUTLINED IN BLUE AND FILLED IN WHITE. THE TOP OF THE LETTER "P" IS REPRESENTED BY A SOLID BLUE CIRCLE AND THE BOTTOM BY A BLUE PIE-SHAPED FIGURE WITH CURVED SIDES, WITH THE TOP AND BOTTOM OF THE "P" HAVING A WHITE SPACE BETWEEN THEM. THE LETTER "A" IS REPRESENTED BY A SMALL BLUE TRIANGLE ABOVE A BLUE TRAPEZOID, WITH A WHITE SPACE IN BETWEEN THEM REPRESENTING THE CROSS-BAR OF THE "A".

FOR HVAC CONTRACTOR SERVICES; INSTALLATION, REPAIR, AND MAINTENANCE OF AIR CONDITIONING APPARATUS; INSTALLATION, REPAIR, AND MAINTENANCE OF HEATING EQUIPMENT; MECHANICAL CONTRACTOR SERVICES; INSTALLATION, MAINTENANCE, AND REPAIR OF REFRIGERATION APPARATUS, AND OF FREEZING MACHINES (U.S. CLS. 100, 103 AND 106).

FIRST USE 11-30-1993; IN COMMERCE 11-30-1993.
BRIAN CALLAGHAN, EXAMINING ATTORNEY

SN 77-654,689. BLUE CANYON SOLUTIONS, LLC, LOUISVILLE, KY. FILED 1-22-2009.

BLUE CANYON FOUNDATION EXPERTS

THE MARK CONSISTS OF STANDARD CHARACTERS WITHOUT CLAIM TO ANY PARTICULAR FONT, STYLE, SIZE, OR COLOR.

OWNER OF U.S. REG. NOS. 3,569,828 AND 3,575,579.

NO CLAIM IS MADE TO THE EXCLUSIVE RIGHT TO USE "FOUNDATION EXPERTS", APART FROM THE MARK AS SHOWN.

FOR FOUNDATION, CHIMNEY, FOOTER, PORCH STOOP, SLAB FLOOR, AND WALL REPAIR SERVICES; CONSULTATION SERVICES IN THE FIELDS OF FOUNDATION, CHIMNEY, FOOTER, PORCH STOOP, SLAB FLOOR, AND WALL REPAIR (U.S. CLS. 100, 103 AND 106).

FIRST USE 2-15-2008; IN COMMERCE 2-15-2008.
NAKIA HENRY, EXAMINING ATTORNEY

CLASS 37—(Continued).

SN 77-655,030. BLUE CANYON SOLUTIONS, LLC, LOUISVILLE, KY. FILED 1-23-2009.



OWNER OF U.S. REG. NOS. 3,569,828 AND 3,575,579.
NO CLAIM IS MADE TO THE EXCLUSIVE RIGHT TO USE "FOUNDATION EXPERTS", APART FROM THE MARK AS SHOWN.

THE COLOR(S) BLUE, YELLOW AND WHITE IS/ARE CLAIMED AS A FEATURE OF THE MARK.

THE MARK CONSISTS OF "BLUE CANYON FOUNDATION EXPERTS" APPEARING WITHIN AN OUTER OVAL DESIGN, AND AN INNER OVAL DESIGN DEPICTING THE SKY, MOUNTAINS, AND A RIVER. IN THE INNER OVAL DESIGN, THE MOUNTAINS ARE DEPICTED IN SHADES OF BLUE; THE SKY IS BLUE WITH LIGHT BLUE CLOUDS; AND THE RIVER IS BLUE WITH LIGHT BLUE ACCENTS DEPICTING SUNLIGHT REFLECTING OFF THE WATER AND DARK BLUE ACCENTS DEPICTING SHADOWS ON THE WATER. THE OUTER OVAL DESIGN IS BLUE TRIMMED WITH YELLOW; THE INNER OVAL DESIGN IS OUTLINED IN YELLOW; THE TWO CIRCLES SEPARATING "BLUE CANYON" AND "FOUNDATION EXPERTS" ARE YELLOW; AND THE WORDING "BLUE CANYON FOUNDATION EXPERTS" IS WHITE.

FOR FOUNDATION, CHIMNEY, FOOTER, PORCH STOOP, SLAB FLOOR, AND WALL REPAIR SERVICES; CONSULTATION SERVICES IN THE FIELDS OF FOUNDATION, CHIMNEY, FOOTER, PORCH STOOP, SLAB FLOOR, AND WALL REPAIR (U.S. CLS. 100, 103 AND 106).

FIRST USE 2-15-2008; IN COMMERCE 2-15-2008.
NAKIA HENRY, EXAMINING ATTORNEY

CLASS 37—(Continued).

SN 77-658,417. ERTL JR., RON, LOUISVILLE, OH. FILED 1-28-2009.



NO CLAIM IS MADE TO THE EXCLUSIVE RIGHT TO USE "FURNACE", APART FROM THE MARK AS SHOWN. THE STIPPLING IS FOR SHADING PURPOSES ONLY.

THE MARK CONSISTS OF A PERSON WEARING A UNIFORM WITH THE STYLIZED TEXT "RON" ON HIS UNIFORM. HE IS ALSO WEARING A HAT WITH THE STYLIZED TEXT "RON". ON HIS RIGHT HAND HE IS HOLDING A WRENCH AND A TOOL BOX ON HIS LEFT HAND WITH THE STYLIZED TEXT "FURNACE MAN".

FOR FURNACE INSTALLATION AND REPAIR; INSTALLATION AND REPAIR OF AIR CONDITIONING APPARATUS (U.S. CLS. 100, 103 AND 106).

FIRST USE 7-9-2005; IN COMMERCE 7-9-2005.
MARK SHINER, EXAMINING ATTORNEY

SN 77-657,125. KOHLER, NATHAN, A, DBA DENT PATROL, BLACK DIAMOND, WA. FILED 1-27-2009.

Dent Patrol

THE MARK CONSISTS OF STANDARD CHARACTERS WITHOUT CLAIM TO ANY PARTICULAR FONT, STYLE, SIZE, OR COLOR.

NO CLAIM IS MADE TO THE EXCLUSIVE RIGHT TO USE "DENT", APART FROM THE MARK AS SHOWN.

FOR AUTOMOBILE BODY REPAIR AND FINISHING FOR OTHERS (U.S. CLS. 100, 103 AND 106).

FIRST USE 5-30-2008; IN COMMERCE 5-30-2008.
INGRID C. EULIN, EXAMINING ATTORNEY

SN 77-661,275. DAL PEZZO ENTERPRISES, LLC, DBA ELEVON, FRESNO, CA. FILED 2-2-2009.

ELEVON, A DAL PEZZO COMPANY

THE MARK CONSISTS OF STANDARD CHARACTERS WITHOUT CLAIM TO ANY PARTICULAR FONT, STYLE, SIZE, OR COLOR.

NO CLAIM IS MADE TO THE EXCLUSIVE RIGHT TO USE "COMPANY", APART FROM THE MARK AS SHOWN.

FOR REAL ESTATE DEVELOPMENT; REAL ESTATE DEVELOPMENT AND CONSTRUCTION OF COMMERCIAL, RESIDENTIAL AND HOTEL PROPERTY; REAL ESTATE SITE SELECTION (U.S. CLS. 100, 103 AND 106).

LINDA LAVACHE, EXAMINING ATTORNEY

CLASS 37—(Continued).

SN 77-661,283. DAL PEZZO ENTERPRISES, LLC, DBA ELEVON, FRESNO, CA. FILED 2-2-2009.

*Taking businesses
to new heights.*



NO CLAIM IS MADE TO THE EXCLUSIVE RIGHT TO USE "COMPANY", APART FROM THE MARK AS SHOWN.

THE MARK CONSISTS OF THE WORD "ELEVON" WITH AN ACCENT MARK OVER THE "L" AND THE RIGHT DIAGONAL OF THE "V" FORMED BY AN ARC EXTENDING UPWARDS TOWARDS THE WORDS "TAKING BUSINESSES TO NEW HEIGHTS." AND THE WORDS "A DAL PEZZO COMPANY" BELOW.

FOR REAL ESTATE DEVELOPMENT; REAL ESTATE DEVELOPMENT AND CONSTRUCTION OF COMMERCIAL, RESIDENTIAL AND HOTEL PROPERTY; REAL ESTATE SITE SELECTION (U.S. CLS. 100, 103 AND 106). LINDA LAVACHE, EXAMINING ATTORNEY

SN 77-661,383. BRITE STARS, LLC, NEW ORLEANS, LA. FILED 2-2-2009.

FERNCLIFF

THE MARK CONSISTS OF STANDARD CHARACTERS WITHOUT CLAIM TO ANY PARTICULAR FONT, STYLE, SIZE, OR COLOR.

FOR REAL ESTATE DEVELOPMENT SERVICES, NAMELY, DEVELOPING AN INDUSTRIAL PARK (U.S. CLS. 100, 103 AND 106). LINDA ESTRADA, EXAMINING ATTORNEY

SN 77-661,437. RACINE INDUSTRIES, INC., RACINE, WI. FILED 2-2-2009.

STRATEGEM

THE MARK CONSISTS OF STANDARD CHARACTERS WITHOUT CLAIM TO ANY PARTICULAR FONT, STYLE, SIZE, OR COLOR.

FOR CARPET-MAINTENANCE SERVICES (U.S. CLS. 100, 103 AND 106). FIRST USE 2-3-2009; IN COMMERCE 2-3-2009. GIANCARLO CASTRO, EXAMINING ATTORNEY

CLASS 37—(Continued).

SN 77-662,742. FORCE PROTECTION INDUSTRIES, INC., LADSON, SC. FILED 2-3-2009.

FORCE PROTECTION

THE MARK CONSISTS OF STANDARD CHARACTERS WITHOUT CLAIM TO ANY PARTICULAR FONT, STYLE, SIZE, OR COLOR.

OWNER OF U.S. REG. NOS. 3,508,175, 3,508,224 AND 3,508,526.

FOR VEHICLE REPAIR AND MAINTENANCE (U.S. CLS. 100, 103 AND 106).

FIRST USE 9-30-2008; IN COMMERCE 9-30-2008. DAVID ELTON, EXAMINING ATTORNEY

SN 77-662,758. FORCE PROTECTION INDUSTRIES, INC., LADSON, SC. FILED 2-3-2009.



OWNER OF U.S. REG. NOS. 3,508,175, 3,508,224 AND 3,508,526.

THE MARK CONSISTS OF TWO ARROWS FACING EACH OTHER WITH THE POINTS OVERLAPPING, THE LEFT ARROW HAVING THE DESIGN OF A NUT AND BOLT AND THE WORD "FORCE" IN UPPER CASE LETTERING AND THE RIGHT ARROW HAVING THE DESIGN OF A NUT AND BOLT AND THE WORD "PROTECTION" IN UPPER CASE LETTERING; AND THE POINTS OF THE ARROWS ARE IN FRONT OF A CIRCLE HAVING TRIANGULAR DESIGNS MADE UP OF LINES IN THE MIDDLE OF THE CIRCLE.

FOR VEHICLE REPAIR AND MAINTENANCE (U.S. CLS. 100, 103 AND 106).

FIRST USE 9-30-2008; IN COMMERCE 9-30-2008. DAVID ELTON, EXAMINING ATTORNEY

SN 77-662,971. WASTECAP WISCONSIN, INC., MILWAUKEE, WI. FILED 2-4-2009.

WASTECAP DIRECT

THE MARK CONSISTS OF STANDARD CHARACTERS WITHOUT CLAIM TO ANY PARTICULAR FONT, STYLE, SIZE, OR COLOR.

FOR ONLINE SEARCHABLE DATABASE OF HAULERS, PROCESSORS AND END-MARKET USERS OF CONSTRUCTION AND DEMOLITION DEBRIS (U.S. CLS. 100, 103 AND 106).

FIRST USE 4-0-2008; IN COMMERCE 4-0-2008. MARK T. MULLEN, EXAMINING ATTORNEY

CLASS 37—(Continued).

SN 77-663,316. MARTIN ENGINEERING COMPANY, NE-
PONSET, IL. FILED 2-4-2009.

MARTINPLUS

THE MARK CONSISTS OF STANDARD CHARACTERS
WITHOUT CLAIM TO ANY PARTICULAR FONT, STYLE,
SIZE, OR COLOR.

OWNER OF U.S. REG. NOS. 1,716,523, 2,179,983 AND
OTHERS.

FOR MAINTENANCE SERVICES FOR BULK STO-
RAGE SILOS AND HOPPERS (U.S. CLS. 100, 103 AND
106).

PAUL MORENO, EXAMINING ATTORNEY

SN 77-664,174. BANNER HEALTH, PHOENIX, AZ. FILED 2-
5-2009.

ENTECH

THE MARK CONSISTS OF STANDARD CHARACTERS
WITHOUT CLAIM TO ANY PARTICULAR FONT, STYLE,
SIZE, OR COLOR.

FOR MAINTENANCE, REPAIR AND INSTALLATION
OF MEDICAL DIAGNOSTIC EQUIPMENT, HEALTH
CARE EQUIPMENT, MEDICAL IMAGING EQUIPMENT,
RESPIRATORY THERAPY EQUIPMENT AND COMMU-
NICATIONS EQUIPMENT IN THE HEALTHCARE IN-
DUSTRY (U.S. CLS. 100, 103 AND 106).

FIRST USE 2-28-2001; IN COMMERCE 2-28-2001.
MAYUR VAGHANI, EXAMINING ATTORNEY

SN 77-664,466. BUFFINGTON CAPITAL HOMES, LTD.,
AUSTIN, TX. FILED 2-5-2009.



NO CLAIM IS MADE TO THE EXCLUSIVE RIGHT TO
USE "SIGNATURE HOMES", APART FROM THE MARK AS
SHOWN.

THE MARK CONSISTS OF A CURSIVE "B" WHICH IS
OVER THE WORDS "BUFFINGTON" WHICH IS ON TOP OF
THE WORDS "SIGNATURE HOMES".

FOR CONSTRUCTION SERVICES, NAMELY, PLAN-
NING, LAYING OUT AND CONSTRUCTION OF RESI-
DENTIAL HOMES AND COMMUNITIES (U.S. CLS. 100,
103 AND 106).

FIRST USE 11-26-2007; IN COMMERCE 11-26-2007.
TOBY BULLOFF, EXAMINING ATTORNEY

CLASS 37—(Continued).

SN 77-664,491. BUFFINGTON CAPITAL HOMES, LTD.,
AUSTIN, TX. FILED 2-5-2009.

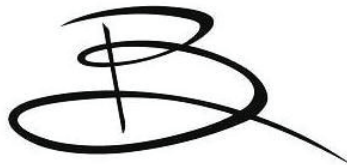

THE MARK CONSISTS OF A STYLIZED B.
FOR CONSTRUCTION SERVICES, NAMELY, PLAN-
NING, LAYING OUT AND CONSTRUCTION OF RESI-
DENTIAL HOMES AND COMMUNITIES (U.S. CLS. 100,
103 AND 106).

FIRST USE 11-26-2007; IN COMMERCE 11-26-2007.
TOBY BULLOFF, EXAMINING ATTORNEY

SN 77-664,528. MURPHY BROS. BUILDING & REMODEL-
ING CO., BLAINE, MN. FILED 2-5-2009.



NO CLAIM IS MADE TO THE EXCLUSIVE RIGHT TO
USE "BATH", APART FROM THE MARK AS SHOWN.

THE MARK CONSISTS OF THE WORDING "7 DAY
BATH" AND DESIGNS. THE DESIGNS CONSIST OF STY-
LIZED LINES UNDER THE WORDS "DAY" AND "BATH"
RESPECTIVELY THAT CREATE A STYLIZED APPEAR-
ANCE OF A BATH TUB.

FOR REMODELING OF BATHROOMS LOCATED IN
RESIDENCES AND/OR COMMERCIAL BUILDINGS
(U.S. CLS. 100, 103 AND 106).

FIRST USE 1-8-2009; IN COMMERCE 1-8-2009.
CORY BOONE, EXAMINING ATTORNEY

SN 77-664,555. LAURENCE-HOVENIER, INC., CORONA, CA.
FILED 2-5-2009.

Building with the Finest Components

THE MARK CONSISTS OF STANDARD CHARACTERS
WITHOUT CLAIM TO ANY PARTICULAR FONT, STYLE,
SIZE, OR COLOR.

FOR CONSTRUCTION SERVICES, NAMELY, PLAN-
NING, LAYING OUT AND CUSTOM CONSTRUCTION
OF RESIDENTIAL AND COMMERCIAL COMMU-
NITIES: HOUSING SERVICES, NAMELY, REPAIR, IMP-
ROVEMENT, AND CONSTRUCTION OF
RESIDENTIAL REAL PROPERTY (U.S. CLS. 100, 103
AND 106).

FIRST USE 12-1-1999; IN COMMERCE 12-1-1999.
TARAH HARDY, EXAMINING ATTORNEY

CLASS 37—(Continued).

SN 77-665,549. GEARHART CONSTRUCTION SERVICES, ASHBURN, VA. FILED 2-6-2009.

CLASS 37—(Continued).

SN 77-666,527. CORKY'S PEST CONTROL, INC., SAN MARCOS, CA. FILED 2-9-2009.

**Building greener today for
a better tomorrow**

CORKY'S PEST CONTROL

THE MARK CONSISTS OF STANDARD CHARACTERS WITHOUT CLAIM TO ANY PARTICULAR FONT, STYLE, SIZE, OR COLOR.

FOR CONSULTING IN THE FIELD OF BUILDING CONSTRUCTION; COMMERCIAL BUILDING CONSTRUCTION; GENERAL CONSTRUCTION CONTRACTING SERVICES (U.S. CLS. 100, 103 AND 106).

FIRST USE 3-0-2007; IN COMMERCE 4-0-2007.
NATALIE POLZER, EXAMINING ATTORNEY

THE MARK CONSISTS OF STANDARD CHARACTERS WITHOUT CLAIM TO ANY PARTICULAR FONT, STYLE, SIZE, OR COLOR.

OWNER OF U.S. REG. NO. 2,360,215.
NO CLAIM IS MADE TO THE EXCLUSIVE RIGHT TO USE "PEST CONTROL", APART FROM THE MARK AS SHOWN.

FOR TERMITE AND PEST CONTROL SERVICES; HOME AND LANDSCAPE INSECTICIDE AND FERTILIZER SPRAYING (U.S. CLS. 100, 103 AND 106).

FIRST USE 3-31-1974; IN COMMERCE 3-31-1974.
KEVIN DINALLO, EXAMINING ATTORNEY

SN 77-665,676. WAY PUNG, ORANGE, CT. FILED 2-7-2009.

Ohsokeen

SN 77-666,664. J3 EXCAVATION COMPANY, LLC, KERRVILLE, TX. FILED 2-9-2009.

THE MARK CONSISTS OF STANDARD CHARACTERS WITHOUT CLAIM TO ANY PARTICULAR FONT, STYLE, SIZE, OR COLOR.

FOR HOUSING SERVICES, NAMELY, REPAIR, IMPROVEMENT, AND CONSTRUCTION OF RESIDENTIAL REAL PROPERTY (U.S. CLS. 100, 103 AND 106).

WILLIAM VERHOSEK, EXAMINING ATTORNEY

J3

SN 77-666,487. CORKY'S PEST CONTROL, INC., SAN MARCOS, CA. FILED 2-9-2009.

CORKY'S

THE MARK CONSISTS OF STANDARD CHARACTERS WITHOUT CLAIM TO ANY PARTICULAR FONT, STYLE, SIZE, OR COLOR.

OWNER OF U.S. REG. NO. 2,360,215.
FOR TERMITE AND PEST CONTROL SERVICES; HOME AND LANDSCAPE INSECTICIDE AND FERTILIZER SPRAYING (U.S. CLS. 100, 103 AND 106).

FIRST USE 3-31-1974; IN COMMERCE 3-31-1974.
KEVIN DINALLO, EXAMINING ATTORNEY

THE MARK CONSISTS OF STANDARD CHARACTERS WITHOUT CLAIM TO ANY PARTICULAR FONT, STYLE, SIZE, OR COLOR.

FOR CONSTRUCTION SERVICES, NAMELY, CONSTRUCTION OF ROADS, UNDERGROUND UTILITIES, AND HOUSING PADS; EXCAVATION SERVICES (U.S. CLS. 100, 103 AND 106).

FIRST USE 2-12-2008; IN COMMERCE 2-12-2008.
INGA ERVIN, EXAMINING ATTORNEY

CLASS 37—(Continued).

SN 77-666,727. LAURENCE-HOVENIER, INC., CORONA, CA.
FILED 2-9-2009.

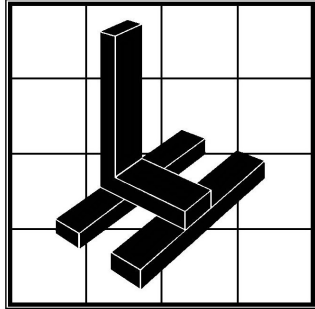

THE MARK CONSISTS OF THE STYLIZED LETTERS "LH". THE LETTER "L" SITS ON TOP OF THE LETTER "H". BEHIND THE LETTERS IS AN OUTLINED SQUARE CONTAINING VERTICAL AND HORIZONTAL LINES FORMING SMALLER BOXES WITHIN THE LARGER SQUARE.

FOR ROUGH CARPENTRY SUBCONTRACTING SERVICES (U.S. CLS. 100, 103 AND 106).

FIRST USE 3-9-1999; IN COMMERCE 3-9-1999.
TARAH HARDY, EXAMINING ATTORNEY

SN 77-688,559. FLUID MANAGEMENT, INC., WHEELING, IL. FILED 3-11-2009.

FMDirect

THE MARK CONSISTS OF STANDARD CHARACTERS WITHOUT CLAIM TO ANY PARTICULAR FONT, STYLE, SIZE, OR COLOR.

FOR REPAIR AND MAINTENANCE SERVICES FOR MACHINERY USED IN TINTING, MIXING AND METERING DEVICES (U.S. CLS. 100, 103 AND 106).

FIRST USE 1-30-2004; IN COMMERCE 1-30-2004.
MATTHEW PAPPAS, EXAMINING ATTORNEY

SN 79-064,475. RUF GRUPPE AG, SWITZERLAND, FILED 10-31-2008.

RUF

THE MARK CONSISTS OF STANDARD CHARACTERS WITHOUT CLAIM TO ANY PARTICULAR FONT, STYLE, SIZE, OR COLOR.

OWNER OF INTERNATIONAL REGISTRATION 0805377 DATED 6-6-2003, EXPIRES 6-6-2013.

OWNER OF U.S. REG. NOS. 3,256,658 AND 3,256,671. THE ENGLISH TRANSLATION OF "RUF" IS "CALL". FOR INSTALLATION, REPAIR AND MAINTENANCE OF COMPUTERS (U.S. CLS. 100, 103 AND 106).
RENEE SERVANCE, EXAMINING ATTORNEY

CLASS 38—COMMUNICATION

SN 77-313,340. GROUP KAITU, LLC, RICHMOND, VA.
FILED 10-25-2007.

THE EROS GUIDE

THE MARK CONSISTS OF STANDARD CHARACTERS WITHOUT CLAIM TO ANY PARTICULAR FONT, STYLE, SIZE, OR COLOR.

OWNER OF U.S. REG. NOS. 2,549,369, 3,134,894 AND OTHERS.

NO CLAIM IS MADE TO THE EXCLUSIVE RIGHT TO USE "GUIDE", APART FROM THE MARK AS SHOWN.

FOR PROVIDING ONLINE CHAT ROOMS AND ELECTRONIC BULLETIN BOARDS FOR TRANSMISSIONS OF MESSAGES AMONG USERS IN THE FIELDS OF ADULT THEMED TOPICS, PRODUCTS, SERVICES AND ENTERTAINMENT; MOBILE MEDIA SERVICES IN THE NATURE OF ELECTRONIC TRANSMISSIONS OF ADULT THEMED TOPICS, PRODUCTS, SERVICES AND ENTERTAINMENT; STREAMING OF AUDIO AND VIDEO MATERIAL ON THE INTERNET (U.S. CLS. 100, 101 AND 104).

LEIGH LOWRY, EXAMINING ATTORNEY

SN 77-354,542. OCC ESTABLISHMENT, FL-9490 VADUZ, LIECHTENSTEIN, FILED 12-18-2007.



THE MARK CONSISTS OF ARABIC CHARACTERS. THE NON-LATIN CHARACTER(S) IN THE MARK TRANSLITERATE INTO AL SAFWA, AND THIS MEANS "THE ELITE" IN ENGLISH.

FOR TELEVISION BROADCASTING SERVICES (U.S. CLS. 100, 101 AND 104).
APRIL ROACH, EXAMINING ATTORNEY

CLASS 38—(Continued).

SN 77-355,697. INTER123 CORPORATION, LAS VEGAS, NV. FILED 12-19-2007.

DEMAND

THE MARK CONSISTS OF STANDARD CHARACTERS WITHOUT CLAIM TO ANY PARTICULAR FONT, STYLE, SIZE, OR COLOR.

FOR ONLINE CHAT ROOM AND BULLETIN BOARDS FOR TRANSMISSION OF MESSAGES AMONG USERS CONCERNING FINANCIAL MATTERS (U.S. CLS. 100, 101 AND 104).

DAVID YONTEF, EXAMINING ATTORNEY

SN 77-485,937. URBACH, JULIAN M., SHERMAN OAKS, CA. FILED 5-29-2008.

OTOY

THE MARK CONSISTS OF STANDARD CHARACTERS WITHOUT CLAIM TO ANY PARTICULAR FONT, STYLE, SIZE, OR COLOR.

FOR PROVIDING MULTIPLE-USER ACCESS TO A GLOBAL COMPUTER INFORMATION NETWORK; ELECTRONIC TRANSMISSION OF DIGITAL FILES, NAMELY, SHARING FILES AMONG COMPUTER USERS VIA COMMUNICATIONS NETWORKS AND VIA PEER TO PEER NETWORKING AND TRANSMISSION OF PEER-TO-PEER NETWORKING AND FILE SHARING INFORMATION VIA COMMUNICATIONS NETWORKS; SHARING INFORMATION AND FILES, NAMELY, AUDIO, VIDEO AND AUDIO-VIDEO FILES VIA COMMUNICATIONS NETWORKS; STREAMING OF AUDIO AND STREAMING OF VIDEO MATERIAL ON THE INTERNET AND WIRELESS DEVICES (U.S. CLS. 100, 101 AND 104).

AMOS T. MATTHEWS, JR., EXAMINING ATTORNEY

SN 77-493,705. IHISPANO.COM, LLC, CHICAGO, IL. FILED 6-8-2008.



NO CLAIM IS MADE TO THE EXCLUSIVE RIGHT TO USE "THE BLACK PROFESSIONAL NETWORKING COMMUNITY", APART FROM THE MARK AS SHOWN.

FOR PROVIDING ON-LINE ELECTRONIC BULLETIN BOARDS FOR TRANSMISSION OF MESSAGES AMONG COMPUTER USERS CONCERNING EMPLOYMENT OPPORTUNITIES AND PROFESSIONAL DEVELOPMENT; PROVIDING ON-LINE FORUMS FOR TRANSMISSION OF MESSAGES AMONG COMPUTER USERS CONCERNING EMPLOYMENT OPPORTUNITIES AND PROFESSIONAL DEVELOPMENT (U.S. CLS. 100, 101 AND 104).

FIRST USE 5-15-2008; IN COMMERCE 5-15-2008.
KATHERINE CHANG, EXAMINING ATTORNEY

CLASS 38—(Continued).

SN 77-519,028. FAMILYNET, LLC, ATLANTA, GA. FILED 7-10-2008.

FAMILYNET

THE MARK CONSISTS OF STANDARD CHARACTERS WITHOUT CLAIM TO ANY PARTICULAR FONT, STYLE, SIZE, OR COLOR.

OWNER OF U.S. REG. NO. 1,518,324. SEC. 2(F).
FOR RADIO BROADCASTING SERVICES (U.S. CLS. 100, 101 AND 104).
FIRST USE 11-10-2005; IN COMMERCE 11-10-2005.
LAURIE MAYES, EXAMINING ATTORNEY

SN 77-522,260. TIME WARNER CABLE INC., STAMFORD, CT. FILED 7-15-2008.



NO CLAIM IS MADE TO THE EXCLUSIVE RIGHT TO USE "CAROLINA" AND "ON DEMAND", APART FROM THE MARK AS SHOWN.

THE MARK CONSISTS OF THE WORDS "CAROLINA HOMES ON DEMAND" WITHIN A GRAPHIC OUTLINE OF A HOUSE FORM SHOWING THE ROOF AND THE LETTER "H" AS THE CHIMNEY; ALSO, A DEPICTION OF A PLAY BUTTON AS SEEN ON REMOTE CONTROLS FOR AUDIO-VISUAL DEVICES IS SHOWN.

FOR VIDEO-ON-DEMAND CABLE TELEVISION TRANSMISSION SERVICES (U.S. CLS. 100, 101 AND 104).
FIRST USE 12-0-2006; IN COMMERCE 12-0-2006.
MARTHA FROMM, EXAMINING ATTORNEY

SN 77-524,781. QWELL TECHNOLOGIES, LLC, LOS ANGELES, CA. FILED 7-17-2008.

QWELL

THE MARK CONSISTS OF STANDARD CHARACTERS WITHOUT CLAIM TO ANY PARTICULAR FONT, STYLE, SIZE, OR COLOR.

FOR COMMUNICATION BY ELECTRONIC COMPUTER TERMINALS; COMMUNICATION BY MOBILE TELEPHONE; FIXED AND MOBILE TELEPHONE SERVICES; INFORMATION TRANSMISSION VIA ELECTRONIC COMMUNICATIONS NETWORKS; VOICE MAIL SERVICES (U.S. CLS. 100, 101 AND 104).

RICHARD A. STRASER, EXAMINING ATTORNEY

CLASS 38—(Continued).

SN 77-525,014. GLOBAL HEALTHCARE EXCHANGE, LLC,
LOUISVILLE, CO. FILED 7-17-2008.

G-FAX

THE MARK CONSISTS OF STANDARD CHARACTERS
WITHOUT CLAIM TO ANY PARTICULAR FONT, STYLE,
SIZE, OR COLOR.

FOR BUSINESS AUTOMATION SERVICES, NAMELY,
ELECTRONIC DATA INTERCHANGE (EDI) SERVICES
FOR USE IN THE HEALTHCARE INDUSTRY (U.S. CLS.
100, 101 AND 104).

GINA FINK, EXAMINING ATTORNEY

CLASS 38—(Continued).

SN 77-554,043. WHAT ARE KIDS SAYING LLC, LONE TREE,
CO. FILED 8-22-2008.

SN 77-527,444. MITCHELL P. DAVIS, TA BROADCAST
INTERVIEW SOURCE, WASHINGTON, DC. FILED 7-21-
2008.

INTERVIEWNET

THE MARK CONSISTS OF STANDARD CHARACTERS
WITHOUT CLAIM TO ANY PARTICULAR FONT, STYLE,
SIZE, OR COLOR.

SEC. 2(F).

FOR TELECOMMUNICATIONS SERVICES, NAMELY,
PROVIDING AN ONLINE INTERACTIVE FORUM FOR
THE TRANSMISSION OF MESSAGES BETWEEN JOUR-
NALISTS AND THEIR SOURCES (U.S. CLS. 100, 101
AND 104).

FIRST USE 2-0-2004; IN COMMERCE 2-0-2004.

KIM MONINGHOFF, EXAMINING ATTORNEY



SN 77-552,974. WHAT ARE KIDS SAYING LLC, LONE TREE,
CO. FILED 8-21-2008.

WHAT ARE KIDS SAYING.COM

THE MARK CONSISTS OF STANDARD CHARACTERS
WITHOUT CLAIM TO ANY PARTICULAR FONT, STYLE,
SIZE, OR COLOR.

FOR PROVIDING A WEBSITE IN THE NATURE OF A
CHAT ROOM OR ELECTRONIC BULLETIN BOARD
FOR THE TRANSMISSION OF MESSAGES AMONG
USERS THAT GIVES CHILDREN THE ABILITY TO
COMMUNICATE THEIR THOUGHTS AND FEELINGS
ON A WIDE VARIETY OF TOPICS OF GENERAL
INTEREST (U.S. CLS. 100, 101 AND 104).

JEFFREY LOOK, EXAMINING ATTORNEY

THE MARK CONSISTS OF A QUESTION MARK WITHIN
A SHADED CIRCULAR BACKGROUND.

FOR PROVIDING A WEBSITE IN THE NATURE OF A
CHAT ROOM OR ELECTRONIC BULLETIN BOARD
FOR THE TRANSMISSIONS OF MESSAGES AMONG
USERS THAT GIVES CHILDREN THE ABILITY TO
COMMUNICATE THEIR THOUGHTS AND FEELINGS
ON A WIDE VARIETY OF TOPICS OF GENERAL
INTEREST (U.S. CLS. 100, 101 AND 104).

JEFFREY LOOK, EXAMINING ATTORNEY

CLASS 38—(Continued).

SN 77-559,804. UNSIGNED MUSICIANS, LLC, BOYNTON BEACH, FL. FILED 9-1-2008.



NO CLAIM IS MADE TO THE EXCLUSIVE RIGHT TO USE "UNSIGNEDMUSICIANS.COM", APART FROM THE MARK AS SHOWN.

THE COLOR(S) RED, BLACK, WHITE AND GRAY IS/ ARE CLAIMED AS A FEATURE OF THE MARK.

THE MARK CONSISTS OF A GUITAR THAT CONTAINS THE WORDS "UNSIGNED", THE LETTER "S" IN THE WORD IS FORMED FROM THE BOTTOM PART OF THE GUITAR AND IS PART OF THE DESIGN THAT FORMS THE MARK. THE BODY OF THE GUITAR IS RED AND WORDS "UNSIGNED MUSICIANS.COM" IN BLACK WITH EXCEPTION OF "S" LETTER IN RED. THE STRINGS ARE IN GRAY.

FOR PROVIDING ON-LINE CHAT ROOMS AND ELECTRONIC BULLETIN BOARDS FOR TRANSMISSION OF MESSAGES AMONG USERS IN THE FIELD OF GENERAL INTEREST; PROVIDING EMAIL AND INSTANT MESSAGING SERVICES; TEXT AND NUMERIC WIRELESS DIGITAL MESSAGING SERVICES; PROVIDING MULTIPLE-USER ACCESS TO A GLOBAL COMPUTER INFORMATION NETWORK FOR THE TRANSFER AND DISSEMINATION OF A WIDE RANGE OF INFORMATION AND SERVICES, AND FOR ACCESSING THIRD PARTY AND PROPRIETARY WEBSITES; COMMUNICATION SERVICES, NAMELY, TRANSMISSION OF VOICE, AUDIO, VISUAL IMAGES AND DATA BY TELECOMMUNICATIONS NETWORKS, WIRELESS COMMUNICATION NETWORKS, THE INTERNET, INFORMATION SERVICES NETWORKS AND DATA NETWORKS; STREAMING AUDIO AND VIDEO MATERIAL ON THE INTERNET; VIDEO-ON-DEMAND TRANSMISSION SERVICES; PROVIDING VOICE COMMUNICATION SERVICES OVER THE INTERNET; PROVIDING ON-LINE FACILITIES FOR REAL-TIME INTERACTION WITH OTHER COMPUTER USERS CONCERNING TOPICS OF GENERAL INTEREST AND PLAYING GAMES; PODCASTING SERVICES; WEBCASTING SERVICES (U.S. CLS. 100, 101 AND 104).

ANGELA M. MICHELI, EXAMINING ATTORNEY

SN 77-595,820. WEAZ-FM RADIO, INC., BALA CYNWYD, PA. FILED 10-20-2008.

PHILADELPHIA'S SOFT ROCK

THE MARK CONSISTS OF STANDARD CHARACTERS WITHOUT CLAIM TO ANY PARTICULAR FONT, STYLE, SIZE, OR COLOR.

SEC. 2(F).
FOR PROVIDING RADIO BROADCASTING SERVICES (U.S. CLS. 100, 101 AND 104).

FIRST USE 3-31-2003; IN COMMERCE 3-31-2003.
HELENE LIWINSKI, EXAMINING ATTORNEY

CLASS 38—(Continued).

SN 77-597,098. WEAZ-FM RADIO, INC., BALA CYNWYD, PA. FILED 10-21-2008.

**PHILADELPHIA'S SOFT ROCK
STATION**

THE MARK CONSISTS OF STANDARD CHARACTERS WITHOUT CLAIM TO ANY PARTICULAR FONT, STYLE, SIZE, OR COLOR.

NO CLAIM IS MADE TO THE EXCLUSIVE RIGHT TO USE "SOFT ROCK STATION", APART FROM THE MARK AS SHOWN.

SEC. 2(F).
FOR PROVIDING RADIO BROADCASTING SERVICES (U.S. CLS. 100, 101 AND 104).

FIRST USE 3-31-2003; IN COMMERCE 3-31-2003.
HELENE LIWINSKI, EXAMINING ATTORNEY

SN 77-634,705. JBN, LLC, HANOVER, PA. FILED 12-17-2008.

VIDEO ROCKS

THE MARK CONSISTS OF STANDARD CHARACTERS WITHOUT CLAIM TO ANY PARTICULAR FONT, STYLE, SIZE, OR COLOR.

NO CLAIM IS MADE TO THE EXCLUSIVE RIGHT TO USE "VIDEO", APART FROM THE MARK AS SHOWN.

FOR DISTRIBUTION, NAMELY, TRANSMISSION VIA A THE INTERNET OF INSTRUCTIONAL HOW-TO VIDEO RECORDINGS IN DIGITAL FORMAT FEATURING INSTRUCTION OF A VARIETY OF TOPICS FOR ONLINE VIEWING OR DOWNLOADING (U.S. CLS. 100, 101 AND 104).

MARY ROSSMAN, EXAMINING ATTORNEY

SN 77-649,921. PROCTOR FINANCIAL, INC., TROY, MI. FILED 1-15-2009.

**IIM INTELLIGENT INSURANCE
MANAGER**

THE MARK CONSISTS OF STANDARD CHARACTERS WITHOUT CLAIM TO ANY PARTICULAR FONT, STYLE, SIZE, OR COLOR.

NO CLAIM IS MADE TO THE EXCLUSIVE RIGHT TO USE "INSURANCE", APART FROM THE MARK AS SHOWN.

FOR PROVIDING ACCESS TO ONLINE DATABASES FEATURING ELECTRONICALLY STORED COMMUNICATIONS, INFORMATION AND DOCUMENTS IN THE FIELD OF INSURANCE (U.S. CLS. 100, 101 AND 104).

CHRISTOPHER BUONGIORNO, EXAMINING ATTORNEY

CLASS 38—(Continued).

SN 77-662,018. TEXAS PUBLIC RADIO, SAN ANTONIO, TX.
FILED 2-3-2009.



OWNER OF U.S. REG. NO. 3,111,844.
NO CLAIM IS MADE TO THE EXCLUSIVE RIGHT TO USE "CLASSICAL" AND "88.3", APART FROM THE MARK AS SHOWN.

THE COLOR(S) BLUE, WHITE AND BLACK IS/ARE CLAIMED AS A FEATURE OF THE MARK.

THE MARK CONSISTS OF A VERTICALLY-ORIENTED RECTANGLE IN WHICH APPEAR IN WHITE, THE CALL LETTERS "KPAC" AND THE NUMBER "88.3", REPRESENTING AN FM RADIO FREQUENCY IN MEGAHERTZ, WITH THE DECIMAL EXPRESSED AS A STAR, ON A BLUE BACKGROUND THAT GRADATES IN SHADE FROM LIGHTER TO DARKER, FROM RIGHT TO LEFT, AND WITH CONCENTRIC CIRCLES EMANATING FROM THE STAR-DECIMAL. BELOW THIS APPEAR IN WHITE LETTERS ON BLACK BACKGROUND THE WORDS "CLASSICAL OASIS".

FOR RADIO BROADCASTING AND STREAMING OF AUDIO MATERIAL ON THE INTERNET (U.S. CLS. 100, 101 AND 104).

FIRST USE 4-30-2008; IN COMMERCE 4-30-2008.
CAROLINE WOOD, EXAMINING ATTORNEY

SN 77-662,042. TEXAS PUBLIC RADIO, SAN ANTONIO, TX.
FILED 2-3-2009.



OWNER OF U.S. REG. NO. 3,111,845.
NO CLAIM IS MADE TO THE EXCLUSIVE RIGHT TO USE "89.1", APART FROM THE MARK AS SHOWN.

THE COLOR(S) GREEN, WHITE AND BLACK IS/ARE CLAIMED AS A FEATURE OF THE MARK.

THE MARK CONSISTS OF A VERTICALLY-ORIENTED

CLASS 38—(Continued).

RECTANGLE IN WHICH APPEAR IN WHITE, THE CALL LETTERS "KSTX" AND THE NUMBER 89.1, REPRESENTING AN FM RADIO FREQUENCY IN MEGAHERTZ, WITH THE DECIMAL EXPRESSED AS A STAR, ON A GREEN BACKGROUND THAT GRADATES IN SHADE FROM LIGHTER TO DARKER, FROM RIGHT TO LEFT, AND WITH CONCENTRIC CIRCLES EMANATING FROM THE STAR-DECIMAL. BELOW THIS APPEAR IN WHITE LETTERS ON BLACK BACKGROUND THE WORDS "NEWS & VIEWS".

FOR RADIO BROADCASTING AND STREAMING OF AUDIO MATERIAL ON THE INTERNET (U.S. CLS. 100, 101 AND 104).

FIRST USE 4-30-2008; IN COMMERCE 4-30-2008.
CAROLINE WOOD, EXAMINING ATTORNEY

SN 77-662,164. TEXAS PUBLIC RADIO, SAN ANTONIO, TX.
FILED 2-3-2009.



OWNER OF U.S. REG. NO. 3,114,178.
NO CLAIM IS MADE TO THE EXCLUSIVE RIGHT TO USE "90.1", APART FROM THE MARK AS SHOWN.

THE COLOR(S) RED, WHITE AND BLACK IS/ARE CLAIMED AS A FEATURE OF THE MARK.

THE MARK CONSISTS OF A VERTICALLY-ORIENTED RECTANGLE IN WHICH APPEAR IN WHITE, THE CALL LETTERS "KTXI" AND THE NUMBER "90.1", REPRESENTING AN FM RADIO FREQUENCY IN MEGAHERTZ, WITH THE DECIMAL EXPRESSED AS A STAR, ON A RED BACKGROUND THAT GRADATES IN SHADE FROM LIGHTER TO DARKER, FROM RIGHT TO LEFT, AND WITH CONCENTRIC CIRCLES EMANATING FROM THE STAR-DECIMAL. BELOW THIS APPEAR IN WHITE LETTERS ON BLACK BACKGROUND THE WORDS "WORDS & MUSIC".

FOR RADIO BROADCASTING AND STREAMING OF AUDIO MATERIAL ON THE INTERNET (U.S. CLS. 100, 101 AND 104).

FIRST USE 4-30-2008; IN COMMERCE 4-30-2008.
CAROLINE WOOD, EXAMINING ATTORNEY

CLASS 38—(Continued).

SN 77-662,175. TEXAS PUBLIC RADIO, SAN ANTONIO, TX. FILED 2-3-2009.

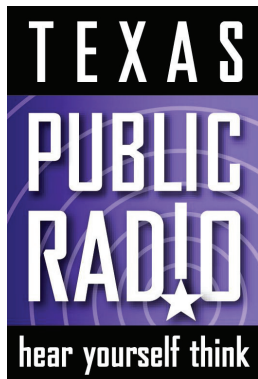

NO CLAIM IS MADE TO THE EXCLUSIVE RIGHT TO USE "TEXAS PUBLIC RADIO", APART FROM THE MARK AS SHOWN.

THE COLOR(S) PURPLE, WHITE AND BLACK IS/ARE CLAIMED AS A FEATURE OF THE MARK.

THE MARK CONSISTS OF A VERTICALLY-ORIENTED RECTANGLE IN WHICH APPEAR IN WHITE, THE WORDS "TEXAS PUBLIC RADIO HEAR YOURSELF THINK". THE WORD "TEXAS" APPEARS ON A BLACK BACKGROUND. BELOW THIS THE WORDS "PUBLIC RADIO" APPEAR ON A PURPLE BACKGROUND THAT GRADATES IN SHADE FROM LIGHTER TO DARKER, FROM RIGHT TO LEFT, AND THE "I" IN "RADIO" IS SUPERSCRIBED ABOVE A STAR FROM WHICH CONCENTRIC CIRCLES EMANATE. BELOW THIS APPEAR IN WHITE LETTERS ON BLACK BACKGROUND THE WORDS "HEAR YOURSELF THINK".

FOR RADIO BROADCASTING AND STREAMING OF AUDIO MATERIAL ON THE INTERNET (U.S. CLS. 100, 101 AND 104).

FIRST USE 4-30-2008; IN COMMERCE 4-30-2008. CAROLINE WOOD, EXAMINING ATTORNEY

CLASS 38—(Continued).

SN 77-662,669. PC LANDING CORP., SAN FRANCISCO, CA. FILED 2-3-2009.

PACIFIC CROSSING

THE MARK CONSISTS OF STANDARD CHARACTERS WITHOUT CLAIM TO ANY PARTICULAR FONT, STYLE, SIZE, OR COLOR.

FOR TELECOMMUNICATIONS SERVICES, NAMELY, PROVIDING TRANSMISSION OF VOICE, VIDEO AND DATA VIA A FIBER OPTIC NETWORK (U.S. CLS. 100, 101 AND 104).

FIRST USE 1-1-2006; IN COMMERCE 1-1-2006. LESLIE RICHARDS, EXAMINING ATTORNEY

SN 77-663,062. IMON COMMUNICATIONS LLC, CEDAR RAPIDS, IA. FILED 2-4-2009.



SN 77-662,667. PC LANDING CORP., SAN FRANCISCO, CA. FILED 2-3-2009.



PACIFIC CROSSING

THE MARK CONSISTS OF THE WORDS "PACIFIC CROSSING" APPEARING BELOW A DESIGN CONSISTING OF SMALL CIRCLES ARRANGED IN A PATTERN TO FORM TWO SQUARES ROTATED AND CONNECTING IN THE CENTER.

FOR TELECOMMUNICATIONS SERVICES, NAMELY, PROVIDING TRANSMISSION OF VOICE, VIDEO AND DATA VIA A FIBER OPTIC NETWORK (U.S. CLS. 100, 101 AND 104).

FIRST USE 11-1-2006; IN COMMERCE 11-1-2006. LESLIE RICHARDS, EXAMINING ATTORNEY

THE COLOR(S) GREEN AND BLUE IS/ARE CLAIMED AS A FEATURE OF THE MARK.

THE MARK CONSISTS OF THE LETTERS "IMON" IN THE COLOR KNOWN AS PANTONE REFLEX BLUE WITHIN A NEARLY COMPLETE ELLIPSE OF THE COLOR KNOWN AS PANTONE 368 GREEN.

FOR CABLE TELEVISION BROADCASTING; INTERNET SERVICE PROVIDER; TELECOMMUNICATION SERVICES, NAMELY, LOCAL AND LONG DISTANCE TRANSMISSION OF VOICE, DATA, GRAPHICS AND VIDEO BY MEANS OF BROADBAND, COPPER AND OPTICAL OR WIRELESS NETWORKS; TELECOMMUNICATION SERVICES, NAMELY, PROVIDING INTERNET ACCESS VIA BROADBAND OPTICAL OR WIRELESS NETWORKS (U.S. CLS. 100, 101 AND 104).

FIRST USE 3-9-2007; IN COMMERCE 3-9-2007. ROSELLE HERRERA, EXAMINING ATTORNEY

CLASS 38—(Continued).

SN 77-663,376. PROCTOR FINANCIAL, INC., TROY, MI.
FILED 2-4-2009.



NO CLAIM IS MADE TO THE EXCLUSIVE RIGHT TO USE "INSURANCE", APART FROM THE MARK AS SHOWN.

THE MARK CONSISTS OF A SHADED CIRCLE INSIDE OF WHICH APPEARS THE LETTERS "IIM" IN A STYLIZED AND DOWNWARD STAGGERED FORMAT; ON THE CIRCUMFERENCE OF THE CIRCLE APPEAR THE WORDS "INTELLIGENT INSURANCE MANAGER", EACH TERM SEPARATED BY SHADED DOTS.

FOR PROVIDING ACCESS TO ONLINE DATABASES FEATURING ELECTRONICALLY STORED COMMUNICATIONS, INFORMATION AND DOCUMENTS IN THE FIELD OF INSURANCE (U.S. CLS. 100, 101 AND 104).

CHRISTOPHER BUONGIORNO, EXAMINING ATTORNEY

SN 77-664,110. THE TELX GROUP, INC., NEW YORK, NY.
FILED 2-5-2009.

TELX|VISION

THE MARK CONSISTS OF STANDARD CHARACTERS WITHOUT CLAIM TO ANY PARTICULAR FONT, STYLE, SIZE, OR COLOR.

OWNER OF U.S. REG. NO. 2,653,237.

FOR BROADCASTING SERVICES AND PROVISION OF TELECOMMUNICATION ACCESS TO VIDEO AND AUDIO CONTENT PROVIDED VIA A VIDEO-ON-DEMAND SERVICE VIA THE INTERNET (U.S. CLS. 100, 101 AND 104).

FIRST USE 6-0-2006; IN COMMERCE 6-0-2006.

JEAN IM, EXAMINING ATTORNEY

CLASS 38—(Continued).

SN 77-664,219. INTEGRICOM, INC., BUFORD, GA. FILED 2-5-2009.

INTEGRICOM

THE MARK CONSISTS OF STANDARD CHARACTERS WITHOUT CLAIM TO ANY PARTICULAR FONT, STYLE, SIZE, OR COLOR.

OWNER OF U.S. REG. NO. 2,682,433.

FOR PROVIDING AN INTERFACE TO TELECOMMUNICATIONS CONNECTIONS TO A GLOBAL COMPUTER NETWORK, NAMELY, PROVIDING AN INTERFACE TO TELECOMMUNICATIONS SERVICE PROVIDER; PROVIDING MULTIPLE-USER ACCESS TO A GLOBAL COMPUTER NETWORK, NAMELY, PROVIDING AN INTERFACE TO TELECOMMUNICATIONS SERVICE PROVIDER; AND VOICE OVER INTERNET PROTOCOL (VOIP) SERVICES (U.S. CLS. 100, 101 AND 104).

FIRST USE 3-0-2000; IN COMMERCE 3-0-2000.

MATTHEW PAPPAS, EXAMINING ATTORNEY

SN 77-664,623. PREVENTION PLUS, INC., SAVAGE, MN.
FILED 2-5-2009.

Resource52

THE MARK CONSISTS OF STANDARD CHARACTERS WITHOUT CLAIM TO ANY PARTICULAR FONT, STYLE, SIZE, OR COLOR.

FOR DELIVERY OF MESSAGES BY ELECTRONIC TRANSMISSION (U.S. CLS. 100, 101 AND 104).

FIRST USE 4-20-2008; IN COMMERCE 7-1-2008.

KIMBERLY FRYE, EXAMINING ATTORNEY

SN 77-664,703. KIRUSA INC., NEW PROVIDENCE, NJ.
FILED 2-5-2009.

KV.SMS

THE MARK CONSISTS OF STANDARD CHARACTERS WITHOUT CLAIM TO ANY PARTICULAR FONT, STYLE, SIZE, OR COLOR.

FOR AUTOMATED TELEPHONE VOICE MESSAGE SERVICES; ELECTRONIC VOICE MESSAGING, NAMELY, THE RECORDING AND SUBSEQUENT TRANSMISSION OF VOICE MESSAGES BY TELEPHONE; ELECTRONIC, ELECTRIC, AND DIGITAL TRANSMISSION OF VOICE, DATA, IMAGES, SIGNALS, AND MESSAGES; MESSAGE SENDING AND RECEIVING SERVICES; PROVISION OF VOICE SHORT MESSAGE SERVICES (VSMS) (U.S. CLS. 100, 101 AND 104).

FIRST USE 12-28-2004; IN COMMERCE 12-11-2006.

JAY BESCH, EXAMINING ATTORNEY

CLASS 38—(Continued).

SN 77-666,510. SHARECARE, LLC, ATLANTA, GA. FILED 2-9-2009.

SHARE CARE

THE MARK CONSISTS OF STANDARD CHARACTERS WITHOUT CLAIM TO ANY PARTICULAR FONT, STYLE, SIZE, OR COLOR.

FOR COMMUNICATIONS SERVICES, NAMELY, TRANSMITTING STREAMED SOUND AND AUDIO-VISUAL RECORDINGS VIA THE INTERNET, CABLE NETWORKS, WIRELESS NETWORKS, SATELLITE, OR INTERACTIVE MULTIMEDIA NETWORKS; AUDIO AND VIDEO BROADCASTING SERVICES OVER THE INTERNET; TRANSMISSION OF INFORMATION IN THE AUDIO-VISUAL FIELD; RADIO AND TELEVISION BROADCASTING SERVICES; CABLE TELEVISION BROADCASTING; CABLE RADIO BROADCASTING; SATELLITE TELEVISION BROADCASTING; MOBILE MEDIA SERVICES IN THE NATURE OF ELECTRONIC TRANSMISSION OF ENTERTAINMENT MEDIA CONTENT; PODCASTING SERVICES; WEBCASTING SERVICES; VIDEO-ON-DEMAND TRANSMISSION SERVICES; PROVIDING ON-LINE CHAT ROOMS AND ELECTRONIC BULLETIN BOARDS FOR TRANSMISSION OF MESSAGES AMONG USERS IN THE FIELD OF GENERAL INTEREST (U.S. CLS. 100, 101 AND 104).
ANDREW RHIM, EXAMINING ATTORNEY

CLASS 38—(Continued).

SN 77-669,215. ECHOSTAR TECHNOLOGIES L.L.C., ENGLEWOOD, CO. FILED 2-12-2009.

ECHOSTAR

THE MARK CONSISTS OF STANDARD CHARACTERS WITHOUT CLAIM TO ANY PARTICULAR FONT, STYLE, SIZE, OR COLOR.

FOR TRANSMITTING VIDEO, IMAGE, AUDIO AND DATA INFORMATION VIA SATELLITE, CABLE, WIRELESS, INTERNET, FIBER OPTICS, AND COMPUTER NETWORKS; STREAMING OF AUDIO AND VIDEO MATERIAL ON THE INTERNET; INFORMATION TRANSMISSION VIA ELECTRONIC COMMUNICATIONS NETWORKS; AUDIO AND VIDEO BROADCASTING SERVICES OVER THE INTERNET OR OTHER COMMUNICATIONS NETWORKS; PROVIDING ACCESS TO ELECTRONIC SITES FEATURING INFORMATION, AUDIO AND VIDEO VIA WEBSITES, ONLINE FORUMS, CHAT ROOMS, ELECTRONIC MAILING LISTS AND BLOGS; PROVIDING ON-LINE CHAT ROOMS AND ELECTRONIC BULLETIN BOARDS FOR TRANSMISSION OF MESSAGES AMONG USERS IN THE FIELDS OF ENTERTAINMENT AND GENERAL INTEREST; SATELLITE COMMUNICATION SERVICES; SATELLITE TELEVISION BROADCASTING; SATELLITE TRANSMISSION SERVICES; TELECOMMUNICATION SERVICES, NAMELY, TRANSMISSION OF VIDEO, IMAGE, AUDIO, AND DATA INFORMATION VIA TELEVISION, SATELLITE, CABLE, WIRELESS, FIBER OPTICS, AUDIO AND VIDEO MEDIA, AND GLOBAL COMPUTER NETWORKS; TRANSMISSION OF TELEVISION BROADCASTING SERVICES VIA COMMUNICATION SATELLITES; TELEVISION TRANSMISSION SERVICES; TELEVISION BROADCASTING; BROADCASTING OF TELEVISION PROGRAMS; BROADCAST OF CABLE TELEVISION PROGRAMS (U.S. CLS. 100, 101 AND 104).
JOHN WILKE, EXAMINING ATTORNEY

SN 77-666,695. VICTORIA JOHNSTON, DBA VICTORIA'S SEDUCTION, SAN DIEGO, CA. AND RUSS EGGLESTON, DBA VICTORIA'S SEDUCTION, SAN DIEGO, CA. FILED 2-9-2009.

Victoria's Seduction

THE MARK CONSISTS OF STANDARD CHARACTERS WITHOUT CLAIM TO ANY PARTICULAR FONT, STYLE, SIZE, OR COLOR.

FOR ELECTRONIC DELIVERY OF IMAGES, PHOTOGRAPHS, ART, GRAPHIC IMAGES AND GRAPHIC DESIGN, NAMELY, NUDE PHOTOS AND BODYSAPES VIA A GLOBAL COMPUTER NETWORK (U.S. CLS. 100, 101 AND 104).

FIRST USE 1-1-2009; IN COMMERCE 1-1-2009.
EMILY CARLSEN, EXAMINING ATTORNEY

CLASS 38—(Continued).

SN 77-669,219. ECHOSTAR TECHNOLOGIES L.L.C., ENGLEWOOD, CO. FILED 2-12-2009.



THE COLOR(S) RED AND BLACK IS/ARE CLAIMED AS A FEATURE OF THE MARK.

THE MARK CONSISTS OF THE WORD "ECHOSTAR" IN A STYLIZED FORMAT, WITH THE COLOR OF THE MARK TRANSITIONING FROM RED AT THE TOP TO BLACK AT THE BOTTOM.

FOR TRANSMITTING VIDEO, IMAGE, AUDIO AND DATA INFORMATION VIA SATELLITE, CABLE, WIRELESS, INTERNET, FIBER OPTICS, AND COMPUTER NETWORKS; STREAMING OF AUDIO AND VIDEO MATERIAL ON THE INTERNET; INFORMATION TRANSMISSION VIA ELECTRONIC COMMUNICATIONS NETWORKS; AUDIO AND VIDEO BROADCASTING SERVICES OVER THE INTERNET OR OTHER COMMUNICATIONS NETWORKS; PROVIDING ACCESS TO ELECTRONIC SITES FEATURING INFORMATION, AUDIO AND VIDEO VIA WEBSITES, ONLINE FORUMS, CHAT ROOMS, ELECTRONIC MAILING LISTS AND BLOGS; PROVIDING ON-LINE CHAT ROOMS AND ELECTRONIC BULLETIN BOARDS FOR TRANSMISSION OF MESSAGES AMONG USERS IN THE FIELDS OF ENTERTAINMENT AND GENERAL INTEREST; SATELLITE COMMUNICATION SERVICES; SATELLITE TELEVISION BROADCASTING; SATELLITE TRANSMISSION SERVICES; TELECOMMUNICATION SERVICES, NAMELY, TRANSMISSION OF VIDEO, IMAGE, AUDIO, AND DATA INFORMATION VIA TELEVISION, SATELLITE, CABLE, WIRELESS, FIBER OPTICS, AUDIO AND VIDEO MEDIA, AND GLOBAL COMPUTER NETWORKS; TRANSMISSION OF TELEVISION BROADCASTING SERVICES VIA COMMUNICATION SATELLITES; TELEVISION TRANSMISSION SERVICES; TELEVISION BROADCASTING; BROADCASTING OF TELEVISION PROGRAMS; BROADCAST OF CABLE TELEVISION PROGRAMS (U.S. CLS. 100, 101 AND 104).
JOHN WILKE, EXAMINING ATTORNEY

SN 78-619,924. PACKETPOINTE VOIP SERVICES OF UTAH, SALT LAKE CITY, UT. FILED 4-29-2005.



THE MARK CONSISTS OF STANDARD CHARACTERS WITHOUT CLAIM TO ANY PARTICULAR FONT, STYLE, SIZE, OR COLOR.

FOR VOICE OVER INTERNET PROTOCOL (VOIP) SERVICES; TELECOMMUNICATION SERVICES, NAMELY, LOCAL AND LONG DISTANCE TRANSMISSION OF VOICE, DATA, GRAPHICS BY MEANS OF TELEPHONE, TELEGRAPHIC, CABLE, AND SATELLITE TRANSMISSIONS; INTERNET TELEPHONY SERVICES (U.S. CLS. 100, 101 AND 104).

FIRST USE 4-21-2005; IN COMMERCE 4-21-2005.
SEAN CROWLEY, EXAMINING ATTORNEY

CLASS 39—TRANSPORTATION AND STORAGE

SN 77-146,325. GLOBALSTOR DATA CORPORATION, CHATSWORTH, CA. FILED 4-2-2007.



THE MARK CONSISTS OF STANDARD CHARACTERS WITHOUT CLAIM TO ANY PARTICULAR FONT, STYLE, SIZE, OR COLOR.

FOR ELECTRONIC STORAGE OF AUDIO AND VIDEO FILES OVER A NETWORK CONNECTION (U.S. CLS. 100 AND 105).

REBECCA SMITH, EXAMINING ATTORNEY

SN 77-359,608. CHINA TRAVEL SERVICE CHICAGO INC., CHICAGO, IL. FILED 12-26-2007.



NO CLAIM IS MADE TO THE EXCLUSIVE RIGHT TO USE "CHINA HOLIDAYS" OR THE CHINESE CHARACTERS MEANING "CHINA HOLIDAYS", APART FROM THE MARK AS SHOWN.

THE MARK CONSISTS OF TWO WORDS "CHINA" AND "HOLIDAYS" WITH FOUR CHINESE CHARACTERS ON TOP OF THE TWO WORDS, THE FOUR CHINESE CHARACTERS REPRESENTING THE CHINESE TRANSLATION OF THE TWO WORDS. EACH CHINESE CHARACTER WAS ON IRREGULAR DARK SQUARE. THE TWO WORDS AND THE FOUR CHINESE CHARACTERS ARE LOCATED ON THE RIGHT SIDE OF A DRAGON SHAPED SIGN WITH DRAGON HEAD UP AND TAIL DOWN.

THE NON-LATIN CHARACTERS IN THE MARK TRANSLITERATE TO "ZHONG HUA JIA QI" AND THIS MEANS "CHINA HOLIDAYS" IN ENGLISH.

FOR TRAVEL AGENCY SERVICES, NAMELY, MAKING RESERVATIONS AND BOOKINGS FOR TRANSPORTATION (U.S. CLS. 100 AND 105).

FIRST USE 1-1-2006; IN COMMERCE 1-1-2006.
CARRIE GENOVESE, EXAMINING ATTORNEY

CLASS 39—(Continued).

SN 77-517,315. PINE CREEK, LLC, WESTERVILLE, OH. FILED 7-8-2008.



NO CLAIM IS MADE TO THE EXCLUSIVE RIGHT TO USE "INTERNATIONAL SOURCING", APART FROM THE MARK AS SHOWN.

THE COLOR(S) GREEN AND WHITE IS/ARE CLAIMED AS A FEATURE OF THE MARK.

THE COLOR LIGHT GREEN APPEARS IN TWO PINE TREE DESIGNS, THE COLOR WHITE APPEARS IN THE WORDING "PINE CREEK INTERNATIONAL SOURCING", WHICH APPEARS TO THE RIGHT OF THE PINE TREE DESIGNS WITH "PINE CREEK" ON ONE LINE, "INTERNATIONAL" ON A SEPARATE LINE BELOW THIS AND "SOURCING" ON ANOTHER SEPARATE LINE BELOW THIS, AND A WHITE WAVY LINE APPEARS BELOW THE PINE TREE DESIGNS AND WORDING, ALL WITHIN A DARK GREEN OVAL.

FOR FREIGHT TRANSPORTATION CONSULTATION IN THE FIELD OF FREIGHT TRANSPORTATION BY TRUCK, RAIL, AIR AND OCEAN COMPRISING THE PROVISION OF ADVICE ABOUT CONTAINER SIZE SELECTION AND UTILIZATION, COORDINATING AND ROUTING OF RAIL SHIPMENTS; BREAK BULK SERVICES, NAMELY, CONSOLIDATION AND DOCUMENTATION SERVICES RELATING TO THE PACKAGING, TRANSPORTATION AND STORAGE OF LOOSE CARGO; PROVIDING ADVICE ABOUT CARTON LOADING SEQUENCE FOR SHIPMENT OF GOODS, PALLET CONFIGURATION SEQUENCE AND CONTAINER UNLOADING INNOVATIONS (U.S. CLS. 100 AND 105).

FIRST USE 6-18-2008; IN COMMERCE 6-18-2008.
GENE MACIOL, EXAMINING ATTORNEY

SN 77-530,556. ETCM LTD., LONDON, UNITED KINGDOM, FILED 7-24-2008.

Parkopedia

THE MARK CONSISTS OF STANDARD CHARACTERS WITHOUT CLAIM TO ANY PARTICULAR FONT, STYLE, SIZE, OR COLOR.

FOR PROVIDING A WEBSITE FEATURING ON-LINE INFORMATION TO ASSIST OTHERS IN LOCATING PARKING AVAILABILITY AT SPECIFIED DESTINATIONS (U.S. CLS. 100 AND 105).

FIRST USE 2-8-2008; IN COMMERCE 2-8-2008.
MARLENE BELL, EXAMINING ATTORNEY

CLASS 39—(Continued).

SN 77-541,791. SOUTHERN MARYLAND ELECTRIC COOPERATIVE, INC., HUGHESVILLE, MD. FILED 8-7-2008.

HOMETOWN POWER YOU CAN DEPEND ON

THE MARK CONSISTS OF STANDARD CHARACTERS WITHOUT CLAIM TO ANY PARTICULAR FONT, STYLE, SIZE, OR COLOR.

NO CLAIM IS MADE TO THE EXCLUSIVE RIGHT TO USE "POWER", APART FROM THE MARK AS SHOWN.

FOR UTILITY AND PUBLIC UTILITY SERVICES IN THE NATURE OF TRANSMISSION AND DISTRIBUTION OF ELECTRICITY (U.S. CLS. 100 AND 105).

FIRST USE 2-19-2008; IN COMMERCE 4-15-2008.
LINDA MICKLEBURGH, EXAMINING ATTORNEY

SN 77-553,000. NEW MEXICO DEPARTMENT OF TRANSPORTATION, SANTA FE, NM. FILED 8-21-2008.

NEW MEXICO RAIL RUNNER EXPRESS

THE MARK CONSISTS OF STANDARD CHARACTERS WITHOUT CLAIM TO ANY PARTICULAR FONT, STYLE, SIZE, OR COLOR.

NO CLAIM IS MADE TO THE EXCLUSIVE RIGHT TO USE "NEW MEXICO RAIL" AND "EXPRESS", APART FROM THE MARK AS SHOWN.

FOR PUBLIC PASSENGER TRANSPORTATION SERVICES (U.S. CLS. 100 AND 105).

FIRST USE 7-25-2005; IN COMMERCE 7-14-2006.
DAVON HATCHETT, EXAMINING ATTORNEY

SN 77-574,828. THE WILLIAM WARREN GROUP, INC, DBA THE WILLIAM WARREN GROUP, SANTA MONICA, CA. FILED 9-19-2008.

STORMAN

THE MARK CONSISTS OF STANDARD CHARACTERS WITHOUT CLAIM TO ANY PARTICULAR FONT, STYLE, SIZE, OR COLOR.

OWNER OF U.S. REG. NO. 3,298,598.
FOR STORAGE SERVICES TO THE PUBLIC, NAMELY, PROVIDING SELF-STORAGE WAREHOUSE FACILITIES (U.S. CLS. 100 AND 105).

FIRST USE 12-2-2006; IN COMMERCE 1-12-2007.
JANET LEE, EXAMINING ATTORNEY

CLASS 39—(Continued).

SN 77-601,476. NORTHLAND AUTO ENTERPRISES, INC.,
BURNSVILLE, MN. FILED 10-27-2008.

LTO

THE MARK CONSISTS OF STANDARD CHARACTERS
WITHOUT CLAIM TO ANY PARTICULAR FONT, STYLE,
SIZE, OR COLOR.

SEC. 2(F).

FOR LEASING OF VEHICLES (U.S. CLS. 100 AND 105).

FIRST USE 0-0-2001; IN COMMERCE 0-0-2001.

JAY BESCH, EXAMINING ATTORNEY

SN 77-642,022. CLIPPER NAVIGATION, INC., SEATTLE, WA.
FILED 12-31-2008.



NO CLAIM IS MADE TO THE EXCLUSIVE RIGHT TO
USE "VACATIONS", APART FROM THE MARK AS
SHOWN.

THE MARK CONSISTS OF THE STYLIZED WORDS
"CLIPPER VACATIONS", SEPARATED BY A LINE.

FOR TRAVEL ARRANGEMENT SERVICES, NAMELY,
MAKING RESERVATIONS AND BOOKINGS FOR
TRANSPORTATION AND TOURS (U.S. CLS. 100 AND
105).

FIRST USE 11-2-2000; IN COMMERCE 11-2-2000.

RICHARD WHITE, EXAMINING ATTORNEY

CLASS 39—(Continued).

SN 77-650,955. GENTLE MOVERS FRANCHISE CORP.,
HYDE PARK, MA. FILED 1-16-2009.



NO CLAIM IS MADE TO THE EXCLUSIVE RIGHT TO
USE "GENTLE MOVERS", APART FROM THE MARK AS
SHOWN.

THE COLOR(S) BLUE, WHITE, AND GOLD IS/ARE
CLAIMED AS A FEATURE OF THE MARK.

THE MARK CONSISTS OF THE WORD "GENTLE" IN
WHITE BLOCK LETTERING WITH AN INITIAL CAPITAL
LETTER "G", TO THE RIGHT OF WHICH IS A GOLD SUN
OVER WHICH IS A SEAGULL WITH A BLUE BODY AND
WHITE BORDERS, ALL OVER THE WORD "MOVERS" IN
WHITE BLOCK, LOWER CASE LETTERS, OVER A GOLD
TRAPAZOID, ALL AGAINST A BLUE BACKGROUND.

FOR LOCAL, INTERSTATE AND INTERNATIONAL
PACKING, MOVING AND STORAGE SERVICES,
NAMELY, PACKING FOR TRANSPORTATION, MOV-
ING TRANSPORTATION FOR HOUSEHOLD AND COM-
MERCIAL GOODS, AND STORAGE OF GOODS;
MOVING TRANSPORTATION CONSULTATION; VEHI-
CLE RELOCATION SERVICES; AND PROVIDING IN-
FORMATION IN THE FIELD OF MOVING
TRANSPORTATION, PACKING FOR TRANSPORTA-
TION, AND STORAGE OF GOODS (U.S. CLS. 100 AND
105).

FIRST USE 5-10-1983; IN COMMERCE 5-10-1983.

MARLENE BELL, EXAMINING ATTORNEY

SN 77-651,349. MEDJET ASSISTANCE, LLC, BIRMINGHAM,
AL. FILED 1-16-2009.

MEDJET

THE MARK CONSISTS OF STANDARD CHARACTERS
WITHOUT CLAIM TO ANY PARTICULAR FONT, STYLE,
SIZE, OR COLOR.

OWNER OF U.S. REG. NOS. 2,558,160 AND 2,616,782.
FOR AIR TRANSPORTATION; AMBULANCE TRANS-
PORT (U.S. CLS. 100 AND 105).

FIRST USE 12-17-1987; IN COMMERCE 12-17-1987.

HOWARD SMIGA, EXAMINING ATTORNEY

CLASS 39—(Continued).

SN 77-662,647. MDU RESOURCES GROUP, INC., BISMARCK, ND. FILED 2-3-2009.



NO CLAIM IS MADE TO THE EXCLUSIVE RIGHT TO USE "GAS COMPANY", APART FROM THE MARK AS SHOWN.

THE MARK CONSISTS OF THE WORDS "INTERMOUNTAIN GAS COMPANY", TO THE LEFT OF WHICH IS A STYLIZED FLAME, AND ABOVE WHICH ARE STYLIZED MOUNTAIN PEAKS.

SEC. 2(F) AS TO "INTERMOUNTAIN GAS COMPANY". FOR PUBLIC UTILITY SERVICES IN THE NATURE OF NATURAL GAS DISTRIBUTION (U.S. CLS. 100 AND 105).

FIRST USE 3-10-2009; IN COMMERCE 3-10-2009. WARREN L. OLANDRIA, EXAMINING ATTORNEY



SN 77-663,416. PATTERSON PLUS, SANTA BARBARA, CA. FILED 2-4-2009.



NO CLAIM IS MADE TO THE EXCLUSIVE RIGHT TO USE "SELF STORAGE", APART FROM THE MARK AS SHOWN.

THE COLOR(S) GREEN, TAN, BLACK, BROWN IS/ARE CLAIMED AS A FEATURE OF THE MARK.

THE MARK CONSISTS OF DESIGN OF A HOUSE WITH A KEYHOLE IN THE MIDDLE, IN GREEN AND OUTLINED IN BLACK; TO THE RIGHT IS A DESIGN OF AN OPEN PACKING BOX, IN TAN AND BROWN AND OUTLINED IN BLACK; BELOW IS THE WORD "PATTERSON," IN GREEN AND OUTLINED IN BLACK; BELOW THAT IS THE WORDING "SELF-STORAGE," IN BLACK.

FOR PROVIDING SELF-STORAGE FACILITIES FOR OTHERS (U.S. CLS. 100 AND 105).

JAMES A. RAUEN, EXAMINING ATTORNEY

CLASS 39—(Continued).

SN 77-664,071. RESTAURANTS ON THE RUN, INC., ALISO VIEJO, CA. FILED 2-5-2009.

FOODGISTICS

THE MARK CONSISTS OF STANDARD CHARACTERS WITHOUT CLAIM TO ANY PARTICULAR FONT, STYLE, SIZE, OR COLOR.

FOR RESTAURANT FOOD DELIVERY SERVICES (U.S. CLS. 100 AND 105).

MATTHEW KLINE, EXAMINING ATTORNEY



SN 77-664,542. MORI MILK & ICE CREAM CO., FRANKLIN PARK, IL. FILED 2-5-2009.

"I WANT TO BE YOUR MILKMAN!"

THE MARK CONSISTS OF STANDARD CHARACTERS WITHOUT CLAIM TO ANY PARTICULAR FONT, STYLE, SIZE, OR COLOR.

FOR MILK AND DAIRY DELIVERY SERVICE (U.S. CLS. 100 AND 105).

FIRST USE 6-1-1990; IN COMMERCE 6-1-1990. BRIAN CALLAGHAN, EXAMINING ATTORNEY



SN 77-664,620. LUGGAGE AHEAD, LLC, MARLTON, NJ. FILED 2-5-2009.

Luggage Ahead

THE MARK CONSISTS OF STANDARD CHARACTERS WITHOUT CLAIM TO ANY PARTICULAR FONT, STYLE, SIZE, OR COLOR.

NO CLAIM IS MADE TO THE EXCLUSIVE RIGHT TO USE "LUGGAGE", APART FROM THE MARK AS SHOWN. FOR SHIPPING OF GOODS (U.S. CLS. 100 AND 105).

KIMBERLY FRYE, EXAMINING ATTORNEY

CLASS 39—(Continued).

SN 77-664,862. ELITE CARGO SYSTEMS, INC., SOUTH ELGIN, IL. FILED 2-6-2009.

ELITEXPO CARGO SYSTEMS

THE MARK CONSISTS OF STANDARD CHARACTERS WITHOUT CLAIM TO ANY PARTICULAR FONT, STYLE, SIZE, OR COLOR.

NO CLAIM IS MADE TO THE EXCLUSIVE RIGHT TO USE "CARGO SYSTEMS", APART FROM THE MARK AS SHOWN.

FOR FREIGHT TRANSPORTATION BY TRUCK AND AIRPLANE (U.S. CLS. 100 AND 105).

FIRST USE 6-1-1996; IN COMMERCE 6-1-1996.

JIM RINGLE, EXAMINING ATTORNEY

SN 77-665,207. ULTIMATE THUNDER LLC, ORLANDO, FL. FILED 2-6-2009.

Ultimate Thunder

THE MARK CONSISTS OF STANDARD CHARACTERS WITHOUT CLAIM TO ANY PARTICULAR FONT, STYLE, SIZE, OR COLOR.

FOR ARRANGING OF TOURS (U.S. CLS. 100 AND 105).

FIRST USE 1-12-2009; IN COMMERCE 1-12-2009.

WON TEAK OH, EXAMINING ATTORNEY

SN 77-665,491. MDU RESOURCES GROUP, INC., BISMARCK, ND. FILED 2-6-2009.

INTERMOUNTAIN GAS COMPANY

THE MARK CONSISTS OF STANDARD CHARACTERS WITHOUT CLAIM TO ANY PARTICULAR FONT, STYLE, SIZE, OR COLOR.

NO CLAIM IS MADE TO THE EXCLUSIVE RIGHT TO USE "GAS COMPANY", APART FROM THE MARK AS SHOWN.

SEC. 2(F).

FOR PUBLIC UTILITY SERVICES IN THE NATURE OF NATURAL GAS DISTRIBUTION (U.S. CLS. 100 AND 105).

FIRST USE 0-0-1955; IN COMMERCE 0-0-1955.

WARREN L. OLANDRIA, EXAMINING ATTORNEY

CLASS 39—(Continued).

SN 77-665,897. PHILLIP RUEDA, RANCHO CUCAMONGA, CA. FILED 2-8-2009.

SCMT

THE MARK CONSISTS OF STANDARD CHARACTERS WITHOUT CLAIM TO ANY PARTICULAR FONT, STYLE, SIZE, OR COLOR.

FOR AMBULANCE TRANSPORT (U.S. CLS. 100 AND 105).

FIRST USE 1-11-2008; IN COMMERCE 1-11-2008.

RENEE SERVANCE, EXAMINING ATTORNEY

SN 77-666,667. MC SQUARED ENERGY SERVICES LLC, DBA MC2 - WHERE ENERGY COMES FROM, CHICAGO, IL. FILED 2-9-2009.



THE COLOR(S) ORANGE AND WHITE IS/ARE CLAIMED AS A FEATURE OF THE MARK.

THE MARK CONSISTS OF AN ORANGE SQUARE WITH THE LETTERS "MC" SUPERIMPOSED IN WHITE NEAR THE BOTTOM EDGE OF THE SQUARE, AND SMALL WHITE SQUARES SUPERIMPOSED ABOVE. AN ORANGE "2" APPEARS TO THE RIGHT OF THE BOX.

FOR DISTRIBUTION OF ELECTRICITY AND NATURAL GAS ENERGY SERVICES TO RETAIL CLIENTS (U.S. CLS. 100 AND 105).

FIRST USE 12-18-2008; IN COMMERCE 12-18-2008.

JANICE KIM, EXAMINING ATTORNEY

CLASS 39—(Continued).

SN 77-667,173. VENTURE 12 LABS, L.L.C., SAN ANTONIO, TX. FILED 2-10-2009.

LAB ARMOR

THE MARK CONSISTS OF STANDARD CHARACTERS WITHOUT CLAIM TO ANY PARTICULAR FONT, STYLE, SIZE, OR COLOR.

NO CLAIM IS MADE TO THE EXCLUSIVE RIGHT TO USE "LAB", APART FROM THE MARK AS SHOWN.

FOR DISTRIBUTION SERVICES, NAMELY, DELIVERY OF LABORATORY EQUIPMENT AND SUPPLIES (U.S. CLS. 100 AND 105).

DAVID MURRAY, EXAMINING ATTORNEY

SN 77-667,430. BEACON TRANSPORT, LLC, LA VERGNE, TN. FILED 2-10-2009.



NO CLAIM IS MADE TO THE EXCLUSIVE RIGHT TO USE "TRANSPORT", APART FROM THE MARK AS SHOWN.

THE COLOR(S) YELLOW IS/ARE CLAIMED AS A FEATURE OF THE MARK.

THE MARK CONSISTS OF THE WORDS "BEACON TRANSPORT" UNDER A LIGHTHOUSE EMITTING A YELLOW BEAM OF LIGHT. THE COLORS BLACK AND WHITE IN THE MARK REPRESENT BACKGROUND, OUTLINING, SHADING AND/OR TRANSPARENT AREAS.

FOR FREIGHT TRANSPORTATION BY TRUCK (U.S. CLS. 100 AND 105).

FIRST USE 6-1-2000; IN COMMERCE 6-1-2000.
JAMES A. RAUEN, EXAMINING ATTORNEY

SN 77-671,616. ADVANCE CAR RENTAL, INC., ARLINGTON, VA. FILED 2-17-2009.

Advance Car Rental

THE MARK CONSISTS OF STANDARD CHARACTERS WITHOUT CLAIM TO ANY PARTICULAR FONT, STYLE, SIZE, OR COLOR.

NO CLAIM IS MADE TO THE EXCLUSIVE RIGHT TO USE "CAR RENTAL", APART FROM THE MARK AS SHOWN.

FOR RENTAL AND LEASING OF CARS (U.S. CLS. 100 AND 105).

FIRST USE 10-13-1998; IN COMMERCE 10-13-1998.
KELLY CHOE, EXAMINING ATTORNEY

CLASS 40—MATERIAL TREATMENT

SN 77-328,002. AMERICAN HANDLING SYSTEMS, INC., DBA POSITECH CORPORATION, LAURENS, IA. FILED 11-13-2007.



NO CLAIM IS MADE TO THE EXCLUSIVE RIGHT TO USE "EQUIPMENT", APART FROM THE MARK AS SHOWN.

THE COLOR(S) BLACK AND YELLOW IS/ARE CLAIMED AS A FEATURE OF THE MARK.

THE MARK CONSISTS OF "COLEMAN" AND "CONCO" IN BLACK STYLIZED TEXT WITH YELLOW SHADING. A BLACK DOT WITH YELLOW SHADING SEPERATES THE WORDS "COLEMAN" AND "CONCO. EQUIPMENT" IN BLACK STYLIZED TEXT WITH YELLOW SHADING DIRECTLY UNDER THE "CONCO COLEMAN" TEXT. A HALF YELLOW HALF BLACK CRESENT IS LOCATED TO THE LEFT OF THE TEXT.

FOR MANUFACTURE OF HANDLING EQUIPMENT, MANIPULATORS, HYDRAULIC ROTARY MANIFOLDS AND LIFT ASSIST DEVICES TO THE ORDER AND/OR SPECIFICATION OF OTHERS; CUSTOM MANUFACTURE OF HANDLING EQUIPMENT, MANIPULATORS, HYDRAULIC ROTARY MANIFOLDS AND LIFT ASSIST DEVICES (U.S. CLS. 100, 103 AND 106).

FIRST USE 10-31-2006; IN COMMERCE 1-14-2007.
HOWARD SMIGA, EXAMINING ATTORNEY

SN 77-341,507. CTS CORPORATION, ELKHART, IN. FILED 11-30-2007.

EMS EXPRESS

THE MARK CONSISTS OF STANDARD CHARACTERS WITHOUT CLAIM TO ANY PARTICULAR FONT, STYLE, SIZE, OR COLOR.

NO CLAIM IS MADE TO THE EXCLUSIVE RIGHT TO USE "EXPRESS", APART FROM THE MARK AS SHOWN.

FOR ASSEMBLY OF PROTOTYPES OF NEW ELECTRONIC PRODUCTS ALL FOR OTHERS IN THE FIELDS OF TELECOMMUNICATIONS INFRASTRUCTURE EQUIPMENT, NETWORKING EQUIPMENT, COMPUTER EQUIPMENT, INDUSTRIAL EQUIPMENT, NAMELY, INDUSTRIAL TEST AND MEASUREMENT EQUIPMENT, INDUSTRIAL SECURITY EQUIPMENT, AND INDUSTRIAL CONTROL EQUIPMENT, MEDICAL EQUIPMENT, MILITARY/DEFENSE EQUIPMENT, AVIONICS EQUIPMENT, AND AEROSPACE EQUIPMENT INCLUDING PRINTED CIRCUIT BOARD ASSEMBLIES, BACKPANEL ASSEMBLIES, MICROELECTRONIC CIRCUIT ASSEMBLIES, FLEX ASSEMBLIES, ENCLOSURES, HOUSINGS, ELECTRICAL CONNECTORS, CABLES, COOLING FANS, POWER SUPPLIES, AND FULLY INTEGRATED BOX-BUILD SYSTEMS FOR SUCH EQUIPMENT (U.S. CLS. 100, 103 AND 106).

CHRISTINE COOPER, EXAMINING ATTORNEY

CLASS 40—(Continued).

SN 77-351,978. VERTUS TECHNOLOGIES LTD., NEW YORK, NY. FILED 12-14-2007.

VERTUS TECHNOLOGIES

THE MARK CONSISTS OF STANDARD CHARACTERS WITHOUT CLAIM TO ANY PARTICULAR FONT, STYLE, SIZE, OR COLOR.

PRIORITY CLAIMED UNDER SEC. 44(D) ON ERPN CMNTY TM OFC APPLICATION NO. 006510391, FILED 12-12-2007, REG. NO. 006510391, DATED 11-13-2008, EXPIRES 12-12-2017.

NO CLAIM IS MADE TO THE EXCLUSIVE RIGHT TO USE "TECHNOLOGIES", APART FROM THE MARK AS SHOWN.

FOR MATERIAL TREATMENT SERVICES, NAMELY, FUEL CLEANING, COAL CLEANING AND COAL PROCESSING; PROVIDING INFORMATION, ADVICE AND CONSULTANCY RELATING TO MATERIAL TREATMENT (U.S. CLS. 100, 103 AND 106).

NAAKWAMA ANKRAH, EXAMINING ATTORNEY

CLASS 40—(Continued).

SN 77-517,402. A2BE CARBON CAPTURE, LLC, BOULDER, CO. FILED 7-8-2008.

algae@work

THE MARK CONSISTS OF STANDARD CHARACTERS WITHOUT CLAIM TO ANY PARTICULAR FONT, STYLE, SIZE, OR COLOR.

FOR GREENHOUSE GAS REDUCTION SERVICES, NAMELY, CONVERSION OF CO2 INTO BIOMASS UTILIZING PHOTOSYNTHETIC PROCESSES THAT OPERATE ON EFFLUENT GAS STREAMS FROM POWER PLANTS AND OTHER SOURCES THAT GENERATE CARBON DIOXIDE; ENERGY RECYCLING AND PRODUCTION SERVICES, NAMELY, THE EXTRACTION OF ENERGY COMPONENTS FROM PRODUCED BIOMASS; DEVELOPMENT OF RENEWABLE ENERGY, NAMELY, CONVERSION OF BIOMASS ENERGY COMPONENTS TO BIOFUELS; ENERGY RECYCLING SERVICES, NAMELY, CONVERSION OF CARBON DIOXIDE INTO BIOFUELS, ANIMAL FEED PROTEINS, AND FERTILIZER (U.S. CLS. 100, 103 AND 106).

DAVID HOFFMAN, EXAMINING ATTORNEY

SN 77-518,831. HUNTER METAL FORGE & IRON WORKS, INC., KINGS BEACH, CA. FILED 7-10-2008.

forge &
Hunter Metal
~ est. 1999 ~
iron works inc.

NO CLAIM IS MADE TO THE EXCLUSIVE RIGHT TO USE "METAL", "FORGE & IRONWORKS INC.", "EST. 1999", APART FROM THE MARK AS SHOWN.

THE MARK CONSISTS OF A HAND-DRAWN HAMMER AND A TONG BETWEEN THE STYLIZED TEXT "EST. 1999 ~", ABOVE THE STYLIZED TEXT "HUNTER METAL FORGE &" APPEARS AND BELOW THE STYLIZED TEXT "IRON WORKS, INC.:" APPEARS.

FOR METAL FABRICATION AND FINISHING SERVICES (U.S. CLS. 100, 103 AND 106).

FIRST USE 4-0-2005; IN COMMERCE 4-0-2005.

EMILY CARLSEN, EXAMINING ATTORNEY

SN 77-460,499. HENDERSON, CRAIG, FRESNO, CA. FILED 4-29-2008.

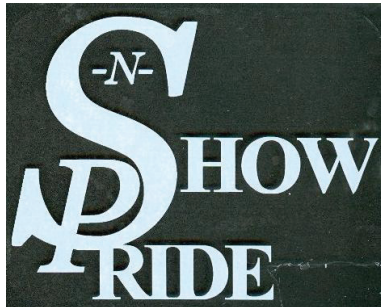

FOR LASER ENGRAVING SERVICES (U.S. CLS. 100, 103 AND 106).

MATTHEW EINSTEIN, EXAMINING ATTORNEY

CLASS 40—(Continued).

SN 77-544,337. TRIEXIEPIXIE GRAPHICS, DBA TRIEXIEPIXIE GRAPHICS, SEATTLE, WA. FILED 8-11-2008.

trixiepixie graphics

THE MARK CONSISTS OF STANDARD CHARACTERS WITHOUT CLAIM TO ANY PARTICULAR FONT, STYLE, SIZE, OR COLOR.

NO CLAIM IS MADE TO THE EXCLUSIVE RIGHT TO USE "GRAPHICS", APART FROM THE MARK AS SHOWN. SEC. 2(F).

FOR BINDERY SERVICES FOR OTHERS, NAMELY, COLLATING, FOLDING, STAPLING, PERFORATING, CUTTING AND BINDING OF PRINTED, PHOTOCOPIED AND TYPEWRITTEN MATERIALS; CUSTOMIZED PRINTING OF COMPANY NAMES AND LOGOS FOR PROMOTIONAL AND ADVERTISING PURPOSES ON THE GOODS OF OTHERS; DESIGN PRINTING FOR OTHERS; DIGITAL ON-DEMAND PRINTING SERVICES OF BOOKS AND OTHER DOCUMENTS; DIGITAL PHOTO PRINTING SERVICES; IMPRINTING MESSAGES ON T-SHIRTS; IMPRINTING MESSAGES ON WEARING APPAREL, ACCESSORIES AND MUGS; INKJET PRINTING SERVICES; LENTICULAR PRINTING SERVICES; LETTERPRESS PRINTING; LITHOGRAPHIC PRINTING; OFFSET PRINTING; PATTERN PRINTING; PHOTOGRAPHIC SLIDE AND/OR PRINT PROCESSING; PHOTOGRAVURE PRINTING; PORTRAIT PRINTING; PRINTING; PRINTING OF ADVERTISING MATTER; PRINTING OF BOOKS; PRINTING OF PATTERNS ON TEXTILES; PRINTING OF PHOTOGRAPHIC IMAGES FROM DIGITAL MEDIA; SCREEN PRINTING; SILK SCREEN PRINTING; STATIONERY PRINTING SERVICES; THERMOGRAPHIC PRINTING SERVICES (U.S. CLS. 100, 103 AND 106).

FIRST USE 1-1-2002; IN COMMERCE 1-1-2002.
MARC LEIPZIG, EXAMINING ATTORNEY

SN 77-617,428. CURTICE, JOSIANNE, DBA SKETCH AND RELEASE, ROCHESTER, NY. FILED 11-19-2008.

Sketch and Release

THE MARK CONSISTS OF STANDARD CHARACTERS WITHOUT CLAIM TO ANY PARTICULAR FONT, STYLE, SIZE, OR COLOR.

NO CLAIM IS MADE TO THE EXCLUSIVE RIGHT TO USE "SKETCH", APART FROM THE MARK AS SHOWN.

FOR CREATION OF CUSTOM PAINTINGS DEPICTING TROPHY FISH BASED ON PHOTOGRAPHS, SNAPSHOTS, OR IMAGES PROVIDED BY CUSTOMERS (U.S. CLS. 100, 103 AND 106).

FIRST USE 3-25-2004; IN COMMERCE 3-31-2004.
JIM RINGLE, EXAMINING ATTORNEY

CLASS 40—(Continued).

SN 77-619,726. MARKETSMART, LLC, BELTSVILLE, MD. FILED 11-21-2008.

Flexible Documents

THE MARK CONSISTS OF STANDARD CHARACTERS WITHOUT CLAIM TO ANY PARTICULAR FONT, STYLE, SIZE, OR COLOR.

NO CLAIM IS MADE TO THE EXCLUSIVE RIGHT TO USE "DOCUMENTS", APART FROM THE MARK AS SHOWN.

FOR CUSTOMIZED PRINTING OF COMPANY NAMES AND LOGOS FOR PROMOTIONAL AND ADVERTISING PURPOSES ON THE GOODS OF OTHERS; DESIGN PRINTING FOR OTHERS; DIGITAL ON-DEMAND PRINTING SERVICES OF BOOKS AND OTHER DOCUMENTS; PRINTING; PRINTING OF ADVERTISING MATTER; PRINTING OF BOOKS (U.S. CLS. 100, 103 AND 106).

FLORENTINA BLANDU, EXAMINING ATTORNEY

SN 77-621,783. CHALABI, RIFAT, CRANFORD, NJ. FILED 11-25-2008.

CHINOOK ENERGY

THE MARK CONSISTS OF STANDARD CHARACTERS WITHOUT CLAIM TO ANY PARTICULAR FONT, STYLE, SIZE, OR COLOR.

OWNER OF U.S. REG. NO. 7,851,889.

NO CLAIM IS MADE TO THE EXCLUSIVE RIGHT TO USE "ENERGY", APART FROM THE MARK AS SHOWN.

FOR METAL RECLAMATION SERVICES; WASTE-TO-ENERGY GENERATION SERVICES; WASTE-TO-FUEL GENERATION SERVICES; ENVIRONMENTAL CLEAN-UP SERVICES (U.S. CLS. 100, 103 AND 106).

FIRST USE 7-21-2008; IN COMMERCE 7-21-2008.

WILLIAM BRECKENFELD, EXAMINING ATTORNEY

CLASS 40—(Continued).

SN 77-622,408. ROBOTHAM, ALTHEA, BROOKLYN, NY. FILED 11-26-2008.

Rekanize

THE MARK CONSISTS OF THE LETTERS "R E K A N I Z E" IN A TRIBAL DESIGNED FONT. BOTH "E'S ARE SCALED SMALLER THAN THE OTHER LETTERS. THE FIRST "E" SITS ON THE TAIL OF THE "R" AND THE SECOND "E" SITS ON THE EXTENDED TAIL OF THE "Z".

FOR IMPRINTING MESSAGES ON WEARING APPAREL, ACCESSORIES AND MUGS (U.S. CLS. 100, 103 AND 106).

FIRST USE 8-23-2008; IN COMMERCE 8-23-2008.
LINDA MICKLEBURGH, EXAMINING ATTORNEY

SN 77-623,583. ELEMENTS UNLIMITED, HIGHLANDS RANCH, CO. FILED 12-1-2008.



THE COLOR(S) GREEN, CHARTREUSE, DARK RED AND BLACK IS/ARE CLAIMED AS A FEATURE OF THE MARK.

THE MARK CONSISTS OF THE LETTERS "EU" PRESENTED IN A GREEN STYLIZED FONT IN THE CENTER OF A DESIGN FEATURING A CHARTREUSE LEAF WITH ITS STEM WINDING DOWN THROUGH THE "E" AND "U" TO INTERSECT WITH A DARK RED CIRCULAR CARRIER THAT ENCLOSES MOST OF THE LEAF AND THE LETTERS "EU". THE WORDS "SIMPLY GREEN TO KEEP THE EARTH CLEAN" ARE PRESENTED IN A BLACK STYLIZED FONT THAT SURROUNDS THE PERIMETER OF THE DARK RED CIRCULAR CARRIER.

FOR CUSTOMIZED IMPRINTING OF COMPANY NAMES AND LOGOS ON THE GOODS OF OTHERS, NAMELY, ON PROMOTIONAL MERCHANDISE, APPAREL AND CORPORATE GIFTS (U.S. CLS. 100, 103 AND 106).

TRACY WHITTAKER-BROWN, EXAMINING ATTORNEY

CLASS 40—(Continued).

SN 77-631,745. POPMOUNT INC., RICHMOND, VA. FILED 12-12-2008.

PopMount

THE MARK CONSISTS OF STANDARD CHARACTERS WITHOUT CLAIM TO ANY PARTICULAR FONT, STYLE, SIZE, OR COLOR.

FOR CUSTOM MOUNTING OF ARTWORK, PHOTOGRAPHS AND DOCUMENTS, NAMELY, MOUNTING OF ARTWORK, PHOTOGRAPHS AND DOCUMENTS ONTO A SHAPED WOOD COMPOSITE BOARD TO GIVE THE ARTWORK, PHOTOGRAPHS AND DOCUMENTS A PLAQUE-LIKE APPEARANCE; CUSTOM PRINTING OF ARTWORK, PHOTOGRAPHS AND DOCUMENTS (U.S. CLS. 100, 103 AND 106).

FIRST USE 11-1-2001; IN COMMERCE 11-1-2001.
ROBERT LAVACHE, EXAMINING ATTORNEY

SN 77-636,248. SHORT GO, INC., LAFAYETTE, LA. FILED 12-18-2008.

TWISTER

THE MARK CONSISTS OF STANDARD CHARACTERS WITHOUT CLAIM TO ANY PARTICULAR FONT, STYLE, SIZE, OR COLOR.

OWNER OF U.S. REG. NO. 3,343,568.
FOR MANUFACTURE OF AUTOMOBILE/TRUCK TRAILERS FOR OTHERS (U.S. CLS. 100, 103 AND 106).
FIRST USE 11-30-1996; IN COMMERCE 3-31-1997.
MATTHEW PAPPAS, EXAMINING ATTORNEY

SN 77-640,632. GOOD EARTHKEEPING ORGANIZATION, INC., DBA G.E.O. INC., ORANGE, CA. FILED 12-29-2008.

G.E.O. Inc.

THE MARK CONSISTS OF STANDARD CHARACTERS WITHOUT CLAIM TO ANY PARTICULAR FONT, STYLE, SIZE, OR COLOR.

NO CLAIM IS MADE TO THE EXCLUSIVE RIGHT TO USE "INC.", APART FROM THE MARK AS SHOWN.

FOR ENVIRONMENTAL REMEDIATION SERVICES, NAMELY, SOIL, WASTE AND/OR WATER TREATMENT SERVICES (U.S. CLS. 100, 103 AND 106).

FIRST USE 11-0-1993; IN COMMERCE 11-0-1993.
KAREN BRACEY, EXAMINING ATTORNEY

CLASS 40—(Continued).

SN 77-651,779. NORTHEAST MARITIME INSTITUTE, INC., FAIRHAVEN, MA. FILED 1-18-2009.



THE MARK CONSISTS OF A DESIGN OF A TORTOISE WITH A PEACE SYMBOL.

FOR APPLICATION OF PROTECTIVE, WATER-REPELLENT CHEMICAL COATINGS OTHER THAN PAINTS FOR OTHERS, NAMELY, APPLICATION OF CHEMICAL COMPOSITIONS HAVING WATER-REPELLENT, OIL-REPELLENT, WEATHERPROOF AND PROTECTIVE PROPERTIES TO MANUFACTURED GOODS AND COMPONENTS OF SUCH GOODS (U.S. CLS. 100, 103 AND 106).

FIRST USE 11-20-2008; IN COMMERCE 11-20-2008. GRETTA YAO, EXAMINING ATTORNEY

SN 77-664,376. FILTERSURE, INC., MCLEAN, VA. FILED 2-5-2009.

FILTERSURE

THE MARK CONSISTS OF STANDARD CHARACTERS WITHOUT CLAIM TO ANY PARTICULAR FONT, STYLE, SIZE, OR COLOR.

FOR WATER AND WASTEWATER MODULAR FILTRATION AND WASTE TREATMENT AND DISPOSAL CONSULTING SERVICES IN THE FIELD OF PROCESSING NUTRIENT REMOVAL AND RECOVERY FROM LIQUID OR ORGANIC WASTE (U.S. CLS. 100, 103 AND 106).

DAVID I, EXAMINING ATTORNEY

CLASS 40—(Continued).

SN 77-664,919. THE HOWDY COMPANY, LLC, ROTHSCHILD, WI. FILED 2-6-2009.



THE STIPPLING IS FOR SHADING PURPOSES ONLY. THE MARK CONSISTS OF THE STYLIZED TEXT "HOWDY BOOBY TIME" WITH A ROPE AROUND THE FIRST LETTER "O" IN THE WORD "BOOBY".

FOR MANUFACTURING SERVICES FOR OTHERS IN THE FIELD OF HOUSEHOLD CLEANING PRODUCTS AND PERSONAL CARE PRODUCTS FOR MEN/WOMEN INCLUDING BUT NOT LIMITED TOO LIQUID SOAPS, LOTIONS, LIP GLOSS, SHAMPOO, BODY BUTTER, LAUNDRY DETERGENT, DISH SOAP, ALL PURPOSE CLEANERS (U.S. CLS. 100, 103 AND 106).

ELLEN B. AWRICH, EXAMINING ATTORNEY

SN 77-665,071. MELVIN, TERRELL, GERING, NE. FILED 2-6-2009.

FITZWELL BREWING

THE MARK CONSISTS OF STANDARD CHARACTERS WITHOUT CLAIM TO ANY PARTICULAR FONT, STYLE, SIZE, OR COLOR.

NO CLAIM IS MADE TO THE EXCLUSIVE RIGHT TO USE "BREWING", APART FROM THE MARK AS SHOWN. FOR BREWERY SERVICES (U.S. CLS. 100, 103 AND 106).

GEOFFREY FOSDICK, EXAMINING ATTORNEY

SN 77-665,733. HOOD, YUSEF, DBA HOODFILMS, CHICAGO, IL. FILED 2-7-2009.

STATE2DALAKE

THE MARK CONSISTS OF STANDARD CHARACTERS WITHOUT CLAIM TO ANY PARTICULAR FONT, STYLE, SIZE, OR COLOR.

FOR IMPRINTING MESSAGES ON WEARING APPAREL, ACCESSORIES AND MUGS (U.S. CLS. 100, 103 AND 106).

MICHAEL SOUDERS, EXAMINING ATTORNEY

CLASS 40—(Continued).

SN 77-665,838. BELIVE, ROBERT J, TA WEINBERG, MICHAEL, SCOTIA, NY. FILED 2-8-2009.

STOP THE PORK NOW

THE MARK CONSISTS OF STANDARD CHARACTERS WITHOUT CLAIM TO ANY PARTICULAR FONT, STYLE, SIZE, OR COLOR.

FOR IMPRINTING MESSAGES ON WEARING APPAREL, ACCESSORIES AND MUGS (U.S. CLS. 100, 103 AND 106).

JOHN DALIER, EXAMINING ATTORNEY

SN 77-666,243. SOLMAR PRECISION, INC., RAMONA, CA. FILED 2-9-2009.

SOLMAR PRECISION

THE MARK CONSISTS OF STANDARD CHARACTERS WITHOUT CLAIM TO ANY PARTICULAR FONT, STYLE, SIZE, OR COLOR.

FOR MACHINE SHOP SERVICES, NAMELY, MACHINING PARTS FOR OTHERS (U.S. CLS. 100, 103 AND 106).

FIRST USE 9-30-1999; IN COMMERCE 11-14-2002.
JILL C. ALT, EXAMINING ATTORNEY

CLASS 40—(Continued).

SN 78-700,106. FABRI-TECH COMPONENTS (S) PTE LTD, SINGAPORE, SINGAPORE, FILED 8-25-2005.

The logo for FABRI-TECH features the word "FABRI" in a solid, bold, sans-serif font, followed by "TECH" in a similar font where the letters are filled with horizontal lines. The entire logo is rendered in a light gray color.

THE COLOR(S) GRAY IS/ARE CLAIMED AS A FEATURE OF THE MARK.

THE MARK CONSISTS OF THE WORD "FABRI" IS SOLID WITH THE WORD "TECH" HAVING HORIZONTAL LINES. THE COLOR GREY APPEARS IN THE WORDING "FABRI-TECH".

FOR CUSTOM FABRICATION BY MOLDING OF ELECTRO-MECHANICAL COMPONENTS MADE OF ADVANCED COMPOSITE MATERIALS; FABRICATION BY MOLDING OF PARTS MADE OF ADVANCED COMPOSITE MATERIALS; LAMINATING OF PHARMACEUTICAL PRODUCTS, ELECTRONIC AND TELECOMMUNICATION EQUIPMENT, AND OF ELECTRO-MECHANICAL COMPONENTS FOR MECHANICAL EQUIPMENT; LAMINATING OF PLASTIC FILMS AND ADHESIVES; SILK SCREEN PRINTING; METAL STAMPING AND PRESSING; CUSTOM ASSEMBLY OF GASKETS, SEALS, MECHANICAL PARTS, LABELS, THERMAL AND ELECTRICAL INSULATING MATERIALS, AND MATERIALS FOR DAMPING OF VIBRATION AND SHOCK ABSORBERS FOR OTHERS; TREATING AND FORMING OF METAL PARTS; MACHINING, NAMELY, PRECISION MANUFACTURING OF ELECTRO-MECHANICAL COMPONENTS FOR OTHERS USING MACHINES; MACHINING OF METALS FOR OTHERS; APPLICATION OF PROTECTIVE COATINGS TO ENGINEERING COMPONENTS; APPLICATION OF WEAR RESISTANT COATINGS TO ENGINEERING COMPONENTS (U.S. CLS. 100, 103 AND 106).

LEIGH LOWRY, EXAMINING ATTORNEY

SN 78-966,422. STISSI, FRANK W, HUNTINGTON, NY. FILED 9-1-2006.

.klik-clak.

THE MARK CONSISTS OF STANDARD CHARACTERS WITHOUT CLAIM TO ANY PARTICULAR FONT, STYLE, SIZE, OR COLOR.

FOR IMPRINTING MESSAGES ON T-SHIRTS (U.S. CLS. 100, 103 AND 106).

CHRISTINE COOPER, EXAMINING ATTORNEY

CLASS 41—EDUCATION AND ENTERTAINMENT

SN 76-690,975. WEED, CHRISTOPHER, EAST HAMPTON, NY. FILED 7-1-2008.

Humans vs Zombies

THE MARK CONSISTS OF STANDARD CHARACTERS WITHOUT CLAIM TO ANY PARTICULAR FONT, STYLE, SIZE, OR COLOR.

FOR ENTERTAINMENT SERVICES, NAMELY, PROVIDING A WEBSITE THAT ALLOWS USERS TO ORGANIZE AND TRACK RESULTS OF LIVE ACTION GAMES (U.S. CLS. 100, 101 AND 107).

FIRST USE 11-17-2005; IN COMMERCE 10-1-2007.
DAVID I, EXAMINING ATTORNEY

CLASS 41—(Continued).

SN 76-691,116. SOCIETY FOR HUMAN RESOURCE MANAGEMENT, ALEXANDRIA, VA. FILED 7-7-2008.

HR NEWS

THE MARK CONSISTS OF STANDARD CHARACTERS WITHOUT CLAIM TO ANY PARTICULAR FONT, STYLE, SIZE, OR COLOR.

OWNER OF U.S. REG. NOS. 2,259,469, 2,297,183 AND OTHERS.

NO CLAIM IS MADE TO THE EXCLUSIVE RIGHT TO USE "NEWS", APART FROM THE MARK AS SHOWN.

SEC. 2(F).
FOR ONLINE NON-DOWNLOADABLE PUBLICATIONS, NAMELY, ONLINE NEWSLETTERS, ARTICLES, VIDEOS, PODCASTS AND WEBCASTS IN THE FIELD OF HUMAN RESOURCE MANAGEMENT (U.S. CLS. 100, 101 AND 107).

FIRST USE 6-30-1995; IN COMMERCE 6-30-1995.
TRACY FLETCHER, EXAMINING ATTORNEY

SN 76-692,107. SPIELBERG, JOHN, FT. LAUDERDALE, FL. FILED 8-15-2008.

GAME GIANT

THE MARK CONSISTS OF STANDARD CHARACTERS WITHOUT CLAIM TO ANY PARTICULAR FONT, STYLE, SIZE, OR COLOR.

NO CLAIM IS MADE TO THE EXCLUSIVE RIGHT TO USE "GAME", APART FROM THE MARK AS SHOWN.

FOR TICKET RESERVATION AND BOOKING SERVICES FOR SPORTING EVENTS AND CONCERTS (U.S. CLS. 100, 101 AND 107).

ANDREA SAUNDERS, EXAMINING ATTORNEY

SN 76-690,976. WEED, CHRISTOPHER, EAST HAMPTON, NY. FILED 7-1-2008.

HvZ

SN 76-693,776. HASBRO, INC., PAWTUCKET, RI. FILED 10-23-2008.

CANDY LAND

THE MARK CONSISTS OF STANDARD CHARACTERS WITHOUT CLAIM TO ANY PARTICULAR FONT, STYLE, SIZE, OR COLOR.

OWNER OF U.S. REG. NOS. 544,328, 2,580,172 AND OTHERS.

FOR ENTERTAINMENT SERVICES, NAMELY, PRODUCTION AND DISTRIBUTION OF MOTION PICTURE FILMS, TELEVISION PROGRAMS, TELEVISION GAME SHOWS AND CARTOON TELEVISION SERIES; PROVIDING INTERACTIVE COMPUTER GAMES BY MEANS OF A GLOBAL COMPUTER NETWORK (U.S. CLS. 100, 101 AND 107).

MARIAM MAHMOUDI, EXAMINING ATTORNEY

THE MARK CONSISTS OF STANDARD CHARACTERS WITHOUT CLAIM TO ANY PARTICULAR FONT, STYLE, SIZE, OR COLOR.

FOR ENTERTAINMENT SERVICES, NAMELY, PROVIDING A WEBSITE THAT ALLOWS USERS TO ORGANIZE AND TRACK RESULTS OF LIVE ACTION GAMES (U.S. CLS. 100, 101 AND 107).

FIRST USE 11-17-2005; IN COMMERCE 10-1-2007.
DAVID I, EXAMINING ATTORNEY

CLASS 41—(Continued).

SN 76-695,218. GROUP PUBLISHING, INC., LOVELAND, CO.
FILED 1-9-2009.

GOD SIGHTINGS

THE MARK CONSISTS OF STANDARD CHARACTERS WITHOUT CLAIM TO ANY PARTICULAR FONT, STYLE, SIZE, OR COLOR.

NO CLAIM IS MADE TO THE EXCLUSIVE RIGHT TO USE "GOD", APART FROM THE MARK AS SHOWN.

FOR EDUCATION SERVICES, NAMELY, PROVIDING RELIGIOUS INSTRUCTION TO BE USED IN CHURCHES AND OTHER CHRISTIAN EDUCATIONAL SETTINGS AND DISTRIBUTING MEMENTOS IN CONNECTION THEREWITH (U.S. CLS. 100, 101 AND 107).

MARK SHINER, EXAMINING ATTORNEY

SN 76-695,525. DENTAL GROUP PRACTICE ASSOCIATION,
MAYFIELD HEIGHTS, OH. FILED 2-2-2009.

DGPA

THE MARK CONSISTS OF STANDARD CHARACTERS WITHOUT CLAIM TO ANY PARTICULAR FONT, STYLE, SIZE, OR COLOR.

FOR EDUCATIONAL SERVICES, NAMELY, PROVIDING LIVE TUTORIAL SESSIONS CONCERNING THE ADVANTAGES AND OPTIONS OF DENTAL GROUP PRACTICE AND THE DISSEMINATION OF WRITTEN MATERIALS FOR USE IN CONNECTION THEREWITH (U.S. CLS. 100, 101 AND 107).

FIRST USE 10-3-2007; IN COMMERCE 10-3-2007.
BRIDGETT SMITH, EXAMINING ATTORNEY

SN 77-000,892. 2 SMART BLONDES, LLC, MALIBU, CA.
FILED 9-15-2006.

2 SMART BLONDES

THE MARK CONSISTS OF STANDARD CHARACTERS WITHOUT CLAIM TO ANY PARTICULAR FONT, STYLE, SIZE, OR COLOR.

FOR ENTERTAINMENT SERVICES, NAMELY, ON-GOING TELEVISION PROGRAMS FEATURING ANIMATION, COMEDY, COMPETITION, DANCING, DRAMA, LIVE ACTION, MUSIC, AND NEWS; ENTERTAINMENT SERVICES RELATED TO THE PRODUCTION OF TELEVISION SHOWS, FASHION SHOWS, TELEVISION NEWS SHOWS, GAME SHOWS, RADIO SHOWS; ON-GOING REALITY BASED TELEVISION PROGRAMS; MULTIMEDIA ENTERTAINMENT SERVICES IN THE NATURE OF RECORDING, PRODUCTION AND POST-PRODUCTION SERVICES IN THE FIELDS OF MUSIC, VIDEO AND FILMS; PROVIDING INFORMATION, NEWS AND COMMENTARY IN THE FIELD OF ENTERTAINMENT CONCERNING TELEVISION SHOWS AND MUSIC SHOWS (U.S. CLS. 100, 101 AND 107).

JESSICA FATHY, EXAMINING ATTORNEY

CLASS 41—(Continued).

SN 77-082,751. GAKHAL, GURVUNDERA PAUL, JUSTICE,
IL. FILED 1-14-2007.



NO CLAIM IS MADE TO THE EXCLUSIVE RIGHT TO USE "WANTED FOR MURDER", APART FROM THE MARK AS SHOWN.

THE COLOR(S) GRAY, BLACK, RED AND WHITE IS/ ARE CLAIMED AS A FEATURE OF THE MARK.

THE MARK CONSISTS OF THE WORD "MURDER" WITH A STYLIZED DEPICTION OF A BADGE WITH THE WORD "FOR" IN THE CENTER OF THE BADGE DIRECTLY BENEATH, AND THE WORD "MURDER" DIRECTLY BELOW THE BADGE. THE COLOR GRAY APPEARS IN THE BACK GROUND AND THE INTERIOR OF THE BADGE, THE COLOR BLACK APPEARS IN THE WORDING "WANTED FOR", IN THE STYLIZED DEPICTION OF A BAGDE AND IN THE RECTANGULAR BOX WITH THE WORD "MURDER" INSIDE, THE COLOR RED APPEARS IN THE UPPER HALF OF THE WORD "MURDER" STREAKED IN THE LOWER HALF OF THE WORD "MURDER" AND THE COLOR WHITE APPEARS IN THE LOWER HALF OF THE WORD "MURDER."

FOR PRODUCTION AND DISTRIBUTION OF TELEVISION SHOWS AND MOVIES; PRODUCTION OF CABLE TELEVISION PROGRAMS; PRODUCTION OF CLOSED CAPTION TELEVISION PROGRAMS; PRODUCTION OF RADIO AND TELEVISION PROGRAMS; PRODUCTION OF RADIO OR TELEVISION PROGRAMS; TELEVISION PRODUCTION; TELEVISION SHOW PRODUCTION (U.S. CLS. 100, 101 AND 107).

FIRST USE 1-12-2007; IN COMMERCE 1-12-2007.
ASMAT KHAN, EXAMINING ATTORNEY

CLASS 41—(Continued).

SN 77-102,228. TRISTAR ATHLETE LLC, NEW YORK, NY.
FILED 2-8-2007.



OWNER OF U.S. REG. NOS. 3,529,710 AND 3,529,711.
NO CLAIM IS MADE TO THE EXCLUSIVE RIGHT TO
USE "ATHLETES", APART FROM THE MARK AS SHOWN.
THE COLOR(S) RED AND BLUE IS/ARE CLAIMED AS A
FEATURE OF THE MARK.

THE MARK CONSISTS OF A BLUE FILLED-IN CIRCLE
WITH "TRI" WRITTEN IN WHITE, FOLLOWED BY "STAR"
IN RED WHEREIN THE A IS REPRESENTED BY A
STYLIZED, FIVE-POINTED STAR, WITH "ATHLETES" IN
SMALLER BLUE LETTERS UNDER THE WORD "STAR".

FOR PERSONAL COACHING SERVICES IN THE
FIELD OF TRIATHLONS, WINTER TRIATHLONS,
DUATHLONS, MARATHONS, ADVENTURE RACING
AND SWIMMING; PERSONAL COACHING AND
TRAINING SERVICES IN THE FIELD OF TRIATHLONS,
WINTER TRIATHLONS, DUATHLONS, MARATHONS,
ADVENTURE RACING AND SWIMMING; PHYSICAL
FITNESS CONSULTATION; HEALTH CLUB AND WELL-
NESS CENTER SERVICES, NAMELY, PROVIDING IN-
STRUCTION AND EQUIPMENT IN THE FIELD OF
TRIATHLONS, WINTER TRIATHLONS, DUATHLONS,
MARATHONS, ADVENTURE RACING AND SWIM-
MING, AND PHYSICAL EXERCISE; ARRANGING
AND CONDUCTING YOUTH SPORTS CAMPS, SPORTS
TRAINING CAMPS, CLINICS, COACHING, PERFOR-
MANCE EVALUATION WORKSHOPS, SEMINARS,
AND CONFERENCES IN CONNECTION WITH TRAIN-
ING AMATEUR, ELITE AND PROFESSIONAL TRIATH-
LON, WINTER TRIATHLON, DUATHLON,
MARATHON, ADVENTURE RACING AND ENDUR-
ANCE SWIMMING ATHLETES; DEVELOPING AND
DISSEMINATING EDUCATIONAL MATERIALS FOR
OTHERS IN THE FIELD OF TRIATHLONS, WINTER
TRIATHLONS, DUATHLONS, MARATHONS, ADVEN-
TURE RACING AND SWIMMING; ALL OF THE FORE-
GOING PROVIDED VIA A WEB SITE, GLOBAL
NETWORKS, THE INTERNET, ELECTRONIC MEANS,
BY TELEPHONE, IN PERSON OR OTHER MEANS;
COACHING EDUCATIONAL SERVICES, NAMELY,
PROVIDING ONLINE INSTRUCTION IN THE FIELD
OF SPORTS AND MANAGING, PLANNING AND AR-
RANGING TRAINING SESSIONS, SEASON PLANS AND
DEVELOPMENT PLANS FOR THE FIELDS OF TRIATH-
LONS, WINTER TRIATHLONS, DUATHLONS, MARA-
THONS, ADVENTURE RACING AND SWIMMING (U.S.
CLS. 100, 101 AND 107).

FIRST USE 1-1-2007; IN COMMERCE 1-1-2007.
ALEXANDER L. POWERS, EXAMINING ATTORNEY

CLASS 41—(Continued).

SN 77-201,856. J THOMAS INVESTMENTS, INC., ALHAM-
BRA, CA. AND GOMEZ, JEFFREY THOMAS, ALHAM-
BRA, CA. FILED 6-8-2007.

The \$nob

THE MARK CONSISTS OF STANDARD CHARACTERS
WITHOUT CLAIM TO ANY PARTICULAR FONT, STYLE,
SIZE, OR COLOR.

THE NAME SHOWN IN THE MARK IDENTIFIES JEF-
FREY THOMAS GOMEZ, WHOSE CONSENT IS OF RE-
CORD.

FOR MULTIMEDIA PUBLISHING OF BOOKS, MAGA-
ZINES, JOURNALS, SOFTWARE, GAMES, MUSIC, AND
ELECTRONIC PUBLICATIONS (U.S. CLS. 100, 101 AND
107).

FIRST USE 6-7-2005; IN COMMERCE 6-7-2005.
JOHN KELLY, EXAMINING ATTORNEY

SN 77-292,510. JEWISH COUNCIL FOR THE AGING OF
GREATER WASHINGTON, INC., ROCKVILLE, MD.
FILED 10-1-2007.

JEWISH COUNCIL FOR THE AGING

THE MARK CONSISTS OF STANDARD CHARACTERS
WITHOUT CLAIM TO ANY PARTICULAR FONT, STYLE,
SIZE, OR COLOR.

SEC. 2(F).

FOR PROVIDING INFORMATION AND ADVICE TO
THE ELDERLY AND THEIR CAREGIVERS REGARD-
ING ACCESS TO RECREATIONAL AND EDUCA-
TIONAL ACTIVITIES FOR THE ELDERLY AND THEIR
CAREGIVERS; PROVIDING TRAINING IN THE FIELDS
OF BASIC COMPUTER SKILLS AND COMPUTER MAN-
AGEMENT FOR THE ELDERLY; PROVISION OF IN-
FORMATION REGARDING TRAINING IN THE FIELDS
OF BASIC COMPUTER SKILLS AND COMPUTER DATA
MANAGEMENT FOR THE ELDERLY; INFORMATION
REGARDING SAME PROVIDED VIA A GLOBAL COM-
PUTER NETWORK (U.S. CLS. 100, 101 AND 107).

FIRST USE 7-25-1973; IN COMMERCE 7-25-1973.
GIANCARLO CASTRO, EXAMINING ATTORNEY

CLASS 41—(Continued).

SN 77-318,669. LEPORE, MARTY, REDMOND, WA. AND KENWORTHY, PHYLLIS, REDMOND, WA. FILED 11-1-2007.

SLIDE FACTOR

THE MARK CONSISTS OF STANDARD CHARACTERS WITHOUT CLAIM TO ANY PARTICULAR FONT, STYLE, SIZE, OR COLOR.

FOR COMPOSITION OF MUSIC FOR OTHERS; ENTERTAINMENT, NAMELY, LIVE PERFORMANCES BY A MUSICAL BAND; ENTERTAINMENT SERVICES, NAMELY, PROVIDING A WEB SITE FEATURING MUSICAL PERFORMANCES, MUSICAL VIDEOS, RELATED FILM CLIPS, PHOTOGRAPHS, AND OTHER MULTIMEDIA MATERIALS; INSTRUCTION IN THE FIELD OF STEEL GUITAR (U.S. CLS. 100, 101 AND 107).

FIRST USE 6-6-2006; IN COMMERCE 5-26-2007.
JOHN DALIER, EXAMINING ATTORNEY

SN 77-319,933. CRYSTAL ENTERTAINMENT LTD., LONDON, UNITED KINGDOM, FILED 11-2-2007.

CRYSTAL

THE MARK CONSISTS OF STANDARD CHARACTERS WITHOUT CLAIM TO ANY PARTICULAR FONT, STYLE, SIZE, OR COLOR.

PRIORITY CLAIMED UNDER SEC. 44(D) ON UNITED KINGDOM APPLICATION NO. 2454481, FILED 5-3-2007, REG. NO. 2454481, DATED 2-15-2008, EXPIRES 5-3-2017.

FOR ENTERTAINMENT SERVICES, NAMELY, TELEVISION AND RADIO PROGRAM PRODUCTION SERVICES; PRESENTATION AND PRODUCTION OF TELEVISION AND RADIO PROGRAMS; PRODUCTION OF SOUND RECORDINGS; LIVE CONCERT AND MUSICAL PERFORMANCES; ENTERTAINMENT SERVICES, NAMELY, LIVE STAGE AND CABARET PRODUCTIONS; PRODUCTION OF MOTION PICTURE FILMS; PRESENTATION, PRODUCTION AND PERFORMANCES OF LIVE SHOWS, MOTION PICTURE FILMS, MUSICAL SHOWS, CONCERTS AND RADIO AND TELEVISION PROGRAMS; PUBLISHING OF BOOKS, MAGAZINES; MUSIC PUBLISHING; MOTION PICTURE FILM PRODUCTION AND DISTRIBUTION SERVICES; ARRANGING AND CONDUCTING OF SEMINARS, CONFERENCES AND EXHIBITIONS IN THE FIELD OF TELEVISION, RADIO, MOTION PICTURE FILM AND MUSIC ENTERTAINMENT; INFORMATION, ADVISORY AND CONSULTANCY SERVICES, ALL RELATING TO THE AFORESAID SERVICES (U.S. CLS. 100, 101 AND 107).

HOWARD B. LEVINE, EXAMINING ATTORNEY

CLASS 41—(Continued).

SN 77-333,451. THE TRUSTEES OF CAMP FOUNDATION, SAN FRANCISCO, CA. FILED 11-19-2007.

CAMP

THE MARK CONSISTS OF STANDARD CHARACTERS WITHOUT CLAIM TO ANY PARTICULAR FONT, STYLE, SIZE, OR COLOR.

FOR MUSEUM AND MUSEUM SERVICES; EDUCATIONAL SERVICES, NAMELY, CLASSES, SEMINARS, WORKSHOPS, LECTURES IN THE FIELD OF ART, ARTISTS, AND ARCHITECTURE; ORGANIZING CULTURAL ACTIVITIES, NAMELY, INFORMATIVE MEETINGS, WORKSHOPS, FILM SCREENINGS, DOCUMENTARY FILM SCREENINGS, AND LIVE PERFORMANCES CONCERNING ART, ARTISTS, AND ARCHITECTURE; PUBLISHING OF BOOKS AND PRINTS IN THE FIELD OF ART, ARTISTS, AND ARCHITECTURE; PROVIDING A WEBSITE IN THE FIELD OF ART AND EDUCATION; PROVIDING A WEBSITE FEATURING CONTEMPORARY ART AND RELATED INFORMATION; ONLINE MUSEUM SERVICES (U.S. CLS. 100, 101 AND 107).

BONNIE LUKEN, EXAMINING ATTORNEY

SN 77-351,038. CINDY BAXTER INTERNATIONAL, INC., NEW MARTINSVILLE, WV. FILED 12-13-2007.

CINDY BAXTER
Masterpiece
STUDIOS

NO CLAIM IS MADE TO THE EXCLUSIVE RIGHT TO USE "STUDIOS", APART FROM THE MARK AS SHOWN.

THE NAME "CINDY BAXTER" IDENTIFIES A LIVING INDIVIDUAL WHOSE CONSENT IS OF RECORD.

THE MARK CONSISTS OF THE WORDING "CINDY BAXTER MASTERPIECE STUDIOS" IN A STYLIZED FONT WITH A SHADOW EFFECT.

FOR PORTRAIT PHOTOGRAPHY (U.S. CLS. 100, 101 AND 107).

FIRST USE 1-1-2007; IN COMMERCE 2-1-2007.
SEAN CROWLEY, EXAMINING ATTORNEY

CLASS 41—(Continued).

SN 77-354,268. JEFFERSON PREP LLC, FALLS CHURCH, VA. FILED 12-18-2007.

Jefferson Prep

THE MARK CONSISTS OF STANDARD CHARACTERS WITHOUT CLAIM TO ANY PARTICULAR FONT, STYLE, SIZE, OR COLOR.

NO CLAIM IS MADE TO THE EXCLUSIVE RIGHT TO USE "PREP", APART FROM THE MARK AS SHOWN.

FOR EDUCATION SERVICES, NAMELY, PROVIDING TUTORING FOR K-12 STUDENTS IN THE FIELDS OF EXAM PREPARATION, LANGUAGE INSTRUCTION, MUSIC INSTRUCTION, AND ACADEMIC TUTORING IN THE FIELDS OF READING, WRITING, MATH, SOCIAL STUDIES, LANGUAGE ARTS, AND SCIENCE (U.S. CLS. 100, 101 AND 107).

JAMES STEIN, EXAMINING ATTORNEY

SN 77-361,724. BLACKHEART HOLDINGS, INC., BRONX, NY. FILED 12-31-2007.

DARK DESIGN WORKS

THE MARK CONSISTS OF STANDARD CHARACTERS WITHOUT CLAIM TO ANY PARTICULAR FONT, STYLE, SIZE, OR COLOR.

NO CLAIM IS MADE TO THE EXCLUSIVE RIGHT TO USE "DESIGN WORKS", APART FROM THE MARK AS SHOWN.

FOR ENTERTAINMENT SERVICES, NAMELY, PROVIDING A WEBSITE FEATURING PHOTOGRAPHIC, AUDIO, VIDEO AND PROSE PRESENTATIONS FEATURING RECORDED MUSICAL PERFORMANCES, MUSICAL VIDEOS AND MOVIE CLIPS; PRODUCTION OF AUDIO CLIPS AND VIDEO CLIPS; PRESENTATION OF LIVE MUSICAL PERFORMANCES; MUSIC VIDEO AND FILM PRODUCTION; ENTERTAINMENT SERVICES, NAMELY, LIVE, TELEVISED AND MOVIE APPEARANCES BY A PROFESSIONAL ENTERTAINER; ENTERTAINMENT SERVICES, NAMELY, PROVIDING A WEB SITE FEATURING RECORDED MUSICAL PERFORMANCES, MUSICAL VIDEOS, RELATED FILM CLIPS, PHOTOGRAPHS, AND OTHER MULTIMEDIA MATERIALS; ENTERTAINMENT SERVICES, NAMELY, PROVIDING ON-LINE COMPUTER GAMES; ENTERTAINMENT SERVICES, NAMELY, PROVIDING PODCASTS IN THE FIELD OF MUSICAL PERFORMANCES FEATURING MUSICAL VIDEOS AND RELATED FILM CLIPS, PHOTOGRAPHS, AND OTHER MULTIMEDIA MATERIALS; MOBILE MEDIA AND ENTERTAINMENT SERVICES IN THE NATURE OF CONTENT PREPARATION, POST-PRODUCTION; MULTIMEDIA ENTERTAINMENT SERVICES IN THE NATURE OF RECORDING, PRODUCTION AND POST-PRODUCTION SERVICES IN THE FIELDS OF MUSIC, VIDEO, AND FILMS; MULTIMEDIA ENTERTAINMENT SOFTWARE PRODUCTION SERVICES (U.S. CLS. 100, 101 AND 107).

EDWARD FENNESSY, EXAMINING ATTORNEY

CLASS 41—(Continued).

SN 77-388,665. MISSY ENTERPRISES, INC., STEAMWOOD, IL. FILED 2-5-2008.

Growth From the Inside Out

THE MARK CONSISTS OF STANDARD CHARACTERS WITHOUT CLAIM TO ANY PARTICULAR FONT, STYLE, SIZE, OR COLOR.

FOR EDUCATIONAL SERVICES, NAMELY, CONDUCTING WORKSHOPS AND SEMINARS IN THE FIELD OF SOCIAL SERVICES, NAMELY, HEALTH CARE AND WEALTH MANAGEMENT AND COURSE MATERIALS IN CONNECTION THEREWITH (U.S. CLS. 100, 101 AND 107).

FIRST USE 8-1-2003; IN COMMERCE 8-1-2003.
LOURDES AYALA, EXAMINING ATTORNEY

SN 77-388,688. MISSY ENTERPRISES, INC., STREAMWOOD, IL. FILED 2-5-2008.

G.F.T.I.O.

THE MARK CONSISTS OF STANDARD CHARACTERS WITHOUT CLAIM TO ANY PARTICULAR FONT, STYLE, SIZE, OR COLOR.

FOR EDUCATIONAL SERVICES, NAMELY, CONDUCTING WORKSHOPS AND SEMINARS IN THE FIELD OF SOCIAL SERVICES, NAMELY, HEALTH CARE AND WEALTH MANAGEMENT AND COURSE MATERIALS IN CONNECTION THEREWITH (U.S. CLS. 100, 101 AND 107).

LOURDES AYALA, EXAMINING ATTORNEY

SN 77-388,742. MISSY ENTERPRISES, INC., STEAMWOOD, IL. FILED 2-5-2008.

The Complete Connection

THE MARK CONSISTS OF STANDARD CHARACTERS WITHOUT CLAIM TO ANY PARTICULAR FONT, STYLE, SIZE, OR COLOR.

FOR CONDUCTING WORKSHOPS AND SEMINARS IN THE FIELD OF SOCIAL NETWORKING (U.S. CLS. 100, 101 AND 107).

FIRST USE 8-1-2003; IN COMMERCE 8-1-2003.
LOURDES AYALA, EXAMINING ATTORNEY

CLASS 41—(Continued).

SN 77-393,131. MARTINEZ, JOSE, NEW YORK, NY. AND KOH, DAVID, NEW YORK, NY. FILED 2-9-2008.

arthouse

THE MARK CONSISTS OF STANDARD CHARACTERS WITHOUT CLAIM TO ANY PARTICULAR FONT, STYLE, SIZE, OR COLOR.

SEC. 2(F).

FOR ENTERTAINMENT SERVICES, NAMELY, THE PRODUCTION AND DISTRIBUTION OF MOTION PICTURES AND MOTION PICTURE EXCERPTS, PRODUCTION OF VIDEOTAPES FEATURING MOTION PICTURES AND DISTRIBUTION OF TELEVISION PROGRAMMING FOR OTHERS; PUBLICATION OF BOOKS, CATALOGS, MAGAZINES AND MANUSCRIPTS PERTAINING TO OR RELATING TO THE MOTION INDUSTRY (U.S. CLS. 100, 101 AND 107).

FIRST USE 8-1-1996; IN COMMERCE 8-1-1996.
SUNG IN, EXAMINING ATTORNEY

CLASS 41—(Continued).

SN 77-417,696. VISTA CABALLO, LLC, DOVE CREEK, CO. FILED 3-10-2008.

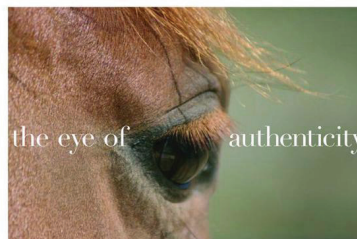

THE COLOR(S) BLACK, WHITE, BROWN, COPPER, AND CHARCOAL GREEN IS/ARE CLAIMED AS A FEATURE OF THE MARK.

THE MARK CONSISTS OF THE WORDING, "THE EYE OF AUTHENTICITY", IN THE COLOR WHITE SUPERIMPOSED OVER A BROWN HORSE FACE WITH BLACK EYES AND COPPER HAIR, WHICH APPEARS INSIDE A CHARCOAL GREEN RECTANGULAR BACKGROUND.

FOR CONDUCTING WORKSHOPS AND SEMINARS IN EQUINE EXPERIENTIAL LEARNING, NAMELY, LEARNING THROUGH REFLECTION ON DIRECT EXPERIENCE (U.S. CLS. 100, 101 AND 107).

KELLY CHOE, EXAMINING ATTORNEY

SN 77-393,133. MARTINEZ, JOSE, NEW YORK, NY. AND KOH, DAVID, NEW YORK, NY. FILED 2-9-2008.

arthouse films

THE MARK CONSISTS OF STANDARD CHARACTERS WITHOUT CLAIM TO ANY PARTICULAR FONT, STYLE, SIZE, OR COLOR.

NO CLAIM IS MADE TO THE EXCLUSIVE RIGHT TO USE "FILMS", APART FROM THE MARK AS SHOWN.

SEC. 2(F).

FOR ENTERTAINMENT SERVICES, NAMELY, THE PRODUCTION AND DISTRIBUTION OF MOTION PICTURES AND MOTION PICTURE EXCERPTS, PRODUCTION OF VIDEOTAPES FEATURING MOTION PICTURES AND DISTRIBUTION OF TELEVISION PROGRAMMING FOR OTHERS; PUBLICATION OF BOOKS, CATALOGS, MAGAZINES AND MANUSCRIPTS PERTAINING TO OR RELATING TO THE MOTION INDUSTRY (U.S. CLS. 100, 101 AND 107).

FIRST USE 8-1-2001; IN COMMERCE 8-1-2001.
SUNG IN, EXAMINING ATTORNEY

SN 77-448,181. DWAYNE WRIGHT AND JABARI GRAHAM, ATLANTA, GA. FILED 4-15-2008.

art beats +lyrics

NO CLAIM IS MADE TO THE EXCLUSIVE RIGHT TO USE "ART BEATS + LYRICS", APART FROM THE MARK AS SHOWN.

THE MARK CONSISTS OF THE TERM "ART BEAT + LYRICS"; THE "Y" IN THE TERM "LYRICS" CONTAINS A STYLIZED HEADPHONE JACK AT THE END.

FOR ART EXHIBITIONS (U.S. CLS. 100, 101 AND 107).
FIRST USE 4-8-2005; IN COMMERCE 4-8-2005.

JIM RINGLE, EXAMINING ATTORNEY

CLASS 41—(Continued).

SN 77-452,330. STANDARD MEDIA GROUP, LLC, THE, NORTH HOLLYWOOD, CA. AND ANGELL, MARC, VENTURA, CA. FILED 4-18-2008.



THE COLOR(S) BLACK, RED AND LIME GREEN IS/ARE CLAIMED AS A FEATURE OF THE MARK.

THE MARK CONSISTS OF "THE STANDARD" IN STYLIZED, LIME GREEN LETTERS WITH BLACK OUTLINING, WITH A BLACK MARTINI GLASS WITH GREEN AND RED OLIVE IN THE GLASS BETWEEN THE WORDS "THE" AND "STANDARD", AND THE STYLIZED LETTERS "THE SOUNDTRACK FOR A LIFESTYLE" IN RED AT THE BOTTOM.

FOR ENTERTAINMENT SERVICES, NAMELY, PROVIDING A RADIO PROGRAM IN THE FIELD OF ADULT STANDARDS MUSIC VIA A GLOBAL COMPUTER NETWORK; ENTERTAINMENT SERVICES, NAMELY, PROVIDING PODCASTS IN THE FIELD OF ADULT STANDARDS MUSIC; ENTERTAINMENT SERVICES, NAMELY, PROVIDING PRERECORDED MUSIC, INFORMATION IN THE FIELD OF MUSIC, AND COMMENTARY AND ARTICLES ABOUT MUSIC, ALL ON-LINE VIA A GLOBAL COMPUTER NETWORK; ENTERTAINMENT SERVICES, NAMELY, PROVIDING WEBCASTS IN THE FIELD OF ADULT STANDARDS MUSIC; MULTIMEDIA ENTERTAINMENT SERVICES IN THE NATURE OF RECORDING, PRODUCTION AND POST-PRODUCTION SERVICES IN THE FIELDS OF MUSIC, VIDEO, AND FILMS; PRODUCTION AND DISTRIBUTION OF RADIO PROGRAMS; RADIO PROGRAM SYNDICATION (U.S. CLS. 100, 101 AND 107).

FIRST USE 12-1-2005; IN COMMERCE 12-1-2005.
LINDA MICKLEBURGH, EXAMINING ATTORNEY

SN 77-454,996. AYU, INC., SEATTLE, WA. FILED 4-22-2008.



NO CLAIM IS MADE TO THE EXCLUSIVE RIGHT TO USE "AYURVEDA", APART FROM THE MARK AS SHOWN.

THE MARK CONSISTS OF A LOTUS DESIGN ALONGSIDE THE WORDS "KERALA AYURVEDA".

FOR EDUCATIONAL SERVICES, NAMELY, PROVIDING COURSES OF INSTRUCTION AND WORK SHOPS IN THE FIELD OF WELLNESS CARE (U.S. CLS. 100, 101 AND 107).

FIRST USE 2-28-2007; IN COMMERCE 2-28-2007.
EDWARD NELSON, EXAMINING ATTORNEY

CLASS 41—(Continued).

SN 77-466,531. DRURY MARKETING, INC., DBA DRURY OUTDOORS, ST. PETERS, MO. FILED 5-6-2008.

DREAM SEASON

THE MARK CONSISTS OF STANDARD CHARACTERS WITHOUT CLAIM TO ANY PARTICULAR FONT, STYLE, SIZE, OR COLOR.

OWNER OF U.S. REG. NO. 2,674,728.

FOR ENTERTAINMENT IN THE NATURE OF ONGOING TELEVISION PROGRAMS IN THE FIELD OF WHITETAILED DEER HUNTING; ENTERTAINMENT SERVICES IN THE NATURE OF AN ONGOING REALITY BASED TELEVISION PROGRAM; ENTERTAINMENT, NAMELY, A CONTINUING TELEVISION SHOW ABOUT HUNTING WHITETAILED DEER BROADCAST OVER TELEVISION, SATELLITE, AUDIO, AND VIDEO MEDIA; PRODUCTION OF DVDS, VIDEOTAPES AND TELEVISION PROGRAMS FEATURING WHITETAILED DEER HUNTING (U.S. CLS. 100, 101 AND 107).

FIRST USE 12-1-1997; IN COMMERCE 4-1-1998.
CYNTHIA TRIPI, EXAMINING ATTORNEY

SN 77-472,482. CITY OF GLENDALE, GLENDALE, CO. FILED 5-12-2008.



WORLD RUGBY
HALL OF FAME

NO CLAIM IS MADE TO THE EXCLUSIVE RIGHT TO USE "WORLD RUGBY HALL OF FAME", APART FROM THE MARK AS SHOWN.

THE MARK CONSISTS OF THE WORDS "WORLD RUGBY HALL OF FAME", WITH A CIRCLE WITH VERTICAL AND HORIZONTAL LINES EXTENDING ACROSS THE CIRCLE.

FOR CONDUCTING EDUCATIONAL EXHIBITIONS IN THE NATURE OF RUGBY; CONDUCTING ENTERTAINMENT EXHIBITIONS IN THE NATURE OF RUGBY; MUSEUMS (U.S. CLS. 100, 101 AND 107).

FIRST USE 8-31-2007; IN COMMERCE 9-8-2007.
MICHAEL TANNER, EXAMINING ATTORNEY

CLASS 41—(Continued).

SN 77-475,650. FINCH, ROBERT, SAN FRANCISCO, CA. FILED 5-15-2008.

GEOMEDICA

THE MARK CONSISTS OF STANDARD CHARACTERS WITHOUT CLAIM TO ANY PARTICULAR FONT, STYLE, SIZE, OR COLOR.

FOR EDUCATIONAL SERVICES IN THE FIELDS OF CONTINUING MEDICAL EDUCATION, PATIENT EDUCATION AND HEALTH CARE, NAMELY, CONDUCTING SEMINARS, GRAND ROUNDS, DEBATES, ROUND TABLE DISCUSSIONS, SELF-DIRECTED COMPUTER INTERACTIVE COURSES, EDUCATIONAL FORUMS, AND EDUCATIONAL LECTURES (U.S. CLS. 100, 101 AND 107).

JOHN E. MICHOS, EXAMINING ATTORNEY

SN 77-477,878. CORBETT COMMUNICATIONS, INC., STATESVILLE, NC. FILED 5-19-2008.

Savvy Socializing

THE MARK CONSISTS OF STANDARD CHARACTERS WITHOUT CLAIM TO ANY PARTICULAR FONT, STYLE, SIZE, OR COLOR.

FOR EDUCATIONAL SERVICES, NAMELY, CONDUCTING WORKSHOPS, SEMINARS, AND LECTURES IN THE FIELD OF BUSINESS NETWORKING AND INTERPERSONAL COMMUNICATIONS AND DISTRIBUTION OF COURSE MATERIAL IN CONNECTION THEREWITH (U.S. CLS. 100, 101 AND 107).

MARY MUNSON, EXAMINING ATTORNEY

SN 77-481,369. 180 FITNESS, LLC, DBA 180 FITNESS, STATESBORO, GA. FILED 5-22-2008.



NO CLAIM IS MADE TO THE EXCLUSIVE RIGHT TO USE "FITNESS", APART FROM THE MARK AS SHOWN.

THE COLOR(S) RED, WHITE, BLACK, AND GRAY IS/ARE CLAIMED AS A FEATURE OF THE MARK.

THE MARK CONSISTS OF A RED CIRCLE WITH A WHITE ARROW WITHIN THE CIRCLE OUTLINED IN BLACK; NUMBERS "180" ARE BLACK; WORD FITNESS IS GRAY AND LOWERCASE; PHRASE "TURN YOUR LIFE AROUND" IS RED, CAPITALIZED, AND ITALICIZED.

FOR HEALTH CLUB SERVICES, NAMELY, PROVIDING INSTRUCTION AND EQUIPMENT IN THE FIELD OF PHYSICAL EXERCISE (U.S. CLS. 100, 101 AND 107).

FIRST USE 1-1-2006; IN COMMERCE 1-1-2006.

ELI HELLMAN, EXAMINING ATTORNEY

CLASS 41—(Continued).

SN 77-485,679. AFRICA MEDIA-IMAGE PROJECT, INC., WASHINGTON, DC. FILED 5-29-2008.

The Africa Minute

THE MARK CONSISTS OF STANDARD CHARACTERS WITHOUT CLAIM TO ANY PARTICULAR FONT, STYLE, SIZE, OR COLOR.

NO CLAIM IS MADE TO THE EXCLUSIVE RIGHT TO USE "AFRICA", APART FROM THE MARK AS SHOWN. FOR DISTRIBUTION OF TELEVISION PROGRAMMING TO CABLE TELEVISION SYSTEMS; PRODUCTION OF TELEVISION PROGRAMS (U.S. CLS. 100, 101 AND 107).

FIRST USE 3-12-2008; IN COMMERCE 3-12-2008.

WANDA KAY PRICE, EXAMINING ATTORNEY

SN 77-487,816. H.S. FILMS, LLC, WOODLAND HILLS, CA. FILED 5-30-2008.

HOLLYWOOD XXXPOSED

THE MARK CONSISTS OF STANDARD CHARACTERS WITHOUT CLAIM TO ANY PARTICULAR FONT, STYLE, SIZE, OR COLOR.

NO CLAIM IS MADE TO THE EXCLUSIVE RIGHT TO USE "HOLLYWOOD", APART FROM THE MARK AS SHOWN.

FOR ENTERTAINMENT SERVICES, NAMELY, PROVIDING A WEBSITE FEATURING IMAGES, GRAPHICS, VIDEO, PHOTOGRAPHS AND TEXT IN THE FIELD OF ADULT ENTERTAINMENT VIA A GLOBAL COMPUTER NETWORK (U.S. CLS. 100, 101 AND 107).

DAVID I, EXAMINING ATTORNEY

CLASS 41—(Continued).

SN 77-490,598. BLAIR, WILLIAM, EUGENE, OR. AND GRUBB, ROBERT W, EUGENE, OR. FILED 6-4-2008.



THE MARK CONSISTS OF AN OVAL WITH A STYLIZED EAGLE DESIGN AND THE WORDS "OUTDOOR VENTURES" ABOVE A PAIR OF CROSSED OARS.

FOR TRAINING SERVICES IN THE FIELD OF RIVER GUIDING, RIVER SAFETY, RIVER RAFTING, RIVER BOATING, WHITEWATER RAFTING, ROWING, PADDLING, ADVANCED RIVER SKILLS IN THE NATURE OF ADVANCED RECOGNITION OF RIVER FEATURES, HAZARDS AND NAVIGATION ISSUES AND WEATHER AND FLOW FACTORS IN SAFETY AND ROUTE CHOICES, MANAGING CREWS OF ROWERS OR PADDLERS OF VARYING EXPERTISE, EQUIPMENT CHOICE, EQUIPMENT SAFETY AND MAINTENANCE, AND RECOGNIZING NATURAL ECOLOGICAL FEATURES AND CONDITIONS OF RIVERS AND ECONOMIC AND LEGAL CONCERNS RELEVANT TO GUIDE SERVICE (U.S. CLS. 100, 101 AND 107).

FIRST USE 1-1-1999; IN COMMERCE 1-1-1999.
JILL PRATER, EXAMINING ATTORNEY

SN 77-491,233. PEACOCK, MARK AARON, OSCEOLA, WI. FILED 6-4-2008.

oCeLoT

THE MARK CONSISTS OF STANDARD CHARACTERS WITHOUT CLAIM TO ANY PARTICULAR FONT, STYLE, SIZE, OR COLOR.

FOR COMPOSITION OF MUSIC FOR OTHERS; MUSIC COMPOSITION FOR OTHERS; PRESENTATION OF MUSICAL PERFORMANCE (U.S. CLS. 100, 101 AND 107).
FIRST USE 4-1-2000; IN COMMERCE 8-8-2001.

SAMUEL E. SHARPER JR., EXAMINING ATTORNEY

CLASS 41—(Continued).

SN 77-491,354. NM ENTERTAINMENT, INC., DBA OMEGA ENTERTAINMENT, INC., BEVERLY HILLS, CA. FILED 6-5-2008.

Omega Entertainment

THE MARK CONSISTS OF STANDARD CHARACTERS WITHOUT CLAIM TO ANY PARTICULAR FONT, STYLE, SIZE, OR COLOR.

NO CLAIM IS MADE TO THE EXCLUSIVE RIGHT TO USE "ENTERTAINMENT", APART FROM THE MARK AS SHOWN.

FOR DISTRIBUTION OF ENTERTAINMENT CONTENT, NAMELY, TELEVISION SHOWS AND MOVIES (U.S. CLS. 100, 101 AND 107).

FIRST USE 10-5-1978; IN COMMERCE 10-5-1978.
RAUL CORDOVA, EXAMINING ATTORNEY

SN 77-491,527. PARKER RACING TEAM, LLC, DBA THE DIRT TRACK RACING SCHOOL, CHARLOTTE, NC. FILED 6-5-2008.



THE COLOR(S) RED, WHITE, AND BLACK IS/ARE CLAIMED AS A FEATURE OF THE MARK.

THE MARK CONSISTS OF THE LETTER "I" AND A RED HEART ABOVE THE WORD "DIRT", THE LETTERS BEING IN THE COLOR WHITE IN BLOCK FORM, ALL ON A BLACK BACKGROUND.

FOR ENTERTAINMENT IN THE NATURE OF AUTOMOBILE, MOTORCYCLE, TRUCK, AND GO-CART RACES (U.S. CLS. 100, 101 AND 107).

INGA ERVIN, EXAMINING ATTORNEY

SN 77-492,235. HOLDER, JOE, LAKE TAPPS, WA. FILED 6-5-2008.

FAST PLAY

THE MARK CONSISTS OF STANDARD CHARACTERS WITHOUT CLAIM TO ANY PARTICULAR FONT, STYLE, SIZE, OR COLOR.

FOR GOLF COURSES; RENTAL OF GOLF EQUIPMENT (U.S. CLS. 100, 101 AND 107).

DAVID ELTON, EXAMINING ATTORNEY

CLASS 41—(Continued).

SN 77-498,537. BR CONSULTING, INC., SEDONA, AZ. FILED 6-13-2008.

BRAIN DAHN YOGA

THE MARK CONSISTS OF STANDARD CHARACTERS WITHOUT CLAIM TO ANY PARTICULAR FONT, STYLE, SIZE, OR COLOR.

OWNER OF U.S. REG. NOS. 3,141,495, 3,301,942 AND OTHERS.

NO CLAIM IS MADE TO THE EXCLUSIVE RIGHT TO USE "BRAIN" AND "YOGA", APART FROM THE MARK AS SHOWN.

THE ENGLISH TRANSLATION OF THE WORD "DAHN" IN THE MARK IS RED OR ENERGY.

FOR EDUCATIONAL SERVICES, NAMELY, CONDUCTING CLASSES, SEMINARS, CONFERENCES, EXHIBITIONS, AND PRIVATE SESSIONS IN THE FIELD OF MEDITATION, RELAXATION AND ENERGY TRAINING (U.S. CLS. 100, 101 AND 107).

KELLY BOULTON, EXAMINING ATTORNEY

SN 77-498,942. JEFFERSON MORTGAGE PARTNERS LP, OAKTON, VA. FILED 6-13-2008.



THE STIPPLING IS FOR SHADING PURPOSES ONLY. THE MARK CONSISTS OF THE STYLIZED WORDS "THE NEGOTIATED SOLUTION" INSIDE A RECTANGLE SHAPE DESIGN WITH ROUNDED EDGES. A THIN LINE BELOW THE WORD "SOLUTION". TO THE LEFT OF THE STYLIZED WORDS IS A CIRCLE WITH THE OUTLINE OF A HOUSE IN THE CENTER.

FOR ONLINE EDUCATIONAL SERVICES, NAMELY, COURSES IN THE FIELD OF HOUSING AND MORTGAGES FEATURING AN ELEVEN STEP PROCESS TO PROVIDE HOMEOWNERS THE KNOWLEDGE AND STRATEGIES TO EFFECTIVELY COMPLETE A RESIDENTIAL REAL ESTATE SHORT SALE AND ADDRESS THE ADVERSE EFFECTS OF THE CURRENT HOUSING AND MORTGAGE CRISIS (U.S. CLS. 100, 101 AND 107).

FIRST USE 5-12-2008; IN COMMERCE 6-3-2008.

JOHN DALIER, EXAMINING ATTORNEY

CLASS 41—(Continued).

SN 77-502,201. CLEVELAND STATE UNIVERSITY, CLEVELAND, OH. FILED 6-18-2008.



THE MARK CONSISTS OF THE IMAGE OF A VIKING PEERING OVER THE WORDS "CLEVELAND STATE".

SEC. 2(F) AS TO "CLEVELAND STATE".

FOR EDUCATIONAL SERVICES, NAMELY, COURSES AT THE UNDERGRADUATE AND GRADUATE UNIVERSITY LEVEL AND DISTRIBUTING COURSE MATERIAL THEREWITH; EXTENSION, CONTINUING, AND COMMUNITY EDUCATIONAL SERVICES, NAMELY, CONDUCTING CLASSES, LECTURES, WORKSHOPS, SEMINARS, CONFERENCES, EXHIBITIONS, AND CAMPS IN THE FIELD OF ATHLETICS; ENTERTAINMENT SERVICES, NAMELY, ARRANGING AND CONDUCTING ATHLETIC EVENTS, TOURNAMENTS, EXHIBITIONS, AND CONFERENCES (U.S. CLS. 100, 101 AND 107).

FIRST USE 9-1-2007; IN COMMERCE 9-1-2007.

MATTHEW MCDOWELL, EXAMINING ATTORNEY

SN 77-503,049. CENTRAL NEW MEXICO COMMUNITY COLLEGE, ALBUQUERQUE, NM. FILED 6-19-2008.



THE MARK CONSISTS OF THE LETTERS "CNM" FOLLOWED BY AN ARROWHEAD POINTING AWAY FROM THE LETTERS.

FOR EDUCATIONAL SERVICES, NAMELY, CONDUCTING DISTANCE LEARNING INSTRUCTION AT THE COLLEGE LEVEL, NOT INCLUDING CONDUCTING DISTANCE LEARNING INSTRUCTION IN THE FIELD OF NUTRITION, AND DISTRIBUTION OF COURSE MATERIALS IN CONNECTION THEREWITH; EDUCATIONAL SERVICES, NAMELY, PROVIDING COURSES OF INSTRUCTION AT THE COLLEGE LEVEL, NOT INCLUDING COURSES OF INSTRUCTION IN THE FIELD OF NUTRITION, AND DISTRIBUTION OF COURSE MATERIALS IN CONNECTION THEREWITH (U.S. CLS. 100, 101 AND 107).

FIRST USE 6-2-2006; IN COMMERCE 6-2-2006.

MICHAEL TANNER, EXAMINING ATTORNEY

CLASS 41—(Continued).

SN 77-504,227. TEAM BUILDING USA, INC, BEDFORD, TX. FILED 6-20-2008.

Team Building USA

THE MARK CONSISTS OF STANDARD CHARACTERS WITHOUT CLAIM TO ANY PARTICULAR FONT, STYLE, SIZE, OR COLOR.

NO CLAIM IS MADE TO THE EXCLUSIVE RIGHT TO USE "TEAM BUILDING", APART FROM THE MARK AS SHOWN.

SEC. 2(F).
FOR BUSINESS TRAINING (U.S. CLS. 100, 101 AND 107).

FIRST USE 4-1-1999; IN COMMERCE 4-1-1999.
COLLEEN DOMBROW, EXAMINING ATTORNEY

CLASS 41—(Continued).

SN 77-504,659. KIC MEDIA, LLC, WINDERMERE, FL. FILED 6-20-2008.



OWNER OF U.S. REG. NO. 3,371,808.
NO CLAIM IS MADE TO THE EXCLUSIVE RIGHT TO USE "HONY TONK TV", APART FROM THE MARK AS SHOWN.

THE COLOR(S) RED, WHITE, BLUE AND BLACK IS/ARE CLAIMED AS A FEATURE OF THE MARK.

THE MARK CONSISTS OF THE WORD "HONKY TONK TV" IN STYLIZED LETTERS. THE COLOR BLUE APPEARS IN THE LETTERS "HON" AND IN THE BOTTOM OF THE LETTER "K". THE COLOR WHITE APPEARS IN VARIOUS SHADES IN THE STARS IN THE LETTERS "HON" AND IN THE STRIPES IN "KY" AND "TONK". THE COLOR RED APPEARS IN THE STRIPS IN "KY" AND IN "TONK". THE SQUARE AND WORD "TV" AND OUTLINES OF "HONKY TONK" ARE IN BLACK.

FOR ENTERTAINMENT SERVICES IN THE NATURE OF AN ON-GOING TELEVISION SERIES FEATURING CELEBRITIES, MUSIC, VIDEOS, LIVE ACTION, CLIPS, COMEDY AND DRAMA; PROVIDING ON-LINE INFORMATION IN THE FIELD OF ENTERTAINMENT CONCERNING MUSIC AND TELEVISION PROGRAMS (U.S. CLS. 100, 101 AND 107).

FIRST USE 9-1-2006; IN COMMERCE 7-4-2007.
JENNIFER MARTIN, EXAMINING ATTORNEY

SN 77-504,470. LASWELL FOUNDATION FOR LEARNING AND LAUGHTER, INC., TAMPA, FL. FILED 6-20-2008.

A DAY TO LAUGH AND PLAY

THE MARK CONSISTS OF STANDARD CHARACTERS WITHOUT CLAIM TO ANY PARTICULAR FONT, STYLE, SIZE, OR COLOR.

FOR CHARITABLE SERVICES, NAMELY, CONDUCTING AND ORGANIZING CULTURAL, EDUCATIONAL AND RECREATIONAL EVENTS AND ACTIVITIES FOR CHILDREN AND FAMILIES (U.S. CLS. 100, 101 AND 107).

FIRST USE 8-10-2007; IN COMMERCE 8-10-2007.
LEIGH LOWRY, EXAMINING ATTORNEY

SN 77-505,209. ONE TRIBE FOUNDATION, MALIBU, CA. FILED 6-23-2008.

INVESTING IN HUMAN POTENTIAL

THE MARK CONSISTS OF STANDARD CHARACTERS WITHOUT CLAIM TO ANY PARTICULAR FONT, STYLE, SIZE, OR COLOR.

FOR CHARITABLE SERVICES, NAMELY, PROVIDING TRAINING IN THE FIELDS OF HEALTHCARE, NURSING AND EDUCATION; CHARITABLE EDUCATION SERVICES, NAMELY, PROVIDING COURSES, SEMINARS AND WORKSHOPS IN THE FIELDS OF HEALTHCARE, NURSING AND EDUCATION; CHARITABLE SERVICES, NAMELY, PROVIDING BOOKS TO PEOPLE; CHARITABLE EDUCATION SERVICES, NAMELY, CONDUCTING DISTANCE LEARNING INSTRUCTION IN THE FIELDS OF HEALTHCARE, NURSING AND EDUCATION; CHARITABLE EDUCATION SERVICES, NAMELY, MENTORING IN THE FIELDS OF HEALTHCARE, NURSING AND EDUCATION (U.S. CLS. 100, 101 AND 107).

COLLEEN KEARNEY, EXAMINING ATTORNEY

CLASS 41—(Continued).

SN 77-509,941. COYOTE SPRINGS INVESTMENT LLC, SPARKS, NV. FILED 6-27-2008.

A SIGNATURE IS OUR PROMISE

THE MARK CONSISTS OF STANDARD CHARACTERS WITHOUT CLAIM TO ANY PARTICULAR FONT, STYLE, SIZE, OR COLOR.

FOR PROVIDING GOLF COURSES; PROVIDING GOLF INSTRUCTION; GOLF CADDIE SERVICES; GOLF COURSE SERVICES; PROVIDING GOLF FACILITIES CONSISTING OF LEARNING AND PRACTICE AREAS; GOLF CLUB SERVICES; PROVIDING A WEBSITE THROUGH WHICH GOLFERS CAN LOCATE INFORMATION RELATED TO GOLF, GOLF COURSES AND GOLF TOURNAMENTS; PROVIDING A WEBSITE WHERE GOLFERS CAN SCHEDULE AND RESERVE TEE TIMES AT GOLF COURSES; PROVIDING A WEBSITE WHERE GOLFERS CAN ARRANGE GOLF OUTINGS AND TOURNAMENTS; ENTERTAINMENT SERVICES, NAMELY, ORGANIZING, CONDUCTING, AND PROVIDING GOLF TOURNAMENTS (U.S. CLS. 100, 101 AND 107).

MICHAEL WIENER, EXAMINING ATTORNEY

SN 77-510,686. JOHN T. BURKE, JR., MIAMI BEACH, FL. FILED 6-28-2008.

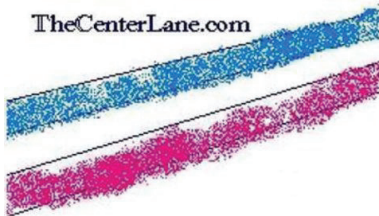

THE COLOR(S) RED, WHITE, AND BLUE IS/ARE CLAIMED AS A FEATURE OF THE MARK.

THE MARK CONSISTS OF DIAGONAL RED AND BLUE STRIPES WITHIN BLACK LINES, RUNNING FROM THE LOWER LEFT CORNER TO THE UPPER RIGHT CORNER OF A RECTANGLE, AGAINST A WHITE BACKGROUND, WITH A WHITE SPACE BETWEEN THE TWO STRIPES AND "THECENTERLANE.COM" WRITTEN WITHIN THE RECTANGLE AT THE TOP, OFFSET TO THE LEFT.

FOR ON-LINE JOURNALS, NAMELY, BLOGS FEATURING NEWS, OPINION AND COMMENTARY, NAMELY, IN THE FIELD OF POLITICS (U.S. CLS. 100, 101 AND 107).

FIRST USE 4-29-2008; IN COMMERCE 4-29-2008.
RONALD DELGIZZI, EXAMINING ATTORNEY

CLASS 41—(Continued).

SN 77-513,730. NICKY MORSE ENTERPRISES, LLC, DELAWARE, OH. FILED 7-2-2008.

The Racing Chef

THE MARK CONSISTS OF STANDARD CHARACTERS WITHOUT CLAIM TO ANY PARTICULAR FONT, STYLE, SIZE, OR COLOR.

NO CLAIM IS MADE TO THE EXCLUSIVE RIGHT TO USE "CHEF", APART FROM THE MARK AS SHOWN.

FOR ENTERTAINMENT, NAMELY, PRODUCTION OF COOKING DEMONSTRATIONS IN THE NATURE OF A TELEVISION SERIES AND LIVE DEMONSTRATIONS FEATURING FOOD (U.S. CLS. 100, 101 AND 107).

FIRST USE 10-8-2007; IN COMMERCE 10-8-2007.
JESSICA A. POWERS, EXAMINING ATTORNEY

SN 77-515,150. PUJOL, JAIME, MIAMI, FL. FILED 7-5-2008.

UNSINKABLE SPIRIT OF AMERICA

THE MARK CONSISTS OF STANDARD CHARACTERS WITHOUT CLAIM TO ANY PARTICULAR FONT, STYLE, SIZE, OR COLOR.

FOR ENTERTAINMENT IN THE NATURE OF AIR SHOWS (U.S. CLS. 100, 101 AND 107).

NICHOLAS COLEMAN, EXAMINING ATTORNEY

SN 77-515,481. LIVEWIRE SERVICES, INC., AUSTIN, TX. FILED 7-7-2008.

USENETPEDIA

THE MARK CONSISTS OF STANDARD CHARACTERS WITHOUT CLAIM TO ANY PARTICULAR FONT, STYLE, SIZE, OR COLOR.

FOR EDUCATIONAL SERVICES, NAMELY, PROVIDING ON-LINE NON-DOWNLOADABLE PUBLICATIONS IN THE NATURE OF AN INTERACTIVE ENCYCLOPEDIA IN THE FIELD OF USENET NEWSGROUPS (U.S. CLS. 100, 101 AND 107).

FIRST USE 2-6-2007; IN COMMERCE 2-6-2007.
LAURIE MAYES, EXAMINING ATTORNEY

CLASS 41—(Continued).

SN 77-519,209. WHERETOFINDCARE.COM LLC, WESTLAND, MI. FILED 7-10-2008.

CARE STARS

THE MARK CONSISTS OF STANDARD CHARACTERS WITHOUT CLAIM TO ANY PARTICULAR FONT, STYLE, SIZE, OR COLOR.

NO CLAIM IS MADE TO THE EXCLUSIVE RIGHT TO USE "CARE", APART FROM THE MARK AS SHOWN.

FOR (BASED ON USE IN COMMERCE) PROVIDING RECOGNITION AND INCENTIVES BY THE WAY OF AWARDS TO DEMONSTRATE EXCELLENCE IN THE FIELD OF HEALTH CARE; (BASED ON INTENT-TO-USE IN COMMERCE) PROVIDING RECOGNITION AND INCENTIVES BY THE WAY OF AWARDS TO DEMONSTRATE EXCELLENCE IN THE FIELD OF MENTAL HEALTH, PHARMACY SERVICES, LABORATORY SERVICES, OCCUPATIONAL THERAPY, SPEECH THERAPY, WEIGHT LOSS SERVICES, VETERINARY CARE, MEDICAL EQUIPMENT SALES, SATISFACTION AND SURVEY SERVICES, SECRET SHOPPER SERVICES, CAR CARE, SALONS, SPAS, DAY CARE, ASSISTED LIVING AND RETIREMENT FACILITIES (U.S. CLS. 100, 101 AND 107).

FIRST USE 4-30-2008; IN COMMERCE 4-30-2008.
WILLIAM VERHOSEK, EXAMINING ATTORNEY

CLASS 41—(Continued).

SN 77-520,998. VORTEX, INC., AUSTIN, TX. FILED 7-14-2008.

THE TEXAS CHAINSAW MASSACRE

THE MARK CONSISTS OF STANDARD CHARACTERS WITHOUT CLAIM TO ANY PARTICULAR FONT, STYLE, SIZE, OR COLOR.

NO CLAIM IS MADE TO THE EXCLUSIVE RIGHT TO USE "TEXAS", APART FROM THE MARK AS SHOWN.

FOR ENTERTAINMENT SERVICES IN THE NATURE OF AN AMUSEMENT PARK ATTRACTION, NAMELY, A THEMED AREA; ENTERTAINMENT SERVICES IN THE NATURE OF AN AMUSEMENT PARK SHOW; PRESENTATION OF LIVE SHOW PERFORMANCES; RECREATIONAL PARK SERVICES (U.S. CLS. 100, 101 AND 107).

ROBERT C. CLARK JR., EXAMINING ATTORNEY

SN 77-520,051. STRATEGIC SAFETY ASSOCIATES, INC., PORTLAND, OR. FILED 7-11-2008.



THE MARK CONSISTS OF THE STYLIZED FIGURE OF A HUMAN BEING WITHIN A CIRCLE, THE FIGURE BEING BISECTED BY A FLARING RIBBON AND PUSHING AGAINST THE SIDE OF THE CIRCLE. THERE IS A CURVED CUT-OUT IN THE ARM OF THE PERSON AND A CIRCULAR CUT-OUT AT THE HIP OF THE PERSON AT THE SAME LEVEL AS THE BISECTING RIBBON.

FOR TRAINING SERVICES IN THE FIELD OF DECREASING MOVEMENT INJURIES IN THE WORKPLACE, IN PUBLIC, AND AT HOME (U.S. CLS. 100, 101 AND 107).

FIRST USE 1-0-2005; IN COMMERCE 1-0-2005.
SARA THOMAS, EXAMINING ATTORNEY

SN 77-522,498. E! ENTERTAINMENT TELEVISION, INC., LOS ANGELES, CA. FILED 7-15-2008.

Peter Perfect

THE MARK CONSISTS OF STANDARD CHARACTERS WITHOUT CLAIM TO ANY PARTICULAR FONT, STYLE, SIZE, OR COLOR.

THE NAME(S), PORTRAIT(S), AND/OR SIGNATURE(S) SHOWN IN THE MARK IDENTIFIES "PETER ISHKHANS", WHOSE CONSENT(S) TO REGISTER IS MADE OF RECORD.

FOR ENTERTAINMENT IN THE NATURE OF ONGOING TELEVISION PROGRAMS ABOUT BEAUTY, STYLE, FASHION, GROOMING, MAKEOVERS, BUSINESS MAKEOVERS, DESIGN, HOME, ENTERTAINING, SELF-IMPROVEMENT, PERSONAL GOAL AND WISH FULFILLMENT; ENTERTAINMENT SERVICES, NAMELY, PROVIDING A WEBSITE FEATURING VIDEO PRESENTATIONS IN THE FIELDS OF BEAUTY, STYLE, FASHION, GROOMING, MAKEOVERS, BUSINESS MAKEOVERS, DESIGN, HOME, ENTERTAINING, SELF-IMPROVEMENT, PERSONAL GOAL AND WISH FULFILLMENT AND INFORMATION RELATED TO SUCH PROGRAMS VIA A GLOBAL COMPUTER NETWORK; PROVIDING ON-LINE PUBLICATIONS IN THE NATURE OF BLOGS IN CONNECTION WITH THE FOREGOING (U.S. CLS. 100, 101 AND 107).

FIRST USE 3-15-2008; IN COMMERCE 3-15-2008.
FRANK LATTUCA, EXAMINING ATTORNEY

CLASS 41—(Continued).

SN 77-522,631. SANCHEZ, CAMILO A, DBA TAO HEALING ARTS, PINEVILLE, NC. FILED 7-15-2008.

Elixir Qigong

THE MARK CONSISTS OF STANDARD CHARACTERS WITHOUT CLAIM TO ANY PARTICULAR FONT, STYLE, SIZE, OR COLOR.

NO CLAIM IS MADE TO THE EXCLUSIVE RIGHT TO USE "QIGONG", APART FROM THE MARK AS SHOWN.

FOR PROVIDING EDUCATION AND INSTRUCTION IN A UNIQUE SEQUENCE OF QIGONG TECHNIQUES, NAMELY, PROVIDING CERTIFICATION TRAININGS, CLASSES, AND WEEKEND WORKSHOPS IN THE FIELD OF QIGONG (U.S. CLS. 100, 101 AND 107).

FIRST USE 6-0-2007; IN COMMERCE 6-0-2007.
LINDA LAVACHE, EXAMINING ATTORNEY

SN 77-523,174. CATALYST HOLDINGS, INC., ORLANDO, FL. FILED 7-16-2008.

THE RACE TO RECOVER AMERICA'S MISSING CHILDREN

THE MARK CONSISTS OF STANDARD CHARACTERS WITHOUT CLAIM TO ANY PARTICULAR FONT, STYLE, SIZE, OR COLOR.

NO CLAIM IS MADE TO THE EXCLUSIVE RIGHT TO USE "RACE" AND "MISSING CHILDREN", APART FROM THE MARK AS SHOWN.

FOR ENTERTAINMENT IN THE NATURE OF MOTOR RACING AND ROAD RALLY EVENTS; ENTERTAINMENT IN THE NATURE OF COMPETITIONS IN THE FIELD OF MOTOR RACING CONTESTS (U.S. CLS. 100, 101 AND 107).

FIRST USE 1-0-2005; IN COMMERCE 5-0-2006.
ELISSA GARBER KON, EXAMINING ATTORNEY

SN 77-524,018. SPORTS LAND GROUP, LLC, FRANKLIN, TN. FILED 7-16-2008.

A-GAME SPORTSPLEX

THE MARK CONSISTS OF STANDARD CHARACTERS WITHOUT CLAIM TO ANY PARTICULAR FONT, STYLE, SIZE, OR COLOR.

NO CLAIM IS MADE TO THE EXCLUSIVE RIGHT TO USE "SPORTSPLEX", APART FROM THE MARK AS SHOWN.

FOR PROVIDING FACILITIES FOR PLAYING MULTIPLE SPORTS AND FITNESS FACILITIES (U.S. CLS. 100, 101 AND 107).

ALEX KEAM, EXAMINING ATTORNEY

CLASS 41—(Continued).

SN 77-524,604. LOYALIST COLLEGE, BELLVILLE, CANADA, FILED 7-17-2008.



The logo for Loyalist Certification Services features the word "Loyalist" in a bold, black, sans-serif font. The letter "o" in "Loyalist" is replaced by a red circle containing a white checkmark. Below the word "Loyalist" is the text "CERTIFICATION SERVICES" in a smaller, black, sans-serif font.

NO CLAIM IS MADE TO THE EXCLUSIVE RIGHT TO USE "CERTIFICATION SERVICES", APART FROM THE MARK AS SHOWN.

THE COLOR(S) BLACK, RED AND WHITE IS/ARE CLAIMED AS A FEATURE OF THE MARK.

THE MARK CONSISTS OF THE WORDS "LOYALIST CERTIFICATION SERVICES" IN BLACK TYPEFACE, EXCEPT THE "O" IN "LOYALIST" IS A RED CIRCLE WITH A WHITE CHECKMARK.

FOR EDUCATIONAL SERVICES, NAMELY, WEB-BASED AND CLASSROOM TRAINING AND EXAMINATION FOR CERTIFICATION OF INFORMATION TECHNOLOGY PROFESSIONALS IN INFORMATION TECHNOLOGY INFRASTRUCTURE LIBRARY AND INFORMATION TECHNOLOGY SERVICE MANAGEMENT (U.S. CLS. 100, 101 AND 107).

FIRST USE 0-0-2005; IN COMMERCE 0-0-2005.
KHANH LE, EXAMINING ATTORNEY

SN 77-524,744. CREDIT MARKETS REAL ESTATE CORP., NEW YORK, NY. FILED 7-17-2008.



The logo for Reno State of Nevada Championship Slots features the word "RENO" in a small, white, sans-serif font inside a black square. To the right of "RENO" is the text "STATE OF NEVADA" in a white, sans-serif font, followed by "CHAMPIONSHIP" in a larger, white, sans-serif font. Below this text is the word "SLOTS" in a large, bold, black, sans-serif font. To the right of "SLOTS" are three stylized slot machine reels, each containing a different symbol.

NO CLAIM IS MADE TO THE EXCLUSIVE RIGHT TO USE "RENO STATE OF NEVADA CHAMPIONSHIP SLOTS" AND THE DESIGN OF THE OUTLINE OF THE STATE OF NEVADA, APART FROM THE MARK AS SHOWN.

THE MARK CONSISTS OF THE TERMS "STATE OF NEVADA CHAMPIONSHIP SLOTS" FEATURING THREE "GSR" LOGOS AND THE TERM "RENO" UPON A BLACK OUTLINE OF THE STATE OF NEVADA.

FOR CASINO SERVICES (U.S. CLS. 100, 101 AND 107).
EMILY CHUO, EXAMINING ATTORNEY

CLASS 41—(Continued).

SN 77-524,747. CREDIT MARKETS REAL ESTATE CORP., NEW YORK, NY. FILED 7-17-2008.



NO CLAIM IS MADE TO THE EXCLUSIVE RIGHT TO USE "STATE OF NEVADA RENO CHAMPIONSHIP POKER" AND THE DESIGN OF THE OUTLINE OF THE STATE OF NEVADA, APART FROM THE MARK AS SHOWN.
 THE MARK CONSISTS OF THE TERMS "STATE OF NEVADA CHAMPIONSHIP POKER" FEATURING THE "GSR" LOGO IN A POKER HAND AND THE TERM "RENO" UPON A BLACK OUTLINE OF THE STATE OF NEVADA.
 FOR CASINO SERVICES (U.S. CLS. 100, 101 AND 107).
 EMILY CHUO, EXAMINING ATTORNEY

SN 77-524,760. CREDIT MARKETS REAL ESTATE CORP., NEW YORK, NY. FILED 7-17-2008.



NO CLAIM IS MADE TO THE EXCLUSIVE RIGHT TO USE "STATE OF NEVADA RENO CHAMPIONSHIP BLACKJACK" AND THE DESIGN OF THE OUTLINE OF THE STATE OF NEVADA, APART FROM THE MARK AS SHOWN.
 THE MARK CONSISTS OF THE TERMS "STATE OF NEVADA CHAMPIONSHIP BLACKJACK" FEATURING A BLACKJACK HAND FEATURING THE "GSR" LOGO AND THE TERM "RENO" UPON A BLACK OUTLINE OF THE STATE OF NEVADA.
 FOR CASINO SERVICES (U.S. CLS. 100, 101 AND 107).
 EMILY CHUO, EXAMINING ATTORNEY

CLASS 41—(Continued).

SN 77-524,761. CREDIT MARKETS REAL ESTATE CORP., NEW YORK, NY. FILED 7-17-2008.

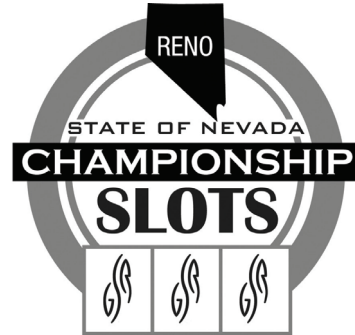

NO CLAIM IS MADE TO THE EXCLUSIVE RIGHT TO USE "RENO STATE OF NEVADA CHAMPIONSHIP SLOTS" AND THE DESIGN OF THE OUTLINE OF THE STATE OF NEVADA, APART FROM THE MARK AS SHOWN.
 THE MARK CONSISTS OF THE TERMS "STATE OF NEVADA CHAMPIONSHIP SLOTS" AGAINST A BACKGROUND OF A CIRCLE DESIGN FEATURING BELOW THREE "GSR" LOGOS AND THE TERM "RENO" ABOVE UPON A BLACK OUTLINE OF THE STATE OF NEVADA.
 FOR CASINO SERVICES (U.S. CLS. 100, 101 AND 107).
 EMILY CHUO, EXAMINING ATTORNEY

SN 77-525,042. BLEDSOE'S INC., ANGOLA, IN. FILED 7-17-2008.

BLEDSOE'S BEACH

THE MARK CONSISTS OF STANDARD CHARACTERS WITHOUT CLAIM TO ANY PARTICULAR FONT, STYLE, SIZE, OR COLOR.
 FOR ENTERTAINMENT SERVICES, NAMELY, PROVIDING LIVE AND PRERECORDED MUSIC CONCERTS; AND DANCE HALL SERVICES (U.S. CLS. 100, 101 AND 107).
 ANN E. SAPPENFIELD, EXAMINING ATTORNEY

CLASS 41—(Continued).

SN 77-525,052. BLEDSOE'S INC., ANGOLA, IN. FILED 7-17-2008.

BLEDSOE'S SAND BAR AT THE
DANCE HALL

THE MARK CONSISTS OF STANDARD CHARACTERS WITHOUT CLAIM TO ANY PARTICULAR FONT, STYLE, SIZE, OR COLOR.

NO CLAIM IS MADE TO THE EXCLUSIVE RIGHT TO USE "DANCE HALL", APART FROM THE MARK AS SHOWN.

FOR ENTERTAINMENT SERVICES, NAMELY, LIVE AND PRERECORDED MUSIC; AND DANCE HALL SERVICES (U.S. CLS. 100, 101 AND 107).

ANN E. SAPPENFIELD, EXAMINING ATTORNEY

SN 77-525,367. BLOOM, HOWARD, BROOKLYN, NY. FILED 7-17-2008.

SpaceAsia

THE MARK CONSISTS OF STANDARD CHARACTERS WITHOUT CLAIM TO ANY PARTICULAR FONT, STYLE, SIZE, OR COLOR.

FOR CONDUCTING ENTERTAINMENT EXHIBITIONS IN THE NATURE OF EDUCATIONAL EXHIBITIONS AND PERMANENT AND TEMPORARY EDUCATIONAL AND ENTERTAINMENT INSTALLATIONS ABOUT SPACE EXPLORATION AND OUTER SPACE (U.S. CLS. 100, 101 AND 107).

BARBARA GAYNOR, EXAMINING ATTORNEY

SN 77-525,732. H-D MICHIGAN, LLC, ANN ARBOR, MI. FILED 7-18-2008.

MILLION MILE MONDAY

THE MARK CONSISTS OF STANDARD CHARACTERS WITHOUT CLAIM TO ANY PARTICULAR FONT, STYLE, SIZE, OR COLOR.

FOR MOTORCYCLE CLUB SERVICES, NAMELY, SOCIAL CLUB SERVICES, NAMELY, ARRANGING, ORGANIZING AND HOSTING SOCIAL EVENTS, GET-TOGETHERS AND PARTIES FOR MOTORCYCLE CLUB MEMBERS; MOTORCYCLING CONTESTS; TRACKING OF DISTANCES TRAVELED BY MOTORCYCLISTS VIA THE INTERNET FOR ENTERTAINMENT PURPOSES; MOTORCYCLIST CONTESTS; ARRANGEMENT OF RECEPTIONS AND MOTORCYCLE RALLIES FOR SOCIAL OR ENTERTAINMENT PURPOSES; ORGANIZATION OF EXHIBITIONS FOR ENTERTAINMENT PURPOSES; PRESENTATION OF LIVE SHOW PERFORMANCES (U.S. CLS. 100, 101 AND 107).

KATHY DE JONGE, EXAMINING ATTORNEY

CLASS 41—(Continued).

SN 77-525,804. MACY'S DEPARTMENT STORES, INC., SAN FRANCISCO, CA. FILED 7-18-2008.

THE PINK PIG

THE MARK CONSISTS OF STANDARD CHARACTERS WITHOUT CLAIM TO ANY PARTICULAR FONT, STYLE, SIZE, OR COLOR.

OWNER OF U.S. REG. NO. 2,810,761.

SEC. 2(F).

FOR ENTERTAINMENT SERVICES, NAMELY, A CHILDREN'S AMUSEMENT RIDE (U.S. CLS. 100, 101 AND 107).

FIRST USE 11-1-1953; IN COMMERCE 11-1-1953.

DANIEL BRODY, EXAMINING ATTORNEY

SN 77-527,702. HAMILTON, MARY JANE, SUGAR LAND, TX. FILED 7-21-2008.

Motivangelism

THE MARK CONSISTS OF STANDARD CHARACTERS WITHOUT CLAIM TO ANY PARTICULAR FONT, STYLE, SIZE, OR COLOR.

FOR EDUCATION SERVICES, NAMELY, PROVIDING PRESENTATIONS IN THE FIELD OF MOTIVATION AND DISTRIBUTING COURSE MATERIALS IN CONNECTION THEREWITH; PROVIDING A WEBSITE FEATURING EDUCATIONAL INFORMATION IN THE FIELD OF MOTIVATION (U.S. CLS. 100, 101 AND 107).

FIRST USE 8-4-2006; IN COMMERCE 7-21-2008.

DAVID YONTEF, EXAMINING ATTORNEY

SN 77-528,838. ACK VENTURES HOLDINGS, LLC, WESTPORT, CT. FILED 7-22-2008.

COME TOGETHER

THE MARK CONSISTS OF STANDARD CHARACTERS WITHOUT CLAIM TO ANY PARTICULAR FONT, STYLE, SIZE, OR COLOR.

FOR ENTERTAINMENT SERVICES, NAMELY, PROVIDING ON-LINE GAMES, CURRENT EVENT NEWS AND INFORMATION, AND ENTERTAINMENT INFORMATION VIA WIRED AND WIRELESS NETWORKS; ON-LINE JOURNALS, NAMELY, BLOGS FEATURING CURRENT EVENT NEWS AND INFORMATION, AND ENTERTAINMENT INFORMATION VIA WIRED AND WIRELESS NETWORKS (U.S. CLS. 100, 101 AND 107).

GEOFFREY FOSDICK, EXAMINING ATTORNEY

CLASS 41—(Continued).

SN 77-530,552. NATIONAL SPORTING GOODS ASSOCIATION, MT. PROSPECT, IL. FILED 7-24-2008.

Team Dealer Summit

THE MARK CONSISTS OF STANDARD CHARACTERS WITHOUT CLAIM TO ANY PARTICULAR FONT, STYLE, SIZE, OR COLOR.

NO CLAIM IS MADE TO THE EXCLUSIVE RIGHT TO USE "SUMMIT", APART FROM THE MARK AS SHOWN. SEC. 2(F).

FOR EDUCATIONAL SERVICES, NAMELY, CONDUCTING SEMINARS IN THE FIELD OF SPORTS AND SPORTING GOODS (U.S. CLS. 100, 101 AND 107).

FIRST USE 8-1-1999; IN COMMERCE 8-1-1999.
MARLENE BELL, EXAMINING ATTORNEY

SN 77-532,116. ADAM DEMERS, GREENVILLE, TX. AND JERMEY BITNER, GREENVILLE, TX. FILED 7-26-2008.



THE MARK CONSISTS OF "FROM THE WOODS" IN A TRIBAL STYLE GRAPHIC DESIGN.

FOR ENTERTAINMENT, NAMELY, LIVE PERFORMANCES BY A MUSICAL BAND (U.S. CLS. 100, 101 AND 107).

FIRST USE 10-1-2004; IN COMMERCE 5-25-2007.
BRENDAN REGAN, EXAMINING ATTORNEY

SN 77-532,210. THE NATIONAL WORLD WAR II MUSEUM, INC., NEW ORLEANS, LA. FILED 7-27-2008.



NO CLAIM IS MADE TO THE EXCLUSIVE RIGHT TO USE "THEATER", APART FROM THE MARK AS SHOWN.

THE MARK CONSISTS OF THE WORDS "VICTORY THEATER" WITH RAYS OF LIGHT EXTENDING THROUGH AND BEHIND THE WORDS.

FOR PROVIDING A THEATER FOR THE SHOWING OF FILMS AND PRESENTATION OF LECTURES AS A PART OF MUSEUM SERVICES (U.S. CLS. 100, 101 AND 107).

BONNIE LUKEN, EXAMINING ATTORNEY

CLASS 41—(Continued).

SN 77-533,901. BIG FISH GAMES, INC., SEATTLE, WA. FILED 7-29-2008.

RAVENHEARST

THE MARK CONSISTS OF STANDARD CHARACTERS WITHOUT CLAIM TO ANY PARTICULAR FONT, STYLE, SIZE, OR COLOR.

OWNER OF U.S. REG. NO. 3,419,177.

FOR ENTERTAINMENT SERVICES, NAMELY, PROVIDING ONLINE INTERACTIVE, COMPUTER, VIDEO AND ELECTRONIC GAMES; COMPUTER GAMES PROVIDED VIA A GLOBAL COMPUTER NETWORK; PROVIDING A COMPUTER GAME THAT MAY BE ACCESSED NETWORK-WIDE BY NETWORK USERS; PROVIDING ON-LINE INFORMATION IN THE FIELD OF GAMES, INTERACTIVE GAME CONTENT, ELECTRONIC GAME CONTENT, COMPUTER GAME CONTENT OR VIDEO GAME CONTENT; PROVIDING TEMPORARY USE OF ONLINE NON-DOWNLOADABLE INTERACTIVE GAMES, ELECTRONIC GAMES, COMPUTER GAMES OR VIDEO GAMES (U.S. CLS. 100, 101 AND 107).

FIRST USE 3-5-2007; IN COMMERCE 3-5-2007.
COURTNEY MCCORMICK, EXAMINING ATTORNEY

SN 77-533,974. FARRELL'S EXTREME BODYSHAPING, INC., WEST DES MOINES, IA. FILED 7-29-2008.

FARRELL'S INFINITE TRANSFORMATION

THE MARK CONSISTS OF STANDARD CHARACTERS WITHOUT CLAIM TO ANY PARTICULAR FONT, STYLE, SIZE, OR COLOR.

FOR PHYSICAL FITNESS INSTRUCTION (U.S. CLS. 100, 101 AND 107).

FIRST USE 5-30-2008; IN COMMERCE 5-30-2008.
JAMES STEIN, EXAMINING ATTORNEY

CLASS 41—(Continued).

SN 77-536,402. E! ENTERTAINMENT TELEVISION, INC.,
LOS ANGELES, CA. FILED 7-31-2008.

Wedding Gown Slim Down

THE MARK CONSISTS OF STANDARD CHARACTERS WITHOUT CLAIM TO ANY PARTICULAR FONT, STYLE, SIZE, OR COLOR.

FOR ENTERTAINMENT IN THE NATURE OF ONGOING TELEVISION PROGRAMS ABOUT WEIGHT LOSS, BEAUTY, STYLE, FASHION, FITNESS, EXERCISE, GROOMING, MAKEOVERS, WEDDINGS, WEDDING PLANNING, WEDDING DESIGN, AND PERSONAL GOAL AND WISH FULFILLMENT; ENTERTAINMENT SERVICES, NAMELY, A SERIES OF TELEVISION PROGRAMS IN THE FIELDS OF WEIGHT LOSS, BEAUTY, STYLE, FASHION, FITNESS, EXERCISE, GROOMING, MAKEOVERS, WEDDINGS, WEDDING PLANNING, WEDDING DESIGN, AND PERSONAL GOAL AND WISH FULFILLMENT; ENTERTAINMENT SERVICES, NAMELY, PROVIDING TELEVISION PROGRAMS ABOUT WEIGHT LOSS, BEAUTY, STYLE, FASHION, FITNESS, EXERCISE, GROOMING, MAKEOVERS, WEDDINGS, WEDDING PLANNING, WEDDING DESIGN, AND PERSONAL GOAL AND WISH FULFILLMENT AND INFORMATION RELATED TO SUCH PROGRAMS VIA A GLOBAL COMPUTER NETWORK; PROVIDING ON-LINE PUBLICATIONS IN THE NATURE OF BLOGS, ARTICLES, TIPS, AND ABOUT WEIGHT LOSS, BEAUTY, STYLE, FASHION, FITNESS, EXERCISE, GROOMING, MAKEOVERS, WEDDINGS, WEDDING PLANNING, WEDDING DESIGN, AND PERSONAL GOAL AND WISH FULFILLMENT (U.S. CLS. 100, 101 AND 107).

FRANK LATTUCA, EXAMINING ATTORNEY

CLASS 41—(Continued).

SN 77-536,424. E! ENTERTAINMENT TELEVISION, INC.,
LOS ANGELES, CA. FILED 7-31-2008.

WEB SOUP

THE MARK CONSISTS OF STANDARD CHARACTERS WITHOUT CLAIM TO ANY PARTICULAR FONT, STYLE, SIZE, OR COLOR.

OWNER OF U.S. REG. NOS. 2,534,409 AND 3,267,684.

NO CLAIM IS MADE TO THE EXCLUSIVE RIGHT TO USE "WEB", APART FROM THE MARK AS SHOWN.

FOR ENTERTAINMENT IN THE NATURE OF ONGOING TELEVISION PROGRAMS, TELEVISION SEGMENTS, PODCASTS, AND WEBCASTS ABOUT ENTERTAINMENT, TELEVISION, THE INTERNET, INTERNET CONTENT, POP CULTURE, NEWS, AND GENERAL INTEREST INFORMATION; ONGOING TELEVISION PROGRAMS, TELEVISION SEGMENTS, PODCASTS, AND WEBCASTS IN THE FIELDS OF ENTERTAINMENT, TELEVISION, THE INTERNET, NEWS, AND GENERAL INTEREST INFORMATION; PROVIDING TELEVISION PROGRAMS, TELEVISION SEGMENTS, PODCASTS, AND WEBCASTS VIA A GLOBAL COMPUTER NETWORK ABOUT ENTERTAINMENT, TELEVISION, THE INTERNET, INTERNET CONTENT, POP CULTURE, NEWS, AND GENERAL INTEREST INFORMATION; PROVIDING NEWS, INFORMATION, AND BLOGS RELATING TO ENTERTAINMENT, TELEVISION, THE INTERNET, INTERNET CONTENT POP CULTURE, AND GENERAL INTEREST TOPICS VIA A GLOBAL COMPUTER NETWORK; ENTERTAINMENT SERVICES, NAMELY, A CONTINUING TELEVISION SHOW AND TELEVISION SEGMENTS BROADCAST OVER TELEVISION, CABLE, THE INTERNET, SATELLITE, MOBILE, WIRELESS, AUDIO, AND VIDEO MEDIA (U.S. CLS. 100, 101 AND 107).

FRANK LATTUCA, EXAMINING ATTORNEY

SN 77-536,982. VIDEO SOLUTIONS WORX, LTD., DBA
CAPTURE THE MARKET, DALLAS, TX. FILED 8-1-2008.

Video Guy

THE MARK CONSISTS OF STANDARD CHARACTERS WITHOUT CLAIM TO ANY PARTICULAR FONT, STYLE, SIZE, OR COLOR.

NO CLAIM IS MADE TO THE EXCLUSIVE RIGHT TO USE "VIDEO", APART FROM THE MARK AS SHOWN.

FOR FILM AND VIDEO FILM PRODUCTION (U.S. CLS. 100, 101 AND 107).

FIRST USE 9-1-2007; IN COMMERCE 9-1-2007.

LYDIA BELZER, EXAMINING ATTORNEY

CLASS 41—(Continued).

SN 77-543,415. IPI INC., DBA AKA ANGELO & HARDIN LLC., CYPRESS, TX. FILED 8-11-2008.



THE COLOR(S) RED, GREEN, WHITE, BLACK, GRAY, AND PEACH IS/ARE CLAIMED AS A FEATURE OF THE MARK.

THE MARK CONSISTS OF SANTA, DRESSED IN RED AND WHITE WITH A PEACH-COLORED FACE, BLACK GLASSES AND BLACK BOOTS, STANDING BEHIND A BLACK AND GRAY CAMERA ON A GRAY TRI-POD. SANTA AND THE CAMERA FACE A GREEN RECTANGULAR SIGN WITH A RED OUTLINE AND THE TEXT "MY SANTA" IN WHITE AND GREEN AND "EXPERIENCE" IN WHITE AND RED. ON THE UPPER RIGHT CORNER OF THE SIGN ARE TWO GREEN HOLLY LEAVES WITH THREE BERRIES IN WHITE AND RED. AROUND THE SIGN ARE SEVERAL GRAY STARS, GRAY STREAKS, AND A GRAY SHADOW OF SANTA. THE BACKGROUND OF THE MARK IS WHITE.

FOR PHOTOGRAPHY SERVICES; PORTRAIT PHOTOGRAPHY; PROVIDING AUDIO OR VIDEO STUDIOS; RENTAL OF PORTABLE PHOTOGRAPHY AND/OR VIDEOGRAPHY BOOTHS FOR TAKING OF PICTURES AND VIDEOS (U.S. CLS. 100, 101 AND 107).

REBECCA EISINGER, EXAMINING ATTORNEY

CLASS 41—(Continued).

SN 77-553,233. WORLD GOLF TOUR, INC., SAN FRANCISCO, CA. FILED 8-22-2008.



WORLD GOLF TOUR

NO CLAIM IS MADE TO THE EXCLUSIVE RIGHT TO USE "WORLD GOLF", APART FROM THE MARK AS SHOWN.

THE MARK CONSISTS OF THE WORDS "WORLD GOLF TOUR" NEXT TO THE DESIGN OF RECTANGLE CONTAINING A GOLFER HOLDING A CLUB, SWINGING IT AT A BALL.

FOR ENTERTAINMENT SERVICES, NAMELY, PROVIDING AN ONLINE INTERACTIVE VIDEO GAMES (U.S. CLS. 100, 101 AND 107).

FRANK LATTUCA, EXAMINING ATTORNEY

SN 77-548,183. BARRETT PRODUCTIONS, INC., MISSOULA, MT. FILED 8-15-2008.

UNTOUCHED AMERICA

THE MARK CONSISTS OF STANDARD CHARACTERS WITHOUT CLAIM TO ANY PARTICULAR FONT, STYLE, SIZE, OR COLOR.

NO CLAIM IS MADE TO THE EXCLUSIVE RIGHT TO USE "AMERICA", APART FROM THE MARK AS SHOWN.

FOR MULTIMEDIA PRODUCTION OF ENTERTAINMENT PROGRAMMING FEATURING NATURAL AND PROTECTED LANDS, ENVIRONMENTAL CONSERVATION, AND OUTDOOR ACTIVITIES (U.S. CLS. 100, 101 AND 107).

MIDGE BUTLER, EXAMINING ATTORNEY

SN 77-553,290. WORLD GOLF TOUR, INC., SAN FRANCISCO, CA. FILED 8-22-2008.

WORLD GOLF TOUR

THE MARK CONSISTS OF STANDARD CHARACTERS WITHOUT CLAIM TO ANY PARTICULAR FONT, STYLE, SIZE, OR COLOR.

NO CLAIM IS MADE TO THE EXCLUSIVE RIGHT TO USE "WORLD GOLF", APART FROM THE MARK AS SHOWN.

FOR ENTERTAINMENT SERVICES, NAMELY, PROVIDING AN ONLINE INTERACTIVE VIDEO GAMES (U.S. CLS. 100, 101 AND 107).

FIRST USE 5-21-2007; IN COMMERCE 5-21-2007.

FRANK LATTUCA, EXAMINING ATTORNEY

CLASS 41—(Continued).

SN 77-553,593. WORLD GOLF TOUR, INC., SAN FRANCISCO, CA. FILED 8-22-2008.



NO CLAIM IS MADE TO THE EXCLUSIVE RIGHT TO USE "WORLD GOLF", APART FROM THE MARK AS SHOWN.

THE COLOR(S) GRAY, WHITE AND GREEN IS/ARE CLAIMED AS A FEATURE OF THE MARK.

THE MARK CONSISTS OF THE WORDS "WORLD GOLF TOUR" IN GRAY WITH A GOLFER DESIGN IN WHICH THE GOLFER AND GOLF BALL ARE WHITE, THE GOLF CLUB IS GRAY, THE LEFT SIDE OF THE BACKGROUND IS GRAY, AND THE RIGHT SIDE OF THE BACKGROUND IS GREEN.

FOR ENTERTAINMENT SERVICES, NAMELY, PROVIDING AN ONLINE INTERACTIVE VIDEO GAMES (U.S. CLS. 100, 101 AND 107).

FRANK LATTUCA, EXAMINING ATTORNEY

SN 77-559,763. VP CONSULTANTS, INC., OSPREY, FL. FILED 9-1-2008.

Edu-trition

THE MARK CONSISTS OF STANDARD CHARACTERS WITHOUT CLAIM TO ANY PARTICULAR FONT, STYLE, SIZE, OR COLOR.

FOR EDUCATIONAL SERVICES, NAMELY, CONDUCTING TRAINING BY CLASSES, SEMINARS, CONFERENCES AND WORKSHOPS IN THE FIELD OF NUTRITION AND DISTRIBUTION OF TRAINING MATERIAL IN CONNECTION THEREWITH (U.S. CLS. 100, 101 AND 107).

DAVID HOFFMAN, EXAMINING ATTORNEY

SN 77-559,764. VP CONSULTANTS, INC., OSPREY, FL. FILED 9-1-2008.

Edu-Triton

THE MARK CONSISTS OF STANDARD CHARACTERS WITHOUT CLAIM TO ANY PARTICULAR FONT, STYLE, SIZE, OR COLOR.

FOR EDUCATIONAL SERVICES, NAMELY, CONDUCTING TRAINING BY CLASSES, SEMINARS, CONFERENCES AND WORKSHOPS IN THE FIELD OF NUTRITION AND DISTRIBUTION OF TRAINING MATERIAL IN CONNECTION THEREWITH (U.S. CLS. 100, 101 AND 107).

DAVID HOFFMAN, EXAMINING ATTORNEY

CLASS 41—(Continued).

SN 77-560,835. ETRAFFIC SOLUTIONS INC., VICTORIA, B.C., CANADA, FILED 9-2-2008.

SCHOOL WAX

THE MARK CONSISTS OF STANDARD CHARACTERS WITHOUT CLAIM TO ANY PARTICULAR FONT, STYLE, SIZE, OR COLOR.

OWNER OF U.S. REG. NO. 3,422,398.

NO CLAIM IS MADE TO THE EXCLUSIVE RIGHT TO USE "SCHOOL", APART FROM THE MARK AS SHOWN.

FOR EDUCATIONAL SERVICES, NAMELY, PROVIDING A WEBSITE WHERE K-12 STUDENTS AND TEACHERS CAN ACCESS ON-LINE LEARNING AND TEACHING RESOURCES IN THE FIELDS OF MATH, ENGLISH, SCIENCE AND SOCIAL STUDIES (U.S. CLS. 100, 101 AND 107).

INGA ERVIN, EXAMINING ATTORNEY

SN 77-560,837. ETRAFFIC SOLUTIONS INC., VICTORIA, B.C., CANADA, FILED 9-2-2008.

SCHOOL WAX TV

THE MARK CONSISTS OF STANDARD CHARACTERS WITHOUT CLAIM TO ANY PARTICULAR FONT, STYLE, SIZE, OR COLOR.

OWNER OF U.S. REG. NO. 3,422,398.

NO CLAIM IS MADE TO THE EXCLUSIVE RIGHT TO USE "SCHOOL" AND "TV", APART FROM THE MARK AS SHOWN.

FOR EDUCATIONAL SERVICES, NAMELY, PROVIDING A WEBSITE WHERE K-12 STUDENTS, THEIR TEACHERS AND THEIR PARENTS CAN ACCESS AND DOWNLOAD EDUCATIONAL VIDEOS IN THE FIELDS OF MATH, LANGUAGES, SCIENCE, LANGUAGE ARTS AND SOCIAL STUDIES (U.S. CLS. 100, 101 AND 107).

INGA ERVIN, EXAMINING ATTORNEY

CLASS 41—(Continued).

SN 77-563,540. BLUE DIAMOND VENTURE, LLC, LAS VEGAS, NV. FILED 9-5-2008.

EXPO CITY

THE MARK CONSISTS OF STANDARD CHARACTERS WITHOUT CLAIM TO ANY PARTICULAR FONT, STYLE, SIZE, OR COLOR.

NO CLAIM IS MADE TO THE EXCLUSIVE RIGHT TO USE "EXPO", APART FROM THE MARK AS SHOWN.

FOR ARRANGING OF SEMINARS; ARRANGING CONFERENCES IN THE FIELD OF ACCOUNTING, ADVERTISING AND MARKETING, AEROSPACE AND AVIATION, AGRICULTURE, AIR CONDITIONING, HEATING AND REFRIGERATION, AMUSEMENT, APPAREL, ARCHITECTURE, ART AND ANTIQUES, ASSOCIATIONS, AUDIO-VISUAL, AUDITORIUMS AND FACILITIES, AUTOMOTIVE AND TRUCKING, BANKING, BEAUTY AND HAIR CARE, BOATS AND SHIPS, BUILDING AND CONSTRUCTION, BUSINESS, CERAMICS AND GLASS, CHEMICAL, CHINA AND GLASSWARE, COMMUNICATIONS, COMPUTERS AND SOFTWARE, DENTAL, EDUCATION, ELECTRICAL AND ELECTRONICS, ENERGY, ENGINEERING, FINANCIAL AND LEGAL, FIRE AND FIRE PROTECTION, FISHING, FLORICULTURE AND HORTICULTURE, FOOD AND BEVERAGE, FOOD PROCESSING AND DISTRIBUTION, FOREST PRODUCTS, FUNERAL INDUSTRY, GIFTS AND GIFTWARE, GOVERNMENT, HARDWARE, HOME ECONOMICS, HOME FURNISHINGS AND INTERIOR DESIGN, HOTELS, HOSPITALITY AND RESORTS, HOUSEWARES, HOUSING, INDUSTRIAL, INSURANCE, JEWELRY AND WATCHES, LANDSCAPE AND GARDEN SUPPLIES, LAUNDRY AND DRY CLEANING, LEATHER GOODS AND LUGGAGE, LIBRARIES, LIGHTING, MANUFACTURED HOUSING, MANUFACTURING, MEDICAL AND HEALTH CARE, METALWORKING, MILITARY, MINING, MOTORCYCLES, MUSIC, NURSING, OCEAN SCIENCE AND EQUIPMENT, OFFICE EQUIPMENT, PACKAGING, PAINT, PAPER AND CARDBOARD, PETROLEUM, OIL AND GAS, PHARMACEUTICALS, PHOTOGRAPHIC, PHYSICAL DISTRIBUTION AND SHIPPING, PLANT ENGINEERING AND OPERATIONS, PLASTICS, POLICE, POLLUTION CONTROL, POWER TRANSMISSION, PRINTING, PUBLISHING, RADIO, TV, CABLE AND BROADCAST, RAILROADS, REAL ESTATE, RECREATIONAL VEHICLES, RECRUITMENT, RELIGIOUS, RENTAL AND LEASING, EQUIPMENT, RESTAURANTS AND FOOD SERVICE, ROBOTICS AND AUTOMATION, SAFETY, SANITATION AND WASTE MANAGEMENT, SCIENCE, SECURITY, SPORTING GOODS AND RECREATION, STORES AND STORE FITTINGS, TELECOMMUNICATIONS, TELEPHONES, TEXTILES, TOYS, HOBBIES AND CRAFTS, TRANSPORTATION, TRAVEL INDUSTRY, VETERINARY, WATER, WELDING, WIRE, WOMEN'S ISSUES, WOODWORKING; PROMOTING THE DISPLAY AND EXHIBITION OF GOODS AND MANUFACTURERS IN THE FIELDS OF ACCOUNTING, ADVERTISING AND MARKETING, AEROSPACE AND AVIATION, AGRICULTURE, AIR CONDITIONING, HEATING AND REFRIGERATION, AMUSEMENT, APPAREL, ARCHITECTURE, ART AND ANTIQUES, ASSOCIATIONS, AUDIO-VISUAL, AUDITORIUMS AND FACILITIES, AUTOMOTIVE AND TRUCKING, BANKING, BEAUTY AND HAIR CARE, BOATS AND SHIPS, BUILDING AND CONSTRUCTION, BUSINESS, CERAMICS AND GLASS, CHEMICAL, CHINA AND GLASSWARE, COMMUNICATIONS, COMPUTERS AND SOFTWARE, DENTAL, EDUCATION, ELECTRICAL AND ELECTRONICS, ENERGY, ENGINEERING, FINANCIAL AND LEGAL, FIRE AND FIRE PROTECTION, FISHING, FLORICULTURE AND HORTICULTURE, FOOD AND BEVERAGE, FOOD PROCESSING AND DISTRIBUTION, FOREST PRODUCTS, FUNERAL INDUSTRY, GIFTS AND GIFTWARE, GOVERNMENT, HARDWARE, HOME ECONOMICS, HOME FURNISHINGS AND INTERIOR DESIGN, HOTELS, HOSPITALITY AND RESORTS, HOUSEWARES, HOUS-

CLASS 41—(Continued).

ING, INDUSTRIAL, INSURANCE, JEWELRY AND WATCHES, LANDSCAPE AND GARDEN SUPPLIES, LAUNDRY AND DRY CLEANING, LEATHER GOODS AND LUGGAGE, LIBRARIES, LIGHTING, MANUFACTURED HOUSING, MANUFACTURING, MEDICAL AND HEALTH CARE, METALWORKING, MILITARY, MINING, MOTORCYCLES, MUSIC, NURSING, OCEAN SCIENCE AND EQUIPMENT, OFFICE EQUIPMENT, PACKAGING, PAINT, PAPER AND CARDBOARD, PETROLEUM, OIL AND GAS, PHARMACEUTICALS, PHOTOGRAPHIC, PHYSICAL DISTRIBUTION AND SHIPPING, PLANT ENGINEERING AND OPERATIONS, PLASTICS, POLICE, POLLUTION CONTROL, POWER TRANSMISSION, PRINTING, PUBLISHING, RADIO, TV, CABLE AND BROADCAST, RAILROADS, REAL ESTATE, RECREATIONAL VEHICLES, RECRUITMENT, RELIGIOUS, RENTAL AND LEASING, EQUIPMENT, RESTAURANTS AND FOOD SERVICE, ROBOTICS AND AUTOMATION, SAFETY, SANITATION AND WASTE MANAGEMENT, SCIENCE, SECURITY, SPORTING GOODS AND RECREATION, STORES AND STORE FITTINGS, TELECOMMUNICATIONS, TELEPHONES, TEXTILES, TOYS, HOBBIES AND CRAFTS, TRANSPORTATION, TRAVEL INDUSTRY, VETERINARY, WATER, WELDING, WIRE, WOMEN'S ISSUES, WOODWORKING (U.S. CLS. 100, 101 AND 107).

CHRISTINA SOBRAL, EXAMINING ATTORNEY

SN 77-567,460. KNOWLES, BEYONCE, BEVERLY HILLS, CA. FILED 9-11-2008.

SASHA FIERCE

THE MARK CONSISTS OF STANDARD CHARACTERS WITHOUT CLAIM TO ANY PARTICULAR FONT, STYLE, SIZE, OR COLOR.

THE NAME(S), PORTRAIT(S), AND/OR SIGNATURE(S) SHOWN IN THE MARK DOES NOT IDENTIFY A PARTICULAR LIVING INDIVIDUAL.

FOR ENTERTAINMENT, NAMELY, LIVE MUSICAL CONCERTS; PRODUCTION OF MOTION PICTURE FILMS (U.S. CLS. 100, 101 AND 107).

SHANNON TWOHIG, EXAMINING ATTORNEY

SN 77-572,885. WASHINGTONPOST.NEWSWEEK INTERACTIVE, LLC, ARLINGTON, VA. FILED 9-18-2008.

EXPLAINER

THE MARK CONSISTS OF STANDARD CHARACTERS WITHOUT CLAIM TO ANY PARTICULAR FONT, STYLE, SIZE, OR COLOR.

FOR ONLINE PUBLICATIONS, NAMELY COLUMNS, FEATURING INFORMATION ON TOPICS OF GENERAL INTEREST (U.S. CLS. 100, 101 AND 107).

FIRST USE 6-10-1998; IN COMMERCE 6-10-1998.
BILL DAWE, EXAMINING ATTORNEY

CLASS 41—(Continued).

SN 77-574,892. SHUTTERBOX ENTERTAINMENT LLC, DBA SHUTTERBOX PHOTOBOTH, ORLAND PARK, IL. FILED 9-19-2008.

ShutterBox photobooth

THE MARK CONSISTS OF STANDARD CHARACTERS WITHOUT CLAIM TO ANY PARTICULAR FONT, STYLE, SIZE, OR COLOR.

NO CLAIM IS MADE TO THE EXCLUSIVE RIGHT TO USE "PHOTOBOTH", APART FROM THE MARK AS SHOWN.

FOR RENTAL OF PORTABLE PHOTOGRAPHY AND/OR VIDEOGRAPHY BOOTHS FOR TAKING OF PICTURES AND VIDEOS (U.S. CLS. 100, 101 AND 107).

FIRST USE 7-30-2008; IN COMMERCE 7-30-2008.
MARIA-VICTORIA SUAREZ, EXAMINING ATTORNEY

SN 77-586,588. MULTIPLEX PROPERTIES, INC., WILMINGTON, DE. FILED 10-6-2008.



THE MARK CONSISTS OF THE LETTER "C" WITH AN ELONGATED BOTTOM AND THE DESIGN OF A SHADED SQUARE.

FOR MOVIE THEATER SERVICES (U.S. CLS. 100, 101 AND 107).

CHRISTINE BLOMQUIST, EXAMINING ATTORNEY

CLASS 41—(Continued).

SN 77-586,894. DAOUST, PETER W., DBA TIME WELL SPENT PRODUCTIONS, HARPER WOODS, MI. FILED 10-7-2008.

TIME WELL SPENT PRODUCTIONS

THE MARK CONSISTS OF STANDARD CHARACTERS WITHOUT CLAIM TO ANY PARTICULAR FONT, STYLE, SIZE, OR COLOR.

NO CLAIM IS MADE TO THE EXCLUSIVE RIGHT TO USE "PRODUCTIONS", APART FROM THE MARK AS SHOWN.

FOR EDUCATION SERVICES, NAMELY, MENTORING IN THE FIELD OF MARKETING A TALENT; EDUCATIONAL AND ENTERTAINMENT SERVICES, NAMELY, PROVIDING MOTIVATIONAL AND EDUCATIONAL SPEAKERS; EDUCATIONAL AND ENTERTAINMENT SERVICES, NAMELY, PROVIDING MOTIVATIONAL SPEAKING SERVICES IN THE FIELD OF MARKETING A TALENT; ENTERTAINMENT IN THE NATURE OF ANNOUNCING SERVICES FOR LIVE AUTO SHOWS, BOAT SHOWS, AND SPORTING EVENTS; ENTERTAINMENT IN THE NATURE OF VISUAL AND AUDIO PERFORMANCES, AND MUSICAL, VARIETY, NEWS AND COMEDY SHOWS; ENTERTAINMENT SERVICES IN THE NATURE OF COMEDY SHOWS; PRESENTATION OF LIVE SHOW PERFORMANCES; PRESENTATION OF LIVE COMEDY SHOWS; PROVIDING VOICE OVERS FOR TAPES, RECORDS AND OTHER RECORDED MEDIA; SPECIAL EFFECTS ANIMATION SERVICES FOR FILM AND VIDEO (U.S. CLS. 100, 101 AND 107).

LINDA MICKLEBURGH, EXAMINING ATTORNEY

SN 77-587,604. BIRINGEN, ZEYNEP, FORT COLLINS, CO. FILED 10-7-2008.



THE COLOR(S) BLUE IS/ARE CLAIMED AS A FEATURE OF THE MARK.

THE MARK CONSISTS OF A DEPICTION OF THE PLANET EARTH IN BLUE, INCLUDING THE CONTINENTS OF NORTH AMERICA, SOUTH AMERICA, EUROPE, AND AFRICA IN A DARKER SHADE OF BLUE, WITH THE WORDS "EMOTIONAL AVAILABILITY" PRINTED IN BLUE LOWER CASE LETTERS DIRECTLY BENEATH THE DEPICTION OF THE PLANET.

FOR EDUCATION SERVICES, NAMELY, PROVIDING TRAINING IN THE FIELDS OF PSYCHOLOGY, PSYCHIATRY, AND INTERPERSONAL RELATIONSHIPS (U.S. CLS. 100, 101 AND 107).

FIRST USE 8-1-1998; IN COMMERCE 10-1-2008.

ROBERT STRUCK, EXAMINING ATTORNEY

CLASS 41—(Continued).

SN 77-591,735. WALTER BECKLEY, RICHTON PARK, IL. FILED 10-13-2008.

STRESS INTO SUCCESS

THE MARK CONSISTS OF STANDARD CHARACTERS WITHOUT CLAIM TO ANY PARTICULAR FONT, STYLE, SIZE, OR COLOR.

FOR PERSONAL COACHING SERVICES IN THE FIELD OF SALES, MARKETING, SELF-IMPROVEMENT AND PERSONAL DEVELOPMENT; EDUCATIONAL SERVICES, NAMELY, CONDUCTING WORKSHOPS, CLASSES AND SEMINARS IN THE FIELD OF SALES, MARKETING, SELF-IMPROVEMENT AND PERSONAL DEVELOPMENT AND DISTRIBUTION OF COURSE MATERIAL IN CONNECTION THEREWITH; CONDUCTING WORKSHOPS AND SEMINARS IN SELF AWARENESS; PROVIDING NEWSLETTERS IN THE FIELD OF SALES, MARKETING, SELF-IMPROVEMENT AND PERSONAL DEVELOPMENT VIA E-MAIL (U.S. CLS. 100, 101 AND 107).

FIRST USE 9-11-2007; IN COMMERCE 5-1-2008.
HELENE LIWINSKI, EXAMINING ATTORNEY

SN 77-591,931. NATIONAL HOT ROD ASSOCIATION, AKA NHRA, GLENDORA, CA. FILED 10-14-2008.

KEYSTONE NATIONALS

THE MARK CONSISTS OF STANDARD CHARACTERS WITHOUT CLAIM TO ANY PARTICULAR FONT, STYLE, SIZE, OR COLOR.

NO CLAIM IS MADE TO THE EXCLUSIVE RIGHT TO USE "NATIONALS", APART FROM THE MARK AS SHOWN.

FOR STAGING OF AUTOMOBILE RACES (U.S. CLS. 100, 101 AND 107).
JILL PRATER, EXAMINING ATTORNEY

CLASS 41—(Continued).

SN 77-594,093. THE MITRE CORPORATION, MCLEAN, VA. FILED 10-16-2008.

MITRE INNOVATION EXCHANGE

THE MARK CONSISTS OF STANDARD CHARACTERS WITHOUT CLAIM TO ANY PARTICULAR FONT, STYLE, SIZE, OR COLOR.

OWNER OF U.S. REG. NO. 739,181.

NO CLAIM IS MADE TO THE EXCLUSIVE RIGHT TO USE "INNOVATION EXCHANGE", APART FROM THE MARK AS SHOWN.

FOR ORGANIZING AND CONDUCTING EDUCATIONAL SYMPOSIA IN THE FIELDS OF TECHNOLOGY RESEARCH AND INNOVATION (U.S. CLS. 100, 101 AND 107).

FIRST USE 5-6-2008; IN COMMERCE 5-6-2008.

ZHALEH DELANEY, EXAMINING ATTORNEY

SN 77-596,158. LATIN INTELLECTUAL PROPERTIES, INC., LOS ANGELES, CA. FILED 10-20-2008.

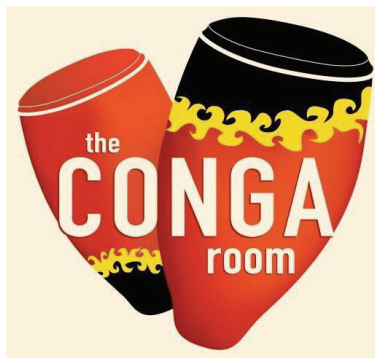

OWNER OF U.S. REG. NOS. 2,230,802 AND 2,685,071.

THE COLOR(S) ORANGE, BLACK, YELLOW AND BEIGE IS/ARE CLAIMED AS A FEATURE OF THE MARK.

THE MARK CONSISTS OF THE TERMS "THE CONGA ROOM" IN THE COLOR BEIGE IN FRONT OF TWO DRUMS IN THE COLORS ORANGE, BLACK AND YELLOW ON A BEIGE BACKGROUND.

SEC. 2(F) AS TO "THE CONGA ROOM".

FOR ENTERTAINMENT SERVICES, NAMELY, PRODUCTION AND DISTRIBUTION OF MOTION PICTURE FILMS AND TELEVISION SHOWS; ENTERTAINMENT SERVICES, NAMELY, PRODUCTION OF MUSICAL SOUND RECORDINGS, NAMELY, PHONOGRAPH RECORDS, AUDIO MAGNETIC TAPES, COMPACT DISCS, DIGITAL AUDIO TAPES, COMPACT DISC VIDEOS AND LASER DISCS; MUSIC PUBLISHING SERVICES; PROVIDING INFORMATION REGARDING MUSICAL ARTISTS AND PROVIDING RECORDED PERFORMANCES BY MUSICAL ARTISTS BY MEANS OF GLOBAL COMPUTER NETWORKS AND TELEVISION; ENTERTAINMENT SERVICES, NAMELY, A CONTINUING MUSIC AND VARIETY SHOW BROADCAST OVER GLOBAL COMPUTER NETWORKS, CABLE AND TELEVISION; PROVIDING A WEBSITE ON GLOBAL COMPUTER NETWORKS FEATURING INFORMATION IN THE FIELD OF ENTERTAINMENT AND CULTURE; NIGHT CLUBS; ENTERTAINMENT AND EDUCATIONAL SERVICES IN THE FIELD OF MUSIC AND DANCING

CLASS 41—(Continued).

INSTRUCTION; ENTERTAINMENT, NAMELY, LIVE MUSIC CONCERTS AND PERFORMANCES; PROVIDING ENTERTAINMENT INFORMATION VIA WIRELESS DEVICES, NAMELY, CELL PHONES, PERSONAL DIGITAL ASSISTANTS AND PORTABLE ENTERTAINMENT AND GAMING DEVICES; PROVIDING A WEBSITE FEATURING MULTIMEDIA MATERIALS ON THE SUBJECTS OF MUSIC, DANCE, CULTURE, RESTAURANTS, NIGHT LIFE, AND ENTERTAINMENT, NAMELY, TEXT, VIDEOS, STILL IMAGES, MUSIC, RING TONES, VOICE TONES, RING BACKS AND INTERACTIVE GAMES, ALL PROVIDED VIA WIRELESS DEVICES, NAMELY, CELL PHONES, PERSONAL DIGITAL ASSISTANTS AND PORTABLE ENTERTAINMENT AND GAMING DEVICES; EDUCATIONAL SERVICES, NAMELY, CONDUCTING SEMINARS, CLASSES AND TRAINING FOR CHILDREN IN THE FIELDS OF MUSIC, HISTORY AND CULTURE; CHILDREN'S ENTERTAINMENT AND AMUSEMENT CENTERS, NAMELY, INTERACTIVE PLAY AREAS (U.S. CLS. 100, 101 AND 107).

B. PARADEWELAI, EXAMINING ATTORNEY

SN 77-597,526. ACTORS EQUITY ASSOCIATION, NEW YORK, NY. FILED 10-21-2008.

THE GYPSY ROBE

THE MARK CONSISTS OF STANDARD CHARACTERS WITHOUT CLAIM TO ANY PARTICULAR FONT, STYLE, SIZE, OR COLOR.

FOR PROVIDING RECOGNITION AND INCENTIVES BY THE WAY OF AWARDS TO DEMONSTRATE EXCELLENCE IN THE FIELD OF ENTERTAINMENT (U.S. CLS. 100, 101 AND 107).

FIRST USE 1-1-1950; IN COMMERCE 1-1-1950.
GEOFFREY FOSDICK, EXAMINING ATTORNEY

SN 77-602,439. WARNKE, MARC, BOISE, ID. FILED 10-28-2008.

FAMILY FIRST ENTREPRENEUR

THE MARK CONSISTS OF STANDARD CHARACTERS WITHOUT CLAIM TO ANY PARTICULAR FONT, STYLE, SIZE, OR COLOR.

NO CLAIM IS MADE TO THE EXCLUSIVE RIGHT TO USE "FAMILY" AND "ENTREPRENEUR", APART FROM THE MARK AS SHOWN.

FOR ONLINE JOURNALS, NAMELY, BLOGS FEATURING NEWS AND INFORMATION RELATING TO TIME MANAGEMENT, FAMILY RELATIONSHIPS, PARENTING, MENTORING, PRIORITIES, ENTREPRENEURIALISM, BUSINESS ETHICS, NETWORKING AND WEALTH BUILDING; EDUCATIONAL SERVICES, NAMELY, PROVIDING SEMINARS, CLASSES AND WORKSHOPS IN THE FIELDS OF TIME MANAGEMENT, FAMILY RELATIONSHIPS, PARENTING, MENTORING, PRIORITIES, ENTREPRENEURIALISM, BUSINESS ETHICS, NETWORKING AND WEALTH BUILDING (U.S. CLS. 100, 101 AND 107).

FIRST USE 6-27-2008; IN COMMERCE 6-27-2008.
RONALD MCMORROW, EXAMINING ATTORNEY

CLASS 41—(Continued).

SN 77-605,908. CAVALERA, RICHARD, PHOENIX, AZ. FILED 11-3-2008.

INCITE

THE MARK CONSISTS OF STANDARD CHARACTERS WITHOUT CLAIM TO ANY PARTICULAR FONT, STYLE, SIZE, OR COLOR.

FOR ENTERTAINMENT, NAMELY, LIVE PERFORMANCES BY A MUSICAL BAND (U.S. CLS. 100, 101 AND 107).

FIRST USE 5-14-2005; IN COMMERCE 5-14-2005.
MICHAEL KEATING, EXAMINING ATTORNEY

SN 77-606,665. LUTTERY, TEISHA L., CHICAGO, IL. FILED 11-4-2008.

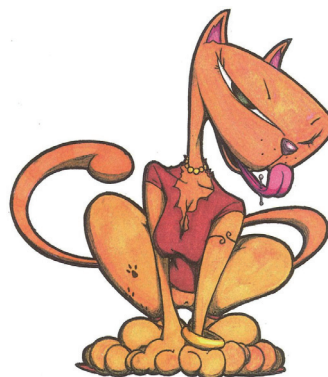

THE COLOR(S) TAN, RED, YELLOW, GREEN, WHITE AND PINK IS/ARE CLAIMED AS A FEATURE OF THE MARK.

THE MARK CONSISTS OF A FEMALE CAT WITH HUMAN ATTRIBUTES IN TAN, WEARING A RED SHIRT AND YELLOW NECKLACE AND BRACELET; THE TONGUE, NOSE AND INNER PORTIONS OF THE CAT'S EARS APPEAR IN PINK AND THE CAT'S EYE APPEAR IN GREEN AND WHITE.

FOR ENTERTAINMENT IN THE NATURE OF LIVE MUSICAL PERFORMANCES (U.S. CLS. 100, 101 AND 107).

RAUL CORDOVA, EXAMINING ATTORNEY

CLASS 41—(Continued).

SN 77-611,246. BRUGAL, MARLENE V., BRONX, NY. FILED 11-10-2008.

Taxi Amarillo

THE MARK CONSISTS OF STANDARD CHARACTERS WITHOUT CLAIM TO ANY PARTICULAR FONT, STYLE, SIZE, OR COLOR.

THE FOREIGN WORDING IN THE MARK TRANSLATES INTO ENGLISH AS YELLOW CAB.

FOR ENTERTAINMENT IN THE NATURE OF LIVE PERFORMANCES BY A VOCAL MUSICAL GROUP AND INSTRUMENTAL MUSICAL GROUP, AUDIO RECORDING AND PRODUCTION AND VIDEO TAPE PRODUCTION (U.S. CLS. 100, 101 AND 107).

MARLENE BELL, EXAMINING ATTORNEY

CLASS 41—(Continued).

SN 77-612,401. G. ADAM GIFFORD, BEVERLY HILLS, CA. FILED 11-11-2008.

Lovechild

THE MARK CONSISTS OF STANDARD CHARACTERS WITHOUT CLAIM TO ANY PARTICULAR FONT, STYLE, SIZE, OR COLOR.

FOR ENTERTAINMENT, NAMELY, LIVE PERFORMANCES BY A MUSICAL BAND (U.S. CLS. 100, 101 AND 107).

FIRST USE 10-1-2008; IN COMMERCE 10-1-2008.
ALLISON HALL, EXAMINING ATTORNEY

SN 77-613,367. THE ROUTE 66 THEATRE COMPANY, CHICAGO, IL. FILED 11-13-2008.

The Route 66 Theatre Company

THE MARK CONSISTS OF STANDARD CHARACTERS WITHOUT CLAIM TO ANY PARTICULAR FONT, STYLE, SIZE, OR COLOR.

NO CLAIM IS MADE TO THE EXCLUSIVE RIGHT TO USE "THEATRE COMPANY", APART FROM THE MARK AS SHOWN.

FOR ENTERTAINMENT SERVICES, NAMELY, LIVE THEATRE PERFORMANCES (U.S. CLS. 100, 101 AND 107).

FIRST USE 2-8-2008; IN COMMERCE 2-8-2008.
TEJBIR SINGH, EXAMINING ATTORNEY

SN 77-621,479. SPRAGUE, JEREMIAH A, DBA PINETOWN RECORDS, HALFWAY, OR. FILED 11-25-2008.

Jeremy Arno

THE MARK CONSISTS OF STANDARD CHARACTERS WITHOUT CLAIM TO ANY PARTICULAR FONT, STYLE, SIZE, OR COLOR.

THE NAME "JEREMY ARNO" IDENTIFIES THE PROFESSIONAL AND STAGE NAME OF A LIVING INDIVIDUAL WHOSE CONSENT IS OF RECORD.

FOR ENTERTAINMENT SERVICES, NAMELY, LIVE ENTERTAINMENT COMPRISING MUSICAL PERFORMANCES, DRAMATIC PERFORMANCES, COMEDIC PERFORMANCES AND MOTIVATIONAL/INSPIRATIONAL SPEAKING BY JEREMY ARNO (U.S. CLS. 100, 101 AND 107).

FIRST USE 7-20-1974; IN COMMERCE 11-1-2008.
MAYUR VAGHANI, EXAMINING ATTORNEY

SN 77-612,181. WELZ & WEISEL COMMUNICATIONS, FAIRFAX, VA. FILED 11-11-2008.



NO CLAIM IS MADE TO THE EXCLUSIVE RIGHT TO USE "SK", APART FROM THE MARK AS SHOWN.

THE COLOR(S) NAVY, ORANGE AND WHITE IS/ARE CLAIMED AS A FEATURE OF THE MARK.

THE MARK CONSISTS OF AN ORANGE RECTANGULAR-BORDERED DESIGN APPEARING ABOVE THE NAVY STYLIZED WORD "RUN", FOLLOWED BY AN ORANGE EXCLAMATION POINT, NAVY STYLIZED WORD "GEEK", FOLLOWED BY AN ORANGE EXCLAMATION POINT, NAVY STYLIZED WORD "RUN", FOLLOWED BY ORANGE EXCLAMATION POINT. THE DESIGN APPEARING INSIDE THE ORANGE RECTANGULAR BORDER CONSISTS OF AN INNER WHITE BORDER, A STYLIZED ORANGE NUMBER "8" ATOP A WHITE BACKGROUND, NEXT TO A STYLIZED ORANGE LETTER "K" ATOP A WHITE BACKGROUND, NAVY SKY WITH WHITE WAVY LINES, WHITE MALE FIGURE RUNNING ON TOP OF AN ORANGE HEAD WITH WHITE SHADING INDICATING A NOSE, WITH NAVY GLASSES AND WHITE EYES WITH NAVY PUPILS.

FOR ORGANIZING AND CONDUCTING A RUNNING EVENT THE PROCEEDS OF WHICH ARE DONATED TO CHARITY (U.S. CLS. 100, 101 AND 107).

FIRST USE 4-1-2008; IN COMMERCE 6-1-2008.
EMILY CARLSEN, EXAMINING ATTORNEY

CLASS 41—(Continued).

SN 77-626,033. GROUP EXCELLENCE LTD., DALLAS, TX. FILED 12-3-2008.



NO CLAIM IS MADE TO THE EXCLUSIVE RIGHT TO USE "GROUP", APART FROM THE MARK AS SHOWN.

THE MARK CONSISTS OF A STYLIZED "G" AND A STYLIZED "E" IN THE BACKGROUND AND THE WORDS "GROUP EXCELLENCE" IN THE FRONT OF THE STYLIZED LETTERS.

FOR EDUCATION SERVICES, NAMELY, PROVIDING TUTORING IN THE FIELDS OF MATH, READING, AND SCIENCE (U.S. CLS. 100, 101 AND 107).

FIRST USE 8-10-2004; IN COMMERCE 8-10-2004.
DAVID ELTON, EXAMINING ATTORNEY

SN 77-626,692. CENTRALKNOWLEDGE, INC., LAVAL, CANADA, FILED 12-4-2008.

CENTRALKNOWLEDGE

THE MARK CONSISTS OF STANDARD CHARACTERS WITHOUT CLAIM TO ANY PARTICULAR FONT, STYLE, SIZE, OR COLOR.

FOR PROVIDING TRAINING PROGRAMS FOR EMPLOYEES OF A BUSINESS IN THE FIELDS OF FINANCIAL TOPICS, TECHNOLOGY, LEADERSHIP SKILLS, SUBJECT EXPERTS AS WELL AS PROVIDING TRAINING FOR IN HOUSE TRAINERS ON HOW TO TRAIN (U.S. CLS. 100, 101 AND 107).

FIRST USE 9-1-2000; IN COMMERCE 9-1-2000.
KIMBERLY PERRY, EXAMINING ATTORNEY

SN 77-626,748. CENTRALKNOWLEDGE, INC., LAVAL, CANADA, FILED 12-4-2008.

LEARNINGSOURCE

THE MARK CONSISTS OF STANDARD CHARACTERS WITHOUT CLAIM TO ANY PARTICULAR FONT, STYLE, SIZE, OR COLOR.

FOR PROVIDING TRAINING PROGRAMS FOR EMPLOYEES OF A BUSINESS, NAMELY, TRAINING EMPLOYEES ON THE USE OF SOFTWARE PROGRAMS (U.S. CLS. 100, 101 AND 107).

FIRST USE 9-1-2000; IN COMMERCE 9-1-2000.
KIMBERLY PERRY, EXAMINING ATTORNEY

CLASS 41—(Continued).

SN 77-626,846. AMERICAN WINE FOUNDATION LTD, PHILADELPHIA, PA. FILED 12-4-2008.

Sommelier Smackdown

THE MARK CONSISTS OF STANDARD CHARACTERS WITHOUT CLAIM TO ANY PARTICULAR FONT, STYLE, SIZE, OR COLOR.

NO CLAIM IS MADE TO THE EXCLUSIVE RIGHT TO USE "SOMMELIER", APART FROM THE MARK AS SHOWN.

FOR ENTERTAINMENT SERVICES, NAMELY, CONDUCTING CONTESTS IN THE FIELD OF FOOD AND WINE PAIRING; ENTERTAINMENT SERVICES, NAMELY, WINE AND FOOD TASTINGS AT WHICH ATTENDANTS TASTE FOOD AND WINE PAIRINGS TO DETERMINE WHICH WINE EXPERT BETTER PAIRS FOOD AND WINES (U.S. CLS. 100, 101 AND 107).

FIRST USE 5-9-2007; IN COMMERCE 5-9-2007.
ROBIN MITTLER, EXAMINING ATTORNEY

SN 77-631,673. SUSTAINABLECIRCLES CORP., SAN FRANCISCO, CA. FILED 12-11-2008.



THE MARK CONSISTS OF A WORLD MAP DESIGN WITH THE WORDS "GORILLA IN THE GREENHOUSE WWW.GREENGORILLA.COM" INSERTED WITHIN THE DESIGN.

FOR EDUCATIONAL AND ENTERTAINMENT SERVICES, NAMELY, A CONTINUING CHILDREN'S ENTERTAINMENT PROGRAM ACCESSIBLE BY RADIO, TELEVISION, SATELLITE, AUDIO, VIDEO AND COMPUTER NETWORKS; ENTERTAINMENT SERVICES, NAMELY, PROVIDING A WEB SITE FEATURING MUSICAL PERFORMANCES, MUSICAL VIDEOS, RELATED FILM CLIPS, PHOTOGRAPHS, AND OTHER MULTIMEDIA MATERIALS IN THE FIELD OF CHILDREN'S ENTERTAINMENT; ENTERTAINMENT SERVICES, NAMELY, PROVIDING PRERECORDED MUSIC ONLINE VIA A GLOBAL COMPUTER NETWORK, ENTERTAINMENT SERVICES IN THE NATURE OF ON-GOING TELEVISION PROGRAMS IN THE FIELD OF CHILDREN'S ENTERTAINMENT (U.S. CLS. 100, 101 AND 107).

ALICIA COLLINS, EXAMINING ATTORNEY

CLASS 41—(Continued).

SN 77-633,886. AMERIPRISE FINANCIAL, INC., MINNEAPOLIS, MN. FILED 12-16-2008.

CLASS 41—(Continued).

SN 77-634,776. AMERIPRISE FINANCIAL, INC., MINNEAPOLIS, MN. FILED 12-17-2008.

EASE



THE MARK CONSISTS OF STANDARD CHARACTERS WITHOUT CLAIM TO ANY PARTICULAR FONT, STYLE, SIZE, OR COLOR.

FOR EDUCATION AND TRAINING, NAMELY, CLASSES, SEMINARS, WORKSHOPS AND TRAINING IN THE FIELD OF CONVERSATION MODELS USED FOR IDENTIFYING AND SATISFYING CLIENTS' NEEDS AND DREAMS (U.S. CLS. 100, 101 AND 107).

KELLY BOULTON, EXAMINING ATTORNEY

THE COLOR(S) BLUE IS/ARE CLAIMED AS A FEATURE OF THE MARK.

THE MARK CONSISTS OF THE WORD "EASE" IN BLUE IN LOWER CASE WITH A SOLID BLUE ARROW AT THE END OF THE WORD POINTED TO THE RIGHT.

FOR EDUCATION AND TRAINING, NAMELY, CLASSES, SEMINARS, WORKSHOPS AND TRAINING IN THE FIELD OF CONVERSATION MODELS USED FOR IDENTIFYING AND SATISFYING CLIENTS' NEEDS AND DREAMS (U.S. CLS. 100, 101 AND 107).

KELLY BOULTON, EXAMINING ATTORNEY

SN 77-635,176. SHERRER, JOEL ALEX, ST. LOUIS, MO. FILED 12-17-2008.

Project Management Road Trip

THE MARK CONSISTS OF STANDARD CHARACTERS WITHOUT CLAIM TO ANY PARTICULAR FONT, STYLE, SIZE, OR COLOR.

NO CLAIM IS MADE TO THE EXCLUSIVE RIGHT TO USE "PROJECT MANAGEMENT", APART FROM THE MARK AS SHOWN.

FOR PROVIDING ON-LINE PUBLICATIONS IN THE NATURE OF AN E-BOOK IN THE FIELD OF PROJECT MANAGEMENT CERTIFICATION (U.S. CLS. 100, 101 AND 107).

FIRST USE 9-1-2007; IN COMMERCE 9-1-2007.

ALLISON SCHRODY, EXAMINING ATTORNEY

SN 77-634,657. GROCHER, MICHAEL, L. AKA HITZONE, CORAL SPRINGS, FL. FILED 12-17-2008.



NO CLAIM IS MADE TO THE EXCLUSIVE RIGHT TO USE "PRODUCTIONS", APART FROM THE MARK AS SHOWN.

THE MARK CONSISTS OF THE WORDS HITZONE PRODUCTIONS ABOVE THREE SPEAKERS ATTACHED TO A PAIR OF WINGS WITH A BANNER BELOW THAT READS WHERE MUSIC IS BORN.

FOR ENTERTAINMENT SERVICES BY A MUSICAL ARTIST AND PRODUCER, NAMELY, MUSICAL COMPOSITION FOR OTHERS AND PRODUCTION OF MUSICAL SOUND RECORDINGS (U.S. CLS. 100, 101 AND 107).

FIRST USE 10-18-2006; IN COMMERCE 11-8-2007.

REGINA DRUMMOND, EXAMINING ATTORNEY

SN 77-635,743. LG ELECTRONICS INC., SEOUL, REPUBLIC OF KOREA, FILED 12-18-2008.

DARE TO DRAW

THE MARK CONSISTS OF STANDARD CHARACTERS WITHOUT CLAIM TO ANY PARTICULAR FONT, STYLE, SIZE, OR COLOR.

FOR ORGANIZING AND CONDUCTING EVENTS AND COMPETITIONS FEATURING THE USE OF MOBILE PHONES TO CREATE PICTURES (U.S. CLS. 100, 101 AND 107).

LINDA MICKLEBURGH, EXAMINING ATTORNEY

CLASS 41—(Continued).

SN 77-636,373. SESAME WORKSHOP, NEW YORK, NY. FILED 12-18-2008.



OWNER OF U.S. REG. NO. 954,372.
THE MARK CONSISTS OF THE WORDS "ONE WORLD, ONE SKY" WITH A SHOOTING STAR ABOVE "ONE SKY" AND THE WORDS "BIG BIRD'S ADVENTURE" BELOW. FOR EDUCATIONAL AND ENTERTAINMENT SERVICES IN THE NATURE OF PLANETARIUM SHOWS (U.S. CLS. 100, 101 AND 107).
PRISCILLA MILTON, EXAMINING ATTORNEY

SN 77-638,820. BUZZWIRE, INC., DENVER, CO. FILED 12-23-2008.

BUZZWIRE

THE MARK CONSISTS OF STANDARD CHARACTERS WITHOUT CLAIM TO ANY PARTICULAR FONT, STYLE, SIZE, OR COLOR.

OWNER OF U.S. REG. NO. 3,531,937.
FOR ELECTRONIC PUBLISHING SERVICES, NAMELY, PUBLICATIONS OF AUDIO-VISUAL WORKS OF OTHERS BASED ON POSTING, RATING, TAGGING, OR SHARING OF USERS OVER THE INTERNET, A WIRELESS COMMUNICATIONS NETWORK, AND OTHER COMMUNICATIONS NETWORKS; PROVIDING ONLINE INFORMATION IN THE FIELD OF THE NEWS IN THE NATURE OF CURRENT EVENT REPORTING AND ENTERTAINMENT (U.S. CLS. 100, 101 AND 107).
FIRST USE 8-1-2007; IN COMMERCE 8-1-2007.
FRED CARL, EXAMINING ATTORNEY

CLASS 41—(Continued).

SN 77-638,846. BUZZWIRE, INC., DENVER, CO. FILED 12-23-2008.



THE COLOR(S) ORANGE, RED, PINK, GREY, BROWN, BEIGE AND BLACK IS/ARE CLAIMED AS A FEATURE OF THE MARK.

THE MARK CONSISTS OF THE COLOR ORANGE IN THE UPPER LEFT POLYGON, THE COLOR RED IN THE TOP TRIANGLE, THE COLOR PINK IN THE UPPER RIGHT POLYGON, THE COLOR GREY IN THE LOWER RIGHT POLYGON, THE COLOR BROWN IN THE BOTTOM TRIANGLE, THE COLOR BEIGE IN THE LOWER LEFT POLYGON AND THE COLOR BLACK IN THE ROUNDED RECTANGLE IN THE CENTER.

FOR ELECTRONIC PUBLISHING SERVICES, NAMELY, PUBLICATIONS OF AUDIO-VISUAL WORKS OF OTHERS BASED ON POSTING, RATING, TAGGING, OR SHARING OF USERS OVER THE INTERNET, A WIRELESS COMMUNICATIONS NETWORK, AND OTHER COMMUNICATIONS NETWORKS; PROVIDING ONLINE INFORMATION IN THE FIELD OF THE NEWS IN THE NATURE OF CURRENT EVENT REPORTING AND ENTERTAINMENT (U.S. CLS. 100, 101 AND 107).
FIRST USE 1-27-2008; IN COMMERCE 1-27-2008.

FRED CARL, EXAMINING ATTORNEY

SN 77-639,528. LEVINE, ANN, SANTA BARBARA, CA. FILED 12-23-2008.

Law School Expert

THE MARK CONSISTS OF STANDARD CHARACTERS WITHOUT CLAIM TO ANY PARTICULAR FONT, STYLE, SIZE, OR COLOR.

NO CLAIM IS MADE TO THE EXCLUSIVE RIGHT TO USE "LAW SCHOOL", APART FROM THE MARK AS SHOWN.

FOR CONSULTING SERVICES FOR STUDENTS IN THE LAW SCHOOL ADMISSION FIELD (U.S. CLS. 100, 101 AND 107).

FIRST USE 8-1-2004; IN COMMERCE 8-1-2004.
PAULA MAHONEY, EXAMINING ATTORNEY

CLASS 41—(Continued).

SN 77-642,237. DERVAES INSTITUTE, PASADENA, CA. FILED 12-31-2008.



OWNER OF U.S. REG. NO. 3,504,141.
THE MARK CONSISTS OF A STYLIZE "P" CONSISTING OF INTERTWINING PATHS IN THE WORDING "PATH TO FREEDOM".

FOR EDUCATIONAL SERVICES, NAMELY, CONDUCTING INFORMAL PROGRAMS IN THE FIELDS OF SUSTAINABLE LIVING, ORGANIC FOODS AND GARDENING, HOMESTEADING, THE ENVIRONMENT, AND CONSERVATION, USING ON-LINE ACTIVITIES AND INTERACTIVE EXHIBITS; ENTERTAINMENT SERVICES, NAMELY, PROVIDING A WEB SITE FEATURING PHOTOGRAPHS, AUDIO, AND VIDEO FEATURING SUSTAINABLE LIVING, ORGANIC FOODS AND GARDENING, HOMESTEADING, THE ENVIRONMENT, AND CONSERVATION; ON-LINE JOURNALS, NAMELY, BLOGS FEATURING SUSTAINABLE LIVING, ORGANIC FOODS AND GARDENING, HOMESTEADING, THE ENVIRONMENT, AND CONSERVATION (U.S. CLS. 100, 101 AND 107).

FIRST USE 11-10-2008; IN COMMERCE 11-12-2008.
JACQUELINE A. LAVINE, EXAMINING ATTORNEY

CLASS 41—(Continued).

SN 77-643,895. BETTINA VON SCHIMMELMANN, DBA HOLLYWOOD PRINCESS PRODUCTIONS, LOS ANGELES, CA. FILED 1-6-2009.



THE MARK CONSISTS OF STANDARD CHARACTERS WITHOUT CLAIM TO ANY PARTICULAR FONT, STYLE, SIZE, OR COLOR.

NO CLAIM IS MADE TO THE EXCLUSIVE RIGHT TO USE "HOLLYWOOD" AND "PRODUCTIONS", APART FROM THE MARK AS SHOWN.

FOR ENTERTAINMENT, NAMELY, PRODUCTION OF VIDEOS AND TELEVISION SHOWS FEATURING CELEBRITY INTERVIEWS AND HOSTING OF TELEVIEWED EVENTS; PRODUCTION OF TELEVISION PROGRAMS (U.S. CLS. 100, 101 AND 107).

FIRST USE 1-3-2008; IN COMMERCE 1-3-2008.
WENDY GOODMAN, EXAMINING ATTORNEY

SN 77-645,218. KALDAWI, VICTORIA E., AKA QUEEN VICTORIA OF SHEBA, TORRANCE, CA. FILED 1-7-2009.

SN 77-643,212. HOLMAN, CHARITY, JOHNSTOWN, OH. FILED 1-5-2009.



THE MARK CONSISTS OF STANDARD CHARACTERS WITHOUT CLAIM TO ANY PARTICULAR FONT, STYLE, SIZE, OR COLOR.

NO CLAIM IS MADE TO THE EXCLUSIVE RIGHT TO USE "CENTRAL OHIO" AND "PERSONAL TRAINING & GROUP EXERCISE", APART FROM THE MARK AS SHOWN.

FOR PHYSICAL FITNESS INSTRUCTION SERVICES IN THE NATURE OF PERSONAL TRAINING, GROUP EXERCISE AND KETTLEBELL INSTRUCTION SERVICES (U.S. CLS. 100, 101 AND 107).

FIRST USE 4-13-2007; IN COMMERCE 4-13-2007.
NICHOLAS ALTREE, EXAMINING ATTORNEY



THE MARK CONSISTS OF STANDARD CHARACTERS WITHOUT CLAIM TO ANY PARTICULAR FONT, STYLE, SIZE, OR COLOR.

THE NAME "QUEEN VICTORIA OF SHEBA" IDENTIFIES A LIVING INDIVIDUAL WHOSE CONSENT IS OF RECORD.

FOR ENTERTAINMENT SERVICES, NAMELY, LIVE, TELEVIEWED AND MOVIE APPEARANCES BY A PROFESSIONAL ENTERTAINER (U.S. CLS. 100, 101 AND 107).

FIRST USE 1-1-2002; IN COMMERCE 9-1-2007.
ANGELA M. MICHELI, EXAMINING ATTORNEY

CLASS 41—(Continued).

SN 77-645,611. PEGACORN PRODUCTIONS, LLC, LARGO, FL. FILED 1-8-2009.

CIGAR CITY TATTOO CONVENTION

THE MARK CONSISTS OF STANDARD CHARACTERS WITHOUT CLAIM TO ANY PARTICULAR FONT, STYLE, SIZE, OR COLOR.

NO CLAIM IS MADE TO THE EXCLUSIVE RIGHT TO USE "TATTOO CONVENTION", APART FROM THE MARK AS SHOWN.

FOR EDUCATION SERVICES, NAMELY, WORK SHOPS, SEMINARS, EXHIBITIONS AND CONTESTS IN THE FIELD OF CREATING AND APPLYING BODY, ART, NAMELY, TATTOOS AND BODY PIERCING; ENTERTAINMENT IN THE NATURE OF ART EXHIBITIONS, AND LIVE MUSICAL PERFORMANCES BY ARTISTS; ENTERTAINMENT SERVICES, NAMELY, THE PLANNING AND ARRANGEMENT OF SHOWING MOVIES (U.S. CLS. 100, 101 AND 107).

FIRST USE 1-8-2009; IN COMMERCE 1-8-2009.

REGINA DRUMMOND, EXAMINING ATTORNEY

SN 77-646,659. DAVID FILIP, WOODINVILLE, WA. FILED 1-9-2009.



THE COLOR(S) BLACK, WHITE, GRAY AND GREEN IS/ARE CLAIMED AS A FEATURE OF THE MARK.

THE MARK CONSISTS OF THE TERM "SMART" IN BLACK. A BLACK GRADUATION CAP IS ABOVE THE LETTER "A" IN BLACK OUTLINED IN GRAY WITH A GREEN TASSEL OVER THE LETTER "R". DUE TO THE THICKNESS OF THE FONT, THE LETTERS "R" AND "T" ARE JOINED.

FOR MULTIMEDIA PUBLISHING OF BOOKS, MAGAZINES, JOURNALS, SOFTWARE, GAMES, MUSIC, AND ELECTRONIC PUBLICATIONS (U.S. CLS. 100, 101 AND 107).

FIRST USE 9-26-2008; IN COMMERCE 9-26-2008.

MICHAEL KEATING, EXAMINING ATTORNEY

CLASS 41—(Continued).

SN 77-648,240. BRADSHAW, CARL J., DBA TUTOR PROFESSIONALS NOW, NORTHBRIDGE, MA. FILED 1-13-2009.

Tutor Professionals Now

THE MARK CONSISTS OF STANDARD CHARACTERS WITHOUT CLAIM TO ANY PARTICULAR FONT, STYLE, SIZE, OR COLOR.

FOR EDUCATION SERVICES, NAMELY, PROVIDING TUTORING SERVICES IN THE FIELDS OF STATE STANDARDIZED TESTS, GED, ASVAB, SAT, ACT, MARCH2SUCCESS, AND GRE (U.S. CLS. 100, 101 AND 107).

RONALD AIKENS, EXAMINING ATTORNEY

SN 77-648,299. NORTH AVENUE STUDIOS, INC., ORANGE CITY, FL. FILED 1-13-2009.

NORTH AVENUE STUDIOS

THE MARK CONSISTS OF STANDARD CHARACTERS WITHOUT CLAIM TO ANY PARTICULAR FONT, STYLE, SIZE, OR COLOR.

NO CLAIM IS MADE TO THE EXCLUSIVE RIGHT TO USE "STUDIOS", APART FROM THE MARK AS SHOWN.

FOR AUDIO AND VIDEO RECORDING AND PRODUCTION SERVICES; DIRECTING SERVICES FOR THE PRODUCTION OF AUDIO AND VIDEO RECORDINGS AND PERFORMANCES; RECORDING, PRODUCTION AND DIRECTING OF MUSICAL PERFORMANCES (U.S. CLS. 100, 101 AND 107).

DAVID ELTON, EXAMINING ATTORNEY

SN 77-648,470. THREE ANGELS BROADCASTING NETWORK, INC., WEST FRANKFORT, IL. FILED 1-13-2009.

SIMPLY STRINGS

THE MARK CONSISTS OF STANDARD CHARACTERS WITHOUT CLAIM TO ANY PARTICULAR FONT, STYLE, SIZE, OR COLOR.

NO CLAIM IS MADE TO THE EXCLUSIVE RIGHT TO USE "STRINGS", APART FROM THE MARK AS SHOWN.

FOR EDUCATIONAL AND ENTERTAINMENT SERVICES, NAMELY, A CONTINUING PROGRAM ABOUT MUSICAL PERFORMANCES ACCESSIBLE BY RADIO, TELEVISION, SATELLITE, AUDIO, VIDEO AND COMPUTER NETWORKS; PRODUCTION OF CABLE TELEVISION PROGRAMS; PRODUCTION OF CLOSED CAPTION TELEVISION PROGRAMS; PRODUCTION OF DVDS, VIDEOTAPES AND TELEVISION PROGRAMS FEATURING MUSICAL PERFORMANCES; PRODUCTION OF RADIO AND TELEVISION PROGRAMS; TELEVISION SHOW PRODUCTION (U.S. CLS. 100, 101 AND 107).

LINDA ESTRADA, EXAMINING ATTORNEY

CLASS 41—(Continued).

SN 77-651,168. NETWORK FOR GOOD, BETHESDA, MD. FILED 1-16-2009.

Nonprofit 911

THE MARK CONSISTS OF STANDARD CHARACTERS WITHOUT CLAIM TO ANY PARTICULAR FONT, STYLE, SIZE, OR COLOR.

NO CLAIM IS MADE TO THE EXCLUSIVE RIGHT TO USE "NONPROFIT", APART FROM THE MARK AS SHOWN.

FOR CHARITABLE SERVICES, NAMELY, PROVIDING TRAINING IN THE FIELD OF FUNDRAISING AND MARKETING (U.S. CLS. 100, 101 AND 107).

FIRST USE 7-12-2007; IN COMMERCE 7-12-2007.
DAVID TAYLOR, EXAMINING ATTORNEY

CLASS 41—(Continued).

SN 77-653,074. HUARACHA, DAVID OMAR, AKA DAVID OMAR, AUSTIN, TX. FILED 1-20-2009.

JANE BLONDE

THE MARK CONSISTS OF STANDARD CHARACTERS WITHOUT CLAIM TO ANY PARTICULAR FONT, STYLE, SIZE, OR COLOR.

FOR ENTERTAINMENT SERVICES IN THE NATURE OF A COMEDY SHOW ABOUT A FEMALE SPY NAME JANE BLONDE (U.S. CLS. 100, 101 AND 107).

FIRST USE 1-19-2009; IN COMMERCE 1-19-2009.
MICHAEL WEBSTER, EXAMINING ATTORNEY

SN 77-653,304. PADWA, THOMAS, WARREN, RI. AND DEVOE, JOANNE, WARREN, RI. FILED 1-21-2009.

Voice Workshop Zero

THE MARK CONSISTS OF STANDARD CHARACTERS WITHOUT CLAIM TO ANY PARTICULAR FONT, STYLE, SIZE, OR COLOR.

NO CLAIM IS MADE TO THE EXCLUSIVE RIGHT TO USE "VOICE WORKSHOP", APART FROM THE MARK AS SHOWN.

FOR TEACHING IN THE FIELD OF MUSIC (U.S. CLS. 100, 101 AND 107).

FIRST USE 11-1-2005; IN COMMERCE 11-1-2005.
TEJBIR SINGH, EXAMINING ATTORNEY

SN 77-653,546. FARM SAFETY FOR "JUST KIDS", EARLHAM, IA. FILED 1-21-2009.

FARM SAFETY 4 JUST KIDS

THE MARK CONSISTS OF STANDARD CHARACTERS WITHOUT CLAIM TO ANY PARTICULAR FONT, STYLE, SIZE, OR COLOR.

NO CLAIM IS MADE TO THE EXCLUSIVE RIGHT TO USE "FARM SAFETY", APART FROM THE MARK AS SHOWN.

FOR EDUCATIONAL SERVICES, NAMELY, CONDUCTING SEMINARS AND DISSEMINATING EDUCATIONAL MATERIALS ON THE HAZARDS TO CHILDREN AND ADOLESCENTS ON THE FAMILY FARM (U.S. CLS. 100, 101 AND 107).

FIRST USE 1-1-1990; IN COMMERCE 1-1-1990.
SHARON MEIER, EXAMINING ATTORNEY

SN 77-652,596. NATIONAL ASSOCIATION OF PROFESSIONAL PET SITTERS, INC., MT. LAUREL, NJ. FILED 1-20-2009.



OWNER OF U.S. REG. NO. 3,575,458.
NO CLAIM IS MADE TO THE EXCLUSIVE RIGHT TO USE "BUSINESS OF THE YEAR", APART FROM THE MARK AS SHOWN.

THE COLOR(S) GREEN AND WHITE IS/ARE CLAIMED AS A FEATURE OF THE MARK.

THE MARK CONSISTS OF A GREEN CAT AND DOG WITHIN A CIRCULAR GREEN SEAL CONTAINING THE WORDS "NATIONAL ASSOCIATION OF PROFESSIONAL PET SITTERS" ALONG WITH A GREEN BANNER TO THE LOWER RIGHT WHICH CONTAINS THE WORDS "BUSINESS OF THE YEAR". COLOR LOCATION IS WHITE FOR THE WORDING AND A PORTION OF THE DESIGN BEHIND THE ANIMALS PICTURES WITH THE BALANCE OF THE MARK IN GREEN FOR THE SEAL, BANNER, AND ANIMAL DESIGN.

SEC. 2(F) AS TO "NATIONAL ASSOCIATION OF PROFESSIONAL PET SITTERS".

FOR PROVIDING RECOGNITION AND INCENTIVES BY THE WAY OF AWARDS TO DEMONSTRATE EXCELLENCE IN THE FIELD OF PET SITTING (U.S. CLS. 100, 101 AND 107).

FIRST USE 5-0-2006; IN COMMERCE 5-0-2006.
RICHARD A. STRASER, EXAMINING ATTORNEY

CLASS 41—(Continued).

SN 77-653,994. V-TRAP RECORDS INC., MIAMI, FL. FILED 1-21-2009.



NO CLAIM IS MADE TO THE EXCLUSIVE RIGHT TO USE "RECORDS", APART FROM THE MARK AS SHOWN. THE STIPLING IS FOR SHADING PURPOSES ONLY.

THE MARK CONSISTS OF A CIRCLE WITH THORNS RESEMBLING BARBED WIRE. IN THE MIDDLE OF THE CIRCLE IS A BIG "V", WITH THE WORD "TRAP" GOING ACROSS THE "V", AND THE WORD "RECORDS" RIGHT UNDER THE WORD "TRAP".

FOR AUDIO RECORDING AND PRODUCTION; MULTIMEDIA ENTERTAINMENT SERVICES IN THE NATURE OF RECORDING, PRODUCTION AND POST-PRODUCTION SERVICES IN THE FIELDS OF MUSIC, VIDEO, AND FILMS; MUSIC PUBLISHING SERVICES; PRODUCTION OF SOUND AND MUSIC VIDEO RECORDINGS (U.S. CLS. 100, 101 AND 107).

FIRST USE 7-20-2006; IN COMMERCE 9-0-2008.
NANCY CLARKE, EXAMINING ATTORNEY

CLASS 41—(Continued).

SN 77-654,660. AMERICAN WORK, INC., LOS ANGELES, CA. FILED 1-22-2009.

AMERICAN WORK

THE MARK CONSISTS OF STANDARD CHARACTERS WITHOUT CLAIM TO ANY PARTICULAR FONT, STYLE, SIZE, OR COLOR.

NO CLAIM IS MADE TO THE EXCLUSIVE RIGHT TO USE "AMERICAN", APART FROM THE MARK AS SHOWN.

FOR ENTERTAINMENT SERVICES, NAMELY, TELEVISION SHOW PRODUCTION SERVICES, FEATURE FILM PRODUCTION SERVICES, SCREENWRITING, FILM AND TELEVISION SCORE COMPOSITION SERVICES, PROVIDING AN INTERNET WEB SITE ACCESSIBLE VIA A GLOBAL COMPUTER NETWORK AND WIRELESS DEVICES FEATURING ENTERTAINMENT INFORMATION RELATING TO MOTION PICTURES, TELEVISION SHOWS, MUSIC AND MEDIA, PRODUCTION AND DISTRIBUTION OF LIVE ACTION AND ANIMATED MOTION PICTURES AND TELEVISION SHOWS, PRESENTATION OF ENTERTAINMENT EXHIBITIONS AND COMPETITIONS, NAMELY, LIVE ACTION AND PRERECORDED MUSIC, ANIMATED, AND MULTIMEDIA SHOWS AND PERFORMANCES (U.S. CLS. 100, 101 AND 107).

KATHERINE CONNOLLY, EXAMINING ATTORNEY

SN 77-654,096. ACCESS INTELLIGENCE LLC, ROCKVILLE, MD. FILED 1-22-2009.

Helicopter News

THE MARK CONSISTS OF STANDARD CHARACTERS WITHOUT CLAIM TO ANY PARTICULAR FONT, STYLE, SIZE, OR COLOR.

OWNER OF U.S. REG. NO. 1,522,582.

NO CLAIM IS MADE TO THE EXCLUSIVE RIGHT TO USE "NEWS", APART FROM THE MARK AS SHOWN. SEC. 2(F).

FOR PROVIDING NEWSLETTERS IN THE FIELD OF AEROSPACE AND DEFENSE VIA E-MAIL; PROVIDING ON-LINE PUBLICATIONS IN THE NATURE OF NEWSLETTERS IN THE FIELD OF AEROSPACE AND DEFENSE (U.S. CLS. 100, 101 AND 107).

FIRST USE 11-3-1975; IN COMMERCE 11-3-1975.
GENE MACIOL, EXAMINING ATTORNEY

SN 77-655,308. VEGAS.COM, LLC, HENDERSON, NV. FILED 1-23-2009.

FREQUENT VEGAS POINTS

THE MARK CONSISTS OF STANDARD CHARACTERS WITHOUT CLAIM TO ANY PARTICULAR FONT, STYLE, SIZE, OR COLOR.

OWNER OF U.S. REG. NOS. 2,920,242, 2,937,159 AND OTHERS.

SEC. 2(F).
FOR ARRANGING FOR TICKET RESERVATIONS FOR SHOWS AND OTHER ENTERTAINMENT EVENTS; THEATRICAL TICKET AGENCIES (U.S. CLS. 100, 101 AND 107).

FIRST USE 1-23-2004; IN COMMERCE 1-23-2004.
YAT SYE, LEE, EXAMINING ATTORNEY

CLASS 41—(Continued).

SN 77-655,451. TIM WELLS, CANTON, IL. FILED 1-23-2009.



THE COLOR(S) RED, BLACK, AND WHITE IS/ARE CLAIMED AS A FEATURE OF THE MARK.

THE MARK CONSISTS OF THE WORD "RELENTLESS" NEAR THE TOP OF THE MARK. BELOW THE WORD "RELENTLESS" NEAR THE LEFT SIDE OF THE MARK IS A BLACK SILHOUETTE OF A MAN HOLDING A BOW AND AIMING IT AT A BLACK SILHOUETTE OF A DEER, WHICH APPEARS TO THE RIGHT OF THE SILHOUETTE OF THE MAN, BEGINNING NEAR THE BOTTOM OF THE SILHOUETTE OF THE MAN HOLDING THE BOW AND CONTINUING TO THE RIGHT, AND BELOW THE SILHOUETTE OF THE DEER, THE WORD "PURSUIT". THE COLOR RED APPEARS IN THE WORDS "RELENTLESS PURSUIT". THE COLOR BLACK APPEARS IN THE SILHOUETTE OF MAN HOLDING A BOW AND AIMING IT AT A SILHOUETTE OF A DEER, AND IN THE OUTLINING AROUND THE WORDING IN THE MARK. THE COLOR WHITE APPEARS ON THE OUTLINING OF THE PORTIONS OF THE WORDING THAT APPEARS ON THE BLACK SILHOUETTE DESIGNS. THE MARK IS PRESENTED ON A TRANSPARENT BACKGROUND AND NO OTHER COLORS ARE CLAIMED.

FOR ENTERTAINMENT, NAMELY, A CONTINUING OUTDOOR SPORTS SHOW FEATURING HUNTING AND FISHING, BROADCAST OVER TELEVISION, SATELLITE, AUDIO, AND VIDEO MEDIA (U.S. CLS. 100, 101 AND 107).

FIRST USE 10-1-1998; IN COMMERCE 10-1-1998.
CURTIS FRENCH, EXAMINING ATTORNEY

SN 77-655,482. PACKET SOLUTIONS INC., CLEARWATER, FL. FILED 1-23-2009.

PACKET ACADEMY

THE MARK CONSISTS OF STANDARD CHARACTERS WITHOUT CLAIM TO ANY PARTICULAR FONT, STYLE, SIZE, OR COLOR.

NO CLAIM IS MADE TO THE EXCLUSIVE RIGHT TO USE "ACADEMY", APART FROM THE MARK AS SHOWN. FOR EDUCATIONAL SERVICES, NAMELY, INSTRUCTOR-LED TRAINING AND COURSES TO FACILITATE INFORMATION TECHNOLOGY EDUCATION AND CERTIFICATION TEST PREPARATION (U.S. CLS. 100, 101 AND 107).

JILL PRATER, EXAMINING ATTORNEY

CLASS 41—(Continued).

SN 77-655,643. FARRELL GENE WOODS, DBA A SHARP DJ SERVICE, DENVER, CO. FILED 1-23-2009.

A SHARP DJ SERVICE

THE MARK CONSISTS OF STANDARD CHARACTERS WITHOUT CLAIM TO ANY PARTICULAR FONT, STYLE, SIZE, OR COLOR.

NO CLAIM IS MADE TO THE EXCLUSIVE RIGHT TO USE "DJ SERVICE", APART FROM THE MARK AS SHOWN. FOR DISC JOCKEYS FOR PARTIES AND SPECIAL EVENTS (U.S. CLS. 100, 101 AND 107).

FIRST USE 7-1-2005; IN COMMERCE 7-1-2005.
GINA FINK, EXAMINING ATTORNEY

SN 77-655,939. AMPLO, CHRISTOPHER J, BROOKLYN, NY. FILED 1-24-2009.



THE MARK CONSISTS OF THE STYLIZED WORDING "UNDERWHELMED," WHICH CONTAINS WING-TYPE EXTENDED STYLIZED LETTERS "N" AND "L."

FOR ENTERTAINMENT IN THE NATURE OF LIVE PERFORMANCES BY ROCK BAND; ENTERTAINMENT IN THE NATURE OF VISUAL AND AUDIO PERFORMANCES, NAMELY, MUSICAL BAND, ROCK GROUP, GYMNASTIC, DANCE, AND BALLET PERFORMANCES; ENTERTAINMENT SERVICES IN THE NATURE OF LIVE MUSICAL PERFORMANCES; ENTERTAINMENT, NAMELY, LIVE MUSIC CONCERTS; ENTERTAINMENT, NAMELY, LIVE PERFORMANCES BY A MUSICAL BAND; ENTERTAINMENT, NAMELY, LIVE PERFORMANCES BY MUSICAL BANDS; ENTERTAINMENT, NAMELY, LIVE PERFORMANCES BY ROCK GROUPS (U.S. CLS. 100, 101 AND 107).

FIRST USE 4-12-1997; IN COMMERCE 4-12-1997.
DAWN HAN, EXAMINING ATTORNEY

SN 77-656,034. LIFE IS NOW, INC., RANCHO SANTA FE, CA. FILED 1-25-2009.

**The David Neagle Honorary
Female Entrepreneur Award**

THE MARK CONSISTS OF STANDARD CHARACTERS WITHOUT CLAIM TO ANY PARTICULAR FONT, STYLE, SIZE, OR COLOR.

NO CLAIM IS MADE TO THE EXCLUSIVE RIGHT TO USE "HONORARY FEMALE ENTREPRENEUR AWARD", APART FROM THE MARK AS SHOWN.

THE NAME(S), PORTRAIT(S), AND/OR SIGNATURE(S) SHOWN IN THE MARK IDENTIFIES "DAVID NEAGLE", WHOSE CONSENT(S) TO REGISTER IS MADE OF RECORD.

FOR PROVIDING RECOGNITION AND INCENTIVES BY THE WAY OF AWARDS TO DEMONSTRATE EXCELLENCE IN THE FIELD OF BUSINESS (U.S. CLS. 100, 101 AND 107).

ANDREW LEASER, EXAMINING ATTORNEY

CLASS 41—(Continued).

SN 77-656,413. POWER ALIGNMENT YOGA ENTERPRISES LLC, TAVARES, FL. FILED 1-26-2009.

Power Alignment Yoga

THE MARK CONSISTS OF STANDARD CHARACTERS WITHOUT CLAIM TO ANY PARTICULAR FONT, STYLE, SIZE, OR COLOR.

NO CLAIM IS MADE TO THE EXCLUSIVE RIGHT TO USE "YOGA", APART FROM THE MARK AS SHOWN.

FOR EDUCATION SERVICES, NAMELY, PROVIDING CLASSES, RETREATS, WORKSHOPS IN THE FIELD OF YOGA AND YOGA MEDITATION; TRAINING SERVICES IN THE FIELD OF YOGA (U.S. CLS. 100, 101 AND 107).

FIRST USE 1-0-2004; IN COMMERCE 1-0-2004.
AMY KERTGATE, EXAMINING ATTORNEY

SN 77-656,738. CLEANEDISON LLC, NEW YORK, NY. FILED 1-26-2009.

CleanEdison

THE MARK CONSISTS OF STANDARD CHARACTERS WITHOUT CLAIM TO ANY PARTICULAR FONT, STYLE, SIZE, OR COLOR.

FOR CONTINUING EDUCATION SERVICES, NAMELY, PROVIDING LIVE AND ON-LINE CONTINUING PROFESSIONAL EDUCATION SEMINARS IN THE FIELD OF RENEWABLE ENERGY/GREEN SERVICES (U.S. CLS. 100, 101 AND 107).

FIRST USE 10-1-2008; IN COMMERCE 10-1-2008.
ANDREA K. NADELMAN, EXAMINING ATTORNEY

SN 77-656,969. WASHIN, JAMES, FORT LAUDERDALE, FL. FILED 1-26-2009.

w.e.t.
Water Emergency Task-force

NO CLAIM IS MADE TO THE EXCLUSIVE RIGHT TO USE "WATER EMERGENCY TASK FORCE", APART FROM THE MARK AS SHOWN.

THE MARK CONSISTS OF THE STYLIZED TEXT "W.E.T. WATER EMERGENCY TASK-FORCE".

FOR EDUCATION SERVICES, NAMELY, PROVIDING CLASSES, SEMINARS, WORKSHOPS IN THE FIELD OF WATER CRISIS AWARENESS (U.S. CLS. 100, 101 AND 107).

SAIMA MAKHDOOM, EXAMINING ATTORNEY

CLASS 41—(Continued).

SN 77-657,525. GOEGLEIN, ANDREA, LAS VEGAS, NV. FILED 1-27-2009.

THE CROOKED ROAD OF SUCCESS

THE MARK CONSISTS OF STANDARD CHARACTERS WITHOUT CLAIM TO ANY PARTICULAR FONT, STYLE, SIZE, OR COLOR.

FOR EDUCATION SERVICES, NAMELY, PROVIDING LIVE AND ON-LINE SEMINARS, LECTURES, TELESEMINARS, TELECLASSES AND WORKSHOPS IN THE FIELD OF PERSONAL AWARENESS; ENTERTAINMENT SERVICES IN THE NATURE OF AN ONGOING IPTV (INTERNET PROTOCOL TELEVISION), TELEVISION PROGRAMMING SEGMENTS IN THE FIELD OF POSITIVE PSYCHOLOGY, PERSONAL RELATIONSHIPS, THE ART AND SCIENCE OF HAPPINESS (U.S. CLS. 100, 101 AND 107).

FIRST USE 11-1-2008; IN COMMERCE 11-1-2008.
CYNTHIA SLOAN, EXAMINING ATTORNEY

SN 77-657,547. COX & SCOTT ENTERTAINMENT, DBA BACCHUS HOUSE, SAN DIEGO, CA. FILED 1-27-2009.



NO CLAIM IS MADE TO THE EXCLUSIVE RIGHT TO USE "HOUSE", APART FROM THE MARK AS SHOWN.

THE MARK CONSISTS OF THE WORDS "BACCHUS HOUSE" IN FANCIFUL STYLIZATION WITH A CURVED ARCH AROUND IT.

FOR ARRANGING AND CONDUCTING NIGHTCLUB ENTERTAINMENT EVENTS; ARRANGING FOR TICKET RESERVATIONS FOR SHOWS AND OTHER ENTERTAINMENT EVENTS; ENTERTAINMENT IN THE NATURE OF DANCE PERFORMANCES; ENTERTAINMENT IN THE NATURE OF FASHION SHOWS; ENTERTAINMENT IN THE NATURE OF GYMNASTIC PERFORMANCES; ENTERTAINMENT IN THE NATURE OF LASER SHOWS; ENTERTAINMENT IN THE NATURE OF LIGHT SHOWS; ENTERTAINMENT IN THE NATURE OF VISUAL AND AUDIO PERFORMANCES, AND MUSICAL, VARIETY, NEWS AND COMEDY SHOWS; ENTERTAINMENT IN THE NATURE OF VISUAL AND AUDIO PERFORMANCES, NAMELY, MUSICAL BAND, ROCK GROUP, GYMNASTIC, DANCE, AND BALLET PERFORMANCES; ENTERTAINMENT SERVICES IN THE NATURE OF LIVE MUSICAL PERFORMANCES; ENTERTAINMENT SERVICES, NAMELY, CONDUCTING CARNIVALS; ENTERTAINMENT SERVICES, NAMELY, CONDUCTING CONTESTS; ENTERTAINMENT SERVICES, NAMELY, CONDUCTING FAIRS; ENTERTAINMENT SERVICES, NAMELY, CONDUCTING PARTIES; ENTERTAINMENT SERVICES, NAMELY, WINE AND FOOD TASTINGS; ENTERTAINMENT, NAMELY, LIVE MUSIC CONCERTS; ENTERTAINMENT, NAMELY, LIVE PERFORMANCES BY A MUSICAL BAND; ENTERTAINMENT, NAMELY, LIVE PERFORMANCES BY MUSICAL BANDS; ENTERTAINMENT, NAMELY, LIVE PERFORMANCES BY ROCK GROUPS (U.S. CLS. 100, 101 AND 107).

FIRST USE 11-15-2001; IN COMMERCE 11-15-2001.
G. MAYERSCHOFF, EXAMINING ATTORNEY

CLASS 41—(Continued).

SN 77-657,591. FORECLOSURE WEALTH MANAGEMENT, LLC, SAINT CHARLES, IL. FILED 1-27-2009.

Jim Fleck's Cash Now System

THE MARK CONSISTS OF STANDARD CHARACTERS WITHOUT CLAIM TO ANY PARTICULAR FONT, STYLE, SIZE, OR COLOR.

NO CLAIM IS MADE TO THE EXCLUSIVE RIGHT TO USE "CASH" AND "SYSTEM", APART FROM THE MARK AS SHOWN.

THE NAME "JIM FLECK" IDENTIFIES A LIVING INDIVIDUAL WHOSE CONSENT IS OF RECORD.

FOR CONTINUING EDUCATION SERVICES, NAMELY, PROVIDING LIVE AND ON-LINE CONTINUING PROFESSIONAL EDUCATION SEMINARS IN THE LEGAL, MEDICAL, ACCOUNTING, AND REAL ESTATE FIELDS (U.S. CLS. 100, 101 AND 107).

MARK SHINER, EXAMINING ATTORNEY

SN 77-657,612. FORECLOSURE WEALTH MANAGEMENT, LLC, SAINT CHARLES, IL. FILED 1-27-2009.

Jim Fleck's Cash Now Real Estate System

THE MARK CONSISTS OF STANDARD CHARACTERS WITHOUT CLAIM TO ANY PARTICULAR FONT, STYLE, SIZE, OR COLOR.

NO CLAIM IS MADE TO THE EXCLUSIVE RIGHT TO USE "CASH" AND "REAL ESTATE SYSTEM", APART FROM THE MARK AS SHOWN.

THE NAME JIM FLECK IDENTIFIES A LIVING INDIVIDUAL WHOSE CONSENT IS OF RECORD.

FOR CONTINUING EDUCATION SERVICES, NAMELY, PROVIDING LIVE AND ON-LINE CONTINUING PROFESSIONAL EDUCATION SEMINARS IN THE LEGAL, MEDICAL, ACCOUNTING, AND REAL ESTATE FIELDS (U.S. CLS. 100, 101 AND 107).

MARK SHINER, EXAMINING ATTORNEY

CLASS 41—(Continued).

SN 77-657,914. PICTURE ME HAPPY, DOVER, KY. FILED 1-27-2009.



THE COLOR(S) BLACK, BLUE, GREEN, ORANGE, RED AND WHITE IS/ARE CLAIMED AS A FEATURE OF THE MARK.

THE MARK CONSISTS OF A SMALL BLUE STAR IN THE UPPER LEFT, A LARGE BLUE STAR ATTACHED TO THE LEFT LOWER CORNER OF A RAINBOW CONSISTING OF ORANGE, YELLOW, GREEN AND BLUE STRIPES. THE RAINBOW IS ATTACHED AT THE RIGHT END TO A BLACK CAMERA WITH FLASH ATTACHMENT WITH A RED BUTTON AND YELLOW SMILEY FACE ON THE FRONT, WITH FACIAL FEATURES DELINEATED IN BLACK. A SMALL BLUE STAR IS LOCATED BESIDE THE UPPER RIGHT CORNER OF THE CAMERA AND ANOTHER BLUE STAR IS BENEATH THE SMALL STAR. "PICTURE ME HAPPY.ORG" IS WRITTEN IN BLUE BENEATH THE IMAGE.

FOR CHARITABLE SERVICES, NAMELY, PROVIDING ARTS AND CRAFTS TO SEVERELY ILL HOSPITALIZED CHILDREN (U.S. CLS. 100, 101 AND 107).

IRA J. GOODSaid, EXAMINING ATTORNEY

SN 77-658,235. AVANTGARDE TRANSLATIONS, INC., CHARLOTTE, NC. FILED 1-28-2009.



NO CLAIM IS MADE TO THE EXCLUSIVE RIGHT TO USE "TRANSLATIONS", APART FROM THE MARK AS SHOWN.

THE COLOR(S) PURPLE, LIGHT PURPLE, BLUE, LIGHT BLUE, AND WHITE IS/ARE CLAIMED AS A FEATURE OF THE MARK.

THE MARK CONSISTS OF A LOGO SYMBOL IN A RECTANGULAR SHAPE COMPOSED OF FOUR TRIANGLES; THE FAR LEFT TRIANGLE IS A LIGHT PURPLE WITH GRADUATED LINES EXTENDING FROM THE LOWER RIGHT SIDE OF THE TRIANGLE CONNECTING THE LEFT TRIANGLE TO THE BOTTOM TRIANGLE WHICH IS BLUE; THE GRADUATED LINES CONNECTING THESE TWO TRIANGLES RANGE FROM PURPLE ON THE LEFT FADING TO WHITE AND THEN GRADUATING TO BLUE ON THE RIGHT; THE FAR RIGHT TRIANGLE IS LIGHT BLUE AND IS CONNECTED TO THE BOTTOM TRIANGLE AND THE TOP TRIANGLE WHICH IS PURPLE; TO THE RIGHT OF THE LOGO SYMBOL IS THE TEXT "AVANTGARDE TRANSLATIONS" IN BLUE.

FOR LANGUAGE INTERPRETATION; LANGUAGE TRANSLATION (U.S. CLS. 100, 101 AND 107).

FIRST USE 6-15-2007; IN COMMERCE 8-25-2008.

DOMINIC FATHY, EXAMINING ATTORNEY

CLASS 41—(Continued).

SN 77-658,497. PETTUGALAN, VERNON G., PASADENA, CA. FILED 1-28-2009.

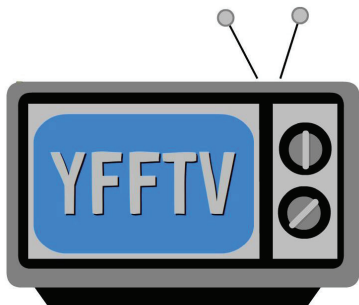

Your Family Friendly TV

NO CLAIM IS MADE TO THE EXCLUSIVE RIGHT TO USE "YOUR FAMILY FRIENDLY TV", APART FROM THE MARK AS SHOWN.

THE COLOR(S) BLUE, GRAY, AND BLACK IS/ARE CLAIMED AS A FEATURE OF THE MARK.

THE MARK CONSISTS OF A CHARACTURE OF A TELEVISION IN BLACK AND GRAY. THE TELEVISION SCREEN FEATURES THE LETTERS "YFFTV" WRITTEN IN GRAY LETTERS WITH A BLACK OUTLINE WRITTEN OVER A BLUE BACKGROUND. BELOW THE TELEVISION, THE WORDS "YOUR FAMILY FRIENDLY TV" ARE WRITTEN IN BLACK LETTERS.

FOR TELEVISION PRODUCTION (U.S. CLS. 100, 101 AND 107).

JEAN IM, EXAMINING ATTORNEY

CLASS 41—(Continued).

GREEN AND COMPRISED OF GREEN LINES OF LONGITUDE AND LATITUDE WITH A LARGE, GREEN, LOWER CASE LETTER "I" IN THE CENTER AND OPPOSING FACIAL SILHOUETTES, ONE IN BLUE FACING WEST AND ONE IN WHITE FACING EAST, WITH THE WORD "INTERFACE" IN BLUE BELOW THE GLOBE, THE WORDING "CONFERENCE GROUP" IN BLACK BOLD CHARACTERS BELOW THAT, AND THE WORDING "A DIVISION OF FRANCE PUBLICATIONS, INC." IN SMALL BLACK FONT BELOW THAT.

FOR ARRANGING AND CONDUCTING EDUCATIONAL CONFERENCES; CONTINUING EDUCATION SERVICES, NAMELY, PROVIDING LIVE AND ON-LINE CONTINUING PROFESSIONAL EDUCATION SEMINARS IN THE LEGAL, MEDICAL, ACCOUNTING, AND REAL ESTATE FIELDS (U.S. CLS. 100, 101 AND 107).

FIRST USE 1-19-2009; IN COMMERCE 1-19-2009.
SANDRA MANIOS, EXAMINING ATTORNEY

SN 77-659,357. EMERALD DREAMS VIDEO PRODUCTIONS, HARVEY, LA. FILED 1-29-2009.

SN 77-659,197. FRANCE PUBLICATIONS, INC., ATLANTA, GA. FILED 1-29-2009.



InterFace
Conference Group
A division of France Publications, Inc.

NO CLAIM IS MADE TO THE EXCLUSIVE RIGHT TO USE "CONFERENCE GROUP A DIVISION OF FRANCE PUBLICATIONS, INC.", APART FROM THE MARK AS SHOWN.

THE COLOR(S) GREEN, BLUE, WHITE AND BLACK IS/ARE CLAIMED AS A FEATURE OF THE MARK.

THE MARK CONSISTS OF A GLOBE OUTLINED IN



Emerald Dreams
Video Productions

NO CLAIM IS MADE TO THE EXCLUSIVE RIGHT TO USE "VIDEO PRODUCTIONS", APART FROM THE MARK AS SHOWN.

THE MARK CONSISTS OF THE STYLIZED TEXT "EMERALD DREAMS VIDEO PRODUCTIONS". ON THE TOP THERE IS AN OCTAGON SHAPED EMERALD THE IS SLIGHTLY OPENED IN THE UPPER RIGHT CORNER WHICH HAS A SPOTLIGHT APPEARING FROM THE OPENING. THE SPOTLIGHT PRODUCES STARS WHICH SURROUNDS THE EMERALD.

FOR VIDEOGRAPHY SERVICES (U.S. CLS. 100, 101 AND 107).

DAVID H. STINE, EXAMINING ATTORNEY

CLASS 41—(Continued).

SN 77-659,669. KALEI HOGAN, LOGAN, UT. FILED 1-29-2009.

KALEI HOGAN

THE MARK CONSISTS OF STANDARD CHARACTERS WITHOUT CLAIM TO ANY PARTICULAR FONT, STYLE, SIZE, OR COLOR.

THE NAME(S), PORTRAIT(S), AND/OR SIGNATURE(S) SHOWN IN THE MARK IDENTIFIES "KALEI HOGAN", WHOSE CONSENT(S) TO REGISTER IS MADE OF RECORD.

FOR ENTERTAINMENT SERVICES, NAMELY, LIVE PERFORMANCES, PERSONAL APPEARANCES AS WELL AS TELEVISION AND RADIO PERFORMANCES BY A MUSICAL ARTIST; ENTERTAINMENT, NAMELY, PRODUCTION OF LIVE THEATRICAL SHOWS, LIVE MUSICAL SHOWS, CONCERTS AND RADIO AND TELEVISION PROGRAMS; VIDEO AND MULTIMEDIA VIDEO PRODUCTION; AUDIO AND VIDEO RECORDING SERVICES; PRODUCTION OF VIDEO AND AUDIO RECORDINGS ON CASSETTES, DVDS, COMPACT DISCS, RECORDS AND IN DIGITAL FORMAT, FEATURING MUSIC; ENTERTAINMENT SERVICES, NAMELY, PROVIDING PRERECORDED MUSIC AND VIDEOS FEATURING MUSIC ONLINE VIA A GLOBAL COMPUTER NETWORK; PROVIDING A WEBSITE FEATURING INFORMATION ON A MUSICAL ARTIST, NAMELY, INFORMATION REGARDING PERFORMANCES, RECORDS, APPEARANCES AND BIOGRAPHICAL INFORMATION ONLINE VIA A GLOBAL COMPUTER NETWORK; MUSIC PUBLISHING SERVICES (U.S. CLS. 100, 101 AND 107).

MARC LEIPZIG, EXAMINING ATTORNEY

CLASS 41—(Continued).

SN 77-660,733. WEST TOWN MEDIA, LLC, FORMERLY WEST TOWN PRODUCTIONS, LLC, CHICAGO, IL. FILED 1-30-2009.

strokes

THE MARK CONSISTS OF STANDARD CHARACTERS WITHOUT CLAIM TO ANY PARTICULAR FONT, STYLE, SIZE, OR COLOR.

FOR ENTERTAINMENT IN THE NATURE OF GOLF TOURNAMENTS (U.S. CLS. 100, 101 AND 107).

JOHN E. MICHOS, EXAMINING ATTORNEY

SN 77-660,848. COUNCIL, JERALD, DBA COUNCIL COMMUNICATIONS LLC, VIENNA, VA. FILED 1-31-2009.



NO CLAIM IS MADE TO THE EXCLUSIVE RIGHT TO USE "MAGAZINE", APART FROM THE MARK AS SHOWN. FOR PROVIDING ON-LINE MAGAZINES IN THE FIELD OF FASHION (U.S. CLS. 100, 101 AND 107).

FIRST USE 12-1-2008; IN COMMERCE 1-18-2009. JENNIFER HETU, EXAMINING ATTORNEY

SN 77-659,721. WEEKEND WARRIOR GOLFER, LLC, YPSILANTI, MI. FILED 1-29-2009.



NO CLAIM IS MADE TO THE EXCLUSIVE RIGHT TO USE "GOLFER", APART FROM THE MARK AS SHOWN.

THE STIPPLING IS FOR SHADING PURPOSES ONLY.

THE MARK CONSISTS OF THE STYLIZED TEXT "WEEKEND WARRIOR GOLFER". TO THE RIGHT THERE IS A MAN WEARING HALF A BUSINESS SUIT AND HALF GOLF ATTIRE. THE MAN IS MOVING TOWARDS A GOLF HOLE WITH A BRIEFCASE IN ONE HAND AND GOLF CLUB IN THE OTHER.

FOR PROVIDING A WEB SITE FEATURING REVIEWS OF GOLF COURSES, GOLF PRODUCTS, AND GOLF RELATED ITEMS (U.S. CLS. 100, 101 AND 107).

FIRST USE 11-10-2008; IN COMMERCE 1-3-2009. KIMBERLY PERRY, EXAMINING ATTORNEY

SN 77-661,058. TRANSAMERICA TRAINING MANAGEMENT, CORAL GABLES, FL. FILED 2-2-2009.

We have class

THE MARK CONSISTS OF STANDARD CHARACTERS WITHOUT CLAIM TO ANY PARTICULAR FONT, STYLE, SIZE, OR COLOR.

FOR COMPUTER EDUCATION TRAINING; COMPUTER EDUCATION TRAINING SERVICES; IT TRAINING SERVICES; PROVIDING ON-LINE TRAINING CLASSES IN THE FIELD OF INFORMATION TECHNOLOGY; TRAINING IN THE USE AND OPERATION OF COMPUTER SOFTWARE (U.S. CLS. 100, 101 AND 107).

ERNEST SHOSHO, EXAMINING ATTORNEY

CLASS 41—(Continued).

SN 77-661,069. WARD ASHMAN, MOUNTAIN VIEW, CA. FILED 2-2-2009.

NINE DOORS

THE MARK CONSISTS OF STANDARD CHARACTERS WITHOUT CLAIM TO ANY PARTICULAR FONT, STYLE, SIZE, OR COLOR.

FOR ANALYZING EDUCATIONAL TESTS SCORES AND DATA FOR OTHERS; ARRANGING AND CONDUCTING EDUCATIONAL CONFERENCES; ARRANGING PROFESSIONAL WORKSHOP AND TRAINING COURSES; CONDUCTING WORKSHOPS AND SEMINARS IN PERSONAL AWARENESS; CONDUCTING WORKSHOPS AND SEMINARS IN SELF AWARENESS; DEVELOPING TRAINING SYSTEMS AND LEARNING METHODOLOGIES FOR OTHERS; EDUCATIONAL SERVICES, NAMELY, CONDUCTING SEMINARS, WORKSHOPS, AND TRAINING IN THE FIELD OF CORPORATE CULTURAL DEVELOPMENT AND BUSINESS MANAGEMENT AND DISTRIBUTION OF COURSE MATERIAL IN CONNECTION THEREWITH; EDUCATIONAL TESTING; INFORMATION RELATING TO ENTERTAINMENT AND EDUCATION, PROVIDED ON-LINE FROM A COMPUTER DATABASE OR THE INTERNET (U.S. CLS. 100, 101 AND 107).

FIRST USE 8-28-2007; IN COMMERCE 8-28-2007.
KIM MONINGHOFF, EXAMINING ATTORNEY

CLASS 41—(Continued).

SN 77-661,335. VIOLET ANDERSON, HONOLULU, HI. FILED 2-2-2009.



THE COLOR(S) PURPLE, PINK IS/ARE CLAIMED AS A FEATURE OF THE MARK.

THE MARK CONSISTS OF A SIMPLE DRAWING OF A BUTTERFLY OUTLINED IN PINK ABOVE THE TERM "CLUBCHARM" IN LOWERCASE LETTERS WITH THE WORD PORTION "CLUB" IN PURPLE AND THE WORD PORTION "CHARM" IN PINK.

FOR ARRANGING, ORGANIZING, CONDUCTING AND HOSTING BIRTHDAY PARTIES; EDUCATION SERVICES, NAMELY, PROVIDING MENTORING, TUTORING, CLASSES, SEMINARS AND WORKSHOPS IN THE FIELD OF PERSONAL DEVELOPMENT, LEADERSHIP, CHARITY, ETHICS, MORALITY, CHARACTER, HEALTH AND WELLNESS, MOVEMENT, CONVERSATION AND ART; ENTERTAINMENT SERVICES, NAMELY, CONDUCTING PARTIES; INSTRUCTION IN THE FIELD OF PERSONAL DEVELOPMENT, LEADERSHIP, CHARITY, ETHICS, MORALITY, CHARACTER, HEALTH AND WELLNESS, MOVEMENT, CONVERSATION AND ART; PROVIDING AFTER SCHOOL EDUCATIONAL PROGRAMS FOR CHILDREN IN GRADES 6 THROUGH 12; PROVIDING EDUCATIONAL MENTORING SERVICES AND PROGRAMS IN THE FIELD OF PERSONAL DEVELOPMENT, LEADERSHIP, CHARITY, ETHICS, MORALITY, CHARACTER, HEALTH AND WELLNESS, MOVEMENT, CONVERSATION AND ART (U.S. CLS. 100, 101 AND 107).

ELLEN BURNS, EXAMINING ATTORNEY

SN 77-661,197. PENN, FAYE, BROOKLYN, NY. FILED 2-2-2009.

Brooklyn

THE MARK CONSISTS OF STANDARD CHARACTERS WITHOUT CLAIM TO ANY PARTICULAR FONT, STYLE, SIZE, OR COLOR.

FOR ON-LINE JOURNALS, NAMELY, BLOGS FEATURING INFORMATION ABOUT BUDGET LIVING IN BROOKLYN (U.S. CLS. 100, 101 AND 107).

DAVID YONTEF, EXAMINING ATTORNEY

SN 77-661,506. HUMANA INC., LOUISVILLE, KY. FILED 2-2-2009.

PERFECT SERVICE

THE MARK CONSISTS OF STANDARD CHARACTERS WITHOUT CLAIM TO ANY PARTICULAR FONT, STYLE, SIZE, OR COLOR.

NO CLAIM IS MADE TO THE EXCLUSIVE RIGHT TO USE "SERVICE", APART FROM THE MARK AS SHOWN.

FOR EDUCATIONAL SERVICES, NAMELY, CONDUCTING, SEMINARS, CLASSES, AND WORKSHOPS THAT PROMOTE CUSTOMER SERVICE AND OPERATIONAL EXCELLENCE, AND CUSTOMER LOYALTY AND ADVOCACY, IN THE FIELD OF HEALTHCARE INSURANCE AND BENEFIT SOLUTIONS; CONDUCTING TRAINING PROGRAMS TO ENGAGE EMPLOYEES AND DEVELOP A HIGH LEVEL OF COMMITMENT TO FULLY ADDRESS INSURANCE SUBSCRIBER AND MEMBER NEEDS (U.S. CLS. 100, 101 AND 107).

KIMBERLY FRYE, EXAMINING ATTORNEY

CLASS 41—(Continued).

SN 77-661,590. VICTORIA JOHNSON, SILVER CITY, NM. AND LOS ALAMOS NATIONAL LABORATORY FOUNDATION, ESPANOLA, NM. FILED 2-2-2009.



THE MARK CONSISTS OF A SILHOUETTE IMAGE OF A STYLIZED HUMAN FIGURE HOLDING UP A STYLIZED INFANT FIGURE.

FOR EDUCATION SERVICES, NAMELY, PROVIDING IN-HOME EDUCATIONAL SEMINARS IN THE FIELDS OF PREGNANCY, SUBSTANCE ABUSE PREVENTION, LABOR AND DELIVERY PREPARATION, POSTPARTUM ISSUES, BREASTFEEDING, BASIC CHILD CARE, ATTACHMENT AND BONDING, CHILD GROWTH AND DEVELOPMENT, CHILD SAFETY, PARENTING SKILLS, FATHER INVOLVEMENT, PROBLEM-SOLVING AND UTILIZATION OF COMMUNITY, MEDICAL AND MENTAL HEALTH RESOURCES TO PREGNANT WOMEN, FIRST-TIME FAMILIES AND THEIR NEWBORNS BY DEGREED AND NON-DEGREED PROFESSIONALS AND DISTRIBUTION OF TRAINING MATERIALS IN CONNECTION THEREWITH (U.S. CLS. 100, 101 AND 107).

FIRST USE 11-30-2006; IN COMMERCE 11-30-2006.
WILLIAM ROSSMAN, EXAMINING ATTORNEY

SN 77-661,685. YOUTH IN ARTS, INC., SAN RAFAEL, CA. FILED 2-2-2009.

'TIL DAWN

THE MARK CONSISTS OF STANDARD CHARACTERS WITHOUT CLAIM TO ANY PARTICULAR FONT, STYLE, SIZE, OR COLOR.

OWNER OF U.S. REG. NO. 2,616,027.

FOR ENTERTAINMENT SERVICES, NAMELY, LIVE MUSICAL PERFORMANCES BY AN A CAPELLA SINGING GROUP COMPRISED OF HIGH SCHOOL STUDENTS (U.S. CLS. 100, 101 AND 107).

FIRST USE 12-0-1994; IN COMMERCE 12-0-1994.
ELLEN PERKINS, EXAMINING ATTORNEY

CLASS 41—(Continued).

SN 77-661,760. BRISTOW, PATRICK, LOS ANGELES, CA. FILED 2-2-2009.

IMPROVATORIUM

THE MARK CONSISTS OF STANDARD CHARACTERS WITHOUT CLAIM TO ANY PARTICULAR FONT, STYLE, SIZE, OR COLOR.

FOR ENTERTAINMENT SERVICES IN THE NATURE IMPROVISATIONAL PERFORMANCE; TRAINING SERVICES IN THE FIELD OF IMPROVISATIONAL ACTING (U.S. CLS. 100, 101 AND 107).

FIRST USE 9-26-2008; IN COMMERCE 9-26-2008.
LESLIE RICHARDS, EXAMINING ATTORNEY

SN 77-661,815. 360ED, INC., ORLANDO, FL. FILED 2-2-2009.



THE COLOR(S) BLUE IS/ARE CLAIMED AS A FEATURE OF THE MARK.

THE MARK CONSISTS OF THE WORD "SITI" IN LARGE, WIDE BLUE LETTERS, WITH A CAPITALIZED "S" AND "T" AND LOWERCASE "I" S.

FOR DEVELOPING ELECTRONIC TRAINING SYSTEMS AND LEARNING METHODOLOGIES FOR OTHERS; EDUCATIONAL SERVICES, NAMELY, DEVELOPING AND CONDUCTING TRAINING COURSES AND DISTRIBUTION OF TRAINING MATERIALS IN CONNECTION THEREWITH FOR SUBJECT MATTERS AS REQUESTED BY CUSTOMERS; ARRANGING PROFESSIONAL WORKSHOP AND TRAINING COURSES; EDUCATIONAL COURSE MONITORING, NAMELY, TRACKING STUDENT PERFORMANCE THROUGH THE USE OF DIGITAL MEDIA AND INTERACTIVE PROGRAMS; SCHEDULING OF EDUCATIONAL PROGRAMS ON A GLOBAL COMPUTER NETWORK (U.S. CLS. 100, 101 AND 107).

IRA J. GOODSAY, EXAMINING ATTORNEY

CLASS 41—(Continued).

SN 77-661,890. BARUNIVERSITY.COM, LLC, SCOTTSDALE, AZ. FILED 2-3-2009.



NO CLAIM IS MADE TO THE EXCLUSIVE RIGHT TO USE "BAR UNIVERSITY", APART FROM THE MARK AS SHOWN.

THE MARK CONSISTS OF A SHIELD WITH A FILIGREE DESIGN ON THE TOP AND BOTTOM WITH THE WORD "BAR" ON THE INSIDE OF THE SHIELD AND BELOW "BAR" A BANNER CROSSING THE SHIELD WITH THE WORD "UNIVERSITY" ON THE BANNER.

FOR EDUCATIONAL SERVICES, NAMELY, PROVIDING LIVE AND ON-LINE CLASSES, SEMINARS, AND WORKSHOPS IN THE FIELDS OF BAR AND RESTAURANT MANAGEMENT (U.S. CLS. 100, 101 AND 107).

B. PARADEWELAI, EXAMINING ATTORNEY

SN 77-661,958. SWAN PHOTO LLC, AKA KEVIN SWAN, ZIONSVILLE, IN. FILED 2-3-2009.



NO CLAIM IS MADE TO THE EXCLUSIVE RIGHT TO USE "PHOTOGRAPHY FOR LUXURY WEDDINGS", APART FROM THE MARK AS SHOWN.

THE MARK CONSISTS OF A CAPITAL "S" TURNED INTO A SWAN WITH AN EYE, BEAK, AND SINGLE WING ABOVE THE WORD "SWAN" IN LOWERCASE LETTERS AND THE WORDING "PHOTOGRAPHY FOR LUXURY WEDDINGS" IN LOWERCASE LETTERS

FOR PHOTOGRAPHY; PHOTOGRAPHY SERVICES; PORTRAIT PHOTOGRAPHY (U.S. CLS. 100, 101 AND 107).

FIRST USE 1-27-2009; IN COMMERCE 1-27-2009.
ANGELA GAW, EXAMINING ATTORNEY

CLASS 41—(Continued).

SN 77-661,993. TELEVISION FOOD NETWORK, G.P., NEW YORK, NY. FILED 2-3-2009.

VIVA DAISY!

THE MARK CONSISTS OF STANDARD CHARACTERS WITHOUT CLAIM TO ANY PARTICULAR FONT, STYLE, SIZE, OR COLOR.

FOR EDUCATIONAL AND ENTERTAINMENT SERVICES, NAMELY, A CONTINUING PROGRAM ABOUT FOOD AND COOKING, ACCESSIBLE BY RADIO, TELEVISION, CABLE, FIBER OPTIC NETWORKS, WIRELESS NETWORKS, SATELLITE, AUDIO VIDEO, AND COMPUTER NETWORKS (U.S. CLS. 100, 101 AND 107).

BRIAN PINO, EXAMINING ATTORNEY

SN 77-662,082. HOGAN, CHRISTOPHER A., DBA SOUTHGANG RECORDS, HEBER SPRINGS, AR. AND SCHLIES-TETT, JAMES RICHARD JR, AKA JESSE HARTE, KENNESAW, GA. FILED 2-3-2009.

Southgang

THE MARK CONSISTS OF STANDARD CHARACTERS WITHOUT CLAIM TO ANY PARTICULAR FONT, STYLE, SIZE, OR COLOR.

FOR ENTERTAINMENT IN THE NATURE OF LIVE PERFORMANCES BY MUSICAL GROUP; ENTERTAINMENT IN THE NATURE OF VISUAL AND AUDIO PERFORMANCES, NAMELY, MUSICAL BAND, ROCK GROUP, GYMNASIAC, DANCE, AND BALLET PERFORMANCES; ENTERTAINMENT SERVICES IN THE NATURE OF LIVE MUSICAL PERFORMANCES; ENTERTAINMENT, NAMELY, LIVE PERFORMANCES BY ROCK GROUPS (U.S. CLS. 100, 101 AND 107).

FIRST USE 1-1-1990; IN COMMERCE 1-1-1990.
MARK PILARO, EXAMINING ATTORNEY

SN 77-662,120. PETRUS, MEGAN, NYC, NY. AND CROWELL, HELANE, NYC, NY. FILED 2-3-2009.

DABA Girls

THE MARK CONSISTS OF STANDARD CHARACTERS WITHOUT CLAIM TO ANY PARTICULAR FONT, STYLE, SIZE, OR COLOR.

FOR ENTERTAINMENT SERVICES, NAMELY, PROVIDING A WEBSITE AT WHICH THE GENERAL PUBLIC CAN RECEIVE ADVICE FROM AN INDIVIDUAL CONCERNING RELATIONSHIPS, SUCH ADVICE BEING FOR ENTERTAINMENT PURPOSES ONLY (U.S. CLS. 100, 101 AND 107).

FIRST USE 11-1-2008; IN COMMERCE 11-1-2008.
KAREN BRACEY, EXAMINING ATTORNEY

CLASS 41—(Continued).

SN 77-662,178. ONE GOOD SHOT AT IT, BEVERLY HILLS, CA. FILED 2-3-2009.

One Good Shot At It

THE MARK CONSISTS OF STANDARD CHARACTERS WITHOUT CLAIM TO ANY PARTICULAR FONT, STYLE, SIZE, OR COLOR.

FOR FILM AND VIDEO PRODUCTION; MOTION PICTURE FILM PRODUCTION (U.S. CLS. 100, 101 AND 107).

CAROLINE WOOD, EXAMINING ATTORNEY

CLASS 41—(Continued).

SN 77-662,287. THE WASHINGTON UNIVERSITY, ST. LOUIS, MO. FILED 2-3-2009.

**TRANSFORMING INDIVIDUALS
WHO TRANSFORM BUSINESS**

THE MARK CONSISTS OF STANDARD CHARACTERS WITHOUT CLAIM TO ANY PARTICULAR FONT, STYLE, SIZE, OR COLOR.

FOR PROVIDING GRADUATE COURSES AND INSTRUCTION IN THE FIELD OF BUSINESS (U.S. CLS. 100, 101 AND 107).

FIRST USE 5-22-2007; IN COMMERCE 5-22-2007.
TRICIA SONNEBORN, EXAMINING ATTORNEY

SN 77-662,241. WARSAW ORTHOPEDIC, INC., WARSAW, IN. FILED 2-3-2009.

MAST

THE MARK CONSISTS OF STANDARD CHARACTERS WITHOUT CLAIM TO ANY PARTICULAR FONT, STYLE, SIZE, OR COLOR.

FOR EDUCATIONAL SERVICES, NAMELY, CONDUCTING CONFERENCES, SEMINAR AND WORKSHOPS IN THE FIELDS OF SPINAL AND ORTHOPEDIC SURGICAL TECHNIQUES (U.S. CLS. 100, 101 AND 107).

ANNE MADDEN, EXAMINING ATTORNEY

SN 77-662,310. ROBERT ZIEGLER, PHOENIX, AZ. FILED 2-3-2009.

FEEL THE MUSIC

THE MARK CONSISTS OF STANDARD CHARACTERS WITHOUT CLAIM TO ANY PARTICULAR FONT, STYLE, SIZE, OR COLOR.

FOR AMUSEMENT PARKS (U.S. CLS. 100, 101 AND 107).

SOPHIA S. KIM, EXAMINING ATTORNEY

SN 77-662,283. THE WASHINGTON UNIVERSITY, ST. LOUIS, MO. FILED 2-3-2009.

**CREATING KNOWLEDGE
...INSPIRING
INDIVIDUALS...TRANSFORMING
BUSINESS**

THE MARK CONSISTS OF STANDARD CHARACTERS WITHOUT CLAIM TO ANY PARTICULAR FONT, STYLE, SIZE, OR COLOR.

FOR PROVIDING UNDERGRADUATE, GRADUATE, AND EXECUTIVE COURSES AND INSTRUCTION IN THE FIELD OF BUSINESS (U.S. CLS. 100, 101 AND 107).

FIRST USE 5-24-2007; IN COMMERCE 5-24-2007.
TRICIA SONNEBORN, EXAMINING ATTORNEY

SN 77-662,559. SAFE BOATING AMERICA, INC., SYOSSET, NY. FILED 2-3-2009.

**THE SAFEST PLACE TO
NAVIGATE**

THE MARK CONSISTS OF STANDARD CHARACTERS WITHOUT CLAIM TO ANY PARTICULAR FONT, STYLE, SIZE, OR COLOR.

FOR EDUCATIONAL SERVICES, NAMELY, INSTRUCTION IN THE FIELD OF MARINE SAFETY, NAVIGATION AND SMALL BOAT HANDLING, AND THE DISTRIBUTION OF COURSE MATERIALS RELATED THERETO, PROVIDE COURSE INSTRUCTION TAUGHT BY LICENSED UNITED STATES COAST GUARD INSTRUCTORS AND STATE CERTIFIED INSTRUCTORS WHO WILL CERTIFY PARTICIPANTS AS STATE CERTIFIED BOAT OPERATORS (U.S. CLS. 100, 101 AND 107).

FIRST USE 8-1-2008; IN COMMERCE 8-1-2008.
GRETTA YAO, EXAMINING ATTORNEY

CLASS 41—(Continued).

SN 77-662,614. BRANDYWINE VALLEY TALENT, INC., CHADDS FORD, PA. FILED 2-3-2009.



THE COLOR(S) BLACK AND PURPLE IS/ARE CLAIMED AS A FEATURE OF THE MARK.

THE MARK CONSISTS OF THE STYLIZED WORD "THE" IN PURPLE FOLLOWED BY THE STYLIZED WORD "QUAKE" IN BLACK, THE WORDING BEING PLACED ABOVE A PURPLE SEISMOGRAPH.

FOR ENTERTAINMENT IN THE NATURE OF LIVE PERFORMANCES BY A MUSICAL BAND (U.S. CLS. 100, 101 AND 107).

FIRST USE 7-1-2002; IN COMMERCE 7-1-2002.
RAUL CORDOVA, EXAMINING ATTORNEY

SN 77-662,661. SIMMONS, DOMINIQUE T., DBA RESILINE ENTERTAINMENT, KILLEEN, TX. FILED 2-3-2009.

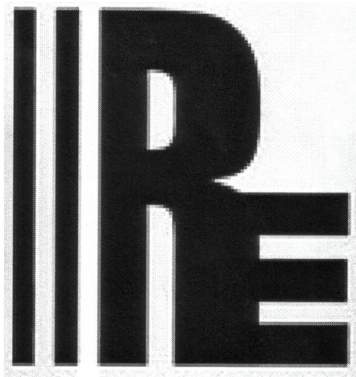

THE MARK CONSISTS OF A STYLIZED LETTER "R" WITH VERTICAL LINES, THE LETTER "E" CONNECTED TO THE LOWER PORTION OF THE LETTER "R".

FOR ARRANGING AND CONDUCTING SPECIAL EVENTS (U.S. CLS. 100, 101 AND 107).

ANDREW LEASER, EXAMINING ATTORNEY

CLASS 41—(Continued).

SN 77-662,739. PORTLAND COMMUNITY COLLEGE, PORTLAND, OR. FILED 2-3-2009.

GATEWAY TO COLLEGE

THE MARK CONSISTS OF STANDARD CHARACTERS WITHOUT CLAIM TO ANY PARTICULAR FONT, STYLE, SIZE, OR COLOR.

NO CLAIM IS MADE TO THE EXCLUSIVE RIGHT TO USE "COLLEGE", APART FROM THE MARK AS SHOWN.

FOR EDUCATIONAL SERVICES, NAMELY, PROVIDING COURSES OF INSTRUCTION VIA CLASSES, SEMINARS, WORKSHOPS AND TUTORING AT THE SECONDARY AND COLLEGE LEVEL TO AT-RISK YOUTH (U.S. CLS. 100, 101 AND 107).

FIRST USE 2-19-2003; IN COMMERCE 2-19-2003.
KAREN BRACEY, EXAMINING ATTORNEY

SN 77-662,795. STEEL CURTAIN PICTURES, LLC, LOS ANGELES, CA. FILED 2-3-2009.

IT MIGHT GET LOUD

THE MARK CONSISTS OF STANDARD CHARACTERS WITHOUT CLAIM TO ANY PARTICULAR FONT, STYLE, SIZE, OR COLOR.

FOR ENTERTAINMENT SERVICES, NAMELY, AN ON-GOING SERIES FEATURING FAMOUS MUSICIANS AND ARTISTS DISCUSSING THEIR LIVES, CAREERS AND THE MUSIC INDUSTRY PROVIDED THROUGH CABLE TELEVISION, NETWORK TELEVISION, SATELLITE TELEVISION, DVD, FILM AND WEBCASTS (U.S. CLS. 100, 101 AND 107).

FONG HSU, EXAMINING ATTORNEY

SN 77-662,995. JEREMY GUTSCHE, TORONTO, CANADA, FILED 2-4-2009.

Exploiting Chaos

THE MARK CONSISTS OF STANDARD CHARACTERS WITHOUT CLAIM TO ANY PARTICULAR FONT, STYLE, SIZE, OR COLOR.

FOR CONDUCTING WORKSHOPS AND SEMINARS IN TREND SPOTTING, INNOVATION, TECHNOLOGY, FASHION, TRAVEL, DESIGN, AND MARKETING; ON-LINE JOURNALS, NAMELY, BLOGS FEATURING TREND SPOTTING, INNOVATION, TECHNOLOGY, FASHION, TRAVEL, DESIGN, AND MARKETING; PUBLICATION OF BOOKS, OF MAGAZINES, OF JOURNALS, OF NEWSPAPERS, OF PERIODICALS, OF CATALOGS, OF BROCHURES; PUBLICATION OF ELECTRONIC MAGAZINES (U.S. CLS. 100, 101 AND 107).

VERNA BETH RIRIE, EXAMINING ATTORNEY

CLASS 41—(Continued).

SN 77-663,022. GRUVER, KATHY, SANTA BARBARA, CA.
FILED 2-4-2009.

Learn to Rub People the Right Way.

THE MARK CONSISTS OF STANDARD CHARACTERS WITHOUT CLAIM TO ANY PARTICULAR FONT, STYLE, SIZE, OR COLOR.

FOR EDUCATIONAL SERVICES, NAMELY, CONDUCTING CLASSES, SEMINARS, AND WORKSHOPS IN THE FIELD OF THERAPEUTIC MASSAGE AND DISTRIBUTION OF TRAINING MATERIAL IN CONNECTION THEREWITH (U.S. CLS. 100, 101 AND 107).

LINDA POWELL, EXAMINING ATTORNEY

CLASS 41—(Continued).

SN 77-663,251. WOMEN'S SOCCER, LLC, SAN FRANCISCO, CA. FILED 2-4-2009.

SEE EXTRAORDINARY

SN 77-663,241. MCLEHOSE, THOMAS, TORRANCE, CA.
FILED 2-4-2009.

Thriving Now

THE MARK CONSISTS OF STANDARD CHARACTERS WITHOUT CLAIM TO ANY PARTICULAR FONT, STYLE, SIZE, OR COLOR.

FOR ARRANGING AND CONDUCTING NIGHTCLUB ENTERTAINMENT EVENTS; ARRANGING FOR TICKET RESERVATIONS FOR SHOWS AND OTHER ENTERTAINMENT EVENTS; EDUCATIONAL AND ENTERTAINMENT SERVICES, NAMELY, PROVIDING MOTIVATIONAL AND EDUCATIONAL SPEAKERS; ENTERTAINMENT AND EDUCATION SERVICES IN THE NATURE OF LIVE DANCE AND MUSICAL PERFORMANCES; ENTERTAINMENT AND EDUCATIONAL SERVICES, NAMELY, PROVIDING ADVICE AND INFORMATION FOR MUSIC, VIDEO AND FILM CONCEPT AND SCRIPT DEVELOPMENT; ENTERTAINMENT IN THE NATURE OF AN ONGOING SPECIAL VARIETY, NEWS, MUSIC OR COMEDY SHOW FEATURING MUSIC BROADCAST OVER TELEVISION, SATELLITE, AUDIO, AND VIDEO MEDIA; ENTERTAINMENT IN THE NATURE OF LIVE PERFORMANCES BY ROCK GROUP; ENTERTAINMENT IN THE NATURE OF VISUAL AND AUDIO PERFORMANCES, AND MUSICAL, VARIETY, NEWS AND COMEDY SHOWS; ENTERTAINMENT IN THE NATURE OF VISUAL AND AUDIO PERFORMANCES, NAMELY, MUSICAL BAND, ROCK GROUP, GYMNASIAC, DANCE, AND BALLET PERFORMANCES; ENTERTAINMENT IN THE NATURE OF LIVE MUSICAL GROUP; ENTERTAINMENT SERVICES, NAMELY, CONDUCTING PARTIES; ENTERTAINMENT SERVICES, NAMELY, PLANNING AND CONDUCTING A SERIES OF FILM FESTIVALS; ENTERTAINMENT SERVICES, NAMELY, PROVIDING PRERECORDED MUSIC, INFORMATION IN THE FIELD OF MUSIC, AND COMMENTARY AND ARTICLES ABOUT MUSIC, ALL ON-LINE VIA A GLOBAL COMPUTER NETWORK; ENTERTAINMENT SERVICES, NAMELY, PROVIDING VIDEO PODCASTS IN THE FIELD OF MUSIC; ENTERTAINMENT SERVICES, NAMELY, PROVIDING WEBCASTS IN THE FIELD OF MUSIC; ENTERTAINMENT, NAMELY, LIVE MUSIC CONCERTS; ENTERTAINMENT, NAMELY, LIVE PERFORMANCES BY A MUSICAL BAND; ENTERTAINMENT, NAMELY, LIVE PERFORMANCES BY ROCK GROUPS (U.S. CLS. 100, 101 AND 107).

KEVIN DINALLO, EXAMINING ATTORNEY

THE MARK CONSISTS OF STANDARD CHARACTERS WITHOUT CLAIM TO ANY PARTICULAR FONT, STYLE, SIZE, OR COLOR.

FOR EDUCATION AND ENTERTAINMENT SERVICES IN THE NATURE OF PROFESSIONAL SOCCER GAMES, COMPETITIONS AND EXHIBITIONS RENDERED LIVE, THROUGH BROADCAST MEDIA INCLUDING TELEVISION AND RADIO AND VIA A GLOBAL COMPUTER NETWORK OR A COMMERCIAL ONLINE SERVICE INCLUDING TELEVISION HIGHLIGHTS, INTERACTIVE TELEVISION HIGHLIGHTS, VIDEO RECORDINGS, VIDEO STREAM RECORDINGS, INTERACTIVE VIDEO HIGHLIGHT SELECTIONS, RADIO PROGRAMS, RADIO HIGHLIGHTS AND AUDIO RECORDINGS; PROVIDING INFORMATION IN THE FIELD OF SOCCER AND RELATED TOPICS AND PROVIDING FOR INFORMATIONAL MESSAGES RELATING THERETO ALL VIA A GLOBAL COMPUTER NETWORK OR A COMMERCIAL ON-LINE SERVICE; ARRANGING AND CONDUCTING SOCCER GAMES AND EXHIBITIONS; PROVIDING SOCCER FAN CLUB SERVICES; ENTERTAINMENT SERVICES PROVIDED DURING INTERVALS AT SPORTS EVENTS, NAMELY, SOCCER CONTESTS, SOCCER TRIVIA, SOCCER HISTORY AND SOCCER COMEDY; APPEARANCES AND INTERVIEWS WITH PLAYERS, COACHES, AND/OR SOCCER PERSONALITIES; EDUCATIONAL SERVICES, NAMELY, PHYSICAL EDUCATION PROGRAMS; CONDUCTING AND ARRANGING SOCCER CLINICS AND CAMPS, COACHES' SOCCER CLINICS AND CAMPS; EDUCATIONAL TV SHOWS, VIDEOS, AND IN-PERSON EVENTS FEATURING WOMEN SOCCER PLAYERS SPEAKING ABOUT HEALTH, NUTRITION AND FITNESS; PUBLICATION OF TEXTS RELATING TO SOCCER; PUBLICATION OF NEWSLETTERS RELATED TO SOCCER, GAME SCHEDULES IN THE FIELD OF SOCCER OVER THE INTERNET TO HELP FANS LEARN WHERE TO WATCH AND ATTEND PROFESSIONAL WOMEN'S SOCCER MATCHES AND EVENTS, PROVIDING AN ON-LINE COMPUTER DATABASE IN THE FIELD OF SOCCER; ENTERTAINMENT AND EDUCATION SERVICES, NAMELY, PROVIDING A WEBSITE FEATURING SOCCER NEWS, INFORMATION, STATISTICS, AND TRIVIA; AND PROVIDING SWEEPSTAKES CONTESTS (U.S. CLS. 100, 101 AND 107).

JEFFERY COWARD, EXAMINING ATTORNEY

CLASS 41—(Continued).

SN 77-663,271. FANDINO, CATHERINE, DBA AMALGAM ENTERTAINMENT, NEW YORK, NY. FILED 2-4-2009.

AMALGAM ENTERTAINMENT

THE MARK CONSISTS OF STANDARD CHARACTERS WITHOUT CLAIM TO ANY PARTICULAR FONT, STYLE, SIZE, OR COLOR.

NO CLAIM IS MADE TO THE EXCLUSIVE RIGHT TO USE "ENTERTAINMENT", APART FROM THE MARK AS SHOWN.

FOR AUDIO RECORDING AND PRODUCTION; ENTERTAINMENT IN THE NATURE OF LIVE PERFORMANCES BY A MUSICAL RECORDING ARTIST; ENTERTAINMENT SERVICES, NAMELY, PROVIDING A WEB SITE FEATURING MUSICAL PERFORMANCES, MUSICAL VIDEOS, RELATED FILM CLIPS, PHOTOGRAPHS, AND OTHER MULTIMEDIA MATERIALS FEATURING MUSICAL ENTERTAINMENT (U.S. CLS. 100, 101 AND 107).

FIRST USE 11-0-2003; IN COMMERCE 11-0-2003.
JORDAN BAKER, EXAMINING ATTORNEY

SN 77-663,538. RIGDON, BILL, LAS VEGAS, NV, AND OLSSON-RIGDON, CARMEN, LAS VEGAS, NV. FILED 2-4-2009.

**The Search for the
Ultimate Ride**

THE MARK CONSISTS OF STANDARD CHARACTERS WITHOUT CLAIM TO ANY PARTICULAR FONT, STYLE, SIZE, OR COLOR.

FOR ENTERTAINMENT SERVICES IN THE NATURE OF AN ON-GOING REALITY BASED TELEVISION PROGRAM (U.S. CLS. 100, 101 AND 107).

MICHAEL WEBSTER, EXAMINING ATTORNEY

SN 77-663,609. SOL KATZ, SAN CLEMENTE, CA. FILED 2-4-2009.

**BULLEAVE: WE CAN DO IT
TOGETHER**

THE MARK CONSISTS OF STANDARD CHARACTERS WITHOUT CLAIM TO ANY PARTICULAR FONT, STYLE, SIZE, OR COLOR.

FOR EDUCATIONAL SERVICES, NAMELY, CONDUCTING PROGRAMS IN THE FIELD OF CHILDREN'S SAFETY SPECIFICALLY GEARED TOWARDS BULLIES AND VICTIMS (U.S. CLS. 100, 101 AND 107).

LINDA POWELL, EXAMINING ATTORNEY

CLASS 41—(Continued).

SN 77-663,641. BALUBA, CEDAR PARK, TX. FILED 2-4-2009.

BALUBA

THE MARK CONSISTS OF STANDARD CHARACTERS WITHOUT CLAIM TO ANY PARTICULAR FONT, STYLE, SIZE, OR COLOR.

THE WORDING "BALUBA" HAS NO MEANING IN A FOREIGN LANGUAGE.

FOR INDOOR FAMILY ENTERTAINMENT CENTER FEATURING AMUSEMENT ARCADES AND INDOOR PLAYGROUND FACILITIES; CONDUCTING PARTIES IN AN INDOOR FAMILY ENTERTAINMENT CENTER (U.S. CLS. 100, 101 AND 107).

AMEEN IMAM, EXAMINING ATTORNEY

SN 77-663,666. SCHMID, PAMELA, CLAYTON, NC. FILED 2-4-2009.

**HEALTHY AND FIT AFTER
CANCER**

THE MARK CONSISTS OF STANDARD CHARACTERS WITHOUT CLAIM TO ANY PARTICULAR FONT, STYLE, SIZE, OR COLOR.

FOR PROFESSIONAL COACHING SERVICES IN THE FIELD OF HEALTH, FITNESS AND WELL-BEING FOR CANCER SURVIVORS ; EDUCATION SERVICES, NAMELY, WORKSHOPS, LIVE AND ONLINE CLASSES IN THE FIELD OF HEALTH, FITNESS AND WELL-BEING FOR CANCER SURVIVORS (U.S. CLS. 100, 101 AND 107).

FIRST USE 10-18-2005; IN COMMERCE 10-18-2005.
BARBARA BROWN, EXAMINING ATTORNEY

SN 77-663,742. TOBIAS, MARICE, BEVERLY HILLS, CA. FILED 2-5-2009.

THE VOICE WHISPERER

THE MARK CONSISTS OF STANDARD CHARACTERS WITHOUT CLAIM TO ANY PARTICULAR FONT, STYLE, SIZE, OR COLOR.

NO CLAIM IS MADE TO THE EXCLUSIVE RIGHT TO USE "VOICE", APART FROM THE MARK AS SHOWN.

FOR EDUCATION SERVICES, NAMELY, PROVIDING MENTORING, TUTORING, CLASSES, SEMINARS AND WORKSHOPS IN THE FIELD OF VOICE OVER (U.S. CLS. 100, 101 AND 107).

FIRST USE 1-15-2009; IN COMMERCE 1-15-2009.
SIMON TENG, EXAMINING ATTORNEY

CLASS 41—(Continued).

SN 77-663,812. ALL ORGANIC COMEDY TOUR, LLC, PALM CITY, FL. FILED 2-5-2009.

ALL ORGANIC COMEDY TOUR

THE MARK CONSISTS OF STANDARD CHARACTERS WITHOUT CLAIM TO ANY PARTICULAR FONT, STYLE, SIZE, OR COLOR.

NO CLAIM IS MADE TO THE EXCLUSIVE RIGHT TO USE "COMEDY TOUR", APART FROM THE MARK AS SHOWN.

FOR ENTERTAINMENT SERVICES IN THE NATURE OF COMEDY SHOWS (U.S. CLS. 100, 101 AND 107).
MARC LEIPZIG, EXAMINING ATTORNEY

SN 77-663,975. SAGE-ING GUILD, DBA SAGE-ING GUILD, CLEVELAND HEIGHTS, OH. FILED 2-5-2009.

Sage-ing

THE MARK CONSISTS OF STANDARD CHARACTERS WITHOUT CLAIM TO ANY PARTICULAR FONT, STYLE, SIZE, OR COLOR.

SEC. 2(F).

FOR EDUCATIONAL SERVICES, NAMELY, CONDUCTING CLASSES, SEMINARS, CONFERENCES, WORKSHOPS IN THE FIELD OF CONSCIOUS AGING AND DISTRIBUTION OF COURSE MATERIAL IN CONNECTION THEREWITH (U.S. CLS. 100, 101 AND 107).

FIRST USE 1-1-1996; IN COMMERCE 1-1-1996.

SUSAN LESLIE DUBOIS, EXAMINING ATTORNEY

SN 77-664,035. MONTESANO, LOUIS, FREEHOLD, NJ. FILED 2-5-2009.

Status Green

THE MARK CONSISTS OF STANDARD CHARACTERS WITHOUT CLAIM TO ANY PARTICULAR FONT, STYLE, SIZE, OR COLOR.

FOR ENTERTAINMENT, NAMELY, LIVE MUSIC CONCERTS; ENTERTAINMENT, NAMELY, LIVE PERFORMANCES BY ROCK GROUPS (U.S. CLS. 100, 101 AND 107).

FIRST USE 1-1-2008; IN COMMERCE 1-1-2008.

BRENDAN REGAN, EXAMINING ATTORNEY

CLASS 41—(Continued).

SN 77-664,036. REDR INTERNATIONAL, UPLOWMAN, TIVERTON, UNITED KINGDOM, FILED 2-5-2009.

RedR

THE MARK CONSISTS OF STANDARD CHARACTERS WITHOUT CLAIM TO ANY PARTICULAR FONT, STYLE, SIZE, OR COLOR.

FOR CONDUCTING TRAINING COURSES, SEMINARS, WORKSHOPS AND EDUCATIONAL CONFERENCES FOR OTHERS TO PREPARE THEM FOR WORK IN GENERAL EMERGENCY, DISASTER, AND HUMANITARIAN RELIEF, PERSONAL SECURITY AND COMMUNICATIONS, HEALTH, ENGINEERING AND LOGISTICS ISSUES AS THEY RELATE TO DISASTERS AND EMERGENCIES, HAZARD CONTAINMENT, SHELTERS AND SETTLEMENTS FOR DISPLACED PERSONS AND REFUGEES, COMMUNITY REBUILDING, EMERGENCY PREPAREDNESS, EMERGENCY MANAGEMENT, EMERGENCY PLANNING AND RESPONSE, DISASTER PREVENTION AND CONTAINMENT, HUMAN RIGHTS, HUMANITARIAN LAW, AND CIVIL-MILITARY COORDINATION (U.S. CLS. 100, 101 AND 107).

FIRST USE 9-24-2000; IN COMMERCE 9-24-2000.

BRENDAN REGAN, EXAMINING ATTORNEY

SN 77-664,089. UP OVER UNDER, INC., NEW YORK, NY. FILED 2-5-2009.

MOMMY POPPINS

THE MARK CONSISTS OF STANDARD CHARACTERS WITHOUT CLAIM TO ANY PARTICULAR FONT, STYLE, SIZE, OR COLOR.

THE NAME "MOMMY POPPINS" DOES NOT IDENTIFY A LIVING INDIVIDUAL.

FOR ON-LINE JOURNALS, NAMELY, BLOGS FEATURING INFORMATION AND GUIDES FOR PARENTS ABOUT THE LIFESTYLES, EDUCATION, AND ACTIVITIES AVAILABLE TO CHILDREN (U.S. CLS. 100, 101 AND 107).

FIRST USE 1-4-2007; IN COMMERCE 1-7-2007.

CURTIS FRENCH, EXAMINING ATTORNEY

CLASS 41—(Continued).

SN 77-664,090. TIXSMART, DBA FLA.VOR.US, LOS ANGELES, CA. FILED 2-5-2009.

Flavor.us

THE MARK CONSISTS OF THE LETTERS "F", "L", AND "A", FOLLOWED BY A PERIOD, THEN THE LETTERS "V", "O", AND "R", FOLLOWED BY A PERIOD, THEN THE LETTERS "U" AND "S", IN THE FONT "BALLPARK WEINER" WITH THE PERIODS SLIGHTLY ELEVATED. FOR PROVIDING AN INTERNET WEBSITE PORTAL IN THE FIELD OF MUSIC (U.S. CLS. 100, 101 AND 107). FIRST USE 1-1-2009; IN COMMERCE 1-1-2009. ANDREA SAUNDERS, EXAMINING ATTORNEY

SN 77-664,190. DIRECTECH, INC., PHOENIX, AZ. FILED 2-5-2009.

WATCHING MY MOM GO BLACK

THE MARK CONSISTS OF STANDARD CHARACTERS WITHOUT CLAIM TO ANY PARTICULAR FONT, STYLE, SIZE, OR COLOR. FOR ENTERTAINMENT SERVICES, NAMELY, PROVIDING A WEB SITE FEATURING ADULT ENTERTAINMENT; AND PROVIDING INFORMATION IN THE FIELD OF ADULT ENTERTAINMENT VIA A GLOBAL COMPUTER NETWORK (U.S. CLS. 100, 101 AND 107). FIRST USE 11-15-2007; IN COMMERCE 11-20-2008. ANDREA K. NADELMAN, EXAMINING ATTORNEY

SN 77-664,241. TELL STUDIOS INC., DENVER, CO. FILED 2-5-2009.

TELL STUDIOS

THE MARK CONSISTS OF STANDARD CHARACTERS WITHOUT CLAIM TO ANY PARTICULAR FONT, STYLE, SIZE, OR COLOR. NO CLAIM IS MADE TO THE EXCLUSIVE RIGHT TO USE "STUDIOS", APART FROM THE MARK AS SHOWN. FOR PUBLISHING OF PRINT BIOGRAPHIES FOR INDIVIDUALS, FAMILIES, ENGAGED COUPLES, PETS, COMPANIES AND RANCHES; VIDEO PRODUCTION SERVICES IN THE FIELD OF BIOGRAPHIES FOR INDIVIDUALS, FAMILIES, ENGAGED COUPLES, PETS, COMPANIES AND RANCHES (U.S. CLS. 100, 101 AND 107). FIRST USE 8-1-2008; IN COMMERCE 2-1-2009. MICHAEL KEATING, EXAMINING ATTORNEY

CLASS 41—(Continued).

SN 77-664,345. RESET MEDICAL, INC., BALTIMORE, MD. FILED 2-5-2009.

FREEZE DISEASE. RESET LIFE.

THE MARK CONSISTS OF STANDARD CHARACTERS WITHOUT CLAIM TO ANY PARTICULAR FONT, STYLE, SIZE, OR COLOR.

FOR TRAINING OF PHYSICIANS AND MEDICAL PERSONNEL IN THE USE OF CRYOTHERAPY AND CRYOSURGERY; TRAINING OF PHYSICIANS AND MEDICAL PERSONNEL IN THE USE OF CRYOTHERAPY AND CRYOSURGICAL EQUIPMENT, NAMELY, SURGICAL AND TREATMENT PROBES, CATHETERS AND ENDOSCOPES; TRAINING OF PHYSICIANS AND MEDICAL PERSONNEL IN THE USE OF CRYOSURGICAL AND CRYOTHERAPY DEVICE CONTROL SYSTEMS, NAMELY, APPARATUSES FOR CONTROLLING THE FLOW OF CRYOGENS, BLEEDER AND PRESSURE REDUCTION VALVES FOR MAINTAINING PRESSURE IN CRYOTHERAPY AND CRYOSURGICAL DEVICES AND DELIVERY SYSTEMS, RIGID AND FLEXIBLE MEDICAL ENDOSCOPES, CATHETERS, LUMEN BLOCKING BALLOONS AND SHIELDS FOR GASTRIC BLOCKING, NASOGASTRIC TUBES, SUCTION DEVICES FOR CRYOGENS REMOVAL AND ENDOSCOPY CAMERAS; TRAINING OF PHYSICIANS AND MEDICAL PERSONNEL IN THE USE OF THERAPY AND SURGICAL DELIVERY SYSTEMS FOR DELIVERING CRYOGENS, NAMELY, RIGID AND FLEXIBLE MEDICAL ENDOSCOPES, CATHETERS, LUMEN BLOCKING BALLOONS AND SHIELDS FOR GASTRIC BLOCKING, NASOGASTRIC TUBES, SUCTION DEVICES FOR CRYOGENS REMOVAL AND ENDOSCOPY CAMERAS; TRAINING OF PHYSICIANS AND MEDICAL PERSONNEL IN PERFORMING MEDICAL PROCEDURES INVOLVING CRYOTHERAPY AND CRYOSURGERY; AND TRAINING OF PHYSICIANS AND MEDICAL PERSONNEL IN PERFORMING MEDICAL PROCEDURES INVOLVING ABDOMINAL, BLADDER, PANCREATIC, KIDNEY, LUNG, STOMACH, ESOPHAGEAL AND UPPER AND LOWER GASTROINTESTINAL TISSUE IDENTIFICATION, SEPARATION, ABLATION OR ERADICATION (U.S. CLS. 100, 101 AND 107).

MICHELLE DUBOIS, EXAMINING ATTORNEY

SN 77-664,534. MICHELS, CLARK, CHICAGO, IL. FILED 2-5-2009.

Soundsherpa

THE MARK CONSISTS OF STANDARD CHARACTERS WITHOUT CLAIM TO ANY PARTICULAR FONT, STYLE, SIZE, OR COLOR.

FOR AUDIO RECORDING FOR TV, FILM, AND MUSIC (U.S. CLS. 100, 101 AND 107). GRETCHEN ULRICH, EXAMINING ATTORNEY

CLASS 41—(Continued).

SN 77-664,631. MATRIX ACHIEVEMENT GROUP, LLC, GERMANTOWN, TN. FILED 2-5-2009.

PAIDA

THE MARK CONSISTS OF STANDARD CHARACTERS WITHOUT CLAIM TO ANY PARTICULAR FONT, STYLE, SIZE, OR COLOR.
FOR TRAINING SERVICES IN THE FIELD OF SALES (U.S. CLS. 100, 101 AND 107).
FIRST USE 3-5-2006; IN COMMERCE 3-12-2006.
ANDREW LEASER, EXAMINING ATTORNEY

SN 77-664,661. SETCHKO, BODHI K., DBA CRYSTAL WIND MUSIC, SAN ANSELMO, CA. FILED 2-5-2009.

DANCE CHANT

THE MARK CONSISTS OF STANDARD CHARACTERS WITHOUT CLAIM TO ANY PARTICULAR FONT, STYLE, SIZE, OR COLOR.
FOR ENTERTAINMENT IN THE NATURE OF LIVE PERFORMANCES BY A MUSICAL BAND (U.S. CLS. 100, 101 AND 107).
FIRST USE 7-1-2008; IN COMMERCE 12-4-2008.
JORDAN BAKER, EXAMINING ATTORNEY

SN 77-664,914. REAL ESTATE EARNING, LLC, DBA REAL ESTATE EDUCATE AND/OR REALESTATEEDUCATE, ST. CHARLES, MO. FILED 2-6-2009.

GOHOMEBUYER

THE MARK CONSISTS OF STANDARD CHARACTERS WITHOUT CLAIM TO ANY PARTICULAR FONT, STYLE, SIZE, OR COLOR.
FOR EDUCATIONAL SERVICES, NAMELY, CONDUCTING ON-LINE PROGRAMS IN THE FIELD OF REAL ESTATE (U.S. CLS. 100, 101 AND 107).
CYNTHIA TRIPI, EXAMINING ATTORNEY

CLASS 41—(Continued).

SN 77-664,942. REAL ESTATE EARNING, LLC, DBA REAL ESTATE EDUCATE AND/OR REALESTATEEDUCATE, ST. CHARLES, MO. FILED 2-6-2009.



THE MARK CONSISTS OF STYLIZED "G" NEXT TO "O" DESIGN CONSISTING OF HOUSE OUTLINE WITHIN A SOLID CIRCLE.
FOR EDUCATIONAL SERVICES, NAMELY, CONDUCTING ON-LINE PROGRAMS IN THE FIELD OF REAL ESTATE (U.S. CLS. 100, 101 AND 107).
CYNTHIA TRIPI, EXAMINING ATTORNEY

SN 77-665,012. MOROSO INVESTMENT PARTNERS, LLC, JUPITER, FL. FILED 2-6-2009.

CONCREATURE

THE MARK CONSISTS OF STANDARD CHARACTERS WITHOUT CLAIM TO ANY PARTICULAR FONT, STYLE, SIZE, OR COLOR.
FOR ENTERTAINMENT SERVICES IN THE NATURE OF DRAG STRIP RACES (U.S. CLS. 100, 101 AND 107).
STEVEN R. FINE, EXAMINING ATTORNEY

SN 77-665,203. EDGE PILATES CORPORATION, FORT LAUDERDALE, FL. FILED 2-6-2009.



THE MARK CONSISTS OF THE LITERAL ELEMENT "EDGE PILATES" AND A REPRESENTATION OF A PERSON BENDING AT THE WAIST.
FOR EDUCATION SERVICES, NAMELY, PROVIDING CLASSES IN THE FIELD OF PILATES; PHYSICAL FITNESS CONSULTATION; PHYSICAL FITNESS INSTRUCTION; PHYSICAL FITNESS TRAINING SERVICES (U.S. CLS. 100, 101 AND 107).
FIRST USE 3-0-2004; IN COMMERCE 3-0-2004.
ESTHER A. BORSUK, EXAMINING ATTORNEY

CLASS 41—(Continued).

SN 77-665,304. TEMME III LLC, DBA MOVIEHATCH.COM, NEW YORK, NY. FILED 2-6-2009.

MovieHatch

THE MARK CONSISTS OF STANDARD CHARACTERS WITHOUT CLAIM TO ANY PARTICULAR FONT, STYLE, SIZE, OR COLOR.

FOR PRODUCTION AND DISTRIBUTION OF TELEVISION SHOWS AND MOVIES (U.S. CLS. 100, 101 AND 107).

DANNEAN HETZEL, EXAMINING ATTORNEY

SN 77-665,559. BOYD GAMING CORPORATION, LAS VEGAS, NV. FILED 2-6-2009.

THE LOCALS' PLACE TO PLAY

THE MARK CONSISTS OF STANDARD CHARACTERS WITHOUT CLAIM TO ANY PARTICULAR FONT, STYLE, SIZE, OR COLOR.

FOR CASINOS; ENTERTAINMENT IN THE NATURE OF LIVE MUSICAL GROUPS, SINGERS, COMEDIANS, HOCKEY GAMES, BASKETBALL GAMES, RODEOS, BOXING MATCHES, MIXED MARTIAL ARTS, LIVE DANCE PERFORMANCES, ICE SKATING, MAGICIANS; PROVIDING CASINO FACILITIES (U.S. CLS. 100, 101 AND 107).

FIRST USE 2-6-2009; IN COMMERCE 2-6-2009.

ALICE SUE CARRUTHERS, EXAMINING ATTORNEY

SN 77-665,609. KOIVISTO, ERIC R, SEATTLE, WA. FILED 2-6-2009.

Fantasy In The Trenches

THE MARK CONSISTS OF STANDARD CHARACTERS WITHOUT CLAIM TO ANY PARTICULAR FONT, STYLE, SIZE, OR COLOR.

FOR ENTERTAINMENT IN THE NATURE OF FOOTBALL GAMES; ENTERTAINMENT SERVICES, NAMELY, PROVIDING AN ON-LINE COMPUTER GAME; PROVIDING A COMPUTER GAME THAT MAY BE ACCESSED NETWORK-WIDE BY NETWORK USERS (U.S. CLS. 100, 101 AND 107).

APRIL HESIK, EXAMINING ATTORNEY

CLASS 41—(Continued).

SN 77-665,615. KOIVISTO, ERIC R, SEATTLE, WA. FILED 2-6-2009.

Trench Fantasy

THE MARK CONSISTS OF STANDARD CHARACTERS WITHOUT CLAIM TO ANY PARTICULAR FONT, STYLE, SIZE, OR COLOR.

FOR ENTERTAINMENT IN THE NATURE OF FOOTBALL GAMES; ENTERTAINMENT SERVICES, NAMELY, PROVIDING AN ON-LINE COMPUTER GAME; PROVIDING A COMPUTER GAME THAT MAY BE ACCESSED NETWORK-WIDE BY NETWORK USERS (U.S. CLS. 100, 101 AND 107).

APRIL HESIK, EXAMINING ATTORNEY

SN 77-665,709. ESTRELLA, DANIEL A., DBA M-16, NEW YORK, NY. FILED 2-7-2009.

M-16

THE MARK CONSISTS OF STANDARD CHARACTERS WITHOUT CLAIM TO ANY PARTICULAR FONT, STYLE, SIZE, OR COLOR.

FOR ENTERTAINMENT IN THE NATURE OF LIVE PERFORMANCES BY MUSICAL GROUP FEATURING ROCK AND HEAVY METAL MUSIC (U.S. CLS. 100, 101 AND 107).

FIRST USE 2-15-1997; IN COMMERCE 2-15-1997.

HANNO RITTNER, EXAMINING ATTORNEY

SN 77-665,714. DYER, PHILLIP W, LAREDO, TX. FILED 2-7-2009.



THE COLOR(S) RED, WHITE, BLUE, YELLOW, PALE PINK, AQUA/TURQUOISE, MUSTARD GOLD IS/ARE CLAIMED AS A FEATURE OF THE MARK.

THE MARK CONSISTS OF AN AQUA/TURQUOISE, MUSTARD GOLD & BLUE BUFFALO WITH A BLUE STREAK ON THE BACK AND MUSTARD GOLD OUTLINE TO THE LOWER BODY PORTION WITH MUSTARD GOLD HORNS ON A PALE PINK FIELD WITH WREATH OF

CLASS 41—(Continued).

LETTERS RINGING THE BUFFALO THAT SET IN 22 PT BOLD ARABIC TYPESETTING THAT READS "THE LAST AMERICAN NEWSPAPER" IN VIOLET BLUE WITH BRIGHT YELLOW BORDERS. THE "A" IN "AMERICAN" IS AFFIXED TO THE LEFT OF THE BUFFALO'S HUMP, WITH THE "M" IN "AMERICAN" AFFIXED TO THE APEX OF THE HUMP, THESE WORDS BEING CONNECTED BY THREE SMALL STARS AFFIXED TO THE LOWER LEFT HAND SIDE OF THE LETTER WREATH AT APPROXIMATELY 240 DEGREES, ONE RED WITH WHITE BORDER, ONE WHITE WITH BLUE BORDER, AND ONE BLUE WITH WHITE BORDER. AN INNER WREATH OF WORDS ALIGNED STARTING BELOW THE T IN THE OUTER WREATH SET IN REGULAR 11 PT ARABIC TYPESETTING READS "TAKING BACK THE AMERICAN DREAM ONE BABY BOOMER AT A TIME" IN BLUE LETTERS.

FOR PUBLICATION OF ELECTRONIC NEWSPAPERS ACCESSIBLE VIA A GLOBAL COMPUTER NETWORK (U.S. CLS. 100, 101 AND 107).

FIRST USE 1-29-2009; IN COMMERCE 1-29-2009.
GRETTA YAO, EXAMINING ATTORNEY

CLASS 41—(Continued).

SN 77-666,020. FEDERICO, NOELLE K, FRANKLIN, TN. FILED 2-9-2009.

Successorize 101

THE MARK CONSISTS OF STANDARD CHARACTERS WITHOUT CLAIM TO ANY PARTICULAR FONT, STYLE, SIZE, OR COLOR.

FOR EDUCATION SERVICES, NAMELY, PROVIDING WORKSHOPS, CLASSES AND SEMINARS FOR TEENAGERS IN THE FIELD OF PERSONAL DEVELOPMENT AND SELF-IMPROVEMENT (U.S. CLS. 100, 101 AND 107).

ANNE E. GUSTASON, EXAMINING ATTORNEY

SN 77-665,792. SEIDEL, SAMUEL STEINBERG, PROVIDENCE, RI. FILED 2-8-2009.

HIP HOP GENIUS

THE MARK CONSISTS OF STANDARD CHARACTERS WITHOUT CLAIM TO ANY PARTICULAR FONT, STYLE, SIZE, OR COLOR.

NO CLAIM IS MADE TO THE EXCLUSIVE RIGHT TO USE "HIP HOP", APART FROM THE MARK AS SHOWN.

FOR ARRANGING AND CONDUCTING EDUCATIONAL CONFERENCES; CONSULTATION IN THE FIELD OF K-12 EDUCATIONAL SYSTEMS; EDUCATION INFORMATION; EDUCATION SERVICES, NAMELY, PROVIDING CLASSES, SEMINARS, WORKSHOPS, TUTORING, AND MENTORING IN THE FIELD OF MIDDLE AND HIGH SCHOOL REFORM; EDUCATIONAL AND ENTERTAINMENT SERVICES, NAMELY, PROVIDING MOTIVATIONAL AND EDUCATIONAL SPEAKERS; EDUCATIONAL SERVICES IN THE NATURE OF CHARTER SCHOOLS; EDUCATIONAL SERVICES, NAMELY, A LEARNING AND INNOVATION CENTER FEATURING FULLY CUSTOMIZED LEADERSHIP, MOTIVATIONAL, EDUCATIONAL, AND BRAINSTORMING TRAINING; EDUCATIONAL SERVICES, NAMELY, CONDUCTING INFORMAL ON-LINE PROGRAMS IN THE FIELDS OF EDUCATION, AND PRINTABLE MATERIALS DISTRIBUTED THEREWITH; INFORMATION RELATING TO ENTERTAINMENT AND EDUCATION, PROVIDED ON-LINE FROM A COMPUTER DATABASE OR THE INTERNET; PROVIDING INFORMATION AND NEWS IN THE FIELD OF TEACHING METHODOLOGY AND EDUCATION (U.S. CLS. 100, 101 AND 107).

JESSICA A. POWERS, EXAMINING ATTORNEY

SN 77-666,022. TVUNDONE, LLC, SAN FRANCISCO, CA. FILED 2-9-2009.



THE MARK CONSISTS OF THE WORD "TVUNDONE" DISPLAYED INSIDE AN IMAGE OF A PIECE OF TAPE WITH THE RIGHT SIDE CORNER FOLDED FORWARD.

FOR ENTERTAINMENT SERVICES IN THE NATURE OF ONGOING VIDEO PROGRAMS IN THE FIELD OF VARIETY, NEWS, COMEDY, PRODUCT REVIEWS, MOVIE REVIEWS, INSTRUCTIONAL VIDEOS AND INTERVIEWS (U.S. CLS. 100, 101 AND 107).

ZACHARY BELLO, EXAMINING ATTORNEY

SN 77-666,023. TVUNDONE, LLC, SAN FRANCISCO, CA. FILED 2-9-2009.

TVUNDONE

THE MARK CONSISTS OF STANDARD CHARACTERS WITHOUT CLAIM TO ANY PARTICULAR FONT, STYLE, SIZE, OR COLOR.

FOR ENTERTAINMENT SERVICES IN THE NATURE OF ONGOING VIDEO PROGRAMS IN THE FIELD OF VARIETY, NEWS, COMEDY, PRODUCT REVIEWS, MOVIE REVIEWS, INSTRUCTIONAL VIDEOS AND INTERVIEWS (U.S. CLS. 100, 101 AND 107).

ZACHARY BELLO, EXAMINING ATTORNEY

CLASS 41—(Continued).

SN 77-666,043. HARRAH'S LICENSE COMPANY, LLC, LAS VEGAS, NV. FILED 2-9-2009.

Driven to Win

THE MARK CONSISTS OF STANDARD CHARACTERS WITHOUT CLAIM TO ANY PARTICULAR FONT, STYLE, SIZE, OR COLOR.

FOR ENTERTAINMENT SERVICES, NAMELY, CONDUCTING SPECIAL EVENTS FEATURING CASINO AND GAMING CONTESTS AND TOURNAMENTS AND ONLINE SWEEPSTAKES (U.S. CLS. 100, 101 AND 107).

DAVID COLLIER, EXAMINING ATTORNEY

SN 77-666,374. SACCO, DAMON J., POCHASSET, MA. FILED 2-9-2009.



THE COLOR(S) ORANGE, YELLOW, BROWN, GRAY, BLACK, AND WHITE IS/ARE CLAIMED AS A FEATURE OF THE MARK.

THE MARK CONSISTS OF A GRAPHIC OF AN ORANGE AND YELLOW SUN WITH A GRAY SHARK IN THE CENTER. THE SHARK IS CURVED AROUND THE INTERIOR OF THE SUN, IS SMILING AND WEARING SUNGLASSES. THE SHARK ALSO HAS BROWN DREADLOCKS. ABOVE THE SUN, THE WORD "CASTAFARI" IS WRITTEN IN YELLOW WITH A BLACK OUTLINE, AND BLACK SHADOWING, AND IS CURVED DOWNWARD AROUND THE TOP OF THE SUN GRAPHIC. BELOW THE SUN IS THE WORD "LIFESTYLE" WRITTEN IN BLACK WITH A YELLOW OUTLINE AND GRAY SHADOWING. "LIFESTYLE" IS CURVED UPWARDS AROUND THE SUN GRAPHIC.

FOR EDUCATIONAL AND ENTERTAINMENT SERVICES, NAMELY, A CONTINUING PROGRAM ABOUT SPORTS FISHING ACCESSIBLE BY RADIO, TELEVISION, SATELLITE, AUDIO, VIDEO AND COMPUTER NETWORKS (U.S. CLS. 100, 101 AND 107).

FIRST USE 1-10-1998; IN COMMERCE 1-10-1998.

RICHARD A. STRASER, EXAMINING ATTORNEY

CLASS 41—(Continued).

SN 77-666,532. DARLING STILETTOS, LLC, LOS ANGELES, CA. FILED 2-9-2009.

DARLING STILETTOS

THE MARK CONSISTS OF STANDARD CHARACTERS WITHOUT CLAIM TO ANY PARTICULAR FONT, STYLE, SIZE, OR COLOR.

FOR ENTERTAINMENT SERVICES IN THE NATURE OF LIVE PERFORMANCES BY A MUSICAL GROUP; ENTERTAINMENT IN THE NATURE OF VISUAL AND AUDIO PERFORMANCES BY A MUSICAL GROUP; ENTERTAINMENT, NAMELY, PERSONAL APPEARANCES BY A MUSICAL GROUP; ENTERTAINMENT SERVICES, NAMELY, PROVIDING A WEBSITE FEATURING MUSICAL PERFORMANCES, MUSICAL VIDEOS; ENTERTAINMENT SERVICES, NAMELY, PROVIDING PRERECORDED MUSIC VIA A GLOBAL COMPUTER NETWORK (U.S. CLS. 100, 101 AND 107).

FIRST USE 11-30-2005; IN COMMERCE 11-30-2005.

KEVIN DINALLO, EXAMINING ATTORNEY

SN 77-666,643. ANGEL DE LA JUSTICIA, INC., WOODLAND HILLS, CA. FILED 2-9-2009.

Angel de la Justicia

THE MARK CONSISTS OF STANDARD CHARACTERS WITHOUT CLAIM TO ANY PARTICULAR FONT, STYLE, SIZE, OR COLOR.

NO CLAIM IS MADE TO THE EXCLUSIVE RIGHT TO USE "DE LA JUSTICIA", APART FROM THE MARK AS SHOWN.

THE ENGLISH TRANSLATION OF THE WORD "DE LA JUSTICIA" IN THE MARK IS OF JUSTICE, EQUALITY, OR FAIRNESS.

FOR ENTERTAINMENT, NAMELY, A CONTINUING NEWS AND TALK SHOW BROADCAST OVER TELEVISION, SATELLITE, AUDIO, AND VIDEO MEDIA (U.S. CLS. 100, 101 AND 107).

FIRST USE 11-2-2007; IN COMMERCE 11-2-2007.

RICHARD A. STRASER, EXAMINING ATTORNEY

SN 77-666,704. STEVENS, ROGER, BAKERSFIELD, CA. FILED 2-9-2009.

DRAGFEST

THE MARK CONSISTS OF STANDARD CHARACTERS WITHOUT CLAIM TO ANY PARTICULAR FONT, STYLE, SIZE, OR COLOR.

FOR ENTERTAINMENT SERVICES, NAMELY, STAGING VEHICLE RACES AND CAR SHOWS (U.S. CLS. 100, 101 AND 107).

FIRST USE 10-31-2007; IN COMMERCE 10-31-2007.

EMILY CARLSEN, EXAMINING ATTORNEY

CLASS 41—(Continued).

SN 77-666,752. MGM MIRAGE, LAS VEGAS, NV. FILED 2-9-2009.

SKYLOFTS

THE MARK CONSISTS OF STANDARD CHARACTERS WITHOUT CLAIM TO ANY PARTICULAR FONT, STYLE, SIZE, OR COLOR.

FOR CASINOS; ENTERTAINMENT IN THE NATURE OF LIVE PERFORMANCES BY A MUSIC GROUP; HEALTH CLUB, NAMELY, PROVIDING INSTRUCTION AND EQUIPMENT IN THE FIELD OF PHYSICAL EXERCISE; AMUSEMENT ARCADES; POOL CLUBS; PROVISION OF SPORTS FACILITIES, SPORTS INSTRUCTION SERVICES, ARRANGING AND CONDUCTING ATHLETIC EVENTS, COMPETITION AND SPORTS EVENTS, ARRANGING AND CONDUCTING OF SEMINARS, ENTERTAINMENT FEATURING MUSIC, DANCING, COMEDY AND DRAMA; ART EXHIBITIONS; NIGHT CLUBS; CABARETS; PHOTOGRAPHY SERVICES; PROVIDING FACILITIES FOR RECREATION ACTIVITIES; SPECIAL EVENT PLANNING; BOOKING OF SEATS FOR SHOWS AND BOOKING OF THEATRE TICKETS (U.S. CLS. 100, 101 AND 107).

GINA HAYES, EXAMINING ATTORNEY

SN 77-666,767. FROG POND PRODUCTIONS, LLC, MURRIETA, CA. FILED 2-9-2009.

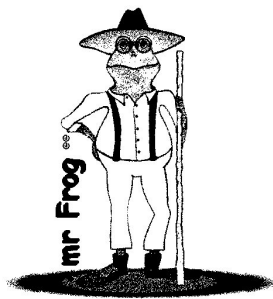

THE STIPPLING IS FOR SHADING PURPOSES ONLY. THE MARK CONSISTS OF A FROG STANDING ON LILY PAD IN POND WITH WOODEN WALKING STICK, BOOTS, PANTS, SHIRT, SUSPENDERS, HAT, AND ROUND GLASSES.

FOR EDUCATIONAL SERVICES, NAMELY, CONDUCTING SEMINARS, LECTURES, WORKSHOPS AND CONFERENCES ON THE SUBJECT OF PERSONAL AND ORGANIZATIONAL INSPIRATION, MOTIVATION, DEVELOPMENT AND TRANSFORMATION (U.S. CLS. 100, 101 AND 107).

MARC LEIPZIG, EXAMINING ATTORNEY

CLASS 41—(Continued).

SN 77-666,831. OGDEN PUBLICATIONS, INC., TOPEKA, KS. FILED 2-9-2009.

GRIT

THE MARK CONSISTS OF STANDARD CHARACTERS WITHOUT CLAIM TO ANY PARTICULAR FONT, STYLE, SIZE, OR COLOR.

OWNER OF U.S. REG. NOS. 1,550,916 AND 2,270,473. FOR ENTERTAINMENT SERVICES, NAMELY, PROVIDING A WEBSITE FEATURING AUDIO PRESENTATIONS, VIDEO PRESENTATIONS AND OTHER MULTIMEDIA MATERIALS IN THE FIELD OF RURAL LIFESTYLES, COMMUNITY AND STEWARDSHIP (U.S. CLS. 100, 101 AND 107).

NELSON SNYDER, EXAMINING ATTORNEY

SN 77-666,844. OGDEN PUBLICATIONS, INC., TOPEKA, KS. FILED 2-9-2009.

UTNE READER

THE MARK CONSISTS OF STANDARD CHARACTERS WITHOUT CLAIM TO ANY PARTICULAR FONT, STYLE, SIZE, OR COLOR.

OWNER OF U.S. REG. NOS. 3,264,163, 3,271,296 AND 3,392,418.

NO CLAIM IS MADE TO THE EXCLUSIVE RIGHT TO USE "READER", APART FROM THE MARK AS SHOWN. SEC. 2(F).

FOR ENTERTAINMENT SERVICES, NAMELY, PROVIDING A WEBSITE FEATURING AUDIO AND VIDEO PRESENTATIONS, OTHER MULTIMEDIA MATERIALS, AND INFORMATION IN THE FIELD OF CULTURAL IDEAS AND TRENDS; ON-LINE JOURNALS, NAMELY, BLOGS FEATURING INFORMATION ABOUT CULTURAL IDEAS AND TRENDS (U.S. CLS. 100, 101 AND 107).

NELSON SNYDER, EXAMINING ATTORNEY

SN 77-667,080. LEADERSHIP WORKS, LLC, HONOLULU, HI. FILED 2-10-2009.

HIVIVE

THE MARK CONSISTS OF STANDARD CHARACTERS WITHOUT CLAIM TO ANY PARTICULAR FONT, STYLE, SIZE, OR COLOR.

FOR EDUCATIONAL SERVICES, NAMELY, PROVIDING ON-LINE CLASSES, SEMINARS, AND WORKSHOPS IN THE FIELD OF LEADERSHIP DEVELOPMENT AND TRAINING; PROVIDING ON-LINE GROUP COACHING AND LEARNING FORUMS IN THE FIELD OF LEADERSHIP DEVELOPMENT AND TRAINING (U.S. CLS. 100, 101 AND 107).

REBECCA GILBERT, EXAMINING ATTORNEY

CLASS 41—(Continued).

SN 77-667,189. UP IN THE AIR PRODUCTIONS LTD, NEW YORK, NY. FILED 2-10-2009.



OWNER OF U.S. REG. NO. 3,553,757.
NO CLAIM IS MADE TO THE EXCLUSIVE RIGHT TO USE "PRODUCTIONS, LTD.", APART FROM THE MARK AS SHOWN.

THE STIPPLING IS FOR SHADING PURPOSES ONLY.
THE MARK CONSISTS OF A SWISH WITH THE WORDS "UP IN THE AIR" IN IT AND THE WORDS "PRODUCTIONS, LTD." UNDER IT.

FOR AUDIO AND VIDEO RECORDING SERVICES; AUDIO RECORDING AND PRODUCTION; MULTIMEDIA ENTERTAINMENT SERVICES IN THE NATURE OF RECORDING, PRODUCTION AND POST-PRODUCTION SERVICES IN THE FIELDS OF MUSIC, VIDEO, AND FILMS; MUSIC PRODUCTION SERVICES (U.S. CLS. 100, 101 AND 107).

JULIE WATSON, EXAMINING ATTORNEY

SN 77-667,301. SB NY INC., HORSHAM, PA. FILED 2-10-2009.

SANDWICH SLAMM

THE MARK CONSISTS OF STANDARD CHARACTERS WITHOUT CLAIM TO ANY PARTICULAR FONT, STYLE, SIZE, OR COLOR.

FOR SANDWICH EATING CONTEST (U.S. CLS. 100, 101 AND 107).

DAVID C. REIHNER, EXAMINING ATTORNEY

SN 77-667,521. SHAUNA C. HENRY, DBA LIFEVENTS BY SHAUNA HENRY, SAN DIEGO, CA. FILED 2-10-2009.

LifEvents

THE MARK CONSISTS OF STANDARD CHARACTERS WITHOUT CLAIM TO ANY PARTICULAR FONT, STYLE, SIZE, OR COLOR.

FOR SPECIAL EVENT, PARTY AND WEDDING PLANNING AND COORDINATION SERVICES; SPECIAL EVENT, PARTY AND WEDDING PLANNING CONSULTATION SERVICES (U.S. CLS. 100, 101 AND 107).

FIRST USE 11-11-2008; IN COMMERCE 11-12-2008.

ALICE SUE CARRUTHERS, EXAMINING ATTORNEY

CLASS 41—(Continued).

SN 77-667,632. COMEN VISUAL EFFECTS, LLC, BEVERLY HILLS, CA. FILED 2-10-2009.

LIFE UNDERCOVER

THE MARK CONSISTS OF STANDARD CHARACTERS WITHOUT CLAIM TO ANY PARTICULAR FONT, STYLE, SIZE, OR COLOR.

FOR ENTERTAINMENT, NAMELY, PRODUCTION OF TELEVISION SHOWS; PRODUCTION AND DISTRIBUTION OF TELEVISION SHOWS AND MOVIES; TELEVISION SHOW PRODUCTION (U.S. CLS. 100, 101 AND 107).
JENNIFER MARTIN, EXAMINING ATTORNEY

SN 77-667,643. MATTEL, INC., EL SEGUNDO, CA. FILED 2-10-2009.

LADYBUGGIN'

THE MARK CONSISTS OF STANDARD CHARACTERS WITHOUT CLAIM TO ANY PARTICULAR FONT, STYLE, SIZE, OR COLOR.

FOR ENTERTAINMENT SERVICES, NAMELY, PROVIDING ONLINE COMPUTER GAMES (U.S. CLS. 100, 101 AND 107).

REBECCA POVARCHUK, EXAMINING ATTORNEY

SN 77-667,743. ELLISON, BRIAN, MOUNT JULIET, TN. FILED 2-10-2009.

TEKMERION PRODUCTIONS

THE MARK CONSISTS OF STANDARD CHARACTERS WITHOUT CLAIM TO ANY PARTICULAR FONT, STYLE, SIZE, OR COLOR.

NO CLAIM IS MADE TO THE EXCLUSIVE RIGHT TO USE "PRODUCTIONS", APART FROM THE MARK AS SHOWN.

FOR AUDIO RECORDING AND PRODUCTION; MEDIA PRODUCTION SERVICES, NAMELY, VIDEO AND FILM PRODUCTION; PRODUCTION OF VISUAL EFFECTS FOR VIDEOS, DVDS, TELEVISION AND FOR INTERNET WEB SITES (U.S. CLS. 100, 101 AND 107).

FIRST USE 1-1-2005; IN COMMERCE 11-5-2008.

DAVID H. STINE, EXAMINING ATTORNEY

CLASS 41—(Continued).

SN 77-667,783. BEATY PARTNERSHIP, ANTIOCH, IL. FILED 2-10-2009.

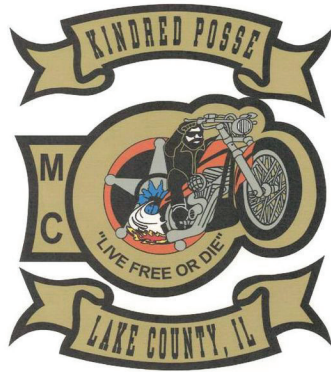

NO CLAIM IS MADE TO THE EXCLUSIVE RIGHT TO USE "LAKE COUNTY, IL" AND "M C", APART FROM THE MARK AS SHOWN.

THE COLOR(S) BLACK, BLUE, RED, WHITE, BROWN, YELLOW AND GREY IS/ARE CLAIMED AS A FEATURE OF THE MARK.

THE MARK CONSISTS OF THE WORDING KINDRED POSSE "LIVE FREE OR DIE" "MC" AND "LAKE COUNTY, IL" APPEARING IN A BANNER AND CIRCLE DESIGN THAT ALSO CONTAINS A PERSON RIDING A MOTORCYCLE WITH AN EXHAUST FLAME SHOWN FLYING OUT OF A FIVE POINTED STAR. THE COLOR BLACK APPEARS IN THE WORDING "KINDRED POSSE" "LIVE FREE OR DIE" "MC" AND "LAKE COUNTY, IL" AS WELL AS ON THE DEPICTION OF TIRE AND FRAME OF THE MOTORCYCLE, THE CLOTHING, GLASSES AND MUSTACHE OF THE PERSON RIDING THE MOTORCYCLE, THE CIRCLE BEHIND THE FIVE-POINTED STAR, THE CENTER OF THE FLOWER IN THE FIVE-POINTED STAR FROM WHICH THE MOTORCYCLE APPEARS TO JUMP THROUGH, AND THE OUTER BORDER OF THE BANNERS AND CIRCLE DESIGN SURROUNDING BOTH THE WORDING IN THE MARK AS WELL AS THE MOTORCYCLE AND FIVE-POINTED STAR; THE COLOR GREY APPEARS ON THE DEPICTION OF RIMS, FRAME, AND ENGINE OF THE MOTORCYCLE AS WELL AS THE FIVE-POINTED STAR LOCATED BEHIND THE MOTORCYCLE; THE COLOR RED APPEARS ON THE DEPICTION OF THE FENDERS AND GAS TANK OF THE MOTORCYCLE, THE FLAME COMING FROM THE EXHAUST OF THE MOTORCYCLE, AS WELL AS THE CIRCLE TOUCHING OUTER POINTS OF THE FIVE-POINTED STAR; THE COLOR YELLOW APPEARS ON THE DEPICTION OF THE EXHAUST OF THE MOTORCYCLE; THE COLOR BLUE APPEARS ON THE DEPICTION OF THE FLOWER IN THE

CLASS 41—(Continued).

FIVE-POINTED STAR FROM WHICH THE MOTORCYCLE APPEARS TO JUMP THROUGH; THE COLOR WHITE APPEARS ON THE DEPICTION OF THE SWOOSH BEHIND THE MOTORCYCLE REPRESENTING THE MOVEMENT OF THE MOTORCYCLE AS WELL AS THE FACE OF THE PERSON RIDING THE MOTORCYCLE; THE COLOR BROWN APPEARS AS THE BACKGROUND SHADING ON THE DEPICTION OF THE BANNERS AND CIRCLE DESIGN SURROUNDING BOTH THE WORDING IN THE MARK AS WELL AS THE MOTORCYCLE AND FIVE-POINTED STAR.

FOR CHARITABLE SERVICES, NAMELY, ACADEMIC MENTORING OF SCHOOL AGE CHILDREN; CHARITABLE SERVICES, NAMELY, PROVIDING ARTS AND CRAFTS AND EDUCATIONAL MATERIALS IN THE NATURE OF RECYCLED MANUFACTURING BY-PRODUCTS TO NEEDY AND UNDERPRIVILEGED CHILDREN; CHARITABLE SERVICES, NAMELY, PROVIDING BOOKS TO PEOPLE; CHARITABLE SERVICES, NAMELY, PROVIDING BOOKS TO CHILDREN AND PEOPLE OF NEED; CHARITABLE SERVICES, NAMELY, PROVIDING MUSICAL INSTRUMENTS TO THOSE IN NEED; CHARITABLE SERVICES, NAMELY, PROVIDING RESOURCE LIBRARY SERVICES TO THOSE IN NEED; CHARITABLE SERVICES, NAMELY, PROVIDING SCHOOL SUPPLIES TO CHILDREN IN NEED; CHARITABLE SERVICES, NAMELY, PROVIDING SPORTING GOODS TO UNDERPRIVILEGED CHILDREN; CHARITABLE SERVICES, NAMELY, PROVIDING TOYS TO NEEDY CHILDREN; ENTERTAINMENT SERVICES, NAMELY, CONDUCTING PARTIES FOR THE PURPOSE OF DATING AND SOCIAL INTRODUCTION FOR ADULTS; PUBLICATION OF DOCUMENTS IN THE FIELD OF TRAINING, SCIENCE, PUBLIC LAW AND SOCIAL AFFAIRS; SOCIAL CLUB SERVICES, NAMELY, ARRANGING, ORGANIZING, AND HOSTING SOCIAL EVENTS, GET-TOGETHERS, AND PARTIES FOR CLUB MEMBERS (U.S. CLS. 100, 101 AND 107).

MICHAEL TANNER, EXAMINING ATTORNEY

SN 77-668,816. MGM MIRAGE, LAS VEGAS, NV. FILED 2-11-2009.



THE MARK CONSISTS OF A VERTICAL RECTANGLE WITH TWO VERTICAL AND TWO HORIZONTAL LINES THAT MEET INSIDE THE RECTANGLE FORMING TWO 90 DEGREE ANGLES AND THE WORD "SKYLOFTS" BELOW THE RECTANGLE.

FOR CASINOS; ENTERTAINMENT IN THE NATURE OF LIVE PERFORMANCES BY A MUSIC GROUP; HEALTH CLUB, NAMELY, PROVIDING INSTRUCTION AND EQUIPMENT IN THE FIELD OF PHYSICAL EXERCISE; AMUSEMENT ARCADES; POOL CLUBS; PROVISION OF SPORTS FACILITIES, SPORTS INSTRUCTION SERVICES, ARRANGING AND CONDUCTING ATHLETIC EVENTS, COMPETITION AND SPORTS EVENTS, ARRANGING AND CONDUCTING OF SEMINARS, ENTERTAINMENT FEATURING MUSIC, DANCING, COMEDY AND DRAMA; ART EXHIBITIONS; NIGHT CLUBS; CABARETS; PHOTOGRAPHY SERVICES; PROVIDING FACILITIES FOR RECREATION ACTIVITIES; SPECIAL EVENT PLANNING; BOOKING OF SEATS FOR SHOWS AND BOOKING OF THEATRE TICKETS (U.S. CLS. 100, 101 AND 107).

GINA HAYES, EXAMINING ATTORNEY

CLASS 41—(Continued).

SN 77-669,069. THE NORTH FACE APPAREL CORP, WILMINGTON, DE. FILED 2-12-2009.



NO CLAIM IS MADE TO THE EXCLUSIVE RIGHT TO USE "SNOWBOARDING", APART FROM THE MARK AS SHOWN.

THE MARK CONSISTS OF STYLIZED WORDS. FOR ENTERTAINMENT IN THE NATURE OF COMPETITIONS IN THE FIELD OF SNOWBOARDING; ORGANIZING SPORTING EVENTS, NAMELY, ATHLETIC COMPETITIONS IN THE FIELD OF SNOWBOARDING (U.S. CLS. 100, 101 AND 107).

DAVON HATCHETT, EXAMINING ATTORNEY

CLASS 41—(Continued).

SN 77-673,080. NATIONAL ASSOCIATION OF PROFESSIONAL PET SITTERS, INC., MT. LAUREL, NJ. FILED 2-18-2009.



NO CLAIM IS MADE TO THE EXCLUSIVE RIGHT TO USE "YOUTH EDUCATION PROGRAM", APART FROM THE MARK AS SHOWN.

THE COLOR(S) BLUE, BROWN, GREEN, PURPLE, YELLOW, RED, WHITE, AND BLACK IS/ARE CLAIMED AS A FEATURE OF THE MARK.

THE MARK CONSISTS OF A CIRCLE LINED BY THE WORDS "T.Y.K.E.S. YOUTH EDUCATION PROGRAM" AND FEATURING A DOG AND A CAT SITTING BEHIND BLUE, BROWN, GREEN, PURPLE, YELLOW, RED, AND WHITE BOOKS. THE WORDING IS IN GREEN; DOG AND CAT DESIGN IS BLACK; BOOKS ARE IN BLUE, BROWN, GREEN, PURPLE, YELLOW, RED, AND WHITE; BACKGROUND IN WHITE.

FOR EDUCATIONAL SERVICES, NAMELY, DEVELOPING CURRICULUM FOR OTHERS IN THE FIELD OF PET COMPANIONSHIP (U.S. CLS. 100, 101 AND 107).

RICHARD A. STRASER, EXAMINING ATTORNEY

SN 77-671,405. NATIONAL ASSOCIATION OF PROFESSIONAL PET SITTERS, INC., MT. LAUREL, NJ. FILED 2-16-2009.

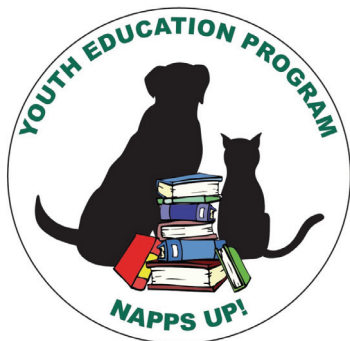

NO CLAIM IS MADE TO THE EXCLUSIVE RIGHT TO USE "YOUTH EDUCATION PROGRAM", APART FROM THE MARK AS SHOWN.

THE COLOR(S) BLUE, BROWN, GREEN, PURPLE, YELLOW, RED, WHITE, AND BLACK IS/ARE CLAIMED AS A FEATURE OF THE MARK.

THE MARK CONSISTS OF A CIRCLE LINED BY THE WORDS "NAPPS UP! YOUTH EDUCATION PROGRAM" AND FEATURING A DOG AND A CAT SITTING BEHIND BLUE, BROWN, GREEN, PURPLE, AND YELLOW BOOKS. THE WORDING IS IN GREEN; DOG AND CAT DESIGN IS BLACK; BOOKS ARE IN BLUE, BROWN, GREEN, PURPLE, YELLOW, RED, AND WHITE; BACKGROUND IN WHITE.

FOR EDUCATIONAL SERVICES, NAMELY, DEVELOPING CURRICULUM FOR OTHERS IN THE FIELD OF PET COMPANIONSHIP (U.S. CLS. 100, 101 AND 107).

RICHARD A. STRASER, EXAMINING ATTORNEY

SN 77-675,683. MISS MATCHED, INC., NEW YORK, NY. FILED 2-23-2009.

LITTLEMISSMATCHED

THE MARK CONSISTS OF STANDARD CHARACTERS WITHOUT CLAIM TO ANY PARTICULAR FONT, STYLE, SIZE, OR COLOR.

OWNER OF U.S. REG. NOS. 3,475,092, 3,565,831 AND OTHERS.

FOR ENTERTAINMENT SERVICES, NAMELY, PROVIDING ON-LINE GAMES, PROVIDING INFORMATION IN THE FIELD OF ENTERTAINMENT ACTIVITIES FOR CHILDREN; ON-LINE JOURNALS, NAMELY, BLOGS FEATURING INTERVIEWS OF INTEREST FOR CHILDREN AND TEENS (U.S. CLS. 100, 101 AND 107).

FIRST USE 8-28-2007; IN COMMERCE 8-28-2007.
WON TEAK OH, EXAMINING ATTORNEY

CLASS 41—(Continued).

SN 77-677,702. UBISOFT ENTERTAINMENT, RENNES, FRANCE, FILED 2-25-2009.

MURDER ON THE SET

THE MARK CONSISTS OF STANDARD CHARACTERS WITHOUT CLAIM TO ANY PARTICULAR FONT, STYLE, SIZE, OR COLOR.

FOR ENTERTAINMENT SERVICES, NAMELY, PROVIDING AN ON-LINE COMPUTER GAME FOR OTHERS OVER GLOBAL AND LOCAL AREA COMPUTER NETWORKS AND PROVIDING INFORMATION ON-LINE RELATING TO COMPUTER GAMES, VIDEO GAMES AND COMPUTER AND VIDEO GAMES RELATED PRODUCTS AND ENTERTAINMENT SERVICES IN THE NATURE OF PRODUCTION OF TELEVISION PROGRAMS (U.S. CLS. 100, 101 AND 107).

JENNIFER MARTIN, EXAMINING ATTORNEY

SN 77-697,749. G. CRAIG CABA, ENOLA, PA. FILED 3-24-2009.



THE MARK CONSISTS OF AN EAGLE DESIGN WITH WINGS SPREAD, HOLDING IN ITS RIGHT TALON A SHIELD SHOWING STARS AND STRIPES.

FOR CONDUCTING EDUCATIONAL EXHIBITIONS FEATURING ART AND ARTIFACTS ON THE SUBJECT OF AMERICAN HISTORY; EDUCATIONAL SERVICES, NAMELY, LECTURES AND SEMINARS ON AMERICAN HISTORY AND THE PRESERVATION OF ARTIFACTS (U.S. CLS. 100, 101 AND 107).

FIRST USE 0-0-1976; IN COMMERCE 0-0-1976.
IRA J. GOODSAD, EXAMINING ATTORNEY

SN 78-703,709. LIGHTHEARTED ENTERTAINMENT, INC., BURBANK, CA. AND BRAINSQUEEEZE, LLC, NEW YORK, NY. FILED 8-30-2005.

SMARTEST PERSON

THE MARK CONSISTS OF STANDARD CHARACTERS WITHOUT CLAIM TO ANY PARTICULAR FONT, STYLE, SIZE, OR COLOR.

FOR ENTERTAINMENT SERVICES IN THE NATURE OF AN ONGOING TELEVISION GAME SHOW; PROVIDING INFORMATION IN THE FIELD OF ENTERTAINMENT, NEWS, HISTORY AND GENERAL TRIVIA VIA A GLOBAL COMPUTER NETWORK; PROVIDING INFORMATION ABOUT AND INTERACTIVE ENTERTAINMENT IN THE FORM OF A QUESTION AND ANSWER GAME CONTEST VIA A GLOBAL COMPUTER NETWORK (U.S. CLS. 100, 101 AND 107).

WILLIAM P. SHANAHAN, EXAMINING ATTORNEY

CLASS 41—(Continued).

SN 79-053,244. INSTITUT DE RECHERCHE SUR LES; CANCERS DE L'APPAREIL DIGESTIF -; IRCAD, FRANCE, FILED 3-26-2008.

AMITS American Institute of TeleSurgery

THE MARK CONSISTS OF STANDARD CHARACTERS WITHOUT CLAIM TO ANY PARTICULAR FONT, STYLE, SIZE, OR COLOR.

PRIORITY DATE OF 11-30-2007 IS CLAIMED.

OWNER OF INTERNATIONAL REGISTRATION 0962675 DATED 3-26-2008, EXPIRES 3-26-2018.

NO CLAIM IS MADE TO THE EXCLUSIVE RIGHT TO USE "AMERICAN INSTITUTE OF TELESURGERY", APART FROM THE MARK AS SHOWN.

FOR ORGANIZATION OF EXHIBITIONS FOR EDUCATIONAL PURPOSES, CONFERENCES, SEMINARS, WORKING GROUPS, RESEARCH GROUPS AND CONVENTIONS FOR EDUCATIONAL PURPOSES IN THE FIELDS OF MEDICINE AND SURGERY; TEACHING, PROVIDING OF TRAINING, CONTINUOUS TRAINING AND ADVANCED TRAINING IN THE FIELDS OF MEDICINE AND SURGERY; ORGANIZATION OF PROFESSIONAL WORKSHOPS AND TRAINING COURSES IN THE FIELDS OF MEDICINE AND SURGERY; MULTIMEDIA PUBLISHING OF BOOKS, MAGAZINES, NEWSPAPERS, SOFTWARE AND ELECTRONIC PUBLICATIONS; EDITING AND PUBLISHING OF MULTIMEDIA CARRIERS, NAMELY, FILM EDITING, VIDEO AND INTERACTIVE VIDEO EDITING, MUSIC PUBLISHING, PUBLISHING OF ELECTRONIC PUBLICATIONS IN THE SCIENTIFIC AND MEDICAL FIELDS; PRODUCTION OF MULTIMEDIA PRESENTATIONS, NAMELY, AUDIO PRODUCTION, FILM, VIDEO AND INTERACTIVE VIDEO PRODUCTION, MULTIMEDIA SCIENTIFIC AND MEDICAL SOFTWARE PRODUCTION SERVICES; PUBLISHING OF BOOKS, JOURNALS, MAGAZINES AND WEB MAGAZINES IN THE FIELDS OF MEDICINE AND SURGERY; ELECTRONIC PUBLISHING OF NEWSPAPERS AND MANUALS IN THE FIELD OF MEDICINE AND SURGERY; EDUCATIONAL SERVICES, NAMELY, PROVIDING CLASSES, SEMINARS, CONFERENCES, WORKSHOPS IN THE MEDICAL FIELD; PUBLISHING, NAMELY, BOOK, MAGAZINE AND REVIEW PUBLISHING, DIGITAL VIDEO, AUDIO, AND MULTIMEDIA PUBLISHING SERVICES, SCIENTIFIC AND MEDICAL INTERACTIVE VIDEO PUBLISHING SERVICES (U.S. CLS. 100, 101 AND 107).

TINA BROWN, EXAMINING ATTORNEY

CLASS 42—SCIENTIFIC AND COMPUTER SERVICES

SN 75-872,849. K.A.O.S., INC., AUSTIN, TX. FILED 12-15-1999.

K.A.O.S.

FOR HAIR CUTTING AND BEAUTY SALON SERVICES FOR CHILDREN AND ADULTS (U.S. CLS. 100 AND 101).

FIRST USE 5-1-1997; IN COMMERCE 5-1-1997.

JILL C. ALT, EXAMINING ATTORNEY

CLASS 42—(Continued).

SN 76-219,121. SALEM, YOUSEF W., NEW ORLEANS, LA. FILED 3-3-2001.



NO CLAIM IS MADE TO THE EXCLUSIVE RIGHT TO USE "BREW PUB", "COCKTAILS", "DAIQUIRIS" AND "TROPICAL BAR", APART FROM THE MARK AS SHOWN.

THE DRAWING IS LINED FOR THE COLORS BROWN, BLUE, GREEN, RED, ORANGE, AND YELLOW.

FOR NIGHTCLUB AND BAR SERVICES (U.S. CLS. 100 AND 101).

FIRST USE 7-24-1997; IN COMMERCE 7-24-1997. JEFFERY COWARD, EXAMINING ATTORNEY

SN 76-691,619. ARLT TECHNOLOGIES, ELLENSBURG, WA. FILED 7-28-2008.

ATHGENICS

THE MARK CONSISTS OF STANDARD CHARACTERS WITHOUT CLAIM TO ANY PARTICULAR FONT, STYLE, SIZE, OR COLOR.

FOR GENETIC RESEARCH, DEVELOPMENT AND ANALYSIS IN THE FIELD OF KNOWN AND UNKNOWN DNA SEQUENCES THAT DETERMINE ATHLETIC ABILITIES FOR COMPETITIVE OR RECREATIONAL ATHLETIC EVENT PERFORMANCES IN HUMANS AND OTHER ANIMALS (U.S. CLS. 100 AND 101).

STEVEN R. FINE, EXAMINING ATTORNEY

SN 76-693,974. CARTOONIMATOR, SARASOTA, FL. FILED 11-3-2008.

CARTOONIMATOR

THE MARK CONSISTS OF STANDARD CHARACTERS WITHOUT CLAIM TO ANY PARTICULAR FONT, STYLE, SIZE, OR COLOR.

FOR PROVIDING TEMPORARY USE OF ON LINE NON-DOWNLOADABLE SOFTWARE FOR CREATING CARTOONS AND ANIMATION (U.S. CLS. 100 AND 101).

MELVIN AXILBUND, EXAMINING ATTORNEY

CLASS 42—(Continued).

SN 76-694,810. SOLEIMANPOUR, ANDISHE, SHERMAN OAKS, CA. FILED 12-15-2008.



NO CLAIM IS MADE TO THE EXCLUSIVE RIGHT TO USE "STICKER", APART FROM THE MARK AS SHOWN.

FOR GRAPHIC DESIGN SERVICES IN THE AUTOMOTIVE FIELD OF LARGE FORMAT VINYL GRAPHICS AND PAINT PROTECTION FILMS (U.S. CLS. 100 AND 101).

FIRST USE 9-8-2000; IN COMMERCE 9-8-2000. MICHAEL ENGEL, EXAMINING ATTORNEY

SN 77-189,079. CONSULTING & ENGINEERING FOR NEXT GENERATION NETWORKS, INC., COLUMBIA, MD. FILED 5-24-2007.



THE COLOR(S) BLUE AND WHITE IS/ARE CLAIMED AS A FEATURE OF THE MARK.

THE MARK CONSISTS OF A ZOOMED-IN, BIRD'S EYE PARTIAL VIEW OF A SLANTED WHITE SPIRAL WHICH CIRCLES IN AN ORBIT FASHION ON A BACKGROUND OF BLUE. THE WHITE SPIRAL IS ROUGH EDGED, AND IS WIDE AT THE OUTER RIM OF THE SPIRAL, AND THINS AS THE SPIRAL TIGHTENS TOWARDS A CENTER.

FOR PROVIDING PLANNING AND ENGINEERING SERVICES IN THE FIELD OF INFORMATION AND COMMUNICATIONS NETWORKS (U.S. CLS. 100 AND 101).

FIRST USE 12-15-2000; IN COMMERCE 12-15-2000. STEPHEN AQUILA, EXAMINING ATTORNEY

CLASS 42—(Continued).

SN 77-291,771. NATIONAL BOARD OF ECHOCARDIOGRAPHY, INC., RALEIGH, NC. FILED 9-28-2007.

NATIONAL BOARD OF
ECHOCARDIOGRAPHY, INC.

THE MARK CONSISTS OF STANDARD CHARACTERS WITHOUT CLAIM TO ANY PARTICULAR FONT, STYLE, SIZE, OR COLOR.

NO CLAIM IS MADE TO THE EXCLUSIVE RIGHT TO USE "BOARD OF ECHOCARDIOGRAPHY, INC.", APART FROM THE MARK AS SHOWN.

SEC. 2(F).
FOR TESTING, ANALYSIS AND EVALUATION OF THE SKILLS, KNOWLEDGE AND COMPETENCE OF PHYSICIANS FOR THE PURPOSE OF CERTIFICATION IN THE FIELD OF ECHOCARDIOGRAPHY (U.S. CLS. 100 AND 101).
FIRST USE 12-31-1999; IN COMMERCE 12-31-1999.
BILL DAWE, EXAMINING ATTORNEY

SN 77-332,021. ENLIVEN MARKETING TECHNOLOGIES CORPORATION, NEW YORK, NY. FILED 11-16-2007.

ENLIVEN

THE MARK CONSISTS OF STANDARD CHARACTERS WITHOUT CLAIM TO ANY PARTICULAR FONT, STYLE, SIZE, OR COLOR.

OWNER OF U.S. REG. NOS. 2,232,558 AND 2,497,451.
FOR PROVIDING TEMPORARY USE OF ON-LINE NON-DOWNLOADABLE SOFTWARE FOR THE PURPOSE OF CREATING, DELIVERING AND REPORTING ON ONLINE ADVERTISEMENTS, RICH MEDIA ADVERTISEMENTS AND ADVERTISING CAMPAIGNS; PROVISION OF ON-LINE NON-DOWNLOADABLE SOFTWARE FOR USE IN MEDIA PLANNING ASSISTANCE, ADVERTISING CAMPAIGN CREATION AND DELIVERY, CONTENT CREATION AND DATA REPORTING USED TO EVALUATE AND MONITOR ADVERTISING CAMPAIGN PERFORMANCE; COMPUTER SOFTWARE DESIGN SERVICES; INFORMATION TECHNOLOGY CONSULTING SERVICES; PROVISION OF WEBSITE DEVELOPMENT SERVICES (U.S. CLS. 100 AND 101).
CURTIS FRENCH, EXAMINING ATTORNEY

CLASS 42—(Continued).

SN 77-340,852. ORDAN THERMAL PRODUCTS LTD., MARKHAM, ONTARIO, CANADA, FILED 11-30-2007.

Man Discovered Fire, Ordan
Provides The Equipment To
Control It!

THE MARK CONSISTS OF STANDARD CHARACTERS WITHOUT CLAIM TO ANY PARTICULAR FONT, STYLE, SIZE, OR COLOR.

FOR TECHNICAL CONSULTATION AND SERVICES IN THE FIELD OF COMBUSTION HEATING AND TECHNOLOGY, NAMELY, ENGINEERING, DESIGN, TESTING AND EVALUATION FOR OTHERS OF BURNER SYSTEMS ON COMBUSTION HEAT PROCESSING EQUIPMENT OPERATING WITH HYDROCARBONS AND/OR OIL AS THE FUEL SOURCE (U.S. CLS. 100 AND 101).

FIRST USE 1-1-1985; IN COMMERCE 1-1-1985.
BARBARA GAYNOR, EXAMINING ATTORNEY

SN 77-406,889. BUILDING SCIENCE CORPORATION, SOMERVILLE, MA. FILED 2-26-2008.

Building Science
Corporation

THE MARK CONSISTS OF STANDARD CHARACTERS WITHOUT CLAIM TO ANY PARTICULAR FONT, STYLE, SIZE, OR COLOR.

NO CLAIM IS MADE TO THE EXCLUSIVE RIGHT TO USE "CORPORATION", APART FROM THE MARK AS SHOWN.

SEC. 2(F).
FOR THE PROVISION OF ARCHITECTURAL SERVICES AND CONSULTING IN THE FIELD OF ARCHITECTURE (U.S. CLS. 100 AND 101).
FIRST USE 1-2-1990; IN COMMERCE 4-28-1992.
SAIMA MAKHDOOM, EXAMINING ATTORNEY

SN 77-414,545. KIM, DANIEL, SAN ANTONIO, TX. FILED 3-6-2008.

ZEIA

THE MARK CONSISTS OF STANDARD CHARACTERS WITHOUT CLAIM TO ANY PARTICULAR FONT, STYLE, SIZE, OR COLOR.

THE WORDING "ZEIA" HAS NO MEANING IN A FOREIGN LANGUAGE.

FOR COMPUTER SERVICES, NAMELY, CREATING AN ON-LINE COMMUNITY FOR REGISTERED USERS TO PARTICIPATE IN DISCUSSIONS, GET FEEDBACK FROM THEIR PEERS, FORM VIRTUAL COMMUNITIES, AND ENGAGE IN SOCIAL NETWORKING (U.S. CLS. 100 AND 101).

JILL PRATER, EXAMINING ATTORNEY

CLASS 42—(Continued).

SN 77-442,037. INTERNATIONAL ASSET SYSTEMS LIMITED, HAMILTON, HM 12, BERMUDA, FILED 4-7-2008.

DISPATCHMANAGER ENVOY

THE MARK CONSISTS OF STANDARD CHARACTERS WITHOUT CLAIM TO ANY PARTICULAR FONT, STYLE, SIZE, OR COLOR.

NO CLAIM IS MADE TO THE EXCLUSIVE RIGHT TO USE "DISPATCH MANAGER", APART FROM THE MARK AS SHOWN.

FOR COMPUTER SERVICES, NAMELY, PROVIDING A WEB-BASED SYSTEM AND ONLINE PORTAL FOR CUSTOMERS TO REMOTELY MANAGE THE COLLECTION AND DELIVERY OF ASSETS IN TRANSIT, NAMELY, VEHICLES, TRAILERS, DRIVERS, CARGO AND DELIVERY CONTAINERS (U.S. CLS. 100 AND 101).
FIRST USE 11-12-2007; IN COMMERCE 11-12-2007.
BARBARA RUTLAND, EXAMINING ATTORNEY

SN 77-442,052. INTERNATIONAL ASSET SYSTEMS LIMITED, HAMILTON, HM 12, BERMUDA, FILED 4-7-2008.

DISPATCHMANAGER DRAY

THE MARK CONSISTS OF STANDARD CHARACTERS WITHOUT CLAIM TO ANY PARTICULAR FONT, STYLE, SIZE, OR COLOR.

NO CLAIM IS MADE TO THE EXCLUSIVE RIGHT TO USE "DISPATCH MANAGER", APART FROM THE MARK AS SHOWN.

FOR COMPUTER SERVICES, NAMELY, PROVIDING A WEB-BASED SYSTEM AND ONLINE PORTAL FOR CUSTOMERS TO REMOTELY MANAGE TRANSPORT ORDERS, DELIVERY SCHEDULES, AND INVOICING FOR THE TRANSPORT INDUSTRY (U.S. CLS. 100 AND 101).

FIRST USE 11-12-2007; IN COMMERCE 11-12-2007.
BARBARA RUTLAND, EXAMINING ATTORNEY

SN 77-462,289. WATSON, ELONDA ELISE, LOS ANGELES, CA. FILED 4-30-2008.

Thyck

THE MARK CONSISTS OF STANDARD CHARACTERS WITHOUT CLAIM TO ANY PARTICULAR FONT, STYLE, SIZE, OR COLOR.

FOR CUSTOM DESIGN OF PANTS/JEANS BASED ON PERSONAL SELECTIONS MADE BY THE CUSTOMER (U.S. CLS. 100 AND 101).

ALLISON HOLTZ, EXAMINING ATTORNEY

CLASS 42—(Continued).

SN 77-477,652. PRISON HEALTH SERVICES, INC., BRENTWOOD, TN. FILED 5-19-2008.



NO CLAIM IS MADE TO THE EXCLUSIVE RIGHT TO USE "CARE", APART FROM THE MARK AS SHOWN.

THE MARK CONSISTS OF THE WORDING "CATALYST" IN STYLIZED FORM, WITH THE "Y" OF "CATALYST" BEING FORMED BY THE DESIGN OF A STETHOSCOPE, AND BELOW THE WORD "CATALYST", THE WORDING "TRANSFORMING CARE" IN STYLIZED FORM.

FOR PROVIDING A WEBSITE FEATURING TEMPORARY USE OF NON-DOWNLOADABLE SOFTWARE FOR INPUTTING, MAINTAINING, REVIEWING, AND UTILIZING MEDICAL INFORMATION ABOUT PRISONERS, FOR USE BY HEALTHCARE PROVIDERS AT CORRECTIONAL FACILITIES (U.S. CLS. 100 AND 101).
FIRST USE 6-26-2007; IN COMMERCE 8-28-2007.

JORDAN BAKER, EXAMINING ATTORNEY

SN 77-485,946. URBACH, JULIAN M., SHERMAN OAKS, CA. FILED 5-29-2008.

OTOY

THE MARK CONSISTS OF STANDARD CHARACTERS WITHOUT CLAIM TO ANY PARTICULAR FONT, STYLE, SIZE, OR COLOR.

FOR SOFTWARE DESIGN AND DEVELOPMENT IN THE FIELD OF ARTIFICIAL INTELLIGENCE; PROVIDING SEARCH ENGINES FOR OBTAINING DATA ON A GLOBAL COMPUTER NETWORK; COMPUTER SERVICES, NAMELY, CREATING INDEXES OF INFORMATION, SITES AND OTHER RESOURCES AVAILABLE ON GLOBAL COMPUTER NETWORKS FOR OTHERS; CUSTOMIZED SEARCHING AT THE SPECIFIC REQUEST OF END USERS, ALLOWING THE END USER TO BROWSE AND RETRIEVE INFORMATION, SITES, AND OTHER RESOURCES AVAILABLE ON GLOBAL COMPUTER NETWORKS (U.S. CLS. 100 AND 101).

AMOS T. MATTHEWS, JR., EXAMINING ATTORNEY

CLASS 42—(Continued).

SN 77-497,633. UNIVERSITY OF SOUTH CAROLINA, CO-
LUMBIA, SC. FILED 6-12-2008.

SENIORSMART COMMUNITIES

THE MARK CONSISTS OF STANDARD CHARACTERS WITHOUT CLAIM TO ANY PARTICULAR FONT, STYLE, SIZE, OR COLOR.

FOR RESEARCH AND DEVELOPMENT OF PRODUCTS THAT ENABLE SENIOR CITIZENS TO MAINTAIN INTELLECTUAL ACTIVITY, BRAIN HEALTH AND MEMORY IN ORDER TO FACILITATE INDEPENDENT LIVING (U.S. CLS. 100 AND 101).

JOHN DALIER, EXAMINING ATTORNEY

SN 77-502,973. NOMIS SOLUTIONS, INC., SAN BRUNO, CA.
FILED 6-19-2008.

SmartRanges

THE MARK CONSISTS OF STANDARD CHARACTERS WITHOUT CLAIM TO ANY PARTICULAR FONT, STYLE, SIZE, OR COLOR.

FOR APPLICATION SERVICE PROVIDER (ASP) FEATURING COMPUTER SOFTWARE FOR THE ANALYSIS, OPTIMIZATION AND EXECUTION OF RETAIL BANKING AND FINANCING PRODUCTS AND SERVICES (U.S. CLS. 100 AND 101).

FIRST USE 10-1-2007; IN COMMERCE 10-1-2007.
GINA FINK, EXAMINING ATTORNEY

SN 77-507,406. DOMINION DIAGNOSTICS, L.C., NORTH KINGSTON, RI. FILED 6-25-2008.

LabSync

THE MARK CONSISTS OF STANDARD CHARACTERS WITHOUT CLAIM TO ANY PARTICULAR FONT, STYLE, SIZE, OR COLOR.

FOR PROVIDING TEMPORARY USE OF ONLINE NON-DOWNLOADABLE SOFTWARE FOR USE IN SYNCHRONIZING LABORATORY RESULTS WITH DOCTORS' RECORDS (U.S. CLS. 100 AND 101).

LAURA HAMMEL, EXAMINING ATTORNEY

CLASS 42—(Continued).

SN 77-509,781. QRI GROUP, LLC, HOUSTON, TX. FILED 6-27-2008.

ERA

THE MARK CONSISTS OF STANDARD CHARACTERS WITHOUT CLAIM TO ANY PARTICULAR FONT, STYLE, SIZE, OR COLOR.

FOR EXPERT SERVICES IN THE FIELD OF EFFICIENT EXTRACTION OF HYDROCARBON RESOURCES, NAMELY, COMPILING AND ANALYZING CRITICAL INFORMATION COVERING OIL AND GAS RESERVOIRS, NAMELY, FORMATION PROPERTIES, GEOLOGIC ATTRIBUTES, PRODUCTION HISTORIES, WELL DESIGN DETAILS AND PRODUCTION FACILITIES FORMATION (U.S. CLS. 100 AND 101).

JOHN GARTNER, EXAMINING ATTORNEY

SN 77-509,789. QRI GROUP, LLC, HOUSTON, TX. FILED 6-27-2008.

EXECUTIVE RESERVOIR ASSESSMENT

THE MARK CONSISTS OF STANDARD CHARACTERS WITHOUT CLAIM TO ANY PARTICULAR FONT, STYLE, SIZE, OR COLOR.

NO CLAIM IS MADE TO THE EXCLUSIVE RIGHT TO USE "RESERVOIR ASSESSMENT", APART FROM THE MARK AS SHOWN.

FOR EXPERT SERVICES IN THE FIELD OF EFFICIENT EXTRACTION OF HYDROCARBON RESOURCES, NAMELY, COMPILING AND ANALYZING CRITICAL INFORMATION COVERING OIL AND GAS RESERVOIRS, NAMELY, FORMATION PROPERTIES, GEOLOGIC ATTRIBUTES, PRODUCTION HISTORIES, WELL DESIGN DETAILS AND PRODUCTION FACILITIES FORMATION (U.S. CLS. 100 AND 101).

JOHN GARTNER, EXAMINING ATTORNEY

CLASS 42—(Continued).

SN 77-517,068. LYREK, INC., HOBOKEN, NJ. FILED 7-8-2008.



THE MARK CONSISTS OF A STYLIZED LOTUS FLOWER ABOVE THE STYLIZED WORD "LYREK".

FOR COMPUTER SOFTWARE FOR MANAGING CONTACT AND EVENTS, NAMELY, PROVIDING TEMPORARY USE OF ONLINE NON-DOWNLOADABLE SOFTWARE FOR USE IN EVENT PLANNING AND PRODUCTION THAT PROVIDES CONTACT MANAGEMENT, SEATING ASSIGNMENTS AND MANAGEMENT, RSVP MANAGEMENT AND CUSTOMIZATION OF E-MAILS AND MAILINGS (U.S. CLS. 100 AND 101).

FIRST USE 8-1-2004; IN COMMERCE 8-1-2004.
LINDA POWELL, EXAMINING ATTORNEY

CLASS 42—(Continued).

SN 77-527,867. MAJESTIC MOUNTAIN ENTERTAINMENT, LLC, FALMOUTH, ME. FILED 7-22-2008.

SOAR HIGHER

THE MARK CONSISTS OF STANDARD CHARACTERS WITHOUT CLAIM TO ANY PARTICULAR FONT, STYLE, SIZE, OR COLOR.

FOR HOSTING AN ONLINE COMMUNITY WEB SITE FEATURING INTERACTIVE GAMES FOR CHILDREN (U.S. CLS. 100 AND 101).

AISHA SALEM, EXAMINING ATTORNEY

SN 77-527,965. ALLAN COWEN, MISSISSAUGA, CANADA,
FILED 7-22-2008.

SN 77-524,096. TRADINGSCREEN, INC., NEW YORK, NY.
FILED 7-16-2008.

Risk-in-a-Box

Trumpire

THE MARK CONSISTS OF STANDARD CHARACTERS WITHOUT CLAIM TO ANY PARTICULAR FONT, STYLE, SIZE, OR COLOR.

FOR PROVIDING ONLINE TOOLS IN THE NATURE OF NON-DOWNLOADABLE SOFTWARE TOOLS FOR USE IN ASSESSING RISK WHEN EXECUTING FINANCIAL TRADES; PROVIDING TEMPORARY USE OF NON-DOWNLOADABLE COMPUTER SOFTWARE FOR ASSESSING RISK WHEN EXECUTING FINANCIAL TRADES (U.S. CLS. 100 AND 101).

YAT SYE, LEE, EXAMINING ATTORNEY

THE MARK CONSISTS OF STANDARD CHARACTERS WITHOUT CLAIM TO ANY PARTICULAR FONT, STYLE, SIZE, OR COLOR.

FOR COMPUTER SERVICES, NAMELY, PROVIDING A WEB-BASED VIRTUAL ON-LINE COMMUNITY FOR REGISTERED USERS TO PARTICIPATE IN THE LIFE STYLE AND VIRTUAL WORLD OF THE RICH AND FAMOUS, AND TO DISCUSS AND GET FEEDBACK FROM OTHER REGISTERED USERS THAT INCLUDE PROFESSIONALS IN THE BUSINESS, CORPORATE AND ENTERTAINMENT FIELDS (U.S. CLS. 100 AND 101).

SOPHIA S. KIM, EXAMINING ATTORNEY

CLASS 42—(Continued).

SN 77-538,339. DOCTATIONS, INC., GARDEN CITY, NY.
FILED 8-4-2008.

WiPP Web Integrated Physician Practice

THE MARK CONSISTS OF STANDARD CHARACTERS WITHOUT CLAIM TO ANY PARTICULAR FONT, STYLE, SIZE, OR COLOR.

NO CLAIM IS MADE TO THE EXCLUSIVE RIGHT TO USE "WEB INTEGRATED PHYSICIAN PRACTICE", APART FROM THE MARK AS SHOWN.

FOR APPLICATION SERVICE PROVIDER (ASP) FEATURING SOFTWARE FOR USE IN INTEGRATING PHYSICIANS IN GEOGRAPHICALLY DISTINCT OFFICES INTO A SINGLE GROUP USING MODERN WEB TECHNOLOGIES; PROVIDING A WEB SITE FOR USE BY PHYSICIANS TO GENERATE, MANAGE AND EXCHANGE MEDICAL INFORMATION AND DOCUMENTS REGARDLESS OF MEDICAL ORGANIZATION OR GEOGRAPHIC LOCATION; PROVIDING ON-LINE NON-DOWNLOADABLE SOFTWARE FOR INTEGRATING PHYSICIANS IN GEOGRAPHICALLY DISTINCT OFFICES INTO A SINGLE GROUP USING MODERN WEB TECHNOLOGIES; PROVIDING TEMPORARY USE OF ON-LINE NON-DOWNLOADABLE SOFTWARE FOR INTEGRATING PHYSICIANS IN GEOGRAPHICALLY DISTINCT OFFICES INTO A SINGLE GROUP USING MODERN WEB TECHNOLOGIES (U.S. CLS. 100 AND 101).

JILL C. ALT, EXAMINING ATTORNEY

SN 77-541,844. THE MCGRAW-HILL COMPANIES, INC.,
NEW YORK, NY. FILED 8-7-2008.

BUSINESS AS A SECOND LANGUAGE

THE MARK CONSISTS OF STANDARD CHARACTERS WITHOUT CLAIM TO ANY PARTICULAR FONT, STYLE, SIZE, OR COLOR.

FOR PROVIDING TEMPORARY USE OF ON-LINE NON-DOWNLOADABLE SOFTWARE, NAMELY, EDUCATIONAL TESTING AND ASSESSMENT SOFTWARE FOR THE IMPROVEMENT AND DEVELOPMENT OF ENGLISH LANGUAGE SKILLS (U.S. CLS. 100 AND 101).

AISHA SALEM, EXAMINING ATTORNEY

CLASS 42—(Continued).

SN 77-547,576. HYDE ENGINEERING + CONSULTING,
FORMERLY JM HYDE CONSULTING, INC., BOULDER,
CO. FILED 8-14-2008.



NO CLAIM IS MADE TO THE EXCLUSIVE RIGHT TO USE "ENGINEERING + CONSULTING", APART FROM THE MARK AS SHOWN.

THE COLOR(S) RED, WHITE AND BLACK IS/ARE CLAIMED AS A FEATURE OF THE MARK.

THE COLOR RED APPEARS AS A SOLID CIRCLE CONTAINING THE LETTER "H" IN THE COLOR WHITE. THE COLOR BLACK APPEARS ON THE WORDING "HYDE" IN LARGE FONT TO THE RIGHT OF THE RED CIRCLE AND ON THE WORDING "ENGINEERING + CONSULTING" IN SMALL FONT AT THE BOTTOM.

FOR COMPLIANCE ENGINEERING (U.S. CLS. 100 AND 101).

FIRST USE 8-1-2008; IN COMMERCE 8-1-2008.

SANDRA MANIOS, EXAMINING ATTORNEY

SN 77-548,599. CERCIS CONSULTING, LLC, GASTON, OR.
FILED 8-15-2008.

CERCIS

THE MARK CONSISTS OF STANDARD CHARACTERS WITHOUT CLAIM TO ANY PARTICULAR FONT, STYLE, SIZE, OR COLOR.

FOR NON DOWNLOADABLE WEB-BASED PROJECT SOFTWARE IN THE FIELD OF PROJECT MANAGEMENT (U.S. CLS. 100 AND 101).

JACQUELINE A. LAVINE, EXAMINING ATTORNEY

SN 77-548,607. CERCIS CONSULTING, LLC, GASTON, OR.
FILED 8-15-2008.

PROGRESSIVE IMPLEMENTATION

THE MARK CONSISTS OF STANDARD CHARACTERS WITHOUT CLAIM TO ANY PARTICULAR FONT, STYLE, SIZE, OR COLOR.

FOR NON DOWNLOADABLE WEB-BASED PROJECT SOFTWARE IN THE FIELD OF PROJECT MANAGEMENT (U.S. CLS. 100 AND 101).

JACQUELINE A. LAVINE, EXAMINING ATTORNEY

CLASS 42—(Continued).

SN 77-548,715. MIC ELECTRONICS LIMITED, HYDERABAD, INDIA, FILED 8-16-2008.

MIC Electronics

THE MARK CONSISTS OF STANDARD CHARACTERS WITHOUT CLAIM TO ANY PARTICULAR FONT, STYLE, SIZE, OR COLOR.

NO CLAIM IS MADE TO THE EXCLUSIVE RIGHT TO USE "ELECTRONICS", APART FROM THE MARK AS SHOWN.

FOR RESEARCH AND DEVELOPMENT AND CONSULTATION RELATED THERETO IN THE FIELD OF LIGHT EMITTING DIODE (LED) VIDEO DISPLAYS AND LIGHT EMITTING DIODE (LED) LIGHTING; RESEARCH AND DEVELOPMENT OF NEW PRODUCTS; SCIENTIFIC RESEARCH AND DEVELOPMENT (U.S. CLS. 100 AND 101).

FIRST USE 10-30-2000; IN COMMERCE 11-15-2000.
JESSICA A. POWERS, EXAMINING ATTORNEY

SN 77-549,042. G&H ASSOCIATES, INC., TYLER, TX. FILED 8-18-2008.



ASSOCIATES, INC.

NO CLAIM IS MADE TO THE EXCLUSIVE RIGHT TO USE "ASSOCIATES, INC.", APART FROM THE MARK AS SHOWN.

THE COLOR(S) BLACK, WHITE AND BLUE IS/ARE CLAIMED AS A FEATURE OF THE MARK.

THE MARK CONSISTS OF THE GRAPHIC LOGO CONSISTING OF A STYLIZED BLUE FLAME WITH WHITE INTERIOR AND BLACK DROPLET WITH UPPERCASE "G&H" OVERLAY IN WHITE LETTERING WITH BLACK OUTLINE. "ASSOCIATES, INC". IS SPELLED OUT IN BLACK UPPERCASE LETTERING DIRECTLY BENEATH THE LOGO AND IS CONSIDERED A PART THEREOF.

FOR EXPLORATION AND SEARCHING OF OIL AND GAS (U.S. CLS. 100 AND 101).

FIRST USE 7-1-1994; IN COMMERCE 7-1-1994.
WILLIAM P. SHANAHAN, EXAMINING ATTORNEY

CLASS 42—(Continued).

SN 77-561,264. KOLO LLC, HARTFORD, CT. FILED 9-3-2008.

MY KOLO ALBUM

THE MARK CONSISTS OF STANDARD CHARACTERS WITHOUT CLAIM TO ANY PARTICULAR FONT, STYLE, SIZE, OR COLOR.

OWNER OF U.S. REG. NOS. 2,356,171, 2,480,117 AND 3,307,673.

NO CLAIM IS MADE TO THE EXCLUSIVE RIGHT TO USE "ALBUM", APART FROM THE MARK AS SHOWN.

FOR PROVIDING ONLINE NON-DOWNLOADABLE SOFTWARE FOR CREATING AN ALBUM OF DIGITAL IMAGES AND/OR PHOTOGRAPHS (U.S. CLS. 100 AND 101).

FIRST USE 9-0-2007; IN COMMERCE 9-0-2007.

MARGARET POWER, EXAMINING ATTORNEY

SN 77-562,053. KOLO LLC, HARTFORD, CT. FILED 9-4-2008.

ALBUM BAR

THE MARK CONSISTS OF STANDARD CHARACTERS WITHOUT CLAIM TO ANY PARTICULAR FONT, STYLE, SIZE, OR COLOR.

NO CLAIM IS MADE TO THE EXCLUSIVE RIGHT TO USE "ALBUM", APART FROM THE MARK AS SHOWN.

FOR PROVIDING DESIGN SERVICES FOR OTHERS IN THE FIELD OF CREATING AN ALBUM OF DIGITAL IMAGES OR PHOTOGRAPHS; PROVIDING ON-LINE NON-DOWNLOADABLE SOFTWARE FOR CREATING AN ALBUM OF DIGITAL IMAGES OR PHOTOGRAPHS (U.S. CLS. 100 AND 101).

MARGARET POWER, EXAMINING ATTORNEY

SN 77-564,877. IDENTRUST, INC., SAN FRANCISCO, CA. FILED 9-8-2008.

TRUST LINK

THE MARK CONSISTS OF STANDARD CHARACTERS WITHOUT CLAIM TO ANY PARTICULAR FONT, STYLE, SIZE, OR COLOR.

NO CLAIM IS MADE TO THE EXCLUSIVE RIGHT TO USE "LINK", APART FROM THE MARK AS SHOWN.

FOR COMPUTER SERVICES, NAMELY, PROVIDING LEGALLY-BINDING ELECTRONIC PAYMENT INSTRUCTION SIGNING SERVICES USING DIGITAL CERTIFICATES AND PROVIDING DIGITAL SIGNATURE VERIFICATION, AUTHENTICATION OF SIGNER IDENTITY, AND DATA ENCRYPTION AND RELATED PUBLIC KEY INFRASTRUCTURE TO FACILITATE AUTHORIZATION COMMUNICATION BETWEEN A COMMERCIAL ENTITY AND ITS FINANCIAL INSTITUTION(S) (U.S. CLS. 100 AND 101).

DAVID C. REIHNER, EXAMINING ATTORNEY

CLASS 42—(Continued).

SN 77-567,764. HOSTOPIA.COM INC., FORT LAUDERDALE, FL. FILED 9-11-2008.

ANNOUNCER

THE MARK CONSISTS OF STANDARD CHARACTERS WITHOUT CLAIM TO ANY PARTICULAR FONT, STYLE, SIZE, OR COLOR.

FOR PROVIDING TEMPORARY USE OF ONLINE SOFTWARE TO CREATE, MANAGE AND DELIVER NEWSLETTERS VIA EMAIL (U.S. CLS. 100 AND 101).

FIRST USE 4-30-2007; IN COMMERCE 4-30-2007.

LINDA MICKLEBURGH, EXAMINING ATTORNEY

SN 77-570,187. ACADEMY ONDEMAND, LLC, COLORADO SPRINGS, CO. FILED 9-15-2008.

Academy OnDemand

THE MARK CONSISTS OF STANDARD CHARACTERS WITHOUT CLAIM TO ANY PARTICULAR FONT, STYLE, SIZE, OR COLOR.

NO CLAIM IS MADE TO THE EXCLUSIVE RIGHT TO USE "ONDEMAND", APART FROM THE MARK AS SHOWN.

FOR APPLICATION SERVICE PROVIDER (ASP) FEATURING SOFTWARE FOR USE IN BACKOFFICE MANAGEMENT, NAMELY, DATA COLLECTION, MANIPULATION AND REPORTING ON STUDENT INFORMATION, FINANCIAL INFORMATION, HUMAN RESOURCES INFORMATION, TRANSPORTATION ASSETS AND SCHEDULING, PROJECT MANAGEMENT, PAYROLL INFORMATION, AND BENEFITS INFORMATION, ALL IN THE FIELD OF EDUCATION; COMPUTER SOFTWARE DEVELOPMENT IN THE FIELD OF EDUCATION (U.S. CLS. 100 AND 101).

FIRST USE 9-14-2007; IN COMMERCE 3-10-2008.

LINDSEY RUBIN, EXAMINING ATTORNEY

CLASS 42—(Continued).

SN 77-572,164. COMMAND C DESIGN, LLC, BROOKLYN, NY. FILED 9-17-2008.



THE STIPPLING IS FOR SHADING PURPOSES ONLY. THE MARK CONSISTS OF A SYMBOL WITH THE LETTER "C" INTERSECTING IT IN THE CENTER. THE SYMBOL IS 4 PETAL-LIKE SHAPES COMING OUT EQUIDISTANT FROM ONE ANOTHER, AROUND THE "C", AND A SILHOUETTE OF A RABBIT STANDING ON ITS TWO HIND LEGS TO THE RIGHT, WITH ONE OF ITS PAWS RESTING ON THE TOP, RIGHT SIDE OF THE SYMBOL AND TO THE LEFT OF THE SYMBOL IS THE WORD "COMMAND".

FOR WEB SITE DESIGN, COMPUTER SOFTWARE DESIGN, GRAPHIC DESIGN; COMPUTER SERVICES, NAMELY, SEARCH ENGINE OPTIMIZATION AND WEB SITE HOSTING SERVICES (U.S. CLS. 100 AND 101).

FIRST USE 1-1-2007; IN COMMERCE 1-1-2007.

MARK T. MULLEN, EXAMINING ATTORNEY

SN 77-578,126. SPRINGER-VERLAG GMBH, HEIDELBERG, FED REP GERMANY, FILED 9-24-2008.

SPRINGERLINK

THE MARK CONSISTS OF STANDARD CHARACTERS WITHOUT CLAIM TO ANY PARTICULAR FONT, STYLE, SIZE, OR COLOR.

PRIORITY CLAIMED UNDER SEC. 44(D) ON FED REP GERMANY APPLICATION NO. 302008061013, FILED 9-18-2008.

OWNER OF U.S. REG. NOS. 3,113,379, 3,371,631 AND OTHERS.

FOR PROVIDING ON-LINE, SEARCHABLE, INTERACTIVE DATABASES IN THE FIELDS OF TECHNOLOGY, SCIENTIFIC RESEARCH, SCIENCE, AND MEDICINE, FEATURING SCIENTIFIC RESEARCH, TECHNOLOGY, PUBLICATIONS, SCIENTIFIC AND TECHNOLOGICAL INFORMATION AND OTHER PERTINENT CONTENT RELATING TO SUCH RESEARCH, TECHNOLOGY, PUBLICATIONS, AND PLANS FOR THE DESIGN AND IMPLEMENTATION OF LABORATORY EXPERIMENTS, ALL RELATING TO THE LIFE, BIOLOGIC, MOLECULAR, BIOTECHNICAL, BIOMEDICAL SCIENCES, EARTH, PHYSICAL, MATHEMATICAL, MEDICAL, SOCIAL SCIENCES, AND ENGINEERING, AND TECHNOLOGIES RELATED THERETO (U.S. CLS. 100 AND 101).

FIRST USE 1-0-2003; IN COMMERCE 1-0-2003.

PAUL MORENO, EXAMINING ATTORNEY

CLASS 42—(Continued).

SN 77-578,148. SPRINGER-VERLAG GMBH, HEIDELBERG, FED REP GERMANY, FILED 9-24-2008.

SPRINGER

THE MARK CONSISTS OF STANDARD CHARACTERS WITHOUT CLAIM TO ANY PARTICULAR FONT, STYLE, SIZE, OR COLOR.

PRIORITY CLAIMED UNDER SEC. 44(D) ON FED REP GERMANY APPLICATION NO. 302008061015, FILED 9-18-2008.

OWNER OF U.S. REG. NOS. 3,118,657, 3,371,631 AND OTHERS.

FOR PROVIDING ON-LINE, SEARCHABLE, INTERACTIVE DATABASES IN THE FIELDS OF TECHNOLOGY, SCIENTIFIC RESEARCH, SCIENCE, AND MEDICINE, FEATURING SCIENTIFIC RESEARCH, TECHNOLOGY, PUBLICATIONS, SCIENTIFIC AND TECHNOLOGICAL INFORMATION AND OTHER PERTINENT CONTENT RELATING TO SUCH RESEARCH, TECHNOLOGY, PUBLICATIONS, AND PLANS FOR THE DESIGN AND IMPLEMENTATION OF LABORATORY EXPERIMENTS, ALL RELATING TO THE LIFE, BIOLOGIC, MOLECULAR, BIOTECHNICAL, BIOMEDICAL SCIENCES, EARTH, PHYSICAL, MATHEMATICAL, MEDICAL, SOCIAL SCIENCES, AND ENGINEERING, AND TECHNOLOGIES RELATED THERETO (U.S. CLS. 100 AND 101).

FIRST USE 1-0-2003; IN COMMERCE 1-0-2003.
PAUL MORENO, EXAMINING ATTORNEY

SN 77-581,424. STAR HINTS, INC., DBA DREEMEE, SAN JOSE, CA. FILED 9-29-2008.

DreeMee

THE MARK CONSISTS OF STANDARD CHARACTERS WITHOUT CLAIM TO ANY PARTICULAR FONT, STYLE, SIZE, OR COLOR.

FOR COMPUTER SERVICES, NAMELY, CREATING AN ON-LINE COMMUNITY FOR REGISTERED USERS TO PARTICIPATE IN DISCUSSIONS, GET FEEDBACK FROM THEIR PEERS, FORM VIRTUAL COMMUNITIES, AND ENGAGE IN SOCIAL NETWORKING BASED ON A THEME OF DREAM SHARING AND INTERPRETATION (U.S. CLS. 100 AND 101).

FIRST USE 4-4-2008; IN COMMERCE 4-4-2008.
ROBIN MITTLER, EXAMINING ATTORNEY

CLASS 42—(Continued).

SN 77-585,161. ENERCOM, INC., EAST POINT, GA. FILED 10-3-2008.

Water Depot

THE MARK CONSISTS OF STANDARD CHARACTERS WITHOUT CLAIM TO ANY PARTICULAR FONT, STYLE, SIZE, OR COLOR.

OWNER OF U.S. REG. NO. 2,273,127.

NO CLAIM IS MADE TO THE EXCLUSIVE RIGHT TO USE "WATER", APART FROM THE MARK AS SHOWN.

FOR PROVIDING ON-LINE NON-DOWNLOADABLE SOFTWARE FOR FOR THE PURPOSE OF PERFORMING HOME AND/OR BUSINESS WATER AUDITS WHICH ANALYZE CURRENT WATER USE, IDENTIFY WATER SAVING OPPORTUNITIES, AND PROVIDE GENERAL WATER CONSERVATION INFORMATION (U.S. CLS. 100 AND 101).

FIRST USE 3-1-1999; IN COMMERCE 3-1-1999.
KELLEY WELLS, EXAMINING ATTORNEY

SN 77-601,625. OLDCOMMUGUY - TIMOTHY A. O' NEILL, ROSWELL, GA. FILED 10-27-2008.

Oldcommguy

THE MARK CONSISTS OF STANDARD CHARACTERS WITHOUT CLAIM TO ANY PARTICULAR FONT, STYLE, SIZE, OR COLOR.

THE PSEUDONYM "OLDCOMMUGUY" IDENTIFIES A LIVING INDIVIDUAL WHOSE CONSENT IS OF RECORD. SEC. 2(F).

FOR CONSULTING IN THE FIELD OF INFORMATION TECHNOLOGY; CONSULTING IN THE FIELD OF TELECOMMUNICATIONS TECHNOLOGY (U.S. CLS. 100 AND 101).

FIRST USE 3-1-2006; IN COMMERCE 5-15-2007.
LIEF MARTIN, EXAMINING ATTORNEY

SN 77-603,336. QTEEK, INC., DBA APPOINTMENTBOARD, NORTH ATTLEBORO, MA. FILED 10-29-2008.



NO CLAIM IS MADE TO THE EXCLUSIVE RIGHT TO USE "APPOINTMENT BOARD", APART FROM THE MARK AS SHOWN.

THE COLOR(S) BROWN, PINK, BLUE, WHITE, AND GREEN IS/ARE CLAIMED AS A FEATURE OF THE MARK. THE MARK CONSISTS OF OF THE WORDING "APPOINTMENT BOARD" ACCOMPANIED BY A DESIGN

CLASS 42—(Continued).

ELEMENT COMPRISED OF THREE EQUIDISTANT VERTICAL LINES AND THREE EQUIDISTANT HORIZONTAL LINES WHICH INTERSECT AND FORM A GRID WITH FOUR QUADRANTS. ALL OF THE INTERSECTING LINES HAVE ROUNDED EDGES. THE DESIGN ELEMENT IS ON THE LEFT AND THE WORDING IS ON THE RIGHT. THE WORDING "APPOINTMENT BOARD" USES STYLIZED BLOCK LETTERING WITH ROUNDED EDGES. THE WORDING IS SPLIT ONTO TWO LINES WITH "APPOINTMENT" ON TOP AND "BOARD" UNDERNEATH. THE TOP OF THE TEXT "APPOINTMENT" IS ALIGNED WITH THE TOP OF THE GRID DESIGN TO ITS LEFT. THE BOTTOM OF THE TEXT "BOARD" IS ALIGNED WITH THE BOTTOM OF THE GRID DESIGN TO ITS LEFT. THE WORDING "APPOINTMENT BOARD" AND THE INTERSECTING VERTICAL AND HORIZONTAL LINES ARE DARK BROWN. THE COLOR BLUE APPEARS IN THE UPPER LEFT QUADRANT OF THE GRID. THE COLOR GREEN APPEARS IN THE UPPER RIGHT QUADRANT OF THE GRID. THE COLOR PINK APPEARS IN THE LOWER RIGHT QUADRANT OF THE GRID. THE COLOR WHITE APPEARS IN THE LOWER LEFT QUADRANT OF THE GRID.

FOR PROVIDING ON-LINE NON-DOWNLOADABLE SOFTWARE FOR SEARCHING FOR APPOINTMENTS, SCHEDULING APPOINTMENTS, CLIENT TRACKING, RECORD KEEPING, AND OFFICE COMMUNICATIONS (U.S. CLS. 100 AND 101).

FIRST USE 4-1-2008; IN COMMERCE 10-1-2008.
NELSON SNYDER, EXAMINING ATTORNEY

CLASS 42—(Continued).

SN 77-604,294. ALPINE ELECTRONICS, INC., TOKYO, JAPAN, FILED 10-30-2008.

ROCK THE DASH

THE MARK CONSISTS OF STANDARD CHARACTERS WITHOUT CLAIM TO ANY PARTICULAR FONT, STYLE, SIZE, OR COLOR.

FOR COMPUTER SERVICES, NAMELY, CREATING AN ON-LINE COMMUNITY FOR REGISTERED USERS TO UPLOAD MUSIC, VOTE ON FAVORITE MUSIC, PARTICIPATE IN AN ON-LINE MUSIC COMMUNITY, AND WIN PRIZES BASED ON VOTING FOR ONE OR MORE FAVORITE SONGS (U.S. CLS. 100 AND 101).

RENEE MCCRAY, EXAMINING ATTORNEY

SN 77-608,089. NOVA DATACOM, LLC, STERLING, VA, FILED 11-5-2008.

Security is in our DNA

THE MARK CONSISTS OF STANDARD CHARACTERS WITHOUT CLAIM TO ANY PARTICULAR FONT, STYLE, SIZE, OR COLOR.

FOR CONSULTING SERVICES TO BUSINESS AND GOVERNMENT CLIENTS IN THE FIELD OF INFORMATION TECHNOLOGY SECURITY (U.S. CLS. 100 AND 101).

DAVID TAYLOR, EXAMINING ATTORNEY

SN 77-603,338. GEOLEARNING, INC., WEST DES MOINES, IA, FILED 10-29-2008.

GEO ON-DEMAND

THE MARK CONSISTS OF STANDARD CHARACTERS WITHOUT CLAIM TO ANY PARTICULAR FONT, STYLE, SIZE, OR COLOR.

OWNER OF U.S. REG. NO. 2,396,191.

NO CLAIM IS MADE TO THE EXCLUSIVE RIGHT TO USE "ON-DEMAND", APART FROM THE MARK AS SHOWN.

FOR PROVIDING AN E-LEARNING DELIVERY PLATFORM IN THE NATURE OF ONLINE NON-DOWNLOADABLE COMPUTER SOFTWARE FOR ONLINE BUSINESS TRAINING IN THE FIELDS OF HUMAN RESOURCES, REGULATORY COMPLIANCE AND SAFETY, BUSINESS MANAGEMENT, AND OPERATION OF SPREADSHEET, DATABASE, PRESENTATION AND WORD PROCESSING SOFTWARE (U.S. CLS. 100 AND 101).

FIRST USE 10-27-2008; IN COMMERCE 10-27-2008.
NELSON SNYDER, EXAMINING ATTORNEY

SN 77-614,168. NUORTHO SURGICAL, INC., FALL RIVER, MA, FILED 11-13-2008.

NUORTHO

THE MARK CONSISTS OF STANDARD CHARACTERS WITHOUT CLAIM TO ANY PARTICULAR FONT, STYLE, SIZE, OR COLOR.

THE WORDING "NUORTHO" HAS NO MEANING IN A FOREIGN LANGUAGE.

FOR RESEARCH AND DEVELOPMENT FOR MEDICAL DEVICES FOR TISSUE PRESERVATION SURGERY AND ELECTROSURGERY, NAMELY, PROBES FOR MEDICAL PURPOSES, PROBES FOR MEDICAL PURPOSES FOR TESTING INTERSTITIAL FLUID FROM BONE, CATHETERS, ELECTRODES, INTERFACES FOR MEDICAL DEVICES AND POWER SUPPLIES FOR THE ELECTRODES (U.S. CLS. 100 AND 101).

SIMON TENG, EXAMINING ATTORNEY

CLASS 42—(Continued).

SN 77-628,673. BRIAN WOLFSON, HADDONFIELD, NJ. AND ROBERT MAYO, HADDONFIELD, NJ. FILED 12-8-2008.

MAYWOLF

THE MARK CONSISTS OF STANDARD CHARACTERS WITHOUT CLAIM TO ANY PARTICULAR FONT, STYLE, SIZE, OR COLOR.

FOR INFORMATION TECHNOLOGY CONSULTING SERVICES, NAMELY, COMPUTER TECHNOLOGY STRATEGY, COMPUTER TECHNOLOGY ANALYSIS AND COMPUTER TECHNOLOGY ASSESSMENTS; INFORMATION TECHNOLOGY MANAGEMENT SERVICES, NAMELY, TECHNOLOGY MANAGEMENT AND DATA MANAGEMENT; PROJECT MANAGEMENT SERVICES IN THE FIELDS OF INFORMATION SYSTEMS DESIGN AND SPECIFICATIONS, AND INFORMATION TECHNOLOGY IMPLEMENTATION, NAMELY, IMPLEMENTATION AND INTEGRATION OF COMPUTER HARDWARE AND SOFTWARE FOR OTHERS (U.S. CLS. 100 AND 101).
JEFFREY LOOK, EXAMINING ATTORNEY

CLASS 42—(Continued).

RIGHT SIDE TO ORANGE ON HIS HEAD AND LEFT SIDE. THE WORDS "BUILDING LIVES THROUGH BUILDING BRIDGES" APPEARS IN BLACK PRINT RUNNING BELOW THEIR FEET. ABOVE THE GLOBE DESIGN IS THE WORDING "GANG OF HOPE" WITH THE LETTER "G" IN RED, "AN" IN LAVENDER, THE SECOND LETTER "G" IN PURPLE, THE LETTER "O" IN DARK BLUE AND THE LETTER "F" IN LIGHT BLUE, THE LETTER "H" IN DARK GREEN, THE LETTER "O" IN LIGHT GREEN AND THE LETTERS "PE" IN ORANGE.

FOR COMPUTER SERVICES, NAMELY, CREATING AN ON-LINE COMMUNITY FOR REGISTERED USERS TO PARTICIPATE IN DISCUSSIONS, GET FEEDBACK FROM THEIR PEERS, FORM VIRTUAL COMMUNITIES, AND ENGAGE IN SOCIAL NETWORKING (U.S. CLS. 100 AND 101).

FIRST USE 6-5-2006; IN COMMERCE 11-11-2008.

JEFFREY LOOK, EXAMINING ATTORNEY

SN 77-634,327. HELPEACHOTHER CORP., SAN RAFAEL, CA. FILED 12-16-2008.

SN 77-632,593. SILVA MIRZOIAN, BEVERLY HILLS, CA. FILED 12-13-2008.



THE COLOR(S) DARK BLUE, LIGHT BLUE, WHITE, RED, BLACK, LAVENDER, PURPLE, GREEN, LIME GREEN, ORANGE IS/ARE CLAIMED AS A FEATURE OF THE MARK.

THE MARK CONSISTS OF 2 INTERLOCKING CIRCLES IN BLUE AND WHITE CONTAINING THE MAP OF THE WORLD WITH THE WESTERN HEMISPHERE FEATURED ON THE LEFT CIRCLE AND THE EASTERN HEMISPHERE SHOWN ON THE RIGHT CIRCLE. THE OUTLINE OF THE CIRCLES AND THE CONTINENTS ON THE MAP ARE IN BLUE WITH THE OCEANS IN WHITE. SUPERIMPOSED ACROSS THE MIDDLE OF THE CIRCLES IS A SET OF STYLIZED YOUNG AND OLD PEOPLE IN DIFFERENT SHADES OF COLOR HOLDING HANDS ACROSS THE GLOBE ATOP. THE COLORS OF THE PEOPLE FROM LEFT TO RIGHT ARE SOLID RED IN THE FIRST, LAVENDER IN THE SECOND, PURPLE IN THE MIDDLE PERSON, THE NEXT PERSON TRANSITIONS FROM A BLUE SHADE ON HIS RIGHT ARM AND LEG TO LIME GREEN ON HIS LEFT ARM, LEG AND HEAD, THE LAST PERSON ON THE RIGHT TRANSITIONS FROM LIME GREEN ON HIS



THE MARK CONSISTS OF TALK BUBBLE WITH LETTERS SPELLING THE WORD "HEO".

FOR COMPUTER SERVICES, NAMELY, CREATING AN ON-LINE COMMUNITY FOR REGISTERED USERS TO PARTICIPATE IN DISCUSSIONS, GET FEEDBACK FROM THEIR PEERS, FORM VIRTUAL COMMUNITIES, AND ENGAGE IN SOCIAL NETWORKING (U.S. CLS. 100 AND 101).

FIRST USE 10-9-2008; IN COMMERCE 10-9-2008.

HOWARD SMIGA, EXAMINING ATTORNEY

CLASS 42—(Continued).

SN 77-637,068. INSCAPE SOFTWARE HOLDING, INC., MONTREAL, QC, CANADA, FILED 12-19-2008.

ISCOPIA MARKETPLACE

THE MARK CONSISTS OF STANDARD CHARACTERS WITHOUT CLAIM TO ANY PARTICULAR FONT, STYLE, SIZE, OR COLOR.

NO CLAIM IS MADE TO THE EXCLUSIVE RIGHT TO USE "MARKETPLACE", APART FROM THE MARK AS SHOWN.

FOR PROVIDING AN INTERACTIVE WEBSITE, INTERNET WEBSITE CONSOLE OR INTERNET WEBSITE PORTAL IN THE FIELD OF ASSESSMENT FOR EMPLOYMENT RECRUITING, CAREER DEVELOPMENT AND CAREER ADVANCEMENT (U.S. CLS. 100 AND 101).

SANDRA MANIOS, EXAMINING ATTORNEY

CLASS 42—(Continued).

SN 77-642,915. GIGOIT, INC., SAINT LOUIS, MO. FILED 1-4-2009.



THE COLOR(S) BLACK AND GREEN IS/ARE CLAIMED AS A FEATURE OF THE MARK.

THE MARK CONSISTS OF THE TERMS "LOCAL REUSE", "LOCAL" APPEARING BLACK IN COLOR, "REUSE" APPEARING GREEN IN COLOR. LAST LETTER "E" IN WORD "REUSE" HAS TWO LEAFS APPEARING IN GREEN SPROUTING FROM ITS TOP, ONE POINTING UP AND TO THE LEFT, THE OTHER LARGER LEAF IS POINTING TO THE RIGHT.

FOR HOSTING AN ONLINE WEBSITE FEATURING A FREE SERVICE WHERE USERS CAN DONATE AND RECEIVE REUSABLE ITEMS WITHIN THEIR NEIGHBORHOOD AND KEEP USEFUL PRODUCTS OUT OF LANDFILLS (U.S. CLS. 100 AND 101).

JILL PRATER, EXAMINING ATTORNEY

SN 77-659,003. CAMBRIDGE PUBLISHING GROUP, INC., COLUMBUS, OH. FILED 1-29-2009.

**Bringing the world to you.
Instantly.**

THE MARK CONSISTS OF STANDARD CHARACTERS WITHOUT CLAIM TO ANY PARTICULAR FONT, STYLE, SIZE, OR COLOR.

FOR PROVIDING TEMPORARY USE OF ONLINE, NON-DOWNLOADABLE SOFTWARE FOR USING THE INTERNET AND WORLD WIDE WEB, NAMELY, SOFTWARE FOR ONLINE FILE SHARING AND FOR CONDUCTING AND PARTICIPATING IN ONLINE MEETINGS, EVENTS, AND CHATS (U.S. CLS. 100 AND 101).

FIRST USE 1-27-2009; IN COMMERCE 1-27-2009.
KIMBERLY FRYE, EXAMINING ATTORNEY

SN 77-660,655. SCIENCE AND TECHNOLOGY INTERNATIONAL, INC., HONOLULU, HI. FILED 1-30-2009.

STI

THE MARK CONSISTS OF STANDARD CHARACTERS WITHOUT CLAIM TO ANY PARTICULAR FONT, STYLE, SIZE, OR COLOR.

FOR TECHNICAL CONSULTATION IN THE FIELD OF MATERIALS TESTING AND ANALYSIS (U.S. CLS. 100 AND 101).

IRA J. GOODSaid, EXAMINING ATTORNEY

SN 77-638,852. BUZZWIRE, INC., DENVER, CO. FILED 12-23-2008.



THE COLOR(S) ORANGE, RED, PINK, GREY, BROWN, BEIGE AND BLACK IS/ARE CLAIMED AS A FEATURE OF THE MARK.

THE MARK CONSISTS OF THE COLOR ORANGE IN THE UPPER LEFT POLYGON, THE COLOR RED IN THE TOP TRIANGLE, THE COLOR PINK IN THE UPPER RIGHT POLYGON, THE COLOR GREY IN THE LOWER RIGHT POLYGON, THE COLOR BROWN IN THE BOTTOM TRIANGLE, THE COLOR BEIGE IN THE LOWER LEFT POLYGON AND THE COLOR BLACK IN THE ROUNDED RECTANGLE IN THE CENTER.

FOR APPLICATION SERVICE PROVIDER (ASP) FEATURING SOFTWARE TO ENABLE THE UPLOADING, POSTING, SHOWING, DISPLAYING, TAGGING, BLOGGING, SHARING OR OTHERWISE PROVIDING OF ELECTRONIC MEDIA OR INFORMATION OVER THE INTERNET, A WIRELESS COMMUNICATIONS NETWORK AND OTHER COMMUNICATIONS NETWORKS (U.S. CLS. 100 AND 101).

FIRST USE 1-27-2008; IN COMMERCE 1-27-2008.
FRED CARL, EXAMINING ATTORNEY

CLASS 42—(Continued).

SN 77-661,076. WARD ASHMAN, MOUNTAIN VIEW, CA. FILED 2-2-2009.

THREE ASSETS

THE MARK CONSISTS OF STANDARD CHARACTERS WITHOUT CLAIM TO ANY PARTICULAR FONT, STYLE, SIZE, OR COLOR.

FOR APPLICATION SERVICE PROVIDER (ASP) FEATURING SOFTWARE FOR USE TO PERFORM SELF ASSESSMENTS; COMPUTER SERVICES, NAMELY, HOSTING AND MAINTAINING AN ON-LINE WEB SITE FOR OTHERS TO PERFORM SELF ASSESSMENTS AND ACCESS INFORMATION ABOUT CORPORATE CULTURAL DEVELOPMENT AND SELF AWARENESS (U.S. CLS. 100 AND 101).

FIRST USE 7-3-2008; IN COMMERCE 7-3-2008.
KIM MONINGHOFF, EXAMINING ATTORNEY

SN 77-661,302. PEOPLECLICK, INC., RALEIGH, NC. FILED 2-2-2009.

PEOPLECLICK

THE MARK CONSISTS OF STANDARD CHARACTERS WITHOUT CLAIM TO ANY PARTICULAR FONT, STYLE, SIZE, OR COLOR.

OWNER OF U.S. REG. NOS. 2,640,732, 2,765,026 AND OTHERS.

FOR PROVIDING USE OF HOSTED ONLINE COMPUTER SOFTWARE TO CAPTURE FULL OR PARTIAL CONTACT INFORMATION MANUALLY OR BY OTHER MEANS, TO ADD, EDIT AND RECORD INTERACTIONS WITH CONTACTS, TO UTILIZE CONTACT INFORMATION TO DEVELOP OUTREACH CAMPAIGNS, TO NOTIFY CONTACTS AND CREATE NOTIFICATION ALERTS, TO PROVIDE THE ABILITY TO CREATE AND CATEGORIZE CONTACTS, GROUPS AND TEAMS AND TO CONFIGURE CONTACT MANAGEMENT OPTIONS FOR ROLES AND PERMISSIONS (U.S. CLS. 100 AND 101).

FIRST USE 12-20-2007; IN COMMERCE 12-20-2007.
JASON BLAIR, EXAMINING ATTORNEY

CLASS 42—(Continued).

SN 77-661,888. THE ATTILIO GROUP, LLC, RACINE, WI. FILED 2-3-2009.

The logo features the letters 'TAG' in a large, bold, sans-serif font. Below the 'A' is a small triangle pointing downwards. Underneath the 'TAG' is the tagline 'Simply Faster' in a smaller, sans-serif font.

OWNER OF U.S. REG. NOS. 3,596,156 AND 3,596,157.
THE MARK CONSISTS OF THE WORDS "SIMPLY FASTER" NEXT TO A STYLIZED "TAG" WHEREIN THE "A" LOOKS SIMILAR TO AN INVERTED "V", WITH A SMALL TRIANGLE BENEATH THE "A".

FOR APPLICATION SERVICE PROVIDER (ASP) IN THE CONSTRUCTION INDUSTRY FEATURING SOFTWARE FOR USE IN BACK OFFICE OPERATIONS, PAYROLL, ACCOUNTS PAYABLE, ACCOUNTS RECEIVABLE, GENERAL LEDGER, CASH MANAGEMENT, JOB ESTIMATING, JOB BILLING, SUBCONTRACT LEDGERS, PURCHASE ORDERS, PROJECT MANAGEMENT AND SCHEDULING, CONTRACT MANAGEMENT, INSURANCE MANAGEMENT, EQUIPMENT MANAGEMENT, INVENTORY, MATERIAL SALES, HUMAN RESOURCES, PROJECT MANAGEMENT, COMMUNICATIONS MONITORING AND MANAGEMENT, AND USER DATABASE MANAGEMENT; COMPUTER SOFTWARE AND HARDWARE CONSULTING (U.S. CLS. 100 AND 101).

B. PARADEWELAI, EXAMINING ATTORNEY

SN 77-662,184. 911 ETC, INC., EVERETT, WA. FILED 2-3-2009.

RedConnect

THE MARK CONSISTS OF STANDARD CHARACTERS WITHOUT CLAIM TO ANY PARTICULAR FONT, STYLE, SIZE, OR COLOR.

FOR SOFTWARE AS A SERVICE (SAAS) SERVICES FEATURING ENHANCED 911 DATABASE MANAGEMENT (U.S. CLS. 100 AND 101).

FIRST USE 1-19-2009; IN COMMERCE 1-29-2009.
CAROLINE WOOD, EXAMINING ATTORNEY

CLASS 42—(Continued).

SN 77-662,185. DAVID V EDELSTEIN, FOREST HILLS, NY.
FILED 2-3-2009.

FieldDoc

THE MARK CONSISTS OF STANDARD CHARACTERS WITHOUT CLAIM TO ANY PARTICULAR FONT, STYLE, SIZE, OR COLOR.

FOR PROVIDING A WEB SITE THAT GIVES MULTIPLE COMPUTER USERS SIMULTANEOUSLY THE ABILITY TO UPLOAD, CREATE AND EDIT DOCUMENTS, PRINTED PUBLICATIONS, ONLINE PUBLICATIONS, PHOTOGRAPHS, PRODUCT PACKAGING AND ADVERTISEMENTS (U.S. CLS. 100 AND 101).

CAROLINE WOOD, EXAMINING ATTORNEY

SN 77-662,367. BYRNE ELECTRICAL SPECIALISTS, INC.,
ROCKFORD, MI. FILED 2-3-2009.

KIVAFLEX

THE MARK CONSISTS OF STANDARD CHARACTERS WITHOUT CLAIM TO ANY PARTICULAR FONT, STYLE, SIZE, OR COLOR.

FOR PLANNING OF BUILDINGS AND INFRASTRUCTURE SYSTEMS FOR BUILDINGS, NAMELY, PROVIDING LAYOUT MATRICES FOR FLEXIBLE BUILDING ENVIRONMENTS (U.S. CLS. 100 AND 101).

DAVID I, EXAMINING ATTORNEY

SN 77-662,404. HUNTER-MCMAN, INC., HOUSTON, TX.
FILED 2-3-2009.

Cheep Cheep Websites

THE MARK CONSISTS OF STANDARD CHARACTERS WITHOUT CLAIM TO ANY PARTICULAR FONT, STYLE, SIZE, OR COLOR.

OWNER OF U.S. REG. NO. 3,004,102.

NO CLAIM IS MADE TO THE EXCLUSIVE RIGHT TO USE "WEBSITES", APART FROM THE MARK AS SHOWN.

FOR COMPUTER SITE DESIGN; COMPUTER SERVICES, NAMELY, DESIGNING AND IMPLEMENTING WEB SITES; COMPUTER SERVICES, NAMELY, CREATING AND MAINTAINING WEB SITES FOR OTHERS (U.S. CLS. 100 AND 101).

LOURDES AYALA, EXAMINING ATTORNEY

CLASS 42—(Continued).

SN 77-662,411. SYSTEM DEVELOPMENT.INTEGRATION,
LLC, CHICAGO, IL. FILED 2-3-2009.



SDI
we're there.

OWNER OF U.S. REG. NOS. 3,097,735, 3,323,435 AND
3,333,927.

THE COLOR(S) DARK GRAY AND RED IS/ARE CLAIMED AS A FEATURE OF THE MARK.

THE MARK CONSISTS OF "SDI" IN DARK GRAY STYLIZED SCRIPT WITH A RED DOT ON THE "I" ABOVE THE WORDS "WE'RE THERE." IN RED STYLIZED SCRIPT.

FOR INFORMATION TECHNOLOGY CONSULTATION (U.S. CLS. 100 AND 101).

FIRST USE 7-0-2008, THE MARK WAS FIRST USED ANYWHERE IN A DIFFERENT FORM OTHER THAN THAT SOUGHT TO BE REGISTERED AT LEAST AS EARLY AS 08/17/2005.; IN COMMERCE 7-0-2008, THE MARK WAS FIRST USED IN COMMERCE IN A DIFFERENT FORM OTHER THAN THAT SOUGHT TO BE REGISTERED AT LEAST AS EARLY AS 08/17/2005..

BRIDGETT SMITH, EXAMINING ATTORNEY

SN 77-662,440. SYSTEM DEVELOPMENT.INTEGRATION,
LLC, CHICAGO, IL. FILED 2-3-2009.



SDI

OWNER OF U.S. REG. NOS. 3,097,735 AND 3,333,927.

THE COLOR(S) DARK GRAY AND RED IS/ARE CLAIMED AS A FEATURE OF THE MARK.

THE MARK CONSISTS OF "SDI" IN DARK GRAY STYLIZED SCRIPT WITH A RED DOT ON THE "I".

FOR INFORMATION TECHNOLOGY CONSULTATION (U.S. CLS. 100 AND 101).

BRIDGETT SMITH, EXAMINING ATTORNEY

CLASS 42—(Continued).

SN 77-662,490. SYSTEM DEVELOPMENT, INTEGRATION, LLC, CHICAGO, IL. FILED 2-3-2009.

SDI

THE MARK CONSISTS OF STANDARD CHARACTERS WITHOUT CLAIM TO ANY PARTICULAR FONT, STYLE, SIZE, OR COLOR.

OWNER OF U.S. REG. NOS. 3,097,735 AND 3,333,927. FOR INFORMATION TECHNOLOGY CONSULTATION (U.S. CLS. 100 AND 101). FIRST USE 12-27-2000; IN COMMERCE 12-27-2000. BRIDGETT SMITH, EXAMINING ATTORNEY

SN 77-662,613. SPINAL SIMPLICITY, LLC, OVERLAND PARK, KS. FILED 2-3-2009.

Spinal Simplicity

THE MARK CONSISTS OF STANDARD CHARACTERS WITHOUT CLAIM TO ANY PARTICULAR FONT, STYLE, SIZE, OR COLOR.

NO CLAIM IS MADE TO THE EXCLUSIVE RIGHT TO USE "SPINAL", APART FROM THE MARK AS SHOWN.

FOR MEDICAL AND SCIENTIFIC RESEARCH, PRODUCT DEVELOPMENT AND DESIGN IN THE FIELD OF SPINAL DISEASE TREATMENT, RELATING TO GOODS SUCH AS OPERATIVE INSTRUMENTS, IMPLANTABLE AND NON-IMPLANTABLE MEDICAL DEVICES, DIAGNOSTIC EQUIPMENT AND REHABILITATION AIDS (U.S. CLS. 100 AND 101). RAUL CORDOVA, EXAMINING ATTORNEY

SN 77-663,245. SARA MAY GUTTMAN, DBA SOBER JOE'S, HOUSTON, TX. FILED 2-4-2009.

Sober Joe's

THE MARK CONSISTS OF STANDARD CHARACTERS WITHOUT CLAIM TO ANY PARTICULAR FONT, STYLE, SIZE, OR COLOR.

FOR HOSTING AN ONLINE WEBSITE FEATURING INSPIRATIONAL AND 12 STEP RECOVERY (U.S. CLS. 100 AND 101).

THOMAS MANOR, EXAMINING ATTORNEY

CLASS 42—(Continued).

SN 77-663,404. LC SCIENCES LLC, HOUSTON, TX. FILED 2-4-2009.

PepCyber

THE MARK CONSISTS OF STANDARD CHARACTERS WITHOUT CLAIM TO ANY PARTICULAR FONT, STYLE, SIZE, OR COLOR.

FOR PROVIDING AN ON-LINE SEARCHABLE DATABASE FOR SCIENTIFIC RESEARCH AND DEVELOPMENT FEATURING A COMPREHENSIVE SOURCE OF PEPTIDES WHICH HAVE FUNCTIONAL PROPERTIES SUCH AS ANTIBODY BINDING, PHOSPHORYLATION SITES, PEPTIDE BOND CLEAVAGE SITES, ALL SEARCHABLE BASED ON KEY WORDS, SEQUENCE DEFINITIONS, AND FUNCTIONS AND OTHER PARAMETERS (U.S. CLS. 100 AND 101).

FIRST USE 7-7-2008; IN COMMERCE 7-7-2008. BONNIE LUKEN, EXAMINING ATTORNEY

SN 77-663,571. ADVANA SCIENCE INC, KIRKLAND, WA. FILED 2-4-2009.

Advana Science

THE MARK CONSISTS OF STANDARD CHARACTERS WITHOUT CLAIM TO ANY PARTICULAR FONT, STYLE, SIZE, OR COLOR.

NO CLAIM IS MADE TO THE EXCLUSIVE RIGHT TO USE "SCIENCE", APART FROM THE MARK AS SHOWN.

THE WORDING "ADVANA" HAS NO MEANING IN A FOREIGN LANGUAGE.

FOR DESIGN AND TESTING FOR NEW PRODUCT DEVELOPMENT; DESIGN AND TESTING OF NEW PRODUCTS FOR OTHERS; DEVELOPMENT OF NEW TECHNOLOGY FOR OTHERS IN THE FIELD OF DIETARY AND NUTRITIONAL SUPPLEMENTS; INFORMATION ON THE SUBJECT OF SCIENTIFIC RESEARCH IN THE FIELD OF BIOCHEMISTRY AND BIOTECHNOLOGY (U.S. CLS. 100 AND 101).

ELLEN PERKINS, EXAMINING ATTORNEY

CLASS 42—(Continued).

SN 77-663,649. SIRSI CORPORATION, PROVO, UT. FILED 2-4-2009.

SIRSIDYNIX STAFFWEB

THE MARK CONSISTS OF STANDARD CHARACTERS WITHOUT CLAIM TO ANY PARTICULAR FONT, STYLE, SIZE, OR COLOR.

OWNER OF U.S. REG. NOS. 3,085,329, 3,558,677 AND OTHERS.

NO CLAIM IS MADE TO THE EXCLUSIVE RIGHT TO USE "STAFF WEB", APART FROM THE MARK AS SHOWN.

FOR APPLICATION SERVICE PROVIDER (ASP) FEATURING SOFTWARE IN THE FIELD OF LIBRARY SCIENCE FOR USE IN AUTOMATED LIBRARY MANAGEMENT (U.S. CLS. 100 AND 101).

FIRST USE 8-31-2007; IN COMMERCE 8-31-2007.
BARNEY CHARLON, EXAMINING ATTORNEY

SN 77-663,778. GENERAL TECHNOLOGY CORPORATION, WARWICK, RI. FILED 2-5-2009.

COMPUTOPIA

THE MARK CONSISTS OF STANDARD CHARACTERS WITHOUT CLAIM TO ANY PARTICULAR FONT, STYLE, SIZE, OR COLOR.

FOR COMPUTER CONSULTATION; COMPUTER CONSULTATION IN THE FIELD OF COMPUTER SECURITY; COMPUTER DIAGNOSTIC SERVICES; COMPUTER DISASTER RECOVERY PLANNING; COMPUTER GRAPHICS SERVICES; COMPUTER HARDWARE AND SOFTWARE CONSULTING SERVICES; COMPUTER MONITORING SERVICE WHICH TRACKS APPLICATION SOFTWARE PERFORMANCE, PERFORMS PERIODIC MAINTENANCE AND PROVIDES REPORTS AND ALERTS CONCERNING SUCH PERFORMANCE; COMPUTER NETWORK DESIGN FOR OTHERS; COMPUTER SECURITY CONSULTANCY; COMPUTER SERVICES, NAMELY, COMPUTER SYSTEM ADMINISTRATION FOR OTHERS; COMPUTER SERVICES, NAMELY, CREATING AND MAINTAINING WEB SITES FOR OTHERS; COMPUTER SERVICES, NAMELY, DATA RECOVERY SERVICES; COMPUTER SOFTWARE CONSULTANCY; COMPUTER SOFTWARE

CLASS 42—(Continued).

CONSULTATION; COMPUTER SOFTWARE DESIGN FOR OTHERS; COMPUTER SOFTWARE DEVELOPMENT; COMPUTER SOFTWARE INSTALLATION AND MAINTENANCE; CONSULTING SERVICES IN THE FIELD OF DESIGN, SELECTION, IMPLEMENTATION AND USE OF COMPUTER HARDWARE AND SOFTWARE SYSTEMS FOR OTHERS; CUSTOMIZATION OF COMPUTER HARDWARE AND SOFTWARE; DESIGN AND DEVELOPMENT OF COMPUTER HARDWARE AND SOFTWARE; DESIGN AND DEVELOPMENT OF NETWORKS; DESIGN AND DEVELOPMENT OF WIRELESS COMPUTER NETWORKS; DESIGN, MAINTENANCE, DEVELOPMENT AND UPDATING OF COMPUTER SOFTWARE; INSTALLATION, MAINTENANCE AND REPAIR OF COMPUTER SOFTWARE; INTEGRATION OF COMPUTER SYSTEMS AND NETWORKS; RECOVERY OF COMPUTER DATA; REMOTE COMPUTER BACKUP SERVICES; TECHNICAL SUPPORT SERVICES, NAMELY, TROUBLESHOOTING OF COMPUTER HARDWARE AND SOFTWARE PROBLEMS (U.S. CLS. 100 AND 101).

FIRST USE 10-1-1981; IN COMMERCE 10-1-1981.
KATHRYN COWARD, EXAMINING ATTORNEY

SN 77-663,866. YOURWORLD.ME, INC, WILMINGTON, DE. FILED 2-5-2009.



THE COLOR(S) BLUE, GRAY, AND WHITE IS/ARE CLAIMED AS A FEATURE OF THE MARK.

THE COLOR(S) BLUE, GRAY, AND WHITE IS/ARE CLAIMED AS A FEATURE OF THE MARK. THE MARK CONSISTS OF THE STYLIZED WORDING "YOURWORLD.ME" IN LOWER CASE LETTERS AND A DIALOGUE BUBBLE CONTAINING TWO HANDS. THE DIALOGUE BUBBLE EXTENDS UP FROM THE LETTER O. "THE TERM "YOUR" IS IN THE COLOR BLUE AND THE TERM "WORLD.ME" IS IN THE COLOR GRAY. THE DIALOGUE BUBBLE IS GRAY AND THE TWO HANDS INSIDE THE DIALOG BUBBLE ARE WHITE.

FOR PROVIDING A WEB SITE FEATURING TECHNOLOGY THAT ENABLES INTERNET USERS TO CREATE, BOOKMARK, ANNOTATE, AND PUBLICLY SHARE DATA (U.S. CLS. 100 AND 101).

ELLEN B. AWRICH, EXAMINING ATTORNEY

CLASS 42—(Continued).

SN 77-663,989. CUMMINGS, KATHLEEN, GAITHERSBURG, MD. FILED 2-5-2009.



THE MARK CONSISTS OF A STYLIZED DESIGN OF A HOUSE AND THE TEXT "STAGEB4USELL".

FOR HOME STAGING CONSULTATION, NAMELY, TEMPORARY INTERIOR AND EXTERIOR HOME DECORATION CONSULTATION FOR THE PURPOSE OF MAKING HOMES MORE APPEALING TO PROSPECTIVE BUYERS (U.S. CLS. 100 AND 101).

KIMBERLY FRYE, EXAMINING ATTORNEY

SN 77-664,103. THE TELX GROUP, INC., NEW YORK, NY. FILED 2-5-2009.

TELXVAULT

THE MARK CONSISTS OF STANDARD CHARACTERS WITHOUT CLAIM TO ANY PARTICULAR FONT, STYLE, SIZE, OR COLOR.

OWNER OF U.S. REG. NO. 2,653,237.

FOR PROVIDING ONLINE NON-DOWNLOADABLE SOFTWARE FOR USE IN MANAGING SECURE AND AUTOMATIC REMOTE BACKUP OF COMPUTER DATA; AND REMOTE ONLINE BACKUP OF COMPUTER DATA (U.S. CLS. 100 AND 101).

FIRST USE 2-0-2008; IN COMMERCE 2-0-2008.

JEAN IM, EXAMINING ATTORNEY

SN 77-664,119. SCIENTIC, INC., HUNTSVILLE, AL. FILED 2-5-2009.



THE COLOR(S) BLUE, GRAY, AND WHITE IS/ARE CLAIMED AS A FEATURE OF THE MARK.

THE MARK CONSISTS OF THE WORD "SCIENTIC" APPEARING WITH AN UPPERCASE "S" FOLLOWED BY LOWERCASE "CIEN TIC"; THERE IS A DASH "-" AS A SUPERSCRIPIT FOLLOWING THE "E" IN "SCIENTIC"; ALL OF THE LETTERS ARE GRAY WITH THE EXCEPTION OF THE LETTER "E" AND THE DASH "-", WHICH ARE BLUE; A BLUE LINE APPEARS UNDER THE WORD "SCIENTIC", BUT NOT UNDER THE LETTER "S", AND TOUCHES THE DESIGN PORTION OF THE MARK, WHICH IS TO THE RIGHT OF THE WORDS "SCIENTIC" AND "VIRESEST"; THE WORDS "VIRESEST" APPEAR IN GRAY COLOR

CLASS 42—(Continued).

BELOW THE BLUE LINE; THE DESIGN PORTION OF THE MARK APPEARS IN BLUE AND WHITE TO THE RIGHT OF THE WORDS "SCIENTIC" AND "VIRESEST"; THE DESIGN PORTION OF THE MARK IS A REPRESENTATION OF A LINE DRAWING WITH THE CENTER POINT REPRESENTING OUR GALAXY AND SURROUNDING GALAXIES LOCATED AT THE END POINT OF EACH LINE ORIGINATING FROM THE CENTER POINT; THE LENGTH OF EACH LINE CORRESPONDS TO HOW FAR ADJACENT GALAXIES ARE TO OUR GALAXY.

THE ENGLISH TRANSLATION OF "VIRESEST" IN THE MARK IS POWER. THE WORDING "SCIENTIC" HAS NO MEANING IN A FOREIGN LANGUAGE.

FOR ENGINEERING SERVICES, NAMELY, ENGINEERING FOR THE RESEARCH, DEVELOPMENT, FABRICATION, PRODUCT DEMONSTRATION, TECHNICAL ENGINEERING CONSULTATION, AND TESTING SERVICES FOR AEROSPACE AND MILITARY SYSTEMS INCLUDING AVIONICS, MISSILE, BOOSTER, COMMUNICATION, SENSORS, SATELLITE, AND GROUND SYSTEMS (U.S. CLS. 100 AND 101).

FIRST USE 10-15-2008; IN COMMERCE 10-15-2008.

FRED MANDIR, EXAMINING ATTORNEY

SN 77-664,224. INTEGRICOM, INC., BUFORD, GA. FILED 2-5-2009.

INTEGRICOM

THE MARK CONSISTS OF STANDARD CHARACTERS WITHOUT CLAIM TO ANY PARTICULAR FONT, STYLE, SIZE, OR COLOR.

OWNER OF U.S. REG. NO. 2,682,433.

FOR COMPUTER SERVICES, NAMELY, REMOTE AND ON-SITE MANAGEMENT OF THE INFORMATION TECHNOLOGY (IT) SYSTEMS OF OTHERS; AND CONSULTING IN THE FIELD OF INFORMATION TECHNOLOGY (U.S. CLS. 100 AND 101).

FIRST USE 1-0-2001; IN COMMERCE 1-0-2001.

MATTHEW PAPPAS, EXAMINING ATTORNEY

SN 77-664,336. CLEARHEART ENTERTAINMENT, INC., GREENVILLE, SC. FILED 2-5-2009.

SITEBUILDERPRO

THE MARK CONSISTS OF STANDARD CHARACTERS WITHOUT CLAIM TO ANY PARTICULAR FONT, STYLE, SIZE, OR COLOR.

FOR PROVIDING A WEBSITE THAT GIVES USERS THE ABILITY TO CREATE CUSTOMIZED WEB PAGES FEATURING USER-DEFINED INFORMATION; PROVIDING A WEBSITE THAT GIVES USERS THE ABILITY TO CREATE CUSTOMIZED WEB PAGES FEATURING USER-DEFINED PROFILES; PROVIDING AN ONLINE WEBSITE FOR CREATING AND HOSTING MICRO WEBSITES FOR BUSINESSES (U.S. CLS. 100 AND 101).

FIRST USE 7-24-2002; IN COMMERCE 7-24-2002.

RUSS HERMAN, EXAMINING ATTORNEY

CLASS 42—(Continued).

SN 77-664,393. O'LENICK, ANTHONY, DACULA, GA. FILED 2-5-2009.

GREENING WITH SILICONES

THE MARK CONSISTS OF STANDARD CHARACTERS WITHOUT CLAIM TO ANY PARTICULAR FONT, STYLE, SIZE, OR COLOR.

NO CLAIM IS MADE TO THE EXCLUSIVE RIGHT TO USE "SILICONES", APART FROM THE MARK AS SHOWN. FOR COSMETIC RESEARCH CONSULTATION (U.S. CLS. 100 AND 101).

FIRST USE 2-3-2009; IN COMMERCE 2-3-2009.
RUSS HERMAN, EXAMINING ATTORNEY

SN 77-664,577. LENDSYS, SIMI VALLEY, CA. FILED 2-5-2009.



NO CLAIM IS MADE TO THE EXCLUSIVE RIGHT TO USE "SOFTWARE SYSTEMS", APART FROM THE MARK AS SHOWN.

THE STIPPLING IS FOR SHADING PURPOSES ONLY.

THE MARK CONSISTS OF THE STYLIZED WORDS "LENDSYS SOFTWARE SYSTEMS". AN IMAGE OF AN ABSTRACT DESIGN BELOW THE TEXT.

FOR APPLICATION SERVICE PROVIDER (ASP) FEATURING SOFTWARE FOR USE IN AUTOMATED LENDING (U.S. CLS. 100 AND 101).

AARON BRODSKY, EXAMINING ATTORNEY

SN 77-664,605. ITECH LAS VEGAS LLC, HENDERSON, NV. FILED 2-5-2009.

Infrastructure of
Efficiency

THE MARK CONSISTS OF STANDARD CHARACTERS WITHOUT CLAIM TO ANY PARTICULAR FONT, STYLE, SIZE, OR COLOR.

NO CLAIM IS MADE TO THE EXCLUSIVE RIGHT TO USE "INFRASTRUCTURE", APART FROM THE MARK AS SHOWN.

FOR COMPUTER HARDWARE AND SOFTWARE CONSULTING SERVICES FOR NETWORK MANAGEMENT IN THE AREAS OF PERFORMANCE MANAGEMENT, SECURITY, COMPLIANCE GOVERNANCE, CHANGE MANAGEMENT, AUTOMATION AND THE LIKE; INFORMATION TECHNOLOGY CONSULTATION (U.S. CLS. 100 AND 101).

IRA J. GOODSID, EXAMINING ATTORNEY

CLASS 42—(Continued).

SN 77-664,829. NEW CLOUD TECHNOLOGIES, DBA NEW CLOUD TECHNOLOGIES, MCHENRY, MD. FILED 2-6-2009.

IT just got easier.

THE MARK CONSISTS OF STANDARD CHARACTERS WITHOUT CLAIM TO ANY PARTICULAR FONT, STYLE, SIZE, OR COLOR.

FOR CONSULTING IN THE FIELD OF INFORMATION TECHNOLOGY (U.S. CLS. 100 AND 101).

JULIE WATSON, EXAMINING ATTORNEY

SN 77-664,860. MEV, LLC, NEW YORK, NY. FILED 2-6-2009.

MEV

THE MARK CONSISTS OF STANDARD CHARACTERS WITHOUT CLAIM TO ANY PARTICULAR FONT, STYLE, SIZE, OR COLOR.

FOR COMPUTER SERVICES, NAMELY, MONITORING AND REPORTING ON THE PERFORMANCE, AVAILABILITY, AND ERRORS OF WEB SITES OF OTHERS; COMPUTER SERVICES, NAMELY, MONITORING, TESTING, ANALYZING, AND REPORTING ON THE INTERNET TRAFFIC CONTROL AND CONTENT CONTROL OF THE WEB SITES OF OTHERS; COMPUTER SITE DESIGN; COMPUTER SOFTWARE DESIGN; COMPUTER SOFTWARE DEVELOPMENT AND COMPUTER PROGRAMMING DEVELOPMENT FOR OTHERS; CONSULTATION SERVICES IN THE FIELDS OF SELECTION, IMPLEMENTATION AND USE OF COMPUTER HARDWARE AND SOFTWARE SYSTEMS FOR OTHERS; CONSULTING SERVICES IN THE FIELD OF DESIGN, SELECTION, IMPLEMENTATION AND USE OF COMPUTER HARDWARE AND SOFTWARE SYSTEMS FOR OTHERS; CREATING, DESIGNING AND MAINTAINING WEB SITES; CUSTOMIZED SOFTWARE DEVELOPMENT SERVICES (U.S. CLS. 100 AND 101).

JIM RINGLE, EXAMINING ATTORNEY

CLASS 42—(Continued).

SN 77-665,096. THE DEPOSITORY TRUST & CLEARING CORPORATION, NEW YORK, NY. FILED 2-6-2009.

IFT ACCESS

THE MARK CONSISTS OF STANDARD CHARACTERS WITHOUT CLAIM TO ANY PARTICULAR FONT, STYLE, SIZE, OR COLOR.

FOR APPLICATION SERVICE PROVIDER (ASP) FEATURING SOFTWARE FOR USE IN THE INSURANCE INDUSTRY, NAMELY, SOFTWARE THAT FACILITATES THE EXCHANGE OF INFORMATION BETWEEN INSURANCE CARRIERS AND DISTRIBUTORS FOR INSURANCE CONTRACT-RELATED CHANGES INCLUDING BROKER/DEALER, REGISTERED REPRESENTATIVE AND BROKER IDENTIFICATION NUMBER (BIN) CHANGES (U.S. CLS. 100 AND 101).
GINA HAYES, EXAMINING ATTORNEY

CLASS 42—(Continued).

SN 77-666,355. JAMES WANG DESIGN ASSOCIATES, INC., SAN GABRIEL, CA. FILED 2-9-2009.

JWDA

THE MARK CONSISTS OF STANDARD CHARACTERS WITHOUT CLAIM TO ANY PARTICULAR FONT, STYLE, SIZE, OR COLOR.

FOR ARCHITECTURAL AND ENGINEERING SERVICES; ARCHITECTURAL CONSULTATION; ARCHITECTURAL DESIGN; DRAWING UP OF PLANS AND ENGINEERING DRAWINGS; INTERIOR DESIGN SERVICES; INTERIOR DESIGN SERVICES INCLUDING SPACE PLANNING, FURNITURE SELECTION, MATERIAL AND SURFACE SELECTION; PLANNING AND LAYOUT DESIGN FOR THE INTERIOR SPACE OF RETAIL BUSINESS ESTABLISHMENTS; PLANNING OF BUILDINGS AND INFRASTRUCTURE SYSTEMS FOR BUILDINGS; RESIDENTIAL BUILDING DESIGN; STRUCTURAL ENGINEERING DESIGN SERVICES (U.S. CLS. 100 AND 101).

FIRST USE 10-11-1994; IN COMMERCE 10-11-1994.
GEORGE LORENZO, EXAMINING ATTORNEY

SN 77-666,436. D4D TECHNOLOGIES, LLC, RICHARDSON, TX. FILED 2-9-2009.

VOIS

THE MARK CONSISTS OF STANDARD CHARACTERS WITHOUT CLAIM TO ANY PARTICULAR FONT, STYLE, SIZE, OR COLOR.

FOR TECHNICAL SUPPORT SERVICES, NAMELY, PROVIDING TECHNICAL ADVICE RELATED TO THE USE OF DENTAL TOOLS, IMAGING SYSTEMS, SOFTWARE AND MILLING MACHINES FOR MANUFACTURING DENTAL PROSTHETICS (U.S. CLS. 100 AND 101).

ALLISON HOLTZ, EXAMINING ATTORNEY

SN 77-666,641. THE NELROD COMPANY, FORT WORTH, TX. FILED 2-9-2009.

SN 77-665,147. POSPISIL, OLIVER STEVE, AKA OLIVER POSPISIL, DUESSELDORF, FED REP GERMANY, FILED 2-6-2009.



THE COLOR(S) WHITE, BLUE IS/ARE CLAIMED AS A FEATURE OF THE MARK.

THE MARK CONSISTS OF A BLUE CIRCLE CONTAINING A WHITE WATER DROP, BENEATH ANOTHER SMALLER BLUE CIRCLE, TO THE LEFT OF THE WORDS "INSPIRED BY", ABOVE "LIFE", WITH ALL WORDS IN BLUE.

FOR COMPUTER SOFTWARE DEVELOPMENT AND COMPUTER PROGRAMMING DEVELOPMENT FOR OTHERS (U.S. CLS. 100 AND 101).

ELISSA GARBER KON, EXAMINING ATTORNEY

THE MARK CONSISTS OF STANDARD CHARACTERS WITHOUT CLAIM TO ANY PARTICULAR FONT, STYLE, SIZE, OR COLOR.

FOR ENVIRONMENTAL SERVICES, NAMELY, TECHNICAL CONSULTATION IN THE FIELD OF ENVIRONMENTAL SCIENCE, ENGINEERING SERVICES, DESIGN FOR OTHERS IN THE FIELD OF ENERGY ENGINEERING, DESIGNING AND TESTING OF ENERGY PRODUCTS FOR OTHERS (U.S. CLS. 100 AND 101).

WILLIAM P. SHANAHAN, EXAMINING ATTORNEY

**Green Begins with Energy
Efficiency.**

CLASS 42—(Continued).

SN 77-666,654. BLACKBAUD, INC., CHARLESTON, SC. FILED 2-9-2009.

BlackbaudNow

THE MARK CONSISTS OF STANDARD CHARACTERS WITHOUT CLAIM TO ANY PARTICULAR FONT, STYLE, SIZE, OR COLOR.

OWNER OF U.S. REG. NOS. 2,397,946 AND 2,473,006. FOR APPLICATION SERVICE PROVIDER (ASP) FEATURING NON-DOWNLOADABLE SOFTWARE FOR USE BY OTHERS THAT WILL ALLOW USERS TO BUILD CUSTOMIZED WEBSITES FOR THE PURPOSE OF FUNDRAISING FOR NON-PROFITS (U.S. CLS. 100 AND 101). MARY CRAWFORD, EXAMINING ATTORNEY

SN 77-666,765. WARRIOR ROOTS, KENSINGTON, MD. FILED 2-9-2009.

Warrior Roots

THE MARK CONSISTS OF STANDARD CHARACTERS WITHOUT CLAIM TO ANY PARTICULAR FONT, STYLE, SIZE, OR COLOR.

FOR DNA ANALYSIS SERVICES (U.S. CLS. 100 AND 101). DORITT L. CARROLL, EXAMINING ATTORNEY

SN 77-669,408. BYRNE ELECTRICAL SPECIALISTS, INC., ROCKFORD, MI. FILED 2-12-2009.

KIVA

THE MARK CONSISTS OF STANDARD CHARACTERS WITHOUT CLAIM TO ANY PARTICULAR FONT, STYLE, SIZE, OR COLOR.

FOR PLANNING OF BUILDINGS AND INFRASTRUCTURE SYSTEMS FOR BUILDINGS, NAMELY, PROVIDING LAYOUT MATRICES FOR FLEXIBLE BUILDING ENVIRONMENTS (U.S. CLS. 100 AND 101). DAVID I. EXAMINING ATTORNEY

CLASS 42—(Continued).

SN 77-669,414. BYRNE ELECTRICAL SPECIALISTS, INC., ROCKFORD, MI. FILED 2-12-2009.

KIVA

THE MARK CONSISTS OF THE WORD "KIVA" WHERE THE EACH POINTS OF THE "V" ARE CIRCLES.

FOR PLANNING OF BUILDINGS AND INFRASTRUCTURE SYSTEMS FOR BUILDINGS, NAMELY, PROVIDING LAYOUT MATRICES FOR FLEXIBLE BUILDING ENVIRONMENTS (U.S. CLS. 100 AND 101). DAVID I. EXAMINING ATTORNEY

SN 77-669,456. MEREDITH CORPORATION, DES MOINES, IA. FILED 2-12-2009.

MIXING BOWL

THE MARK CONSISTS OF STANDARD CHARACTERS WITHOUT CLAIM TO ANY PARTICULAR FONT, STYLE, SIZE, OR COLOR.

FOR COMPUTER SERVICES, NAMELY, CREATING AN ON-LINE COMMUNITY FOR REGISTERED USERS TO PARTICIPATE IN DISCUSSIONS, GET FEEDBACK FROM THEIR PEERS, FORM VIRTUAL GROUPS, AND ENGAGE IN SOCIAL NETWORKING; PROVIDING A WEB SITE THAT GIVES COMPUTER USERS THE ABILITY TO UPLOAD, EXCHANGE AND SHARE INFORMATION (U.S. CLS. 100 AND 101). FIRST USE 1-9-2009; IN COMMERCE 1-9-2009. MICHELLE DUBOIS, EXAMINING ATTORNEY

SN 77-670,304. HILL-ROM SERVICES, INC., BATESVILLE, IN. FILED 2-13-2009.

TAP

THE MARK CONSISTS OF STANDARD CHARACTERS WITHOUT CLAIM TO ANY PARTICULAR FONT, STYLE, SIZE, OR COLOR.

FOR LEASING OF MEDICAL EQUIPMENT (U.S. CLS. 100 AND 101). ANDREA K. NADELMAN, EXAMINING ATTORNEY

CLASS 42—(Continued).

SN 77-676,385. SIRSI CORPORATION, PROVO, UT. FILED 2-23-2009.

SMARTSOURCE

THE MARK CONSISTS OF STANDARD CHARACTERS WITHOUT CLAIM TO ANY PARTICULAR FONT, STYLE, SIZE, OR COLOR.

FOR APPLICATION SERVICE PROVIDER (ASP) FEATURING SOFTWARE FOR USE IN PROVIDING ACCESS TO LIBRARY CATALOG INFORMATION AND RECORDS (U.S. CLS. 100 AND 101).

FIRST USE 3-31-2002; IN COMMERCE 3-31-2002.
BARNEY CHARLON, EXAMINING ATTORNEY

SN 77-678,084. SCIENTIC, INC., HUNTSVILLE, AL. FILED 2-25-2009.



THE MARK CONSISTS OF THE WORD "SCIENTIC" APPEARING WITH AN UPPERCASE "S" FOLLOWED BY LOWERCASE "CIEN TIC"; THERE IS A DASH "-" AS A SUPERSCRIPT FOLLOWING THE "E" IN "SCIENTIC"; ALL OF THE LETTERS ARE GRAY WITH THE EXCEPTION OF THE LETTER "E" AND THE DASH "-", WHICH ARE BLACK; A LINE APPEARS UNDER THE WORD "SCIENTIC", BUT NOT UNDER THE LETTER "S", AND TOUCHES THE DESIGN PORTION OF THE MARK, WHICH IS TO THE RIGHT OF THE WORDS "SCIENTIC" AND "VIRES EST"; THE WORDS "VIRES EST" APPEAR IN GRAY COLOR BELOW THE LINE; THE DESIGN PORTION OF THE MARK APPEARS IN BLACK AND WHITE TO THE RIGHT OF THE WORDS "SCIENTIC" AND "VIRES EST"; THE DESIGN PORTION OF THE MARK IS A REPRESENTATION OF A LINE DRAWING WITH THE CENTER POINT REPRESENTING OUR GALAXY AND SURROUNDING GALAXIES LOCATED AT THE END POINT OF EACH LINE ORIGINATING FROM THE CENTER POINT; THE LENGTH OF EACH LINE CORRESPONDS TO HOW FAR ADJACENT GALAXIES ARE TO OUR GALAXY.

THE ENGLISH TRANSLATION OF "VIRES EST" IN THE MARK IS POWER. THE WORDING "SCIENTIC" HAS NO MEANING IN A FOREIGN LANGUAGE

FOR ENGINEERING SERVICES, NAMELY, ENGINEERING FOR THE RESEARCH, DEVELOPMENT, FABRICATION, PRODUCT DEMONSTRATION, TECHNICAL ENGINEERING CONSULTATION, AND TESTING SERVICES FOR AEROSPACE AND MILITARY SYSTEMS INCLUDING AVIONICS, MISSILE, BOOSTER, COMMUNICATION, SENSORS, SATELLITE, AND GROUND SYSTEMS (U.S. CLS. 100 AND 101).

FIRST USE 10-15-2008; IN COMMERCE 10-15-2008.
FRED MANDIR, EXAMINING ATTORNEY

CLASS 42—(Continued).

SN 79-061,176. JABBLA BVBA.; BESLOTEN VENNOOTSCHAP MET; BEPERKTE AANSPRAKELIJKHEID, BELGIUM, FILED 9-30-2008.



PRIORITY DATE OF 5-29-2008 IS CLAIMED.
OWNER OF INTERNATIONAL REGISTRATION 0982815 DATED 9-30-2008, EXPIRES 9-30-2018.

THE COLOR(S) BROWN, GREEN AND WHITE IS/ARE CLAIMED AS A FEATURE OF THE MARK.

THE MARK CONSISTS OF THE COLORS BROWN, GREEN AND WHITE, WITH THE COLOR BROWN APPEARING IN THE TERM "JABBLA", GREEN APPEARING IN THE WORDING "WE ALL HAVE A VOICE" AND THE CIRCULAR DESIGN, AND THE BACKGROUND IS WHITE.

FOR SCIENTIFIC RESEARCH AND DESIGN FOR OTHERS IN THE FIELD OF COMPUTERS, COMPUTER HARDWARE AND SOFTWARE FOR DISABLED PERSONS AND PERSONS WITH SPEECH IMPEDIMENTS; INDUSTRIAL RESEARCH IN THE FIELD OF COMPUTERS, COMPUTER HARDWARE AND SOFTWARE FOR DISABLED PERSONS AND PERSONS WITH SPEECH IMPEDIMENTS; DESIGN AND DEVELOPMENT OF COMPUTER HARDWARE AND SOFTWARE FOR DISABLED PERSONS AND PERSONS WITH SPEECH IMPEDIMENTS (U.S. CLS. 100 AND 101).

JOHN DWYER, EXAMINING ATTORNEY

SN 79-063,664. XIAMEN LONGTOP SYSTEM CO., LTD, CHINA, FILED 10-3-2006.

东南融通

OWNER OF INTERNATIONAL REGISTRATION 0988508 DATED 10-3-2006, EXPIRES 10-3-2016.

OWNER OF U.S. REG. NOS. 3,283,319 AND 3,356,683.
THE ENGLISH TRANSLATION OF THE FOREIGN WORD(S) IN THE MARK IS: THE LONG TOP.

THE TRANSLITERATION OF THE NON-LATIN CHARACTERS IN THE MARK IS: DONG NAN RONG TONG.

FOR RENTAL OF COMPUTERS, RENTAL OF DATABASE SERVERS TO THIRD PARTIES, COMPUTER SOFTWARE DESIGN, UPDATING OF COMPUTER SOFTWARE, COMPUTER HARDWARE CONSULTATION, RECOVERY OF COMPUTER DATA, RENTAL OF COMPUTER SOFTWARE, COMPUTER SYSTEMS ANALYSIS, MAINTENANCE OF COMPUTER SOFTWARE, COMPUTER PROGRAMMING (U.S. CLS. 100 AND 101).

TOBY BULLOFF, EXAMINING ATTORNEY

CLASS 42—(Continued).

SN 79-066,983. ERICSOFT SRL, ITALY, FILED 1-2-2009.

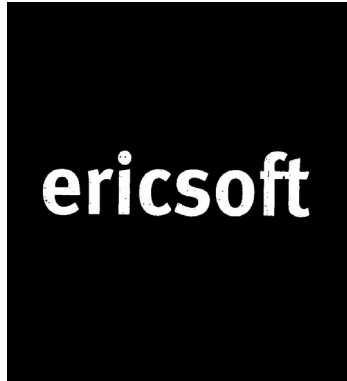

OWNER OF INTERNATIONAL REGISTRATION 0997966 DATED 1-2-2009, EXPIRES 1-2-2019.
THE MARK CONSISTS OF THE WORD "ERICSOFT" FOR COMPUTER PROGRAMMING (U.S. CLS. 100 AND 101).
MATTHEW EINSTEIN, EXAMINING ATTORNEY

CLASS 43—(Continued).

SN 76-691,460. DES PES, INC., NEW YORK, NY. FILED 7-21-2008.

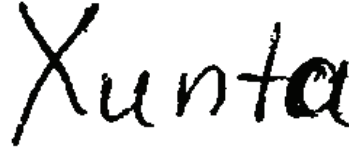

THE MARK CONSISTS OF STANDARD CHARACTERS WITHOUT CLAIM TO ANY PARTICULAR FONT, STYLE, SIZE, OR COLOR.
THE ENGLISH TRANSLATION OF THE WORD "XUNTA" IN THE MARK IS "PLACE OF MEETING."
FOR BAR AND RESTAURANT (U.S. CLS. 100 AND 101).
FIRST USE 1-20-1999; IN COMMERCE 1-20-1999.
ANTHONY RINKER, EXAMINING ATTORNEY

SN 76-695,424. CHINA SHUTTLE, INC., DBA KING CHUAN, SAN CARLOS, CA. FILED 1-23-2009.

Joseph Kao's King Chuan

THE MARK CONSISTS OF STANDARD CHARACTERS WITHOUT CLAIM TO ANY PARTICULAR FONT, STYLE, SIZE, OR COLOR.
THE NAME "JOSEPH KAO" IDENTIFIES A LIVING INDIVIDUAL WHOSE CONSENT IS OF RECORD.
THE ENGLISH TRANSLATION OF "CHUAN" IN THE MARK IS RIVER.
FOR TAKE-OUT RESTAURANT SERVICES IN THE FIELD OF CHINESE FOODS (U.S. CLS. 100 AND 101).
DAVID H. STINE, EXAMINING ATTORNEY

CLASS 43—HOTEL AND RESTAURANT SERVICES

SN 76-628,307. SPARKLING WINE INTERNATIONAL LIMITED, TORTOLA, BR. VIRGIN ISLANDS, FILED 1-19-2005.



Dusk till Dawn

FOR RESTAURANT, BAR, COCKTAIL LOUNGE SERVICES, PUBLIC HOUSE AND CATERING SERVICES (U.S. CLS. 100 AND 101).
KRISTINA MORRIS, EXAMINING ATTORNEY

SN 76-695,648. ALAMO HOTELS, INC., HOUSTON, TX. FILED 2-6-2009.

EMILY MORGAN

THE MARK CONSISTS OF STANDARD CHARACTERS WITHOUT CLAIM TO ANY PARTICULAR FONT, STYLE, SIZE, OR COLOR.
"EMILY MORGAN" DOES NOT IDENTIFY A LIVING INDIVIDUAL.
FOR HOTEL SERVICES; RESTAURANT, CATERING, BAR AND COCKTAIL LOUNGE SERVICES; RESORT LODGING SERVICES; PROVISION OF GENERAL PURPOSE FACILITIES FOR MEETINGS, CONFERENCES AND EXHIBITIONS; PROVISION OF BANQUET AND SOCIAL FUNCTION FACILITIES FOR SPECIAL OCCASIONS; AND RESERVATION SERVICES FOR HOTEL ACCOMMODATIONS (U.S. CLS. 100 AND 101).
FIRST USE 0-0-1985; IN COMMERCE 0-0-1985.
COURTNEY MCCORMICK, EXAMINING ATTORNEY

CLASS 43—(Continued).

SN 77-070,411. THE MAJESTIC STAR CASINO, PLLC, GARY, IN. FILED 12-22-2006.

WHOOPLA!

THE MARK CONSISTS OF STANDARD CHARACTERS WITHOUT CLAIM TO ANY PARTICULAR FONT, STYLE, SIZE, OR COLOR.

FOR HOTEL AND RESTAURANT SERVICES (U.S. CLS. 100 AND 101).
THEODORE MCBRIDE, EXAMINING ATTORNEY

CLASS 43—(Continued).

SN 77-229,287. STACY DALGLEISH, LOS ANGELES, CA. FILED 7-13-2007.

P.S. Blu

THE MARK CONSISTS OF STANDARD CHARACTERS WITHOUT CLAIM TO ANY PARTICULAR FONT, STYLE, SIZE, OR COLOR.

FOR (BASED ON INTENT TO USE) HOTEL, BAR AND RESTAURANT SERVICES (U.S. CLS. 100 AND 101).
SHARON MEIER, EXAMINING ATTORNEY

SN 77-217,738. DEWEESE MANAGEMENT SERVICES, INC., INDIANAPOLIS, IN. FILED 6-28-2007.

BadaBoomz

THE MARK CONSISTS OF STANDARD CHARACTERS WITHOUT CLAIM TO ANY PARTICULAR FONT, STYLE, SIZE, OR COLOR.

FOR RESTAURANT AND BAR SERVICES (U.S. CLS. 100 AND 101).
FIRST USE 2-1-2007; IN COMMERCE 4-1-2007.
LESLIE RICHARDS, EXAMINING ATTORNEY

SN 77-380,434. GOLDEN, JONATHAN D., ROSWELL, GA. FILED 1-25-2008.

Drink Coffee. Do Good.

THE MARK CONSISTS OF STANDARD CHARACTERS WITHOUT CLAIM TO ANY PARTICULAR FONT, STYLE, SIZE, OR COLOR.

FOR COFFEE SHOPS (U.S. CLS. 100 AND 101).
FIRST USE 3-1-2005; IN COMMERCE 3-1-2005.
REBECCA EISINGER, EXAMINING ATTORNEY

SN 77-220,690. THE METROPOLITAN CLUB, INC., CHESTNUT HILL, MA. FILED 7-2-2007.

Met Burger Bar Boston

THE MARK CONSISTS OF STANDARD CHARACTERS WITHOUT CLAIM TO ANY PARTICULAR FONT, STYLE, SIZE, OR COLOR.

NO CLAIM IS MADE TO THE EXCLUSIVE RIGHT TO USE "BURGER BAR BOSTON", APART FROM THE MARK AS SHOWN.

FOR RESTAURANT AND BAR SERVICES (U.S. CLS. 100 AND 101).
DAWN FELDMAN, EXAMINING ATTORNEY

SN 77-442,653. IQ CORAL GABLES, LLC, COCONUT GROVE, FL. FILED 4-8-2008.

IQ INTERNATIONAL QUESADILLA COMPANY

THE MARK CONSISTS OF STANDARD CHARACTERS WITHOUT CLAIM TO ANY PARTICULAR FONT, STYLE, SIZE, OR COLOR.

NO CLAIM IS MADE TO THE EXCLUSIVE RIGHT TO USE "INTERNATIONAL QUESADILLA COMPANY", APART FROM THE MARK AS SHOWN.

FOR RESTAURANT SERVICES (U.S. CLS. 100 AND 101).
DAVID H. STINE, EXAMINING ATTORNEY

CLASS 43—(Continued).

SN 77-501,391. EMAAR PROPERTIES PJSC, DUBAI, UNITED ARAB EMIR., FILED 6-18-2008.



THE MARK CONSISTS OF THE LETTER "V" IN UPSIDE DOWN FORM INSIDE A SHADED SQUARE.

FOR CATERING FOR THE PROVISION OF FOOD AND BEVERAGES; ARRANGING TEMPORARY HOUSING ACCOMMODATIONS PROVIDED BY INDIVIDUALS AND INSTITUTIONS; PREPARATION OF FOOD AND BEVERAGES FOR CONSUMPTION; CAFES; CAFETERIAS; RESTAURANTS; SNACK BARS; RESERVATION OF ROOMS FOR TRAVELERS (U.S. CLS. 100 AND 101).

DAWN HAN, EXAMINING ATTORNEY

SN 77-515,741. STRUTZEL ENTERPRISES, INC., MONITOR, WA. FILED 7-7-2008.

TASTEBUDS COFFEE AND WINE

THE MARK CONSISTS OF STANDARD CHARACTERS WITHOUT CLAIM TO ANY PARTICULAR FONT, STYLE, SIZE, OR COLOR.

NO CLAIM IS MADE TO THE EXCLUSIVE RIGHT TO USE "COFFEE AND WINE", APART FROM THE MARK AS SHOWN.

FOR COFFEE AND WINE BAR SERVICES; CATERING SERVICES (U.S. CLS. 100 AND 101).

FIRST USE 4-13-2007; IN COMMERCE 4-13-2007.
MATTHEW KLINE, EXAMINING ATTORNEY

CLASS 43—(Continued).

SN 77-519,064. IROHA CORP., NEW YORK, NY. FILED 7-10-2008.

HAGI

THE MARK CONSISTS OF STANDARD CHARACTERS WITHOUT CLAIM TO ANY PARTICULAR FONT, STYLE, SIZE, OR COLOR.

THE TERM "HAGI" DOES NOT HAVE ANY MEANING IN A FOREIGN LANGUAGE.

FOR RESTAURANT AND BAR SERVICES, NAMELY, PROVIDING FOOD AND DRINKS BASED ON JAPANESE CUISINE (U.S. CLS. 100 AND 101).

FIRST USE 12-0-2003; IN COMMERCE 12-0-2003.
CHRISTINA SOBRAL, EXAMINING ATTORNEY

SN 77-519,298. COBRA RESTAURANT INC., DBA THE PARLOUR, NEW YORK, NY. FILED 7-10-2008.

The Parlour

THE MARK CONSISTS OF THE WORDING "THE PARLOUR" ALONG WITH THE DESIGN OF A CLOVER.

SEC. 2(F) AS TO "PARLOUR". FOR RESTAURANT AND BAR SERVICES (U.S. CLS. 100 AND 101).

FIRST USE 9-24-1997; IN COMMERCE 9-24-1997.
MARY MUNSON, EXAMINING ATTORNEY

SN 77-520,159. AMOJE CO., LTD., SEOUL, REPUBLIC OF KOREA, FILED 7-11-2008.

omuto tomato

THE MARK CONSISTS OF STANDARD CHARACTERS WITHOUT CLAIM TO ANY PARTICULAR FONT, STYLE, SIZE, OR COLOR.

NO CLAIM IS MADE TO THE EXCLUSIVE RIGHT TO USE "TOMATO", APART FROM THE MARK AS SHOWN.

THE WORDING "OMUTO" HAS NO MEANING IN A FOREIGN LANGUAGE.

FOR RESTAURANT SERVICES (U.S. CLS. 100 AND 101).

SEAN CROWLEY, EXAMINING ATTORNEY

CLASS 43—(Continued).

SN 77-525,055. BLEDSOE'S INC., ANGOLA, IN. FILED 7-17-2008.

**BLEDSOE'S SAND BAR AT THE
DANCE HALL**

THE MARK CONSISTS OF STANDARD CHARACTERS WITHOUT CLAIM TO ANY PARTICULAR FONT, STYLE, SIZE, OR COLOR.

NO CLAIM IS MADE TO THE EXCLUSIVE RIGHT TO USE "DANCE HALL", APART FROM THE MARK AS SHOWN.

FOR BAR AND RESTAURANT SERVICES (U.S. CLS. 100 AND 101).

ANN E. SAPPENFIELD, EXAMINING ATTORNEY

SN 77-525,058. BLEDSOE'S INC., ANGOLA, IN. FILED 7-17-2008.

BLEDSOE'S BEACH

THE MARK CONSISTS OF STANDARD CHARACTERS WITHOUT CLAIM TO ANY PARTICULAR FONT, STYLE, SIZE, OR COLOR.

THE WORDING "BLEDSOE" AND "BLEDSOE'S BEACH" HAS NO MEANING IN A FOREIGN LANGUAGE.

FOR BAR AND RESTAURANT SERVICES (U.S. CLS. 100 AND 101).

ANN E. SAPPENFIELD, EXAMINING ATTORNEY

SN 77-525,707. MARCHI, NICHOLAS, DBA GRANDSTAND BURGERS, SHAWNEE MISSION, KS. AND MARCHI, LINDA L., DBA GRANDSTAND BURGERS, SHAWNEE MISSION, KS. FILED 7-18-2008.



NO CLAIM IS MADE TO THE EXCLUSIVE RIGHT TO USE "BURGERS", APART FROM THE MARK AS SHOWN.

THE COLOR(S) BLACK, WHITE, GOLD, RED, BLACK AND BLUE IS/ARE CLAIMED AS A FEATURE OF THE MARK.

THE MARK CONSISTS OF TWO BLACK AND WHITE CHECKERBOARD FLAGS APPEARING ABOVE THE WORDING "GRANDSTAND" IN RED WITH BLACK SHADOW OVER A BLUE MARK OUTLINED IN GOLD AND THE WORDING "BURGERS" IN BLACK APPEARING IN A MODIFIED GOLD LOZENGE SHAPE WITH RED OUTLINE AND STRIPES. A BLACK AND WHITE CHECKERBOARD STRIPE APPEARS IN THE BACKGROUND.

FOR RESTAURANT SERVICES (U.S. CLS. 100 AND 101).

FIRST USE 10-0-2005; IN COMMERCE 10-0-2005.
LINDSEY RUBIN, EXAMINING ATTORNEY

CLASS 43—(Continued).

SN 77-539,733. LUKE'S, PHOENIX, AZ. FILED 8-5-2008.



NO CLAIM IS MADE TO THE EXCLUSIVE RIGHT TO USE "OF CHICAGO", APART FROM THE MARK AS SHOWN.

THE STIPPLING IS FOR SHADING PURPOSES ONLY. THE MARK CONSISTS OF THE WORDING "LUKE'S OF CHICAGO" WITH THE DESIGN OF A STYLIZED MAN IN A HAT AND A COAT HOLDING A SANDWICH BETWEEN THE WORDS "OF" AND "CHICAGO".

FOR PROVIDING OF FOOD AND DRINK (U.S. CLS. 100 AND 101).

FIRST USE 8-1-1989; IN COMMERCE 8-1-1989.
JAMES LOVELACE, EXAMINING ATTORNEY

SN 77-550,069. TAJ INTERNATIONAL HOTELS (HK) LIMITED, HONG KONG, HONG KONG, FILED 8-19-2008.

VIVANTA BY TAJ

THE MARK CONSISTS OF STANDARD CHARACTERS WITHOUT CLAIM TO ANY PARTICULAR FONT, STYLE, SIZE, OR COLOR.

OWNER OF U.S. REG. NOS. 1,325,115, 1,605,126 AND 3,317,996.

"TAJ", TRANSLATED INTO ENGLISH, MEANS "CROWN."

FOR SERVICES FOR PROVIDING FOOD AND DRINK INCLUDING RESTAURANT, BAR AND CATERING SERVICES; PROVIDING TEMPORARY ACCOMMODATION INCLUDING PROVISION OF HOLIDAY ACCOMMODATION; BOOKING AND RESERVATION SERVICES FOR RESTAURANTS AND TEMPORARY LODGING (U.S. CLS. 100 AND 101).

PAUL E. FAHRENKOPF, EXAMINING ATTORNEY

SN 77-550,221. THE SOUPER CAFE, INC., BAY CITY, MI. FILED 8-19-2008.

Freshmade from Souper Cafe

THE MARK CONSISTS OF STANDARD CHARACTERS WITHOUT CLAIM TO ANY PARTICULAR FONT, STYLE, SIZE, OR COLOR.

OWNER OF U.S. REG. NO. 3,462,817.

NO CLAIM IS MADE TO THE EXCLUSIVE RIGHT TO USE "FRESHMADE" AND "CAFE", APART FROM THE MARK AS SHOWN.

FOR RESTAURANT SERVICES (U.S. CLS. 100 AND 101).

ZACHARY BELLO, EXAMINING ATTORNEY

CLASS 43—(Continued).

SN 77-563,550. BLUE DIAMOND VENTURE, LLC, LAS VEGAS, NV. FILED 9-5-2008.

EXPO CITY

THE MARK CONSISTS OF STANDARD CHARACTERS WITHOUT CLAIM TO ANY PARTICULAR FONT, STYLE, SIZE, OR COLOR.

NO CLAIM IS MADE TO THE EXCLUSIVE RIGHT TO USE "EXPO", APART FROM THE MARK AS SHOWN.

FOR PROVISION OF GENERAL PURPOSE FACILITIES FOR CONFERENCE MEETINGS, AND EXHIBITIONS; TRAVEL AGENCY SERVICES, MAKING RESERVATIONS AND BOOKING FOR TEMPORARY LODGING (U.S. CLS. 100 AND 101).

CHRISTINA SOBRAL, EXAMINING ATTORNEY

CLASS 43—(Continued).

SN 77-584,549. EL PERIHUETE, INC., PARAMOUNT, CA. FILED 10-2-2008.

Mariscos El Perihuate - Seafood Restaurant

THE MARK CONSISTS OF STANDARD CHARACTERS WITHOUT CLAIM TO ANY PARTICULAR FONT, STYLE, SIZE, OR COLOR.

NO CLAIM IS MADE TO THE EXCLUSIVE RIGHT TO USE "MARISCOS" AND "SEAFOOD RESTAURANT", APART FROM THE MARK AS SHOWN.

THE ENGLISH TRANSLATION OF "MARISCOS" IN THE MARK IS SEAFOOD.

FOR RESTAURANT; RESTAURANT AND BAR SERVICES; RESTAURANT AND CAFE SERVICES; RESTAURANT AND CATERING SERVICES; RESTAURANT SERVICES, INCLUDING SIT-DOWN SERVICE OF FOOD AND TAKE-OUT RESTAURANT SERVICES; RESTAURANT, BAR AND CATERING SERVICES; RESTAURANTS (U.S. CLS. 100 AND 101).

FIRST USE 6-1-2002; IN COMMERCE 6-1-2002.

KAREN BRACEY, EXAMINING ATTORNEY

SN 77-582,929. MARYBELLS CAJUN KITCHEN & COOKING, LLC, MAPLE VALLEY, WA. FILED 10-1-2008.

**Marybell's Cajun
& Creole Catering**

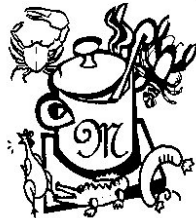

NO CLAIM IS MADE TO THE EXCLUSIVE RIGHT TO USE "CAJUN & CREOLE CATERING", APART FROM THE MARK AS SHOWN.

THE MARK CONSISTS OF THE WORDING "M MARYBELL'S CAJUN & CREOLE CATERING" AND DESIGN WITH THE DESIGN FEATURING A COOKING POT WITH LID AND LADLE AND WITH A CRAB, A CRAWFISH, A CHICKEN, AN ALLIGATOR, AND A SAUSAGE, WITH THE POT RESTING ON A SQUARE CLOTH.

FOR CATERING (U.S. CLS. 100 AND 101).

FIRST USE 5-1-2007; IN COMMERCE 5-1-2007.

KAREN SEVERSON, EXAMINING ATTORNEY

SN 77-596,178. LATIN INTELLECTUAL PROPERTIES, INC., LOS ANGELES, CA. FILED 10-20-2008.

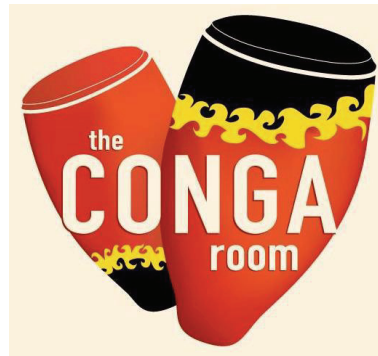

OWNER OF U.S. REG. NOS. 2,230,802 AND 2,685,071.

THE COLOR(S) ORANGE, BLACK, YELLOW AND BEIGE IS/ARE CLAIMED AS A FEATURE OF THE MARK.

THE MARK CONSISTS OF THE TERMS "THE CONGA ROOM" IN THE COLOR BEIGE IN FRONT OF TWO DRUMS IN THE COLORS ORANGE, BLACK AND YELLOW ON A BEIGE BACKGROUND.

SEC. 2(F) AS TO "THE CONGA ROOM".

FOR RESTAURANT SERVICES; BAR SERVICES; RESTAURANTS FEATURING EAT-IN, TAKE-OUT AND DELIVERY SERVICES; AND SELF-SERVICE RESTAURANTS; CATERING OF FOOD AND DRINKS; FOOD PREPARATION; AND CONTRACT FOOD SERVICES (U.S. CLS. 100 AND 101).

B. PARADEWELAI, EXAMINING ATTORNEY

CLASS 43—(Continued).

SN 77-597,361. VELASQUEZ CONTRACTOR, INC., CHANTILLY, VA. FILED 10-21-2008.

AP

THE MARK CONSISTS OF STANDARD CHARACTERS WITHOUT CLAIM TO ANY PARTICULAR FONT, STYLE, SIZE, OR COLOR.

FOR RESTAURANT, BAR, FOOD AND BEVERAGE TAKEOUT AND RESTAURANT AND CATERING SERVICES (U.S. CLS. 100 AND 101).

FIRST USE 10-15-2007; IN COMMERCE 10-15-2007.

ANTHONY RINKER, EXAMINING ATTORNEY

SN 77-620,917. INNSUITES HOTELS, INC., PHOENIX, AZ. FILED 11-24-2008.



OWNER OF U.S. REG. NOS. 1,426,029, 2,415,330 AND 2,443,901.

NO CLAIM IS MADE TO THE EXCLUSIVE RIGHT TO USE "INNSUITES BOUTIQUE HOTEL COLLECTION", APART FROM THE MARK AS SHOWN.

THE MARK CONSISTS OF THE STYLIZED WORDING "INNSUITES" ON TOP, THE WORDING "BOUTIQUE" WITH THE LETTER "B" OVERSIZED IN THE MIDDLE, THE WORDING "HOTEL COLLECTION" ON THE BOTTOM, TWO CIRCLES, ONE LARGER THAN THE OTHER, APPEARING ON THE TOP RIGHT CORNER, AND TWO CIRCLES, ONE LARGER THAN THE OTHER, APPEARING ON THE BOTTOM RIGHT CORNER.

FOR HOTEL SERVICES (U.S. CLS. 100 AND 101).

FIRST USE 10-1-2008; IN COMMERCE 10-1-2008.

JENNY PARK, EXAMINING ATTORNEY

SN 77-626,264. TOUCHMARK LIVING CENTERS, INC., BEAVERTON, OR. FILED 12-4-2008.

MEADOW LAKE VILLAGE

THE MARK CONSISTS OF STANDARD CHARACTERS WITHOUT CLAIM TO ANY PARTICULAR FONT, STYLE, SIZE, OR COLOR.

OWNER OF U.S. REG. NO. 2,904,666.

FOR PROVIDING CONGREGATE, INDEPENDENT, AND ASSISTED LIVING FACILITIES FOR ACTIVE AND SENIOR ADULTS; RETIREMENT HOMES FOR ACTIVE AND SENIOR ADULTS (U.S. CLS. 100 AND 101).

FIRST USE 8-1-2002; IN COMMERCE 8-1-2002.

EDWARD NELSON, EXAMINING ATTORNEY

CLASS 43—(Continued).

SN 77-627,325. UNITED CEREBRAL PALSY ASSOCIATION OF GREATER CHICAGO, CHICAGO, IL. FILED 12-5-2008.



OWNER OF U.S. REG. NOS. 2,195,074, 2,254,174 AND OTHERS.

NO CLAIM IS MADE TO THE EXCLUSIVE RIGHT TO USE "CHEFS TASTING PARTY", APART FROM THE MARK AS SHOWN.

THE MARK CONSISTS OF A STYLIZED CHEF TO THE RIGHT OF THE STYLIZED WORDING "GREAT CHEFS TASTING PARTY".

FOR PROVIDING RECIPES ON AN INTERNET WEBSITE (U.S. CLS. 100 AND 101).

FIRST USE 5-30-2008; IN COMMERCE 5-30-2008.

KELLY BOULTON, EXAMINING ATTORNEY

SN 77-627,338. UNITED CEREBRAL PALSY ASSOCIATION OF GREATER CHICAGO, CHICAGO, IL. FILED 12-5-2008.

GREAT CHEFS TASTING PARTY

THE MARK CONSISTS OF STANDARD CHARACTERS WITHOUT CLAIM TO ANY PARTICULAR FONT, STYLE, SIZE, OR COLOR.

OWNER OF U.S. REG. NOS. 2,195,074, 2,254,174 AND OTHERS.

NO CLAIM IS MADE TO THE EXCLUSIVE RIGHT TO USE "CHEFS TASTING PARTY", APART FROM THE MARK AS SHOWN.

FOR PROVIDING RECIPES ON AN INTERNET WEBSITE (U.S. CLS. 100 AND 101).

FIRST USE 5-30-2008; IN COMMERCE 5-30-2008.

KELLY BOULTON, EXAMINING ATTORNEY

CLASS 43—(Continued).

SN 77-627,399. ALADDIN FOOD MANAGEMENT SERVICES, LLC, WHEELING, WV. FILED 12-5-2008.



NO CLAIM IS MADE TO THE EXCLUSIVE RIGHT TO USE "FOOD MANAGEMENT SERVICES, LLC", APART FROM THE MARK AS SHOWN.

THE COLOR(S) BLUE, GREEN, AND WHITE IS/ARE CLAIMED AS A FEATURE OF THE MARK.

THE MARK CONSISTS OF THE SILHOUETTES OF HOUSES IN A GROUP IN BLUE AND WHITE ABOVE THE WORDING "RESIDENTS" IN BLUE AND "FIRST" IN GREEN, AND THE WORDING APPEARS IN BETWEEN TWO GREEN CURVED BANDS. THE "R" IN "RESIDENTS" IS OVERSIZED AND A SMALL DESIGN ELEMENT ALL IN GREEN CONSISTING OF THE WORDING "ALADDIN FOOD MANAGEMENT SERVICES, LLC" WITH THE IMAGE OF A GENIE'S LAMP, APPEARS UNDERNEATH THE LEFT CORNER OF THE LETTER "R".

FOR CONTRACTED FOOD SERVICE (U.S. CLS. 100 AND 101).

FIRST USE 10-21-2008; IN COMMERCE 10-21-2008. ELLEN BURNS, EXAMINING ATTORNEY

CLASS 43—(Continued).

SN 77-631,032. THE BELL HOUSE, INC., GREENSBORO, NC. FILED 12-11-2008.



THE MARK CONSISTS OF STYLIZED IMAGE OF PERSON IN A WHEELCHAIR.

FOR PROVIDING ASSISTED LIVING HOUSING FACILITIES TO PEOPLE HAVING PHYSICAL DISABILITIES (U.S. CLS. 100 AND 101).

FIRST USE 12-4-2008; IN COMMERCE 12-4-2008. CHERYL CLAYTON, EXAMINING ATTORNEY

SN 77-634,831. RYDGES HOTELS LIMITED, SYDNEY, AUSTRALIA, FILED 12-17-2008.

SN 77-631,020. THE BELL HOUSE, INC., GREENSBORO, NC. FILED 12-11-2008.

ABODE BY RYDGES



THE MARK CONSISTS OF STYLIZED IMAGE OF PERSON IN A WHEELCHAIR WITH WORDS "BELL HOUSE WHERE INDEPENDENCE LIVES".

FOR PROVIDING ASSISTED LIVING HOUSING FACILITIES TO PEOPLE HAVING PHYSICAL DISABILITIES (U.S. CLS. 100 AND 101).

FIRST USE 12-4-2008; IN COMMERCE 12-4-2008. CHERYL CLAYTON, EXAMINING ATTORNEY

THE MARK CONSISTS OF STANDARD CHARACTERS WITHOUT CLAIM TO ANY PARTICULAR FONT, STYLE, SIZE, OR COLOR.

PRIORITY CLAIMED UNDER SEC. 44(D) ON AUSTRALIA APPLICATION NO. 1247402, FILED 6-18-2008.

OWNER OF AUSTRALIA REG. NO. 1247402, DATED 1-27-2009, EXPIRES 1-27-2019.

FOR HOTEL AND RESORT HOTEL SERVICES; RESERVATION SERVICES FOR HOTEL AND RESORT ACCOMMODATIONS; TEMPORARY ACCOMMODATION SERVICES; RESTAURANT, CAFE AND BAR SERVICES; CATERING SERVICES; PROVIDING FACILITIES FOR EXHIBITIONS AND CONFERENCES (U.S. CLS. 100 AND 101).

RENEE SERVANCE, EXAMINING ATTORNEY

CLASS 43—(Continued).

SN 77-636,957. THE DEPARTMENT, INC., JOLIET, IL. FILED 12-19-2008.



NO CLAIM IS MADE TO THE EXCLUSIVE RIGHT TO USE "CASUAL FINE DINING & MARTINI BAR", APART FROM THE MARK AS SHOWN.

THE MARK CONSISTS OF THE WORDS "THE DEPARTMENT CASUAL FINE DINING & MARTINI BAR". A MARTINI GLASS FORMS A PART OF THE LETTER "P" IN THE WORD "DEPARTMENT". AN OFFICER'S SHIELD APPEARS INSIDE THE MARTINI GLASS.

FOR RESTAURANT AND BAR SERVICES (U.S. CLS. 100 AND 101).

WENDY GOODMAN, EXAMINING ATTORNEY

CLASS 43—(Continued).

SN 77-644,764. CARL VON LUGER, LLC, DBA CARL VON LUGER, CLARKS SUMMIT, PA. FILED 1-7-2009.

Carl von Luger

THE MARK CONSISTS OF STANDARD CHARACTERS WITHOUT CLAIM TO ANY PARTICULAR FONT, STYLE, SIZE, OR COLOR.

THE NAME(S), PORTRAIT(S), AND/OR SIGNATURE(S) SHOWN IN THE MARK DOES NOT IDENTIFY A PARTICULAR LIVING INDIVIDUAL.

FOR BAR AND RESTAURANT SERVICES; CAFE AND RESTAURANT SERVICES; CAFE-RESTAURANTS; RESTAURANT; RESTAURANT AND BAR SERVICES; RESTAURANT AND CAFE SERVICES; RESTAURANT SERVICES, INCLUDING SIT-DOWN SERVICE OF FOOD AND TAKE-OUT RESTAURANT SERVICES; RESTAURANT, BAR AND CATERING SERVICES (U.S. CLS. 100 AND 101).

BONNIE LUKEN, EXAMINING ATTORNEY

SN 77-647,558. MARSHLACK, DEAN G., ST. PETERSBURG, FL. FILED 1-12-2009.

Bishop Tavern

THE MARK CONSISTS OF STANDARD CHARACTERS WITHOUT CLAIM TO ANY PARTICULAR FONT, STYLE, SIZE, OR COLOR.

NO CLAIM IS MADE TO THE EXCLUSIVE RIGHT TO USE "TAVERN", APART FROM THE MARK AS SHOWN.

FOR BAR SERVICES (U.S. CLS. 100 AND 101).

FIRST USE 5-1-2005; IN COMMERCE 5-1-2005.

DAVID TAYLOR, EXAMINING ATTORNEY

SN 77-648,672. SHSD, LLC, LAS VEGAS, NV. FILED 1-13-2009.

SUITE&TENDER

THE MARK CONSISTS OF STANDARD CHARACTERS WITHOUT CLAIM TO ANY PARTICULAR FONT, STYLE, SIZE, OR COLOR.

FOR RESTAURANT AND BAR SERVICES (U.S. CLS. 100 AND 101).

FIRST USE 12-11-2008; IN COMMERCE 12-11-2008.

DEIRDRE ROBERTSON, EXAMINING ATTORNEY

SN 77-637,487. WRIGHT, DALE, B, EVANSVILLE, IN. FILED 12-21-2008.



NO CLAIM IS MADE TO THE EXCLUSIVE RIGHT TO USE "RED" OR "LODGE", APART FROM THE MARK AS SHOWN.

THE COLOR(S) IMITATION GOLD, TAN, BLACK, ORANGE, GREEN, AND RED IS/ARE CLAIMED AS A FEATURE OF THE MARK.

THE MARK CONSISTS OF A LODGING DESIGN IN TAN WITH A RED ROOF WITH A BLACK DOG WEARING A GREEN BANDANA INSIDE, WITH THE WORDING "RED WOOF LODGE" IN BLACK LETTERING OUTLINED IN GOLD, AND AN ORANGE AND YELLOW GRADIENT SUN OVER THE ROOF.

FOR PET BOARDING SERVICES (U.S. CLS. 100 AND 101).

FIRST USE 6-15-2008; IN COMMERCE 6-20-2008.

DOMINIC J. FERRAIUOLO, EXAMINING ATTORNEY

CLASS 43—(Continued).

SN 77-650,435. LEAN AND GREEN, INC., LA JOLLA, CA. FILED 1-15-2009.



NO CLAIM IS MADE TO THE EXCLUSIVE RIGHT TO USE "ORGANIC HEALTH BAR", APART FROM THE MARK AS SHOWN.

THE MARK CONSISTS OF A CIRCULAR SEAL COMPRISED OF TWO COCENTRIC CIRCLES. THE OUTER CIRCLE CONTAINS THE WORDING "LEAN AND GREEN" AT THE TOP OF THE CIRCLE AND "ORGANIC HEALTH BAR" AT THE BOTTOM OF THE CIRCLE AND ONE LEAF IN BETWEEN "LEAN" AND "ORGANIC" AND ONE LEAF IN BETWEEN "GREEN" AND "BAR". THE INSIDE CIRCLE CONTAINS A BOWL WITH A FORK COMING OUT OF THE MIDDLE OF THE BOWL AND THE HANDLE OF THE FORK BRANCHES OUT INTO A TREE.

FOR CAFE AND RESTAURANT SERVICES FEATURING ONLY ORGANIC FOOD AND BEVERAGES (U.S. CLS. 100 AND 101).

FIRST USE 7-1-2007; IN COMMERCE 7-1-2007.
SETH A. RAPPAPORT, EXAMINING ATTORNEY

CLASS 43—(Continued).

SN 77-656,210. CFR CORP., NEW YORK, NY. FILED 1-26-2009.



THE COLOR(S) RED, WHITE, BLACK, GREEN AND GRAY IS/ARE CLAIMED AS A FEATURE OF THE MARK. THE MARK CONSISTS OF A BOUQUET OF RED ROSES WITH GREEN LEAVES AND WITH BLACK COLOR OUTLINES, AND THE ROSES ARE RESTING ON A GRAY, WHITE AND BLACK CHAMPAGNE FLUTE GLASS VASE. FOR BAR SERVICES (U.S. CLS. 100 AND 101). FIRST USE 12-20-2007; IN COMMERCE 12-20-2007. TEJBIR SINGH, EXAMINING ATTORNEY

SN 77-659,657. JAYS NICKELS AND DIMES INC, DBA WESTVILLE, NEW YORK, NY. FILED 1-29-2009.

WESTVILLE

THE MARK CONSISTS OF STANDARD CHARACTERS WITHOUT CLAIM TO ANY PARTICULAR FONT, STYLE, SIZE, OR COLOR.

FOR RESTAURANT SERVICES, INCLUDING SIT-DOWN SERVICE OF FOOD AND TAKE-OUT RESTAURANT SERVICES (U.S. CLS. 100 AND 101).

FIRST USE 3-5-2001; IN COMMERCE 3-5-2001.
GRETTA YAO, EXAMINING ATTORNEY

SN 77-655,086. DOCTOR'S ASSOCIATES INC., PLANTATION, FL. FILED 1-23-2009.



NO CLAIM IS MADE TO THE EXCLUSIVE RIGHT TO USE \$5, APART FROM THE MARK AS SHOWN.

THE MARK CONSISTS OF OULINE OF HAND WITH \$5 IN PALM OF HAND.

FOR RESTAURANT SERVICES (U.S. CLS. 100 AND 101). FIRST USE 5-12-2008; IN COMMERCE 5-12-2008. CYNTHIA SLOAN, EXAMINING ATTORNEY

SN 77-661,139. MALLOY, SHAKEETA, UPPER DARBY, PA. FILED 2-2-2009.

Wiz Kidz Academy

THE MARK CONSISTS OF STANDARD CHARACTERS WITHOUT CLAIM TO ANY PARTICULAR FONT, STYLE, SIZE, OR COLOR.

NO CLAIM IS MADE TO THE EXCLUSIVE RIGHT TO USE "KIDS ACADEMY", APART FROM THE MARK AS SHOWN.

FOR CHILD CARE CENTERS; CHILD CARE SERVICES (U.S. CLS. 100 AND 101). MICHAEL ENGEL, EXAMINING ATTORNEY

CLASS 43—(Continued).

SN 77-661,718. EL PATO MEXICAN FOOD, LP, MCALLEN, TX. FILED 2-2-2009.

PATOZAZO

THE MARK CONSISTS OF STANDARD CHARACTERS WITHOUT CLAIM TO ANY PARTICULAR FONT, STYLE, SIZE, OR COLOR.

THE WORDING PATOZAZO HAS NO MEANING IN A FOREIGN LANGUAGE.

FOR RESTAURANT SERVICES (U.S. CLS. 100 AND 101).

LAKEISHA LEWIS, EXAMINING ATTORNEY



SN 77-662,624. JJP, LLC, CHICAGO, IL. FILED 2-3-2009.

Officetel

THE MARK CONSISTS OF STANDARD CHARACTERS WITHOUT CLAIM TO ANY PARTICULAR FONT, STYLE, SIZE, OR COLOR.

FOR RESIDENTIAL HOTELS (U.S. CLS. 100 AND 101).

ALICE SUE CARRUTHERS, EXAMINING ATTORNEY



SN 77-662,636. LANDIAK, WENDY, WALNUTPORT, PA. FILED 2-3-2009.

BALASIA

THE MARK CONSISTS OF STANDARD CHARACTERS WITHOUT CLAIM TO ANY PARTICULAR FONT, STYLE, SIZE, OR COLOR.

FOR RESTAURANT SERVICES (U.S. CLS. 100 AND 101).

FIRST USE 8-14-2005; IN COMMERCE 5-1-2006.
AMY C. KEAN, EXAMINING ATTORNEY

CLASS 43—(Continued).

SN 77-662,922. SODEXO OPERATIONS, LLC, GAITHERSBURG, MD. FILED 2-4-2009.

MOMENTS TO SAVOR

THE MARK CONSISTS OF STANDARD CHARACTERS WITHOUT CLAIM TO ANY PARTICULAR FONT, STYLE, SIZE, OR COLOR.

FOR CONTRACT FOOD SERVICES (U.S. CLS. 100 AND 101).

HEATHER BIDDULPH, EXAMINING ATTORNEY



SN 77-664,101. MY COMPANY 4, INC., ATLANTA, GA. FILED 2-5-2009.

FUEGOMUNDO

THE MARK CONSISTS OF STANDARD CHARACTERS WITHOUT CLAIM TO ANY PARTICULAR FONT, STYLE, SIZE, OR COLOR.

THE ENGLISH TRANSLATION OF "FUEGO" IS FIRE AND "MUNDO" IS WORLD.

FOR RESTAURANT SERVICES (U.S. CLS. 100 AND 101).

TARAH HARDY, EXAMINING ATTORNEY



SN 77-664,326. CONCEPT ACQUISITIONS II, LLC, LAKE MARY, FL. FILED 2-5-2009.

QUICKFIRE'S GRILLE

THE MARK CONSISTS OF STANDARD CHARACTERS WITHOUT CLAIM TO ANY PARTICULAR FONT, STYLE, SIZE, OR COLOR.

NO CLAIM IS MADE TO THE EXCLUSIVE RIGHT TO USE "GRILLE", APART FROM THE MARK AS SHOWN.

FOR CAFES; RESTAURANTS; CAFETERIAS; CARRY-OUT RESTAURANTS; FAST FOOD AND NONSTOP RESTAURANTS; SNACK BARS; CATERING SERVICES; RESTAURANTS FEATURING SIT-DOWN AND TAKE-OUT SERVICES; PROVIDING FOOD AND BEVERAGES FOR CONSUMPTION ON AND OFF THE PREMISES (U.S. CLS. 100 AND 101).

ALICE SUE CARRUTHERS, EXAMINING ATTORNEY

CLASS 43—(Continued).

SN 77-664,404. ISLE OF CAPRI CASINOS, INC., ST. LOUIS, MO. FILED 2-5-2009.



NO CLAIM IS MADE TO THE EXCLUSIVE RIGHT TO USE "BAR AND GRILL", APART FROM THE MARK AS SHOWN.

THE MARK CONSISTS OF THE LETTERS "O" AND "H" SUPERIMPOSED BY AN AMPERSAND AND ABOVE THE WORDING "OTIS & HENRY'S BAR AND GRILL".

FOR BAR AND RESTAURANT SERVICES (U.S. CLS. 100 AND 101).

GRETCHEN ULRICH, EXAMINING ATTORNEY

SN 77-664,409. ISLE OF CAPRI CASINOS, INC., ST. LOUIS, MO. FILED 2-5-2009.

OTIS & HENRY'S

THE MARK CONSISTS OF STANDARD CHARACTERS WITHOUT CLAIM TO ANY PARTICULAR FONT, STYLE, SIZE, OR COLOR.

FOR BAR AND RESTAURANT SERVICES (U.S. CLS. 100 AND 101).

GRETCHEN ULRICH, EXAMINING ATTORNEY

SN 77-664,731. WYNDHAM TM CORP., LAS VEGAS, NV. FILED 2-6-2009.

INVENTIVE MEETINGS & EVENTS

THE MARK CONSISTS OF STANDARD CHARACTERS WITHOUT CLAIM TO ANY PARTICULAR FONT, STYLE, SIZE, OR COLOR.

NO CLAIM IS MADE TO THE EXCLUSIVE RIGHT TO USE "MEETINGS & EVENTS", APART FROM THE MARK AS SHOWN.

FOR HOTEL SERVICES, NAMELY, PROVIDING TEMPORARY ACCOMMODATION AND RESTAURANT SERVICES; MAKING HOTEL AND RESTAURANT RESERVATIONS FOR OTHERS; CATERING; AND PROVIDING BANQUET AND MEETING FACILITIES (U.S. CLS. 100 AND 101).

FIRST USE 10-0-2008; IN COMMERCE 10-0-2008.

MARK PILARO, EXAMINING ATTORNEY

CLASS 43—(Continued).

SN 77-664,756. SNYDER, GREGG R, RUSHVILLE, IL. FILED 2-6-2009.

LICK MY BOWLS

THE MARK CONSISTS OF STANDARD CHARACTERS WITHOUT CLAIM TO ANY PARTICULAR FONT, STYLE, SIZE, OR COLOR.

FOR RESTAURANT (U.S. CLS. 100 AND 101).

REBECCA SMITH, EXAMINING ATTORNEY

SN 77-664,910. SCATTOLINI, OSCAR DANIEL CREMASCO, MIAMI, FL. FILED 2-6-2009.



NO CLAIM IS MADE TO THE EXCLUSIVE RIGHT TO USE "PUERTO MADERO", APART FROM THE MARK AS SHOWN.

THE COLOR(S) BLACK AND ORANGE IS/ARE CLAIMED AS A FEATURE OF THE MARK.

THE MARK CONSISTS OF AN OVAL, WITH AN ORANGE BORDER AND BLACK SCREWS AND BLACK BACKGROUND. THE WORDS "PUERTO MADERO" ARE LOCATED INSIDE THE OVAL.

THE ENGLISH TRANSLATION OF "PUERTO MADERO" IS "PORT BEAM".

FOR RESTAURANT AND BAR SERVICES (U.S. CLS. 100 AND 101).

ERIN FALK, EXAMINING ATTORNEY

SN 77-665,119. LEWIS, WILLIAM R., GRAND RAPIDS, MI. FILED 2-6-2009.

MR. FABLES

THE MARK CONSISTS OF STANDARD CHARACTERS WITHOUT CLAIM TO ANY PARTICULAR FONT, STYLE, SIZE, OR COLOR.

FOR RESTAURANT SERVICES (U.S. CLS. 100 AND 101).

KATHERINE CHANG, EXAMINING ATTORNEY

CLASS 43—(Continued).

SN 77-665,452. FULLER, JEFFREY R., MEQUON, WI. FILED 2-6-2009.

ME@T

THE MARK CONSISTS OF STANDARD CHARACTERS WITHOUT CLAIM TO ANY PARTICULAR FONT, STYLE, SIZE, OR COLOR.

FOR RESTAURANT AND BAR SERVICES (U.S. CLS. 100 AND 101).

BARBARA A. GOLD, EXAMINING ATTORNEY

SN 77-665,571. CARL KARCHER ENTERPRISES, INC., CARPINTERIA, CA. FILED 2-6-2009.

MORE THAN JUST A PIECE OF
MEAT

THE MARK CONSISTS OF STANDARD CHARACTERS WITHOUT CLAIM TO ANY PARTICULAR FONT, STYLE, SIZE, OR COLOR.

FOR RESTAURANT SERVICES (U.S. CLS. 100 AND 101).

RUSS HERMAN, EXAMINING ATTORNEY

SN 77-665,803. MB FLORIDA LIMITED, L.P, MIAMI BEACH, FL. FILED 2-8-2009.

GRAND BEACH

THE MARK CONSISTS OF STANDARD CHARACTERS WITHOUT CLAIM TO ANY PARTICULAR FONT, STYLE, SIZE, OR COLOR.

NO CLAIM IS MADE TO THE EXCLUSIVE RIGHT TO USE "BEACH", APART FROM THE MARK AS SHOWN.

FOR HOTELS; CONDOMINIUM HOTELS (U.S. CLS. 100 AND 101).

KAREN SEVERSON, EXAMINING ATTORNEY

CLASS 43—(Continued).

SN 77-665,844. THEATER RESTAURANT PARTNERS INC., HOUSTON, TX. FILED 2-8-2009.

BIRRA PORETTI'S

THE MARK CONSISTS OF STANDARD CHARACTERS WITHOUT CLAIM TO ANY PARTICULAR FONT, STYLE, SIZE, OR COLOR.

NO CLAIM IS MADE TO THE EXCLUSIVE RIGHT TO USE "BIRRA", APART FROM THE MARK AS SHOWN.

THE ENGLISH TRANSLATION OF "BIRRA" IN THE MARK IS BEER.

FOR BAR AND RESTAURANT SERVICES; CARRY-OUT RESTAURANTS; CATERING FOR THE PROVISION OF FOOD AND BEVERAGES (U.S. CLS. 100 AND 101).

FIRST USE 7-0-1974; IN COMMERCE 7-0-1974.

RONALD MCMORROW, EXAMINING ATTORNEY

SN 77-665,845. THEATER RESTAURANT PARTNERS INC., HOUSTON, TX. FILED 2-8-2009.



NO CLAIM IS MADE TO THE EXCLUSIVE RIGHT TO USE "BIRRA", APART FROM THE MARK AS SHOWN.

THE MARK CONSISTS OF THE WORDS "BIRRA PORETTI'S" TOPPED BY A SHAMROCK AND ATOP A CLUMP OF GRAPES.

THE ENGLISH TRANSLATION OF "BIRRA" IS "BEER".

FOR BAR AND RESTAURANT SERVICES; CARRY-OUT RESTAURANTS; CATERING FOR THE PROVISION OF FOOD AND BEVERAGES (U.S. CLS. 100 AND 101).

FIRST USE 7-0-1974; IN COMMERCE 7-0-1974.

RONALD MCMORROW, EXAMINING ATTORNEY

CLASS 43—(Continued).

SN 77-667,036. CANAD CORPORATION OF MANITOBA LTD., WINNIPEG, CANADA, FILED 2-10-2009.

WINTERLICIOUS

THE MARK CONSISTS OF STANDARD CHARACTERS WITHOUT CLAIM TO ANY PARTICULAR FONT, STYLE, SIZE, OR COLOR.

FOR RESTAURANT AND BAR SERVICES (U.S. CLS. 100 AND 101).

DAVID C. REIHNER, EXAMINING ATTORNEY



SN 77-668,563. MGM MIRAGE, LAS VEGAS, NV. FILED 2-11-2009.

SKYLOFTS

THE MARK CONSISTS OF STANDARD CHARACTERS WITHOUT CLAIM TO ANY PARTICULAR FONT, STYLE, SIZE, OR COLOR.

FOR HOTELS AND HOTEL RESORT SERVICES (U.S. CLS. 100 AND 101).

FIRST USE 12-23-2004; IN COMMERCE 12-23-2004.
GINA HAYES, EXAMINING ATTORNEY

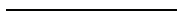

SN 77-669,221. MGM MIRAGE, LAS VEGAS, NV. FILED 2-12-2009.



SKYLOFTS

THE MARK CONSISTS OF A VERTICAL RECTANGLE WITH TWO VERTICAL AND TWO HORIZONTAL LINES THAT MEET INSIDE THE RECTANGLE FORMING TWO 90 DEGREE ANGLES AND THE WORD "SKYLOFTS" BELOW THE RECTANGLE.

FOR HOTEL AND HOTEL RESORT SERVICES (U.S. CLS. 100 AND 101).

FIRST USE 12-23-2004; IN COMMERCE 12-23-2004.
GINA HAYES, EXAMINING ATTORNEY

CLASS 43—(Continued).

SN 77-676,482. KHOURY, SALIM, LONG BEACH, CA. FILED 2-23-2009.



NO CLAIM IS MADE TO THE EXCLUSIVE RIGHT TO USE "FRESH SEAFOOD DAILY", APART FROM THE MARK AS SHOWN.

THE COLOR(S) NAVY BLUE AND LIGHT GREEN IS/ARE CLAIMED AS A FEATURE OF THE MARK.

THE MARK CONSISTS OF THE WORDS "FISH-O-LICIOUS" WITH THE "O" CONSISTING OF A CIRCULAR DESIGN PICTURING A FISH (LIGHT GREEN COLOR) JUMPING OUT OF A BODY OF WATER. THE WORDS "FRESH SEAFOOD DAILY" BELOW AND THE WORDS "FISH-O-LICIOUS" AT THE TOP OF THE CIRCLE. THE WATER AND WORDS "FISH-O-LICIOUS" ARE IN NAVY BLUE.

FOR RESTAURANT SERVICES (U.S. CLS. 100 AND 101).

AARON BRODSKY, EXAMINING ATTORNEY

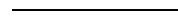

SN 77-676,500. KHOURY, SALIM, LONG BEACH, CA. FILED 2-23-2009.



NO CLAIM IS MADE TO THE EXCLUSIVE RIGHT TO USE "FRESH SEAFOOD DAILY", APART FROM THE MARK AS SHOWN.

THE COLOR(S) NAVY BLUE AND LIGHT GREEN IS/ARE CLAIMED AS A FEATURE OF THE MARK.

THE MARK CONSISTS OF A CIRCULAR DESIGN WITH THE WORDS "FISH-O-LICIOUS" IN NAVY BLUE AT THE TOP OF THE CIRCLE, A FISH (LIGHT GREEN) JUMPING OUT OF A BODY OF WATER IN THE MIDDLE OF THE CIRCLE AND THE WATER (NAVY BLUE) WITH THE WORDS "FRESH SEAFOOD DAILY" AT THE BOTTOM OF THE CIRCLE.

FOR RESTAURANT SERVICES (U.S. CLS. 100 AND 101).

AARON BRODSKY, EXAMINING ATTORNEY

CLASS 43—(Continued).

SN 77-678,933. ISLE OF CAPRI CASINOS, INC., ST. LOUIS, MO. FILED 2-26-2009.

O & H EXPRESS

THE MARK CONSISTS OF STANDARD CHARACTERS WITHOUT CLAIM TO ANY PARTICULAR FONT, STYLE, SIZE, OR COLOR.

NO CLAIM IS MADE TO THE EXCLUSIVE RIGHT TO USE "EXPRESS", APART FROM THE MARK AS SHOWN.

FOR RESTAURANT SERVICES (U.S. CLS. 100 AND 101).

GRETCHEN ULRICH, EXAMINING ATTORNEY

SN 78-245,635. S & S HAWAII B.B.Q., LLC, ROLAND HEIGHTS, CA. FILED 5-5-2003.



NO CLAIM IS MADE TO THE EXCLUSIVE RIGHT TO USE "HAWAIIAN BBQ", APART FROM THE MARK AS SHOWN.

THE MARK CONSISTS OF THE WORDING "ONO HAWAIIAN BBQ" WITH A STYLIZED FLOWER DESIGN AND TWO PALM FRONDS ON THE TOP OF EACH LETTER "I" IN "HAWAIIAN" ON A DARK RECTANGULAR BACKGROUND WITH A WAVY BORDER AT THE BOTTOM.

THE WORD "ONO" IS TRANSLATED AS "DELICIOUS" IN HAWAIIAN.

FOR QUICK SERVICE RESTAURANT SERVING INTERNATIONAL FOOD SUCH AS JAPANESE, CHINESE, PHILIPINO, AMERICAN, POLYNESIAN AND HAWAIIAN FOOD (U.S. CLS. 100 AND 101).

JOHN E. MICHOS, EXAMINING ATTORNEY

SN 79-066,976. DIETIQUETTE DI FABRIZIO BARBAGLIA, ITALY, FILED 12-23-2008.

DIETIQUETTE

THE MARK CONSISTS OF STANDARD CHARACTERS WITHOUT CLAIM TO ANY PARTICULAR FONT, STYLE, SIZE, OR COLOR.

PRIORITY DATE OF 8-7-2008 IS CLAIMED.

OWNER OF INTERNATIONAL REGISTRATION 0997943 DATED 12-23-2008, EXPIRES 12-23-2018.

FOR CATERING OF FOOD AND DRINK; CATERING FOR THE PROVISION OF FOOD AND BEVERAGES; PROVIDING OF FOODS, MEALS AND BEVERAGES (U.S. CLS. 100 AND 101).

JEFFREY LOOK, EXAMINING ATTORNEY

CLASS 44—MEDICAL, BEAUTY AND AGRICULTURAL SERVICES

SN 76-673,107. STEPHANIE S. SMITH, D.D.S., M.S., P.A., MCKINNEY, TX. FILED 2-23-2007.



FOR DENTISTRY AND ORTHODONTIC SERVICES OF ALL KINDS, NAMELY, GENERAL, PEDIATRIC, ADOLESCENT, COSMETIC, AND ADULT DENTISTRY, ORTHODONTIC, AND HYGIENIST TREATMENT, AND ADVICE AND COUNSELING IN THE FIELD OF DENTAL AND ORTHODONTIC TREATMENT (U.S. CLS. 100 AND 101).

JENNY PARK, EXAMINING ATTORNEY

SN 76-696,331. JOHNSON & JOHNSON, NEW BRUNSWICK, NJ. FILED 3-16-2009.

SIMPONIONE

THE MARK CONSISTS OF STANDARD CHARACTERS WITHOUT CLAIM TO ANY PARTICULAR FONT, STYLE, SIZE, OR COLOR.

FOR PROVIDING MEDICAL INFORMATION IN THE FIELD OF IMMUNOLOGY (U.S. CLS. 100 AND 101).

DAVID COLLIER, EXAMINING ATTORNEY

CLASS 44—(Continued).

SN 77-124,090. KEEP US SAFER, LLC, HOUSTON, TX. FILED 3-7-2007.



NO CLAIM IS MADE TO THE EXCLUSIVE RIGHT TO USE "MED STATS", "HEALTH RECORDS 24/7" AND THE CADUCEUS SYMBOL, APART FROM THE MARK AS SHOWN.

THE MARK CONSISTS OF THE WORDING "MY MED STATS HEALTH RECORDS 24/7" AND TWO STYLIZED FIGURES FORMING A STYLIZED HEART DESIGN WITH A CADUCEUS SYMBOL IN THE MIDDLE OF THE HEART.

FOR MAINTAINING FILES AND RECORDS CONCERNING THE MEDICAL CONDITION OF INDIVIDUALS; MAINTAINING PERSONAL MEDICAL HISTORY RECORDS AND FILES; MEDICAL SERVICES, NAMELY, PROVIDING MEDICAL INFORMATION DURING TIMES OF NEED VIA PHONE; MEDICAL ASSISTANCE SERVICES (U.S. CLS. 100 AND 101).

JAY FLOWERS, EXAMINING ATTORNEY

SN 77-163,250. EHEALTH INITIATIVE, WASHINGTON, DC. FILED 4-23-2007.

eHI HIE VALUE AND SUSTAINABILITY MODEL

THE MARK CONSISTS OF STANDARD CHARACTERS WITHOUT CLAIM TO ANY PARTICULAR FONT, STYLE, SIZE, OR COLOR.

NO CLAIM IS MADE TO THE EXCLUSIVE RIGHT TO USE "HIE VALUE AND SUSTAINABILITY MODEL", APART FROM THE MARK AS SHOWN.

FOR PROVIDING AN INTERNET WEB SITE FOR MEDICAL PROFESSIONALS AND MEDICAL PATIENTS ALLOWING FOR THE EXCHANGE OF COMMUNITY-BASED HEALTH INFORMATION THAT CAN BE ACCESSED IN REAL-TIME BY USERS (U.S. CLS. 100 AND 101).

FIRST USE 2-20-2007; IN COMMERCE 2-20-2007.
CAROLYN CATALDO, EXAMINING ATTORNEY

SN 77-242,948. FLOYD, EDDIE, AUSTIN, TX. FILED 7-31-2007.

Bark 'n Purr

THE MARK CONSISTS OF STANDARD CHARACTERS WITHOUT CLAIM TO ANY PARTICULAR FONT, STYLE, SIZE, OR COLOR.

FOR PET CARE SERVICES, NAMELY, NON-MEDICATED PET GROOMING SERVICES (U.S. CLS. 100 AND 101).

FIRST USE 10-31-1966; IN COMMERCE 10-31-1966.
BRIAN CALLAGHAN, EXAMINING ATTORNEY

CLASS 44—(Continued).

SN 77-352,358. GATEWAY HEALTH PLAN, L.P., PITTSBURGH, PA. FILED 12-14-2007.

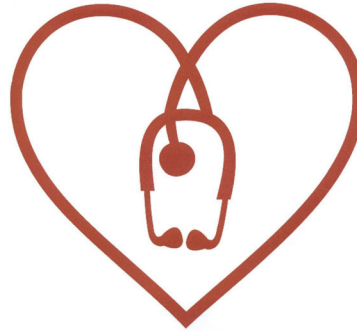

THE COLOR(S) RED IS/ARE CLAIMED AS A FEATURE OF THE MARK.

THE MARK CONSISTS OF A RED STETHOSCOPE CONFIGURED IN THE SHAPE OF A HEART NOT INCLUDING ANY BACKGROUND COLOR.

FOR PROVIDING MANAGED HEALTH CARE SERVICES FOR MEMBERS (U.S. CLS. 100 AND 101).

LAURIE MAYES, EXAMINING ATTORNEY

SN 77-387,121. SANOFI-AVENTIS, PARIS, FRANCE, FILED 2-2-2008.



OWNER OF U.S. REG. NO. 2,380,297.

NO CLAIM IS MADE TO THE EXCLUSIVE RIGHT TO USE "(CLOPIDOGREL BISULFATE) 75 MG TABLETS" AND "INFO CENTRAL 1.800.720.1647", APART FROM THE MARK AS SHOWN.

THE MARK CONSISTS OF THE TERM "PLAVIX" OVER WHICH THERE ARE DOTTED LINES. BELOW "PLAVIX" IS THE WORDING "(CLOPIDOGREL BISULFATE) 75 MG TABLETS." BELOW THAT, "INFO CENTRAL" APPEARS IN ALL CAPITAL LETTERS SURROUNDED BY AN ELLIPSE OR OVAL. THE BOTTOM PART OF THE ELLIPSE OR OVAL COMPRISES THE LITERAL ELEMENT "1.800.720.1647". BELOW THE ELLIPSE AND PHONE NUMBER, THE WORDING "WWW.PLAVIXINFOCENTRAL.COM" APPEARS.

FOR PROVIDING MEDICAL AND HEALTH INFORMATION; MEDICAL INFORMATION SERVICES, NAMELY, PROVIDING MEDICAL INFORMATION TO DOCTORS AND PHYSICIANS ABOUT CARDIOVASCULAR DISEASES, DISORDERS AND CONDITIONS (U.S. CLS. 100 AND 101).

FIRST USE 5-31-2008; IN COMMERCE 5-31-2008.
SAIMA MAKHDOOM, EXAMINING ATTORNEY

CLASS 44—(Continued).

SN 77-505,495. AGNESIAN HEALTHCARE, INC., FOND DU LAC, WI. FILED 6-23-2008.

AGNESIAN EZ CARE

THE MARK CONSISTS OF STANDARD CHARACTERS WITHOUT CLAIM TO ANY PARTICULAR FONT, STYLE, SIZE, OR COLOR.

OWNER OF U.S. REG. NOS. 2,444,254, 3,212,736 AND OTHERS.

NO CLAIM IS MADE TO THE EXCLUSIVE RIGHT TO USE "CARE", APART FROM THE MARK AS SHOWN.

THE WORDING "AGNESIAN" HAS NO MEANING IN A FOREIGN LANGUAGE.

FOR CONDUCTING MEDICAL PHYSICAL EVALUATIONS; HEALTHCARE; MEDICAL AND PHARMACEUTICAL CONSULTATION; MEDICAL CLINICS; MEDICAL CONSULTATIONS; MEDICAL COUNSELING; MEDICAL SERVICES (U.S. CLS. 100 AND 101).

LAURA HAMMEL, EXAMINING ATTORNEY

CLASS 44—(Continued).

SN 77-513,448. ST. FRANCIS HEALTH SYSTEM, INC., GREENVILLE, SC. FILED 7-2-2008.

MINISURGERY AT ST. FRANCIS

THE MARK CONSISTS OF STANDARD CHARACTERS WITHOUT CLAIM TO ANY PARTICULAR FONT, STYLE, SIZE, OR COLOR.

NO CLAIM IS MADE TO THE EXCLUSIVE RIGHT TO USE "MINISURGERY", APART FROM THE MARK AS SHOWN.

FOR MEDICAL SERVICES, NAMELY, PERFORMING OR PROVIDING INFORMATION ABOUT VARIOUS MEDICAL PROCEDURES, NAMELY, THORACOSOPIC LOBECTOMIES, HYSTERECTOMIES, GASTROINTESTINAL PROCEDURES, UROLOGICAL PROCEDURES, APPENDECTOMIES, HERNIA REPAIRS, AND GASTRIC BYPASS (U.S. CLS. 100 AND 101).

FIRST USE 9-2-2005; IN COMMERCE 9-2-2005.

JAMES LOVELACE, EXAMINING ATTORNEY

SN 77-509,259. NEW MEDICAL HORIZONS II, LTD., DALLAS, TX. FILED 6-26-2008.

Cypress Fairbanks Leg Pain Program



OWNER OF U.S. REG. NOS. 3,391,286, 3,440,204 AND OTHERS.

NO CLAIM IS MADE TO THE EXCLUSIVE RIGHT TO USE "LEG PAIN PROGRAM" AND "A PART OF CY-FAIR REGIONAL HEALTH NETWORK", APART FROM THE MARK AS SHOWN.

THE COLOR(S) WHITE, LIME GREEN, LIGHT TURQUOISE BLUE, AND DARK TURQUOISE BLUE IS/ARE CLAIMED AS A FEATURE OF THE MARK IS/ARE CLAIMED AS A FEATURE OF THE MARK.

THE MARK CONSISTS OF THE WORDS "CYPRESS FAIRBANKS LEG PAIN PROGRAM" IN DARK TURQUOISE BLUE ABOVE A DARK TURQUOISE BLUE LINE AND DIRECTLY BELOW THE LINE, A WHITE BOX, TWO LIGHT TURQUOISE BLUE BOXES, TWO DARK TURQUOISE BLUE BOXES AND TWO LIME GREEN BOXES WHICH ALL OVERLAP EACH OTHER AND PRECEDING THE WORDS "A PART OF CY-FAIR REGIONAL HEALTH NETWORK" IN DARK TURQUOISE BLUE.

SEC. 2(F) CYPRESS FAIRBANKS HAS BECOME DISTINCTIVE OF THE GOODS/SERVICES THROUGH THE APPLICANT'S SUBSTANTIALLY EXCLUSIVE AND CONTINUOUS USE IN COMMERCE FOR AT LEAST THE FIVE YEARS IMMEDIATELY BEFORE THE DATE OF THIS STATEMENT.

FOR HEALTHCARE (U.S. CLS. 100 AND 101).

EUGENIA MARTIN, EXAMINING ATTORNEY

SN 77-524,551. BARIATRIX NUTRITION INC., LACHINE, CANADA, FILED 7-17-2008.

NUTRIFORME

THE MARK CONSISTS OF STANDARD CHARACTERS WITHOUT CLAIM TO ANY PARTICULAR FONT, STYLE, SIZE, OR COLOR.

FOR PROVIDING WELLNESS SERVICES, NAMELY, PERSONAL ASSESSMENTS, PERSONALIZED ROUTINES, MAINTENANCE SCHEDULES, AND COUNSELING; NUTRITION COUNSELLING; PROVIDING MEDICAL INFORMATION, CONSULTANCY AND ADVISORY SERVICES, NAMELY, DESIGNING AND IMPLEMENTING OF PROGRAMS AND ADVICE AND PROVIDING INFORMATION FOR OTHERS IN THE FIELD OF WEIGHT MANAGEMENT, OBESITY MANAGEMENT, DIET, HEALTH AND NUTRITION, HEALTH CARE; WEIGHT REDUCTION DIET PLANNING AND SUPERVISION; DIETARY AND NUTRITIONAL GUIDANCE; FOOD NUTRITION CONSULTATION; PROVIDING INFORMATION ABOUT DIETARY SUPPLEMENTS AND NUTRITION; HEALTH CARE SERVICES, NAMELY, WELLNESS PROGRAMS; MEDICAL TESTING SERVICES; NAMELY, FITNESS EVALUATION (U.S. CLS. 100 AND 101).

FIRST USE 1-31-2008; IN COMMERCE 1-31-2008.

MATTHEW KLINE, EXAMINING ATTORNEY

CLASS 44—(Continued).

SN 77-525,757. JOHNSON, DEREK K., FAIRFAX, VA. FILED 7-18-2008.



NO CLAIM IS MADE TO THE EXCLUSIVE RIGHT TO USE "FAIRFAX ALLERGY", APART FROM THE MARK AS SHOWN.

THE MARK CONSISTS OF THE STYLIZED WORDS "FAIRFAX ALLERGY" TO THE LEFT OF A FLOWER DESIGN.

FOR PHYSICIAN SERVICES (U.S. CLS. 100 AND 101).
FIRST USE 3-1-2008; IN COMMERCE 3-1-2008.
B. PARADEWELAI, EXAMINING ATTORNEY

CLASS 44—(Continued).

SN 77-550,635. UHS OF DELAWARE, INC., KING OF PRUSSIA, PA. FILED 8-19-2008.



OWNER OF U.S. REG. NOS. 3,441,149 AND 3,496,950.
NO CLAIM IS MADE TO THE EXCLUSIVE RIGHT TO USE "THE WOMEN'S CENTER" AND "HOSPITAL", APART FROM THE MARK AS SHOWN.

THE MARK CONSISTS OF THE WORDING "THE WOMEN'S CENTER AT CENTENNIAL HILLS HOSPITAL" WITH A BUTTERFLY IMAGE TO THE RIGHT OF THE WORDING.

SEC. 2(F) AS TO "CENTENNIAL HILLS".
FOR MEDICAL AND HEALTH CARE SERVICES (U.S. CLS. 100 AND 101).

ROBERT STRUCK, EXAMINING ATTORNEY

SN 77-536,693. MAXIMACARE LLC, DBA MAXIMACARE HOME HEALTH SERVICES, CARROLLTON, TX. FILED 8-1-2008.

MaximaCare
Home Health Care Services

THE MARK CONSISTS OF STANDARD CHARACTERS WITHOUT CLAIM TO ANY PARTICULAR FONT, STYLE, SIZE, OR COLOR.

NO CLAIM IS MADE TO THE EXCLUSIVE RIGHT TO USE "HOME HEALTH CARE SERVICES", APART FROM THE MARK AS SHOWN.

FOR GERIATRIC HEALTH CARE MANAGEMENT SERVICES; HEALTH CARE; HEALTH CARE SERVICES, NAMELY, DISEASE MANAGEMENT PROGRAMS; HEALTH CARE SERVICES, NAMELY, WELLNESS PROGRAMS; HOME HEALTH CARE SERVICES (U.S. CLS. 100 AND 101).

FIRST USE 5-4-2004; IN COMMERCE 5-4-2004.
BERYL GARDNER, EXAMINING ATTORNEY

SN 77-565,414. REX HOSPITAL, INC., DBA REX HEALTH-CARE, RALEIGH, NC. FILED 9-9-2008.



NO CLAIM IS MADE TO THE EXCLUSIVE RIGHT TO USE "HEALTH CARE", APART FROM THE MARK AS SHOWN.

THE COLOR(S) PURPLE, LIGHT BLUE AND WHITE IS/ARE CLAIMED AS A FEATURE OF THE MARK.

THE MARK CONSISTS OF A STYLIZED ILLUSTRATION OF A WELL IN THE COLOR WHITE AND THE COLOR LIGHT BLUE WITHIN A LIGHT BLUE FRAME APPEARING TO THE LEFT OF THE STYLIZED WORD "REX" IN THE COLOR PURPLE. THE STYLIZED WORDS "UNC HEALTH CARE" APPEAR BELOW THE STYLIZED ILLUSTRATION OF THE WELL AND THE STYLIZED WORD "REX" IN SMALLER TYPE AND IN THE COLOR LIGHT BLUE, SEPARATED BY A LINE IN THE COLOR PURPLE. THE RECTANGULAR SHAPED BACKGROUND IS NOT A FEATURE OF THE MARK.

FOR HEALTH CARE; HOSPITALS (U.S. CLS. 100 AND 101).

FIRST USE 9-15-2007; IN COMMERCE 9-15-2007.
JULIE GUTTADAURO, EXAMINING ATTORNEY

CLASS 44—(Continued).

SN 77-598,694. ORASI MEDICAL, INC., EDINA, MN. FILED 10-23-2008.



OWNER OF U.S. REG. NOS. 3,418,022 AND 3,547,760.
NO CLAIM IS MADE TO THE EXCLUSIVE RIGHT TO USE "MEDICAL", APART FROM THE MARK AS SHOWN.
THE MARK CONSISTS OF A SERIES OF HEXAGONS WHEREIN EACH HEXAGON PARTIALLY OVERLAPS AT LEAST ONE OTHER HEXAGON AND THE WORDS "ORASI MEDICAL".

FOR EFFECTING ANALYSES AND/OR DIAGNOSES, NAMELY, TESTING, DIAGNOSIS, AND MONITORING OF BRAIN AND NEUROLOGICAL CONDITIONS; CONSULTATION ON ISSUES OF MEDICAL AND SCIENTIFIC DIAGNOSES AND ANALYSES, NAMELY, DISEASE, NEUROLOGICAL OR BRAIN CONDITION DIAGNOSIS CONSULTATION (U.S. CLS. 100 AND 101).

FIRST USE 8-1-2007; IN COMMERCE 8-1-2007.
MARIA-VICTORIA SUAREZ, EXAMINING ATTORNEY

SN 77-601,075. ERICKSON RETIREMENT COMMUNITIES, LLC, BALTIMORE, MD. FILED 10-27-2008.

FREEDOM YEARS

THE MARK CONSISTS OF STANDARD CHARACTERS WITHOUT CLAIM TO ANY PARTICULAR FONT, STYLE, SIZE, OR COLOR.

FOR PROVIDING A WEBSITE FEATURING NEWS OF INTEREST AND INFORMATION TO SENIORS IN THE FIELD OF HEALTH AND WELLNESS (U.S. CLS. 100 AND 101).

FIRST USE 12-15-2007; IN COMMERCE 12-15-2007.
STEVEN JACKSON, EXAMINING ATTORNEY

CLASS 44—(Continued).

SN 77-605,962. ARBOR TECH, INC., DBA ARBOR TECH, INC., REMINGTON, VA. FILED 11-3-2008.



THE COLOR(S) GREEN IS/ARE CLAIMED AS A FEATURE OF THE MARK.

THE MARK CONSISTS OF STYLIZED WORDING "ARBOR TECH" WITH A SOLID LINE UNDERNEATH THE WORD "ARBOR" AND THE LETTERS "A" AND "T" CONNECTED. THE ENTIRE MARK IS GREEN.

FOR TREE CARE SERVICES; TREE REMOVAL SERVICES (U.S. CLS. 100 AND 101).

FIRST USE 0-0-2003; IN COMMERCE 0-0-2003.
DOUGLAS LEE, EXAMINING ATTORNEY

SN 77-619,429. EARTH OCEAN FARMS USA, LLC, PALO ALTO, CA. FILED 11-21-2008.



THE COLOR(S) GREEN, BLUE, AND WHITE IS/ARE CLAIMED AS A FEATURE OF THE MARK.

THE MARK CONSISTS OF A BLUE JUMPING FISH WITH 7 BLUE STYLIZED FINS, 2 GREEN STYLIZED FINS, AND GREEN EYE.

FOR AQUACULTURE SERVICES, NAMELY, THE CULTIVATION AND BREEDING OF MARINE LIFE (U.S. CLS. 100 AND 101).

DAVID COLLIER, EXAMINING ATTORNEY

CLASS 44—(Continued).

SN 77-622,764. INTERNET MATRIX, INC. DBA CHIROMATRIX, SAN DIEGO, CA. FILED 11-26-2008.



THE COLOR(S) PURPLE AND GRAY IS/ARE CLAIMED AS A FEATURE OF THE MARK.

THE MARK CONSISTS OF THE COLOR PURPLE APPEARING ON THE DESIGN ELEMENT IN THE NATURE OF 3 UPSIDE DOWN "V" SHAPED VERTEBRAE REPRESENTING THE HUMAN SPINE ENCAPSULATED BY A < AND > SIGN WHICH SYMBOLIZES HTML SOURCE CODE AND ON THE WORDING "CHIRO", WITH THE COLOR GRAY APPEARING IN THE WORDING "MATRIX". THE COLOR WHITE IS BACKGROUND OR TRANSPARENT AREA AND IS NOT A PART OF THE MARK.

FOR PROVIDING A WEBSITE FEATURING INFORMATION IN THE FIELD OF CHIROPRACTICES (U.S. CLS. 100 AND 101).

FIRST USE 1-2-2003; IN COMMERCE 1-2-2003.
LINDA ESTRADA, EXAMINING ATTORNEY

SN 77-632,653. MARCO A. DE LA TORRE BARRANCO, SAN ANTONIO, TX. FILED 12-13-2008.



THE COLOR(S) BLUE, GREEN, WHITE AND BLACK IS/ARE CLAIMED AS A FEATURE OF THE MARK.

THE MARK CONSISTS OF THE COLORS BLUE, GREEN AND BLACK. THE COLOR GREEN APPEARS IN THE WORDING "HISP" AND IN THE DESIGN OF THE BUTTONS ON A STYLIZED CELL PHONE. THE COLOR BLUE APPEARS IN THE WORDING "ASSIST" AND THE OUTLINE OF THE STYLIZED CELL PHONE. THE COLOR BLACK APPEARS IN THE SCREEN OF THE CELL PHONE AND THE COLOR WHITE APPEARS IN THE BODY OF THE CELL PHONE.

FOR NON-EMERGENCY BINATIONAL AND BICULTURAL MEDICAL AND WELL-BEING PREVENTIVE ASSISTANCE SPECIALIZING IN THE HISPANIC AMERICAN COMMUNITY OF MEXICAN ORIGIN, NAMELY, PROVIDING MEDICAL ASSISTANCE SERVICES (U.S. CLS. 100 AND 101).

SEAN CROWLEY, EXAMINING ATTORNEY

CLASS 44—(Continued).

SN 77-634,545. BARTHOLOMEW, SEAN, RIMFOREST, CA. FILED 12-16-2008.

The Bartholomew Method

THE MARK CONSISTS OF STANDARD CHARACTERS WITHOUT CLAIM TO ANY PARTICULAR FONT, STYLE, SIZE, OR COLOR.

NO CLAIM IS MADE TO THE EXCLUSIVE RIGHT TO USE "METHOD", APART FROM THE MARK AS SHOWN.

FOR BODYWORK AND MASSAGE THERAPIES INCLUDING MYOMASSOLOGY IN THE NATURE OF AROMA THERAPY, REFLEXOLOGY, NUTRITIONAL COUNSELING AND VARIOUS FORMS OF MASSAGE THERAPY; HOT STONE THERAPY IN THE NATURE OF APPLYING HEATED STONES TO THE FEET TO FACILITATE WELLNESS (U.S. CLS. 100 AND 101).

FIRST USE 0-0-2005; IN COMMERCE 11-15-2008.
JEFFREY LOOK, EXAMINING ATTORNEY

SN 77-640,657. LINCARE LICENSING, INC., CLEARWATER, FL. FILED 12-29-2008.

CARING RESPONDERS

THE MARK CONSISTS OF STANDARD CHARACTERS WITHOUT CLAIM TO ANY PARTICULAR FONT, STYLE, SIZE, OR COLOR.

NO CLAIM IS MADE TO THE EXCLUSIVE RIGHT TO USE "RESPONDERS", APART FROM THE MARK AS SHOWN.

FOR EMERGENCY MEDICAL MONITORING AND ALERT SERVICES IN THE NATURE OF PROVIDING NOTICE TO EMERGENCY RESPONDERS, MEDICAL PERSONNEL AND DESIGNEES OF INDIVIDUALS THAT AN INDIVIDUAL MAY REQUIRE EMERGENCY MEDICAL ASSISTANCE THROUGH THE USE OF A PERSONAL EMERGENCY RESPONSE SYSTEM (U.S. CLS. 100 AND 101).

KIMBERLY PERRY, EXAMINING ATTORNEY

SN 77-642,448. CARDANO, LAWRENCE, DBA HEARING CENTER OF LONG ISLAND, PORT WASHINGTON, NY. FILED 1-1-2009.

We're listening to you.

THE MARK CONSISTS OF STANDARD CHARACTERS WITHOUT CLAIM TO ANY PARTICULAR FONT, STYLE, SIZE, OR COLOR.

FOR HEARING AID SERVICES; SPEECH AND HEARING THERAPY (U.S. CLS. 100 AND 101).

FIRST USE 5-20-1998; IN COMMERCE 5-20-1998.
ANGELA GAW, EXAMINING ATTORNEY

CLASS 44—(Continued).

SN 77-646,273. BALANCE SOLUTIONS PHYSICAL THERAPY, INC., UNIVERISTY HEIGHTS, OH. FILED 1-9-2009.

**CHANGING THE QUALITY OF
LIFE ONE PATIENT AT A TIME**

THE MARK CONSISTS OF STANDARD CHARACTERS WITHOUT CLAIM TO ANY PARTICULAR FONT, STYLE, SIZE, OR COLOR.

FOR HEALTH CARE SERVICES, NAMELY, PHYSICAL THERAPY SERVICES AND CONSULTING SERVICES IN THE FIELD OF PHYSICAL REHABILITATION; HEALTHCARE INFORMATION SERVICES, NAMELY, PROVIDING INFORMATION RELATING TO TREATMENT AND MEDICAL PROCEDURES IN THE FIELD OF BALANCE RESTORATION TO THE GENERAL PUBLIC, PATIENTS, HEALTH CARE PROVIDERS, PHYSICIANS, AND PHYSICAL THERAPISTS (U.S. CLS. 100 AND 101).

FIRST USE 11-1-2003; IN COMMERCE 11-1-2003.
REGINA DRUMMOND, EXAMINING ATTORNEY

SN 77-655,893. ANGEL OAK TREE CARE ANGEL'S TOUCH LAWN CARE, INC., INDIANAPOLIS, IN. FILED 1-24-2009.



NO CLAIM IS MADE TO THE EXCLUSIVE RIGHT TO USE "OAK TREE CARE", APART FROM THE MARK AS SHOWN.

THE MARK CONSISTS OF A STYLIZED ACORN AND THE STYLIZED WORDING "ANGEL OAK TREE CARE".

FOR TREE CARE SERVICES; TREE REMOVAL SERVICES; TREE SURGERY (U.S. CLS. 100 AND 101).
BRIAN PINO, EXAMINING ATTORNEY

SN 77-657,296. SHAMIR INSIGHT, INC., SAN DIEGO, CA. FILED 1-27-2009.

RESULTANT Rx

THE MARK CONSISTS OF STANDARD CHARACTERS WITHOUT CLAIM TO ANY PARTICULAR FONT, STYLE, SIZE, OR COLOR.

NO CLAIM IS MADE TO THE EXCLUSIVE RIGHT TO USE "Rx", APART FROM THE MARK AS SHOWN.

FOR PROVIDING CUSTOMIZED EYEGGLASS PRESCRIPTIONS TO OPTOMETRISTS AND OPHTHALMOLOGISTS FOR USE IN PATIENT EYE GLASS LENSES (U.S. CLS. 100 AND 101).

FIRST USE 1-1-2008; IN COMMERCE 1-1-2008.
DANNEAN HETZEL, EXAMINING ATTORNEY

CLASS 44—(Continued).

SN 77-659,402. REHABILITATION INSTITUTE, INC., DBA REHABILITATION INSTITUTE OF MICHIGAN, DETROIT, MI. FILED 1-29-2009.



**CENTER FOR
BRAIN INJURY RECOVERY**

OWNER OF U.S. REG. NO. 3,115,552.

NO CLAIM IS MADE TO THE EXCLUSIVE RIGHT TO USE "CENTER FOR BRAIN INJURY RECOVERY", APART FROM THE MARK AS SHOWN.

THE MARK CONSISTS OF THE LITERAL ELEMENTS "CENTER FOR BRAIN INJURY RECOVERY" DISPOSED BELOW A STYLIZED DESIGN OF A HUMAN HEAD.

FOR MEDICAL EVALUATION SERVICES, NAMELY, FUNCTIONAL ASSESSMENT PROGRAM FOR PATIENTS RECEIVING MEDICAL REHABILITATION SERVICES FOR PURPOSES OF GUIDING TREATMENT AND ASSESSING PROGRAM EFFECTIVENESS; MEDICAL SERVICES, NAMELY, MEDICAL REHABILITATION TREATMENT SERVICES FOR PATIENTS; PHYSICAL REHABILITATION; PROVIDING PHYSICAL REHABILITATION FACILITIES (U.S. CLS. 100 AND 101).
STEVEN R. FINE, EXAMINING ATTORNEY

SN 77-660,624. SCIENCE AND TECHNOLOGY INTERNATIONAL, INC., HONOLULU, HI. FILED 1-30-2009.

STI MEDICAL SYSTEMS

THE MARK CONSISTS OF STANDARD CHARACTERS WITHOUT CLAIM TO ANY PARTICULAR FONT, STYLE, SIZE, OR COLOR.

NO CLAIM IS MADE TO THE EXCLUSIVE RIGHT TO USE "MEDICAL SYSTEMS", APART FROM THE MARK AS SHOWN.

FOR TECHNICAL CONSULTATION IN THE FIELD OF MEDICAL DATA ACQUISITION AND ANALYSIS (U.S. CLS. 100 AND 101).

IRA J. GOODSaid, EXAMINING ATTORNEY

SN 77-660,776. NORTHEAST PATHOLOGISTS INC., HANNIBAL, MO. FILED 1-31-2009.

CELLDOX

THE MARK CONSISTS OF STANDARD CHARACTERS WITHOUT CLAIM TO ANY PARTICULAR FONT, STYLE, SIZE, OR COLOR.

FOR MEDICAL SERVICES BY PATHOLOGISTS, NAMELY, DRUG USE SCREENING SERVICES (U.S. CLS. 100 AND 101).

BRIAN CALLAGHAN, EXAMINING ATTORNEY

CLASS 44—(Continued).

SN 77-661,356. U.S. MEDICAL MANAGEMENT, INC.,
FARMINGTON HILLS, MI. FILED 2-2-2009.

BRINGING INTEGRATED HEALTH
CARE HOME

THE MARK CONSISTS OF STANDARD CHARACTERS
WITHOUT CLAIM TO ANY PARTICULAR FONT, STYLE,
SIZE, OR COLOR.

NO CLAIM IS MADE TO THE EXCLUSIVE RIGHT TO
USE "INTEGRATED HEALTH CARE", APART FROM THE
MARK AS SHOWN.

FOR MEDICAL SERVICES (U.S. CLS. 100 AND 101).
DAVID I, EXAMINING ATTORNEY

SN 77-661,483. PIONEER ROOFING, LLC, JOHNSON
CREEK, WI. FILED 2-2-2009.



THE MARK CONSISTS OF STYLIZED LETTERS "PG"
INSIDE A SQUARE FRAME.

FOR LANDSCAPE DESIGN; LANDSCAPE GARDEN-
ING SERVICES (U.S. CLS. 100 AND 101).

FIRST USE 4-0-2008; IN COMMERCE 4-0-2008.
DAVID HOFFMAN, EXAMINING ATTORNEY

SN 77-662,710. WHRITENOUR, KEVIN, SAN ANTONIO, TX.
FILED 2-3-2009.

Dr. Kevin J. Whritenour
Au.D

THE MARK CONSISTS OF STANDARD CHARACTERS
WITHOUT CLAIM TO ANY PARTICULAR FONT, STYLE,
SIZE, OR COLOR.

NO CLAIM IS MADE TO THE EXCLUSIVE RIGHT TO
USE "DR." AND "AU. D", APART FROM THE MARK AS
SHOWN.

THE NAME "KEVIN J. WHRITENOUR" IDENTIFIES A
LIVING INDIVIDUAL WHOSE CONSENT IS OF RECORD.
FOR AUDIOLOGY SERVICES, NAMELY, DIAGNOS-
ING AND TREATING HEARING LOSS AND BALANCE
DISORDERS (U.S. CLS. 100 AND 101).

FIRST USE 1-1-1993; IN COMMERCE 1-10-1993.
CHARLES L. JENKINS, EXAMINING ATTORNEY

CLASS 44—(Continued).

SN 77-662,846. DIETERLE, NANETTE, DBA FULL CIRCLE
FARM, BETHLEHEM, CT. FILED 2-4-2009.

FULL CIRCLE FARM

THE MARK CONSISTS OF STANDARD CHARACTERS
WITHOUT CLAIM TO ANY PARTICULAR FONT, STYLE,
SIZE, OR COLOR.

NO CLAIM IS MADE TO THE EXCLUSIVE RIGHT TO
USE "FARM", APART FROM THE MARK AS SHOWN.

FOR HORSE CARE, NAMELY, FEEDING THE
HORSES OF ABSENT OWNERS; HORSE FARMS (U.S.
CLS. 100 AND 101).

FIRST USE 4-1-2005; IN COMMERCE 4-1-2005.
STEVEN R. FINE, EXAMINING ATTORNEY

SN 77-663,099. MAHESH TIPIRNENI, MD, TUCSON, AZ.
FILED 2-4-2009.



NO CLAIM IS MADE TO THE EXCLUSIVE RIGHT TO
USE "MEDICAL CENTER & SPA", APART FROM THE
MARK AS SHOWN.

THE MARK CONSISTS OF THE STYLIZED WORDS
"VITALITY MEDICAL CENTER & SPA TAP INTO YOUR
INNER VITALITY!". ABOVE THE STYLIZED WORDS IS AN
IMAGE OF A SQUARE WITH A ABSTRACT DESIGN OF A
FLOWER IN THE CENTER.

FOR SKIN CARE SERVICES, NAMELY, HAIR RE-
MOVAL AND REDUCTION USING MEDICAL GRADE
LASERS; PHOTO REJUVENATION; REMOVAL OF SUN
SPOTS; PROVIDING INJECTIONS OF BOTULINUM
TOXIN AND DERMAL FILLERS TO REDUCE WRIN-
KLES AND UNWANTED SKIN FOLDS AND CREASES;
CHEMICAL PEELS AND MICRODERMABRASION,
NAMELY, A TOPICAL SKIN TREATMENT INVOLVING
ABRASION OF THE SKIN WITH A HIGH-PRESSURE
FLOW OF CRYSTALS (U.S. CLS. 100 AND 101).

ELISSA GARBER KON, EXAMINING ATTORNEY

CLASS 44—(Continued).

SN 77-663,102. MAHESH TIPIRNICI, MD, TUCSON, AZ. FILED 2-4-2009.



NO CLAIM IS MADE TO THE EXCLUSIVE RIGHT TO USE "MEDICAL & WELLNESS CENTER", APART FROM THE MARK AS SHOWN.

THE MARK CONSISTS OF THE STYLIZED WORDS "VITALITY MEDICAL & WELLNESS CENTER TAP INTO YOUR INNER VITALITY!". ABOVE THE STYLIZED WORDS IS AN IMAGE OF A SQUARE WITH AN ABSTRACT DESIGN OF A FLOWER IN THE CENTER.

FOR COUNSELING SERVICES IN THE FIELDS OF HEALTH, NUTRITION AND LIFESTYLE WELLNESS; HEALTH SPA SERVICES FOR HEALTH AND WELLNESS OF THE BODY AND SPIRIT; PROVIDING ASSISTANCE, FITNESS EVALUATION AND CONSULTATION TO INDIVIDUALS TO HELP THEM MAKE HEALTH, WELLNESS AND NUTRITIONAL CHANGES IN THEIR DAILY LIVING TO IMPROVE HEALTH (U.S. CLS. 100 AND 101).

ELISSA GARBER KON, EXAMINING ATTORNEY

SN 77-663,361. YO!BRACES ORTHODONTICS, PLLC, BROOKLYN, NY. FILED 2-4-2009.

YO BRACES

THE MARK CONSISTS OF STANDARD CHARACTERS WITHOUT CLAIM TO ANY PARTICULAR FONT, STYLE, SIZE, OR COLOR.

NO CLAIM IS MADE TO THE EXCLUSIVE RIGHT TO USE "BRACES", APART FROM THE MARK AS SHOWN.

FOR ORTHODONTIC SERVICES (U.S. CLS. 100 AND 101).

JACLYN KIDWELL, EXAMINING ATTORNEY

CLASS 44—(Continued).

SN 77-663,486. ALLIED MINDS, INC., QUINCY, MA. FILED 2-4-2009.



NO CLAIM IS MADE TO THE EXCLUSIVE RIGHT TO USE "COMPANY", APART FROM THE MARK AS SHOWN. THE COLOR(S) WHITE, GREY, AND RED IS/ARE CLAIMED AS A FEATURE OF THE MARK.

THE MARK CONSISTS OF A RED CHECK MARK IN A WHITE BOX OUTLINED IN GREY, "SALT" IS GREY AND "CHECK" IS RED AND THE WORDS "AN ALLIED MINDS COMPANY" ARE GREY.

FOR MEDICAL SERVICES, NAMELY, PROVIDING CUSTOMIZED MONITORING OF SODIUM INTAKE LEVELS (U.S. CLS. 100 AND 101).

FIRST USE 11-1-2006; IN COMMERCE 12-31-2006.

JOHN WILKE, EXAMINING ATTORNEY

SN 77-664,020. THE LIVING CHRISTMAS COMPANY LLC, PALOS VERDES ESTATES, CA. FILED 2-5-2009.



NO CLAIM IS MADE TO THE EXCLUSIVE RIGHT TO USE "THE LIVING CHRISTMAS CO.", APART FROM THE MARK AS SHOWN.

THE COLOR(S) RED, GREEN, GOLD, AND BROWN IS/ARE CLAIMED AS A FEATURE OF THE MARK.

THE MARK CONSISTS OF THREE GREEN CHRISTMAS TREES, DECORATED WITH GREEN AND GOLD GARLANDS AND RED BALLS TOPPED WITH GOLD STARS AND IN BROWN POTS, ARRANGED IN A TRIANGLE SURROUNDING THE RED WORDING "THE LIVING CHRISTMAS CO."

FOR ON-LINE RENTAL SERVICES FEATURING LIVE CHRISTMAS TREES (U.S. CLS. 100 AND 101).

FIRST USE 7-28-2008; IN COMMERCE 8-4-2008.

KIMBERLY FRYE, EXAMINING ATTORNEY

CLASS 44—(Continued).

SN 77-664,244. ERIC R. MANDEL, M.D., P.C., NEW YORK, NY. FILED 2-5-2009.

MANDEL VISION

THE MARK CONSISTS OF STANDARD CHARACTERS WITHOUT CLAIM TO ANY PARTICULAR FONT, STYLE, SIZE, OR COLOR.

NO CLAIM IS MADE TO THE EXCLUSIVE RIGHT TO USE "VISION", APART FROM THE MARK AS SHOWN.

SEC. 2(F).
FOR OPHTHALMOLOGIC SERVICES (U.S. CLS. 100 AND 101).

FIRST USE 3-8-2002; IN COMMERCE 3-8-2002.
THOMAS MANOR, EXAMINING ATTORNEY

CLASS 44—(Continued).

SN 77-664,576. MARGARET BENNETT, AUSTIN, TX. FILED 2-5-2009.

Hormone Detective

THE MARK CONSISTS OF STANDARD CHARACTERS WITHOUT CLAIM TO ANY PARTICULAR FONT, STYLE, SIZE, OR COLOR.

NO CLAIM IS MADE TO THE EXCLUSIVE RIGHT TO USE "HORMONE", APART FROM THE MARK AS SHOWN.

FOR MEDICAL CLINICS; MEDICAL INFORMATION; PROVIDING MEDICAL INFORMATION; MEDICAL CONSULTATIONS; MEDICAL COUNSELING; MEDICAL SERVICES; PROVIDING A WEB SITE FEATURING MEDICAL INFORMATION (U.S. CLS. 100 AND 101).

AARON BRODSKY, EXAMINING ATTORNEY

SN 77-664,346. RESET MEDICAL, INC., BALTIMORE, MD. FILED 2-5-2009.

FREEZE DISEASE. RESET LIFE.

THE MARK CONSISTS OF STANDARD CHARACTERS WITHOUT CLAIM TO ANY PARTICULAR FONT, STYLE, SIZE, OR COLOR.

FOR MEDICAL PROCEDURES, NAMELY, PERFORMING CRYOTHERAPY AND CRYOSURGERY; PERFORMING MEDICAL PROCEDURES INVOLVING ABDOMINAL, BLADDER, PANCREATIC, KIDNEY, LUNG, STOMACH, ESOPHAGEAL, UPPER AND LOWER GASTROINTESTINAL TISSUE IDENTIFICATION, SEPARATION, ABLATION OR ERADICATION OF UNWANTED LESIONS USING ENDOSCOPIC SURGERY (U.S. CLS. 100 AND 101).

MICHELLE DUBOIS, EXAMINING ATTORNEY

SN 77-664,886. COMMUNITIES IN SCHOOLS OF CAPE FEAR, INC., WILMINGTON, NC. FILED 2-6-2009.

POSITIVE PEERS

THE MARK CONSISTS OF STANDARD CHARACTERS WITHOUT CLAIM TO ANY PARTICULAR FONT, STYLE, SIZE, OR COLOR.

FOR STRESS REDUCTION THERAPY; COUNSELING SERVICES, NAMELY, STRESS MANAGEMENT AND STRESS REDUCTION COUNSELING FOR INDIVIDUALS TO ENHANCE THEIR LIVES; MENTAL HEALTH COUNSELING AS IT RELATES TO RELATIONSHIPS; RELAXATION THERAPY IN THE NATURE OF ANGER MANAGEMENT, RELATIONSHIP SKILLS AND COMMUNICATION SKILLS (U.S. CLS. 100 AND 101).

FIRST USE 8-1-2007; IN COMMERCE 8-1-2007.
DAVON HATCHETT, EXAMINING ATTORNEY

SN 77-664,566. MARGARET BENNETT, AUSTIN, TX. FILED 2-5-2009.

The Hormone Detective

THE MARK CONSISTS OF STANDARD CHARACTERS WITHOUT CLAIM TO ANY PARTICULAR FONT, STYLE, SIZE, OR COLOR.

NO CLAIM IS MADE TO THE EXCLUSIVE RIGHT TO USE "HORMONE", APART FROM THE MARK AS SHOWN.

FOR MEDICAL CLINICS; MEDICAL INFORMATION; PROVIDING MEDICAL INFORMATION; MEDICAL CONSULTATIONS; MEDICAL COUNSELING; MEDICAL SERVICES; PROVIDING A WEB SITE FEATURING MEDICAL INFORMATION (U.S. CLS. 100 AND 101).

AARON BRODSKY, EXAMINING ATTORNEY

SN 77-665,031. CENTER FOR APPLICATIONS OF PSYCHOLOGICAL TYPE, INC., GAINESVILLE, FL. FILED 2-6-2009.

**GREAT TEAMS AREN'T JUST
THROWN TOGETHER**

THE MARK CONSISTS OF STANDARD CHARACTERS WITHOUT CLAIM TO ANY PARTICULAR FONT, STYLE, SIZE, OR COLOR.

OWNER OF U.S. REG. NO. 3,609,680.

FOR PSYCHOLOGICAL TESTING SERVICES IN THE FIELDS OF GROUP DYNAMICS, TEAM BUILDING, DEVELOPING INDIVIDUAL SKILLS AND BEHAVIORS TO IMPROVE TEAM PERFORMANCE AND PRODUCTIVITY, LEADERSHIP DEVELOPMENT AND ORGANIZATIONAL DEVELOPMENT (U.S. CLS. 100 AND 101).

FIRST USE 10-6-2008; IN COMMERCE 10-6-2008.
MICHAEL SOUDERS, EXAMINING ATTORNEY

CLASS 44—(Continued).

SN 77-665,075. CENTER FOR APPLICATIONS OF PSYCHOLOGICAL TYPE, INC., GAINESVILLE, FL. FILED 2-6-2009.



OWNER OF U.S. REG. NO. 3,609,696.
THE MARK CONSISTS OF A COMPOSITE DRAWING OF AN ANIMAL, COMPOSED OF PARTS FROM A GIRAFFE, A CRANE, A CHICKEN, A PIG AND HUMAN LEGS WEARING HIGH-HEELED SHOES.

FOR PSYCHOLOGICAL TESTING SERVICES IN THE FIELDS OF GROUP DYNAMICS, TEAM BUILDING, DEVELOPING INDIVIDUAL SKILLS AND BEHAVIORS TO IMPROVE TEAM PERFORMANCE AND PRODUCTIVITY, LEADERSHIP DEVELOPMENT AND ORGANIZATIONAL DEVELOPMENT (U.S. CLS. 100 AND 101).

FIRST USE 10-6-2008; IN COMMERCE 10-6-2008.
MICHAEL SOUDERS, EXAMINING ATTORNEY

SN 77-665,581. H2 DIGITAL PRODUCTIONS, INC., SCOTTSDALE, AZ. FILED 2-6-2009.

INTRAFRACTIVE

THE MARK CONSISTS OF STANDARD CHARACTERS WITHOUT CLAIM TO ANY PARTICULAR FONT, STYLE, SIZE, OR COLOR.

FOR OPHTHALMOLOGY SURGERY SERVICES, NAMELY, CORNEAL REFRACTIVE AND INTRAOCULAR SURGERY COMBINED (U.S. CLS. 100 AND 101).

RUSS HERMAN, EXAMINING ATTORNEY

CLASS 44—(Continued).

SN 77-666,029. FEDERICO, NOELLE, FRANKLIN, TN. FILED 2-9-2009.

Rapid Excellence

THE MARK CONSISTS OF STANDARD CHARACTERS WITHOUT CLAIM TO ANY PARTICULAR FONT, STYLE, SIZE, OR COLOR.

FOR PROVIDING WEIGHT REDUCTION PLANNING, TREATMENT AND SUPERVISION THROUGH WEIGHT REDUCTION PROGRAMS FEATURING COUNSELING, CREATING DIET REGIMES AND DISCUSSIONS, PROVIDING ADVICE, CONSULTATION AND INFORMATION IN THE FIELD OF WEIGHT CONTROL AND NUTRITION (U.S. CLS. 100 AND 101).

LAURIE MAYES, EXAMINING ATTORNEY

SN 77-666,366. YOUR KEY TO HEALTH, INC., BROWNSVILLE, TX. FILED 2-9-2009.



NO CLAIM IS MADE TO THE EXCLUSIVE RIGHT TO USE "INC." AND "AN INTEGRATIVE HEALTH CENTER", APART FROM THE MARK AS SHOWN.

THE COLOR(S) CORAL, YELLOW, TURQUOISE, BLUE, AND PURPLE IS/ARE CLAIMED AS A FEATURE OF THE MARK.

THE MARK CONSISTS OF THE PHRASE "YOUR KEY TO HEALTH, INC." WRITTEN IN TURQUOISE LETTERING WITH A BLUE OUTLINE. BELOW THE PHRASE "YOUR KEY TO HEALTH, INC." IS WRITTEN THE PHRASE "AN INTEGRATIVE HEALTH CENTER" IN SMALLER PURPLE FONT. BELOW BOTH PHRASES, THERE IS A TURQUOISE LINE THAT IS ALSO A GRAPHIC OF A KEY WITH THE RING OF THE KEY ON THE RIGHT END OF THE LINE, AND THE TEETH OF THE KEY ON THE LEFT END OF THE LINE. TO THE LEFT OF THE WORD MARK, THERE IS AN OVER LAPPING PATTERN OF FOUR LINES THAT DIMINISH AT EACH END OF THE LINE. THE BOTTOM LINE IS TURQUOISE AND GOES DIAGONALLY FROM THE TOP LEFT TO THE BOTTOM RIGHT OF THE PATTERN. THE NEXT LINE IS YELLOW AND OVERLAPS AT THE BOTTOM THIRD OF THE TURQUOISE. IT RUNS FROM THE TOP RIGHT TO THE BOTTOM LEFT OF THE PATTERN. THE THIRD LINE IS CORAL AND OVERLAPS THE YELLOW LINE AT THE BOTTOM THIRD AS WELL. IT RUNS PARALLEL TO THE TURQUOISE LINE. THE FOURTH AND FINAL LINE IS PURPLE AND OVERLAPS THE TURQUOISE AND CORAL LINES. IT RUNS PARALLEL TO THE YELLOW LINE.

FOR MEDICAL SERVICES, NAMELY, INTEGRATIVE MEDICAL SERVICES (U.S. CLS. 100 AND 101).

FIRST USE 9-24-2008; IN COMMERCE 9-24-2008.

KAREN K. BUSH, EXAMINING ATTORNEY

CLASS 44—(Continued).

SN 77-676,674. BIO-REFERENCE LABORATORIES, INC.,
ELMWOOD PARK, NJ. FILED 2-24-2009.

GenArray

THE MARK CONSISTS OF STANDARD CHARACTERS
WITHOUT CLAIM TO ANY PARTICULAR FONT, STYLE,
SIZE, OR COLOR.

FOR ARRAY COMPARATIVE GENOMIC HYBRIDI-
ZATION ("ARRAY CGH") MEDICAL TESTING SER-
VICES (U.S. CLS. 100 AND 101).

FIRST USE 11-15-2008; IN COMMERCE 12-1-2008.
STEVEN R. FINE, EXAMINING ATTORNEY

SN 78-824,941. HERZIG EYE INSTITUTE INC., TORONTO,
ONTARIO, CANADA, FILED 2-28-2006.

HD VISION

THE MARK CONSISTS OF STANDARD CHARACTERS
WITHOUT CLAIM TO ANY PARTICULAR FONT, STYLE,
SIZE, OR COLOR.

PRIORITY CLAIMED UNDER SEC. 44(D) ON CANADA
APPLICATION NO. 1288721, FILED 2-6-2006.

OWNER OF CANADA REG. NO. TMA735,459, DATED 3-2-
2009, EXPIRES 3-2-2024.

OWNER OF U.S. REG. NOS. 3,022,893 AND 3,170,532.
NO CLAIM IS MADE TO THE EXCLUSIVE RIGHT TO
USE "VISION", APART FROM THE MARK AS SHOWN.

FOR EYECARE SERVICES, NAMELY, OPHTHALMO-
LOGY SERVICES; OPERATION OF AN EYECARE
CLINIC; AND OPTOMETRY SERVICES (U.S. CLS. 100
AND 101).

WARREN L. OLANDRIA, EXAMINING ATTORNEY

SN 78-862,047. TODOROV, GERMAN, ATLANTA, GA.
FILED 4-14-2006.

SmartSkinCare.com

THE MARK CONSISTS OF STANDARD CHARACTERS
WITHOUT CLAIM TO ANY PARTICULAR FONT, STYLE,
SIZE, OR COLOR.

FOR INFORMATIONAL WEBSITE FEATURING SKIN
CARE INFORMATION (U.S. CLS. 100 AND 101).

FIRST USE 1-25-1999; IN COMMERCE 1-25-1999.
JENNIFER MARTIN, EXAMINING ATTORNEY

CLASS 44—(Continued).

SN 79-047,785. DR. BABOR GMBH & CO. KG, 52078
AACHEN, FED REP GERMANY, FILED 12-4-2007.

BABOR VITALITY CHECK

THE MARK CONSISTS OF STANDARD CHARACTERS
WITHOUT CLAIM TO ANY PARTICULAR FONT, STYLE,
SIZE, OR COLOR.

PRIORITY DATE OF 6-4-2007 IS CLAIMED.

OWNER OF INTERNATIONAL REGISTRATION 0947623
DATED 12-4-2007, EXPIRES 12-4-2017.

NO CLAIM IS MADE TO THE EXCLUSIVE RIGHT TO
USE "VITALITY CHECK", APART FROM THE MARK AS
SHOWN.

FOR HYGIENIC AND BEAUTY CARE FOR HUMAN
BEINGS (U.S. CLS. 100 AND 101).

SAIMA MAKHDOOM, EXAMINING ATTORNEY

SN 79-060,707. NATURA BISSE INTERNATIONAL, S.A.,
SPAIN, FILED 8-12-2008.

DESTINO BARCELONA

THE MARK CONSISTS OF STANDARD CHARACTERS
WITHOUT CLAIM TO ANY PARTICULAR FONT, STYLE,
SIZE, OR COLOR.

PRIORITY DATE OF 7-31-2008 IS CLAIMED.

OWNER OF INTERNATIONAL REGISTRATION 0981562
DATED 8-12-2008, EXPIRES 8-12-2018.

NO CLAIM IS MADE TO THE EXCLUSIVE RIGHT TO
USE "BARCELONA", APART FROM THE MARK AS
SHOWN.

THE ENGLISH TRANSLATION OF "DESTINO" IN THE
MARK IS DESTINATION.

FOR PERSONAL HYGIENE AND BEAUTY CARE
SERVICES FOR PERSONS (U.S. CLS. 100 AND 101).

MARILYN IZZI, EXAMINING ATTORNEY

CLASS 45—PERSONAL AND LEGAL SERVICES

SN 77-387,983. VIP ENTERPRISES LLC, ALBUQUERQUE, NM. FILED 2-4-2008.



NO CLAIM IS MADE TO THE EXCLUSIVE RIGHT TO USE "CONCIERGE" AND "PRIVATE MEMBER SERVICE", APART FROM THE MARK AS SHOWN.

THE MARK CONSISTS OF THE WORD "ACCESS" IN LARGE GREY LETTERS WITH A WHITE STAR BEHIND IT AND THE WORD "CONCIERGE" IN WHITE LETTERS BELOW IT WITH A BLACK BACKGROUND. THE WORDS "PRIVATE MEMBER SERVICE" IN BLACK WITHIN A WHITE STRIPE, AND THE WORDS "ENTERTAINMENT TRAVEL LIFESTYLE" IN WHITE LETTER WITH A BLACK BACKGROUND AND THE BOTTOM OF THE LOGO.

FOR PERSONAL CONCIERGE SERVICES FOR OTHERS COMPRISING MAKING REQUESTED PERSONAL ARRANGEMENTS AND RESERVATIONS, RUNNING ERRANDS AND PROVIDING CUSTOMER SPECIFIC INFORMATION TO MEET INDIVIDUAL NEEDS, ALL RENDERED IN BUSINESS ESTABLISHMENTS, OFFICE BUILDINGS, HOTELS, RESIDENTIAL COMPLEXES AND HOMES (U.S. CLS. 100 AND 101).

FIRST USE 2-1-2003; IN COMMERCE 2-1-2003.

ANGELA M. MICHELI, EXAMINING ATTORNEY

SN 77-412,428. AMICA MATURE LIFESTYLES INC., VANCOUVER, CANADA, FILED 3-4-2008.

SAPPHIRA

THE MARK CONSISTS OF STANDARD CHARACTERS WITHOUT CLAIM TO ANY PARTICULAR FONT, STYLE, SIZE, OR COLOR.

OWNER OF CANADA REG. NO. TMA737332, DATED 4-1-2009, EXPIRES 4-1-2024.

FOR (BASED ON INTENT TO USE) CONCIERGE SERVICES FOR OTHERS COMPRISING MAKING REQUESTED PERSONAL ARRANGEMENTS AND RESERVATIONS AND PROVIDING CUSTOMER-SPECIFIC INFORMATION TO MEET INDIVIDUAL NEEDS RENDERED TOGETHER IN A RESIDENTIAL COMPLEX; PROVIDING NON-MEDICAL PERSONAL ASSISTANT SERVICES FOR OTHERS IN THE NATURE OF PLANNING, ORGANIZING, COORDINATING, ARRANGING AND ASSISTING INDIVIDUALS TO PERFORM DAILY TASKS (BASED ON 44(D) PRIORITY APPLICATION) CONCIERGE SERVICES FOR OTHERS COMPRISING MAKING REQUESTED PERSONAL ARRANGEMENTS AND RESERVATIONS AND PROVIDING CUSTOMER-SPECIFIC INFORMATION TO MEET INDIVIDUAL NEEDS RENDERED TOGETHER IN A RESIDENTIAL COMPLEX; PROVIDING NON-MEDICAL PERSONAL ASSISTANT SERVICES FOR OTHERS IN THE NATURE OF PLANNING, ORGANIZING, COORDINATING, ARRANGING AND ASSISTING INDIVIDUALS TO PERFORM DAILY TASKS (U.S. CLS. 100 AND 101).

CIMMERIAN COLEMAN, EXAMINING ATTORNEY

CLASS 45—(Continued).

SN 77-442,626. MAGOO GLOBAL LLC, BOCA RATON, FL. FILED 4-8-2008.



THE COLOR(S) BLUE, ORANGE, GREEN AND WHITE IS/ ARE CLAIMED AS A FEATURE OF THE MARK.

THE MARK CONSISTS OF THE COLORS BLUE, ORANGE, GREEN AND WHITE, WITH THE COLOR WHITE APPEARING IN THE WORDING "MAGOOMIX.COM", THE COLOR BLUE APPEARING IN THE BACKGROUND, AND THE COLORS ORANGE, GREEN AND BLUE APPEARING IN THE CIRCLE DESIGNS BEHIND THE WORDING.

FOR ONLINE SOCIAL NETWORKING SERVICES (U.S. CLS. 100 AND 101).

FIRST USE 9-1-2007; IN COMMERCE 9-1-2007.

MATTHEW EINSTEIN, EXAMINING ATTORNEY

SN 77-475,261. THE LINCOLN NATIONAL LIFE INSURANCE COMPANY, FORT WAYNE, IN. FILED 5-15-2008.

EXEC-U-CARE CONCIERGE

THE MARK CONSISTS OF STANDARD CHARACTERS WITHOUT CLAIM TO ANY PARTICULAR FONT, STYLE, SIZE, OR COLOR.

OWNER OF U.S. REG. NO. 1,173,602.

NO CLAIM IS MADE TO THE EXCLUSIVE RIGHT TO USE "CONCIERGE", APART FROM THE MARK AS SHOWN.

FOR PERSONAL SERVICES FOR OTHERS COMPRISING MAKING REQUESTED PERSONAL ARRANGEMENTS AND RESERVATIONS, RUNNING ERRANDS AND PROVIDING CUSTOMER SPECIFIC INFORMATION TO MEET INDIVIDUAL NEEDS (U.S. CLS. 100 AND 101).

FIRST USE 8-1-2008; IN COMMERCE 8-1-2008.

ALLISON HOLTZ, EXAMINING ATTORNEY

SN 77-503,099. NPC, INC., CLAYSBURG, PA. FILED 6-19-2008.

InfoLaunch

THE MARK CONSISTS OF STANDARD CHARACTERS WITHOUT CLAIM TO ANY PARTICULAR FONT, STYLE, SIZE, OR COLOR.

FOR CONSULTING SERVICES IN THE FIELD OF MAINTAINING AND MONITORING THE SECURITY AND INTEGRITY OF DATABASES, ARCHIVAL INFORMATION AND DOCUMENTS CONTAINING SENSITIVE OR PERSONAL INFORMATION AND NOTIFICATION OF SECURITY BREACHES TO RELEVANT PERSONNEL AND DATABASE PARTICIPANTS (U.S. CLS. 100 AND 101).

RONALD AIKENS, EXAMINING ATTORNEY

CLASS 45—(Continued).

SN 77-527,979. PILGRIM TELEPHONE, INC., LEXINGTON, MA. FILED 7-22-2008.

SPANISH CONNECTIONS

THE MARK CONSISTS OF STANDARD CHARACTERS WITHOUT CLAIM TO ANY PARTICULAR FONT, STYLE, SIZE, OR COLOR.

NO CLAIM IS MADE TO THE EXCLUSIVE RIGHT TO USE "SPANISH", APART FROM THE MARK AS SHOWN.

FOR DATING SERVICES; MATCHMAKING SERVICES (U.S. CLS. 100 AND 101).

INGRID C. EULIN, EXAMINING ATTORNEY

CLASS 45—(Continued).

SN 77-569,300. CAMPBELL, ROBERT E, MURFREESBORO, TN. FILED 9-12-2008.



THE COLOR(S) LIGHT GREY, DARK GREY, AND RED IS/ARE CLAIMED AS A FEATURE OF THE MARK.

THE MARK CONSISTS OF A STYLIZED DANCING PERSON IN RED. THERE IS A LIGHT GREY SHADOW AT THE BOTTOM OF THE FOOT THAT IS ON THE GROUND. THE DANCING PERSON IS TO THE RIGHT OF THE WORDS DOTDANCER, WITH THE WORD "DOT" IN DARK GREY AND THE WORD "DANCER" IN RED. THE PHRASE "GET DOWN TO BUSINESS!" APPEARS BELOW THE "DOTDANCER," WITH THE WORDS "GET DOWN" IN DARK GREY AND THE WORDS "TO BUSINESS!" IN LIGHT GREY.

FOR REGISTRATION OF DOMAIN NAMES FOR OTHERS FOR IDENTIFICATION OF USERS ON A GLOBAL COMPUTER NETWORK (U.S. CLS. 100 AND 101).

FIRST USE 9-28-2007; IN COMMERCE 9-28-2007.
LINDSEY RUBIN, EXAMINING ATTORNEY

SN 77-550,041. MYCAMPFIRES LLC, LOS ANGELES, CA. FILED 8-19-2008.



THE COLOR(S) GREEN, BROWN, YELLOW, ORANGE, WHITE IS/ARE CLAIMED AS A FEATURE OF THE MARK.

THE MARK CONSISTS OF THE LITERAL ELEMENT "SMORECAMP" IN GREEN AT THE BOTTOM OF THE MARK. A TOP THE LITERAL ELEMENT IS A BROWN BRANCH PIERCING A WHITE TRANSPARENT MARSHMALLOW. BEHIND THE WHITE TRANSPARENT MARSHMALLOW AND INTERTWINED WITH THE BRANCH IS A LARGE FLAME. THIS LARGER ORANGE AND YELLOW FLAME IS IN THE SHAPE OF AN "S". TO THE RIGHT OF THE LARGE FLAME IS A SMALLER ORANGE AND YELLOW FLAME IN THE SHAPE OF A "C".

FOR ON-LINE SOCIAL NETWORKING SERVICES (U.S. CLS. 100 AND 101).

FIRST USE 6-13-2008; IN COMMERCE 8-8-2008.
FONG HSU, EXAMINING ATTORNEY

SN 77-601,168. RICHARD A. HARRIS, A PROFESSIONAL CORPORATION, LAS VEGAS, NV. FILED 10-27-2008.

TICKET BUSTERS

THE MARK CONSISTS OF STANDARD CHARACTERS WITHOUT CLAIM TO ANY PARTICULAR FONT, STYLE, SIZE, OR COLOR.

1) APPLICANT SEEKS REGISTRATION OF THE MARK "TICKET BUSTERS" FOR LEGAL SERVICES, IN THE GEOGRAPHIC AREA OF THE ENTIRE UNITED STATES WITH THE EXCEPTION OF THE STATE OF FLORIDA, THE CITIES OF FLUSHING, NEW YORK; NEW YORK CITY, NEW YORK; AND SOMERSET NEW JERSEY. 2) APPLICANT IS PROVIDING LEGAL SERVICES AND LICENSING ITS MARK FOR LEGAL SERVICES UNDER THE MARK "TICKET BUSTERS" WHICH IS USED IN ADVERTISING THE LEGAL SERVICES THROUGH PRINT ADVERTISING, OUTDOOR ADVERTISING, TELEVISION AND RADIO COMMERCIALS, AND INTERNET ADVERTISING, AND OTHER FORMS OF ADVERTISING FOR SERVICES. 3) APPLICANT CLAIMS AN EXCEPTION TO ITS EXCLUSIVE USE OF THE MARK "TICKET BUSTERS" BY THREE OTHER THIRD PARTY USES OF SIMILAR MARKS WHICH INCLUDE THE TERMS "TICKET" AND "BUSTERS" IN THE STATE OF FLORIDA, THE CITIES OF FLUSHING, NEW YORK; NEW YORK CITY, NEW YORK; AND SOMERSET NEW JERSEY. 4) APPLICANT BELIEVES THE CORRECT NAMES AND ADDRESSES OF THE CONCURRENT USERS TO BE: A) "TICKET BUSTERS", INC., A FLORIDA CORPORATION, LOCATED AT 11900 BISCAYNE BOULEVARD SUITE 400, MIAMI, FLORIDA 33181. THIS BUSINESS HOLDS A FLORIDA STATE TRADEMARK REGISTRATION, AND ITS FIRST DATE OF USE IS CLAIMED AS JUNE 8, 1994. B) "TICKET BUSTERS", INC., A NEW YORK

CLASS 45—(Continued).

CORPORATION, LOCATED AT 4078 MAIN STREET, FLUSHING, NY 11355. NO TRADEMARK APPLICATION OR REGISTRATION HAS BEEN OBTAINED. C) PARKING "TICKET BUSTERS", LOCATED AT 212 WEST 91ST STREET, NEW YORK CITY, NY 10024, WITH A SECOND LOCATION IN SOMERSET, NEW JERSEY. NO TRADEMARK APPLICATION OR REGISTRATION HAS BEEN OBTAINED. APPLICANT DECLARES THAT NO ONE ELSE EXCEPT AS SPECIFIED IN THE APPLICATION HAS THE RIGHT TO USE THE MARK.

NO CLAIM IS MADE TO THE EXCLUSIVE RIGHT TO USE "TICKET", APART FROM THE MARK AS SHOWN. FOR LEGAL SERVICES (U.S. CLS. 100 AND 101). FIRST USE 10-22-2002; IN COMMERCE 10-22-2002. SHANNON TWOHIG, EXAMINING ATTORNEY

CLASS 45—(Continued).

SN 77-612,399. GOZA, WASHINGTON & COLEMAN, PLLC, OKLAHOMA CITY, OK. FILED 11-11-2008.



SN 77-601,383. RICHARD A. HARRIS, A PROFESSIONAL CORPORATION, LAS VEGAS, NV. FILED 10-27-2008.



NO CLAIM IS MADE TO THE EXCLUSIVE RIGHT TO USE "TICKET", APART FROM THE MARK AS SHOWN.

THE COLOR(S) YELLOW, GREEN, BROWN, ORANGE, BEIGE, WHITE, GRAY, BLACK AND RED IS/ARE CLAIMED AS A FEATURE OF THE MARK.

THE MARK CONSISTS OF A BEIGE CARICATURE DEPICTING A LAW ENFORCEMENT OFFICER WEARING A BROWN UNIFORM WITH A YELLOW STAR ON ITS HAT AND ARM, AN ORANGE HOLSTER WITH A YELLOW BUCKLE, BLACK SUNGLASSES AND WHITE TEETH, WRITING A TICKET WITH A YELLOW PENCIL WITH A RED ERASER ON A GREY AND WHITE PAD AGAINST A GREEN STAR NEXT TO THE STYLIZED YELLOW WORDS "TICKET BUSTERS" WITH A GREEN NARROW BORDER AROUND THEM.

FOR LEGAL SERVICES (U.S. CLS. 100 AND 101). FIRST USE 11-0-2005; IN COMMERCE 11-0-2005. SHANNON TWOHIG, EXAMINING ATTORNEY

NO CLAIM IS MADE TO THE EXCLUSIVE RIGHT TO USE "LAWYERS", APART FROM THE MARK AS SHOWN.

THE COLOR(S) BLACK AND GOLD IS/ARE CLAIMED AS A FEATURE OF THE MARK.

THE MARK CONSISTS OF THE LETTERS "GWC" IN GOLD INSIDE A BLACK DIAMOND DESIGN WITH GOLD COLORED EXTERIOR; THE WORDING "LAWYERS" APPEARS IN BLACK STYLIZED FONT AND THE WORDING "1-800-MY-LAWYER" APPEARS IN BLACK STYLIZED FONT.

FOR LEGAL SERVICES (U.S. CLS. 100 AND 101). FIRST USE 1-1-2008; IN COMMERCE 1-1-2008. DANIEL CAPSHAW, EXAMINING ATTORNEY

SN 77-609,249. INTERMOUNTAIN THERAPY ANIMALS, SALT LAKE CITY, UT. FILED 11-6-2008.

R.E.A.D.

THE MARK CONSISTS OF STANDARD CHARACTERS WITHOUT CLAIM TO ANY PARTICULAR FONT, STYLE, SIZE, OR COLOR.

OWNER OF U.S. REG. NO. 2,751,510. SEC. 2(F).

FOR ANIMAL-ASSISTED THERAPY SERVICES, NAMELY, PROVIDING TRAINED THERAPY ANIMALS TO HELP INDIVIDUALS IMPROVE LITERACY AND SELF-ESTEEM (U.S. CLS. 100 AND 101).

FIRST USE 11-1-1999; IN COMMERCE 11-1-1999. INGRID C. EULIN, EXAMINING ATTORNEY

SN 77-639,008. MAYFIELD-KISER, LLC, FORT WORTH, TX. FILED 12-23-2008.



NO CLAIM IS MADE TO THE EXCLUSIVE RIGHT TO USE "CREMATION", APART FROM THE MARK AS SHOWN.

THE MARK CONSISTS OF THE WORD "LONE STAR" SEPARATED BY A FIVE-POINT STAR WHICH HAS EVERY ALTERNATE STAR POINT SHADED IN BLACK WITH THE WORDS "CREMATION SOCIETY" IMMEDIATELY BELOW SEPARATED BY A SOLID BLACK LINE.

SEC. 2(F) AS TO: "LONE STAR CREMATION SOCIETY". FOR CREMATION SERVICES (U.S. CLS. 100 AND 101). FIRST USE 1-1-2003; IN COMMERCE 1-1-2003. MICHAEL LITZAU, EXAMINING ATTORNEY

CLASS 45—(Continued).

SN 77-652,777. CHRISTAR, FORMERLY INTERNATIONAL MISSIONS INC., READING, PA. FILED 1-20-2009.

Eden Vigil

THE MARK CONSISTS OF STANDARD CHARACTERS WITHOUT CLAIM TO ANY PARTICULAR FONT, STYLE, SIZE, OR COLOR.

FOR MINISTERIAL SERVICES PROVIDED FOR PEOPLE LIVING IN POOR ENVIRONMENTAL CONDITIONS IN VARIOUS COUNTRIES (U.S. CLS. 100 AND 101).

FIRST USE 10-22-2008; IN COMMERCE 1-16-2009.
DAVID TAYLOR, EXAMINING ATTORNEY

CLASS 45—(Continued).

SN 77-661,232. CHARISMATIC LIFESTYLE LLC, NEW YORK, NY. FILED 2-2-2009.

Window Shopping for Women

THE MARK CONSISTS OF STANDARD CHARACTERS WITHOUT CLAIM TO ANY PARTICULAR FONT, STYLE, SIZE, OR COLOR.

NO CLAIM IS MADE TO THE EXCLUSIVE RIGHT TO USE "WOMEN", APART FROM THE MARK AS SHOWN. FOR PERSONAL LIFESTYLE CONSULTING SERVICES (U.S. CLS. 100 AND 101).

FIRST USE 5-1-2008; IN COMMERCE 5-1-2008.
REGINA DRUMMOND, EXAMINING ATTORNEY

SN 77-658,060. STAIMAN, RUTH W, JUPITER, FL. FILED 1-28-2009.

The Fashion Office

THE MARK CONSISTS OF STANDARD CHARACTERS WITHOUT CLAIM TO ANY PARTICULAR FONT, STYLE, SIZE, OR COLOR.

NO CLAIM IS MADE TO THE EXCLUSIVE RIGHT TO USE "FASHION", APART FROM THE MARK AS SHOWN.

FOR FASHION CONSULTING SERVICES; FASHION TREND CONSULTING FOR THE FASHION INDUSTRY; FASHION TREND CONSULTING SERVICES; PROVIDING INFORMATION IN THE FIELD OF FASHION TRENDS (U.S. CLS. 100 AND 101).

BONNIE LUKEN, EXAMINING ATTORNEY

SN 77-661,936. AGNICK, THEODORE A., TEMPE, AZ. FILED 2-3-2009.

Arizona DUI/DWI Survival Guide

THE MARK CONSISTS OF STANDARD CHARACTERS WITHOUT CLAIM TO ANY PARTICULAR FONT, STYLE, SIZE, OR COLOR.

NO CLAIM IS MADE TO THE EXCLUSIVE RIGHT TO USE "ARIZONA DUI/DWI" AND "GUIDE", APART FROM THE MARK AS SHOWN.

FOR LEGAL SERVICES (U.S. CLS. 100 AND 101).
SIMON TENG, EXAMINING ATTORNEY

SN 77-660,875. SUSAN KEENBERG, DBA SUSAN KEENBERG, ATTORNEY / MEDIATOR, TORRANCE, CA. FILED 2-1-2009.

A Lawyer with Smarts and a Heart

THE MARK CONSISTS OF STANDARD CHARACTERS WITHOUT CLAIM TO ANY PARTICULAR FONT, STYLE, SIZE, OR COLOR.

NO CLAIM IS MADE TO THE EXCLUSIVE RIGHT TO USE "LAWYER", APART FROM THE MARK AS SHOWN.

FOR ATTORNEY SERVICES (U.S. CLS. 100 AND 101).
FIRST USE 1-1-2009; IN COMMERCE 1-1-2009.
DAWN HAN, EXAMINING ATTORNEY

SN 77-661,946. AGNICK, THEODORE A., TEMPE, AZ. FILED 2-3-2009.

DUI/DWI Survival Guide

THE MARK CONSISTS OF STANDARD CHARACTERS WITHOUT CLAIM TO ANY PARTICULAR FONT, STYLE, SIZE, OR COLOR.

NO CLAIM IS MADE TO THE EXCLUSIVE RIGHT TO USE "DUI/DWI" AND "GUIDE", APART FROM THE MARK AS SHOWN.

FOR LEGAL SERVICES (U.S. CLS. 100 AND 101).
SIMON TENG, EXAMINING ATTORNEY

CLASS 45—(Continued).

SN 77-662,076. MOTORS IN MOTION, LLC, NORTH PALM BEACH, FL. FILED 2-3-2009.



THE COLOR(S) RED, BLACK, SILVER AND WHITE IS/ ARE CLAIMED AS A FEATURE OF THE MARK.

THE MARK CONSISTS OF THE WORDS "PUSH START" IN WHITE SHADED IN RED INSIDE A BLACK CIRCLE, WHICH IS INSIDE A SILVER CIRCLE.

FOR ON-LINE SOCIAL NETWORKING SERVICES (U.S. CLS. 100 AND 101).

FIRST USE 12-31-2007; IN COMMERCE 12-31-2007.
PAM WILLIS, EXAMINING ATTORNEY

SN 77-662,421. MARK A. NACOL, DBA THE NACOL LAW FIRM PC, RICHARDSON, TX. FILED 2-3-2009.



The Nacol
Law Firm PC

NO CLAIM IS MADE TO THE EXCLUSIVE RIGHT TO USE "LAW FIRM PC", APART FROM THE MARK AS SHOWN.

THE COLOR(S) BURGUNDY, GRAY AND BLACK IS/ ARE CLAIMED AS A FEATURE OF THE MARK.

THE MARK CONSISTS OF A BURGUNDY BOX WITH AN ITALICIZED GRAY "N" IN THE MIDDLE OF THE BOX THAT FLOWS OUTSIDE THE MIDDLE RIGHT OF THE BOX. "THE NACOL" APPEARS IN STYLIZED BLACK FONT ON TOP LINE OUTSIDE RIGHT OF BOX AND "LAW FIRM PC" APPEARS IN STYLIZED BLACK FONT ON LOWER LINE OUTSIDE RIGHT OF BOX.

FOR LEGAL SERVICES (U.S. CLS. 100 AND 101).
FIRST USE 1-1-2009; IN COMMERCE 1-1-2009.
BRENDAN REGAN, EXAMINING ATTORNEY

CLASS 45—(Continued).

SN 77-662,578. STOCKBRIDGE/SBE HOLDINGS LLC, DBA SAHARA HOTEL & CASINO, LAS VEGAS, NV. FILED 2-3-2009.

Sahara

THE MARK CONSISTS OF STANDARD CHARACTERS WITHOUT CLAIM TO ANY PARTICULAR FONT, STYLE, SIZE, OR COLOR.

OWNER OF U.S. REG. NOS. 824,612, 3,546,734 AND OTHERS.

FOR WEDDING CHAPEL SERVICES (U.S. CLS. 100 AND 101).

JUDITH HELFMAN, EXAMINING ATTORNEY

SN 77-662,745. JUDITH ARONSON, TENAFLY, NJ. FILED 2-3-2009.

Keeping Your Sense of Tumor

THE MARK CONSISTS OF STANDARD CHARACTERS WITHOUT CLAIM TO ANY PARTICULAR FONT, STYLE, SIZE, OR COLOR.

FOR PROVIDING PERSONAL SUPPORT SERVICES FOR FAMILIES OF PATIENTS WITH LIFE THREATENING DISORDERS, NAMELY, COMPANIONSHIP, HELP WITH MEDICAL FORMS, COUNSELING AND EMOTIONAL SUPPORT (U.S. CLS. 100 AND 101).

DAVID I, EXAMINING ATTORNEY

SN 77-663,511. EINBINDER, HILLARD N., ORANGE, CT. FILED 2-4-2009.



NO CLAIM IS MADE TO THE EXCLUSIVE RIGHT TO USE "LEGAL CLOSING .COM", APART FROM THE MARK AS SHOWN.

THE COLOR(S) BROWN, WHITE AND YELLOW IS/ ARE CLAIMED AS A FEATURE OF THE MARK.

THE MARK CONSISTS OF THE WORD "LEGAL" IN BROWN, A GAVEL IN SHADES OF BROWN WITH WHITE HIGHLIGHTS, AND DESIGNATION "CLOSING.COM" IN YELLOW.

FOR CLOSING SERVICES FOR BUSINESS LOANS AND MORTGAGE LOANS; PREPARING AND ORGANIZING LOAN CLOSING DOCUMENTS; REAL ESTATE CLOSING SERVICES; BUSINESS TRANSACTION CLOSING SERVICES (U.S. CLS. 100 AND 101).

FIRST USE 5-15-2007; IN COMMERCE 5-15-2007.
DAVID C. REIHNER, EXAMINING ATTORNEY

CLASS 45—(Continued).

SN 77-663,531. SYMBYOZ, LLC, MOUNTAIN VIEW, CA. FILED 2-4-2009.

SYMBYOZ

THE MARK CONSISTS OF STANDARD CHARACTERS WITHOUT CLAIM TO ANY PARTICULAR FONT, STYLE, SIZE, OR COLOR.
FOR ON-LINE SOCIAL NETWORKING SERVICES (U.S. CLS. 100 AND 101).
MICHAEL WEBSTER, EXAMINING ATTORNEY

CLASS 45—(Continued).

SN 77-664,286. PATHWAY GENOMICS CORPORATION, DEL MAR, CA. FILED 2-5-2009.

PATHWAY

THE MARK CONSISTS OF STANDARD CHARACTERS WITHOUT CLAIM TO ANY PARTICULAR FONT, STYLE, SIZE, OR COLOR.
FOR ONLINE SOCIAL NETWORKING SERVICES IN THE FIELD OF GENETICS; ONLINE SOCIAL NETWORKING SERVICES IN THE FIELDS OF HEALTH AND WELLNESS (U.S. CLS. 100 AND 101).
MARK SPARACINO, EXAMINING ATTORNEY

SN 77-663,667. ZIEMS, P.C., LAS VEGAS, NV. FILED 2-4-2009.

Using The Law To Get Business Done

THE MARK CONSISTS OF STANDARD CHARACTERS WITHOUT CLAIM TO ANY PARTICULAR FONT, STYLE, SIZE, OR COLOR.
FOR LEGAL SERVICES (U.S. CLS. 100 AND 101).
BARBARA BROWN, EXAMINING ATTORNEY

SN 77-664,979. PET PROTECTION AGREEMENT, LLC, OLD TAPPAN, NJ. FILED 2-6-2009.

PETRIARCH

THE MARK CONSISTS OF STANDARD CHARACTERS WITHOUT CLAIM TO ANY PARTICULAR FONT, STYLE, SIZE, OR COLOR.
FOR LEGAL DOCUMENT PREPARATION SERVICES AND PROVIDING GENERAL LEGAL INFORMATION REGARDING PETS (U.S. CLS. 100 AND 101).
FIRST USE 9-0-2007; IN COMMERCE 9-0-2007.
CHRISTINE COOPER, EXAMINING ATTORNEY

SN 77-664,185. CHRISTOPHER K. CASWELL, PA, SARASOTA, FL. FILED 2-5-2009.

BizCare

THE MARK CONSISTS OF STANDARD CHARACTERS WITHOUT CLAIM TO ANY PARTICULAR FONT, STYLE, SIZE, OR COLOR.
FOR LEGAL SERVICES (U.S. CLS. 100 AND 101).
FIRST USE 7-1-2002; IN COMMERCE 7-1-2002.
MARC LEIPZIG, EXAMINING ATTORNEY

SN 77-665,001. PET PROTECTION AGREEMENT, LLC, OLD TAPPAN, NJ. FILED 2-6-2009.

LOVE CONTINUES

THE MARK CONSISTS OF STANDARD CHARACTERS WITHOUT CLAIM TO ANY PARTICULAR FONT, STYLE, SIZE, OR COLOR.
FOR LEGAL DOCUMENT PREPARATION SERVICES AND PROVIDING GENERAL LEGAL INFORMATION REGARDING PETS (U.S. CLS. 100 AND 101).
FIRST USE 12-16-2008; IN COMMERCE 12-16-2008.
CHRISTINE COOPER, EXAMINING ATTORNEY

CLASS 45—(Continued).

SN 77-665,672. HILL, WARD & HENDERSON, PROFESSIONAL ASSOCIATION, TAMPA, FL. FILED 2-7-2009.

HILL WARD HENDERSON

THE MARK CONSISTS OF STANDARD CHARACTERS WITHOUT CLAIM TO ANY PARTICULAR FONT, STYLE, SIZE, OR COLOR.

FOR LEGAL SERVICES (U.S. CLS. 100 AND 101).
FIRST USE 12-14-2007; IN COMMERCE 12-14-2007.
WILLIAM VERHOSEK, EXAMINING ATTORNEY

SN 77-665,675. HILL, WARD & HENDERSON, PROFESSIONAL ASSOCIATION, TAMPA, FL. FILED 2-7-2009.



THE MARK CONSISTS OF THE STYLIZED LETTERS "HWH" ON A RECTANGULAR BACKGROUND.

FOR LEGAL SERVICES (U.S. CLS. 100 AND 101).
FIRST USE 12-14-2007; IN COMMERCE 12-14-2007.
WILLIAM VERHOSEK, EXAMINING ATTORNEY

SN 77-672,604. CHRISTOPHER K. CASWELL, PA, SARASOTA, FL. FILED 2-18-2009.

ClosingCare

THE MARK CONSISTS OF STANDARD CHARACTERS WITHOUT CLAIM TO ANY PARTICULAR FONT, STYLE, SIZE, OR COLOR.

FOR LEGAL SERVICES (U.S. CLS. 100 AND 101).
FIRST USE 2-8-2008; IN COMMERCE 2-8-2008.
MARC LEIPZIG, EXAMINING ATTORNEY

CLASS 45—(Continued).

SN 77-678,935. G. MACHER ENTERPRISES, INC., SHERMAN OAKS, CA. FILED 2-26-2009.

WHERE THE HONEYS MEET THE MONEY

THE MARK CONSISTS OF STANDARD CHARACTERS WITHOUT CLAIM TO ANY PARTICULAR FONT, STYLE, SIZE, OR COLOR.

FOR DATING SERVICES, NAMELY, PROVIDING AN ON-LINE COMPUTER DATABASE FEATURING SINGLE PEOPLE INTERESTED IN MEETING OTHER SINGLE PEOPLE; INTERNET-BASED DATING, SOCIAL INTRODUCTION AND SOCIAL NETWORKING SERVICES (U.S. CLS. 100 AND 101).
NELSON SNYDER, EXAMINING ATTORNEY

SN 77-682,646. WILSON, BARRY, P, AKA 1-800-UNLOCKS, INC., RICHMOND, VA. FILED 3-3-2009.

**1-800-UNLOCKS
Nationwide Automated
Locksmith Dispatch**

THE MARK CONSISTS OF STANDARD CHARACTERS WITHOUT CLAIM TO ANY PARTICULAR FONT, STYLE, SIZE, OR COLOR.

NO CLAIM IS MADE TO THE EXCLUSIVE RIGHT TO USE "LOCKSMITH DISPATCH", APART FROM THE MARK AS SHOWN.

SEC. 2(F).
FOR LOCKSMITHING, NAMELY, OPENING OF LOCKS (U.S. CLS. 100 AND 101).

FIRST USE 10-5-1995; IN COMMERCE 10-5-1995.
NICHOLAS COLEMAN, EXAMINING ATTORNEY

SN 78-965,050. FIFTH THIRD BANCORP, CINCINNATI, OH. FILED 8-31-2006.

VISTA SETTLEMENT SERVICES

THE MARK CONSISTS OF STANDARD CHARACTERS WITHOUT CLAIM TO ANY PARTICULAR FONT, STYLE, SIZE, OR COLOR.

NO CLAIM IS MADE TO THE EXCLUSIVE RIGHT TO USE "SETTLEMENT SERVICES", APART FROM THE MARK AS SHOWN.

FOR REAL ESTATE SETTLEMENT SERVICES (U.S. CLS. 100 AND 101).
DAWN FELDMAN, EXAMINING ATTORNEY

SECTION 4.—PRIOR UNITED STATES CLASSIFICATION

APPLICATION IN ONE CLASS

COLLECTIVE MEMBERSHIP MARKS

SN 77-431,024. GLYCEMIC RESEARCH INSTITUTE, WASHINGTON, DC. FILED 3-25-2008.

CLASS 200—COLLECTIVE MEMBERSHIP
SN 77-508,541. UNITED WAY OF AMERICA, ALEXANDRIA, VA. FILED 6-26-2008.

LIVE UNITED

THE MARK CONSISTS OF STANDARD CHARACTERS WITHOUT CLAIM TO ANY PARTICULAR FONT, STYLE, SIZE, OR COLOR.
FOR INDICATING MEMBERSHIP IN ASSOCIATION OF CHARITABLE FUND RAISING AND HUMAN CARE SERVICES ORGANIZATIONS.
FIRST USE 5-1-2008; IN COMMERCE 5-1-2008.
ANGELA GAW, EXAMINING ATTORNEY



SN 77-601,839. NATIONAL BOARD FOR RESPIRATORY CARE, INC., OLATHE, KS. FILED 10-28-2008.

RRT-SDS

THE MARK CONSISTS OF STANDARD CHARACTERS WITHOUT CLAIM TO ANY PARTICULAR FONT, STYLE, SIZE, OR COLOR.
OWNER OF U.S. REG. NOS. 1,121,235 AND 2,870,210.
FOR INDICATING MEMBERSHIP IN AN ORGANIZATION OF RESPIRATORY THERAPISTS SPECIALIZING IN THE TREATMENT OF SLEEP DISORDERS.
PAUL MORENO, EXAMINING ATTORNEY

OWNER OF U.S. REG. NOS. 2,572,688, 3,419,072 AND OTHERS.

NO CLAIM IS MADE TO THE EXCLUSIVE RIGHT TO USE "CERTIFIED BY THE GLYCEMIC RESEARCH INSTITUTE", "WASHINGTON D.C.", AND "LOW GLYCEMIC PHARMACEUTICALS", APART FROM THE MARK AS SHOWN.

THE MARK CONSISTS OF A LARGE TRIANGLE CONTAINING THE WORDS "CERTIFIED BY THE GLYCEMIC RESEARCH INSTITUTE WASHINGTON D.C." ENCOMPASSING A SMALLER TRIANGLE CONTAINING THE WORDS "LOW GLYCEMIC PHARMACEUTICALS" WITH AN IMAGE OF A MORTAR AND PESTLE BETWEEN THE WORDS.

THE CERTIFICATION MARK, AS USED BY PERSONS AUTHORIZED BY THE CERTIFIER, CERTIFIES THAT THE GOODS PROVIDED HAVE BEEN TESTED AND MEET THE STANDARDS OF ACCEPTABLE GLYCEMIC LEVELS AS SET FORTH BY THE CERTIFIER.

FOR FOOD, BEVERAGES, AND PHARMACEUTICAL PRODUCTS, NAMELY, IV'S, DIABETIC MEAL REPLACEMENTS, COUGH SYRUPS, OVER-THE-COUNTER MEDICATIONS, ELECTROLYTE PREPARATIONS, POST-SURGICAL DRINKS, ORAL DRUGS.
NAPOLEON SHARMA, EXAMINING ATTORNEY

CERTIFICATION MARKS

CLASS A—GOODS

SN 77-451,124. CERTIFIED MINT, INC., DOVER, DE. FILED 4-17-2008.

SN 77-518,794. ASOCIACION COLOMBIANA DE EXPORTADORES DE FLORES ASOCOLFLORES, BOGOTA, COLOMBIA, FILED 7-10-2008.



NO CLAIM IS MADE TO THE EXCLUSIVE RIGHT TO USE "CERTIFIED MINT 100% GUARANTEED", APART FROM THE MARK AS SHOWN.

THE STIPLING IS A FEATURE OF THE MARK.

THE COLOR(S) BLACK, YELLOW, GREEN IS/ARE CLAIMED AS A FEATURE OF THE MARK.

THE MARK CONSISTS OF A BLACK BACKGROUND IN THE CENTER OF WHICH IS INSCRIBED A YELLOW CIRCLE WITH A SERRATED OUTSIDE EDGE; WITHIN THE YELLOW CIRCLE IS A SMALLER GREEN CIRCLE; THE WORD "MINT" IN BLACK LETTERS EXTENDS HORIZONTALLY COMPLETELY ACROSS THE SERRATED EDGES AND FACE OF BOTH THE YELLOW CIRCLE WITH SERRATED EDGE AND THE GREEN CIRCLE; THE WORDS "CERTIFIED 100%" ARE INSCRIBED IN BLACK LETTERS IN A CIRCULAR FASHION AROUND THE INSIDE EDGE OF THE GREEN CIRCLE AND EXTEND COMPLETELY AROUND THE CIRCUMFERENCE OF THE GREEN CIRCLE; THE GREEN CIRCLE HAS A CENTRAL CORE COMPRISING APPROXIMATELY TWO-THIRDS OF ITS DIAMETER ON WHICH IS INSCRIBED A YELLOW RANDOM PATTERN.

THE CERTIFICATION MARK, AS USED BY AUTHORIZED PERSONS, CERTIFIES THAT WHILE "CERTIFIED MINT" MERCHANDISE CANNOT BE SOLD AS NEW, IT IS OTHERWISE EQUAL IN ALMOST EVERY SUBSTANTIVE ASPECT TO BRAND-NEW, MINT-CONDITION MERCHANDISE EXCEPT FOR "CERTIFIED MINT" INSPECTIONS, ADJUSTMENTS, LABELING AND PACKAGING AND INCLUDES THE EXCLUSIVE USA (USER SATISFACTION ASSURED) FACTORY WARRANTY WHICH IS OFFERED IN LIEU OF THE ORIGINAL FACTORY WARRANTY.

FOR AUDIO-VIDEO EQUIPMENT.

FIRST USE 1-1-1999; IN COMMERCE 1-1-1999.

ALLISON HOLTZ, EXAMINING ATTORNEY



OWNER OF U.S. REG. NO. 2,897,547.

THE MARK CONSISTS OF THE WORD "FLORVERDE" DISPLAYED AS AN ARC OVER A PICTURE OF FLOWERS. THE TERM "GOOD" APPEARS UNDERNEATH THE FLOWER DESIGN IN A SHADED, INCOMPLETE RECTANGLE TO THE LEFT OF THE WORDS "FOR THE EARTH", WHICH IS DISPLAYED ON TOP OF THE TERM "FOR THE WORKERS", WHICH IS DISPLAYED ON TOP OF THE TERM "FOR YOU".

THE ENGLISH TRANSLATION OF "FLORVERDE" IN THE MARK IS "GREEN FLOWER".

THE CERTIFICATION MARK, AS USED BY AUTHORIZED PERSONS, CERTIFIES MAINTAINING AND PROTECTING THE ENVIRONMENT AS WELL AS A WELL-BEING OF THE WORKERS IN GROWING SUCH FLOWERS.

FOR CUT FLOWERS, FRESH FLOWERS.

FIRST USE 3-5-2008; IN COMMERCE 3-5-2008.

LINDA POWELL, EXAMINING ATTORNEY

SN 77-559,252. COALITION FOR QUALITY CHILDREN'S MEDIA, SANTA FE, NM. FILED 8-29-2008.



OWNER OF U.S. REG. NO. 2,185,297.

NO CLAIM IS MADE TO THE EXCLUSIVE RIGHT TO USE "APPROVED BY", APART FROM THE MARK AS SHOWN.

THE MARK CONSISTS OF THE MARK CONSISTS OF A BLACK CIRCLE. AN ANGEL IS FLYING OUT OF THE UPPER RIGHT-HAND SIDE OF THE CIRCLE AND THE PART OF THE ANGEL THAT IS OUTSIDE THE CIRCLE IS BLACK, WHILE THE PART STILL IN THE CIRCLE IS WHITE. THERE IS A WHITE HAND EXTENDING PALM UPWARD INTO THE CIRCLE FROM THE LEFT-HAND LOWER PORTION UPWARD TOWARD THE MIDDLE SECTION OF THE CIRCLE. THE WORDS "KIDS FIRST!"

ARE IN LARGE BLACK LETTERS JUST OUTSIDE THE CIRCLE, FOLLOWING THE SAME CURVATURE OF THE CIRCLE. THE WORDS "APPROVED BY" ARE WHITE AND ARE LOCATED WITHIN THE CIRCLE, BEGINNING FROM MIDDLE LOWER PART OF THE CIRCLE TOWARD MIDDLE RIGHT-HAND SIDE OF THE CIRCLE. "COALITION FOR QUALITY CHILDREN'S MEDIA" BEGINS OUTSIDE THE LEFT-HAND SIDE OF THE CIRCLE INTO ALMOST THE MIDDLE OF THE CIRCLE. THE PORTION OF THE WORDS OUTSIDE THE CIRCLE ARE BLACK, WHILE THE PORTION OF THE WORDS EXTENDING INTO THE CIRCLE ARE WHITE.

THE CERTIFICATION MARK, AS USED BY AUTHORIZED PERSONS, CERTIFIES THE CHILDREN'S MEDIA HAVE BEEN REVIEWED AND HAVE BEEN CERTIFIED AS MEETING STANDARDS FOR QUALITY AND SUITABILITY ESTABLISHED BY THE CERTIFIER.

SEC. 2(F).

FOR CHILDREN'S PROGRAM RECORDINGS DESIGNED FOR CHILDREN AGES INFANT TO 18 YEARS, NAMELY, FILMS, TV SHOWS, VIDEO TAPE RECORDINGS, DVDS, VIDEOGAMES, AUDIO CDS.

FIRST USE 3-1-1999; IN COMMERCE 3-1-1999.
BARBARA BROWN, EXAMINING ATTORNEY

SN 77-509,877. LANGUAGE LINE UNIVERSITY, A DIVISION OF LANGUAGE LINE SERVICES, INC., MONTEREY, CA. FILED 6-27-2008.

CHI

THE MARK CONSISTS OF STANDARD CHARACTERS WITHOUT CLAIM TO ANY PARTICULAR FONT, STYLE, SIZE, OR COLOR.

THE CERTIFICATION MARK, AS INTENDED TO BE USED BY AUTHORIZED PERSONS, IS INTENDED TO CERTIFY LANGUAGE INTERPRETERS FOR HEALTHCARE AND HEALTHCARE INDUSTRY LANGUAGE INTERPRETATION AND TRANSLATION SERVICES WHO HAVE MET SPECIFIC REQUIREMENTS OF, AND HAVE BEEN TRAINED AND EXAMINED BY LANGUAGE LINE UNIVERSITY AND THEREBY QUALIFY AS HIGH LEVEL HEALTH RELATED LANGUAGE INTERPRETERS.

FOR LANGUAGE INTERPRETATION AND TRANSLATION SERVICES FOR THE HEALTHCARE INDUSTRY AND HEALTHCARE PROVIDERS.

PAULA MAHONEY, EXAMINING ATTORNEY

SN 77-658,372. INTERNATIONAL ASSOCIATION OF PLUMBING AND MECHANICAL OFFICIALS, ONTARIO, CA. FILED 1-28-2009.



OWNER OF U.S. REG. NOS. 1,148,170, 3,234,197 AND OTHERS.

NO CLAIM IS MADE TO THE EXCLUSIVE RIGHT TO USE "ELECTRICAL", APART FROM THE MARK AS SHOWN.

THE MARK CONSISTS OF A SHIELD DESIGN WITH THE WORD "ELECTRICAL" APPEARING AT THE TOP OF THE SHIELD AND THE LETTERS "IAPMO" APPEARING INSIDE TWO DIAGONAL LINES.

THE CERTIFICATION MARK, AS INTENDED TO BE USED BY AUTHORIZED PERSONS, IS INTENDED TO CERTIFY THAT MANUFACTURERS AUTHORIZED BY THE CERTIFIER WILL MANUFACTURE THE GOODS IN CONFORMITY WITH STANDARDS SPECIFIED BY THE CERTIFIER.

FOR ELECTRIC DEVICES FOR PLUMBING, WATER TREATMENT, POOL, AND SPA.

JASON LOTT, EXAMINING ATTORNEY

SN 77-535,063. GREEN ADVANTAGE, INC., LOVETTSVILLE, VA. FILED 7-30-2008.



OWNER OF U.S. REG. NO. 3,068,597.

THE MARK CONSISTS OF A DRAWING OF A TREE AND HOUSE.

THE CERTIFICATION MARK, AS USED BY AUTHORIZED PERSONS, CERTIFIES THAT AN INDIVIDUAL HAS ACHIEVED A SPECIFIC LEVEL OF PROFESSIONAL KNOWLEDGE, TRAINING AND EXPERIENCE IN THE FIELD OF ENVIRONMENTALLY FRIENDLY TECHNIQUES AND APPROACHES TO LAND DEVELOPMENT, LAND MAINTENANCE, CONSTRUCTION AND PROPERTY MAINTENANCE.

FOR LAND DEVELOPMENT, NAMELY, PLANNING, LAYING OUT, AND CONSTRUCTING COMMERCIAL AND RESIDENTIAL BUILDINGS; PROPERTY MAINTENANCE.

FIRST USE 1-31-2005; IN COMMERCE 1-31-2005.
LAURA KOVALSKY, EXAMINING ATTORNEY

CLASS B—SERVICES

SN 77-565,620. INTERNATIONAL INFORMATION SYSTEMS SECURITY CERTIFICATION CONSORTIUM, INC., PALM HARBOR, FL. FILED 9-9-2008.

SN 77-665,453. ECOBROKER INTERNATIONAL, EVERGREEN, CO. FILED 2-6-2009.

CSSLP

THE MARK CONSISTS OF STANDARD CHARACTERS WITHOUT CLAIM TO ANY PARTICULAR FONT, STYLE, SIZE, OR COLOR.

THE CERTIFICATION MARK, AS INTENDED TO BE USED BY AUTHORIZED PERSONS, IS INTENDED TO CERTIFY COMPLETION OF APPROPRIATE WORK EXPERIENCE AND SUCCESSFULLY PASSING AN EXAMINATION AS ESTABLISHED BY THE CERTIFIER IN THE FIELD OF SECURE SOFTWARE DEVELOPMENT.

FOR COMPUTER SOFTWARE DEVELOPMENT AND PROGRAMMING SERVICES IN THE FIELD OF SOFTWARE LIFECYCLE DEVELOPMENT.

SOPHIA S. KIM, EXAMINING ATTORNEY

ECOTARY

THE MARK CONSISTS OF STANDARD CHARACTERS WITHOUT CLAIM TO ANY PARTICULAR FONT, STYLE, SIZE, OR COLOR.

THE CERTIFICATION MARK, AS INTENDED TO BE USED BY AUTHORIZED PERSONS, IS INTENDED TO CERTIFY THAT THE CERTIFIED BUSINESS PROFESSIONAL HAS COMPLETED AN APPLIED ENERGY AND ENVIRONMENTAL BUILDING SCIENCE CURRICULUM SPECIFIED BY THE CERTIFYING AUTHORITY.

FOR REAL ESTATE CONSULTATION TO ASSIST CONSUMERS IN OBTAINING THE MOST CURRENT ENERGY AND ENVIRONMENTAL PRODUCTS AND SERVICES IN CONNECTION WITH RESIDENTIAL AND COMMERCIAL BUILDINGS.

BARBARA A. GOLD, EXAMINING ATTORNEY

* * * * *

TRADEMARK REGISTRATIONS ISSUED

PRINCIPAL REGISTER

SECTION 1.— INTERNATIONAL CLASSIFICATION

The short titles associated below with the international class numbers are terms designed merely for quick identification and are not an official part of the international classification. The full names of international classes are given in section 6.1 of the trademark rules of practice.

The designation "U.S. Cl." appearing in this section refers to the U.S. class in effect prior to Sep. 1, 1973 rather than the international class which applies to applications filed on or after that date. For adoption of international classification see notice in the OFFICIAL GAZETTE of Jun. 26, 1973 (911 O.G. TM 210).

CLASS 1—CHEMICALS

- 3,629,139. **P4 (BLOCK FORM)**. BROADLEAF INDUSTRIES INC., (U.S. CLS. 1, 5, 6, 10, 26 AND 46). SN 76-679,491. PUB. 3-17-2009. FILED 7-13-2007.
- 3,629,223. **DRI-GARD (BLOCK FORM)**. VAN DIEST SUPPLY COMPANY, (U.S. CLS. 1, 5, 6, 10, 26 AND 46). SN 76-694,290. PUB. 3-17-2009. FILED 11-17-2008.
- 3,629,233. **MISCELLANEOUS DESIGN**. GOODRICH CORPORATION, MULTIPLE CLASS, (INT. CLS. 1, 2, 6, 7, 9, 11, 12, 13, 20 AND 21), (U.S. CLS. 1, 2, 5, 6, 9, 10, 11, 12, 13, 14, 16, 19, 21, 22, 23, 25, 26, 29, 30, 31, 32, 33, 34, 35, 36, 38, 40, 44, 46 AND 50). SN 77-007,731. PUB. 3-17-2009. FILED 9-26-2006.
- 3,629,357. **UNLIGHT PATCH (BLOCK FORM)**. CASTER, MULTIPLE CLASS, (INT. CLS. 1 AND 3), (U.S. CLS. 1, 4, 5, 6, 10, 26, 46, 50, 51 AND 52). SN 77-269,613. PUB. 3-17-2009. FILED 8-31-2007.
- 3,629,379. **FAREWAY ECONOMICAL FOOD STORES AND DESIGN**. FAREWAY STORES, INC., MULTIPLE CLASS, (INT. CLS. 1, 29, 30, 32 AND 35), (U.S. CLS. 1, 5, 6, 10, 26, 45, 46, 48, 100, 101 AND 102). SN 77-290,187. PUB. 3-17-2009. FILED 9-27-2007.
- 3,629,404. **DUPONT (BLOCK FORM)**. E. I. DU PONT DE NEMOURS AND COMPANY, (U.S. CLS. 1, 5, 6, 10, 26 AND 46). SN 77-309,503. PUB. 3-17-2009. FILED 10-22-2007.
- 3,629,439. **ENCLOSURE (BLOCK FORM)**. DEVGEN, NAAMLOZE VENNOOTSCHAP, MULTIPLE CLASS, (INT. CLS. 1 AND 5), (U.S. CLS. 1, 5, 6, 10, 18, 26, 44, 46, 51 AND 52). SN 77-336,626. PUB. 3-17-2009. FILED 11-26-2007.
- 3,629,440. **ICARNO (BLOCK FORM)**. DEVGEN, NAAMLOZE VENNOOTSCHAP, MULTIPLE CLASS, (INT. CLS. 1 AND 5), (U.S. CLS. 1, 5, 6, 10, 18, 26, 44, 46, 51 AND 52). SN 77-336,651. PUB. 3-17-2009. FILED 11-26-2007.
- 3,629,469. **QUINOXP* (BLOCK FORM)**. NIPPON KAGAKU KOGYO KABUSHIKI KAISHA, DBA NIPPON CHEMICAL INDUSTRIAL CO., LTD., (U.S. CLS. 1, 5, 6, 10, 26 AND 46). SN 77-356,027. PUB. 3-17-2009. FILED 12-19-2007.
- 3,629,475. **PASSAID (BLOCK FORM)**. STEM CELL SCIENCES HOLDINGS LIMITED, MULTIPLE CLASS, (INT. CLS. 1 AND 5), (U.S. CLS. 1, 5, 6, 10, 18, 26, 44, 46, 51 AND 52). SN 77-361,115. PUB. 3-17-2009. FILED 12-28-2007.
- 3,629,479. **AQUA MICROBICS (BLOCK FORM)**. AQUA MICROBICS L.L.C., MULTIPLE CLASS, (INT. CLS. 1, 35, 40 AND 42), (U.S. CLS. 1, 5, 6, 10, 26, 46, 100, 101, 102, 103 AND 106). SN 77-362,854. PUB. 3-17-2009. FILED 1-2-2008.
- 3,629,577. **NFS-CEMENT SHIELD (BLOCK FORM)**. NEW FLUID SOLUTIONS, INC., (U.S. CLS. 1, 5, 6, 10, 26 AND 46). SN 77-413,258. PUB. 3-17-2009. FILED 3-5-2008.
- 3,629,671. **DUROS (BLOCK FORM)**. KONICA MINOLTA MEDICAL & GRAPHIC, INC., MULTIPLE CLASS, (INT. CLS. 1 AND 7), (U.S. CLS. 1, 5, 6, 10, 13, 19, 21, 23, 26, 31, 34, 35 AND 46). SN 77-440,093. PUB. 3-17-2009. FILED 4-4-2008.
- 3,629,692. **TETRA CHEMICALS (BLOCK FORM)**. TETRA TECHNOLOGIES, INC., MULTIPLE CLASS, (INT. CLS. 1 AND 5), (U.S. CLS. 1, 5, 6, 10, 18, 26, 44, 46, 51 AND 52). SN 77-442,639. PUB. 3-17-2009. FILED 4-8-2008.
- 3,629,697. **MYST STIK (BLOCK FORM)**. WESTECH AEROSOL CORPORATION, (U.S. CLS. 1, 5, 6, 10, 26 AND 46). SN 77-443,422. PUB. 3-17-2009. FILED 4-8-2008.
- 3,629,944. **ASTRINE (BLOCK FORM)**. EADS ASTRIUM GMBH, (U.S. CLS. 1, 5, 6, 10, 26 AND 46). SN 77-477,576. PUB. 3-17-2009. FILED 5-19-2008.
- 3,630,061. **FRICTION TERMINATOR (BLOCK FORM)**. HIGH PERFORMANCE PLUS, (U.S. CLS. 1, 5, 6, 10, 26 AND 46). SN 77-509,275. PUB. 3-17-2009. FILED 6-26-2008.
- 3,630,084. **ENVIROLAGOON (BLOCK FORM)**. BIO TECH NUTRIENTS, LLC, (U.S. CLS. 1, 5, 6, 10, 26 AND 46). SN 77-517,623. PUB. 3-17-2009. FILED 7-9-2008.
- 3,630,120. **CAMO PATCH AND DESIGN**. A.P. OUTDOOR PRODUCTS, (U.S. CLS. 1, 5, 6, 10, 26 AND 46). SN 77-525,289. PUB. 3-17-2009. FILED 7-17-2008.
- 3,630,170. **COAT 45 (BLOCK FORM)**. SPECIAL SHAPES REFRACTORY COMPANY, INC., (U.S. CLS. 1, 5, 6, 10, 26 AND 46). SN 77-539,276. PUB. 3-17-2009. FILED 8-5-2008.
- 3,630,183. **EFLUOR (BLOCK FORM)**. EBIOSCIENCE, INC., (U.S. CLS. 1, 5, 6, 10, 26 AND 46). SN 77-543,550. PUB. 3-17-2009. FILED 8-11-2008.
- 3,630,184. **AFT (BLOCK FORM)**. HELENA HOLDING COMPANY, MULTIPLE CLASS, (INT. CLS. 1 AND 5), (U.S. CLS. 1, 5, 6, 10, 18, 26, 44, 46, 51 AND 52). SN 77-543,588. PUB. 3-17-2009. FILED 8-11-2008.
- 3,630,234. **ULTRA PLAS (BLOCK FORM)**. MEADWESTVACO CORPORATION, (U.S. CLS. 1, 5, 6, 10, 26 AND 46). SN 77-554,895. PUB. 3-17-2009. FILED 8-25-2008.
- 3,630,369. **ABSORB-IT (BLOCK FORM)**. SHIVASHADE, DBA SHIVASHADE INC, (U.S. CLS. 1, 5, 6, 10, 26 AND 46). SN 77-574,817. PUB. 3-17-2009. FILED 9-19-2008.
- 3,630,434. **BONDED CHEMICAL INTERCEPT DEEP PENETRATING HIGH GLOSS RESTORATION + STAIN RESISTANCE AND DESIGN**. D&B INDUSTRIAL FLOOR COATINGS, INC., (U.S. CLS. 1, 5, 6, 10, 26 AND 46). SN 77-583,343. PUB. 3-17-2009. FILED 10-1-2008.
- 3,630,585. **CLONEEZ (BLOCK FORM)**. GENSCRIPT CORPORATION, (U.S. CLS. 1, 5, 6, 10, 26 AND 46). SN 77-595,361. PUB. 3-17-2009. FILED 10-17-2008.
- 3,630,594. **BLACK-GOLD (BLOCK FORM)**. HISTO-CHEM, INC., (U.S. CLS. 1, 5, 6, 10, 26 AND 46). SN 77-595,689. PUB. 3-17-2009. FILED 10-19-2008.
- 3,630,799. **STELSTEROL (BLOCK FORM)**. CAROTECH BHD., (U.S. CLS. 1, 5, 6, 10, 26 AND 46). SN 77-599,627. PUB. 3-17-2009. FILED 10-24-2008.
- 3,630,931. **HORTUS IBA WATER SOLUBLE SALTS (BLOCK FORM)**. HORTUS USA CORP., (U.S. CLS. 1, 5, 6, 10, 26 AND 46). SN 77-601,284. PUB. 3-17-2009. FILED 10-27-2008.
- 3,631,039. **NOVUS BIOLOGICALS (BLOCK FORM)**. NOVUS BIOLOGICALS, LLC, (U.S. CLS. 1, 5, 6, 10, 26 AND 46). SN 77-602,752. PUB. 3-17-2009. FILED 10-31-2008.
- 3,631,147. **HAPPY HARVEST (BLOCK FORM)**. BRITE IDEAS HYDROPONICS AND ORGANICS, (U.S. CLS. 1, 5, 6, 10, 26 AND 46). SN 77-604,588. PUB. 3-17-2009. FILED 10-30-2008.
- 3,631,176. **STERIC MKS (BLOCK FORM)**. NORTHWEST AGRICULTURAL PRODUCTS, (U.S. CLS. 1, 5, 6, 10, 26 AND 46). SN 77-605,238. PUB. 3-17-2009. FILED 10-31-2008.
- 3,631,283. **PROVIDE (BLOCK FORM)**. VALENT BIOSCIENCES CORPORATION, (U.S. CLS. 1, 5, 6, 10, 26 AND 46). SN 77-610,027. PUB. 3-17-2009. FILED 11-7-2008.
- 3,631,352. **STERIC P DS (BLOCK FORM)**. NORTHWEST AGRICULTURAL PRODUCTS, (U.S. CLS. 1, 5, 6, 10, 26 AND 46). SN 77-635,832. PUB. 3-17-2009. FILED 12-18-2008.

- 3,631,378. **MONTICELLI (STYLIZED)**. S.S. TARIS ZEY TIN VE ZEY TINYAGI TARIM SATIS KOOPERATIFLERI BIR-LIGI, MULTIPLE CLASS, (INT. CLS. 1, 2, 3, 29, 30, 32, 39 AND 40), (U.S. CLS. 1, 4, 5, 6, 10, 11, 16, 26, 45, 46, 48, 50, 51, 52, 100, 103, 105 AND 106). SN 78-253,658. PUB. 3-17-2009. FILED 5-23-2003.
- 3,631,432. **NUCASA MILLING COMPANY EST. 1983 NUCASA MILLING COMPANY AND DESIGN**. NUCASA MILLING COMPANY LIMITED, MULTIPLE CLASS, (INT. CLS. 1, 2, 19, 35, 37, 40 AND 42), (U.S. CLS. 1, 5, 6, 10, 11, 12, 16, 26, 33, 46, 50, 100, 101, 102, 103 AND 106). SN 78-885,170. PUB. 1-13-2009. FILED 5-16-2006.
- 3,631,433. **NUCASA MILLING COMPANY (BLOCK FORM)**. NUCASA MILLING COMPANY LIMITED, MULTIPLE CLASS, (INT. CLS. 1, 2, 19, 20, 35, 37, 40 AND 42), (U.S. CLS. 1, 2, 5, 6, 10, 11, 12, 13, 16, 22, 25, 26, 32, 33, 46, 50, 100, 101, 102, 103 AND 106). SN 78-885,174. PUB. 1-13-2009. FILED 5-16-2006.
- 3,631,452. **GOODRICH (BLOCK FORM)**. GOODRICH CORPORATION, MULTIPLE CLASS, (INT. CLS. 1, 2, 6, 7, 9, 11, 12, 13, 20 AND 21), (U.S. CLS. 1, 2, 5, 6, 9, 10, 11, 12, 13, 14, 16, 19, 21, 22, 23, 25, 26, 29, 30, 31, 32, 33, 34, 35, 36, 38, 40, 44, 46 AND 50). SN 78-966,892. PUB. 3-17-2009. FILED 9-5-2006.
- 3,631,464. **SOMA (STYLIZED)**. OKYANUS KIMYA HIRDAVAT ELEKTRIKLI; EL ALETLERİ VE ELEKTRONIK MALZEMELERİ; İTHALAT İHRACAT; SANAYİ TİCARİET LIMITED SİRKETİ, MULTIPLE CLASS, (INT. CLS. 1, 2, 4 AND 17), (U.S. CLS. 1, 5, 6, 10, 11, 12, 13, 15, 16, 26, 35, 46 AND 50). SN 79-028,019. PUB. 3-17-2009. FILED 6-9-2006.
- 3,631,504. **ZWEZ (BLOCK FORM)**. ZWEZ-CHEMIE GMBH, MULTIPLE CLASS, (INT. CLS. 1, 2, 3 AND 4), (U.S. CLS. 1, 4, 5, 6, 10, 11, 15, 16, 26, 46, 50, 51 AND 52). SN 79-046,590. PUB. 3-17-2009. FILED 7-18-2007.
- 3,631,510. **S AND DESIGN**. SHIN NIPPON SEITETSU KABUSHIKI KAISHA; (ALSO DOING BUSINESS AS; NIPPON STEEL CORPORATION), MULTIPLE CLASS, (INT. CLS. 1, 2, 4, 6, 7, 9, 11, 17, 19, 37 AND 42), (U.S. CLS. 1, 2, 5, 6, 10, 11, 12, 13, 14, 15, 16, 19, 21, 23, 25, 26, 31, 33, 34, 35, 36, 38, 46, 50, 100, 101, 103 AND 106). SN 79-047,631. PUB. 3-17-2009. FILED 1-29-2007.
- 3,631,511. **CODEX (STYLIZED)**. UZIN UTZ AKTIENGESELLSCHAFT, MULTIPLE CLASS, (INT. CLS. 1, 2, 8, 9, 12, 17, 19, 21, 37, 41 AND 42), (U.S. CLS. 1, 2, 5, 6, 10, 11, 12, 13, 16, 19, 21, 23, 26, 28, 29, 30, 31, 33, 35, 36, 38, 40, 44, 46, 50, 100, 101, 103, 106 AND 107). SN 79-047,633. PUB. 3-17-2009. FILED 4-17-2007.
- 3,631,513. **EXACTLY YOUR CHEMISTRY. (BLOCK FORM)**. CLARIANT AG, MULTIPLE CLASS, (INT. CLS. 1, 2, 3 AND 42), (U.S. CLS. 1, 4, 5, 6, 10, 11, 16, 26, 46, 50, 51, 52, 100 AND 101). SN 79-048,015. PUB. 3-17-2009. FILED 8-9-2007.
- 3,631,516. **BORREGUM (BLOCK FORM)**. BORREGAARD INDUSTRIES LIMITED NORGE, (U.S. CLS. 1, 5, 6, 10, 26 AND 46). SN 79-048,137. PUB. 3-17-2009. FILED 10-24-2007.
- 3,631,518. **AAK AND DESIGN**. AARHUSKARLSHAMN AB (PUBL), MULTIPLE CLASS, (INT. CLS. 1, 3, 4, 5 AND 29), (U.S. CLS. 1, 4, 5, 6, 10, 15, 18, 26, 44, 46, 50, 51 AND 52). SN 79-048,299. PUB. 3-17-2009. FILED 11-22-2007.
- 3,631,554. **OTC (STYLIZED)**. OSAKA TITANIUM TECHNOLOGIES CO., LTD., MULTIPLE CLASS, (INT. CLS. 1, 2, 6, 7, 9, 10, 11, 40 AND 42), (U.S. CLS. 1, 2, 5, 6, 10, 11, 12, 13, 14, 16, 19, 21, 23, 25, 26, 31, 34, 35, 36, 38, 39, 44, 46, 50, 100, 101, 103 AND 106). SN 79-051,897. PUB. 3-17-2009. FILED 9-19-2007.
- 3,631,566. **ADEKIT (BLOCK FORM)**. AXSON TECHNOLOGIES (SOCIÉTÉ ANONYME), (U.S. CLS. 1, 5, 6, 10, 26 AND 46). SN 79-052,775. PUB. 3-17-2009. FILED 3-5-2008.
- 3,631,591. **POMP (BLOCK FORM)**. UBE INDUSTRIES, LTD., (U.S. CLS. 1, 5, 6, 10, 26 AND 46). SN 79-053,660. PUB. 3-17-2009. FILED 4-18-2008.
- 3,631,597. **SABIC INNOVATIVE PLASTICS (BLOCK FORM)**. SABIC HOLDING EUROPE BV, MULTIPLE CLASS, (INT. CLS. 1 AND 17), (U.S. CLS. 1, 5, 6, 10, 12, 13, 26, 35, 46 AND 50). SN 79-053,977. PUB. 3-17-2009. FILED 12-28-2007.
- 3,631,620. **LEVESOFIT (STYLIZED)**. ENTWICKLUNGSGESSELLSCHAFT FÜR AKUSTIK (EFA) MIT; BESCHRÄNKTER HAFTUNG, MULTIPLE CLASS, (INT. CLS. 1, 12, 17 AND 27), (U.S. CLS. 1, 5, 6, 10, 12, 13, 19, 20, 21, 23, 26, 31, 35, 37, 42, 44, 46 AND 50). SN 79-054,335. PUB. 3-17-2009. FILED 1-21-2008.
- 3,631,624. **C-NERGY (BLOCK FORM)**. TIMCAL SA (TIMCAL AG) (TIMCAL LTD), (U.S. CLS. 1, 5, 6, 10, 26 AND 46). SN 79-054,360. PUB. 3-17-2009. FILED 5-30-2008.
- 3,631,641. **POMP-OPT (BLOCK FORM)**. UBE INDUSTRIES, LTD., (U.S. CLS. 1, 5, 6, 10, 26 AND 46). SN 79-054,843. PUB. 3-17-2009. FILED 5-23-2008.
- 3,631,643. **AQUASULF (BLOCK FORM)**. H.E.F., MULTIPLE CLASS, (INT. CLS. 1 AND 40), (U.S. CLS. 1, 5, 6, 10, 26, 46, 100, 103 AND 106). SN 79-054,898. PUB. 3-17-2009. FILED 3-7-2008.
- 3,631,674. **CEMENTIUM (BLOCK FORM)**. CONSTRUCTION RESEARCH & TECHNOLOGY GMBH, (U.S. CLS. 1, 5, 6, 10, 26 AND 46). SN 79-055,823. PUB. 3-17-2009. FILED 5-8-2008.
- 3,631,681. **FLORENETTE (BLOCK FORM)**. SERA WERKE HEIMTIERBEDARF; J. RAVNAK GMBH & CO. KG, (U.S. CLS. 1, 5, 6, 10, 26 AND 46). SN 79-056,338. PUB. 3-17-2009. FILED 4-17-2008.
- 3,631,729. **ENVIOMET (BLOCK FORM)**. INNOSPEC LIMITED, (U.S. CLS. 1, 5, 6, 10, 26 AND 46). SN 79-058,310. PUB. 3-17-2009. FILED 2-12-2008.
- 3,631,762. **STABILUREN (BLOCK FORM)**. AGRA GROUP A.S., MULTIPLE CLASS, (INT. CLS. 1 AND 5), (U.S. CLS. 1, 5, 6, 10, 18, 26, 44, 46, 51 AND 52). SN 79-060,993. PUB. 3-17-2009. FILED 9-3-2008.
- 3,631,777. **DRYFLOC (BLOCK FORM)**. S.P.C.M. SA, (U.S. CLS. 1, 5, 6, 10, 26 AND 46). SN 79-062,989. PUB. 3-17-2009. FILED 10-23-2008.

CLASS 2—PAINTS

- 3,629,233 (*See Class 1 for this trademark*).
- 3,629,380. **TUFFGRIP (BLOCK FORM)**. RHINO LININGS USA, INC., MULTIPLE CLASS, (INT. CLS. 2 AND 40), (U.S. CLS. 6, 11, 16, 100, 103 AND 106). SN 77-290,856. PUB. 3-17-2009. FILED 9-27-2007.
- 3,629,856. **REPAIR RESTORE REVIVE (BLOCK FORM)**. EASTHILL GROUP, INC., (U.S. CLS. 6, 11 AND 16). SN 77-458,156. PUB. 3-17-2009. FILED 4-25-2008.
- 3,629,921. **VERSASURF (BLOCK FORM)**. WAXLESS SURFBOARD SYSTEMS INC., (U.S. CLS. 6, 11 AND 16). SN 77-472,030. PUB. 10-14-2008. FILED 5-12-2008.
- 3,630,001. **FERRIT (BLOCK FORM)**. LANXESS DEUTSCHLAND GMBH, (U.S. CLS. 6, 11 AND 16). SN 77-494,029. PUB. 3-17-2009. FILED 6-9-2008.
- 3,630,442. **IN-FOCUS (BLOCK FORM)**. VISION OPTICS TECHNOLOGIES LTD., (U.S. CLS. 6, 11 AND 16). SN 77-584,348. PUB. 3-17-2009. FILED 10-2-2008.
- 3,630,464. **SUPERFINISH CERAMIC (BLOCK FORM)**. THE MURALO COMPANY, INC., (U.S. CLS. 6, 11 AND 16). SN 77-586,991. PUB. 3-17-2009. FILED 10-7-2008.
- 3,630,923. **FRANKOTE (BLOCK FORM)**. LAFRANCE MANUFACTURING CO., (U.S. CLS. 6, 11 AND 16). SN 77-601,189. PUB. 3-17-2009. FILED 10-27-2008.
- 3,631,378 (*See Class 1 for this trademark*).
- 3,631,387. **33 (BLOCK FORM)**. AKZO NOBEL COATINGS INTERNATIONAL B.V., (U.S. CLS. 6, 11 AND 16). SN 78-454,923. PUB. 3-17-2009. FILED 7-22-2004.
- 3,631,432 (*See Class 1 for this trademark*).
- 3,631,433 (*See Class 1 for this trademark*).
- 3,631,436. **VELVACOAT (BLOCK FORM)**. PROTECH CHEMICALS LTD/PROTECH CHIMIE LTEE, (U.S. CLS. 6, 11 AND 16). SN 78-907,601. PUB. 3-17-2009. FILED 6-14-2006.
- 3,631,437. **MONTANA AND DESIGN**. MONTANA PRODUCTS, INC., (U.S. CLS. 6, 11 AND 16). SN 78-912,713. PUB. 3-17-2009. FILED 6-20-2006.
- 3,631,452 (*See Class 1 for this trademark*).
- 3,631,464 (*See Class 1 for this trademark*).
- 3,631,504 (*See Class 1 for this trademark*).
- 3,631,510 (*See Class 1 for this trademark*).
- 3,631,511 (*See Class 1 for this trademark*).
- 3,631,513 (*See Class 1 for this trademark*).
- 3,631,546. **HERLITZ AND DESIGN**. HERLITZ PBS AG; PAPIER-, BÜRO UND SCHREIBWAREN, MULTIPLE CLASS, (INT. CLS. 2, 9, 16 AND 18), (U.S. CLS. 1, 2, 3, 5, 6, 11, 16, 21, 22, 23, 26, 29, 36, 37, 38, 41 AND 50). SN 79-

051,278. PUB. 3-17-2009. FILED 6-29-2007.
 3,631,554 (*See Class 1 for this trademark*).
 3,631,701. **GREENVALUE AND DESIGN**. GREENVALUE SA,
 MULTIPLE CLASS, (INT. CLS. 2, 35, 36 AND 42), (U.S. CLS.
 6, 11, 16, 100, 101 AND 102). SN 79-057,178. PUB. 3-17-2009.
 FILED 6-18-2008.

CLASS 3—COSMETICS AND CLEANING PREPARATIONS

- 3,629,153. **I AND DESIGN**. IMCLONE SYSTEMS INCORPORATED, (U.S. CLS. 1, 4, 6, 50, 51 AND 52). SN 76-687,742. PUB. 3-17-2009. FILED 3-14-2008.
- 3,629,171. **SKINDECOR (BLOCK FORM)**. UNIVERSAL ABC INTERNATIONAL INC., (U.S. CLS. 1, 4, 6, 50, 51 AND 52). SN 76-689,450. PUB. 3-17-2009. FILED 5-6-2008.
- 3,629,189. **STRIPPER JUICE (BLOCK FORM)**. EZWARD, LLC, (U.S. CLS. 1, 4, 6, 50, 51 AND 52). SN 76-692,305. PUB. 3-17-2009. FILED 8-22-2008.
- 3,629,244. **FUEL FOR LIFE (BLOCK FORM)**. L'OREAL, (U.S. CLS. 1, 4, 6, 50, 51 AND 52). SN 77-061,034. PUB. 3-17-2009. FILED 12-11-2006.
- 3,629,245. **ALORA AMBIANCE (BLOCK FORM)**. ATG CORPORATION, MULTIPLE CLASS, (INT. CLS. 3 AND 11), (U.S. CLS. 1, 4, 6, 13, 21, 23, 31, 34, 50, 51 AND 52). SN 77-063,434. PUB. 3-17-2009. FILED 12-13-2006.
- 3,629,292. **MISTURA (BLOCK FORM)**. MISTURA INC., (U.S. CLS. 1, 4, 6, 50, 51 AND 52). SN 77-170,512. PUB. 3-17-2009. FILED 5-1-2007.
- 3,629,299. **PRONATURAMEX (BLOCK FORM)**. PRONATUR-AMEX, INC., MULTIPLE CLASS, (INT. CLS. 3, 5 AND 35), (U.S. CLS. 1, 4, 6, 18, 44, 46, 50, 51, 52, 100, 101 AND 102). SN 77-189,735. PUB. 3-17-2009. FILED 5-24-2007.
- 3,629,334. **MISCELLANEOUS DESIGN**. LIZ EARLE BEAUTY CO., LIMITED, MULTIPLE CLASS, (INT. CLS. 3, 35 AND 44), (U.S. CLS. 1, 4, 6, 50, 51, 52, 100, 101 AND 102). SN 77-242,577. PUB. 3-31-2009. FILED 7-30-2007.
- 3,629,335. **LIZ EARLE NATURALLY ACTIVE SKINCARE (BLOCK FORM)**. LIZ EARLE BEAUTY CO., LIMITED, MULTIPLE CLASS, (INT. CLS. 3, 35 AND 44), (U.S. CLS. 1, 4, 6, 50, 51, 52, 100, 101 AND 102). SN 77-243,643. PUB. 3-31-2009. FILED 7-31-2007.
- 3,629,336. **BB (STYLIZED)**. NATURAL PLANTATION INC., (U.S. CLS. 1, 4, 6, 50, 51 AND 52). SN 77-245,119. PUB. 9-2-2008. FILED 8-2-2007.
- 3,629,337. **QWEST (BLOCK FORM)**. QWEST COMMUNICATIONS INTERNATIONAL INC., MULTIPLE CLASS, (INT. CLS. 3 AND 25), (U.S. CLS. 1, 4, 6, 22, 39, 50, 51 AND 52). SN 77-246,716. PUB. 3-17-2009. FILED 8-3-2007.
- 3,629,353. **YOU ARE UNIQUE, YOU ARE MAGNIFIQUE (BLOCK FORM)**. LANCOME PARFUMS ET BEAUTE & CIE, (U.S. CLS. 1, 4, 6, 50, 51 AND 52). SN 77-266,028. PUB. 3-17-2009. FILED 8-28-2007.
- 3,629,357 (*See Class 1 for this trademark*).
- 3,629,367. **EAZYCARE (BLOCK FORM)**. AM DENMARK A/S, MULTIPLE CLASS, (INT. CLS. 3 AND 21), (U.S. CLS. 1, 2, 4, 6, 13, 23, 29, 30, 33, 40, 50, 51 AND 52). SN 77-280,801. PUB. 3-17-2009. FILED 9-17-2007.
- 3,629,368. **ONECLEAN (BLOCK FORM)**. AM DENMARK A/S, MULTIPLE CLASS, (INT. CLS. 3 AND 21), (U.S. CLS. 1, 2, 4, 6, 13, 23, 29, 30, 33, 40, 50, 51 AND 52). SN 77-280,806. PUB. 3-17-2009. FILED 9-17-2007.
- 3,629,424. **DUNHILL LONDON (STYLIZED)**. ALFRED DUNHILL LIMITED, MULTIPLE CLASS, (INT. CLS. 3, 9, 14, 16, 18, 25 AND 34), (U.S. CLS. 1, 2, 3, 4, 5, 6, 8, 9, 17, 21, 22, 23, 26, 27, 28, 29, 36, 37, 38, 39, 41, 50, 51 AND 52). SN 77-322,994. PUB. 3-17-2009. FILED 11-6-2007.
- 3,629,432. **ABSTRACT (BLOCK FORM)**. MOSHE INC, DBA SCENT-SATION, (U.S. CLS. 1, 4, 6, 50, 51 AND 52). SN 77-328,738. PUB. 3-17-2009. FILED 11-13-2007.
- 3,629,433. **LIBIDO (BLOCK FORM)**. MOSHE INC, DBA SCENT-SATION, (U.S. CLS. 1, 4, 6, 50, 51 AND 52). SN 77-329,290. PUB. 3-17-2009. FILED 11-14-2007.
- 3,629,472. **COLOR ARTIST (BLOCK FORM)**. SPILLER, MANUEL, (U.S. CLS. 1, 4, 6, 50, 51 AND 52). SN 77-359,010. PUB. 3-17-2009. FILED 12-24-2007.
- 3,629,474. **WITCH (BLOCK FORM)**. E.C. DE WITT AND COMPANY LIMITED, MULTIPLE CLASS, (INT. CLS. 3, 5 AND 41), (U.S. CLS. 1, 4, 6, 18, 44, 46, 50, 51, 52, 100, 101 AND 107). SN 77-360,907. PUB. 3-17-2009. FILED 12-28-2007.
- 3,629,493. **INSTANT THIGH LIFT (BLOCK FORM)**. LAROSA, PENILOPEE L., DBA LAROSA INNOVATIONS, LLC, (U.S. CLS. 1, 4, 6, 50, 51 AND 52). SN 77-370,874. PUB. 3-17-2009. FILED 1-14-2008.
- 3,629,560. **HYPNOSE FELINE (BLOCK FORM)**. LANCOME PARFUMS ET BEAUTE & CIE, (U.S. CLS. 1, 4, 6, 50, 51 AND 52). SN 77-403,481. PUB. 3-17-2009. FILED 2-22-2008.
- 3,629,568. **BIO COSMETIQUE CHARTE COSMEBIO AND DESIGN**. COSMEBIO, (U.S. CLS. 1, 4, 6, 50, 51 AND 52). SN 77-408,733. PUB. 3-17-2009. FILED 2-28-2008.
- 3,629,611. **EXP (BLOCK FORM)**. CORPORATE EXPRESS US INC., MULTIPLE CLASS, (INT. CLS. 3, 8, 16, 17 AND 21), (U.S. CLS. 1, 2, 4, 5, 6, 12, 13, 22, 23, 28, 29, 30, 33, 35, 37, 38, 40, 44, 50, 51 AND 52). SN 77-428,694. PUB. 3-17-2009. FILED 3-21-2008.
- 3,629,623. **RENEW EYELASH REVITALIZER (BLOCK FORM)**. CDM CORP., (U.S. CLS. 1, 4, 6, 50, 51 AND 52). SN 77-433,081. PUB. 3-17-2009. FILED 3-27-2008.
- 3,629,624. **RENEW EYEBROW REVITALIZER (BLOCK FORM)**. CDM CORP., (U.S. CLS. 1, 4, 6, 50, 51 AND 52). SN 77-433,089. PUB. 3-17-2009. FILED 3-27-2008.
- 3,629,626. **WARTS 'N' ALL (BLOCK FORM)**. TAUREAN SYSTEMS LIMITED, MULTIPLE CLASS, (INT. CLS. 3 AND 5), (U.S. CLS. 1, 4, 6, 18, 44, 46, 50, 51 AND 52). SN 77-433,129. PUB. 3-17-2009. FILED 3-27-2008.
- 3,629,768. **PANPURI (BLOCK FORM)**. PURI COMPANY LIMITED, (U.S. CLS. 1, 4, 6, 50, 51 AND 52). SN 77-449,977. PUB. 3-17-2009. FILED 4-16-2008.
- 3,629,849. **A ARWIN AND DESIGN**. ARWIN BIO-TECH. (TAIWAN) CO., LTD., (U.S. CLS. 1, 4, 6, 50, 51 AND 52). SN 77-456,830. PUB. 3-17-2009. FILED 4-24-2008.
- 3,629,908. **PROMAXYL PROFESSIONAL SKIN SOLUTIONS (BLOCK FORM)**. LIFETECH RESOURCES, (U.S. CLS. 1, 4, 6, 50, 51 AND 52). SN 77-468,678. PUB. 3-17-2009. FILED 5-7-2008.
- 3,630,057. **ANGEL BABY (BLOCK FORM)**. EARTH MAMA ANGEL BABY, LLC, (U.S. CLS. 1, 4, 6, 50, 51 AND 52). SN 77-507,963. PUB. 3-17-2009. FILED 6-25-2008.
- 3,630,132. **COLOURCAFÉ (BLOCK FORM)**. RHYTHM & BLUE INC. LIMITED, (U.S. CLS. 1, 4, 6, 50, 51 AND 52). SN 77-527,904. PUB. 3-17-2009. FILED 7-22-2008.
- 3,630,216. **ZAPP IT! (STYLIZED)**. ZAPP IT BOWLING PRODUCTS, (U.S. CLS. 1, 4, 6, 50, 51 AND 52). SN 77-551,381. PUB. 3-17-2009. FILED 8-20-2008.
- 3,630,247. **MONGOLIAN HOLY STONE (BLOCK FORM)**. EFREIN, JOEL, (U.S. CLS. 1, 4, 6, 50, 51 AND 52). SN 77-556,522. PUB. 3-17-2009. FILED 8-27-2008.
- 3,630,261. **OXY SCRUB (BLOCK FORM)**. OXYWIPES LLC., (U.S. CLS. 1, 4, 6, 50, 51 AND 52). SN 77-558,670. PUB. 3-17-2009. FILED 8-29-2008.
- 3,630,290. **SKIN ENVY AND DESIGN**. FIVE PHARMS, INC., DBA MERCY PLAZA PHARMACY, (U.S. CLS. 1, 4, 6, 50, 51 AND 52). SN 77-563,198. PUB. 3-17-2009. FILED 9-5-2008.
- 3,630,355. **R RANIMER CHANGING YOUR LOOK AND LIFE AND DESIGN**. VECHERA, SVITLANA, (U.S. CLS. 1, 4, 6, 50, 51 AND 52). SN 77-573,160. PUB. 3-17-2009. FILED 9-18-2008.
- 3,630,384. **SUGAR OF THE NILE (BLOCK FORM)**. INGRAM, RAFFAELINA LYNN, TA SUGAR OF THE NILE, MULTIPLE CLASS, (INT. CLS. 3, 35 AND 41), (U.S. CLS. 1, 4, 6, 50, 51, 52, 100, 101, 102 AND 107). SN 77-577,341. PUB. 3-17-2009. FILED 9-24-2008.
- 3,630,418. **LUMIERE D'HIVER (BLOCK FORM)**. COSWAY COMPANY, INC., DBA BUREAU NUMBER FOUR, (U.S. CLS. 1, 4, 6, 50, 51 AND 52). SN 77-580,652. PUB. 3-17-2009. FILED 9-28-2008.
- 3,630,419. **FLEURES DE TEMPS (BLOCK FORM)**. COSWAY COMPANY, INC., DBA BUREAU NUMBER FOUR, (U.S. CLS. 1, 4, 6, 50, 51 AND 52). SN 77-580,654. PUB. 3-17-2009. FILED 9-28-2008.
- 3,630,420. **JOUR D'AUTOMNE (BLOCK FORM)**. COSWAY COMPANY, INC., DBA BUREAU NUMBER FOUR, (U.S. CLS. 1, 4, 6, 50, 51 AND 52). SN 77-580,656. PUB. 3-17-2009. FILED 9-28-2008.
- 3,630,456. **DE LA TERRE SKIN CARE AND DESIGN**. ANNE C.

- WILLIS ENTERPRISES, LLC, (U.S. CLS. 1, 4, 6, 50, 51 AND 52). SN 77-586,169. PUB. 3-17-2009. FILED 10-6-2008.
- 3,630,500. **WHERE GREAT FLOORS BEGIN (BLOCK FORM)**. COLUMBIA INSURANCE COMPANY, (U.S. CLS. 1, 4, 6, 50, 51 AND 52). SN 77-589,543. PUB. 3-17-2009. FILED 10-9-2008.
- 3,630,548. **WAX AS-U-DRY (BLOCK FORM)**. ASHLAND LICENSING AND INTELLECTUAL PROPERTY LLC, (U.S. CLS. 1, 4, 6, 50, 51 AND 52). SN 77-593,165. PUB. 3-17-2009. FILED 10-15-2008.
- 3,630,580. **HIGH MAINTENANCE (BLOCK FORM)**. TYLER CANDLE COMPANY, L.L.C., MULTIPLE CLASS, (INT. CLS. 3 AND 4), (U.S. CLS. 1, 4, 6, 15, 50, 51 AND 52). SN 77-595,089. PUB. 3-17-2009. FILED 10-17-2008.
- 3,630,597. **ICON (BLOCK FORM)**. TYLER CANDLE COMPANY, L.L.C., MULTIPLE CLASS, (INT. CLS. 3 AND 4), (U.S. CLS. 1, 4, 6, 15, 50, 51 AND 52). SN 77-595,937. PUB. 3-17-2009. FILED 10-20-2008.
- 3,630,599. **INTENSE (BLOCK FORM)**. TYLER CANDLE COMPANY, L.L.C., MULTIPLE CLASS, (INT. CLS. 3 AND 4), (U.S. CLS. 1, 4, 6, 15, 50, 51 AND 52). SN 77-595,959. PUB. 3-17-2009. FILED 10-20-2008.
- 3,630,600. **IRA JEAN (BLOCK FORM)**. TYLER CANDLE COMPANY, L.L.C., MULTIPLE CLASS, (INT. CLS. 3 AND 4), (U.S. CLS. 1, 4, 6, 15, 50, 51 AND 52). SN 77-595,977. PUB. 3-17-2009. FILED 10-20-2008.
- 3,630,603. **KATHINA (BLOCK FORM)**. TYLER CANDLE COMPANY, L.L.C., MULTIPLE CLASS, (INT. CLS. 3 AND 4), (U.S. CLS. 1, 4, 6, 15, 50, 51 AND 52). SN 77-596,012. PUB. 3-17-2009. FILED 10-20-2008.
- 3,630,604. **LAVISH (BLOCK FORM)**. TYLER CANDLE COMPANY, L.L.C., MULTIPLE CLASS, (INT. CLS. 3 AND 4), (U.S. CLS. 1, 4, 6, 15, 50, 51 AND 52). SN 77-596,022. PUB. 3-17-2009. FILED 10-20-2008.
- 3,630,606. **MISS PRISS (BLOCK FORM)**. TYLER CANDLE COMPANY, L.L.C., MULTIPLE CLASS, (INT. CLS. 3 AND 4), (U.S. CLS. 1, 4, 6, 15, 50, 51 AND 52). SN 77-596,057. PUB. 3-17-2009. FILED 10-20-2008.
- 3,630,638. **PINEAPPLE CRUSH (BLOCK FORM)**. TYLER CANDLE COMPANY, L.L.C., MULTIPLE CLASS, (INT. CLS. 3 AND 4), (U.S. CLS. 1, 4, 6, 15, 50, 51 AND 52). SN 77-596,876. PUB. 3-17-2009. FILED 10-21-2008.
- 3,630,654. **CANDY KISSES (STYLIZED)**. PENSELS LTD., (U.S. CLS. 1, 4, 6, 50, 51 AND 52). SN 77-597,191. PUB. 3-17-2009. FILED 10-21-2008.
- 3,630,793. **BRAZILIAN MANGO GRAPEFRUIT (BLOCK FORM)**. PACIFICA, INC., (U.S. CLS. 1, 4, 6, 50, 51 AND 52). SN 77-599,539. PUB. 3-17-2009. FILED 10-23-2008.
- 3,630,794. **THAI LEMONGRASS (BLOCK FORM)**. PACIFICA, INC., (U.S. CLS. 1, 4, 6, 50, 51 AND 52). SN 77-599,550. PUB. 3-17-2009. FILED 10-23-2008.
- 3,630,829. **VERSASPA (BLOCK FORM)**. MT MANUFACTURING, INC., (U.S. CLS. 1, 4, 6, 50, 51 AND 52). SN 77-599,993. PUB. 3-17-2009. FILED 10-24-2008.
- 3,630,831. **TIBETAN MOUNTAIN TEMPLE (BLOCK FORM)**. PACIFICA, INC., MULTIPLE CLASS, (INT. CLS. 3 AND 4), (U.S. CLS. 1, 4, 6, 15, 50, 51 AND 52). SN 77-600,038. PUB. 3-17-2009. FILED 10-24-2008.
- 3,630,873. **SKIN ILLUSTRATOR (BLOCK FORM)**. CINEMA-MAKEUP, INC. (U.S. CLS. 1, 4, 6, 50, 51 AND 52). SN 77-600,491. PUB. 3-17-2009. FILED 10-24-2008.
- 3,630,981. **CAESARS MAN EMPEROR (BLOCK FORM)**. CAESARS WORLD, INC., (U.S. CLS. 1, 4, 6, 50, 51 AND 52). SN 77-602,014. PUB. 3-17-2009. FILED 10-28-2008.
- 3,631,008. **MULIER (BLOCK FORM)**. LABORATORIOS NORUEL C. POR A., (U.S. CLS. 1, 4, 6, 50, 51 AND 52). SN 77-602,303. PUB. 3-17-2009. FILED 10-28-2008.
- 3,631,015. **CAESARS WOMAN GODDESS (BLOCK FORM)**. CAESARS WORLD, INC., (U.S. CLS. 1, 4, 6, 50, 51 AND 52). SN 77-602,393. PUB. 3-17-2009. FILED 10-28-2008.
- 3,631,188. **SHEA RADIANCE (BLOCK FORM)**. SHEA RADIANCE, (U.S. CLS. 1, 4, 6, 50, 51 AND 52). SN 77-605,408. PUB. 3-17-2009. FILED 10-31-2008.
- 3,631,235. **NUTT SO RUFF (BLOCK FORM)**. DOMARADZKI, IRENA A., (U.S. CLS. 1, 4, 6, 50, 51 AND 52). SN 77-606,047. PUB. 3-17-2009. FILED 11-3-2008.
- 3,631,246. **IMAGEM (BLOCK FORM)**. HANNA LABS, INC., (U.S. CLS. 1, 4, 6, 50, 51 AND 52). SN 77-606,223. PUB. 3-17-2009. FILED 11-3-2008.
- 3,631,307. **IFOAM (BLOCK FORM)**. SHIELD INDUSTRIES, INC., DBA SHIELD INDUSTRIES, INC. (U.S. CLS. 1, 4, 6, 50, 51 AND 52). SN 77-616,331. PUB. 3-17-2009. FILED 11-18-2008.
- 3,631,378 (*See Class 1 for this trademark*).
- 3,631,399. **THE DAVID BECKHAM ACADEMY AND DESIGN**. BECKHAM BRAND LIMITED, MULTIPLE CLASS, (INT. CLS. 3, 6, 9, 14, 16, 18, 21, 24, 25, 28, 29, 30, 32, 41 AND 43), (U.S. CLS. 1, 2, 3, 4, 5, 6, 12, 13, 14, 21, 22, 23, 25, 26, 27, 28, 29, 30, 33, 36, 37, 38, 39, 40, 41, 42, 45, 46, 48, 50, 51, 52, 100, 101 AND 107). SN 78-584,486. PUB. 3-17-2009. FILED 3-10-2005.
- 3,631,427. **GOOD VIBRATIONS (BLOCK FORM)**. OPEN ENTERPRISES, INC., MULTIPLE CLASS, (INT. CLS. 3, 5, 9, 10, 16, 18, 28 AND 30), (U.S. CLS. 1, 2, 3, 4, 5, 6, 18, 21, 22, 23, 26, 29, 36, 37, 38, 39, 41, 44, 46, 50, 51 AND 52). SN 78-855,571. PUB. 3-17-2009. FILED 4-6-2006.
- 3,631,428. **ROOT EXTEND (BLOCK FORM)**. ALBERTO-CULVER USA, INC., (U.S. CLS. 1, 4, 6, 50, 51 AND 52). SN 78-859,071. PUB. 3-17-2009. FILED 4-11-2006.
- 3,631,472. **EXTRO' (BLOCK FORM)**. COMPAGNIA DELL'OROLOGIO S.P.A., MULTIPLE CLASS, (INT. CLS. 3, 9, 11, 14, 16, 18, 25, 35 AND 43), (U.S. CLS. 1, 2, 3, 4, 5, 6, 13, 21, 22, 23, 26, 27, 28, 29, 31, 34, 36, 37, 38, 39, 41, 50, 51, 52, 100, 101 AND 102). SN 79-036,934. PUB. 3-17-2009. FILED 1-9-2007.
- 3,631,477. **STONE ISLAND DENIMS AND DESIGN**. SPORTS-WEAR COMPANY - S.P.A.; (IN SIGLA SPW S.P.A.), MULTIPLE CLASS, (INT. CLS. 3, 9, 14, 18 AND 25), (U.S. CLS. 1, 2, 3, 4, 6, 21, 22, 23, 26, 27, 28, 36, 38, 39, 41, 50, 51 AND 52). SN 79-038,505. PUB. 3-17-2009. FILED 10-3-2006.
- 3,631,481. **JUNGLE ESSENCE (STYLIZED)**. V. MANE FILS, MULTIPLE CLASS, (INT. CLS. 3 AND 30), (U.S. CLS. 1, 4, 6, 46, 50, 51 AND 52). SN 79-040,992. PUB. 3-17-2009. FILED 4-13-2007.
- 3,631,482. **SKINTECH BY GIL BRICE (STYLIZED)**. BRICE-LINE COSMETICS SA, MULTIPLE CLASS, (INT. CLS. 3, 21 AND 35), (U.S. CLS. 1, 2, 4, 6, 13, 23, 29, 30, 33, 40, 50, 51, 52, 100, 101 AND 102). SN 79-041,190. PUB. 3-17-2009. FILED 6-26-2007.
- 3,631,504 (*See Class 1 for this trademark*).
- 3,631,512. **D-WAR (STYLIZED)**. YOUNGGU ART CO., LTD., MULTIPLE CLASS, (INT. CLS. 3, 6, 9, 14, 16, 18, 20, 24, 25, 26, 28, 29, 30, 32, 34, 41 AND 43), (U.S. CLS. 1, 2, 3, 4, 5, 6, 8, 9, 12, 13, 14, 17, 21, 22, 23, 25, 26, 27, 28, 29, 32, 36, 37, 38, 39, 40, 41, 42, 45, 46, 48, 50, 51, 52, 100, 101 AND 107). SN 79-047,968. PUB. 3-17-2009. FILED 1-5-2007.
- 3,631,513 (*See Class 1 for this trademark*).
- 3,631,518 (*See Class 1 for this trademark*).
- 3,631,560. **NATRUE (STYLIZED)**. LAVERANA GMBH, MULTIPLE CLASS, (INT. CLS. 3, 5 AND 35), (U.S. CLS. 1, 4, 6, 18, 44, 46, 50, 51, 52, 100, 101 AND 102). SN 79-052,347. PUB. 3-17-2009. FILED 1-7-2008.
- 3,631,580. **AGRONATURA ASSOCIATION (STYLIZED)**. IDEA INTERNATIONAL CO., LTD., (U.S. CLS. 1, 4, 6, 50, 51 AND 52). SN 79-053,473. PUB. 3-17-2009. FILED 5-1-2008.
- 3,631,586. **BIORISTA (STYLIZED)**. IDEA INTERNATIONAL CO., LTD., (U.S. CLS. 1, 4, 6, 50, 51 AND 52). SN 79-053,572. PUB. 3-17-2009. FILED 5-1-2008.
- 3,631,612. **G AND DESIGN**. M.J. DE BEL MANAGEMENT B.V., MULTIPLE CLASS, (INT. CLS. 3, 9, 14, 18 AND 25), (U.S. CLS. 1, 2, 3, 4, 6, 21, 22, 23, 26, 27, 28, 36, 38, 39, 41, 50, 51 AND 52). SN 79-054,208. PUB. 3-17-2009. FILED 3-6-2008.
- 3,631,617. **POUR L'ANIMAL QUI DORT EN VOUS (STYLIZED)**. GUERLAIN S.A., (U.S. CLS. 1, 4, 6, 50, 51 AND 52). SN 79-054,253. PUB. 3-17-2009. FILED 5-2-2008.
- 3,631,621. **BLU MEDITERRANEO MIRTO DI PANAREA AND DESIGN**. ACQUA DI PARMA S.R.L., MULTIPLE CLASS, (INT. CLS. 3 AND 4), (U.S. CLS. 1, 4, 6, 15, 50, 51 AND 52). SN 79-054,339. PUB. 3-17-2009. FILED 1-25-2008.
- 3,631,637. **ANTOS (STYLIZED)**. IDEA INTERNATIONAL CO., LTD., (U.S. CLS. 1, 4, 6, 50, 51 AND 52). SN 79-054,722. PUB. 3-17-2009. FILED 5-1-2008.
- 3,631,638. **BIOLEAVES (STYLIZED)**. IDEA INTERNATIONAL CO., LTD., (U.S. CLS. 1, 4, 6, 50, 51 AND 52). SN 79-054,723. PUB. 3-17-2009. FILED 5-1-2008.
- 3,631,648. **ST SANTANDREA (STYLIZED)**. SARTORIA SAINT ANDREWS; MILANO S.P.A., MULTIPLE CLASS, (INT. CLS. 3, 9 AND 18), (U.S. CLS. 1, 2, 3, 4, 6, 21, 22, 23, 26, 36, 38,

- 41, 50, 51 AND 52). SN 79-055,122. PUB. 3-17-2009. FILED 4-15-2008.
- 3,631,652. **CHEAP MONDAY (BLOCK FORM)**. WEEKDAY BRANDS AB, MULTIPLE CLASS, (INT. CLS. 3, 14 AND 35), (U.S. CLS. 1, 2, 4, 6, 27, 28, 50, 51, 52, 100, 101 AND 102). SN 79-055,207. PUB. 3-17-2009. FILED 6-5-2008.
- 3,631,665. **MTWTFSS WEEKDAY (BLOCK FORM)**. WEEKDAY AB, MULTIPLE CLASS, (INT. CLS. 3, 14 AND 35), (U.S. CLS. 1, 2, 4, 6, 27, 28, 50, 51, 52, 100, 101 AND 102). SN 79-055,656. PUB. 3-17-2009. FILED 6-5-2008.
- 3,631,705. **GLITTER FIZZ (BLOCK FORM)**. BOURJOIS, (U.S. CLS. 1, 4, 6, 50, 51 AND 52). SN 79-057,253. PUB. 3-17-2009. FILED 7-16-2008.
- 3,631,726. **CREMOTURE (BLOCK FORM)**. KABOUREK, ILKA DANIELA, (U.S. CLS. 1, 4, 6, 50, 51 AND 52). SN 79-058,204. PUB. 3-17-2009. FILED 7-16-2008.
- 3,631,741. **DIOR 5 COULEURS DESIGNER (STYLIZED)**. PARFUMS CHRISTIAN DIOR, (U.S. CLS. 1, 4, 6, 50, 51 AND 52). SN 79-059,109. PUB. 3-17-2009. FILED 8-4-2008.
- 3,631,744. **BEAUTILOGY (BLOCK FORM)**. WHIZ BRANDS PTY LTD, (U.S. CLS. 1, 4, 6, 50, 51 AND 52). SN 79-059,142. PUB. 3-17-2009. FILED 4-17-2008.
- 3,631,747. **FANCL AC (STYLIZED)**. FANCL CORPORATION, (U.S. CLS. 1, 4, 6, 50, 51 AND 52). SN 79-059,343. PUB. 3-17-2009. FILED 8-1-2008.

CLASS 4—LUBRICANTS AND FUELS

- 3,629,338. **E AND DESIGN**. EDPRO CAPITAL INC., MULTIPLE CLASS, (INT. CLS. 4, 6, 7, 9 AND 20), (U.S. CLS. 1, 2, 6, 12, 13, 14, 15, 19, 21, 22, 23, 25, 26, 31, 32, 34, 35, 36, 38 AND 50). SN 77-246,729. PUB. 3-17-2009. FILED 8-3-2007.
- 3,629,339. **GLOBAL VIEWS (BLOCK FORM)**. GLOBAL VIEWS, L.P., MULTIPLE CLASS, (INT. CLS. 4, 6, 9, 11, 14, 16, 18, 19, 20, 21 AND 24), (U.S. CLS. 1, 2, 3, 5, 6, 12, 13, 14, 15, 21, 22, 23, 25, 26, 27, 28, 29, 30, 31, 32, 33, 34, 36, 37, 38, 40, 41, 42 AND 50). SN 77-247,871. PUB. 3-17-2009. FILED 8-6-2007.
- 3,629,576. **TEALIFE (BLOCK FORM)**. TEA LIFE, LLC, (U.S. CLS. 1, 6 AND 15). SN 77-412,111. PUB. 3-17-2009. FILED 3-4-2008.
- 3,629,897. **ENTERTAINING WELL DONE (BLOCK FORM)**. OUTSET, INC., MULTIPLE CLASS, (INT. CLS. 4, 9 AND 21), (U.S. CLS. 1, 2, 6, 13, 15, 21, 23, 26, 29, 30, 33, 36, 38, 40 AND 50). SN 77-465,905. PUB. 3-17-2009. FILED 5-5-2008.
- 3,630,580 (*See Class 3 for this trademark*).
- 3,630,597 (*See Class 3 for this trademark*).
- 3,630,599 (*See Class 3 for this trademark*).
- 3,630,600 (*See Class 3 for this trademark*).
- 3,630,603 (*See Class 3 for this trademark*).
- 3,630,604 (*See Class 3 for this trademark*).
- 3,630,605. **LIPSTICK (BLOCK FORM)**. TYLER CANDLE COMPANY, L.L.C., (U.S. CLS. 1, 6 AND 15). SN 77-596,037. PUB. 3-17-2009. FILED 10-20-2008.
- 3,630,606 (*See Class 3 for this trademark*).
- 3,630,607. **MULBERRY MOMENTS (BLOCK FORM)**. TYLER CANDLE COMPANY, L.L.C., (U.S. CLS. 1, 6 AND 15). SN 77-596,066. PUB. 3-17-2009. FILED 10-20-2008.
- 3,630,638 (*See Class 3 for this trademark*).
- 3,630,639. **PMS (BLOCK FORM)**. TYLER CANDLE COMPANY, L.L.C., (U.S. CLS. 1, 6 AND 15). SN 77-596,888. PUB. 3-17-2009. FILED 10-21-2008.
- 3,630,640. **PRESTIGE (BLOCK FORM)**. TYLER CANDLE COMPANY, L.L.C., (U.S. CLS. 1, 6 AND 15). SN 77-596,894. PUB. 3-17-2009. FILED 10-21-2008.
- 3,630,831 (*See Class 3 for this trademark*).
- 3,631,464 (*See Class 1 for this trademark*).
- 3,631,504 (*See Class 1 for this trademark*).
- 3,631,510 (*See Class 1 for this trademark*).
- 3,631,518 (*See Class 1 for this trademark*).
- 3,631,621 (*See Class 3 for this trademark*).

CLASS 5—PHARMACEUTICALS

- 3,629,126. **XCESS**. 649355 B.C. LTD., (U.S. CLS. 6, 18, 44, 46, 51 AND 52). SN 76-517,676. PUB. 1-13-2009. FILED 5-5-2003.
- 3,629,135. **NAELEEN'S (BLOCK FORM)**. WONG, SENG, (U.S. CLS. 6, 18, 44, 46, 51 AND 52). SN 76-670,455. PUB. 9-30-2008. FILED 12-18-2006.
- 3,629,138. **DOGGIE-BITES (STYLIZED)**. VB HOLDING LLC, (U.S. CLS. 6, 18, 44, 46, 51 AND 52). SN 76-676,247. PUB. 3-17-2009. FILED 4-30-2007.
- 3,629,140. **TECNOSAN (BLOCK FORM)**. HERAEUS KULZER GMBH, (U.S. CLS. 6, 18, 44, 46, 51 AND 52). SN 76-680,695. PUB. 3-17-2009. FILED 8-15-2007.
- 3,629,237. **MISCELLANEOUS DESIGN**. JOSHUA PHARMACEUTICAL PTE LTD, (U.S. CLS. 6, 18, 44, 46, 51 AND 52). SN 77-036,162. PUB. 3-17-2009. FILED 11-3-2006.
- 3,629,298. **MISCELLANEOUS DESIGN**. BAYER AKTIENGESELLSCHAFT, (U.S. CLS. 6, 18, 44, 46, 51 AND 52). SN 77-186,248. PUB. 3-17-2009. FILED 5-21-2007.
- 3,629,299 (*See Class 3 for this trademark*).
- 3,629,315. **FLEXSOLVE 24-7 (BLOCK FORM)**. AMERICAN BIOSCIENCES, INC., (U.S. CLS. 6, 18, 44, 46, 51 AND 52). SN 77-206,313. PUB. 3-17-2009. FILED 6-14-2007.
- 3,629,370. **LE VENEZIANE (BLOCK FORM)**. MOLINO DI FERRO S.P.A., MULTIPLE CLASS, (INT. CLS. 5 AND 29), (U.S. CLS. 6, 18, 44, 46, 51 AND 52). SN 77-282,437. PUB. 8-5-2008. FILED 9-18-2007.
- 3,629,439 (*See Class 1 for this trademark*).
- 3,629,440 (*See Class 1 for this trademark*).
- 3,629,441. **FAT STOP AQUA (BLOCK FORM)**. FONT I MAS, JUAN CARLOS, (U.S. CLS. 6, 18, 44, 46, 51 AND 52). SN 77-336,730. PUB. 3-17-2009. FILED 11-26-2007.
- 3,629,454. **UNITHER (BLOCK FORM)**. UNITHER DEVELOPMENT, MULTIPLE CLASS, (INT. CLS. 5, 10 AND 42), (U.S. CLS. 6, 18, 26, 39, 44, 46, 51, 52, 100 AND 101). SN 77-347,088. PUB. 3-17-2009. FILED 12-7-2007.
- 3,629,458. **NANOPRO PRP (BLOCK FORM)**. BIOPHARMA SCIENTIFIC, INC., (U.S. CLS. 6, 18, 44, 46, 51 AND 52). SN 77-350,192. PUB. 3-17-2009. FILED 12-12-2007.
- 3,629,474 (*See Class 3 for this trademark*).
- 3,629,475 (*See Class 1 for this trademark*).
- 3,629,481. **ADVANCED FIBRIN DEFENSE (BLOCK FORM)**. ARTHUR ANDREW MEDICAL, INC, (U.S. CLS. 6, 18, 44, 46, 51 AND 52). SN 77-363,662. PUB. 3-17-2009. FILED 1-3-2008.
- 3,629,521. **SANITEX (BLOCK FORM)**. PRECARE CORP., DBA PREMIER CARE INDUSTRIES, (U.S. CLS. 6, 18, 44, 46, 51 AND 52). SN 77-385,066. PUB. 3-17-2009. FILED 1-31-2008.
- 3,629,541. **IPS E.MAX ZIRCAD (BLOCK FORM)**. IVOCLAR VIVADENT, INC., MULTIPLE CLASS, (INT. CLS. 5 AND 10), (U.S. CLS. 6, 18, 26, 39, 44, 46, 51 AND 52). SN 77-396,632. PUB. 3-17-2009. FILED 2-14-2008.
- 3,629,547. **CILASE (BLOCK FORM)**. CILIAN AG, (U.S. CLS. 6, 18, 44, 46, 51 AND 52). SN 77-397,869. PUB. 3-17-2009. FILED 2-15-2008.
- 3,629,592. **FOCUSED ENERGY (BLOCK FORM)**. SULLIVAN, MICHELLE, (U.S. CLS. 6, 18, 44, 46, 51 AND 52). SN 77-419,814. PUB. 3-17-2009. FILED 3-12-2008.
- 3,629,613. **FUNGASIL (BLOCK FORM)**. WAYNE K KNOLL JR, (U.S. CLS. 6, 18, 44, 46, 51 AND 52). SN 77-429,606. PUB. 12-9-2008. FILED 3-24-2008.
- 3,629,626 (*See Class 3 for this trademark*).
- 3,629,670. **MISCELLANEOUS DESIGN**. SCHERING CORPORATION, (U.S. CLS. 6, 18, 44, 46, 51 AND 52). SN 77-439,814. PUB. 3-17-2009. FILED 4-4-2008.
- 3,629,692 (*See Class 1 for this trademark*).
- 3,629,701. **XENADRINE RFA-1 (BLOCK FORM)**. IOMEDIX DEVELOPMENT INTERNATIONAL SRL, (U.S. CLS. 6, 18, 44, 46, 51 AND 52). SN 77-443,674. PUB. 3-17-2009. FILED 4-9-2008.
- 3,629,725. **LITTLE ANGELS (BLOCK FORM)**. MAXIMUM LIVING, INC., DBA BAY TO BAY DISTRIBUTION, INC., (U.S. CLS. 6, 18, 44, 46, 51 AND 52). SN 77-445,432. PUB. 3-17-2009. FILED 4-10-2008.
- 3,629,797. **MOISTURE SMART (STYLIZED)**. RECKITT BENCKISER, INC., (U.S. CLS. 6, 18, 44, 46, 51 AND 52). SN 77-451,648. PUB. 3-17-2009. FILED 4-18-2008.
- 3,629,892. **RETRIEVE HEALTH (BLOCK FORM)**. WILDERNESS ATHLETE, INC., (U.S. CLS. 6, 18, 44, 46, 51 AND 52).

- SN 77-464,601. PUB. 3-17-2009. FILED 5-2-2008.
- 3,629,902. **VICKERY AND DESIGN. SUPERNUTRIENT CORPORATION**, (U.S. CLS. 6, 18, 44, 46, 51 AND 52). SN 77-466,974. PUB. 3-17-2009. FILED 5-6-2008.
- 3,630,021. **TEZUVAR (BLOCK FORM). SIGMA-TAU PHARMACEUTICALS, INC.**, (U.S. CLS. 6, 18, 44, 46, 51 AND 52). SN 77-497,150. PUB. 3-17-2009. FILED 6-12-2008.
- 3,630,022. **ARLIAMA (BLOCK FORM). SIGMA-TAU PHARMACEUTICALS, INC.**, (U.S. CLS. 6, 18, 44, 46, 51 AND 52). SN 77-497,198. PUB. 3-17-2009. FILED 6-12-2008.
- 3,630,025. **NUARTEZ (BLOCK FORM). SIGMA-TAU PHARMACEUTICALS, INC.**, (U.S. CLS. 6, 18, 44, 46, 51 AND 52). SN 77-497,473. PUB. 3-17-2009. FILED 6-12-2008.
- 3,630,115. **ESSENTIAL NEEDS (BLOCK FORM). LONG, DAVID, AND LONG, JOANNE**, (U.S. CLS. 6, 18, 44, 46, 51 AND 52). SN 77-524,638. PUB. 3-17-2009. FILED 7-17-2008.
- 3,630,184 (*See Class 1 for this trademark*).
- 3,630,188. **OTO-PLEX (BLOCK FORM). WEBER & WEBER GMBH & CO. KG**, (U.S. CLS. 6, 18, 44, 46, 51 AND 52). SN 77-545,193. PUB. 3-17-2009. FILED 8-12-2008.
- 3,630,224. **DING ZING (BLOCK FORM). DING-ZING CHEMICAL PRODUCTS CO., LTD.**, MULTIPLE CLASS, (INT. CLS. 5, 7, 10, 17, 24, 25 AND 26), (U.S. CLS. 1, 5, 6, 12, 13, 18, 19, 21, 22, 23, 26, 31, 34, 35, 37, 39, 40, 42, 44, 46, 50, 51 AND 52). SN 77-552,875. PUB. 12-9-2008. FILED 8-21-2008.
- 3,630,344. **URAMAXIN (BLOCK FORM). MEDIMETRIKS PHARMACEUTICALS, INC.**, (U.S. CLS. 6, 18, 44, 46, 51 AND 52). SN 77-572,151. PUB. 3-17-2009. FILED 9-17-2008.
- 3,630,345. **PACNEX (BLOCK FORM). MEDIMETRIKS PHARMACEUTICALS, INC.**, (U.S. CLS. 6, 18, 44, 46, 51 AND 52). SN 77-572,186. PUB. 3-17-2009. FILED 9-17-2008.
- 3,630,346. **SUMAXIN (BLOCK FORM). MEDIMETRIKS PHARMACEUTICALS, INC.**, (U.S. CLS. 6, 18, 44, 46, 51 AND 52). SN 77-572,219. PUB. 3-17-2009. FILED 9-17-2008.
- 3,630,361. **LEVOPHED (BLOCK FORM). HOSPIRA, INC.**, (U.S. CLS. 6, 18, 44, 46, 51 AND 52). SN 77-573,754. PUB. 3-17-2009. FILED 9-18-2008.
- 3,630,367. **PUPPY BOOST (BLOCK FORM). PETLAND, INC.**, (U.S. CLS. 6, 18, 44, 46, 51 AND 52). SN 77-574,541. PUB. 3-17-2009. FILED 9-19-2008.
- 3,630,397. **VIKER VIKER MANUFACTURE CO., LTD. AND DESIGN. VIKER MANUFACTURE CO LTD.**, (U.S. CLS. 6, 18, 44, 46, 51 AND 52). SN 77-579,043. PUB. 3-17-2009. FILED 9-25-2008.
- 3,630,411. **SLIM & YOUNG (BLOCK FORM). AMERINUTRITION LLC**, (U.S. CLS. 6, 18, 44, 46, 51 AND 52). SN 77-580,163. PUB. 3-17-2009. FILED 9-26-2008.
- 3,630,436. **CARALLUMA GOLD (BLOCK FORM). TSN LABS, INC.**, (U.S. CLS. 6, 18, 44, 46, 51 AND 52). SN 77-583,499. PUB. 3-17-2009. FILED 10-1-2008.
- 3,630,467. **DIP-SAN (BLOCK FORM). MCALLAN INNOVATIONS LIMITED, MULTIPLE CLASS, (INT. CLS. 5 AND 21)**, (U.S. CLS. 2, 6, 13, 18, 23, 29, 30, 33, 40, 44, 46, 50, 51 AND 52). SN 77-587,095. PUB. 3-17-2009. FILED 10-7-2008.
- 3,630,526. **CAL D SUISSE (BLOCK FORM). LABATEC PHARMA SA**, (U.S. CLS. 6, 18, 44, 46, 51 AND 52). SN 77-591,939. PUB. 3-17-2009. FILED 10-14-2008.
- 3,630,622. **MISCELLANEOUS DESIGN. GILEAD SCIENCES, INC.**, (U.S. CLS. 6, 18, 44, 46, 51 AND 52). SN 77-596,619. PUB. 3-17-2009. FILED 10-20-2008.
- 3,630,663. **CATEGORY CREATORS AND DESIGN. CATEGORY CREATORS**, (U.S. CLS. 6, 18, 44, 46, 51 AND 52). SN 77-597,447. PUB. 3-17-2009. FILED 10-21-2008.
- 3,630,681. **BIOPRIN (BLOCK FORM). JBNI, DBA BIODRUX**, (U.S. CLS. 6, 18, 44, 46, 51 AND 52). SN 77-597,895. PUB. 3-17-2009. FILED 10-22-2008.
- 3,630,718. **WATER& (STYLIZED). YB COMPANY INC., DBA KPD**, (U.S. CLS. 6, 18, 44, 46, 51 AND 52). SN 77-598,518. PUB. 3-17-2009. FILED 10-22-2008.
- 3,630,756. **KEEPS THE OUTDOORS FROM GETTING RASH WITH YOU (BLOCK FORM). TEC LABORATORIES, INC.**, (U.S. CLS. 6, 18, 44, 46, 51 AND 52). SN 77-598,979. PUB. 3-17-2009. FILED 10-23-2008.
- 3,630,785. **SPORTS ONE (BLOCK FORM). SPORTS ONE INCORPORATED**, (U.S. CLS. 6, 18, 44, 46, 51 AND 52). SN 77-599,419. PUB. 3-17-2009. FILED 10-23-2008.
- 3,630,818. **AVISTATIN (BLOCK FORM). NUTRITIONAL SERVICES CONSULTING**, (U.S. CLS. 6, 18, 44, 46, 51 AND 52). SN 77-599,899. PUB. 3-17-2009. FILED 10-24-2008.
- 3,630,851. **AURAUPELL (BLOCK FORM). OTO MEDICINE**, (U.S. CLS. 6, 18, 44, 46, 51 AND 52). SN 77-600,211. PUB. 3-17-2009. FILED 10-24-2008.
- 3,630,856. **MYOMEGA (BLOCK FORM). CONCEPT LABORATORIES, INC.**, (U.S. CLS. 6, 18, 44, 46, 51 AND 52). SN 77-600,322. PUB. 3-17-2009. FILED 10-24-2008.
- 3,630,905. **MOUSE POUCH (BLOCK FORM). EARTH-KIND, INC.**, (U.S. CLS. 6, 18, 44, 46, 51 AND 52). SN 77-600,964. PUB. 3-17-2009. FILED 10-27-2008.
- 3,630,908. **HEIGHTFX (BLOCK FORM). ROYER, DANIEL**, (U.S. CLS. 6, 18, 44, 46, 51 AND 52). SN 77-601,010. PUB. 3-17-2009. FILED 10-27-2008.
- 3,630,926. **ON-TRACT (BLOCK FORM). PROGRESSIVE LABORATORIES, INC.**, (U.S. CLS. 6, 18, 44, 46, 51 AND 52). SN 77-601,263. PUB. 3-17-2009. FILED 10-27-2008.
- 3,630,930. **MAGNEZYME (BLOCK FORM). PROGRESSIVE LABORATORIES, INC.**, (U.S. CLS. 6, 18, 44, 46, 51 AND 52). SN 77-601,283. PUB. 3-17-2009. FILED 10-27-2008.
- 3,630,941. **FROTAL (BLOCK FORM). INDUSTRIA FARMACEUTICA, S.A.**, (U.S. CLS. 6, 18, 44, 46, 51 AND 52). SN 77-601,377. PUB. 3-17-2009. FILED 10-27-2008.
- 3,630,963. **PANODYNE (BLOCK FORM). HUSSAIN, IMRAN, AND HUSSAIN, RIZWANA, AND HUSSAIN, MAARIAH, AND HUSSAIN, DANYAAL, AND HUSSAIN, ZAHRA**, (U.S. CLS. 6, 18, 44, 46, 51 AND 52). SN 77-601,763. PUB. 3-17-2009. FILED 10-28-2008.
- 3,631,011. **NOVA CARE (BLOCK FORM). TSN LABS, INC.**, (U.S. CLS. 6, 18, 44, 46, 51 AND 52). SN 77-602,336. PUB. 3-17-2009. FILED 10-28-2008.
- 3,631,018. **PROLONG (BLOCK FORM). CHAMELEON DENTAL PRODUCTS, INC.**, (U.S. CLS. 6, 18, 44, 46, 51 AND 52). SN 77-602,435. PUB. 3-17-2009. FILED 10-28-2008.
- 3,631,124. **DOXISOME (BLOCK FORM). TAIWAN LIPO-SOME CO., LTD.**, (U.S. CLS. 6, 18, 44, 46, 51 AND 52). SN 77-604,290. PUB. 3-17-2009. FILED 10-30-2008.
- 3,631,210. **SKUNKIES (BLOCK FORM). SKUNKIES, LLC**, (U.S. CLS. 6, 18, 44, 46, 51 AND 52). SN 77-605,527. PUB. 3-17-2009. FILED 10-31-2008.
- 3,631,242. **PROLATIS' (BLOCK FORM). TMP NEVADA, INC.**, (U.S. CLS. 6, 18, 44, 46, 51 AND 52). SN 77-606,171. PUB. 3-17-2009. FILED 11-3-2008.
- 3,631,247. **COQ-CLEAR (BLOCK FORM). NUMEDICA, L.L.C., FORMERLY XYMOGEN NUMEDICA**, (U.S. CLS. 6, 18, 44, 46, 51 AND 52). SN 77-606,232. PUB. 3-17-2009. FILED 11-3-2008.
- 3,631,262. **VASOLEX (STYLIZED). JCA DEVELOPMENT OF MIAMI, INC.**, (U.S. CLS. 6, 18, 44, 46, 51 AND 52). SN 77-607,102. PUB. 3-17-2009. FILED 11-4-2008.
- 3,631,287. **A-ATP (BLOCK FORM). M. A. D. SYNERGISTICS, INC.**, (U.S. CLS. 6, 18, 44, 46, 51 AND 52). SN 77-610,912. PUB. 3-17-2009. FILED 11-10-2008.
- 3,631,289. **VIDAZA AND DESIGN. CELGENE CORPORATION**, (U.S. CLS. 6, 18, 44, 46, 51 AND 52). SN 77-611,079. PUB. 3-17-2009. FILED 11-10-2008.
- 3,631,321. **VITAMENS HEALTHY BODIES FOR ACTIVE LIVING (BLOCK FORM). INTERNATIONAL DESIGN ASSOCIATES LTD.**, (U.S. CLS. 6, 18, 44, 46, 51 AND 52). SN 77-618,980. PUB. 3-17-2009. FILED 11-20-2008.
- 3,631,392. **SUISSE PROGRAMME AND DESIGN. SUISSE PROGRAMME LIMITED**, (U.S. CLS. 6, 18, 44, 46, 51 AND 52). SN 78-531,500. PUB. 10-2-2007. FILED 12-13-2004.
- 3,631,427 (*See Class 3 for this trademark*).
- 3,631,466. **SYDNEY IVF AND DESIGN. SYDNEY IVF LIMITED, MULTIPLE CLASS, (INT. CLS. 5, 42 AND 44)**, (U.S. CLS. 6, 18, 44, 46, 51, 52, 100 AND 101). SN 79-029,725. PUB. 3-17-2009. FILED 7-24-2006.
- 3,631,476. **DYSPORT BOTULINUM TOXIN TYPE A AND DESIGN. IPSEN BIOPHARM LIMITED**, (U.S. CLS. 6, 18, 44, 46, 51 AND 52). SN 79-038,019. PUB. 10-14-2008. FILED 3-9-2007.
- 3,631,491. **TOXMAP (BLOCK FORM). TOXICELL APS, MULTIPLE CLASS, (INT. CLS. 5, 9 AND 42)**, (U.S. CLS. 6, 18, 21, 23, 26, 36, 38, 44, 46, 51, 52, 100 AND 101). SN 79-043,974. PUB. 3-17-2009. FILED 6-22-2007.
- 3,631,518 (*See Class 1 for this trademark*).
- 3,631,519. **DISCOVERPRINT AND DESIGN. AGENDIA BV**, MULTIPLE CLASS, (INT. CLS. 5, 10 AND 44), (U.S. CLS. 6,

- 18, 26, 39, 44, 46, 51, 52, 100 AND 101), SN 79-048,381. PUB. 10-14-2008. FILED 11-27-2007.
- 3,631,520. **CUPPRINT AND DESIGN**. AGENDIA BV, MULTIPLE CLASS, (INT. CLS. 5, 10 AND 44), (U.S. CLS. 6, 18, 26, 39, 44, 46, 51, 52, 100 AND 101). SN 79-048,382. PUB. 10-14-2008. FILED 11-27-2007.
- 3,631,526. **DROGLICAN (BLOCK FORM)**. BIOIBERICA, S.A., (U.S. CLS. 6, 18, 44, 46, 51 AND 52). SN 79-048,983. PUB. 3-17-2009. FILED 11-30-2007.
- 3,631,527. **ARTROACTIVE (BLOCK FORM)**. BIOIBERICA, S.A., (U.S. CLS. 6, 18, 44, 46, 51 AND 52). SN 79-048,984. PUB. 3-17-2009. FILED 11-30-2007.
- 3,631,528. **TENDOACTIVE (BLOCK FORM)**. BIOIBERICA, S.A., (U.S. CLS. 6, 18, 44, 46, 51 AND 52). SN 79-048,985. PUB. 3-17-2009. FILED 11-30-2007.
- 3,631,529. **HIALSORB (STYLIZED)**. BIOIBERICA, S.A., (U.S. CLS. 6, 18, 44, 46, 51 AND 52). SN 79-048,986. PUB. 3-17-2009. FILED 11-30-2007.
- 3,631,553. **NICOSORB (BLOCK FORM)**. EASTLAND MEDICAL SYSTEMS LTD, (U.S. CLS. 6, 18, 44, 46, 51 AND 52). SN 79-051,772. PUB. 3-17-2009. FILED 2-4-2008.
- 3,631,559. **PHEBRA (BLOCK FORM)**. PHEBRA PTY LTD, MULTIPLE CLASS, (INT. CLS. 5, 10 AND 42), (U.S. CLS. 6, 18, 26, 39, 44, 46, 51, 52, 100 AND 101). SN 79-052,219. PUB. 3-17-2009. FILED 3-20-2008.
- 3,631,560 (*See Class 3 for this trademark*).
- 3,631,564. **GYNEAS (BLOCK FORM)**. LABORATOIRES GYNEAS, MULTIPLE CLASS, (INT. CLS. 5 AND 10), (U.S. CLS. 6, 18, 26, 39, 44, 46, 51 AND 52). SN 79-052,623. PUB. 3-17-2009. FILED 3-25-2008.
- 3,631,571. **O-IN BAG (BLOCK FORM)**. OTSUKA PHARMACEUTICAL FACTORY, INC., (U.S. CLS. 6, 18, 44, 46, 51 AND 52). SN 79-052,977. PUB. 3-17-2009. FILED 4-2-2008.
- 3,631,581. **INFLUVANCE (BLOCK FORM)**. SOLVAY BIOLOGICALS B.V., (U.S. CLS. 6, 18, 44, 46, 51 AND 52). SN 79-053,480. PUB. 3-17-2009. FILED 4-9-2008.
- 3,631,605. **XIANZHILOU AND DESIGN**. FUJIAN XIANZHILOU BIOLOGICAL; SCIENCE AND TECHNOLOGY CO., LTD, MULTIPLE CLASS, (INT. CLS. 5 AND 30), (U.S. CLS. 6, 18, 44, 46, 51 AND 52). SN 79-054,089. PUB. 3-17-2009. FILED 5-22-2007.
- 3,631,630. **DROSSADOLOR (BLOCK FORM)**. DROSSAPHARM AG, (U.S. CLS. 6, 18, 44, 46, 51 AND 52). SN 79-054,469. PUB. 3-17-2009. FILED 5-27-2008.
- 3,631,631. **BICENTURY SLIMDELIS AND DESIGN**. BIOCENTURY, S.L., MULTIPLE CLASS, (INT. CLS. 5 AND 30), (U.S. CLS. 6, 18, 44, 46, 51 AND 52). SN 79-054,475. PUB. 3-17-2009. FILED 5-26-2008.
- 3,631,655. **AMBUTYRATE (BLOCK FORM)**. SPECIAL PRODUCTS LIMITED, (U.S. CLS. 6, 18, 44, 46, 51 AND 52). SN 79-055,323. PUB. 3-17-2009. FILED 5-13-2008.
- 3,631,657. **BEPPY (BLOCK FORM)**. FERDINAND M.J.C. WILLEMS, (U.S. CLS. 6, 18, 44, 46, 51 AND 52). SN 79-055,348. PUB. 3-17-2009. FILED 6-10-2008.
- 3,631,675. **MUBIO (BLOCK FORM)**. MUBIO PRODUCTS B.V., (U.S. CLS. 6, 18, 44, 46, 51 AND 52). SN 79-055,839. PUB. 3-17-2009. FILED 4-17-2008.
- 3,631,679. **LACTOCLONE (STYLIZED)**. LACTOSAN GMBH & CO. KG, MULTIPLE CLASS, (INT. CLS. 5 AND 42), (U.S. CLS. 6, 18, 44, 46, 51, 52, 100 AND 101). SN 79-056,099. PUB. 3-17-2009. FILED 1-16-2008.
- 3,631,748. **REDECTANE (BLOCK FORM)**. WILEX AG, MULTIPLE CLASS, (INT. CLS. 5 AND 42), (U.S. CLS. 6, 18, 44, 46, 51, 52, 100 AND 101). SN 79-059,409. PUB. 3-17-2009. FILED 6-23-2008.
- 3,631,753. **TENDRA (BLOCK FORM)**. MÖLNLYCKE HEALTH CARE AB, (U.S. CLS. 6, 18, 44, 46, 51 AND 52). SN 79-059,805. PUB. 3-17-2009. FILED 5-20-2008.
- 3,631,762 (*See Class 1 for this trademark*).
- 3,631,768. **BEMIDETACH (BLOCK FORM)**. ISHIHARA SANGYO KAIsha, LTD., (U.S. CLS. 6, 18, 44, 46, 51 AND 52). SN 79-062,010. PUB. 3-17-2009. FILED 10-17-2008.
- 3,631,775. **KEVONDEO (BLOCK FORM)**. SANOFI-AVENTIS, (U.S. CLS. 6, 18, 44, 46, 51 AND 52). SN 79-062,546. PUB. 3-17-2009. FILED 11-14-2008.
- 3,631,776. **BEMIZODA (BLOCK FORM)**. SANOFI-AVENTIS, (U.S. CLS. 6, 18, 44, 46, 51 AND 52). SN 79-062,547. PUB. 3-17-2009. FILED 11-14-2008.
- 3,631,780. **DEMLEZZA (STYLIZED)**. SANOFI-AVENTIS, (U.S. CLS. 6, 18, 44, 46, 51 AND 52). SN 79-063,289. PUB. 3-17-2009. FILED 11-20-2008.

CLASS 6—METAL GOODS

- 3,629,233 (*See Class 1 for this trademark*).
- 3,629,250. **GRAPHIX SERIES (BLOCK FORM)**. CENTRIA, (U.S. CLS. 2, 12, 13, 14, 23, 25 AND 50). SN 77-078,883. PUB. 3-17-2009. FILED 1-9-2007.
- 3,629,268. **SJ AND DESIGN**. HARBIN SONGJIANG COPPER TRADE (GROUP) CO., LTD., (U.S. CLS. 2, 12, 13, 14, 23, 25 AND 50). SN 77-115,716. PUB. 3-17-2009. FILED 2-26-2007.
- 3,629,294. **DAGGERZ (BLOCK FORM)**. INTERNATIONAL FASTENERS, INC., (U.S. CLS. 2, 12, 13, 14, 23, 25 AND 50). SN 77-174,427. PUB. 3-17-2009. FILED 5-7-2007.
- 3,629,305. **METALTECH (BLOCK FORM)**. METALTECH-OMEGA INC., MULTIPLE CLASS, (INT. CLS. 6 AND 35), (U.S. CLS. 2, 12, 13, 14, 23, 25, 50, 100, 101 AND 102). SN 77-195,543. PUB. 3-17-2009. FILED 6-1-2007.
- 3,629,321. **ESSEN (STYLIZED)**. ESSENTECH CO., LTD., MULTIPLE CLASS, (INT. CLS. 6, 7, 9, 11, 35 AND 40), (U.S. CLS. 2, 12, 13, 14, 19, 21, 23, 25, 26, 31, 34, 35, 36, 38, 50, 100, 101, 102, 103 AND 106). SN 77-221,547. PUB. 3-17-2009. FILED 7-3-2007.
- 3,629,326. **R HOUSE (BLOCK FORM)**. HESCO BASTION LIMITED, MULTIPLE CLASS, (INT. CLS. 6, 19 AND 20), (U.S. CLS. 1, 2, 12, 13, 14, 22, 23, 25, 32, 33 AND 50). SN 77-233,748. PUB. 3-17-2009. FILED 7-19-2007.
- 3,629,338 (*See Class 4 for this trademark*).
- 3,629,339 (*See Class 4 for this trademark*).
- 3,629,422. **CORONET AND DESIGN**. CORONET SCAFFOLD EQUIPMENT SUZHOU CO., LTD., (U.S. CLS. 2, 12, 13, 14, 23, 25 AND 50). SN 77-322,075. PUB. 3-17-2009. FILED 11-6-2007.
- 3,629,525. **BIGBEE (BLOCK FORM)**. BIGBEE STEEL BUILDINGS, INC., MULTIPLE CLASS, (INT. CLS. 6, 40 AND 42), (U.S. CLS. 2, 12, 13, 14, 23, 25, 50, 100, 101, 103 AND 106). SN 77-388,609. PUB. 3-17-2009. FILED 2-5-2008.
- 3,629,526. **BIGBEE AND DESIGN**. BIGBEE STEEL BUILDINGS, INC., MULTIPLE CLASS, (INT. CLS. 6, 40 AND 42), (U.S. CLS. 2, 12, 13, 14, 23, 25, 50, 100, 101, 103 AND 106). SN 77-388,642. PUB. 3-17-2009. FILED 2-5-2008.
- 3,629,527. **SKY FACTORY (BLOCK FORM)**. THE SKY FACTORY, L.C., MULTIPLE CLASS, (INT. CLS. 6, 19 AND 42), (U.S. CLS. 1, 2, 12, 13, 14, 23, 25, 33, 50, 100 AND 101). SN 77-389,176. PUB. 3-17-2009. FILED 2-5-2008.
- 3,629,649. **VIPERTRACK (BLOCK FORM)**. WARE INDUSTRIES, INC., DBA MARINO/WARE, (U.S. CLS. 2, 12, 13, 14, 23, 25 AND 50). SN 77-436,430. PUB. 3-17-2009. FILED 4-1-2008.
- 3,629,683. **TRANSAIR (BLOCK FORM)**. LEGRIS S.A., MULTIPLE CLASS, (INT. CLS. 6, 9, 11 AND 17), (U.S. CLS. 1, 2, 5, 12, 13, 14, 21, 23, 25, 26, 31, 34, 35, 36, 38 AND 50). SN 77-441,250. PUB. 3-17-2009. FILED 4-7-2008.
- 3,629,718. **BINGO (BLOCK FORM)**. LTL WHOLESALE, INC., DBA LTL HOME PRODUCTS, INC., MULTIPLE CLASS, (INT. CLS. 6 AND 20), (U.S. CLS. 2, 12, 13, 14, 22, 23, 25, 32 AND 50). SN 77-444,649. PUB. 3-17-2009. FILED 4-10-2008.
- 3,629,804. **E2 (STYLIZED)**. SCHÜCO INTERNATIONAL KG, MULTIPLE CLASS, (INT. CLS. 6, 9, 11 AND 19), (U.S. CLS. 1, 2, 12, 13, 14, 21, 23, 25, 26, 31, 33, 34, 36, 38 AND 50). SN 77-452,356. PUB. 3-17-2009. FILED 4-18-2008.
- 3,629,965. **ACTRONIX (BLOCK FORM)**. ACTRONIX, INC., MULTIPLE CLASS, (INT. CLS. 6 AND 9), (U.S. CLS. 2, 12, 13, 14, 21, 23, 25, 26, 36, 38 AND 50). SN 77-483,555. PUB. 3-17-2009. FILED 5-27-2008.
- 3,629,969. **POSITROL WORKHOLDING (BLOCK FORM)**. POSITROL, INC., (U.S. CLS. 2, 12, 13, 14, 23, 25 AND 50). SN 77-484,674. PUB. 3-17-2009. FILED 5-28-2008.
- 3,630,088. **PARTNER DOOR (BLOCK FORM)**. A.J. MANUFACTURING, INC., (U.S. CLS. 2, 12, 13, 14, 23, 25 AND 50). SN 77-518,413. PUB. 3-17-2009. FILED 7-9-2008.
- 3,630,098. **GUTTER WORKS (STYLIZED)**. HAMMOND, DONALD R., (U.S. CLS. 2, 12, 13, 14, 23, 25 AND 50). SN 77-519,679. PUB. 3-17-2009. FILED 7-10-2008.

- 3,630,245. **WAN HAI (BLOCK FORM)**. WAN HAI LINES, LTD., DBA WAN HAI LINES, LTD., MULTIPLE CLASS, (INT. CLS. 6, 12 AND 39), (U.S. CLS. 2, 12, 13, 14, 19, 21, 23, 25, 31, 35, 44, 50, 100 AND 105). SN 77-556,347. PUB. 3-17-2009. FILED 8-26-2008.
- 3,630,246. **WE CARRY, WE CARE (BLOCK FORM)**. WAN HAI LINES, LTD., DBA WAN HAI LINES, LTD., MULTIPLE CLASS, (INT. CLS. 6 AND 39), (U.S. CLS. 2, 12, 13, 14, 23, 25, 50, 100 AND 105). SN 77-556,384. PUB. 3-17-2009. FILED 8-26-2008.
- 3,630,250. **AAP ATLANTIC ALUMINUM PRODUCTS INCORPORATED AND DESIGN**. ATLANTIC ALUMINUM PRODUCTS INCORPORATED, MULTIPLE CLASS, (INT. CLS. 6, 35 AND 37), (U.S. CLS. 2, 12, 13, 14, 23, 25, 50, 100, 101, 102, 103 AND 106). SN 77-556,843. PUB. 3-17-2009. FILED 8-27-2008.
- 3,630,649. **CLEARLY THE BEST. (BLOCK FORM)**. MILGARD MANUFACTURING INCORPORATED, MULTIPLE CLASS, (INT. CLS. 6 AND 19), (U.S. CLS. 1, 2, 12, 13, 14, 23, 25, 33 AND 50). SN 77-597,036. PUB. 3-17-2009. FILED 10-21-2008.
- 3,630,678. **PENTAGON ELITE (BLOCK FORM)**. PENTAGON PROTECTION USA, LLC, (U.S. CLS. 2, 12, 13, 14, 23, 25 AND 50). SN 77-597,831. PUB. 3-17-2009. FILED 10-22-2008.
- 3,630,854. **OVERBUILT, NOT OVERPRICED! (BLOCK FORM)**. QUICK FITTING, INC., MULTIPLE CLASS, (INT. CLS. 6 AND 11), (U.S. CLS. 2, 12, 13, 14, 21, 23, 25, 31, 34 AND 50). SN 77-600,286. PUB. 3-17-2009. FILED 10-24-2008.
- 3,630,912. **A AND DESIGN**. D.H. PACE COMPANY, INC., MULTIPLE CLASS, (INT. CLS. 6, 19 AND 37), (U.S. CLS. 1, 2, 12, 13, 14, 23, 25, 33, 50, 100, 103 AND 106). SN 77-601,031. PUB. 3-17-2009. FILED 10-27-2008.
- 3,630,916. **THE DOOR YOU COME HOME TO! (BLOCK FORM)**. D.H. PACE COMPANY, INC., MULTIPLE CLASS, (INT. CLS. 6, 19 AND 37), (U.S. CLS. 1, 2, 12, 13, 14, 23, 25, 33, 50, 100, 103 AND 106). SN 77-601,066. PUB. 3-17-2009. FILED 10-27-2008.
- 3,630,995. **BOSS TANK (BLOCK FORM)**. TANK CONNECTION, L.L.C., (U.S. CLS. 2, 12, 13, 14, 23, 25 AND 50). SN 77-602,156. PUB. 3-17-2009. FILED 10-28-2008.
- 3,630,997. **EVERDUR (BLOCK FORM)**. PERFECTION FENCE CORPORATION, (U.S. CLS. 2, 12, 13, 14, 23, 25 AND 50). SN 77-602,166. PUB. 3-17-2009. FILED 10-28-2008.
- 3,631,375. **ELINE (BLOCK FORM)**. REXROTH STAR GMBH, MULTIPLE CLASS, (INT. CLS. 6 AND 20), (U.S. CLS. 2, 12, 13, 14, 22, 23, 25, 32 AND 50). SN 77-976,574. PUB. 3-17-2009. FILED 1-15-2008.
- 3,631,399 (*See Class 3 for this trademark*).
- 3,631,452 (*See Class 1 for this trademark*).
- 3,631,454. **SUPERGALV (BLOCK FORM)**. DUNROSE TRADING 57 (PROPRIETARY) LIMITED, (U.S. CLS. 2, 12, 13, 14, 23, 25 AND 50). SN 78-971,541. PUB. 3-17-2009. FILED 9-11-2006.
- 3,631,488. **POPPIT BY BIGHEAD AND DESIGN**. BIGHEAD BONDING FASTENERS LIMITED, MULTIPLE CLASS, (INT. CLS. 6 AND 19), (U.S. CLS. 1, 2, 12, 13, 14, 23, 25, 33 AND 50). SN 79-042,649. PUB. 3-17-2009. FILED 8-20-2007.
- 3,631,494. **EGMO (STYLIZED)**. NEUMO ARMATURENFABRIK-APPARATEBAU-METALLGIEBEREI; GMBH + CO. KG, MULTIPLE CLASS, (INT. CLS. 6, 7, 9, 11 AND 20), (U.S. CLS. 2, 12, 13, 14, 19, 21, 22, 23, 25, 26, 31, 32, 34, 35, 36, 38 AND 50). SN 79-044,535. PUB. 3-17-2009. FILED 7-20-2007.
- 3,631,510 (*See Class 1 for this trademark*).
- 3,631,512 (*See Class 3 for this trademark*).
- 3,631,517. **PILSEN STEEL AND DESIGN**. PILSEN STEEL S.R.O., MULTIPLE CLASS, (INT. CLS. 6, 7, 12, 35, 39, 40 AND 42), (U.S. CLS. 2, 12, 13, 14, 19, 21, 23, 25, 31, 34, 35, 44, 50, 100, 101, 102, 103, 105 AND 106). SN 79-048,224. PUB. 3-17-2009. FILED 9-12-2007.
- 3,631,521. **AUSTRIALPIN (BLOCK FORM)**. FRANZ WURZER, MULTIPLE CLASS, (INT. CLS. 6, 8 AND 28), (U.S. CLS. 2, 12, 13, 14, 22, 23, 25, 28, 38, 44 AND 50). SN 79-048,454. PUB. 3-17-2009. FILED 9-18-2007.
- 3,631,525. **FAST (STYLIZED)**. NINGBO ZHONGBIN FASTENER; MANUFACTURE CO., LTD; (NINGBO ZHONGBIN JINGUIJIAN; ZHIZAO YOUXIAN GONGSI), AND NINGBO ZHONGLIAN FASTENER; MANUFACTURE CO., LTD.; (NINGBOSHI ZHONGLIAN JINGUIJIAN; ZHIZAO YOUXIAN GONGSI), AND NINGBO ZHONGJIE METAL PRODUCT; CO., LTD.; (NINGBO ZHONGJIE JINSHU; ZHIPIN YOUXIAN GONGSI), AND NINGBO ZHENHAI TONGBIAO; INDUSTRIAL GENERAL COMPANY; (NINGBOSHI ZHENHAI TONGBIAO; SHIYE ZONGGONGSI), AND NINGBO ZHENHAI LIANTONG; SCREW MANUFACTURE CO., LTD.; (NINGBOSHI ZHENHAI LIANTONG; LUOSI ZHIZAO YOUXIAN GONGSI), (U.S. CLS. 2, 12, 13, 14, 23, 25 AND 50). SN 79-048,879. PUB. 3-17-2009. FILED 1-7-2008.
- 3,631,547. **IHI (STYLIZED)**. IHI CORPORATION, MULTIPLE CLASS, (INT. CLS. 6, 7, 9, 10, 11, 37 AND 42), (U.S. CLS. 2, 12, 13, 14, 19, 21, 23, 25, 26, 31, 34, 35, 36, 38, 39, 44, 50, 100, 101, 103 AND 106). SN 79-051,462. PUB. 3-17-2009. FILED 2-23-2007.
- 3,631,550. **KALP AND DESIGN**. KALP MOBILYA AKSESUAR SANAYI VE TEKSTIL DIS TICARET LIMITED SIRKETI, MULTIPLE CLASS, (INT. CLS. 6 AND 20), (U.S. CLS. 2, 12, 13, 14, 22, 23, 25, 32 AND 50). SN 79-051,570. PUB. 3-17-2009. FILED 6-22-2007.
- 3,631,554 (*See Class 1 for this trademark*).
- 3,631,561. **F-MOTION (STYLIZED)**. FESTO AG & CO. KG, MULTIPLE CLASS, (INT. CLS. 6, 7, 9, 17 AND 20), (U.S. CLS. 1, 2, 5, 12, 13, 14, 19, 21, 22, 23, 25, 26, 31, 32, 34, 35, 36, 38 AND 50). SN 79-052,370. PUB. 3-17-2009. FILED 1-23-2008.
- 3,631,577. **PECAFORM (BLOCK FORM)**. PECA VERBUND-TECHNIK GMBH, (U.S. CLS. 2, 12, 13, 14, 23, 25 AND 50). SN 79-053,268. PUB. 3-17-2009. FILED 2-5-2008.
- 3,631,589. **TP AND DESIGN**. TRUCKPROTECT LIMITED, MULTIPLE CLASS, (INT. CLS. 6, 12, 20 AND 35), (U.S. CLS. 2, 12, 13, 14, 19, 21, 22, 23, 25, 31, 32, 35, 44, 50, 100, 101 AND 102). SN 79-053,642. PUB. 3-17-2009. FILED 4-18-2008.
- 3,631,692. **CORIALIS CORE INNOVATIVE ALUMINIUM INTEGRATED SOLUTIONS AND DESIGN**. PLU HOLDING SAS, MULTIPLE CLASS, (INT. CLS. 6 AND 19), (U.S. CLS. 1, 2, 12, 13, 14, 23, 25, 33 AND 50). SN 79-056,956. PUB. 3-17-2009. FILED 6-16-2008.
- 3,631,704. **SILENT SYSTEM AND DESIGN**. HETTICH MARKETING- UND VERTRIEBS; GMBH & CO. KG, MULTIPLE CLASS, (INT. CLS. 6 AND 20), (U.S. CLS. 2, 12, 13, 14, 22, 23, 25, 32 AND 50). SN 79-057,241. PUB. 3-17-2009. FILED 7-2-2008.
- 3,631,711. **EGE (STYLIZED)**. EGE, SPOL. S R.O., MULTIPLE CLASS, (INT. CLS. 6, 9, 37, 41 AND 42), (U.S. CLS. 2, 12, 13, 14, 21, 23, 25, 26, 36, 38, 50, 100, 101, 103, 106 AND 107). SN 79-057,447. PUB. 3-17-2009. FILED 4-22-2008.
- 3,631,725. **LICHTGITTER (BLOCK FORM)**. LICHTGITTER GESELLSCHAFT; MIT BESCHRÄNKTER HAFTUNG, (U.S. CLS. 2, 12, 13, 14, 23, 25 AND 50). SN 79-058,159. PUB. 3-17-2009. FILED 5-28-2008.
- 3,631,772. **JOHN GJERDE (BLOCK FORM)**. JOHN GJERDE AS, (U.S. CLS. 2, 12, 13, 14, 23, 25 AND 50). SN 79-062,355. PUB. 3-17-2009. FILED 9-11-2008.

CLASS 7—MACHINERY

- 3,629,162. **MILLER STANDS THE TEST OF TIME (BLOCK FORM)**. MILLER SPREADER COMPANY, (U.S. CLS. 13, 19, 21, 23, 31, 34 AND 35). SN 76-688,518. PUB. 3-17-2009. FILED 4-10-2008.
- 3,629,167. **THE MILLER SPREADER COMPANY STANDS THE TEST OF TIME AND DESIGN**. MILLER SPREADER COMPANY, (U.S. CLS. 13, 19, 21, 23, 31, 34 AND 35). SN 76-688,848. PUB. 3-17-2009. FILED 4-21-2008.
- 3,629,179. **JOHNNY VAC AND DESIGN**. JOHNNY VAC INC., (U.S. CLS. 13, 19, 21, 23, 31, 34 AND 35). SN 76-690,575. PUB. 3-17-2009. FILED 6-16-2008.
- 3,629,190. **OUTBACK WILDLIFE FEEDERS (BLOCK FORM)**. RICK MERRITT INVESTMENTS, LTD., MULTIPLE CLASS, (INT. CLS. 7 AND 21), (U.S. CLS. 2, 13, 19, 21, 23, 29, 30, 31, 33, 34, 35, 40 AND 50). SN 76-692,572. PUB. 3-17-2009. FILED 9-4-2008.
- 3,629,193. **SKAT BLAST AND DESIGN**. SKAT BLAST, INC., (U.S. CLS. 13, 19, 21, 23, 31, 34 AND 35). SN 76-692,926. PUB. 3-17-2009. FILED 9-17-2008.

- 3,629,233 (See Class 1 for this trademark).
- 3,629,255. **MISCELLANEOUS DESIGN. DIMPLEX (UK) LIMITED, MULTIPLE CLASS, (INT. CLS. 7, 9 AND 11), (U.S. CLS. 13, 19, 21, 23, 26, 31, 34, 35, 36 AND 38).** SN 77-087,217. PUB. 3-17-2009. FILED 1-19-2007.
- 3,629,275. **PRIME CHOICE (BLOCK FORM). PRIME CHOICE AUTO PARTS, INC., MULTIPLE CLASS, (INT. CLS. 7, 9, 11, 12 AND 35), (U.S. CLS. 13, 19, 21, 23, 26, 31, 34, 35, 36, 38, 44, 100, 101 AND 102).** SN 77-136,482. PUB. 3-17-2009. FILED 3-21-2007.
- 3,629,281. **S S-MAX AND DESIGN. YI, JOON TAE, (U.S. CLS. 13, 19, 21, 23, 31, 34 AND 35).** SN 77-149,534. PUB. 3-17-2009. FILED 4-5-2007.
- 3,629,321 (See Class 6 for this trademark).
- 3,629,338 (See Class 4 for this trademark).
- 3,629,361. **RL HUDSON (BLOCK FORM). R.L. HUDSON & COMPANY, DBA RL HUDSON, MULTIPLE CLASS, (INT. CLS. 7, 12, 17 AND 40), (U.S. CLS. 1, 5, 12, 13, 19, 21, 23, 31, 34, 35, 44, 50, 100, 103 AND 106).** SN 77-273,545. PUB. 3-17-2009. FILED 9-6-2007.
- 3,629,504. **BUNN-O-MATIC (BLOCK FORM). BUNN-O-MATIC CORPORATION, MULTIPLE CLASS, (INT. CLS. 7, 11 AND 21), (U.S. CLS. 2, 13, 19, 21, 23, 29, 30, 31, 33, 34, 35, 40 AND 50).** SN 77-375,011. PUB. 3-17-2009. FILED 1-18-2008.
- 3,629,524. **GARAGE PRO (BLOCK FORM). BISSELL HOME-CARE, INC., (U.S. CLS. 13, 19, 21, 23, 31, 34 AND 35).** SN 77-387,726. PUB. 3-17-2009. FILED 2-4-2008.
- 3,629,553. **MARTIN (STYLIZED). JOSEF MARTIN GMBH, (U.S. CLS. 13, 19, 21, 23, 31, 34 AND 35).** SN 77-401,305. PUB. 3-17-2009. FILED 2-20-2008.
- 3,629,559. **SOLAJET AND DESIGN. SOLAS SCIENCE & ENGINEERING CO., LTD., MULTIPLE CLASS, (INT. CLS. 7 AND 12), (U.S. CLS. 13, 19, 21, 23, 31, 34, 35 AND 44).** SN 77-403,471. PUB. 3-17-2009. FILED 2-22-2008.
- 3,629,564. **ERGOSTYLE (BLOCK FORM). ELESIA S.P.A., (U.S. CLS. 13, 19, 21, 23, 31, 34 AND 35).** SN 77-407,027. PUB. 3-17-2009. FILED 2-27-2008.
- 3,629,589. **FREDDY AND DESIGN. FREDDY PRODUCTS LIMITED, (U.S. CLS. 13, 19, 21, 23, 31, 34 AND 35).** SN 77-418,763. PUB. 3-17-2009. FILED 3-11-2008.
- 3,629,603. **CLEANDRIVE TECHNOLOGIES (BLOCK FORM). DAIMLER AG, MULTIPLE CLASS, (INT. CLS. 7, 9 AND 12), (U.S. CLS. 13, 19, 21, 23, 26, 31, 34, 35, 36, 38 AND 44).** SN 77-423,674. PUB. 3-17-2009. FILED 3-17-2008.
- 3,629,607. **WEMA VOGTLAND AND DESIGN. WEMA VOGTLAND GMBH, (U.S. CLS. 13, 19, 21, 23, 31, 34 AND 35).** SN 77-425,991. PUB. 1-13-2009. FILED 3-19-2008.
- 3,629,671 (See Class 1 for this trademark).
- 3,629,696. **NO-THREAD (BLOCK FORM). WULFTEC INTERNATIONAL INC., (U.S. CLS. 13, 19, 21, 23, 31, 34 AND 35).** SN 77-443,297. PUB. 3-17-2009. FILED 4-8-2008.
- 3,629,711. **AMERIMEX POWER SYSTEMS (BLOCK FORM). AMERIMEX POWER SYSTEMS, INC., MULTIPLE CLASS, (INT. CLS. 7, 9 AND 37), (U.S. CLS. 13, 19, 21, 23, 26, 31, 34, 35, 36, 38, 100, 103 AND 106).** SN 77-444,276. PUB. 3-17-2009. FILED 4-9-2008.
- 3,629,722. **TOOL FIND AND DESIGN. RIMROCK AUTOMATION INC., (U.S. CLS. 13, 19, 21, 23, 31, 34 AND 35).** SN 77-445,172. PUB. 3-17-2009. FILED 4-10-2008.
- 3,629,873. **LINX (STYLIZED). JOBS S.P.A., MULTIPLE CLASS, (INT. CLS. 7 AND 9), (U.S. CLS. 13, 19, 21, 23, 26, 31, 34, 35, 36 AND 38).** SN 77-460,610. PUB. 3-17-2009. FILED 4-29-2008.
- 3,629,885. **KMAX (STYLIZED). HENSLEY INDUSTRIES, INC., (U.S. CLS. 13, 19, 21, 23, 31, 34 AND 35).** SN 77-462,759. PUB. 3-17-2009. FILED 5-1-2008.
- 3,629,913. **SRC (BLOCK FORM). SPX COOLING TECHNOLOGIES, INC., (U.S. CLS. 13, 19, 21, 23, 31, 34 AND 35).** SN 77-469,506. PUB. 3-17-2009. FILED 5-8-2008.
- 3,629,959. **THE OZONE MAN, INC. (BLOCK FORM). THE OZONE MAN, INC., MULTIPLE CLASS, (INT. CLS. 7, 40 AND 42), (U.S. CLS. 13, 19, 21, 23, 31, 34, 35, 100, 101, 103 AND 106).** SN 77-480,528. PUB. 3-17-2009. FILED 5-21-2008.
- 3,629,970. **IBOTIC (BLOCK FORM). CEFLA S.C., (U.S. CLS. 13, 19, 21, 23, 31, 34 AND 35).** SN 77-485,076. PUB. 3-17-2009. FILED 5-28-2008.
- 3,629,994. **FIFTEEN ° DEGREES (STYLIZED). FIFTEEN DEGREES CORP., MULTIPLE CLASS, (INT. CLS. 7, 11 AND 28), (U.S. CLS. 13, 19, 21, 22, 23, 31, 34, 35, 38 AND 50).** SN 77-492,109. PUB. 3-17-2009. FILED 6-5-2008.
- 3,630,005. **FABRIS (BLOCK FORM). FABRIS INC., MULTIPLE CLASS, (INT. CLS. 7 AND 40), (U.S. CLS. 13, 19, 21, 23, 31, 34, 35, 100, 103 AND 106).** SN 77-495,051. PUB. 3-17-2009. FILED 6-10-2008.
- 3,630,034. **LORAIN (BLOCK FORM). MINNPAR LLC, (U.S. CLS. 13, 19, 21, 23, 31, 34 AND 35).** SN 77-499,506. PUB. 3-17-2009. FILED 6-16-2008.
- 3,630,063. **TERRA XTREME 3200 (STYLIZED). MURPHY PRODUCTS, INC., (U.S. CLS. 13, 19, 21, 23, 31, 34 AND 35).** SN 77-509,821. PUB. 3-17-2009. FILED 6-27-2008.
- 3,630,095. **BCO (BLOCK FORM). THE BRADBURY CO., INC., MULTIPLE CLASS, (INT. CLS. 7 AND 9), (U.S. CLS. 13, 19, 21, 23, 26, 31, 34, 35, 36 AND 38).** SN 77-519,225. PUB. 3-17-2009. FILED 7-10-2008.
- 3,630,174. **POWER PRODUCTS AND DESIGN. SEGMA POWER PRODUCTS CO., (U.S. CLS. 13, 19, 21, 23, 31, 34 AND 35).** SN 77-541,307. PUB. 2-10-2009. FILED 8-7-2008.
- 3,630,222. **SWF COMPANIES AND DESIGN. THIELE TECHNOLOGIES, INC., (U.S. CLS. 13, 19, 21, 23, 31, 34 AND 35).** SN 77-552,054. PUB. 3-17-2009. FILED 8-20-2008.
- 3,630,224 (See Class 5 for this trademark).
- 3,630,232. **CHERRY AND DESIGN. SPS TECHNOLOGIES, LLC, MULTIPLE CLASS, (INT. CLS. 7 AND 8), (U.S. CLS. 13, 19, 21, 23, 28, 31, 34, 35 AND 44).** SN 77-554,826. PUB. 3-17-2009. FILED 8-25-2008.
- 3,630,251. **Z3 (BLOCK FORM). ABRASIC 90, INC., DBA CGW CAMEL GRINDING WHEELS, USA, (U.S. CLS. 13, 19, 21, 23, 31, 34 AND 35).** SN 77-557,211. PUB. 3-17-2009. FILED 8-27-2008.
- 3,630,252. **Z-THRU (BLOCK FORM). ABRASIVE 90, INC., DBA CGW CAMEL GRINDING WHEELS, USA, (U.S. CLS. 13, 19, 21, 23, 31, 34 AND 35).** SN 77-557,228. PUB. 3-17-2009. FILED 8-27-2008.
- 3,630,255. **CHERRY (BLOCK FORM). SPS TECHNOLOGIES, LLC, MULTIPLE CLASS, (INT. CLS. 7 AND 8), (U.S. CLS. 13, 19, 21, 23, 28, 31, 34, 35 AND 44).** SN 77-557,882. PUB. 3-17-2009. FILED 8-28-2008.
- 3,630,302. **E AND DESIGN. SIGMATEK GMBH & CO KG, MULTIPLE CLASS, (INT. CLS. 7, 9 AND 42), (U.S. CLS. 13, 19, 21, 23, 26, 31, 34, 35, 36, 38, 100 AND 101).** SN 77-566,705. PUB. 3-17-2009. FILED 9-10-2008.
- 3,630,353. **BLOCKSAYER (BLOCK FORM). MINNOVATION LIMITED, (U.S. CLS. 13, 19, 21, 23, 31, 34 AND 35).** SN 77-573,040. PUB. 3-17-2009. FILED 9-18-2008.
- 3,630,373. **KSI AND DESIGN. KSI SWISS, (U.S. CLS. 13, 19, 21, 23, 31, 34 AND 35).** SN 77-575,891. PUB. 3-17-2009. FILED 9-22-2008.
- 3,630,482. **TECHINJECTOR (BLOCK FORM). TECHNIFAB PRODUCTS, INC., (U.S. CLS. 13, 19, 21, 23, 31, 34 AND 35).** SN 77-588,050. PUB. 3-17-2009. FILED 10-8-2008.
- 3,630,938. **TRU STAR AND DESIGN. TRUSTAR, INCORPORATED, (U.S. CLS. 13, 19, 21, 23, 31, 34 AND 35).** SN 77-601,368. PUB. 3-17-2009. FILED 10-27-2008.
- 3,631,155. **HAMMERHEAD (BLOCK FORM). PORTA-NAILS, INC., (U.S. CLS. 13, 19, 21, 23, 31, 34 AND 35).** SN 77-604,778. PUB. 3-17-2009. FILED 10-31-2008.
- 3,631,266. **XSTEAM (BLOCK FORM). SY KESSLER SALES, INC., (U.S. CLS. 13, 19, 21, 23, 31, 34 AND 35).** SN 77-607,551. PUB. 3-17-2009. FILED 11-5-2008.
- 3,631,278. **AVIATIONVAC (BLOCK FORM). PROTEAM, INC., (U.S. CLS. 13, 19, 21, 23, 31, 34 AND 35).** SN 77-608,960. PUB. 3-17-2009. FILED 11-6-2008.
- 3,631,298. **VARIFIT ORTHOTICS (BLOCK FORM). ITERATIONS, INC. DBA VARIFIT ORTHOTICS, MULTIPLE CLASS, (INT. CLS. 7 AND 25), (U.S. CLS. 13, 19, 21, 22, 23, 31, 34, 35 AND 39).** SN 77-612,947. PUB. 3-17-2009. FILED 11-12-2008.
- 3,631,371. **ETHERCAT (BLOCK FORM). BECKHOFF AUTOMATION GMBH, (U.S. CLS. 13, 19, 21, 23, 31, 34 AND 35).** SN 77-975,570. PUB. 3-17-2009. FILED 4-3-2008.
- 3,631,413. **NIKKISO AND DESIGN. NIKKISO CO., LTD., MULTIPLE CLASS, (INT. CLS. 7, 9, 10, 11, 12, 37 AND 42), (U.S. CLS. 13, 19, 21, 23, 26, 31, 34, 35, 36, 38, 39, 44, 100, 101, 103 AND 106).** SN 78-721,937. PUB. 3-17-2009. FILED 9-28-2005.
- 3,631,419. **QUANTUM (BLOCK FORM). SALINA VORTEX**

- CORPORATION, (U.S. CLS. 13, 19, 21, 23, 31, 34 AND 35). SN 78-803,681. PUB. 10-30-2007. FILED 1-31-2006.
- 3,631,431. **MISCELLANEOUS DESIGN**. PRECISION TWIST DRILL CO., MULTIPLE CLASS, (INT. CLS. 7 AND 8), (U.S. CLS. 13, 19, 21, 23, 28, 31, 34, 35 AND 44). SN 78-868,769. PUB. 3-17-2009. FILED 4-25-2006.
- 3,631,438. **GMV INNOVATING SOLUTIONS (STYLIZED)**. GRUPO TECNOLÓGICO E INDUSTRIAL GMV, S.A., MULTIPLE CLASS, (INT. CLS. 7, 9, 12, 16, 35, 37, 38, 41, 42, 44 AND 45), (U.S. CLS. 2, 5, 13, 19, 21, 22, 23, 26, 29, 31, 34, 35, 36, 37, 38, 44, 50, 100, 101, 102, 103, 104, 106 AND 107). SN 78-912,867. PUB. 1-13-2009. FILED 6-21-2006.
- 3,631,442. **POLYPOWER (BLOCK FORM)**. DANFOSS A/S, MULTIPLE CLASS, (INT. CLS. 7, 9 AND 17), (U.S. CLS. 1, 5, 12, 13, 19, 21, 23, 26, 31, 34, 35, 36, 38 AND 50). SN 78-932,055. PUB. 3-17-2009. FILED 7-18-2006.
- 3,631,444. **RAPID MIX AND DESIGN**. MOFFAT PTY LIMITED, (U.S. CLS. 13, 19, 21, 23, 31, 34 AND 35). SN 78-935,816. PUB. 3-17-2009. FILED 7-24-2006.
- 3,631,452 (*See Class 1 for this trademark*).
- 3,631,461. **COMET AND DESIGN**. COMET HOLDING AG, MULTIPLE CLASS, (INT. CLS. 7 AND 9), (U.S. CLS. 13, 19, 21, 23, 26, 31, 34, 35, 36 AND 38). SN 79-004,389. PUB. 3-17-2009. FILED 7-9-2004.
- 3,631,474. **GRUNDORAM (STYLIZED)**. TRACTO-TECHNIK GMBH & CO. KG, (U.S. CLS. 13, 19, 21, 23, 31, 34 AND 35). SN 79-037,263. PUB. 3-17-2009. FILED 1-26-2007.
- 3,631,487. **INOVELIS (STYLIZED)**. CONVERTEAM GROUP, MULTIPLE CLASS, (INT. CLS. 7 AND 9), (U.S. CLS. 13, 19, 21, 23, 26, 31, 34, 35, 36 AND 38). SN 79-042,271. PUB. 3-17-2009. FILED 3-20-2007.
- 3,631,492. **NANOSOFT (BLOCK FORM)**. SURREY NANOSYSTEMS LIMITED, MULTIPLE CLASS, (INT. CLS. 7 AND 9), (U.S. CLS. 13, 19, 21, 23, 26, 31, 34, 35, 36 AND 38). SN 79-044,454. PUB. 3-17-2009. FILED 8-30-2007.
- 3,631,493. **NANOGROWTH (BLOCK FORM)**. SURREY NANOSYSTEMS LIMITED, MULTIPLE CLASS, (INT. CLS. 7 AND 9), (U.S. CLS. 13, 19, 21, 23, 26, 31, 34, 35, 36 AND 38). SN 79-044,455. PUB. 3-17-2009. FILED 8-30-2007.
- 3,631,494 (*See Class 6 for this trademark*).
- 3,631,500. **VARIO-COMB AND DESIGN**. STAEDTLER & UHL KG, (U.S. CLS. 13, 19, 21, 23, 31, 34 AND 35). SN 79-045,910. PUB. 3-17-2009. FILED 10-16-2007.
- 3,631,507. **DRIMOTEC AND DESIGN**. BOCK, KLAUS, MULTIPLE CLASS, (INT. CLS. 7, 9 AND 20), (U.S. CLS. 2, 13, 19, 21, 22, 23, 25, 26, 31, 32, 34, 35, 36, 38 AND 50). SN 79-047,194. PUB. 3-17-2009. FILED 6-22-2007.
- 3,631,510 (*See Class 1 for this trademark*).
- 3,631,517 (*See Class 6 for this trademark*).
- 3,631,524. **S SENA AND DESIGN**. CONG TY TRACH NHIEM HUU HAN; SENA VIET NAM, MULTIPLE CLASS, (INT. CLS. 7 AND 11), (U.S. CLS. 13, 19, 21, 23, 31, 34 AND 35). SN 79-048,798. PUB. 3-17-2009. FILED 7-12-2007.
- 3,631,539. **KRIWAN AND DESIGN**. KRIWAN INDUSTRIE-ELEKTRONIK GMBH, MULTIPLE CLASS, (INT. CLS. 7, 9 AND 42), (U.S. CLS. 13, 19, 21, 23, 26, 31, 34, 35, 36, 38, 100 AND 101). SN 79-050,793. PUB. 3-17-2009. FILED 1-23-2008.
- 3,631,547 (*See Class 6 for this trademark*).
- 3,631,554 (*See Class 1 for this trademark*).
- 3,631,556. **ETC (BLOCK FORM)**. ENRICHMENT TECHNOLOGY COMPANY LIMITED, MULTIPLE CLASS, (INT. CLS. 7, 37 AND 42), (U.S. CLS. 13, 19, 21, 23, 31, 34, 35, 100, 101, 103 AND 106). SN 79-052,076. PUB. 3-17-2009. FILED 3-13-2008.
- 3,631,561 (*See Class 6 for this trademark*).
- 3,631,572. **PICK-O-LIGHT (BLOCK FORM)**. HÄNEL GMBH & CO. KG, (U.S. CLS. 13, 19, 21, 23, 31, 34 AND 35). SN 79-053,036. PUB. 3-17-2009. FILED 4-15-2008.
- 3,631,587. **N—CHARGE (BLOCK FORM)**. NANOGATE AG, MULTIPLE CLASS, (INT. CLS. 7, 9 AND 11), (U.S. CLS. 13, 19, 21, 23, 26, 31, 34, 35, 36 AND 38). SN 79-053,608. PUB. 3-17-2009. FILED 5-9-2008.
- 3,631,592. **ECO ADVANCED AND DESIGN**. PALLMANN MASCHINENFABRIK; GMBH & CO. KG, (U.S. CLS. 13, 19, 21, 23, 31, 34 AND 35). SN 79-053,672. PUB. 3-17-2009. FILED 9-21-2007.
- 3,631,601. **VACUUMATOR (BLOCK FORM)**. JETS AS, MULTIPLE CLASS, (INT. CLS. 7 AND 11), (U.S. CLS. 13, 19, 21, 23, 31, 34 AND 35). SN 79-054,040. PUB. 3-17-2009. FILED 3-12-2008.
- 3,631,608. **FY AND DESIGN**. HANGZHOU FANGYUAN PLASTICS; MACHINERY CO., LTD, (U.S. CLS. 13, 19, 21, 23, 31, 34 AND 35). SN 79-054,146. PUB. 3-17-2009. FILED 4-9-2008.
- 3,631,623. **CRIMPY AND DESIGN**. PUNZ TEC SRL, (U.S. CLS. 13, 19, 21, 23, 31, 34 AND 35). SN 79-054,356. PUB. 3-17-2009. FILED 4-30-2008.
- 3,631,626. **YELLOW XL (STYLIZED)**. KJELLBERG STIFTUNG, RECHTSFÄHIGE STIFTUNG DES; BÜRGERLICHEN RECHTS, MULTIPLE CLASS, (INT. CLS. 7, 8 AND 9), (U.S. CLS. 13, 19, 21, 23, 26, 28, 31, 34, 35, 36, 38 AND 44). SN 79-054,384. PUB. 3-17-2009. FILED 1-4-2008.
- 3,631,629. **SAPELEM (STYLIZED)**. SAPELEM; (SOCIÉTÉ PAR ACTIONS SIMPLIFIÉE), (U.S. CLS. 13, 19, 21, 23, 31, 34 AND 35). SN 79-054,463. PUB. 3-17-2009. FILED 2-1-2008.
- 3,631,632. **YELLOWXLIFE (STYLIZED)**. KJELLBERG STIFTUNG, RECHTSFÄHIGE STIFTUNG DES; BÜRGERLICHEN RECHTS, MULTIPLE CLASS, (INT. CLS. 7, 8 AND 9), (U.S. CLS. 13, 19, 21, 23, 26, 28, 31, 34, 35, 36, 38 AND 44). SN 79-054,479. PUB. 3-17-2009. FILED 1-4-2008.
- 3,631,633. **BIOFRESHPLUS (BLOCK FORM)**. LIEBHERR-INTERNATIONAL AG, MULTIPLE CLASS, (INT. CLS. 7, 11 AND 21), (U.S. CLS. 2, 13, 19, 21, 23, 29, 30, 31, 33, 34, 35, 40 AND 50). SN 79-054,512. PUB. 3-17-2009. FILED 5-14-2008.
- 3,631,639. **M MAGGIORA AND DESIGN**. FILIPPO GEMELLI, MULTIPLE CLASS, (INT. CLS. 7, 12, 25 AND 28), (U.S. CLS. 13, 19, 21, 22, 23, 31, 34, 35, 38, 39, 44 AND 50). SN 79-054,751. PUB. 3-17-2009. FILED 5-6-2008.
- 3,631,667. **HFSAB (BLOCK FORM)**. H. FOLKE SANDELIN AB, MULTIPLE CLASS, (INT. CLS. 7, 37 AND 42), (U.S. CLS. 13, 19, 21, 23, 31, 34, 35, 100, 101, 103 AND 106). SN 79-055,673. PUB. 3-17-2009. FILED 4-9-2008.
- 3,631,677. **POWER LINK (STYLIZED)**. PALFINGER AG, (U.S. CLS. 13, 19, 21, 23, 31, 34 AND 35). SN 79-055,963. PUB. 3-17-2009. FILED 6-9-2008.
- 3,631,682. **NANOMAT (BLOCK FORM)**. DEPRAG SCHULZ GMBH U. CO, (U.S. CLS. 13, 19, 21, 23, 31, 34 AND 35). SN 79-056,446. PUB. 3-17-2009. FILED 6-16-2008.
- 3,631,683. **KARL MAYER - GRIFFIN (BLOCK FORM)**. KARL MAYER TEXTILMASCHINENFABRIK GMBH, (U.S. CLS. 13, 19, 21, 23, 31, 34 AND 35). SN 79-056,498. PUB. 3-17-2009. FILED 6-4-2008.
- 3,631,684. **KARL MAYER - SUCKER (BLOCK FORM)**. KARL MAYER TEXTILMASCHINENFABRIK GMBH, (U.S. CLS. 13, 19, 21, 23, 31, 34 AND 35). SN 79-056,499. PUB. 3-17-2009. FILED 6-4-2008.
- 3,631,690. **HENGYOU AND DESIGN**. ZHEJIANG HENGYOU; MACHINE & ELECTRON CO., LTD, (U.S. CLS. 13, 19, 21, 23, 31, 34 AND 35). SN 79-056,823. PUB. 3-17-2009. FILED 7-9-2008.
- 3,631,707. **GIBIDI (BLOCK FORM)**. GI.B.I.DI. S.R.L., MULTIPLE CLASS, (INT. CLS. 7, 9 AND 37), (U.S. CLS. 13, 19, 21, 23, 26, 31, 34, 35, 36, 38, 100, 103 AND 106). SN 79-057,307. PUB. 3-17-2009. FILED 5-9-2008.
- 3,631,720. **PWB TECHNOLOGIES (STYLIZED)**. PWB-RUHLATEC INDUSTRIEPRODUKTE GMBH, MULTIPLE CLASS, (INT. CLS. 7, 9, 16, 35 AND 42), (U.S. CLS. 2, 5, 13, 19, 21, 22, 23, 26, 29, 31, 34, 35, 36, 37, 38, 50, 100, 101 AND 102). SN 79-057,906. PUB. 3-17-2009. FILED 12-21-2007.
- 3,631,731. **YENMAK AND DESIGN**. YENMAK MOTOR GÖMLEKLERİ; SANAYİ VE TİCARET; ANONİM ŞİRKETİ, MULTIPLE CLASS, (INT. CLS. 7 AND 12), (U.S. CLS. 13, 19, 21, 23, 31, 34, 35 AND 44). SN 79-058,428. PUB. 3-17-2009. FILED 3-21-2008.
- 3,631,733. **MISCELLANEOUS DESIGN**. GUILIN STARS POWER; ELECTRONICS CO. LTD., MULTIPLE CLASS, (INT. CLS. 7 AND 9), (U.S. CLS. 13, 19, 21, 23, 26, 31, 34, 35, 36 AND 38). SN 79-058,516. PUB. 3-17-2009. FILED 3-20-2008.
- 3,631,737. **HOTANI (STYLIZED)**. HOTANI CO., LTD., (U.S. CLS. 13, 19, 21, 23, 31, 34 AND 35). SN 79-058,759. PUB. 3-17-2009. FILED 5-13-2008.
- 3,631,740. **PRISM (BLOCK FORM)**. SNAP-ON EQUIPMENT GMBH, MULTIPLE CLASS, (INT. CLS. 7, 9 AND 37), (U.S. CLS. 13, 19, 21, 23, 26, 31, 34, 35, 36, 38, 100, 103 AND 106). SN 79-059,038. PUB. 3-17-2009. FILED 3-28-2008.
- 3,631,758. **SARITOR (BLOCK FORM)**. HARDI INTERNA-

TIONAL A/S, (U.S. CLS. 13, 19, 21, 23, 31, 34 AND 35). SN 79-060,062. PUB. 3-17-2009. FILED 8-19-2008.

3,631,759. **MISCELLANEOUS DESIGN. M&J INDUSTRIES A/S, MULTIPLE CLASS.** (INT. CLS. 7, 37 AND 40), (U.S. CLS. 13, 19, 21, 23, 31, 34, 35, 100, 103 AND 106). SN 79-060,165. PUB. 3-17-2009. FILED 8-18-2008.

3,631,760. **R (STYLIZED).** RIGO S.R.L., MULTIPLE CLASS, (INT. CLS. 7 AND 8), (U.S. CLS. 13, 19, 21, 23, 28, 31, 34, 35 AND 44). SN 79-060,202. PUB. 3-17-2009. FILED 7-22-2008.

3,631,774. **ROTOBRAILLE (BLOCK FORM).** CHESAPEAKE PLC, (U.S. CLS. 13, 19, 21, 23, 31, 34 AND 35). SN 79-062,477. PUB. 3-17-2009. FILED 10-21-2008.

CLASS 8—HAND TOOLS

3,629,356. **ACCU-TITE WEDGE AND DESIGN.** INDUSTRIAS AUXILIARES FAUS S.L., (U.S. CLS. 23, 28 AND 44). SN 77-269,143. PUB. 3-17-2009. FILED 8-31-2007.

3,629,535. **GRIP WRAP (BLOCK FORM).** BATTIATO, VICTOR J., MULTIPLE CLASS, (INT. CLS. 8, 10 AND 28), (U.S. CLS. 22, 23, 26, 28, 38, 39, 44 AND 50). SN 77-395,652. PUB. 3-17-2009. FILED 2-13-2008.

3,629,611 (*See Class 3 for this trademark*).

3,629,798. **EST. B 1902 BUCK KNIVES AND DESIGN.** BUCK KNIVES, INC., (U.S. CLS. 23, 28 AND 44). SN 77-451,722. PUB. 9-30-2008. FILED 4-18-2008.

3,629,839. **STRONG HAND TOOLS BETTER TOOLS. BETTER PRICE. AND DESIGN.** VALTRA, INC., (U.S. CLS. 23, 28 AND 44). SN 77-455,713. PUB. 3-17-2009. FILED 4-23-2008.

3,629,841. **TREASURE COVE (BLOCK FORM).** WELLS, WILLIAM, MULTIPLE CLASS, (INT. CLS. 8 AND 9), (U.S. CLS. 21, 23, 26, 28, 36, 38 AND 44). SN 77-455,940. PUB. 3-17-2009. FILED 4-23-2008.

3,629,961. **FIRMGRIP (BLOCK FORM).** MALHOTRA SHAVING PRODUCTS PRIVATE LIMITED, (U.S. CLS. 23, 28 AND 44). SN 77-481,500. PUB. 3-17-2009. FILED 5-22-2008.

3,630,146. **POWER NOTCH (BLOCK FORM).** DYNO, LLC, (U.S. CLS. 23, 28 AND 44). SN 77-531,861. PUB. 3-17-2009. FILED 7-25-2008.

3,630,232 (*See Class 7 for this trademark*).

3,630,255 (*See Class 7 for this trademark*).

3,630,380. **CRIMPALL (BLOCK FORM).** GREENLEE TEXTRON INC., (U.S. CLS. 23, 28 AND 44). SN 77-576,437. PUB. 3-17-2009. FILED 9-23-2008.

3,630,665. **TRICRIMP (BLOCK FORM).** POWERWERX, INC., (U.S. CLS. 23, 28 AND 44). SN 77-597,454. PUB. 3-17-2009. FILED 10-21-2008.

3,630,693. **BONANZA (BLOCK FORM).** THORO'BRED RACING PLATE CO., INC., (U.S. CLS. 23, 28 AND 44). SN 77-598,132. PUB. 3-17-2009. FILED 10-22-2008.

3,630,729. **MICRO-PRO (BLOCK FORM).** CRESTWOOD PARTNERS, LLC, (U.S. CLS. 23, 28 AND 44). SN 77-598,677. PUB. 3-17-2009. FILED 10-23-2008.

3,630,828. **GLASSWEDGE (BLOCK FORM).** JOHN D. SHEPHERD LLC, (U.S. CLS. 23, 28 AND 44). SN 77-599,982. PUB. 3-17-2009. FILED 10-24-2008.

3,630,950. **AUGERSHARP (BLOCK FORM).** FORTUNE PRODUCTS, INC., (U.S. CLS. 23, 28 AND 44). SN 77-601,579. PUB. 3-17-2009. FILED 10-27-2008.

3,631,070. **CS AND DESIGN.** SOUTHERN NEVADA WATER AUTHORITY, MULTIPLE CLASS, (INT. CLS. 8, 14, 16, 26 AND 28), (U.S. CLS. 2, 5, 22, 23, 27, 28, 29, 37, 38, 39, 40, 42, 44 AND 50). SN 77-603,403. PUB. 3-17-2009. FILED 10-29-2008.

3,631,360. **GET OUT OF THE STONE AGE AND DESIGN.** FORTUNE PRODUCTS, INC., (U.S. CLS. 23, 28 AND 44). SN 77-638,864. PUB. 3-17-2009. FILED 12-23-2008.

3,631,431 (*See Class 7 for this trademark*).

3,631,505. **TIOLOGIC (BLOCK FORM).** DENTAURUM J.P. WINKELSTROETER KG, MULTIPLE CLASS, (INT. CLS. 8 AND 10), (U.S. CLS. 23, 26, 28, 39 AND 44). SN 79-046,780. PUB. 3-17-2009. FILED 10-11-2007.

3,631,511 (*See Class 1 for this trademark*).

3,631,521 (*See Class 6 for this trademark*).

3,631,595. **MU AND DESIGN.** KAWASHIMA INDUSTRY CO. LTD., (U.S. CLS. 23, 28 AND 44). SN 79-053,919. PUB. 3-17-2009. FILED 4-30-2008.

3,631,626 (*See Class 7 for this trademark*).

3,631,632 (*See Class 7 for this trademark*).

3,631,760 (*See Class 7 for this trademark*).

CLASS 9—ELECTRICAL AND SCIENTIFIC APPARATUS

3,629,119. **ELAN.** ADVANCED MICRO DEVICES, INC., (U.S. CLS. 21, 23, 26, 36 AND 38). SN 75-542,527. PUB. 3-17-2009. FILED 8-24-1998.

3,629,121. **T INFO AND DESIGN.** DEUTSCHE TELEKOM AG, MULTIPLE CLASS, (INT. CLS. 9, 16, 35, 36, 38, 41 AND 42), (U.S. CLS. 2, 5, 21, 22, 23, 26, 29, 36, 37, 38, 50, 100, 101, 102, 104 AND 107). SN 76-177,036. PUB. 10-28-2003. FILED 12-7-2000.

3,629,122. **T AND DESIGN.** DEUTSCHE TELEKOM AG, MULTIPLE CLASS, (INT. CLS. 9, 16, 35, 36, 38, 39, 41 AND 42), (U.S. CLS. 2, 5, 21, 22, 23, 26, 29, 36, 37, 38, 50, 100, 101, 102, 104, 105 AND 107). SN 76-222,033. PUB. 12-9-2003. FILED 3-8-2001.

3,629,127. **DUALEL (BLOCK FORM).** SEMICONDUCTOR ENERGY LABORATORY CO., LTD., (U.S. CLS. 21, 23, 26, 36 AND 38). SN 76-589,123. PUB. 3-17-2009. FILED 4-28-2004.

3,629,136. **GUILDLINE INSTRUMENTS AND DESIGN.** GUILDLINE INSTRUMENTS LTD., MULTIPLE CLASS, (INT. CLS. 9 AND 42), (U.S. CLS. 21, 23, 26, 36, 38, 100 AND 101). SN 76-670,929. PUB. 3-17-2009. FILED 12-29-2006.

3,629,176. **SHINY TOY GUNS (BLOCK FORM).** PETREE, CHAD, AND DAWSON, JEREMY, MULTIPLE CLASS, (INT. CLS. 9 AND 41), (U.S. CLS. 21, 23, 26, 36, 38, 100, 101 AND 107). SN 76-689,643. PUB. 3-17-2009. FILED 5-14-2008.

3,629,207. **COMPLETE CONTROL (BLOCK FORM).** UNIVERSAL REMOTE CONTROL, INC., (U.S. CLS. 21, 23, 26, 36 AND 38). SN 76-693,729. PUB. 3-17-2009. FILED 10-21-2008.

3,629,208. **MISCELLANEOUS DESIGN.** UNIVERSAL REMOTE CONTROL, INC., (U.S. CLS. 21, 23, 26, 36 AND 38). SN 76-693,730. PUB. 3-17-2009. FILED 10-21-2008.

3,629,233 (*See Class 1 for this trademark*).

3,629,241. **MEINL (BLOCK FORM).** ROLAND MEINL MUSIKINSTRUMENTE GMBH & CO. KG, MULTIPLE CLASS, (INT. CLS. 9 AND 15), (U.S. CLS. 2, 21, 23, 26, 36 AND 38). SN 77-057,274. PUB. 12-9-2008. FILED 12-5-2006.

3,629,247. **MISCELLANEOUS DESIGN.** AVG TECHNOLOGIES CZ, S.R.O., MULTIPLE CLASS, (INT. CLS. 9, 16 AND 42), (U.S. CLS. 2, 5, 21, 22, 23, 26, 29, 36, 37, 38, 50, 100 AND 101). SN 77-066,331. PUB. 3-17-2009. FILED 12-18-2006.

3,629,251. **RCIE (BLOCK FORM).** METTLER-TOLEDO AG, (U.S. CLS. 21, 23, 26, 36 AND 38). SN 77-079,603. PUB. 3-17-2009. FILED 1-10-2007.

3,629,255 (*See Class 7 for this trademark*).

3,629,256. **HEALTHPHONE AND DESIGN.** HEALTHPHONE HOLDINGS LIMITED, MULTIPLE CLASS, (INT. CLS. 9, 35 AND 44), (U.S. CLS. 21, 23, 26, 36, 38, 100, 101 AND 102). SN 77-087,592. PUB. 1-20-2009. FILED 1-22-2007.

3,629,261. **BRAIN STATE TECHNOLOGIES AND DESIGN.** BRAIN STATE TECHNOLOGIES, L.L.C., MULTIPLE CLASS, (INT. CLS. 9 AND 41), (U.S. CLS. 21, 23, 26, 36, 38, 100, 101 AND 107). SN 77-094,564. PUB. 3-17-2009. FILED S.R. 1-30-2007; AM. P.R. 2-2-2007.

3,629,267. **PULSE (BLOCK FORM).** OTIS ELEVATOR COMPANY, (U.S. CLS. 21, 23, 26, 36 AND 38). SN 77-112,550. PUB. 3-17-2009. FILED 2-21-2007.

3,629,273. **V-EMAIL (BLOCK FORM).** AUERSOFT LLC, (U.S. CLS. 21, 23, 26, 36 AND 38). SN 77-135,631. PUB. 9-16-2008. FILED 3-20-2007.

3,629,275 (*See Class 7 for this trademark*).

3,629,285. **AIRCAT (BLOCK FORM).** RADALINK, INC., (U.S. CLS. 21, 23, 26, 36 AND 38). SN 77-151,538. PUB. 3-17-2009. FILED 4-9-2007.

3,629,291. **EAGLE AND DESIGN.** EAGLE INDUSTRIES UNLIMITED, INC., MULTIPLE CLASS, (INT. CLS. 9, 10, 13, 18, 20, 21, 25, 35 AND 40), (U.S. CLS. 1, 2, 3, 9, 13, 21, 22, 23, 25, 26, 29, 30, 32, 33, 36, 38, 39, 40, 41, 44, 50, 100, 101, 102, 103 AND 106). SN 77-160,825. PUB. 10-14-2008. FILED 4-19-2007.

3,629,293. **TCSS (BLOCK FORM).** SUZUKI MOTOR COR-

- PORATION, (U.S. CLS. 21, 23, 26, 36 AND 38). SN 77-173,666. PUB. 8-5-2008. FILED 5-4-2007.
- 3,629,307. **SIMPLY INNOVATIVE (BLOCK FORM)**. A.C. DISPENSING EQUIPMENT INC., MULTIPLE CLASS, (INT. CLS. 9, 11 AND 21), (U.S. CLS. 2, 13, 21, 23, 26, 29, 30, 31, 33, 34, 36, 38, 40 AND 50). SN 77-196,717. PUB. 9-16-2008. FILED 6-4-2007.
- 3,629,319. **LODAR (BLOCK FORM)**. SKIDMORE FOUR WHEEL DRIVE LIMITED, (U.S. CLS. 21, 23, 26, 36 AND 38). SN 77-211,201. PUB. 3-17-2009. FILED 6-20-2007.
- 3,629,321 (*See Class 6 for this trademark*).
- 3,629,323. **LOWBORN (BLOCK FORM)**. LOWBORN, LLC, MULTIPLE CLASS, (INT. CLS. 9, 25 AND 41), (U.S. CLS. 21, 22, 23, 26, 36, 38, 39, 100, 101 AND 107). SN 77-229,107. PUB. 3-17-2009. FILED 7-13-2007.
- 3,629,324. **TERMINALBOSS (BLOCK FORM)**. KILOWATTS DESIGN COMPANY INC., (U.S. CLS. 21, 23, 26, 36 AND 38). SN 77-231,319. PUB. 3-17-2009. FILED 7-17-2007.
- 3,629,331. **LYNX TECHNIK AG AND DESIGN**. LYNX TECHNIK INC, (U.S. CLS. 21, 23, 26, 36 AND 38). SN 77-241,252. PUB. 3-17-2009. FILED 7-27-2007.
- 3,629,338 (*See Class 4 for this trademark*).
- 3,629,339 (*See Class 4 for this trademark*).
- 3,629,346. **EDGEFRONTIER MANAGER (BLOCK FORM)**. AUGUSTA SYSTEMS, INC., (U.S. CLS. 21, 23, 26, 36 AND 38). SN 77-254,934. PUB. 3-17-2009. FILED 8-14-2007.
- 3,629,355. **PLATEAU MUSIC AND DESIGN**. PLATEAU MUSIC LLC, (U.S. CLS. 21, 23, 26, 36 AND 38). SN 77-268,873. PUB. 3-17-2009. FILED 8-30-2007.
- 3,629,365. **NET-X (STYLIZED)**. TECHNETIX GROUP LIMITED, (U.S. CLS. 21, 23, 26, 36 AND 38). SN 77-280,401. PUB. 10-7-2008. FILED 9-14-2007.
- 3,629,374. **US-YELLOW (BLOCK FORM)**. GLOBAL DIRECTORIES, INC., MULTIPLE CLASS, (INT. CLS. 9, 16 AND 35), (U.S. CLS. 2, 5, 21, 22, 23, 26, 29, 36, 37, 38, 50, 100, 101 AND 102). SN 77-287,364. PUB. 3-17-2009. FILED 9-24-2007.
- 3,629,376. **US-YELLOW.COM (BLOCK FORM)**. GLOBAL DIRECTORIES, INC., MULTIPLE CLASS, (INT. CLS. 9 AND 16), (U.S. CLS. 2, 5, 21, 22, 23, 26, 29, 36, 37, 38 AND 50). SN 77-288,440. PUB. 3-17-2009. FILED 9-25-2007.
- 3,629,382. **COMPOSER AND DESIGN**. JAMF SOFTWARE, LLC, (U.S. CLS. 21, 23, 26, 36 AND 38). SN 77-294,114. PUB. 3-17-2009. FILED 10-2-2007.
- 3,629,388. **ALTAVIEW (BLOCK FORM)**. ALTAVIEW TECHNOLOGY, INC., MULTIPLE CLASS, (INT. CLS. 9 AND 41), (U.S. CLS. 21, 23, 26, 36, 38, 100, 101 AND 107). SN 77-298,825. PUB. 3-17-2009. FILED 10-8-2007.
- 3,629,390. **PROGNEST (BLOCK FORM)**. FORMING TECHNOLOGIES INCORPORATED, (U.S. CLS. 21, 23, 26, 36 AND 38). SN 77-299,489. PUB. 3-17-2009. FILED 10-9-2007.
- 3,629,392. **BINMASTER (BLOCK FORM)**. GARNER INDUSTRIES, INC., (U.S. CLS. 21, 23, 26, 36 AND 38). SN 77-300,810. PUB. 3-17-2009. FILED 10-10-2007.
- 3,629,393. **COMPOSER (BLOCK FORM)**. JAMF SOFTWARE, LLC, (U.S. CLS. 21, 23, 26, 36 AND 38). SN 77-301,369. PUB. 3-17-2009. FILED 10-11-2007.
- 3,629,395. **MASTER SIFO (BLOCK FORM)**. SUMITOMO ELECTRIC INDUSTRIES, LTD., (U.S. CLS. 21, 23, 26, 36 AND 38). SN 77-304,218. PUB. 3-17-2009. FILED 10-15-2007.
- 3,629,413. **SPONGELAB INTERACTIVE (BLOCK FORM)**. INVIVO COMMUNICATIONS INC., MULTIPLE CLASS, (INT. CLS. 9, 16, 28, 35, 41 AND 42), (U.S. CLS. 2, 5, 21, 22, 23, 26, 29, 36, 37, 38, 50, 100, 101, 102 AND 107). SN 77-317,015. PUB. 3-17-2009. FILED 10-30-2007.
- 3,629,414. **ALLURE (STYLIZED)**. WING CHEUNG JIAN, (U.S. CLS. 21, 23, 26, 36 AND 38). SN 77-317,881. PUB. 3-17-2009. FILED 10-31-2007.
- 3,629,420. **FINEREADER (BLOCK FORM)**. ABBYY SOFTWARE LTD., DBA BIT SOFTWARE, INC., (U.S. CLS. 21, 23, 26, 36 AND 38). SN 77-320,330. PUB. 3-17-2009. FILED 11-2-2007.
- 3,629,424 (*See Class 3 for this trademark*).
- 3,629,425. **CANARY AIR QUALITY ASSURANCE (BLOCK FORM)**. AIRTECH INNOVATIONS INC., MULTIPLE CLASS, (INT. CLS. 9 AND 42), (U.S. CLS. 21, 23, 26, 36, 38, 100 AND 101). SN 77-323,316. PUB. 3-17-2009. FILED 11-7-2007.
- 3,629,426. **CANARY AIR QUALITY ASSURANCE AND DESIGN**. AIRTECH INNOVATIONS INC., MULTIPLE CLASS, (INT. CLS. 9 AND 42), (U.S. CLS. 21, 23, 26, 36, 38, 100 AND 101). SN 77-323,333. PUB. 3-17-2009. FILED 11-7-2007.
- 3,629,429. **WAVESAT (BLOCK FORM)**. WAVESAT INC., MULTIPLE CLASS, (INT. CLS. 9 AND 42), (U.S. CLS. 21, 23, 26, 36, 38, 100 AND 101). SN 77-327,826. PUB. 3-17-2009. FILED 11-13-2007.
- 3,629,442. **INSILCO (BLOCK FORM)**. INELCO GMBH, (U.S. CLS. 21, 23, 26, 36 AND 38). SN 77-336,796. PUB. 3-17-2009. FILED 11-26-2007.
- 3,629,445. **SWISS TRAVEL PRODUCTS AND DESIGN**. WORLD CONNECT AG, MULTIPLE CLASS, (INT. CLS. 9 AND 18), (U.S. CLS. 1, 2, 3, 21, 22, 23, 26, 36, 38 AND 41). SN 77-338,636. PUB. 3-17-2009. FILED 11-28-2007.
- 3,629,448. **NES POWERED BY ECHELON (BLOCK FORM)**. ECHELON CORPORATION, (U.S. CLS. 21, 23, 26, 36 AND 38). SN 77-341,537. PUB. 3-17-2009. FILED 11-30-2007.
- 3,629,450. **TREASURES OF THE PYRAMIDS (BLOCK FORM)**. ATRONIC INTERNATIONAL GMBH, MULTIPLE CLASS, (INT. CLS. 9 AND 41), (U.S. CLS. 21, 23, 26, 36, 38, 100, 101 AND 107). SN 77-345,078. PUB. 3-17-2009. FILED 12-5-2007.
- 3,629,453. **PIXELPOD (BLOCK FORM)**. SHOWCRAFT, INC., (U.S. CLS. 21, 23, 26, 36 AND 38). SN 77-346,040. PUB. 5-6-2008. FILED 12-6-2007.
- 3,629,468. **YUAN DYNASTY (BLOCK FORM)**. ATRONIC INTERNATIONAL GMBH, MULTIPLE CLASS, (INT. CLS. 9 AND 41), (U.S. CLS. 21, 23, 26, 36, 38, 100, 101 AND 107). SN 77-355,972. PUB. 3-17-2009. FILED 12-19-2007.
- 3,629,492. **MISCELLANEOUS DESIGN**. EAGLE INDUSTRIES UNLIMITED, INC., MULTIPLE CLASS, (INT. CLS. 9, 10, 13, 18, 20, 21, 25, 35 AND 40), (U.S. CLS. 1, 2, 3, 9, 13, 21, 22, 23, 25, 26, 29, 30, 32, 33, 36, 38, 39, 40, 41, 44, 50, 100, 101, 102, 103 AND 106). SN 77-370,003. PUB. 10-14-2008. FILED 1-11-2008.
- 3,629,496. **SPIN OFF SOFT AND DESIGN**. GUIMARAES, RICARDO P., (U.S. CLS. 21, 23, 26, 36 AND 38). SN 77-373,334. PUB. 3-17-2009. FILED 1-16-2008.
- 3,629,499. **SOFTSHUTTER (BLOCK FORM)**. KABUSHIKI KAISHA MORPHO (MORPHO, INC.), (U.S. CLS. 21, 23, 26, 36 AND 38). SN 77-374,119. PUB. 1-13-2009. FILED 1-17-2008.
- 3,629,503. **OCELOT (BLOCK FORM)**. OCELOT ENGINEERING, INC., (U.S. CLS. 21, 23, 26, 36 AND 38). SN 77-374,671. PUB. 3-17-2009. FILED 1-17-2008.
- 3,629,507. **FINDWHERE MOBILE (BLOCK FORM)**. TEYDO HOLDING INC., MULTIPLE CLASS, (INT. CLS. 9 AND 38), (U.S. CLS. 21, 23, 26, 36, 38, 100, 101 AND 104). SN 77-378,897. PUB. 12-9-2008. FILED 1-23-2008.
- 3,629,519. **EL MENSAJERO DEL AMOR (BLOCK FORM)**. OSCAR MEDINA, MULTIPLE CLASS, (INT. CLS. 9 AND 41), (U.S. CLS. 21, 23, 26, 36, 38, 100, 101 AND 107). SN 77-383,811. PUB. 3-17-2009. FILED 1-30-2008.
- 3,629,523. **DTX (STYLIZED)**. DTX INC, (U.S. CLS. 21, 23, 26, 36 AND 38). SN 77-385,590. PUB. 2-10-2009. FILED 1-31-2008.
- 3,629,565. **FINANCIAL SOFTWARE SYSTEMS BRILLIANT PERFORMANCE IN FINANCIAL TECHNOLOGY AND DESIGN**. FINANCIAL SOFTWARE SYSTEMS, INC., (U.S. CLS. 21, 23, 26, 36 AND 38). SN 77-407,277. PUB. 3-17-2009. FILED 2-27-2008.
- 3,629,567. **CONTENTS LIBRARY (BLOCK FORM)**. SAMSUNG ELECTRONICS CO., LTD., (U.S. CLS. 21, 23, 26, 36 AND 38). SN 77-408,243. PUB. 3-17-2009. FILED 2-28-2008.
- 3,629,571. **RAMP-HI (BLOCK FORM)**. ASSOCIATED RESEARCH, INC., (U.S. CLS. 21, 23, 26, 36 AND 38). SN 77-410,014. PUB. 3-17-2009. FILED 2-29-2008.
- 3,629,572. **CHARGE-LO (BLOCK FORM)**. ASSOCIATED RESEARCH, INC., (U.S. CLS. 21, 23, 26, 36 AND 38). SN 77-410,028. PUB. 3-17-2009. FILED 2-29-2008.
- 3,629,598. **ARMORY (STYLIZED)**. FISHER, CHAD M, DBA ARMORY, AND KURLAND, JOSEPH, DBA ARMORY, (U.S. CLS. 21, 23, 26, 36 AND 38). SN 77-421,956. PUB. 3-17-2009. FILED 3-14-2008.
- 3,629,603 (*See Class 7 for this trademark*).
- 3,629,605. **DISH AND DESIGN**. DISH NETWORK L.L.C., (U.S. CLS. 21, 23, 26, 36 AND 38). SN 77-425,130. PUB. 3-17-2009. FILED 3-18-2008.
- 3,629,612. **QUEST (BLOCK FORM)**. QUANTUM3D, (U.S. CLS.

- 21, 23, 26, 36 AND 38). SN 77-429,565. PUB. 3-17-2009. FILED 3-24-2008.
- 3,629,618. **CHILL & HOT (BLOCK FORM)**. EVOLUTION LASER COSMETIC SOLUTIONS LLC. (U.S. CLS. 21, 23, 26, 36 AND 38). SN 77-431,761. PUB. 3-17-2009. FILED 3-26-2008.
- 3,629,627. **CALDERA DIAGN STIC RESOURCE AND DESIGN**. WATKINS MANUFACTURING CORPORATION. (U.S. CLS. 21, 23, 26, 36 AND 38). SN 77-433,142. PUB. 3-17-2009. FILED 3-27-2008.
- 3,629,639. **HAND 2 HAND ENTERTAINMENT (BLOCK FORM)**. HAND 2 HAND ENTERTAINMENT. (U.S. CLS. 21, 23, 26, 36 AND 38). SN 77-434,970. PUB. 3-17-2009. FILED 3-28-2008.
- 3,629,653. **YOUR PERSONAL MENTOR - PROJECT MANAGEMENT (BLOCK FORM)**. WESTMINSTER & YORK, LTD. (U.S. CLS. 21, 23, 26, 36 AND 38). SN 77-436,897. PUB. 3-17-2009. FILED 4-1-2008.
- 3,629,682. **MINDMAPPER (BLOCK FORM)**. CHUNG, YOUNG G., DBA SIMTECH USA. (U.S. CLS. 21, 23, 26, 36 AND 38). SN 77-441,213. PUB. 3-17-2009. FILED 4-7-2008.
- 3,629,683 (*See Class 6 for this trademark*).
- 3,629,686. **AXIS PRO (BLOCK FORM)**. OVERWATCH SYSTEMS, LTD.. (U.S. CLS. 21, 23, 26, 36 AND 38). SN 77-441,809. PUB. 3-17-2009. FILED 4-7-2008.
- 3,629,693. **REMOTE SENTRY (BLOCK FORM)**. VIGILOS, INC.. (U.S. CLS. 21, 23, 26, 36 AND 38). SN 77-442,669. PUB. 3-17-2009. FILED 4-8-2008.
- 3,629,708. **CLASSICBOARD (BLOCK FORM)**. DIGI INTERNATIONAL INC.. (U.S. CLS. 21, 23, 26, 36 AND 38). SN 77-443,920. PUB. 3-17-2009. FILED 4-9-2008.
- 3,629,711 (*See Class 7 for this trademark*).
- 3,629,716. **MISCELLANEOUS DESIGN**. DISH NETWORK L.L.C.. (U.S. CLS. 21, 23, 26, 36 AND 38). SN 77-444,611. PUB. 3-17-2009. FILED 4-10-2008.
- 3,629,724. **OCEANWORKS (BLOCK FORM)**. OCEANWORKS INTERNATIONAL, INC.. (U.S. CLS. 21, 23, 26, 36 AND 38). SN 77-445,308. PUB. 3-17-2009. FILED 4-10-2008.
- 3,629,736. **SOUTHEND INTERACTIVE (BLOCK FORM)**. SOUTHEND INTERACTIVE AB. (U.S. CLS. 21, 23, 26, 36 AND 38). SN 77-447,055. PUB. 3-17-2009. FILED 4-14-2008.
- 3,629,739. **MISCELLANEOUS DESIGN**. UNION/OSG, LLC. (U.S. CLS. 21, 23, 26, 36 AND 38). SN 77-447,227. PUB. 3-17-2009. FILED 4-14-2008.
- 3,629,743. **THE SPEED OF TRUST (BLOCK FORM)**. COVEY/LINK, LLC. (U.S. CLS. 21, 23, 26, 36 AND 38). SN 77-447,459. PUB. 3-17-2009. FILED 4-14-2008.
- 3,629,747. **TREES (BLOCK FORM)**. TRIRIGA INC., MULTIPLE CLASS, (INT. CLS. 9, 36 AND 42), (U.S. CLS. 21, 23, 26, 36, 38, 100, 101 AND 102). SN 77-447,954. PUB. 3-17-2009. FILED 4-14-2008.
- 3,629,769. **VIBE LABS (BLOCK FORM)**. VIBE LABS, INC.. (U.S. CLS. 21, 23, 26, 36 AND 38). SN 77-450,079. PUB. 3-17-2009. FILED 4-16-2008.
- 3,629,802. **QUANTUM SWING TRADER (BLOCK FORM)**. PROFITS RUN, INC., MULTIPLE CLASS, (INT. CLS. 9 AND 16), (U.S. CLS. 2, 5, 21, 22, 23, 26, 29, 36, 37, 38 AND 50). SN 77-452,226. PUB. 3-17-2009. FILED 4-18-2008.
- 3,629,803. **ETF PROFIT DRIVER (BLOCK FORM)**. PROFITS RUN, INC., MULTIPLE CLASS, (INT. CLS. 9 AND 16), (U.S. CLS. 2, 5, 21, 22, 23, 26, 29, 36, 37, 38 AND 50). SN 77-452,261. PUB. 3-17-2009. FILED 4-18-2008.
- 3,629,804 (*See Class 6 for this trademark*).
- 3,629,814. **GHOST LASER (BLOCK FORM)**. B.E. MEYERS & COMPANY, INC.. (U.S. CLS. 21, 23, 26, 36 AND 38). SN 77-453,539. PUB. 3-17-2009. FILED S.R. 4-21-2008; AM. P.R. 1-13-2009.
- 3,629,820. **TEAMQUEST ALERT (BLOCK FORM)**. TEAMQUEST CORPORATION. (U.S. CLS. 21, 23, 26, 36 AND 38). SN 77-453,805. PUB. 3-17-2009. FILED 4-21-2008.
- 3,629,823. **TEAMQUEST ON THE WEB (BLOCK FORM)**. TEAMQUEST CORPORATION. (U.S. CLS. 21, 23, 26, 36 AND 38). SN 77-453,915. PUB. 3-17-2009. FILED 4-21-2008.
- 3,629,826. **DELTA HEALTH TECHNOLOGIES (BLOCK FORM)**. DELTA HEALTH TECHNOLOGIES, LLC, MULTIPLE CLASS, (INT. CLS. 9, 41 AND 42), (U.S. CLS. 21, 23, 26, 36, 38, 100, 101 AND 107). SN 77-454,572. PUB. 3-17-2009. FILED 4-22-2008.
- 3,629,829. **UBIDYNE AND DESIGN**. UBIDYNE, INC.. (U.S. CLS. 21, 23, 26, 36 AND 38). SN 77-454,880. PUB. 3-17-2009. FILED 4-22-2008.
- 3,629,841 (*See Class 8 for this trademark*).
- 3,629,845. **OVISLINK (BLOCK FORM)**. HO, JAMES W. (U.S. CLS. 21, 23, 26, 36 AND 38). SN 77-456,535. PUB. 3-17-2009. FILED 4-24-2008.
- 3,629,847. **UB 900 AND DESIGN**. UBIDYNE, INC.. (U.S. CLS. 21, 23, 26, 36 AND 38). SN 77-456,679. PUB. 3-17-2009. FILED 4-24-2008.
- 3,629,866. **DEMATIC IT (BLOCK FORM)**. DEMATIC GMBH. (U.S. CLS. 21, 23, 26, 36 AND 38). SN 77-459,690. PUB. 3-17-2009. FILED 4-28-2008.
- 3,629,873 (*See Class 7 for this trademark*).
- 3,629,884. **TEAMQUEST MANAGER (BLOCK FORM)**. TEAMQUEST CORPORATION. (U.S. CLS. 21, 23, 26, 36 AND 38). SN 77-462,696. PUB. 3-17-2009. FILED 5-1-2008.
- 3,629,889. **PAY CHASER (BLOCK FORM)**. ACRES-FIORE PATENTS. (U.S. CLS. 21, 23, 26, 36 AND 38). SN 77-463,772. PUB. 3-17-2009. FILED 5-1-2008.
- 3,629,894. **EZ NUMBERS (BLOCK FORM)**. HYNEK, PAUL. (U.S. CLS. 21, 23, 26, 36 AND 38). SN 77-465,046. PUB. 3-17-2009. FILED 5-3-2008.
- 3,629,896. **DIGIVICE (BLOCK FORM)**. BANDAI AMERICA INCORPORATED. (U.S. CLS. 21, 23, 26, 36 AND 38). SN 77-465,864. PUB. 3-17-2009. FILED 5-5-2008.
- 3,629,897 (*See Class 4 for this trademark*).
- 3,629,898. **POPS (BLOCK FORM)**. CARTTRONICS, LLC. (U.S. CLS. 21, 23, 26, 36 AND 38). SN 77-466,032. PUB. 3-17-2009. FILED 5-5-2008.
- 3,629,905. **MACH5 (BLOCK FORM)**. MACH 5 DISTRIBUTING, INC., MULTIPLE CLASS, (INT. CLS. 9 AND 41), (U.S. CLS. 21, 23, 26, 36, 38, 100, 101 AND 107). SN 77-467,777. PUB. 3-17-2009. FILED 5-7-2008.
- 3,629,910. **CINTEX AND DESIGN**. ILLINOIS TOOL WORKS. (U.S. CLS. 21, 23, 26, 36 AND 38). SN 77-469,041. PUB. 3-17-2009. FILED 5-8-2008.
- 3,629,920. **BUILDING NETWORKS FOR PEOPLE (BLOCK FORM)**. D-LINK SYSTEMS, INC., MULTIPLE CLASS, (INT. CLS. 9 AND 42), (U.S. CLS. 21, 23, 26, 36, 38, 100 AND 101). SN 77-471,853. PUB. 3-17-2009. FILED 5-12-2008.
- 3,629,926. **MONITOR (BLOCK FORM)**. PEOPLECLICK, INC.. (U.S. CLS. 21, 23, 26, 36 AND 38). SN 77-473,381. PUB. 3-17-2009. FILED 5-13-2008.
- 3,629,928. **CHLORITROL (BLOCK FORM)**. ROPER HOLDINGS, INC.. (U.S. CLS. 21, 23, 26, 36 AND 38). SN 77-473,942. PUB. 3-17-2009. FILED 5-14-2008.
- 3,629,935. **PROSENSE (BLOCK FORM)**. AUTOMATIONDIRECT.COM INC.. (U.S. CLS. 21, 23, 26, 36 AND 38). SN 77-475,706. PUB. 3-17-2009. FILED 5-15-2008.
- 3,629,937. **MEDIALOUNGE ENTERTAINMENT NETWORK AND DESIGN**. D-LINK SYSTEMS, INC.. (U.S. CLS. 21, 23, 26, 36 AND 38). SN 77-475,961. PUB. 3-17-2009. FILED 5-15-2008.
- 3,629,948. **XIUS-BCGI AND DESIGN**. CELLULAR EXPRESS, INC., MULTIPLE CLASS, (INT. CLS. 9, 35 AND 42), (U.S. CLS. 21, 23, 26, 36, 38, 100, 101 AND 102). SN 77-478,857. PUB. 3-17-2009. FILED 5-20-2008.
- 3,629,949. **MISCELLANEOUS DESIGN**. DIALOG COACH LLC. (U.S. CLS. 21, 23, 26, 36 AND 38). SN 77-478,972. PUB. 3-17-2009. FILED 5-20-2008.
- 3,629,950. **VERUS (BLOCK FORM)**. SNAP-ON INCORPORATED. (U.S. CLS. 21, 23, 26, 36 AND 38). SN 77-478,974. PUB. 3-17-2009. FILED 5-20-2008.
- 3,629,955. **CVSIM (BLOCK FORM)**. CARDIOVASCULAR SIMULATION INC. (U.S. CLS. 21, 23, 26, 36 AND 38). SN 77-479,785. PUB. 3-17-2009. FILED 5-21-2008.
- 3,629,958. **SMARTAPP NEXT GENERATION (BLOCK FORM)**. AMERICAN FAMILY LIFE ASSURANCE COMPANY OF COLUMBUS. (U.S. CLS. 21, 23, 26, 36 AND 38). SN 77-480,393. PUB. 3-17-2009. FILED 5-21-2008.
- 3,629,965 (*See Class 6 for this trademark*).
- 3,629,974. **PAYSTAT (BLOCK FORM)**. PEOPLECLICK, INC.. (U.S. CLS. 21, 23, 26, 36 AND 38). SN 77-487,322. PUB. 3-17-2009. FILED 5-30-2008.
- 3,629,978. **NEOTEMP (BLOCK FORM)**. NOVAMED-USA INC.. (U.S. CLS. 21, 23, 26, 36 AND 38). SN 77-488,716. PUB. 3-17-2009. FILED 6-2-2008.

- 3,629,983. **PRODIGY (BLOCK FORM)**. VIDEO SECURITY SPECIALISTS, INC., (U.S. CLS. 21, 23, 26, 36 AND 38). SN 77-489,037. PUB. 3-17-2009. FILED 6-2-2008.
- 3,629,990. **VITAMIN STRING QUARTET (BLOCK FORM)**. CMH RECORDS, INC., (U.S. CLS. 21, 23, 26, 36 AND 38). SN 77-490,967. PUB. 3-17-2009. FILED 6-4-2008.
- 3,630,015. **CITYTREX (BLOCK FORM)**. CITY TREX, LLC, (U.S. CLS. 21, 23, 26, 36 AND 38). SN 77-496,170. PUB. 3-17-2009. FILED 6-11-2008.
- 3,630,018. **REVIVE (BLOCK FORM)**. REVIVE PARTNERSHIP, (U.S. CLS. 21, 23, 26, 36 AND 38). SN 77-496,486. PUB. 3-17-2009. FILED 6-11-2008.
- 3,630,041. **VOICE ELEMENTS AND DESIGN**. INVENTIVE LABS CORPORATION, (U.S. CLS. 21, 23, 26, 36 AND 38). SN 77-503,139. PUB. 3-17-2009. FILED 6-19-2008.
- 3,630,043. **MPH900 (BLOCK FORM)**. ELSAG NORTH AMERICA, LLC, (U.S. CLS. 21, 23, 26, 36 AND 38). SN 77-503,775. PUB. 3-17-2009. FILED 6-20-2008.
- 3,630,060. **PORNFIDELITY (BLOCK FORM)**. 413, INC., MULTIPLE CLASS, (INT. CLS. 9 AND 41), (U.S. CLS. 21, 23, 26, 36, 38, 100, 101 AND 107). SN 77-508,796. PUB. 12-9-2008. FILED 6-26-2008.
- 3,630,089. **BROWN COMFORT SYSTEMS HEATING & AIR CONDITIONING SERVICE YOU CAN TRUST AND DESIGN**. BROWN COMFORT SYSTEMS, (U.S. CLS. 21, 23, 26, 36 AND 38). SN 77-518,523. PUB. 3-17-2009. FILED 7-9-2008.
- 3,630,092. **ROCKWARE (BLOCK FORM)**. ROCKWARE, INC., MULTIPLE CLASS, (INT. CLS. 9, 41 AND 42), (U.S. CLS. 21, 23, 26, 36, 38, 100, 101 AND 107). SN 77-518,802. PUB. 3-17-2009. FILED 7-10-2008.
- 3,630,093. **TOUCHPOINT ED (BLOCK FORM)**. PICIS, INC., (U.S. CLS. 21, 23, 26, 36 AND 38). SN 77-519,106. PUB. 3-17-2009. FILED 7-10-2008.
- 3,630,094. **INSIGHT ED (BLOCK FORM)**. PICIS, INC., (U.S. CLS. 21, 23, 26, 36 AND 38). SN 77-519,148. PUB. 3-17-2009. FILED 7-10-2008.
- 3,630,095 (*See Class 7 for this trademark*).
- 3,630,097. **SECURESP T AND DESIGN**. D-LINK SYSTEMS, INC., (U.S. CLS. 21, 23, 26, 36 AND 38). SN 77-519,424. PUB. 3-17-2009. FILED 7-10-2008.
- 3,630,103. **CDG RIPPER (BLOCK FORM)**. TRICERASOFT, (U.S. CLS. 21, 23, 26, 36 AND 38). SN 77-520,304. PUB. 3-17-2009. FILED 7-11-2008.
- 3,630,105. **IAS (BLOCK FORM)**. INTERNATIONAL ACCOUNTING STANDARDS COMMITTEE FOUNDATION, MULTIPLE CLASS, (INT. CLS. 9, 16 AND 35), (U.S. CLS. 2, 5, 21, 22, 23, 26, 29, 36, 37, 38, 50, 100, 101 AND 102). SN 77-522,118. PUB. 3-17-2009. FILED 7-15-2008.
- 3,630,107. **THE ONE MINUTE MONK (BLOCK FORM)**. BELMONT ABBEY COLLEGE, INCORPORATED, MULTIPLE CLASS, (INT. CLS. 9 AND 16), (U.S. CLS. 2, 5, 21, 22, 23, 26, 29, 36, 37, 38 AND 50). SN 77-522,564. PUB. 12-9-2008. FILED 7-15-2008.
- 3,630,175. **ARA-SHOCK (BLOCK FORM)**. CENTRAL LAKE ARMOR EXPRESS, INC., (U.S. CLS. 21, 23, 26, 36 AND 38). SN 77-541,495. PUB. 12-9-2008. FILED 8-7-2008.
- 3,630,176. **HD FUEL (BLOCK FORM)**. D-LINK SYSTEMS, INC., (U.S. CLS. 21, 23, 26, 36 AND 38). SN 77-541,501. PUB. 3-17-2009. FILED 8-7-2008.
- 3,630,177. **XSTACK (STYLIZED)**. D-LINK SYSTEMS, INC., (U.S. CLS. 21, 23, 26, 36 AND 38). SN 77-541,617. PUB. 3-17-2009. FILED 8-7-2008.
- 3,630,178. **KERUVE (BLOCK FORM)**. VISION SISTEMAS DE LOCALIZACION, S.L., MULTIPLE CLASS, (INT. CLS. 9, 35 AND 38), (U.S. CLS. 21, 23, 26, 36, 38, 100, 101, 102 AND 104). SN 77-542,310. PUB. 3-17-2009. FILED 8-8-2008.
- 3,630,185. **SAFEGUARD ENGINE (BLOCK FORM)**. D-LINK SYSTEMS, INC., (U.S. CLS. 21, 23, 26, 36 AND 38). SN 77-544,284. PUB. 3-17-2009. FILED 8-11-2008.
- 3,630,194. **NEWSMAKER AND DESIGN**. WILKERSON, OWEN MICHAEL, (U.S. CLS. 21, 23, 26, 36 AND 38). SN 77-546,168. PUB. 3-17-2009. FILED 8-13-2008.
- 3,630,201. **TIME GUARDIAN PRO AND DESIGN**. AMANO USA HOLDINGS, INC., FORMERLY AMANO INTERNATIONAL USA, INC. AND AMANO USA, INC., (U.S. CLS. 21, 23, 26, 36 AND 38). SN 77-547,004. PUB. 3-17-2009. FILED 8-14-2008.
- 3,630,202. **TIME GUARDIAN PRO (BLOCK FORM)**. AMANO USA HOLDINGS, INC., FORMERLY AMANO INTERNATIONAL USA, INC. AND AMANO USA, INC., (U.S. CLS. 21, 23, 26, 36 AND 38). SN 77-547,015. PUB. 3-17-2009. FILED 8-14-2008.
- 3,630,215. **KIDCHECK (BLOCK FORM)**. BARKING SOFTWARE, (U.S. CLS. 21, 23, 26, 36 AND 38). SN 77-550,775. PUB. 3-17-2009. FILED 8-19-2008.
- 3,630,228. **CLARUS DATAMINE (BLOCK FORM)**. REAL ESTATE BUSINESS SERVICES, INC., (U.S. CLS. 21, 23, 26, 36 AND 38). SN 77-553,938. PUB. 3-17-2009. FILED 8-22-2008.
- 3,630,233. **STRIPPERS GONE CRAZY (BLOCK FORM)**. RED LIGHT, LLC, (U.S. CLS. 21, 23, 26, 36 AND 38). SN 77-554,866. PUB. 3-17-2009. FILED 8-25-2008.
- 3,630,262. **KEYTROLLER (BLOCK FORM)**. DATAKEY ELECTRONICS, INC., (U.S. CLS. 21, 23, 26, 36 AND 38). SN 77-558,747. PUB. 3-17-2009. FILED 8-29-2008.
- 3,630,272. **TEST KING (BLOCK FORM)**. CERTIFICATION TRENDZ, LTD., MULTIPLE CLASS, (INT. CLS. 9 AND 16), (U.S. CLS. 2, 5, 21, 22, 23, 26, 29, 36, 37, 38 AND 50). SN 77-560,273. PUB. 3-17-2009. FILED 9-2-2008.
- 3,630,283. **EM RESEARCH AND DESIGN**. EM RESEARCH, INC., (U.S. CLS. 21, 23, 26, 36 AND 38). SN 77-562,319. PUB. 2-10-2009. FILED 9-4-2008.
- 3,630,288. **KAMA (BLOCK FORM)**. NYKO TECHNOLOGIES, (U.S. CLS. 21, 23, 26, 36 AND 38). SN 77-562,876. PUB. 3-17-2009. FILED 9-4-2008.
- 3,630,297. **THE LOST RING (BLOCK FORM)**. COMITÉ INTERNATIONAL OLYMPIQUE, MULTIPLE CLASS, (INT. CLS. 9, 35, 38, 41 AND 43), (U.S. CLS. 21, 23, 26, 36, 38, 100, 101, 102, 104 AND 107). SN 77-565,269. PUB. 3-17-2009. FILED 9-9-2008.
- 3,630,302 (*See Class 7 for this trademark*).
- 3,630,311. **OMNIPRISE AND DESIGN**. HITCENTS.COM, (U.S. CLS. 21, 23, 26, 36 AND 38). SN 77-567,541. PUB. 3-17-2009. FILED 9-11-2008.
- 3,630,317. **MEDTECH MATTERS (BLOCK FORM)**. RONALD TRAHAN ASSOCIATES, INC., (U.S. CLS. 21, 23, 26, 36 AND 38). SN 77-568,556. PUB. 3-17-2009. FILED 9-12-2008.
- 3,630,319. **LYYN AND DESIGN**. LYNN AB, (U.S. CLS. 21, 23, 26, 36 AND 38). SN 77-568,897. PUB. 3-17-2009. FILED 9-12-2008.
- 3,630,322. **GRAPHIC PRODUCTS (BLOCK FORM)**. GRAPHIC PRODUCTS, INCORPORATED, (U.S. CLS. 21, 23, 26, 36 AND 38). SN 77-569,011. PUB. 3-17-2009. FILED 9-12-2008.
- 3,630,324. **MISCELLANEOUS DESIGN**. GRAPHIC PRODUCTS, INCORPORATED, (U.S. CLS. 21, 23, 26, 36 AND 38). SN 77-569,081. PUB. 3-17-2009. FILED 9-12-2008.
- 3,630,333. **MIND WINGS AUDIO AND DESIGN**. MC GREEN ENTERPRISES LLC, MULTIPLE CLASS, (INT. CLS. 9 AND 41), (U.S. CLS. 21, 23, 26, 36, 38, 100, 101 AND 107). SN 77-569,792. PUB. 3-17-2009. FILED 9-15-2008.
- 3,630,337. **I IDEASTYLE AND DESIGN**. IDEASTYLE DEVELOPMENT INT'L CORP., (U.S. CLS. 21, 23, 26, 36 AND 38). SN 77-570,582. PUB. 3-17-2009. FILED 9-16-2008.
- 3,630,415. **ONE-STOP SHOP FOR EMR (BLOCK FORM)**. ITELAGEN, INC., MULTIPLE CLASS, (INT. CLS. 9, 35 AND 42), (U.S. CLS. 21, 23, 26, 36, 38, 100, 101 AND 102). SN 77-580,437. PUB. 3-17-2009. FILED 9-27-2008.
- 3,630,433. **KANSAS CITY SYMPHONY (BLOCK FORM)**. KANSAS CITY SYMPHONY, MULTIPLE CLASS, (INT. CLS. 9, 16, 36 AND 41), (U.S. CLS. 2, 5, 21, 22, 23, 26, 29, 36, 37, 38, 50, 100, 101, 102 AND 107). SN 77-583,238. PUB. 3-17-2009. FILED 10-1-2008.
- 3,630,437. **PHORAD (BLOCK FORM)**. SPECTRA CINE RESEARCH CORPORATION, DBA SPECTRA CINE, (U.S. CLS. 21, 23, 26, 36 AND 38). SN 77-583,582. PUB. 3-17-2009. FILED 10-1-2008.
- 3,630,460. **ACSELERATOR ANALYTIC ASSISTANT (BLOCK FORM)**. SCHWEITZER ENGINEERING LABORATORIES, INC., (U.S. CLS. 21, 23, 26, 36 AND 38). SN 77-586,703. PUB. 3-17-2009. FILED 10-6-2008.
- 3,630,461. **ACSELERATOR REPORT VIEWER (BLOCK FORM)**. SCHWEITZER ENGINEERING LABORATORIES, INC., (U.S. CLS. 21, 23, 26, 36 AND 38). SN 77-586,721. PUB. 3-17-2009. FILED 10-6-2008.
- 3,630,465. **ACSELERATOR INSITE (BLOCK FORM)**. SCHWEITZER ENGINEERING LABORATORIES, INC.,

- (U.S. CLS. 21, 23, 26, 36 AND 38). SN 77-587,024. PUB. 3-17-2009. FILED 10-7-2008.
- 3,630,466. **ACCELERATOR REPORT SERVER (BLOCK FORM)**. SCHWEITZER ENGINEERING LABORATORIES, INC., (U.S. CLS. 21, 23, 26, 36 AND 38). SN 77-587,054. PUB. 3-17-2009. FILED 10-7-2008.
- 3,630,504. **WALKER'S (BLOCK FORM)**. I.P. HOLDINGS, (U.S. CLS. 21, 23, 26, 36 AND 38). SN 77-590,089. PUB. 3-17-2009. FILED 10-10-2008.
- 3,630,524. **MYSTORE XPRESS AND DESIGN**. MARTHA, GARCIA, (U.S. CLS. 21, 23, 26, 36 AND 38). SN 77-591,895. PUB. 3-17-2009. FILED 10-14-2008.
- 3,630,555. **TEXTCONNECT (STYLIZED)**. VIRTUAL HOLD TECHNOLOGY, LLC, (U.S. CLS. 21, 23, 26, 36 AND 38). SN 77-593,678. PUB. 3-17-2009. FILED 10-15-2008.
- 3,630,556. **THE SOURCE CODE (BLOCK FORM)**. VISION QUEST MEDIA, INC., (U.S. CLS. 21, 23, 26, 36 AND 38). SN 77-593,702. PUB. 3-17-2009. FILED 10-15-2008.
- 3,630,566. **SECNOLOGY (BLOCK FORM)**. SECNOLOGY (USA), INC., (U.S. CLS. 21, 23, 26, 36 AND 38). SN 77-594,201. PUB. 3-17-2009. FILED 10-16-2008.
- 3,630,575. **PMA NEWSLINE (BLOCK FORM)**. PHOTO MARKETING ASSOCIATION INTERNATIONAL, (U.S. CLS. 21, 23, 26, 36 AND 38). SN 77-594,735. PUB. 3-17-2009. FILED 10-17-2008.
- 3,630,581. **MULTISTAR (BLOCK FORM)**. THAKKAR, INC., (U.S. CLS. 21, 23, 26, 36 AND 38). SN 77-595,116. PUB. 3-17-2009. FILED 10-17-2008.
- 3,630,586. **COOPERSCAN (BLOCK FORM)**. COOPERVISION, INC., (U.S. CLS. 21, 23, 26, 36 AND 38). SN 77-595,412. PUB. 3-17-2009. FILED 10-17-2008.
- 3,630,615. **THERMOFIND (BLOCK FORM)**. INFRARED, INC., (U.S. CLS. 21, 23, 26, 36 AND 38). SN 77-596,383. PUB. 3-17-2009. FILED 10-20-2008.
- 3,630,617. **MORPHOSMART (BLOCK FORM)**. SAGEM SECURITE, (U.S. CLS. 21, 23, 26, 36 AND 38). SN 77-596,395. PUB. 3-17-2009. FILED 10-20-2008.
- 3,630,630. **VDU (BLOCK FORM)**. VAN DORN DEMAG CORPORATION, (U.S. CLS. 21, 23, 26, 36 AND 38). SN 77-596,712. PUB. 3-17-2009. FILED 10-21-2008.
- 3,630,644. **WURDLE (BLOCK FORM)**. SEMI SECRET SOFTWARE LLC, (U.S. CLS. 21, 23, 26, 36 AND 38). SN 77-596,980. PUB. 3-17-2009. FILED 10-21-2008.
- 3,630,645. **STATKEY (BLOCK FORM)**. ORGANIZE THE ESSENTIALS, LLC, (U.S. CLS. 21, 23, 26, 36 AND 38). SN 77-596,985. PUB. 3-17-2009. FILED 10-21-2008.
- 3,630,646. **CAL-PAK (BLOCK FORM)**. HENRY TROEMNER LLC, (U.S. CLS. 21, 23, 26, 36 AND 38). SN 77-596,986. PUB. 3-17-2009. FILED 10-21-2008.
- 3,630,655. **MI MUSICIANS INSTITUTE (BLOCK FORM)**. MUSICIANS INSTITUTE INCORPORATED, MULTIPLE CLASS, (INT. CLS. 9, 16, 21 AND 25), (U.S. CLS. 2, 5, 13, 21, 22, 23, 26, 29, 30, 33, 36, 37, 38, 39, 40 AND 50). SN 77-597,260. PUB. 3-17-2009. FILED 10-21-2008.
- 3,630,659. **MI MUSICIANS INSTITUTE AND DESIGN**. MUSICIANS INSTITUTE INCORPORATED, MULTIPLE CLASS, (INT. CLS. 9, 16, 21 AND 25), (U.S. CLS. 2, 5, 13, 21, 22, 23, 26, 29, 30, 33, 36, 37, 38, 39, 40 AND 50). SN 77-597,402. PUB. 3-17-2009. FILED 10-21-2008.
- 3,630,695. **SMART COMPANIES THINKING BIGGER (BLOCK FORM)**. KANSAS CITY SMALL BUSINESS MONTHLY, INC., MULTIPLE CLASS, (INT. CLS. 9, 16 AND 41), (U.S. CLS. 2, 5, 21, 22, 23, 26, 29, 36, 37, 38, 50, 100, 101 AND 107). SN 77-598,152. PUB. 3-17-2009. FILED 10-22-2008.
- 3,630,709. **OVERDRIVE (BLOCK FORM)**. NUGENT, STEVEN F., DBA EMPIRICAL AUDIO, (U.S. CLS. 21, 23, 26, 36 AND 38). SN 77-598,403. PUB. 3-17-2009. FILED 10-22-2008.
- 3,630,712. **MOBILE VIDEO PATROLLER (BLOCK FORM)**. KCI COMMUNICATIONS, INC., (U.S. CLS. 21, 23, 26, 36 AND 38). SN 77-598,427. PUB. 3-17-2009. FILED 10-22-2008.
- 3,630,726. **GREENLITEBITES (BLOCK FORM)**. SKINNYMINNYMEDIA, LLC, (U.S. CLS. 21, 23, 26, 36 AND 38). SN 77-598,633. PUB. 3-17-2009. FILED 10-23-2008.
- 3,630,733. **KCDW (BLOCK FORM)**. DESIGN-A-KITCHEN, INC., (U.S. CLS. 21, 23, 26, 36 AND 38). SN 77-598,744. PUB. 3-17-2009. FILED 10-23-2008.
- 3,630,752. **ECONOWHINER (BLOCK FORM)**. WORDJEMS INC., (U.S. CLS. 21, 23, 26, 36 AND 38). SN 77-598,952. PUB. 3-17-2009. FILED 10-23-2008.
- 3,630,760. **JNST (BLOCK FORM)**. A.J. BOGGS & COMPANY, (U.S. CLS. 21, 23, 26, 36 AND 38). SN 77-599,008. PUB. 3-17-2009. FILED 10-23-2008.
- 3,630,768. **Q-SEE (STYLIZED)**. DIGITAL PERIPHERAL SOLUTIONS, INC., (U.S. CLS. 21, 23, 26, 36 AND 38). SN 77-599,160. PUB. 3-17-2009. FILED 10-23-2008.
- 3,630,777. **GREENLINK (BLOCK FORM)**. PREMIER, INC., MULTIPLE CLASS, (INT. CLS. 9 AND 41), (U.S. CLS. 21, 23, 26, 36, 38, 100, 101 AND 107). SN 77-599,262. PUB. 3-17-2009. FILED 10-23-2008.
- 3,630,788. **MAD DOG (BLOCK FORM)**. DUNN, RYAN M., (U.S. CLS. 21, 23, 26, 36 AND 38). SN 77-599,470. PUB. 3-17-2009. FILED 10-23-2008.
- 3,630,813. **10 J Q K A 1 2 S LET IT RIDE BONUS AND DESIGN**. SHUFFLE MASTER, INC., (U.S. CLS. 21, 23, 26, 36 AND 38). SN 77-599,844. PUB. 3-17-2009. FILED 10-24-2008.
- 3,630,819. **WORK 2500 (BLOCK FORM)**. WELLS LAMONT CORPORATION, (U.S. CLS. 21, 23, 26, 36 AND 38). SN 77-599,907. PUB. 3-17-2009. FILED 10-24-2008.
- 3,630,821. **WORK 3500 (BLOCK FORM)**. WELLS LAMONT CORPORATION, (U.S. CLS. 21, 23, 26, 36 AND 38). SN 77-599,928. PUB. 3-17-2009. FILED 10-24-2008.
- 3,630,847. **ORIGA (BLOCK FORM)**. INFINEON TECHNOLOGIES AG, (U.S. CLS. 21, 23, 26, 36 AND 38). SN 77-600,187. PUB. 3-17-2009. FILED 10-24-2008.
- 3,630,895. **FIREWALL (BLOCK FORM)**. EBAGS, INC., MULTIPLE CLASS, (INT. CLS. 9 AND 18), (U.S. CLS. 1, 2, 3, 21, 22, 23, 26, 36, 38 AND 41). SN 77-600,904. PUB. 3-17-2009. FILED 10-27-2008.
- 3,630,917. **AIINDEX (BLOCK FORM)**. MENTIS TECHNOLOGY, LLC, (U.S. CLS. 21, 23, 26, 36 AND 38). SN 77-601,068. PUB. 3-17-2009. FILED 10-27-2008.
- 3,630,922. **MANTOOTH MUSIC AND DESIGN**. WIL I S INC, (U.S. CLS. 21, 23, 26, 36 AND 38). SN 77-601,179. PUB. 3-17-2009. FILED 10-27-2008.
- 3,630,947. **MISCELLANEOUS DESIGN**. FARM CREDIT SERVICES OF AMERICA, ACA, (U.S. CLS. 21, 23, 26, 36 AND 38). SN 77-601,518. PUB. 3-17-2009. FILED 10-27-2008.
- 3,630,948. **MISCELLANEOUS DESIGN**. FARM CREDIT SERVICES OF AMERICA, ACA, (U.S. CLS. 21, 23, 26, 36 AND 38). SN 77-601,520. PUB. 3-17-2009. FILED 10-27-2008.
- 3,630,949. **PINHUNTER (BLOCK FORM)**. LEUPOLD & STEVENS, INC., (U.S. CLS. 21, 23, 26, 36 AND 38). SN 77-601,552. PUB. 3-17-2009. FILED 10-27-2008.
- 3,630,960. **CORRELOG (BLOCK FORM)**. FAUCHER, GEORGE P, (U.S. CLS. 21, 23, 26, 36 AND 38). SN 77-601,689. PUB. 3-17-2009. FILED 10-27-2008.
- 3,630,967. **CARENADO (BLOCK FORM)**. COMERCIAL CARENADO LIMITADA, (U.S. CLS. 21, 23, 26, 36 AND 38). SN 77-601,886. PUB. 3-17-2009. FILED 10-28-2008.
- 3,630,973. **AMR ARLINGTON MEDICAL RESOURCES INC. (STYLIZED)**. ARLINGTON MEDICAL RESOURCES, INC., (U.S. CLS. 21, 23, 26, 36 AND 38). SN 77-601,950. PUB. 3-17-2009. FILED 10-28-2008.
- 3,630,975. **SF AND DESIGN**. SAN FRANCISCO FORTY NINERS, LIMITED, MULTIPLE CLASS, (INT. CLS. 9, 25 AND 28), (U.S. CLS. 21, 22, 23, 26, 36, 38, 39 AND 50). SN 77-601,963. PUB. 3-17-2009. FILED 10-28-2008.
- 3,630,988. **INTELLISTATUS (BLOCK FORM)**. IOLO TECHNOLOGIES, LLC, (U.S. CLS. 21, 23, 26, 36 AND 38). SN 77-602,090. PUB. 3-17-2009. FILED 10-28-2008.
- 3,630,990. **MOLDED TO YOUR MUSIC (BLOCK FORM)**. MIRANDA, FRANCES, (U.S. CLS. 21, 23, 26, 36 AND 38). SN 77-602,114. PUB. 3-17-2009. FILED 10-28-2008.
- 3,630,992. **SYSTEMGUARD (BLOCK FORM)**. IOLO TECHNOLOGIES, LLC, (U.S. CLS. 21, 23, 26, 36 AND 38). SN 77-602,131. PUB. 3-17-2009. FILED 10-28-2008.
- 3,630,999. **PEACOCK PEEKS (BLOCK FORM)**. MSNBC CABLE L.L.C., (U.S. CLS. 21, 23, 26, 36 AND 38). SN 77-602,178. PUB. 3-17-2009. FILED 10-28-2008.
- 3,631,006. **SYNCJE (BLOCK FORM)**. NEXTHAUS CORPORATION, (U.S. CLS. 21, 23, 26, 36 AND 38). SN 77-602,284. PUB. 3-17-2009. FILED 10-28-2008.
- 3,631,009. **ANY ASSET, ONE NETWORK (BLOCK FORM)**. EPCSOLUTIONS, INC., (U.S. CLS. 21, 23, 26, 36 AND 38). SN 77-602,316. PUB. 3-17-2009. FILED 10-28-2008.

- 3,631,013. **EMR3 (BLOCK FORM)**. VEEDER-ROOT COMPANY, (U.S. CLS. 21, 23, 26, 36 AND 38). SN 77-602,351. PUB. 3-17-2009. FILED 10-28-2008.
- 3,631,050. **GEARBOX SOFTWARE (STYLIZED)**. GEARBOX SOFTWARE, LLC, (U.S. CLS. 21, 23, 26, 36 AND 38). SN 77-602,972. PUB. 3-17-2009. FILED 10-29-2008.
- 3,631,063. **OMERICA (BLOCK FORM)**. PACIFIC CENTURY, LLC, (U.S. CLS. 21, 23, 26, 36 AND 38). SN 77-603,305. PUB. 3-17-2009. FILED 10-29-2008.
- 3,631,064. **PHASHOW (BLOCK FORM)**. PHASHOW INC., MULTIPLE CLASS, (INT. CLS. 9, 16, 25, 28 AND 41), (U.S. CLS. 2, 5, 21, 22, 23, 26, 29, 36, 37, 38, 39, 50, 100, 101 AND 107). SN 77-603,314. PUB. 3-17-2009. FILED 10-29-2008.
- 3,631,076. **AQUAFORM (BLOCK FORM)**. COOPERVISION, INC., (U.S. CLS. 21, 23, 26, 36 AND 38). SN 77-603,539. PUB. 3-17-2009. FILED 10-29-2008.
- 3,631,079. **OH THATS WRONG .COM SO WRONG IT HAS TO BE RIGHT AND DESIGN**. PINK UNICORN PRODUCTIONS LLC, (U.S. CLS. 21, 23, 26, 36 AND 38). SN 77-603,572. PUB. 3-17-2009. FILED 10-29-2008.
- 3,631,084. **PROTEC (BLOCK FORM)**. SUNJEEAN, INC., DBA PROTEC, MULTIPLE CLASS, (INT. CLS. 9 AND 15), (U.S. CLS. 2, 21, 23, 26, 36 AND 38). SN 77-603,609. PUB. 3-17-2009. FILED 10-29-2008.
- 3,631,097. **TIMEGATE T AND DESIGN**. TIMEGATE STUDIOS, INC., (U.S. CLS. 21, 23, 26, 36 AND 38). SN 77-603,820. PUB. 3-17-2009. FILED 10-30-2008.
- 3,631,116. **DAVIO (BLOCK FORM)**. CINE-TAL SYSTEMS, INC., (U.S. CLS. 21, 23, 26, 36 AND 38). SN 77-604,101. PUB. 3-17-2009. FILED 10-30-2008.
- 3,631,121. **FJ (BLOCK FORM)**. CHOU, YU, (U.S. CLS. 21, 23, 26, 36 AND 38). SN 77-604,215. PUB. 3-17-2009. FILED 10-30-2008.
- 3,631,135. **PLUMERAE (BLOCK FORM)**. RAE SYSTEMS INC., (U.S. CLS. 21, 23, 26, 36 AND 38). SN 77-604,484. PUB. 3-17-2009. FILED 10-30-2008.
- 3,631,137. **MONSOON (BLOCK FORM)**. MONSOON, INC., (U.S. CLS. 21, 23, 26, 36 AND 38). SN 77-604,534. PUB. 3-17-2009. FILED 10-30-2008.
- 3,631,138. **MISCELLANEOUS DESIGN**. MONSOON, INC., (U.S. CLS. 21, 23, 26, 36 AND 38). SN 77-604,542. PUB. 3-17-2009. FILED 10-30-2008.
- 3,631,139. **DEXAWARE (BLOCK FORM)**. OSTEO METER MEDITECH, INC., (U.S. CLS. 21, 23, 26, 36 AND 38). SN 77-604,544. PUB. 3-17-2009. FILED 10-30-2008.
- 3,631,143. **MOBILE MANAGER (BLOCK FORM)**. STETON TECHNOLOGY GROUP, INC., (U.S. CLS. 21, 23, 26, 36 AND 38). SN 77-604,557. PUB. 3-17-2009. FILED 10-30-2008.
- 3,631,149. **PE AND DESIGN**. PRO EBIZ LLC, (U.S. CLS. 21, 23, 26, 36 AND 38). SN 77-604,624. PUB. 3-17-2009. FILED 10-30-2008.
- 3,631,165. **LIFE (BLOCK FORM)**. BAUER TYPES SA, (U.S. CLS. 21, 23, 26, 36 AND 38). SN 77-604,954. PUB. 3-17-2009. FILED 10-31-2008.
- 3,631,169. **VOLTA (BLOCK FORM)**. BAUER TYPES SA, (U.S. CLS. 21, 23, 26, 36 AND 38). SN 77-604,982. PUB. 3-17-2009. FILED 10-31-2008.
- 3,631,183. **READING SUCCESS LAB EDUCATIONAL HELP INC. SOFTWARE SOLUTIONS FOR IDENTIFYING READING PROBLEMS AND IMPROVING READING SKILLS AND DESIGN**. EDUCATIONAL HELP, INC., (U.S. CLS. 21, 23, 26, 36 AND 38). SN 77-605,345. PUB. 3-17-2009. FILED 10-31-2008.
- 3,631,198. **MISCELLANEOUS DESIGN**. TOUCH NETWORKS, INC., (U.S. CLS. 21, 23, 26, 36 AND 38). SN 77-605,456. PUB. 3-17-2009. FILED 10-31-2008.
- 3,631,204. **ACADIA (BLOCK FORM)**. LEUPOLD & STEVENS, INC., (U.S. CLS. 21, 23, 26, 36 AND 38). SN 77-605,502. PUB. 3-17-2009. FILED 10-31-2008.
- 3,631,207. **SURVIVING SUNRISE (BLOCK FORM)**. SURVIVING SUNRISE, INC., MULTIPLE CLASS, (INT. CLS. 9 AND 41), (U.S. CLS. 21, 23, 26, 36, 38, 100, 101 AND 107). SN 77-605,515. PUB. 3-17-2009. FILED 10-31-2008.
- 3,631,226. **JOHN—DOE—RECORDS (BLOCK FORM)**. JOHN DOE RECORDS, LLC, MULTIPLE CLASS, (INT. CLS. 9 AND 35), (U.S. CLS. 21, 23, 26, 36, 38, 100, 101 AND 102). SN 77-605,787. PUB. 3-17-2009. FILED 11-3-2008.
- 3,631,229. **BRAVO! (BLOCK FORM)**. C3 SOFTWARES, INC., DBA C3 SOFTWARES, (U.S. CLS. 21, 23, 26, 36 AND 38). SN 77-605,939. PUB. 3-17-2009. FILED 11-3-2008.
- 3,631,250. **WHEEL POKER (BLOCK FORM)**. IGT, (U.S. CLS. 21, 23, 26, 36 AND 38). SN 77-606,287. PUB. 3-17-2009. FILED 11-3-2008.
- 3,631,263. **LIGHT FLIGHT AND DESIGN**. VOUGHLOHN, DEE, AND THOMPSON, DON, AND HARTUNG, STAN, (U.S. CLS. 21, 23, 26, 36 AND 38). SN 77-607,326. PUB. 3-17-2009. FILED 11-4-2008.
- 3,631,270. **TRACKKEEPER (STYLIZED)**. COOPER TECHNOLOGY COMPANY, (U.S. CLS. 21, 23, 26, 36 AND 38). SN 77-608,179. PUB. 3-17-2009. FILED 11-5-2008.
- 3,631,282. **MISCELLANEOUS DESIGN**. GE FANUC INTELLIGENT PLATFORMS, INC., MULTIPLE CLASS, (INT. CLS. 9 AND 42), (U.S. CLS. 21, 23, 26, 36, 38, 100 AND 101). SN 77-609,916. PUB. 3-17-2009. FILED 11-7-2008.
- 3,631,292. **SCRENJOT (BLOCK FORM)**. LIQUIDTHOUGHT LLC, (U.S. CLS. 21, 23, 26, 36 AND 38). SN 77-611,480. PUB. 3-17-2009. FILED 11-10-2008.
- 3,631,304. **ZIPSCAN (BLOCK FORM)**. NEW TECHNOLOGY PARTNERS, INC., (U.S. CLS. 21, 23, 26, 36 AND 38). SN 77-615,705. PUB. 3-17-2009. FILED 11-17-2008.
- 3,631,323. **ADJUST-A-BOX (BLOCK FORM)**. THOMAS & BETTS INTERNATIONAL, INC., (U.S. CLS. 21, 23, 26, 36 AND 38). SN 77-619,357. PUB. 3-17-2009. FILED 11-21-2008.
- 3,631,328. **LOCALTAP (BLOCK FORM)**. MOBILESPORTS, LLC, (U.S. CLS. 21, 23, 26, 36 AND 38). SN 77-622,525. PUB. 3-17-2009. FILED 11-26-2008.
- 3,631,332. **TGM DETECTORS (BLOCK FORM)**. SAINT-GOBAIN CERAMICS & PLASTICS, INC., (U.S. CLS. 21, 23, 26, 36 AND 38). SN 77-624,027. PUB. 3-17-2009. FILED 12-1-2008.
- 3,631,339. **DFS DATA FLOW SYSTEMS AND DESIGN**. DATA FLOW SYSTEMS, INC, (U.S. CLS. 21, 23, 26, 36 AND 38). SN 77-626,494. PUB. 3-17-2009. FILED 12-4-2008.
- 3,631,358. **ETHOS (BLOCK FORM)**. SNAP-ON INCORPORATED, (U.S. CLS. 21, 23, 26, 36 AND 38). SN 77-638,049. PUB. 3-17-2009. FILED 12-22-2008.
- 3,631,382. **THE LINK BETWEEN US (BLOCK FORM)**. DEUTSCHE TELEKOM AG, (U.S. CLS. 21, 23, 26, 36 AND 38). SN 78-420,756. PUB. 11-11-2008. FILED 5-18-2004.
- 3,631,389. **AVIMET (BLOCK FORM)**. VAISALA OYJ, MULTIPLE CLASS, (INT. CLS. 9, 37 AND 42), (U.S. CLS. 21, 23, 26, 36, 38, 100, 101, 103 AND 106). SN 78-480,929. PUB. 8-8-2006. FILED 9-9-2004.
- 3,631,390. **AVICAST (BLOCK FORM)**. VAISALA OYJ, MULTIPLE CLASS, (INT. CLS. 9, 37 AND 42), (U.S. CLS. 21, 23, 26, 36, 38, 100, 101, 103 AND 106). SN 78-480,948. PUB. 2-28-2006. FILED 9-9-2004.
- 3,631,397. **PANVITAL (BLOCK FORM)**. PAN.PRO VERTRIEBS AG, MULTIPLE CLASS, (INT. CLS. 9, 10, 28, 35, 41, 42 AND 44), (U.S. CLS. 21, 22, 23, 26, 36, 38, 39, 44, 50, 100, 101, 102 AND 107). SN 78-581,796. PUB. 3-17-2009. FILED 3-7-2005.
- 3,631,398. **PRO PANVITAL SYSTEMS (BLOCK FORM)**. PAN.PRO VERTRIEBS AG, MULTIPLE CLASS, (INT. CLS. 9, 10, 28, 35, 41, 42 AND 44), (U.S. CLS. 21, 22, 23, 26, 36, 38, 39, 44, 50, 100, 101, 102 AND 107). SN 78-581,802. PUB. 3-17-2009. FILED 3-7-2005.
- 3,631,399 (See Class 3 for this trademark).
- 3,631,410. **EPOCH-BY-EPOCH (BLOCK FORM)**. GEODETICS, INC., (U.S. CLS. 21, 23, 26, 36 AND 38). SN 78-691,882. PUB. 3-17-2009. FILED 8-12-2005.
- 3,631,412. **AGATE (BLOCK FORM)**. ALSTOM TRANSPORT SA, (U.S. CLS. 21, 23, 26, 36 AND 38). SN 78-711,968. PUB. 3-17-2009. FILED 9-13-2005.
- 3,631,413 (See Class 7 for this trademark).
- 3,631,416. **COOLBLADE (BLOCK FORM)**. KNUERR AG, (U.S. CLS. 21, 23, 26, 36 AND 38). SN 78-751,331. PUB. 3-17-2009. FILED 11-10-2005.
- 3,631,426. **SPRUCE MEADOWS JUNIOR AMATEUR WORLD CHAMPIONSHIP (BLOCK FORM)**. SPRUCE MEADOWS, MULTIPLE CLASS, (INT. CLS. 9, 25 AND 41), (U.S. CLS. 21, 22, 23, 26, 36, 38, 39, 100, 101 AND 107). SN 78-847,369. PUB. 1-13-2009. FILED 3-27-2006.
- 3,631,427 (See Class 3 for this trademark).
- 3,631,429. **DACS (BLOCK FORM)**. HAMILTON SAFE COMPANY, (U.S. CLS. 21, 23, 26, 36 AND 38). SN 78-864,417. PUB. 3-17-2009. FILED 4-19-2006.

- 3,631,435. **CHECKPOINT (BLOCK FORM)**. THE FLUID LIFE COMPANY, (U.S. CLS. 21, 23, 26, 36 AND 38). SN 78-905,256. PUB. 1-6-2009. FILED 6-9-2006.
- 3,631,438 (*See Class 7 for this trademark*).
- 3,631,442 (*See Class 7 for this trademark*).
- 3,631,443. **DAN DIAL'S MOLECULAR ENHANCER (BLOCK FORM)**. DANIEL C. DIAL, (U.S. CLS. 21, 23, 26, 36 AND 38). SN 78-935,333. PUB. 3-17-2009. FILED 7-21-2006.
- 3,631,448. **LO-RAY-LIGH AND DESIGN**. SHIMADZU CORPORATION, (U.S. CLS. 21, 23, 26, 36 AND 38). SN 78-952,312. PUB. 1-13-2009. FILED 8-15-2006.
- 3,631,449. **É (STYLIZED)**. ELEVEE CUSTOM CLOTHING, INC., (U.S. CLS. 21, 23, 26, 36 AND 38). SN 78-954,233. PUB. 3-17-2009. FILED 8-17-2006.
- 3,631,452 (*See Class 1 for this trademark*).
- 3,631,461 (*See Class 7 for this trademark*).
- 3,631,465. **SLIMWAVE (STYLIZED)**. SERCEL, MULTIPLE CLASS, (INT. CLS. 9, 12 AND 42), (U.S. CLS. 19, 21, 23, 26, 31, 35, 36, 38, 44, 100 AND 101). SN 79-028,937. PUB. 3-17-2009. FILED 5-23-2006.
- 3,631,469. **G2G (BLOCK FORM)**. MOODY STREET KIDS PTY LTD, MULTIPLE CLASS, (INT. CLS. 9, 16, 25, 28 AND 41), (U.S. CLS. 2, 5, 21, 22, 23, 26, 29, 36, 37, 38, 39, 50, 100, 101 AND 107). SN 79-034,105. PUB. 3-17-2009. FILED 6-20-2006.
- 3,631,472 (*See Class 3 for this trademark*).
- 3,631,477 (*See Class 3 for this trademark*).
- 3,631,480. **LOCAL LIFE (STYLIZED)**. LOCALIFE LIMITED, MULTIPLE CLASS, (INT. CLS. 9, 16, 35, 38 AND 42), (U.S. CLS. 2, 5, 21, 22, 23, 26, 29, 36, 37, 38, 50, 100, 101, 102 AND 104). SN 79-040,629. PUB. 3-17-2009. FILED 5-31-2007.
- 3,631,483. **EVERVOX AND DESIGN**. ZHOUYONGSHENG, MULTIPLE CLASS, (INT. CLS. 9 AND 12), (U.S. CLS. 19, 21, 23, 26, 31, 35, 36, 38 AND 44). SN 79-041,597. PUB. 3-17-2009. FILED 7-6-2007.
- 3,631,487 (*See Class 7 for this trademark*).
- 3,631,491 (*See Class 5 for this trademark*).
- 3,631,492 (*See Class 7 for this trademark*).
- 3,631,493 (*See Class 7 for this trademark*).
- 3,631,494 (*See Class 6 for this trademark*).
- 3,631,496. **ESET SMART SECURITY (BLOCK FORM)**. ESET, SPOL. S R.O., MULTIPLE CLASS, (INT. CLS. 9, 38, 41 AND 42), (U.S. CLS. 21, 23, 26, 36, 38, 100, 101, 104 AND 107). SN 79-044,627. PUB. 3-17-2009. FILED 7-12-2007.
- 3,631,502. **BEOCONNECT (BLOCK FORM)**. BANG & OLUFSEN A/S, MULTIPLE CLASS, (INT. CLS. 9, 35, 38 AND 39), (U.S. CLS. 21, 23, 26, 36, 38, 100, 101, 102, 104 AND 105). SN 79-046,291. PUB. 3-17-2009. FILED 6-12-2007.
- 3,631,507 (*See Class 7 for this trademark*).
- 3,631,509. **POW'R LICENSE (BLOCK FORM)**. PHILIPP W. MARX, MULTIPLE CLASS, (INT. CLS. 9, 37, 41 AND 42), (U.S. CLS. 21, 23, 26, 36, 38, 100, 101, 103, 106 AND 107). SN 79-047,391. PUB. 3-17-2009. FILED 6-6-2007.
- 3,631,510 (*See Class 1 for this trademark*).
- 3,631,511 (*See Class 1 for this trademark*).
- 3,631,512 (*See Class 3 for this trademark*).
- 3,631,531. **HADOSAN AND DESIGN**. BURKHARD HANS SCHINDLER C/O IFBIO BIOENERGETIKGERÄTEHANDLS GMBH, MULTIPLE CLASS, (INT. CLS. 9, 35, 41, 42 AND 44), (U.S. CLS. 21, 23, 26, 36, 38, 100, 101, 102 AND 107). SN 79-049,275. PUB. 3-17-2009. FILED 11-14-2007.
- 3,631,532. **PURELITE XSTREAM (STYLIZED)**. HELMET INTEGRATED SYSTEMS LIMITED, (U.S. CLS. 21, 23, 26, 36 AND 38). SN 79-049,578. PUB. 3-17-2009. FILED 11-29-2007.
- 3,631,534. **BIZANGA (BLOCK FORM)**. BIZANGA LTD, MULTIPLE CLASS, (INT. CLS. 9, 35, 37, 38 AND 42), (U.S. CLS. 21, 23, 26, 36, 38, 100, 101, 102, 103, 104 AND 106). SN 79-049,902. PUB. 3-17-2009. FILED 3-9-2007.
- 3,631,535. **COMPOSITOR AND DESIGN**. JOHN BESSELING, MULTIPLE CLASS, (INT. CLS. 9, 16 AND 18), (U.S. CLS. 1, 2, 3, 5, 21, 22, 23, 26, 29, 36, 37, 38, 41 AND 50). SN 79-050,009. PUB. 3-17-2009. FILED 12-13-2007.
- 3,631,538. **SOS TEAM SOS - SAVE OUR SEAS FOUNDATION AND DESIGN**. FONDATION SAVE OUR SEAS, MULTIPLE CLASS, (INT. CLS. 9, 14, 16, 18, 24, 28, 41 AND 42), (U.S. CLS. 1, 2, 3, 5, 21, 22, 23, 26, 27, 28, 29, 36, 37, 38, 41, 42, 50, 100, 101 AND 107). SN 79-050,477. PUB. 12-9-2008. FILED 11-7-2007.
- 3,631,539 (*See Class 7 for this trademark*).
- 3,631,546 (*See Class 2 for this trademark*).
- 3,631,547 (*See Class 6 for this trademark*).
- 3,631,548. **EXOTRACK (BLOCK FORM)**. EXOSUN SAS, (U.S. CLS. 21, 23, 26, 36 AND 38). SN 79-051,477. PUB. 3-17-2009. FILED 2-26-2008.
- 3,631,549. **SKYSTAR (BLOCK FORM)**. TECHNISAT DIGITAL GMBH, (U.S. CLS. 21, 23, 26, 36 AND 38). SN 79-051,551. PUB. 3-17-2009. FILED 3-11-2008.
- 3,631,554 (*See Class 1 for this trademark*).
- 3,631,557. **CAREER UP (BLOCK FORM)**. ADECCO S.A., MULTIPLE CLASS, (INT. CLS. 9, 35, 41 AND 42), (U.S. CLS. 21, 23, 26, 36, 38, 100, 101, 102 AND 107). SN 79-052,177. PUB. 3-17-2009. FILED 1-29-2008.
- 3,631,558. **SENSHE AND DESIGN**. XI'AN SENSHE ELECTRONIC TECHNOLOGY; CORPORATION, (U.S. CLS. 21, 23, 26, 36 AND 38). SN 79-052,200. PUB. 3-17-2009. FILED 3-11-2008.
- 3,631,561 (*See Class 6 for this trademark*).
- 3,631,573. **EFFITEK (BLOCK FORM)**. DYNAVET, MULTIPLE CLASS, (INT. CLS. 9 AND 18), (U.S. CLS. 1, 2, 3, 21, 22, 23, 26, 36, 38 AND 41). SN 79-053,057. PUB. 3-17-2009. FILED 3-27-2008.
- 3,631,575. **PLANETSUN PHOTOVOLTAIC SYSTEM AND DESIGN**. BEGHELLI S.P.A., MULTIPLE CLASS, (INT. CLS. 9 AND 11), (U.S. CLS. 13, 21, 23, 26, 31, 34, 36 AND 38). SN 79-053,160. PUB. 3-17-2009. FILED 3-26-2008.
- 3,631,576. **SAVE THE PLANET LINE AND DESIGN**. BEGHELLI S.P.A., MULTIPLE CLASS, (INT. CLS. 9 AND 11), (U.S. CLS. 13, 21, 23, 26, 31, 34, 36 AND 38). SN 79-053,161. PUB. 3-17-2009. FILED 3-26-2008.
- 3,631,578. **MC4 (BLOCK FORM)**. MULTI-HOLDING AG, (U.S. CLS. 21, 23, 26, 36 AND 38). SN 79-053,347. PUB. 3-17-2009. FILED 5-2-2008.
- 3,631,579. **MC3 (BLOCK FORM)**. MULTI-HOLDING AG, (U.S. CLS. 21, 23, 26, 36 AND 38). SN 79-053,348. PUB. 3-17-2009. FILED 5-2-2008.
- 3,631,587 (*See Class 7 for this trademark*).
- 3,631,588. **MODULAR LIGHTING INSTRUMENTS AND DESIGN**. KONINKLIJKE PHILIPS ELECTRONICS N.V., MULTIPLE CLASS, (INT. CLS. 9 AND 11), (U.S. CLS. 13, 21, 23, 26, 31, 34, 36 AND 38). SN 79-053,631. PUB. 3-17-2009. FILED 3-13-2008.
- 3,631,594. **SKINVADERS (STYLIZED)**. MXP4, MULTIPLE CLASS, (INT. CLS. 9, 15 AND 28), (U.S. CLS. 2, 21, 22, 23, 26, 36, 38 AND 50). SN 79-053,875. PUB. 3-17-2009. FILED 2-15-2008.
- 3,631,600. **HUGO BOSS (BLOCK FORM)**. HUGO BOSS; TRADE MARK MANAGEMENT GMBH & CO. KG, (U.S. CLS. 21, 23, 26, 36 AND 38). SN 79-054,017. PUB. 3-17-2009. FILED 4-26-2008.
- 3,631,603. **ENGINE (BLOCK FORM)**. THIRSTY FISH PTY LTD, MULTIPLE CLASS, (INT. CLS. 9, 25 AND 28), (U.S. CLS. 21, 22, 23, 26, 36, 38, 39 AND 50). SN 79-054,046. PUB. 3-17-2009. FILED 3-28-2008.
- 3,631,611. **ALUNA (STYLIZED)**. PETER GILES, AND YASMINE GILES, MULTIPLE CLASS, (INT. CLS. 9 AND 41), (U.S. CLS. 21, 23, 26, 36, 38, 100, 101 AND 107). SN 79-054,196. PUB. 3-17-2009. FILED 4-9-2008.
- 3,631,612 (*See Class 3 for this trademark*).
- 3,631,618. **JONATHAN KELSEY (STYLIZED)**. KELSEY, JONATHAN, MULTIPLE CLASS, (INT. CLS. 9, 18 AND 25), (U.S. CLS. 1, 2, 3, 21, 22, 23, 26, 36, 38, 39 AND 41). SN 79-054,278. PUB. 3-17-2009. FILED 12-14-2007.
- 3,631,622. **DECOSTUDIO (BLOCK FORM)**. WILCOM PTY LIMITED, (U.S. CLS. 21, 23, 26, 36 AND 38). SN 79-054,346. PUB. 3-17-2009. FILED 4-23-2008.
- 3,631,626 (*See Class 7 for this trademark*).
- 3,631,632 (*See Class 7 for this trademark*).
- 3,631,640. **TB AND DESIGN**. NINGBO TIANBO GANGLIAN; ELECTRONICS CO., LTD., (U.S. CLS. 21, 23, 26, 36 AND 38). SN 79-054,804. PUB. 3-17-2009. FILED 4-14-2008.
- 3,631,646. **LIFE IS ON (BLOCK FORM)**. SONOVA HOLDING AG, MULTIPLE CLASS, (INT. CLS. 9, 10, 42 AND 44), (U.S. CLS. 21, 23, 26, 36, 38, 39, 44, 100 AND 101). SN 79-055,099. PUB. 3-17-2009. FILED 12-14-2007.
- 3,631,647. **FELAM (BLOCK FORM)**. FELA HOLDING GMBH, MULTIPLE CLASS, (INT. CLS. 9, 35 AND 40), (U.S. CLS. 21,

23, 26, 36, 38, 100, 101, 102, 103 AND 106). SN 79-055,113. PUB. 3-17-2009. FILED 3-14-2008.

3,631,648 (*See Class 3 for this trademark*).

3,631,650. **RÖMER AND DESIGN**. GABRIELE ROLEFF, (U.S. CLS. 21, 23, 26, 36 AND 38). SN 79-055,204. PUB. 3-17-2009. FILED 8-17-2007.

3,631,663. **MISCELLANEOUS DESIGN**. TATAMI SCHUH GMBH, MULTIPLE CLASS, (INT. CLS. 9, 10, 18 AND 25), (U.S. CLS. 1, 2, 3, 21, 22, 23, 26, 36, 38, 39, 41 AND 44). SN 79-055,513. PUB. 3-17-2009. FILED 2-4-2008.

3,631,671. **SCATTER PIRATES AND DESIGN**. ARUZE CORPORATION, MULTIPLE CLASS, (INT. CLS. 9 AND 28), (U.S. CLS. 21, 22, 23, 26, 36, 38 AND 50). SN 79-055,790. PUB. 3-17-2009. FILED 4-16-2008.

3,631,676. **JAPIRA (BLOCK FORM)**. JAPIRA AG, MULTIPLE CLASS, (INT. CLS. 9 AND 38), (U.S. CLS. 21, 23, 26, 36, 38, 100, 101 AND 104). SN 79-055,909. PUB. 3-17-2009. FILED 6-16-2008.

3,631,680. **VISIONOX (STYLIZED)**. BEIJING VISIONOX TECHNOLOGY CO., LTD., MULTIPLE CLASS, (INT. CLS. 9, 11 AND 14), (U.S. CLS. 2, 13, 21, 23, 26, 27, 28, 31, 34, 36, 38 AND 50). SN 79-056,321. PUB. 3-17-2009. FILED 4-14-2008.

3,631,685. **ZIMMERMANN (BLOCK FORM)**. ZIMMERMANN WEAR PTY LTD, MULTIPLE CLASS, (INT. CLS. 9, 18, 25, 35 AND 42), (U.S. CLS. 1, 2, 3, 21, 22, 23, 26, 36, 38, 39, 41, 100, 101 AND 102). SN 79-056,535. PUB. 3-17-2009. FILED 2-1-2008.

3,631,693. **FOXBOX (BLOCK FORM)**. GÜNTHER SPELSBERG GMBH & CO. KG, AND MULTI-CONTACT AG, (U.S. CLS. 21, 23, 26, 36 AND 38). SN 79-056,984. PUB. 3-17-2009. FILED 4-28-2008.

3,631,697. **MILICOR (BLOCK FORM)**. EADS SECURE NETWORKS, (U.S. CLS. 21, 23, 26, 36 AND 38). SN 79-057,063. PUB. 3-17-2009. FILED 4-3-2008.

3,631,698. **FORTECOR (BLOCK FORM)**. EADS SECURE NETWORKS, (U.S. CLS. 21, 23, 26, 36 AND 38). SN 79-057,076. PUB. 3-17-2009. FILED 4-25-2008.

3,631,699. **Y.QUICKSCAN (BLOCK FORM)**. YXLON INTERNATIONAL GMBH, MULTIPLE CLASS, (INT. CLS. 9, 37 AND 42), (U.S. CLS. 21, 23, 26, 36, 38, 100, 101, 103 AND 106). SN 79-057,092. PUB. 3-17-2009. FILED 6-2-2008.

3,631,707 (*See Class 7 for this trademark*).

3,631,711 (*See Class 6 for this trademark*).

3,631,718. **POWER OF SIMPLICITY (BLOCK FORM)**. QLIK-TECH INTERNATIONAL AB, MULTIPLE CLASS, (INT. CLS. 9 AND 42), (U.S. CLS. 21, 23, 26, 36, 38, 100 AND 101). SN 79-057,746. PUB. 3-17-2009. FILED 3-28-2008.

3,631,720 (*See Class 7 for this trademark*).

3,631,724. **PODIAXP (BLOCK FORM)**. SELSEK MATTHIEU, (U.S. CLS. 21, 23, 26, 36 AND 38). SN 79-058,155. PUB. 3-17-2009. FILED 4-11-2008.

3,631,733 (*See Class 7 for this trademark*).

3,631,740 (*See Class 7 for this trademark*).

3,631,743. **RBSM (BLOCK FORM)**. THE ROYAL BANK OF SCOTLAND GROUP PLC, MULTIPLE CLASS, (INT. CLS. 9, 16, 35, 36, 38 AND 42), (U.S. CLS. 2, 5, 21, 22, 23, 26, 29, 36, 37, 38, 50, 100, 101, 102 AND 104). SN 79-059,140. PUB. 3-17-2009. FILED 2-5-2008.

3,631,751. **NOKIA TRAFFIC SERVICE (STYLIZED)**. NOKIA CORPORATION, MULTIPLE CLASS, (INT. CLS. 9, 38 AND 39), (U.S. CLS. 21, 23, 26, 36, 38, 100, 101, 104 AND 105). SN 79-059,651. PUB. 3-17-2009. FILED 9-4-2008.

3,631,761. **CECE (BLOCK FORM)**. WIENER BÖRSE AG, MULTIPLE CLASS, (INT. CLS. 9, 16, 35, 36, 37, 41 AND 42), (U.S. CLS. 2, 5, 21, 22, 23, 26, 29, 36, 37, 38, 50, 100, 101, 102, 103, 106 AND 107). SN 79-060,622. PUB. 3-17-2009. FILED 6-17-2008.

3,631,765. **MICROEJ (BLOCK FORM)**. INDUSTRIAL SOFTWARE TECHNOLOGY, MULTIPLE CLASS, (INT. CLS. 9 AND 42), (U.S. CLS. 21, 23, 26, 36, 38, 100 AND 101). SN 79-061,347. PUB. 3-17-2009. FILED 9-5-2008.

3,631,767. **DOLPHIN DREAM (BLOCK FORM)**. LIGHTNING BOX GAMES PTY LTD, MULTIPLE CLASS, (INT. CLS. 9 AND 28), (U.S. CLS. 21, 22, 23, 26, 36, 38 AND 50). SN 79-061,993. PUB. 3-17-2009. FILED 10-29-2008.

3,631,773. **OIO (BLOCK FORM)**. ESCHENBACH OPTIK GMBH, (U.S. CLS. 21, 23, 26, 36 AND 38). SN 79-062,383.

PUB. 3-17-2009. FILED 10-22-2008.

3,631,785. **MOMODESIGN (STYLIZED)**. MOMO S.R.L., (U.S. CLS. 21, 23, 26, 36 AND 38). SN 79-975,051. PUB. 3-17-2009. FILED 11-2-2005.

CLASS 10—MEDICAL APPARATUS

3,629,149. **MJX 2000 (BLOCK FORM)**. WILLIAMS, MICHAEL O., (U.S. CLS. 26, 39 AND 44). SN 76-687,335. PUB. 3-17-2009. FILED 3-4-2008.

3,629,154. **THE TOOL BEHIND THE TALENT (BLOCK FORM)**. SOUND SURGICAL TECHNOLOGIES LLC., (U.S. CLS. 26, 39 AND 44). SN 76-687,768. PUB. 3-17-2009. FILED 3-17-2008.

3,629,160. **HERO 642 (BLOCK FORM)**. MICRO-MEGA INTERNATIONAL MANUFACTURES, (U.S. CLS. 26, 39 AND 44). SN 76-688,460. PUB. 3-17-2009. FILED 4-8-2008.

3,629,206. **BT-CATH (BLOCK FORM)**. UTAH MEDICAL PRODUCTS, INC., (U.S. CLS. 26, 39 AND 44). SN 76-693,715. PUB. 3-17-2009. FILED 10-20-2008.

3,629,291 (*See Class 9 for this trademark*).

3,629,443. **MICROPLASTY (BLOCK FORM)**. BIOMET MANUFACTURING CORP., (U.S. CLS. 26, 39 AND 44). SN 77-337,493. PUB. 3-17-2009. FILED 11-27-2007.

3,629,454 (*See Class 5 for this trademark*).

3,629,491. **IGUANASKINZ AND DESIGN**. WALRUS BRANDS, LLC, MULTIPLE CLASS, (INT. CLS. 10 AND 25), (U.S. CLS. 22, 26, 39 AND 44). SN 77-369,668. PUB. 3-17-2009. FILED S.R. 1-11-2008; AM. P.R. 1-17-2008.

3,629,492 (*See Class 9 for this trademark*).

3,629,535 (*See Class 8 for this trademark*).

3,629,541 (*See Class 5 for this trademark*).

3,629,587. **SEROJECT (BLOCK FORM)**. ARES TRADING S.A., (U.S. CLS. 26, 39 AND 44). SN 77-418,577. PUB. 3-17-2009. FILED 3-11-2008.

3,629,731. **FLUOROPRO (BLOCK FORM)**. VIRTUAL IMAGING, INC., (U.S. CLS. 26, 39 AND 44). SN 77-445,745. PUB. 3-17-2009. FILED 4-11-2008.

3,629,749. **ANDERSON (BLOCK FORM)**. CARE FOR DISABLED ANIMALS, INC., (U.S. CLS. 26, 39 AND 44). SN 77-448,178. PUB. 3-17-2009. FILED 4-15-2008.

3,629,750. **CDA PRODUCTS (BLOCK FORM)**. CARE FOR DISABLED ANIMALS, INC., (U.S. CLS. 26, 39 AND 44). SN 77-448,205. PUB. 3-17-2009. FILED 4-15-2008.

3,629,809. **SENSIBLE LINES (BLOCK FORM)**. SENSIBLE LINES, LLC, FORMERLY SLIM LINES, LLC, (U.S. CLS. 26, 39 AND 44). SN 77-452,819. PUB. 3-17-2009. FILED 4-19-2008.

3,629,818. **BACK - PAK (BLOCK FORM)**. ATLAS SPINE, INC., (U.S. CLS. 26, 39 AND 44). SN 77-453,634. PUB. 3-17-2009. FILED 4-21-2008.

3,629,964. **HIP N GO (BLOCK FORM)**. FH ORTHOPEDICS, (U.S. CLS. 26, 39 AND 44). SN 77-482,203. PUB. 3-17-2009. FILED 5-23-2008.

3,630,181. **MUSCLE MAXX (BLOCK FORM)**. CALIFORNIA EXOTIC NOVELTIES LLC, (U.S. CLS. 26, 39 AND 44). SN 77-542,968. PUB. 3-17-2009. FILED 8-8-2008.

3,630,224 (*See Class 5 for this trademark*).

3,630,334. **GOTTFRIED (BLOCK FORM)**. GOTTFRIED MEDICAL, INC., (U.S. CLS. 26, 39 AND 44). SN 77-569,948. PUB. 3-17-2009. FILED 9-15-2008.

3,630,351. **PET STICK (BLOCK FORM)**. RELAXACIZOR PRODUCTS, INC., (U.S. CLS. 26, 39 AND 44). SN 77-572,999. PUB. 3-17-2009. FILED 9-18-2008.

3,630,443. **F3 (BLOCK FORM)**. KARL STORZ IMAGING, INC., (U.S. CLS. 26, 39 AND 44). SN 77-584,395. PUB. 3-17-2009. FILED 10-2-2008.

3,630,740. **VISMARX (BLOCK FORM)**. VISCOT MEDICAL, LLC, (U.S. CLS. 26, 39 AND 44). SN 77-598,834. PUB. 3-17-2009. FILED 10-23-2008.

3,630,746. **COLDURE TECHNOLOGY (BLOCK FORM)**. KING BRAND HEALTHCARE PRODUCTS, (U.S. CLS. 26, 39 AND 44). SN 77-598,864. PUB. 3-17-2009. FILED 10-23-2008.

3,630,766. **PONSETI (BLOCK FORM)**. MD ORTHOPAEDICS, INC., (U.S. CLS. 26, 39 AND 44). SN 77-599,149. PUB. 3-17-

2009. FILED 10-23-2008.
 3,630,920. **PULSTAR (BLOCK FORM)**. ENCOMPASS GROUP, LLC, DBA ALBAHEALTH LLC, (U.S. CLS. 26, 39 AND 44). SN 77-601,162. PUB. 3-17-2009. FILED 10-27-2008.
 3,631,012. **EARFORMS (BLOCK FORM)**. FEDORJAKA, JOHN, (U.S. CLS. 26, 39 AND 44). SN 77-602,350. PUB. 3-17-2009. FILED 10-28-2008.
 3,631,066. **PYNG MEDICAL (BLOCK FORM)**. PYNG MEDICAL CORP., (U.S. CLS. 26, 39 AND 44). SN 77-603,375. PUB. 3-17-2009. FILED 10-29-2008.
 3,631,102. **VORTRAN (BLOCK FORM)**. VORTRAN MEDICAL TECHNOLOGY1, INC., (U.S. CLS. 26, 39 AND 44). SN 77-603,980. PUB. 3-17-2009. FILED 10-30-2008.
 3,631,106. **VAR (BLOCK FORM)**. VORTRAN MEDICAL TECHNOLOGY1, INC., (U.S. CLS. 26, 39 AND 44). SN 77-604,015. PUB. 3-17-2009. FILED 10-30-2008.
 3,631,111. **PERCUSSIVENE (BLOCK FORM)**. VORTRAN MEDICAL TECHNOLOGY1, INC., (U.S. CLS. 26, 39 AND 44). SN 77-604,066. PUB. 3-17-2009. FILED 10-30-2008.
 3,631,134. **DEXACARE (BLOCK FORM)**. OSTEOMETER MEDITHECH, INC., (U.S. CLS. 26, 39 AND 44). SN 77-604,478. PUB. 3-17-2009. FILED 10-30-2008.
 3,631,178. **VRTIS (BLOCK FORM)**. ASICO LLC, (U.S. CLS. 26, 39 AND 44). SN 77-605,260. PUB. 3-17-2009. FILED 10-31-2008.
 3,631,205. **2 SECOND MIRACLE (BLOCK FORM)**. THERATIVE, INC., (U.S. CLS. 26, 39 AND 44). SN 77-605,505. PUB. 3-17-2009. FILED 10-31-2008.
 3,631,272. **DREAMDIRECTOR (BLOCK FORM)**. DREAMSCI INC, (U.S. CLS. 26, 39 AND 44). SN 77-608,421. PUB. 3-17-2009. FILED 11-5-2008.
 3,631,380. **FIESTA (BLOCK FORM)**. LRC PRODUCTS LIMITED, (U.S. CLS. 26, 39 AND 44). SN 78-392,556. PUB. 3-17-2009. FILED 3-29-2004.
 3,631,397 (*See Class 9 for this trademark*).
 3,631,398 (*See Class 9 for this trademark*).
 3,631,404. **T TURNER TECHNOLOGY INSTRUMENTS AND DESIGN**. TTI TURNER TECHNOLOGY INSTRUMENTS INC., MULTIPLE CLASS, (INT. CLS. 10 AND 42), (U.S. CLS. 26, 39, 44, 100 AND 101). SN 78-651,405. PUB. 3-17-2009. FILED 6-15-2005.
 3,631,413 (*See Class 7 for this trademark*).
 3,631,418. **BAREFOOT SCIENCE (BLOCK FORM)**. BAREFOOT SCIENCE TECHNOLOGIES, INC., (U.S. CLS. 26, 39 AND 44). SN 78-801,321. PUB. 3-17-2009. FILED 1-27-2006.
 3,631,427 (*See Class 3 for this trademark*).
 3,631,441. **MEDDYNAMIX (STYLIZED)**. MED-I-DYNAMIX FLUID MONITORING LTD., MULTIPLE CLASS, (INT. CLS. 10, 35 AND 44), (U.S. CLS. 26, 39, 44, 100, 101 AND 102). SN 78-927,609. PUB. 3-17-2009. FILED 7-12-2006.
 3,631,505 (*See Class 8 for this trademark*).
 3,631,519 (*See Class 5 for this trademark*).
 3,631,520 (*See Class 5 for this trademark*).
 3,631,540. **SECUTEMP (BLOCK FORM)**. W.E.T. AUTOMOTIVE SYSTEMS AG, MULTIPLE CLASS, (INT. CLS. 10, 11, 17 AND 24), (U.S. CLS. 1, 5, 12, 13, 21, 23, 26, 31, 34, 35, 39, 42, 44 AND 50). SN 79-050,880. PUB. 3-17-2009. FILED 9-21-2007.
 3,631,547 (*See Class 6 for this trademark*).
 3,631,554 (*See Class 1 for this trademark*).
 3,631,559 (*See Class 5 for this trademark*).
 3,631,564 (*See Class 5 for this trademark*).
 3,631,590. **SOUNDLEARNING (BLOCK FORM)**. SIEMENS AUDIOLOGISCHE TECHNIK GMBH, (U.S. CLS. 26, 39 AND 44). SN 79-053,649. PUB. 3-17-2009. FILED 4-18-2008.
 3,631,609. **PEGARO (BLOCK FORM)**. HOCOMA AG, MULTIPLE CLASS, (INT. CLS. 10 AND 28), (U.S. CLS. 22, 23, 26, 38, 39, 44 AND 50). SN 79-054,157. PUB. 3-17-2009. FILED 4-10-2008.
 3,631,642. **MR RESOCARD AND DESIGN**. KEERSMAEKERS GERT, (U.S. CLS. 26, 39 AND 44). SN 79-054,897. PUB. 3-17-2009. FILED 4-22-2008.
 3,631,646 (*See Class 9 for this trademark*).
 3,631,654. **ENERGY (BLOCK FORM)**. SIEMENS AUDIOLOGISCHE TECHNIK GMBH, (U.S. CLS. 26, 39 AND 44). SN 79-055,311. PUB. 3-17-2009. FILED 6-5-2008.
 3,631,663 (*See Class 9 for this trademark*).
 3,631,670. **SPIRE IT (BLOCK FORM)**. MICROVAL, (U.S. CLS. 26, 39 AND 44). SN 79-055,767. PUB. 3-17-2009. FILED 6-2-

2008.
 3,631,719. **LDM (BLOCK FORM)**. WELLCOMET GMBH, (U.S. CLS. 26, 39 AND 44). SN 79-057,763. PUB. 3-17-2009. FILED 5-23-2008.
 3,631,770. **MOTION (BLOCK FORM)**. SIEMENS AUDIOLOGISCHE TECHNIK GMBH, (U.S. CLS. 26, 39 AND 44). SN 79-062,122. PUB. 3-17-2009. FILED 10-17-2008.

CLASS 11—ENVIRONMENTAL CONTROL APPARATUS

3,629,233 (*See Class 1 for this trademark*).
 3,629,245 (*See Class 3 for this trademark*).
 3,629,252. **NANO O2 (BLOCK FORM)**. PHARMATROPIC, LTD., (U.S. CLS. 13, 21, 23, 31 AND 34). SN 77-081,607. PUB. 3-17-2009. FILED 1-12-2007.
 3,629,255 (*See Class 7 for this trademark*).
 3,629,275 (*See Class 7 for this trademark*).
 3,629,307 (*See Class 9 for this trademark*).
 3,629,321 (*See Class 6 for this trademark*).
 3,629,339 (*See Class 4 for this trademark*).
 3,629,410. **ZONEFIRST AND DESIGN**. TROLEX CORPORATION, (U.S. CLS. 13, 21, 23, 31 AND 34). SN 77-311,083. PUB. 3-17-2009. FILED 10-23-2007.
 3,629,437. **EARLY CHOICES (BLOCK FORM)**. CONCEVA INNOVATIVE PRODUCTS LTD., (U.S. CLS. 13, 21, 23, 31 AND 34). SN 77-335,018. PUB. 3-17-2009. FILED 11-21-2007.
 3,629,438. **FLUSH2O (BLOCK FORM)**. BEAUPRÉ, PIERRE, (U.S. CLS. 13, 21, 23, 31 AND 34). SN 77-336,037. PUB. 8-12-2008. FILED 11-23-2007.
 3,629,465. **AMASOND (BLOCK FORM)**. AMASOND VERTRIEBS GMBH, MULTIPLE CLASS, (INT. CLS. 11, 17 AND 37), (U.S. CLS. 1, 5, 12, 13, 21, 23, 31, 34, 35, 50, 100, 103 AND 106). SN 77-354,470. PUB. 3-17-2009. FILED 12-18-2007.
 3,629,470. **RICHFORD (BLOCK FORM)**. ROYAL RICH (CHINA) LTD., (U.S. CLS. 13, 21, 23, 31 AND 34). SN 77-356,365. PUB. 3-17-2009. FILED 12-19-2007.
 3,629,504 (*See Class 7 for this trademark*).
 3,629,550. **LIGHTKULTURE (STYLIZED)**. LIGHTKULTURE-COM, LLC, MULTIPLE CLASS, (INT. CLS. 11, 14 AND 20), (U.S. CLS. 2, 13, 21, 22, 23, 25, 27, 28, 31, 32, 34 AND 50). SN 77-399,385. PUB. 3-17-2009. FILED 2-18-2008.
 3,629,551. **HH2 HH2+ (BLOCK FORM)**. ZUPANCIC, DEREK J., DBA HYDROELECTRICPOWER LLC, (U.S. CLS. 13, 21, 23, 31 AND 34). SN 77-399,890. PUB. 3-17-2009. FILED 2-19-2008.
 3,629,630. **AIRPORT THE SPA AIR SOLUTION (BLOCK FORM)**. PARAMOUNT LEISURE INDUSTRIES, INC., (U.S. CLS. 13, 21, 23, 31 AND 34). SN 77-433,517. PUB. 3-17-2009. FILED 3-27-2008.
 3,629,638. **NITE SAVER AND DESIGN**. NG, KENNY KA WAH, DBA CCS, (U.S. CLS. 13, 21, 23, 31 AND 34). SN 77-434,966. PUB. 3-17-2009. FILED 3-28-2008.
 3,629,683 (*See Class 6 for this trademark*).
 3,629,715. **NOAH'S COLLECTION (BLOCK FORM)**. WHITE'S PLUMBING SUPPLIES, INC., (U.S. CLS. 13, 21, 23, 31 AND 34). SN 77-444,603. PUB. 3-17-2009. FILED 4-10-2008.
 3,629,786. **PORT.A.COOL AND DESIGN**. PORT-A-COOL, LLC, (U.S. CLS. 13, 21, 23, 31 AND 34). SN 77-451,373. PUB. 3-17-2009. FILED 4-17-2008.
 3,629,804 (*See Class 6 for this trademark*).
 3,629,875. **FREYTECH INC. (STYLIZED)**. FREYTECH INC., (U.S. CLS. 13, 21, 23, 31 AND 34). SN 77-461,317. PUB. 3-17-2009. FILED 4-29-2008.
 3,629,912. **AQUAOX WATER PURIFYING SYSTEMS AND DESIGN**. AQUAOX, (U.S. CLS. 13, 21, 23, 31 AND 34). SN 77-469,086. PUB. 3-17-2009. FILED 5-8-2008.
 3,629,994 (*See Class 7 for this trademark*).
 3,630,073. **FITS-ALL (BLOCK FORM)**. FLUIDMASTER, INC., (U.S. CLS. 13, 21, 23, 31 AND 34). SN 77-514,071. PUB. 3-17-2009. FILED 7-2-2008.
 3,630,113. **SAFE STEP WALK IN TUB CO. (BLOCK FORM)**. SAFE STEP WALK IN TUB CO., (U.S. CLS. 13, 21, 23, 31 AND 34). SN 77-524,584. PUB. 3-17-2009. FILED 7-17-2008.
 3,630,114. **SAFE STEP WALK IN TUB CO. SAFETY NEVER FELT SO GOOD (BLOCK FORM)**. SAFE STEP WALK IN

- TUB CO., (U.S. CLS. 13, 21, 23, 31 AND 34). SN 77-524,622. PUB. 3-17-2009. FILED 7-17-2008.
- 3,630,125. **HEADCELL (BLOCK FORM)**. EUTEK SYSTEMS, INC., (U.S. CLS. 13, 21, 23, 31 AND 34). SN 77-526,544. PUB. 3-17-2009. FILED 7-19-2008.
- 3,630,137. **EARTH WATER (BLOCK FORM)**. ANDERSON, JANE E. AND RENDA, ED. AND CASSIDY, MARIE A., (U.S. CLS. 13, 21, 23, 31 AND 34). SN 77-529,442. PUB. 3-17-2009. FILED 7-23-2008.
- 3,630,156. **ECOSWIM (BLOCK FORM)**. ECOSWIM USA INC., (U.S. CLS. 13, 21, 23, 31 AND 34). SN 77-534,098. PUB. 3-17-2009. FILED 7-29-2008.
- 3,630,249. **HEAT ON DEMAND ULTRA (BLOCK FORM)**. ALADDIN TEMP-RITE, LLC, (U.S. CLS. 13, 21, 23, 31 AND 34). SN 77-556,825. PUB. 3-17-2009. FILED 8-27-2008.
- 3,630,328. **T AND DESIGN**. TOPCO ENERGY SAVING SYSTEM CORPORATION, (U.S. CLS. 13, 21, 23, 31 AND 34). SN 77-569,610. PUB. 3-17-2009. FILED 9-15-2008.
- 3,630,377. **TUNS (BLOCK FORM)**. AIRKOR HEATING AND AIR CONDITIONING, INC., AKA TRANSAMERICA UNDERWRITERS NATIONAL SUPPLY, (U.S. CLS. 13, 21, 23, 31 AND 34). SN 77-576,269. PUB. 3-17-2009. FILED 9-23-2008.
- 3,630,378. **RESTORER (BLOCK FORM)**. HMI INDUSTRIES INC., (U.S. CLS. 13, 21, 23, 31 AND 34). SN 77-576,345. PUB. 3-17-2009. FILED 9-23-2008.
- 3,630,471. **GROUND HEATERS (BLOCK FORM)**. WACKER NEUSON CORPORATION, (U.S. CLS. 13, 21, 23, 31 AND 34). SN 77-587,478. PUB. 3-17-2009. FILED 10-7-2008.
- 3,630,539. **COURTLY CHECK (BLOCK FORM)**. MACKENZIE-CHILDS AURORA LLC, MULTIPLE CLASS, (INT. CLS. 11, 20, 21, 24 AND 27), (U.S. CLS. 2, 13, 19, 20, 21, 22, 23, 25, 29, 30, 31, 32, 33, 34, 37, 40, 42 AND 50). SN 77-592,501. PUB. 3-17-2009. FILED 10-14-2008.
- 3,630,571. **TIDY TANK (BLOCK FORM)**. IBT CONSULTANTS INC., (U.S. CLS. 13, 21, 23, 31 AND 34). SN 77-594,615. PUB. 3-17-2009. FILED 10-16-2008.
- 3,630,582. **MULTISTAR (BLOCK FORM)**. THAKKAR, INC., (U.S. CLS. 13, 21, 23, 31 AND 34). SN 77-595,135. PUB. 3-17-2009. FILED 10-17-2008.
- 3,630,626. **SOLARIS (BLOCK FORM)**. JME INCORPORATED, DBA TMB, (U.S. CLS. 13, 21, 23, 31 AND 34). SN 77-596,650. PUB. 3-17-2009. FILED 10-21-2008.
- 3,630,664. **SWANK LIGHTING AND DESIGN**. SWANK LIGHTING LP, (U.S. CLS. 13, 21, 23, 31 AND 34). SN 77-597,449. PUB. 3-17-2009. FILED 10-21-2008.
- 3,630,786. **KOOL-LIGHT-O-SCOPE (BLOCK FORM)**. GREAT AMERICAN DUCK RACES, INC., DBA GREAT AMERICAN MERCHANDISE AND EVENTS, (U.S. CLS. 13, 21, 23, 31 AND 34). SN 77-599,427. PUB. 3-17-2009. FILED 10-23-2008.
- 3,630,854 (*See Class 6 for this trademark*).
- 3,630,858. **HOTZONE (BLOCK FORM)**. RADIANT OPTICS, INC., (U.S. CLS. 13, 21, 23, 31 AND 34). SN 77-600,335. PUB. 3-17-2009. FILED 10-24-2008.
- 3,630,891. **DEFIANT (BLOCK FORM)**. MONESSEN HEARTH SYSTEMS COMPANY, (U.S. CLS. 13, 21, 23, 31 AND 34). SN 77-600,817. PUB. 3-17-2009. FILED 10-27-2008.
- 3,630,902. **LIZ JORDAN LIGHTING (BLOCK FORM)**. DECORATIVE PRODUCT SOURCE, INC., (U.S. CLS. 13, 21, 23, 31 AND 34). SN 77-600,949. PUB. 3-17-2009. FILED 10-27-2008.
- 3,630,915. **PDI AND DESIGN**. PEACHTREE DISTRIBUTING INC., (U.S. CLS. 13, 21, 23, 31 AND 34). SN 77-601,064. PUB. 3-17-2009. FILED 10-27-2008.
- 3,631,005. **ICY-GLOW (BLOCK FORM)**. ATICO INTERNATIONAL USA, INC., MULTIPLE CLASS, (INT. CLS. 11 AND 20), (U.S. CLS. 2, 13, 21, 22, 23, 25, 31, 32, 34 AND 50). SN 77-602,267. PUB. 3-17-2009. FILED 10-28-2008.
- 3,631,035. **ETORUS FEH (BLOCK FORM)**. ETORUS FEH LLC, (U.S. CLS. 13, 21, 23, 31 AND 34). SN 77-602,685. PUB. 3-17-2009. FILED 10-29-2008.
- 3,631,131. **PROFSR AND DESIGN**. KEITH LAVIMODIERE, (U.S. CLS. 13, 21, 23, 31 AND 34). SN 77-604,429. PUB. 3-17-2009. FILED 10-30-2008.
- 3,631,391. **CAMELION (BLOCK FORM)**. CAMELION ENTERPRISES LIMITED, (U.S. CLS. 13, 21, 23, 31 AND 34). SN 77-525,584. PUB. 3-17-2009. FILED 12-1-2004.
- 3,631,413 (*See Class 7 for this trademark*).
- 3,631,452 (*See Class 1 for this trademark*).
- 3,631,472 (*See Class 3 for this trademark*).
- 3,631,494 (*See Class 6 for this trademark*).
- 3,631,498. **CHROMLECH (BLOCK FORM)**. CHROMLECH, MULTIPLE CLASS, (INT. CLS. 11 AND 42), (U.S. CLS. 13, 21, 23, 31, 34, 100 AND 101). SN 79-045,137. PUB. 3-17-2009. FILED 9-27-2007.
- 3,631,508. **SOMMELIER (BLOCK FORM)**. BRAUN GMBH, (U.S. CLS. 13, 21, 23, 31 AND 34). SN 79-047,334. PUB. 3-17-2009. FILED 11-13-2007.
- 3,631,510 (*See Class 1 for this trademark*).
- 3,631,524 (*See Class 7 for this trademark*).
- 3,631,540 (*See Class 10 for this trademark*).
- 3,631,547 (*See Class 6 for this trademark*).
- 3,631,554 (*See Class 1 for this trademark*).
- 3,631,562. **MISCELLANEOUS DESIGN**. BBMG GROUP CORPORATION, MULTIPLE CLASS, (INT. CLS. 11, 35, 37, 42, 43 AND 45), (U.S. CLS. 13, 21, 23, 31, 34, 100, 101, 102, 103 AND 106). SN 79-052,476. PUB. 3-17-2009. FILED 2-2-2008.
- 3,631,575 (*See Class 9 for this trademark*).
- 3,631,576 (*See Class 9 for this trademark*).
- 3,631,587 (*See Class 7 for this trademark*).
- 3,631,588 (*See Class 9 for this trademark*).
- 3,631,601 (*See Class 7 for this trademark*).
- 3,631,628. **FULGOR (STYLIZED)**. FULGOR EUROPE SPA, (U.S. CLS. 13, 21, 23, 31 AND 34). SN 79-054,462. PUB. 3-17-2009. FILED 12-20-2007.
- 3,631,633 (*See Class 7 for this trademark*).
- 3,631,668. **GLACIALLIGHT AND DESIGN**. GLACIALTECH, INC., (U.S. CLS. 13, 21, 23, 31 AND 34). SN 79-055,728. PUB. 3-17-2009. FILED 7-9-2008.
- 3,631,680 (*See Class 9 for this trademark*).
- 3,631,782. **MISCELLANEOUS DESIGN**. ENEL S.P.A., MULTIPLE CLASS, (INT. CLS. 11, 39 AND 40), (U.S. CLS. 13, 21, 23, 31, 34, 100, 103, 105 AND 106). SN 79-063,791. PUB. 3-17-2009. FILED 10-14-2008.
- 3,631,783. **MISCELLANEOUS DESIGN**. ENEL S.P.A., MULTIPLE CLASS, (INT. CLS. 11, 39 AND 40), (U.S. CLS. 13, 21, 23, 31, 34, 100, 103, 105 AND 106). SN 79-063,792. PUB. 3-17-2009. FILED 10-14-2008.
- 3,631,784. **MISCELLANEOUS DESIGN**. ENEL S.P.A., MULTIPLE CLASS, (INT. CLS. 11, 39 AND 40), (U.S. CLS. 13, 21, 23, 31, 34, 100, 103, 105 AND 106). SN 79-063,793. PUB. 3-17-2009. FILED 10-14-2008.

CLASS 12—VEHICLES

- 3,629,233 (*See Class 1 for this trademark*).
- 3,629,275 (*See Class 7 for this trademark*).
- 3,629,286. **SCOOTER SUPERSTORE OF AMERICA, INC AND DESIGN**. SCOOTER SUPERSTORE OF AMERICA, INC., (U.S. CLS. 19, 21, 23, 31, 35 AND 44). SN 77-151,559. PUB. 3-17-2009. FILED 4-9-2007.
- 3,629,361 (*See Class 7 for this trademark*).
- 3,629,455. **DURA AUTOMOTIVE SYSTEMS (BLOCK FORM)**. DURA GLOBAL TECHNOLOGIES, INC., (U.S. CLS. 19, 21, 23, 31, 35 AND 44). SN 77-347,792. PUB. 3-17-2009. FILED 12-10-2007.
- 3,629,484. **MISCELLANEOUS DESIGN**. ASPEN CUSTOM TRAILERS, (U.S. CLS. 19, 21, 23, 31, 35 AND 44). SN 77-365,985. PUB. 12-2-2008. FILED 1-7-2008.
- 3,629,497. **HOUGHTON (BLOCK FORM)**. JERALD, INC., (U.S. CLS. 19, 21, 23, 31, 35 AND 44). SN 77-373,456. PUB. 3-17-2009. FILED 1-16-2008.
- 3,629,510. **MAGIS (BLOCK FORM)**. GURU BICYCLE MANUFACTURING INC., (U.S. CLS. 19, 21, 23, 31, 35 AND 44). SN 77-381,759. PUB. 3-17-2009. FILED 1-28-2008.
- 3,629,511. **MERUS (BLOCK FORM)**. GURU BICYCLE MANUFACTURING INC., (U.S. CLS. 19, 21, 23, 31, 35 AND 44). SN 77-381,789. PUB. 3-17-2009. FILED 1-28-2008.
- 3,629,512. **VENTUS (BLOCK FORM)**. GURU BICYCLE MANUFACTURING INC., (U.S. CLS. 19, 21, 23, 31, 35 AND 44). SN 77-381,797. PUB. 3-17-2009. FILED 1-28-2008.
- 3,629,513. **EVOLO (BLOCK FORM)**. GURU BICYCLE MANUFACTURING INC., (U.S. CLS. 19, 21, 23, 31, 35 AND 44). SN 77-381,809. PUB. 3-17-2009. FILED 1-28-2008.

- 3,629,514. **VENIO (BLOCK FORM)**. GURU BICYCLE MANUFACTURING INC., (U.S. CLS. 19, 21, 23, 31, 35 AND 44). SN 77-381,832. PUB. 3-17-2009. FILED 1-28-2008.
- 3,629,540. **BOB (BLOCK FORM)**. BOB TRAILERS, INC., (U.S. CLS. 19, 21, 23, 31, 35 AND 44). SN 77-396,123. PUB. 3-17-2009. FILED 2-13-2008.
- 3,629,559 (*See Class 7 for this trademark*).
- 3,629,593. **GUARDIAN WEATHERALL (BLOCK FORM)**. DOWCO, INC., (U.S. CLS. 19, 21, 23, 31, 35 AND 44). SN 77-420,096. PUB. 3-17-2009. FILED 3-12-2008.
- 3,629,603 (*See Class 7 for this trademark*).
- 3,629,732. **TIRE BEE (BLOCK FORM)**. KUPELIAN, CHARLES H., (U.S. CLS. 19, 21, 23, 31, 35 AND 44). SN 77-445,898. PUB. 3-17-2009. FILED 4-11-2008.
- 3,629,738. **MERLOT (BLOCK FORM)**. MERLOT TARPAULIN & SIDEKIT MANUFACTURING CO., INC., MULTIPLE CLASS, (INT. CLS. 12 AND 22), (U.S. CLS. 1, 2, 7, 19, 21, 22, 23, 31, 35, 42, 44 AND 50). SN 77-447,217. PUB. 3-17-2009. FILED 4-14-2008.
- 3,629,741. **VANGO (BLOCK FORM)**. MERLOT TARPAULIN & SIDEKIT MANUFACTURING CO., INC., MULTIPLE CLASS, (INT. CLS. 12 AND 22), (U.S. CLS. 1, 2, 7, 19, 21, 22, 23, 31, 35, 42, 44 AND 50). SN 77-447,292. PUB. 3-17-2009. FILED 4-14-2008.
- 3,629,746. **SOFTDASH (BLOCK FORM)**. JONES, DERIK T, (U.S. CLS. 19, 21, 23, 31, 35 AND 44). SN 77-447,776. PUB. 3-17-2009. FILED 4-14-2008.
- 3,629,808. **CIELO (BLOCK FORM)**. CHRISTOPHER D. KING, (U.S. CLS. 19, 21, 23, 31, 35 AND 44). SN 77-452,523. PUB. 3-17-2009. FILED 4-18-2008.
- 3,629,838. **C 2 AND DESIGN**. AERO INDUSTRIES, INC., (U.S. CLS. 19, 21, 23, 31, 35 AND 44). SN 77-455,538. PUB. 3-17-2009. FILED 4-23-2008.
- 3,629,946. **PIED-A-MER (BLOCK FORM)**. MIDNIGHT EXPRESS POWER BOATS, INC., (U.S. CLS. 19, 21, 23, 31, 35 AND 44). SN 77-478,260. PUB. 3-17-2009. FILED 5-19-2008.
- 3,630,086. **CRESCENT TANK MFG. AND DESIGN**. CRESCENT SERVICES, INC., DBA CRESCENT TANK MFG, (U.S. CLS. 19, 21, 23, 31, 35 AND 44). SN 77-518,151. PUB. 3-17-2009. FILED 7-9-2008.
- 3,630,141. **BELSHE (BLOCK FORM)**. BELSHE INDUSTRIES, INC., (U.S. CLS. 19, 21, 23, 31, 35 AND 44). SN 77-531,245. PUB. 3-17-2009. FILED 7-25-2008.
- 3,630,143. **BELSHE AND DESIGN**. BELSHE INDUSTRIES, INC., (U.S. CLS. 19, 21, 23, 31, 35 AND 44). SN 77-531,321. PUB. 3-17-2009. FILED 7-25-2008.
- 3,630,147. **KARPIEL AND DESIGN**. KARPIEL, JAN, (U.S. CLS. 19, 21, 23, 31, 35 AND 44). SN 77-532,484. PUB. 3-17-2009. FILED 7-28-2008.
- 3,630,245 (*See Class 6 for this trademark*).
- 3,630,338. **UTILACART AND DESIGN**. CAPE CORAL CART COMPANY, INC., (U.S. CLS. 19, 21, 23, 31, 35 AND 44). SN 77-570,661. PUB. 3-17-2009. FILED 9-16-2008.
- 3,630,363. **4000D-X COMPOSITE (BLOCK FORM)**. UTILITY TRAILER MANUFACTURING CO., (U.S. CLS. 19, 21, 23, 31, 35 AND 44). SN 77-574,232. PUB. 3-17-2009. FILED 9-19-2008.
- 3,630,601. **ORGANIZER WHEEL ACCESSORIES AND DESIGN**. VISION WHEEL, INC., (U.S. CLS. 19, 21, 23, 31, 35 AND 44). SN 77-595,986. PUB. 3-17-2009. FILED 10-20-2008.
- 3,630,670. **PROWASH AND DESIGN**. PRO WASH MOBILE CAR WASH SERVICE, LLC, (U.S. CLS. 19, 21, 23, 31, 35 AND 44). SN 77-597,618. PUB. 3-17-2009. FILED 10-22-2008.
- 3,630,763. **ERIDZ ELECTRIC POWERED BIKE AND DESIGN**. WANG, JING XIN, (U.S. CLS. 19, 21, 23, 31, 35 AND 44). SN 77-599,099. PUB. 3-17-2009. FILED 10-23-2008.
- 3,630,879. **LABYRINTH (BLOCK FORM)**. SABERTOOTH MOTORCYCLES, LLC, (U.S. CLS. 19, 21, 23, 31, 35 AND 44). SN 77-600,646. PUB. 3-17-2009. FILED 10-25-2008.
- 3,631,044. **SYNDICATE (BLOCK FORM)**. SANTA CRUZ BICYCLES, INC., (U.S. CLS. 19, 21, 23, 31, 35 AND 44). SN 77-602,860. PUB. 3-17-2009. FILED 10-29-2008.
- 3,631,065. **SELENE (BLOCK FORM)**. JET-TERN MARINE COMPANY, (U.S. CLS. 19, 21, 23, 31, 35 AND 44). SN 77-603,318. PUB. 3-17-2009. FILED 10-29-2008.
- 3,631,284. **ABP (BLOCK FORM)**. TREK BICYCLE CORPORATION, (U.S. CLS. 19, 21, 23, 31, 35 AND 44). SN 77-610,130. PUB. 3-17-2009. FILED 11-7-2008.
- 3,631,413 (*See Class 7 for this trademark*).
- 3,631,438 (*See Class 7 for this trademark*).
- 3,631,450. **YBN (BLOCK FORM)**. YABAN CHAIN INDUSTRIAL CO., LTD., (U.S. CLS. 19, 21, 23, 31, 35 AND 44). SN 78-958,973. PUB. 3-17-2009. FILED 8-23-2006.
- 3,631,452 (*See Class 1 for this trademark*).
- 3,631,455. **GENEO (BLOCK FORM)**. GURU BICYCLE MANUFACTURING INC., (U.S. CLS. 19, 21, 23, 31, 35 AND 44). SN 78-973,007. PUB. 3-17-2009. FILED 9-13-2006.
- 3,631,462. **COPPERHEAD (BLOCK FORM)**. ADI LIMITED, (U.S. CLS. 19, 21, 23, 31, 35 AND 44). SN 79-025,359. PUB. 3-17-2009. FILED 4-4-2006.
- 3,631,465 (*See Class 9 for this trademark*).
- 3,631,471. **AVUS RACING AND DESIGN**. CROWLEY INVESTMENT, S.A., (U.S. CLS. 19, 21, 23, 31, 35 AND 44). SN 79-035,694. PUB. 3-17-2009. FILED 9-18-2006.
- 3,631,483 (*See Class 9 for this trademark*).
- 3,631,501. **RED RACING PARTS (BLOCK FORM)**. RED RACING PARTS D.I.; DI GIOVANNI BERTONE, (U.S. CLS. 19, 21, 23, 31, 35 AND 44). SN 79-046,207. PUB. 3-17-2009. FILED 9-21-2007.
- 3,631,511 (*See Class 1 for this trademark*).
- 3,631,517 (*See Class 6 for this trademark*).
- 3,631,543. **MISCELLANEOUS DESIGN**. YOUNGMAN AUTOMOBILE; GROUP CO.,LTD., (U.S. CLS. 19, 21, 23, 31, 35 AND 44). SN 79-050,976. PUB. 3-17-2009. FILED 2-14-2008.
- 3,631,567. **DORSODURO (BLOCK FORM)**. PIAGGIO & C. S.P.A., (U.S. CLS. 19, 21, 23, 31, 35 AND 44). SN 79-052,777. PUB. 3-17-2009. FILED 2-20-2008.
- 3,631,583. **EILEAN AND DESIGN**. EILEAN SRL, MULTIPLE CLASS, (INT. CLS. 12 AND 39), (U.S. CLS. 19, 21, 23, 31, 35, 44, 100 AND 105). SN 79-053,489. PUB. 3-17-2009. FILED 4-18-2008.
- 3,631,589 (*See Class 6 for this trademark*).
- 3,631,610. **MING HUU LIEN AND DESIGN**. CONG TY CO PHAN MINH HUU LIEN, MULTIPLE CLASS, (INT. CLS. 12 AND 20), (U.S. CLS. 2, 13, 19, 21, 22, 23, 25, 31, 32, 35, 44 AND 50). SN 79-054,165. PUB. 3-17-2009. FILED 4-14-2008.
- 3,631,620 (*See Class 1 for this trademark*).
- 3,631,625. **TUMMY SHIELD AND DESIGN**. TUMMY SHIELD COMPANY PTY LTD, (U.S. CLS. 19, 21, 23, 31, 35 AND 44). SN 79-054,378. PUB. 3-17-2009. FILED 5-1-2008.
- 3,631,639 (*See Class 7 for this trademark*).
- 3,631,645. **TYREX WOODCRAFT AND DESIGN**. OTKRYTOE AKTSIONERNOE; OBSHESTVO "SIBUR - RUSSKIE SHINY", (U.S. CLS. 19, 21, 23, 31, 35 AND 44). SN 79-055,038. PUB. 3-17-2009. FILED 5-5-2008.
- 3,631,696. **SOJOY AND DESIGN**. XIAOMING HU, (U.S. CLS. 19, 21, 23, 31, 35 AND 44). SN 79-057,054. PUB. 3-17-2009. FILED 6-5-2008.
- 3,631,708. **UT AND DESIGN**. TIANJIN UNITED TIRE & RUBBER; INTERNATIONAL CO., LTD, (U.S. CLS. 19, 21, 23, 31, 35 AND 44). SN 79-057,316. PUB. 3-17-2009. FILED 6-17-2008.
- 3,631,731 (*See Class 7 for this trademark*).

CLASS 13—FIREARMS

- 3,629,233 (*See Class 1 for this trademark*).
- 3,629,291 (*See Class 9 for this trademark*).
- 3,629,492 (*See Class 9 for this trademark*).
- 3,629,991. **DILLON PRECISION (BLOCK FORM)**. DILLON PRECISION PRODUCTS, INC., (U.S. CLS. 2 AND 9). SN 77-491,075. PUB. 3-17-2009. FILED 6-4-2008.
- 3,629,992. **DILLON AERO (BLOCK FORM)**. DILLON PRECISION PRODUCTS, INC., (U.S. CLS. 2 AND 9). SN 77-491,090. PUB. 3-17-2009. FILED 6-4-2008.
- 3,630,704. **BIG BEAR ASSORTMENT (BLOCK FORM)**. B.J. ALAN COMPANY, (U.S. CLS. 2 AND 9). SN 77-598,333. PUB. 3-17-2009. FILED 10-22-2008.
- 3,630,738. **FLASHPOINT BARRAGE (BLOCK FORM)**. B.J. ALAN COMPANY, (U.S. CLS. 2 AND 9). SN 77-598,818. PUB. 3-17-2009. FILED 10-23-2008.
- 3,630,801. **PEARLS OF THE ORIENT (BLOCK FORM)**. B.J. ALAN COMPANY, (U.S. CLS. 2 AND 9). SN 77-599,654. PUB. 3-17-2009. FILED 10-24-2008.

- 3,630,802. **THUNDER FEST FOUNTAIN (BLOCK FORM)**. B.J. ALAN COMPANY, (U.S. CLS. 2 AND 9). SN 77-599,660. PUB. 3-17-2009. FILED 10-24-2008.
- 3,630,806. **WHALE TAIL FOUNTAIN (BLOCK FORM)**. B.J. ALAN COMPANY, (U.S. CLS. 2 AND 9). SN 77-599,711. PUB. 3-17-2009. FILED 10-24-2008.
- 3,631,452 (*See Class 1 for this trademark*).

CLASS 14—JEWELRY

- 3,629,180. **C B AND DESIGN**. CHINA BAROQUE, INC., (U.S. CLS. 2, 27, 28 AND 50). SN 76-691,130. PUB. 3-17-2009. FILED 7-9-2008.
- 3,629,235. **RELIGIONS WEREN'T MEANT TO LEAD TO WARS (BLOCK FORM)**. ONE SUN SOLAR SYSTEMS INC., MULTIPLE CLASS, (INT. CLS. 14, 16, 18 AND 25), (U.S. CLS. 1, 2, 3, 5, 22, 23, 27, 28, 29, 37, 38, 39, 41 AND 50). SN 77-029,272. PUB. 3-17-2009. FILED 10-25-2006.
- 3,629,262. **GOT ALL YOUR MARBLES? (BLOCK FORM)**. GOT ALL YOUR MARBLES, LLC, (U.S. CLS. 2, 27, 28 AND 50). SN 77-096,248. PUB. 3-17-2009. FILED 1-31-2007.
- 3,629,322. **SOL RAFAEL DREAM JEWELS AND DESIGN**. SR 2003 CORP, (U.S. CLS. 2, 27, 28 AND 50). SN 77-226,983. PUB. 3-17-2009. FILED 7-11-2007.
- 3,629,339 (*See Class 4 for this trademark*).
- 3,629,424 (*See Class 3 for this trademark*).
- 3,629,451. **ALABAMA CHANIN (BLOCK FORM)**. NATALIE CHANIN, MULTIPLE CLASS, (INT. CLS. 14, 25, 35 AND 41), (U.S. CLS. 2, 22, 27, 28, 39, 50, 100, 101, 102 AND 107). SN 77-345,372. PUB. 3-17-2009. FILED 12-6-2007.
- 3,629,501. **SEXY BODY CHAIN (BLOCK FORM)**. BEAUTIFL-STUFF, LLC, (U.S. CLS. 2, 27, 28 AND 50). SN 77-374,568. PUB. 3-17-2009. FILED 1-17-2008.
- 3,629,550 (*See Class 11 for this trademark*).
- 3,629,554. **T-HOME (BLOCK FORM)**. DEUTSHE TELEKOM, (U.S. CLS. 2, 27, 28 AND 50). SN 77-402,784. PUB. 3-17-2009. FILED 2-21-2008.
- 3,629,610. **BONNIE JONAS JUST.FOR.ME (BLOCK FORM)**. SANJOY INC., (U.S. CLS. 2, 27, 28 AND 50). SN 77-428,285. PUB. 3-17-2009. FILED 3-21-2008.
- 3,629,664. **TOWER OF LONDON (BLOCK FORM)**. FLITCHAM LIMITED, (U.S. CLS. 2, 27, 28 AND 50). SN 77-438,834. PUB. 3-17-2009. FILED 4-3-2008.
- 3,629,720. **MARY LOGING DESIGNS SWEET SPOT JEWELRY WHERE IS YOUR SWEET SPOT? AND DESIGN**. LOGING, MARY S, DBA MARY LOGING DESIGNS, (U.S. CLS. 2, 27, 28 AND 50). SN 77-444,676. PUB. 3-17-2009. FILED 4-10-2008.
- 3,629,729. **CLARIS (BLOCK FORM)**. JEANE WAN CHING, (U.S. CLS. 2, 27, 28 AND 50). SN 77-445,606. PUB. 3-17-2009. FILED 4-10-2008.
- 3,629,773. **T SYSTEMS AND DESIGN**. DEUTSCHE TELEKOM, (U.S. CLS. 2, 27, 28 AND 50). SN 77-450,596. PUB. 3-17-2009. FILED 4-17-2008.
- 3,629,787. **T HOME AND DESIGN**. DEUTSCHE TELEKOM, (U.S. CLS. 2, 27, 28 AND 50). SN 77-451,386. PUB. 1-13-2009. FILED 4-17-2008.
- 3,629,887. **FUNFASHIONFACTORY AND DESIGN**. MARCUS SCHARZENBERGER, (U.S. CLS. 2, 27, 28 AND 50). SN 77-463,423. PUB. 3-17-2009. FILED 5-1-2008.
- 3,630,028. **KSAR (BLOCK FORM)**. KSAR JEWELS LLC, MULTIPLE CLASS, (INT. CLS. 14 AND 35), (U.S. CLS. 2, 27, 28, 50, 100, 101 AND 102). SN 77-498,254. PUB. 3-17-2009. FILED 6-13-2008.
- 3,630,038. **DIAMONDSCAPE AND DESIGN**. FABRIKANT-TARA INTERNATIONAL LLC, (U.S. CLS. 2, 27, 28 AND 50). SN 77-501,067. PUB. 3-17-2009. FILED 6-17-2008.
- 3,630,162. **MISCELLANEOUS DESIGN**. DEPARTMENT OF DEFENSE, (U.S. CLS. 2, 27, 28 AND 50). SN 77-537,031. PUB. 3-17-2009. FILED 8-1-2008.
- 3,630,238. **FLUTTER NYC (BLOCK FORM)**. GOLDEN, JILL, DBA FLUTTER NYC, (U.S. CLS. 2, 27, 28 AND 50). SN 77-555,899. PUB. 3-17-2009. FILED 8-26-2008.
- 3,630,417. **YELLOWSTONE TRACKS (BLOCK FORM)**. GRAND COMPANY INC., DBA B-DAZZLED, (U.S. CLS. 2, 27, 28 AND 50). SN 77-580,650. PUB. 3-17-2009. FILED 9-28-2008.
- 3,630,430. **MICHELLE OF MADISON (BLOCK FORM)**. CAPEZZA, MICHELLE, DBA MICHELLE OF MADISON, (U.S. CLS. 2, 27, 28 AND 50). SN 77-581,904. PUB. 3-17-2009. FILED 9-30-2008.
- 3,630,455. **AVI-8 (STYLIZED)**. SOLAR TIME LIMITED, (U.S. CLS. 2, 27, 28 AND 50). SN 77-585,864. PUB. 3-17-2009. FILED 10-6-2008.
- 3,630,558. **STUDIO BARSE AND DESIGN**. BARSE AND COMPANY, INC., (U.S. CLS. 2, 27, 28 AND 50). SN 77-593,813. PUB. 3-17-2009. FILED 10-16-2008.
- 3,630,807. **ETTIKA (STYLIZED)**. ETTIKA, (U.S. CLS. 2, 27, 28 AND 50). SN 77-599,730. PUB. 3-17-2009. FILED 10-24-2008.
- 3,630,815. **MISCELLANEOUS DESIGN**. ANDREA & CO., LLC, MULTIPLE CLASS, (INT. CLS. 14, 18 AND 25), (U.S. CLS. 1, 2, 3, 22, 27, 28, 39, 41 AND 50). SN 77-599,848. PUB. 3-17-2009. FILED 10-24-2008.
- 3,631,070 (*See Class 8 for this trademark*).
- 3,631,075. **BELLA'S CHARM BRACELET (BLOCK FORM)**. MASSEY, KRISTINE RENE, AND MITCHELL, JANET AILEEN, (U.S. CLS. 2, 27, 28 AND 50). SN 77-603,519. PUB. 3-17-2009. FILED 10-29-2008.
- 3,631,094. **UNITED STATES NAVY FIGHTER WEAPONS SCHOOL (BLOCK FORM)**. THE CHIEF OF NAVAL INFORMATION, THE DEPARTMENT OF THE NAVY, (U.S. CLS. 2, 27, 28 AND 50). SN 77-603,749. PUB. 3-17-2009. FILED 10-30-2008.
- 3,631,167. **CRISTINA V. (BLOCK FORM)**. CRISTINA VITIELLO, LLC, (U.S. CLS. 2, 27, 28 AND 50). SN 77-604,970. PUB. 3-17-2009. FILED 10-31-2008.
- 3,631,236. **GIORA (BLOCK FORM)**. GIORA, LLC, (U.S. CLS. 2, 27, 28 AND 50). SN 77-606,069. PUB. 3-17-2009. FILED 11-3-2008.
- 3,631,344. **VC AND DESIGN**. CRISTINA VITIELLO, LLC, (U.S. CLS. 2, 27, 28 AND 50). SN 77-629,009. PUB. 3-17-2009. FILED 12-8-2008.
- 3,631,399 (*See Class 3 for this trademark*).
- 3,631,401. **AMASWISS (BLOCK FORM)**. MIRZAEI, TERESA DBA AMA JEWELS, (U.S. CLS. 2, 27, 28 AND 50). SN 78-640,137. PUB. 3-17-2009. FILED 5-31-2005.
- 3,631,460. **WISHLIST**. STROZAR, INC, MULTIPLE CLASS, (INT. CLS. 14, 18 AND 25), (U.S. CLS. 1, 2, 3, 22, 27, 28, 39, 41 AND 50). SN 78-980,458. PUB. 3-17-2009. FILED 12-31-2002.
- 3,631,463. **BREITLING STARLINER (BLOCK FORM)**. BREITLING SA, (U.S. CLS. 2, 27, 28 AND 50). SN 79-025,830. PUB. 3-17-2009. FILED 7-4-2006.
- 3,631,472 (*See Class 3 for this trademark*).
- 3,631,473. **THE ONE FOUR ALL FOUNDATION (BLOCK FORM)**. THE ONE FOUR ALL FOUNDATION; C/O RITTER RECHTSANWÄLTE, MULTIPLE CLASS, (INT. CLS. 14, 16, 25, 28, 32, 35, 41 AND 43), (U.S. CLS. 2, 5, 22, 23, 27, 28, 29, 37, 38, 39, 45, 46, 48, 50, 100, 101, 102 AND 107). SN 79-036,970. PUB. 3-17-2009. FILED 12-4-2006.
- 3,631,477 (*See Class 3 for this trademark*).
- 3,631,512 (*See Class 3 for this trademark*).
- 3,631,538 (*See Class 9 for this trademark*).
- 3,631,593. **GANCINO (BLOCK FORM)**. SALVATORE FERRAGAMO ITALIA S.P.A., (U.S. CLS. 2, 27, 28 AND 50). SN 79-053,685. PUB. 3-17-2009. FILED 3-27-2008.
- 3,631,612 (*See Class 3 for this trademark*).
- 3,631,619. **MARUI ONE.JP (STYLIZED)**. MARUI GROUP CO., LTD., MULTIPLE CLASS, (INT. CLS. 14, 16, 18, 21, 25 AND 35), (U.S. CLS. 1, 2, 3, 5, 13, 22, 23, 27, 28, 29, 30, 33, 37, 38, 39, 40, 41, 50, 100, 101 AND 102). SN 79-054,334. PUB. 3-17-2009. FILED 12-28-2007.
- 3,631,652 (*See Class 3 for this trademark*).
- 3,631,665 (*See Class 3 for this trademark*).
- 3,631,680 (*See Class 9 for this trademark*).
- 3,631,703. **Q-POT. (STYLIZED)**. GRAMME CO., MULTIPLE CLASS, (INT. CLS. 14 AND 18), (U.S. CLS. 1, 2, 3, 22, 27, 28, 41 AND 50). SN 79-057,223. PUB. 3-17-2009. FILED 3-31-2008.
- 3,631,778. **TANGENTE (BLOCK FORM)**. NOMOS GLASHÜTTE/SA ROLAND SCHWERTNER KG, (U.S. CLS. 2, 27, 28 AND 50). SN 79-063,017. PUB. 3-17-2009. FILED 10-24-2008.

CLASS 15—MUSICAL INSTRUMENTS

- 3,629,199. **JON PAUL STRINGS AND DESIGN. JONPAUL BOWS, INC.**, (U.S. CLS. 2, 21 AND 36). SN 76-693,535. PUB. 3-17-2009. FILED 10-15-2008.
 3,629,241 (*See Class 9 for this trademark*).
 3,629,585. **MISCELLANEOUS DESIGN. THE ECJC GRANTOR TRUST**, (U.S. CLS. 2, 21 AND 36). SN 77-417,978. PUB. 3-17-2009. FILED 3-10-2008.
 3,630,010. **PERAGALLO (STYLIZED). PERAGALLO PIPE ORGAN CO.**, (U.S. CLS. 2, 21 AND 36). SN 77-495,433. PUB. 3-17-2009. FILED 6-10-2008.
 3,630,012. **PERAGALLO (BLOCK FORM). PERAGALLO PIPE ORGAN CO.**, (U.S. CLS. 2, 21 AND 36). SN 77-495,467. PUB. 3-17-2009. FILED 6-10-2008.
 3,630,227. **STEELDEVILLE (BLOCK FORM). JAMES TRUSSART, DBA JAMES TRUSSART CUSTOM GUITARS**, (U.S. CLS. 2, 21 AND 36). SN 77-553,802. PUB. 3-17-2009. FILED 8-22-2008.
 3,631,084 (*See Class 9 for this trademark*).
 3,631,253. **MAX (BLOCK FORM). SUNJEEN, INC.**, (U.S. CLS. 2, 21 AND 36). SN 77-606,406. PUB. 3-17-2009. FILED 11-3-2008.
 3,631,568. **J.R.LAFIN AND DESIGN. LAFIN, JÖRG-RAINER**, (U.S. CLS. 2, 21 AND 36). SN 79-052,910. PUB. 3-17-2009. FILED 4-9-2008.
 3,631,594 (*See Class 9 for this trademark*).

CLASS 16—PAPER GOODS AND PRINTED MATTER

- 3,629,121 (*See Class 9 for this trademark*).
 3,629,122 (*See Class 9 for this trademark*).
 3,629,197. **MALT ADVOCATE (BLOCK FORM). MALT ADVOCATE, INC.**, (U.S. CLS. 2, 5, 22, 23, 29, 37, 38 AND 50). SN 76-693,177. PUB. 3-17-2009. FILED 9-29-2008.
 3,629,235 (*See Class 14 for this trademark*).
 3,629,247 (*See Class 9 for this trademark*).
 3,629,254. **JACKIE SHAPIRO AND DESIGN. JACQUELINE SHAPIRO**, MULTIPLE CLASS, (INT. CLS. 16 AND 21), (U.S. CLS. 2, 5, 13, 22, 23, 29, 30, 33, 37, 38, 40 AND 50). SN 77-086,954. PUB. 3-17-2009. FILED 1-19-2007.
 3,629,257. **POLYNEX (BLOCK FORM). SOFTBOX SYSTEMS LIMITED**, MULTIPLE CLASS, (INT. CLS. 16, 17, 20 AND 22), (U.S. CLS. 1, 2, 5, 7, 12, 13, 19, 22, 23, 25, 29, 32, 35, 37, 38, 42 AND 50). SN 77-089,267. PUB. 3-17-2009. FILED 1-23-2007.
 3,629,271. **MIXX (STYLIZED). INTERACTIVE ADVERTISING BUREAU, INC.**, MULTIPLE CLASS, (INT. CLS. 16 AND 41), (U.S. CLS. 2, 5, 22, 23, 29, 37, 38, 50, 100, 101 AND 107). SN 77-129,268. PUB. 3-17-2009. FILED 3-13-2007.
 3,629,302. **I ILLUSTRATUS AND DESIGN. UHLIG, LLC**, MULTIPLE CLASS, (INT. CLS. 16, 35, 39 AND 41), (U.S. CLS. 2, 5, 22, 23, 29, 37, 38, 50, 100, 101, 102, 105 AND 107). SN 77-191,051. PUB. 4-29-2008. FILED 5-25-2007.
 3,629,303. **INTERPRETIVE IMPRESSIONISM (BLOCK FORM). ASPIRING ARTISTS, LLC**, (U.S. CLS. 2, 5, 22, 23, 29, 37, 38 AND 50). SN 77-191,499. PUB. 3-17-2009. FILED 5-28-2007.
 3,629,313. **PLAY BIG (BLOCK FORM). CAROL NEWELL**, MULTIPLE CLASS, (INT. CLS. 16 AND 41), (U.S. CLS. 2, 5, 22, 23, 29, 37, 38, 50, 100, 101 AND 107). SN 77-203,288. PUB. 3-17-2009. FILED 6-11-2007.
 3,629,314. **CORN AND SOYBEAN DIGEST (BLOCK FORM). PENTON BUSINESS MEDIA, INC.**, MULTIPLE CLASS, (INT. CLS. 16 AND 41), (U.S. CLS. 2, 5, 22, 23, 29, 37, 38, 50, 100, 101 AND 107). SN 77-205,745. PUB. 3-17-2009. FILED 6-14-2007.
 3,629,320. **IMAGINE.DREAM.BELIEVE 3.6.5 BE GREAT TODAY! AND DESIGN. 3*6*5 PRODUCTIONS LTD.**, (U.S. CLS. 2, 5, 22, 23, 29, 37, 38 AND 50). SN 77-220,301. PUB. 4-22-2008. FILED 7-2-2007.
 3,629,339 (*See Class 4 for this trademark*).
 3,629,369. **T.I.P.S. TEACHERS IMPROVING PERFORMANCE OF STUDENTS (BLOCK FORM). CANUP, HOLLY E.**, (U.S. CLS. 2, 5, 22, 23, 29, 37, 38 AND 50). SN 77-280,958. PUB. 3-17-2009. FILED 9-17-2007.
 3,629,372. **PSYCHIC COURTESAN AND DESIGN. ROSSON, SALLY BAIN**, MULTIPLE CLASS, (INT. CLS. 16, 25, 41 AND 45), (U.S. CLS. 2, 5, 22, 23, 29, 37, 38, 39, 50, 100, 101 AND 107). SN 77-283,161. PUB. 3-17-2009. FILED 9-19-2007.
 3,629,373. **TINY PRINTS (BLOCK FORM). TINY PRINTS, INC.**, MULTIPLE CLASS, (INT. CLS. 16, 35, 40 AND 42), (U.S. CLS. 2, 5, 22, 23, 29, 37, 38, 50, 100, 101, 102, 103 AND 106). SN 77-283,346. PUB. 3-17-2009. FILED 9-19-2007.
 3,629,374 (*See Class 9 for this trademark*).
 3,629,376 (*See Class 9 for this trademark*).
 3,629,394. **ORIGINAL CHOICE (BLOCK FORM). MILES-BRAMWELL EXECUTIVE SERVICES LIMITED**, MULTIPLE CLASS, (INT. CLS. 16, 41 AND 44), (U.S. CLS. 2, 5, 22, 23, 29, 37, 38, 50, 100, 101 AND 107). SN 77-304,201. PUB. 3-17-2009. FILED 10-15-2007.
 3,629,405. **TRADE & CULTURE (BLOCK FORM). BOETTCHER, THOMAS D.**, (U.S. CLS. 2, 5, 22, 23, 29, 37, 38 AND 50). SN 77-309,798. PUB. 3-17-2009. FILED 10-22-2007.
 3,629,413 (*See Class 9 for this trademark*).
 3,629,424 (*See Class 3 for this trademark*).
 3,629,516. **WONDERLIFICIOUS (BLOCK FORM). WONDERLAND BAKERY, INC.**, MULTIPLE CLASS, (INT. CLS. 16 AND 28), (U.S. CLS. 2, 5, 22, 23, 29, 37, 38 AND 50). SN 77-382,546. PUB. 3-17-2009. FILED 1-28-2008.
 3,629,544. **KNOWLEDGE FOR GENERATIONS (BLOCK FORM). JOHN WILEY & SONS, INC.**, (U.S. CLS. 2, 5, 22, 23, 29, 37, 38 AND 50). SN 77-396,859. PUB. 3-17-2009. FILED 2-14-2008.
 3,629,590. **IMPRESSIONISTS' TABLE (BLOCK FORM). FOOD TRAVEL AND THE ARTS, LLC**, MULTIPLE CLASS, (INT. CLS. 16 AND 41), (U.S. CLS. 2, 5, 22, 23, 29, 37, 38, 50, 100, 101 AND 107). SN 77-418,829. PUB. 3-17-2009. FILED 3-11-2008.
 3,629,611 (*See Class 3 for this trademark*).
 3,629,617. **MISCELLANEOUS DESIGN. TOO MARKER PRODUCTS, INC.**, (U.S. CLS. 2, 5, 22, 23, 29, 37, 38 AND 50). SN 77-431,383. PUB. 3-17-2009. FILED 3-25-2008.
 3,629,633. **MASHA D'YANS AND DESIGN. D'YANS, MASHA**, (U.S. CLS. 2, 5, 22, 23, 29, 37, 38 AND 50). SN 77-433,768. PUB. 3-17-2009. FILED 3-27-2008.
 3,629,640. **TELEMATE (BLOCK FORM). BAILEY, RICHARD J, DBA TOP DECK PUBLICATIONS**, (U.S. CLS. 2, 5, 22, 23, 29, 37, 38 AND 50). SN 77-435,017. PUB. 3-17-2009. FILED 3-29-2008.
 3,629,660. **THE OPTIMIST (BLOCK FORM). OPTIMIST INTERNATIONAL**, (U.S. CLS. 2, 5, 22, 23, 29, 37, 38 AND 50). SN 77-437,929. PUB. 3-17-2009. FILED 4-2-2008.
 3,629,681. **AOTA'S CENTENNIAL VISION 100 2017 AND DESIGN. AMERICAN OCCUPATIONAL THERAPY ASSOCIATION, INC.**, (U.S. CLS. 2, 5, 22, 23, 29, 37, 38 AND 50). SN 77-441,020. PUB. 3-17-2009. FILED 4-6-2008.
 3,629,726. **SNAP-BACK (BLOCK FORM). SPRING LEAF CONCEPTS & DESIGN**, (U.S. CLS. 2, 5, 22, 23, 29, 37, 38 AND 50). SN 77-445,437. PUB. 3-17-2009. FILED 4-10-2008.
 3,629,728. **LARRY HAGMAN (BLOCK FORM). MAJLAR PRODUCTIONS CORPORATION**, (U.S. CLS. 2, 5, 22, 23, 29, 37, 38 AND 50). SN 77-445,519. PUB. 3-17-2009. FILED 4-10-2008.
 3,629,802 (*See Class 9 for this trademark*).
 3,629,803 (*See Class 9 for this trademark*).
 3,629,819. **NELVANA ART EDITIONS AND DESIGN. NELVANA LIMITED**, (U.S. CLS. 2, 5, 22, 23, 29, 37, 38 AND 50). SN 77-453,800. PUB. 3-17-2009. FILED 4-21-2008.
 3,629,855. **RUMINATIONS (BLOCK FORM). KARO, AARON**, MULTIPLE CLASS, (INT. CLS. 16, 41 AND 45), (U.S. CLS. 2, 5, 22, 23, 29, 37, 38, 50, 100, 101 AND 107). SN 77-457,620. PUB. 3-17-2009. FILED 4-24-2008.
 3,629,956. **BROOKLYN (BLOCK FORM). LISA FRANK, INC.**, (U.S. CLS. 2, 5, 22, 23, 29, 37, 38 AND 50). SN 77-480,003. PUB. 3-17-2009. FILED 5-21-2008.
 3,629,995. **THE BLUE PRESS (BLOCK FORM). DILLON PRECISION PRODUCTS, INC.**, (U.S. CLS. 2, 5, 22, 23, 29, 37, 38 AND 50). SN 77-492,227. PUB. 3-17-2009. FILED 6-5-2008.
 3,630,004. **AMERICAN EDUCATION PUBLISHING AND DESIGN. SCHOOL SPECIALTY, INC.**, (U.S. CLS. 2, 5, 22, 23, 29, 37, 38 AND 50). SN 77-494,985. PUB. 3-17-2009. FILED 6-10-2008.
 3,630,049. **DAILY REPORT (BLOCK FORM). ALM PROPER-**

- TIES, INC., MULTIPLE CLASS, (INT. CLS. 16 AND 41), (U.S. CLS. 2, 5, 22, 23, 29, 37, 38, 50, 100, 101 AND 107). SN 77-505,440. PUB. 3-17-2009. FILED 6-23-2008.
- 3,630,091. **AFP EXCHANGE (BLOCK FORM)**. ASSOCIATION FOR FINANCIAL PROFESSIONALS, MULTIPLE CLASS, (INT. CLS. 16 AND 41), (U.S. CLS. 2, 5, 22, 23, 29, 37, 38, 50, 100, 101 AND 107). SN 77-518,774. PUB. 12-9-2008. FILED 7-10-2008.
- 3,630,096. **TREMERE (BLOCK FORM)**. CCP HF, (U.S. CLS. 2, 5, 22, 23, 29, 37, 38 AND 50). SN 77-519,356. PUB. 3-17-2009. FILED 7-10-2008.
- 3,630,105 (*See Class 9 for this trademark*).
- 3,630,107 (*See Class 9 for this trademark*).
- 3,630,110. **NURSING SPECTRUM (BLOCK FORM)**. GANNETT SATELLITE INFORMATION NETWORK, INC., (U.S. CLS. 2, 5, 22, 23, 29, 37, 38 AND 50). SN 77-523,804. PUB. 3-17-2009. FILED 7-16-2008.
- 3,630,112. **ACPA (BLOCK FORM)**. AMERICAN COLLEGE PERSONNEL ASSOCIATION, MULTIPLE CLASS, (INT. CLS. 16 AND 41), (U.S. CLS. 2, 5, 22, 23, 29, 37, 38, 50, 100, 101 AND 107). SN 77-524,472. PUB. 3-17-2009. FILED 7-17-2008.
- 3,630,135. **UNIVERSITY OF PENNSYLVANIA ABRAMSON CANCER CENTER AND DESIGN**. THE TRUSTEES OF THE UNIVERSITY OF PENNSYLVANIA, MULTIPLE CLASS, (INT. CLS. 16, 41, 42 AND 44), (U.S. CLS. 2, 5, 22, 23, 29, 37, 38, 50, 100, 101 AND 107). SN 77-528,309. PUB. 3-17-2009. FILED 7-22-2008.
- 3,630,140. **BUBBLE BUNNYS AND DESIGN**. VIZNMETA4, LLC, MULTIPLE CLASS, (INT. CLS. 16 AND 28), (U.S. CLS. 2, 5, 22, 23, 29, 37, 38 AND 50). SN 77-530,209. PUB. 3-17-2009. FILED 7-24-2008.
- 3,630,152. **CARDPAK (BLOCK FORM)**. CARDPAK, INC., (U.S. CLS. 2, 5, 22, 23, 29, 37, 38 AND 50). SN 77-533,547. PUB. 3-17-2009. FILED 7-29-2008.
- 3,630,157. **QWIK-CODE AND DESIGN**. LAWTECH PUBLISHING CO., LTD., (U.S. CLS. 2, 5, 22, 23, 29, 37, 38 AND 50). SN 77-534,942. PUB. 3-17-2009. FILED 7-30-2008.
- 3,630,189. **MENSCHWERKS (BLOCK FORM)**. DENNIS W MILLER AND JOEL J MILLER, DBA OAKDOWN BOOKS, (U.S. CLS. 2, 5, 22, 23, 29, 37, 38 AND 50). SN 77-545,293. PUB. 3-17-2009. FILED 8-12-2008.
- 3,630,190. **CAMOUFLAGE (BLOCK FORM)**. TANK DESIGN, (U.S. CLS. 2, 5, 22, 23, 29, 37, 38 AND 50). SN 77-545,628. PUB. 3-17-2009. FILED 8-13-2008.
- 3,630,272 (*See Class 9 for this trademark*).
- 3,630,274. **FUNNELFIT (BLOCK FORM)**. XENOSEP TECHNOLOGIES LLC, (U.S. CLS. 2, 5, 22, 23, 29, 37, 38 AND 50). SN 77-560,655. PUB. 3-17-2009. FILED 9-2-2008.
- 3,630,298. **THE SOURCE FOR INVESTMENT PROFESSIONALS (BLOCK FORM)**. PENTON BUSINESS MEDIA, INC., MULTIPLE CLASS, (INT. CLS. 16 AND 41), (U.S. CLS. 2, 5, 22, 23, 29, 37, 38, 50, 100, 101 AND 107). SN 77-565,476. PUB. 3-17-2009. FILED 9-9-2008.
- 3,630,329. **HERMITAGE ART (BLOCK FORM)**. HERMITAGE GROUP, INC., (U.S. CLS. 2, 5, 22, 23, 29, 37, 38 AND 50). SN 77-569,654. PUB. 3-17-2009. FILED 9-15-2008.
- 3,630,332. **HERMITAGE ART AND DESIGN**. HERMITAGE GROUP, INC., (U.S. CLS. 2, 5, 22, 23, 29, 37, 38 AND 50). SN 77-569,763. PUB. 3-17-2009. FILED 9-15-2008.
- 3,630,407. **CONNECTION & COLLABORATION (BLOCK FORM)**. COLORADO BUSINESS ROUNDTABLE, MULTIPLE CLASS, (INT. CLS. 16 AND 41), (U.S. CLS. 2, 5, 22, 23, 29, 37, 38, 50, 100, 101 AND 107). SN 77-579,650. PUB. 3-17-2009. FILED 9-26-2008.
- 3,630,429. **VIN TOTE AND DESIGN**. HARDER, DIANE C., MULTIPLE CLASS, (INT. CLS. 16 AND 21), (U.S. CLS. 2, 5, 13, 22, 23, 29, 30, 33, 37, 38, 40 AND 50). SN 77-581,675. PUB. 3-17-2009. FILED 9-29-2008.
- 3,630,433 (*See Class 9 for this trademark*).
- 3,630,501. **CORNERSTONE CONNECTIONS AND DESIGN**. GENERAL CONFERENCE CORPORATION OF SEVENTH-DAY ADVENTISTS, MULTIPLE CLASS, (INT. CLS. 16 AND 45), (U.S. CLS. 2, 5, 22, 23, 29, 37, 38, 50, 100 AND 101). SN 77-589,679. PUB. 3-17-2009. FILED 10-9-2008.
- 3,630,519. **AMERICAN SOCIETY OF TRANSPORTATION & LOGISTICS (BLOCK FORM)**. AMERICAN SOCIETY OF TRANSPORTATION AND LOGISTICS, INC., (U.S. CLS. 2, 5, 22, 23, 29, 37, 38 AND 50). SN 77-591,125. PUB. 3-17-2009. FILED 10-13-2008.
- 3,630,577. **DOGIPOT AND DESIGN**. DP PET PRODUCTS, INC., MULTIPLE CLASS, (INT. CLS. 16 AND 21), (U.S. CLS. 2, 5, 13, 22, 23, 29, 30, 33, 37, 38, 40 AND 50). SN 77-594,826. PUB. 3-17-2009. FILED 10-17-2008.
- 3,630,653. **WILLIE DIXON AND DESIGN**. DIXON, MARIE, (U.S. CLS. 2, 5, 22, 23, 29, 37, 38 AND 50). SN 77-597,168. PUB. 3-17-2009. FILED 10-21-2008.
- 3,630,655 (*See Class 9 for this trademark*).
- 3,630,659 (*See Class 9 for this trademark*).
- 3,630,695 (*See Class 9 for this trademark*).
- 3,630,724. **BRAININSIGHTS (STYLIZED)**. MCNELIS, DEBORAH, (U.S. CLS. 2, 5, 22, 23, 29, 37, 38 AND 50). SN 77-598,586. PUB. 3-17-2009. FILED 10-22-2008.
- 3,630,744. **FOOTPRINTLESS (BLOCK FORM)**. 152310 CANADA, DBA AS HANGING SYSTEMS, (U.S. CLS. 2, 5, 22, 23, 29, 37, 38 AND 50). SN 77-598,850. PUB. 3-17-2009. FILED 10-23-2008.
- 3,630,773. **HANG UPS (BLOCK FORM)**. THE FRAGRANCE FACTORY, LLC, (U.S. CLS. 2, 5, 22, 23, 29, 37, 38 AND 50). SN 77-599,246. PUB. 3-17-2009. FILED 10-23-2008.
- 3,630,808. **ART OF ENGLISH AND DESIGN**. CAMILLE LINEN, (U.S. CLS. 2, 5, 22, 23, 29, 37, 38 AND 50). SN 77-599,762. PUB. 3-17-2009. FILED 10-24-2008.
- 3,630,860. **ARTOOZIE (BLOCK FORM)**. ART RENAISSANCE, LLC, (U.S. CLS. 2, 5, 22, 23, 29, 37, 38 AND 50). SN 77-600,350. PUB. 3-17-2009. FILED 10-24-2008.
- 3,630,886. **RECETAS PARA LA VIDA (BLOCK FORM)**. RECETAS PARA LA VIDA LLC, (U.S. CLS. 2, 5, 22, 23, 29, 37, 38 AND 50). SN 77-600,727. PUB. 3-17-2009. FILED 10-26-2008.
- 3,630,935. **HOW MANY HALVES ARE IN A FOURTH? (BLOCK FORM)**. LARSON TEXTS, INC., MULTIPLE CLASS, (INT. CLS. 16 AND 41), (U.S. CLS. 2, 5, 22, 23, 29, 37, 38, 50, 100, 101 AND 107). SN 77-601,341. PUB. 3-17-2009. FILED 10-27-2008.
- 3,630,951. **NEON ROSE (BLOCK FORM)**. MOSCOSO, VICTOR, (U.S. CLS. 2, 5, 22, 23, 29, 37, 38 AND 50). SN 77-601,580. PUB. 3-17-2009. FILED 10-27-2008.
- 3,631,021. **MISCELLANEOUS DESIGN**. DR. SEUSS ENTERPRISES, L.P., (U.S. CLS. 2, 5, 22, 23, 29, 37, 38 AND 50). SN 77-602,531. PUB. 3-17-2009. FILED 10-28-2008.
- 3,631,027. **MISCELLANEOUS DESIGN**. DR. SEUSS ENTERPRISES, L.P., (U.S. CLS. 2, 5, 22, 23, 29, 37, 38 AND 50). SN 77-602,574. PUB. 3-17-2009. FILED 10-28-2008.
- 3,631,028. **MISCELLANEOUS DESIGN**. DR. SEUSS ENTERPRISES, L.P., (U.S. CLS. 2, 5, 22, 23, 29, 37, 38 AND 50). SN 77-602,578. PUB. 3-17-2009. FILED 10-28-2008.
- 3,631,046. **WATER SMART AND DESIGN**. SOUTHERN NEVADA WATER AUTHORITY, (U.S. CLS. 2, 5, 22, 23, 29, 37, 38 AND 50). SN 77-602,922. PUB. 3-17-2009. FILED 10-29-2008.
- 3,631,047. **MR. MUM (BLOCK FORM)**. WILLIAM S. THOMAS, (U.S. CLS. 2, 5, 22, 23, 29, 37, 38 AND 50). SN 77-602,946. PUB. 3-17-2009. FILED 10-29-2008.
- 3,631,056. **WHISPERING PINES PORCELAIN (BLOCK FORM)**. MILLER, ELIZABETH M., (U.S. CLS. 2, 5, 22, 23, 29, 37, 38 AND 50). SN 77-603,147. PUB. 3-17-2009. FILED 10-29-2008.
- 3,631,064 (*See Class 9 for this trademark*).
- 3,631,070 (*See Class 8 for this trademark*).
- 3,631,087. **SEIZE THE RAY! (BLOCK FORM)**. KEHRES MATERIALS COMPANY, INC., (U.S. CLS. 2, 5, 22, 23, 29, 37, 38 AND 50). SN 77-603,648. PUB. 3-17-2009. FILED 10-29-2008.
- 3,631,091. **TALES OF THE COCKTAIL NEW ORLEANS AND DESIGN**. ANN ROGERS, (U.S. CLS. 2, 5, 22, 23, 29, 37, 38 AND 50). SN 77-603,718. PUB. 3-17-2009. FILED 10-30-2008.
- 3,631,092. **HT AND DESIGN**. HEART THOUGHTS DESIGNS, INC., (U.S. CLS. 2, 5, 22, 23, 29, 37, 38 AND 50). SN 77-603,722. PUB. 3-17-2009. FILED 10-30-2008.
- 3,631,103. **CWPT AND DESIGN**. CIVIL WAR PRESERVATION TRUST, (U.S. CLS. 2, 5, 22, 23, 29, 37, 38 AND 50). SN 77-603,986. PUB. 3-17-2009. FILED 10-30-2008.
- 3,631,105. **CIVIL WAR PRESERVATION TRUST (BLOCK FORM)**. CIVIL WAR PRESERVATION TRUST, (U.S. CLS. 2, 5, 22, 23, 29, 37, 38 AND 50). SN 77-603,995. PUB. 3-17-2009. FILED 10-30-2008.

- 3,631,107. **CWPT (BLOCK FORM)**. CIVIL WAR PRESERVATION TRUST, (U.S. CLS. 2, 5, 22, 23, 29, 37, 38 AND 50). SN 77-604,016. PUB. 3-17-2009. FILED 10-30-2008.
- 3,631,118. **HISTORY UNDER SIEGE (BLOCK FORM)**. CIVIL WAR PRESERVATION TRUST, (U.S. CLS. 2, 5, 22, 23, 29, 37, 38 AND 50). SN 77-604,120. PUB. 3-17-2009. FILED 10-30-2008.
- 3,631,125. **PURPLE MOUNTAINS' MAJESTY (BLOCK FORM)**. CRAYOLA PROPERTIES, INC., (U.S. CLS. 2, 5, 22, 23, 29, 37, 38 AND 50). SN 77-604,330. PUB. 3-17-2009. FILED 10-30-2008.
- 3,631,126. **PURPLE PIZZAZZ (BLOCK FORM)**. CRAYOLA PROPERTIES, INC., (U.S. CLS. 2, 5, 22, 23, 29, 37, 38 AND 50). SN 77-604,340. PUB. 3-17-2009. FILED 10-30-2008.
- 3,631,127. **RAZZLE DAZZLE ROSE (BLOCK FORM)**. CRAYOLA PROPERTIES, INC., (U.S. CLS. 2, 5, 22, 23, 29, 37, 38 AND 50). SN 77-604,352. PUB. 3-17-2009. FILED 10-30-2008.
- 3,631,128. **RAZZMATAZZ (BLOCK FORM)**. CRAYOLA PROPERTIES, INC., (U.S. CLS. 2, 5, 22, 23, 29, 37, 38 AND 50). SN 77-604,359. PUB. 3-17-2009. FILED 10-30-2008.
- 3,631,132. **UNMELLOW YELLOW (BLOCK FORM)**. CRAYOLA PROPERTIES, INC., (U.S. CLS. 2, 5, 22, 23, 29, 37, 38 AND 50). SN 77-604,434. PUB. 3-17-2009. FILED 10-30-2008.
- 3,631,133. **WILD WATERMELON (BLOCK FORM)**. CRAYOLA PROPERTIES, INC., (U.S. CLS. 2, 5, 22, 23, 29, 37, 38 AND 50). SN 77-604,448. PUB. 3-17-2009. FILED 10-30-2008.
- 3,631,151. **THE TIDE (BLOCK FORM)**. GOSPEL TIDE BROADCASTING ASSOCIATION, MULTIPLE CLASS, (INT. CLS. 16, 38 AND 41), (U.S. CLS. 2, 5, 22, 23, 29, 37, 38, 50, 100, 101, 104 AND 107). SN 77-604,741. PUB. 3-17-2009. FILED 10-31-2008.
- 3,631,153. **PINK PRINCESS (BLOCK FORM)**. BATTER UP KIDS INC., (U.S. CLS. 2, 5, 22, 23, 29, 37, 38 AND 50). SN 77-604,767. PUB. 3-17-2009. FILED 10-31-2008.
- 3,631,163. **THE BIBLE OF HIP-HOP (BLOCK FORM)**. SOURCE ENTERPRISES, INC., (U.S. CLS. 2, 5, 22, 23, 29, 37, 38 AND 50). SN 77-604,939. PUB. 3-17-2009. FILED 10-31-2008.
- 3,631,181. **BRICKPAPER (BLOCK FORM)**. NATHAN SAWAYA, INC., (U.S. CLS. 2, 5, 22, 23, 29, 37, 38 AND 50). SN 77-605,313. PUB. 3-17-2009. FILED 10-31-2008.
- 3,631,231. **SOUTHERN NEVADA WATER AUTHORITY AND DESIGN**. SOUTHERN NEVADA WATER AUTHORITY, MULTIPLE CLASS, (INT. CLS. 16, 35 AND 40), (U.S. CLS. 2, 5, 22, 23, 29, 37, 38, 50, 100, 101, 102, 103 AND 106). SN 77-606,011. PUB. 3-17-2009. FILED 11-3-2008.
- 3,631,259. **WATER SMART LIVING (BLOCK FORM)**. SOUTHERN NEVADA WATER AUTHORITY, (U.S. CLS. 2, 5, 22, 23, 29, 37, 38 AND 50). SN 77-606,985. PUB. 3-17-2009. FILED 11-4-2008.
- 3,631,268. **TSS PHOTOGRAPHY AND DESIGN**. TSS PHOTOGRAPHY, INC., MULTIPLE CLASS, (INT. CLS. 16 AND 41), (U.S. CLS. 2, 5, 22, 23, 29, 37, 38, 50, 100, 101 AND 107). SN 77-607,680. PUB. 3-17-2009. FILED 11-5-2008.
- 3,631,269. **THE SPORTS SECTION AND DESIGN**. TSS PHOTOGRAPHY, INC., MULTIPLE CLASS, (INT. CLS. 16 AND 41), (U.S. CLS. 2, 5, 22, 23, 29, 37, 38, 50, 100, 101 AND 107). SN 77-607,851. PUB. 3-17-2009. FILED 11-5-2008.
- 3,631,288. **DUOFLEX (BLOCK FORM)**. NEXTEP, INC., (U.S. CLS. 2, 5, 22, 23, 29, 37, 38 AND 50). SN 77-610,955. PUB. 3-17-2009. FILED 11-10-2008.
- 3,631,302. **BABYGAP (BLOCK FORM)**. GAP (APPAREL), LLC, (U.S. CLS. 2, 5, 22, 23, 29, 37, 38 AND 50). SN 77-615,143. PUB. 3-17-2009. FILED 11-14-2008.
- 3,631,334. **CIP (BLOCK FORM)**. ORGANIZATION OF AMERICAN STATES, (U.S. CLS. 2, 5, 22, 23, 29, 37, 38 AND 50). SN 77-624,266. PUB. 3-17-2009. FILED 12-1-2008.
- 3,631,369. **NEVER ENDING RADICAL DUDES (BLOCK FORM)**. CULBERTSON, MARK SAXON, MULTIPLE CLASS, (INT. CLS. 16 AND 41), (U.S. CLS. 2, 5, 22, 23, 29, 37, 38, 50, 100, 101 AND 107). SN 77-975,157. PUB. 3-17-2009. FILED 2-11-2007.
- 3,631,399 (*See Class 3 for this trademark*).
- 3,631,414. **ECO-LOGICAL RECYCLED FIBRE AND DESIGN**. KRUGER PRODUCTS LIMITED, MULTIPLE CLASS, (INT. CLS. 16 AND 21), (U.S. CLS. 2, 5, 13, 22, 23, 29, 30, 33, 37, 38, 40 AND 50). SN 78-733,722. PUB. 3-17-2009. FILED 10-14-2005.
- 3,631,415. **THUM THRU: (BLOCK FORM)**. JAMES, JALANDA, (U.S. CLS. 2, 5, 22, 23, 29, 37, 38 AND 50). SN 78-741,044. PUB. 3-17-2009. FILED 10-26-2005.
- 3,631,427 (*See Class 3 for this trademark*).
- 3,631,438 (*See Class 7 for this trademark*).
- 3,631,469 (*See Class 9 for this trademark*).
- 3,631,472 (*See Class 3 for this trademark*).
- 3,631,473 (*See Class 14 for this trademark*).
- 3,631,478. **SPEEDY POST (BLOCK FORM)**. ARTOZ PAPIER AG, (U.S. CLS. 2, 5, 22, 23, 29, 37, 38 AND 50). SN 79-038,597. PUB. 3-17-2009. FILED 2-26-2007.
- 3,631,479. **TVDIGITAL AND DESIGN**. AXEL SPRINGER AG, MULTIPLE CLASS, (INT. CLS. 16, 35, 38 AND 41), (U.S. CLS. 2, 5, 22, 23, 29, 37, 38, 50, 100, 101, 102, 104 AND 107). SN 79-039,874. PUB. 3-17-2009. FILED 4-4-2007.
- 3,631,480 (*See Class 9 for this trademark*).
- 3,631,497. **CPI AND DESIGN**. CPI, MULTIPLE CLASS, (INT. CLS. 16, 35 AND 40), (U.S. CLS. 2, 5, 22, 23, 29, 37, 38, 50, 100, 101, 102, 103 AND 106). SN 79-044,821. PUB. 12-9-2008. FILED 9-6-2007.
- 3,631,503. **CATWALK KATZENKRATZBAUMSYSTEM AND DESIGN**. SIERINGER, SVEN, AND STÖWER, JENS, MULTIPLE CLASS, (INT. CLS. 16 AND 31), (U.S. CLS. 1, 2, 5, 22, 23, 29, 37, 38, 46 AND 50). SN 79-046,535. PUB. 3-17-2009. FILED 10-22-2007.
- 3,631,512 (*See Class 3 for this trademark*).
- 3,631,535 (*See Class 9 for this trademark*).
- 3,631,538 (*See Class 9 for this trademark*).
- 3,631,542. **MISCELLANEOUS DESIGN**. INTERNATIONAL ENTERPRISE; SINGAPORE BOARD, MULTIPLE CLASS, (INT. CLS. 16, 35, 38, 41 AND 42), (U.S. CLS. 2, 5, 22, 23, 29, 37, 38, 50, 100, 101, 102, 104 AND 107). SN 79-050,932. PUB. 3-17-2009. FILED 10-30-2007.
- 3,631,546 (*See Class 2 for this trademark*).
- 3,631,565. **MISCELLANEOUS DESIGN**. EL BAIK FOOD SYSTEMS COMPANY S.A., MULTIPLE CLASS, (INT. CLS. 16, 29, 30 AND 43), (U.S. CLS. 2, 5, 22, 23, 29, 37, 38, 46, 50, 100 AND 101). SN 79-052,722. PUB. 3-17-2009. FILED 3-11-2008.
- 3,631,607. **ZEXY (BLOCK FORM)**. RECRUIT CO., LTD., MULTIPLE CLASS, (INT. CLS. 16, 35, 43 AND 45), (U.S. CLS. 2, 5, 22, 23, 29, 37, 38, 50, 100, 101 AND 102). SN 79-054,101. PUB. 3-17-2009. FILED 1-10-2008.
- 3,631,619 (*See Class 14 for this trademark*).
- 3,631,636. **STILNUOVO (BLOCK FORM)**. RICHEMONT ITALIA S.P.A., (U.S. CLS. 2, 5, 22, 23, 29, 37, 38 AND 50). SN 79-054,563. PUB. 3-17-2009. FILED 4-9-2008.
- 3,631,651. **CHRONO EXPRESS (STYLIZED)**. CHRONOPOST (SOCIÉTÉ ANONYME), MULTIPLE CLASS, (INT. CLS. 16, 38 AND 39), (U.S. CLS. 2, 5, 22, 23, 29, 37, 38, 50, 100, 101, 104 AND 105). SN 79-055,206. PUB. 3-17-2009. FILED 4-15-2008.
- 3,631,672. **ZIMMERMANN & PARTNER PROTECTING YOUR VISIONS (BLOCK FORM)**. GERD ZIMMERMANN, AND DR. THOMAS LEIDESCHER, AND DR. CHRISTIAN GINZEL, MULTIPLE CLASS, (INT. CLS. 16, 41 AND 45), (U.S. CLS. 2, 5, 22, 23, 29, 37, 38, 50, 100, 101 AND 107). SN 79-055,800. PUB. 3-17-2009. FILED 12-12-2007.
- 3,631,720 (*See Class 7 for this trademark*).
- 3,631,730. **ACROBALL (STYLIZED)**. KABUSHIKI KAISHA PILOT CORPORATION; (ALSO TRADING AS PILOT CORPORATION), (U.S. CLS. 2, 5, 22, 23, 29, 37, 38 AND 50). SN 79-058,343. PUB. 3-17-2009. FILED 8-14-2008.
- 3,631,739. **KEMIART (BLOCK FORM)**. M-REAL CORPORATION, (U.S. CLS. 2, 5, 22, 23, 29, 37, 38 AND 50). SN 79-058,924. PUB. 3-17-2009. FILED 8-25-2008.
- 3,631,743 (*See Class 9 for this trademark*).
- 3,631,761 (*See Class 9 for this trademark*).

CLASS 17—RUBBER GOODS

- 3,629,257 (*See Class 16 for this trademark*).
- 3,629,361 (*See Class 7 for this trademark*).
- 3,629,363. **CAPILLARY-CHANNELED POLYMER (BLOCK FORM)**. SPECIALTY & CUSTOM FIBERS, LLC, (U.S. CLS. 1, 5, 12, 13, 35 AND 50). SN 77-274,317. PUB. 3-17-2009. FILED 9-7-2007.

- 3,629,465 (*See Class 11 for this trademark.*)
 3,629,611 (*See Class 3 for this trademark.*)
 3,629,683 (*See Class 6 for this trademark.*)
 3,630,014. **FANCYTHAT! (BLOCK FORM)**. FANCY THAT PARTNERS, (U.S. CLS. 1, 5, 12, 13, 35 AND 50). SN 77-495,719. PUB. 3-17-2009. FILED 6-10-2008.
 3,630,186. **SL 1 (BLOCK FORM)**. CONSTRUCTION RESEARCH & TECHNOLOGY GMBH, (U.S. CLS. 1, 5, 12, 13, 35 AND 50). SN 77-544,444. PUB. 3-17-2009. FILED 8-12-2008.
 3,630,224 (*See Class 5 for this trademark.*)
 3,630,423. **DESIGN IT: SILKS & NATURALS (BLOCK FORM)**. FLORACRAFT CORPORATION, (U.S. CLS. 1, 5, 12, 13, 35 AND 50). SN 77-581,167. PUB. 3-17-2009. FILED 9-29-2008.
 3,630,457. **QUIETPATH (BLOCK FORM)**. WOLVERINE ADVANCED MATERIALS L.L.C., (U.S. CLS. 1, 5, 12, 13, 35 AND 50). SN 77-586,235. PUB. 3-17-2009. FILED 10-6-2008.
 3,630,499. **RD-6 (BLOCK FORM)**. POLYGUARD PRODUCTS, INC., (U.S. CLS. 1, 5, 12, 13, 35 AND 50). SN 77-589,519. PUB. 3-17-2009. FILED 10-9-2008.
 3,631,206. **COVER CURL (BLOCK FORM)**. COVER CURL, LLC, (U.S. CLS. 1, 5, 12, 13, 35 AND 50). SN 77-605,508. PUB. 3-17-2009. FILED 10-31-2008.
 3,631,315. **MEDALIST (BLOCK FORM)**. TEKNOR APEX COMPANY, (U.S. CLS. 1, 5, 12, 13, 35 AND 50). SN 77-617,208. PUB. 3-17-2009. FILED 11-19-2008.
 3,631,442 (*See Class 7 for this trademark.*)
 3,631,464 (*See Class 1 for this trademark.*)
 3,631,510 (*See Class 1 for this trademark.*)
 3,631,511 (*See Class 1 for this trademark.*)
 3,631,540 (*See Class 10 for this trademark.*)
 3,631,561 (*See Class 6 for this trademark.*)
 3,631,597 (*See Class 1 for this trademark.*)
 3,631,620 (*See Class 1 for this trademark.*)

CLASS 18—LEATHER GOODS

- 3,629,131. **GLO N GO AND DESIGN**. I DID IT, INC., (U.S. CLS. 1, 2, 3, 22 AND 41). SN 76-650,663. PUB. 3-17-2009. FILED 11-21-2005.
 3,629,177. **MISCELLANEOUS DESIGN**. BAHAMA CLIPPER, L. L. C., MULTIPLE CLASS, (INT. CLS. 18 AND 25), (U.S. CLS. 1, 2, 3, 22, 39 AND 41). SN 76-689,813. PUB. 3-17-2009. FILED 5-19-2008.
 3,629,235 (*See Class 14 for this trademark.*)
 3,629,246. **BB BELEDINA AND DESIGN**. JMB S.A.S. DI KAPLLANI BELEDINA & C., MULTIPLE CLASS, (INT. CLS. 18 AND 25), (U.S. CLS. 1, 2, 3, 22, 39 AND 41). SN 77-065,319. PUB. 12-9-2008. FILED 12-15-2006.
 3,629,291 (*See Class 9 for this trademark.*)
 3,629,333. **HIMMEL ARSCH & ZWIRN AND DESIGN**. TIBOR RUMSZAUER, MULTIPLE CLASS, (INT. CLS. 18, 21, 25 AND 32), (U.S. CLS. 1, 2, 3, 13, 22, 23, 29, 30, 33, 39, 40, 41, 45, 46, 48 AND 50). SN 77-242,166. PUB. 3-17-2009. FILED 7-30-2007.
 3,629,339 (*See Class 4 for this trademark.*)
 3,629,424 (*See Class 3 for this trademark.*)
 3,629,445 (*See Class 9 for this trademark.*)
 3,629,471. **JJ JACK RABBIT AND DESIGN**. THE JACK RABBIT COLLECTION, (U.S. CLS. 1, 2, 3, 22 AND 41). SN 77-357,825. PUB. 3-17-2009. FILED 12-21-2007.
 3,629,492 (*See Class 9 for this trademark.*)
 3,629,555. **T-HOME (BLOCK FORM)**. DEUTSHE TELEKOM, (U.S. CLS. 1, 2, 3, 22 AND 41). SN 77-402,795. PUB. 3-17-2009. FILED 2-21-2008.
 3,629,625. **FREEDOM WRAP (BLOCK FORM)**. NORTECH LABORATORIES, INC., (U.S. CLS. 1, 2, 3, 22 AND 41). SN 77-433,090. PUB. 3-17-2009. FILED 3-27-2008.
 3,629,676. **STUDIO COLLECTION (BLOCK FORM)**. SEWING CENTER SUPPLY CO., INC., (U.S. CLS. 1, 2, 3, 22 AND 41). SN 77-440,534. PUB. 3-17-2009. FILED 4-4-2008.
 3,629,685. **RIHANNA (BLOCK FORM)**. RORAJ TRADE, LLC, (U.S. CLS. 1, 2, 3, 22 AND 41). SN 77-441,771. PUB. 3-17-2009. FILED 4-7-2008.
 3,629,687. **BOWLER AND DESIGN**. HALO INTERNATIONAL HOLDINGS LIMITED, (U.S. CLS. 1, 2, 3, 22 AND 41). SN 77-442,107. PUB. 3-17-2009. FILED 4-7-2008.
 3,629,774. **T SYSTEMS AND DESIGN**. DEUTSCHE TELEKOM, (U.S. CLS. 1, 2, 3, 22 AND 41). SN 77-450,608. PUB. 3-17-2009. FILED 4-17-2008.
 3,629,788. **T HOME AND DESIGN**. DEUTSCHE TELEKOM, (U.S. CLS. 1, 2, 3, 22 AND 41). SN 77-451,388. PUB. 1-13-2009. FILED 4-17-2008.
 3,629,799. **TRUMPETTE (BLOCK FORM)**. TRUMPETTE, INC., MULTIPLE CLASS, (INT. CLS. 18, 25, 28 AND 35), (U.S. CLS. 1, 2, 3, 22, 23, 38, 39, 41, 50, 100, 101 AND 102). SN 77-451,792. PUB. 3-17-2009. FILED 4-18-2008.
 3,629,916. **TIE ONE ON BABY WRAP (BLOCK FORM)**. KACER, DAWN, (U.S. CLS. 1, 2, 3, 22 AND 41). SN 77-470,140. PUB. 3-17-2009. FILED 5-9-2008.
 3,630,301. **E AND DESIGN**. SONYGOOD INDUSTRIES CO., LTD., (U.S. CLS. 1, 2, 3, 22 AND 41). SN 77-566,392. PUB. 3-17-2009. FILED 9-10-2008.
 3,630,305. **BITTER WORKS (BLOCK FORM)**. PETLAND, INC., (U.S. CLS. 1, 2, 3, 22 AND 41). SN 77-567,086. PUB. 3-17-2009. FILED 9-10-2008.
 3,630,339. **GEORGETOWN FOLDER (BLOCK FORM)**. WIND-BRELLA PRODUCTS CORP., (U.S. CLS. 1, 2, 3, 22 AND 41). SN 77-570,796. PUB. 3-17-2009. FILED 9-16-2008.
 3,630,450. **GG GOVALI (STYLIZED)**. GEORGE VERANO USA LLC, (U.S. CLS. 1, 2, 3, 22 AND 41). SN 77-584,928. PUB. 3-17-2009. FILED 10-3-2008.
 3,630,484. **RUFFWEAR (BLOCK FORM)**. RUFF WEAR, INC., (U.S. CLS. 1, 2, 3, 22 AND 41). SN 77-588,086. PUB. 3-17-2009. FILED 10-8-2008.
 3,630,516. **DARE GEAR DG SINCE 1978 AND DESIGN**. GEORGE VERANO USA LLC, (U.S. CLS. 1, 2, 3, 22 AND 41). SN 77-591,060. PUB. 3-17-2009. FILED 10-12-2008.
 3,630,546. **VICARLO (BLOCK FORM)**. DECARLO, VICTORIA, (U.S. CLS. 1, 2, 3, 22 AND 41). SN 77-592,864. PUB. 3-17-2009. FILED 10-15-2008.
 3,630,591. **PARISUN (BLOCK FORM)**. QINGWEN XU, (U.S. CLS. 1, 2, 3, 22 AND 41). SN 77-595,638. PUB. 3-17-2009. FILED 10-18-2008.
 3,630,613. **MISCELLANEOUS DESIGN**. STACIA, INC., MULTIPLE CLASS, (INT. CLS. 18, 25 AND 35), (U.S. CLS. 1, 2, 3, 22, 39, 41, 100, 101 AND 102). SN 77-596,196. PUB. 3-17-2009. FILED 10-20-2008.
 3,630,745. **GOT FLIES? (BLOCK FORM)**. GUN-MUNRO, BEVERLY JOY, DBA FLY WRAPS, (U.S. CLS. 1, 2, 3, 22 AND 41). SN 77-598,858. PUB. 3-17-2009. FILED 10-23-2008.
 3,630,815 (*See Class 14 for this trademark.*)
 3,630,866. **ECO-WALK (BLOCK FORM)**. KELEEN LEATHERS, INC., MULTIPLE CLASS, (INT. CLS. 18 AND 19), (U.S. CLS. 1, 2, 3, 12, 22, 33, 41 AND 50). SN 77-600,417. PUB. 3-17-2009. FILED 10-24-2008.
 3,630,895 (*See Class 9 for this trademark.*)
 3,630,971. **BEYOND THE MAT (BLOCK FORM)**. BEARY, BETH, MULTIPLE CLASS, (INT. CLS. 18 AND 25), (U.S. CLS. 1, 2, 3, 22, 39 AND 41). SN 77-601,940. PUB. 3-17-2009. FILED 10-28-2008.
 3,630,976. **BEYOND THE MAT AND DESIGN**. BEARY, BETH, MULTIPLE CLASS, (INT. CLS. 18 AND 25), (U.S. CLS. 1, 2, 3, 22, 39 AND 41). SN 77-601,969. PUB. 3-17-2009. FILED 10-28-2008.
 3,631,256. **SWADDLESPOUT (BLOCK FORM)**. MCEVOY, RICHARD, MULTIPLE CLASS, (INT. CLS. 18 AND 24), (U.S. CLS. 1, 2, 3, 22, 41, 42 AND 50). SN 77-606,843. PUB. 3-17-2009. FILED 11-4-2008.
 3,631,275. **THE GOLDEN AGE OF TRAVEL (BLOCK FORM)**. INTERNATIONAL DESIGN ASSOCIATES LTD, (U.S. CLS. 1, 2, 3, 22 AND 41). SN 77-608,749. PUB. 3-17-2009. FILED 11-6-2008.
 3,631,276. **SAIL AWAY (BLOCK FORM)**. INTERNATIONAL DESIGN ASSOCIATES LTD, (U.S. CLS. 1, 2, 3, 22 AND 41). SN 77-608,785. PUB. 3-17-2009. FILED 11-6-2008.
 3,631,277. **GILT TRIP (BLOCK FORM)**. INTERNATIONAL DESIGN ASSOCIATES LTD, (U.S. CLS. 1, 2, 3, 22 AND 41). SN 77-608,843. PUB. 3-17-2009. FILED 11-6-2008.
 3,631,303. **GB (STYLIZED)**. G + P NYC BRANDS, INC., (U.S. CLS. 1, 2, 3, 22 AND 41). SN 77-615,556. PUB. 3-17-2009. FILED 11-17-2008.
 3,631,399 (*See Class 3 for this trademark.*)
 3,631,403. **MISCELLANEOUS DESIGN**. FASHION IMPORT (1986) LIMITED, (U.S. CLS. 1, 2, 3, 22 AND 41). SN 78-

648,367. PUB. 9-9-2008. FILED 6-10-2005.
 3,631,427 (*See Class 3 for this trademark*).
 3,631,460 (*See Class 14 for this trademark*).
 3,631,472 (*See Class 3 for this trademark*).
 3,631,477 (*See Class 3 for this trademark*).
 3,631,495. **HIDEX (BLOCK FORM)**. OOO "HIDEX", MULTIPLE CLASS, (INT. CLS. 18, 19 AND 25), (U.S. CLS. 1, 2, 3, 12, 22, 33, 39, 41 AND 50). SN 79-044,586. PUB. 3-17-2009. FILED 12-13-2006.
 3,631,512 (*See Class 3 for this trademark*).
 3,631,535 (*See Class 9 for this trademark*).
 3,631,538 (*See Class 9 for this trademark*).
 3,631,546 (*See Class 2 for this trademark*).
 3,631,573 (*See Class 9 for this trademark*).
 3,631,584. **VISKOTEPAK (BLOCK FORM)**. VISKO TEEPAP BELGIUM NV, (U.S. CLS. 1, 2, 3, 22 AND 41). SN 79-053,512. PUB. 3-17-2009. FILED 5-7-2008.
 3,631,585. **VISKOTEPAK AND DESIGN**. VISKO TEEPAP BELGIUM NV, (U.S. CLS. 1, 2, 3, 22 AND 41). SN 79-053,513. PUB. 3-17-2009. FILED 5-7-2008.
 3,631,602. **E DESIGN BY ENZO FUSCO (STYLIZED)**. FUSCO VINCENZO, MULTIPLE CLASS, (INT. CLS. 18 AND 25), (U.S. CLS. 1, 2, 3, 22, 39 AND 41). SN 79-054,043. PUB. 3-17-2009. FILED 3-19-2008.
 3,631,612 (*See Class 3 for this trademark*).
 3,631,618 (*See Class 9 for this trademark*).
 3,631,619 (*See Class 14 for this trademark*).
 3,631,648 (*See Class 3 for this trademark*).
 3,631,660. **JML AND DESIGN**. YANG QINGBO, (U.S. CLS. 1, 2, 3, 22 AND 41). SN 79-055,489. PUB. 3-17-2009. FILED 6-18-2008.
 3,631,663 (*See Class 9 for this trademark*).
 3,631,685 (*See Class 9 for this trademark*).
 3,631,702. **MISCELLANEOUS DESIGN**. ACE CO., LTD., (U.S. CLS. 1, 2, 3, 22 AND 41). SN 79-057,222. PUB. 3-17-2009. FILED 3-11-2008.
 3,631,703 (*See Class 14 for this trademark*).
 3,631,722. **MARUMAN AND DESIGN**. MARUMAN & CO., LTD., MULTIPLE CLASS, (INT. CLS. 18, 25 AND 28), (U.S. CLS. 1, 2, 3, 22, 23, 38, 39, 41 AND 50). SN 79-057,986. PUB. 3-17-2009. FILED 7-2-2008.

CLASS 19—NON-METALLIC BUILDING MATERIALS

3,629,184. **TANK PRO (BLOCK FORM)**. BASEMENT TECHNOLOGIES, INC., (U.S. CLS. 1, 12, 33 AND 50). SN 76-691,647. PUB. 3-17-2009. FILED 7-28-2008.
 3,629,192. **CITYWALK SF 25 YEAR AND DESIGN**. MURCHISON, DENNIS, (U.S. CLS. 1, 12, 33 AND 50). SN 76-692,788. PUB. 3-17-2009. FILED 9-11-2008.
 3,629,326 (*See Class 6 for this trademark*).
 3,629,339 (*See Class 4 for this trademark*).
 3,629,419. **VENDOME (BLOCK FORM)**. OLDCASTLE BUILDING PRODUCTS CANADA, INC., (U.S. CLS. 1, 12, 33 AND 50). SN 77-319,192. PUB. 3-17-2009. FILED 11-1-2007.
 3,629,434. **PARVIS (BLOCK FORM)**. OLDCASTLE BUILDING PRODUCTS CANADA, INC., (U.S. CLS. 1, 12, 33 AND 50). SN 77-329,361. PUB. 3-17-2009. FILED 11-14-2007.
 3,629,452. **ACORN HOMES (BLOCK FORM)**. EMPYREAN INTERNATIONAL LLC, MULTIPLE CLASS, (INT. CLS. 19 AND 42), (U.S. CLS. 1, 12, 33, 50, 100 AND 101). SN 77-345,504. PUB. 3-17-2009. FILED 12-6-2007.
 3,629,527 (*See Class 6 for this trademark*).
 3,629,668. **PHOENICIAN STONE (BLOCK FORM)**. SAYEGH, JOSEPH, (U.S. CLS. 1, 12, 33 AND 50). SN 77-439,621. PUB. 3-17-2009. FILED 4-3-2008.
 3,629,804 (*See Class 6 for this trademark*).
 3,629,985. **FIELDER'S CHOICE (BLOCK FORM)**. S&S PROCESSING INCORPORATED, (U.S. CLS. 1, 12, 33 AND 50). SN 77-489,732. PUB. 3-17-2009. FILED 6-3-2008.
 3,630,064. **J SSON DESIGNS AND DESIGN**. JASSON INTERNATIONAL LLC, MULTIPLE CLASS, (INT. CLS. 19 AND 27), (U.S. CLS. 1, 12, 19, 20, 33, 37, 42 AND 50). SN 77-510,214. PUB. 3-17-2009. FILED 6-27-2008.
 3,630,100. **GREAT LAKES WOOD FLOORS (BLOCK FORM)**.

MULLICAN FLOORING, L.P., (U.S. CLS. 1, 12, 33 AND 50). SN 77-519,822. PUB. 3-17-2009. FILED 7-11-2008.
 3,630,221. **FORMAPILE INDUSTRIES, INC. AND DESIGN**. FORMAPILE INDUSTRIES, INC., (U.S. CLS. 1, 12, 33 AND 50). SN 77-551,983. PUB. 3-17-2009. FILED 8-20-2008.
 3,630,229. **DRAINSCAPE (BLOCK FORM)**. PRGRESSIVE CONCRETE WORKS, INC., (U.S. CLS. 1, 12, 33 AND 50). SN 77-554,453. PUB. 3-17-2009. FILED 8-25-2008.
 3,630,307. **METAL-ROK (BLOCK FORM)**. ALLIED MINERAL PRODUCTS, INC., (U.S. CLS. 1, 12, 33 AND 50). SN 77-567,356. PUB. 3-17-2009. FILED 9-11-2008.
 3,630,649 (*See Class 6 for this trademark*).
 3,630,706. **PROJECT STONE (BLOCK FORM)**. BRUSKIN INTERNATIONAL LLC, DBA BELSTONE MARBLE & GRANITE, (U.S. CLS. 1, 12, 33 AND 50). SN 77-598,361. PUB. 3-17-2009. FILED 10-22-2008.
 3,630,719. **RAM BOARD TEMPORARY FLOOR PROTECTION AND DESIGN**. MUX INDUSTRIES INC., (U.S. CLS. 1, 12, 33 AND 50). SN 77-598,523. PUB. 3-17-2009. FILED 10-22-2008.
 3,630,776. **ROLL-N-RIDE (BLOCK FORM)**. JET-PORT, INC., (U.S. CLS. 1, 12, 33 AND 50). SN 77-599,259. PUB. 3-17-2009. FILED 10-23-2008.
 3,630,866 (*See Class 18 for this trademark*).
 3,630,912 (*See Class 6 for this trademark*).
 3,630,916 (*See Class 6 for this trademark*).
 3,631,164. **SENTIMENTS IN STONE (BLOCK FORM)**. BRACCI, PAUL, (U.S. CLS. 1, 12, 33 AND 50). SN 77-604,947. PUB. 3-17-2009. FILED 10-31-2008.
 3,631,202. **DECCOWOOD (BLOCK FORM)**. CPS GARTEN CORPORATION, (U.S. CLS. 1, 12, 33 AND 50). SN 77-605,491. PUB. 3-17-2009. FILED 10-31-2008.
 3,631,249. **THINK GREEN WITH ZING AND DESIGN**. ZING ENTERPRISES, LLC, (U.S. CLS. 1, 12, 33 AND 50). SN 77-606,240. PUB. 3-17-2009. FILED 11-3-2008.
 3,631,432 (*See Class 1 for this trademark*).
 3,631,433 (*See Class 1 for this trademark*).
 3,631,453. **R REGULAR PANEL DE YESO REGULAR GYPSUM WALLBOARD AND DESIGN**. PANEL REY, S.A., (U.S. CLS. 1, 12, 33 AND 50). SN 78-968,899. PUB. 2-12-2008. FILED 9-7-2006.
 3,631,488 (*See Class 6 for this trademark*).
 3,631,495 (*See Class 18 for this trademark*).
 3,631,510 (*See Class 1 for this trademark*).
 3,631,511 (*See Class 1 for this trademark*).
 3,631,673. **DLH. AND DESIGN**. DALHOFF LARSEN & HORNEMAN, MULTIPLE CLASS, (INT. CLS. 19, 31 AND 35), (U.S. CLS. 1, 12, 33, 46, 50, 100, 101 AND 102). SN 79-055,801. PUB. 3-17-2009. FILED 2-7-2008.
 3,631,678. **MINEGRID (BLOCK FORM)**. HUESKER SYNTHETIC GMBH, (U.S. CLS. 1, 12, 33 AND 50). SN 79-056,085. PUB. 3-17-2009. FILED 4-23-2008.
 3,631,692 (*See Class 6 for this trademark*).
 3,631,706. **QUARTZIA (BLOCK FORM)**. LEVANTINA Y ASOCIADOS DE MINERALES, S.A., MULTIPLE CLASS, (INT. CLS. 19, 20 AND 27), (U.S. CLS. 1, 2, 12, 13, 19, 20, 22, 25, 32, 33, 37, 42 AND 50). SN 79-057,279. PUB. 3-17-2009. FILED 2-28-2008.

CLASS 20—FURNITURE AND ARTICLES NOT OTHERWISE CLASSIFIED

3,629,141. **ACRISHIELD (STYLIZED)**. RETAIL SOLUTION CENTER, INC., (U.S. CLS. 2, 13, 22, 25, 32 AND 50). SN 76-681,473. PUB. 3-17-2009. FILED 9-4-2007.
 3,629,233 (*See Class 1 for this trademark*).
 3,629,257 (*See Class 16 for this trademark*).
 3,629,291 (*See Class 9 for this trademark*).
 3,629,326 (*See Class 6 for this trademark*).
 3,629,329. **BABYSMART (BLOCK FORM)**. BABYSMART, LLC, MULTIPLE CLASS, (INT. CLS. 20 AND 24), (U.S. CLS. 2, 13, 22, 25, 32, 42 AND 50). SN 77-238,339. PUB. 3-17-2009. FILED 7-25-2007.
 3,629,338 (*See Class 4 for this trademark*).
 3,629,339 (*See Class 4 for this trademark*).
 3,629,350. **LADY CHAIR AND DESIGN**. STEIFENSAND,

- GERNOT M., (U.S. CLS. 2, 13, 22, 25, 32 AND 50). SN 77-260,239. PUB. 10-7-2008. FILED 8-21-2007.
 3,629,492 (*See Class 9 for this trademark*).
 3,629,550 (*See Class 11 for this trademark*).
 3,629,677. **KOALA CABINETS AND DESIGN. SEWING CENTER SUPPLY CO., INC.**, MULTIPLE CLASS, (INT. CLS. 20 AND 26), (U.S. CLS. 2, 13, 22, 25, 32, 37, 39, 40, 42 AND 50). SN 77-440,574. PUB. 3-17-2009. FILED 4-4-2008.
 3,629,718 (*See Class 6 for this trademark*).
 3,629,836. **THE TUCKER SLING (BLOCK FORM)**. TUCKER DESIGNS, LTD., (U.S. CLS. 2, 13, 22, 25, 32 AND 50). SN 77-455,199. PUB. 3-17-2009. FILED 4-22-2008.
 3,629,876. **MAXILOAD (BLOCK FORM)**. GIORDANO POULTRY PLAST S.P.A., AND LINCO ITALIA S.R.L., (U.S. CLS. 2, 13, 22, 25, 32 AND 50). SN 77-461,338. PUB. 3-17-2009. FILED 4-29-2008.
 3,629,952. **NORTHLAND FURNITURE COMPANY (BLOCK FORM)**. GENESIS ACQUISITION COMPANY, INC., (U.S. CLS. 2, 13, 22, 25, 32 AND 50). SN 77-479,106. PUB. 3-17-2009. FILED 5-20-2008.
 3,630,024. **MICHAEL AMINI CASUAL IMPRESSIONS (BLOCK FORM)**. AMINI INNOVATION CORPORATION, (U.S. CLS. 2, 13, 22, 25, 32 AND 50). SN 77-497,450. PUB. 3-17-2009. FILED 6-12-2008.
 3,630,300. **ORGAMED (BLOCK FORM)**. OELERICH, KEITH, (U.S. CLS. 2, 13, 22, 25, 32 AND 50). SN 77-566,129. PUB. 3-17-2009. FILED 9-9-2008.
 3,630,359. **BURN LOCKER AND DESIGN. DITEX BEDDING CORP.**, (U.S. CLS. 2, 13, 22, 25, 32 AND 50). SN 77-573,581. PUB. 3-17-2009. FILED 9-18-2008.
 3,630,410. **DELUXE (BLOCK FORM)**. WESTERN PACIFIC STORAGE SOLUTIONS, INC., (U.S. CLS. 2, 13, 22, 25, 32 AND 50). SN 77-579,949. PUB. 3-17-2009. FILED 9-26-2008.
 3,630,469. **MULTI-VU (BLOCK FORM)**. BRIDGES, LORI A., (U.S. CLS. 2, 13, 22, 25, 32 AND 50). SN 77-587,287. PUB. 3-17-2009. FILED 10-7-2008.
 3,630,539 (*See Class 11 for this trademark*).
 3,630,557. **AMERICAN OFFICE (BLOCK FORM)**. AMERICAN OFFICE EQUIPMENT COMPANY, INC., (U.S. CLS. 2, 13, 22, 25, 32 AND 50). SN 77-593,773. PUB. 3-17-2009. FILED 10-16-2008.
 3,630,574. **AMERICAN OFFICE AND DESIGN. AMERICAN OFFICE EQUIPMENT COMPANY, INC.**, (U.S. CLS. 2, 13, 22, 25, 32 AND 50). SN 77-594,708. PUB. 3-17-2009. FILED 10-17-2008.
 3,630,619. **SURFACETECH (BLOCK FORM)**. SURFACE TECHNOLOGIES, INC., (U.S. CLS. 2, 13, 22, 25, 32 AND 50). SN 77-596,475. PUB. 3-17-2009. FILED 10-20-2008.
 3,630,629. **H.O.T. SL AND DESIGN. THE NORTH FACE APPAREL CORP.** (U.S. CLS. 2, 13, 22, 25, 32 AND 50). SN 77-596,694. PUB. 3-17-2009. FILED 10-21-2008.
 3,630,731. **KARTRI (BLOCK FORM)**. KARTRI SALES COMPANY, INC., (U.S. CLS. 2, 13, 22, 25, 32 AND 50). SN 77-598,683. PUB. 3-17-2009. FILED 10-23-2008.
 3,630,741. **BOARDLESS (BLOCK FORM)**. 152310 CANADA, DBA AS HANGING SYSTEMS, (U.S. CLS. 2, 13, 22, 25, 32 AND 50). SN 77-598,838. PUB. 3-17-2009. FILED 10-23-2008.
 3,630,747. **OZBADGE (BLOCK FORM)**. NEVILLE MICHAEL, DBA OZBADGE, (U.S. CLS. 2, 13, 22, 25, 32 AND 50). SN 77-598,892. PUB. 3-17-2009. FILED 10-23-2008.
 3,630,884. **POST BUTLER AND DESIGN. PRACTICAL PRODUCTS, LLC**, (U.S. CLS. 2, 13, 22, 25, 32 AND 50). SN 77-600,689. PUB. 3-17-2009. FILED 10-26-2008.
 3,630,986. **RUSTIC ROOSTER INTERIORS AND DESIGN. RUSTIC ROOSTER, INC.**, MULTIPLE CLASS, (INT. CLS. 20, 35 AND 42), (U.S. CLS. 2, 13, 22, 25, 32, 50, 100, 101 AND 102). SN 77-602,073. PUB. 3-17-2009. FILED 10-28-2008.
 3,631,005 (*See Class 11 for this trademark*).
 3,631,159. **SMARTSKID (BLOCK FORM)**. PALLET SOLUTION, (U.S. CLS. 2, 13, 22, 25, 32 AND 50). SN 77-604,888. PUB. 3-17-2009. FILED 10-31-2008.
 3,631,305. **SPIDER WRAP (BLOCK FORM)**. CHECKPOINT SYSTEMS, INC., (U.S. CLS. 2, 13, 22, 25, 32 AND 50). SN 77-615,949. PUB. 3-17-2009. FILED 11-17-2008.
 3,631,306. **ALPHA (BLOCK FORM)**. CHECKPOINT SYSTEMS, INC., (U.S. CLS. 2, 13, 22, 25, 32 AND 50). SN 77-616,317. PUB. 3-17-2009. FILED 11-18-2008.
 3,631,368. **PIZZA-SAVOR (BLOCK FORM)**. SID HAUSEN, (U.S. CLS. 2, 13, 22, 25, 32 AND 50). SN 77-653,759. PUB. 3-17-2009. FILED 1-21-2009.
 3,631,375 (*See Class 6 for this trademark*).
 3,631,433 (*See Class 1 for this trademark*).
 3,631,452 (*See Class 1 for this trademark*).
 3,631,494 (*See Class 6 for this trademark*).
 3,631,507 (*See Class 7 for this trademark*).
 3,631,512 (*See Class 3 for this trademark*).
 3,631,545. **CYCLOC (BLOCK FORM)**. ANDREW LANG PRODUCT DESIGN LIMITED, (U.S. CLS. 2, 13, 22, 25, 32 AND 50). SN 79-051,111. PUB. 3-17-2009. FILED 4-16-2007.
 3,631,550 (*See Class 6 for this trademark*).
 3,631,561 (*See Class 6 for this trademark*).
 3,631,589 (*See Class 6 for this trademark*).
 3,631,610 (*See Class 12 for this trademark*).
 3,631,704 (*See Class 6 for this trademark*).
 3,631,706 (*See Class 19 for this trademark*).
 3,631,715. **FP FULL-POINT AND DESIGN. FULL POINT CORPORATION S.R.L.**, MULTIPLE CLASS, (INT. CLS. 20 AND 24), (U.S. CLS. 2, 13, 22, 25, 32, 42 AND 50). SN 79-057,513. PUB. 3-17-2009. FILED 3-20-2008.
 3,631,736. **TAKE APART U-B NORWAY (BLOCK FORM)**. SURFACE BALANCE NORWAY LTD, (U.S. CLS. 2, 13, 22, 25, 32 AND 50). SN 79-058,708. PUB. 3-17-2009. FILED 4-8-2008.
 3,631,755. **SUNLIGHT AND DESIGN. HANGZHOU SUNLIGHT SANITARY; CO., LTD.**, (U.S. CLS. 2, 13, 22, 25, 32 AND 50). SN 79-059,836. PUB. 3-17-2009. FILED 8-12-2008.
-
- CLASS 21—HOUSEWARES AND GLASS**
- 3,629,150. **"GRANDPA" SNIFFWHISKERS BIRD HOUSE FACTORY AND DESIGN.** SNIFFEN, R. DONN, (U.S. CLS. 2, 13, 23, 29, 30, 33, 40 AND 50). SN 76-687,356. PUB. 3-17-2009. FILED 3-4-2008.
 3,629,190 (*See Class 7 for this trademark*).
 3,629,233 (*See Class 1 for this trademark*).
 3,629,254 (*See Class 16 for this trademark*).
 3,629,291 (*See Class 9 for this trademark*).
 3,629,307 (*See Class 9 for this trademark*).
 3,629,333 (*See Class 18 for this trademark*).
 3,629,339 (*See Class 4 for this trademark*).
 3,629,367 (*See Class 3 for this trademark*).
 3,629,368 (*See Class 3 for this trademark*).
 3,629,492 (*See Class 9 for this trademark*).
 3,629,504 (*See Class 7 for this trademark*).
 3,629,611 (*See Class 3 for this trademark*).
 3,629,821. **BODY SPA (BLOCK FORM)**. EMPIRE LABORATORIES, INC, (U.S. CLS. 2, 13, 23, 29, 30, 33, 40 AND 50). SN 77-453,849. PUB. 3-17-2009. FILED 4-21-2008.
 3,629,842. **PACIFIC UNIVERSITY (BLOCK FORM)**. PACIFIC UNIVERSITY, (U.S. CLS. 2, 13, 23, 29, 30, 33, 40 AND 50). SN 77-456,166. PUB. 3-17-2009. FILED 4-23-2008.
 3,629,859. **SEAVEGGIES (BLOCK FORM)**. TWO LITTLE FISHIES, (U.S. CLS. 2, 13, 23, 29, 30, 33, 40 AND 50). SN 77-458,562. PUB. 3-17-2009. FILED 4-25-2008.
 3,629,897 (*See Class 4 for this trademark*).
 3,629,924. **CLASSICOR GO GREEN (BLOCK FORM)**. PATHWAY INVESTMENT CORPORATION, (U.S. CLS. 2, 13, 23, 29, 30, 33, 40 AND 50). SN 77-472,761. PUB. 3-17-2009. FILED 5-13-2008.
 3,629,942. **THERMA-GLASS (BLOCK FORM)**. HOWELL, LAUREN ASHLEY, DBA CARLETON, LAUREN ASHLEY, (U.S. CLS. 2, 13, 23, 29, 30, 33, 40 AND 50). SN 77-477,504. PUB. 3-17-2009. FILED 5-18-2008.
 3,630,026. **BAKING 101 BY TABLETOPS (BLOCK FORM)**. TABLETOPS UNLIMITED, INC., (U.S. CLS. 2, 13, 23, 29, 30, 33, 40 AND 50). SN 77-497,907. PUB. 3-17-2009. FILED 6-12-2008.
 3,630,136. **CASA FUENTE (BLOCK FORM)**. FUENTE MARKETING LTD., (U.S. CLS. 2, 13, 23, 29, 30, 33, 40 AND 50). SN 77-528,369. PUB. 3-17-2009. FILED 7-22-2008.
 3,630,357. **FRESHVAC VACUUM FOOD STORAGE AND DESIGN.** FRESHVAC, LLC, (U.S. CLS. 2, 13, 23, 29, 30, 33, 40 AND 50). SN 77-573,525. PUB. 3-17-2009. FILED 9-18-2008.
 3,630,429 (*See Class 16 for this trademark*).

3,630,467 (*See Class 5 for this trademark*).
 3,630,496. **WHERE GREAT FLOORS BEGIN (BLOCK FORM)**. COLUMBIA INSURANCE COMPANY, (U.S. CLS. 2, 13, 23, 29, 30, 33, 40 AND 50). SN 77-589,155. PUB. 3-17-2009. FILED 10-9-2008.
 3,630,497. **ORABRUSH (BLOCK FORM)**. DR. BOBS LTD, DBA DR. BOBS LTD, (U.S. CLS. 2, 13, 23, 29, 30, 33, 40 AND 50). SN 77-589,404. PUB. 3-17-2009. FILED 10-9-2008.
 3,630,539 (*See Class 11 for this trademark*).
 3,630,577 (*See Class 16 for this trademark*).
 3,630,609. **MIRACLE BAKER (BLOCK FORM)**. KITCHEN MARVELS LLC, (U.S. CLS. 2, 13, 23, 29, 30, 33, 40 AND 50). SN 77-596,077. PUB. 3-17-2009. FILED 10-20-2008.
 3,630,642. **AO COOLERS AND DESIGN**. HATCH, BRIAN MICHAEL, (U.S. CLS. 2, 13, 23, 29, 30, 33, 40 AND 50). SN 77-596,953. PUB. 3-17-2009. FILED 10-21-2008.
 3,630,655 (*See Class 9 for this trademark*).
 3,630,659 (*See Class 9 for this trademark*).
 3,630,713. **PLEDGE (BLOCK FORM)**. S. C. JOHNSON & SON, INC., (U.S. CLS. 2, 13, 23, 29, 30, 33, 40 AND 50). SN 77-598,444. PUB. 3-17-2009. FILED 10-22-2008.
 3,630,775. **SCRUBEX (BLOCK FORM)**. REMPAK L.L.C., (U.S. CLS. 2, 13, 23, 29, 30, 33, 40 AND 50). SN 77-599,249. PUB. 3-17-2009. FILED 10-23-2008.
 3,630,954. **ONE PLANET, ONE YOU! (BLOCK FORM)**. CRESSLINE DISTRIBUTING, INCORPORATED, DBA KLEAN KANTEEN, (U.S. CLS. 2, 13, 23, 29, 30, 33, 40 AND 50). SN 77-601,612. PUB. 3-17-2009. FILED 10-27-2008.
 3,631,033. **THE BROWNIE PAN FOR EDGE LOVERS (BLOCK FORM)**. GRIFFINVENT INC., DBA BAKER'S EDGE, (U.S. CLS. 2, 13, 23, 29, 30, 33, 40 AND 50). SN 77-602,644. PUB. 3-17-2009. FILED 10-28-2008.
 3,631,308. **DE LA TERRE SKIN CARE AND DESIGN**. ANNE C. WILLIS ENTERPRISES, LLC, (U.S. CLS. 2, 13, 23, 29, 30, 33, 40 AND 50). SN 77-616,337. PUB. 3-17-2009. FILED 11-18-2008.
 3,631,399 (*See Class 3 for this trademark*).
 3,631,406. **HOUDINI (BLOCK FORM)**. HOUDINI, INC., (U.S. CLS. 2, 13, 23, 29, 30, 33, 40 AND 50). SN 78-655,517. PUB. 3-17-2009. FILED 6-21-2005.
 3,631,414 (*See Class 16 for this trademark*).
 3,631,434. **ITHERMO (STYLIZED)**. TOP CREATION (ASIA) LTD., (U.S. CLS. 2, 13, 23, 29, 30, 33, 40 AND 50). SN 78-894,758. PUB. 3-17-2009. FILED 5-26-2006.
 3,631,451. **MICROFIBER TECHNOLOGIES AND DESIGN**. IMPACT PRODUCTS LLC, (U.S. CLS. 2, 13, 23, 29, 30, 33, 40 AND 50). SN 78-965,974. PUB. 3-17-2009. FILED 9-1-2006.
 3,631,452 (*See Class 1 for this trademark*).
 3,631,470. **DOOGIE (BLOCK FORM)**. TERENCE JEFFERY LAPIDGE, (U.S. CLS. 2, 13, 23, 29, 30, 33, 40 AND 50). SN 79-035,453. PUB. 3-17-2009. FILED 9-11-2006.
 3,631,482 (*See Class 3 for this trademark*).
 3,631,511 (*See Class 1 for this trademark*).
 3,631,619 (*See Class 14 for this trademark*).
 3,631,633 (*See Class 7 for this trademark*).
 3,631,781. **MISCELLANEOUS DESIGN**. AZUMA INDUSTRIAL, CO., LTD., (U.S. CLS. 2, 13, 23, 29, 30, 33, 40 AND 50). SN 79-063,585. PUB. 3-17-2009. FILED 8-27-2008.

CLASS 22—CORDAGE AND FIBERS

3,629,257 (*See Class 16 for this trademark*).
 3,629,738 (*See Class 12 for this trademark*).
 3,629,741 (*See Class 12 for this trademark*).
 3,630,205. **FAST BACK (BLOCK FORM)**. FAST BACK ROPES, INC., (U.S. CLS. 1, 2, 7, 19, 22, 42 AND 50). SN 77-547,461. PUB. 3-17-2009. FILED 8-14-2008.
 3,630,934. **TEAMSTRAP (BLOCK FORM)**. AGS MARKETING, INC., (U.S. CLS. 1, 2, 7, 19, 22, 42 AND 50). SN 77-601,336. PUB. 3-17-2009. FILED 10-27-2008.

CLASS 23—YARNS AND THREADS

3,631,604. **LORO PIANA "THE WAVE" (BLOCK FORM)**. LORO PIANA S.P.A., (U.S. CL. 43). SN 79-054,064. PUB. 3-17-2009. FILED 4-30-2008.

CLASS 24—FABRICS

3,629,329 (*See Class 20 for this trademark*).
 3,629,339 (*See Class 4 for this trademark*).
 3,629,343. **MARQUIS AND DESIGN**. LES LAINAGES VICTOR LTÉE, (U.S. CLS. 42 AND 50). SN 77-252,754. PUB. 3-17-2009. FILED 8-10-2007.
 3,629,344. **ARCADE AND DESIGN**. LES LAINAGES VICTOR LTÉE, (U.S. CLS. 42 AND 50). SN 77-252,773. PUB. 3-17-2009. FILED 8-10-2007.
 3,629,345. **SPEEDBALL AND DESIGN**. LES LAINAGES VICTOR LTÉE, (U.S. CLS. 42 AND 50). SN 77-252,800. PUB. 3-17-2009. FILED 8-10-2007.
 3,629,447. **SOPHAND (BLOCK FORM)**. STERLING PRODUCTS LTD., MULTIPLE CLASS, (INT. CLS. 24, 25 AND 40), (U.S. CLS. 22, 39, 42, 50, 100, 103 AND 106). SN 77-341,399. PUB. 3-17-2009. FILED 11-30-2007.
 3,630,224 (*See Class 5 for this trademark*).
 3,630,539 (*See Class 11 for this trademark*).
 3,630,936. **SLEEP AND PEACE (BLOCK FORM)**. DAVIS, MARY E, (U.S. CLS. 42 AND 50). SN 77-601,361. PUB. 3-17-2009. FILED 10-27-2008.
 3,631,177. **MATTEO (BLOCK FORM)**. MATTEO LLC, (U.S. CLS. 42 AND 50). SN 77-605,257. PUB. 3-17-2009. FILED 10-31-2008.
 3,631,256 (*See Class 18 for this trademark*).
 3,631,285. **BARROW FABRICS (BLOCK FORM)**. BARROW INDUSTRIES INC., (U.S. CLS. 42 AND 50). SN 77-610,408. PUB. 3-17-2009. FILED 11-8-2008.
 3,631,399 (*See Class 3 for this trademark*).
 3,631,424. **KEEDO AND DESIGN**. KEEDO INTERNATIONAL (PTY) LIMITED, MULTIPLE CLASS, (INT. CLS. 24, 25 AND 35), (U.S. CLS. 22, 39, 42, 50, 100, 101 AND 102). SN 78-838,077. PUB. 3-17-2009. FILED 3-15-2006.
 3,631,456. **THE LIL ANGEL AND DESIGN**. PARENTAL SOLUTIONS, INC., (U.S. CLS. 42 AND 50). SN 78-973,397. PUB. 3-17-2009. FILED 9-13-2006.
 3,631,512 (*See Class 3 for this trademark*).
 3,631,538 (*See Class 9 for this trademark*).
 3,631,540 (*See Class 10 for this trademark*).
 3,631,715 (*See Class 20 for this trademark*).

CLASS 25—CLOTHING

3,629,128. **WOOD LAND TRAIL (BLOCK FORM)**. LORD DANIEL SPORTSWEAR, INC., (U.S. CLS. 22 AND 39). SN 76-601,606. PUB. 3-17-2009. FILED 7-9-2004.
 3,629,177 (*See Class 18 for this trademark*).
 3,629,202. **KEYS DISEASE AND DESIGN**. STAB-THE-CAT INTERNATIONAL, INC., (U.S. CLS. 22 AND 39). SN 76-693,694. PUB. 3-17-2009. FILED 10-20-2008.
 3,629,211. **I SOCIETY (BLOCK FORM)**. P-MAX APPAREL, INC., (U.S. CLS. 22 AND 39). SN 76-693,941. PUB. 3-17-2009. FILED 10-30-2008.
 3,629,213. **EYE OF THE STORM (STYLIZED)**. WORK FORCE, INC., (U.S. CLS. 22 AND 39). SN 76-693,996. PUB. 3-17-2009. FILED 11-3-2008.
 3,629,235 (*See Class 14 for this trademark*).
 3,629,239. **UNBRAND LOGO APPAREL AND DESIGN**. KRAUSS, LARRY C., DBA UNBRANDAPPAREL, (U.S. CLS. 22 AND 39). SN 77-050,702. PUB. 3-17-2009. FILED 11-26-2006.
 3,629,246 (*See Class 18 for this trademark*).
 3,629,258. **FIASCO (BLOCK FORM)**. HUANTE, XAVIER, AND HUANTE, GABRIEL, (U.S. CLS. 22 AND 39). SN 77-090,209. PUB. 3-17-2009. FILED 1-24-2007.
 3,629,270. **CAROLINA MUD DUDS (STYLIZED)**. CAROLINA MUD DUDS INC., (U.S. CLS. 22 AND 39). SN 77-120,252.

- PUB. 3-17-2009. FILED 3-1-2007.
- 3,629,279. **ERACIZM AND DESIGN**. ERACIZM, INC., (U.S. CLS. 22 AND 39). SN 77-145,472. PUB. 3-17-2009. FILED 3-31-2007.
- 3,629,291 (*See Class 9 for this trademark*).
- 3,629,309. **45SURF AND DESIGN**. MCGUCKEN, ELLIOT, DR., (U.S. CLS. 22 AND 39). SN 77-199,640. PUB. 3-17-2009. FILED 6-6-2007.
- 3,629,311. **CYCLE THERAPY (BLOCK FORM)**. DO RAGS, INC., (U.S. CLS. 22 AND 39). SN 77-202,030. PUB. 3-17-2009. FILED 6-8-2007.
- 3,629,317. **NEO BLUE (BLOCK FORM)**. T.O.W., INC., (U.S. CLS. 22 AND 39). SN 77-208,517. PUB. 3-17-2009. FILED 6-18-2007.
- 3,629,323 (*See Class 9 for this trademark*).
- 3,629,333 (*See Class 18 for this trademark*).
- 3,629,337 (*See Class 3 for this trademark*).
- 3,629,341. **S.I.C. (STYLIZED)**. ANA MARIA HENAO, AND ERIN DARBY GALLAGHER, (U.S. CLS. 22 AND 39). SN 77-249,948. PUB. 3-17-2009. FILED 8-8-2007.
- 3,629,349. **ALASKAN'S KODIAK AND DESIGN**. KODIAK GROUP INC., (U.S. CLS. 22 AND 39). SN 77-259,192. PUB. 3-17-2009. FILED 8-20-2007.
- 3,629,372 (*See Class 16 for this trademark*).
- 3,629,387. **EST. 1963 RICH TASTE COLLECTION AND DESIGN**. RICH TASTE, INC., (U.S. CLS. 22 AND 39). SN 77-296,770. PUB. 3-17-2009. FILED 10-4-2007.
- 3,629,415. **DEBA CAT (BLOCK FORM)**. RESTIVO, SANDRA, AND NUCKOLLS, DEBBIE, (U.S. CLS. 22 AND 39). SN 77-318,666. PUB. 3-17-2009. FILED 11-1-2007.
- 3,629,424 (*See Class 3 for this trademark*).
- 3,629,435. **JIMMY'S BURGER SHACK AND DESIGN**. BROTHER JIMMY'S NYC RESTAURANT HOLDINGS, LLC, MULTIPLE CLASS, (INT. CLS. 25 AND 43), (U.S. CLS. 22, 39, 100 AND 101). SN 77-329,560. PUB. 3-17-2009. FILED 11-14-2007.
- 3,629,436. **WAND FIGHT CO. (BLOCK FORM)**. SILVA, TEA, (U.S. CLS. 22 AND 39). SN 77-332,147. PUB. 3-17-2009. FILED 11-16-2007.
- 3,629,447 (*See Class 24 for this trademark*).
- 3,629,451 (*See Class 14 for this trademark*).
- 3,629,461. **E EMNACE AND DESIGN**. EMNACE LLC, (U.S. CLS. 22 AND 39). SN 77-352,924. PUB. 3-17-2009. FILED 12-14-2007.
- 3,629,464. **ACE CAFE ACE RACER AND DESIGN**. ACE CAFE LONDON LIMITED, (U.S. CLS. 22 AND 39). SN 77-354,217. PUB. 3-17-2009. FILED 12-17-2007.
- 3,629,473. **DIRTY VIOLET (BLOCK FORM)**. NEW NAME, INC., (U.S. CLS. 22 AND 39). SN 77-360,022. PUB. 3-17-2009. FILED 12-27-2007.
- 3,629,491 (*See Class 10 for this trademark*).
- 3,629,492 (*See Class 9 for this trademark*).
- 3,629,556. **T-HOME (BLOCK FORM)**. DEUTSHE TELEKOM, (U.S. CLS. 22 AND 39). SN 77-402,806. PUB. 3-17-2009. FILED 2-21-2008.
- 3,629,558. **ON IT AND DESIGN**. NORDSKOG, ERIK, AND SINGER, RANDY, (U.S. CLS. 22 AND 39). SN 77-403,188. PUB. 3-17-2009. FILED 2-21-2008.
- 3,629,561. **DRESSYOURGEEK.COM AND DESIGN**. LINUX SOLUTIONS PROVIDER, INC., (U.S. CLS. 22 AND 39). SN 77-405,263. PUB. 3-17-2009. FILED 2-25-2008.
- 3,629,583. **NEW EARTH AND DESIGN**. NEW EARTH, (U.S. CLS. 22 AND 39). SN 77-417,091. PUB. 3-17-2009. FILED 3-9-2008.
- 3,629,601. **DALE RANCH HAPPY MEAT COMPANY AND DESIGN**. DALE, SUSAN, AND DALE, DOYLE, MULTIPLE CLASS, (INT. CLS. 25 AND 29), (U.S. CLS. 22, 39 AND 46). SN 77-422,548. PUB. 12-9-2008. FILED 3-14-2008.
- 3,629,621. **FIRST CALL (BLOCK FORM)**. O'REILLY AUTOMOTIVE, INC., (U.S. CLS. 22 AND 39). SN 77-432,115. PUB. 3-17-2009. FILED 3-26-2008.
- 3,629,648. **MIKE ML LANES AND DESIGN**. MIKE LANES, LLC, (U.S. CLS. 22 AND 39). SN 77-436,361. PUB. 3-17-2009. FILED 3-31-2008.
- 3,629,663. **ML (STYLIZED)**. MIKE LANES, L.L.C., (U.S. CLS. 22 AND 39). SN 77-438,598. PUB. 3-17-2009. FILED 4-3-2008.
- 3,629,667. **THE EMPEROR'S NEW CLOTHES (BLOCK FORM)**. WHEELER, RICHARD A., (U.S. CLS. 22 AND 39). SN 77-439,374. PUB. 3-17-2009. FILED 4-3-2008.
- 3,629,691. **H HIGHCROFT RACING AND DESIGN**. HIGHCROFT RACING, INC., MULTIPLE CLASS, (INT. CLS. 25, 37 AND 41), (U.S. CLS. 22, 39, 100, 101, 103, 106 AND 107). SN 77-442,464. PUB. 3-17-2009. FILED 4-8-2008.
- 3,629,721. **BELLINGHAM BELLS (BLOCK FORM)**. BELLINGHAM BELLS, LLC, MULTIPLE CLASS, (INT. CLS. 25 AND 41), (U.S. CLS. 22, 39, 100, 101 AND 107). SN 77-444,945. PUB. 3-17-2009. FILED 4-10-2008.
- 3,629,748. **MIKE LANES (BLOCK FORM)**. MIKE LANES, LLC, (U.S. CLS. 22 AND 39). SN 77-448,096. PUB. 3-17-2009. FILED 4-15-2008.
- 3,629,751. **SHYAMAL & BHUMIKA (BLOCK FORM)**. SHODHAN, SHYAMAL, (U.S. CLS. 22 AND 39). SN 77-448,216. PUB. 3-17-2009. FILED 4-15-2008.
- 3,629,756. **WHAT NUMBER R U? (BLOCK FORM)**. FIGHT WORLD AIDS CORP, (U.S. CLS. 22 AND 39). SN 77-448,985. PUB. 3-17-2009. FILED 4-15-2008.
- 3,629,761. **MUKLUCKY KNIT SLIPPERS (STYLIZED)**. SOURCE ADVANTAGE, LLC, DBA RED CARPET STUDIOS, INC., (U.S. CLS. 22 AND 39). SN 77-449,613. PUB. 3-17-2009. FILED 4-16-2008.
- 3,629,763. **OLINDA (STYLIZED)**. OLINDA ELIZABETH LOPEZ DE GALILEA, (U.S. CLS. 22 AND 39). SN 77-449,814. PUB. 3-17-2009. FILED 4-16-2008.
- 3,629,766. **CHARLES RIVER APPAREL AND DESIGN**. CHARLES RIVER APPAREL, INC., (U.S. CLS. 22 AND 39). SN 77-449,956. PUB. 3-17-2009. FILED 4-16-2008.
- 3,629,775. **T SYSTEMS AND DESIGN**. DEUTSCHE TELEKOM, (U.S. CLS. 22 AND 39). SN 77-450,618. PUB. 3-17-2009. FILED 4-17-2008.
- 3,629,789. **T HOME AND DESIGN**. DEUTSCHE TELEKOM, (U.S. CLS. 22 AND 39). SN 77-451,389. PUB. 1-13-2009. FILED 4-17-2008.
- 3,629,795. **MAGNUM RESEARCH (BLOCK FORM)**. MAGNUM RESEARCH, INC., (U.S. CLS. 22 AND 39). SN 77-451,622. PUB. 12-23-2008. FILED 4-18-2008.
- 3,629,796. **DESERT EAGLE (BLOCK FORM)**. MAGNUM RESEARCH, INC., (U.S. CLS. 22 AND 39). SN 77-451,634. PUB. 3-17-2009. FILED 4-18-2008.
- 3,629,799 (*See Class 18 for this trademark*).
- 3,629,811. **MISSY (BLOCK FORM)**. SUPA DUPA FLY, INC., (U.S. CLS. 22 AND 39). SN 77-452,913. PUB. 3-17-2009. FILED 4-20-2008.
- 3,629,837. **PIA AND DESIGN**. PIA GROUP, LLC, (U.S. CLS. 22 AND 39). SN 77-455,274. PUB. 3-17-2009. FILED 4-22-2008.
- 3,629,879. **MISCELLANEOUS DESIGN**. MOTHERBEARWARE, INC., (U.S. CLS. 22 AND 39). SN 77-461,660. PUB. 3-17-2009. FILED 4-30-2008.
- 3,629,901. **ULTIMATE U GIRLS SWIMWEAR AND DESIGN**. JACK WHITE APPAREL, INC., (U.S. CLS. 22 AND 39). SN 77-466,500. PUB. 3-17-2009. FILED 5-6-2008.
- 3,629,939. **MOZO (BLOCK FORM)**. EDGE QUEST, INC., (U.S. CLS. 22 AND 39). SN 77-477,151. PUB. 3-17-2009. FILED 5-16-2008.
- 3,629,986. **SOUND CANNON (BLOCK FORM)**. TALKING TABS, L.L.C., MULTIPLE CLASS, (INT. CLS. 25 AND 41), (U.S. CLS. 22, 39, 100, 101 AND 107). SN 77-489,749. PUB. 3-17-2009. FILED 6-3-2008.
- 3,629,987. **SC SOUND CANNON AND DESIGN**. TALKING TABS, L.L.C., MULTIPLE CLASS, (INT. CLS. 25 AND 41), (U.S. CLS. 22, 39, 100, 101 AND 107). SN 77-489,904. PUB. 3-17-2009. FILED 6-3-2008.
- 3,629,993. **BROHAN NATION (BLOCK FORM)**. BROHAN NATION APPAREL, (U.S. CLS. 22 AND 39). SN 77-491,607. PUB. 3-17-2009. FILED 6-5-2008.
- 3,630,002. **ONQUE (BLOCK FORM)**. SPORT ELLE, INC., (U.S. CLS. 22 AND 39). SN 77-494,089. PUB. 3-17-2009. FILED 6-9-2008.
- 3,630,027. **TADY LURES AND DESIGN**. TADY LURE CORPORATION, MULTIPLE CLASS, (INT. CLS. 25 AND 28), (U.S. CLS. 22, 23, 38, 39 AND 50). SN 77-498,012. PUB. 3-17-2009. FILED 6-12-2008.
- 3,630,056. **COTTONKING (BLOCK FORM)**. A&W DISTRIBUTION CENTER, (U.S. CLS. 22 AND 39). SN 77-507,830. PUB. 3-17-2009. FILED 6-25-2008.
- 3,630,067. **NURSEJOE.COM (BLOCK FORM)**. MANCHENO, JOSEPH, (U.S. CLS. 22 AND 39). SN 77-511,020. PUB. 3-17-

2009. FILED 6-30-2008.
- 3,630,078. **SURF ROYALTY (BLOCK FORM)**. PEEK...AREN'T YOU CURIOUS, INC. (U.S. CLS. 22 AND 39). SN 77-516,378. PUB. 3-17-2009. FILED 7-7-2008.
- 3,630,079. **LITTLE PEANUT (BLOCK FORM)**. PEEK...AREN'T YOU CURIOUS, INC. (U.S. CLS. 22 AND 39). SN 77-516,379. PUB. 3-17-2009. FILED 7-7-2008.
- 3,630,083. **JASPER CONRAN (BLOCK FORM)**. CONRAN, JASPER, (U.S. CLS. 22 AND 39). SN 77-517,113. PUB. 3-17-2009. FILED 7-8-2008.
- 3,630,106. **LIFE SIZE (BLOCK FORM)**. RON ROBINSON, INC., (U.S. CLS. 22 AND 39). SN 77-522,239. PUB. 12-9-2008. FILED 7-15-2008.
- 3,630,108. **SHOES THAT SERVE (BLOCK FORM)**. MOZO, INC., (U.S. CLS. 22 AND 39). SN 77-522,767. PUB. 3-17-2009. FILED 7-15-2008.
- 3,630,131. **CRYSTAL NATION (BLOCK FORM)**. CRYSTAL NATION, LLC, (U.S. CLS. 22 AND 39). SN 77-527,092. PUB. 12-9-2008. FILED 7-21-2008.
- 3,630,151. **SUSTAINABLE KIDS MADE IN USA AND DESIGN**. ANDERSEN, MAIA, (U.S. CLS. 22 AND 39). SN 77-533,149. PUB. 3-17-2009. FILED 7-28-2008.
- 3,630,158. **THE MAUDS (BLOCK FORM)**. ROGERS, JIMY, (U.S. CLS. 22 AND 39). SN 77-535,327. PUB. 3-17-2009. FILED 7-30-2008.
- 3,630,159. **BANSHEE (BLOCK FORM)**. BIG RIVER INNOVATIONS, INC., MULTIPLE CLASS, (INT. CLS. 25 AND 28), (U.S. CLS. 22, 23, 38, 39 AND 50). SN 77-536,043. PUB. 3-17-2009. FILED 7-31-2008.
- 3,630,224 (*See Class 5 for this trademark*).
- 3,630,253. **SLEDGE USA AND DESIGN**. SLEDGE USA, INC., (U.S. CLS. 22 AND 39). SN 77-557,298. PUB. 3-17-2009. FILED 8-27-2008.
- 3,630,291. **7" 4 - 1/8" (BLOCK FORM)**. ZAK'S MONOGRAMMING INC., DBA INITIAL IMPACT EMBROIDERY, (U.S. CLS. 22 AND 39). SN 77-563,675. PUB. 3-17-2009. FILED 9-5-2008.
- 3,630,341. **7" 11-5/8" (BLOCK FORM)**. ZAK'S MONOGRAMMING INC., DBA INITIAL IMPACT EMBROIDERY, (U.S. CLS. 22 AND 39). SN 77-571,196. PUB. 3-17-2009. FILED 9-16-2008.
- 3,630,370. **ST & SURF CO. (BLOCK FORM)**. SHIMABUKURO, KYLE, DBA HI LIFE CLOTHING CO., MULTIPLE CLASS, (INT. CLS. 25 AND 28), (U.S. CLS. 22, 23, 38, 39 AND 50). SN 77-575,031. PUB. 3-17-2009. FILED 9-20-2008.
- 3,630,398. **SPUN HONEY (BLOCK FORM)**. BRYANT, BRANDI VANIECE, (U.S. CLS. 22 AND 39). SN 77-579,133. PUB. 3-17-2009. FILED 9-25-2008.
- 3,630,413. **THE SHAWE FOUNDATION OF AMERICA AND DESIGN**. THE SHAWE FOUNDATION, (U.S. CLS. 22 AND 39). SN 77-580,208. PUB. 3-17-2009. FILED 9-26-2008.
- 3,630,424. **LIVE LONG (BLOCK FORM)**. SELLINGER, ART, (U.S. CLS. 22 AND 39). SN 77-581,294. PUB. 3-17-2009. FILED 9-29-2008.
- 3,630,446. **ATTACKMODE SPORTS (BLOCK FORM)**. HAUGEN, JEFF, (U.S. CLS. 22 AND 39). SN 77-584,567. PUB. 3-17-2009. FILED 10-2-2008.
- 3,630,507. **UA (STYLIZED)**. UNDER ARMOUR, INC., (U.S. CLS. 22 AND 39). SN 77-590,378. PUB. 3-17-2009. FILED 10-10-2008.
- 3,630,515. **DARE GEAR DG SINCE 1978 AND DESIGN**. GEORGE VERANO USA LLC, (U.S. CLS. 22 AND 39). SN 77-591,058. PUB. 3-17-2009. FILED 10-12-2008.
- 3,630,517. **UA POWER IN PINK AND DESIGN**. UNDER ARMOUR, INC., (U.S. CLS. 22 AND 39). SN 77-591,108. PUB. 3-17-2009. FILED 10-13-2008.
- 3,630,550. **HYDROSEAL (BLOCK FORM)**. THE NORTH FACE APPAREL CORP, (U.S. CLS. 22 AND 39). SN 77-593,315. PUB. 3-17-2009. FILED 10-15-2008.
- 3,630,565. **THE NORTH FACE AND DESIGN**. THE NORTH FACE APPAREL CORP, (U.S. CLS. 22 AND 39). SN 77-594,171. PUB. 3-17-2009. FILED 10-16-2008.
- 3,630,567. **JO AND DESIGN**. GUY, ERIC EDWARD, DBA JO APPAREL, (U.S. CLS. 22 AND 39). SN 77-594,230. PUB. 3-17-2009. FILED 10-16-2008.
- 3,630,613 (*See Class 18 for this trademark*).
- 3,630,623. **GIRL KRAZY (STYLIZED)**. KRAZY KAT SPORTS-WEAR LLC, (U.S. CLS. 22 AND 39). SN 77-596,625. PUB. 3-17-2009. FILED 10-20-2008.
- 3,630,625. **NEWBORN APPLE (BLOCK FORM)**. CRUZ, JOHN D. DELA, DBA NEWBORN APPLE, (U.S. CLS. 22 AND 39). SN 77-596,643. PUB. 3-17-2009. FILED 10-21-2008.
- 3,630,655 (*See Class 9 for this trademark*).
- 3,630,659 (*See Class 9 for this trademark*).
- 3,630,661. **PLOW TO PLATE (BLOCK FORM)**. NEW MILFORD HOSPITAL, (U.S. CLS. 22 AND 39). SN 77-597,430. PUB. 3-17-2009. FILED 10-21-2008.
- 3,630,757. **WICKID EMPIRE (BLOCK FORM)**. RYAN NEEDLES, (U.S. CLS. 22 AND 39). SN 77-598,984. PUB. 3-17-2009. FILED 10-23-2008.
- 3,630,810. **IDC I DON'T CARE WEAR (BLOCK FORM)**. PALOMBO, GINO, (U.S. CLS. 22 AND 39). SN 77-599,795. PUB. 3-17-2009. FILED 10-24-2008.
- 3,630,815 (*See Class 14 for this trademark*).
- 3,630,835. **PITA PAN AND DESIGN**. PITA KING, INC., MULTIPLE CLASS, (INT. CLS. 25 AND 43), (U.S. CLS. 22, 39, 100 AND 101). SN 77-600,087. PUB. 3-17-2009. FILED 10-24-2008.
- 3,630,836. **NATIVE BEAUTY NB AND DESIGN**. HARDER, TODD, (U.S. CLS. 22 AND 39). SN 77-600,104. PUB. 3-17-2009. FILED 10-24-2008.
- 3,630,837. **APLOMB (BLOCK FORM)**. DON XIANGDONG HO, (U.S. CLS. 22 AND 39). SN 77-600,111. PUB. 3-17-2009. FILED 10-24-2008.
- 3,630,846. **THE NORTH FACE AND DESIGN**. THE NORTH FACE APPAREL CORP, (U.S. CLS. 22 AND 39). SN 77-600,179. PUB. 3-17-2009. FILED 10-24-2008.
- 3,630,850. **MISCELLANEOUS DESIGN**. THE NORTH FACE APPAREL CORP, (U.S. CLS. 22 AND 39). SN 77-600,199. PUB. 3-17-2009. FILED 10-24-2008.
- 3,630,861. **ARTOOZIE (BLOCK FORM)**. ART RENAISSANCE, LLC, (U.S. CLS. 22 AND 39). SN 77-600,369. PUB. 3-17-2009. FILED 10-24-2008.
- 3,630,867. **ENCANTO (BLOCK FORM)**. PALOS VERDES FOOTWEAR, INC., (U.S. CLS. 22 AND 39). SN 77-600,460. PUB. 3-17-2009. FILED 10-24-2008.
- 3,630,874. **TUICOUTURE (BLOCK FORM)**. MINERAL SPRINGS FARM LLC, (U.S. CLS. 22 AND 39). SN 77-600,492. PUB. 3-17-2009. FILED 10-24-2008.
- 3,630,913. **INMATE TEASE AND DESIGN**. INMATE TEASE LLC, (U.S. CLS. 22 AND 39). SN 77-601,046. PUB. 3-17-2009. FILED 10-27-2008.
- 3,630,953. **IRON DOG (BLOCK FORM)**. IRON DOG, INC., MULTIPLE CLASS, (INT. CLS. 25 AND 41), (U.S. CLS. 22, 39, 100, 101 AND 107). SN 77-601,590. PUB. 3-17-2009. FILED 10-27-2008.
- 3,630,955. **MISCELLANEOUS DESIGN**. IRON DOG, INC., MULTIPLE CLASS, (INT. CLS. 25 AND 41), (U.S. CLS. 22, 39, 100, 101 AND 107). SN 77-601,614. PUB. 3-17-2009. FILED 10-27-2008.
- 3,630,966. **COWGIRL SAVVY (BLOCK FORM)**. COWGIRL SAVVY, LLC, (U.S. CLS. 22 AND 39). SN 77-601,864. PUB. 3-17-2009. FILED 10-28-2008.
- 3,630,971 (*See Class 18 for this trademark*).
- 3,630,975 (*See Class 9 for this trademark*).
- 3,630,976 (*See Class 18 for this trademark*).
- 3,630,979. **DIFFS CLOTHING AND DESIGN**. PRECHEL, SHERI, (U.S. CLS. 22 AND 39). SN 77-602,004. PUB. 3-17-2009. FILED 10-28-2008.
- 3,630,996. **T 4 AND DESIGN**. TRINITY 3 INTERNATIONAL, (U.S. CLS. 22 AND 39). SN 77-602,157. PUB. 3-17-2009. FILED 10-28-2008.
- 3,630,998. **THERAFEET (BLOCK FORM)**. UNIVERSAL HOSIERY INC, DBA UNIVERSAL HOSIERY, (U.S. CLS. 22 AND 39). SN 77-602,177. PUB. 3-17-2009. FILED 10-28-2008.
- 3,631,034. **DROPKNEE OR DIE (BLOCK FORM)**. RAGEVOL LLC, (U.S. CLS. 22 AND 39). SN 77-602,647. PUB. 3-17-2009. FILED 10-28-2008.
- 3,631,037. **MERCY SHIPS (BLOCK FORM)**. MERCY SHIPS, (U.S. CLS. 22 AND 39). SN 77-602,737. PUB. 3-17-2009. FILED 10-29-2008.
- 3,631,052. **SHERRI HILL (BLOCK FORM)**. HILL, SHERRI K., (U.S. CLS. 22 AND 39). SN 77-603,008. PUB. 3-17-2009. FILED 10-29-2008.
- 3,631,054. **BMZ (BLOCK FORM)**. TAKAHASHI, TSUYOSHI, (U.S. CLS. 22 AND 39). SN 77-603,126. PUB. 3-17-2009.

- FILED 10-29-2008.
3,631,064 (*See Class 9 for this trademark*).
3,631,073. **WILD 1 (BLOCK FORM)**, SCHULTZ JR., DONALD F., (U.S. CLS. 22 AND 39), SN 77-603,512. PUB. 3-17-2009. FILED 10-29-2008.
3,631,082. **FLYER & BOBBIN (BLOCK FORM)**, BARMAK BADAEL AND JIM SAUER, (U.S. CLS. 22 AND 39), SN 77-603,606. PUB. 3-17-2009. FILED 10-29-2008.
3,631,098. **NDY NOT DEAD YET NOT DONE YET (BLOCK FORM)**, APRIL, CAROL, (U.S. CLS. 22 AND 39), SN 77-603,831. PUB. 3-17-2009. FILED 10-30-2008.
3,631,117. **UP SCENE AND DESIGN**, MCKENZIE, SEAN, (U.S. CLS. 22 AND 39), SN 77-604,104. PUB. 3-17-2009. FILED 10-30-2008.
3,631,166. **MISCELLANEOUS DESIGN**, WARREN MILLER COMPANY, LLC, (U.S. CLS. 22 AND 39), SN 77-604,964. PUB. 3-17-2009. FILED 10-31-2008.
3,631,208. **HAT.A.GIRL (BLOCK FORM)**, JED TRADERS, INC., DBA HAT.A.GIRL, (U.S. CLS. 22 AND 39), SN 77-605,519. PUB. 3-17-2009. FILED 10-31-2008.
3,631,211. **PLATINUM INK (BLOCK FORM)**, HONG, MICHAEL, (U.S. CLS. 22 AND 39), SN 77-605,541. PUB. 3-17-2009. FILED 10-31-2008.
3,631,212. **KEY AND DESIGN**, HONG, MICHAEL, (U.S. CLS. 22 AND 39), SN 77-605,542. PUB. 3-17-2009. FILED 10-31-2008.
3,631,213. **MISCELLANEOUS DESIGN**, REFUSE2COMPROMISE, LLC, (U.S. CLS. 22 AND 39), SN 77-605,568. PUB. 3-17-2009. FILED 11-1-2008.
3,631,243. **INCITE (BLOCK FORM)**, CAVALERA, RICHARD, (U.S. CLS. 22 AND 39), SN 77-606,186. PUB. 3-17-2009. FILED 11-3-2008.
3,631,251. **INFIDRY (BLOCK FORM)**, MICHAEL AKIRA WEST, (U.S. CLS. 22 AND 39), SN 77-606,342. PUB. 3-17-2009. FILED 11-3-2008.
3,631,255. **THE CLASSIC PUP (BLOCK FORM)**, THE AGAPE ALLIANCE, LLC, (U.S. CLS. 22 AND 39), SN 77-606,825. PUB. 3-17-2009. FILED 11-4-2008.
3,631,279. **CRCLM (BLOCK FORM)**, BADAEL, BARMAK, AND SAUER, JIM, (U.S. CLS. 22 AND 39), SN 77-609,407. PUB. 3-17-2009. FILED 11-6-2008.
3,631,280. **CURRICULUM (BLOCK FORM)**, BADAEL, BARMAK, AND SAUER, JIM, (U.S. CLS. 22 AND 39), SN 77-609,413. PUB. 3-17-2009. FILED 11-6-2008.
3,631,291. **DARYL K (BLOCK FORM)**, DARYL KERRIGAN CONSULTING, LTD., (U.S. CLS. 22 AND 39), SN 77-611,379. PUB. 3-17-2009. FILED S.R. 11-10-2008; AM. P.R. 11-24-2008.
3,631,298 (*See Class 7 for this trademark*).
3,631,309. **LADY IRISH (BLOCK FORM)**, UNIVERSITY OF NOTRE DAME DU LAC, (U.S. CLS. 22 AND 39), SN 77-616,595. PUB. 3-17-2009. FILED 11-18-2008.
3,631,311. **R AND DESIGN**, TAKE-TWO INTERACTIVE SOFTWARE, INC., (U.S. CLS. 22 AND 39), SN 77-616,894. PUB. 3-17-2009. FILED 11-18-2008.
3,631,337. **MARRIED TO THE MOB AND DESIGN**, MTTM WORLDWIDE, LLC, (U.S. CLS. 22 AND 39), SN 77-624,701. PUB. 3-17-2009. FILED 12-2-2008.
3,631,341. **RAWKN JEANS (BLOCK FORM)**, HONG, MICHAEL, (U.S. CLS. 22 AND 39), SN 77-627,731. PUB. 3-17-2009. FILED 12-5-2008.
3,631,342. **MARRIED TO THE MOB AND DESIGN**, MTTM WORLDWIDE, LLC, (U.S. CLS. 22 AND 39), SN 77-628,085. PUB. 3-17-2009. FILED 12-7-2008.
3,631,343. **OUTRAGEOUS COMFORT (BLOCK FORM)**, SCHERING-PLOUGH HEALTHCARE PRODUCTS, INC., (U.S. CLS. 22 AND 39), SN 77-628,632. PUB. 3-17-2009. FILED 12-8-2008.
3,631,355. **SNOZU (BLOCK FORM)**, STRETCH-O-RAMA, INC., (U.S. CLS. 22 AND 39), SN 77-636,582. PUB. 3-17-2009. FILED 12-19-2008.
3,631,399 (*See Class 3 for this trademark*).
3,631,417. **GRATUITEEZ (BLOCK FORM)**, ELLIS, JOWAN ELIZA, (U.S. CLS. 22 AND 39), SN 78-766,089. PUB. 3-17-2009. FILED S.R. 12-3-2005; AM. P.R. 2-7-2009.
3,631,424 (*See Class 24 for this trademark*).
3,631,426 (*See Class 9 for this trademark*).
3,631,460 (*See Class 14 for this trademark*).
3,631,469 (*See Class 9 for this trademark*).
3,631,472 (*See Class 3 for this trademark*).
3,631,473 (*See Class 14 for this trademark*).
3,631,477 (*See Class 3 for this trademark*).
3,631,495 (*See Class 18 for this trademark*).
3,631,512 (*See Class 3 for this trademark*).
3,631,551. **GUIA LAB AND DESIGN**, I.G.E.A.T. S.R.L., (U.S. CLS. 22 AND 39), SN 79-051,654. PUB. 3-17-2009. FILED 2-6-2008.
3,631,569. **GREYSTONE AND DESIGN**, RAINBOW CAPITAL GMBH, (U.S. CLS. 22 AND 39), SN 79-052,949. PUB. 3-17-2009. FILED 1-24-2008.
3,631,602 (*See Class 18 for this trademark*).
3,631,603 (*See Class 9 for this trademark*).
3,631,612 (*See Class 3 for this trademark*).
3,631,618 (*See Class 9 for this trademark*).
3,631,619 (*See Class 14 for this trademark*).
3,631,639 (*See Class 7 for this trademark*).
3,631,649. **IRONTRUCK AND DESIGN**, HLC SB DISTRIBUTION, S.L., MULTIPLE CLASS, (INT. CLS. 25 AND 28), (U.S. CLS. 22, 23, 38, 39 AND 50), SN 79-055,133. PUB. 3-17-2009. FILED 4-2-2008.
3,631,656. **DRAGSTER (BLOCK FORM)**, COTTONCASUAL B.V., (U.S. CLS. 22 AND 39), SN 79-055,324. PUB. 3-17-2009. FILED 1-31-2008.
3,631,663 (*See Class 9 for this trademark*).
3,631,685 (*See Class 9 for this trademark*).
3,631,722 (*See Class 18 for this trademark*).
3,631,728. **ISTORIA (STYLIZED)**, XANADU - SOCIETÀ PER AZIONI, (U.S. CLS. 22 AND 39), SN 79-058,275. PUB. 3-17-2009. FILED 7-7-2008.
3,631,734. **MISCELLANEOUS DESIGN**, HARRY MARK ZINSSER-KRYS, AND KURT RUHFAB, MULTIPLE CLASS, (INT. CLS. 25, 41 AND 43), (U.S. CLS. 22, 39, 100, 101 AND 107), SN 79-058,528. PUB. 3-17-2009. FILED 7-7-2008.
3,631,735. **GEISHA JEANS (BLOCK FORM)**, GEISHA TRADING B.V., MULTIPLE CLASS, (INT. CLS. 25 AND 35), (U.S. CLS. 22, 39, 100, 101 AND 102), SN 79-058,546. PUB. 3-17-2009. FILED 7-14-2008.
3,631,738. **FNNISS (STYLIZED)**, WU QIHU, (U.S. CLS. 22 AND 39), SN 79-058,854. PUB. 3-17-2009. FILED 7-21-2008.
3,631,763. **SWISSIES (BLOCK FORM)**, BLUE OZEAN AG, (U.S. CLS. 22 AND 39), SN 79-061,098. PUB. 3-17-2009. FILED 9-18-2008.
3,631,766. **VANISHING ELEPHANT AND DESIGN**, INCU PTY LIMITED, (U.S. CLS. 22 AND 39), SN 79-061,781. PUB. 3-17-2009. FILED 8-7-2008.
3,631,771. **PASHMERE (BLOCK FORM)**, GALASSIA S.R.L., (U.S. CLS. 22 AND 39), SN 79-062,257. PUB. 3-17-2009. FILED 9-19-2008.
3,631,779. **STRONA (STYLIZED)**, RHEE, JUNG HUN, (U.S. CLS. 22 AND 39), SN 79-063,277. PUB. 3-17-2009. FILED 10-28-2008.
-
- CLASS 26—FANCY GOODS**
- 3,629,358. **SERVICE EDUCATION PROGRESS FBLA B AND DESIGN**, FUTURE BUSINESS LEADERS OF AMERICAPHI BETA LAMBDA, INC., (U.S. CLS. 37, 39, 40, 42 AND 50), SN 77-269,811. PUB. 3-17-2009. FILED 8-31-2007.
3,629,371. **LUXURY TRESS BY MARCIA (BLOCK FORM)**, RAYMA COMPANIES CO., DBA LUXURY TRESS BY MARCIA, (U.S. CLS. 37, 39, 40, 42 AND 50), SN 77-282,989. PUB. 3-17-2009. FILED 9-19-2007.
3,629,677 (*See Class 20 for this trademark*).
3,629,783. **NEXUS (BLOCK FORM)**, ILLINOIS TOOL WORKS INC., (U.S. CLS. 37, 39, 40, 42 AND 50), SN 77-451,229. PUB. 3-17-2009. FILED 4-17-2008.
3,629,784. **NX (BLOCK FORM)**, ILLINOIS TOOL WORKS INC., (U.S. CLS. 37, 39, 40, 42 AND 50), SN 77-451,260. PUB. 3-17-2009. FILED 4-17-2008.
3,629,862. **KEPIES AND DESIGN**, KEPIES, LLC, (U.S. CLS. 37, 39, 40, 42 AND 50), SN 77-458,899. PUB. 3-17-2009. FILED 4-26-2008.
3,630,082. **HOT WATER SET CREATED BY KANEKALON JAPAN AND DESIGN**, KANEKA CORPORATION, (U.S.

CLS. 37, 39, 40, 42 AND 50). SN 77-517,039. PUB. 3-17-2009. FILED 7-8-2008.
 3,630,224 (*See Class 5 for this trademark*).
 3,630,590. **PAMPERED PRINCESS (STYLIZED)**. ROYAL COUTURE, INC., (U.S. CLS. 37, 39, 40, 42 AND 50). SN 77-595,575. PUB. 3-17-2009. FILED 10-18-2008.
 3,630,774. **EZ COMBS (BLOCK FORM)**. TV WINNERS, INC., (U.S. CLS. 37, 39, 40, 42 AND 50). SN 77-599,247. PUB. 3-17-2009. FILED 10-23-2008.
 3,631,070 (*See Class 8 for this trademark*).
 3,631,145. **FLAUNT (BLOCK FORM)**. TROIKA INTERNATIONAL, INC., (U.S. CLS. 37, 39, 40, 42 AND 50). SN 77-604,560. PUB. 3-17-2009. FILED 10-30-2008.
 3,631,512 (*See Class 3 for this trademark*).

CLASS 27—FLOOR COVERINGS

3,629,398. **RUG STUDIO (BLOCK FORM)**. LANART RUG INC., (U.S. CLS. 19, 20, 37, 42 AND 50). SN 77-305,234. PUB. 3-17-2009. FILED 10-16-2007.
 3,629,485. **STICKY MAT (BLOCK FORM)**. POLY-TAK PROTECTION SYSTEMS, INC., (U.S. CLS. 19, 20, 37, 42 AND 50). SN 77-367,506. PUB. 3-17-2009. FILED 1-9-2008.
 3,629,707. **FIELDTURF SIGNATURE SERIES (BLOCK FORM)**. FIELDTURF TARKETT INC., (U.S. CLS. 19, 20, 37, 42 AND 50). SN 77-443,876. PUB. 3-17-2009. FILED 4-9-2008.
 3,630,064 (*See Class 19 for this trademark*).
 3,630,539 (*See Class 11 for this trademark*).
 3,631,049. **ULTRASET (BLOCK FORM)**. MOHAWK BRANDS, INC., (U.S. CLS. 19, 20, 37, 42 AND 50). SN 77-602,952. PUB. 3-17-2009. FILED 10-29-2008.
 3,631,530. **ALTRO SUPREMA (BLOCK FORM)**. ALTRO LIMITED, (U.S. CLS. 19, 20, 37, 42 AND 50). SN 79-049,175. PUB. 3-17-2009. FILED 1-4-2008.
 3,631,620 (*See Class 1 for this trademark*).
 3,631,706 (*See Class 19 for this trademark*).
 3,631,746. **NEWWEAVE AND DESIGN**. NARMA LV AS, (U.S. CLS. 19, 20, 37, 42 AND 50). SN 79-059,241. PUB. 3-17-2009. FILED 8-28-2008.

CLASS 28—TOYS AND SPORTING GOODS

3,629,132. **PINOKIO (BLOCK FORM)**. ESTRATE, EVAN A., (U.S. CLS. 22, 23, 38 AND 50). SN 76-660,248. PUB. 3-17-2009. FILED 5-18-2006.
 3,629,156. **PACE (BLOCK FORM)**. WINANS, LOUIS A., (U.S. CLS. 22, 23, 38 AND 50). SN 76-688,095. PUB. 3-17-2009. FILED 3-27-2008.
 3,629,157. **FUZZY BUDDIES (BLOCK FORM)**. COOPSPORT INTERNATIONAL LP, (U.S. CLS. 22, 23, 38 AND 50). SN 76-688,436. PUB. 3-17-2009. FILED 4-7-2008.
 3,629,222. **CUDDLE PILLOW (BLOCK FORM)**. BABY BOOM CONSUMER PRODUCTS, INC., (U.S. CLS. 22, 23, 38 AND 50). SN 76-694,280. PUB. 3-17-2009. FILED 11-17-2008.
 3,629,408. **MICRO BEE (BLOCK FORM)**. CHENG, RANDY, (U.S. CLS. 22, 23, 38 AND 50). SN 77-310,803. PUB. 3-17-2009. FILED 10-23-2007.
 3,629,409. **MICRO SAFARIS (BLOCK FORM)**. CHENG, RANDY, (U.S. CLS. 22, 23, 38 AND 50). SN 77-310,839. PUB. 3-17-2009. FILED 10-23-2007.
 3,629,413 (*See Class 9 for this trademark*).
 3,629,463. **GRIP GEAR (BLOCK FORM)**. MATTEL, INC., (U.S. CLS. 22, 23, 38 AND 50). SN 77-354,089. PUB. 3-17-2009. FILED 12-17-2007.
 3,629,488. **IM BOT (STYLIZED)**. INDUSTRIAL TECHNOLOGY RESEARCH INSTITUTE, (U.S. CLS. 22, 23, 38 AND 50). SN 77-367,885. PUB. 3-17-2009. FILED 1-9-2008.
 3,629,505. **HORSEPLAY AND DESIGN**. SPIN PRODUCTS, INC., DBA BURLINGHAM SPORTS, (U.S. CLS. 22, 23, 38 AND 50). SN 77-375,902. PUB. 12-9-2008. FILED 1-18-2008.
 3,629,516 (*See Class 16 for this trademark*).
 3,629,533. **LI AND DESIGN**. LARGO INTERGALACTIC VIE

CORPORATION, (U.S. CLS. 22, 23, 38 AND 50). SN 77-394,339. PUB. 3-17-2009. FILED 2-12-2008.
 3,629,535 (*See Class 8 for this trademark*).
 3,629,562. **CRIMINAL MATTERS (BLOCK FORM)**. DFR MEDIA CORP., (U.S. CLS. 22, 23, 38 AND 50). SN 77-406,085. PUB. 3-17-2009. FILED 2-26-2008.
 3,629,609. **NITERAC AND DESIGN**. GOLF RACK SYSTEMS, L.L.C., (U.S. CLS. 22, 23, 38 AND 50). SN 77-428,235. PUB. 3-17-2009. FILED 3-21-2008.
 3,629,733. **FITWALL (BLOCK FORM)**. BRENDLE CLIMBING SYSTEMS, LLC, (U.S. CLS. 22, 23, 38 AND 50). SN 77-446,522. PUB. 3-17-2009. FILED 4-11-2008.
 3,629,762. **MAKE & MOVE (BLOCK FORM)**. J.C. TOYS GROUP, INC., (U.S. CLS. 22, 23, 38 AND 50). SN 77-449,678. PUB. 3-17-2009. FILED 4-16-2008.
 3,629,776. **T SYSTEMS AND DESIGN**. DEUTSCHE TELEKOM, (U.S. CLS. 22, 23, 38 AND 50). SN 77-450,644. PUB. 3-17-2009. FILED 4-17-2008.
 3,629,790. **T HOME AND DESIGN**. DEUTSCHE TELEKOM, (U.S. CLS. 22, 23, 38 AND 50). SN 77-451,391. PUB. 1-13-2009. FILED 4-17-2008.
 3,629,799 (*See Class 18 for this trademark*).
 3,629,822. **SKASK (BLOCK FORM)**. WAYNE STEPHEN RE-SLOW, DBA TCOB ASSOCIATES, (U.S. CLS. 22, 23, 38 AND 50). SN 77-453,850. PUB. 3-17-2009. FILED 4-21-2008.
 3,629,832. **RAVE SPORTS (BLOCK FORM)**. RAVE SPORTS, INC., (U.S. CLS. 22, 23, 38 AND 50). SN 77-454,938. PUB. 3-17-2009. FILED 4-22-2008.
 3,629,888. **PCI (BLOCK FORM)**. WINN INCORPORATED, (U.S. CLS. 22, 23, 38 AND 50). SN 77-463,517. PUB. 3-17-2009. FILED 5-1-2008.
 3,629,932. **SKILLASTICS (BLOCK FORM)**. SLADE, SANDY, (U.S. CLS. 22, 23, 38 AND 50). SN 77-475,141. PUB. 3-17-2009. FILED 5-15-2008.
 3,629,963. **NEMIRE LURES AND DESIGN**. BUCKEYE LTD, (U.S. CLS. 22, 23, 38 AND 50). SN 77-482,108. PUB. 3-17-2009. FILED 5-23-2008.
 3,629,994 (*See Class 7 for this trademark*).
 3,630,027 (*See Class 25 for this trademark*).
 3,630,029. **ROCKET FORCE (BLOCK FORM)**. MATTEL, INC., (U.S. CLS. 22, 23, 38 AND 50). SN 77-498,422. PUB. 3-17-2009. FILED 6-13-2008.
 3,630,031. **MARIE OSMOND DOLLS (BLOCK FORM)**. MARIE, INC., (U.S. CLS. 22, 23, 38 AND 50). SN 77-498,864. PUB. 3-17-2009. FILED 6-13-2008.
 3,630,032. **MARIE OSMOND FINE COLLECTIBLES (BLOCK FORM)**. MARIE, INC., (U.S. CLS. 22, 23, 38 AND 50). SN 77-498,886. PUB. 3-17-2009. FILED 6-13-2008.
 3,630,055. **G JET (BLOCK FORM)**. SCALE AUTO, (U.S. CLS. 22, 23, 38 AND 50). SN 77-507,015. PUB. 3-17-2009. FILED 6-24-2008.
 3,630,076. **MAYHEM (BLOCK FORM)**. RAWLINGS SPORTING GOODS COMPANY, INC., (U.S. CLS. 22, 23, 38 AND 50). SN 77-515,679. PUB. 3-17-2009. FILED 7-7-2008.
 3,630,081. **BEVERLY HILLS TEDDY BEAR COMPANY (BLOCK FORM)**. BEVERLY HILLS TEDDY BEAR COMPANY, (U.S. CLS. 22, 23, 38 AND 50). SN 77-516,972. PUB. 3-17-2009. FILED 7-8-2008.
 3,630,117. **LPL CHAMPS (BLOCK FORM)**. FRANKLIN SPORTS, INC., (U.S. CLS. 22, 23, 38 AND 50). SN 77-525,060. PUB. 3-17-2009. FILED 7-17-2008.
 3,630,140 (*See Class 16 for this trademark*).
 3,630,159 (*See Class 25 for this trademark*).
 3,630,212. **THE ACE CARD COMPANY (BLOCK FORM)**. THE ACE CARD COMPANY, (U.S. CLS. 22, 23, 38 AND 50). SN 77-549,539. PUB. 3-17-2009. FILED 8-18-2008.
 3,630,248. **BINGO AND DESIGN**. POLLARD BANKNOTE LIMITED PARTNERSHIP, (U.S. CLS. 22, 23, 38 AND 50). SN 77-556,570. PUB. 3-17-2009. FILED 8-27-2008.
 3,630,365. **DREAM PHONE (BLOCK FORM)**. FUNDEX GAMES, LTD., (U.S. CLS. 22, 23, 38 AND 50). SN 77-574,436. PUB. 3-17-2009. FILED 9-19-2008.
 3,630,370 (*See Class 25 for this trademark*).
 3,630,374. **PFLUEGER (BLOCK FORM)**. SHAKESPEARE COMPANY, LLC, (U.S. CLS. 22, 23, 38 AND 50). SN 77-575,915. PUB. 3-17-2009. FILED 9-22-2008.
 3,630,389. **CALIENTE (BLOCK FORM)**. ACELERANT INCORPORATED, DBA STINGRAY TACKLE COMPANY,

- (U.S. CLS. 22, 23, 38 AND 50). SN 77-578,236. PUB. 3-17-2009. FILED 9-24-2008.
- 3,630,408. **GAMES FOR YOUR PASSIONS (BLOCK FORM)**. FLYING PIG GAMES, LLC. (U.S. CLS. 22, 23, 38 AND 50). SN 77-579,772. PUB. 3-17-2009. FILED 9-26-2008.
- 3,630,481. **SQUG AND DESIGN**. SQUG, LLC. (U.S. CLS. 22, 23, 38 AND 50). SN 77-587,948. PUB. 3-17-2009. FILED 10-7-2008.
- 3,630,505. **MISCELLANEOUS DESIGN**. BECKER, MICHAEL. (U.S. CLS. 22, 23, 38 AND 50). SN 77-590,207. PUB. 3-17-2009. FILED 10-10-2008.
- 3,630,544. **POWER RESISTIX (BLOCK FORM)**. CALDWELL, JAMIN. (U.S. CLS. 22, 23, 38 AND 50). SN 77-592,806. PUB. 3-17-2009. FILED 10-14-2008.
- 3,630,707. **WHIMZALS AND DESIGN**. THE IMAGINARY PET COMPANY, LLC. (U.S. CLS. 22, 23, 38 AND 50). SN 77-598,395. PUB. 3-17-2009. FILED 10-22-2008.
- 3,630,739. **MUTTHEADS (BLOCK FORM)**. DARF, INCORPORATED. (U.S. CLS. 22, 23, 38 AND 50). SN 77-598,820. PUB. 3-17-2009. FILED 10-23-2008.
- 3,630,888. **ADROIT (STYLIZED)**. MCCLURE, TODD. (U.S. CLS. 22, 23, 38 AND 50). SN 77-600,762. PUB. 3-17-2009. FILED 10-27-2008.
- 3,630,914. **SUCKADELIC (BLOCK FORM)**. LIPMAN, SIMON. (U.S. CLS. 22, 23, 38 AND 50). SN 77-601,054. PUB. 3-17-2009. FILED 10-27-2008.
- 3,630,940. **E-FLEX (BLOCK FORM)**. MIKEN SPORTS LLC. (U.S. CLS. 22, 23, 38 AND 50). SN 77-601,375. PUB. 3-17-2009. FILED 10-27-2008.
- 3,630,975 (*See Class 9 for this trademark*).
- 3,631,030. **PYRAMATH (BLOCK FORM)**. I SEE CARDS LLC. (U.S. CLS. 22, 23, 38 AND 50). SN 77-602,592. PUB. 3-17-2009. FILED 10-28-2008.
- 3,631,042. **G FORCE (BLOCK FORM)**. G5 OUTDOORS, LLC. (U.S. CLS. 22, 23, 38 AND 50). SN 77-602,791. PUB. 3-17-2009. FILED 10-29-2008.
- 3,631,064 (*See Class 9 for this trademark*).
- 3,631,070 (*See Class 8 for this trademark*).
- 3,631,129. **STRIKE FORCE (BLOCK FORM)**. TEAM ATHLETIC GOODS, INC.. (U.S. CLS. 22, 23, 38 AND 50). SN 77-604,388. PUB. 3-17-2009. FILED 10-30-2008.
- 3,631,130. **STRIKE FORCE AND DESIGN**. TEAM ATHLETIC GOODS, INC.. (U.S. CLS. 22, 23, 38 AND 50). SN 77-604,393. PUB. 3-17-2009. FILED 10-30-2008.
- 3,631,162. **POWER TACKLE AND DESIGN**. POWER TACKLE INC.. (U.S. CLS. 22, 23, 38 AND 50). SN 77-604,926. PUB. 3-17-2009. FILED 10-31-2008.
- 3,631,238. **MAD (BLOCK FORM)**. FLAMBEAU INC.. (U.S. CLS. 22, 23, 38 AND 50). SN 77-606,121. PUB. 3-17-2009. FILED 11-3-2008.
- 3,631,294. **MYSTIC SMOKE FROM FINGERTIPS (BLOCK FORM)**. S. S. ADAMS, L.L.C.. (U.S. CLS. 22, 23, 38 AND 50). SN 77-611,790. PUB. 3-17-2009. FILED 11-11-2008.
- 3,631,388. **GOOGLES (BLOCK FORM)**. ASPEN PET PRODUCTS, INC.. (U.S. CLS. 22, 23, 38 AND 50). SN 78-471,127. PUB. 7-19-2005. FILED 8-20-2004.
- 3,631,397 (*See Class 9 for this trademark*).
- 3,631,398 (*See Class 9 for this trademark*).
- 3,631,399 (*See Class 3 for this trademark*).
- 3,631,427 (*See Class 3 for this trademark*).
- 3,631,469 (*See Class 9 for this trademark*).
- 3,631,473 (*See Class 14 for this trademark*).
- 3,631,512 (*See Class 3 for this trademark*).
- 3,631,521 (*See Class 6 for this trademark*).
- 3,631,538 (*See Class 9 for this trademark*).
- 3,631,555. **E SKY (STYLIZED)**. SHENZHEN GRAND WING; INVESTMENT, INC.. (U.S. CLS. 22, 23, 38 AND 50). SN 79-051,976. PUB. 3-17-2009. FILED 3-11-2008.
- 3,631,594 (*See Class 9 for this trademark*).
- 3,631,603 (*See Class 9 for this trademark*).
- 3,631,609 (*See Class 10 for this trademark*).
- 3,631,639 (*See Class 7 for this trademark*).
- 3,631,649 (*See Class 25 for this trademark*).
- 3,631,664. **LSPAS AND DESIGN**. DONGGUAN SHENGYA SANITARY WARE CO., LTD.. (U.S. CLS. 22, 23, 38 AND 50). SN 79-055,534. PUB. 3-17-2009. FILED 4-17-2008.
- 3,631,666. **HUGMEEZ BY PAUL GREENWOOD AND DESIGN**. HIP DESIGNS LIMITED. (U.S. CLS. 22, 23, 38 AND 50). SN 79-055,672. PUB. 3-17-2009. FILED 3-26-2008.
- 3,631,671 (*See Class 9 for this trademark*).
- 3,631,722 (*See Class 18 for this trademark*).
- 3,631,742. **BLUE HEAVEN (BLOCK FORM)**. OTSUKA TAKASHI. (U.S. CLS. 22, 23, 38 AND 50). SN 79-059,134. PUB. 3-17-2009. FILED 8-15-2008.
- 3,631,745. **NICOTOY (BLOCK FORM)**. SIMBA TOYS GMBH & CO. KG. (U.S. CLS. 22, 23, 38 AND 50). SN 79-059,239. PUB. 3-17-2009. FILED 8-18-2008.
- 3,631,749. **FULLING MILL (BLOCK FORM)**. FULLING MILL LIMITED, MULTIPLE CLASS, (INT. CLS. 28 AND 35). (U.S. CLS. 22, 23, 38, 50, 100, 101 AND 102). SN 79-059,423. PUB. 3-17-2009. FILED 3-11-2008.
- 3,631,767 (*See Class 9 for this trademark*).

CLASS 29—MEATS AND PROCESSED FOODS

- 3,629,134. **EDEN NATURAL CERTIFIED BERKSHIRE PORK AND DESIGN**. BIENSEN, KELLY M.. (U.S. CL. 46). SN 76-670,220. PUB. 3-17-2009. FILED 12-11-2006.
- 3,629,142. **ON THE FLY (BLOCK FORM)**. HOME SLICE, LLC, MULTIPLE CLASS, (INT. CLS. 29 AND 30). (U.S. CL. 46). SN 76-682,370. PUB. 3-17-2009. FILED 9-27-2007.
- 3,629,227. **AFCC AZUMA FOODS CANADA CO LTD AND DESIGN**. AZUMA FOODS (CANADA) CO., LTD.. (U.S. CL. 46). SN 77-001,039. PUB. 3-17-2009. FILED 9-15-2006.
- 3,629,229. **MISCELLANEOUS DESIGN**. PHILLIPS FOODS, INC.. (U.S. CL. 46). SN 77-002,648. PUB. 3-17-2009. FILED 9-19-2006.
- 3,629,301. **ROBERTSON'S (BLOCK FORM)**. ROBERTSON'S HAMS, INC.. (U.S. CL. 46). SN 77-190,371. PUB. 3-17-2009. FILED 5-25-2007.
- 3,629,318. **PHILLY CHILI DOG AND DESIGN**. ROBINSON, JAMES G.. (U.S. CL. 46). SN 77-210,281. PUB. 3-17-2009. FILED 6-20-2007.
- 3,629,370 (*See Class 5 for this trademark*).
- 3,629,379 (*See Class 1 for this trademark*).
- 3,629,400. **OCEAN PARK (BLOCK FORM)**. T & T INTERNATIONAL SEAFOOD, INC.. (U.S. CL. 46). SN 77-306,194. PUB. 4-1-2008. FILED 10-17-2007.
- 3,629,403. **CALIFORNIA RED (BLOCK FORM)**. JONMOR INVESTMENTS, INC.. (U.S. CL. 46). SN 77-307,649. PUB. 3-17-2009. FILED 10-18-2007.
- 3,629,594. **COCOA CARDONA (BLOCK FORM)**. CARR VALLEY CHEESE COMPANY, INC.. (U.S. CL. 46). SN 77-420,926. PUB. 3-17-2009. FILED 3-13-2008.
- 3,629,596. **CARDONA (BLOCK FORM)**. CARR VALLEY CHEESE COMPANY, INC.. (U.S. CL. 46). SN 77-421,094. PUB. 3-17-2009. FILED 3-13-2008.
- 3,629,601 (*See Class 25 for this trademark*).
- 3,629,637. **TAMAYA GOURMET AND DESIGN**. TAMAYA GOURMET S.A.. (U.S. CL. 46). SN 77-434,404. PUB. 3-17-2009. FILED 3-28-2008.
- 3,629,824. **MISCELLANEOUS DESIGN**. LEFTY'S SPICES, LLC, MULTIPLE CLASS, (INT. CLS. 29 AND 30). (U.S. CL. 46). SN 77-454,130. PUB. 3-17-2009. FILED 4-21-2008.
- 3,629,909. **PRINGLES SELECT BOLD CRUNCH (BLOCK FORM)**. THE PROCTER & GAMBLE COMPANY, (U.S. CL. 46). SN 77-469,028. PUB. 3-17-2009. FILED 5-8-2008.
- 3,629,981. **ANNASEA (BLOCK FORM)**. WESTERN UNITED FISH COMPANY INC.. (U.S. CL. 46). SN 77-489,001. PUB. 3-17-2009. FILED 6-2-2008.
- 3,629,982. **ANNASEA AND DESIGN**. WESTERN UNITED FISH COMPANY INC.. (U.S. CL. 46). SN 77-489,010. PUB. 3-17-2009. FILED 6-2-2008.
- 3,629,997. **GARY WEST (BLOCK FORM)**. OLD FOUR STEAM, LLC, DBA GARY WEST MEATS, (U.S. CL. 46). SN 77-493,097. PUB. 3-17-2009. FILED 6-6-2008.
- 3,630,003. **VEGANISE (BLOCK FORM)**. OLD FRIENDS HOLDINGS, LLC, MULTIPLE CLASS, (INT. CLS. 29 AND 30). (U.S. CL. 46). SN 77-494,778. PUB. 3-17-2009. FILED 6-9-2008.
- 3,630,090. **LA QUERIDA (BLOCK FORM)**. CHARLEY & SONS, INC.. (U.S. CL. 46). SN 77-518,773. PUB. 3-17-2009. FILED 7-10-2008.
- 3,630,116. **ARZ (BLOCK FORM)**. KAROUN DAIRIES, INC.. (U.S. CL. 46). SN 77-525,056. PUB. 3-17-2009. FILED 7-17-

- 2008.
- 3,630,119. **BASAVINA PEARL (BLOCK FORM)**. QVD USA LLC, (U.S. CL. 46). SN 77-525,269. PUB. 3-17-2009. FILED 7-17-2008.
- 3,630,150. **SUBMARINA CALIFORNIA SUBS (BLOCK FORM)**. SUBMARINA, INC., MULTIPLE CLASS, (INT. CLS. 29, 30 AND 43), (U.S. CLS. 46, 100 AND 101). SN 77-533,116. PUB. 3-17-2009. FILED 7-28-2008.
- 3,630,165. **WONDER FRIES (BLOCK FORM)**. GLACIER SALES INC., (U.S. CL. 46). SN 77-537,086. PUB. 3-17-2009. FILED 8-1-2008.
- 3,630,172. **CAFE GRATITUDE (BLOCK FORM)**. CAFE GRATITUDE, LLC, (U.S. CL. 46). SN 77-539,841. PUB. 3-17-2009. FILED 8-5-2008.
- 3,630,187. **JUST NUTTY (BLOCK FORM)**. TROPICAL NUT & FRUIT CO., (U.S. CL. 46). SN 77-544,933. PUB. 3-17-2009. FILED 8-12-2008.
- 3,630,280. **FIRECRACKER HOT & SPICY (BLOCK FORM)**. TROPICAL NUT & FRUIT CO., (U.S. CL. 46). SN 77-561,353. PUB. 3-17-2009. FILED 9-3-2008.
- 3,630,281. **FIVE STAR NUT MIX (BLOCK FORM)**. TROPICAL NUT & FRUIT CO., (U.S. CL. 46). SN 77-561,378. PUB. 3-17-2009. FILED 9-3-2008.
- 3,630,286. **RICOS AND DESIGN**. RICOS INTELLECTUAL PROPERTY, LTD., MULTIPLE CLASS, (INT. CLS. 29 AND 30), (U.S. CL. 46). SN 77-562,755. PUB. 3-17-2009. FILED 9-4-2008.
- 3,630,387. **PB&J MIX (BLOCK FORM)**. TROPICAL NUT & FRUIT CO., (U.S. CL. 46). SN 77-578,035. PUB. 3-17-2009. FILED 9-24-2008.
- 3,630,400. **RAPHY'S (BLOCK FORM)**. CLASSIC RAPHY'S KOSHER FOODS, (U.S. CL. 46). SN 77-579,264. PUB. 3-17-2009. FILED 9-25-2008.
- 3,630,478. **SOYGO (BLOCK FORM)**. SAVING OPUS ONE, LLC, TA SOYGO, (U.S. CL. 46). SN 77-587,874. PUB. 3-17-2009. FILED 10-7-2008.
- 3,630,583. **OLD HOME (BLOCK FORM)**. OLD HOME FOODS, INC., (U.S. CL. 46). SN 77-595,235. PUB. 3-17-2009. FILED 10-17-2008.
- 3,630,614. **OLD HOME AND DESIGN**. OLD HOME FOODS, INC., (U.S. CL. 46). SN 77-596,238. PUB. 3-17-2009. FILED 10-20-2008.
- 3,630,689. **100% AMERICAN GROWN APPLES AND DESIGN**. KNOUSE FOODS COOPERATIVE, INC., MULTIPLE CLASS, (INT. CLS. 29 AND 32), (U.S. CLS. 45, 46 AND 48). SN 77-598,054. PUB. 3-17-2009. FILED 10-22-2008.
- 3,630,708. **JUMBLEBERRY TOPPING (BLOCK FORM)**. CALIFORNIA WAFFLE BAR, INC., (U.S. CL. 46). SN 77-598,402. PUB. 3-17-2009. FILED 10-22-2008.
- 3,630,762. **NISSUI AND DESIGN**. NIPPON SUISAN KABUSHIKI KAISHA, TA NIPPON SUISAN KAISHA, LTD., (U.S. CL. 46). SN 77-599,059. PUB. 3-17-2009. FILED 10-23-2008.
- 3,630,770. **CAPTURING THE ESSENCE OF NATURE (BLOCK FORM)**. KERR CONCENTRATES, INC., MULTIPLE CLASS, (INT. CLS. 29, 30 AND 32), (U.S. CLS. 45, 46 AND 48). SN 77-599,181. PUB. 3-17-2009. FILED 10-23-2008.
- 3,630,841. **ROSE-DALE (BLOCK FORM)**. CORLIB BRAND HOLDING LTD., (U.S. CL. 46). SN 77-600,137. PUB. 3-17-2009. FILED 10-24-2008.
- 3,630,991. **POPBALL (BLOCK FORM)**. TENGFEI, INC., (U.S. CL. 46). SN 77-602,117. PUB. 3-17-2009. FILED 10-28-2008.
- 3,631,001. **NUTS ABOUT NEW YORK (BLOCK FORM)**. NUTS ABOUT NEW YORK, INC, (U.S. CL. 46). SN 77-602,221. PUB. 3-17-2009. FILED 10-28-2008.
- 3,631,174. **100% AMERICAN GROWN APPLES AND DESIGN**. KNOUSE FOODS COOPERATIVE, INC., MULTIPLE CLASS, (INT. CLS. 29 AND 32), (U.S. CLS. 45, 46 AND 48). SN 77-605,161. PUB. 3-17-2009. FILED 10-31-2008.
- 3,631,175. **100% AMERICAN GROWN APPLES AND DESIGN**. KNOUSE FOODS COOPERATIVE, INC., MULTIPLE CLASS, (INT. CLS. 29 AND 32), (U.S. CLS. 45, 46 AND 48). SN 77-605,167. PUB. 3-17-2009. FILED 10-31-2008.
- 3,631,244. **GREAT FOR GRILLING (BLOCK FORM)**. JONMOR INVESTMENTS, INC., (U.S. CL. 46). SN 77-606,217. PUB. 3-17-2009. FILED 11-3-2008.
- 3,631,327. **GRAB 'EM FOR THE GAME (BLOCK FORM)**. FRITO-LAY NORTH AMERICA, INC., (U.S. CL. 46). SN 77-622,524. PUB. 3-17-2009. FILED 11-26-2008.
- 3,631,330. **TIMELY FARE (BLOCK FORM)**. MAPLE LEAF FOODS INC., (U.S. CL. 46). SN 77-623,639. PUB. 3-17-2009. FILED 12-1-2008.
- 3,631,378 (*See Class 1 for this trademark*).
- 3,631,381. **FIESTA PARTY DIP (BLOCK FORM)**. TASTE-FULLY SIMPLE, INC., (U.S. CL. 46). SN 78-419,011. PUB. 3-17-2009. FILED 5-14-2004.
- 3,631,399 (*See Class 3 for this trademark*).
- 3,631,400. **CHUNGSOOLIM AND DESIGN**. YOUNG LIM ENTERPRISE CO., LTD., MULTIPLE CLASS, (INT. CLS. 29 AND 30), (U.S. CL. 46). SN 78-637,623. PUB. 3-17-2009. FILED 5-26-2005.
- 3,631,512 (*See Class 3 for this trademark*).
- 3,631,518 (*See Class 1 for this trademark*).
- 3,631,565 (*See Class 16 for this trademark*).
- 3,631,687. **AVIKO AND DESIGN**. AVIKO B.V., (U.S. CL. 46). SN 79-056,582. PUB. 3-17-2009. FILED 3-6-2008.
- 3,631,688. **DELICO (STYLIZED)**. UNIMILLS B.V., (U.S. CL. 46). SN 79-056,592. PUB. 3-17-2009. FILED 6-6-2008.
- 3,631,691. **COBRAM ESTATE AND DESIGN**. COBRAM ESTATE PTY LTD, (U.S. CL. 46). SN 79-056,825. PUB. 3-17-2009. FILED 5-23-2008.
- 3,631,700. **PASTREX (STYLIZED)**. UNIMILLS B.V., (U.S. CL. 46). SN 79-057,158. PUB. 3-17-2009. FILED 6-6-2008.
- 3,631,710. **VV VILLA VISCONTI (STYLIZED)**. ENOSWISS GMBH, MULTIPLE CLASS, (INT. CLS. 29, 32 AND 33), (U.S. CLS. 45, 46, 47, 48 AND 49). SN 79-057,392. PUB. 3-17-2009. FILED 7-28-2008.
- 3,631,717. **GUSHEN AND DESIGN**. GUSHEN BIOLOGICAL TECHNOLOGY GROUP CO., LTD, (U.S. CL. 46). SN 79-057,572. PUB. 3-17-2009. FILED 5-21-2008.
- 3,631,732. **HERMANN THE GERMAN (BLOCK FORM)**. PROFESSOR DR. MED. HERMANN HOLZHÜTER, MULTIPLE CLASS, (INT. CLS. 29, 30 AND 43), (U.S. CLS. 46, 100 AND 101). SN 79-058,449. PUB. 3-17-2009. FILED 7-4-2008.

CLASS 30—STAPLE FOODS

- 3,629,133. **BEHZAD TEA (BLOCK FORM)**. (GLOBAL TRADING LLC), (U.S. CL. 46). SN 76-663,701. PUB. 3-17-2009. FILED 7-26-2006.
- 3,629,142 (*See Class 29 for this trademark*).
- 3,629,147. **KING STREET BLUES (BLOCK FORM)**. TIME FOR GOOD FOOD INC., MULTIPLE CLASS, (INT. CLS. 30 AND 43), (U.S. CLS. 46, 100 AND 101). SN 76-686,444. PUB. 3-17-2009. FILED 2-4-2008.
- 3,629,178. **VAN OTIS (STYLIZED)**. VAN OTIS CHOCOLATES, LLC, MULTIPLE CLASS, (INT. CLS. 30, 33, 35 AND 45), (U.S. CLS. 46, 47, 49, 100, 101 AND 102). SN 76-690,060. PUB. 3-17-2009. FILED 5-28-2008.
- 3,629,198. **GOODIES ON THE GO (STYLIZED)**. QUALITY DAIRY COMPANY, (U.S. CL. 46). SN 76-693,530. PUB. 3-17-2009. FILED 10-15-2008.
- 3,629,236. **NURON CYBERCRUNCH AND DESIGN**. NUTRI-TEL FOOD TECHNOLOGIES INC., (U.S. CL. 46). SN 77-035,025. PUB. 3-17-2009. FILED 11-2-2006.
- 3,629,304. **KARMAKISSES AND DESIGN**. EVER COMPANION FOOD CORP., (U.S. CL. 46). SN 77-194,584. PUB. 11-4-2008. FILED 5-31-2007.
- 3,629,332. **QUISQUELLA (BLOCK FORM)**. PAN AMERICAN COFFEE CO., INC., (U.S. CL. 46). SN 77-241,979. PUB. 3-17-2009. FILED 7-30-2007.
- 3,629,366. **ALOHA SALADS (BLOCK FORM)**. ALOHA SALADS INC., DBA ALOHA SALADS, MULTIPLE CLASS, (INT. CLS. 30 AND 43), (U.S. CLS. 46, 100 AND 101). SN 77-280,416. PUB. 3-17-2009. FILED 9-14-2007.
- 3,629,379 (*See Class 1 for this trademark*).
- 3,629,391. **THE MILK SHAKE FACTORY AND DESIGN**. CHOCOLATE CELEBRATIONS, INC., (U.S. CL. 46). SN 77-300,706. PUB. 3-17-2009. FILED 10-10-2007.
- 3,629,579. **TWISTED BEAN COFFEE COMPANY (BLOCK FORM)**. LAKECO ENTERPRISES, INC., DBA TWISTED BEAN COFFEE COMPANY, (U.S. CL. 46). SN 77-415,400. PUB. 3-17-2009. FILED 3-6-2008.
- 3,629,684. **CHESAPEAKE FIELDS AND DESIGN**. CHESAPEAKE FIELDS INSTITUTE, INC., (U.S. CL. 46). SN 77-

- 441,517. PUB. 3-17-2009. FILED 4-7-2008.
 3,629,824 (*See Class 29 for this trademark*).
 3,629,865. **CORTES DIP'N (BLOCK FORM)**. SUCESORES PEDRO CORTES, INC., (U.S. CL. 46). SN 77-459,597. PUB. 3-17-2009. FILED 4-28-2008.
 3,629,945. **B AND DESIGN**. DEAN DISTRIBUTORS, INC., MULTIPLE CLASS, (INT. CLS. 30 AND 32), (U.S. CLS. 45, 46 AND 48). SN 77-477,908. PUB. 3-17-2009. FILED 5-19-2008.
 3,630,003 (*See Class 29 for this trademark*).
 3,630,037. **BINGGO (BLOCK FORM)**. DIVVIES LLC, (U.S. CL. 46). SN 77-500,977. PUB. 3-17-2009. FILED 6-17-2008.
 3,630,065. **MILLENNIUM SIMPLY THE BEST (BLOCK FORM)**. SYED, JAWED, (U.S. CL. 46). SN 77-510,438. PUB. 3-17-2009. FILED 6-27-2008.
 3,630,068. **NATURE'S OWN (BLOCK FORM)**. BROOKLYN BOTTLING OF MILTON, NY, INC., (U.S. CL. 46). SN 77-511,213. PUB. 12-9-2008. FILED 6-30-2008.
 3,630,085. **SUGAR SWEET SUNSHINE BAKERY (BLOCK FORM)**. SUGAR SWEET SUNSHINE, INC., MULTIPLE CLASS, (INT. CLS. 30 AND 43), (U.S. CLS. 46, 100 AND 101). SN 77-517,947. PUB. 12-9-2008. FILED 7-9-2008.
 3,630,127. **LITTLE MISS CUPCAKE (BLOCK FORM)**. LITTLE MISS CUPCAKE LLC, (U.S. CL. 46). SN 77-526,567. PUB. 12-9-2008. FILED 7-19-2008.
 3,630,150 (*See Class 29 for this trademark*).
 3,630,173. **CAFE GRATITUDE (BLOCK FORM)**. CAFE GRATITUDE, LLC, (U.S. CL. 46). SN 77-539,907. PUB. 3-17-2009. FILED 8-5-2008.
 3,630,197. **DEADMAN'S REACH RAVEN'S BREW HIGH SPEED BLEND COFFEE BARANOF ISLAND AND DESIGN**. RAVEN'S BREW COFFEE, INC., (U.S. CL. 46). SN 77-546,573. PUB. 3-17-2009. FILED 8-13-2008.
 3,630,235. **AFTIC CORPORATION AND DESIGN**. AFTIC CORPORATION, (U.S. CL. 46). SN 77-555,358. PUB. 3-17-2009. FILED 8-25-2008.
 3,630,286 (*See Class 29 for this trademark*).
 3,630,474. **LA POD AND DESIGN**. POD PACK INTERNATIONAL, LTD., (U.S. CL. 46). SN 77-587,676. PUB. 3-17-2009. FILED 10-7-2008.
 3,630,498. **PATRIOT'S BOLD BARBEQUE SAUCE AND DESIGN**. PATRIOT'S BOLD BARBEQUE, LLC, (U.S. CL. 46). SN 77-589,493. PUB. 3-17-2009. FILED 10-9-2008.
 3,630,522. **MISCELLANEOUS DESIGN**. BETTERBODY FOODS & NUTRITION LLC, (U.S. CL. 46). SN 77-591,829. PUB. 3-17-2009. FILED 10-13-2008.
 3,630,525. **MISCELLANEOUS DESIGN**. GENERAL MILLS MARKETING, INC., (U.S. CL. 46). SN 77-591,920. PUB. 3-17-2009. FILED 10-14-2008.
 3,630,545. **SPRINGLIFE (STYLIZED)**. TIANJIN BOATGEM ORGANIC FOOD MANUFACTURING CO.,LTD, (U.S. CL. 46). SN 77-592,845. PUB. 3-17-2009. FILED 10-15-2008.
 3,630,551. **S. O. ESPRESSO (BLOCK FORM)**. PARADISE ROASTERS INC, (U.S. CL. 46). SN 77-593,518. PUB. 3-17-2009. FILED 10-15-2008.
 3,630,652. **LIU LIU SHUN AND DESIGN**. SHANDONG LIULIUSHUN FOODS CO., LTD., (U.S. CL. 46). SN 77-597,143. PUB. 3-17-2009. FILED 10-21-2008.
 3,630,658. **MISCELLANEOUS DESIGN**. HUDSON, HARVEY NUNLEY, (U.S. CL. 46). SN 77-597,365. PUB. 3-17-2009. FILED 10-21-2008.
 3,630,764. **WORKING COW (BLOCK FORM)**. WORKING COW HOMEMADE, INC., (U.S. CL. 46). SN 77-599,126. PUB. 3-17-2009. FILED 10-23-2008.
 3,630,770 (*See Class 29 for this trademark*).
 3,630,809. **TICKLEBELLY AND DESIGN**. STEVEN ROBERTS ORIGINAL DESSERTS, (U.S. CL. 46). SN 77-599,780. PUB. 3-17-2009. FILED 10-24-2008.
 3,630,939. **PITTSBURGH POWDER (BLOCK FORM)**. PBP LLC, (U.S. CL. 46). SN 77-601,372. PUB. 3-17-2009. FILED 10-27-2008.
 3,630,945. **CATTLE DOG COFFEE ROASTERS (BLOCK FORM)**. CATTLE DOG COFFEE ROASTERS, INC., (U.S. CL. 46). SN 77-601,430. PUB. 3-17-2009. FILED 10-27-2008.
 3,630,970. **FAVORA AND DESIGN**. PROCESADORA DE LA ALIMENTOS KRIS, S.A., AKA PRAKSA, (U.S. CL. 46). SN 77-601,937. PUB. 3-17-2009. FILED 10-28-2008.
 3,631,109. **PORTLAND BLEND (BLOCK FORM)**. COFFEE BEAN INTERNATIONAL, INC., (U.S. CL. 46). SN 77-604,042. PUB. 3-17-2009. FILED 10-30-2008.
 3,631,110. **NORTHWEST ESPRESSO (BLOCK FORM)**. COFFEE BEAN INTERNATIONAL, INC., (U.S. CL. 46). SN 77-604,047. PUB. 3-17-2009. FILED 10-30-2008.
 3,631,120. **YESHI INJERA (BLOCK FORM)**. YERGE, HE-NOCK MEKONNEN, DBA YESHI INJERA, (U.S. CL. 46). SN 77-604,155. PUB. 3-17-2009. FILED 10-30-2008.
 3,631,184. **SPECIAL DARK (BLOCK FORM)**. HERSHEY CHOCOLATE & CONFECTIONERY CORPORATION, (U.S. CL. 46). SN 77-605,351. PUB. 3-17-2009. FILED 10-31-2008.
 3,631,218. **SUGARS BY SHARON (BLOCK FORM)**. SUGARS BY SHARON, (U.S. CL. 46). SN 77-605,629. PUB. 3-17-2009. FILED 11-1-2008.
 3,631,230. **ATOMIC FIREBALL (BLOCK FORM)**. FERRARA PAN CANDY CO., INC., (U.S. CL. 46). SN 77-605,971. PUB. 3-17-2009. FILED 11-3-2008.
 3,631,239. **PURE HERSHEY'S (BLOCK FORM)**. HERSHEY CHOCOLATE & CONFECTIONERY CORPORATION, (U.S. CL. 46). SN 77-606,126. PUB. 3-17-2009. FILED 11-3-2008.
 3,631,258. **SAMBUSAC (BLOCK FORM)**. SAMBUSAC LLC, (U.S. CL. 46). SN 77-606,888. PUB. 3-17-2009. FILED 11-4-2008.
 3,631,260. **POPCORN MAKES YOU POPULAR (BLOCK FORM)**. TARANCE ENTERPRISES, LLC, (U.S. CL. 46). SN 77-607,008. PUB. 3-17-2009. FILED 11-4-2008.
 3,631,293. **NUTTY MOOSE TRACKS (BLOCK FORM)**. DENALI CO., LLC, (U.S. CL. 46). SN 77-611,699. PUB. 3-17-2009. FILED 11-11-2008.
 3,631,295. **NUTTY MOOSE TRACKS AND DESIGN**. DENALI CO., LLC, (U.S. CL. 46). SN 77-612,041. PUB. 3-17-2009. FILED 11-11-2008.
 3,631,297. **PERSONALITIES (BLOCK FORM)**. LITTLE I, INC., (U.S. CL. 46). SN 77-612,331. PUB. 3-17-2009. FILED 11-11-2008.
 3,631,314. **DR. CHAO AND DESIGN**. U.S. PANDA FOODS & BEVERAGES, INC, (U.S. CL. 46). SN 77-617,173. PUB. 3-17-2009. FILED 11-19-2008.
 3,631,319. **HERSHEY'S AND DESIGN**. HERSHEY CHOCOLATE & CONFECTIONERY CORPORATION, (U.S. CL. 46). SN 77-618,421. PUB. 3-17-2009. FILED 11-20-2008.
 3,631,320. **REESE'S AND DESIGN**. HERSHEY CHOCOLATE & CONFECTIONERY CORPORATION, (U.S. CL. 46). SN 77-618,514. PUB. 3-17-2009. FILED 11-20-2008.
 3,631,331. **INNOVATING FOR GOOD HEALTH AND GREAT TASTE. (BLOCK FORM)**. STURM FOODS, INC., MULTIPLE CLASS, (INT. CLS. 30, 32 AND 40), (U.S. CLS. 45, 46, 48, 100, 103 AND 106). SN 77-623,855. PUB. 3-17-2009. FILED 12-1-2008.
 3,631,376. **OHANA HARBOR COFFEE OH! THAT'S GOOD! AND DESIGN**. GRINDSTONEMANAGEMENT, LLC, DBA F/K/A "ADA BLANCHE W. SCHREINER FAMILY LLC", MULTIPLE CLASS, (INT. CLS. 30 AND 31), (U.S. CLS. 1 AND 46). SN 77-977,033. PUB. 11-11-2008. FILED 4-25-2008.
 3,631,378 (*See Class 1 for this trademark*).
 3,631,399 (*See Class 3 for this trademark*).
 3,631,400 (*See Class 29 for this trademark*).
 3,631,402. **BAKERY DELUXE (BLOCK FORM)**. FIERA FOODS COMPANY, MULTIPLE CLASS, (INT. CLS. 30 AND 40), (U.S. CLS. 46, 100, 103 AND 106). SN 78-642,455. PUB. 9-16-2008. FILED 6-2-2005.
 3,631,427 (*See Class 3 for this trademark*).
 3,631,481 (*See Class 3 for this trademark*).
 3,631,512 (*See Class 3 for this trademark*).
 3,631,565 (*See Class 16 for this trademark*).
 3,631,599. **BONDOLCE DESSERTS AND DESIGN**. GIORGIO GIORGIS, (U.S. CL. 46). SN 79-054,008. PUB. 3-17-2009. FILED 4-17-2008.
 3,631,605 (*See Class 5 for this trademark*).
 3,631,631 (*See Class 5 for this trademark*).
 3,631,634. **MISCELLANEOUS DESIGN**. ANHUI HONGHUI FOOD (GROUP); CORPORATION, (U.S. CL. 46). SN 79-054,524. PUB. 3-17-2009. FILED 3-18-2008.
 3,631,653. **TAT AND DESIGN**. TAT MAKARNACILIK; SANAYI VE TICARET ANONIM SIRKETI, (U.S. CL. 46). SN 79-055,239. PUB. 3-17-2009. FILED 5-8-2008.
 3,631,686. **VICENZI GROUP AND DESIGN**. VICENZI BIS-

COTTI S.P.A., (U.S. CL. 46). SN 79-056,554. PUB. 3-17-2009. FILED 4-17-2008.
 3,631,689. **DARK DUDES BY DEPESCHE (BLOCK FORM)**. "DEPESCHE" VERTIEB GMBH & CO. KG, MULTIPLE CLASS, (INT. CLS. 30, 32 AND 33), (U.S. CLS. 45, 46, 47, 48 AND 49). SN 79-056,778. PUB. 3-17-2009. FILED 6-3-2008.
 3,631,694. **MOUTARDE DES CHEFS (BLOCK FORM)**. EUROPEENNE DE CONDIMENTS, (U.S. CL. 46). SN 79-057,001. PUB. 3-17-2009. FILED 7-7-2008.
 3,631,732 (*See Class 29 for this trademark*).

CLASS 31—NATURAL AGRICULTURAL PRODUCTS

3,629,170. **DEL PUEBLO AND DESIGN**. YELL-O-GLOW CORPORATION, (U.S. CLS. 1 AND 46). SN 76-689,217. PUB. 3-17-2009. FILED 5-2-2008.
 3,629,224. **PLANT AND GROW (BLOCK FORM)**. KRAEMER'S NURSERY, INC., (U.S. CLS. 1 AND 46). SN 76-694,480. PUB. 3-17-2009. FILED 11-24-2008.
 3,629,230. **SUNMET (BLOCK FORM)**. ETCHEGARAY FARMS, LLC, (U.S. CLS. 1 AND 46). SN 77-005,925. PUB. 5-8-2007. FILED 9-23-2006.
 3,629,231. **SUNMET AND DESIGN**. ETCHEGARAY FARMS, LLC, (U.S. CLS. 1 AND 46). SN 77-005,926. PUB. 5-8-2007. FILED 9-23-2006.
 3,629,232. **SUNMET AND DESIGN**. ETCHEGARAY FARMS, LLC, (U.S. CLS. 1 AND 46). SN 77-005,927. PUB. 5-15-2007. FILED 9-23-2006.
 3,629,284. **AMERICA'S FAVORITE MOM (BLOCK FORM)**. FFP, A CALIFORNIA GENERAL PARTNERSHIP, MULTIPLE CLASS, (INT. CLS. 31, 39 AND 41), (U.S. CLS. 1, 46, 100, 101, 105 AND 107). SN 77-151,182. PUB. 3-17-2009. FILED 4-6-2007.
 3,629,360. **RUBIERO (BLOCK FORM)**. MASTRONARDI PRODUCE, LTD., (U.S. CLS. 1 AND 46). SN 77-273,543. PUB. 3-17-2009. FILED 9-6-2007.
 3,629,858. **SEAVEGGIES (BLOCK FORM)**. TWO LITTLE FISHIES, (U.S. CLS. 1 AND 46). SN 77-458,325. PUB. 3-17-2009. FILED 4-25-2008.
 3,630,138. **CLEAN & FREE (BLOCK FORM)**. SMG BRANDS, INC., (U.S. CLS. 1 AND 46). SN 77-529,930. PUB. 3-17-2009. FILED 7-23-2008.
 3,630,470. **EARTH SOURCE AND DESIGN**. EARTH SOURCE TRADING, INC., (U.S. CLS. 1 AND 46). SN 77-587,354. PUB. 3-17-2009. FILED 10-7-2008.
 3,630,952. **TASTY GREENS AND DESIGN**. PACIFIC INTERNATIONAL VEGETABLE MARKETING, INC., (U.S. CLS. 1 AND 46). SN 77-601,585. PUB. 3-17-2009. FILED S.R. 10-27-2008; AM. P.R. 2-10-2009.
 3,631,122. **FAT LAW'S FARM (BLOCK FORM)**. FAT LAW'S FARM, INC., (U.S. CLS. 1 AND 46). SN 77-604,235. PUB. 3-17-2009. FILED 10-30-2008.
 3,631,160. **BENETREATS (BLOCK FORM)**. SPECTRUM PET CARE, INC., (U.S. CLS. 1 AND 46). SN 77-604,907. PUB. 3-17-2009. FILED 10-31-2008.
 3,631,286. **FREELANDER (BLOCK FORM)**. NEWFLORA LLC, (U.S. CLS. 1 AND 46). SN 77-610,470. PUB. 3-17-2009. FILED 11-8-2008.
 3,631,376 (*See Class 30 for this trademark*).
 3,631,486. **MISCELLANEOUS DESIGN**. QIAQIA FOOD CO., LTD., (U.S. CLS. 1 AND 46). SN 79-042,104. PUB. 3-17-2009. FILED 6-28-2007.
 3,631,503 (*See Class 16 for this trademark*).
 3,631,635. **KABIR AND DESIGN**. KABIR INTERNATIONAL S.R.L., MULTIPLE CLASS, (INT. CLS. 31 AND 44), (U.S. CLS. 1, 46, 100 AND 101). SN 79-054,534. PUB. 3-17-2009. FILED 4-17-2008.
 3,631,673 (*See Class 19 for this trademark*).

CLASS 32—LIGHT BEVERAGES

3,629,333 (*See Class 18 for this trademark*).

3,629,379 (*See Class 1 for this trademark*).
 3,629,536. **TRUE TO THE FRUIT (BLOCK FORM)**. GLOBAL JUICES AND FRUITS, LLC, (U.S. CLS. 45, 46 AND 48). SN 77-395,689. PUB. 3-17-2009. FILED 2-13-2008.
 3,629,573. **CERVEZA LA CERVEZA MAS FINA CORONA LIGHT CONT. NET. 340 ML AND DESIGN**. CERVECERIA MODELO, S.A. DE C.V., (U.S. CLS. 45, 46 AND 48). SN 77-410,946. PUB. 3-17-2009. FILED 3-3-2008.
 3,629,575. **ALPINE SPRING WATER AND DESIGN**. CG ROXANE LLC, (U.S. CLS. 45, 46 AND 48). SN 77-411,446. PUB. 3-17-2009. FILED 3-3-2008.
 3,629,777. **T SYSTEMS AND DESIGN**. DEUTSCHE TELEKOM, (U.S. CLS. 45, 46 AND 48). SN 77-450,649. PUB. 3-17-2009. FILED 4-17-2008.
 3,629,791. **T HOME AND DESIGN**. DEUTSCHE TELEKOM, (U.S. CLS. 45, 46 AND 48). SN 77-451,394. PUB. 1-13-2009. FILED 4-17-2008.
 3,629,800. **C AND DESIGN**. CARIBBOUT EXPORT, CORP., (U.S. CLS. 45, 46 AND 48). SN 77-451,892. PUB. 3-17-2009. FILED 4-18-2008.
 3,629,900. **ZULU JUICE AND DESIGN**. EAST COAST GROUP NY LTD, (U.S. CLS. 45, 46 AND 48). SN 77-466,171. PUB. 3-17-2009. FILED 5-5-2008.
 3,629,945 (*See Class 30 for this trademark*).
 3,629,971. **MISCELLANEOUS DESIGN**. DIAGEO NORTH AMERICA, INC., (U.S. CLS. 45, 46 AND 48). SN 77-486,354. PUB. 3-17-2009. FILED 5-29-2008.
 3,629,973. **#S ALE (BLOCK FORM)**. THOMAS LIAM MURPHY, (U.S. CLS. 45, 46 AND 48). SN 77-487,222. PUB. 3-17-2009. FILED 5-30-2008.
 3,630,180. **NUVISION AND DESIGN**. NUVISION WATER, LLC, (U.S. CLS. 45, 46 AND 48). SN 77-542,929. PUB. 3-17-2009. FILED 8-8-2008.
 3,630,452. **BLUETONGUE (BLOCK FORM)**. BLUETONGUE BREWERY PTY LIMITED, (U.S. CLS. 45, 46 AND 48). SN 77-585,150. PUB. 3-17-2009. FILED 10-3-2008.
 3,630,569. **SANTA'S PRIVATE RESERVE ALE (BLOCK FORM)**. OREGON BREWING COMPANY, (U.S. CLS. 45, 46 AND 48). SN 77-594,466. PUB. 3-17-2009. FILED 10-16-2008.
 3,630,633. **SWORD SWALLOWER (BLOCK FORM)**. JEREMY COWAN, (U.S. CLS. 45, 46 AND 48). SN 77-596,781. PUB. 3-17-2009. FILED 10-21-2008.
 3,630,660. **ROLICK (BLOCK FORM)**. PYRAMID BREWERIES INC., (U.S. CLS. 45, 46 AND 48). SN 77-597,423. PUB. 3-17-2009. FILED 10-21-2008.
 3,630,689 (*See Class 29 for this trademark*).
 3,630,770 (*See Class 29 for this trademark*).
 3,630,834. **UNPASTEURIZED FOR YOUR PROTECTION (BLOCK FORM)**. ZOE SAKOUTIS, LLC, DBA BLUEPRINT CLEANSE, (U.S. CLS. 45, 46 AND 48). SN 77-600,084. PUB. 3-17-2009. FILED 10-24-2008.
 3,630,974. **TROPI-KÜHL (STYLIZED)**. PROCESADORA DE LA ALIMENTOS KRIS, S.A., AKA PRAKSA, (U.S. CLS. 45, 46 AND 48). SN 77-601,959. PUB. 3-17-2009. FILED 10-28-2008.
 3,630,977. **DRINKI (STYLIZED)**. PROCESADORA DE LA ALIMENTOS KRIS, S.A., AKA PRAKSA, (U.S. CLS. 45, 46 AND 48). SN 77-601,978. PUB. 3-17-2009. FILED 10-28-2008.
 3,631,150. **OOH WEE (BLOCK FORM)**. JENKINS, TERRA, (U.S. CLS. 45, 46 AND 48). SN 77-604,691. PUB. 3-17-2009. FILED 10-30-2008.
 3,631,174 (*See Class 29 for this trademark*).
 3,631,175 (*See Class 29 for this trademark*).
 3,631,331 (*See Class 30 for this trademark*).
 3,631,378 (*See Class 1 for this trademark*).
 3,631,399 (*See Class 3 for this trademark*).
 3,631,473 (*See Class 14 for this trademark*).
 3,631,475. **IDRATE AND DESIGN**. IDRATE SÀRL, MULTIPLE CLASS, (INT. CLS. 32, 36, 42 AND 45), (U.S. CLS. 45, 46, 48, 100, 101 AND 102). SN 79-037,423. PUB. 12-9-2008. FILED 1-22-2007.
 3,631,512 (*See Class 3 for this trademark*).
 3,631,552. **PALM AND DESIGN**. PALM BREWERIES,; NAAMLOZE VENNOOTSCHAP, (U.S. CLS. 45, 46 AND 48). SN 79-051,724. PUB. 12-9-2008. FILED 2-14-2008.
 3,631,659. **1859 (BLOCK FORM)**. EUROINVERSIONES AGUA DE SOUSAS, S.L.U., (U.S. CLS. 45, 46 AND 48). SN 79-

055,404. PUB. 3-17-2009. FILED 4-29-2008.
 3,631,689 (*See Class 30 for this trademark*).
 3,631,710 (*See Class 29 for this trademark*).

CLASS 33—WINES AND SPIRITS

3,629,178 (*See Class 30 for this trademark*).
 3,629,412. **B2 2004 PINOT NOIR OREGON ALC. 13.0% BY VOLUME AND DESIGN.** EUGENE WINE CELLARS, LLC, (U.S. CLS. 47 AND 49). SN 77-315,915. PUB. 4-22-2008. FILED 10-29-2007.
 3,629,489. **ATTO PRIMO (BLOCK FORM).** GANCIA S.P.A., (U.S. CLS. 47 AND 49). SN 77-368,858. PUB. 12-9-2008. FILED 1-10-2008.
 3,629,615. **ESTAPOR VENIR (BLOCK FORM).** BIBENDUM WINE LIMITED, (U.S. CLS. 47 AND 49). SN 77-430,960. PUB. 3-17-2009. FILED 3-25-2008.
 3,629,674. **OBSELLO (BLOCK FORM).** ESMERALDA LIQUORS S.L., (U.S. CLS. 47 AND 49). SN 77-440,411. PUB. 3-17-2009. FILED 4-4-2008.
 3,629,825. **LA LUNA LAMBRUSCO CANTINE CECI IL VINO DI UNA VOLTA... IMBOTTIGLIATO A LUNA CRESCENTE ALC. 11% BY VOL. NET CONT. 750ML E AND DESIGN.** RAGE RECORDS INC, DBA ROSALIE SENDELBACH IMPORTS, (U.S. CLS. 47 AND 49). SN 77-454,562. PUB. 3-17-2009. FILED 4-22-2008.
 3,629,844. **SHOW YOUR BETTER NATURE (BLOCK FORM).** VEEV SPIRITS, LLC, (U.S. CLS. 47 AND 49). SN 77-456,386. PUB. 3-17-2009. FILED 4-23-2008.
 3,629,850. **WINE TO DIE FOR ! (BLOCK FORM).** GRAVEYARD VINEYARDS, (U.S. CLS. 47 AND 49). SN 77-456,877. PUB. 3-17-2009. FILED 4-24-2008.
 3,629,899. **MISCELLANEOUS DESIGN.** DIAGEO CHATEAU & ESTATE WINES COMPANY, (U.S. CLS. 47 AND 49). SN 77-466,120. PUB. 3-17-2009. FILED 5-5-2008.
 3,629,933. **LA BRACCESCA (BLOCK FORM).** MARCHESI ANTINORI S.R.L., (U.S. CLS. 47 AND 49). SN 77-475,446. PUB. 3-17-2009. FILED 5-15-2008.
 3,629,968. **TIMELESS PALATES (BLOCK FORM).** TIMELESS PALATES WINE LLC, (U.S. CLS. 47 AND 49). SN 77-483,924. PUB. 3-17-2009. FILED 5-27-2008.
 3,630,167. **QUEEN OF SYRAH (BLOCK FORM).** CAVE DE TAIN L'HERMITAGE, UNION DES PROPRIETAIRES, (U.S. CLS. 47 AND 49). SN 77-537,204. PUB. 12-23-2008. FILED 8-1-2008.
 3,630,169. **CM CHATEAU MARGENE ESTABLISHED 1997 AND DESIGN.** CHATEAU MARGENE, (U.S. CLS. 47 AND 49). SN 77-538,330. PUB. 3-17-2009. FILED 8-4-2008.
 3,630,256. **LUCHADOR (BLOCK FORM).** DANIEL PHILIPS, (U.S. CLS. 47 AND 49). SN 77-558,075. PUB. 3-17-2009. FILED 9-3-2008.
 3,630,265. **MERLOT OVER AND PLAY DEAD (BLOCK FORM).** MUTT LYNCH WINERY, INC., DBA MUTT LYNCH WINERY, (U.S. CLS. 47 AND 49). SN 77-559,326. PUB. 3-17-2009. FILED 8-29-2008.
 3,630,458. **AXIAL AND DESIGN.** AXIAL GLOBALIZACION DE VINOS, S.L., (U.S. CLS. 47 AND 49). SN 77-586,301. PUB. 3-17-2009. FILED 10-6-2008.
 3,630,589. **ZIPPERS THE ORIGINAL GELATIN SHOT GET CAUGHT IN ONE (BLOCK FORM).** BPNC, INC., (U.S. CLS. 47 AND 49). SN 77-595,569. PUB. 3-17-2009. FILED 10-18-2008.
 3,630,648. **PARAVI (BLOCK FORM).** BROWN, THOMAS O., DBA PARAVI VINEYARDS, (U.S. CLS. 47 AND 49). SN 77-597,013. PUB. 3-17-2009. FILED 10-21-2008.
 3,630,685. **CROOKED RITA (BLOCK FORM).** CHANTILLY MARKS, LLC, (U.S. CLS. 47 AND 49). SN 77-597,963. PUB. 3-17-2009. FILED 10-22-2008.
 3,630,759. **KRIS AND DESIGN.** WINEBOW, INC., (U.S. CLS. 47 AND 49). SN 77-599,000. PUB. 3-17-2009. FILED 10-23-2008.
 3,630,962. **IJALBA (BLOCK FORM).** VIÑA IJALBA S.A., (U.S. CLS. 47 AND 49). SN 77-601,741. PUB. 3-17-2009. FILED 10-28-2008.
 3,631,000. **PENCA AZUL (BLOCK FORM).** AGAVE DE PLATA S.A. DE C.V., (U.S. CLS. 47 AND 49). SN 77-602,207. PUB. 3-17-2009. FILED 10-28-2008.

3,631,072. **"MAKING LIFE BETTER...ONE SIP AT A TIME" (BLOCK FORM).** TAJ CELLARS, LLC, (U.S. CLS. 47 AND 49). SN 77-603,501. PUB. 3-17-2009. FILED 10-29-2008.
 3,631,187. **GF (BLOCK FORM).** JELMA, INC., (U.S. CLS. 47 AND 49). SN 77-605,405. PUB. 3-17-2009. FILED 10-31-2008.
 3,631,189. **GF (STYLIZED).** JELMA, INC., (U.S. CLS. 47 AND 49). SN 77-605,411. PUB. 3-17-2009. FILED 10-31-2008.
 3,631,190. **GO FIGURE (BLOCK FORM).** JELMA, INC., (U.S. CLS. 47 AND 49). SN 77-605,415. PUB. 3-17-2009. FILED 10-31-2008.
 3,631,196. **GO FIGURE (STYLIZED).** JELMA, INC., (U.S. CLS. 47 AND 49). SN 77-605,425. PUB. 3-17-2009. FILED 10-31-2008.
 3,631,274. **PRAGER (BLOCK FORM).** PRAGER WINERY & PORT WORKS, INC., (U.S. CLS. 47 AND 49). SN 77-608,675. PUB. 3-17-2009. FILED 11-6-2008.
 3,631,329. **DUSSEK (BLOCK FORM).** WOODHOUSE FAMILY CELLARS, INC., (U.S. CLS. 47 AND 49). SN 77-622,895. PUB. 3-17-2009. FILED 11-26-2008.
 3,631,405. **HOUDINI (BLOCK FORM).** HOUDINI, INC., (U.S. CLS. 47 AND 49). SN 78-655,512. PUB. 3-17-2009. FILED 6-21-2005.
 3,631,440. **GOTTO D'ORO (STYLIZED).** GOTTO D'ORO SOCIETA COOPERATIVA, (U.S. CLS. 47 AND 49). SN 78-921,887. PUB. 3-17-2009. FILED 7-3-2006.
 3,631,445. **IXIA (BLOCK FORM).** JNP & EG JORDAAN, (U.S. CLS. 47 AND 49). SN 78-942,029. PUB. 3-17-2009. FILED 8-1-2006.
 3,631,484. **CANARD-DUCHENE CUVÉE LEONIE AND DESIGN.** CHAMPAGNE ALAIN THIENOT, (U.S. CLS. 47 AND 49). SN 79-041,719. PUB. 3-17-2009. FILED 7-13-2007.
 3,631,570. **NEMIROFF BIRCH UKRAINIAN SPECIAL VODKA AND DESIGN.** NEMIROFF; INTELLECTUAL PROPERTY ESTABLISHMENT, MULTIPLE CLASS, (INT. CLS. 33 AND 35), (U.S. CLS. 47, 49, 100, 101 AND 102). SN 79-052,972. PUB. 3-17-2009. FILED 2-28-2008.
 3,631,596. **LOS CANTOS DE TORREMILANOS (BLOCK FORM).** BODEGAS PEÑALBA LÓPEZ, S.L., (U.S. CLS. 47 AND 49). SN 79-053,938. PUB. 3-17-2009. FILED 4-30-2008.
 3,631,627. **PIEDRA AND DESIGN.** ESTANCIA PIEDRA, S.L., (U.S. CLS. 47 AND 49). SN 79-054,415. PUB. 3-17-2009. FILED 2-15-2008.
 3,631,689 (*See Class 30 for this trademark*).
 3,631,710 (*See Class 29 for this trademark*).
 3,631,712. **013 (BLOCK FORM).** ALTIA PLC, (U.S. CLS. 47 AND 49). SN 79-057,486. PUB. 3-17-2009. FILED 7-2-2008.
 3,631,713. **KOSKEN (STYLIZED).** ALTIA PLC, (U.S. CLS. 47 AND 49). SN 79-057,493. PUB. 3-17-2009. FILED 7-2-2008.
 3,631,714. **NKORVA (STYLIZED).** ALTIA PLC, (U.S. CLS. 47 AND 49). SN 79-057,494. PUB. 3-17-2009. FILED 7-2-2008.
 3,631,750. **LAMOUREUX (BLOCK FORM).** CHATEAU RAUZAN-SEGLA, (U.S. CLS. 47 AND 49). SN 79-059,627. PUB. 3-17-2009. FILED 8-27-2008.
 3,631,754. **GABBIANO (BLOCK FORM).** BERINGER BLASS ITALIA S.R.L., (U.S. CLS. 47 AND 49). SN 79-059,819. PUB. 3-17-2009. FILED 8-1-2008.

CLASS 34—SMOKERS' ARTICLES

3,629,169. **F&K (BLOCK FORM).** FREIDMAN-KLINGE CIGAR CO., (U.S. CLS. 2, 8, 9 AND 17). SN 76-689,135. PUB. 3-17-2009. FILED 4-30-2008.
 3,629,424 (*See Class 3 for this trademark*).
 3,629,966. **BINGO (BLOCK FORM).** N.V. SUMATRA TOBACCO TRADING COMPANY, (U.S. CLS. 2, 8, 9 AND 17). SN 77-483,658. PUB. 1-13-2009. FILED 5-27-2008.
 3,629,972. **BASIC NON-FILTER . SMOOTH RICH TASTE . 20 CLASS A CIGARETTES A CLASS A CIGARETTES ACCO AND DESIGN.** PHILIP MORRIS USA INC., (U.S. CLS. 2, 8, 9 AND 17). SN 77-487,093. PUB. 3-17-2009. FILED 5-30-2008.
 3,630,299. **FREDERICK TOWNE (BLOCK FORM).** DAVIDUS CIGARS, LTD., (U.S. CLS. 2, 8, 9 AND 17). SN 77-565,584. PUB. 3-17-2009. FILED 9-9-2008.
 3,630,611. **ROCKY PATEL RP RENAISSANCE (BLOCK FORM).** PATEL, RAKESH, (U.S. CLS. 2, 8, 9 AND 17). SN 77-596,144. PUB. 3-17-2009. FILED 10-20-2008.

- 3,630,643. **THE FUTURE OF TOBACCO (BLOCK FORM)**. STAR SCIENTIFIC, INC., (U.S. CLS. 2, 8, 9 AND 17). SN 77-596,976. PUB. 3-17-2009. FILED 10-21-2008.
- 3,631,310. **TAUROS THE BULL (BLOCK FORM)**. FUENTE MARKETING LTD., (U.S. CLS. 2, 8, 9 AND 17). SN 77-616,881. PUB. 3-17-2009. FILED 11-18-2008.
- 3,631,512 (*See Class 3 for this trademark*).
- 3,631,515. **GOLDFIELD (BLOCK FORM)**. LIDL STIFTUNG & CO. KG, (U.S. CLS. 2, 8, 9 AND 17). SN 79-048,053. PUB. 3-17-2009. FILED 7-16-2007.
- 3,631,613. **VOGUE ARÔME DÎNER EN VILLE AND DESIGN**. AMERICAN-CIGARETTE COMPANY; (OVERSEAS) LIMITED, (U.S. CLS. 2, 8, 9 AND 17). SN 79-054,235. PUB. 3-17-2009. FILED 4-28-2008.
- 3,631,614. **MISCELLANEOUS DESIGN**. AMERICAN-CIGARETTE COMPANY; (OVERSEAS) LIMITED, (U.S. CLS. 2, 8, 9 AND 17). SN 79-054,242. PUB. 3-17-2009. FILED 4-7-2008.
- 3,631,615. **VOGUE ARÔME TERRASSE AU SOLEIL AND DESIGN**. AMERICAN-CIGARETTE COMPANY; (OVERSEAS) LIMITED, (U.S. CLS. 2, 8, 9 AND 17). SN 79-054,243. PUB. 3-17-2009. FILED 4-29-2008.
- 3,631,616. **VOGUE ARÔME BALADE AU PARC AND DESIGN**. AMERICAN-CIGARETTE COMPANY; (OVERSEAS) LIMITED, (U.S. CLS. 2, 8, 9 AND 17). SN 79-054,246. PUB. 3-17-2009. FILED 4-28-2008.
- 3,631,661. **RUYAN C-GAR (STYLIZED)**. SHENYANG SBT TECHNOLOGY; & DEVELOPMENT CO., LTD., (U.S. CLS. 2, 8, 9 AND 17). SN 79-055,495. PUB. 3-17-2009. FILED 5-21-2008.
- 3,631,723. **VOGUE CARACTERE (BLOCK FORM)**. AMERICAN-CIGARETTE COMPANY; (OVERSEAS) LIMITED, (U.S. CLS. 2, 8, 9 AND 17). SN 79-058,112. PUB. 3-17-2009. FILED 7-29-2008.
- PUB. 3-17-2009. FILED 5-8-2008.
- 3,629,174. **ESSENTIAL INGREDIENTS (BLOCK FORM)**. ESSENTIAL INGREDIENTS, INC., (U.S. CLS. 100, 101 AND 102). SN 76-689,532. PUB. 3-17-2009. FILED 5-12-2008.
- 3,629,178 (*See Class 30 for this trademark*).
- 3,629,185. **VISIONS FROM THE ROOF AND DESIGN**. KUYUMCUOVIC, GARO, (U.S. CLS. 100, 101 AND 102). SN 76-691,818. PUB. 3-17-2009. FILED 8-4-2008.
- 3,629,186. **L LAWSUIT.COM AND DESIGN**. JZJ, LLC, (U.S. CLS. 100, 101 AND 102). SN 76-691,981. PUB. 3-17-2009. FILED 8-12-2008.
- 3,629,191. **SHOP US FIRST TO SAVE THE MOST (BLOCK FORM)**. CONTRACTOR'S BEST HOLDINGS, INC., (U.S. CLS. 100, 101 AND 102). SN 76-692,654. PUB. 3-17-2009. FILED 9-9-2008.
- 3,629,195. **FASTTRACK (BLOCK FORM)**. SHC DIRECT, LLC, (U.S. CLS. 100, 101 AND 102). SN 76-693,151. PUB. 3-17-2009. FILED 9-26-2008.
- 3,629,200. **SEEKING HR (BLOCK FORM)**. EMPLOYOU, LLC, (U.S. CLS. 100, 101 AND 102). SN 76-693,583. PUB. 3-17-2009. FILED 10-16-2008.
- 3,629,201. **MAXISIT (BLOCK FORM)**. MAXISIT, INC., MULTIPLE CLASS, (INT. CLS. 35, 42 AND 44), (U.S. CLS. 100, 101 AND 102). SN 76-693,676. PUB. 3-17-2009. FILED 10-20-2008.
- 3,629,209. **WHERE GREAT TALENT LIVES (BLOCK FORM)**. MDC PARTNERS INC., (U.S. CLS. 100, 101 AND 102). SN 76-693,813. PUB. 3-17-2009. FILED 10-24-2008.
- 3,629,212. **RBDA REGIONAL BOND DEALERS ASSOCIATION (BLOCK FORM)**. REGIONAL BOND DEALERS ASSOCIATION, INC., (U.S. CLS. 100, 101 AND 102). SN 76-693,966. PUB. 3-17-2009. FILED 10-31-2008.
- 3,629,215. **HAVE AN EXIT STRATEGY AND DESIGN**. THINKSTREET, (U.S. CLS. 100, 101 AND 102). SN 76-694,030. PUB. 3-17-2009. FILED 11-4-2008.
- 3,629,216. **FREEBORDERS (BLOCK FORM)**. FREEBORDERS.COM, INC., (U.S. CLS. 100, 101 AND 102). SN 76-694,032. PUB. 3-17-2009. FILED 11-4-2008.
- 3,629,217. **ATLAS (BLOCK FORM)**. FREEBORDERS.COM, INC., (U.S. CLS. 100, 101 AND 102). SN 76-694,033. PUB. 3-17-2009. FILED 11-4-2008.
- 3,629,218. **CHINDUS (BLOCK FORM)**. FREEBORDERS.COM, INC., (U.S. CLS. 100, 101 AND 102). SN 76-694,034. PUB. 3-17-2009. FILED 11-4-2008.
- 3,629,219. **HAVE AN EXIT STRATEGY (BLOCK FORM)**. THINKSTREET, (U.S. CLS. 100, 101 AND 102). SN 76-694,035. PUB. 3-17-2009. FILED 11-4-2008.
- 3,629,220. **MISCELLANEOUS DESIGN**. MOO & OINK, INC., (U.S. CLS. 100, 101 AND 102). SN 76-694,083. PUB. 3-17-2009. FILED 11-4-2008.
- 3,629,221. **MISCELLANEOUS DESIGN**. MOO & OINK, INC., (U.S. CLS. 100, 101 AND 102). SN 76-694,084. PUB. 3-17-2009. FILED 11-4-2008.
- 3,629,234. **THE SCARLET TASSEL (BLOCK FORM)**. THE SCARLET TASSEL, INC., (U.S. CLS. 100, 101 AND 102). SN 77-027,717. PUB. 3-17-2009. FILED 10-24-2006.
- 3,629,242. **CALIMAX AND DESIGN**. CENTRAL DETALLISTA, S.A. DE C.V., (U.S. CLS. 100, 101 AND 102). SN 77-057,285. PUB. 7-31-2007. FILED 12-5-2006.
- 3,629,249. **VERIFARE (BLOCK FORM)**. WNS NORTH AMERICA, INC., (U.S. CLS. 100, 101 AND 102). SN 77-071,241. PUB. 4-1-2008. FILED 12-26-2006.
- 3,629,256 (*See Class 9 for this trademark*).
- 3,629,275 (*See Class 7 for this trademark*).
- 3,629,276. **PIL (BLOCK FORM)**. PACIFIC INTERNATIONAL LINES (PRIVATE) LIMITED, MULTIPLE CLASS, (INT. CLS. 35 AND 39), (U.S. CLS. 100, 101, 102 AND 105). SN 77-136,507. PUB. 3-17-2009. FILED 3-21-2007.
- 3,629,277. **PIL AND DESIGN**. PACIFIC INTERNATIONAL LINES (PRIVATE) LIMITED, MULTIPLE CLASS, (INT. CLS. 35 AND 39), (U.S. CLS. 100, 101, 102 AND 105). SN 77-136,512. PUB. 3-17-2009. FILED 3-21-2007.
- 3,629,278. **G G G AND DESIGN**. FINANCIAL ONE CORP., MULTIPLE CLASS, (INT. CLS. 35 AND 36), (U.S. CLS. 100, 101 AND 102). SN 77-144,841. PUB. 3-17-2009. FILED 3-30-2007.
- 3,629,282. **COMPOSITE FENCE & DECK ASSOCIATION A DIVISION OF THE AMERICAN FENCE ASSOCIATION**

SERVICE MARKS

CLASS 35—ADVERTISING AND BUSINESS

- 3,629,121 (*See Class 9 for this trademark*).
- 3,629,122 (*See Class 9 for this trademark*).
- 3,629,130. **NGPA NATIONAL PROPANE GAS ASSOCIATION AND DESIGN**. NATIONAL PROPANE GAS ASSOCIATION, (U.S. CLS. 100, 101 AND 102). SN 76-631,035. PUB. 3-17-2009. FILED 2-16-2005.
- 3,629,137. **CIRCLE OF FRIENDS (BLOCK FORM)**. WOMEN'S HEALTH AMERICA, INC., MULTIPLE CLASS, (INT. CLS. 35 AND 42), (U.S. CLS. 100, 101 AND 102). SN 76-672,468. PUB. 3-17-2009. FILED 2-8-2007.
- 3,629,143. **THE ULTIMATE GUIDE TO EROS ESCORTS (BLOCK FORM)**. GROUP KAITU, LLC, (U.S. CLS. 100, 101 AND 102). SN 76-683,742. PUB. 3-17-2009. FILED 11-7-2007.
- 3,629,145. **SUSTAINABLE TEXAS (BLOCK FORM)**. MOMENTUM BAY LLC, (U.S. CLS. 100, 101 AND 102). SN 76-684,705. PUB. 3-17-2009. FILED 12-7-2007.
- 3,629,151. **504 CHEF.COM BY KELLEY & ABIDE AND DESIGN**. KELLEY AND ABIDE COMPANY, INC., (U.S. CLS. 100, 101 AND 102). SN 76-687,410. PUB. 3-17-2009. FILED 3-6-2008.
- 3,629,152. **ANDIAMO! SYSTEMS AND DESIGN**. ANDIAMO SYSTEMS, INC., (U.S. CLS. 100, 101 AND 102). SN 76-687,486. PUB. 3-17-2009. FILED 3-7-2008.
- 3,629,158. **GWA (BLOCK FORM)**. GARDEN WRITERS ASSOCIATION, (U.S. CLS. 100, 101 AND 102). SN 76-688,448. PUB. 3-17-2009. FILED 4-7-2008.
- 3,629,159. **GWA AND DESIGN**. GARDEN WRITERS ASSOCIATION, (U.S. CLS. 100, 101 AND 102). SN 76-688,457. PUB. 3-17-2009. FILED 4-7-2008.
- 3,629,165. **AARON'S OFFICE FURNITURE AND DESIGN**. AARON INVESTMENT COMPANY, MULTIPLE CLASS, (INT. CLS. 35, 36, 41, 42 AND 43), (U.S. CLS. 100, 101, 102 AND 107). SN 76-688,799. PUB. 3-17-2009. FILED 4-21-2008.
- 3,629,172. **FUTURE VISIONARIES (BLOCK FORM)**. ANDERSON, KENT G., (U.S. CLS. 100, 101 AND 102). SN 76-689,451.

- AND DESIGN.** AMERICAN FENCE ASSOCIATION, INC., (U.S. CLS. 100, 101 AND 102). SN 77-150,612. PUB. 3-17-2009. FILED 4-6-2007.
- 3,629,283. **LONE STAR RESTAURANT SUPPLY AND DESIGN.** LONE STAR RESTAURANT SUPPLY, (U.S. CLS. 100, 101 AND 102). SN 77-151,129. PUB. 3-17-2009. FILED 4-6-2007.
- 3,629,291 (*See Class 9 for this trademark.*)
- 3,629,299 (*See Class 3 for this trademark.*)
- 3,629,300. **GO DIGITAL (BLOCK FORM).** DAKTRONICS, INC., (U.S. CLS. 100, 101 AND 102). SN 77-190,325. PUB. 3-17-2009. FILED 5-25-2007.
- 3,629,302 (*See Class 16 for this trademark.*)
- 3,629,305 (*See Class 6 for this trademark.*)
- 3,629,308. **SECOND SATURDAY (BLOCK FORM).** TOO SOFT, LLC, (U.S. CLS. 100, 101 AND 102). SN 77-199,060. PUB. 3-17-2009. FILED 6-6-2007.
- 3,629,312. **CARS4CLASSMATES.COM (BLOCK FORM).** CARS4CLASSMATES, (U.S. CLS. 100, 101 AND 102). SN 77-202,950. PUB. 12-9-2008. FILED 6-11-2007.
- 3,629,316. **OVERSEE.NET (BLOCK FORM).** OVERSEE.NET, MULTIPLE CLASS, (INT. CLS. 35 AND 42), (U.S. CLS. 100, 101 AND 102). SN 77-206,695. PUB. 3-17-2009. FILED 6-14-2007.
- 3,629,321 (*See Class 6 for this trademark.*)
- 3,629,330. **PRESERVING MAINSTREET AMERICA (BLOCK FORM).** USADVISORS INSURANCE AGENCY, LLC, MULTIPLE CLASS, (INT. CLS. 35 AND 36), (U.S. CLS. 100, 101 AND 102). SN 77-241,112. PUB. 3-17-2009. FILED 7-27-2007.
- 3,629,334 (*See Class 3 for this trademark.*)
- 3,629,335 (*See Class 3 for this trademark.*)
- 3,629,340. **WINECREATOR (STYLIZED).** THALASSA TALLER DE VINO, S.L., MULTIPLE CLASS, (INT. CLS. 35 AND 41), (U.S. CLS. 100, 101, 102 AND 107). SN 77-248,805. PUB. 3-17-2009. FILED 8-7-2007.
- 3,629,342. **GONTOR (STYLIZED).** ALLIED FORWARDING CORP., (U.S. CLS. 100, 101 AND 102). SN 77-250,706. PUB. 3-17-2009. FILED 8-8-2007.
- 3,629,352. **CMMS (BLOCK FORM).** HON HAI PRECISION INDUSTRY CO., LTD., MULTIPLE CLASS, (INT. CLS. 35, 40 AND 42), (U.S. CLS. 100, 101, 102, 103 AND 106). SN 77-264,861. PUB. 3-17-2009. FILED 8-27-2007.
- 3,629,354. **LIFEGUARD (BLOCK FORM).** LIFEGUARD AIR AMBULANCE, INC, MULTIPLE CLASS, (INT. CLS. 35 AND 37), (U.S. CLS. 100, 101, 102, 103 AND 106). SN 77-267,852. PUB. 3-17-2009. FILED 8-30-2007.
- 3,629,373 (*See Class 16 for this trademark.*)
- 3,629,374 (*See Class 9 for this trademark.*)
- 3,629,377. **US-YELLOW.COM (BLOCK FORM).** GLOBAL DIRECTORIES, INC., (U.S. CLS. 100, 101 AND 102). SN 77-288,491. PUB. 3-17-2009. FILED 9-25-2007.
- 3,629,379 (*See Class 1 for this trademark.*)
- 3,629,383. **LIFE RUNS ON ENERGY (BLOCK FORM).** TECO ENERGY, INC., MULTIPLE CLASS, (INT. CLS. 35 AND 39), (U.S. CLS. 100, 101, 102 AND 105). SN 77-294,626. PUB. 3-17-2009. FILED 10-2-2007.
- 3,629,384. **YOUR EXCLUSIVE ACCESS AND DESIGN.** LIVE-360, LLC, MULTIPLE CLASS, (INT. CLS. 35 AND 41), (U.S. CLS. 100, 101, 102 AND 107). SN 77-295,188. PUB. 3-17-2009. FILED 10-3-2007.
- 3,629,397. **GBO AND DESIGN.** GBO INC., MULTIPLE CLASS, (INT. CLS. 35, 39 AND 40), (U.S. CLS. 100, 101, 102, 103, 105 AND 106). SN 77-304,854. PUB. 3-17-2009. FILED 10-16-2007.
- 3,629,411. **MISCELLANEOUS DESIGN.** GRAND TARGHEE RESORT, LLC, MULTIPLE CLASS, (INT. CLS. 35, 36, 37, 41, 43 AND 44), (U.S. CLS. 100, 101, 102, 103, 106 AND 107). SN 77-314,530. PUB. 3-17-2009. FILED 10-26-2007.
- 3,629,413 (*See Class 9 for this trademark.*)
- 3,629,427. **MOVIE CLIQUE (BLOCK FORM).** BLOCKBUSTER INC., MULTIPLE CLASS, (INT. CLS. 35, 38 AND 41), (U.S. CLS. 100, 101, 102, 104 AND 107). SN 77-323,767. PUB. 3-17-2009. FILED 11-7-2007.
- 3,629,430. **THE MBA EXCHANGE (BLOCK FORM).** MBA EXCHANGE, LTD., MULTIPLE CLASS, (INT. CLS. 35 AND 41), (U.S. CLS. 100, 101, 102 AND 107). SN 77-327,923. PUB. 3-17-2009. FILED 11-13-2007.
- 3,629,451 (*See Class 14 for this trademark.*)
- 3,629,456. **V (STYLIZED).** VOLOMEDIA, INC., MULTIPLE CLASS, (INT. CLS. 35 AND 42), (U.S. CLS. 100, 101 AND 102). SN 77-348,585. PUB. 3-17-2009. FILED 12-11-2007.
- 3,629,459. **UPROAR AND DESIGN.** UPROAR, INC., MULTIPLE CLASS, (INT. CLS. 35 AND 42), (U.S. CLS. 100, 101 AND 102). SN 77-351,310. PUB. 3-17-2009. FILED 12-13-2007.
- 3,629,462. **CENTER FOR ENERGY WORKFORCE DEVELOPMENT AND DESIGN.** EDISON ELECTRIC INSTITUTE, (U.S. CLS. 100, 101 AND 102). SN 77-353,482. PUB. 3-17-2009. FILED 12-17-2007.
- 3,629,467. **DMN3 AND DESIGN.** THE SUNBELT SOWER COMPANIES, INC, DBA DMN3, (U.S. CLS. 100, 101 AND 102). SN 77-355,919. PUB. 3-17-2009. FILED 12-19-2007.
- 3,629,479 (*See Class 1 for this trademark.*)
- 3,629,483. **VOLOMEDIA (BLOCK FORM).** VOLOMEDIA, INC., MULTIPLE CLASS, (INT. CLS. 35 AND 42), (U.S. CLS. 100, 101 AND 102). SN 77-365,850. PUB. 3-17-2009. FILED 1-7-2008.
- 3,629,486. **INFORMATION TECHNOLOGY RESOURCE OPTIMIZATION (BLOCK FORM).** MARYVILLE DATA SYSTEMS, INC., DBA MARYVILLE TECHNOLOGIES, (U.S. CLS. 100, 101 AND 102). SN 77-367,722. PUB. 3-17-2009. FILED 1-9-2008.
- 3,629,487. **IT RESOURCE OPTIMIZATION (BLOCK FORM).** MARYVILLE DATA SYSTEMS, INC., DBA MARYVILLE TECHNOLOGIES, (U.S. CLS. 100, 101 AND 102). SN 77-367,744. PUB. 3-17-2009. FILED 1-9-2008.
- 3,629,492 (*See Class 9 for this trademark.*)
- 3,629,495. **REWARDPOST.COM AND DESIGN.** GLOBAL REWARDS ENTERPRISES, INC., DBA REWARDPOST-COM, (U.S. CLS. 100, 101 AND 102). SN 77-372,043. PUB. 3-17-2009. FILED 1-15-2008.
- 3,629,500. **STREETSELECT (BLOCK FORM).** WEST VIRGINIA EMPLOYER'S MUTUAL INSURANCE COMPANY, (U.S. CLS. 100, 101 AND 102). SN 77-374,470. PUB. 3-17-2009. FILED 1-17-2008.
- 3,629,502. **STREETSELECT BY BRICKSTREET AND DESIGN.** WEST VIRGINIA EMPLOYERS' MUTUAL INSURANCE COMPANY, (U.S. CLS. 100, 101 AND 102). SN 77-374,591. PUB. 3-17-2009. FILED 1-17-2008.
- 3,629,506. **THE NORTH CENTRAL GROUP (BLOCK FORM).** NORTH CENTRAL MANAGEMENT, INC., MULTIPLE CLASS, (INT. CLS. 35 AND 37), (U.S. CLS. 100, 101, 102, 103 AND 106). SN 77-378,258. PUB. 3-17-2009. FILED 1-23-2008.
- 3,629,520. **IRANIAN AMERICAN SOCIETY INC. AND DESIGN.** IRANIAN AMERICAN SOCIETY, (U.S. CLS. 100, 101 AND 102). SN 77-384,671. PUB. 3-17-2009. FILED 1-30-2008.
- 3,629,528. **MERLIN (BLOCK FORM).** THE AVALON CONSULTING GROUP, INC., (U.S. CLS. 100, 101 AND 102). SN 77-389,568. PUB. 3-17-2009. FILED 2-5-2008.
- 3,629,530. **FLEETPARTS US UNI-SELECT USA AND DESIGN.** UNI-SELECT INC., (U.S. CLS. 100, 101 AND 102). SN 77-390,986. PUB. 3-17-2009. FILED 2-7-2008.
- 3,629,537. **HILLSBORO (BLOCK FORM).** UNITED STATES STEEL CORPORATION, MULTIPLE CLASS, (INT. CLS. 35, 36, 37 AND 41), (U.S. CLS. 100, 101, 102, 103, 106 AND 107). SN 77-396,033. PUB. 3-17-2009. FILED 2-13-2008.
- 3,629,539. **MISCELLANEOUS DESIGN.** UNITED STATES STEEL CORPORATION, MULTIPLE CLASS, (INT. CLS. 35, 36, 37 AND 41), (U.S. CLS. 100, 101, 102, 103, 106 AND 107). SN 77-396,076. PUB. 3-17-2009. FILED 2-13-2008.
- 3,629,542. **G2 DIRECT & DIGITAL (BLOCK FORM).** GREY GLOBAL GROUP INC., MULTIPLE CLASS, (INT. CLS. 35 AND 42), (U.S. CLS. 100, 101 AND 102). SN 77-396,825. PUB. 3-17-2009. FILED 2-14-2008.
- 3,629,543. **G2 PROMOTIONAL MARKETING (BLOCK FORM).** GREY GLOBAL GROUP INC., (U.S. CLS. 100, 101 AND 102). SN 77-396,835. PUB. 3-17-2009. FILED 2-14-2008.
- 3,629,545. **J.A.M. PR (BLOCK FORM).** ARMOUR, MICHELLE, DBA J.A.M. PR, (U.S. CLS. 100, 101 AND 102). SN 77-397,711. PUB. 2-10-2009. FILED 2-14-2008.
- 3,629,552. **LAWPARTNER (BLOCK FORM).** LAWPARTNER, LLC, DBA KOSCHAK LEGAL SEARCH, LLC, (U.S. CLS. 100, 101 AND 102). SN 77-400,701. PUB. 3-17-2009. FILED 2-19-2008.
- 3,629,566. **DON'T PAY MORE AND DESIGN.** OFF LEASE ONLY, INC., DBA E&M MOTORS, (U.S. CLS. 100, 101 AND

- 102). SN 77-407,628. PUB. 3-17-2009. FILED 2-27-2008.
- 3,629,569. **A GOVERNMENTPRINTMANAGEMENT - THE PRINT INDUSTRY EXPERTS AND DESIGN**. E-LYNXX CORPORATION, (U.S. CLS. 100, 101 AND 102). SN 77-408,927. PUB. 3-17-2009. FILED 2-28-2008.
- 3,629,578. **INHABIT (BLOCK FORM)**. INHABIT, LLC, (U.S. CLS. 100, 101 AND 102). SN 77-414,306. PUB. 3-17-2009. FILED 3-5-2008.
- 3,629,582. **LOVE BUCKS (BLOCK FORM)**. LOVER'S LANE I.P. LTD., (U.S. CLS. 100, 101 AND 102). SN 77-417,029. PUB. 3-17-2009. FILED 3-9-2008.
- 3,629,584. **BBS PRONET (BLOCK FORM)**. BEST BUSINESS SYSTEMS, INC., DBA BBS PRONET, MULTIPLE CLASS, (INT. CLS. 35 AND 40), (U.S. CLS. 100, 101, 102, 103 AND 106). SN 77-417,735. PUB. 3-17-2009. FILED 3-10-2008.
- 3,629,586. **RANCH HOUSE DESIGNS, INC. (BLOCK FORM)**. WILLIAMS, RACHEL ANN, MULTIPLE CLASS, (INT. CLS. 35 AND 42), (U.S. CLS. 100, 101 AND 102). SN 77-418,383. PUB. 3-17-2009. FILED 3-11-2008.
- 3,629,604. **SIMPLE GREEN (BLOCK FORM)**. SUNSHINE MAKERS, INC., (U.S. CLS. 100, 101 AND 102). SN 77-423,731. PUB. 3-17-2009. FILED 3-17-2008.
- 3,629,620. **O'REILLY RACING (BLOCK FORM)**. O'REILLY AUTOMOTIVE, INC., (U.S. CLS. 100, 101 AND 102). SN 77-432,110. PUB. 3-17-2009. FILED 3-26-2008.
- 3,629,622. **THAT'S A FACT! (BLOCK FORM)**. ESSERMAN NISSAN, LTD., (U.S. CLS. 100, 101 AND 102). SN 77-432,969. PUB. 3-17-2009. FILED 3-27-2008.
- 3,629,634. **FISHINGFEST (BLOCK FORM)**. KEVIN, INC., (U.S. CLS. 100, 101 AND 102). SN 77-434,053. PUB. 3-17-2009. FILED 3-28-2008.
- 3,629,635. **JUNEFEST (BLOCK FORM)**. KEVIN, INC., (U.S. CLS. 100, 101 AND 102). SN 77-434,061. PUB. 3-17-2009. FILED 3-28-2008.
- 3,629,644. **MASS MARKET NO. 6104 COPYRIGHTED (STYLIZED)**. PSYOP, INC., MULTIPLE CLASS, (INT. CLS. 35 AND 41), (U.S. CLS. 100, 101, 102 AND 107). SN 77-435,754. PUB. 3-17-2009. FILED 3-31-2008.
- 3,629,645. **NORTH AMERICAN RESCUE PRODUCTS (BLOCK FORM)**. NORTH AMERICAN RESCUE PRODUCTS, INC., DBA NORTH AMERICAN RESCUE, (U.S. CLS. 100, 101 AND 102). SN 77-435,916. PUB. 3-17-2009. FILED 3-31-2008.
- 3,629,646. **ON COURT TENNIS AND DESIGN**. ON-COURT TENNIS, (U.S. CLS. 100, 101 AND 102). SN 77-436,189. PUB. 3-17-2009. FILED 3-31-2008.
- 3,629,661. **MAN ON THE STREET (BLOCK FORM)**. MITCHELL, LINDBERG AND TAYLOR, INC., (U.S. CLS. 100, 101 AND 102). SN 77-438,242. PUB. 3-17-2009. FILED 4-2-2008.
- 3,629,662. **SCIENTIFIC IMAGE CENTER MANAGEMENT, INC. AND DESIGN**. SCIENTIFIC IMAGE CENTER MANAGEMENT, L.L.C., (U.S. CLS. 100, 101 AND 102). SN 77-438,492. PUB. 3-17-2009. FILED 4-2-2008.
- 3,629,665. **VINOVIBE (BLOCK FORM)**. DEANGELIS, RICHARD JAMES, (U.S. CLS. 100, 101 AND 102). SN 77-439,074. PUB. 3-17-2009. FILED 4-3-2008.
- 3,629,669. **MINI BAZAAR (BLOCK FORM)**. MINI BAZAAR & CO LLC, (U.S. CLS. 100, 101 AND 102). SN 77-439,764. PUB. 3-17-2009. FILED 4-3-2008.
- 3,629,675. **SCRI AND DESIGN**. SCRIB HOLDINGS, LLC, MULTIPLE CLASS, (INT. CLS. 35 AND 42), (U.S. CLS. 100, 101 AND 102). SN 77-440,466. PUB. 3-17-2009. FILED 4-4-2008.
- 3,629,678. **PERSONAL HEALTH PORTFOLIO (BLOCK FORM)**. W M MEDICAL MANAGEMENT, INC., (U.S. CLS. 100, 101 AND 102). SN 77-440,952. PUB. 3-17-2009. FILED 4-5-2008.
- 3,629,679. **PERSONAL HEALTH PORTFOLIO (STYLIZED)**. W M MEDICAL MANAGEMENT, INC., (U.S. CLS. 100, 101 AND 102). SN 77-440,955. PUB. 3-17-2009. FILED 4-5-2008.
- 3,629,680. **PROFILE COMPLETE (BLOCK FORM)**. JFM CONCEPTS LLC, (U.S. CLS. 100, 101 AND 102). SN 77-440,969. PUB. 3-17-2009. FILED 4-5-2008.
- 3,629,688. **LARRY G SCALE MINIATURES FOR MODELING! AND DESIGN**. GUIDER, LAWRENCE J., (U.S. CLS. 100, 101 AND 102). SN 77-442,222. PUB. 3-17-2009. FILED 4-7-2008.
- 3,629,690. **MIKE'S (BLOCK FORM)**. HEADLANDS VENTURES, LLC, (U.S. CLS. 100, 101 AND 102). SN 77-442,309. PUB. 3-17-2009. FILED 4-8-2008.
- 3,629,702. **KNOWLEDGEBANK (BLOCK FORM)**. KNOWLEDGEBANK, INC., (U.S. CLS. 100, 101 AND 102). SN 77-443,679. PUB. 3-17-2009. FILED 4-9-2008.
- 3,629,703. **KNOWLEDGEBANK (BLOCK FORM)**. KNOWLEDGEBANK, INC., MULTIPLE CLASS, (INT. CLS. 35, 41 AND 45), (U.S. CLS. 100, 101, 102 AND 107). SN 77-443,691. PUB. 3-17-2009. FILED 4-9-2008.
- 3,629,712. **IN CELEBRATION OF THE SPACE YOU CALL HOME (BLOCK FORM)**. CELEBRATE ME HOME, INCORPORATED, (U.S. CLS. 100, 101 AND 102). SN 77-444,476. PUB. 3-17-2009. FILED 4-9-2008.
- 3,629,727. **POTREROMEDIA AND DESIGN**. POTRERO MEDIA CORPORATION, (U.S. CLS. 100, 101 AND 102). SN 77-445,449. PUB. 3-17-2009. FILED 4-10-2008.
- 3,629,730. **BLOODHOUND RESEARCH AND DESIGN**. BLOODHOUND RESEARCH, LLC, AND MOKED, NEELY, AND MOKED, EYTAN, MULTIPLE CLASS, (INT. CLS. 35 AND 45), (U.S. CLS. 100, 101 AND 102). SN 77-445,628. PUB. 3-17-2009. FILED 4-10-2008.
- 3,629,734. **NEAT (BLOCK FORM)**. DAMASCHINO, ELLEN L., MULTIPLE CLASS, (INT. CLS. 35 AND 41), (U.S. CLS. 100, 101, 102 AND 107). SN 77-446,945. PUB. 3-17-2009. FILED 4-13-2008.
- 3,629,735. **SKINANDHAIRBEAUTY.COM AND DESIGN**. COMPLETE BEAUTY SOLUTIONS, INC., (U.S. CLS. 100, 101 AND 102). SN 77-446,951. PUB. 3-17-2009. FILED 4-13-2008.
- 3,629,740. **PARTNERS IN MINISTRY (BLOCK FORM)**. NORTH AMERICAN INSURANCE AGENCY, INC., MULTIPLE CLASS, (INT. CLS. 35 AND 36), (U.S. CLS. 100, 101 AND 102). SN 77-447,266. PUB. 3-17-2009. FILED 4-14-2008.
- 3,629,742. **VETVISION (BLOCK FORM)**. VETVISION, INC., (U.S. CLS. 100, 101 AND 102). SN 77-447,408. PUB. 3-17-2009. FILED 4-14-2008.
- 3,629,744. **REEF CHECK AND DESIGN**. REEF CHECK FOUNDATION, (U.S. CLS. 100, 101 AND 102). SN 77-447,477. PUB. 3-17-2009. FILED 4-14-2008.
- 3,629,745. **EZ! (STYLIZED)**. EZLOCAL.COM, INC., (U.S. CLS. 100, 101 AND 102). SN 77-447,691. PUB. 3-17-2009. FILED 4-14-2008.
- 3,629,754. **SOCIAL MOTIVATION AT WORK (BLOCK FORM)**. VIBE SMG US, LLC, MULTIPLE CLASS, (INT. CLS. 35 AND 42), (U.S. CLS. 100, 101 AND 102). SN 77-448,694. PUB. 3-17-2009. FILED 4-15-2008.
- 3,629,755. **VETVISION AND DESIGN**. VETVISION, INC., (U.S. CLS. 100, 101 AND 102). SN 77-448,916. PUB. 3-17-2009. FILED 4-15-2008.
- 3,629,758. **HOW ARE THE CHILDREN? (BLOCK FORM)**. BOARD OF COUNTY COMMISSIONERS OF MESA COUNTY, COLORADO, MULTIPLE CLASS, (INT. CLS. 35 AND 45), (U.S. CLS. 100, 101 AND 102). SN 77-449,382. PUB. 3-17-2009. FILED 4-16-2008.
- 3,629,771. **MISCELLANEOUS DESIGN**. LIFE PERSPECTIVES, INC., MULTIPLE CLASS, (INT. CLS. 35 AND 36), (U.S. CLS. 100, 101 AND 102). SN 77-450,182. PUB. 3-17-2009. FILED 4-16-2008.
- 3,629,772. **VEGAS.COM (BLOCK FORM)**. VEGAS.COM, LLC, (U.S. CLS. 100, 101 AND 102). SN 77-450,183. PUB. 3-17-2009. FILED 4-16-2008.
- 3,629,778. **WHERE TO START, WHEN YOUR CAR WON'T (BLOCK FORM)**. MYAUTONETWORK, INC., (U.S. CLS. 100, 101 AND 102). SN 77-450,664. PUB. 3-17-2009. FILED 4-17-2008.
- 3,629,779. **T SYSTEMS AND DESIGN**. DEUTSCHE TELEKOM, (U.S. CLS. 100, 101 AND 102). SN 77-450,690. PUB. 3-17-2009. FILED 4-17-2008.
- 3,629,785. **KNOWLEDGE SHARING MADE EASY (BLOCK FORM)**. JAIN ALOK K, AND GOYAL DEEPAK K, (U.S. CLS. 100, 101 AND 102). SN 77-451,324. PUB. 3-17-2009. FILED 4-17-2008.
- 3,629,792. **T HOME AND DESIGN**. DEUTSCHE TELEKOM, (U.S. CLS. 100, 101 AND 102). SN 77-451,399. PUB. 1-13-2009. FILED 4-17-2008.
- 3,629,794. **EVOLUTION ENTERPRISES INC. AND DESIGN**. ILKA T. DE LEON, (U.S. CLS. 100, 101 AND 102). SN 77-451,450. PUB. 3-17-2009. FILED 4-17-2008.

- 3,629,799 (*See Class 18 for this trademark*).
- 3,629,806. **MAPDENTIST (BLOCK FORM)**. SAID, SAED, AND SAID, SEPEHR, (U.S. CLS. 100, 101 AND 102). SN 77-452,471. PUB. 3-17-2009. FILED 4-18-2008.
- 3,629,807. **DAILYPAGES.COM (BLOCK FORM)**. SAID, SAED, AND SAID, SEPEHR, (U.S. CLS. 100, 101 AND 102). SN 77-452,490. PUB. 3-17-2009. FILED 4-18-2008.
- 3,629,812. **AREAA ASIAN REAL ESTATE ASSOCIATION OF AMERICA AND DESIGN**. ASIAN REAL ESTATE ASSOCIATION OF AMERICA, (U.S. CLS. 100, 101 AND 102). SN 77-453,020. PUB. 3-17-2009. FILED 4-20-2008.
- 3,629,813. **GPMS GLOBAL PROJECT MANAGEMENT SYSTEMS (BLOCK FORM)**. AKYEAMPONG, KWAKU APIAH NUAMAH, (U.S. CLS. 100, 101 AND 102). SN 77-453,119. PUB. 3-17-2009. FILED 4-21-2008.
- 3,629,840. **THE FUTURE OF THE INDEPENDENT FLOORING RETAILER (BLOCK FORM)**. FCA NETWORK, INC., (U.S. CLS. 100, 101 AND 102). SN 77-455,807. PUB. 3-17-2009. FILED 4-23-2008.
- 3,629,846. **WELLCARE SIGNATURE (BLOCK FORM)**. THE WELLCARE MANAGEMENT GROUP, INC., (U.S. CLS. 100, 101 AND 102). SN 77-456,615. PUB. 3-17-2009. FILED 4-24-2008.
- 3,629,851. **BRAND NEW (BLOCK FORM)**. BRAND NEW MARKETING & DESIGN INC, (U.S. CLS. 100, 101 AND 102). SN 77-456,948. PUB. 3-17-2009. FILED 4-24-2008.
- 3,629,852. **BN AND DESIGN**. BRAND NEW MARKETING & DESIGN INC, (U.S. CLS. 100, 101 AND 102). SN 77-456,952. PUB. 3-17-2009. FILED 4-24-2008.
- 3,629,853. **SOUTHWEST STRATEGIES AND DESIGN**. SOUTHWEST STRATEGIES LLC., (U.S. CLS. 100, 101 AND 102). SN 77-457,180. PUB. 3-17-2009. FILED 4-24-2008.
- 3,629,860. **WINE ISLANDS (BLOCK FORM)**. WINE ISLANDS VINTNERS ASSOCIATION, (U.S. CLS. 100, 101 AND 102). SN 77-458,660. PUB. 3-17-2009. FILED 4-25-2008.
- 3,629,867. **POLLUTION PATROL (BLOCK FORM)**. AUNTIE LITTER, INC., (U.S. CLS. 100, 101 AND 102). SN 77-460,262. PUB. 3-17-2009. FILED 4-29-2008.
- 3,629,878. **COMMUNICATIONS PLUS (BLOCK FORM)**. PAUMIER, KATHRYN, (U.S. CLS. 100, 101 AND 102). SN 77-461,641. PUB. 3-17-2009. FILED 4-30-2008.
- 3,629,883. **ALLOY ACCESS (BLOCK FORM)**. ALLOY MARKETING & PROMOTIONS, LLC, (U.S. CLS. 100, 101 AND 102). SN 77-462,626. PUB. 3-17-2009. FILED 5-1-2008.
- 3,629,890. **WE DELIVER SUCCESS. (BLOCK FORM)**. BLUE MOUNTAIN EQUIPMENT RENTAL CORPORATION, MULTIPLE CLASS, (INT. CLS. 35 AND 37), (U.S. CLS. 100, 101, 102, 103 AND 106). SN 77-463,992. PUB. 3-17-2009. FILED 5-2-2008.
- 3,629,893. **ROSA CLARÁ (BLOCK FORM)**. CLARA PALARES, ROSA MARIA, (U.S. CLS. 100, 101 AND 102). SN 77-464,646. PUB. 3-17-2009. FILED 5-2-2008.
- 3,629,903. **IMPRE (BLOCK FORM)**. IMPREMEDIA OPERATING COMPANY, LLC, MULTIPLE CLASS, (INT. CLS. 35 AND 41), (U.S. CLS. 100, 101, 102 AND 107). SN 77-467,228. PUB. 3-17-2009. FILED 5-6-2008.
- 3,629,904. **NSA NORTH SHORE AGENCY, INC. AN NCO COMPANY AND DESIGN**. NCO HOLDINGS, INC., MULTIPLE CLASS, (INT. CLS. 35 AND 36), (U.S. CLS. 100, 101 AND 102). SN 77-467,646. PUB. 3-17-2009. FILED 5-7-2008.
- 3,629,906. **WM AND DESIGN**. WESTWAY MACHINERY LTD., (U.S. CLS. 100, 101 AND 102). SN 77-468,192. PUB. 12-2-2008. FILED 5-7-2008.
- 3,629,919. **INNUA (BLOCK FORM)**. INTERNATIONAL NORTHERN NETWORK USERS ASSOCIATION, MULTIPLE CLASS, (INT. CLS. 35 AND 41), (U.S. CLS. 100, 101, 102 AND 107). SN 77-471,628. PUB. 3-17-2009. FILED 5-12-2008.
- 3,629,927. **ILMA INSTITUTIONAL LIFE MARKETS ASSOCIATION (BLOCK FORM)**. THE INSTITUTIONAL LIFE MARKETS ASSOCIATION, INC., (U.S. CLS. 100, 101 AND 102). SN 77-473,412. PUB. 3-17-2009. FILED 5-13-2008.
- 3,629,931. **KIGHT'S MEDICAL DME (BLOCK FORM)**. KIGHT'S GROUP, LLC, MULTIPLE CLASS, (INT. CLS. 35 AND 44), (U.S. CLS. 100, 101 AND 102). SN 77-474,835. PUB. 3-17-2009. FILED S.R. 5-15-2008; AM. P.R. 9-30-2008.
- 3,629,934. **AXACT (STYLIZED)**. AXACT FZ-LLC, MULTIPLE CLASS, (INT. CLS. 35 AND 42), (U.S. CLS. 100, 101 AND 102). SN 77-475,462. PUB. 3-17-2009. FILED 5-15-2008.
- 3,629,936. **M CHANNEL (BLOCK FORM)**. FAMOUS FRAMES MI, LLC, (U.S. CLS. 100, 101 AND 102). SN 77-475,862. PUB. 10-14-2008. FILED 5-15-2008.
- 3,629,940. **N I P S AND DESIGN**. NEURAL INFORMATION PROCESSING SYSTEMS FOUNDATION, INC., MULTIPLE CLASS, (INT. CLS. 35 AND 41), (U.S. CLS. 100, 101, 102 AND 107). SN 77-477,258. PUB. 3-17-2009. FILED 5-16-2008.
- 3,629,948 (*See Class 9 for this trademark*).
- 3,629,951. **JOE DREGS (BLOCK FORM)**. FORGY, TERRY L., DBA JOE DREGS, (U.S. CLS. 100, 101 AND 102). SN 77-478,996. PUB. 3-17-2009. FILED 5-20-2008.
- 3,629,960. **LIFE WITHOUT BOUNDARIES (BLOCK FORM)**. AMERICAN COMMUNICATIONS NETWORK, INC., MULTIPLE CLASS, (INT. CLS. 35 AND 38), (U.S. CLS. 100, 101, 102 AND 104). SN 77-481,001. PUB. 3-17-2009. FILED 5-22-2008.
- 3,629,975. **EMPLOYMENT ENTERPRISES INC POWERED BY PEOPLE . DRIVEN BY SOLUTIONS AND DESIGN**. EMPLOYMENT ENTERPRISES, INC., (U.S. CLS. 100, 101 AND 102). SN 77-488,275. PUB. 3-17-2009. FILED 6-2-2008.
- 3,629,976. **ENTREX PCI PRIVATE COMPANY INDEX AND DESIGN**. UBIQUE HOLDINGS LP, (U.S. CLS. 100, 101 AND 102). SN 77-488,550. PUB. 3-17-2009. FILED 6-2-2008.
- 3,629,980. **LIVEBOLT (BLOCK FORM)**. LIVEBOLT IDENTITY, LLC, MULTIPLE CLASS, (INT. CLS. 35 AND 45), (U.S. CLS. 100, 101 AND 102). SN 77-488,845. PUB. 3-17-2009. FILED 6-2-2008.
- 3,629,988. **ALL STATES AG PARTS PARTS A.S.A.P. AND DESIGN**. ALL STATES AG PARTS, INC., (U.S. CLS. 100, 101 AND 102). SN 77-490,334. PUB. 3-17-2009. FILED 6-4-2008.
- 3,630,006. **NSPS AND DESIGN**. NATIONAL SOCIETY OF PROFESSIONAL SURVEYORS INC, (U.S. CLS. 100, 101 AND 102). SN 77-495,321. PUB. 3-17-2009. FILED 6-10-2008.
- 3,630,007. **MEDINGENUITY (BLOCK FORM)**. MEDINGENUITY, LLC, (U.S. CLS. 100, 101 AND 102). SN 77-495,346. PUB. 3-17-2009. FILED 6-10-2008.
- 3,630,028 (*See Class 14 for this trademark*).
- 3,630,030. **SUDDEN DEALS (BLOCK FORM)**. SUDDEN DEALS, LLC, (U.S. CLS. 100, 101 AND 102). SN 77-498,535. PUB. 3-17-2009. FILED 6-13-2008.
- 3,630,036. **REAL PEOPLE. REAL GRASSROOTS. (BLOCK FORM)**. SOAPBOX LLC, DBA SOAPBOX CONSULTING LLC, MULTIPLE CLASS, (INT. CLS. 35 AND 41), (U.S. CLS. 100, 101, 102 AND 107). SN 77-500,915. PUB. 3-17-2009. FILED 6-17-2008.
- 3,630,039. **YOUR TRUSTED AUTOMOTIVE RESOURCE (BLOCK FORM)**. MYAUTONETWORK, INC., (U.S. CLS. 100, 101 AND 102). SN 77-501,639. PUB. 3-17-2009. FILED 6-18-2008.
- 3,630,040. **POWERED BY PEOPLE DRIVEN BY SOLUTIONS (BLOCK FORM)**. EMPLOYMENT ENTERPRISES, INC., (U.S. CLS. 100, 101 AND 102). SN 77-502,520. PUB. 3-17-2009. FILED 6-19-2008.
- 3,630,052. **PALM WINDOW FASHIONS (BLOCK FORM)**. PALM WINDOW FASHIONS, LLC, (U.S. CLS. 100, 101 AND 102). SN 77-506,615. PUB. 3-17-2009. FILED 6-24-2008.
- 3,630,053. **BECKETT CHANNEL INTERGRATION AND DESIGN**. BECKETT MEDIA LP, MULTIPLE CLASS, (INT. CLS. 35, 38 AND 42), (U.S. CLS. 100, 101, 102 AND 104). SN 77-506,834. PUB. 3-17-2009. FILED 6-24-2008.
- 3,630,071. **HAMLYN (BLOCK FORM)**. HAMLYN SENIOR MARKETING, (U.S. CLS. 100, 101 AND 102). SN 77-513,596. PUB. 3-17-2009. FILED 7-2-2008.
- 3,630,099. **GROKVILLE (BLOCK FORM)**. WOVEN SOFTWARE CORPORATION, (U.S. CLS. 100, 101 AND 102). SN 77-519,752. PUB. 3-17-2009. FILED 7-11-2008.
- 3,630,105 (*See Class 9 for this trademark*).
- 3,630,118. **COX COMMUNICATIONS TWEEN INTERNET SAFETY SURVEY (BLOCK FORM)**. COX COMMUNICATIONS, INC., (U.S. CLS. 100, 101 AND 102). SN 77-525,163. PUB. 3-17-2009. FILED 7-17-2008.
- 3,630,122. **SCAN FOUNDATION (BLOCK FORM)**. SCAN FOUNDATION, INC., (U.S. CLS. 100, 101 AND 102). SN 77-525,946. PUB. 12-9-2008. FILED 7-18-2008.
- 3,630,123. **THE M N SOCIAL AND DESIGN**. THE MINI SOCIAL, (U.S. CLS. 100, 101 AND 102). SN 77-526,041. PUB. 3-17-2009. FILED 7-18-2008.

- 3,630,130. **DELICIOUS DEALS (BLOCK FORM)**. SIMEK'S, (U.S. CLS. 100, 101 AND 102). SN 77-527,076. PUB. 3-17-2009. FILED 7-21-2008.
- 3,630,133. **THE POWDER GROUP (BLOCK FORM)**. THE POWDER GROUP, LLC, (U.S. CLS. 100, 101 AND 102). SN 77-527,930. PUB. 3-17-2009. FILED 7-22-2008.
- 3,630,142. **UNCOMPROMISING STANDARDS UNCONVENTIONAL THINKING UNLIMITED SUCCESS (BLOCK FORM)**. BERDON LLP, MULTIPLE CLASS, (INT. CLS. 35, 36 AND 45), (U.S. CLS. 100, 101 AND 102). SN 77-531,299. PUB. 3-17-2009. FILED 7-25-2008.
- 3,630,148. **CAPGROW (BLOCK FORM)**. CAPITAL GROWTH ADVISORS, LLC, (U.S. CLS. 100, 101 AND 102). SN 77-532,647. PUB. 3-17-2009. FILED 7-28-2008.
- 3,630,154. **HECHO EN MEXICO AND DESIGN**. URIBE, PABLO, (U.S. CLS. 100, 101 AND 102). SN 77-533,666. PUB. 3-17-2009. FILED 7-29-2008.
- 3,630,168. **BLACKNIGHT SOLUTIONS (BLOCK FORM)**. BLACKNIGHT INTERNET SOLUTIONS LTD., MULTIPLE CLASS, (INT. CLS. 35, 42 AND 45), (U.S. CLS. 100, 101 AND 102). SN 77-537,348. PUB. 3-17-2009. FILED 8-1-2008.
- 3,630,171. **MAGIC DISPLAY (BLOCK FORM)**. S & J ASSOCIATES, INC., DBA STEIN LITE TECHNOLOGIES, INC. AND MAGIC DISPLAY, (U.S. CLS. 100, 101 AND 102). SN 77-539,426. PUB. 3-17-2009. FILED 8-5-2008.
- 3,630,178 (*See Class 9 for this trademark*).
- 3,630,191. **PHYSICIANS HEALTH PROGRAM (BLOCK FORM)**. UNITED SUPER ACCOUNT PROGRAM, INC., DBA PHYSICIANS HEALTH PROGRAM, (U.S. CLS. 100, 101 AND 102). SN 77-545,776. PUB. 3-17-2009. FILED 8-13-2008.
- 3,630,195. **B AND DESIGN**. SEIDNER ENTERPRISES, LLC, DBA BERT'S MEGA MALL, (U.S. CLS. 100, 101 AND 102). SN 77-546,416. PUB. 3-17-2009. FILED 8-13-2008.
- 3,630,196. **BERT'S MEGA MALL (BLOCK FORM)**. SEIDNER ENTERPRISES, LLC, DBA BERT'S MEGA MALL, (U.S. CLS. 100, 101 AND 102). SN 77-546,442. PUB. 3-17-2009. FILED 8-13-2008.
- 3,630,198. **MISBO AND DESIGN**. MID-SOUTH INDEPENDENT SCHOOL BUSINESS OFFICERS, INC., (U.S. CLS. 100, 101 AND 102). SN 77-546,753. PUB. 3-17-2009. FILED 8-14-2008.
- 3,630,203. **VIVERAE (BLOCK FORM)**. VIVERAE, MULTIPLE CLASS, (INT. CLS. 35 AND 44), (U.S. CLS. 100, 101 AND 102). SN 77-547,438. PUB. 3-17-2009. FILED 8-14-2008.
- 3,630,204. **K KMART SUPERCENTER (STYLIZED)**. SEARS BRANDS, LLC, (U.S. CLS. 100, 101 AND 102). SN 77-547,439. PUB. 3-17-2009. FILED 8-14-2008.
- 3,630,206. **VISUAL INCITE (BLOCK FORM)**. US VISUAL INCITE, LLC, DBA VISUAL INCITE, (U.S. CLS. 100, 101 AND 102). SN 77-547,857. PUB. 3-17-2009. FILED 8-15-2008.
- 3,630,207. **THE POWER OF WHAT'S POSSIBLE (BLOCK FORM)**. PROGRESSUS THERAPY, LLC, (U.S. CLS. 100, 101 AND 102). SN 77-548,232. PUB. 3-17-2009. FILED 8-15-2008.
- 3,630,208. **MISCELLANEOUS DESIGN**. PROGRESSUS THERAPY, LLC, (U.S. CLS. 100, 101 AND 102). SN 77-548,330. PUB. 3-17-2009. FILED 8-15-2008.
- 3,630,211. **MSDP AND DESIGN**. MENTAL HEALTH AND SUBSTANCE ABUSE CORPORATIONS OF MASSACHUSETTS, INC., (U.S. CLS. 100, 101 AND 102). SN 77-549,101. PUB. 3-17-2009. FILED 8-18-2008.
- 3,630,218. **THE BEEHIVE (BLOCK FORM)**. ONE ECONOMY CORPORATION, (U.S. CLS. 100, 101 AND 102). SN 77-551,516. PUB. 3-17-2009. FILED 8-20-2008.
- 3,630,220. **SELL IT. BUY IT. LOVE IT. (BLOCK FORM)**. SECONDHAND CONCEPTS, INC., (U.S. CLS. 100, 101 AND 102). SN 77-551,843. PUB. 3-17-2009. FILED 8-20-2008.
- 3,630,223. **K KIMBERLEY'S A DAY SPA, LTD. AND DESIGN**. KIMBERLEY'S A DAY SPA LTD., MULTIPLE CLASS, (INT. CLS. 35 AND 44), (U.S. CLS. 100, 101 AND 102). SN 77-552,406. PUB. 3-17-2009. FILED 8-21-2008.
- 3,630,226. **IAS360 (BLOCK FORM)**. INTEGRATED ASSET SERVICES, LLC, (U.S. CLS. 100, 101 AND 102). SN 77-553,209. PUB. 3-17-2009. FILED 8-22-2008.
- 3,630,236. **AD SHOPPE AND DESIGN**. DAVE GALLIGOS, DBA THE AD SHOPPE, (U.S. CLS. 100, 101 AND 102). SN 77-555,483. PUB. 3-17-2009. FILED 8-26-2008.
- 3,630,237. **FINDYOURCARE.COM (BLOCK FORM)**. DAD SERVICES, INC., DBA IN CALIFORNIA AS FINDYOURCARE.COM, (U.S. CLS. 100, 101 AND 102). SN 77-555,728. PUB. 3-17-2009. FILED 8-26-2008.
- 3,630,239. **SUCCESS STRATEGIES AND DESIGN**. SUCCESS STRATEGIES, INC., MULTIPLE CLASS, (INT. CLS. 35 AND 36), (U.S. CLS. 100, 101 AND 102). SN 77-555,926. PUB. 3-17-2009. FILED 8-26-2008.
- 3,630,240. **SUCCESS STRATEGIES ADVANTAGE (BLOCK FORM)**. SUCCESS STRATEGIES, INC., MULTIPLE CLASS, (INT. CLS. 35 AND 36), (U.S. CLS. 100, 101 AND 102). SN 77-555,947. PUB. 3-17-2009. FILED 8-26-2008.
- 3,630,242. **CAMPAIGN FOR TOBACCO-FREE KIDS (BLOCK FORM)**. CAMPAIGN FOR TOBACCO-FREE KIDS, MULTIPLE CLASS, (INT. CLS. 35 AND 41), (U.S. CLS. 100, 101, 102 AND 107). SN 77-556,159. PUB. 3-17-2009. FILED 8-26-2008.
- 3,630,243. **CAMPAIGN FOR TOBACCO-FREE KIDS AND DESIGN**. CAMPAIGN FOR TOBACCO-FREE KIDS, MULTIPLE CLASS, (INT. CLS. 35 AND 41), (U.S. CLS. 100, 101, 102 AND 107). SN 77-556,160. PUB. 3-17-2009. FILED 8-26-2008.
- 3,630,244. **CAMPAIGN FOR TOBACCO-FREE KIDS AND DESIGN**. CAMPAIGN FOR TOBACCO-FREE KIDS, MULTIPLE CLASS, (INT. CLS. 35 AND 41), (U.S. CLS. 100, 101, 102 AND 107). SN 77-556,171. PUB. 3-17-2009. FILED 8-26-2008.
- 3,630,250 (*See Class 6 for this trademark*).
- 3,630,254. **MARKETEERS CLUB (BLOCK FORM)**. FENG, JENNY C., DBA MARKETEERS CLUB, (U.S. CLS. 100, 101 AND 102). SN 77-557,527. PUB. 3-17-2009. FILED 8-28-2008.
- 3,630,267. **AMRITHIKA (BLOCK FORM)**. AMRITHIKA, (U.S. CLS. 100, 101 AND 102). SN 77-559,689. PUB. 3-17-2009. FILED 9-1-2008.
- 3,630,275. **HIMALAYAS SALT LAMPS & MORE AND DESIGN**. HS ROCKS LLC, (U.S. CLS. 100, 101 AND 102). SN 77-560,747. PUB. 3-17-2009. FILED 9-2-2008.
- 3,630,278. **MISCELLANEOUS DESIGN**. CHEMNAVIGATOR, INC., MULTIPLE CLASS, (INT. CLS. 35 AND 42), (U.S. CLS. 100, 101 AND 102). SN 77-561,125. PUB. 3-17-2009. FILED 9-3-2008.
- 3,630,285. **BLACKDOG ADVERTISING AND DESIGN**. THE PENNEY GROUP, INC., MULTIPLE CLASS, (INT. CLS. 35 AND 42), (U.S. CLS. 100, 101 AND 102). SN 77-562,731. PUB. 3-17-2009. FILED 9-4-2008.
- 3,630,289. **GAME HEADZ (BLOCK FORM)**. GAME HEADZ INC, (U.S. CLS. 100, 101 AND 102). SN 77-562,983. PUB. 3-17-2009. FILED 9-5-2008.
- 3,630,293. **SMV SPANISH MOSS VINTAGE AND DESIGN**. FORD, AMY SUZANNE, DBA SPANISH MOSS VINTAGE, (U.S. CLS. 100, 101 AND 102). SN 77-564,017. PUB. 3-17-2009. FILED 9-6-2008.
- 3,630,295. **H HALGO POWER AND DESIGN**. HALGO POWER, INC., MULTIPLE CLASS, (INT. CLS. 35 AND 37), (U.S. CLS. 100, 101, 102, 103 AND 106). SN 77-564,914. PUB. 3-17-2009. FILED 9-8-2008.
- 3,630,297 (*See Class 9 for this trademark*).
- 3,630,303. **CROWE (BLOCK FORM)**. CROWE HORWATH LLP, (U.S. CLS. 100, 101 AND 102). SN 77-566,963. PUB. 3-17-2009. FILED 9-10-2008.
- 3,630,309. **EXPERT HEALTH CONNECTIONS (BLOCK FORM)**. HEALTH ADVOCATE, INC., MULTIPLE CLASS, (INT. CLS. 35 AND 36), (U.S. CLS. 100, 101 AND 102). SN 77-567,431. PUB. 3-17-2009. FILED 9-11-2008.
- 3,630,313. **EXEMPLAR (BLOCK FORM)**. EXEMPLAR COMPANIES, INC., MULTIPLE CLASS, (INT. CLS. 35 AND 36), (U.S. CLS. 100, 101 AND 102). SN 77-568,060. PUB. 3-17-2009. FILED 9-11-2008.
- 3,630,318. **THE MAP (BLOCK FORM)**. FRIENDS OF "THE MAP", (U.S. CLS. 100, 101 AND 102). SN 77-568,776. PUB. 3-17-2009. FILED 9-12-2008.
- 3,630,330. **INTEGRA VENTURES (BLOCK FORM)**. INTEGRA VENTURES, (U.S. CLS. 100, 101 AND 102). SN 77-569,685. PUB. 3-17-2009. FILED 9-15-2008.
- 3,630,336. **PET DISTRICT (BLOCK FORM)**. PET DISTRICT CORPORATION, AKA PET DISTRICT, (U.S. CLS. 100, 101 AND 102). SN 77-570,319. PUB. 3-17-2009. FILED 9-15-2008.
- 3,630,343. **AUDIOVEND WIRELESS SYSTEMS AND DESIGN**.

- AUDIOVEND WIRELESS SYSTEMS, INC., MULTIPLE CLASS, (INT. CLS. 35, 37 AND 41), (U.S. CLS. 100, 101, 102, 103, 106 AND 107). SN 77-572,107. PUB. 3-17-2009. FILED 9-17-2008.
- 3,630,349. **PET DISTRICT AND DESIGN**. PET DISTRICT CORPORATION, AKA PET DISTRICT, (U.S. CLS. 100, 101 AND 102). SN 77-572,861. PUB. 3-17-2009. FILED 9-18-2008.
- 3,630,352. **AMERICAN ACADEMY OF OPHTHALMIC EXECUTIVES (BLOCK FORM)**. AMERICAN ACADEMY OF OPHTHALMOLOGY, INC., (U.S. CLS. 100, 101 AND 102). SN 77-573,020. PUB. 3-17-2009. FILED 9-18-2008.
- 3,630,356. **APPROVED, COMPLETE PACKAGES SUBMITTED, BROADPOINT SOLUTIONS, SHORT SALE EXPEDITOR AND DESIGN**. BROADPOINT SOLUTIONS LLC, (U.S. CLS. 100, 101 AND 102). SN 77-573,343. PUB. 3-17-2009. FILED 9-18-2008.
- 3,630,371. **PAMA...FOR PEACE OF MIND SOLUTIONS (BLOCK FORM)**. PRISCO A. MONACO & ASSOCIATES, LLC, DBA PRISCO A. MONACO & ASSOCIATES, LLC, (U.S. CLS. 100, 101 AND 102). SN 77-575,145. PUB. 3-17-2009. FILED 9-21-2008.
- 3,630,375. **TURNING MATTER INTO ENERGY (BLOCK FORM)**. BALANCE ORGANIZING SERVICE CO., (U.S. CLS. 100, 101 AND 102). SN 77-576,051. PUB. 3-17-2009. FILED 9-22-2008.
- 3,630,379. **RELOCATION ASAP AND DESIGN**. ALLQUEST REAL ESTATE CORP., (U.S. CLS. 100, 101 AND 102). SN 77-576,352. PUB. 3-17-2009. FILED 9-23-2008.
- 3,630,384 (*See Class 3 for this trademark*).
- 3,630,385. **DIREC SOURCE (BLOCK FORM)**. BARBARAS DEVELOPMENT, INC., MULTIPLE CLASS, (INT. CLS. 35, 39, 40 AND 42), (U.S. CLS. 100, 101, 102, 103, 105 AND 106). SN 77-577,720. PUB. 3-17-2009. FILED 9-24-2008.
- 3,630,396. **MISCELLANEOUS DESIGN**. SYNCHRONOUS MEDIA INTERNATIONAL, LTD., DBA MESSAGE MAKERS, (U.S. CLS. 100, 101 AND 102). SN 77-578,865. PUB. 3-17-2009. FILED 9-25-2008.
- 3,630,415 (*See Class 9 for this trademark*).
- 3,630,421. **CDS GLOBAL AND DESIGN**. COMMUNICATIONS DATA SERVICES, INC., (U.S. CLS. 100, 101 AND 102). SN 77-580,808. PUB. 3-17-2009. FILED 9-29-2008.
- 3,630,425. **BOATWIZARD (BLOCK FORM)**. DOMINION ENTERPRISES, (U.S. CLS. 100, 101 AND 102). SN 77-581,440. PUB. 3-17-2009. FILED 9-29-2008.
- 3,630,445. **P.E.O. EST 1869 AND DESIGN**. INTERNATIONAL CHAPTER P.E.O. SISTERHOOD, (U.S. CLS. 100, 101 AND 102). SN 77-584,562. PUB. 3-17-2009. FILED 10-2-2008.
- 3,630,463. **REAL. TEXAS. FLAVOR. (BLOCK FORM)**. THE CITY OF MESQUITE, (U.S. CLS. 100, 101 AND 102). SN 77-586,773. PUB. 3-17-2009. FILED 10-6-2008.
- 3,630,468. **AMPLIFY BUSINESS ADVISORS AND DESIGN**. SAMPLES, J. DWAYNE, (U.S. CLS. 100, 101 AND 102). SN 77-587,234. PUB. 3-17-2009. FILED 10-7-2008.
- 3,630,472. **HELPING PEOPLE REGAIN THEIR LIVES (BLOCK FORM)**. REHABCARE GROUP, INC., (U.S. CLS. 100, 101 AND 102). SN 77-587,559. PUB. 3-17-2009. FILED 10-7-2008.
- 3,630,473. **MISCELLANEOUS DESIGN**. REHABCARE GROUP, INC., (U.S. CLS. 100, 101 AND 102). SN 77-587,595. PUB. 3-17-2009. FILED 10-7-2008.
- 3,630,476. **DALLASFAMILYHOMES.COM AND DESIGN**. DALLASFAMILYHOMES.COM, DBA DALLASFAMILYHOMES.COM, (U.S. CLS. 100, 101 AND 102). SN 77-587,740. PUB. 3-17-2009. FILED S.R. 10-7-2008; AM. P.R. 2-5-2009.
- 3,630,483. **BEEP! AND DESIGN**. GOODWAY GROUP, (U.S. CLS. 100, 101 AND 102). SN 77-588,060. PUB. 3-17-2009. FILED 10-8-2008.
- 3,630,502. **NAPKINNIGHTS (BLOCK FORM)**. NTS INTERACTIVE, LLC, DBA NAPKINNIGHTS.COM, MULTIPLE CLASS, (INT. CLS. 35 AND 41), (U.S. CLS. 100, 101, 102 AND 107). SN 77-589,790. PUB. 3-17-2009. FILED 10-9-2008.
- 3,630,503. **NN AND DESIGN**. NTS INTERACTIVE, LLC, DBA NAPKINNIGHTS.COM, MULTIPLE CLASS, (INT. CLS. 35 AND 41), (U.S. CLS. 100, 101, 102 AND 107). SN 77-589,820. PUB. 3-17-2009. FILED 10-9-2008.
- 3,630,511. **ENVISIONIT MEDIA AND DESIGN**. ENVISIONIT MEDIA, INC., (U.S. CLS. 100, 101 AND 102). SN 77-590,870. PUB. 3-17-2009. FILED 10-11-2008.
- 3,630,512. **TEXASSURE VEHICLE INSURANCE VERIFICATION AND DESIGN**. TEXAS DEPARTMENT OF TRANSPORTATION, (U.S. CLS. 100, 101 AND 102). SN 77-590,951. PUB. 3-17-2009. FILED 10-11-2008.
- 3,630,513. **GARNET RIVER AND DESIGN**. IMG LLC, (U.S. CLS. 100, 101 AND 102). SN 77-590,965. PUB. 3-17-2009. FILED 10-12-2008.
- 3,630,520. **PARAFROG AIRSOFT AND DESIGN**. PULLEY WORKS ENTERPRISES, INC., DBA PARAFROG AIRSOFT, INC., (U.S. CLS. 100, 101 AND 102). SN 77-591,190. PUB. 3-17-2009. FILED 10-13-2008.
- 3,630,523. **REWARDING CREATIVITY (BLOCK FORM)**. RUBBER STAMP MANAGEMENT, INCORPORATED, (U.S. CLS. 100, 101 AND 102). SN 77-591,891. PUB. 3-17-2009. FILED 10-14-2008.
- 3,630,530. **YELLOWPOINTS (BLOCK FORM)**. YELLOW-SPACES INC., (U.S. CLS. 100, 101 AND 102). SN 77-592,097. PUB. 3-17-2009. FILED 10-14-2008.
- 3,630,535. **MARKET STREET (STYLIZED)**. UNITED SUPERMARKETS, L.L.C., (U.S. CLS. 100, 101 AND 102). SN 77-592,456. PUB. 3-17-2009. FILED 10-14-2008.
- 3,630,538. **MARKET STREET UNITED (STYLIZED)**. UNITED SUPERMARKETS, L.L.C., (U.S. CLS. 100, 101 AND 102). SN 77-592,486. PUB. 3-17-2009. FILED 10-14-2008.
- 3,630,540. **ANDERSON ZURMUEHLEN (BLOCK FORM)**. ANDERSON ZURMUEHLEN & CO., P.C., MULTIPLE CLASS, (INT. CLS. 35 AND 45), (U.S. CLS. 100, 101 AND 102). SN 77-592,687. PUB. 3-17-2009. FILED 10-14-2008.
- 3,630,553. **FRANCHISE FOUNDRY (BLOCK FORM)**. FRANCHISE FOUNDRY, LLC, (U.S. CLS. 100, 101 AND 102). SN 77-593,550. PUB. 3-17-2009. FILED 10-15-2008.
- 3,630,559. **PONDBIZ AND DESIGN**. PONDBIZ, INC., (U.S. CLS. 100, 101 AND 102). SN 77-593,845. PUB. 3-17-2009. FILED 10-16-2008.
- 3,630,562. **SKINFLUENTIALS (BLOCK FORM)**. JUNE ALLEN, MULTIPLE CLASS, (INT. CLS. 35 AND 44), (U.S. CLS. 100, 101 AND 102). SN 77-593,918. PUB. 3-17-2009. FILED 10-16-2008.
- 3,630,564. **NEVER STOP EXPLORING (BLOCK FORM)**. THE NORTH FACE APPAREL CORP, (U.S. CLS. 100, 101 AND 102). SN 77-594,166. PUB. 3-17-2009. FILED 10-16-2008.
- 3,630,570. **SPINSIX (BLOCK FORM)**. SPINSIX STRATEGIC MARKETING DESIGN, LLC, (U.S. CLS. 100, 101 AND 102). SN 77-594,500. PUB. 3-17-2009. FILED 10-16-2008.
- 3,630,573. **C&A ADVERTISING (BLOCK FORM)**. CHESSEN & ASSOCIATES, INC., DBA C&A ADVERTISING, (U.S. CLS. 100, 101 AND 102). SN 77-594,693. PUB. 3-17-2009. FILED 10-17-2008.
- 3,630,587. **MUD-THROWERS (BLOCK FORM)**. MUD-THROWERS, LLC, (U.S. CLS. 100, 101 AND 102). SN 77-595,414. PUB. 3-17-2009. FILED 10-17-2008.
- 3,630,588. **RESUPPLIES (BLOCK FORM)**. RUBBER STAMP MANAGEMENT, INCORPORATED, (U.S. CLS. 100, 101 AND 102). SN 77-595,556. PUB. 3-17-2009. FILED 10-18-2008.
- 3,630,593. **UNITED STATES FENCING ASSOCIATION (BLOCK FORM)**. UNITED STATES FENCING ASSOCIATION, (U.S. CLS. 100, 101 AND 102). SN 77-595,645. PUB. 3-17-2009. FILED 10-19-2008.
- 3,630,595. **PRACTICE YOGA CHANGE THE PLANET (BLOCK FORM)**. YOGA WHAT LLC, (U.S. CLS. 100, 101 AND 102). SN 77-595,692. PUB. 3-17-2009. FILED 10-19-2008.
- 3,630,598. **POTHOS A LIFESTYLE... AN EXPERIENCE AND DESIGN**. POTHOS, INC, (U.S. CLS. 100, 101 AND 102). SN 77-595,952. PUB. 3-17-2009. FILED 10-20-2008.
- 3,630,608. **SHOPPORTUNITY (BLOCK FORM)**. BARNES, JASON, (U.S. CLS. 100, 101 AND 102). SN 77-596,073. PUB. 3-17-2009. FILED 10-20-2008.
- 3,630,613 (*See Class 18 for this trademark*).
- 3,630,621. **THE PORTABLE BABY AND DESIGN**. THE PORTABLE BABY, INC., (U.S. CLS. 100, 101 AND 102). SN 77-596,547. PUB. 3-17-2009. FILED 10-20-2008.
- 3,630,624. **THE LOUD CLOUD AND DESIGN**. GORCHOV, JOSHUA, (U.S. CLS. 100, 101 AND 102). SN 77-596,635. PUB. 3-17-2009. FILED 10-21-2008.
- 3,630,634. **YOGURT MONKEY AND DESIGN**. YOGURT MONKEY, LLC, (U.S. CLS. 100, 101 AND 102). SN 77-596,791. PUB. 3-17-2009. FILED 10-21-2008.

- 3,630,635. **MUSIC SQUARE AND DESIGN**. BOYNTON STUDIO INC., DBA BOYNTON PRO AUDIO. MUSIC SQUARE, (U.S. CLS. 100, 101 AND 102). SN 77-596,794. PUB. 3-17-2009. FILED 10-21-2008.
- 3,630,647. **KBK KIDZ B KIDZ AND DESIGN**. KIDZ B KIDZ, INC., (U.S. CLS. 100, 101 AND 102). SN 77-596,999. PUB. 3-17-2009. FILED 10-21-2008.
- 3,630,656. **RUNMYERRAND AND DESIGN**. RUNMYERRAND, INC., (U.S. CLS. 100, 101 AND 102). SN 77-597,301. PUB. 3-17-2009. FILED 10-21-2008.
- 3,630,666. **MANAGAZOO (BLOCK FORM)**. PLANGEA INC., (U.S. CLS. 100, 101 AND 102). SN 77-597,457. PUB. 3-17-2009. FILED 10-21-2008.
- 3,630,671. **EVERYTHING TO LIGHT UP YOUR RIDE! (BLOCK FORM)**. CUSTOM DYNAMICS, LLC, (U.S. CLS. 100, 101 AND 102). SN 77-597,621. PUB. 3-17-2009. FILED 10-22-2008.
- 3,630,673. **\$ \$ CASH-COW.COM COUPON CENTRAL AND DESIGN**. CASH-COW COUPON CENTRAL, INC., (U.S. CLS. 100, 101 AND 102). SN 77-597,703. PUB. 3-17-2009. FILED 10-22-2008.
- 3,630,682. **DEFINITELY WORTH THE TRIP (BLOCK FORM)**. BAIERL CHEVROLET, INC., (U.S. CLS. 100, 101 AND 102). SN 77-597,932. PUB. 3-17-2009. FILED 10-22-2008.
- 3,630,684. **DEFINITELY WORTH THE CLICK (BLOCK FORM)**. BAIERL CHEVROLET, INC., (U.S. CLS. 100, 101 AND 102). SN 77-597,959. PUB. 3-17-2009. FILED 10-22-2008.
- 3,630,690. **NRI (BLOCK FORM)**. NRI, INC., (U.S. CLS. 100, 101 AND 102). SN 77-598,069. PUB. 3-17-2009. FILED 10-22-2008.
- 3,630,692. **POCKET SMART WIRELESS AND DESIGN**. YOUGHIOGHENY COMMUNICAITONS-IP, LLC, (U.S. CLS. 100, 101 AND 102). SN 77-598,124. PUB. 3-17-2009. FILED 10-22-2008.
- 3,630,696. **THE SCIENCE OF SEARCH (BLOCK FORM)**. WYCKOFF CONSULTING LLC, (U.S. CLS. 100, 101 AND 102). SN 77-598,163. PUB. 3-17-2009. FILED 10-22-2008.
- 3,630,697. **INSIGHT GLOBAL A STAFFING SERVICES COMPANY AND DESIGN**. INSIGHT GLOBAL, INC., (U.S. CLS. 100, 101 AND 102). SN 77-598,185. PUB. 3-17-2009. FILED 10-22-2008.
- 3,630,698. **DISASTER RELIEF AND DESIGN**. HEARTS WITH HANDS, INC., (U.S. CLS. 100, 101 AND 102). SN 77-598,229. PUB. 3-17-2009. FILED 10-22-2008.
- 3,630,699. **ISN (BLOCK FORM)**. ISN SOFTWARE CORPORATION, (U.S. CLS. 100, 101 AND 102). SN 77-598,249. PUB. 3-17-2009. FILED 10-22-2008.
- 3,630,701. **BACK TO SCHOOL BACK TO SAVINGS AND DESIGN**. NEWS AMERICA MARKETING PROPERTIES, LLC, (U.S. CLS. 100, 101 AND 102). SN 77-598,279. PUB. 3-17-2009. FILED 10-22-2008.
- 3,630,720. **INDIGO CHIC (BLOCK FORM)**. PISCITELLI, JOSEPH, (U.S. CLS. 100, 101 AND 102). SN 77-598,536. PUB. 3-17-2009. FILED 10-22-2008.
- 3,630,727. **WEALTHTRACKER (BLOCK FORM)**. DATA SOURCE OF LOUDOUN, INC., (U.S. CLS. 100, 101 AND 102). SN 77-598,640. PUB. 3-17-2009. FILED 10-23-2008.
- 3,630,728. **WEALTHTRACKER BY HEP AND DESIGN**. DATA SOURCE OF LOUDOUN, INC., (U.S. CLS. 100, 101 AND 102). SN 77-598,643. PUB. 3-17-2009. FILED 10-23-2008.
- 3,630,749. **HUDSON BOOKSELLERS (BLOCK FORM)**. HUDSON NEWS COMPANY, (U.S. CLS. 100, 101 AND 102). SN 77-598,923. PUB. 3-17-2009. FILED 10-23-2008.
- 3,630,750. **ENTERPRISE TRANSFORMATION SOLUTIONS E AND DESIGN**. ENTERPRISE TRANSFORMATION SOLUTIONS INC, (U.S. CLS. 100, 101 AND 102). SN 77-598,929. PUB. 3-17-2009. FILED 10-23-2008.
- 3,630,767. **4MYBABY (BLOCK FORM)**. CHILDREN'S LEGAL SERVICES, PLLC, MULTIPLE CLASS, (INT. CLS. 35 AND 45), (U.S. CLS. 100, 101 AND 102). SN 77-599,158. PUB. 3-17-2009. FILED 10-23-2008.
- 3,630,771. **WISDOM 3 (BLOCK FORM)**. WISDOM 3 CONSULTING, INC., (U.S. CLS. 100, 101 AND 102). SN 77-599,192. PUB. 3-17-2009. FILED 10-23-2008.
- 3,630,772. **SIMPLE. FUNCTIONAL. SUPER CUTE. (BLOCK FORM)**. BABBACO LLC, (U.S. CLS. 100, 101 AND 102). SN 77-599,239. PUB. 3-17-2009. FILED 10-23-2008.
- 3,630,780. **ADVISOR ADVANTAGE (BLOCK FORM)**. ACT II JEWELRY LLC, (U.S. CLS. 100, 101 AND 102). SN 77-599,329. PUB. 3-17-2009. FILED 10-23-2008.
- 3,630,783. **EXCELLENT BEGINNINGS (BLOCK FORM)**. ACT II JEWELRY LLC, (U.S. CLS. 100, 101 AND 102). SN 77-599,351. PUB. 3-17-2009. FILED 10-23-2008.
- 3,630,790. **KABOCO AND DESIGN**. POOLE, DELMA, (U.S. CLS. 100, 101 AND 102). SN 77-599,513. PUB. 3-17-2009. FILED 10-23-2008.
- 3,630,795. **BABY HANDS PRODUCTIONS (BLOCK FORM)**. BABY HANDS PRODUCTIONS, INC., (U.S. CLS. 100, 101 AND 102). SN 77-599,553. PUB. 3-17-2009. FILED 10-23-2008.
- 3,630,811. **STENPARTS.COM (BLOCK FORM)**. SAFETY HARBOR FIREARMS, INC., (U.S. CLS. 100, 101 AND 102). SN 77-599,812. PUB. 3-17-2009. FILED 10-24-2008.
- 3,630,814. **MTGMINTCARD (BLOCK FORM)**. BRAND CREATIONS HOLDINGS LIMITED, (U.S. CLS. 100, 101 AND 102). SN 77-599,847. PUB. 3-17-2009. FILED 10-24-2008.
- 3,630,820. **HOPMEUP (BLOCK FORM)**. TOWNSITE PARTNERS, LLC, (U.S. CLS. 100, 101 AND 102). SN 77-599,922. PUB. 3-17-2009. FILED 10-24-2008.
- 3,630,830. **PREMIER LEGAL PLACEMENT (BLOCK FORM)**. TALIERI, PETER, (U.S. CLS. 100, 101 AND 102). SN 77-600,010. PUB. 3-17-2009. FILED 10-24-2008.
- 3,630,833. **PET ANGEL MEMORIALS AND DESIGN**. PET ANGEL WORLD SERVICES, LLC, (U.S. CLS. 100, 101 AND 102). SN 77-600,068. PUB. 3-17-2009. FILED 10-24-2008.
- 3,630,839. **SAVING YOU TIME & MONEY IS WHAT WE'RE ALL ABOUT (BLOCK FORM)**. SUMMIT CONSULTING AND APEX PLANNING INC., DBA R & G BRENNER INCOME TAX CENTERS, (U.S. CLS. 100, 101 AND 102). SN 77-600,118. PUB. 3-17-2009. FILED 10-24-2008.
- 3,630,843. **MERIT CLUB (BLOCK FORM)**. UNITED KENNEL CLUB, INC., (U.S. CLS. 100, 101 AND 102). SN 77-600,157. PUB. 3-17-2009. FILED 10-24-2008.
- 3,630,845. **THE NONPROFIT NOOK (BLOCK FORM)**. TRIO SOLUTIONS, INC., (U.S. CLS. 100, 101 AND 102). SN 77-600,172. PUB. 3-17-2009. FILED 10-24-2008.
- 3,630,849. **RESELLERRATINGS.COM (BLOCK FORM)**. ALL ENTHUSIAST, INC., (U.S. CLS. 100, 101 AND 102). SN 77-600,196. PUB. 3-17-2009. FILED 10-24-2008.
- 3,630,855. **MC (STYLIZED)**. UNITED KENNEL CLUB, INC., (U.S. CLS. 100, 101 AND 102). SN 77-600,293. PUB. 3-17-2009. FILED 10-24-2008.
- 3,630,857. **ARTOOZIE (BLOCK FORM)**. ART RENAISSANCE, LLC, (U.S. CLS. 100, 101 AND 102). SN 77-600,327. PUB. 3-17-2009. FILED 10-24-2008.
- 3,630,862. **THE CHOICE OF CHAMPIONS (BLOCK FORM)**. HILLYARD ENTERPRISES, INC., (U.S. CLS. 100, 101 AND 102). SN 77-600,380. PUB. 3-17-2009. FILED 10-24-2008.
- 3,630,864. **BETTER MATTERS (BLOCK FORM)**. BETTER MATTERS, INC, (U.S. CLS. 100, 101 AND 102). SN 77-600,409. PUB. 3-17-2009. FILED 10-24-2008.
- 3,630,880. **RAIL TOWN USA (BLOCK FORM)**. ORIGINAL TOWN ASSOCIATION, INC., (U.S. CLS. 100, 101 AND 102). SN 77-600,658. PUB. 3-17-2009. FILED 10-26-2008.
- 3,630,882. **TARGET 250 (BLOCK FORM)**. TARGET 250 INC., MULTIPLE CLASS, (INT. CLS. 35 AND 41), (U.S. CLS. 100, 101, 102 AND 107). SN 77-600,674. PUB. 3-17-2009. FILED 10-26-2008.
- 3,630,887. **THE ORGANIZED BARN & TRAILER (BLOCK FORM)**. ROONEY, MICHELLE, (U.S. CLS. 100, 101 AND 102). SN 77-600,732. PUB. 3-17-2009. FILED 10-26-2008.
- 3,630,889. **SCHOOLOUTFITTERS.COM (BLOCK FORM)**. SCHOOLHOUSE OUTFITTERS, LLC, (U.S. CLS. 100, 101 AND 102). SN 77-600,813. PUB. 3-17-2009. FILED 10-27-2008.
- 3,630,900. **MYBLUE BOOK (STYLIZED)**. CONTRACTORS REGISTER, INC., (U.S. CLS. 100, 101 AND 102). SN 77-600,936. PUB. 3-17-2009. FILED 10-27-2008.
- 3,630,911. **THE GREASE POLICE AND DESIGN**. BRYAN, MATT, (U.S. CLS. 100, 101 AND 102). SN 77-601,022. PUB. 3-17-2009. FILED 10-27-2008.
- 3,630,918. **YOU DESERVE THE LOWEST PRICES AND WE DELIVER THEM (BLOCK FORM)**. GEM BARCODING INC., (U.S. CLS. 100, 101 AND 102). SN 77-601,144. PUB. 3-17-2009. FILED 10-27-2008.
- 3,630,919. **THE AZTEC STORE (BLOCK FORM)**. AZTEC SHOPS LTD., (U.S. CLS. 100, 101 AND 102). SN 77-601,158. PUB. 3-17-2009. FILED 10-27-2008.
- 3,630,921. **TRIPLETHEGIFT.COM AND DESIGN**. TRI-

- PLETHEGIFT LLC, (U.S. CLS. 100, 101 AND 102). SN 77-601,173. PUB. 3-17-2009. FILED 10-27-2008.
- 3,630,925. **JITTERGRAM (BLOCK FORM)**. JITTERGRAM, INC., (U.S. CLS. 100, 101 AND 102). SN 77-601,227. PUB. 3-17-2009. FILED 10-27-2008.
- 3,630,928. **WILHELMINA (BLOCK FORM)**. WILHELMINA INTERNATIONAL, LTD., (U.S. CLS. 100, 101 AND 102). SN 77-601,276. PUB. 3-17-2009. FILED 10-27-2008.
- 3,630,959. **CELEBRATION (BLOCK FORM)**. ALLIANCE TRADING, INC., (U.S. CLS. 100, 101 AND 102). SN 77-601,663. PUB. 3-17-2009. FILED 10-27-2008.
- 3,630,961. **THE MARKETING DEMOCRACY AND DESIGN**. FRANKS, JUDY, DBA THE MARKETING DEMOCRACY, (U.S. CLS. 100, 101 AND 102). SN 77-601,690. PUB. 3-17-2009. FILED 10-27-2008.
- 3,630,969. **YIELDAUCTION (BLOCK FORM)**. GRANT STREET GROUP, INC., MULTIPLE CLASS, (INT. CLS. 35 AND 42), (U.S. CLS. 100, 101 AND 102). SN 77-601,927. PUB. 3-17-2009. FILED 10-28-2008.
- 3,630,986 (*See Class 20 for this trademark*).
- 3,630,989. **PSI (BLOCK FORM)**. PSYCHIATRIC SOLUTIONS, INC., (U.S. CLS. 100, 101 AND 102). SN 77-602,097. PUB. 3-17-2009. FILED 10-28-2008.
- 3,630,993. **MYWORLD MYFUTURE MYPLAN (BLOCK FORM)**. PEORIA UNIFIED SCHOOL DISTRICT, (U.S. CLS. 100, 101 AND 102). SN 77-602,132. PUB. 3-17-2009. FILED 10-28-2008.
- 3,631,024. **CHAMPIONS OF DISCOVERY (BLOCK FORM)**. CHAMPIONS OF DISCOVERY, (U.S. CLS. 100, 101 AND 102). SN 77-602,553. PUB. 3-17-2009. FILED 10-28-2008.
- 3,631,041. **FLOWER TENT (BLOCK FORM)**. ANSILIO, THOMAS F., (U.S. CLS. 100, 101 AND 102). SN 77-602,787. PUB. 3-17-2009. FILED 10-29-2008.
- 3,631,043. **EXPERIENCE (BLOCK FORM)**. PJS & RHS EXPERIENCES LLC, (U.S. CLS. 100, 101 AND 102). SN 77-602,806. PUB. 3-17-2009. FILED 10-29-2008.
- 3,631,051. **SAVINGS YOU CAN SLEEP ON (BLOCK FORM)**. MATTRESS OUTLET, INC., (U.S. CLS. 100, 101 AND 102). SN 77-602,982. PUB. 3-17-2009. FILED 10-29-2008.
- 3,631,055. **SMARTSHOTS (BLOCK FORM)**. PICTUREU PROMOTIONS, INC., (U.S. CLS. 100, 101 AND 102). SN 77-603,136. PUB. 3-17-2009. FILED 10-29-2008.
- 3,631,058. **FACETS IP, INC. (BLOCK FORM)**. FACETS IP, INC., MULTIPLE CLASS, (INT. CLS. 35, 41 AND 42), (U.S. CLS. 100, 101, 102 AND 107). SN 77-603,175. PUB. 3-17-2009. FILED 10-29-2008.
- 3,631,061. **CATCHALL (BLOCK FORM)**. PICTUREU PROMOTIONS, INC., (U.S. CLS. 100, 101 AND 102). SN 77-603,238. PUB. 3-17-2009. FILED 10-29-2008.
- 3,631,077. **MOBILE DREAMS FACTORY AND DESIGN**. MOBILE DREAMS FACTORY S.L., (U.S. CLS. 100, 101 AND 102). SN 77-603,544. PUB. 3-17-2009. FILED 10-29-2008.
- 3,631,078. **SEATHOUND (BLOCK FORM)**. FREE PRO MARKETING, LLC, (U.S. CLS. 100, 101 AND 102). SN 77-603,569. PUB. 3-17-2009. FILED 10-29-2008.
- 3,631,083. **PRACTICEPAINT.COM AND DESIGN**. PRIME-LINK INC., (U.S. CLS. 100, 101 AND 102). SN 77-603,608. PUB. 3-17-2009. FILED 10-29-2008.
- 3,631,089. **PROFORCE LAW ENFORCEMENT AND DESIGN**. PROFORCE MARKETING, INC., (U.S. CLS. 100, 101 AND 102). SN 77-603,702. PUB. 3-17-2009. FILED 10-30-2008.
- 3,631,090. **PROFORCE LAW ENFORCEMENT (BLOCK FORM)**. PROFORCE MARKETING, INC., (U.S. CLS. 100, 101 AND 102). SN 77-603,703. PUB. 3-17-2009. FILED 10-30-2008.
- 3,631,112. **MOVING PEOPLE FORWARD (BLOCK FORM)**. ELITE LEGAL SEARCH LLC, (U.S. CLS. 100, 101 AND 102). SN 77-604,078. PUB. 3-17-2009. FILED 10-30-2008.
- 3,631,113. **WHERE CREATIVITY & SCIENCE MEET (BLOCK FORM)**. METRIC, LLC, (U.S. CLS. 100, 101 AND 102). SN 77-604,086. PUB. 3-17-2009. FILED 10-30-2008.
- 3,631,114. **SALEMAIL (BLOCK FORM)**. SHOP IT TO ME, INC., (U.S. CLS. 100, 101 AND 102). SN 77-604,090. PUB. 3-17-2009. FILED 10-30-2008.
- 3,631,119. **SOCIETY OF DERMATOLOGY PHYSICIAN ASSISTANTS (BLOCK FORM)**. SOCIETY OF DERMATOLOGY PHYSICIAN ASSISTANTS, INCORPORATED, (U.S. CLS. 100, 101 AND 102). SN 77-604,139. PUB. 3-17-2009. FILED 10-30-2008.
- 3,631,140. **REACH HIGHER GROUND (BLOCK FORM)**. GATLINBURG DEPARTMENT OF TOURISM, (U.S. CLS. 100, 101 AND 102). SN 77-604,547. PUB. 3-17-2009. FILED 10-30-2008.
- 3,631,141. **MISCELLANEOUS DESIGN**. MONSOON, INC., (U.S. CLS. 100, 101 AND 102). SN 77-604,554. PUB. 3-17-2009. FILED 10-30-2008.
- 3,631,148. **ANCILLA AND DESIGN**. ANCILLA RESOURCE CORPORATION, (U.S. CLS. 100, 101 AND 102). SN 77-604,603. PUB. 3-17-2009. FILED 10-30-2008.
- 3,631,157. **LET IT RAIN (BLOCK FORM)**. PREFERRED HOME BUYERS NETWORK, INC., (U.S. CLS. 100, 101 AND 102). SN 77-604,871. PUB. 3-17-2009. FILED 10-31-2008.
- 3,631,161. **GOLDEN GIRLS (BLOCK FORM)**. GOLDEN GIRLS LLC, (U.S. CLS. 100, 101 AND 102). SN 77-604,925. PUB. 3-17-2009. FILED 10-31-2008.
- 3,631,168. **BY JESSICA KIM (BLOCK FORM)**. KIM, JESSICA NAM, (U.S. CLS. 100, 101 AND 102). SN 77-604,976. PUB. 3-17-2009. FILED 10-31-2008.
- 3,631,179. **SMOKIN' STAMPEDE (BLOCK FORM)**. TBB GLOBAL LOGISTICS, INC., MULTIPLE CLASS, (INT. CLS. 35 AND 39), (U.S. CLS. 100, 101, 102 AND 105). SN 77-605,290. PUB. 3-17-2009. FILED 10-31-2008.
- 3,631,180. **TRUCKLOAD SERVICE THAT'S A BREED ABOVE THE REST (BLOCK FORM)**. TBB GLOBAL LOGISTICS, INC., MULTIPLE CLASS, (INT. CLS. 35 AND 39), (U.S. CLS. 100, 101, 102 AND 105). SN 77-605,310. PUB. 3-17-2009. FILED 10-31-2008.
- 3,631,185. **ONE STORE. ONE STOP. ONE SUPER IDEA. (BLOCK FORM)**. SEARS BRANDS, LLC, (U.S. CLS. 100, 101 AND 102). SN 77-605,366. PUB. 3-17-2009. FILED 10-31-2008.
- 3,631,191. **SUNSHINE GUARANTEE (BLOCK FORM)**. VRL INTERNATIONAL LTD., (U.S. CLS. 100, 101 AND 102). SN 77-605,416. PUB. 3-17-2009. FILED 10-31-2008.
- 3,631,192. **HURRICANE GUARANTEE (BLOCK FORM)**. VRL INTERNATIONAL LTD., (U.S. CLS. 100, 101 AND 102). SN 77-605,417. PUB. 3-17-2009. FILED 10-31-2008.
- 3,631,194. **SATISFACTION GUARANTEE (BLOCK FORM)**. VRL INTERNATIONAL LTD., (U.S. CLS. 100, 101 AND 102). SN 77-605,420. PUB. 3-17-2009. FILED 10-31-2008.
- 3,631,199. **TRILOGY MARKETING GROUP AND DESIGN**. TRILOGY MARKETING GROUP, (U.S. CLS. 100, 101 AND 102). SN 77-605,471. PUB. 3-17-2009. FILED 10-31-2008.
- 3,631,200. **AUTOSENSE AND DESIGN**. FIRST FINANCIAL FEDERAL CREDIT UNION, (U.S. CLS. 100, 101 AND 102). SN 77-605,476. PUB. 3-17-2009. FILED 10-31-2008.
- 3,631,214. **PRIZE REBEL (BLOCK FORM)**. IANGELIC, (U.S. CLS. 100, 101 AND 102). SN 77-605,593. PUB. 3-17-2009. FILED 11-1-2008.
- 3,631,215. **ZENVIRONMENT (BLOCK FORM)**. RUIZ, JOSEPH R., (U.S. CLS. 100, 101 AND 102). SN 77-605,617. PUB. 3-17-2009. FILED 11-1-2008.
- 3,631,221. **YELLOWTAGS (BLOCK FORM)**. YELLOWSPACES INC., (U.S. CLS. 100, 101 AND 102). SN 77-605,671. PUB. 3-17-2009. FILED 11-2-2008.
- 3,631,225. **BECONTINUOUS (BLOCK FORM)**. TFC SYSTEMS, INC., (U.S. CLS. 100, 101 AND 102). SN 77-605,768. PUB. 3-17-2009. FILED 11-2-2008.
- 3,631,226 (*See Class 9 for this trademark*).
- 3,631,231 (*See Class 16 for this trademark*).
- 3,631,267. **IMAGINATION STATION (BLOCK FORM)**. PICTUREU PROMOTIONS, INC., (U.S. CLS. 100, 101 AND 102). SN 77-607,622. PUB. 3-17-2009. FILED 11-5-2008.
- 3,631,271. **SITE TO STORE AND DESIGN**. WAL-MART STORES, INC., (U.S. CLS. 100, 101 AND 102). SN 77-608,272. PUB. 3-17-2009. FILED 11-5-2008.
- 3,631,273. **WSJWINE (BLOCK FORM)**. DOW JONES & COMPANY, INC., MULTIPLE CLASS, (INT. CLS. 35, 39 AND 43), (U.S. CLS. 100, 101, 102 AND 105). SN 77-608,628. PUB. 3-17-2009. FILED 11-6-2008.
- 3,631,296. **MISCELLANEOUS DESIGN**. OROMO LIBERATION FRONT, (U.S. CLS. 100, 101 AND 102). SN 77-612,213. PUB. 3-17-2009. FILED 11-11-2008.
- 3,631,301. **SAVE TIME SAVE GAS SAVE MONEY (BLOCK FORM)**. FRED MEYER STORES, INC., (U.S. CLS. 100, 101 AND 102). SN 77-615,118. PUB. 3-17-2009. FILED 11-14-2008.
- 3,631,312. **PHYDBACK AND DESIGN**. RIENZI & RIENZI

- COMMUNICATIONS, INC., (U.S. CLS. 100, 101 AND 102). SN 77-616,964. PUB. 3-17-2009. FILED 11-18-2008.
- 3,631,313. **BIZFANS (BLOCK FORM)**, YELLOWSPACES INC., (U.S. CLS. 100, 101 AND 102). SN 77-617,118. PUB. 3-17-2009. FILED 11-18-2008.
- 3,631,322. **A SINGLE DESTINATION WEBSITE (BLOCK FORM)**, PREFERRED HOME BUYERS NETWORK, INC., MULTIPLE CLASS, (INT. CLS. 35 AND 36), (U.S. CLS. 100, 101 AND 102). SN 77-619,032. PUB. 3-17-2009. FILED 11-20-2008.
- 3,631,325. **SERVICEREQUESTS (BLOCK FORM)**, YELLOWSPACES INC., (U.S. CLS. 100, 101 AND 102). SN 77-620,170. PUB. 3-17-2009. FILED 11-22-2008.
- 3,631,333. **EM EXTRAMILE AND DESIGN**, CHEVRON INTELLECTUAL PROPERTY LLC, (U.S. CLS. 100, 101 AND 102). SN 77-624,117. PUB. 3-17-2009. FILED 12-1-2008.
- 3,631,348. **DON'T BE AN * (BLOCK FORM)**, UNITED STATES OLYMPIC COMMITTEE, (U.S. CLS. 100, 101 AND 102). SN 77-633,111. PUB. 3-17-2009. FILED 12-15-2008.
- 3,631,353. **DON'T BE AN ASTERISK (BLOCK FORM)**, UNITED STATES OLYMPIC COMMITTEE, (U.S. CLS. 100, 101 AND 102). SN 77-635,845. PUB. 3-17-2009. FILED 12-18-2008.
- 3,631,354. **ALL THINGS HOLIDAY (BLOCK FORM)**, FRED MEYER STORES, INC., (U.S. CLS. 100, 101 AND 102). SN 77-635,883. PUB. 3-17-2009. FILED 12-18-2008.
- 3,631,359. **NCPRS (BLOCK FORM)**, NATIONAL CENTER FOR PREVENTION AND RESEARCH SOLUTIONS, INC., MULTIPLE CLASS, (INT. CLS. 35 AND 41), (U.S. CLS. 100, 101, 102 AND 107). SN 77-638,601. PUB. 3-17-2009. FILED 12-23-2008.
- 3,631,361. **RANCHERIA STYLE (BLOCK FORM)**, JACKSON RANCHERIA BAND OF MIWUK INDIANS, MULTIPLE CLASS, (INT. CLS. 35, 41 AND 43), (U.S. CLS. 100, 101, 102 AND 107). SN 77-638,870. PUB. 3-17-2009. FILED 12-23-2008.
- 3,631,362. **CONNECT AND SIMPLIFY (BLOCK FORM)**, EXTREME REACH INC., (U.S. CLS. 100, 101 AND 102). SN 77-643,734. PUB. 3-17-2009. FILED 1-6-2009.
- 3,631,364. **CATALYZING RESEARCH, THEORY AND PRACTICE (BLOCK FORM)**, NATIONAL COUNCIL ON FAMILY RELATIONS, DBA NCFR, (U.S. CLS. 100, 101 AND 102). SN 77-646,463. PUB. 3-17-2009. FILED 1-9-2009.
- 3,631,370. **AU AMERICANS UNITED FOR SEPARATION OF CHURCH AND STATE AND DESIGN**, AMERICANS UNITED FOR SEPARATION OF CHURCH AND STATE, MULTIPLE CLASS, (INT. CLS. 35, 41 AND 45), (U.S. CLS. 100, 101, 102 AND 107). SN 77-975,474. PUB. 3-17-2009. FILED 8-31-2007.
- 3,631,383. **THE LINK BETWEEN US (BLOCK FORM)**, DEUTSCHE TELEKOM AG, (U.S. CLS. 100, 101 AND 102). SN 78-420,760. PUB. 11-11-2008. FILED 5-18-2004.
- 3,631,385. **SATIN (STYLIZED)**, METHVEN LIMITED, MULTIPLE CLASS, (INT. CLS. 35 AND 42), (U.S. CLS. 100, 101 AND 102). SN 78-427,571. PUB. 3-17-2009. FILED 5-31-2004.
- 3,631,394. **GLOBAL (BLOCK FORM)**, GLOBAL AUTO MALL, MULTIPLE CLASS, (INT. CLS. 35, 36 AND 39), (U.S. CLS. 100, 101, 102 AND 105). SN 78-560,671. PUB. 3-17-2009. FILED 2-4-2005.
- 3,631,397 (See Class 9 for this trademark).
- 3,631,398 (See Class 9 for this trademark).
- 3,631,407. **PROJECT OPUS (BLOCK FORM)**, PROJECT OPUS TECHNOLOGIES INC., MULTIPLE CLASS, (INT. CLS. 35 AND 38), (U.S. CLS. 100, 101, 102 AND 104). SN 78-668,910. PUB. 3-17-2009. FILED 7-12-2005.
- 3,631,420. **ASSURANCE AND DESIGN**, ASSURANCE AGENCY, LTD., MULTIPLE CLASS, (INT. CLS. 35, 36 AND 45), (U.S. CLS. 100, 101 AND 102). SN 78-809,372. PUB. 4-24-2007. FILED 2-7-2006.
- 3,631,421. **WORLD FISHING NETWORK (BLOCK FORM)**, WORLD FISHING NETWORK LTD., MULTIPLE CLASS, (INT. CLS. 35, 38 AND 41), (U.S. CLS. 100, 101, 102, 104 AND 107). SN 78-812,440. PUB. 3-17-2009. FILED 2-10-2006.
- 3,631,422. **WFN (BLOCK FORM)**, WORLD FISHING NETWORK LTD., MULTIPLE CLASS, (INT. CLS. 35, 38 AND 41), (U.S. CLS. 100, 101, 102, 104 AND 107). SN 78-812,473. PUB. 3-17-2009. FILED 2-10-2006.
- 3,631,424 (See Class 24 for this trademark).
- 3,631,430. **RAILAGENT (BLOCK FORM)**, WANDRIAN, INC., MULTIPLE CLASS, (INT. CLS. 35, 39 AND 42), (U.S. CLS. 100, 101, 102 AND 105). SN 78-864,482. PUB. 3-17-2009. FILED 4-19-2006.
- 3,631,432 (See Class 1 for this trademark).
- 3,631,433 (See Class 1 for this trademark).
- 3,631,438 (See Class 7 for this trademark).
- 3,631,439. **LUXURY LIFESTYLE HOTELS & RESORTS AND DESIGN**, LUXURY LIFESTYLE HOTELS, S.L., MULTIPLE CLASS, (INT. CLS. 35, 39 AND 43), (U.S. CLS. 100, 101, 102 AND 105). SN 78-920,565. PUB. 3-17-2009. FILED 6-30-2006.
- 3,631,441 (See Class 10 for this trademark).
- 3,631,457. **VERVE (BLOCK FORM)**, VERVE PUBLIC RELATIONS, INC., (U.S. CLS. 100, 101 AND 102). SN 78-974,426. PUB. 3-17-2009. FILED 9-14-2006.
- 3,631,472 (See Class 3 for this trademark).
- 3,631,473 (See Class 14 for this trademark).
- 3,631,479 (See Class 16 for this trademark).
- 3,631,480 (See Class 9 for this trademark).
- 3,631,482 (See Class 3 for this trademark).
- 3,631,485. **MOMAGRI (BLOCK FORM)**, LIMAGRAIN, MULTIPLE CLASS, (INT. CLS. 35, 41, 42 AND 44), (U.S. CLS. 100, 101, 102 AND 107). SN 79-041,726. PUB. 3-17-2009. FILED 1-19-2007.
- 3,631,489. **GROWLIVE AND DESIGN**, GROW LIVE LIMITED, MULTIPLE CLASS, (INT. CLS. 35, 38 AND 42), (U.S. CLS. 100, 101, 102 AND 104). SN 79-043,261. PUB. 3-17-2009. FILED 6-22-2007.
- 3,631,497 (See Class 16 for this trademark).
- 3,631,499. **TAQA (BLOCK FORM)**, ABU DHABI NATIONAL ENERGY COMPANY PJSC, MULTIPLE CLASS, (INT. CLS. 35 AND 36), (U.S. CLS. 100, 101 AND 102). SN 79-045,539. PUB. 3-17-2009. FILED 4-17-2007.
- 3,631,502 (See Class 9 for this trademark).
- 3,631,506. **BUSINESS COMMUNITY CONFINDUSTRIA - BCC (BLOCK FORM)**, CONSORZIO RETE INDUSTRIA, MULTIPLE CLASS, (INT. CLS. 35, 36 AND 41), (U.S. CLS. 100, 101, 102 AND 107). SN 79-046,938. PUB. 3-17-2009. FILED 6-28-2007.
- 3,631,514. **TELEPERFORMANCE AND DESIGN**, TELEPERFORMANCE, MULTIPLE CLASS, (INT. CLS. 35, 38 AND 41), (U.S. CLS. 100, 101, 102, 104 AND 107). SN 79-048,052. PUB. 3-17-2009. FILED 3-14-2007.
- 3,631,517 (See Class 6 for this trademark).
- 3,631,531 (See Class 9 for this trademark).
- 3,631,533. **THE TAPLOW GROUP (STYLIZED)**, THE TAPLOW GROUP S.A., MULTIPLE CLASS, (INT. CLS. 35, 41 AND 42), (U.S. CLS. 100, 101, 102 AND 107). SN 79-049,665. PUB. 3-17-2009. FILED 12-13-2007.
- 3,631,534 (See Class 9 for this trademark).
- 3,631,536. **JEUNES RESTAURATEURS AND DESIGN**, JEUNES RESTAURATEURS D'EUROPE; (ASSOCIATION RÉGIE PAR LA LOI; DU 1ER JUILLET 1901), MULTIPLE CLASS, (INT. CLS. 35, 41 AND 43), (U.S. CLS. 100, 101, 102 AND 107). SN 79-050,114. PUB. 3-17-2009. FILED 1-10-2008.
- 3,631,537. **TOPTEN AND DESIGN**, TOPTEST GMBH, MULTIPLE CLASS, (INT. CLS. 35, 38, 41, 42 AND 45), (U.S. CLS. 100, 101, 102, 104 AND 107). SN 79-050,229. PUB. 3-17-2009. FILED 7-30-2007.
- 3,631,541. **ORBEXCORP (STYLIZED)**, ORBEXCORP (ASIA) PTE. LTD., (U.S. CLS. 100, 101 AND 102). SN 79-050,900. PUB. 3-17-2009. FILED 2-15-2008.
- 3,631,542 (See Class 16 for this trademark).
- 3,631,544. **CORE CARBON GROUP (BLOCK FORM)**, CORE CARBON GROUP APS, MULTIPLE CLASS, (INT. CLS. 35, 36 AND 42), (U.S. CLS. 100, 101 AND 102). SN 79-051,023. PUB. 3-17-2009. FILED 12-17-2007.
- 3,631,557 (See Class 9 for this trademark).
- 3,631,560 (See Class 3 for this trademark).
- 3,631,562 (See Class 11 for this trademark).
- 3,631,570 (See Class 33 for this trademark).
- 3,631,589 (See Class 6 for this trademark).
- 3,631,598. **STOXX CUSTOMISED AND DESIGN**, STOXX AG, MULTIPLE CLASS, (INT. CLS. 35 AND 41), (U.S. CLS. 100, 101, 102 AND 107). SN 79-054,002. PUB. 3-17-2009. FILED 4-1-2008.
- 3,631,607 (See Class 16 for this trademark).
- 3,631,619 (See Class 14 for this trademark).
- 3,631,644. **STRATETHICS (BLOCK FORM)**, INTERNATIONAL EXECUTIVE CONSULTING GROUP SARL.; C/

O GEMTRUST SA, MULTIPLE CLASS, (INT. CLS. 35 AND 41), (U.S. CLS. 100, 101, 102 AND 107). SN 79-054,978. PUB. 3-17-2009. FILED 1-23-2008.

3,631,647 (*See Class 9 for this trademark.*).

3,631,652 (*See Class 3 for this trademark.*).

3,631,658. **W V G H AND DESIGN**. WVGH B.V., MULTIPLE CLASS, (INT. CLS. 35, 36 AND 45), (U.S. CLS. 100, 101 AND 102). SN 79-055,374. PUB. 3-17-2009. FILED 3-18-2008.

3,631,662. **S GROUPE SEB (STYLIZED)**. SEB S.A., MULTIPLE CLASS, (INT. CLS. 35, 37 AND 41), (U.S. CLS. 100, 101, 102, 103, 106 AND 107). SN 79-055,507. PUB. 3-17-2009. FILED 4-25-2008.

3,631,665 (*See Class 3 for this trademark.*).

3,631,673 (*See Class 19 for this trademark.*).

3,631,685 (*See Class 9 for this trademark.*).

3,631,701 (*See Class 2 for this trademark.*).

3,631,716. **QWÖRKS (BLOCK FORM)**. PETER KUBASCH, (U.S. CLS. 100, 101 AND 102). SN 79-057,519. PUB. 3-17-2009. FILED 7-18-2008.

3,631,720 (*See Class 7 for this trademark.*).

3,631,721. **FRANCFRANC (STYLIZED)**. BALS CORPORATION, (U.S. CLS. 100, 101 AND 102). SN 79-057,961. PUB. 3-17-2009. FILED 5-14-2008.

3,631,727. **WUNDERLOOP CONNECT AND DESIGN**. WUNDERLOOP S.A., MULTIPLE CLASS, (INT. CLS. 35, 36, 38, 41, 42 AND 45), (U.S. CLS. 100, 101, 102, 104 AND 107). SN 79-058,220. PUB. 3-17-2009. FILED 12-20-2007.

3,631,735 (*See Class 25 for this trademark.*).

3,631,743 (*See Class 9 for this trademark.*).

3,631,749 (*See Class 28 for this trademark.*).

3,631,761 (*See Class 9 for this trademark.*).

3,631,764. **PLOUGMANN & VINGTOFT (BLOCK FORM)**. PLOUGMANN & VINGTOFT A/S, MULTIPLE CLASS, (INT. CLS. 35 AND 42), (U.S. CLS. 100, 101 AND 102). SN 79-061,258. PUB. 3-17-2009. FILED 4-7-2008.

CLASS 36—INSURANCE AND FINANCIAL

3,629,121 (*See Class 9 for this trademark.*).

3,629,122 (*See Class 19 for this trademark.*).

3,629,123. **DYNAMIC MONEY MARKET CLASS**. DUNDEE CORPORATION, (U.S. CLS. 100, 101 AND 102). SN 76-225,303. PUB. 3-17-2009. FILED 3-14-2001.

3,629,124. **DYNAMIC EUROPEAN VALUE CLASS**. DUNDEE CORPORATION, (U.S. CLS. 100, 101 AND 102). SN 76-225,484. PUB. 3-17-2009. FILED 3-14-2001.

3,629,161. **GET A HOME...GET A LOAN...GET A REFUND!!! (BLOCK FORM)**. REFUND REALTY & MORTGAGE, LLC, (U.S. CLS. 100, 101 AND 102). SN 76-688,482. PUB. 3-17-2009. FILED 4-9-2008.

3,629,165 (*See Class 35 for this trademark.*).

3,629,182. **KASH KING (BLOCK FORM)**. LEVY FAMILY ASSOCIATES, LLC, (U.S. CLS. 100, 101 AND 102). SN 76-691,487. PUB. 3-17-2009. FILED 7-22-2008.

3,629,183. **KASH KING AND DESIGN**. LEVY FAMILY ASSOCIATES, LLC, (U.S. CLS. 100, 101 AND 102). SN 76-691,488. PUB. 3-17-2009. FILED 7-22-2008.

3,629,225. **B AND DESIGN**. BELLATORE, LLC, MULTIPLE CLASS, (INT. CLS. 36 AND 41), (U.S. CLS. 100, 101, 102 AND 107). SN 76-978,939. PUB. 3-17-2009. FILED 11-9-2007.

3,629,226. **BELLATORE (BLOCK FORM)**. BELLATORE, LLC, MULTIPLE CLASS, (INT. CLS. 36 AND 41), (U.S. CLS. 100, 101, 102 AND 107). SN 76-978,940. PUB. 3-17-2009. FILED 11-9-2007.

3,629,240. **UNITED NEGRO COLLEGE FUND (BLOCK FORM)**. UNITED NEGRO COLLEGE FUND, INC., (U.S. CLS. 100, 101 AND 102). SN 77-054,531. PUB. 3-17-2009. FILED 11-30-2006.

3,629,260. **MORSE (BLOCK FORM)**. MORSE PLC, MULTIPLE CLASS, (INT. CLS. 36, 41 AND 45), (U.S. CLS. 100, 101, 102 AND 107). SN 77-092,230. PUB. 3-17-2009. FILED 1-26-2007.

3,629,263. **VERO CM (BLOCK FORM)**. VERO CAPITAL MANAGEMENT, LLC, (U.S. CLS. 100, 101 AND 102). SN 77-096,503. PUB. 3-17-2009. FILED 2-1-2007.

3,629,264. **WEATHERBILL (BLOCK FORM)**. WEATHERBILL INC., (U.S. CLS. 100, 101 AND 102). SN 77-099,832. PUB. 3-17-2009. FILED 2-6-2007.

3,629,278 (*See Class 35 for this trademark.*).

3,629,289. **GONEUTRAL (BLOCK FORM)**. JEWISH NATIONAL FUND (KEREN KAYEMETH LEISRAEL), INC., MULTIPLE CLASS, (INT. CLS. 36 AND 41), (U.S. CLS. 100, 101, 102 AND 107). SN 77-156,394. PUB. 3-17-2009. FILED 4-13-2007.

3,629,290. **HSA(K) (BLOCK FORM)**. BENEFIT STRATEGIES, LLC, (U.S. CLS. 100, 101 AND 102). SN 77-157,485. PUB. 3-17-2009. FILED S.R. 4-16-2007; AM. P.R. 7-31-2008.

3,629,297. **MORTGAGE MENSCH (BLOCK FORM)**. DAVID GROSSMAN, (U.S. CLS. 100, 101 AND 102). SN 77-180,136. PUB. 5-20-2008. FILED 5-14-2007.

3,629,328. **MISCELLANEOUS DESIGN**. TANDEM ENTREPRENEUR MANAGEMENT SERVICES, LLC, (U.S. CLS. 100, 101 AND 102). SN 77-236,694. PUB. 3-17-2009. FILED 7-23-2007.

3,629,330 (*See Class 35 for this trademark.*).

3,629,411 (*See Class 35 for this trademark.*).

3,629,416. **PMI BUSTER (BLOCK FORM)**. QUICKEN LOANS INC., (U.S. CLS. 100, 101 AND 102). SN 77-318,844. PUB. 3-17-2009. FILED 11-1-2007.

3,629,444. **NELIX (BLOCK FORM)**. NELIX, INC., MULTIPLE CLASS, (INT. CLS. 36 AND 42), (U.S. CLS. 100, 101 AND 102). SN 77-338,113. PUB. 3-17-2009. FILED 11-27-2007.

3,629,476. **CB COLUMBIA BANK AND DESIGN**. COLUMBIA STATE BANK, (U.S. CLS. 100, 101 AND 102). SN 77-361,248. PUB. 3-17-2009. FILED 12-28-2007.

3,629,477. **CB COLUMBIA BANK YOU'LL NOTICE THE DIFFERENCE. AND DESIGN**. COLUMBIA STATE BANK, (U.S. CLS. 100, 101 AND 102). SN 77-361,299. PUB. 3-17-2009. FILED 12-28-2007.

3,629,480. **GS LABORATORIES (BLOCK FORM)**. G.S. LABORATORIES OF AMERICA, INC., MULTIPLE CLASS, (INT. CLS. 36 AND 42), (U.S. CLS. 100, 101 AND 102). SN 77-363,502. PUB. 3-17-2009. FILED 1-3-2008.

3,629,498. **PROCEDANT (BLOCK FORM)**. PROCEDANT INSURANCE COMPANY, (U.S. CLS. 100, 101 AND 102). SN 77-373,691. PUB. 3-17-2009. FILED 1-16-2008.

3,629,509. **CHARITY: WATER (BLOCK FORM)**. CHARITY GLOBAL, INC., (U.S. CLS. 100, 101 AND 102). SN 77-380,987. PUB. 3-17-2009. FILED 1-25-2008.

3,629,517. **THE CALIFORNIA ENDOWMENT AND DESIGN**. THE CALIFORNIA ENDOWMENT, MULTIPLE CLASS, (INT. CLS. 36 AND 44), (U.S. CLS. 100, 101 AND 102). SN 77-383,605. PUB. 3-17-2009. FILED 1-29-2008.

3,629,537 (*See Class 35 for this trademark.*).

3,629,539 (*See Class 35 for this trademark.*).

3,629,546. **LUCY GATEWAY (BLOCK FORM)**. CYNERGY DATA, LLC, (U.S. CLS. 100, 101 AND 102). SN 77-397,821. PUB. 3-17-2009. FILED 2-15-2008.

3,629,600. **R REDLINE AND DESIGN**. REDLINE, MULTIPLE CLASS, (INT. CLS. 36 AND 41), (U.S. CLS. 100, 101, 102 AND 107). SN 77-422,264. PUB. 3-17-2009. FILED 3-14-2008.

3,629,602. **ROBBINS WEALTHPARTNERS (BLOCK FORM)**. ROBBINS WEALTHPARTNERS LLC, (U.S. CLS. 100, 101 AND 102). SN 77-422,634. PUB. 3-17-2009. FILED 3-14-2008.

3,629,606. **FIGHTING CANCER SUPPORT FROZEN PEA FUND AND DESIGN**. REECE, CONNIE, (U.S. CLS. 100, 101 AND 102). SN 77-425,507. PUB. 3-17-2009. FILED 3-18-2008.

3,629,616. **WHEDA WE DO SO YOU CAN. AND DESIGN**. WISCONSIN HOUSING AND ECONOMIC DEVELOPMENT AUTHORITY, DBAWHEDA, (U.S. CLS. 100, 101 AND 102). SN 77-431,165. PUB. 3-17-2009. FILED 3-25-2008.

3,629,619. **AUTO 360 CAPITAL SOLUTIONS (BLOCK FORM)**. FLATIRON FINANCIAL SERVICES INC., (U.S. CLS. 100, 101 AND 102). SN 77-431,773. PUB. 3-17-2009. FILED 3-26-2008.

3,629,628. **BETTERLIFESTYLES (BLOCK FORM)**. FRANCHISE WINNER, INC., (U.S. CLS. 100, 101 AND 102). SN 77-433,152. PUB. 3-17-2009. FILED 3-27-2008.

3,629,632. **FREMONT REWARDS (BLOCK FORM)**. FREMONT BANK, (U.S. CLS. 100, 101 AND 102). SN 77-433,716. PUB. 3-17-2009. FILED 3-27-2008.

3,629,650. **WHEDA WE DO SO YOU CAN. AND DESIGN**. WISCONSIN HOUSING AND ECONOMIC DEVELOPMENT AUTHORITY, DBA WHEDA, (U.S. CLS. 100, 101

- AND 102). SN 77-436,522. PUB. 3-17-2009. FILED 4-1-2008.
- 3,629,672. **SHORTRETIME (BLOCK FORM)**. HOMEFREEME, LLC, (U.S. CLS. 100, 101 AND 102). SN 77-440,306. PUB. 3-17-2009. FILED 4-4-2008.
- 3,629,700. **JAMES CAIRD (BLOCK FORM)**. JAMES CAIRD ASSET MANAGEMENT LLP, (U.S. CLS. 100, 101 AND 102). SN 77-443,621. PUB. 3-17-2009. FILED 4-9-2008.
- 3,629,740 (*See Class 35 for this trademark*).
- 3,629,747 (*See Class 9 for this trademark*).
- 3,629,771 (*See Class 35 for this trademark*).
- 3,629,780. **T SYSTEMS AND DESIGN**. DEUTSCHE TELEKOM, (U.S. CLS. 100, 101 AND 102). SN 77-450,728. PUB. 3-17-2009. FILED 4-17-2008.
- 3,629,793. **T HOME AND DESIGN**. DEUTSCHE TELEKOM, (U.S. CLS. 100, 101 AND 102). SN 77-451,403. PUB. 1-13-2009. FILED 4-17-2008.
- 3,629,801. **. PORTABLE PRACTICAL EDUCATIONAL PREPARATION, INC., SINCE 1967, PPEP INC. AND DESIGN**. PORTABLE PRACTICAL EDUCATIONAL PREPARATION, INC., (U.S. CLS. 100, 101 AND 102). SN 77-451,977. PUB. 3-17-2009. FILED 4-18-2008.
- 3,629,805. **SIGNAPAY AND DESIGN**. SIGNAPAY, LTD., (U.S. CLS. 100, 101 AND 102). SN 77-452,363. PUB. 3-17-2009. FILED 4-18-2008.
- 3,629,854. **MISCELLANEOUS DESIGN**. SELECTHEALTH, INC., (U.S. CLS. 100, 101 AND 102). SN 77-457,311. PUB. 3-17-2009. FILED 4-24-2008.
- 3,629,864. **WATKINS: CSI (BLOCK FORM)**. WATKINS, MEEGAN, DRURY, & COMPANY, L.L.C., (U.S. CLS. 100, 101 AND 102). SN 77-459,261. PUB. 3-17-2009. FILED 4-28-2008.
- 3,629,868. **REALTYPLUS (STYLIZED)**. NAVY FEDERAL CREDIT UNION, (U.S. CLS. 100, 101 AND 102). SN 77-460,287. PUB. 3-17-2009. FILED 4-29-2008.
- 3,629,869. **COVERX THE COVERAGE EXPERTS (BLOCK FORM)**. COVERX CORPORATION, (U.S. CLS. 100, 101 AND 102). SN 77-460,462. PUB. 3-17-2009. FILED 4-29-2008.
- 3,629,877. **MISCELLANEOUS DESIGN**. SCHOLARSHIP AMERICA, INC., MULTIPLE CLASS, (INT. CLS. 36 AND 41), (U.S. CLS. 100, 101, 102 AND 107). SN 77-461,564. PUB. 3-17-2009. FILED 4-30-2008.
- 3,629,895. **ORANGE PROTECTION PROGRAM (BLOCK FORM)**. KUBOTA TRACTOR CORPORATION, (U.S. CLS. 100, 101 AND 102). SN 77-465,707. PUB. 3-17-2009. FILED 5-5-2008.
- 3,629,904 (*See Class 35 for this trademark*).
- 3,629,907. **EMERALD CARD (BLOCK FORM)**. HRB INNOVATIONS, INC., (U.S. CLS. 100, 101 AND 102). SN 77-468,479. PUB. 10-14-2008. FILED 5-7-2008.
- 3,629,922. **OCTOMOD AND DESIGN**. OCTOMOD, INC., (U.S. CLS. 100, 101 AND 102). SN 77-472,183. PUB. 3-17-2009. FILED 5-12-2008.
- 3,630,000. **LINDA "Z" (BLOCK FORM)**. Z, LINDA, (U.S. CLS. 100, 101 AND 102). SN 77-493,653. PUB. 3-17-2009. FILED 6-8-2008.
- 3,630,016. **THE CARTER CENTER AND DESIGN**. THE CARTER CENTER, INC., MULTIPLE CLASS, (INT. CLS. 36 AND 41), (U.S. CLS. 100, 101, 102 AND 107). SN 77-496,374. PUB. 3-17-2009. FILED 6-11-2008.
- 3,630,017. **MISCELLANEOUS DESIGN**. THE CARTER CENTER, INC., MULTIPLE CLASS, (INT. CLS. 36 AND 41), (U.S. CLS. 100, 101, 102 AND 107). SN 77-496,425. PUB. 3-17-2009. FILED 6-11-2008.
- 3,630,020. **WAMU FREE CHECKING (BLOCK FORM)**. WASHINGTON MUTUAL, INC., (U.S. CLS. 100, 101 AND 102). SN 77-496,903. PUB. 3-17-2009. FILED 6-11-2008.
- 3,630,035. **MEMORIAL SLOAN-KETTERING CANCER CENTER ROCK & RUN ON THE RIVER CELEBRATING LIFE BEYOND CANCER AND DESIGN**. MEMORIAL SLOAN-KETTERING CANCER CENTER, (U.S. CLS. 100, 101 AND 102). SN 77-500,096. PUB. 3-17-2009. FILED 6-16-2008.
- 3,630,048. **MORTGAGE PROTECTION CENTER (BLOCK FORM)**. SUPERIOR PERFORMERS, INC., (U.S. CLS. 100, 101 AND 102). SN 77-505,405. PUB. 3-17-2009. FILED 6-23-2008.
- 3,630,062. **MISCELLANEOUS DESIGN**. QUADRANT INFORMATION SERVICES, LLC, (U.S. CLS. 100, 101 AND 102). SN 77-509,307. PUB. 3-17-2009. FILED 6-26-2008.
- 3,630,077. **AMAZON CURRENCY CONVERTER (BLOCK FORM)**. AMAZON TECHNOLOGIES, INC., (U.S. CLS. 100, 101 AND 102). SN 77-516,259. PUB. 3-17-2009. FILED 7-7-2008.
- 3,630,111. **NGL AND DESIGN**. NORTHWEST GEMOLOGICAL LABORATORY, INC., (U.S. CLS. 100, 101 AND 102). SN 77-524,085. PUB. 3-17-2009. FILED 7-16-2008.
- 3,630,142 (*See Class 35 for this trademark*).
- 3,630,210. **THE WILLIAM E. PROUDFORD SICKLE CELL FUND, INC. AND DESIGN**. WILLIAM E. PROUDFORD SICKLE CELL FUND, INC., (U.S. CLS. 100, 101 AND 102). SN 77-549,078. PUB. 3-17-2009. FILED 8-18-2008.
- 3,630,219. **PRONTO! PASS (BLOCK FORM)**. TA OPERATING LLC, (U.S. CLS. 100, 101 AND 102). SN 77-551,696. PUB. 3-17-2009. FILED 8-20-2008.
- 3,630,231. **THE CFO COMPANY CUSTOM FINANCIAL (BLOCK FORM)**. FOCUS BUSINESS SOLUTIONS, LLC, (U.S. CLS. 100, 101 AND 102). SN 77-554,564. PUB. 3-17-2009. FILED S.R. 8-25-2008; AM. P.R. 12-8-2008.
- 3,630,239 (*See Class 35 for this trademark*).
- 3,630,240 (*See Class 35 for this trademark*).
- 3,630,241. **CASH FLOW ENHANCER (BLOCK FORM)**. SUCCESS STRATEGIES, INC., (U.S. CLS. 100, 101 AND 102). SN 77-555,971. PUB. 3-17-2009. FILED 8-26-2008.
- 3,630,258. **UC (STYLIZED)**. UNITED CONSUMERS CREDIT UNION, (U.S. CLS. 100, 101 AND 102). SN 77-558,287. PUB. 3-17-2009. FILED 8-28-2008.
- 3,630,268. **IHOME YOUR HOME LOAN FROM START TO FINISH AND DESIGN**. NORTHERN MASSACHUSETTS TELEPHONE WORKERS CREDIT UNION, (U.S. CLS. 100, 101 AND 102). SN 77-559,910. PUB. 3-17-2009. FILED 9-2-2008.
- 3,630,270. **THE HARTFORD (BLOCK FORM)**. HARTFORD FIRE INSURANCE COMPANY, DBA DBA, (U.S. CLS. 100, 101 AND 102). SN 77-560,080. PUB. 3-17-2009. FILED 9-2-2008.
- 3,630,271. **MISCELLANEOUS DESIGN**. HARTFORD FIRE INSURANCE COMPANY, (U.S. CLS. 100, 101 AND 102). SN 77-560,089. PUB. 3-17-2009. FILED 9-2-2008.
- 3,630,277. **CONCORDIA PLUS (BLOCK FORM)**. UNITED CONCORDIA COMPANIES, INC., (U.S. CLS. 100, 101 AND 102). SN 77-561,010. PUB. 3-17-2009. FILED 9-3-2008.
- 3,630,284. **THE BANK OF MIAMI AND DESIGN**. THE BANK OF MIAMI, NATIONAL ASSOCIATION, (U.S. CLS. 100, 101 AND 102). SN 77-562,504. PUB. 3-17-2009. FILED 9-4-2008.
- 3,630,294. **ANDERSON HENDRIX (BLOCK FORM)**. ANDERSON HENDRIX, MULTIPLE CLASS, (INT. CLS. 36 AND 42), (U.S. CLS. 100, 101 AND 102). SN 77-564,021. PUB. 3-17-2009. FILED 9-6-2008.
- 3,630,309 (*See Class 35 for this trademark*).
- 3,630,313 (*See Class 35 for this trademark*).
- 3,630,315. **THE C.F.O APPROACH CASH FLOW FINANCE OPERATIONS AND DESIGN**. FOCUS BUSINESS SOLUTIONS, LLC, (U.S. CLS. 100, 101 AND 102). SN 77-568,378. PUB. 3-17-2009. FILED 9-12-2008.
- 3,630,368. **SELCO FINANCIAL SOLUTIONS (BLOCK FORM)**. SELCO COMMUNITY CREDIT UNION, (U.S. CLS. 100, 101 AND 102). SN 77-574,743. PUB. 3-17-2009. FILED 9-19-2008.
- 3,630,405. **KIDD'S KIDS (BLOCK FORM)**. GLEA LLC, (U.S. CLS. 100, 101 AND 102). SN 77-579,463. PUB. 3-17-2009. FILED 9-26-2008.
- 3,630,406. **GO NO FEE ! COM AND DESIGN**. K & R REALTY INC MANAGEMENT INC., (U.S. CLS. 100, 101 AND 102). SN 77-579,600. PUB. 3-17-2009. FILED 9-26-2008.
- 3,630,412. **SEURAT (BLOCK FORM)**. LOCKTON, INC., (U.S. CLS. 100, 101 AND 102). SN 77-580,201. PUB. 3-17-2009. FILED 9-26-2008.
- 3,630,414. **SEURAT A STRATEGIC APPROACH TO HEALTH RISK MANAGEMENT AND DESIGN**. LOCKTON, INC., (U.S. CLS. 100, 101 AND 102). SN 77-580,243. PUB. 3-17-2009. FILED 9-26-2008.
- 3,630,426. **ORVIS CUSHMAN & WAKEFIELD (STYLIZED)**. ORVIS/CUSHMAN & WAKEFIELD RANCH AND RECREATIONAL PROPERTIES, LLC, (U.S. CLS. 100, 101 AND 102). SN 77-581,567. PUB. 3-17-2009. FILED 9-29-2008.
- 3,630,433 (*See Class 9 for this trademark*).
- 3,630,444. **P.E.O. PROGRAM FOR CONTINUING EDUCATION AND DESIGN**. INTERNATIONAL CHAPTER P.E.O.

- SISTERHOOD, (U.S. CLS. 100, 101 AND 102). SN 77-584,541. PUB. 3-17-2009. FILED 10-2-2008.
- 3,630,448. **FIREMAN'S FUND INSURANCE COMPANY AND DESIGN.** FIREMAN'S FUND INSURANCE COMPANY, (U.S. CLS. 100, 101 AND 102). SN 77-584,899. PUB. 3-17-2009. FILED 10-3-2008.
- 3,630,459. **G GREENERGY CAPITAL HOLDINGS (STYLIZED).** GREENERGY CAPITAL HOLDINGS, LLC, (U.S. CLS. 100, 101 AND 102). SN 77-586,674. PUB. 3-17-2009. FILED 10-6-2008.
- 3,630,462. **SIGNATURE ESTATE & INVESTMENT ADVISORS (BLOCK FORM).** SIGNATURE ESTATE & INVESTMENT ADVISORS, LLC, (U.S. CLS. 100, 101 AND 102). SN 77-586,733. PUB. 3-17-2009. FILED 10-6-2008.
- 3,630,485. **DAVINCI INSURANCE SERVICES (BLOCK FORM).** DAVINCI INSURANCE SERVICES, INC., (U.S. CLS. 100, 101 AND 102). SN 77-588,151. PUB. 3-17-2009. FILED 10-8-2008.
- 3,630,486. **ENVIROFINANCE (BLOCK FORM).** ENVIROFINANCE GROUP, LLC, (U.S. CLS. 100, 101 AND 102). SN 77-588,241. PUB. 3-17-2009. FILED 10-8-2008.
- 3,630,528. **TINAFOUNTAIN.COM (BLOCK FORM).** TINA FOUNTAIN, INC., (U.S. CLS. 100, 101 AND 102). SN 77-592,001. PUB. 3-17-2009. FILED 10-14-2008.
- 3,630,529. **IH INVESTORHELPERS AND DESIGN.** MOORE, DARIAN, (U.S. CLS. 100, 101 AND 102). SN 77-592,028. PUB. 3-17-2009. FILED 10-14-2008.
- 3,630,531. **STARMAZING RACE (BLOCK FORM).** STARLIGHT CHILDREN'S FOUNDATION, (U.S. CLS. 100, 101 AND 102). SN 77-592,169. PUB. 3-17-2009. FILED 10-14-2008.
- 3,630,536. **COMMUNITYAMERICAN (BLOCK FORM).** COMMUNITYAMERICA CREDIT UNION, (U.S. CLS. 100, 101 AND 102). SN 77-592,471. PUB. 3-17-2009. FILED 10-14-2008.
- 3,630,537. **JOIN IN AT WORK (BLOCK FORM).** COMMUNITYAMERICA CREDIT UNION, (U.S. CLS. 100, 101 AND 102). SN 77-592,479. PUB. 3-17-2009. FILED 10-14-2008.
- 3,630,541. **ANDERSON ZURMUEHLEN (BLOCK FORM).** ANDERSON ZURMUEHLEN & CO., P.C., (U.S. CLS. 100, 101 AND 102). SN 77-592,692. PUB. 3-17-2009. FILED 10-14-2008.
- 3,630,547. **DUNBAR ATM CASH OPTIMIZATION AND DESIGN.** DUNBAR ARMORED, INC, MULTIPLE CLASS, (INT. CLS. 36 AND 39), (U.S. CLS. 100, 101, 102 AND 105). SN 77-592,926. PUB. 3-17-2009. FILED 10-15-2008.
- 3,630,554. **JAPAN LINK (STYLIZED).** ENTREPIA GP III, LLC, (U.S. CLS. 100, 101 AND 102). SN 77-593,631. PUB. 3-17-2009. FILED 10-15-2008.
- 3,630,620. **IFX (BLOCK FORM).** INTEGRITY FX, LLC, (U.S. CLS. 100, 101 AND 102). SN 77-596,546. PUB. 3-17-2009. FILED 10-20-2008.
- 3,630,628. **C CHINA INVESTMENT CORPORATION AND DESIGN.** CHINA INVESTMENT CORPORATION, (U.S. CLS. 100, 101 AND 102). SN 77-596,675. PUB. 3-17-2009. FILED 10-21-2008.
- 3,630,650. **FINANCIAL ONE (BLOCK FORM).** FINANCIAL ONE MORTGAGE CORPORATION, (U.S. CLS. 100, 101 AND 102). SN 77-597,053. PUB. 3-17-2009. FILED 10-21-2008.
- 3,630,694. **QUADRANT (BLOCK FORM).** QUADRANT STRUCTURED PRODUCTS COMPANY, LTD., (U.S. CLS. 100, 101 AND 102). SN 77-598,146. PUB. 3-17-2009. FILED 10-22-2008.
- 3,630,717. **FREEDOM GROWTH IRA REAL ESTATE INVESTING AND DESIGN.** COEMINGLE INVESTMENTS LLC, AND RITTER REAL ESTATE SERVICES, INC., (U.S. CLS. 100, 101 AND 102). SN 77-598,478. PUB. 3-17-2009. FILED 10-22-2008.
- 3,630,743. **IBKR (BLOCK FORM).** INTERACTIVE BROKERS LLC, (U.S. CLS. 100, 101 AND 102). SN 77-598,848. PUB. 3-17-2009. FILED 10-23-2008.
- 3,630,758. **WE WERE HERE FOR YOU YESTERDAY. WE ARE HERE FOR YOU TODAY. WE WILL BE HERE FOR YOU TOMORROW. (BLOCK FORM).** REPUBLIC BANK & TRUST COMPANY, (U.S. CLS. 100, 101 AND 102). SN 77-598,988. PUB. 3-17-2009. FILED 10-23-2008.
- 3,630,769. **SSU AND DESIGN.** SPORTS SCHOLARSHIPS USA, LLC, (U.S. CLS. 100, 101 AND 102). SN 77-599,175. PUB. 3-17-2009. FILED 10-23-2008.
- 3,630,791. **CELLTHISHOME.COM AND DESIGN.** HENDERSON, LYNN, (U.S. CLS. 100, 101 AND 102). SN 77-599,525. PUB. 3-17-2009. FILED 10-23-2008.
- 3,630,805. **POWER DEPOSIT (BLOCK FORM).** FIRST CITIZENS NATIONAL BANK, (U.S. CLS. 100, 101 AND 102). SN 77-599,707. PUB. 3-17-2009. FILED 10-24-2008.
- 3,630,848. **SEVEN BRIDGES PARTNERS, L.P. (BLOCK FORM).** SEVEN BRIDGES MANAGEMENT, L.P., (U.S. CLS. 100, 101 AND 102). SN 77-600,188. PUB. 3-17-2009. FILED 10-24-2008.
- 3,630,859. **ANGELS DONATE FF MILES (BLOCK FORM).** ANGELS DONATE FF MILES, (U.S. CLS. 100, 101 AND 102). SN 77-600,344. PUB. 3-17-2009. FILED 10-24-2008.
- 3,630,904. **SUNSIETSLANDRUSH.COM (BLOCK FORM).** CAMINO REAL LAND CORPORATION, (U.S. CLS. 100, 101 AND 102). SN 77-600,952. PUB. 3-17-2009. FILED 10-27-2008.
- 3,630,924. **NETWORK CAPITAL (BLOCK FORM).** NETWORK CAPITAL FUNDING CORPORATION, (U.S. CLS. 100, 101 AND 102). SN 77-601,218. PUB. 3-17-2009. FILED 10-27-2008.
- 3,630,932. **MAXIM (BLOCK FORM).** GREAT-WEST LIFE & ANNUITY INSURANCE COMPANY, (U.S. CLS. 100, 101 AND 102). SN 77-601,289. PUB. 3-17-2009. FILED 10-27-2008.
- 3,630,933. **GLOBEWALLET (BLOCK FORM).** M2 INTERNATIONAL, LTD., (U.S. CLS. 100, 101 AND 102). SN 77-601,327. PUB. 3-17-2009. FILED 10-27-2008.
- 3,630,946. **ROUTE 66 EXTENDED WARRANTY AND DESIGN.** AUTO SERVICES COMPANY, INC., (U.S. CLS. 100, 101 AND 102). SN 77-601,498. PUB. 3-17-2009. FILED 10-27-2008.
- 3,631,002. **LCBA AND DESIGN.** LOYAL CHRISTIAN BENEFIT ASSOCIATION, (U.S. CLS. 100, 101 AND 102). SN 77-602,224. PUB. 3-17-2009. FILED 10-28-2008.
- 3,631,004. **LCBA TOMORROW.TOGETHER. AND DESIGN.** LOYAL CHRISTIAN BENEFIT ASSOCIATION, (U.S. CLS. 100, 101 AND 102). SN 77-602,257. PUB. 3-17-2009. FILED 10-28-2008.
- 3,631,017. **CHECKPOINT MORTGAGE (BLOCK FORM).** CHECKPOINT MORTGAGE, INC., (U.S. CLS. 100, 101 AND 102). SN 77-602,417. PUB. 3-17-2009. FILED 10-28-2008.
- 3,631,026. **CHAMPIONS OF DISCOVERY (BLOCK FORM).** CHAMPIONS OF DISCOVERY, (U.S. CLS. 100, 101 AND 102). SN 77-602,560. PUB. 3-17-2009. FILED 10-28-2008.
- 3,631,060. **RACE4RWANDA (BLOCK FORM).** LIQUIDNET HOLDINGS, INC., (U.S. CLS. 100, 101 AND 102). SN 77-603,219. PUB. 3-17-2009. FILED 10-29-2008.
- 3,631,062. **THE BLVD B (STYLIZED).** FLAHERTY & COLLINS MANAGEMENT, INC., (U.S. CLS. 100, 101 AND 102). SN 77-603,249. PUB. 3-17-2009. FILED 10-29-2008.
- 3,631,067. **MISCELLANEOUS DESIGN.** NDG INVESTMENT GROUP L.L.C., (U.S. CLS. 100, 101 AND 102). SN 77-603,382. PUB. 3-17-2009. FILED 10-29-2008.
- 3,631,068. **NDG (BLOCK FORM).** NDG INVESTMENT GROUP L.L.C., (U.S. CLS. 100, 101 AND 102). SN 77-603,386. PUB. 3-17-2009. FILED 10-29-2008.
- 3,631,074. **PENNYMAC AND DESIGN.** PRIVATE NATIONAL MORTGAGE ACCEPTANCE COMPANY, LLC, (U.S. CLS. 100, 101 AND 102). SN 77-603,514. PUB. 3-17-2009. FILED 10-29-2008.
- 3,631,081. **HOPE FOR FAMILIES, WORLDWIDE (BLOCK FORM).** HOPE FOR FAMILIES INC, DBA HOPE FOR FAMILIES, WORLDWIDE, (U.S. CLS. 100, 101 AND 102). SN 77-603,605. PUB. 3-17-2009. FILED 10-29-2008.
- 3,631,099. **HONESTLY FREE CHECKING (BLOCK FORM).** UNIVEST CORPORATION OF PENNSYLVANIA, (U.S. CLS. 100, 101 AND 102). SN 77-603,836. PUB. 3-17-2009. FILED 10-30-2008.
- 3,631,173. **A FLEXIBLE ALTERNATIVE TO INSURANCE (BLOCK FORM).** COASTAL DENTAL, INC., (U.S. CLS. 100, 101 AND 102). SN 77-605,103. PUB. 3-17-2009. FILED 10-31-2008.
- 3,631,182. **WE WERE MADE FOR TIMES LIKE THESE (STYLIZED).** BANCINSURE, INC., (U.S. CLS. 100, 101 AND 102). SN 77-605,314. PUB. 3-17-2009. FILED 10-31-2008.
- 3,631,209. **QUICK ALERT (BLOCK FORM).** PREFERRED HOME BUYERS NETWORK, INC., (U.S. CLS. 100, 101 AND 102). SN 77-605,521. PUB. 3-17-2009. FILED 10-31-2008.
- 3,631,220. **FINALYZ (BLOCK FORM).** FINALYZ AG, (U.S. CLS. 100, 101 AND 102). SN 77-605,658. PUB. 3-17-2009. FILED 11-2-2008.
- 3,631,252. **ENVIROFINANCE GROUP (BLOCK FORM).** EN-

- VIROFINANCE GROUP, LLC, (U.S. CLS. 100, 101 AND 102). SN 77-606,357. PUB. 3-17-2009. FILED 11-3-2008.
- 3,631,299. **WHAT'S YOUR EQ? (BLOCK FORM)**, EQ GROUP, INC., (U.S. CLS. 100, 101 AND 102). SN 77-612,974. PUB. 3-17-2009. FILED 11-12-2008.
- 3,631,317. **MISCELLANEOUS DESIGN**, UNIVEST CORPORATION OF PENNSYLVANIA, (U.S. CLS. 100, 101 AND 102). SN 77-617,867. PUB. 3-17-2009. FILED 11-19-2008.
- 3,631,322 (*See Class 35 for this trademark*).
- 3,631,326. **QUARTER BACK (BLOCK FORM)**, LIBERTY BANK, (U.S. CLS. 100, 101 AND 102). SN 77-620,423. PUB. 3-17-2009. FILED 11-24-2008.
- 3,631,338. **TINA FOUNTAIN, REALTORS (BLOCK FORM)**, TINA FOUNTAIN, INC., (U.S. CLS. 100, 101 AND 102). SN 77-624,884. PUB. 3-17-2009. FILED 12-2-2008.
- 3,631,340. **L AND DESIGN**, TOYOTA JIDOSHA KABUSHIKI KAISHA, TA TOYOTA MOTOR CORPORATION, (U.S. CLS. 100, 101 AND 102). SN 77-627,615. PUB. 3-17-2009. FILED 12-5-2008.
- 3,631,350. **A.I.R. PROGRAM (BLOCK FORM)**, NYCOMED GMBH, (U.S. CLS. 100, 101 AND 102). SN 77-635,152. PUB. 3-17-2009. FILED 12-17-2008.
- 3,631,386. **DYNAMIC STRATEGIC ALL INCOME PORTFOLIO (BLOCK FORM)**, DUNDEE CORPORATION, (U.S. CLS. 100, 101 AND 102). SN 78-451,989. PUB. 3-17-2009. FILED 7-16-2004.
- 3,631,394 (*See Class 35 for this trademark*).
- 3,631,420 (*See Class 35 for this trademark*).
- 3,631,475 (*See Class 32 for this trademark*).
- 3,631,490. **CHAMPIONS FOR CHILDREN THE SOUL OF EDUCATION AND DESIGN**, FONDAZIONE CHAMPIONS FOR CHILDREN O.N.L.U.S., MULTIPLE CLASS, (INT. CLS. 36 AND 41), (U.S. CLS. 100, 101, 102 AND 107). SN 79-043,597. PUB. 3-17-2009. FILED 5-25-2007.
- 3,631,499 (*See Class 35 for this trademark*).
- 3,631,506 (*See Class 35 for this trademark*).
- 3,631,523. **F&C JADE FUND (BLOCK FORM)**, F&C MANAGEMENT LIMITED, (U.S. CLS. 100, 101 AND 102). SN 79-048,653. PUB. 3-17-2009. FILED 9-19-2007.
- 3,631,544 (*See Class 35 for this trademark*).
- 3,631,563. **SELINUS CAPITAL (BLOCK FORM)**, KULKE & ENGELKE MARKENVERWALTUNGS GBR; (AUTHORISED TO PRESENT: PARTICIPATOR; MATHIAS KULKE, 61348 BAD HOMBURG AND; VALÉRY-CHRISTOPH ENGELKE, 60322 FRANKFURT), (U.S. CLS. 100, 101 AND 102). SN 79-052,617. PUB. 3-17-2009. FILED 3-18-2008.
- 3,631,658 (*See Class 35 for this trademark*).
- 3,631,701 (*See Class 2 for this trademark*).
- 3,631,727 (*See Class 35 for this trademark*).
- 3,631,743 (*See Class 9 for this trademark*).
- 3,631,761 (*See Class 9 for this trademark*).
- 3,629,155. **DUCTMAN (BLOCK FORM)**, KIMBERLY, ROBERT, (U.S. CLS. 100, 103 AND 106). SN 76-687,967. PUB. 3-17-2009. FILED 3-21-2008.
- 3,629,168. **THE CONSTRUCTION PROFESSIONALS (BLOCK FORM)**, ROBERTSON-CECO II CORPORATION, MULTIPLE CLASS, (INT. CLS. 37 AND 42), (U.S. CLS. 100, 101, 103 AND 106). SN 76-688,991. PUB. 3-17-2009. FILED 4-25-2008.
- 3,629,188. **WOODMEISTER (BLOCK FORM)**, WOODMEISTER MASTER BUILDERS, INC., (U.S. CLS. 100, 103 AND 106). SN 76-692,120. PUB. 3-17-2009. FILED 8-18-2008.
- 3,629,203. **COMPASS DIRECTIONAL GUIDANCE, INC. AND DESIGN**, COMPASS DIRECTIONAL GUIDANCE, INC., (U.S. CLS. 100, 103 AND 106). SN 76-693,702. PUB. 3-17-2009. FILED 10-20-2008.
- 3,629,204. **COMPASS (BLOCK FORM)**, COMPASS DIRECTIONAL GUIDANCE, INC., (U.S. CLS. 100, 103 AND 106). SN 76-693,703. PUB. 3-17-2009. FILED 10-20-2008.
- 3,629,214. **MISCELLANEOUS DESIGN**, MCCLOSKEY MECHANICAL CONTRACTORS, INC., (U.S. CLS. 100, 103 AND 106). SN 76-693,997. PUB. 3-17-2009. FILED 11-3-2008.
- 3,629,253. **BRIDAS (STYLIZED)**, BRIDAS CORPORATION, MULTIPLE CLASS, (INT. CLS. 37 AND 42), (U.S. CLS. 100, 101, 103 AND 106). SN 77-084,450. PUB. 3-17-2009. FILED 1-17-2007.
- 3,629,265. **T TOSCANA AND DESIGN**, OMEGA GROUP OF HIGHLAND BEACH, LP, (U.S. CLS. 100, 103 AND 106). SN 77-101,839. PUB. 3-17-2009. FILED 2-7-2007.
- 3,629,295. **ECOCLEAN (BLOCK FORM)**, CORTAZZO, CARRIE K., AND CORTAZZO, MARC W., (U.S. CLS. 100, 103 AND 106). SN 77-174,798. PUB. 3-17-2009. FILED 5-7-2007.
- 3,629,354 (*See Class 35 for this trademark*).
- 3,629,364. **CAROLINA AND DESIGN**, CAROLINA LAND REALTY, LLC, (U.S. CLS. 100, 103 AND 106). SN 77-278,865. PUB. 3-17-2009. FILED 9-13-2007.
- 3,629,378. **VICTORIA GROVE A PLANNED COMMUNITY . RIVERSIDE, CALIFORNIA AND DESIGN**, DEVELOPMENT STRATEGIES LLC, (U.S. CLS. 100, 103 AND 106). SN 77-288,750. PUB. 3-17-2009. FILED 9-25-2007.
- 3,629,411 (*See Class 35 for this trademark*).
- 3,629,465 (*See Class 11 for this trademark*).
- 3,629,506 (*See Class 35 for this trademark*).
- 3,629,537 (*See Class 35 for this trademark*).
- 3,629,539 (*See Class 35 for this trademark*).
- 3,629,691 (*See Class 25 for this trademark*).
- 3,629,705. **D SH AND DESIGN**, DISH NETWORK L.L.C., MULTIPLE CLASS, (INT. CLS. 37 AND 38), (U.S. CLS. 100, 101, 103, 104 AND 106). SN 77-443,754. PUB. 3-17-2009. FILED 4-9-2008.
- 3,629,711 (*See Class 7 for this trademark*).
- 3,629,765. **MISCELLANEOUS DESIGN**, STUTH, WILLIAM L., SR., MULTIPLE CLASS, (INT. CLS. 37 AND 42), (U.S. CLS. 100, 101, 103 AND 106). SN 77-449,896. PUB. 3-17-2009. FILED 4-16-2008.
- 3,629,834. **GRAVEL TO GREEN (BLOCK FORM)**, SUDBERRY PROPERTIES/ENTITLEMENT, L.P., (U.S. CLS. 100, 103 AND 106). SN 77-455,104. PUB. 3-17-2009. FILED 4-22-2008.
- 3,629,835. **FROM GRAVEL TO GREEN (BLOCK FORM)**, SUDBERRY PROPERTIES/ENTITLEMENT, L.P., (U.S. CLS. 100, 103 AND 106). SN 77-455,114. PUB. 3-17-2009. FILED 4-22-2008.
- 3,629,890 (*See Class 35 for this trademark*).
- 3,629,925. **FREEDOM ELECTRONICS (BLOCK FORM)**, FREEDOM ELECTRONICS, INC., (U.S. CLS. 100, 103 AND 106). SN 77-473,019. PUB. 3-17-2009. FILED 5-13-2008.
- 3,629,962. **FBD (BLOCK FORM)**, FBD PARTNERSHIP, LP, (U.S. CLS. 100, 103 AND 106). SN 77-481,681. PUB. 3-17-2009. FILED 5-22-2008.
- 3,630,008. **PERAGALLO (STYLIZED)**, PERAGALLO PIPE ORGAN CO., (U.S. CLS. 100, 103 AND 106). SN 77-495,400. PUB. 3-17-2009. FILED 6-10-2008.
- 3,630,011. **PERAGALLO (BLOCK FORM)**, PERAGALLO PIPE ORGAN CO., (U.S. CLS. 100, 103 AND 106). SN 77-495,453. PUB. 3-17-2009. FILED 6-10-2008.
- 3,630,023. **ELECTRIX AND DESIGN**, KELLY, RAYMOND, AND MARSH, JEFF, (U.S. CLS. 100, 103 AND 106). SN 77-497,217. PUB. 3-17-2009. FILED 6-12-2008.
- 3,630,050. **ERS EQUIPMENT RELIABILITY SOLUTIONS AND DESIGN**, EQUIPMENT RELIABILITY SOLUTIONS LLC, (U.S. CLS. 100, 103 AND 106). SN 77-505,725. PUB. 3-17-2009. FILED 6-23-2008.
- 3,630,066. **AFTER HOURS OFFICE CLEANING AND DESIGN**, GLENN BOUDREAU, DBA AFTER HOURS OFFICE CLEANING, (U.S. CLS. 100, 103 AND 106). SN 77-510,937. PUB. 3-17-2009. FILED 6-30-2008.
- 3,630,160. **GUIDO AUTOMATIC GATES CAMERAS AND MORE AND DESIGN**, GUIDO AUTOMATIC GATES, CAMERAS AND MORE, LLC, DBA AUTOMATIC GATES, CAMERAS AND MORE, (U.S. CLS. 100, 103 AND 106). SN 77-536,644. PUB. 3-17-2009. FILED 7-31-2008.
- 3,630,250 (*See Class 6 for this trademark*).
- 3,630,257. **BUY MY BIKES (BLOCK FORM)**, BUY MY BIKES, INC., (U.S. CLS. 100, 103 AND 106). SN 77-558,241. PUB. 3-17-2009. FILED 8-28-2008.
- 3,630,263. **THINKWELL PROJECT MANAGEMENT AND DESIGN**, THINKWELL GROUP INC., (U.S. CLS. 100, 103 AND 106). SN 77-558,865. PUB. 3-17-2009. FILED 8-29-2008.
- 3,630,264. **THINKWELL DEVELOPMENT AND DESIGN**, THINKWELL GROUP INC., (U.S. CLS. 100, 103 AND 106). SN 77-559,117. PUB. 3-17-2009. FILED 8-29-2008.

CLASS 37—CONSTRUCTION AND REPAIR

- 3,630,279. **SMELL AND FEEL THE DIFFERENCE (BLOCK FORM)**. KEELING, BRAD, DBA ORGANIC CLEANERS LLC, (U.S. CLS. 100, 103 AND 106). SN 77-561,282. PUB. 3-17-2009. FILED 9-3-2008.
- 3,630,295 (*See Class 35 for this trademark*).
- 3,630,314. **A R2 AND DESIGN**. ADVANTAGE RAPID RESPONSE, LP, (U.S. CLS. 100, 103 AND 106). SN 77-568,072. PUB. 3-17-2009. FILED 9-11-2008.
- 3,630,325. **LUXCRETE (BLOCK FORM)**. CONCRETE POLISHING TECHNOLOGIES, INC., (U.S. CLS. 100, 103 AND 106). SN 77-569,259. PUB. 3-17-2009. FILED 9-12-2008.
- 3,630,343 (*See Class 35 for this trademark*).
- 3,630,388. **NATIONAL WATER SERVICES (BLOCK FORM)**. NATIONAL WATER SERVICES, INC., (U.S. CLS. 100, 103 AND 106). SN 77-578,209. PUB. 3-17-2009. FILED 9-24-2008.
- 3,630,390. **THE FUTURE OF FRAMING IS HERE (BLOCK FORM)**. PARR LUMBER COMPANY, MULTIPLE CLASS, (INT. CLS. 37 AND 40), (U.S. CLS. 100, 103 AND 106). SN 77-578,252. PUB. 3-17-2009. FILED 9-24-2008.
- 3,630,391. **NSCI NW STRUCTURAL COMPONENTS INSTALLATION AND DESIGN**. PARR LUMBER COMPANY, (U.S. CLS. 100, 103 AND 106). SN 77-578,256. PUB. 3-17-2009. FILED 9-24-2008.
- 3,630,394. **MISCELLANEOUS DESIGN**. FITNESS FIXX SERVICES, INC., (U.S. CLS. 100, 103 AND 106). SN 77-578,609. PUB. 3-17-2009. FILED 9-25-2008.
- 3,630,401. **"WE FIX WHAT YOUR HUSBAND REPAIRS" (BLOCK FORM)**. WALSH, TIMOTHY, DBA THE PROBLEM SOLVERS LLC, (U.S. CLS. 100, 103 AND 106). SN 77-579,283. PUB. 3-17-2009. FILED 9-26-2008.
- 3,630,439. **SUBMITTALPRO (BLOCK FORM)**. CLARKWESTERN BUILDING SYSTEMS, INC., (U.S. CLS. 100, 103 AND 106). SN 77-584,042. PUB. 3-17-2009. FILED 10-2-2008.
- 3,630,451. **SO CAL TINT (BLOCK FORM)**. RODRIGUEZ, MOISES, (U.S. CLS. 100, 103 AND 106). SN 77-584,944. PUB. 3-17-2009. FILED 10-3-2008.
- 3,630,477. **TBR TOTAL BATHROOM REMODELING & DESIGN (BLOCK FORM)**. KIRKPATRICK, NICK L, (U.S. CLS. 100, 103 AND 106). SN 77-587,819. PUB. 3-17-2009. FILED 10-7-2008.
- 3,630,487. **MISCELLANEOUS DESIGN**. IERNA, RONALD F., (U.S. CLS. 100, 103 AND 106). SN 77-588,502. PUB. 3-17-2009. FILED 10-8-2008.
- 3,630,532. **HOLIDEALS (BLOCK FORM)**. KB HOME, (U.S. CLS. 100, 103 AND 106). SN 77-592,303. PUB. 3-17-2009. FILED 10-14-2008.
- 3,630,592. **GREENWATT (BLOCK FORM)**. COOPER, ROBERT J, (U.S. CLS. 100, 103 AND 106). SN 77-595,639. PUB. 3-17-2009. FILED 10-18-2008.
- 3,630,616. **NORTHGATE AVIATION CHICO JET CENTER (BLOCK FORM)**. NORTHGATE AVIATION, INC., (U.S. CLS. 100, 103 AND 106). SN 77-596,387. PUB. 3-17-2009. FILED 10-20-2008.
- 3,630,627. **TITAN WRECKING & ENVIRONMENTAL (BLOCK FORM)**. TITAN WRECKING & ENVIRONMENTAL, LLC, MULTIPLE CLASS, (INT. CLS. 37 AND 40), (U.S. CLS. 100, 103 AND 106). SN 77-596,672. PUB. 3-17-2009. FILED 10-21-2008.
- 3,630,631. **WINDOVER CONSTRUCTION WHERE TEAMWORK BUILDS RESULTS AND DESIGN**. WINDOVER, LLC, (U.S. CLS. 100, 103 AND 106). SN 77-596,770. PUB. 3-17-2009. FILED 10-21-2008.
- 3,630,632. **WINDOVER DEVELOPMENT WHERE TEAMWORK BUILDS RESULTS AND DESIGN**. WINDOVER, LLC, (U.S. CLS. 100, 103 AND 106). SN 77-596,780. PUB. 3-17-2009. FILED 10-21-2008.
- 3,630,679. **W WEST ELECTRIC GROUP AND DESIGN**. WEST ELECTRIC GROUP, INC., (U.S. CLS. 100, 103 AND 106). SN 77-597,837. PUB. 3-17-2009. FILED 10-22-2008.
- 3,630,680. **TEAR-N-IT UP AND DESIGN**. TEAR-N-IT UP DEMOLITION, (U.S. CLS. 100, 103 AND 106). SN 77-597,854. PUB. 3-17-2009. FILED 10-22-2008.
- 3,630,716. **PINNACLE TELECOMMUNICATIONS (BLOCK FORM)**. PINNACLE TELECOMMUNICATIONS, INC., MULTIPLE CLASS, (INT. CLS. 37 AND 38), (U.S. CLS. 100, 101, 103, 104 AND 106). SN 77-598,470. PUB. 3-17-2009. FILED 10-22-2008.
- 3,630,754. **ZOOM AND DESIGN**. ZOOM SEWER & DRAIN CLEANING SERVICE, INC., (U.S. CLS. 100, 103 AND 106). SN 77-598,968. PUB. 3-17-2009. FILED 10-23-2008.
- 3,630,792. **STAR AND DESIGN**. SOUTH TEXAS AUTO REBUILDERS, INC., (U.S. CLS. 100, 103 AND 106). SN 77-599,528. PUB. 3-17-2009. FILED 10-23-2008.
- 3,630,800. **ASI FOOD SAFETY CONSULTANTS AND DESIGN**. ASI FOOD SAFETY CONSULTANTS, (U.S. CLS. 100, 103 AND 106). SN 77-599,640. PUB. 3-17-2009. FILED 10-24-2008.
- 3,630,817. **INTELLIGENTDESIGN AND DESIGN**. SIMPLE HOME SOLUTIONS, (U.S. CLS. 100, 103 AND 106). SN 77-599,885. PUB. 3-17-2009. FILED 10-24-2008.
- 3,630,852. **DEEM (BLOCK FORM)**. DEEM, LLC, (U.S. CLS. 100, 103 AND 106). SN 77-600,212. PUB. 3-17-2009. FILED 10-24-2008.
- 3,630,853. **DEEM DON EDWARDS ELECTRICAL . MECHANICAL (BLOCK FORM)**. DEEM, LLC, (U.S. CLS. 100, 103 AND 106). SN 77-600,228. PUB. 3-17-2009. FILED 10-24-2008.
- 3,630,868. **CHIMNEY DOCTORS (BLOCK FORM)**. CHIMNEY DOCTORS, (U.S. CLS. 100, 103 AND 106). SN 77-600,469. PUB. 3-17-2009. FILED 10-24-2008.
- 3,630,912 (*See Class 6 for this trademark*).
- 3,630,916 (*See Class 6 for this trademark*).
- 3,630,927. **BRANDCARE (BLOCK FORM)**. IMAGEPOINT INC., (U.S. CLS. 100, 103 AND 106). SN 77-601,275. PUB. 3-17-2009. FILED 10-27-2008.
- 3,630,942. **AMP ELECTRIC COMPANY (BLOCK FORM)**. SUN STATE ELECTRIC COMPANY, INC., (U.S. CLS. 100, 103 AND 106). SN 77-601,387. PUB. 3-17-2009. FILED 10-27-2008.
- 3,630,964. **BATTERYMAX (BLOCK FORM)**. ALPINE POWER SYSTEMS, INC., AKA BATTERYMAX, POWERMAX, DYTRON POWER SYSTEMS, DELTA POWER SYSTEMS, SYSTEMS BY DESIGN, POWER SERVICE GROUP, EXPO POWER, SYSTEMS, ALPINE BATTERY, TFI BATTERY, MID-OHIO BATTERY, ESHELMAN POWER, MILLER-EADS TELECOM, WEST MICHIGAN BATTERY, BATTERYTESTING.COM., (U.S. CLS. 100, 103 AND 106). SN 77-601,846. PUB. 3-17-2009. FILED 10-28-2008.
- 3,630,965. **DIGNIFIED MOTORS (BLOCK FORM)**. DIGNIFIED LIVING, LLC, (U.S. CLS. 100, 103 AND 106). SN 77-601,862. PUB. 3-17-2009. FILED 10-28-2008.
- 3,631,019. **GERALD PELLETIER, INC. (BLOCK FORM)**. GERALD PELLETIER, INC., MULTIPLE CLASS, (INT. CLS. 37, 39 AND 40), (U.S. CLS. 100, 103, 105 AND 106). SN 77-602,460. PUB. 3-17-2009. FILED 10-28-2008.
- 3,631,228. **WHERE CLEAN MEETS GREEN (BLOCK FORM)**. GREEN EARTH DETAIL, LLC, (U.S. CLS. 100, 103 AND 106). SN 77-605,934. PUB. 3-17-2009. FILED 11-3-2008.
- 3,631,389 (*See Class 9 for this trademark*).
- 3,631,390 (*See Class 9 for this trademark*).
- 3,631,413 (*See Class 7 for this trademark*).
- 3,631,432 (*See Class 1 for this trademark*).
- 3,631,433 (*See Class 1 for this trademark*).
- 3,631,438 (*See Class 7 for this trademark*).
- 3,631,509 (*See Class 9 for this trademark*).
- 3,631,510 (*See Class 1 for this trademark*).
- 3,631,511 (*See Class 1 for this trademark*).
- 3,631,534 (*See Class 9 for this trademark*).
- 3,631,547 (*See Class 6 for this trademark*).
- 3,631,556 (*See Class 7 for this trademark*).
- 3,631,562 (*See Class 11 for this trademark*).
- 3,631,662 (*See Class 35 for this trademark*).
- 3,631,667 (*See Class 7 for this trademark*).
- 3,631,699 (*See Class 9 for this trademark*).
- 3,631,707 (*See Class 7 for this trademark*).
- 3,631,711 (*See Class 6 for this trademark*).
- 3,631,740 (*See Class 7 for this trademark*).
- 3,631,759 (*See Class 7 for this trademark*).
- 3,631,761 (*See Class 9 for this trademark*).

CLASS 38—COMMUNICATION

- 3,629,121 (*See Class 9 for this trademark*).
- 3,629,122 (*See Class 9 for this trademark*).
- 3,629,362. **GLOBE KABABAYAN (BLOCK FORM)**. GLOBE TELECOM, INC., (U.S. CLS. 100, 101 AND 104). SN 77-273,546. PUB. 3-17-2009. FILED 9-6-2007.

- 3,629,396. **YOUMAIL (BLOCK FORM)**. YOUMAIL, INC., (U.S. CLS. 100, 101 AND 104). SN 77-304,424. PUB. 3-17-2009. FILED 10-15-2007.
- 3,629,401. **RIBBIT AND DESIGN**. RIBBIT CORPORATION, DBA DUALITY, INC., MULTIPLE CLASS, (INT. CLS. 38 AND 39), (U.S. CLS. 100, 101, 104 AND 105). SN 77-306,303. PUB. 3-17-2009. FILED 10-17-2007.
- 3,629,402. **RIBBIT AND DESIGN**. RIBBIT CORPORATION, DBA DUALITY, INC., MULTIPLE CLASS, (INT. CLS. 38 AND 39), (U.S. CLS. 100, 101, 104 AND 105). SN 77-306,320. PUB. 3-17-2009. FILED 10-17-2007.
- 3,629,427 (*See Class 35 for this trademark*).
- 3,629,507 (*See Class 9 for this trademark*).
- 3,629,658. **COMIC VINE (BLOCK FORM)**. DIGITAL COMMONS LLC, MULTIPLE CLASS, (INT. CLS. 38, 41 AND 42), (U.S. CLS. 100, 101, 104 AND 107). SN 77-437,750. PUB. 3-17-2009. FILED 4-2-2008.
- 3,629,705 (*See Class 37 for this trademark*).
- 3,629,709. **MISCELLANEOUS DESIGN**. GLOBO COMUNICAÇÃO E PARTICIPAÇÕES S.A., MULTIPLE CLASS, (INT. CLS. 38, 41 AND 42), (U.S. CLS. 100, 101, 104 AND 107). SN 77-444,171. PUB. 3-17-2009. FILED 4-9-2008.
- 3,629,830. **UBIDYNE AND DESIGN**. UBIDYNE, INC., (U.S. CLS. 100, 101 AND 104). SN 77-454,893. PUB. 3-17-2009. FILED 4-22-2008.
- 3,629,848. **UB 900 AND DESIGN**. UBIDYNE, INC., (U.S. CLS. 100, 101 AND 104). SN 77-456,702. PUB. 3-17-2009. FILED 4-24-2008.
- 3,629,960 (*See Class 35 for this trademark*).
- 3,630,053 (*See Class 35 for this trademark*).
- 3,630,166. **SHIFTING DIGITAL IMAGINATION (BLOCK FORM)**. BRIGGS DIGITAL MEDIA, LLC, (U.S. CLS. 100, 101 AND 104). SN 77-537,195. PUB. 3-17-2009. FILED 8-1-2008.
- 3,630,178 (*See Class 9 for this trademark*).
- 3,630,297 (*See Class 9 for this trademark*).
- 3,630,321. **SAFELINK WIRELESS AND DESIGN**. TRACFONE WIRELESS, INC., (U.S. CLS. 100, 101 AND 104). SN 77-568,998. PUB. 3-17-2009. FILED 9-12-2008.
- 3,630,454. **ROADWARRIOR (BLOCK FORM)**. THE ILLUMEN GROUP, INC., (U.S. CLS. 100, 101 AND 104). SN 77-585,706. PUB. 3-17-2009. FILED 10-4-2008.
- 3,630,579. **G360° ADVANTAGE (BLOCK FORM)**. GHN-ONLINE, INC., (U.S. CLS. 100, 101 AND 104). SN 77-595,038. PUB. 3-17-2009. FILED 10-17-2008.
- 3,630,716 (*See Class 37 for this trademark*).
- 3,630,838. **AFN RADIO (BLOCK FORM)**. DEPARTMENT OF DEFENSE, MULTIPLE CLASS, (INT. CLS. 38 AND 41), (U.S. CLS. 100, 101, 104 AND 107). SN 77-600,114. PUB. 3-17-2009. FILED 10-24-2008.
- 3,631,038. **MERCY SHIPS (BLOCK FORM)**. MERCY SHIPS, (U.S. CLS. 100, 101 AND 104). SN 77-602,750. PUB. 3-17-2009. FILED 10-29-2008.
- 3,631,108. **AIRCCELL BROADBAND (BLOCK FORM)**. AIRCELL BUSINESS AVIATION SERVICES LLC, (U.S. CLS. 100, 101 AND 104). SN 77-604,031. PUB. 3-17-2009. FILED 10-30-2008.
- 3,631,144. **NEWSY (BLOCK FORM)**. MEDIA CONVERGENCE GROUP, INC., DBA MEDIA CONVERGENCE GROUP, INC., (U.S. CLS. 100, 101 AND 104). SN 77-604,559. PUB. 3-17-2009. FILED 10-30-2008.
- 3,631,151 (*See Class 16 for this trademark*).
- 3,631,245. **IVANS THE EXPERIENCE MAKES YOUR JOB EASIER (BLOCK FORM)**. IVANS, INC., (U.S. CLS. 100, 101 AND 104). SN 77-606,220. PUB. 3-17-2009. FILED 11-3-2008.
- 3,631,261. **L AND DESIGN**. MICHAEL R. LIMOTTA & CO., INC., DBA LIMOTTA INTERNET TECHNOLOGIES, MULTIPLE CLASS, (INT. CLS. 38 AND 42), (U.S. CLS. 100, 101 AND 104). SN 77-607,087. PUB. 3-17-2009. FILED 11-4-2008.
- 3,631,349. **WEEI (BLOCK FORM)**. ENTERCOM COMMUNICATIONS CORP., MULTIPLE CLASS, (INT. CLS. 38 AND 41), (U.S. CLS. 100, 101, 104 AND 107). SN 77-633,751. PUB. 3-17-2009. FILED 12-16-2008.
- 3,631,407 (*See Class 35 for this trademark*).
- 3,631,408. **TRIPLE-WEAVE (BLOCK FORM)**. BROADWEAVE NETWORKS, INC., (U.S. CLS. 100, 101 AND 104). SN 78-673,639. PUB. 3-17-2009. FILED 7-19-2005.
- 3,631,421 (*See Class 35 for this trademark*).
- 3,631,422 (*See Class 35 for this trademark*).
- 3,631,425. **FONCIA (BLOCK FORM)**. FONCIA, (U.S. CLS. 100, 101 AND 104). SN 78-845,655. PUB. 3-17-2009. FILED 3-24-2006.
- 3,631,438 (*See Class 7 for this trademark*).
- 3,631,479 (*See Class 16 for this trademark*).
- 3,631,480 (*See Class 9 for this trademark*).
- 3,631,489 (*See Class 35 for this trademark*).
- 3,631,496 (*See Class 9 for this trademark*).
- 3,631,502 (*See Class 9 for this trademark*).
- 3,631,514 (*See Class 35 for this trademark*).
- 3,631,534 (*See Class 9 for this trademark*).
- 3,631,537 (*See Class 35 for this trademark*).
- 3,631,542 (*See Class 16 for this trademark*).
- 3,631,651 (*See Class 16 for this trademark*).
- 3,631,676 (*See Class 9 for this trademark*).
- 3,631,727 (*See Class 35 for this trademark*).
- 3,631,743 (*See Class 9 for this trademark*).
- 3,631,751 (*See Class 9 for this trademark*).
- 3,631,757. **LUME (BLOCK FORM)**. BOEHRINGER INGELHEIM INTERNATIONAL GMBH, MULTIPLE CLASS, (INT. CLS. 38, 41 AND 42), (U.S. CLS. 100, 101, 104 AND 107). SN 79-059,998. PUB. 3-17-2009. FILED 8-28-2008.

CLASS 39—TRANSPORTATION AND STORAGE

- 3,629,122 (*See Class 9 for this trademark*).
- 3,629,175. **MISCELLANEOUS DESIGN**. THE FORT WAYNE-ALLEN COUNTY AIRPORT AUTHORITY, (U.S. CLS. 100 AND 105). SN 76-689,615. PUB. 3-17-2009. FILED 5-14-2008.
- 3,629,248. **JP POST (BLOCK FORM)**. JAPAN POST HOLDINGS CO., LTD, (U.S. CLS. 100 AND 105). SN 77-070,501. PUB. 3-17-2009. FILED 12-22-2006.
- 3,629,276 (*See Class 35 for this trademark*).
- 3,629,277 (*See Class 35 for this trademark*).
- 3,629,284 (*See Class 31 for this trademark*).
- 3,629,302 (*See Class 16 for this trademark*).
- 3,629,375. **JAMF SOFTWARE (BLOCK FORM)**. JAMF SOFTWARE, LLC, MULTIPLE CLASS, (INT. CLS. 39 AND 42), (U.S. CLS. 100, 101 AND 105). SN 77-287,837. PUB. 3-17-2009. FILED 9-25-2007.
- 3,629,381. **FR8 AND DESIGN**. FR8 SINGAPORE PTE LIMITED, (U.S. CLS. 100 AND 105). SN 77-293,831. PUB. 3-17-2009. FILED 10-2-2007.
- 3,629,383 (*See Class 35 for this trademark*).
- 3,629,397 (*See Class 35 for this trademark*).
- 3,629,401 (*See Class 38 for this trademark*).
- 3,629,402 (*See Class 38 for this trademark*).
- 3,629,570. **TECHEDU (BLOCK FORM)**. TECHEDU, (U.S. CLS. 100 AND 105). SN 77-409,617. PUB. 3-17-2009. FILED 2-29-2008.
- 3,629,631. **COSCO (BLOCK FORM)**. CHINA OCEAN SHIPPING (GROUP) COMPANY, (U.S. CLS. 100 AND 105). SN 77-433,637. PUB. 3-17-2009. FILED 3-27-2008.
- 3,629,753. **PHOENIX LANDING (BLOCK FORM)**. PHOENIX LANDING FOUNDATION, (U.S. CLS. 100 AND 105). SN 77-448,603. PUB. 3-17-2009. FILED 4-15-2008.
- 3,629,815. **PALM BEACH STEAMSHIP AGENCY (BLOCK FORM)**. PALM BEACH STEAMSHIP AGENCY, INC., (U.S. CLS. 100 AND 105). SN 77-453,544. PUB. 3-17-2009. FILED 4-21-2008.
- 3,629,870. **NEW FAT CAR SERVICE (718) 328-3333 FN AND DESIGN**. NEW FAT INC., (U.S. CLS. 100 AND 105). SN 77-460,466. PUB. 3-17-2009. FILED 4-29-2008.
- 3,629,871. **FIELD STUDIES INTERNATIONAL (BLOCK FORM)**. LAKELAND FINANCE, LLC, MULTIPLE CLASS, (INT. CLS. 39 AND 41), (U.S. CLS. 100, 101, 105 AND 107). SN 77-460,473. PUB. 3-17-2009. FILED 4-29-2008.
- 3,629,874. **BIO STATE AND DESIGN**. BAYOU STATE OIL CORPORATION, (U.S. CLS. 100 AND 105). SN 77-460,774. PUB. 3-17-2009. FILED 4-29-2008.
- 3,629,880. **GRS AND DESIGN**. GILL RANCH STORAGE, LLC, (U.S. CLS. 100 AND 105). SN 77-462,461. PUB. 3-17-2009. FILED 4-30-2008.

- 3,629,881. **GILL RANCH STORAGE (BLOCK FORM)**. GILL RANCH STORAGE, LLC, (U.S. CLS. 100 AND 105). SN 77-462,464. PUB. 3-17-2009. FILED 4-30-2008.
- 3,630,009. **PERAGALLO (STYLIZED)**. PERAGALLO PIPE ORGAN CO., (U.S. CLS. 100 AND 105). SN 77-495,410. PUB. 3-17-2009. FILED 6-10-2008.
- 3,630,128. **MOTORCYCLEROADS.US YOUR ONE-STOP RESOURCE FOR GREAT MOTORCYCLE ROADS IN THE US (BLOCK FORM)**. SCREAMING EAGLE WEB SOLUTIONS, LLC, (U.S. CLS. 100 AND 105). SN 77-526,816. PUB. 3-17-2009. FILED 7-21-2008.
- 3,630,245 (*See Class 6 for this trademark*).
- 3,630,246 (*See Class 6 for this trademark*).
- 3,630,320. **UNION PACIFIC AND DESIGN**. UNION PACIFIC RAILROAD COMPANY, (U.S. CLS. 100 AND 105). SN 77-568,974. PUB. 3-17-2009. FILED 9-12-2008.
- 3,630,323. **DESERT MINI-STORAGE AND DESIGN**. SPENSA DEVELOPMENT GROUP, LLC, (U.S. CLS. 100 AND 105). SN 77-569,061. PUB. 2-10-2009. FILED 9-12-2008.
- 3,630,385 (*See Class 35 for this trademark*).
- 3,630,547 (*See Class 36 for this trademark*).
- 3,630,568. **WHEELCHAIR ANYWHERE ASC TRANSPORTATION AND DESIGN**. AFFORDABLE SENIOR CARE INC., DBA ASC TRANSPORTATION, (U.S. CLS. 100 AND 105). SN 77-594,353. PUB. 3-17-2009. FILED 10-16-2008.
- 3,630,612. **GET A MOVE ON (BLOCK FORM)**. GET A MOVE ON, INC., (U.S. CLS. 100 AND 105). SN 77-596,188. PUB. 3-17-2009. FILED 10-20-2008.
- 3,630,618. **PREFERRED ACCESS (BLOCK FORM)**. MHC TT LEASING COMPANY, INC., MULTIPLE CLASS, (INT. CLS. 39 AND 43), (U.S. CLS. 100, 101 AND 105). SN 77-596,417. PUB. 3-17-2009. FILED 10-20-2008.
- 3,631,019 (*See Class 37 for this trademark*).
- 3,631,053. **GOPHILANTHROPIC (BLOCK FORM)**. DEAN, LYDIA A., (U.S. CLS. 100 AND 105). SN 77-603,064. PUB. 3-17-2009. FILED 10-29-2008.
- 3,631,136. **TAKE A DUMPER (BLOCK FORM)**. FOY, KEEN-AN T., (U.S. CLS. 100 AND 105). SN 77-604,504. PUB. 3-17-2009. FILED 10-30-2008.
- 3,631,179 (*See Class 35 for this trademark*).
- 3,631,180 (*See Class 35 for this trademark*).
- 3,631,186. **GLS TRANSPORT AND DESIGN**. GLS TRANSPORT INC., (U.S. CLS. 100 AND 105). SN 77-605,394. PUB. 3-17-2009. FILED 10-31-2008.
- 3,631,273 (*See Class 35 for this trademark*).
- 3,631,347. **YAMPU LATIN AMERICA TOURS AND DESIGN**. KON-TIKI TOURS & TRAVEL INC., (U.S. CLS. 100 AND 105). SN 77-632,439. PUB. 3-17-2009. FILED 12-12-2008.
- 3,631,378 (*See Class 1 for this trademark*).
- 3,631,379. **ZONE CUISINE (BLOCK FORM)**. SEARS PH.D., BARRY D., (U.S. CLS. 100 AND 105). SN 78-383,282. PUB. 3-17-2009. FILED 3-12-2004.
- 3,631,394 (*See Class 35 for this trademark*).
- 3,631,430 (*See Class 35 for this trademark*).
- 3,631,439 (*See Class 35 for this trademark*).
- 3,631,502 (*See Class 9 for this trademark*).
- 3,631,517 (*See Class 6 for this trademark*).
- 3,631,583 (*See Class 12 for this trademark*).
- 3,631,606. **A 1847 C. STEINWEG AND DESIGN**. HANDELS-VEEM B.V., (U.S. CLS. 100 AND 105). SN 79-054,093. PUB. 3-17-2009. FILED 1-3-2008.
- 3,631,651 (*See Class 16 for this trademark*).
- 3,631,751 (*See Class 9 for this trademark*).
- 3,631,756. **ISC AND DESIGN**. ISC CO., LTD., MULTIPLE CLASS, (INT. CLS. 39 AND 40), (U.S. CLS. 100, 103, 105 AND 106). SN 79-059,967. PUB. 3-17-2009. FILED 9-3-2008.
- 3,631,782 (*See Class 11 for this trademark*).
- 3,631,783 (*See Class 11 for this trademark*).
- 3,631,784 (*See Class 11 for this trademark*).
- 3,629,321 (*See Class 6 for this trademark*).
- 3,629,352 (*See Class 35 for this trademark*).
- 3,629,361 (*See Class 7 for this trademark*).
- 3,629,373 (*See Class 16 for this trademark*).
- 3,629,380 (*See Class 2 for this trademark*).
- 3,629,397 (*See Class 35 for this trademark*).
- 3,629,447 (*See Class 24 for this trademark*).
- 3,629,479 (*See Class 1 for this trademark*).
- 3,629,492 (*See Class 9 for this trademark*).
- 3,629,525 (*See Class 6 for this trademark*).
- 3,629,526 (*See Class 6 for this trademark*).
- 3,629,584 (*See Class 35 for this trademark*).
- 3,629,629. **HARBOR GRAPHICS (STYLIZED)**. VOMELA SPECIALTY COMPANY, MULTIPLE CLASS, (INT. CLS. 40 AND 42), (U.S. CLS. 100, 101, 103 AND 106). SN 77-433,512. PUB. 3-17-2009. FILED 3-27-2008.
- 3,629,723. **OCEANWORKS (BLOCK FORM)**. OCEANWORKS INTERNATIONAL, INC., MULTIPLE CLASS, (INT. CLS. 40 AND 42), (U.S. CLS. 100, 101, 103 AND 106). SN 77-445,286. PUB. 3-17-2009. FILED 4-10-2008.
- 3,629,817. **MALIBU GALLERY (BLOCK FORM)**. TORRES, LOUIS, (U.S. CLS. 100, 103 AND 106). SN 77-453,616. PUB. 3-17-2009. FILED 4-21-2008.
- 3,629,872. **FOTO FIX AND DESIGN**. FOTOFIX, LLC, (U.S. CLS. 100, 103 AND 106). SN 77-460,608. PUB. 12-9-2008. FILED 4-29-2008.
- 3,629,911. **PHOTO FIX AND DESIGN**. FOTOFIX, LLC, (U.S. CLS. 100, 103 AND 106). SN 77-469,072. PUB. 12-9-2008. FILED 5-8-2008.
- 3,629,959 (*See Class 7 for this trademark*).
- 3,629,967. **YOURPHOTOS (BLOCK FORM)**. LYONS & ASSOCIATES, DBA YOUR PHOTOS, INC., (U.S. CLS. 100, 103 AND 106). SN 77-483,816. PUB. 3-17-2009. FILED 5-27-2008.
- 3,630,005 (*See Class 7 for this trademark*).
- 3,630,121. **MIN-TEC (BLOCK FORM)**. MINERAL TECHNOLOGIES INC., (U.S. CLS. 100, 103 AND 106). SN 77-525,352. PUB. 12-9-2008. FILED 7-17-2008.
- 3,630,304. **CROWE (BLOCK FORM)**. CROWE HORWATH LLP, MULTIPLE CLASS, (INT. CLS. 40, 42 AND 45), (U.S. CLS. 100, 101, 103 AND 106). SN 77-566,977. PUB. 3-17-2009. FILED 9-10-2008.
- 3,630,354. **UNIQUE RENEWABLES (BLOCK FORM)**. UNIQUE RENEWABLES LLC, (U.S. CLS. 100, 103 AND 106). SN 77-573,059. PUB. 3-17-2009. FILED 9-18-2008.
- 3,630,372. **EZ-SHOP (BLOCK FORM)**. MAINTENANCE SUPPLY HEADQUARTERS, LP, (U.S. CLS. 100, 103 AND 106). SN 77-575,882. PUB. 3-17-2009. FILED 9-22-2008.
- 3,630,385 (*See Class 35 for this trademark*).
- 3,630,390 (*See Class 37 for this trademark*).
- 3,630,402. **RAPID SHEET METAL (BLOCK FORM)**. RAPID SHEET METAL INC., (U.S. CLS. 100, 103 AND 106). SN 77-579,369. PUB. 3-17-2009. FILED 9-26-2008.
- 3,630,561. **MISCELLANEOUS DESIGN**. VOIGT & SCHWEITZER, INC., (U.S. CLS. 100, 103 AND 106). SN 77-593,914. PUB. 3-17-2009. FILED 10-16-2008.
- 3,630,563. **MISCELLANEOUS DESIGN**. VOIGT & SCHWEITZER, INC., (U.S. CLS. 100, 103 AND 106). SN 77-593,919. PUB. 3-17-2009. FILED 10-16-2008.
- 3,630,627 (*See Class 37 for this trademark*).
- 3,630,676. **AH AGGRESSIVE HYDRAULICS AND DESIGN**. AGGRESSIVE HYDRAULICS, (U.S. CLS. 100, 103 AND 106). SN 77-597,809. PUB. 3-17-2009. FILED 10-22-2008.
- 3,630,691. **PHOTOSPLITS (BLOCK FORM)**. CANVAS ON DEMAND, LLC, (U.S. CLS. 100, 103 AND 106). SN 77-598,100. PUB. 3-17-2009. FILED 10-22-2008.
- 3,630,714. **PHOTOREALISTIC (BLOCK FORM)**. CANVAS ON DEMAND, LLC, (U.S. CLS. 100, 103 AND 106). SN 77-598,455. PUB. 3-17-2009. FILED 10-22-2008.
- 3,630,735. **COZYMYPHOTO.COM (STYLIZED)**. CANVAS ON DEMAND, LLC, (U.S. CLS. 100, 103 AND 106). SN 77-598,797. PUB. 3-17-2009. FILED 10-23-2008.
- 3,630,787. **WE PAY IN TWO DOLLAR BILLS (BLOCK FORM)**. C&D SCRAP METAL RECYCLERS CO., INC., (U.S. CLS. 100, 103 AND 106). SN 77-599,454. PUB. 3-17-2009. FILED 10-23-2008.
- 3,630,797. **YOU GOT SOMETHIN' TO SAY? PUT IT ON A T-SHIRT! (BLOCK FORM)**. INDIVIDUALITEES, LLC, (U.S. CLS. 100, 103 AND 106). SN 77-599,620. PUB. 3-17-2009.

CLASS 40—MATERIAL TREATMENT

- 3,629,173. **NORTHWIRE DIRECT (STYLIZED)**. NORTHWIRE, INC., (U.S. CLS. 100, 103 AND 106). SN 76-689,481. PUB. 3-17-2009. FILED 5-9-2008.
- 3,629,291 (*See Class 9 for this trademark*).

FILED 10-24-2008.
 3,630,869. **RICNO TECHNOLOGIES INC. AND DESIGN.** RICNO TECHNOLOGIES, INC., (U.S. CLS. 100, 103 AND 106). SN 77-600,475. PUB. 3-17-2009. FILED 10-24-2008.
 3,630,906. **ACUTRACK (BLOCK FORM).** ACUTRACK, (U.S. CLS. 100, 103 AND 106). SN 77-600,977. PUB. 3-17-2009. FILED 10-27-2008.
 3,631,019 (*See Class 37 for this trademark*).
 3,631,231 (*See Class 16 for this trademark*).
 3,631,331 (*See Class 30 for this trademark*).
 3,631,378 (*See Class 1 for this trademark*).
 3,631,402 (*See Class 30 for this trademark*).
 3,631,432 (*See Class 1 for this trademark*).
 3,631,433 (*See Class 1 for this trademark*).
 3,631,497 (*See Class 16 for this trademark*).
 3,631,517 (*See Class 6 for this trademark*).
 3,631,554 (*See Class 1 for this trademark*).
 3,631,643 (*See Class 1 for this trademark*).
 3,631,647 (*See Class 9 for this trademark*).
 3,631,756 (*See Class 39 for this trademark*).
 3,631,759 (*See Class 7 for this trademark*).
 3,631,782 (*See Class 11 for this trademark*).
 3,631,783 (*See Class 11 for this trademark*).
 3,631,784 (*See Class 11 for this trademark*).

CLASS 41—EDUCATION AND ENTERTAINMENT

3,629,121 (*See Class 9 for this trademark*).
 3,629,122 (*See Class 9 for this trademark*).
 3,629,144. **EROS TRANSEXUALS (BLOCK FORM).** GROUP KAITU, LLC, (U.S. CLS. 100, 101 AND 107). SN 76-683,780. PUB. 3-17-2009. FILED 11-7-2007.
 3,629,163. **PURSUING TRUTH . DEFENDING LIBERTY SINCE 1844 (BLOCK FORM).** HILLSDALE COLLEGE, (U.S. CLS. 100, 101 AND 107). SN 76-688,695. PUB. 3-17-2009. FILED 4-17-2008.
 3,629,165 (*See Class 35 for this trademark*).
 3,629,176 (*See Class 9 for this trademark*).
 3,629,187. **THE BLACK DOLL AFFAIR WE'RE PRETTY... PHILANTHROPIC! (STYLIZED).** HILL, DANA, (U.S. CLS. 100, 101 AND 107). SN 76-691,988. PUB. 3-17-2009. FILED S.R. 8-12-2008; AM. P.R. 2-5-2009.
 3,629,210. **SPIRITUAL LIFE COACH AND DESIGN.** WATCH AND PRAY MINISTRIES, INC., (U.S. CLS. 100, 101 AND 107). SN 76-693,834. PUB. 3-17-2009. FILED 10-27-2008.
 3,629,225 (*See Class 36 for this trademark*).
 3,629,226 (*See Class 36 for this trademark*).
 3,629,228. **MISCELLANEOUS DESIGN.** BR CONSULTING, INC., (U.S. CLS. 100, 101 AND 107). SN 77-002,617. PUB. 1-13-2009. FILED 9-19-2006.
 3,629,243. **FOOLING APRIL (BLOCK FORM).** ANDERSON, BRIAN KENNETH, (U.S. CLS. 100, 101 AND 107). SN 77-060,534. PUB. 3-17-2009. FILED 12-8-2006.
 3,629,259. **SOCCERTOTS (BLOCK FORM).** SOCCERTOTS INCORPORATED, (U.S. CLS. 100, 101 AND 107). SN 77-090,665. PUB. 3-17-2009. FILED 1-25-2007.
 3,629,260 (*See Class 36 for this trademark*).
 3,629,261 (*See Class 9 for this trademark*).
 3,629,266. **OREGON HEALTH & SCIENCE UNIVERSITY OHSU AND DESIGN.** OREGON HEALTH & SCIENCE UNIVERSITY, MULTIPLE CLASS, (INT. CLS. 41, 42 AND 44), (U.S. CLS. 100, 101 AND 107). SN 77-109,958. PUB. 3-17-2009. FILED 2-16-2007.
 3,629,269. **BREWSTER TECHNOLOGY WWW.BREWSTER-TECH.NET BREWSTER TECHNOLOGY WWW.BREWSTERTECH.NET BT AND DESIGN.** U.S. TECHNICAL SERVICES, INC., (U.S. CLS. 100, 101 AND 107). SN 77-120,112. PUB. 9-4-2007. FILED 3-1-2007.
 3,629,271 (*See Class 16 for this trademark*).
 3,629,272. **SOCCERTOTS AND DESIGN.** SOCCERTOTS INCORPORATED, (U.S. CLS. 100, 101 AND 107). SN 77-135,159. PUB. 3-17-2009. FILED 3-20-2007.
 3,629,274. **BLUE RIBBON BAKER (BLOCK FORM).** JOHNSON, MARJORIE, (U.S. CLS. 100, 101 AND 107). SN 77-135,743. PUB. 3-17-2009. FILED 3-20-2007.

3,629,280. **THE ON LOCATION VIDEO EXPERIENCE AND DESIGN.** VIRCIGLIO JR., JOHN B., (U.S. CLS. 100, 101 AND 107). SN 77-145,770. PUB. 10-14-2008. FILED 4-1-2007.
 3,629,284 (*See Class 31 for this trademark*).
 3,629,289 (*See Class 36 for this trademark*).
 3,629,302 (*See Class 16 for this trademark*).
 3,629,310. **WCDM (BLOCK FORM).** DIVERSIFIED BUSINESS COMMUNICATIONS CANADA, (U.S. CLS. 100, 101 AND 107). SN 77-201,656. PUB. 3-17-2009. FILED 6-8-2007.
 3,629,313 (*See Class 16 for this trademark*).
 3,629,314 (*See Class 16 for this trademark*).
 3,629,323 (*See Class 9 for this trademark*).
 3,629,340 (*See Class 35 for this trademark*).
 3,629,347. **BEAULIEU GARDEN (BLOCK FORM).** HELENE DE LATOUR DE PINS TRUST, MULTIPLE CLASS, (INT. CLS. 41 AND 43), (U.S. CLS. 100, 101 AND 107). SN 77-257,577. PUB. 3-17-2009. FILED 8-16-2007.
 3,629,351. **GRAVY (BLOCK FORM).** GRAVY, LLC, DBA GRAVY, (U.S. CLS. 100, 101 AND 107). SN 77-261,072. PUB. 3-17-2009. FILED 8-21-2007.
 3,629,372 (*See Class 16 for this trademark*).
 3,629,384 (*See Class 35 for this trademark*).
 3,629,386. **LOS ANGELES TENNIS CLUB LA TC AND DESIGN.** LOS ANGELES TENNIS CLUB, (U.S. CLS. 100, 101 AND 107). SN 77-296,765. PUB. 3-17-2009. FILED 10-4-2007.
 3,629,388 (*See Class 9 for this trademark*).
 3,629,394 (*See Class 16 for this trademark*).
 3,629,406. **TOP POCKET (BLOCK FORM).** ALRED, DAVID EDWARD, (U.S. CLS. 100, 101 AND 107). SN 77-309,941. PUB. 12-23-2008. FILED 10-22-2007.
 3,629,407. **J-SHAPE (BLOCK FORM).** ALRED, DAVID EDWARD, (U.S. CLS. 100, 101 AND 107). SN 77-309,950. PUB. 12-23-2008. FILED 10-22-2007.
 3,629,411 (*See Class 35 for this trademark*).
 3,629,413 (*See Class 9 for this trademark*).
 3,629,418. **CHEFS 2 B COOKING SCHOOL AND DESIGN.** ALL 4 KIDS LLC, DBA CHEFS 2 B, (U.S. CLS. 100, 101 AND 107). SN 77-319,058. PUB. 3-17-2009. FILED 11-1-2007.
 3,629,421. **INSIGHTFUL IMAGING (BLOCK FORM).** BLACK, WILSON H., DBA WILSON BLACK PHOTOGRAPHY, LLC, (U.S. CLS. 100, 101 AND 107). SN 77-320,704. PUB. 3-17-2009. FILED 11-3-2007.
 3,629,427 (*See Class 35 for this trademark*).
 3,629,428. **CHILLOUNGE NIGHT (BLOCK FORM).** SCHEER, RAINER, (U.S. CLS. 100, 101 AND 107). SN 77-326,542. PUB. 3-17-2009. FILED 11-10-2007.
 3,629,430 (*See Class 35 for this trademark*).
 3,629,431. **SOFLUSION (BLOCK FORM).** SOFLUSION LLC, (U.S. CLS. 100, 101 AND 107). SN 77-328,199. PUB. 3-17-2009. FILED 11-13-2007.
 3,629,450 (*See Class 9 for this trademark*).
 3,629,451 (*See Class 14 for this trademark*).
 3,629,466. **ADVANTAGE NUTRITION & WELLNESS, LLC AND DESIGN.** ADVANTAGE NUTRITION & WELLNESS, LLC, MULTIPLE CLASS, (INT. CLS. 41 AND 44), (U.S. CLS. 100, 101 AND 107). SN 77-355,174. PUB. 3-17-2009. FILED 12-18-2007.
 3,629,468 (*See Class 9 for this trademark*).
 3,629,474 (*See Class 3 for this trademark*).
 3,629,478. **MYSPEACE (BLOCK FORM).** MYSPEACE INC., (U.S. CLS. 100, 101 AND 107). SN 77-361,699. PUB. 3-17-2009. FILED 12-31-2007.
 3,629,482. **LET'S CHAT ABOUT IT (BLOCK FORM).** JANICE D. ROBINSON ENTERPRISES, (U.S. CLS. 100, 101 AND 107). SN 77-365,324. PUB. 3-17-2009. FILED 1-7-2008.
 3,629,494. **DSP DESIGNLINE (BLOCK FORM).** UNITED BUSINESS MEDIA LLC, MULTIPLE CLASS, (INT. CLS. 41 AND 42), (U.S. CLS. 100, 101 AND 107). SN 77-372,011. PUB. 3-17-2009. FILED 1-15-2008.
 3,629,508. **HERITAGE HARBOR DAYS (BLOCK FORM).** FOLEY CONVENTION & VISITORS BUREAU, (U.S. CLS. 100, 101 AND 107). SN 77-379,682. PUB. 3-17-2009. FILED 1-24-2008.
 3,629,518. **MINNESOTA GREENSTAR (BLOCK FORM).** MINNESOTA GREENSTAR, MULTIPLE CLASS, (INT. CLS. 41 AND 42), (U.S. CLS. 100, 101 AND 107). SN 77-383,783. PUB. 3-17-2009. FILED 1-29-2008.
 3,629,519 (*See Class 9 for this trademark*).

- 3,629,529. **MISCELLANEOUS DESIGN. MEMBERS OF CHURCHES OF CHRIST FOR SCOUTING.** (U.S. CLS. 100, 101 AND 107). SN 77-389,728. PUB. 3-17-2009. FILED 2-6-2008.
- 3,629,531. **PRISON DHARMA NETWORK (BLOCK FORM).** PRISON DHARMA NETWORK, (U.S. CLS. 100, 101 AND 107). SN 77-391,732. PUB. 3-17-2009. FILED 2-7-2008.
- 3,629,534. **BALL STATE UNIVERSITY ELECTRONIC FIELD TRIPS (BLOCK FORM).** BALL STATE UNIVERSITY, (U.S. CLS. 100, 101 AND 107). SN 77-394,779. PUB. 3-17-2009. FILED 2-12-2008.
- 3,629,537 (*See Class 35 for this trademark.*).
- 3,629,538. **STRATIGEM (BLOCK FORM).** VANDIVER GROUP, INC., (U.S. CLS. 100, 101 AND 107). SN 77-396,052. PUB. 3-17-2009. FILED 2-13-2008.
- 3,629,539 (*See Class 35 for this trademark.*).
- 3,629,548. **THE BIG LEAD (BLOCK FORM).** THE BIG LEAD, LLC, (U.S. CLS. 100, 101 AND 107). SN 77-397,916. PUB. 3-17-2009. FILED 2-15-2008.
- 3,629,549. **AUTOLINE (BLOCK FORM).** BLUE SKY PRODUCTIONS, (U.S. CLS. 100, 101 AND 107). SN 77-399,207. PUB. 10-14-2008. FILED 2-17-2008.
- 3,629,557. **ECO FITNESS AND DESIGN.** FOX RIED PARTNERS, LLC, (U.S. CLS. 100, 101 AND 107). SN 77-403,139. PUB. 3-17-2009. FILED 2-21-2008.
- 3,629,580. **MOMILATES (BLOCK FORM).** MARTENS, ANNE E., DBA BELLA BELLIES STUDIO, (U.S. CLS. 100, 101 AND 107). SN 77-415,684. PUB. 3-17-2009. FILED 3-7-2008.
- 3,629,581. **NMM PRODUCTIONS (BLOCK FORM).** NMM PRODUCTIONS, (U.S. CLS. 100, 101 AND 107). SN 77-416,610. PUB. 3-17-2009. FILED 3-7-2008.
- 3,629,590 (*See Class 16 for this trademark.*).
- 3,629,591. **CLASS ACT BAND (BLOCK FORM).** BOEHM, JAMES A. (U.S. CLS. 100, 101 AND 107). SN 77-419,278. PUB. 3-17-2009. FILED 3-11-2008.
- 3,629,595. **LIZA'S 5K RUN (BLOCK FORM).** LIZA'S LEGACY FOUNDATION, INC., (U.S. CLS. 100, 101 AND 107). SN 77-421,029. PUB. 10-14-2008. FILED 3-13-2008.
- 3,629,597. **BODY PHOTAGE INC. AND DESIGN.** BODY-PHOTAGE, INC., (U.S. CLS. 100, 101 AND 107). SN 77-421,607. PUB. 3-17-2009. FILED 3-13-2008.
- 3,629,599. **OFF KEY WITH ERIC D. (BLOCK FORM).** ERIC ANTHONY D'ORAZIO, (U.S. CLS. 100, 101 AND 107). SN 77-421,957. PUB. 3-17-2009. FILED 3-14-2008.
- 3,629,600 (*See Class 36 for this trademark.*).
- 3,629,608. **SHOWCASE COLUMBUS GAIL HOGAN AND DESIGN.** GMH MEDIA, LTD., (U.S. CLS. 100, 101 AND 107). SN 77-428,180. PUB. 3-17-2009. FILED 3-21-2008.
- 3,629,614. **TEACHERS COLLEGE RECORD THE VOICE OF SCHOLARSHIP IN EDUCATION (BLOCK FORM).** TEACHERS COLLEGE, COLUMBIA UNIVERSITY, (U.S. CLS. 100, 101 AND 107). SN 77-430,384. PUB. 3-17-2009. FILED 3-25-2008.
- 3,629,641. **WALDENSTORIES (BLOCK FORM).** LAUREATE EDUCATION, INC., (U.S. CLS. 100, 101 AND 107). SN 77-435,194. PUB. 3-17-2009. FILED 3-30-2008.
- 3,629,642. **MYWALDENSTORY (BLOCK FORM).** LAUREATE EDUCATION, INC., (U.S. CLS. 100, 101 AND 107). SN 77-435,195. PUB. 3-17-2009. FILED 3-30-2008.
- 3,629,643. **SECRETS IN THE SUBURBS (BLOCK FORM).** SHIELDS, COLLEEN M., (U.S. CLS. 100, 101 AND 107). SN 77-435,273. PUB. 3-17-2009. FILED 3-30-2008.
- 3,629,644 (*See Class 35 for this trademark.*).
- 3,629,647. **THE LITERACY LENS (BLOCK FORM).** LEARNING UNLIMITED, LLC, (U.S. CLS. 100, 101 AND 107). SN 77-436,283. PUB. 3-17-2009. FILED 3-31-2008.
- 3,629,651. **DIRTNEWZ.COM (STYLIZED).** ROCK ON MOTORSPORTS MANAGEMENT, INC., (U.S. CLS. 100, 101 AND 107). SN 77-436,526. PUB. 3-17-2009. FILED 4-1-2008.
- 3,629,652. **MOUNTAIN STATE UNIVERSITY AND DESIGN.** MOUNTAIN STATE UNIVERSITY, INC., (U.S. CLS. 100, 101 AND 107). SN 77-436,564. PUB. 3-17-2009. FILED 4-1-2008.
- 3,629,657. **MUSICA CON CALLE (BLOCK FORM).** SPANISH BROADCASTING SYSTEM, INC., (U.S. CLS. 100, 101 AND 107). SN 77-437,594. PUB. 3-17-2009. FILED 4-2-2008.
- 3,629,658 (*See Class 38 for this trademark.*).
- 3,629,659. **CRUCIAL CONFRONTATIONS (BLOCK FORM).** VITALSMARTS, LLC, (U.S. CLS. 100, 101 AND 107). SN 77-437,815. PUB. 3-17-2009. FILED 4-2-2008.
- 3,629,673. **VOCAL FREEDOM CAMP (BLOCK FORM).** WATERS, CAROLINE, (U.S. CLS. 100, 101 AND 107). SN 77-440,389. PUB. 3-17-2009. FILED 4-4-2008.
- 3,629,691 (*See Class 25 for this trademark.*).
- 3,629,694. **EMPOWER BEAUTY! (BLOCK FORM).** FITNESS4HER, INC., (U.S. CLS. 100, 101 AND 107). SN 77-442,689. PUB. 3-17-2009. FILED 4-8-2008.
- 3,629,695. **ID (STYLIZED).** MORI SEIKI U.S.A., INC., (U.S. CLS. 100, 101 AND 107). SN 77-442,729. PUB. 3-17-2009. FILED 4-8-2008.
- 3,629,698. **COUP D'ETAT (BLOCK FORM).** PROJECT WABASH LLC, (U.S. CLS. 100, 101 AND 107). SN 77-443,451. PUB. 3-17-2009. FILED 4-8-2008.
- 3,629,699. **IF IT'S ENTERTAINMENT, WE ENTERTAIN IT! (BLOCK FORM).** GRAVES, JESSE, (U.S. CLS. 100, 101 AND 107). SN 77-443,583. PUB. 3-17-2009. FILED 4-9-2008.
- 3,629,703 (*See Class 35 for this trademark.*).
- 3,629,704. **KNOWLEDGEBANK (BLOCK FORM).** KNOWLEDGEBANK, INC., (U.S. CLS. 100, 101 AND 107). SN 77-443,695. PUB. 3-17-2009. FILED 4-9-2008.
- 3,629,709 (*See Class 38 for this trademark.*).
- 3,629,713. **THE COMMUNICATIONS DOCTOR AND DESIGN.** THE COMMUNICATIONS DOCTOR, INC., (U.S. CLS. 100, 101 AND 107). SN 77-444,569. PUB. 3-17-2009. FILED 4-10-2008.
- 3,629,721 (*See Class 25 for this trademark.*).
- 3,629,734 (*See Class 35 for this trademark.*).
- 3,629,760. **THE DEVI CLINIC (BLOCK FORM).** THE DEVI CLINIC, LLC, MULTIPLE CLASS, (INT. CLS. 41 AND 44), (U.S. CLS. 100, 101 AND 107). SN 77-449,514. PUB. 3-17-2009. FILED 4-16-2008.
- 3,629,770. **VEGAS.COM (BLOCK FORM).** VEGAS.COM, LLC, (U.S. CLS. 100, 101 AND 107). SN 77-450,178. PUB. 3-17-2009. FILED 4-16-2008.
- 3,629,781. **AD WIRE (BLOCK FORM).** ANDO MEDIA, LLC, (U.S. CLS. 100, 101 AND 107). SN 77-450,823. PUB. 3-17-2009. FILED 4-17-2008.
- 3,629,782. **ESPRESSO (BLOCK FORM).** ESPRESSO EDUCATION LIMITED, (U.S. CLS. 100, 101 AND 107). SN 77-450,950. PUB. 3-17-2009. FILED 4-17-2008.
- 3,629,810. **MEMORY HUNTING (BLOCK FORM).** RUBYELLEN N. BRATCHER, DBA RUBYELLEN C. NAVALES, (U.S. CLS. 100, 101 AND 107). SN 77-452,899. PUB. 3-17-2009. FILED 4-20-2008.
- 3,629,826 (*See Class 9 for this trademark.*).
- 3,629,828. **FRESH MIND CUISINE (BLOCK FORM).** CRAYTON, SHARON L., (U.S. CLS. 100, 101 AND 107). SN 77-454,797. PUB. 3-17-2009. FILED 4-22-2008.
- 3,629,855 (*See Class 16 for this trademark.*).
- 3,629,871 (*See Class 39 for this trademark.*).
- 3,629,877 (*See Class 36 for this trademark.*).
- 3,629,882. **CHANNEL ONE CONNECTION (BLOCK FORM).** CHANNEL ONE LTD., (U.S. CLS. 100, 101 AND 107). SN 77-462,623. PUB. 3-17-2009. FILED 5-1-2008.
- 3,629,886. **THE NAUGHTY AMERICAN (BLOCK FORM).** LA TOURAINE, INC., (U.S. CLS. 100, 101 AND 107). SN 77-463,213. PUB. 3-17-2009. FILED 5-1-2008.
- 3,629,903 (*See Class 35 for this trademark.*).
- 3,629,905 (*See Class 9 for this trademark.*).
- 3,629,917. **WIN4REAL.COM AND DESIGN.** DNI HOLDINGS, LTD, (U.S. CLS. 100, 101 AND 107). SN 77-470,174. PUB. 3-17-2009. FILED 5-9-2008.
- 3,629,919 (*See Class 35 for this trademark.*).
- 3,629,923. **WEBOOK (STYLIZED).** WEBOOK, INC., (U.S. CLS. 100, 101 AND 107). SN 77-472,750. PUB. 10-14-2008. FILED 5-13-2008.
- 3,629,930. **GARAGE MUSICALS (BLOCK FORM).** JOHN LEVY, DBA GARAGE MUSICALS, (U.S. CLS. 100, 101 AND 107). SN 77-474,252. PUB. 3-17-2009. FILED 5-14-2008.
- 3,629,940 (*See Class 35 for this trademark.*).
- 3,629,941. **H HARMONIC HEALTH AND DESIGN.** HARMONIC HEALTH, (U.S. CLS. 100, 101 AND 107). SN 77-477,451. PUB. 3-17-2009. FILED 5-18-2008.
- 3,629,943. **TRUCLASS EVENTS (BLOCK FORM).** BRITT, TRULINDA E., DBA TRUCLASS EVENTS, (U.S. CLS. 100, 101 AND 107). SN 77-477,512. PUB. 3-17-2009. FILED 5-18-

- 2008.
- 3,629,957. **CALIFORNIA CONFERENCE . ARSON INVESTIGATORS AND DESIGN**. CALIFORNIA CONFERENCE OF ARSON INVESTIGATORS, (U.S. CLS. 100, 101 AND 107). SN 77-480,128. PUB. 3-17-2009. FILED 5-21-2008.
- 3,629,984. **NATIONAL HIGH SCHOOL HALL OF FAME (BLOCK FORM)**. NATIONAL FEDERATION OF STATE HIGH SCHOOL ASSOCIATIONS, (U.S. CLS. 100, 101 AND 107). SN 77-489,499. PUB. 3-17-2009. FILED 6-3-2008.
- 3,629,986 (*See Class 25 for this trademark*).
- 3,629,987 (*See Class 25 for this trademark*).
- 3,629,996. **SPARKAMERICA (BLOCK FORM)**. SPARKPEOPLE, INC., MULTIPLE CLASS, (INT. CLS. 41 AND 44), (U.S. CLS. 100, 101 AND 107). SN 77-492,890. PUB. 3-17-2009. FILED 6-6-2008.
- 3,630,013. **EMPIRE DRIFT (BLOCK FORM)**. EMPIRE DRIFT RECORDS, LTD., (U.S. CLS. 100, 101 AND 107). SN 77-495,497. PUB. 3-17-2009. FILED 6-10-2008.
- 3,630,016 (*See Class 36 for this trademark*).
- 3,630,017 (*See Class 36 for this trademark*).
- 3,630,019. **REVIVE (BLOCK FORM)**. REVIVE PARTNERSHIP, (U.S. CLS. 100, 101 AND 107). SN 77-496,494. PUB. 3-17-2009. FILED 6-11-2008.
- 3,630,036 (*See Class 35 for this trademark*).
- 3,630,045. **SOLA YOGA AND DESIGN**. HAMORY, NICOLE MARTIN, (U.S. CLS. 100, 101 AND 107). SN 77-504,615. PUB. 3-17-2009. FILED 6-20-2008.
- 3,630,046. **KEY KIDS EXERCISE AND YOGA (STYLIZED)**. DELAY, LAURA M, DBA KIDS EXERCISE AND YOGA, (U.S. CLS. 100, 101 AND 107). SN 77-504,865. PUB. 3-17-2009. FILED S.R. 6-21-2008; AM. P.R. 1-8-2009.
- 3,630,049 (*See Class 16 for this trademark*).
- 3,630,051. **GRILLSEEKERS (BLOCK FORM)**. GRILLSEEKERS LLC, DBA MICHAEL PETIT AND JOHN CROATTI, (U.S. CLS. 100, 101 AND 107). SN 77-506,091. PUB. 3-17-2009. FILED 6-24-2008.
- 3,630,058. **CONSULATE (BLOCK FORM)**. CONSULATE LTD., (U.S. CLS. 100, 101 AND 107). SN 77-507,978. PUB. 3-17-2009. FILED 6-25-2008.
- 3,630,060 (*See Class 9 for this trademark*).
- 3,630,069. **LEARNING LANDSCAPE AND DESIGN**. LEARNING LANDSCAPE, LLC, (U.S. CLS. 100, 101 AND 107). SN 77-513,023. PUB. 3-17-2009. FILED 7-1-2008.
- 3,630,070. **WIZARD TRAINING CAMP (BLOCK FORM)**. PEAK POTENTIALS TRAINING, INC., (U.S. CLS. 100, 101 AND 107). SN 77-513,254. PUB. 12-9-2008. FILED 7-2-2008.
- 3,630,074. **HEYLATINO (BLOCK FORM)**. ROSARIO, MIGUEL, (U.S. CLS. 100, 101 AND 107). SN 77-514,192. PUB. 3-17-2009. FILED 7-3-2008.
- 3,630,075. **TRAINING AT THE SPEED OF LIFE (BLOCK FORM)**. MURRAY, KENNETH R., (U.S. CLS. 100, 101 AND 107). SN 77-515,117. PUB. 3-17-2009. FILED 7-4-2008.
- 3,630,080. **THE KAVLI PRIZE (BLOCK FORM)**. THE KAVLI FOUNDATION, (U.S. CLS. 100, 101 AND 107). SN 77-516,781. PUB. 3-17-2009. FILED 7-8-2008.
- 3,630,087. **NORTH MASON LIFE (BLOCK FORM)**. BRV, LLC, (U.S. CLS. 100, 101 AND 107). SN 77-518,202. PUB. 3-17-2009. FILED 7-9-2008.
- 3,630,091 (*See Class 16 for this trademark*).
- 3,630,092 (*See Class 9 for this trademark*).
- 3,630,101. **RESULTS FIT CAMP 707.725.8735 AND DESIGN**. PALMER, KARI, DBA RESULTS FIT CAMP, AND AGUIAR, SANDY, DBA RESULTS FIT CAMP, (U.S. CLS. 100, 101 AND 107). SN 77-520,019. PUB. 3-17-2009. FILED 7-11-2008.
- 3,630,104. **TODAY, EVERY DAY, FOR LIFE (BLOCK FORM)**. HAWAII MEDICAL SERVICE ASSOCIATION, (U.S. CLS. 100, 101 AND 107). SN 77-521,556. PUB. 3-17-2009. FILED 7-14-2008.
- 3,630,112 (*See Class 16 for this trademark*).
- 3,630,134. **SNOPES.COM RUMOR HAS IT AND DESIGN**. BARDAV INC., (U.S. CLS. 100, 101 AND 107). SN 77-528,118. PUB. 3-17-2009. FILED 7-22-2008.
- 3,630,135 (*See Class 16 for this trademark*).
- 3,630,139. **FORD SAEKS (BLOCK FORM)**. SAEKS, FORD, (U.S. CLS. 100, 101 AND 107). SN 77-529,950. PUB. 12-16-2008. FILED 7-23-2008.
- 3,630,145. **HARMONY AND DESIGN**. HARMONY: ATLANTA'S INTERNATIONAL YOUTH CHORUS, (U.S. CLS. 100, 101 AND 107). SN 77-531,823. PUB. 3-17-2009. FILED 7-25-2008.
- 3,630,155. **CONNECTIONS CAFÉ (BLOCK FORM)**. SENIOR CONNECTIONS, INC., (U.S. CLS. 100, 101 AND 107). SN 77-533,758. PUB. 3-17-2009. FILED 7-29-2008.
- 3,630,163. **HATE BY NUMBERS (BLOCK FORM)**. GLADSTONE, WAYNE L., (U.S. CLS. 100, 101 AND 107). SN 77-537,039. PUB. 3-17-2009. FILED 8-1-2008.
- 3,630,179. **DJTRANCE AND DESIGN**. OMNI ENTERTAINMENT GROUP, INC., DBA DJTRANCE, (U.S. CLS. 100, 101 AND 107). SN 77-542,451. PUB. 3-17-2009. FILED 8-8-2008.
- 3,630,192. **LIVE BREW (BLOCK FORM)**. MOJO REPUBLIC LLC, (U.S. CLS. 100, 101 AND 107). SN 77-545,908. PUB. 3-17-2009. FILED 8-13-2008.
- 3,630,199. **PLAYHOORAY (BLOCK FORM)**. HIGH HOPES PRODUCTIONS LLC, (U.S. CLS. 100, 101 AND 107). SN 77-546,791. PUB. 3-17-2009. FILED 8-14-2008.
- 3,630,200. **PLAYHOORAY MUSIC & FUN FOR YOUR LITTLE ONE AND DESIGN**. HIGH HOPES PRODUCTIONS LLC, (U.S. CLS. 100, 101 AND 107). SN 77-546,796. PUB. 3-17-2009. FILED 8-14-2008.
- 3,630,209. **MARIE (BLOCK FORM)**. MARIE, INC., (U.S. CLS. 100, 101 AND 107). SN 77-548,342. PUB. 3-17-2009. FILED 8-15-2008.
- 3,630,213. **A KID'S LIFE (BLOCK FORM)**. ECHO PICTURES, LLC, (U.S. CLS. 100, 101 AND 107). SN 77-549,965. PUB. 3-17-2009. FILED 8-18-2008.
- 3,630,214. **THE EAGLE PASS (BLOCK FORM)**. DRAPER, ALLEN, (U.S. CLS. 100, 101 AND 107). SN 77-550,481. PUB. 3-17-2009. FILED 8-19-2008.
- 3,630,225. **SCRAP N WIN AND DESIGN**. KNIGHT, PAULA, (U.S. CLS. 100, 101 AND 107). SN 77-553,112. PUB. 3-17-2009. FILED 8-21-2008.
- 3,630,230. **FREEDOM GARDENS (BLOCK FORM)**. DERVAES INSTITUTE, (U.S. CLS. 100, 101 AND 107). SN 77-554,457. PUB. 3-17-2009. FILED 8-25-2008.
- 3,630,242 (*See Class 35 for this trademark*).
- 3,630,243 (*See Class 35 for this trademark*).
- 3,630,244 (*See Class 35 for this trademark*).
- 3,630,266. **TESSA G. PHOXX (BLOCK FORM)**. TERESA, GRAPHOS TESSA, (U.S. CLS. 100, 101 AND 107). SN 77-559,520. PUB. 3-17-2009. FILED 8-30-2008.
- 3,630,273. **MISCELLANEOUS DESIGN**. GUNDERSEN LUTHERAN MEDICAL FOUNDATION, INC., (U.S. CLS. 100, 101 AND 107). SN 77-560,304. PUB. 3-17-2009. FILED 9-2-2008.
- 3,630,287. **DENSHO (BLOCK FORM)**. DENSHO, DBA DENSHO: THE JAPANESE AMERICAN LEGACY PROJECT, (U.S. CLS. 100, 101 AND 107). SN 77-562,868. PUB. 3-17-2009. FILED 9-4-2008.
- 3,630,292. **INN AND DESIGN**. IMPACT NATIONAL NEWS, LLC, (U.S. CLS. 100, 101 AND 107). SN 77-563,956. PUB. 3-17-2009. FILED 9-6-2008.
- 3,630,297 (*See Class 9 for this trademark*).
- 3,630,298 (*See Class 16 for this trademark*).
- 3,630,308. **FITNESS 2 A TEE AND DESIGN**. THOMAS E MCAULIFFE ENTERPRISES, (U.S. CLS. 100, 101 AND 107). SN 77-567,419. PUB. 3-17-2009. FILED 9-11-2008.
- 3,630,333 (*See Class 9 for this trademark*).
- 3,630,342. **MILTON HERSHEY SCHOOL (BLOCK FORM)**. MILTON HERSHEY SCHOOL, (U.S. CLS. 100, 101 AND 107). SN 77-571,899. PUB. 3-17-2009. FILED 9-17-2008.
- 3,630,343 (*See Class 35 for this trademark*).
- 3,630,348. **FIERO (BLOCK FORM)**. FIERO EDUCATIONAL SERVICES, INC., (U.S. CLS. 100, 101 AND 107). SN 77-572,293. PUB. 3-17-2009. FILED 9-17-2008.
- 3,630,350. **CURIOSITY CREEK (BLOCK FORM)**. ARNONE, MARILYN P., (U.S. CLS. 100, 101 AND 107). SN 77-572,964. PUB. 3-17-2009. FILED 9-18-2008.
- 3,630,358. **ASK US NOW! INFO EXPERTS 24/7 AND DESIGN**. MARYLAND STATE DEPARTMENT OF EDUCATION/DIVISION OF LIBRARY DEVELOPMENT AND SERVICES, DBA DIVISION OF LIBRARY DEVELOPMENT AND SERVICES, (U.S. CLS. 100, 101 AND 107). SN 77-573,576. PUB. 3-17-2009. FILED 9-18-2008.
- 3,630,362. **BULLS & BEAVERS (BLOCK FORM)**. BURGET,

- CHRIS, (U.S. CLS. 100, 101 AND 107). SN 77-573,776. PUB. 3-17-2009. FILED 9-18-2008.
- 3,630,364. **DR. CASH FLOW (BLOCK FORM)**. SIDOTI, NICK, (U.S. CLS. 100, 101 AND 107). SN 77-574,249. PUB. 3-17-2009. FILED 9-19-2008.
- 3,630,366. **MAXIMUM ARCHERY (BLOCK FORM)**. MAXIMUM INC., (U.S. CLS. 100, 101 AND 107). SN 77-574,483. PUB. 3-17-2009. FILED 9-19-2008.
- 3,630,384 (*See Class 3 for this trademark*).
- 3,630,386. **ANZURI (BLOCK FORM)**. ANZURI INC., (U.S. CLS. 100, 101 AND 107). SN 77-577,935. PUB. 3-17-2009. FILED 9-24-2008.
- 3,630,392. **THE CURIOUS KIDS AND DESIGN**. ARNONE, MARILYN, (U.S. CLS. 100, 101 AND 107). SN 77-578,280. PUB. 3-17-2009. FILED 9-25-2008.
- 3,630,403. **COMPANY 77 (BLOCK FORM)**. OWENS, CHRISTOPHER DAVID, MULTIPLE CLASS, (INT. CLS. 41 AND 43), (U.S. CLS. 100, 101 AND 107). SN 77-579,372. PUB. 3-17-2009. FILED 9-26-2008.
- 3,630,404. **77 AND DESIGN**. OWENS, CHRISTOPHER DAVID, MULTIPLE CLASS, (INT. CLS. 41 AND 43), (U.S. CLS. 100, 101 AND 107). SN 77-579,429. PUB. 3-17-2009. FILED 9-26-2008.
- 3,630,407 (*See Class 16 for this trademark*).
- 3,630,409. **EVERYONE'S YOGA (BLOCK FORM)**. YOGAGLO, LLC, (U.S. CLS. 100, 101 AND 107). SN 77-579,888. PUB. 3-17-2009. FILED 9-26-2008.
- 3,630,422. **EXPLORE. CONNECT. MAKE IT HAPPEN (BLOCK FORM)**. BABSON COLLEGE, (U.S. CLS. 100, 101 AND 107). SN 77-580,875. PUB. 3-17-2009. FILED 9-29-2008.
- 3,630,432. **DA' HEART (BLOCK FORM)**. FITNESS FOR ALL, LLC, (U.S. CLS. 100, 101 AND 107). SN 77-582,366. PUB. 3-17-2009. FILED 9-30-2008.
- 3,630,433 (*See Class 9 for this trademark*).
- 3,630,440. **KNOCK (BLOCK FORM)**. ANTIOCH UNIVERSITY, (U.S. CLS. 100, 101 AND 107). SN 77-584,255. PUB. 3-17-2009. FILED 10-2-2008.
- 3,630,449. **KARLAADAMS EDUCATE. MOTIVATE. CHANGE. AND DESIGN**. KARLA ADAM, INC., (U.S. CLS. 100, 101 AND 107). SN 77-584,906. PUB. 3-17-2009. FILED 10-3-2008.
- 3,630,475. **ASPIRATIONAL YOGA (BLOCK FORM)**. DOUGLASS, SUSAN UPTON, (U.S. CLS. 100, 101 AND 107). SN 77-587,714. PUB. 3-17-2009. FILED 10-7-2008.
- 3,630,489. **CONSERVATION QUEST (BLOCK FORM)**. STEPPING STONES MUSEUM FOR CHILDREN, INC., (U.S. CLS. 100, 101 AND 107). SN 77-588,610. PUB. 3-17-2009. FILED 10-8-2008.
- 3,630,491. **SMART DRIVING SYSTEM (BLOCK FORM)**. JOE DARDEN GROUP LLC, (U.S. CLS. 100, 101 AND 107). SN 77-588,868. PUB. 3-17-2009. FILED 10-8-2008.
- 3,630,502 (*See Class 35 for this trademark*).
- 3,630,503 (*See Class 35 for this trademark*).
- 3,630,506. **SPORTS ACCESS (BLOCK FORM)**. FOX SPORTS NET, INC., (U.S. CLS. 100, 101 AND 107). SN 77-590,260. PUB. 3-17-2009. FILED 10-10-2008.
- 3,630,508. **INTUITION GIRL (BLOCK FORM)**. WHELAN, JOAN MARIE, (U.S. CLS. 100, 101 AND 107). SN 77-590,530. PUB. 3-17-2009. FILED 10-10-2008.
- 3,630,514. **RICK FM (BLOCK FORM)**. DEES ENTERTAINMENT, INC., (U.S. CLS. 100, 101 AND 107). SN 77-590,971. PUB. 3-17-2009. FILED 10-12-2008.
- 3,630,521. **CHIRO + PLUS KINESIOLOGY AND DESIGN**. MILTON E. DOWTY, (U.S. CLS. 100, 101 AND 107). SN 77-591,592. PUB. 3-17-2009. FILED 10-13-2008.
- 3,630,534. **J.STILES (BLOCK FORM)**. STILES, JACKIE, (U.S. CLS. 100, 101 AND 107). SN 77-592,352. PUB. 3-17-2009. FILED 10-14-2008.
- 3,630,542. **YOGA INTUITION AND DESIGN**. HARDCASTLE, ASHLEY, (U.S. CLS. 100, 101 AND 107). SN 77-592,742. PUB. 3-17-2009. FILED 10-14-2008.
- 3,630,549. **TOS TON'S OFFICE SOLUTIONS OUR EXCELLENCE FOR YOUR SUCCESS AND DESIGN**. T TIME SOLUTIONS, (U.S. CLS. 100, 101 AND 107). SN 77-593,185. PUB. 3-17-2009. FILED 10-15-2008.
- 3,630,552. **NATIONAL HISTORIC CHEESEMAKING CENTER MONROE, WISCONSIN AND DESIGN**. NATIONAL HISTORIC CHEESEMAKING CENTER, INC., (U.S. CLS. 100, 101 AND 107). SN 77-593,528. PUB. 3-17-2009. FILED 10-15-2008.
- 3,630,560. **ISLE CASINO HOTEL (BLOCK FORM)**. ISLE OF CAPRI CASINOS, INC., MULTIPLE CLASS, (INT. CLS. 41 AND 43), (U.S. CLS. 100, 101 AND 107). SN 77-593,866. PUB. 3-17-2009. FILED 10-16-2008.
- 3,630,572. **CEO Q (BLOCK FORM)**. MED YONES, DBA INTERNATIONAL INSTITUTE OF MANAGEMENT, (U.S. CLS. 100, 101 AND 107). SN 77-594,681. PUB. 3-17-2009. FILED 10-17-2008.
- 3,630,576. **CLUB BETWEEN (STYLIZED)**. HOWARD, JULES, DBA CLUB BETWEEN, (U.S. CLS. 100, 101 AND 107). SN 77-594,738. PUB. 3-17-2009. FILED 10-17-2008.
- 3,630,596. **RAMEN REVOLUTION AND DESIGN**. AZINDIES PRODUCTIONS LLC, (U.S. CLS. 100, 101 AND 107). SN 77-595,924. PUB. 3-17-2009. FILED 10-20-2008.
- 3,630,602. **A NIGHT WITH FRANK (BLOCK FORM)**. D'EGIDIO, NICK, (U.S. CLS. 100, 101 AND 107). SN 77-595,990. PUB. 3-17-2009. FILED 10-20-2008.
- 3,630,610. **BURL'S RIDE (BLOCK FORM)**. CHRIS HARDY, AND STEVE SMITH, (U.S. CLS. 100, 101 AND 107). SN 77-596,107. PUB. 3-17-2009. FILED 10-20-2008.
- 3,630,636. **I'M NOT OBSESSED! (BLOCK FORM)**. I'M NOT OBSESSED INC., (U.S. CLS. 100, 101 AND 107). SN 77-596,803. PUB. 3-17-2009. FILED 10-21-2008.
- 3,630,637. **GOSSIP . . . WITHOUT THE GUILT (BLOCK FORM)**. I'M NOT OBSESSED INC., (U.S. CLS. 100, 101 AND 107). SN 77-596,805. PUB. 3-17-2009. FILED 10-21-2008.
- 3,630,641. **BATTLEFRONT AND DESIGN**. OSBURN, ANDREW, AND VINEYARD, JEREMY, AND ZIEMER, SEAN, AND SCHORNACK, STEVE, (U.S. CLS. 100, 101 AND 107). SN 77-596,924. PUB. 3-17-2009. FILED 10-21-2008.
- 3,630,651. **KAHUNA LAGUNA (BLOCK FORM)**. RED JACKET MOUNTAIN VIEW, LLC, (U.S. CLS. 100, 101 AND 107). SN 77-597,072. PUB. 3-17-2009. FILED 10-21-2008.
- 3,630,662. **ZEJ (BLOCK FORM)**. KOZLOWSKI, ANDRZEJ, AKA ZEJ, (U.S. CLS. 100, 101 AND 107). SN 77-597,441. PUB. 3-17-2009. FILED 10-21-2008.
- 3,630,667. **LITTLE DIVA DANCE (BLOCK FORM)**. BEHRENS ENTERPRISES, INCORPORATED, DBA LAUNCH YOUR KID, (U.S. CLS. 100, 101 AND 107). SN 77-597,508. PUB. 3-17-2009. FILED 10-21-2008.
- 3,630,668. **RETRO FITNESS AND DESIGN**. RETROFITNESS IP, LLC, (U.S. CLS. 100, 101 AND 107). SN 77-597,605. PUB. 3-17-2009. FILED 10-22-2008.
- 3,630,674. **SPORTSTAP (BLOCK FORM)**. MOBILE1SPORTS, LLC, (U.S. CLS. 100, 101 AND 107). SN 77-597,736. PUB. 3-17-2009. FILED 10-22-2008.
- 3,630,677. **EXCELLOR (BLOCK FORM)**. ADAEQUARE INC, MULTIPLE CLASS, (INT. CLS. 41 AND 42), (U.S. CLS. 100, 101 AND 107). SN 77-597,811. PUB. 3-17-2009. FILED 10-22-2008.
- 3,630,683. **PLAIN TALK/HABLANO CLARO (BLOCK FORM)**. THE ANNIE E. CASEY FOUNDATION, INC., (U.S. CLS. 100, 101 AND 107). SN 77-597,936. PUB. 3-17-2009. FILED 10-22-2008.
- 3,630,695 (*See Class 9 for this trademark*).
- 3,630,700. **DEMOCRACY 2.0 (BLOCK FORM)**. MOBILING AMERICA'S YOUTH, INC., (U.S. CLS. 100, 101 AND 107). SN 77-598,276. PUB. 3-17-2009. FILED 10-22-2008.
- 3,630,702. **CRITICAL MASSIVE (BLOCK FORM)**. IGNITION NORTHWEST, (U.S. CLS. 100, 101 AND 107). SN 77-598,297. PUB. 3-17-2009. FILED 10-22-2008.
- 3,630,705. **SEACOMPRESSION (BLOCK FORM)**. IGNITION NORTHWEST, (U.S. CLS. 100, 101 AND 107). SN 77-598,338. PUB. 3-17-2009. FILED 10-22-2008.
- 3,630,710. **EN PROFUNDIDAD AND DESIGN**. UNIVISION COMMUNICATIONS INC., (U.S. CLS. 100, 101 AND 107). SN 77-598,407. PUB. 3-17-2009. FILED 10-22-2008.
- 3,630,715. **WARRIORS (BLOCK FORM)**. A&E TELEVISION NETWORKS, (U.S. CLS. 100, 101 AND 107). SN 77-598,465. PUB. 3-17-2009. FILED 10-22-2008.
- 3,630,722. **THE CONSCIOUS CAFE (BLOCK FORM)**. ROSEN, ALICE, (U.S. CLS. 100, 101 AND 107). SN 77-598,559. PUB. 3-17-2009. FILED 10-22-2008.
- 3,630,734. **DREAMVIZION (BLOCK FORM)**. SCHERER, MICHAEL D., DBA DREAMVIZION PRODUCTIONS, (U.S. CLS. 100, 101 AND 107). SN 77-598,788. PUB. 3-17-2009. FILED 10-23-2008.

- 3,630,737. **B. GIORGIO PRODUCTIONS (BLOCK FORM)**. BUZICA, GHEORGHE, (U.S. CLS. 100, 101 AND 107). SN 77-598,812. PUB. 3-17-2009. FILED 10-23-2008.
- 3,630,751. **PARTYPAINTER (BLOCK FORM)**. PARTYPAINTER, (U.S. CLS. 100, 101 AND 107). SN 77-598,946. PUB. 3-17-2009. FILED 10-23-2008.
- 3,630,755. **SUPER MER KA 2 (STYLIZED)**. SANDRO HUGO CILINGO, (U.S. CLS. 100, 101 AND 107). SN 77-598,969. PUB. 3-17-2009. FILED 10-23-2008.
- 3,630,761. **CLASS.COM AND DESIGN**. CLASS.COM, INC., (U.S. CLS. 100, 101 AND 107). SN 77-599,058. PUB. 3-17-2009. FILED 10-23-2008.
- 3,630,765. **DEAD MAN'S CAFE (BLOCK FORM)**. RAE, SHARA, (U.S. CLS. 100, 101 AND 107). SN 77-599,129. PUB. 3-17-2009. FILED 10-23-2008.
- 3,630,777 (*See Class 9 for this trademark*).
- 3,630,796. **INTELLIGENTSIA, INC. (BLOCK FORM)**. INTELLIGENTSIA, INC., (U.S. CLS. 100, 101 AND 107). SN 77-599,612. PUB. 3-17-2009. FILED 10-24-2008.
- 3,630,798. **BATISTE FAMILY INTERNATIONAL SCHOOL (BLOCK FORM)**. BATISTE, PAUL A., DBA BATISTE BROTHERS BAND, (U.S. CLS. 100, 101 AND 107). SN 77-599,621. PUB. 3-17-2009. FILED S.R. 10-24-2008; AM. P.R. 2-5-2009.
- 3,630,803. **ART OF ENGLISH AND DESIGN**. LINEN, CAMILLE, (U.S. CLS. 100, 101 AND 107). SN 77-599,679. PUB. 3-17-2009. FILED 10-24-2008.
- 3,630,812. **YOU SERVED (BLOCK FORM)**. MORTGAGE RESEARCH CENTER, LLC, (U.S. CLS. 100, 101 AND 107). SN 77-599,815. PUB. 3-17-2009. FILED 10-24-2008.
- 3,630,816. **WENDY IDA FITNESS WI AND DESIGN**. IDA, WENDY, (U.S. CLS. 100, 101 AND 107). SN 77-599,882. PUB. 3-17-2009. FILED 10-24-2008.
- 3,630,822. **GRAMMY CELEBRATION (BLOCK FORM)**. NATIONAL ACADEMY OF RECORDING ARTS & SCIENCES, INC., (U.S. CLS. 100, 101 AND 107). SN 77-599,940. PUB. 3-17-2009. FILED 10-24-2008.
- 3,630,823. **ENTERTAINMENT LAW INITIATIVE (BLOCK FORM)**. NATIONAL ACADEMY OF RECORDING ARTS & SCIENCES, INC., (U.S. CLS. 100, 101 AND 107). SN 77-599,945. PUB. 3-17-2009. FILED 10-24-2008.
- 3,630,824. **ACTIVE MINDS AND DESIGN**. SJB ENTERPRISES, LLC, (U.S. CLS. 100, 101 AND 107). SN 77-599,949. PUB. 3-17-2009. FILED 10-24-2008.
- 3,630,825. **GRAMMY SALUTE TO FASHION (BLOCK FORM)**. NATIONAL ACADEMY OF RECORDING ARTS & SCIENCES, INC., (U.S. CLS. 100, 101 AND 107). SN 77-599,970. PUB. 3-17-2009. FILED 10-24-2008.
- 3,630,826. **GRAMMY SALUTE TO INDUSTRY ICONS (BLOCK FORM)**. NATIONAL ACADEMY OF RECORDING ARTS & SCIENCES, INC., (U.S. CLS. 100, 101 AND 107). SN 77-599,972. PUB. 3-17-2009. FILED 10-24-2008.
- 3,630,827. **GRAMMY SALUTE TO GOSPEL MUSIC (BLOCK FORM)**. NATIONAL ACADEMY OF RECORDING ARTS & SCIENCES, INC., (U.S. CLS. 100, 101 AND 107). SN 77-599,978. PUB. 3-17-2009. FILED 10-24-2008.
- 3,630,832. **GUIDING MINDFUL CHANGE (BLOCK FORM)**. FRANCES, BILLIE, DBA GUIDING MINDFUL CHANGE, (U.S. CLS. 100, 101 AND 107). SN 77-600,067. PUB. 3-17-2009. FILED 10-24-2008.
- 3,630,838 (*See Class 38 for this trademark*).
- 3,630,842. **PC (STYLIZED)**. THE POINSETT CLUB, (U.S. CLS. 100, 101 AND 107). SN 77-600,154. PUB. 3-17-2009. FILED 10-24-2008.
- 3,630,844. **THIRD RAIL (BLOCK FORM)**. THE WEINSTEIN COMPANY LLC, (U.S. CLS. 100, 101 AND 107). SN 77-600,166. PUB. 3-17-2009. FILED 10-24-2008.
- 3,630,870. **MISCELLANEOUS DESIGN**. MOVING BOX STUDIOS, (U.S. CLS. 100, 101 AND 107). SN 77-600,478. PUB. 3-17-2009. FILED 10-24-2008.
- 3,630,872. **THE DISTANT SECONDS (BLOCK FORM)**. BAAB, MATTHEW W., (U.S. CLS. 100, 101 AND 107). SN 77-600,487. PUB. 3-17-2009. FILED 10-24-2008.
- 3,630,876. **YOGA DEVA (BLOCK FORM)**. YOGA DEVA, (U.S. CLS. 100, 101 AND 107). SN 77-600,627. PUB. 3-17-2009. FILED 10-25-2008.
- 3,630,877. **CKMP (BLOCK FORM)**. HUDSON ASSOCIATES CONSULTING, INC., (U.S. CLS. 100, 101 AND 107). SN 77-600,642. PUB. 3-17-2009. FILED 10-25-2008.
- 3,630,878. **MKMP (BLOCK FORM)**. HUDSON ASSOCIATES CONSULTING, INC., (U.S. CLS. 100, 101 AND 107). SN 77-600,645. PUB. 3-17-2009. FILED 10-25-2008.
- 3,630,881. **IN HIS IMAGE (BLOCK FORM)**. IN HIS IMAGE, INC., (U.S. CLS. 100, 101 AND 107). SN 77-600,669. PUB. 3-17-2009. FILED 10-26-2008.
- 3,630,882 (*See Class 35 for this trademark*).
- 3,630,883. **CHEF-K (BLOCK FORM)**. CHEF-K, INC., (U.S. CLS. 100, 101 AND 107). SN 77-600,681. PUB. 3-17-2009. FILED 10-26-2008.
- 3,630,896. **GREENPAGES (BLOCK FORM)**. GREENPAGES, INC., (U.S. CLS. 100, 101 AND 107). SN 77-600,908. PUB. 3-17-2009. FILED 10-27-2008.
- 3,630,898. **G AND DESIGN**. GREENPAGES, INC., (U.S. CLS. 100, 101 AND 107). SN 77-600,926. PUB. 3-17-2009. FILED 10-27-2008.
- 3,630,903. **KNOCKREAL ENTERTAINMENT (BLOCK FORM)**. RICHMOND, BRODICK G, (U.S. CLS. 100, 101 AND 107). SN 77-600,950. PUB. 3-17-2009. FILED 10-27-2008.
- 3,630,907. **VET NOV TES TAM EN TVM AND DESIGN**. THE TRUSTEES OF PRINCETON UNIVERSITY, (U.S. CLS. 100, 101 AND 107). SN 77-600,998. PUB. 3-17-2009. FILED 10-27-2008.
- 3,630,909. **GOOFYFACES CARICATURES LC AND DESIGN**. GOOFY FACES, (U.S. CLS. 100, 101 AND 107). SN 77-601,013. PUB. 3-17-2009. FILED 10-27-2008.
- 3,630,910. **HOCUS FOCUS (BLOCK FORM)**. SPENCER, KEVIN, (U.S. CLS. 100, 101 AND 107). SN 77-601,015. PUB. 3-17-2009. FILED 10-27-2008.
- 3,630,935 (*See Class 16 for this trademark*).
- 3,630,943. **FORTIFY (BLOCK FORM)**. FORTIFY SOFTWARE, INC., (U.S. CLS. 100, 101 AND 107). SN 77-601,388. PUB. 3-17-2009. FILED 10-27-2008.
- 3,630,953 (*See Class 25 for this trademark*).
- 3,630,955 (*See Class 25 for this trademark*).
- 3,630,956. **MONEY CAN HEAR (BLOCK FORM)**. CLARKE, LLOYD, (U.S. CLS. 100, 101 AND 107). SN 77-601,634. PUB. 3-17-2009. FILED 10-27-2008.
- 3,630,957. **SEW FUN! PARTIES AND MORE... AND DESIGN**. SEW FUN, LLC, (U.S. CLS. 100, 101 AND 107). SN 77-601,636. PUB. 3-17-2009. FILED 10-27-2008.
- 3,630,968. **IAPD (BLOCK FORM)**. BRIAN W. TURNER, LLC, DBA INTERNATIONAL ACADEMY FOR PROFESSIONAL DRIVING, LLC, (U.S. CLS. 100, 101 AND 107). SN 77-601,923. PUB. 3-17-2009. FILED 10-28-2008.
- 3,630,972. **SF AND DESIGN**. SAN FRANCISCO FORTY NINERS, LIMITED, (U.S. CLS. 100, 101 AND 107). SN 77-601,946. PUB. 3-17-2009. FILED 10-28-2008.
- 3,630,978. **PEACE THROUGH YOGA (BLOCK FORM)**. BROWN, SALLY, (U.S. CLS. 100, 101 AND 107). SN 77-601,986. PUB. 3-17-2009. FILED 10-28-2008.
- 3,630,983. **PSYKILL (BLOCK FORM)**. PRIME, SPYDER, (U.S. CLS. 100, 101 AND 107). SN 77-602,051. PUB. 3-17-2009. FILED 10-28-2008.
- 3,630,985. **AMERICAN HEIST (BLOCK FORM)**. MARC STYLES PRODUCTIONS, INC., (U.S. CLS. 100, 101 AND 107). SN 77-602,063. PUB. 3-17-2009. FILED 10-28-2008.
- 3,631,007. **BEAT CANCER BOOT CAMP (BLOCK FORM)**. BC BOOTCAMP LLC, (U.S. CLS. 100, 101 AND 107). SN 77-602,296. PUB. 3-17-2009. FILED 10-28-2008.
- 3,631,014. **GOALS IN MOTION (BLOCK FORM)**. GOALS IN MOTION, LLC, (U.S. CLS. 100, 101 AND 107). SN 77-602,371. PUB. 3-17-2009. FILED 10-28-2008.
- 3,631,020. **TIER ONE STUDY SMART, NOT HARD. (STYLIZED)**. TIER ONE TUTORS, (U.S. CLS. 100, 101 AND 107). SN 77-602,472. PUB. 3-17-2009. FILED 10-28-2008.
- 3,631,025. **ACADEMY FOR PRECISION LEARNING (BLOCK FORM)**. ACADEMY FOR PRECISION LEARNING, (U.S. CLS. 100, 101 AND 107). SN 77-602,554. PUB. 3-17-2009. FILED 10-28-2008.
- 3,631,029. **THE ITALIAN OPERATIC EXPERIENCE (BLOCK FORM)**. OPERATIC EXPERIENCE, INC., DBA ITALIAN OPERATIC EXPERIENCE, (U.S. CLS. 100, 101 AND 107). SN 77-602,589. PUB. 3-17-2009. FILED 10-28-2008.
- 3,631,032. **NOSSIP (BLOCK FORM)**. ARISCO, LAUREN, (U.S. CLS. 100, 101 AND 107). SN 77-602,604. PUB. 3-17-2009. FILED 10-28-2008.

- 3,631,048. **WHITE NOISE (BLOCK FORM)**. ROSE, CHARLIE, (U.S. CLS. 100, 101 AND 107). SN 77-602,951. PUB. 3-17-2009. FILED 10-29-2008.
- 3,631,057. **BLUE KNIGHT AND DESIGN**. BLUE KNIGHT BATTLEFIELD SEMINARS, LLC, (U.S. CLS. 100, 101 AND 107). SN 77-603,174. PUB. 3-17-2009. FILED 10-29-2008.
- 3,631,058 (*See Class 35 for this trademark*).
- 3,631,064 (*See Class 9 for this trademark*).
- 3,631,069. **GO DEEP WITH DISC (BLOCK FORM)**. SWITZER RESOURCE GROUP, INC., (U.S. CLS. 100, 101 AND 107). SN 77-603,399. PUB. 3-17-2009. FILED 10-29-2008.
- 3,631,085. **DJ CENTER (BLOCK FORM)**. EMIL HERSCHER, (U.S. CLS. 100, 101 AND 107). SN 77-603,634. PUB. 3-17-2009. FILED 10-29-2008.
- 3,631,086. **MEDIA BLITZ PRODUCTIONS (BLOCK FORM)**. LANDERS MARK L, DBA MEDIA BLITZ PRODUCTIONS, (U.S. CLS. 100, 101 AND 107). SN 77-603,635. PUB. 3-17-2009. FILED 10-29-2008.
- 3,631,088. **PUSH THE FADER (BLOCK FORM)**. EMIL HERSCHER, (U.S. CLS. 100, 101 AND 107). SN 77-603,656. PUB. 3-17-2009. FILED 10-30-2008.
- 3,631,093. **TALES OF THE COCKTAIL NEW ORLEANS AND DESIGN**. ANN ROGERS, (U.S. CLS. 100, 101 AND 107). SN 77-603,747. PUB. 3-17-2009. FILED 10-30-2008.
- 3,631,104. **SIBO (BLOCK FORM)**. VANCE COMMUNICATIONS CANADA, (U.S. CLS. 100, 101 AND 107). SN 77-603,993. PUB. 3-17-2009. FILED 10-30-2008.
- 3,631,115. **ESSENTIAL ENTERTAINMENT (BLOCK FORM)**. ESSENTIAL ENTERTAINMENT MEDIA, LLC, (U.S. CLS. 100, 101 AND 107). SN 77-604,096. PUB. 3-17-2009. FILED 10-30-2008.
- 3,631,146. **FIRST (BLOCK FORM)**. UNITED STATES FOUNDATION FOR INSPIRATION AND RECOGNITION OF SCIENCE AND TECHNOLOGY, AKA FIRST, (U.S. CLS. 100, 101 AND 107). SN 77-604,573. PUB. 3-17-2009. FILED 10-30-2008.
- 3,631,151 (*See Class 16 for this trademark*).
- 3,631,156. **PHOTO WALK (BLOCK FORM)**. SCOTT G. KELBY, (U.S. CLS. 100, 101 AND 107). SN 77-604,815. PUB. 3-17-2009. FILED 10-31-2008.
- 3,631,171. **MISCELLANEOUS DESIGN**. PRENTISS, LUKE S, (U.S. CLS. 100, 101 AND 107). SN 77-605,001. PUB. 3-17-2009. FILED 10-31-2008.
- 3,631,172. **THE JAM CATS (STYLIZED)**. THE JAM CATS, (U.S. CLS. 100, 101 AND 107). SN 77-605,008. PUB. 3-17-2009. FILED 10-31-2008.
- 3,631,207 (*See Class 9 for this trademark*).
- 3,631,237. **LEARN AHEAD (BLOCK FORM)**. LEARN AHEAD, (U.S. CLS. 100, 101 AND 107). SN 77-606,112. PUB. 3-17-2009. FILED 11-3-2008.
- 3,631,248. **O'SHEAS (BLOCK FORM)**. HARRAH'S LICENSE COMPANY, LLC, (U.S. CLS. 100, 101 AND 107). SN 77-606,233. PUB. 3-17-2009. FILED 11-3-2008.
- 3,631,257. **REAL SIMPLE. REAL LIFE. (BLOCK FORM)**. TIME INC., (U.S. CLS. 100, 101 AND 107). SN 77-606,874. PUB. 3-17-2009. FILED 11-4-2008.
- 3,631,268 (*See Class 16 for this trademark*).
- 3,631,269 (*See Class 16 for this trademark*).
- 3,631,281. **RETURN TO CARE (BLOCK FORM)**. VHA INC., (U.S. CLS. 100, 101 AND 107). SN 77-609,899. PUB. 3-17-2009. FILED 11-7-2008.
- 3,631,300. **RADIO HEARTLAND (BLOCK FORM)**. MINNESOTA PUBLIC RADIO, (U.S. CLS. 100, 101 AND 107). SN 77-614,875. PUB. 3-17-2009. FILED 11-14-2008.
- 3,631,318. **ALL IS ONE (BLOCK FORM)**. HARD ROCK CAFE INTERNATIONAL (USA), INC., (U.S. CLS. 100, 101 AND 107). SN 77-618,048. PUB. 3-17-2009. FILED 11-19-2008.
- 3,631,324. **EQUIP (BLOCK FORM)**. AMERICAN ACADEMY OF PEDIATRICS, (U.S. CLS. 100, 101 AND 107). SN 77-619,809. PUB. 3-17-2009. FILED 11-21-2008.
- 3,631,345. **FARK IT (BLOCK FORM)**. FARK, INC., (U.S. CLS. 100, 101 AND 107). SN 77-632,084. PUB. 3-17-2009. FILED 12-12-2008.
- 3,631,346. **THE CONNECTOR (BLOCK FORM)**. CONNECT FOR EDUCATION, INC., (U.S. CLS. 100, 101 AND 107). SN 77-632,303. PUB. 3-17-2009. FILED 12-12-2008.
- 3,631,349 (*See Class 38 for this trademark*).
- 3,631,351. **MISCELLANEOUS DESIGN. FOCUS ON THE FAMILY**, (U.S. CLS. 100, 101 AND 107). SN 77-635,655. PUB. 3-17-2009. FILED 12-18-2008.
- 3,631,356. **FLL (BLOCK FORM)**. UNITED STATES FOUNDATION FOR INSPIRATION AND RECOGNITION OF SCIENCE AND TECHNOLOGY, (U.S. CLS. 100, 101 AND 107). SN 77-637,478. PUB. 3-17-2009. FILED 12-21-2008.
- 3,631,357. **WAIT NO MORE (BLOCK FORM)**. FOCUS ON THE FAMILY, (U.S. CLS. 100, 101 AND 107). SN 77-638,019. PUB. 3-17-2009. FILED 12-22-2008.
- 3,631,359 (*See Class 35 for this trademark*).
- 3,631,361 (*See Class 35 for this trademark*).
- 3,631,363. **LUNACY (BLOCK FORM)**. UNITED STATES FOUNDATION FOR INSPIRATION AND RECOGNITION OF SCIENCE AND TECHNOLOGY, (U.S. CLS. 100, 101 AND 107). SN 77-644,522. PUB. 3-17-2009. FILED 1-7-2009.
- 3,631,366. **FTC (BLOCK FORM)**. UNITED STATES FOUNDATION FOR INSPIRATION AND RECOGNITION OF SCIENCE AND TECHNOLOGY, (U.S. CLS. 100, 101 AND 107). SN 77-647,261. PUB. 3-17-2009. FILED 1-11-2009.
- 3,631,367. **PCC INSIDER (BLOCK FORM)**. UNITED STATES POSTAL SERVICE, (U.S. CLS. 100, 101 AND 107). SN 77-649,279. PUB. 3-17-2009. FILED 1-14-2009.
- 3,631,369 (*See Class 16 for this trademark*).
- 3,631,370 (*See Class 35 for this trademark*).
- 3,631,372. **HEARTLAND ALLIANCE (BLOCK FORM)**. HEARTLAND ALLIANCE FOR HUMAN NEEDS AND HUMAN RIGHTS, MULTIPLE CLASS, (INT. CLS. 41 AND 45), (U.S. CLS. 100, 101 AND 107). SN 77-975,941. PUB. 12-2-2008. FILED 8-17-2007.
- 3,631,374. **DEAD MEN TALKING (BLOCK FORM)**. A&E TELEVISION NETWORKS, (U.S. CLS. 100, 101 AND 107). SN 77-976,352. PUB. 3-17-2009. FILED 8-16-2007.
- 3,631,393. **FESTIVAL OF SPEED (BLOCK FORM)**. BUTTAR, INC., (U.S. CLS. 100, 101 AND 107). SN 78-542,852. PUB. 3-17-2009. FILED 1-5-2005.
- 3,631,397 (*See Class 9 for this trademark*).
- 3,631,398 (*See Class 9 for this trademark*).
- 3,631,399 (*See Class 3 for this trademark*).
- 3,631,411. **LIVING WELL AND DESIGN**. UNITED SUPERMARKETS, L.L.C., (U.S. CLS. 100, 101 AND 107). SN 78-694,308. PUB. 3-17-2009. FILED 8-17-2005.
- 3,631,421 (*See Class 35 for this trademark*).
- 3,631,422 (*See Class 35 for this trademark*).
- 3,631,426 (*See Class 9 for this trademark*).
- 3,631,438 (*See Class 7 for this trademark*).
- 3,631,446. **DIALOGOS POR MÉXICO (BLOCK FORM)**. TELE-VISA, S.A. DE C.V., (U.S. CLS. 100, 101 AND 107). SN 78-942,563. PUB. 3-17-2009. FILED 8-1-2006.
- 3,631,447. **ROXY SAINT (BLOCK FORM)**. SAINT, ROXANNE, (U.S. CLS. 100, 101 AND 107). SN 78-945,900. PUB. 3-27-2007. FILED 8-6-2006.
- 3,631,458. **DISCOVERLINK (BLOCK FORM)**. DISCOVERLINK, INC., (U.S. CLS. 100, 101 AND 107). SN 78-980,358. PUB. 3-17-2009. FILED 3-29-2006.
- 3,631,459. **SERVE U (BLOCK FORM)**. DISCOVERLINK, INC., (U.S. CLS. 100, 101 AND 107). SN 78-980,364. PUB. 3-17-2009. FILED 3-29-2006.
- 3,631,468. **PICTUREFORUNITY (STYLIZED)**. PICTURE FOR UNITY LTD., (U.S. CLS. 100, 101 AND 107). SN 79-033,007. PUB. 3-17-2009. FILED 9-29-2006.
- 3,631,469 (*See Class 9 for this trademark*).
- 3,631,473 (*See Class 14 for this trademark*).
- 3,631,479 (*See Class 16 for this trademark*).
- 3,631,485 (*See Class 35 for this trademark*).
- 3,631,490 (*See Class 36 for this trademark*).
- 3,631,496 (*See Class 9 for this trademark*).
- 3,631,506 (*See Class 35 for this trademark*).
- 3,631,509 (*See Class 9 for this trademark*).
- 3,631,511 (*See Class 1 for this trademark*).
- 3,631,512 (*See Class 3 for this trademark*).
- 3,631,514 (*See Class 35 for this trademark*).
- 3,631,522. **GRAPHICALIA (STYLIZED)**. MONSIEUR FABIEN OUDOT, MULTIPLE CLASS, (INT. CLS. 41, 42 AND 43), (U.S. CLS. 100, 101 AND 107). SN 79-048,644. PUB. 3-17-2009. FILED 12-4-2007.
- 3,631,531 (*See Class 9 for this trademark*).
- 3,631,533 (*See Class 35 for this trademark*).
- 3,631,536 (*See Class 35 for this trademark*).

3,631,537 (*See Class 35 for this trademark.*)
 3,631,538 (*See Class 9 for this trademark.*)
 3,631,542 (*See Class 16 for this trademark.*)
 3,631,557 (*See Class 9 for this trademark.*)
 3,631,574. **STATE SWIM SWIMMING SCHOOLS AND DESIGN.** STATE SWIM SYSTEMS PTY LTD, (U.S. CLS. 100, 101 AND 107). SN 79-053,129. PUB. 3-17-2009. FILED 4-3-2008.
 3,631,598 (*See Class 35 for this trademark.*)
 3,631,611 (*See Class 9 for this trademark.*)
 3,631,644 (*See Class 35 for this trademark.*)
 3,631,662 (*See Class 35 for this trademark.*)
 3,631,669. **TARGET CANCER COMMITMENT IN ACTION AND DESIGN.** SANOFI-AVENTIS, MULTIPLE CLASS, (INT. CLS. 41 AND 44), (U.S. CLS. 100, 101 AND 107). SN 79-055,757. PUB. 3-17-2009. FILED 4-18-2008.
 3,631,672 (*See Class 16 for this trademark.*)
 3,631,711 (*See Class 6 for this trademark.*)
 3,631,727 (*See Class 35 for this trademark.*)
 3,631,734 (*See Class 25 for this trademark.*)
 3,631,757 (*See Class 38 for this trademark.*)
 3,631,761 (*See Class 9 for this trademark.*)

CLASS 42—SCIENTIFIC AND COMPUTER SERVICES

3,629,120. **PC PITSTOP (BLOCK FORM).** PC PITSTOP L.L.C., (U.S. CLS. 100 AND 101). SN 76-010,581. PUB. 3-17-2009. FILED 3-27-2000.
 3,629,121 (*See Class 9 for this trademark.*)
 3,629,122 (*See Class 9 for this trademark.*)
 3,629,136 (*See Class 9 for this trademark.*)
 3,629,137 (*See Class 35 for this trademark.*)
 3,629,164. **CORGAN AND DESIGN.** CORGAN ASSOCIATES, INC., (U.S. CLS. 100 AND 101). SN 76-688,796. PUB. 3-17-2009. FILED 4-21-2008.
 3,629,165 (*See Class 35 for this trademark.*)
 3,629,168 (*See Class 37 for this trademark.*)
 3,629,194. **ZETABOARDS (BLOCK FORM).** ZATHYUS NETWORKS, INC., (U.S. CLS. 100 AND 101). SN 76-693,083. PUB. 3-17-2009. FILED 9-24-2008.
 3,629,201 (*See Class 35 for this trademark.*)
 3,629,205. **TOUGH SHIP TECHNOLOGY AND DESIGN.** M SHIP CO., LLC., (U.S. CLS. 100 AND 101). SN 76-693,706. PUB. 3-17-2009. FILED 10-20-2008.
 3,629,247 (*See Class 9 for this trademark.*)
 3,629,253 (*See Class 37 for this trademark.*)
 3,629,266 (*See Class 41 for this trademark.*)
 3,629,296. **SALESTRONG (BLOCK FORM).** SALESTRONG LLC, (U.S. CLS. 100 AND 101). SN 77-179,552. PUB. 10-14-2008. FILED 5-12-2007.
 3,629,316 (*See Class 35 for this trademark.*)
 3,629,352 (*See Class 35 for this trademark.*)
 3,629,359. **OBSESSIVE SUPPORT (BLOCK FORM).** MOMENTUM ADVANCED SOLUTIONS INC., (U.S. CLS. 100 AND 101). SN 77-271,382. PUB. 3-17-2009. FILED 9-4-2007.
 3,629,373 (*See Class 16 for this trademark.*)
 3,629,375 (*See Class 39 for this trademark.*)
 3,629,413 (*See Class 9 for this trademark.*)
 3,629,417. **R (STYLIZED).** RALINK TECHNOLOGY CORPORATION, (U.S. CLS. 100 AND 101). SN 77-319,055. PUB. 3-17-2009. FILED 11-1-2007.
 3,629,423. **TIGRESS (BLOCK FORM).** GEOTRACE TECHNOLOGIES, INC., (U.S. CLS. 100 AND 101). SN 77-322,664. PUB. 3-17-2009. FILED 11-6-2007.
 3,629,425 (*See Class 9 for this trademark.*)
 3,629,426 (*See Class 9 for this trademark.*)
 3,629,429 (*See Class 9 for this trademark.*)
 3,629,444 (*See Class 36 for this trademark.*)
 3,629,446. **ORGANIC REACTIONS (BLOCK FORM).** ORGANIC REACTIONS, (U.S. CLS. 100 AND 101). SN 77-340,052. PUB. 3-17-2009. FILED 11-29-2007.
 3,629,452 (*See Class 19 for this trademark.*)
 3,629,454 (*See Class 5 for this trademark.*)
 3,629,456 (*See Class 35 for this trademark.*)
 3,629,457. **KEY TECH (BLOCK FORM).** KEY TECHNOLOGIES, INC., (U.S. CLS. 100 AND 101). SN 77-349,001. PUB. 3-17-2009. FILED 12-11-2007.
 3,629,459 (*See Class 35 for this trademark.*)
 3,629,479 (*See Class 1 for this trademark.*)
 3,629,480 (*See Class 36 for this trademark.*)
 3,629,483 (*See Class 35 for this trademark.*)
 3,629,490. **WEATHEREXTREME (BLOCK FORM).** WEATHEREXTREME LTD., MULTIPLE CLASS, (INT. CLS. 42 AND 45), (U.S. CLS. 100 AND 101). SN 77-369,620. PUB. 3-17-2009. FILED 1-11-2008.
 3,629,494 (*See Class 41 for this trademark.*)
 3,629,518 (*See Class 41 for this trademark.*)
 3,629,522. **NEOSCAN (BLOCK FORM).** OPTEOS, INC., (U.S. CLS. 100 AND 101). SN 77-385,196. PUB. 3-17-2009. FILED 1-31-2008.
 3,629,525 (*See Class 6 for this trademark.*)
 3,629,526 (*See Class 6 for this trademark.*)
 3,629,527 (*See Class 6 for this trademark.*)
 3,629,542 (*See Class 35 for this trademark.*)
 3,629,563. **PROSKALO (BLOCK FORM).** PROSKALO INC., (U.S. CLS. 100 AND 101). SN 77-406,179. PUB. 3-17-2009. FILED 2-26-2008.
 3,629,574. **IITRI AND DESIGN.** IIT RESEARCH INSTITUTE, (U.S. CLS. 100 AND 101). SN 77-411,131. PUB. 3-17-2009. FILED 3-3-2008.
 3,629,586 (*See Class 35 for this trademark.*)
 3,629,629 (*See Class 40 for this trademark.*)
 3,629,654. **GARDENGENETICS (BLOCK FORM).** GARDENGENETICS, LLC, MULTIPLE CLASS, (INT. CLS. 42 AND 44), (U.S. CLS. 100 AND 101). SN 77-437,090. PUB. 3-17-2009. FILED 4-1-2008.
 3,629,658 (*See Class 38 for this trademark.*)
 3,629,666. **EPR (BLOCK FORM).** MEDKINETICS, LLC, (U.S. CLS. 100 AND 101). SN 77-439,281. PUB. 3-17-2009. FILED 4-3-2008.
 3,629,675 (*See Class 35 for this trademark.*)
 3,629,706. **POINT TO VERIFY (BLOCK FORM).** COMODO CA LIMITED, MULTIPLE CLASS, (INT. CLS. 42 AND 45), (U.S. CLS. 100 AND 101). SN 77-443,869. PUB. 3-17-2009. FILED 4-9-2008.
 3,629,709 (*See Class 38 for this trademark.*)
 3,629,714. **RESTORA (BLOCK FORM).** COMMUNITY ISP, INC., (U.S. CLS. 100 AND 101). SN 77-444,575. PUB. 3-17-2009. FILED 4-10-2008.
 3,629,717. **YAMLI (BLOCK FORM).** LANGUAGE ANALYTICS LLC, (U.S. CLS. 100 AND 101). SN 77-444,617. PUB. 3-17-2009. FILED 4-10-2008.
 3,629,719. **RAGE WRAPS (BLOCK FORM).** RAGE WRAPS, INC., (U.S. CLS. 100 AND 101). SN 77-444,654. PUB. 3-17-2009. FILED 4-10-2008.
 3,629,723 (*See Class 40 for this trademark.*)
 3,629,747 (*See Class 9 for this trademark.*)
 3,629,754 (*See Class 35 for this trademark.*)
 3,629,757. **EXECTA (BLOCK FORM).** TETHYS TECHNOLOGY, (U.S. CLS. 100 AND 101). SN 77-449,003. PUB. 3-17-2009. FILED 4-15-2008.
 3,629,759. **TOTALTCA (BLOCK FORM).** TETHYS TECHNOLOGY, (U.S. CLS. 100 AND 101). SN 77-449,405. PUB. 3-17-2009. FILED 4-16-2008.
 3,629,764. **REPROS THERAPEUTICS INC (BLOCK FORM).** REPROS THERAPEUTICS INC, (U.S. CLS. 100 AND 101). SN 77-449,849. PUB. 3-17-2009. FILED 4-16-2008.
 3,629,765 (*See Class 37 for this trademark.*)
 3,629,826 (*See Class 9 for this trademark.*)
 3,629,831. **UBIDYNE AND DESIGN.** UBIDYNE, INC., (U.S. CLS. 100 AND 101). SN 77-454,912. PUB. 3-17-2009. FILED 4-22-2008.
 3,629,833. **SIGNUM (BLOCK FORM).** EXXON MOBIL CORPORATION, (U.S. CLS. 100 AND 101). SN 77-454,997. PUB. 3-17-2009. FILED 4-22-2008.
 3,629,857. **SHADY LADY INC. (BLOCK FORM).** SHADY LADY, INC., (U.S. CLS. 100 AND 101). SN 77-458,299. PUB. 12-9-2008. FILED 4-25-2008.
 3,629,861. **ENVIROCHECK (BLOCK FORM).** ENVIROCHECK, INC., (U.S. CLS. 100 AND 101). SN 77-458,762. PUB. 3-17-2009. FILED 4-25-2008.
 3,629,915. **RAPIDRESPONSE (BLOCK FORM).** KINAXIS CORP., (U.S. CLS. 100 AND 101). SN 77-470,008. PUB. 3-17-

2009. FILED 5-9-2008.
3,629,920 (*See Class 9 for this trademark*).
3,629,934 (*See Class 35 for this trademark*).
3,629,948 (*See Class 9 for this trademark*).
3,629,953. **LOGOSPORTSWEAR.COM AND DESIGN**. LOGO'D SOFTWARE, INC., DBA LOGOSPORTSWEAR.COM, (U.S. CLS. 100 AND 101). SN 77-479,376. PUB. 3-17-2009. FILED 5-20-2008.
3,629,954. **TEAM SPORTSWEAR.COM AND DESIGN**. LOGO'D SOFTWARE, INC., DBA TEAMSPORTSWEAR.COM, (U.S. CLS. 100 AND 101). SN 77-479,426. PUB. 3-17-2009. FILED 5-20-2008.
3,629,959 (*See Class 7 for this trademark*).
3,629,977. **WEBOOK (STYLIZED)**. WEBOOK, INC., (U.S. CLS. 100 AND 101). SN 77-488,636. PUB. 10-14-2008. FILED 6-2-2008.
3,629,979. **WILD APRICOT (BLOCK FORM)**. BONASOURCE INC., (U.S. CLS. 100 AND 101). SN 77-488,791. PUB. 3-17-2009. FILED 6-2-2008.
3,629,989. **GOODBARRY (BLOCK FORM)**. BUSINESS CATALYST SYSTEMS LLC, (U.S. CLS. 100 AND 101). SN 77-490,962. PUB. 3-17-2009. FILED 6-4-2008.
3,630,044. **AMITY 360 (BLOCK FORM)**. AMITY 360 LLC, (U.S. CLS. 100 AND 101). SN 77-503,946. PUB. 3-17-2009. FILED 6-20-2008.
3,630,053 (*See Class 35 for this trademark*).
3,630,059. **DEV-MONKEY (BLOCK FORM)**. REED ELSEVIER PROPERTIES INC., (U.S. CLS. 100 AND 101). SN 77-508,631. PUB. 3-17-2009. FILED 6-26-2008.
3,630,072. **GRAPHIC ILLUSIONS (BLOCK FORM)**. LANGLOIS, ANDREW, (U.S. CLS. 100 AND 101). SN 77-513,921. PUB. 3-17-2009. FILED 7-2-2008.
3,630,092 (*See Class 9 for this trademark*).
3,630,102. **INTERIOR REVIVALS INC TRANSFORM YOUR INTERIOR FORM NOW TO WOW! AND DESIGN**. SERRA MELANIE L, DBA INTERIOR REVIVALS INC., (U.S. CLS. 100 AND 101). SN 77-520,196. PUB. 3-17-2009. FILED 7-11-2008.
3,630,126. **PORTLAND TRAILS AND DESIGN**. PORTLAND TRAILS, (U.S. CLS. 100 AND 101). SN 77-526,552. PUB. 3-17-2009. FILED 7-19-2008.
3,630,135 (*See Class 16 for this trademark*).
3,630,149. **TECHNOLOGY SOLUTIONS BUILDING FOR THE FUTURE (BLOCK FORM)**. DATACOM DESIGN GROUP, L.L.C., DBA DATACOM DESIGN GROUP, (U.S. CLS. 100 AND 101). SN 77-532,833. PUB. 3-17-2009. FILED 7-28-2008.
3,630,153. **BLACK WOLF STUDIO (STYLIZED)**. REUSS, DAVID, (U.S. CLS. 100 AND 101). SN 77-533,554. PUB. 3-17-2009. FILED 7-29-2008.
3,630,168 (*See Class 35 for this trademark*).
3,630,193. **DOODAT DESIGN AND DESIGN**. CURRERI, TRACY L., (U.S. CLS. 100 AND 101). SN 77-546,136. PUB. 3-17-2009. FILED 8-13-2008.
3,630,217. **247 TOWNHALL (BLOCK FORM)**. ONE ECONOMY CORPORATION, (U.S. CLS. 100 AND 101). SN 77-551,505. PUB. 3-17-2009. FILED 8-20-2008.
3,630,259. **WET RECORDS (BLOCK FORM)**. VERDOONER, STEVEN, AND YVONNE COLEBANK, (U.S. CLS. 100 AND 101). SN 77-558,355. PUB. 12-9-2008. FILED 8-28-2008.
3,630,260. **XSB WARWICK N NE E SE S SW W NW AND DESIGN**. XSB, INC., (U.S. CLS. 100 AND 101). SN 77-558,358. PUB. 3-17-2009. FILED 8-28-2008.
3,630,278 (*See Class 35 for this trademark*).
3,630,285 (*See Class 35 for this trademark*).
3,630,294 (*See Class 36 for this trademark*).
3,630,296. **LITMAVEN (BLOCK FORM)**. KRONENBERGER BURGOYNE, LLP, DBA LITMAVEN, MULTIPLE CLASS, (INT. CLS. 42 AND 45), (U.S. CLS. 100 AND 101). SN 77-564,944. PUB. 3-17-2009. FILED 9-8-2008.
3,630,302 (*See Class 7 for this trademark*).
3,630,304 (*See Class 40 for this trademark*).
3,630,306. **PRO DEPOT THE PLACE TO GO, TO FIND A PRO. PRODEPOT.COM "THE PLACE TO GO TO FIND A PRO!" AND DESIGN**. HURT, KELLY LLOYD, DBA FREELANCE CONSULTING SERVICES, INC., (U.S. CLS. 100 AND 101). SN 77-567,174. PUB. 3-17-2009. FILED 9-10-2008.
3,630,316. **ACCREDITATION NOW (BLOCK FORM)**. ACCREDITATION NOW, INC., (U.S. CLS. 100 AND 101). SN 77-568,450. PUB. 3-17-2009. FILED 9-12-2008.
3,630,360. **FIRSTLOOK (BLOCK FORM)**. FIRST LOOK, INC., (U.S. CLS. 100 AND 101). SN 77-573,611. PUB. 2-10-2009. FILED 9-18-2008.
3,630,376. **THINKWELL OPUS AND DESIGN**. THINKWELL GROUP INC., (U.S. CLS. 100 AND 101). SN 77-576,119. PUB. 3-17-2009. FILED 9-22-2008.
3,630,381. **LEGAL ARTS (BLOCK FORM)**. LEGAL ARTS, INC., (U.S. CLS. 100 AND 101). SN 77-576,687. PUB. 3-17-2009. FILED 9-23-2008.
3,630,385 (*See Class 35 for this trademark*).
3,630,393. **LT LEAD-TEK LLC HELPING TECHNOLOGY LEADERS RECONNECT AND DESIGN**. WILLIAMS, JOSEPH J., TA LEAD-TEK LLC, (U.S. CLS. 100 AND 101). SN 77-578,312. PUB. 3-17-2009. FILED 9-25-2008.
3,630,395. **! COGNIVATION ACTION BASED ON KNOWING AND DESIGN**. COGNIVATION, (U.S. CLS. 100 AND 101). SN 77-578,671. PUB. 3-17-2009. FILED 9-25-2008.
3,630,415 (*See Class 9 for this trademark*).
3,630,428. **PHARMASONIC TECHNOLOGIES (BLOCK FORM)**. BIOVALUATION & ANALYSIS, INC., (U.S. CLS. 100 AND 101). SN 77-581,644. PUB. 3-17-2009. FILED 9-29-2008.
3,630,493. **GOOGENIUS AND DESIGN**. GOOGENIUS, LLC, (U.S. CLS. 100 AND 101). SN 77-589,076. PUB. 3-17-2009. FILED 10-9-2008.
3,630,494. **DOMAIN FIGHT (BLOCK FORM)**. USPEAKWE-TYPE TECHNOLOGIES LLC, (U.S. CLS. 100 AND 101). SN 77-589,115. PUB. 3-17-2009. FILED 10-9-2008.
3,630,518. **FOCUSING SCIENCE TO ADVANCE MEDICINE (BLOCK FORM)**. JOHNSON & JOHNSON, (U.S. CLS. 100 AND 101). SN 77-591,112. PUB. 3-17-2009. FILED 10-13-2008.
3,630,543. **SOCIOUS (BLOCK FORM)**. SOCIOUS, INC., (U.S. CLS. 100 AND 101). SN 77-592,782. PUB. 3-17-2009. FILED 10-14-2008.
3,630,657. **BHR PHARMA (BLOCK FORM)**. BESINS HEALTHCARE, INC., (U.S. CLS. 100 AND 101). SN 77-597,317. PUB. 3-17-2009. FILED 10-21-2008.
3,630,669. **TWISTHINK (STYLIZED)**. TWISTHINK, LLC, (U.S. CLS. 100 AND 101). SN 77-597,616. PUB. 3-17-2009. FILED 10-22-2008.
3,630,677 (*See Class 41 for this trademark*).
3,630,686. **SLIP (BLOCK FORM)**. INFINITY SOFTWARE DEVELOPMENT, INC., (U.S. CLS. 100 AND 101). SN 77-597,997. PUB. 3-17-2009. FILED 10-22-2008.
3,630,687. **RAPID (BLOCK FORM)**. INFINITY SOFTWARE DEVELOPMENT, INC., (U.S. CLS. 100 AND 101). SN 77-598,005. PUB. 3-17-2009. FILED 10-22-2008.
3,630,711. **WEATHERFORYOU.COM (BLOCK FORM)**. WEATHERFORYOU.COM LLC, (U.S. CLS. 100 AND 101). SN 77-598,408. PUB. 3-17-2009. FILED 10-22-2008.
3,630,721. **LOISTA (BLOCK FORM)**. USMLEWORLD, LLC, (U.S. CLS. 100 AND 101). SN 77-598,550. PUB. 3-17-2009. FILED 10-22-2008.
3,630,723. **FAULTWIRE (BLOCK FORM)**. VAN GILLUWE, FRANK, L., DBA FAQWARE, (U.S. CLS. 100 AND 101). SN 77-598,578. PUB. 3-17-2009. FILED 10-22-2008.
3,630,725. **BLOG TO LOSE (BLOCK FORM)**. SKINNYMIN-NYMEDIA, LLC, (U.S. CLS. 100 AND 101). SN 77-598,631. PUB. 3-17-2009. FILED 10-23-2008.
3,630,730. **DROR (BLOCK FORM)**. STUDIO DROR, (U.S. CLS. 100 AND 101). SN 77-598,681. PUB. 3-17-2009. FILED 10-23-2008.
3,630,732. **AXON AND DESIGN**. AXON MARKETING & DESIGN, (U.S. CLS. 100 AND 101). SN 77-598,697. PUB. 3-17-2009. FILED 10-23-2008.
3,630,736. **CHOOSEWHAT AND DESIGN**. CHOOSEWHAT.COM, LLC, (U.S. CLS. 100 AND 101). SN 77-598,804. PUB. 3-17-2009. FILED 10-23-2008.
3,630,742. **TEKINSIL (BLOCK FORM)**. AZZOZ NEZAR, (U.S. CLS. 100 AND 101). SN 77-598,845. PUB. 3-17-2009. FILED 10-23-2008.
3,630,753. **LINCS (BLOCK FORM)**. SPINSIX STRATEGIC MARKETING DESIGN, LLC, (U.S. CLS. 100 AND 101). SN 77-598,961. PUB. 3-17-2009. FILED 10-23-2008.
3,630,779. **WWW.MESOSCALE.COM (BLOCK FORM)**. MESO SCALE DIAGNOSTICS, LLC, (U.S. CLS. 100 AND 101). SN 77-599,322. PUB. 3-17-2009. FILED 10-23-2008.

- 3,630,781. **DESIGNHOP (BLOCK FORM)**. DANA'S DESIGN STUDIO, L.L.C., (U.S. CLS. 100 AND 101). SN 77-599,346. PUB. 3-17-2009. FILED 10-23-2008.
- 3,630,782. **PROSUITE (BLOCK FORM)**. CORPORATE NETWORK SERVICES, INC., (U.S. CLS. 100 AND 101). SN 77-599,348. PUB. 3-17-2009. FILED 10-23-2008.
- 3,630,890. **ARCAMETRICS (BLOCK FORM)**. ARCAMETRICS, LLC, (U.S. CLS. 100 AND 101). SN 77-600,815. PUB. 3-17-2009. FILED 10-27-2008.
- 3,630,893. **OPTURO (BLOCK FORM)**. OPTURO INC., (U.S. CLS. 100 AND 101). SN 77-600,888. PUB. 3-17-2009. FILED 10-27-2008.
- 3,630,894. **GREENPAGES (BLOCK FORM)**. GREENPAGES, INC., (U.S. CLS. 100 AND 101). SN 77-600,900. PUB. 3-17-2009. FILED 10-27-2008.
- 3,630,899. **G AND DESIGN**. GREENPAGES, INC., (U.S. CLS. 100 AND 101). SN 77-600,930. PUB. 3-17-2009. FILED 10-27-2008.
- 3,630,901. **LIQUIDTHOUGHT (BLOCK FORM)**. LIQUIDTHOUGHT LLC, (U.S. CLS. 100 AND 101). SN 77-600,939. PUB. 3-17-2009. FILED 10-27-2008.
- 3,630,929. **OPPORTUNITYDRIVER (BLOCK FORM)**. TRANSACTIONDRIVERS LLC, (U.S. CLS. 100 AND 101). SN 77-601,282. PUB. 3-17-2009. FILED 10-27-2008.
- 3,630,969 (See Class 35 for this trademark).
- 3,630,980. **DRAG AND FLY (BLOCK FORM)**. MOHAWK BRANDS, INC., (U.S. CLS. 100 AND 101). SN 77-602,012. PUB. 3-17-2009. FILED 10-28-2008.
- 3,630,986 (See Class 20 for this trademark).
- 3,630,994. **LUMI-CELL (BLOCK FORM)**. XENOBIOTIC DETECTION SYSTEMS INTERNATIONAL, INC., (U.S. CLS. 100 AND 101). SN 77-602,136. PUB. 3-17-2009. FILED 10-28-2008.
- 3,631,022. **CWEB SEARCH (BLOCK FORM)**. SHOKROLA, GEORGE, (U.S. CLS. 100 AND 101). SN 77-602,534. PUB. 3-17-2009. FILED 10-28-2008.
- 3,631,031. **TRINDIGO AND DESIGN**. TRINDIGO LLC, (U.S. CLS. 100 AND 101). SN 77-602,603. PUB. 3-17-2009. FILED 10-28-2008.
- 3,631,045. **MAILWISE (BLOCK FORM)**. J2 GLOBAL HOLDINGS LIMITED, (U.S. CLS. 100 AND 101). SN 77-602,885. PUB. 3-17-2009. FILED 10-29-2008.
- 3,631,058 (See Class 35 for this trademark).
- 3,631,071. **ADVERTEK (BLOCK FORM)**. ADVERTEK, INC., DBA ADVERTEK, (U.S. CLS. 100 AND 101). SN 77-603,437. PUB. 3-17-2009. FILED 10-29-2008.
- 3,631,080. **HIRED HAND SOFTWARE (BLOCK FORM)**. HIRED HAND SOFTWARE, LLC, (U.S. CLS. 100 AND 101). SN 77-603,591. PUB. 3-17-2009. FILED 10-29-2008.
- 3,631,123. **GUIDINGCARE (BLOCK FORM)**. ALTRUISTA HEALTH, (U.S. CLS. 100 AND 101). SN 77-604,251. PUB. 3-17-2009. FILED 10-30-2008.
- 3,631,154. **HERSHEY CENTER FOR HEALTH & NUTRITION HERSHEY'S AND DESIGN**. HERSHEY CHOCOLATE & CONFECTIONERY CORPORATION, (U.S. CLS. 100 AND 101). SN 77-604,774. PUB. 3-17-2009. FILED 10-31-2008.
- 3,631,170. **SNAPMYLIFE AND DESIGN**. MOBICIOUS, INC., (U.S. CLS. 100 AND 101). SN 77-604,996. PUB. 3-17-2009. FILED 10-31-2008.
- 3,631,197. **SNOOKIT (BLOCK FORM)**. TECHRADIUM INC., (U.S. CLS. 100 AND 101). SN 77-605,426. PUB. 3-17-2009. FILED 10-31-2008.
- 3,631,201. **PROJEKT202 WE MAKE SOFTWARE MAKE SENSE. (STYLIZED)**. PROJEKT202, LP, (U.S. CLS. 100 AND 101). SN 77-605,480. PUB. 3-17-2009. FILED 10-31-2008.
- 3,631,216. **MYBANDSTOCK THE MUSIC REVOLUTION. AND DESIGN**. MY STOCKS ENTERPRISES LLC, (U.S. CLS. 100 AND 101). SN 77-605,618. PUB. 3-17-2009. FILED 11-1-2008.
- 3,631,217. **HEADMAGNET (BLOCK FORM)**. WANG, ANDREW C, DBA IDUMPLING.COM, (U.S. CLS. 100 AND 101). SN 77-605,624. PUB. 3-17-2009. FILED 11-1-2008.
- 3,631,240. **GIVINGPOINT (BLOCK FORM)**. MYFIFIDENT FOUNDATION, (U.S. CLS. 100 AND 101). SN 77-606,142. PUB. 3-17-2009. FILED 11-3-2008.
- 3,631,261 (See Class 38 for this trademark).
- 3,631,264. **SMILE REMINDER (BLOCK FORM)**. COMMUNICTECT, INC., (U.S. CLS. 100 AND 101). SN 77-607,460. PUB. 3-17-2009. FILED 11-5-2008.
- 3,631,265. **SMILE REMINDER AND DESIGN**. COMMUNICTECT, INC., MULTIPLE CLASS, (INT. CLS. 42 AND 45), (U.S. CLS. 100 AND 101). SN 77-607,463. PUB. 3-17-2009. FILED 11-5-2008.
- 3,631,282 (See Class 9 for this trademark).
- 3,631,335. **DEEDEXPRESS (BLOCK FORM)**. GRANT STREET GROUP, INC., FORMERLY MUNIAUCTION, INC., (U.S. CLS. 100 AND 101). SN 77-624,361. PUB. 3-17-2009. FILED 12-2-2008.
- 3,631,336. **ESCROWEXPRESS (BLOCK FORM)**. GRANT STREET GROUP, INC., FORMERLY MUNIAUCTION, INC., (U.S. CLS. 100 AND 101). SN 77-624,375. PUB. 3-17-2009. FILED 12-2-2008.
- 3,631,384. **THE LINK BETWEEN US (BLOCK FORM)**. DEUTSCHE TELEKOM AG, (U.S. CLS. 100 AND 101). SN 78-420,778. PUB. 11-11-2008. FILED 5-18-2004.
- 3,631,385 (See Class 35 for this trademark).
- 3,631,389 (See Class 9 for this trademark).
- 3,631,390 (See Class 9 for this trademark).
- 3,631,395. **MAXSECURE (BLOCK FORM)**. NUVO NETWORK MANAGEMENT INC., MULTIPLE CLASS, (INT. CLS. 42 AND 45), (U.S. CLS. 100 AND 101). SN 78-564,367. PUB. 4-29-2008. FILED 2-10-2005.
- 3,631,397 (See Class 9 for this trademark).
- 3,631,398 (See Class 9 for this trademark).
- 3,631,404 (See Class 10 for this trademark).
- 3,631,413 (See Class 7 for this trademark).
- 3,631,430 (See Class 35 for this trademark).
- 3,631,432 (See Class 1 for this trademark).
- 3,631,433 (See Class 1 for this trademark).
- 3,631,438 (See Class 7 for this trademark).
- 3,631,465 (See Class 9 for this trademark).
- 3,631,466 (See Class 5 for this trademark).
- 3,631,467. **NO BETTER CHANCE, NO GREATER CARE (BLOCK FORM)**. SYDNEY IVF LIMITED, MULTIPLE CLASS, (INT. CLS. 42 AND 44), (U.S. CLS. 100 AND 101). SN 79-030,617. PUB. 3-17-2009. FILED 7-24-2006.
- 3,631,475 (See Class 32 for this trademark).
- 3,631,480 (See Class 9 for this trademark).
- 3,631,485 (See Class 35 for this trademark).
- 3,631,489 (See Class 35 for this trademark).
- 3,631,491 (See Class 5 for this trademark).
- 3,631,496 (See Class 9 for this trademark).
- 3,631,498 (See Class 11 for this trademark).
- 3,631,509 (See Class 9 for this trademark).
- 3,631,510 (See Class 1 for this trademark).
- 3,631,511 (See Class 1 for this trademark).
- 3,631,513 (See Class 1 for this trademark).
- 3,631,517 (See Class 6 for this trademark).
- 3,631,522 (See Class 41 for this trademark).
- 3,631,531 (See Class 9 for this trademark).
- 3,631,533 (See Class 35 for this trademark).
- 3,631,534 (See Class 9 for this trademark).
- 3,631,537 (See Class 35 for this trademark).
- 3,631,538 (See Class 9 for this trademark).
- 3,631,539 (See Class 7 for this trademark).
- 3,631,542 (See Class 16 for this trademark).
- 3,631,544 (See Class 35 for this trademark).
- 3,631,547 (See Class 6 for this trademark).
- 3,631,554 (See Class 1 for this trademark).
- 3,631,556 (See Class 7 for this trademark).
- 3,631,557 (See Class 9 for this trademark).
- 3,631,559 (See Class 5 for this trademark).
- 3,631,562 (See Class 11 for this trademark).
- 3,631,646 (See Class 9 for this trademark).
- 3,631,667 (See Class 7 for this trademark).
- 3,631,679 (See Class 5 for this trademark).
- 3,631,685 (See Class 9 for this trademark).
- 3,631,699 (See Class 9 for this trademark).
- 3,631,701 (See Class 2 for this trademark).
- 3,631,711 (See Class 6 for this trademark).
- 3,631,718 (See Class 9 for this trademark).
- 3,631,720 (See Class 7 for this trademark).
- 3,631,727 (See Class 35 for this trademark).
- 3,631,743 (See Class 9 for this trademark).
- 3,631,748 (See Class 5 for this trademark).
- 3,631,752. **DIAFECOL (BLOCK FORM)**. INDEX DIAGNOS-

TICS AB, (U.S. CLS. 100 AND 101). SN 79-059,712. PUB. 3-17-2009. FILED 10-3-2008.
 3,631,757 (*See Class 38 for this trademark*).
 3,631,761 (*See Class 9 for this trademark*).
 3,631,764 (*See Class 35 for this trademark*).
 3,631,765 (*See Class 9 for this trademark*).
 3,631,769. **DRINDO (BLOCK FORM)**. PROJETIX LTD., (U.S. CLS. 100 AND 101). SN 79-062,025. PUB. 3-17-2009. FILED 10-15-2008.

CLASS 43—HOTEL AND RESTAURANT SERVICES

3,629,125. **PARDO'S CHICKEN (STYLIZED)**. SERVICIOS DE FRANQUICIA PARDO'S S. A. C., (U.S. CLS. 100 AND 101). SN 76-467,468. PUB. 3-17-2009. FILED 11-14-2002.
 3,629,146. **HURRICANE GRILL . WINGS AND DESIGN**. HURRICANE BRAND HOLDINGS, LLC., (U.S. CLS. 100 AND 101). SN 76-686,198. PUB. 3-17-2009. FILED 1-28-2008.
 3,629,147 (*See Class 30 for this trademark*).
 3,629,148. **MALECON (BLOCK FORM)**. GOMEZ, PABLO, (U.S. CLS. 100 AND 101). SN 76-687,228. PUB. 3-17-2009. FILED 2-29-2008.
 3,629,165 (*See Class 35 for this trademark*).
 3,629,181. **SULZIP (BLOCK FORM)**. KEVIN & DAVID INC., (U.S. CLS. 100 AND 101). SN 76-691,153. PUB. 3-17-2009. FILED 7-9-2008.
 3,629,238. **LIME RICKEY'S BEACH FOOD (BLOCK FORM)**. DEVEREAU BEACH CORPORATION, (U.S. CLS. 100 AND 101). SN 77-039,738. PUB. 3-17-2009. FILED 11-8-2006.
 3,629,287. **MEI'S ASIAN BISTRO (BLOCK FORM)**. ASIAN BISTRO - ARLINGTON, INC., (U.S. CLS. 100 AND 101). SN 77-153,566. PUB. 3-17-2009. FILED 4-10-2007.
 3,629,288. **MEI'S ASIAN BISTRO AND DESIGN**. ASIAN BISTRO - ARLINGTON INC., (U.S. CLS. 100 AND 101). SN 77-155,987. PUB. 3-17-2009. FILED 4-13-2007.
 3,629,347 (*See Class 41 for this trademark*).
 3,629,348. **INSPIRED HOTELS LLC (BLOCK FORM)**. CHAUHAN, RAKESH, (U.S. CLS. 100 AND 101). SN 77-258,907. PUB. 3-17-2009. FILED 8-20-2007.
 3,629,366 (*See Class 30 for this trademark*).
 3,629,411 (*See Class 35 for this trademark*).
 3,629,435 (*See Class 25 for this trademark*).
 3,629,449. **BETTER EVERYTHING (BLOCK FORM)**. SIMPLICITY VENTURES INC, (U.S. CLS. 100 AND 101). SN 77-344,769. PUB. 3-17-2009. FILED 12-5-2007.
 3,629,655. **LAS MARGARITAS FAMILY MEXICAN RESTAURANT AND DESIGN**. MORALES, JOSE NICHOLAS, AND MORALES, MANUAL, (U.S. CLS. 100 AND 101). SN 77-437,120. PUB. 3-17-2009. FILED 4-1-2008.
 3,629,689. **SKINNY KITTY TEAHOUSE (BLOCK FORM)**. COSTA, MICHELLE, A., (U.S. CLS. 100 AND 101). SN 77-442,234. PUB. 3-17-2009. FILED 4-7-2008.
 3,629,816. **TENKAIPPIN AND DESIGN**. KABUSHIKI KAISHA TEN-ICHI SYOKUHUIN SHOJI (TEN-ICHI FOODS TRADING CO., LTD.), (U.S. CLS. 100 AND 101). SN 77-453,606. PUB. 3-17-2009. FILED 4-21-2008.
 3,629,827. **NUBI YOGURT (STYLIZED)**. LUSH YOGURT, INC., (U.S. CLS. 100 AND 101). SN 77-454,709. PUB. 3-17-2009. FILED 4-22-2008.
 3,629,843. **MISCELLANEOUS DESIGN**. LEFTY'S BARBECUE UNLIMITED, INC., (U.S. CLS. 100 AND 101). SN 77-456,323. PUB. 3-17-2009. FILED 4-23-2008.
 3,629,863. **QUICKLY AND DESIGN**. QUICKLY CORPORATION, (U.S. CLS. 100 AND 101). SN 77-458,994. PUB. 3-17-2009. FILED 4-27-2008.
 3,629,891. **ELMER'S NORTHWEST FRESH! AND DESIGN**. ELMER'S RESTAURANTS, INC., (U.S. CLS. 100 AND 101). SN 77-464,247. PUB. 3-17-2009. FILED 5-2-2008.
 3,629,914. **FRESH TO THE EXTREME (BLOCK FORM)**. THE EXTREME PITA FRANCHISING USA, INC., (U.S. CLS. 100 AND 101). SN 77-469,711. PUB. 3-17-2009. FILED 5-8-2008.
 3,629,938. **MISCELLANEOUS DESIGN**. TACO BELL CORP., (U.S. CLS. 100 AND 101). SN 77-476,663. PUB. 3-17-2009. FILED 5-16-2008.
 3,629,947. **YASAI JAPANESE GRILL (BLOCK FORM)**. SONG, SOOK HEE, (U.S. CLS. 100 AND 101). SN 77-478,649. PUB. 3-17-2009. FILED 5-20-2008.
 3,630,085 (*See Class 30 for this trademark*).
 3,630,109. **THE DOG HOUSE - THE ULTIMATE DOG TREAT (BLOCK FORM)**. GRAND TRAVERSE RESORT & SPA, LLC, (U.S. CLS. 100 AND 101). SN 77-523,405. PUB. 3-17-2009. FILED 7-16-2008.
 3,630,150 (*See Class 29 for this trademark*).
 3,630,161. **HOUSTON FOOD BANK AND DESIGN**. HOUSTON FOOD BANK, (U.S. CLS. 100 AND 101). SN 77-537,030. PUB. 3-17-2009. FILED 8-1-2008.
 3,630,164. **HOUSTON FOOD BANK FILLING PANTRIES, FILLING LIVES, AND DESIGN**. HOUSTON FOOD BANK, (U.S. CLS. 100 AND 101). SN 77-537,062. PUB. 3-17-2009. FILED 8-1-2008.
 3,630,182. **PITA STOP (BLOCK FORM)**. PITA STOP, INC, (U.S. CLS. 100 AND 101). SN 77-543,135. PUB. 3-17-2009. FILED 8-9-2008.
 3,630,297 (*See Class 9 for this trademark*).
 3,630,383. **HUARINGAS (STYLIZED)**. DULANTO, MARIA DEL ROSARIO ALCORTA, (U.S. CLS. 100 AND 101). SN 77-576,946. PUB. 3-17-2009. FILED 9-23-2008.
 3,630,403 (*See Class 41 for this trademark*).
 3,630,404 (*See Class 41 for this trademark*).
 3,630,438. **THE BEST BOZZELLI'S SINCE ITALIAN DELI 1978 AND DESIGN**. BOZZELLI'S ITALIAN DELI, INC., (U.S. CLS. 100 AND 101). SN 77-583,971. PUB. 3-17-2009. FILED 10-2-2008.
 3,630,492. **GOIN' COASTAL SUSTAINABLE SEAFOOD JOINT (BLOCK FORM)**. GOIN' COASTAL SEAFOOD, LLC, TA GOIN' COASTAL, (U.S. CLS. 100 AND 101). SN 77-588,992. PUB. 3-17-2009. FILED 10-8-2008.
 3,630,510. **DON CHURRO CAFE (BLOCK FORM)**. GARCORT GROUP LLC, AKA DON CHURRO CAFE, (U.S. CLS. 100 AND 101). SN 77-590,826. PUB. 3-17-2009. FILED 10-10-2008.
 3,630,560 (*See Class 41 for this trademark*).
 3,630,584. **HOME BURGER USA (BLOCK FORM)**. PRISMA CONSULTING LLC, DBA HOME BURGER USA, (U.S. CLS. 100 AND 101). SN 77-595,252. PUB. 3-17-2009. FILED 10-17-2008.
 3,630,618 (*See Class 39 for this trademark*).
 3,630,675. **PRIMIZIE OSTERIA . CAFE . (STYLIZED)**. PRIMIZIE, INC., (U.S. CLS. 100 AND 101). SN 77-597,775. PUB. 3-17-2009. FILED 10-22-2008.
 3,630,748. **PELICAN COVE INN (BLOCK FORM)**. PELICAN COVE INN, INC., (U.S. CLS. 100 AND 101). SN 77-598,922. PUB. 3-17-2009. FILED 10-23-2008.
 3,630,804. **MISCELLANEOUS DESIGN**. SKIPPER DIPPER, LLC, (U.S. CLS. 100 AND 101). SN 77-599,687. PUB. 3-17-2009. FILED 10-24-2008.
 3,630,835 (*See Class 25 for this trademark*).
 3,630,840. **BEAUTY BAR (BLOCK FORM)**. JINX PROOF LLC, DBA BEAUTY BAR, (U.S. CLS. 100 AND 101). SN 77-600,120. PUB. 3-17-2009. FILED 10-24-2008.
 3,630,885. **SORORITY GOURMET AND DESIGN**. SORORITY GOURMET, (U.S. CLS. 100 AND 101). SN 77-600,710. PUB. 3-17-2009. FILED 10-26-2008.
 3,630,897. **HEAVENLY CHICKEN & RIBS AND DESIGN**. ARMSTRONG COMPANIES, (U.S. CLS. 100 AND 101). SN 77-600,922. PUB. 3-17-2009. FILED 10-27-2008.
 3,630,944. **SON CUBANO RESTAURANT - BAR AND DESIGN**. SOUNDS OF CUBA, INC., DBA SON CUBANO, (U.S. CLS. 100 AND 101). SN 77-601,418. PUB. 3-17-2009. FILED 10-27-2008.
 3,631,059. **ARVEDA AND DESIGN**. TREE OF LIFE CARE GROUP, LLC, (U.S. CLS. 100 AND 101). SN 77-603,202. PUB. 3-17-2009. FILED 10-29-2008.
 3,631,095. **TALES OF THE COCKTAIL NEW ORLEANS AND DESIGN**. ANN ROGERS, (U.S. CLS. 100 AND 101). SN 77-603,754. PUB. 3-17-2009. FILED 10-30-2008.
 3,631,096. **SPIRITED DINNER (BLOCK FORM)**. ANN ROGERS, (U.S. CLS. 100 AND 101). SN 77-603,760. PUB. 3-17-2009. FILED 10-30-2008.
 3,631,158. **GEORGE'S HAPPY HOG BAR-B-Q (BLOCK FORM)**. GEORGE'S HAPPY HOG BAR-B-Q, INC., (U.S. CLS. 100 AND 101). SN 77-604,881. PUB. 3-17-2009. FILED 10-31-2008.

- 3,631,241. **URBAN PANTRY AND DESIGN**. URBAN PANTRY LLC, (U.S. CLS. 100 AND 101). SN 77-606,143. PUB. 3-17-2009. FILED 11-3-2008.
- 3,631,273 (*See Class 35 for this trademark*).
- 3,631,361 (*See Class 35 for this trademark*).
- 3,631,377. **SKY HOTEL**. ASPEN CLUB LODGE PROPERTIES, LLC, (U.S. CLS. 100 AND 101). SN 78-210,211. PUB. 3-17-2009. FILED 2-3-2003.
- 3,631,396. **GIOVANNI'S PIZZA POWER AND DESIGN**. GIOVANNI'S PIZZA, INC., (U.S. CLS. 100 AND 101). SN 78-571,747. PUB. 3-17-2009. FILED 2-21-2005.
- 3,631,399 (*See Class 3 for this trademark*).
- 3,631,409. **TRANS WORLD ROOMS (BLOCK FORM)**. BBR LIMITED, (U.S. CLS. 100 AND 101). SN 78-682,756. PUB. 5-6-2008. FILED 8-1-2005.
- 3,631,423. **IT'S ALWAYS A WEEKEND AT BERNIE'S (BLOCK FORM)**. TT 648 LLC, (U.S. CLS. 100 AND 101). SN 78-813,612. PUB. 3-17-2009. FILED 2-13-2006.
- 3,631,439 (*See Class 35 for this trademark*).
- 3,631,472 (*See Class 3 for this trademark*).
- 3,631,473 (*See Class 14 for this trademark*).
- 3,631,512 (*See Class 3 for this trademark*).
- 3,631,522 (*See Class 41 for this trademark*).
- 3,631,536 (*See Class 35 for this trademark*).
- 3,631,562 (*See Class 11 for this trademark*).
- 3,631,565 (*See Class 16 for this trademark*).
- 3,631,582. **SOFITEL LEGEND (STYLIZED)**. SOLUXURY HMC, (U.S. CLS. 100 AND 101). SN 79-053,483. PUB. 3-17-2009. FILED 4-23-2008.
- 3,631,607 (*See Class 16 for this trademark*).
- 3,631,695. **ALCHYMIST (BLOCK FORM)**. ALCHYMIST, S.R.O., (U.S. CLS. 100 AND 101). SN 79-057,040. PUB. 3-17-2009. FILED 5-12-2008.
- 3,631,709. **ALCHYMIST GRAND HOTEL AND SPA AND DESIGN**. ALCHYMIST, S.R.O., MULTIPLE CLASS, (INT. CLS. 43 AND 44), (U.S. CLS. 100 AND 101). SN 79-057,375. PUB. 3-17-2009. FILED 5-12-2008.
- 3,631,732 (*See Class 29 for this trademark*).
- 3,631,734 (*See Class 25 for this trademark*).
- 3,629,201 (*See Class 35 for this trademark*).
- 3,629,256 (*See Class 9 for this trademark*).
- 3,629,266 (*See Class 41 for this trademark*).
- 3,629,325. **BRIDALICIOUS (BLOCK FORM)**. RICE, DOUGLAS R., DBA THE FITWIT GROUP, LLC, (U.S. CLS. 100 AND 101). SN 77-231,587. PUB. 3-17-2009. FILED 7-17-2007.
- 3,629,327. **SOUPERSLIM (BLOCK FORM)**. REZENERATION, INC., (U.S. CLS. 100 AND 101). SN 77-234,419. PUB. 3-17-2009. FILED 7-20-2007.
- 3,629,334 (*See Class 3 for this trademark*).
- 3,629,335 (*See Class 3 for this trademark*).
- 3,629,385. **MISCELLANEOUS DESIGN**. VANDERVEER, LLC, DBA THE VANDERVEER CENTER, (U.S. CLS. 100 AND 101). SN 77-295,296. PUB. 3-17-2009. FILED 10-3-2007.
- 3,629,394 (*See Class 16 for this trademark*).
- 3,629,399. **UHEALTH UNIVERSITY OF MIAMI HEALTH SYSTEM AND DESIGN**. UNIVERSITY OF MIAMI, (U.S. CLS. 100 AND 101). SN 77-305,895. PUB. 3-17-2009. FILED 10-17-2007.
- 3,629,411 (*See Class 35 for this trademark*).
- 3,629,460. **OUR DEER SPEAK FOR THEMSELVES (BLOCK FORM)**. BLEX EXCHANGE III, L.P., (U.S. CLS. 100 AND 101). SN 77-351,607. PUB. 3-17-2009. FILED 12-13-2007.
- 3,629,466 (*See Class 41 for this trademark*).
- 3,629,517 (*See Class 36 for this trademark*).
- 3,629,654 (*See Class 42 for this trademark*).
- 3,629,710. **B O AND DESIGN**. YAMADA, MERILYNN, (U.S. CLS. 100 AND 101). SN 77-444,240. PUB. 3-17-2009. FILED 4-9-2008.
- 3,629,737. **WELLCARE AND DESIGN**. THE WELLCARE MANAGEMENT GROUP, INC., (U.S. CLS. 100 AND 101). SN 77-447,198. PUB. 3-17-2009. FILED 4-14-2008.
- 3,629,752. **ARCH AND DESIGN**. ANESTHESIA RESOURCES FOR CHILDREN, LLP, (U.S. CLS. 100 AND 101). SN 77-448,494. PUB. 3-17-2009. FILED 4-15-2008.
- 3,629,760 (*See Class 41 for this trademark*).
- 3,629,918. **THE SEVEN PILLARS OF PERSONAL RECOVERY (BLOCK FORM)**. PATHFINDERS INTERNATIONAL, LLC, MULTIPLE CLASS, (INT. CLS. 44 AND 45), (U.S. CLS. 100 AND 101). SN 77-470,489. PUB. 10-14-2008. FILED 5-9-2008.
- 3,629,931 (*See Class 35 for this trademark*).
- 3,629,996 (*See Class 41 for this trademark*).
- 3,629,998. **VITALITY SELECT (BLOCK FORM)**. VITALITY SELECT, INC., (U.S. CLS. 100 AND 101). SN 77-493,232. PUB. 3-17-2009. FILED 6-6-2008.
- 3,629,999. **VS AND DESIGN**. VITALITY SELECT, INC., (U.S. CLS. 100 AND 101). SN 77-493,267. PUB. 3-17-2009. FILED 6-6-2008.
- 3,630,033. **NAVA SHAKTI (BLOCK FORM)**. PRANA GYANA, (U.S. CLS. 100 AND 101). SN 77-498,993. PUB. 3-17-2009. FILED 6-13-2008.
- 3,630,042. **ZOOWIKI (BLOCK FORM)**. CHAOTICFOX, L.L.C., (U.S. CLS. 100 AND 101). SN 77-503,651. PUB. 3-17-2009. FILED 6-19-2008.
- 3,630,047. **CHILDREN'S DENTAL CENTER AND BIG PEOPLE, TOO! (BLOCK FORM)**. CHILDREN'S DENTAL CENTER AND BIG PEOPLE, TOO!, (U.S. CLS. 100 AND 101). SN 77-505,151. PUB. 3-17-2009. FILED 6-23-2008.
- 3,630,124. **CONVENIENT CARE WALK-IN MEDICAL CENTER AND DESIGN**. HUNTER, JERRY ANN, (U.S. CLS. 100 AND 101). SN 77-526,331. PUB. 12-9-2008. FILED 7-18-2008.
- 3,630,129. **DR. CASSELBERRY'S INTEGRATIVE HEALTH CENTER AND DESIGN**. DR. CASSELBERRY'S INTEGRATIVE HEALTH CENTER, INC., (U.S. CLS. 100 AND 101). SN 77-527,040. PUB. 3-17-2009. FILED 7-21-2008.
- 3,630,135 (*See Class 16 for this trademark*).
- 3,630,203 (*See Class 35 for this trademark*).
- 3,630,223 (*See Class 35 for this trademark*).
- 3,630,282. **NETCONNECT (BLOCK FORM)**. UNITED AMERICAN INSURANCE COMPANY, (U.S. CLS. 100 AND 101). SN 77-561,599. PUB. 3-17-2009. FILED 9-3-2008.
- 3,630,310. **DR. WELL BEE (BLOCK FORM)**. SAINT LUKE'S HOSPITAL OF BETHLEHEM, PENNSYLVANIA, (U.S. CLS. 100 AND 101). SN 77-567,516. PUB. 3-17-2009. FILED 9-11-2008.
- 3,630,312. **ASK ME AND DESIGN**. SAINT LUKE'S HOSPITAL OF BETHLEHEM, PENNSYLVANIA, (U.S. CLS. 100 AND 101). SN 77-567,786. PUB. 3-17-2009. FILED 9-11-2008.
- 3,630,326. **GROW (BLOCK FORM)**. GROW, INC., (U.S. CLS. 100 AND 101). SN 77-569,363. PUB. 3-17-2009. FILED 9-13-2008.
- 3,630,327. **GROW AND DESIGN**. GROW, INC., (U.S. CLS. 100 AND 101). SN 77-569,364. PUB. 3-17-2009. FILED 9-13-2008.
- 3,630,331. **MISCELLANEOUS DESIGN**. ACCOLADE LLC, (U.S. CLS. 100 AND 101). SN 77-569,748. PUB. 3-17-2009. FILED 9-15-2008.
- 3,630,347. **ASSURE DENTAL AND DESIGN**. ASSURE DENTAL, (U.S. CLS. 100 AND 101). SN 77-572,247. PUB. 3-17-2009. FILED 9-17-2008.
- 3,630,382. **TURN YOUR WRECK INTO A CHECK (BLOCK FORM)**. PICCIRILLO, DANA, (U.S. CLS. 100 AND 101). SN 77-576,889. PUB. 3-17-2009. FILED 9-23-2008.
- 3,630,427. **BODIBRONZE SUNLESS SPA AND DESIGN**. KLINKER, TERRI L, DBA BODIBRONZE SUNLESS SPA, AND KLINKER, KRISTIN J, DBA BODIBRONZE SUNLESS SPA, (U.S. CLS. 100 AND 101). SN 77-581,623. PUB. 3-17-2009. FILED 9-29-2008.
- 3,630,431. **RED RIVER RECOVERY CENTER (BLOCK FORM)**. ASCEND HEALTH CORPORATION, (U.S. CLS. 100 AND 101). SN 77-582,320. PUB. 3-17-2009. FILED 9-30-2008.
- 3,630,435. **THE TEXAS LICE SQUAD AND DESIGN**. THE TEXAS LICE SQUAD RN LLC, (U.S. CLS. 100 AND 101). SN 77-583,415. PUB. 3-17-2009. FILED 10-1-2008.
- 3,630,441. **FIESTA SALONS (BLOCK FORM)**. REGIS INC., (U.S. CLS. 100 AND 101). SN 77-584,274. PUB. 3-17-2009. FILED 10-2-2008.
- 3,630,480. **INSTINCTIVE WELLNESS AND DESIGN**. REID, DEBORAH, (U.S. CLS. 100 AND 101). SN 77-587,912. PUB. 3-17-2009. FILED 10-7-2008.
- 3,630,488. **WEEDPRO LAWN CARE AND DESIGN**. WEED-

CLASS 44—MEDICAL, BEAUTY AND AGRICULTURAL SERVICES

- PRO, INC., (U.S. CLS. 100 AND 101), SN 77-588,561. PUB. 3-17-2009. FILED 10-8-2008.
- 3,630,527. **ASCENDHEALTH CORPORATION (BLOCK FORM)**. ASCEND HEALTH CORPORATION, (U.S. CLS. 100 AND 101), SN 77-591,962. PUB. 3-17-2009. FILED 10-14-2008.
- 3,630,562 (*See Class 35 for this trademark*).
- 3,630,578. **ARMOR CORRECTIONAL HEALTH SERVICES, INC. AND DESIGN**. ARMOR CORRECTIONAL HEALTH SERVICES, INC., (U.S. CLS. 100 AND 101), SN 77-594,852. PUB. 3-17-2009. FILED 10-17-2008.
- 3,630,672. **URBAN TREE SPECIALISTS RENTED IN A GREENER FUTURE AND DESIGN**. URBAN TREE SPECIALISTS, LLC, (U.S. CLS. 100 AND 101), SN 77-597,652. PUB. 3-17-2009. FILED 10-22-2008.
- 3,630,703. **DEDICATED TO COTTON, COMMITTED TO YOU. (BLOCK FORM)**. D&PL TECHNOLOGY HOLDING CO., LLC, (U.S. CLS. 100 AND 101), SN 77-598,314. PUB. 3-17-2009. FILED 10-22-2008.
- 3,630,778. **EXPERIENCE THE LIGHT FANTASTIC! (BLOCK FORM)**. BACK TO HEALTH WELLNESS CENTER, LLC, (U.S. CLS. 100 AND 101), SN 77-599,286. PUB. 3-17-2009. FILED 10-23-2008.
- 3,630,789. **D.TOUR (BLOCK FORM)**. DETROIT ENTERTAINMENT, L.L.C., (U.S. CLS. 100 AND 101), SN 77-599,507. PUB. 3-17-2009. FILED 10-23-2008.
- 3,630,863. **MASSAGE ENVY SPA (BLOCK FORM)**. MASSAGE ENVY LIMITED, LLC, (U.S. CLS. 100 AND 101), SN 77-600,408. PUB. 3-17-2009. FILED 10-24-2008.
- 3,630,865. **LUSIC (BLOCK FORM)**. MOELLEKEN, BRENT R.W., (U.S. CLS. 100 AND 101), SN 77-600,410. PUB. 3-17-2009. FILED 10-24-2008.
- 3,630,871. **FAMILY THERAPEUTICS AND DESIGN**. DR. PREETPAL S. SANDHU, M.D., P.C., DBA FAMILY THERAPEUTICS, (U.S. CLS. 100 AND 101), SN 77-600,481. PUB. 3-17-2009. FILED 10-24-2008.
- 3,630,875. **BIENMOYO (BLOCK FORM)**. THE BIENMOYO FOUNDATION, INC., (U.S. CLS. 100 AND 101), SN 77-600,525. PUB. 3-17-2009. FILED 10-24-2008.
- 3,630,984. **MINERAL SPRINGS FARM LLC AND DESIGN**. MINERAL SPRINGS FARM LLC, (U.S. CLS. 100 AND 101), SN 77-602,053. PUB. 3-17-2009. FILED 10-28-2008.
- 3,631,003. **PINELAWN (BLOCK FORM)**. PINELAWN CEMETERY, MULTIPLE CLASS, (INT. CLS. 44 AND 45), (U.S. CLS. 100 AND 101), SN 77-602,241. PUB. 3-17-2009. FILED 10-28-2008.
- 3,631,010. **RETINA CONSULTANTS OF SOUTHWEST FLORIDA (BLOCK FORM)**. RETINA CONSULTANTS OF SOUTHWEST FLORIDA, P.A., (U.S. CLS. 100 AND 101), SN 77-602,327. PUB. 3-17-2009. FILED 10-28-2008.
- 3,631,036. **PIONEER URGENT CARE (BLOCK FORM)**. IMMEDIATE MEDICAL CARE OF PENNSYLVANIA, LP, DBA PIONEER URGENT CARE, (U.S. CLS. 100 AND 101), SN 77-602,714. PUB. 3-17-2009. FILED 10-29-2008.
- 3,631,040. **PIONEERURGENTCARE AND DESIGN**. IMMEDIATE MEDICAL CARE OF PENNSYLVANIA, LP, DBA PIONEER URGENT CARE, (U.S. CLS. 100 AND 101), SN 77-602,784. PUB. 3-17-2009. FILED 10-29-2008.
- 3,631,152. **SMARTIAN (BLOCK FORM)**. MAXFIT, INC., (U.S. CLS. 100 AND 101), SN 77-604,757. PUB. 3-17-2009. FILED 10-31-2008.
- 3,631,195. **QUICKLIFT (BLOCK FORM)**. M.D. COMMUNICATIONS, INC., (U.S. CLS. 100 AND 101), SN 77-605,422. PUB. 3-17-2009. FILED 10-31-2008.
- 3,631,203. **AACO (BLOCK FORM)**. AACO-A1 HEALTHCARE SERVICES, INC., (U.S. CLS. 100 AND 101), SN 77-605,495. PUB. 3-17-2009. FILED 10-31-2008.
- 3,631,227. **VOLUNSHEAR (BLOCK FORM)**. BONNIE STEPHENS, (U.S. CLS. 100 AND 101), SN 77-605,902. PUB. 3-17-2009. FILED 11-3-2008.
- 3,631,232. **BLUE OAK (BLOCK FORM)**. INTERDENT SERVICE CORPORATION, (U.S. CLS. 100 AND 101), SN 77-606,023. PUB. 3-17-2009. FILED 11-3-2008.
- 3,631,233. **THE RANCH SALON A GREAT PLACE TO GET A GREAT HAIRCUT AND DESIGN**. THE RANCH SALONS, (U.S. CLS. 100 AND 101), SN 77-606,028. PUB. 3-17-2009. FILED 11-3-2008.
- 3,631,316. **NEUMEDICINE INTERNATIONAL AND DESIGN**. NEUMEDICINE TECHNOLOGIES, INC., AKA NEUMEDICINE INTERNATIONAL, (U.S. CLS. 100 AND 101), SN 77-617,527. PUB. 3-17-2009. FILED 11-19-2008.
- 3,631,373. **ECOLOG (BLOCK FORM)**. ECOLOG AG, (U.S. CLS. 100 AND 101), SN 77-976,203. PUB. 3-17-2009. FILED 3-12-2007.
- 3,631,397 (*See Class 9 for this trademark*).
- 3,631,398 (*See Class 9 for this trademark*).
- 3,631,438 (*See Class 7 for this trademark*).
- 3,631,441 (*See Class 10 for this trademark*).
- 3,631,466 (*See Class 5 for this trademark*).
- 3,631,467 (*See Class 42 for this trademark*).
- 3,631,485 (*See Class 35 for this trademark*).
- 3,631,519 (*See Class 5 for this trademark*).
- 3,631,520 (*See Class 5 for this trademark*).
- 3,631,531 (*See Class 9 for this trademark*).
- 3,631,635 (*See Class 31 for this trademark*).
- 3,631,646 (*See Class 9 for this trademark*).
- 3,631,669 (*See Class 41 for this trademark*).
- 3,631,709 (*See Class 43 for this trademark*).

CLASS 45—PERSONAL AND LEGAL SERVICES

- 3,629,166. **LEADING EDGE FILINGS (BLOCK FORM)**. LEADING EDGE FILINGS, INC., (U.S. CLS. 100 AND 101), SN 76-688,845. PUB. 3-17-2009. FILED 4-21-2008.
- 3,629,178 (*See Class 30 for this trademark*).
- 3,629,196. **A GLOBAL MOVEMENT FOR CREATING A CIVILIZATION OF LOVE THROUGH THE ENTHRONEMENT (BLOCK FORM)**. SACRED HEART APOSTOLATE, INC., (U.S. CLS. 100 AND 101), SN 76-693,154. PUB. 3-17-2009. FILED 9-26-2008.
- 3,629,260 (*See Class 36 for this trademark*).
- 3,629,372 (*See Class 16 for this trademark*).
- 3,629,389. **INTERNATIONAL ALLIANCE OF LAW FIRMS AND DESIGN**. INTERNATIONAL ALLIANCE OF LAW FIRMS, (U.S. CLS. 100 AND 101), SN 77-299,221. PUB. 12-2-2008. FILED 10-9-2007.
- 3,629,490 (*See Class 42 for this trademark*).
- 3,629,515. **MISCELLANEOUS DESIGN**. ONLINE BUDDIES, INC., (U.S. CLS. 100 AND 101), SN 77-382,273. PUB. 3-17-2009. FILED 1-28-2008.
- 3,629,532. **ALLIED INTERNATIONAL EMERGENCY HAZMAT / FIRE / SAFETY AND DESIGN**. ALLIED INTERNATIONAL EMERGENCY, (U.S. CLS. 100 AND 101), SN 77-392,913. PUB. 3-17-2009. FILED 2-8-2008.
- 3,629,656. **TRPSA ATTORNEYS AT LAW TUGGEY ROSENTHAL PAUERSTEIN SANDOLOSKI AGATHER LLP AND DESIGN**. TUGGEY ROSENTHAL PAUERSTEIN SANDOLOSKI AGATHER LLP, (U.S. CLS. 100 AND 101), SN 77-437,203. PUB. 3-17-2009. FILED 4-1-2008.
- 3,629,703 (*See Class 35 for this trademark*).
- 3,629,706 (*See Class 42 for this trademark*).
- 3,629,730 (*See Class 35 for this trademark*).
- 3,629,758 (*See Class 35 for this trademark*).
- 3,629,767. **COACH JOELLE (BLOCK FORM)**. COACH JOELLE INC., (U.S. CLS. 100 AND 101), SN 77-449,961. PUB. 3-17-2009. FILED 4-16-2008.
- 3,629,855 (*See Class 16 for this trademark*).
- 3,629,918 (*See Class 44 for this trademark*).
- 3,629,929. **SOUL WORKS AND DESIGN**. CHURCH OF THE NATIONS, (U.S. CLS. 100 AND 101), SN 77-474,068. PUB. 3-17-2009. FILED 5-14-2008.
- 3,629,980 (*See Class 35 for this trademark*).
- 3,630,054. **SELF-IMPROVEMENTCENTER AND DESIGN**. SOUL OVERHAUL CORP, (U.S. CLS. 100 AND 101), SN 77-506,998. PUB. 3-17-2009. FILED 6-24-2008.
- 3,630,142 (*See Class 35 for this trademark*).
- 3,630,144. **CALTRIS (BLOCK FORM)**. CALTRIS MEDICAL-LEGAL CONSULTING, LLC, (U.S. CLS. 100 AND 101), SN 77-531,593. PUB. 3-17-2009. FILED 7-25-2008.
- 3,630,168 (*See Class 35 for this trademark*).
- 3,630,269. **AMPUTEE EMPOWERMENT PARTNERS AND DESIGN**. HANGER ORTHOPEDIC GROUP, INC., (U.S. CLS. 100 AND 101), SN 77-560,045. PUB. 3-17-2009. FILED 9-

- 2-2008.
 3,630,296 (*See Class 42 for this trademark.*)
 3,630,304 (*See Class 40 for this trademark.*)
 3,630,335. **ADAM (BLOCK FORM)**, ADAM MANAGEMENT CO., INC., (U.S. CLS. 100 AND 101). SN 77-570,204. PUB. 3-17-2009. FILED 9-15-2008.
 3,630,340. **WATSON BENNETT (BLOCK FORM)**, WATSON, BENNETT, COLLIGAN, JOHNSON & SCHECHTER, LLP, (U.S. CLS. 100 AND 101). SN 77-570,802. PUB. 3-17-2009. FILED 9-16-2008.
 3,630,399. **RAPPERS I.Q. (BLOCK FORM)**, CARTER, CURTIS, (U.S. CLS. 100 AND 101). SN 77-579,159. PUB. 3-17-2009. FILED 9-25-2008.
 3,630,416. **LUCKY LEASH A PET SITTING SERVICE AND DESIGN**, LUCKY LEASH, (U.S. CLS. 100 AND 101). SN 77-580,589. PUB. 3-17-2009. FILED 9-28-2008.
 3,630,447. **FIRECHECK (BLOCK FORM)**, E.E. NEWCOMER ENTERPRISES, INC., (U.S. CLS. 100 AND 101). SN 77-584,575. PUB. 3-17-2009. FILED 10-2-2008.
 3,630,453. **ESSENTIAL DISCOVERY (BLOCK FORM)**, TEG STAFFING, INC., (U.S. CLS. 100 AND 101). SN 77-585,594. PUB. 3-17-2009. FILED 10-3-2008.
 3,630,479. **CONNECTING YOU TO GOD, WHEREVER, WHENEVER, HOWEVER (BLOCK FORM)**, CRYSTAL CATHEDRAL MINISTRIES, (U.S. CLS. 100 AND 101). SN 77-587,887. PUB. 3-17-2009. FILED 10-7-2008.
 3,630,490. **CAMP MAKEBELIEVE (BLOCK FORM)**, CAMP MAKEBELIEVE, INC., (U.S. CLS. 100 AND 101). SN 77-588,754. PUB. 3-17-2009. FILED 10-8-2008.
 3,630,495. **FIFTH THIRD IDENTITY ALERT (BLOCK FORM)**, FIFTH THIRD BANCORP, (U.S. CLS. 100 AND 101). SN 77-589,130. PUB. 3-17-2009. FILED 10-9-2008.
 3,630,501 (*See Class 16 for this trademark.*)
 3,630,509. **SERVANTS OF THE LORD (BLOCK FORM)**, COUPLES FOR CHRIST, METROPOLITAN-WASHINGTON, D.C., INCORPORATED, (U.S. CLS. 100 AND 101). SN 77-590,613. PUB. 3-17-2009. FILED 10-10-2008.
 3,630,533. **PRIVILEGED PETS (BLOCK FORM)**, RICHARDS, FIONA MCGREGOR, DBA PRIVILEGED PETS LLC, AND RICHARDS, JOHN P. DBA PRIVILEGED PETS LLC, (U.S. CLS. 100 AND 101). SN 77-592,331. PUB. 3-17-2009. FILED 10-14-2008.
 3,630,540 (*See Class 35 for this trademark.*)
 3,630,688. **SELECT KEY HOLDER'S 24/7 RESIDENTIAL ESTATE MANAGEMENT CERTIFIED HOUSE CHECKS AND DESIGN**, HARBOR PROPERTY MANAGEMENT GROUP, LLC, (U.S. CLS. 100 AND 101). SN 77-598,027. PUB. 3-17-2009. FILED 10-22-2008.
 3,630,767 (*See Class 35 for this trademark.*)
 3,630,784. **DUCKDUCKDATE! AND DESIGN**, LIM, MICHAEL Z, (U.S. CLS. 100 AND 101). SN 77-599,362. PUB. 3-17-2009. FILED 10-23-2008.
 3,630,892. **MISCELLANEOUS DESIGN**, CENTER FOR ARKANSAS LEGAL SERVICES, (U.S. CLS. 100 AND 101). SN 77-600,875. PUB. 3-17-2009. FILED 10-27-2008.
 3,630,937. **DUNLAP | GRUBB | WEAVER AND DESIGN**, DUNLAP, GRUBB & WEAVER, PLLC, DBA DUNLAP GRUBB WEAVER, (U.S. CLS. 100 AND 101). SN 77-601,366. PUB. 3-17-2009. FILED 10-27-2008.
 3,630,958. **DIVINE CHOICES AND DESIGN**, DIVINE CHOICES, INC., (U.S. CLS. 100 AND 101). SN 77-601,645. PUB. 3-17-2009. FILED 10-27-2008.
 3,630,982. **SENIOR EXPRESS LIMITED LIABILITY COMPANY (BLOCK FORM)**, SENIOR EXPRESS LIMITED LIABILITY COMPANY, (U.S. CLS. 100 AND 101). SN 77-602,045. PUB. 3-17-2009. FILED 10-28-2008.
 3,630,987. **THE WILD RIDE (BLOCK FORM)**, CITY PORTAL GROUP, INC, (U.S. CLS. 100 AND 101). SN 77-602,075. PUB. 3-17-2009. FILED 10-28-2008.
 3,631,003 (*See Class 44 for this trademark.*)
 3,631,016. **SS (STYLIZED)**, STELLATO & SCHWARTZ, LTD., (U.S. CLS. 100 AND 101). SN 77-602,403. PUB. 3-17-2009. FILED 10-28-2008.
 3,631,023. **CWEB SINGLES (BLOCK FORM)**, SHOKROLA, GEORGE, (U.S. CLS. 100 AND 101). SN 77-602,548. PUB. 3-17-2009. FILED 10-28-2008.
 3,631,100. **MCCORMICK FORENSICS INC. AND DESIGN**, MCCORMICK FORENSICS, INC., (U.S. CLS. 100 AND 101). SN 77-603,876. PUB. 3-17-2009. FILED 10-30-2008.
 3,631,101. **SPIRITUALITY IS SEXY (BLOCK FORM)**, SPIRITUALITY IS SEXY, LLC, (U.S. CLS. 100 AND 101). SN 77-603,954. PUB. 3-17-2009. FILED 10-30-2008.
 3,631,142. **PRESERVE PROTECT PROMOTE (BLOCK FORM)**, GIBSON, FERRIN & RIGGS, PLC, (U.S. CLS. 100 AND 101). SN 77-604,555. PUB. 3-17-2009. FILED 10-30-2008.
 3,631,193. **BARON & BUDD (BLOCK FORM)**, BARON & BUDD, P.C., (U.S. CLS. 100 AND 101). SN 77-605,418. PUB. 3-17-2009. FILED 10-31-2008.
 3,631,219. **SOMETHING TO WEAR (BLOCK FORM)**, WOSTENBERG, MICHELLE L, DBA SOMETHING TO WEAR, STYLE CONSULTING, (U.S. CLS. 100 AND 101). SN 77-605,633. PUB. 3-17-2009. FILED 11-1-2008.
 3,631,222. **TRANSFORMING THE CONSTRUCTION LANDSCAPE (BLOCK FORM)**, HAYNSWORTH SINKLER BOYD, P.A., (U.S. CLS. 100 AND 101). SN 77-605,685. PUB. 3-17-2009. FILED 11-2-2008.
 3,631,223. **TRANSFORMING THE MANUFACTURING LANDSCAPE (BLOCK FORM)**, HAYNSWORTH SINKLER BOYD, P.A., (U.S. CLS. 100 AND 101). SN 77-605,686. PUB. 3-17-2009. FILED 11-2-2008.
 3,631,224. **TRANSFORMING THE REAL ESTATE LANDSCAPE (BLOCK FORM)**, HAYNSWORTH SINKLER BOYD, P.A., (U.S. CLS. 100 AND 101). SN 77-605,687. PUB. 3-17-2009. FILED 11-2-2008.
 3,631,234. **AFP AMERICAN FORCE PROTECTION (STYLIZED)**, AMERICAN FORCE PROTECTION, LLC, (U.S. CLS. 100 AND 101). SN 77-606,032. PUB. 3-17-2009. FILED 11-3-2008.
 3,631,254. **COMMON FATE AND DESIGN**, HEART OF FASHION, L.L.C., DBA COMMON FATE, (U.S. CLS. 100 AND 101). SN 77-606,794. PUB. 3-17-2009. FILED 11-4-2008.
 3,631,265 (*See Class 42 for this trademark.*)
 3,631,290. **WE TAKE YOUR INJURY AS PERSONALLY AS YOU DO (BLOCK FORM)**, KATHERMAN, BRIGGS & GREENBERG, LLP, (U.S. CLS. 100 AND 101). SN 77-611,083. PUB. 3-17-2009. FILED 11-10-2008.
 3,631,365. **ACTI-KARE AND DESIGN**, ACTIKARE, INC., (U.S. CLS. 100 AND 101). SN 77-647,087. PUB. 3-17-2009. FILED 10-2009.
 3,631,370 (*See Class 35 for this trademark.*)
 3,631,372 (*See Class 41 for this trademark.*)
 3,631,395 (*See Class 42 for this trademark.*)
 3,631,420 (*See Class 35 for this trademark.*)
 3,631,438 (*See Class 7 for this trademark.*)
 3,631,475 (*See Class 32 for this trademark.*)
 3,631,537 (*See Class 35 for this trademark.*)
 3,631,562 (*See Class 11 for this trademark.*)
 3,631,607 (*See Class 16 for this trademark.*)
 3,631,658 (*See Class 35 for this trademark.*)
 3,631,672 (*See Class 16 for this trademark.*)
 3,631,727 (*See Class 35 for this trademark.*)

* * * * *

SECTION 2.—PRIOR UNITED STATES CLASSIFICATION

COLLECTIVE MEMBERSHIP MARKS

NAFA AND DESIGN. NATIONAL ALFALFA AND FORAGE ALLIANCE, SN 77-560,871. PUB. 3-17-2009. FILED 9-2-2008.

CLASS 200—COLLECTIVE MEMBERSHIP

3,629,129. **MEMBER NPGA NATIONAL PROPANE GAS ASSOCIATION AND DESIGN.** NATIONAL PROPANE GAS ASSOCIATION, SN 76-624,209. PUB. 3-17-2009. FILED 12-9-2004.

3,629,306. **SPINA BIFIDA ASSOCIATION (BLOCK FORM).** SPINA BIFIDA ASSOCIATION OF AMERICA, SN 77-195,812. PUB. 3-17-2009. FILED 6-1-2007.

3,629,588. **L KDOWN RIDERZ AND DESIGN.** PRITCHETT, KAREEM, AND PINEDO, VICTOR, SN 77-418,657. PUB. 3-17-2009. FILED 3-11-2008.

3,630,276. **NATIONAL ALFALFA & FORAGE ALLIANCE**

CERTIFICATION MARKS

CLASS B—SERVICES
3,629,636. **BBB ACCREDITED CHARITY BBB.ORG/CHARITY AND DESIGN.** COUNCIL OF BETTER BUSINESS BUREAUS, INC., SN 77-434,214. PUB. 3-17-2009. FILED 3-28-2008.

* * * * *

TRADEMARK REGISTRATIONS ISSUED UNDER SECTION 1(d)

The following marks have registered on the Principal Register pursuant to the intent-to-use provisions of Section 1(d) of the Trademark Act of 1946, as amended.

SECTION 1.— INTERNATIONAL CLASSIFICATION

The short titles associated below with the international class numbers are terms designed merely for quick identification and are not an official part of the international classification. The full names of international classes are given in section 6.1 of the trademark rules of practice.

The designation "U.S. Cl." appearing in this section refers to the U.S. class in effect prior to Sep. 1, 1973 rather than the international class which applies to applications filed on or after that date. For adoption of international classification see notice in the OFFICIAL GAZETTE of Jun. 26, 1973 (911 O.G. TM 210).

Application in more than one class

3,631,794. HULL, JERI K., DBA BUNNY HULL AND BRASSHEART MUSIC AND KIDS CREATIVE CLASSICS, BEVERLY HILLS, CA. SN 76-609,909. PUB. 2-28-2006, FILED 9-2-2004.

DREAM A WORLD

THE MARK CONSISTS OF STANDARD CHARACTERS WITHOUT CLAIM TO ANY PARTICULAR FONT, STYLE, SIZE, OR COLOR.

CLASS 9—ELECTRICAL AND SCIENTIFIC APPARATUS

FOR DVD'S AND VIDEO CASSETTES FEATURING MOVIES AND MUSIC (U.S. CLS. 21, 23, 26, 36 AND 38). FIRST USE 11-14-2007; IN COMMERCE 11-19-2007.

CLASS 41—EDUCATION AND ENTERTAINMENT

FOR ENTERTAINMENT IN THE NATURE OF ONGOING TELEVISION SHOWS AIRED ON THE INTERNET IN THE FIELD OF CHILDREN'S PROGRAMMING; MUSIC PRODUCTION SERVICES; LIVE THEATRE PRODUCTIONS (U.S. CLS. 100, 101 AND 107). FIRST USE 6-21-2008; IN COMMERCE 6-29-2008.

3,631,795. DIVINE PHYSICS HOLISTIC LIFESTYLES, INC., CENTENNIAL, CO. SN 76-611,149. PUB. 6-19-2007, FILED 9-13-2004.

EXECUTIVE REGENERATION

THE MARK CONSISTS OF STANDARD CHARACTERS WITHOUT CLAIM TO ANY PARTICULAR FONT, STYLE, SIZE, OR COLOR.

NO CLAIM IS MADE TO THE EXCLUSIVE RIGHT TO USE "REGENERATION", APART FROM THE MARK AS SHOWN.

CLASS 41—EDUCATION AND ENTERTAINMENT

FOR EDUCATION SERVICES, NAMELY, PROVIDING CLASSES, SEMINARS, AND WORKSHOPS IN THE FIELDS OF MEDICAL, SOCIAL, SPIRITUAL, POLITICAL, ENVIRONMENTAL, HEALTH CARE, AND CULTURAL ISSUES (U.S. CLS. 100, 101 AND 107). FIRST USE 1-5-2009; IN COMMERCE 1-5-2009.

CLASS 44—MEDICAL, BEAUTY AND AGRICULTURAL SERVICES

FOR CULTURAL MEDICAL, HEALTH CARE, AND HYGIENIC SERVICES IN THE NATURE OF IN-HOUSE, CORPORATE AND INDIVIDUALIZED PROGRAMS OFFERING MASSAGE, CHIROPRACTIC, NATUROPATHIC, NUTRITIONAL AND HOLISTIC MEDICAL SERVICES, AND HOMEOPATHY AND ENERGY MEDICAL SERVICES; PSYCHOTHERAPY AND HEALTH SPA SERVICES FOR THE HEALTH AND WELLNESS OF THE BODY AND SPIRIT (U.S. CLS. 100 AND 101). FIRST USE 1-5-2009; IN COMMERCE 1-5-2009.

3,631,804. EMORY UNIVERSITY, ATLANTA, GA. SN 76-644,461. PUB. 7-17-2007, FILED 8-8-2005.



CLASS 25—CLOTHING

FOR CLOTHING, NAMELY, BASEBALL CAPS, SWEAT SHIRTS, T-SHIRTS, AND POLO SHIRTS (U.S. CLS. 22 AND 39). FIRST USE 3-30-2009; IN COMMERCE 3-30-2009.

CLASS 41—EDUCATION AND ENTERTAINMENT

FOR ENTERTAINMENT SERVICES, NAMELY, ARRANGING AND CONDUCTING ATHLETIC COMPETITIONS, ATHLETIC TOURNAMENTS, AND ATHLETIC EVENTS (U.S. CLS. 100, 101 AND 107).

FIRST USE 3-30-2009; IN COMMERCE 3-30-2009.

3,631,820. TENNESSEE MEDIATION ARBITRATION SERVICES, INC., BRENTWOOD, TN. SN 76-676,290. PUB. 10-30-2007, FILED 5-1-2007.

CONFLICT MANAGEMENT SYNCHRONIZATION

THE MARK CONSISTS OF STANDARD CHARACTERS WITHOUT CLAIM TO ANY PARTICULAR FONT, STYLE, SIZE, OR COLOR.

NO CLAIM IS MADE TO THE EXCLUSIVE RIGHT TO USE "CONFLICT MANAGEMENT", APART FROM THE MARK AS SHOWN.

CLASS 16—PAPER GOODS AND PRINTED MATTER

FOR PRINTED COURSE MATERIALS IN THE FIELD OF USING MEDIATION SKILLS AND TECHNIQUES TO RESOLVE BUSINESS DISPUTES (U.S. CLS. 2, 5, 22, 23, 29, 37, 38 AND 50).

FIRST USE 8-16-2007; IN COMMERCE 8-29-2007.

CLASS 41—EDUCATION AND ENTERTAINMENT

FOR TRAINING IN THE USE OF MEDIATION SKILLS AND TECHNIQUES TO RESOLVE BUSINESS DISPUTES (U.S. CLS. 100, 101 AND 107).

FIRST USE 8-16-2007; IN COMMERCE 8-16-2007.

3,631,865. VAN BEURDEN INSURANCE SERVICES, INC., KINGSBURG, CA. SN 77-002,272. PUB. 1-22-2008, FILED 9-19-2006.

VERY WELL

THE MARK CONSISTS OF STANDARD CHARACTERS WITHOUT CLAIM TO ANY PARTICULAR FONT, STYLE, SIZE, OR COLOR.

CLASS 35—ADVERTISING AND BUSINESS

FOR PROVIDING ASSISTANCE, FITNESS EVALUATION, AND CONSULTATION TO CORPORATE CLIENTS TO HELP THEIR EMPLOYEES MAKE HEALTH, WELLNESS AND NUTRITIONAL CHANGES IN THEIR DAILY LIVING IN ORDER TO INCREASE PRODUCTIVITY AND LOWER HEALTH CARE COSTS (U.S. CLS. 100, 101 AND 102).

FIRST USE 6-14-2006; IN COMMERCE 6-29-2006.

CLASS 36—INSURANCE AND FINANCIAL

FOR INSURANCE BROKERAGE AND ADMINISTRATION SERVICES IN THE FIELDS OF WORKERS' COMPENSATION, GROUP HEALTH, AND HEALTH AND WELLNESS; AND INSURANCE CONSULTATION IN THE FIELDS OF WORKERS' COMPENSATION, GROUP HEALTH, AND HEALTH AND WELLNESS (U.S. CLS. 100, 101 AND 102).

FIRST USE 6-14-2006; IN COMMERCE 6-29-2006.

CLASS 44—MEDICAL, BEAUTY AND AGRICULTURAL SERVICES

FOR HEALTH CARE, NAMELY, PROVIDING WELLNESS PROGRAMS (U.S. CLS. 100 AND 101).

FIRST USE 6-14-2006; IN COMMERCE 6-29-2006.

3,631,873. PROBUILD HOLDINGS, INC., DENVER, CO. SN 77-016,137. PUB. 3-11-2008, FILED 10-6-2006.

PRO-BUILD

THE MARK CONSISTS OF STANDARD CHARACTERS WITHOUT CLAIM TO ANY PARTICULAR FONT, STYLE, SIZE, OR COLOR.

OWNER OF U.S. REG. NO. 1,262,713.

CLASS 37—CONSTRUCTION AND REPAIR

FOR CONSTRUCTION SERVICES, NAMELY, PLANNING, FRAMING, BUILDING, AND INSTALLATION SERVICES IN THE FIELDS OF BUILDING AND CONSTRUCTION; BUILDING MATERIAL INSTALLATION AND REPAIR SERVICES; PROVIDING INFORMATION IN THE FIELDS OF BUILDING AND CONSTRUCTION; CONSULTATION IN THE FIELDS OF BUILDING AND CONSTRUCTION (U.S. CLS. 100, 103 AND 106).

FIRST USE 1-27-2007; IN COMMERCE 1-27-2007.

CLASS 40—MATERIAL TREATMENT

FOR ASSEMBLY OF BUILDING CONSTRUCTION MATERIALS FOR OTHERS (U.S. CLS. 100, 103 AND 106).

FIRST USE 1-27-2007; IN COMMERCE 1-27-2007.

3,631,877. INTERDESIGN, INC., SOLON, OH. SN 77-020,041. PUB. 10-21-2008, FILED 10-12-2006.

AXIS

THE MARK CONSISTS OF STANDARD CHARACTERS WITHOUT CLAIM TO ANY PARTICULAR FONT, STYLE, SIZE, OR COLOR.

CLASS 6—METAL GOODS

FOR METAL GOODS, NAMELY, METAL CLOSET ACCESSORIES, NAMELY, OVER THE DOOR HOOKS; METAL CLOTHES HOOKS, SCREW-MOUNTED METAL HOOKS, METAL BATHROOM BASKETS OF COMMON METALS, METAL BASKET FOR STORAGE (U.S. CLS. 2, 12, 13, 14, 23, 25 AND 50).

FIRST USE 12-19-2006; IN COMMERCE 12-19-2006.

CLASS 20—FURNITURE AND ARTICLES NOT OTHERWISE CLASSIFIED

FOR SINK MATS, STORAGE RACKS FOR WINE, METAL CLOSET ACCESSORIES, NAMELY, VALETS FOR HOLDING HANGERS, HOOKS, AND RACKS FOR TIES, BELTS AND SCARVES; METAL RACKS FOR CLOTHING, HATS, APRONS, COATS, JACKETS, SCARVES, BROOMS, MOPS, DUSTPANS, UMBRELLAS, BAGS, LADDERS, AND RAKES; HOUSEHOLD ACCESSORIES, NAMELY, SINK MATS, MUG RACKS, SINK PROTECTION MATS; SINK GRIDS IN THE NATURE OF METAL OR PLASTIC GRIDS FOR PROTECTING THE BOTTOM OF A SINK FROM DISHES AND SILVERWARE (U.S. CLS. 2, 13, 22, 25, 32 AND 50).

FIRST USE 12-19-2006; IN COMMERCE 12-19-2006.

CLASS 21—HOUSEWARES AND GLASS

FOR HOUSEHOLD ACCESSORIES, NAMELY, SPONGE TRAYS; WASTE PAPER BASKETS, BOWLS, GARBAGE CANS; HOUSEHOLD UTENSILS, NAMELY, DRAINERS IN THE NATURE OF A DRYING RACK FOR WET DISHES, KITCHEN SCRUBBER AND SPONGE HOLDERS, SINK TRAYS IN THE NATURE OF HOLDERS FOR HOLDING KITCHEN SINK ACCESSORIES, NAMELY, SCRUB PADS, SCRUBBERS, SOAP, SOAP CRADLES AND SPONGE CRADLES IN THE NATURE OF METAL OR PLASTIC CONTAINERS SECURED BY SUCTION MOUNT FOR HOLDING SOAP AND SPONGES; SCRUB PAD HOLDERS, BASKETS SECURABLE TO SINKS FOR DRAINING SCRUBBERS; TOWEL BARS, SPONGE HOLDERS AND SHOWER CADDIES; METAL TOILET TISSUE ROLL STANDS, METAL TOILET TISSUE HOLDERS, METAL WASTE BASKETS, METAL PAPER TOWEL HOLDERS; NAPKIN HOLDERS, SPOON REST, PAPER TOWEL HOLDER, PAPER TOWEL STAND, FLATWARE ORGANIZER, WASTE BASKETS AND WASTE CANS, TOILET PAPER HOLDERS AND DISPENSERS, METAL TOWEL HOLDERS, METAL TOWEL STANDS, TISSUE PAPER HOLDERS MADE OF METAL, SCRUB SPONGE HOLDERS MADE OF METAL, SHOWER CADDIES OF METAL, SOAP AND SCRUBBER CADDIES AND HOLDERS OF METAL, SPONGE HOLDERS OF METAL (U.S. CLS. 2, 13, 23, 29, 30, 33, 40 AND 50).

FIRST USE 12-19-2006; IN COMMERCE 12-19-2006.

CLASS 9—ELECTRICAL AND SCIENTIFIC APPARATUS

FOR DIVING SUITS; LIFE PRESERVERS, LIFE JACKETS; DIVING GLOVES, GOGGLES FOR SPORTS, ACCESSORIES FOR GOGGLES FOR SPORTS, NAMELY, CASES AND STRAPS; SNORKELS, WEIGHT BELTS FOR DIVING; LEG, ARM AND NECK CUFFS FOR DIVERS FOR SEALING THE ENDS OF DIVE SUITS TO PREVENT THE ENTRY OF WATER; DIVING GLOVES; SCUBA DIVING MASKS, PROTECTIVE CLOTHING, PROTECTIVE CLOTHING FOR LOW TEMPERATURES, PROTECTIVE CLOTHING WITH BUILT -IN IMPACT AND SHOCK PROTECTIVE CUSHIONS (U.S. CLS. 21, 23, 26, 36 AND 38).

FIRST USE 11-26-1974; IN COMMERCE 11-26-1974.

CLASS 18—LEATHER GOODS

FOR RUCKSACKS; BAGS, NAMELY, ALL-PURPOSE SPORTS BAGS, ALL-PURPOSE ATHLETIC BAGS, ALL-PURPOSE CARRYING BAGS, ATHLETIC BAGS, BAGS AND HOLDALLS FOR SPORTS CLOTHING, CARRY-ALL BAGS (U.S. CLS. 1, 2, 3, 22 AND 41).

FIRST USE 11-26-1974; IN COMMERCE 11-26-1974.

CLASS 28—TOYS AND SPORTING GOODS

FOR GOLF CLUBS, SKI STICKS, SKI POLES, CROSS-COUNTRY SKI POLES (U.S. CLS. 22, 23, 38 AND 50).

FIRST USE 11-26-1974; IN COMMERCE 11-26-1974.

3,631,880. FIDELITY WARRANTY SERVICES, INC., DEERFIELD BEACH, FL. SN 77-022,077. PUB. 11-13-2007, FILED 10-16-2006.



3,631,879. MAG. THOMAS ROISER, MONDSEE, AUSTRIA. SN 77-021,801. PUB. 7-8-2008, FILED 10-16-2006.

CAMARO

THE MARK CONSISTS OF STANDARD CHARACTERS WITHOUT CLAIM TO ANY PARTICULAR FONT, STYLE, SIZE, OR COLOR.

OWNER OF U.S. REG. NO. 1,276,243.

NO CLAIM IS MADE TO THE EXCLUSIVE RIGHT TO USE "PRE-OWNED VEHICLES", APART FROM THE MARK AS SHOWN.

THE COLOR(S) GOLD, BLACK, WHITE, AND GRAY IS/ARE CLAIMED AS A FEATURE OF THE MARK.

THE MARK CONSISTS OF THE FRAME, THE WORDING "GOLD ASSURED", AND THE BACKGROUND BEHIND THE WORDING "PRE-OWNED VEHICLES" IN GOLD; THE WORDING "PRE-OWNED VEHICLES" IN BLACK; AND THE BACKGROUND BEHIND THE WORDING "GOLD ASSURED" IN BLACK, WHITE, AND GRAY.

CLASS 35—ADVERTISING AND BUSINESS

FOR RATING THE CONDITION OF PRE-OWNED CARS FOR BUYERS PRIOR TO PURCHASE TO ENSURE AND CERTIFY THAT PRE-OWNED CARS HAVE BEEN RECONDITIONED AND ARE IN GOOD WORKING ORDER (U.S. CLS. 100, 101 AND 102).

FIRST USE 9-0-2002; IN COMMERCE 9-0-2002.

CLASS 42—SCIENTIFIC AND COMPUTER SERVICES

FOR EVALUATING AND ANALYZING THE CONDITION OF PRE-OWNED CARS FOR BUYERS PRIOR TO PURCHASE TO ENSURE AND CERTIFY THAT PRE-OWNED CARS HAVE BEEN RECONDITIONED AND ARE IN GOOD WORKING ORDER (U.S. CLS. 100 AND 101).

FIRST USE 9-0-2002; IN COMMERCE 9-0-2002.

3,631,881. FIDELITY WARRANTY SERVICES, INC., DEERFIELD BEACH, FL. SN 77-022,083. PUB. 11-13-2007, FILED 10-16-2006.

GOLD ASSURED

THE MARK CONSISTS OF STANDARD CHARACTERS WITHOUT CLAIM TO ANY PARTICULAR FONT, STYLE, SIZE, OR COLOR.

CLASS 35—ADVERTISING AND BUSINESS

FOR RATING THE CONDITION OF PRE-OWNED CARS FOR BUYERS PRIOR TO PURCHASE TO ENSURE AND CERTIFY THAT PRE-OWNED CARS HAVE BEEN RECONDITIONED AND ARE IN GOOD WORKING ORDER (U.S. CLS. 100, 101 AND 102).

FIRST USE 9-0-2002; IN COMMERCE 9-0-2002.

CLASS 42—SCIENTIFIC AND COMPUTER SERVICES

FOR EVALUATING AND ANALYZING THE CONDITION OF PRE-OWNED CARS FOR BUYERS PRIOR TO PURCHASE TO ENSURE AND CERTIFY THAT PRE-OWNED CARS HAVE BEEN RECONDITIONED AND ARE IN GOOD WORKING ORDER (U.S. CLS. 100 AND 101).

FIRST USE 9-0-2002; IN COMMERCE 9-0-2002.

3,631,887. ALL MEDIA GUIDE, LLC, ANN ARBOR, MI. SN 77-032,354. PUB. 5-27-2008, FILED 10-30-2006.

TAPESTRY

THE MARK CONSISTS OF STANDARD CHARACTERS WITHOUT CLAIM TO ANY PARTICULAR FONT, STYLE, SIZE, OR COLOR.

CLASS 9—ELECTRICAL AND SCIENTIFIC APPARATUS

FOR COMPUTER SOFTWARE FOR USE TO CLASSIFY, RECOMMEND OR RELATE DIGITAL OR PHYSICAL MEDIA FILES (U.S. CLS. 21, 23, 26, 36 AND 38).

FIRST USE 1-0-2006; IN COMMERCE 8-0-2007.

CLASS 42—SCIENTIFIC AND COMPUTER SERVICES

FOR COMPUTER SERVICES, NAMELY, HOSTING AND MAINTAINING AN ONLINE WEBSITE FOR OTHERS FOR USE TO CLASSIFY, RECOMMEND OR RELATE DIGITAL OR PHYSICAL MEDIA FILES (U.S. CLS. 100 AND 101).

FIRST USE 1-0-2006; IN COMMERCE 8-0-2007.

3,631,888. VIVA! CHOICES, INC., MARYSVILLE, CA. SN 77-035,694. PUB. 11-27-2007, FILED 11-2-2006.

VIVA! CHOICES

THE MARK CONSISTS OF STANDARD CHARACTERS WITHOUT CLAIM TO ANY PARTICULAR FONT, STYLE, SIZE, OR COLOR.

THE FOREIGN WORDING IN THE MARK TRANSLATES INTO ENGLISH AS "LIVE."

CLASS 39—TRANSPORTATION AND STORAGE

FOR LOCAL TRANSPORTATION SERVICES FOR INDIVIDUALS BY CAR OR BUS TO PERSONAL AND SOCIAL EVENTS (U.S. CLS. 100 AND 105).

FIRST USE 3-1-2008; IN COMMERCE 3-1-2008.

CLASS 41—EDUCATION AND ENTERTAINMENT

FOR ENTERTAINMENT PLANNING, NAMELY, PARTY PLANNING FOR INDIVIDUALS (U.S. CLS. 100, 101 AND 107).

FIRST USE 5-15-2008; IN COMMERCE 7-15-2008.

CLASS 45—PERSONAL AND LEGAL SERVICES

FOR PERSONAL AND IN-HOME SERVICES FOR INDIVIDUALS, NAMELY, RUNNING ERRANDS; PERSONAL CONCIERGE SERVICES FOR OTHERS COMPRISING OF MAKING REQUESTED PERSONAL ARRANGEMENTS AND RESERVATIONS, RUNNING ERRANDS AND PROVIDING CUSTOMER SPECIFIC INFORMATION TO MEET INDIVIDUAL NEEDS, ALL RENDERED WITHIN MEMBERSHIP NETWORK (U.S. CLS. 100 AND 101).

FIRST USE 3-1-2008; IN COMMERCE 3-1-2008.

3,631,889. HOEBEL FITNESS INC., NEW YORK, NY. SN 77-036,591. PUB. 7-10-2007, FILED 11-3-2006.

**vinyasaBrasil
by Hoebel Fitness**

THE MARK CONSISTS OF STANDARD CHARACTERS WITHOUT CLAIM TO ANY PARTICULAR FONT, STYLE, SIZE, OR COLOR.

NO CLAIM IS MADE TO THE EXCLUSIVE RIGHT TO USE "VINYASA BRAZIL" AND "FITNESS", APART FROM

THE MARK AS SHOWN.

THE ENGLISH TRANSLATION OF THE WORD "VINYA-SABRASIL BY HOEBEL FITNESS" IN THE MARK IS MOVEMENT.

CLASS 9—ELECTRICAL AND SCIENTIFIC APPARATUS

FOR PRE-RECORDED AUDIOVISUAL PROGRAMS, NAMELY, DIGITAL VIDEO DISKS AND VIDEOCASSETTES ON THE SUBJECTS OF CAPOEIRA, MARTIAL ARTS, YOGA, MEDITATION, PHYSICAL FITNESS, STRENGTH AND CONDITIONING, DANCE, WEIGHT-LOSS AND MOTIVATION (U.S. CLS. 21, 23, 26, 36 AND 38).

FIRST USE 10-1-2004; IN COMMERCE 10-1-2004.

CLASS 41—EDUCATION AND ENTERTAINMENT

FOR PHYSICAL FITNESS INSTRUCTION; PERSONAL TRAINING SERVICES, NAMELY, CAPOEIRA, MARTIAL ARTS, YOGA, MEDITATION, PHYSICAL FITNESS, STRENGTH AND CONDITIONING, DANCE, WEIGHT-LOSS AND MOTIVATION; EDUCATIONAL SERVICES, NAMELY, CONDUCTING INDIVIDUAL AND GROUP PROGRAMS, SEMINARS AND WORKSHOPS IN THE FIELDS OF CAPOEIRA, MARTIAL ARTS, YOGA, MEDITATION, PHYSICAL AND MENTAL CONDITIONING, PHYSICAL FITNESS, DANCE, WEIGHT-LOSS, MOTIVATION, GENERAL HEALTH AND WELLNESS, STRESS REDUCTION, LIFESTYLE MANAGEMENT AND INTEGRATIVE WELLNESS PHILOSOPHY OFFERED LIVE AND THROUGH BROADCAST MEDIA AND ON-LINE INSTRUCTION; ENTERTAINMENT SERVICES, NAMELY, PRODUCTION OF PROGRAMMING BROADCAST VIA TELEVISION, RADIO AND A GLOBAL COMPUTER NETWORK OR A COMMERCIAL ON-LINE SERVICE (U.S. CLS. 100, 101 AND 107).

FIRST USE 9-30-2003; IN COMMERCE 9-30-2003.

CLASS 10—MEDICAL APPARATUS

FOR PATIENT TREATMENT TABLES FOR MASSAGE AND PHYSIOTHERAPY, JOINT MOBILIZATION TREATMENT TABLES, CHIROPRACTIC TREATMENT TABLES, MEDICAL EXAMINATION COUCHES, EQUIPMENT FOR PHYSICAL REHABILITATION, NAMELY, FORCE AND MOTION TRAINING APPARATUS (U.S. CLS. 26, 39 AND 44).

FIRST USE 10-1-2006; IN COMMERCE 3-10-2009.

CLASS 28—TOYS AND SPORTING GOODS

FOR FITNESS CLUB EQUIPMENT, NAMELY, EXERCISING PULLEYS; EQUIPMENT FOR PHYSICAL EXERCISES, NAMELY, MANUALLY-OPERATED EXERCISE EQUIPMENT (U.S. CLS. 22, 23, 38 AND 50).

FIRST USE 10-1-2006; IN COMMERCE 3-10-2009.

3,631,899. RODRIGUEZ INTERNATIONAL PICTURES, L.P., AUSTIN, TX. SN 77-044,111. PUB. 7-24-2007, FILED 11-14-2006.



NO CLAIM IS MADE TO THE EXCLUSIVE RIGHT TO USE "INTERNATIONAL PICTURES", APART FROM THE MARK AS SHOWN.

THE MARK CONSISTS OF A GRAVESTONE BEARING THE LETTERS "RIP" SURROUNDED BY FLAMES WITH THE WORDS "RODRIGUEZ INTERNATIONAL PICTURES" UNDERNEATH.

3,631,898. LOJER OY, 38200 VAMMALA, FINLAND. SN 77-043,387. PUB. 1-15-2008, FILED 11-14-2006.



PRIORITY CLAIMED UNDER SEC. 44(D) ON ERPN CMNTY TM OFC APPLICATION NO. 005335641, FILED 9-25-2006, REG. NO. 005335641, DATED 7-27-2007, EXPIRES 9-25-2016.

THE COLOR(S) BLUE AND RED IS/ARE CLAIMED AS A FEATURE OF THE MARK.

THE COLOR RED APPEARS IN THE MISCELLANEOUS OVAL DESIGN AND THE COLOR BLUE APPEARS IN THE LETTER "L", IN THE WORD "LOJER", AND IN THE WORDING "FOR EASY CARE".

CLASS 9—ELECTRICAL AND SCIENTIFIC APPARATUS

FOR VIDEO RECORDINGS OF MOTION PICTURES (U.S. CLS. 21, 23, 26, 36 AND 38).

FIRST USE 4-0-2007; IN COMMERCE 4-0-2007.

CLASS 41—EDUCATION AND ENTERTAINMENT

FOR PRODUCTION AND DISTRIBUTION OF MOTION PICTURES (U.S. CLS. 100, 101 AND 107).

FIRST USE 4-0-2007; IN COMMERCE 4-0-2007.

3,631,906. COLEMAN-KAMMULA, SEETHA, NEWARK, DE. AND COLEMAN, BRIAN, NEWARK, DE. SN 77-053,091. PUB. 12-11-2007, FILED 11-29-2006.

Simply Sustain

THE MARK CONSISTS OF STANDARD CHARACTERS WITHOUT CLAIM TO ANY PARTICULAR FONT, STYLE, SIZE, OR COLOR.

CLASS 40—MATERIAL TREATMENT

FOR CONSULTING IN FIELD OF RECYCLING AND REUSE OF MATERIALS SUCH AS POLYMERS, PLASTICS, AND METALS (U.S. CLS. 100, 103 AND 106).
FIRST USE 2-1-2007; IN COMMERCE 2-1-2007.

CLASS 42—SCIENTIFIC AND COMPUTER SERVICES

FOR ENVIRONMENTAL SERVICES, NAMELY, TECHNICAL CONSULTATION IN THE FIELD OF ENVIRONMENTAL SCIENCE, TECHNICAL CONSULTATION IN THE FIELD OF ENGINEERING SERVICES, TECHNICAL CONSULTATION IN DESIGNING AND TESTING OF NEW ENVIRONMENTALLY FRIENDLY PRODUCTS, TECHNICAL CONSULTATION IN RESEARCH AND DEVELOPMENT FOR NEW PRODUCTS (U.S. CLS. 100 AND 101).
FIRST USE 2-1-2007; IN COMMERCE 2-1-2007.

3,631,911. TUGBOAT ENTERPRISES LTD., POWELL RIVER, B.C., CANADA. SN 77-060,600. PUB. 2-19-2008, FILED 12-8-2006.

SELKIE

THE MARK CONSISTS OF STANDARD CHARACTERS WITHOUT CLAIM TO ANY PARTICULAR FONT, STYLE, SIZE, OR COLOR.

PRIORITY CLAIMED UNDER SEC. 44(D) ON CANADA APPLICATION NO. 1321175, FILED 10-18-2006, REG. NO. 698323, DATED 10-12-2007, EXPIRES 10-12-2022.

CLASS 9—ELECTRICAL AND SCIENTIFIC APPARATUS

FOR (BASED ON USE IN COMMERCE) AND (BASED ON 44(E)) COMPUTER SOFTWARE FOR OPERATING SYSTEM UTILITIES IN THE FIELDS OF DATA AND FILE RESCUE AND RECOVERY, DATA AND FILE TRANSFER, ANTI-VIRUS SOFTWARE, FIREWALL SOFTWARE, ANTI-SPAM AND COMPUTER INTEGRITY SOFTWARE, SERVER SECURITY SOFTWARE, COVERT SURVEILLANCE AND SECURITY, OFF-SITE DATA STORAGE, DATA BACKUP, WEBSITE HOSTING, ENCRYPTED BACKUP, DATA DESTRUCTION, DATA MANAGEMENT AND NETWORKED DATA RECOVERY (U.S. CLS. 21, 23, 26, 36 AND 38).
FIRST USE 1-0-2007; IN COMMERCE 1-0-2007.

CLASS 42—SCIENTIFIC AND COMPUTER SERVICES

FOR (BASED ON 44(E)) DESIGN AND DEVELOPMENT OF SOFTWARE IN THE FIELDS OF DATA AND FILE RESCUE AND RECOVERY, DATA AND FILE TRANSFER, ANTI-VIRUS SOFTWARE, FIREWALL SOFTWARE, ANTI-SPAM AND COMPUTER INTEGRITY SOFTWARE, SERVER SECURITY SOFTWARE, COVERT SURVEILLANCE AND SECURITY, OFF-SITE DATA STORAGE, DATA BACKUP, WEBSITE HOSTING, ENCRYPTED BACKUP, DATA DESTRUCTION, DATA MANAGEMENT AND NETWORKED DATA RECOVERY (U.S. CLS. 100 AND 101).

3,631,933. INTEGRATED EQUINE TECHNOLOGIES, LLC, ALLENTOWN, NJ. SN 77-083,109. PUB. 1-15-2008, FILED 1-15-2007.

PRACTICE VU

THE MARK CONSISTS OF STANDARD CHARACTERS WITHOUT CLAIM TO ANY PARTICULAR FONT, STYLE, SIZE, OR COLOR.

CLASS 9—ELECTRICAL AND SCIENTIFIC APPARATUS

FOR ELECTRONIC VIDEO IMAGING SYSTEMS COMPRISED OF VIDEO CAMERAS, RADIO SENSORS FOR ANIMATE AND INANIMATE OBJECT TRACKING, VIDEO TRANSMISSION APPARATUS, VIDEO DISPLAY SCREENS, COMPUTER HARDWARE AND SOFTWARE FOR USE IN VIDEO IMAGING, ANIMATE AND INANIMATE OBJECT TRACKING, VIDEO TRANSMISSION AND VIDEO DISPLAY (U.S. CLS. 21, 23, 26, 36 AND 38).
FIRST USE 8-31-2007; IN COMMERCE 8-31-2007.

CLASS 37—CONSTRUCTION AND REPAIR

FOR INSTALLATION AND REPAIR OF VIDEO IMAGING SYSTEMS; COMPUTER HARDWARE INSTALLATION AND REPAIR (U.S. CLS. 100, 103 AND 106).
FIRST USE 8-31-2007; IN COMMERCE 8-31-2007.

CLASS 42—SCIENTIFIC AND COMPUTER SERVICES

FOR COMPUTER SOFTWARE INSTALLATION AND REPAIR (U.S. CLS. 100 AND 101).
FIRST USE 8-31-2007; IN COMMERCE 3-31-2007.

3,631,934. LUNCHBOX ENTERPRISES, INC., STUDIO CITY, CA. SN 77-083,172. PUB. 7-15-2008, FILED 1-15-2007.

LunchBox

THE MARK CONSISTS OF STANDARD CHARACTERS WITHOUT CLAIM TO ANY PARTICULAR FONT, STYLE, SIZE, OR COLOR.

CLASS 16—PAPER GOODS AND PRINTED MATTER

FOR CHILDREN'S BOOKS (U.S. CLS. 2, 5, 22, 23, 29, 37, 38 AND 50).
FIRST USE 8-1-2008; IN COMMERCE 8-1-2008.

CLASS 24—FABRICS

FOR TEXTILES FOR CHILDREN AND INFANTS, NAMELY, BLANKETS (U.S. CLS. 42 AND 50).
FIRST USE 7-1-2008; IN COMMERCE 7-1-2008.

CLASS 25—CLOTHING

FOR APPAREL FOR CHILDREN, NAMELY, CHILDREN'S SHIRTS, PANTS, HATS, SOCKS; OUTERWEAR FOR CHILDREN, NAMELY, VESTS, JACKETS, WIND COATS, HOODED SWEAT SHIRTS, SWEAT SHIRTS; APPAREL FOR INFANTS, NAMELY, INFANTS' SHIRTS, PANTS, HATS; OUTERWEAR FOR INFANTS, NAMELY, JACKETS, COATS, WIND COATS, HOODED SWEAT SHIRTS, SWEAT SHIRTS (U.S. CLS. 22 AND 39).

FIRST USE 3-1-2008; IN COMMERCE 3-1-2008.

CLASS 28—TOYS AND SPORTING GOODS

FOR TOYS FOR CHILDREN AND INFANTS, NAMELY, PLUSH TOYS, STUFFED TOY ANIMALS (U.S. CLS. 22, 23, 38 AND 50).

FIRST USE 1-1-2008; IN COMMERCE 1-1-2008.

3,631,939. WILLIAMS, CAITLIN, LOS GATOS, CA. SN 77-088,078. PUB. 6-24-2008, FILED 1-22-2007.

THIRD QUARTER FORUM

THE MARK CONSISTS OF STANDARD CHARACTERS WITHOUT CLAIM TO ANY PARTICULAR FONT, STYLE, SIZE, OR COLOR.

NO CLAIM IS MADE TO THE EXCLUSIVE RIGHT TO USE "FORUM", APART FROM THE MARK AS SHOWN.

CLASS 9—ELECTRICAL AND SCIENTIFIC APPARATUS

FOR PRE-RECORDED ELECTRONIC MEDIA, NAMELY, AUDIO AND VIDEO DISCS AND TAPES, DIGITAL RECORDING DISCS AND TAPES, SERIES OF PRE-RECORDED COMPACT SOUND RECORDING DISCS, VIDEO DISCS AND VIDEOTAPES ALL FEATURING MUSIC, SOUND EFFECTS, AND INFORMATION IN THE FIELD OF AGING, BUSINESS, COMMUNICATION, FINANCES, HEALTH AND WELLNESS, IDENTITY, LEADERSHIP, LIFESTYLE, RELATIONSHIPS, SELF-REALIZATION, SPIRITUALITY AND TRAVEL OPTIONS LEADING TO RETIREMENT; PROVIDING DOWNLOADABLE AUDIO FILES, MULTIMEDIA FILES, TEXT FILES, E-MAILS, WRITTEN DOCUMENTS, AUDIO MATERIAL AND VIDEO MATERIAL ALL FEATURING INFORMATION IN THE FIELDS OF AGING, BUSINESS, INTERPERSONAL COMMUNICATION, FINANCES, HEALTH AND WELLNESS, PERSONAL IDENTITY, LEADERSHIP, LIFESTYLE, PERSONAL RELATIONSHIPS, SELF-REALIZATION, SPIRITUALITY AND TRAVEL OPTIONS LEADING TO RETIREMENT (U.S. CLS. 21, 23, 26, 36 AND 38).

FIRST USE 2-22-2007; IN COMMERCE 2-22-2007.

CLASS 16—PAPER GOODS AND PRINTED MATTER

FOR PAPER AND PRINTED MATTER, NAMELY, A SERIES OF WRITTEN ARTICLES FOR PUBLICATION IN MAGAZINES AND PERIODICALS FEATURING INFORMATION IN THE FIELD OF AGING, BUSINESS, INTERPERSONAL COMMUNICATION, FINANCES, HEALTH AND WELLNESS, PERSONAL IDENTITY, LEADERSHIP, LIFESTYLE, PERSONAL RELATIONSHIPS, SELF-REALIZATION, SPIRITUALITY AND TRAVEL OPTIONS LEADING TO RETIREMENT; BOOKLETS, BROCHURES, NEWSLETTERS AND PAMPHLETS FEATURING INFORMATION IN THE FIELD OF AGING, BUSINESS, INTERPERSONAL COMMUNICATION, FINANCES, HEALTH AND WELLNESS, PERSONAL IDENTITY, LEADERSHIP, LIFESTYLE, RELATIONSHIPS, SELF-REALIZATION, SPIRITUALITY AND TRAVEL OPTIONS LEADING TO RETIREMENT; PRINTED EDUCATIONAL, INSTRUCTIONAL AND TEACHING MATERIALS FEATURING INFORMATION IN THE FIELD OF AGING, BUSINESS, COMMUNICATION, FINANCES, HEALTH AND WELLNESS, IDENTITY, LEADERSHIP, LIFESTYLE, RELATIONSHIPS, SELF-REALIZATION, SPIRITUALITY AND TRAVEL OPTIONS LEADING TO RETIREMENT; PRINTED PUBLICATIONS, NAMELY, MAGAZINES, TRADE JOURNALS AND PERIODICALS IN THE FIELD OF AGING, BUSINESS, COMMUNICATION, FINANCES, HEALTH AND WELLNESS, IDENTITY, LEADERSHIP, LIFESTYLE, RELATIONSHIPS, SELF-REALIZATION, SPIRITUALITY AND TRAVEL OPTIONS LEADING TO RETIREMENT; PROMOTIONAL POSTCARDS AND POSTERS; SERIES OF NON-FICTION BOOKS AND WORKBOOKS IN THE FIELD OF AGING, BUSINESS, COMMUNICATION, FINANCES, HEALTH AND WELLNESS, IDENTITY, LEADERSHIP, LIFESTYLE, RELATIONSHIPS, SELF-REALIZATION, SPIRITUALITY AND TRAVEL OPTIONS LEADING TO RETIREMENT; STATIONERY, NAMELY, LETTERHEAD AND ENVELOPES, WRITING PADS, FOLDERS AND STICKERS (U.S. CLS. 2, 5, 22, 23, 29, 37, 38 AND 50).

FIRST USE 2-22-2007; IN COMMERCE 2-22-2007.

CLASS 35—ADVERTISING AND BUSINESS

FOR CONSULTING SERVICES IN THE FIELD OF BUSINESS AND BUSINESS LEADERSHIP; PROVIDING ONLINE COMPUTER DATA BASES FEATURING BUSINESS INFORMATION AND BUSINESS LEADERSHIP INFORMATION (U.S. CLS. 100, 101 AND 102).

FIRST USE 2-22-2007; IN COMMERCE 2-22-2007.

CLASS 38—COMMUNICATION

FOR INTERNET BROADCASTING SERVICES, NAMELY, RADIO, TELEVISION AND FILM BROADCASTING VIA A GLOBAL COMPUTER NETWORK; TELEPHONE COMMUNICATION SERVICES FEATURING TELEPHONE AND FACSIMILE TRANSMISSION; ELECTRONIC, ELECTRIC, AND DIGITAL TRANSMISSION OF VOICE, DATA, IMAGES, SOUND, SIGNAL AND MESSAGES; TRANSMISSION OF INFORMATION BY ELECTRONIC COMMUNICATIONS NETWORKS; ELECTRONIC DATA TRANSMISSION OF BOOKS AND NEWSLETTERS VIA A GLOBAL COMPUTER NETWORK; ELECTRONIC DATA TRANSMISSION OF GREETING CARDS VIA A GLOBAL COMPUTER NETWORK (U.S. CLS. 100, 101 AND 104).

FIRST USE 2-22-2007; IN COMMERCE 2-22-2007.

CLASS 41—EDUCATION AND ENTERTAINMENT

FOR EDUCATIONAL SERVICES, NAMELY, ARRANGING AND CONDUCTING LIVE AND ONLINE SEMINARS, CONFERENCES, WORKSHOPS, AND LECTURES IN THE FIELDS OF AGING, BUSINESS, COMMUNICATION, FINANCES, HEALTH AND WELLNESS, IDENTITY, LEADERSHIP, LIFESTYLE, RELATIONSHIPS, SELF-REALIZATION, SPIRITUALITY AND TRAVEL OPTIONS LEADING TO RETIREMENT; ENTERTAINMENT SERVICES, NAMELY, LIVE SPEAKING PERFORMANCES AND SPEAKING ENGAGEMENTS ON A VARIETY OF EDUCATIONAL, ENTERTAINING AND MOTIVATIONAL SUBJECTS IN THE FIELDS OF

AGING, BUSINESS, COMMUNICATION, FINANCES, HEALTH AND WELLNESS, IDENTITY, LEADERSHIP, LIFESTYLE, RELATIONSHIPS, SELF-REALIZATION, SPIRITUALITY AND TRAVEL OPTIONS LEADING TO RETIREMENT; COACHING SERVICES IN THE FIELDS OF AGING, BUSINESS, COMMUNICATION, FINANCES, HEALTH AND WELLNESS, IDENTITY, LEADERSHIP, LIFESTYLE, RELATIONSHIPS, SELF-REALIZATION, SPIRITUALITY AND TRAVEL OPTIONS LEADING TO RETIREMENT; PRODUCTION AND DISTRIBUTION OF TELEVISION AND RADIO PROGRAMS (U.S. CLS. 100, 101 AND 107).

FIRST USE 2-22-2007; IN COMMERCE 2-22-2007.

3,631,941. INTEGRATED MEDICAL SYSTEMS INTERNATIONAL, INC., BIRMINGHAM, AL. SN 77-090,722. PUB. 7-17-2007, FILED 1-25-2007.

ENDOREADY

THE MARK CONSISTS OF STANDARD CHARACTERS WITHOUT CLAIM TO ANY PARTICULAR FONT, STYLE, SIZE, OR COLOR.

CLASS 35—ADVERTISING AND BUSINESS

FOR MEDICAL BUSINESS CONSULTING SERVICES FOR PHYSICIANS, HOSPITALS AND OUT-PATIENT CARE FACILITIES (U.S. CLS. 100, 101 AND 102).

FIRST USE 4-7-2009; IN COMMERCE 4-7-2009.

CLASS 37—CONSTRUCTION AND REPAIR

FOR MEDICAL EQUIPMENT REPAIR SERVICES, NAMELY, REPAIRING SURGICAL INSTRUMENTS FOR PHYSICIANS, HOSPITALS AND OUT-PATIENT CARE FACILITIES (U.S. CLS. 100, 103 AND 106).

FIRST USE 4-7-2009; IN COMMERCE 4-7-2009.

CLASS 44—MEDICAL, BEAUTY AND AGRICULTURAL SERVICES

FOR MEDICAL CONSULTING SERVICES FOR PHYSICIANS, HOSPITALS AND OUT-PATIENT CARE FACILITIES (U.S. CLS. 100 AND 101).

FIRST USE 4-7-2009; IN COMMERCE 4-7-2009.

3,631,950. ALLTECH, INC., NICHOLASVILLE, KY. SN 77-095,352. PUB. 1-22-2008, FILED 1-31-2007.



OWNER OF U.S. REG. NO. 2,699,945.

THE MARK CONSISTS OF THE LETTER "A", WITH THE INTERIOR THEREOF FORMING THE OUTLINE OF A MICROSCOPE.

CLASS 25—CLOTHING

FOR CLOTHING, NAMELY, T-SHIRTS, JACKETS, HATS, GOLF SHIRTS, KNIT SHIRTS AND POLO SHIRTS (U.S. CLS. 22 AND 39).

FIRST USE 4-26-2007; IN COMMERCE 4-26-2007.

CLASS 32—LIGHT BEVERAGES

FOR ALE AND BEER (U.S. CLS. 45, 46 AND 48).

FIRST USE 4-10-2000; IN COMMERCE 6-27-2001.

3,631,955. COSCIA, ROBERT, BAYSIDE, NY. SN 77-101,120. PUB. 7-8-2008, FILED 2-7-2007.

BONGTENDER

THE MARK CONSISTS OF STANDARD CHARACTERS WITHOUT CLAIM TO ANY PARTICULAR FONT, STYLE, SIZE, OR COLOR.

CLASS 25—CLOTHING

FOR CLOTHING, NAMELY, SHIRTS, HATS, SHORTS, PANTS, FOOTWEAR, SWEATSHIRTS, SWEATERS, SWEATPANTS, AND JACKETS (U.S. CLS. 22 AND 39).

FIRST USE 1-0-2008; IN COMMERCE 3-20-2008.

CLASS 34—SMOKERS' ARTICLES

FOR SMOKER'S ARTICLES, NAMELY, LIGHTERS; WATER PIPE BOWL WITH STEM HOLDER CONSISTING OF A STAND, CLEANER, PACKER, POKER, ASH TRAY, AND STORAGE DOME FOR FRESHNESS (U.S. CLS. 2, 8, 9 AND 17).

FIRST USE 1-0-2008; IN COMMERCE 3-20-2008.

3,631,958. MUNNY JOURNEY LLC, COEUR D'ALENE, ID. SN 77-102,018. PUB. 1-22-2008, FILED 2-7-2007.

MUNNY JOURNEY

THE MARK CONSISTS OF STANDARD CHARACTERS WITHOUT CLAIM TO ANY PARTICULAR FONT, STYLE, SIZE, OR COLOR.

NO CLAIM IS MADE TO THE EXCLUSIVE RIGHT TO USE "MONEY", APART FROM THE MARK AS SHOWN.

CLASS 16—PAPER GOODS AND PRINTED MATTER

FOR PRINTED MATERIALS, NAMELY, JOURNALS WITH EDUCATIONAL TEXT AND BLANK SPACES FOR WRITING IN THE FIELDS OF FINANCIAL LITERACY, FINANCIAL EDUCATION, FINANCIAL KNOWLEDGE, FINANCIAL INSTRUCTION AND ADVICE, AND PERSONAL FINANCIAL ORGANIZATION (U.S. CLS. 2, 5, 22, 23, 29, 37, 38 AND 50).

FIRST USE 7-1-2008; IN COMMERCE 7-1-2008.

CLASS 41—EDUCATION AND ENTERTAINMENT

FOR EDUCATIONAL SERVICES, NAMELY, DEVELOPING, ARRANGING, CONDUCTING AND HOSTING WORKSHOPS AND SEMINARS PROVIDING INSTRUCTION AND TRAINING IN THE FIELDS OF FINANCIAL LITERACY, KNOWLEDGE AND INFORMATION, FINANCIAL PLANNING, SAVING AND INVESTMENT PLANNING, FINANCIAL TERMINOLOGY, FINANCIAL MANAGEMENT AND BUDGETING STRATEGIES, BORROWING, CREDIT USAGE, DEBT MANAGEMENT, INSURANCE, RETIREMENT PLANNING, AND ESTATE PLANNING (U.S. CLS. 100, 101 AND 107).

FIRST USE 8-7-2008; IN COMMERCE 8-7-2008.

3,631,962. INTELLIMAT, INC., ROANOKE, VA. SN 77-106,963. PUB. 10-7-2008, FILED 2-14-2007.

ENGAGING CUSTOMERS

THE MARK CONSISTS OF STANDARD CHARACTERS WITHOUT CLAIM TO ANY PARTICULAR FONT, STYLE, SIZE, OR COLOR.

CLASS 9—ELECTRICAL AND SCIENTIFIC APPARATUS

FOR DIGITAL SIGNAGE SYSTEMS AND RELATED EQUIPMENT, NAMELY, ELECTRIC SIGNS, ELECTRONIC DISPLAYS, CHANGEABLE ELECTRONIC ADVERTISING AND MESSAGE DISPLAY UNITS WITH STAND-ALONE CAPABILITIES, MULTI-NETWORKING CAPABILITIES, AND REMOTE CONNECTIVITY, LIQUID-CRYSTAL DISPLAYS, LIGHT EMITTING DIODE DISPLAYS, ELECTRONIC PAPER DISPLAYS, OPTICAL FIBER ARRAY DISPLAYS, CHANGEABLE ELECTRONIC DISPLAYS, CHANGEABLE ELECTRONIC ADVERTISING AND MESSAGE DISPLAY UNITS, SURROUNDS AND SUPPORTING STRUCTURES FOR DIGITAL SIGNAGE SYSTEMS, PORTABLE AND COMPACT COMPUTING DEVICES FOR OPERATING DIGITAL SIGNAGE SYSTEMS, AND PORTABLE AND COMPACT POWER SUPPLY UNITS FOR POWERING DIGITAL SIGNAGE SYSTEMS; WIRED AND WIRELESS NETWORKING SYSTEMS FOR DIGITAL SIGNAGE SYSTEMS AND CHANGEABLE ELECTRONIC ADVERTISING AND MESSAGE DISPLAY UNITS, NAMELY, COMPUTER HARDWARE AND SOFTWARE FOR OPERATING ELECTRONIC DISPLAYS AND DIGITAL SIGNAGE SYSTEMS, COMPUTER HARDWARE AND SOFTWARE FOR ADMINISTRATION AND OPERATION OF COMPUTER LOCAL AREA NETWORKS, COMPUTER NETWORKING HARDWARE AND NETWORK OPERATING SOFTWARE AND TELECOMMUNICATIONS AND NETWORKING HARDWARE, NAMELY, DEVICES FOR TRANSPORTING AND AGGREGATING AUDIO, DATA, AND VIDEO COMMUNICATIONS ACROSS MULTIPLE NETWORK INFRASTRUCTURES AND COMMUNICATIONS PROTOCOLS (U.S. CLS. 21, 23, 26, 36 AND 38).

FIRST USE 2-16-2009; IN COMMERCE 2-16-2009.

CLASS 35—ADVERTISING AND BUSINESS

FOR OPERATION AND ADMINISTRATION OF DIGITAL SIGNAGE SYSTEMS FOR OTHERS, NAMELY, PROVIDING ADVERTISING SPACE BY ELECTRONIC MEANS AND GLOBAL COMPUTER INFORMATION NETWORKS; RETAIL STORE SERVICES FEATURING EQUIPMENT FOR DIGITAL SIGNAGE SYSTEMS (U.S. CLS. 100, 101 AND 102).

FIRST USE 2-16-2009; IN COMMERCE 2-16-2009.

3,631,964. THE MOST HONORABLE ORDER OF CHRISTIAN KNIGHTS OF THE ROSE, SEASIDE, CA. SN 77-109,949. PUB. 3-25-2008, FILED 2-16-2007.

THE HONORABLE ORDER OF
KNIGHTS OF SAINT MICHAEL
THE ARCHANGEL ~ DAGGER SUB
ROSA ORDER OF MERIT

THE MARK CONSISTS OF STANDARD CHARACTERS WITHOUT CLAIM TO ANY PARTICULAR FONT, STYLE, SIZE, OR COLOR.

NO CLAIM IS MADE TO THE EXCLUSIVE RIGHT TO USE "HONORABLE ORDER" AND "ORDER OF MERIT", APART FROM THE MARK AS SHOWN.

CLASS 35—ADVERTISING AND BUSINESS

FOR CHARITABLE SERVICES, NAMELY, ORGANIZING AND CONDUCTING VOLUNTEER PROGRAMS AND COMMUNITY SERVICE PROJECTS; PROMOTING PUBLIC AWARENESS OF SAFETY AND COMMON DEFENSE ISSUES (U.S. CLS. 100, 101 AND 102).

FIRST USE 11-30-2008; IN COMMERCE 11-30-2008.

CLASS 36—INSURANCE AND FINANCIAL

FOR ACCEPTING AND ADMINISTERING MONETARY CHARITABLE CONTRIBUTIONS; CHARITABLE FUND RAISING; PROVIDING EDUCATIONAL SCHOLARSHIPS; PROVIDING GRANTS TO MISSIONARY GROUPS (U.S. CLS. 100, 101 AND 102).

FIRST USE 11-30-2008; IN COMMERCE 11-30-2008.

3,631,965. LIPZIPZ LLC, CENTERVILLE, UT. SN 77-111,162. PUB. 8-14-2007, FILED 2-20-2007.

Lipzipz

THE MARK CONSISTS OF STANDARD CHARACTERS WITHOUT CLAIM TO ANY PARTICULAR FONT, STYLE, SIZE, OR COLOR.

CLASS 3—COSMETICS AND CLEANING PREPARATIONS

FOR COSMETICS, NAMELY, LIP REPAIRERS; LIP BALM; LIP BALM; LIP CREAM; LIP GLOSS; NON-MEDICATED LIP CARE PREPARATIONS; NON-MEDICATED LIP PROTECTOR (U.S. CLS. 1, 4, 6, 50, 51 AND 52).

FIRST USE 11-1-2007; IN COMMERCE 11-1-2007.

CLASS 5—PHARMACEUTICALS

FOR MEDICATED LIP BALM (U.S. CLS. 6, 18, 44, 46, 51 AND 52).
FIRST USE 11-1-2007; IN COMMERCE 11-1-2007.

3,631,983. KGEN POWER CORPORATION, HOUSTON, TX.
SN 77-132,505. PUB. 11-27-2007, FILED 3-15-2007.

3,631,966. BARRY, HAMLET J., DENVER, CO. AND BARRY,
GAIL N., DENVER, CO. SN 77-112,721. PUB. 9-4-2007,
FILED 2-21-2007.

KGEN

THE MARK CONSISTS OF STANDARD CHARACTERS
WITHOUT CLAIM TO ANY PARTICULAR FONT, STYLE,
SIZE, OR COLOR.

MACAMANIA

THE MARK CONSISTS OF STANDARD CHARACTERS
WITHOUT CLAIM TO ANY PARTICULAR FONT, STYLE,
SIZE, OR COLOR.

CLASS 36—INSURANCE AND FINANCIAL

FOR BROKERAGE OF ELECTRICITY (U.S. CLS. 100,
101 AND 102).
FIRST USE 3-15-2009; IN COMMERCE 3-15-2009.

CLASS 29—MEATS AND PROCESSED FOODS

FOR NUT BUTTER; PROCESSED NUTS; DIPS; NUT
TOPPING (U.S. CL. 46).
FIRST USE 4-1-2009; IN COMMERCE 4-7-2009.

CLASS 40—MATERIAL TREATMENT

FOR GENERATION OF ELECTRICITY (U.S. CLS. 100,
103 AND 106).
FIRST USE 3-15-2009; IN COMMERCE 3-15-2009.

CLASS 30—STAPLE FOODS

FOR HONEY; SYRUP TOPPING; DESSERT SAUCE;
CANDY (U.S. CL. 46).
FIRST USE 4-1-2009; IN COMMERCE 4-7-2009.

3,631,984. MICROSOFT CORPORATION, REDMOND, WA.
SN 77-133,506. PUB. 9-2-2008, FILED 3-16-2007.

3,631,970. ILLUMINATED RESEARCH, ARLINGTON, TX.
SN 77-117,085. PUB. 7-8-2008, FILED 2-27-2007.

RESPONSE POINT

ILLUMINATED RESEARCH

THE MARK CONSISTS OF STANDARD CHARACTERS
WITHOUT CLAIM TO ANY PARTICULAR FONT, STYLE,
SIZE, OR COLOR.

NO CLAIM IS MADE TO THE EXCLUSIVE RIGHT TO
USE "RESEARCH", APART FROM THE MARK AS SHOWN.

THE MARK CONSISTS OF STANDARD CHARACTERS
WITHOUT CLAIM TO ANY PARTICULAR FONT, STYLE,
SIZE, OR COLOR.

PRIORITY CLAIMED UNDER SEC. 44(D) ON FED REP
GERMANY APPLICATION NO. 30712376.6, FILED 2-23-2007.

CLASS 41—EDUCATION AND ENTERTAINMENT

FOR WRITTEN TEXT EDITING INCLUDING MANU-
SCRIPTS, WHITE PAPERS, PRODUCT MONOGRAPHS,
ABSTRACTS, POSTER PRESENTATIONS, AND PROMO-
TIONAL SLIDE PACKETS (U.S. CLS. 100, 101 AND 107).
FIRST USE 1-29-2007; IN COMMERCE 3-2-2007.

CLASS 9—ELECTRICAL AND SCIENTIFIC APPARATUS

FOR AUTOMATIC TELEPHONE EXCHANGES; COM-
PUTER HARDWARE AND SOFTWARE FOR PROVID-
ING VOICE OVER IP SERVICES; COMPUTER
HARDWARE AND SOFTWARE FOR OPERATING,
MANAGING, AND PROVIDING AUTOMATED TELE-
PHONE ANSWERING AND MESSAGING SERVICES;
COMPUTER TELEPHONY SOFTWARE (U.S. CLS. 21,
23, 26, 36 AND 38).
FIRST USE 3-0-2007; IN COMMERCE 3-0-2007.

CLASS 42—SCIENTIFIC AND COMPUTER SERVICES

FOR TECHNICAL WRITING FOR OTHERS, NAMELY,
PROVIDING WRITING SUPPORT FOR PRE-APPROVAL
SUBMISSIONS TO REGULATORY AGENCIES OF DRUG
AND DEVICE DOSSIERS, TECHNICAL ADVICE AND
GUIDANCE ON CLINICAL DEVELOPMENT SOPs,
CLINICAL TRIAL DESIGN AND STUDY IMPLEMEN-
TATION AND CONDUCT (U.S. CLS. 100 AND 101).
FIRST USE 1-29-2007; IN COMMERCE 3-2-2007.

CLASS 38—COMMUNICATION

FOR TELECOMMUNICATIONS SERVICES, NAMELY,
VOICE OVER IP SERVICES; INTERNET TELEPHONY
SERVICES; PROVIDING TELECOMMUNICATIONS IN-
FORMATION IN THE FIELDS OF VOICE OVER IP
SERVICES AND AUTOMATED TELEPHONE ANSWER-
ING AND MESSAGING (U.S. CLS. 100, 101 AND 104).
FIRST USE 3-0-2007; IN COMMERCE 3-0-2007.

CLASS 42—SCIENTIFIC AND COMPUTER SERVICES

FOR TECHNICAL SUPPORT SERVICES, NAMELY, TROUBLESHOOTING OF COMPUTER HARDWARE AND SOFTWARE PROBLEMS AND MONITORING OF NETWORK SYSTEMS IN THE FIELDS OF TELECOMMUNICATIONS, VOICE OVER IP SERVICES AND AUTOMATED TELEPHONE ANSWERING AND MESSAGING; PROVIDING TECHNICAL INFORMATION IN THE FIELD OF COMPUTER SOFTWARE FOR USE WITH TELEPHONY, AUTOMATED TELEPHONE ANSWERING AND MESSAGING SERVICES, AND VOICE OVER IP (U.S. CLS. 100 AND 101).

FIRST USE 3-0-2007; IN COMMERCE 3-0-2007.

3,631,990. QUALCOMM INCORPORATED, SAN DIEGO, CA. SN 77-140,847. PUB. 7-8-2008, FILED 3-26-2007.



NO CLAIM IS MADE TO THE EXCLUSIVE RIGHT TO USE "TV", APART FROM THE MARK AS SHOWN.

THE MARK CONSISTS OF A STYLIZED IMAGE OF A TELEVISION SET.

CLASS 35—ADVERTISING AND BUSINESS

FOR DATA PROCESSING SERVICES; PREPARING AND PROCESSING DATA AND AUDIO-VISUAL DISPLAYS IN THE FIELD OF TELECOMMUNICATIONS, TRANSMITTED BY SATELLITE AND TERRESTRIAL COMMUNICATION SYSTEMS, NETWORK SYSTEMS, AND WIRELESS COMMUNICATIONS SYSTEMS (U.S. CLS. 100, 101 AND 102).

FIRST USE 1-31-2007; IN COMMERCE 1-31-2007.

CLASS 38—COMMUNICATION

FOR TELECOMMUNICATIONS SERVICES, NAMELY, ELECTRONIC TRANSMISSION AND RECEIVER SERVICES FOR DATA AND AUDIO-VISUAL DISPLAYS VIA COMPUTER TERMINALS AND WIRELESS COMMUNICATION DEVICES; SATELLITE AND TERRESTRIAL COMMUNICATION SERVICES; TEXT AND NUMERIC WIRELESS DIGITAL MESSAGING SERVICES; ONLINE DOCUMENT DELIVERY VIA A GLOBAL COMPUTER NETWORK (U.S. CLS. 100, 101 AND 104).

FIRST USE 1-31-2007; IN COMMERCE 1-31-2007.

CLASS 41—EDUCATION AND ENTERTAINMENT

FOR AUDIO-VISUAL PRODUCTION SERVICES (U.S. CLS. 100, 101 AND 107).

FIRST USE 1-31-2007; IN COMMERCE 1-31-2007.

3,632,000. YKK CORPORATION OF AMERICA, MARIETTA, GA. SN 77-154,071. PUB. 4-15-2008, FILED 4-11-2007.

QUALITY INSPIRES

THE MARK CONSISTS OF STANDARD CHARACTERS WITHOUT CLAIM TO ANY PARTICULAR FONT, STYLE, SIZE, OR COLOR.

NO CLAIM IS MADE TO THE EXCLUSIVE RIGHT TO

USE "QUALITY", APART FROM THE MARK AS SHOWN.

CLASS 6—METAL GOODS

FOR A FULL LINE OF METAL FENESTRATION AND ENTRANCEWAY ARCHITECTURAL COMPONENTS IN THE NATURE OF CONSTRUCTION ELEMENTS MADE PRIMARILY OF METAL, NAMELY, SUPPORTS, ENTRANCES, STOREFRONTS, WINDOW WALLS, CURTAIN WALLS, BALCONIES, WINDOWS AND DOORS; FRAMES, MULLIONS AND HARDWARE (U.S. CLS. 2, 12, 13, 14, 23, 25 AND 50).

FIRST USE 6-0-2007; IN COMMERCE 8-0-2007.

CLASS 19—NON-METALLIC BUILDING MATERIALS

FOR A FULL LINE OF NON-METAL FENESTRATION AND ENTRANCEWAY ARCHITECTURAL COMPONENTS IN THE NATURE OF CONSTRUCTION ELEMENTS NOT MADE OF METAL, NAMELY, SUPPORTS, FRAMES AND GLASS GLAZING (U.S. CLS. 1, 12, 33 AND 50).

FIRST USE 6-0-2007; IN COMMERCE 8-0-2007.

3,632,008. WHITE HOUSE TELEVISION PRODUCTION, L.L.C., SPRINGFIELD, MO. SN 77-159,694. PUB. 4-1-2008, FILED 4-18-2007.

WHITE HOUSE TELEVISION PRODUCTIONS

THE MARK CONSISTS OF STANDARD CHARACTERS WITHOUT CLAIM TO ANY PARTICULAR FONT, STYLE, SIZE, OR COLOR.

NO CLAIM IS MADE TO THE EXCLUSIVE RIGHT TO USE "TELEVISION PRODUCTIONS", APART FROM THE MARK AS SHOWN.

CLASS 38—COMMUNICATION

FOR TELEVISION BROADCASTING IN THE FIELD OF VARIETY SHOWS (U.S. CLS. 100, 101 AND 104).

FIRST USE 9-28-2007; IN COMMERCE 9-28-2007.

CLASS 41—EDUCATION AND ENTERTAINMENT

FOR ENTERTAINMENT SERVICES, NAMELY, TELEVISION PRODUCTION IN THE FIELD OF VARIETY SHOWS (U.S. CLS. 100, 101 AND 107).

FIRST USE 5-5-2007; IN COMMERCE 5-5-2007.

3,632,013. GUANGDONG BRIGHT STAR LIGHT & ELECTRICITY CO., LTD., FOSHAN, CHINA. SN 77-161,308. PUB. 9-23-2008, FILED 4-19-2007.

3,632,016. HARDWOOD MARKET REPORT, LP, MEMPHIS, TN. SN 77-163,155. PUB. 12-18-2007, FILED 4-23-2007.



THE MARK CONSISTS OF A CIRCLE AND A STYLIZED NUMBER 3.

CLASS 9—ELECTRICAL AND SCIENTIFIC APPARATUS

FOR CURRENT RECTIFIERS; LIGHTING BALLASTS; STAGE LIGHTING REGULATORS; MATERIALS FOR ELECTRICITY MAINS WIRES, NAMELY, ELECTRIC CABLES AND WIRES; ELECTRICITY CELL SWITCHES; DISCHARGE TUBES, ELECTRIC, OTHER THAN FOR LIGHTING; SEMI-CONDUCTOR DEVICE, NAMELY, ELECTRIC SEMI-CONDUCTORS, MICROPROCESSORS AND SEMI-CONDUCTORS, QUANTUM DOTS, NAMELY, CRYSTALLINE SEMI-CONDUCTOR MATERIAL, SEMI-CONDUCTOR MEMORIES, SEMI-CONDUCTOR MEMORY UNITS, SEMI-CONDUCTORS, STRUCTURED SEMI-CONDUCTOR WAFERS; MAGNETISM MATERIAL AND APPARATUS, NAMELY, MAGNETIC GYROCOMPASSES, SOLENOID VALVES, NAMELY, ELECTROMAGNETIC SWITCHES, MAGNETIC METERS AND TESTERS, DETECTORS FOR ELECTROMAGNETIC MEASUREMENT, MAGNETIC DISKS, MAGNETIC ENCODERS, MAGNETIC INVESTIGATION INSTRUMENT, NAMELY, MAGNETIC FINDERS, MAGNETIC DETECTORS, MAGNETIC TAPES, DEMAGNETIZING APPARATUS FOR MAGNETIC TAPES, MAGNETIC TAPE UNITS FOR COMPUTERS, MAGNETIC CREDIT CARDS; THERMIONIC LAMPS AND TUBES THEREFOR; PHOTOVOLTAIC CELLS (U.S. CLS. 21, 23, 26, 36 AND 38).

FIRST USE 9-15-2006; IN COMMERCE 1-8-2008.

CLASS 11—ENVIRONMENTAL CONTROL APPARATUS

FOR LIGHTING APPARATUS AND INSTALLATIONS, NAMELY, LAMPS, ENERGY SAVING LAMPS, ENERGY SAVING FLUORESCENT LAMPS, TORCHES FOR LIGHTING, HEADLIGHTS FOR AUTOMOBILES, LIGHTING APPARATUS FOR VEHICLES, LIGHTS FOR AUTOMOBILES, POCKET SEARCHLIGHTS, ELECTRIC POCKET TORCHES, ELECTRIC DISCHARGE TUBES FOR LIGHTING, GERMICIDAL LAMPS FOR PURIFYING AIR, ULTRAVIOLET RAY LAMPS, NOT FOR MEDICAL PURPOSES, STAGE LAMPS AND LANTERNS, FLUORESCENT BULBS, SEWAGE DISPOSAL PLANTS, STANDARD LAMPS; WATER PURIFICATION INSTALLATIONS FOR WASTE WATER AND SEWAGE CONSISTING OF CURTAINS AND TEXTILE FABRICS (U.S. CLS. 13, 21, 23, 31 AND 34).

FIRST USE 9-15-2006; IN COMMERCE 1-8-2008.

HMR

THE MARK CONSISTS OF STANDARD CHARACTERS WITHOUT CLAIM TO ANY PARTICULAR FONT, STYLE, SIZE, OR COLOR.

CLASS 16—PAPER GOODS AND PRINTED MATTER

FOR NEWSLETTERS IN THE FIELD OF LUMBER (U.S. CLS. 2, 5, 22, 23, 29, 37, 38 AND 50).

FIRST USE 9-30-2008; IN COMMERCE 9-30-2008.

CLASS 41—EDUCATION AND ENTERTAINMENT

FOR PROVIDING NEWSLETTERS IN THE FIELD OF LUMBER VIA THE INTERNET (U.S. CLS. 100, 101 AND 107).

FIRST USE 9-30-2008; IN COMMERCE 9-30-2008.

CLASS 42—SCIENTIFIC AND COMPUTER SERVICES

FOR COMPUTER SERVICES, NAMELY, PROVIDING SEARCH ENGINES FOR OBTAINING DATA VIA THE INTERNET (U.S. CLS. 100 AND 101).

FIRST USE 9-30-2008; IN COMMERCE 9-30-2008.

3,632,019. GREAT HARVEST FRANCHISING, INC., DILLON, MT. SN 77-164,857. PUB. 9-16-2008, FILED 4-25-2007.

GREAT HARVEST

THE MARK CONSISTS OF STANDARD CHARACTERS WITHOUT CLAIM TO ANY PARTICULAR FONT, STYLE, SIZE, OR COLOR.

OWNER OF U.S. REG. NOS. 2,318,706, 2,509,676, AND OTHERS.

CLASS 16—PAPER GOODS AND PRINTED MATTER

FOR PAPER, WRITING PENS, CARDS, NAMELY, GIFT CARDS, TISSUES PAPER FOR GIFT BAGS, PAPER NAME TAGS, PAPER GIFT TAGS, STATIONERY, ENVELOPES AND BUSINESS CARDS (U.S. CLS. 2, 5, 22, 23, 29, 37, 38 AND 50).

FIRST USE 5-30-1996; IN COMMERCE 5-30-1996.

CLASS 21—HOUSEWARES AND GLASS

FOR CUTTING BOARDS (U.S. CLS. 2, 13, 23, 29, 30, 33, 40 AND 50).

FIRST USE 9-1-1997; IN COMMERCE 9-1-1997.

CLASS 25—CLOTHING

FOR A FULL LINE OF CLOTHING (U.S. CLS. 22 AND 39).
FIRST USE 3-27-1996; IN COMMERCE 5-23-1996.

CLASS 29—MEATS AND PROCESSED FOODS

FOR JAMS AND JELLIES (U.S. CL. 46).
FIRST USE 10-14-1996; IN COMMERCE 10-14-1996.

CLASS 30—STAPLE FOODS

FOR BAKERY GOODS AND DELI SANDWICHES (U.S. CL. 46).
FIRST USE 1-25-1976; IN COMMERCE 3-15-1977.

CLASS 31—NATURAL AGRICULTURAL PRODUCTS

FOR RAW WHEAT (U.S. CLS. 1 AND 46).
FIRST USE 11-18-1996; IN COMMERCE 11-18-1996.

CLASS 35—ADVERTISING AND BUSINESS

FOR FRANCHISING SERVICES, NAMELY, OFFERING AND PROVIDING TECHNICAL ASSISTANCE IN THE ESTABLISHMENT AND OPERATION OF RETAIL BAKERIES AND RETAIL BAKERY SHOP SERVICE (U.S. CLS. 100, 101 AND 102).
FIRST USE 1-0-1984; IN COMMERCE 5-0-1984.

CLASS 40—MATERIAL TREATMENT

FOR MANUFACTURE OF BAKERY PRODUCTS TO ORDER AND/OR SPECIFICATION OF OTHERS (U.S. CLS. 100, 103 AND 106).
FIRST USE 1-25-1976; IN COMMERCE 3-15-1977.

CLASS 43—HOTEL AND RESTAURANT SERVICES

FOR RESTAURANT SERVICES (U.S. CLS. 100 AND 101).
FIRST USE 4-0-1976; IN COMMERCE 4-0-1976.

3,632,026. REPLAY SOLUTIONS, INC., REDWOOD CITY, CA. SN 77-167,019. PUB. 6-24-2008, FILED 4-26-2007.

REPLAY SOLUTIONS

THE MARK CONSISTS OF STANDARD CHARACTERS WITHOUT CLAIM TO ANY PARTICULAR FONT, STYLE, SIZE, OR COLOR.

NO CLAIM IS MADE TO THE EXCLUSIVE RIGHT TO USE "SOLUTIONS", APART FROM THE MARK AS SHOWN.

CLASS 9—ELECTRICAL AND SCIENTIFIC APPARATUS

FOR COMPUTER SOFTWARE FOR TESTING, TRANSFORMING, EVALUATING, AND DEVELOPING OTHER SOFTWARE APPLICATIONS (U.S. CLS. 21, 23, 26, 36 AND 38).
FIRST USE 4-22-2004; IN COMMERCE 4-22-2004.

CLASS 42—SCIENTIFIC AND COMPUTER SERVICES

FOR CONSULTING SERVICES FOR TESTING, TRANSFORMING, EVALUATING, AND DEVELOPING SOFTWARE APPLICATIONS (U.S. CLS. 100 AND 101).
FIRST USE 4-22-2004; IN COMMERCE 4-22-2004.

3,632,028. LINKPLACE LIMITED, TA OAKWOOD REMEDIES, HARROW HA2 0DH, UNITED KINGDOM. SN 77-172,895. PUB. 3-18-2008, FILED 5-4-2007.

NITTY GRITTY

THE MARK CONSISTS OF STANDARD CHARACTERS WITHOUT CLAIM TO ANY PARTICULAR FONT, STYLE, SIZE, OR COLOR.

CLASS 3—COSMETICS AND CLEANING PREPARATIONS

FOR BLEACHING PREPARATIONS FOR COSMETIC PURPOSES; SKIN ABRASIVE PREPARATIONS; SOAPS; PERFUMERY; ESSENTIAL OILS, COSMETICS, HAIR LOTIONS; DENTIFRICES; SHAMPOOS (U.S. CLS. 1, 4, 6, 50, 51 AND 52).
FIRST USE 7-0-1999; IN COMMERCE 7-13-2000.

CLASS 5—PHARMACEUTICALS

FOR PHARMACEUTICAL AND VETERINARY PREPARATIONS FOR THE TREATMENT OF HAIR LICE; SANITARY PREPARATIONS FOR MEDICAL PURPOSES; DIETETIC FOODS ADAPTED FOR MEDICAL USE; FOOD FOR BABIES; MEDICAL PLASTERS; DRESSINGS FOR WOUNDS, BURNS AND SURGERIES; MATERIAL FOR STOPPING TEETH, DENTAL WAX; PREPARATIONS FOR DESTROYING VERMIN; FUNGICIDES, HERBICIDES; PREPARATIONS FOR TREATING HEAD LICE IN HAIR (U.S. CLS. 6, 18, 44, 46, 51 AND 52).
FIRST USE 7-0-1999; IN COMMERCE 7-13-2000.

CLASS 21—HOUSEWARES AND GLASS

FOR HOUSEHOLD OR KITCHEN UTENSILS, NAMELY, GRATERS, SIEVES, SPATULAS, STRAINERS, GRILLS, ROLLING PINS; CONTAINERS FOR HOUSEHOLD AND KITCHEN USE; COMBS; BRUSHES FOR HAIR; BRUSH-MAKING MATERIALS FOR HAIR BRUSHES; UN-WORKED OR SEMI-WORKED GLASS; BEVERAGE GLASSWARE; PORCELAIN AND EARTHENWARE MUGS, FIGURES AND SCULPTURES (U.S. CLS. 2, 13, 23, 29, 30, 33, 40 AND 50).
FIRST USE 7-0-1999; IN COMMERCE 3-31-2004.

3,632,030. GLU MOBILE INC., SAN MATEO, CA. SN 77-175,674. PUB. 10-23-2007, FILED 5-8-2007.

SPACE MONKEY

THE MARK CONSISTS OF STANDARD CHARACTERS WITHOUT CLAIM TO ANY PARTICULAR FONT, STYLE,

SIZE, OR COLOR.

CLASS 9—ELECTRICAL AND SCIENTIFIC APPARATUS

FOR COMPUTER GAME SOFTWARE; COMPUTER SCREEN SAVER SOFTWARE; ELECTRONIC GAME SOFTWARE; ELECTRONIC GAME SOFTWARE FOR CELLULAR TELEPHONES; ELECTRONIC GAME SOFTWARE FOR HANDHELD ELECTRONIC DEVICES; ELECTRONIC GAME SOFTWARE FOR WIRELESS DEVICES (U.S. CLS. 21, 23, 26, 36 AND 38).
FIRST USE 2-0-2008; IN COMMERCE 2-0-2008.

CLASS 41—EDUCATION AND ENTERTAINMENT

FOR ENTERTAINMENT SERVICES, NAMELY, PROVIDING ON-LINE COMPUTER GAMES; MULTIMEDIA PUBLISHING OF GAMES; PROVIDING A COMPUTER GAME THAT MAY BE ACCESSED NETWORK-WIDE BY NETWORK USERS; PROVIDING INFORMATION ON-LINE RELATING TO COMPUTER GAMES AND COMPUTER ENHANCEMENTS FOR GAMES (U.S. CLS. 100, 101 AND 107).
FIRST USE 2-0-2008; IN COMMERCE 2-0-2008.

3,632,035. RHEON AUTOMATIC MACHINERY CO., LTD., UTSUNOMIYA CITY, JAPAN. SN 77-178,574. PUB. 4-1-2008, FILED 5-11-2007.

RHEON CAFE

THE MARK CONSISTS OF STANDARD CHARACTERS WITHOUT CLAIM TO ANY PARTICULAR FONT, STYLE, SIZE, OR COLOR.

NO CLAIM IS MADE TO THE EXCLUSIVE RIGHT TO USE "CAFE", APART FROM THE MARK AS SHOWN.

CLASS 30—STAPLE FOODS

FOR CONFECTIONERY PRODUCTS, NAMELY, FROZEN CONFECTIONS, CAKES, COOKIES, BAKERY PRODUCTS, BAKERY GOODS, AND BAKERY DESSERTS; BREAD AND BUNS (U.S. CL. 46).
FIRST USE 12-5-2007; IN COMMERCE 12-5-2007.

CLASS 43—HOTEL AND RESTAURANT SERVICES

FOR RESTAURANT AND CAFE SERVICES (U.S. CLS. 100 AND 101).
FIRST USE 12-5-2007; IN COMMERCE 12-5-2007.

3,632,041. CHASE ERGONOMICS INC., ALBUQUERQUE, NM. SN 77-189,869. PUB. 7-22-2008, FILED 5-24-2007.

GFÔM

THE MARK CONSISTS OF STANDARD CHARACTERS

WITHOUT CLAIM TO ANY PARTICULAR FONT, STYLE, SIZE, OR COLOR.

CLASS 9—ELECTRICAL AND SCIENTIFIC APPARATUS

FOR COMPOSITE ANTI-VIBRATION PADDING SOLD AS AN INTEGRAL COMPONENT OF SAFETY GLOVES (U.S. CLS. 21, 23, 26, 36 AND 38).
FIRST USE 7-9-2007; IN COMMERCE 1-2-2008.

CLASS 17—RUBBER GOODS

FOR LAYERED COMPOSITE PADDING OF POLYURETHANE FOAM AND PLASTISOL FOR USE IN THE MANUFACTURE OF INSULATORS FOR TOOL HANDLES, SAFETY GLOVES, AND SPORTS EQUIPMENT, NAMELY, GLOVES, BATS, RACQUETS AND FISHING POLES (U.S. CLS. 1, 5, 12, 13, 35 AND 50).
FIRST USE 7-9-2007; IN COMMERCE 1-2-2008.

CLASS 28—TOYS AND SPORTING GOODS

FOR COMPOSITE ANTI-VIBRATION PADDING SOLD AS AN INTEGRAL COMPONENT OF SPORTS EQUIPMENT, NAMELY, GLOVES, BATS, RACQUETS AND FISHING POLES (U.S. CLS. 22, 23, 38 AND 50).
FIRST USE 7-9-2007; IN COMMERCE 1-2-2008.

3,632,043. MERKLE INTERNATIONAL, INC., GALENA, IL. SN 77-191,715. PUB. 11-18-2008, FILED 5-29-2007.

MERKLE INTERNATIONAL

THE MARK CONSISTS OF STANDARD CHARACTERS WITHOUT CLAIM TO ANY PARTICULAR FONT, STYLE, SIZE, OR COLOR.

OWNER OF U.S. REG. NO. 1,550,738.

NO CLAIM IS MADE TO THE EXCLUSIVE RIGHT TO USE "INTERNATIONAL", APART FROM THE MARK AS SHOWN.

SEC. 2(F) AS TO "MERKLE".

CLASS 7—MACHINERY

FOR MACHINES, NAMELY, BATCH CHARGING MACHINES FOR USE IN THE GLASS INDUSTRY, CHARGING MACHINERY USED TO FEED MATERIALS TO A FURNACE (U.S. CLS. 13, 19, 21, 23, 31, 34 AND 35).
FIRST USE 3-26-2009; IN COMMERCE 3-26-2009.

CLASS 11—ENVIRONMENTAL CONTROL APPARATUS

FOR SHAPED FURNACE REFRACTORIES AND FURNACE REFRACTORY HANGERS; METALLIC HOLDERS AS STRUCTURAL COMPONENTS FOR FURNACES; METALLIC HOLDERS AND OTHER STRUCTURAL COMPONENTS FOR HIGH TEMPERATURE FURNACES (U.S. CLS. 13, 21, 23, 31 AND 34).
FIRST USE 3-26-2009; IN COMMERCE 3-26-2009.

CLASS 19—NON-METALLIC BUILDING MATERIALS

FOR NON-METAL BUILDING MATERIALS, NAMELY, REFRACTORY BRICKS AND REFRACTORY STRUCTURES, SUSPENDED REFRACTORY WALLS AND ROOFS, FURNACE LININGS; UNIT ASSEMBLIES OF REFRACTORY BRICKS WITH HANGER ASSEMBLIES AND FRAMES FOR USE IN HIGH TEMPERATURE INDUSTRIAL FURNACE ROOFS (U.S. CLS. 1, 12, 33 AND 50).

FIRST USE 3-26-2009; IN COMMERCE 3-26-2009.

CLASS 42—SCIENTIFIC AND COMPUTER SERVICES

FOR ENGINEERING AND DESIGN OF MACHINERY, FURNACES, REFRACTORIES, AND REFRACTORY STRUCTURES INCLUDING SUSPENDED REFRACTORY WALLS AND ROOFS, SUCH AS RELATED TO THE GLASS INDUSTRY (U.S. CLS. 100 AND 101).

FIRST USE 12-5-2007; IN COMMERCE 3-26-2009.

CLASS 42—SCIENTIFIC AND COMPUTER SERVICES

FOR ENGINEERING AND DESIGN OF MACHINERY, FURNACES, REFRACTORIES, AND REFRACTORY STRUCTURES, NAMELY, SUSPENDED REFRACTORY WALLS AND ROOFS, SUCH AS RELATED TO THE GLASS INDUSTRY (U.S. CLS. 100 AND 101).

FIRST USE 12-5-2007; IN COMMERCE 3-26-2009.

3,632,049. DAPTIV, INC., SEATTLE, WA. SN 77-193,477. PUB. 12-18-2007, FILED 5-30-2007.

3,632,044. MERKLE INTERNATIONAL, INC., GALENA, IL. SN 77-191,784. PUB. 9-23-2008, FILED 5-29-2007.



THE MARK CONSISTS OF A STYLIZED LETTER "M".

CLASS 7—MACHINERY

FOR MACHINES, NAMELY, BATCH CHARGING MACHINES FOR USE IN THE GLASS INDUSTRY, CHARGING MACHINERY USED TO FEED MATERIALS TO A FURNACE (U.S. CLS. 13, 19, 21, 23, 31, 34 AND 35).

FIRST USE 3-26-2009; IN COMMERCE 3-26-2009.

CLASS 11—ENVIRONMENTAL CONTROL APPARATUS

FOR SHAPED FURNACE REFRACTORIES AND FURNACE REFRACTORY HANGERS; METALLIC HOLDERS AS STRUCTURAL COMPONENTS FOR FURNACES; METALLIC HOLDERS AND OTHER STRUCTURAL COMPONENTS FOR HIGH TEMPERATURE FURNACES (U.S. CLS. 13, 21, 23, 31 AND 34).

FIRST USE 3-26-2009; IN COMMERCE 3-26-2009.

CLASS 19—NON-METALLIC BUILDING MATERIALS

FOR NON-METAL BUILDING MATERIALS, NAMELY, REFRACTORY BRICKS AND REFRACTORY STRUCTURES, SUSPENDED REFRACTORY WALLS AND ROOFS, FURNACE LININGS; UNIT ASSEMBLIES OF REFRACTORY BRICKS WITH HANGER ASSEMBLIES AND FRAMES FOR USE IN HIGH TEMPERATURE INDUSTRIAL FURNACE ROOFS (U.S. CLS. 1, 12, 33 AND 50).

FIRST USE 3-26-2009; IN COMMERCE 3-26-2009.

DAPTIV

THE MARK CONSISTS OF STANDARD CHARACTERS WITHOUT CLAIM TO ANY PARTICULAR FONT, STYLE, SIZE, OR COLOR.

CLASS 9—ELECTRICAL AND SCIENTIFIC APPARATUS

FOR COMPUTER SOFTWARE FOR PROJECT MANAGEMENT; COMPUTER SOFTWARE FOR BUSINESS, PROJECT AND PERSONNEL PRODUCTIVITY MANAGEMENT; ENTERPRISE RESOURCE MANAGEMENT SOFTWARE; SOFTWARE DEVELOPMENT TOOLS; COMPUTER SOFTWARE PLATFORMS FOR DEVELOPING A WIDE VARIETY OF SOFTWARE APPLICATIONS; COMPUTER SOFTWARE FOR USE IN CUSTOMER SERVICE, HELP DESK AND TROUBLE TICKETING MANAGEMENT; COMPUTER SOFTWARE FOR USE IN EXPENSE MANAGEMENT AND TRACKING; COMPUTER SOFTWARE FOR USE IN PRODUCT RESEARCH AND DEVELOPMENT; COMPUTER SOFTWARE FOR TRANSMITTING INFORMATION OVER A GLOBAL ELECTRONIC AND OPTICAL COMMUNICATIONS NETWORK; COMPUTER SOFTWARE FOR COMPUTER SYSTEM AND APPLICATION DEVELOPMENT, DEPLOYMENT AND MANAGEMENT; COMPUTER SOFTWARE FOR INFORMATION TECHNOLOGY MANAGEMENT (U.S. CLS. 21, 23, 26, 36 AND 38).

FIRST USE 11-1-2007; IN COMMERCE 11-1-2007.

CLASS 38—COMMUNICATION

FOR PROVIDING ELECTRONIC BULLETIN BOARDS AND MESSAGE BOARDS AMONG USERS FOR TRANSMISSION OF A WIDE RANGE OF INFORMATION FOR GENERAL INTEREST (U.S. CLS. 100, 101 AND 104).

FIRST USE 11-1-2007; IN COMMERCE 11-1-2007.

CLASS 42—SCIENTIFIC AND COMPUTER SERVICES

FOR PROVIDING TEMPORARY USE OF ON-LINE NON DOWNLOADABLE SOFTWARE FOR PROJECT MANAGEMENT; PROVIDING TEMPORARY USE OF ON-LINE NON DOWNLOADABLE SOFTWARE FOR BUSINESS, PROJECT AND PERSONNEL PRODUCTIVITY MANAGEMENT; PROVIDING TEMPORARY USE OF ON-LINE NON DOWNLOADABLE ENTERPRISE RESOURCE MANAGEMENT SOFTWARE; COMPUTER CONSULTATION SERVICES, NAMELY, TECHNICAL CONSULTING SERVICES IN THE FIELDS OF BUSINESS, PROJECT AND PERSONNEL PRODUCTIVITY MANAGEMENT; CONSULTING SERVICES IN THE FIELD OF DESIGN, SELECTION, IMPLEMENTATION AND USE OF COMPUTER HARDWARE AND SOFTWARE SYSTEMS FOR OTHERS; COMPUTER SOFTWARE DEVELOPMENT, NAMELY, DESIGN AND IMPLEMENTATION OF SECURE ELECTRONIC NETWORKS FOR TRANSMISSION OF CONFIDENTIAL INFORMATION; COMPUTER PROJECT MANAGEMENT SERVICES; INSTALLATION OF COMPUTER SOFTWARE; PROVIDING TEMPORARY USE OF ON-LINE NON DOWNLOADABLE SOFTWARE AND SOFTWARE TOOLS FOR SOFTWARE DEVELOPMENT BY OTHERS; PROVIDING TEMPORARY USE OF ON-LINE NON DOWNLOADABLE SOFTWARE FOR USE IN CUSTOMER SERVICE, HELP DESK AND TROUBLE TICKETING MANAGEMENT; PROVIDING TEMPORARY USE OF ON-LINE NON DOWNLOADABLE SOFTWARE FOR TRANSMITTING INFORMATION OVER A GLOBAL ELECTRONIC AND OPTICAL COMMUNICATIONS NETWORK; PROVIDING TEMPORARY USE ON-LINE OF NON DOWNLOADABLE COMPUTER SOFTWARE FOR USE IN PRODUCT RESEARCH AND DEVELOPMENT; PROVIDING TEMPORARY USE OF ON-LINE NON DOWNLOADABLE COMPUTER SOFTWARE FOR INFORMATION TECHNOLOGY MANAGEMENT; APPLICATION SERVICE PROVIDER, NAMELY, PROVIDING, HOSTING, MANAGING, DEVELOPING, AND MAINTAINING APPLICATIONS, SOFTWARE, WEBSITES, AND DATABASES IN THE FIELDS OF PERSONAL PRODUCTIVITY, WIRELESS COMMUNICATION, MOBILE INFORMATION ACCESS, AND REMOTE DATA MANAGEMENT (U.S. CLS. 100 AND 101).

FIRST USE 11-1-2007; IN COMMERCE 11-1-2007.

3,632,052. SANKO HOLDING ANONIM SIRKETI, SEHIT-KAMIL-GAZIANTEP, TURKEY. SN 77-194,895. PUB. 7-1-2008, FILED 5-31-2007.

ZEUGMA

THE MARK CONSISTS OF STANDARD CHARACTERS WITHOUT CLAIM TO ANY PARTICULAR FONT, STYLE, SIZE, OR COLOR.

THE WORDING "ZEUGMA" HAS NO MEANING IN A FOREIGN LANGUAGE.

CLASS 25—CLOTHING

FOR CLOTHING, NAMELY, TROUSERS, JACKETS, OVERCOATS, COATS, SKIRTS, SUITS, JERSEYS, WAISTCOATS, SHIRTS, T-SHIRTS, SWEATSHIRTS, DRESSES, BLOUSONS, PULLOVERS, UNDERWEAR, TRACKSUITS, RAINWEAR, SWIMWEAR, SHIRTS, PULLOVERS, KNITWEAR, NAMELY, KNIT SHIRTS, KNIT SWEATERS, KNIT SHORTS, KNITTED CAPS, KNITTED UNDERWEAR, JEANS WEAR, NAMELY, JEANS, JEAN SHORTS, JEAN SHIRTS, JEAN JACKETS, JEAN CAPS, SPORTS SHORTS, NAMELY, SHORTS, SWEAT SHORTS, WALKING SHORTS, RUGBY SHORTS, TENNIS SHORTS, GYM SHORTS, CLOTHING BELTS, SWIM CAPS, SHORTS, GLOVES, CAPS, SOCKS, STOCKINGS; SHOES, BOOTS, SANDALS, AND SLIPPERS, FOOTWEAR FOR SPORTS, NAMELY, GOLF, FOOTBALL AND SOCCER CLEATS, TENNIS SHOES, BOXING SHOES, RUNNING SHOES, BASEBALL SHOES, BOWLING SHOES, RUGBY SHOES (U.S. CLS. 22 AND 39).

FIRST USE 3-18-2009; IN COMMERCE 3-18-2009.

CLASS 27—FLOOR COVERINGS

FOR CARPETS, RUGS, MATS AND MATTING, LINOLEUM FOR COVERING EXISTING FLOORS; MATERIAL FOR COVERING EXISTING FLOORS, NAMELY, RUBBER BATH MATS, RUBBER DOOR MATS, CORK FOR USE AS AFLOOR COVERING, CORK MATS, VINYL FLOOR COVERINGS, TEXTILE FLOOR MATS FOR USE IN THE HOME; NON-TEXTILE WALL HANGINGS (U.S. CLS. 19, 20, 37, 42 AND 50).

FIRST USE 3-18-2009; IN COMMERCE 3-18-2009.

CLASS 29—MEATS AND PROCESSED FOODS

FOR MEAT, FISH, POULTRY, GAME, MEAT EXTRACTS, BROTH, BOUILLON, SHELLFISH, NAMELY, SHRIMP, LOBSTER, CLAMS, PROCESSED MEAT, FROZEN MEAT, DRIED MEAT, FRIED MEAT, MEAT JELLIES, MEAT JUICES; CANNED, DRIED, PRESERVED AND PROCESSED FRUITS AND VEGETABLES, NAMELY, PEACHES, APRICOTS, BEANS; INSTANT AND PRE-COOKED SOUPS; FROZEN, PREPARED AND PACKAGED MEALS CONSISTING PRIMARILY OF MEAT, FISH, POULTRY OR VEGETABLES, TOMATO PASTE, PRESERVED OR PROCESSED BEANS, CHICKPEAS, LENTIL, SOY BEANS, GROUND ALMONDS, PROCESSED OLIVES, PICKLES, RAISINS, PREPARED WALNUTS, OLIVE OIL, SUNFLOWER OIL, SESAME OIL; MILK AND MILK PRODUCTS, NAMELY, MILK, CHEESE, YOGURT, AYRAN YOGURT BASED DRINKS, CREAM, MILK POWDER, MILK BASED BEVERAGES CONTAINING FRUITS, EDIBLE OILS AND FATS, BUTTER, MARGARINE, JAMS, MARMALADES, EGGS, FRUIT JELLIES, UNFLAVORED AND UNSWEETENED GELATINS; PROCESSED AND ROASTED NUTS, PROTEINS FOR USE AS FOOD ADDITIVES, PROCESSED BEE POLLEN FOR FOOD PURPOSES, POTATO CHIPS, POTATO CRISPS, POTATO FRITTERS (U.S. CL. 46).

FIRST USE 3-18-2009; IN COMMERCE 3-18-2009.

CLASS 30—STAPLE FOODS

FOR COFFEE, COCOA, ARTIFICIAL COFFEE, VEGETABLE PREPARATIONS FOR USE AS COFFEE SUBSTITUTES, COCOA-BASED BEVERAGES, COFFEE-BASED BEVERAGES; TAPIOCA, SAGO, MACARONI, RAVIOLI, BAKERY PRODUCTS, NAMELY, SWEET BAKERY GOODS; PASTRIES, FLOUR FOR FOOD, FLOUR BASED PRODUCTS; NAMELY, CHIPS, PASTA; DOUGH PRODUCTS, NAMELY, PIZZA DOUGH, CAKE DOUGH, BREAD DOUGH, BISCUITS; WAFFLES, CRACKERS, TARTS, CAKES, BREAD, PIZZAS, SANDWICHES; PUDDINGS, READY CAKE MIXES, BAKING POWDERS, CHOCOLATE FOOD BEVERAGES NOT

BEING DAIRY-BASED OR VEGETABLE BASED, HONEY, ROYAL JELLY FOR HUMAN CONSUMPTION, PROPOLIS FOR HUMAN CONSUMPTION, TURKISH DELIGHT CANDY, HALVAH, FLOUR, SUGAR, MALT FOR FOOD, CHEWING GUMS NOT FOR MEDICAL PURPOSES; ICE CREAM, ICE, EDIBLE FRUIT ICES, SORBETS, SALT; RICE; TEA; KETCHUPS, MAYONNAISES, MUSTARDS, FLAVORINGS OF LEMONS, SAUCES, SALAD DRESSINGS, SPICES, NAMELY, PEPPER, GINGER, CINNAMON POWDER; SNACKS MADE OF CEREALS, NAMELY, CORN FLAKES, OATMEAL (U.S. CL. 46).

FIRST USE 3-18-2009; IN COMMERCE 3-18-2009.

3,632,054. PANTONE, INC., CARLSTADT, NJ. SN 77-196,560. PUB. 12-11-2007, FILED 6-4-2007.

PANTONE GOE

THE MARK CONSISTS OF STANDARD CHARACTERS WITHOUT CLAIM TO ANY PARTICULAR FONT, STYLE, SIZE, OR COLOR.

OWNER OF U.S. REG. NOS. 2,029,439, 3,155,095, AND OTHERS.

CLASS 16—PAPER GOODS AND PRINTED MATTER

FOR PRINTED MATTER DISPLAYING COLOR FOR USE IN THE FIELD OF COLOR SELECTION AND REPRODUCTION, NAMELY, BULLETINS, CATALOGS, BOOKS, FAN DECKS, NON-ADHESIVE AND SELF-ADHESIVE SWATCHES; AND PRINTED CARDS FOR APPLICATION OF SELF-ADHESIVE COLOR SWATCHES (U.S. CLS. 2, 5, 22, 23, 29, 37, 38 AND 50).

FIRST USE 9-5-2007; IN COMMERCE 9-5-2007.

CLASS 42—SCIENTIFIC AND COMPUTER SERVICES

FOR DEVELOPING CUSTOMIZED STANDARDS TO ASSURE COLOR CONSISTENCY AND ACCURACY IN THE REPRODUCTION AND SPECIFICATION OF COLORS; SPECIFYING AND VERIFYING COLOR AS USED BY PRINTERS AND GRAPHIC ARTISTS IN MANY AREAS OF DESIGN, NAMELY, GRAPHIC DESIGN, WEB DESIGN, INDUSTRIAL DESIGN, ARCHITECTURE AND INTERIOR DESIGN, COSMETICS AND FASHION DESIGN; PROVIDING INFORMATION IN THE FIELD OF COLOR REPRODUCTION TECHNOLOGY, DIGITAL WORKFLOW, COLOR CONSISTENCY IN WORKFLOW AND PRODUCT INTERFACE (U.S. CLS. 100 AND 101).

FIRST USE 9-5-2007; IN COMMERCE 9-5-2007.

3,632,070. HIGHMOUNT EXPLORATION & PRODUCTION HOLDING CORP., NEW YORK, NY. SN 77-209,064. PUB. 12-4-2007, FILED 6-18-2007.

HIGHMOUNT EXPLORATION & PRODUCTION CORP.

THE MARK CONSISTS OF STANDARD CHARACTERS WITHOUT CLAIM TO ANY PARTICULAR FONT, STYLE,

SIZE, OR COLOR.

NO CLAIM IS MADE TO THE EXCLUSIVE RIGHT TO USE "EXPLORATION & PRODUCTION CORP.", APART FROM THE MARK AS SHOWN.

CLASS 37—CONSTRUCTION AND REPAIR

FOR OIL AND GAS DRILLING, PUMPING AND EXTRACTION (U.S. CLS. 100, 103 AND 106).

FIRST USE 8-0-2007; IN COMMERCE 8-0-2007.

CLASS 40—MATERIAL TREATMENT

FOR OIL AND GAS PRODUCTION (U.S. CLS. 100, 103 AND 106).

FIRST USE 8-0-2007; IN COMMERCE 8-0-2007.

CLASS 42—SCIENTIFIC AND COMPUTER SERVICES

FOR OIL AND GAS EXPLORATION (U.S. CLS. 100 AND 101).

FIRST USE 8-0-2007; IN COMMERCE 8-0-2007.

3,632,082. ANAZAOHEALTH CORPORATION, TAMPA, FL. SN 77-217,246. PUB. 12-4-2007, FILED 6-27-2007.

Zao

THE MARK CONSISTS OF STANDARD CHARACTERS WITHOUT CLAIM TO ANY PARTICULAR FONT, STYLE, SIZE, OR COLOR.

THE FOREIGN WORDING IN THE MARK TRANSLATES INTO ENGLISH AS LIVE OR TO LIVE.

CLASS 3—COSMETICS AND CLEANING PREPARATIONS

FOR AFTER SUN CREAMS; AFTER-SUN LOTIONS; AGE RETARDANT GEL; AGE RETARDANT LOTION; AGE SPOT REDUCING CREAMS; ANTI-AGING CREAM; ANTI-FRECKLE CREAMS; ANTI-WRINKLE CREAM; ANTI-WRINKLE CREAMS; AROMATHERAPY CREAMS; AROMATHERAPY LOTIONS; ASTRINGENTS FOR COSMETIC PURPOSES; BEAUTY CREAMS; BEAUTY CREAMS FOR BODY CARE; BEAUTY GELS; BEAUTY LOTIONS; BEAUTY MASKS; BEAUTY MILKS; BEAUTY SERUMS; BLEACHING PREPARATIONS FOR COSMETIC PURPOSES; BODY AND BEAUTY CARE COSMETICS; BODY CREAM; BODY CREAM SOAP; BODY CREAMS; BODY LOTION; BODY LOTIONS; BODY MASK CREAM; BODY MASK LOTION; CLEANSING CREAMS; COLD CREAM; COLD CREAMS; COLORING PREPARATIONS FOR COSMETIC PURPOSES; COSMETIC CREAMS; COSMETIC CREAMS FOR SKIN CARE; COSMETIC OILS FOR THE EPIDERMIS; COSMETIC PREPARATIONS FOR BODY CARE; COSMETIC PREPARATIONS FOR SKIN RENEWAL; COSMETICS; COSMETICS, NAMELY, LIP REPAIRERS; CREAM SOAPS; CREAMS FOR CELLULITE REDUCTION; EXFOLIANT CREAMS; FACE AND BODY BEAUTY CREAMS; FACE AND BODY CREAMS; FACE AND BODY LOTIONS; FACE CREAMS; FACE CREAMS FOR COSMETIC USE; FACIAL CLEANSERS; FACIAL CLEANSING MILK; FACIAL CREAM; FACIAL CREAMS; FACIAL EMULSIONS; FACIAL LOTION; FACIAL MASKS; FACIAL SCRUBS; FACIAL WASHES; FAIR COMPLEXION CREAM; FOAM CLEANING PREPARATIONS; GEL EYE MASKS; LIQUID SOAP; LIQUID SOAPS; LIQUID SOAPS FOR HANDS AND FACE; LIQUID SOAPS FOR HANDS, FACE AND BODY; LOTIONS FOR CELLULITE REDUCTION; LOTIONS FOR FACE AND BODY CARE; NON-MEDICATED ACNE TREATMENT PREPARATIONS; NON-MEDICATED LIP CARE PREPARATIONS; NON-MEDICATED LIP PROTECTOR; NON-MEDICATED OINTMENTS FOR THE PREVENTION AND TREATMENT OF SUNBURN; NON-MEDICATED SKIN CARE PREPARATIONS; NON-MEDICATED SKIN CREAMS; NON-MEDICATED STIMULATING LOTIONS FOR THE SKIN; NUTRITIONAL OILS FOR COSMETIC PURPOSES; RETINOL CREAM FOR COSMETIC PURPOSES; SKIN AND BODY TOPICAL LOTIONS, CREAMS AND OILS FOR COSMETIC USE; SKIN CARE PREPARATIONS, NAMELY, CHEMICAL PEELS FOR SKIN; SKIN CARE PREPARATIONS, NAMELY, FRUIT ACID PEELS FOR SKIN; SKIN CARE PRODUCTS, NAMELY, NON-MEDICATED SKIN SERUM; SKIN CLARIFIERS; SKIN CLEANSERS; SKIN CLEANSING CREAM; SKIN CLEANSING LOTION; SKIN CONDITIONERS; SKIN CREAM; SKIN CREAMS; SKIN CREAMS IN LIQUID AND IN SOLID FORM; SKIN CREAMS IN LIQUID AND SOLID; SKIN CREAMS IN LIQUID AND SOLID FORM; SKIN EMOLLIENTS; SKIN GELS FOR ACCELERATING, ENHANCING OR EXTENDING TANS; SKIN LIGHTENERS; SKIN LIGHTENING CREAMS; SKIN LOTION; SKIN LOTIONS; SKIN MASKS; SKIN MOISTURIZER; SKIN MOISTURIZER MASKS; SKIN SOAP; SKIN TEXTURIZERS; SKIN TONERS; SKIN WHITENING CREAMS; SKIN WHITENING PREPARATIONS; SOAP POWDER; SOAPS FOR BODY CARE; TONING LOTION, FOR THE FACE, BODY AND HANDS; VANISHING CREAM; WRINKLE REMOVING SKIN CARE PREPARATIONS; WRINKLE RESISTANT CREAM; LIP CREAM (U.S. CLS. 1, 4, 6, 50, 51 AND 52).
FIRST USE 8-8-2007; IN COMMERCE 8-8-2007.

CLASS 5—PHARMACEUTICALS

FOR ACNE MEDICATIONS; ACNE TREATMENT PREPARATIONS; ADRENAL HORMONE PREPARATIONS; ANALGESIC BALM; ANESTHETICS FOR NON-SURGICAL USE; APPETITE SUPPRESSANTS; ASTRINGENTS; ASTRINGENTS FOR MEDICINAL PURPOSES; BIOLOGICAL PREPARATIONS FOR MEDICAL PURPOSES; BIOMEDICAL COMPOUNDS, NAMELY, PEPTIDE SUBSTRATES USED IN ANALYZING AND DETECTING CERTAIN TOXINS FOR CLINICAL OR MEDICAL LABORATORY USE; CALCIUM SUPPLEMENTS; DERMATOLOGICAL PHARMACEUTICAL PRODUCTS; DERMATOLOGICALS; DIET CAPSULES; DIETARY AND NUTRITIONAL SUPPLEMENTS; DIETARY SUPPLEMENTS; DIETARY SUPPLEMENTS FOR HUMAN CONSUMPTION; DRUG DELIVERY AGENTS CONSIST-

ING OF COMPOUNDS THAT FACILITATE DELIVERY OF A WIDE RANGE OF PHARMACEUTICALS; GELS FOR USE AS PERSONAL LUBRICANT; GENERAL ANESTHETICS; GROUND FLAXSEED FIBER FOR USE AS A DIETARY SUPPLEMENT; HAIR GROWTH STIMULANTS; HERBAL SUPPLEMENTS; HORMONES; HORMONES FOR MEDICAL PURPOSES; HUMAN GROWTH HORMONE; LOCAL ANESTHETICS; MEDICAL LUBRICANT, NAMELY, VAGINAL LUBRICANTS; MEDICATED LIP BALM; MEDICATED SKIN CARE PREPARATIONS; MEDICATED SUN CARE PREPARATIONS; MEDICINAL CREAMS FOR SKIN CARE; MEDICINAL HERB EXTRACTS; MEDICINAL HERBAL EXTRACTS FOR MEDICAL PURPOSES; NUTRACEUTICALS FOR USE AS A DIETARY SUPPLEMENT; NUTRITIONAL ADDITIVES FOR MEDICAL PURPOSES FOR USE IN FOODS AND DIETARY SUPPLEMENTS FOR HUMAN CONSUMPTION; NUTRITIONAL SUPPLEMENTS IN LOTION FORM SOLD AS A COMPONENT OF NUTRITIONAL SKIN CARE PRODUCTS; ORGASM CREAMS; PARAPHARMACEUTICAL PRODUCTS FOR USE IN DERMATOLOGY; PHARMACEUTICAL FOR THE TREATMENT OF ERECTILE DYSFUNCTION; PHARMACEUTICAL PREPARATIONS FOR THE TREATMENT OF HORMONAL DISORDERS AND THE PREVENTION OF OSTEOPOROSIS; PHARMACEUTICAL PREPARATIONS FOR TREATING SKIN DISORDERS; PHARMACEUTICAL PREPARATIONS FOR USE IN DERMATOLOGY; PHARMACEUTICAL PREPARATIONS FOR USE IN UROLOGY; PHARMACEUTICAL PREPARATIONS, NAMELY, APPETITE SUPPRESSANTS; PHARMACEUTICAL PRODUCTS AND PREPARATIONS TO PREVENT STRETCH MARKS; PHARMACEUTICAL SKIN LOTIONS; PHARMACEUTICALS, NAMELY, INDUCERS OF ERECTIONS; PLANT EXTRACTS FOR MEDICAL, VETERINARY AND PHARMACEUTICAL PURPOSES; PREPARATIONS FOR CLEANSING THE SKIN FOR MEDICAL USE; PRODUCTS AND PREPARATIONS FOR CLEANSING THE SKIN FOR MEDICAL USE; TOPICAL ANALGESICS; TOPICAL ANESTHETICS; VITAMIN AND MINERAL PREPARATIONS FOR MEDICAL USE; VITAMIN AND MINERAL PREPARATIONS FOR USE AS INGREDIENTS IN THE FOOD AND PHARMACEUTICAL INDUSTRY; WITCH HAZEL; MULTI-VITAMIN PREPARATIONS; VITAMIN B PREPARATIONS; VITAMIN C PREPARATIONS; VITAMIN D PREPARATIONS; VITAMIN AND MINERAL SUPPLEMENTS; VITAMIN SUPPLEMENTS; VITAMIN TABLETS; VITAMINS (U.S. CLS. 6, 18, 44, 46, 51 AND 52).
FIRST USE 8-8-2007; IN COMMERCE 8-8-2007.

3,632,092. LULA LU, LLC, SAN MATEO, CA. SN 77-223,166.
PUB. 7-29-2008, FILED 7-6-2007.

Lula Lu

THE MARK CONSISTS OF STANDARD CHARACTERS WITHOUT CLAIM TO ANY PARTICULAR FONT, STYLE, SIZE, OR COLOR.

THE NAME "LULA LU" DOES NOT IDENTIFY A LIVING INDIVIDUAL.

CLASS 25—CLOTHING

FOR UNDERGARMENTS; LADIES' UNDERWEAR; THONGS; UNDERWEAR; WOMEN'S UNDERWEAR; LINGERIE; BRAS; STRAPLESS BRAS; UNDER GARMENTS; PANTIES; CORSETS (U.S. CLS. 22 AND 39).
FIRST USE 8-1-2007; IN COMMERCE 8-1-2007.

CLASS 35—ADVERTISING AND BUSINESS

FOR RETAIL STORES FEATURING WOMEN'S LINGERIE; RETAIL LINGERIE STORES; RETAIL SHOPS FEATURING WOMEN'S LINGERIE; RETAIL STORE SERVICES FEATURING WOMEN'S LINGERIE; ON-LINE RETAIL STORE SERVICES FEATURING WOMEN'S LINGERIE; COMPUTERIZED ON-LINE RETAIL STORE SERVICES IN THE FIELD OF WOMEN'S LINGERIE (U.S. CLS. 100, 101 AND 102).

FIRST USE 1-12-2005; IN COMMERCE 1-12-2005.

3,632,093. BIO-LAB, INC., LAWRENCEVILLE, GA. SN 77-223,660. PUB. 7-29-2008, FILED 7-6-2007.

WKND.

THE MARK CONSISTS OF STANDARD CHARACTERS WITHOUT CLAIM TO ANY PARTICULAR FONT, STYLE, SIZE, OR COLOR.

CLASS 35—ADVERTISING AND BUSINESS

FOR RETAIL STORES FEATURING, POOLS, SPAS AND HOT TUBS; EQUIPMENT FOR POOLS, SPAS AND HOT TUBS; WATER TREATMENT CHEMICALS AND PRODUCTS FOR POOLS, SPAS AND HOT TUBS; SWIM MASKS, SWIM FINNS, SWIM BOARDS, AND SWIM FLOATS ALL FOR RECREATIONAL USE; POOL COVERS; REFERRAL SERVICES IN THE AREA OF POOL, SPA AND HOT TUB CONSTRUCTION, PATIO AND DECK DESIGN AND INSTALLATION, FENCES INSTALLATION AND TOTAL BACKYARD DESIGN AND ARCHITECTURE (U.S. CLS. 100, 101 AND 102).

FIRST USE 5-3-2008; IN COMMERCE 5-3-2008.

CLASS 37—CONSTRUCTION AND REPAIR

FOR INSTALLATION, MAINTENANCE AND REPAIR OF POOLS, SPAS, HOT TUBS, PATIOS AND DECKS (U.S. CLS. 100, 103 AND 106).

FIRST USE 5-3-2008; IN COMMERCE 5-3-2008.

CLASS 42—SCIENTIFIC AND COMPUTER SERVICES

FOR SWIMMING POOL, SPA AND HOT TUB DESIGN FOR OTHERS (U.S. CLS. 100 AND 101).

FIRST USE 5-3-2008; IN COMMERCE 5-3-2008.

3,632,097. LUXOTTICA U.S. HOLDINGS CORP., PORT WASHINGTON, NY. SN 77-225,541. PUB. 2-12-2008, FILED 7-10-2007.



OWNER OF U.S. REG. NOS. 1,475,511, 1,800,295, AND OTHERS.

NO CLAIM IS MADE TO THE EXCLUSIVE RIGHT TO USE "SUNGLASS", APART FROM THE MARK AS SHOWN. THE STIPPLING IS FOR SHADING PURPOSES ONLY. THE MARK CONSISTS OF A CIRCLE REPRESENTING A

SUN DESIGN TO THE LEFT OF THE WORD MARK "SUNGLASS HUT" IN STYLIZED LETTERING.

CLASS 9—ELECTRICAL AND SCIENTIFIC APPARATUS

FOR EYEWEAR ACCESSORIES, NAMELY, CASES AND CORDS (U.S. CLS. 21, 23, 26, 36 AND 38).

FIRST USE 11-1-2008; IN COMMERCE 11-1-2008.

CLASS 35—ADVERTISING AND BUSINESS

FOR RETAIL STORE SERVICES, MAIL ORDER CATALOG SERVICES AND ONLINE RETAIL STORE SERVICES ALL FEATURING SUNGLASSES, EYEGLASSES AND EYEWEAR ACCESSORIES, NAMELY, CASES, CORDS, STRAPS (U.S. CLS. 100, 101 AND 102).

FIRST USE 4-9-2007; IN COMMERCE 4-9-2007.

3,632,122. BABCOCK POWER SERVICES INC., WORCESTER, MA. SN 77-233,456. PUB. 6-24-2008, FILED 7-19-2007.

CLAD-TECH

THE MARK CONSISTS OF STANDARD CHARACTERS WITHOUT CLAIM TO ANY PARTICULAR FONT, STYLE, SIZE, OR COLOR.

CLASS 37—CONSTRUCTION AND REPAIR

FOR REPAIR OF METALS AND METAL EQUIPMENT (U.S. CLS. 100, 103 AND 106).

FIRST USE 10-31-2006; IN COMMERCE 10-31-2006.

CLASS 40—MATERIAL TREATMENT

FOR METAL TREATMENT SERVICES, NAMELY, HARD SURFACING OF METAL AND METAL EQUIPMENT (U.S. CLS. 100, 103 AND 106).

FIRST USE 10-31-2006; IN COMMERCE 10-31-2006.

3,632,131. GLOBAL INSIGHT COMMUNICATIONS, LLC, LAS VEGAS, NV. SN 77-238,997. PUB. 1-15-2008, FILED 7-26-2007.

PERSONAL BRAND BUSTERS

THE MARK CONSISTS OF STANDARD CHARACTERS WITHOUT CLAIM TO ANY PARTICULAR FONT, STYLE, SIZE, OR COLOR.

NO CLAIM IS MADE TO THE EXCLUSIVE RIGHT TO USE "PERSONAL BRAND", APART FROM THE MARK AS SHOWN.

CLASS 9—ELECTRICAL AND SCIENTIFIC APPARATUS

FOR PRE-RECORDED CDS FEATURING INFORMATION IN THE FIELD OF BRANDING AND MARKETING (U.S. CLS. 21, 23, 26, 36 AND 38).

FIRST USE 4-3-2009; IN COMMERCE 4-3-2009.

CLASS 16—PAPER GOODS AND PRINTED MATTER

FOR PRINTED INSTRUCTIONAL, EDUCATIONAL AND TEACHING MATERIALS IN THE FIELD OF BRANDING AND MARKETING (U.S. CLS. 2, 5, 22, 23, 29, 37, 38 AND 50).

FIRST USE 1-2-2008; IN COMMERCE 1-2-2008.

CLASS 41—EDUCATION AND ENTERTAINMENT

FOR EDUCATIONAL SERVICES, NAMELY, PROVIDING WORKSHOPS AND SEMINARS IN THE FIELDS OF BRANDING AND MARKETING (U.S. CLS. 100, 101 AND 107).

FIRST USE 1-2-2008; IN COMMERCE 1-2-2008.

3,632,153. PREPAK PRODUCTS, INC., OCEANSIDE, CA. SN 77-249,450. PUB. 3-25-2008, FILED 8-7-2007.

NutriMirror

THE MARK CONSISTS OF STANDARD CHARACTERS WITHOUT CLAIM TO ANY PARTICULAR FONT, STYLE, SIZE, OR COLOR.

CLASS 16—PAPER GOODS AND PRINTED MATTER

FOR BOOKS IN THE FIELD OF NUTRITION AND DIET; PRE-PRINTED JOURNALS FOR MONITORING NUTRITION AND DIET (U.S. CLS. 2, 5, 22, 23, 29, 37, 38 AND 50).

FIRST USE 2-0-2008; IN COMMERCE 2-0-2008.

CLASS 44—MEDICAL, BEAUTY AND AGRICULTURAL SERVICES

FOR AN ONLINE WEBSITE PROVIDING PERSONAL DIETARY AND NUTRITIONAL DATA COLLECTION FOR THE PURPOSE OF PROVIDING PERSONALIZED DIETARY AND NUTRITION RECOMMENDATIONS; AN ONLINE WEBSITE PROVIDING PERSONALIZED DIETARY AND NUTRITION RECOMMENDATIONS; AN ONLINE WEBSITE PROVIDING PERSONALIZED OR GROUP DIETARY ANALYSIS BASED ON STANDARDIZED DATA AND/OR PERSONALIZED DATA; AN ONLINE WEBSITE PROVIDING MEDICAL AND NUTRITIONAL DIAGNOSIS ADVICE AND CONSULTATION IN THE FIELD OF FOOD INTAKE, NUTRITION, AND DIETARY SUPPLEMENTATION (U.S. CLS. 100 AND 101).

FIRST USE 2-0-2008; IN COMMERCE 2-0-2008.

3,632,157. MEISGEIER, CHARLES, RICHMOND, TX. AND MURPHY, ELIZABETH, KELLER, TX. SN 77-250,436. PUB. 10-7-2008, FILED 8-8-2007.

MMTIC

THE MARK CONSISTS OF STANDARD CHARACTERS WITHOUT CLAIM TO ANY PARTICULAR FONT, STYLE, SIZE, OR COLOR.

CLASS 9—ELECTRICAL AND SCIENTIFIC APPARATUS

FOR DOWNLOADABLE PSYCHOLOGICAL TEST BOOKLETS AND ANSWER SHEETS FOR THE USE IN THE FIELD OF CHILDHOOD EDUCATION (U.S. CLS. 21, 23, 26, 36 AND 38).

FIRST USE 6-1-1987; IN COMMERCE 11-15-2007.

CLASS 16—PAPER GOODS AND PRINTED MATTER

FOR PRINTED MATTER, NAMELY, PSYCHOLOGICAL TESTS, TEST BOOKLETS AND ANSWER SHEETS (U.S. CLS. 2, 5, 22, 23, 29, 37, 38 AND 50).

FIRST USE 6-1-1987; IN COMMERCE 1-1-1988.

CLASS 44—MEDICAL, BEAUTY AND AGRICULTURAL SERVICES

FOR ONLINE PSYCHOLOGICAL TESTING SERVICES FOR USE IN THE FIELD OF CHILDHOOD EDUCATION (U.S. CLS. 100 AND 101).

FIRST USE 6-1-1987; IN COMMERCE 8-1-2001.

3,632,159. HEALTHE MID-AMERICA, INC., KANSAS CITY, MO. SN 77-251,596. PUB. 7-1-2008, FILED 8-9-2007.

CAREENTRUST

THE MARK CONSISTS OF STANDARD CHARACTERS WITHOUT CLAIM TO ANY PARTICULAR FONT, STYLE, SIZE, OR COLOR.

CLASS 42—SCIENTIFIC AND COMPUTER SERVICES

FOR COMPUTER SERVICES, NAMELY, PROVIDING A SEARCH ENGINE FOR OBTAINING HEALTH CARE DATA ON A GLOBAL COMPUTER INFORMATION NETWORK; COMPUTER SERVICES, NAMELY, HOSTING AND MAINTAINING AN ONLINE WEBSITE FOR OTHERS TO PROVIDE A SECURE ON-LINE INTERFACE FOR STORAGE, ACCESS, MAINTENANCE, AND UTILIZATION OF ELECTRONIC HEALTH RECORDS (U.S. CLS. 100 AND 101).

FIRST USE 11-8-2007; IN COMMERCE 11-8-2007.

CLASS 44—MEDICAL, BEAUTY AND AGRICULTURAL SERVICES

FOR PROVIDING A WEBSITE FEATURING INFORMATION IN THE FIELD OF HEALTHCARE; PROVIDING INFORMATION IN THE FIELDS OF HEALTH MAINTENANCE ORGANIZATIONAL SERVICES AND PREFERRED HEALTHCARE PROVIDERS; PROVIDING AN INTERNET WEBSITE FOR MEDICAL PROFESSIONALS AND MEDICAL PATIENTS THAT ALLOWS FOR THE EXCHANGE OF INFORMATION FROM REMOTE LOCATIONS USING ELECTRONIC PATIENT MONITORING DEVICES THAT FEED INFORMATION TO THE WEBSITE THAT CAN BE ACCESSED IN REAL TIME BY MEDICAL PROFESSIONALS FOR PURPOSES OF MONITORING AND DIAGNOSING MEDICAL CONDITIONS (U.S. CLS. 100 AND 101).

FIRST USE 11-8-2007; IN COMMERCE 11-8-2007.

3,632,160. RADIX INTERNATIONAL LLC, EAST ALTON, IL. SN 77-251,659. PUB. 6-17-2008, FILED 8-9-2007.

RADIX

THE MARK CONSISTS OF STANDARD CHARACTERS WITHOUT CLAIM TO ANY PARTICULAR FONT, STYLE, SIZE, OR COLOR.

CLASS 35—ADVERTISING AND BUSINESS

FOR BUSINESS CONSULTATION; MARKET RESEARCH; ACQUISITION AND MERGER CONSULTATION; BUSINESS MARKETING CONSULTING SERVICES; BUSINESS MANAGEMENT CONSULTING SERVICES; COMMERCIAL ADMINISTRATION OF THE LICENSING OF THE GOODS AND SERVICES OF OTHERS (U.S. CLS. 100, 101 AND 102).

FIRST USE 2-1-2009; IN COMMERCE 2-1-2009.

CLASS 36—INSURANCE AND FINANCIAL

FOR FINANCIAL ANALYSIS AND CONSULTATION (U.S. CLS. 100, 101 AND 102).

FIRST USE 2-1-2009; IN COMMERCE 2-1-2009.

CLASS 42—SCIENTIFIC AND COMPUTER SERVICES

FOR RESEARCH AND DEVELOPMENT OF NEW PRODUCTS FOR OTHERS; DEVELOPMENT OF NEW TECHNOLOGY FOR OTHERS IN THE FIELD OF MECHANICAL ENGINEERING, ELECTRICAL ENGINEERING AND SOFTWARE ENGINEERING (U.S. CLS. 100 AND 101).

FIRST USE 2-1-2009; IN COMMERCE 2-1-2009.

3,632,166. WGBH EDUCATIONAL FOUNDATION, BOSTON, MA. SN 77-254,420. PUB. 8-5-2008, FILED 8-14-2007.

Engineer Your Life

THE MARK CONSISTS OF STANDARD CHARACTERS

WITHOUT CLAIM TO ANY PARTICULAR FONT, STYLE, SIZE, OR COLOR.

NO CLAIM IS MADE TO THE EXCLUSIVE RIGHT TO USE "ENGINEER" FOR CLASSES 9 AND 41, APART FROM THE MARK AS SHOWN.

CLASS 9—ELECTRICAL AND SCIENTIFIC APPARATUS

FOR DIGITAL MATERIALS, NAMELY, DOWNLOADABLE VIDEO FEATURING ENGINEERING AND THE PROMOTION OF ENGINEERING FOR GIRLS (U.S. CLS. 21, 23, 26, 36 AND 38).

FIRST USE 1-30-2008; IN COMMERCE 1-30-2008.

CLASS 38—COMMUNICATION

FOR STREAMING OF VIDEO MATERIAL ON THE INTERNET (U.S. CLS. 100, 101 AND 104).

FIRST USE 9-30-2007; IN COMMERCE 9-30-2007.

CLASS 41—EDUCATION AND ENTERTAINMENT

FOR ENTERTAINMENT SERVICES, NAMELY, PROVIDING A WEBSITE FEATURING, PHOTOGRAPHIC, AUDIO, VIDEO AND PROSE PRESENTATIONS FEATURING ENGINEERING FOR GIRLS; EDUCATIONAL SERVICES, NAMELY, CONDUCTING ONLINE AND LIVE WORKSHOPS AND SEMINARS IN THE FIELD OF PROMOTING ENGINEERING FOR GIRLS AND DISTRIBUTION OF COURSE MATERIAL IN CONNECTION THEREWITH (U.S. CLS. 100, 101 AND 107).

FIRST USE 9-30-2007; IN COMMERCE 9-30-2007.

3,632,168. ADVANDX, INC., WOBURN, MA. SN 77-255,572. PUB. 2-19-2008, FILED 8-15-2007.

Yeast Traffic Light

THE MARK CONSISTS OF STANDARD CHARACTERS WITHOUT CLAIM TO ANY PARTICULAR FONT, STYLE, SIZE, OR COLOR.

NO CLAIM IS MADE TO THE EXCLUSIVE RIGHT TO USE "YEAST", APART FROM THE MARK AS SHOWN.

CLASS 1—CHEMICALS

FOR CHEMICAL TEST KITS FOR MICROBIAL DETECTION AND/OR IDENTIFICATION FOR LABORATORY OR RESEARCH USE; DIAGNOSTIC PREPARATIONS FOR SCIENTIFIC OR RESEARCH USE; REAGENTS FOR SCIENTIFIC OR MEDICAL RESEARCH USE (U.S. CLS. 1, 5, 6, 10, 26 AND 46).

FIRST USE 5-29-2007; IN COMMERCE 2-17-2009.

CLASS 5—PHARMACEUTICALS

FOR CLINICAL MEDICAL REAGENTS; DIAGNOSTIC REAGENTS FOR CLINICAL OR MEDICAL LABORATORY USE; DIAGNOSTIC REAGENTS FOR IN VITRO USE IN BIOCHEMISTRY, CLINICAL CHEMISTRY AND MICROBIOLOGY (U.S. CLS. 6, 18, 44, 46, 51 AND 52).

FIRST USE 5-29-2007; IN COMMERCE 2-17-2009.

3,632,170. NATIONAL ENDOWMENT FOR FINANCIAL EDUCATION, GREENWOOD VILLAGE, CO. SN 77-257,405. PUB. 7-22-2008, FILED 8-16-2007.

CASHCOURSE

THE MARK CONSISTS OF STANDARD CHARACTERS WITHOUT CLAIM TO ANY PARTICULAR FONT, STYLE, SIZE, OR COLOR.

CLASS 35—ADVERTISING AND BUSINESS

FOR PROVIDING A WEBSITE FEATURING FINANCIAL LITERACY MATERIALS, NAMELY, CUSTOMIZABLE ADVERTISEMENTS FOR COLLEGES AND UNIVERSITIES IN THE FIELD OF FINANCIAL LITERACY EDUCATIONAL PROGRAMS FOR COLLEGE STUDENTS (U.S. CLS. 100, 101 AND 102).

FIRST USE 3-6-2009; IN COMMERCE 3-6-2009.

CLASS 36—INSURANCE AND FINANCIAL

FOR PROVIDING INFORMATION IN THE FIELD OF FINANCIAL LITERACY TO COLLEGES AND UNIVERSITIES; PROVIDING A WEBSITE FEATURING FINANCIAL LITERACY INFORMATION FOR COLLEGE STUDENTS (U.S. CLS. 100, 101 AND 102).

FIRST USE 8-0-2007; IN COMMERCE 8-0-2007.

CLASS 41—EDUCATION AND ENTERTAINMENT

FOR PROVIDING ONLINE PUBLICATIONS IN THE NATURE OF WRITTEN ARTICLES, PRINTED VISUALS IN THE NATURE OF INFORMATION GRAPHICS, WRITTEN PRESENTATIONS, AND CURRICULUM OUTLINES, IN THE FIELD OF FINANCIAL LITERACY (U.S. CLS. 100, 101 AND 107).

FIRST USE 12-18-2008; IN COMMERCE 12-18-2008.

3,632,171. ZERODAY ENTERPRISES, LLC, WILSONVILLE, OR. SN 77-257,989. PUB. 10-28-2008, FILED 8-17-2007.

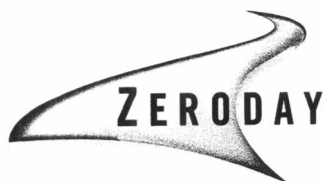

THE MARK CONSISTS OF A WAVE, WITH THE WORD "ZERO" APPEARING INSIDE OF THE WAVE AND DAY APPEARING ON THE OUTSIDE OF THE WAVE.

CLASS 1—CHEMICALS

FOR CHEMICALS FOR USE IN WATER, WASTE WATER, SOLID-LIQUID AND SOLID WASTE TREATMENT, NAMELY, COAGULANTS, POLYMERS, METAL AND OTHER ION CONTROL CHEMICALS, WATER CHEMISTRY MODIFICATION AND ION REMOVAL CHEMICALS, DISPERSANTS AND ANTISCALANTS; BACTERIA FOR USE IN WASTE WATER TREATMENT, AND ACTIVATED CARBON (U.S. CLS. 1, 5, 6, 10, 26 AND 46).

FIRST USE 9-0-2007; IN COMMERCE 9-0-2007.

CLASS 11—ENVIRONMENTAL CONTROL APPARATUS

FOR WATER TREATMENT EQUIPMENT, WASTE-WATER TREATMENT EQUIPMENT, AND SOLID AND LIQUID WASTE TREATMENT EQUIPMENT ALL COMPRISED PRIMARILY OF FILTERS, FILTRATION UNITS, MIXERS, PUMPS AND TANKS SOLD IN COMBINATION FOR USE IN COMMERCIAL, INDUSTRIAL, MUNICIPAL AND MINING APPLICATIONS (U.S. CLS. 13, 21, 23, 31 AND 34).

FIRST USE 9-0-2007; IN COMMERCE 9-0-2007.

CLASS 40—MATERIAL TREATMENT

FOR CONSULTING SERVICES IN THE FIELD OF WATER TREATMENT, WASTE-WATER TREATMENT, AND SOLID AND LIQUID WASTE TREATMENT (U.S. CLS. 100, 103 AND 106).

FIRST USE 9-0-2007; IN COMMERCE 9-0-2007.

3,632,172. COHEN, DANIEL E., CHASKA, MN. SN 77-258,038. PUB. 2-12-2008, FILED 8-17-2007.



CLASS 9—ELECTRICAL AND SCIENTIFIC APPARATUS

FOR ELECTRONIC APPARATUS CONSISTING OF AUDIO SPEAKERS INCORPORATED INTO SEATING; AUDIO AMPLIFIERS (U.S. CLS. 21, 23, 26, 36 AND 38).

FIRST USE 9-0-2008; IN COMMERCE 9-0-2008.

CLASS 20—FURNITURE AND ARTICLES NOT OTHERWISE CLASSIFIED

FOR FURNITURE (U.S. CLS. 2, 13, 22, 25, 32 AND 50).

FIRST USE 9-0-2008; IN COMMERCE 9-0-2008.

3,632,176. SANYANG INDUSTRY CO., LTD., HUKOU HSINCHU, TAIWAN. SN 77-259,198. PUB. 7-22-2008, FILED 8-20-2007.



OWNER OF U.S. REG. NOS. 2,089,581 AND 2,271,340.
THE COLOR(S) BLUE AND RED IS/ARE CLAIMED AS A FEATURE OF THE MARK.

THE MARK CONSISTS OF THE STYLIZED LETTERS "SYM" WHERE "S" AND "M" APPEAR IN BLUE AND "Y" APPEARS IN RED AND BLUE.

CLASS 4—LUBRICANTS AND FUELS

FOR INDUSTRIAL OIL AND GREASES, NAMELY, LUBRICATING OIL, GEAR OIL, CYLINDER OIL, OLEINE, ENGINE OIL, MOTOR OIL, CLUTCH OIL, TRANSMISSION OIL, CARBURETOR CLEANSING OIL, ENGINE CLEANSING OIL, LUBRICATING OIL FOR TRANSMISSION BELTS, GREASE FOR BELTS, GREASE FOR CHAINS, PETROLEUM JELLY, OIL PETROL, WHITE MINERAL OIL AND OIL OF PETROLEUM, ALL FOR INDUSTRIAL USE; OIL FOR THE PRESERVATION OF LEATHER; INDUSTRIAL WAX; RAW WAX; RAW-MATERIAL WAX; BELTING WAX; CARNAUBA WAX; PARAFFIN; CIRCULATING OIL, NAMELY, HEAT TRANSFER OILS (U.S. CLS. 1, 6 AND 15).
FIRST USE 2-3-2006; IN COMMERCE 1-10-2009.

CLASS 11—ENVIRONMENTAL CONTROL APPARATUS

FOR LIGHTING APPARATUS FOR MOTORCYCLES, NAMELY, HEADLIGHTS, TURN-SIGNAL LIGHTS FOR MOTORCYCLES; ANTI-GLARE APPARATUS, NAMELY, ANTI-GLARE MOTORCYCLE HEADLIGHTS; LIGHT BULBS FOR DIRECTIONAL SIGNALS FOR MOTORCYCLES; HEATING APPARATUS FOR DEFROSTING MOTORCYCLES; MOTORCYCLE REFLECTORS; MOTORCYCLE HEADLIGHTS; AIR CONDITIONERS FOR MOTORCYCLES; LIGHTS FOR MOTORCYCLES; COURTESY LIGHTS FOR MOTORCYCLES (U.S. CLS. 13, 21, 23, 31 AND 34).
FIRST USE 2-3-2006; IN COMMERCE 1-10-2009.

3,632,180. SCHERING-PLOUGH HEALTHCARE PRODUCTS, INC., MEMPHIS, TN. SN 77-261,252. PUB. 7-22-2008, FILED 8-22-2007.



OWNER OF U.S. REG. NOS. 511,379, 2,703,163, AND OTHERS.

"DR. SCHOLL" DOES NOT IDENTIFY A LIVING INDIVIDUAL.

THE MARK CONSISTS OF "DR. SCHOLL'S" IN COMPLETELY SHADED OVAL WITHIN OVAL.

CLASS 10—MEDICAL APPARATUS

FOR MEDICAL GRADUATED COMPRESSION HOSIERY, NAMELY, ELASTIC HOSE SUPPORTERS, KNEE HIGH HOSE, THIGH HIGH HOSE (U.S. CLS. 26, 39 AND 44).

FIRST USE 4-1-2007; IN COMMERCE 4-1-2007.

CLASS 25—CLOTHING

FOR HOSIERY AND SOCKS (U.S. CLS. 22 AND 39).
FIRST USE 12-1-2003; IN COMMERCE 12-1-2003.

3,632,183. WGBH EDUCATIONAL FOUNDATION, BOSTON, MA. SN 77-261,333. PUB. 8-5-2008, FILED 8-22-2007.

Engineer your Life
Dream Big. Love What You
Do.

THE MARK CONSISTS OF STANDARD CHARACTERS WITHOUT CLAIM TO ANY PARTICULAR FONT, STYLE, SIZE, OR COLOR.

NO CLAIM IS MADE TO THE EXCLUSIVE RIGHT TO USE "ENGINEER" FOR CLASSES 9 AND 41, APART FROM THE MARK AS SHOWN.

CLASS 9—ELECTRICAL AND SCIENTIFIC APPARATUS

FOR DIGITAL MATERIALS, NAMELY, DOWNLOADABLE VIDEO FEATURING ENGINEERING AND THE PROMOTION OF ENGINEERING FOR GIRLS (U.S. CLS. 21, 23, 26, 36 AND 38).

FIRST USE 1-30-2008; IN COMMERCE 1-30-2008.

CLASS 38—COMMUNICATION

FOR STREAMING OF VIDEO MATERIAL ON THE INTERNET (U.S. CLS. 100, 101 AND 104).

FIRST USE 9-30-2007; IN COMMERCE 9-30-2007.

CLASS 41—EDUCATION AND ENTERTAINMENT

FOR ENTERTAINMENT SERVICES, NAMELY, PROVIDING A WEBSITE FEATURING, PHOTOGRAPHIC, AUDIO, VIDEO AND PROSE PRESENTATIONS FEATURING ENGINEERING FOR GIRLS; EDUCATIONAL SERVICES, NAMELY, CONDUCTING ONLINE AND LIVE SEMINARS AND WORKSHOPS IN THE FIELD OF PROMOTING ENGINEERING FOR GIRLS AND DISTRIBUTION OF COURSE MATERIAL IN CONNECTION THEREWITH (U.S. CLS. 100, 101 AND 107).

FIRST USE 9-30-2007; IN COMMERCE 9-30-2007.

3,632,189. RISESMART, INC., SUNNYVALE, CA. SN 77-262,600. PUB. 7-29-2008, FILED 8-23-2007.

RISESMART

THE MARK CONSISTS OF STANDARD CHARACTERS WITHOUT CLAIM TO ANY PARTICULAR FONT, STYLE, SIZE, OR COLOR.

CLASS 35—ADVERTISING AND BUSINESS

FOR ONLINE EMPLOYMENT COUNSELING AND RECRUITING SERVICES; RESUME WRITING SERVICES (U.S. CLS. 100, 101 AND 102).

FIRST USE 2-20-2007; IN COMMERCE 11-17-2007.

CLASS 41—EDUCATION AND ENTERTAINMENT

FOR CAREER COUNSELING; TRAINING IN THE FIELD OF EMPLOYMENT INTERVIEWS AND INTERVIEW TECHNIQUES (U.S. CLS. 100, 101 AND 107).

FIRST USE 8-1-2008; IN COMMERCE 8-1-2008.

3,632,192. SC INTERNATIONAL ENTERPRISES INC., VANCOUVER, BRITISH COLUMBIA, CANADA. SN 77-264,075. PUB. 8-19-2008, FILED 8-24-2007.

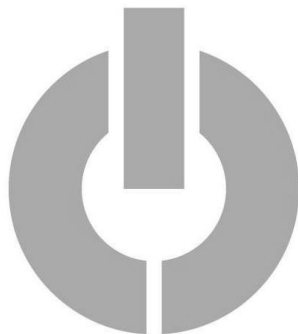

THE MARK CONSISTS OF A DESIGN REPRESENTATIVE OF THE START OR POWER BUTTON FOUND ON COMPUTERS, AND CONSISTS OF THE LETTER "O" WHICH IS THE FIRST LETTER OF THE WORD "ONE" WITH THE NUMBER "1" PARTIALLY INSIDE THE LETTER "O".

CLASS 25—CLOTHING

FOR CLOTHING, NAMELY, T-SHIRTS, TANK TOPS, SWEAT SHIRTS, NO-SLEEVE TECH SHIRTS, SHORT-SLEEVE TECH SHIRTS, LONG-SLEEVE TECH SHIRTS, JACKETS, PANTS, SHORTS, HEADBANDS, WRISTBANDS, HATS AND CAPS (U.S. CLS. 22 AND 39).

FIRST USE 9-30-2007; IN COMMERCE 9-30-2007.

CLASS 35—ADVERTISING AND BUSINESS

FOR RETAIL STORES AND RETAIL ONLINE ORDERING SERVICES FEATURING CLOTHING, FASHION ACCESSORIES, SPORTING GOODS, BACKPACKS, GYM BAGS, AND PLASTIC WATER BOTTLES SOLD EMPTY (U.S. CLS. 100, 101 AND 102).

FIRST USE 9-30-1997; IN COMMERCE 9-30-1997.

3,632,210. SNOLA, INC., LOS ANGELES, CA. SN 77-271,764. PUB. 8-19-2008, FILED 9-5-2007.

sno:la

THE MARK CONSISTS OF THE LOWERCASE LETTERS "SNO", WITH THE "O" HAVING A SNOWFLAKE DESIGN INSIDE IT; A SEMI-COLON; AND THE LOWERCASE LETTERS "LA".

CLASS 30—STAPLE FOODS

FOR FROZEN YOGURT, FROZEN YOGURT MIXES, ICE CREAM, GELATO, SHERBET, COOKIES, CRACKERS, CEREAL BASED ENERGY BARS (U.S. CL. 46).

FIRST USE 8-1-2006; IN COMMERCE 8-1-2006.

CLASS 35—ADVERTISING AND BUSINESS

FOR RETAIL STORE SERVICES FEATURING FROZEN YOGURT, YOGURT, FROZEN YOGURT MIXES, ICE CREAM, GELATO, SHERBET, FROZEN DESSERTS, COOKIES, CRACKERS, BOTTLED DRINKING WATER, BOTTLED WATER, FRUIT JUICES, VEGETABLE JUICES, ENERGY DRINKS, FRUIT DRINKS, SPORTS DRINKS, FROZEN FRUIT BEVERAGES, SMOOTHIES, FROZEN FRUIT-BASED BEVERAGES, ENERGY BARS, COOK BOOKS, GUIDE BOOKS FEATURING RESTAURANTS, ENTERTAINMENT AND ORGANIC PRODUCTS, GREETING CARDS, PAPER STATIONERY, INSULATED CONTAINERS FOR FOOD OR BEVERAGE, INSULATED BAGS FOR FOOD OR BEVERAGES, PARASOLS, DIGITAL MEDIA, NAMELY, CD'S, DVD'S, DOWNLOADABLE AUDIO FILES, FEATURING MUSIC, APRONS, T-SHIRTS, CAPS, HATS, SWEATSHIRTS, SWEAT PANTS, SWEAT SHORTS, SHIRTS AND JACKETS (U.S. CLS. 100, 101 AND 102).

FIRST USE 8-1-2006; IN COMMERCE 8-1-2006.

3,632,211. THE AMYOTROPHIC LATERAL SCLEROSIS ASSOCIATION, CALABASAS HILLS, CA. SN 77-272,227. PUB. 8-26-2008, FILED 9-5-2007.

3,632,216. VIVONET INCORPORATED, BELLINGHAM, WA. SN 77-274,208. PUB. 7-15-2008, FILED 9-7-2007.

FIGHTING ON EVERY FRONT TO
IMPROVE LIVING WITH ALS

THE MARK CONSISTS OF STANDARD CHARACTERS WITHOUT CLAIM TO ANY PARTICULAR FONT, STYLE, SIZE, OR COLOR.

NO CLAIM IS MADE TO THE EXCLUSIVE RIGHT TO USE "ALS", APART FROM THE MARK AS SHOWN.

CLASS 35—ADVERTISING AND BUSINESS

FOR ASSOCIATION SERVICES, NAMELY, PROMOTING PUBLIC AWARENESS OF THE NEED FOR RESEARCH AND FUNDING FOR AMYOTROPHIC LATERAL SCLEROSIS BY PROVIDING INFORMATION IN THE FIELD OF AMYOTROPHIC LATERAL SCLEROSIS (U.S. CLS. 100, 101 AND 102).

FIRST USE 4-30-2007; IN COMMERCE 4-30-2007.

CLASS 36—INSURANCE AND FINANCIAL

FOR CHARITABLE FUND RAISING; CHARITABLE FUND RAISING SERVICES FOR FUNDING RESEARCH PROGRAMS, PATIENT SERVICES PROGRAMS, CLINICAL CENTERS, AND RELATED PROGRAMS AND ACTIVITIES RELATING TO THE TREATMENT OF AND FINDING A CURE OF AMYOTROPHIC LATERAL SCLEROSIS; FINANCIAL SPONSORSHIP OF RESEARCH IN THE FIELD OF AMYOTROPHIC LATERAL SCLEROSIS (U.S. CLS. 100, 101 AND 102).

FIRST USE 4-30-2007; IN COMMERCE 4-30-2007.

3,632,215. ENVITIA PLC, HORSHAM, UNITED KINGDOM. SN 77-273,855. PUB. 7-22-2008, FILED 9-7-2007.

ENVITIA

THE MARK CONSISTS OF STANDARD CHARACTERS WITHOUT CLAIM TO ANY PARTICULAR FONT, STYLE, SIZE, OR COLOR.

CLASS 9—ELECTRICAL AND SCIENTIFIC APPARATUS

FOR COMPUTER SOFTWARE FOR THE ANALYSIS, MANAGEMENT AND VISUALISATION OF GEOSPATIAL INTELLIGENCE (U.S. CLS. 21, 23, 26, 36 AND 38).

FIRST USE 10-21-2008; IN COMMERCE 10-21-2008.

CLASS 42—SCIENTIFIC AND COMPUTER SERVICES

FOR COMPUTER SOFTWARE CONSULTATION; COMPUTER SOFTWARE DESIGN FOR OTHERS (U.S. CLS. 100 AND 101).

FIRST USE 10-21-2008; IN COMMERCE 10-21-2008.

HALO

THE MARK CONSISTS OF STANDARD CHARACTERS WITHOUT CLAIM TO ANY PARTICULAR FONT, STYLE, SIZE, OR COLOR.

CLASS 9—ELECTRICAL AND SCIENTIFIC APPARATUS

FOR DOWNLOADABLE WEB-BASED POINT OF SALE COMPUTER SOFTWARE USED TO CAPTURE SALES DATA, GENERATE RECEIPTS, TAKE PAYMENTS, PROCESS DEBIT CARDS, PROCESS CREDIT CARDS, PROCESS AND UPDATE ACCOUNT INFORMATION, COMPARE CHANGES IN REVENUE PERFORMANCE, COMPARE CHANGES IN CUSTOMER ACCOUNT PERFORMANCE AND COMPARE CHANGES IN SALES PERFORMANCE, TRANSMIT ORDERS TO REMOTE LOCATIONS, AND PROVIDE REPORTING WITH RESPECT TO THE FOREGOING FOR USE IN RESTAURANTS AND RETAIL STORES (U.S. CLS. 21, 23, 26, 36 AND 38).

FIRST USE 8-27-2004; IN COMMERCE 8-27-2004.

CLASS 42—SCIENTIFIC AND COMPUTER SERVICES

FOR PROVIDING TEMPORARY USE OF NON-DOWNLOADABLE WEB-BASED POINT OF SALE COMPUTER SOFTWARE USED TO CAPTURE SALES DATA, GENERATE RECEIPTS, TAKE PAYMENTS, PROCESS DEBIT CARDS, PROCESS CREDIT CARDS, PROCESS AND UPDATE ACCOUNT INFORMATION, COMPARE CHANGES IN REVENUE PERFORMANCE, COMPARE CHANGES IN CUSTOMER ACCOUNT PERFORMANCE AND COMPARE CHANGES IN SALES PERFORMANCE, TRANSMIT ORDERS TO REMOTE LOCATIONS, AND PROVIDE REPORTING WITH RESPECT TO THE FOREGOING FOR USE IN RESTAURANTS AND RETAIL STORES; MAINTENANCE SERVICES FOR POINT OF SALE COMPUTER SOFTWARE; TECHNICAL SUPPORT SERVICES FOR POINT OF SALE COMPUTER SOFTWARE, NAMELY, TROUBLESHOOTING OF COMPUTER SOFTWARE PROBLEMS, PROVIDING BACK-UP OF COMPUTER SOFTWARE; COMPUTER SERVICES, NAMELY, MONITORING AND REPORTING DATA COLLECTED FROM POINT OF SALE COMPUTER SOFTWARE (U.S. CLS. 100 AND 101).

FIRST USE 8-27-2004; IN COMMERCE 8-27-2004.

CLASS 45—PERSONAL AND LEGAL SERVICES

FOR LICENSING OF POINT OF SALE COMPUTER SOFTWARE (U.S. CLS. 100 AND 101).

FIRST USE 3-0-2005; IN COMMERCE 3-0-2005.

3,632,220. HARVIESTOUN BREWERY LIMITED, ALVA, CLACKMANNANSHIRE, UNITED KINGDOM. SN 77-277,421. PUB. 7-15-2008, FILED 9-12-2007.

3,632,232. VANCEINFO TECHNOLOGIES INC., GEORGE TOWN, CAYMAN ISLANDS. SN 77-281,682. PUB. 7-22-2008, FILED 9-17-2007.

Ola Dubh

THE MARK CONSISTS OF STANDARD CHARACTERS WITHOUT CLAIM TO ANY PARTICULAR FONT, STYLE, SIZE, OR COLOR.

THE FOREIGN WORDING IN THE MARK TRANSLATES INTO ENGLISH AS "OIL BLACK".

CLASS 21—HOUSEWARES AND GLASS

FOR BEER MUGS; JUGS; DRINKING GLASSES (U.S. CLS. 2, 13, 23, 29, 30, 33, 40 AND 50).
FIRST USE 2-1-2008; IN COMMERCE 2-1-2008.

CLASS 32—LIGHT BEVERAGES

FOR BEER; ALE; PORTER; STOUT; LAGER (U.S. CLS. 45, 46 AND 48).
FIRST USE 2-1-2008; IN COMMERCE 2-1-2008.

3,632,228. PREMIERE VISION, LYON, FRANCE. SN 77-279,897. PUB. 5-27-2008, FILED 9-14-2007.

DENIM BY PREMIERE VISION

THE MARK CONSISTS OF STANDARD CHARACTERS WITHOUT CLAIM TO ANY PARTICULAR FONT, STYLE, SIZE, OR COLOR.

OWNER OF U.S. REG. NOS. 1,541,813, 2,920,633, AND 3,162,034.

NO CLAIM IS MADE TO THE EXCLUSIVE RIGHT TO USE "DENIM", APART FROM THE MARK AS SHOWN.

CLASS 35—ADVERTISING AND BUSINESS

FOR PROMOTING TRADE SHOWS IN THE FIELDS OF FABRICS, TEXTILES AND FASHION (U.S. CLS. 100, 101 AND 102).
FIRST USE 1-0-2008; IN COMMERCE 1-0-2008.

CLASS 45—PERSONAL AND LEGAL SERVICES

FOR PROVIDING INFORMATION IN THE FIELDS OF FASHION AND TEXTILES, NAMELY, PRESENTATION OF FASHION TRENDS AND FABRIC COLLECTIONS (U.S. CLS. 100 AND 101).
FIRST USE 1-0-2008; IN COMMERCE 1-0-2008.

VANCEINFO

THE MARK CONSISTS OF STANDARD CHARACTERS WITHOUT CLAIM TO ANY PARTICULAR FONT, STYLE, SIZE, OR COLOR.

CLASS 35—ADVERTISING AND BUSINESS

FOR IT OUTSOURCING SERVICES, NAMELY, OUTSOURCING IN THE FIELD OF INFORMATION TECHNOLOGY (U.S. CLS. 100, 101 AND 102).
FIRST USE 8-10-2007; IN COMMERCE 8-10-2007.

CLASS 41—EDUCATION AND ENTERTAINMENT

FOR TRANSLATION SERVICES, NAMELY, THE TRANSLATION OF SOFTWARE CONTENT, AVAILABLE IN AT LEAST ONE GEOGRAPHIC AREA (U.S. CLS. 100, 101 AND 107).
FIRST USE 8-10-2007; IN COMMERCE 8-10-2007.

CLASS 42—SCIENTIFIC AND COMPUTER SERVICES

FOR ADVISORY SERVICES IN THE FIELD OF PRODUCT DEVELOPMENT AND QUALITY IMPROVEMENT OF SOFTWARE; APPLICATION SERVICE PROVIDER, NAMELY, PROVIDING, HOSTING, MANAGING, DEVELOPING, AND MAINTAINING APPLICATIONS, SOFTWARE, WEBSITES, AND DATABASES IN THE FIELDS OF PERSONAL PRODUCTIVITY, WIRELESS COMMUNICATION, MOBILE INFORMATION ACCESS, AND REMOTE DATA MANAGEMENT FOR WIRELESS DELIVERY OF CONTENT TO HANDHELD COMPUTERS, LAPTOPS AND MOBILE ELECTRONIC DEVICES; COMPUTER PROGRAMMING FOR OTHERS; COMPUTER SERVICE, NAMELY, ACTING AS AN APPLICATION SERVICE PROVIDER IN THE FIELD OF KNOWLEDGE MANAGEMENT TO HOST COMPUTER APPLICATION SOFTWARE FOR CREATING SEARCHABLE DATABASES OF INFORMATION AND DATA; COMPUTER SERVICE, NAMELY, ACTING AS AN APPLICATION SERVICE PROVIDER IN THE FIELD OF KNOWLEDGE MANAGEMENT TO HOST COMPUTER APPLICATION SOFTWARE FOR THE COLLECTION, EDITING, ORGANIZING, MODIFYING, BOOK MARKING, TRANSMISSION, STORAGE AND SHARING OF DATA AND INFORMATION; COMPUTER SERVICES, NAMELY, MONITORING, TESTING, ANALYZING, AND REPORTING ON THE INTERNET TRAFFIC CONTROL AND CONTENT OF THE WEBSITES OF OTHERS; COMPUTER SOFTWARE DEVELOPMENT; COMPUTER SOFTWARE DESIGN; COMPUTER PROGRAMMING, AND MAINTENANCE OF COMPUTER SOFTWARE; CONSULTING SERVICES IN THE FIELD OF DESIGN, SELECTION, IMPLEMENTATION AND USE OF COMPUTER HARDWARE AND SOFTWARE SYSTEMS FOR OTHERS; DESIGN AND DEVELOPMENT OF COMPUTER HARDWARE AND SOFTWARE; DESIGN, DEVELOPMENT AND IMPLEMENTATION OF SOFTWARE; DESIGN OF HOMEPAGES AND WEB-SITES; DESIGN FOR OTHERS IN THE FIELD OF COMPUTER NETWORKS, SOFTWARE, AND ENGINEERING FOR THE INFORMATION TECHNOLOGY, FINANCIAL SERVICES, MANUFACTURING, RETAIL, DISTRIBUTION AND TELECOMMUNICATIONS INDUSTRIES; DESIGN OF COMPUTER HARDWARE, INTEGRATED CIRCUITS, COMMUNICATIONS HARDWARE, COMPUTER SOFTWARE AND COMPUTER NETWORKS FOR OTHERS; DEVELOPMENT OF SOFTWARE FOR SECURE NETWORK OPERATIONS; DEVELOPMENT, UPDATING AND MAINTENANCE OF SOFTWARE AND

DATA BASES; ENGINEERING SERVICES, NAMELY, ENGINEERING OF COMPUTER HARDWARE AND SOFTWARE FOR THE INFORMATION TECHNOLOGY, FINANCIAL SERVICES, MANUFACTURING, RETAIL, DISTRIBUTION AND TELECOMMUNICATIONS INDUSTRIES; PLANNING, DEVELOPMENT AND TECHNICAL SUPPORT OF ELECTRONIC COMMUNICATIONS NETWORKS; PROVIDING QUALITY ASSURANCE SERVICES IN THE FIELD OF INFORMATION TECHNOLOGY; TECHNICAL SUPPORT SERVICES; TROUBLESHOOTING OF COMPUTER HARDWARE AND SOFTWARE PROBLEMS, MONITORING OF NETWORK SYSTEMS, AND PROVIDING BACK-UP COMPUTER PROGRAMS AND FACILITIES; SOFTWARE LOCALIZATION AND GLOBALIZATION, NAMELY, THE UPDATING OF COMPUTER SOFTWARE CONTENT AND PROGRAMMING, TESTING, AND ENGINEERING IN THE FIELD OF COMPUTER SOFTWARE AVAILABLE FOR USE IN AT LEAST ONE GEOGRAPHIC AREA; COMPUTER SOFTWARE APPLICATION DEVELOPMENT; CONSULTING SERVICES IN THE FIELD OF IMPLEMENTATION OF COMPUTER HARDWARE AND SOFTWARE SYSTEMS FOR OTHERS (U.S. CLS. 100 AND 101).

FIRST USE 8-10-2007; IN COMMERCE 8-10-2007.

3,632,239. STERIS INC., TEMECULA, CA. SN 77-285.660. PUB. 7-29-2008, FILED 9-21-2007.

V-PRO

THE MARK CONSISTS OF STANDARD CHARACTERS WITHOUT CLAIM TO ANY PARTICULAR FONT, STYLE, SIZE, OR COLOR.

CLASS 10—MEDICAL APPARATUS

FOR MEDICAL STERILIZER UNITS FOR DENTAL AND SURGICAL USE (U.S. CLS. 26, 39 AND 44).
FIRST USE 10-31-2007; IN COMMERCE 10-31-2007.

CLASS 11—ENVIRONMENTAL CONTROL APPARATUS

FOR STERILIZERS FOR INDUSTRIAL AND COMMERCIAL USE (U.S. CLS. 13, 21, 23, 31 AND 34).
FIRST USE 10-31-2007; IN COMMERCE 10-31-2007.

3,632,244. ASTHEBURGERTURNS HOLDINGS, LLC, BIRMINGHAM, AL. SN 77-287,802. PUB. 3-11-2008, FILED 9-25-2007.

ASTHEBURGERTURNS

THE MARK CONSISTS OF STANDARD CHARACTERS WITHOUT CLAIM TO ANY PARTICULAR FONT, STYLE, SIZE, OR COLOR.

CLASS 38—COMMUNICATION

FOR PROVIDING ONLINE BULLETIN BOARDS FOR COMMUNICATION BETWEEN RESTAURANT MANAGERS, EMPLOYEES AND POTENTIAL EMPLOYEES IN THE FIELD OF RESTAURANT SERVICES (U.S. CLS. 100, 101 AND 104).

FIRST USE 3-4-2009; IN COMMERCE 3-4-2009.

CLASS 41—EDUCATION AND ENTERTAINMENT

FOR PROVIDING AN INTERACTIVE WEBSITE AND TRAINING SERVICES, NAMELY, ONLINE TRAINING COURSES FOR RESTAURANT MANAGERS, EMPLOYEES AND POTENTIAL EMPLOYEES IN THE FIELD OF RESTAURANT SERVICES (U.S. CLS. 100, 101 AND 107).

FIRST USE 3-4-2009; IN COMMERCE 3-4-2009.

3,632,252. SERVICE STRATEGIES CORPORATION, SAN DIEGO, CA. SN 77-290,792. PUB. 8-5-2008, FILED 9-27-2007.



OWNER OF U.S. REG. NO. 2,561,007.

NO CLAIM IS MADE TO THE EXCLUSIVE RIGHT TO USE "SERVICE" AND "STANDARDS", APART FROM THE MARK AS SHOWN.

CLASS 16—PAPER GOODS AND PRINTED MATTER

FOR PRINTED MATERIALS, NAMELY, BOOKS, PAMPHLETS AND FLIERS FEATURING INFORMATION ABOUT STANDARDS, CERTIFICATION AND BEST PRACTICES IN TECHNOLOGY SERVICE AND SUPPORT (U.S. CLS. 2, 5, 22, 23, 29, 37, 38 AND 50).
FIRST USE 2-1-2007; IN COMMERCE 2-1-2007.

CLASS 41—EDUCATION AND ENTERTAINMENT

FOR COMPUTER EDUCATION TRAINING SERVICES IN THE FIELD OF INFORMATION TECHNOLOGY (U.S. CLS. 100, 101 AND 107).

FIRST USE 2-1-2007; IN COMMERCE 2-1-2007.

CLASS 42—SCIENTIFIC AND COMPUTER SERVICES

FOR TECHNICAL SUPPORT SERVICES, NAMELY, TROUBLESHOOTING OF COMPUTER HARDWARE AND SOFTWARE PROBLEMS AND MONITORING OF NETWORK SYSTEMS IN THE FIELD OF INFORMATION TECHNOLOGY; AND ACCREDITATION SERVICES, NAMELY, DEVELOPING, EVALUATING, AND TESTING STANDARDS FOR TECHNICAL SUPPORT AND SERVICES FOR THE PURPOSE OF ACCREDITATION (U.S. CLS. 100 AND 101).

FIRST USE 2-1-2007; IN COMMERCE 2-1-2007.

3,632,253. SERVICE STRATEGIES CORPORATION, SAN DIEGO, CA. SN 77-290,821. PUB. 8-5-2008, FILED 9-27-2007.



OWNER OF U.S. REG. NO. 2,561,007.
NO CLAIM IS MADE TO THE EXCLUSIVE RIGHT TO USE "SERVICE" AND "CERTIFIED", APART FROM THE MARK AS SHOWN.

CLASS 16—PAPER GOODS AND PRINTED MATTER

FOR PRINTED MATERIALS, NAMELY, BOOKS, PAMPHLETS AND FLIERS FEATURING INFORMATION ABOUT STANDARDS, CERTIFICATION AND BEST PRACTICES IN TECHNOLOGY SERVICE AND SUPPORT (U.S. CLS. 2, 5, 22, 23, 29, 37, 38 AND 50).
FIRST USE 2-1-2007; IN COMMERCE 2-1-2007.

CLASS 41—EDUCATION AND ENTERTAINMENT

FOR COMPUTER EDUCATION TRAINING SERVICES IN THE FIELD OF INFORMATION TECHNOLOGY (U.S. CLS. 100, 101 AND 107).
FIRST USE 2-1-2007; IN COMMERCE 2-1-2007.

CLASS 42—SCIENTIFIC AND COMPUTER SERVICES

FOR TECHNICAL SUPPORT SERVICES, NAMELY, TROUBLESHOOTING OF COMPUTER HARDWARE AND SOFTWARE PROBLEMS AND MONITORING OF NETWORK SYSTEMS IN THE FIELD OF INFORMATION TECHNOLOGY; AND ACCREDITATION SERVICES, NAMELY, DEVELOPING, EVALUATING, AND TESTING STANDARDS FOR TECHNICAL SUPPORT AND SERVICES FOR THE PURPOSE OF ACCREDITATION (U.S. CLS. 100 AND 101).
FIRST USE 2-1-2007; IN COMMERCE 2-1-2007.

3,632,254. SERVICE STRATEGIES CORPORATION, SAN DIEGO, CA. SN 77-290,843. PUB. 8-5-2008, FILED 9-27-2007.



OWNER OF U.S. REG. NO. 2,561,007.
NO CLAIM IS MADE TO THE EXCLUSIVE RIGHT TO USE "SERVICE" AND "CAREER CERTIFICATION", APART FROM THE MARK AS SHOWN.

CLASS 16—PAPER GOODS AND PRINTED MATTER

FOR PRINTED MATERIALS, NAMELY, BOOKS, PAMPHLETS AND FLIERS FEATURING INFORMATION ABOUT STANDARDS, CERTIFICATION TRAINING AND BEST PRACTICES IN TECHNOLOGY SERVICE AND SUPPORT (U.S. CLS. 2, 5, 22, 23, 29, 37, 38 AND 50).
FIRST USE 2-1-2007; IN COMMERCE 2-1-2007.

CLASS 41—EDUCATION AND ENTERTAINMENT

FOR COMPUTER EDUCATION TRAINING SERVICES IN THE FIELD OF INFORMATION TECHNOLOGY (U.S. CLS. 100, 101 AND 107).
FIRST USE 2-1-2007; IN COMMERCE 2-1-2007.

CLASS 42—SCIENTIFIC AND COMPUTER SERVICES

FOR TECHNICAL SUPPORT SERVICES, NAMELY, TROUBLESHOOTING OF COMPUTER HARDWARE AND SOFTWARE PROBLEMS AND MONITORING OF NETWORK SYSTEMS IN THE FIELD OF INFORMATION TECHNOLOGY; AND ACCREDITATION SERVICES, NAMELY, DEVELOPING, EVALUATING, AND TESTING STANDARDS FOR TECHNICAL SUPPORT AND SERVICES FOR THE PURPOSE OF ACCREDITATION (U.S. CLS. 100 AND 101).
FIRST USE 2-1-2007; IN COMMERCE 2-1-2007.

3,632,255. AERO DESIGN AND MANUFACTURING COMPANY, INC., DULUTH, MN. SN 77-291,115. PUB. 3-18-2008, FILED 9-28-2007.

WHEN IN DOUBT, RIDE.

THE MARK CONSISTS OF STANDARD CHARACTERS WITHOUT CLAIM TO ANY PARTICULAR FONT, STYLE, SIZE, OR COLOR.

CLASS 25—CLOTHING

FOR CLOTHING, NAMELY, T-SHIRTS (U.S. CLS. 22 AND 39).
FIRST USE 4-0-2008; IN COMMERCE 4-0-2008.

CLASS 35—ADVERTISING AND BUSINESS

FOR MAIL ORDER AND ELECTRONIC CATALOG SERVICES FEATURING CLOTHING AND ACCESSORIES FOR MOTORCYCLE RIDERS (U.S. CLS. 100, 101 AND 102).
FIRST USE 2-0-2009; IN COMMERCE 2-0-2009.

3,632,280. NOVALAR PHARMACEUTICALS, INC., SAN DIEGO, CA. SN 77-304,442. PUB. 3-25-2008, FILED 10-15-2007.

ORAVVERSE

THE MARK CONSISTS OF STANDARD CHARACTERS WITHOUT CLAIM TO ANY PARTICULAR FONT, STYLE, SIZE, OR COLOR.

CLASS 5—PHARMACEUTICALS

FOR PHARMACEUTICAL PREPARATIONS FOR USE IN THE CARE AND TREATMENT OF ORAL HEALTH; PHARMACEUTICAL PREPARATIONS AND DRUG DELIVERY AGENTS CONSISTING OF COMPOUNDS, NAMELY, REVERSAL AGENTS TO COUNTERACT THE EFFECTS OF OTHER PHARMACEUTICAL AGENTS, NAMELY, ANESTHETICS (U.S. CLS. 6, 18, 44, 46, 51 AND 52).

FIRST USE 2-27-2009; IN COMMERCE 2-27-2009.

CLASS 10—MEDICAL APPARATUS

FOR DEVICES FOR USE IN THE CARE AND TREATMENT OF ORAL HEALTH, NAMELY, DENTAL APPARATUS FOR INTRODUCING PHARMACEUTICAL PREPARATIONS INTO THE HUMAN BODY, NAMELY, DENTAL CARTRIDGES AND DELIVERY APPLICATORS IN THE FORM OF DRUG DELIVERY SYSTEMS (U.S. CLS. 26, 39 AND 44).

FIRST USE 2-27-2009; IN COMMERCE 2-27-2009.

CLASS 9—ELECTRICAL AND SCIENTIFIC APPARATUS

FOR COMPUTER SOFTWARE FOR USE BY HEALTHCARE PROVIDERS FOR DEVELOPING APPLICATION SOFTWARE AND DEVICE DRIVERS TO WORK AS PART OF A HEALTHCARE INFORMATION SHARING SYSTEM; COMPUTER SOFTWARE FOR COLLECTING, STORING, EDITING, ORGANIZING, MODIFYING, REVIEWING, ANALYZING, TRANSMITTING AND SHARING OF DATA AND INFORMATION IN THE FIELDS OF HEALTHCARE, SOCIAL CARE, MEDICINE AND PRESCRIBING OF MEDICINES INCLUDING PATIENT RECORDS, CLINICAL CARE INFORMATION, FACILITIES INFORMATION, HEALTH PROVIDER ADMINISTRATION AND HUMAN RESOURCES INFORMATION, INVENTORY INFORMATION AND ACCOUNTING AND FINANCIAL INFORMATION; COMPUTER NETWORK INTERFACE SOFTWARE FOR USE BY HEALTHCARE PROVIDERS TO FACILITATE DOCUMENTATION, STORAGE AND ANALYSIS OF PATIENTS' HEALTH AND HEALTHCARE RECORDS (U.S. CLS. 21, 23, 26, 36 AND 38).

FIRST USE 10-4-2007; IN COMMERCE 10-4-2007.

CLASS 39—TRANSPORTATION AND STORAGE

FOR PHYSICAL STORAGE SERVICES FOR ARCHIVING DATABASES, IMAGES AND OTHER ELECTRONIC DATA (U.S. CLS. 100 AND 105).

FIRST USE 10-4-2007; IN COMMERCE 10-4-2007.

CLASS 42—SCIENTIFIC AND COMPUTER SERVICES

FOR COMPUTER SERVICES, NAMELY, PROVIDING A WEBSITE FEATURING SEARCH ENGINE FOR OBTAINING DATA ON THE INTERNET (U.S. CLS. 100 AND 101).

FIRST USE 10-4-2007; IN COMMERCE 10-4-2007.

CLASS 44—MEDICAL, BEAUTY AND AGRICULTURAL SERVICES

FOR PROVIDING ONLINE INFORMATION IN THE FIELD OF HEALTHCARE (U.S. CLS. 100 AND 101).

FIRST USE 10-4-2007; IN COMMERCE 10-4-2007.

3,632,287. MICROSOFT CORPORATION, REDMOND, WA. SN 77-305,400. PUB. 8-26-2008, FILED 10-16-2007.

3,632,288. MICROSOFT CORPORATION, REDMOND, WA. SN 77-305,411. PUB. 8-26-2008, FILED 10-16-2007.

HEALTHVAULT



THE MARK CONSISTS OF STANDARD CHARACTERS WITHOUT CLAIM TO ANY PARTICULAR FONT, STYLE, SIZE, OR COLOR.

PRIORITY CLAIMED UNDER SEC. 44(D) ON FED REP GERMANY APPLICATION NO. 30743686.1, FILED 7-4-2007. OWNER OF U.S. REG. NO. 2,935,997.

PRIORITY CLAIMED UNDER SEC. 44(D) ON FED REP GERMANY APPLICATION NO. 30757729.5, FILED 9-3-2007.

THE COLOR(S) WHITE, LIGHT BLUE, AND DARK BLUE IS/ARE CLAIMED AS A FEATURE OF THE MARK.

THE MARK CONSISTS OF A SWIRL DESIGN IN THE COLORS WHITE, LIGHT BLUE, AND DARK BLUE.

CLASS 9—ELECTRICAL AND SCIENTIFIC APPARATUS

FOR COMPUTER SOFTWARE FOR USE BY HEALTHCARE PROVIDERS FOR DEVELOPING APPLICATION SOFTWARE AND DEVICE DRIVERS TO WORK AS PART OF A HEALTHCARE INFORMATION SHARING SYSTEM; COMPUTER SOFTWARE FOR COLLECTING, STORING, EDITING, ORGANIZING, MODIFYING, REVIEWING, ANALYZING, TRANSMITTING AND SHARING OF DATA AND INFORMATION IN THE FIELDS OF HEALTHCARE, SOCIAL CARE, MEDICINE AND PRESCRIBING OF MEDICINES INCLUDING PATIENT RECORDS, CLINICAL CARE INFORMATION, FACILITIES INFORMATION, HEALTH PROVIDER ADMINISTRATION AND HUMAN RESOURCES INFORMATION, INVENTORY INFORMATION AND ACCOUNTING AND FINANCIAL INFORMATION; COMPUTER NETWORK INTERFACE SOFTWARE FOR USE BY HEALTHCARE PROVIDERS TO FACILITATE DOCUMENTATION, STORAGE AND ANALYSIS OF PATIENTS' HEALTH AND HEALTHCARE RECORDS (U.S. CLS. 21, 23, 26, 36 AND 38).

FIRST USE 10-4-2007; IN COMMERCE 10-4-2007.

CLASS 39—TRANSPORTATION AND STORAGE

FOR PHYSICAL STORAGE SERVICES FOR ARCHIVING DATABASES, IMAGES AND OTHER ELECTRONIC DATA (U.S. CLS. 100 AND 105).

FIRST USE 10-4-2007; IN COMMERCE 10-4-2007.

CLASS 42—SCIENTIFIC AND COMPUTER SERVICES

FOR COMPUTER SERVICES, NAMELY, PROVIDING A WEBSITE FEATURING SEARCH ENGINE FOR OBTAINING DATA ON THE INTERNET (U.S. CLS. 100 AND 101).

FIRST USE 10-4-2007; IN COMMERCE 10-4-2007.

CLASS 44—MEDICAL, BEAUTY AND AGRICULTURAL SERVICES

FOR PROVIDING ONLINE INFORMATION IN THE FIELD OF HEALTHCARE (U.S. CLS. 100 AND 101).

FIRST USE 10-4-2007; IN COMMERCE 10-4-2007.

3,632,317. HOFFMASTER GROUP, INC., INDIANAPOLIS, IN. SN 77-323,384. PUB. 6-3-2008, FILED 11-7-2007.



OWNER OF U.S. REG. NOS. 1,462,761, 3,280,287, AND OTHERS.

NO CLAIM IS MADE TO THE EXCLUSIVE RIGHT TO USE "COLOR FASHION DESIGN", APART FROM THE MARK AS SHOWN.

CLASS 16—PAPER GOODS AND PRINTED MATTER

FOR PAPER PRODUCTS, NAMELY, NAPKINS, TRAY COVERS, COASTERS, PLACEMATS, AND TABLECLOTHS (U.S. CLS. 2, 5, 22, 23, 29, 37, 38 AND 50).

FIRST USE 1-1-1996; IN COMMERCE 1-1-1996.

CLASS 21—HOUSEWARES AND GLASS

FOR PAPER PLATES (U.S. CLS. 2, 13, 23, 29, 30, 33, 40 AND 50).

FIRST USE 1-1-1996; IN COMMERCE 1-1-1996.

CLASS 40—MATERIAL TREATMENT

FOR CUSTOM MANUFACTURE OF PAPER PRODUCTS, NAMELY, NAPKINS, TRAY COVERS, COASTERS, PLACEMATS, AND TABLE COVERS (U.S. CLS. 100, 103 AND 106).

FIRST USE 1-1-1996; IN COMMERCE 1-1-1996.

CLASS 42—SCIENTIFIC AND COMPUTER SERVICES

FOR DESIGN FOR OTHERS IN THE FIELD OF PAPER PRODUCTS, NAMELY, NAPKINS, TRAY COVERS, COASTERS, PLACEMATS, AND TABLE COVERS (U.S. CLS. 100 AND 101).

FIRST USE 1-1-1996; IN COMMERCE 1-1-1996.

3,632,319. DAWSON, STUART, PLYMOUTH, MA. SN 77-324,277. PUB. 9-30-2008, FILED 11-8-2007.

THE CHANNEL BOSTON'S BEST LIVE ROCK

THE MARK CONSISTS OF STANDARD CHARACTERS WITHOUT CLAIM TO ANY PARTICULAR FONT, STYLE, SIZE, OR COLOR.

NO CLAIM IS MADE TO THE EXCLUSIVE RIGHT TO USE "BOSTON'S BEST LIVE ROCK", APART FROM THE MARK AS SHOWN.

CLASS 16—PAPER GOODS AND PRINTED MATTER

FOR BUMPER STICKERS (U.S. CLS. 2, 5, 22, 23, 29, 37, 38 AND 50).

FIRST USE 4-16-2008; IN COMMERCE 4-16-2008.

CLASS 25—CLOTHING

FOR APPAREL, SPECIFICALLY SHIRTS (U.S. CLS. 22 AND 39).

FIRST USE 12-14-2007; IN COMMERCE 12-14-2007.

CLASS 35—ADVERTISING AND BUSINESS

FOR ONLINE STORE SERVICES FEATURING APPAREL, PRINTED PUBLICATIONS, AND BUMPER STICKERS (U.S. CLS. 100, 101 AND 102).

FIRST USE 12-5-2007; IN COMMERCE 12-5-2007.

CLASS 41—EDUCATION AND ENTERTAINMENT

FOR ENTERTAINMENT SERVICES, NAMELY, PROVIDING PRERECORDED MUSIC, VIDEOS, AND INFORMATION IN THE FIELD OF MUSIC, ALL ONLINE VIA A GLOBAL COMPUTER NETWORK (U.S. CLS. 100, 101 AND 107).

FIRST USE 12-31-2006; IN COMMERCE 12-31-2006.

3,632,327. FULBRIGHT & JAWORSKI L.L.P., HOUSTON, TX. SN 77-327,386. PUB. 10-14-2008, FILED 11-12-2007.



NO CLAIM IS MADE TO THE EXCLUSIVE RIGHT TO USE "GLOBAL INFRASTRUCTURE", APART FROM THE MARK AS SHOWN.

CLASS 9—ELECTRICAL AND SCIENTIFIC APPARATUS

FOR DOWNLOADABLE ELECTRONIC PUBLICATIONS IN THE NATURE OF JOURNALS IN THE FIELD OF LAW AND BUSINESS (U.S. CLS. 21, 23, 26, 36 AND 38).

FIRST USE 1-4-2008; IN COMMERCE 1-4-2008.

CLASS 16—PAPER GOODS AND PRINTED MATTER

FOR PUBLICATIONS, NAMELY, JOURNALS IN THE FIELD OF LAW AND BUSINESS (U.S. CLS. 2, 5, 22, 23, 29, 37, 38 AND 50).

FIRST USE 1-0-2008; IN COMMERCE 1-0-2008.

3,632,331. MAGNIFY360, INC., LOS ANGELES, CA. SN 77-329,747. PUB. 6-24-2008, FILED 11-14-2007.

Magnify360

THE MARK CONSISTS OF STANDARD CHARACTERS WITHOUT CLAIM TO ANY PARTICULAR FONT, STYLE, SIZE, OR COLOR.

CLASS 35—ADVERTISING AND BUSINESS

FOR MARKETING SERVICES, NAMELY, WEB SITE BASED SALES LEADS GENERATION AND MANAGEMENT, AND WEB SITE BASED MARKETING CONSULTATION RELATING TO CONVERSION OPTIMIZATION FOR OTHERS (U.S. CLS. 100, 101 AND 102).

FIRST USE 11-20-2007; IN COMMERCE 11-20-2007.

CLASS 42—SCIENTIFIC AND COMPUTER SERVICES

FOR WEB SITE DEVELOPMENT SERVICES FOR OTHERS, NAMELY, ENABLING WEB SITE TRAFFIC PROFILING, WEB SITE PERSONALIZATION, WEB SITE CONTENT CUSTOMIZATION, AND WEB SITE TRAFFIC QUALITY SCORING, AND AUTOMATED TESTING AND OPTIMIZATION OF CONTENT; PROVIDING NON-DOWNLOADABLE COMPUTER SOFTWARE THAT ENABLES GENERATION, MANAGEMENT, AND CONVERSION OPTIMIZATION OF LEADS AND SALES; PROVIDING NON-DOWNLOADABLE COMPUTER SOFTWARE THAT ENABLES WEB SITE TRAFFIC PROFILING, WEB SITE AND LANDING PAGE PERSONALIZATION, WEB SITE CONTENT CUSTOMIZATION, WEB SITE TRAFFIC QUALITY SCORING, AND AUTOMATED TESTING AND OPTIMIZATION OF CONTENT (U.S. CLS. 100 AND 101).

FIRST USE 11-20-2007; IN COMMERCE 11-20-2007.

3,632,341. HOFFMASTER GROUP, INC., INDIANAPOLIS, IN. SN 77-332,715. PUB. 9-2-2008, FILED 11-19-2007.

hoffmaster GROUP, Inc.

OWNER OF U.S. REG. NOS. 1,462,761, 3,280,287, AND OTHERS.

NO CLAIM IS MADE TO THE EXCLUSIVE RIGHT TO USE "GROUP, INC.", APART FROM THE MARK AS SHOWN.

SEC. 2(F).

CLASS 40—MATERIAL TREATMENT

FOR CUSTOM MANUFACTURE OF PAPER PRODUCTS, NAMELY, CUPS, PLATES, NAPKINS, TRAY COVERS, COASTERS, PLACEMATS, AND TABLE COVERS (U.S. CLS. 100, 103 AND 106).

FIRST USE 12-1-2007; IN COMMERCE 12-1-2007.

CLASS 42—SCIENTIFIC AND COMPUTER SERVICES

FOR DESIGN FOR OTHERS IN THE FIELD OF PAPER PRODUCTS, NAMELY, CUPS, PLATES, NAPKINS, TRAY COVERS, COASTERS, PLACEMATS, AND TABLE COVERS (U.S. CLS. 100 AND 101).

FIRST USE 12-1-2007; IN COMMERCE 12-1-2007.

3,632,344. 7 DIGITAL INCORPORATED, DBA 7 DIGITAL MEDIA LIMITED, LONDON, UNITED KINGDOM. SN 77-333,707. PUB. 7-22-2008, FILED 11-20-2007.



NO CLAIM IS MADE TO THE EXCLUSIVE RIGHT TO USE "DIGITAL", APART FROM THE MARK AS SHOWN.

THE COLOR(S) RED, ORANGE AND YELLOW IS/ARE CLAIMED AS A FEATURE OF THE MARK.

THE MARK CONSISTS OF THE GRAPHIC PORTION OF THE LOGO CONSISTS OF SEVEN COLORED DOTS: 1ST ROW, LEFT TO RIGHT THERE IS AN ORANGE DOT, ADJACENT TO A RED DOT, ADJACENT TO ANOTHER ORANGE DOT; 2ND ROW: THERE IS A RED DOT UNDER-

NEATH THE FAR RIGHT ORANGE DOT OF THE 1ST ROW AND A YELLOW DOT TO THE RIGHT OF THE ORANGE DOT; 3RD ROW: THERE IS A RED DOT BELOW THE RED DOT IN THE 1ST ROW BUT NOT DIRECTLY BELOW ANY DOT IN THE 2ND ROW, A YELLOW DOT IS TO THE RIGHT OF THIS RED DOT, DIRECTLY BELOW THE RED DOT OF THE 2ND ROW, WHICH IS BELOW THE FAR RIGHT ORANGE DOT OF THE 1ST ROW; THE DOTS AS A WHOLE LOOSELY REPRESENT THE NUMERAL "7". DIRECTLY ADJACENT TO THE YELLOW DOT IN THE 2ND ROW, THE LITERAL ELEMENT BEGINS AND CONSISTS OF THE NUMERAL "7" IMMEDIATELY FOLLOWED BY "DIGITAL" IN LOWER CASE. THE LITERAL ELEMENT "7DIGITAL" IS RED.

CLASS 9—ELECTRICAL AND SCIENTIFIC APPARATUS

FOR DOWNLOADABLE MP3 FILES, MP3 RECORDINGS, ONLINE DISCUSSION BOARDS, WEBCASTS AND PODCASTS FEATURING MUSIC, AUDIO BOOKS AND NEWS BROADCASTS; DOWNLOADABLE MUSICAL SOUND RECORDINGS; DOWNLOADABLE RING TONES, GRAPHICS AND MUSIC VIA A GLOBAL COMPUTER NETWORK AND WIRELESS DEVICES; DOWNLOADABLE VIDEO RECORDINGS FEATURING MUSICAL PERFORMANCES; DOWNLOADABLE MUSIC AND AUDIO FILES VIA THE INTERNET AND WIRELESS DEVICES; MUSICAL SOUND RECORDINGS; MUSICAL VIDEO RECORDINGS; SOUND RECORDINGS FEATURING MAJOR LABEL AND INDEPENDENT ARTIST MUSICAL RECORDINGS; VISUAL RECORDINGS AND AUDIO VISUAL RECORDINGS FEATURING MUSIC AND ANIMATION (U.S. CLS. 21, 23, 26, 36 AND 38).

FIRST USE 6-15-2005; IN COMMERCE 6-15-2005.

CLASS 35—ADVERTISING AND BUSINESS

FOR ADVERTISING AND PUBLICITY SERVICES, NAMELY, PROMOTING THE GOODS, SERVICES, BRAND IDENTITY AND COMMERCIAL INFORMATION AND NEWS OF THIRD PARTIES THROUGH PRINT, AUDIO, VIDEO, DIGITAL AND ON-LINE MEDIUM; ON-LINE RETAIL STORE SERVICES FEATURING DOWNLOADABLE PRE-RECORDED MUSIC AND VIDEO; RETAIL MUSIC AND RECORD STORES (U.S. CLS. 100, 101 AND 102).

FIRST USE 6-15-2005; IN COMMERCE 6-15-2005.

CLASS 38—COMMUNICATION

FOR COMMUNICATION SERVICES, NAMELY, ELECTRONIC TRANSMISSION OF DATA AND DOCUMENTS AMONG USERS OF COMPUTERS; COMMUNICATION BY ELECTRONIC COMPUTER TERMINALS; COMMUNICATIONS SERVICES, NAMELY, TRANSMITTING STREAMED SOUND AND AUDIO-VISUAL RECORDINGS VIA THE INTERNET (U.S. CLS. 100, 101 AND 104).

FIRST USE 6-15-2005; IN COMMERCE 6-15-2005.

CLASS 41—EDUCATION AND ENTERTAINMENT

FOR DIGITAL VIDEO, AUDIO, AND MULTIMEDIA PUBLISHING SERVICES; ENTERTAINMENT IN THE NATURE OF VISUAL AND AUDIO PERFORMANCES, NAMELY, MUSICAL BAND, ROCK GROUP, GYMNAS-TIC, DANCE, AND BALLET PERFORMANCES; ENTERTAINMENT SERVICES, NAMELY, NON-DOWNLOADABLE RINGTONES, PRE-RECORDED MUSIC, VIDEO AND GRAPHICS PRESENTED TO MOBILE COMMUNICATIONS DEVICES VIA A GLOBAL COMPUTER NETWORK AND WIRELESS NETWORKS; ENTERTAINMENT SERVICES, NAMELY, PROVIDING A WEB SITE FEATURING MUSICAL PERFORMANCES, MUSICAL VIDEOS, RELATED FILM CLIPS, PHOTOGRAPHS, AND OTHER MULTIMEDIA MATERIALS; ENTERTAINMENT SERVICES, NAMELY, PROVIDING ON-LINE REVIEWS OF MUSIC AND ARTIST PERFORMANCES; ENTERTAINMENT SERVICES, NAMELY, PROVIDING PRERECORDED MUSIC, INFORMATION IN THE FIELD OF MUSIC, AND COMMENTARY AND ARTICLES ABOUT MUSIC, ALL ON-LINE VIA A GLOBAL COMPUTER NETWORK (U.S. CLS. 100, 101 AND 107).

FIRST USE 6-15-2005; IN COMMERCE 6-15-2005.

CLASS 42—SCIENTIFIC AND COMPUTER SERVICES

FOR COMPUTER SERVICES, NAMELY, DIGITAL FORMATTING AND COMPRESSION OF MUSIC AND IMAGES, NAMELY, PROCESSING OF DIGITAL MUSIC AND VIDEO IMAGES INTO DOWNLOADABLE PRODUCTS; COMPUTER SERVICES, NAMELY, UPLOADING MUSIC TO THE INTERNET FOR OTHERS; CONVERSION OF CDS INTO DIGITAL FORMATS; CROSS-PLATFORM CONVERSION OF DIGITAL CONTENT INTO OTHER FORMS OF DIGITAL CONTENT; HOSTING OF DIGITAL CONTENT ON THE INTERNET; PROVIDING ELECTRONIC VERIFICATION OF ON-LINE ORDERS OF DIGITAL CONTENT AND GENERATING ELECTRONIC PERMISSION CODES WHICH THEN ALLOW USERS TO ACCESS SAID DIGITAL CONTENT; COMPUTER SERVICE, NAMELY, ACTING AS AN APPLICATION SERVICE PROVIDER IN THE FIELD OF KNOWLEDGE MANAGEMENT TO HOST COMPUTER APPLICATION SOFTWARE FOR CREATING SEARCHABLE DATABASES OF INFORMATION AND DATA; COMPUTER SERVICES, NAMELY, CREATING AND MAINTAINING WEB SITES FOR OTHERS; COMPUTER SERVICES, NAMELY, DESIGNING AND IMPLEMENTING NETWORK WEB PAGES FOR OTHERS; COMPUTER SERVICES, NAMELY, INTERACTIVE HOSTING SERVICES WHICH ALLOW THE USER TO PUBLISH AND SHARE THEIR OWN CONTENT AND IMAGES ONLINE; COMPUTER SERVICES, NAMELY, MANAGING WEB SITES FOR OTHERS; COMPUTER SERVICES, NAMELY, PROVIDING SEARCH PLATFORMS TO ALLOW USERS TO REQUEST CONTENT FROM AND RECEIVE CONTENT TO A MOBILE DEVICE; COMPUTER SOFTWARE DESIGN; COMPUTER PROGRAMMING, OR MAINTENANCE OF COMPUTER SOFTWARE; COMPUTER SOFTWARE DEVELOPMENT; PROGRAMMING OF MULTIMEDIA APPLICATIONS; WEB SITE HOSTING SERVICES (U.S. CLS. 100 AND 101).

FIRST USE 6-15-2005; IN COMMERCE 6-15-2005.

3,632,348. DOGY BAGZ INC., MALIBU, CA. SN 77-336,237. PUB. 6-17-2008, FILED 11-25-2007.

toys RX

THE MARK CONSISTS OF STANDARD CHARACTERS WITHOUT CLAIM TO ANY PARTICULAR FONT, STYLE, SIZE, OR COLOR.

NO CLAIM IS MADE TO THE EXCLUSIVE RIGHT TO USE "TOYS", APART FROM THE MARK AS SHOWN.

3,632,355. PARK, IN JAE, SEOUL, REPUBLIC OF KOREA. SN 77-338,929. PUB. 12-2-2008, FILED 11-28-2007.

CLASS 5—PHARMACEUTICALS

FOR GELS FOR USE AS PERSONAL LUBRICANT, WATER-BASED PERSONAL LUBRICANTS, SILICONE-BASED PERSONAL LUBRICANTS, MEDICAL LUBRICANTS, NAMELY, VAGINAL LUBRICANTS THAT CAN BE OBTAINED WITHOUT A PRESCRIPTION (U.S. CLS. 6, 18, 44, 46, 51 AND 52).

FIRST USE 3-1-2009; IN COMMERCE 3-1-2009.

CLASS 10—MEDICAL APPARATUS

FOR ADULT SEXUAL AIDS, NAMELY, VIBRATORS, DILDOS, CONDOMS, AND PROSTATE MASSAGERS (U.S. CLS. 26, 39 AND 44).

FIRST USE 9-19-2008; IN COMMERCE 9-19-2008.

CLASS 9—ELECTRICAL AND SCIENTIFIC APPARATUS

FOR SOUND RECORDING APPARATUS, SOUND RECORDING CARRIERS, NAMELY, BLANK CD-ROMS FOR SOUND RECORDING, SOUND RECORDING DISCS, NAMELY, BLANK RECORDABLE OPTICAL DISCS; COMPACT DISCS FEATURING MUSIC AND TRAINING IN THE USE AND CARE OF MUSICAL INSTRUMENTS; SOUND RECORDING STRIPS FEATURING TRAINING IN THE USE AND CARE OF MUSICAL INSTRUMENTS; BLANK VIDEOTAPES, SOUND REPRODUCTION APPARATUS, SOUND TRANSMITTING APPARATUS, TAPE RECORDERS, VIDEO RECORDERS, TONE ARMS FOR RECORD PLAYERS, SPEED REGULATORS FOR RECORD PLAYERS, STYLI FOR RECORD PLAYERS, AUDIO SPEAKERS, LOUD SPEAKERS, SOUND RECORDING DISC PLAYERS, NAMELY, COMPACT DISC PLAYERS, DVD PLAYERS, SOUND CASSETTES, NAMELY, BLANK AUDIO CASSETTES, AUDIO CASSETTES FEATURING MUSIC AND TRAINING IN THE USE AND CARE OF MUSICAL INSTRUMENTS, VIDEO CASSETTES, NAMELY, BLANK VIDEO CASSETTES, PRERECORDED VIDEO CASSETTES FEATURING MUSIC VIDEOS AND TRAINING IN THE USE AND CARE OF MUSICAL INSTRUMENTS, CASSETTE PLAYERS, AUDIO-VIDEO COMPACT DISCS FEATURING TRAINING IN THE USE AND CARE OF MUSICAL INSTRUMENTS, READ-ONLY MEMORY COMPACT DISCS FEATURING MUSIC; BLANK COMPUTER FLOPPY DISKS, RECORDED EDUCATIONAL COMPUTER PROGRAMS, FEATURING TRAINING IN THE USE AND CARE OF MUSICAL INSTRUMENTS; COMPUTER GAME PROGRAMS, COMPUTER OPERATING PROGRAMS, DOWNLOADABLE SOFTWARE COMPUTER PROGRAMS, NAMELY, DOWNLOADABLE COMPUTER SOFTWARE FOR USE AS A SPREADSHEET, WORD PROCESSING, ACOUSTIC COUPLERS, ELECTRIC COUPLINGS, AUDIO AND VIDEO RECORDER HEAD CLEANING TAPES, HEADPHONES, MICROPHONES, NEEDLES FOR RECORD PLAYERS, PHONOGRAPH RECORDS FEATURING MUSIC, AUDIO AND VIDEO RECEIVERS, ACOUSTIC CONDUITS, ACOUSTIC COUPLERS, AMPLIFIERS, ELECTRICAL ANTI-INTERFERENCE DEVICES, NAMELY, FILTERS FOR RADIO INTERFERENCE SUPPRESSION, JUNCTION SLEEVES FOR ELECTRIC CABLES; PREAMPLIFIERS FOR MUSICAL INSTRUMENTS; AMPLIFIERS FOR MUSICAL INSTRUMENTS; PICKUPS FOR MUSICAL INSTRUMENTS, NAMELY, ELECTRICAL PICKUPS FOR USE WITH MUSICAL INSTRUMENTS; MAGNETIC PICKUPS FOR MUSICAL INSTRUMENTS, NAMELY, ELECTRONIC SOUND PICKUPS FOR GUITARS AND BASSES (U.S. CLS. 21, 23, 26, 36 AND 38).

FIRST USE 4-30-2008; IN COMMERCE 4-30-2008.

CLASS 15—MUSICAL INSTRUMENTS

FOR ACOUSTIC GUITARS, ELECTRIC GUITARS, BASS GUITARS, PIANOS, DRUMS, VIOLINS, MANDOLINS, BANJOS, RESONATOR GUITARS, ORGANS, HARMONICAS, ACCORDIONS, HARPS, FLUTES, MELODEONS, CAPOS FOR GUITARS, PEDALS FOR GUITARS, MACHINE HEADS FOR GUITARS, STRINGS FOR MUSICAL INSTRUMENTS, TUNERS FOR MUSICAL INSTRUMENTS (U.S. CLS. 2, 21 AND 36).

FIRST USE 4-30-2008; IN COMMERCE 4-30-2008.

3,632,354. SKINNY LITTLE THINGS, LLC, WOODSIDE, CA. SN 77-338,707. PUB. 7-15-2008, FILED 11-28-2007.

SKINNYSONGS

THE MARK CONSISTS OF STANDARD CHARACTERS WITHOUT CLAIM TO ANY PARTICULAR FONT, STYLE, SIZE, OR COLOR.

CLASS 9—ELECTRICAL AND SCIENTIFIC APPARATUS

FOR DIGITAL MEDIA, NAMELY, DOWNLOADABLE AUDIO FILES FEATURING MUSIC IN THE FIELD OF HEALTH, FITNESS AND WELL-BEING (U.S. CLS. 21, 23, 26, 36 AND 38).

FIRST USE 12-0-1007; IN COMMERCE 12-0-1007.

CLASS 25—CLOTHING

FOR CLOTHING, NAMELY, SHIRTS, T-SHIRTS, TANK-TOPS (U.S. CLS. 22 AND 39).

FIRST USE 1-0-2008; IN COMMERCE 1-0-2008.

3,632,357. STEVENSON, MICHAEL J., CLARKDALE, AZ. SN 77-339,737. PUB. 4-1-2008, FILED 11-29-2007.

MIG

THE MARK CONSISTS OF STANDARD CHARACTERS WITHOUT CLAIM TO ANY PARTICULAR FONT, STYLE, SIZE, OR COLOR.

CLASS 2—PAINTS

FOR SEALER COATINGS FOR USE IN THE ROTATIONAL MOLDING INDUSTRY (U.S. CLS. 6, 11 AND 16).

FIRST USE 10-16-2008; IN COMMERCE 10-16-2008.

CLASS 16—PAPER GOODS AND PRINTED MATTER

FOR PLASTIC TRANSFERS FOR APPLYING GRAPHICS AND PRINTED MATTER TO MOLDED THERMOPLASTIC PARTS (U.S. CLS. 2, 5, 22, 23, 29, 37, 38 AND 50).

FIRST USE 10-16-2008; IN COMMERCE 10-16-2008.

3,632,365. F-MATIC, INC., LEHI, UT. SN 77-343,339. PUB. 5-6-2008, FILED 12-4-2007.

INNOVATION IN SANITATION

THE MARK CONSISTS OF STANDARD CHARACTERS WITHOUT CLAIM TO ANY PARTICULAR FONT, STYLE, SIZE, OR COLOR.

CLASS 5—PHARMACEUTICALS

FOR AIR DEODORANT; AIR DEODORIZER; ALL PURPOSE DISINFECTING AND DEODORIZING PREPARATIONS; CARPET DEODORIZERS; DEODORIZING PRODUCTS, NAMELY, ALL PURPOSE DEODORIZER PREPARATIONS FOR HOUSEHOLD, COMMERCIAL AND INDUSTRIAL USE; ROOM DEODORANTS; ROOM DEODORIZING COMPOSITIONS; SANITIZING PREPARATIONS FOR USE IN INSTITUTIONAL AND INDUSTRIAL AREAS; SANITIZING WIPES (U.S. CLS. 6, 18, 44, 46, 51 AND 52).

FIRST USE 11-0-2007; IN COMMERCE 11-0-2007.

CLASS 35—ADVERTISING AND BUSINESS

FOR BUSINESS MANAGEMENT SERVICES, NAMELY, MANAGING LOGISTICS, REVERSE LOGISTICS, SUPPLY CHAIN SERVICES, SUPPLY CHAIN VISIBILITY AND SYNCHRONIZATION, SUPPLY AND DEMAND FORECASTING AND PRODUCT DISTRIBUTION PROCESSES FOR OTHERS; SUPPLY CHAIN MANAGEMENT SERVICES; INVENTORY MANAGEMENT IN THE FIELD OF DEODORANT AND SANITATION PRODUCTS; LOGISTICS MANAGEMENT IN THE FIELD OF DEODORANT AND SANITATION PRODUCTS (U.S. CLS. 100, 101 AND 102).

FIRST USE 11-0-2007; IN COMMERCE 11-0-2007.

3,632,397. JEANNE B. MCCOY COMMUNITY CENTER FOR THE ARTS, NEW ALBANY, OH. SN 77-356,971. PUB. 12-9-2008, FILED 12-20-2007.



JEANNE B. MCCOY
COMMUNITY
CENTER FOR THE ARTS

NO CLAIM IS MADE TO THE EXCLUSIVE RIGHT TO USE "COMMUNITY CENTER FOR THE ARTS", APART FROM THE MARK AS SHOWN.

THE NAME "JEANNE B. MCCOY" DOES NOT IDENTIFY A LIVING INDIVIDUAL.

THE MARK CONSISTS OF A SHADED STARBURST DESIGN WITH EIGHT EXTENSIONS FROM A CENTRAL CIRCLE ABOVE THE STYLIZED ARRANGEMENT OF THE WORDS "JEANNE B. MCCOY COMMUNITY CENTER FOR THE ARTS".

CLASS 35—ADVERTISING AND BUSINESS

FOR PROMOTING TICKET SALES FOR THIRD PARTIES (U.S. CLS. 100, 101 AND 102).

FIRST USE 2-19-2008; IN COMMERCE 2-19-2008.

CLASS 41—EDUCATION AND ENTERTAINMENT

FOR EDUCATIONAL AND ENTERTAINMENT SERVICES, NAMELY, ORGANIZING, PRODUCING, PRESENTING SPECIAL EVENTS, AND PROVIDING FACILITIES FOR THE PERFORMING ARTS, EDUCATIONAL LECTURES, AND PUBLIC ENTERTAINMENT EVENTS; PERFORMING ARTS CENTER (U.S. CLS. 100, 101 AND 107).

FIRST USE 2-19-2008; IN COMMERCE 2-19-2008.

3,632,408. D'AQUINO ITALIAN IMPORTING CO., INC., DUARTE, CA. SN 77-362,551. PUB. 7-22-2008, FILED 1-2-2008.

VILLA D'AQUINO

THE MARK CONSISTS OF STANDARD CHARACTERS WITHOUT CLAIM TO ANY PARTICULAR FONT, STYLE, SIZE, OR COLOR.

OWNER OF U.S. REG. NOS. 2,470,698 AND 3,167,375.

THE FOREIGN WORDING "VILLA" IN THE MARK TRANSLATES INTO ENGLISH AS HOUSE OR ESTATE.

SEC. 2(F).

CLASS 29—MEATS AND PROCESSED FOODS

FOR OLIVE OIL (U.S. CL. 46).

FIRST USE 5-30-2002; IN COMMERCE 7-30-2002.

CLASS 30—STAPLE FOODS

FOR VINEGAR; PASTA; TOMATO SAUCE (U.S. CL. 46).
FIRST USE 2-1-2002; IN COMMERCE 3-1-2002.

CLASS 32—LIGHT BEVERAGES

FOR BOTTLED WATER; BEER (U.S. CLS. 45, 46 AND 48).
FIRST USE 2-1-2002; IN COMMERCE 3-1-2002.

CLASS 33—WINES AND SPIRITS

FOR WINE AND LIQUOR (U.S. CLS. 47 AND 49).
FIRST USE 10-1-1999; IN COMMERCE 10-1-1999.

CLASS 5—PHARMACEUTICALS

FOR PHARMACEUTICAL PRODUCTS AND PHARMACEUTICAL DRUG DELIVERY SYSTEM, NAMELY, DRUG DELIVERY FORMULATIONS USED WITH VARIOUS ACTIVE INGREDIENTS FOR IMMEDIATE RELEASE OR CONTROLLED RELEASE OF ACTIVE INGREDIENT INTO THE BODY (U.S. CLS. 6, 18, 44, 46, 51 AND 52).
FIRST USE 1-7-2009; IN COMMERCE 1-7-2009.

3,632,474. INTERTHINX, INC., AGOURA HILLS, CA. SN 77-388,444. PUB. 7-1-2008, FILED 2-5-2008.

3,632,440. LEVY PREMIUM FOODSERVICE LIMITED PARTNERSHIP, CHICAGO, IL. SN 77-374,924. PUB. 7-22-2008, FILED 1-18-2008.

JJ STAX

THE MARK CONSISTS OF STANDARD CHARACTERS WITHOUT CLAIM TO ANY PARTICULAR FONT, STYLE, SIZE, OR COLOR.

THE NAME "JJ STAX" DOES NOT IDENTIFY A LIVING INDIVIDUAL.

CLASS 35—ADVERTISING AND BUSINESS

FOR CONCESSION STANDS FEATURING FOOD AND BEVERAGES (U.S. CLS. 100, 101 AND 102).
FIRST USE 9-1-2006; IN COMMERCE 9-1-2006.

CLASS 43—HOTEL AND RESTAURANT SERVICES

FOR CONTRACT FOOD SERVICES; SERVING FOOD AND DRINKS (U.S. CLS. 100 AND 101).
FIRST USE 9-1-2006; IN COMMERCE 9-1-2006.

3,632,451. MALLINCKRODT BAKER, INC., PHILLIPSBURG, NJ. SN 77-380,463. PUB. 6-24-2008, FILED 1-25-2008.

PANEXCEA

THE MARK CONSISTS OF STANDARD CHARACTERS WITHOUT CLAIM TO ANY PARTICULAR FONT, STYLE, SIZE, OR COLOR.

CLASS 1—CHEMICALS

FOR CHEMICAL ADDITIVES FOR USE AS A BINDING AGENT, FILLER, SOLUBILIZER, OR DISINTEGRANT IN THE MANUFACTURE OF PHARMACEUTICAL PRODUCTS (U.S. CLS. 1, 5, 6, 10, 26 AND 46).
FIRST USE 1-7-2009; IN COMMERCE 1-7-2009.

FRAUD ANGELS

THE MARK CONSISTS OF STANDARD CHARACTERS WITHOUT CLAIM TO ANY PARTICULAR FONT, STYLE, SIZE, OR COLOR.

NO CLAIM IS MADE TO THE EXCLUSIVE RIGHT TO USE "FRAUD", APART FROM THE MARK AS SHOWN.

CLASS 9—ELECTRICAL AND SCIENTIFIC APPARATUS

FOR PRE-RECORDED TRAINING FILMS FOR THE MORTGAGE INDUSTRY FEATURING INFORMATION ON MORTGAGE FRAUD (U.S. CLS. 21, 23, 26, 36 AND 38).
FIRST USE 3-0-2008; IN COMMERCE 3-0-2008.

CLASS 41—EDUCATION AND ENTERTAINMENT

FOR EDUCATIONAL SERVICES, NAMELY, PROVIDING TRAINING TO OTHERS IN THE FIELD OF MORTGAGE FRAUD (U.S. CLS. 100, 101 AND 107).
FIRST USE 3-0-2008; IN COMMERCE 3-0-2008.

3,632,476. SHERIDAN HEALTHCARE, INC., SUNRISE, FL. SN 77-389,254. PUB. 12-16-2008, FILED 2-5-2008.



SHERIDAN

OWNER OF U.S. REG. NOS. 3,221,885 AND 3,221,886.
THE COLOR(S) RED, GREEN, PURPLE, YELLOW, AND BLUE IS/ARE CLAIMED AS A FEATURE OF THE MARK.
THE MARK CONSISTS OF THE WORD "SHERIDAN" IN BLUE UNDER A SQUARE DESIGN, WITH THE SIDES OF THE SQUARE IN RED, GREEN, PURPLE, AND YELLOW.

CLASS 35—ADVERTISING AND BUSINESS

FOR MEDICAL PRACTICE MANAGEMENT FOR OTHERS; MEDICAL PRACTICE BUSINESS ADMINISTRATION (U.S. CLS. 100, 101 AND 102).
FIRST USE 6-0-2002; IN COMMERCE 6-0-2002.

CLASS 44—MEDICAL, BEAUTY AND AGRICULTURAL SERVICES

FOR MEDICAL SERVICES IN THE FIELDS OF ANESTHESIOLOGY, NEONATOLOGY, PEDIATRICS, PAIN MANAGEMENT, EMERGENCY MEDICINE, AND RADIOLOGY (U.S. CLS. 100 AND 101).

FIRST USE 6-0-2002; IN COMMERCE 6-0-2002.

3,632,478. 4 MY MOM, FRANKLIN LAKES, NJ. SN 77-389,320. PUB. 7-1-2008, FILED 2-5-2008.



3,632,477. 4 MY MOM, FRANKLIN LAKES, NJ. SN 77-389,312. PUB. 7-1-2008, FILED 2-5-2008.

4 MY MOM

THE MARK CONSISTS OF STANDARD CHARACTERS WITHOUT CLAIM TO ANY PARTICULAR FONT, STYLE, SIZE, OR COLOR.

CLASS 16—PAPER GOODS AND PRINTED MATTER

FOR PHOTOGRAPHIC ALBUM; MEMORY BOOKS; DIARIES (U.S. CLS. 2, 5, 22, 23, 29, 37, 38 AND 50).

FIRST USE 3-11-2008; IN COMMERCE 3-11-2008.

CLASS 18—LEATHER GOODS

FOR DIAPER BAGS (U.S. CLS. 1, 2, 3, 22 AND 41).

FIRST USE 3-11-2008; IN COMMERCE 3-11-2008.

CLASS 20—FURNITURE AND ARTICLES NOT OTHERWISE CLASSIFIED

FOR PILLOWS; NAP SACKS IN THE NATURE OF LIGHT SLEEPING BAGS (U.S. CLS. 2, 13, 22, 25, 32 AND 50).

FIRST USE 3-11-2008; IN COMMERCE 3-11-2008.

CLASS 24—FABRICS

FOR CHILDREN'S BLANKETS; RECEIVING BLANKETS; BURP CLOTHS NOT OF PAPER; CRIB BUMPERS; COMFORTERS; HOODED TOWELS; WASH CLOTHS; FABRIC DIAPER STACKERS; DIAPER CHANGING PADS NOT OF PAPER (U.S. CLS. 42 AND 50).

FIRST USE 3-11-2008; IN COMMERCE 3-11-2008.

CLASS 25—CLOTHING

FOR CHILDREN'S EATING BIBS NOT OF PAPER; BOXERS; PAJAMAS; TANK TOPS (U.S. CLS. 22 AND 39).

FIRST USE 3-11-2008; IN COMMERCE 3-11-2008.

CLASS 16—PAPER GOODS AND PRINTED MATTER

FOR PHOTOGRAPHIC ALBUM; MEMORY BOOKS; DIARIES (U.S. CLS. 2, 5, 22, 23, 29, 37, 38 AND 50).

FIRST USE 3-11-2008; IN COMMERCE 3-11-2008.

CLASS 18—LEATHER GOODS

FOR DIAPER BAGS (U.S. CLS. 1, 2, 3, 22 AND 41).

FIRST USE 3-11-2008; IN COMMERCE 3-11-2008.

CLASS 20—FURNITURE AND ARTICLES NOT OTHERWISE CLASSIFIED

FOR PILLOWS; NAP SACKS IN THE NATURE OF LIGHT SLEEPING BAGS (U.S. CLS. 2, 13, 22, 25, 32 AND 50).

FIRST USE 3-11-2008; IN COMMERCE 3-11-2008.

CLASS 24—FABRICS

FOR CHILDREN'S BLANKETS; RECEIVING BLANKETS; BURP CLOTHS NOT OF PAPER; CRIB BUMPERS; COMFORTERS; HOODED TOWELS; WASH CLOTHS; FABRIC DIAPER STACKERS; DIAPER CHANGING PADS NOT OF PAPER (U.S. CLS. 42 AND 50).

FIRST USE 3-11-2008; IN COMMERCE 3-11-2008.

CLASS 25—CLOTHING

FOR CHILDREN'S EATING BIBS NOT OF PAPER; BOXERS; PAJAMAS; TANK TOPS (U.S. CLS. 22 AND 39).

FIRST USE 3-11-2008; IN COMMERCE 3-11-2008.

3,632,484. PRIMAVERA LIFE GMBH, SULZBERG, FED REP GERMANY. SN 77-390,907. PUB. 6-10-2008, FILED 2-7-2008.

PRIMAVERA

THE MARK CONSISTS OF STANDARD CHARACTERS WITHOUT CLAIM TO ANY PARTICULAR FONT, STYLE, SIZE, OR COLOR.

OWNER OF U.S. REG. NOS. 1,055,372, 3,051,081, AND OTHERS.

CLASS 3—COSMETICS AND CLEANING PREPARATIONS

FOR PERFUMERY; COSMETICS; ESSENTIAL OILS FOR PERSONAL USE; ESSENTIAL OILS FOR PERFUMED CANDLES; ESSENTIAL OILS FOR OIL BURNERS, ESSENTIAL OILS FOR SAUNAS; ESSENTIAL OILS IN AIRSPRAYS, FRAGRANCE OIL COMPRISED OF ESSENTIAL OILS; PERFUME OILS FOR THE MANUFACTURE OF COSMETIC PREPARATIONS (U.S. CLS. 1, 4, 6, 50, 51 AND 52).

FIRST USE 3-31-1997; IN COMMERCE 3-31-1997.

CLASS 21—HOUSEWARES AND GLASS

FOR FRAGRANCE OIL BURNERS, OIL DIFFUSER INCENSE BURNERS (U.S. CLS. 2, 13, 23, 29, 30, 33, 40 AND 50).

FIRST USE 3-31-1997; IN COMMERCE 3-31-1997.

CLASS 35—ADVERTISING AND BUSINESS

FOR WHOLESALE STORES AND RETAIL STORE SERVICES FEATURING COSMETICS, PERFUMERY, HAIR LOTIONS, SOAPS AND ESSENTIAL OILS, OIL BURNERS, INCENSE BURNERS AND STONE DIFFUSERS (U.S. CLS. 100, 101 AND 102).

FIRST USE 11-30-2005; IN COMMERCE 11-30-2005.

3,632,497. CBG, INC., LAS VEGAS, NV. SN 77-393,733. PUB. 6-24-2008, FILED 2-11-2008.

COLONIAL REWARDS

THE MARK CONSISTS OF STANDARD CHARACTERS WITHOUT CLAIM TO ANY PARTICULAR FONT, STYLE, SIZE, OR COLOR.

OWNER OF U.S. REG. NOS. 2,420,665, 2,949,066, AND OTHERS.

NO CLAIM IS MADE TO THE EXCLUSIVE RIGHT TO USE "REWARDS" IN INTERNATIONAL CLASS 35., APART FROM THE MARK AS SHOWN.

CLASS 35—ADVERTISING AND BUSINESS

FOR PROMOTING THE SALE OF THE GOODS AND SERVICES OF OTHERS THROUGH THE ADMINISTRATION OF CONSUMER LOYALTY INCENTIVE PROGRAMS FOR OTHERS WHEREIN PARTICIPANTS ACCUMULATE VALUE FROM PURCHASES THROUGH THE USE OF DEBIT CARD ACCOUNTS AND OTHER BANKING SERVICES ASSOCIATED WITH THE PROGRAM WHICH MAY BE REDEEMED FOR MERCHANDISE, DISCOUNTS, AND CASH PRIZES (U.S. CLS. 100, 101 AND 102).

FIRST USE 8-19-2008; IN COMMERCE 8-19-2008.

CLASS 36—INSURANCE AND FINANCIAL

FOR FINANCIAL SERVICES, NAMELY, BANKING, DEBIT AND CREDIT CARD SERVICES (U.S. CLS. 100, 101 AND 102).

FIRST USE 8-19-2008; IN COMMERCE 8-19-2008.

3,632,502. REMOTIS TECHNOLOGIES LLC, ALPHARETTA, GA. SN 77-394,490. PUB. 8-19-2008, FILED 2-12-2008.

REMOTIS

THE MARK CONSISTS OF STANDARD CHARACTERS WITHOUT CLAIM TO ANY PARTICULAR FONT, STYLE, SIZE, OR COLOR.

CLASS 9—ELECTRICAL AND SCIENTIFIC APPARATUS

FOR COMMUNICATIONS SERVERS; COMPUTER SERVERS; COMPUTER SOFTWARE FOR CONTROLLING AND MANAGING ACCESS SERVER APPLICATIONS; INTERNET SERVERS; NETWORK ACCESS SERVER HARDWARE; NETWORK ACCESS SERVER OPERATING SOFTWARE; GATEWAY ROUTERS IN THE NATURE OF COMPUTER CONTROL HARDWARE; COMPUTER NETWORK HUBS, SWITCHES AND ROUTERS (U.S. CLS. 21, 23, 26, 36 AND 38).

FIRST USE 5-14-2008; IN COMMERCE 5-14-2008.

CLASS 42—SCIENTIFIC AND COMPUTER SERVICES

FOR TECHNICAL SUPPORT SERVICES, NAMELY, TROUBLESHOOTING OF COMPUTER HARDWARE AND SOFTWARE PROBLEMS; CONSULTING SERVICES IN THE FIELD OF IDENTIFICATION, SUPPORT, AND IMPLEMENTATION OF COMPUTER-BASED INFORMATION SYSTEMS FOR BUSINESSES; TECHNICAL SUPPORT SERVICES, NAMELY, TROUBLESHOOTING OF COMPUTER SOFTWARE PROBLEMS; TECHNICAL SUPPORT, NAMELY, MONITORING OF NETWORK SYSTEMS; TECHNICAL SUPPORT, NAMELY, PROVIDING BACK-UP COMPUTER PROGRAMS AND FACILITIES; TECHNOLOGY ADVICE PROVIDED TO INTERNET USERS BY MEANS OF A SUPPORT HOTLINE; COMPUTER TECHNOLOGY SUPPORT SERVICES, NAMELY, HELP DESK SERVICES; APPLICATION SERVICE PROVIDER, NAMELY, PROVIDING, HOSTING, MANAGING, DEVELOPING, AND MAINTAINING APPLICATIONS, SOFTWARE, WEB SITES, AND DATABASES IN THE FIELDS OF PERSONAL PRODUCTIVITY, WIRELESS COMMUNICATION, MOBILE INFORMATION ACCESS, AND REMOTE DATA MANAGEMENT FOR WIRELESS DELIVERY OF CONTENT TO HANDHELD COMPUTERS, LAPTOPS AND MOBILE ELECTRONIC DEVICES; COMPUTER SERVICES, NAMELY, REMOTE AND ON-SITE MANAGEMENT OF ELECTRONIC MESSAGING SYSTEMS AND APPLICATIONS FOR OTHERS; COMPUTER SERVICES, NAMELY, REMOTE MANAGEMENT OF COMPUTER APPLICATIONS FOR OTHERS; COMPUTER COLOCATION SERVICES, NAMELY, PROVIDING FACILITIES FOR THE LOCATION OF COMPUTER SERVERS WITH THE EQUIPMENT OF OTHERS; DISPLAYING THE WEB SITES AND IMAGES OF OTHERS ON A COMPUTER SERVER; HOSTING THE WEB SITES OF OTHERS ON A COMPUTER SERVER FOR A GLOBAL COMPUTER NETWORK; RENTAL OF A DATABASE SERVER (TO THIRD PARTIES); RENTAL OF WEB SERVERS (U.S. CLS. 100 AND 101).

FIRST USE 12-1-2004; IN COMMERCE 12-1-2004.

3,632,503. CAMPCAST, LTD., LOVELAND, OH. SN 77-395,486. PUB. 10-14-2008, FILED 2-13-2008.

3,632,509. ALCHEMY IV, LLC, SALT LAKE CITY, UT. SN 77-396,419. PUB. 7-22-2008, FILED 2-13-2008.

SORC

THE MARK CONSISTS OF STANDARD CHARACTERS WITHOUT CLAIM TO ANY PARTICULAR FONT, STYLE, SIZE, OR COLOR.

CLASS 16—PAPER GOODS AND PRINTED MATTER

FOR PRINTED MATTER, NAMELY, EDUCATIONAL AND TEACHING MATERIALS IN THE FIELDS OF SALES PERFORMANCE, BUSINESS MANAGEMENT AND BUSINESS OPERATIONS (U.S. CLS. 2, 5, 22, 23, 29, 37, 38 AND 50).

FIRST USE 3-23-2009; IN COMMERCE 3-23-2009.

CLASS 35—ADVERTISING AND BUSINESS

FOR PROVIDING A WEBSITE FEATURING ANALYSIS AND REPORTING OF SALES PERFORMANCE, BUSINESS MANAGEMENT AND BUSINESS OPERATIONS DATA; BUSINESS MANAGEMENT AND BUSINESS CONSULTING SERVICES IN THE FIELDS OF SALES PERFORMANCE, BUSINESS MANAGEMENT AND BUSINESS OPERATIONS; ANALYSIS AND ADVISORY SERVICES RELATING TO SALES PERFORMANCE, BUSINESS MANAGEMENT AND BUSINESS OPERATIONS; PROVIDING BUSINESS REPORTS RELATING TO SALES PERFORMANCE, BUSINESS MANAGEMENT AND BUSINESS OPERATIONS (U.S. CLS. 100, 101 AND 102).

FIRST USE 3-10-2008; IN COMMERCE 3-10-2008.

3,632,504. UNITED VISION OF NEW YORK CORPORATION, NEW YORK, NY. SN 77-395,616. PUB. 7-29-2008, FILED 2-13-2008.



THE STIPPLING IS FOR SHADING PURPOSES ONLY. THE MARK CONSISTS OF THE STYLIZED WORD "UVCO" FOLLOWED BY AN ABSTRACT DESIGN AFTER THE LETTER "O".

CLASS 9—ELECTRICAL AND SCIENTIFIC APPARATUS

FOR OPHTHALMIC LENSES (U.S. CLS. 21, 23, 26, 36 AND 38).

FIRST USE 3-25-2004; IN COMMERCE 3-31-2006.

CLASS 10—MEDICAL APPARATUS

FOR EYE TESTING MACHINES AND APPARATUS (U.S. CLS. 26, 39 AND 44).

FIRST USE 3-25-2004; IN COMMERCE 3-31-2006.

Be Right Here

THE MARK CONSISTS OF STANDARD CHARACTERS WITHOUT CLAIM TO ANY PARTICULAR FONT, STYLE, SIZE, OR COLOR.

CLASS 16—PAPER GOODS AND PRINTED MATTER

FOR BUMPER STICKERS, BOOKMARKS AND PAPERWEIGHTS (U.S. CLS. 2, 5, 22, 23, 29, 37, 38 AND 50).

FIRST USE 7-11-2008; IN COMMERCE 7-11-2008.

CLASS 21—HOUSEWARES AND GLASS

FOR MUGS (U.S. CLS. 2, 13, 23, 29, 30, 33, 40 AND 50).

FIRST USE 7-11-2008; IN COMMERCE 7-11-2008.

CLASS 25—CLOTHING

FOR CLOTHING, NAMELY, T-SHIRTS, SWEATSHIRTS, VISORS AND CAPS (U.S. CLS. 22 AND 39).

FIRST USE 7-11-2008; IN COMMERCE 7-11-2008.

3,632,510. HEALTHY REBATES, INC., ALPHARETTA, GA. SN 77-396,642. PUB. 7-1-2008, FILED 2-14-2008.

My HSA Rewards

THE MARK CONSISTS OF STANDARD CHARACTERS WITHOUT CLAIM TO ANY PARTICULAR FONT, STYLE, SIZE, OR COLOR.

NO CLAIM IS MADE TO THE EXCLUSIVE RIGHT TO USE "HSA REWARDS", APART FROM THE MARK AS SHOWN.

CLASS 35—ADVERTISING AND BUSINESS

FOR ADMINISTERING CUSTOMER LOYALTY PROGRAMS THAT PROMOTE THE GOODS AND SERVICES OF OTHERS BY GENERATING REBATES PAYABLE TO CUSTOMERS' DESIGNATED SAVINGS ACCOUNTS THROUGH PRINTED AND ELECTRONIC MEDIA AND THROUGH THE GLOBAL COMPUTER NETWORK (U.S. CLS. 100, 101 AND 102).

FIRST USE 3-19-2009; IN COMMERCE 3-19-2009.

CLASS 36—INSURANCE AND FINANCIAL

FOR FINANCIAL SERVICES, NAMELY, GENERATING STORED VALUE ACCOUNTS AND ALLOCATING THEM TO EXISTING SAVINGS DEPOSIT ACCOUNTS (U.S. CLS. 100, 101 AND 102).

FIRST USE 3-19-2009; IN COMMERCE 3-19-2009.

3,632,522. BROWNELL, SUSAN, SPARTA, WI. SN 77-398,364. PUB. 7-8-2008, FILED 2-15-2008.

Sanctucare

THE MARK CONSISTS OF STANDARD CHARACTERS WITHOUT CLAIM TO ANY PARTICULAR FONT, STYLE, SIZE, OR COLOR.

CLASS 9—ELECTRICAL AND SCIENTIFIC APPARATUS

FOR DIGITAL MATERIALS, NAMELY, CDS, DVDS, AUDIO TAPES AND DOWNLOADABLE AUDIO FILES FEATURING INFORMATION IN THE FIELD OF CANCER PATIENT CARE (U.S. CLS. 21, 23, 26, 36 AND 38). FIRST USE 8-30-2008; IN COMMERCE 8-30-2008.

CLASS 16—PAPER GOODS AND PRINTED MATTER

FOR EDUCATIONAL PUBLICATIONS, NAMELY, BOOKS, HAND-OUTS, WORKBOOKS, PAMPHLETS, SERIES OF WRITTEN ARTICLES AND NEWSLETTERS IN THE FIELD OF CANCER PATIENT CARE (U.S. CLS. 2, 5, 22, 23, 29, 37, 38 AND 50). FIRST USE 8-30-2008; IN COMMERCE 8-30-2008.

CLASS 41—EDUCATION AND ENTERTAINMENT

FOR EDUCATION SERVICES, NAMELY, PROVIDING TELESEMINARS IN THE FIELD OF CANCER PATIENT CARE (U.S. CLS. 100, 101 AND 107). FIRST USE 8-30-2008; IN COMMERCE 8-30-2008.

CLASS 44—MEDICAL, BEAUTY AND AGRICULTURAL SERVICES

FOR PROVIDING INFORMATION IN THE FIELD OF CANCER PATIENT CARE VIA THE INTERNET (U.S. CLS. 100 AND 101). FIRST USE 8-30-2008; IN COMMERCE 8-30-2008.

CLASS 9—ELECTRICAL AND SCIENTIFIC APPARATUS

FOR RADIO FREQUENCY IDENTIFICATION (RFID) TAGS; RADIO FREQUENCY IDENTIFICATION (RFID) READERS; MODEMS; RADIO FREQUENCY IDENTIFICATION (RFID) TRACKING SYSTEMS COMPRISED OF RFID TAGS AND RFID READERS; COMPUTER HARDWARE SYSTEMS FOR TRACKING ASSETS AND PEOPLE USING RADIO FREQUENCY IDENTIFICATION (RFID) DEVICES (U.S. CLS. 21, 23, 26, 36 AND 38). FIRST USE 4-6-2009; IN COMMERCE 4-6-2009.

CLASS 35—ADVERTISING AND BUSINESS

FOR TRACKING, LOCATING AND MONITORING OF ASSETS AND PEOPLE FOR COMMERCIAL PURPOSES USING RADIO FREQUENCY IDENTIFICATION (RFID) TRACKING SYSTEMS; BUSINESS MANAGEMENT CONSULTANCY AND ADVISORY SERVICES, NAMELY, TRACKING ON-SITE BUSINESS ASSETS (U.S. CLS. 100, 101 AND 102). FIRST USE 4-6-2009; IN COMMERCE 4-6-2009.

CLASS 42—SCIENTIFIC AND COMPUTER SERVICES

FOR PROVIDING ON-LINE NON-DOWNLOADABLE SOFTWARE FOR TRACKING, LOCATING AND MONITORING OF ASSETS AND PEOPLE FOR USE WITH RADIO FREQUENCY IDENTIFICATION (RFID) TRACKING SYSTEMS; TECHNOLOGY CONSULTATION IN THE FIELD OF LOGISTICS AND RADIO FREQUENCY IDENTIFICATION (RFID) TRACKING SYSTEMS (U.S. CLS. 100 AND 101). FIRST USE 4-6-2009; IN COMMERCE 4-6-2009.

3,632,529. LES SHOEMMELIERS LLC, ST. HELENA, CA. SN 77-399,814. PUB. 11-18-2008, FILED 2-18-2008.

SHOEMMELIER

THE MARK CONSISTS OF STANDARD CHARACTERS WITHOUT CLAIM TO ANY PARTICULAR FONT, STYLE, SIZE, OR COLOR.

CLASS 36—INSURANCE AND FINANCIAL

FOR CHARITABLE FUND RAISING SERVICES (U.S. CLS. 100, 101 AND 102). FIRST USE 11-30-2007; IN COMMERCE 11-30-2007.

CLASS 41—EDUCATION AND ENTERTAINMENT

FOR EDUCATION SERVICES, NAMELY, PROVIDING SEMINARS AND SPECIAL EVENTS IN THE FIELD OF WINE TASTING AND APPRECIATION; ENTERTAINMENT SERVICES, NAMELY, WINE TASTINGS (U.S. CLS. 100, 101 AND 107). FIRST USE 11-30-2007; IN COMMERCE 11-30-2007.

3,632,524. INTERACTIVE LOT TECHNOLOGIES, INC., SOUTHAMPTON, PA. SN 77-399,031. PUB. 7-15-2008, FILED 2-16-2008.



NO CLAIM IS MADE TO THE EXCLUSIVE RIGHT TO USE "INTERACTIVE", APART FROM THE MARK AS SHOWN.

3,632,531. SWAN ENTERPRISES, INC., RENO, NV. SN 77-400,813. PUB. 7-8-2008, FILED 2-19-2008.

3,632,565. RADIOLOGICAL IMAGING TECHNOLOGY, INC., COLORADO SPRINGS, CO. SN 77-406,805. PUB. 7-15-2008, FILED 2-26-2008.

GLACIER OUTDOOR

THE MARK CONSISTS OF STANDARD CHARACTERS WITHOUT CLAIM TO ANY PARTICULAR FONT, STYLE, SIZE, OR COLOR.

OWNER OF U.S. REG. NO. 1,386,865.

NO CLAIM IS MADE TO THE EXCLUSIVE RIGHT TO USE "OUTDOOR", APART FROM THE MARK AS SHOWN.

CLASS 18—LEATHER GOODS

FOR BACKPACKS, HIKING BAGS, HUNTING BAGS (U.S. CLS. 1, 2, 3, 22 AND 41).

FIRST USE 7-1-2008; IN COMMERCE 7-1-2008.

CLASS 25—CLOTHING

FOR CLOTHING, NAMELY, SHIRTS, T-SHIRTS, SWEATSHIRTS, PANTS, GLOVES, SOCKS, HATS, CAPS, FISHING WADERS, BOOTS (U.S. CLS. 22 AND 39).

FIRST USE 7-1-2008; IN COMMERCE 7-1-2008.

3,632,556. INTERNET CONNECTIVITY GROUP, INC., LAKE FOREST, CA. SN 77-405,766. PUB. 7-8-2008, FILED 2-25-2008.



THE COLOR(S) BLACK, WHITE, GRAY AND GREEN IS/ARE CLAIMED AS A FEATURE OF THE MARK.

THE MARK CONSISTS OF DUAL HALF RINGS, GRAY AND GREEN IN COLOR, DEPICTING WIRELESS SIGNALS EMANATING FROM BLACK TEXT READING "ICNET" WITH A WHITE BACKGROUND.

CLASS 38—COMMUNICATION

FOR PROVIDING MOBILE MEDIA WIRELESS TELECOMMUNICATIONS SERVICES BY TRANSMISSION OF MEDIA CONTENT FOR DIGITAL SIGNAGE AND ALLOWING CUSTOMERS TO USE MOBILE TECHNOLOGY PRODUCTS TO WIRELESSLY INPUT AND OUTPUT DATA, AUDIO, VIDEO, TEXT AND VOICE TO AND FROM WIRELESSLY ENABLED DEVICES, NAMELY, MEDIA SERVERS, MEDIA ADAPTERS AND MEDIA PLAYERS; PROVIDING WIRELESS TELECOMMUNICATIONS SERVICES FOR WIFI USAGE IN HOT SPOTS AND WIFI ENVIRONMENTS (U.S. CLS. 100, 101 AND 104).

FIRST USE 2-26-2008; IN COMMERCE 2-26-2008.

CLASS 42—SCIENTIFIC AND COMPUTER SERVICES

FOR COMPUTER SERVICES, NAMELY, FILTERING OF UNWANTED CONTENT FROM THE INTERNET (U.S. CLS. 100 AND 101).

FIRST USE 2-26-2008; IN COMMERCE 2-26-2008.

MATHMAGICAL

THE MARK CONSISTS OF STANDARD CHARACTERS WITHOUT CLAIM TO ANY PARTICULAR FONT, STYLE, SIZE, OR COLOR.

CLASS 9—ELECTRICAL AND SCIENTIFIC APPARATUS

FOR COMPUTER HARDWARE AND SOFTWARE FOR MEDICAL IMAGING PROCESSING AND QUALITY CONTROL TESTING (U.S. CLS. 21, 23, 26, 36 AND 38).

FIRST USE 2-0-2009; IN COMMERCE 2-0-2009.

CLASS 42—SCIENTIFIC AND COMPUTER SERVICES

FOR QUALITY CONTROL TESTING OF THE MEDICAL IMAGE QUALITY OF MEDICAL IMAGING EQUIPMENT; CONSULTING SERVICES IN THE FIELD OF MEDICAL IMAGING HARDWARE AND SOFTWARE (U.S. CLS. 100 AND 101).

FIRST USE 0-0-2008; IN COMMERCE 0-0-2008.

CLASS 44—MEDICAL, BEAUTY AND AGRICULTURAL SERVICES

FOR MAINTAINING MEDICAL IMAGING FILES AND CONSULTING SERVICES IN THE FIELD OF MEDICAL IMAGING (U.S. CLS. 100 AND 101).

FIRST USE 0-0-2008; IN COMMERCE 0-0-2008.

3,632,577. RAPOI, INC., LAKE OSWEGO, OR. SN 77-409,627. PUB. 7-22-2008, FILED 2-29-2008.

RAPOI

THE MARK CONSISTS OF STANDARD CHARACTERS WITHOUT CLAIM TO ANY PARTICULAR FONT, STYLE, SIZE, OR COLOR.

CLASS 16—PAPER GOODS AND PRINTED MATTER

FOR LUNCH BAGS (U.S. CLS. 2, 5, 22, 23, 29, 37, 38 AND 50).

FIRST USE 8-12-2008; IN COMMERCE 8-12-2008.

CLASS 22—CORDAGE AND FIBERS

FOR POLY PROPYLENE BAGS USED FOR THE STORAGE OF FOOD AND BEVERAGE ITEMS (U.S. CLS. 1, 2, 7, 19, 22, 42 AND 50).

FIRST USE 8-12-2008; IN COMMERCE 8-12-2008.

3,632,578. RAPOI, INC., LAKE OSWEGO, OR. SN 77-409,650.
PUB. 7-22-2008, FILED 2-29-2008.



NO CLAIM IS MADE TO THE EXCLUSIVE RIGHT TO USE "REUSABLE RECYCLABLE", APART FROM THE MARK AS SHOWN.

THE MARK CONSISTS OF THE WORD "RAPOI" SURROUNDED BY A CIRCULAR SHAPE FORMED BY THE WORDS "REUSABLE RECYCLABLE AND PROUD OF IT", WHICH CIRCULAR SHAPE CONTAINS A DOT THAT PRECEDES THE WORD "REUSABLE", A DOT THAT PRECEDES THE WORD "RECYCLABLE", AND A DOT THAT FOLLOWS THE WORD "RECYCLABLE".

CLASS 16—PAPER GOODS AND PRINTED MATTER

FOR LUNCH BAGS (U.S. CLS. 2, 5, 22, 23, 29, 37, 38 AND 50).
FIRST USE 8-12-2008; IN COMMERCE 8-12-2008.

CLASS 22—CORDAGE AND FIBERS

FOR POLY PROPYLENE BAGS USED FOR THE STORAGE OF FOOD AND BEVERAGE ITEMS (U.S. CLS. 1, 2, 7, 19, 22, 42 AND 50).
FIRST USE 8-12-2008; IN COMMERCE 8-12-2008.

3,632,580. THE PROCTER & GAMBLE COMPANY, CINCINNATI, OH. SN 77-409,932. PUB. 7-22-2008, FILED 2-29-2008.



OWNER OF U.S. REG. NOS. 950,612, 3,340,962, AND OTHERS.

THE MARK CONSISTS OF THE WORD "BOUNCE" IN BUBBLE LETTERS OUT-LINED WITH TWO LINES.

CLASS 3—COSMETICS AND CLEANING PREPARATIONS

FOR FABRIC SOFTENERS (U.S. CLS. 1, 4, 6, 50, 51 AND 52).
FIRST USE 7-31-2008; IN COMMERCE 7-31-2008.

CLASS 21—HOUSEWARES AND GLASS

FOR LINT REMOVERS AND SCENT-DEPOSITING LINT REMOVERS (U.S. CLS. 2, 13, 23, 29, 30, 33, 40 AND 50).

FIRST USE 12-31-2008; IN COMMERCE 12-31-2008.

3,632,582. HALO LABS, LLC, NEW YORK, NY. SN 77-409,944.
PUB. 7-15-2008, FILED 2-29-2008.

Get Back to Life

THE MARK CONSISTS OF STANDARD CHARACTERS WITHOUT CLAIM TO ANY PARTICULAR FONT, STYLE, SIZE, OR COLOR.

CLASS 5—PHARMACEUTICALS

FOR ELECTROLYTE REPLACEMENT SOLUTIONS (U.S. CLS. 6, 18, 44, 46, 51 AND 52).

FIRST USE 1-13-2009; IN COMMERCE 1-13-2009.

CLASS 32—LIGHT BEVERAGES

FOR FRUIT-FLAVORED BEVERAGES (U.S. CLS. 45, 46 AND 48).

FIRST USE 1-13-2009; IN COMMERCE 1-13-2009.

3,632,593. EXPROSEED CO., LTD., TOKYO, JAPAN. SN 77-412,489. PUB. 7-22-2008, FILED 3-4-2008.

BackChannel

THE MARK CONSISTS OF "BACKCHANNEL" IN A STYLIZED FONT.

CLASS 18—LEATHER GOODS

FOR ALL PURPOSE SPORTS BAGS, BACKPACK, BEACH BAGS, BOOK BAGS, CALLING CARD CASES, CHANGE PURSES, COIN PURSES, DUFFEL BAGS, GYM BAGS, HANDBAGS, KNAPSACKS, SHOULDER BAGS, WAIST BAGS, KEY CASES, LEATHER KEY CHAINS, OVERNIGHT BAGS, PURSES, SATCHELS, TOTE BAGS, UMBRELLAS, WALLETS, BELT BAGS AND HIP BAGS, BOSTON BAGS, MESSENGER BAGS (U.S. CLS. 1, 2, 3, 22 AND 41).

FIRST USE 4-1-2000; IN COMMERCE 3-27-2008.

CLASS 25—CLOTHING

FOR FOOTWEAR; HEADWEAR, NAMELY, HATS AND CAPS, VISORS, SKULL CAPS, KNITTED CAPS; CLOTHING, NAMELY, BEACHWEAR, BELTS, GLOVES, SWEATBANDS, WRISTBANDS, HEAD SCARVES, HEAD SWEATBANDS, BOXER SHORTS, BRIEFS, UNDERWEAR, SOCKS, SHIRTS, JERSEY, T-SHIRTS, TANK TOPS, SWEATSHIRTS, HOODED SWEATSHIRTS, SWEATERS, VESTS, JACKETS, COATS, FLEECE PULLOVER SHIRTS, FLEECE PULLOVER JACKETS, FLEECE PULLOVER SWEATERS, WARM-UP SUITS, WIND JACKETS, WIND RESISTANT JACKETS, SHORTS, SWEATPANTS, PANTS AND TROUSERS, JEANS, OVERALLS, PARKAS (U.S. CLS. 22 AND 39).

FIRST USE 4-1-2000; IN COMMERCE 3-27-2008.

3,632,595. SAM ASH MUSIC CORPORATION, HICKSVILLE, NY. SN 77-412,766. PUB. 9-16-2008, FILED 3-4-2008.

GIG READY! GUITARS PREPARED WITH PRIDE

THE MARK CONSISTS OF STANDARD CHARACTERS WITHOUT CLAIM TO ANY PARTICULAR FONT, STYLE, SIZE, OR COLOR.

NO CLAIM IS MADE TO THE EXCLUSIVE RIGHT TO USE "GUITARS", APART FROM THE MARK AS SHOWN.

CLASS 15—MUSICAL INSTRUMENTS

FOR GUITARS (U.S. CLS. 2, 21 AND 36).
FIRST USE 5-31-2008; IN COMMERCE 5-31-2008.

CLASS 35—ADVERTISING AND BUSINESS

FOR RETAIL STORE SERVICES FEATURING MUSICAL INSTRUMENTS, NAMELY, GUITARS (U.S. CLS. 100, 101 AND 102).

FIRST USE 5-31-2008; IN COMMERCE 5-31-2008.

3,632,603. BILLY GRAHAM EVANGELISTIC ASSOCIATION, CHARLOTTE, NC. SN 77-413,248. PUB. 7-22-2008, FILED 3-5-2008.

ALWAYS GOOD NEWS

THE MARK CONSISTS OF STANDARD CHARACTERS WITHOUT CLAIM TO ANY PARTICULAR FONT, STYLE, SIZE, OR COLOR.

CLASS 9—ELECTRICAL AND SCIENTIFIC APPARATUS

FOR MOTION PICTURE FILMS AND MOTION PICTURE FILMS RECORDED ON DVDS FEATURING RELIGIOUS AND MORAL SUBJECTS (U.S. CLS. 21, 23, 26, 36 AND 38).

FIRST USE 2-9-2008; IN COMMERCE 2-9-2008.

CLASS 16—PAPER GOODS AND PRINTED MATTER

FOR NEWSLETTERS FEATURING RELIGIOUS AND MORAL TOPICS; MONTHLY MAGAZINES CONTAINING ARTICLES DEALING WITH RELIGIOUS AND MORAL TOPICS; BOOKS FEATURING RELIGIOUS AND MORAL TOPICS; TRAINING MANUALS, BROCHURES AND INFORMATIONAL FLYERS, ALL IN THE FIELD OF EVANGELICAL TRAINING (U.S. CLS. 2, 5, 22, 23, 29, 37, 38 AND 50).

FIRST USE 2-9-2008; IN COMMERCE 2-9-2008.

CLASS 35—ADVERTISING AND BUSINESS

FOR RETAIL STORES FEATURING BOOKS, GIFTS AND SOUVENIRS; ON-LINE RETAIL STORE SERVICES FEATURING BOOKS, PRE-RECORDED DIGITAL VIDEO DISKS (U.S. CLS. 100, 101 AND 102).

FIRST USE 2-9-2008; IN COMMERCE 2-9-2008.

CLASS 38—COMMUNICATION

FOR RADIO BROADCASTING (U.S. CLS. 100, 101 AND 104).

FIRST USE 2-9-2008; IN COMMERCE 2-9-2008.

CLASS 41—EDUCATION AND ENTERTAINMENT

FOR RELIGIOUS EDUCATIONAL SERVICES, NAMELY, TRAINING, SEMINARS, CONFERENCES, WORKSHOPS TO TEACH RELIGIOUS DOCTRINE AND GOSPEL, AND DISTRIBUTING COURSE MATERIALS IN CONNECTION THEREWITH; ENTERTAINMENT, NAMELY, A CONTINUING RELIGIOUS AND INSPIRATIONAL SHOW BROADCAST OVER TELEVISION, SATELLITE, AUDIO, AND VIDEO MEDIA (U.S. CLS. 100, 101 AND 107).

FIRST USE 2-9-2008; IN COMMERCE 2-9-2008.

CLASS 45—PERSONAL AND LEGAL SERVICES

FOR EVANGELISTIC MINISTERIAL SERVICES (U.S. CLS. 100 AND 101).

FIRST USE 2-9-2008; IN COMMERCE 2-9-2008.

3,632,616. KUSHNER, RICK A., LAKEWOOD, CO. SN 77-414,589. PUB. 10-28-2008, FILED 3-6-2008.

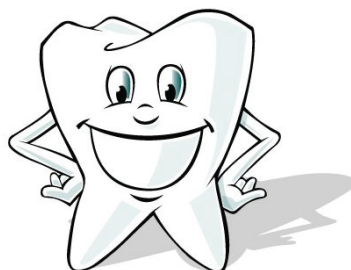

THE COLOR(S) LIGHT BLUE, BLACK, WHITE, AND GRAY IS/ARE CLAIMED AS A FEATURE OF THE MARK.

THE MARK CONSISTS OF A STYLIZED TOOTH WITH HUMAN CHARACTERISTICS WITH ITS HANDS ON ITS HIPS, WHEREIN THE TOOTH IS LIGHT BLUE, BLACK AND WHITE, AND A GRAY SHADOW OF THE TOOTH APPEARS ON THE BOTTOM OF THE MARK .

CLASS 41—EDUCATION AND ENTERTAINMENT

FOR ENTERTAINMENT SERVICES, NAMELY, PERSONAL APPEARANCES BY A MASCOT; ENTERTAINMENT SERVICES, NAMELY, CONDUCTING CONTESTS; CONDUCTING OF CONTESTS FOR CHILDREN IN THE AREA OF PROFESSIONAL SPORTS (U.S. CLS. 100, 101 AND 107).

FIRST USE 3-0-2009; IN COMMERCE 3-0-2009.

CLASS 44—MEDICAL, BEAUTY AND AGRICULTURAL SERVICES

FOR DENTIST SERVICES; DENTISTRY; ORTHODONTIC SERVICES; PROVIDING NEWS AND INFORMATION IN THE FIELD OF DENTISTRY (U.S. CLS. 100 AND 101).

FIRST USE 3-0-2009; IN COMMERCE 3-0-2009.

3,632,619. BP CORPORATION NORTH AMERICA INC., WARRENVILLE, IL. SN 77-415,148. PUB. 12-30-2008, FILED 3-6-2008.

OATS

THE MARK CONSISTS OF STANDARD CHARACTERS WITHOUT CLAIM TO ANY PARTICULAR FONT, STYLE, SIZE, OR COLOR.

CLASS 42—SCIENTIFIC AND COMPUTER SERVICES

FOR RESEARCH AND DEVELOPMENT OF TECHNOLOGY FOR OTHERS; CONSULTING SERVICES RELATING TO PROCESS TECHNOLOGY; LIAISON SERVICES TO FACILITATE THE EXCHANGE OF TECHNICAL AND TECHNOLOGICAL INFORMATION, NAMELY, PROVIDING INFORMATION IN THE FIELDS OF OIL REFINING TECHNOLOGY AND PETROCHEMICAL PROCESSING; INDUSTRIAL DESIGN SERVICES FOR OTHERS; PREPARATION OF ENGINEERING DRAWINGS, TECHNICAL DOCUMENTATION AND REPORTS; CHEMICAL ANALYSIS SERVICES; TECHNICAL SUPERVISION AND INSPECTION SERVICES; ALL SERVICES IN THE FIELDS OF OIL REFINING TECHNOLOGY AND PETROCHEMICAL PROCESSING (U.S. CLS. 100 AND 101).

FIRST USE 12-18-2008; IN COMMERCE 12-18-2008.

CLASS 45—PERSONAL AND LEGAL SERVICES

FOR LICENSING OF INTELLECTUAL PROPERTY; SUPPORT SERVICES IN THE FORM OF CONSULTANCY AND ADVISORY ASSISTANCE TO INTELLECTUAL PROPERTY LICENSEES (U.S. CLS. 100 AND 101).

FIRST USE 12-18-2008; IN COMMERCE 12-18-2008.

3,632,626. NATIONAL NETWORK OF DIGITAL SCHOOLS MANAGEMENT FOUNDATION, BEAVER, PA. SN 77-415,710. PUB. 7-22-2008, FILED 3-7-2008.



THE MARK CONSISTS OF AN IONIC COLUMN WITH FOUR SQUARES BEHIND IT AND THE WORDS "LITTLE LINCOLN" UNDERNEATH IT.

CLASS 16—PAPER GOODS AND PRINTED MATTER

FOR EDUCATIONAL PUBLICATIONS, NAMELY, WORKBOOKS, TEXT BOOKS, ACTIVITY BOOKS, AND A SERIES OF FICTION BOOKS FOR USE IN ELEMENTARY SCHOOL CURRICULUM (U.S. CLS. 2, 5, 22, 23, 29, 37, 38 AND 50).

FIRST USE 8-18-2008; IN COMMERCE 8-18-2008.

CLASS 41—EDUCATION AND ENTERTAINMENT

FOR EDUCATIONAL SERVICES, NAMELY, PROVIDING ONLINE COURSES OF INSTRUCTION AT THE ELEMENTARY SCHOOL LEVEL AND DISTRIBUTION OF COURSE MATERIAL IN CONNECTION THEREWITH (U.S. CLS. 100, 101 AND 107).

FIRST USE 8-18-2008; IN COMMERCE 8-18-2008.

3,632,627. TABRIO COMMUNICATIONS INC., VANCOUVER, CANADA. SN 77-416,355. PUB. 7-22-2008, FILED 3-7-2008.

TABRIO

THE MARK CONSISTS OF STANDARD CHARACTERS WITHOUT CLAIM TO ANY PARTICULAR FONT, STYLE, SIZE, OR COLOR.

CLASS 9—ELECTRICAL AND SCIENTIFIC APPARATUS

FOR COMPUTER SOFTWARE DOWNLOADABLE TO COMPUTERS OR MOBILE PHONES TO ENABLE CALLING USING VOICE OVER INTERNET PROTOCOLS (U.S. CLS. 21, 23, 26, 36 AND 38).

FIRST USE 6-26-2008; IN COMMERCE 6-26-2008.

CLASS 35—ADVERTISING AND BUSINESS

FOR COMMERCIAL INFORMATION SERVICES, NAMELY, ADVERTISING MANAGEMENT BY PLACING REPORTS, ADVERTISING TARGETING, AND MANAGEMENT OF ELECTRONICALLY STORED ADVERTISING, FOR USE ON A GLOBAL NETWORK OF PERSONAL COMPUTERS AND MOBILE PHONES (U.S. CLS. 100, 101 AND 102).

FIRST USE 6-26-2008; IN COMMERCE 6-26-2008.

CLASS 38—COMMUNICATION

FOR COMMUNICATION SERVICES, NAMELY, PROVIDING LONG DISTANCE CALLING SERVICES VIA MOBILE PHONES OR COMPUTERS USING VOICE OVER INTERNET PROTOCOLS THROUGH DOWNLOADABLE SOFTWARE ONLINE (U.S. CLS. 100, 101 AND 104).

FIRST USE 6-26-2008; IN COMMERCE 6-26-2008.

3,632,628. TABRIO COMMUNICATIONS INC., VANCOUVER, CANADA. SN 77-416,364. PUB. 7-22-2008, FILED 3-7-2008.

SAY IT YOUR WAY

THE MARK CONSISTS OF STANDARD CHARACTERS WITHOUT CLAIM TO ANY PARTICULAR FONT, STYLE, SIZE, OR COLOR.

CLASS 9—ELECTRICAL AND SCIENTIFIC APPARATUS

FOR COMPUTER SOFTWARE DOWNLOADABLE TO COMPUTERS OR MOBILE PHONES TO ENABLE CALLING USING VOICE OVER INTERNET PROTOCOLS (U.S. CLS. 21, 23, 26, 36 AND 38).

FIRST USE 6-26-2008; IN COMMERCE 6-26-2008.

CLASS 35—ADVERTISING AND BUSINESS

FOR COMMERCIAL INFORMATION SERVICES, NAMELY, ADVERTISING MANAGEMENT BY PLACING REPORTS, ADVERTISING TARGETING, AND MANAGEMENT OF ELECTRONICALLY STORED ADVERTISING, FOR USE ON A GLOBAL NETWORK OF PERSONAL COMPUTERS AND MOBILE PHONES (U.S. CLS. 100, 101 AND 102).

FIRST USE 6-26-2008; IN COMMERCE 6-26-2008.

CLASS 38—COMMUNICATION

FOR COMMUNICATION SERVICES, NAMELY, PROVIDING LONG DISTANCE CALLING SERVICES VIA MOBILE PHONES OR COMPUTERS USING VOICE OVER INTERNET PROTOCOLS THROUGH DOWNLOADABLE SOFTWARE ONLINE (U.S. CLS. 100, 101 AND 104).

FIRST USE 6-26-2008; IN COMMERCE 6-26-2008.

3,632,629. ORGANIC HAND, LLC, SIMSBURY, CT. SN 77-416,366. PUB. 7-22-2008, FILED 3-7-2008.

Organic Pick

THE MARK CONSISTS OF STANDARD CHARACTERS WITHOUT CLAIM TO ANY PARTICULAR FONT, STYLE, SIZE, OR COLOR.

NO CLAIM IS MADE TO THE EXCLUSIVE RIGHT TO USE "ORGANIC", APART FROM THE MARK AS SHOWN.

CLASS 29—MEATS AND PROCESSED FOODS

FOR ORGANIC FOODS, NAMELY, ORGANIC DRIED VEGETABLES, ORGANIC DRIED FRUITS, ORGANIC DRIED BEANS AND ORGANIC DRIED MILK (U.S. CL. 46).

FIRST USE 3-30-2009; IN COMMERCE 3-30-2009.

CLASS 30—STAPLE FOODS

FOR ORGANIC TEA, ORGANIC FLAVORED TEA, ORGANIC CHAI, ORGANIC COFFEE, ORGANIC TISANE, ORGANIC HONEY, ORGANIC SPICES, ORGANIC CONDIMENTS, NAMELY, MUSTARD, PEPPER, RELISH, AND CHUTNEY (U.S. CL. 46).

FIRST USE 2-15-2009; IN COMMERCE 2-15-2009.

3,632,637. 4 MY MOM, FRANKLIN LAKES, NJ. SN 77-417,640. PUB. 7-1-2008, FILED 3-10-2008.

CALL YOUR MOTHER

THE MARK CONSISTS OF STANDARD CHARACTERS WITHOUT CLAIM TO ANY PARTICULAR FONT, STYLE, SIZE, OR COLOR.

CLASS 16—PAPER GOODS AND PRINTED MATTER

FOR PHOTOGRAPHIC ALBUM; MEMORY BOOKS; DIARIES (U.S. CLS. 2, 5, 22, 23, 29, 37, 38 AND 50).

FIRST USE 3-11-2008; IN COMMERCE 3-11-2008.

CLASS 18—LEATHER GOODS

FOR DIAPER BAGS (U.S. CLS. 1, 2, 3, 22 AND 41).

FIRST USE 3-11-2008; IN COMMERCE 3-11-2008.

CLASS 20—FURNITURE AND ARTICLES NOT OTHERWISE CLASSIFIED

FOR PILLOWS; NAP SACKS IN THE NATURE OF LIGHT SLEEPING BAGS (U.S. CLS. 2, 13, 22, 25, 32 AND 50).

FIRST USE 3-11-2008; IN COMMERCE 3-11-2008.

CLASS 24—FABRICS

FOR CHILDREN'S BLANKETS; RECEIVING BLANKETS; BURP CLOTHS NOT OF PAPER; CRIB BUMPERS; COMFORTERS; HOODED TOWELS; WASH CLOTHS; FABRIC DIAPER STACKERS; DIAPER CHANGING PADS NOT OF PAPER (U.S. CLS. 42 AND 50).

FIRST USE 3-11-2008; IN COMMERCE 3-11-2008.

CLASS 25—CLOTHING

FOR CHILDREN'S EATING BIBS NOT OF PAPER; BOXERS; PAJAMAS; TANK TOPS (U.S. CLS. 22 AND 39).

FIRST USE 3-11-2008; IN COMMERCE 3-11-2008.

3,632,638. MILESTONE AV TECHNOLOGIES LLC, SAVAGE, MN. SN 77-417,867. PUB. 7-8-2008, FILED 3-10-2008.

THINSTALL

THE MARK CONSISTS OF STANDARD CHARACTERS WITHOUT CLAIM TO ANY PARTICULAR FONT, STYLE, SIZE, OR COLOR.

CLASS 6—METAL GOODS

FOR METAL AUDIO, VIDEO, AND COMPUTER WALL AND CEILING MOUNTS (U.S. CLS. 2, 12, 13, 14, 23, 25 AND 50).

FIRST USE 12-5-2008; IN COMMERCE 12-5-2008.

CLASS 20—FURNITURE AND ARTICLES NOT OTHERWISE CLASSIFIED

FOR NON-METAL AUDIO, VIDEO, AND COMPUTER WALL AND CEILING MOUNTS; FURNITURE, NAMELY, AUDIO SPEAKER STANDS AND AUDIO AND VIDEO EQUIPMENT STANDS, CABINETS, AND TABLES (U.S. CLS. 2, 13, 22, 25, 32 AND 50).

FIRST USE 12-5-2008; IN COMMERCE 12-5-2008.

CLASS 5—PHARMACEUTICALS

FOR GELS FOR USE AS PERSONAL LUBRICANTS; WATER-BASED PERSONAL LUBRICANTS; SILICONE-BASED PERSONAL LUBRICANTS; AIR FRESHENERS (U.S. CLS. 6, 18, 44, 46, 51 AND 52).

FIRST USE 12-1-2008; IN COMMERCE 12-1-2008.

CLASS 6—METAL GOODS

FOR NON-LUMINOUS AND NON-MECHANICAL METAL SIGNS; METAL KEY CHAINS (U.S. CLS. 2, 12, 13, 14, 23, 25 AND 50).

FIRST USE 9-1-2008; IN COMMERCE 9-1-2008.

CLASS 9—ELECTRICAL AND SCIENTIFIC APPARATUS

FOR DECORATIVE MAGNETS (U.S. CLS. 21, 23, 26, 36 AND 38).

FIRST USE 7-1-2008; IN COMMERCE 7-1-2008.

CLASS 10—MEDICAL APPARATUS

FOR PERSONAL MASSAGE APPARATUS (U.S. CLS. 26, 39 AND 44).

FIRST USE 11-1-2008; IN COMMERCE 11-1-2008.

CLASS 14—JEWELRY

FOR JEWELRY AND IMITATION JEWELRY (U.S. CLS. 2, 27, 28 AND 50).

FIRST USE 11-1-2008; IN COMMERCE 11-1-2008.

CLASS 20—FURNITURE AND ARTICLES NOT OTHERWISE CLASSIFIED

FOR PILLOWS; MIRRORS ENHANCED BY ELECTRIC LIGHTS; NON-METAL AND NON-LEATHER KEY CHAINS (U.S. CLS. 2, 13, 22, 25, 32 AND 50).

FIRST USE 7-1-2008; IN COMMERCE 7-1-2008.

CLASS 21—HOUSEWARES AND GLASS

FOR BEVERAGE GLASSWARE (U.S. CLS. 2, 13, 23, 29, 30, 33, 40 AND 50).

FIRST USE 9-1-2008; IN COMMERCE 9-1-2008.

CLASS 24—FABRICS

FOR BLANKET THROWS (U.S. CLS. 42 AND 50).

FIRST USE 8-1-2008; IN COMMERCE 8-1-2008.

3,632,649. GULF SOUTH MEDICAL SUPPLY, INC., JACKSONVILLE, FL. SN 77-421,203. PUB. 7-29-2008, FILED 3-13-2008.

NIGHTINGALE

THE MARK CONSISTS OF STANDARD CHARACTERS WITHOUT CLAIM TO ANY PARTICULAR FONT, STYLE, SIZE, OR COLOR.

OWNER OF U.S. REG. NO. 2,849,333.

CLASS 5—PHARMACEUTICALS

FOR MEDICATED SKIN CARE PREPARATIONS, NAMELY, CREAMS, LOTIONS, GELS, WASHES AND CLEANSERS INTENDED FOR SALE TO HOSPITALS AND OTHER MEDICAL INSTITUTIONS; NURSING PADS (U.S. CLS. 6, 18, 44, 46, 51 AND 52).

FIRST USE 8-31-2002; IN COMMERCE 8-31-2002.

CLASS 10—MEDICAL APPARATUS

FOR BED UNDERPADS, BED LINEN PROTECTORS, LOW-FRICTION BED UNDERPADS, LOW-FRICTION BED LINERS, ALL FOR MEDICAL USE (U.S. CLS. 26, 39 AND 44).

FIRST USE 1-31-2008; IN COMMERCE 1-31-2008.

3,632,667. SPENCER GIFTS L.L.C., EGG HARBOR TOWNSHIP, NJ. SN 77-425,026. PUB. 12-2-2008, FILED 3-18-2008.

SEXY BITCH

THE MARK CONSISTS OF STANDARD CHARACTERS WITHOUT CLAIM TO ANY PARTICULAR FONT, STYLE, SIZE, OR COLOR.

CLASS 3—COSMETICS AND CLEANING PREPARATIONS

FOR BODY LOTIONS, BODY CREAMS AND MASSAGE OILS; COSMETICS, NAMELY, LIP GLOSS (U.S. CLS. 1, 4, 6, 50, 51 AND 52).

FIRST USE 12-1-2008; IN COMMERCE 12-1-2008.

3,632,673. BATH & BODY WORKS BRAND MANAGEMENT, INC., REYNOLDSBURG, OH. SN 77-426,942. PUB. 6-24-2008, FILED 3-20-2008.

POCKETBAC

THE MARK CONSISTS OF STANDARD CHARACTERS WITHOUT CLAIM TO ANY PARTICULAR FONT, STYLE, SIZE, OR COLOR.

CLASS 3—COSMETICS AND CLEANING PREPARATIONS

FOR ANTIBACTERIAL SKIN SOAPS; HAND CLEANERS; HAND SOAPS; LIQUID SOAP (U.S. CLS. 1, 4, 6, 50, 51 AND 52).

FIRST USE 7-0-2008; IN COMMERCE 7-0-2008.

CLASS 5—PHARMACEUTICALS

FOR ANTIBACTERIAL ALCOHOL SKIN SANITIZER GEL; HAND-SANITIZING PREPARATIONS (U.S. CLS. 6, 18, 44, 46, 51 AND 52).

FIRST USE 7-0-2008; IN COMMERCE 7-0-2008.

3,632,674. CELEBDIRECT, INC., BEVERLY HILLS, CA. SN 77-427,335. PUB. 8-5-2008, FILED 3-20-2008.

EXTREME MACHINE

THE MARK CONSISTS OF STANDARD CHARACTERS WITHOUT CLAIM TO ANY PARTICULAR FONT, STYLE, SIZE, OR COLOR.

NO CLAIM IS MADE TO THE EXCLUSIVE RIGHT TO USE "MACHINE", APART FROM THE MARK AS SHOWN.

CLASS 10—MEDICAL APPARATUS

FOR EXERCISE MACHINES FOR THERAPEUTIC PURPOSES (U.S. CLS. 26, 39 AND 44).

FIRST USE 4-11-2008; IN COMMERCE 6-15-2008.

CLASS 28—TOYS AND SPORTING GOODS

FOR EXERCISE MACHINES; MANUAL LEG EXERCISERS; MANUALLY-OPERATED EXERCISE EQUIPMENT (U.S. CLS. 22, 23, 38 AND 50).

FIRST USE 4-11-2008; IN COMMERCE 6-15-2008.

3,632,715. TOTAL SYSTEM SERVICES, INC., COLUMBUS, GA. SN 77-436,158. PUB. 8-12-2008, FILED 3-31-2008.

n>genuity

THE MARK CONSISTS OF STANDARD CHARACTERS WITHOUT CLAIM TO ANY PARTICULAR FONT, STYLE, SIZE, OR COLOR.

CLASS 9—ELECTRICAL AND SCIENTIFIC APPARATUS

FOR ELECTRONIC PUBLICATIONS, NAMELY, MAGAZINE FEATURING ARTICLES AND INFORMATION IN THE FIELD OF ELECTRONIC PAYMENTS ADMINISTRATION AND PROCESSING RECORDED ON COMPUTER MEDIA (U.S. CLS. 21, 23, 26, 36 AND 38).

FIRST USE 10-20-2008; IN COMMERCE 10-20-2008.

CLASS 16—PAPER GOODS AND PRINTED MATTER

FOR MAGAZINES FEATURING ARTICLES AND INFORMATION IN THE FIELD OF ELECTRONIC PAYMENTS ADMINISTRATION AND PROCESSING (U.S. CLS. 2, 5, 22, 23, 29, 37, 38 AND 50).

FIRST USE 10-20-2008; IN COMMERCE 10-20-2008.

3,632,717. SCALLO, DIANE, WESTWOOD, NJ. SN 77-436,579. PUB. 9-2-2008, FILED 4-1-2008.

THE DIET DIRECTOR

THE MARK CONSISTS OF STANDARD CHARACTERS WITHOUT CLAIM TO ANY PARTICULAR FONT, STYLE, SIZE, OR COLOR.

NO CLAIM IS MADE TO THE EXCLUSIVE RIGHT TO USE "DIET", APART FROM THE MARK AS SHOWN.

CLASS 5—PHARMACEUTICALS

FOR DIET CAPSULES; DIET PILLS; DIETARY AND NUTRITIONAL SUPPLEMENTS; DIETARY DRINK MIX FOR USE AS A MEAL REPLACEMENT; DIETARY FOOD SUPPLEMENTS; DIETARY SUPPLEMENTAL DRINKS; DIETARY SUPPLEMENTS; DIETARY SUPPLEMENTS FOR HUMAN CONSUMPTION; FOOD FOR MEDICALLY RESTRICTED DIETS; FOOD SUPPLEMENTS; HERBAL SUPPLEMENTS; MEAL REPLACEMENT AND DIETARY SUPPLEMENT DRINK MIXES; MEAL REPLACEMENT BARS; MEAL REPLACEMENT DRINKS; MEAL REPLACEMENT POWDERS; MEAL REPLACEMENT SHAKES; MINERAL FOOD SUPPLEMENTS; MINERAL SUPPLEMENTS; NUTRITIONAL DRINK MIX FOR USE AS A MEAL REPLACEMENT; NUTRITIONAL ENERGY BARS FOR USE AS A MEAL SUBSTITUTE; NUTRITIONAL SHAKES FOR USE AS A MEAL SUBSTITUTE; NUTRITIONAL SUPPLEMENTS; NUTRITIONALLY FORTIFIED BEVERAGES; NUTRITIONALLY FORTIFIED WATER; POWDERED FRUIT-FLAVORED DIETARY SUPPLEMENT DRINK MIX; POWDERED NUTRITIONAL SUPPLEMENT DRINK MIX; SOY PROTEIN FOR USE AS A NUTRITIONAL INGREDIENT IN VARIOUS POWDERED AND READY-TO-DRINK BEVERAGES; THERAPEUTIC AGENTS FOR WEIGHT CONTROL AND APPETITE SUPPRESSION; VITAMIN AND MINERAL SUPPLEMENTS; VITAMIN ENRICHED WATER; VITAMIN SUPPLEMENTS; NUTRITIONAL ADDITIVES FOR MEDICAL PURPOSES FOR USE IN FOODS AND DIETARY SUPPLEMENTS FOR HUMAN CONSUMPTION (U.S. CLS. 6, 18, 44, 46, 51 AND 52).

FIRST USE 4-1-2008; IN COMMERCE 4-1-2008.

CLASS 35—ADVERTISING AND BUSINESS

FOR ON-LINE ORDERING SERVICES FEATURING DIETARY SUPPLEMENTS; OPERATING AN ONLINE SHOPPING SITE IN THE FIELD OF DIETARY SUPPLEMENTS; PROMOTING PUBLIC AWARENESS OF HEALTH, NUTRITION AND LIFESTYLE WELLNESS; PROVIDING ASSISTANCE, FITNESS EVALUATION AND CONSULTATION TO CORPORATE CLIENTS TO HELP THEIR EMPLOYEES MAKE HEALTH, WELLNESS AND NUTRITIONAL CHANGES IN THEIR DAILY LIVING TO INCREASE PRODUCTIVITY AND LOWER HEALTH CARE COSTS (U.S. CLS. 100, 101 AND 102).

FIRST USE 4-1-2008; IN COMMERCE 4-1-2008.

CLASS 44—MEDICAL, BEAUTY AND AGRICULTURAL SERVICES

FOR COUNSELING SERVICES IN THE FIELDS OF HEALTH, NUTRITION AND LIFESTYLE WELLNESS; FOOD NUTRITION CONSULTATION; NUTRITION COUNSELING; PROVIDING A WEB SITE FEATURING INFORMATION ON HEALTH AND NUTRITION; PROVIDING A WEB SITE THAT FEATURES INFORMATION ON CHILDREN'S NUTRITION; PROVIDING AN ON-LINE COMPUTER DATABASE FEATURING INFORMATION REGARDING HEALTH AND NUTRITION; PROVIDING ASSISTANCE, FITNESS EVALUATION AND CONSULTATION TO INDIVIDUALS TO HELP THEM MAKE HEALTH, WELLNESS AND NUTRITIONAL CHANGES IN THEIR DAILY LIVING TO IMPROVE HEALTH; PROVIDING INFORMATION ABOUT DIETARY SUPPLEMENTS AND NUTRITION; PROVIDING WELLNESS SERVICES, NAMELY, PERSONAL ASSESSMENTS, PERSONALIZED ROUTINES, MAINTENANCE SCHEDULES, AND COUNSELING; VITAMIN THERAPY; PROVIDING A WEB SITE FEATURING EDUCATIONAL INFORMATION REGARDING NUTRITION AND GENETICS; DIETARY AND NUTRITIONAL GUIDANCE; WEIGHT REDUCTION DIET PLANNING AND SUPERVISION; PROVIDING ASSISTANCE, FITNESS EVALUATION AND CONSULTATION TO CORPORATE CLIENTS TO HELP THEIR EMPLOYEES MAKE HEALTH, WELLNESS AND NUTRITIONAL CHANGES IN THEIR DAILY LIVING TO IMPROVE HEALTH (U.S. CLS. 100 AND 101).

FIRST USE 4-1-2008; IN COMMERCE 4-1-2008.

3,632,729. CELEBDIRECT, INC., BEVERLY HILLS, CA. SN 77-440,186. PUB. 7-29-2008, FILED 4-4-2008.

MUSCLE FLEX

THE MARK CONSISTS OF STANDARD CHARACTERS WITHOUT CLAIM TO ANY PARTICULAR FONT, STYLE, SIZE, OR COLOR.

CLASS 10—MEDICAL APPARATUS

FOR EXERCISE MACHINES FOR THERAPEUTIC PURPOSES (U.S. CLS. 26, 39 AND 44).

FIRST USE 4-11-2008; IN COMMERCE 6-15-2008.

CLASS 28—TOYS AND SPORTING GOODS

FOR EXERCISE MACHINES; MANUAL LEG EXERCISERS; MANUALLY-OPERATED EXERCISE EQUIPMENT (U.S. CLS. 22, 23, 38 AND 50).

FIRST USE 4-11-2008; IN COMMERCE 6-15-2008.

3,632,736. TROPICAL NUT & FRUIT CO., CHARLOTTE, NC. SN 77-441,968. PUB. 7-22-2008, FILED 4-7-2008.

CHRISTILLE BAY

THE MARK CONSISTS OF STANDARD CHARACTERS WITHOUT CLAIM TO ANY PARTICULAR FONT, STYLE, SIZE, OR COLOR.

CLASS 29—MEATS AND PROCESSED FOODS

FOR PROCESSED NUTS; CANDIED NUTS; DRIED FRUIT; SNACK MIXES CONSISTING PRIMARILY OF PROCESSED NUTS AND DRIED FRUIT (U.S. CL. 46).

FIRST USE 7-1-2008; IN COMMERCE 7-1-2008.

CLASS 30—STAPLE FOODS

FOR CANDY; CANDIED NUTS; SNACK MIXES CONSISTING PRIMARILY OF CRACKERS, PRETZELS AND CANDIED NUTS; PRETZELS, SESAME STICKS AND CRACKERS (U.S. CL. 46).

FIRST USE 7-1-2008; IN COMMERCE 7-1-2008.

3,632,738. THE PROCTER & GAMBLE COMPANY, CINCINNATI, OH. SN 77-442,496. PUB. 7-29-2008, FILED 4-8-2008.



OWNER OF U.S. REG. NO. 3,389,568.

THE COLOR(S) BLUE, YELLOW AND RED IS/ARE CLAIMED AS A FEATURE OF THE MARK.

THE MARK CONSISTS OF THE WORD "TIDE" IN THE COLOR BLUE, SUPERIMPOSED ON THREE RADIAL SYMMETRICAL BANDS IN THE COLORS YELLOW, RED AND YELLOW, RESPECTIVELY.

CLASS 3—COSMETICS AND CLEANING PREPARATIONS

FOR DRY CLEANING FLUIDS (U.S. CLS. 1, 4, 6, 50, 51 AND 52).

FIRST USE 9-4-2008; IN COMMERCE 9-4-2008.

CLASS 37—CONSTRUCTION AND REPAIR

FOR DRY CLEANING (U.S. CLS. 100, 103 AND 106).

FIRST USE 9-4-2008; IN COMMERCE 9-4-2008.

3,632,739. IMED, LLC, DBA IMED COST CONTAINMENT SOLUTION, AURORA, CO. SN 77-442,621. PUB. 9-9-2008, FILED 4-8-2008.

IMED COST CONTAINMENT SOLUTION

THE MARK CONSISTS OF STANDARD CHARACTERS WITHOUT CLAIM TO ANY PARTICULAR FONT, STYLE, SIZE, OR COLOR.

NO CLAIM IS MADE TO THE EXCLUSIVE RIGHT TO

USE "COST CONTAINMENT SOLUTION", APART FROM THE MARK AS SHOWN.

3,632,751. HOBBS BROOK MANAGEMENT LLC, WALTHAM, MA. SN 77-445,818. PUB. 11-4-2008, FILED 4-11-2008.

CLASS 35—ADVERTISING AND BUSINESS

FOR WORKER'S COMPENSATION INSURANCE CLAIMS AUDITING SERVICES; BUSINESS NETWORKING REFERRAL SERVICES, NAMELY, PROMOTING THE GOODS AND SERVICES OF OTHERS BY REFERRING CLIENTS TO NETWORKS OFFERING ADDITIONAL DISCOUNTS ON DURABLE MEDICAL EQUIPMENT, PRESCRIPTION SERVICES AND SPECIFIC FORMULARY DRUGS, AND PREFERRED PROVIDER SERVICES (U.S. CLS. 100, 101 AND 102).

FIRST USE 3-11-2009; IN COMMERCE 3-11-2009.

CLASS 36—INSURANCE AND FINANCIAL

FOR PROVIDING INFORMATION IN INSURANCE MATTERS, NAMELY, PROVIDING INFORMATION TO FACILITATE WORKER'S COMPENSATION INSURANCE CLAIMS AUDITING (U.S. CLS. 100, 101 AND 102).

FIRST USE 3-11-2009; IN COMMERCE 3-11-2009.



CLASS 36—INSURANCE AND FINANCIAL

FOR COMMERCIAL REAL ESTATE ACQUISITION, MANAGEMENT, AND LEASING (U.S. CLS. 100, 101 AND 102).

FIRST USE 3-10-2009; IN COMMERCE 3-10-2009.

CLASS 37—CONSTRUCTION AND REPAIR

FOR COMMERCIAL REAL ESTATE DEVELOPMENT (U.S. CLS. 100, 103 AND 106).

FIRST USE 3-10-2009; IN COMMERCE 3-10-2009.

3,632,747. CHILDREN, INC., COVINGTON, KY. SN 77-445,221. PUB. 8-26-2008, FILED 4-10-2008.

3,632,754. WRIGHT, RICHARD K., KENNEWICK, WA. SN 77-446,264. PUB. 9-2-2008, FILED 4-11-2008.

GROWING SOUND

THE MARK CONSISTS OF STANDARD CHARACTERS WITHOUT CLAIM TO ANY PARTICULAR FONT, STYLE, SIZE, OR COLOR.

CLASS 9—ELECTRICAL AND SCIENTIFIC APPARATUS

FOR PRE-RECORDED AUDIO AND AUDIOVISUAL WORKS AND RELATED MERCHANDISE FEATURING MUSIC AND ENTERTAINMENT FOR CHILDREN (U.S. CLS. 21, 23, 26, 36 AND 38).

FIRST USE 2-24-2009; IN COMMERCE 2-24-2009.

CLASS 35—ADVERTISING AND BUSINESS

FOR ON-LINE RETAIL STORE SERVICES IN THE FIELD OF CHILDREN'S MUSIC AND ENTERTAINMENT FEATURING PRE-RECORDED AUDIO AND AUDIOVISUAL WORKS AND RELATED MERCHANDISE, PROVIDED VIA THE INTERNET AND OTHER COMPUTER AND ELECTRONIC COMMUNICATION NETWORKS (U.S. CLS. 100, 101 AND 102).

FIRST USE 2-24-2009; IN COMMERCE 2-24-2009.

Disc Comfort

THE MARK CONSISTS OF STANDARD CHARACTERS WITHOUT CLAIM TO ANY PARTICULAR FONT, STYLE, SIZE, OR COLOR.

CLASS 9—ELECTRICAL AND SCIENTIFIC APPARATUS

FOR PRE-RECORDED MEDIA, NAMELY, DVDS RELATING TO PERSONAL HEALTH AND WELLNESS, NAMELY, BACK INJURY PREVENTION AND TREATMENT (U.S. CLS. 21, 23, 26, 36 AND 38).

FIRST USE 6-1-2000; IN COMMERCE 6-1-2000.

CLASS 16—PAPER GOODS AND PRINTED MATTER

FOR PRINTED PUBLICATIONS, NAMELY, BOOKS, BOOKLETS, MANUALS, PAMPHLETS, BROCHURES, AND ARTICLES RELATING TO PERSONAL HEALTH AND WELLNESS, NAMELY, BACK INJURY PREVENTION AND TREATMENT (U.S. CLS. 2, 5, 22, 23, 29, 37, 38 AND 50).

FIRST USE 8-17-1990; IN COMMERCE 8-17-1990.

CLASS 41—EDUCATION AND ENTERTAINMENT

FOR PROVIDING TRAINING TO OTHERS RELATING TO PERSONAL HEALTH AND WELLNESS, NAMELY, BACK INJURY PREVENTION AND TREATMENT (U.S. CLS. 100, 101 AND 107).

FIRST USE 8-17-1990; IN COMMERCE 8-17-1990.

CLASS 44—MEDICAL, BEAUTY AND AGRICULTURAL SERVICES

FOR PROVIDING INFORMATION IN THE FIELDS OF PERSONAL HEALTH AND WELLNESS, NAMELY, BACK INJURY PREVENTION AND TREATMENT (U.S. CLS. 100 AND 101).

FIRST USE 8-17-1990; IN COMMERCE 8-17-1990.

CLASS 36—INSURANCE AND FINANCIAL

FOR MANAGEMENT OF REAL ESTATE; LEASING OF REAL ESTATE; REAL ESTATE ACQUISITION SERVICES; REAL ESTATE EQUITY SHARING, NAMELY, MANAGING AND ARRANGING FOR CO-OWNERSHIP OF REAL ESTATE; COMMERCIAL REAL ESTATE INVESTMENT; AND REAL ESTATE SYNDICATION (U.S. CLS. 100, 101 AND 102).

FIRST USE 10-24-2008; IN COMMERCE 10-24-2008.

3,632,773. WAL-MART STORES, INC., BENTONVILLE, AR. SN 77-451,109. PUB. 7-22-2008, FILED 4-17-2008.

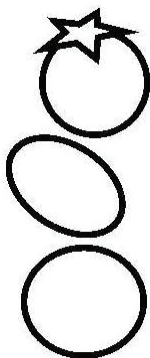

THE MARK CONSISTS OF A STYLIZED DEPICTION OF THREE FRUITS STACKED VERTICALLY ON TOP OF EACH OTHER WITH THE SHAPE OF A STAR ON TOP OF THE STACK, REPRESENTING A LEAF OR STEM.

CLASS 37—CONSTRUCTION AND REPAIR

FOR REAL ESTATE DEVELOPMENT (U.S. CLS. 100, 103 AND 106).

FIRST USE 10-24-2008; IN COMMERCE 10-24-2008.

3,632,805. BOWMAN, DAVID J., LOS ANGELES, CA. SN 77-463,218. PUB. 10-7-2008, FILED 5-1-2008.

School's Over -- Now What?

CLASS 35—ADVERTISING AND BUSINESS

FOR ONLINE RETAIL GROCERY STORE SERVICES; RETAIL GROCERY STORE SERVICES; RETAIL DELICATESSEN SERVICES (U.S. CLS. 100, 101 AND 102).

FIRST USE 10-6-2008; IN COMMERCE 10-6-2008.

CLASS 43—HOTEL AND RESTAURANT SERVICES

FOR PREPARATION OF FOOD AND BEVERAGES (U.S. CLS. 100 AND 101).

FIRST USE 10-6-2008; IN COMMERCE 10-6-2008.

THE MARK CONSISTS OF STANDARD CHARACTERS WITHOUT CLAIM TO ANY PARTICULAR FONT, STYLE, SIZE, OR COLOR.

3,632,793. RXR PROPERTY MANAGEMENT LLC, UNIONDALE, NY. SN 77-457,423. PUB. 9-23-2008, FILED 4-24-2008.



THE MARK CONSISTS OF STANDARD CHARACTERS WITHOUT CLAIM TO ANY PARTICULAR FONT, STYLE, SIZE, OR COLOR.

CLASS 9—ELECTRICAL AND SCIENTIFIC APPARATUS

FOR PRE-RECORDED AUDIO TAPES, AUDIO COMPACT DISCS, AND MP3 FORMAT COMPUTER FILES FEATURING EMPLOYMENT COUNSELING AND CAREER PLANNING ADVICE AND STRATEGIES (U.S. CLS. 21, 23, 26, 36 AND 38).

FIRST USE 11-4-2008; IN COMMERCE 11-4-2008.

CLASS 16—PAPER GOODS AND PRINTED MATTER

FOR WORKBOOKS, TRAINING MANUALS, AND PRINTED COURSE MATERIALS IN THE FIELDS OF EMPLOYMENT COUNSELING AND CAREER PLANNING ADVICE AND STRATEGIES (U.S. CLS. 2, 5, 22, 23, 29, 37, 38 AND 50).

FIRST USE 11-4-2008; IN COMMERCE 11-4-2008.

3,632,855. SAWA AMANA & JAHA, INC., FAIRFIELD, CA.
SN 77-482,941. PUB. 10-28-2008, FILED 5-23-2008.



THE MARK CONSISTS OF STYLIZED LETTERS "JD4U".

CLASS 9—ELECTRICAL AND SCIENTIFIC APPARATUS

FOR AIR TANKS; AIR TANKS FOR USE IN SCUBA DIVING; BAGS AND CASES SPECIALLY ADAPTED FOR HOLDING OR CARRYING PORTABLE TELEPHONES AND TELEPHONE EQUIPMENT AND ACCESSORIES; BAGS FOR CAMERAS AND PHOTOGRAPHIC EQUIPMENT; BAGS SPECIALLY ADAPTED FOR PROTECTIVE HELMETS; BIVOUAC SACKS, NAMELY, WIND AND WATER RESISTANT BAGS INTO WHICH A PERSON CAN FIT TO PROTECT THEMSELVES FROM EXPOSURE TO THE ELEMENTS; BULLET-PROOF VESTS; BULLET-PROOF VESTS AND CLOTHING; BUOYANCY COMPENSATOR JACKET FOR USE IN SCUBA DIVING; CAMERA STABILITY ACCESSORY, NAMELY, A SUPPORT ARM, VEST AND SLED FOR FILM AND VIDEO CAMERAS TO ABSORB SHAKING MOVES WHILE SHOOTING; CELL PHONE COVERS; CLEAR PROTECTIVE COVERS SPECIALLY ADAPTED FOR PERSONAL ELECTRONIC DEVICES; CONTROL SYSTEMS FOR AIRPORT BAGGAGE HANDLING SYSTEMS, CONSISTING OF A SINGLE OR MULTIPLE PROGRAMMABLE CONTROLLERS (PLC) WITH INPUT AND OUTPUT FEATURES FOR DIGITAL DEVICES, WITH CAPABILITY OF BEING CONNECTED TO EXTERNAL SUPERVISORY COMPUTERS; COVERS FOR TELEPHONE RECEIVERS NOT MADE OF PAPER; DECORATIVE AND FANCIFUL ITEMS FOR COVERING OF, AND FOR USE IN CONNECTION WITH PROTECTIVE HELMETS; DECORATIVE COVERS FOR SMOKE DETECTORS; DECORATIVE SWITCH PLATE COVERS; DESK OR CAR MOUNTED UNITS INCORPORATING A LOUDSPEAKER TO ALLOW A TELEPHONE HANDSET TO BE USED HANDS-FREE; DIVING SUITS; DUST COVERS FOR COMPUTERS; ELASTOMERIC APPLIQUES FOR PLACEMENT ONTO ELECTRONIC DEVICES TO PREVENT SLIPPING; ELECTRIC OUTLET COVERS; EYE COVERS FOR PROTECTIVE PURPOSES; FIRE BLANKETS; FIRE BLANKETS AND FIRE EXTINGUISHERS; FIRE-RESISTANT FLYING SUITS; FITTED FABRIC COVER FOR A GARMENT STEAMER HEAD; FITTED PLASTIC FILMS KNOWN AS SKINS FOR COVERING AND PROVIDING A SCRATCH PROOF BARRIER OR PROTECTION FOR ELECTRONIC DEVICES, NAMELY, MP3 PLAYERS, MOBILE TELEPHONES, SMART TELEPHONES, DIGITAL CAMERAS, GLOBAL POSITIONING SYSTEMS AND PERSONAL DIGITAL ASSISTANTS; FITTED RADIO COVERS USED TO PROTECT AUTOMOBILE RADIOS; FLOTATION VESTS; HARD HATS; IMAGE FUSER UNITS FOR COMPUTER PRINTERS COMPRISING ELECTRO-MECHANICAL ROLLERS FOR THE PURPOSE OF TRANSFERRING TONER ONTO PAPER; IMAGE TRANSFER KITS FOR COMPUTER PRINTERS, NAMELY, KITS FORMING PARTS OF PRINTERS COMPRISING BELTS, TONER AND DRUMS FOR THE PURPOSE OF TRANSFERRING IMAGES ONTO PAPER; INTEGRATED SUITE OF GLOBAL TAX MANAGEMENT SOFTWARE; JACKETS FOR COMPUTER DISKS; JACKETS FOR VIDEO CASSETTES; LIFE JACKETS; LIFESAVING VESTS FOR

USE BY DOGS; MESSENGER BAGS ESPECIALLY ADAPTED FOR HOLDING LAPTOPS; PROTECTIVE EAR COVERINGS; PROTECTIVE INDUSTRIAL BOOTS; PROTECTIVE SUITS FOR AVIATORS; ROBOTIC EXOSKELETON SUITS WORN BY HUMANS FOR THE PURPOSE OF ENHANCING THE STRENGTH AND ENDURANCE OF THE PERSON WEARING THE SUIT; SAFETY PRODUCTS, NAMELY, REFLECTIVE HELMET SKIRTS; SAFETY RESTRAINTS; SPACE SUITS; SPECIALLY ADAPTED COMPUTER INPUT DEVICE COVER FEATURING A DISINFECTING CAPABILITY; SURVIVAL SUITS; SURVIVAL SUITS, NAMELY, INSULATED OVERALL WET SUITS AND DRY SUITS; WATER SKI SAFETY VESTS; WATERPROOF SURVIVAL SUITS FOR THE PREVENTION OF DROWNING; WIND SOCKS FOR INDICATING WIND DIRECTION AND INTENSITY (U.S. CLS. 21, 23, 26, 36 AND 38).

FIRST USE 11-17-2008; IN COMMERCE 2-2-2009.

CLASS 16—PAPER GOODS AND PRINTED MATTER

FOR ADVERTISING BOARDS OF PAPER OR CARDBOARD; ADVERTISING SIGNS OF PAPER OR CARDBOARD; ALUMINUM FOIL LAMINATED PAPER FOR PRINTING PURPOSES; ART PAPER; AUTOMATIC PAPER CLIP DISPENSING MACHINES FOR OFFICE OR STATIONERY USE; BABIES' DIAPERS OF PAPER; BAGS FOR MICROWAVE COOKING; BANNERS OF PAPER; BIBS OF PAPER; BINDING MATERIALS FOR BOOKS AND PAPERS; BLANK OR PARTIALLY PRINTED PAPER LABELS; BLANK PAPER COMPUTER TAPES; BLANK PAPER COMPUTER TAPES FOR RECORDING PROGRAMS; BLANK PAPER NOTEBOOKS; BLANK PAPER TAPES AND CARDS FOR THE RECORDING OF COMPUTER PROGRAMS; BOND PAPER; BOOK-COVER PAPER; BOTTLE WRAPPERS OF CARDBOARD OR PAPER; BOXES OF PAPER OR CARDBOARD; BUSINESS CARD PAPER; CALENDAR-FINISHED PAPER; CALLIGRAPHY PAPER; CARBON PAPER; CARBON PAPER; CARDBOARD MADE FROM PAPER MULBERRY (SENKASI); CARRYING CASES MADE OF PAPER; CHECKBOOK COVERS; COASTERS MADE OF PAPER; COASTERS OF PAPER; COLLAPSIBLE BOXES OF PAPER; COMPOSITE PANELS CONSISTING OF A SPECIALLY-FORMULATED PAPERBOARD CORE WITH DENSE PAPER FACES FOR USE IN FURTHER MANUFACTURING; CONSTRUCTION PAPER; COPIER PAPER; COPY PAPER; CORRUGATED BOARD AND PAPER CONTAINERS; CORRUGATED PAPER; CORRUGATED PAPER PANELS LAMINATED WITH BLEACHED WHITE PAPER PRIMARILY FOR APPLICATION OF PRINTED MEDIA FOR FURTHER USE IN SIGNAGE APPLICATIONS; CORRUGATED PAPER PANELS LAMINATED WITH KRAFT LINERBOARD PRIMARILY FOR LAMINATION WITH DECORATIVE OVERLAYS FOR FURTHER USE IN THE CONSTRUCTION OF WALL PARTITIONS, ROOM DIVIDERS, DESKTOPS PS AND TABLETOPS; COSMETIC REMOVING PAPER; COVERS OF PAPER FOR FLOWER POTS; CRAFT PAPER; CREPE PAPER; CREPE PAPER FOR MEDICAL, SANITARY OR DOMESTIC USE; CUSHIONING OR PADDING MADE OF PAPER FOR PACKING PURPOSES; DECORATIVE PAPER CENTERPIECES; DIGITAL PRINTING PAPER; DIRECTORY PAPER; DISPOSABLE PAPER SHEETS FOR PERSONAL HYGIENIC USE IN THE NATURE OF DISPOSABLE HEADREST COVERS NOT FOR MEDICAL USE; DISPOSABLE SWIM PANTS FOR CHILDREN AND INFANTS; DOCUMENT COVERS; DRAWING PAPER; DUPLICATING PAPER; DYE-SUBLIMATION PRINT PAPER; EKG PAPER; ELECTROCARDIOGRAPH PAPER; ELECTROSTATIC PAPER; EMBROIDERY DESIGN PATTERNS; ENVELOPE PAPER; ENVELOPE PAPERS; EXERCISE-BOOK COVERS; FABRIC GIFT BAGS; FACE TOWELS OF PAPER; FACSIMILE TRANSMISSION PAPER; FIBER PAPER; FILING FOLDERS, PAPER LABELS AND PRINTED INSTRUCTIONAL MATERIALS FOR ORGANIZING PERSONAL FILES; FILLER PAPER; FILTER PAPER; FLAGS AND PENNANTS OF PAPER; FLAGS OF PAPER; FLUORESCENT PAPER; FLUTING PAPER; FOOD BAG TAPE FOR FREEZER USE; FREE-STANDING AND WALL-MOUNTED PAPER AND CARDBOARD BOXES FOR DEPOSITING A WRITTEN MESSAGE OR PRAYER WISHING A LOVED ONE WELL, FOR USE IN HOSPITALS, ELDER CARE RESIDENCES, SCHOOLS, AND INSTITUTIONS FOR CHILDREN WITH SPECIAL NEEDS; GARBAGE BAGS OF PAPER; GARBAGE BAGS

OF PAPER; GARBAGE BAGS OF PLASTIC; GARBAGE BAGS OF PLASTICS; GENERAL PURPOSE PLASTIC BAGS; GIFT WRAP PAPER; GIFT WRAPPING PAPER; GIFT-WRAPPING PAPER; GLASSINE PAPER; GRAPH PAPER; GROCERY BAGS; GROCERY PAPER; GUMMED PAPER; GUNPOWDER WRAPPING PAPER; HALLOWEEN GOODIE BAGS OF PAPER OR PLASTIC; HAND TOWELS OF PAPER; HANDKERCHIEFS OF PAPER; HANDPAINTED PAPER WINE BOTTLE LABELS; HAT BOXES OF CARDBOARD; HAT BOXES OF PAPER; HEAT SENSITIVE PAPER; HEAT TRANSFER PAPER; HONEYCOMB PAPER; HYGIENIC PAPER; ILLUSTRATION PAPER; IMITATION LEATHER PAPER; INDIA PAPER; INDUSTRIAL PACKAGING CONTAINERS OF PAPER; JAPANESE CEREMONIAL PAPER STRINGS (MIZUHIKI); JAPANESE HANDICRAFT PAPER; JAPANESE PAPER; JAPANESE PAPER (TORINO-KO-GAMI); KRAFT PAPER; LABEL PAPER; LAMINATED PAPER; LAMINATED PAPERS TO BE AFFIXED TO THE SURFACE OF FURNITURE; LASER PRINT PAPER; LASER PRINTING PAPER; LAWN AND LEAF DISPOSAL BAGS; LEAF DISPOSAL BAGS; LEATHER APPOINTMENT BOOK COVERS; LEATHER BOOK COVERS; LETTER PAPER; LETTERHEAD PAPER; LINING PAPER; LOOSE LEAF PAPER; LUMINOUS PAPER; LUNCH BAGS; LUNCH BAGS MADE OF TEXTILE; MAGAZINE PAPER; MAGNETIC PAPER; MANIFOLD PAPER; MASKING PAPER; MERCHANDISE BAGS; METALLIC GIFT WRAPPING PAPER; METALLIC PAPER PARTY DECORATIONS; MICROWAVE COOKING BAGS; MILDEWPROOF PAPER; MIMEOGRAPH PAPER; MODELING MATERIALS FOR USE IN MAKING CAST PAPER SCULPTURED FLOWERS; MOISTUREPROOF CELLOPHANE PAPER; MULCH PAPER; NAPKIN PAPER; NAPKINS OF PAPER FOR REMOVING MAKE-UP; NEWSPRINT PAPER; NOTE PAPER; NOTE PAPERS; NOTEBOOK PAPER; OFFICE PAPER DRILL MACHINES; OFFICE PAPER STATIONERY; OFFSET PAPER; OFFSET PRINTING PAPER FOR PAMPHLETS; OILED PAPER FOR PAPER UMBRELLAS (KASA-GAMI); OILPROOF PAPER; ONION SKIN PAPER; OPAQUE PAPER; PACKAGING AND CONTAINERS COMPRISED OF STARCH-BASED MATERIALS IN THE NATURE OF A PAPER SUBSTITUTE FOR FOOD, BEVERAGES AND CONSUMER PRODUCTS; PACKAGING CONTAINERS OF PAPER; PACKING PAPER; PAINT ROLLER COVERS; PAPER; PAPER AND CARDBOARD; PAPER BABY BIBS; PAPER BADGES; PAPER BAGS; PAPER BAGS AND SACKS; PAPER BAGS FOR PACKAGING; PAPER BANNERS; PAPER BOARD; PAPER BOARDS; PAPER BOWS FOR GIFT WRAP; PAPER BOXES; PAPER BOXES FOR STORING GREETING CARDS; PAPER BUNTING; PAPER CAKE DECORATIONS; PAPER CARTON SEALING TAPE; PAPER CARTONS FOR DELIVERING GOODS; PAPER CLIP HOLDERS; PAPER CLIPS; PAPER CLOSURES FOR CONTAINERS; PAPER CLOSURES FOR SEALING CONTAINERS; PAPER CONTAINERS; PAPER CONTAINING MICA; PAPER COVERS FOR TELEPHONE RECEIVERS; PAPER CUTTERS; PAPER DIAPERS; PAPER DIE CUT SHAPES; PAPER DISPLAY BOXES; PAPER DOILIES; PAPER DROP CLOTHS; PAPER EGG CARTONS; PAPER EMBLEMS; PAPER EMBOSSERS; PAPER ENVELOPES FOR PACKAGING; PAPER EXPANDING FILES; PAPER FASTENERS; PAPER FILE JACKETS; PAPER FILTERS FOR COFFEE MAKERS; PAPER FLAGS; PAPER FLOOR MATS; PAPER FLOWER POT COVERS; PAPER FOLDERS; PAPER FOR BAGS AND SACKS; PAPER FOR JAPANESE INDOOR SLIDING PARTITIONS (FUSUMA-GAMI); PAPER FOR JAPANESE SLIDING SCREENS (SHOJI-GAMI); PAPER FOR PHOTOCOPIES; PAPER FOR PHOTOCOPYING; PAPER FOR RECORDING MACHINES; PAPER FOR USE AS MATERIAL OF STOCK CERTIFICATES (SHOKENSHI); PAPER FOR USE IN THE GRAPHIC ARTS INDUSTRY; PAPER FOR USE IN THE MANUFACTURE OF WALLPAPER; PAPER FOR WRAPPING AND PACKAGING; PAPER FUTON COVERS; PAPER GARBAGE BAGS; PAPER GIFT BAGS; PAPER GIFT BAGS FOR WINE; PAPER GIFT TAGS; PAPER GIFT WRAP; PAPER GIFT WRAP BOWS; PAPER GIFT WRAPPING RIBBONS; PAPER HAND-TOWELS; PAPER HANDKERCHIEFS; PAPER HANDTOWELS; PAPER HANG TAGS; PAPER HOLE PUNCHES; PAPER IDENTIFICATION TAGS; PAPER ILLUSTRATION BOARDS; PAPER KNIVES; PAPER LABELS; PAPER LACE; PAPER LINERS FOR DIAPERS; PAPER MACHE; PAPER MACHE FIGURINES; PAPER MADE FROM PAPER MULBERRY (KOHZO-GAMI); PAPER MADE FROM PAPER MULBERRY (TENGUJOSI); PAPER MAIL

POUCHES; PAPER MATS; PAPER NAME BADGES; PAPER NAPKINS; PAPER NOTE TABLETS; PAPER NOTEBOOKS; PAPER PACKAGING AND CONTAINERS FOR FOOD AND BEVERAGES COMPRISED OF MATERIALS DESIGNED TO LESSEN ADVERSE EFFECTS ON THE ENVIRONMENT; PAPER PADDING; PAPER PADS FOR CHANGING DIAPERS; PAPER PARTY BAGS; PAPER PARTY DECORATIONS; PAPER PARTY FAVORS; PAPER PATCHES FOR CLOTHING; PAPER PENNANTS; PAPER PET CRATE MATS; PAPER PICTURE MOUNTS; PAPER PILLOWCASES; PAPER PLACE MATS; PAPER POUCHES FOR PACKAGING; PAPER PRODUCTS, NAMELY, PAPER TUBES; PAPER PRODUCTS, NAMELY, PAPER TUBES AND PAPER CORES; PAPER RACKS; PAPER REFUSE BAGS; PAPER REPORT COVERS; PAPER RIBBONS; PAPER ROLLS FOR CALCULATING MACHINES; PAPER SHEETS FOR NOTE TAKING; PAPER SHOPPING BAGS; PAPER SHREDDERS; PAPER SIGN HOLDERS; PAPER STAPLERS; PAPER STAPLES; PAPER STATIONERY; PAPER STOCK; PAPER TABLE CLOTHS; PAPER TABLE LINENS; PAPER TAGS; PAPER TAKE-OUT CARTONS FOR FOOD; PAPER TAPE; PAPER TAPES; PAPER TAPES FOR CALCULATING MACHINES; PAPER TAPES FOR CALCULATORS; PAPER TISSUES FOR COSMETIC USE; PAPER TOILET BOWL LINERS; PAPER TOWELS; PAPER TRANSPARENCIES; PAPER TRAY COVERS; PAPER WASHCLOTHS; PAPER WEIGHTS; PAPER WINE GIFT BAGS; PAPER-FEEDING MACHINES FOR OFFICE USE; PAPERS FOR HOUSEHOLD AND INDUSTRIAL USE; PAPERS FOR USE IN THE GRAPHIC ARTS INDUSTRY; PARAFFINED PAPER; PARCHMENT PAPER; PARTY GOODIE BAGS OF PAPER OR PLASTIC; PARTY ORNAMENTS OF PAPER; PASSBOOK COVERS; PASSPORT COVERS; PENNANTS OF PAPER; PHOTOCOPY PAPERS; PICTURE MOUNTS OF PAPER; PLACARDS OF PAPER OR CARDBOARD; PLACE MATS OF PAPER; PLASTIC BAGS FOR DISPOSABLE DIAPERS; PLASTIC BAGS FOR DISPOSING OF PET WASTE; PLASTIC BAGS FOR PACKAGING; PLASTIC BAGS FOR PACKAGING ICE; PLASTIC BAGS FOR PACKING; PLASTIC BAGS FOR UNDERGARMENT DISPOSAL; PLASTIC COATED COPYING PAPER; PLASTIC DISPOSABLE DIAPER BAGS; PLASTIC FOOD STORAGE BAGS FOR HOUSEHOLD USE; PLASTIC GARBAGE BAGS; PLASTIC OR PAPER BAGS FOR HOUSEHOLD USE; PLASTIC OR PAPER BAGS FOR MERCHANDISE PACKAGING; PLASTIC OVEN COOKING BAGS; PLASTIC SANDWICH BAGS; PLASTIC SHOPPING BAGS; PLASTIC TRASH BAGS; PLASTIC TRASH COMPACTOR BAGS; PLASTIC-COATED COPYING PAPER; PLOTTING PAPERS; POLYESTER FILM FOR USE AS A PAPER SUBSTITUTE FOR DRY TONER XEROGRAPHIC IMAGING, NAMELY, LASER PRINTING, COLOR COPIER PRINTING, DRY TONER PRINTING, SCREEN PRINTING, AND OFFSET PRINTING; POSTCARD PAPER; POSTERS MADE OF PAPER; PRINTED PAPER LABELS; PRINTED PAPER SIGNS; PRINTED PAPER SIGNS, NAMELY, TABLE TENTS; PRINTERS' BLANKETS, NOT OF TEXTILE; PRINTING PAPER; PRINTING PAPERS; PROOFING PAPER; PROTECTIVE COVERS FOR BOOKS; PROTECTIVE COVERS FOR SHEETS OR PAPER AND PAGES OF BOOKS AND THE LIKE; PUBLICATION PAPER; RECYCLED BOND PAPER; RECYCLED PAPER; REEL PAPER FOR PRINTERS; REPRODUCTION PAPER; RICE PAPER; RUBBISH BAGS (MADE OF PAPER OR PLASTIC MATERIALS); RULED PAPER; SAFETY PAPER; SCENTED PAPER DRAWER LINERS; SCHOOL SUPPLY KITS CONTAINING VARIOUS COMBINATIONS OF SELECTED SCHOOL SUPPLIES, NAMELY, WRITING INSTRUMENTS, PENS, PENCILS, MECHANICAL PENCILS, ERASERS, MARKERS, CRAYONS, HIGHLIGHTERS, FOLDERS, NOTEBOOKS, PAPER, PROTRACTORS, PAPER CLIPS, PENCIL SHARPENERS, WRITING GRIPS, GLUE AND BOOK MARKS; SEMI-PROCESSED PAPER; SHELF PAPER; SPECIALTY PAPERS, NAMELY, VEGETABLE PARCHMENT, FOR USE IN FOOD WRAPPING, PREPARATION, PROCESSING AND PACKAGING APPLICATIONS; STATIONERY WRITING PAPER AND ENVELOPES; STENCIL PAPER; STENCIL PAPER; STENCILS AND PATTERNS, BEING OF PAPER AND PLASTIC, FOR THE TRANSFERRING OF GRAPHIC DESIGNS TO PUMPKINS, MINI-PUMPKINS, GOURDS, AND OTHER FRUITS AND VEGETABLES; STORAGE CONTAINERS MADE OF PAPER; STRIPS OF FANCY PAPER (TANZAKU); SUPERCALANDERED PRINTING PAPER; SYNTHETIC BOND PAPER; SYNTHETIC PAPER; TABLE CLOTHS OF PAPER; TABLE LINENS OF PAPER; TABLE MATS OF PAPER;

TABLE NAPKINS OF PAPER; TEXTILE GIFT BAGS FOR WINE; TEXTILE WINE GIFT BAGS; THERMOSENSITIVE PAPER; THICK JAPANESE PAPER; TISSUE PAPER; TISSUE PAPER FOR USE AS MATERIAL OF STENCIL PAPER (GANPISHI); TISSUES OF PAPER FOR REMOVING MAKE-UP; TOILET PAPER; TOILET SEAT COVER PAPER; TOILET TRAINING TARGETS MADE OF PAPER; TRACING PAPER; TRADING CARD DISCS OF PAPER OR CARDBOARD; TRADING CARD MILK BOTTLE CAPS; TRASH BAGS; TRASH CAN LINERS; TREATED PAPER FOR WRAPPING FLOWERS AND FLORAL DISPLAYS; TYPEWRITER PAPER; UNFITTED FURNITURE COVERS OF PAPER; UNPRINTED PAPER; UNSENSITIZED PHOTO PAPER; WATERPROOF PAPER; WAX BOND PAPER; WAX PAPER; WOOD PULP PAPER; WORKS OF ART MADE FROM CUSTOM MANUFACTURED PAPER; WRAPPING PAPER; WRITING PAPER; WRITING PAPER HOLDERS; WRITING PAPER PADS; XEROGRAPHIC PAPER (U.S. CLS. 2, 5, 22, 23, 29, 37, 38 AND 50).

FIRST USE 9-15-2008; IN COMMERCE 2-2-2009.

CLASS 18—LEATHER GOODS

FOR ALL PURPOSE SPORT BAGS; ALL-PURPOSE ATHLETIC BAGS; ALL-PURPOSE CARRYING BAGS; ANIMAL GAME BAGS; ATHLETIC BAGS; BABY CARRYING BAGS; BACKPACKS, BOOK BAGS, SPORTS BAGS, BUM BAGS, WALLETS AND HANDBAGS; BAGS AND HOLDALLS FOR SPORTS CLOTHING; BAGS FOR CARRYING BABIES' ACCESSORIES; BAGS FOR SPORTS; BAGS FOR UMBRELLAS; BANDS OF LEATHER; BARREL BAGS; BEACH BAGS; BELT BAGS; BELT BAGS AND HIP BAGS; BOOK BAGS; BOSTON BAGS; BRIEFCASES; BUM BAGS; CANTLE BAGS; CANVAS SHOPPING BAGS; CARRY-ALL BAGS; CARRY-ON BAGS; CHALK BAGS; CHARM BAGS (OMAMORI-IRE); CLUTCH BAGS; COSMETIC BAGS SOLD EMPTY; DIAPER BAGS; DUFFEL BAGS; DUFFEL BAGS FOR TRAVEL; DUFFEL BAGS; FEED BAGS FOR ANIMALS; FLEXIBLE BAGS FOR GARMENTS; GAITERS, NAMELY, JUMPING BOOTS FOR HORSES; GARMENT BAGS FOR TRAVEL; GENERAL PURPOSE BAGS FOR CARRYING YOGA EQUIPMENT; GLADSTONE BAGS; GYM BAGS; HAT BOXES FOR TRAVEL NOT OF PAPER OR CARDBOARD; HAT BOXES OF LEATHER; HIKING BAGS; HORSE FLANKS AND SHANKS, NAMELY, HORSE PROTECTIVE PADDING, BRACES, AND LEG BOOTS FOR THE FLANKS AND LEGS; HORSE TAIL BAGS; HUNTERS' GAME BAGS; HUNTING BAGS; IMITATION LEATHER; IMITATION LEATHER KEY CHAINS; IMITATION LEATHER SOLD IN BULK; INFANT CARRIERS WORN ON THE BODY; JAPANESE OILED-PAPER UMBRELLAS (JANOME-GASA); JAPANESE PAPER UMBRELLAS (KARAKASA); KEY BAGS; KEY-CASES OF LEATHER AND SKINS; KIT BAGS; LEATHER; LEATHER AND IMITATION LEATHER; LEATHER AND IMITATION LEATHER BAGS; LEATHER BAGS FOR MERCHANDISE PACKAGING; LEATHER BAGS, SUITCASES AND WALLETS; LEATHER BOXES FOR STORING GREETING CARDS; LEATHER BRIEFCASES; LEATHER CASES; LEATHER CASES FOR KEYS; LEATHER FOR FURNITURE; LEATHER FOR HARNESES; LEATHER FOR SHOES; LEATHER HANDBAGS; LEATHER KEY CASES; LEATHER KEY CHAINS; LEATHER POUCHES; LEATHER PURSES; LEATHER SHOPPING BAGS; LEATHER SHOULDER BELTS; LEATHER SOLD IN BULK; LEATHER STRAPS; LEATHER THONGS; LEATHER THREAD; LUGGAGE; LUGGAGE AND TRUNKS; LUGGAGE TAGS; MAKE-UP BAGS SOLD EMPTY; MEN'S CLUTCH BAGS; MESH SHOPPING BAGS; MESSENGER BAGS; NON-MOTORIZED, COLLAPSIBLE LUGGAGE CARTS; OVERNIGHT BAGS; PAPER FOR USE AS ANIMAL BEDDING; PAPER-REINFORCED CELLULOSE FOOD CASINGS; PET ACCESSORIES, NAMELY, CANVAS, VINYL AND LEATHER POUCHES FOR HOLDING DISPOSABLE BAGS TO PLACE PET WASTE IN; PET ACCESSORIES, NAMELY, SPECIALLY DESIGNED CANVAS, VINYL OR LEATHER BAGS ATTACHED TO ANIMAL LEASHES FOR HOLDING SMALL ITEMS SUCH AS KEYS, CREDIT CARDS, MONEY OR DISPOSABLE BAGS FOR DISPOSING OF PET WASTE; POMMEL BAGS; POUCHES AND BAGS SOLD EMPTY FOR ATTACHMENT TO BACKPACKS; POUCHES OF LEATHER; PROTECTIVE FITTED LINERS FOR BACKPACKS AND LUGGAGE; ROLL BAGS; SADDLE BLANKETS; SADDLE COVERS;

SADDLE HORN BAGS; SADDLERY OF LEATHER; SADDLERY, NAMELY, HORN BAGS; SCHOOL BAGS; SCHOOL BOOK BAGS; SHAVING BAGS SOLD EMPTY; SHOE BAGS FOR TRAVEL; SHOPPING BAGS MADE OF SKIN; SHOPPING BAGS WITH WHEELS ATTACHED; SHOULDER BAGS; SLING BAGS; SLING BAGS FOR CARRYING INFANTS; SLINGS FOR CARRYING INFANTS; SMALL BAGS FOR MEN; SOUVENIR BAGS; SPORT BAGS; SPORTS BAGS; SPORTSMAN'S HUNTING BAGS; STRAPS FOR LUGGAGE; STRING BAGS FOR SHOPPING; SUIT BAGS; SUIT CARRIERS; TANNED LEATHER; TEXTILE SHOPPING BAGS; THONGS; TOILETRY BAGS SOLD EMPTY; TOOL BAGS SOLD EMPTY; TOTE BAGS; TRAVEL BAGS; TRAVELING BAGS; TRAVELLING BAGS; TRAVELLING CASES OF LEATHER; TRUNKS; UMBRELLA COVERS; WAIST BAGS; WALKING STICK SEATS; WASH BAGS FOR CARRYING TOILETRIES; WHEELED BAGS; WHEELED DUFFLE BAGS; WHEELED MESSENGER BAGS; WHEELED SHOPPING BAGS; WHEELED TOTE BAGS; WINE BAGS WITH HANDLES FOR CARRYING OR HOLDING WINE; WRIST MOUNTED CARRYALL BAGS; WRISTLET BAGS (U.S. CLS. 1, 2, 3, 22 AND 41).

FIRST USE 9-15-2008; IN COMMERCE 10-13-2008.

CLASS 24—FABRICS

FOR BED AND TABLE LINEN, WALL HANGINGS OF TEXTILE; BED BLANKETS; BED SHEETS OF PAPER; BED SKIRTS; BLANKET THROWS; BLANKETS FOR OUTDOOR USE; BURP CLOTHS; CASHMERE BLANKETS; CHILDREN'S BLANKETS; COVERED RUBBER YARN FABRICS; COVERINGS OF PLASTIC FOR FURNITURE; COVERS FOR CUSHIONS; CURTAIN LOOPS OF TEXTILE MATERIAL; CURTAINS MADE OF TEXTILE FABRICS; CURTAINS OF TEXTILE OR PLASTIC; CUSHION COVERS; DIAPER CHANGING PADS NOT OF PAPER; DUVET COVERS; EIDERDOWN COVERS; FABRIC COVERS FOR USE ON VARIOUS STRAPS; FABRIC WINDOW COVERINGS AND TREATMENTS, NAMELY, CURTAINS, DRAPERIES, SHEERS, SWAGS AND VALANCES; FABRICS FOR TEXTILE USE; FACE TOWELS; FACE TOWELS OF TEXTILES; FELT AND NON-WOVEN TEXTILE FABRICS; FIBERGLASS FABRIC FOR TEXTILE USE; FIBERGLASS FABRICS FOR TEXTILE USE; FIBREGLASS FABRICS FOR TEXTILE USE; FITTED FUTON COVERS NOT OF PAPER; FITTED TOILET LID COVERS; GIFT WRAP OF TEXTILE; HAND TOWELS OF TEXTILE; HAND-TOWELS MADE OF TEXTILE FABRICS; HANDKERCHIEFS OF TEXTILE; HANDKERCHIEFS OF TEXTILES; LAMINATED TEXTILES TO BE AFFIXED TO THE SURFACE OF FURNITURE; MATTRESS COVERS; NON-PAPER DOILIES; NON-WOVEN TEXTILE FABRICS; PAPER BED COVERS; PET BLANKETS; PILLOW COVERS; PILLOWCASES; PLACE MATS NOT OF PAPER; PLACE MATS OF TEXTILE MATERIAL; PRINTED TEXTILE LABELS; QUILTS OF TEXTILE; RAGS FOR PAPER MAKING; RECEIVING BLANKETS; SERVIETTES OF TEXTILE; SILK BED BLANKETS; SILK BLANKETS; TABLE CLOTHS NOT OF PAPER; TABLE LINEN OF TEXTILE; TABLE MATS NOT OF PAPER; TABLE NAPKINS OF TEXTILE; TABLECLOTHS OF TEXTILES; TABLECLOTHS, NOT OF PAPER; TAPESTRIES OF TEXTILE; TEXTILE FABRIC INCORPORATING WATERPROOF AND GAS PERMEABLE MEMBRANE MADE OF EXPANDED POLYTETRAFLUOROETHYLENE (EPTFE) FOR THE PROTECTION OF SENSITIVE EQUIPMENT AND PACKAGING FROM CONTAMINATES; TEXTILE FABRIC OF ANIMAL SKINS IMITATIONS; TEXTILE FABRICS FOR HOME AND COMMERCIAL INTERIORS; TEXTILE FABRICS FOR LINGERIE; TEXTILE FABRICS FOR THE MANUFACTURE OF CLOTHING; TEXTILE GOODS, NAMELY, A SYNTHETIC SHEET WITH FRAGRANCE FOR THE PURPOSE OF INSERTING INTO PILLOW SLIP AND UNDER FITTED SHEET TO EMIT FRAGRANCE; TEXTILE HANDKERCHIEFS; TEXTILE HANG TAGS; TEXTILE LABELS; TEXTILE NAPKINS; TEXTILE NAPKINS FOR REMOVING MAKE-UP; TEXTILE PLACE MATS; TEXTILE PRINTERS' BLANKETS; TEXTILE SERVIETTES; TEXTILE SIGNAGE PANELS; TEXTILE SUBSTITUTE MATERIALS MADE FROM SYNTHETIC MATERIALS; TEXTILE TABLECLOTHS; TEXTILE TISSUES FOR REMOVING MAKE-UP; TEXTILE USED AS LINING FOR CLOTHING; TEXTILE WALL HANGINGS; TEXTILE WALL HANGINGS,

NAMELY, CLOTH POSTERS; TEXTILES FOR DYE-SUBLIMATION PRINTING; TOILET TANK COVERS MADE OF FABRIC OR FABRIC SUBSTITUTES; TOWELS; UNFITTED COVERS FOR BOATS AND MARINE VEHICLES; UNFITTED FABRIC FURNITURE COVERS; UNFITTED FURNITURE COVERS NOT OF PAPER; UNFITTED FUTON COVERS NOT OF PAPER; WALL HANGINGS OF TEXTILE; WATERPROOF FABRIC FOR MANUFACTURING CLOTHING, FURNITURE AND AUTOMOBILE UPHOLSTERY, AND LUGGAGE; WAVY FIBER TEXTILES; WOOLLEN BLANKETS (U.S. CLS. 42 AND 50).

FIRST USE 11-17-2008; IN COMMERCE 2-2-2009.

CLASS 25—CLOTHING

FOR A-SHIRTS; ADHESIVE BRAS; AFTER SKI BOOTS; ANKLE BOOTS; ANKLE SOCKS; ANKLETS; ANTI-PERSPIRANT SOCKS; BABY BIBS NOT OF PAPER; BALLET SLIPPERS; BALLOON PANTS; BANDANAS; BASEBALL CAPS; BATH SLIPPERS; BATHING CAPS; BATHING SUITS; BATHING SUITS FOR MEN; BEACH COVER-UPS; BEANIES; BED JACKETS; BELTS MADE OF LEATHER; BELTS OF TEXTILE; BERMUDA SHORTS; BIB OVERALLS; BIBS NOT OF CLOTH OR PAPER; BLOUSES; BOARD SHORTS; BODY SUITS; BOLO TIES; Bomber JACKETS; BOOTS; BOW TIES; BOXER BRIEFS; BOXER SHORTS; BRAS; BRIDESMAID DRESSES; BRIEFS; BRIEFS; BUTTON-FRONT ALOHA SHIRTS; CAMISOLES; CAMP SHIRTS; CAP VISORS; CAPRI PANTS; CAPS; CAPS WITH VISORS; CARGO PANTS; CHEF'S HATS; CHILDREN'S AND INFANTS' CLOTH BIBS; CHILDREN'S CLOTH EATING BIBS; CLIMBING BOOTS; CLOGS; CLOTH BIBS; CLOTH BIBS FOR ADULT DINERS; CLOTH BIBS FOR USE BY SENIOR CITIZENS OR PHYSICALLY- OR MENTALLY-CHALLENGED PERSONS; COMPETITORS' NUMBERS OF TEXTILE; CREWNECK SWEATERS; CUMMERBUNDS; DENIM JACKETS; DENIMS; DISPOSABLE SLIPPERS; DISPOSABLE UNDERWEAR; DOWN JACKETS; DRESS SHIELDS; DRESS SHIRTS; DRESS SUITS; DRESSES; DRESSES MADE FROM SKINS; DRESSING GOWNS; DRY SUITS; EAR MUFFS; EVENING DRESSES; EVENING GOWNS; FINISHED TEXTILE LININGS FOR GARMENTS; FISHERMEN'S JACKETS; FISHING VESTS; FITTED SHOE OR BOOT COVERING TO PROTECT THE SHOES OR BOOT FROM WATER OR OTHER DAMAGE; FITTED SWIMMING COSTUMES WITH BRA CUPS; FLEECE SHORTS; FLEECE VESTS; FLIGHT SUITS; FOAM PEDICURE SLIPPERS; FOOTBALL BOOTS AND STUDS THEREFOR; FOOTWEAR, NAMELY, WORK BOOTS; FUR COATS AND JACKETS; FUR HATS; FUR JACKETS; FUR MUFFS; GIRDLES; GOLF CAPS; GOLF SHIRTS; GOWNS; GYM SHORTS; GYM SUITS; HAT BANDS; HATS; HEADBANDS; HEADBANDS AGAINST SWEATING; HEAVY JACKETS; HIGH RAIN CLOGS (ASHIDA); HIKING BOOTS; HOODED SWEAT SHIRTS; HORSE-RIDING BOOTS; HOSIERY; HUNTING BOOT BAGS; HUNTING VESTS; INFANT AND TODDLER ONE PIECE CLOTHING; INFANT CLOTH DIAPERS; INFANT DIAPER COVERS; INFANT SLEEPERS; INFANT WEAR; INFANTS' SHOES AND BOOTS; INFANTS' TROUSERS; INSOLES; JACKET LINERS; JACKETS; JAPANESE STYLE CLOGS AND SANDALS; JAPANESE STYLE SANDALS (ZORI); JAPANESE STYLE SANDALS OF FELT; JAPANESE STYLE SANDALS OF LEATHER; JAPANESE STYLE SOCKS (TABI COVERS); JAPANESE STYLE SOCKS (TABI); JAPANESE STYLE WOODEN CLOGS (GETA); JAPANESE TOE-STRAP SANDALS (ASAURA-ZORI); JOGGING OUTFITS; JOGGING PANTS; JOGGING SUITS; JUDO SUITS; KARATE SUITS; KNIT SHIRTS; KNITTED CAPS; KNITTED UNDERWEAR; LACE BOOTS; LADIES' BOOTS; LADIES' SUITS; LADIES' UNDERWEAR; LEATHER BELTS; LEATHER COATS; LEATHER HEADWEAR; LEATHER JACKETS; LEATHER PANTS; LEATHER SHOES; LEATHER SLIPPERS; LEOTARDS AND TIGHTS FOR WOMEN, MEN AND CHILDREN OF NYLON, COTTON OR OTHER TEXTILE FIBERS; LIGHT-REFLECTING JACKETS; LINGERIE ACCESSORIES, NAMELY, REMOVABLE SILICONE BREAST ENHANCER PADS USED IN A BRA; LONG JACKETS; LONG SLEEVED VESTS; LONG UNDERWEAR; LONG-SLEEVED SHIRTS; LOUNGE PANTS; LOW WOODEN CLOGS (HIYORI-GETA); LOW WOODEN CLOGS (KOMA-GETA); MATERNITY SLEEPWEAR; MEN'S AND WOMEN'S JACKETS, COATS, TROUSERS, VESTS; MEN'S SOCKS; MEN'S SUITS; MEN'S SUITS, WOMEN'S

SUITS; METAL FITTINGS FOR JAPANESE STYLE WOODEN CLOGS; MOCCASINS; MOCK TURTLE-NECK SWEATERS; MOISTURE-WICKING SPORTS BRAS; MOISTURE-WICKING SPORTS PANTS; MOISTURE-WICKING SPORTS SHIRTS; MOTORCYCLIST BOOTS; MOUNTAINEERING BOOTS; MUFFS; NIGHT GOWNS; NIGHT SHIRTS; NIGHTGOWNS; NON-DISPOSABLE CLOTH TRAINING PANTS; NURSE DRESSES; NURSE PANTS; ONE PIECE GARMENT FOR INFANTS AND TODDLERS; ONE-PIECE PLAY SUITS; OPEN-NECKED SHIRTS; PADDED JACKETS; PADDING JACKETS; PAJAMA BOTTOMS; PAJAMAS; PANTIES; PANTIES, SHORTS AND BRIEFS; PANTS; PAPER HATS FOR USE AS CLOTHING ITEMS; PAPER SHOES USED WHEN GOING THROUGH METAL DETECTORS TO KEEP FEET AND SOCKS CLEAN; PARTS OF CLOTHING, NAMELY, GUSSETS FOR TIGHTS, GUSSETS FOR STOCKINGS, GUSSETS FOR BATHING SUITS, GUSSETS FOR UNDERWEAR, GUSSETS FOR LEOTARDS AND GUSSETS FOR FOOTLETS; PEDICURE SANDALS; PEDICURE SLIPPERS; PERSPIRATION ABSORBENT UNDERWEAR CLOTHING; PETTI-PANTS; PIQUE SHIRTS; PLASTIC BABY BIBS; PLAY SUITS; PLEATED SKIRTS FOR FORMAL KIMONOS (HAKAMA); POLO SHIRTS; PROTECTIVE METAL MEMBERS FOR SHOES AND BOOTS; QUILTED VESTS; RAIN BOOTS; RAIN JACKETS; RAIN SUITS; RAINPROOF JACKETS; REVERSIBLE JACKETS; RIDING BOOTS; RUGBY SHIRTS; RUGBY SHORTS; SANDAL-CLOGS; SANDALS; SEDGE HATS (SUGE-GASA); SHELL JACKETS; SHIRT FRONTS; SHIRT YOKES; SHIRTS; SHIRTS FOR SUITS; SHORT OVERCOAT FOR KIMONO (HAORI); SHORT PETTI-COATS; SHORT SETS; SHORT TROUSERS; SHORT-SLEEVED OR LONG-SLEEVED T-SHIRTS; SHORT-SLEEVED SHIRTS; SHORTS; SHOWER CAPS; SKI BIBS; SKI BOOT BAGS; SKI BOOTS; SKI JACKETS; SKI PANTS; SKI SUITS; SKI SUITS FOR COMPETITION; SKIRT SUITS; SKIRTS; SKIRTS AND DRESSES; SKIWEAR; SKULL CAPS; SLACKS; SLEEP SHIRTS; SLEEPWEAR; SLEEVED OR SLEEVELESS JACKETS; SLIDING SHORTS; SLIPPER SOLES; SLIPPERS; SLIPS; SMALL HATS; SMOKING JACKETS; SNOW BOARDING SUITS; SNOW BOOTS; SNOW PANTS; SNOW SUITS; SNOWBOARD BOOTS; SNOWBOARD PANTS; SOCCER BOOTS; SOCK SUSPENDERS; SOCKS; SOCKS AND STOCKINGS; SOLES FOR JAPANESE STYLE SANDALS; SPORT SHIRTS; SPORTS BRA; SPORTS BRAS; SPORTS JACKETS; SPORTS PANTS; SPORTS SHIRTS; SPORTS SHIRTS WITH SHORT SLEEVES; STOCKINGS; STRAPLESS BRAS; STRAPS FOR BRAS; STRETCH PANTS; STUFF JACKETS; SUEDE JACKETS; SUIT COATS; SUITS; SUITS OF LEATHER; SUN VISORS; SUSPENDER BELTS FOR MEN; SUSPENDER BELTS FOR WOMEN; SUSPENDERS; SUSPENDERS; SWEAT BANDS; SWEAT JACKETS; SWEAT PANTS; SWEAT SHIRTS; SWEAT SHORTS; SWEAT SUITS; SWEATERS; SWIM CAPS; SWIMMING CAPS; SWIMMING CAPS; SWIMSUITS; T-SHIRTS; TANK TOPS; TANK-TOPS; TAP PANTS; TEE SHIRTS; TEXTILE DIAPERS; TEXTILE NAPPIES; THERMAL SOCKS; THERMAL UNDERWEAR; THONGS; THONGS; TIES; TOBOGGAN HATS, PANTS AND CAPS; TOE CAPS; TOE STRAPS FOR JAPANESE STYLE WOODEN CLOGS; TONGUE OR PULLSTRAP FOR SHOES AND BOOTS; TRACK JACKETS; TRACK PANTS; TRACK SUITS; TRAINING SUITS; TRIATHLON CLOTHING, NAMELY, TRIATHLON TIGHTS, TRIATHLON SHORTS, TRIATHLON SINGLETS, TRIATHLON SHIRTS, TRIATHLON SUITS; TROUSERS FOR SWEATING; TROUSERS OF LEATHER; TURTLENECK SWEATERS; UNDERGARMENT ACCESSORIES, NAMELY, REMOVABLE SILICONE BUTTOCK ENHANCER PADS; UNDERGARMENTS; UNDERWEAR; UNDERWEAR, NAMELY, BOY SHORTS; UNION SUITS; UPPERS FOR JAPANESE STYLE SANDALS; UPPERS OF WOVEN RATTAN FOR JAPANESE STYLE SANDALS; V-NECK SWEATERS; VEST EXTENDERS; VESTED SUITS; VESTS; VISORS; WALKING SHORTS; WARM UP SUITS; WATER SOCKS; WATERPROOF JACKETS AND PANTS; WED-

DING DRESSES; WEDDING GOWNS; WET SUIT GLOVES; WET SUITS; WET SUITS FOR WATER-SKIING AND SUB-AQUA; WIND PANTS; WIND RESISTANT JACKETS; WIND SHIRTS; WIND VESTS; WIND-JACKETS; WINTER BOOTS; WOMEN'S CEREMONIAL DRESSES; WOMEN'S UNDERWEAR; WOODEN MAIN BODIES OF JAPANESE STYLE WOODEN CLOGS; WOODEN SUPPORTS OF JAPANESE STYLE WOODEN CLOGS; WOOLLEN SOCKS; WOOLLY HATS; WORK SHOES AND BOOTS; WOVEN OR KNITTED UNDERWEAR; YOGA PANTS; YOGA SHIRTS; ZOOT SUITS (U.S. CLS. 22 AND 39).

FIRST USE 9-15-2008; IN COMMERCE 10-13-2008.

3,632,872. CHOI, MOON HEE, PALISADES, NY. SN 77-490,709. PUB. 12-16-2008, FILED 6-4-2008.

Saec

THE MARK CONSISTS OF STANDARD CHARACTERS WITHOUT CLAIM TO ANY PARTICULAR FONT, STYLE, SIZE, OR COLOR.

THE WORDING "SAEC" HAS NO MEANING IN ENGLISH.

3,632,861. ROCKVIEW DAIRIES, INC., DOWNEY, CA. SN 77-486,249. PUB. 10-28-2008, FILED 5-29-2008.



NO CLAIM IS MADE TO THE EXCLUSIVE RIGHT TO USE "ALL NATURAL" AND "FAMILY FARMS", APART FROM THE MARK AS SHOWN.

THE COLOR(S) BLUE, RED, GREEN, BLACK AND WHITE IS/ARE CLAIMED AS A FEATURE OF THE MARK.

THE MARK CONSISTS OF THE WORD "ROCK" ABOVE THE WORD "VIEW" BOTH IN BLUE ABOVE A RED BANNER CONTAINING THE WORDS "FAMILY FARMS" IN WHITE, ALL ABOVE A SCENIC IMAGE OF COWS ON A PATCH OF GREEN WITH A WHITE FENCE; THE WORDS "ALL NATURAL" IN GREEN APPEAR UNDER THE SCENIC IMAGE.

CLASS 29—MEATS AND PROCESSED FOODS

FOR DAIRY PRODUCTS, NAMELY, SOUR CREAM, BUTTER, MARGARINE, COTTAGE CHEESE, CREAM CHEESE, AND CHEESE; LIQUID DAIRY PRODUCTS, NAMELY, MILK, ORGANIC MILK, REDUCED FAT AND FAT FREE MILK, LACTOSE REDUCED MILK, CHOCOLATE MILK, HALF MILK/HALF CREAM LIQUID MIXTURE, BUTTERMILK, AND WHIPPING CREAM AND; CULTURES, NAMELY, YOGURT (U.S. CL. 46).

FIRST USE 7-18-2008; IN COMMERCE 7-18-2008.

CLASS 30—STAPLE FOODS

FOR FROZEN DAIRY PRODUCTS, NAMELY, ICE CREAM, ICE MILK, SHERBET AND FROZEN YOGURT (U.S. CL. 46).

FIRST USE 7-18-2008; IN COMMERCE 7-18-2008.

CLASS 30—STAPLE FOODS

FOR CONES FOR ICE CREAM; CONES FOR ICE-CREAM; CREAM BUNS; CREAM PUFFS; EDIBLE FRUIT ICES; EDIBLE ICES; FLAVORED ICES; FREEZABLE LIQUID FOR USE IN MAKING FROZEN CONFECTIONS; FROZEN DESSERT CONSISTING OF FRUIT AND CREAM OR CREAM SUBSTITUTES; FROZEN YOGHURT; FROZEN YOGURT; FROZEN YOGURT MIXES; FRUIT CAKES; FRUIT ICE; FRUIT ICE BAR; FRUIT ICES; FRUIT PASTE FOR FLAVOURING OF FOOD; FRUIT PIES; FRUIT SAUCES EXCLUDING CRANBERRY SAUCE AND APPLESAUCE; FRUIT TEAS; ICE; ICE CREAM; ICE CREAM DRINKS; ICE CREAM MIXES; ICE CREAM POWDER; ICE CREAM SANDWICHES; ICE CREAM SUBSTITUTE; ICE CREAMS; ICE CUBES; ICE MILK; ICE MILK BARS; ICE-CREAM; ICE-CREAM CAKES; ICED CAKES; ICED COFFEE; ICED TEA; ICES AND ICE CREAMS; ICING; ICING MIXES; ITALIAN ICE; SHAVED ICE CONFECTIONS; SOY-BASED ICE CREAM SUBSTITUTE; STARCH-BASED BINDING AGENTS FOR ICE CREAM; STARCH-BASED THICKENERS FOR WHIPPED CREAM; SWEETENED YOGURT COVERED RAISINS; TEA-BASED BEVERAGES WITH FRUIT FLAVORING; WATER ICE (U.S. CL. 46).

FIRST USE 2-1-2009; IN COMMERCE 2-1-2009.

CLASS 43—HOTEL AND RESTAURANT SERVICES

FOR CAFE-RESTAURANTS; ICE CREAM SHOP SERVICES IN THE NATURE OF A RESTAURANT; RESTAURANT AND CAFE SERVICES; RESTAURANT SERVICES, INCLUDING SIT-DOWN SERVICE OF FOOD AND TAKE-OUT RESTAURANT SERVICES; RESTAURANTS (U.S. CLS. 100 AND 101).

FIRST USE 2-1-2009; IN COMMERCE 2-1-2009.

3,632,884. GRUPO TICHY, LLC, NORTH BARRINGTON, IL. SN 77-496,702. PUB. 10-21-2008, FILED 6-11-2008.

pair

THE MARK CONSISTS OF STANDARD CHARACTERS WITHOUT CLAIM TO ANY PARTICULAR FONT, STYLE, SIZE, OR COLOR.

CLASS 29—MEATS AND PROCESSED FOODS

FOR CHOCOLATE MILK; DAIRY-BASED CHOCOLATE FOOD BEVERAGES; VEGETABLE-BASED CHOCOLATE FOOD BEVERAGES (U.S. CL. 46).

FIRST USE 10-18-2008; IN COMMERCE 10-18-2008.

CLASS 30—STAPLE FOODS

FOR CANDY WITH COCOA; CHOCOLATE; CHOCOLATE AND CHOCOLATES; CHOCOLATE BARS; CHOCOLATE CANDIES; CHOCOLATE CHIPS; CHOCOLATE COVERED NUTS; CHOCOLATE COVERED RAISINS; CHOCOLATE FONDUE; CHOCOLATE FOOD BEVERAGES NOT BEING DAIRY-BASED OR VEGETABLE BASED; CHOCOLATE PASTES; CHOCOLATE POWDER; CHOCOLATE SYRUP; CHOCOLATE TOPPING; CHOCOLATE TRUFFLES; CHOCOLATE-BASED FILLINGS FOR CAKES AND PIES; CHOCOLATES AND CHOCOLATE BASED READY TO EAT CANDIES AND SNACKS; COCOA; COCOA; COCOA BEVERAGES WITH MILK; COCOA EXTRACTS FOR HUMAN CONSUMPTION; COCOA MIXES; COCOA POWDER; COCOA SPREADS; COCOA-BASED BEVERAGES; COCOA-BASED CONDIMENTS AND SEASONINGS FOR FOOD AND DRINK; COCOA-BASED INGREDIENT IN CONFECTIONERY PRODUCTS; FILLED CHOCOLATE; HOT CHOCOLATE; MILK CHOCOLATE; PREPARED COCOA AND COCOA-BASED BEVERAGES; SPREAD CONTAINING CHOCOLATE AND NUTS (U.S. CL. 46).

FIRST USE 10-18-2008; IN COMMERCE 10-18-2008.

3,632,887. BEHIND THE BURNER LLC, NEW YORK, NY. SN 77-497,515. PUB. 11-18-2008, FILED 6-12-2008.



THE COLOR(S) YELLOW, ORANGE, RED, MAROON AND BLUE IS/ARE CLAIMED AS A FEATURE OF THE MARK.

THE MARK CONSISTS OF THE STYLIZED WORDING "BEHIND THE" IS IN A DARK BLUE FONT. THE STYLIZED WORDING "BURNER" IS IN AN ORANGE FONT. THE WORD "BEHIND" IS LOCATED ABOVE WORD "THE" AND ABOVE THE "BUR" AND HALF OF THE "N" IN "BURNER". TO THE RIGHT OF THE WORD "BEHIND" AND DIRECTLY ABOVE THE "NER" IN "BURNER", IS A FLAME DESIGN CONSISTING OF AN INNER FLAME IN YELLOW THAT GRADUALLY CHANGES TO AN ORANGE, RED, AND THEN MAROON FLAME AT THE TOP.

CLASS 35—ADVERTISING AND BUSINESS

FOR PROMOTING THE GOODS AND SERVICES OF OTHERS BY PROVIDING A WEB SITE FEATURING COUPONS, REBATES, PRICE-COMPARISON INFORMATION, PRODUCT REVIEWS, LINKS TO THE RETAIL WEB SITES OF OTHERS, AND DISCOUNT INFORMATION; PROVIDING A WEB SITE WHERE USERS CAN POST RATINGS, REVIEWS AND RECOMMENDATIONS ON PRODUCTS AND SERVICES; PROVIDING SPACE AT A WEB SITE FOR THE ADVERTISEMENT OF THE GOODS AND SERVICES OF OTHERS (U.S. CLS. 100, 101 AND 102).

FIRST USE 7-1-2008; IN COMMERCE 10-31-2008.

CLASS 41—EDUCATION AND ENTERTAINMENT

FOR PROVIDING A WEB SITE THAT FEATURES INFORMAL INSTRUCTION ON COOKING AND MAINTAINING A HEALTHY AND NUTRITIONAL LIFESTYLE (U.S. CLS. 100, 101 AND 107).

FIRST USE 7-1-2008; IN COMMERCE 10-31-2008.

CLASS 44—MEDICAL, BEAUTY AND AGRICULTURAL SERVICES

FOR PROVIDING A WEB SITE FEATURING INFORMATION ON HEALTH AND NUTRITION (U.S. CLS. 100 AND 101).

FIRST USE 10-31-2008; IN COMMERCE 10-31-2008.

3,632,888. KDC PLATFORM LLC, DALLAS, TX. SN 77-497,716. PUB. 11-11-2008, FILED 6-12-2008.



THE MARK CONSISTS OF THE LETTERS "KDC" DISPOSED NEXT TO A CIRCLE FORMED FROM A NUMBER OF SEPARATE SMALLER SQUARES.

CLASS 35—ADVERTISING AND BUSINESS

FOR REAL ESTATE MARKETING SERVICES IN THE FIELD OF LAND AND COMMERCIAL REAL ESTATE PROPERTIES (U.S. CLS. 100, 101 AND 102).

FIRST USE 1-5-2009; IN COMMERCE 1-5-2009.

CLASS 36—INSURANCE AND FINANCIAL

FOR COMMERCIAL LAND AND REAL ESTATE SERVICES, NAMELY, ACQUISITION, LEASING, INVESTING, FINANCING, AND MANAGEMENT OF COMMERCIAL LAND AND REAL ESTATE PROPERTIES (U.S. CLS. 100, 101 AND 102).

FIRST USE 1-5-2009; IN COMMERCE 1-5-2009.

CLASS 37—CONSTRUCTION AND REPAIR

FOR COMMERCIAL REAL ESTATE DEVELOPMENT SERVICES; COMMERCIAL REAL ESTATE CONSTRUCTION SERVICES, NAMELY, CONSTRUCTION AND RENOVATION OF COMMERCIAL BUILDINGS AND PROPERTY (U.S. CLS. 100, 103 AND 106).

FIRST USE 1-5-2009; IN COMMERCE 1-5-2009.

3,632,892. FLORIDA ASSOCIATION OF CHRISTIAN COLLEGES AND SCHOOLS, INC., DBA FACCS, MIRAMAR, FL. SN 77-499,224. PUB. 12-23-2008, FILED 6-14-2008.



THE COLOR(S) GREEN, BLUE AND WHITE IS/ARE CLAIMED AS A FEATURE OF THE MARK.

THE MARK CONSISTS OF THE LOWER-CASE LETTERS "IACCS" IN GREEN ARIAL BLACK FONT, WITH THE LETTER "A" HAVING A BLUE GLOBE IN THE CENTER, WITH THE LATITUDE AND LONGITUDE LINES DEPICTED BY WHITE, CURVED LINES.

CLASS 16—PAPER GOODS AND PRINTED MATTER

FOR EDUCATIONAL PUBLICATIONS, NAMELY, TRAINING MANUALS IN THE FIELD OF EDUCATION, RELIGION, TEACHING, INSTRUCTION, SCHOOLS AND TRAINING; EDUCATIONAL PUBLICATIONS, NAMELY, BOOKS, MAGAZINES, PERIODICALS, NEWSPAPERS, PAMPHLETS AND ARTICLES, BOTH ONLINE AND IN PRINT IN THE FIELDS OF EDUCATION, RELIGION, TEACHING, INSTRUCTION, SCHOOLS AND TRAINING; PUBLICATIONS, NAMELY, BROCHURES, BOOKLETS, AND TEACHING MATERIALS IN THE FIELD OF EDUCATION, RELIGION, TEACHING, INSTRUCTION, SCHOOLS AND TRAINING; PUBLICATIONS, NAMELY, BOOKS, MAGAZINES, PERIODICALS, NEWSPAPERS, PAMPHLETS AND ARTICLES, BOTH ONLINE AND IN PRINT IN THE FIELDS OF EDUCATION, RELIGION, TEACHING, INSTRUCTION, SCHOOLS AND TRAINING (U.S. CLS. 2, 5, 22, 23, 29, 37, 38 AND 50).

FIRST USE 7-31-2008; IN COMMERCE 7-31-2008.

CLASS 35—ADVERTISING AND BUSINESS

FOR JOB AND PERSONNEL PLACEMENT; JOB PLACEMENT (U.S. CLS. 100, 101 AND 102).

FIRST USE 11-19-2007; IN COMMERCE 6-10-2008.

CLASS 41—EDUCATION AND ENTERTAINMENT

FOR ARRANGING AND CONDUCTING EDUCATIONAL CONFERENCES; ARRANGING OF SEMINARS; CHARITABLE SERVICES, NAMELY, PROVIDING TRAINING IN THE FIELD OF TEACHING, TRAINING, EDUCATION AND INSTRUCTION; CONDUCTING WORKSHOPS AND SEMINARS IN EDUCATION, TEACHING AND INSTRUCTION; EDUCATION SERVICES, NAMELY, PROVIDING LIVE AND ON-LINE SEMINARS, COURSES AND WORKSHOPS IN THE FIELD OF EDUCATION, TRAINING AND TEACHING; EDUCATION SERVICES, NAMELY, PROVIDING MENTORING, TUTORING, CLASSES, SEMINARS AND WORKSHOPS IN THE FIELD OF EDUCATION, TEACHING, TRAINING AND INSTRUCTION; EDUCATIONAL AND ENTERTAINMENT SERVICES, NAMELY, PROVIDING MOTIVATIONAL AND EDUCATIONAL SPEAKERS; EDUCATIONAL AND ENTERTAINMENT SERVICES, NAMELY, PROVIDING MOTIVATIONAL AND EDUCATIONAL SPEAKERS IN THE FIELD OF SELF- AND PERSONAL IMPROVEMENT; EDUCATIONAL SERVICES, NAMELY, CONDUCTING SEMINARS, CONFERENCES, ONLINE COURSES AND TRAINING IN THE FIELD OF EDUCATION, TEACHING, TRAINING AND INSTRUCTION AND DISTRIBUTION OF COURSE MATERIAL IN CONNECTION THEREWITH; EDUCATIONAL SERVICES, NAMELY, DEVELOPING, ARRANGING, AND CONDUCTING EDUCATIONAL CONFERENCES AND PROGRAMS AND PROVIDING COURSES OF INSTRUCTION IN THE FIELD OF EDUCATION, TEACHING, TRAINING AND INSTRUCTION; EDUCATIONAL SERVICES, NAMELY, OFFERING OF ASSESSMENTS AND SURVEYS IN THE FIELD OF EDUCATOR TRAINING AND PERFORMANCE FOR THE PURPOSE OF IMPROVING TEACHING PROCEDURES; EDUCATIONAL SERVICES, NAMELY, THE OFFERING OF WEB BASED AND CLASSROOM TRAINING FOR CERTIFICATION OF TEACHERS AND CONTINUING EDUCATION FOR TEACHERS AND PRINCIPALS (U.S. CLS. 100, 101 AND 107).

FIRST USE 11-19-2007; IN COMMERCE 6-10-2008.

CLASS 42—SCIENTIFIC AND COMPUTER SERVICES

FOR ACCREDITATION SERVICES, NAMELY, EVALUATING ORGANIZATIONS TO DETERMINE WHETHER THE ORGANIZATIONS CONFORM TO AN ESTABLISHED STANDARD; ACCREDITATION SERVICES, NAMELY, SETTING AND PROVIDING STANDARDS FOR CHRISTIAN SCHOOLS FOR THE PURPOSE OF ACCREDITATION (U.S. CLS. 100 AND 101).

FIRST USE 10-21-2008; IN COMMERCE 10-21-2008.

3,632,893. DOTERRA HOLDINGS, LLC, OREM, UT. SN 77-501,117. PUB. 11-18-2008, FILED 6-17-2008.

EO Mega

THE MARK CONSISTS OF STANDARD CHARACTERS WITHOUT CLAIM TO ANY PARTICULAR FONT, STYLE, SIZE, OR COLOR.

CLASS 3—COSMETICS AND CLEANING PREPARATIONS

FOR ESSENTIAL OILS; ESSENTIAL OILS FOR USE IN MANUFACTURING OF GELCAPS AND OTHER DIETARY SUPPLEMENTS (U.S. CLS. 1, 4, 6, 50, 51 AND 52).

FIRST USE 7-29-2008; IN COMMERCE 7-29-2008.

CLASS 5—PHARMACEUTICALS

FOR DIETARY AND NUTRITIONAL SUPPLEMENTS (U.S. CLS. 6, 18, 44, 46, 51 AND 52).

FIRST USE 7-29-2008; IN COMMERCE 7-29-2008.

3,632,898. GRUPO TICHY, LLC, DBA PAIR CHOCOLATES, NORTH BARRINGTON, IL. SN 77-502,876. PUB. 10-21-2008, FILED 6-19-2008.



THE COLOR(S) GREEN, BROWN IS/ARE CLAIMED AS A FEATURE OF THE MARK.

THE MARK CONSISTS OF A GREEN BOX CONTAINING A GREEN OUTLINE OF A PEAR FEATURING A BROWN STEM WITH A SINGLE GREEN LEAF TO ITS RIGHT-HAND SIDE. THE WORD "PAIR" IS WRITTEN IN BROWN LETTERING AND IS LOCATED ENTIRELY WITHIN THE PEAR IN ITS BOTTOM RIGHT-HAND CORNER.

CLASS 29—MEATS AND PROCESSED FOODS

FOR CHOCOLATE MILK; DAIRY-BASED CHOCOLATE FOOD BEVERAGES; VEGETABLE-BASED CHOCOLATE FOOD BEVERAGES (U.S. CL. 46).

FIRST USE 10-18-2008; IN COMMERCE 10-18-2008.

CLASS 30—STAPLE FOODS

FOR CANDY WITH COCOA; CHOCOLATE; CHOCOLATE AND CHOCOLATES; CHOCOLATE BARS; CHOCOLATE CANDIES; CHOCOLATE CHIPS; CHOCOLATE COVERED NUTS; CHOCOLATE COVERED RAISINS; CHOCOLATE FONDUE; CHOCOLATE FOOD BEVERAGES NOT BEING DAIRY-BASED OR VEGETABLE BASED; CHOCOLATE PASTES; CHOCOLATE POWDER; CHOCOLATE SYRUP; CHOCOLATE TOPPING; CHOCOLATE TRUFFLES; CHOCOLATE-BASED FILLINGS FOR CAKES AND PIES; CHOCOLATES AND CHOCOLATE BASED READY TO EAT CANDIES AND SNACKS; COCOA; COCOA; COCOA BEVERAGES WITH MILK; COCOA EXTRACTS FOR HUMAN CONSUMPTION; COCOA MIXES; COCOA POWDER; COCOA SPREADS; COCOA-BASED BEVERAGES; COCOA-BASED CONDIMENTS AND SEASONINGS FOR FOOD AND DRINK; COCOA-BASED INGREDIENT IN CONFECTIONERY PRODUCTS; FILLED CHOCOLATE; HOT CHOCOLATE; MILK CHOCOLATE; PREPARED COCOA AND COCOA-BASED BEVERAGES; SPREAD CONTAINING CHOCOLATE AND NUTS (U.S. CL. 46).

FIRST USE 10-18-2008; IN COMMERCE 10-18-2008.

3,632,906. EGGETT, RICH, WEST BOUNTIFUL, UT. SN 77-505,566. PUB. 1-20-2009, FILED 6-23-2008.

ROCKWELL

THE MARK CONSISTS OF STANDARD CHARACTERS WITHOUT CLAIM TO ANY PARTICULAR FONT, STYLE, SIZE, OR COLOR.

CLASS 14—JEWELRY

FOR WATCHES (U.S. CLS. 2, 27, 28 AND 50).
FIRST USE 11-0-2007; IN COMMERCE 11-0-2007.

CLASS 25—CLOTHING

FOR CLOTHING, NAMELY, SHIRTS AND HATS (U.S. CLS. 22 AND 39).
FIRST USE 1-0-2008; IN COMMERCE 1-0-2008.

3,632,910. CORVIRTUS, INC., COLORADO SPRINGS, CO. SN 77-508,237. PUB. 12-16-2008, FILED 6-25-2008.



OWNER OF U.S. REG. NOS. 3,077,719 AND 3,077,820.
THE MARK CONSISTS OF IN PART A DIAMOND SHAPE

WITH TWENTY-FOUR (24) TRIANGLES, WHICH CAN ALSO BE VIEWED AS A THREE-DIMENSIONAL CUBE WITH FOUR (4) SQUARES ON A SIDE, TO THE LEFT OF "CORVIRTUS".

CLASS 35—ADVERTISING AND BUSINESS

FOR BUSINESS CONSULTING AND MANAGEMENT; BUSINESS CONSULTING IN THE FIELD OF STRATEGIC PLANNING; BUSINESS RESEARCH, NAMELY, CONDUCTING CUSTOMER AND EMPLOYEE SURVEY RESEARCH AND ANALYSIS THEREOF; HUMAN RESOURCES CONSULTATION; HUMAN RESOURCES MANAGEMENT AND SERVING AS A HUMAN RESOURCE DEPARTMENT FOR OTHERS (U.S. CLS. 100, 101 AND 102).

FIRST USE 1-1-2009; IN COMMERCE 1-1-2009.

CLASS 41—EDUCATION AND ENTERTAINMENT

FOR EDUCATIONAL SERVICES, NAMELY, TRAINING, COURSES OF INSTRUCTION AND SEMINARS IN THE FIELD OF BUSINESS CONSULTING AND MANAGEMENT, STRATEGIC PLANNING, BUSINESS RESEARCH, CUSTOMER AND EMPLOYEE SURVEY RESEARCH, HUMAN RESOURCES CONSULTATION AND HUMAN RESOURCE MANAGEMENT (U.S. CLS. 100, 101 AND 107).

FIRST USE 1-1-2009; IN COMMERCE 1-1-2009.

3,632,937. UNIVERSAL HEALTH CARD, LLC, CANTON, OH. SN 77-517,407. PUB. 11-18-2008, FILED 7-8-2008.

YOUR TEAM IS READY

THE MARK CONSISTS OF STANDARD CHARACTERS WITHOUT CLAIM TO ANY PARTICULAR FONT, STYLE, SIZE, OR COLOR.

CLASS 16—PAPER GOODS AND PRINTED MATTER

FOR MEMBERSHIP CARDS FOR PARTICIPANTS OF DISCOUNT MEDICAL SERVICES PLAN, NOT MAGNETICALLY ENCODED (U.S. CLS. 2, 5, 22, 23, 29, 37, 38 AND 50).

FIRST USE 8-25-2008; IN COMMERCE 8-25-2008.

CLASS 36—INSURANCE AND FINANCIAL

FOR ADMINISTRATION OF DISCOUNT MEDICAL SERVICES PLAN FOR THE PROVISION OF DISCOUNTS ON MEDICAL AND DENTAL SERVICES AND PRESCRIPTION DRUGS (U.S. CLS. 100, 101 AND 102).

FIRST USE 8-25-2008; IN COMMERCE 8-25-2008.

3,632,943. SNIPI, INC., PHILADELPHIA, PA. SN 77-518,834. PUB. 12-2-2008, FILED 7-10-2008.

Snipi

THE MARK CONSISTS OF STANDARD CHARACTERS WITHOUT CLAIM TO ANY PARTICULAR FONT, STYLE, SIZE, OR COLOR.

CLASS 35—ADVERTISING AND BUSINESS

FOR PROVIDING CONSUMER PRODUCT INFORMATION VIA THE INTERNET (U.S. CLS. 100, 101 AND 102). FIRST USE 3-1-2009; IN COMMERCE 3-1-2009.

CLASS 39—TRANSPORTATION AND STORAGE

FOR ON-LINE COMPUTER SERVICES FOR STORING CONTENT ITEMS SELECTED BY USERS FROM INTERNET WEB PAGES (U.S. CLS. 100 AND 105). FIRST USE 3-1-2009; IN COMMERCE 3-1-2009.

CLASS 45—PERSONAL AND LEGAL SERVICES

FOR INTERNET BASED SOCIAL NETWORKING AND INTRODUCTION SERVICES; INTERNET-BASED SOCIAL INTRODUCTION AND SOCIAL NETWORKING SERVICES (U.S. CLS. 100 AND 101). FIRST USE 3-1-2009; IN COMMERCE 3-1-2009.

3,632,952. U-NGOEN U-THONG LTD., PARTNERSHIPS, DISTRICT PHAKHAI, THAILAND. SN 77-520,157. PUB. 12-16-2008, FILED 7-11-2008.



THE MARK CONSISTS OF THE STYLIZED WORD "TIP".

CLASS 3—COSMETICS AND CLEANING PREPARATIONS

FOR COSMETIC PREPARATIONS FOR SKIN CARE, COSMETICS, SOAPS, NAMELY, HAND SOAPS AND BODY SOAPS, BREATH FRESHENING SPRAYS, DENTIFRICES, COSMETIC PREPARATIONS FOR SLIMMING PURPOSES, SKIN WHITENING CREAM, ESSENTIAL OILS, HAIR SPRAYS, LOTION FOR COSMETIC PURPOSES, MAKE-UP REMOVING PREPARATIONS, MAKE-UP POWDERS, NAIL POLISH, LIPSTICKS, AND NON-MEDICATED TOILETRIES (U.S. CLS. 1, 4, 6, 50, 51 AND 52).

FIRST USE 6-0-2008; IN COMMERCE 3-15-2009.

CLASS 5—PHARMACEUTICALS

FOR DIETARY AND NUTRITIONAL SUPPLEMENTS, FOOD SUPPLEMENTS, DIETETIC FOOD PREPARATIONS ADAPTED FOR MEDICAL PURPOSES, MEDICINAL HERBS, HERBS TEAS FOR MEDICINAL PURPOSES, LIPOSOME FOR MEDICAL PURPOSES, GELATIN FOR MEDICAL PURPOSES, ENZYMES FOR MEDICAL PURPOSES, COLLAGEN FOR MEDICAL PURPOSES (U.S. CLS. 6, 18, 44, 46, 51 AND 52). FIRST USE 6-0-2008; IN COMMERCE 3-15-2009.

CLASS 30—STAPLE FOODS

FOR COFFEE, COFFEE-BASED BEVERAGES, COCOA, COCOA-BASED BEVERAGES, COFFEE FLAVORINGS, UNROASTED COFFEE, ARTIFICIAL COFFEE, TEA, TEA-BASED BEVERAGES (U.S. CL. 46). FIRST USE 6-0-2008; IN COMMERCE 3-15-2009.

3,632,958. BUDDY MEDIA, INC., NEW YORK, NY. SN 77-522,362. PUB. 12-9-2008, FILED 7-15-2008.

EVERY BRAND NEEDS A BUDDY

THE MARK CONSISTS OF STANDARD CHARACTERS WITHOUT CLAIM TO ANY PARTICULAR FONT, STYLE, SIZE, OR COLOR.

CLASS 35—ADVERTISING AND BUSINESS

FOR ADVERTISING, MARKETING AND PROMOTION SERVICES; ADVERTISING CONSULTATION; MARKETING CONSULTATION IN THE FIELD OF ON-LINE ADVERTISING AND MARKETING SERVICES; ADVERTISING SERVICES, NAMELY, PROVIDING AN ONLINE ADVERTISING NETWORK FOR MANAGING ONLINE ADVERTISING CAMPAIGNS AND FOR TARGETING CONSUMERS; SOCIAL MEDIA STRATEGY AND MARKETING CONSULTANCY FOCUSING ON HELPING CLIENTS CREATE AND EXTEND THEIR PRODUCT AND BRAND STRATEGIES BY BUILDING VIRALLY ENGAGING MARKETING SOLUTIONS (U.S. CLS. 100, 101 AND 102). FIRST USE 7-31-2008; IN COMMERCE 7-31-2008.

CLASS 42—SCIENTIFIC AND COMPUTER SERVICES

FOR SOFTWARE DESIGN AND DEVELOPMENT; APPLICATION SERVICE PROVIDER, NAMELY, PROVIDING, HOSTING, MANAGING, DEVELOPING, AND MAINTAINING APPLICATIONS AND SOFTWARE IN THE FIELDS OF SOCIAL MEDIA AND SOCIAL NETWORKING; DESIGNING AND DEVELOPING COMPUTER GAME SOFTWARE AND SOCIAL GAME SOFTWARE FOR USE ON COMPUTER NETWORKS; PROVIDING TEMPORARY USE OF ONLINE, NON-DOWNLOADABLE SOFTWARE FOR CREATING AND MANAGING ADVERTISING CAMPAIGNS IN THE FIELDS OF SOCIAL MEDIA AND SOCIAL NETWORKING (U.S. CLS. 100 AND 101).

FIRST USE 7-31-2008; IN COMMERCE 7-31-2008.

3,632,963. UNIVERSITY OF CINCINNATI FOUNDATION, THE, CINCINNATI, OH. SN 77-523,529. PUB. 12-9-2008, FILED 7-16-2008.



NO CLAIM IS MADE TO THE EXCLUSIVE RIGHT TO USE "CINCINNATI", APART FROM THE MARK AS SHOWN.

THE COLOR(S) BLACK, WHITE, AND RED (PMS 186) IS/ARE CLAIMED AS A FEATURE OF THE MARK.

THE MARK CONSISTS OF A BLACK BOX CONTAINING THE WORDS "PROUDLY CINCINNATI" AND A TRIANGLE-SHAPED ARROW, WITH "PROUDLY" IN WHITE AND "CINCINNATI" IN PMS 186 RED, AND THE ARROW IN WHITE.

CLASS 35—ADVERTISING AND BUSINESS

FOR ADVERTISING AND MARKETING (U.S. CLS. 100, 101 AND 102).

FIRST USE 8-1-2008; IN COMMERCE 8-15-2008.

CLASS 36—INSURANCE AND FINANCIAL

FOR CHARITABLE FUND RAISING (U.S. CLS. 100, 101 AND 102).

FIRST USE 8-1-2008; IN COMMERCE 8-15-2008.

CLASS 41—EDUCATION AND ENTERTAINMENT

FOR EDUCATING AT UNIVERSITY OR COLLEGES (U.S. CLS. 100, 101 AND 107).

FIRST USE 8-1-2008; IN COMMERCE 8-15-2008.

3,632,982. ION MEDIA NETWORKS, INC., WEST PALM BEACH, FL. SN 77-530,999. PUB. 12-16-2008, FILED 7-24-2008.



OWNER OF U.S. REG. NOS. 3,442,624 AND 3,442,627.

NO CLAIM IS MADE TO THE EXCLUSIVE RIGHT TO USE "TELEVISION" AND "ENTERTAINING", APART FROM THE MARK AS SHOWN.

THE MARK CONSISTS OF THE WORD "ION" IN LOWER CASE LETTERS, FOLLOWED BY A PLUS SIGN IN A SHADED CIRCLE ABOVE THE WORD "TELEVISION", WHICH IS ABOVE THE WORDS "POSITIVELY ENTERTAINING".

CLASS 38—COMMUNICATION

FOR CABLE TELEVISION BROADCASTING; TELEVISION BROADCASTING; VIDEO BROADCASTING (U.S. CLS. 100, 101 AND 104).

FIRST USE 5-1-2008; IN COMMERCE 5-1-2008.

CLASS 41—EDUCATION AND ENTERTAINMENT

FOR DISTRIBUTION OF TELEVISION PROGRAMMING TO CABLE TELEVISION SYSTEMS; ENTERTAINMENT IN THE NATURE OF ON-GOING TELEVISION PROGRAMS IN THE FIELD OF SPORTS, COMEDY, TRAVEL, DRAMA, VARIETY, HEALTH RELATED ISSUES, CHILDRENS PROGRAMMING, WEATHER AND NEWS (U.S. CLS. 100, 101 AND 107).

FIRST USE 5-1-2008; IN COMMERCE 5-1-2008.

3,632,971. ACELL, INC., COLUMBIA, MD. SN 77-526,850. PUB. 12-23-2008, FILED 7-21-2008.

MATRISTEM

THE MARK CONSISTS OF STANDARD CHARACTERS WITHOUT CLAIM TO ANY PARTICULAR FONT, STYLE, SIZE, OR COLOR.

CLASS 5—PHARMACEUTICALS

FOR SCAFFOLD COMPOSED OF BIOLOGICAL TISSUE, NAMELY, NATURALLY OCCURRING BIO-SCAFFOLD FOR REPAIR OR RESTORATION OF TISSUE IN A PATIENT (U.S. CLS. 6, 18, 44, 46, 51 AND 52).

FIRST USE 7-21-2008; IN COMMERCE 7-21-2008.

CLASS 10—MEDICAL APPARATUS

FOR SCAFFOLD COMPRISED OF SYNTHETIC MATTER FOR REPAIR OR RESTORATION OF TISSUE IN A PATIENT (U.S. CLS. 26, 39 AND 44).

FIRST USE 7-21-2008; IN COMMERCE 7-21-2008.

3,632,983. TURN IT UP MEDIA, LLC, BRENTWOOD, TN. SN 77-531,324. PUB. 12-16-2008, FILED 7-25-2008.

ARE YOU TURNED ON?

THE MARK CONSISTS OF STANDARD CHARACTERS WITHOUT CLAIM TO ANY PARTICULAR FONT, STYLE, SIZE, OR COLOR.

CLASS 9—ELECTRICAL AND SCIENTIFIC APPARATUS

FOR DOWNLOADABLE MP3 FILES FEATURING MUSIC (U.S. CLS. 21, 23, 26, 36 AND 38).

FIRST USE 1-23-2009; IN COMMERCE 1-23-2009.

CLASS 35—ADVERTISING AND BUSINESS

FOR ONLINE ADVERTISING AND MARKETING (U.S. CLS. 100, 101 AND 102).

FIRST USE 1-23-2009; IN COMMERCE 1-23-2009.

3,633,000. COUNCIL FOR RELATIONSHIPS, PHILADELPHIA, PA. SN 77-539,195. PUB. 1-6-2009, FILED 8-5-2008.

3,633,019. MARK ANTHONY INTERNATIONAL SRL, ROCKLEY, CHRIST CHURCH, BARBADOS. SN 77-546,111. PUB. 12-30-2008, FILED 8-13-2008.

Operation Home and Healing

THE MARK CONSISTS OF STANDARD CHARACTERS WITHOUT CLAIM TO ANY PARTICULAR FONT, STYLE, SIZE, OR COLOR.

CLASS 44—MEDICAL, BEAUTY AND AGRICULTURAL SERVICES

FOR MENTAL HEALTH SERVICES AND PSYCHOLOGICAL COUNSELING SERVICES FOR VETERANS AND THEIR FAMILIES, SPOUSES AND PARTNERS (U.S. CLS. 100 AND 101).

FIRST USE 10-1-2008; IN COMMERCE 10-1-2008.

CLASS 45—PERSONAL AND LEGAL SERVICES

FOR PROVIDING EMOTIONAL COUNSELING AND EMOTIONAL SUPPORT SERVICES FOR VETERANS AND THEIR FAMILIES, SPOUSES AND PARTNERS (U.S. CLS. 100 AND 101).

FIRST USE 10-1-2008; IN COMMERCE 10-1-2008.

3,633,018. MARK ANTHONY INTERNATIONAL SRL, ROCKLEY, CHRIST CHURCH, BARBADOS. SN 77-546,097. PUB. 12-30-2008, FILED 8-13-2008.



OWNER OF U.S. REG. NOS. 3,295,391, 3,415,138, AND OTHERS.

NO CLAIM IS MADE TO THE EXCLUSIVE RIGHT TO USE "LEMONADE", APART FROM THE MARK AS SHOWN.

THE MARK CONSISTS OF THE WORDS "MIKE'S HARDER LEMONADE" IN A STYLIZED FONT, WITHIN A STYLIZED DRAWING OF A LEMON.

CLASS 32—LIGHT BEVERAGES

FOR FLAVORED BREWED MALT-BASED ALCOHOLIC BEVERAGES IN THE NATURE OF BEER (U.S. CLS. 45, 46 AND 48).

FIRST USE 1-19-2009; IN COMMERCE 1-19-2009.

CLASS 33—WINES AND SPIRITS

FOR ALCOHOLIC FLAVORED MALT COOLERS (U.S. CLS. 47 AND 49).

FIRST USE 1-19-2009; IN COMMERCE 1-19-2009.



OWNER OF U.S. REG. NOS. 3,295,391, 3,415,138, AND OTHERS.

NO CLAIM IS MADE TO THE EXCLUSIVE RIGHT TO USE "CRANBERRY LEMONADE", APART FROM THE MARK AS SHOWN.

THE MARK CONSISTS OF THE WORDS "MIKE'S HARDER CRANBERRY LEMONADE" IN A STYLIZED FONT, WITHIN A STYLIZED DRAWING OF A LEMON.

CLASS 32—LIGHT BEVERAGES

FOR FLAVORED BREWED MALT-BASED ALCOHOLIC BEVERAGES IN THE NATURE OF BEER (U.S. CLS. 45, 46 AND 48).

FIRST USE 1-19-2009; IN COMMERCE 1-19-2009.

CLASS 33—WINES AND SPIRITS

FOR ALCOHOLIC FLAVORED MALT COOLERS (U.S. CLS. 47 AND 49).

FIRST USE 1-19-2009; IN COMMERCE 1-19-2009.

3,633,036. CONTESSA PREMIUM FOODS, INC., SAN PEDRO, CA. SN 77-555,464. PUB. 12-2-2008, FILED 8-25-2008.

MICRO-STEAM

THE MARK CONSISTS OF STANDARD CHARACTERS WITHOUT CLAIM TO ANY PARTICULAR FONT, STYLE, SIZE, OR COLOR.

CLASS 29—MEATS AND PROCESSED FOODS

FOR FROZEN SEAFOOD; FROZEN PREPARED DINNERS, ENTREES AND SIDE DISHES CONSISTING PRIMARILY OF SEAFOOD, POULTRY, MEAT, OR VEGETABLES (U.S. CL. 46).

FIRST USE 1-1-2009; IN COMMERCE 2-5-2009.

CLASS 30—STAPLE FOODS

FOR FROZEN PREPARED DINNERS, ENTREES AND SIDE DISHES CONSISTING PRIMARILY OF PASTA OR GRAINS (U.S. CL. 46).

FIRST USE 8-8-2008; IN COMMERCE 10-2-2008.

3,633,037. VISUAL MANUAL LLC, DBA IL FUSTINO, SANTA BARBARA, CA. SN 77-557,743. PUB. 1-20-2009, FILED 8-28-2008.

il Fustino

THE MARK CONSISTS OF STANDARD CHARACTERS WITHOUT CLAIM TO ANY PARTICULAR FONT, STYLE, SIZE, OR COLOR.

THE FOREIGN WORDING IN THE MARK TRANSLATES INTO ENGLISH AS THE TANK.

CLASS 29—MEATS AND PROCESSED FOODS

FOR EDIBLE OIL (U.S. CL. 46).
FIRST USE 11-21-2008; IN COMMERCE 11-21-2008.

CLASS 30—STAPLE FOODS

FOR VINEGAR (U.S. CL. 46).
FIRST USE 11-21-2008; IN COMMERCE 11-21-2008.

3,633,041. PENTON BUSINESS MEDIA, INC., NEW YORK, NY. SN 77-573,390. PUB. 12-23-2008, FILED 9-18-2008.



THE COLOR(S) RED IS/ARE CLAIMED AS A FEATURE OF THE MARK.

THE MARK CONSISTS OF AN EXCLAMATION POINT WITH THE TOP AND BOTTOM OF THE EXCLAMATION POINT CUT OFF.

CLASS 35—ADVERTISING AND BUSINESS

FOR PROVIDING AN INTERNET WEBSITE WITH INFORMATION IN THE FIELD OF MARKETING; PROVIDING INFORMATION IN THE FIELD OF MARKETING VIA THE INTERNET; PROVIDING DATABASES OF INFORMATION IN THE FIELD OF MARKETING; PROVIDING RESEARCH SERVICES IN THE FIELD OF MARKETING (U.S. CLS. 100, 101 AND 102).
FIRST USE 10-8-2008; IN COMMERCE 10-8-2008.

CLASS 41—EDUCATION AND ENTERTAINMENT

FOR PROVIDING ONLINE PUBLICATIONS IN THE NATURE OF MAGAZINES AND NEWSLETTERS FEATURING INFORMATION IN FIELD OF MARKETING; PROVIDING NEWSLETTERS IN THE FIELD OF MARKETING DELIVERED BY ELECTRONIC MAIL; PROVIDING ONLINE SEMINARS IN THE FIELD OF MARKETING (U.S. CLS. 100, 101 AND 107).
FIRST USE 10-8-2008; IN COMMERCE 10-8-2008.

3,633,048. ANNA'S LINENS, INC., COSTA MESA, CA. SN 77-975,925. PUB. 1-1-2008, FILED 5-2-2007.



THE MARK CONSISTS OF HOUSE IN CIRCLE.

CLASS 20—FURNITURE AND ARTICLES NOT OTHERWISE CLASSIFIED

FOR BED PILLOWS, NON-METALLIC SHOWER CURTAIN HOOKS, DECORATIVE PILLOWS, FITTED FABRIC FURNITURE SLIPCOVERS; MIRRORS; HAMPERS; WINDOW SHADES; FLOOR CUSHIONS (U.S. CLS. 2, 13, 22, 25, 32 AND 50).
FIRST USE 10-31-2007; IN COMMERCE 10-31-2007.

CLASS 24—FABRICS

FOR LINENS, WINDOW COVERINGS, NAMELY, DRAPERIES, CURTAINS, WINDOW TREATMENTS IN THE NATURE OF WINDOW PANELS OF POLYESTER, AND COTTON, FABRIC VALANCES; TEXTILE TABLECLOTHS, TEXTILE PLACEMATS, TEXTILE NAPKINS, MATTRESS PADS, COMFORTERS, BED SKIRTS, SHAMS, BED BLANKETS, PILLOW PROTECTORS IN THE NATURE OF DECORATIVE PILLOW COVERS, BED SHEETS, PILLOWCASES, BATH TOWELS, SHOWER CURTAINS, FURNITURE TROWS, DECORATIVE TROWS, KITCHEN LINENS, KITCHEN TOWELS, POT HOLDERS, OVEN MITTS; SHEET SETS COMPRISED OF BED SHEETS, LINEN AND PILLOWCASES (U.S. CLS. 42 AND 50).
FIRST USE 11-30-2007; IN COMMERCE 11-30-2007.

CLASS 35—ADVERTISING AND BUSINESS

FOR RETAIL STORE SERVICES IN THE FIELDS OF LINENS, HOUSEWARES, WINDOW BLINDS, TABLEWARE, CARPETS, PILLOWS, AND RELATED HOUSEHOLD PRODUCTS (U.S. CLS. 100, 101 AND 102).
FIRST USE 5-14-2007; IN COMMERCE 5-14-2007.

3,633,049. DIAMOND RESORTS HOLDINGS, LAS VEGAS, NV. SN 77-976,141. PUB. 2-5-2008, FILED 8-9-2007.



THE MARK CONSISTS OF FANCIFUL LETTER "D" WITH THREE UPWARD CURVING ARCS.

CLASS 36—INSURANCE AND FINANCIAL

FOR REAL ESTATE EQUITY SHARING, NAMELY, MANAGING AND ARRANGING FOR CO-OWNERSHIP OF REAL ESTATE; REAL ESTATE TIME-SHARING; VACATION REAL ESTATE TIME SHARE EXCHANGE SERVICES; VACATION REAL ESTATE TIME-SHARING (U.S. CLS. 100, 101 AND 102).

FIRST USE 10-1-2007; IN COMMERCE 10-1-2007.

CLASS 43—HOTEL AND RESTAURANT SERVICES

FOR HOTEL SERVICES; HOTEL SERVICES FOR PREFERRED CUSTOMERS; HOTELS; MAKING HOTEL RESERVATIONS FOR OTHERS; PROVIDING TEMPORARY LODGING SERVICES IN THE NATURE OF A CONDOMINIUM HOTEL; RESERVATION OF HOTEL ROOMS FOR TRAVELERS; TRAVEL AGENCY SERVICES, NAMELY, MAKING RESERVATIONS AND BOOKING FOR TEMPORARY LODGING (U.S. CLS. 100 AND 101).

FIRST USE 10-1-2007; IN COMMERCE 10-1-2007.

3,633,050. LABORATORIUM KOSMETYCZNE DR IRENA ERIS SPOKLA AKCYJNA, PIASECZNO, POLAND. SN 77-976,815. PUB. 5-13-2008, FILED 6-13-2007.

DR IRENA ERIS

THE MARK CONSISTS OF STANDARD CHARACTERS WITHOUT CLAIM TO ANY PARTICULAR FONT, STYLE, SIZE, OR COLOR.

OWNER OF U.S. REG. NO. 3,211,502.

THE NAME "DR. IRENA ERIS" IDENTIFIES A LIVING INDIVIDUAL WHOSE CONSENT IS OF RECORD.

CLASS 43—HOTEL AND RESTAURANT SERVICES

FOR HOTEL SERVICES, GUESTHOUSE SERVICES, TOURIST HOME SERVICES, CAFES, CAFETERIAS AND RESTAURANT SERVICES, SPA CENTRES SERVICES, NAMELY, PROVIDING TEMPORARY ACCOMMODATIONS AND MEALS TO CLIENTS OF A HEALTH OR BEAUTY SPA, SERVICES FOR PROVIDING FOOD AND DRINK, CATERING SERVICES (U.S. CLS. 100 AND 101).

FIRST USE 0-0-2006; IN COMMERCE 0-0-2006.

CLASS 44—MEDICAL, BEAUTY AND AGRICULTURAL SERVICES

FOR COSMETIC CLINIC SERVICES, NAMELY, BEAUTY CARE SERVICES RENDERED BY BEAUTICIANS, COSMETOLOGISTS, DERMATOLOGISTS AND PLASTIC SURGEONS; BEAUTY SALON SERVICES; HEALTH SPA CENTER SERVICES, NAMELY, COSMETIC BODY CARE SERVICES (U.S. CLS. 100 AND 101).

FIRST USE 0-0-2006; IN COMMERCE 0-0-2006.

3,633,051. AWANA CLUBS INTERNATIONAL, STREAMWOOD, IL. SN 77-976,819. PUB. 5-27-2008, FILED 1-18-2008.



OWNER OF U.S. REG. NOS. 1,377,869, 2,936,189, AND OTHERS.

NO CLAIM IS MADE TO THE EXCLUSIVE RIGHT TO USE "CLUBS", APART FROM THE MARK AS SHOWN.

THE MARK CONSISTS OF THE TEXT "AWANA" WITH THE TEXT "CLUBS" APPEARING DIRECTLY BENEATH "AWANA". CURVED LINES APPEAR ON EACH END OF THE TEXT AND CURVE TOWARD THE TEXT.

CLASS 9—ELECTRICAL AND SCIENTIFIC APPARATUS

FOR DIGITAL MATERIALS, NAMELY, PRE-RECORDED CDS AND DVDS FEATURING RELIGIOUS CONTENT (U.S. CLS. 21, 23, 26, 36 AND 38).

FIRST USE 7-1-2008; IN COMMERCE 7-1-2008.

CLASS 16—PAPER GOODS AND PRINTED MATTER

FOR PRINTED TEACHING MATERIALS IN THE FIELD OF CHRISTIAN EDUCATION FOR USE IN CHRISTIAN CHURCHES (U.S. CLS. 2, 5, 22, 23, 29, 37, 38 AND 50).

FIRST USE 7-1-2008; IN COMMERCE 7-1-2008.

3,633,060. MAJID, INC., NEW YORK, NY. SN 77-976,951. PUB. 5-27-2008, FILED 8-24-2007.

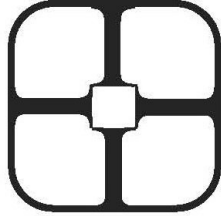

CLASS 9—ELECTRICAL AND SCIENTIFIC APPARATUS

FOR SUNGLASSES AND READING GLASSES (U.S. CLS. 21, 23, 26, 36 AND 38). FIRST USE 7-31-2008; IN COMMERCE 7-31-2008.

CLASS 14—JEWELRY

FOR JEWELRY AND WATCHES (U.S. CLS. 2, 27, 28 AND 50). FIRST USE 12-1-2007; IN COMMERCE 12-1-2007.

CLASS 18—LEATHER GOODS

FOR HANDBAGS, TRAVEL BAGS AND TOTE BAGS (U.S. CLS. 1, 2, 3, 22 AND 41). FIRST USE 12-1-2007; IN COMMERCE 12-1-2007.

CLASS 25—CLOTHING

FOR CLOTHING FOR WOMEN AND CHILDREN, NAMELY, DRESSES, SHIRTS, PANTS, WRAPS, STOLES, SHRUGS, SCARVES; FOOTWEAR FOR WOMEN AND CHILDREN (U.S. CLS. 22 AND 39). FIRST USE 12-1-2007; IN COMMERCE 12-1-2007.

CLASS 35—ADVERTISING AND BUSINESS

FOR PROVIDING FACILITIES FOR BUSINESS MEETINGS; ARRANGING AND CONDUCTING FAIRS AND EXHIBITIONS FOR BUSINESS AND ADVERTISING PURPOSES; RETAIL MUSEUM STORES (U.S. CLS. 100, 101 AND 102). FIRST USE 5-31-2001; IN COMMERCE 5-31-2001.

CLASS 36—INSURANCE AND FINANCIAL

FOR BUILDING MANAGEMENT (U.S. CLS. 100, 101 AND 102). FIRST USE 12-31-2005; IN COMMERCE 12-31-2005.

CLASS 41—EDUCATION AND ENTERTAINMENT

FOR PROVIDING FACILITIES FOR RECREATIONAL ACTIVITIES; PROVIDING FACILITIES FOR MOVIES, SHOWS, PLAYS, MUSIC OR EDUCATIONAL TRAINING; ARRANGING OF EXHIBITIONS, SEMINARS AND CONFERENCES; MUSEUMS; GUIDED TOURS OF AN HISTORICAL SITE; EDUCATION RESEARCH (U.S. CLS. 100, 101 AND 107). FIRST USE 5-31-2001; IN COMMERCE 5-31-2001.

CLASS 43—HOTEL AND RESTAURANT SERVICES

FOR PROVIDING FACILITIES FOR EXHIBITIONS; PROVISION OF CONFERENCE, EXHIBITION AND MEETING FACILITIES (U.S. CLS. 100 AND 101). FIRST USE 5-31-2001; IN COMMERCE 5-31-2001.

3,633,074. ESPRIT IP LIMITED, ROAD TOWN, TORTOLA, BR.VIRGIN ISLANDS. SN 77-977,063. PUB. 1-1-2008, FILED 7-26-2007.

3,633,068. MAYO HOTEL & LOFTS LIMITED PARTNERSHIP, TULSA, OK. SN 77-977,004. PUB. 7-8-2008, FILED 8-8-2007.



THE MARK CONSISTS OF A STYLIZED DESIGN CONSISTING OF THE SUPERIMPOSITION AND INTERTWINEMENT OF THE LETTERS "M", "A", "Y", AND "O".

EDC

THE MARK CONSISTS OF STANDARD CHARACTERS WITHOUT CLAIM TO ANY PARTICULAR FONT, STYLE, SIZE, OR COLOR.

CLASS 18—LEATHER GOODS

FOR HANDBAGS, SHOULDER BAGS, TOTE BAGS, WALLETS, COIN PURSES (U.S. CLS. 1, 2, 3, 22 AND 41). FIRST USE 0-0-2004; IN COMMERCE 0-0-2004.

CLASS 25—CLOTHING

FOR WOMEN'S WEARING APPAREL, NAMELY, DRESSES, COATS, SHORTS, SHIRTS, PANTS, SWEATERS, JACKETS, T-SHIRTS, UNDERSHIRTS, BLOUSES, KNIT TOPS (U.S. CLS. 22 AND 39). FIRST USE 0-0-2004; IN COMMERCE 0-0-2004.

3,633,081. FAMILY FOOD DISTRIBUTOR, INC., KEARNY, NJ. SN 77-977,121. PUB. 7-15-2008, FILED 10-22-2007.

MAMA TERE

THE MARK CONSISTS OF STANDARD CHARACTERS WITHOUT CLAIM TO ANY PARTICULAR FONT, STYLE, SIZE, OR COLOR.

THE WORDING "TERE" HAS NO MEANING IN A FOREIGN LANGUAGE.

CLASS 29—MEATS AND PROCESSED FOODS

FOR FRUIT AND VEGETABLES PRESERVES; PROCESSED FRUIT AND VEGETABLES; VEGETABLE SALADS; FROZEN FRUITS AND VEGETABLES; FLOUR PATTIES; CORN PATTIES; PLANTAIN PATTIES; DRIED BEANS; LENTILS; FROZEN FRUITS (U.S. CL. 46).

FIRST USE 10-24-2003; IN COMMERCE 10-24-2003.

CLASS 30—STAPLE FOODS

FOR SEASONINGS; HOT SAUCE; SPICES; MARINADES; COOKIES; TAMALES; CORN TAMALE; GRAIN-BASED FOOD BEVERAGE, NAMELY, OAT BASED BEVERAGE NOT BEING MILK SUBSTITUTE (U.S. CL. 46).

FIRST USE 10-24-2003; IN COMMERCE 10-24-2003.

CLASS 32—LIGHT BEVERAGES

FOR HORCHATA (U.S. CLS. 45, 46 AND 48).
FIRST USE 10-24-2003; IN COMMERCE 10-24-2003.

3,633,089. MANUFACTURERA DE IMPLEMENTOS, S.A. DE C.V., CORDOBA, VERACRUZ, MEXICO. SN 78-277,211. PUB. 6-28-2005, FILED 7-22-2003.

MANUFACTURERA  DE IMPLEMENTOS

PRIORITY CLAIMED UNDER SEC. 44(D) ON MEXICO APPLICATION NO. 609752, FILED 7-11-2003, REG. NO. 826944, DATED 7-11-2003, EXPIRES 7-11-2013.

NO CLAIM IS MADE TO THE EXCLUSIVE RIGHT TO USE "MANUFACTURERA" AND "DE IMPLEMENTOS", APART FROM THE MARK AS SHOWN.

THE STIPPLING IS FOR SHADING PURPOSES ONLY.

THE MARK CONSISTS OF THE WORDS AND A GRASSHOPPER.

THE FOREIGN WORDING IN THE MARK TRANSLATES INTO ENGLISH AS MANUFACTURER OF TOOLS.

CLASS 7—MACHINERY

FOR (BASED ON USE) AND (BASED ON 44(D) PRIORITY APPLICATION) SUGAR CANE LOADERS, MILL YARD EQUIPMENT, NAMELY, MECHANICAL GRABS, STACKERS, CANE FEED TABLES, SUGAR CANE SLINGS, PORTABLE TEMPLES; CENTRIFUGAL SEPARATORS, MECHANICAL CIRCULATORS FOR USE IN MANUFACTURING SUGAR, CRYSTALLIZERS (U.S. CLS. 13, 19, 21, 23, 31, 34 AND 35).

FIRST USE 4-8-1980; IN COMMERCE 1-16-1981.

CLASS 11—ENVIRONMENTAL CONTROL APPARATUS

FOR EVAPORATORS FOR COMMERCIAL USE; JUICE HEATERS; BAGASSE DRYING SYSTEM COMPRISING VACUUM PANS, MECHANICAL CIRCULATORS ALL FOR MANUFACTURING SUGAR (U.S. CLS. 13, 21, 23, 31 AND 34).

FIRST USE 4-8-1980; IN COMMERCE 1-16-1981.

CLASS 12—VEHICLES

FOR HYDRAULIC DUMP SEMI-TRAILERS, PNEUMATIC DISCHARGE HOPPER TANK SEMI-TRAILERS, BULK PRODUCT HOPPER TANK SEMI-TRAILERS, ELLIPTICAL TANK SEMI-TRAILER, CYLINDRICAL TANK SEMI-TRAILERS, CRANES (U.S. CLS. 19, 21, 23, 31, 35 AND 44).

FIRST USE 4-8-1980; IN COMMERCE 1-16-1981.

3,633,096. NATIONWIDE CHILDREN'S HOSPITAL, COLUMBUS, OH. SN 78-416,056. PUB. 7-26-2005, FILED 5-10-2004.

MEDIGLYPHS

THE MARK CONSISTS OF STANDARD CHARACTERS WITHOUT CLAIM TO ANY PARTICULAR FONT, STYLE, SIZE, OR COLOR.

CLASS 9—ELECTRICAL AND SCIENTIFIC APPARATUS

FOR COMPUTER SOFTWARE THAT FACILITATES THE COMMUNICATION OF PHARMACEUTICAL, MEDICAL AND HEALTHCARE INFORMATION TO THE GENERAL PUBLIC BY RENDERING THE INFORMATION IN A MANNER THAT IS BROADLY COMPREHENSIBLE TO PEOPLE OF VARYING LEVELS OF LITERACY FOR USE IN THE PHARMACEUTICAL, MEDICAL AND HEALTHCARE FIELDS; COMPUTER SOFTWARE THAT FACILITATES THE WRITING OF PRESCRIPTIONS IN THE PHARMACEUTICAL, MEDICAL AND HEALTHCARE FIELDS; EDUCATIONAL COMPUTER SOFTWARE FEATURING INSTRUCTION IN THE PHARMACEUTICAL, MEDICAL AND HEALTHCARE FIELDS (U.S. CLS. 21, 23, 26, 36 AND 38).

FIRST USE 9-16-2003; IN COMMERCE 9-16-2003.

CLASS 16—PAPER GOODS AND PRINTED MATTER

FOR PRINTED INSTRUCTIONAL MATERIAL FOR USE IN THE DESIGN AND TEACHING OF LITERACY AND COMMUNICATION CLASSES, TRAINING PROGRAMS AND SEMINARS BY PHARMACEUTICAL, MEDICAL AND HEALTHCARE PROFESSIONALS; PRINTED MATERIALS, NAMELY, EDUCATIONAL HAND-OUTS, RESEARCH REPORTS AND STUDIES USED TO FACILITATE THE COMMUNICATION OF INFORMATION BETWEEN PHARMACEUTICAL, MEDICAL AND HEALTHCARE PROFESSIONALS AND THE GENERAL PUBLIC (U.S. CLS. 2, 5, 22, 23, 29, 37, 38 AND 50).

FIRST USE 2-29-2004; IN COMMERCE 2-29-2004.

CLASS 41—EDUCATION AND ENTERTAINMENT

FOR EDUCATIONAL SERVICES, NAMELY, OFFERING CLASSES, TRAINING PROGRAMS AND SEMINARS, IN THE PHARMACEUTICAL, MEDICAL AND HEALTHCARE FIELDS AND DISTRIBUTING COURSE MATERIALS IN CONNECTION THEREWITH (U.S. CLS. 100, 101 AND 107).
FIRST USE 2-29-2004; IN COMMERCE 2-29-2004.

3,633,098. SESAME WORKSHOP, NEW YORK, NY. SN 78-472,026. PUB. 9-20-2005, FILED 8-23-2004.

HAPPY HEALTHY MONSTERS

THE MARK CONSISTS OF STANDARD CHARACTERS WITHOUT CLAIM TO ANY PARTICULAR FONT, STYLE, SIZE, OR COLOR.

CLASS 9—ELECTRICAL AND SCIENTIFIC APPARATUS

FOR VIDEO TAPES AND DVDS FEATURING EDUCATIONAL AND ENTERTAINMENT THEMES DIRECTED TO CHILDREN, PARENTS AND FAMILIES (U.S. CLS. 21, 23, 26, 36 AND 38).
FIRST USE 2-1-2007; IN COMMERCE 2-1-2007.

CLASS 16—PAPER GOODS AND PRINTED MATTER

FOR PRINTED MATERIALS, NAMELY, BOOKS, MAGAZINES, NEWSLETTERS, BROCHURES, AND PAMPHLETS ALL FEATURING INFORMATION AND ENTERTAINMENT FOR CHILDREN, PARENTS AND FAMILIES; STORY BOOKS, CHILDREN'S BOOKS, CHILDREN'S ACTIVITY BOOKS, COLORING BOOKS; POSTERS, PRINTED EDUCATIONAL BROCHURES AND PAMPHLETS, STICKERS, AND INSTRUCTIONAL VIDEOS AND DVDS SOLD TOGETHER AS A UNIT (U.S. CLS. 2, 5, 22, 23, 29, 37, 38 AND 50).
FIRST USE 4-0-2005; IN COMMERCE 4-0-2005.

3,633,099. MIMOSA SYSTEMS, INC., SANTA CLARA, CA. SN 78-473,258. PUB. 12-20-2005, FILED 8-25-2004.

MIMOSA

THE MARK CONSISTS OF STANDARD CHARACTERS WITHOUT CLAIM TO ANY PARTICULAR FONT, STYLE, SIZE, OR COLOR.

CLASS 9—ELECTRICAL AND SCIENTIFIC APPARATUS

FOR COMPUTER SOFTWARE FOR ARCHIVING E-MAIL SYSTEMS, INSTANT MESSAGING SYSTEMS, COLLABORATION SYSTEMS, APPLICATIONS AND FILE SYSTEMS; COMPUTER SOFTWARE FOR REPLICATING FILES; INSTRUCTION MANUALS SUPPLIED AS A UNIT WITH THE FOREGOING; PUBLICATIONS IN ELECTRONIC FORM, ON MAGNETIC AND OPTICAL COMPUTER-READABLE MEDIA OR DOWNLOADABLE VIA COMPUTER AND COMMUNICATION NETWORKS, INCLUDING THE INTERNET, NAMELY, WORK BOOKS, QUICK REFERENCE GUIDES, TECHNICAL REFERENCE MANUALS, COMPUTER USER MANUALS, EVALUATION GUIDES AND CONFERENCE MATERIALS IN THE FIELD OF COMPUTERS, COMPUTER SOFTWARE, COMPUTER PERIPHERALS, AND COMPUTER NETWORKS (U.S. CLS. 21, 23, 26, 36 AND 38).
FIRST USE 6-0-2005; IN COMMERCE 2-0-2007.

CLASS 42—SCIENTIFIC AND COMPUTER SERVICES

FOR COMPUTER CONSULTATION; PROVISION OF TECHNICAL ASSISTANCE AND TECHNICAL SUPPORT, NAMELY, TROUBLESHOOTING OF COMPUTER HARDWARE AND SOFTWARE PROBLEMS (U.S. CLS. 100 AND 101).
FIRST USE 10-0-2005; IN COMMERCE 11-0-2005.

3,633,100. MIMOSA SYSTEMS, INC., SANTA CLARA, CA. SN 78-473,297. PUB. 12-20-2005, FILED 8-25-2004.

MIMOSA SYSTEMS

THE MARK CONSISTS OF STANDARD CHARACTERS WITHOUT CLAIM TO ANY PARTICULAR FONT, STYLE, SIZE, OR COLOR.

NO CLAIM IS MADE TO THE EXCLUSIVE RIGHT TO USE "SYSTEMS", APART FROM THE MARK AS SHOWN.

CLASS 9—ELECTRICAL AND SCIENTIFIC APPARATUS

FOR COMPUTER SOFTWARE FOR ARCHIVING E-MAIL SYSTEMS, INSTANT MESSAGING SYSTEMS, COLLABORATION SYSTEMS, APPLICATIONS AND FILE SYSTEMS; COMPUTER SOFTWARE FOR REPLICATING FILES; INSTRUCTION MANUALS SUPPLIED AS A UNIT WITH THE FOREGOING; PUBLICATIONS IN ELECTRONIC FORM, ON MAGNETIC AND OPTICAL COMPUTER-READABLE MEDIA OR DOWNLOADABLE VIA COMPUTER AND COMMUNICATION NETWORKS, INCLUDING THE INTERNET, NAMELY, WORK BOOKS, QUICK REFERENCE GUIDES, TECHNICAL REFERENCE MANUALS, COMPUTER USER MANUALS, EVALUATION GUIDES AND CONFERENCE MATERIALS IN THE FIELD OF COMPUTERS, COMPUTER SOFTWARE, COMPUTER PERIPHERALS, AND COMPUTER NETWORKS (U.S. CLS. 21, 23, 26, 36 AND 38).
FIRST USE 6-0-2005; IN COMMERCE 2-0-2007.

CLASS 42—SCIENTIFIC AND COMPUTER SERVICES

FOR COMPUTER CONSULTATION; PROVISION OF TECHNICAL ASSISTANCE AND TECHNICAL SUPPORT, NAMELY, TROUBLESHOOTING OF COMPUTER HARDWARE AND SOFTWARE PROBLEMS (U.S. CLS. 100 AND 101).

FIRST USE 10-0-2005; IN COMMERCE 11-0-2005.

3,633,109. JOHN JO LEWIS AND JAY WADE PARTNERSHIP, THE, BELLINGHAM, WA. SN 78-500,859. PUB. 1-10-2006, FILED 10-15-2004.



THE MARK CONSISTS OF TWO WINGS, EACH CONTAINING A DOLPHIN, CONNECTED TO A CIRCLE CONTAINING THE LETTERS "SAS".

CLASS 12—VEHICLES

FOR SUBMARINES (U.S. CLS. 19, 21, 23, 31, 35 AND 44).

FIRST USE 5-31-2007; IN COMMERCE 5-31-2007.

CLASS 25—CLOTHING

FOR T-SHIRTS, HATS AND JACKETS, SOLD ONLY IN CONNECTION WITH SUBMARINE EXCURSIONS AND PROMOTING PUBLIC AWARENESS AND KNOWLEDGE OF SUBMARINES (U.S. CLS. 22 AND 39).

FIRST USE 5-31-2007; IN COMMERCE 5-31-2007.

CLASS 35—ADVERTISING AND BUSINESS

FOR PROMOTING PUBLIC AWARENESS AND KNOWLEDGE OF SUBMARINES (U.S. CLS. 100, 101 AND 102).

FIRST USE 1-31-2006; IN COMMERCE 1-31-2006.

CLASS 39—TRANSPORTATION AND STORAGE

FOR ARRANGING AND CONDUCTING SUBMARINE SIGHTSEEING EXCURSIONS (U.S. CLS. 100 AND 105).

FIRST USE 1-31-2006; IN COMMERCE 1-31-2006.

3,633,106. WAGNER, ANNE MCGEE, NEW CANAAN, CT. SN 78-493,170. PUB. 12-27-2005, FILED 10-1-2004.

ADD A GIRL

THE MARK CONSISTS OF STANDARD CHARACTERS WITHOUT CLAIM TO ANY PARTICULAR FONT, STYLE, SIZE, OR COLOR.

CLASS 16—PAPER GOODS AND PRINTED MATTER

FOR PRINTED MATTER, NAMELY, NOTE CARDS IN THE FIELD OF EMPOWERING YOUNG WOMEN THROUGH MATHEMATICS (U.S. CLS. 2, 5, 22, 23, 29, 37, 38 AND 50).

FIRST USE 3-15-2009; IN COMMERCE 3-15-2009.

CLASS 41—EDUCATION AND ENTERTAINMENT

FOR EDUCATIONAL SERVICES, NAMELY, SEMINARS, COURSES, AND WORKSHOPS, ALL IN THE FIELD OF EMPOWERING YOUNG WOMEN THROUGH MATHEMATICS, AND DISTRIBUTING COURSE MATERIALS IN CONNECTION THEREWITH (U.S. CLS. 100, 101 AND 107).

FIRST USE 3-18-2009; IN COMMERCE 3-18-2009.

3,633,112. LUSTER CREATIONS, MILL VALLEY, CA. SN 78-514,032. PUB. 1-17-2006, FILED 11-9-2004.

CAN DO KID

THE MARK CONSISTS OF STANDARD CHARACTERS WITHOUT CLAIM TO ANY PARTICULAR FONT, STYLE,

SIZE, OR COLOR.

CLASS 16—PAPER GOODS AND PRINTED MATTER

FOR BOOKS, NAMELY, BOOKS FOR CHILDREN AND TEENAGERS AND COLORING BOOKS, GREETING CARDS, STICKERS, AND TEMPORARY TATOOS (U.S. CLS. 2, 5, 22, 23, 29, 37, 38 AND 50).
FIRST USE 11-30-2004; IN COMMERCE 12-31-2004.

CLASS 25—CLOTHING

FOR BLOUSES, BOXER SHORTS, SHIRTS, SWEAT SHIRTS, SWEATERS, T-SHIRTS, AND TOPS (U.S. CLS. 22 AND 39).
FIRST USE 11-30-2004; IN COMMERCE 1-31-2005.

CLASS 29—MEATS AND PROCESSED FOODS

FOR PROTEIN BASED, NUTRIENT DENSE SNACK FOOD (U.S. CL. 46).
FIRST USE 8-31-2005; IN COMMERCE 8-31-2005.

CLASS 30—STAPLE FOODS

FOR CEREAL, WHEAT AND RICE BASED SNACK FOODS; GRAIN-BASED FOOD BARS; AND NUTRITIONAL CANDY BARS (U.S. CL. 46).
FIRST USE 8-31-2005; IN COMMERCE 8-31-2005.

CLASS 29—MEATS AND PROCESSED FOODS

FOR PROTEIN BASED, NUTRIENT DENSE SNACK FOOD (U.S. CL. 46).
FIRST USE 8-31-2005; IN COMMERCE 8-31-2005.

CLASS 30—STAPLE FOODS

FOR CEREAL, WHEAT AND RICE BASED SNACK FOODS; GRAIN-BASED FOOD BARS; AND NUTRITIONAL CANDY BARS (U.S. CL. 46).
FIRST USE 8-31-2005; IN COMMERCE 8-31-2005.

3,633,128. STARS 4 STUDENTS, INC., NEW YORK, NY. SN 78-570,593. PUB. 1-23-2007, FILED 2-18-2005.

3,633,113. LUSTER CREATIONS, MILL VALLEY, CA. SN 78-514,077. PUB. 1-24-2006, FILED 11-9-2004.

Stars 4 Students



THE MARK CONSISTS OF THE WORD "CAN'T" IN A CIRCLE WITH A DIAGONAL LINE THROUGH IT.

CLASS 16—PAPER GOODS AND PRINTED MATTER

FOR BOOKS, NAMELY, BOOKS FOR CHILDREN AND TEENAGERS AND COLORING BOOKS, GREETING CARDS, STICKERS, AND TEMPORARY TATTOOS (U.S. CLS. 2, 5, 22, 23, 29, 37, 38 AND 50).
FIRST USE 11-30-2004; IN COMMERCE 12-31-2004.

CLASS 25—CLOTHING

FOR BLOUSES, BOXER SHORTS, SHIRTS, SWEAT SHIRTS, SWEATERS, T-SHIRTS, AND TOPS (U.S. CLS. 22 AND 39).
FIRST USE 9-30-2005; IN COMMERCE 9-30-2005.

THE MARK CONSISTS OF STANDARD CHARACTERS WITHOUT CLAIM TO ANY PARTICULAR FONT, STYLE, SIZE, OR COLOR.

NO CLAIM IS MADE TO THE EXCLUSIVE RIGHT TO USE "STUDENTS", APART FROM THE MARK AS SHOWN.

CLASS 35—ADVERTISING AND BUSINESS

FOR MARKETING AND ADVERTISING SERVICES RELATED TO PROMOTING THE GOODS OR SERVICES OF OTHERS BY MEANS OF CHARITABLE, VOLUNTEER, EDUCATIONAL, AND ENTERTAINMENT RELATED PROGRAMS, CAMPAIGNS, AND WEBSITES; DEVELOPING AND MANAGING PROMOTIONAL CAMPAIGNS FOR BUSINESSES, GOVERNMENTAL ENTITIES, PUBLIC FIGURES, NOT-FOR-PROFIT ORGANIZATIONS, AND INDIVIDUALS AND ORGANIZATIONS IN EDUCATION, NAMELY, CHARITABLE, EDUCATIONAL, AND ENTERTAINMENT RELATED PROGRAMS, CAMPAIGNS, AND WEBSITES BY PREPARING AND PLACING ADVERTISEMENTS THROUGH VARIOUS MEDIA, NAMELY, TELEVISION, CABLE STATIONS, RADIO, CLOSED-CIRCUIT MEDIA, PRINT MATERIALS, AND WEBSITES ACCESSED THROUGH THE INTERNET AND INTRANET; CONDUCTING COMPUTERIZED ON-LINE RETAIL STORE SERVICES FEATURING APPAREL WEAR, CLOTHING ACCESSORIES, BOOKS, MUSIC, ELECTRONICS, CELLULAR TELEPHONES, FOOD AND BEVERAGE PRODUCTS, AND NATURAL RESOURCE PRODUCTS; AND CONDUCTING COMPUTERIZED ON-LINE CHARITABLE CAUSE PROMOTIONS (U.S. CLS. 100, 101 AND 102).
FIRST USE 5-19-2004; IN COMMERCE 7-20-2004.

CLASS 41—EDUCATION AND ENTERTAINMENT

FOR EDUCATIONAL SERVICES, NAMELY, DEVELOPING AND PROVIDING INSTRUCTIONS IN SERVICE LEARNING, JOB, AND WORK PROGRAMS IN THE FIELD OF CHARITABLE AND EDUCATIONAL FUNDRAISING, COMMUNITY AND ECONOMIC DEVELOPMENT, THIRD WORLD AND DISASTER RELIEF EFFORTS, PUBLIC HEALTH AWARENESS, AND POLITICAL INVOLVEMENT; ENTERTAINMENT SERVICES, NAMELY, ORGANIZING LIVE CONCERTS, CELEBRITY APPEARANCES, FORUMS, PRESS CONFERENCES, AWARD AND RECOGNITION CEREMONIES, SOCIAL GATHERINGS, PARTIES, FESTIVALS, AND GOLF, BASKETBALL, AND BILLIARD GAMES, AND VARIETY, ART, AND FASHION SHOWS DESIGNED TO BENEFIT CHARITABLE AND EDUCATIONAL FUNDRAISING, COMMUNITY AND ECONOMIC DEVELOPMENT, THIRD WORLD AND DISASTER RELIEF EFFORTS, PUBLIC HEALTH AWARENESS, AND POLITICAL INVOLVEMENT; CONDUCTING COMPUTERIZED ON-LINE EDUCATIONAL PROGRAMS IN THE AREA OF CHARITABLE AND EDUCATIONAL FUNDRAISING, COMMUNITY AND ECONOMIC DEVELOPMENT, THIRD WORLD AND DISASTER RELIEF EFFORTS, PUBLIC HEALTH AWARENESS, AND POLITICAL INVOLVEMENT; CONDUCTING COMPUTERIZED ON-LINE ENTERTAINMENT SERVICES, NAMELY, ORGANIZING LIVE CONCERTS, CELEBRITY APPEARANCES, FORUMS, PRESS CONFERENCES, AWARD AND RECOGNITION CEREMONIES, SOCIAL GATHERINGS, PARTIES, FESTIVALS, AND GOLF, BASKETBALL, AND BILLIARD GAMES, AND VARIETY, ART, AND FASHION SHOWS DESIGNED TO BENEFIT CHARITABLE AND EDUCATIONAL FUNDRAISING, COMMUNITY AND ECONOMIC DEVELOPMENT, THIRD WORLD AND DISASTER RELIEF EFFORTS, PUBLIC HEALTH AWARENESS, AND POLITICAL INVOLVEMENT (U.S. CLS. 100, 101 AND 107).

FIRST USE 5-19-2005; IN COMMERCE 7-20-2005.

3,633,129. OMEGA CREATIONS, LLC, DALLAS, TX. SN 78-573,077. PUB. 1-24-2006, FILED 2-23-2005.

GuildZone

THE MARK CONSISTS OF STANDARD CHARACTERS WITHOUT CLAIM TO ANY PARTICULAR FONT, STYLE, SIZE, OR COLOR.

CLASS 41—EDUCATION AND ENTERTAINMENT

FOR PROVIDING INFORMATION IN THE FIELD OF ELECTRONIC GAMING (U.S. CLS. 100, 101 AND 107).

FIRST USE 4-18-2005; IN COMMERCE 4-18-2009.

CLASS 42—SCIENTIFIC AND COMPUTER SERVICES

FOR HOSTING THE WEBSITES OF OTHERS IN THE FIELD OF ELECTRONIC GAMING (U.S. CLS. 100 AND 101).

FIRST USE 4-18-2005; IN COMMERCE 4-18-2009.

3,633,133. BOWTIE, INC., IRVINE, CA. SN 78-581,725. PUB. 11-21-2006, FILED 3-7-2005.

COUNTRY DOGS

THE MARK CONSISTS OF STANDARD CHARACTERS WITHOUT CLAIM TO ANY PARTICULAR FONT, STYLE, SIZE, OR COLOR.

NO CLAIM IS MADE TO THE EXCLUSIVE RIGHT TO USE "DOGS", APART FROM THE MARK AS SHOWN.

CLASS 16—PAPER GOODS AND PRINTED MATTER

FOR PRINTED PUBLICATIONS, NAMELY, BOOKS IN THE FIELD OF ANIMALS, PETS AND FEATURES OF GENERAL FEATURES TO ANIMAL AND PET OWNERS (U.S. CLS. 2, 5, 22, 23, 29, 37, 38 AND 50).

FIRST USE 12-0-2008; IN COMMERCE 12-0-2008.

CLASS 41—EDUCATION AND ENTERTAINMENT

FOR PROVIDING ON-LINE INFORMATION IN THE FIELDS OF ANIMALS AND PETS, RELATING TO HUNTING, ANIMAL HERDING, ANIMAL TRAINING AND ANIMAL EXHIBITIONS (U.S. CLS. 100, 101 AND 107).

FIRST USE 4-20-2009; IN COMMERCE 4-20-2009.

3,633,138. ITRAIN, LLC, BEVERLY HILLS, CA. SN 78-598,664. PUB. 7-18-2006, FILED 3-30-2005.

ITRAIN

THE MARK CONSISTS OF STANDARD CHARACTERS WITHOUT CLAIM TO ANY PARTICULAR FONT, STYLE, SIZE, OR COLOR.

CLASS 35—ADVERTISING AND BUSINESS

FOR RETAIL STORE SERVICES ON THE INTERNET FEATURING PRE-RECORDED COMPUTER PROGRAMS FEATURING FITNESS AND HEALTH RELATED ISSUES AND PRE-RECORDED DVDS AND DOWNLOADABLE MEDIA FEATURING FITNESS AND HEALTH RELATED ISSUES (U.S. CLS. 100, 101 AND 102).

FIRST USE 11-25-2005; IN COMMERCE 11-25-2005.

CLASS 41—EDUCATION AND ENTERTAINMENT

FOR PHYSICAL FITNESS INSTRUCTION; PHYSICAL FITNESS CONSULTATION; EDUCATION IN THE FIELD OF PHYSICAL FITNESS RENDERED THROUGH CORRESPONDENCE COURSES (U.S. CLS. 100, 101 AND 107).
FIRST USE 11-25-2005; IN COMMERCE 11-25-2005.

3,633,150. PURITY ORGANICS, INC., FRESNO, CA. SN 78-636,447. PUB. 3-21-2006, FILED 5-24-2005.

PURITY ORGANICS

THE MARK CONSISTS OF STANDARD CHARACTERS WITHOUT CLAIM TO ANY PARTICULAR FONT, STYLE, SIZE, OR COLOR.

NO CLAIM IS MADE TO THE EXCLUSIVE RIGHT TO USE "ORGANICS", APART FROM THE MARK AS SHOWN.

CLASS 35—ADVERTISING AND BUSINESS

FOR PACKAGING OF MERCHANDISE, NAMELY, ORGANIC NUTS INCLUDING ALMONDS FOR OTHERS (U.S. CLS. 100, 101 AND 102).
FIRST USE 2-27-2009; IN COMMERCE 2-27-2009.

CLASS 40—MATERIAL TREATMENT

FOR PROCESSING OF ORGANIC NUTS INCLUDING ALMONDS (U.S. CLS. 100, 103 AND 106).
FIRST USE 2-27-2009; IN COMMERCE 2-27-2009.

3,633,151. BEN WACHTER ASSOCIATES, INC., NEW YORK, NY. SN 78-637,173. PUB. 8-1-2006, FILED 5-25-2005.

PORTO THE BEAR

THE MARK CONSISTS OF STANDARD CHARACTERS WITHOUT CLAIM TO ANY PARTICULAR FONT, STYLE, SIZE, OR COLOR.

NO CLAIM IS MADE TO THE EXCLUSIVE RIGHT TO USE "THE BEAR" FOR GOODS IN CLASS 28, APART FROM THE MARK AS SHOWN.

THE ENGLISH TRANSLATION OF "PORTO" FROM PORTUGUESE IS PORT.

CLASS 28—TOYS AND SPORTING GOODS

FOR PLUSH TOY BEARS (U.S. CLS. 22, 23, 38 AND 50).
FIRST USE 9-0-2005; IN COMMERCE 9-0-2005.

CLASS 35—ADVERTISING AND BUSINESS

FOR PROMOTING PUBLIC AWARENESS OF THE NEED FOR USING FLANNEL FABRIC MADE IN PORTUGAL FOR THE MANUFACTURE OF CLOTHING, SLEEPWEAR AND CLOTHING ACCESSORIES; PROMOTING THE GOODS OF OTHERS, NAMELY, FLANNEL FABRIC MADE IN PORTUGAL FOR USE AND THE MANUFACTURE OF CLOTHING, SLEEPWEAR AND CLOTHING ACCESSORIES (U.S. CLS. 100, 101 AND 102).

FIRST USE 9-0-2005; IN COMMERCE 9-0-2005.

3,633,152. INTERNATIONAL SHARED SERVICES, INC., WEST LANGHORNE, PA. SN 78-638,082. PUB. 2-14-2006, FILED 5-26-2005.

ISS SOLUTIONS

THE MARK CONSISTS OF STANDARD CHARACTERS WITHOUT CLAIM TO ANY PARTICULAR FONT, STYLE, SIZE, OR COLOR.

CLASS 9—ELECTRICAL AND SCIENTIFIC APPARATUS

FOR SOFTWARE FOR MONITORING MEDICAL AND INFORMATION TECHNOLOGY EQUIPMENT AND IDENTIFYING EQUIPMENT FAILURE (U.S. CLS. 21, 23, 26, 36 AND 38).

FIRST USE 1-0-2008; IN COMMERCE 1-0-2008.

CLASS 37—CONSTRUCTION AND REPAIR

FOR PROVIDING AN ON-LINE DATABASE FEATURING CLIENT REPORTS AND ANALYSES REGARDING SERVICING OF CLIENT'S MEDICAL AND INFORMATION TECHNOLOGY EQUIPMENT (U.S. CLS. 100, 103 AND 106).

FIRST USE 3-0-2009; IN COMMERCE 3-0-2009.

3,633,153. INTERNATIONAL SHARED SERVICES, INC., WEST LANGHORNE, PA. SN 78-638,090. PUB. 2-14-2006, FILED 5-26-2005.



THE COLORS BLUE AND RED ARE CLAIMED AS A FEATURE OF THE MARK.

THE MARK CONSISTS OF THE WORDING "ISS SOLUTIONS" IN BLUE AND TWO HORIZONTAL LINES. THE TOP LINE IS RED AND THE BOTTOM LINE IS BLUE.

CLASS 9—ELECTRICAL AND SCIENTIFIC APPARATUS

FOR SOFTWARE FOR MONITORING MEDICAL AND INFORMATION TECHNOLOGY EQUIPMENT AND IDENTIFYING EQUIPMENT FAILURE (U.S. CLS. 21, 23, 26, 36 AND 38).

FIRST USE 1-0-2008; IN COMMERCE 1-0-2008.

CLASS 37—CONSTRUCTION AND REPAIR

FOR PROVIDING AN ON-LINE DATABASE FEATURING CLIENT REPORTS AND ANALYSES REGARDING SERVICING OF CLIENT'S MEDICAL AND INFORMATION TECHNOLOGY EQUIPMENT (U.S. CLS. 100, 103 AND 106).

FIRST USE 3-0-2009; IN COMMERCE 3-0-2009.

3,633,161. LUCASFILM LTD., SAN FRANCISCO, CA. SN 78-662,724. PUB. 12-26-2006, FILED 7-1-2005.



LUCAS ONLINE

OWNER OF U.S. REG. NO. 2,823,644.

NO CLAIM IS MADE TO THE EXCLUSIVE RIGHT TO USE "ONLINE", APART FROM THE MARK AS SHOWN.

THE MARK CONSISTS OF THE WORDS "LUCAS ONLINE" WITH THE DESIGN OF TWO OVERLAPPING FACES.

CLASS 35—ADVERTISING AND BUSINESS

FOR RETAIL STORE SERVICES AND COMPUTERIZED ON-LINE RETAILING AND ORDERING SERVICES FEATURING GENERAL MERCHANDISE, INTERACTIVE SOFTWARE, COMPUTER GAME SOFTWARE, INTERACTIVE VIDEO GAMES, INTERACTIVE COMPUTER GAMES, CLOTHING, MOTION PICTURES, COMPUTER PROGRAMS AND OTHER AUDIO-VISUAL WORKS (U.S. CLS. 100, 101 AND 102).

FIRST USE 11-0-2005; IN COMMERCE 11-0-2005.

CLASS 41—EDUCATION AND ENTERTAINMENT

FOR ENTERTAINMENT SERVICES, NAMELY, THE PRODUCTION AND DISTRIBUTION OF VIDEO PROGRAMMING FEATURING VIDEOS, MUSIC VIDEOS, GENERAL ENTERTAINMENT, CONTINUING NEWS, COMEDY, OVER AUDIO AND VIDEO MEDIA; PROVIDING AUDIOVISUAL ENTERTAINMENT IN THE NATURE OF NEWS, COMEDY, SCIENCE FICTION, EDUCATION AND COMPUTER VIDEO GAMES VIA GLOBAL INFORMATION NETWORK AND OTHER ELECTRONIC COMPUTER NETWORKS; PROVIDING INTERACTIVE ON-LINE COMPUTER GAMES THAT MAY BE ACCESSED NETWORK-WIDE BY NETWORK USERS; FAN CLUBS; ENTERTAINMENT IN THE NATURE OF COMPETITIONS IN THE FIELD OF ENTERTAINMENT TRIVIA; CONTINUING VARIETY, NEWS, COMEDY, SCIENCE FICTION, EDUCATIONAL AND ENTERTAINMENT MOTION PICTURE, TELEVISION, CABLE, AND SATELLITE SHOWS DISTRIBUTED OVER AUDIO AND VIDEO MEDIA; PROVIDING AUDIO VISUAL, AND AUDIO-VISUAL ENTERTAINMENT, NAMELY, SCIENCE FICTION, ACTION, ADVENTURE, ANIMATION, COMEDY, DRAMA AND MUSIC IN THE FIELD OF EDUCATION; ENTERTAINMENT, NAMELY, SCIENCE FICTION, ACTION, ADVENTURE, ANIMATION, COMEDY, DRAMA AND MUSIC VIA GLOBAL COMPUTER NETWORKS AND OTHER ELECTRONIC COMPUTER NETWORKS; AND PROVIDING NEWS AND INFORMATION IN THE FIELD OF EDUCATION, ENTERTAINMENT, SCIENCE FICTION TOPICS, COMPUTER GAMES AND MOTION PICTURE FILMS VIA GLOBAL COMPUTER NETWORKS AND OTHER ELECTRONIC COMPUTER NETWORKS (U.S. CLS. 100, 101 AND 107).

FIRST USE 11-0-2005; IN COMMERCE 11-0-2005.

3,633,166. SAHARA SAM'S OASIS, LLC, WEST BERLIN, NJ. SN 78-677,074. PUB. 4-18-2006, FILED 7-25-2005.



NO CLAIM IS MADE TO THE EXCLUSIVE RIGHT TO USE "INDOOR WATER PARK" IN CLASS 41, APART FROM THE MARK AS SHOWN.

THE MARK CONSISTS OF THE WORDS "SAHARA SAM'S OASIS INDOOR WATER PARK", WITH A CARTOON CAMEL AND SPLASHES OF WATER VISIBLE IN THE "O" OF "OASIS".

CLASS 35—ADVERTISING AND BUSINESS

FOR CONCESSION STANDS FEATURING FOOD, BEVERAGES, AND SOUVENIRS (U.S. CLS. 100, 101 AND 102).

FIRST USE 3-24-2009; IN COMMERCE 3-24-2009.

CLASS 41—EDUCATION AND ENTERTAINMENT

FOR AMUSEMENT PARK AND INDOOR WATER PARK SERVICES (U.S. CLS. 100, 101 AND 107).

FIRST USE 3-22-2009; IN COMMERCE 3-22-2009.

3,633,167. GLOTO CORP., FULTON, MD. SN 78-678,969. PUB. 10-24-2006, FILED 7-26-2005.

GLOTO

THE MARK CONSISTS OF STANDARD CHARACTERS WITHOUT CLAIM TO ANY PARTICULAR FONT, STYLE, SIZE, OR COLOR.

CLASS 9—ELECTRICAL AND SCIENTIFIC APPARATUS

FOR VIDEO CONFERENCING SOFTWARE; SOFTWARE FOR TRANSMITTING, RECEIVING, STORING, EDITING AND MANAGING AUDIO, VIDEO AND DATA FILES; SOFTWARE USED FOR TRANSMITTING MESSAGES AMONG COMPUTER USERS IN ON-LINE CHAT-ROOMS; SOFTWARE FOR THE OPERATION OF HANDHELD ELECTRONIC DEVICES, NAMELY, CELL-PHONES, PERSONAL DATA ASSISTANTS AND WIRELESS DEVICES FOR TRANSMITTING AND RECEIVING E-MAIL; SOFTWARE USED FOR CREATING AND DESIGNING ONLINE BLOGS; SOFTWARE USED FOR CREATING AND DESIGNING ONLINE VIDEO LOGS; SOFTWARE USED FOR PODCASTING, NAMELY, RECORDING, TRANSMITTING, STORING AND LISTING DIRECTORIS FOR PODCASTS; SOFTWARE FOR TRANSMITTING ELECTRONIC MAIL (U.S. CLS. 21, 23, 26, 36 AND 38).

FIRST USE 4-0-2006; IN COMMERCE 4-0-2006.

CLASS 35—ADVERTISING AND BUSINESS

FOR ADVERTISING SERVICES; ONLINE RETAIL STORE SERVICES FEATURING SOFTWARE, ELECTRONICS, CLOTHING, BOOKS AND GAMES (U.S. CLS. 100, 101 AND 102).
FIRST USE 4-0-2005; IN COMMERCE 4-0-2005.

CLASS 38—COMMUNICATION

FOR ELECTRONIC STORE AND FORWARD MESSAGING; TELECOMMUNICATION SERVICES IN THE NATURE OF TRANSMISSION OF AUDIO, VIDEO AND DATA ACROSS A GLOBAL COMMUNICATIONS NETWORK; ELECTRONIC TRANSMISSION OF AUDIO, VIDEO AND DATA TO HANDHELD DEVICES; PROVISION OF ACCESS TO DATA OR DOCUMENTS STORED ELECTRONICALLY IN CENTRAL FILES FOR REMOTE CONSULTATION; PROVIDING ON-LINE CHAT ROOMS AND ELECTRONIC BULLETIN BOARDS FOR TRANSMISSION OF MESSAGES AMONG USERS IN THE FIELD OF GENERAL INTEREST; PROVIDING ON-LINE FORUMS FOR TRANSMISSION OF MESSAGES AMONG COMPUTER USERS CONCERNING A WIDE VARIETY OF SUBJECTS; PROVIDING ON-LINE LISTSERVERS FOR TRANSMISSION OF MESSAGES AMONG COMPUTER USERS CONCERNING A WIDE VARIETY OF SUBJECTS (U.S. CLS. 100, 101 AND 104).
FIRST USE 4-0-2005; IN COMMERCE 4-0-2005.

CLASS 39—TRANSPORTATION AND STORAGE

FOR STORAGE OF ELECTRONIC MEDIA, NAMELY, VIDEO, TEXT AND AUDIO DATA FILES (U.S. CLS. 100 AND 105).
FIRST USE 4-0-2005; IN COMMERCE 4-0-2005.

CLASS 42—SCIENTIFIC AND COMPUTER SERVICES

FOR HOSTING WEBSITES, BLOGS AND WEBPAGES FOR OTHERS ON A COMPUTER SERVER ON GLOBAL COMPUTER NETWORK; DEVELOPMENT OF COMPUTER SOFTWARE FOR OTHERS USED TO CREATE AUDIO, VIDEO AND DATA FILES (U.S. CLS. 100 AND 101).
FIRST USE 4-0-2005; IN COMMERCE 4-0-2005.

3,633,169. CE RESOURCE, INC., GRANITE BAY, CA. SN 78-685,956. PUB. 11-28-2006, FILED 8-4-2005.



**EVIDENCE-BASED
PRACTICE
RECOMMENDATION**

NO CLAIM IS MADE TO THE EXCLUSIVE RIGHT TO USE "EVIDENCE-BASED PRACTICE RECOMMENDATION", APART FROM THE MARK AS SHOWN.
THE MARK CONSISTS OF THE LETTERS "E" AND "B" ON TWO PIECES OF PAPERS.

CLASS 16—PAPER GOODS AND PRINTED MATTER

FOR BOOKLETS AND CATALOGS OF INSTRUCTIONAL TEACHING MATERIAL IN THE AREA OF CONTINUING MEDICAL EDUCATION (U.S. CLS. 2, 5, 22, 23, 29, 37, 38 AND 50).
FIRST USE 2-16-2006; IN COMMERCE 2-16-2006.

CLASS 41—EDUCATION AND ENTERTAINMENT

FOR CONTINUING EDUCATION SERVICES, NAMELY, CONDUCTING ONLINE CONTINUING EDUCATION CLASSES IN THE FIELD OF MEDICAL EDUCATION (U.S. CLS. 100, 101 AND 107).
FIRST USE 1-11-2006; IN COMMERCE 1-11-2006.

3,633,179. ECOWASH MOBILE INTERNATIONAL PTY LTD, PARRAMATTA NSW 2150, AUSTRALIA. SN 78-695,494. PUB. 7-3-2007, FILED 8-18-2005.



NO CLAIM IS MADE TO THE EXCLUSIVE RIGHT TO USE "MOBILE", APART FROM THE MARK AS SHOWN.

CLASS 35—ADVERTISING AND BUSINESS

FOR BUSINESS CONSULTANCY SERVICES; ADVERTISING SERVICES; FRANCHISING SERVICES, NAMELY, RENDERING TECHNICAL ASSISTANCE TO OTHERS IN THE ESTABLISHMENT, MANAGEMENT, EQUIPPING AND OPERATION OF A FRANCHISE FOR THE CLEANING OF AUTOMOBILES AND OTHER MOTOR VEHICLES (U.S. CLS. 100, 101 AND 102).
FIRST USE 8-9-2007; IN COMMERCE 8-9-2007.

CLASS 37—CONSTRUCTION AND REPAIR

FOR CLEANING AND DETAILING OF AUTOMOBILES AND OTHER MOTOR VEHICLES INCLUDING AIRCRAFT, BOATS AND OTHER WATERCRAFT; MOTOR VEHICLE WASHING SERVICES; RENTAL OF CLEANING MACHINES; VEHICLE MAINTENANCE SERVICES (U.S. CLS. 100, 103 AND 106).
FIRST USE 8-15-2007; IN COMMERCE 8-15-2007.

3,633,185. KEY TECHNOLOGY, INC., WALLA WALLA, WA. SN 78-705,688. PUB. 2-13-2007, FILED 9-1-2005.



THE MARK CONSISTS OF STANDARD CHARACTERS WITHOUT CLAIM TO ANY PARTICULAR FONT, STYLE, SIZE, OR COLOR.

CLASS 7—MACHINERY

FOR PHARMACEUTICAL PROCESSING EQUIPMENT, NAMELY, A CONVEYOR FOR TRANSPORTING PHARMACEUTICALS ALONG A COURSE OF TRAVEL; AN AIR SORTING MANIFOLD FOR SORTING PHARMACEUTICALS POSITIONED ON A CONVEYOR; A GRADER; POLISHER; AND A DRYER FOR DRYING PHARMACEUTICAL PRODUCTS TRAVELING ALONG A CONVEYOR (U.S. CLS. 13, 19, 21, 23, 31, 34 AND 35).
FIRST USE 3-17-2009; IN COMMERCE 3-17-2009.

CLASS 9—ELECTRICAL AND SCIENTIFIC APPARATUS

FOR PHARMACEUTICAL PROCESSING EQUIPMENT, NAMELY, A CAMERA FOR INSPECTING PHARMACEUTICALS TRAVELING ALONG A CONVEYOR AND A COMPUTER COUPLED TO THE CAMERA AND WHICH IMAGES THE CONVEYOR (U.S. CLS. 21, 23, 26, 36 AND 38).
FIRST USE 3-17-2009; IN COMMERCE 3-17-2009.

CLASS 11—ENVIRONMENTAL CONTROL APPARATUS

FOR PHARMACEUTICAL PROCESSING EQUIPMENT, NAMELY, A SOURCE OF LIGHTING FOR ILLUMINATING A CONVEYOR WHICH IS TRANSPORTING PHARMACEUTICALS (U.S. CLS. 13, 21, 23, 31 AND 34).
FIRST USE 3-17-2009; IN COMMERCE 3-17-2009.

3,633,188. SIBEAM, INC., SUNNYVALE, CA. SN 78-721,738. PUB. 1-2-2007, FILED 9-27-2005.

SIBEAM

THE MARK CONSISTS OF STANDARD CHARACTERS WITHOUT CLAIM TO ANY PARTICULAR FONT, STYLE, SIZE, OR COLOR.

CLASS 9—ELECTRICAL AND SCIENTIFIC APPARATUS

FOR COMPUTER HARDWARE; SEMICONDUCTORS; SEMICONDUCTOR CHIPS; SEMICONDUCTOR DEVICES; SEMICONDUCTOR POWER ELEMENTS; COMPUTER CHIPS; INTEGRATED CIRCUITS; COMPUTER CHIPSET FOR USE IN TRANSMITTING DATA TO AND FROM A CENTRAL PROCESSING UNIT; COMPUTER CHIPSET SYSTEMS, CONSISTING PRIMARILY OF COMPUTER CHIPSETS, COMPUTER HARDWARE, AND SOFTWARE FOR USE IN TELEVISIONS AND OTHER ELECTRONIC DEVICES FOR TRANSMISSION AND DELIVERY OF AUDIO, VIDEO AND MULTIMEDIA CONTENT; COMPUTER PERIPHERALS; COMPUTER HARDWARE AND SOFTWARE FOR WIRELESS CONTENT DELIVERY; COMPUTER HARDWARE AND SOFTWARE FOR STREAMING OF AUDIO AND VIDEO CONTENT BETWEEN SOURCE DEVICES AND HIGH-DEFINITION DISPLAYS; COMMUNICATIONS HARDWARE, NAMELY, COMMUNICATIONS SERVERS; COMPUTER NETWORKING HARDWARE AND SOFTWARE; WIRELESS COMPUTER PERIPHERALS (U.S. CLS. 21, 23, 26, 36 AND 38).
FIRST USE 3-0-2008; IN COMMERCE 3-0-2009.

CLASS 42—SCIENTIFIC AND COMPUTER SERVICES

FOR COMPUTER SERVICES, NAMELY, COMPUTER PROGRAMMING FOR OTHERS, COMPUTER SERVICES, NAMELY, DESIGN OF COMPUTER HARDWARE, INTEGRATED CIRCUITS, COMMUNICATIONS HARDWARE AND SOFTWARE AND COMPUTER NETWORKS FOR OTHERS (U.S. CLS. 100 AND 101).
FIRST USE 1-0-2009; IN COMMERCE 1-0-2009.

3,633,192. KONICA MINOLTA BUSINESS TECHNOLOGIES, INC., TOKYO, JAPAN. SN 78-732,814. PUB. 1-9-2007, FILED 10-13-2005.

OUTWARD

THE MARK CONSISTS OF STANDARD CHARACTERS WITHOUT CLAIM TO ANY PARTICULAR FONT, STYLE, SIZE, OR COLOR.

CLASS 37—CONSTRUCTION AND REPAIR

FOR INSTALLATION, MAINTENANCE AND REPAIR OF COPIERS, PRINTERS, FACSIMILE MACHINES, SCANNERS AND MULTIFUNCTIONAL PRODUCTS, NAMELY, MACHINES WHICH PERFORM SOME OR ALL OF THE ABOVE-MENTIONED FUNCTIONS IN ONE UNIT (U.S. CLS. 100, 103 AND 106).
FIRST USE 9-1-2005; IN COMMERCE 9-1-2005.

CLASS 42—SCIENTIFIC AND COMPUTER SERVICES

FOR INSTALLATION, MAINTENANCE AND REPAIR OF COMPUTER OPERATION SOFTWARE FOR COPIERS, FACSIMILE MACHINES, AND SCANNERS (U.S. CLS. 100 AND 101).
FIRST USE 9-1-2005; IN COMMERCE 9-1-2005.

3,633,201. MANIFEST YOUR DESTINY FOUNDATION, LOS ANGELES, CA. SN 78-746,916. PUB. 7-29-2008, FILED 11-3-2005.

MANIFEST YOUR DESTINY

THE MARK CONSISTS OF STANDARD CHARACTERS WITHOUT CLAIM TO ANY PARTICULAR FONT, STYLE, SIZE, OR COLOR.

CLASS 35—ADVERTISING AND BUSINESS

FOR PROVIDING AN INFORMATIONAL WEBSITE PROMOTING PUBLIC AWARENESS OF THE NEED FOR POSITIVE ROLE MODELS AND EDUCATIONAL AND EMPLOYMENT OPPORTUNITIES FOR DISADVANTAGED YOUTHS (U.S. CLS. 100, 101 AND 102).
FIRST USE 0-0-2007; IN COMMERCE 0-0-2007.

CLASS 36—INSURANCE AND FINANCIAL

FOR CHARITABLE FUND RAISING (U.S. CLS. 100, 101 AND 102).
FIRST USE 0-0-2007; IN COMMERCE 0-0-2007.

3,633,204. ILAN AZOURI, TEL-AVIV, ISRAEL. SN 78-747,737.
PUB. 6-17-2008, FILED 11-4-2005.

FLOW

THE MARK CONSISTS OF STANDARD CHARACTERS WITHOUT CLAIM TO ANY PARTICULAR FONT, STYLE, SIZE, OR COLOR.

CLASS 5—PHARMACEUTICALS

FOR HEALTH AND HOLISTIC BEVERAGES THAT PROMOTES WELL-BEING, NAMELY, DIETARY SUPPLEMENTAL DRINKS (U.S. CLS. 6, 18, 44, 46, 51 AND 52).
FIRST USE 2-27-2007; IN COMMERCE 2-27-2007.

CLASS 9—ELECTRICAL AND SCIENTIFIC APPARATUS

FOR PRE-RECORDED VIDEOTAPES, VIDEODISCS, DVDS, CD-ROMS, AUDIO CASSETTES AND AUDIO CDS THAT FEATURE INFORMATION REGARDING HOLISTIC BEVERAGES, FOOD SUPPLEMENTS, AND VIBRATION MEDICAL TREATMENT, ALL PROMOTING WELL BEING (U.S. CLS. 21, 23, 26, 36 AND 38).
FIRST USE 2-27-2007; IN COMMERCE 2-27-2007.

CLASS 25—CLOTHING

FOR HOLISTIC HEALTH CLOTHING, NAMELY, T-SHIRTS, CASUAL SHIRTS, SWEATSHIRTS, SWEATERS AND PANTS, HEADGEAR, NAMELY, HATS AND CAPS AND FOOTWEAR, ALL PROMOTING WELL BEING AND OFFERED IN CONJUNCTION WITH SALE OF HOLISTIC BEVERAGES, SALE OF FOOD SUPPLEMENTS, OR PROVISION OF VIBRATION MEDICAL TREATMENT (U.S. CLS. 22 AND 39).
FIRST USE 2-27-2007; IN COMMERCE 2-27-2007.

CLASS 44—MEDICAL, BEAUTY AND AGRICULTURAL SERVICES

FOR HEALTH CARE AND HEALING SERVICES FOR PROMOTING WELL-BEING, NAMELY, CONSULTATION, ADVICE, AND TREATMENT THROUGH VIBRATION MEDICAL TREATMENT AND SELF CONSCIOUSNESS THERAPY; THERAPY SERVICES TO INCREASE A LEVEL OF SELF CONSCIOUSNESS; CONSULTATION, ADVICE, TREATMENT AND THERAPY IN THE FIELD OF WELLNESS PROGRAMS THAT UTILIZE FLOWER REMEDIES AND FLOWER ESSENCES AND NATURAL METHODS OF HEALING (U.S. CLS. 100 AND 101).
FIRST USE 2-27-2007; IN COMMERCE 2-27-2007.

3,633,216. ZYLTEC, INC., ISSAQUAH, WA. SN 78-759,830.
PUB. 8-1-2006, FILED 11-22-2005.

LegalSquire

THE MARK CONSISTS OF STANDARD CHARACTERS WITHOUT CLAIM TO ANY PARTICULAR FONT, STYLE, SIZE, OR COLOR.

CLASS 9—ELECTRICAL AND SCIENTIFIC APPARATUS

FOR COMPUTER SOFTWARE FOR MANAGING DOCUMENTS AND INTELLECTUAL PROPERTY (U.S. CLS. 21, 23, 26, 36 AND 38).
FIRST USE 9-28-2006; IN COMMERCE 4-30-2008.

CLASS 16—PAPER GOODS AND PRINTED MATTER

FOR COMPUTER PROGRAM MANUALS FOR DOCUMENT AND INTELLECTUAL PROPERTY SOFTWARE (U.S. CLS. 2, 5, 22, 23, 29, 37, 38 AND 50).
FIRST USE 9-28-2006; IN COMMERCE 4-30-2008.

3,633,223. NUANCE COMMUNICATIONS, INC., BURLINGTON, MA. SN 78-778,416. PUB. 1-23-2007, FILED 12-21-2005.

DRAGON

THE MARK CONSISTS OF STANDARD CHARACTERS WITHOUT CLAIM TO ANY PARTICULAR FONT, STYLE, SIZE, OR COLOR.

OWNER OF U.S. REG. NOS. 1,419,515, 1,428,200, AND 1,480,770.

CLASS 9—ELECTRICAL AND SCIENTIFIC APPARATUS

FOR SPEECH PROCESSING SOFTWARE; COMPUTER SOFTWARE FOR DOCUMENT MANAGEMENT; COMPUTER APPLICATION SOFTWARE FOR MOBILE PHONES TO ENABLE VOICE ACTIVATED DIALING, INTERNET SEARCHING AND NAVIGATING VIA A WORLDWIDE COMPUTER NETWORK, AND DICTATION OF MESSAGES; COMPUTER APPLICATION SOFTWARE FOR HANDHELD COMPUTING DEVICES TO ENABLE VOICE ACTIVATED DIALING, INTERNET SEARCHING AND NAVIGATING VIA A WORLDWIDE COMPUTER NETWORK, AND DICTATION OF MESSAGES (U.S. CLS. 21, 23, 26, 36 AND 38).
FIRST USE 12-31-1985; IN COMMERCE 12-31-1985.

CLASS 42—SCIENTIFIC AND COMPUTER SERVICES

FOR COMPUTER CONSULTING SERVICES, NAMELY, CONSULTING SERVICES IN THE FIELD OF AUTOMATED TRANSCRIPTION PROCESSING; COMPUTER CONSULTING SERVICES, NAMELY, CONSULTING SERVICES IN THE FIELD OF SPEECH RECOGNITION SYSTEMS (U.S. CLS. 100 AND 101).
FIRST USE 12-31-1982; IN COMMERCE 12-31-1982.

3,633,227. NEW ARMY, INC., WAYNESBORO, PA. SN 78-788,412. PUB. 5-15-2007, FILED 1-10-2006.



THE MARK CONSISTS OF A STYLIZED LETTER "A".

CLASS 25—CLOTHING

FOR CLOTHING FOR MEN, WOMEN AND CHILDREN, NAMELY, SHIRTS, PANTS, HATS, SOCKS, SWEATERS, SPORT COATS, COATS, JACKETS, DRESSES, UNDERWEAR, HEADWEAR, LOUNGEWEAR, NECKWEAR; FOOTWEAR (U.S. CLS. 22 AND 39).

FIRST USE 5-0-2007; IN COMMERCE 4-1-2008.

CLASS 35—ADVERTISING AND BUSINESS

FOR RETAIL AND ON-LINE RETAIL CLOTHING STORE SERVICES (U.S. CLS. 100, 101 AND 102).

FIRST USE 5-0-2007; IN COMMERCE 4-1-2008.

3,633,231. WESLEY COLLEGE, DOVER, DE. SN 78-807,638. PUB. 5-15-2007, FILED 2-6-2006.

WESLEY

THE MARK CONSISTS OF STANDARD CHARACTERS WITHOUT CLAIM TO ANY PARTICULAR FONT, STYLE, SIZE, OR COLOR.

CLASS 21—HOUSEWARES AND GLASS

FOR GLASSWARE, NAMELY, MUGS (U.S. CLS. 2, 13, 23, 29, 30, 33, 40 AND 50).

FIRST USE 1-6-2006; IN COMMERCE 1-6-2006.

CLASS 25—CLOTHING

FOR CLOTHING FOR MEN, WOMEN AND CHILDREN, NAMELY, SHIRTS, SHORTS, T-SHIRTS, HATS, CAPS, SOCKS, JACKETS, PANTS, SWEATSUITS, SWEATSHIRTS, SWEATPANTS, SLEEPWEAR, RAINWEAR, SWEATERS AND VISORS (U.S. CLS. 22 AND 39).

FIRST USE 9-0-1958; IN COMMERCE 9-0-1958.

CLASS 41—EDUCATION AND ENTERTAINMENT

FOR EDUCATION AND ENTERTAINMENT SERVICES, NAMELY, PROVIDING EDUCATIONAL COURSES AT THE COLLEGE AND GRADUATE LEVEL, AND ARRANGING AND CONDUCTING COLLEGE LEVEL MEN'S AND WOMEN'S SPORTING EVENTS (U.S. CLS. 100, 101 AND 107).

FIRST USE 6-0-1917; IN COMMERCE 6-0-1917.

3,633,232. LS RETAIL EHF., REYKJAVIK, ICELAND. SN 78-810,283. PUB. 6-19-2007, FILED 2-8-2006.

LS RETAIL

THE MARK CONSISTS OF STANDARD CHARACTERS WITHOUT CLAIM TO ANY PARTICULAR FONT, STYLE, SIZE, OR COLOR.

NO CLAIM IS MADE TO THE EXCLUSIVE RIGHT TO USE "RETAIL", APART FROM THE MARK AS SHOWN.

CLASS 9—ELECTRICAL AND SCIENTIFIC APPARATUS

FOR COMPUTER SOFTWARE FOR RETAIL PLANNING AND MERCHANDISE ANALYSIS FOR USE IN STORE RETAIL OPERATIONS AND POINT OF SALE TERMINALS AND USER MANUALS SOLD AS A UNIT; DATA PROCESSING EQUIPMENT IN THE NATURE OF DATA PROCESSORS AND COMPUTERS FOR USE IN STORE RETAIL OPERATIONS AND POINT OF SALE TERMINALS AND USER MANUALS SOLD AS A UNIT (U.S. CLS. 21, 23, 26, 36 AND 38).

FIRST USE 6-16-2007; IN COMMERCE 6-16-2007.

CLASS 16—PAPER GOODS AND PRINTED MATTER

FOR PRINTED INSTRUCTIONAL AND TEACHING MATERIAL IN FIELD OF COMPUTER EQUIPMENT FOR RETAIL OPERATIONS (U.S. CLS. 2, 5, 22, 23, 29, 37, 38 AND 50).

FIRST USE 6-16-2007; IN COMMERCE 6-16-2007.

CLASS 42—SCIENTIFIC AND COMPUTER SERVICES

FOR DESIGN AND DEVELOPMENT OF COMPUTER HARDWARE AND COMPUTER SOFTWARE RELATING TO RETAIL SALES; COMPUTER PROGRAMMING FOR OTHERS IN THE FIELD OF STORE RETAIL OPERATION AND POINT OF SALE TERMINALS (U.S. CLS. 100 AND 101).

FIRST USE 6-16-2007; IN COMMERCE 6-16-2007.

3,633,254. VELOCITI ALLIANCE NORTH AMERICA, INC., GREENVILLE, SC. SN 78-845,487. PUB. 4-22-2008, FILED 3-24-2006.

VELOCITI ALLIANCE

THE MARK CONSISTS OF STANDARD CHARACTERS WITHOUT CLAIM TO ANY PARTICULAR FONT, STYLE, SIZE, OR COLOR.

OWNER OF U.S. REG. NO. 3,001,285.

NO CLAIM IS MADE TO THE EXCLUSIVE RIGHT TO USE "ALLIANCE", APART FROM THE MARK AS SHOWN.

CLASS 9—ELECTRICAL AND SCIENTIFIC APPARATUS

FOR COMPUTER EMULATION HARDWARE AND SOFTWARE TO INTERFACE BETWEEN A SIMULATION PROCESSOR AND A PROGRAMMABLE LOGIC CONTROLLER; SOFTWARE IN THE FIELD OF CONTROLLING INDUSTRIAL EQUIPMENT (U.S. CLS. 21, 23, 26, 36 AND 38).

FIRST USE 7-31-2007; IN COMMERCE 7-31-2007.

CLASS 42—SCIENTIFIC AND COMPUTER SERVICES

FOR CONSULTATION, DESIGN, DEVELOPMENT, ENGINEERING AND IMPLEMENTATION OF COMPUTER SOFTWARE FOR OTHERS, IN THE FIELD OF DISTRIBUTION CENTER AUTOMATION AND SUPPLY CHAIN MANAGEMENT (U.S. CLS. 100 AND 101).

FIRST USE 8-1-2004; IN COMMERCE 10-1-2004.

3,633,259. WELLPOINT, INC., INDIANAPOLIS, IN. SN 78-861,625. PUB. 7-24-2007, FILED 4-14-2006.

NEXTRX

THE MARK CONSISTS OF STANDARD CHARACTERS WITHOUT CLAIM TO ANY PARTICULAR FONT, STYLE, SIZE, OR COLOR.

CLASS 35—ADVERTISING AND BUSINESS

FOR ADMINISTERING PHARMACY REIMBURSEMENT PROGRAMS AND SERVICES; COMPUTERIZED ONLINE ORDERING SERVICES FEATURING PRESCRIPTION DRUGS AND OVER THE COUNTER MEDICATION; PROVIDING ONLINE INFORMATION IN THE FIELDS OF RETAIL PHARMACY STORE LOCATIONS AND STATUS OF PHARMACY ORDERS (U.S. CLS. 100, 101 AND 102).

FIRST USE 5-0-2007; IN COMMERCE 5-0-2007.

CLASS 36—INSURANCE AND FINANCIAL

FOR PROVIDING ONLINE INFORMATION IN THE FIELDS OF MEDICARE, HIPAA, AND DRUG INSURANCE PLAN BENEFITS AND EXCLUSIONS; PHARMACY BENEFIT MANAGEMENT SERVICES (U.S. CLS. 100, 101 AND 102).

FIRST USE 5-0-2007; IN COMMERCE 5-0-2007.

CLASS 44—MEDICAL, BEAUTY AND AGRICULTURAL SERVICES

FOR PROVIDING ONLINE INFORMATION IN THE FIELDS OF PRESCRIPTION MEDICATION AND PRESCRIPTION MEDICATION HISTORIES (U.S. CLS. 100 AND 101).

FIRST USE 1-0-2008; IN COMMERCE 1-0-2008.

3,633,262. A.V. DENIM, INC., D/B/A A&V DENIM, INC., NEW YORK, NY. SN 78-868,944. PUB. 7-22-2008, FILED 4-25-2006.

VGS

THE MARK CONSISTS OF STANDARD CHARACTERS WITHOUT CLAIM TO ANY PARTICULAR FONT, STYLE, SIZE, OR COLOR.

CLASS 18—LEATHER GOODS

FOR SHOULDER BAGS, TOTE BAGS, CLUTCH BAGS, CLUTCH PURSES, HANDBAGS, KNAPSACKS, POCKETBOOKS, PURSES (U.S. CLS. 1, 2, 3, 22 AND 41).

FIRST USE 11-15-2008; IN COMMERCE 11-15-2008.

CLASS 25—CLOTHING

FOR BLAZERS, BLOUSES, BOTTOMS, CARDIGANS, COATS, DRESSES, GOLF SHIRTS, HOUSECOATS, JACKETS, JEANS, LOUNGEWEAR, PANTS, POLO SHIRTS, SHIRTS, SPORT SHIRTS, SWEAT SHIRTS, SHORTS, SWEAT SHORTS, SKIRTS, SLACKS, SUITS, SWEATERS, T-SHIRTS, TOPS, TROUSERS (U.S. CLS. 22 AND 39).

FIRST USE 11-15-2008; IN COMMERCE 11-15-2008.

3,633,265. SCHÜTZ GMBH & CO. KGAA, D-56242 SELTERS, FED REP GERMANY. SN 78-877,032. PUB. 7-17-2007, FILED 5-4-2006.

ReContainer

THE MARK CONSISTS OF STANDARD CHARACTERS WITHOUT CLAIM TO ANY PARTICULAR FONT, STYLE, SIZE, OR COLOR.

CLASS 6—METAL GOODS

FOR TANK CONTAINERS, INTERMEDIATE BULK CONTAINERS, DRUMS AND INDUSTRIAL CONTAINERS, ALL OF METAL FOR TRANSPORT AND GENERAL PURPOSE STORAGE AND PACKAGING USE (U.S. CLS. 2, 12, 13, 14, 23, 25 AND 50).

FIRST USE 1-20-2004; IN COMMERCE 1-20-2004.

CLASS 20—FURNITURE AND ARTICLES NOT OTHERWISE CLASSIFIED

FOR TANK CONTAINERS, INTERMEDIATE BULK CONTAINERS, DRUMS AND INDUSTRIAL CONTAINERS, ALL OF NON-METAL FOR TRANSPORT AND GENERAL PURPOSE STORAGE AND PACKAGING USE (U.S. CLS. 2, 13, 22, 25, 32 AND 50).

FIRST USE 1-20-2004; IN COMMERCE 1-20-2004.

CLASS 37—CONSTRUCTION AND REPAIR

FOR REPAIR, RECONDITIONING AND WASHING OF TANK CONTAINERS, INTERMEDIATE BULK CONTAINERS, DRUMS, AND INDUSTRIAL CONTAINERS (U.S. CLS. 100, 103 AND 106).

FIRST USE 1-20-2004; IN COMMERCE 1-20-2004.

3,633,269. GFTA ANALYTICS LTD., NASSAU, BAHAMAS.
SN 78-884,332. PUB. 1-16-2007, FILED 5-16-2006.

MATHTEC

THE MARK CONSISTS OF STANDARD CHARACTERS WITHOUT CLAIM TO ANY PARTICULAR FONT, STYLE, SIZE, OR COLOR.

CLASS 9—ELECTRICAL AND SCIENTIFIC APPARATUS

FOR SOFTWARE FOR FINANCIAL SERVICES, NAMELY, PROVIDING INFORMATION ON CURRENCY EXCHANGE RATES (U.S. CLS. 21, 23, 26, 36 AND 38).

FIRST USE 6-18-2008; IN COMMERCE 6-18-2008.

CLASS 36—INSURANCE AND FINANCIAL

FOR FINANCIAL SERVICES, NAMELY, FINANCIAL ANALYSIS AND CONSULTATION; PROVIDING FINANCIAL INFORMATION, NAMELY, INFORMATION ABOUT EXCHANGE RATES, CURRENCY EXCHANGE AND ADVICE (U.S. CLS. 100, 101 AND 102).

FIRST USE 6-18-2008; IN COMMERCE 6-18-2008.

3,633,277. CHILDREN OF THE NATIONS, SILVERDALE, WA. SN 78-903,238. PUB. 6-24-2008, FILED 6-7-2006.

CHILDREN OF THE NATIONS

THE MARK CONSISTS OF STANDARD CHARACTERS WITHOUT CLAIM TO ANY PARTICULAR FONT, STYLE, SIZE, OR COLOR.

CLASS 16—PAPER GOODS AND PRINTED MATTER

FOR PUBLICATIONS, PROMOTIONAL MATERIALS, AND TRAINING MATERIALS, NAMELY, NEWSLETTERS AND BROCHURES, IN THE FIELD OF HOW TO ASSIST AND CARE FOR ORPHANED AND DESTITUTE CHILDREN WORLDWIDE (U.S. CLS. 2, 5, 22, 23, 29, 37, 38 AND 50).

FIRST USE 11-13-1995; IN COMMERCE 11-13-1995.

CLASS 25—CLOTHING

FOR CLOTHING, NAMELY, T-SHIRTS, HATS, SWEATERS, VESTS, COATS, JACKET, TIES (U.S. CLS. 22 AND 39).

FIRST USE 11-13-1995; IN COMMERCE 11-13-1995.

CLASS 36—INSURANCE AND FINANCIAL

FOR CHARITABLE FUNDRAISING SERVICES THAT PROVIDE SUPPORT TO ORPHANED AND DESTITUTE CHILDREN WORLDWIDE, CHILD SPONSORSHIP, COMMUNITY DEVELOPMENT, HUMANITARIAN PROGRAMS AND RELIGIOUS PROGRAMS (U.S. CLS. 100, 101 AND 102).

FIRST USE 11-13-1995; IN COMMERCE 11-13-1995.

CLASS 41—EDUCATION AND ENTERTAINMENT

FOR EDUCATIONAL SERVICES, NAMELY, SEMINARS, WORKSHOPS AND MENTORING IN THE FIELD OF PROVIDING ASSISTANCE TO ORPHANED AND DESTITUTE CHILDREN WORLDWIDE BY WORK WITH GOVERNMENTAL AND NON-GOVERNMENTAL ORGANIZATIONS; TRAINING SERVICES IN THE FIELD OF PROVIDING ASSISTANCE TO ORPHANED AND DESTITUTE CHILDREN WORLDWIDE BY WORKING WITH GOVERNMENTAL AND NON-GOVERNMENTAL ORGANIZATIONS (U.S. CLS. 100, 101 AND 107).

FIRST USE 3-16-2009; IN COMMERCE 3-16-2009.

CLASS 43—HOTEL AND RESTAURANT SERVICES

FOR CHARITABLE SERVICES, NAMELY, PROVIDING FOOD TO ORPHANED AND DESTITUTE CHILDREN WORLDWIDE (U.S. CLS. 100 AND 101).

FIRST USE 11-13-1995; IN COMMERCE 11-13-1995.

CLASS 44—MEDICAL, BEAUTY AND AGRICULTURAL SERVICES

FOR MEDICAL SERVICES FOR ORPHANED AND DESTITUTE CHILDREN WORLDWIDE (U.S. CLS. 100 AND 101).

FIRST USE 3-16-2009; IN COMMERCE 3-16-2009.

3,633,280. ALL SURFACE RESTORATION & PRESERVATION, INC., DANIA BEACH, FL. SN 78-903,590. PUB. 7-1-2008, FILED 6-8-2006.



ROOFPROTECT Seals, Restores and Preserves.

NO CLAIM IS MADE TO THE EXCLUSIVE RIGHT TO USE "WEATHERPROOF AT 1/2 THE COST" AND "THE ORIGINAL LIQUID APPLIED RUBBER ROOF SHIELD SYSTEM" AND "SEALS, RESTORES AND PRESERVES",

APART FROM THE MARK AS SHOWN.

THE MARK CONSISTS OF A RECTANGLE, WHICH CONTAINS TWO BOLTS OF LIGHTNING ABOVE A ROOF WHICH CONTAINS THE WORDS "DON'T REROOF - WEATHERPROOF AT 1/2 THE COST", THERE IS A THIRD BOLT OF HORIZONTAL LIGHTENING AND ON THE RIGHT SIDE THERE IS A SHIELD WITH THE LETTERS "SSS" IN FRONT OF AN EAGLE WITH WINGS SPREAD. UNDER THE RECTANGLE APPEAR THE WORDS "THE ORIGINAL LIQUID APPLIED RUBBER ROOF SHIELD SYSTEM ROOFPROTECT SEALS, RESTORES AND PRESERVES".

CLASS 2—PAINTS

FOR ELASTOMERIC-BASED LIQUID ROOF AND TILE WEATHERPROOFING COATING USED FOR PERMANENTLY LOCKING DOWN ROOF TILES MADE OF CEMENT, METAL, CLAY, FIBERGLASS COMPOSITES, PLASTICS, MODIFIED BITUMEN, SYNTHETIC RESINS, SHINGLES, TILE MATERIALS AND SUBSTRATES (U.S. CLS. 6, 11 AND 16).

FIRST USE 4-10-2003; IN COMMERCE 4-10-2003.

CLASS 37—CONSTRUCTION AND REPAIR

FOR ROOFING INSTALLATION AND ROOFING REPAIR SERVICES (U.S. CLS. 100, 103 AND 106).

FIRST USE 1-20-2004; IN COMMERCE 1-20-2004.

CLASS 40—MATERIAL TREATMENT

FOR TREATMENT OF MATERIALS IN THE FIELD OF ROOF CONSTRUCTION, NAMELY, WEATHERPROOFING AND WATERPROOFING ROOF SURFACES BY MONOLITHICALLY COVERING AND SEALING ROOF TILES AND ROOF PANELS WITH A WATERPROOF AND WEATHERPROOF MEMBRANE THAT RESTORES, PROTECTS AND PRESERVES THE ROOF SURFACE (U.S. CLS. 100, 103 AND 106).

FIRST USE 2-10-2003; IN COMMERCE 2-10-2003.

3,633,282. LIQUIDMETAL TECHNOLOGIES, INC., RANCHO SANTA MARGARITA, CA. SN 78-911,296. PUB. 2-13-2007, FILED 6-19-2006.



The logo for LIQUIDMETAL features the word "LIQUIDMETAL" in a bold, sans-serif font. The letter "I" in "LIQUID" is stylized to resemble a single drop of liquid falling from the bottom of the letter.

OWNER OF U.S. REG. NOS. 2,435,529, 2,438,871, AND OTHERS.

CLASS 9—ELECTRICAL AND SCIENTIFIC APPARATUS

FOR CELLULAR TELEPHONES, PERSONAL DATA ASSISTANTS, MP3 PLAYERS, AND COMPUTER MEMORY HARDWARE (U.S. CLS. 21, 23, 26, 36 AND 38).

FIRST USE 3-1-1997; IN COMMERCE 1-1-2004.

CLASS 14—JEWELRY

FOR WATCHES (U.S. CLS. 2, 27, 28 AND 50).

FIRST USE 3-1-1997; IN COMMERCE 1-2-2004.

3,633,286. WELLPOINT, INC., INDIANAPOLIS, IN. SN 78-915,045. PUB. 9-4-2007, FILED 6-22-2006.

WELLPOINT NEXTRX

THE MARK CONSISTS OF STANDARD CHARACTERS WITHOUT CLAIM TO ANY PARTICULAR FONT, STYLE, SIZE, OR COLOR.

OWNER OF U.S. REG. NOS. 2,002,076, 2,171,893, AND OTHERS.

CLASS 35—ADVERTISING AND BUSINESS

FOR ADMINISTERING PHARMACY REIMBURSEMENT PROGRAMS AND SERVICES; COMPUTERIZED ONLINE ORDERING SERVICES FEATURING PRESCRIPTION DRUGS AND OVER THE COUNTER MEDICATION; PROVIDING ONLINE INFORMATION IN THE FIELDS OF RETAIL PHARMACY STORE LOCATIONS AND STATUS OF PHARMACY ORDERS (U.S. CLS. 100, 101 AND 102).

FIRST USE 5-0-2007; IN COMMERCE 5-0-2007.

CLASS 36—INSURANCE AND FINANCIAL

FOR PROVIDING ONLINE INFORMATION IN THE FIELDS OF MEDICARE, HIPAA, AND DRUG INSURANCE PLAN BENEFITS AND EXCLUSIONS; PHARMACY BENEFIT MANAGEMENT SERVICES (U.S. CLS. 100, 101 AND 102).

FIRST USE 5-0-2007; IN COMMERCE 5-0-2007.

CLASS 44—MEDICAL, BEAUTY AND AGRICULTURAL SERVICES

FOR PROVIDING ONLINE INFORMATION IN THE FIELDS OF PRESCRIPTION MEDICATION AND PRESCRIPTION MEDICATION HISTORIES (U.S. CLS. 100 AND 101).

FIRST USE 1-0-2008; IN COMMERCE 1-0-2008.

3,633,300. BACHMAN COMPANY, THE, WYOMISSING, PA. SN 78-935,731. PUB. 3-20-2007, FILED 7-24-2006.



OWNER OF U.S. REG. NOS. 658,890, 1,223,601, AND OTHERS.

NO CLAIM IS MADE TO THE EXCLUSIVE RIGHT TO USE "CLASSIC QUALITY SINCE 1884", APART FROM THE MARK AS SHOWN.

THE MARK CONSISTS OF A PICTURE OF A PRETZEL WITH THE WORDS "BACHMAN CLASSIC QUALITY SINCE 1884" WITHIN A BORDER AND A BANNER UNDER THE PRETZEL.

CLASS 29—MEATS AND PROCESSED FOODS

FOR POTATO CHIPS; SNACK FOOD DIPS (U.S. CL. 46).
FIRST USE 3-6-2009; IN COMMERCE 3-30-2009.

CLASS 30—STAPLE FOODS

FOR CHEESE FLAVORED SNACKS, NAMELY, CHEESE CURLS; CORN CHIPS; POPCORN; PRETZELS; SALSA; TORTILLA CHIPS (U.S. CL. 46).
FIRST USE 7-24-2006; IN COMMERCE 3-19-2007.

3,633,306. LOUISIANA-PACIFIC CORPORATION, NASHVILLE, TN. SN 78-940,395. PUB. 7-8-2008, FILED 7-28-2006.

LP FIELD

THE MARK CONSISTS OF STANDARD CHARACTERS WITHOUT CLAIM TO ANY PARTICULAR FONT, STYLE, SIZE, OR COLOR.

OWNER OF U.S. REG. NOS. 1,057,631, 2,687,125, AND OTHERS.

NO CLAIM IS MADE TO THE EXCLUSIVE RIGHT TO USE "FIELD", APART FROM THE MARK AS SHOWN.

CLASS 16—PAPER GOODS AND PRINTED MATTER

FOR POSTERS, CALENDARS, TRADING CARDS, BOOKS RELATING TO FOOTBALL, MAGAZINES ON THE SUBJECT OF FOOTBALL, NEWSLETTERS ON THE SUBJECT OF FOOTBALL, STICKERS, BUMPER STICKERS, CREDIT CARDS WITHOUT MAGNETIC CODING, BUSINESS CARDS, NOTE PADS, PAPER PENNANTS AND GREETING CARDS, TICKETS TO SPORTS GAMES AND EVENTS, GREETING CARDS, PENS, PENCILS, PENCIL CASES, RUB-ON DECORATIVE TRANSFERS, NOTE PAPER, PICTORIAL PRINTS, PICTURE POSTCARDS, ART PICTURES, STATIONERY, ENVELOPES, STATIONERY-TYPE PORTFOLIOS, PHOTO ALBUMS, SCRAPBOOK ALBUMS, RING BINDERS, PLASTIC SPORTS CARD HOLDERS, AND PERIODICALLY ISSUED SOUVENIR PROGRAMS FOR SPORT EVENTS (U.S. CLS. 2, 5, 22, 23, 29, 37, 38 AND 50).

FIRST USE 8-0-2006; IN COMMERCE 8-0-2006.

CLASS 21—HOUSEWARES AND GLASS

FOR HOUSEWARES AND GLASS, NAMELY, CUPS, PLATES, BOWLS, MUGS, BEVERAGE STEMWARE, BEVERAGE GLASSWARE, ICE BUCKETS, TANKARDS OF NON-PRECIOUS METAL, PORTABLE COOLERS, THERMAL INSULATED CONTAINERS FOR FOOD AND BEVERAGES, CORKSCREWS, BOTTLE OPENERS, AND FOOD CONTAINERS (U.S. CLS. 2, 13, 23, 29, 30, 33, 40 AND 50).

FIRST USE 8-0-2006; IN COMMERCE 8-0-2006.

CLASS 24—FABRICS

FOR TOWELS; CLOTH PENNANTS (U.S. CLS. 42 AND 50).

FIRST USE 8-0-2006; IN COMMERCE 8-0-2006.

CLASS 25—CLOTHING

FOR MEN'S, WOMEN'S AND CHILDREN'S CLOTHING, NAMELY, FLEECE TOPS AND BOTTOMS, CAPS, HEADWEAR, T-SHIRTS, SWEATSHIRTS, SHORTS, TANK TOPS, SWEATERS, PANTS, JACKETS, TURTLE-NECKS, JUMPSUITS, GOLF SHIRTS, JERSEYS, WRISTBANDS, WARM UP SUITS, WIND RESISTANT JACKETS, RAINCOATS, PARKAS, PONCHOS, TIES, SUSPENDERS, CLOTH BIBS, SLEEPWEAR, NAMELY, ROBES, NIGHT SHIRTS AND PAJAMAS, GLOVES, MITTENS, KNIT HATS AND CAPS, SCARVES, APRONS, HEADBANDS, AND EAR MUFFS (U.S. CLS. 22 AND 39).
FIRST USE 8-0-2006; IN COMMERCE 8-0-2006.

CLASS 28—TOYS AND SPORTING GOODS

FOR TOYS, NAMELY, PLUSH TOYS, STUFFED ANIMALS, TOY BANKS, PLAY FIGURES, BALLOONS, JIGSAW PUZZLES, BOARD GAMES RELATING TO THE SPORT OF FOOTBALL; SPORTING GOODS, NAMELY, GOLF BALLS, GOLF BAGS, GOLF CLUBS, GOLF CLUB COVERS, BOWLING BAGS, AND FOOTBALLS (U.S. CLS. 22, 23, 38 AND 50).

FIRST USE 8-0-2006; IN COMMERCE 8-0-2006.

CLASS 41—EDUCATION AND ENTERTAINMENT

FOR PROVIDING STADIUM FACILITIES FOR COMMUNITY SPORTING AND CULTURAL EVENTS AND EDUCATIONAL EXHIBITIONS IN THE NATURE OF BUILDING PRODUCTS; PROVIDING SPORTS AND ENTERTAINMENT INFORMATION VIA A GLOBAL COMPUTER NETWORK OR A COMMERCIAL ON-LINE SERVICE; PRODUCTION OF RADIO AND TELEVISION PROGRAMS AND LIVE SHOWS FEATURING FOOTBALL GAMES, SPORTING EVENTS, ATHLETIC COMPETITIONS, EXHIBITIONS, AND MUSICAL, COMEDY AND DANCE PERFORMANCES (U.S. CLS. 100, 101 AND 107).

FIRST USE 6-1-2006; IN COMMERCE 6-1-2006.

3,633,307. TOWATCH B.V., VOORBURG, NETHERLANDS. SN 78-950,842. PUB. 11-27-2007, FILED 8-12-2006.



THE MARK CONSISTS OF AN ELLIPSE, SHOWING THE LOW PART OF THE LETTER "S" OR A SWIRL, WITH THE WORD "SMOovie" UNDERNEATH.

CLASS 9—ELECTRICAL AND SCIENTIFIC APPARATUS

FOR MP3 PLAYERS; REMOTE CONTROLS FOR TELEVISION, RADIO, STEREO AND COMPUTER FOR ACCESSING THE INTERNET; TELEVISION DECODER; TELEVISION MONITORS; TRANSMITTING AND RECEIVING APPARATUS FOR RADIO AND TELEVISION BROADCASTING AND FOR LONG-DISTANCE TRANSMISSION (U.S. CLS. 21, 23, 26, 36 AND 38).

FIRST USE 8-31-2007; IN COMMERCE 8-31-2007.

CLASS 35—ADVERTISING AND BUSINESS

FOR ADVERTISING AND PUBLICITY SERVICES, NAMELY, PROMOTING THE GOODS, SERVICES, BRAND IDENTITY AND COMMERCIAL INFORMATION AND NEWS OF THIRD PARTIES THROUGH PRINT, AUDIO, VIDEO, DIGITAL AND ON-LINE MEDIUM (U.S. CLS. 100, 101 AND 102).

FIRST USE 8-31-2007; IN COMMERCE 8-31-2007.

CLASS 38—COMMUNICATION

FOR BROADCASTING SERVICES AND PROVISION OF TELECOMMUNICATION ACCESS TO FILMS AND TV PROGRAMMES PROVIDED VIA A VIDEO-ON-DEMAND SERVICE; CABLE TELEVISION BROADCASTING; RADIO BROADCASTING; SATELLITE TELEVISION BROADCASTING; STREAMING OF VIDEO MATERIAL ON THE INTERNET; TELEVISION BROADCASTING (U.S. CLS. 100, 101 AND 104).

FIRST USE 8-31-2007; IN COMMERCE 8-31-2007.

3,633,312. CALIFORNIA CORRECTIONAL FOODS, INC., ENCINITAS, CA. SN 78-961,013. PUB. 8-14-2007, FILED 8-25-2006.

SMART GRAINS

THE MARK CONSISTS OF STANDARD CHARACTERS WITHOUT CLAIM TO ANY PARTICULAR FONT, STYLE, SIZE, OR COLOR.

NO CLAIM IS MADE TO THE EXCLUSIVE RIGHT TO USE "GRAINS", APART FROM THE MARK AS SHOWN.

CLASS 29—MEATS AND PROCESSED FOODS

FOR PREPARED FROZEN FOODS, NAMELY, MEAT, FISH, AND POULTRY; PRE-PACKAGED AND PREPARED FOODS, NAMELY, MEAT, FISH, POULTRY; FROZEN, PREPARED OR PACKAGED MEALS CONSISTING PRIMARILY OF MEAT, FISH, POULTRY OR VEGETABLES; PREPARED ENTREES MADE OF MEAT, FISH, POULTRY OR VEGETABLES; SNACK FOODS, NAMELY, FRUIT-BASED SNACKS, POTATO-BASED SNACKS, CHICKEN NUGGETS; READY-TO-EAT VACUUM-PACKAGED ENTREES, MEALS, AND SNACKS, NAMELY, MEAT, FISH, POULTRY, FRUITS, AND VEGETABLES; PREPARED FROZEN FOODS, NAMELY, PREPARED ENTREES CONSISTING PRIMARILY OF MEAT, FISH, POULTRY, FRUITS, OR VEGETABLES; PRE-PACKAGED AND PREPARED FOODS, NAMELY, MEAT, FISH, AND POULTRY; SNACK FOODS, NAMELY, MEAT, FISH, POULTRY, AND FRUITS; READY-TO-EAT VACUUM-PACKAGED ENTREES, MEALS AND SNACKS, NAMELY, PREPARED ENTREES PRIMARILY CONSISTING OF MEAT, FISH, POULTRY, FRUITS, VEGETABLES; ALL OF THE FOREGOING GOODS ARE FOR INSTITUTIONAL DISTRIBUTION, AND NONE OF THE FOREGOING GOODS INCLUDE SNACK BARS, ENERGY BARS, OR MEAL-REPLACEMENT BARS (U.S. CL. 46).

FIRST USE 1-0-2008; IN COMMERCE 1-0-2008.

CLASS 30—STAPLE FOODS

FOR READY-TO-EAT VACUUM-PACKAGED ENTREES, MEALS, AND SNACKS, NAMELY, BREADS; PREPARED FROZEN FOODS, NAMELY, PREPARED ENTREES AND SIDE-DISHES CONSISTING OF BREADS AND PROCESSED GRAINS; PRE-PACKAGED AND PREPARED FOODS, NAMELY, BREADS AND PROCESSED GRAINS; FROZEN, PREPARED OR PACKAGED MEALS CONSISTING PRIMARILY OF PASTA OR RICE; SNACK FOODS, NAMELY, BREADS AND PROCESSED GRAINS; BURRITOS; READY-TO-EAT VACUUM-PACKAGED ENTREES, MEALS AND SNACKS, NAMELY, PREPARED ENTREES AND SIDE-DISHES PRIMARILY CONSISTING OF BREADS AND PROCESSED GRAINS; ALL OF THE FOREGOING GOODS ARE FOR INSTITUTIONAL DISTRIBUTION, AND NONE OF THE FOREGOING GOODS INCLUDE SNACK BARS, ENERGY BARS, OR MEAL-REPLACEMENT BARS, OR BREAKFAST CEREALS OR CEREAL BARS (U.S. CL. 46).

FIRST USE 1-0-2008; IN COMMERCE 1-0-2008.

3,633,315. MARKMONITOR INC., BOISE, ID. SN 78-967,786. PUB. 5-1-2007, FILED 9-6-2006.

TRUST GUARD

THE MARK CONSISTS OF STANDARD CHARACTERS WITHOUT CLAIM TO ANY PARTICULAR FONT, STYLE, SIZE, OR COLOR.

CLASS 42—SCIENTIFIC AND COMPUTER SERVICES

FOR APPLICATION SERVICE PROVIDER (ASP) FEATURING SOFTWARE IN THE FIELD OF DATA THEFT AND IDENTITY THEFT (U.S. CLS. 100 AND 101).

FIRST USE 9-27-2006; IN COMMERCE 9-27-2006.

CLASS 45—PERSONAL AND LEGAL SERVICES

FOR CONSULTATION IN THE FIELD OF DATA THEFT AND IDENTITY THEFT (U.S. CLS. 100 AND 101).

FIRST USE 9-27-2006; IN COMMERCE 9-27-2006.

3,633,316. LOVE CULTURE LLC, LOS ANGELES, CA. SN 78-967,861. PUB. 1-8-2008, FILED 9-6-2006.

LOVE CULTURE

THE MARK CONSISTS OF STANDARD CHARACTERS WITHOUT CLAIM TO ANY PARTICULAR FONT, STYLE, SIZE, OR COLOR.

CLASS 14—JEWELRY

FOR WATCHES, FASHION JEWELRY, NECKLACES, EARRINGS, AND BRACELETS (U.S. CLS. 2, 27, 28 AND 50).

FIRST USE 9-1-2007; IN COMMERCE 9-1-2007.

CLASS 25—CLOTHING

FOR CLOTHING FOR MEN, WOMEN, JUNIOR WOMEN AND CHILDREN; NAMELY, KNITS, NAMELY, SHIRTS, PANTS, SWEATERS, SCARVES AND GLOVES, AND T-SHIRTS, WOVEN TOPS, SHIRTS AND BLOUSES, SWEATERS, JACKETS, COATS, PANTS, SHORTS, SKIRTS, JEANS, DRESSES, ATHLETIC WEAR, NAMELY, SHIRTS, PANTS, JACKETS, SWEATSHIRTS, AND SWEATPANTS, SUITS, SWIMWEAR, LINGERIE, SLEEP WEAR, HOSIERY AND SOCKS, FOOT WEAR, BELTS, HATS, SCARVES AND WRAPS (U.S. CLS. 22 AND 39).

FIRST USE 9-1-2007; IN COMMERCE 9-1-2007.

3,633,324. FREEFORM PRODUCTIONS LIMITED, LONDON, UNITED KINGDOM. SN 78-978,763. PUB. 7-15-2008, FILED 11-29-2004.

A PLACE IN THE SUN

THE MARK CONSISTS OF STANDARD CHARACTERS WITHOUT CLAIM TO ANY PARTICULAR FONT, STYLE, SIZE, OR COLOR.

CLASS 9—ELECTRICAL AND SCIENTIFIC APPARATUS

FOR DOWNLOADABLE ELECTRONIC PUBLICATIONS RELATING TO THE BUYING, SELLING, LEASING AND LETTING OF REAL ESTATE PROPERTY IN THE FORM OF NEWSPAPERS AND MAGAZINES; AND COMPUTER PROGRAMS AND SOFTWARE RELATING TO THE BUYING, SELLING, LEASING AND LETTING OF REAL ESTATE PROPERTY CARRIED ON PRE-RECORDED MAGNETIC OR OPTICAL DATA CARRIERS (U.S. CLS. 21, 23, 26, 36 AND 38).

FIRST USE 9-0-2008; IN COMMERCE 9-0-2008.

CLASS 16—PAPER GOODS AND PRINTED MATTER

FOR PRINTED PUBLICATIONS RELATING TO THE BUYING, SELLING, LEASING AND LETTING OF REAL ESTATE PROPERTY, NAMELY, PRESS RELEASES, NEWSPAPERS, MAGAZINES, BOOKS, PAMPHLETS, PERIODICALS, NEWSLETTERS, CATALOGUES, BOOKLETS, BROCHURES, REPORTS, AND JOURNALS; MANUALS, GUIDES AND HANDBOOKS RELATING TO THE BUYING, SELLING, LEASING AND LETTING OF REAL ESTATE PROPERTY (U.S. CLS. 2, 5, 22, 23, 29, 37, 38 AND 50).

FIRST USE 9-0-2001; IN COMMERCE 9-0-2008.

CLASS 35—ADVERTISING AND BUSINESS

FOR ARRANGING, CONDUCTING AND ORGANIZING EXHIBITIONS, TRADE FAIRS, BUSINESS FAIRS, EVENTS AND SHOWS RELATING TO THE BUYING, SELLING, LEASING AND LETTING OF REAL ESTATE PROPERTY FOR TRADE, COMMERCIAL AND ADVERTISING PURPOSES; ADVERTISING SERVICES RELATING TO THE BUYING, SELLING, LEASING AND LETTING OF REAL ESTATE PROPERTY, NAMELY, RENTAL OR LEASING OF ADVERTISING SPACE (U.S. CLS. 100, 101 AND 102).

FIRST USE 4-0-2005; IN COMMERCE 9-0-2008.

CLASS 41—EDUCATION AND ENTERTAINMENT

FOR RADIO AND TELEVISION ENTERTAINMENT SERVICES RELATING TO THE BUYING, SELLING, LEASING AND LETTING OF REAL ESTATE PROPERTY, NAMELY, PRODUCTION AND PRESENTATION OF TELEVISION, RADIO, CABLE, SATELLITE AND INTERNET PROGRAMS; PRODUCTION OF PRE-RECORDED VIDEOTAPES RELATING TO THE BUYING, SELLING, LEASING AND LETTING OF REAL ESTATE PROPERTY (U.S. CLS. 100, 101 AND 107).

FIRST USE 9-0-2000; IN COMMERCE 9-0-2008.

3,633,326. RYAN BASICS LLC, NEW YORK, NY. SN 78-980,692. PUB. 12-11-2007, FILED 3-1-2006.

SEXY BEAST

THE MARK CONSISTS OF STANDARD CHARACTERS WITHOUT CLAIM TO ANY PARTICULAR FONT, STYLE, SIZE, OR COLOR.

CLASS 3—COSMETICS AND CLEANING PREPARATIONS

FOR BATH OILS; BATH AND SHOWER GELS; BODY MASSAGE OILS; FRAGRANCES FOR PERSONAL USE; FRAGRANCE ROOM SPRAYS; FACIAL POWDERS; FACIAL CLEANSERS; SKIN MOISTURIZERS; SKIN CONDITIONERS; MASSAGE OILS; ESSENTIAL OILS FOR PERSONAL USE; TALCUM POWDER; BATH GELS; BATH POWDERS; SKIN CLEANSERS; BODY FRAGRANCES; BODY GELS; SHOWER GELS; BODY OILS; BODY POWDERS; PERFUME; COLOGNE; EAU DE TOILETTE; EAU DE PERFUME; EAU DE COLOGNE AND TOILETTE WATER; NON-MEDICATED TOPICAL SKIN CREAMS, OINTMENTS; GELS, LOTIONS, SPRAYS AND POWDERS; AROMATHERAPY CREAMS, LOTIONS AND OILS; HAIR CARE PRODUCTS, NAMELY, SHAMPOOS CONDITIONERS, CREAMS, RINSES, SPRAYS, HAIR STYLING PREPARATIONS AND HAIR CARE PREPARATIONS FOR PET USE; PET FRAGRANCES (U.S. CLS. 1, 4, 6, 50, 51 AND 52).

FIRST USE 10-19-2006; IN COMMERCE 10-19-2006.

CLASS 14—JEWELRY

FOR JEWELRY, NAMELY, PET CHARMS (U.S. CLS. 2, 27, 28 AND 50).

FIRST USE 12-22-2006; IN COMMERCE 12-22-2006.

CLASS 18—LEATHER GOODS

FOR CLOTHING FOR PETS; ALL PURPOSE ATHLETIC BAGS; BEACH BAGS; BOOK BAGS; CARRY-ON BAGS; GYM BAGS; MULTI-USE SPORTS BAGS; PURSES; SCHOOL BAGS; TEXTILE SHOPPING BAGS; SHOULDER BAGS; SPORTS BAGS; TOTE BAGS; TRAVEL BAGS (U.S. CLS. 1, 2, 3, 22 AND 41).

FIRST USE 5-18-2007; IN COMMERCE 7-9-2007.

CLASS 35—ADVERTISING AND BUSINESS

FOR ON-LINE RETAIL PET STORE SERVICES; ON-LINE RETAIL STORE SERVICES FEATURING BEAUTY PRODUCTS, COSMETICS, TOILETRIES, SKIN CARE PREPARATIONS, HAIR CARE PREPARATIONS FOR PET USE, FRAGRANCES, PERSONAL CARE PRODUCTS, CLOTHING AND GIFT AND NOVELTY ITEMS (U.S. CLS. 100, 101 AND 102).

FIRST USE 10-19-2006; IN COMMERCE 10-19-2006.

CLASS 44—MEDICAL, BEAUTY AND AGRICULTURAL SERVICES

FOR GROOMING SERVICES FOR DOMESTICATED ANIMALS (U.S. CLS. 100 AND 101).
FIRST USE 8-19-2006; IN COMMERCE 8-19-2006.

3,633,327. BARMENSEN LABS, LLC, EDISON, NJ. SN 78-980,769. PUB. 8-15-2006, FILED 5-27-2005.

BLBarmensen Labs

NO CLAIM IS MADE TO THE EXCLUSIVE RIGHT TO USE "LABS", APART FROM THE MARK AS SHOWN.

THE MARK CONSISTS OF THE LETTERS "BL" IN BLOCK CAPITALS BEFORE THE WORDS "BARMENSEN LABS" IN SMALLER BLOCK LETTERS.

CLASS 3—COSMETICS AND CLEANING PREPARATIONS

FOR TOPICAL PREPARATIONS AND CREAMS FOR REVITALIZING THE SKIN AREAS MOST INVOLVED IN SEXUAL AROUSAL AND ORGASM; TOPICAL PREPARATIONS AND CREAMS FOR ENHANCING THE LOOK AND FEEL OF ERECTIONS; TOPICAL PREPARATIONS AND CREAMS FOR IMPROVING LOOK AND APPEARANCE DURING EXERCISE, WEIGHT LIFTING AND BODY BUILDING; TOPICAL SKIN SPRAYS FOR COSMETIC PURPOSES (U.S. CLS. 1, 4, 6, 50, 51 AND 52).
FIRST USE 10-31-2004; IN COMMERCE 10-31-2004.

CLASS 5—PHARMACEUTICALS

FOR DIETARY AND HERBAL SUPPLEMENTS (U.S. CLS. 6, 18, 44, 46, 51 AND 52).
FIRST USE 7-1-2008; IN COMMERCE 7-1-2008.

3,633,329. O'BYRNE, KRISTIN KOETTING, LEAWOOD, KS. SN 78-981,015. PUB. 11-21-2006, FILED 4-7-2006.

LIVE WHAT YOU WEAR

THE MARK CONSISTS OF STANDARD CHARACTERS WITHOUT CLAIM TO ANY PARTICULAR FONT, STYLE, SIZE, OR COLOR.

CLASS 14—JEWELRY

FOR JEWELRY (U.S. CLS. 2, 27, 28 AND 50).
FIRST USE 8-13-2008; IN COMMERCE 8-13-2008.

CLASS 25—CLOTHING

FOR HATS, HEADGEAR, NAMELY, CAPS, SHIRTS (U.S. CLS. 22 AND 39).
FIRST USE 8-13-2008; IN COMMERCE 8-13-2008.

CLASS 41—EDUCATION AND ENTERTAINMENT

FOR ENTERTAINMENT IN THE NATURE OF PROVIDING WEBSITES RELATED TO SOCIAL SKILLS, SOCIAL CONSCIOUSNESS, PERSONAL GROWTH AND INSPIRATION (U.S. CLS. 100, 101 AND 107).
FIRST USE 8-13-2008; IN COMMERCE 8-13-2008.

3,633,331. R + A DESIGN, LLC, CHICAGO, IL. SN 78-981,024. PUB. 1-1-2008, FILED 4-7-2006.

UNISON

THE MARK CONSISTS OF STANDARD CHARACTERS WITHOUT CLAIM TO ANY PARTICULAR FONT, STYLE, SIZE, OR COLOR.

CLASS 24—FABRICS

FOR QUILTS, BED LINENS, DUVETS, PILLOWCASES, BED SHEETS, NON-ELECTRIC BED BLANKETS, TEXTILE TABLECLOTHS, TEXTILE NAPKINS, FABRIC TABLE RUNNERS, PLACEMATS OF TEXTILE, ALL FOR DECORATIVE RESIDENTIAL USE AND NOT FOR USE IN COMMERCIAL APPLICATIONS (U.S. CLS. 42 AND 50).
FIRST USE 9-8-2006; IN COMMERCE 9-8-2006.

CLASS 35—ADVERTISING AND BUSINESS

FOR WHOLESALE AND ONLINE RETAIL SERVICES FEATURING HOUSEHOLD GOODS MADE PRIMARILY OF FABRIC FOR RESIDENTIAL USE AND NOT FOR USE IN COMMERCIAL APPLICATIONS (U.S. CLS. 100, 101 AND 102).
FIRST USE 8-11-2006; IN COMMERCE 8-11-2006.

3,633,335. REEBOK INTERNATIONAL LTD., CANTON, MA. SN 78-981,056. PUB. 4-8-2008, FILED 3-9-2006.



THE NAME "CROSBY" IDENTIFIES A LIVING INDIVIDUAL WHOSE CONSENT IS OF RECORD.

THE MARK CONSISTS OF THE WORD "CROSBY" ABOVE A TRIANGLE ENCLOSING THE STYLIZED LETTERS "SC" AND THE NUMBER "87".

CLASS 18—LEATHER GOODS

FOR ALL-PURPOSE ATHLETIC BAGS (U.S. CLS. 1, 2, 3, 22 AND 41).
FIRST USE 11-15-2008; IN COMMERCE 11-15-2008.

CLASS 25—CLOTHING

FOR ATHLETIC FOOTWEAR; HEADGEAR, NAMELY, CAPS; CLOTHING, NAMELY, T-SHIRTS, PANTS, LONG SLEEVE TOPS, SWEATSHIRTS, POLO SHIRTS, JACKETS, TRAINING SUITS, SHORTS, AND HOODED SWEATERS (U.S. CLS. 22 AND 39).
FIRST USE 10-15-2008; IN COMMERCE 10-15-2008.

CLASS 28—TOYS AND SPORTING GOODS

FOR ICE HOCKEY STICKS, ICE SKATES, AND PROTECTIVE EQUIPMENT FOR HOCKEY, NAMELY, SHOULDER PADS, ELBOW PADS, SHIN GUARDS, PROTECTIVE PANTS, HOCKEY GLOVES (U.S. CLS. 22, 23, 38 AND 50).
FIRST USE 12-5-2007; IN COMMERCE 12-5-2007.

3,633,337. MYSTAKAS, GEORGE, LEBANON, PA. SN 78-981,073. PUB. 1-22-2008, FILED 7-25-2006.

FITOPIA

THE MARK CONSISTS OF STANDARD CHARACTERS WITHOUT CLAIM TO ANY PARTICULAR FONT, STYLE, SIZE, OR COLOR.

CLASS 18—LEATHER GOODS

FOR CARRY-ALL BAGS FOR GYM, FITNESS, YOGA, DIET, AND NUTRITION RELATED MATERIALS (U.S. CLS. 1, 2, 3, 22 AND 41).
FIRST USE 10-0-2006; IN COMMERCE 2-0-2009.

CLASS 25—CLOTHING

FOR T-SHIRTS, SHIRTS, SHORTS (U.S. CLS. 22 AND 39).
FIRST USE 2-0-2009; IN COMMERCE 2-0-2009.

CLASS 41—EDUCATION AND ENTERTAINMENT

FOR PERSONAL TRAINING SERVICES, NAMELY, STRENGTH AND CONDITIONING TRAINING; PHYSICAL EDUCATION SERVICES; PHYSICAL FITNESS CONSULTATION; EDUCATIONAL SERVICES, NAMELY, CONDUCTING PROGRAMS IN THE FIELD OF FITNESS, WELLNESS, EXERCISE, DIET, AND NUTRITION; PHYSICAL FITNESS INSTRUCTION; BODY-BUILDING INSTRUCTION SERVICES; YOGA INSTRUCTION; FITNESS, WELLNESS, EXERCISE, DIET, BODYBUILDING, YOGA, AND NUTRITION INSTRUCTION PROVIDED VIA THE INTERNET; PERSONAL COACHING SERVICES IN THE FIELD OF PERSONAL CARE, BODY CARE, FITNESS, EXERCISE, NUTRITION, DIET, AND RECOVERY METHODS; INSTRUCTION IN THE FIELDS OF HEALTH, FITNESS, WELLNESS, AND NUTRITION, RECOVERY METHODS, MASSAGE METHODS, PERSONAL CARE REGIMENS, FITNESS REGIMENS, NUTRITION REGIMENS, NUTRITIONAL SUPPLEMENT REGIMENS, AND MEAL PLANS; PROVIDING INFORMATION IN THE FIELDS OF EXERCISE TRAINING, FITNESS TRAINING, BODY-BUILDING TRAINING (U.S. CLS. 100, 101 AND 107).
FIRST USE 1-0-2006; IN COMMERCE 7-0-2006.

CLASS 44—MEDICAL, BEAUTY AND AGRICULTURAL SERVICES

FOR NUTRITION COUNSELING SERVICES; DIETARY AND NUTRITIONAL GUIDANCE; PROVIDING INFORMATION ABOUT DIETARY SUPPLEMENTS AND NUTRITION, HEALTH, WELLNESS, DIET, AND NUTRITION; PROVIDING INFORMATION ABOUT BEAUTY; PROVIDING HEALTH AND WELLNESS INFORMATION; PROVIDING INFORMATION RELATING TO NUTRITION (U.S. CLS. 100 AND 101).
FIRST USE 1-0-2006; IN COMMERCE 7-0-2006.

3,633,339. VISAN, CORNEL, BORING, OR. SN 78-981,087. PUB. 9-26-2006, FILED 2-2-2006.

PEAR-DOCS

THE MARK CONSISTS OF STANDARD CHARACTERS WITHOUT CLAIM TO ANY PARTICULAR FONT, STYLE, SIZE, OR COLOR.

CLASS 35—ADVERTISING AND BUSINESS

FOR CONSULTING IN THE FIELD OF BUSINESS ORGANIZATION AND MANAGEMENT; PROVIDING INFORMATION IN THE FIELD OF BUSINESS ORGANIZATION AND MANAGEMENT VIA THE INTERNET (U.S. CLS. 100, 101 AND 102).
FIRST USE 3-24-2009; IN COMMERCE 3-24-2009.

CLASS 41—EDUCATION AND ENTERTAINMENT

FOR CONDUCTING WORKSHOPS AND SEMINARS IN THE FIELD OF BUSINESS MANAGEMENT AND ORGANIZATION; EDUCATIONAL SERVICES, NAMELY, SEMINARS, WORKSHOPS, AND RECREATIONAL YOUTH CAMP RETREATS DIRECTED TOWARD SELF DEVELOPMENT (U.S. CLS. 100, 101 AND 107).
FIRST USE 3-24-2009; IN COMMERCE 3-24-2009.

3,633,340. ARITZIA LP, VANCOUVER, CANADA. SN 78-981,093. PUB. 11-27-2007, FILED 4-13-2006.

TNA

THE MARK CONSISTS OF STANDARD CHARACTERS WITHOUT CLAIM TO ANY PARTICULAR FONT, STYLE, SIZE, OR COLOR.

OWNER OF U.S. REG. NOS. 2,259,494, 3,562,638, AND OTHERS.

CLASS 18—LEATHER GOODS

FOR BAGS, NAMELY, LEATHER AND IMITATION LEATHER BAGS, TRAVELING BAGS, ATHLETIC BAGS, BEACH BAGS, HANDBAGS, SHOULDER BAGS, AND TOTE BAGS; PURSES, WALLETS (U.S. CLS. 1, 2, 3, 22 AND 41).
FIRST USE 11-7-2007; IN COMMERCE 11-7-2007.

CLASS 25—CLOTHING

FOR CLOTHING, NAMELY, SWEATSHIRTS, T-SHIRTS, BLOUSES, SHORTS, SKIRTS, SLACKS, JEANS, SWEATERS, VESTS, SPORT JACKETS, OUTER JACKETS, WIND-RESISTANT JACKETS, COATS, OVERCOATS, DRESSES, SUITS, SHIRTS, SPORT SHIRTS, DRESS SHIRTS, HOSIERY, TIES, BELTS, PANTS, TOPS, TANK-TOPS, LINGERIE, OVERALLS, SLEEPWEAR, SOCKS, SWEAT PANTS, TIGHTS, UNDERWEAR AND SCARVES, HEADWEAR, NAMELY, CAPS, HATS, HEADBANDS, AND TOQUES; HANDWEAR, NAMELY, GLOVES AND MITTENS (U.S. CLS. 22 AND 39).
FIRST USE 11-7-2007; IN COMMERCE 11-7-2007.

* * * * *

SECTION 2.— INTERNATIONAL CLASSIFICATION

The short titles associated below with the international class numbers are terms designed merely for quick identification and are not an official part of the international classification. The full names of international classes are given in section 6.1 of the trademark rules of practice.

The designation "U.S. Cl." appearing in this section refers to the U.S. class in effect prior to Sep. 1, 1973 rather than the international class which applies to applications filed on or after that date. For adoption of international classification see notice in the OFFICIAL GAZETTE of Jun. 26, 1973 (911 O.G. TM 210).

Application in one class

CLASS 1—CHEMICALS

3,631,823. THERMO-TECHNOLOGIES, LLC, BISMARCK, ND. SN 76-677,692. PUB. 6-3-2008, FILED 6-1-2007.

CLASS 1—(Continued).

3,631,853. ATOTECH DEUTSCHLAND GMBH, BERLIN, FED REP GERMANY. SN 76-688,843. PUB. 9-2-2008, FILED 4-21-2008.

SAFE-T-SHIELD

THE MARK CONSISTS OF STANDARD CHARACTERS WITHOUT CLAIM TO ANY PARTICULAR FONT, STYLE, SIZE, OR COLOR.

FOR FIRE EXTINGUISHING COMPOSITION, NAMELY, A GRANULAR POLYMER WHICH WHEN MIXED WITH WATER FORMS A WATER GEL TO BE USED FOR FIRE FIGHTING AND FIRE PROTECTION (U.S. CLS. 1, 5, 6, 10, 26 AND 46).

FIRST USE 2-26-2009; IN COMMERCE 2-26-2009.

FERROPLATE

OWNER OF FED REP GERMANY REG. NO. 30769337, DATED 1-2-2008, EXPIRES 10-31-2017.

FOR CHEMICALS USED IN SURFACE TREATMENT OF METALS, SEMICONDUCTORS AND POLYMERS, PARTICULARLY FOR GALVANO PLATING; GALVANIZING BATHS; GALVANIZING PREPARATIONS; TEMPERING AND SOLDERING PREPARATIONS; CHEMICALS USED FOR GALVANIZING (U.S. CLS. 1, 5, 6, 10, 26 AND 46).

FIRST USE 10-29-2008; IN COMMERCE 10-29-2008.

3,631,834. STEVENSON, MICHAEL J., CLARKDALE, AZ. SN 76-683,213. PUB. 4-1-2008, FILED 10-22-2007.

RMC³

OWNER OF U.S. REG. NO. 2,943,322.

FOR POLYETHYLENE RESIN MIXTURE FOR APPLICATION TO THE INSIDE SURFACES OF A ROTATIONAL MOLD USED IN THE MANUFACTURE OF ROTATIONALLY MOLDED POLYETHYLENE PRODUCTS (U.S. CLS. 1, 5, 6, 10, 26 AND 46).

FIRST USE 10-23-2008; IN COMMERCE 10-23-2008.

3,631,902. ELASTOGRAN GMBH, LEMFÖRDE, FED REP GERMANY. SN 77-045,318. PUB. 7-17-2007, FILED 11-16-2006.

ELASTOTRACK

THE MARK CONSISTS OF STANDARD CHARACTERS WITHOUT CLAIM TO ANY PARTICULAR FONT, STYLE, SIZE, OR COLOR.

OWNER OF U.S. REG. NOS. 1,400,802, 1,415,445, AND OTHERS.

FOR TWO POLYURETHANE COMPONENTS COMBINED TO FORM AN ELASTOMER FOR USE IN STABILIZING GRAVEL FOR INDUSTRIAL APPLICATIONS IN THE RAILROAD INDUSTRY (U.S. CLS. 1, 5, 6, 10, 26 AND 46).

FIRST USE 11-0-2006; IN COMMERCE 12-0-2007.

CLASS 1—(Continued).

3,632,062. OMS INVESTMENTS, INC., LOS ANGELES, CA. SN 77-200,788. PUB. 1-1-2008, FILED 6-7-2007.

WATER SMART

THE MARK CONSISTS OF STANDARD CHARACTERS WITHOUT CLAIM TO ANY PARTICULAR FONT, STYLE, SIZE, OR COLOR.

FOR SOIL AMENDMENTS, SOIL CONDITIONERS, AND SOIL IMPROVING AGENTS FOR DOMESTIC AND HORTICULTURAL USE; PLANT FOOD; POTTING SOIL; PLANTING SOIL; GROWING MEDIA FOR PLANTS; PEAT; COMPOST (U.S. CLS. 1, 5, 6, 10, 26 AND 46).

FIRST USE 1-31-2009; IN COMMERCE 1-31-2009.

3,632,197. ARBORSYSTEMS, INC., OMAHA, NE. SN 77-265,986. PUB. 7-15-2008, FILED 8-28-2007.

GREEN TREE PRO NUTRIBOOSTERS

THE MARK CONSISTS OF STANDARD CHARACTERS WITHOUT CLAIM TO ANY PARTICULAR FONT, STYLE, SIZE, OR COLOR.

NO CLAIM IS MADE TO THE EXCLUSIVE RIGHT TO USE "TREE", APART FROM THE MARK AS SHOWN.

FOR NUTRIENT SUPPLEMENTS FOR TREES (U.S. CLS. 1, 5, 6, 10, 26 AND 46).

FIRST USE 4-9-2008; IN COMMERCE 4-9-2008.

3,632,428. NALCO COMPANY, NAPERVILLE, IL. SN 77-370,727. PUB. 6-3-2008, FILED 1-14-2008.

MERCONTROL

THE MARK CONSISTS OF STANDARD CHARACTERS WITHOUT CLAIM TO ANY PARTICULAR FONT, STYLE, SIZE, OR COLOR.

FOR ADDITIVES TO CONTROL MERCURY IN COMBUSTION GASES (U.S. CLS. 1, 5, 6, 10, 26 AND 46).

FIRST USE 1-30-2009; IN COMMERCE 1-30-2009.

CLASS 1—(Continued).

3,632,449. NALCO COMPANY, NAPERVILLE, IL. SN 77-377,576. PUB. 6-3-2008, FILED 1-22-2008.

SCI-FOAM

THE MARK CONSISTS OF STANDARD CHARACTERS WITHOUT CLAIM TO ANY PARTICULAR FONT, STYLE, SIZE, OR COLOR.

FOR CHEMICAL COMPOSITION IN THE NATURE OF FOAMERS FOR USE IN OIL AND GAS PRODUCTION (U.S. CLS. 1, 5, 6, 10, 26 AND 46).

FIRST USE 2-1-2009; IN COMMERCE 2-1-2009.

3,632,459. SUNOPTA INGREDIENTS, INC., BEDFORD, MA. SN 77-383,829. PUB. 6-17-2008, FILED 1-30-2008.

OPTAYIELD

THE MARK CONSISTS OF STANDARD CHARACTERS WITHOUT CLAIM TO ANY PARTICULAR FONT, STYLE, SIZE, OR COLOR.

OWNER OF U.S. REG. NOS. 1,832,356, 2,185,283, AND OTHERS.

FOR FOOD ADDITIVES FOR NON-NUTRITIONAL PURPOSES FOR USE AS A YIELD EXTENDER IN THE MANUFACTURE OF FOOD PRODUCTS (U.S. CLS. 1, 5, 6, 10, 26 AND 46).

FIRST USE 2-27-2009; IN COMMERCE 2-27-2009.

3,632,511. KELCO SUPPLY COMPANY, MINNEAPOLIS, MN. SN 77-396,664. PUB. 7-1-2008, FILED 2-14-2008.

THANATECH

THE MARK CONSISTS OF STANDARD CHARACTERS WITHOUT CLAIM TO ANY PARTICULAR FONT, STYLE, SIZE, OR COLOR.

FOR CHEMICALS AND CHEMICAL PREPARATIONS USED IN EMBALMING (U.S. CLS. 1, 5, 6, 10, 26 AND 46).

FIRST USE 10-1-2008; IN COMMERCE 10-1-2008.

CLASS 1—(Continued).

3,632,661. SPEX CERTIPREP, INC., METUCHEN, NJ. SN 77-423,381. PUB. 8-5-2008, FILED 3-17-2008.

CALIBRATE WITH CONFIDENCE

THE MARK CONSISTS OF STANDARD CHARACTERS WITHOUT CLAIM TO ANY PARTICULAR FONT, STYLE, SIZE, OR COLOR.

FOR CHEMICAL REFERENCE STANDARDS FOR LABORATORY AND INDUSTRIAL USE (U.S. CLS. 1, 5, 6, 10, 26 AND 46).

FIRST USE 8-1-2008; IN COMMERCE 8-1-2008.

3,632,934. AMCOL INTERNATIONAL CORPORATION, HOFFMAN ESTATES, IL. SN 77-515,691. PUB. 12-9-2008, FILED 7-7-2008.

ACCU-VIS

THE MARK CONSISTS OF STANDARD CHARACTERS WITHOUT CLAIM TO ANY PARTICULAR FONT, STYLE, SIZE, OR COLOR.

FOR NON-FERMENTING, HIGH ACTIVITY LIQUID POLYMER, DESIGNED TO PROVIDE EXCELLENT DRILL FLUID CONTROL (U.S. CLS. 1, 5, 6, 10, 26 AND 46).

FIRST USE 10-15-2008; IN COMMERCE 10-15-2008.

3,632,947. SPRADLING HOLDINGS, INC., PELHAM, AL. SN 77-519,735. PUB. 12-2-2008, FILED 7-11-2008.

SILVERGUARD

THE MARK CONSISTS OF STANDARD CHARACTERS WITHOUT CLAIM TO ANY PARTICULAR FONT, STYLE, SIZE, OR COLOR.

FOR CHEMICAL COMPOSITION FOR APPLICATION ON VINYL TEXTILES FOR USE IN UPHOLSTERING COMMERCIAL INTERIORS, NAMELY, RESTAURANT, HOTEL AND HEALTH CARE SEATING, TO PROVIDE STAIN AND BACTERIA RESISTANCE (U.S. CLS. 1, 5, 6, 10, 26 AND 46).

FIRST USE 10-8-2008; IN COMMERCE 10-8-2008.

CLASS 1—(Continued).

3,632,981. COLONIAL CHEMICAL, SOUTH PITTSBURG, TN. SN 77-530,482. PUB. 12-16-2008, FILED 7-24-2008.

EPOQUAT

THE MARK CONSISTS OF STANDARD CHARACTERS WITHOUT CLAIM TO ANY PARTICULAR FONT, STYLE, SIZE, OR COLOR.

FOR CHEMICAL ADDITIVES FOR USE IN THE MANUFACTURE OF HYDROXY PROPYL QUATERNARY COMPOUNDS (U.S. CLS. 1, 5, 6, 10, 26 AND 46).

FIRST USE 4-2-2009; IN COMMERCE 4-2-2009.

3,633,145. THE DOW CHEMICAL COMPANY, MIDLAND, MI. SN 78-615,043. PUB. 1-10-2006, FILED 4-22-2005.

HPL

THE MARK CONSISTS OF STANDARD CHARACTERS WITHOUT CLAIM TO ANY PARTICULAR FONT, STYLE, SIZE, OR COLOR.

FOR CHEMICAL PRODUCTS USED IN INDUSTRY, NAMELY, LATEX ADHESIVES AND BINDERS FOR INDUSTRIAL PURPOSES (U.S. CLS. 1, 5, 6, 10, 26 AND 46).

FIRST USE 1-1-2007; IN COMMERCE 1-1-2007.

CLASS 2—PAINTS

3,632,135. ROMAN DECORATING PRODUCTS, INC., CALUMET CITY, IL. SN 77-240,394. PUB. 1-15-2008, FILED 7-27-2007.

ARMORSHIELD

THE MARK CONSISTS OF STANDARD CHARACTERS WITHOUT CLAIM TO ANY PARTICULAR FONT, STYLE, SIZE, OR COLOR.

FOR DECORATIVE INTERIOR WALL PAINTS (U.S. CLS. 6, 11 AND 16).

FIRST USE 4-30-2008; IN COMMERCE 4-30-2008.

CLASS 2—(Continued).

3,632,513. THE MEGA SHED PTY LTD, SALISBURY, AUSTRALIA. SN 77-396,830. PUB. 7-8-2008, FILED 2-14-2008.

CLASS 2—(Continued).

3,632,765. SUN CHEMICAL CORPORATION, PARSIPPANY, NJ. SN 77-448,585. PUB. 7-8-2008, FILED 4-15-2008.

MONT MARTE

THE MARK CONSISTS OF STANDARD CHARACTERS WITHOUT CLAIM TO ANY PARTICULAR FONT, STYLE, SIZE, OR COLOR.

OWNER OF U.S. REG. NO. 3,409,637.
FOR PAINTS, NAMELY, ACRYLIC AND OIL PAINTS; VARNISHES FOR ARTISTS (U.S. CLS. 6, 11 AND 16).
FIRST USE 1-26-2009; IN COMMERCE 1-26-2009.

SUNSPECTRO

THE MARK CONSISTS OF STANDARD CHARACTERS WITHOUT CLAIM TO ANY PARTICULAR FONT, STYLE, SIZE, OR COLOR.

FOR PRINTING INKS (U.S. CLS. 6, 11 AND 16).
FIRST USE 9-30-2008; IN COMMERCE 9-30-2008.

3,632,648. SUN CHEMICAL CORPORATION, PARSIPPANY, NJ. SN 77-420,958. PUB. 7-8-2008, FILED 3-13-2008.

METALRAY

THE MARK CONSISTS OF STANDARD CHARACTERS WITHOUT CLAIM TO ANY PARTICULAR FONT, STYLE, SIZE, OR COLOR.

FOR PIGMENTS (U.S. CLS. 6, 11 AND 16).
FIRST USE 3-1-2008; IN COMMERCE 3-1-2008.

3,632,785. MURATA MACHINERY, LTD., KYOTO, JAPAN. SN 77-454,428. PUB. 10-7-2008, FILED 4-22-2008.

3,632,764. SUN CHEMICAL CORPORATION, PARSIPPANY, NJ. SN 77-448,550. PUB. 7-8-2008, FILED 4-15-2008.



SUNVISTO

THE MARK CONSISTS OF STANDARD CHARACTERS WITHOUT CLAIM TO ANY PARTICULAR FONT, STYLE, SIZE, OR COLOR.

FOR PRINTING INKS (U.S. CLS. 6, 11 AND 16).
FIRST USE 9-30-2008; IN COMMERCE 9-30-2008.

OWNER OF U.S. REG. NOS. 1,835,877, 2,131,533, AND 3,113,306.

THE MARK CONSISTS OF STYLIZED LETTERING FOR THE LITERAL ELEMENTS.

FOR TONER CARTRIDGES FILLED FOR PRINTERS AND PHOTOCOPIERS; TONER BOTTLES FILLED FOR PRINTERS AND PHOTOCOPIERS (U.S. CLS. 6, 11 AND 16).

FIRST USE 10-31-1991; IN COMMERCE 1-31-2009.

CLASS 2—(Continued).

3,633,022. OPALSTONE INKJET PTY. LTD., ASHMORE QLD, AUSTRALIA. SN 77-547,815. PUB. 1-6-2009, FILED 8-15-2008.



THE COLOR(S) AQUA, MAGENTA, YELLOW, RED, GREEN, BLUE AND BLACK IS/ARE CLAIMED AS A FEATURE OF THE MARK.

THE MARK CONSISTS OF A BLACK OVAL BAND WITH THE WORDING "OPALSTONE" IN BLACK, SURROUNDING AN INNER OVAL. THE INNER OVAL SHAPE CONSISTS OF SIX SECTIONS. THE TOP SECTION IS SHADED RED. THE LEFT SECTION IS SHADED GREEN. THE RIGHT SECTION IS SHADED BLUE. THE BOTTOM SECTION IS SHADED AQUA. THE UPPER MIDDLE SECTION IS SHADED YELLOW. THE LOWER MIDDLE SECTION IS SHADED MAGENTA. THE LETTERING "BIOSOL" APPEARS IN BLACK BENEATH THE OVAL SHAPE.

FOR COLORANTS FOR USE IN THE MANUFACTURE OF PRINTING INK; COPYING INKS; DRY INKS; ENGRAVING INK; INK CARTRIDGES FOR PRINTERS; INK JET CARTRIDGES; INK JET PRINTER INK; INKS, TONERS AND DYES FOR USE WITH OR ON TEXTILES AND FABRICS; INTAGLIO INK; METALLIC INKS; PLANOGRAPHIC INK; PRINTERS' INK; PRINTERS' PASTES; PRINTING COMPOSITIONS; PRINTING INK; PRINTING INKS; PRINTING INKS, COATINGS, PIGMENTS AND DISPERSIONS FOR USE IN THE GRAPHIC ARTS INDUSTRY (U.S. CLS. 6, 11 AND 16).

FIRST USE 1-1-2009; IN COMMERCE 1-1-2009.

CLASS 2—(Continued).

3,633,023. OPALSTONE INKJET PTY. LTD., ASHMORE QLD, AUSTRALIA. SN 77-547,819. PUB. 1-6-2009, FILED 8-15-2008.



THE COLOR(S) AQUA, MAGENTA, YELLOW, RED, GREEN, BLUE AND BLACK IS/ARE CLAIMED AS A FEATURE OF THE MARK.

THE MARK CONSISTS OF A BLACK OVAL BAND WITH THE WORDING "OPALSTONE" IN BLACK, SURROUNDING AN INNER OVAL. THE INNER OVAL SHAPE CONSISTS OF SIX SECTIONS. THE TOP SECTION IS SHADED RED. THE LEFT SECTION IS SHADED GREEN. THE RIGHT SECTION IS SHADED BLUE. THE BOTTOM SECTION IS SHADED AQUA. THE UPPER MIDDLE SECTION IS SHADED YELLOW. THE LOWER MIDDLE SECTION IS SHADED MAGENTA. THE LETTERING "AQUAFLO" APPEARS IN BLACK BENEATH THE OVAL SHAPE.

FOR COLORANTS FOR USE IN THE MANUFACTURE OF PRINTING INK; COPYING INKS; DRY INKS; ENGRAVING INK; INK CARTRIDGES FOR PRINTERS; INK JET CARTRIDGES; INK JET PRINTER INK; INKS, TONERS AND DYES FOR USE WITH OR ON TEXTILES AND FABRICS; INTAGLIO INK; METALLIC INKS; PLANOGRAPHIC INK; PRINTERS' INK; PRINTERS' PASTES; PRINTING COMPOSITIONS; PRINTING INK; PRINTING INKS; PRINTING INKS, COATINGS, PIGMENTS AND DISPERSIONS FOR USE IN THE GRAPHIC ARTS INDUSTRY (U.S. CLS. 6, 11 AND 16).

FIRST USE 1-1-2009; IN COMMERCE 1-1-2009.

CLASS 3—COSMETICS AND CLEANING PREPARATIONS

3,631,798. TRACIE MARTYN, INC., NEW YORK, NY. SN 76-629,200. PUB. 1-10-2006, FILED 1-28-2005.

ELECTRIFYING RADIANCE

THE MARK CONSISTS OF STANDARD CHARACTERS WITHOUT CLAIM TO ANY PARTICULAR FONT, STYLE, SIZE, OR COLOR.

FOR NON-MEDICATED SKIN CARE PREPARATIONS (U.S. CLS. 1, 4, 6, 50, 51 AND 52).

FIRST USE 4-6-2009; IN COMMERCE 4-6-2009.

CLASS 3—(Continued).

3,631,863. DR. ROBIN, INC., WEST HOLLYWOOD, CA. SN 77-000,710. PUB. 4-10-2007, FILED 9-15-2006.

DR. ROBIN

THE MARK CONSISTS OF STANDARD CHARACTERS WITHOUT CLAIM TO ANY PARTICULAR FONT, STYLE, SIZE, OR COLOR.

THE NAME "ROBIN SCHAFFRAN, M.D.", IDENTIFIES A LIVING INDIVIDUAL WHOSE CONSENT IS OF RECORD. FOR SUNSCREEN CREAMS, SKIN MOISTURIZERS, HAIR SHAMPOO, NON-MEDICATED DIAPER RASH OINTMENTS AND LOTIONS, COSMETICS (U.S. CLS. 1, 4, 6, 50, 51 AND 52).

FIRST USE 4-6-2009; IN COMMERCE 4-6-2009.

CLASS 3—(Continued).

3,631,884. MISSONI S.P.A., SUMIRAGO, VARESE, ITALY. SN 77-029,727. PUB. 8-14-2007, FILED 10-26-2006.

MISSONI ACQUA

THE MARK CONSISTS OF STANDARD CHARACTERS WITHOUT CLAIM TO ANY PARTICULAR FONT, STYLE, SIZE, OR COLOR.

OWNER OF U.S. REG. NO. 1,724,884. THE FOREIGN WORDING IN THE MARK TRANSLATES INTO ENGLISH AS "WATER"

FOR NON-MEDICATED TOILETRIES (U.S. CLS. 1, 4, 6, 50, 51 AND 52).

FIRST USE 6-1-2007; IN COMMERCE 6-1-2007.

3,631,867. EMALANGE, FRIDA, BELLINGHAM, WA. SN 77-004,798. PUB. 5-8-2007, FILED 9-21-2006.



THE MARK CONSISTS OF AN ABSTRACT DESIGN AND THE STYLIZED TEXT OF THE WORDING "ZORGANICS".

FOR HAIR SHAMPOO; HAIR CONDITIONER; LEAVE-IN CONDITIONER; HAIR CREAMS; STYLING LOTION; HAIR GEL; HAIR SERUM; POMADE; FACIAL CLEANSER; SKIN MOISTURIZER; FACIAL SCRUB; FACIAL MASK; FACIAL TONER; EYE CREAM; BODY WASH; BODY LOTION; AND HAND CREAM (U.S. CLS. 1, 4, 6, 50, 51 AND 52).

FIRST USE 1-1-2007; IN COMMERCE 6-1-2006.

3,631,903. FAITH COSMETIC CO., LTD., OSAKI-SHI, OSAKA, JAPAN. SN 77-049,816. PUB. 6-19-2007, FILED 11-22-2006.

ELFIN

THE MARK CONSISTS OF STANDARD CHARACTERS WITHOUT CLAIM TO ANY PARTICULAR FONT, STYLE, SIZE, OR COLOR.

FOR SKIN NOURISHING CREAMS, BEAUTY MASKS, SKIN MASKS, MASSAGE OILS, MASSAGE GELS, SKIN CREAMS, SKIN MILKS, SKIN TONERS, SKIN CLEANSING CREAMS, CLEANSING MILK, SKIN WHITENING CREAMS, SKIN LOTIONS, COLD CREAMS, CREAM SOAPS (U.S. CLS. 1, 4, 6, 50, 51 AND 52).

FIRST USE 5-16-2007; IN COMMERCE 5-16-2007.

3,631,870. STG PRODUCTS, LLC., WOODBURY, NY. SN 77-008,427. PUB. 12-16-2008, FILED 9-27-2006.

Cosmetic Surgeon in a Jar

THE MARK CONSISTS OF STANDARD CHARACTERS WITHOUT CLAIM TO ANY PARTICULAR FONT, STYLE, SIZE, OR COLOR.

FOR COSMETIC CREAMS FOR SKIN CARE (U.S. CLS. 1, 4, 6, 50, 51 AND 52).

FIRST USE 10-15-2007; IN COMMERCE 10-15-2007.

3,631,914. VICTORIA'S SECRET STORES BRAND MANAGEMENT, INC., REYNOLDSBURG, OH. SN 77-063,002. PUB. 4-17-2007, FILED 12-13-2006.

SQUEAKY PINK

THE MARK CONSISTS OF STANDARD CHARACTERS WITHOUT CLAIM TO ANY PARTICULAR FONT, STYLE, SIZE, OR COLOR.

FOR SHOWER GELS (U.S. CLS. 1, 4, 6, 50, 51 AND 52).

FIRST USE 7-10-2007; IN COMMERCE 7-10-2007.

CLASS 3—(Continued).

3,631,992. TEENAIN CO., LTD, SEOUL, REPUBLIC OF KOREA. SN 77-143,577. PUB. 10-2-2007, FILED 3-29-2007.



coverQueen

FOR COSMETICS, NAMELY, EYELINER, EYESHADOW, EYEBROW COSMETICS, FACE POWDER, OILS FOR COSMETIC PURPOSE, FOUNDATIONS, BLUSHER, LIP GLOSS, LIP LINER, MASCARAS, SKIN WHITENING CREAM, COSMETIC COMPACT; EYE CREAMS; EYE MAKE-UP REMOVER; FACIAL CREAMS; FACIAL LOTIONS; BEAUTY MASKS; MAKE-UP REMOVER; NIGHT CREAMS; SUN-BLOCK LOTIONS; VANISHING CREAMS; PERFUMES; AND TOILET WATER (U.S. CLS. 1, 4, 6, 50, 51 AND 52).

FIRST USE 3-13-2009; IN COMMERCE 3-13-2009.

3,631,994. UNILEVER SUPPLY CHAIN, INC., CLINTON, CT. SN 77-148,104. PUB. 8-21-2007, FILED 4-4-2007.

AXE DARK TEMPTATION

THE MARK CONSISTS OF STANDARD CHARACTERS WITHOUT CLAIM TO ANY PARTICULAR FONT, STYLE, SIZE, OR COLOR.

OWNER OF U.S. REG. NOS. 2,700,941, 2,754,454, AND OTHERS.

FOR DEODORANTS AND ANTIPERSPIRANTS (U.S. CLS. 1, 4, 6, 50, 51 AND 52).

FIRST USE 1-0-2009; IN COMMERCE 1-0-2009.

CLASS 3—(Continued).

3,632,021. NAMASTE LABORATORIES, L.L.C., BLUE ISLAND, IL. SN 77-165,679. PUB. 4-1-2008, FILED 4-25-2007.

**ORGANIC ROOT STIMULATOR
WEAVE RX**

THE MARK CONSISTS OF STANDARD CHARACTERS WITHOUT CLAIM TO ANY PARTICULAR FONT, STYLE, SIZE, OR COLOR.

OWNER OF U.S. REG. NOS. 2,570,801 AND 2,697,020.

NO CLAIM IS MADE TO THE EXCLUSIVE RIGHT TO USE "ORGANIC" AND "WEAVE", APART FROM THE MARK AS SHOWN.

SEC. 2(F) AS TO "ORGANIC ROOT STIMULATOR".

FOR HAIR CARE PREPARATIONS (U.S. CLS. 1, 4, 6, 50, 51 AND 52).

FIRST USE 7-27-2007; IN COMMERCE 7-27-2007.

3,632,038. NAMASTE LABORATORIES, L.L.C., BLUE ISLAND, IL. SN 77-185,646. PUB. 4-1-2008, FILED 5-21-2007.

**ORGANIC ROOT STIMULATOR
HAIR FERTILIZER**

THE MARK CONSISTS OF STANDARD CHARACTERS WITHOUT CLAIM TO ANY PARTICULAR FONT, STYLE, SIZE, OR COLOR.

OWNER OF U.S. REG. NOS. 2,570,801 AND 2,697,020.

NO CLAIM IS MADE TO THE EXCLUSIVE RIGHT TO USE "ORGANIC" AND "HAIR", APART FROM THE MARK AS SHOWN.

SEC. 2(F) AS TO "ORGANIC ROOT STIMULATOR".

FOR HAIR CARE PREPARATIONS (U.S. CLS. 1, 4, 6, 50, 51 AND 52).

FIRST USE 9-28-2008; IN COMMERCE 9-28-2008.

3,632,048. DENNIS GROSS, NEW YORK, NY. SN 77-193,210. PUB. 8-5-2008, FILED 5-30-2007.

SKIN HAPPENS

THE MARK CONSISTS OF STANDARD CHARACTERS WITHOUT CLAIM TO ANY PARTICULAR FONT, STYLE, SIZE, OR COLOR.

NO CLAIM IS MADE TO THE EXCLUSIVE RIGHT TO USE "SKIN", APART FROM THE MARK AS SHOWN.

FOR A KIT FOR COSMETICS, NAMELY, A KIT COMPRISING FACE AND SKIN CARE LOTIONS, PEELS, CLEANSERS AND CREAMS (U.S. CLS. 1, 4, 6, 50, 51 AND 52).

FIRST USE 5-15-2008; IN COMMERCE 5-15-2008.

CLASS 3—(Continued).

3,632,083. STAR BRITE, INC, FORT LAUDERDALE, FL. SN 77-217,326. PUB. 11-20-2007, FILED 6-27-2007.

BOAT PRO

THE MARK CONSISTS OF STANDARD CHARACTERS WITHOUT CLAIM TO ANY PARTICULAR FONT, STYLE, SIZE, OR COLOR.

NO CLAIM IS MADE TO THE EXCLUSIVE RIGHT TO USE "BOAT", APART FROM THE MARK AS SHOWN.

FOR BOAT CLEANING PRODUCTS, NAMELY, BOAT WASHES, BOAT WAXES, AND BOAT POLISHES (U.S. CLS. 1, 4, 6, 50, 51 AND 52).

FIRST USE 1-19-2009; IN COMMERCE 1-19-2009.

3,632,145. BEER, KENNETH R., WEST PALM BEACH, FL. SN 77-247,464. PUB. 7-15-2008, FILED 8-5-2007.

KENNETH BEER MD SCIENTIFIC SKINCARE

THE MARK CONSISTS OF STANDARD CHARACTERS WITHOUT CLAIM TO ANY PARTICULAR FONT, STYLE, SIZE, OR COLOR.

NO CLAIM IS MADE TO THE EXCLUSIVE RIGHT TO USE "MD SCIENTIFIC SKINCARE", APART FROM THE MARK AS SHOWN.

THE NAME(S), PORTRAIT(S), AND/OR SIGNATURE(S) SHOWN IN THE MARK IDENTIFIES "KENNETH R. BEER", A LIVING INDIVIDUAL, WHOSE CONSENT(S) TO REGISTER IS SUBMITTED.

FOR PERSONAL CARE PRODUCTS, NAMELY, BODY LOTIONS, SOAPS, NON-MEDICATED BATH SALTS, SKIN MOISTURIZERS, HAIR AND SKIN NEUTRALIZERS FOR CLEANSING, FACIAL AND BODY CLEANSERS, EXFOLIATORS AND SCRUBS, SKIN CLEANSERS, EYE, BODY AND SKIN CREAMS, ANTI-AGING AND ANTI-WRINKLE CLEANSERS, GELS, TONERS, CREAMS, BEAUTY SERUMS, LOTIONS AND FOAMS, NON-MEDICATED ACNE TREATMENT CLEANSERS, GELS, TONERS, CREAMS, LOTIONS AND FOAMS, COSMETIC PADS, SKIN CARE COSMETIC PADS, NON-MEDICATED ANTI-ITCH FOAMS AND NON-MEDICATED FOAMS FOR SKIN RASHES, NON-MEDICATED SKIN BRIGHTENERS AND LIGHTENERS, BODY WASHES, BODY AND BATH OILS AND GELS, SUN SCREEN AND MAKEUP (U.S. CLS. 1, 4, 6, 50, 51 AND 52).

FIRST USE 8-1-2007; IN COMMERCE 1-13-2009.

CLASS 3—(Continued).

3,632,188. REVLON CONSUMER PRODUCTS CORPORATION, NEW YORK, NY. SN 77-262,488. PUB. 2-19-2008, FILED 8-23-2007.

TOTAL DEFINITION

THE MARK CONSISTS OF STANDARD CHARACTERS WITHOUT CLAIM TO ANY PARTICULAR FONT, STYLE, SIZE, OR COLOR.

FOR COSMETICS; MAKE-UP (U.S. CLS. 1, 4, 6, 50, 51 AND 52).

FIRST USE 6-1-2008; IN COMMERCE 6-1-2008.

3,632,203. ORENDA INTERNATIONAL LLC, TEMPE, AZ. SN 77-267,166. PUB. 1-15-2008, FILED 8-29-2007.



THE MARK CONSISTS OF THE WORD "AGING" INSCRIBED IN A HEXAGON WITH A DIAGONAL LINE BISECTING THE HEXAGON.

FOR ANTI-WRINKLE CREAM (U.S. CLS. 1, 4, 6, 50, 51 AND 52).

FIRST USE 8-1-2008; IN COMMERCE 8-1-2008.

3,632,266. CHURCH & DWIGHT CO., INC., PRINCETON, NJ. SN 77-298,619. PUB. 3-18-2008, FILED 10-8-2007.

LAVENDER & LINEN

THE MARK CONSISTS OF STANDARD CHARACTERS WITHOUT CLAIM TO ANY PARTICULAR FONT, STYLE, SIZE, OR COLOR.

NO CLAIM IS MADE TO THE EXCLUSIVE RIGHT TO USE "LAVENDER", APART FROM THE MARK AS SHOWN.

FOR FABRIC SOFTENERS (U.S. CLS. 1, 4, 6, 50, 51 AND 52).

FIRST USE 12-31-2007; IN COMMERCE 12-31-2007.

CLASS 3—(Continued).

3,632,301. COSMETIC INDUSTRIAL & TRADE CORP., RIVERSIDE, CA. SN 77-313,373. PUB. 8-19-2008, FILED 10-25-2007.



NO CLAIM IS MADE TO THE EXCLUSIVE RIGHT TO USE "CHAP LIP" AND "LIP BALM", APART FROM THE MARK AS SHOWN.

THE MARK CONSIST OF THE STYLIZED WORD "CHAP" WITH THE PICTURE OF LIPS TO THE RIGHT OF "CHAP" FOLLOWING BY THE STYLIZED WORD "LIP", WITH THE WORDING, "LIP BALM" BELOW.

FOR LIP BALM (U.S. CLS. 1, 4, 6, 50, 51 AND 52).
FIRST USE 7-1-1998; IN COMMERCE 8-25-1998.

3,632,340. ANAZAOHEALTH CORPORATION, TAMPA, FL. SN 77-332,604. PUB. 7-15-2008, FILED 11-19-2007.

Palette Primer

THE MARK CONSISTS OF STANDARD CHARACTERS WITHOUT CLAIM TO ANY PARTICULAR FONT, STYLE, SIZE, OR COLOR.

NO CLAIM IS MADE TO THE EXCLUSIVE RIGHT TO USE "PRIMER", APART FROM THE MARK AS SHOWN.

FOR AGE RETARDANT GEL; BEAUTY GELS; BODY AND BEAUTY CARE COSMETICS; COSMETIC PREPARATIONS; COSMETICS AND COSMETIC PREPARATIONS; COSMETICS AND MAKE-UP; FACE CREAMS FOR COSMETIC USE; GEL FOR USE AS A MAKE-UP PRIMER; MAKE-UP PREPARATIONS; NON-MEDICATED SKIN CARE PREPARATIONS; NON-MEDICATED SKIN CARE PREPARATIONS, NAMELY, CREAMS, LOTIONS, GELS, TONERS, CLEANERS AND PEELS; SKIN CONDITIONERS; SKIN TEXTURIZERS (U.S. CLS. 1, 4, 6, 50, 51 AND 52).

FIRST USE 12-13-2007; IN COMMERCE 12-13-2007.

CLASS 3—(Continued).

3,632,375. SHENUI INC., ISSAQUAH, WA. SN 77-347,641. PUB. 7-1-2008, FILED 12-10-2007.

SHENUI

THE MARK CONSISTS OF STANDARD CHARACTERS WITHOUT CLAIM TO ANY PARTICULAR FONT, STYLE, SIZE, OR COLOR.

FOR HAIR CARE PREPARATIONS; LOTIONS FOR FACE AND BODY CARE; SKIN ABRASIVE PREPARATIONS; SKIN BRONZER; SKIN CLARIFIERS; SKIN CLEANSERS; SKIN CLEANSING CREAM; SKIN CLEANSING LOTION; SKIN CONDITIONERS; SKIN CREAMS; SKIN EMOLLIENTS; SKIN GELS FOR ACCELERATING, ENHANCING OR EXTENDING TANS; SKIN LIGHTENERS; SKIN LOTIONS; SKIN MASKS; SKIN MOISTURIZER; SKIN SOAP; SKIN TEXTURIZERS; SKIN TONERS; SKIN WHITENING PREPARATIONS; AFTER SUN CREAMS; AFTER-SUN LOTIONS; AFTER-SUN MILKS; COSMETIC SUN-PROTECTING PREPARATIONS; COSMETIC SUN-TANNING PREPARATIONS; COLORING PREPARATIONS FOR COSMETIC PURPOSES; HAIR CLEANING PREPARATIONS; HAIR COLORING PREPARATIONS; HAIR CONDITIONERS; HAIR SHAMPOOS AND CONDITIONERS (U.S. CLS. 1, 4, 6, 50, 51 AND 52).

FIRST USE 10-1-2008; IN COMMERCE 10-1-2008.

3,632,441. THE GLASS GURU FRANCHISE SYSTEMS INC., SACRAMENTO, CA. SN 77-375,354. PUB. 6-10-2008, FILED 1-18-2008.

GLASSTASTIC

THE MARK CONSISTS OF STANDARD CHARACTERS WITHOUT CLAIM TO ANY PARTICULAR FONT, STYLE, SIZE, OR COLOR.

FOR GLASS CLEANERS (U.S. CLS. 1, 4, 6, 50, 51 AND 52).

FIRST USE 1-31-2009; IN COMMERCE 1-31-2009.

CLASS 3—(Continued).

3,632,574. PRIMA TECHNOLOGIES, INCORPORATED, NES-
CONSET, NY. SN 77-409,120. PUB. 7-15-2008, FILED 2-28-
2008.

CLASS 3—(Continued).

3,632,600. WOODBURY-SCHMIDT, INC., KUNKLETOWN,
PA. SN 77-413,172. PUB. 7-22-2008, FILED 3-5-2008.

CITRA

WOOSCH

THE MARK CONSISTS OF STANDARD CHARACTERS
WITHOUT CLAIM TO ANY PARTICULAR FONT, STYLE,
SIZE, OR COLOR.
FOR NAIL CARE PREPARATIONS (U.S. CLS. 1, 4, 6,
50, 51 AND 52).
FIRST USE 6-0-2008; IN COMMERCE 6-0-2008.

THE MARK CONSISTS OF STANDARD CHARACTERS
WITHOUT CLAIM TO ANY PARTICULAR FONT, STYLE,
SIZE, OR COLOR.
FOR BAR SOAP; LIQUID SOAPS; LOTIONS FOR THE
FACE, BODY, HANDS AND SKIN; HAIR SHAMPOOS
AND CONDITIONERS (U.S. CLS. 1, 4, 6, 50, 51 AND 52).
FIRST USE 7-0-2008; IN COMMERCE 7-0-2008.

3,632,589. CARMA LABORATORIES, INC., FRANKLIN, WI.
SN 77-411,551. PUB. 12-9-2008, FILED 3-3-2008.

3,632,645. CAL TAN, LLC, LOS ANGELES, CA. SN 77-420,085.
PUB. 7-29-2008, FILED 3-12-2008.

CARMEX MOISTURE PLUS

METRO 365

THE MARK CONSISTS OF STANDARD CHARACTERS
WITHOUT CLAIM TO ANY PARTICULAR FONT, STYLE,
SIZE, OR COLOR.
OWNER OF U.S. REG. NOS. 1,526,475 AND 2,093,176.
NO CLAIM IS MADE TO THE EXCLUSIVE RIGHT TO
USE "MOISTURE", APART FROM THE MARK AS SHOWN.
FOR LIP BALM (U.S. CLS. 1, 4, 6, 50, 51 AND 52).
FIRST USE 7-20-2008; IN COMMERCE 7-20-2008.

THE MARK CONSISTS OF STANDARD CHARACTERS
WITHOUT CLAIM TO ANY PARTICULAR FONT, STYLE,
SIZE, OR COLOR.
FOR SUNTANNING PREPARATIONS, SUN TAN LO-
TION, SUN TAN GEL, SUN TAN CREAMS ALL FOR
USE IN INDOOR SUNTANNING (U.S. CLS. 1, 4, 6, 50, 51
AND 52).
FIRST USE 11-1-2008; IN COMMERCE 11-1-2008.

3,632,598. RUNBERG, INC., DBA ZEPHYRS, EASTON, PA.
SN 77-413,003. PUB. 7-29-2008, FILED 3-4-2008.

3,632,646. CAL TAN, LLC, LOS ANGELES, CA. SN 77-420,118.
PUB. 7-29-2008, FILED 3-12-2008.

GLAMOUR GLUE

POLARIS P3

THE MARK CONSISTS OF STANDARD CHARACTERS
WITHOUT CLAIM TO ANY PARTICULAR FONT, STYLE,
SIZE, OR COLOR.
NO CLAIM IS MADE TO THE EXCLUSIVE RIGHT TO
USE "GLUE", APART FROM THE MARK AS SHOWN.
FOR ADHESIVE USED ON THE BODY TO ATTACH
CLOTHING, JEWELRY, BODY DECORATIVES, AND
OTHER ACCESSORIES, NAMELY, A BODY ADHESIVE
(U.S. CLS. 1, 4, 6, 50, 51 AND 52).
FIRST USE 6-29-2007; IN COMMERCE 6-29-2007.

THE MARK CONSISTS OF STANDARD CHARACTERS
WITHOUT CLAIM TO ANY PARTICULAR FONT, STYLE,
SIZE, OR COLOR.
FOR SUNTANNING PREPARATIONS, SUN TAN LO-
TION, SUN TAN GEL, SUN TAN CREAMS, ALL FOR
USE IN INDOOR TANNING (U.S. CLS. 1, 4, 6, 50, 51 AND
52).
FIRST USE 11-1-2008; IN COMMERCE 11-1-2008.

CLASS 3—(Continued).

3,632,708. JAMIE KERN, BEAVERTON, OR. SN 77-433,944.
 PUB. 8-19-2008, FILED 3-28-2008.

**GROUND BREAKING COSMETIC
 BODY SCULPTING**

THE MARK CONSISTS OF STANDARD CHARACTERS WITHOUT CLAIM TO ANY PARTICULAR FONT, STYLE, SIZE, OR COLOR.

NO CLAIM IS MADE TO THE EXCLUSIVE RIGHT TO USE "COSMETIC BODY SCULPTING", APART FROM THE MARK AS SHOWN.

FOR COSMETICS; MAKE-UP; BODY CREAMS AND BODY LOTIONS; NON-MEDICATED SKINCARE PREPARATIONS; BEAUTY CREAMS FOR BODY CARE; BODY CARE COSMETICS; COSMETIC PREPARATIONS FOR BODY CARE; LOTIONS; AND KITS CONTAINING ONE OR MORE OF THE FOREGOING ITEMS (U.S. CLS. 1, 4, 6, 50, 51 AND 52).

FIRST USE 6-0-2008; IN COMMERCE 6-0-2008.

3,632,723. STEMMERMAN, JANE, HALLANDALE BEACH, FL. SN 77-438,009. PUB. 8-19-2008, FILED 4-2-2008.

**FREAK
 ASS**

THE MARK CONSISTS OF STANDARD CHARACTERS WITHOUT CLAIM TO ANY PARTICULAR FONT, STYLE, SIZE, OR COLOR.

FOR ANTIBACTERIAL SKIN SOAPS; AROMATHERAPY BODY CARE PRODUCTS, NAMELY, BODY LOTION, SHOWER GEL, CUTICLE CREAM, SHAMPOO, CONDITIONER, NON-MEDICATED LIP BALM, SOAP, BODY POLISH, BODY AND FOOT SCRUB AND NON-MEDICATED FOOT CREAM; BEAUTY CREAMS FOR BODY CARE; BODY AND BEAUTY CARE COSMETICS; COSMETIC CREAMS FOR SKIN CARE; COSMETIC PREPARATIONS FOR BODY CARE; COSMETIC PREPARATIONS FOR SKIN RENEWAL; COSMETIC PREPARATIONS FOR THE CARE OF MOUTH AND TEETH; EXFOLIANTS FOR FACE, BODY CARE; HAIR CARE CREAMS; HAIR CARE LOTIONS; HAIR CARE PREPARATIONS; HAIR CARE PREPARATIONS CONSISTING OF ORGANIC COCONUT VIRGIN OIL AND COCONUT VIRGIN OIL; HOME DENTAL CARE PRODUCTS FOR DOGS AND CATS, NAMELY, TOOTH PASTE; LOTIONS FOR FACE AND BODY CARE; LOTIONS FOR SKIN, HAIR; NON-MEDICATED COSMETIC SKIN CARE PREPARATIONS CONSISTING OF ORGANIC COCONUT VIRGIN OIL AND COCONUT VIRGIN OIL; NON-MEDICATED LIP CARE PREPARATIONS; NON-MEDICATED PREPARATIONS ALL FOR THE CARE OF SKIN, HAIR AND SCALP; NON-MEDICATED SKIN CARE PREPARATIONS; NON-MEDICATED SKIN CARE PREPARATIONS, NAMELY, CREAMS, LOTIONS, GELS, TONERS, CLEANERS AND PEELS; NON-MEDICATED SKIN CREAMS; NON-MEDICATED STIMULATING LOTIONS FOR THE SKIN; NON-MEDICATED SUN CARE PREPARATIONS; PATCHES CONTAINING SUN SCREEN AND SUN BLOCK FOR USE ON THE SKIN; PET CARE KITS COMPRISING SHAMPOO, CONDITIONER, BODY SPRAY; SKIN ABRASIVE PREPARATIONS; SKIN AND BODY TOPICAL LOTIONS, CREAMS AND OILS FOR COSMETIC USE; SKIN CARE PREPARATION, NAMELY, BODY

CLASS 3—(Continued).

POLISH; SKIN CARE PREPARATIONS, NAMELY, CHEMICAL PEELS FOR SKIN; SKIN CARE PREPARATIONS, NAMELY, FRUIT ACID PEELS FOR SKIN; SKIN CARE PREPARATIONS, NAMELY, BODY BALM; SKIN CARE PRODUCTS, NAMELY, NON-MEDICATED SKIN SERUM; SKIN CLARIFIERS; SKIN CLEANSERS; SKIN CLEANSING CREAM; SKIN CLEANSING LOTION; SKIN CONDITIONERS; SKIN CREAM; SKIN CREAMS; SKIN CREAMS IN LIQUID AND IN SOLID FORM; SKIN CREAMS IN LIQUID AND SOLID; SKIN CREAMS IN LIQUID AND SOLID FORM; SKIN EMOLLIENTS; SKIN GELS FOR ACCELERATING, ENHANCING OR EXTENDING TANS; SKIN LIGHTENERS; SKIN LIGHTENING CREAMS; SKIN LOTION; SKIN LOTIONS; SKIN MASKS; SKIN MOISTURIZER; SKIN MOISTURIZER MASKS; SKIN POLISHING RICE BRAN (ARAI-NUKA); SKIN SOAP; SKIN TEXTURIZERS; SKIN TONERS; SKIN WHITENING CREAMS; SKIN WHITENING PREPARATIONS; SOAPS FOR BODY CARE; SUN CARE LOTIONS; TOPICAL SKIN SPRAYS FOR COSMETIC PURPOSES; WRINKLE REMOVING SKIN CARE PREPARATIONS (U.S. CLS. 1, 4, 6, 50, 51 AND 52).

FIRST USE 5-1-2008; IN COMMERCE 3-1-2009.

3,632,726. NOXELL CORPORATION, HUNT VALLEY, MD. SN 77-439,908. PUB. 7-22-2008, FILED 4-4-2008.

2000 CALORIE EXTREME

THE MARK CONSISTS OF STANDARD CHARACTERS WITHOUT CLAIM TO ANY PARTICULAR FONT, STYLE, SIZE, OR COLOR.

OWNER OF U.S. REG. NO. 1,556,445.
 FOR COSMETICS (U.S. CLS. 1, 4, 6, 50, 51 AND 52).
 FIRST USE 12-8-2008; IN COMMERCE 12-8-2008.

CLASS 3—(Continued).

3,632,737. BECKMAN, JAMES S., SPRINGDALE, AR. SN 77-442,007. PUB. 12-9-2008, FILED 4-7-2008.

THERAPON SKIN HEALTH

THE MARK CONSISTS OF STANDARD CHARACTERS WITHOUT CLAIM TO ANY PARTICULAR FONT, STYLE, SIZE, OR COLOR.

OWNER OF U.S. REG. NOS. 1,774,011 AND 2,301,187.

NO CLAIM IS MADE TO THE EXCLUSIVE RIGHT TO USE "SKIN HEALTH", APART FROM THE MARK AS SHOWN.

FOR FOOT AND HAND CREAM, SKIN MOISTURIZER, SUN SCREEN PREPARATIONS, SKIN LOTION, SKIN CLEANSING LOTION, NON-MEDICATED COSMETIC SKIN CHEMICAL PEELS, SKIN LIGHTENERS, NON-MEDICATED COSMETIC ACNE PREPARATIONS, SKIN REJUVENATION PREPARATIONS, NAMELY, SKIN CREAM, NON-MEDICATED SKIN CARE PREPARATIONS, OIL FREE SKIN GEL, NON-MEDICATED SUNBURN RELIEF PREPARATIONS, NAMELY, NON-MEDICATED OINTMENTS FOR THE PREVENTION AND TREATMENT OF SUNBURN, SKIN EMOLLIENTS, SKIN SOAP, SKIN TONERS AND SKIN CREAM (U.S. CLS. 1, 4, 6, 50, 51 AND 52).

FIRST USE 3-1-2000; IN COMMERCE 3-1-2000.

3,632,781. MARTATOS, DANIEL, CORONA, CA. SN 77-453,452. PUB. 11-18-2008, FILED 4-21-2008.

EARTHLY BOTANICALS

THE MARK CONSISTS OF STANDARD CHARACTERS WITHOUT CLAIM TO ANY PARTICULAR FONT, STYLE, SIZE, OR COLOR.

NO CLAIM IS MADE TO THE EXCLUSIVE RIGHT TO USE "BOTANICALS", APART FROM THE MARK AS SHOWN.

FOR NON-MEDICATED SKIN AND HAIR CARE PREPARATIONS, COSMETICS, HAIR SHAMPOO, HAIR CONDITIONER, SKIN AND FACE MOISTURIZERS AND CONDITIONERS (U.S. CLS. 1, 4, 6, 50, 51 AND 52).

FIRST USE 9-1-2008; IN COMMERCE 10-15-2008.

3,632,814. LUSTER PRODUCTS, INC., CHICAGO, IL. SN 77-467,079. PUB. 7-15-2008, FILED 5-6-2008.

A REASON TO GLOSS**CLASS 3—(Continued).**

THE MARK CONSISTS OF STANDARD CHARACTERS WITHOUT CLAIM TO ANY PARTICULAR FONT, STYLE, SIZE, OR COLOR.

FOR NON-MEDICATED HAIR CARE PREPARATIONS (U.S. CLS. 1, 4, 6, 50, 51 AND 52).

FIRST USE 3-0-2009; IN COMMERCE 3-0-2009.

3,632,817. LUSTER PRODUCTS, INC., CHICAGO, IL. SN 77-468,295. PUB. 7-15-2008, FILED 5-7-2008.

GO GLITZ

THE MARK CONSISTS OF STANDARD CHARACTERS WITHOUT CLAIM TO ANY PARTICULAR FONT, STYLE, SIZE, OR COLOR.

FOR NON-MEDICATED HAIR CARE PREPARATIONS (U.S. CLS. 1, 4, 6, 50, 51 AND 52).

FIRST USE 3-0-2009; IN COMMERCE 3-0-2009.

3,632,833. THE ARMOR ALL/STP PRODUCTS COMPANY, OAKLAND, CA. SN 77-475,737. PUB. 7-29-2008, FILED 5-15-2008.

ARMOR ALL

THE MARK CONSISTS OF STANDARD CHARACTERS WITHOUT CLAIM TO ANY PARTICULAR FONT, STYLE, SIZE, OR COLOR.

OWNER OF U.S. REG. NOS. 986,280, 1,032,674, AND OTHERS.

FOR CLEANING PREPARATIONS FOR USE ON DECKS, SIDINGS, CONCRETE, WINDOWS, STUCCO, FENCES, AND PAINTED WOOD (U.S. CLS. 1, 4, 6, 50, 51 AND 52).

FIRST USE 10-31-1997; IN COMMERCE 10-31-1997.

CLASS 3—(Continued).

3,632,840. LIQUID GLASS ENTERPRISES, INC., TEANECK, NJ. SN 77-478,238. PUB. 12-16-2008, FILED 5-19-2008.

CARPERFECT

THE MARK CONSISTS OF STANDARD CHARACTERS WITHOUT CLAIM TO ANY PARTICULAR FONT, STYLE, SIZE, OR COLOR.

FOR POLISH SOLD EXCLUSIVELY ON THE RETAIL MARKET FOR USE ON PAINTED AND UNPAINTED METAL AND PLASTIC SURFACES ON AUTOMOBILES, LAND VEHICLES, AIRPLANES, SHIPS AND BOATS (U.S. CLS. 1, 4, 6, 50, 51 AND 52).

FIRST USE 6-1-2005; IN COMMERCE 6-1-2005.

3,632,851. LIQUID GLASS ENTERPRISES, INC., TEANECK, NJ. SN 77-482,260. PUB. 12-16-2008, FILED 5-23-2008.



THE MARK CONSISTS OF A GLOBE HELD BY A SILHOUETTE OF A WINGED WOMAN, LUNGING UPON A MOUNTAIN TOP.

FOR POLISH SOLD EXCLUSIVELY ON THE RETAIL MARKET FOR USE ON PAINTED AND UNPAINTED METAL AND PLASTIC SURFACES ON AUTOMOBILES, LAND VEHICLES, AIRPLANES, SHIPS AND BOATS (U.S. CLS. 1, 4, 6, 50, 51 AND 52).

FIRST USE 9-1-2007; IN COMMERCE 9-1-2007.

CLASS 3—(Continued).

3,632,858. HEALTH CENTER FOR BETTER LIVING, INC., NAPLES, FL. SN 77-484,614. PUB. 9-2-2008, FILED 5-28-2008.

DERMASATIN

THE MARK CONSISTS OF STANDARD CHARACTERS WITHOUT CLAIM TO ANY PARTICULAR FONT, STYLE, SIZE, OR COLOR.

FOR ANTI-AGING CREAMS; ANTI-WRINKLE CREAMS; EYE CREAM; NON-MEDICATED ACNE TREATMENT PREPARATIONS; NON-MEDICATED SKIN CARE PREPARATIONS, NAMELY, CREAMS, LOTIONS, GELS, TONERS, CLEANERS AND PEELS; NON-MEDICATED SKIN CREAMS (U.S. CLS. 1, 4, 6, 50, 51 AND 52).

FIRST USE 7-1-2008; IN COMMERCE 7-1-2008.

3,632,957. TRESSA, INC., ERLANGER, KY. SN 77-521,553. PUB. 12-2-2008, FILED 7-14-2008.



THE MARK CONSISTS OF THE WORD "LITENUP" WITH THE RIGHT SIDE OF THE "U" AN ARROW THAT EXTENDS UPWARD.

FOR HAIR BLEACH (U.S. CLS. 1, 4, 6, 50, 51 AND 52).

FIRST USE 7-1-2008; IN COMMERCE 7-1-2008.

3,632,967. BEAUTY SOLUTIONS, LTD., NEW YORK, NY. SN 77-526,151. PUB. 12-9-2008, FILED 7-18-2008.

RETINOL-X

THE MARK CONSISTS OF STANDARD CHARACTERS WITHOUT CLAIM TO ANY PARTICULAR FONT, STYLE, SIZE, OR COLOR.

FOR ANTI-AGING CREAM; ANTI-WRINKLE CREAM; COSMETIC CREAMS FOR SKIN CARE; COSMETIC PREPARATIONS FOR SKIN RENEWAL; NON-MEDICATED ANTI-AGING SERUM; WRINKLE REMOVING SKIN CARE PREPARATIONS (U.S. CLS. 1, 4, 6, 50, 51 AND 52).

FIRST USE 2-1-2009; IN COMMERCE 2-1-2009.

CLASS 3—(Continued).

3,632,999. BLISS WORLD LLC, NEW YORK, NY. SN 77-538,499. PUB. 12-30-2008, FILED 8-4-2008.

PEELING GROOVY

THE MARK CONSISTS OF STANDARD CHARACTERS WITHOUT CLAIM TO ANY PARTICULAR FONT, STYLE, SIZE, OR COLOR.

FOR BEAUTY SERUMS; COSMETIC CREAMS; COSMETICS; LOTIONS FOR COSMETIC PURPOSES; SKIN AND BODY TOPICAL LOTIONS, CREAMS AND OILS FOR COSMETIC USE (U.S. CLS. 1, 4, 6, 50, 51 AND 52).
FIRST USE 12-15-2008; IN COMMERCE 12-15-2008.

3,633,020. L'OREAL USA CREATIVE, INC., NEW YORK, NY. SN 77-546,279. PUB. 12-23-2008, FILED 8-13-2008.

RICH RECOVERY

THE MARK CONSISTS OF STANDARD CHARACTERS WITHOUT CLAIM TO ANY PARTICULAR FONT, STYLE, SIZE, OR COLOR.

FOR HAIR CARE PREPARATION (U.S. CLS. 1, 4, 6, 50, 51 AND 52).
FIRST USE 3-1-2009; IN COMMERCE 3-1-2009.

3,633,053. GALDERMA S.A., CHAM, SWITZERLAND. SN 77-976,855. PUB. 9-4-2007, FILED 10-13-2006.

DAILYADVANCE

THE MARK CONSISTS OF STANDARD CHARACTERS WITHOUT CLAIM TO ANY PARTICULAR FONT, STYLE, SIZE, OR COLOR.

FOR COSMETICS AND SKIN CARE PREPARATIONS, NAMELY, FACE, HAND AND BODY SOAPS, CLEANSERS AND MOISTURIZERS; HAIR SHAMPOOS AND CONDITIONERS (U.S. CLS. 1, 4, 6, 50, 51 AND 52).
FIRST USE 11-15-2007; IN COMMERCE 11-15-2007.

CLASS 3—(Continued).

3,633,055. 24/8 LLC, NEW YORK, NY. SN 77-976,876. PUB. 9-16-2008, FILED 11-7-2007.

YBF

THE MARK CONSISTS OF STANDARD CHARACTERS WITHOUT CLAIM TO ANY PARTICULAR FONT, STYLE, SIZE, OR COLOR.

FOR COSMETICS (U.S. CLS. 1, 4, 6, 50, 51 AND 52).
FIRST USE 6-0-2008; IN COMMERCE 6-0-2008.

3,633,056. CELLCEUTICALS SKIN CARE INC., BEVERLY HILLS, CA. SN 77-976,881. PUB. 7-8-2008, FILED 12-15-2007.

**ONLY A PLASTIC SURGEON CAN
DO MORE**

THE MARK CONSISTS OF STANDARD CHARACTERS WITHOUT CLAIM TO ANY PARTICULAR FONT, STYLE, SIZE, OR COLOR.

FOR NON-MEDICATED SKINCARE PRODUCTS, NAMELY, ANTI-AGING CREAMS, LOTIONS, SERUMS AND GELS; EXFOLIANTS; SKIN MOISTURIZERS (U.S. CLS. 1, 4, 6, 50, 51 AND 52).
FIRST USE 1-19-2009; IN COMMERCE 1-19-2009.

3,633,072. EXHALE ENTERPRISES, INC., NEW YORK, NY. SN 77-977,054. PUB. 7-8-2008, FILED 8-13-2007.

GROW RESTORE NURTURE

THE MARK CONSISTS OF STANDARD CHARACTERS WITHOUT CLAIM TO ANY PARTICULAR FONT, STYLE, SIZE, OR COLOR.

FOR NON-MEDICATED SKIN CARE PREPARATIONS AND HAIR CARE PREPARATIONS (U.S. CLS. 1, 4, 6, 50, 51 AND 52).
FIRST USE 12-0-2007; IN COMMERCE 12-0-2007.

CLASS 3—(Continued).

3,633,075. LIFETHERAPY, L.L.C., ADDISON, IL. SN 77-977,068. PUB. 7-22-2008, FILED 2-12-2008.

LIFETHERAPY

THE MARK CONSISTS OF STANDARD CHARACTERS WITHOUT CLAIM TO ANY PARTICULAR FONT, STYLE, SIZE, OR COLOR.

FOR BODY OILS AND HAND CREAMS (U.S. CLS. 1, 4, 6, 50, 51 AND 52).

FIRST USE 11-13-2007; IN COMMERCE 11-13-2007.

3,633,078. BIGELOW MERCHANDISING, LLC, COLUMBUS, OH. SN 77-977,106. PUB. 1-8-2008, FILED 2-9-2007.

ELIXIR RED

THE MARK CONSISTS OF STANDARD CHARACTERS WITHOUT CLAIM TO ANY PARTICULAR FONT, STYLE, SIZE, OR COLOR.

FOR PERSONAL CARE PRODUCTS, NAMELY, AFTER SHAVE CREAMS, GELS AND EMULSIONS, AFTER SHAVE BALM, AFTER SHAVE LOTION, NON-MEDICATED ALUM BLOCK FOR USE AFTER SHAVING, ANTIPERSPIRANT, ASTRINGENT FOR THE FACE, ASTRINGENT FOR THE SKIN, BATH BEADS, BATH GEL, BATH OIL, BATH SOAK, BLUSH, BODY BALM, SKIN AND FACIAL CLEANSERS, BODY CREAM, BODY LOTION, BODY MOISTURIZER, NON-MEDICATED BODY OINTMENT, NON-MEDICATED BODY SALVE, BODY SCRUB, BODY WASH, CLEANSING CREAM, COLD CREAM, COLOGNE, COSMETICS, DENTIFRICE, DEODORANT, DEPILATORIES, DUSTING POWDER, ESSENTIAL OIL, EYE CREAM, EYE GEL, EYELINER, EYE SHADOW, FACE CLEANSER, FACE CREAM, FACE GEL, FACE LOTION, FACE MASK, FACE MIST, FACE MOISTURIZER, FACE POWDER, FACE SCRUB, FACE SERUM, FACE TONER, FACE WASH, FOOT CREAM, NON-MEDICATED FOOT POWDER, FOOT SALVE, FRAGRANCE, FRAGRANT BODY SPRAY FOR COSMETIC PURPOSES, HAIR BLEACHES, HAIR CONDITIONER, HAIR DETANGLER, HAIR POMADE, HAIR SHAMPOO, HAIR STYLING PREPARATIONS, HAIR WAXES, HAND CLEANSER, HAND CREAM, HAND LOTION, LIP BALM, LIP BUFFER, LIP EXFOLIATOR, NON-MEDICATED LIP SALVE, LIP SHINE, LIP STICK, MAKE UP REMOVER, MASCARA, MASSAGE CREAM, MASSAGE OIL, NON-MEDICATED MOUTHWASH, NAIL CREAM, NAIL POLISH, NOSE BALM, PERFUME, POST SUN TANNING CREAM, POST SUN TANNING LOTION, PRE-SHAVE OIL, PUMICE STONE FOR PERSONAL USE, SCENTED ROOM SPRAY, NON-MEDICATED BODY SALVE, NAMELY, ROSE SALVE, TOILET WATER, NAMELY, ROSE WATER, SHAVING BALM, SHAVING CREAM, SHAVING FOAM, SHAVING GEL, SHAVE LATHER, SHOWER GEL, SKIN CREAM, SKIN LOTION, SKIN TONIC, SKIN SCRUB, SKIN WASH, SOAP, SUN CARE LOTIONS, GELS, AND SPRAYS, TALCUM POWDER, MEDICATED SOAP (U.S. CLS. 1, 4, 6, 50, 51 AND 52).

FIRST USE 6-4-2007; IN COMMERCE 6-4-2007.

CLASS 3—(Continued).

3,633,079. BIGELOW MERCHANDISING, LLC, COLUMBUS, OH. SN 77-977,107. PUB. 1-8-2008, FILED 2-9-2007.

ELIXIR BLACK

THE MARK CONSISTS OF STANDARD CHARACTERS WITHOUT CLAIM TO ANY PARTICULAR FONT, STYLE, SIZE, OR COLOR.

FOR PERSONAL CARE PRODUCTS, NAMELY, AFTER SHAVE CREAMS, GELS AND EMULSIONS, AFTER SHAVE BALM, AFTER SHAVE LOTION, NON-MEDICATED ALUM BLOCK FOR USE AFTER SHAVING, ANTIPERSPIRANT, ASTRINGENT FOR THE FACE, ASTRINGENT FOR THE SKIN, BATH BEADS, BATH GEL, BATH OIL, BATH SOAK, BLUSH, BODY BALM, SKIN AND FACIAL CLEANSERS, BODY CREAM, BODY LOTION, BODY MOISTURIZER, NON-MEDICATED BODY OINTMENT, NON-MEDICATED BODY SALVE, BODY SCRUB, BODY WASH, CLEANSING CREAM, COLD CREAM, COLOGNE, COSMETICS, DENTIFRICE, DEODORANT, DEPILATORIES, DUSTING POWDER, ESSENTIAL OIL, EYE CREAM, EYE GEL, EYELINER, EYE SHADOW, FACE CLEANSER, FACE CREAM, FACE GEL, FACE LOTION, FACE MASK, FACE MIST, FACE MOISTURIZER, FACE POWDER, FACE SCRUB, FACE SERUM, FACE TONER, FACE WASH, FOOT CREAM, NON-MEDICATED FOOT POWDER, FOOT SALVE, FRAGRANCE, FRAGRANT BODY SPRAY FOR COSMETIC PURPOSES, HAIR BLEACHES, HAIR CONDITIONER, HAIR DETANGLER, HAIR POMADE, HAIR SHAMPOO, HAIR STYLING PREPARATIONS, HAIR WAXES, HAND CLEANSER, HAND CREAM, HAND LOTION, LIP BALM, LIP BUFFER, LIP EXFOLIATOR, NON-MEDICATED LIP SALVE, LIP SHINE, LIP STICK, MAKE UP REMOVER, MASCARA, MASSAGE CREAM, MASSAGE OIL, NON-MEDICATED MOUTHWASH, NAIL CREAM, NAIL POLISH, NOSE BALM, PERFUME, POST SUN TANNING CREAM, POST SUN TANNING LOTION, PRE-SHAVE OIL, PUMICE STONE FOR PERSONAL USE, SCENTED ROOM SPRAY, NON-MEDICATED BODY SALVE, NAMELY, ROSE SALVE, TOILET WATER, NAMELY, ROSE WATER, SHAVING BALM, SHAVING CREAM, SHAVING FOAM, SHAVING GEL, SHAVE LATHER, SHOWER GEL, SKIN CREAM, SKIN LOTION, SKIN TONIC, SKIN SCRUB, SKIN WASH, SOAP, SUN CARE LOTIONS, GELS AND SPRAYS, TALCUM POWDER, MEDICATED SOAP (U.S. CLS. 1, 4, 6, 50, 51 AND 52).

FIRST USE 6-4-2007; IN COMMERCE 6-4-2007.

3,633,087. THIERRY MUGLER PARFUMS S.A.S., NEUILLY-SUR-SEINE, FRANCE. SN 78-252,808. PUB. 7-31-2007, FILED 5-21-2003.

OWNER OF FRANCE REG. NO. 96621735, DATED 4-18-

CLASS 3—(Continued).

1996, EXPIRES 4-18-2016.
OWNER OF U.S. REG. NO. 815,080 AND OTHERS.
NO CLAIM IS MADE TO THE EXCLUSIVE RIGHT TO
USE "MEN", APART FROM THE MARK AS SHOWN.
FOR PERFUMERY FOR USE BY MEN (U.S. CLS. 1, 4,
6, 50, 51 AND 52).
FIRST USE 0-0-1996; IN COMMERCE 1-0-2009.

CLASS 3—(Continued).

3,633,103. FERNDAL LABORATORIES, INC., FERNDAL,
MI. SN 78-487,812. PUB. 2-21-2006, FILED 9-22-2004.

3,633,088. ROMANO, JULIO MARIO, LOS ANGELES, CA. SN
78-263,417. PUB. 12-27-2005, FILED 6-17-2003.

SHAMPOOLIO

FOR BEAUTY PRODUCTS, NAMELY, SHAMPOOS,
HAND SOAP, HAND LOTIONS, BODY LOTIONS, HAIR
CONDITIONERS, HAIR OILS, HAIR NOURISHERS,
HAIR POMADES, HAIR CARE PREPARATIONS IN
THE NATURE OF FINISHING SPRAYS, SKIN LOTIONS,
SKIN OILS, PERFUMES, COLOGNES, DEODORANTS
(U.S. CLS. 1, 4, 6, 50, 51 AND 52).
FIRST USE 3-19-2009; IN COMMERCE 3-19-2009.

3,633,093. SLC SKINCARE, INC., CALABASAS, CA. SN 78-
402,075. PUB. 1-24-2006, FILED 4-15-2004.

SOMERSMILE

THE MARK CONSISTS OF STANDARD CHARACTERS
WITHOUT CLAIM TO ANY PARTICULAR FONT, STYLE,
SIZE, OR COLOR.

OWNER OF U.S. REG. NOS. 2,789,710 AND 2,860,084.
FOR TEETH WHITENING SYSTEM, NAMELY, A KIT
CONTAINING BLEACHING AGENTS, NAMELY, DEN-
TAL BLEACHING GEL, WHITENING AGENTS,
NAMELY, TEETH WHITENING PREPARATIONS, AND
HYDROGEN PEROXIDE GELS FOR WHITENING
TEETH, AND APPLICATORS FOR THE TEETH
WHITENING AGENTS AND GELS, TEETH COLOR
SHADE GUIDES AND LITERATURE IN THE NATURE
OF INFORMATIONAL USER GUIDES DESCRIBING
THE USE OF THE AFOREMENTIONED PRODUCTS;
COSMETIC TOOTH WHITENER; DENTAL AND PERI-
ODONTIC PRODUCTS FOR CLEANING AND WHITEN-
ING TEETH, NAMELY, DENTAL BLEACHING GEL
FOR WHITENING TEETH (U.S. CLS. 1, 4, 6, 50, 51 AND
52).
FIRST USE 4-0-2004; IN COMMERCE 1-0-2005.

OC EIGHT

THE MARK CONSISTS OF STANDARD CHARACTERS
WITHOUT CLAIM TO ANY PARTICULAR FONT, STYLE,
SIZE, OR COLOR.

FOR NON-MEDICATED TOPICAL SKIN CARE PRE-
PARATIONS (U.S. CLS. 1, 4, 6, 50, 51 AND 52).
FIRST USE 3-23-2009; IN COMMERCE 3-23-2009.

3,633,108. AMERIMARK DIRECT LLC, CLEVELAND, OH.
SN 78-500,641. PUB. 1-15-2008, FILED 10-15-2004.

**MIRACLE MINUTE
FACE LIFT CREAM BY
BEAUTY BOUTIQUE**

THE MARK CONSISTS OF STANDARD CHARACTERS
WITHOUT CLAIM TO ANY PARTICULAR FONT, STYLE,
SIZE, OR COLOR.

OWNER OF U.S. REG. NO. 2,994,762.
NO CLAIM IS MADE TO THE EXCLUSIVE RIGHT TO
USE "FACE LIFT CREAM" AND "BEAUTY", APART FROM
THE MARK AS SHOWN.
FOR FACE LIFT CREAM (U.S. CLS. 1, 4, 6, 50, 51 AND
52).
FIRST USE 1-19-2009; IN COMMERCE 1-19-2009.

CLASS 3—(Continued).

3,633,142. DESIGNER SKIN, L.L.C., INDIANAPOLIS, IN. SN 78-607,524. PUB. 8-8-2006, FILED 4-13-2005.

BOUTIQUE WHISPER

THE MARK CONSISTS OF STANDARD CHARACTERS WITHOUT CLAIM TO ANY PARTICULAR FONT, STYLE, SIZE, OR COLOR.

FOR INDOOR COSMETIC SUNTANNING PREPARATIONS SOLD EXCLUSIVELY AT TANNING SALONS, NAMELY, SKIN GELS FOR ACCELERATING, ENHANCING OR EXTENDING TANS; AND LOTIONS (U.S. CLS. 1, 4, 6, 50, 51 AND 52).

FIRST USE 11-1-2005; IN COMMERCE 11-1-2005.

3,633,159. BUMBLE AND BUMBLE, LLC, NEW YORK, NY. SN 78-655,209. PUB. 5-8-2007, FILED 6-21-2005.



THE MARK CONSISTS OF THE WORDS "BB. LITTLE SHINE" IN A STYLIZED FORM.

FOR HAIR CARE PREPARATIONS, NAMELY, HAIR GLOSS (U.S. CLS. 1, 4, 6, 50, 51 AND 52).

FIRST USE 3-1-2006; IN COMMERCE 3-1-2006.

3,633,250. COLGATE-PALMOLIVE COMPANY, NEW YORK, NY. SN 78-839,789. PUB. 6-27-2006, FILED 3-17-2006.

VISIBLE WHITE

THE MARK CONSISTS OF STANDARD CHARACTERS WITHOUT CLAIM TO ANY PARTICULAR FONT, STYLE, SIZE, OR COLOR.

NO CLAIM IS MADE TO THE EXCLUSIVE RIGHT TO USE "WHITE", APART FROM THE MARK AS SHOWN.

FOR ORAL CARE PRODUCTS, NAMELY, DENTIFRICES, BREATH-FRESHENERS, TOOTH-WHITENING GELS AND STRIPS (U.S. CLS. 1, 4, 6, 50, 51 AND 52).

FIRST USE 2-23-2009; IN COMMERCE 2-23-2009.

CLASS 3—(Continued).

3,633,299. QHEMET BIOLOGICS, INC., TAMPA, FL. SN 78-934,021. PUB. 8-21-2007, FILED 7-20-2006.

**ANCESTRAL HAIR CARE FOR
MODERN NATURALS**

THE MARK CONSISTS OF STANDARD CHARACTERS WITHOUT CLAIM TO ANY PARTICULAR FONT, STYLE, SIZE, OR COLOR.

NO CLAIM IS MADE TO THE EXCLUSIVE RIGHT TO USE "HAIR CARE", APART FROM THE MARK AS SHOWN.

FOR HAIR CARE PRODUCTS, NAMELY, CONDITIONERS, HAIR CARE CREAMS, STYLING GEL AND HAIR CARE PREPARATIONS (U.S. CLS. 1, 4, 6, 50, 51 AND 52).

FIRST USE 7-0-2006; IN COMMERCE 7-0-2006.

3,633,302. COACH SERVICES, INC., NEW YORK, NY. SN 78-936,743. PUB. 1-9-2007, FILED 7-25-2006.

COACH

THE MARK CONSISTS OF STANDARD CHARACTERS WITHOUT CLAIM TO ANY PARTICULAR FONT, STYLE, SIZE, OR COLOR.

OWNER OF U.S. REG. NOS. 2,045,676, 2,291,341, AND OTHERS.

FOR BODY SPRAYS; COLOGNE; COSMETICS; HAND LOTIONS; PERFUMES; SKIN LOTIONS; SKIN MOISTURIZER; SKIN SOAP; TOILET SOAPS (U.S. CLS. 1, 4, 6, 50, 51 AND 52).

FIRST USE 4-1-2007; IN COMMERCE 4-1-2007.

3,633,330. GALDERMA S.A., CH - 1000 LAUSANNE 30, SWITZERLAND. SN 78-981,018. PUB. 9-25-2007, FILED 7-5-2006.

**CETAPHIL DAILYADVANCE
ULTRA HYDRATING LOTION**

THE MARK CONSISTS OF STANDARD CHARACTERS WITHOUT CLAIM TO ANY PARTICULAR FONT, STYLE, SIZE, OR COLOR.

NO CLAIM IS MADE TO THE EXCLUSIVE RIGHT TO USE "ULTRA HYDRATING LOTION", APART FROM THE MARK AS SHOWN.

FOR COSMETICS AND SKIN CARE PREPARATIONS, NAMELY, FACE, HAND AND BODY SOAPS, CLEANSERS AND MOISTURIZERS; HAIR SHAMPOOS AND CONDITIONERS (U.S. CLS. 1, 4, 6, 50, 51 AND 52).

FIRST USE 11-15-2007; IN COMMERCE 11-15-2007.

CLASS 3—(Continued).

3,633,332. HORPHAG RESEARCH MANAGEMENT SA, 1216 COINTRIN, GENEVA, SWITZERLAND. SN 78-981,044. PUB. 12-12-2006, FILED 2-2-2006.

PYCNOGENOL

THE MARK CONSISTS OF STANDARD CHARACTERS WITHOUT CLAIM TO ANY PARTICULAR FONT, STYLE, SIZE, OR COLOR.

OWNER OF U.S. REG. NOS. 1,769,633 AND 2,796,485. FOR COSMETIC PREPARATIONS FOR THE CARE OF THE MOUTH AND TEETH, NAMELY, BREATH SPRAYS (U.S. CLS. 1, 4, 6, 50, 51 AND 52). FIRST USE 3-1-2006; IN COMMERCE 3-1-2006.

CLASS 4—(Continued).

3,632,790. SUNMARKS, LLC, WILMINGTON, DE. SN 77-457,062. PUB. 7-22-2008, FILED 4-24-2008.

260 GOLD

THE MARK CONSISTS OF STANDARD CHARACTERS WITHOUT CLAIM TO ANY PARTICULAR FONT, STYLE, SIZE, OR COLOR.

FOR RACING GASOLINE (U.S. CLS. 1, 6 AND 15). FIRST USE 5-28-2008; IN COMMERCE 5-28-2008.

3,632,841. LIQUID GLASS ENTERPRISES, INC., TEANECK, NJ. SN 77-478,319. PUB. 12-16-2008, FILED 5-19-2008.

3,633,336. APFEL, DENNIS, COMMACK, NY. SN 78-981,069. PUB. 7-4-2006, FILED 10-20-2005.

EXCEPTIONAL . . . BECAUSE YOU ARE

THE MARK CONSISTS OF STANDARD CHARACTERS WITHOUT CLAIM TO ANY PARTICULAR FONT, STYLE, SIZE, OR COLOR.

FOR NON-MEDICATED SKIN CARE PREPARATIONS, NAMELY, CREAM (U.S. CLS. 1, 4, 6, 50, 51 AND 52). FIRST USE 10-15-2008; IN COMMERCE 10-15-2008.

CARPERFECT

THE MARK CONSISTS OF STANDARD CHARACTERS WITHOUT CLAIM TO ANY PARTICULAR FONT, STYLE, SIZE, OR COLOR.

FOR LIQUID PROTECTOR FOR LEATHER, VINYL UPHOLSTERY, AND RUBBER, NAMELY, PRESERVING OIL FOR USE ON AUTOMOBILES, LAND VEHICLES, AIRPLANES, SHIPS AND BOATS (U.S. CLS. 1, 6 AND 15).

FIRST USE 6-1-2005; IN COMMERCE 6-1-2005.

3,632,852. LIQUID GLASS ENTERPRISES, INC., TEANECK, NJ. SN 77-482,377. PUB. 12-16-2008, FILED 5-23-2008.

3,633,338. AGUSTIN REYES, INC., HIALEAH, FL. SN 78-981,086. PUB. 1-9-2007, FILED 6-5-2006.

PURE ELEGANCE

THE MARK CONSISTS OF STANDARD CHARACTERS WITHOUT CLAIM TO ANY PARTICULAR FONT, STYLE, SIZE, OR COLOR.

FOR PERFUME (U.S. CLS. 1, 4, 6, 50, 51 AND 52). FIRST USE 2-10-2009; IN COMMERCE 2-10-2009.



THE MARK CONSISTS OF A GLOBE HELD BY A SILHOUETTE OF A WINGED WOMAN, LUNGING UPON A MOUNTAIN TOP.

FOR LIQUID PROTECTOR FOR LEATHER, VINYL UPHOLSTERY, AND RUBBER, NAMELY, PRESERVING OIL FOR USE ON AUTOMOBILES, LAND VEHICLES, AIRPLANES, SHIPS AND BOATS (U.S. CLS. 1, 6 AND 15).

FIRST USE 9-1-2007; IN COMMERCE 9-1-2007.

CLASS 5—(Continued).

3,631,790. INNOVATIVE BEVERAGE CONCEPTS, INC., ALISO VIEJO, CA. SN 76-584,060. PUB. 9-6-2005, FILED 3-30-2004.

TEAOLOGY

FOR POWDERED DRINK MIXES CONTAINING TEA FOR USE AS MEAL REPLACEMENTS (U.S. CLS. 6, 18, 44, 46, 51 AND 52).
FIRST USE 11-1-2005; IN COMMERCE 11-1-2005.

3,631,791. ARCHER-DANIELS-MIDLAND COMPANY, DECATUR, IL. SN 76-588,896. PUB. 1-31-2006, FILED 4-23-2004.

BENEFLAX

THE MARK CONSISTS OF STANDARD CHARACTERS WITHOUT CLAIM TO ANY PARTICULAR FONT, STYLE, SIZE, OR COLOR.
FOR DIETARY AND NUTRITIONAL SUPPLEMENTS DERIVED FROM WHOLE FLAXSEED OR COMPONENTS OF FLAXSEED FOR USE IN ADDITION TO DAILY FOODS (U.S. CLS. 6, 18, 44, 46, 51 AND 52).
FIRST USE 11-21-2007; IN COMMERCE 11-21-2007.

3,631,808. JOHNSON & JOHNSON, NEW BRUNSWICK, NJ. SN 76-655,168. PUB. 11-4-2008, FILED 2-13-2006.

EVICEL

THE MARK CONSISTS OF STANDARD CHARACTERS WITHOUT CLAIM TO ANY PARTICULAR FONT, STYLE, SIZE, OR COLOR.
FOR FIBRIN SURGICAL SEALANT (U.S. CLS. 6, 18, 44, 46, 51 AND 52).
FIRST USE 8-16-2006; IN COMMERCE 8-16-2006.

CLASS 5—(Continued).

3,631,817. MCNEIL NUTRITIONALS, LLC, FORT WASHINGTON, PA. SN 76-672,167. PUB. 7-17-2007, FILED 2-2-2007.

DON'T JUST TAKE YOUR VITAMIN, ENJOY IT

THE MARK CONSISTS OF STANDARD CHARACTERS WITHOUT CLAIM TO ANY PARTICULAR FONT, STYLE, SIZE, OR COLOR.
FOR NUTRITIONAL AND DIETARY SUPPLEMENTS (U.S. CLS. 6, 18, 44, 46, 51 AND 52).
FIRST USE 10-0-2008; IN COMMERCE 10-0-2008.

3,631,821. MCNEIL NUTRITIONALS, LLC, FORT WASHINGTON, PA. SN 76-676,530. PUB. 7-17-2007, FILED 5-7-2007.

DON'T JUST TAKE YOUR CALCIUM, ENJOY IT

THE MARK CONSISTS OF STANDARD CHARACTERS WITHOUT CLAIM TO ANY PARTICULAR FONT, STYLE, SIZE, OR COLOR.
FOR NUTRITIONAL AND DIETARY SUPPLEMENTS (U.S. CLS. 6, 18, 44, 46, 51 AND 52).
FIRST USE 2-11-2009; IN COMMERCE 3-25-2009.

3,631,822. MIONIX CORPORATION, ROUND ROCK, TX. SN 76-677,502. PUB. 7-15-2008, FILED 5-29-2007.

MYCOTEK

THE MARK CONSISTS OF STANDARD CHARACTERS WITHOUT CLAIM TO ANY PARTICULAR FONT, STYLE, SIZE, OR COLOR.
THE WORDING "MYCOTEK" HAS NO MEANING IN A FOREIGN LANGUAGE.
FOR CHEMICAL MIXTURES USED AS ANTIMOLD TREATMENTS FOR APPLICATION TO PAPER PRODUCTS (U.S. CLS. 6, 18, 44, 46, 51 AND 52).
FIRST USE 2-28-2007; IN COMMERCE 2-28-2007.

CLASS 5—(Continued).

3,631,835. PACIFIC ELEMENTS, LLC, TURLOCK, CA. SN 76-683,899. PUB. 4-22-2008, FILED 11-9-2007.



FOR LIVESTOCK AND POULTRY FOOD SUPPLEMENTS IN GRANULAR AND PELLETED FORMULATIONS (U.S. CLS. 6, 18, 44, 46, 51 AND 52).
FIRST USE 11-23-2008; IN COMMERCE 11-23-2008.



3,631,872. AKORN INC., LAKE FOREST, IL. SN 77-012,922. PUB. 5-15-2007, FILED 10-3-2006.

AKTEN

THE MARK CONSISTS OF STANDARD CHARACTERS WITHOUT CLAIM TO ANY PARTICULAR FONT, STYLE, SIZE, OR COLOR.
FOR PHARMACEUTICAL FOR OPHTHALMIC TREATMENT, NAMELY, AN OCULAR ANESTHETIC (U.S. CLS. 6, 18, 44, 46, 51 AND 52).
FIRST USE 10-8-2008; IN COMMERCE 10-8-2008.



3,631,937. ULTIMATE GENETICS, LLC, WHEELOCK, TX. SN 77-084,361. PUB. 1-22-2008, FILED 1-17-2007.

ADVANTAGE TECHNOLOGY

THE MARK CONSISTS OF STANDARD CHARACTERS WITHOUT CLAIM TO ANY PARTICULAR FONT, STYLE, SIZE, OR COLOR.
NO CLAIM IS MADE TO THE EXCLUSIVE RIGHT TO USE "TECHNOLOGY", APART FROM THE MARK AS SHOWN.
FOR MEDIA ADDITIVES, NAMELY, PROSTAGLANDIN INHIBITOR ADDITIVE, FOR SUSTAINING EMBRYOS PRIOR TO TRANSFER (U.S. CLS. 6, 18, 44, 46, 51 AND 52).
FIRST USE 4-30-2008; IN COMMERCE 4-30-2008.

CLASS 5—(Continued).

3,631,959. CHEMINOVA, INC., RESEARCH TRIANGLE PARK, NC. SN 77-104,810. PUB. 7-31-2007, FILED 2-12-2007.

TACKLE

THE MARK CONSISTS OF STANDARD CHARACTERS WITHOUT CLAIM TO ANY PARTICULAR FONT, STYLE, SIZE, OR COLOR.
FOR HERBICIDES FOR AGRICULTURAL USE (U.S. CLS. 6, 18, 44, 46, 51 AND 52).
FIRST USE 4-14-2009; IN COMMERCE 4-14-2009.



3,631,975. MERCK & CO., INC., WHITEHOUSE STATION, NJ. SN 77-121,908. PUB. 8-7-2007, FILED 3-5-2007.



THE MARK CONSISTS OF STYLIZED "V" SHAPE WITH A DIAMOND SHAPE PLACED IN THE CENTER OF THE STYLIZED "V" SHAPE, WHICH IS DIRECTLY OVER THE "I" IN "ISENTRESS".
FOR PHARMACEUTICAL PREPARATIONS, NAMELY, ANTI-INFECTIVE PREPARATIONS, ANTIVIRAL PREPARATIONS (U.S. CLS. 6, 18, 44, 46, 51 AND 52).
FIRST USE 3-0-2008; IN COMMERCE 3-0-2008.



3,632,007. BARRY, RICHARD. FAIR HAVEN, NJ. SN 77-159,468. PUB. 10-23-2007, FILED 4-18-2007.

KIDStrong

FOR NUTRITIONAL DRINK MIX FOR USE AS A MEAL REPLACEMENT (U.S. CLS. 6, 18, 44, 46, 51 AND 52).
FIRST USE 12-29-2008; IN COMMERCE 12-29-2008.

CLASS 5—(Continued).

3,632,073. E. I. DU PONT DE NEMOURS AND COMPANY, WILMINGTON, DE. SN 77-212,267. PUB. 10-9-2007, FILED 6-21-2007.

ENVIVE

THE MARK CONSISTS OF STANDARD CHARACTERS WITHOUT CLAIM TO ANY PARTICULAR FONT, STYLE, SIZE, OR COLOR.

FOR HERBICIDES FOR USE IN AGRICULTURE (U.S. CLS. 6, 18, 44, 46, 51 AND 52).

FIRST USE 7-1-2007; IN COMMERCE 7-1-2007.

3,632,074. ACCURA HEALTH LIMITED, IRVINE, AYRSHIRE, UNITED KINGDOM. SN 77-212,734. PUB. 8-5-2008, FILED 6-22-2007.



THE MARK CONSISTS OF A REPRESENTATION OF AN ANGEL CONSISTING OF A FACE, WINGS AND A HALO LOCATED ABOVE THE WORDS "AM:ANGEL".

FOR DIETARY FOOD AND NUTRITIONAL SUPPLEMENTS; NON-MEDICATED FOOD SUPPLEMENTS CONTAINING AMINO ACIDS, AMINO ACID DERIVATIVES, VITAMINS AND MINERALS; NON-PRESCRIPTION DIETARY SUPPLEMENTS CONSISTING OF AMINO ACIDS AND AMINO ACID DERIVATIVES, MINERALS, VITAMINS, TRACE ELEMENTS; HEALTH FOOD SUPPLEMENTS MADE PRINCIPALLY OF AMINO ACIDS AND AMINO ACID DERIVATIVES; HEALTH FOOD SUPPLEMENTS MADE OF VITAMINS; HEALTH FOOD SUPPLEMENTS MADE OF MINERALS; FOOD SUPPLEMENTS ADAPTED FOR MEDICAL PURPOSES; MEDICATED FOOD SUPPLEMENTS; VITAMIN SUPPLEMENTS; DIETETIC DRINKS ADAPTED FOR MEDICAL PURPOSES; DRINKS PREDOMINANTLY OF AMINO ACIDS, MINERALS AND VITAMINS; DIETARY FOOD AND NUTRITIONAL SUPPLEMENTS IN LIQUID FORM; DIETARY FOOD AND NUTRITIONAL SUPPLEMENTS IN TABLET FORM; DIETARY FOOD AND NUTRITIONAL SUPPLEMENTS IN CAPSULE FORM; DIETARY SUPPLEMENTS OTHER THAN FOR MEDICAL USE; FOOD SUPPLEMENT PREPARATIONS IN LIQUID FORM; FOOD SUPPLEMENT PREPARATIONS IN POWDERED FORM; NON-MEDICATED DRINKS CONTAINING AMINO ACIDS; AMINO ACIDS DERIVATIVES, VITAMINS AND MINERALS (U.S. CLS. 6, 18, 44, 46, 51 AND 52).

FIRST USE 10-0-2007; IN COMMERCE 10-0-2007.

CLASS 5—(Continued).

3,632,105. MATTHEW G. DAVIDSON, LOS ANGELES, CA. SN 77-228,438. PUB. 12-9-2008, FILED 7-12-2007.

Brain-Boosting Chewing Gum

THE MARK CONSISTS OF STANDARD CHARACTERS WITHOUT CLAIM TO ANY PARTICULAR FONT, STYLE, SIZE, OR COLOR.

NO CLAIM IS MADE TO THE EXCLUSIVE RIGHT TO USE "CHEWING GUM", APART FROM THE MARK AS SHOWN.

FOR BREATH-FRESHENING CHEWING GUM FOR MEDICINAL PURPOSES; HERBAL CHEWING GUM PROVIDING MENTAL ALERTNESS (U.S. CLS. 6, 18, 44, 46, 51 AND 52).

FIRST USE 3-29-2007; IN COMMERCE 10-1-2007.

3,632,129. HYATT, GRIFFIN TROY, SANTA MONICA, CA. SN 77-238,913. PUB. 7-15-2008, FILED 7-25-2007.

Joint Formula One

THE MARK CONSISTS OF STANDARD CHARACTERS WITHOUT CLAIM TO ANY PARTICULAR FONT, STYLE, SIZE, OR COLOR.

NO CLAIM IS MADE TO THE EXCLUSIVE RIGHT TO USE "JOINT FORMULA", APART FROM THE MARK AS SHOWN.

FOR MEDICINAL HERB EXTRACTS (U.S. CLS. 6, 18, 44, 46, 51 AND 52).

FIRST USE 1-24-2009; IN COMMERCE 1-24-2009.

3,632,138. KENKO INTERNATIONAL, INC., LOS ANGELES, CA. SN 77-242,362. PUB. 2-12-2008, FILED 7-30-2007.

LOQUORO

THE MARK CONSISTS OF STANDARD CHARACTERS WITHOUT CLAIM TO ANY PARTICULAR FONT, STYLE, SIZE, OR COLOR.

FOR DIETARY AND NUTRITIONAL SUPPLEMENTS (U.S. CLS. 6, 18, 44, 46, 51 AND 52).

FIRST USE 3-24-2008; IN COMMERCE 3-24-2008.

CLASS 5—(Continued).

3,632,150. SEABIOTICS, INC., PROSPER, TX. SN 77-248,492.
PUB. 1-22-2008, FILED 8-6-2007.

SEALYTE

THE MARK CONSISTS OF STANDARD CHARACTERS WITHOUT CLAIM TO ANY PARTICULAR FONT, STYLE, SIZE, OR COLOR.

FOR DIETARY AND NUTRITIONAL SUPPLEMENTS; DIETARY FOOD SUPPLEMENTS; DIETARY SUPPLEMENTS; MINERAL NUTRITIONAL SUPPLEMENTS; VITAMIN AND MINERAL SUPPLEMENTS (U.S. CLS. 6, 18, 44, 46, 51 AND 52).

FIRST USE 9-0-2007; IN COMMERCE 9-0-2007.

3,632,187. PFIZER INC., NEW YORK, NY. SN 77-261,627.
PUB. 1-22-2008, FILED 8-22-2007.

FLUSURE XP

THE MARK CONSISTS OF STANDARD CHARACTERS WITHOUT CLAIM TO ANY PARTICULAR FONT, STYLE, SIZE, OR COLOR.

OWNER OF U.S. REG. NO. 2,787,087.
FOR SWINE INFLUENZA VACCINES (U.S. CLS. 6, 18, 44, 46, 51 AND 52).

FIRST USE 9-19-2008; IN COMMERCE 9-19-2008.

3,632,261. PACELINE PRODUCTS, INC., PLEASANT VALLEY, MO. SN 77-296,187. PUB. 9-23-2008, FILED 10-4-2007.

PACELINE PRODUCTS BUTT WAXX

THE MARK CONSISTS OF STANDARD CHARACTERS WITHOUT CLAIM TO ANY PARTICULAR FONT, STYLE, SIZE, OR COLOR.

OWNER OF U.S. REG. NO. 3,132,210.
NO CLAIM IS MADE TO THE EXCLUSIVE RIGHT TO USE "PRODUCTS BUTT WAXX", APART FROM THE MARK AS SHOWN.

FOR SKIN LUBRICANTS, NAMELY, CREAMS TO PREVENT CHAFING AND BLISTERS AND TO SOOTHE SKIN IRRITATION (U.S. CLS. 6, 18, 44, 46, 51 AND 52).
FIRST USE 9-4-2008; IN COMMERCE 9-4-2008.

CLASS 5—(Continued).

3,632,376. SCHIFF NUTRITION INTERNATIONAL, INC., SALT LAKE CITY, UT. SN 77-348,442. PUB. 5-6-2008, FILED 12-10-2007.

INFINI-D

THE MARK CONSISTS OF STANDARD CHARACTERS WITHOUT CLAIM TO ANY PARTICULAR FONT, STYLE, SIZE, OR COLOR.

FOR NUTRITIONAL SUPPLEMENTS; DIETARY AND NUTRITIONAL SUPPLEMENTS; DIETARY FOOD SUPPLEMENTS; DIETARY SUPPLEMENTS; DIETARY SUPPLEMENTS FOR HUMAN CONSUMPTION (U.S. CLS. 6, 18, 44, 46, 51 AND 52).

FIRST USE 2-26-2009; IN COMMERCE 2-26-2009.

3,632,386. AGRAQUEST, INC., DAVIS, CA. SN 77-353,602.
PUB. 5-13-2008, FILED 12-17-2007.

Requiem

THE MARK CONSISTS OF STANDARD CHARACTERS WITHOUT CLAIM TO ANY PARTICULAR FONT, STYLE, SIZE, OR COLOR.

FOR PESTICIDES (U.S. CLS. 6, 18, 44, 46, 51 AND 52).
FIRST USE 1-9-2009; IN COMMERCE 1-9-2009.

3,632,453. HERBN TONICS, LLC, HENDERSON, NV. SN 77-382,065. PUB. 6-10-2008, FILED 1-28-2008.

SUTRAMAX

THE MARK CONSISTS OF STANDARD CHARACTERS WITHOUT CLAIM TO ANY PARTICULAR FONT, STYLE, SIZE, OR COLOR.

FOR HERBAL DIETARY SUPPLEMENT FOR SEXUAL ENHANCEMENT (U.S. CLS. 6, 18, 44, 46, 51 AND 52).
FIRST USE 7-15-2008; IN COMMERCE 7-15-2008.

CLASS 5—(Continued).

3,632,499. ARBOR PHARMACEUTICALS, INC., RALEIGH, NC. SN 77-393,977. PUB. 7-1-2008, FILED 2-11-2008.

XYLAREX

THE MARK CONSISTS OF STANDARD CHARACTERS WITHOUT CLAIM TO ANY PARTICULAR FONT, STYLE, SIZE, OR COLOR.

FOR PHARMACEUTICAL OR MEDICAL FOOD AGENTS FOR THE TREATMENT OF RESPIRATORY CONDITIONS AND INFECTIONS (U.S. CLS. 6, 18, 44, 46, 51 AND 52).

FIRST USE 1-23-2009; IN COMMERCE 1-23-2009.

CLASS 5—(Continued).

3,632,666. VITAL PHARMACEUTICALS, INC., DAVIE, FL. SN 77-424,878. PUB. 7-22-2008, FILED 3-18-2008.

COP

THE MARK CONSISTS OF STANDARD CHARACTERS WITHOUT CLAIM TO ANY PARTICULAR FONT, STYLE, SIZE, OR COLOR.

FOR NUTRITIONAL SUPPLEMENTS; NUTRITIONALLY FORTIFIED BEVERAGES (U.S. CLS. 6, 18, 44, 46, 51 AND 52).

FIRST USE 3-15-2007; IN COMMERCE 3-15-2007.

3,632,570. EUROPHARMA, INC., GREEN BAY, WI. SN 77-408,397. PUB. 7-15-2008, FILED 2-28-2008.

CuraMed

THE MARK CONSISTS OF STANDARD CHARACTERS WITHOUT CLAIM TO ANY PARTICULAR FONT, STYLE, SIZE, OR COLOR.

FOR DIETARY SUPPLEMENTS (U.S. CLS. 6, 18, 44, 46, 51 AND 52).

FIRST USE 3-21-2008; IN COMMERCE 3-21-2008.

3,632,684. E. I. DU PONT DE NEMOURS AND COMPANY, WILMINGTON, DE. SN 77-430,824. PUB. 7-29-2008, FILED 3-25-2008.

FIRSTSHOT

THE MARK CONSISTS OF STANDARD CHARACTERS WITHOUT CLAIM TO ANY PARTICULAR FONT, STYLE, SIZE, OR COLOR.

FOR HERBICIDE FOR AGRICULTURAL USE (U.S. CLS. 6, 18, 44, 46, 51 AND 52).

FIRST USE 3-25-2008; IN COMMERCE 3-25-2008.

3,632,617. MARESMA, FRANK A., PALMETTO BAY, FL. SN 77-414,692. PUB. 7-22-2008, FILED 3-6-2008.

Nutralenda

THE MARK CONSISTS OF STANDARD CHARACTERS WITHOUT CLAIM TO ANY PARTICULAR FONT, STYLE, SIZE, OR COLOR.

FOR NUTRACEUTICALS FOR USE AS A DIETARY SUPPLEMENT (U.S. CLS. 6, 18, 44, 46, 51 AND 52).

FIRST USE 10-21-2008; IN COMMERCE 10-21-2008.

3,632,711. DESERT LAKE TECHNOLOGIES, LLC, KLAMATH FALLS, OR. SN 77-435,178. PUB. 7-22-2008, FILED 3-30-2008.

CYANIN-PLUS

THE MARK CONSISTS OF STANDARD CHARACTERS WITHOUT CLAIM TO ANY PARTICULAR FONT, STYLE, SIZE, OR COLOR.

FOR DIETARY SUPPLEMENTS (U.S. CLS. 6, 18, 44, 46, 51 AND 52).

FIRST USE 1-26-2009; IN COMMERCE 2-5-2009.

CLASS 5—(Continued).

3,632,742. DENTSPLY INTERNATIONAL INC., YORK, PA.
SN 77-443,895. PUB. 8-19-2008, FILED 4-9-2008.

CLASS 5—(Continued).

3,632,784. THE HARTZ MOUNTAIN CORPORATION, SE-
CAUCUS, NJ. SN 77-454,304. PUB. 7-29-2008, FILED 4-22-
2008.

CALM-IT

THE MARK CONSISTS OF STANDARD CHARACTERS
WITHOUT CLAIM TO ANY PARTICULAR FONT, STYLE,
SIZE, OR COLOR.

FOR DENTAL RESTORATION COMPOUNDS (U.S.
CLS. 6, 18, 44, 46, 51 AND 52).
FIRST USE 5-15-2008; IN COMMERCE 5-15-2008.

INCONTROL ADVANCED

THE MARK CONSISTS OF STANDARD CHARACTERS
WITHOUT CLAIM TO ANY PARTICULAR FONT, STYLE,
SIZE, OR COLOR.

FOR FLEA AND TICK TOPICAL DROPS FOR DOGS
AND CATS (U.S. CLS. 6, 18, 44, 46, 51 AND 52).
FIRST USE 1-1-2009; IN COMMERCE 1-1-2009.

3,632,755. ALFARO DE MARON, ANA ELOISA DEL CAR-
MEN, DBA LABORATORIOS COMBISA, SAN MARCOS,
EL SALVADOR. SN 77-446,692. PUB. 8-26-2008, FILED 4-11-
2008.

3,632,789. ALFARO DE MARON, ANA ELOISA DEL CAR-
MEN, DBA LABORATORIOS COMBISA, SAN MARCOS,
EL SALVADOR. SN 77-456,120. PUB. 9-2-2008, FILED 4-23-
2008.

NEUROFERRITOL

THE MARK CONSISTS OF STANDARD CHARACTERS
WITHOUT CLAIM TO ANY PARTICULAR FONT, STYLE,
SIZE, OR COLOR.

FOR ANTIANEMIC DIETARY SUPPLEMENT FOR
HUMAN CONSUMPTION (U.S. CLS. 6, 18, 44, 46, 51
AND 52).

FIRST USE 0-0-2003; IN COMMERCE 0-0-2008.

DOLOREUMAX

THE MARK CONSISTS OF STANDARD CHARACTERS
WITHOUT CLAIM TO ANY PARTICULAR FONT, STYLE,
SIZE, OR COLOR.

THE TERMS IN THE MARK HAVE NO MEANING IN A
FOREIGN LANGUAGE.

FOR MUSCULAR PAIN RELIEVING CREAM (U.S.
CLS. 6, 18, 44, 46, 51 AND 52).

FIRST USE 0-0-1996; IN COMMERCE 3-10-2009.

3,632,771. VASCULAR SOLUTIONS, INC., MINNEAPOLIS,
MN. SN 77-450,693. PUB. 7-29-2008, FILED 4-17-2008.

3,632,811. GASPARI NUTRITION INC., LAKEWOOD, NJ. SN
77-465,263. PUB. 9-30-2008, FILED 5-4-2008.

Thrombi-Gel

THE MARK CONSISTS OF STANDARD CHARACTERS
WITHOUT CLAIM TO ANY PARTICULAR FONT, STYLE,
SIZE, OR COLOR.

FOR HEMOSTATS IN THE NATURE OF GELATIN
FOAM USED FOR MEDICAL TREATMENT TO STOP
BLEEDING (U.S. CLS. 6, 18, 44, 46, 51 AND 52).

FIRST USE 6-29-2005; IN COMMERCE 6-29-2005.

MITOTROPIN

THE MARK CONSISTS OF STANDARD CHARACTERS
WITHOUT CLAIM TO ANY PARTICULAR FONT, STYLE,
SIZE, OR COLOR.

FOR DIETARY AND NUTRITIONAL SUPPLEMENTS
(U.S. CLS. 6, 18, 44, 46, 51 AND 52).

FIRST USE 11-1-2008; IN COMMERCE 11-1-2008.

CLASS 5—(Continued).

3,632,818. CORR-JENSEN LABS, INC., CENTENNIAL, CO.
SN 77-468,352. PUB. 10-7-2008, FILED 5-7-2008.

CLASS 5—(Continued).

3,632,900. CORR-JENSEN LABS, INC., CENTENNIAL, CO.
SN 77-503,579. PUB. 10-7-2008, FILED 6-19-2008.

TRAINING DAY

THE MARK CONSISTS OF STANDARD CHARACTERS
WITHOUT CLAIM TO ANY PARTICULAR FONT, STYLE,
SIZE, OR COLOR.

FOR NUTRITIONAL SUPPLEMENTS (U.S. CLS. 6, 18,
44, 46, 51 AND 52).

FIRST USE 11-30-2008; IN COMMERCE 11-30-2008.

GAME TIME

THE MARK CONSISTS OF STANDARD CHARACTERS
WITHOUT CLAIM TO ANY PARTICULAR FONT, STYLE,
SIZE, OR COLOR.

FOR NUTRITIONAL AND DIETARY SUPPLEMENTS
(U.S. CLS. 6, 18, 44, 46, 51 AND 52).

FIRST USE 11-30-2008; IN COMMERCE 11-30-2008.

3,632,828. QUALITY OF LIFE LABS, PURCHASE, NY. SN 77-
473,249. PUB. 9-2-2008, FILED 5-13-2008.

3,632,901. CORR-JENSEN LABS, INC., CENTENNIAL, CO.
SN 77-503,584. PUB. 10-14-2008, FILED 6-19-2008.

HAMPTONS DIET

THE MARK CONSISTS OF STANDARD CHARACTERS
WITHOUT CLAIM TO ANY PARTICULAR FONT, STYLE,
SIZE, OR COLOR.

NO CLAIM IS MADE TO THE EXCLUSIVE RIGHT TO
USE "DIET", APART FROM THE MARK AS SHOWN.

FOR DIETARY AND NUTRITIONAL SUPPLEMENTS
(U.S. CLS. 6, 18, 44, 46, 51 AND 52).

FIRST USE 9-23-2008; IN COMMERCE 2-17-2009.

PRE SEASON

THE MARK CONSISTS OF STANDARD CHARACTERS
WITHOUT CLAIM TO ANY PARTICULAR FONT, STYLE,
SIZE, OR COLOR.

FOR NUTRITIONAL AND DIETARY SUPPLEMENTS
(U.S. CLS. 6, 18, 44, 46, 51 AND 52).

FIRST USE 11-30-2008; IN COMMERCE 11-30-2008.

3,632,894. TISHCON CORP, WESTBURY, NY. SN 77-501,509.
PUB. 11-11-2008, FILED 6-18-2008.

3,632,903. LITTLE I, INC., BLAINE, WA. SN 77-504,852. PUB.
11-18-2008, FILED 6-21-2008.

GLYCO-Q-SORB

THE MARK CONSISTS OF STANDARD CHARACTERS
WITHOUT CLAIM TO ANY PARTICULAR FONT, STYLE,
SIZE, OR COLOR.

FOR DIETARY AND NUTRITIONAL SUPPLEMENTS
(U.S. CLS. 6, 18, 44, 46, 51 AND 52).

FIRST USE 1-1-2009; IN COMMERCE 1-1-2009.

Sleeping Beauty

THE MARK CONSISTS OF STANDARD CHARACTERS
WITHOUT CLAIM TO ANY PARTICULAR FONT, STYLE,
SIZE, OR COLOR.

FOR SLEEPING PILLS/TABLETS (U.S. CLS. 6, 18, 44,
46, 51 AND 52).

FIRST USE 3-9-2009; IN COMMERCE 3-9-2009.

CLASS 5—(Continued).

3,632,925. QUALITY OF LIFE LABS, PURCHASE, NY. SN 77-513,394. PUB. 11-25-2008, FILED 7-2-2008.

CLASS 5—(Continued).

3,632,985. CORR-JENSEN LABS, INC., CENTENNIAL, CO. SN 77-533,178. PUB. 12-16-2008, FILED 7-28-2008.

ProstaCell

EVERY ATHLETE. EVERY SPORT.

THE MARK CONSISTS OF STANDARD CHARACTERS WITHOUT CLAIM TO ANY PARTICULAR FONT, STYLE, SIZE, OR COLOR.
FOR DIETARY SUPPLEMENTS FOR HUMAN CONSUMPTION (U.S. CLS. 6, 18, 44, 46, 51 AND 52).
FIRST USE 9-26-2008; IN COMMERCE 9-26-2008.

THE MARK CONSISTS OF STANDARD CHARACTERS WITHOUT CLAIM TO ANY PARTICULAR FONT, STYLE, SIZE, OR COLOR.
FOR NUTRITIONAL AND DIETARY SUPPLEMENTS (U.S. CLS. 6, 18, 44, 46, 51 AND 52).
FIRST USE 11-30-2008; IN COMMERCE 11-30-2008.

3,632,945. JULIUS SÄMANN LTD., HAMILTON HM12, BERMUDA. SN 77-519,297. PUB. 12-2-2008, FILED 7-10-2008.

3,633,007. SOURCE ONE GLOBAL PARTNERS, CHICAGO, IL. SN 77-540,978. PUB. 12-9-2008, FILED 8-6-2008.

BLACK FOREST

VESISORB

THE MARK CONSISTS OF STANDARD CHARACTERS WITHOUT CLAIM TO ANY PARTICULAR FONT, STYLE, SIZE, OR COLOR.
OWNER OF U.S. REG. NO. 3,126,834.
FOR AIR FRESHENERS (U.S. CLS. 6, 18, 44, 46, 51 AND 52).
FIRST USE 10-15-2008; IN COMMERCE 10-15-2008.

THE MARK CONSISTS OF THE WORD "VESISORB" WITH THE LETTER "O" FORMED IN THE SHAPE OF A DROPLET AND A SHADOW OF THE DROPLET BELOW THE DROPLET OF DOTS IN A CIRCULAR PATTERN.
FOR DIETARY SUPPLEMENTS (U.S. CLS. 6, 18, 44, 46, 51 AND 52).
FIRST USE 4-8-2007; IN COMMERCE 4-8-2007.

3,632,961. SOURCE ONE GLOBAL PARTNERS, CHICAGO, IL. SN 77-523,220. PUB. 12-9-2008, FILED 7-16-2008.

3,633,008. SOURCE ONE GLOBAL PARTNERS, CHICAGO, IL. SN 77-541,150. PUB. 12-9-2008, FILED 8-7-2008.



VESISORB

OWNER OF U.S. REG. NO. 3,468,749.
THE MARK CONSISTS OF THE WORD "COQSOURCE" WITH THE LETTER "Q" CONTAINED IN A DROPLET AND A SHADOW OF THE DROPLET BELOW THE DROPLET OF DOTS IN A CIRCULAR PATTERN.
FOR DIETARY SUPPLEMENTS (U.S. CLS. 6, 18, 44, 46, 51 AND 52).
FIRST USE 4-19-2007; IN COMMERCE 4-19-2007.

THE MARK CONSISTS OF STANDARD CHARACTERS WITHOUT CLAIM TO ANY PARTICULAR FONT, STYLE, SIZE, OR COLOR.
FOR DIETARY SUPPLEMENTS (U.S. CLS. 6, 18, 44, 46, 51 AND 52).
FIRST USE 4-8-2009; IN COMMERCE 4-8-2009.

CLASS 5—(Continued).

3,633,061. MINRAD INC., ORCHARD PARK, NY. SN 77-976,954. PUB. 6-17-2008, FILED 7-18-2007.



FOR INHALATION ANESTHETICS FOR SURGICAL USE AND NON-SURGICAL USE; PHARMACEUTICALS, NAMELY, INHALATION PHARMACEUTICALS FOR CONSCIOUS SEDATION IN SURGICAL USE AND NON-SURGICAL USE (U.S. CLS. 6, 18, 44, 46, 51 AND 52).
FIRST USE 10-0-2006; IN COMMERCE 10-0-2006.

3,633,064. OMS INVESTMENTS, INC., LOS ANGELES, CA. SN 77-976,969. PUB. 3-25-2008, FILED 6-25-2007.

OUTDOOR DEFENSE

THE MARK CONSISTS OF STANDARD CHARACTERS WITHOUT CLAIM TO ANY PARTICULAR FONT, STYLE, SIZE, OR COLOR.
NO CLAIM IS MADE TO THE EXCLUSIVE RIGHT TO USE "OUTDOOR", APART FROM THE MARK AS SHOWN. FOR PESTICIDES AND INSECTICIDES FOR DOMESTIC USE (U.S. CLS. 6, 18, 44, 46, 51 AND 52).
FIRST USE 3-31-2008; IN COMMERCE 3-31-2008.

3,633,146. CERAGENIX CORPORATION, DENVER, CO. SN 78-620,018. PUB. 1-24-2006, FILED 4-29-2005.

NEOCERAM

THE MARK CONSISTS OF STANDARD CHARACTERS WITHOUT CLAIM TO ANY PARTICULAR FONT, STYLE, SIZE, OR COLOR.
FOR PHARMACEUTICAL PRODUCTS AND PREPARATIONS FOR USE IN DERMATOLOGY (U.S. CLS. 6, 18, 44, 46, 51 AND 52).
FIRST USE 4-6-2009; IN COMMERCE 4-6-2009.

CLASS 5—(Continued).

3,633,165. MAITAKE PRODUCTS, INC., EAST RUTHERFORD, NJ. SN 78-671,090. PUB. 4-11-2006, FILED 7-15-2005.



THE COLOR(S) YELLOW-GOLD AND BLACK IS/ARE CLAIMED AS A FEATURE OF THE MARK.
THE MARK CONSISTS OF YELLOW-GOLD LETTERS AND SYMBOLS WITH BLACK OUTLINES.
FOR DIETARY, NUTRITIONAL AND FOOD SUPPLEMENTS MADE FROM MUSHROOMS AND/OR HERBS IN THE FORM OF TABLETS, CAPSULES, TINCTURE, EXTRACT, POWDER AND TEA (U.S. CLS. 6, 18, 44, 46, 51 AND 52).
FIRST USE 2-6-2009; IN COMMERCE 2-24-2009.

3,633,176. NUTRAMAX LABORATORIES, INC., EDGEWOOD, MD. SN 78-694,350. PUB. 1-17-2006, FILED 8-17-2005.

THINK INSIDE THE BOTTLE

THE MARK CONSISTS OF STANDARD CHARACTERS WITHOUT CLAIM TO ANY PARTICULAR FONT, STYLE, SIZE, OR COLOR.
FOR DIETARY SUPPLEMENTS; NUTRITIONAL SUPPLEMENTS (U.S. CLS. 6, 18, 44, 46, 51 AND 52).
FIRST USE 2-16-2009; IN COMMERCE 2-16-2009.

3,633,177. NUTRAMAX LABORATORIES, INC., EDGEWOOD, MD. SN 78-694,359. PUB. 1-17-2006, FILED 8-17-2005.

THINK INSIDE THE BOX

THE MARK CONSISTS OF STANDARD CHARACTERS WITHOUT CLAIM TO ANY PARTICULAR FONT, STYLE, SIZE, OR COLOR.
FOR DIETARY SUPPLEMENTS; NUTRITIONAL SUPPLEMENTS (U.S. CLS. 6, 18, 44, 46, 51 AND 52).
FIRST USE 2-16-2009; IN COMMERCE 2-16-2009.

CLASS 5—(Continued).

3,633,219. KOEHN, RICHARD K., SALT LAKE CITY, UT. SN 78-771,206. PUB. 10-2-2007, FILED 12-12-2005.

SENTRX ANIMAL CARE

THE MARK CONSISTS OF STANDARD CHARACTERS WITHOUT CLAIM TO ANY PARTICULAR FONT, STYLE, SIZE, OR COLOR.

NO CLAIM IS MADE TO THE EXCLUSIVE RIGHT TO USE "ANIMAL CARE", APART FROM THE MARK AS SHOWN.

FOR PHARMACEUTICAL PREPARATIONS MADE OF BIOMATERIALS, NAMELY, CHEMICAL COMPOUNDS, BIOPOLYMERS AND HYDROGELS FORMULATED TO BE DELIVERED AS SOLIDS, FILMS, SPONGES, GELS AND LIQUIDS FOR THE TREATMENT OF WOUNDS, SCAR PREVENTION, INFLAMMATION, PAIN AND INFECTIONS (U.S. CLS. 6, 18, 44, 46, 51 AND 52).

FIRST USE 11-1-2007; IN COMMERCE 11-1-2007.

3,633,239. INNOVATIVE BEVERAGES, L. L. C., BATON ROUGE, LA. SN 78-827,230. PUB. 1-13-2009, FILED 3-2-2006.

REV IT UP

THE MARK CONSISTS OF STANDARD CHARACTERS WITHOUT CLAIM TO ANY PARTICULAR FONT, STYLE, SIZE, OR COLOR.

FOR POWDERED NUTRITIONAL SUPPLEMENT DRINK MIX (U.S. CLS. 6, 18, 44, 46, 51 AND 52).

FIRST USE 7-7-2006; IN COMMERCE 7-7-2006.

3,633,240. ELI LILLY AND COMPANY, INDIANAPOLIS, IN. SN 78-827,249. PUB. 7-31-2007, FILED 3-2-2006.

FIRSTTEST

THE MARK CONSISTS OF STANDARD CHARACTERS WITHOUT CLAIM TO ANY PARTICULAR FONT, STYLE, SIZE, OR COLOR.

FOR DIAGNOSTIC TEST KIT TO IDENTIFY PATHOGENS OR RESIDUES OF BIOLOGICAL INTEREST FOR VETERINARY USE (U.S. CLS. 6, 18, 44, 46, 51 AND 52).

FIRST USE 6-0-2008; IN COMMERCE 6-0-2008.

CLASS 5—(Continued).

3,633,255. 1660929 ONTARIO LIMITED, TORONTO, CANADA. SN 78-845,788. PUB. 6-19-2007, FILED 3-24-2006.

SLEEP MD

THE MARK CONSISTS OF STANDARD CHARACTERS WITHOUT CLAIM TO ANY PARTICULAR FONT, STYLE, SIZE, OR COLOR.

NO CLAIM IS MADE TO THE EXCLUSIVE RIGHT TO USE "SLEEP", APART FROM THE MARK AS SHOWN.

FOR NUTRITIONAL SUPPLEMENTS (U.S. CLS. 6, 18, 44, 46, 51 AND 52).

FIRST USE 9-0-2006; IN COMMERCE 9-0-2006.

3,633,261. MARINE POLYMER TECHNOLOGIES, INC., DANVERS, MA. SN 78-868,086. PUB. 1-8-2008, FILED 4-24-2006.

SYVEK EXCEL VASCULAR ACCESS HEMOSTASIS SYSTEM

THE MARK CONSISTS OF STANDARD CHARACTERS WITHOUT CLAIM TO ANY PARTICULAR FONT, STYLE, SIZE, OR COLOR.

OWNER OF U.S. REG. NOS. 2,228,475 AND 2,229,164. NO CLAIM IS MADE TO THE EXCLUSIVE RIGHT TO USE "VASCULAR ACCESS HEMOSTASIS SYSTEM", APART FROM THE MARK AS SHOWN.

FOR PHARMACEUTICAL AGENT USED TO STOP BLEEDING, PROMOTE WOUND CLOSURE AND AID IN WOUND HEALING; WOUND DRESSINGS IMPREGNATED WITH A PHARMACEUTICAL PREPARATION USED TO STOP BLEEDING, PROMOTE WOUND CLOSURE AND AID IN WOUND HEALING (U.S. CLS. 6, 18, 44, 46, 51 AND 52).

FIRST USE 8-0-2006; IN COMMERCE 8-0-2006.

CLASS 5—(Continued).

3,633,266. NOVARTIS AG, BASEL, SWITZERLAND. SN 78-877,622. PUB. 1-2-2007, FILED 5-5-2006.

PRESCRIPTION PROTECTED

THE MARK CONSISTS OF STANDARD CHARACTERS WITHOUT CLAIM TO ANY PARTICULAR FONT, STYLE, SIZE, OR COLOR.

NO CLAIM IS MADE TO THE EXCLUSIVE RIGHT TO USE "PRESCRIPTION", APART FROM THE MARK AS SHOWN.

FOR ANTI-PARASITIC VETERINARY PREPARATIONS FOR CATS AND DOGS (U.S. CLS. 6, 18, 44, 46, 51 AND 52).

FIRST USE 7-0-2006; IN COMMERCE 7-0-2006.

3,633,276. 1660929 ONTARIO LIMITED, OAKVILLE, ONTARIO, CANADA. SN 78-899,335. PUB. 11-27-2007, FILED 6-2-2006.

QUICKSLEEP

THE MARK CONSISTS OF STANDARD CHARACTERS WITHOUT CLAIM TO ANY PARTICULAR FONT, STYLE, SIZE, OR COLOR.

FOR INGREDIENT BLEND CONTAINING MELATONIN SOLD AS AN INTEGRAL COMPONENT IN NUTRITIONAL SUPPLEMENTS (U.S. CLS. 6, 18, 44, 46, 51 AND 52).

FIRST USE 9-0-2006; IN COMMERCE 9-0-2006.

3,633,281. 1660929 ONTARIO LIMITED, OAKVILLE, ONTARIO, CANADA. SN 78-910,366. PUB. 11-27-2007, FILED 6-16-2006.

CHOLESTEROL MD

THE MARK CONSISTS OF STANDARD CHARACTERS WITHOUT CLAIM TO ANY PARTICULAR FONT, STYLE, SIZE, OR COLOR.

NO CLAIM IS MADE TO THE EXCLUSIVE RIGHT TO USE "CHOLESTEROL", APART FROM THE MARK AS SHOWN.

FOR DIETARY SUPPLEMENTS; NUTRITIONAL INGREDIENTS SOLD AS AN INTEGRAL COMPONENT OF DIETARY SUPPLEMENTS (U.S. CLS. 6, 18, 44, 46, 51 AND 52).

FIRST USE 2-0-2007; IN COMMERCE 2-0-2007.

CLASS 5—(Continued).

3,633,287. MCKESSON CORPORATION, SAN FRANCISCO, CA. SN 78-915,622. PUB. 2-13-2007, FILED 6-23-2006.

MOORECAST

THE MARK CONSISTS OF STANDARD CHARACTERS WITHOUT CLAIM TO ANY PARTICULAR FONT, STYLE, SIZE, OR COLOR.

FOR CASTING TAPE FOR MEDICAL AND SURGICAL USE (U.S. CLS. 6, 18, 44, 46, 51 AND 52).

FIRST USE 9-30-2006; IN COMMERCE 9-30-2006.

CLASS 6—METAL GOODS

3,631,803. NORTH CAROLINA A&T STATE UNIVERSITY, GREENSBORO, NC. SN 76-643,682. PUB. 9-18-2007, FILED 7-27-2005.

NC A&T AGGIES

THE MARK CONSISTS OF STANDARD CHARACTERS WITHOUT CLAIM TO ANY PARTICULAR FONT, STYLE, SIZE, OR COLOR.

FOR METAL KEY RINGS; LICENSE PLATES MADE OF METAL (U.S. CLS. 2, 12, 13, 14, 23, 25 AND 50).

FIRST USE 9-1-2006; IN COMMERCE 9-1-2006.

3,631,957. VERIDIAM, INC., EL CAJON, CA. SN 77-101,492. PUB. 3-4-2008, FILED 2-7-2007.

XCALIBER

THE MARK CONSISTS OF STANDARD CHARACTERS WITHOUT CLAIM TO ANY PARTICULAR FONT, STYLE, SIZE, OR COLOR.

FOR PRECISION METAL TUBING FOR THE MEDICAL, DENTAL, NUCLEAR POWER, AEROSPACE, AND POWER GENERATION INDUSTRIES (U.S. CLS. 2, 12, 13, 14, 23, 25 AND 50).

FIRST USE 1-5-2007; IN COMMERCE 1-26-2007.

CLASS 6—(Continued).

3,631,987. ZELCO INDUSTRIES, INC., NEW YORK, NY. SN 77-136,936. PUB. 4-1-2008, FILED 3-21-2007.

PurseGuard ULTRA

THE MARK CONSISTS OF STANDARD CHARACTERS WITHOUT CLAIM TO ANY PARTICULAR FONT, STYLE, SIZE, OR COLOR.
 FOR METAL HOOK FOR HANGING A PURSE FEATURING A BUILT-IN BATTERY OPERATED ALARM AND FLASHLIGHT TO PREVENT LOSS OR THEFT (U.S. CLS. 2, 12, 13, 14, 23, 25 AND 50).
 FIRST USE 2-5-2009; IN COMMERCE 2-5-2009.

3,632,063. TRUTH HARDWARE CORPORATION, OWATONA, MN. SN 77-201,446. PUB. 4-22-2008, FILED 6-8-2007.

SIGNATURE

THE MARK CONSISTS OF STANDARD CHARACTERS WITHOUT CLAIM TO ANY PARTICULAR FONT, STYLE, SIZE, OR COLOR.
 FOR DOOR AND WINDOW HARDWARE, MADE PRIMARILY OF METAL, NAMELY, BRACKETS, TRACKS, LATCHES, KNOBS, HANDLES, HINGES, OPERATORS, LEVERSETS (U.S. CLS. 2, 12, 13, 14, 23, 25 AND 50).
 FIRST USE 4-30-2007; IN COMMERCE 4-30-2007.

3,632,133. NATIONAL ASBESTOS FLOORING ENCASUREMENT SYSTEMS, INC., PLACERVILLE, CA. SN 77-240,173. PUB. 7-15-2008, FILED 7-27-2007.



NO CLAIM IS MADE TO THE EXCLUSIVE RIGHT TO USE "ASBESTOS BARRIER SYSTEM", APART FROM THE MARK AS SHOWN.
 THE MARK CONSISTS OF TWO LATERALLY DISPOSED BLOCK PYRAMID-LIKE ICONS WITH THE LITERAL WORD MARK CENTERED BETWEEN EACH LATERALLY DISPOSED ICON.
 FOR ASBESTOS CONTAINMENT SAFETY SYSTEM COMPRISING AN ALUMINUM FOIL SCRIM FOR ASBESTOS ENCASUREMENT AND CONTAINMENT (U.S. CLS. 2, 12, 13, 14, 23, 25 AND 50).
 FIRST USE 1-15-2009; IN COMMERCE 1-15-2009.

CLASS 6—(Continued).

3,632,178. HOMECARE PRODUCTS, INC., ALGONA, WA. SN 77-260,946. PUB. 7-15-2008, FILED 8-21-2007.

SIGNATURE SERIES

THE MARK CONSISTS OF STANDARD CHARACTERS WITHOUT CLAIM TO ANY PARTICULAR FONT, STYLE, SIZE, OR COLOR.
 NO CLAIM IS MADE TO THE EXCLUSIVE RIGHT TO USE "SERIES", APART FROM THE MARK AS SHOWN.
 FOR RAMPS MADE OF METAL (U.S. CLS. 2, 12, 13, 14, 23, 25 AND 50).
 FIRST USE 10-4-2007; IN COMMERCE 10-4-2007.

3,632,196. SOUTHERN WIRE PTY LTD., BASSENDEAN, AUSTRALIA. SN 77-265,674. PUB. 7-15-2008, FILED 8-28-2007.

FAST LOCK

THE MARK CONSISTS OF STANDARD CHARACTERS WITHOUT CLAIM TO ANY PARTICULAR FONT, STYLE, SIZE, OR COLOR.
 FOR WIRE GOODS OF METAL, NAMELY, FENCING, PLAIN AND BARBED WIRE, PREFABRICATED WIRE FENCING, WIRE FENCING PANELS, WIRE MESH, MINING MESH; GATES OF METAL; METAL REINFORCING MESH; METAL FITTINGS FOR USE IN FENCING; METAL BAR FOR METAL FENCING; METAL FENCING PANELS; METAL STRAINERS FOR FENCING AND DRIVERS FOR FENCING; METAL FENCE POST DRIVERS; STEEL POSTS AND PICKETS (U.S. CLS. 2, 12, 13, 14, 23, 25 AND 50).
 FIRST USE 9-4-2006; IN COMMERCE 8-8-2007.

3,632,442. LONG VIEW ENTERPRISES, LLC, BRANDON, WI. SN 77-375,615. PUB. 7-1-2008, FILED 1-18-2008.

RIDGE RUNNER

THE MARK CONSISTS OF STANDARD CHARACTERS WITHOUT CLAIM TO ANY PARTICULAR FONT, STYLE, SIZE, OR COLOR.
 NO CLAIM IS MADE TO THE EXCLUSIVE RIGHT TO USE "RIDGE", APART FROM THE MARK AS SHOWN.
 FOR METAL PORTABLE TEMPORARY SUPPORT FOR WORKERS DURING TRUSS SETTING; METAL TRUSS SPACERS (U.S. CLS. 2, 12, 13, 14, 23, 25 AND 50).
 FIRST USE 11-28-2008; IN COMMERCE 11-28-2008.

CLASS 6—(Continued).

3,632,463. NPC, INC., MILFORD, NH. SN 77-384,959. PUB. 6-17-2008, FILED 1-31-2008.

WAVEBAND

THE MARK CONSISTS OF STANDARD CHARACTERS WITHOUT CLAIM TO ANY PARTICULAR FONT, STYLE, SIZE, OR COLOR.

FOR CLAMPING BANDS MADE OF METAL (U.S. CLS. 2, 12, 13, 14, 23, 25 AND 50).
FIRST USE 2-0-2008; IN COMMERCE 2-0-2008.

3,632,465. SCHOUTEN, ERIK, LITITZ, PA. SN 77-385,221. PUB. 7-8-2008, FILED 1-31-2008.

ROCKSTEADY

THE MARK CONSISTS OF STANDARD CHARACTERS WITHOUT CLAIM TO ANY PARTICULAR FONT, STYLE, SIZE, OR COLOR.

FOR METAL CLIPS, METAL HOLDERS, AND METAL FASTENERS, NAMELY, A BRACKET WITH A COMPLIANT TAB USED TO SECURE AN ELONGATED FLEXIBLE LINK ELEMENT, USED FOR HOLDING AND SECURING STACKED DRY WALL OR WALL PANELS FOR SAFETY PURPOSES (U.S. CLS. 2, 12, 13, 14, 23, 25 AND 50).

FIRST USE 11-0-2008; IN COMMERCE 11-0-2008.

3,632,581. CK TECHNOLOGIES, LLC, MONTEPELIER, OH. SN 77-409,940. PUB. 7-22-2008, FILED 2-29-2008.



THE MARK CONSISTS OF THE LETTER "K" INSIDE THE LETTER "C" WITH "ROCK-GUARD" EXTENDING THROUGH THE MOUTH OF THE LETTER "C".

FOR WIRE MESH (U.S. CLS. 2, 12, 13, 14, 23, 25 AND 50).
FIRST USE 4-2-2008; IN COMMERCE 4-2-2008.

CLASS 7—MACHINERY**CLASS 7—(Continued).**

3,631,837. EA BROEKEMA BV TRANSPORTBANDENFABRIEK, NL-9640 AB VEENDAM, NETHERLANDS. SN 76-684,075. PUB. 7-1-2008, FILED 11-15-2007.

ULTRA

THE MARK CONSISTS OF STANDARD CHARACTERS WITHOUT CLAIM TO ANY PARTICULAR FONT, STYLE, SIZE, OR COLOR.

FOR ROD BELTS FOR ROD BELT CONVEYORS, NAMELY, ROD BELTS FOR ROD BELT CONVEYORS OF AGRICULTURAL MACHINERY (U.S. CLS. 13, 19, 21, 23, 31, 34 AND 35).
FIRST USE 3-11-2009; IN COMMERCE 3-11-2009.

3,631,859. STRATASYS, INC., EDEN PRAIRIE, MN. SN 76-690,426. PUB. 11-4-2008, FILED 6-9-2008.

UPRINT

THE MARK CONSISTS OF STANDARD CHARACTERS WITHOUT CLAIM TO ANY PARTICULAR FONT, STYLE, SIZE, OR COLOR.

FOR RAPID PROTOTYPING MACHINES FOR MAKING THREE-DIMENSIONAL MODELS BY A MATERIAL DEPOSITION PROCESS (U.S. CLS. 13, 19, 21, 23, 31, 34 AND 35).

FIRST USE 12-23-2008; IN COMMERCE 12-23-2008.

3,631,936. ELECTROLUX HOME CARE PRODUCTS, INC., CLEVELAND, OH. SN 77-084,355. PUB. 6-26-2007, FILED 1-17-2007.

ON-GUARD

THE MARK CONSISTS OF STANDARD CHARACTERS WITHOUT CLAIM TO ANY PARTICULAR FONT, STYLE, SIZE, OR COLOR.

FOR DIRT RECEPTACLE SOLD AS AN INTEGRAL COMPONENT OF DOMESTIC AND COMMERCIAL CENTRAL VACUUM CLEANERS (U.S. CLS. 13, 19, 21, 23, 31, 34 AND 35).

FIRST USE 1-31-2007; IN COMMERCE 1-31-2007.

CLASS 7—(Continued).

3,631,943. LG ELECTRONICS INC., SEOUL, REPUBLIC OF KOREA. SN 77-091,912. PUB. 1-15-2008, FILED 1-26-2007.

KOMPRESSOR

FOR ELECTRIC WASHING MACHINES FOR HOUSEHOLD PURPOSES; ELECTRIC VACUUM CLEANERS; AUTOMATIC DISHWASHERS FOR HOUSEHOLD PURPOSES; ELECTRIC MIXERS FOR HOUSEHOLD PURPOSES; DC GENERATORS (U.S. CLS. 13, 19, 21, 23, 31, 34 AND 35).

FIRST USE 1-26-2007; IN COMMERCE 1-26-2007.

CLASS 7—(Continued).

3,631,967. GE HEALTHCARE BIO-SCIENCES AB, UPPSALA, SWEDEN. SN 77-113,088. PUB. 4-1-2008, FILED 2-22-2007.

MEDIA WAND

THE MARK CONSISTS OF STANDARD CHARACTERS WITHOUT CLAIM TO ANY PARTICULAR FONT, STYLE, SIZE, OR COLOR.

FOR SCIENTIFIC APPARATUS AND INSTRUMENTS, NAMELY, MACHINE TOOL FOR USE IN HANDLING LARGE SCALE BIOPROCESS CHEMICALS BY SPECIFICALLY, REMOVAL OF SUPERNATANT, ADDITION OF WATER OR BUFFER, CREATION OF HOMOGENOUS MEDIA SLURRIES IN SHIPPING CONTAINERS, AND TRANSFER OF MEDIA TO SLURRY TANKS; APPARATUS AND INSTRUMENTS FOR BIOPROCESS MEDIA HANDLING TASKS, NAMELY, MACHINE TOOL COMPRISED OF AN AIR OPERATED DIAPHRAGM PUMP STATION, OPERATOR CONTROL PANEL, PTFE TUBING, AND MECHANICAL MIXING IMPLEMENT (U.S. CLS. 13, 19, 21, 23, 31, 34 AND 35).

FIRST USE 9-0-2007; IN COMMERCE 9-0-2007.

3,631,947. INTEVAC, INC., SANTA CLARA, CA. SN 77-094,023. PUB. 8-28-2007, FILED 1-29-2007.

ACCULUBER

THE MARK CONSISTS OF STANDARD CHARACTERS WITHOUT CLAIM TO ANY PARTICULAR FONT, STYLE, SIZE, OR COLOR.

FOR MACHINES AND MACHINE TOOLS FOR THE DEPOSITION OF THIN LIQUID LAYERS ACROSS SURFACES, NAMELY, LUBRICANT DEPOSITION EQUIPMENT FOR DEPOSITING LUBRICANTS ACROSS THE SURFACE OF DISKS IN THE MANUFACTURE OF MAGNETIC DISKS FOR DISK DRIVES (U.S. CLS. 13, 19, 21, 23, 31, 34 AND 35).

FIRST USE 2-4-2008; IN COMMERCE 2-4-2008.

3,632,024. GENERAL ELECTRIC COMPANY, SCHENECTADY, NY. SN 77-166,372. PUB. 9-18-2007, FILED 4-26-2007.

RAINSHOWER

THE MARK CONSISTS OF STANDARD CHARACTERS WITHOUT CLAIM TO ANY PARTICULAR FONT, STYLE, SIZE, OR COLOR.

FOR CLOTHES WASHING MACHINE FEATURING A SPRAY RINSE SYSTEM (U.S. CLS. 13, 19, 21, 23, 31, 34 AND 35).

FIRST USE 5-0-2008; IN COMMERCE 5-0-2008.

CLASS 7—(Continued).

3,632,099. TREMONT ELECTRIC LLC, CLEVELAND, OH. SN 77-227,194. PUB. 12-25-2007, FILED 7-11-2007.



THE MARK CONSISTS OF FROG DESIGN. FOR PERSONAL MOBILE ELECTRICAL ENERGY GENERATOR (U.S. CLS. 13, 19, 21, 23, 31, 34 AND 35). FIRST USE 1-8-2009; IN COMMERCE 1-8-2009.

3,632,100. TREMONT ELECTRIC LLC, CLEVELAND, OH. SN 77-227,234. PUB. 12-25-2007, FILED 7-11-2007.

NPOWER

THE MARK CONSISTS OF STANDARD CHARACTERS WITHOUT CLAIM TO ANY PARTICULAR FONT, STYLE, SIZE, OR COLOR.

FOR PERSONAL MOBILE ELECTRICAL ENERGY GENERATOR (U.S. CLS. 13, 19, 21, 23, 31, 34 AND 35). FIRST USE 1-8-2009; IN COMMERCE 1-8-2009.

3,632,101. TREMONT ELECTRIC LLC, CLEVELAND, OH. SN 77-227,257. PUB. 12-25-2007, FILED 7-11-2007.

THE POWER IS IN YOU

THE MARK CONSISTS OF STANDARD CHARACTERS WITHOUT CLAIM TO ANY PARTICULAR FONT, STYLE, SIZE, OR COLOR.

FOR PERSONAL MOBILE ELECTRICAL ENERGY GENERATOR (U.S. CLS. 13, 19, 21, 23, 31, 34 AND 35). FIRST USE 1-8-2009; IN COMMERCE 1-8-2009.

CLASS 7—(Continued).

3,632,148. LAM RESEARCH CORPORATION, FREMONT, CA. SN 77-248,207. PUB. 1-22-2008, FILED 8-6-2007.

SYNDION

THE MARK CONSISTS OF STANDARD CHARACTERS WITHOUT CLAIM TO ANY PARTICULAR FONT, STYLE, SIZE, OR COLOR.

FOR SEMICONDUCTOR MANUFACTURING MACHINES; SEMICONDUCTOR SUBSTRATES MANUFACTURING MACHINES; SEMICONDUCTOR WAFER PROCESSING EQUIPMENT; SEMICONDUCTOR WAFER PROCESSING MACHINES (U.S. CLS. 13, 19, 21, 23, 31, 34 AND 35).

FIRST USE 8-20-2007; IN COMMERCE 8-20-2007.

3,632,256. JALBERT, STEVE, SPOKANE, WA. SN 77-291,243. PUB. 4-1-2008, FILED 9-28-2007.

GRATE ESCAPE

THE MARK CONSISTS OF STANDARD CHARACTERS WITHOUT CLAIM TO ANY PARTICULAR FONT, STYLE, SIZE, OR COLOR.

NO CLAIM IS MADE TO THE EXCLUSIVE RIGHT TO USE "GRATE", APART FROM THE MARK AS SHOWN.

FOR LIFTING DEVICE, NAMELY, A POWER OPERATED LIFT USED TO LIFT AND REMOVE GRATES FROM EGRESS WINDOW WELLS (U.S. CLS. 13, 19, 21, 23, 31, 34 AND 35).

FIRST USE 6-1-2007; IN COMMERCE 6-1-2007.

3,632,257. J.H. FENNER & CO. LIMITED, EAST YORKSHIRE, UNITED KINGDOM. SN 77-292,943. PUB. 9-23-2008, FILED 10-1-2007.

ZR1

THE MARK CONSISTS OF STANDARD CHARACTERS WITHOUT CLAIM TO ANY PARTICULAR FONT, STYLE, SIZE, OR COLOR.

FOR CHEMICAL COMPOUND SOLD AS AN INTEGRAL COMPONENT OF CONVEYOR BELTS FOR THE PURPOSE OF INCREASED ABRASION RESISTANCE (U.S. CLS. 13, 19, 21, 23, 31, 34 AND 35).

FIRST USE 8-25-2008; IN COMMERCE 8-25-2008.

CLASS 7—(Continued).

3,632,372. CTB IP, INC., WILMINGTON, DE. SN 77-346,598.
PUB. 5-6-2008, FILED 12-7-2007.

CLASS 7—(Continued).

3,632,486. VSM GROUP AB, HUSKVARNA, SWEDEN. SN 77-
391,404. PUB. 6-24-2008, FILED 2-7-2008.

GENESIS

THE MARK CONSISTS OF STANDARD CHARACTERS
WITHOUT CLAIM TO ANY PARTICULAR FONT, STYLE,
SIZE, OR COLOR.

FOR MECHANIZED POULTRY FEEDERS (U.S. CLS.
13, 19, 21, 23, 31, 34 AND 35).
FIRST USE 3-25-2009; IN COMMERCE 3-25-2009.



3,632,378. THE COAST DISTRIBUTION SYSTEM, INC.,
MORGAN HILL, CA. SN 77-350,573. PUB. 7-22-2008, FILED
12-12-2007.

POWERHOUSE

THE MARK CONSISTS OF STANDARD CHARACTERS
WITHOUT CLAIM TO ANY PARTICULAR FONT, STYLE,
SIZE, OR COLOR.

OWNER OF U.S. REG. NO. 3,327,098.
FOR MULTI-PURPOSE HIGH PRESSURE WASHERS
(U.S. CLS. 13, 19, 21, 23, 31, 34 AND 35).
FIRST USE 2-0-2009; IN COMMERCE 2-0-2009.

THE MARK CONSISTS OF TWO STYLIZED "D" LETTERS
WITH A DIAMOND DESIGN AND SWIRLS.
FOR SEWING MACHINES (U.S. CLS. 13, 19, 21, 23, 31,
34 AND 35).
FIRST USE 6-15-2008; IN COMMERCE 6-15-2008.

3,632,539. SMITH INTERNATIONAL, INC., HOUSTON, TX.
SN 77-403,017. PUB. 7-15-2008, FILED 2-21-2008.

3,632,480. HARRIS WASTE MANAGEMENT GROUP, INC.,
PEACHTREE CITY, GA. SN 77-389,788. PUB. 6-24-2008,
FILED 2-6-2008.

COPPERHEAD

GRIZZLY

THE MARK CONSISTS OF STANDARD CHARACTERS
WITHOUT CLAIM TO ANY PARTICULAR FONT, STYLE,
SIZE, OR COLOR.

FOR COMPRESSION MACHINES FOR USE IN SCRAP
METAL PROCESSING AND RECYCLING OF GOODS
(U.S. CLS. 13, 19, 21, 23, 31, 34 AND 35).
FIRST USE 9-1-2008; IN COMMERCE 9-1-2008.

THE MARK CONSISTS OF STANDARD CHARACTERS
WITHOUT CLAIM TO ANY PARTICULAR FONT, STYLE,
SIZE, OR COLOR.

FOR DOWNHOLE OIL FIELD EQUIPMENT,
NAMESLY, BRIDGE PLUGS AND PACKERS (U.S. CLS.
13, 19, 21, 23, 31, 34 AND 35).
FIRST USE 10-1-2007; IN COMMERCE 10-1-2007.

CLASS 7—(Continued).

3,632,622. GREAPO POWER TOOLS (SUZHOU) CO., LTD., SUZHOU, CHINA. SN 77-415,278. PUB. 7-22-2008, FILED 3-6-2008.

WORX AIR

THE MARK CONSISTS OF STANDARD CHARACTERS WITHOUT CLAIM TO ANY PARTICULAR FONT, STYLE, SIZE, OR COLOR.

OWNER OF U.S. REG. NOS. 2,932,683, 3,102,904, AND 3,200,297.

NO CLAIM IS MADE TO THE EXCLUSIVE RIGHT TO USE "AIR", APART FROM THE MARK AS SHOWN.

FOR POWER OPERATED BLOWERS (U.S. CLS. 13, 19, 21, 23, 31, 34 AND 35).

FIRST USE 6-6-2008; IN COMMERCE 6-6-2008.

3,632,624. GREAPO POWER TOOLS (SUZHOU) CO., LTD., SUZHOU, CHINA. SN 77-415,406. PUB. 7-22-2008, FILED 3-6-2008.

WORX ECO

THE MARK CONSISTS OF STANDARD CHARACTERS WITHOUT CLAIM TO ANY PARTICULAR FONT, STYLE, SIZE, OR COLOR.

OWNER OF U.S. REG. NOS. 2,932,683, 3,102,904, AND 3,200,297.

FOR LAWN MOWERS (U.S. CLS. 13, 19, 21, 23, 31, 34 AND 35).

FIRST USE 6-30-2008; IN COMMERCE 6-30-2008.

3,632,703. THE ARMOR ALL/STP PRODUCTS COMPANY, OAKLAND, CA. SN 77-433,252. PUB. 7-22-2008, FILED 3-27-2008.

ARMOR ALL

THE MARK CONSISTS OF STANDARD CHARACTERS WITHOUT CLAIM TO ANY PARTICULAR FONT, STYLE, SIZE, OR COLOR.

OWNER OF U.S. REG. NOS. 1,032,674, 3,043,112, AND OTHERS.

FOR VACUUM CLEANERS (U.S. CLS. 13, 19, 21, 23, 31, 34 AND 35).

FIRST USE 10-15-2008; IN COMMERCE 10-15-2008.

CLASS 7—(Continued).

3,632,704. ILLINOIS TOOL WORKS INC., GLENVIEW, IL. SN 77-433,434. PUB. 8-5-2008, FILED 3-27-2008.



OWNER OF U.S. REG. NO. 1,633,722.

THE MARK CONSISTS OF "TRANS TECH" AND CIRCLES IN GRID DESIGN.

FOR PRINTING MACHINES AND PARTS THEREOF, NAMELY, CONTROL MECHANISM, DRIVE MECHANISM, PRINTING PADS, PRINTING BLOCKS, PRINTING HEADS, FEED HOPPERS, SORTERS, ELECTRODES, PLATES, DOCTORS, BLADES, SPATULAS, MOLDERS, JIGS, INK PUMPS, INK POTS, STANDS, TABLES, SWITCHES, MOTORS, IONIZERS, DRIERS AND WASHERS (U.S. CLS. 13, 19, 21, 23, 31, 34 AND 35).

FIRST USE 5-15-2008; IN COMMERCE 5-15-2008.

3,632,815. SAGINAW MACHINES SYSTEMS, INC, SAGINAW, MI. SN 77-467,181. PUB. 10-7-2008, FILED 5-6-2008.

COMMANDER

THE MARK CONSISTS OF STANDARD CHARACTERS WITHOUT CLAIM TO ANY PARTICULAR FONT, STYLE, SIZE, OR COLOR.

FOR METAL WORKING MACHINES, NAMELY, MACHINING CENTERS (U.S. CLS. 13, 19, 21, 23, 31, 34 AND 35).

FIRST USE 8-31-2008; IN COMMERCE 8-31-2008.

3,632,924. TENNECO AUTOMOTIVE OPERATING COMPANY INC., LAKE FOREST, IL. SN 77-512,590. PUB. 11-25-2008, FILED 7-1-2008.

CALCAT

THE MARK CONSISTS OF STANDARD CHARACTERS WITHOUT CLAIM TO ANY PARTICULAR FONT, STYLE, SIZE, OR COLOR.

FOR CATALYTIC CONVERTERS FOR USE IN CONNECTION WITH LAND VEHICLE EXHAUST SYSTEMS (U.S. CLS. 13, 19, 21, 23, 31, 34 AND 35).

FIRST USE 1-1-2009; IN COMMERCE 1-1-2009.

CLASS 7—(Continued).

3,632,938. DAYS CORPORATION, ELKHART, IN. SN 77-517,984. PUB. 12-9-2008, FILED 7-9-2008.

Pool Boy

THE MARK CONSISTS OF STANDARD CHARACTERS WITHOUT CLAIM TO ANY PARTICULAR FONT, STYLE, SIZE, OR COLOR.

FOR AUTOMATIC POOL COVER REEL (U.S. CLS. 13, 19, 21, 23, 31, 34 AND 35).

FIRST USE 11-18-2008; IN COMMERCE 11-18-2008.

CLASS 8—(Continued).

3,632,364. COLD STEEL, INC., VENTURA, CA. SN 77-342,286. PUB. 12-16-2008, FILED 12-3-2007.

ESPADA

THE MARK CONSISTS OF STANDARD CHARACTERS WITHOUT CLAIM TO ANY PARTICULAR FONT, STYLE, SIZE, OR COLOR.

THE FOREIGN WORDING IN THE MARK TRANSLATES INTO ENGLISH AS "SWORD".

FOR FOLDING KNIVES (U.S. CLS. 23, 28 AND 44).
FIRST USE 2-2-2008; IN COMMERCE 2-2-2008.

CLASS 8—HAND TOOLS

3,632,081. M. S. INTERESTS, LTD., SCHULENBURG, TX. SN 77-216,716. PUB. 6-17-2008, FILED 6-27-2007.

ATTICUS

THE MARK CONSISTS OF STANDARD CHARACTERS WITHOUT CLAIM TO ANY PARTICULAR FONT, STYLE, SIZE, OR COLOR.

FOR CAKE KNIFE, FLATWARE, FORKS, KNIVES, SPOONS, STEAK KNIVES, OLIVE FORKS, OLIVE KNIVES (U.S. CLS. 23, 28 AND 44).

FIRST USE 6-0-2007; IN COMMERCE 6-0-2007.

3,632,689. BARENTHAL NORTH AMERICA, INC., RUTHERFORD, NJ. SN 77-431,636. PUB. 8-5-2008, FILED 3-26-2008.

GOURMET SELECT

THE MARK CONSISTS OF STANDARD CHARACTERS WITHOUT CLAIM TO ANY PARTICULAR FONT, STYLE, SIZE, OR COLOR.

NO CLAIM IS MADE TO THE EXCLUSIVE RIGHT TO USE "SELECT", APART FROM THE MARK AS SHOWN.

FOR CUTLÉRY AND FLATWARE (U.S. CLS. 23, 28 AND 44).

FIRST USE 5-26-2008; IN COMMERCE 5-26-2008.

3,632,272. SPECIALIZED PRODUCTS COMPANY, SOUTHLAKE, TX. SN 77-301,503. PUB. 7-22-2008, FILED 10-11-2007.

SPCTELCO

THE MARK CONSISTS OF STANDARD CHARACTERS WITHOUT CLAIM TO ANY PARTICULAR FONT, STYLE, SIZE, OR COLOR.

FOR HAND TOOLS, NAMELY, PLIERS, WIRE CRIMPERS, CRIMPERS FOR METAL CONNECTORS, BOLT CUTTERS, WIRE STRIPPERS, WIRE CUTTERS, CABLE CUTTERS, AND WIRE PULLERS (U.S. CLS. 23, 28 AND 44).

FIRST USE 4-4-2008; IN COMMERCE 4-4-2008.

3,632,939. TULLIS, ERIC, MASON, OH. SN 77-518,351. PUB. 12-2-2008, FILED 7-9-2008.

DireWare

THE MARK CONSISTS OF STANDARD CHARACTERS WITHOUT CLAIM TO ANY PARTICULAR FONT, STYLE, SIZE, OR COLOR.

FOR SIDE ARMS, NAMELY, TACTICAL KNIVES (U.S. CLS. 23, 28 AND 44).

FIRST USE 6-18-2008; IN COMMERCE 7-18-2008.

CLASS 8—(Continued).

3,633,046. BUCK KNIVES, INC., POST FALLS, ID. SN 77-604,899. PUB. 1-13-2009, FILED 10-31-2008.

CLASS 9—(Continued).

3,631,810. ABANDON INTERACTIVE ENTERTAINMENT, LLC, PACIFIC PALISADES, CA. SN 76-661,904. PUB. 1-16-2007, FILED 6-21-2006.

FREAKY CREATURES**ErgoHunter**

THE MARK CONSISTS OF STANDARD CHARACTERS WITHOUT CLAIM TO ANY PARTICULAR FONT, STYLE, SIZE, OR COLOR.

FOR HUNTING KNIVES; KNIVES; SIDE ARMS, NOT INCLUDING FIREARMS, NAMELY, HUNTING KNIVES; SPORT KNIVES (U.S. CLS. 23, 28 AND 44).

FIRST USE 11-2-2008; IN COMMERCE 11-2-2008.

THE MARK CONSISTS OF STANDARD CHARACTERS WITHOUT CLAIM TO ANY PARTICULAR FONT, STYLE, SIZE, OR COLOR.

FOR COMPUTER SOFTWARE FOR ELECTRONIC GAMES AND ENTERTAINMENT, NAMELY, COMPUTER GAME SOFTWARE USED AND PLAYED ON MOBILE AND CELLULAR TELEPHONES, HANDHELD COMPUTERS, PERSONAL COMPUTERS AND PERSONAL DIGITAL ASSISTANTS; DOWNLOADABLE ELECTRONIC GAME PROGRAMS; DOWNLOADABLE RING TONES, PRERECORDED MUSIC AND GRAPHICS IN THE FORM OF COMPUTER SCREEN SAVERS; VOICE RINGERS; WALL PAPERS, NAMELY, STILL IMAGES FOR BACKGROUNDS ON PHONE SCREENS; ANIMATED IMAGES FOR USE ON PHONE SCREENS; AND PROGRAMS FOR DOWNLOADING IMAGES FOR MOBILE TELECOMMUNICATION DEVICES, NAMELY, MOBILE AND CELLULAR TELEPHONES, HANDHELD COMPUTERS, PERSONAL COMPUTERS AND PERSONAL DIGITAL ASSISTANTS ALL VIA THE GLOBAL COMPUTER NETWORK AND WIRELESS DEVICES; COMPUTER SOFTWARE FOR USE IN THE DESIGN, DEVELOPMENT AND EXECUTION OF WIRELESS COMPUTER GAMES; AND DIGITAL MAGNETIC DISCS, VHS TAPES, AND SOFTWARE FEATURING TELEVISION PROGRAMS AND MOTION PICTURE FILMS (U.S. CLS. 21, 23, 26, 36 AND 38).

FIRST USE 3-24-2009; IN COMMERCE 3-24-2009.

CLASS 9—ELECTRICAL AND SCIENTIFIC APPARATUS

3,631,802. CULLETT, DANIEL, DBA DADDYSLAND RECORDS, LONG BEACH, CA. SN 76-635,214. PUB. 11-27-2007, FILED 4-4-2005.

3,631,840. GREAT-CIRCLE TECHNOLOGIES, INC., CHANTILLY, VA. SN 76-684,610. PUB. 6-24-2008, FILED 12-3-2007.

AUTOORTHO

THE MARK CONSISTS OF STANDARD CHARACTERS WITHOUT CLAIM TO ANY PARTICULAR FONT, STYLE, SIZE, OR COLOR.

FOR COMPUTER SOFTWARE FOR PROVIDING RELEVANT BUSINESS DATA, NAMELY, STRUCTURED, UNSTRUCTURED AND GEOSPATIAL DATA TYPES FOR THE PURPOSE OF GEOSPATIAL ANALYSIS IN THE FIELD OF GEOSPATIAL INTELLIGENCE; COMPUTER SOFTWARE FOR AUTOMATING THE CHARACTERIZATION, EXPLOITATION, AND DISSEMINATION OF GEOSPATIAL DATA INTO KNOWLEDGE BASED PRODUCTS, NAMELY, GEOSPATIAL CHARTS TO BE UTILIZED BY ANALYST AND DECISION MAKERS IN THE FIELD OF GEOSPATIAL INTELLIGENCE (U.S. CLS. 21, 23, 26, 36 AND 38).

FIRST USE 9-15-2006; IN COMMERCE 9-15-2006.

FOR COMPACT DISCS AND DVDS FEATURING MUSIC (U.S. CLS. 21, 23, 26, 36 AND 38).

FIRST USE 11-13-1974; IN COMMERCE 11-13-1974.

CLASS 9—(Continued).

3,631,843. NCI GROUP, INC., HOUSTON, TX. SN 76-685,865. PUB. 9-9-2008, FILED 1-17-2008.

FASTAR

THE MARK CONSISTS OF STANDARD CHARACTERS WITHOUT CLAIM TO ANY PARTICULAR FONT, STYLE, SIZE, OR COLOR.

FOR SOFTWARE FOR PRICING ENGINEERED BUILDING SYSTEMS (U.S. CLS. 21, 23, 26, 36 AND 38). FIRST USE 6-0-2008; IN COMMERCE 6-0-2008.

CLASS 9—(Continued).

3,631,857. VENTEX TECHNOLOGY, INC., JUPITER, FL. SN 76-690,033. PUB. 12-9-2008, FILED 5-27-2008.

VenBrite

THE MARK CONSISTS OF STANDARD CHARACTERS WITHOUT CLAIM TO ANY PARTICULAR FONT, STYLE, SIZE, OR COLOR.

THE NAME "VENBRITE" DOES NOT IDENTIFY A LIVING INDIVIDUAL.

FOR ELECTRONIC POWER SUPPLIES, LIGHT EMITTING DIODES AND ELECTRONIC CIRCUITS (U.S. CLS. 21, 23, 26, 36 AND 38).

FIRST USE 12-31-2008; IN COMMERCE 12-31-2008.

3,631,844. GREAT-CIRCLE TECHNOLOGIES, INC., CHANTILLY, VA. SN 76-685,907. PUB. 6-24-2008, FILED 1-17-2008.



THE MARK CONSISTS OF THE STYLIZED WORDS "AUTOORTHO" TO THE RIGHT OF A DESIGN OF A GLOBE WITH A HORIZONTAL LINE THROUGH MIDDLE, AN ARROW GOING OVER GLOBE, AND DOTTED LINES LEADING UP TO GLOBE.

FOR COMPUTER SOFTWARE FOR PROVIDING RELEVANT BUSINESS DATA, NAMELY, STRUCTURED, UNSTRUCTURED AND GEOSPATIAL DATA TYPES FOR THE PURPOSE OF GEOSPATIAL ANALYSIS IN THE FIELD OF GEOSPATIAL INTELLIGENCE; COMPUTER SOFTWARE FOR AUTOMATING THE CHARACTERIZATION, EXPLOITATION, AND DISSEMINATION OF GEOSPATIAL DATA INTO KNOWLEDGE BASED PRODUCTS, NAMELY, GEOSPATIAL CHARTS TO BE UTILIZED BY ANALYST AND DECISION MAKERS IN THE FIELD OF GEOSPATIAL INTELLIGENCE (U.S. CLS. 21, 23, 26, 36 AND 38).

FIRST USE 9-15-2006; IN COMMERCE 9-15-2006.

3,631,866. TEXAS INSTRUMENTS INCORPORATED, DALLAS, TX. SN 77-003,824. PUB. 1-29-2008, FILED 9-20-2006.

ti.com

3,631,852. SUNRISE LED INC., PLEASANT HILL, CA. SN 76-688,371. PUB. 11-18-2008, FILED 4-4-2008.

SUNRISE LED

THE MARK CONSISTS OF STANDARD CHARACTERS WITHOUT CLAIM TO ANY PARTICULAR FONT, STYLE, SIZE, OR COLOR.

NO CLAIM IS MADE TO THE EXCLUSIVE RIGHT TO USE "LED", APART FROM THE MARK AS SHOWN.

FOR LIGHT EMITTING DIODE (LED) DISPLAYS AND ELECTRONIC LED SIGNS (U.S. CLS. 21, 23, 26, 36 AND 38).

FIRST USE 1-1-2006; IN COMMERCE 1-1-2006.

THE MARK CONSISTS OF STANDARD CHARACTERS WITHOUT CLAIM TO ANY PARTICULAR FONT, STYLE, SIZE, OR COLOR.

OWNER OF U.S. REG. NOS. 755,376, 2,634,930, AND OTHERS.

FOR DOWNLOADABLE ELECTRONIC PUBLICATIONS IN THE NATURE OF APPLICATION GUIDES, JOURNALS, NOTES, AND REPORTS; BLOCK DIAGRAMS; BROCHURES; CATALOGS; CROSS-REFERENCE GUIDES; DATASHEETS; GUIDEBOOKS; SIMULATION MODELS; NEWSLETTERS; REFERENCE GUIDES; SELECTION GUIDES; SOLUTION GUIDES; TECHNICAL DOCUMENTS AND NOTES; USER GUIDES; AND WHITE PAPERS; ALL IN THE FIELD OF SEMICONDUCTOR DEVICES (U.S. CLS. 21, 23, 26, 36 AND 38).

FIRST USE 3-31-1997; IN COMMERCE 3-31-1997.

CLASS 9—(Continued).

3,631,868. IN DEMAND L.L.C., NEW YORK, NY. SN 77-005,180. PUB. 6-26-2007, FILED 9-22-2006.

WALL STREET WARRIORS

THE MARK CONSISTS OF STANDARD CHARACTERS WITHOUT CLAIM TO ANY PARTICULAR FONT, STYLE, SIZE, OR COLOR.

NO CLAIM IS MADE TO THE EXCLUSIVE RIGHT TO USE "WALL STREET", APART FROM THE MARK AS SHOWN.

FOR PRE-RECORDED CDS, VIDEO TAPES, LASER DISKS AND DVDS FEATURING ON-GOING REALITY TELEVISION PROGRAMS (U.S. CLS. 21, 23, 26, 36 AND 38).

FIRST USE 4-24-2007; IN COMMERCE 4-24-2007.

3,631,894. BRINKMANN INSTRUMENTS, INC., WESTBURY, NY. SN 77-041,541. PUB. 11-27-2007, FILED 11-10-2006.

1-TOUCH INTELLIGENCE

THE MARK CONSISTS OF STANDARD CHARACTERS WITHOUT CLAIM TO ANY PARTICULAR FONT, STYLE, SIZE, OR COLOR.

FOR LABORATORY EQUIPMENT, NAMELY, TITRATORS (U.S. CLS. 21, 23, 26, 36 AND 38).

FIRST USE 4-30-2007; IN COMMERCE 4-30-2007.

3,631,901. AQUBANC, LLC, BUFFALO GROVE, IL. SN 77-044,986. PUB. 10-7-2008, FILED 11-15-2006.

CHEQUE 21

THE MARK CONSISTS OF STANDARD CHARACTERS WITHOUT CLAIM TO ANY PARTICULAR FONT, STYLE, SIZE, OR COLOR.

FOR COMPUTER HARDWARE AND SOFTWARE IN THE FIELD OF FORM PROCESSING, NAMELY, FOR HANDLING DONOR GIFT CORRESPONDENCE AND CORRESPONDENCE TO NON-PROFIT ORGANIZATIONS (U.S. CLS. 21, 23, 26, 36 AND 38).

FIRST USE 6-15-2007; IN COMMERCE 6-15-2007.

CLASS 9—(Continued).

3,631,924. CBS STUDIOS INC., STUDIO CITY, CA. SN 77-078,282. PUB. 8-21-2007, FILED 1-8-2007.

SWINGTOWN

THE MARK CONSISTS OF STANDARD CHARACTERS WITHOUT CLAIM TO ANY PARTICULAR FONT, STYLE, SIZE, OR COLOR.

FOR PRE-RECORDED DIGITAL VIDEO DISCS/DIGITAL VERSATILE DISCS FEATURING EPISODES OF A TELEVISION SERIES (U.S. CLS. 21, 23, 26, 36 AND 38).

FIRST USE 12-9-2008; IN COMMERCE 12-9-2008.

3,631,954. WARD MACHINERY CO., INC., HUNT VALLEY, MD. SN 77-100,015. PUB. 10-23-2007, FILED 2-6-2007.

InstaRegister

THE MARK CONSISTS OF STANDARD CHARACTERS WITHOUT CLAIM TO ANY PARTICULAR FONT, STYLE, SIZE, OR COLOR.

FOR COMPUTER ASSISTED REGISTRATION SOFTWARE FOR FLEXOGRAPHIC PRINTERS AND DIE CUTTERS, NAMELY, COMPUTER SOFTWARE USED TO CONTROL FLEXOGRAPHIC PRINTERS AND DIE CUTTERS AND INSTRUCTIONAL MANUALS SOLD AS A UNIT THEREWITH (U.S. CLS. 21, 23, 26, 36 AND 38).

FIRST USE 3-21-2007; IN COMMERCE 3-21-2007.

3,631,960. AIR SEMICONDUCTOR INC., WILMINGTON, DE. SN 77-106,280. PUB. 7-29-2008, FILED 2-13-2007.

Air

THE MARK CONSISTS OF STANDARD CHARACTERS WITHOUT CLAIM TO ANY PARTICULAR FONT, STYLE, SIZE, OR COLOR.

FOR SEMICONDUCTORS, NAMELY, SEMICONDUCTOR CHIPS (U.S. CLS. 21, 23, 26, 36 AND 38).

FIRST USE 0-0-2006; IN COMMERCE 2-13-2009.

CLASS 9—(Continued).

3,631,978. BRIDGENET SOLUTIONS, INC., CHICAGO, IL. SN 77-128,102. PUB. 10-9-2007, FILED 3-12-2007.



THE COLOR(S) BLACK, GREEN AND BLUE IS/ARE CLAIMED AS A FEATURE OF THE MARK.

THE MARK CONSISTS OF THE COLOR BLACK APPEARS IN THE LETTERS "X", "N", "A" AND "R". BETWEEN THE LETTERS "X" AND "N" THERE IS A GLOBE INSTEAD OF THE LETTER "O". ON THE GLOBE THE COLOR GREEN APPEARS AS THE CONTINENTS AND THE COLOR BLUE APPEARS AS THE OCEANS.

FOR COMPUTER SOFTWARE FOR APPLICATION AND DATABASE INTEGRATION (U.S. CLS. 21, 23, 26, 36 AND 38).
FIRST USE 7-31-2007; IN COMMERCE 7-31-2007.

3,631,982. IDEAVILLAGE PRODUCTS CORP., WAYNE, NJ. SN 77-131,958. PUB. 1-15-2008, FILED 3-15-2007.

WALLET PIX

THE MARK CONSISTS OF STANDARD CHARACTERS WITHOUT CLAIM TO ANY PARTICULAR FONT, STYLE, SIZE, OR COLOR.

NO CLAIM IS MADE TO THE EXCLUSIVE RIGHT TO USE "WALLET", APART FROM THE MARK AS SHOWN. FOR DIGITAL PHOTO FRAMES FOR DISPLAYING DIGITAL PICTURES (U.S. CLS. 21, 23, 26, 36 AND 38).
FIRST USE 6-23-2007; IN COMMERCE 6-23-2007.

3,631,985. HYNIX SEMICONDUCTOR INC., KYOUNGKI-DO, REPUBLIC OF KOREA. SN 77-134,747. PUB. 12-11-2007, FILED 3-19-2007.



NO CLAIM IS MADE TO THE EXCLUSIVE RIGHT TO USE "ROHS COMPLIANCE", APART FROM THE MARK AS SHOWN.

THE COLOR(S) GREEN, WHITE AND YELLOW IS/ARE CLAIMED AS A FEATURE OF THE MARK.

CLASS 9—(Continued).

THE MARK CONSISTS OF THE LETTERS "ECO" IN A STYLIZED GREEN FONT, ABOVE WHICH IS A STYLIZED DRAWING OF TWO LEAVES IN GREEN WITH WHITE SPECKLES AND YELLOW, TO THE RIGHT OF WHICH ARE THE WORDS "ROHS COMPLIANCE" IN A STYLIZED WHITE FONT WITHIN A GREEN SQUARE, THE RECTANGULAR OUTLINE OF THE ENTIRE MARK IS IN THE COLOR GREEN.

FOR SEMICONDUCTORS; SILICON WAFERS, STRUCTURED SEMI-CONDUCTOR WAFERS; INTEGRATED CIRCUITS; FLASH MEMORY CARDS, FLASH MEMORIES, AND SEMICONDUCTOR MEMORIES (U.S. CLS. 21, 23, 26, 36 AND 38).
FIRST USE 4-8-2007; IN COMMERCE 4-8-2007.

3,631,995. PIXELWORKS, INC., PORTLAND, OR. SN 77-148,827. PUB. 6-17-2008, FILED 4-4-2007.

MOTIONENGINE

THE MARK CONSISTS OF STANDARD CHARACTERS WITHOUT CLAIM TO ANY PARTICULAR FONT, STYLE, SIZE, OR COLOR.

FOR INTEGRATED CIRCUIT MODULES; INTEGRATED CIRCUITS; COMPUTER SOFTWARE FOR GRAPHICS AND VIDEO PROCESSING (U.S. CLS. 21, 23, 26, 36 AND 38).
FIRST USE 6-30-2005; IN COMMERCE 6-30-2005.

3,631,997. HARMONIC, INC., SUNNYVALE, CA. SN 77-151,780. PUB. 1-8-2008, FILED 4-9-2007.

FLEX

THE MARK CONSISTS OF STANDARD CHARACTERS WITHOUT CLAIM TO ANY PARTICULAR FONT, STYLE, SIZE, OR COLOR.

FOR ELECTRONIC SYSTEMS, NAMELY, DIGITAL VIDEO AND AUDIO ENCODERS; MPEG2 REMULTIPLEXERS AND SCRAMBLERS, DIGITAL VIDEO AND AUDIO DECODERS; STREAM PROCESSORS, NETWORK MANAGEMENT SOFTWARE AND GIGABIT ETHERNET INTERFACES FOR THE RECEPTION, REMULTIPLEXING, DESCRAMBLING DECODING, COMPRESSION, MULTIPLEXING, SCRAMBLING TRANSMISSION AND MONITORING OF DIGITAL VIDEO, AUDIO AND DATA SIGNALS BY TELECOMMUNICATIONS OR BROADCAST COMPANIES WITH BROADBAND NETWORKS, AND INSTRUCTION AND MAINTENANCE MANUALS SUPPLIED AS A UNIT (U.S. CLS. 21, 23, 26, 36 AND 38).
FIRST USE 9-0-2008; IN COMMERCE 9-0-2008.

CLASS 9—(Continued).

3,631,998. FUJITSU LIMITED, KANAGAWA-KEN, 211-8588, JAPAN. SN 77-153,398. PUB. 1-8-2008, FILED 4-10-2007.

SCIGRESS EXPLORER

THE MARK CONSISTS OF STANDARD CHARACTERS WITHOUT CLAIM TO ANY PARTICULAR FONT, STYLE, SIZE, OR COLOR.

FOR COMPUTER MODELING SOFTWARE FOR USE IN DISPLAYING AND MODELING MOLECULAR ORBITAL, FOR CREATING COMPUTATIONAL MODELS FOR ALL TYPES OF MOLECULAR SYSTEMS, AND FOR PREDICTIONS, ANALYSIS AND COMPUTATIONS OF CHEMICAL PROPERTIES (U.S. CLS. 21, 23, 26, 36 AND 38).

FIRST USE 7-30-2007; IN COMMERCE 7-30-2007.

3,631,999. MICROSOFT CORPORATION, REDMOND, WA. SN 77-153,416. PUB. 12-18-2007, FILED 4-10-2007.

SILVERLIGHT

THE MARK CONSISTS OF STANDARD CHARACTERS WITHOUT CLAIM TO ANY PARTICULAR FONT, STYLE, SIZE, OR COLOR.

PRIORITY CLAIMED UNDER SEC. 44(D) ON FED REP GERMANY APPLICATION NO. 30662760.4, FILED 10-13-2006, REG. NO. 30662760, DATED 11-22-2006, EXPIRES 10-31-2016.

FOR COMPUTER SOFTWARE FOR BROWSING THE INTERNET AND PRIVATE NETWORKS; COMPUTER SOFTWARE FOR ENHANCING THE CAPABILITIES OF WEB BROWSER SOFTWARE; COMPUTER SOFTWARE FOR VIEWING AND LISTENING TO VIDEO, ANIMATION AND AUDIO; AND COMPUTER SOFTWARE FOR CREATING AND AUTHORIZING WEB-BASED APPLICATIONS, VIDEO, ANIMATION AND AUDIO (U.S. CLS. 21, 23, 26, 36 AND 38).

FIRST USE 4-30-2007; IN COMMERCE 4-30-2007.

CLASS 9—(Continued).

3,632,005. EPIC SYSTEMS CORPORATION, VERONA, WI. SN 77-157,778. PUB. 10-16-2007, FILED 4-16-2007.

Lucy

THE MARK CONSISTS OF STANDARD CHARACTERS WITHOUT CLAIM TO ANY PARTICULAR FONT, STYLE, SIZE, OR COLOR.

FOR COMPUTER SOFTWARE FOR USE IN MEDICAL AND HEALTHCARE FIELDS, NAMELY, COMPUTER SOFTWARE FOR MANAGING, ACQUIRING, STORING, ANALYZING, MAINTAINING, PROCESSING, STRUCTURING, REVIEWING, BUILDING, EDITING, DISTRIBUTING, COMMUNICATING, ORGANIZING, SHARING, REFERENCING, MONITORING AND INTEGRATING INFORMATION, AND ACCOMPANYING MANUALS SOLD AS A UNIT; COMPUTER SOFTWARE FOR AUTOMATING CLINICAL AND ADMINISTRATIVE HEALTHCARE PROCESSES (U.S. CLS. 21, 23, 26, 36 AND 38).

FIRST USE 3-24-2007; IN COMMERCE 3-20-2009.

3,632,006. IMMERSIVE TECHNOLOGIES INC., SANDY, UT. SN 77-158,107. PUB. 9-23-2008, FILED 4-17-2007.



NO CLAIM IS MADE TO THE EXCLUSIVE RIGHT TO USE "ORIGINAL EQUIPMENT MANUFACTURER" AND "SUPPORTED AND RECOMMENDED PRODUCT", APART FROM THE MARK AS SHOWN.

THE COLOR(S) BLACK, ORANGE, GREY AND WHITE IS/ARE CLAIMED AS A FEATURE OF THE MARK.

THE MARK CONSISTS OF A BLACK GEAR WITH WHITE RINGS SURROUNDING AN ORANGE RING WITH THE BLACK WORDING "ORIGINAL EQUIPMENT MANUFACTURER SUPPORTED & RECOMMENDED PRODUCT" AND TWO BLACK DIAMONDS, A WHITE CENTER WITH A GREY CHECKMARK WITH THE BLACK WORDING "EXCLUSIVE ALLIANCE" ON TOP.

FOR VEHICLE DRIVE TRAINING SIMULATORS (U.S. CLS. 21, 23, 26, 36 AND 38).

FIRST USE 1-0-2008; IN COMMERCE 1-0-2008.

CLASS 9—(Continued).

3,632,010. ANTS SOFTWARE INC., BURLINGAME, CA. SN 77-160,028. PUB. 4-8-2008, FILED 4-18-2007.

ANTS COMPATIBILITY SERVER

THE MARK CONSISTS OF STANDARD CHARACTERS WITHOUT CLAIM TO ANY PARTICULAR FONT, STYLE, SIZE, OR COLOR.

OWNER OF U.S. REG. NO. 2,669,412.

NO CLAIM IS MADE TO THE EXCLUSIVE RIGHT TO USE "COMPATIBILITY SERVER", APART FROM THE MARK AS SHOWN.

FOR COMPUTER SOFTWARE THAT ALLOWS APPLICATIONS TO OPERATE WITH DATABASE SERVERS OTHER THAN THOSE DATABASE SERVERS THEY WERE ORIGINALLY DEPLOYED WITH; COMPUTER SOFTWARE FOR TRANSLATING DATABASE QUERIES AND STORED PROCEDURES AMONG DATABASE QUERY AND PROCEDURE LANGUAGES (U.S. CLS. 21, 23, 26, 36 AND 38).

FIRST USE 4-18-2008; IN COMMERCE 4-18-2008.

3,632,012. CONTROL4 CORPORATION, SALT LAKE CITY, UT. SN 77-160,578. PUB. 7-1-2008, FILED 4-19-2007.

Everyday Easy

THE MARK CONSISTS OF STANDARD CHARACTERS WITHOUT CLAIM TO ANY PARTICULAR FONT, STYLE, SIZE, OR COLOR.

FOR ELECTRONIC INTEGRATED CONTROL SYSTEMS FOR MANAGEMENT OF ELECTRICAL APPLIANCES, FIXTURES AND EQUIPMENT, NAMELY, ENTERTAINMENT SYSTEMS, LIGHTING SYSTEMS, CLIMATE CONTROL SYSTEMS, COMPRISED OF WIRE-BASED AND WIRELESS TRANSMITTERS, RECEIVERS, SENSORS; AUDIO EQUIPMENT, NAMELY, AMPLIFIERS, SWITCHES, RECEIVERS, TUNERS, DIGITAL MEDIA PLAYERS, AUDIO AND VIDEO MEDIA CHANGERS, COMPUTER-BASED AUDIO AND VIDEO SERVERS, AUDIO VOLUME LEVEL CONTROLLERS AND SPEAKERS; COMPUTER AND WIRELESS AND WIRED NETWORK-CONTROLLED KEYPADS, TOUCH SCREENS, SWITCHES, ELECTRICAL CONTROLLERS, ETHERNET CONTROLLERS, REMOTE CONTROLS, ELECTRICAL AND DATA CABLES, ADAPTERS, CONNECTORS, INTERFACE CARDS AND CIRCUITS, JUNCTION BOXES, DIMMERS, LIGHTING SWITCHES, LIGHTING BALLASTS AND COMPUTER SOFTWARE FOR MANAGING ELECTRICAL APPLIANCES, FIXTURES AND EQUIPMENT (U.S. CLS. 21, 23, 26, 36 AND 38).

FIRST USE 3-1-2007; IN COMMERCE 3-1-2007.

CLASS 9—(Continued).

3,632,042. NEW LINE PRODUCTIONS, INC., NEW YORK, NY. SN 77-190,548. PUB. 9-30-2008, FILED 5-25-2007.

RUSH HOUR

THE MARK CONSISTS OF STANDARD CHARACTERS WITHOUT CLAIM TO ANY PARTICULAR FONT, STYLE, SIZE, OR COLOR.

FOR MOTION PICTURE FILMS FEATURING COMEDY, DRAMA, ACTION AND ADVENTURE, AND MOTION PICTURE FILMS FOR BROADCAST ON TELEVISION FEATURING COMEDY, DRAMA, ACTION AND ADVENTURE; DIGITAL VERSATILE DISCS FEATURING COMEDY, DRAMA, ACTION AND ADVENTURE (U.S. CLS. 21, 23, 26, 36 AND 38).

FIRST USE 9-18-1998; IN COMMERCE 9-18-1998.

3,632,050. ZOTAC INTERNATIONAL (MCO) LIMITED, FO TAN, SHATIN, N.T., HONG KONG. SN 77-193,766. PUB. 3-11-2008, FILED 5-30-2007.

ZONE
EDITION

NO CLAIM IS MADE TO THE EXCLUSIVE RIGHT TO USE "EDITION", APART FROM THE MARK AS SHOWN. THE COLOR(S) SILVER AND BLACK IS/ARE CLAIMED AS A FEATURE OF THE MARK.

THE WORD "ZONE" IS SILVER AND APPEARS IN A 3-DIMENSIONAL FONT, AND THE WORD "EDITION" IS BLACK.

FOR COMPUTER HARDWARE (U.S. CLS. 21, 23, 26, 36 AND 38).

FIRST USE 5-1-2007; IN COMMERCE 8-1-2007.

CLASS 9—(Continued).

3,632,055. E-FILLIATE, INC., RANCHO CORDOVA, CA. SN 77-196,743. PUB. 12-25-2007, FILED 6-4-2007.

USB SQUID

THE MARK CONSISTS OF STANDARD CHARACTERS WITHOUT CLAIM TO ANY PARTICULAR FONT, STYLE, SIZE, OR COLOR.

NO CLAIM IS MADE TO THE EXCLUSIVE RIGHT TO USE "USB", APART FROM THE MARK AS SHOWN.

FOR CABLES FOR TRANSMISSION OF DATA IN ELECTRONIC FORM BETWEEN COMPUTERS AND COMPUTER PERIPHERAL DEVICES AND FOR TRANSMISSION OF DATA IN ELECTRONIC FORM BETWEEN ELECTRONIC COMPONENTS (U.S. CLS. 21, 23, 26, 36 AND 38).

FIRST USE 10-23-2007; IN COMMERCE 10-23-2007.

3,632,069. VDOOTEK, INC, MIAMI, FL. SN 77-208,914. PUB. 12-4-2007, FILED 6-18-2007.

TEXBOARD

THE MARK CONSISTS OF STANDARD CHARACTERS WITHOUT CLAIM TO ANY PARTICULAR FONT, STYLE, SIZE, OR COLOR.

FOR COMPUTER WHITEBOARDS; COMPUTER GRAPHICS BOARDS (U.S. CLS. 21, 23, 26, 36 AND 38).

FIRST USE 8-11-2008; IN COMMERCE 8-11-2008.

3,632,075. SUNOVIA ENERGY TECHNOLOGIES, INC., SARASOTA, FL. SN 77-213,138. PUB. 1-1-2008, FILED 6-22-2007.

WILDLITE

THE MARK CONSISTS OF STANDARD CHARACTERS WITHOUT CLAIM TO ANY PARTICULAR FONT, STYLE, SIZE, OR COLOR.

FOR ENVIRONMENTALLY FRIENDLY LIGHT EMITTING DIODES (LED) FOR USE IN RESIDENTIAL AND COMMERCIAL LIGHTS AT A FREQUENCY INVISIBLE TO ANIMALS (U.S. CLS. 21, 23, 26, 36 AND 38).

FIRST USE 5-0-2008; IN COMMERCE 5-0-2008.

CLASS 9—(Continued).

3,632,076. IGT, RENO, NV. SN 77-213,590. PUB. 12-11-2007, FILED 6-22-2007.

MAID OF MONEY

THE MARK CONSISTS OF STANDARD CHARACTERS WITHOUT CLAIM TO ANY PARTICULAR FONT, STYLE, SIZE, OR COLOR.

FOR GAMING MACHINES, NAMELY, DEVICES WHICH ACCEPT A WAGER (U.S. CLS. 21, 23, 26, 36 AND 38).

FIRST USE 10-8-2008; IN COMMERCE 11-12-2008.

3,632,087. W2BI, INC., UNION, NJ. SN 77-219,321. PUB. 5-6-2008, FILED 6-29-2007.

MVANTAGE

THE MARK CONSISTS OF STANDARD CHARACTERS WITHOUT CLAIM TO ANY PARTICULAR FONT, STYLE, SIZE, OR COLOR.

FOR COMPUTER SOFTWARE FOR DEVICE MANAGEMENT SYSTEM OF MOBILE TELEPHONES AND SMART DEVICES, NAMELY, POCKET PERSONAL COMPUTERS, PERSONAL DIGITAL ASSISTANTS, HANDHELD ELECTRONIC WIRELESS COMMUNICATION DEVICES, TABLET PERSONAL COMPUTERS, MP3 PLAYERS, MULTI-FUNCTION ELECTRONIC WIRELESS DIGITAL DEVICES FOR MANAGING, PLAYING AND RECORDING AUDIO, TEXT, AND DATA FILES; PERSONAL MESSENGER DEVICES FOR THE REGISTERING OF USERS, CONFIGURING COMPANY AND USER PROFILES, ISSUING LICENSES TO COMPANIES AND USERS, ORGANIZING DEVICES INTO GROUPS AND DEPLOYING COMMON SOFTWARE APPLICATIONS, CONFIGURATIONS AND SETTINGS; SOFTWARE FOR DEVICE ASSET MANAGEMENT, VIEWING DEVICE ASSETS AND VIEWING DEVICE FILES; SOFTWARE FOR REMOTE LAUNCHING OF COMMANDS ON THE SPECIFIED DEVICES; SOFTWARE FOR GENERATION OF OPERATIONAL REPORTS FOR SPECIFIED DEVICES; SOFTWARE FOR TRACKING DEVICES, LOCKING SELECTED DEVICES, AND DISABLING OR RESETING SELECTED DEVICES; SOFTWARE FOR MANAGING THE DESKTOP OF MOBILE WIRELESS DEVICES, TROUBLESHOOTING DEVICE CONNECTIVITY AND DEPLOYING INFORMATION TO THE DEVICES, NAMELY, ELECTRONIC FILES, ADVERTISEMENTS, DESKTOP BRANDING AND OVER THE AIR DEVICE BACK-UP AND RESTORE SERVICES, NAMELY, BACK-UP AND RESTORE OF SHORT MESSAGE SERVICE, MULTIMEDIA SERVICE AND USER FILES (U.S. CLS. 21, 23, 26, 36 AND 38).

FIRST USE 6-28-2007; IN COMMERCE 6-28-2007.

CLASS 9—(Continued).

3,632,095. GREER, DOUGLAS S., CARLSBAD, CA. SN 77-224,276. PUB. 6-17-2008, FILED 7-8-2007.

GENERAL MANIFOLDS

THE MARK CONSISTS OF STANDARD CHARACTERS WITHOUT CLAIM TO ANY PARTICULAR FONT, STYLE, SIZE, OR COLOR.

FOR COMPUTER PROGRAMS FOR EXECUTING NEURAL NETWORK MODELS FOR IMAGE ANALYSIS AND SIGNAL ANALYSIS; COMPUTER PROGRAMS FOR EXECUTING NEURAL NETWORK MODELS FOR ENHANCEMENT AND RECONSTRUCTION OF IMAGES AND SIGNALS (U.S. CLS. 21, 23, 26, 36 AND 38).
FIRST USE 10-0-2006; IN COMMERCE 12-0-2007.

3,632,107. ENVISION TELEPHONY, INC., SEATTLE, WA. SN 77-228,581. PUB. 1-1-2008, FILED 7-12-2007.

ENVISION CENTRICITY

THE MARK CONSISTS OF STANDARD CHARACTERS WITHOUT CLAIM TO ANY PARTICULAR FONT, STYLE, SIZE, OR COLOR.

FOR COMPUTER SOFTWARE FOR USE IN PERSONNEL TRAINING, EVALUATION, MONITORING AND MOTIVATION (U.S. CLS. 21, 23, 26, 36 AND 38).
FIRST USE 12-19-2008; IN COMMERCE 12-19-2008.

3,632,120. ELECTRIC VISUAL EVOLUTION, LLC, SAN CLEMENTE, CA. SN 77-232,672. PUB. 10-14-2008, FILED 7-18-2007.

FIEND

THE MARK CONSISTS OF STANDARD CHARACTERS WITHOUT CLAIM TO ANY PARTICULAR FONT, STYLE, SIZE, OR COLOR.

FOR SUNGLASSES AND CASES FOR SUNGLASSES (U.S. CLS. 21, 23, 26, 36 AND 38).
FIRST USE 10-13-2008; IN COMMERCE 10-13-2008.

CLASS 9—(Continued).

3,632,125. IOLO TECHNOLOGIES, LLC, LOS ANGELES, CA. SN 77-236,932. PUB. 1-15-2008, FILED 7-24-2007.

TOTALCARE

THE MARK CONSISTS OF STANDARD CHARACTERS WITHOUT CLAIM TO ANY PARTICULAR FONT, STYLE, SIZE, OR COLOR.

FOR SOFTWARE, NAMELY, SOFTWARE THAT PROTECTS, REPAIRS AND OPTIMIZES THE PERFORMANCE OF PERSONAL COMPUTERS (U.S. CLS. 21, 23, 26, 36 AND 38).
FIRST USE 9-30-2005; IN COMMERCE 12-31-2008.

3,632,128. ADAPTIVE NEURAL BIOMETRICS LTD., LONDON, UNITED KINGDOM. SN 77-237,610. PUB. 1-8-2008, FILED 7-24-2007.

BGP

THE MARK CONSISTS OF STANDARD CHARACTERS WITHOUT CLAIM TO ANY PARTICULAR FONT, STYLE, SIZE, OR COLOR.

FOR COMPUTER SOFTWARE, NAMELY, SOFTWARE TO CONTROL PRIVACY AND SECURITY SYSTEMS, SOFTWARE FOR MANAGING SECURITY, AND PRIVACY PARAMETERS, SOFTWARE FOR MANAGING PERSONAL INFORMATION AND INDICIA AND AUTHENTICATING IDENTITY, AND SOFTWARE USED TO MANAGE AND SECURE SECURITY AND PRIVACY SYSTEMS (U.S. CLS. 21, 23, 26, 36 AND 38).
FIRST USE 6-1-2007; IN COMMERCE 6-1-2007.

3,632,142. IGT, RENO, NV. SN 77-245,782. PUB. 1-15-2008, FILED 8-2-2007.

SPACE FOR RENT

THE MARK CONSISTS OF STANDARD CHARACTERS WITHOUT CLAIM TO ANY PARTICULAR FONT, STYLE, SIZE, OR COLOR.

FOR GAMING MACHINES, NAMELY, DEVICES WHICH ACCEPT A WAGER (U.S. CLS. 21, 23, 26, 36 AND 38).
FIRST USE 1-14-2008; IN COMMERCE 1-14-2008.

CLASS 9—(Continued).

3,632,143. TELEMANAGEMENT FORUM, MORRISTOWN, NJ. SN 77-245,856. PUB. 2-5-2008, FILED 8-2-2007.

 The logo for tmforum features the letters 'tm' in blue, 'fo' in orange, and 'rum' in black. A stylized globe icon is integrated into the letter 'o'.

THE COLOR(S) BLUE, ORANGE AND BLACK IS/ARE CLAIMED AS A FEATURE OF THE MARK.

THE MARK CONSISTS OF THE LETTERS "TM" AND THE WORD "FORUM" WITH THE LETTERS "TM" APPEARING IN THE COLOR BLUE, THE LETTERS "F, "R", "U" AND THE SECOND "M" IN THE WORD "FORUM" APPEARING IN THE COLOR ORANGE; AND THE LETTER "O" IN THE WORD "FORUM" REPRESENTED BY TWO CURLING ARROWS, ONE IN THE COLORS ORANGE AND BLACK AND ONE IN THE COLORS BLUE AND BLACK.

FOR COMPUTER SOFTWARE FOR USE BY TELECOMMUNICATIONS, CABLE, SATELLITE AND COMPUTER SERVICE PROVIDERS IN SYSTEM DESIGN, PROCESS MANAGEMENT AND PROCESS DEFINITION AND FOR USE BY SUPPLIERS FOR THE TELECOMMUNICATIONS, CABLE, SATELLITE AND COMPUTER INDUSTRY IN DEFINING THE BOUNDARIES AND INTERFACES FOR THEIR PRODUCTS; REPORTS AND MANUALS RELATING TO SUCH COMPUTER SOFTWARE (U.S. CLS. 21, 23, 26, 36 AND 38).

FIRST USE 11-20-2008; IN COMMERCE 11-20-2008.

3,632,147. FIREFLY ENERGY INC., PEORIA, IL. SN 77-247,792. PUB. 7-8-2008, FILED 8-6-2007.

OASIS

THE MARK CONSISTS OF STANDARD CHARACTERS WITHOUT CLAIM TO ANY PARTICULAR FONT, STYLE, SIZE, OR COLOR.

FOR ENERGY STORAGE DEVICES, NAMELY, BATTERIES AND FUEL CELLS (U.S. CLS. 21, 23, 26, 36 AND 38).

FIRST USE 10-29-2007; IN COMMERCE 10-29-2007.

CLASS 9—(Continued).

3,632,152. SIGHTRON, INC., YOUNGSVILLE, NC. SN 77-249,212. PUB. 6-10-2008, FILED 8-7-2007.

SII BLUE SKY

THE MARK CONSISTS OF STANDARD CHARACTERS WITHOUT CLAIM TO ANY PARTICULAR FONT, STYLE, SIZE, OR COLOR.

FOR BINOCULAR, SPORTING SCOPES AND RIFLE-SCOPES (U.S. CLS. 21, 23, 26, 36 AND 38).

FIRST USE 11-5-2008; IN COMMERCE 11-5-2008.

3,632,154. SPINTOP MEDIA, INC., VANCOUVER, CANADA. SN 77-249,491. PUB. 1-29-2008, FILED 8-7-2007.

SPINTOP

THE MARK CONSISTS OF STANDARD CHARACTERS WITHOUT CLAIM TO ANY PARTICULAR FONT, STYLE, SIZE, OR COLOR.

FOR INTERACTIVE GAME SOFTWARE; COMPUTER GAME SOFTWARE; VIDEO GAME PROGRAMS AND CARTRIDGES; ELECTRONIC GAME PROGRAMS; GAME SOFTWARE FOR USE ON ANY COMPUTERIZED PLATFORM, INCLUDING GAME CONSOLES, TELEVISIONS, HAND-HELD ELECTRONIC DEVICES, ELECTRONIC ENTERTAINMENT DEVICES, TELECOMMUNICATIONS DEVICES, DOWNLOADABLE INTERACTIVE, COMPUTER, VIDEO AND ELECTRONIC GAME PROGRAMS (U.S. CLS. 21, 23, 26, 36 AND 38).

FIRST USE 11-30-2004; IN COMMERCE 11-30-2004.

CLASS 9—(Continued).

3,632,194. SONY ERICSSON MOBILE COMMUNICATIONS AB, LUND, SWEDEN. SN 77-265,159. PUB. 9-30-2008, FILED 8-27-2007.

SensMe

THE MARK CONSISTS OF STANDARD CHARACTERS WITHOUT CLAIM TO ANY PARTICULAR FONT, STYLE, SIZE, OR COLOR.

PRIORITY CLAIMED UNDER SEC. 44(D) ON UNITED KINGDOM APPLICATION NO. 2448475, FILED 3-5-2007.

FOR A COMPUTER SOFTWARE PROGRAM USED AS AN ELECTRONIC FEATURE FOUND ON CELLULAR OR MOBILE PHONES THAT ALLOWS USERS TO IDENTIFY, ORGANIZE AND PLAY MUSIC BASED SOLELY ON CHOICE OF MOOD (U.S. CLS. 21, 23, 26, 36 AND 38).

FIRST USE 6-0-2007; IN COMMERCE 10-0-2008.

CLASS 9—(Continued).

3,632,217. MEDSHARE INC., CAMBRIDGE, ONTARIO, CANADA. SN 77-276,334. PUB. 8-19-2008, FILED 9-11-2007.

MEDSHARE

THE MARK CONSISTS OF STANDARD CHARACTERS WITHOUT CLAIM TO ANY PARTICULAR FONT, STYLE, SIZE, OR COLOR.

FOR COMPUTER SOFTWARE FOR USE IN THE HEALTHCARE SECTOR, NAMELY, COMPUTER SOFTWARE THAT FACILITATES THE SHARING OF ELECTRONIC HEALTH RECORDS, HEALTH CARE BILLING AND REIMBURSEMENT, STAFF SCHEDULING AND PERFORMANCE REPORTING (U.S. CLS. 21, 23, 26, 36 AND 38).

FIRST USE 7-18-2006; IN COMMERCE 7-18-2006.

3,632,200. NORDOST CORPORATION, ASHLAND, MA. SN 77-266,922. PUB. 7-15-2008, FILED 8-29-2007.

OMNI KONNEKT

THE MARK CONSISTS OF STANDARD CHARACTERS WITHOUT CLAIM TO ANY PARTICULAR FONT, STYLE, SIZE, OR COLOR.

NO CLAIM IS MADE TO THE EXCLUSIVE RIGHT TO USE "CONNECT", APART FROM THE MARK AS SHOWN. FOR SPEAKER CABLES AND INTERCONNECTS (U.S. CLS. 21, 23, 26, 36 AND 38).

FIRST USE 9-14-2007; IN COMMERCE 9-14-2007.

3,632,219. CRANE CO., STAMFORD, CT. SN 77-277,328. PUB. 7-22-2008, FILED 9-12-2007.

ULTRA-FLEX

THE MARK CONSISTS OF STANDARD CHARACTERS WITHOUT CLAIM TO ANY PARTICULAR FONT, STYLE, SIZE, OR COLOR.

FOR VENDING MACHINES AND STRUCTURAL OR REPLACEMENT PARTS THEREFOR (U.S. CLS. 21, 23, 26, 36 AND 38).

FIRST USE 6-13-2008; IN COMMERCE 6-15-2008.

3,632,212. ADAPTION TECHNOLOGIES VENTURES, LTD., THE WOODLANDS, TX. SN 77-272,999. PUB. 2-26-2008, FILED 9-6-2007.

FOSSA

THE MARK CONSISTS OF STANDARD CHARACTERS WITHOUT CLAIM TO ANY PARTICULAR FONT, STYLE, SIZE, OR COLOR.

FOR COMPUTER SOFTWARE FOR THE MANAGEMENT OF INTERNET PROTOCOL (IP) ENABLED TERMINALS, SUCH AS VOICE OVER INTERNET PROTOCOL (VOIP) TELEPHONE SETS (U.S. CLS. 21, 23, 26, 36 AND 38).

FIRST USE 1-23-2009; IN COMMERCE 1-23-2009.

3,632,222. ATLANTIC SOFTWARE EXCHANGE, INC., MEDIA, PA. SN 77-277,831. PUB. 7-1-2008, FILED 9-12-2007.

METABILITY

THE MARK CONSISTS OF STANDARD CHARACTERS WITHOUT CLAIM TO ANY PARTICULAR FONT, STYLE, SIZE, OR COLOR.

FOR COMPUTER SOFTWARE FOR INFORMATION AND KNOWLEDGE MANAGEMENT, NAMELY, EXTRACTION, STORAGE AND AGGREGATION OF DATA FROM UNSTRUCTURED DATA FILES (U.S. CLS. 21, 23, 26, 36 AND 38).

FIRST USE 8-13-2007; IN COMMERCE 9-1-2007.

CLASS 9—(Continued).

3,632,230. ACCURI CYTOMETERS, INC., ANN ARBOR, MI. SN 77-280,928. PUB. 3-4-2008, FILED 9-17-2007.

VIRTUALGAIN

THE MARK CONSISTS OF STANDARD CHARACTERS WITHOUT CLAIM TO ANY PARTICULAR FONT, STYLE, SIZE, OR COLOR.

FOR COMPUTER SOFTWARE FOR ANALYZING AND DISPLAYING DATA IN THE FIELD OF CELL ANALYSIS (U.S. CLS. 21, 23, 26, 36 AND 38).

FIRST USE 3-0-2009; IN COMMERCE 3-0-2009.

3,632,231. OTTER PRODUCTS, LLC, FORT COLLINS, CO. SN 77-280,984. PUB. 7-8-2008, FILED 9-17-2007.

ARMOR SERIES

THE MARK CONSISTS OF STANDARD CHARACTERS WITHOUT CLAIM TO ANY PARTICULAR FONT, STYLE, SIZE, OR COLOR.

NO CLAIM IS MADE TO THE EXCLUSIVE RIGHT TO USE "SERIES", APART FROM THE MARK AS SHOWN.

FOR PROTECTIVE CASES FOR INTERACTIVE, HANDHELD ELECTRONIC DEVICES, NAMELY, PORTABLE MUSIC PLAYERS, PORTABLE VIDEO PLAYERS AND TABLET COMPUTERS (U.S. CLS. 21, 23, 26, 36 AND 38).

FIRST USE 9-27-2007; IN COMMERCE 9-27-2007.

CLASS 9—(Continued).

3,632,234. BAIDU.COM, INC., GRAND CAYMAN, CAYMAN ISLANDS. SN 77-282,947. PUB. 7-22-2008, FILED 9-18-2007.

百度

THE MARK CONSISTS OF TWO CHINESE CHARACTERS.

THE NON-LATIN CHARACTERS IN THE MARK TRANSLITERATE TO "BAI DU" AND THIS MEANS "HUNDRED DEGREE" IN ENGLISH.

FOR DATA PROCESSORS; COMPUTER MEMORIES; COMPUTERS; COMPUTER PROGRAMMES FOR DOCUMENT MANAGEMENT; COMPUTER OPERATING PROGRAMS; COMMUNICATIONS SOFTWARE FOR CONNECTING COMPUTER NETWORK USERS; DOWNLOADABLE MP3 FILES, MP3 RECORDINGS, ONLINE DISCUSSION BOARDS, WEBCASTS AND PODCASTS FEATURING MUSIC, AUDIO BOOKS AND NEWS BROADCASTS; DOWNLOADABLE SOFTWARE FOR USE IN DATABASE MANAGEMENT, FOR USE AS A SPREADSHEET AND FOR WORD PROCESSING; COMPUTER PERIPHERALS (U.S. CLS. 21, 23, 26, 36 AND 38).

FIRST USE 2-15-2000; IN COMMERCE 2-15-2000.

3,632,265. LINEAGE OVERSEAS CORP., LOS ANGELES, CA. SN 77-298,230. PUB. 7-29-2008, FILED 10-8-2007.

NAOS RAPTOR

THE MARK CONSISTS OF STANDARD CHARACTERS WITHOUT CLAIM TO ANY PARTICULAR FONT, STYLE, SIZE, OR COLOR.

THE ENGLISH TRANSLATION OF THE GREEK WORD "NAOS" IN THE MARK IS "TEMPLE".

FOR POWER MODULES FOR USE IN TELECOMMUNICATION, DATA PROCESSING, AND NETWORKING EQUIPMENT (U.S. CLS. 21, 23, 26, 36 AND 38).

FIRST USE 1-1-2008; IN COMMERCE 1-1-2008.

CLASS 9—(Continued).

3,632,285. SUSSMAN-AUTOMATIC CORPORATION, LONG ISLAND CITY, NY. SN 77-305,092. PUB. 6-3-2008, FILED 10-16-2007.

MUSIC THERAPY

THE MARK CONSISTS OF STANDARD CHARACTERS WITHOUT CLAIM TO ANY PARTICULAR FONT, STYLE, SIZE, OR COLOR.

FOR IN-SHOWER AUDIO SPEAKERS FOR USE IN RESIDENTIAL STEAM BATHS (U.S. CLS. 21, 23, 26, 36 AND 38).

FIRST USE 6-19-2006; IN COMMERCE 6-19-2006.

3,632,297. LONG, SHUNYOU, BALTIMORE, MD. SN 77-309,293. PUB. 4-8-2008, FILED 10-20-2007.

BatteryDAQ

THE MARK CONSISTS OF STANDARD CHARACTERS WITHOUT CLAIM TO ANY PARTICULAR FONT, STYLE, SIZE, OR COLOR.

FOR MEASURING INSTRUMENTATION AND APPARATUS, NAMELY, DIGITIZERS (U.S. CLS. 21, 23, 26, 36 AND 38).

FIRST USE 2-1-2009; IN COMMERCE 4-1-2009.

3,632,302. HARDY LIFE, LLC, LOS ANGELES, CA. SN 77-315,074. PUB. 2-26-2008, FILED 10-26-2007.

ED HARDY

THE MARK CONSISTS OF STANDARD CHARACTERS WITHOUT CLAIM TO ANY PARTICULAR FONT, STYLE, SIZE, OR COLOR.

OWNER OF U.S. REG. NOS. 3,124,710, 3,135,603, AND 3,141,658.

THE NAME "ED HARDY" ALSO KNOWN AS "DON ED HARDY" IDENTIFIES A LIVING INDIVIDUAL WHOSE CONSENT IS OF RECORD.

FOR SUNGLASSES, EYEGLASSES, EYEGLASS FRAMES, EYEGLASS CASES, SKI GOGGLES, GOGGLES FOR SPORTS (U.S. CLS. 21, 23, 26, 36 AND 38).

FIRST USE 7-2-2007; IN COMMERCE 7-2-2007.

CLASS 9—(Continued).

3,632,307. EBX OPTIK, L.C., MIAMI, FL. SN 77-316,982. PUB. 7-22-2008, FILED 10-30-2007.

 The logo for "EYE GLOW" features the word "EYE" in a bold, black, sans-serif font, followed by "GLOW" in a white, bold, sans-serif font. The "GLOW" text is set against a solid black rectangular background.

FOR ILLUMINATED EYEGLASSES, EYEGLASS FRAMES AND EYEGLASS LENSES (U.S. CLS. 21, 23, 26, 36 AND 38).

FIRST USE 4-15-2008; IN COMMERCE 4-15-2008.

3,632,311. KIDRO PRODUCTIONS, INC., NEW YORK, NY. SN 77-319,353. PUB. 9-2-2008, FILED 11-1-2007.



NO CLAIM IS MADE TO THE EXCLUSIVE RIGHT TO USE "PRODUCTIONS, INC.", APART FROM THE MARK AS SHOWN.

THE MARK CONSISTS OF THE WORDING "KIDRO" WHERE THE "I" IS AN EXCLAMATION POINT AND THE "O" IS A HEART, WITH THE WORDING "PRODUCTIONS, INC." BELOW. THIS WORDING APPEARS AGAINST AN IRREGULAR BACKGROUND WITH AN OVERALL RECTANGULAR SHAPE.

FOR PRE-RECORDED TAPE CASSETTES, DVDS, DOWNLOADABLE AUDIO BOOKS AND DOWNLOADABLE ELECTRONIC BOOKS FEATURING CHILDREN'S ENTERTAINMENT; PRERECORDED MUSICAL CDS (U.S. CLS. 21, 23, 26, 36 AND 38).

FIRST USE 9-21-2008; IN COMMERCE 9-21-2008.

CLASS 9—(Continued).

3,632,315. ZMARK, INC., VENTURA, CA. SN 77-322,289. PUB. 4-22-2008, FILED 11-6-2007.



NO CLAIM IS MADE TO THE EXCLUSIVE RIGHT TO USE "TECHNOLOGIES", APART FROM THE MARK AS SHOWN.

THE MARK CONSISTS OF THE WORD "ZMARK" BEING SITUATED ON TOP OF THE WORD "TECHNOLOGIES." A SOLID DIAMOND SHAPE ENCOMPASSES THE "Z" IN "ZMARK".

FOR BARCODE PRINTERS, BARCODE SCANNERS, AND PORTABLE DATA TERMINALS (U.S. CLS. 21, 23, 26, 36 AND 38).

FIRST USE 9-7-2007; IN COMMERCE 9-7-2007.

3,632,328. HOT BUTTERED INTERNATIONAL PTY LTD, WARRIEWOOD, AUSTRALIA. SN 77-327,769. PUB. 9-9-2008, FILED 11-13-2007.

HOT BUTTERED SOUL

THE MARK CONSISTS OF STANDARD CHARACTERS WITHOUT CLAIM TO ANY PARTICULAR FONT, STYLE, SIZE, OR COLOR.

OWNER OF U.S. REG. NO. 1,108,112.

FOR PRE-RECORDED DVDS FEATURING MOVIES RELATING TO SURFING AND SURF CULTURE (U.S. CLS. 21, 23, 26, 36 AND 38).

FIRST USE 3-19-2008; IN COMMERCE 3-19-2008.

CLASS 9—(Continued).

3,632,338. INNCOM INTERNATIONAL, INC., NIANTIC, CT. SN 77-331,676. PUB. 10-28-2008, FILED 11-16-2007.

ECOMODE

THE MARK CONSISTS OF STANDARD CHARACTERS WITHOUT CLAIM TO ANY PARTICULAR FONT, STYLE, SIZE, OR COLOR.

FOR THERMOSTATS; SMART THERMOSTATS; SMART DIGITAL THERMOSTATS; CLIMATE CONTROL SYSTEMS CONSISTING OF DIGITAL THERMOSTATS, AIR CONDITIONING, HEATING, VENTILATION AND DRYING CONTROL DEVICES; THERMOSTAT COMPONENT DEVICES, NAMELY, TOUCHSCREENS, PROGRAMMABLE SWITCHES, THERMOSTAT DEVICE COMPONENT THAT ALLOWS USERS TO ENABLE A PROPERTY'S ENERGY CONSERVATION AND SAVINGS STRATEGIES, AND NOTIFIES A PROPERTY THAT THE USER IS ELECTING TO PARTICIPATE IN ENVIRONMENTAL SUSTAINABILITY PROGRAMS (U.S. CLS. 21, 23, 26, 36 AND 38).

FIRST USE 1-28-2008; IN COMMERCE 1-28-2008.

3,632,350. L&I COMPANY LIMITED, KOWLOON, HONG KONG. SN 77-336,336. PUB. 9-16-2008, FILED 11-26-2007.

iSofa

THE MARK CONSISTS OF STANDARD CHARACTERS WITHOUT CLAIM TO ANY PARTICULAR FONT, STYLE, SIZE, OR COLOR.

FOR APPARATUS FOR RECORDING, TRANSMISSION OR REPRODUCTION OF SOUND OR IMAGES; ELECTRICAL CONDUCTORS; ELECTRIC SWITCHES; ELECTRICAL TRANSFORMERS; ELECTRIC ACCUMULATORS; VOLTAGE REGULATORS; ELECTRICAL CONTROLLERS; PERSONAL STEREOS; CABINETS FOR LOUDSPEAKERS; AMPLIFIERS; ACOUSTIC CONDUITS; ACOUSTIC COUPLERS; SCIENTIFIC APPARATUS, NAMELY, SENSING AND SIGNALING DEVICES FOR MEASUREMENT AND QUALITY CONTROL OF MATERIALS PROCESSING BY LASER; SURVEYING INSTRUMENTS; PHOTOGRAPHIC CAMERAS; SOUND RECORDING APPARATUS AND INSTRUMENTS CINEMATOGRAPHIC APPARATUS; BLANK OPTICAL DISCS; WEIGHING APPARATUS AND INSTRUMENTS; MEASURING INSTRUMENTATION AND APPARATUS, NAMELY, DIGITIZERS; BLANK MAGNETIC DATA CARRIERS; DISC MEMORIES; VENDING MACHINES; COIN ACCEPTORS FOR SEPARATING GOOD COINS FROM COUNTERFEITS; CASH REGISTERS, CALCULATING SCALES; CALCULATORS; CURRENCY COUNTING MACHINES; DATA PROCESSORS; COMPUTERS; FIRE EXTINGUISHERS (U.S. CLS. 21, 23, 26, 36 AND 38).

FIRST USE 5-30-2008; IN COMMERCE 5-30-2008.

CLASS 9—(Continued).

3,632,351. L&I COMPANY LIMITED, KOWLOON, HONG KONG. SN 77-336,340. PUB. 9-16-2008, FILED 11-26-2007.

Lars & Ivan

THE MARK CONSISTS OF STANDARD CHARACTERS WITHOUT CLAIM TO ANY PARTICULAR FONT, STYLE, SIZE, OR COLOR.

FOR APPARATUS FOR RECORDING, TRANSMISSION OR REPRODUCTION OF SOUND OR IMAGES; ELECTRICAL CONDUCTORS; ELECTRIC SWITCHES; ELECTRICAL TRANSFORMERS; ELECTRIC ACCUMULATORS; VOLTAGE REGULATORS; ELECTRICAL CONTROLLERS; PERSONAL STEREO; CABINETS FOR LOUDSPEAKERS; AMPLIFIERS; ACOUSTIC CONDUITS; ACOUSTIC COUPLERS; SCIENTIFIC APPARATUS, NAMELY, SENSING AND SIGNALING DEVICES FOR MEASUREMENT AND QUALITY CONTROL OF MATERIALS PROCESSING BY LASER; SURVEYING INSTRUMENTS; PHOTOGRAPHIC CAMERAS; SOUND RECORDING APPARATUS AND INSTRUMENTS CINEMATOGRAPHIC APPARATUS; BLANK OPTICAL DISCS; WEIGHING APPARATUS AND INSTRUMENTS; MEASURING INSTRUMENTATION AND APPARATUS, NAMELY, DIGITIZERS; BLANK MAGNETIC DATA CARRIERS; DISC MEMORIES; VENDING MACHINES; COIN ACCEPTORS FOR SEPARATING GOOD COINS FROM COUNTERFEITS; CASH REGISTERS, CALCULATING SCALES; CALCULATORS; CURRENCY COUNTING MACHINES; DATA PROCESSORS; COMPUTERS; FIRE EXTINGUISHERS (U.S. CLS. 21, 23, 26, 36 AND 38).

FIRST USE 10-8-2006; IN COMMERCE 10-7-2007.

3,632,352. IDEXX LABORATORIES, INC., WESTBROOK, ME. SN 77-337,765. PUB. 12-9-2008, FILED 11-27-2007.

SINGLESPOT

THE MARK CONSISTS OF STANDARD CHARACTERS WITHOUT CLAIM TO ANY PARTICULAR FONT, STYLE, SIZE, OR COLOR.

FOR SINGLE-WELL GLASS SLIDE USED FOR MICROSCOPIC EXAMINATION OF WATERBORNE PATHOGENS (U.S. CLS. 21, 23, 26, 36 AND 38).

FIRST USE 3-28-2008; IN COMMERCE 3-28-2008.

CLASS 9—(Continued).

3,632,361. FORTISPHERE, INC., CHANTILLY, VA. SN 77-341,815. PUB. 8-19-2008, FILED 12-1-2007.

VIRTUAL ESSENTIALS

THE MARK CONSISTS OF STANDARD CHARACTERS WITHOUT CLAIM TO ANY PARTICULAR FONT, STYLE, SIZE, OR COLOR.

NO CLAIM IS MADE TO THE EXCLUSIVE RIGHT TO USE "VIRTUAL", APART FROM THE MARK AS SHOWN.

FOR COMPUTER SOFTWARE FOR USE IN DEPLOYING, MONITORING AND MANAGING VIRTUAL MACHINES AND VIRTUAL ENVIRONMENTS COMPRISED OF COMPUTERS, COMPUTER OPERATING SYSTEMS, AND COMPUTER SOFTWARE APPLICATIONS; COMPUTER SOFTWARE FOR THE ENFORCEMENT OF AUTHORIZATION AND NETWORK POLICIES IN A VIRTUAL ENVIRONMENT; COMPUTER SOFTWARE FOR THE DETECTION, PREVENTION AND REMEDIATION OF VIRTUAL ENVIRONMENT SECURITY THREATS; COMPUTER SOFTWARE FOR USE IN EVALUATING AND MONITORING COMPUTERS, COMPUTER OPERATING SYSTEMS, AND COMPUTER NETWORKS FOR INFORMATION TECHNOLOGY SECURITY RISKS (U.S. CLS. 21, 23, 26, 36 AND 38).

FIRST USE 12-0-2008; IN COMMERCE 12-0-2008.

3,632,362. FORTISPHERE, INC., CHANTILLY, VA. SN 77-341,816. PUB. 8-19-2008, FILED 12-1-2007.

VIRTUAL FORESIGHT

THE MARK CONSISTS OF STANDARD CHARACTERS WITHOUT CLAIM TO ANY PARTICULAR FONT, STYLE, SIZE, OR COLOR.

NO CLAIM IS MADE TO THE EXCLUSIVE RIGHT TO USE "VIRTUAL", APART FROM THE MARK AS SHOWN.

FOR COMPUTER SOFTWARE FOR USE IN DEPLOYING, MONITORING AND MANAGING VIRTUAL MACHINES AND VIRTUAL ENVIRONMENTS COMPRISED OF COMPUTERS, COMPUTER OPERATING SYSTEMS, AND COMPUTER SOFTWARE APPLICATIONS; COMPUTER SOFTWARE FOR THE ENFORCEMENT OF AUTHORIZATION AND NETWORK POLICIES IN A VIRTUAL ENVIRONMENT; COMPUTER SOFTWARE FOR THE DETECTION, PREVENTION AND REMEDIATION OF VIRTUAL ENVIRONMENT SECURITY THREATS; COMPUTER SOFTWARE FOR USE IN EVALUATING AND MONITORING COMPUTERS, COMPUTER OPERATING SYSTEMS, AND COMPUTER NETWORKS FOR INFORMATION TECHNOLOGY SECURITY RISKS (U.S. CLS. 21, 23, 26, 36 AND 38).

FIRST USE 1-0-2008; IN COMMERCE 1-0-2008.

CLASS 9—(Continued).

3,632,363. FORTISPHERE, INC., CHANTILLY, VA. SN 77-341,817. PUB. 8-19-2008, FILED 12-1-2007.

VIRTUAL INSIGHT

THE MARK CONSISTS OF STANDARD CHARACTERS WITHOUT CLAIM TO ANY PARTICULAR FONT, STYLE, SIZE, OR COLOR.

NO CLAIM IS MADE TO THE EXCLUSIVE RIGHT TO USE "VIRTUAL", APART FROM THE MARK AS SHOWN.

FOR COMPUTER SOFTWARE FOR USE IN DEPLOYING, MONITORING AND MANAGING VIRTUAL MACHINES AND VIRTUAL ENVIRONMENTS COMPRISED OF COMPUTERS, COMPUTER OPERATING SYSTEMS, AND COMPUTER SOFTWARE APPLICATIONS; COMPUTER SOFTWARE FOR THE ENFORCEMENT OF AUTHORIZATION AND NETWORK POLICIES IN A VIRTUAL ENVIRONMENT; COMPUTER SOFTWARE FOR THE DETECTION, PREVENTION AND REMEDIATION OF VIRTUAL ENVIRONMENT SECURITY THREATS; COMPUTER SOFTWARE FOR USE IN EVALUATING AND MONITORING COMPUTERS, COMPUTER OPERATING SYSTEMS, AND COMPUTER NETWORKS FOR INFORMATION TECHNOLOGY SECURITY RISKS (U.S. CLS. 21, 23, 26, 36 AND 38).

FIRST USE 1-0-2008; IN COMMERCE 1-0-2008.

CLASS 9—(Continued).

3,632,377. CHAWLA, ANUJ, CHANDIGARH, INDIA. SN 77-349,291. PUB. 5-20-2008, FILED 12-11-2007.

PROAIM

THE MARK CONSISTS OF STANDARD CHARACTERS WITHOUT CLAIM TO ANY PARTICULAR FONT, STYLE, SIZE, OR COLOR.

FOR HAND HELD FILM CAMERA, VIDEO CAMERA AND PHOTO CAMERA ACCESSORIES, NAMELY, STABILIZING SYSTEMS COMPRISED OF RESTS AND PLATFORMS, BODY SUPPORTS AND SHOULDER SUPPORTS BEING STABILIZERS, MADE OUT OF METAL, PLASTIC, FOAM AND CLOTH; LIGHT DIRECTORS FOR USE WITH PHOTOGRAPHIC LIGHTING EQUIPMENT FOR PROFESSIONAL AND HIGH-END PHOTOGRAPHY, NAMELY, SUNSHADES; FOLLOW FOCUS DEVICES, FOLLOW FOCUS DEVICE GEARED RINGS; HAND HELD FILM CAMERA, VIDEO CAMERA AND PHOTO CAMERA ACCESSORIES, NAMELY, DEPTH OF FIELD ADAPTERS, ROD SUPPORT MOUNTS FOR SECURING ADD-ON EQUIPMENT, SUPPORTS, AND JIBS; MICROPHONE ACCESSORIES, NAMELY, MICROPHONE WIND SHIELDS, MICROPHONE STANDS (U.S. CLS. 21, 23, 26, 36 AND 38).

FIRST USE 1-1-2008; IN COMMERCE 1-1-2008.

3,632,366. ATI TECHNOLOGIES ULC, CALGARY, ALBERTA, CANADA. SN 77-343,969. PUB. 12-2-2008, FILED 12-4-2007.

FIRESTREAM

THE MARK CONSISTS OF STANDARD CHARACTERS WITHOUT CLAIM TO ANY PARTICULAR FONT, STYLE, SIZE, OR COLOR.

OWNER OF U.S. REG. NO. 2,357,902.

FOR MICROPROCESSORS, MICROPROCESSOR FOR USE IN STREAM PROCESSING, AND SOFTWARE RELATED THERETO (U.S. CLS. 21, 23, 26, 36 AND 38).

FIRST USE 7-31-2006; IN COMMERCE 7-31-2006.

3,632,380. MULTIMEDIA GAMES, INC., AUSTIN, TX. SN 77-352,333. PUB. 7-22-2008, FILED 12-14-2007.

Shopping Spree

THE MARK CONSISTS OF STANDARD CHARACTERS WITHOUT CLAIM TO ANY PARTICULAR FONT, STYLE, SIZE, OR COLOR.

FOR GAMING MACHINES, NAMELY, ELECTRONIC SLOT AND BINGO MACHINES; VIDEO LOTTERY TERMINALS (U.S. CLS. 21, 23, 26, 36 AND 38).

FIRST USE 4-22-2008; IN COMMERCE 4-22-2008.

CLASS 9—(Continued).

3,632,383. SCT PERFORMANCE, LLC, LONGWOOD, FL. SN 77-352,907. PUB. 12-9-2008, FILED 12-14-2007.

X3

THE MARK CONSISTS OF STANDARD CHARACTERS WITHOUT CLAIM TO ANY PARTICULAR FONT, STYLE, SIZE, OR COLOR.

FOR ELECTRONIC AUTOMOTIVE TUNING DEVICE, NAMELY, ELECTRONIC CONTROL HARDWARE UNIT WHICH INTERFACES WITH A CAR'S DRIVE-TRAIN COMPUTER SYSTEM AND REPROGRAMS THE CAR'S MICROCHIP TO MAKE IT GO FASTER, HAVE MORE POWER AND GET BETTER GAS MILEAGE (U.S. CLS. 21, 23, 26, 36 AND 38).

FIRST USE 3-15-2007; IN COMMERCE 3-15-2007.

3,632,389. SONY CORPORATION, TOKYO, JAPAN. SN 77-355,486. PUB. 7-8-2008, FILED 12-19-2007.

S-FRAME

THE MARK CONSISTS OF STANDARD CHARACTERS WITHOUT CLAIM TO ANY PARTICULAR FONT, STYLE, SIZE, OR COLOR.

FOR DIGITAL PHOTO FRAMES FOR DISPLAYING DIGITAL PICTURES AND VIDEO CLIPS (U.S. CLS. 21, 23, 26, 36 AND 38).

FIRST USE 3-31-2008; IN COMMERCE 3-31-2008.

3,632,391. SPEAKERCRAFT, INC., RIVERSIDE, CA. SN 77-355,776. PUB. 5-13-2008, FILED 12-19-2007.

THE SOURCE

THE MARK CONSISTS OF STANDARD CHARACTERS WITHOUT CLAIM TO ANY PARTICULAR FONT, STYLE, SIZE, OR COLOR.

FOR COMPUTER KEYPADS (U.S. CLS. 21, 23, 26, 36 AND 38).

FIRST USE 12-30-2008; IN COMMERCE 12-30-2008.

CLASS 9—(Continued).

3,632,392. CMMS DATA GROUP, INC., CHICAGO, IL. SN 77-355,887. PUB. 1-13-2009, FILED 12-19-2007.



NO CLAIM IS MADE TO THE EXCLUSIVE RIGHT TO USE "PLANT", APART FROM THE MARK AS SHOWN.

THE MARKS CONSISTS OF THE WORDING "MVP PLANT", TO THE RIGHT OF WHICH IS A DESIGN COMPRISED OF THREE COGS.

FOR COMPUTER SOFTWARE FOR COMPUTERIZED MAINTENANCE MANAGEMENT FOR CAPITAL ASSETS (U.S. CLS. 21, 23, 26, 36 AND 38).

FIRST USE 2-15-2008; IN COMMERCE 2-15-2008.

3,632,425. KELTON, HAL, SALINAS, CA. SN 77-369,137. PUB. 6-10-2008, FILED 1-11-2008.

Door Data Solutions

THE MARK CONSISTS OF STANDARD CHARACTERS WITHOUT CLAIM TO ANY PARTICULAR FONT, STYLE, SIZE, OR COLOR.

NO CLAIM IS MADE TO THE EXCLUSIVE RIGHT TO USE "DATA SOLUTIONS", APART FROM THE MARK AS SHOWN.

FOR COMPUTER SOFTWARE AND HARDWARE FOR THE COLLECTION, EDITING, ORGANIZING, MODIFYING, BOOK MARKING, TRANSMISSION, STORAGE AND SHARING OF DATA AND INFORMATION (U.S. CLS. 21, 23, 26, 36 AND 38).

FIRST USE 2-1-2008; IN COMMERCE 8-16-2008.

3,632,431. CENTRIA, MOON TOWNSHIP, PA. SN 77-371,110. PUB. 5-27-2008, FILED 1-14-2008.

EnergyPeak

THE MARK CONSISTS OF STANDARD CHARACTERS WITHOUT CLAIM TO ANY PARTICULAR FONT, STYLE, SIZE, OR COLOR.

FOR ROOFING SYSTEMS CONTAINING PHOTOVOLTAIC CELLS FOR USE BY EXISTING MANUFACTURERS OF STANDING SEAM METAL ROOFING PRODUCTS (U.S. CLS. 21, 23, 26, 36 AND 38).

FIRST USE 10-10-2008; IN COMMERCE 10-10-2008.

CLASS 9—(Continued).

3,632,436. DIEBOLD, INCORPORATED, NORTH CANTON, OH. SN 77-372,633. PUB. 11-18-2008, FILED 1-15-2008.

INNOVATION DELIVERED

THE MARK CONSISTS OF STANDARD CHARACTERS WITHOUT CLAIM TO ANY PARTICULAR FONT, STYLE, SIZE, OR COLOR.

FOR AUTOMATED BANKING MACHINES, NAMELY, CUSTOMER-ACTIVATED AND TELLER-ACTIVATED AUTOMATED BANKING MACHINES; SELF-SERVICE AUTOMATED BANKING TERMINALS; CURRENCY MACHINES, NAMELY, DEVICES FOR ASSESSING THE TYPE AND VALIDITY OF CURRENCY (U.S. CLS. 21, 23, 26, 36 AND 38).

FIRST USE 4-15-2009; IN COMMERCE 4-15-2009.

CLASS 9—(Continued).

3,632,473. DATACORE SOFTWARE CORPORATION, FORT LAUDERDALE, FL. SN 77-388,061. PUB. 7-1-2008, FILED 2-4-2008.

SANHARMONY

THE MARK CONSISTS OF STANDARD CHARACTERS WITHOUT CLAIM TO ANY PARTICULAR FONT, STYLE, SIZE, OR COLOR.

OWNER OF U.S. REG. NOS. 2,488,736, 3,012,086, AND OTHERS.

FOR COMPUTER SOFTWARE FOR THE PURPOSE OF DATA AND INFORMATION STORAGE, ACCESS, AND RETRIEVAL (U.S. CLS. 21, 23, 26, 36 AND 38).

FIRST USE 11-26-2008; IN COMMERCE 11-26-2008.

3,632,447. POWER MONITORS, INC., MOUNT CRAWFORD, VA. SN 77-377,150. PUB. 6-3-2008, FILED 1-22-2008.

PROVISION MOBILE

THE MARK CONSISTS OF STANDARD CHARACTERS WITHOUT CLAIM TO ANY PARTICULAR FONT, STYLE, SIZE, OR COLOR.

OWNER OF U.S. REG. NO. 3,365,102.

FOR VOLTAGE MEASUREMENT AND RECORDING EQUIPMENT AND ASSOCIATED SOFTWARE FOR USE IN RESIDENTIAL, COMMERCIAL, RETAIL, INSTITUTIONAL, INDUSTRIAL, AND SUBSTATION APPLICATIONS (U.S. CLS. 21, 23, 26, 36 AND 38).

FIRST USE 9-1-2008; IN COMMERCE 9-1-2008.

3,632,483. SECURE-IT, INC., EAST LONGMEADOW, MA. SN 77-390,870. PUB. 6-24-2008, FILED 2-7-2008.

PRIVATEVUE

THE MARK CONSISTS OF STANDARD CHARACTERS WITHOUT CLAIM TO ANY PARTICULAR FONT, STYLE, SIZE, OR COLOR.

FOR INTEGRATED COMPUTER SCREEN AND PRIVACY FILTER (U.S. CLS. 21, 23, 26, 36 AND 38).

FIRST USE 4-24-2008; IN COMMERCE 9-26-2008.

3,632,452. GALMACCI, ANDREA, LIDO DI CAMAIORE, ITALY. SN 77-381,643. PUB. 6-17-2008, FILED 1-28-2008.

polpreco

THE MARK CONSISTS OF STANDARD CHARACTERS WITHOUT CLAIM TO ANY PARTICULAR FONT, STYLE, SIZE, OR COLOR.

FOR ILLUMINATION REGULATORS (U.S. CLS. 21, 23, 26, 36 AND 38).

FIRST USE 1-1-2008; IN COMMERCE 1-12-2008.

3,632,485. A.C.E. INTERNATIONAL COMPANY, INC., TAUNTON, MA. SN 77-391,087. PUB. 12-16-2008, FILED 2-7-2008.

Be Unique

THE MARK CONSISTS OF THE WORDS "BE UNIQUE" WITH A THUMBPRINT BEHIND THE LETTERS "U", "N" AND "I" OF THE WORD "UNIQUE."

FOR WELDING HELMETS AND FILTERS, NAMELY, FILTER LENS FOR WELDING HELMETS (U.S. CLS. 21, 23, 26, 36 AND 38).

FIRST USE 3-6-2008; IN COMMERCE 3-6-2008.

CLASS 9—(Continued).

3,632,500. CELARTEM, INC, DBA EXTENSIS, PORTLAND, OR. SN 77-394,045. PUB. 6-24-2008, FILED 2-11-2008.

CLASS 9—(Continued).

3,632,537. MADCAP LOGIC, LLC, DURANGO, CO. SN 77-402,417. PUB. 7-8-2008, FILED 2-21-2008.

TYPE SERVER

THE MARK CONSISTS OF STANDARD CHARACTERS WITHOUT CLAIM TO ANY PARTICULAR FONT, STYLE, SIZE, OR COLOR.

NO CLAIM IS MADE TO THE EXCLUSIVE RIGHT TO USE "SERVER", APART FROM THE MARK AS SHOWN.

FOR DOWNLOADABLE SOFTWARE FOR USE IN TRADITIONAL PUBLISHING AND FOR USE IN DIGITAL PUBLISHING (U.S. CLS. 21, 23, 26, 36 AND 38).

FIRST USE 6-30-2008; IN COMMERCE 6-30-2008.

CREATIVITY EXPRESS

THE MARK CONSISTS OF STANDARD CHARACTERS WITHOUT CLAIM TO ANY PARTICULAR FONT, STYLE, SIZE, OR COLOR.

FOR INTERACTIVE EDUCATIONAL SOFTWARE FOR CHILDREN AGES 7-12 HAVING A BLEND OF ANIMATED MOVIES AND INTERACTIVE ACTIVITIES THAT TEACH THE PRINCIPLES OF ART, AND PROVIDE TOOLS FOR SELF EXPRESSION (U.S. CLS. 21, 23, 26, 36 AND 38).

FIRST USE 10-0-2007; IN COMMERCE 11-7-2007.

3,632,516. FFL PRODUCTIONS, LLC, NEW YORK, NY. SN 77-397,329. PUB. 7-1-2008, FILED 2-14-2008.



THE COLOR(S) LIGHT GREEN, GREEN AND YELLOW IS/ARE CLAIMED AS A FEATURE OF THE MARK.

THE MARK CONSISTS OF A CURVED YELLOW LINE ABOVE THE WORDING "FUNCTION FOR LIFE". THE WORD "FUNCTION" IS IN LIGHT GREEN AND THE WORDS "FOR LIFE" ARE IN GREEN.

FOR PRE-RECORDED AUDIO AND VIDEO TAPES, CDS AND DVDS IN THE FIELD OF HEALTH, EXERCISE, FITNESS AND PERSONAL MOTIVATION (U.S. CLS. 21, 23, 26, 36 AND 38).

FIRST USE 8-16-2006; IN COMMERCE 8-16-2006.

3,632,550. WORKPLACE HEARING, INC., GREENSBORO, NC. SN 77-404,758. PUB. 7-15-2008, FILED 2-25-2008.

INTEGRAFIT

3,632,518. EDDIE MIZRAHI, BROOKLYN, NY. SN 77-397,795. PUB. 7-8-2008, FILED 2-15-2008.

MY HOME YOUR HOME

THE MARK CONSISTS OF STANDARD CHARACTERS WITHOUT CLAIM TO ANY PARTICULAR FONT, STYLE, SIZE, OR COLOR.

FOR A PAIR OF WEBCAMS SOLD TOGETHER WITH A PRE-PAID MAILER FOR SHIPPING ONE OF THE WEBCAMS TO A PURCHASER-SELECTED DESTINATION (U.S. CLS. 21, 23, 26, 36 AND 38).

FIRST USE 3-21-2009; IN COMMERCE 3-21-2009.

THE MARK CONSISTS OF STANDARD CHARACTERS WITHOUT CLAIM TO ANY PARTICULAR FONT, STYLE, SIZE, OR COLOR.

FOR HEARING PROTECTOR TESTING AND VALIDATION SYSTEM COMPRISED OF A SIGNAL PROCESSOR, SOFTWARE AND HEADSET USED TO DETERMINE THE LEVEL OF NOISE PROTECTION DELIVERED TO AN INDIVIDUAL BY HEARING PROTECTIVE DEVICES (U.S. CLS. 21, 23, 26, 36 AND 38).

FIRST USE 3-31-2009; IN COMMERCE 3-31-2009.

CLASS 9—(Continued).

3,632,551. SUPERCIRCUITS, INC., AUSTIN, TX. SN 77-404,910. PUB. 7-22-2008, FILED 2-25-2008.

CLASS 9—(Continued).

3,632,561. PRENATAL PRESCHOOL, INC., BOCA RATON, FL. SN 77-406,467. PUB. 1-13-2009, FILED 2-26-2008.

S|C BLACK

PRENATAL PRESCHOOL

THE MARK CONSISTS OF STANDARD CHARACTERS WITHOUT CLAIM TO ANY PARTICULAR FONT, STYLE, SIZE, OR COLOR.

OWNER OF U.S. REG. NO. 2,993,235.

FOR PHOTOGRAPHIC CAMERAS, VIDEO CAMERAS, CAMERA LENSES, CAMERA HOUSINGS, VCR RECORDERS, ELECTRIC SWITCHES, DIGITAL QUAD UNITS FOR VIEWING MULTIPLE VIDEO IMAGES ON ONE MONITOR, AUDIO MONITORS, VIDEO MONITORS, AUDIO TRANSMITTERS, VIDEO TRANSMITTERS, AUDIO RECEIVERS, VIDEO RECEIVERS, ANTENNAS, ROBOTS FOR PERSONAL AND/OR HOBBY USE, MICROPHONES, SECURITY EQUIPMENT, NAMELY, BURGLAR ALARMS, MOTION SENSORS, ELECTRONIC EQUIPMENT FOR ACCESS CONTROL; AND INTRUSION DETECTION EQUIPMENT, NAMELY, BURGLAR ALARMS, MOTION SENSORS, AND ELECTRONIC EQUIPMENT FOR ACCESS CONTROL (U.S. CLS. 21, 23, 26, 36 AND 38).

FIRST USE 3-0-2008; IN COMMERCE 4-0-2008.

THE MARK CONSISTS OF STANDARD CHARACTERS WITHOUT CLAIM TO ANY PARTICULAR FONT, STYLE, SIZE, OR COLOR.

NO CLAIM IS MADE TO THE EXCLUSIVE RIGHT TO USE "PRENATAL", APART FROM THE MARK AS SHOWN.

FOR EARLY ENRICHMENT SYSTEM USED TO STIMULATE BRAIN DEVELOPMENT DURING EARLY PREGNANCY, COMPRISED OF HEADPHONES, PORTABLE AND HANDHELD DIGITAL ELECTRONIC DEVICES FOR RECORDING, ORGANIZING, TRANSMITTING, MANIPULATING, AND REVIEWING AUDIO FILES, MUSIC FILES AND STORIES, AN ABDOMINAL BELT CONTAINING BUILT-IN SPEAKERS FOR PURPOSES OF TRANSMITTING MUSIC, SOUNDS, AND EDUCATIONAL STORIES TO A FETUS AND BUILT-IN POCKETS IN WHICH TO CARRY AUDIO TRANSMITTERS, AND WRITTEN STORIES SOLD AS A UNIT (U.S. CLS. 21, 23, 26, 36 AND 38).

FIRST USE 2-15-2008; IN COMMERCE 2-15-2008.

3,632,560. INTERNET CONNECTIVITY GROUP, INC., LAKE FOREST, CA. SN 77-406,445. PUB. 7-8-2008, FILED 2-26-2008.

3,632,563. DNA DIGITAL MEDIA GROUP, CHICAGO, IL. SN 77-406,634. PUB. 7-15-2008, FILED 2-26-2008.

Proco Solutions

MeMail

THE MARK CONSISTS OF STANDARD CHARACTERS WITHOUT CLAIM TO ANY PARTICULAR FONT, STYLE, SIZE, OR COLOR.

NO CLAIM IS MADE TO THE EXCLUSIVE RIGHT TO USE "SOLUTIONS", APART FROM THE MARK AS SHOWN.

FOR FIRMWARE AND SOFTWARE THAT ALLOWS FOR REAL TIME COMBINATION, SYNCHRONIZATION, COMPRESSION, AND DECOMPRESSION OF AUDIO, VIDEO AND OTHER MULTIMEDIA THAT IS TRANSMITTED WIRELESSLY (U.S. CLS. 21, 23, 26, 36 AND 38).

FIRST USE 2-27-2008; IN COMMERCE 2-27-2008.

THE MARK CONSISTS OF STANDARD CHARACTERS WITHOUT CLAIM TO ANY PARTICULAR FONT, STYLE, SIZE, OR COLOR.

FOR COMPUTER SOFTWARE TO ENHANCE THE AUDIO-VISUAL CAPABILITIES OF MULTIMEDIA APPLICATIONS, NAMELY, FOR THE INTEGRATION OF TEXT, AUDIO, GRAPHICS, STILL IMAGES AND MOVING PICTURES (U.S. CLS. 21, 23, 26, 36 AND 38).

FIRST USE 6-8-2008; IN COMMERCE 6-8-2008.

CLASS 9—(Continued).

3,632,586. KONAMI GAMING, INC., LAS VEGAS, NV. SN 77-410,470. PUB. 7-15-2008, FILED 2-29-2008.

CLASS 9—(Continued).

3,632,612. WANG, ZHAOMING, WUHAN, HUBEI, CHINA. SN 77-414,350. PUB. 7-29-2008, FILED 3-5-2008.

MYSTICAL TEMPLE

THE MARK CONSISTS OF STANDARD CHARACTERS WITHOUT CLAIM TO ANY PARTICULAR FONT, STYLE, SIZE, OR COLOR.

FOR ELECTRONIC GAME PROGRAMS; GAMING EQUIPMENT, NAMELY, SLOT MACHINES WITH OR WITHOUT VIDEO OUTPUT; GAMING MACHINES; MACHINES FOR PLAYING GAMES OF CHANCE; SLOT MACHINES (U.S. CLS. 21, 23, 26, 36 AND 38).

FIRST USE 12-1-2006; IN COMMERCE 12-1-2006.

MICANI



THE MARK CONSISTS OF SIX CAPITALIZED ENGLISH LETTERS "MICANI" AND A SPHERE POSITIONED BELOW THE LETTERS.

THE WORDING "MICANI" HAS NO MEANING IN A FOREIGN LANGUAGE.

FOR CASES FOR PORTABLE TELEPHONES; CD STORAGE WALLETS; MESSENGER BAGS ESPECIALLY ADAPTED FOR HOLDING LAPTOPS; CAMERA CASES AND BAGS; PROTECTIVE CARRYING CASES FOR PORTABLE ELECTRONIC DEVICES AND MUSIC PLAYERS, NAMELY, MP3 PLAYERS, PERSONAL DIGITAL ASSISTANTS (PDAS) (U.S. CLS. 21, 23, 26, 36 AND 38).

FIRST USE 3-5-2008; IN COMMERCE 3-5-2008.

3,632,587. RGB SYSTEMS, INC., ANAHEIM, CA. SN 77-410,779. PUB. 7-22-2008, FILED 3-2-2008.

VOICELIFT

THE MARK CONSISTS OF STANDARD CHARACTERS WITHOUT CLAIM TO ANY PARTICULAR FONT, STYLE, SIZE, OR COLOR.

FOR CLASSROOM AUDIO AMPLIFICATION SYSTEM COMPRISING MICROPHONES, SOUND MIXERS WITH INTEGRATED AMPLIFIERS, AND SPEAKERS (U.S. CLS. 21, 23, 26, 36 AND 38).

FIRST USE 6-29-2008; IN COMMERCE 6-29-2008.

3,632,625. POSITEC GROUP LIMITED, HONG KONG ADM. REGION, CHINA. SN 77-415,699. PUB. 7-29-2008, FILED 3-7-2008.



3,632,610. HODGES, RICHARD, CULVER CITY, CA. SN 77-414,226. PUB. 7-22-2008, FILED 3-5-2008.

ZAPLEX

THE MARK CONSISTS OF STANDARD CHARACTERS WITHOUT CLAIM TO ANY PARTICULAR FONT, STYLE, SIZE, OR COLOR.

FOR DISPOSABLE, ELASTOMERIC, TRANSPARENT PROTECTIVE COVER FOR ENTERTAINMENT EQUIPMENT REMOTE CONTROLS (U.S. CLS. 21, 23, 26, 36 AND 38).

FIRST USE 2-25-2009; IN COMMERCE 2-25-2009.

THE MARK CONSISTS OF "POWERSHARE" IN STYLIZED FORMAT WITH THREE ARROWS EXTENDING FROM THE "SHARE" PORTION OF THE MARK, ONE OF WHICH EXTENDS ABOVE THE LETTER "H", ONE OF WHICH EXTENDS BELOW THE LETTER "H", AND THE THIRD OF WHICH EXTENDS FROM THE RIGHT OF THE LETTER "E".

FOR BATTERIES FOR POWER TOOLS; BATTERIES FOR LIGHTING; BATTERY CHARGERS; BATTERY PACKS (U.S. CLS. 21, 23, 26, 36 AND 38).

FIRST USE 6-6-2008; IN COMMERCE 6-6-2008.

CLASS 9—(Continued).

3,632,636. ERIKSFJORD, INC., HOUSTON, TX. SN 77-417,485.
PUB. 7-22-2008, FILED 3-10-2008.

Vinland Software Suite

THE MARK CONSISTS OF STANDARD CHARACTERS WITHOUT CLAIM TO ANY PARTICULAR FONT, STYLE, SIZE, OR COLOR.

NO CLAIM IS MADE TO THE EXCLUSIVE RIGHT TO USE "SOFTWARE SUITE", APART FROM THE MARK AS SHOWN.

FOR COMPUTER SOFTWARE PLATFORMS FOR INTERPRETATION AND PROCESSING OF GEOLOGICAL DATA (U.S. CLS. 21, 23, 26, 36 AND 38).

FIRST USE 8-15-2008; IN COMMERCE 8-15-2008.

3,632,639. GAMELOFT S.A., PARIS, FRANCE. SN 77-418,159.
PUB. 7-22-2008, FILED 3-10-2008.

DATE OR DITCH

THE MARK CONSISTS OF STANDARD CHARACTERS WITHOUT CLAIM TO ANY PARTICULAR FONT, STYLE, SIZE, OR COLOR.

FOR COMPUTER SOFTWARE FOR ELECTRONIC GAMES AND ENTERTAINMENT, NAMELY, COMPUTER GAME SOFTWARE USED AND PLAYED ON MOBILE AND CELLULAR TELEPHONES, HANDHELD COMPUTERS, PERSONAL COMPUTERS AND PERSONAL DIGITAL ASSISTANTS; DOWNLOADABLE ELECTRONIC GAME PROGRAMS; DOWNLOADABLE RING TONES; DOWNLOADABLE VOICE RINGERS FOR MOBILE TELECOMMUNICATIONS DEVICES; COMPUTER SOFTWARE FOR WALL PAPERS, NAMELY, STILL IMAGES FOR USE IN BACKGROUNDS ON MOBILE PHONE SCREENS; COMPUTER SCREEN SAVER SOFTWARE; COMPUTER SOFTWARE FOR PROCESSING ANIMATED IMAGES FOR USE ON MOBILE PHONE SCREENS; AND PROGRAMS FOR DOWNLOADING IMAGES TO MOBILE TELECOMMUNICATION DEVICES, NAMELY, MOBILE AND CELLULAR TELEPHONES, HANDHELD COMPUTERS, PERSONAL COMPUTERS AND PERSONAL DIGITAL ASSISTANTS VIA THE GLOBAL COMPUTER NETWORK AND WIRELESS DEVICES; AND COMPUTER SOFTWARE FOR USE IN THE DESIGN, DEVELOPMENT AND EXECUTION OF WIRELESS COMPUTER GAMES (U.S. CLS. 21, 23, 26, 36 AND 38).

FIRST USE 1-31-2009; IN COMMERCE 1-31-2009.

CLASS 9—(Continued).

3,632,640. THE ARMOR ALL/STP PRODUCTS COMPANY, OAKLAND, CA. SN 77-418,758. PUB. 7-29-2008, FILED 3-11-2008.

STP

THE MARK CONSISTS OF STANDARD CHARACTERS WITHOUT CLAIM TO ANY PARTICULAR FONT, STYLE, SIZE, OR COLOR.

OWNER OF U.S. REG. NOS. 648,087, 2,704,259, AND OTHERS.

FOR BAROMETERS (U.S. CLS. 21, 23, 26, 36 AND 38).
FIRST USE 10-1-2008; IN COMMERCE 10-1-2008.

3,632,652. RAYSPAN CORPORATION, SAN DIEGO, CA. SN 77-421,624. PUB. 7-29-2008, FILED 3-13-2008.

METACOMBINER

THE MARK CONSISTS OF STANDARD CHARACTERS WITHOUT CLAIM TO ANY PARTICULAR FONT, STYLE, SIZE, OR COLOR.

FOR AMPLIFIER FOR WIRELESS COMMUNICATIONS; ANTENNAS FOR WIRELESS COMMUNICATIONS APPARATUS; APPARATUS FOR WIRELESS TRANSMISSION OF ACOUSTIC INFORMATION; COMPUTER HARDWARE, NAMELY, WIRELESS ACCESS POINT (WAP) DEVICES; COMPUTER SOFTWARE FOR WIRELESS CONTENT DELIVERY; ANTENNA PARAMETER MEASURING APPARATUS; ANTENNAE; ANTENNAE FILTERS; ANTENNAS; ANTENNAS FOR RADIO, FOR TELEVISION; DEVICES FOR WIRELESS RADIO TRANSMISSION; ELECTRONIC COMBINERS FOR CONNECTING ANTENNAS AND RECEIVERS; HOME AND OFFICE AUTOMATION SYSTEMS COMPRISING WIRELESS AND WIRED CONTROLLERS, CONTROLLED DEVICES, AND SOFTWARE FOR LIGHTING, HVAC, SECURITY, SAFETY AND OTHER HOME AND OFFICE MONITORING AND CONTROL APPLICATIONS; INTEGRATED CIRCUITS AND INTEGRATED CIRCUIT CORES FOR USE IN WIRELESS COMMUNICATIONS AND WIRELESS COMMUNICATION EQUIPMENT AND APPARATUS AND DIGITAL SIGNAL PROCESSORS (DSP); MICROWAVE ANTENNAE; MOBILE COMPUTING AND OPERATING PLATFORMS CONSISTING OF DATA TRANSCEIVERS, WIRELESS NETWORKS AND GATEWAYS FOR COLLECTION AND MANAGEMENT OF DATA; VEHICLE LOCATING, TRACKING AND SECURITY SYSTEM COMPRISED OF AN ANTENNA AND RADIO TRANSMITTER TO BE PLACED IN A VEHICLE; WIRELESS COMPUTER PERIPHERALS; WIRELESS NARROW-BAND RADIOS; WIRELESS TELEPHONES; WIRELESS TELEPHONY APPARATUS (U.S. CLS. 21, 23, 26, 36 AND 38).

FIRST USE 3-13-2008; IN COMMERCE 11-18-2008.

CLASS 9—(Continued).

3,632,653. RAYSPAN CORPORATION, SAN DIEGO, CA. SN 77-421,661. PUB. 7-29-2008, FILED 3-13-2008.

METAMPLIFIER

THE MARK CONSISTS OF STANDARD CHARACTERS WITHOUT CLAIM TO ANY PARTICULAR FONT, STYLE, SIZE, OR COLOR.

FOR AMPLIFIER FOR WIRELESS COMMUNICATIONS; ANTENNA PARAMETER MEASURING APPARATUS; ANTENNAE; ANTENNAE FILTERS; ANTENNAS; ANTENNAS FOR RADIO; FOR TELEVISION; ANTENNAS FOR WIRELESS COMMUNICATIONS APPARATUS; APPARATUS FOR WIRELESS TRANSMISSION OF ACOUSTIC INFORMATION; COMPUTER HARDWARE, NAMELY, WIRELESS ACCESS POINT (WAP) DEVICES; DEVICES FOR WIRELESS RADIO TRANSMISSION; ELECTRONIC COMBINERS FOR CONNECTING ANTENNAS AND RECEIVERS; HOME AND OFFICE AUTOMATION SYSTEMS COMPRISING WIRELESS AND WIRED CONTROLLERS, CONTROLLED DEVICES, AND SOFTWARE FOR LIGHTING, HVAC, SECURITY, SAFETY AND OTHER HOME AND OFFICE MONITORING AND CONTROL APPLICATIONS; INTEGRATED CIRCUITS AND INTEGRATED CIRCUIT CORES FOR USE IN WIRELESS COMMUNICATIONS AND WIRELESS COMMUNICATION EQUIPMENT AND APPARATUS AND DIGITAL SIGNAL PROCESSORS (DSP); MICROWAVE ANTENNAE; MOBILE COMPUTING AND OPERATING PLATFORMS CONSISTING OF DATA TRANSCIVERS, WIRELESS NETWORKS AND GATEWAYS FOR COLLECTION AND MANAGEMENT OF DATA; VEHICLE LOCATING, TRACKING AND SECURITY SYSTEM COMPRISED OF AN ANTENNA AND RADIO TRANSMITTER TO BE PLACED IN A VEHICLE; WIRELESS COMPUTER PERIPHERALS; WIRELESS NARROWBAND RADIOS; WIRELESS TELEPHONES; WIRELESS TELEPHONY APPARATUS (U.S. CLS. 21, 23, 26, 36 AND 38).
FIRST USE 3-13-2008; IN COMMERCE 11-18-2008.

3,632,655. POINT CREATIVE, INC., BEAVERTON, OR. SN 77-422,344. PUB. 7-29-2008, FILED 3-14-2008.

Aspen

THE MARK CONSISTS OF STANDARD CHARACTERS WITHOUT CLAIM TO ANY PARTICULAR FONT, STYLE, SIZE, OR COLOR.

FOR COMPUTER SOFTWARE FRAMEWORK FOR ORGANIZING, RUNNING AND DEVELOPING INSTALLABLE MODULES FOR WEB SITES AND WEB BASED APPLICATIONS (U.S. CLS. 21, 23, 26, 36 AND 38).
FIRST USE 2-1-2008; IN COMMERCE 4-1-2008.

CLASS 9—(Continued).

3,632,683. MULTIMEDIA GAMES, INC., AUSTIN, TX. SN 77-428,681. PUB. 7-8-2008, FILED 3-21-2008.

JALAPENNY-O

THE MARK CONSISTS OF STANDARD CHARACTERS WITHOUT CLAIM TO ANY PARTICULAR FONT, STYLE, SIZE, OR COLOR.

FOR GAMING MACHINES, NAMELY, ELECTRONIC SLOT AND BINGO MACHINES; VIDEO LOTTERY TERMINALS (U.S. CLS. 21, 23, 26, 36 AND 38).
FIRST USE 11-18-2008; IN COMMERCE 11-18-2008.

3,632,691. STRYKER CORPORATION, KALAMAZOO, MI. SN 77-431,920. PUB. 12-9-2008, FILED 3-26-2008.

SPINEMAP

THE MARK CONSISTS OF STANDARD CHARACTERS WITHOUT CLAIM TO ANY PARTICULAR FONT, STYLE, SIZE, OR COLOR.

FOR SOFTWARE FOR PROVIDING REFERENCE INFORMATION TO A MEDICAL PRACTITIONER DURING THE PERFORMANCE OF A MEDICAL OR SURGICAL PROCEDURE (U.S. CLS. 21, 23, 26, 36 AND 38).
FIRST USE 1-23-2009; IN COMMERCE 1-23-2009.

3,632,695. KONAMI GAMING, INC., LAS VEGAS, NV. SN 77-432,728. PUB. 7-15-2008, FILED 3-27-2008.

THAILAND FANTASY

THE MARK CONSISTS OF STANDARD CHARACTERS WITHOUT CLAIM TO ANY PARTICULAR FONT, STYLE, SIZE, OR COLOR.

FOR ELECTRONIC GAME PROGRAMS; GAMING EQUIPMENT, NAMELY, SLOT MACHINES WITH OR WITHOUT VIDEO OUTPUT; GAMING MACHINES; MACHINES FOR PLAYING GAMES OF CHANCE; SLOT MACHINES (U.S. CLS. 21, 23, 26, 36 AND 38).
FIRST USE 11-25-2008; IN COMMERCE 11-25-2008.

CLASS 9—(Continued).

3,632,710. PENTAIR WATER POOL AND SPA, INC., SANFORD, NC. SN 77-435,052. PUB. 8-12-2008, FILED 3-29-2008.

INTELLIBRITE

THE MARK CONSISTS OF STANDARD CHARACTERS WITHOUT CLAIM TO ANY PARTICULAR FONT, STYLE, SIZE, OR COLOR.

OWNER OF U.S. REG. NO. 3,349,770.
FOR ELECTRICAL CONTROLLERS FOR POOL, SPA, AND LANDSCAPE LIGHTING INSTALLATIONS (U.S. CLS. 21, 23, 26, 36 AND 38).

FIRST USE 2-4-2009; IN COMMERCE 2-4-2009.

3,632,734. EYEBANDZ, LLC, CORAL SPRINGS, FL. SN 77-441,363. PUB. 8-26-2008, FILED 4-7-2008.

EYEBANDZ

THE MARK CONSISTS OF STANDARD CHARACTERS WITHOUT CLAIM TO ANY PARTICULAR FONT, STYLE, SIZE, OR COLOR.

FOR EYEWEAR; EYEWEAR ACCESSORIES, NAMELY, STRAPS, NECK CORDS AND HEAD STRAPS WHICH RESTRAIN EYEWEAR FROM MOVEMENT ON A WEARER (U.S. CLS. 21, 23, 26, 36 AND 38).

FIRST USE 3-0-2009; IN COMMERCE 3-0-2009.

CLASS 9—(Continued).

3,632,745. SEAGATE TECHNOLOGY LLC, SCOTTS VALLEY, CA. SN 77-444,392. PUB. 9-2-2008, FILED 4-9-2008.



OWNER OF U.S. REG. NOS. 2,828,589, 2,957,890, AND OTHERS.

NO CLAIM IS MADE TO THE EXCLUSIVE RIGHT TO USE "SECURE", APART FROM THE MARK AS SHOWN.

FOR COMPUTER DISK DRIVES; HARD DISK DRIVES; DIGITAL DISK DRIVES; EXTERNAL COMPUTER HARD DRIVES; SELF-ENCRYPTED HARD DRIVES; COMPUTER SOFTWARE FOR ENCRYPTION OF DISK DRIVES; COMPUTER HARDWARE AND SOFTWARE FOR SECURE DATA STORAGE; COMPUTER MEMORY HARDWARE; COMPUTER HARDWARE AND PERIPHERAL DEVICES; COMPUTERS; NOTEBOOK AND LAPTOP COMPUTERS, DESKTOP COMPUTERS, AND COMPUTER SERVERS (U.S. CLS. 21, 23, 26, 36 AND 38).

FIRST USE 10-1-2007; IN COMMERCE 10-1-2007.

3,632,748. E. I. DU PONT DE NEMOURS AND COMPANY, WILMINGTON, DE. SN 77-445,261. PUB. 7-22-2008, FILED 4-10-2008.

RELIATRAN

THE MARK CONSISTS OF STANDARD CHARACTERS WITHOUT CLAIM TO ANY PARTICULAR FONT, STYLE, SIZE, OR COLOR.

FOR POWER AND DISTRIBUTION TRANSFORMERS (U.S. CLS. 21, 23, 26, 36 AND 38).

FIRST USE 4-21-2008; IN COMMERCE 4-21-2008.

CLASS 9—(Continued).

3,632,757. KONAMI GAMING, INC., LAS VEGAS, NV. SN 77-447,010. PUB. 7-15-2008, FILED 4-13-2008.

ARABIAN LAMP

THE MARK CONSISTS OF STANDARD CHARACTERS WITHOUT CLAIM TO ANY PARTICULAR FONT, STYLE, SIZE, OR COLOR.

OWNER OF U.S. REG. NO. 3,038,445.
FOR ELECTRONIC GAME PROGRAMS; GAMING EQUIPMENT, NAMELY, SLOT MACHINES WITH OR WITHOUT VIDEO OUTPUT; GAMING MACHINES; MACHINES FOR PLAYING GAMES OF CHANCE; SLOT MACHINES (U.S. CLS. 21, 23, 26, 36 AND 38).
FIRST USE 8-22-2008; IN COMMERCE 8-22-2008.

3,632,763. IKONIK TECHNOLOGY CO., LTD., TAIPEI 231, TAIWAN. SN 77-448,457. PUB. 10-28-2008, FILED 4-15-2008.



THE MARK CONSISTS OF WORD "IKONIK" WITH STYLIZED "O".

FOR COMPUTER CHASSIS; COMPUTER HEAT SINKS; COMPUTER KEYBOARDS; COMPUTER MOUSE; COMPUTER PERIPHERAL DEVICES; NOTEBOOK COMPUTER COOLING PADS; COMPUTER HARD DRIVE ENCLOSURES; BLANK DIGITAL STORAGE MEDIA; BLANK ELECTRONIC STORAGE MEDIA (U.S. CLS. 21, 23, 26, 36 AND 38).
FIRST USE 9-30-2008; IN COMMERCE 9-30-2008.

3,632,800. LEVI, RAY & SHOUP, INC., SPRINGFIELD, IL. SN 77-461,175. PUB. 9-23-2008, FILED 4-29-2008.

Innovate/Mill

THE MARK CONSISTS OF STANDARD CHARACTERS WITHOUT CLAIM TO ANY PARTICULAR FONT, STYLE, SIZE, OR COLOR.

FOR SOFTWARE PRODUCT THAT PROVIDES PROCESSING FLEXIBILITY TO THE INPUT DATA STREAM BY ALLOWING THE DATA TO BE MERGED MODIFIED INDEXED OR SPLIT (U.S. CLS. 21, 23, 26, 36 AND 38).
FIRST USE 12-2-2008; IN COMMERCE 12-2-2008.

CLASS 9—(Continued).

3,632,816. TYCO ELECTRONICS CORPORATION, BERWYN, PA. SN 77-467,209. PUB. 10-7-2008, FILED 5-6-2008.

VAL-U-LOK

THE MARK CONSISTS OF STANDARD CHARACTERS WITHOUT CLAIM TO ANY PARTICULAR FONT, STYLE, SIZE, OR COLOR.

FOR ELECTRICAL CONNECTORS (U.S. CLS. 21, 23, 26, 36 AND 38).
FIRST USE 6-30-2008; IN COMMERCE 6-30-2008.

3,632,819. TRI-TRONICS, INC., TUCSON, AZ. SN 77-468,607. PUB. 10-14-2008, FILED 5-7-2008.



OWNER OF U.S. REG. NOS. 1,219,788, 1,345,689, AND 2,993,860.

THE MARK CONSISTS OF MINOR AND INVERTED LETTERS "T" WITHIN A CIRCLE.

FOR ELECTRONIC ANIMAL TRAINING APPARATUS ATTACHED TO A COLLAR, WHICH IS USED FOR OBEDIENCE TRAINING, AND PARTS THEREOF (U.S. CLS. 21, 23, 26, 36 AND 38).

FIRST USE 2-19-2009; IN COMMERCE 2-19-2009.

CLASS 9—(Continued).

3,632,823. IP TECHNOLOGIES HOLDINGS, LLC, WEST LIBERTY, OH. SN 77-470,535. PUB. 10-14-2008, FILED 5-9-2008.

D-FOAM-R

THE MARK CONSISTS OF STANDARD CHARACTERS WITHOUT CLAIM TO ANY PARTICULAR FONT, STYLE, SIZE, OR COLOR.

FOR ULTRASONIC EQUIPMENT USED TO SUPPRESS BUBBLES IN ORDER TO MINIMIZE SPILLAGE WHILE FILLING BEVERAGE CONTAINERS (U.S. CLS. 21, 23, 26, 36 AND 38).

FIRST USE 2-25-2009; IN COMMERCE 2-25-2009.

3,632,824. BOSMA, MARINUS BERNARD, TIPP CITY, OH. AND BOSMA, VIRGINIA MARIE, TIPP CITY, OH. SN 77-471,238. PUB. 10-14-2008, FILED 5-10-2008.

CPF

THE MARK CONSISTS OF STANDARD CHARACTERS WITHOUT CLAIM TO ANY PARTICULAR FONT, STYLE, SIZE, OR COLOR.

FOR BACKPACKS ESPECIALLY ADAPTED FOR HOLDING LAPTOPS AND NOTEBOOK COMPUTERS; LAPTOP CARRYING CASES; MESSENGER BAGS ESPECIALLY ADAPTED FOR HOLDING LAPTOPS; PROTECTIVE SLEEVES FOR LAPTOP COMPUTERS; ROLLING CASES ESPECIALLY ADAPTED FOR HOLDING LAPTOPS AND NOTEBOOK COMPUTERS; WHEELED BACKPACKS ESPECIALLY ADAPTED FOR HOLDING LAPTOPS; WHEELED MESSENGER BAGS ESPECIALLY ADAPTED FOR HOLDING LAPTOPS; BAGS FOR CAMERAS AND PHOTOGRAPHIC EQUIPMENT (U.S. CLS. 21, 23, 26, 36 AND 38).

FIRST USE 2-1-2009; IN COMMERCE 2-1-2009.

CLASS 9—(Continued).

3,632,831. LAWMATE TECHNOLOGY CO., LTD., TAIPEI, TAIWAN. SN 77-474,977. PUB. 10-14-2008, FILED 5-15-2008.

LawMate

THE MARK CONSISTS OF STANDARD CHARACTERS WITHOUT CLAIM TO ANY PARTICULAR FONT, STYLE, SIZE, OR COLOR.

FOR COLOR MONITORING VIDEO CAMERAS; ELECTRONIC CAMERAS; MONITORING CAMCORDERS; CLOSED CIRCUIT TELEVISION MONITORS; TV CAMERAS; HEADPHONES; VIDEO RECORDERS; PORTABLE PERSONAL ALARMS FOR SELF-DEFENSE; BATTERIES; BATTERY BOXES; VIDEO CAMERAS (U.S. CLS. 21, 23, 26, 36 AND 38).

FIRST USE 10-1-2003; IN COMMERCE 10-1-2003.

3,632,842. ACHIEVIA DIRECT INC., DBA ACHIEVIA OPTICAL SOLUTIONS, DAYTONA BEACH, FL. SN 77-479,432. PUB. 10-21-2008, FILED 5-20-2008.

Ashby Grace

THE MARK CONSISTS OF STANDARD CHARACTERS WITHOUT CLAIM TO ANY PARTICULAR FONT, STYLE, SIZE, OR COLOR.

THE NAME "ASHBY GRACE" DOES NOT IDENTIFY A LIVING INDIVIDUAL.

FOR SUNGLASSES AND SPECTACLES (U.S. CLS. 21, 23, 26, 36 AND 38).

FIRST USE 6-30-2008; IN COMMERCE 8-9-2008.

3,632,844. COHERENT, INC., SANTA CLARA, CA. SN 77-479,624. PUB. 9-9-2008, FILED 5-20-2008.

GENESIS

THE MARK CONSISTS OF STANDARD CHARACTERS WITHOUT CLAIM TO ANY PARTICULAR FONT, STYLE, SIZE, OR COLOR.

FOR LASERS NOT FOR MEDICAL USE (U.S. CLS. 21, 23, 26, 36 AND 38).

FIRST USE 9-0-2007; IN COMMERCE 9-0-2007.

CLASS 9—(Continued).

3,632,856. GROVES INTERNET CONSULTING, INC., DBA SWIFT WEATHER, MINNEAPOLIS, MN. SN 77-483,633. PUB. 11-18-2008, FILED 5-27-2008.



WEATHER DEFENDER

NO CLAIM IS MADE TO THE EXCLUSIVE RIGHT TO USE "WEATHER", APART FROM THE MARK AS SHOWN.

THE MARK CONSISTS OF A SHIELD DIVIDED INTO FOUR QUADRANTS WITH A WEATHER ELEMENT IN EACH: WAVES IN UPPER-LEFT, TORNADO IN UPPER-RIGHT, HURRICANE SYMBOL IN LOWER-RIGHT, AND LIGHTNING BOLT IN LOWER-LEFT.

FOR COMPUTER SOFTWARE FOR THE PURPOSE OF WEATHER FORECASTING AND SEVERE WEATHER ALERTING (U.S. CLS. 21, 23, 26, 36 AND 38).

FIRST USE 11-24-2008; IN COMMERCE 3-6-2009.

CLASS 9—(Continued).

3,632,867. PROPERTY MUSIC GROUP, LLC, HOUSTON, TX. SN 77-487,271. PUB. 11-4-2008, FILED 5-30-2008.

PROPERTY MUSIC GROUP

THE MARK CONSISTS OF STANDARD CHARACTERS WITHOUT CLAIM TO ANY PARTICULAR FONT, STYLE, SIZE, OR COLOR.

NO CLAIM IS MADE TO THE EXCLUSIVE RIGHT TO USE "MUSIC GROUP", APART FROM THE MARK AS SHOWN.

FOR DIGITAL MEDIA, NAMELY, CDS AND DOWNLOADABLE AUDIO FILES FEATURING A MUSICAL GROUP (U.S. CLS. 21, 23, 26, 36 AND 38).

FIRST USE 6-23-2008; IN COMMERCE 9-14-2008.

3,632,866. AIPTEK INTERNATIONAL INC., HSINCHU, TAIWAN. SN 77-487,112. PUB. 10-28-2008, FILED 5-30-2008.

POCKETCINEMA

THE MARK CONSISTS OF STANDARD CHARACTERS WITHOUT CLAIM TO ANY PARTICULAR FONT, STYLE, SIZE, OR COLOR.

FOR TRANSCIEVERS FOR WIRELESS TRANSMISSION OF MULTIMEDIA DATA; TRANSCIEVERS FOR MULTIMEDIA DATA TRANSMISSION OF WIRELESS NETWORK; TRANSCIEVERS FOR MULTIMEDIA DATA TRANSMISSION OF WIRELESS BROADBAND COMMUNICATIONS; DIGITAL VIDEO CAMERAS; DIGITAL CAMERAS; RECEIVERS FOR RECEIVING DIGITAL TELEVISION; PORTABLE MEDIA PLAYERS; TV CAMERAS FOR ELECTRONICALLY SECURITY GUARD PURPOSES; TELEVISION SETS; DIGITAL CAMERA ACCESSORY IN THE NATURE OF A DIGITAL PHOTO VIEWER; DIGITAL VIDEO RECORDERS; DIGITAL PHOTO FRAMES FOR DISPLAYING DIGITAL PICTURES, VIDEO CLIPS AND MUSIC; MULTIMEDIA PROJECTORS; PROJECTORS PARTICULARLY PROJECTORS FOR THE ENTERTAINMENT INDUSTRY; VIDEO PROJECTORS (U.S. CLS. 21, 23, 26, 36 AND 38).

FIRST USE 10-27-2008; IN COMMERCE 10-27-2008.

3,632,869. ESCUDIE, JEAN-CLAUDE R., PORTLAND, OR. SN 77-489,178. PUB. 10-28-2008, FILED 6-2-2008.

Hottie

THE MARK CONSISTS OF STANDARD CHARACTERS WITHOUT CLAIM TO ANY PARTICULAR FONT, STYLE, SIZE, OR COLOR.

FOR ELECTRICAL PICKUPS FOR USE WITH MUSICAL INSTRUMENTS (U.S. CLS. 21, 23, 26, 36 AND 38).

FIRST USE 6-1-2008; IN COMMERCE 8-23-2008.

CLASS 9—(Continued).

3,632,880. USA PEACE SIGNAL EQUIPMENT LLC, NEW CASTLE, DE. SN 77-494,782. PUB. 11-11-2008, FILED 6-9-2008.

USPESI

THE MARK CONSISTS OF STANDARD CHARACTERS WITHOUT CLAIM TO ANY PARTICULAR FONT, STYLE, SIZE, OR COLOR.

THE WORD "USPESI" IS AN INVENTED WORD AND HAS NO MEANING OR SIGNIFICANCE IN THE RELEVANT TRADE OR IN ANY LANGUAGES.

FOR ELECTRIC WARNING LIGHTS; FLASHING SAFETY LIGHTS; TRAFFIC LIGHTS; TRANSMITTERS OF ELECTRONIC SIGNALS; FIRE ALARMS; ELECTRIC SWITCHES; POWER-LINE TRANSMISSION MACHINES AND APPARATUS; ELECTRICAL POWER DISTRIBUTION UNITS; VOLTAGE REGULATORS FOR ELECTRIC POWER; CIGAR LIGHTERS FOR AUTOMOBILES; ELECTRIC RELAYS; ELECTRIC CABLES AND WIRES; LASER SPEED DETECTORS; ELECTRIC ACCUMULATORS FOR VEHICLES (U.S. CLS. 21, 23, 26, 36 AND 38).
FIRST USE 2-5-2008; IN COMMERCE 6-7-2008.

3,632,882. LIMELIGHT INNOVATIONS L.L.C., WESTLAKE VILLAGE, CA. SN 77-495,645. PUB. 12-30-2008, FILED 6-10-2008.

ASSET WHIZ

THE MARK CONSISTS OF STANDARD CHARACTERS WITHOUT CLAIM TO ANY PARTICULAR FONT, STYLE, SIZE, OR COLOR.

NO CLAIM IS MADE TO THE EXCLUSIVE RIGHT TO USE "ASSET", APART FROM THE MARK AS SHOWN.

FOR DOWNLOADABLE COMPUTER SOFTWARE FOR DATABASE MANAGEMENT IN THE FIELD OF INVENTORY AND ASSET MANAGEMENT (U.S. CLS. 21, 23, 26, 36 AND 38).
FIRST USE 10-11-2008; IN COMMERCE 10-11-2008.

CLASS 9—(Continued).

3,632,896. BEIJING SHENG WANG ACOUSTIC-ELECTRIC TECHNOLOGY CO.LTD. BEIJING 100029, CHINA. SN 77-502,517. PUB. 11-18-2008, FILED 6-19-2008.



NO CLAIM IS MADE TO THE EXCLUSIVE RIGHT TO USE "MIC", APART FROM THE MARK AS SHOWN.

FOR LOUDSPEAKERS, HEADPHONES, MICROPHONES AND CD PLAYERS; MICROPHONE CABLES; MICROPHONE STANDS; MICROPHONES; PUBLIC ADDRESS (PA) AND SOUND SYSTEM ACCESSORIES, NAMELY, MICROPHONE STANDS, SPEAKER STANDS, MICROPHONE CABLES, SPEAKER CABLES, SPEAKER BOXES AND SOUND MIXERS (U.S. CLS. 21, 23, 26, 36 AND 38).

FIRST USE 1-1-2009; IN COMMERCE 1-15-2009.

3,632,928. HADEAN, INC., LEESBURG, VA. SN 77-514,470. PUB. 11-25-2008, FILED 7-3-2008.

Hadean

THE MARK CONSISTS OF STANDARD CHARACTERS WITHOUT CLAIM TO ANY PARTICULAR FONT, STYLE, SIZE, OR COLOR.

FOR COMMUNICATIONS SERVERS; COMMUNICATIONS SOFTWARE FOR CONNECTING USERS PLAYING DIFFERENT COMPUTER GAMES; COMPUTER ACCELERATOR BOARD; COMPUTER DATABASE MANAGEMENT SOFTWARE FOR USE IN PERSONALIZING THE CONTENT OF E-MAIL COMMUNICATIONS; COMPUTER GAME PROGRAMS; COMPUTER GAME SOFTWARE; COMPUTER GRAPHICS BOARDS; COMPUTER GRAPHICS SOFTWARE; COMPUTER HARDWARE AND COMPUTER PERIPHERAL DEVICES; COMPUTER PROGRAMS FOR VIDEO AND COMPUTER GAMES; COMPUTER SOFTWARE, NAMELY, GAME ENGINE SOFTWARE FOR VIDEO GAME DEVELOPMENT AND OPERATION; ELECTRONIC GAME PROGRAMS; ELECTRONIC GAME SOFTWARE; ELECTRONIC GAME SOFTWARE FOR CELLULAR TELEPHONES; ELECTRONIC GAME SOFTWARE FOR HANDHELD ELECTRONIC DEVICES; ELECTRONIC GAME SOFTWARE FOR WIRELESS DEVICES; GAME SOFTWARE; VIDEO GAME SOFTWARE (U.S. CLS. 21, 23, 26, 36 AND 38).
FIRST USE 5-1-2008; IN COMMERCE 7-1-2008.

CLASS 9—(Continued).

3,632,944. SAMSUNG ELECTRONICS CO., LTD., SUWON-SI, GYEONGGI-DO, REPUBLIC OF KOREA. SN 77-518,962. PUB. 11-11-2008, FILED 7-10-2008.



OWNER OF U.S. REG. NOS. 2,751,708 AND 2,882,774.
 THE MARK CONSISTS OF THE STYLIZED WORDS "SAMSUNG OMNIA", WITH "SAMSUNG" SMALLER THAN "OMNIA".
 FOR MOBILE PHONES (U.S. CLS. 21, 23, 26, 36 AND 38).
 FIRST USE 11-21-2008; IN COMMERCE 11-21-2008.

3,632,959. SAMSUNG ELECTRONICS CO., LTD., SUWON-SI, GYEONGGI-DO, REPUBLIC OF KOREA. SN 77-522,444. PUB. 1-6-2009, FILED 7-15-2008.

HIGHNOTE

THE MARK CONSISTS OF STANDARD CHARACTERS WITHOUT CLAIM TO ANY PARTICULAR FONT, STYLE, SIZE, OR COLOR.
 PRIORITY CLAIMED UNDER SEC. 44(D) ON REPUBLIC OF KOREA APPLICATION NO. 2008-0033304, FILED 7-7-2008.
 FOR MOBILE PHONES (U.S. CLS. 21, 23, 26, 36 AND 38).
 FIRST USE 10-19-2008; IN COMMERCE 10-19-2008.

CLASS 9—(Continued).

3,632,966. SCHWEITZER ENGINEERING LABORATORIES, INC., PULLMAN, WA. SN 77-525,311. PUB. 12-9-2008, FILED 7-17-2008.

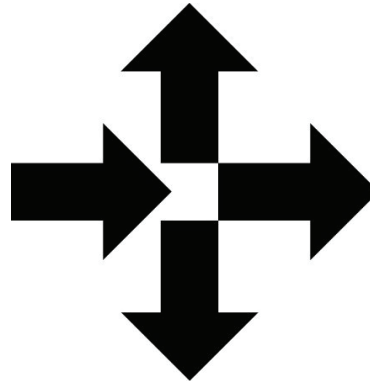

THE MARK CONSISTS OF FOUR ARROWS.
 FOR ELECTRONIC APPARATUS FOR PROTECTION, CONTROL, MONITORING, AND AUTOMATION OF INDUSTRIAL EQUIPMENT; ELECTRONIC APPARATUS FOR PROTECTION, CONTROL, MONITORING, AND AUTOMATION OF ELECTRIC POWER TRANSMISSION OR DISTRIBUTION SYSTEMS; COMMUNICATIONS COMPUTERS (U.S. CLS. 21, 23, 26, 36 AND 38).
 FIRST USE 10-31-2008; IN COMMERCE 10-31-2008.

3,632,973. MCLEAN, JAMES, RIVERSIDE, IL. SN 77-527,303. PUB. 11-25-2008, FILED 7-21-2008.

FLASHHARP

THE MARK CONSISTS OF STANDARD CHARACTERS WITHOUT CLAIM TO ANY PARTICULAR FONT, STYLE, SIZE, OR COLOR.
 FOR COMPUTER STORAGE DEVICES, NAMELY, FLASH DRIVES (U.S. CLS. 21, 23, 26, 36 AND 38).
 FIRST USE 11-8-2007; IN COMMERCE 11-8-2007.

CLASS 9—(Continued).

3,632,976. OPHIR-SPIRICON INC., LOGAN, UT. SN 77-528,127. PUB. 12-9-2008, FILED 7-22-2008.

BeamGage

THE MARK CONSISTS OF STANDARD CHARACTERS WITHOUT CLAIM TO ANY PARTICULAR FONT, STYLE, SIZE, OR COLOR.

FOR SOFTWARE FOR PROCESSING IMAGES, GRAPHICS AND TEXT (U.S. CLS. 21, 23, 26, 36 AND 38).
FIRST USE 1-27-2009; IN COMMERCE 1-27-2009.

3,632,988. CALLPOD, INC., CHICAGO, IL. SN 77-533,504. PUB. 12-23-2008, FILED 7-29-2008.



NO CLAIM IS MADE TO THE EXCLUSIVE RIGHT TO USE "V2", APART FROM THE MARK AS SHOWN.

THE COLOR(S) ORANGE, BLACK, AND GREEN IS/ARE CLAIMED AS A FEATURE OF THE MARK.

THE MARK CONSISTS OF THE LETTER "V" AND THE NUMBER "2" IN THE COLOR ORANGE. THE TOP RIGHT CORNER OF THE LETTER "V" MERGES INTO THE NUMBER "2". THE LETTERS "C", "H", "A", "R", "G", "E", "P", AND "D" ARE IN BLACK AND ARE LOCATED UNDER THE LETTER "V" AND NUMBER "2". THE LETTER "O" IS IN GREEN AND IS LOCATED UNDER THE LETTER "V" AND NUMBER "2".

FOR COMBINED MULTI-HEAD BATTERY CHARGER AND ELECTRICITY ADAPTER HAVING A SINGLE ALTERNATING CURRENT POWER CORD FOR CHARGING MULTIPLE ELECTRONIC DEVICES, INCORPORATING MULTIPLE SMALLER ELECTRICITY ADAPTERS EACH FITTING ON AN INDIVIDUAL HEAD OF THE CHARGER AND DESIGNED TO MATE WITH EACH DEVICE'S CONNECTOR (U.S. CLS. 21, 23, 26, 36 AND 38).

FIRST USE 3-24-2009; IN COMMERCE 3-24-2009.

3,632,989. OPTAMETRA, LLC, VERONA, WI. SN 77-534,108. PUB. 12-16-2008, FILED 7-29-2008.

OPTAMETRA

CLASS 9—(Continued).

THE MARK CONSISTS OF STANDARD CHARACTERS WITHOUT CLAIM TO ANY PARTICULAR FONT, STYLE, SIZE, OR COLOR.

FOR ELECTRONIC AND OPTICAL COMMUNICATIONS INSTRUMENTS AND COMPONENTS, NAMELY, COMMUNICATION LINK TESTERS FOR TESTING COMMUNICATION LINKS; ELECTRONIC AND OPTICAL COMMUNICATIONS INSTRUMENTS AND COMPONENTS, NAMELY, OPTICAL RECEIVERS; ELECTRONIC AND OPTICAL COMMUNICATIONS INSTRUMENTS AND COMPONENTS, NAMELY, OPTICAL TRANSCIEVERS; ELECTRONIC AND OPTICAL COMMUNICATIONS INSTRUMENTS AND COMPONENTS, NAMELY, OPTICAL TRANSMITTERS (U.S. CLS. 21, 23, 26, 36 AND 38).

FIRST USE 3-19-2009; IN COMMERCE 3-19-2009.

3,632,991. T-MOBILE USA, INC., BELLEVUE, WA. SN 77-534,155. PUB. 12-30-2008, FILED 7-29-2008.

T-MOBILE G1

THE MARK CONSISTS OF STANDARD CHARACTERS WITHOUT CLAIM TO ANY PARTICULAR FONT, STYLE, SIZE, OR COLOR.

OWNER OF U.S. REG. NOS. 2,282,432, 2,911,878, AND OTHERS.

FOR COMPUTER SOFTWARE FOR OPERATING MOBILE TELEPHONES AND WIRELESS MODEMS AND COMPUTER SOFTWARE FOR WIRELESS CONTENT CREATION, MANAGEMENT AND DELIVERY; MOBILE TELEPHONES AND WIRELESS MODEMS AND RELATED ACCESSORIES, NAMELY, ANTENNAS, SMART CARDS CONTAINING PROGRAMMING USED TO INTERACT WITH A MOBILE TELEPHONE AND RESPOND TO A SIGNAL CONTACT THAT REQUESTS CUSTOMER IDENTIFICATION AND ACCOUNT INFORMATION, HANDS-FREE MICROPHONES AND EARPHONE ADAPTERS; REPLACEMENT PARTS FOR MOBILE TELEPHONES AND WIRELESS MODEMS, NAMELY, HEADSET ADAPTERS, BATTERIES, BATTERY CHARGERS AND FACEPLATES FOR CELL PHONES (U.S. CLS. 21, 23, 26, 36 AND 38).

FIRST USE 9-23-2008; IN COMMERCE 9-23-2008.

CLASS 9—(Continued).

3,632,992. T-MOBILE USA, INC., BELLEVUE, WA. SN 77-534,166. PUB. 1-6-2009, FILED 7-29-2008.

CLASS 9—(Continued).

3,632,998. NEXTCEA, INC., WOBURN, MA. SN 77-537,981. PUB. 12-23-2008, FILED 8-4-2008.

G1

THE MARK CONSISTS OF STANDARD CHARACTERS WITHOUT CLAIM TO ANY PARTICULAR FONT, STYLE, SIZE, OR COLOR.

FOR COMPUTER SOFTWARE FOR OPERATING MOBILE TELEPHONES AND WIRELESS MODEMS AND COMPUTER SOFTWARE FOR WIRELESS CONTENT CREATION, MANAGEMENT AND DELIVERY; MOBILE TELEPHONES AND WIRELESS MODEMS AND RELATED ACCESSORIES, NAMELY, ANTENNAS, SMART CARDS CONTAINING PROGRAMMING USED TO INTERACT WITH A MOBILE TELEPHONE AND RESPOND TO A SIGNAL CONTACT THAT REQUESTS CUSTOMER IDENTIFICATION AND ACCOUNT INFORMATION, HANDS-FREE MICROPHONES AND EARPHONE ADAPTERS; REPLACEMENT PARTS FOR MOBILE TELEPHONES AND WIRELESS MODEMS, NAMELY, HEADSET ADAPTERS, BATTERIES, BATTERY CHARGERS AND FACEPLATES FOR CELL PHONES (U.S. CLS. 21, 23, 26, 36 AND 38).

FIRST USE 9-23-2008; IN COMMERCE 9-23-2008.

Admetry

THE MARK CONSISTS OF STANDARD CHARACTERS WITHOUT CLAIM TO ANY PARTICULAR FONT, STYLE, SIZE, OR COLOR.

FOR COMPUTER SOFTWARE FOR PROVIDING AN ON-LINE DATABASE IN THE FIELD OF TRANSACTION PROCESSING TO UPLOAD TRANSACTIONAL DATA, PROVIDE STATISTICAL ANALYSIS, AND PRODUCE NOTIFICATIONS AND REPORTS (U.S. CLS. 21, 23, 26, 36 AND 38).

FIRST USE 9-3-2008; IN COMMERCE 12-3-2008.

3,633,009. ADVANCE GAMES, LLC, BATON ROUGE, LA. SN 77-542,392. PUB. 12-30-2008, FILED 8-8-2008.

3,632,993. SPEEDO INTERNATIONAL LIMITED, LONDON, UNITED KINGDOM. SN 77-534,592. PUB. 12-30-2008, FILED 7-30-2008.

THE MARK CONSISTS OF STANDARD CHARACTERS WITHOUT CLAIM TO ANY PARTICULAR FONT, STYLE, SIZE, OR COLOR.

FOR CHILDREN'S EDUCATIONAL SOFTWARE (U.S. CLS. 21, 23, 26, 36 AND 38).

FIRST USE 11-28-2008; IN COMMERCE 11-28-2008.

3,633,016. ELECTRIC VISUAL EVOLUTION, LLC, SAN CLEMENTE, CA. SN 77-544,938. PUB. 11-18-2008, FILED 8-12-2008.

AIR SEAL TRI

THE MARK CONSISTS OF STANDARD CHARACTERS WITHOUT CLAIM TO ANY PARTICULAR FONT, STYLE, SIZE, OR COLOR.

NO CLAIM IS MADE TO THE EXCLUSIVE RIGHT TO USE "AIR SEAL", APART FROM THE MARK AS SHOWN, FOR SWIM GOGGLES (U.S. CLS. 21, 23, 26, 36 AND 38).

FIRST USE 7-1-2008; IN COMMERCE 7-1-2008.

CB4

THE MARK CONSISTS OF STANDARD CHARACTERS WITHOUT CLAIM TO ANY PARTICULAR FONT, STYLE, SIZE, OR COLOR.

FOR SUNGLASSES AND CASES FOR SUNGLASSES (U.S. CLS. 21, 23, 26, 36 AND 38).

FIRST USE 2-17-2009; IN COMMERCE 2-17-2009.

CLASS 9—(Continued).

3,633,021. CALLPOD, INC., CHICAGO, IL. SN 77-546,916.
PUB. 1-6-2009, FILED 8-14-2008.



The logo for "dragon v2" features the word "dragon" in a lowercase, sans-serif font. The letter "o" is green, while the other letters are black. Below "dragon" is "v2" in a smaller, red, lowercase font.

NO CLAIM IS MADE TO THE EXCLUSIVE RIGHT TO USE "V2", APART FROM THE MARK AS SHOWN.

THE COLOR(S) WHITE, BLACK, ORANGE, GREEN IS/ARE CLAIMED AS A FEATURE OF THE MARK.

THE MARK CONSISTS OF THE COLOR WHITE APPEARS AS BACKGROUND TO THE ENTIRE MARK. THE COLOR BLACK APPEARS IN THE LETTERING "DRAG N". THE COLOR GREEN APPEARS IN THE LETTERING "O" MAKING UP THE WORD "DRAGON". THE COLOR ORANGE APPEARS IN THE LETTERING "V2".

FOR WIRELESS HEADSETS FOR TELEPHONES (U.S. CLS. 21, 23, 26, 36 AND 38).

FIRST USE 4-6-2009; IN COMMERCE 4-6-2009.

3,633,025. KABUSHIKI KAISHA SEGA, DBA SEGA CORPORATION, OHTA-KU, TOKYO, JAPAN. SN 77-547,959.
PUB. 1-6-2009, FILED 8-15-2008.



The logo for "THE HOUSE OF THE DEAD OVERKILL" features the words "THE HOUSE OF THE DEAD" in a smaller, bold, black font above the word "OVERKILL" in a larger, bold, black font. The letters are slightly irregular and have a distressed, hand-painted appearance.

OWNER OF U.S. REG. NOS. 3,288,923 AND 3,366,879.
THE MARK CONSISTS OF THE WORDS "THE HOUSE OF THE DEAD" AND "OVERKILL" IN A STYLIZED FONT.
FOR VIDEO GAME SOFTWARE (U.S. CLS. 21, 23, 26, 36 AND 38).

FIRST USE 2-0-2009; IN COMMERCE 2-0-2009.

CLASS 9—(Continued).

3,633,026. PILYUGIN, ANDREY B, BARNAUL, RUSSIAN FED.. SN 77-548,834. PUB. 1-6-2009, FILED 8-17-2008.



The logo for "iBear" features the word "iBear" in a lowercase, sans-serif font. The letter "i" is lowercase and black, while "Bear" is uppercase and black.

THE MARK CONSISTS OF STANDARD CHARACTERS WITHOUT CLAIM TO ANY PARTICULAR FONT, STYLE, SIZE, OR COLOR.

FOR COMPUTER APPLICATION SOFTWARE FOR MOBILE PHONES (U.S. CLS. 21, 23, 26, 36 AND 38).
FIRST USE 7-16-2008; IN COMMERCE 9-9-2008.

3,633,038. THOMPSON, BRIAN, HOUSTON, TX. SN 77-561,859. PUB. 12-9-2008, FILED 9-3-2008.



The logo for "FLASHKAPS" features the word "FLASHKAPS" in a bold, black, sans-serif font. Above the word is the word "FLASHKAPS" in a smaller, black, sans-serif font. Below the word is the tagline "WHAT'S ON YOUR DRIVE" in a smaller, black, sans-serif font.

NO CLAIM IS MADE TO THE EXCLUSIVE RIGHT TO USE "FLASH CAPS", APART FROM THE MARK AS SHOWN.

THE MARK CONSISTS OF THE WORDING "FLASHKAPS" APPEARING ABOVE THE WORD "FLASHKAPS" IN STYLIZED LETTERING WHERE THE LETTER "F" IS CREATED BY A MISCELLANEOUS DESIGN AND SHAPE. THIS WORDING APPEARS ABOVE THE WORDING "WHAT'S ON YOU DRIVE".

FOR PROTECTIVE COVER FOR A USB FLASH MEMORY STORAGE DRIVE (U.S. CLS. 21, 23, 26, 36 AND 38).
FIRST USE 2-22-2009; IN COMMERCE 2-22-2009.

3,633,052. NATURE AMERICA, INC., NEW YORK, NY. SN 77-976,840. PUB. 5-27-2008, FILED 1-16-2008.



The logo for "SCIBX" features the word "SCIBX" in a bold, black, sans-serif font.

THE MARK CONSISTS OF STANDARD CHARACTERS WITHOUT CLAIM TO ANY PARTICULAR FONT, STYLE, SIZE, OR COLOR.

FOR DOWNLOADABLE ELECTRONIC PUBLICATIONS IN THE NATURE OF MAGAZINES AND NEWSLETTERS, IN THE FIELD OF IDENTIFICATION OF DEVELOPMENTS IN SCIENCE AND TECHNOLOGY WITH COMMERCIAL AND INVESTMENT IMPACT (U.S. CLS. 21, 23, 26, 36 AND 38).

FIRST USE 1-31-2008; IN COMMERCE 1-31-2008.

CLASS 9—(Continued).

3,633,054. ELEMENT ELECTRONICS, LLC, MINNEAPOLIS, MN. SN 77-976,860. PUB. 7-3-2007, FILED 10-25-2006.



NO CLAIM IS MADE TO THE EXCLUSIVE RIGHT TO USE "ELECTRONICS", APART FROM THE MARK AS SHOWN.

FOR CAMERAS (U.S. CLS. 21, 23, 26, 36 AND 38).
FIRST USE 8-31-2007; IN COMMERCE 8-31-2007.

CLASS 9—(Continued).

3,633,094. VACCARO, HENRY S., BRADENTON, FL. SN 78-406,851. PUB. 8-5-2008, FILED 4-23-2004.

Retail Heartbeat

THE MARK CONSISTS OF STANDARD CHARACTERS WITHOUT CLAIM TO ANY PARTICULAR FONT, STYLE, SIZE, OR COLOR.

NO CLAIM IS MADE TO THE EXCLUSIVE RIGHT TO USE "RETAIL", APART FROM THE MARK AS SHOWN.

FOR COMPUTER SOFTWARE FOR ANALYZING RETAIL TRANSACTION DATA AND DETECTING OUT OF STOCK CONDITIONS AND IMPACTS ON CUSTOMERS (U.S. CLS. 21, 23, 26, 36 AND 38).

FIRST USE 7-10-2004; IN COMMERCE 7-10-2004.

3,633,071. SWANSON TOOL CO., INC., FRANKFORT, IL. SN 77-977,046. PUB. 1-15-2008, FILED 5-7-2007.

SPEEDLITE

THE MARK CONSISTS OF STANDARD CHARACTERS WITHOUT CLAIM TO ANY PARTICULAR FONT, STYLE, SIZE, OR COLOR.

OWNER OF U.S. REG. NOS. 1,383,080 AND 1,570,674.

FOR LEVELS, NAMELY, PLUMB LEVELS, SPIRIT LEVELS AND TORPEDO LEVELS (U.S. CLS. 21, 23, 26, 36 AND 38).

FIRST USE 12-1-2006; IN COMMERCE 12-1-2006.

3,633,114. NOVA RESEARCH, INC., SOLVANG, CA. SN 78-514,925. PUB. 2-14-2006, FILED 11-10-2004.

VASI

3,633,077. GALE BANKS ENGINEERING, AZUSA, CA. SN 77-977,101. PUB. 12-9-2008, FILED 7-15-2008.

ECONOMIND

THE MARK CONSISTS OF STANDARD CHARACTERS WITHOUT CLAIM TO ANY PARTICULAR FONT, STYLE, SIZE, OR COLOR.

FOR ELECTRONIC ENGINE, FUEL AND TRANSMISSION CONTROLLERS AND TUNING MODULES FOR OPERATING AND TUNING THE ENGINES, FUEL SYSTEMS AND TRANSMISSIONS FOR LAND VEHICLES, AND ELECTRONIC USER INTERFACE THEREFOR (U.S. CLS. 21, 23, 26, 36 AND 38).

FIRST USE 10-31-2008; IN COMMERCE 10-31-2008.

THE MARK CONSISTS OF STANDARD CHARACTERS WITHOUT CLAIM TO ANY PARTICULAR FONT, STYLE, SIZE, OR COLOR.

FOR VISIBLE OPTICAL SENSORS FOR SURVEILLANCE, MOTION-SENSING, GUNSHOT DETECTION AND MISSILE DETECTION APPLICATIONS (U.S. CLS. 21, 23, 26, 36 AND 38).

FIRST USE 12-23-2008; IN COMMERCE 12-23-2008.

CLASS 9—(Continued).

3,633,117. IGT, RENO, NV. SN 78-526,242. PUB. 1-17-2006, FILED 12-2-2004.

CLASS 9—(Continued).

3,633,120. TMW SYSTEMS, INC., BEACHWOOD, OH. SN 78-550,242. PUB. 12-20-2005, FILED 1-19-2005.

CAPTAIN PAYBACK

THE MARK CONSISTS OF STANDARD CHARACTERS WITHOUT CLAIM TO ANY PARTICULAR FONT, STYLE, SIZE, OR COLOR.

FOR GAMING MACHINES, NAMELY, DEVICES WHICH ACCEPT A WAGER (U.S. CLS. 21, 23, 26, 36 AND 38).

FIRST USE 2-4-2009; IN COMMERCE 2-4-2009.

D2LINK

THE MARK CONSISTS OF STANDARD CHARACTERS WITHOUT CLAIM TO ANY PARTICULAR FONT, STYLE, SIZE, OR COLOR.

FOR MOBILE COMMUNICATIONS INTERFACE SOFTWARE FOR GLOBAL POSITIONING SYSTEM BASED CELL PHONES (U.S. CLS. 21, 23, 26, 36 AND 38).

FIRST USE 11-29-2004; IN COMMERCE 11-29-2004.

3,633,118. ORB NETWORKS, INC., OAKLAND, CA. SN 78-538,592. PUB. 7-22-2008, FILED 12-27-2004.

3,633,121. ATHENA SEMICONDUCTORS, LLC, FREMONT, CA. SN 78-552,074. PUB. 7-25-2006, FILED 1-21-2005.

ORB

THE MARK CONSISTS OF STANDARD CHARACTERS WITHOUT CLAIM TO ANY PARTICULAR FONT, STYLE, SIZE, OR COLOR.

FOR COMPUTER SOFTWARE TO ACCESS AND CONTROL DIGITAL MEDIA THROUGH REMOTE WEB BROWSERS; MOTION-ACTIVATED COMPUTER SOFTWARE FOR VIEWING, RECORDING AND SENDING DIGITAL MEDIA; COMPUTER SOFTWARE FOR SYNCHRONIZATION OF DIGITAL CONTENT BETWEEN A PERSONAL COMPUTER AND A REMOTE COMPUTER OR DEVICE; WIRELESS PHONE SOFTWARE TO SEND PHOTOGRAPHS FROM WIRELESS PHONES TO PERSONAL COMPUTERS (U.S. CLS. 21, 23, 26, 36 AND 38).

FIRST USE 11-3-2008; IN COMMERCE 11-3-2008.

OPTIMRF

THE MARK CONSISTS OF STANDARD CHARACTERS WITHOUT CLAIM TO ANY PARTICULAR FONT, STYLE, SIZE, OR COLOR.

FOR SEMICONDUCTORS, PRINTED CIRCUIT BOARDS, AND SOFTWARE FOR USING AND CONTROLLING WIRELESS BROADBAND COMMUNICATION TECHNOLOGY (U.S. CLS. 21, 23, 26, 36 AND 38).

FIRST USE 12-28-2007; IN COMMERCE 12-28-2007.

CLASS 9—(Continued).

3,633,137. THERADOC, INC., SALT LAKE CITY, UT. SN 78-597,711. PUB. 12-20-2005, FILED 3-29-2005.

OLKP

THE MARK CONSISTS OF STANDARD CHARACTERS WITHOUT CLAIM TO ANY PARTICULAR FONT, STYLE, SIZE, OR COLOR.

FOR COMPUTER SOFTWARE EXPERT SYSTEMS FOR CLINICAL DECISION SUPPORT, NAMELY, COMPUTER SOFTWARE FOR INTEGRATING MEDICAL CLINIC DATA AND MEDICAL PROTOCOLS, AND DOCUMENTATION SOLD AS A UNIT THEREWITH (U.S. CLS. 21, 23, 26, 36 AND 38).

FIRST USE 8-31-2006; IN COMMERCE 8-31-2006.

3,633,154. FUJIFILM U.S.A., INC., VALHALLA, NY. SN 78-642,055. PUB. 7-22-2008, FILED 6-2-2005.

GET THE PICTURE

THE MARK CONSISTS OF STANDARD CHARACTERS WITHOUT CLAIM TO ANY PARTICULAR FONT, STYLE, SIZE, OR COLOR.

FOR ONE-TIME USE CAMERAS AND DIGITAL PRINTERS (U.S. CLS. 21, 23, 26, 36 AND 38).

FIRST USE 10-1-2005; IN COMMERCE 10-1-2005.

CLASS 9—(Continued).

3,633,170. THE CARTOON NETWORK, INC. ATLANTA, GA. SN 78-686,225. PUB. 5-2-2006, FILED 8-5-2005.

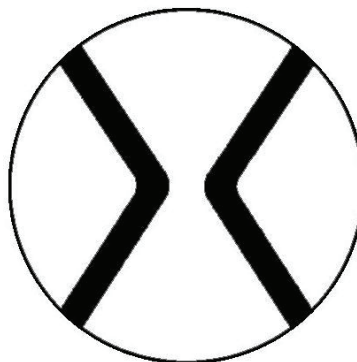

THE MARK CONSISTS OF AN HOURGLASS DESIGN INSIDE A CIRCLE.

FOR MOTION PICTURE FILMS FOR BROADCAST ON TELEVISION FEATURING COMEDY, DRAMA, ACTION, ADVENTURE AND/OR ANIMATION; AUDIO-VISUAL DISCS, AND DIGITAL VERSATILE DISCS FEATURING MUSIC, COMEDY, DRAMA, ACTION, ADVENTURE, AND/OR ANIMATION; PRE-RECORDED, SHORT MOTION PICTURE FILM CASSETTES FEATURING COMEDY, DRAMA, ACTION, ADVENTURE AND/OR ANIMATION TO BE USED WITH HAND-HELD VIEWERS OR PROJECTORS; EYEGLASSES, SUNGLASSES AND CASES THEREFOR; COMPUTER PROGRAMS, NAMELY, SOFTWARE LINKING DIGITIZED VIDEO AND AUDIO MEDIA TO A GLOBAL COMPUTER INFORMATION NETWORK; COMPUTER GAME EQUIPMENT CONTAINING MEMORY DEVICES, NAMELY, DISCS, SOLD AS A UNIT FOR PLAYING A PARLOR-TYPE COMPUTER GAME; VIDEO AND COMPUTER GAME PROGRAMS; VIDEO GAME PROGRAMS; VIDEO GAME CARTRIDGES AND CASSETTES (U.S. CLS. 21, 23, 26, 36 AND 38).

FIRST USE 4-1-2009; IN COMMERCE 4-1-2009.

3,633,178. SAFEAWAKE, LLC, COLUMBIA, MD. SN 78-695,486. PUB. 8-29-2006, FILED 8-18-2005.

SAFEAWAKE

THE MARK CONSISTS OF STANDARD CHARACTERS WITHOUT CLAIM TO ANY PARTICULAR FONT, STYLE, SIZE, OR COLOR.

FOR SMOKE DETECTION AND ALERT SYSTEMS, NAMELY, DEVICES FOR ALERTING INDIVIDUALS TO THE PRESENCE OF AN ALARMING SMOKE DETECTOR (U.S. CLS. 21, 23, 26, 36 AND 38).

FIRST USE 3-12-2009; IN COMMERCE 3-12-2009.

CLASS 9—(Continued).

3,633,183. ILS TECHNOLOGY, LLC, BOCA RATON, FL. SN 78-703,596. PUB. 1-17-2006, FILED 8-30-2005.

SECUREWISE

THE MARK CONSISTS OF STANDARD CHARACTERS WITHOUT CLAIM TO ANY PARTICULAR FONT, STYLE, SIZE, OR COLOR.

FOR SOFTWARE APPLICATIONS FOR THE SECURE TRANSPORT OF PRODUCTION DATA AND COLLABORATION INFORMATION FROM WITHIN A FACILITY TO EITHER AN EXTERNAL PARTNER OR TO AN INTERNAL APPLICATION OR USER; COMPUTER SOFTWARE DATA TRANSMISSION SECURITY TOOLS TO PREVENT THE INTERCEPTION OF SENSITIVE DATA (U.S. CLS. 21, 23, 26, 36 AND 38).

FIRST USE 10-0-2008; IN COMMERCE 10-0-2008.

CLASS 9—(Continued).

3,633,194. SIEMENS MEDICAL SOLUTIONS USA, INC., MALVERN, PA. SN 78-733,443. PUB. 6-20-2006, FILED 10-14-2005.

REMIND

THE MARK CONSISTS OF STANDARD CHARACTERS WITHOUT CLAIM TO ANY PARTICULAR FONT, STYLE, SIZE, OR COLOR.

FOR COMPUTER HARDWARE AND SOFTWARE SOLD AS AN INTEGRAL COMPONENT OF COMPUTER SYSTEMS, FOR ANALYZING AND INTEGRATING MEDICAL AND HEALTHCARE DATA (U.S. CLS. 21, 23, 26, 36 AND 38).

FIRST USE 11-30-2002; IN COMMERCE 7-13-2006.

3,633,196. B&B ELECTRONICS MANUFACTURING COMPANY, OTTAWA, IL. SN 78-735,905. PUB. 7-8-2008, FILED 10-19-2005.

ZLINX

THE MARK CONSISTS OF STANDARD CHARACTERS WITHOUT CLAIM TO ANY PARTICULAR FONT, STYLE, SIZE, OR COLOR.

FOR COMPUTER NETWORKING HARDWARE; DEVICES FOR WIRELESS RADIO TRANSMISSION; NETWORK ACCESS SERVER HARDWARE; WIRELESS COMPUTER PERIPHERALS (U.S. CLS. 21, 23, 26, 36 AND 38).

FIRST USE 11-1-2006; IN COMMERCE 11-1-2006.

3,633,191. MAJOR LEAGUE BASEBALL PROPERTIES, INC., NEW YORK, NY. SN 78-728,584. PUB. 7-4-2006, FILED 10-7-2005.

I LIVE FOR THIS

THE MARK CONSISTS OF STANDARD CHARACTERS WITHOUT CLAIM TO ANY PARTICULAR FONT, STYLE, SIZE, OR COLOR.

FOR ELECTRICAL AND SCIENTIFIC APPARATUS, NAMELY, PRE-RECORDED VIDEODISCS RELATING TO BASEBALL, CELL PHONE ACCESSORIES, NAMELY, CASES; DECORATIVE MAGNETS; VIDEO AND COMPUTER GAME CARTRIDGES, VIDEO AND COMPUTER GAME DISCS, VIDEO AND COMPUTER GAME CASSETTES; COMPUTER ACCESSORIES, NAMELY, MOUSE PADS; COMPUTER GAME PROGRAMS (U.S. CLS. 21, 23, 26, 36 AND 38).

FIRST USE 3-0-2004; IN COMMERCE 3-0-2004.

3,633,203. ANTENNAS DIRECT, INC., WILDWOOD, MO. SN 78-747,534. PUB. 1-16-2007, FILED 11-4-2005.

ANTENNAS DIRECT

THE MARK CONSISTS OF STANDARD CHARACTERS WITHOUT CLAIM TO ANY PARTICULAR FONT, STYLE, SIZE, OR COLOR.

NO CLAIM IS MADE TO THE EXCLUSIVE RIGHT TO USE "ANTENNAS", APART FROM THE MARK AS SHOWN, FOR ANTENNAS (U.S. CLS. 21, 23, 26, 36 AND 38).

FIRST USE 12-31-2002; IN COMMERCE 12-31-2002.

CLASS 9—(Continued).

3,633,217. BENCHWORKZZ LLC, AUSTIN, TX. SN 78-767,035. PUB. 9-5-2006, FILED 12-5-2005.

BENCHWORKZZ

THE MARK CONSISTS OF STANDARD CHARACTERS WITHOUT CLAIM TO ANY PARTICULAR FONT, STYLE, SIZE, OR COLOR.

FOR COMPUTER APPLICATIONS SOFTWARE FOR THE COLLECTION, EDITING, ORGANIZING, MODIFYING, BOOK MARKING, TRANSMISSION, STORAGE AND SHARING OF DATA AND INFORMATION (U.S. CLS. 21, 23, 26, 36 AND 38).

FIRST USE 8-1-2008; IN COMMERCE 9-17-2008.

CLASS 9—(Continued).

3,633,234. PHOTON TECHNOLOGY INTERNATIONAL, INC., BIRMINGHAM, NJ. SN 78-816,840. PUB. 1-22-2008, FILED 2-16-2006.

WARP DRIVE IMAGING

THE MARK CONSISTS OF STANDARD CHARACTERS WITHOUT CLAIM TO ANY PARTICULAR FONT, STYLE, SIZE, OR COLOR.

NO CLAIM IS MADE TO THE EXCLUSIVE RIGHT TO USE "DRIVE IMAGING", APART FROM THE MARK AS SHOWN.

FOR MICROSCOPE IMAGING SYSTEM COMPRISED OF SOFTWARE AND HARDWARE, NAMELY, CAMERA, ILLUMINATION, IMAGE CAPTURING, AND CONTROL COMPONENTS, USED FOR THE PURPOSE OF ACQUIRING, PROCESSING AND ANALYZING SCIENTIFIC IMAGES (U.S. CLS. 21, 23, 26, 36 AND 38).

FIRST USE 3-1-2009; IN COMMERCE 3-1-2009.

3,633,230. DIGGING RECORDS, INC., HOMER GLEN, IL. SN 78-807,255. PUB. 7-3-2007, FILED 2-4-2006.

The Neverly Brothers

THE MARK CONSISTS OF STANDARD CHARACTERS WITHOUT CLAIM TO ANY PARTICULAR FONT, STYLE, SIZE, OR COLOR.

NO CLAIM IS MADE TO THE EXCLUSIVE RIGHT TO USE "BROTHERS", APART FROM THE MARK AS SHOWN.

FOR DOWNLOADABLE VIDEO RECORDINGS FEATURING MUSICAL PERFORMANCES BY A BAND; DOWNLOADABLE SOUND RECORDINGS FEATURING MUSIC; SOUND RECORDINGS FEATURING MUSIC; VIDEO RECORDINGS FEATURING MUSICAL PERFORMANCES BY A BAND (U.S. CLS. 21, 23, 26, 36 AND 38).

FIRST USE 11-12-2007; IN COMMERCE 2-25-2009.

3,633,249. MESHBESHER HEALTH CORPORATION, CLEARWATER, FL. SN 78-838,432. PUB. 7-15-2008, FILED 3-16-2006.

Primer

THE MARK CONSISTS OF STANDARD CHARACTERS WITHOUT CLAIM TO ANY PARTICULAR FONT, STYLE, SIZE, OR COLOR.

FOR DOWNLOADABLE PUBLICATIONS IN THE NATURE OF BULLETINS, RESEARCH PAPERS, ARTICLES, MANUALS, BOOKLETS, BOOKS, PAMPHLETS, BROCHURES, AND INSTRUCTION GUIDES ON DO-IT-YOURSELF AND/OR CONSULTANT-ASSISTED AND/OR HEALTH PROFESSIONAL DELIVERED HEALTH PROGRAMS OF CARE, CLEANSING, PREVENTATIVE HEALTH, NATURAL HEALTH AND NUTRITION, DIET AND HEALTH REGENERATION PROCEDURES; DOWNLOADABLE ELECTRONIC NEWSLETTERS AND MAGAZINES ABOUT HEALTH-RELATED PROGRAMS, HEALTH CLEANSING, PREVENTATIVE HEALTH, NATURAL HEALTH AND NUTRITION, DIET AND HEALTH REGENERATION (U.S. CLS. 21, 23, 26, 36 AND 38).

FIRST USE 5-1-2008; IN COMMERCE 5-1-2008.

CLASS 9—(Continued).

3,633,251. JMBP, INC., LOS ANGELES, CA. SN 78-840,053.
PUB. 7-10-2007, FILED 3-17-2006.

CLASS 9—(Continued).

3,633,285. INTERNATIONAL TRADE SOLUTIONS, INC.,
GRAND FORKS, ND. SN 78-912,441. PUB. 8-21-2007, FILED
6-20-2006.

SUPERNOVA

THE MARK CONSISTS OF STANDARD CHARACTERS
WITHOUT CLAIM TO ANY PARTICULAR FONT, STYLE,
SIZE, OR COLOR.

FOR PRE-RECORDED AUDIO AND VIDEO CAS-
SETTES, CDS, DVDS, AUDIO AND VIDEO TAPES AND
PHONOGRAPH RECORDS ALL FEATURING MUSIC
AND ENTERTAINMENT (U.S. CLS. 21, 23, 26, 36 AND
38).

FIRST USE 11-21-2006; IN COMMERCE 11-21-2006.



3,633,272. NORTHSTAR PRODUCTIONS, LLC, TREASURE
ISLAND, FL. SN 78-889,271. PUB. 12-25-2007, FILED 5-22-
2006.

NO CLAIM IS MADE TO THE EXCLUSIVE RIGHT TO
USE "EXPORT", APART FROM THE MARK AS SHOWN.

FOR DOWNLOADABLE SOFTWARE FOR PRODU-
CING CUSTOMS DOCUMENTS, NAMELY, SHIPPING
MANIFEST AND INVOICES RELATED TO THE IMPOR-
TATION AND EXPORTATION OF GOODS ACROSS
INTERNATIONAL BORDERS (U.S. CLS. 21, 23, 26, 36
AND 38).

FIRST USE 6-0-2007; IN COMMERCE 6-0-2007.

BUG RANGERS

THE MARK CONSISTS OF STANDARD CHARACTERS
WITHOUT CLAIM TO ANY PARTICULAR FONT, STYLE,
SIZE, OR COLOR.

FOR PRERECORDED DVD'S FEATURING CAR-
TOONS AND MUSIC (U.S. CLS. 21, 23, 26, 36 AND 38).

FIRST USE 10-17-2006; IN COMMERCE 10-17-2006.

3,633,291. SYPRIS ELECTRONICS, LLC, TAMPA, FL. SN 78-
920,630. PUB. 8-7-2007, FILED 6-30-2006.

3,633,278. S A S SAFETY CORP., LONG BEACH, CA. SN 78-
903,366. PUB. 6-24-2008, FILED 6-7-2006.

RASKL

BANDIT

THE MARK CONSISTS OF STANDARD CHARACTERS
WITHOUT CLAIM TO ANY PARTICULAR FONT, STYLE,
SIZE, OR COLOR.

FOR RESPIRATORS OTHER THAN FOR ARTIFICIAL
RESPIRATION (U.S. CLS. 21, 23, 26, 36 AND 38).

FIRST USE 11-1-2007; IN COMMERCE 12-1-2007.

THE MARK CONSISTS OF STANDARD CHARACTERS
WITHOUT CLAIM TO ANY PARTICULAR FONT, STYLE,
SIZE, OR COLOR.

FOR DEVICE FOR LOADING CRYPTOGRAPHIC
KEYS INTO ENCRYPTION EQUIPMENT, NAMELY,
AN ELECTRONIC KEY FILL DEVICE CAPABLE OF
RECEIVING, STORING AND TRANSFERRING CRYP-
TOGRAPHIC KEYS AND STORING USER PROFILES
FOR USE BY MILITARY AND GOVERNMENT PER-
SONNEL IN COMMUNICATIONS SECURITY APPLICA-
TIONS (U.S. CLS. 21, 23, 26, 36 AND 38).

FIRST USE 1-25-2007; IN COMMERCE 1-25-2007.

CLASS 9—(Continued).

3,633,295. PANORAMA TECHNOLOGIES, INC., HOUSTON, TX. SN 78-925,864. PUB. 2-20-2007, FILED 7-10-2006.

MERLIN

THE MARK CONSISTS OF STANDARD CHARACTERS WITHOUT CLAIM TO ANY PARTICULAR FONT, STYLE, SIZE, OR COLOR.

FOR SOFTWARE FOR SEISMIC IMAGING, NAMELY, TWO WAY FULL WAVE FORM SEISMIC IMAGING (U.S. CLS. 21, 23, 26, 36 AND 38).

FIRST USE 10-1-2006; IN COMMERCE 3-1-2008.

3,633,296. ORION IMAGES CORPORATION, WESTMINSTER, CA. SN 78-928,680. PUB. 7-17-2007, FILED 7-13-2006.

OIC

THE MARK CONSISTS OF STANDARD CHARACTERS WITHOUT CLAIM TO ANY PARTICULAR FONT, STYLE, SIZE, OR COLOR.

FOR VIDEO MONITORS FOR INDUSTRIAL AND SURVEILLANCE USE, COMPUTER MONITORS, DIGITAL DISPLAYS, NAMELY, LIGHT EMITTING DIODE DISPLAYS, LIQUID CRYSTAL DISPLAYS (U.S. CLS. 21, 23, 26, 36 AND 38).

FIRST USE 3-16-2009; IN COMMERCE 3-16-2009.

CLASS 9—(Continued).

3,633,305. DX ANTENNA COMPANY, LIMITED, HYOGOKEN, JAPAN. SN 78-939,944. PUB. 2-26-2008, FILED 7-28-2006.



OWNER OF U.S. REG. NOS. 2,803,065 AND 3,133,720. NO CLAIM IS MADE TO THE EXCLUSIVE RIGHT TO USE "ANTENNA", APART FROM THE MARK AS SHOWN.

THE MARK CONSISTS OF THE WORDS "DX ANTENNA" WITH AN ELONGATED ANTENNA SHAPE ELONGATED AT BOTH ENDS IN A STRIPE FORMATION.

FOR SIGNAL BAND FILTERS, ANTENNAS AND ANTENNA PARTS, NAMELY, ANTENNA MOUNTING MEANS, ANTENNA MATCHING TRANSFORMERS, AMPLIFIERS AND PREAMPLIFIERS, ANTENNA MIXERS, SPLITTERS, TAPOFFS, HEAD-END SYSTEMS, COUPLERS; CABLE TELEVISION CONVERTERS; RECEIVERS FOR RECEIVING CABLE TELEVISION; TELEVISION TRANSMITTERS; REMOTE CONTROLS FOR ANTENNAS; AUDIO MODULATORS; VIDEO MODULATORS; TELEVISION TUNERS; POWER SUPPLY, COMBINERS, ELECTRICAL SOCKETS, TRANSMISSION LINE COMBINER-FILTERS, TRANSFORMERS, VOLTAGE SURGE SUPPRESSORS, INTERCOMS AND REPLACEMENT PARTS THEREFOR; WIRELESS TELECOMMUNICATIONS TRANSMITTERS AND RECEIVERS; ELECTRIC BUZZERS; ELECTRIC PLUGS, ANTI-INTRUSION ALARMS, ELECTRIC DOOR CHIMES, WIRELESS ELECTRONIC VISITOR SIGNAL CHIMES; ELECTRONIC CABLES; ELECTRIC PLUGS; ELECTRICAL CONNECTORS; ELECTRIC SWITCHES; VOLTAGE STABILIZERS; TELEVISION DECODERS; SIGNAL BAND SEPARATORS; ELECTRIC FIELD INTENSITY METERS, SIGNAL LEVEL METERS; AND DATA PROCESSORS (U.S. CLS. 21, 23, 26, 36 AND 38).

FIRST USE 10-1-1991; IN COMMERCE 10-1-2003.

3,633,308. PERFECT SENSE GREETING GIFT CARDS, INC., CINCINNATI, OH. SN 78-955,318. PUB. 1-15-2008, FILED 8-18-2006.

PERFECT SENSE

THE MARK CONSISTS OF STANDARD CHARACTERS WITHOUT CLAIM TO ANY PARTICULAR FONT, STYLE, SIZE, OR COLOR.

FOR MAGNETICALLY ENCODED CARDS THAT MAY BE USED AS GIFT CARDS FOR THE REDEMPTION OF GOODS AND SERVICES (U.S. CLS. 21, 23, 26, 36 AND 38).

FIRST USE 6-0-2006; IN COMMERCE 6-0-2006.

CLASS 10—MEDICAL APPARATUS

CLASS 10—(Continued).

3,631,811. ORTHOSPORTS & AQUATIC PHYSICAL THERAPY, PC, NEEDHAM, MA. SN 76-663,383. PUB. 1-16-2007, FILED 7-20-2006.

THERA-ROLL

THE MARK CONSISTS OF STANDARD CHARACTERS WITHOUT CLAIM TO ANY PARTICULAR FONT, STYLE, SIZE, OR COLOR.

FOR MEDICAL AND FITNESS APPARATUS IN THE NATURE OF A CYLINDRICAL ROLLING DEVICE WITH PROTRUSIONS FOR MOBILIZING TISSUE OF THE HUMAN BODY TO ENHANCE FITNESS, SPORTS PERFORMANCE, PHYSICAL THERAPY, OCCUPATIONAL THERAPY, ACTIVITIES OF DAILY LIVING, ACCELERATING HEALING, AND DECREASING PAIN (U.S. CLS. 26, 39 AND 44).

FIRST USE 6-1-2008; IN COMMERCE 6-1-2008.

3,631,826. MEDEGEN, INC., ONTARIO, CA. SN 76-680,583. PUB. 7-8-2008, FILED 8-13-2007.

MEDEGEN

THE MARK CONSISTS OF STANDARD CHARACTERS WITHOUT CLAIM TO ANY PARTICULAR FONT, STYLE, SIZE, OR COLOR.

FOR MOLDED TUBING APPARATUS FOR MEDICAL USE, NAMELY, UNIVERSAL CONNECTORS AND PROTECTIVE CAPS, NEEDLELESS CONNECTORS, AND INTRAVENOUS MANIFOLD CONNECTORS; DEVICE THAT ALLOWS INTRAVENOUS ACCESS VIA A SYRINGE OR MALE LURE; MEDICAL BANDAGES FOR KEEPING INTRAVENOUS NEEDLES AND LURE FITTINGS IN PLACE (U.S. CLS. 26, 39 AND 44).

FIRST USE 0-0-2003; IN COMMERCE 0-0-2003.

CLASS 10—(Continued).

3,631,830. CARDIAC PACEMAKERS, INC., ST. PAUL, MN. SN 76-681,551. PUB. 3-4-2008, FILED 9-6-2007.

ALTRUA

THE MARK CONSISTS OF STANDARD CHARACTERS WITHOUT CLAIM TO ANY PARTICULAR FONT, STYLE, SIZE, OR COLOR.

FOR PACEMAKER WITH FEATURES DESIGNED TO AUTOMATICALLY OPTIMIZE PACING THERAPY WITHOUT THE NEED FOR EXTENSIVE PROGRAMMING (U.S. CLS. 26, 39 AND 44).

FIRST USE 5-10-2008; IN COMMERCE 5-10-2008.

3,631,869. ACCURAY INCORPORATED, SUNNYVALE, CA. SN 77-007,570. PUB. 5-1-2007, FILED 9-26-2006.

XCHANGE

THE MARK CONSISTS OF STANDARD CHARACTERS WITHOUT CLAIM TO ANY PARTICULAR FONT, STYLE, SIZE, OR COLOR.

FOR MEDICAL GOODS, NAMELY, A ROBOTIC RADIOTHERAPY DEVICE IN THE NATURE OF FIXED COLLIMATOR CHANGER PRODUCT USED WITHIN A THERAPEUTIC RADIOTHERAPY SYSTEM (U.S. CLS. 26, 39 AND 44).

FIRST USE 11-6-2006; IN COMMERCE 11-6-2006.

3,631,882. MINOS MEDICAL, INC., IRVINE, CA. SN 77-022,799. PUB. 7-31-2007, FILED 10-17-2006.

APPENDOECTOMY

THE MARK CONSISTS OF STANDARD CHARACTERS WITHOUT CLAIM TO ANY PARTICULAR FONT, STYLE, SIZE, OR COLOR.

NO CLAIM IS MADE TO THE EXCLUSIVE RIGHT TO USE "APPENDECTOMY", APART FROM THE MARK AS SHOWN.

FOR MEDICAL DEVICE AND SURGICAL INSTRUMENT FOR USE IN DIAGNOSIS AND SURGERY OF THE GASTRO-INTESTINAL TRACT; MEDICAL INSTRUMENTS FOR CUTTING TISSUE; SURGICAL AND MEDICAL APPARATUS AND INSTRUMENTS FOR USE IN GENERAL SURGERY (U.S. CLS. 26, 39 AND 44).

FIRST USE 9-1-2008; IN COMMERCE 9-1-2008.

CLASS 10—(Continued).

3,631,925. MONTERIS MEDICAL INC., WINNIPEG, MANITOBA, CANADA. SN 77-078,336. PUB. 7-10-2007, FILED 1-8-2007.

AUTOLITT

THE MARK CONSISTS OF STANDARD CHARACTERS WITHOUT CLAIM TO ANY PARTICULAR FONT, STYLE, SIZE, OR COLOR.
FOR MEDICAL DEVICE USING LASER-INDUCED THERMAL COAGULATION THERAPY FOR THE TREATMENT AND CONTROL OF LESIONS AND TUMORS (U.S. CLS. 26, 39 AND 44).
FIRST USE 9-24-2008; IN COMMERCE 9-24-2008.

3,631,948. MONTERIS MEDICAL INC., WINNIPEG, MB, CANADA. SN 77-094,364. PUB. 9-4-2007, FILED 1-30-2007.

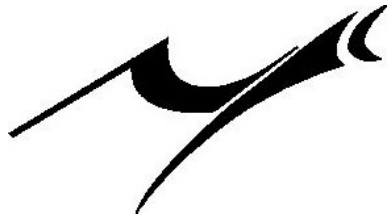

THE MARK CONSISTS OF A STYLIZED LETTER "M".
FOR MEDICAL DEVICE USING LASER-INDUCED THERMAL COAGULATION THERAPY FOR THE TREATMENT AND CONTROL OF LESIONS AND TUMORS (U.S. CLS. 26, 39 AND 44).
FIRST USE 9-24-2008; IN COMMERCE 9-24-2008.

3,631,979. CLEVEMED NEUROWAVE INC., CLEVELAND, OH. SN 77-128,435. PUB. 9-11-2007, FILED 3-12-2007.

NEUROMEDIC

THE MARK CONSISTS OF STANDARD CHARACTERS WITHOUT CLAIM TO ANY PARTICULAR FONT, STYLE, SIZE, OR COLOR.
FOR NEUROPHYSIOLOGICAL MEDICAL MONITOR (U.S. CLS. 26, 39 AND 44).
FIRST USE 5-1-2008; IN COMMERCE 5-1-2008.

CLASS 10—(Continued).

3,632,144. DILON TECHNOLOGIES, INC., NEWPORT NEWS, VA. SN 77-246,751. PUB. 5-13-2008, FILED 8-3-2007.

DILON TECHNOLOGIES

THE MARK CONSISTS OF STANDARD CHARACTERS WITHOUT CLAIM TO ANY PARTICULAR FONT, STYLE, SIZE, OR COLOR.
NO CLAIM IS MADE TO THE EXCLUSIVE RIGHT TO USE "TECHNOLOGIES", APART FROM THE MARK AS SHOWN.
FOR MEDICAL APPARATUS AND INSTRUMENTS FOR USE IN MEDICAL GAMMA IMAGING (U.S. CLS. 26, 39 AND 44).
FIRST USE 10-31-2004; IN COMMERCE 10-31-2004.

3,632,177. C. R. BARD, INC., MURRAY HILL, NJ. SN 77-259,685. PUB. 9-9-2008, FILED 8-20-2007.

FLEXURA

THE MARK CONSISTS OF STANDARD CHARACTERS WITHOUT CLAIM TO ANY PARTICULAR FONT, STYLE, SIZE, OR COLOR.
THE FOREIGN WORDING IN THE MARK TRANSLATES INTO ENGLISH AS "BENDING".
FOR MEDICAL DEVICES AND APPARATUS, NAMELY, MEDICAL GUIDEWIRES AND PARTS AND FITTINGS THEREFOR (U.S. CLS. 26, 39 AND 44).
FIRST USE 12-29-2007; IN COMMERCE 12-29-2007.

3,632,179. SCHERING-PLOUGH HEALTHCARE PRODUCTS, INC., MEMPHIS, TN. SN 77-261,251. PUB. 7-22-2008, FILED 8-22-2007.

DR. SCHOLL'S

THE MARK CONSISTS OF STANDARD CHARACTERS WITHOUT CLAIM TO ANY PARTICULAR FONT, STYLE, SIZE, OR COLOR.
OWNER OF U.S. REG. NOS. 512,484, 2,017,964, AND OTHERS.
"DR. SCHOLL" DOES NOT IDENTIFY A LIVING INDIVIDUAL.
FOR MEDICAL GRADUATED COMPRESSION HOSIERY, NAMELY, ELASTIC HOSE SUPPORTERS, KNEE HIGH HOSE, THIGH HIGH HOSE (U.S. CLS. 26, 39 AND 44).
FIRST USE 4-1-2007; IN COMMERCE 4-1-2007.

CLASS 10—(Continued).

3,632,204. CONCENTRIC MEDICAL, INC., MOUNTAIN VIEW, CA. SN 77-267,229. PUB. 7-15-2008, FILED 8-29-2007.

MERCI RETRIEVAL SYSTEM

THE MARK CONSISTS OF STANDARD CHARACTERS WITHOUT CLAIM TO ANY PARTICULAR FONT, STYLE, SIZE, OR COLOR.

OWNER OF U.S. REG. NOS. 2,744,451 AND 2,744,452.

NO CLAIM IS MADE TO THE EXCLUSIVE RIGHT TO USE "RETRIEVAL SYSTEM", APART FROM THE MARK AS SHOWN.

THE ENGLISH TRANSLATION OF THE WORD "MERCY" IN THE MARK IS THANK YOU.

FOR MEDICAL DEVICES, NAMELY, CATHETERS, GUIDEWIRES AND RETRIEVERS FOR USE IN RADIOLOGY, NEURORADIOLOGY, CARDIOLOGY AND SURGERY, FOR TREATING STROKES AND TO RETRIEVE CLOTS AND FOREIGN BODIES (U.S. CLS. 26, 39 AND 44).

FIRST USE 6-23-2008; IN COMMERCE 6-23-2008.

3,632,236. TRUDELL MEDICAL INTERNATIONAL, LONDON, ONTARIO, CANADA. SN 77-283,651. PUB. 9-9-2008, FILED 9-19-2007.

AEROCONTROL

THE MARK CONSISTS OF STANDARD CHARACTERS WITHOUT CLAIM TO ANY PARTICULAR FONT, STYLE, SIZE, OR COLOR.

PRIORITY CLAIMED UNDER SEC. 44(D) ON ERP CMNTY TM OFC APPLICATION NO. 005856596, FILED 4-25-2007.

OWNER OF U.S. REG. NOS. 2,700,773, 3,146,385, AND OTHERS.

FOR AEROSOL DELIVERY DEVICES FOR MEDICAL USE, NAMELY, NEBULIZERS FOR ATOMIZING LIQUIDS (U.S. CLS. 26, 39 AND 44).

FIRST USE 4-3-2009; IN COMMERCE 4-3-2009.

3,632,245. WOUND SYSTEMS, LLC, ATLANTA, GA. SN 77-288,225. PUB. 3-18-2008, FILED 9-25-2007.

**Dolphin Pressure
Redistribution System**

THE MARK CONSISTS OF STANDARD CHARACTERS WITHOUT CLAIM TO ANY PARTICULAR FONT, STYLE, SIZE, OR COLOR.

CLASS 10—(Continued).

NO CLAIM IS MADE TO THE EXCLUSIVE RIGHT TO USE "PRESSURE REDISTRIBUTION SYSTEM", APART FROM THE MARK AS SHOWN.

FOR AIR MATTRESSES FOR MEDICAL PURPOSES (U.S. CLS. 26, 39 AND 44).

FIRST USE 3-3-2009; IN COMMERCE 3-3-2009.

3,632,246. WOUND SYSTEMS, LLC, ATLANTA, GA. SN 77-288,260. PUB. 3-18-2008, FILED 9-25-2007.

Dolphin Pad

THE MARK CONSISTS OF STANDARD CHARACTERS WITHOUT CLAIM TO ANY PARTICULAR FONT, STYLE, SIZE, OR COLOR.

NO CLAIM IS MADE TO THE EXCLUSIVE RIGHT TO USE "PAD", APART FROM THE MARK AS SHOWN.

FOR AIR MATTRESSES FOR MEDICAL PURPOSES (U.S. CLS. 26, 39 AND 44).

FIRST USE 3-3-2009; IN COMMERCE 3-3-2009.

3,632,247. WOUND SYSTEMS, LLC, ATLANTA, GA. SN 77-288,358. PUB. 3-18-2008, FILED 9-25-2007.

Dolphin Mattress

THE MARK CONSISTS OF STANDARD CHARACTERS WITHOUT CLAIM TO ANY PARTICULAR FONT, STYLE, SIZE, OR COLOR.

NO CLAIM IS MADE TO THE EXCLUSIVE RIGHT TO USE "MATTRESS", APART FROM THE MARK AS SHOWN.

FOR AIR MATTRESSES FOR MEDICAL PURPOSES (U.S. CLS. 26, 39 AND 44).

FIRST USE 3-3-2009; IN COMMERCE 3-3-2009.

CLASS 10—(Continued).

3,632,275. MALLINCKRODT INC., HAZELWOOD, MO. SN 77-302,540. PUB. 6-3-2008, FILED 10-12-2007.

OPTISTAR ELITE

THE MARK CONSISTS OF STANDARD CHARACTERS WITHOUT CLAIM TO ANY PARTICULAR FONT, STYLE, SIZE, OR COLOR.

OWNER OF U.S. REG. NOS. 2,483,445 AND 2,877,635.
FOR ELECTRICALLY POWERED MEDICAL DEVICES, NAMELY, MEDICAL FLUID INJECTORS (U.S. CLS. 26, 39 AND 44).

FIRST USE 6-24-2008; IN COMMERCE 6-24-2008.

CLASS 10—(Continued).

3,632,415. CYNOSURE, INC., WESTFORD, MA. SN 77-366,162. PUB. 7-1-2008, FILED 1-8-2008.

SMARTSENSE

THE MARK CONSISTS OF STANDARD CHARACTERS WITHOUT CLAIM TO ANY PARTICULAR FONT, STYLE, SIZE, OR COLOR.

FOR MEDICAL EQUIPMENT, NAMELY, SAFETY CONTROL ASSEMBLIES CONSISTING OF SENSORS AND CONTROLLERS FOR LASER SURGERY DEVICES, NAMELY, TISSUE TREATMENT LASERS (U.S. CLS. 26, 39 AND 44).

FIRST USE 4-3-2008; IN COMMERCE 4-3-2008.

3,632,345. AMERICAN HEARING SYSTEMS INC., DBA INTERTON INC., BLOOMINGTON, MN. SN 77-334,231. PUB. 5-13-2008, FILED 11-20-2007.

ZIO

THE MARK CONSISTS OF STANDARD CHARACTERS WITHOUT CLAIM TO ANY PARTICULAR FONT, STYLE, SIZE, OR COLOR.

THE FOREIGN WORDING IN THE MARK TRANSLATES INTO ENGLISH AS "UNCLE".

FOR HEARING AIDS (U.S. CLS. 26, 39 AND 44).
FIRST USE 6-0-2008; IN COMMERCE 6-0-2008.

3,632,548. IMPLANT DIRECT INT'L, LAS VEGAS, NV. SN 77-404,396. PUB. 7-8-2008, FILED 2-22-2008.

SWISSPLANT

THE MARK CONSISTS OF STANDARD CHARACTERS WITHOUT CLAIM TO ANY PARTICULAR FONT, STYLE, SIZE, OR COLOR.

FOR DENTAL IMPLANTS AND ADAPTERS FOR DENTAL IMPLANTS (U.S. CLS. 26, 39 AND 44).

FIRST USE 2-15-2009; IN COMMERCE 2-15-2009.

3,632,359. ORTHO TECHNOLOGY, INC., TAMPA, FL. SN 77-341,254. PUB. 5-20-2008, FILED 11-30-2007.

TONGUE TAMERS

THE MARK CONSISTS OF STANDARD CHARACTERS WITHOUT CLAIM TO ANY PARTICULAR FONT, STYLE, SIZE, OR COLOR.

NO CLAIM IS MADE TO THE EXCLUSIVE RIGHT TO USE "TONGUE", APART FROM THE MARK AS SHOWN.

FOR DENTAL APPLIANCE, NAMELY, TOOTH BRACKET WITH SPIKE (U.S. CLS. 26, 39 AND 44).
FIRST USE 3-31-2006; IN COMMERCE 3-31-2006.

3,632,564. GAYMAR INDUSTRIES, INC., ORCHARD PARK, NY. SN 77-406,643. PUB. 7-15-2008, FILED 2-26-2008.

TRUTURN ELITE

THE MARK CONSISTS OF STANDARD CHARACTERS WITHOUT CLAIM TO ANY PARTICULAR FONT, STYLE, SIZE, OR COLOR.

OWNER OF U.S. REG. NO. 2,771,837.
NO CLAIM IS MADE TO THE EXCLUSIVE RIGHT TO USE "ELITE", APART FROM THE MARK AS SHOWN.

FOR THERAPEUTIC MATTRESS FOR MEDICAL PURPOSES (U.S. CLS. 26, 39 AND 44).
FIRST USE 11-13-2008; IN COMMERCE 11-13-2008.

CLASS 10—(Continued).

3,632,572. CAGENIX, INC., MEMPHIS, TN. SN 77-408,724.
PUB. 7-15-2008, FILED 2-28-2008.

ACCUFRAME

THE MARK CONSISTS OF STANDARD CHARACTERS WITHOUT CLAIM TO ANY PARTICULAR FONT, STYLE, SIZE, OR COLOR.
FOR DENTAL IMPLANT FRAMEWORKS (U.S. CLS. 26, 39 AND 44).
FIRST USE 11-1-2008; IN COMMERCE 11-1-2008.

CLASS 10—(Continued).

3,632,680. SYLMARK HOLDINGS LIMITED, DUBLIN 2, IRELAND. SN 77-427,794. PUB. 7-22-2008, FILED 3-20-2008.

WALKFIT PLATINUM

THE MARK CONSISTS OF STANDARD CHARACTERS WITHOUT CLAIM TO ANY PARTICULAR FONT, STYLE, SIZE, OR COLOR.
OWNER OF U.S. REG. NOS. 3,009,563, 3,248,271, AND 3,250,024.
FOR ORTHOTIC INSERTS FOR FOOTWEAR (U.S. CLS. 26, 39 AND 44).
FIRST USE 8-28-2008; IN COMMERCE 8-28-2008.

3,632,596. OSSUR HF., REYKJAVIK, ICELAND. SN 77-412,829. PUB. 12-16-2008, FILED 3-4-2008.

UNLOADER ONE

THE MARK CONSISTS OF STANDARD CHARACTERS WITHOUT CLAIM TO ANY PARTICULAR FONT, STYLE, SIZE, OR COLOR.
OWNER OF U.S. REG. NOS. 1,690,007 AND 2,161,047.
FOR MEDICAL KNEE BRACES (U.S. CLS. 26, 39 AND 44).
FIRST USE 12-22-2006; IN COMMERCE 12-22-2006.

3,632,660. SYNAPSE BIOMEDICAL, INC., OBERLIN, OH. SN 77-422,603. PUB. 7-29-2008, FILED 3-14-2008.

NEURX

THE MARK CONSISTS OF STANDARD CHARACTERS WITHOUT CLAIM TO ANY PARTICULAR FONT, STYLE, SIZE, OR COLOR.
FOR NERVE STIMULATOR APPARATUS (U.S. CLS. 26, 39 AND 44).
FIRST USE 2-19-2007; IN COMMERCE 2-19-2007.

3,632,706. COOLTOUCH INCORPORATED, ROSEVILLE, CA. SN 77-433,799. PUB. 8-5-2008, FILED 3-27-2008.

**COOLBLUE**

OWNER OF U.S. REG. NOS. 2,153,205, 3,374,858, AND OTHERS.
THE MARK CONSISTS OF THE WORD "COOLBLUE" ALL IN CAPITAL LETTER AND THE OVAL LOGO OF COOLTOUCH INCORPORATED APPEARS IN THE UPPER LEFT CORNER.
FOR MEDICAL LASERS, DERMATOLOGICAL DEVICES AND ASSOCIATED SYSTEMS, NAMELY, LASER ENERGY DELIVERY HANDPIECES (U.S. CLS. 26, 39 AND 44).
FIRST USE 4-5-2008; IN COMMERCE 5-1-2008.

3,632,713. ORCAWEST HOLDINGS, LLC, GLENDALE, CO. SN 77-435,791. PUB. 8-12-2008, FILED 3-31-2008.

DURASCAN

THE MARK CONSISTS OF STANDARD CHARACTERS WITHOUT CLAIM TO ANY PARTICULAR FONT, STYLE, SIZE, OR COLOR.
FOR ULTRASOUND DIAGNOSTIC APPARATUS (U.S. CLS. 26, 39 AND 44).
FIRST USE 3-18-2009; IN COMMERCE 3-18-2009.

CLASS 10—(Continued).

3,632,749. ZIMMER GMBH, WINTERTHUR, SWITZERLAND. SN 77-445,277. PUB. 12-23-2008, FILED 4-10-2008.

DTO

THE MARK CONSISTS OF STANDARD CHARACTERS WITHOUT CLAIM TO ANY PARTICULAR FONT, STYLE, SIZE, OR COLOR.

OWNER OF SWITZERLAND REG. NO. 560999, DATED 8-8-2007, EXPIRES 4-20-2017.

FOR SPINAL IMPLANTS COMPOSED OF ARTIFICIAL MATERIAL; SURGICAL APPARATUS, INSTRUMENTS AND TOOLS FOR MEDICAL USE, NAMELY, HAND PRESSES, ANTI TORQUE INSTRUMENTS, COMPRESSOR PINCER, SURGICAL AWLS, SURGICAL GUIDE PINS, SCREW DRIVERS, GUIDE WIRES, ROD BENDERS, ROD HOLDERS, TORQUE WRENCHES, HEX DRIVERS AND CORD TENSIONING INSTRUMENTS FOR IMPLANTING PROSTHESES AND PARTS THEREOF (U.S. CLS. 26, 39 AND 44).

FIRST USE 11-30-2008; IN COMMERCE 11-30-2008.

3,632,762. DENTSPLY INTERNATIONAL INC., YORK, PA. SN 77-448,224. PUB. 8-19-2008, FILED 4-15-2008.

INTERRA

THE MARK CONSISTS OF STANDARD CHARACTERS WITHOUT CLAIM TO ANY PARTICULAR FONT, STYLE, SIZE, OR COLOR.

OWNER OF U.S. REG. NO. 3,243,076.

FOR INTRA ORAL DENTAL APPLIANCES, NAMELY, NIGHT GUARDS; POLYMERIZATION APPARATUS FOR DENTAL PURPOSES (U.S. CLS. 26, 39 AND 44).

FIRST USE 6-5-2008; IN COMMERCE 6-5-2008.

3,632,830. PEARSON DENTAL SUPPLIES, INC., SYLMAR, CA. SN 77-474,235. PUB. 8-26-2008, FILED 5-14-2008.

Magic Touch

THE MARK CONSISTS OF STANDARD CHARACTERS WITHOUT CLAIM TO ANY PARTICULAR FONT, STYLE, SIZE, OR COLOR.

FOR DENTAL GLOVES (U.S. CLS. 26, 39 AND 44).

FIRST USE 1-1-2009; IN COMMERCE 1-1-2009.

CLASS 10—(Continued).

3,633,032. PARI PHARMA GMBH, STARNBERG, FED REP GERMANY. SN 77-551,247. PUB. 12-9-2008, FILED 8-20-2008.

ALTERA

THE MARK CONSISTS OF STANDARD CHARACTERS WITHOUT CLAIM TO ANY PARTICULAR FONT, STYLE, SIZE, OR COLOR.

FOR MEDICAL DEVICES, NAMELY, INHALATION DEVICES AND NEBULIZERS FOR RESPIRATORY THERAPY (U.S. CLS. 26, 39 AND 44).

FIRST USE 8-31-2008; IN COMMERCE 8-31-2008.

3,633,164. USGI MEDICAL, INC., SAN CLEMENTE, CA. SN 78-667,444. PUB. 4-29-2008, FILED 7-11-2005.

TRANSPORT

THE MARK CONSISTS OF STANDARD CHARACTERS WITHOUT CLAIM TO ANY PARTICULAR FONT, STYLE, SIZE, OR COLOR.

FOR MEDICAL DEVICES, NAMELY, LAPROSCOPIC/ENDOSCOPIC DIAGNOSTIC AND SURGICAL INSTRUMENTS FOR GASTROINTESTINAL AND NATURAL ORIFICE TRANSLUMINAL ENDOSCOPIC PROCEDURES (U.S. CLS. 26, 39 AND 44).

FIRST USE 1-29-2007; IN COMMERCE 1-29-2007.

3,633,247. DEPUY SPINE, INC., RAYNHAM, MA. SN 78-835,096. PUB. 6-12-2007, FILED 3-12-2006.

CONFIDENCE

THE MARK CONSISTS OF STANDARD CHARACTERS WITHOUT CLAIM TO ANY PARTICULAR FONT, STYLE, SIZE, OR COLOR.

FOR MEDICAL DEVICES, NAMELY, INSTRUMENTS USED TO PREPARE AND INTRODUCE BONE CEMENT INTO THE HUMAN BODY (U.S. CLS. 26, 39 AND 44).

FIRST USE 6-10-2008; IN COMMERCE 6-10-2008.

CLASS 10—(Continued).

3,633,248. ORTHO-TAIN, INC., TOA ALTA, PUERTO RICO. SN 78-837,630. PUB. 1-15-2008, FILED 3-15-2006.

HAWLEY-FORM

THE MARK CONSISTS OF STANDARD CHARACTERS WITHOUT CLAIM TO ANY PARTICULAR FONT, STYLE, SIZE, OR COLOR.

FOR DENTAL APPLIANCES, NAMELY, ORTHODONTIC AND DENTAL DEVICES FOR ADVANCING THE LOWER JAW AND EXPANDING THE ARCHES, DENTAL AND ORTHODONTIC EXPANDERS, JAW ADVANCEMENT APPLIANCES, DENTAL AND ORTHODONTIC RETAINERS AND TOOTH MOVEMENT APPLIANCES AND DEVICES (U.S. CLS. 26, 39 AND 44).

FIRST USE 5-25-2007; IN COMMERCE 5-25-2007.

CLASS 10—(Continued).

3,633,288. GEHR. BRASSELER GMBH & CO. KG, LEMGO, FED REP GERMANY. SN 78-919,102. PUB. 9-18-2007, FILED 6-28-2006.

Q-FINISHERS

THE MARK CONSISTS OF STANDARD CHARACTERS WITHOUT CLAIM TO ANY PARTICULAR FONT, STYLE, SIZE, OR COLOR.

FOR DENTAL INSTRUMENTS, NAMELY, FINISHING INSTRUMENTS (U.S. CLS. 26, 39 AND 44).

FIRST USE 1-1-1999; IN COMMERCE 1-1-2007.

3,633,289. GEHR. BRASSELER GMBH & CO. KG, LEMGO, FED REP GERMANY. SN 78-919,727. PUB. 9-18-2007, FILED 6-29-2006.

UM-CUTTERS

THE MARK CONSISTS OF STANDARD CHARACTERS WITHOUT CLAIM TO ANY PARTICULAR FONT, STYLE, SIZE, OR COLOR.

FOR DRILLING AND CUTTING INSTRUMENTS, FOR USE IN DENTAL PROSTHETICS, NAMELY, CUTTERS (U.S. CLS. 26, 39 AND 44).

FIRST USE 1-1-2000; IN COMMERCE 1-1-2007.

3,633,271. IBALANCE MEDICAL, INC., BOULDER, CO. SN 78-888,728. PUB. 7-10-2007, FILED 5-22-2006.

iFX

THE MARK CONSISTS OF STANDARD CHARACTERS WITHOUT CLAIM TO ANY PARTICULAR FONT, STYLE, SIZE, OR COLOR.

FOR MEDICAL DEVICES FOR JOINT RESTORATION, NAMELY, SURGICAL INSTRUMENTS IN THE NATURE OF SAWS AND SAW GUIDES FOR CUTTING A BONE, JACKS FOR OPENING A WEDGE-SHAPED VOID IN THE BONE SO AS TO ADJUST THE ORIENTATION OF THE BONE, AND A WEDGE-SHAPED SURGICAL IMPLANT CONSISTING OF ARTIFICIAL MATERIALS FOR DISPOSITION IN THE WEDGE-SHAPED VOID SO AS TO MAINTAIN THE ADJUSTED ORIENTATION OF THE BONE FOR USE IN THE SAME (U.S. CLS. 26, 39 AND 44).

FIRST USE 8-22-2008; IN COMMERCE 8-22-2008.

3,633,310. GEHR. BRASSELER GMBH & CO. KG, LEMGO, FED REP GERMANY. SN 78-958,321. PUB. 9-11-2007, FILED 8-23-2006.

FS

THE MARK CONSISTS OF STANDARD CHARACTERS WITHOUT CLAIM TO ANY PARTICULAR FONT, STYLE, SIZE, OR COLOR.

FOR DENTAL INSTRUMENTS, NAMELY, FINISHING INSTRUMENTS (U.S. CLS. 26, 39 AND 44).

FIRST USE 1-1-2007; IN COMMERCE 1-1-2007.

CLASS 10—(Continued).

3,633,311. GEBR. BRASSELER GMBH & CO. KG, LEMGO, FED REP GERMANY. SN 78-958,333. PUB. 9-18-2007, FILED 8-23-2006.

FSD

THE MARK CONSISTS OF STANDARD CHARACTERS WITHOUT CLAIM TO ANY PARTICULAR FONT, STYLE, SIZE, OR COLOR.

FOR DENTAL INSTRUMENTS, NAMELY, FINISHING INSTRUMENTS (U.S. CLS. 26, 39 AND 44).
FIRST USE 1-1-2007; IN COMMERCE 1-1-2007.

CLASS 11—ENVIRONMENTAL CONTROL APPARATUS

3,631,839. THE SY-KLONE COMPANY, JACKSONVILLE, FL. SN 76-684,472. PUB. 7-1-2008, FILED 11-29-2007.

POWER-KLONE

THE MARK CONSISTS OF STANDARD CHARACTERS WITHOUT CLAIM TO ANY PARTICULAR FONT, STYLE, SIZE, OR COLOR.

FOR POWERED AIR PRECLEANERS CONTAINING AN INLET SHROUD, FAN, MOTOR, LOUVERS, SEPARATION CHAMBER, OUTLET AND EJECTION PORT, PROVIDING EXTREMELY HIGH PRECLEANING EFFICIENCY FOR ENGINE INTAKES AND FRESH AIR INTAKES FOR HVAC (HEATING, VENTILATION AND AIR CONDITIONING SYSTEMS) (U.S. CLS. 13, 21, 23, 31 AND 34).

FIRST USE 5-0-2007; IN COMMERCE 5-0-2007.

3,631,864. MINTIE TECHNOLOGIES, INC., LOS ANGELES, CA. SN 77-000,986. PUB. 7-15-2008, FILED 9-15-2006.

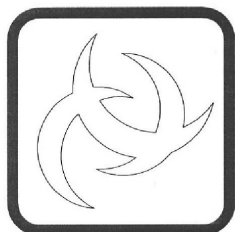

ICOROOM

CLASS 11—(Continued).

THE MARK CONSISTS OF INTERSECTING CRESCENTS WITHIN A RECTANGLE WITH THE WORD "ICOROOM" UNDERNEATH THE RECTANGLE.

FOR AIR TREATMENT UNIT, NAMELY, A COLLAPSIBLE PORTABLE ROOM WITH NEGATIVE AIR MACHINE, MADE OF FABRIC OR SPUN PLASTIC, WHICH PURIFIES THE AIR AS IT LEAVES THE ENCLOSED SPACE FOR USE IN HOSPITALIZING TUBERCULOSIS PATIENTS AND IN ISOLATING THE SPACE AND PREVENTING THE SPREAD OF CONTAMINANTS INTO OR OUT OF THE SPACE (U.S. CLS. 13, 21, 23, 31 AND 34).

FIRST USE 6-8-2007; IN COMMERCE 6-8-2007.

3,631,908. FUME-LOK PTY LTD, NORWOOD, AUSTRALIA. SN 77-057,162. PUB. 1-8-2008, FILED 12-5-2006.

ODORSOK

THE MARK CONSISTS OF STANDARD CHARACTERS WITHOUT CLAIM TO ANY PARTICULAR FONT, STYLE, SIZE, OR COLOR.

FOR AIR PURIFICATION EQUIPMENT, APPARATUS AND MEDIA, NAMELY, AIR PURIFICATION UNITS AND SEPARATORS FOR THE CLEANING AND PURIFICATION OF AIR; AIR FILTRATION EQUIPMENT APPARATUS AND MEDIA, NAMELY, FILTERING MEDIA FOR GENERAL INDUSTRIAL USE IN THE PURIFICATION OF AIR; AIR FILTERS, NAMELY, AIR FILTERS USING ACTIVATED CARBON AS THE FILTER MEDIUM FOR GENERAL INDUSTRIAL USE, DOMESTIC USE AND USE IN AIR CONDITIONING INSTALLATIONS (U.S. CLS. 13, 21, 23, 31 AND 34).

FIRST USE 2-28-2008; IN COMMERCE 2-28-2008.

3,631,930. LG ELECTRONICS INC., SEOUL, REPUBLIC OF KOREA. SN 77-080,576. PUB. 12-18-2007, FILED 1-11-2007.

LVN Compressor

NO CLAIM IS MADE TO THE EXCLUSIVE RIGHT TO USE "COMPRESSOR", APART FROM THE MARK AS SHOWN.

FOR ELECTRIC REFRIGERATORS; ELECTRIC FANS; ELECTRIC REFRIGERATING SHOWCASES; MICROWAVE OVENS; AIR CONDITIONERS; GAS OVEN RANGES; ELECTRIC TORCHES FOR LIGHTING (U.S. CLS. 13, 21, 23, 31 AND 34).

FIRST USE 1-11-2007; IN COMMERCE 1-11-2007.

CLASS 11—(Continued).

3,631,961. UNIMEX INDUSTRIES, INC., DBA BRIDGE-WATER INTERNATIONAL, WOODS CROSS, UT. SN 77-106,343. PUB. 8-14-2007, FILED 2-13-2007.

TITAN

THE MARK CONSISTS OF STANDARD CHARACTERS WITHOUT CLAIM TO ANY PARTICULAR FONT, STYLE, SIZE, OR COLOR.

FOR PLUMBING FITTINGS, NAMELY, SINK STRAINERS, SINK TRAPS, SINK SPRAYERS; SINKS (U.S. CLS. 13, 21, 23, 31 AND 34).

FIRST USE 1-31-2005; IN COMMERCE 6-30-2005.

3,632,296. MASCO BATH CORPORATIN, MOORESTOWN, NJ. SN 77-308,104. PUB. 6-17-2008, FILED 10-19-2007.

HAVEN

THE MARK CONSISTS OF STANDARD CHARACTERS WITHOUT CLAIM TO ANY PARTICULAR FONT, STYLE, SIZE, OR COLOR.

FOR UTILITY TUBS TO BE CONNECTED TO A PLUMBING SYSTEM (U.S. CLS. 13, 21, 23, 31 AND 34).

FIRST USE 10-28-2008; IN COMMERCE 10-28-2008.

3,632,360. TRUE VALUE COMPANY, CHICAGO, IL. SN 77-341,557. PUB. 6-17-2008, FILED 11-30-2007.

HOLIDAY WONDERLAND

THE MARK CONSISTS OF STANDARD CHARACTERS WITHOUT CLAIM TO ANY PARTICULAR FONT, STYLE, SIZE, OR COLOR.

OWNER OF U.S. REG. NOS. 2,591,693 AND 2,815,011.

NO CLAIM IS MADE TO THE EXCLUSIVE RIGHT TO USE "HOLIDAY", APART FROM THE MARK AS SHOWN.

FOR ELECTRIC OUTDOOR DECORATIVE LIGHTS (U.S. CLS. 13, 21, 23, 31 AND 34).

FIRST USE 3-0-2003; IN COMMERCE 3-0-2003.

CLASS 11—(Continued).

3,632,371. VARIABLE LUMINAIRE CORP., SHULIN CITY, TAIWAN. SN 77-346,306. PUB. 7-15-2008, FILED 12-7-2007.



THE MARK CONSISTS OF STYLIZED WORDS "TAI JAN".

FOR CEILING LIGHTS; ELECTRIC LIGHTING FIXTURES; ELECTRIC TRACK LIGHTING UNITS; LED AND HID LIGHT FIXTURES (U.S. CLS. 13, 21, 23, 31 AND 34).

FIRST USE 5-12-2008; IN COMMERCE 10-20-2008.

3,632,455. VICTORY ENERGY OPERATIONS, L.L.C., COLLINSVILLE, OK. SN 77-382,268. PUB. 12-9-2008, FILED 1-28-2008.



NO CLAIM IS MADE TO THE EXCLUSIVE RIGHT TO USE "SERIES", APART FROM THE MARK AS SHOWN.

THE COLOR(S) PURPLE AND TEAL IS/ARE CLAIMED AS A FEATURE OF THE MARK.

THE WORD "DISCOVERY" IS TEAL AND THE CURVED LINES AND WORD "SERIES" ARE PURPLE.

FOR INDUSTRIAL BOILERS (U.S. CLS. 13, 21, 23, 31 AND 34).

FIRST USE 8-25-2008; IN COMMERCE 8-25-2008.

CLASS 11—(Continued).

3,632,456. VICTORY ENERGY OPERATIONS, L.L.C., COLLINSVILLE, OK. SN 77-382,300. PUB. 12-30-2008, FILED 1-28-2008.



NO CLAIM IS MADE TO THE EXCLUSIVE RIGHT TO USE "SERIES", APART FROM THE MARK AS SHOWN. THE COLOR(S) PURPLE AND TEAL IS/ARE CLAIMED AS A FEATURE OF THE MARK. THE WORD "HORIZON" IS PURPLE AND THE CURVED LINES AND WORD "SERIES" ARE TEAL. FOR STEAM GENERATORS (U.S. CLS. 13, 21, 23, 31 AND 34). FIRST USE 3-0-2009; IN COMMERCE 3-0-2009.

CLASS 11—(Continued).

3,632,604. KINETICO INCORPORATED, NEWBURY, OH. SN 77-413,271. PUB. 7-22-2008, FILED 3-5-2008.

AquaKinetic

THE MARK CONSISTS OF STANDARD CHARACTERS WITHOUT CLAIM TO ANY PARTICULAR FONT, STYLE, SIZE, OR COLOR. FOR WATER CONDITIONING AND PURIFYING UNITS FOR DOMESTIC, COMMERCIAL AND INDUSTRIAL USE, NAMELY, WATER SOFTENING, MEMBRANE FILTRATION, REVERSE OSMOSIS, ION EXCHANGE AND FILTERING UNITS (U.S. CLS. 13, 21, 23, 31 AND 34). FIRST USE 8-1-2008; IN COMMERCE 8-1-2008.

3,632,672. NINGBO WAYWELL INTERNATIONAL CO., LTD., ZHEJIANG PROVINCE, CHINA. SN 77-426,851. PUB. 12-9-2008, FILED 3-20-2008.



THE MARK CONSISTS OF THE STYLIZED LETTERS "WW" DIRECTLY ABOVE THE WORD "WAYWELL". FOR AIR COOLING APPARATUS; ELECTRIC SPACE AIR HEATERS; AIR CONDITIONING INSTALLATIONS; AIR CONDITIONERS; AIR CONDITIONERS FOR VEHICLES; HEATERS FOR VEHICLES; AIR CONDITIONING APPARATUS; AIR PURIFYING APPARATUS AND MACHINES; AIR CONDITIONING, AIR COOLING AND VENTILATION APPARATUS AND INSTRUMENTS; AIR CONDITIONING VENTILATION INSTALLATIONS FOR VEHICLES (U.S. CLS. 13, 21, 23, 31 AND 34). FIRST USE 12-19-2007; IN COMMERCE 3-30-2009.

3,632,464. VICTORY ENERGY OPERATIONS, L.L.C., COLLINSVILLE, OK. SN 77-385,050. PUB. 1-6-2009, FILED 1-31-2008.



NO CLAIM IS MADE TO THE EXCLUSIVE RIGHT TO USE "SERIES", APART FROM THE MARK AS SHOWN. THE COLOR(S) BLUE AND GRAY IS/ARE CLAIMED AS A FEATURE OF THE MARK. THE MARK CONSISTS OF THE WORD "FRONTIER" IN BLUE ABOVE THE WORD "SERIES" IN GRAY WITH THREE VERTICAL WAVY LINES OVER THE "F" IN GRAY AND TWO ROUGHLY HORIZONTAL ARCS WHICH ARE ALSO GRAY. FOR INDUSTRIAL BOILERS (U.S. CLS. 13, 21, 23, 31 AND 34). FIRST USE 1-0-2009; IN COMMERCE 1-0-2009.

CLASS 11—(Continued).

3,632,766. DIMPLEX NORTH AMERICA LIMITED, CAMBRIDGE, ONTARIO, CANADA. SN 77-448,707. PUB. 10-28-2008, FILED 4-15-2008.

CLASS 11—(Continued).

3,632,859. MARIANNA INDUSTRIES, INC., OMAHA, NE. SN 77-485,113. PUB. 1-13-2009, FILED 5-28-2008.

CITROBLOCK**GENERIC VALUE PRODUCTS**

THE MARK CONSISTS OF STANDARD CHARACTERS WITHOUT CLAIM TO ANY PARTICULAR FONT, STYLE, SIZE, OR COLOR.

PRIORITY CLAIMED UNDER SEC. 44(D) ON CANADA APPLICATION NO. 1390561, FILED 4-9-2008.

FOR OUTDOOR ELECTRIC STOVES (U.S. CLS. 13, 21, 23, 31 AND 34).

FIRST USE 3-0-2008; IN COMMERCE 3-0-2008.

THE MARK CONSISTS OF STANDARD CHARACTERS WITHOUT CLAIM TO ANY PARTICULAR FONT, STYLE, SIZE, OR COLOR.

OWNER OF U.S. REG. NOS. 2,180,526, 3,245,401, AND OTHERS.

NO CLAIM IS MADE TO THE EXCLUSIVE RIGHT TO USE "GENERIC AND PRODUCTS", APART FROM THE MARK AS SHOWN.

SEC. 2(F).

FOR HAND-HELD ELECTRIC HAIR DRYERS (U.S. CLS. 13, 21, 23, 31 AND 34).

FIRST USE 10-19-2008; IN COMMERCE 10-19-2008.

3,632,807. COOPER TECHNOLOGIES COMPANY, HOUSTON, TX. SN 77-463,489. PUB. 1-6-2009, FILED 5-1-2008.

3,632,964. ENVIRODOCK, INC., PALMER, MA. SN 77-523,566. PUB. 12-16-2008, FILED 7-16-2008.

**PRECISION PLUS DOPPLER
RADAR****ENVIRODOCK**

THE MARK CONSISTS OF STANDARD CHARACTERS WITHOUT CLAIM TO ANY PARTICULAR FONT, STYLE, SIZE, OR COLOR.

NO CLAIM IS MADE TO THE EXCLUSIVE RIGHT TO USE "PRECISION" AND "DOPPLER RADAR", APART FROM THE MARK AS SHOWN.

FOR MOTION ACTIVATED LIGHTING PRODUCTS FEATURING DOPPLER RADAR, NAMELY, ELECTRICAL, SOLAR AND BATTERY OPERATED MOTION ACTIVATED LIGHTING FIXTURES FOR USE WITH INCANDESCENT, HALOGEN, FLUORESCENT AND LED LAMPS (U.S. CLS. 13, 21, 23, 31 AND 34).

FIRST USE 2-1-2008; IN COMMERCE 2-1-2008.

THE MARK CONSISTS OF STANDARD CHARACTERS WITHOUT CLAIM TO ANY PARTICULAR FONT, STYLE, SIZE, OR COLOR.

FOR PORTABLE HEATING, VENTILATION AND AIR CONDITIONING UNITS FOR VEHICLES (U.S. CLS. 13, 21, 23, 31 AND 34).

FIRST USE 9-1-2008; IN COMMERCE 9-1-2008.

CLASS 11—(Continued).

3,633,082. SARA LEE DE/N.V., 3532 AD UTRECHT, NETHERLANDS. SN 78-077,343. PUB. 7-16-2002, FILED 8-3-2001.



NO CLAIM IS MADE TO THE EXCLUSIVE RIGHT TO USE "ANNO" OR "1753", APART FROM THE MARK AS SHOWN.

FOR ELECTRIC APPARATUS FOR THE PREPARATION AND DISTRIBUTION OF HOT AND COLD BEVERAGES, NAMELY, COFFEE, TEA AND COCOA BREWING AND DISPENSING MACHINES, AND HOT AND COLD WATER DISPENSING MACHINES (U.S. CLS. 13, 21, 23, 31 AND 34).

FIRST USE 7-3-2001; IN COMMERCE 1-1-2003.

3,633,111. SHAGHAL, LTD., LOS ANGELES, CA. SN 78-510,981. PUB. 10-24-2006, FILED 11-3-2004.

EMATIC

THE MARK CONSISTS OF STANDARD CHARACTERS WITHOUT CLAIM TO ANY PARTICULAR FONT, STYLE, SIZE, OR COLOR.

FOR ELECTRIC COFFEE MAKER, ELECTRIC WAFFLE TOASTER, CONVECTION OVENS, MICROWAVE OVENS, ELECTRIC RICE COOKER, ELECTRIC SANDWICH MAKER, MINI REFRIGERATORS (U.S. CLS. 13, 21, 23, 31 AND 34).

FIRST USE 1-1-2005; IN COMMERCE 1-1-2005.

CLASS 11—(Continued).

3,633,168. ANOXKALDNES, INC., PROVIDENCE, RI. SN 78-685,539. PUB. 8-21-2007, FILED 8-4-2005.

LAGOONGUARD

THE MARK CONSISTS OF STANDARD CHARACTERS WITHOUT CLAIM TO ANY PARTICULAR FONT, STYLE, SIZE, OR COLOR.

FOR WATER TREATMENT SYSTEMS, NAMELY, WASTEWATER PURIFICATION UNITS COMPRISING REACTORS AND TREATMENT TANKS UTILIZING POLYETHYLENE MEDIA AND AERATION SYSTEMS, TREATMENT APPARATUS, EFFLUENT FILTERS, PUMPING STATIONS, FILTRATION DEVICES AND ELECTRONIC CONTROL UNITS (U.S. CLS. 13, 21, 23, 31 AND 34).

FIRST USE 0-0-2004; IN COMMERCE 0-0-2004.

3,633,317. BIXBY ENERGY SYSTEMS, RAMSEY, MN. SN 78-967,902. PUB. 7-24-2007, FILED 9-6-2006.



Bixby Energy

NO CLAIM IS MADE TO THE EXCLUSIVE RIGHT TO USE "ENERGY", APART FROM THE MARK AS SHOWN.

FOR BIOMASS STOVES, NAMELY, SOLID FUEL BURNING STOVES, FURNACES; ELECTRIC SPACE HEATERS; AND FIREPLACE BURNERS, NAMELY, FIREPLACE INSERTS IN THE NATURE OF SOLID FUEL BURNERS (U.S. CLS. 13, 21, 23, 31 AND 34).

FIRST USE 12-0-2007; IN COMMERCE 12-0-2007.

CLASS 12—VEHICLES

3,632,040. AUDI AG, INGOLSTADT, FED REP GERMANY. SN 77-189,847. PUB. 10-30-2007, FILED 5-24-2007.

RO1

THE MARK CONSISTS OF STANDARD CHARACTERS WITHOUT CLAIM TO ANY PARTICULAR FONT, STYLE, SIZE, OR COLOR.

FOR LAND VEHICLES AND STRUCTURAL PARTS THEREFORE; VEHICLE TIRES (U.S. CLS. 19, 21, 23, 31, 35 AND 44).

FIRST USE 10-1-2007; IN COMMERCE 10-1-2007.

CLASS 12—(Continued).

3,632,139. E. THIRTEEN INCORPORATED, EDGARTOWN, MA. SN 77-243,768. PUB. 1-22-2008, FILED 7-31-2007.

Turbocharger

THE MARK CONSISTS OF STANDARD CHARACTERS WITHOUT CLAIM TO ANY PARTICULAR FONT, STYLE, SIZE, OR COLOR.

FOR BICYCLE PARTS, NAMELY, BASHGUARDS (U.S. CLS. 19, 21, 23, 31, 35 AND 44).

FIRST USE 9-15-2008; IN COMMERCE 2-2-2009.

3,632,185. FEDERAL-MOGUL WORLD WIDE INC., SOUTHFIELD, MI. SN 77-261,445. PUB. 12-18-2007, FILED 8-22-2007.

ONESOURCE
WORLDWIDE PRODUCT SUPPLY

NO CLAIM IS MADE TO THE EXCLUSIVE RIGHT TO USE "WORLDWIDE PRODUCT SUPPLY", APART FROM THE MARK AS SHOWN.

THE MARK CONSISTS OF THE WORD "ONESOURCE" WITH A DEPICTION OF A GLOBE IN PLACE OF THE "O" IN "SOURCE".

FOR BRAKES, BRAKE PADS, BRAKE LININGS AND BRAKE ROTORS, ALL FOR LAND VEHICLES; DRIVE-LINE PRODUCTS FOR LAND VEHICLES, NAMELY, UNIVERSAL JOINTS; CHASSIS PARTS FOR LAND VEHICLES, NAMELY, BUSHINGS, BALL JOINTS, BUMP STOPS, CENTER LINKS, CONTROL ARMS, DRAG LINKS, STEERING STABILIZERS, STRUTS, STRUT MOUNTS, SUSPENSION SPRINGS, SWAY BARS, TIE RODS, TORSION ARMS, SHOCKS; WHEEL HUB ASSEMBLIES FOR LAND VEHICLES (U.S. CLS. 19, 21, 23, 31, 35 AND 44).

FIRST USE 6-28-2007; IN COMMERCE 6-28-2007.

3,632,233. R.A. ALLEN COMPANY, INC., VERO BEACH, FL. SN 77-282,340. PUB. 7-29-2008, FILED 9-18-2007.

ALLEN SPORTS

THE MARK CONSISTS OF STANDARD CHARACTERS WITHOUT CLAIM TO ANY PARTICULAR FONT, STYLE, SIZE, OR COLOR.

OWNER OF U.S. REG. NOS. 1,463,413 AND 2,984,828.

NO CLAIM IS MADE TO THE EXCLUSIVE RIGHT TO USE "SPORTS", APART FROM THE MARK AS SHOWN.

FOR BICYCLE RACKS FOR VEHICLES, BICYCLE ADAPTER BARS FOR ATTACHING BICYCLES TO BICYCLE RACKS FOR VEHICLES (U.S. CLS. 19, 21, 23, 31, 35 AND 44).

FIRST USE 1-30-2008; IN COMMERCE 1-30-2008.

CLASS 12—(Continued).

3,632,268. JYMGER MARKETING AND ENGINEERING, GOSHEN, IN. SN 77-298,922. PUB. 4-15-2008, FILED 10-8-2007.

camplite

THE MARK CONSISTS OF STANDARD CHARACTERS WITHOUT CLAIM TO ANY PARTICULAR FONT, STYLE, SIZE, OR COLOR.

FOR RECREATIONAL VEHICLES, NAMELY, TRAVEL TRAILERS, CAMPING TRAILERS, TENT CAMPERS AND MOTOR HOMES (U.S. CLS. 19, 21, 23, 31, 35 AND 44).

FIRST USE 4-1-2009; IN COMMERCE 3-31-2009.

3,632,481. BRAD CROMARTIE, MT. PLEASANT, SC. SN 77-390,190. PUB. 6-24-2008, FILED 2-6-2008.

SUPERSTICK

THE MARK CONSISTS OF STANDARD CHARACTERS WITHOUT CLAIM TO ANY PARTICULAR FONT, STYLE, SIZE, OR COLOR.

FOR TELESCOPIC AND NON-TELESCOPIC POLES SPECIFICALLY ADAPTED FOR A BOAT FOR USE IN PROPELLING BOATS IN SHALLOW WATER AND PUSHING BOATS OFF DOCKS AND PIERS (U.S. CLS. 19, 21, 23, 31, 35 AND 44).

FIRST USE 1-23-2009; IN COMMERCE 1-23-2009.

3,632,592. TIRECO, INC., COMPTON, CA. SN 77-411,951. PUB. 7-22-2008, FILED 3-3-2008.

 **MILESTAR**

OWNER OF U.S. REG. NO. 2,652,751.

FOR TIRES, INNER TUBES FOR VEHICLE TIRES, INNER TUBE PROTECTOR FLAPS, VALVE STEMS FOR TIRES (U.S. CLS. 19, 21, 23, 31, 35 AND 44).

FIRST USE 10-31-2007; IN COMMERCE 5-31-2008.

CLASS 12—(Continued).

3,632,877. BLACKWOOD BOATS, LLC, GROVELAND, FL. SN 77-494,216. PUB. 11-4-2008, FILED 6-9-2008.

BLACKWOOD

THE MARK CONSISTS OF STANDARD CHARACTERS WITHOUT CLAIM TO ANY PARTICULAR FONT, STYLE, SIZE, OR COLOR.
FOR BOATS (U.S. CLS. 19, 21, 23, 31, 35 AND 44).
FIRST USE 10-29-2008; IN COMMERCE 1-2-2009.

3,632,886. HSIN YI CHANG INDUSTRY CO., LTD., TAINAN CITY, TAIWAN. SN 77-497,196. PUB. 11-18-2008, FILED 6-12-2008.



THE MARK CONSISTS OF AN OVAL DESIGN WITH THE WORDING "HIC" APPEARING IN STYLIZED FONT WITHIN THE OVAL. A DESIGN OF AN ARCUATE BRACKET APPEARS WITHIN THE OVAL BENEATH THE STYLIZED WORDING "HIC".
FOR AUTOMOBILE WINDSHIELD SUNSHADES; HOOD SHIELDS AS STRUCTURAL PARTS OF VEHICLES; LAND VEHICLE PARTS, NAMELY, FENDERS AND WINDSHIELDS; SPOILERS FOR VEHICLES; SUN SHIELDS AND VISORS FOR MOTOR CARS; VEHICLE PARTS, NAMELY, SUN VISORS; VEHICLE PARTS, NAMELY, WINDSHIELD VISORS; WINDSCREENS FOR MOTOR CARS (U.S. CLS. 19, 21, 23, 31, 35 AND 44).
FIRST USE 11-4-2008; IN COMMERCE 11-4-2008.

3,632,905. TIEN YUEN MACHINERY MFG. CO., LTD., TAICHUNG, TAIWAN. SN 77-505,251. PUB. 11-18-2008, FILED 6-23-2008.



THE MARK CONSISTS OF A STYLIZED VERSION OF THE TERM "NOVA".
FOR ANTI-SKID CHAINS FOR VEHICLES; CHAINS FOR MOTOR CARS; LAND VEHICLE PARTS, NAMELY, TIRE CHAINS, AND TIRE SNOW CHAINS; TRANSMISSION CHAINS FOR LAND VEHICLES; BICYCLE CHAINS; BICYCLE PARTS, NAMELY, DRIVE CHAINS, AND SPROCKETS (U.S. CLS. 19, 21, 23, 31, 35 AND 44).
FIRST USE 1-20-2009; IN COMMERCE 1-20-2009.

CLASS 12—(Continued).

3,632,979. SUNRISE MEDICAL HHG INC., LONGMONT, CO. SN 77-528,818. PUB. 12-16-2008, FILED 7-22-2008.

Q-FIT

THE MARK CONSISTS OF STANDARD CHARACTERS WITHOUT CLAIM TO ANY PARTICULAR FONT, STYLE, SIZE, OR COLOR.
FOR A WHEELCHAIR FEATURE SOLD AS AN INTEGRAL PART OF A WHEELCHAIR, NAMELY, AN ANTI-RATTLE FEATURE USING BUSHINGS AND INSERTS WHICH ASSURE SNUG FITNESS BETWEEN WHEELCHAIR PARTS (U.S. CLS. 19, 21, 23, 31, 35 AND 44).
FIRST USE 9-15-2008; IN COMMERCE 9-15-2008.

3,633,125. FORD MOTOR COMPANY, DEARBORN, MI. SN 78-562,419. PUB. 10-25-2005, FILED 2-8-2005.

NAVIGATOR L

THE MARK CONSISTS OF STANDARD CHARACTERS WITHOUT CLAIM TO ANY PARTICULAR FONT, STYLE, SIZE, OR COLOR.
OWNER OF U.S. REG. NOS. 2,111,095 AND 2,267,250.
FOR LAND MOTOR VEHICLES, NAMELY, AUTOMOBILES AND EXTERIOR INSIGNIA BADGES FOR VEHICLES (U.S. CLS. 19, 21, 23, 31, 35 AND 44).
FIRST USE 2-10-2006; IN COMMERCE 2-10-2006.

3,633,186. HENDRICKSON USA, L.L.C., ITASCA, IL. SN 78-711,069. PUB. 1-30-2007, FILED 9-12-2005.



THE MARK CONSISTS OF STANDARD CHARACTERS WITHOUT CLAIM TO ANY PARTICULAR FONT, STYLE, SIZE, OR COLOR.
FOR SUSPENSION SYSTEMS FOR LAND VEHICLES; VEHICLE SUSPENSION PARTS, STRUCTURAL PARTS AND SUB-ASSEMBLIES, NAMELY, TORQUE BOX ASSEMBLIES (U.S. CLS. 19, 21, 23, 31, 35 AND 44).
FIRST USE 11-30-2008; IN COMMERCE 11-30-2008.

CLASS 12—(Continued).

3,633,253. MCCAULEY'S SMALL ENGINE REPAIR, LLC, LANSING, MI. SN 78-843,274. PUB. 11-20-2007, FILED 3-22-2006.

SHATTERED DREAMS

THE MARK CONSISTS OF STANDARD CHARACTERS WITHOUT CLAIM TO ANY PARTICULAR FONT, STYLE, SIZE, OR COLOR.

FOR COFFINS CONVERTED INTO A MOTORIZED DRIVABLE CART FOR USE AS VISUAL AIDS IN CONNECTION WITH WORKSHOPS AND SEMINARS ON THE DANGERS OF DRUG AND ALCOHOL ABUSE (U.S. CLS. 19, 21, 23, 31, 35 AND 44).

FIRST USE 4-6-2006; IN COMMERCE 2-27-2008.

3,633,341. CARROLL HALL SHELBY TRUST, COMPRISING CARROLL HALL SHELBY, A UNITED STATES CITIZEN, LOS ANGELES, CA. SN 78-981,097. PUB. 12-12-2006, FILED 5-15-2006.

CS6

THE MARK CONSISTS OF STANDARD CHARACTERS WITHOUT CLAIM TO ANY PARTICULAR FONT, STYLE, SIZE, OR COLOR.

OWNER OF U.S. REG. NOS. 864,154, 1,423,787, AND OTHERS.

FOR LAND VEHICLES, AUTOMOBILES AND ENGINES FOR LAND VEHICLES (U.S. CLS. 19, 21, 23, 31, 35 AND 44).

FIRST USE 5-20-2008; IN COMMERCE 5-20-2008.

CLASS 13—FIREARMS

3,631,931. TDI, INC., WASHINGTON, DC. SN 77-081,034. PUB. 1-8-2008, FILED 1-11-2007.

SUPER V SYSTEM

THE MARK CONSISTS OF STANDARD CHARACTERS WITHOUT CLAIM TO ANY PARTICULAR FONT, STYLE, SIZE, OR COLOR.

NO CLAIM IS MADE TO THE EXCLUSIVE RIGHT TO USE "SUPER" AND "SYSTEM", APART FROM THE MARK AS SHOWN.

FOR FIREARM COMPONENT PART, NAMELY, RE-COIL CONTROL MECHANISM (U.S. CLS. 2 AND 9).

FIRST USE 11-29-2006; IN COMMERCE 11-29-2006.

CLASS 13—(Continued).

3,631,945. ALLIANT TECHSYSTEMS INC., MINNEAPOLIS, MN. SN 77-092,299. PUB. 6-24-2008, FILED 1-26-2007.



NO CLAIM IS MADE TO THE EXCLUSIVE RIGHT TO USE "FORCE ON FORCE", APART FROM THE MARK AS SHOWN.

THE MARK CONSISTS OF THE WORDS "FORCE ON FORCE" WITH THE "O" HAVING A TARGET DESIGN, ALL OVERLAYING DISTINCTIVE IMAGES IN THE BACKGROUND.

FOR AMMUNITION (U.S. CLS. 2 AND 9).

FIRST USE 11-0-2007; IN COMMERCE 10-1-2008.

3,632,918. GAMO USA CORP., FT. LAUDERDALE, FL. SN 77-511,250. PUB. 9-23-2008, FILED 6-30-2008.

RED FIRE

THE MARK CONSISTS OF STANDARD CHARACTERS WITHOUT CLAIM TO ANY PARTICULAR FONT, STYLE, SIZE, OR COLOR.

FOR AIR PISTOL BULLETS; AIR PISTOLS; AIR RIFLES; AIR SHOT OR PELLETS (U.S. CLS. 2 AND 9).

FIRST USE 1-15-2009; IN COMMERCE 1-15-2009.

3,632,953. GAMO USA CORP., FT. LAUDERDALE, FL. SN 77-521,138. PUB. 12-9-2008, FILED 7-14-2008.

LADY RECON

THE MARK CONSISTS OF STANDARD CHARACTERS WITHOUT CLAIM TO ANY PARTICULAR FONT, STYLE, SIZE, OR COLOR.

FOR AIR PISTOLS; AIR RIFLES (U.S. CLS. 2 AND 9).

FIRST USE 1-15-2009; IN COMMERCE 1-15-2009.

CLASS 13—(Continued).

3,632,954. GAMO USA CORP., FT. LAUDERDALE, FL. SN 77-521,142. PUB. 12-9-2008, FILED 7-14-2008.

SILENT CAT

THE MARK CONSISTS OF STANDARD CHARACTERS WITHOUT CLAIM TO ANY PARTICULAR FONT, STYLE, SIZE, OR COLOR.
FOR AIR PISTOLS; AIR RIFLES (U.S. CLS. 2 AND 9).
FIRST USE 1-15-2009; IN COMMERCE 1-15-2009.

CLASS 14—JEWELRY

3,631,845. SCHURHAMMER MANUFACTURING, INC., WABASHA, MN. SN 76-686,531. PUB. 7-8-2008, FILED 2-4-2008.

THE DIAMOND NATURE INTENDED

THE MARK CONSISTS OF STANDARD CHARACTERS WITHOUT CLAIM TO ANY PARTICULAR FONT, STYLE, SIZE, OR COLOR.
NO CLAIM IS MADE TO THE EXCLUSIVE RIGHT TO USE "DIAMOND", APART FROM THE MARK AS SHOWN.
FOR DIAMONDS (U.S. CLS. 2, 27, 28 AND 50).
FIRST USE 10-4-2008; IN COMMERCE 10-4-2008.

3,632,014. HENDIAZAD, ANNOUSH, MORRIS PLAINS, NJ. SN 77-162,368. PUB. 3-25-2008, FILED 4-20-2007.



THE MARK CONSISTS OF "SORELLE SISTERS" INSIDE A DOUBLE OVAL CAPPED WITH A CROWN.
THE ENGLISH TRANSLATION OF THE WORD "SORELLE" IN THE MARK IS SISTERS.
FOR JEWELRY (U.S. CLS. 2, 27, 28 AND 50).
FIRST USE 3-6-2008; IN COMMERCE 3-6-2008.

CLASS 14—(Continued).

3,632,110. LAKE, MICHAEL, SEATTLE, WA. SN 77-229,351. PUB. 1-1-2008, FILED 7-13-2007.

MS. TAKEN

THE MARK CONSISTS OF STANDARD CHARACTERS WITHOUT CLAIM TO ANY PARTICULAR FONT, STYLE, SIZE, OR COLOR.
FOR JEWELRY (U.S. CLS. 2, 27, 28 AND 50).
FIRST USE 3-21-2009; IN COMMERCE 3-21-2009.

3,632,136. WU, WEN CHEN K, PORT WASHINGTON, NY. SN 77-240,581. PUB. 10-21-2008, FILED 7-27-2007.

NEW HAVEN

THE MARK CONSISTS OF STANDARD CHARACTERS WITHOUT CLAIM TO ANY PARTICULAR FONT, STYLE, SIZE, OR COLOR.
FOR CLOCKS (U.S. CLS. 2, 27, 28 AND 50).
FIRST USE 1-1-2009; IN COMMERCE 1-1-2009.

3,632,155. CHARLES WINSTON LUXURY GROUP, LLC, HOLLYWOOD, FL. SN 77-249,759. PUB. 7-15-2008, FILED 8-8-2007.

MADDY EMERSON

THE MARK CONSISTS OF STANDARD CHARACTERS WITHOUT CLAIM TO ANY PARTICULAR FONT, STYLE, SIZE, OR COLOR.
THE NAME "MADDY EMERSON" DOES NOT IDENTIFY A LIVING INDIVIDUAL.
FOR JEWELRY (U.S. CLS. 2, 27, 28 AND 50).
FIRST USE 10-1-2007; IN COMMERCE 10-1-2007.

CLASS 14—(Continued).

3,632,294. NELSON JEWELLERY ARTS CO. LTD., HUNGHOM KOWLOON, HONG KONG. SN 77-306,987. PUB. 9-30-2008, FILED 10-18-2007.



OWNER OF U.S. REG. NO. 3,304,447.
 THE MARK CONSISTS OF THE WORD "CALLA", WITH THE LETTER "C" WITHIN A LILY DESIGN.
 FOR PRECIOUS STONES, NAMELY, DIAMONDS HAVING TWO DIAGONALLY OPPOSED POINTED CORNERS AND TWO DIAGONALLY OPPOSED ROUNDED CORNERS MOUNTED ON RINGS AND EARRINGS (U.S. CLS. 2, 27, 28 AND 50).
 FIRST USE 10-0-2007; IN COMMERCE 10-0-2007.

3,632,569. AZRIELANT, OFER, NEW YORK, NY. SN 77-408,379. PUB. 7-8-2008, FILED 2-28-2008.

OCTOBER IS RIGHT HAND RING MONTH

THE MARK CONSISTS OF STANDARD CHARACTERS WITHOUT CLAIM TO ANY PARTICULAR FONT, STYLE, SIZE, OR COLOR.
 OWNER OF U.S. REG. NO. 3,280,609.
 NO CLAIM IS MADE TO THE EXCLUSIVE RIGHT TO USE "RIGHT HAND RING", APART FROM THE MARK AS SHOWN.
 FOR JEWELRY; GEMSTONES (U.S. CLS. 2, 27, 28 AND 50).
 FIRST USE 4-0-2005; IN COMMERCE 4-0-2005.

CLASS 14—(Continued).

3,632,668. JEWELEX NEW YORK, LTD., NEW YORK, NY. SN 77-425,183. PUB. 7-29-2008, FILED 3-18-2008.



OWNER OF U.S. REG. NOS. 3,313,214, 3,335,752, AND OTHERS.
 THE MARK CONSISTS OF THE MARK CONSISTS OF THE WORDS "PERFEKT TREASURES" IN THE STYLIZED LETTERING.
 FOR JEWELRY, NAMELY, GOLD, PLATINUM, TITANIUM AND SILVER JEWELRY; AND GOLD, PLATINUM, TITANIUM AND SILVER JEWELRY WITH PRECIOUS STONES, NAMELY, DIAMONDS, RUBIES, EMERALDS, SAPPHIRES, AND SEMI-PRECIOUS COLORED STONES EMBEDDED THEREIN, AND PEARLS EMBEDDED THEREIN (U.S. CLS. 2, 27, 28 AND 50).
 FIRST USE 3-19-2008; IN COMMERCE 3-19-2008.

3,632,707. PATEL DEVIYANI, NORTH BERGEN, NJ. SN 77-433,830. PUB. 10-7-2008, FILED 3-27-2008.



NO CLAIM IS MADE TO THE EXCLUSIVE RIGHT TO USE "DIAMONDS", APART FROM THE MARK AS SHOWN.
 FOR JEWELRY, JEWELRY BOXES, AND JEWELRY ORGANIZERS COMPRISED IN WHOLE OR SUBSTANTIALLY IN PART OF DIAMONDS, NAMELY, BRACELETS, BRONZE JEWELRY, BROOCHES, CHARMS, DIAMOND JEWELRY, GEMSTONE JEWELRY, JEWELRY, JEWELRY BOXES, JEWELRY BOXES NOT OF METAL, JEWELRY BOXES OF METAL, JEWELRY BOXES OF PRECIOUS METAL, JEWELRY CHAINS, JEWELRY FINDINGS, JEWELRY FOR ATTACHMENT TO CLOTHING, JEWELRY FOR THE HEAD, JEWELRY IN THE NATURE OF ARMBANDS, JEWELRY ORGANIZERS, JEWELRY PINS FOR USE ON HATS, JEWELRY RING HOLDERS, JEWELRY TO BE AFFIXED TO BIKINIS, JEWELRY WATCHES, PRECIOUS METAL PLATED REAL LEAVES AND FLOWERS, LAPEL PINS, LEATHER JEWELRY AND ACCESSORY BOXES, PET JEWELRY, PLASTIC BRACELETS IN THE NATURE OF JEWELRY, RINGS, RINGS BEING JEWELRY, WATCHES AND JEWELRY, CLOCKS (U.S. CLS. 2, 27, 28 AND 50).
 FIRST USE 2-2-2009; IN COMMERCE 2-2-2009.

CLASS 14—(Continued).

3,632,731. GLENN MILLER ASSOCIATES, LOS ALAMITOS, CA. SN 77-440,576. PUB. 7-29-2008, FILED 4-4-2008.



THE MARK CONSISTS OF THE STYLIZED LETTERS "D" AND "T" LINKED TOGETHER.
FOR JEWELRY (U.S. CLS. 2, 27, 28 AND 50).
FIRST USE 2-14-2008; IN COMMERCE 3-13-2008.

3,632,970. SABINE DEBRUS, GLONS, BELGIUM. SN 77-526,817. PUB. 12-16-2008, FILED 7-21-2008.



THE MARK CONSISTS OF THE STYLIZED HEAD OF A DOG, WHOSE EARS ARE LIKE THE WINGS OF AN ANGEL. HE IS WEARING A THREE-POINTED FAIRY CROWN WITH A TULIP, A STAR AND A CRESCENT MOON ON THE POINTS OF THE CROWN. A CURVED BONE IS DIRECTLY UNDERNEATH, WITH THE WORD "CHERUBINE" IN STYLIZED LETTERING INSIDE THE BONE.
FOR JEWELRY (U.S. CLS. 2, 27, 28 AND 50).
FIRST USE 4-4-2009; IN COMMERCE 4-4-2009.

3,633,017. SPD GROUP, INC., DBA JR DUNN JEWELERS, LIGHTHOUSE POINT, FL. SN 77-545,169. PUB. 12-30-2008, FILED 8-12-2008.

PRECIOUS EARTH

THE MARK CONSISTS OF STANDARD CHARACTERS WITHOUT CLAIM TO ANY PARTICULAR FONT, STYLE, SIZE, OR COLOR.
FOR JEWELRY (U.S. CLS. 2, 27, 28 AND 50).
FIRST USE 1-12-2009; IN COMMERCE 1-12-2009.

CLASS 14—(Continued).

3,633,122. DUESENBERG, LLC, MAPLE PLAIN, MN. SN 78-558,936. PUB. 1-17-2006, FILED 2-2-2005.

DUESENBERG

THE MARK CONSISTS OF STANDARD CHARACTERS WITHOUT CLAIM TO ANY PARTICULAR FONT, STYLE, SIZE, OR COLOR.
OWNER OF U.S. REG. NOS. 1,173,102, 1,276,873, AND 2,331,124.
FOR GOODS OF PRECIOUS METALS AND THEIR ALLOYS OR COATED THEREWITH, NAMELY, JEWELRY, KEY RINGS MADE OF PRECIOUS METALS, ORNAMENTAL PINS, ORNAMENTAL LAPEL PINS, TIE PINS, AND CUFFLINKS, CLOCKS (U.S. CLS. 2, 27, 28 AND 50).
FIRST USE 9-29-2008; IN COMMERCE 9-29-2008.

3,633,171. THE CARTOON NETWORK, INC., ATLANTA, GA. SN 78-686,226. PUB. 5-2-2006, FILED 8-5-2005.

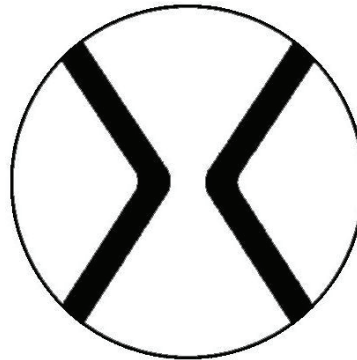

THE MARK CONSISTS OF AN HOURGLASS DESIGN INSIDE A CIRCLE.
FOR WRISTWATCHES (U.S. CLS. 2, 27, 28 AND 50).
FIRST USE 3-2-2009; IN COMMERCE 3-2-2009.

3,633,184. YIFENG, ZHENG, ZHUJI, CHINA. SN 78-704,949. PUB. 8-8-2006, FILED 9-1-2005.



First-Lady

CLASS 14—(Continued).

THE MARK CONSISTS OF THE FEMALE FIGURE IS FORMED BY THE DISTORTION OF TWO CHARACTERS "F" AND "L".

FOR AGATE AND SARDONYX; DIAMONDS; JADE; NECKLACES; PEARLS; PLATINUM AND ITS ALLOYS; PRECIOUS METALS AND THEIR ALLOYS, NAMELY, GOLD, SILVER, PLATINUM; PRECIOUS METALS, NAMELY, GOLD, SILVER, PLATINUM; PRECIOUS STONES; SMALL JEWELLERY BOXES OF PRECIOUS METALS (U.S. CLS. 2, 27, 28 AND 50).

FIRST USE 6-1-2006; IN COMMERCE 2-1-2007.

3,633,264. MANILAL, SALIL, NEW YORK, NY. SN 78-873,145. PUB. 7-1-2008, FILED 5-1-2006.

THE NIKITA DIAMOND

THE MARK CONSISTS OF STANDARD CHARACTERS WITHOUT CLAIM TO ANY PARTICULAR FONT, STYLE, SIZE, OR COLOR.

NO CLAIM IS MADE TO THE EXCLUSIVE RIGHT TO USE "DIAMOND", APART FROM THE MARK AS SHOWN.

FOR JEWELRY MADE IN WHOLE OR SIGNIFICANT PART OF DIAMONDS (U.S. CLS. 2, 27, 28 AND 50).

FIRST USE 3-19-2009; IN COMMERCE 3-19-2009.

3,633,292. HK DESIGNS, NEW YORK, NY. SN 78-924,041. PUB. 7-31-2007, FILED 7-6-2006.

MONEY GREEN

THE MARK CONSISTS OF STANDARD CHARACTERS WITHOUT CLAIM TO ANY PARTICULAR FONT, STYLE, SIZE, OR COLOR.

NO CLAIM IS MADE TO THE EXCLUSIVE RIGHT TO USE "GREEN", APART FROM THE MARK AS SHOWN.

FOR JEWELRY (U.S. CLS. 2, 27, 28 AND 50).

FIRST USE 11-15-2008; IN COMMERCE 11-15-2008.

CLASS 15—MUSICAL INSTRUMENTS**CLASS 15—(Continued).**

3,631,953. MCNAIR, JOHN, CAROLINA, PUERTO RICO. SN 77-098,572. PUB. 10-9-2007, FILED 2-3-2007.

The logo features the words "RED DOG'S" in a large, bold, stylized font with a slightly irregular, hand-drawn appearance. Below this, the words "CIGAR BOX GUITARS" are written in a smaller, clean, sans-serif font.

NO CLAIM IS MADE TO THE EXCLUSIVE RIGHT TO USE "CIGAR BOX GUITARS", APART FROM THE MARK AS SHOWN.

THE MARK CONSISTS OF LARGE STYLIZED WORDS "RED DOG'S" ABOVE THE WORDS IN A SMALLER WRITING BELOW THAT SAY "CIGAR BOX GUITARS".

FOR ACOUSTIC GUITARS; BASS GUITARS; ELECTRIC GUITARS; GUITARS (U.S. CLS. 2, 21 AND 36).

FIRST USE 5-2-2008; IN COMMERCE 5-2-2008.

3,632,772. JA MUSIC, LLC, ORANGE, CT. SN 77-450,701. PUB. 9-16-2008, FILED 4-17-2008.

THE LIFT

THE MARK CONSISTS OF STANDARD CHARACTERS WITHOUT CLAIM TO ANY PARTICULAR FONT, STYLE, SIZE, OR COLOR.

FOR DEVICE TO POSITION A BASS DRUM AT A PREDETERMINED HEIGHT TO ALLOW THE BEATER TO STRIKE THE DRUMHEAD AT A DESIRED LOCATION (U.S. CLS. 2, 21 AND 36).

FIRST USE 1-31-2009; IN COMMERCE 1-31-2009.

CLASS 16—PAPER GOODS AND PRINTED MATTER

CLASS 16—(Continued).

3,631,792. PHASE FOUR, LLC, MARCO ISLAND, FL. SN 76-607,837. PUB. 1-31-2006, FILED 8-16-2004.

THE KRASH KLUB

THE MARK CONSISTS OF STANDARD CHARACTERS WITHOUT CLAIM TO ANY PARTICULAR FONT, STYLE, SIZE, OR COLOR.

FOR CHILDREN'S BOOKS, COMIC BOOKS, SERIES OF FICTION BOOKS, CALENDARS, BOOKMARKS, COLOR PRINTS, POSTERS, POST CARDS, GREETING CARDS, TRADING CARDS, BOOK COVERS, DECALCOMANIA, STICKERS, NOTEBOOKS, NOTEPADS, RING BINDERS, PEN AND PENCIL CASES, TEMPORARY TATTOOS, PAPER SIGNS AND BANNERS FOR DECORATIVE PURPOSES; PAPER PARTY GOODS, NAMELY, HATS, NAPKINS, PLACE MATS AND DECORATIONS, LUNCH BAGS, PAPER BAGS AND MERCHANDISE BAGS, GIFT WRAPPING MATERIALS, PAPER HOLIDAY DECORATIONS, ALL BASED ON AN ANIMATED TELEVISION SERIES (U.S. CLS. 2, 5, 22, 23, 29, 37, 38 AND 50).

FIRST USE 3-31-2009; IN COMMERCE 3-31-2009.

3,631,799. WAUSAU PAPER TOWEL & TISSUE, LLC, MOSINEE, WI. SN 76-634,851. PUB. 12-27-2005, FILED 4-1-2005.

OPTI-TOWLS

THE MARK CONSISTS OF STANDARD CHARACTERS WITHOUT CLAIM TO ANY PARTICULAR FONT, STYLE, SIZE, OR COLOR.

FOR PAPER TOWELS (U.S. CLS. 2, 5, 22, 23, 29, 37, 38 AND 50).

FIRST USE 3-16-2009; IN COMMERCE 3-16-2009.

3,631,800. WAUSAU PAPER TOWEL & TISSUE, LLC, MOSINEE, WI. SN 76-634,856. PUB. 12-27-2005, FILED 4-1-2005.

OPTIROLL

THE MARK CONSISTS OF STANDARD CHARACTERS WITHOUT CLAIM TO ANY PARTICULAR FONT, STYLE, SIZE, OR COLOR.

FOR PAPER TOWELS (U.S. CLS. 2, 5, 22, 23, 29, 37, 38 AND 50).

FIRST USE 3-14-2009; IN COMMERCE 3-14-2009.

CLASS 16—(Continued).

3,631,801. WAUSAU PAPER TOWEL & TISSUE, LLC, MOSINEE, WI. SN 76-634,858. PUB. 12-27-2005, FILED 4-1-2005.

OPTITOWEL

THE MARK CONSISTS OF STANDARD CHARACTERS WITHOUT CLAIM TO ANY PARTICULAR FONT, STYLE, SIZE, OR COLOR.

FOR PAPER TOWELS (U.S. CLS. 2, 5, 22, 23, 29, 37, 38 AND 50).

FIRST USE 3-14-2009; IN COMMERCE 3-14-2009.

3,631,849. EMPIRE ROAD PRODUCTIONS, LLC, OGDEN, UT. SN 76-687,751. PUB. 7-15-2008, FILED 3-17-2008.

WHERE WOMEN CREATE

THE MARK CONSISTS OF STANDARD CHARACTERS WITHOUT CLAIM TO ANY PARTICULAR FONT, STYLE, SIZE, OR COLOR.

FOR SERIES OF NON-FICTION EDUCATIONAL AND INSTRUCTIONAL REFERENCE BOOKS, WORKBOOKS, AND MANUALS IN THE FIELD OF ARTS, CRAFTS, SCRAPBOOKING, KNITTING, STAINED GLASS MAKING, SMALL BUSINESS DEVELOPMENT; MAGAZINES IN THE FIELD OF ARTS, CRAFTS, SCRAPBOOKING, KNITTING, STAINED GLASS MAKING, SMALL BUSINESS DEVELOPMENT; MAGAZINE AND NEWSPAPER ADVICE AND INSTRUCTIONAL COLUMNS ABOUT ARTS, CRAFTS, SCRAPBOOKING, KNITTING, STAINED GLASS MAKING, SMALL BUSINESS DEVELOPMENT (U.S. CLS. 2, 5, 22, 23, 29, 37, 38 AND 50).

FIRST USE 11-0-2008; IN COMMERCE 11-0-2008.

3,631,896. CRAM CREW, INC., KATY, TX. SN 77-041,985. PUB. 6-5-2007, FILED 11-11-2006.

cram  crew

THE MARK CONSISTS OF THREE VERTICALLY ORIENTED BOOKS LOCATED BETWEEN THE WORDS "CRAM" AND "CREW", WHEREIN THE CENTER BOOK IS THE TALLEST AND THE RIGHT BOOK IS THE SHORTEST.

FOR PRINTED MATTER, NAMELY, BOOKS, GUIDES, PAMPHLETS, HANDOUTS, WORKSHEETS, MANUALS AND WORKBOOKS, CONTAINING INSTRUCTION AND MATERIALS FEATURING PREPARATION FOR STANDARDIZED AND NON-STANDARDIZED TESTS (U.S. CLS. 2, 5, 22, 23, 29, 37, 38 AND 50).

FIRST USE 4-17-2006; IN COMMERCE 3-9-2007.

CLASS 16—(Continued).

3,631,912. HOWARD, SHARON D., DAYTON, OH. SN 77-061,047. PUB. 5-6-2008, FILED 12-11-2006.

Crown Jewels

THE MARK CONSISTS OF STANDARD CHARACTERS WITHOUT CLAIM TO ANY PARTICULAR FONT, STYLE, SIZE, OR COLOR.

FOR PRINTED MATERIALS, NAMELY, CALENDARS, STATIONERY, POSTERS (U.S. CLS. 2, 5, 22, 23, 29, 37, 38 AND 50).

FIRST USE 10-1-2006; IN COMMERCE 10-1-2006.

3,631,913. TAPPED OUT, LLC, GRANADA HILLS, CA. SN 77-062,339. PUB. 12-11-2007, FILED 12-12-2006.

PURE ADRENALINE

THE MARK CONSISTS OF STANDARD CHARACTERS WITHOUT CLAIM TO ANY PARTICULAR FONT, STYLE, SIZE, OR COLOR.

FOR STICKERS, BUMPER STICKERS, AND DECORATIVE STICKERS FOR HELMETS (U.S. CLS. 2, 5, 22, 23, 29, 37, 38 AND 50).

FIRST USE 8-20-2008; IN COMMERCE 8-20-2008.

3,631,976. FARMER, DIANE, CLOVERDALE, CA. AND GRACE-BRAUN, VIRGINIA, CLOVERDALE, CA. SN 77-123,012. PUB. 9-18-2007, FILED 3-6-2007.

Grace Guides

THE MARK CONSISTS OF STANDARD CHARACTERS WITHOUT CLAIM TO ANY PARTICULAR FONT, STYLE, SIZE, OR COLOR.

NO CLAIM IS MADE TO THE EXCLUSIVE RIGHT TO USE "GUIDES", APART FROM THE MARK AS SHOWN.

FOR CHILDREN'S INTERACTIVE EDUCATIONAL BOOKS; FLIP BOOKS; SCHOOL WRITING BOOKS (U.S. CLS. 2, 5, 22, 23, 29, 37, 38 AND 50).

FIRST USE 1-1-2009; IN COMMERCE 1-1-2009.

CLASS 16—(Continued).

3,632,058. EVERSIO, INC., DBA SUSTAINABLE GROUP, INC., SEATTLE, WA. SN 77-198,580. PUB. 7-15-2008, FILED 6-5-2007.



NO CLAIM IS MADE TO THE EXCLUSIVE RIGHT TO USE THE RECYCLING SYMBOL, APART FROM THE MARK AS SHOWN.

THE COLOR(S) GREEN AND BLACK IS/ARE CLAIMED AS A FEATURE OF THE MARK.

THE MARK CONSISTS OF A RECYCLING SYMBOL NEXT TO THE WORD "REBINDER". THE COLOR BLACK APPEARS IN THE LETTERS "RE", AS OUTLINE FOR THE RECYCLING SYMBOL AND OUTLINING FOR THE WORDING "BINDER"; THE COLOR GREEN APPEARS IN THE RECYCLING SYMBOL AND THE LETTERS "BINDER".

FOR THREE-RING BINDERS (U.S. CLS. 2, 5, 22, 23, 29, 37, 38 AND 50).

FIRST USE 6-0-2004; IN COMMERCE 6-0-2004.

3,632,059. EVERSIO, INC., DBA SUSTAINABLE GROUP, INC., SEATTLE, WA. SN 77-198,590. PUB. 7-15-2008, FILED 6-5-2007.



NO CLAIM IS MADE TO THE EXCLUSIVE RIGHT TO USE THE RECYCLED SYMBOL, APART FROM THE MARK AS SHOWN.

THE COLOR(S) GREEN AND BLACK IS/ARE CLAIMED AS A FEATURE OF THE MARK.

THE MARK CONSISTS OF A RECYCLING SYMBOL NEXT TO THE WORD "REPOCKET". THE COLOR BLACK APPEARS IN THE LETTERS "RE", AS OUTLINE FOR THE RECYCLING SYMBOL AND OUTLINING FOR THE WORDING "POCKET"; THE COLOR GREEN APPEARS IN THE RECYCLING SYMBOL AND THE LETTERS "POCKET".

FOR PRESENTATION FOLDERS (U.S. CLS. 2, 5, 22, 23, 29, 37, 38 AND 50).

FIRST USE 4-0-2005; IN COMMERCE 4-0-2005.

CLASS 16—(Continued).

3,632,067. ALLERGIK-ID, LLC, MERION STATION, PA. SN 77-205,634. PUB. 8-5-2008, FILED 6-13-2007.

STATKIDS

THE MARK CONSISTS OF STANDARD CHARACTERS WITHOUT CLAIM TO ANY PARTICULAR FONT, STYLE, SIZE, OR COLOR.

FOR LUNCH BAGS; STICKERS; POSTERS; PAPER SNACK BOXES SOLD EMPTY; PRINTED CARDS CONTAINING EMERGENCY INFORMATION REGARDING THE CARD CARRIER; STICKER AND PAPER IDENTIFICATION TAGS FOR USE ON BAGS (U.S. CLS. 2, 5, 22, 23, 29, 37, 38 AND 50).

FIRST USE 7-31-2007; IN COMMERCE 7-31-2007.

CLASS 16—(Continued).

3,632,109. ALLOY ENTERTAINMENT, NEW YORK, NY. SN 77-228,719. PUB. 1-1-2008, FILED 7-12-2007.

TALENT

THE MARK CONSISTS OF STANDARD CHARACTERS WITHOUT CLAIM TO ANY PARTICULAR FONT, STYLE, SIZE, OR COLOR.

THE MARK "TALENT" HAS NO GEOGRAPHICAL, HISTORICAL, FOREIGN OR ANY OTHER MEANING.

FOR SERIES OF FICTION BOOKS (U.S. CLS. 2, 5, 22, 23, 29, 37, 38 AND 50).

FIRST USE 7-0-2007; IN COMMERCE 6-0-2008.

3,632,117. GLORIA SPAHN, PITTSBURG, CA. SN 77-231,657. PUB. 7-1-2008, FILED 7-17-2007.

Where's My Ticket

THE MARK CONSISTS OF STANDARD CHARACTERS WITHOUT CLAIM TO ANY PARTICULAR FONT, STYLE, SIZE, OR COLOR.

FOR SELF-ADHESIVE PLASTIC DOCUMENT COVERS (U.S. CLS. 2, 5, 22, 23, 29, 37, 38 AND 50).

FIRST USE 8-4-2007; IN COMMERCE 2-27-2008.

3,632,123. INVESTOOLS INC., DRAPER, UT. SN 77-233,469. PUB. 1-1-2008, FILED 7-19-2007.

thinkmoney

THE MARK CONSISTS OF STANDARD CHARACTERS WITHOUT CLAIM TO ANY PARTICULAR FONT, STYLE, SIZE, OR COLOR.

FOR PUBLICATIONS, NAMELY, MAGAZINES, NEWSLETTERS AND REPORTS IN THE FIELD OF FINANCIAL AND SECURITIES ADVICE AND INFORMATION (U.S. CLS. 2, 5, 22, 23, 29, 37, 38 AND 50).

FIRST USE 10-0-2007; IN COMMERCE 10-0-2007.

3,632,071. THE RED REPORT, LLC, HENDERSON, NV. SN 77-211,072. PUB. 12-25-2007, FILED 6-20-2007.



NO CLAIM IS MADE TO THE EXCLUSIVE RIGHT TO USE "REPORT", APART FROM THE MARK AS SHOWN.

THE COLOR(S) BLACK, RED, WHITE IS/ARE CLAIMED AS A FEATURE OF THE MARK.

THE MARK CONSISTS OF A BLACK SQUARE WITH THE WORD "RED", WRITTEN IN RED, SUPERIMPOSED ON THE SQUARE, AND THE WORD "REPORT", WRITTEN IN WHITE, SUPERIMPOSED OVER THE "E" AND "D" IN THE WORD "RED".

FOR PRINTED MAGAZINES FEATURING TRANSACTIONS, PRESS RELEASES AND COMMENTARIES IN THE FIELD OF REAL ESTATE (U.S. CLS. 2, 5, 22, 23, 29, 37, 38 AND 50).

FIRST USE 10-1-2008; IN COMMERCE 10-1-2008.

CLASS 16—(Continued).

3,632,199. ATHLETES' PERFORMANCE, INC., TEMPE, AZ. SN 77-266,908. PUB. 1-22-2008, FILED 8-29-2007.

CORE PERFORMANCE

THE MARK CONSISTS OF STANDARD CHARACTERS WITHOUT CLAIM TO ANY PARTICULAR FONT, STYLE, SIZE, OR COLOR.

OWNER OF U.S. REG. NOS. 3,016,023, 3,016,024, AND 3,124,046.

FOR PRINTED LAMINATED REFERENCE GUIDES AND FACT SHEETS IN THE FIELD OF NUTRITION, RESISTANCE TRAINING, MOVEMENT TRAINING, FLEXIBILITY TRAINING, SPORTS TRAINING, FITNESS, BIOMECHANICS AND INJURY REHABILITATION (U.S. CLS. 2, 5, 22, 23, 29, 37, 38 AND 50).
FIRST USE 3-1-2009; IN COMMERCE 3-1-2009.

3,632,209. MITSUBISHI PENCIL CO., LTD., TOKYO, JAPAN. SN 77-269,181. PUB. 2-26-2008, FILED 8-31-2007.

JETSTREAM
PREMIER

OWNER OF U.S. REG. NO. 2,902,446.

THE MARK CONSISTS OF THE WORDS "JETSTREAM PREMIER".

FOR WRITING INSTRUMENTS (U.S. CLS. 2, 5, 22, 23, 29, 37, 38 AND 50).

FIRST USE 3-1-2008; IN COMMERCE 3-1-2008.

3,632,281. RIMINI FIERA SPA, 47900 RIMINI, ITALY. SN 77-304,618. PUB. 5-13-2008, FILED 10-15-2007.

SIGEP U.S.A.

THE MARK CONSISTS OF STANDARD CHARACTERS WITHOUT CLAIM TO ANY PARTICULAR FONT, STYLE, SIZE, OR COLOR.

NO CLAIM IS MADE TO THE EXCLUSIVE RIGHT TO USE "U.S.A.", APART FROM THE MARK AS SHOWN.

FOR PRINTED MATTER, NAMELY, PERIODICALS, BULLETINS, BROCHURES, PAMPHLETS, NEWSPAPERS, MAGAZINES, BOOKS AND CATALOGUES, ALL IN THE FIELD OF TRADE-FAIRS AND EXHIBITIONS (U.S. CLS. 2, 5, 22, 23, 29, 37, 38 AND 50).

FIRST USE 4-1-2008; IN COMMERCE 4-1-2008.

CLASS 16—(Continued).

3,632,290. STEVENSON, MICHAEL J., CLARKDALE, AZ. SN 77-305,975. PUB. 4-8-2008, FILED 10-17-2007.

MOLD IN GRAPHICS

THE MARK CONSISTS OF STANDARD CHARACTERS WITHOUT CLAIM TO ANY PARTICULAR FONT, STYLE, SIZE, OR COLOR.

OWNER OF U.S. REG. NOS. 1,574,897, 2,590,631, AND OTHERS.

NO CLAIM IS MADE TO THE EXCLUSIVE RIGHT TO USE "GRAPHICS", APART FROM THE MARK AS SHOWN.

FOR PLASTIC TRANSFERS (U.S. CLS. 2, 5, 22, 23, 29, 37, 38 AND 50).

FIRST USE 11-30-2003; IN COMMERCE 11-30-2003.

3,632,291. STEVENSON, MICHAEL J., CLARKDALE, AZ. SN 77-305,999. PUB. 4-8-2008, FILED 10-17-2007.

MOLD ON GRAPHIC SYSTEMS

THE MARK CONSISTS OF STANDARD CHARACTERS WITHOUT CLAIM TO ANY PARTICULAR FONT, STYLE, SIZE, OR COLOR.

OWNER OF U.S. REG. NOS. 1,574,897 AND 2,590,631.

NO CLAIM IS MADE TO THE EXCLUSIVE RIGHT TO USE "GRAPHIC SYSTEMS", APART FROM THE MARK AS SHOWN.

FOR PLASTIC TRANSFERS FOR APPLYING GRAPHICS TO MOLDED PRODUCTS (U.S. CLS. 2, 5, 22, 23, 29, 37, 38 AND 50).

FIRST USE 10-16-2008; IN COMMERCE 10-16-2008.

3,632,303. ALDI INC., BATAVIA, IL. SN 77-315,497. PUB. 7-15-2008, FILED 10-29-2007.

Twin Lock

THE MARK CONSISTS OF STANDARD CHARACTERS WITHOUT CLAIM TO ANY PARTICULAR FONT, STYLE, SIZE, OR COLOR.

FOR PLASTIC OR PAPER BAGS FOR HOUSEHOLD USE (U.S. CLS. 2, 5, 22, 23, 29, 37, 38 AND 50).

FIRST USE 1-23-2009; IN COMMERCE 1-23-2009.

CLASS 16—(Continued).

3,632,332. ALLERGAN, INC., IRVINE, CA. SN 77-329,753.
PUB. 12-16-2008, FILED 11-14-2007.



Our pursuit. Life's potential.

OWNER OF U.S. REG. NOS. 1,740,803, 2,147,765, AND OTHERS.

FOR PRINTED MATTER, NAMELY, CORPORATE COLLATERAL MATERIALS IN THE NATURE OF CORPORATE INFORMATIONAL FOLDERS, BROCHURES, AND PRINTED FORMS CONCERNING PHARMACEUTICAL PREPARATIONS AND MEDICAL DEVICES; PRINTED REPORTS IN THE NATURE OF CORPORATE REPORTS FEATURING COMPANY INFORMATION ABOUT PHARMACEUTICAL PREPARATIONS AND MEDICAL DEVICES (U.S. CLS. 2, 5, 22, 23, 29, 37, 38 AND 50).

FIRST USE 10-22-2007; IN COMMERCE 1-31-2008.

3,632,342. WRITE HOOK, LLC, WHITEFISH BAY, WI. SN 77-333,175. PUB. 4-29-2008, FILED 11-19-2007.

Say it with impact

THE MARK CONSISTS OF STANDARD CHARACTERS WITHOUT CLAIM TO ANY PARTICULAR FONT, STYLE, SIZE, OR COLOR.

FOR GREETING CARDS (U.S. CLS. 2, 5, 22, 23, 29, 37, 38 AND 50).

FIRST USE 11-20-2008; IN COMMERCE 11-20-2008.

3,632,369. HOLMER, MARTHA, NEW YORK, NY. SN 77-346,007. PUB. 5-6-2008, FILED 12-6-2007.

Carry Ease

THE MARK CONSISTS OF STANDARD CHARACTERS WITHOUT CLAIM TO ANY PARTICULAR FONT, STYLE, SIZE, OR COLOR.

FOR ARTIST PORTFOLIO CARRIER (U.S. CLS. 2, 5, 22, 23, 29, 37, 38 AND 50).

FIRST USE 2-20-2008; IN COMMERCE 2-20-2008.

CLASS 16—(Continued).

3,632,404. SHROFF GARY, HICKSVILLE, NY. SN 77-358,768.
PUB. 12-9-2008, FILED 12-22-2007.

iScholar

THE MARK CONSISTS OF STANDARD CHARACTERS WITHOUT CLAIM TO ANY PARTICULAR FONT, STYLE, SIZE, OR COLOR.

FOR BLANK PAPER NOTEBOOKS; NOTEBOOK DIVIDERS; NOTEBOOK PAPER; NOTEBOOKS; PAPER NOTEBOOKS; REPORTERS' NOTEBOOKS; SCHOOL SUPPLY KITS CONTAINING VARIOUS COMBINATIONS OF SELECTED SCHOOL SUPPLIES, NAMELY, FOLDERS, NOTEBOOKS, PAPER, GRADUATED RULERS, PROTRACTORS, PAPER CLIPS, GLUE AND BOOK MARKS; STENOGRAPHERS' NOTEBOOKS; WIRE-BOUND NOTEBOOKS (U.S. CLS. 2, 5, 22, 23, 29, 37, 38 AND 50).

FIRST USE 1-5-2008; IN COMMERCE 1-5-2008.

3,632,411. STEVENSON, MICHAEL J., CLARKDALE, AZ. SN 77-364,931. PUB. 4-8-2008, FILED 1-5-2008.

MOULD IN GRAPHICS

THE MARK CONSISTS OF STANDARD CHARACTERS WITHOUT CLAIM TO ANY PARTICULAR FONT, STYLE, SIZE, OR COLOR.

OWNER OF U.S. REG. NOS. 1,574,897 AND 2,590,631.
NO CLAIM IS MADE TO THE EXCLUSIVE RIGHT TO USE "GRAPHICS", APART FROM THE MARK AS SHOWN.

FOR PLASTIC TRANSFERS FOR APPLYING GRAPHICS TO MOLDED PRODUCTS (U.S. CLS. 2, 5, 22, 23, 29, 37, 38 AND 50).

FIRST USE 10-20-2008; IN COMMERCE 10-20-2008.

CLASS 16—(Continued).

3,632,419. ADDIS INTELLECTUAL CAPITAL, LLC, KING OF PRUSSIA, PA. SN 77-367,188. PUB. 12-9-2008, FILED 1-9-2008.

QCard

THE MARK CONSISTS OF STANDARD CHARACTERS WITHOUT CLAIM TO ANY PARTICULAR FONT, STYLE, SIZE, OR COLOR.

FOR COMPLIANCE TOOL, NAMELY, PRINTED MATERIALS IN THE NATURE OF WORKSHEETS FOR USE IN QUALIFYING AND ASSESSING PROSPECTS IN THE INSURANCE INDUSTRY (U.S. CLS. 2, 5, 22, 23, 29, 37, 38 AND 50).

FIRST USE 11-30-2007; IN COMMERCE 11-30-2007.

3,632,472. SYSTEM WIDE SOLUTIONS, INC., COLUMBIA, SC. SN 77-387,461. PUB. 12-16-2008, FILED 2-4-2008.

CHOICES

THE MARK CONSISTS OF STANDARD CHARACTERS WITHOUT CLAIM TO ANY PARTICULAR FONT, STYLE, SIZE, OR COLOR.

FOR PRINTED INSTRUCTIONAL, EDUCATIONAL, AND TEACHING MATERIALS IN THE FIELD OF ANGER MANAGEMENT AND USED IN CONNECTION WITH ANGER MANAGEMENT COURSES FOR PERSONS REQUIRED BY AN OFFICIAL AUTHORITY TO TAKE SUCH COURSES (U.S. CLS. 2, 5, 22, 23, 29, 37, 38 AND 50).

FIRST USE 3-0-2004; IN COMMERCE 10-0-2005.

3,632,494. NEW ORDER ORGANIZERS LLC, MENTOR, OH. SN 77-393,203. PUB. 6-24-2008, FILED 2-10-2008.

COLORWORKS

THE MARK CONSISTS OF STANDARD CHARACTERS WITHOUT CLAIM TO ANY PARTICULAR FONT, STYLE, SIZE, OR COLOR.

FOR STORAGE AND ORGANIZATION SYSTEMS COMPRISING BINDERS, FOLDERS, COLORED STICKERS, LABELS, ADHESIVE NOTES AND TABS FOR ORGANIZING, SORTING, STORING, AND ACTING UPON DOCUMENTS AND THE LIKE (U.S. CLS. 2, 5, 22, 23, 29, 37, 38 AND 50).

FIRST USE 3-1-2009; IN COMMERCE 3-1-2009.

CLASS 16—(Continued).

3,632,546. RIMINI FIERA S.P.A., 47900 RIMINI, ITALY. SN 77-403,891. PUB. 7-8-2008, FILED 2-22-2008.



NO CLAIM IS MADE TO THE EXCLUSIVE RIGHT TO USE "U.S.A.", APART FROM THE MARK AS SHOWN.

THE COLOR(S) BLACK, RED, WHITE, AND BLUE IS/ARE CLAIMED AS A FEATURE OF THE MARK.

THE MARK CONSISTS OF NON-STANDARD CHARACTERS, WHEREIN "S", "G", "E", AND "P" IN "SIGEP" ARE PRESENTED IN THE COLOR BLACK; "U.S.A." IS PRESENTED IN THE COLOR RED; THE "I" IN "SIGEP" CONTAINS THE COLORS RED, WHITE AND BLUE.

FOR PRINTED MATTER, NAMELY, PERIODICALS, BULLETINS, BROCHURES, PAMPHLETS, NEWSPAPERS, MAGAZINES, BOOKS, AND CATALOGUES, ALL IN THE FIELD OF TRADE-FAIRS AND EXHIBITIONS (U.S. CLS. 2, 5, 22, 23, 29, 37, 38 AND 50).

FIRST USE 4-1-2008; IN COMMERCE 4-1-2008.

3,632,576. TAYLOR, JENNIFER, BURBANK, CA. SN 77-409,311. PUB. 7-15-2008, FILED 2-28-2008.

G-BAG IT

THE MARK CONSISTS OF STANDARD CHARACTERS WITHOUT CLAIM TO ANY PARTICULAR FONT, STYLE, SIZE, OR COLOR.

FOR GROCERY BAGS; PAPER BAGS AND SACKS; PLASTIC OR PAPER BAGS FOR HOUSEHOLD USE; GENERAL PURPOSE PLASTIC BAGS (U.S. CLS. 2, 5, 22, 23, 29, 37, 38 AND 50).

FIRST USE 2-28-2008; IN COMMERCE 4-1-2008.

CLASS 16—(Continued).

3,632,601. HEALTHCARE REGIONAL MARKETING, LLC, CINCINNATI, OH. SN 77-413,194. PUB. 7-29-2008, FILED 3-5-2008.

PRACTICESHARE

THE MARK CONSISTS OF STANDARD CHARACTERS WITHOUT CLAIM TO ANY PARTICULAR FONT, STYLE, SIZE, OR COLOR.

FOR NEWSLETTERS AND WHITE PAPERS PROVIDING MEDICAL AND CLINICAL DEVELOPMENTS AND INFORMATION FOR DOCTORS TO BETTER UNDERSTAND AND MORE EFFECTIVELY DIAGNOSE AND TREAT VARIOUS DISEASES (U.S. CLS. 2, 5, 22, 23, 29, 37, 38 AND 50).

FIRST USE 4-8-2009; IN COMMERCE 4-8-2009.

CLASS 16—(Continued).

3,632,676. KNIGHT, KEITH, NEW YORK, NY. SN 77-427,345. PUB. 9-9-2008, FILED 3-20-2008.

THE KNIGHT LIFE

THE MARK CONSISTS OF STANDARD CHARACTERS WITHOUT CLAIM TO ANY PARTICULAR FONT, STYLE, SIZE, OR COLOR.

FOR COMIC STRIPS (U.S. CLS. 2, 5, 22, 23, 29, 37, 38 AND 50).

FIRST USE 5-5-2008; IN COMMERCE 5-5-2008.

3,632,692. CAMPANA, MICHAEL, WINDSOR, CO. SN 77-432,323. PUB. 8-5-2008, FILED 3-26-2008.

DESTINATION STATION

THE MARK CONSISTS OF STANDARD CHARACTERS WITHOUT CLAIM TO ANY PARTICULAR FONT, STYLE, SIZE, OR COLOR.

FOR CHILDREN'S BOOKS (U.S. CLS. 2, 5, 22, 23, 29, 37, 38 AND 50).

FIRST USE 10-1-2008; IN COMMERCE 10-1-2008.

3,632,699. THE PROCTER & GAMBLE COMPANY, CINCINNATI, OH. SN 77-433,120. PUB. 8-5-2008, FILED 3-27-2008.

ABSORBENT CUSHIONS

THE MARK CONSISTS OF STANDARD CHARACTERS WITHOUT CLAIM TO ANY PARTICULAR FONT, STYLE, SIZE, OR COLOR.

NO CLAIM IS MADE TO THE EXCLUSIVE RIGHT TO USE "ABSORBENT", APART FROM THE MARK AS SHOWN.

FOR BATHROOM TISSUE (U.S. CLS. 2, 5, 22, 23, 29, 37, 38 AND 50).

FIRST USE 3-15-2009; IN COMMERCE 3-15-2009.

3,632,614. SCHILLER CARD & GIFT LLC, SAN MATEO, CA. SN 77-414,396. PUB. 8-5-2008, FILED 3-6-2008.



THE MARK CONSISTS OF A PICTURE OF A CAT SITTING ON A MANTLE WITH THE WORDS "I LOVE MEOWMEOW" WRITTEN ABOVE THE CAT, WITH THE WORD "MEOW" WRITTEN ON EITHER SIDE OF THE CAT.

FOR GREETING CARDS, STATIONERY, NOTE CARDS, POSTCARDS, INVITATION CARDS, PRINTED FOLDERS, PRINTED BINDERS, FOLDERS, EVENT ALBUMS, PHOTO ALBUMS, STAMP ALBUMS, SCRAPBOOK ALBUMS, NOTEBOOKS, ADDRESS BOOKS, GUEST BOOKS, DESK PADS, DOCUMENT HOLDERS OF PAPER OR CARDBOARD, PAPER BOXES, PAPER STORAGE BOXES, CARDBOARD STORAGE BOXES, COLLECTIBLE BOXES OF PAPER OR CARDBOARD, STICKERS, GIFT WRAPPING PAPER, PAPER GIFT BAGS, AND PAPER GIFT TAGS (U.S. CLS. 2, 5, 22, 23, 29, 37, 38 AND 50).

FIRST USE 5-15-2008; IN COMMERCE 5-15-2008.

CLASS 16—(Continued).

3,632,714. STARWAY CO., LTD., MINATO-KU, TOKYO, JAPAN. SN 77-435,829. PUB. 8-12-2008, FILED 3-31-2008.

CLASS 16—(Continued).

3,632,904. PARIS BUSINESS PRODUCTS, INC., WESTAMPTON, NJ. SN 77-505,115. PUB. 12-23-2008, FILED 6-23-2008.

MottainaiBako

THE MARK CONSISTS OF STANDARD CHARACTERS WITHOUT CLAIM TO ANY PARTICULAR FONT, STYLE, SIZE, OR COLOR.

THE JAPANESE WORD "MOTTAINAI" TRANSLATES INTO ENGLISH AS WASTEFUL; THE JAPANESE WORD "BAKO" TRANSLATES INTO ENGLISH AS BOX.

FOR BOXES FOR TRANSPORTATION OF CARDBOARD OR PAPER (U.S. CLS. 2, 5, 22, 23, 29, 37, 38 AND 50).

FIRST USE 7-15-2008; IN COMMERCE 7-15-2008.

PRINTWORKS PROFESSIONAL

THE MARK CONSISTS OF STANDARD CHARACTERS WITHOUT CLAIM TO ANY PARTICULAR FONT, STYLE, SIZE, OR COLOR.

OWNER OF U.S. REG. NO. 2,064,649.

NO CLAIM IS MADE TO THE EXCLUSIVE RIGHT TO USE "PROFESSIONAL", APART FROM THE MARK AS SHOWN.

FOR COMPUTER PAPER; COPIER PAPER; LASER PRINTING PAPER; PAPER FOR PHOTOCOPYING; REPRODUCTION PAPER (U.S. CLS. 2, 5, 22, 23, 29, 37, 38 AND 50).

FIRST USE 10-6-2008; IN COMMERCE 10-6-2008.

3,632,720. ILLINOIS TOOL WORKS INC., GLENVIEW, IL. SN 77-437,151. PUB. 8-19-2008, FILED 4-1-2008.

FOOD MARKIT

THE MARK CONSISTS OF STANDARD CHARACTERS WITHOUT CLAIM TO ANY PARTICULAR FONT, STYLE, SIZE, OR COLOR.

NO CLAIM IS MADE TO THE EXCLUSIVE RIGHT TO USE "FOOD", APART FROM THE MARK AS SHOWN.

FOR FOOD GRADE INK (U.S. CLS. 2, 5, 22, 23, 29, 37, 38 AND 50).

FIRST USE 3-26-2008; IN COMMERCE 3-26-2008.

3,633,004. KIMC INVESTMENTS, INC., WEST PALM BEACH, FL. SN 77-540,486. PUB. 1-6-2009, FILED 8-6-2008.

3,632,870. SPAFINDER, INC., NEW YORK, NY. SN 77-489,452. PUB. 11-4-2008, FILED 6-3-2008.

GLOBAL SPAFINDER

THE MARK CONSISTS OF STANDARD CHARACTERS WITHOUT CLAIM TO ANY PARTICULAR FONT, STYLE, SIZE, OR COLOR.

OWNER OF U.S. REG. NOS. 2,111,806, 3,004,327, AND 3,272,044.

NO CLAIM IS MADE TO THE EXCLUSIVE RIGHT TO USE "GLOBAL", APART FROM THE MARK AS SHOWN.

FOR PRINTED PUBLICATIONS, NAMELY, DIRECTORIES, MAGAZINES, AND CATALOGS FEATURING INFORMATION IN THE FIELDS OF HEALTH SPAS, BEAUTY SALONS, RESORTS, HOTELS, TRAVEL AND VACATION TRAVEL (U.S. CLS. 2, 5, 22, 23, 29, 37, 38 AND 50).

FIRST USE 9-0-2006; IN COMMERCE 9-0-2006.

ACCESS MEDVANCE

THE MARK CONSISTS OF STANDARD CHARACTERS WITHOUT CLAIM TO ANY PARTICULAR FONT, STYLE, SIZE, OR COLOR.

OWNER OF U.S. REG. NOS. 2,548,056 AND 3,497,952.

FOR NEWSLETTERS IN THE FIELD OF HEALTH-CARE CAREER TRAINING AND RELATED FINANCIAL AID AND CAREER PLACEMENT (U.S. CLS. 2, 5, 22, 23, 29, 37, 38 AND 50).

FIRST USE 9-26-2008; IN COMMERCE 9-26-2008.

CLASS 16—(Continued).

3,633,035. WALDMAN, OWEN, SCOTTSDALE, AZ. SN 77-555,278. PUB. 1-13-2009, FILED 8-25-2008.



NO CLAIM IS MADE TO THE EXCLUSIVE RIGHT TO USE "IN-HOUSE", APART FROM THE MARK AS SHOWN. THE STIPPLING IS FOR SHADING PURPOSES ONLY. THE MARK CONSISTS OF THE STYLIZED WORDS "THE IN-HOUSE ADVANTAGE LETS YOU PRACTICE ON YOUR OWN TERMS". ABOVE THE STYLIZED WORDS IS AN IMAGE OF A DOLLAR SIGN INCORPORATING A WINDOW, WITH A FRAME OF THE ROOF OF A HOUSE ABOVE IT. FOR EDUCATIONAL PUBLICATIONS, NAMELY, TRAINING MANUALS IN THE FIELD OF DENTAL PRACTICE MANAGEMENT (U.S. CLS. 2, 5, 22, 23, 29, 37, 38 AND 50). FIRST USE 11-1-2008; IN COMMERCE 11-1-2008.

3,633,044. BY GEORGE! INC., LAKE FOREST, CA. SN 77-587,406. PUB. 1-6-2009, FILED 10-7-2008.

Bearly There

THE MARK CONSISTS OF STANDARD CHARACTERS WITHOUT CLAIM TO ANY PARTICULAR FONT, STYLE, SIZE, OR COLOR. FOR SERIES OF BOOKS FEATURING CHILDREN'S STORIES (U.S. CLS. 2, 5, 22, 23, 29, 37, 38 AND 50). FIRST USE 3-1-2008; IN COMMERCE 12-1-2008.

CLASS 16—(Continued).

3,633,063. TAKE-TWO INTERACTIVE SOFTWARE, INC., NEW YORK, NY. SN 77-976,968. PUB. 6-24-2008, FILED 1-11-2008.



NO CLAIM IS MADE TO THE EXCLUSIVE RIGHT TO USE "GAMES", APART FROM THE MARK AS SHOWN. FOR PRINTED MATTER, NAMELY, BOOKS, PAMPHLETS, AND MANUALS IN THE FIELD OF VIDEO GAMES (U.S. CLS. 2, 5, 22, 23, 29, 37, 38 AND 50). FIRST USE 8-27-2007; IN COMMERCE 8-27-2007.

3,633,070. TAKE-TWO INTERACTIVE SOFTWARE, INC., NEW YORK, NY. SN 77-977,007. PUB. 6-24-2008, FILED 1-8-2008.

CARNIVAL GAMES

THE MARK CONSISTS OF STANDARD CHARACTERS WITHOUT CLAIM TO ANY PARTICULAR FONT, STYLE, SIZE, OR COLOR. NO CLAIM IS MADE TO THE EXCLUSIVE RIGHT TO USE "GAMES", APART FROM THE MARK AS SHOWN. FOR PRINTED MATTER, NAMELY, BOOKS, PAMPHLETS, AND MANUALS IN THE FIELD OF VIDEO GAMES (U.S. CLS. 2, 5, 22, 23, 29, 37, 38 AND 50). FIRST USE 8-27-2007; IN COMMERCE 8-27-2007.

3,633,073. TAKE-TWO INTERACTIVE SOFTWARE, INC., NEW YORK, NY. SN 77-977,055. PUB. 7-8-2008, FILED 8-14-2007.

2K PLAY

THE MARK CONSISTS OF STANDARD CHARACTERS WITHOUT CLAIM TO ANY PARTICULAR FONT, STYLE, SIZE, OR COLOR. OWNER OF U.S. REG. NOS. 3,139,226 AND 3,168,810. FOR PRINTED MATTER, NAMELY, BOOKS, PAMPHLETS, AND MANUALS IN THE FIELD OF VIDEO GAMES (U.S. CLS. 2, 5, 22, 23, 29, 37, 38 AND 50). FIRST USE 10-29-2007; IN COMMERCE 10-29-2007.

CLASS 16—(Continued).

3,633,084. PLUS COMMUNICATIONS, INC., DBA STRANG COMMUNICATIONS COMPANY, LAKE MARY, FL. SN 78-211,618. PUB. 5-15-2007, FILED 2-6-2003.

CHARISMAKIDS

OWNER OF U.S. REG. NOS. 1,468,310, 1,993,269, AND 2,008,792.

FOR PRINTED MATERIALS, NAMELY, A SERIES OF CHILDREN'S BOOKS FEATURING RELIGIOUS TOPICS (U.S. CLS. 2, 5, 22, 23, 29, 37, 38 AND 50).

FIRST USE 1-0-2004; IN COMMERCE 1-0-2004.

3,633,110. MURAK, GERALD E., WILLIAMSVILLE, NY. SN 78-507,486. PUB. 10-4-2005, FILED 10-28-2004.

WHO ART IN HEAVEN

THE MARK CONSISTS OF STANDARD CHARACTERS WITHOUT CLAIM TO ANY PARTICULAR FONT, STYLE, SIZE, OR COLOR.

FOR SERIES OF NON-FICTION BOOKS IN THE FIELD OF INSPIRATION (U.S. CLS. 2, 5, 22, 23, 29, 37, 38 AND 50).

FIRST USE 12-29-2008; IN COMMERCE 12-29-2008.

3,633,119. STAPLES THE OFFICE SUPERSTORE, LLC, FRAMINGHAM, MA. SN 78-548,998. PUB. 5-20-2008, FILED 1-18-2005.

DESK APPRENTICE

THE MARK CONSISTS OF STANDARD CHARACTERS WITHOUT CLAIM TO ANY PARTICULAR FONT, STYLE, SIZE, OR COLOR.

NO CLAIM IS MADE TO THE EXCLUSIVE RIGHT TO USE "DESK", APART FROM THE MARK AS SHOWN.

FOR ORGANIZER FOR OFFICE SUPPLIES AND FILES (U.S. CLS. 2, 5, 22, 23, 29, 37, 38 AND 50).

FIRST USE 4-0-2005; IN COMMERCE 4-0-2005.

CLASS 16—(Continued).

3,633,172. THE CARTOON NETWORK, INC., ATLANTA, GA. SN 78-686,228. PUB. 5-2-2006, FILED 8-5-2005.

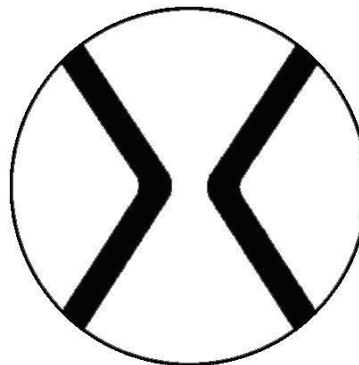

THE MARK CONSISTS OF AN HOURGLASS DESIGN INSIDE A CIRCLE.

FOR PRINTED MATTER AND PAPER GOODS, NAMELY, BOOKS FEATURING CHARACTERS FROM ANIMATED, ACTION ADVENTURE, COMEDY AND/OR DRAMA FEATURES, COMIC BOOKS, CHILDREN'S BOOKS, MAGAZINES FEATURING CHARACTERS FROM ANIMATED, ACTION ADVENTURE, COMEDY AND/OR DRAMA FEATURES, COLORING BOOKS, CHILDREN'S ACTIVITY BOOKS; STATIONERY; NOTEBOOKS, GREETING CARDS; TRADING CARDS, PENS, PENCILS, CASES THEREFOR ERASERS, CRAYONS, MARKERS, COLORED PENCILS, GIFT WRAPPING PAPER; PAPER PARTY FAVORS AND PAPER PARTY DECORATIONS, NAMELY, PAPER NAPKINS, PAPER PLACE MATS, CREPE PAPER, PAPER HATS, INVITATIONS, PAPER TABLE CLOTHS, PAPER CAKE DECORATIONS (U.S. CLS. 2, 5, 22, 23, 29, 37, 38 AND 50).

FIRST USE 3-2-2009; IN COMMERCE 3-2-2009.

3,633,209. BLUE GROTTO MEDIA, INC., WESTBURY, NY. SN 78-757,752. PUB. 2-6-2007, FILED 11-19-2005.

PASH

THE MARK CONSISTS OF STANDARD CHARACTERS WITHOUT CLAIM TO ANY PARTICULAR FONT, STYLE, SIZE, OR COLOR.

FOR PUBLICATIONS IN THE NATURE OF BOOKS, PAMPHLETS AND INSTRUCTIONAL GUIDES FEATURING INFORMATION IN THE FIELDS OF ENGAGEMENTS, MARRIAGE, WEDDINGS, PARTIES AND OF INTEREST TO ENGAGED COUPLES AND NEWLY-WEDS (U.S. CLS. 2, 5, 22, 23, 29, 37, 38 AND 50).

FIRST USE 4-20-2009; IN COMMERCE 4-20-2009.

CLASS 16—(Continued).

3,633,221. MARTIN, STELLA W., ATLANTA, GA. SN 78-774,276. PUB. 8-8-2006, FILED 12-15-2005.

N.U.T.S.

THE MARK CONSISTS OF STANDARD CHARACTERS WITHOUT CLAIM TO ANY PARTICULAR FONT, STYLE, SIZE, OR COLOR.

FOR ADHESIVE LABELS, MEMO PADS, NOTE PADS, PAPER NAPKINS, PRINTED PAPER LABELS (U.S. CLS. 2, 5, 22, 23, 29, 37, 38 AND 50).

FIRST USE 2-22-2006; IN COMMERCE 2-22-2006.

3,633,237. SWEET PEOPLE APPAREL, INC., LOS ANGELES, CA. SN 78-825,892. PUB. 10-17-2006, FILED 2-28-2006.

Miss Me

FOR CALENDARS (U.S. CLS. 2, 5, 22, 23, 29, 37, 38 AND 50).

FIRST USE 3-5-2009; IN COMMERCE 3-5-2009.

3,633,258. ST. BARTHOLOMEW'S CHURCH IN THE CITY OF NEW YORK, NEW YORK, NY. SN 78-857,041. PUB. 7-31-2007, FILED 4-7-2006.

CENTER FOR RELIGIOUS INQUIRY

THE MARK CONSISTS OF STANDARD CHARACTERS WITHOUT CLAIM TO ANY PARTICULAR FONT, STYLE, SIZE, OR COLOR.

NO CLAIM IS MADE TO THE EXCLUSIVE RIGHT TO USE "CENTER", APART FROM THE MARK AS SHOWN. SEC. 2(F).

FOR BOOKS, PAMPHLETS, AND PRINTED INSTRUCTIONAL AND TEACHING MATERIALS FOR USE IN RELIGIOUS LECTURES, CLASSES AND PROGRAMS, ALL IN THE FIELDS OF RELIGION, THEOLOGY, HISTORY, ETHICS, LITERATURE, AND MUSIC (U.S. CLS. 2, 5, 22, 23, 29, 37, 38 AND 50).

FIRST USE 3-15-2007; IN COMMERCE 3-15-2007.

CLASS 16—(Continued).

3,633,274. THE OCCASIONS GROUP, INC., NORTH MAN-KATO, MN. SN 78-891,645. PUB. 4-17-2007, FILED 5-24-2006.



FOR WEDDING AND SOCIAL STATIONERY, NAMELY, INVITATIONS, ANNOUNCEMENTS AND CARDS; WEDDING AND SOCIAL ACCESSORIES, NAMELY, PAPER WRAPPERS FOR CANDY AND CANDLES, PAPER FAVOR BOXES, BOOKMARKS, SCROLLS, PAPER MATCHBOOK BOXES AND COVERS, PAPER NAPKINS, PHOTO ALBUMS AND MEMORY BOOKS, GUEST BOOKS, SEALS, PROGRAMS, PROGRAM FANS, NOTEBOOKS, NOTEPADS (U.S. CLS. 2, 5, 22, 23, 29, 37, 38 AND 50).

FIRST USE 12-31-2005; IN COMMERCE 12-31-2005.

3,633,297. SK8BRDKRW, LLC, LOS ANGELES, CA. SN 78-932,220. PUB. 1-15-2008, FILED 7-18-2006.

SKATE FARM

THE MARK CONSISTS OF STANDARD CHARACTERS WITHOUT CLAIM TO ANY PARTICULAR FONT, STYLE, SIZE, OR COLOR.

NO CLAIM IS MADE TO THE EXCLUSIVE RIGHT TO USE "SKATE", APART FROM THE MARK AS SHOWN.

FOR GRAPHIC NOVELS (U.S. CLS. 2, 5, 22, 23, 29, 37, 38 AND 50).

FIRST USE 2-21-2007; IN COMMERCE 2-21-2007.

CLASS 17—RUBBER GOODS

CLASS 17—(Continued).

3,632,086. THE SHERWIN-WILLIAMS COMPANY, CLEVELAND, OH. SN 77-218,807. PUB. 11-27-2007, FILED 6-29-2007.

PROMAX

THE MARK CONSISTS OF STANDARD CHARACTERS WITHOUT CLAIM TO ANY PARTICULAR FONT, STYLE, SIZE, OR COLOR.

FOR ADHESIVE SEALANT AND CAULKING COMPOUND (U.S. CLS. 1, 5, 12, 13, 35 AND 50).
FIRST USE 4-16-2009; IN COMMERCE 4-16-2009.

3,632,106. BIOBASED SYSTEMS, LLC, ROGERS, AR. SN 77-228,484. PUB. 1-1-2008, FILED 7-12-2007.

WE ENABLE SUSTAINABILITY

THE MARK CONSISTS OF STANDARD CHARACTERS WITHOUT CLAIM TO ANY PARTICULAR FONT, STYLE, SIZE, OR COLOR.

FOR SPRAY FOAM INSULATION FOR BUILDINGS (U.S. CLS. 1, 5, 12, 13, 35 AND 50).
FIRST USE 12-15-2008; IN COMMERCE 12-15-2008.

3,632,141. ILLINOIS TOOL WORKS INC., GLENVIEW, IL. SN 77-245,514. PUB. 6-3-2008, FILED 8-2-2007.

PERMASORB

THE MARK CONSISTS OF STANDARD CHARACTERS WITHOUT CLAIM TO ANY PARTICULAR FONT, STYLE, SIZE, OR COLOR.

FOR ABSORBENT PRODUCTS, NAMELY, GRANULAR CELLULOSE FOR THE CONTAINMENT AND CLEANUP OF OIL/SOLVENT BASED LIQUIDS FROM FLOORS AND WORK AREAS (U.S. CLS. 1, 5, 12, 13, 35 AND 50).
FIRST USE 3-6-2009; IN COMMERCE 3-6-2009.

CLASS 17—(Continued).

3,632,269. WINTECH AMERICA, INC., NORWALK, CA. SN 77-300,404. PUB. 4-29-2008, FILED 10-10-2007.



NO CLAIM IS MADE TO THE EXCLUSIVE RIGHT TO USE "FILM", APART FROM THE MARK AS SHOWN.

THE MARK CONSISTS OF THE STYLIZED WORD "FEELM".

FOR TINTED, LAMINATED AND REFLECTIVE PLASTIC FILMS FOR USE IN HOME OR AUTO WINDOWS (U.S. CLS. 1, 5, 12, 13, 35 AND 50).
FIRST USE 10-1-2007; IN COMMERCE 10-30-2007.

3,632,498. BAG INNOVATIONS GROUP, LLC, CHANHASSEN, MN. SN 77-393,829. PUB. 6-24-2008, FILED 2-11-2008.

INFRESH

THE MARK CONSISTS OF STANDARD CHARACTERS WITHOUT CLAIM TO ANY PARTICULAR FONT, STYLE, SIZE, OR COLOR.

FOR PLASTIC FILM FOR INDUSTRIAL AND COMMERCIAL PACKING USE (U.S. CLS. 1, 5, 12, 13, 35 AND 50).
FIRST USE 1-9-2009; IN COMMERCE 1-9-2009.

3,632,791. PRIMO SPORT, INC., NEWARK, DE. SN 77-457,313. PUB. 7-1-2008, FILED 4-24-2008.

NITROBLOCK

THE MARK CONSISTS OF STANDARD CHARACTERS WITHOUT CLAIM TO ANY PARTICULAR FONT, STYLE, SIZE, OR COLOR.

FOR RUBBER FOR USE IN THE MANUFACTURE OF INFLATED SPORTS ARTICLES AND TIRES (U.S. CLS. 1, 5, 12, 13, 35 AND 50).
FIRST USE 8-0-2008; IN COMMERCE 8-0-2008.

CLASS 17—(Continued).

3,632,801. GENFLEX ROOFING SYSTEMS, LLC, INDIANA-POLIS, IN. SN 77-461,483. PUB. 10-7-2008, FILED 4-30-2008.

GENTITE

THE MARK CONSISTS OF STANDARD CHARACTERS WITHOUT CLAIM TO ANY PARTICULAR FONT, STYLE, SIZE, OR COLOR.

FOR ADHESIVE SEALANTS FOR USE IN ROOFING; SEALANTS FOR BUILDINGS (U.S. CLS. 1, 5, 12, 13, 35 AND 50).

FIRST USE 10-29-2008; IN COMMERCE 10-29-2008.

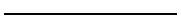

3,632,810. LEADER WINDOW FILM CO. LTD, KAOHSIUNG, TAIWAN. SN 77-465,210. PUB. 10-14-2008, FILED 5-4-2008.



THE COLOR(S) RED IS/ARE CLAIMED AS A FEATURE OF THE MARK.

THE MARK CONSISTS OF A STYLIZED SUN WITH A FACE ADJACENT TO THE LETTERS "USL", ALL IN RED. FOR HEAT INSULATING FILM FOR USE ON CAR WINDOWS; HEAT INSULATING FILM FOR USE IN GLASS LAMINATION (U.S. CLS. 1, 5, 12, 13, 35 AND 50). FIRST USE 9-12-1996; IN COMMERCE 6-1-2008.



3,632,908. KNAUF INSULATION GMBH, SHELBYVILLE, IN. SN 77-506,337. PUB. 8-12-2008, FILED 6-24-2008.

ECOBATT

THE MARK CONSISTS OF STANDARD CHARACTERS WITHOUT CLAIM TO ANY PARTICULAR FONT, STYLE, SIZE, OR COLOR.

FOR FIBERGLASS INSULATION FOR BUILDINGS (U.S. CLS. 1, 5, 12, 13, 35 AND 50).

FIRST USE 11-1-2008; IN COMMERCE 11-1-2008.

CLASS 17—(Continued).

3,633,045. KNAUF INSULATION GMBH, SHELBYVILLE, IN. SN 77-596,514. PUB. 12-30-2008, FILED 10-20-2008.

ECOBATT

THE MARK CONSISTS OF THE TERM "ECOBATT" WITH A LEAF IN THE CENTER OF THE LETTER "O".

FOR FIBERGLASS INSULATION FOR BUILDINGS (U.S. CLS. 1, 5, 12, 13, 35 AND 50).

FIRST USE 11-1-2008; IN COMMERCE 11-1-2008.

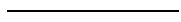

3,633,143. BOSTIK, INC., WAUWATOSA, WI. SN 78-611,726. PUB. 1-10-2006, FILED 4-19-2005.

TOTALMELT

THE MARK CONSISTS OF STANDARD CHARACTERS WITHOUT CLAIM TO ANY PARTICULAR FONT, STYLE, SIZE, OR COLOR.

OWNER OF U.S. REG. NO. 2,727,675.

FOR PACKAGING MATERIALS, NAMELY, NON-TACKY PACKAGING OR WRAPPING FILM FOR COMMERCIAL OR INDUSTRIAL PURPOSES (U.S. CLS. 1, 5, 12, 13, 35 AND 50).

FIRST USE 3-31-2009; IN COMMERCE 3-31-2009.

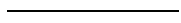

CLASS 18—LEATHER GOODS

3,631,910. TAPPED OUT, LLC, GRANDA HILLS, CA. SN 77-060,549. PUB. 7-3-2007, FILED 12-8-2006.



THE MARK CONSISTS OF THE LETTERS "PA" STYLIZED INSIDE A CIRCLE.

FOR ALL PURPOSE CARRYING BAGS, BACKPACKS, KNAPSACKS (U.S. CLS. 1, 2, 3, 22 AND 41).

FIRST USE 2-1-2009; IN COMMERCE 2-1-2009.

CLASS 18—(Continued).

3,631,935. EQUILIBRIUM PRODUCTS LIMITED, BUCKINGHAMSHIRE HP5 3, ENGLAND. SN 77-083,708. PUB. 7-15-2008, FILED 1-16-2007.

**EQUILIBRIUM**

THE MARK CONSISTS OF THE WORD "EQUILIBRIUM" UNDERNEATH A DRAWING OF A HORSE'S HEAD. FOR MASKS FOR USE BY HORSES, BOOTS FOR HORSES, HORSE GAITERS IN THE NATURE OF CHAPS AND LEGGINGS, SADDLE BLANKETS, AND SEAT PADS FOR USE ON HORSES (U.S. CLS. 1, 2, 3, 22 AND 41).

FIRST USE 9-0-2005; IN COMMERCE 9-0-2005.

3,632,119. WRANGLER APPAREL CORP., WILMINGTON, DE. SN 77-232,223. PUB. 1-1-2008, FILED 7-18-2007.

TIMBER CREEK BY WRANGLER

THE MARK CONSISTS OF STANDARD CHARACTERS WITHOUT CLAIM TO ANY PARTICULAR FONT, STYLE, SIZE, OR COLOR.

OWNER OF U.S. REG. NOS. 1,699,851 AND 2,229,189. FOR LEATHER BELTS (U.S. CLS. 1, 2, 3, 22 AND 41). FIRST USE 12-19-2003; IN COMMERCE 12-19-2003.

3,632,224. NETCESSITIES, LLC, LOGANSPOUT, IN. SN 77-278,314. PUB. 3-11-2008, FILED 9-12-2007.

NETCESSITY THE UNIVERSAL BAG

THE MARK CONSISTS OF STANDARD CHARACTERS WITHOUT CLAIM TO ANY PARTICULAR FONT, STYLE, SIZE, OR COLOR.

NO CLAIM IS MADE TO THE EXCLUSIVE RIGHT TO USE "BAG", APART FROM THE MARK AS SHOWN. FOR UNIQUELY DESIGNED CARRY-ALL NET BAGS (U.S. CLS. 1, 2, 3, 22 AND 41).

FIRST USE 8-15-2007; IN COMMERCE 10-1-2007.

CLASS 18—(Continued).

3,632,277. DISNEY ENTERPRISES, INC., BURBANK, CA. SN 77-303,263. PUB. 6-24-2008, FILED 10-12-2007.

CAMP ROCK

THE MARK CONSISTS OF STANDARD CHARACTERS WITHOUT CLAIM TO ANY PARTICULAR FONT, STYLE, SIZE, OR COLOR.

FOR ARTICLES MADE FROM LEATHER AND IMITATIONS OF LEATHER, NAMELY, LUGGAGE, LUGGAGE TAGS, SATCHELS, BAGS, NAMELY, BACKPACKS, BOOK BAGS, DUFFEL BAGS, OVERNIGHT BAGS; TOTE BAGS; PURSES; HANDBAGS; UMBRELLAS (U.S. CLS. 1, 2, 3, 22 AND 41).

FIRST USE 6-20-2008; IN COMMERCE 6-20-2008.

3,632,295. APOSTROPHE DESIGNS, LLC, ATLANTA, GA. SN 77-307,045. PUB. 3-11-2008, FILED 10-18-2007.

TRAVEL THERAPY

THE MARK CONSISTS OF STANDARD CHARACTERS WITHOUT CLAIM TO ANY PARTICULAR FONT, STYLE, SIZE, OR COLOR.

NO CLAIM IS MADE TO THE EXCLUSIVE RIGHT TO USE "TRAVEL", APART FROM THE MARK AS SHOWN. FOR BAGS FOR TRAVEL ACCESSORIES (U.S. CLS. 1, 2, 3, 22 AND 41).

FIRST USE 7-5-2008; IN COMMERCE 7-5-2008.

3,632,330. OKKATOTS LLC, OREM, UT. SN 77-328,655. PUB. 7-8-2008, FILED 11-13-2007.

EXTEND-TO-TEND

THE MARK CONSISTS OF STANDARD CHARACTERS WITHOUT CLAIM TO ANY PARTICULAR FONT, STYLE, SIZE, OR COLOR.

FOR A FEATURE OF BABY BACKPACKS, BABY CARRIERS WORN ON THE BODY, BABY CARRYING BAGS AND INFANT CARRIERS WORN ON THE BODY, NAMELY, AN EXTENDING STRAP ALLOWING THE BABY TO LEAN BACK (U.S. CLS. 1, 2, 3, 22 AND 41).

FIRST USE 2-11-2009; IN COMMERCE 2-11-2009.

CLASS 18—(Continued).

3,632,367. BIN, LIEW, PUCHONG, MALAYSIA. SN 77-345,422.
PUB. 9-2-2008, FILED 12-6-2007.

DATALITE

THE MARK CONSISTS OF STANDARD CHARACTERS WITHOUT CLAIM TO ANY PARTICULAR FONT, STYLE, SIZE, OR COLOR.

FOR BAGS, NAMELY, SHOPPING BAGS WITH WHEELS ATTACHED, BACKPACKS, DOCUMENT BAGS, SLING BAGS, TOTE BAGS, TRAVEL BAGS, HANDBAGS AND LEATHER POUCHES; LUGGAGE; WALLETS AND SHOULDER BAGS (U.S. CLS. 1, 2, 3, 22 AND 41).

FIRST USE 5-4-2006; IN COMMERCE 5-4-2006.

3,632,368. BIN, LIEW, PUCHONG, MALAYSIA. SN 77-345,455.
PUB. 9-2-2008, FILED 12-6-2007.

TERMINUS

THE MARK CONSISTS OF STANDARD CHARACTERS WITHOUT CLAIM TO ANY PARTICULAR FONT, STYLE, SIZE, OR COLOR.

FOR BAGS, NAMELY, SHOPPING BAGS WITH WHEELS ATTACHED, BACKPACKS, DOCUMENT BAGS, SLING BAGS, TOTE BAGS, TRAVEL BAGS, HANDBAGS AND LEATHER POUCHES; LUGGAGE; WALLETS AND SHOULDER BAGS (U.S. CLS. 1, 2, 3, 22 AND 41).

FIRST USE 5-4-2006; IN COMMERCE 5-4-2006.

3,632,611. WANG, ZHAOMING, WUHAN, HUBEI, CHINA.
SN 77-414,346. PUB. 7-29-2008, FILED 3-5-2008.

MICANI**CLASS 18—(Continued).**

THE MARK CONSISTS OF SIX CAPITALIZED ENGLISH LETTERS "MICANI" AND A SPHERE POSITIONED BELOW THE LETTERS.

THE WORDING "MICANI" HAS NO MEANING IN A FOREIGN LANGUAGE.

FOR LEATHER BAGS, SUITCASES AND WALLETS; LEATHER BAGS FOR MERCHANDISE PACKAGING; LEATHER BRIEFCASES; LEATHER CASES; LEATHER FOR FURNITURE; LEATHER PURSES; LUGGAGE (U.S. CLS. 1, 2, 3, 22 AND 41).

FIRST USE 3-5-2008; IN COMMERCE 3-5-2008.

3,633,091. FALCHI, MARCOS, NEW YORK, NY. SN 78-331,576. PUB. 4-26-2005, FILED 11-21-2003.

Chi by Falchi

FOR HANDBAGS; POCKETBOOKS; PURSES; WALLETS; SHOULDER BAGS; CLUTCH BAGS (U.S. CLS. 1, 2, 3, 22 AND 41).

FIRST USE 1-1-2004; IN COMMERCE 1-1-2004.

3,633,163. THE CARTOON NETWORK, INC., ATLANTA, GA.
SN 78-667,361. PUB. 4-4-2006, FILED 7-11-2005.

BEN 10

THE MARK CONSISTS OF STANDARD CHARACTERS WITHOUT CLAIM TO ANY PARTICULAR FONT, STYLE, SIZE, OR COLOR.

FOR BACKPACKS AND BOOK BAGS (U.S. CLS. 1, 2, 3, 22 AND 41).

FIRST USE 4-1-2009; IN COMMERCE 4-1-2009.

3,633,263. ARBITRAGE ENTERPRISES, INC., NEW YORK, NY. SN 78-869,132. PUB. 12-26-2006, FILED 4-25-2006.

Arbitrage

THE MARK CONSISTS OF STANDARD CHARACTERS WITHOUT CLAIM TO ANY PARTICULAR FONT, STYLE, SIZE, OR COLOR.

FOR LEATHER WALLETS (U.S. CLS. 1, 2, 3, 22 AND 41).

FIRST USE 5-5-2008; IN COMMERCE 5-5-2008.

CLASS 19—NON-METALLIC BUILDING MATERIALS

3,631,932. ENDURIS, LLC, JACKSONVILLE, FL. SN 77-082,939. PUB. 1-8-2008, FILED 1-15-2007.

ENDECK

THE MARK CONSISTS OF STANDARD CHARACTERS WITHOUT CLAIM TO ANY PARTICULAR FONT, STYLE, SIZE, OR COLOR.

FOR CONSTRUCTION MATERIALS COMPRISED OF NON-METALLIC PLASTICS FOR FABRICATING PORCHES, DOCKS, AND DECKS (U.S. CLS. 1, 12, 33 AND 50).

FIRST USE 2-1-2008; IN COMMERCE 4-1-2008.

3,632,004. F. VON LANGSDORFF LICENSING LIMITED, CALEDON, ONTARIO. SN 77-156,845. PUB. 10-28-2008, FILED 4-14-2007.

PRIORA

THE MARK CONSISTS OF STANDARD CHARACTERS WITHOUT CLAIM TO ANY PARTICULAR FONT, STYLE, SIZE, OR COLOR.

PRIORITY CLAIMED UNDER SEC. 44(D) ON CANADA APPLICATION NO. 1,340,965, FILED 3-27-2007, REG. NO. TMA719753, DATED 7-30-2008, EXPIRES 7-30-2023.

FOR PAVING STONES (U.S. CLS. 1, 12, 33 AND 50).

FIRST USE 5-31-1999; IN COMMERCE 10-31-2007.

3,632,039. AMVIC INC., TORONTO, ONTARIO, CANADA. SN 77-188,162. PUB. 10-28-2008, FILED 5-23-2007.

AMBUCK

THE MARK CONSISTS OF STANDARD CHARACTERS WITHOUT CLAIM TO ANY PARTICULAR FONT, STYLE, SIZE, OR COLOR.

PRIORITY CLAIMED UNDER SEC. 44(D) ON CANADA APPLICATION NO. 1,343,945, FILED 4-28-2007, REG. NO. TMA712,750, DATED 7-31-2008, EXPIRES 7-31-2023.

FOR NON-METAL CASTING FORM FOR CONCRETE USED IN THE CONSTRUCTION INDUSTRY (U.S. CLS. 1, 12, 33 AND 50).

FIRST USE 1-0-2007; IN COMMERCE 1-0-2007.

CLASS 19—(Continued).

3,632,258. INTIGRAL, INC., DBA EDGE SEAL TECHNOLOGIES, WALTON HILLS, OH. SN 77-292,983. PUB. 8-19-2008, FILED 10-1-2007.

INTIGRAL

THE MARK CONSISTS OF STANDARD CHARACTERS WITHOUT CLAIM TO ANY PARTICULAR FONT, STYLE, SIZE, OR COLOR.

FOR WINDOW GLASS; INSULATED GLASS; GLASS PANES; DECORATIVE GLASS; LAMINATED FLAT GLASS; MODIFIED SHEET GLASS; SAFETY GLASS FOR BUILDING PURPOSES; STAINED GLASS WINDOWS; GLASS PANELS FOR BUILDING CONSTRUCTION PURPOSES (U.S. CLS. 1, 12, 33 AND 50).

FIRST USE 9-1-2007; IN COMMERCE 9-20-2007.

3,632,259. INTIGRAL, INC., DBA EDGE SEAL TECHNOLOGIES, WALTON HILLS, OH. SN 77-293,032. PUB. 8-19-2008, FILED 10-1-2007.

Your Edge in Glass

THE MARK CONSISTS OF STANDARD CHARACTERS WITHOUT CLAIM TO ANY PARTICULAR FONT, STYLE, SIZE, OR COLOR.

FOR WINDOW GLASS; INSULATED GLASS; GLASS PANES; DECORATIVE GLASS; LAMINATED FLAT GLASS; MODIFIED SHEET GLASS; SAFETY GLASS FOR BUILDING PURPOSES; STAINED GLASS WINDOWS; GLASS PANELS FOR BUILDING CONSTRUCTION PURPOSES (U.S. CLS. 1, 12, 33 AND 50).

FIRST USE 9-1-2007; IN COMMERCE 9-20-2007.

CLASS 19—(Continued).

3,632,271. XIAO, YAN, ARCADIA, CA. SN 77-301,457. PUB. 9-2-2008, FILED 10-11-2007.

GLUBAM

THE MARK CONSISTS OF STANDARD CHARACTERS WITHOUT CLAIM TO ANY PARTICULAR FONT, STYLE, SIZE, OR COLOR.

FOR LAMINATED BAMBOO COMPONENTS, NAMELY, BEAMS, GIRDERS, COLUMNS, SLABS, TRUSSES, JOISTS, FOR USE IN STRUCTURES; CONSTRUCTION ELEMENTS PRIMARILY NOT MADE OF METAL, NAMELY, SUPPORTS MADE OF COMPOSITES OF BAMBOO COMBINED WITH TIMBER, METALS, AND FIBER REINFORCED PLASTICS, FOR USE IN SUPPORTING LOADS IN STRUCTURES (U.S. CLS. 1, 12, 33 AND 50).

FIRST USE 10-28-2007; IN COMMERCE 2-3-2009.

CLASS 19—(Continued).

3,632,407. EAGLE ONE GOLF PRODUCTS, INC., ANAHEIM, CA. SN 77-361,251. PUB. 12-9-2008, FILED 12-28-2007.

GREENWOOD

FOR NON-METAL BUILDING MATERIALS, NAMELY, RECYCLED PLASTIC LUMBER IN STANDARD DIMENSIONAL LUMBER SIZES USED IN PRODUCTS MARKETED TO GOLF COURSES (U.S. CLS. 1, 12, 33 AND 50).

FIRST USE 1-31-2008; IN COMMERCE 1-31-2008.

3,632,410. THE GARLAND COMPANY, INC., CLEVELAND, OH. SN 77-363,388. PUB. 4-29-2008, FILED 1-3-2008.

BIFLEX

THE MARK CONSISTS OF STANDARD CHARACTERS WITHOUT CLAIM TO ANY PARTICULAR FONT, STYLE, SIZE, OR COLOR.

OWNER OF U.S. REG. NO. 3,068,143.
FOR BUILDING MATERIAL, NAMELY, MODIFIED BITUMEN ROOFING MEMBRANES AND MODIFIED BITUMEN MEMBRANES FOR USE ON THE SIDES OF HOUSES AND BUILDINGS (U.S. CLS. 1, 12, 33 AND 50).
FIRST USE 3-1-2009; IN COMMERCE 3-1-2009.

3,632,514. POLYMER GROUP, LLC, DBA POLYCON MANUFACTURING DIVISION OF POLYMER GROUP, MADISON, MS. SN 77-397,033. PUB. 7-1-2008, FILED 2-14-2008.

PCMO

THE MARK CONSISTS OF STANDARD CHARACTERS WITHOUT CLAIM TO ANY PARTICULAR FONT, STYLE, SIZE, OR COLOR.

FOR CEMENT MIXES (U.S. CLS. 1, 12, 33 AND 50).
FIRST USE 8-31-2006; IN COMMERCE 8-31-2006.

3,632,276. INTIGRAL, INC., DBA EDGE SEAL TECHNOLOGIES, WALTON HILLS, OH. SN 77-302,677. PUB. 8-19-2008, FILED 10-12-2007.

INTIGRAL

THE MARK CONSISTS OF THE WORD "INTIGRAL" WITH AN ARCH ON TOP OF THE WORD EXTENDING FROM THE LETTER "T" TO THE LETTER "R" AND AN ARCH BENEATH THE WORD EXTENDING FROM THE LETTER "R" TO THE LETTER "T".

FOR GLASS PANES; INSULATED GLASS; WINDOW GLASS; DECORATIVE GLASS; GLASS PANELS FOR BUILDING CONSTRUCTION PURPOSES; LAMINATED FLAT GLASS; MODIFIED SHEET GLASS; SAFETY GLASS FOR BUILDING PURPOSES; STAINED GLASS WINDOWS (U.S. CLS. 1, 12, 33 AND 50).

FIRST USE 9-1-2007; IN COMMERCE 9-20-2007.

CLASS 19—(Continued).

3,632,633. PAVE TECH, INC., PRIOR LAKE, MN. SN 77-417,059. PUB. 7-22-2008, FILED 3-9-2008.

GEOTECH

THE MARK CONSISTS OF STANDARD CHARACTERS WITHOUT CLAIM TO ANY PARTICULAR FONT, STYLE, SIZE, OR COLOR.

FOR EROSION CONTROL MATTING, MESHES AND BLANKETS FOR STABILIZING SOIL AND VEGETATION (U.S. CLS. 1, 12, 33 AND 50).

FIRST USE 4-8-2009; IN COMMERCE 4-8-2009.

CLASS 19—(Continued).

3,632,962. INGENUUS INDUSTRIES, BREA, CA. SN 77-523,476. PUB. 12-9-2008, FILED 7-16-2008.

KIDOODLYROCKS

THE MARK CONSISTS OF STANDARD CHARACTERS WITHOUT CLAIM TO ANY PARTICULAR FONT, STYLE, SIZE, OR COLOR.

FOR GRAVE MARKERS FOR PETS MADE OF STONE, CONCRETE, MARBLE, GRANITE AND SLATE (U.S. CLS. 1, 12, 33 AND 50).

FIRST USE 9-0-2008; IN COMMERCE 9-0-2008.

3,632,670. ALLIANCE LUMBER, LLC, SCOTTSDALE, AZ. SN 77-425,326. PUB. 8-26-2008, FILED 3-18-2008.

INTEGRI LAM

THE MARK CONSISTS OF STANDARD CHARACTERS WITHOUT CLAIM TO ANY PARTICULAR FONT, STYLE, SIZE, OR COLOR.

NO CLAIM IS MADE TO THE EXCLUSIVE RIGHT TO USE "LAM", APART FROM THE MARK AS SHOWN.

FOR ENGINEERED LUMBER, NAMELY, BEAMS, COLUMNS, HEADERS, JOISTS, STRUCTURAL FRAMING, DECKING, SCAFFOLDING AND BLEACHER PLANKING, ALL FABRICATED OF LAMINATED VENEER LUMBER OR OTHER WOOD-BASED ENGINEERED PRODUCTS (U.S. CLS. 1, 12, 33 AND 50).

FIRST USE 1-10-2009; IN COMMERCE 1-10-2009.

3,633,147. MEADWESTVACO CORPORATION, GLEN ALLEN, VA. SN 78-628,413. PUB. 1-31-2006, FILED 5-12-2005.

EVOTHERM

THE MARK CONSISTS OF STANDARD CHARACTERS WITHOUT CLAIM TO ANY PARTICULAR FONT, STYLE, SIZE, OR COLOR.

FOR ASPHALT, ASPHALT PAVEMENTS AND ASPHALT PAVING COMPOSITIONS (U.S. CLS. 1, 12, 33 AND 50).

FIRST USE 5-16-2006; IN COMMERCE 5-16-2006.

3,632,913. MITY-LITE, INC., OREM, UT. SN 77-509,356. PUB. 11-18-2008, FILED 6-26-2008.

ENCORE STAGING

THE MARK CONSISTS OF STANDARD CHARACTERS WITHOUT CLAIM TO ANY PARTICULAR FONT, STYLE, SIZE, OR COLOR.

NO CLAIM IS MADE TO THE EXCLUSIVE RIGHT TO USE "STAGING", APART FROM THE MARK AS SHOWN.

FOR PORTABLE STAGES (U.S. CLS. 1, 12, 33 AND 50).

FIRST USE 12-15-2008; IN COMMERCE 2-15-2009.

3,633,174. MONDO USA, INC., GRAPEVINE, TX. SN 78-687,090. PUB. 12-2-2008, FILED 8-5-2005.

PUNTI

THE MARK CONSISTS OF STANDARD CHARACTERS WITHOUT CLAIM TO ANY PARTICULAR FONT, STYLE, SIZE, OR COLOR.

PRIORITY CLAIMED UNDER SEC. 44(D) ON CANADA APPLICATION NO. 1263376, FILED 7-4-2005, REG. NO. TMA679077, DATED 1-9-2007, EXPIRES 1-9-2017.

THE FOREIGN WORDING IN THE MARK TRANSLATES INTO ENGLISH AS "POINT."

FOR RUBBER FLOORING, SYNTHETIC RUBBER FLOORING, SYNTHETIC SURFACES FOR PLAY-GROUNDS, SPORTS TERRAINS AND PLAY AREAS, AND TILED SYNTHETIC FLOORING FOR INDOOR AND OUTDOOR USE (U.S. CLS. 1, 12, 33 AND 50).

FIRST USE 1-1-2003; IN COMMERCE 1-1-2003.

CLASS 19—(Continued).

3,633,241. THE W. W. HENRY COMPANY, L.P., ALIQUIPPA, PA. SN 78-827,261. PUB. 6-6-2006, FILED 3-2-2006.

ReadyFlex

THE MARK CONSISTS OF STANDARD CHARACTERS WITHOUT CLAIM TO ANY PARTICULAR FONT, STYLE, SIZE, OR COLOR.

FOR PREMIXED THINSET MORTAR (U.S. CLS. 1, 12, 33 AND 50).

FIRST USE 6-0-2007; IN COMMERCE 6-0-2007.

CLASS 20—FURNITURE AND ARTICLES NOT OTHERWISE CLASSIFIED

3,631,805. TWIN STAR INTERNATIONAL, INC., DELRAY BEACH, FL. SN 76-647,871. PUB. 12-12-2006, FILED 10-3-2005.

TRESANTI 
FASHION BATH

NO CLAIM IS MADE TO THE EXCLUSIVE RIGHT TO USE "FASHION BATH", APART FROM THE MARK AS SHOWN.

THE FOREIGN WORDING IN THE MARK TRANSLATES INTO ENGLISH AS THREE SAINTS.

FOR BATHROOM VANITIES, MEDICINE CABINETS AND BATHROOM ACCESSORIES, NAMELY, MIRRORS, SHELVES (U.S. CLS. 2, 13, 22, 25, 32 AND 50).

FIRST USE 10-1-2004; IN COMMERCE 10-1-2005.

3,631,824. WINDSOR SMITH HOMES, INC., BRENTWOOD, CA. SN 76-679,721. PUB. 7-22-2008, FILED 7-20-2007.

WINDSOR SMITH HOME

NO CLAIM IS MADE TO THE EXCLUSIVE RIGHT TO USE "HOME", APART FROM THE MARK AS SHOWN.

THE NAME(S), PORTRAIT(S), AND/OR SIGNATURE(S) SHOWN IN THE MARK IDENTIFIES "WINDSOR SMITH", WHOSE CONSENT(S) TO REGISTER IS SUBMITTED.

FOR INDOOR FURNITURE, NAMELY, DINING ROOM, LIVING ROOM, KITCHEN, BEDROOM, OCCASIONAL, CASUAL, UPHOLSTERED, AND VINTAGE FURNITURE; OUTDOOR FURNITURE, NAMELY, LAWN, GARDEN, DECK, PATIO AND POOL FURNITURE; PICTURE FRAMES; CLOSET ACCESSORIES, NAMELY, CLOTHES BARS; SHOWER GRAB BARS NOT OF METAL; WINDOW BLINDS; WINDOW SHADES (U.S. CLS. 2, 13, 22, 25, 32 AND 50).

FIRST USE 9-23-2003; IN COMMERCE 10-16-2006.

CLASS 20—(Continued).

3,631,883. REXAM CLOSURE SYSTEMS INC., PERRYSBURG, OH. SN 77-022,805. PUB. 9-18-2007, FILED 10-17-2006.

OptiSeal

THE MARK CONSISTS OF STANDARD CHARACTERS WITHOUT CLAIM TO ANY PARTICULAR FONT, STYLE, SIZE, OR COLOR.

FOR MOLDED-IN LINERS MARKETED TO PACKAGERS FOR COLD FILL, HOT FILL AND ASEPTIC FILL CLOSURE APPLICATIONS (U.S. CLS. 2, 13, 22, 25, 32 AND 50).

FIRST USE 7-1-2001; IN COMMERCE 7-1-2001.

3,632,011. BONEYARD RECYCLED CREATIONS, LLC, COLORADO SPRINGS, CO. SN 77-160,415. PUB. 12-18-2007, FILED 4-19-2007.

BONEYARD RECYCLED CREATIONS

THE MARK CONSISTS OF STANDARD CHARACTERS WITHOUT CLAIM TO ANY PARTICULAR FONT, STYLE, SIZE, OR COLOR.

NO CLAIM IS MADE TO THE EXCLUSIVE RIGHT TO USE "RECYCLED CREATIONS", APART FROM THE MARK AS SHOWN.

FOR FURNITURE, NAMELY, TABLES (U.S. CLS. 2, 13, 22, 25, 32 AND 50).

FIRST USE 11-15-2008; IN COMMERCE 11-15-2008.

3,632,037. EXEMPLIS CORPORATION, CYPRESS, CA. SN 77-183,691. PUB. 11-13-2007, FILED 5-17-2007.

IDEON

THE MARK CONSISTS OF STANDARD CHARACTERS WITHOUT CLAIM TO ANY PARTICULAR FONT, STYLE, SIZE, OR COLOR.

FOR FURNITURE, NAMELY, LOUNGE SEATING AND LOBBY SEATING; SOFT SEATING; CHAIRS, SOFAS, SETTEES, OTTOMANS, BENCHES; FREE-STANDING AND INTEGRATED TABLES; HOME FURNITURE; FURNITURE IN DIFFERENT COMMERCIAL SETTINGS, NAMELY, FURNITURE FOR EDUCATIONAL, OFFICE, AND HEALTHCARE SETTINGS (U.S. CLS. 2, 13, 22, 25, 32 AND 50).

FIRST USE 2-1-2008; IN COMMERCE 9-30-2008.

CLASS 20—(Continued).

3,632,072. HILLSDALE FURNITURE LLC, LOUISVILLE, KY.
SN 77-211,891. PUB. 1-15-2008, FILED 6-21-2007.



OWNER OF U.S. REG. NO. 2,269,006.
NO CLAIM IS MADE TO THE EXCLUSIVE RIGHT TO
USE "FURNITURE" AND "LLC", APART FROM THE
MARK AS SHOWN.

THE MARK CONSISTS OF THE FLEUR DE LIS DESIGN
PLACED BESIDE THE WORDS "HILLSDALE FURNITURE,
LLC".

FOR FURNITURE (U.S. CLS. 2, 13, 22, 25, 32 AND 50).
FIRST USE 6-0-2007; IN COMMERCE 6-0-2007.

3,632,077. CR CHROMCRAFT, INC., SENATOBIA, MS. SN 77-
214,163. PUB. 4-29-2008, FILED 6-25-2007.

TRAK

THE MARK CONSISTS OF STANDARD CHARACTERS
WITHOUT CLAIM TO ANY PARTICULAR FONT, STYLE,
SIZE, OR COLOR.

FOR OFFICE CHAIRS (U.S. CLS. 2, 13, 22, 25, 32 AND
50).

FIRST USE 4-1-2006; IN COMMERCE 4-1-2006.

3,632,098. CHEESMAN, MARK M., SAN DIEGO, CA. SN 77-
225,806. PUB. 12-25-2007, FILED 7-10-2007.

SNOWTWIG

THE MARK CONSISTS OF STANDARD CHARACTERS
WITHOUT CLAIM TO ANY PARTICULAR FONT, STYLE,
SIZE, OR COLOR.

FOR SCULPTURES AND TROPHIES MADE OF PLAS-
TIC, WOOD OR PLASTER; ORNAMENTS, NOT IN-
CLUDING CHRISTMAS TREE ORNAMENTS, MADE
OF PLASTIC, WOOD OR PLASTER; WALL AND DOOR
DECORATIONS CONSISTING OF SCULPTURES MADE
OF PLASTIC, WOOD OR PLASTER (U.S. CLS. 2, 13, 22,
25, 32 AND 50).

FIRST USE 3-11-2009; IN COMMERCE 3-11-2009.

CLASS 20—(Continued).

3,632,173. COHEN, DANIEL E., CHASKA, MN. SN 77-258,061.
PUB. 2-19-2008, FILED 8-17-2007.

EXPERIENTIAL

THE MARK CONSISTS OF STANDARD CHARACTERS
WITHOUT CLAIM TO ANY PARTICULAR FONT, STYLE,
SIZE, OR COLOR.

FOR FURNITURE (U.S. CLS. 2, 13, 22, 25, 32 AND 50).
FIRST USE 9-0-2008; IN COMMERCE 9-0-2008.

3,632,238. WRANGLER APPAREL CORP., WILMINGTON,
DE. SN 77-284,305. PUB. 1-15-2008, FILED 9-20-2007.

REAL. COMFORTABLE. HOME.

THE MARK CONSISTS OF STANDARD CHARACTERS
WITHOUT CLAIM TO ANY PARTICULAR FONT, STYLE,
SIZE, OR COLOR.

OWNER OF U.S. REG. NO. 2,904,981.

NO CLAIM IS MADE TO THE EXCLUSIVE RIGHT TO
USE "HOME", APART FROM THE MARK AS SHOWN.

FOR FURNITURE, NAMELY, SOFAS, COUCHES,
OCCASIONAL CHAIRS AND OTTOMANS, BOOKCASES,
CHINA CABINETS, COFFEE TABLES, SOFA TABLES,
END TABLES, DINING TABLES, KITCHEN TABLES,
OCCASIONAL TABLES, ENTERTAINMENT CENTERS,
ETAGERES, BUFFETS, ARMOIRES, BEDS, HOLLY-
WOOD BEDS, HEADBOARDS, FOOTBOARDS, CHEST
OF DRAWERS, DRESSERS, CHESTS AND NIGHT-
STANDS; MIRRORS (U.S. CLS. 2, 13, 22, 25, 32 AND 50).
FIRST USE 10-19-2006; IN COMMERCE 10-19-2006.

3,632,448. HARTZ MOUNTAIN CORPORATION, THE, SE-
CAUCUS, NJ. SN 77-377,162. PUB. 7-22-2008, FILED 1-22-
2008.



OWNER OF U.S. REG. NOS. 2,524,782, 3,222,910, AND

CLASS 20—(Continued).

OTHERS.

NO CLAIM IS MADE TO THE EXCLUSIVE RIGHT TO USE "HOME DECOR", APART FROM THE MARK AS SHOWN.

THE MARK CONSISTS OF A DESIGN OF HALF A HOUSE DESIGN WITH THE WORDS "HARTZ" WITHIN A SQUARE ABOVE THE WORDS "HOME DECOR" ON THE RIGHT SIDE FOR THE HOUSE.

FOR BEDS FOR PETS (U.S. CLS. 2, 13, 22, 25, 32 AND 50).

FIRST USE 5-1-2008; IN COMMERCE 5-1-2008.

3,632,482. SYMBOL MATTRESS COMPANY, RICHMOND, VA. SN 77-390,346. PUB. 6-3-2008, FILED 2-6-2008.

NATURE'S SENSATIONS

THE MARK CONSISTS OF STANDARD CHARACTERS WITHOUT CLAIM TO ANY PARTICULAR FONT, STYLE, SIZE, OR COLOR.

FOR MATTRESSES (U.S. CLS. 2, 13, 22, 25, 32 AND 50).

FIRST USE 6-0-2008; IN COMMERCE 6-0-2008.

3,632,553. SONIC INTEGRITY CANADA LTD., MISSISSAUGA, ONTARIO, CANADA. SN 77-405,190. PUB. 7-15-2008, FILED 2-25-2008.

GAME ON

THE MARK CONSISTS OF STANDARD CHARACTERS WITHOUT CLAIM TO ANY PARTICULAR FONT, STYLE, SIZE, OR COLOR.

FOR SHELVES; SHELVES FOR STORAGE OF ELECTRONIC OR COMPUTER EQUIPMENT (U.S. CLS. 2, 13, 22, 25, 32 AND 50).

FIRST USE 10-31-2008; IN COMMERCE 3-31-2009.

3,632,728. SEALY TECHNOLOGY LLC, TRINITY, NC. SN 77-440,118. PUB. 7-8-2008, FILED 4-4-2008.

**INSPIRED BY NATURE.
PERFECTED BY TECHNOLOGY.**

THE MARK CONSISTS OF STANDARD CHARACTERS WITHOUT CLAIM TO ANY PARTICULAR FONT, STYLE, SIZE, OR COLOR.

FOR MATTRESSES; BOX SPRINGS (U.S. CLS. 2, 13, 22, 25, 32 AND 50).

FIRST USE 3-0-2008; IN COMMERCE 3-0-2008.

CLASS 20—(Continued).

3,632,768. AS IP HOLDCO, LLC, PISCATAWAY, NJ. SN 77-449,603. PUB. 7-22-2008, FILED 4-16-2008.

STUDIO

THE MARK CONSISTS OF STANDARD CHARACTERS WITHOUT CLAIM TO ANY PARTICULAR FONT, STYLE, SIZE, OR COLOR.

OWNER OF U.S. REG. NO. 3,002,495.

FOR BATHROOM VANITIES; BATHROOM CONSOLES; BATHROOM MIRRORS (U.S. CLS. 2, 13, 22, 25, 32 AND 50).

FIRST USE 2-1-2008; IN COMMERCE 2-1-2008.

3,632,857. JAZZI G, INC., SAN MARCOS, CA. SN 77-483,722. PUB. 10-28-2008, FILED 5-27-2008.



NO CLAIM IS MADE TO THE EXCLUSIVE RIGHT TO USE "GEL", APART FROM THE MARK AS SHOWN.

THE STIPPLING IS FOR SHADING PURPOSES ONLY.

THE MARK CONSISTS OF 3 HEXAGONS FOLLOWED BY THE WORDING "GEL LOGIC" IN GARAMOND BOOK FONT.

FOR MATTRESSES, NAMELY, POLYURETHANE, HIGH RESILIENCY URETHANE, FOAM AND GEL MATTRESSES; VISCO ELASTOMER AND GEL MATTRESSES, LATEX AND GEL MATTRESSES, AIR AND GEL MATTRESSES, SPRING AND GEL MATTRESSES; ADJUSTABLE MATTRESSES; AND MATTRESS TOPPERS (U.S. CLS. 2, 13, 22, 25, 32 AND 50).

FIRST USE 8-1-2008; IN COMMERCE 8-1-2008.

3,632,936. ADVANCED SLEEP CONCEPTS, INC., ROME, GA. SN 77-516,606. PUB. 12-2-2008, FILED 7-8-2008.

REST & RESTORE

THE MARK CONSISTS OF STANDARD CHARACTERS WITHOUT CLAIM TO ANY PARTICULAR FONT, STYLE, SIZE, OR COLOR.

FOR MATTRESSES (U.S. CLS. 2, 13, 22, 25, 32 AND 50).

FIRST USE 10-0-2008; IN COMMERCE 10-0-2008.

CLASS 20—(Continued).

3,632,955. M & JT INVESTMENTS, LLC, BOWLING GREEN, KY. SN 77-521,343. PUB. 12-9-2008, FILED 7-14-2008.

SLEEP ESSENCE
ESSENTIALS FOR A HEALTHY
LIFE

THE MARK CONSISTS OF STANDARD CHARACTERS WITHOUT CLAIM TO ANY PARTICULAR FONT, STYLE, SIZE, OR COLOR.

FOR BOX SPRINGS; MATTRESS TOPPERS; MATTRESSES; PILLOWS (U.S. CLS. 2, 13, 22, 25, 32 AND 50).
FIRST USE 8-18-2008; IN COMMERCE 8-28-2008.

3,632,986. SHERWIN-WILLIAMS COMPANY, THE, CLEVELAND, OH. SN 77-533,257. PUB. 12-23-2008, FILED 7-29-2008.

TRU-MIX

THE MARK CONSISTS OF STANDARD CHARACTERS WITHOUT CLAIM TO ANY PARTICULAR FONT, STYLE, SIZE, OR COLOR.

FOR DISPOSABLE, NON-ELECTRIC, INDUSTRIAL CARTRIDGES, NAMELY, PLASTIC CONTAINERS USED FOR MIXING AND DISPENSING PAINTS AND COATINGS (U.S. CLS. 2, 13, 22, 25, 32 AND 50).

FIRST USE 11-12-2008; IN COMMERCE 11-12-2008.

3,633,057. VIRCO MGMT. CORPORATION, TORRANCE, CA. SN 77-976,898. PUB. 6-10-2008, FILED 8-29-2007.

TEXT

THE MARK CONSISTS OF STANDARD CHARACTERS WITHOUT CLAIM TO ANY PARTICULAR FONT, STYLE, SIZE, OR COLOR.

FOR TABLES AND DESKS (U.S. CLS. 2, 13, 22, 25, 32 AND 50).

FIRST USE 11-4-2008; IN COMMERCE 11-4-2008.

CLASS 20—(Continued).

3,633,319. FERGUSON ENTERPRISES, INC., NEWPORT NEWS, VA. SN 78-969,443. PUB. 10-23-2007, FILED 9-7-2006.

RIVERS COLLECTION

THE MARK CONSISTS OF STANDARD CHARACTERS WITHOUT CLAIM TO ANY PARTICULAR FONT, STYLE, SIZE, OR COLOR.

NO CLAIM IS MADE TO THE EXCLUSIVE RIGHT TO USE "COLLECTION", APART FROM THE MARK AS SHOWN.

FOR BATHROOM VANITIES MADE OF STONE (U.S. CLS. 2, 13, 22, 25, 32 AND 50).

FIRST USE 2-1-2008; IN COMMERCE 2-1-2008.

CLASS 21—HOUSEWARES AND GLASS

3,631,938. HY CITE CORPORATION, MADISON, WI. SN 77-086,056. PUB. 11-20-2007, FILED 1-18-2007.

The Ultimate Culinary Experience

THE MARK CONSISTS OF STANDARD CHARACTERS WITHOUT CLAIM TO ANY PARTICULAR FONT, STYLE, SIZE, OR COLOR.

NO CLAIM IS MADE TO THE EXCLUSIVE RIGHT TO USE "THE", APART FROM THE MARK AS SHOWN.

FOR COOKING UTENSILS WITH PLASTIC HANDLES, NAMELY, LADLES, SKIMMERS, SOLID TURNERS, SLOTTED SERVING SPOONS, LADLES, SERVING FORKS, PASTA SERVERS AND SERVING SPATULAS; AND SOLID VEGETABLE MASHERS; BAKEWARE; STAINLESS STEEL SERVING UTENSILS, NAMELY, CAKE SERVERS, COLD MEAT FORKS, SALAD SERVING SPOONS, SALAD SERVING FORKS, SOLID SERVING SPOONS, SLOTTED SERVING SPOONS, LADLES, SERVING FORKS, PASTA SERVERS AND SERVING SPATULAS; COOKWARE, NAMELY, SAUCE PANS, SKILLETS, DUTCH OVENS, STEAMER/COLANDERS, FLAT AND DOME COVERS FOR POTS AND PANS; KITCHENWARE, NAMELY, COOKIE SHEETS, CAKE PANS, PIZZA PANS, OMELET PANS, SALAD SPINNERS, MIXING BOWLS, NON-ELECTRIC GRIDDLES; CHINA, NAMELY, DINNER PLATES, LUNCH PLATES, CUPS, SAUCERS, SERVING BOWLS, GRAVY BOATS AND PLATTERS; GLASS, DINNERWARE, NAMELY, GLASS DISHES, DINNER PLATES, LUNCH PLATES, CUPS, SAUCERS, SERVING BOWLS, GRAVY BOATS AND PLATTERS; CHINA AND PORCELAIN DINERWARE, NAMELY, PLATES AND BOWLS; AND GLASS BEVERAGE WARE; COOKWARE LIDS HAVING A WHISTLE WHICH SOUNDS WHEN THE COOKWARE REACHES THE PROPER TEMPERATURE; STAINLESS STEEL COOKWARE, NAMELY, POTS AND PANS (U.S. CLS. 2, 13, 23, 29, 30, 33, 40 AND 50).

FIRST USE 2-0-2007; IN COMMERCE 2-0-2007.

CLASS 21—(Continued).

3,631,956. RODIN, JOHN B., CHESTERLAND, OH. SN 77-101,150. PUB. 8-7-2007, FILED 2-7-2007.

CLASS 21—(Continued).

3,632,111. AEROGROW INTERNATIONAL, INC., BOULDER, CO. SN 77-229,682. PUB. 1-1-2008, FILED 7-13-2007.

tablewinks

AEROGARDEN

THE MARK CONSISTS OF STANDARD CHARACTERS WITHOUT CLAIM TO ANY PARTICULAR FONT, STYLE, SIZE, OR COLOR.

FOR KNIFE RESTS; NAPKIN HOLDERS; NAPKIN HOLDERS AND NAPKIN RINGS NOT OF PRECIOUS METAL; NAPKIN HOLDERS OF PRECIOUS METAL; SPOON RESTS; TABLE PLACE CARD HOLDERS NOT OF PRECIOUS METAL (U.S. CLS. 2, 13, 23, 29, 30, 33, 40 AND 50).

FIRST USE 4-11-2009; IN COMMERCE 4-11-2009.

THE MARK CONSISTS OF STANDARD CHARACTERS WITHOUT CLAIM TO ANY PARTICULAR FONT, STYLE, SIZE, OR COLOR.

FOR PLANT GROWING KIT COMPRISED PRIMARILY OF A PLANT GROWING POT AND ONE OR MORE OF THE FOLLOWING: GROW LIGHT FIXTURES, GROW BULBS, ELECTRONIC CONTROL PANEL, WATER PUMP, AIR PUMP, GROWING MEDIA, SEEDS FOR AGRICULTURAL PURPOSES, SEEDS FOR FLOWERS, SEEDS FOR FRUITS AND VEGETABLES, SEEDS FOR HERBS, SEEDS FOR HORTICULTURAL PURPOSES, PLANT NUTRIENTS, GROWING BASKETS, GERMINATION COVERS, PRINTED INSTRUCTIONS (U.S. CLS. 2, 13, 23, 29, 30, 33, 40 AND 50).

FIRST USE 3-1-2006; IN COMMERCE 3-1-2006.

3,632,088. IPOUR, LLC, CHARLOTTE, NC. SN 77-219,709. PUB. 8-19-2008, FILED 6-29-2007.

3,632,237. FUJIKURA LTD., TOKYO, JAPAN. SN 77-284,154. PUB. 7-15-2008, FILED 9-20-2007.

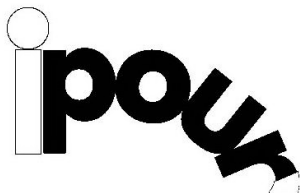

ONE-CLICK

THE MARK CONSISTS OF THE STYLIZED TEXT "IPOUR", SET IN A LOWERCASE SAN SERIF FONT WHERE THE "OUR" BEND DOWN ENABLING THE "R" TO POUR A GRAPHIC THAT REPRESENTS LIQUID.

FOR FLEXIBLE / DIRECTIONAL POUR CAP THAT DIRECTS FLUIDS FROM ONE CONTAINER TO ANOTHER ORIFICE OR CONTAINER FOR HOUSEHOLD AND AUTOMOTIVE USE (U.S. CLS. 2, 13, 23, 29, 30, 33, 40 AND 50).

FIRST USE 10-13-2005; IN COMMERCE 8-28-2007.

THE MARK CONSISTS OF STANDARD CHARACTERS WITHOUT CLAIM TO ANY PARTICULAR FONT, STYLE, SIZE, OR COLOR.

FOR OPTICAL FIBER CONNECTOR CLEANING CLOTHS (U.S. CLS. 2, 13, 23, 29, 30, 33, 40 AND 50).

FIRST USE 1-16-2008; IN COMMERCE 4-16-2008.

CLASS 21—(Continued).

3,632,322. BISSELL HOMECARE, INC., GRAND RAPIDS, MI.
SN 77-325,070. PUB. 4-8-2008, FILED 11-8-2007.



OWNER OF U.S. REG. NOS. 698,093, 878,197, AND OTHERS.

THE MARK CONSISTS OF AN ANGEL WITH A STAR ON HER HEAD, HOLDING A CARPET SWEEPER, SWEEPING OVER THE WORLD, WITH THE SUN DEPICTED WITH A SMILING FACE AND SUN RAYS BURSTING FORTH FROM THE SUN AND TREES IN THE BACKGROUND, ALL ENCLOSED IN A CIRCLE WITH A LAUREL SPRAY UNDERNEATH THE CIRCLE.

FOR NON-ELECTRIC CARPET SWEEPERS (U.S. CLS. 2, 13, 23, 29, 30, 33, 40 AND 50).

FIRST USE 0-0-1959; IN COMMERCE 4-3-2009.

3,632,374. EVRIHOLDER PRODUCTS, LLC, ANAHEIM, CA.
SN 77-346,995. PUB. 9-16-2008, FILED 12-7-2007.

GLAM-GLOVES

THE MARK CONSISTS OF STANDARD CHARACTERS WITHOUT CLAIM TO ANY PARTICULAR FONT, STYLE, SIZE, OR COLOR.

NO CLAIM IS MADE TO THE EXCLUSIVE RIGHT TO USE "GLOVES", APART FROM THE MARK AS SHOWN.

FOR HOUSEHOLD GLOVES FOR GENERAL USE (U.S. CLS. 2, 13, 23, 29, 30, 33, 40 AND 50).

FIRST USE 2-1-2008; IN COMMERCE 2-1-2008.

3,632,387. GRAHAM PACKAGING COMPANY, L.P., YORK, PA. SN 77-354,750. PUB. 5-20-2008, FILED 12-18-2007.

ESCAPE**CLASS 21—(Continued).**

THE MARK CONSISTS OF STANDARD CHARACTERS WITHOUT CLAIM TO ANY PARTICULAR FONT, STYLE, SIZE, OR COLOR.

FOR PLASTIC BOTTLES, SOLD EMPTY, FOR USE IN THE FOOD AND BEVERAGE, HOUSEHOLD AND PERSONAL CARE, AND AUTOMOTIVE INDUSTRIES (U.S. CLS. 2, 13, 23, 29, 30, 33, 40 AND 50).

FIRST USE 1-7-2008; IN COMMERCE 1-7-2008.

3,632,542. MAJOR LEAGUE BASEBALL PROPERTIES, INC., NEW YORK, NY. SN 77-403,519. PUB. 6-24-2008, FILED 2-22-2008.

BASEBALL FEVER

THE MARK CONSISTS OF STANDARD CHARACTERS WITHOUT CLAIM TO ANY PARTICULAR FONT, STYLE, SIZE, OR COLOR.

OWNER OF U.S. REG. NO. 1,230,519.

FOR FIGURINES MADE OF CERAMIC; CERAMIC VILLAGES, CERAMIC BUILDINGS, STRUCTURES AND FIGURINES; SCULPTURES, MINIATURE HOUSES AND STADIUM REPLICAS OF CERAMIC (U.S. CLS. 2, 13, 23, 29, 30, 33, 40 AND 50).

FIRST USE 3-0-2008; IN COMMERCE 3-0-2008.

3,632,549. GLASSAUTOMATIC INC., MOUNT PLEASANT, PA. SN 77-404,738. PUB. 7-8-2008, FILED 2-25-2008.

POURSURE

THE MARK CONSISTS OF STANDARD CHARACTERS WITHOUT CLAIM TO ANY PARTICULAR FONT, STYLE, SIZE, OR COLOR.

FOR BEVERAGE GLASSWARE, NAMELY, WINE GLASSES, STEMWARE, CORDIAL GLASSES, BRANDY SNIFTERS, LIQUOR GLASSES, LIQUEUR GLASSES, AND CHAMPAGNE FLUTES; AND BEVERAGE GLASSWARE (U.S. CLS. 2, 13, 23, 29, 30, 33, 40 AND 50).

FIRST USE 3-30-2009; IN COMMERCE 3-30-2009.

CLASS 21—(Continued).

3,632,579. THE HARTZ MOUNTAIN CORPORATION, SECAUCUS, NJ. SN 77-409,744. PUB. 8-5-2008, FILED 2-29-2008.

HARTZ FRESHENING BRUSH

THE MARK CONSISTS OF STANDARD CHARACTERS WITHOUT CLAIM TO ANY PARTICULAR FONT, STYLE, SIZE, OR COLOR.

OWNER OF U.S. REG. NOS. 2,524,782, 3,222,910, AND OTHERS.

NO CLAIM IS MADE TO THE EXCLUSIVE RIGHT TO USE "FRESHENING BRUSH", APART FROM THE MARK AS SHOWN.

FOR BRUSHES WITH PRE-MOISTENED CLOTH FOR PETS (U.S. CLS. 2, 13, 23, 29, 30, 33, 40 AND 50).

FIRST USE 1-0-2007; IN COMMERCE 1-0-2007.

3,632,630. BIOSENSORY, INC., PUTNAM, CT. SN 77-416,422. PUB. 7-22-2008, FILED 3-7-2008.

NIGHT WATCH

THE MARK CONSISTS OF STANDARD CHARACTERS WITHOUT CLAIM TO ANY PARTICULAR FONT, STYLE, SIZE, OR COLOR.

FOR BED BUG TRAPS, MOSQUITO TRAPS, INSECT TRAPS, PEST TRAPS (U.S. CLS. 2, 13, 23, 29, 30, 33, 40 AND 50).

FIRST USE 7-31-2008; IN COMMERCE 7-31-2008.

3,632,632. LEVINE, STEPHEN K., FAR HILLS, NJ. SN 77-416,631. PUB. 11-25-2008, FILED 3-7-2008.

CLEAN TRAX

THE MARK CONSISTS OF STANDARD CHARACTERS WITHOUT CLAIM TO ANY PARTICULAR FONT, STYLE, SIZE, OR COLOR.

FOR SHOE COVER DISPENSERS (U.S. CLS. 2, 13, 23, 29, 30, 33, 40 AND 50).

FIRST USE 7-0-2006; IN COMMERCE 7-0-2006.

CLASS 21—(Continued).

3,632,688. BARENTHAL NORTH AMERICA, INC., RUTHERFORD, NJ. SN 77-431,633. PUB. 8-5-2008, FILED 3-26-2008.

GOURMET SELECT

THE MARK CONSISTS OF STANDARD CHARACTERS WITHOUT CLAIM TO ANY PARTICULAR FONT, STYLE, SIZE, OR COLOR.

NO CLAIM IS MADE TO THE EXCLUSIVE RIGHT TO USE "SELECT", APART FROM THE MARK AS SHOWN.

FOR COOKWARE AND KITCHEN EQUIPMENT, NAMELY, POTS, PANS, NAMELY, SERVING TRAYS NOT MADE OF PRECIOUS METAL AND BAKING DISHES (U.S. CLS. 2, 13, 23, 29, 30, 33, 40 AND 50).

FIRST USE 5-26-2008; IN COMMERCE 5-26-2008.

3,632,829. CHITAYAT, DAVID, SHANGHAI, CHINA. SN 77-473,779. PUB. 10-14-2008, FILED 5-13-2008.

Full Circle

THE MARK CONSISTS OF STANDARD CHARACTERS WITHOUT CLAIM TO ANY PARTICULAR FONT, STYLE, SIZE, OR COLOR.

FOR LOOFAHS FOR HOUSEHOLD PURPOSES; SCRAPERS FOR HOUSEHOLD PURPOSES; SPONGES FOR HOUSEHOLD PURPOSES; FLOOR BRUSHES; MUSHROOM BRUSHES; POT CLEANING BRUSHES; SCRAPING BRUSHES; SCRUBBING BRUSHES; TUB BRUSHES; WASHING BRUSHES; CLEANING AND POLISHING CLOTHS; CLEANING PADS; CLEANING SPONGES; DUSTING OR CLEANING CLOTHS; MITTS OF FABRIC FOR CLEANING; SCOURING SPONGES; SCRUB SPONGES; TOILET SPONGES (U.S. CLS. 2, 13, 23, 29, 30, 33, 40 AND 50).

FIRST USE 1-12-2009; IN COMMERCE 3-22-2009.

3,632,902. JAME UGONE, TOPSFIELD, MA. SN 77-504,230. PUB. 11-25-2008, FILED 6-20-2008.

THE U CAN

THE MARK CONSISTS OF STANDARD CHARACTERS WITHOUT CLAIM TO ANY PARTICULAR FONT, STYLE, SIZE, OR COLOR.

NO CLAIM IS MADE TO THE EXCLUSIVE RIGHT TO USE "CAN", APART FROM THE MARK AS SHOWN.

FOR WATERING CANS (U.S. CLS. 2, 13, 23, 29, 30, 33, 40 AND 50).

FIRST USE 3-1-2009; IN COMMERCE 3-1-2009.

CLASS 21—(Continued).

3,632,917. PATTIE BROCKWELL, DRACUT, MA. AND STEPHEN JESUS, DRACUT, MA. SN 77-511,158. PUB. 11-25-2008, FILED 6-30-2008.

dumpster dome

THE MARK CONSISTS OF STANDARD CHARACTERS WITHOUT CLAIM TO ANY PARTICULAR FONT, STYLE, SIZE, OR COLOR.

NO CLAIM IS MADE TO THE EXCLUSIVE RIGHT TO USE "DUMPSTER", APART FROM THE MARK AS SHOWN. FOR FITTED TRASH RECEPTACLE COVERS (U.S. CLS. 2, 13, 23, 29, 30, 33, 40 AND 50).

FIRST USE 3-28-2009; IN COMMERCE 3-28-2009.

3,632,974. VILLAGE PANTRY, LLC, INDIANAPOLIS, IN. SN 77-527,427. PUB. 11-4-2008, FILED 7-21-2008.

VP CHILLER

THE MARK CONSISTS OF STANDARD CHARACTERS WITHOUT CLAIM TO ANY PARTICULAR FONT, STYLE, SIZE, OR COLOR.

NO CLAIM IS MADE TO THE EXCLUSIVE RIGHT TO USE "CHILLER", APART FROM THE MARK AS SHOWN. FOR THERMAL INSULATED BAGS FOR FOOD OR BEVERAGES (U.S. CLS. 2, 13, 23, 29, 30, 33, 40 AND 50).

FIRST USE 3-1-2009; IN COMMERCE 3-1-2009.

3,633,031. AEROGROW INTERNATIONAL, INC., BOULDER, CO. SN 77-550,915. PUB. 1-13-2009, FILED 8-19-2008.

HERB 'N SAVE

THE MARK CONSISTS OF STANDARD CHARACTERS WITHOUT CLAIM TO ANY PARTICULAR FONT, STYLE, SIZE, OR COLOR.

FOR PLASTIC STORAGE CONTAINERS FOR HOUSEHOLD USE, NAMELY, PLASTIC CONTAINERS FOR STORING HARVESTED EDIBLE PLANTS SUCH AS HERBS AND FLOWERS (U.S. CLS. 2, 13, 23, 29, 30, 33, 40 AND 50).

FIRST USE 8-19-2008; IN COMMERCE 4-1-2009.

CLASS 21—(Continued).

3,633,080. STERLING INTERNATIONAL INC., SPOKANE, WA. SN 77-977,119. PUB. 3-18-2008, FILED 5-24-2007.

W·H·Y

THE MARK CONSISTS OF STYLIZED LETTERS "WHY". FOR INSECT TRAPS; PEST CONTROL TRAPS (U.S. CLS. 2, 13, 23, 29, 30, 33, 40 AND 50).

FIRST USE 12-22-2008; IN COMMERCE 12-22-2008.

3,633,090. NATIONAL GEOGRAPHIC SOCIETY, WASHINGTON, DC. SN 78-308,612. PUB. 8-9-2005, FILED 10-2-2003.

INSPIRED BY THE WORLD

FOR PLATES; BOWLS; PORCELAIN FIGURINES; HOLIDAY ORNAMENTS MADE OF CHINA, CRYSTAL, GLASS, PORCELAIN OR TERRA COTTA; SERVING TRAYS, NOT MADE OF PRECIOUS METAL; CANDLE HOLDERS, NOT MADE OF PRECIOUS METAL; BIRD-FEEDERS; BIRD HOUSES, NOT BEING STRUCTURES; BIRD BATHS, NOT BEING STRUCTURES; STATUARY MADE OF CHINA, CRYSTAL, EARTHENWARE, GLASS, PORCELAIN OR TERRA COTTA; TRAYS; DECORATIVE PLATES; DECORATIVE PLATTERS; DECORATIVE JARS; PLATE STANDS; DECORATIVE BOWLS; TRAY STANDS; PLANTERS; DECORATIVE CONTAINERS; NATURAL FIBER BOWLS, TRAYS; HAND PAINTED BATHROOM ACCESSORIES, NAMELY, TOWEL BARS, TOWEL RINGS, TISSUE HOLDERS, SOAP DISHES, SHAVING DISHES, TOOTHBRUSH HOLDERS, TUMBLED (U.S. CLS. 2, 13, 23, 29, 30, 33, 40 AND 50).

FIRST USE 4-0-2004; IN COMMERCE 4-0-2004.

3,633,144. TOPCO ASSOCIATES, LLC, SKOKIE, IL. SN 78-612,855. PUB. 1-10-2006, FILED 4-20-2005.

SUPREME ELEGANCE

THE MARK CONSISTS OF STANDARD CHARACTERS WITHOUT CLAIM TO ANY PARTICULAR FONT, STYLE, SIZE, OR COLOR.

FOR DESIGNER PAPER PLATES, BOWLS AND CUPS (U.S. CLS. 2, 13, 23, 29, 30, 33, 40 AND 50).

FIRST USE 4-1-2009; IN COMMERCE 4-1-2009.

CLASS 23—YARNS AND THREADS

CLASS 23—(Continued).

3,632,709. NOTIONS MARKETING CORPORATION,
GRAND RAPIDS, MI. SN 77-434,071. PUB. 8-19-2008,
FILED 3-28-2008.

MELROSE

THE MARK CONSISTS OF STANDARD CHARACTERS
WITHOUT CLAIM TO ANY PARTICULAR FONT, STYLE,
SIZE, OR COLOR.

FOR TRILOBAL POLYESTER EMBROIDERING
THREAD (U.S. CL. 43).
FIRST USE 5-1-2008; IN COMMERCE 5-1-2008.

CLASS 24—(Continued).

3,632,002. DOWN LITE INTERNATIONAL, MASON, OH. SN
77-155,000. PUB. 8-5-2008, FILED 4-12-2007.

SUREGRIP

THE MARK CONSISTS OF STANDARD CHARACTERS
WITHOUT CLAIM TO ANY PARTICULAR FONT, STYLE,
SIZE, OR COLOR.

FOR MATTRESS PADS; BED-SKIRTING MATERIAL
USED AS A COMPONENT OF MATTRESS PADS (U.S.
CLS. 42 AND 50).

FIRST USE 9-0-2007; IN COMMERCE 9-0-2007.

3,633,226. KP-CHEMICAL CORP., DONGJAK-GU, SEOUL,
REPUBLIC OF KOREA. SN 78-787,549. PUB. 6-19-2007,
FILED 1-9-2006.

LOTTE

THE MARK CONSISTS OF STANDARD CHARACTERS
WITHOUT CLAIM TO ANY PARTICULAR FONT, STYLE,
SIZE, OR COLOR.

FOR SILK BASED MIXED THREAD AND YARN,
COVERED RUBBER THREAD AND YARN FOR TEXTILE
USE, COTTON THREAD AND YARN, WASTE
COTTON YARN, LINEN THREAD AND YARN, FLAX
THREAD AND YARN, SYNTHETIC FIBER THREAD
AND YARN FOR TEXTILE USE, INORGANIC FIBER
BASE MIXED THREAD AND YARN, THREAD OF
PLASTIC MATERIALS FOR TEXTILE USE, PLASTIC
THREAD AND YARN FOR TEXTILE USE, AND SPUN
WOOL (U.S. CL. 43).

FIRST USE 7-1-2006; IN COMMERCE 7-1-2006.

3,632,543. SUNBEAM PRODUCTS, INC., BOCA RATON, FL.
SN 77-403,522. PUB. 7-8-2008, FILED 2-22-2008.

Comfy Toes

THE MARK CONSISTS OF STANDARD CHARACTERS
WITHOUT CLAIM TO ANY PARTICULAR FONT, STYLE,
SIZE, OR COLOR.

NO CLAIM IS MADE TO THE EXCLUSIVE RIGHT TO
USE "TOES", APART FROM THE MARK AS SHOWN.

FOR HEATED MATTRESS PAD FOR FOOT WARM-
ING (U.S. CLS. 42 AND 50).

FIRST USE 9-30-2008; IN COMMERCE 9-30-2008.

CLASS 24—FABRICS

3,631,847. GOODDINE, RICHARD, DECATUR, GA. SN 76-
686,819. PUB. 7-29-2008, FILED 2-14-2008.

Travel Sham

THE MARK CONSISTS OF STANDARD CHARACTERS
WITHOUT CLAIM TO ANY PARTICULAR FONT, STYLE,
SIZE, OR COLOR.

NO CLAIM IS MADE TO THE EXCLUSIVE RIGHT TO
USE "SHAM", APART FROM THE MARK AS SHOWN.

FOR PILLOW SHAMS (U.S. CLS. 42 AND 50).
FIRST USE 11-5-2008; IN COMMERCE 12-15-2008.

3,632,585. TRIANGLE HOME FASHIONS LLC, CRANBURY,
NJ. SN 77-410,425. PUB. 7-15-2008, FILED 2-29-2008.

EXPRESS

THE MARK CONSISTS OF STANDARD CHARACTERS
WITHOUT CLAIM TO ANY PARTICULAR FONT, STYLE,
SIZE, OR COLOR.

FOR BED AND TABLE LINEN, WALL HANGINGS OF
TEXTILE; HOUSEHOLD LINEN; BED BLANKETS; BED
CANOPIES; BED SHEETS; BED SKIRTS; BED SPREADS;
FEATHER BEDS; BATH LINEN; BATH SHEETS; BATH
TOWELS; THROWS; KITCHEN LINENS; KITCHEN TO-
WELS; CURTAINS; SHOWER CURTAINS; WINDOW
CURTAINS; COMFORTERS; DRAPERIES; DUVETS; PIL-
LOW CASES; PILLOW COVERS; PILLOW SHAMS;
QUILTS; SHAMS; TABLE NAPKINS OF TEXTILE;
CUSHION COVERS; MATTRESS COVERS; UNFITTED
FABRIC FURNITURE COVERS (U.S. CLS. 42 AND 50).

FIRST USE 12-31-2008; IN COMMERCE 12-31-2008.

CLASS 24—(Continued).

3,632,721. WRANGLER APPAREL CORP., WILMINGTON, DE. SN 77-437,527. PUB. 7-22-2008, FILED 4-2-2008.

WRANGLER

THE MARK CONSISTS OF STANDARD CHARACTERS WITHOUT CLAIM TO ANY PARTICULAR FONT, STYLE, SIZE, OR COLOR.

OWNER OF U.S. REG. NOS. 1,075,094, 1,259,491, AND OTHERS.

FOR BLANKET THROWS; CHILDREN'S BLANKETS (U.S. CLS. 42 AND 50).

FIRST USE 1-28-2008; IN COMMERCE 1-28-2008.

CLASS 24—(Continued).

3,632,850. SHEEX, LLC, MYRTLE BEACH, SC. SN 77-481,626. PUB. 11-11-2008, FILED 5-22-2008.



THE MARK CONSISTS OF MIRROR IMAGES OF GENERALLY A CRESCENT SHAPE THAT RESEMBLES THE LETTER "X".

FOR PILLOW CASES; PILLOW COVERS; BED SHEETS; BED LINEN (U.S. CLS. 42 AND 50).

FIRST USE 10-31-2007; IN COMMERCE 10-31-2007.

3,632,848. SHEEX, LLC, MYRTLE BEACH, SC. SN 77-481,615. PUB. 11-18-2008, FILED 5-22-2008.

SHEEX PERFORMANCE SHEETS

THE MARK CONSISTS OF STANDARD CHARACTERS WITHOUT CLAIM TO ANY PARTICULAR FONT, STYLE, SIZE, OR COLOR.

NO CLAIM IS MADE TO THE EXCLUSIVE RIGHT TO USE "PERFORMANCE SHEETS", APART FROM THE MARK AS SHOWN.

FOR PILLOW CASES; PILLOW COVERS; BED SHEETS; BED LINEN (U.S. CLS. 42 AND 50).

FIRST USE 10-31-2007; IN COMMERCE 10-31-2007.

3,633,126. MIGLUS DESIGN, INC., PROVIDENCE, RI. SN 78-567,358. PUB. 12-20-2005, FILED 2-15-2005.

WOVEN ANIMATION

3,632,849. SHEEX, LLC, MYRTLE BEACH, SC. SN 77-481,623. PUB. 11-11-2008, FILED 5-22-2008.

SHEEX

THE MARK CONSISTS OF STANDARD CHARACTERS WITHOUT CLAIM TO ANY PARTICULAR FONT, STYLE, SIZE, OR COLOR.

FOR PILLOW CASES; PILLOW COVERS; BED SHEETS; BED LINEN (U.S. CLS. 42 AND 50).

FIRST USE 10-31-2007; IN COMMERCE 10-31-2007.

THE MARK CONSISTS OF STANDARD CHARACTERS WITHOUT CLAIM TO ANY PARTICULAR FONT, STYLE, SIZE, OR COLOR.

NO CLAIM IS MADE TO THE EXCLUSIVE RIGHT TO USE "WOVEN", APART FROM THE MARK AS SHOWN.

FOR WOVEN FABRICS (U.S. CLS. 42 AND 50).

FIRST USE 3-13-2009; IN COMMERCE 3-13-2009.

CLASS 24—(Continued).

3,633,200. OM BRANDS LICENSIVE LICENCIAMENTOS LTDA., RIO DE JANEIRO, CEP 20940-180 - RJ, BRAZIL. SN 78-744,712. PUB. 1-23-2007, FILED 11-1-2005.



FOR COTTON CLOTH; COTTON BASE MIXED CLOTH (U.S. CLS. 42 AND 50).
FIRST USE 1-0-2008; IN COMMERCE 1-0-2008.

CLASS 25—(Continued).

3,631,786. PIERRE BALMAIN SA, 75008 PARIS, FRANCE. SN 75-862,119. PUB. 7-22-2008, FILED 12-1-1999.

BALMAIN

OWNER OF FRANCE REG. NO. 99776880, DATED 2-16-1999, RENEWED AS REG. NO. 99776880, DATED 2-16-2009, EXPIRES 2-16-2019.

OWNER OF U.S. REG. NOS. 699,890, 1,787,916, AND OTHERS.

FOR CLOTHING CONSISTING OF ACTIVE WEAR, NAMELY, SWEAT PANTS AND SWEAT SHIRTS; SPORTS WEAR, NAMELY, SHORTS, SHIRTS AND SPORT COATS; CASUAL WEAR, NAMELY, SLACKS, DRESSES, JACKETS, MEN'S PANTS AND SHORTS, OPEN BOTTOM ALTERABLE DRESS PANTS, SUITS AND TOPCOATS; FORMAL WEAR, NAMELY, EVENING GOWNS AND TUXEDOS; KNITWEAR, NAMELY, SKIRTS, SHIRTS, SWEATERS; SLEEPWEAR; UNDERWEAR; LEATHER WEAR, NAMELY, JACKETS, BELTS, SHOES, BOOTS AND COATS; RAIN WEAR; SWIMMING WEAR; SHIRTS; SHORTS; SKIRTS; PANTS; DRESSES; SWEATSUITS; RAINCOATS; JACKETS; COATS; SHOES; BOOTS; HATS AND HEAD WEAR; SOCKS; HOISERY; SCARVES; FUR JACKETS AND COATS; FUR STOLEES; BELTS; TIES (U.S. CLS. 22 AND 39).
FIRST USE 1-0-2007; IN COMMERCE 1-0-2007.

3,631,793. XNATION INC., SALT LAKE CITY, UT. SN 76-609,161. PUB. 1-10-2006, FILED 8-25-2004.

BLACK ANGEL

THE MARK CONSISTS OF STANDARD CHARACTERS WITHOUT CLAIM TO ANY PARTICULAR FONT, STYLE, SIZE, OR COLOR.

FOR CLOTHING, HEADGEAR AND RELATED PRODUCTS, NAMELY, HATS, CAPS, AND T-SHIRTS (U.S. CLS. 22 AND 39).

FIRST USE 10-11-2003; IN COMMERCE 10-11-2003.

3,633,275. WARD, JOHNNY, COLLEGE STATION, TX. SN 78-896,076. PUB. 1-9-2007, FILED 5-30-2006.

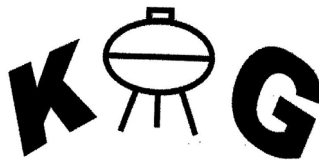

THE MARK CONSISTS OF THE LETTERS "KOG" WITH THE "O" BEING FORMED BY A BARBECUE GRILL. FOR BARBECUE MITTS (U.S. CLS. 42 AND 50).
FIRST USE 10-2-2008; IN COMMERCE 10-2-2008.

3,631,815. FLIGHT CLUB LOS ANGELES, LTD., LOS ANGELES, CA. SN 76-669,858. PUB. 6-26-2007, FILED 12-4-2006.

FCLA

THE MARK CONSISTS OF STANDARD CHARACTERS WITHOUT CLAIM TO ANY PARTICULAR FONT, STYLE, SIZE, OR COLOR.

FOR HEAD WEAR, JACKETS, SHIRTS, TSHIRTS, SOCKS (U.S. CLS. 22 AND 39).

FIRST USE 9-0-2006; IN COMMERCE 9-0-2006.

CLASS 25—CLOTHING

CLASS 25—(Continued).

3,631,871. AMOS, PEGGY B., SARASOTA, FL. SN 77-009,891.
PUB. 6-26-2007, FILED 9-28-2006.



THE MARK CONSISTS OF THE LETTER "I" IN WHICH THE SILHOUETTE OF A MAN IS STANDING IN FRONT OF SOME BUILDINGS. UNDER THE LETTER "I" IS THE WORD "STAND". UNDER THE WORD STAND IS THE WORD "FOR". INSIDE THE "O" OF "FOR" ARE THE UPPER-CASE LETTERS "ISF".

FOR T-SHIRTS, TANK TOPS, SWEATSHIRTS (U.S. CLS. 22 AND 39).

FIRST USE 1-5-2007; IN COMMERCE 1-5-2007.

3,631,892. GIMASGIRLS, LLC, MANCHESTER, NH. SN 77-038,389. PUB. 8-21-2007, FILED 11-7-2006.

STOKETHEGLOW

THE MARK CONSISTS OF STANDARD CHARACTERS WITHOUT CLAIM TO ANY PARTICULAR FONT, STYLE, SIZE, OR COLOR.

FOR CLOTHING, NAMELY, SHIRTS, T-SHIRTS AND POLO SHIRTS (U.S. CLS. 22 AND 39).

FIRST USE 6-0-2007; IN COMMERCE 6-0-2007.

CLASS 25—(Continued).

3,631,909. CLARK, KEVIN V., CARPINTERIA, CA. SN 77-059,696. PUB. 7-10-2007, FILED 12-7-2006.

On Planet Me

THE MARK CONSISTS OF STANDARD CHARACTERS WITHOUT CLAIM TO ANY PARTICULAR FONT, STYLE, SIZE, OR COLOR.

FOR CLOTHING, NAMELY, SHIRTS, SHORTS, T-SHIRTS, SWEATSHIRTS, JACKETS, CAPS, HATS (U.S. CLS. 22 AND 39).

FIRST USE 11-21-2008; IN COMMERCE 11-21-2008.

3,631,929. BYER CALIFORNIA, SAN FRANCISCO, CA. SN 77-079,980. PUB. 7-8-2008, FILED 1-10-2007.

BRANNAN

THE MARK CONSISTS OF STANDARD CHARACTERS WITHOUT CLAIM TO ANY PARTICULAR FONT, STYLE, SIZE, OR COLOR.

FOR CLOTHING, NAMELY, DRESSES, SKIRTS, BLOUSES, SKORTS, SHORTS, SHIRTS, PANTS, JACKETS, SWEATERS, VESTS AND JUMPSUITS (U.S. CLS. 22 AND 39).

FIRST USE 3-30-2007; IN COMMERCE 3-30-2007.

3,631,944. ALLIANT TECHSYSTEMS INC., MINNEAPOLIS, MN. SN 77-092,296. PUB. 7-1-2008, FILED 1-26-2007.



THE MARK CONSISTS OF THE WORDS "FORCE ON FORCE" WITH THE "O" HAVING A TARGET DESIGN, ALL OVERLAYING DISTINCTIVE IMAGES IN THE BACKGROUND.

FOR CLOTHING, NAMELY, PANTS, GLOVES, SHIRTS, AND JACKETS; HEADWEAR (U.S. CLS. 22 AND 39).

FIRST USE 11-0-2007; IN COMMERCE 2-1-2008.

CLASS 25—(Continued).

3,631,949. GABRIEL, LEONARD JR., VANCOUVER, WA. SN 77-094,948. PUB. 1-22-2008, FILED 1-30-2007.

FISTICUFFS

THE MARK CONSISTS OF STANDARD CHARACTERS WITHOUT CLAIM TO ANY PARTICULAR FONT, STYLE, SIZE, OR COLOR.

FOR CLOTHING, NAMELY, T-SHIRTS, SWEAT-SHIRTS, SWEAT SUITS, HOODED SWEAT SHIRTS, AND HATS (U.S. CLS. 22 AND 39).

FIRST USE 4-12-2009; IN COMMERCE 4-12-2009.



3,631,952. KIM, JEAN S., VENICE, CA. SN 77-097,417. PUB. 3-11-2008, FILED 2-1-2007.

Rabbit Kinney

THE MARK CONSISTS OF STANDARD CHARACTERS WITHOUT CLAIM TO ANY PARTICULAR FONT, STYLE, SIZE, OR COLOR.

FOR CAPS; HATS; CHILDREN'S HEADWEAR; T-SHIRTS; CHILDREN'S AND INFANTS' CLOTH BIBS; JACKETS; INFANT AND TODDLER ONE PIECE CLOTHING; PANTS (U.S. CLS. 22 AND 39).

FIRST USE 5-31-2007; IN COMMERCE 5-31-2007.



3,631,968. AFTERIMAGE, LLC, WATERFORD, WI. SN 77-116,204. PUB. 8-21-2007, FILED 2-26-2007.

PINEAPPLE BOWL

THE MARK CONSISTS OF STANDARD CHARACTERS WITHOUT CLAIM TO ANY PARTICULAR FONT, STYLE, SIZE, OR COLOR.

FOR POLO SHIRTS; SHORT-SLEEVED OR LONG-SLEEVED T-SHIRTS; SWEAT SHIRTS; SWEAT SHORTS (U.S. CLS. 22 AND 39).

FIRST USE 5-10-2008; IN COMMERCE 5-10-2008.

CLASS 25—(Continued).

3,631,981. MARC SOREL, RUMFORD, RI. AND RACHEL NOAH, RUMFORD, RI. SN 77-129,819. PUB. 8-5-2008, FILED 3-13-2007.



THE MARK CONSISTS OF A SMILEY FACE WITH THE WORD "HAPPILY" ABOVE THE SMILEY FACE, AND THE WORD "DIVORCED" WITH AN EXCLAMATION POINT BELOW THE SMILEY FACE.

FOR CLOTHING, NAMELY, T-SHIRTS, TANK TOPS, SPORT SHIRTS, SWEATSHIRTS, SWEAT SHORTS, SWEAT PANTS, SWEAT SOCKS, JACKETS, SWEATERS, SCARVES, NIGHT SHIRTS, PAJAMAS, UNDERWEAR, AND BASEBALL CAPS (U.S. CLS. 22 AND 39).

FIRST USE 4-6-2009; IN COMMERCE 4-6-2009.



3,632,003. THE CARTOON NETWORK, INC., ATLANTA, GA. SN 77-155,834. PUB. 9-11-2007, FILED 4-13-2007.

THE DRINKY CROW SHOW

THE MARK CONSISTS OF STANDARD CHARACTERS WITHOUT CLAIM TO ANY PARTICULAR FONT, STYLE, SIZE, OR COLOR.

FOR T-SHIRTS (U.S. CLS. 22 AND 39).

FIRST USE 1-29-2009; IN COMMERCE 1-29-2009.

CLASS 25—(Continued).

3,632,017. YA FASHION, INC., MONTEREY PARK, CA. SN 77-163,601. PUB. 8-12-2008, FILED 4-23-2007.



NO CLAIM IS MADE TO THE EXCLUSIVE RIGHT TO USE "YA FASHION", APART FROM THE MARK AS SHOWN.

THE COLOR(S) BLUE, GREEN, YELLOW, RED, WHITE, BLACK AND BROWN IS/ARE CLAIMED AS A FEATURE OF THE MARK.

THE MARK CONSISTS OF A YELLOW MOON, A YELLOW AND WHITE SUN OUTLINED IN RED, A YELLOW, WHITE AND BROWN SHIP, GREEN LAND, BLUE WATER, BLUE SKY, WHITE STARS, WHITE CLOUD, BLACK AND WHITE PLANE, WHITE, YELLOW AND BLUE TRAIN, A GREEN SHEEP OUTLINED IN BLACK, A GREEN GOAT OUTLINED IN BLACK, BLUE AND WHITE CLOUDS, THE WORDING "FASHION" IN RED AND THE WORDING "YA" IN YELLOW, OUTLINED IN RED.

FOR PANTS, JEANS, SHIRT, DRESS, SKIRT, SUIT, JACKET AND COAT (U.S. CLS. 22 AND 39).

FIRST USE 6-1-2006; IN COMMERCE 6-1-2006.

3,632,020. HERMAN KAY COMPANY, INC., NEW YORK, NY. SN 77-165,146. PUB. 10-23-2007, FILED 4-25-2007.

AQUA SHIELD

THE MARK CONSISTS OF STANDARD CHARACTERS WITHOUT CLAIM TO ANY PARTICULAR FONT, STYLE, SIZE, OR COLOR.

FOR CLOTHING, NAMELY, MEN'S AND WOMEN'S COATS AND JACKETS (U.S. CLS. 22 AND 39).

FIRST USE 3-25-2007; IN COMMERCE 3-25-2007.

CLASS 25—(Continued).

3,632,057. SYL, LLC, WILMINGTON, DE. SN 77-196,931. PUB. 7-1-2008, FILED 6-4-2007.

SYMS LABELS YOU KNOW AT PRICES YOU WANT

THE MARK CONSISTS OF STANDARD CHARACTERS WITHOUT CLAIM TO ANY PARTICULAR FONT, STYLE, SIZE, OR COLOR.

OWNER OF U.S. REG. NOS. 1,047,869, 1,358,576, AND OTHERS.

FOR WEARING APPAREL FOR MEN, LADIES, BOYS AND GIRLS, NAMELY, SUITS, DRESSES, TIES, FORMAL WEAR, SKIRTS, PANTS, SHIRTS, SLACKS, BLOUSES, COATS, JACKETS, SHOES (U.S. CLS. 22 AND 39).

FIRST USE 3-27-2007; IN COMMERCE 3-27-2007.

3,632,061. NAN YANG FABRIC CO., LTD, AMBOL KHOA-YOI, THAILAND. SN 77-200,243. PUB. 1-15-2008, FILED 6-7-2007.

GREEN-TECH

THE MARK CONSISTS OF STANDARD CHARACTERS WITHOUT CLAIM TO ANY PARTICULAR FONT, STYLE, SIZE, OR COLOR.

FOR JACKETS AND T-SHIRTS (U.S. CLS. 22 AND 39).

FIRST USE 11-30-2008; IN COMMERCE 11-30-2008.

3,632,078. THORNE, CHRISTAN, ATLANTA, GA. SN 77-215,089. PUB. 12-4-2007, FILED 6-25-2007.

Korporate Kutie

THE MARK CONSISTS OF STANDARD CHARACTERS WITHOUT CLAIM TO ANY PARTICULAR FONT, STYLE, SIZE, OR COLOR.

FOR HATS; JACKETS; PANTS; SHIRTS; SUITS; T-SHIRTS (U.S. CLS. 22 AND 39).

FIRST USE 5-7-2007; IN COMMERCE 7-10-2007.

CLASS 25—(Continued).

3,632,084. OLSEN, MATTHEW E., NEWPORT BEACH, CA. SN 77-217,410. PUB. 8-5-2008, FILED 6-27-2007.



THE MARK CONSISTS OF A HUMAN SKULL WITH THE SKULL'S RIGHT EYE IN THE SHAPE OF A GEAR.
FOR CLOTHING, NAMELY, TOPS, SHIRTS, SWEATSHIRTS, T-SHIRTS, TANK TOPS; HATS, CAPS AND BEANIES (U.S. CLS. 22 AND 39).
FIRST USE 11-10-2008; IN COMMERCE 11-10-2008.

3,632,104. KNOG PTY LTD, RICHMOND, AUSTRALIA. SN 77-227,616. PUB. 12-25-2007, FILED 7-12-2007.

KNOG

THE MARK CONSISTS OF STANDARD CHARACTERS WITHOUT CLAIM TO ANY PARTICULAR FONT, STYLE, SIZE, OR COLOR.
FOR CLOTHING, NAMELY, HAND-WARMERS; CLOTHING, NAMELY, KNEE WARMERS; CLOTHING, NAMELY, NECK TUBES; SWEATERS; SHIRTS; PANTS; CAPS; HATS; SOCKS; SNEAKERS; FOOTWEAR (U.S. CLS. 22 AND 39).
FIRST USE 3-1-2008; IN COMMERCE 3-1-2008.

CLASS 25—(Continued).

3,632,115. DEBRA E. ORTIZ, FELTON, CA. SN 77-230,847. PUB. 6-24-2008, FILED 7-16-2007.



THE MARK CONSISTS OF THE WORDS "GET UP & WALK EVERYDAY", WITH THE AMPERSAND SYMBOL DESIGNED AS A PERSON WALKING.
FOR CLOTHING FOR WALKING AND SPORTS ACTIVITIES, NAMELY, T-SHIRTS, SWEATSHIRTS, WALKING SHORTS AND PANTS; FOOTWEAR, NAMELY, SOCKS; HEADWEAR, NAMELY, HATS, CAPS AND VISORS (U.S. CLS. 22 AND 39).
FIRST USE 9-4-2007; IN COMMERCE 1-24-2009.

3,632,137. HORBLITT, ANDREA G., TRUMBULL, CT. SN 77-241,691. PUB. 6-10-2008, FILED 7-30-2007.

NEED WANT LOVE

THE MARK CONSISTS OF STANDARD CHARACTERS WITHOUT CLAIM TO ANY PARTICULAR FONT, STYLE, SIZE, OR COLOR.
FOR CLOTHING, NAMELY, BEACHWEAR, SWIMSUITS, BELTS, FOOTWEAR, UNDERGARMENTS, COATS, JACKETS, HOODS, DRESSES, SKIRTS, GLOVES, HATS, HOSIERY, NIGHTWEAR, SLEEPWEAR, ONE-PIECE GARMENTS FOR INFANTS AND TODDLERS, SHIRTS AND T-SHIRTS, TANK TOPS, SHORTS, PANTS, AND SOCKS FOR MEN, WOMEN, CHILDREN AND INFANTS (U.S. CLS. 22 AND 39).
FIRST USE 5-1-2008; IN COMMERCE 5-1-2008.

3,632,205. JEM SPORTSWEAR, INC., SAN FERNANDO, CA. SN 77-267,676. PUB. 1-8-2008, FILED 8-29-2007.

WORLD WISE

THE MARK CONSISTS OF STANDARD CHARACTERS WITHOUT CLAIM TO ANY PARTICULAR FONT, STYLE, SIZE, OR COLOR.
FOR SHIRTS; T-SHIRTS (U.S. CLS. 22 AND 39).
FIRST USE 10-14-2008; IN COMMERCE 10-14-2008.

CLASS 25—(Continued).

3,632,206. JEM SPORTSWEAR, INC., SAN FERNANDO, CA. SN 77-267,683. PUB. 1-8-2008, FILED 8-29-2007.

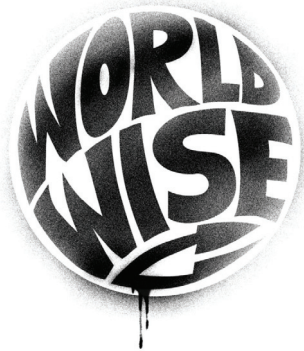

THE MARK CONSISTS OF "WORLD WISE" AND ARROW IN THE SHAPE OF A GLOBE. FOR SHIRTS; T-SHIRTS (U.S. CLS. 22 AND 39). FIRST USE 10-14-2008; IN COMMERCE 10-14-2008.

3,632,213. WRANGLER APPAREL CORP., WILMINGTON, DE. SN 77-273,049. PUB. 1-22-2008, FILED 9-6-2007.



OWNER OF U.S. REG. NO. 3,023,373. FOR MEN'S HATS AND CAPS (U.S. CLS. 22 AND 39). FIRST USE 9-18-2008; IN COMMERCE 9-18-2008.

CLASS 25—(Continued).

3,632,243. GALVAN, MANUEL, COVINA, CA. SN 77-287,272. PUB. 3-11-2008, FILED 9-24-2007.



THE MARK CONSISTS OF A STYLIZED TEXT OF THE WORDS "ADDICTED 2 RIDING A II R MAYHEM IN MOTION". THE WORDS "ADDICTED 2 RIDING" ARE LOCATED ABOVE A STYLIZED DESIGN WITH THE LETTER "A" AND "R" WHICH MAKE A ROMAN NUMERAL 2 (II) IN BETWEEN BOTH LETTER. THE LETTERS "A" AND "R" WITH THE ROMAN NUMERAL (2 II) REPRESENTS "ADDICTED 2 RIDING". ABOVE THE LETTERS "A" AND "R" WITH THE ROMAN NUMERAL (2 II) IS A CROWN. UNDERNEATH THE LETTERS "A" AND "R" WITH THE ROMAN NUMERAL (2 II) IS A BANNER WITH THE WORDS "MAYHEM IN MOTION".

FOR T-SHIRTS, BASEBALL CAPS, TANK TOPS, SHORTS, UNDERGARMENTS, JACKETS, HOODED SWEAT SHIRTS, SWEAT SHIRTS, SWEATERS, POLO SHIRTS, TOPS, BOTTOMS, DRESS SHIRTS, SPORTS SHIRTS, KNIT SHIRTS, WOVEN TOPS, KNITTED TOPS, OVER SHIRTS, BLOUSES, HALTER TOPS, TURTLE NECK SHIRTS, MOCK TURTLE NECK SHIRTS, SWEAT TOPS, JERSEYS, CAMISOLES, CHEMISES, BASEBALL SHIRTS, LONG SLEEVE SHIRTS, PULL OVER TOPS WITH POUCH POCKETS, KANGAROO TOPS, MUSCLE TOPS, GOLF SHIRTS, NIGHT SHIRTS, CARDIGANS, SLEEVELESS SWEATERS, SHORT SLEEVE SWEATERS, LONG SLEEVE SWEATERS, PULLOVERS, WARM UP TOPS, SINGLETS, PANTS, TROUSERS, SLACKS, JEANS, BOTTOMS, SWEAT PANTS, WARM UP PANTS, PANTALOONS, ROMPERS, JODHPURS, JUMPERS, WALKING SHORTS, BERMUDA SHORTS, BOARDWALK SHORTS, CULOTTES, PARKAS, PEA COATS, DUFFLE COATS, RAIN COATS, TRENCH COATS, WAIST COATS, OVER COATS, SWEAT JACKETS, JACKETS, SUITS, BLAZERS, INFANTWEAR, WIND RESISTANT JACKETS, PONCHOS, RAIN SUITS, TRAINING SUIT, PLAY SUIT, JOGGING SUITS, COVERALLS, OVERALLS, SHORTALLS, JUMP SUITS, JOGGING SUITS, SWEAT SUITS, SUN SUITS, WARM UP SUITS, UNIFORMS, DRESSES, SKIRTS, KIMONOS, BOOTY SHORTS, SWEAT SHORTS, COATS, HOUSE COATS, SMOCK AND SHOP COATS, PAJAMAS, SLEEPWEAR, DRESSING GOWNS, ROBES, BATHROBES, SLEEPING GARMENTS, UNDERWEAR, BOXER SHORTS, BRIEFS, SKI WEAR, SWIM SUITS, SWIM WEAR, SHOES, SLIPPERS, BOOTS, SANDALS, RUNNING SHOES, TENNIS SHOES, WALKING SHOES, SPORT SHOES, DECK SHOES, SNEAKERS, SPECIFIC PURPOSE ATHLETIC SHOES AND GENERAL PURPOSE SPORT SHOES, TIGHTS, MITTENS, GLOVES, BABY BIBS NOT MADE OF PAPER, BIB OVERALLS, SKI BIBS, WRIST BANS, BANDANAS, NECK TIES, HATS, CAPS, VISORS, TOQUES, BERETS, BELTS, SUSPENDERS, SCARVES, HEADBANDS, HOSIERY, AND SOCKS (U.S. CLS. 22 AND 39). FIRST USE 8-16-2008; IN COMMERCE 8-16-2008.

CLASS 25—(Continued).

3,632,305. CHRISSA AND CO., LTD., CAUSEWAY BAY, HONG KONG. SN 77-316,544. PUB. 5-27-2008, FILED 10-30-2007.

CHRIS AND JAIME

THE MARK CONSISTS OF STANDARD CHARACTERS WITHOUT CLAIM TO ANY PARTICULAR FONT, STYLE, SIZE, OR COLOR.

THE NAME(S), PORTRAIT(S), AND/OR SIGNATURE(S) SHOWN IN THE MARK IDENTIFIES LIVING INDIVIDUALS, WHOSE CONSENT(S) TO REGISTER IS SUBMITTED.

FOR WOMEN'S CLOTHING, NAMELY, COATS, SWEATERS, BLOUSES, TOPS, SKIRTS, PANTS, DRESSES, TUNICS, PONCHOS, SHORTS AND TANK TOPS (U.S. CLS. 22 AND 39).

FIRST USE 12-11-2007; IN COMMERCE 12-11-2007.

3,632,306. CHRISSA AND CO., LTD., CAUSEWAY BAY, HONG KONG. SN 77-316,563. PUB. 5-27-2008, FILED 10-30-2007.

chris and jaime

THE NAME SHOWN IN THE MARK IDENTIFIES LIVING INDIVIDUALS, WHOSE CONSENT IS OF RECORD.

THE MARK CONSISTS OF THE WORDS AND/OR NAMES "CHRIS AND JAIME" IN STYLIZED FORM.

FOR WOMEN'S CLOTHING, NAMELY, COATS, SWEATERS, BLOUSES, TOPS, SKIRTS, PANTS, DRESSES, TUNICS, PONCHOS, SHORTS AND TANK TOPS (U.S. CLS. 22 AND 39).

FIRST USE 12-11-2007; IN COMMERCE 12-11-2007.

3,632,337. MIROGLIO S.P.A., ALBA, CUNEO, ITALY. SN 77-331,558. PUB. 6-24-2008, FILED 11-16-2007.

MOTIVI

THE MARK CONSISTS OF STANDARD CHARACTERS WITHOUT CLAIM TO ANY PARTICULAR FONT, STYLE, SIZE, OR COLOR.

OWNER OF U.S. REG. NOS. 2,607,840, 3,056,727, AND 3,362,720.

CLASS 25—(Continued).

THE ENGLISH TRANSLATIONS OF "MOTIVI" ARE MOTIVES, REASONS, GROUNDS.

FOR COATS, JACKETS, RAINCOATS, SWEATERS, CARDIGANS, BELTS, SKIRTS, DRESSES, SHIRTS, TROUSERS, BLOUSES, T-SHIRTS, CLOAKS, SHOES AND BOOTS (U.S. CLS. 22 AND 39).

FIRST USE 12-31-1994; IN COMMERCE 3-1-2000.

3,632,339. JIT PARTNERS, INC. DBA J.I.T. PARTNERS, INC., TARZANA, CA. SN 77-332,488. PUB. 9-23-2008, FILED 11-18-2007.

ENIKO

THE MARK CONSISTS OF STANDARD CHARACTERS WITHOUT CLAIM TO ANY PARTICULAR FONT, STYLE, SIZE, OR COLOR.

THE MARK "ENIKO" HAS NO SIGNIFICANCE IN THE TRADE, NOR ANY MEANING IN A FOREIGN LANGUAGE.

FOR KNIT SHIRTS; MEN AND WOMEN JACKETS, COATS, TROUSERS, VESTS; CREWNECK SWEATERS; SWEATERS; TURTLENECK SWEATERS; V-NECK SWEATERS; CAMP SHIRTS; POLO SHIRTS; SHIRTS; SHORT-SLEEVED OR LONG-SLEEVED T-SHIRTS; T-SHIRTS; TEE SHIRTS; SKIRTS; SKIRTS AND DRESSES; DENIM JACKETS; JACKETS; CARDIGANS; TUNICS; TANK TOPS; TOPS; CAMISOLES; JEANS; MOCKNECKS; VESTS (U.S. CLS. 22 AND 39).

FIRST USE 1-10-2009; IN COMMERCE 3-9-2009.

3,632,358. INABINETT, LAMAR, SPRINGFIELD GARDEN, NY. SN 77-340,831. PUB. 8-26-2008, FILED 11-30-2007.

GOD BLESS ALL PEOPLE AND THE WORLD

THE MARK CONSISTS OF STANDARD CHARACTERS WITHOUT CLAIM TO ANY PARTICULAR FONT, STYLE, SIZE, OR COLOR.

FOR CLOTHING, NAMELY, SHIRTS, T-SHIRTS, SWEATSHIRTS, JACKETS AND HATS (U.S. CLS. 22 AND 39).

FIRST USE 11-8-2008; IN COMMERCE 11-8-2008.

CLASS 25—(Continued).

3,632,379. LEWIS JR., LORRIS, ARLINGTON, TX. SN 77-350,717. PUB. 7-8-2008, FILED 12-12-2007.



NO CLAIM IS MADE TO THE EXCLUSIVE RIGHT TO USE "A GAME", APART FROM THE MARK AS SHOWN.

FOR BASEBALL SHOES; BOWLING SHOES; BOXING SHOES; CANVAS SHOES; LEATHER SHOES; MEN AND WOMEN JACKETS, COATS, TROUSERS, VESTS; PANTS; SHORT-SLEEVED OR LONG-SLEEVED T-SHIRTS; SHORT-SLEEVED SHIRTS (U.S. CLS. 22 AND 39).

FIRST USE 9-1-2008; IN COMMERCE 9-1-2008.

3,632,381. PJ DREAMWEAR, ANAHEIM, CA. SN 77-352,799. PUB. 12-16-2008, FILED 12-14-2007.

PJ Harlow

THE MARK CONSISTS OF STANDARD CHARACTERS WITHOUT CLAIM TO ANY PARTICULAR FONT, STYLE, SIZE, OR COLOR.

THE NAME(S), PORTRAIT(S), AND/OR SIGNATURE(S) SHOWN IN THE MARK DOES NOT IDENTIFY A PARTICULAR LIVING INDIVIDUAL.

FOR LOUNGEWEAR; SLEEPWEAR (U.S. CLS. 22 AND 39).

FIRST USE 1-1-2008; IN COMMERCE 1-1-2008.

3,632,390. A & H SPORTSWEAR CO., INC., STOCKERTOWN, PA. SN 77-355,724. PUB. 5-27-2008, FILED 12-19-2007.

MAGIC JEANS

THE MARK CONSISTS OF STANDARD CHARACTERS WITHOUT CLAIM TO ANY PARTICULAR FONT, STYLE, SIZE, OR COLOR.

OWNER OF U.S. REG. NOS. 2,756,417, 3,187,721, AND 3,335,611.

NO CLAIM IS MADE TO THE EXCLUSIVE RIGHT TO USE "JEANS", APART FROM THE MARK AS SHOWN.

FOR JEANS (U.S. CLS. 22 AND 39).

FIRST USE 4-2-2009; IN COMMERCE 4-2-2009.

CLASS 25—(Continued).

3,632,399. PLANET HOLLYWOOD (REGION IV), INC., ORLANDO, FL. SN 77-357,837. PUB. 5-13-2008, FILED 12-21-2007.

PLANET BOLLYWOOD

THE MARK CONSISTS OF STANDARD CHARACTERS WITHOUT CLAIM TO ANY PARTICULAR FONT, STYLE, SIZE, OR COLOR.

OWNER OF U.S. REG. NOS. 1,798,442, 3,386,957, AND OTHERS.

FOR CLOTHING, NAMELY, T-SHIRTS, SHIRTS, SWEATSHIRTS, POLO SHIRTS, SPORT SHIRTS, SHORTS, JACKETS AND CAPS (U.S. CLS. 22 AND 39).

FIRST USE 1-18-2008; IN COMMERCE 1-18-2008.

3,632,403. DAIMLER TRUCKS NORTH AMERICA LLC, PORTLAND, OR. SN 77-358,499. PUB. 11-25-2008, FILED 12-21-2007.

WESTERN STAR

THE MARK CONSISTS OF STANDARD CHARACTERS WITHOUT CLAIM TO ANY PARTICULAR FONT, STYLE, SIZE, OR COLOR.

OWNER OF U.S. REG. NO. 1,097,365.

FOR CLOTHING, NAMELY, T-SHIRTS, SHIRTS, JACKETS, HATS (U.S. CLS. 22 AND 39).

FIRST USE 12-31-1999; IN COMMERCE 12-31-1999.

CLASS 25—(Continued).

3,632,427. WRIGHT GROUP ENTERPRISES, INC, SACRAMENTO, CA. SN 77-370,346. PUB. 9-16-2008, FILED 1-13-2008.



THE MARK CONSISTS OF ONE BIG STAR WITH ONE MEDIUM AND ONE SMALL STAR INSIDE IT. THE STARS SIT OVER THE WRITING "THE PROPHECY" DONE IN A CURSIVE TYPE FONT. UNDER THE WRITING "THE PROPHECY" THERE IS A TWO SWOOSH MARKS WITH A SPACE IN BETWEEN THEM.

FOR FOOTWEAR FOR MEN AND WOMEN; SHIRTS; CAPRI PANTS; CARGO PANTS; DENIMS; NURSE PANTS; PANTS; SNOW PANTS; SNOWBOARD PANTS; STRETCH PANTS; SWEAT PANTS; YOGA PANTS; TRACK PANTS; JOGGING PANTS; LEATHER PANTS; LOUNGE PANTS; SWEATERS; JACKETS; BRIDESMAID DRESSES; DRESS SHIRTS; DRESS SUITS; DRESSES; EVENING DRESSES; NURSE DRESSES; SKIRTS AND DRESSES; WEDDING DRESSES; HATS; SOCKS; SOCKS AND STOCKINGS; GLOVES; BRIEFS; KNITTED UNDERWEAR; LADIES' UNDERWEAR; LONG UNDERWEAR; PARTS OF CLOTHING, NAMELY, GUSSETS FOR TIGHTS, GUSSETS FOR STOCKINGS, GUSSETS FOR BATHING SUITS, GUSSETS FOR UNDERWEAR, GUSSETS FOR LEOTARDS AND GUSSETS FOR FOOTLETS; THONGS; UNDERWEAR; WOMEN'S UNDERWEAR; COATS; COATS FOR MEN AND WOMEN; BOARD SHORTS; GYM SHORTS; SHORT SETS; SHORT-SLEEVED OR LONG-SLEEVED T-SHIRTS; SHORT-SLEEVED SHIRTS; SHORTS; SWEAT SHORTS; BRAS; LINGERIE ACCESSORIES, NAMELY, REMOVABLE SILICONE BREAST ENHANCER PADS USED IN A BRA; SPORTS BRAS; STRAPLESS BRAS; SWIMSUITS; BIKINIS; BEACH COVERUPS; BEACH FOOTWEAR; CHOIR ROBES; ROBES; BATHING SUITS; BATHING SUITS FOR MEN; FLIGHT SUITS; GYM SUITS; JOGGING SUITS; LADIES' SUITS; MEN'S SUITS; MEN'S SUITS, WOMEN'S SUITS; SHIRTS FOR SUITS; SNOW BOARDING SUITS; SWEAT SUITS; TRACK SUITS; WARM UP SUITS; MATERNITY SLEEPWEAR; SLEEPWEAR; BELTS; BELTS MADE OF LEATHER; BELTS OF TEXTILE; FABRIC BELTS; GARTER BELTS; LEATHER BELTS; MONEY BELTS; SUSPENDER BELTS FOR MEN; WAIST BELTS; ATHLETIC FOOTWEAR; ATHLETIC UNIFORMS; ATHLETIC SHOES; FOOTWEAR FOR TRACK AND FIELD ATHLETICS; SCRUBS NOT FOR MEDICAL PURPOSES; HEADBANDS; HEADBANDS AGAINST SWEATING; WRISTBANDS; BOW TIES; TIES; SKIRTS; DRESSING GOWNS (U.S. CLS. 22 AND 39).
FIRST USE 8-22-2007; IN COMMERCE 8-22-2007.

CLASS 25—(Continued).

3,632,430. TORRES, EDGAR, BROWNSTOWN, MI. SN 77-371,066. PUB. 7-29-2008, FILED 1-14-2008.



THE COLOR(S) GREEN AND BLACK IS/ARE CLAIMED AS A FEATURE OF THE MARK.

THE MARK CONSISTS OF THE COLORS GREEN AND BLACK, WITH THE COLOR GREEN APPEARING IN THE BODY OF THE FROG DESIGN AND THE COLOR BLACK APPEARING IN THE OUTLINE OF THE FROG DESIGN.

FOR CLOTHING, NAMELY, POLO SHIRTS (U.S. CLS. 22 AND 39).

FIRST USE 4-27-2007; IN COMMERCE 3-4-2008.

3,632,444. TWIN TIGER WORLD MARKETS, LTD., VANCOUVER, CANADA. SN 77-376,894. PUB. 6-3-2008, FILED 1-21-2008.

TWIN PALM

THE MARK CONSISTS OF STANDARD CHARACTERS WITHOUT CLAIM TO ANY PARTICULAR FONT, STYLE, SIZE, OR COLOR.

FOR (BASED ON USE IN COMMERCE) FOOTWEAR; SHORTS; DRESSES; HEADWEAR; PANTS; SHIRTS; SWIM WEAR; T-SHIRTS (U.S. CLS. 22 AND 39).

FIRST USE 9-12-2007; IN COMMERCE 9-12-2007.

CLASS 25—(Continued).

3,632,457. ATALANTA FMA CORP., PISCATAWAY, NJ. SN 77-383,308. PUB. 6-10-2008, FILED 1-29-2008.



THE MARK CONSISTS OF FEMALE MOTORCYCLE RIDER ON A MOTORCYCLE.

FOR SWEATERS; SHORT-SLEEVED OR LONG-SLEEVED T-SHIRTS; SHORTS; BELTS; SOCKS; SANDALS; GLOVES; HATS; SCARVES; TANK TOPS; SWEAT SUITS; DRESSES; LINGERIE; BATHING COSTUMES FOR WOMEN; JACKETS; COATS; SWEAT PANTS; PANTS; SKIRTS; SLIPPERS (U.S. CLS. 22 AND 39).
FIRST USE 3-1-2008; IN COMMERCE 3-1-2008.

CLASS 25—(Continued).

3,632,495. CAI GLOBAL GROUP LTD., KOWLOON, HONG KONG. SN 77-393,215. PUB. 7-8-2008, FILED 2-10-2008.

RPET

THE MARK CONSISTS OF STANDARD CHARACTERS WITHOUT CLAIM TO ANY PARTICULAR FONT, STYLE, SIZE, OR COLOR.

FOR FABRIC SOLD AS AN INTEGRAL COMPONENT OF FINISHED CLOTHING ITEMS, NAMELY, SUITS, BLOUSES, SHIRTS, SKIRTS, PANTS, SHORTS, VESTS, COATS, JACKETS, BLAZERS, COVERALLS, UNIFORMS, ATHLETIC UNIFORMS, MILITARY UNIFORMS, LOUNGEWEAR, SWIMWEAR, ACTIVEWEAR, NAMELY, TOPS, BOTTOMS, AND COORDINATED SETS OF TOPS AND BOTTOMS, APRONS AND GLOVES; CLOTHING, NAMELY, SUITS, BLOUSES, SHIRTS, SKIRTS, PANTS, SHORTS, VESTS, COATS, JACKETS, BLAZERS, COVERALLS, UNIFORMS, ATHLETIC UNIFORMS, MILITARY UNIFORMS, LOUNGEWEAR, SWIMWEAR, ACTIVEWEAR, NAMELY, TOPS, BOTTOMS, AND COORDINATED SETS OF TOPS AND BOTTOMS, APRONS AND GLOVES (U.S. CLS. 22 AND 39).

FIRST USE 2-1-2008; IN COMMERCE 2-1-2008.

3,632,493. EDENFIELD, CARRIE, WAUCHULA, FL. AND EDENFIELD, WILLIAM, WAUCHULA, FL. SN 77-392,968. PUB. 6-24-2008, FILED 2-8-2008.



THE STIPPLING IS FOR SHADING PURPOSES ONLY. THE MARK CONSISTS OF TWO CAPITAL R'S BACK TO BACK WITH A CROWN OVER THE TOP. THE WORDS "REDNECK ROYALTY" ENCIRCLE THE TWO R'S AND THE CROWN.

FOR CAPS; HATS; JACKETS; PANTS; VISORS (U.S. CLS. 22 AND 39).

FIRST USE 11-13-2007; IN COMMERCE 2-13-2008.

3,632,501. E.S. ORIGINALS, INC., NEW YORK, NY. SN 77-394,470. PUB. 7-8-2008, FILED 2-12-2008.



THE MARK CONSISTS OF A SIDE BRACE DESIGN. THE MATERIAL SHOWN IN THE DOTTED LINES SERVES TO SHOW THE POSITION OF THE MARK ON THE GOODS.

FOR FOOTWEAR (U.S. CLS. 22 AND 39).
FIRST USE 5-10-2008; IN COMMERCE 5-10-2008.

3,632,515. FLOAT TECH, INC., TROY, NY. SN 77-397,205. PUB. 7-8-2008, FILED 2-14-2008.

Sea Tee

THE MARK CONSISTS OF THE WORD "SEA" AND "TEE" AND A CIRCLE AND A CURVED LINE.

FOR T-SHIRTS INCORPORATING AN INFLATABLE FLOTATION AID (U.S. CLS. 22 AND 39).

FIRST USE 9-16-2008; IN COMMERCE 9-16-2008.

CLASS 25—(Continued).

3,632,523. VANITY FAIR, INC., BOWLING GREEN, KY. SN 77-398,636. PUB. 7-1-2008, FILED 2-15-2008.

VANITIES BY VANITY FAIR

THE MARK CONSISTS OF STANDARD CHARACTERS WITHOUT CLAIM TO ANY PARTICULAR FONT, STYLE, SIZE, OR COLOR.

OWNER OF U.S. REG. NOS. 239,000, 502,941, AND OTHERS.

FOR PANTIES; LINGERIE; BRAS (U.S. CLS. 22 AND 39).

FIRST USE 4-14-2008; IN COMMERCE 4-14-2008.

3,632,526. J. T. DESIGN STUDIO, INC., LOS ANGELES, CA. SN 77-399,596. PUB. 7-8-2008, FILED 2-18-2008.

FAITH & ME

THE MARK CONSISTS OF STANDARD CHARACTERS WITHOUT CLAIM TO ANY PARTICULAR FONT, STYLE, SIZE, OR COLOR.

FOR TOPS; SHIRTS; DRESSES; SKIRTS; PANTS; SWEATERS; KNIT SHIRTS (U.S. CLS. 22 AND 39).

FIRST USE 3-21-2008; IN COMMERCE 3-21-2008.

3,632,527. SHORT, PATRICIA L., INDIAN LAND, SC. SN 77-399,602. PUB. 7-8-2008, FILED 2-18-2008.

PLAYPRONS

THE MARK CONSISTS OF STANDARD CHARACTERS WITHOUT CLAIM TO ANY PARTICULAR FONT, STYLE, SIZE, OR COLOR.

FOR APRONS (U.S. CLS. 22 AND 39).

FIRST USE 4-1-2009; IN COMMERCE 4-1-2009.

3,632,538. SOUTH ALLIANCE, INC., LAS VEGAS, NV. SN 77-402,987. PUB. 7-8-2008, FILED 2-21-2008.

MOST WANTED JEANS**CLASS 25—(Continued).**

THE MARK CONSISTS OF STANDARD CHARACTERS WITHOUT CLAIM TO ANY PARTICULAR FONT, STYLE, SIZE, OR COLOR.

NO CLAIM IS MADE TO THE EXCLUSIVE RIGHT TO USE "JEANS", APART FROM THE MARK AS SHOWN.

FOR JEANS, TOPS, T-SHIRTS, SHIRTS, COATS, SWEATSHIRTS, SWEAT BOTTOMS, BELTS, HATS, GLOVES, UNDERWEAR, SHORTS AND FOOTWEAR (U.S. CLS. 22 AND 39).

FIRST USE 1-15-2009; IN COMMERCE 1-15-2009.

3,632,583. LEONA DRUCE, ROCK SPRINGS, WY. SN 77-410,011. PUB. 7-15-2008, FILED 2-29-2008.

I DRESSED MYSELF

THE MARK CONSISTS OF STANDARD CHARACTERS WITHOUT CLAIM TO ANY PARTICULAR FONT, STYLE, SIZE, OR COLOR.

FOR CHILDREN'S CLOTHING, NAMELY, SHIRTS, SOCKS AND HATS (U.S. CLS. 22 AND 39).

FIRST USE 4-7-2009; IN COMMERCE 4-7-2009.

3,632,591. PRAKASH, KARUN SHASHI. SEASIDE, CA. SN 77-411,799. PUB. 7-15-2008, FILED 3-3-2008.



THE COLOR(S) BLACK, WHITE AND GRAY IS/ARE CLAIMED AS A FEATURE OF THE MARK.

THE MARK CONSISTS OF THE LETTERS "KSP" BORDERED BY SHADOW IMAGES OF TWO LONG LEAVES OR BRANCHES WITH ALL OBJECTS DISPLAYING SLIGHT SHADOWS.

FOR CLOTHING, NAMELY, PANTS, SHORTS, SWEATPANTS, OVERALLS, SHIRTS, TEE-SHIRTS, SWEATSHIRTS, BLOUSES, SKIRTS, DRESSES, JACKETS, VESTS, COATS, RAINWEAR, SHOES, LINGERIE, SLEEPWEAR, LOUNGEWEAR, SWIMWEAR, GLOVES, SOCKS, HOSIERY, BELTS, SCARVES, HATS, TIES, SLIPPERS (U.S. CLS. 22 AND 39).

FIRST USE 2-11-2009; IN COMMERCE 2-11-2009.

CLASS 25—(Continued).

3,632,608. WARNACO U.S., INC., MILFORD, CT. SN 77-413,807. PUB. 7-29-2008, FILED 3-5-2008.

LUXURY LIFT

THE MARK CONSISTS OF STANDARD CHARACTERS WITHOUT CLAIM TO ANY PARTICULAR FONT, STYLE, SIZE, OR COLOR.

OWNER OF U.S. REG. NOS. 1,952,806 AND 2,450,241.

NO CLAIM IS MADE TO THE EXCLUSIVE RIGHT TO USE "LIFT", APART FROM THE MARK AS SHOWN.

FOR INTIMATE APPAREL, NAMELY, BRAS (U.S. CLS. 22 AND 39).

FIRST USE 1-15-2009; IN COMMERCE 1-15-2009.

3,632,650. PASSARELLI, MADELINE, NEW YORK, NY. SN 77-421,277. PUB. 7-29-2008, FILED 3-13-2008.

WEAR TODAY GONE TOMORROW

THE MARK CONSISTS OF STANDARD CHARACTERS WITHOUT CLAIM TO ANY PARTICULAR FONT, STYLE, SIZE, OR COLOR.

FOR SKIRTS AND DRESSES; JACKETS; BLOUSES (U.S. CLS. 22 AND 39).

FIRST USE 3-17-2009; IN COMMERCE 3-17-2009.

3,632,654. ACUSHNET COMPANY, FAIRHAVEN, MA. SN 77-422,078. PUB. 11-11-2008, FILED 3-14-2008.

THE MARK CONSISTS OF THE STYLIZED TERM "SYNTR·G" WITH A DOT BETWEEN "SYNR" AND "G".

FOR GOLF SHOES (U.S. CLS. 22 AND 39).
FIRST USE 1-0-2009; IN COMMERCE 1-0-2009.

CLASS 25—(Continued).

3,632,698. WRANGLER APPAREL CORP., WILMINGTON, DE. SN 77-432,847. PUB. 7-22-2008, FILED 3-27-2008.

WRANGLER

THE MARK CONSISTS OF STANDARD CHARACTERS WITHOUT CLAIM TO ANY PARTICULAR FONT, STYLE, SIZE, OR COLOR.

OWNER OF U.S. REG. NOS. 849,477, 1,108,076, AND OTHERS.

FOR SCARVES (U.S. CLS. 22 AND 39).

FIRST USE 4-5-2008; IN COMMERCE 4-5-2008.

3,632,725. JOHN RICH & SONS INVESTMENT HOLDING COMPANY, WILMINGTON, DE. SN 77-439,890. PUB. 7-22-2008, FILED 4-4-2008.

THE TETON GROUP

THE MARK CONSISTS OF STANDARD CHARACTERS WITHOUT CLAIM TO ANY PARTICULAR FONT, STYLE, SIZE, OR COLOR.

OWNER OF U.S. REG. NO. 861,412.

NO CLAIM IS MADE TO THE EXCLUSIVE RIGHT TO USE "GROUP", APART FROM THE MARK AS SHOWN.

FOR JACKETS; PARKAS (U.S. CLS. 22 AND 39).

FIRST USE 5-28-2008; IN COMMERCE 5-28-2008.

3,632,727. NEW BALANCE ATHLETIC SHOE, INC., BOSTON, MA. SN 77-439,963. PUB. 8-19-2008, FILED 4-4-2008.

STABILICORE

THE MARK CONSISTS OF STANDARD CHARACTERS WITHOUT CLAIM TO ANY PARTICULAR FONT, STYLE, SIZE, OR COLOR.

FOR BASKETBALL SNEAKERS; SNEAKERS; SHOE SOLES; ATHLETIC SHOES; BASEBALL SHOES; FOOTBALL SHOES; GOLF SHOES; GYMNASIIC SHOES; LEATHER SHOES; RUNNING SHOES; SHOES; SOCCER SHOES; TENNIS SHOES; TRACK AND FIELD SHOES; TRAINING SHOES (U.S. CLS. 22 AND 39).

FIRST USE 4-7-2009; IN COMMERCE 4-7-2009.

CLASS 25—(Continued).

3,632,732. OCHOA, SYLVIA F., DBA GAY PRIDE FASHIONS, GLENDALE, AZ. SN 77-441,055. PUB. 8-19-2008, FILED 4-6-2008.



NO CLAIM IS MADE TO THE EXCLUSIVE RIGHT TO USE "FASHIONS, LLC", APART FROM THE MARK AS SHOWN.

FOR ANGLERS' SHOES; APRONS; ATHLETIC FOOTWEAR; ATHLETIC SHOES; BABY TOPS; BALLROOM DANCING SHOES; BASEBALL CAPS; BASEBALL SHOES; BATH SLIPPERS; BATHING CAPS; BATHING COSTUMES FOR WOMEN; BATHING SUITS; BEACH COVER-UPS; BEACH COVERUPS; BEACH FOOTWEAR; BEACH SHOES; BEANIES; BED JACKETS; BELTS; BELTS MADE OF LEATHER; BELTS OF TEXTILE; BERMUDA SHORTS; BOARD SHORTS; BODY SUITS; BOOTS; BOWLING SHOES; BOXER BRIEFS; BOXER SHORTS; BOXING SHOES; BRIDESMAID DRESSES; BRIEFS; BRIEFS; BUTTON-FRONT ALOHA SHIRTS; CAMP SHIRTS; CANVAS SHOES; CAP VISORS; CAPRI PANTS; CAPRIS; CAPS; CAPS WITH VISORS; CARGO PANTS; CHEF'S HATS; CHILDREN'S AND INFANTS' CLOTH BIBS; CHILDREN'S CLOTH EATING BIBS; CHOIR ROBES; CLIMBING BOOTS; CLOTH BIBS; CLOTH BIBS FOR ADULT DINERS; CLOTH BIBS FOR USE BY SENIOR CITIZENS OR PHYSICALLY- OR MENTALLY-CHALLENGED PERSONS; CLOTH DIAPERS; CLOTHING FOR WEAR IN JUDO PRACTICES; CLOTHING, NAMELY, ARM WARMERS; CLOTHING, NAMELY, FOLK COSTUMES; CLOTHING, NAMELY, HAND-WARMERS; CLOTHING, NAMELY, KNEE WARMERS; CLOTHING, NAMELY, NECK TUBES; CLOTHING, NAMELY, WRAP-AROUNDS; COATS; COATS FOR MEN AND WOMEN; COATS MADE OF COTTON; COATS OF DENIM; COBBLERS' APRONS; COMPETITORS' NUMBERS OF TEXTILE; CORSETS; COSTUMES FOR USE IN ROLE-PLAYING GAMES; CREWNECK SWEATERS; CROP TOPS; CYCLING SHOES; CYCLISTS' JERSEYS; DANCE COSTUMES; DANCE SHOES; DECK-SHOES; DENIM JACKETS; DENIMS; DETACHABLE NECKPIECES FOR KIMONOS (HANERI); DISPOSABLE SLIPPERS; DISPOSABLE UNDERWEAR; DOWN JACKETS; DRESS SHIELDS; DRESS SHIRTS; DRESS SUITS; DRESSES; DRESSES MADE FROM SKINS; DRESSING GOWNS; DRIVERS; DRY SUITS; DUST COATS; DUSTERS; EMBOSSED SOLES AND HEELS OF RUBBER OR OF PLASTIC MATERIALS; EVENING DRESSES; EVENING GOWNS; FABRIC BELTS; FINISHED TEXTILE LININGS FOR GARMENTS; FISHERMEN'S JACKETS; FISHING VESTS; FITTED SHOE OR BOOT COVERING TO PROTECT THE SHOES OR BOOT FROM WATER OR OTHER DAMAGE; FITTED SWIMMING COSTUMES WITH BRA CUPS; FLEECE PULLOVERS; FLEECE SHORTS; FLEECE VESTS; FLIGHT SUITS; FLIP FLOPS; FOAM PEDICURE SLIPPERS; FOOTBALL BOOTS AND STUDES THEREFOR; FOOTBALL SHOES; FOOTWEAR; FOOTWEAR; FOOTWEAR FOR MEN; FOOTWEAR FOR MEN AND WOMEN; FOOTWEAR FOR TRACK AND FIELD ATHLETICS; FOOTWEAR FOR WOMEN; FOOTWEAR MADE OF WOOD; FOOTWEAR NOT FOR SPORTS; FOOTWEAR, NAMELY, PUMPS; FOOTWEAR, NAMELY, RUBBERS; FOOTWEAR, NAMELY, WORK BOOTS; FOULARDS; FULL-LENGTH KIMONOS (NAGAI); FUR COATS; FUR COATS AND JACKETS; FUR HATS; FUR JACKETS; GARTER BELTS; GARTERS; GLOVES FOR PERSONAL HAND CONDITIONING USE; GLOVES INCLUDING THOSE MADE OF SKIN,

CLASS 25—(Continued).

HIDE OR FUR; GOLF CAPS; GOLF CLEATS; GOLF SHIRTS; GOLF SHOES; GOLF SPIKES; GOLF TROUSERS; GOWNS; GYM SHORTS; GYM SUITS; GYMNAS-TIC SHOES; HALLOWEEN COSTUMES AND MASKS SOLD IN CONNECTION THEREWITH; HALTER TOPS; HANDBALL SHOES; HAT BANDS; HATS; HEADBANDS AGAINST SWEATING; HEAVY COATS; HEAVY JACKETS; HEEL INSERTS; HEEL PIECES FOR SHOES; HEELS; HIGH RAIN CLOGS (ASHIDA); HIKING BOOTS; HIP-GUARDS ESPECIALLY MADE FOR FISHING; HOCKEY SHOES; HOODED PULLOVERS; HOODED SWEAT SHIRTS; HOODS; HOODS; HORSE-RIDING BOOTS; HUNTING BOOT BAGS; HUNTING VESTS; INFANT AND TODDLER ONE PIECE CLOTHING; INFANTS' TROUSERS; INNER SOLES; INSOLES; JACKET LINERS; JACKETS; JAPANESE FOOTWEAR OF RICE STRAW (WARAJI); JAPANESE STYLE CLOGS AND SANDALS; JAPANESE STYLE SANDALS (ZORI); JAPANESE STYLE SANDALS OF FELT; JAPANESE STYLE SANDALS OF LEATHER; JAPANESE TOE-STRAP SANDALS (ASAURA-ZORI); JERSEYS; JOGGING OUTFITS; JOGGING PANTS; JOGGING SUITS; JUDO SUITS; KARATE SUITS; KIMONOS; KNIT SHIRTS; KNITTED CAPS; KNITTED UNDERWEAR; LAB COATS; LACE BOOTS; LADIES' BOOTS; LADIES' SUITS; LADIES' UNDERWEAR; LEATHER BELTS; LEATHER COATS; LEATHER HEADWEAR; LEATHER JACKETS; LEATHER PANTS; LEATHER SHOES; LEATHER SLIPPERS; LEOTARDS AND TIGHTS FOR WOMEN, MEN AND CHILDREN OF NYLON, COTTON OR OTHER TEXTILE FIBERS; LIGHT-REFLECTING COATS; LIGHT-REFLECTING JACKETS; LINGERIE; LINGERIE ACCESSORIES, NAMELY, REMOVABLE SILICONE BREAST ENHANCER PADS USED IN A BRA; LONG JACKETS; LONG SLEEVED VESTS; LONG UNDERWEAR; LONG-SLEEVED SHIRTS; LOUNGE PANTS; LOUNGEWEAR; MANTLES; MASQUERADE COSTUMES AND MASKS SOLD IN CONNECTION THEREWITH; MATERNITY LINGERIE; MEN AND WOMEN JACKETS, COATS, TROUSERS, VESTS; MEN'S SOCKS; MEN'S SUITS; MEN'S SUITS, WOMEN'S SUITS; MOCK TURTLE-NECK SWEATERS; MONEY BELTS; MORNING COATS; MOTORCYCLIST BOOTS; MOUNTAIN-NEERING BOOTS; MUFFLERS; MUSCLE TOPS; NECK BANDS; NECK GAITERS; NIGHT GOWNS; NIGHT SHIRTS; NON-DISPOSABLE CLOTH TRAINING PANTS; NOVELTY HEADWEAR WITH ATTACHED WIGS; NURSE DRESSES; NURSE PANTS; ONE PIECE GARMENT FOR INFANTS AND TODDLERS; ONE-PIECE PLAY SUITS; OPEN-NECKED SHIRTS; OVER COATS; OVER-TROUSERS; PADDED JACKETS; PADDING JACKETS; PAJAMA BOTTOMS; PAJAMAS; PANTIES; PANTIES, SHORTS AND BRIEFS; PANTS; PAPER HATS FOR USE AS CLOTHING ITEMS; PAPER SHOES USED WHEN GOING THROUGH METAL DETECTORS TO KEEP FEET AND SOCKS CLEAN; PARTS OF CLOTHING, NAMELY, GUSSETS FOR TIGHTS, GUSSETS FOR STOCKINGS, GUSSETS FOR BATHING SUITS, GUSSETS FOR UNDERWEAR, GUSSETS FOR LEOTARDS AND GUSSETS FOR FOOTLETS; PEDICURE SANDALS; PEDICURE SLIPPERS; PERSPIRATION ABSORBENT UNDERWEAR CLOTHING; PETTI-PANTS; PETTI-COATS; PIQUE SHIRTS; PLAY SUITS; PLEATED SKIRTS FOR FORMAL KIMONOS (HAKAMA); POLO SHIRTS; PROTECTIVE METAL MEMBERS FOR SHOES AND BOOTS; PULLOVERS; PUMPS; PUTTEES AND GAITERS; QUILTED VESTS; RAIN BOOTS; RAIN COATS; RAIN JACKETS; RAIN SLICKERS; RAIN SUITS; RAIN TROUSERS; RAINPROOF JACKETS; REVERSIBLE JACKETS; RIDING BOOTS; RIDING COATS; ROBES; RUBBER SHOES; RUBBER SOLES FOR JIKATABI; RUBBERS; RUGBY SHIRTS; RUGBY SHOES; RUGBY SHORTS; RUGBY TOPS; RUNNING SHOES; SANDAL-CLOGS; SANDALS; SASH BANDS FOR KIMONO (OBI); SCRUBS NOT FOR MEDICAL PURPOSES; SEDGE HATS (SUGE-GASA); SHAWLS AND HEADSCARVES; SHAWLS AND STOLE; SHELL JACKETS; SHIRT FRONTS; SHIRT YOKES; SHIRTS; SHIRTS FOR SUITS; SHOE DOWELS; SHOE INSERTS FOR PRIMARILY NON-ORTHOPEDIC PURPOSES; SHOE PEGS; SHOE SOLES; SHOE STRAPS; SHOES; SHOES SOLES FOR REPAIR; SHORT OVERCOAT FOR KIMONO (HAORI); SHORT PETTICOATS; SHORT SETS; SHORT TROUSERS; SHORT-SLEEVED OR LONG-SLEEVED T-SHIRTS; SHORT-SLEEVED SHIRTS; SHORTS; SHOULDER WRAPS; SHOWER CAPS; SINGLETS; SKI AND SNOWBOARD SHOES AND PARTS THEREOF; SKI BIBS; SKI

CLASS 25—(Continued).

BOOT BAGS; SKI BOOTS; SKI GLOVES; SKI JACKETS; SKI MASKS; SKI PANTS; SKI SUITS; SKI SUITS FOR COMPETITION; SKI TROUSERS; SKI WEAR; SKIING SHOES; SKIRT SUITS; SKIRTS; SKIRTS AND DRESSES; SKULL CAPS; SLEEP SHIRTS; SLEEVED OR SLEEVELESS JACKETS; SLEEVELESS JERSEYS; SLIDING SHORTS; SLIPPER SOLES; SLIPPERS; SMALL HATS; SMOKING JACKETS; SNOW BOARDING SUITS; SNOW BOOTS; SNOW PANTS; SNOW SUITS; SNOWBOARD BOOTS; SNOWBOARD GLOVES; SNOWBOARD MITTENS; SNOWBOARD PANTS; SOCCER BOOTS; SOCCER SHOES; SOCK SUSPENDERS; SOCKS AND STOCKINGS; SOLES; SOLES FOR JAPANESE STYLE SANDALS; SPORT COATS; SPORT SHIRTS; SPORTS BRA; SPORTS BRAS; SPORTS JACKETS; SPORTS JERSEYS; SPORTS JERSEYS AND BREECHES FOR SPORTS; SPORTS OVERUNIFORMS; SPORTS SHIRTS; SPORTS SHIRTS WITH SHORT SLEEVES; STOCKINGS; STRAPS FOR BRAS; STRETCH PANTS; STRING FASTENERS FOR HAORI (HAORI-HIMO); STUFF JACKETS; SUEDE JACKETS; SUIT COATS; SUITS; SUITS OF LEATHER; SUN SLEEVES; SUN VISORS; SUSPENDER BELTS FOR MEN; SUSPENDER BELTS FOR WOMEN; SUSPENDERS; SUSPENDERS; SWADDLING CLOTHES; SWEAT BANDS; SWEAT JACKETS; SWEAT PANTS; SWEAT SHIRTS; SWEAT SHORTS; SWEAT SUITS; SWEATERS; SWIM CAPS; SWIM WEAR FOR GENTLEMEN AND LADIES; SWIMMING CAPS; SWIMMING CAPS; SWIMWEAR; T-SHIRTS; TANK TOPS; TANK-TOPS; TAP PANTS; TAP SHOES; TEE SHIRTS; TENNIS SHOES; TENNIS WEAR; TEXTILE DIAPERS; TEXTILE NAPPIES; THERMAL UNDERWEAR; THONGS; THONGS; TIES; TIGHTENING-UP STRINGS FOR KIMONOS (DATEJIME); TIGHTS; TIPS FOR FOOTWEAR; TOBOGGAN HATS, PANTS AND CAPS; TOE CAPS; TOE STRAPS FOR JAPANESE STYLE SANDALS; TOE STRAPS FOR JAPANESE STYLE WOODEN CLOGS; TONGUE OR PULLSTRAP FOR SHOES AND BOOTS; TOP COATS; TOPS; TRACK AND FIELD SHOES; TRACK JACKETS; TRACK PANTS; TRACK SUITS; TRAINING SHOES; TRAINING SUITS; TRENCH COATS; TRIATHLON CLOTHING, NAMELY, TRIATHLON TIGHTS, TRIATHLON SHORTS, TRIATHLON SINGLET, TRIATHLON SHIRTS, TRIATHLON SUITS; TROUSERS; TROUSERS FOR SWEATING; TROUSERS OF LEATHER; TUBE TOPS; TURTLENECK SWEATERS; TUXEDO BELTS; TWIN SETS; UNDERARM CLOTHING SHIELDS; UNDERGARMENT ACCESSORIES, NAMELY, REMOVABLE SILICONE BUTTOCK ENHANCER PADS; UNDERSHIRTS FOR KIMONOS (JUBAN); UNDERSHIRTS FOR KIMONOS (KOSHIMAKI); UNDERWEAR; UNDERWEAR, NAMELY, BOY SHORTS; UNION SUITS; UPPERS FOR JAPANESE STYLE SANDALS; UPPERS OF WOVEN RATTAN FOR JAPANESE STYLE SANDALS; V-NECK SWEATERS; VEST EXTENDERS; VESTED SUITS; VESTS; VISORS; VOLLEYBALL SHOES; WAIST BELTS; WAIST STRINGS FOR KIMONOS (KOSHIHIMO); WALKING SHORTS; WARM UP SUITS; WATER SOCKS; WATERPROOF JACKETS AND PANTS; WEDDING DRESSES; WEDDING GOWNS; WET SUIT GLOVES; WET SUITS; WET SUITS FOR WATER-SKIING AND SUB-AQUA; WIND COATS; WIND PANTS; WIND RESISTANT JACKETS; WIND SHIRTS; WIND VESTS; WIND-JACKETS; WINTER BOOTS; WOMEN'S CEREMONIAL DRESSES; WOMEN'S SHOES; WOMEN'S UNDERWEAR; WOODEN MAIN BODIES OF JAPANESE STYLE WOODEN CLOGS; WOODEN SUPPORTS OF JAPANESE STYLE WOODEN CLOGS; WOOLLY HATS; WORK SHOES AND BOOTS; WORKING OVERALLS; WOVEN OR KNITTED UNDERWEAR; WRAP BELTS FOR KIMONOS (DATEMAKI); WRAPS; WRIST BANDS; WRISTBANDS; WRISTBANDS CONTAINING A COOLING SUBSTANCE TO COOL THE WEARER; YOGA PANTS; YOGA SHIRTS; ZOOT SUITS (U.S. CLS. 22 AND 39).
FIRST USE 6-1-2008; IN COMMERCE 10-4-2008.

CLASS 25—(Continued).

3,632,735. SOLSTICE OUTDOOR, INC., PORTLAND, OR. SN 77-441,493. PUB. 8-26-2008, FILED 4-7-2008.

BARN OWL

THE MARK CONSISTS OF STANDARD CHARACTERS WITHOUT CLAIM TO ANY PARTICULAR FONT, STYLE, SIZE, OR COLOR.

FOR COMPONENT PARTS OF JACKETS AND PARKAS, NAMELY, HOODS (U.S. CLS. 22 AND 39).
FIRST USE 1-0-2008; IN COMMERCE 1-0-2008.

3,632,760. LIVING ON THE EDGE INC., WEATHERFORD, TX. SN 77-447,252. PUB. 9-2-2008, FILED 4-14-2008.



THE MARK CONSISTS OF THE STYLIZED TEXT "XHAUST NATION" WITH THREE LINES IN THE BACKGROUND, ABOVE THE TEXT ARE FIVE STARS.

FOR BELTS, SHORTS, JACKETS, COATS, SHIRTS, PANTS, HATS, HEADWEAR, T-SHIRTS, JEANS, AND SWEAT SHIRTS (U.S. CLS. 22 AND 39).
FIRST USE 9-17-2008; IN COMMERCE 9-17-2008.

3,632,783. KING, KYLE JOHN, NORTH HOLLYWOOD, CA. SN 77-454,159. PUB. 9-23-2008, FILED 4-22-2008.



NO CLAIM IS MADE TO THE EXCLUSIVE RIGHT TO USE "UNDERWEAR", APART FROM THE MARK AS SHOWN.

THE LIKENESS (OR, "PORTRAIT") IN THE MARK IDENTIFIES A LIVING INDIVIDUAL WHOSE CONSENT IS OF RECORD.

CLASS 25—(Continued).

THE MARK CONSISTS OF TWO CAPITAL LETTERS "K" BACK TO BACK MIRRORING EACH OTHER, WITH THE WORDS "KYLE KING UNDERWEAR".

FOR BRIEFS; LADIES' UNDERWEAR; LONG UNDERWEAR; THERMAL UNDERWEAR; THONGS; UNDERWEAR; WOMEN'S UNDERWEAR; SLEEPWEAR; T-SHIRTS; BRAS; UNDERWEAR, NAMELY, BOY SHORTS; BOXER BRIEFS; BOXER SHORTS; PANTIES, SHORTS AND BRIEFS; SHORT-SLEEVED OR LONG-SLEEVED T-SHIRTS; ROBES; TEDDIES; MUSCLE TOPS; TANK TOPS; SWIMWEAR; LOUNGEWEAR; UNDERSHIRTS; PAJAMA BOTTOMS; PAJAMAS; BIKINIS; SLIPS; CAMISOLES (U.S. CLS. 22 AND 39).

FIRST USE 5-1-2006; IN COMMERCE 6-1-2008.

3,632,795. JACQUELINE COY GIST, CHICAGO, IL. SN 77-458,093. PUB. 9-23-2008, FILED 4-25-2008.

F@B

THE MARK CONSISTS OF STANDARD CHARACTERS WITHOUT CLAIM TO ANY PARTICULAR FONT, STYLE, SIZE, OR COLOR.

FOR CLOTHING, NAMELY, T-SHIRTS, APRONS, ATHLETIC FOOTWEAR, BANDANAS, BATHROBES, BEACH SHOES, BEACHWEAR, BELTS, CAPS, COATS, DENIM JACKETS, FLEECE PULLOVERS, FOOTWEAR, HALTER TOPS, HATS, HEADBANDS, HEADWEAR, INFANTWEAR, JACKETS, JERSEYS, JOGGING SUITS, LEATHER JACKETS, PAJAMAS, POLO SHIRTS, SCARVES, SOCKS, SHIRTS, SHORTS, SWEATERS, SWEAT BANDS, SWEAT SHIRTS, SWEAT PANTS, TANK TOPS, TENNIS WEAR, TIES, T-SHIRTS, VESTS, WARM UP SUITS AND WRISTBANDS (U.S. CLS. 22 AND 39).

FIRST USE 7-2-2008; IN COMMERCE 7-2-2008.

3,632,825. FIFTYONEFIFTYCC LLC, MESA, AZ. SN 77-471,255. PUB. 12-9-2008, FILED 5-11-2008.

FIFTYONEFIFTYCC

THE MARK CONSISTS OF STANDARD CHARACTERS WITHOUT CLAIM TO ANY PARTICULAR FONT, STYLE, SIZE, OR COLOR.

FOR SHIRTS; SHORT-SLEEVED OR LONG-SLEEVED T-SHIRTS; SHORT-SLEEVED SHIRTS; SWEAT SHIRTS; T-SHIRTS; HATS; PANTIES, SHORTS AND BRIEFS; UNDERWEAR, NAMELY, BOY SHORTS; JACKETS; SLEEVED OR SLEEVELESS JACKETS; HOODED PULLOVERS; HOODED SWEAT SHIRTS; JOGGING PANTS; LOUNGE PANTS; SWEAT PANTS; HEADGEAR, NAMELY, BEANIES; BEANIES; SWEAT SHORTS; WIND RESISTANT JACKETS; BANDANAS (U.S. CLS. 22 AND 39).

FIRST USE 7-15-1999; IN COMMERCE 2-21-2007.

CLASS 25—(Continued).

3,632,826. MIZUNO CORPORATION, OSAKA, JAPAN. SN 77-472,080. PUB. 10-14-2008, FILED 5-12-2008.

WAVE MUSHA

THE MARK CONSISTS OF STANDARD CHARACTERS WITHOUT CLAIM TO ANY PARTICULAR FONT, STYLE, SIZE, OR COLOR.

FOR FOOTWEAR, NAMELY, ATHLETIC FOOTWEAR, SPORTS SHOES, AND CASUAL SHOES (U.S. CLS. 22 AND 39).

FIRST USE 5-1-2008; IN COMMERCE 5-1-2008.

3,632,827. MIZUNO CORPORATION, OSAKA, JAPAN. SN 77-472,119. PUB. 10-14-2008, FILED 5-12-2008.

WAVE RONIN

THE MARK CONSISTS OF STANDARD CHARACTERS WITHOUT CLAIM TO ANY PARTICULAR FONT, STYLE, SIZE, OR COLOR.

FOR FOOTWEAR, NAMELY, ATHLETIC FOOTWEAR AND SPORTS SHOES (U.S. CLS. 22 AND 39).

FIRST USE 5-1-2007; IN COMMERCE 5-1-2007.

3,632,832. MORE CUPCAKES, LLC, CHICAGO, IL. SN 77-475,640. PUB. 10-14-2008, FILED 5-15-2008.

love MORE

THE MARK CONSISTS OF STANDARD CHARACTERS WITHOUT CLAIM TO ANY PARTICULAR FONT, STYLE, SIZE, OR COLOR.

FOR T-SHIRTS (U.S. CLS. 22 AND 39).

FIRST USE 10-1-2008; IN COMMERCE 10-1-2008.

CLASS 25—(Continued).

3,632,864. WARNER BROS. ENTERTAINMENT INC., BURBANK, CA. SN 77-486,721. PUB. 10-7-2008, FILED 5-29-2008.

POPULARITY HAS ITS PRICE

THE MARK CONSISTS OF STANDARD CHARACTERS WITHOUT CLAIM TO ANY PARTICULAR FONT, STYLE, SIZE, OR COLOR.

FOR CLOTHING FOR MEN, WOMEN AND CHILDREN, NAMELY, SHIRTS, T-SHIRTS, SWEATSHIRTS (U.S. CLS. 22 AND 39).

FIRST USE 4-0-2008; IN COMMERCE 4-0-2008.

3,632,865. JOYFUL TRADING CO., LTD, TAIPEI, TAIWAN. SN 77-486,889. PUB. 11-18-2008, FILED 5-30-2008.

SAFETY STOP

THE MARK CONSISTS OF STANDARD CHARACTERS WITHOUT CLAIM TO ANY PARTICULAR FONT, STYLE, SIZE, OR COLOR.

FOR FOOTWEAR FOR MEN AND WOMEN WORK SHOES AND BOOTS (U.S. CLS. 22 AND 39).

FIRST USE 6-1-2008; IN COMMERCE 9-1-2008.

CLASS 25—(Continued).

3,632,890. CHRISTIAN R. SCHAARE AND JOSEPH INFANTE, NYACK, NY. SN 77-498,565. PUB. 11-4-2008, FILED 6-13-2008.



THE MARK CONSISTS OF THE SILHOUETTE OF A LACROSSE PLAYER IN A STANDING POSE WEARING LACROSSE GLOVES; WITH THE RIGHT LEG CROSSED OVER THE LEFT; THE LEFT ARM SITTING ON THE WAIST; THE RIGHT ARM HOLDING A LACROSSE STICK.

FOR ATHLETIC FOOTWEAR; BASEBALL CAPS; BEANIES; BOXER BRIEFS; BOXER SHORTS; CAP VISORS; CREWNECKS; FLEECE PULLOVERS; GYM SHORTS; HATS; HOODED PULLOVERS; HOODED SWEAT SHIRTS; JACKETS; KNITTED CAPS; LONG-SLEEVED SHIRTS; MEN'S SOCKS; PANTS; POLO SHIRTS; PULLOVERS; SHIRTS; SHORT-SLEEVED OR LONG-SLEEVED T-SHIRTS; SHORT-SLEEVED SHIRTS; SHORTS; SKULL CAPS; SOCKS; SPORTS JERSEYS; SWEAT BANDS; SWEAT PANTS; SWEAT SHIRTS; SWEAT SUITS; T-SHIRTS; TOPS; UNDERGARMENTS; UNDERWEAR; VISORS; WRISTBANDS (U.S. CLS. 22 AND 39).

FIRST USE 12-15-2008; IN COMMERCE 12-15-2008.

3,632,891. BABYGAGS, INC., SAN FRANCISCO, CA. SN 77-499,180. PUB. 11-4-2008, FILED 6-14-2008.

Silly Souls

THE MARK CONSISTS OF STANDARD CHARACTERS WITHOUT CLAIM TO ANY PARTICULAR FONT, STYLE, SIZE, OR COLOR.

FOR ANKLE SOCKS; BALLET SHOES; BIBS NOT OF CLOTH OR PAPER; CANVAS SHOES; CHILDREN'S AND INFANTS' CLOTH BIBS; CHILDREN'S CLOTH EATING BIBS; CLOTH BIBS; CLOTH DIAPERS; DANCE SHOES; FOOTWEAR; FOOTWEAR NOT FOR SPORTS; HATS; INFANT AND TODDLER ONE PIECE CLOTHING; INFANT CLOTH DIAPERS; INFANTS' SHOES AND BOOTS; LEATHER SHOES; RUBBER SHOES; SHOES; SOCKS; SOCKS AND STOCKINGS; SWADDLING CLOTHES; T-SHIRTS; TOPS; WEARABLE GARMENTS AND CLOTHING, NAMELY, SHIRTS (U.S. CLS. 22 AND 39).

FIRST USE 9-14-2007; IN COMMERCE 6-1-2008.

CLASS 25—(Continued).

3,632,965. URBAN REPUBLIC CLOTHING, ANAHEIM, CA. SN 77-524,230. PUB. 12-23-2008, FILED 7-16-2008.



FOR BOXER SHORTS; DENIMS; DENIM, CANVAS, COTTON, LINEN, SILK, NYLON AND POLYESTER FABRIC SOLD AS AN INTEGRAL COMPONENT OF FINISHED CLOTHING ITEMS, NAMELY, JEANS, SHIRTS, PANTS, TOPS; JEANS; WEARABLE GARMENTS AND CLOTHING, NAMELY, SHIRTS; ATHLETIC APPAREL, NAMELY, SHIRTS, PANTS, JACKETS, FOOTWEAR, HATS AND CAPS, ATHLETIC UNIFORMS; DENIM JACKETS; DRESS SHIRTS; FUR COATS AND JACKETS; FUR JACKETS; HOODED SWEAT SHIRTS; KNIT SHIRTS; LONG-SLEEVED SHIRTS; SHIRTS; SHORT-SLEEVED OR LONG-SLEEVED T-SHIRTS; SHORT-SLEEVED SHIRTS; SHORTS; SWEAT SHIRTS; SWEAT SHORTS; T-SHIRTS; TEE SHIRTS; TOPS (U.S. CLS. 22 AND 39).
FIRST USE 7-13-2007; IN COMMERCE 8-1-2007.

CLASS 25—(Continued).

3,632,975. I2WI2, INC., NEWBURY, MA. SN 77-527,468. PUB. 12-9-2008, FILED 7-21-2008.

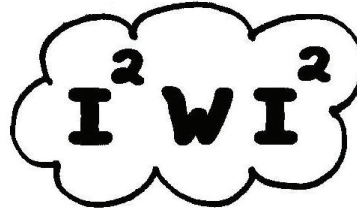

THE MARK CONSISTS OF THE TEXT, "I2WI2", LOCATED WITHIN A CLOUD.

FOR A-SHIRTS; ATHLETIC APPAREL, NAMELY, SHIRTS, PANTS, JACKETS, FOOTWEAR, HATS AND CAPS, ATHLETIC UNIFORMS; CAMP SHIRTS; CAPS; DRESS SHIRTS; GOLF SHIRTS; HATS; HOODED SWEAT SHIRTS; KNIT SHIRTS; LONG-SLEEVED SHIRTS; NIGHT SHIRTS; OPEN-NECKED SHIRTS; POLO SHIRTS; RUGBY SHIRTS; SHIRTS; SHORT-SLEEVED OR LONG-SLEEVED T-SHIRTS; SHORT-SLEEVED SHIRTS; SLEEP SHIRTS; SPORT SHIRTS; SPORTS SHIRTS; SPORTS SHIRTS WITH SHORT SLEEVES; SWEAT SHIRTS; T-SHIRTS; TEE SHIRTS; TRIATHLON CLOTHING, NAMELY, TRIATHLON TIGHTS, TRIATHLON SHORTS, TRIATHLON SINGLET, TRIATHLON SHIRTS, TRIATHLON SUITS; WEARABLE GARMENTS AND CLOTHING, NAMELY, SHIRTS; WIND SHIRTS; YOGA SHIRTS (U.S. CLS. 22 AND 39).
FIRST USE 5-1-2008; IN COMMERCE 5-1-2008.

3,632,968. JUYL DESIGNS LLC, BROOKLYN, NY. SN 77-526,582. PUB. 12-9-2008, FILED 7-19-2008.

YUNHI

THE MARK CONSISTS OF STANDARD CHARACTERS WITHOUT CLAIM TO ANY PARTICULAR FONT, STYLE, SIZE, OR COLOR.
THE NAME "YUNHI" IDENTIFIES A LIVING INDIVIDUAL WHOSE CONSENT IS OF RECORD.
FOR BLAZERS; BLOUSES; BOTTOMS; CAMISOLES; CARDIGANS; COATS; DRESSES; JACKETS; PANTS; PULLOVERS; SHIRTS; SHORTS; SKIRTS; SLACKS; SLIPS; SWEATERS; T-SHIRTS; TOPS; TROUSERS; VESTS (U.S. CLS. 22 AND 39).
FIRST USE 9-12-2008; IN COMMERCE 9-12-2008.

3,632,977. GRIMES, ELI DAVID, ST. AUGUSTINE, FL. SN 77-528,417. PUB. 12-16-2008, FILED 7-22-2008.

St. Johns River Life

THE MARK CONSISTS OF STANDARD CHARACTERS WITHOUT CLAIM TO ANY PARTICULAR FONT, STYLE, SIZE, OR COLOR.
FOR SHOES, SOCKS, PANTS, SHORTS, SHIRTS, UNDERWEAR, UNDERCLOTHES, PANTIES, DRESSES, HALTER TOPS, BRAS, COATS, JACKETS, SHAWLS, PANTYHOSE, HATS, CAPS, SANDALS, SMOCKS, PAJAMAS, BED CLOTHES, GOWNS, BELTS, SUSPENDERS, VISORS, BANDANAS, TIES, GLOVES, SCARVES (U.S. CLS. 22 AND 39).
FIRST USE 4-1-2008; IN COMMERCE 4-15-2008.

CLASS 25—(Continued).

3,632,990. CARTER, NORWARD, BLOOMINGTON, IN. SN 77-534,127. PUB. 12-16-2008, FILED 7-29-2008.

GREEN BANANAS CLOTHING

THE MARK CONSISTS OF STANDARD CHARACTERS WITHOUT CLAIM TO ANY PARTICULAR FONT, STYLE, SIZE, OR COLOR.

NO CLAIM IS MADE TO THE EXCLUSIVE RIGHT TO USE "CLOTHING", APART FROM THE MARK AS SHOWN. FOR CLOTHING, NAMELY, SHIRTS, PANTS, SHORTS, ROBES, BELTS, HATS (U.S. CLS. 22 AND 39). FIRST USE 4-1-2009; IN COMMERCE 4-1-2009.

3,633,029. GILROY, TIMOTHY, EAST STROUDSBURG, PA. SN 77-549,857. PUB. 1-6-2009, FILED 8-18-2008.

8TH DEGREE BLACK

THE MARK CONSISTS OF STANDARD CHARACTERS WITHOUT CLAIM TO ANY PARTICULAR FONT, STYLE, SIZE, OR COLOR.

FOR BOXER SHORTS; BRIEFS; CAPS; DRESSES; G-STRINGS; HATS; HOODED SWEAT SHIRTS; JACKETS; JERSEYS; PANTS; PULLOVERS; SHIRTS; SHORTS; SKIRTS; SWEAT SHIRTS; T-SHIRTS; TANK TOPS; THONGS; UNDERWEAR (U.S. CLS. 22 AND 39). FIRST USE 9-9-2008; IN COMMERCE 10-22-2008.

3,633,058. REEBOK INTERNATIONAL LTD., CANTON, MA. SN 77-976,913. PUB. 12-4-2007, FILED 8-16-2007.

BLACKTOP

THE MARK CONSISTS OF STANDARD CHARACTERS WITHOUT CLAIM TO ANY PARTICULAR FONT, STYLE, SIZE, OR COLOR.

FOR FOOTWEAR (U.S. CLS. 22 AND 39). FIRST USE 7-0-2008; IN COMMERCE 7-0-2008.

CLASS 25—(Continued).

3,633,065. B.A.M. MEDIA LLC, NEW YORK, NY. SN 77-976,971. PUB. 8-7-2007, FILED 2-8-2007.

CRAZY EDDIE

THE MARK CONSISTS OF STANDARD CHARACTERS WITHOUT CLAIM TO ANY PARTICULAR FONT, STYLE, SIZE, OR COLOR.

OWNER OF U.S. REG. NO. 2,820,934. FOR CLOTHING, NAMELY, TEE-SHIRTS (U.S. CLS. 22 AND 39). FIRST USE 1-0-1975; IN COMMERCE 1-0-1975.

3,633,069. AETHER, LLC., LOS ANGELES, CA. SN 77-977,005. PUB. 7-8-2008, FILED 4-3-2008.

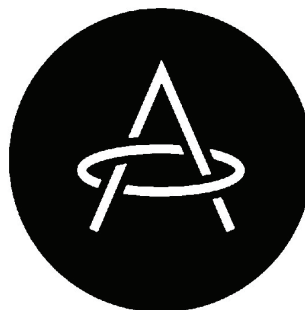

THE MARK CONSISTS OF A CIRCLE WITH THE LETTER "A" INSIDE OF WHICH THE "A" IS CROSSED BY USING AN INFINITY CIRCLE.

FOR JACKETS; SWEAT SHIRTS; T-SHIRTS; POLO SHIRTS; SHIRTS; RAIN JACKETS (U.S. CLS. 22 AND 39). FIRST USE 1-28-2009; IN COMMERCE 1-28-2009.

CLASS 25—(Continued).

3,633,085. WNBA ENTERPRISES, LLC, SECAUCUS, NJ. SN 78-216,110. PUB. 6-22-2004, FILED 2-18-2003.



OWNER OF U.S. REG. NOS. 254,062, 2,465,903, AND OTHERS.

NO CLAIM IS MADE TO THE EXCLUSIVE RIGHT TO USE "SAN ANTONIO", APART FROM THE MARK AS SHOWN.

FOR CLOTHING, NAMELY, HOSIERY, T-SHIRTS, SHIRTS, SWEATSHIRTS, SWEATPANTS, PANTS, TANK TOPS, JERSEYS, SHORTS, PAJAMAS, SPORT SHIRTS, RUGBY SHIRTS, SWEATERS, BELTS, TIES, NIGHTSHIRTS, HATS, WARM-UP SUITS, WARM-UP PANTS, WARM-UP TOPS, JACKETS, WIND RESISTANT JACKETS, PARKAS, COATS, CLOTH BABY BIBS, HEAD BANDS, WRIST BANDS, APRONS, BOXER SHORTS, SLACKS, CAPS, EAR MUFFS, GLOVES, MITTENS, SCARVES, WOVEN AND KNIT SHIRTS, CHEERLEADING DRESSES AND UNIFORMS (U.S. CLS. 22 AND 39).
FIRST USE 2-19-2003; IN COMMERCE 2-19-2003.

CLASS 25—(Continued).

3,633,124. RETAIL ROYALTY COMPANY, LAS VEGAS, NV. SN 78-562,208. PUB. 12-20-2005, FILED 2-7-2005.



THE MARK CONSISTS OF STANDARD CHARACTERS WITHOUT CLAIM TO ANY PARTICULAR FONT, STYLE, SIZE, OR COLOR.

FOR SWIMWEAR, CLOTHING BELTS, BOTTOMS, AND COATS (U.S. CLS. 22 AND 39).

FIRST USE 7-0-2006; IN COMMERCE 7-0-2006.

3,633,092. PODI, LLC, CHICAGO, IL. SN 78-350,117. PUB. 12-27-2005, FILED 1-9-2004.



THE MARK CONSISTS OF STANDARD CHARACTERS WITHOUT CLAIM TO ANY PARTICULAR FONT, STYLE, SIZE, OR COLOR.

THE ENGLISH TRANSLATION OF THE WORD "PODI" IN THE MARK IS FOOT.

FOR CLOTHING, NAMELY, SHIRTS (U.S. CLS. 22 AND 39).

FIRST USE 11-16-2008; IN COMMERCE 11-17-2008.

3,633,127. CUPID FOUNDATIONS, INC., NEW YORK, NY. SN 78-568,469. PUB. 12-20-2005, FILED 2-16-2005.



THE MARK CONSISTS OF STANDARD CHARACTERS WITHOUT CLAIM TO ANY PARTICULAR FONT, STYLE, SIZE, OR COLOR.

NO CLAIM IS MADE TO THE EXCLUSIVE RIGHT TO USE "TUMMY", APART FROM THE MARK AS SHOWN.

FOR FOUNDATION GARMENTS (U.S. CLS. 22 AND 39).

FIRST USE 1-7-2009; IN COMMERCE 1-7-2009.

CLASS 25—(Continued).

3,633,134. LIFTED RESEARCH GROUP INC., IRVINE, CA.
SN 78-582,168. PUB. 11-29-2005, FILED 3-7-2005.

LUXIRIE

THE MARK CONSISTS OF STANDARD CHARACTERS WITHOUT CLAIM TO ANY PARTICULAR FONT, STYLE, SIZE, OR COLOR.

FOR CLOTHING, AND HEADWEAR, NAMELY, SWEATSHIRTS, ANORAKS, PARKAS, UNDERSHIRTS, SKI WEAR, SNOWBOARD WEAR (U.S. CLS. 22 AND 39).
FIRST USE 11-1-2005; IN COMMERCE 11-1-2005.

3,633,148. PRUDEAUX, MARK, NORTHRIDGE, CA. SN 78-628,510. PUB. 1-31-2006, FILED 5-12-2005.



The Path of
Pussanonda

THE MARK CONSISTS OF "THE PATH OF PUSSANONDA" IN STYLIZED LETTERING AND DESIGN.

FOR CLOTHING, NAMELY, SLEEPWEAR, UNDERWEAR, LINGERIE, ROBES, SLIPPERS, SHOES, ATHLETIC SHOES, HEADWEAR, HATS, CAPS, SUN VISORS, SWIM WEAR, SHIRTS, TANK TOPS, PANTS, SHORTS, SOCKS, SWEATERS, COATS, JACKETS, RAINWEAR, NECKWEAR, SCARVES, BELTS, SUSPENDERS, GLOVES, SWEAT SHIRTS, SWEAT SUITS, HALLOWEEN AND MASQUERADE COSTUMES AND MASKS SOLD IN CONNECTION THEREWITH (U.S. CLS. 22 AND 39).
FIRST USE 4-16-2009; IN COMMERCE 4-16-2009.

CLASS 25—(Continued).

3,633,187. JUICY COUTURE, INC., PACOIMA, CA. SN 78-720,344. PUB. 11-4-2008, FILED 9-26-2005.

JUICY

THE MARK CONSISTS OF STANDARD CHARACTERS WITHOUT CLAIM TO ANY PARTICULAR FONT, STYLE, SIZE, OR COLOR.

OWNER OF U.S. REG. NOS. 2,348,674, 2,882,280, AND OTHERS.
FOR FOOTWEAR (U.S. CLS. 22 AND 39).
FIRST USE 7-1-2006; IN COMMERCE 7-1-2006.

3,633,190. MAJOR LEAGUE BASEBALL PROPERTIES, INC., NEW YORK, NY. SN 78-728,581. PUB. 7-4-2006, FILED 10-7-2005.

I LIVE FOR THIS

THE MARK CONSISTS OF STANDARD CHARACTERS WITHOUT CLAIM TO ANY PARTICULAR FONT, STYLE, SIZE, OR COLOR.

FOR CLOTHING, NAMELY, CAPS, HATS, KNITTED HEADWEAR, SHIRTS, T-SHIRTS, TANK TOPS, SHORTS, PANTS, BASEBALL UNIFORMS, JERSEYS, SWEATSHIRTS, SWEATPANTS, JACKETS, TIES, FOOTWEAR, SLIPPERS (U.S. CLS. 22 AND 39).
FIRST USE 3-0-2004; IN COMMERCE 3-0-2004.

3,633,193. THE CARTOON NETWORK, INC., ATLANTA, GA. SN 78-733,250. PUB. 6-20-2006, FILED 10-14-2005.

THE MARVELOUS
MISADVENTURES OF FLAPJACK

THE MARK CONSISTS OF STANDARD CHARACTERS WITHOUT CLAIM TO ANY PARTICULAR FONT, STYLE, SIZE, OR COLOR.

FOR CLOTHING FOR MEN, WOMEN AND CHILDREN, NAMELY, SHIRTS, T-SHIRTS, TANK TOPS (U.S. CLS. 22 AND 39).
FIRST USE 4-1-2009; IN COMMERCE 4-1-2009.

CLASS 25—(Continued).

3,633,199. DYSON RACING SWAG.COM, LLC, WINNETKA, IL. SN 78-738,925. PUB. 3-6-2007, FILED 10-24-2005.



NO CLAIM IS MADE TO THE EXCLUSIVE RIGHT TO USE "RACING", APART FROM THE MARK AS SHOWN. THE MARK CONSISTS OF THE WORDS "DYSON RACING" IN STYLIZED LETTERS AND/OR WITH DESIGN, FOR CLOTHING, NAMELY, T-SHIRTS, POLO-SHIRTS, SWEATSHIRTS, HATS AND CAPS (U.S. CLS. 22 AND 39). FIRST USE 5-17-2005; IN COMMERCE 5-17-2005.

CLASS 25—(Continued).

3,633,211. OFFICE OF THE COMMISSIONER OF BASEBALL, NEW YORK, NY. SN 78-758,369. PUB. 8-1-2006, FILED 11-21-2005.

AMERICAN LEAGUE

THE MARK CONSISTS OF STANDARD CHARACTERS WITHOUT CLAIM TO ANY PARTICULAR FONT, STYLE, SIZE, OR COLOR. OWNER OF U.S. REG. NOS. 1,357,826, 1,566,178, AND OTHERS. FOR CLOTHING, NAMELY, CAPS, HATS, SHIRTS, T-SHIRTS, TANK TOPS, PULLOVERS, BASEBALL UNIFORMS, JERSEYS, SWEATSHIRTS, JACKETS (U.S. CLS. 22 AND 39). FIRST USE 3-0-1981; IN COMMERCE 3-0-1981.

3,633,207. THE U.S. SECRET SERVICE UNIFORMED DIVISION BENEFIT FUND, WASHINGTON, DC. SN 78-753,201. PUB. 11-6-2007, FILED 11-14-2005.

AMERICA'S LEGACY

THE MARK CONSISTS OF STANDARD CHARACTERS WITHOUT CLAIM TO ANY PARTICULAR FONT, STYLE, SIZE, OR COLOR. FOR CLOTHING FOR MEN, WOMEN, AND CHILDREN, NAMELY, T-SHIRTS, SWEATSHIRTS, UNDERWEAR, PAJAMAS, ROBES, AND HEADWEAR (U.S. CLS. 22 AND 39). FIRST USE 1-15-2008; IN COMMERCE 1-5-2009.

3,633,212. OFFICE OF THE COMMISSIONER OF BASEBALL, NEW YORK, NY. SN 78-758,370. PUB. 7-25-2006, FILED 11-21-2005.

AMERICAN LEAGUE CHAMPIONS

3,633,210. OFFICE OF THE COMMISSIONER OF BASEBALL, NEW YORK, NY. SN 78-758,364. PUB. 7-25-2006, FILED 11-21-2005.

AL CHAMPIONS

THE MARK CONSISTS OF STANDARD CHARACTERS WITHOUT CLAIM TO ANY PARTICULAR FONT, STYLE, SIZE, OR COLOR. OWNER OF U.S. REG. NOS. 1,550,251, 2,204,150, AND OTHERS. FOR CLOTHING, NAMELY, CAPS, HATS, SHIRTS, T-SHIRTS, PULLOVERS, SWEATSHIRTS, JACKETS (U.S. CLS. 22 AND 39). FIRST USE 10-0-1997; IN COMMERCE 10-0-1997.

THE MARK CONSISTS OF STANDARD CHARACTERS WITHOUT CLAIM TO ANY PARTICULAR FONT, STYLE, SIZE, OR COLOR. OWNER OF U.S. REG. NO. 1,357,826 AND OTHERS. FOR CLOTHING, NAMELY, CAPS, HATS, SHIRTS, T-SHIRTS, SWEATSHIRTS, JACKETS (U.S. CLS. 22 AND 39). FIRST USE 10-0-1989; IN COMMERCE 10-0-1989.

CLASS 25—(Continued).

3,633,213. OFFICE OF THE COMMISSIONER OF BASEBALL, NEW YORK, NY. SN 78-758,376. PUB. 8-1-2006, FILED 11-21-2005.



OWNER OF U.S. REG. NO. 1,357,826 AND OTHERS.
FOR CLOTHING, NAMELY, CAPS, HATS, SHIRTS,
JACKETS (U.S. CLS. 22 AND 39).
FIRST USE 3-0-1981; IN COMMERCE 3-0-1981.

3,633,228. MILWAUKEE BREWERS BASEBALL CLUB, MILWAUKEE, WI. SN 78-798,713. PUB. 8-1-2006, FILED 1-25-2006.



OWNER OF U.S. REG. NOS. 2,378,717, 2,384,821, AND OTHERS.
THE MARK CONSISTS OF A TWO-DIMENSIONAL DEPICTION OF A THREE-DIMENSIONAL COSTUMED CHARACTER.
FOR CLOTHING, NAMELY, CAPS, HATS, SHIRTS, T-SHIRTS (U.S. CLS. 22 AND 39).
FIRST USE 4-0-2000; IN COMMERCE 4-0-2000.

CLASS 25—(Continued).

3,633,229. MILWAUKEE BREWERS BASEBALL CLUB, MILWAUKEE, WI. SN 78-798,720. PUB. 8-1-2006, FILED 1-25-2006.

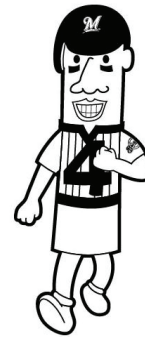

OWNER OF U.S. REG. NOS. 2,378,717, 2,384,821, AND OTHERS.
THE MARK CONSISTS OF A TWO-DIMENSIONAL DEPICTION OF A THREE-DIMENSIONAL COSTUMED CHARACTER.
FOR CLOTHING, NAMELY, CAPS, HATS, SHIRTS, T-SHIRTS (U.S. CLS. 22 AND 39).
FIRST USE 4-0-2000; IN COMMERCE 4-0-2000.

3,633,242. ATHLETICS INVESTMENT GROUP LLC, DBA THE OAKLAND ATHLETICS BASEBALL COMPANY, OAKLAND, CA. SN 78-832,003. PUB. 7-10-2007, FILED 3-8-2006.

PHILADELPHIA ATHLETICS

THE MARK CONSISTS OF STANDARD CHARACTERS WITHOUT CLAIM TO ANY PARTICULAR FONT, STYLE, SIZE, OR COLOR.
NO CLAIM IS MADE TO THE EXCLUSIVE RIGHT TO USE "PHILADELPHIA", APART FROM THE MARK AS SHOWN.
FOR CLOTHING, NAMELY, CAPS, HATS, BASEBALL UNIFORMS, JERSEYS (U.S. CLS. 22 AND 39).
FIRST USE 0-0-1984; IN COMMERCE 0-0-1984.

CLASS 25—(Continued).

3,633,243. ATHLETICS INVESTMENT GROUP LLC, DBA THE OAKLAND ATHLETICS BASEBALL COMPANY, OAKLAND, CA. SN 78-832,013. PUB. 7-10-2007, FILED 3-8-2006.

KANSAS CITY ATHLETICS

THE MARK CONSISTS OF STANDARD CHARACTERS WITHOUT CLAIM TO ANY PARTICULAR FONT, STYLE, SIZE, OR COLOR.

NO CLAIM IS MADE TO THE EXCLUSIVE RIGHT TO USE "KANSAS CITY", APART FROM THE MARK AS SHOWN.

FOR CLOTHING, NAMELY, CAPS, HATS (U.S. CLS. 22 AND 39).

FIRST USE 0-0-1989; IN COMMERCE 0-0-1989.

3,633,244. LOS ANGELES DODGERS LLC, LOS ANGELES, CA. SN 78-832,044. PUB. 12-26-2006, FILED 3-8-2006.

BROOKLYN DODGERS

THE MARK CONSISTS OF STANDARD CHARACTERS WITHOUT CLAIM TO ANY PARTICULAR FONT, STYLE, SIZE, OR COLOR.

OWNER OF U.S. REG. NOS. 1,562,301 AND 1,859,757.

FOR CLOTHING, NAMELY, CAPS, HATS, SHIRTS, T-SHIRTS, BASEBALL UNIFORMS, JERSEYS, SWEAT-SHIRTS, JACKETS, SOCKS, HOSIERY (U.S. CLS. 22 AND 39).

FIRST USE 10-24-1985; IN COMMERCE 10-24-1985.

3,633,245. SIMON DE WINTER GROUP PTY LIMITED, MELBOURNE, VICTORIA, AUSTRALIA. SN 78-834,319. PUB. 10-24-2006, FILED 3-10-2006.



FOR LINGERIE, BRAS, CORSETRY, UNDERWEAR (U.S. CLS. 22 AND 39).

FIRST USE 6-17-2008; IN COMMERCE 6-17-2008.

CLASS 25—(Continued).

3,633,268. ROBERT GRAHAM HOLDINGS LLC, NEW YORK, NY. SN 78-881,081. PUB. 8-21-2007, FILED 5-11-2006.



OWNER OF U.S. REG. NO. 2,845,738.
"ROBERT GRAHAM" DOES NOT IDENTIFY A LIVING INDIVIDUAL

"THE COLOR(S) BLACK AND RED IS/ARE CLAIMED AS A FEATURE OF THE MARK."

THE COLOR RED APPEARS IN THE STYLIZED "E" IN THE TERM "ZEN." THE COLOR BLACK APPEARS IN THE LETTERS "Z" AND "N" IN THE TERM "ZEN", IN THE DESIGN FEATURE AND IN THE LETTERS COMPRISING THE NAME ROBERT GRAHAM.

FOR MEN'S CLOTHING, NAMELY, SHIRTS, PANTS, JACKETS, SPORTCOATS, JEANS AND KNIT SHIRTS (U.S. CLS. 22 AND 39).

FIRST USE 2-28-2007; IN COMMERCE 2-28-2007.

3,633,284. DISNEY ENTERPRISES, INC., BURBANK, CA. SN 78-911,878. PUB. 7-31-2007, FILED 6-20-2006.

TINKER BELL

THE MARK CONSISTS OF STANDARD CHARACTERS WITHOUT CLAIM TO ANY PARTICULAR FONT, STYLE, SIZE, OR COLOR.

FOR ATHLETIC SHOES; BASEBALL CAPS; BEACH COVER-UPS; BEACHWEAR; CLOTH BIBS FOR BABIES AND INFANTS; BIKINIS; BLAZERS; BOOTS; CAPS; CLOTH BIBS; COATS; DRESSES; EAR MUFFS; FOOTWEAR; GLOVES; HALLOWEEN COSTUMES; HATS; HEAD BANDS; HEAD WEAR; INFANTWEAR; JACKETS; JEANS; JERSEYS; NIGHT SHIRTS; NIGHT GOWNS; PAJAMAS; PANTS; POLO SHIRTS; PONCHOS; RAINWEAR; ROBES; SANDALS; SCARVES; SHIRTS; SHOES; SKIRTS; SHORTS; SLIPPERS; SLEEPWEAR; SWEATERS; SWEAT PANTS; SWEAT SHIRTS; SWIMSUITS; TANK TOPS; T-SHIRTS; VESTS; WRIST BANDS (U.S. CLS. 22 AND 39).

FIRST USE 7-30-2008; IN COMMERCE 7-30-2008.

CLASS 25—(Continued).

3,633,293. KARSTEN MANUFACTURING CORPORATION, PHOENIX, AZ. SN 78-924,533. PUB. 2-13-2007, FILED 7-7-2006.

I10

THE MARK CONSISTS OF STANDARD CHARACTERS WITHOUT CLAIM TO ANY PARTICULAR FONT, STYLE, SIZE, OR COLOR.
FOR CAPS (U.S. CLS. 22 AND 39).
FIRST USE 4-15-2009; IN COMMERCE 4-15-2009.

3,633,309. HERNANDEZ, MICHELLE DAWN, PHOENIX, AZ. SN 78-955,652. PUB. 5-6-2008, FILED 8-18-2006.

RACE MOM

THE MARK CONSISTS OF STANDARD CHARACTERS WITHOUT CLAIM TO ANY PARTICULAR FONT, STYLE, SIZE, OR COLOR.
SEC. 2(F).
FOR T-SHIRTS, PANTS, JACKETS, CAPS, SHORTS, SKIRTS, DRESSES, BELTS, SWEATSHIRTS, SWEATPANTS, UNDERWEAR, SWIMSUITS, PAJAMAS (U.S. CLS. 22 AND 39).
FIRST USE 8-30-2008; IN COMMERCE 8-30-2008.

3,633,323. NINTENDO OF AMERICA INC., REDMOND, WA. SN 78-973,956. PUB. 1-15-2008, FILED 9-13-2006.

WII PLAY

THE MARK CONSISTS OF STANDARD CHARACTERS WITHOUT CLAIM TO ANY PARTICULAR FONT, STYLE, SIZE, OR COLOR.
FOR CLOTHING, NAMELY, SHIRTS; T-SHIRTS; TOPS (U.S. CLS. 22 AND 39).
FIRST USE 9-10-2007; IN COMMERCE 9-10-2007.

CLASS 25—(Continued).

3,633,334. KIPP, MASTIN, LOS ANGELES, CA. SN 78-981,047. PUB. 7-3-2007, FILED 10-23-2005.

LOVE YOURSELF

THE MARK CONSISTS OF STANDARD CHARACTERS WITHOUT CLAIM TO ANY PARTICULAR FONT, STYLE, SIZE, OR COLOR.
FOR PANTS, SWEATPANTS, SWEATSHIRTS (U.S. CLS. 22 AND 39).
FIRST USE 10-31-2008; IN COMMERCE 2-28-2009.

CLASS 26—FANCY GOODS

3,631,940. BROWN, MICHAEL A., HINSDALE, IL. AND BROWN, BETTY L., HINSDALE, IL. SN 77-088,851. PUB. 1-22-2008, FILED 1-23-2007.

VHISH

THE MARK CONSISTS OF STANDARD CHARACTERS WITHOUT CLAIM TO ANY PARTICULAR FONT, STYLE, SIZE, OR COLOR.
FOR BELT BUCKLES (U.S. CLS. 37, 39, 40, 42 AND 50).
FIRST USE 3-25-2009; IN COMMERCE 3-25-2009.

3,631,972. SHAKE-N-GO FASHION, INC., PORT WASHINGTON, NY. SN 77-118,039. PUB. 1-15-2008, FILED 2-28-2007.



OWNER OF U.S. REG. NO. 3,095,385.
THE COLOR(S) YELLOW, BLUE, WHITE, PURPLE, RED AND ORANGE IS/ARE CLAIMED AS A FEATURE OF THE MARK.
THE MARK CONSISTS OF THE DISTINCTIVE TRADE DRESS CHARACTERIZING THE FRONT OF THE PACKA-

CLASS 26—(Continued).

GING FOR APPLICANT'S GOODS. THE PACKAGING IS SUBSTANTIALLY RECTANGULAR IN SHAPE, WITH THE LOWER SIDE BEING CURVED IN SHAPE. A BLUE CURVE DESIGN IS LOCATED AT THE BOTTOM OF THE PACKAGE. A FIRST YELLOW CURVE DESIGN IS LOCATED DIRECTLY ABOVE THE BLUE CURVE DESIGN, AND A SECOND YELLOW CURVE DESIGN IS LOCATED AT THE TOP OF THE PACKAGE. THE CENTER OF THE PACKAGE BETWEEN THE FIRST AND SECOND YELLOW CURVE DESIGNS IS WHITE AND INCLUDES THE STYLIZED WORD "FREETRESS", WHICH INCLUDES THE COLOR PURPLE IN THE ELEMENT "FREE" AND THE COLORS RED, ORANGE AND YELLOW IN THE ELEMENT "TRESS". THE BROKEN LINES ARE INTENDED TO SHOW THE PRODUCT ASSOCIATED WITH THE MARK AND ARE NOT CLAIMED AS A PART OF THE MARK.

FOR HAIR PRODUCTS AND ACCESSORIES, NAMELY, WIGS, HAIR PIECES, PONYTAIL HAIR PIECES, PONYTAIL HOLDERS, ADD-ON HAIR ACCESSORIES CONSTRUCTED PRIMARILY OF SYNTHETIC AND/OR HUMAN HAIR, HAIR EXTENSIONS, HAIR BRAIDS, HAIR WEAVES (U.S. CLS. 37, 39, 40, 42 AND 50).

FIRST USE 4-6-2005; IN COMMERCE 4-6-2005.

3,632,162. LITTLE RAPIDS CORPORATION, GREEN BAY, WI. SN 77-252,797. PUB. 5-27-2008, FILED 8-10-2007.

MEGA WRAPSTRIP

THE MARK CONSISTS OF STANDARD CHARACTERS WITHOUT CLAIM TO ANY PARTICULAR FONT, STYLE, SIZE, OR COLOR.

NO CLAIM IS MADE TO THE EXCLUSIVE RIGHT TO USE "WRAP STRIP", APART FROM THE MARK AS SHOWN.

FOR HAIR STYLING WRAPS USED IN APPLYING HAIR CARE PREPARATIONS (U.S. CLS. 37, 39, 40, 42 AND 50).

FIRST USE 9-1-2002; IN COMMERCE 9-1-2002.

CLASS 26—(Continued).

3,632,837. MAHER, SARA MONICA, DUNELLEN, NJ. SN 77-477,481. PUB. 10-14-2008, FILED 5-18-2008.



THE MARK CONSISTS OF A FLOWER DRAWN BY COMPUTER VECTOR CURVES. THE FLOWER HAS FIVE PETALS AND AN ELABORATE CENTER. THE FIVE PETALS ARE CREATED BY TWELVE DECORATIVE AND BROKEN CURVED LINES. THE CENTER IS A SERIES OF FIFTEEN INTERLOCKING CURVED SHAPES CREATING A CIRCULAR FORM.

FOR ARTIFICIAL FLOWERS OF TEXTILE (U.S. CLS. 37, 39, 40, 42 AND 50).

FIRST USE 7-16-2008; IN COMMERCE 7-16-2008.

CLASS 27—FLOOR COVERINGS

3,632,424. BEAULIEU GROUP, LLC, DALTON, GA. SN 77-368,541. PUB. 7-22-2008, FILED 1-10-2008.

SILVER RELEASE

THE MARK CONSISTS OF STANDARD CHARACTERS WITHOUT CLAIM TO ANY PARTICULAR FONT, STYLE, SIZE, OR COLOR.

NO CLAIM IS MADE TO THE EXCLUSIVE RIGHT TO USE "SILVER", APART FROM THE MARK AS SHOWN.

FOR ANTIMICROBIAL CARPET TREATMENT SOLD AS AN INTEGRAL COMPONENT OF CARPETING (U.S. CLS. 19, 20, 37, 42 AND 50).

FIRST USE 2-6-2008; IN COMMERCE 2-6-2008.

CLASS 27—(Continued).

3,632,845. NEW PENDULUM CORP., WILMINGTON, DE. SN 77-480,482. PUB. 12-30-2008, FILED 5-21-2008.

DRIVE-OVER DRAINBLOCKER

THE MARK CONSISTS OF STANDARD CHARACTERS WITHOUT CLAIM TO ANY PARTICULAR FONT, STYLE, SIZE, OR COLOR.

OWNER OF U.S. REG. NO. 2,838,258, SEC. 2(F) AS TO "DRAINBLOCKER".
FOR FLEXIBLE IMPERVIOUS POLYURETHANE AND NITRILE RUBBER MAT FOR SEALING OFF OPENINGS AGAINST PASSAGE OF SURFACE LIQUIDS (U.S. CLS. 19, 20, 37, 42 AND 50).

FIRST USE 1-7-2009; IN COMMERCE 1-7-2009.

3,633,101. HELLAS CONSTRUCTION, AUSTIN, TX. SN 78-484,313. PUB. 1-17-2006, FILED 9-15-2004.

Grasso

THE MARK CONSISTS OF STANDARD CHARACTERS WITHOUT CLAIM TO ANY PARTICULAR FONT, STYLE, SIZE, OR COLOR.

FOR SYNTHETIC LAWN, NAMELY, ARTIFICIAL TURF (U.S. CLS. 19, 20, 37, 42 AND 50).

FIRST USE 4-30-2005; IN COMMERCE 3-31-2009.

CLASS 28—TOYS AND SPORTING GOODS

CLASS 28—(Continued).

3,631,829. HASBRO, INC., PAWTUCKET, RI. SN 76-681,546. PUB. 6-17-2008, FILED 9-6-2007.

BELIEVE IN PLAY

THE MARK CONSISTS OF STANDARD CHARACTERS WITHOUT CLAIM TO ANY PARTICULAR FONT, STYLE, SIZE, OR COLOR.

FOR TOYS, GAMES AND PLAYTHINGS, NAMELY, TOY ACTION FIGURES, TOY VEHICLES, DOLLS, DOLL CLOTHING, STUFFED TOYS, PLUSH TOYS, FOAM TOYS, CHILDREN'S MULTIPLE ACTIVITY TOYS, BATH TOYS, BATHTUB TOYS, INFLATABLE TOYS, RIDE-ON TOYS, VINYL AND PLASTIC TOY ANIMALS AND CHARACTERS, TOY CONSTRUCTION BLOCKS, SORTING, STACKING AND NESTING TOYS, ROCKING TOYS, WIND-UP TOYS, TOY WOODEN BLOCKS (U.S. CLS. 22, 23, 38 AND 50).

FIRST USE 7-9-2007; IN COMMERCE 7-9-2007.

3,631,848. HASBRO, INC., PAWTUCKET, RI. SN 76-687,444. PUB. 7-15-2008, FILED 3-6-2008.

TAG OR BE TAGGED

THE MARK CONSISTS OF STANDARD CHARACTERS WITHOUT CLAIM TO ANY PARTICULAR FONT, STYLE, SIZE, OR COLOR.

FOR TOY DART SHOOTERS AND FOAM TOY DARTS FOR USE THEREWITH (U.S. CLS. 22, 23, 38 AND 50).

FIRST USE 7-7-2008; IN COMMERCE 7-7-2008.

3,631,850. KWIK GOAL, LTD., QUAKERTOWN, PA. SN 76-687,862. PUB. 7-29-2008, FILED 3-19-2008.

CREATIVE COACHING

THE MARK CONSISTS OF STANDARD CHARACTERS WITHOUT CLAIM TO ANY PARTICULAR FONT, STYLE, SIZE, OR COLOR.

NO CLAIM IS MADE TO THE EXCLUSIVE RIGHT TO USE "COACHING", APART FROM THE MARK AS SHOWN.

FOR SPORTING GOODS AND EQUIPMENT FOR USE IN FIELD SPORTS TRAINING, NAMELY, RINGS, CONES, LADDERS, HURDLES, COACHING STICKS, TRAINING ARCHES, PNEUMATIC BALLS, GOALS, AND TRAINING MANNEQUINS (U.S. CLS. 22, 23, 38 AND 50).

FIRST USE 1-31-2009; IN COMMERCE 1-31-2009.

CLASS 28—(Continued).

3,631,854. HASBRO, INC., PAWTUCKET, RI. SN 76-688,905.
PUB. 7-15-2008, FILED 4-21-2008.

AUTOBOT BLADES

THE MARK CONSISTS OF STANDARD CHARACTERS WITHOUT CLAIM TO ANY PARTICULAR FONT, STYLE, SIZE, OR COLOR.

OWNER OF U.S. REG. NOS. 1,348,233, 2,666,290, AND OTHERS.

FOR TOY ACTION FIGURES, TOY VEHICLES AND TOY ROBOTS CONVERTIBLE INTO OTHER VISUAL TOY FORMS (U.S. CLS. 22, 23, 38 AND 50).

FIRST USE 9-1-1986; IN COMMERCE 9-1-1986.

CLASS 28—(Continued).

3,631,895. DISNEY ENTERPRISES, INC., BURBANK, CA. SN 77-041,559. PUB. 7-24-2007, FILED 11-10-2006.

HANDY MANNY

THE MARK CONSISTS OF STANDARD CHARACTERS WITHOUT CLAIM TO ANY PARTICULAR FONT, STYLE, SIZE, OR COLOR.

FOR CARD GAMES; CHILDREN'S MULTIPLE ACTIVITY TOYS; BATH TOYS; JIGSAW PUZZLES; PARTY FAVORS IN THE NATURE OF SMALL TOYS; RUBBER BALLS (U.S. CLS. 22, 23, 38 AND 50).

FIRST USE 10-16-2008; IN COMMERCE 10-16-2008.

3,631,855. HASBRO, INC., PAWTUCKET, RI. SN 76-688,913.
PUB. 7-8-2008, FILED 4-21-2008.

LUGNUT

THE MARK CONSISTS OF STANDARD CHARACTERS WITHOUT CLAIM TO ANY PARTICULAR FONT, STYLE, SIZE, OR COLOR.

FOR TOY ACTION FIGURES, TOY VEHICLES AND TOY ROBOTS CONVERTIBLE INTO OTHER VISUAL TOY FORMS (U.S. CLS. 22, 23, 38 AND 50).

FIRST USE 3-1-2007; IN COMMERCE 3-1-2007.

3,631,919. ESPOSITO, DAVID A., DOYLESTOWN, PA. SN 77-068,702. PUB. 7-24-2007, FILED 12-20-2006.

ABUNDANT HARVEST

THE MARK CONSISTS OF STANDARD CHARACTERS WITHOUT CLAIM TO ANY PARTICULAR FONT, STYLE, SIZE, OR COLOR.

FOR EQUIPMENT SOLD AS A UNIT FOR PLAYING BOARD GAMES (U.S. CLS. 22, 23, 38 AND 50).

FIRST USE 12-8-2008; IN COMMERCE 12-8-2008.

3,631,878. WINSPUR, FRANK, GLENWOOD, FL. SN 77-021,277. PUB. 5-22-2007, FILED 10-14-2006.

DR. JEKYLL AS MR. HYDE

THE MARK CONSISTS OF STANDARD CHARACTERS WITHOUT CLAIM TO ANY PARTICULAR FONT, STYLE, SIZE, OR COLOR.

FOR MODELED PLASTIC TOY FIGURINES; TOY MODEL HOBBYCRAFT KITS; COLLECTABLE TOY FIGURES (U.S. CLS. 22, 23, 38 AND 50).

FIRST USE 5-31-2007; IN COMMERCE 5-31-2007.

3,631,942. JOHNSON HEALTH TECH NORTH AMERICA, INC., COTTAGE GROVE, WI. SN 77-090,780. PUB. 4-15-2008, FILED 1-25-2007.

ADVANCED FITNESS GROUP

THE MARK CONSISTS OF STANDARD CHARACTERS WITHOUT CLAIM TO ANY PARTICULAR FONT, STYLE, SIZE, OR COLOR.

NO CLAIM IS MADE TO THE EXCLUSIVE RIGHT TO USE "FITNESS GROUP", APART FROM THE MARK AS SHOWN.

FOR EXERCISE EQUIPMENT, NAMELY, TREADMILLS, ELLIPTICALS, STATIONARY BIKES; STRENGTH EQUIPMENT, NAMELY, HOME GYMS, WEIGHT LIFTING MACHINES (U.S. CLS. 22, 23, 38 AND 50).

FIRST USE 3-21-2009; IN COMMERCE 3-21-2009.

CLASS 28—(Continued).

3,631,971. TELEVISA, S.A. DE C.V., COLONIA ZEDEC SANTA FE, MEXICO. SN 77-117,446. PUB. 7-17-2007, FILED 2-27-2007.

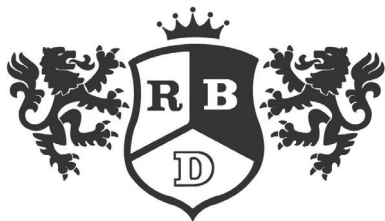

OWNER OF U.S. REG. NOS. 3,215,401, 3,215,468, AND 3,229,463.
FOR DOLLS (U.S. CLS. 22, 23, 38 AND 50).
FIRST USE 5-29-2007; IN COMMERCE 5-29-2007.

3,632,009. MIZUNO USA, INC., NORCROSS, GA. SN 77-159,834. PUB. 9-2-2008, FILED 4-18-2007.

FEEL IMPACT TECHNOLOGY FACE

THE MARK CONSISTS OF STANDARD CHARACTERS WITHOUT CLAIM TO ANY PARTICULAR FONT, STYLE, SIZE, OR COLOR.

NO CLAIM IS MADE TO THE EXCLUSIVE RIGHT TO USE "IMPACT TECHNOLOGY FACE", APART FROM THE MARK AS SHOWN.

FOR GOLF CLUBS (U.S. CLS. 22, 23, 38 AND 50).
FIRST USE 8-0-2007; IN COMMERCE 9-0-2007.

3,632,029. REFINEMENT CANADA INC., RICHMOND HILL, ONTARIO, CANADA. SN 77-173,360. PUB. 10-14-2008, FILED 5-4-2007.

EASY CYCLE

THE MARK CONSISTS OF STANDARD CHARACTERS WITHOUT CLAIM TO ANY PARTICULAR FONT, STYLE, SIZE, OR COLOR.

PRIORITY CLAIMED UNDER SEC. 44(D) ON CANADA APPLICATION NO. 1347398, FILED 5-4-2007, REG. NO. TMA715,316, DATED 5-27-2008, EXPIRES 5-27-2023.

NO CLAIM IS MADE TO THE EXCLUSIVE RIGHT TO USE "CYCLE", APART FROM THE MARK AS SHOWN.

FOR EXERCISE MACHINES (U.S. CLS. 22, 23, 38 AND 50).
FIRST USE 11-30-2003; IN COMMERCE 5-31-2004.

CLASS 28—(Continued).

3,632,094. JAKKS PACIFIC, INC., MALIBU, CA. SN 77-224,088. PUB. 12-25-2007, FILED 7-7-2007.

WICKED RIVALS

THE MARK CONSISTS OF STANDARD CHARACTERS WITHOUT CLAIM TO ANY PARTICULAR FONT, STYLE, SIZE, OR COLOR.

FOR TOYS GAMES AND PLAYTHINGS, NAMELY, ACTION FIGURES, TOY VEHICLES, AND PLAY SETS AND ACCESSORIES FOR ALL THE AFOREMENTIONED (U.S. CLS. 22, 23, 38 AND 50).

FIRST USE 5-12-2008; IN COMMERCE 5-12-2008.

3,632,116. BURWELL, SCOTT, ALISO VIEJO, CA. SN 77-231,418. PUB. 1-1-2008, FILED 7-17-2007.

GYPSY

THE MARK CONSISTS OF STANDARD CHARACTERS WITHOUT CLAIM TO ANY PARTICULAR FONT, STYLE, SIZE, OR COLOR.

FOR BALL BEARINGS FOR SKATEBOARDS; NUTS AND BOLTS FOR SKATEBOARDS; SKATEBOARD DECKS; SKATEBOARD GRIP TAPES; SKATEBOARD RAILS; SKATEBOARD RISER PADS; SKATEBOARD TRUCKS; SKATEBOARD WHEELS; SKATEBOARDS (U.S. CLS. 22, 23, 38 AND 50).

FIRST USE 2-1-2008; IN COMMERCE 2-1-2008.

3,632,130. WALLACH, MARK S., SAN JUAN CAPISTRANO, CA. SN 77-238,931. PUB. 6-24-2008, FILED 7-25-2007.

CROSS CONDITIONER XV

THE MARK CONSISTS OF STANDARD CHARACTERS WITHOUT CLAIM TO ANY PARTICULAR FONT, STYLE, SIZE, OR COLOR.

NO CLAIM IS MADE TO THE EXCLUSIVE RIGHT TO USE "CROSS CONDITIONER", APART FROM THE MARK AS SHOWN.

FOR EXERCISE MACHINES (U.S. CLS. 22, 23, 38 AND 50).
FIRST USE 10-15-2008; IN COMMERCE 10-15-2008.

CLASS 28—(Continued).

3,632,149. RINK, DONNA M., ELGIN, IL. AND RINK, DEBORAH M., ELGIN, IL. SN 77-248,288. PUB. 7-15-2008, FILED 8-6-2007.

ALPHABET BUDDIES

THE MARK CONSISTS OF STANDARD CHARACTERS WITHOUT CLAIM TO ANY PARTICULAR FONT, STYLE, SIZE, OR COLOR.

OWNER OF U.S. REG. NO. 2,375,764.

NO CLAIM IS MADE TO THE EXCLUSIVE RIGHT TO USE "ALPHABET", APART FROM THE MARK AS SHOWN.

FOR SOFT CONNECTABLE, STUFFED LETTERS OF THE ALPHABET AND NUMBERS FOR USE BY SMALL CHILDREN AS A TEACHING TOY TO LEARN THE ALPHABET TO CREATE BEGINNING WORDS (U.S. CLS. 22, 23, 38 AND 50).

FIRST USE 4-3-2009; IN COMMERCE 4-3-2009.

CLASS 28—(Continued).

3,632,201. ATHLETES' PERFORMANCE, INC., TEMPE, AZ. SN 77-266,949. PUB. 1-22-2008, FILED 8-29-2007.

CORE PERFORMANCE

THE MARK CONSISTS OF STANDARD CHARACTERS WITHOUT CLAIM TO ANY PARTICULAR FONT, STYLE, SIZE, OR COLOR.

OWNER OF U.S. REG. NOS. 3,016,023, 3,016,024, AND 3,124,046.

FOR EXERCISE MACHINES; EXERCISE EQUIPMENT, NAMELY, MANUALLY OPERATED AND ELECTRONICALLY OPERATED EXERCISE EQUIPMENT; WEIGHT LIFTING CAGES; WEIGHT LIFTING BARS; BAR-BELLS FOR WEIGHT LIFTING; DUMB-BELLS FOR WEIGHT LIFTING; DUMB-BELL SHAFTS FOR WEIGHT LIFTING; EXERCISE WEIGHTS; WEIGHT LIFTING MACHINES; LEG WEIGHTS; WEIGHT LIFTING BENCHES AND BENCH ACCESSORIES (U.S. CLS. 22, 23, 38 AND 50).

FIRST USE 6-1-2008; IN COMMERCE 6-1-2008.

3,632,163. DISGUISE, INC., MALIBU, CA. SN 77-253,424. PUB. 1-15-2008, FILED 8-13-2007.

DOUBLERZ

THE MARK CONSISTS OF STANDARD CHARACTERS WITHOUT CLAIM TO ANY PARTICULAR FONT, STYLE, SIZE, OR COLOR.

FOR HALLOWEEN AND MASQUERADE MASKS (U.S. CLS. 22, 23, 38 AND 50).

FIRST USE 6-18-2008; IN COMMERCE 6-18-2008.

3,632,218. WOWWEE GROUP LIMITED, TSIM SHA TSUI EAST, KOWLOON, HONG KONG. SN 77-276,775. PUB. 11-4-2008, FILED 9-11-2007.

BUGBOTS

THE MARK CONSISTS OF STANDARD CHARACTERS WITHOUT CLAIM TO ANY PARTICULAR FONT, STYLE, SIZE, OR COLOR.

FOR TOY ROBOTS (U.S. CLS. 22, 23, 38 AND 50).

FIRST USE 6-1-2008; IN COMMERCE 6-1-2008.

CLASS 28—(Continued).

3,632,396. LUCKY GROUP (H. K.) LIMITED, KOWLOON, HONG KONG. SN 77-356,771. PUB. 9-30-2008, FILED 12-20-2007.



THE MARK CONSISTS OF THE WORDING "FLEXIFRIENDS" WITH STYLIZED "X" IN THE FORM OF AN UPSIDE DOWN STICK FIGURE.

FOR TOY BEAR CLOTHING AND COSTUMES; TOY BEARS MADE OF TEXTILE MATERIAL, RAG MATERIAL, STUFF, PLUSH, WOOL, KNITTING WOOL, WOOD, PLASTICS AND/OR ETHYLENE ACETATE; PLAYTHINGS AND ACCESSORIES FOR PARTIES FOR TOY BEARS, NAMELY, PAPER PARTY HATS; TOY BEAR HOUSE FURNISHINGS; TOY PET DOLLS FOR TOY BEARS; TOYS, NAMELY, DOLLS AND TOY BEARS; TOY BEAR BEDS; TOY BEAR HOUSES; TOY BEAR ROOMS; TOY HOUSES AND PARTS THEREFOR, NAMELY, INTERIOR PARTS; JIGSAW MANIPULATIVE PUZZLES, TOY BEARS HAVING A SPRING; BALLOONS; TOYS FOR PLAYING ON SANDY BEACHES; MUSIC TOY BEARS; AND STUFFED DOLLS (U.S. CLS. 22, 23, 38 AND 50).

FIRST USE 1-20-2008; IN COMMERCE 1-20-2008.

3,632,437. MICHIGAN INTERNATIONAL SPEEDWAY, INC., DAYTONA BEACH, FL. SN 77-373,267. PUB. 10-7-2008, FILED 1-16-2008.



OWNER OF U.S. REG. NOS. 1,355,877 AND 2,778,174.

NO CLAIM IS MADE TO THE EXCLUSIVE RIGHT TO USE "MICHIGAN", APART FROM THE MARK AS SHOWN. THE MARK CONSISTS OF SWOOSH DESIGN WITH HILLS, SUN AND TREES AND THE WORDS "MICHIGAN INTERNATIONAL SPEEDWAY".

FOR TOYS AND PLAYTHINGS, NAMELY, DIECAST AND PLASTIC MINIATURE CARS, PUZZLES AND STUFFED TOY ANIMALS (U.S. CLS. 22, 23, 38 AND 50).

FIRST USE 6-14-2008; IN COMMERCE 6-14-2008.

3,632,443. PFEIFER, DAVID J., PITTSBURGH, PA. SN 77-376,713. PUB. 9-23-2008, FILED 1-21-2008.



NO CLAIM IS MADE TO THE EXCLUSIVE RIGHT TO

CLASS 28—(Continued).

USE "GAMES", APART FROM THE MARK AS SHOWN.

THE COLOR(S) RED, BLUE, GREEN, YELLOW, BLACK AND WHITE IS/ARE CLAIMED AS A FEATURE OF THE MARK.

THE MARK CONSISTS OF A PAIR OF EYES COLORED BLUE, BLACK AND WHITE WITH A CURVED ARCH ABOVE EACH EYE. IT ALSO CONTAINS FOUR LINES EMANATING FROM THE TOP OF EACH ARCH. THE CURVED ARCH AND LINES CREATE EYELIDS AND LASHES, WHICH APPEAR IN BLACK. THE WORD "BRIGHT" APPEARS IN RED WITH BLACK SHADOWING. THE WORD "EYES" APPEARS IN YELLOW WITH BLACK SHADOWING. THE WORD "GAMES" APPEARS IN GREEN WITH BLACK SHADOWING.

FOR BOARD GAMES; LCD GAME MACHINES; PARTY GAMES; PLAYING CARDS AND CARD GAMES; PROMOTIONAL GAME CARDS; PROMOTIONAL GAME MATERIALS; ACTION SKILL GAMES; CARD GAMES; EQUIPMENT SOLD AS A UNIT FOR PLAYING BOARD GAMES; EQUIPMENT SOLD AS A UNIT FOR PLAYING CARD GAMES; TARGET GAMES; TRADING CARD GAMES; ELECTRONIC GAMES OTHER THAN THOSE ADAPTED FOR USE WITH TELEVISION RECEIVERS ONLY; GO GAMES; MEMORY GAMES (U.S. CLS. 22, 23, 38 AND 50).

FIRST USE 1-27-2009; IN COMMERCE 4-5-2009.

3,632,491. KSIN LUXEMBOURG III, S.A.R.L., L-1628, LUXEMBOURG. SN 77-392,451. PUB. 6-24-2008, FILED 2-8-2008.

SINGER

THE MARK CONSISTS OF STANDARD CHARACTERS WITHOUT CLAIM TO ANY PARTICULAR FONT, STYLE, SIZE, OR COLOR.

FOR HOBBY CRAFT KIT FOR WEAVING, COMPRISING WEAVING FRAME, NEEDLES, NEEDLE THREADING DEVICE, JEWELRY BOXES, FISHING LINE, COTTON FLOSS, INSTRUCTION GUIDES, BEADS AND THREAD; HOBBY CRAFT KIT FOR KNITTING, COMPRISING KNITTING LOOM, YARN, CROCHET HOOKS, SCISSORS, HOOK PINS AND INSTRUCTION GUIDES; AND TOY SEWING MACHINES (U.S. CLS. 22, 23, 38 AND 50).

FIRST USE 2-27-2007; IN COMMERCE 2-27-2007.

3,632,520. BALANCE ADJUSTABLE TECHNOLOGY LLC, WIND LAKE, WI. SN 77-397,945. PUB. 7-1-2008, FILED 2-15-2008.

EASY BITE

THE MARK CONSISTS OF STANDARD CHARACTERS WITHOUT CLAIM TO ANY PARTICULAR FONT, STYLE, SIZE, OR COLOR.

FOR BOBBERS ATTACHED TO ICE FISHING RODS (U.S. CLS. 22, 23, 38 AND 50).

FIRST USE 11-14-2008; IN COMMERCE 11-14-2008.

CLASS 28—(Continued).

3,632,621. THE HARTZ MOUNTAIN CORPORATION, SECAUCUS, NJ. SN 77-415,172. PUB. 8-5-2008, FILED 3-6-2008.

HARTZ ROUND ABOUT ANIMALS

THE MARK CONSISTS OF STANDARD CHARACTERS WITHOUT CLAIM TO ANY PARTICULAR FONT, STYLE, SIZE, OR COLOR.

OWNER OF U.S. REG. NOS. 2,524,782, 3,222,910, AND OTHERS.

FOR PET TOYS (U.S. CLS. 22, 23, 38 AND 50).
FIRST USE 5-1-2007; IN COMMERCE 5-1-2007.

CLASS 28—(Continued).

3,632,718. PERAITA, JOSE A., NEW YORK, NY. SN 77-436,636. PUB. 8-19-2008, FILED 4-1-2008.



FOR DICE GAMES (U.S. CLS. 22, 23, 38 AND 50).
FIRST USE 7-1-2008; IN COMMERCE 9-13-2008.

3,632,631. WORLDWISE, INC., SN RAFAEL, CA. SN 77-416,531. PUB. 7-22-2008, FILED 3-7-2008.

DOGTRONICS

THE MARK CONSISTS OF STANDARD CHARACTERS WITHOUT CLAIM TO ANY PARTICULAR FONT, STYLE, SIZE, OR COLOR.

FOR PET TOYS (U.S. CLS. 22, 23, 38 AND 50).
FIRST USE 3-1-2008; IN COMMERCE 3-1-2008.

3,632,776. THE HARTZ MOUNTAIN CORPORATION, SECAUCUS, NJ. SN 77-451,872. PUB. 7-29-2008, FILED 4-18-2008.

MICE MANIA

THE MARK CONSISTS OF STANDARD CHARACTERS WITHOUT CLAIM TO ANY PARTICULAR FONT, STYLE, SIZE, OR COLOR.

FOR PET TOYS (U.S. CLS. 22, 23, 38 AND 50).
FIRST USE 8-1-2008; IN COMMERCE 8-1-2008.

3,632,662. DANBAR INTERNATIONAL LTD., WELHAM GREEN, UNITED KINGDOM. SN 77-423,681. PUB. 8-19-2008, FILED 3-17-2008.

NANO COMBAT

THE MARK CONSISTS OF STANDARD CHARACTERS WITHOUT CLAIM TO ANY PARTICULAR FONT, STYLE, SIZE, OR COLOR.

FOR REMOTE CONTROL TOYS, NAMELY, HELICOPTERS, ROAD VEHICLES, AIR PLANES, TANKS, AND UFOS (U.S. CLS. 22, 23, 38 AND 50).
FIRST USE 3-30-2009; IN COMMERCE 3-30-2009.

3,632,843. DAVIS JILES, LLC, BENTONVILLE, AR. SN 77-479,609. PUB. 11-25-2008, FILED 5-20-2008.

My First Skateboard

THE MARK CONSISTS OF STANDARD CHARACTERS WITHOUT CLAIM TO ANY PARTICULAR FONT, STYLE, SIZE, OR COLOR.

NO CLAIM IS MADE TO THE EXCLUSIVE RIGHT TO USE "SKATEBOARD", APART FROM THE MARK AS SHOWN.

FOR BAGS FOR SKATEBOARDS; SKATEBOARD DECKS; SKATEBOARD WHEELS SOLD SEPARATELY OR SOLD AS A UNIT WITH SKATEBOARDS; SKATEBOARDS (U.S. CLS. 22, 23, 38 AND 50).
FIRST USE 8-1-2008; IN COMMERCE 8-1-2008.

CLASS 28—(Continued).

3,632,846. BASS PRO INTELLECTUAL PROPERTY, L.L.C., SPRINGFIELD, MO. SN 77-480,655. PUB. 11-11-2008, FILED 5-21-2008.

DEEP CREEPER

THE MARK CONSISTS OF STANDARD CHARACTERS WITHOUT CLAIM TO ANY PARTICULAR FONT, STYLE, SIZE, OR COLOR.

NO CLAIM IS MADE TO THE EXCLUSIVE RIGHT TO USE "DEEP", APART FROM THE MARK AS SHOWN.

FOR FISHING LURES (U.S. CLS. 22, 23, 38 AND 50).
FIRST USE 12-0-2008; IN COMMERCE 12-0-2008.

3,632,853. DYNAMIC BRANDS, LLC, RICHMOND, VA. SN 77-482,623. PUB. 10-21-2008, FILED 5-23-2008.



THE MARK CONSISTS OF A STYLIZED RAMPANT LION WITH A GOLF CLUB IN ITS FRONT RIGHT PAW.
FOR GOLF CLUBS (U.S. CLS. 22, 23, 38 AND 50).
FIRST USE 11-1-2008; IN COMMERCE 11-1-2008.

3,632,922. ETHICAL PRODUCTS, INC., BLOOMFIELD, NJ. SN 77-512,387. PUB. 10-21-2008, FILED 7-1-2008.

SKINNEEZ

THE MARK CONSISTS OF STANDARD CHARACTERS WITHOUT CLAIM TO ANY PARTICULAR FONT, STYLE, SIZE, OR COLOR.

FOR DOG TOYS (U.S. CLS. 22, 23, 38 AND 50).
FIRST USE 10-31-2007; IN COMMERCE 10-31-2007.

CLASS 28—(Continued).

3,633,028. BY GEORGE! INC., LAKE FOREST, CA. SN 77-549,556. PUB. 1-6-2009, FILED 8-18-2008.

MUSICOLOR

THE MARK CONSISTS OF STANDARD CHARACTERS WITHOUT CLAIM TO ANY PARTICULAR FONT, STYLE, SIZE, OR COLOR.

FOR CHILDREN'S MULTIPLE ACTIVITY TOYS, NAMELY, ELECTRONIC ARTS AND CRAFTS ACTIVITY TOYS THAT ALLOW ONE TO WRITE AND READ MUSIC THROUGH THE USE OF COLOR (U.S. CLS. 22, 23, 38 AND 50).

FIRST USE 2-9-2007; IN COMMERCE 10-1-2008.

3,633,062. DISCOVERY GREEN CONSERVANCY, HOUSTON, TX. SN 77-976,962. PUB. 12-25-2007, FILED 6-29-2007.



THE COLOR(S) BLUE AND GREEN IS/ARE CLAIMED AS A FEATURE OF THE MARK.

THE MARK CONSISTS OF A WATERFALL CHANGING FROM BLUE (LEFT) TO GREEN (RIGHT).

FOR TOYS, NAMELY, STUFFED ANIMALS; AND SPORTS EQUIPMENT, NAMELY, TOY FLYING SAUCERS FOR TOSS GAMES, VOLLEYBALLS, AND GOLF BALLS (U.S. CLS. 22, 23, 38 AND 50).

FIRST USE 10-20-2008; IN COMMERCE 10-20-2008.

3,633,083. SUNKARA, SWAMY, CINCINNATI, OH. SN 78-150,289. PUB. 1-31-2006, FILED 8-2-2002.

BREAK 90 CHIP 'N CHARGE

THE MARK CONSISTS OF STANDARD CHARACTERS WITHOUT CLAIM TO ANY PARTICULAR FONT, STYLE, SIZE, OR COLOR.

FOR GOLF TRAINING DEVICES IN THE NATURE OF A DEVICE USED IN CONNECTION WITH A GOLF CLUB TO GUIDE THE HANDS DURING SWINGING (U.S. CLS. 22, 23, 38 AND 50).

FIRST USE 9-27-2008; IN COMMERCE 9-27-2008.

CLASS 28—(Continued).

3,633,107. DANA FREED, NEW YORK, NY. SN 78-499,611.
PUB. 1-10-2006, FILED 10-14-2004.

CLASS 28—(Continued).

3,633,123. DUESENBERG, LLC, MAPLE PLAIN, MN. SN 78-558,942. PUB. 1-31-2006, FILED 2-2-2005.

PIN PALS

THE MARK CONSISTS OF STANDARD CHARACTERS WITHOUT CLAIM TO ANY PARTICULAR FONT, STYLE, SIZE, OR COLOR.

FOR HOBBY CRAFT KIT COMPRISING OF PINS AND BEADS (U.S. CLS. 22, 23, 38 AND 50).
FIRST USE 3-28-2009; IN COMMERCE 3-28-2009.

DUESENBERG

THE MARK CONSISTS OF STANDARD CHARACTERS WITHOUT CLAIM TO ANY PARTICULAR FONT, STYLE, SIZE, OR COLOR.

OWNER OF U.S. REG. NOS. 1,173,102, 1,276,873, AND 2,331,124.

FOR SCALE MODEL TOY VEHICLES, SCALE MODEL TOY CARS, SCALE TOY MODEL VEHICLES AND RELATED ACCESSORIES SOLD AS UNITS (U.S. CLS. 22, 23, 38 AND 50).

FIRST USE 8-1-1997; IN COMMERCE 8-1-1997.

3,633,189. MATTEL, INC., EL SEGUNDO, CA. SN 78-726,005.
PUB. 2-20-2007, FILED 10-4-2005.

MADFAST

THE MARK CONSISTS OF STANDARD CHARACTERS WITHOUT CLAIM TO ANY PARTICULAR FONT, STYLE, SIZE, OR COLOR.

FOR TOY VEHICLES AND ACCESSORIES THEREFOR (U.S. CLS. 22, 23, 38 AND 50).

FIRST USE 3-12-2009; IN COMMERCE 3-12-2009.

3,633,115. PHILOSOPHY, INC., PHOENIX, AZ. SN 78-520,887.
PUB. 9-6-2005, FILED 11-22-2004.

PHILOSOPHY

THE MARK CONSISTS OF STANDARD CHARACTERS WITHOUT CLAIM TO ANY PARTICULAR FONT, STYLE, SIZE, OR COLOR.

FOR CHRISTMAS TREE DECORATIONS AND ORNAMENTS (U.S. CLS. 22, 23, 38 AND 50).
FIRST USE 9-8-2008; IN COMMERCE 9-8-2008.

3,633,246. WALLACH MARK S, SAN JUAN CAPISTRANO, CA. SN 78-834,973. PUB. 1-1-2008, FILED 3-11-2006.

Curvalinear

THE MARK CONSISTS OF STANDARD CHARACTERS WITHOUT CLAIM TO ANY PARTICULAR FONT, STYLE, SIZE, OR COLOR.

FOR EXERCISE MACHINES (U.S. CLS. 22, 23, 38 AND 50).
FIRST USE 10-15-2008; IN COMMERCE 10-15-2008.

CLASS 28—(Continued).

3,633,273. SPENCER, CHERYL V, VALLEY STREAM, NY. SN 78-890,698. PUB. 1-2-2007, FILED 5-23-2006.

NSG.LAB

THE MARK CONSISTS OF STANDARD CHARACTERS WITHOUT CLAIM TO ANY PARTICULAR FONT, STYLE, SIZE, OR COLOR.
FOR BOARD GAMES (U.S. CLS. 22, 23, 38 AND 50).
FIRST USE 3-20-2009; IN COMMERCE 3-20-2009.

3,633,290. KARSTEN MANUFACTURING CORPORATION, PHOENIX, AZ. SN 78-920,179. PUB. 2-13-2007, FILED 6-29-2006.

I10

THE MARK CONSISTS OF STANDARD CHARACTERS WITHOUT CLAIM TO ANY PARTICULAR FONT, STYLE, SIZE, OR COLOR.
FOR GOLF CLUBS (U.S. CLS. 22, 23, 38 AND 50).
FIRST USE 4-25-2009; IN COMMERCE 4-25-2009.

3,633,328. GEORGE A. POWELL, SUMMERLAND, CA. SN 78-980,980. PUB. 7-31-2007, FILED 6-6-2006.

RAT BONES

THE MARK CONSISTS OF STANDARD CHARACTERS WITHOUT CLAIM TO ANY PARTICULAR FONT, STYLE, SIZE, OR COLOR.
FOR SPORTING GOODS, NAMELY, SKATEBOARD WHEELS, SKATEBOARD WHEEL ASSEMBLIES AND PARTS AND FITTINGS FOR ANY THEREOF (U.S. CLS. 22, 23, 38 AND 50).
FIRST USE 12-28-1983; IN COMMERCE 12-28-1983.

CLASS 29—MEATS AND PROCESSED FOODS**CLASS 29—(Continued).**

3,631,926. SF INVESTMENTS, INC., WILMINGTON, DE. SN 77-079,662. PUB. 6-26-2007, FILED 1-10-2007.



THE COLOR(S) THE APPLICANT CLAIMS COLOR AS A FEATURE OF THE MARK, NAMELY, YELLOW-GOLD, WHITE, AND BLACK. IS/ARE CLAIMED AS A FEATURE OF THE MARK.

THE MARK CONSISTS OF A CLOCK DEPICTION WITH A WHITE BACKGROUND INCLUDING A BLACK FACE OF A CLOCK WITH A WHITE HOUR-HAND AND A WHITE MINUTE-HAND. BELOW THE CLOCK DEPICTION IS A YELLOW-GOLD SECTION BELOW THE WHITE BACKGROUND.

FOR FROZEN, PREPARED OR PACKAGED ENTREES CONSISTING PRIMARILY OF MEAT, FISH, POULTRY OR VEGETABLES (U.S. CL. 46).

FIRST USE 11-0-2007; IN COMMERCE 11-0-2007.

3,631,927. SF INVESTMENTS, INC., WILMINGTON, DE. SN 77-079,681. PUB. 6-26-2007, FILED 1-10-2007.



NO CLAIM IS MADE TO THE EXCLUSIVE RIGHT TO USE "SERVES", APART FROM THE MARK AS SHOWN.

THE COLOR(S) THE APPLICANT CLAIMS COLOR AS A FEATURE OF THE MARK, NAMELY, RED, WHITE, AND BLACK. IS/ARE CLAIMED AS A FEATURE OF THE MARK.

THE MARK CONSISTS OF A TABLE-SETTING DEPICTION WITH A WHITE BACKGROUND INCLUDING A BLACK PLATE. ON THE LEFT OF THE BLACK PLATE IS A BLACK FORK AND ON THE RIGHT OF THE BLACK PLATE IS A BLACK KNIFE. BELOW THE PLACE-SETTING DEPICTION IS A RED SECTION WITH THE LITERAL ELEMENT: "SERVES" IN BLACK.

FOR FROZEN, PREPARED OR PACKAGED ENTREES CONSISTING PRIMARILY OF MEAT, FISH, POULTRY OR VEGETABLES (U.S. CL. 46).

FIRST USE 11-0-2007; IN COMMERCE 11-0-2007.

CLASS 29—(Continued).

3,631,928. SF INVESTMENTS, INC., WILMINGTON, DE. SN 77-079,698. PUB. 6-26-2007, FILED 1-10-2007.



NO CLAIM IS MADE TO THE EXCLUSIVE RIGHT TO USE "OK TO FREEZE", APART FROM THE MARK AS SHOWN.

THE COLOR(S) THE APPLICANT CLAIMS COLOR AS A FEATURE OF THE MARK, NAMELY, BLUE, WHITE, AND BLACK, IS/ARE CLAIMED AS A FEATURE OF THE MARK.

THE MARK CONSISTS OF A WHITE BACKGROUND INCLUDING A BLACK CIRCLE. WITHIN THE BLACK CIRCLE IS A WHITE SNOWFLAKE. BELOW THE COLOR DESIGN IS A BLUE SECTION INCLUDING THE LITERAL ELEMENT: "OK TO FREEZE" IN BLACK PRINT.

FOR FROZEN, PREPARED OR PACKAGED ENTREES CONSISTING PRIMARILY OF MEAT, FISH, POULTRY OR VEGETABLES (U.S. CL. 46).

FIRST USE 11-0-2007; IN COMMERCE 11-0-2007.

CLASS 29—(Continued).

3,632,193. MARQUEZ BROTHERS INTERNATIONAL, INC., SAN JOSE, CA. SN 77-265,105. PUB. 6-3-2008, FILED 8-27-2007.

OAXAQUEÑO

THE MARK CONSISTS OF STANDARD CHARACTERS WITHOUT CLAIM TO ANY PARTICULAR FONT, STYLE, SIZE, OR COLOR.

THE FOREIGN WORDING IN THE MARK TRANSLATES INTO ENGLISH AS A MALE FROM OAXACA.

FOR CHEESE AND DAIRY PRODUCTS EXCLUDING ICE CREAM, ICE MILK AND FROZEN YOGURT, NAMELY, CREAM, CREAM CHEESE, COTTAGE CHEESE, SOUR CREAM, AND EGG NOG (U.S. CL. 46).

FIRST USE 2-22-2008; IN COMMERCE 2-22-2008.

3,632,235. KANSAS CITY STEAK COMPANY, LLC, KANSAS CITY, KS. SN 77-282,992. PUB. 3-18-2008, FILED 9-19-2007.

THE ULTIMATE SOURCE FOR EVERYTHING BEEF

THE MARK CONSISTS OF STANDARD CHARACTERS WITHOUT CLAIM TO ANY PARTICULAR FONT, STYLE, SIZE, OR COLOR.

NO CLAIM IS MADE TO THE EXCLUSIVE RIGHT TO USE "BEEF", APART FROM THE MARK AS SHOWN.

FOR BEEF (U.S. CL. 46).

FIRST USE 3-6-2009; IN COMMERCE 3-6-2009.

3,631,993. DOW AGROSCIENCES LLC, INDIANAPOLIS, IN. SN 77-147,142. PUB. 7-10-2007, FILED 4-3-2007.



NO CLAIM IS MADE TO THE EXCLUSIVE RIGHT TO USE "OMEGA-9 OILS", APART FROM THE MARK AS SHOWN.

THE MARK CONSIST OF THE DESIGN PORTION OF A COMBINATION HEART, NUMBER "9" AND STYLIZED REPRESENTATION OF AN OMEGA CHARACTER.

FOR EDIBLE OILS (U.S. CL. 46).

FIRST USE 4-30-2007; IN COMMERCE 4-30-2007.

3,632,370. KAHIKI FOODS, INC., GAHANNA, OH. SN 77-346,073. PUB. 9-16-2008, FILED 12-6-2007.

EASYCRISP

THE MARK CONSISTS OF STANDARD CHARACTERS WITHOUT CLAIM TO ANY PARTICULAR FONT, STYLE, SIZE, OR COLOR.

FOR PREPARED FROZEN OR PACKAGED FOODS, NAMELY, APPETIZERS CONSISTING PRIMARILY OF MEAT, FISH, POULTRY AND/OR VEGETABLES IN A PACKAGE FOR MICROWAVE COOKING (U.S. CL. 46).

FIRST USE 6-30-2008; IN COMMERCE 6-30-2008.

CLASS 29—(Continued).

3,632,382. KING TUNA INC., LOS ANGELES, CA. SN 77-352,883. PUB. 5-13-2008, FILED 12-14-2007.

KING TUNA

THE MARK CONSISTS OF STANDARD CHARACTERS WITHOUT CLAIM TO ANY PARTICULAR FONT, STYLE, SIZE, OR COLOR.

NO CLAIM IS MADE TO THE EXCLUSIVE RIGHT TO USE "TUNA", APART FROM THE MARK AS SHOWN.

FOR SEAFOOD; SEAFOOD, NAMELY, TUNA (U.S. CL. 46).

FIRST USE 7-15-2003; IN COMMERCE 12-23-2007.

CLASS 29—(Continued).

3,632,559. ORION SEAFOOD INTERNATIONAL, INC., PORTSMOUTH, NH. SN 77-406,401. PUB. 7-22-2008, FILED 2-26-2008.

APOLLO

THE MARK CONSISTS OF STANDARD CHARACTERS WITHOUT CLAIM TO ANY PARTICULAR FONT, STYLE, SIZE, OR COLOR.

FOR SEAFOOD, BOTH FRESH AND FROZEN (U.S. CL. 46).

FIRST USE 1-1-2009; IN COMMERCE 1-1-2009.

3,632,409. CAPE COD SHELLFISH & SEA FOOD CO., INC., BOSTON, MA. SN 77-362,664. PUB. 7-15-2008, FILED 1-2-2008.

MAINE BLUE

THE MARK CONSISTS OF STANDARD CHARACTERS WITHOUT CLAIM TO ANY PARTICULAR FONT, STYLE, SIZE, OR COLOR.

NO CLAIM IS MADE TO THE EXCLUSIVE RIGHT TO USE "MAINE", APART FROM THE MARK AS SHOWN.

FOR SEAFOOD (U.S. CL. 46).

FIRST USE 1-0-2008; IN COMMERCE 1-0-2008.

3,632,566. CARGILL MEAT SOLUTIONS CORPORATION, WICHITA, KS. SN 77-407,020. PUB. 7-15-2008, FILED 2-27-2008.

GRANTWOOD MEATS

THE MARK CONSISTS OF STANDARD CHARACTERS WITHOUT CLAIM TO ANY PARTICULAR FONT, STYLE, SIZE, OR COLOR.

NO CLAIM IS MADE TO THE EXCLUSIVE RIGHT TO USE "MEATS", APART FROM THE MARK AS SHOWN.

FOR MEAT (U.S. CL. 46).

FIRST USE 10-15-2008; IN COMMERCE 10-15-2008.

3,632,438. SUN-RYPE PRODUCTS LTD., KELOWNA, CANADA. SN 77-373,641. PUB. 8-26-2008, FILED 1-16-2008.

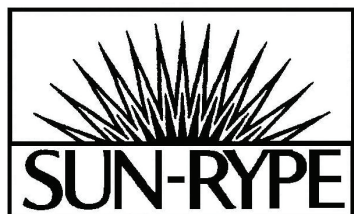

OWNER OF CANADA REG. NO. TMA547851, DATED 7-9-2001, EXPIRES 7-9-2016.

THE MARK CONSISTS OF FANCIFUL SUNBURST AND RECTANGLES DESIGN.

FOR FOOD PRODUCTS, NAMELY, FRUIT-BASED SNACK FOOD; FOOD PRODUCTS, NAMELY, DRIED FRUIT SNACKS; FOOD PRODUCTS, NAMELY, FRUIT BASED SNACK BARS; FOOD PRODUCTS, NAMELY, FRUIT LEATHERS (U.S. CL. 46).

FIRST USE 0-0-1996; IN COMMERCE 1-9-2008.

3,632,647. SIGMA ALIMENTOS, S.A. DE C.V., SAN PEDRO GARZA GARCIA, MEXICO. SN 77-420,668. PUB. 9-2-2008, FILED 3-13-2008.

FUD EXTRA FRESCO

THE MARK CONSISTS OF STANDARD CHARACTERS WITHOUT CLAIM TO ANY PARTICULAR FONT, STYLE, SIZE, OR COLOR.

OWNER OF U.S. REG. NOS. 2,910,970, 3,191,237, AND 3,378,473.

NO CLAIM IS MADE TO THE EXCLUSIVE RIGHT TO USE "EXTRA FRESCO", APART FROM THE MARK AS SHOWN.

THE FOREIGN WORDING IN THE MARK TRANSLATES INTO ENGLISH AS EXTRA FRESH.

FOR CHEESE (U.S. CL. 46).

FIRST USE 10-0-2008; IN COMMERCE 10-0-2008.

CLASS 29—(Continued).

3,632,694. CASCADE FRESH, INC., SEATTLE, WA. SN 77-432,586. PUB. 12-30-2008, FILED 3-26-2008.

ACTIV8 PROBIOTIC CRUNCH BAR

THE MARK CONSISTS OF STANDARD CHARACTERS WITHOUT CLAIM TO ANY PARTICULAR FONT, STYLE, SIZE, OR COLOR.

OWNER OF U.S. REG. NO. 3,166,722.

NO CLAIM IS MADE TO THE EXCLUSIVE RIGHT TO USE "PROBIOTIC CRUNCH BAR", APART FROM THE MARK AS SHOWN.

FOR READY-TO-EAT FRUIT AND NUT-BASED PROBIOTIC FOOD BAR (U.S. CL. 46).

FIRST USE 3-14-2008; IN COMMERCE 9-8-2008.

CLASS 29—(Continued).

3,632,740. JOAQUIN T. LU, LOS ANGELES, CA. SN 77-443,362. PUB. 9-2-2008, FILED 4-8-2008.



NO CLAIM IS MADE TO THE EXCLUSIVE RIGHT TO USE "BRAND", APART FROM THE MARK AS SHOWN. THE COLOR(S) WHITE, BLUE AND LIGHT BLUE IS/ARE CLAIMED AS A FEATURE OF THE MARK.

THE MARK CONSISTS OF A ROTATED SQUARE OUTLINED IN LIGHT BLUE AND WHITE AND FILLED WITH DARK BLUE. THE SQUARE IS CUT OFF AT THE BOTTOM WITH A WHITE BANNER ACCENTED IN BLUE AND THE WORDS "CITRA" AND "MINA" IN BLUE. BELOW THE BANNER IS THE WORD "BRAND" IN BLUE. AT THE CENTER OF THE MARK IS A BLUE FISH OUTLINED IN WHITE. THE FISH TAIL IS OUTLINED IN BLUE AND CONTAIN THE COLORS LIGHT BLUE AND WHITE. UNDER THE FISH HEAD ON THE SQUARE AND ABOVE THE BANNER IS A WHITE JAGGED LINE FORMING A STYLIZED WAVE. SURROUNDING THE FISH ARE TWELVE TEAR SHAPES IN VARIOUS POSITIONS IN LIGHT BLUE.

FOR SEAFOOD: FISH; TUNA FISH; TUNA FISH; SEAFOOD, NAMELY, FROZEN OCTOPUS; FISH SAUSAGES; FISH, NAMELY, FROZEN MAHI MAHI, SCAD, BLUE MARLIN, GROUPER, TUNA (U.S. CL. 46).

FIRST USE 4-15-2007; IN COMMERCE 4-23-2008.

3,632,724. JOAQUIN T. LU, LOS ANGELES, CA. SN 77-439,577. PUB. 8-26-2008, FILED 4-3-2008.

PHILFRESH

THE MARK CONSISTS OF STANDARD CHARACTERS WITHOUT CLAIM TO ANY PARTICULAR FONT, STYLE, SIZE, OR COLOR.

FOR SEAFOOD; FISH; TUNA FISH (U.S. CL. 46). FIRST USE 11-1-2008; IN COMMERCE 3-6-2009.

3,632,741. LU, JOAQUIN T., SALEM, OR. SN 77-443,378. PUB. 9-16-2008, FILED 4-8-2008.

CITRA MINA

THE MARK CONSISTS OF STANDARD CHARACTERS WITHOUT CLAIM TO ANY PARTICULAR FONT, STYLE, SIZE, OR COLOR.

THE WORDING "CITRA MINA" HAS NO MEANING IN ANOTHER LANGUAGE.

FOR SEAFOOD; SEAFOOD, NAMELY, FROZEN OCTOPUS; FISH; FISH CAKES; FISH FILLETS; FISH SAUSAGES; FISH, NAMELY, FROZEN MAHI MAHI, SCAD, BLUE MARLIN, GROUPER, TUNA; TUNA FISH (U.S. CL. 46).

FIRST USE 1-1-2006; IN COMMERCE 4-23-2008.

CLASS 29—(Continued).

3,632,923. FARIBAULT DAIRY COMPANY, INC., FARIBAULT, MN. SN 77-512,432. PUB. 11-25-2008, FILED 7-1-2008.

ST. PETE'S SELECT

THE MARK CONSISTS OF STANDARD CHARACTERS WITHOUT CLAIM TO ANY PARTICULAR FONT, STYLE, SIZE, OR COLOR.

NO CLAIM IS MADE TO THE EXCLUSIVE RIGHT TO USE "SELECT", APART FROM THE MARK AS SHOWN. FOR CHEESE (U.S. CL. 46). FIRST USE 11-25-2002; IN COMMERCE 11-25-2002.

3,633,059. FRANKLIN BAKER, INC., CORDOVA, TN. SN 77-976,943. PUB. 11-4-2008, FILED 6-9-2008.



THE NAME "FRANKLIN BAKER" DOES NOT IDENTIFY A LIVING INDIVIDUAL.

THE MARK CONSISTS OF STYLIZED LETTERS "FB" FOLLOWED BY THE WORDS "FRANKLIN BAKER" IN STYLIZED FONT.

FOR DESICCATED COCONUTS, FLAKED COCONUT, COCONUT CONCENTRATE USED AS INGREDIENTS OF FOODS, COCONUT CREAM (U.S. CL. 46). FIRST USE 10-30-2006; IN COMMERCE 10-30-2006.

3,633,066. WESTERN DAIRY SPECIALTIES, LLC, RENO, NV. SN 77-976,974. PUB. 8-19-2008, FILED 2-6-2008.



NO CLAIM IS MADE TO THE EXCLUSIVE RIGHT TO USE "DAIRY", APART FROM THE MARK AS SHOWN. THE COLOR(S) GREEN AND LIGHT GREEN IS/ARE

CLASS 29—(Continued).

CLAIMED AS A FEATURE OF THE MARK.

THE MARK CONSISTS OF THE COLOR GREEN AND LIGHT GREEN WITH THE COLOR GREEN APPEARING IN THE LEAF DESIGN AND THE WORDING "WESTERN DAIRY INNOVATIONS" "CLEAN, GREEN AND SIMPLE" AND THE COLOR LIGHT GREEN APPEARS IN THE LOWER RIGHT HAND SIDE OF THE LEAF. FOR MILK (U.S. CL. 46). FIRST USE 9-18-2008; IN COMMERCE 9-18-2008.

3,633,095. VLASSARA, HELEN, NEW YORK, NY. SN 78-409,927. PUB. 9-20-2005, FILED 4-28-2004.

AGE-LESS

THE MARK CONSISTS OF STANDARD CHARACTERS WITHOUT CLAIM TO ANY PARTICULAR FONT, STYLE, SIZE, OR COLOR.

FOR FOOD PRODUCTS, NAMELY, MEAT, FISH, POULTRY AND GAME; MEAT EXTRACTS, PRESERVED, DRIED AND COOKED FRUITS AND VEGETABLES; JELLIES, JAMS, FRUIT SAUCES, EGGS, MILK AND DAIRY PRODUCTS EXCLUDING ICE CREAM, ICE MILK AND FROZEN YOGURT MILK PRODUCTS; EDIBLE OILS AND FATS; ALL HAVING A REDUCED CONTENT OF UNHEALTHY SUBSTANCES ARISING DURING PROCESSING (U.S. CL. 46). FIRST USE 3-27-2008; IN COMMERCE 6-12-2008.

3,633,198. COMPAGNIE GERVAIS DANONE, PARIS, FRANCE. SN 78-738,255. PUB. 4-3-2007, FILED 10-21-2005.

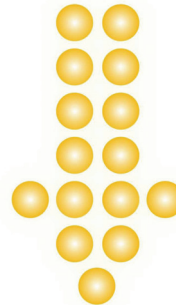

THE COLORS YELLOW AND WHITE ARE CLAIMED AS

CLASS 29—(Continued).

A FEATURE OF THE MARK.
 THE MARK CONSISTS OF A DOWNWARD POINTING
 ARROW DESIGN FORMED BY YELLOW CIRCLES WITH
 WHITE CENTERS.
 FOR PLAIN AND AROMATIZED FERMENTED
 DAIRY PRODUCTS EXCLUDING ICE CREAM, ICE
 MILK, AND FROZEN YOGURT (U.S. CL. 46).
 FIRST USE 1-24-2006; IN COMMERCE 1-24-2006.

CLASS 30—(Continued).

3,631,813. KAL-MOCHA ENTERPRISES, INC., MIAMI, FL.
 SN 76-667,120. PUB. 11-6-2007, FILED 10-10-2006.



3,633,318. ELK RIDGE ALMONDS, INC., MADERA, CA. SN
 78-968,540. PUB. 7-17-2007, FILED 9-6-2006.

HANDMADE FARMS

NO CLAIM IS MADE TO THE EXCLUSIVE RIGHT TO
 USE "COFFEE", APART FROM THE MARK AS SHOWN.
 THE COLOR(S) BROWN, TAN, BLACK, AND WHITE IS/
 ARE CLAIMED AS A FEATURE OF THE MARK.
 THE CENTER BEAN FIGURE, SHOES, AND SMALL
 BEANS ON THE CIRCULAR BORDER ARE BROWN. THE
 ARMS, LEGS AND BACKGROUND BEHIND THE CUP ARE
 TAN. THE CIRCULAR BORDER, LIPS AND EYE PUPILS
 ARE BLACK. THE CUP, SAUCER, GLOVES, MOUTH, EYE
 WHITES, AND WORDS OF THE MARK ARE WHITE.
 FOR COFFEE PRODUCTS, NAMELY, HOUSE BLEND
 COFFEE, GOURMET COFFEE, DARK ROAST COFFEE,
 DECAFF COFFEE, ESPRESSO COFFEE, ORGANIC
 BLEND COFFEE, LOW ACID COFFEE, ELITE BLEND
 COFFEE, HAZELNUT COFFEE, VANILLA COFFEE,
 CHOCOLATE COVERED BEAN COFFEE, COLOMBIAN
 SUPREMO COFFEE, FRENCH ROAST COFFEE, GUA-
 TEMALAN ANTIQUE COFFEE, ARABIAN MOCHA
 COFFEE, ROASTMASTER BLEND COFFEE, SUMATRA
 COFFEE, KENYAN AA COFFEE, ENGLISH CARAMEL
 COFFEE, BELGIUM CHOCOLATE COFFEE, VIENNA
 CINNAMON COFFEE, AND STRUESSEL CAKE COFFEE
 (U.S. CL. 46).
 FIRST USE 1-31-2007; IN COMMERCE 1-31-2007.

THE MARK CONSISTS OF STANDARD CHARACTERS
 WITHOUT CLAIM TO ANY PARTICULAR FONT, STYLE,
 SIZE, OR COLOR.
 NO CLAIM IS MADE TO THE EXCLUSIVE RIGHT TO
 USE "FARMS", APART FROM THE MARK AS SHOWN.
 FOR PROCESSED NUTS; ROASTED NUTS (U.S. CL.
 46).
 FIRST USE 12-4-2008; IN COMMERCE 12-4-2008.

3,631,828. DICHOS, L.L.C., TUCSON, AZ. SN 76-681,343. PUB.
 2-26-2008, FILED 8-30-2007.

DICHOS

CLASS 30—STAPLE FOODS

THE MARK CONSISTS OF STANDARD CHARACTERS
 WITHOUT CLAIM TO ANY PARTICULAR FONT, STYLE,
 SIZE, OR COLOR.
 THE ENGLISH TRANSLATION OF "DICHOS" IS "SAY-
 INGS."
 FOR PASTRY AND CONFECTIONERY, NAMELY,
 COOKIES (U.S. CL. 46).
 FIRST USE 11-1-2007; IN COMMERCE 12-1-2007.

CLASS 30—(Continued).

3,631,900. SARA LEE BAKERY GROUP, INC., DOWNERS GROVE, IL. SN 77-044,790. PUB. 6-19-2007, FILED 11-15-2006.

RESTAURANT RESERVE

THE MARK CONSISTS OF STANDARD CHARACTERS WITHOUT CLAIM TO ANY PARTICULAR FONT, STYLE, SIZE, OR COLOR.

FOR BAKERY GOODS (U.S. CL. 46).
FIRST USE 1-31-2007; IN COMMERCE 1-31-2007.

3,631,917. ILENE C. SHANE, INC., NEW YORK, NY. SN 77-064,974. PUB. 6-12-2007, FILED 12-15-2006.

BLISS ON A STICK

THE MARK CONSISTS OF STANDARD CHARACTERS WITHOUT CLAIM TO ANY PARTICULAR FONT, STYLE, SIZE, OR COLOR.

NO CLAIM IS MADE TO THE EXCLUSIVE RIGHT TO USE "ON A STICK", APART FROM THE MARK AS SHOWN. FOR CHOCOLATE; CHOCOLATE CANDY AND CHOCOLATE PASTRY (U.S. CL. 46).

FIRST USE 5-29-2007; IN COMMERCE 5-29-2007.

3,631,973. SOCIETE DES PRODUITS NESTLE, S.A., 1800 VEVEY, SWITZERLAND. SN 77-118,413. PUB. 1-15-2008, FILED 2-28-2007.



THE MARK CONSISTS OF A DESIGN OF A HEAD WITH RAISED ARMS OVER A STARBURST IN A PARTIAL CIRCLE, WITH THE WORDING "EVERY BITE COUNTS" ABOVE THE DESIGN, ALL ABOVE A BANNER.

FOR CRACKERS (U.S. CL. 46).
FIRST USE 12-31-2007; IN COMMERCE 12-31-2007.

CLASS 30—(Continued).

3,632,027. DUTCHER, MICHAEL ALLEN, FORT DODGE, IA. SN 77-168,519. PUB. 12-11-2007, FILED 4-29-2007.

JiMi J's

THE MARK CONSISTS OF STANDARD CHARACTERS WITHOUT CLAIM TO ANY PARTICULAR FONT, STYLE, SIZE, OR COLOR.

FOR BARBECUE SAUCE; DIPPING SAUCES; HOT SAUCE; SAUCES; SAUCES FOR BARBECUED MEAT; SPICES (U.S. CL. 46).
FIRST USE 9-14-2006; IN COMMERCE 9-14-2006.

3,632,064. BIG TRAIN, INC., FOOTHILL RANCH, CA. SN 77-202,677. PUB. 6-3-2008, FILED 6-11-2007.

TRADITIONAL MEXICAN BEVERAGES WITH A TWIST

THE MARK CONSISTS OF STANDARD CHARACTERS WITHOUT CLAIM TO ANY PARTICULAR FONT, STYLE, SIZE, OR COLOR.

FOR POWDERED MIXES FOR MAKING A FRUIT-FLAVORED BEVERAGE; POWDERED MIXES CONTAINING TEA FOR MAKING A BEVERAGE; AND POWDERED MIXES CONTAINING CINNAMON AND RICE FOR MAKING A BEVERAGE (U.S. CL. 46).
FIRST USE 5-8-2007; IN COMMERCE 5-8-2007.

3,632,080. TIMOTHY'S COFFEES OF THE WORLD INC., TORONTO, ONTARIO. SN 77-216,065. PUB. 2-12-2008, FILED 6-26-2007.

JAZZED UP DECAF

THE MARK CONSISTS OF STANDARD CHARACTERS WITHOUT CLAIM TO ANY PARTICULAR FONT, STYLE, SIZE, OR COLOR.

NO CLAIM IS MADE TO THE EXCLUSIVE RIGHT TO USE "DECAF", APART FROM THE MARK AS SHOWN. FOR COFFEE (U.S. CL. 46).
FIRST USE 9-1-2007; IN COMMERCE 9-1-2007.

CLASS 30—(Continued).

3,632,085. HOT SOFT PRETZEL COMPANY, LLC, FT. THOMAS, KY. SN 77-218,129. PUB. 12-4-2007, FILED 6-28-2007.

LOVE ME KNOTS

THE MARK CONSISTS OF STANDARD CHARACTERS WITHOUT CLAIM TO ANY PARTICULAR FONT, STYLE, SIZE, OR COLOR.
FOR PRETZELS AND PRETZEL DOUGH (U.S. CL. 46).
FIRST USE 6-0-2003; IN COMMERCE 6-0-2003.

CLASS 30—(Continued).

3,632,140. ELEANOR JUAREZ, DBA "MAMA J'S", IRVINE, CA. SN 77-244,382. PUB. 1-22-2008, FILED 8-1-2007.



NO CLAIM IS MADE TO THE EXCLUSIVE RIGHT TO USE "ORIGINAL SEASONING MIX", APART FROM THE MARK AS SHOWN.

THE COLOR(S) GREEN, ORANGE, GRAY, LIGHT-BROWN, AND YELLOW IS/ARE CLAIMED AS A FEATURE OF THE MARK.

THE MARK CONSISTS OF THE STYLIZED WORD "MAMA" IS WRITTEN IN GREEN, FOLLOWED BY A STYLIZED CAPITAL LETTER "J" IN ORANGE COLOR, FOLLOWED BY A STYLIZED APOSTROPHE REPRESENTED BY GREEN LEAF IMAGE, AFTER WHICH A SMALL ORANGE LETTER "S" IS WRITTEN; UNDER THE WORD "MAMA" IS WRITTEN "ORIGINAL SEASONING MIX" IN STYLIZED GRAY LETTERS; A STYLIZED LIGHT-BROWN SPICE-SHAKER IS DEPICTED OVER THE WORD "MAMA" AS SHAKING OUT DOTS REPRESENTING YELLOW SPICES.

FOR SEASONINGS, NAMELY, DRY MIXES FOR FOOD FLAVORING (U.S. CL. 46).
FIRST USE 9-1-2008; IN COMMERCE 9-1-2008.

3,632,127. 1197217 ONTARIO LIMITED, CHATHAM, CANADA. SN 77-237,468. PUB. 1-8-2008, FILED 7-24-2007.

TWIRLEES ICE CREAM

THE MARK CONSISTS OF STANDARD CHARACTERS WITHOUT CLAIM TO ANY PARTICULAR FONT, STYLE, SIZE, OR COLOR.

NO CLAIM IS MADE TO THE EXCLUSIVE RIGHT TO USE "ICE CREAM", APART FROM THE MARK AS SHOWN.

FOR ICE CREAM FOR CONSUMPTION ON AND OFF THE PREMISES (U.S. CL. 46).
FIRST USE 12-31-2008; IN COMMERCE 12-31-2008.

3,632,186. BERRY CHILL LLC, CHICAGO, IL. SN 77-261,458. PUB. 9-2-2008, FILED 8-22-2007.



NO CLAIM IS MADE TO THE EXCLUSIVE RIGHT TO USE "BERRY", APART FROM THE MARK AS SHOWN.

THE MARK CONSISTS OF THE WORDS "BERRY CHILL" UNDERNEATH A STYLIZED SWIRL.

FOR FROZEN YOGURT (U.S. CL. 46).
FIRST USE 3-14-2008; IN COMMERCE 3-14-2008.

CLASS 30—(Continued).

3,632,312. GENERAL MILLS MARKETING, INC., MINNEAPOLIS, MN. SN 77-320,120. PUB. 4-1-2008, FILED 11-2-2007.

AIRCRISP

THE MARK CONSISTS OF STANDARD CHARACTERS WITHOUT CLAIM TO ANY PARTICULAR FONT, STYLE, SIZE, OR COLOR.

FOR FROZEN PIZZA (U.S. CL. 46).
FIRST USE 12-22-2008; IN COMMERCE 12-22-2008.

3,632,314. BLISS BROS DAIRY, INC., ATTLEBORO, MA. SN 77-321,090. PUB. 4-22-2008, FILED 11-5-2007.

Yo Bliss

THE MARK CONSISTS OF STANDARD CHARACTERS WITHOUT CLAIM TO ANY PARTICULAR FONT, STYLE, SIZE, OR COLOR.

FOR NON-FAT FROZEN YOGURT BASE (U.S. CL. 46).
FIRST USE 2-25-2009; IN COMMERCE 2-25-2009.

3,632,405. ARIANNA FARMS 'ONO KONA COFFEE, LLC, CAMARILLO, CA. SN 77-359,767. PUB. 7-15-2008, FILED 12-26-2007.

'Ono Kona Cookies

THE MARK CONSISTS OF STANDARD CHARACTERS WITHOUT CLAIM TO ANY PARTICULAR FONT, STYLE, SIZE, OR COLOR.

NO CLAIM IS MADE TO THE EXCLUSIVE RIGHT TO USE "COOKIES", APART FROM THE MARK AS SHOWN.

THE FOREIGN WORDING IN THE MARK TRANSLATES INTO ENGLISH AS DELICIOUS.

FOR COOKIES AND BAKERY PRODUCTS (U.S. CL. 46).
FIRST USE 3-25-2009; IN COMMERCE 3-25-2009.

CLASS 30—(Continued).

3,632,412. CARGILL, INCORPORATED, WAYZATA, MN. SN 77-365,258. PUB. 5-20-2008, FILED 1-7-2008.



NO CLAIM IS MADE TO THE EXCLUSIVE RIGHT TO USE "SODIUM REDUCTION SYSTEM", APART FROM THE MARK AS SHOWN.

THE MARK CONSISTS OF AN INVERTED TRIANGLE THE WORDS "SALTWISE SODIUM REDUCTION SYSTEM" AT THE TOP.

FOR FOOD ADDITIVES FOR NON-NUTRITIONAL PURPOSES FOR USE AS A FLAVORING (U.S. CL. 46).
FIRST USE 3-5-2008; IN COMMERCE 3-5-2008.

3,632,416. BEYOND COFFEE & CAPPUCCINO LLC, FREDERICKSBURG, VA. SN 77-366,234. PUB. 5-27-2008, FILED 1-8-2008.



NO CLAIM IS MADE TO THE EXCLUSIVE RIGHT TO USE "JAVA", APART FROM THE MARK AS SHOWN.

THE COLOR(S) ORANGE, LIGHT-ORANGE, DARK COFFEE-BROWN AND GOLD IS/ARE CLAIMED AS A FEATURE OF THE MARK.

THE MARK CONSISTS OF THE WORDS "MY JAVA" IN LOWERCASE BLOCK LETTERING, WITH THE WORD "MY" IN THE COLOR ORANGE WITH A THIN LIGHT-ORANGE BORDER AND DARK COFFEE-BROWN BACKGROUND, AND THE WORD "JAVA" IN THE COLOR DARK COFFEE-BROWN WITH AN ORANGE BORDER AND A GOLD BACKGROUND, ALL BORDERED BY A TRIPLE ORANGE, DARK COFFEE-BROWN, ORANGE BORDER.

FOR BEVERAGES MADE OF COFFEE; CAFFEINE-FREE COFFEE; COFFEE; COFFEE AND TEA; COFFEE BASED BEVERAGES; COFFEE BEANS; COFFEE BEVERAGES WITH MILK; COFFEE ESSENCES; COFFEE EXTRACTS; COFFEE FLAVORED SYRUP USED IN MAKING FOOD BEVERAGES; COFFEE-BASED BEVERAGE CONTAINING MILK; COFFEE-BASED BEVERAGES; INSTANT COFFEE; PREPARED COFFEE AND COFFEE-BASED BEVERAGES; ROASTED COFFEE BEANS; ESPRESSO (U.S. CL. 46).

FIRST USE 2-1-2008; IN COMMERCE 2-1-2008.

CLASS 30—(Continued).

3,632,571. CHANG, CALVIN, ANAHEIM, CA. SN 77-408,654.
PUB. 7-15-2008, FILED 2-28-2008.

SUGAR-FREE FACTORY

THE MARK CONSISTS OF STANDARD CHARACTERS WITHOUT CLAIM TO ANY PARTICULAR FONT, STYLE, SIZE, OR COLOR.

NO CLAIM IS MADE TO THE EXCLUSIVE RIGHT TO USE "SUGAR-FREE", APART FROM THE MARK AS SHOWN.

FOR CONFECTIONS, NAMELY, CHOCOLATES, AND BAKED GOODS, NAMELY, COOKIES (U.S. CL. 46).
FIRST USE 3-3-2009; IN COMMERCE 3-3-2009.

3,632,605. COPPERLEAF GOURMET FOODS, INC., LAWRENCE, KS. SN 77-413,275. PUB. 7-22-2008, FILED 3-5-2008.

COPPERLEAF GOURMET

THE MARK CONSISTS OF STANDARD CHARACTERS WITHOUT CLAIM TO ANY PARTICULAR FONT, STYLE, SIZE, OR COLOR.

NO CLAIM IS MADE TO THE EXCLUSIVE RIGHT TO USE "GOURMET", APART FROM THE MARK AS SHOWN.

FOR SEASONINGS, MARINADES, DIPPING SAUCES, BARBEQUE SAUCE, AND STEAK SAUCE (U.S. CL. 46).
FIRST USE 3-26-2009; IN COMMERCE 3-26-2009.

3,632,607. KASHI COMPANY, LA JOLLA, CA, CA. SN 77-413,647. PUB. 7-22-2008, FILED 3-5-2008.

HONEY SUNSHINE

THE MARK CONSISTS OF STANDARD CHARACTERS WITHOUT CLAIM TO ANY PARTICULAR FONT, STYLE, SIZE, OR COLOR.

NO CLAIM IS MADE TO THE EXCLUSIVE RIGHT TO USE "HONEY", APART FROM THE MARK AS SHOWN.

FOR CEREAL-DERIVED FOOD PRODUCT TO BE USED AS A BREAKFAST FOOD, SNACK FOOD, OR INGREDIENT FOR MAKING FOOD (U.S. CL. 46).
FIRST USE 6-2-2008; IN COMMERCE 6-2-2008.

CLASS 30—(Continued).

3,632,623. KENNEDY & ASSOCIATES CREATIVE CONSULTANTS GROUP, INC., CINCINNATI, OH. SN 77-415,307.
PUB. 7-15-2008, FILED 3-6-2008.



NO CLAIM IS MADE TO THE EXCLUSIVE RIGHT TO USE "CERTIFIED LOCAL", APART FROM THE MARK AS SHOWN.

THE COLOR(S) YELLOW AND GREEN IS/ARE CLAIMED AS A FEATURE OF THE MARK.

THE MARK CONSISTS OF A GREEN CIRCLE WITH A DOUBLE YELLOW BORDER. CENTERED IN THE GREEN CIRCLE ARE THE FOLLOWING WORDS IN YELLOW "CERTIFIED LOCAL!" STACKED ON TOP OF EACH OTHER AND BREAKING CONTINUITY OF THE INNER YELLOW BORDER OF THE CIRCLE IN FOUR PLACES.

FOR SALSA; PICKLE RELISH; HONEY; HORSERADISH (U.S. CL. 46).
FIRST USE 1-20-2009; IN COMMERCE 1-20-2009.

3,632,657. BORNAY DESSERTS S.L., 28340 VALDEMORO MADRID, SPAIN. SN 77-422,456. PUB. 8-26-2008, FILED 3-14-2008.

MESTRE CARLES

THE MARK CONSISTS OF STANDARD CHARACTERS WITHOUT CLAIM TO ANY PARTICULAR FONT, STYLE, SIZE, OR COLOR.

THE ENGLISH TRANSLATION OF THE WORD "MESTRE" IN THE MARK IS "MASTER".

FOR ICE CREAM (U.S. CL. 46).
FIRST USE 11-6-2008; IN COMMERCE 11-6-2008.

CLASS 30—(Continued).

3,632,658. BORNAY DESSERTS S.L., 28340 VALDEMORO MADRID, SPAIN. SN 77-422,481. PUB. 7-29-2008, FILED 3-14-2008.

DRACULA

THE MARK CONSISTS OF STANDARD CHARACTERS WITHOUT CLAIM TO ANY PARTICULAR FONT, STYLE, SIZE, OR COLOR.

FOR ICE CREAM (U.S. CL. 46).
FIRST USE 11-6-2008; IN COMMERCE 11-6-2008.

3,632,659. BORNAY DESSERTS S.L., 28340 VALDEMORO MADRID, SPAIN. SN 77-422,504. PUB. 7-29-2008, FILED 3-14-2008.

CAPTAIN PIRATE

THE MARK CONSISTS OF STANDARD CHARACTERS WITHOUT CLAIM TO ANY PARTICULAR FONT, STYLE, SIZE, OR COLOR.

FOR ICE CREAM (U.S. CL. 46).
FIRST USE 11-6-2008; IN COMMERCE 11-6-2008.

3,632,679. BORNAY DESSERTS S.L., 28340 VALDEMORO MADRID, SPAIN. SN 77-427,716. PUB. 7-29-2008, FILED 3-20-2008.



THE MARK CONSISTS OF A MAN'S FACE/HEAD. FOR ICE CREAM (U.S. CL. 46).
FIRST USE 11-6-2008; IN COMMERCE 11-6-2008.

CLASS 30—(Continued).

3,632,690. YOSWIRL, FREMONT, CA. SN 77-431,701. PUB. 8-5-2008, FILED 3-26-2008.

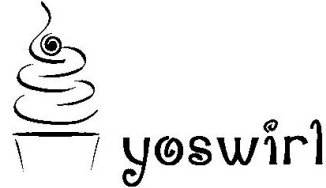

THE MARK CONSISTS OF THE STYLIZED WORD "YOSWIRL". TO THE LEFT OF THE STYLIZED WORDS IS A IMAGE OF OUTLINED CUP WITH OUTLINED FROZEN YOGURT ABOVE THE CUP WITH SWIRL TOPPING.

FOR FROZEN YOGURT WITH TOPPING, NAMELY, FRUITS, CEREALS, CANDIES, AND NUTS (U.S. CL. 46).
FIRST USE 5-17-2008; IN COMMERCE 5-17-2008.

3,632,716. MOUNTANOS BROTHERS COFFEE COMPANY, INC., SOUTH SAN FRANCISCO, CA. SN 77-436,190. PUB. 8-19-2008, FILED 3-31-2008.

MANOLIN

THE MARK CONSISTS OF STANDARD CHARACTERS WITHOUT CLAIM TO ANY PARTICULAR FONT, STYLE, SIZE, OR COLOR.

FOR COFFEE (U.S. CL. 46).
FIRST USE 2-25-2009; IN COMMERCE 3-23-2009.

CLASS 30—(Continued).

3,632,761. BORNAY DESSERTS S.L., 28340 VALDEMORO MADRID, SPAIN. SN 77-447,368. PUB. 7-29-2008, FILED 4-14-2008.



THE MARK CONSISTS OF A DRAWING OF A VAMPIRE-LIKE FIGURE.
FOR ICE CREAM (U.S. CL. 46).
FIRST USE 11-6-2008; IN COMMERCE 11-6-2008.

3,632,820. PIZZA HUT, INC., DALLAS, TX. SN 77-469,003. PUB. 9-30-2008, FILED 5-8-2008.



NO CLAIM IS MADE TO THE EXCLUSIVE RIGHT TO USE "CHOCOLATE", APART FROM THE MARK AS SHOWN.

THE COLOR(S) BROWN, DARK BROWN, BEIGE, AND LIGHT BEIGE IS/ARE CLAIMED AS A FEATURE OF THE MARK.

THE MARK CONSISTS OF THE WORDS "CHOCOLATE DUNKERS" OUTLINED IN DARK BROWN. THE WORD "CHOCOLATE" IN BROWN AND OUTLINED IN BEIGE; AND THE WORD "DUNKERS" IN A TRANSITION FROM BOTTOM TO TOP OF LIGHT BEIGE TO WHITE.

FOR STICK-LIKE DESSERT PRODUCT CONSISTING OF BREADSTICKS AND CHOCOLATE (U.S. CL. 46).
FIRST USE 11-6-2007; IN COMMERCE 11-6-2007.

CLASS 30—(Continued).

3,632,860. MERISANT COMPANY, CHICAGO, IL. SN 77-485,354. PUB. 11-4-2008, FILED 5-28-2008.

SENSIBLY SWEET

THE MARK CONSISTS OF STANDARD CHARACTERS WITHOUT CLAIM TO ANY PARTICULAR FONT, STYLE, SIZE, OR COLOR.

NO CLAIM IS MADE TO THE EXCLUSIVE RIGHT TO USE "SWEET", APART FROM THE MARK AS SHOWN.

FOR SUGAR SUBSTITUTES FOR USE AS AN INGREDIENT IN BEVERAGES (U.S. CL. 46).
FIRST USE 11-0-2007; IN COMMERCE 11-0-2007.

3,632,863. NIETO, ANDREAS, BEVERLY HILLS, CA. SN 77-486,621. PUB. 10-28-2008, FILED 5-29-2008.

Chef Andreas

THE MARK CONSISTS OF STANDARD CHARACTERS WITHOUT CLAIM TO ANY PARTICULAR FONT, STYLE, SIZE, OR COLOR.

THE NAME "CHEF ANDREAS" IDENTIFIES A LIVING INDIVIDUAL WHOSE CONSENT IS OF RECORD.

FOR CANDIES; COOKIES; SPICES (U.S. CL. 46).
FIRST USE 5-11-2008; IN COMMERCE 8-1-2008.

3,632,907. KERDOON, DAVID, LOS ANGELES, CA. SN 77-505,806. PUB. 11-25-2008, FILED 6-23-2008.



NO CLAIM IS MADE TO THE EXCLUSIVE RIGHT TO USE "SEN CHA NATURALS", APART FROM THE MARK AS SHOWN.

THE MARK CONSISTS OF THE TERMS "SEN CHA NATURALS" ARRANGED VERTICALLY AND A LEAF DESIGN SPROUTING FROM THE TERM "CHA".

THE ENGLISH TRANSLATION OF "SEN CHA" IN THE MARK IS "GREEN TEA".

FOR GRAIN BASED READY-TO-EAT FOOD BARS; COOKIES; GRAIN-BASED SNACK FOODS; NON-MEDICATED LOZENGES; CANDY MINTS; CHEWING GUM (U.S. CL. 46).

FIRST USE 1-31-2005; IN COMMERCE 1-31-2005.

CLASS 30—(Continued).

3,632,933. RICE INVESTMENTS, LP, HANOVER, PA. SN 77-515,561. PUB. 11-25-2008, FILED 7-7-2008.

UTZ BISTRO BLEND

THE MARK CONSISTS OF STANDARD CHARACTERS WITHOUT CLAIM TO ANY PARTICULAR FONT, STYLE, SIZE, OR COLOR.

NO CLAIM IS MADE TO THE EXCLUSIVE RIGHT TO USE "BLEND", APART FROM THE MARK AS SHOWN.

FOR SNACK MIX CONSISTING PRIMARILY OF WHEAT, RICE AND CORN BASED CRACKERS AND PRETZELS (U.S. CL. 46).

FIRST USE 11-1-2008; IN COMMERCE 11-1-2008.

3,632,978. KANGAROO BRANDS, INC., MILWAUKEE, WI. SN 77-528,625. PUB. 12-16-2008, FILED 7-22-2008.

KANGAROO

THE MARK CONSISTS OF STANDARD CHARACTERS WITHOUT CLAIM TO ANY PARTICULAR FONT, STYLE, SIZE, OR COLOR.

OWNER OF U.S. REG. NOS. 1,469,921 AND 2,164,114.

FOR PITA CHIPS (U.S. CL. 46).

FIRST USE 12-0-2006; IN COMMERCE 12-0-2006.

3,633,033. HERSHEY CHOCOLATE & CONFECTIONERY CORPORATION, WHEAT RIDGE, CO. SN 77-553,512. PUB. 11-25-2008, FILED 8-22-2008.

MEGASSORTMENT

THE MARK CONSISTS OF STANDARD CHARACTERS WITHOUT CLAIM TO ANY PARTICULAR FONT, STYLE, SIZE, OR COLOR.

FOR CANDY (U.S. CL. 46).

FIRST USE 1-18-2007; IN COMMERCE 1-18-2007.

CLASS 30—(Continued).

3,633,039. TL ENTERPRISES LLC, PHILADELPHIA, PA. SN 77-563,511. PUB. 12-23-2008, FILED 9-5-2008.



OWNER OF U.S. REG. NOS. 2,912,248 AND 2,986,813.

THE NAME SHOWN IN THE MARK IDENTIFIES TONY LUKE, JR., A LIVING INDIVIDUAL WHOSE CONSENT IS OF RECORD.

THE MARK CONSISTS OF THE WORD MARK "TONY LUKE'S" ABOVE A LINE OF STARS WITH THE WORD "PRONTO" REPEATED CIRCLING A STAR TO THE RIGHT OF THE "TONY LUKE'S" PORTION OF THE MARK.

FOR PRE-COOKED, FROZEN, MICROWAVEABLE FOODS, NAMELY, SANDWICHES (U.S. CL. 46).

FIRST USE 3-1-2009; IN COMMERCE 3-1-2009.

3,633,135. REAL WASABI, LLC, HILTON HEAD ISLAND, SC. SN 78-583,978. PUB. 5-6-2008, FILED 3-9-2005.



NO CLAIM IS MADE TO THE EXCLUSIVE RIGHT TO USE "REAL WASABI, AUTHENTIC MOUNTAIN GROWN, FIERY TASTE, SMOOTH FINISH" AND THE FOREIGN CHARACTERS THAT TRANSLITERATE TO "WASABI", APART FROM THE MARK AS SHOWN.

THE NON-LATIN CHARACTERS IN THE MARK TRANSLITERATE TO THE ENGLISH WORDING "WASABI".

FOR ROOTS, STEMS AND RHIZOMES OF WASABI JAPONICA IN POWDER AND PASTE FORM (U.S. CL. 46).

FIRST USE 1-31-2005; IN COMMERCE 1-31-2005.

CLASS 30—(Continued).

3,633,149. CLASSIC BREAD COMPANY, NAMPA, ID. SN 78-629,188. PUB. 1-31-2006, FILED 5-12-2005.

BUNLOVER'S

THE MARK CONSISTS OF STANDARD CHARACTERS WITHOUT CLAIM TO ANY PARTICULAR FONT, STYLE, SIZE, OR COLOR.

FOR BAKERY GOODS, BREADS, BUNS, AND ROLLS (U.S. CL. 46).
FIRST USE 4-21-2009; IN COMMERCE 4-21-2009.

3,633,202. SEATTLE'S BEST COFFEE, LLC, SEATTLE, WA. SN 78-747,376. PUB. 1-23-2007, FILED 11-4-2005.



NO CLAIM IS MADE TO THE EXCLUSIVE RIGHT TO USE "BAKERY", APART FROM THE MARK AS SHOWN.

THE MARK CONSISTS OF A HALF CIRCLE OVAL DESIGN WITH A CHEF'S HAT IN THE MIDDLE AND THE WORD "OVENSONG" OVER THE CHEF'S HAT; THE HALF CIRCLE IS SITTING ON TOP A RIBBON DESIGN WITH THE WORDS "BAKERY" WITHIN THE RIBBON.

FOR BAKED GOODS, NAMELY, MUFFINS, SCONES, BISCUITS, COOKIES, PASTRIES AND BREAD; SANDWICHES (U.S. CL. 46).

FIRST USE 3-31-2005; IN COMMERCE 3-31-2005.

3,633,208. HERSHEY CHOCOLATE & CONFECTIONERY CORPORATION, WHEAT RIDGE, CO. SN 78-757,335. PUB. 3-20-2007, FILED 11-18-2005.

**THREE GREAT TASTES THAT
TASTE GREAT TOGETHER**

THE MARK CONSISTS OF STANDARD CHARACTERS WITHOUT CLAIM TO ANY PARTICULAR FONT, STYLE,

CLASS 30—(Continued).

SIZE, OR COLOR.
OWNER OF U.S. REG. NO. 1,286,224.
FOR CANDY (U.S. CL. 46).
FIRST USE 3-1-2009; IN COMMERCE 3-1-2009.

CLASS 31—NATURAL AGRICULTURAL PRODUCTS

3,631,807. NUTRO PRODUCTS, INC., FRANKLIN, TN. SN 76-652,852. PUB. 8-8-2006, FILED 1-4-2006.

SMART START

THE MARK CONSISTS OF STANDARD CHARACTERS WITHOUT CLAIM TO ANY PARTICULAR FONT, STYLE, SIZE, OR COLOR.

FOR PET FOOD, NAMELY, PUPPY FOOD (U.S. CLS. 1 AND 46).
FIRST USE 6-0-2005; IN COMMERCE 6-0-2005.

3,631,827. CELL RESPONSE FORMULATIONS, LLC, JACKSON, WY. SN 76-681,112. PUB. 7-15-2008, FILED 8-24-2007.



OWNER OF U.S. REG. NO. 3,209,761.
NO CLAIM IS MADE TO THE EXCLUSIVE RIGHT TO USE "FORMULATION GUARANTEE", APART FROM THE MARK AS SHOWN.

THE MARK CONSISTS OF AN OUTER CIRCLE WITH POINTED PROTRUSIONS BEARING THE WORDS "FORMULATION GUARANTEE". A STAR IN THE CENTER OF THE CIRCLE WITH THE TERM "VISIT" AND A BANNER HORIZONTALLY SITUATED ACROSS THE CIRCLE AND CONTAINING "MULLIGANSTEWPETFOOD.COM".

FOR CANNED PET FOOD (U.S. CLS. 1 AND 46).
FIRST USE 11-0-2007; IN COMMERCE 11-0-2007.

CLASS 31—(Continued).

3,631,836. NUTRO PRODUCTS, INC., FRANKLIN, TN. SN 76-683,939. PUB. 4-22-2008, FILED 11-13-2007.

SMART START

THE MARK CONSISTS OF STANDARD CHARACTERS WITHOUT CLAIM TO ANY PARTICULAR FONT, STYLE, SIZE, OR COLOR.

FOR PET FOOD, NAMELY, KITTEN FOOD (U.S. CLS. 1 AND 46).

FIRST USE 1-0-2008; IN COMMERCE 1-0-2008.

CLASS 31—(Continued).

3,632,065. JUBILEE BLUEBERRY FARMS, LLC, GRAND JUNCTION, MI. SN 77-204,974. PUB. 7-1-2008, FILED 6-13-2007.



NO CLAIM IS MADE TO THE EXCLUSIVE RIGHT TO USE "JUBILEE, BLUEBERRY FARMS" & "FARMING SINCE 1979", APART FROM THE MARK AS SHOWN.

THE MARK CONSISTS OF FRUIT ABOVE A BANNER THAT CONTAINS THE WORDS "JUBILEE BLUEBERRY FARMS" AND A CIRCLE CONTAINING THE WORDS "GOD REWARD FAITHFULNESS FARMING SINCE 1979".

FOR FRESH BLUEBERRIES (U.S. CLS. 1 AND 46).
FIRST USE 4-0-2007; IN COMMERCE 4-0-2007.

3,631,851. SUNTORY FLOWERS LIMITED, TOKYO, JAPAN. SN 76-688,176. PUB. 9-23-2008, FILED 3-31-2008.

STARS & STRIPES

THE MARK CONSISTS OF STANDARD CHARACTERS WITHOUT CLAIM TO ANY PARTICULAR FONT, STYLE, SIZE, OR COLOR.

FOR ORNAMENTAL LIVE PLANTS EXCLUDING GERANIUMS AND AMARYLLIS PLANTS (U.S. CLS. 1 AND 46).

FIRST USE 1-14-2009; IN COMMERCE 1-14-2009.

3,632,190. CERES, INC, THOUSAND OAKS, CA. SN 77-263,684. PUB. 3-25-2008, FILED 8-24-2007.

BLADE ENERGY CROPS

3,631,886. VERITAS V, LLC, SALINAS, CA. SN 77-032,224. PUB. 7-17-2007, FILED 10-30-2006.

OrganicGirl

THE MARK CONSISTS OF STANDARD CHARACTERS WITHOUT CLAIM TO ANY PARTICULAR FONT, STYLE, SIZE, OR COLOR.

FOR FRESH VEGETABLES (U.S. CLS. 1 AND 46).
FIRST USE 5-4-2007; IN COMMERCE 5-4-2007.

THE MARK CONSISTS OF STANDARD CHARACTERS WITHOUT CLAIM TO ANY PARTICULAR FONT, STYLE, SIZE, OR COLOR.

NO CLAIM IS MADE TO THE EXCLUSIVE RIGHT TO USE "ENERGY CROPS", APART FROM THE MARK AS SHOWN.

FOR AGRICULTURAL SEEDS AND LIVE PLANTS, ALL FOR GROWING AGRICULTURAL CROPS USED AS FEEDSTOCK FOR THE MANUFACTURE OF BIO-FUELS (U.S. CLS. 1 AND 46).

FIRST USE 2-25-2009; IN COMMERCE 2-25-2009.

CLASS 31—(Continued).

3,632,318. BARENBRUG USA, INC., TANGENT, OR. SN 77-323,952. PUB. 12-9-2008, FILED 11-7-2007.

POLAR BLUE

THE MARK CONSISTS OF STANDARD CHARACTERS WITHOUT CLAIM TO ANY PARTICULAR FONT, STYLE, SIZE, OR COLOR.
NO CLAIM IS MADE TO THE EXCLUSIVE RIGHT TO USE "BLUE", APART FROM THE MARK AS SHOWN.
FOR GRASS SEED (U.S. CLS. 1 AND 46).
FIRST USE 6-1-2008; IN COMMERCE 6-1-2008.

3,632,321. CULTIVARIS NORTH AMERICA LLC, SAN DIEGO, CA. SN 77-324,783. PUB. 10-7-2008, FILED 11-8-2007.

Kia Ora Flora

THE MARK CONSISTS OF STANDARD CHARACTERS WITHOUT CLAIM TO ANY PARTICULAR FONT, STYLE, SIZE, OR COLOR.
NO CLAIM IS MADE TO THE EXCLUSIVE RIGHT TO USE "FLORA", APART FROM THE MARK AS SHOWN.
FOR LIVE PLANTS (U.S. CLS. 1 AND 46).
FIRST USE 3-21-2008; IN COMMERCE 3-21-2008.

3,632,356. BARENBRUG USA, INC., TANGENT, OR. SN 77-339,421. PUB. 7-22-2008, FILED 11-28-2007.

YELLOW JACKET

THE MARK CONSISTS OF STANDARD CHARACTERS WITHOUT CLAIM TO ANY PARTICULAR FONT, STYLE, SIZE, OR COLOR.
FOR GRASS SEED COATING SOLD AS A COMPONENT OF GRASS SEED USED TO FACILITATE SEEDLING MOISTURE PRESERVATION, SEEDLING ESTABLISHMENT AND SEEDLING GERMINATION (U.S. CLS. 1 AND 46).
FIRST USE 2-0-2008; IN COMMERCE 2-0-2008.

CLASS 31—(Continued).

3,632,445. RAY MARKS CO. LLC, NEW YORK, NY. SN 77-377,066. PUB. 6-10-2008, FILED 1-22-2008.

Rachael Ray

THE MARK CONSISTS OF STANDARD CHARACTERS WITHOUT CLAIM TO ANY PARTICULAR FONT, STYLE, SIZE, OR COLOR.
THE NAME(S), PORTRAIT(S), AND/OR SIGNATURE(S) SHOWN IN THE MARK IDENTIFIES "RACHAEL RAY", WHOSE CONSENT(S) TO REGISTER IS MADE OF RECORD.
FOR PET FOOD AND EDIBLE PET TREATS (U.S. CLS. 1 AND 46).
FIRST USE 6-18-2008; IN COMMERCE 6-18-2008.

3,632,446. RAY MARKS CO. LLC, NEW YORK, NY. SN 77-377,100. PUB. 6-10-2008, FILED 1-22-2008.

RACHAELRAY

THE NAME(S), PORTRAIT(S), AND/OR SIGNATURE(S) SHOWN IN THE MARK IDENTIFIES "RACHAEL RAY", WHOSE CONSENT(S) TO REGISTER IS MADE OF RECORD.
THE MARK CONSISTS OF A STYLIZED VERSION OF THE WORDS "RACHAEL RAY".
FOR PET FOOD AND EDIBLE PET TREATS (U.S. CLS. 1 AND 46).
FIRST USE 6-18-2008; IN COMMERCE 6-18-2008.

3,632,512. MORGAN, JERRY L., BROOKFIELD, WI. AND HURLEY, JAMES C., WOODBURY, MN. SN 77-396,748. PUB. 7-8-2008, FILED 2-14-2008.

EMERALD PASTURES

THE MARK CONSISTS OF STANDARD CHARACTERS WITHOUT CLAIM TO ANY PARTICULAR FONT, STYLE, SIZE, OR COLOR.
FOR EDIBLE HORSE TREATS (U.S. CLS. 1 AND 46).
FIRST USE 1-16-2009; IN COMMERCE 1-21-2009.

CLASS 31—(Continued).

3,632,774. THE HARTZ MOUNTAIN CORPORATION, SECAUCUS, NJ. SN 77-451,659. PUB. 7-29-2008, FILED 4-18-2008.

HARTZ NUTRI-PELLETS

THE MARK CONSISTS OF STANDARD CHARACTERS WITHOUT CLAIM TO ANY PARTICULAR FONT, STYLE, SIZE, OR COLOR.

OWNER OF U.S. REG. NOS. 782,948 AND 3,110,431. FOR BIRD FOOD, NAMELY, SEEDS AND PELLETS (U.S. CLS. 1 AND 46).
FIRST USE 7-2-2008; IN COMMERCE 7-2-2008.

3,632,775. THE HARTZ MOUNTAIN CORPORATION, SECAUCUS, NJ. SN 77-451,867. PUB. 7-29-2008, FILED 4-18-2008.

HARTZ VITA-MIX

THE MARK CONSISTS OF STANDARD CHARACTERS WITHOUT CLAIM TO ANY PARTICULAR FONT, STYLE, SIZE, OR COLOR.

OWNER OF U.S. REG. NOS. 782,948 AND 3,110,431. FOR BIRD FOOD, NAMELY, SEEDS AND PELLETS (U.S. CLS. 1 AND 46).
FIRST USE 7-2-2008; IN COMMERCE 7-2-2008.

3,632,868. TOZER SEEDS AMERICA, LLC, SANTA MARIA, CA. SN 77-487,871. PUB. 10-28-2008, FILED 5-30-2008.

PETITPOSY

THE MARK CONSISTS OF STANDARD CHARACTERS WITHOUT CLAIM TO ANY PARTICULAR FONT, STYLE, SIZE, OR COLOR.

FOR AGRICULTURAL SEEDS (U.S. CLS. 1 AND 46).
FIRST USE 1-20-2009; IN COMMERCE 1-20-2009.

CLASS 31—(Continued).

3,633,294. DOLE FOOD COMPANY, INC., WESTLAKE VILLAGE, CA. SN 78-924,988. PUB. 1-9-2007, FILED 7-7-2006.

BANANA-NANAS

THE MARK CONSISTS OF STANDARD CHARACTERS WITHOUT CLAIM TO ANY PARTICULAR FONT, STYLE, SIZE, OR COLOR.

FOR FRESH BANANAS (U.S. CLS. 1 AND 46).
FIRST USE 5-1-2008; IN COMMERCE 5-1-2008.

CLASS 32—LIGHT BEVERAGES

3,631,788. SOUTH CONE, INC., CARLSBAD, CA. SN 76-428,114. PUB. 3-14-2006, FILED 6-27-2002.

REEF

FOR BEER (U.S. CLS. 45, 46 AND 48).
FIRST USE 4-15-2009; IN COMMERCE 4-15-2009.

3,631,789. DEJA VU CONSULTING, INC., LANSING, MI. SN 76-515,830. PUB. 8-22-2006, FILED 5-21-2003.

DEJA VU FOUNTAIN OF YOUTH ARTESIAN SPRING WATER

NO CLAIM IS MADE TO THE EXCLUSIVE RIGHT TO USE "ARTESIAN SPRING WATER", APART FROM THE MARK AS SHOWN.

FOR BOTTLED DRINKING WATER (U.S. CLS. 45, 46 AND 48).
FIRST USE 8-27-2003; IN COMMERCE 8-27-2003.

CLASS 32—(Continued).

3,631,796. DZAMBULING IMPORTS, LLC, EL CERRITO, CA.
SN 76-616,258. PUB. 1-31-2006, FILED 10-18-2004.

LHASA BEER

THE MARK CONSISTS OF STANDARD CHARACTERS WITHOUT CLAIM TO ANY PARTICULAR FONT, STYLE, SIZE, OR COLOR.

NO CLAIM IS MADE TO THE EXCLUSIVE RIGHT TO USE "BEER", APART FROM THE MARK AS SHOWN.

FOR LIGHT BEVERAGES, NAMELY, BEERS (U.S. CLS. 45, 46 AND 48).

FIRST USE 1-1-2000; IN COMMERCE 12-22-2008.

CLASS 32—(Continued).

3,632,034. CUBA BEVERAGE COMPANY, SAN DIEGO, CA.
SN 77-177,536. PUB. 5-20-2008, FILED 5-10-2007.

CUBA HERBAL ENERGY JUICE

THE MARK CONSISTS OF STANDARD CHARACTERS WITHOUT CLAIM TO ANY PARTICULAR FONT, STYLE, SIZE, OR COLOR.

NO CLAIM IS MADE TO THE EXCLUSIVE RIGHT TO USE "HERBAL ENERGY JUICE", APART FROM THE MARK AS SHOWN.

FOR HERBAL JUICES AND ENERGY DRINKS (U.S. CLS. 45, 46 AND 48).

FIRST USE 7-28-2007; IN COMMERCE 7-28-2007.

3,632,032. CUBA BEVERAGE COMPANY, SAN DIEGO, CA.
SN 77-177,438. PUB. 5-20-2008, FILED 5-10-2007.

CUBA

THE MARK CONSISTS OF STANDARD CHARACTERS WITHOUT CLAIM TO ANY PARTICULAR FONT, STYLE, SIZE, OR COLOR.

FOR HERBAL JUICES AND ENERGY DRINKS (U.S. CLS. 45, 46 AND 48).

FIRST USE 7-28-2007; IN COMMERCE 7-28-2007.

3,632,046. BERNARD G. REICH, BARRINGTON HILLS, IL.
SN 77-192,058. PUB. 5-20-2008, FILED 5-29-2007.

BIG GREEDY REDNECK BEER

THE MARK CONSISTS OF STANDARD CHARACTERS WITHOUT CLAIM TO ANY PARTICULAR FONT, STYLE, SIZE, OR COLOR.

NO CLAIM IS MADE TO THE EXCLUSIVE RIGHT TO USE "BEER", APART FROM THE MARK AS SHOWN.

FOR BEER (U.S. CLS. 45, 46 AND 48).

FIRST USE 2-6-2009; IN COMMERCE 2-6-2009.

3,632,033. CUBA BEVERAGE COMPANY, SAN DIEGO, CA.
SN 77-177,475. PUB. 5-20-2008, FILED 5-10-2007.

CUBA BEVERAGE COMPANY

THE MARK CONSISTS OF STANDARD CHARACTERS WITHOUT CLAIM TO ANY PARTICULAR FONT, STYLE, SIZE, OR COLOR.

NO CLAIM IS MADE TO THE EXCLUSIVE RIGHT TO USE "BEVERAGE COMPANY", APART FROM THE MARK AS SHOWN.

FOR HERBAL JUICES AND ENERGY DRINKS (U.S. CLS. 45, 46 AND 48).

FIRST USE 7-28-2007; IN COMMERCE 7-28-2007.

3,632,181. BARBATO, A J, FT LAUDERDALE, FL. SN 77-261,256. PUB. 2-26-2008, FILED 8-22-2007.

Revolutionary

THE MARK CONSISTS OF STANDARD CHARACTERS WITHOUT CLAIM TO ANY PARTICULAR FONT, STYLE, SIZE, OR COLOR.

OWNER OF U.S. REG. NOS. 3,172,469 AND 3,187,348.

FOR NON-ALCOHOLIC BEVERAGES, NAMELY, CONCENTRATES, SYRUPS USED IN THE PREPARATION OF ENERGY, NUTRITIONAL, SOFT OR SPORTS DRINKS; ENERGY DRINKS, FRUIT FLAVORED DRINKS, AND SYRUPS FOR BEVERAGES (U.S. CLS. 45, 46 AND 48).

FIRST USE 3-15-2009; IN COMMERCE 3-15-2009.

CLASS 32—(Continued).

3,632,182. BARBATO, A J, OAKLAND PARK, FL. SN 77-261,266. PUB. 2-26-2008, FILED 8-22-2007.

Revolutionist

THE MARK CONSISTS OF STANDARD CHARACTERS WITHOUT CLAIM TO ANY PARTICULAR FONT, STYLE, SIZE, OR COLOR.

OWNER OF U.S. REG. NOS. 3,172,469 AND 3,187,348.
FOR NON-ALCOHOLIC BEVERAGES, NAMELY, CONCENTRATES, SYRUPS USED IN THE PREPARATION OF ENERGY, NUTRITIONAL, SOFT OR SPORTS DRINKS; ENERGY DRINKS, FRUIT FLAVORED DRINKS, AND SYRUPS FOR BEVERAGES (U.S. CLS. 45, 46 AND 48).

FIRST USE 3-15-2009; IN COMMERCE 3-15-2009.

CLASS 32—(Continued).

3,632,469. STOKELY-VAN CAMP, INC., CHICAGO, IL. SN 77-385,749. PUB. 12-9-2008, FILED 1-31-2008.

GATORADE TIGER THIRST QUENCHER

THE MARK CONSISTS OF STANDARD CHARACTERS WITHOUT CLAIM TO ANY PARTICULAR FONT, STYLE, SIZE, OR COLOR.

OWNER OF U.S. REG. NOS. 848,245, 2,856,121, AND OTHERS.

NO CLAIM IS MADE TO THE EXCLUSIVE RIGHT TO USE "THIRST QUENCHER", APART FROM THE MARK AS SHOWN.

FOR NON-CARBONATED FRUIT FLAVORED SPORTS DRINKS (U.S. CLS. 45, 46 AND 48).

FIRST USE 2-8-2008; IN COMMERCE 2-8-2008.

3,632,496. OSOTSPA CO., LTD., BANGKOK, THAILAND. SN 77-393,272. PUB. 8-26-2008, FILED 2-10-2008.

3,632,184. TRAVIS BELL, MISSISSAUGA, CANADA. SN 77-261,361. PUB. 6-24-2008, FILED 8-22-2007.

ARTHUR'S FRESH COMPANY

THE MARK CONSISTS OF STANDARD CHARACTERS WITHOUT CLAIM TO ANY PARTICULAR FONT, STYLE, SIZE, OR COLOR.

NO CLAIM IS MADE TO THE EXCLUSIVE RIGHT TO USE "FRESH COMPANY", APART FROM THE MARK AS SHOWN.

THE NAME(S), PORTRAIT(S), AND/OR SIGNATURE(S) SHOWN IN THE MARK DOES NOT IDENTIFY A PARTICULAR LIVING INDIVIDUAL.

FOR FRUIT DRINKS, NAMELY, NON-ALCOHOLIC FRUIT JUICES, FRUIT DRINKS AND SMOOTHIES (U.S. CLS. 45, 46 AND 48).

FIRST USE 12-30-2007; IN COMMERCE 10-30-2008.



M-150

OWNER OF U.S. REG. NO. 2,371,205.
THE MARK CONSISTS OF A SHERIFFS'S BADGE COMPOSED OF A SEAL WITH THE WORDS "DEVOTION" "COURAGE" AND "SACRIFICE" THE LETTER "M", CIRCLES, A SIX-SIDED STAR WITH CIRCLES AT THE ENDS OF THE ARMS, AND THE DESIGNATION "M-150".

FOR ENERGY DRINKS (U.S. CLS. 45, 46 AND 48).

FIRST USE 0-0-2000; IN COMMERCE 12-31-2008.

CLASS 32—(Continued).

3,632,796. JACK ROSE, MALIBU, CA. SN 77-458,109. PUB. 9-23-2008, FILED 4-25-2008.

RAINCATCHER

THE MARK CONSISTS OF STANDARD CHARACTERS WITHOUT CLAIM TO ANY PARTICULAR FONT, STYLE, SIZE, OR COLOR.
FOR BOTTLED WATER (U.S. CLS. 45, 46 AND 48).
FIRST USE 7-14-2008; IN COMMERCE 7-14-2008.

CLASS 32—(Continued).

3,633,116. POMWONDERFUL LLC, LOS ANGELES, CA. SN 78-526,128. PUB. 1-10-2006, FILED 12-2-2004.

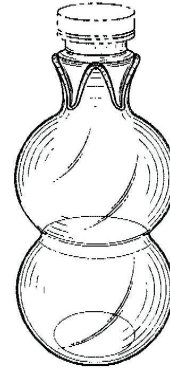

OWNER OF U.S. REG. NOS. 2,832,657 AND 2,832,658.
THE LINING IN THE DRAWING IS FOR SHADING PURPOSES ONLY.

THE MARK CONSISTS OF A THREE-DIMENSIONAL PACKAGE DESIGN OF A BOTTLE FEATURING TWO GLOBULAR SECTIONS. THE TOP PORTION OF THE BOTTLE WHICH IS PRESENTED IN DOTTED LINES IS NOT PART OF THE MARK.

FOR FRUIT DRINKS; FRUIT JUICE CONCENTRATES; FRUIT SMOOTHIES (U.S. CLS. 45, 46 AND 48).
FIRST USE 6-30-2004; IN COMMERCE 6-30-2004.

3,633,042. ANHEUSER-BUSCH, INCORPORATED, ST. LOUIS, MO. SN 77-573,491. PUB. 12-30-2008, FILED 9-18-2008.

LA DIFERENCIA ES TOMABILIDAD

THE MARK CONSISTS OF STANDARD CHARACTERS WITHOUT CLAIM TO ANY PARTICULAR FONT, STYLE, SIZE, OR COLOR.

THE ENGLISH TRANSLATION OF THE WORD "LA DIFERENCIA ES TOMABILIDAD" IN THE MARK IS THE DIFFERENCE IS DRINKABILITY.

FOR BEER (U.S. CLS. 45, 46 AND 48).
FIRST USE 11-17-2008; IN COMMERCE 11-17-2008.

3,633,175. MADISON PARK, LLC, WILMINGTON, DE. SN 78-693,969. PUB. 1-17-2006, FILED 8-16-2005.

TIRO

THE MARK CONSISTS OF STANDARD CHARACTERS WITHOUT CLAIM TO ANY PARTICULAR FONT, STYLE, SIZE, OR COLOR.

FOR NON-ALCOHOLIC BEVERAGES, NAMELY, MINERAL AND SPRING WATER, AERATED WATER, FRUIT JUICES, FRUIT-FLAVORED BEVERAGES, SOFT DRINKS; SYRUPS FOR BEVERAGES (U.S. CLS. 45, 46 AND 48).

FIRST USE 2-0-2009; IN COMMERCE 2-0-2009.

CLASS 33—WINES AND SPIRITS

CLASS 33—(Continued).

3,631,816. AIKEN, AMY, ST. HELENA, CA. SN 76-670,295.
PUB. 7-10-2007, FILED 12-13-2006.

CLASS 33—(Continued).

3,631,946. LAUREL GLEN VINEYARD, LLC, SANTA ROSA,
CA. SN 77-093,758. PUB. 7-17-2007, FILED 1-29-2007.

CONSPIRE

THE MARK CONSISTS OF STANDARD CHARACTERS
WITHOUT CLAIM TO ANY PARTICULAR FONT, STYLE,
SIZE, OR COLOR.

FOR WINE (U.S. CLS. 47 AND 49).
FIRST USE 12-8-2006; IN COMMERCE 3-18-2009.

FUERZA

THE MARK CONSISTS OF STANDARD CHARACTERS
WITHOUT CLAIM TO ANY PARTICULAR FONT, STYLE,
SIZE, OR COLOR.

THE FOREIGN WORDING IN THE MARK TRANSLATES
INTO ENGLISH AS "FORCE".

FOR WINE (U.S. CLS. 47 AND 49).
FIRST USE 2-6-2009; IN COMMERCE 2-6-2009.

3,631,860. F. KORBEL & BROS., GUERNEVILLE, CA. SN 76-
691,808. PUB. 12-23-2008, FILED 8-4-2008.

PURVEYORS OF GOOD TASTE

THE MARK CONSISTS OF STANDARD CHARACTERS
WITHOUT CLAIM TO ANY PARTICULAR FONT, STYLE,
SIZE, OR COLOR.

FOR WINE (U.S. CLS. 47 AND 49).
FIRST USE 1-0-2009; IN COMMERCE 1-0-2009.

3,631,980. BERGEVIN LANE VINEYARDS, LLC, WALLA
WALLA, WA. SN 77-129,756. PUB. 11-25-2008, FILED 3-13-
2007.

3,631,916. JAMIE KELLNER, SANTA BARBARA, CA. SN 77-
064,834. PUB. 7-10-2007, FILED 12-14-2006.

Fruit Bomb**CENT'ANNI**

THE MARK CONSISTS OF STANDARD CHARACTERS
WITHOUT CLAIM TO ANY PARTICULAR FONT, STYLE,
SIZE, OR COLOR.

THE FOREIGN WORDING IN THE MARK TRANSLATES
INTO ENGLISH AS A HUNDRED YEARS.

FOR WINE; WINES (U.S. CLS. 47 AND 49).
FIRST USE 3-16-2009; IN COMMERCE 3-16-2009.

THE MARK CONSISTS OF STANDARD CHARACTERS
WITHOUT CLAIM TO ANY PARTICULAR FONT, STYLE,
SIZE, OR COLOR.

NO CLAIM IS MADE TO THE EXCLUSIVE RIGHT TO
USE "FRUIT", APART FROM THE MARK AS SHOWN.

FOR WINE (U.S. CLS. 47 AND 49).
FIRST USE 9-15-2007; IN COMMERCE 9-15-2007.

CLASS 33—(Continued).

3,632,066. JJE PROPERTIES LLC, GLEN ELLYN, IL. SN 77-205,265. PUB. 11-25-2008, FILED 6-13-2007.

Fruition

THE MARK CONSISTS OF STANDARD CHARACTERS WITHOUT CLAIM TO ANY PARTICULAR FONT, STYLE, SIZE, OR COLOR.

FOR ALCOHOLIC BEVERAGES OF FRUIT; ALCOHOLIC BEVERAGES, NAMELY, PREPARED COCKTAILS AND COCKTAIL MIXES AND THOSE PRODUCED FROM FRUIT AND BREWED MALT BASE, COFFEE BASED BEVERAGES, TEA-BASED BEVERAGES, WINES, BRANDY, BRANDY SPIRITS, CHAMPAGNE, LIQUORS, COGNAC, DISTILLED SPIRITS, GINS, GRAPPA, HARD CIDER, HERB LIQUEURS, RUM, SAKE, SANGRIAS, SCHNAPPS, SHERRY, TEQUILA, VERMOUTH, VODKA, WHISKEY, CALVADOS; ALCOHOLIC COCKTAIL MIXES; APERITIFS WITH A DISTILLED ALCOHOLIC LIQUOR BASE; PREPARED ALCOHOLIC COCKTAIL; ALCOHOLIC COFFEE-BASED BEVERAGE; FLAVORED BREWED MALT BEVERAGE; LIQUOR AND LIQUEUR BEVERAGES, NAMELY, ALCOHOLIC COCKTAIL MIXES; RUM (U.S. CLS. 47 AND 49).

FIRST USE 6-1-2007; IN COMMERCE 8-6-2008.

3,632,114. RUMSEY INDIAN RANCHERIA OF WINTUN INDIANS OF CALIFORNIA, BROOKS, CA. SN 77-230,415. PUB. 1-15-2008, FILED 7-16-2007.

CHAMA

THE MARK CONSISTS OF STANDARD CHARACTERS WITHOUT CLAIM TO ANY PARTICULAR FONT, STYLE, SIZE, OR COLOR.

FOR WINE (U.S. CLS. 47 AND 49).
FIRST USE 10-11-2008; IN COMMERCE 10-11-2008.

CLASS 33—(Continued).

3,632,262. THE WINE GROUP LLC, TRACY, CA. SN 77-297,142. PUB. 3-11-2008, FILED 10-5-2007.



THE MARK CONSISTS OF STYLIZED BARBED WIRE DISPLAYED ABOVE AND BELOW AND THE WORDS "BIG HOUSE".

FOR WINE (U.S. CLS. 47 AND 49).
FIRST USE 12-12-2007; IN COMMERCE 12-12-2007.

3,632,343. VINO TABI, INC., SANTA CRUZ, CA. SN 77-333,617. PUB. 7-1-2008, FILED 11-19-2007.

VINO TABI

THE MARK CONSISTS OF STANDARD CHARACTERS WITHOUT CLAIM TO ANY PARTICULAR FONT, STYLE, SIZE, OR COLOR.

NO CLAIM IS MADE TO THE EXCLUSIVE RIGHT TO USE "VINO", APART FROM THE MARK AS SHOWN. THE ENGLISH TRANSLATION OF THE WORD "VINO" IN THE MARK IS WINE.

FOR WINE (U.S. CLS. 47 AND 49).
FIRST USE 4-1-2008; IN COMMERCE 4-1-2008.

3,632,435. HALL WINES, LLC, ST. HELENA, CA. SN 77-371,453. PUB. 5-27-2008, FILED 1-14-2008.



THE MARK CONSISTS OF A SERIES OF WAVY INTERSECTING LINES IN A THREE BY THREE GRID.

FOR WINE (U.S. CLS. 47 AND 49).
FIRST USE 2-9-2008; IN COMMERCE 2-9-2008.

CLASS 33—(Continued).

3,632,521. DUCKHORN WINE COMPANY, ST. HELENA, CA.
SN 77-398,075. PUB. 7-8-2008, FILED 2-15-2008.

TEN DEGREES

THE MARK CONSISTS OF STANDARD CHARACTERS
WITHOUT CLAIM TO ANY PARTICULAR FONT, STYLE,
SIZE, OR COLOR.
FOR WINES (U.S. CLS. 47 AND 49).
FIRST USE 3-1-2009; IN COMMERCE 3-16-2009.

3,632,541. JOHN RAYTEK WINES, HEALDSBURG, CA. SN
77-403,179. PUB. 7-8-2008, FILED 2-21-2008.

ESCARPA

THE MARK CONSISTS OF STANDARD CHARACTERS
WITHOUT CLAIM TO ANY PARTICULAR FONT, STYLE,
SIZE, OR COLOR.
THE FOREIGN WORDING IN THE MARK TRANSLATES
INTO ENGLISH AS SCARP.
FOR RED WINE; WHITE WINE; WINE; WINES (U.S.
CLS. 47 AND 49).
FIRST USE 8-28-2008; IN COMMERCE 3-11-2009.

3,632,677. EAGLE'S TRACE, LLC, ST. HELENA, CA. SN 77-
427,505. PUB. 7-29-2008, FILED 3-20-2008.

BECAUSE

THE MARK CONSISTS OF STANDARD CHARACTERS
WITHOUT CLAIM TO ANY PARTICULAR FONT, STYLE,
SIZE, OR COLOR.
FOR WINE (U.S. CLS. 47 AND 49).
FIRST USE 1-19-2009; IN COMMERCE 1-19-2009.

CLASS 33—(Continued).

3,632,678. IRISH THUNDER, LLC, PEARL RIVER, NY. SN
77-427,515. PUB. 8-5-2008, FILED 3-20-2008.

F317

THE MARK CONSISTS OF STANDARD CHARACTERS
WITHOUT CLAIM TO ANY PARTICULAR FONT, STYLE,
SIZE, OR COLOR.
FOR ALCOHOLIC BEVERAGES, NAMELY, COR-
DIALS AND LIQUEURS (U.S. CLS. 47 AND 49).
FIRST USE 2-2-2009; IN COMMERCE 2-2-2009.

3,632,730. E. & J. GALLO WINERY, MODESTO, CA. SN 77-
440,546. PUB. 7-15-2008, FILED 4-4-2008.

STOP AND SMELL THE ROSEHAVEN

THE MARK CONSISTS OF STANDARD CHARACTERS
WITHOUT CLAIM TO ANY PARTICULAR FONT, STYLE,
SIZE, OR COLOR.
FOR WINES (U.S. CLS. 47 AND 49).
FIRST USE 6-2-2008; IN COMMERCE 6-2-2008.

3,632,769. MURPHY, BARRY JOSEPH, DBA SILVERPOINT
CELLARS LLC, NAPA, CA. SN 77-450,077. PUB. 9-9-2008,
FILED 4-16-2008.

Silverpoint Cellars

THE MARK CONSISTS OF STANDARD CHARACTERS
WITHOUT CLAIM TO ANY PARTICULAR FONT, STYLE,
SIZE, OR COLOR.
NO CLAIM IS MADE TO THE EXCLUSIVE RIGHT TO
USE "CELLARS", APART FROM THE MARK AS SHOWN.
FOR WINES (U.S. CLS. 47 AND 49).
FIRST USE 4-14-2008; IN COMMERCE 9-25-2008.

CLASS 33—(Continued).

3,632,812. LUXCO, INC., ST. LOUIS, MO. SN 77-465,392. PUB. 10-14-2008, FILED 5-5-2008.

CLASS 33—(Continued).

3,632,932. NATURAL MERCHANTS, LLC., ROGUE RIVER, OR. SN 77-515,454. PUB. 12-30-2008, FILED 7-7-2008.

REBEL RESERVE

THE MARK CONSISTS OF STANDARD CHARACTERS WITHOUT CLAIM TO ANY PARTICULAR FONT, STYLE, SIZE, OR COLOR.

NO CLAIM IS MADE TO THE EXCLUSIVE RIGHT TO USE "RESERVE", APART FROM THE MARK AS SHOWN, FOR LIQUORS AND DISTILLED SPIRITS (U.S. CLS. 47 AND 49).

FIRST USE 9-29-2008; IN COMMERCE 9-29-2008.

ALBERO

THE MARK CONSISTS OF STANDARD CHARACTERS WITHOUT CLAIM TO ANY PARTICULAR FONT, STYLE, SIZE, OR COLOR.

THE FOREIGN WORDING IN THE MARK TRANSLATES INTO ENGLISH AS THE INNER CIRCLE OF THE BULL-FIGHT RING.

FOR GRAPE WINE (U.S. CLS. 47 AND 49).
FIRST USE 3-3-2008; IN COMMERCE 9-9-2008.

3,632,912. MALBEC HOLDINGS, INC., DBA DAME DE LA COUR, LOCKWOOD, CA. SN 77-509,183. PUB. 12-30-2008, FILED 6-26-2008.

3,632,994. SAINT MAXIMUS LLC, PHILADELPHIA, PA. SN 77-534,669. PUB. 12-23-2008, FILED 7-30-2008.

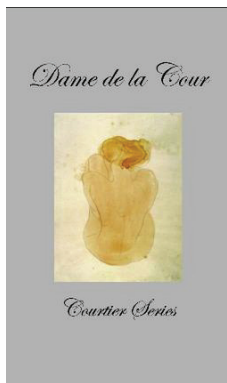

NO CLAIM IS MADE TO THE EXCLUSIVE RIGHT TO USE "SERIES", APART FROM THE MARK AS SHOWN.

THE COLOR(S) BROWN, GRAY AND BLACK IS/ARE CLAIMED AS A FEATURE OF THE MARK.

THE MARK CONSISTS OF A FOUR COLOR SERIGRAPH OF THE BACK OF A NUDE IN SHADES OF BROWN WITH A BACKGROUND OF THE LIGHTEST SHADES, WITH THE WORDS "DAME DE LA COUR" AND "COURTIER SERIES" IN BLACK EDWARDIAN SCRIPT ON ALL GRAY BACKGROUND.

THE ENGLISH TRANSLATION OF THE WORD "DAME DE LA COUR COURTIER SERIES" IN THE MARK IS WOMAN OF THE COURT.

FOR GRAPE WINE; RED WINE; RED WINES; TABLE WINES; WHITE WINE; WINE; WINES; WINES AND FORTIFIED WINES (U.S. CLS. 47 AND 49).

FIRST USE 8-15-2008; IN COMMERCE 8-15-2008.



THE STIPPLING IS FOR SHADING PURPOSES ONLY. THE MARK CONSISTS OF A DESIGN OF A MALE SKIER RAISING HIS SKI POLES IN THE AIR WITH A WOMAN AT HIS SIDE. BELOW THEIR IS THE STYLIZED TEXT "ST MAX".

FOR HERB LIQUEURS (U.S. CLS. 47 AND 49).
FIRST USE 2-15-2009; IN COMMERCE 2-15-2009.

CLASS 33—(Continued).

3,633,173. TRANS-SCRIPTO (PTY) LTD, MILNERTON 7441, SOUTH AFRICA. SN 78-686,712. PUB. 5-16-2006, FILED 8-5-2005.

EMINEO

THE MARK CONSISTS OF STANDARD CHARACTERS WITHOUT CLAIM TO ANY PARTICULAR FONT, STYLE, SIZE, OR COLOR.

FOR ALCOHOLIC BEVERAGES, NAMELY, WINES (U.S. CLS. 47 AND 49).

FIRST USE 9-2-2008; IN COMMERCE 3-13-2009.

3,633,267. ILLVA SARONNO S.P.A., SARONNO, ITALY. SN 78-878,848. PUB. 10-31-2006, FILED 5-8-2006.

NORTHERN ARCTIC

THE MARK CONSISTS OF STANDARD CHARACTERS WITHOUT CLAIM TO ANY PARTICULAR FONT, STYLE, SIZE, OR COLOR.

FOR VODKA (U.S. CLS. 47 AND 49).

FIRST USE 9-30-2006; IN COMMERCE 9-30-2006.

3,633,333. AGAVERA CAMICHINES, S.A. DE C.V., JALISCO, C.P. 45601, MEXICO, MEXICO. SN 78-981,045. PUB. 6-24-2008, FILED 2-12-2004.

1800

THE MARK CONSISTS OF STANDARD CHARACTERS WITHOUT CLAIM TO ANY PARTICULAR FONT, STYLE, SIZE, OR COLOR.

OWNER OF U.S. REG. NOS. 2,151,166, 2,547,535, AND OTHERS.

FOR TEQUILA; PREPARED ALCOHOLIC COCKTAIL MIXES CONTAINING TEQUILA (U.S. CLS. 47 AND 49). FIRST USE 3-22-2005; IN COMMERCE 3-22-2005.

CLASS 34—SMOKERS' ARTICLES

3,631,825. VINTAGE ENTERPRISES, INC., EAST STROUDSBURG, PA. SN 76-680,045. PUB. 1-15-2008, FILED 7-30-2007.

DUPES

THE MARK CONSISTS OF STANDARD CHARACTERS WITHOUT CLAIM TO ANY PARTICULAR FONT, STYLE, SIZE, OR COLOR.

FOR CIGARS (U.S. CLS. 2, 8, 9 AND 17).

FIRST USE 3-24-2009; IN COMMERCE 3-24-2009.

3,632,208. STUSSY, INC., IRVINE, CA. SN 77-268,799. PUB. 2-19-2008, FILED 8-30-2007.

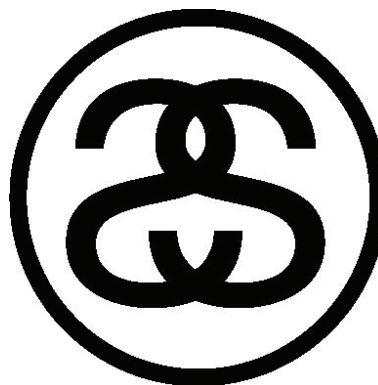

OWNER OF U.S. REG. NOS. 2,225,736, 2,399,916, AND OTHERS.

FOR CIGARETTE LIGHTERS (U.S. CLS. 2, 8, 9 AND 17).

FIRST USE 3-30-2009; IN COMMERCE 3-30-2009.

3,632,487. TROPICAL TOBACCO, INC., MIAMI, FL. SN 77-391,951. PUB. 9-9-2008, FILED 2-8-2008.

ARSENIO

THE MARK CONSISTS OF STANDARD CHARACTERS WITHOUT CLAIM TO ANY PARTICULAR FONT, STYLE, SIZE, OR COLOR.

THE NAME(S), PORTRAIT(S), AND/OR SIGNATURE(S) SHOWN IN THE MARK DOES NOT IDENTIFY A PARTICULAR LIVING INDIVIDUAL.

FOR CIGARS (U.S. CLS. 2, 8, 9 AND 17).

FIRST USE 2-19-2009; IN COMMERCE 2-19-2009.

CLASS 34—(Continued).

3,632,780. PHILIP MORRIS USA INC., RICHMOND, VA. SN 77-453,387. PUB. 7-29-2008, FILED 4-21-2008.

MARLBORO WHEN YOU WANT IT

THE MARK CONSISTS OF STANDARD CHARACTERS WITHOUT CLAIM TO ANY PARTICULAR FONT, STYLE, SIZE, OR COLOR.

OWNER OF U.S. REG. NOS. 68,502, 3,365,560, AND OTHERS.

FOR TOBACCO PRODUCTS, NAMELY, SMOKELESS TOBACCO (U.S. CLS. 2, 8, 9 AND 17).

FIRST USE 5-0-2008; IN COMMERCE 5-0-2008.

3,632,972. TAMPA SWEETHEARTS CIGAR COMPANY, TAMPA, FL. SN 77-527,272. PUB. 12-9-2008, FILED 7-21-2008.

CARRITO 413

THE MARK CONSISTS OF STANDARD CHARACTERS WITHOUT CLAIM TO ANY PARTICULAR FONT, STYLE, SIZE, OR COLOR.

THE FOREIGN WORDING IN THE MARK TRANSLATES INTO ENGLISH AS CART.

FOR CIGARS (U.S. CLS. 2, 8, 9 AND 17).

FIRST USE 11-8-2008; IN COMMERCE 11-8-2008.

3,633,043. TAMPA SWEETHEARTS CIGAR COMPANY, TAMPA, FL. SN 77-573,592. PUB. 12-9-2008, FILED 9-18-2008.

LA ESTAMPA

THE MARK CONSISTS OF STANDARD CHARACTERS WITHOUT CLAIM TO ANY PARTICULAR FONT, STYLE, SIZE, OR COLOR.

THE ENGLISH TRANSLATION OF THE WORD "LA ESTAMPA" IN THE MARK IS "STAMP".

FOR CIGARS (U.S. CLS. 2, 8, 9 AND 17).

FIRST USE 11-8-2008; IN COMMERCE 11-8-2008.

CLASS 34—(Continued).

3,633,130. HOLT'S COMPANY, PHILADELPHIA, PA. SN 78-573,111. PUB. 12-20-2005, FILED 2-23-2005.

OCEAN CLUB

THE MARK CONSISTS OF STANDARD CHARACTERS WITHOUT CLAIM TO ANY PARTICULAR FONT, STYLE, SIZE, OR COLOR.

FOR CIGARS (U.S. CLS. 2, 8, 9 AND 17).

FIRST USE 2-27-2009; IN COMMERCE 2-27-2009.

SERVICE MARKS**CLASS 35—ADVERTISING AND BUSINESS**

3,631,819. VOLKSWAGEN GROUP OF AMERICA, INC., AUBURN HILLS, MI. SN 76-675,956. PUB. 4-8-2008, FILED 4-24-2007.

TRUTH IN ENGINEERING

THE MARK CONSISTS OF STANDARD CHARACTERS WITHOUT CLAIM TO ANY PARTICULAR FONT, STYLE, SIZE, OR COLOR.

FOR PROMOTING THE SERVICES OF AUTOMOBILE DEALERSHIPS THROUGH THE DISTRIBUTION OF PRINTED, AUDIO AND AUDIOVISUAL PROMOTIONAL MATERIALS AND BY RENDERING SALES PROMOTION ADVICE (U.S. CLS. 100, 101 AND 102).

FIRST USE 5-7-2007; IN COMMERCE 5-7-2007.

3,631,833. ECOLOGY AND ENVIRONMENT, INC., LANCASTER, NY. SN 76-682,831. PUB. 5-20-2008, FILED 10-11-2007.



NO CLAIM IS MADE TO THE EXCLUSIVE RIGHT TO USE "METER", APART FROM THE MARK AS SHOWN.

FOR PROVIDING ENERGY USAGE MANAGEMENT; AND ENERGY USAGE MANAGEMENT INFORMATION SERVICES FOR THIRD PARTIES (U.S. CLS. 100, 101 AND 102).

FIRST USE 1-8-2008; IN COMMERCE 6-15-2007.

CLASS 35—(Continued).

3,631,862. PEACE STORE, INC., SANTA BARBARA, CA. SN 76-978,969. PUB. 7-17-2007, FILED 12-22-2005.

PEACE STORE

THE MARK CONSISTS OF STANDARD CHARACTERS WITHOUT CLAIM TO ANY PARTICULAR FONT, STYLE, SIZE, OR COLOR.

NO CLAIM IS MADE TO THE EXCLUSIVE RIGHT TO USE "STORE", APART FROM THE MARK AS SHOWN.

FOR RETAIL STORE SERVICES IN THE FIELD OF CLOTHING (U.S. CLS. 100, 101 AND 102).

FIRST USE 2-2-2007; IN COMMERCE 4-13-2007.

3,631,890. LIVETIME 24/7 LTD., COLWYN BAY, WALES. SN 77-037,334. PUB. 3-4-2008, FILED 11-6-2006.

VET ENVOY

THE MARK CONSISTS OF STANDARD CHARACTERS WITHOUT CLAIM TO ANY PARTICULAR FONT, STYLE, SIZE, OR COLOR.

PRIORITY CLAIMED UNDER SEC. 44(D) ON ERP CMNTY TM OFC APPLICATION NO. 5432001, FILED 11-1-2006, REG. NO. 5432001, DATED 10-29-2007, EXPIRES 11-1-2016.

NO CLAIM IS MADE TO THE EXCLUSIVE RIGHT TO USE "VET", APART FROM THE MARK AS SHOWN.

FOR ONLINE BUSINESS MANAGEMENT AND ADMINISTRATION SERVICES FOR VETERINARY PRACTICES; COMPUTERIZED BUSINESS MANAGEMENT AND ADMINISTRATION SERVICES FOR VETERINARY PRACTICES (U.S. CLS. 100, 101 AND 102).

FIRST USE 11-1-2006; IN COMMERCE 1-1-2009.

CLASS 35—(Continued).

3,631,897. KUKUI'ULA DEVELOPMENT COMPANY (HAWAII), LLC, KAUAI, HI. SN 77-043,101. PUB. 8-28-2007, FILED 11-13-2006.

KUKUI'ULA

THE MARK CONSISTS OF STANDARD CHARACTERS WITHOUT CLAIM TO ANY PARTICULAR FONT, STYLE, SIZE, OR COLOR.

OWNER OF U.S. REG. NO. 3,059,243.

THE FOREIGN WORDING IN THE MARK TRANSLATES INTO ENGLISH AS RED BURNING TORCH LIGHT OF THE KUKUI NUT.

FOR ASSOCIATION SERVICES, NAMELY, PROMOTING THE INTERESTS OF HOMEOWNERS THAT RESIDE IN THE PLANNED AND LOCAL COMMUNITY; COMMERCIAL BUSINESS MANAGEMENT; BUSINESS MANAGEMENT OF COMMERCIAL REAL ESTATE AND RETAIL STORES FOR OTHERS; PROMOTING THE GOODS AND SERVICES OF OTHERS BY DISTRIBUTING ADVERTISING MATERIALS THROUGH A VARIETY OF METHODS (U.S. CLS. 100, 101 AND 102).

FIRST USE 1-0-2005; IN COMMERCE 1-0-2005.

3,631,904. OMNISOLV, INC., SALISBURY, NC. SN 77-050,794. PUB. 7-17-2007, FILED 11-27-2006.

OmniChat

THE MARK CONSISTS OF STANDARD CHARACTERS WITHOUT CLAIM TO ANY PARTICULAR FONT, STYLE, SIZE, OR COLOR.

FOR BRINGING TOGETHER, FOR THE BENEFIT OF OTHERS, OF A VARIETY OF GOODS, ENABLING CUSTOMERS TO CONVENIENTLY VIEW AND PURCHASE THOSE GOODS (U.S. CLS. 100, 101 AND 102).

FIRST USE 4-2-2007; IN COMMERCE 4-2-2007.

CLASS 35—(Continued).

3,631,905. OMNISOLV, INC., SALISBURY, NC. SN 77-050,864. PUB. 7-17-2007, FILED 11-27-2006.

OmniLink

THE MARK CONSISTS OF STANDARD CHARACTERS WITHOUT CLAIM TO ANY PARTICULAR FONT, STYLE, SIZE, OR COLOR.

FOR THE BRINGING TOGETHER, FOR THE BENEFIT OF OTHERS, OF A VARIETY OF GOODS, ENABLING CUSTOMERS TO CONVENIENTLY VIEW AND PURCHASE THOSE GOODS (U.S. CLS. 100, 101 AND 102).

FIRST USE 4-2-2007; IN COMMERCE 4-2-2007.

CLASS 35—(Continued).

3,631,988. COOKIN' DINNERS LICENSING COMPANY, NORWALK, CT. SN 77-136,939. PUB. 1-15-2008, FILED 3-21-2007.

THE PREP'S ALL DONE SO YOU
CAN HAVE FUN

THE MARK CONSISTS OF STANDARD CHARACTERS WITHOUT CLAIM TO ANY PARTICULAR FONT, STYLE, SIZE, OR COLOR.

FOR FRANCHISING SERVICES, NAMELY, OFFERING TECHNICAL AND BUSINESS MANAGEMENT ASSISTANCE IN THE ESTABLISHMENT AND OPERATION OF FOOD SERVICE OPERATIONS WHEREBY CUSTOMERS ASSEMBLE THEIR OWN MEALS (U.S. CLS. 100, 101 AND 102).

FIRST USE 1-0-2008; IN COMMERCE 1-0-2008.

3,631,989. RITA'S WATER ICE FRANCHISE COMPANY, LLC, TREVOSE, PA. SN 77-136,999. PUB. 4-15-2008, FILED 3-21-2007.



3,631,915. CHAN, MICHELLE, SINGAPORE, SINGAPORE. SN 77-064,142. PUB. 7-1-2008, FILED 12-14-2006.



NO CLAIM IS MADE TO THE EXCLUSIVE RIGHT TO USE "CLASSIFIED" AND "BUY & SELL WITH MOBILE CLASSIFIED", APART FROM THE MARK AS SHOWN.

THE MARK CONSISTS OF A STYLIZED RENDITION OF THE FANCIFUL WORD "MCLASSIFIED" SET ON TOP OF THE TAG LINE "BUY & SELL WITH MOBILE CLASSIFIEDS" SET IN A SANS SERIF FONT.

FOR ADVERTISING BY TRANSMISSION OF PUBLICITY FOR THIRD PARTIES THROUGH MOBILE TELEPHONIC NETWORKS AND ELECTRONIC COMMUNICATIONS NETWORKS (U.S. CLS. 100, 101 AND 102).

FIRST USE 3-23-2007; IN COMMERCE 3-23-2007.

OWNER OF U.S. REG. NOS. 2,614,810, 3,109,750, AND OTHERS.

NO CLAIM IS MADE TO THE EXCLUSIVE RIGHT TO USE "ICE" AND "CUSTARD", APART FROM THE MARK AS SHOWN.

THE COLOR(S) RED, GREEN, WHITE AND LIGHT BLUE IS/ARE CLAIMED AS A FEATURE OF THE MARK.

THE MARK CONSISTS OF THE WORDING "RITA'S RITA'S ICE CUSTARD HAPPINESS", WITH THE COLOR GREEN APPEARING IN THE WORDING "RITA'S", WITH THE WORDING "ICE CUSTARD HAPPINESS" APPEARING IN RED, WITH GREEN DOTS BETWEEN ON EITHER SIDE OF THE WORD "CUSTARD", ALL APPEARING IN A SINGLE LINE. THE WHITE WORDING "RITA'S" APPEARS IN A GREEN BANNER, OUTLINED IN WHITE, APPEARING ON A CUP WHICH HAS RED AND WHITE VERTICAL STRIPES AND GREEN AND WHITE HORIZONTAL STRIPES AT THE TOP AND BOTTOM, WITH A RED TOP AND WHITE OVER THE RED, ALL IN THE SHAPE OF A CUP OUTLINED IN LIGHT BLUE, AND APPEARING BEFORE THE GREEN WORD "RITA'S".

FOR RETAIL STORE SERVICES FEATURING ITALIAN ICE, FROZEN CUSTARD AND OTHER FROZEN CONFECTIONS, FOR CONSUMPTION ON AND OFF THE PREMISES; RESTAURANT FRANCHISING (U.S. CLS. 100, 101 AND 102).

FIRST USE 4-13-2007; IN COMMERCE 4-13-2007.

CLASS 35—(Continued).

3,632,025. NCS PEARSON, INC., BLOOMINGTON, MN. SN 77-166,637. PUB. 11-6-2007, FILED 4-26-2007.

TALENTLENS

THE MARK CONSISTS OF STANDARD CHARACTERS WITHOUT CLAIM TO ANY PARTICULAR FONT, STYLE, SIZE, OR COLOR.

FOR PROVIDING ONLINE ASSESSMENTS AND TESTS FOR EMPLOYERS TO USE IN EVALUATING THE WORK SKILLS OF EMPLOYMENT APPLICANTS (U.S. CLS. 100, 101 AND 102).

FIRST USE 8-1-2007; IN COMMERCE 8-1-2007.

3,632,060. LIZA SHTROMBERG CO LLC, LOS ANGELES, CA. SN 77-199,696. PUB. 6-24-2008, FILED 6-6-2007.



THE COLOR(S) GREEN IS/ARE CLAIMED AS A FEATURE OF THE MARK.

THE MARK CONSISTS OF THE FIRST LEAF AND THE WORD "GREEN" IS A DARK OLIVE GREEN, THE SECOND LEAF IS A LIGHT OLIVE GREEN, THE THIRD LEAF IS A KELLY GREEN, AND THE "ALL SHADES OF" IS A LIGHT KELLY GREEN.

FOR RETAIL OUTLETS FEATURING HOME IMPROVEMENT ITEMS, BATH CARE ITEMS AND COSMETICS INCLUDING SOAPS, LOTIONS, SHAMPOO AND MAKE-UP, JEWELRY, PERSONAL ACCESSORIES, AND ENVIRONMENTALLY-FRIENDLY GOODS LIKE WATER FILTERS, RECHARGEABLE BATTERIES, ENERGY SAVING DEVICES AND ITEMS INCLUDING POOL HEATING AND LIGHTING SYSTEMS, WATER HEATING SYSTEMS, SOLAR HEATING AND LIGHTING SYSTEMS AND SPACE LIGHTING AND HEATING SYSTEMS (U.S. CLS. 100, 101 AND 102).

FIRST USE 12-9-2008; IN COMMERCE 12-9-2008.

CLASS 35—(Continued).

3,632,089. DENTAL IMAGE SOLUTIONS CORP., ENCINO, CA. SN 77-220,855. PUB. 10-7-2008, FILED 7-2-2007.



NO CLAIM IS MADE TO THE EXCLUSIVE RIGHT TO USE "DENTAL MEDICAL STORES ONLINE", APART FROM THE MARK AS SHOWN.

THE COLOR(S) DARK BLUE, LIGHT BLUE, RED, YELLOW, ORANGE AND PINK IS/ARE CLAIMED AS A FEATURE OF THE MARK.

THE MARK CONSISTS OF THE COLORS YELLOW, ORANGE, RED AND PINK APPEAR IN THE FLOWER, WHICH IS LOCATED TO THE LEFT OF THE TERM "DEN". THE COLORS LIGHT BLUE AND DARK BLUE ARE THE COLORS OF THE WORDING "DEN-MED-PRO", THE HORIZONTAL LINE UNDER "DEN-MED-PRO", AND THE WORDING "DENTAL MEDICAL STORES ONLINE".

FOR ONLINE RETAIL STORE SERVICES FEATURING DENTAL EQUIPMENT, DENTAL SUPPLIES, MEDICAL EQUIPMENT, AND MEDICAL SUPPLIES (U.S. CLS. 100, 101 AND 102).

FIRST USE 7-2-2007; IN COMMERCE 9-21-2008.

3,632,091. CROWN MELBOURNE LIMITED, SOUTHBANK, MELBOURNE, AUSTRALIA. SN 77-222,545. PUB. 4-22-2008, FILED 7-5-2007.



NO CLAIM IS MADE TO THE EXCLUSIVE RIGHT TO USE "CLUB", APART FROM THE MARK AS SHOWN.

THE MARK CONSISTS OF AN OVAL CONTAINING THE IMAGE OF A CROWN, AND THE WORDS "CROWN CLUB" PRESENTED IN A STYLIZED FASHION.

FOR CUSTOMER LOYALTY SERVICES AND CUSTOMER CLUB SERVICES, FOR COMMERCIAL, PROMOTIONAL AND/OR ADVERTISING PURPOSES, ENABLING PARTICIPANTS TO OBTAIN DISCOUNTS, REWARDS, AND OTHER INCENTIVES AT HOTELS AND CASINOS (U.S. CLS. 100, 101 AND 102).

FIRST USE 7-31-2004; IN COMMERCE 7-31-2004.

CLASS 35—(Continued).

3,632,103. LFC, INC., SAN DIEGO, CA. SN 77-227,604. PUB. 1-1-2008, FILED 7-12-2007.

FUTONOLOGY

THE MARK CONSISTS OF STANDARD CHARACTERS WITHOUT CLAIM TO ANY PARTICULAR FONT, STYLE, SIZE, OR COLOR.

FOR ONLINE RETAIL AND RETAIL STORES FEATURING BEDROOM FURNITURE, FUTONS, MATTRESSES, BED FRAMES, DECORATIVE FUTON MATTRESS COVERS, PILLOWS, AND SOFAS (U.S. CLS. 100, 101 AND 102).

FIRST USE 6-14-2007; IN COMMERCE 10-1-2008.

CLASS 35—(Continued).

3,632,158. KAREN VALENTINE, SHEPHERDSTOWN, WV. SN 77-251,171. PUB. 7-8-2008, FILED 8-9-2007.



THE COLOR(S) TURQUOISE, BROWN, LIGHT BROWN, PURPLE, WHITE AND GREEN IS/ARE CLAIMED AS A FEATURE OF THE MARK.

THE MARK CONSISTS OF A GIRL HOLDING FLOWERS IN HER HANDS; THE PETALS OF THE FLOWERS ARE PURPLE, THE CENTER OF THE FLOWERS IS WHITE, THE STEMS OF THE FLOWERS ARE GREEN; THE GIRL HAS BROWN HAIR AND LIGHT BROWN COMPLEXION; THE DRESS IS TURQUOISE AND THE TWO INVERTED VERTICAL FLOWERS ON THE DRESS HAVE GREEN PETALS, WHITE STEMS AND WHITE AT THE TIP OF THE PETALS.

FOR PROMOTING THE GOODS AND SERVICES OF OTHERS, NAMELY, THIRD PARTIES COMMITTED TO PRESERVATION OF THE ENVIRONMENT, BY PROVIDING A WEB SITE AT WHICH USERS CAN LINK TO ENVIRONMENTALLY CONSCIOUS COMPANIES (U.S. CLS. 100, 101 AND 102).

FIRST USE 1-31-2008; IN COMMERCE 1-31-2008.

3,632,134. PAGES BBDO, S.A., SANTO DOMINGO, DOMINICAN REP. SN 77-240,373. PUB. 1-15-2008, FILED 7-27-2007.

GREENCARD

THE MARK CONSISTS OF STANDARD CHARACTERS WITHOUT CLAIM TO ANY PARTICULAR FONT, STYLE, SIZE, OR COLOR.

FOR ADVERTISING AGENCIES (U.S. CLS. 100, 101 AND 102).

FIRST USE 3-3-2009; IN COMMERCE 3-3-2009.

3,632,161. HALLIBURTON ENERGY SERVICES, INC., CARROLLTON, TX. SN 77-252,619. PUB. 4-1-2008, FILED 8-10-2007.

ENABLING THE DIGITAL ASSET

THE MARK CONSISTS OF STANDARD CHARACTERS WITHOUT CLAIM TO ANY PARTICULAR FONT, STYLE, SIZE, OR COLOR.

FOR BUSINESS CONSULTATION IN THE FIELD OF OIL AND GAS WELL DRILLING, INCLUDING WELL PLANNING, WELL CONSTRUCTION, AND WELL DRILLING; BUSINESS PROJECT MANAGEMENT FOR OTHERS IN THE FIELD OF OIL AND GAS WELL DRILLING; BUSINESS CONSULTING, NAMELY, PROJECT COLLABORATION SERVICES IN THE FIELD OF OIL AND GAS WELL DRILLING; ECONOMIC ANALYSIS IN THE FIELD OF OIL AND GAS WELL DRILLING; BUSINESS PLAN DEVELOPMENT SERVICES IN THE FIELD OF OIL AND GAS WELL DRILLING (U.S. CLS. 100, 101 AND 102).

FIRST USE 9-30-2007; IN COMMERCE 9-30-2007.

CLASS 35—(Continued).

3,632,164. PIPER COMMUNICATIONS, INC., IRVINE, CA. SN 77-253,694. PUB. 7-15-2008, FILED 8-13-2007.

CLASS 35—(Continued).

3,632,198. INTERNATIONAL DATA GROUP, INC., FRAMINGHAM, MA. SN 77-266,282. PUB. 11-4-2008, FILED 8-28-2007.

PQ

ONE EARTH. ONE EVENT.

THE MARK CONSISTS OF STANDARD CHARACTERS WITHOUT CLAIM TO ANY PARTICULAR FONT, STYLE, SIZE, OR COLOR.

FOR PROVIDING ELECTRONIC CATALOG SERVICES FEATURING AFTER MARKET AUTOMOTIVE PARTS AND ACCESSORIES, AND ON-LINE ORDERING SERVICES IN THE FIELD OF AUTOMOTIVE PARTS AND ACCESSORIES (U.S. CLS. 100, 101 AND 102).

FIRST USE 0-0-1999; IN COMMERCE 0-0-1999.

THE MARK CONSISTS OF STANDARD CHARACTERS WITHOUT CLAIM TO ANY PARTICULAR FONT, STYLE, SIZE, OR COLOR.

FOR ADVERTISING SERVICES; ARRANGING AND CONDUCTING EVENTS IN THE NATURE OF TRADE SHOW EXPOSITIONS AND TRADE SHOW EXHIBITIONS FEATURING ENVIRONMENTALLY FRIENDLY TECHNOLOGIES, PRODUCTS AND SERVICES (U.S. CLS. 100, 101 AND 102).

FIRST USE 12-31-2007; IN COMMERCE 12-31-2007.

3,632,165. PIPER COMMUNICATIONS, INC., IRVINE, CA. SN 77-253,697. PUB. 7-15-2008, FILED 8-13-2007.

3,632,223. SEA & GREEN, LLC, TOMS RIVER, NJ. SN 77-278,204. PUB. 7-22-2008, FILED 9-12-2007.



SEA & GREEN

FOR PROVIDING ELECTRONIC CATALOG SERVICES FEATURING AFTER MARKET AUTOMOTIVE PARTS AND ACCESSORIES, AND ON-LINE ORDERING SERVICES IN THE FIELD OF AUTOMOTIVE PARTS AND ACCESSORIES (U.S. CLS. 100, 101 AND 102).

FIRST USE 9-0-2003; IN COMMERCE 9-0-2003.

THE MARK CONSISTS OF STANDARD CHARACTERS WITHOUT CLAIM TO ANY PARTICULAR FONT, STYLE, SIZE, OR COLOR.

NO CLAIM IS MADE TO THE EXCLUSIVE RIGHT TO USE "GREEN", APART FROM THE MARK AS SHOWN.

FOR BUSINESS CONSULTING SERVICES IN THE FIELD OF ENVIRONMENTALLY FRIENDLY COMPANY PROCEDURES AND POLICIES; RETAIL STORE AND COMPUTERIZED ONLINE RETAIL STORE SERVICES FEATURING ENVIRONMENTALLY FRIENDLY PRODUCTS FOR THE HOME (U.S. CLS. 100, 101 AND 102).

FIRST USE 7-31-2008; IN COMMERCE 7-31-2008.

CLASS 35—(Continued).

3,632,229. CLEAR LIGHT INTERACTIVE CORP., NEW YORK, NY. SN 77-280,212. PUB. 5-20-2008, FILED 9-14-2007.



NO CLAIM IS MADE TO THE EXCLUSIVE RIGHT TO USE "MUSIC", APART FROM THE MARK AS SHOWN.
 THE MARK CONSISTS OF THE WORDS "RING OF FIRE MUSIC" IN A STYLIZED TEXT.
 FOR DISTRIBUTORSHIPS IN THE FIELD OF CD'S AND DVD'S (U.S. CLS. 100, 101 AND 102).
 FIRST USE 9-30-2007; IN COMMERCE 9-30-2007.

3,632,248. ODYSSEY, L.P., SAN FRANCISCO, CA. SN 77-288,597. PUB. 8-5-2008, FILED 9-25-2007.

SLEDGEHAMMER

THE MARK CONSISTS OF STANDARD CHARACTERS WITHOUT CLAIM TO ANY PARTICULAR FONT, STYLE, SIZE, OR COLOR.
 FOR MARKET RESEARCH; CONDUCTING MARKET RESEARCH STUDIES; MARKET RESEARCH CONSULTATION; MARKETING CONSULTING; STATISTICAL EVALUATIONS OF MARKETING DATA; MARKET REPORTS AND STUDIES; MARKET STUDY AND ANALYSIS OF MARKET STUDIES; MARKET ANALYSIS (U.S. CLS. 100, 101 AND 102).
 FIRST USE 5-0-2008; IN COMMERCE 5-0-2008.

CLASS 35—(Continued).

3,632,249. HDS IP HOLDING, LLC, HENDERSON, NV. SN 77-290,158. PUB. 7-15-2008, FILED 9-27-2007.

WE GOT IT YOU GET IT AND YOU'RE GONE

THE MARK CONSISTS OF STANDARD CHARACTERS WITHOUT CLAIM TO ANY PARTICULAR FONT, STYLE, SIZE, OR COLOR.
 FOR WHOLESALE AND RETAIL STORE, CATALOG, MAIL ORDER AND ELECTRONIC ORDERING SERVICES FEATURING LUMBER, BUILDING MATERIALS, HOME IMPROVEMENT PRODUCTS, TRUSSES, SIDING, ROOFING, MILLWORK, WINDOWS AND DOORS; REFERRALS TO OTHER BUSINESSES IN THE FIELDS OF WATER TREATMENT, SEWAGE, PLUMBING AND ELECTRICAL UTILITY SERVICES, BUILDING AND CONSTRUCTION MATERIALS, CARPET CLEANING SERVICES, CONSTRUCTION, HOME REPAIR AND RENOVATION, HOME CONSTRUCTION SERVICES, DECORATING AND HOME DESIGN SERVICES, HOME MAINTENANCE AND REPAIR SERVICES; RETAIL STORE AND DISTRIBUTORSHIP SERVICES PROVIDED TO OTHER BUSINESSES FEATURING APPLIANCES, HVAC EQUIPMENT, FASTENING AND INDUSTRIAL SUPPLIES, LIGHTING FIXTURES, FLOORING, COUNTERTOPS, AND WINDOW COVERINGS, CONSTRUCTION HARDWARE EQUIPMENT AND TOOLS, SAFETY EQUIPMENT AND WORK CLOTHING, PAINT, GARDEN SUPPLIES AND TOOLS, PLANTS, AND LANDSCAPING SUPPLIES (U.S. CLS. 100, 101 AND 102).
 FIRST USE 4-1-2004; IN COMMERCE 4-1-2004.

3,632,260. PRIME NUMBERS TECHNOLOGY, LLC, MEDFIELD, MA. SN 77-293,757. PUB. 7-22-2008, FILED 10-2-2007.

GOAL METRICS GPA

THE MARK CONSISTS OF STANDARD CHARACTERS WITHOUT CLAIM TO ANY PARTICULAR FONT, STYLE, SIZE, OR COLOR.
 NO CLAIM IS MADE TO THE EXCLUSIVE RIGHT TO USE "GOAL METRICS", APART FROM THE MARK AS SHOWN.
 FOR TRAVEL MANAGEMENT CONSULTING SERVICES FEATURING THE PROVISION OF BENCHMARKING DATA, THE ANALYSIS OF TRAVEL EXPENDITURES, AND PREPARATION OF REPORTS RELATING THERETO (U.S. CLS. 100, 101 AND 102).
 FIRST USE 11-0-2007; IN COMMERCE 11-0-2007.

CLASS 35—(Continued).

3,632,270. EGGZACK.COM, LLC, FLEMINGTON, NJ. SN 77-301,036. PUB. 9-9-2008, FILED 10-10-2007.



THE COLOR(S) LIGHT-BLUE, LIGHT-GREY, YELLOW, BLACK AND WHITE IS/ARE CLAIMED AS A FEATURE OF THE MARK.

THE MARK CONSISTS OF THE WORDING "EGGZACK.COM" IN LIGHT-BLUE LETTERS. BELOW THAT APPEARS THE WORDING "THE LOCAL AND HUMAN WEB" IN YELLOW LETTERS. PROCEEDING THE WORDS THERE APPEARS A BLACK OUTLINED STYLIZED REPRESENTATION OF A SMILING EGG WEARING GLASSES. THE EGG IS WHITE WITH YELLOW EYES. BELOW THE EGG APPEARS STYLIZED LIGHT GREY SHADING AND THE WORDING "EGGY" IN BLACK LETTERS. THE BACKGROUND IS TRANSPARENT.

FOR PROVIDING A WIDE RANGE OF CONSUMER REFERRAL INFORMATION OVER GLOBAL COMPUTER COMMUNICATIONS NETWORKS, PARTICULARLY CONCERNING PRODUCTS, SERVICES, EVENTS, ACTIVITIES, ATTRACTIONS AND FACILITIES IN PARTICULAR GEOGRAPHIC LOCATIONS (U.S. CLS. 100, 101 AND 102).

FIRST USE 6-0-2008; IN COMMERCE 6-0-2008.

CLASS 35—(Continued).

3,632,286. GREGGORY, BERNADETTE, DBA SKELSKEY, BERNADETTE, HOLIDAY, FL. SN 77-305,230. PUB. 8-19-2008, FILED 10-16-2007.

THE LAST WIVES CLUB

THE MARK CONSISTS OF STANDARD CHARACTERS WITHOUT CLAIM TO ANY PARTICULAR FONT, STYLE, SIZE, OR COLOR.

FOR PROVIDING REFERRALS FOR WIDOWS IN THE FIELDS OF MEDICAL, LEGAL, FINANCIAL, HOME REPAIR AND HOME MAINTENANCE SERVICES; PROVIDING REFERRALS IN THE FIELD OF COMMUNITY ASSISTANCE PROGRAMS FOR WIDOWS (U.S. CLS. 100, 101 AND 102).

FIRST USE 10-2-2007; IN COMMERCE 3-26-2008.

3,632,282. RIMINI FIERA SPA, 47900 RIMINI, ITALY. SN 77-304,632. PUB. 5-13-2008, FILED 10-15-2007.

3,632,298. EXTREME ROCK RACE ASSOCIATION, JELICO, TN. SN 77-309,513. PUB. 12-16-2008, FILED 10-22-2007.

SIGEP U.S.A.

THE MARK CONSISTS OF STANDARD CHARACTERS WITHOUT CLAIM TO ANY PARTICULAR FONT, STYLE, SIZE, OR COLOR.

NO CLAIM IS MADE TO THE EXCLUSIVE RIGHT TO USE "U.S.A.", APART FROM THE MARK AS SHOWN.

FOR ADVERTISING SERVICES, NAMELY, PROMOTING THE SERVICES OF THIRD-PARTY FAIRGROUNDS THROUGH THE DISTRIBUTION OF PRINTED AND AUDIO PROMOTIONAL MATERIALS AND BY RENDERING SALES PROMOTION ADVICE; RENTAL OF ADVERTISING SPACE; ORGANIZING EXHIBITIONS FOR THE MARKETING AND PROMOTION OF COMMERCIAL, INDUSTRIAL AND CONSUMER PRODUCTS; LOGISTICS MANAGEMENT IN THE FIELD OF TRADE-FAIRS AND EXHIBITIONS; BUSINESS MANAGEMENT CONSULTATION; ON-LINE ADVERTISING SUPPORT SERVICES; PUBLIC RELATIONS SERVICES (U.S. CLS. 100, 101 AND 102).

FIRST USE 4-1-2008; IN COMMERCE 4-1-2008.



NO CLAIM IS MADE TO THE EXCLUSIVE RIGHT TO USE "EXTREME" AND "ROCK RACING", APART FROM THE MARK AS SHOWN.

FOR PROMOTING OFF-ROAD RACING EVENTS OF OTHERS (U.S. CLS. 100, 101 AND 102).

FIRST USE 11-1-2007; IN COMMERCE 11-1-2007.

CLASS 35—(Continued).

3,632,308. KIDRO PRODUCTIONS, INC., NEW YORK, NY. SN 77-318,213. PUB. 9-9-2008, FILED 10-31-2007.

CLASS 35—(Continued).

3,632,316. CASE, JOHN, PLYMOUTH, MI. SN 77-323,075. PUB. 4-1-2008, FILED 11-6-2007.



F.A.T. LEADERSHIP

THE NAME SHOWN IN THE MARK IDENTIFIES ROSIE O'DONNELL, WHOSE CONSENT TO REGISTER IS SUBMITTED.

THE MARK CONSISTS OF THE WORDING "ROSIE.COM" WHERE THE "I" IS AN EXCLAMATION POINT AND A HEART FORMS THE PERIOD. THE WORDING APPEARS AGAINST AN IRREGULAR BACKGROUND WITH AN OVERALL RECTANGULAR SHAPE.

FOR COMPUTERIZED ON-LINE RETAIL STORE SERVICES FEATURING TOYS, ELECTRONIC GOODS, ADULT AND CHILDREN'S CLOTHING AND ACCESSORIES, JEWELRY, CRAFTS, AND PAPER PRODUCTS (U.S. CLS. 100, 101 AND 102).

FIRST USE 12-15-2007; IN COMMERCE 12-15-2007.

THE MARK CONSISTS OF STANDARD CHARACTERS WITHOUT CLAIM TO ANY PARTICULAR FONT, STYLE, SIZE, OR COLOR.

NO CLAIM IS MADE TO THE EXCLUSIVE RIGHT TO USE "LEADERSHIP", APART FROM THE MARK AS SHOWN.

FOR CONSULTING SERVICES USING A SPECIFIC METHODOLOGY TO DEVELOP LEADERSHIP IN BUSINESSES (U.S. CLS. 100, 101 AND 102).

FIRST USE 5-20-2006; IN COMMERCE 6-1-2008.

3,632,323. CLICK SIZE, LLC, JULIAN, CA. SN 77-325,203. PUB. 4-22-2008, FILED 11-8-2007.

3,632,313. HEYBUTLER.COM LLC, SOLON, OH. SN 77-321,012. PUB. 9-9-2008, FILED 11-5-2007.

Clicksize.com

HEY BUTLER

THE MARK CONSISTS OF STANDARD CHARACTERS WITHOUT CLAIM TO ANY PARTICULAR FONT, STYLE, SIZE, OR COLOR.

FOR PROMOTING THE GOODS AND SERVICES OF OTHERS BY PROVIDING A WEB SITE FEATURING COUPONS, REBATES, AND DISCOUNT INFORMATION (U.S. CLS. 100, 101 AND 102).

FIRST USE 1-3-2008; IN COMMERCE 1-3-2008.

THE MARK CONSISTS OF STANDARD CHARACTERS WITHOUT CLAIM TO ANY PARTICULAR FONT, STYLE, SIZE, OR COLOR.

FOR PROVIDING A USER-RESTRICTED ON-LINE COMPUTER DATABASE IN THE FIELD OF SHOPPING INFORMATION, NAMELY, INFORMATION AND DATA PROVIDED BY INTERNET USERS ABOUT INDIVIDUALS' PERSONAL PHYSICAL CHARACTERISTICS, FAVORED PRODUCT LINES, AND SPECIFIC PRODUCT CHOICES WHEN BUYING PERSONAL ITEMS SUCH AS CLOTHING, SHOES, HATS, COSMETICS AND GLOVES, SO AS TO FACILITATE THE APPROPRIATE PURCHASE OF SUCH ITEMS AS GIFTS FOR OTHERS (U.S. CLS. 100, 101 AND 102).

FIRST USE 1-1-2008; IN COMMERCE 1-1-2008.

CLASS 35—(Continued).

3,632,333. SCANSOURCE, INC., GREENVILLE, SC. SN 77-330,057. PUB. 4-29-2008, FILED 11-15-2007.

SCANSOURCE COMMUNICATIONS

THE MARK CONSISTS OF STANDARD CHARACTERS WITHOUT CLAIM TO ANY PARTICULAR FONT, STYLE, SIZE, OR COLOR.

NO CLAIM IS MADE TO THE EXCLUSIVE RIGHT TO USE "COMMUNICATIONS", APART FROM THE MARK AS SHOWN.

FOR DISTRIBUTORSHIP SERVICES IN THE FIELDS OF AUTOMATIC IDENTIFICATION AND DATA CAPTURE PRODUCTS, POINT-OF-SALE PRODUCTS, BUSINESS TELEPHONE EQUIPMENT, TELEPHONY PRODUCTS AND COMPUTER TELEPHONY INTEGRATION PRODUCTS, CONVERGED COMMUNICATIONS PRODUCTS, VIDEO AND AUDIO CONFERENCING (U.S. CLS. 100, 101 AND 102).

FIRST USE 1-1-2008; IN COMMERCE 1-1-2008.

3,632,349. CARTER COMMUNICATIONS INTERNATIONAL, INC., NEW YORK, NY. SN 77-336,307. PUB. 11-4-2008, FILED 11-25-2007.

**Clear Thinking.
Creative Writing.**

THE MARK CONSISTS OF STANDARD CHARACTERS WITHOUT CLAIM TO ANY PARTICULAR FONT, STYLE, SIZE, OR COLOR.

FOR ADVERTISING SERVICES, NAMELY, PROMOTING AND MARKETING THE GOODS AND SERVICES OF OTHERS THROUGH ALL PUBLIC COMMUNICATION MEANS (U.S. CLS. 100, 101 AND 102).

FIRST USE 12-1-2003; IN COMMERCE 3-6-2009.

CLASS 35—(Continued).

3,632,373. DAYTON DEVELOPMENT COALITION, INC., DAYTON, OH. SN 77-346,823. PUB. 10-7-2008, FILED 12-7-2007.

BE MIDWEST

THE MARK CONSISTS OF STANDARD CHARACTERS WITHOUT CLAIM TO ANY PARTICULAR FONT, STYLE, SIZE, OR COLOR.

NO CLAIM IS MADE TO THE EXCLUSIVE RIGHT TO USE "MIDWEST", APART FROM THE MARK AS SHOWN.

FOR ADVERTISING AND PROMOTIONAL SERVICES IN THE FIELDS OF JOB CREATION, CAPITAL DEVELOPMENT AND PROMOTING ECONOMIC DEVELOPMENT (U.S. CLS. 100, 101 AND 102).

FIRST USE 3-1-2008; IN COMMERCE 3-1-2008.

3,632,395. ENGINE MANUFACTURERS ASSOCIATION, CHICAGO, IL. SN 77-356,506. PUB. 8-26-2008, FILED 12-20-2007.

**BRINGING CLEANER POWER TO
THE WORLD SINCE 1968**

THE MARK CONSISTS OF STANDARD CHARACTERS WITHOUT CLAIM TO ANY PARTICULAR FONT, STYLE, SIZE, OR COLOR.

NO CLAIM IS MADE TO THE EXCLUSIVE RIGHT TO USE "SINCE 1968", APART FROM THE MARK AS SHOWN.

FOR ASSOCIATION SERVICES, NAMELY, PROMOTING THE INTERESTS OF ENGINE MANUFACTURERS (U.S. CLS. 100, 101 AND 102).

FIRST USE 1-0-2008; IN COMMERCE 1-0-2008.

3,632,420. DAYTON DEVELOPMENT COALITION, INC., DAYTON, OH. SN 77-367,211. PUB. 10-7-2008, FILED 1-9-2008.

**GET MIDWEST, WE THINK OF
EVERYTHING**

THE MARK CONSISTS OF STANDARD CHARACTERS WITHOUT CLAIM TO ANY PARTICULAR FONT, STYLE, SIZE, OR COLOR.

FOR ADVERTISING AND PROMOTIONAL SERVICES IN THE FIELDS OF JOB CREATION, CAPITAL DEVELOPMENT AND PROMOTING ECONOMIC DEVELOPMENT (U.S. CLS. 100, 101 AND 102).

FIRST USE 1-1-2008; IN COMMERCE 6-1-2008.

CLASS 35—(Continued).

3,632,421. DAYTON DEVELOPMENT COALITION, INC., DAYTON, OH. SN 77-367,238. PUB. 10-7-2008, FILED 1-9-2008.

BE MIDWEST, WE THINK OF EVERYTHING

THE MARK CONSISTS OF STANDARD CHARACTERS WITHOUT CLAIM TO ANY PARTICULAR FONT, STYLE, SIZE, OR COLOR.

FOR ADVERTISING AND PROMOTIONAL SERVICES IN THE FIELDS OF JOB CREATION, CAPITAL DEVELOPMENT AND PROMOTING ECONOMIC DEVELOPMENT (U.S. CLS. 100, 101 AND 102).

FIRST USE 3-1-2008; IN COMMERCE 3-1-2008.

3,632,429. COREY COLWELL-LIPSON, ISSAQUAH, WA. SN 77-370,832. PUB. 6-3-2008, FILED 1-14-2008.



NO CLAIM IS MADE TO THE EXCLUSIVE RIGHT TO USE "GREEN", APART FROM THE MARK AS SHOWN.

THE MARK CONSISTS OF A SERIES OF FOUR SHADED SIDE BY SIDE RECTANGLES FEATURING VARIED DESIGNS OF A SUN, A LEAF, A SNOWFLAKE, AND A FLOWER REPRESENTING THE FOUR SEASONS SHOWN ABOVE THE WORDS "THE GREEN YEAR".

FOR PROMOTING PUBLIC AWARENESS IN COMMUNITIES OF THE NEED FOR EARTH-FRIENDLY PRACTICES DURING TRADITIONAL HOLIDAYS AND CELEBRATIONS (U.S. CLS. 100, 101 AND 102).

FIRST USE 9-5-2008; IN COMMERCE 9-5-2008.

3,632,450. DISNEY ENTERPRISES, INC., BURBANK, CA. SN 77-377,796. PUB. 11-18-2008, FILED 1-22-2008.

BRING HOME THE MAGIC

THE MARK CONSISTS OF STANDARD CHARACTERS WITHOUT CLAIM TO ANY PARTICULAR FONT, STYLE, SIZE, OR COLOR.

FOR ON-LINE RETAIL STORE SERVICES FEATURING SOAP, SHAMPOO, CONDITIONER, LOTION, BEDDING, LINENS, FURNITURE, LAMPS, RUGS, DECORATIVE ACCESSORIES, AND CLOCKS; MAIL ORDER CATALOG SERVICES FEATURING SOAP, SHAMPOO, CONDITIONER, LOTION, BEDDING, LINENS, FURNITURE, LAMPS, DECORATIVE ACCESSORIES, AND CLOCKS (U.S. CLS. 100, 101 AND 102).

FIRST USE 2-0-2008; IN COMMERCE 2-0-2008.

CLASS 35—(Continued).

3,632,454. NEOSAEJ CORPORATION, BURLINGTON, MA. SN 77-382,109. PUB. 12-30-2008, FILED 1-28-2008.

MONEY AISLE

THE MARK CONSISTS OF STANDARD CHARACTERS WITHOUT CLAIM TO ANY PARTICULAR FONT, STYLE, SIZE, OR COLOR.

FOR ONLINE MARKETPLACE SERVICES, NAMELY, PROVIDING ONLINE AUCTION SERVICES (U.S. CLS. 100, 101 AND 102).

FIRST USE 6-9-2008; IN COMMERCE 6-9-2008.

3,632,458. HOLDEN ADVISORS CORP., CONCORD, MA. SN 77-383,737. PUB. 6-10-2008, FILED 1-29-2008.

PRICING WITH CONFIDENCE

THE MARK CONSISTS OF STANDARD CHARACTERS WITHOUT CLAIM TO ANY PARTICULAR FONT, STYLE, SIZE, OR COLOR.

FOR CONSULTING SERVICES IN THE FIELD OF ECONOMICS AND MARKETING (U.S. CLS. 100, 101 AND 102).

FIRST USE 2-5-2008; IN COMMERCE 2-5-2008.

3,632,470. ZEN WORLD ENTERTAINMENT, INC., UPLAND, CA. SN 77-387,007. PUB. 7-29-2008, FILED 2-1-2008.

HIT AND SUBMIT

THE MARK CONSISTS OF STANDARD CHARACTERS WITHOUT CLAIM TO ANY PARTICULAR FONT, STYLE, SIZE, OR COLOR.

FOR ON-LINE RETAIL STORE SERVICES FEATURING CLOTHING APPAREL AND FIGHT GEAR IN THE NATURE OF CLOTHING USED FOR SPORT FIGHTING AND SPORTING EQUIPMENT USED FOR SPORT FIGHTING; RETAIL STORES FEATURING CLOTHING APPAREL AND FIGHT GEAR IN THE NATURE OF CLOTHING USED FOR SPORT FIGHTING AND SPORTING EQUIPMENT USED FOR SPORT FIGHTING (U.S. CLS. 100, 101 AND 102).

FIRST USE 9-13-2007; IN COMMERCE 9-13-2007.

CLASS 35—(Continued).

3,632,475. CONEXION HISPANA INC., AVENTURA, FL. SN 77-389,250. PUB. 12-30-2008, FILED 2-5-2008.



NO CLAIM IS MADE TO THE EXCLUSIVE RIGHT TO USE "HISPANA", APART FROM THE MARK AS SHOWN.

THE COLOR(S) RED, BLUE, YELLOW, BLACK, GRAY IS/ARE CLAIMED AS A FEATURE OF THE MARK.

THE MARK CONSISTS OF RED "X", BLUE CIRCLE, YELLOW CIRCLE, BLACK FONT, GRAY CURVE.

THE ENGLISH TRANSLATION OF THE WORD "CONEXION HISPANA" IN THE MARK IS HISPANIC CONNECTION.

FOR COMMERCIAL INFORMATION AND DIRECTORY AGENCY; ON-LINE BUSINESS DIRECTORIES FEATURING COMPANY ADDRESSES, TELEPHONE, FAX, LOGO, EMAIL, WEBSITE ON-LINE ADDRESSES IN THE FIELDS OF RESTAURANTS, CONSUMER SERVICES, PROFESSIONAL SERVICES, SCHOOLS, DAY CARES AND RETAIL STORES; ONLINE BUSINESS NETWORKING SERVICES; OPERATING AN ONLINE SHOPPING SITE IN THE FIELDS OF RESTAURANTS, CONSUMER SERVICES, PROFESSIONAL SERVICES, SCHOOLS, DAY CARES AND RETAIL STORES; PROVIDING AN ONLINE DIRECTORY INFORMATION SERVICE FEATURING COMPANY ADDRESSES, TELEPHONE, FAX, LOGO, EMAIL, WEBSITE IN THE FIELDS OF RESTAURANTS, CONSUMER SERVICES, PROFESSIONAL SERVICES, SCHOOLS, DAY CARES AND RETAIL STORES (U.S. CLS. 100, 101 AND 102).

FIRST USE 2-1-2008; IN COMMERCE 2-1-2008.

3,632,525. WHIRLPOOL PROPERTIES, INC., ST. JOSEPH, MI. SN 77-399,344. PUB. 7-8-2008, FILED 2-18-2008.

DREAMLAUNDRY

THE MARK CONSISTS OF STANDARD CHARACTERS WITHOUT CLAIM TO ANY PARTICULAR FONT, STYLE, SIZE, OR COLOR.

FOR RETAIL STORES FEATURING HOME APPLIANCES (U.S. CLS. 100, 101 AND 102).

FIRST USE 9-10-2008; IN COMMERCE 9-10-2008.

CLASS 35—(Continued).

3,632,530. NATIONAL STONE, SAND & GRAVEL ASSOCIATION, ALEXANDRIA, VA. SN 77-400,061. PUB. 7-8-2008, FILED 2-19-2008.

AGG1

THE MARK CONSISTS OF STANDARD CHARACTERS WITHOUT CLAIM TO ANY PARTICULAR FONT, STYLE, SIZE, OR COLOR.

FOR ARRANGING AND CONDUCTING TRADE SHOWS IN THE FIELD OF STONE, SAND, AND GRAVEL (U.S. CLS. 100, 101 AND 102).

FIRST USE 3-10-2009; IN COMMERCE 3-10-2009.

3,632,533. NATIONAL STONE, SAND & GRAVEL ASSOCIATION, ALEXANDRIA, VA. SN 77-402,282. PUB. 7-8-2008, FILED 2-21-2008.



THE COLOR(S) GREEN AND BLUE IS/ARE CLAIMED AS A FEATURE OF THE MARK.

THE MARK CONSISTS OF THE WORDING "AGG1" WITH THE SECOND "G" AND THE "1" SET AGAINST A CIRCLE CONTAINS VARIOUS SHADES OF BLUE AND GREEN. THE WHITE IN THE MARK IS NOT A FEATURE OF THE MARK; IT IS MERELY FOR BACKGROUND PURPOSES.

FOR ARRANGING AND CONDUCTING TRADE SHOW EXHIBITIONS IN THE FIELD OF STONE, SAND, AND GRAVEL (U.S. CLS. 100, 101 AND 102).

FIRST USE 3-10-2009; IN COMMERCE 3-10-2009.

3,632,552. O2 HOLDINGS, LLC, NEW YORK, NY. SN 77-404,958. PUB. 7-15-2008, FILED 2-25-2008.

GENERATION O

THE MARK CONSISTS OF STANDARD CHARACTERS WITHOUT CLAIM TO ANY PARTICULAR FONT, STYLE, SIZE, OR COLOR.

FOR ADVERTISING AND MARKETING SERVICES (U.S. CLS. 100, 101 AND 102).

FIRST USE 4-0-2008; IN COMMERCE 4-0-2008.

CLASS 35—(Continued).

3,632,554. VOICE CLOUD, INC., SAN DIEGO, CA. SN 77-405,682. PUB. 7-15-2008, FILED 2-25-2008.

VOICECLOUD

THE MARK CONSISTS OF STANDARD CHARACTERS WITHOUT CLAIM TO ANY PARTICULAR FONT, STYLE, SIZE, OR COLOR.

FOR AN INTERNET BASED VOICE TRANSCRIPTION SERVICE (U.S. CLS. 100, 101 AND 102).

FIRST USE 3-27-2008; IN COMMERCE 3-27-2008.

3,632,568. INFOARMOR, INC., SCOTTSDALE, AZ. SN 77-408,254. PUB. 7-15-2008, FILED 2-28-2008.

PrivacyArmor

THE MARK CONSISTS OF STANDARD CHARACTERS WITHOUT CLAIM TO ANY PARTICULAR FONT, STYLE, SIZE, OR COLOR.

FOR DATA MANAGEMENT SERVICE IN THE FIELD OF PRIVACY PROTECTION; DIRECT MARKETING SERVICES, NAMELY, REDUCTION OF UNWANTED SOLICITATIONS AND OTHER SOURCES OF RISKS TO INDIVIDUAL IDENTITY THEFT; SERVICE TO REDUCE THE DISSEMINATION OF ADVERTISING MATTER (U.S. CLS. 100, 101 AND 102).

FIRST USE 6-1-2007; IN COMMERCE 8-1-2008.

3,632,573. MR. HANDYMAN INTERNATIONAL, LLC, ANN ARBOR, MI. SN 77-408,953. PUB. 7-15-2008, FILED 2-28-2008.

MRS. HANDYMAN

THE MARK CONSISTS OF STANDARD CHARACTERS WITHOUT CLAIM TO ANY PARTICULAR FONT, STYLE, SIZE, OR COLOR.

OWNER OF U.S. REG. NOS. 2,290,057, 2,620,745, AND OTHERS.

NO CLAIM IS MADE TO THE EXCLUSIVE RIGHT TO USE "HANDYMAN", APART FROM THE MARK AS SHOWN.

FOR FRANCHISE SERVICES, NAMELY, OFFERING BUSINESS MANAGEMENT ASSISTANCE IN THE ESTABLISHMENT AND OPERATION OF A HOME REPAIR AND GENERAL MAINTENANCE BUSINESS (U.S. CLS. 100, 101 AND 102).

FIRST USE 12-20-2007; IN COMMERCE 12-20-2007.

CLASS 35—(Continued).

3,632,575. CARE CO INTERNATIONAL, INC., OMAHA, NE. SN 77-409,213. PUB. 7-15-2008, FILED 2-28-2008.

PACK N TOTE

THE MARK CONSISTS OF STANDARD CHARACTERS WITHOUT CLAIM TO ANY PARTICULAR FONT, STYLE, SIZE, OR COLOR.

FOR ON-LINE WHOLESALE STORE SERVICES FEATURING GROCERY CART BAGS, GROCERY BAGS, WINE BAGS, TOTE BAGS, COUPON BAGS AND BOAT BAGS (U.S. CLS. 100, 101 AND 102).

FIRST USE 12-31-2007; IN COMMERCE 12-31-2007.

3,632,609. TMI PROMOTIONS INC., NEW BERLIN, WI. SN 77-414,110. PUB. 7-29-2008, FILED 3-5-2008.

SAGE COLLECTIVE

THE MARK CONSISTS OF STANDARD CHARACTERS WITHOUT CLAIM TO ANY PARTICULAR FONT, STYLE, SIZE, OR COLOR.

FOR BUSINESS MARKETING AND CONSULTING SERVICES, NAMELY, BRAND DEVELOPMENT, MANAGING SPONSORSHIPS AND PROMOTIONAL EVENTS, AND CREATING ADVERTISING CONCEPTS AND PROGRAMS FOR BUSINESSES TO PROMOTE THEIR BUSINESSES, SERVICES, GOODS, AND BRANDS (U.S. CLS. 100, 101 AND 102).

FIRST USE 3-31-2008; IN COMMERCE 3-31-2008.

3,632,656. USA DISCOUNTERS, LTD., VIRGINIA BEACH, VA. SN 77-422,417. PUB. 7-29-2008, FILED 3-14-2008.

FLETCHER'S FINE JEWELERS

THE MARK CONSISTS OF STANDARD CHARACTERS WITHOUT CLAIM TO ANY PARTICULAR FONT, STYLE, SIZE, OR COLOR.

NO CLAIM IS MADE TO THE EXCLUSIVE RIGHT TO USE "FINE JEWELERS", APART FROM THE MARK AS SHOWN.

FOR RETAIL JEWELRY STORES (U.S. CLS. 100, 101 AND 102).

FIRST USE 6-18-2008; IN COMMERCE 6-18-2008.

CLASS 35—(Continued).

3,632,719. LEEDSWORLD, INC., NEW KENSINGTON, PA.
SN 77-436,768. PUB. 7-22-2008, FILED 4-1-2008.

WORLDSOURCE MEMORY XPRESS

THE MARK CONSISTS OF STANDARD CHARACTERS WITHOUT CLAIM TO ANY PARTICULAR FONT, STYLE, SIZE, OR COLOR.

OWNER OF U.S. REG. NO. 2,957,228.

NO CLAIM IS MADE TO THE EXCLUSIVE RIGHT TO USE "MEMORY EXPRESS", APART FROM THE MARK AS SHOWN.

FOR WHOLESALE DISTRIBUTORSHIPS FEATURING COMPUTER STORAGE DEVICES, NAMELY, FLASH DRIVES (U.S. CLS. 100, 101 AND 102).

FIRST USE 4-1-2008; IN COMMERCE 4-1-2008.

3,632,733. MORGAN STANLEY, NEW YORK, NY. SN 77-441,319. PUB. 9-2-2008, FILED 4-7-2008.

SOLAR ACCESS

THE MARK CONSISTS OF STANDARD CHARACTERS WITHOUT CLAIM TO ANY PARTICULAR FONT, STYLE, SIZE, OR COLOR.

NO CLAIM IS MADE TO THE EXCLUSIVE RIGHT TO USE "SOLAR", APART FROM THE MARK AS SHOWN.

FOR BUSINESS CONSULTING SERVICES, NAMELY, PROVIDING ASSISTANCE IN DEVELOPMENT OF BUSINESS STRATEGIES AND CREATIVE IDEATION, NAMELY, DEVELOPMENT OF SOLAR ENERGY PROJECTS (U.S. CLS. 100, 101 AND 102).

FIRST USE 11-0-2008; IN COMMERCE 11-0-2008.

3,632,746. ZIONS BANCORPORATION, SALT LAKE CITY, UT. SN 77-444,985. PUB. 9-9-2008, FILED 4-10-2008.

TREASURY GATEWAY

THE MARK CONSISTS OF STANDARD CHARACTERS WITHOUT CLAIM TO ANY PARTICULAR FONT, STYLE, SIZE, OR COLOR.

FOR DISTRIBUTION OF ADVERTISEMENTS, ALERTS, AND COMMERCIAL ANNOUNCEMENTS (U.S. CLS. 100, 101 AND 102).

FIRST USE 4-7-2008; IN COMMERCE 4-7-2008.

CLASS 35—(Continued).

3,632,750. NEUROMATION STUDIO, LLC, WALTHAM, MA.
SN 77-445,717. PUB. 9-2-2008, FILED 4-11-2008.

NEUROGEAR

THE MARK CONSISTS OF STANDARD CHARACTERS WITHOUT CLAIM TO ANY PARTICULAR FONT, STYLE, SIZE, OR COLOR.

FOR ON-LINE RETAIL STORE SERVICES FEATURING CLOTHING, BLANKETS, HATS, CAPS, COFFEE MUGS, JARS, PADFOLIOS, GREETING CARDS, BUSINESS CARD HOLDERS, POSTAGE STAMP HOLDERS, PEN AND PENCIL HOLDERS, CLIPBOARDS, MOUSEPADS, PRINTED POSTERS, CD AND DVD HOLDERS, MAGNETS, PAPERCLIP HOLDERS, BRIEFCASES, COMPUTER CASES, KEY CHAINS, DESK CADDIES AND POSTAGE STAMPS (U.S. CLS. 100, 101 AND 102).

FIRST USE 3-16-2009; IN COMMERCE 3-16-2009.

3,632,759. NATIONAL ALLIANCE OF FOREST OWNERS, WASHINGTON, DC. SN 77-447,098. PUB. 9-2-2008, FILED 4-14-2008.

NAFO

THE MARK CONSISTS OF STANDARD CHARACTERS WITHOUT CLAIM TO ANY PARTICULAR FONT, STYLE, SIZE, OR COLOR.

FOR LOBBYING SERVICES, NAMELY, PROMOTING THE INTERESTS OF FOREST OWNERS IN THE FIELDS OF POLITICS, LEGISLATION, AND REGULATION (U.S. CLS. 100, 101 AND 102).

FIRST USE 4-1-2008; IN COMMERCE 4-1-2008.

CLASS 35—(Continued).

3,632,779. MAINTENANCE RUBBER AND PUMP CO., L.L.C., CHATTANOOGA, TN. SN 77-453,177. PUB. 9-16-2008, FILED 4-21-2008.

Best Little Hose House In Tennessee

THE MARK CONSISTS OF STANDARD CHARACTERS WITHOUT CLAIM TO ANY PARTICULAR FONT, STYLE, SIZE, OR COLOR.

NO CLAIM IS MADE TO THE EXCLUSIVE RIGHT TO USE "TENNESSEE", APART FROM THE MARK AS SHOWN.

FOR RETAIL STORE SERVICES FEATURING HOSES, PUMPS, GASKETS, TUBING, TUBE FITTINGS, HOSE ENDS, DUCTING, GLOVES, CLAMPS, FILTERS, REGULATORS, LUBRICATORS, GAGES, THERMOMETERS, VALVES AND STRAINERS; WHOLESALE DISTRIBUTORSHIPS FEATURING HOSES, PUMPS, GASKETS, TUBING, TUBE FITTINGS, HOSE ENDS, DUCTING, GLOVES, CLAMPS, FILTERS, REGULATORS, LUBRICATORS, GAGES, THERMOMETERS, VALVES AND STRAINERS (U.S. CLS. 100, 101 AND 102).

FIRST USE 8-26-2008; IN COMMERCE 8-26-2008.

CLASS 35—(Continued).

3,632,799. LABROOTS, INC., KAILUA, HI. SN 77-460,080. PUB. 10-21-2008, FILED 4-28-2008.



THE COLOR(S) GREEN, WHITE, BLACK IS/ARE CLAIMED AS A FEATURE OF THE MARK.

THE MARK CONSISTS OF GREEN GRAPHIC WITH THREE PEOPLE, "LABROOTS.COM AND YOUR SCIENCE NETWORK" IN BLACK, BACKGROUND IN WHITE.

FOR PROVIDING A WEBSITE FEATURING AUDIO AND VIDEO INTERVIEWS, TRANSCRIPTS AND OTHER EDUCATIONAL MATERIALS ALL CONCERNING BUSINESS TOPICS; PROVISION OF SPACE ON WEBSITES FOR ADVERTISING GOODS AND SERVICES; THE BRINGING TOGETHER, FOR THE BENEFIT OF OTHERS, OF A VARIETY OF GOODS AND SERVICES, ENABLING CUSTOMERS TO CONVENIENTLY VIEW AND PURCHASE THOSE GOODS AND SERVICES FROM AN INTERNET WEBSITE PARTICULARLY SPECIALIZING IN THE MARKETING OF THE SALE OF GOODS AND SERVICES OF OTHERS (U.S. CLS. 100, 101 AND 102).

FIRST USE 10-15-2008; IN COMMERCE 10-15-2008.

3,632,798. SKIHEART INC., AMBLER, PA. SN 77-459,530. PUB. 10-7-2008, FILED 4-28-2008.

SKIHEART

THE MARK CONSISTS OF STANDARD CHARACTERS WITHOUT CLAIM TO ANY PARTICULAR FONT, STYLE, SIZE, OR COLOR.

FOR ADVERTISING SERVICES, NAMELY, PROVIDING INFORMATION AS TO THE AVAILABILITY OF SKI EQUIPMENT AND SKI RESORTS FOR RENT OR PURCHASE; PROMOTING THE GOODS AND SERVICES OF OTHERS BY PROVIDING A WEB SITE FEATURING COUPONS, REBATES, PRICE-COMPARISON INFORMATION, PRODUCT REVIEWS, LINKS TO THE RETAIL WEB SITES OF OTHERS, AND DISCOUNT INFORMATION; ELECTRONIC COMMERCE SERVICES, NAMELY, PROVIDING INFORMATION ABOUT PRODUCTS VIA TELECOMMUNICATION NETWORKS FOR ADVERTISING AND SALES PURPOSES; ONLINE BUYERS GUIDE SERVICE PROVIDING INFORMATION IN THE FIELD OF SKI EQUIPMENT AND SKI RESORTS (U.S. CLS. 100, 101 AND 102).

FIRST USE 4-10-2008; IN COMMERCE 4-10-2008.

3,632,834. HARRAH'S LICENSE COMPANY, LLC, LAS VEGAS, NV. SN 77-475,923. PUB. 10-21-2008, FILED 5-15-2008.

Seven Stars Signature Event

THE MARK CONSISTS OF STANDARD CHARACTERS WITHOUT CLAIM TO ANY PARTICULAR FONT, STYLE, SIZE, OR COLOR.

OWNER OF U.S. REG. NOS. 2,951,635, 3,293,190, AND 3,293,192.

NO CLAIM IS MADE TO THE EXCLUSIVE RIGHT TO USE "EVENT", APART FROM THE MARK AS SHOWN.

FOR CUSTOMER LOYALTY SERVICES FOR CASINOS FOR PROMOTIONAL AND/OR ADVERTISING PURPOSES, NAMELY, FREQUENT CUSTOMER REWARD PROGRAM SERVICE WHICH ALLOWS PARTICIPANTS TO EARN DISCOUNTS AND FREE GIFTS (U.S. CLS. 100, 101 AND 102).

FIRST USE 2-10-2009; IN COMMERCE 3-16-2009.

CLASS 35—(Continued).

3,632,835. VICTORINOX AG, IBACH-SCHWYZ, SWITZERLAND. SN 77-476,866. PUB. 12-23-2008, FILED 5-16-2008.



OWNER OF U.S. REG. NOS. 3,036,388, 3,077,338, AND 3,428,307.

FOR RETAIL STORE SERVICES FEATURING CUTLERY, WATCHES, CLOCKS, JEWELRY, CLOTHING, HEADWEAR, FOOTWEAR, TRAVEL GEAR AND PERFUMERY (U.S. CLS. 100, 101 AND 102).

FIRST USE 10-29-2008; IN COMMERCE 10-29-2008.

3,632,874. BRAGFOLIO, INC., OCOEE, FL. SN 77-493,178. PUB. 11-4-2008, FILED 6-6-2008.

Bragfolio

THE MARK CONSISTS OF STANDARD CHARACTERS WITHOUT CLAIM TO ANY PARTICULAR FONT, STYLE, SIZE, OR COLOR.

FOR PROVIDING AN ON-LINE DIRECTORY INFORMATION SERVICE FEATURING INFORMATION REGARDING JOB LISTINGS AND EMPLOYMENT RESOURCES (U.S. CLS. 100, 101 AND 102).

FIRST USE 3-10-2009; IN COMMERCE 3-10-2009.

CLASS 35—(Continued).

3,632,878. FIRST NATIONAL OF NEBRASKA, INC., OMAHA, NE. SN 77-494,221. PUB. 9-23-2008, FILED 6-9-2008.

FIRST CIRCLE

THE MARK CONSISTS OF STANDARD CHARACTERS WITHOUT CLAIM TO ANY PARTICULAR FONT, STYLE, SIZE, OR COLOR.

FOR PROMOTING THE SALE OF CREDIT CARD ACCOUNTS THROUGH THE ADMINISTRATION OF INCENTIVE AWARD PROGRAMS (U.S. CLS. 100, 101 AND 102).

FIRST USE 10-1-2008; IN COMMERCE 10-1-2008.

3,632,881. VILLAGE PANTRY, LLC, INDIANAPOLIS, IN. SN 77-495,440. PUB. 11-4-2008, FILED 6-10-2008.

VARIETY IS EVERYTHING

THE MARK CONSISTS OF STANDARD CHARACTERS WITHOUT CLAIM TO ANY PARTICULAR FONT, STYLE, SIZE, OR COLOR.

FOR RETAIL CONVENIENCE STORES (U.S. CLS. 100, 101 AND 102).

FIRST USE 7-7-2008; IN COMMERCE 7-7-2008.

3,632,883. UNITED HARDWARE DISTRIBUTING CO., PLYMOUTH, MN. SN 77-496,299. PUB. 11-4-2008, FILED 6-11-2008.

BACKYARD CHEF

THE MARK CONSISTS OF STANDARD CHARACTERS WITHOUT CLAIM TO ANY PARTICULAR FONT, STYLE, SIZE, OR COLOR.

NO CLAIM IS MADE TO THE EXCLUSIVE RIGHT TO USE "CHEF", APART FROM THE MARK AS SHOWN.

FOR RETAIL STORE SERVICES FEATURING BARBECUE GRILLS, BARBECUE UTENSILS AND GRILLING ACCESSORIES (U.S. CLS. 100, 101 AND 102).

FIRST USE 9-11-2008; IN COMMERCE 9-11-2008.

CLASS 35—(Continued).

3,632,911. KNOWLEDGE NETWORKS, INC., MENLO PARK, CA. SN 77-508,903. PUB. 11-25-2008, FILED 6-26-2008.

KN PANEL

THE MARK CONSISTS OF STANDARD CHARACTERS WITHOUT CLAIM TO ANY PARTICULAR FONT, STYLE, SIZE, OR COLOR.

OWNER OF U.S. REG. NO. 3,363,778.

NO CLAIM IS MADE TO THE EXCLUSIVE RIGHT TO USE "PANEL", APART FROM THE MARK AS SHOWN.

FOR MARKET RESEARCH REPORTS AND STUDIES, MARKET RESEARCH CONSULTING, MEDIA PLANNING, NAMELY, PREPARATION AND REALIZATION OF MEDIA AND ADVERTISING PLANS AND CONCEPTS; CONDUCTING BUSINESS, MARKET AND PUBLIC OPINION RESEARCH SURVEYS; ADVERTISEMENT ASSESSMENT, NAMELY, ADVERTISING CONSULTATION; PROVIDING A COMPUTERIZED ONLINE INTERACTIVE DATABASE FOR BUSINESS AND MARKETING RESEARCH SURVEYS OF SUBSCRIBERS FEATURING SURVEY DATA AND ANALYSES; AND MARKET RESEARCH, NAMELY, GATHERING, ANALYZING AND INTERPRETING DATA REGARDING CONSUMER CHARACTERISTICS, BEHAVIOR AND PREFERENCES (U.S. CLS. 100, 101 AND 102).

FIRST USE 6-0-2008; IN COMMERCE 6-0-2008.

CLASS 35—(Continued).

3,632,920. C & S NET, INC., FAIRHOPE, AL. SN 77-511,984. PUB. 11-25-2008, FILED 7-1-2008.

SITEENCORE

THE MARK CONSISTS OF STANDARD CHARACTERS WITHOUT CLAIM TO ANY PARTICULAR FONT, STYLE, SIZE, OR COLOR.

FOR ADVERTISING, MARKETING AND PROMOTION SERVICES (U.S. CLS. 100, 101 AND 102).

FIRST USE 9-21-2008; IN COMMERCE 9-21-2008.

3,632,927. SALES CONSULTANTS OF LAKE OSWEGO, LLC, DBA UNITED HUMAN CAPITAL SOLUTIONS, LAKE OSWEGO, OR. SN 77-514,097. PUB. 12-2-2008, FILED 7-2-2008.

3,632,916. SCIENCE CENTER, PHILADELPHIA, PA. SN 77-511,067. PUB. 11-25-2008, FILED 6-30-2008.

**Staffing the Heart of
Healthcare****GLOBAL SOFT LANDING**

THE MARK CONSISTS OF STANDARD CHARACTERS WITHOUT CLAIM TO ANY PARTICULAR FONT, STYLE, SIZE, OR COLOR.

NO CLAIM IS MADE TO THE EXCLUSIVE RIGHT TO USE "GLOBAL", APART FROM THE MARK AS SHOWN.

FOR ASSISTING BUSINESS VENTURES OF OTHERS IN THE FIELDS OF LIFE SCIENCE AND TECHNOLOGY TO ORGANIZE AND TO SECURE FUNDING, MANAGEMENT SERVICES AND FACILITIES (U.S. CLS. 100, 101 AND 102).

FIRST USE 12-31-2007; IN COMMERCE 12-31-2007.

THE MARK CONSISTS OF STANDARD CHARACTERS WITHOUT CLAIM TO ANY PARTICULAR FONT, STYLE, SIZE, OR COLOR.

NO CLAIM IS MADE TO THE EXCLUSIVE RIGHT TO USE "STAFFING", APART FROM THE MARK AS SHOWN.

FOR EMPLOYMENT SERVICES, NAMELY, PROVIDING PERMANENT AND TEMPORARY CONTRACT HEALTHCARE STAFFING FOR GOVERNMENT AND COMMERCIAL CLIENTS; EMPLOYMENT STAFFING IN THE FIELD OF HEALTHCARE; EMPLOYMENT PLACEMENT OF PERMANENT AND CONTRACT HEALTHCARE PROFESSIONALS; EMPLOYMENT RECRUITING, PLACEMENT AND STAFFING SERVICES IN THE FIELD OF HEALTHCARE; EMPLOYMENT AGENCY AND CONSULTING SERVICES FOR THE HEALTHCARE INDUSTRY, NAMELY, LOCUM TENENS, PERMANENT AND TEMPORARY PLACEMENT FOR PHYSICIANS, NURSES, PHARMACISTS, ALLIED HEALTH PROFESSIONALS, AND OTHER HEALTHCARE PERSONNEL (U.S. CLS. 100, 101 AND 102).

FIRST USE 1-1-2009; IN COMMERCE 1-1-2009.

CLASS 35—(Continued).

3,632,931. 901 VINYL, L.L.C., CHICAGO, IL. SN 77-514,743.
PUB. 12-2-2008, FILED 7-3-2008.



THE MARK CONSISTS OF A MONSTER.
FOR RETAIL STORE SERVICES AND ONLINE RE-
TAIL STORE SERVICES FEATURING COMICS, GRA-
PHIC NOVELS, ART BOOKS, RECORDS AND
DESIGNER TOYS (U.S. CLS. 100, 101 AND 102).
FIRST USE 7-30-2008; IN COMMERCE 7-30-2008.

3,632,941. FASTENERS FOR RETAIL, INC., CLEVELAND,
OH. SN 77-518,719. PUB. 12-16-2008, FILED 7-10-2008.

FFR-DSI YELLOW PAGES

THE MARK CONSISTS OF STANDARD CHARACTERS
WITHOUT CLAIM TO ANY PARTICULAR FONT, STYLE,
SIZE, OR COLOR.

OWNER OF U.S. REG. NO. 2,262,370.
NO CLAIM IS MADE TO THE EXCLUSIVE RIGHT TO
USE "YELLOW PAGES", APART FROM THE MARK AS
SHOWN.

FOR DISTRIBUTORSHIP SERVICES IN THE FIELD
OF DISPLAY ACCESSORIES FOR USE BY BUSINESSES
AND OTHER RETAIL ESTABLISHMENTS (U.S. CLS.
100, 101 AND 102).

FIRST USE 1-16-2009; IN COMMERCE 1-16-2009.

CLASS 35—(Continued).

3,632,948. ACRYNESS, INC., MOORESVILLE, NC. SN 77-
519,846. PUB. 12-9-2008, FILED 7-11-2008.

ACRYNESS

THE MARK CONSISTS OF STANDARD CHARACTERS
WITHOUT CLAIM TO ANY PARTICULAR FONT, STYLE,
SIZE, OR COLOR.

FOR BILLING SERVICES, NAMELY, PRINTING AND
MAILING OF BILLS, INVOICES, AND STATEMENTS
(U.S. CLS. 100, 101 AND 102).

FIRST USE 1-5-2009; IN COMMERCE 1-5-2009.

3,632,950. CARSON PIRIE SCOTT II, INC., YORK, PA. SN 77-
520,071. PUB. 11-18-2008, FILED 7-11-2008.

**CELEBRATIONS REGISTRY FOR
VERY SPECIAL OCCASIONS**

THE MARK CONSISTS OF STANDARD CHARACTERS
WITHOUT CLAIM TO ANY PARTICULAR FONT, STYLE,
SIZE, OR COLOR.

OWNER OF U.S. REG. NO. 2,646,804.
NO CLAIM IS MADE TO THE EXCLUSIVE RIGHT TO
USE "REGISTRY FOR VERY SPECIAL OCCASIONS",
APART FROM THE MARK AS SHOWN.

FOR GIFT REGISTRY SERVICES (U.S. CLS. 100, 101
AND 102).

FIRST USE 7-31-2008; IN COMMERCE 7-31-2008.

3,632,995. THOMAS, DAVID C, DBA FAQTORS, LOS GATOS,
CA. SN 77-534,680. PUB. 1-13-2009, FILED 7-30-2008.

CHANNELS 2.0

THE MARK CONSISTS OF STANDARD CHARACTERS
WITHOUT CLAIM TO ANY PARTICULAR FONT, STYLE,
SIZE, OR COLOR.

FOR ARRANGING AND CONDUCTING BUSINESS
CONFERENCES (U.S. CLS. 100, 101 AND 102).

FIRST USE 12-15-2008; IN COMMERCE 12-15-2008.

CLASS 35—(Continued).

3,633,005. BEST WESTERN INTERNATIONAL, INC., PHOENIX, AZ. SN 77-540,742. PUB. 12-9-2008, FILED 8-6-2008.



OWNER OF U.S. REG. NOS. 1,072,360, 1,933,830, AND OTHERS.

NO CLAIM IS MADE TO THE EXCLUSIVE RIGHT TO USE "REWARDS", APART FROM THE MARK AS SHOWN.

THE COLOR(S) RED, YELLOW AND BLUE IS/ARE CLAIMED AS A FEATURE OF THE MARK.

THE COLORS BLUE, RED, AND YELLOW ARE CLAIMED AS A FEATURE OF THE MARK, WITH THE COLOR BLUE APPEARING IN THE FIVE-SIDED SHAPE AND IN THE WORDING "BEST WESTERN" ON THE RIGHT SIDE OF THE FIVE-SIDED SHAPE, THE COLOR RED APPEARING IN THE CROWN DESIGN ON THE FIVE-SIDED SHAPE, AND THE COLOR YELLOW APPEARING IN THE WORDING "BEST WESTERN" ON THE FIVE-SIDED SHAPE, IN THE BORDER OF THE FIVE-SIDED SHAPE, AND IN THE WORDING "REWARDS".

FOR CUSTOMER LOYALTY SERVICES AND CUSTOMER CLUB SERVICES, FOR COMMERCIAL, PROMOTIONAL AND/OR ADVERTISING PURPOSES (U.S. CLS. 100, 101 AND 102).

FIRST USE 12-15-2008; IN COMMERCE 12-15-2008.

3,633,024. OS ASSET, INC., TAMPA, FL. SN 77-547,860. PUB. 1-6-2009, FILED 8-15-2008.

Boomerang Club

THE MARK CONSISTS OF STANDARD CHARACTERS WITHOUT CLAIM TO ANY PARTICULAR FONT, STYLE, SIZE, OR COLOR.

NO CLAIM IS MADE TO THE EXCLUSIVE RIGHT TO USE "CLUB", APART FROM THE MARK AS SHOWN.

FOR CUSTOMER LOYALTY SERVICES AND CUSTOMER CLUB SERVICES, FOR COMMERCIAL, PROMOTIONAL AND/OR ADVERTISING PURPOSES (U.S. CLS. 100, 101 AND 102).

FIRST USE 9-30-2008; IN COMMERCE 1-31-2009.

CLASS 35—(Continued).

3,633,030. UBURG CORP, TA WWW.UBURG.COM, MENLO PARK, CA. SN 77-549,927. PUB. 1-6-2009, FILED 8-18-2008.

uBurg

THE MARK CONSISTS OF STANDARD CHARACTERS WITHOUT CLAIM TO ANY PARTICULAR FONT, STYLE, SIZE, OR COLOR.

FOR PROVIDING A WEB SITE WHERE USERS CAN POST RATINGS, REVIEWS AND RECOMMENDATIONS ON PRODUCTS AND SERVICES; PROVIDING A WEB SITE WHICH FEATURES ADVERTISEMENTS FOR THE GOODS AND SERVICES OF OTHERS ON A GLOBAL COMPUTER NETWORK; PROVIDING AN ON-LINE DIRECTORY INFORMATION SERVICE FEATURING INFORMATION REGARDING COMMUNITY LIFE (U.S. CLS. 100, 101 AND 102).

FIRST USE 1-15-2008; IN COMMERCE 6-15-2008.

3,633,047. BIO-LAB, INC., LAWRENCEVILLE, GA. SN 77-975,591. PUB. 8-5-2008, FILED 7-6-2007.

WKND.

THE MARK CONSISTS OF STANDARD CHARACTERS WITHOUT CLAIM TO ANY PARTICULAR FONT, STYLE, SIZE, OR COLOR.

FOR RETAIL STORES FEATURING LAWN SPORTING GOODS, LAWN EQUIPMENT, AND DECORATIVE LAWN ORNAMENTS, SUCH AS, LAWN SCULPTURES, GAZING BALLS (U.S. CLS. 100, 101 AND 102).

FIRST USE 5-3-2008; IN COMMERCE 5-3-2008.

3,633,104. LANSDON, PATRICK D., SANTA BARBARA, CA. SN 78-488,387. PUB. 12-27-2005, FILED 9-23-2004.

BLACKBEARD'S

THE MARK CONSISTS OF STANDARD CHARACTERS WITHOUT CLAIM TO ANY PARTICULAR FONT, STYLE, SIZE, OR COLOR.

FOR ON-LINE RETAIL STORE SERVICES FEATURING CLOTHING AND ACCESSORIES FOR MEN AND CHILDREN (U.S. CLS. 100, 101 AND 102).

FIRST USE 10-31-2007; IN COMMERCE 10-31-2007.

CLASS 35—(Continued).

3,633,141. DEGENNARO, RAFAEL, BRANFORD, CT. SN 78-604,920. PUB. 1-17-2006, FILED 4-8-2005.

INDIEAMERICA

THE MARK CONSISTS OF STANDARD CHARACTERS WITHOUT CLAIM TO ANY PARTICULAR FONT, STYLE, SIZE, OR COLOR.

FOR PROVIDING INFORMATION IN THE FIELD OF GOVERNMENT AFFAIRS AND POLITICS; PROMOTING PUBLIC AWARENESS IN THE FIELD OF GOVERNMENT AFFAIRS AND POLITICS; PROMOTING PUBLIC AWARENESS OF THE IMPORTANCE OF HAVING ALTERNATIVE SOURCES FOR REPORTING CURRENT EVENTS (U.S. CLS. 100, 101 AND 102).

FIRST USE 4-5-2009; IN COMMERCE 4-5-2009.

CLASS 35—(Continued).

3,633,206. MEGO, INC., LOS ANGELES, CA. SN 78-750,621. PUB. 7-11-2006, FILED 11-9-2005.

MEGO

THE MARK CONSISTS OF STANDARD CHARACTERS WITHOUT CLAIM TO ANY PARTICULAR FONT, STYLE, SIZE, OR COLOR.

FOR BUSINESS SERVICES, NAMELY, PLACING ADVERTISEMENTS AND PROMOTIONS FOR OTHERS VIA COMPUTER NETWORKS AND WIRELESS NETWORKS (U.S. CLS. 100, 101 AND 102).

FIRST USE 9-18-2007; IN COMMERCE 6-1-2008.

3,633,180. ECHELON RESORTS CORPORATION, LAS VEGAS, NV. SN 78-695,812. PUB. 1-17-2006, FILED 8-18-2005.

ECHELON

THE MARK CONSISTS OF STANDARD CHARACTERS WITHOUT CLAIM TO ANY PARTICULAR FONT, STYLE, SIZE, OR COLOR.

FOR RETAIL SHOPS FEATURING SALE OF SUNDRIES, WEARING APPAREL AND SOUVENIR ITEMS AND A WIDE VARIETY OF CONSUMER GOODS OF OTHERS (U.S. CLS. 100, 101 AND 102).

FIRST USE 4-10-2009; IN COMMERCE 4-10-2009.

3,633,220. MAYNOV PRODUCTIONS L.L.C., LONG ISLAND CITY, NY. SN 78-773,637. PUB. 1-23-2007, FILED 12-14-2005.

Bridge Pride International

THE MARK CONSISTS OF STANDARD CHARACTERS WITHOUT CLAIM TO ANY PARTICULAR FONT, STYLE, SIZE, OR COLOR.

FOR PROMOTING PUBLIC AWARENESS OF HOUSING PROJECTS, HOUSING DEVELOPMENTS, HOUSING COMMUNITIES AND HOUSING RESIDENTS (U.S. CLS. 100, 101 AND 102).

FIRST USE 3-21-2009; IN COMMERCE 3-21-2009.

3,633,182. SILVERBACK, LLC, FORT WORTH, TX. SN 78-699,768. PUB. 8-28-2007, FILED 8-24-2005.

QUALQUANT

THE MARK CONSISTS OF STANDARD CHARACTERS WITHOUT CLAIM TO ANY PARTICULAR FONT, STYLE, SIZE, OR COLOR.

FOR CONSULTATION SERVICES IN THE FIELD OF HEALTH CARE INSURANCE, NAMELY, PROVIDING ADVICE AND ASSISTANCE RELATED TO THE USE OF CLAIMS DATA IN THE NATURE OF DATA COMPILATION AND ANALYSIS FOR THE PURPOSES OF IDENTIFYING PERFORMANCE MEASURES FOR HEALTH CARE PROVIDERS (U.S. CLS. 100, 101 AND 102).

FIRST USE 1-7-2008; IN COMMERCE 1-7-2008.

3,633,225. MARC A. GALLO, COMMUNICATIONS CONSULTANT, INC., DREXEL HILL, PA. SN 78-786,661. PUB. 10-21-2008, FILED 1-6-2006.

MIND THE GAP

THE MARK CONSISTS OF STANDARD CHARACTERS WITHOUT CLAIM TO ANY PARTICULAR FONT, STYLE, SIZE, OR COLOR.

FOR PROVIDING ON-HOLD MUSIC AND INFORMATION MESSAGING SERVICES FOR OTHERS, NAMELY, PROMOTING THE GOODS AND SERVICES OF OTHERS BY PROVIDING PRERECORDED MESSAGES IN THE NATURE OF MUSIC AND CUSTOM MESSAGES TO BE PLAYED THROUGH TELEPHONE SYSTEMS AND OTHER AUDIO EQUIPMENT (U.S. CLS. 100, 101 AND 102).

FIRST USE 1-1-2006; IN COMMERCE 1-1-2006.

CLASS 35—(Continued).

3,633,256. JMBP, INC., LOS ANGELES, CA. SN 78-847,364.
PUB. 7-10-2007, FILED 3-27-2006.

SUPERNOVA

THE MARK CONSISTS OF STANDARD CHARACTERS WITHOUT CLAIM TO ANY PARTICULAR FONT, STYLE, SIZE, OR COLOR.

FOR MAIL ORDER SERVICES AND COMPUTERIZED ON-LINE ORDERING SERVICES FEATURING PRE-RECORDED ANALOG AND DIGITAL MEDIA INCLUDING, BUT NOT LIMITED TO, AUDIO AND VIDEO CASSETTES, CDS, DVDS, TAPES, PHONOGRAPH RECORDS, MAGNETIC DISC AND FLASH MEDIA ALL FEATURING MUSIC AND ENTERTAINMENT, PAPER GOODS, NAMELY, POSTERS, CALENDARS, TEMPORARY TATTOOS, STICKERS, DECALS, SHEET MUSIC, TOUR BOOKS, NOTE PADS, NOTE BOOKS, NOTE PAPER AND STATIONERY, KEY CHAINS, TOYS, GAMES, HOME FURNISHINGS AND HOUSEWARES (U.S. CLS. 100, 101 AND 102).

FIRST USE 11-21-2006; IN COMMERCE 11-21-2006.

CLASS 35—(Continued).

3,633,313. SCANA CORPORATION, COLUMBIA, SC. SN 78-964,945. PUB. 3-13-2007, FILED 8-31-2006.



OWNER OF U.S. REG. NOS. 2,249,684, 2,260,911, AND OTHERS.

NO CLAIM IS MADE TO THE EXCLUSIVE RIGHT TO USE "ENERGY.COM", APART FROM THE MARK AS SHOWN.

THE MARK CONSISTS OF THE WORDS "SCANA ENERGY.COM" PRECEDED BY A STYLIZED RENDITION OF AN EDGE. THE COLOR GRAY IS INTENDED TO SHOW SHADING OR CONTRAST ONLY.

FOR PROVIDING CONSUMER INFORMATION IN THE FIELD OF POWER GENERATION AND TRANSMISSION VIA THE INTERNET (U.S. CLS. 100, 101 AND 102).

FIRST USE 9-11-2006; IN COMMERCE 9-11-2006.

3,633,321. AGGREGATE KNOWLEDGE, INC., SAN MATEO, CA. SN 78-972,715. PUB. 11-20-2007, FILED 9-12-2006.

AGKNOW

Destination 10

THE MARK CONSISTS OF STANDARD CHARACTERS WITHOUT CLAIM TO ANY PARTICULAR FONT, STYLE, SIZE, OR COLOR.

FOR BUSINESS CONSULTATION TO THE HEALTHCARE FOOD SERVICES INDUSTRY (U.S. CLS. 100, 101 AND 102).

FIRST USE 12-30-2002; IN COMMERCE 12-30-2004.

THE MARK CONSISTS OF STANDARD CHARACTERS WITHOUT CLAIM TO ANY PARTICULAR FONT, STYLE, SIZE, OR COLOR.

FOR PROVIDING ONLINE ADVERTISING AND MARKETING SERVICES FOR OTHERS; BUSINESS CONSULTATION SERVICES; PROMOTING THE GOODS, SERVICES OR CONTENT OF OTHERS BY PROVIDING TO END USERS OF WEB SITES CONTENT THAT SUGGESTS ITEMS OF INTEREST BASED ON CORRELATED RELATIONSHIPS (U.S. CLS. 100, 101 AND 102).

FIRST USE 6-30-2006; IN COMMERCE 6-30-2006.

3,633,304. DON MILLER & ASSOCIATES, INC., BONITA, CA. SN 78-938,672. PUB. 11-18-2008, FILED 7-27-2006.

CLASS 35—(Continued).

3,633,325. ARITZIA LP, VANCOUVER, CANADA. SN 78-980,365. PUB. 11-27-2007, FILED 4-13-2006.

TNA

THE MARK CONSISTS OF STANDARD CHARACTERS WITHOUT CLAIM TO ANY PARTICULAR FONT, STYLE, SIZE, OR COLOR.

OWNER OF U.S. REG. NOS. 2,259,494, 3,562,638, AND OTHERS.

FOR RETAIL STORE SERVICES FEATURING BAGS, CLOTHING, HEADWEAR, HANDWEAR, FOOTWEAR, AND CLOTHING ACCESSORIES (U.S. CLS. 100, 101 AND 102).

FIRST USE 11-7-2007; IN COMMERCE 11-0-2007.

CLASS 36—(Continued).

3,631,832. RENTAL LINK, LLC, FORT MYERS, FL. SN 76-682,674. PUB. 8-19-2008, FILED 10-5-2007.

RENTAL LINK

THE MARK CONSISTS OF STANDARD CHARACTERS WITHOUT CLAIM TO ANY PARTICULAR FONT, STYLE, SIZE, OR COLOR.

NO CLAIM IS MADE TO THE EXCLUSIVE RIGHT TO USE "RENTAL", APART FROM THE MARK AS SHOWN.

FOR FULL SERVICE PROPERTY MANAGEMENT SERVICES, NAMELY, REAL ESTATE MANAGEMENT; AND TENANT PLACEMENT SERVICES, NAMELY, RENTAL REAL ESTATE LOCATING SERVICES FOR RENTAL REAL ESTATE TENANTS AND RENTAL REAL ESTATE OWNERS (U.S. CLS. 100, 101 AND 102).

FIRST USE 1-1-2008; IN COMMERCE 1-1-2008.

3,631,856. 3MV BANCORP, INC., OMAHA, NE. SN 76-689,026. PUB. 9-23-2008, FILED 4-25-2008.

CLASS 36—INSURANCE AND FINANCIAL

3,631,831. OUTSOURCEONE, INC., MINNEAPOLIS, MN. SN 76-681,586. PUB. 7-22-2008, FILED 9-6-2007.

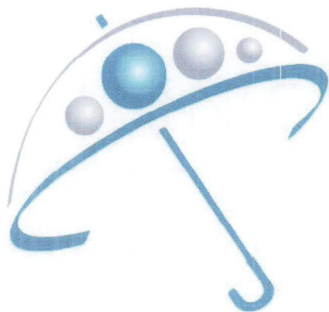

THE COLOR(S) TEAL AND GRAY IS/ARE CLAIMED AS A FEATURE OF THE MARK.

THE MARK CONSISTS OF THE COLORS GRAY AND TEAL APPEAR IN THE DESIGN OF THE UMBRELLA AND THE CIRCLES.

FOR BENEFIT ADMINISTRATION SERVICES, NAMELY, ADMINISTRATION OF EMPLOYEE BENEFIT PLANS (U.S. CLS. 100, 101 AND 102).

FIRST USE 2-19-2009; IN COMMERCE 2-19-2009.

ACCESSIONLINE

THE MARK CONSISTS OF STANDARD CHARACTERS WITHOUT CLAIM TO ANY PARTICULAR FONT, STYLE, SIZE, OR COLOR.

OWNER OF U.S. REG. NO. 3,013,203.

FOR FINANCIAL TRANSACTION SERVICES, NAMELY, ELECTRONIC BANKING SERVICES OVER THE INTERNET AND ONLINE OVER A GLOBAL COMPUTER NETWORK (U.S. CLS. 100, 101 AND 102).

FIRST USE 12-31-2008; IN COMMERCE 12-31-2008.

3,631,875. VISIONBANK OF IOWA, WEST DES MOINES, IA. SN 77-018,529. PUB. 1-15-2008, FILED 10-11-2006.



Virtual Business Checking

NO CLAIM IS MADE TO THE EXCLUSIVE RIGHT TO USE "VIRTUAL BUSINESS CHECKING", APART FROM THE MARK AS SHOWN.

FOR BANKING; ISSUANCE OF BANK CHECKS (U.S. CLS. 100, 101 AND 102).

FIRST USE 5-15-2006; IN COMMERCE 5-15-2006.

CLASS 36—(Continued).

3,631,891. BANK FORWARD, HANNAFORD, ND. SN 77-037,370. PUB. 7-10-2007, FILED 11-6-2006.

BANK FORWARD

THE MARK CONSISTS OF STANDARD CHARACTERS WITHOUT CLAIM TO ANY PARTICULAR FONT, STYLE, SIZE, OR COLOR.

NO CLAIM IS MADE TO THE EXCLUSIVE RIGHT TO USE "BANK", APART FROM THE MARK AS SHOWN.

FOR BANKING SERVICES; REAL ESTATE MORTGAGE BROKERAGE; INSURANCE BROKERAGE SERVICES (U.S. CLS. 100, 101 AND 102).

FIRST USE 1-2-2007; IN COMMERCE 1-2-2007.

3,631,907. UTA PIPPIG, BOCA RATON, FL. SN 77-054,091. PUB. 6-26-2007, FILED 11-30-2006.

**TAKE THE MAGIC STEP
FOUNDATION**

THE MARK CONSISTS OF STANDARD CHARACTERS WITHOUT CLAIM TO ANY PARTICULAR FONT, STYLE, SIZE, OR COLOR.

OWNER OF U.S. REG. NO. 3,063,662.

NO CLAIM IS MADE TO THE EXCLUSIVE RIGHT TO USE "FOUNDATION", APART FROM THE MARK AS SHOWN.

FOR CHARITABLE FUND RAISING (U.S. CLS. 100, 101 AND 102).

FIRST USE 4-2-2008; IN COMMERCE 4-2-2008.

3,631,920. JOHNSON, ERIC, NASHVILLE, TN. SN 77-069,145. PUB. 7-31-2007, FILED 12-21-2006.

YOUR MOVE REAL ESTATE

THE MARK CONSISTS OF STANDARD CHARACTERS WITHOUT CLAIM TO ANY PARTICULAR FONT, STYLE, SIZE, OR COLOR.

NO CLAIM IS MADE TO THE EXCLUSIVE RIGHT TO USE "REAL ESTATE", APART FROM THE MARK AS SHOWN.

FOR REAL ESTATE AGENCY AND BROKERAGE SERVICES AND REAL ESTATE CONSULTING SERVICES (U.S. CLS. 100, 101 AND 102).

FIRST USE 2-23-2007; IN COMMERCE 2-23-2007.

CLASS 36—(Continued).

3,632,031. VALUEGATE HOLDINGS LIMITED, TORTOLA, BR.VIRGIN ISLANDS. SN 77-175,901. PUB. 7-22-2008, FILED 5-8-2007.



FOR FINANCIAL ANALYSIS; SECURITIES BROKERAGE; TRADING OF SECURITIES AND EQUITY OPTIONS; TRADING IN FUTURES CONTRACTS AND ROLLING FOREIGN EXCHANGE CONTRACTS, AND LEVERAGED FOREIGN EXCHANGE CONTRACTS; INVESTING FUNDS FOR OTHERS; FINANCIAL CONSULTANCY; FINANCIAL EVALUATION OF INSURANCE, BANKING, AND REAL ESTATE FOR INVESTMENT PURPOSES; FINANCIAL MANAGEMENT; FINANCING SERVICES; FISCAL ASSESSMENTS; FUNDS INVESTMENTS; PROVIDING FINANCIAL INFORMATION; ADMINISTRATION OF MUTUAL FUNDS; REAL ESTATE MANAGEMENT; SECURITIES BROKERAGE; STOCK EXCHANGE PRICE QUOTATIONS; STOCKS AND BONDS BROKERAGE (U.S. CLS. 100, 101 AND 102).

FIRST USE 5-31-2007; IN COMMERCE 5-31-2007.

3,632,056. JONESTRADING INSTITUTIONAL SERVICES LLC, WESTLAKE VILLAGE, CA. SN 77-196,886. PUB. 5-6-2008, FILED 6-4-2007.

CAPITAL ON DEMAND

THE MARK CONSISTS OF STANDARD CHARACTERS WITHOUT CLAIM TO ANY PARTICULAR FONT, STYLE, SIZE, OR COLOR.

NO CLAIM IS MADE TO THE EXCLUSIVE RIGHT TO USE "CAPITAL", APART FROM THE MARK AS SHOWN.

FOR FINANCIAL SERVICES, NAMELY, BROKERAGE SERVICES FOR LARGE SECURITIES TRANSACTIONS; CREATING LIQUIDITY IN TRANSACTIONS FOR INSTITUTIONAL CUSTOMERS AND ISSUERS OF CORPORATE SECURITIES (U.S. CLS. 100, 101 AND 102).

FIRST USE 8-0-2008; IN COMMERCE 9-8-2008.

CLASS 36—(Continued).

3,632,169. TRAVELERS INDEMNITY COMPANY, THE, HARTFORD, CT. SN 77-257,250. PUB. 6-17-2008, FILED 8-16-2007.

PUBLIC ENTITY CYBER+ LIABILITY

THE MARK CONSISTS OF STANDARD CHARACTERS WITHOUT CLAIM TO ANY PARTICULAR FONT, STYLE, SIZE, OR COLOR.

NO CLAIM IS MADE TO THE EXCLUSIVE RIGHT TO USE "PUBLIC ENTITY" OR "LIABILITY", APART FROM THE MARK AS SHOWN.

FOR PROPERTY AND CASUALTY INSURANCE UNDERWRITING SERVICES (U.S. CLS. 100, 101 AND 102). FIRST USE 8-1-2007; IN COMMERCE 8-1-2007.

3,632,191. COMMUNITY BANK CBD, DELAVAN, WI. SN 77-263,861. PUB. 7-22-2008, FILED 8-24-2007.

COMMUNITY BANK CBD

THE MARK CONSISTS OF STANDARD CHARACTERS WITHOUT CLAIM TO ANY PARTICULAR FONT, STYLE, SIZE, OR COLOR.

NO CLAIM IS MADE TO THE EXCLUSIVE RIGHT TO USE "COMMUNITY BANK", APART FROM THE MARK AS SHOWN.

FOR BANKING SERVICES; ELECTRONIC BANKING SERVICES; INTERNET BANKING SERVICES; PERSONAL AND CONSUMER BANKING SERVICES; BUSINESS, COMMERCIAL AND RETAIL BANKING SERVICES; CHECKING AND SAVINGS ACCOUNT SERVICES; MONEY MARKET ACCOUNT SERVICES; OFFERING REGULAR AND JUMBO CERTIFICATES OF DEPOSIT; HOME MORTGAGE LENDING SERVICES; HOME EQUITY LOAN SERVICES; OFFERING AND PROVIDING PERSONAL AND CONSUMER LOANS AND LINES OF CREDIT; COMMERCIAL MORTGAGE LENDING AND LOAN SERVICES; OFFERING AND PROVIDING COMMERCIAL LINES OF CREDIT; TERM FINANCING; INDIVIDUAL RETIREMENT ACCOUNT SERVICES; PERSONALIZED FINANCIAL PLANNING SERVICES; AUTOMATIC TELLER MACHINE SERVICES; AUTOMATED BANKING SERVICES AND AUTOMATIC BILL PAYMENT SERVICES; MONEY WIRE TRANSFER SERVICES; ELECTRONIC FUNDS TRANSFER SERVICES; CREDIT AND DEBIT CARD SERVICES; CREDIT CARD SERVICES IN THE NATURE OF BUSINESS TRAVEL CARD SERVICES; OFFERING AND PROVIDING CASHIERS AND TRAVELERS CHECKS; MERCHANT BANK CARD PROCESSING SERVICES, NAMELY, CREDIT CARD PROCESSING SERVICES; SAFETY DEPOSIT BOX SERVICES; BUSI-

CLASS 36—(Continued).

NESS CASH MANAGEMENT SERVICES; CASH MANAGEMENT SERVICES, NAMELY, AUTOMATIC SWEEP ACCOUNT SERVICES, CONTROLLED DISBURSEMENT SERVICES, DEPOSIT REPORTING SERVICES, FINANCIAL ACCOUNT RECONCILIATION SERVICES, LOCK-BOX SERVICES, POSITIVE PAY SERVICES, AND ZERO BALANCE ACCOUNT SERVICES; AUTOMATED FINANCIAL CLEARING HOUSE SERVICES; FINANCIAL ACCOUNT ANALYSIS SERVICES; BANKING SERVICES, NAMELY, REPURCHASE AGREEMENT SERVICES AND INVESTMENT ACCOUNT SERVICES; INTERNATIONAL MONEY WIRE TRANSFER AND BILL PAYMENT SERVICES; OFFERING AND PROVIDING IMPORT, EXPORT AND STANDBY LETTERS OF CREDIT; PROVIDING INFORMATION AND ADVICE REGARDING FOREIGN CURRENCY AND RATES OF EXCHANGE; PROVIDING ON-LINE BANKING SERVICES AND ON-LINE CASH MANAGEMENT SERVICES VIA A GLOBAL COMPUTER OR COMMUNICATION NETWORK; AND PROVIDING FINANCIAL INFORMATION BY ELECTRONIC MEANS (U.S. CLS. 100, 101 AND 102). FIRST USE 9-26-2007; IN COMMERCE 9-26-2007.

3,632,207. AFRIFINANCE LLC, NEW YORK, NY. SN 77-268,232. PUB. 6-17-2008, FILED 8-30-2007.

AFRICINDEX

THE MARK CONSISTS OF STANDARD CHARACTERS WITHOUT CLAIM TO ANY PARTICULAR FONT, STYLE, SIZE, OR COLOR.

FOR FINANCIAL AND INVESTMENT ADVISORY SERVICES; FINANCIAL AND INVESTMENT INFORMATION SERVICES; FINANCIAL CONSULTATION AND RESEARCH; RATING SERVICES, NAMELY, PROVIDING RATINGS REGARDING PERFORMANCE OF SECURITIES AND INVESTMENTS; FINANCIAL DATA AND STOCK RESEARCH (U.S. CLS. 100, 101 AND 102). FIRST USE 11-24-2008; IN COMMERCE 11-24-2008.

CLASS 36—(Continued).

3,632,226. FEDERAL RESERVE BANKS COMPOSED OF FEDERAL RESERVE BANK OF ATLANTA, FEDERAL RESERVE BANK OF NEW YORK, FEDERAL RESERVE BANK OF BOSTON, FEDERAL RESERVE BANK OF CHICAGO, FEDERAL RESERVE BANK OF CLEVELAND, FEDERAL RESERVE BANK OF DALLAS, FEDERAL RESERVE BANK OF KANSAS CITY, FEDERAL RESERVE BANK OF MINNEAPOLIS, FEDERAL RESERVE BANK OF PHILADELPHIA, FEDERAL RESERVE BANK OF RICHMOND, FEDERAL RESERVE BANK OF ST. LOUIS, FEDERAL RESERVE BANK OF SAN FRANCISCO, CHICAGO, IL. SN 77-279,601. PUB. 7-29-2008, FILED 9-14-2007.

CLASS 36—(Continued).

3,632,279. COLONIAL LIFE & ACCIDENT INSURANCE COMPANY, COLUMBIA, SC. SN 77-304,033. PUB. 9-23-2008, FILED 10-15-2007.



FEDINSIGHTS

THE MARK CONSISTS OF STANDARD CHARACTERS WITHOUT CLAIM TO ANY PARTICULAR FONT, STYLE, SIZE, OR COLOR.

FOR FINANCIAL SERVICES, NAMELY, PROVIDING FINANCIAL INFORMATION REGARDING PAYMENT TRANSACTION AND ACCOUNT BALANCES (U.S. CLS. 100, 101 AND 102).

FIRST USE 11-30-2007; IN COMMERCE 11-30-2007.

OWNER OF U.S. REG. NOS. 2,730,258 AND 3,195,055. NO CLAIM IS MADE TO THE EXCLUSIVE RIGHT TO USE "LIFE", APART FROM THE MARK AS SHOWN.

THE MARK CONSISTS OF THE WORDS "COLONIAL LIFE MAKING BENEFITS COUNT" WITH A SERIES OF SMALL OVALS FORMING A RANDOM DESIGN ABOVE THE WORDS.

FOR INSURANCE SERVICES, NAMELY, PROVIDING INFORMATION TO OTHERS IN THE FIELD OF EMPLOYEE BENEFITS ENROLLMENT, INSURANCE INFORMATION FOCUSING ON EMPLOYEE BENEFITS FOR THE PURPOSE OF GENERAL CONSUMER EDUCATION; INSURANCE UNDERWRITING IN THE FIELD OF LIFE AND ACCIDENT AND HEALTH (U.S. CLS. 100, 101 AND 102).

FIRST USE 1-9-2008; IN COMMERCE 1-9-2008.

3,632,278. COLONIAL LIFE & ACCIDENT INSURANCE COMPANY, COLUMBIA, SC. SN 77-304,016. PUB. 9-23-2008, FILED 10-15-2007.

3,632,299. OPTIQUE CAPITAL MANAGEMENT, RACINE, WI. SN 77-312,285. PUB. 7-1-2008, FILED 10-24-2007.



OPTIQUE CAPITAL MANAGEMENT

OWNER OF U.S. REG. NOS. 2,730,258 AND 3,195,055. NO CLAIM IS MADE TO THE EXCLUSIVE RIGHT TO USE "LIFE", APART FROM THE MARK AS SHOWN.

THE MARK CONSISTS OF THE WORDS "COLONIAL LIFE" WITH A SERIES OF SMALL OVALS FORMING A RANDOM DESIGN ABOVE THE WORDS.

FOR INSURANCE SERVICES, NAMELY, PROVIDING INFORMATION TO OTHERS IN THE FIELD OF EMPLOYEE BENEFITS ENROLLMENT, INSURANCE INFORMATION FOCUSING ON EMPLOYEE BENEFITS FOR THE PURPOSE OF GENERAL CONSUMER EDUCATION; INSURANCE UNDERWRITING IN THE FIELD OF LIFE AND ACCIDENT AND HEALTH (U.S. CLS. 100, 101 AND 102).

FIRST USE 1-9-2008; IN COMMERCE 1-9-2008.

THE MARK CONSISTS OF STANDARD CHARACTERS WITHOUT CLAIM TO ANY PARTICULAR FONT, STYLE, SIZE, OR COLOR.

NO CLAIM IS MADE TO THE EXCLUSIVE RIGHT TO USE "CAPITAL MANAGEMENT", APART FROM THE MARK AS SHOWN.

"THE FOREIGN WORDING IN THE MARK TRANSLATES INTO ENGLISH AS OPTICAL."

FOR FINANCIAL MANAGEMENT AND INVESTMENT MANAGEMENT SERVICES, NAMELY, ASSET MANAGEMENT SERVICES; MANAGEMENT OF PUBLICLY TRADED EQUITIES AND FIXED INCOME INSTRUMENTS (U.S. CLS. 100, 101 AND 102).

FIRST USE 11-30-2007; IN COMMERCE 11-30-2007.

CLASS 36—(Continued).

3,632,300. OPTIQUE CAPITAL MANAGEMENT, RACINE, WI. SN 77-312,292. PUB. 7-1-2008, FILED 10-24-2007.

OPTIQUE CAPITAL

THE MARK CONSISTS OF STANDARD CHARACTERS WITHOUT CLAIM TO ANY PARTICULAR FONT, STYLE, SIZE, OR COLOR.

NO CLAIM IS MADE TO THE EXCLUSIVE RIGHT TO USE "CAPITAL", APART FROM THE MARK AS SHOWN.

"THE FOREIGN WORDING IN THE MARK TRANSLATES INTO ENGLISH AS OPTICAL."

FOR FINANCIAL MANAGEMENT AND INVESTMENT MANAGEMENT SERVICES; MANAGEMENT OF PUBLICLY TRADED EQUITIES AND FIXED INCOME INSTRUMENTS (U.S. CLS. 100, 101 AND 102).

FIRST USE 11-30-2007; IN COMMERCE 11-30-2007.

3,632,309. A&E TELEVISION NETWORKS, NEW YORK, NY. SN 77-318,934. PUB. 7-29-2008, FILED 11-1-2007.

GIVE A LINCOLN FOR LINCOLN

THE MARK CONSISTS OF STANDARD CHARACTERS WITHOUT CLAIM TO ANY PARTICULAR FONT, STYLE, SIZE, OR COLOR.

FOR CHARITABLE FUNDRAISING SERVICES (U.S. CLS. 100, 101 AND 102).

FIRST USE 11-18-2008; IN COMMERCE 11-18-2008.

3,632,324. THE BALTIMORE LIFE INSURANCE COMPANY, BALTIMORE, MD. SN 77-325,893. PUB. 12-9-2008, FILED 11-9-2007.

LIFETIME NAVIGATOR

THE MARK CONSISTS OF STANDARD CHARACTERS WITHOUT CLAIM TO ANY PARTICULAR FONT, STYLE, SIZE, OR COLOR.

FOR INSURANCE UNDERWRITING IN THE FIELD OF UNIVERSAL LIFE (U.S. CLS. 100, 101 AND 102).

FIRST USE 1-23-2008; IN COMMERCE 1-23-2008.

CLASS 36—(Continued).

3,632,325. BRIGHTPATH MORTGAGE, LLC, FAYETTESVILLE, GA. SN 77-326,425. PUB. 6-17-2008, FILED 11-9-2007.

Brightpath Lending

THE MARK CONSISTS OF STANDARD CHARACTERS WITHOUT CLAIM TO ANY PARTICULAR FONT, STYLE, SIZE, OR COLOR.

NO CLAIM IS MADE TO THE EXCLUSIVE RIGHT TO USE "LENDING", APART FROM THE MARK AS SHOWN.

FOR MORTGAGE BANKING SERVICES, NAMELY, MORTGAGE LENDING; MORTGAGE SERVICES, NAMELY, ORIGINATION, ACQUISITION, SECURITIZATION, BROKERAGE AND SERVICING OF CONSTRUCTION MORTGAGE LOANS, BUYER PRE-QUALIFICATION OF MORTGAGES, MORTGAGE BROKERAGE, MORTGAGE PROCUREMENT FOR OTHERS, HOME EQUITY LOANS, LOAN FINANCING; ALTERNATIVE LENDING SERVICES; HOME FINANCING AND REFINANCING; AND FINANCIAL LOAN CONSULTATION; MORTGAGE BROKERAGE SERVICES (U.S. CLS. 100, 101 AND 102).

FIRST USE 11-15-2007; IN COMMERCE 11-15-2007.

3,632,335. ONDRASIK, JOHN, LOS ANGELES, CA. SN 77-331,546. PUB. 7-22-2008, FILED 11-16-2007.

HISTORY STARTS NOW

THE MARK CONSISTS OF STANDARD CHARACTERS WITHOUT CLAIM TO ANY PARTICULAR FONT, STYLE, SIZE, OR COLOR.

FOR CHARITABLE FUNDRAISING SERVICES FOR NON-PROFIT INSTITUTIONS VIA A GLOBAL COMPUTER NETWORK; PROVIDING A WEB SITE ON A GLOBAL COMPUTER NETWORK FEATURING INFORMATION ON CHARITABLE FUNDRAISING FOR NON-PROFIT INSTITUTIONS AND CHARITABLE FUNDRAISING; PROVIDING A WEB SITE ON A GLOBAL COMPUTER NETWORK PROVIDING COMMENTARY AND INFORMATION ABOUT CHARITABLE FUNDRAISING AND CHARITABLE FUNDRAISING FOR PROMOTING SOCIAL ISSUES; CHARITABLE FUNDRAISING SERVICES, NAMELY, PROVIDING INFORMATION AND OPPORTUNITIES FOR OTHERS TO MAKE MONETARY DONATIONS TO NON-PROFIT INSTITUTIONS (U.S. CLS. 100, 101 AND 102).

FIRST USE 12-1-2006; IN COMMERCE 12-1-2006.

CLASS 36—(Continued).

3,632,336. ONDRASIK, JOHN, LOS ANGELES, CA. SN 77-331,549. PUB. 7-22-2008, FILED 11-16-2007.

WHAT KIND OF WORLD DO YOU WANT

THE MARK CONSISTS OF STANDARD CHARACTERS WITHOUT CLAIM TO ANY PARTICULAR FONT, STYLE, SIZE, OR COLOR.

FOR CHARITABLE FUNDRAISING SERVICES FOR NON-PROFIT INSTITUTIONS VIA A GLOBAL COMPUTER NETWORK; PROVIDING A WEB SITE ON A GLOBAL COMPUTER NETWORK FEATURING INFORMATION ON CHARITABLE FUNDRAISING FOR NON-PROFIT INSTITUTIONS AND CHARITABLE FUNDRAISING; PROVIDING A WEB SITE ON A GLOBAL COMPUTER NETWORK PROVIDING COMMENTARY AND INFORMATION ABOUT CHARITABLE FUNDRAISING AND CHARITABLE FUNDRAISING FOR PROMOTING SOCIAL ISSUES; CHARITABLE FUNDRAISING SERVICES, NAMELY, PROVIDING INFORMATION AND OPPORTUNITIES FOR OTHERS TO MAKE MONETARY DONATIONS TO NON-PROFIT INSTITUTIONS (U.S. CLS. 100, 101 AND 102).

FIRST USE 12-1-2006; IN COMMERCE 12-1-2006.

3,632,384. THORNHAM INCORPORATED, HALIFAX, CANADA. SN 77-353,360. PUB. 10-28-2008, FILED 12-17-2007.

PAINTING WITH PURPOSE

THE MARK CONSISTS OF STANDARD CHARACTERS WITHOUT CLAIM TO ANY PARTICULAR FONT, STYLE, SIZE, OR COLOR.

FOR CHARITABLE FUND RAISING SERVICES BY MEANS OF ONLINE AND RETAIL SALES OF CHILDREN'S ART (U.S. CLS. 100, 101 AND 102).

FIRST USE 11-14-2008; IN COMMERCE 11-14-2008.

3,632,385. THORNHAM INCORPORATED, HALIFAX, CANADA. SN 77-353,362. PUB. 10-28-2008, FILED 12-17-2007.



THE MARK CONSISTS OF A STYLIZED VERSION OF THE PHRASE "PAINTING WITH PURPOSE" WITH A PAINTBRUSH ABOVE THE WORDS "PURPOSE".

FOR CHARITABLE FUND RAISING SERVICES BY MEANS OF ONLINE AND RETAIL SALES OF CHILDREN'S ART (U.S. CLS. 100, 101 AND 102).

FIRST USE 11-14-2008; IN COMMERCE 11-14-2008.

CLASS 36—(Continued).

3,632,406. OMNI BROKERAGE, INC., SOUTH JORDAN, UT. SN 77-360,426. PUB. 9-16-2008, FILED 12-27-2007.

OMNI BROKERAGE

THE MARK CONSISTS OF STANDARD CHARACTERS WITHOUT CLAIM TO ANY PARTICULAR FONT, STYLE, SIZE, OR COLOR.

NO CLAIM IS MADE TO THE EXCLUSIVE RIGHT TO USE "BROKERAGE", APART FROM THE MARK AS SHOWN.

FOR FINANCIAL AND INVESTMENT SERVICES, NAMELY, BROKERAGE AND MANAGEMENT IN THE FIELDS OF STOCKS, BONDS, OPTIONS, COMMODITIES, FUTURES AND OTHER SECURITIES, AND THE INVESTMENT OF FUNDS OF OTHERS; FINANCIAL CONSULTATION; REAL ESTATE BROKERAGE (U.S. CLS. 100, 101 AND 102).

FIRST USE 7-8-2005; IN COMMERCE 7-8-2005.

3,632,417. RAYMOND JAMES FINANCIAL, INC., ST. PETERSBURG, FL. SN 77-366,290. PUB. 6-24-2008, FILED 1-8-2008.

CREATING PEACE OF MIND THROUGH GENERATIONS

THE MARK CONSISTS OF STANDARD CHARACTERS WITHOUT CLAIM TO ANY PARTICULAR FONT, STYLE, SIZE, OR COLOR.

FOR FINANCIAL PLANNING, SECURITIES TRADING AND INVESTING SERVICES FOR OTHERS, FINANCIAL PORTFOLIO MANAGEMENT, TRUST SERVICES, NAMELY, INVESTMENT AND TRUST COMPANY SERVICES; ASSET MANAGEMENT; PROVIDING ONLINE INFORMATION IN THE FIELD OF CHARITABLE GIVING THROUGH FINANCIAL AND ESTATE PLANNING (U.S. CLS. 100, 101 AND 102).

FIRST USE 3-31-2007; IN COMMERCE 3-31-2007.

CLASS 36—(Continued).

3,632,432. KEYSTONE MUTUAL INSURANCE COMPANY, CHESTERFIELD, MO. SN 77-371,344. PUB. 12-9-2008, FILED 1-14-2008.

CONSENT TO SETTLE PLUS

THE MARK CONSISTS OF STANDARD CHARACTERS WITHOUT CLAIM TO ANY PARTICULAR FONT, STYLE, SIZE, OR COLOR.

NO CLAIM IS MADE TO THE EXCLUSIVE RIGHT TO USE "CONSENT TO SETTLE", APART FROM THE MARK AS SHOWN.

FOR INSURANCE UNDERWRITING AND ADMINISTRATION IN THE FIELD OF MEDICAL AND DENTAL PROFESSIONAL LIABILITY INSURANCE (U.S. CLS. 100, 101 AND 102).

FIRST USE 6-15-2008; IN COMMERCE 6-15-2008.

CLASS 36—(Continued).

3,632,517. PROMUTUAL GROUP, INC., BOSTON, MA. SN 77-397,478. PUB. 7-8-2008, FILED 2-14-2008.

**PROMUTUAL SOLUTIONS
INSURANCE COMPANY**

THE MARK CONSISTS OF STANDARD CHARACTERS WITHOUT CLAIM TO ANY PARTICULAR FONT, STYLE, SIZE, OR COLOR.

OWNER OF U.S. REG. NOS. 2,005,226 AND 2,076,428.

NO CLAIM IS MADE TO THE EXCLUSIVE RIGHT TO USE "INSURANCE COMPANY", APART FROM THE MARK AS SHOWN.

FOR INSURANCE UNDERWRITING IN THE FIELD OF PROFESSIONAL LIABILITY INSURANCE FOR HEALTH CARE PROFESSIONALS (U.S. CLS. 100, 101 AND 102).

FIRST USE 3-6-2009; IN COMMERCE 3-6-2009.

3,632,519. NATIONAL MULTIPLE SCLEROSIS SOCIETY, NEW YORK, NY. SN 77-397,920. PUB. 7-15-2008, FILED 2-15-2008.

BIKE MS

THE MARK CONSISTS OF STANDARD CHARACTERS WITHOUT CLAIM TO ANY PARTICULAR FONT, STYLE, SIZE, OR COLOR.

NO CLAIM IS MADE TO THE EXCLUSIVE RIGHT TO USE "MS", APART FROM THE MARK AS SHOWN.

FOR CHARITABLE FUNDRAISING SERVICES (U.S. CLS. 100, 101 AND 102).

FIRST USE 8-0-2007; IN COMMERCE 8-0-2007.

3,632,492. AUTONATION HOLDING CORP., FT. LAUDERDALE, FL. SN 77-392,708. PUB. 6-24-2008, FILED 2-8-2008.

**IT'S ABOUT CONVENIENCE.
IT'S ABOUT SAVINGS. IT'S
ABOUT TIME.**

THE MARK CONSISTS OF STANDARD CHARACTERS WITHOUT CLAIM TO ANY PARTICULAR FONT, STYLE, SIZE, OR COLOR.

FOR FINANCIAL SERVICES, NAMELY, LOAN FINANCING FOR THE PURCHASE OF NEW AND USED MOTOR VEHICLES; INSURANCE SERVICES, NAMELY, UNDERWRITING EXTENDED WARRANTY CONTRACTS IN THE FIELD OF MOTOR VEHICLES (U.S. CLS. 100, 101 AND 102).

FIRST USE 4-0-2008; IN COMMERCE 4-0-2008.

3,632,534. NEWDOMINION FINANCIAL CORPORATION, CHARLOTTE, NC. SN 77-402,324. PUB. 7-8-2008, FILED 2-21-2008.

**THE MOST EFFICIENT BANK IS
YOUR PC**

THE MARK CONSISTS OF STANDARD CHARACTERS WITHOUT CLAIM TO ANY PARTICULAR FONT, STYLE, SIZE, OR COLOR.

FOR BANKING SERVICES (U.S. CLS. 100, 101 AND 102).

FIRST USE 9-15-2008; IN COMMERCE 9-15-2008.

CLASS 36—(Continued).

3,632,634. FIRST SECURITY BANK, BOZEMAN, MT. SN 77-417,359. PUB. 7-22-2008, FILED 3-10-2008.

CLASS 36—(Continued).

3,632,643. TOP 20 REALTY INC., TUSTIN, CA. SN 77-418,979. PUB. 7-22-2008, FILED 3-11-2008.

TOP 20 REALTY

SUCCESS. TOGETHER.

THE MARK CONSISTS OF STANDARD CHARACTERS WITHOUT CLAIM TO ANY PARTICULAR FONT, STYLE, SIZE, OR COLOR.

FOR BANKING AND FINANCING SERVICES; MORTGAGE BANKING; FINANCIAL AND INVESTMENT SERVICES, NAMELY, MANAGEMENT AND BROKERAGE IN THE FIELDS OF STOCKS, BONDS, OPTIONS, COMMODITIES, FUTURES AND OTHER SECURITIES, AND THE INVESTMENT OF FUNDS OF OTHERS; FINANCIAL PLANNING AND INVESTMENT ADVISORY SERVICES; INSURANCE AND FINANCIAL INFORMATION AND CONSULTANCY SERVICES (U.S. CLS. 100, 101 AND 102).

FIRST USE 4-8-2009; IN COMMERCE 4-8-2009.

THE MARK CONSISTS OF STANDARD CHARACTERS WITHOUT CLAIM TO ANY PARTICULAR FONT, STYLE, SIZE, OR COLOR.

NO CLAIM IS MADE TO THE EXCLUSIVE RIGHT TO USE "REALTY", APART FROM THE MARK AS SHOWN.

FOR APPRAISAL OF REAL ESTATE; EVALUATION OF REAL PROPERTY; PROVIDING INFORMATION IN THE FIELD OF REAL ESTATE BY MEANS OF LINKING THE WEB SITE TO OTHER WEB SITES FEATURING REAL ESTATE INFORMATION; PROVIDING INFORMATION IN THE FIELD OF REAL ESTATE VIA THE INTERNET; PROVIDING REAL ESTATE LISTINGS AND REAL ESTATE INFORMATION VIA THE INTERNET; REAL ESTATE APPRAISAL AND VALUATION; REAL ESTATE ESCROW SERVICES; REAL ESTATE INVESTMENT; REAL ESTATE LISTING; REAL ESTATE MULTIPLE LISTING SERVICES; REAL ESTATE RENTAL SERVICES, NAMELY, RENTAL OF RESIDENTIAL HOUSING; REAL ESTATE SERVICES, NAMELY, RENTAL OF VACATION HOMES, CONDOMINIUMS, CABINS, AND VILLAS USING PAY PER CLICK ADVERTISING ON A GLOBAL COMPUTER NETWORK; REAL ESTATE VALUATIONS; VACATION REAL ESTATE TIME-SHARING (U.S. CLS. 100, 101 AND 102).

FIRST USE 2-10-2009; IN COMMERCE 3-1-2009.

3,632,635. FIRST SECURITY BANK, BOZEMAN, MT. SN 77-417,453. PUB. 7-22-2008, FILED 3-10-2008.

3,632,681. NATIONAL MULTIPLE SCLEROSIS SOCIETY, NEW YORK, NY. SN 77-427,820. PUB. 7-1-2008, FILED 3-20-2008.

SUCCESS. TOGETHER.



THE MARK CONSISTS OF STANDARD CHARACTERS WITHOUT CLAIM TO ANY PARTICULAR FONT, STYLE, SIZE, OR COLOR.

FOR INSURANCE AGENCY AND BROKERAGE (U.S. CLS. 100, 101 AND 102).

FIRST USE 4-8-2009; IN COMMERCE 4-8-2009.

THE MARK CONSISTS OF THE WORDS "BIKE MS" WITH TIRE TRACKS OVER "MS".

FOR CHARITABLE FUNDRAISING SERVICES (U.S. CLS. 100, 101 AND 102).

FIRST USE 8-0-2007; IN COMMERCE 8-0-2007.

CLASS 36—(Continued).

3,632,682. NATIONAL MULTIPLE SCLEROSIS SOCIETY, NEW YORK, NY. SN 77-427,826. PUB. 7-29-2008, FILED 3-20-2008.



OWNER OF U.S. REG. NOS. 2,334,304 AND 2,828,494.
THE MARK CONSISTS OF THE WORDS "WALK MS" WITH FOOTPRINTS OVER THE "MS".
FOR CHARITABLE FUNDRAISING SERVICES (U.S. CLS. 100, 101 AND 102).
FIRST USE 8-0-2007; IN COMMERCE 8-0-2007.

3,632,685. U.S. BANK N.A., MINNEAPOLIS, MN. SN 77-430,941. PUB. 8-5-2008, FILED 3-25-2008.

U.S. BANK FIVE STAR PLATINUM

THE MARK CONSISTS OF STANDARD CHARACTERS WITHOUT CLAIM TO ANY PARTICULAR FONT, STYLE, SIZE, OR COLOR.
OWNER OF U.S. REG. NOS. 2,662,840, 2,736,040, AND OTHERS.
NO CLAIM IS MADE TO THE EXCLUSIVE RIGHT TO USE "BANK", APART FROM THE MARK AS SHOWN.
SEC. 2(F) AS TO "U.S.". FOR BANKING SERVICES (U.S. CLS. 100, 101 AND 102).
FIRST USE 4-30-2008; IN COMMERCE 4-30-2008.

CLASS 36—(Continued).

3,632,686. U.S. BANK N.A., MINNEAPOLIS, MN. SN 77-430,946. PUB. 8-5-2008, FILED 3-25-2008.

U.S. BANK FIVE STAR GOLD

THE MARK CONSISTS OF STANDARD CHARACTERS WITHOUT CLAIM TO ANY PARTICULAR FONT, STYLE, SIZE, OR COLOR.
OWNER OF U.S. REG. NOS. 2,662,840, 2,736,040, AND OTHERS.
NO CLAIM IS MADE TO THE EXCLUSIVE RIGHT TO USE "BANK", APART FROM THE MARK AS SHOWN.
SEC. 2(F) AS TO "U.S.". FOR BANKING SERVICES (U.S. CLS. 100, 101 AND 102).
FIRST USE 4-30-2008; IN COMMERCE 4-30-2008.

3,632,687. U.S. BANK N.A., MINNEAPOLIS, MN. SN 77-430,950. PUB. 8-5-2008, FILED 3-25-2008.

U.S. BANK FIVE STAR SILVER

THE MARK CONSISTS OF STANDARD CHARACTERS WITHOUT CLAIM TO ANY PARTICULAR FONT, STYLE, SIZE, OR COLOR.
OWNER OF U.S. REG. NOS. 2,662,840, 2,736,040, AND OTHERS.
NO CLAIM IS MADE TO THE EXCLUSIVE RIGHT TO USE "BANK", APART FROM THE MARK AS SHOWN.
SEC. 2(F) AS TO "U.S.". FOR BANKING SERVICES (U.S. CLS. 100, 101 AND 102).
FIRST USE 4-30-2008; IN COMMERCE 4-30-2008.

3,632,705. NATIONWIDE BIWEEKLY ADMINISTRATION, INC., XENIA, OH. SN 77-433,565. PUB. 11-4-2008, FILED 3-27-2008.

HELPING MILLIONS SAVE BILLIONS

THE MARK CONSISTS OF STANDARD CHARACTERS WITHOUT CLAIM TO ANY PARTICULAR FONT, STYLE, SIZE, OR COLOR.
FOR ADMINISTRATION OF WEEKLY, BI-WEEKLY, AND SEMI-MONTHLY MORTGAGE LOAN PAYMENT PROGRAM (U.S. CLS. 100, 101 AND 102).
FIRST USE 9-0-2007; IN COMMERCE 9-0-2007.

CLASS 36—(Continued).

3,632,712. NATIONAL CENTER FOR FAMILY LITERACY, INC., LOUISVILLE, KY. SN 77-435,458. PUB. 8-12-2008, FILED 3-31-2008.

CLASS 36—(Continued).

3,632,777. ASSURANT, INC., NEW YORK, NY. SN 77-452,438. PUB. 9-9-2008, FILED 4-18-2008.

PENNY A BOOK

THE MARK CONSISTS OF STANDARD CHARACTERS WITHOUT CLAIM TO ANY PARTICULAR FONT, STYLE, SIZE, OR COLOR.
 FOR FUNDRAISING SERVICES, NAMELY, RAISING FUNDS FOR LITERACY EDUCATION (U.S. CLS. 100, 101 AND 102).
 FIRST USE 3-13-2009; IN COMMERCE 3-13-2009.

ASSURANT. ON YOUR TERMS.

3,632,770. U.S. RISK INSURANCE GROUP, INC., DALLAS, TX. SN 77-450,563. PUB. 9-16-2008, FILED 4-17-2008.

THE MARK CONSISTS OF STANDARD CHARACTERS WITHOUT CLAIM TO ANY PARTICULAR FONT, STYLE, SIZE, OR COLOR.

QUOTE NOW

THE MARK CONSISTS OF STANDARD CHARACTERS WITHOUT CLAIM TO ANY PARTICULAR FONT, STYLE, SIZE, OR COLOR.
 NO CLAIM IS MADE TO THE EXCLUSIVE RIGHT TO USE "QUOTE", APART FROM THE MARK AS SHOWN.
 FOR INSURANCE SERVICES, NAMELY, PROVIDING INSURANCE POLICY INFORMATION VIA AN INTERACTIVE WEBSITE (U.S. CLS. 100, 101 AND 102).
 FIRST USE 12-0-2008; IN COMMERCE 12-0-2008.

FOR INSURANCE UNDERWRITING SERVICES IN THE FIELDS OF PROPERTY, TRADITIONAL AND MANUFACTURED HOUSING HOMEOWNER'S, RENTER'S, SINGLE INTEREST, FLOOD, DISASTER AND HAZARD, CREDITOR PLACED INSURANCE, CASUALTY, HEALTH, LIFE, FUNERAL NEEDS COVERAGE, DENTAL, DISABILITY, ACCIDENTAL DEATH, DISMEMBERMENT, INVOLUNTARY UNEMPLOYMENT, CONTRACTUAL LIABILITY, SURETY, CREDIT, MORTGAGE LOAN PROTECTION, AND CREDITOR PAID INSURANCE; REINSURANCE UNDERWRITING AND REINSURANCE MANAGEMENT SERVICES FOR DISABILITY AND OTHER INSURANCE POLICIES; CREATION AND ADMINISTRATION OF PREFERRED PROVIDER, PREPAID AND DISCOUNT HEALTHCARE PLANS; ADMINISTRATION OF INSURANCE-BASED SELF-FUNDED GROUP BENEFIT PLANS; DISABILITY CLAIM ADMINISTRATION IN THE NATURE OF PROCESSING AND PAYMENT SERVICES; ADMINISTRATION OF EXTENDED WARRANTY CONTRACTS AND REPAIR AND REPLACEMENT CONTRACTS IN THE FIELDS OF CONSUMER APPLIANCES, ELECTRONICS, COMPUTERS, WIRELESS AND OTHER COMMUNICATION DEVICES, TIRES, FURNITURE, JEWELRY, MOTOR VEHICLES, NON-MOTORIZED VEHICLES, AND OTHER CONSUMER AND COMMERCIAL PRODUCTS; INSURANCE TRACKING SERVICES FOR LOAN COLLATERAL; INSURANCE ADMINISTRATION IN THE FIELD OF DEBT PROTECTION ADMINISTRATION AND SUPPLEMENTAL DEBT (U.S. CLS. 100, 101 AND 102).
 FIRST USE 8-20-2008; IN COMMERCE 8-20-2008.

CLASS 36—(Continued).

3,632,797. HAYS, GARY, GRESHAM, OR. SN 77-458,778. PUB. 11-25-2008, FILED 4-25-2008.



THE COLOR(S) RED AND GREEN IS/ARE CLAIMED AS A FEATURE OF THE MARK.

THE MARK CONSISTS OF A CIRCLE CONTAINING A TRANSPARENT DEPICTION OF THE COUNTRY OF MEXICO, WITH RED SHADING WITHIN THE TOP OF THE CIRCLE AND GREEN SHADING WITHIN THE BOTTOM OF THE CIRCLE.

FOR REAL ESTATE BROKERAGE; REAL ESTATE SERVICES, NAMELY, REAL ESTATE ACQUISITION SERVICES, REAL ESTATE LISTING SERVICES FOR THE HOUSING RENTALS AND APARTMENT RENTALS, REAL ESTATE MULTIPLE LISTING SERVICES, REAL ESTATE VALUATION SERVICES, REAL ESTATE CONSULTATION; REAL ESTATE EQUITY SHARING, NAMELY, MANAGING AND ARRANGING FOR CO-OWNERSHIP OF REAL ESTATE; REAL ESTATE INVESTMENT; REAL ESTATE LISTING; REAL ESTATE MANAGEMENT; REAL ESTATE MANAGEMENT CONSULTATION; REAL ESTATE RENTAL SERVICES, NAMELY, RENTAL OF RESIDENTIAL HOUSING; REAL ESTATE SERVICES, NAMELY, PROVIDING ON-LINE QUESTIONNAIRE TO HELP USERS DETERMINE THE BEST NEIGHBORHOODS AND COMMUNITIES SUITED TO THEIR INDIVIDUAL NEEDS AND PREFERENCES; REAL ESTATE TIME-SHARING; PROVIDING A DATABASE OF INFORMATION ABOUT RESIDENTIAL REAL ESTATE LISTINGS IN DIFFERENT NEIGHBORHOODS AND COMMUNITIES; PROVIDING INFORMATION IN THE FIELD OF REAL ESTATE BY MEANS OF LINKING THE WEB SITE TO OTHER WEB SITES FEATURING REAL ESTATE INFORMATION; PROVIDING REAL ESTATE LISTINGS AND REAL ESTATE INFORMATION VIA THE INTERNET (U.S. CLS. 100, 101 AND 102).

FIRST USE 12-20-2007; IN COMMERCE 3-31-2009.

CLASS 36—(Continued).

3,632,804. PLURAL HOLDINGS, LLC, NEW YORK, NY. SN 77-462,186. PUB. 11-4-2008, FILED 4-30-2008.



PLURAL
INVESTMENTS, LLC

NO CLAIM IS MADE TO THE EXCLUSIVE RIGHT TO USE "INVESTMENTS, LLC", APART FROM THE MARK AS SHOWN.

THE MARK CONSISTS OF HORIZONTAL CIRCULAR DESIGNS WITH THE WORDS "PLURAL INVESTMENTS, LLC" PLACED TO THE RIGHT OF THE DESIGN.

FOR FINANCIAL CONSULTATION, FUND INVESTMENT CONSULTATION, INVESTMENT SERVICES, NAMELY, PRIVATE AND INSTITUTIONAL ASSET MANAGEMENT, AND FINANCIAL MANAGEMENT, NAMELY, FUND MANAGEMENT; PRIVATE PLACEMENTS OF HEDGE FUNDS, PRIVATE EQUITY FUNDS, SECURITIES AND DERIVATIVES FOR OTHERS; CONSULTATION AND INVESTMENT ADVICE FOR PRIVATE CLIENTS AND INSTITUTIONS (U.S. CLS. 100, 101 AND 102).

FIRST USE 4-4-2008; IN COMMERCE 4-4-2008.

3,632,806. HONOR AND REMEMBER, INC., CHESAPEAKE, VA. SN 77-463,336. PUB. 9-30-2008, FILED 5-1-2008.

HONOR AND REMEMBER

THE MARK CONSISTS OF STANDARD CHARACTERS WITHOUT CLAIM TO ANY PARTICULAR FONT, STYLE, SIZE, OR COLOR.

FOR CHARITABLE FUNDRAISING SERVICES (U.S. CLS. 100, 101 AND 102).

FIRST USE 5-26-2008; IN COMMERCE 5-26-2008.

3,632,813. CVS PHARMACY, INC., WOONSOCKET, RI. SN 77-465,749. PUB. 7-22-2008, FILED 5-5-2008.

MAINTENANCE CHOICE

THE MARK CONSISTS OF STANDARD CHARACTERS WITHOUT CLAIM TO ANY PARTICULAR FONT, STYLE, SIZE, OR COLOR.

FOR PHARMACY BENEFIT MANAGEMENT SERVICES, INCLUDING, PERMITTING PLAN PARTICIPANTS TO FILL PRESCRIPTIONS AT RETAIL LOCATIONS OR BY MAIL ORDER (U.S. CLS. 100, 101 AND 102).

FIRST USE 3-31-2008; IN COMMERCE 3-31-2008.

CLASS 36—(Continued).

3,632,854. HS MANAGEMENT PARTNERS, LLC, NEW YORK, NY. SN 77-482,905. PUB. 10-21-2008, FILED 5-23-2008.

HS MANAGEMENT PARTNERS, LLC

THE MARK CONSISTS OF STANDARD CHARACTERS WITHOUT CLAIM TO ANY PARTICULAR FONT, STYLE, SIZE, OR COLOR.

NO CLAIM IS MADE TO THE EXCLUSIVE RIGHT TO USE "MANAGEMENT PARTNERS, LLC", APART FROM THE MARK AS SHOWN.

FOR INVESTMENT OF FUNDS FOR HIGH NET WORTH INDIVIDUALS AND INSTITUTIONS (U.S. CLS. 100, 101 AND 102).

FIRST USE 2-2-2009; IN COMMERCE 2-2-2009.

3,632,862. MERCHANT ADVOCATE LLC, SOUTH AMBOY, NJ. SN 77-486,259. PUB. 10-28-2008, FILED 5-29-2008.



NO CLAIM IS MADE TO THE EXCLUSIVE RIGHT TO USE "MERCHANT ADVOCATE", APART FROM THE MARK AS SHOWN.

THE MARK CONSISTS OF THE LETTERS "M" AND "A" IN STYLIZED FORM, A GYROSCOPE AND THE WORDS "MERCHANT ADVOCATE" AND "BALANCING YOUR BUSINESS".

FOR FINANCIAL CONSULTING (U.S. CLS. 100, 101 AND 102).

FIRST USE 5-29-2008; IN COMMERCE 9-1-2008.

CLASS 36—(Continued).

3,632,871. MPOWER LABS, INC., AUSTIN, TX. SN 77-489,928. PUB. 10-21-2008, FILED 6-3-2008.



THE MARK CONSISTS OF THE LITERAL ELEMENT "REV", WITH A STYLIZED PAYMENT CARD FORMING A PORTION OF THE LETTER "R".

FOR FINANCIAL SERVICES, NAMELY, CREDIT, DEBIT, AND PRE-PAID CARD SERVICES (U.S. CLS. 100, 101 AND 102).

FIRST USE 5-1-2008; IN COMMERCE 9-15-2008.

3,632,879. COLORADO SCHOOL DISTRICTS SELF INSURANCE POOL, DENVER, CO. SN 77-494,303. PUB. 11-25-2008, FILED 6-9-2008.



NO CLAIM IS MADE TO THE EXCLUSIVE RIGHT TO USE "COLORADO SCHOOL DISTRICTS SELF INSURANCE POOL", APART FROM THE MARK AS SHOWN.

THE MARK CONSISTS OF THE LETTERS "CSDSIP" ABOVE THE WORDS "COLORADO SCHOOL DISTRICTS" ABOVE THE WORDS "SELF INSURANCE POOL", WITH A DEPICTION OF AN OPEN BOOK AT THE UPPER RIGHT-HAND SIDE OF THE MARK.

FOR INSURANCE SERVICES, NAMELY, UNDERWRITING AND ADMINISTERING SELF-INSURANCE IN THE FIELDS OF PROPERTY, CASUALTY, EQUIPMENT BREAKDOWN, THEFT OF MONEY OR SECURITIES, AND COMMERCIAL VEHICLE; CLAIMS ADMINISTRATION; AND LOSS CONTROL MANAGEMENT FOR OTHERS (U.S. CLS. 100, 101 AND 102).

FIRST USE 5-28-2008; IN COMMERCE 5-28-2008.

3,632,885. FIRST COMMERCIAL GROUP COMPANIES, LLC., HIALEAH, FL. SN 77-497,098. PUB. 12-2-2008, FILED 6-12-2008.



NO CLAIM IS MADE TO THE EXCLUSIVE RIGHT TO USE "FIRST COMMERCIAL INSURANCE GROUP", APART FROM THE MARK AS SHOWN.

FOR INSURANCE UNDERWRITING IN THE FIELD OF COMMERCIAL INSURANCE (U.S. CLS. 100, 101 AND 102).

FIRST USE 5-1-2008; IN COMMERCE 5-1-2008.

CLASS 36—(Continued).

3,632,895. APPLE BANK FOR SAVINGS, NEW YORK, NY. SN 77-501,802. PUB. 11-11-2008, FILED 6-18-2008.

APPLEGRAM

THE MARK CONSISTS OF STANDARD CHARACTERS WITHOUT CLAIM TO ANY PARTICULAR FONT, STYLE, SIZE, OR COLOR.

OWNER OF U.S. REG. NOS. 1,286,422, 1,958,484, AND OTHERS.

FOR BANKING SERVICES, NAMELY, INTERNATIONAL FUNDS TRANSFER SERVICES (U.S. CLS. 100, 101 AND 102).

FIRST USE 10-15-2008; IN COMMERCE 10-15-2008.

3,632,897. SPEARS ABACUS ADVISORS LLC, NEW YORK, NY. SN 77-502,606. PUB. 11-18-2008, FILED 6-19-2008.

The BeeHive Fund

THE MARK CONSISTS OF STANDARD CHARACTERS WITHOUT CLAIM TO ANY PARTICULAR FONT, STYLE, SIZE, OR COLOR.

NO CLAIM IS MADE TO THE EXCLUSIVE RIGHT TO USE "FUND", APART FROM THE MARK AS SHOWN.

FOR MUTUAL FUNDS AND CAPITAL INVESTMENT (U.S. CLS. 100, 101 AND 102).

FIRST USE 9-2-2008; IN COMMERCE 9-2-2008.

3,632,914. LMG INSURANCE, LLC, WEST CONSHOHOCKEN, PA. SN 77-510,230. PUB. 12-16-2008, FILED 6-27-2008.

**LifeSetCapital**

THE MARK CONSISTS OF THE WORDS "LIFESETCAPITAL" AND THE DESIGN OF A STYLIZED FLOWER WITH A STYLIZED PERSON INSIDE.

FOR LIFE INSURANCE SETTLEMENT SERVICES (U.S. CLS. 100, 101 AND 102).

FIRST USE 9-2-2008; IN COMMERCE 9-2-2008.

CLASS 36—(Continued).

3,632,919. PROCURESTAFF, LTD., NEW YORK, NY. SN 77-511,564. PUB. 12-16-2008, FILED 6-30-2008.

CEBREA

THE MARK CONSISTS OF STANDARD CHARACTERS WITHOUT CLAIM TO ANY PARTICULAR FONT, STYLE, SIZE, OR COLOR.

THE WORD "CEBREA" HAS NO MEANING IN A FOREIGN LANGUAGE.

FOR MAINTAINING BANKRUPTCY REMOTE ESCROW ACCOUNTS FOR OTHERS IN CONNECTION WITH VENDOR MANAGEMENT SERVICES AND MANAGED SERVICES PROGRAMS (U.S. CLS. 100, 101 AND 102).

FIRST USE 10-0-2008; IN COMMERCE 10-0-2008.

3,632,921. TAYLOR, SCOTT, INDIANAPOLIS, IN. SN 77-511,995. PUB. 11-25-2008, FILED 7-1-2008.

PULLANTHROPY

THE MARK CONSISTS OF STANDARD CHARACTERS WITHOUT CLAIM TO ANY PARTICULAR FONT, STYLE, SIZE, OR COLOR.

FOR CHARITABLE FUNDRAISING SERVICES, NAMELY, SECURING INDIVIDUAL DONATIONS THROUGH THE USE OF A PULL-TAB DOCUMENT (U.S. CLS. 100, 101 AND 102).

FIRST USE 7-8-2008; IN COMMERCE 7-8-2008.

3,632,942. AAXA DISCOUNT MORTGAGE, INC., WILMINGTON, NC. SN 77-518,736. PUB. 12-9-2008, FILED 7-10-2008.

Save Money. Feel Better.

THE MARK CONSISTS OF STANDARD CHARACTERS WITHOUT CLAIM TO ANY PARTICULAR FONT, STYLE, SIZE, OR COLOR.

FOR INSURANCE BROKERAGE (U.S. CLS. 100, 101 AND 102).

FIRST USE 10-1-2008; IN COMMERCE 10-1-2008.

CLASS 36—(Continued).

3,632,960. SIEPKA, SCOTT L, ALGONQUIN, IL. SN 77-522,993. PUB. 12-9-2008, FILED 7-15-2008.

Deductible-Bridge

THE MARK CONSISTS OF STANDARD CHARACTERS WITHOUT CLAIM TO ANY PARTICULAR FONT, STYLE, SIZE, OR COLOR.
 FOR HEALTH INSURANCE UNDERWRITING; MEDICAL INSURANCE UNDERWRITING (U.S. CLS. 100, 101 AND 102).
 FIRST USE 7-1-2008; IN COMMERCE 4-1-2009.

3,632,996. TRIAD PARTNERS, LLC, CROSSVILLE, TN. SN 77-536,802. PUB. 12-23-2008, FILED 8-1-2008.

BNControl

THE MARK CONSISTS OF STANDARD CHARACTERS WITHOUT CLAIM TO ANY PARTICULAR FONT, STYLE, SIZE, OR COLOR.
 FOR BANKING SERVICES (U.S. CLS. 100, 101 AND 102).
 FIRST USE 7-23-2008; IN COMMERCE 8-7-2008.

3,633,002. AMERICAN EXPRESS MARKETING & DEVELOPMENT CORP., NEW YORK, NY. SN 77-539,611. PUB. 11-25-2008, FILED 8-5-2008.

SURPASS

THE MARK CONSISTS OF STANDARD CHARACTERS WITHOUT CLAIM TO ANY PARTICULAR FONT, STYLE, SIZE, OR COLOR.
 FOR CHARGE CARD AND CREDIT CARD SERVICES (U.S. CLS. 100, 101 AND 102).
 FIRST USE 2-10-2009; IN COMMERCE 2-10-2009.

CLASS 36—(Continued).

3,633,015. ATLANTA FINE HOMES, LLC, ATLANTA, GA. SN 77-544,926. PUB. 12-30-2008, FILED 8-12-2008.

SKYRISE GROUP

THE MARK CONSISTS OF STANDARD CHARACTERS WITHOUT CLAIM TO ANY PARTICULAR FONT, STYLE, SIZE, OR COLOR.
 NO CLAIM IS MADE TO THE EXCLUSIVE RIGHT TO USE "GROUP", APART FROM THE MARK AS SHOWN.
 FOR REAL ESTATE BROKERAGE (U.S. CLS. 100, 101 AND 102).
 FIRST USE 7-0-2008; IN COMMERCE 7-0-2008.

3,633,086. IDT NETHERLANDS, B.V. (PUERTO RICO BRANCH), SAN JUAN, PUERTO RICO. SN 78-236,280. PUB. 12-23-2003, FILED 4-10-2003.

RED

FOR PREPAID TELEPHONE CALLING CARD SERVICES, NOT RELATING TO SPORTS OR SPORTS TEAMS (U.S. CLS. 100, 101 AND 102).
 FIRST USE 10-16-2002; IN COMMERCE 10-16-2002.

3,633,139. DAIMLER TRUCKS NORTH AMERICA LLC, PORTLAND, OR. SN 78-600,379. PUB. 3-14-2006, FILED 4-1-2005.



NO CLAIM IS MADE TO THE EXCLUSIVE RIGHT TO USE "ONLINE WARRANTY LINK", APART FROM THE MARK AS SHOWN.
 FOR LAND VEHICLE WARRANTY SERVICES, NAMELY, PROVIDING EXTENDED LAND VEHICLE WARRANTIES THAT ARE ADMINISTERED ONLINE VIA A GLOBAL COMMUNICATIONS NETWORK (U.S. CLS. 100, 101 AND 102).
 FIRST USE 1-7-2009; IN COMMERCE 1-7-2009.

CLASS 36—(Continued).

3,633,303. DEFRATE & PAAVOLA LLC, NEW YORK, NY. SN 78-938,439. PUB. 4-3-2007, FILED 7-26-2006.

GOAL SEGMENTATION MODEL

THE MARK CONSISTS OF STANDARD CHARACTERS WITHOUT CLAIM TO ANY PARTICULAR FONT, STYLE, SIZE, OR COLOR.

NO CLAIM IS MADE TO THE EXCLUSIVE RIGHT TO USE "SEGMENTATION MODEL", APART FROM THE MARK AS SHOWN.

FOR FINANCIAL PLANNING (U.S. CLS. 100, 101 AND 102).

FIRST USE 2-1-2007; IN COMMERCE 2-1-2007.

3,633,314. GAP (APPAREL) LLC, SAN FRANCISCO, CA. SN 78-967,377. PUB. 1-16-2007, FILED 9-5-2006.

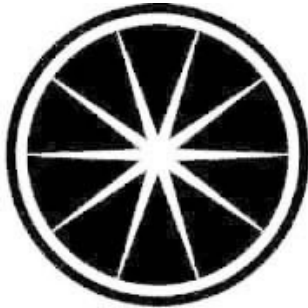

THE MARK CONSISTS OF A STYLIZED DRAWING OF A LIME CROSS SECTION.

FOR PRE-PAID CASH CARD SERVICES, NAMELY, PROCESSING ELECTRONIC PAYMENTS MADE IN CONNECTION WITH PREPAID CARDS; CHARITABLE FUNDRAISING SERVICES (U.S. CLS. 100, 101 AND 102).

FIRST USE 11-1-2007; IN COMMERCE 11-1-2007.

CLASS 37—CONSTRUCTION AND REPAIR**CLASS 37—(Continued).**

3,631,806. MID-ATLANTIC COMPANIES, INC., ROCKVILLE, MD. SN 76-647,928. PUB. 7-25-2006, FILED 10-4-2005.

THE VILLAGES OF
Savannah

NO CLAIM IS MADE TO THE EXCLUSIVE RIGHT TO USE "VILLAGES", APART FROM THE MARK AS SHOWN.

FOR CONSTRUCTION SERVICES; RESIDENTIAL HOME CONSTRUCTION SERVICES; LAND DEVELOPMENT SERVICES, NAMELY, PLANNING AND LAYING OUT OF RESIDENTIAL COMMUNITIES; REAL ESTATE DEVELOPMENT (U.S. CLS. 100, 103 AND 106).

FIRST USE 4-10-2009; IN COMMERCE 4-10-2009.

3,631,812. LUCAS OIL PRODUCTS, INC., CORONA, CA. SN 76-666,505. PUB. 2-6-2007, FILED 9-25-2006.

LUCAS

THE MARK CONSISTS OF STANDARD CHARACTERS WITHOUT CLAIM TO ANY PARTICULAR FONT, STYLE, SIZE, OR COLOR.

OWNER OF U.S. REG. NO. 2,904,296.
FOR VEHICLE LUBRICATION AND OIL CHANGE SERVICES (U.S. CLS. 100, 103 AND 106).

FIRST USE 5-1-2007; IN COMMERCE 5-1-2007.

CLASS 37—(Continued).

3,631,861. KLEMM BOHRTECHNIK ZWEIGNIEDERLASSUNG DER BAUER MASCHINEN GMBH, DROLSHAGEN, FED REP GERMANY. SN 76-978,406. PUB. 11-4-2008, FILED 4-8-2005.

KLEMM

THE MARK CONSISTS OF STANDARD CHARACTERS WITHOUT CLAIM TO ANY PARTICULAR FONT, STYLE, SIZE, OR COLOR.

OWNER OF U.S. REG. NO. 2,720,252.

THE ENGLISH TRANSLATION OF "KLEMM" IS "CLAMP" OR "WEDGE".

FOR FOUNDATION CONSTRUCTION, PARTICULARLY SPECIALIST FOUNDATION CONSTRUCTION, BUILDING CONSTRUCTION AND STRUCTURAL CONSTRUCTION RELATING TO BUILDING STRUCTURAL CONSTRUCTION (U.S. CLS. 100, 103 AND 106).

FIRST USE 12-31-1969; IN COMMERCE 12-31-1969.

CLASS 37—(Continued).

NO CLAIM IS MADE TO THE EXCLUSIVE RIGHT TO USE "BATHS", APART FROM THE MARK AS SHOWN.

FOR BATHROOM RENOVATION AND REMODELING SERVICES (U.S. CLS. 100, 103 AND 106).
FIRST USE 12-0-2007; IN COMMERCE 12-0-2007.

3,632,015. ABSOLUTELY SPOTLESS PROFESSIONAL CLEANING SERVICE, LLC, LAS VEGAS, NV. SN 77-163,100. PUB. 7-22-2008, FILED 4-23-2007.

FROM HOUSES TO HIGH RISES
WE CLEAN IT ALL ...

3,631,963. INTEGRATED MEDICAL SYSTEMS INTERNATIONAL, INC., BIRMINGHAM, AL. SN 77-108,630. PUB. 7-17-2007, FILED 2-15-2007.

IMS READY

THE MARK CONSISTS OF STANDARD CHARACTERS WITHOUT CLAIM TO ANY PARTICULAR FONT, STYLE, SIZE, OR COLOR.

OWNER OF U.S. REG. NOS. 1,948,969, 2,824,739, AND 2,839,779.

FOR MEDICAL EQUIPMENT REPAIR SERVICES, NAMELY, REPAIRING SURGICAL INSTRUMENTS FOR PHYSICIANS, HOSPITALS AND OUT-PATIENT CARE FACILITIES (U.S. CLS. 100, 103 AND 106).

FIRST USE 4-6-2009; IN COMMERCE 4-6-2009.

THE MARK CONSISTS OF STANDARD CHARACTERS WITHOUT CLAIM TO ANY PARTICULAR FONT, STYLE, SIZE, OR COLOR.

FOR CLEANING OF OFFICES, RESIDENTIAL HOUSES, COMMERCIAL FACILITIES, CARPET, TILE, GROUT, FLOORS AND EXTERIOR BUILDING SURFACES (U.S. CLS. 100, 103 AND 106).

FIRST USE 12-20-2006; IN COMMERCE 1-30-2008.

3,632,068. ENDER, GEORGE, LOS ANGELES, CA. SN 77-207,738. PUB. 12-11-2007, FILED 6-15-2007.

ENDER ENTERPRISES

3,631,974. HEIT, WARREN, MOUNT VERNON, NY. AND MILLER, BARRY, BROOKFIELD, CT. SN 77-121,186. PUB. 11-6-2007, FILED 3-2-2007.

SIMPLY BATHS

THE MARK CONSISTS OF STANDARD CHARACTERS WITHOUT CLAIM TO ANY PARTICULAR FONT, STYLE, SIZE, OR COLOR.

THE MARK CONSISTS OF STANDARD CHARACTERS WITHOUT CLAIM TO ANY PARTICULAR FONT, STYLE, SIZE, OR COLOR.

NO CLAIM IS MADE TO THE EXCLUSIVE RIGHT TO USE "ENTERPRISES", APART FROM THE MARK AS SHOWN.

FOR BUILDING, RENOVATION, AND CONSTRUCTION OF HOMES AND COMMERCIAL PROPERTY (U.S. CLS. 100, 103 AND 106).

FIRST USE 5-31-2007; IN COMMERCE 5-31-2007.

CLASS 37—(Continued).

3,632,108. GORGEOUS GARAGE LLC, REXBURG, ID. SN 77-228,639. PUB. 12-25-2007, FILED 7-12-2007.

Rise Above The Mess

THE MARK CONSISTS OF STANDARD CHARACTERS WITHOUT CLAIM TO ANY PARTICULAR FONT, STYLE, SIZE, OR COLOR.

FOR INSTALLATION OF GARAGE SHELVES, ACCESSORIES, AND FLOORING (U.S. CLS. 100, 103 AND 106). FIRST USE 9-1-2007; IN COMMERCE 1-10-2008.

3,632,121. ICRETE LLC, BEVERLY HILLS, CA. SN 77-232,894. PUB. 1-1-2008, FILED 7-18-2007.

INTELLIGENT CONCRETE

THE MARK CONSISTS OF STANDARD CHARACTERS WITHOUT CLAIM TO ANY PARTICULAR FONT, STYLE, SIZE, OR COLOR.

NO CLAIM IS MADE TO THE EXCLUSIVE RIGHT TO USE "CONCRETE", APART FROM THE MARK AS SHOWN. FOR CONSTRUCTION CONSULTATION, NAMELY, PROVIDING CUSTOMIZED FORMULATIONS FOR PREFERRED, LOWER COST, AND HIGHER STRENGTH CONCRETE APPLICATIONS AND BATCHING PROCESSES (U.S. CLS. 100, 103 AND 106).

FIRST USE 10-0-2008; IN COMMERCE 10-0-2008.

3,632,242. INTEGRATED MEDICAL SYSTEMS INTERNATIONAL, INC., BIRMINGHAM, AL. SN 77-286,738. PUB. 7-8-2008, FILED 9-24-2007.

IMS CAMERA READY

THE MARK CONSISTS OF STANDARD CHARACTERS WITHOUT CLAIM TO ANY PARTICULAR FONT, STYLE, SIZE, OR COLOR.

OWNER OF U.S. REG. NOS. 1,948,969, 2,839,779, AND OTHERS.

NO CLAIM IS MADE TO THE EXCLUSIVE RIGHT TO USE "CAMERA", APART FROM THE MARK AS SHOWN.

FOR MEDICAL EQUIPMENT REPAIR SERVICES, NAMELY, REPAIRING SURGICAL INSTRUMENTS FOR PHYSICIANS, HOSPITALS AND OUT-PATIENT CARE FACILITIES (U.S. CLS. 100, 103 AND 106).

FIRST USE 11-1-2008; IN COMMERCE 11-1-2008.

CLASS 37—(Continued).

3,632,426. NEW ENGLAND TEA & COFFEE CO., INC., MALDEN, MA. SN 77-369,937. PUB. 5-13-2008, FILED 1-11-2008.

NER

THE MARK CONSISTS OF STANDARD CHARACTERS WITHOUT CLAIM TO ANY PARTICULAR FONT, STYLE, SIZE, OR COLOR.

FOR MAINTENANCE AND REPAIR SERVICES FOR HOT BEVERAGE BREWING MACHINES (U.S. CLS. 100, 103 AND 106).

FIRST USE 10-9-2008; IN COMMERCE 10-30-2008.

3,632,584. NUKOTE INTERNATIONAL, INC., ROCHESTER, NY. SN 77-410,131. PUB. 7-15-2008, FILED 2-29-2008.

SecondNature

THE MARK CONSISTS OF STANDARD CHARACTERS WITHOUT CLAIM TO ANY PARTICULAR FONT, STYLE, SIZE, OR COLOR.

FOR ENVIRONMENTAL AND CORPORATE SUSTAINABILITY SERVICES, NAMELY, COLLECTION OF PRINTER CARTRIDGES FOR REMANUFACTURING (U.S. CLS. 100, 103 AND 106).

FIRST USE 4-22-2008; IN COMMERCE 4-22-2008.

3,632,588. R & B LEASING, FRUITA, CO. SN 77-411,277. PUB. 12-16-2008, FILED 3-3-2008.

GCS

THE MARK CONSISTS OF STANDARD CHARACTERS WITHOUT CLAIM TO ANY PARTICULAR FONT, STYLE, SIZE, OR COLOR.

FOR CONSTRUCTION AND INSTALLATION OF STRUCTURES USED TO STABILIZE SOIL AND ROCK FORMATIONS RESIDING ON AND ADJACENT TO MAN MADE STRUCTURES IN THE FIELD OF CIVIL ENGINEERING INCLUDING ROADS, BRIDGES, BUILDINGS, ABUTMENTS, RETAINING WALLS, PILLINGS, ROCK WALLS, EXCAVATION SUPPORTS, RAILROAD LINES, CULVERTS, AND SHORING (U.S. CLS. 100, 103 AND 106).

FIRST USE 3-24-2009; IN COMMERCE 3-24-2009.

CLASS 37—(Continued).

3,632,606. AMERICAN RESIDENTIAL SERVICES, L.L.C., MEMPHIS, TN. SN 77-413,585. PUB. 7-22-2008, FILED 3-5-2008.



OWNER OF U.S. REG. NOS. 1,053,076, 1,787,059, AND OTHERS.

THE COLOR(S) RED, WHITE, BLUE, BEIGE, GREY AND BLACK IS/ARE CLAIMED AS A FEATURE OF THE MARK.

THE MARK CONSISTS OF TWO CHARACTERS COMPRISING A MAN AND A ROOTER WEARING RED HATS WITH WHITE FEATHERS, THE MAN HAVING RED GLOVES, RED SHIRT, BLUE PANTS, RED AND BLACK BOOTS AND BEIGE ARMS AND FACE, THE ROOTER IN BLUE AND GREY WITH BLACK WHEELS.

FOR PLUMBING SERVICES, NAMELY, PLUMBING REPAIR, DRAIN CLEANING AND SEWER CLEANING (U.S. CLS. 100, 103 AND 106).

FIRST USE 2-0-2008; IN COMMERCE 2-0-2008.

3,632,651. SUBARU OF AMERICA, INC., WEST CHERRY HILL, NJ. SN 77-421,284. PUB. 9-2-2008, FILED 3-13-2008.

QUALITY DRIVEN. TECHNICIAN
POWERED.

THE MARK CONSISTS OF STANDARD CHARACTERS WITHOUT CLAIM TO ANY PARTICULAR FONT, STYLE, SIZE, OR COLOR.

OWNER OF U.S. REG. NO. 2,333,858.
FOR AUTOMOBILE REPAIR AND MAINTENANCE SERVICES (U.S. CLS. 100, 103 AND 106).
FIRST USE 4-12-2008; IN COMMERCE 4-12-2008.

CLASS 37—(Continued).

3,632,700. ORKIN EXPANSION, INC., WILMINGTON, DE. SN 77-433,219. PUB. 7-15-2008, FILED 3-27-2008.



THE COLOR(S) RED, WHITE, AND BLACK IS/ARE CLAIMED AS A FEATURE OF THE MARK.

THE MARK CONSISTS OF A WHITE MOSQUITO INSIDE OF A REG TARGET SIGHT DESIGN AND SET AGAINST A BLACK BACKGROUND.

FOR PEST CONTROL (U.S. CLS. 100, 103 AND 106).
FIRST USE 3-6-2008; IN COMMERCE 3-6-2008.

3,632,752. ALLGREENIT LLC, BRISTOL, CT. SN 77-445,863. PUB. 11-4-2008, FILED 4-11-2008.



NO CLAIM IS MADE TO THE EXCLUSIVE RIGHT TO USE "ALL GREEN IT" AND "SOLAR & COMPUTING SOLUTIONS", APART FROM THE MARK AS SHOWN.

THE STIPPLING IS FOR SHADING PURPOSES ONLY.
THE MARK CONSISTS OF OF AN IMAGE OF THE SUN WITH A LEAF IN THE CENTER. TO THE RIGHT OF THE SUN AND LEAF IS THE STYLIZED TEXT "ALL GREEN IT INNOVATIVE SOLAR & COMPUTING SOLUTIONS".

FOR INSTALLATION, MAINTENANCE AND REPAIR OF SOLAR EQUIPMENT, NAMELY, SOLAR PANELS AND THE ACCOMPANYING ELECTRONIC CONTROLS AND ENERGY EFFICIENT COMPUTER SYSTEMS (U.S. CLS. 100, 103 AND 106).

FIRST USE 10-20-2008; IN COMMERCE 11-11-2008.

3,632,808. BICYCLE CITY LLC, CINCINNATI, OH. SN 77-464,093. PUB. 12-2-2008, FILED 5-2-2008.

Drive Less. Live More.

CLASS 37—(Continued).

THE MARK CONSISTS OF STANDARD CHARACTERS WITHOUT CLAIM TO ANY PARTICULAR FONT, STYLE, SIZE, OR COLOR.

FOR LAND DEVELOPMENT SERVICES, NAMELY, PLANNING AND LAYING OUT OF RESIDENTIAL AND/OR COMMERCIAL COMMUNITIES; REAL ESTATE DEVELOPMENT (U.S. CLS. 100, 103 AND 106).

FIRST USE 4-22-2008; IN COMMERCE 4-22-2008.

CLASS 37—(Continued).

3,633,252. NORFORD, DAVID A., KING GEORGE, VA. SN 78-841,279. PUB. 9-30-2008, FILED 3-20-2006.

CLEAN AS A WHISTLE

THE MARK CONSISTS OF STANDARD CHARACTERS WITHOUT CLAIM TO ANY PARTICULAR FONT, STYLE, SIZE, OR COLOR.

OWNER OF U.S. REG. NO. 1,430,552.

FOR DRY CLEANING (U.S. CLS. 100, 103 AND 106).

FIRST USE 8-1-1988; IN COMMERCE 8-1-1988.

3,632,847. CAMPBELL, LISA, WESTMINSTER, CO. SN 77-481,587. PUB. 10-21-2008, FILED 5-22-2008.

ENCOMPASS CLEAN

THE MARK CONSISTS OF STANDARD CHARACTERS WITHOUT CLAIM TO ANY PARTICULAR FONT, STYLE, SIZE, OR COLOR.

NO CLAIM IS MADE TO THE EXCLUSIVE RIGHT TO USE "CLEAN", APART FROM THE MARK AS SHOWN.

FOR CLEANING OF HOMES AND OFFICES (U.S. CLS. 100, 103 AND 106).

FIRST USE 5-31-2008; IN COMMERCE 5-31-2008.

CLASS 38—COMMUNICATION

3,632,113. JAMES DECRESCENZO REPORTING, LLC, PHILADELPHIA, PA. SN 77-230,222. PUB. 1-22-2008, FILED 7-16-2007.

NETDEP

THE MARK CONSISTS OF STANDARD CHARACTERS WITHOUT CLAIM TO ANY PARTICULAR FONT, STYLE, SIZE, OR COLOR.

FOR BROADCASTING SERVICES AND PROVISION OF LIVE TELECOMMUNICATIONS ACCESS FOR VIDEO, AUDIO AND TEXT OF DEPOSITIONS AND DEPOSITION CONTENT TO CONNECTED COMPUTERS VIA THE INTERNET (U.S. CLS. 100, 101 AND 104).

FIRST USE 1-8-2008; IN COMMERCE 4-15-2008.

3,633,013. THE PROCTER & GAMBLE COMPANY, CINCINNATI, OH. SN 77-543,980. PUB. 12-30-2008, FILED 8-11-2008.

TIDE COLORGUARD

THE MARK CONSISTS OF STANDARD CHARACTERS WITHOUT CLAIM TO ANY PARTICULAR FONT, STYLE, SIZE, OR COLOR.

OWNER OF U.S. REG. NOS. 1,063,680, 3,373,965, AND OTHERS.

FOR DRY CLEANING (U.S. CLS. 100, 103 AND 106).

FIRST USE 9-4-2008; IN COMMERCE 9-4-2008.

3,632,263. AT&T INTELLECTUAL PROPERTY II, L.P., RENO, NV. SN 77-297,409. PUB. 7-15-2008, FILED 10-5-2007.

AT&T MEXICO VALUE CALLING

THE MARK CONSISTS OF STANDARD CHARACTERS WITHOUT CLAIM TO ANY PARTICULAR FONT, STYLE, SIZE, OR COLOR.

OWNER OF U.S. REG. NOS. 1,298,084, 1,970,579, AND OTHERS.

NO CLAIM IS MADE TO THE EXCLUSIVE RIGHT TO USE "MEXICO AND CALLING", APART FROM THE MARK AS SHOWN.

FOR LOCAL AND LONG DISTANCE TELEPHONE SERVICES (U.S. CLS. 100, 101 AND 104).

FIRST USE 4-2-2007; IN COMMERCE 4-2-2007.

CLASS 38—(Continued).

3,632,264. AT&T INTELLECTUAL PROPERTY II, L.P., RENO, NV. SN 77-297,424. PUB. 7-15-2008, FILED 10-5-2007.

AT&T ONE RATE USA

THE MARK CONSISTS OF STANDARD CHARACTERS WITHOUT CLAIM TO ANY PARTICULAR FONT, STYLE, SIZE, OR COLOR.

OWNER OF U.S. REG. NOS. 1,298,084, 1,970,579, AND OTHERS.

NO CLAIM IS MADE TO THE EXCLUSIVE RIGHT TO USE "ONE RATE USA", APART FROM THE MARK AS SHOWN.

FOR LOCAL AND LONG DISTANCE TELEPHONE SERVICES (U.S. CLS. 100, 101 AND 104).

FIRST USE 4-28-2003; IN COMMERCE 4-28-2003.

3,632,400. PADRES L.P., SAN DIEGO, CA. SN 77-358,065. PUB. 6-3-2008, FILED 12-21-2007.

PADRES

THE MARK CONSISTS OF STANDARD CHARACTERS WITHOUT CLAIM TO ANY PARTICULAR FONT, STYLE, SIZE, OR COLOR.

OWNER OF U.S. REG. NOS. 1,158,446, 3,136,500, AND OTHERS.

FOR TELECOMMUNICATION SERVICES, NAMELY, BROADCASTING SERVICES NAMELY, AUDIO BROADCASTING, TELEVISION BROADCASTING, SUBSCRIPTION TELEVISION BROADCASTING, CABLE TELEVISION BROADCASTING, VIDEO BROADCASTING, VIDEO-ON-DEMAND BROADCASTING, RADIO BROADCASTING, CABLE RADIO BROADCASTING, SATELLITE BROADCASTING, DIGITAL TELEVISION BROADCASTING, MOBILE PHONE BROADCASTING, AND BROADCASTING VIA A GLOBAL COMPUTER NETWORK; TRANSMISSION SERVICES, NAMELY, AUDIO TRANSMISSION, TELEVISION TRANSMISSION, SUBSCRIPTION TELEVISION TRANSMISSION, CABLE TELEVISION TRANSMISSION, VIDEO TRANSMISSION, VIDEO-ON-DEMAND TRANSMISSION, RADIO TRANSMISSION, CABLE RADIO TRANSMISSION, SATELLITE TRANSMISSION, DIGITAL TELEVISION TRANSMISSION, MOBILE PHONE TRANSMISSION, AND TRANSMISSION VIA A GLOBAL COMPUTER NETWORK; COMMUNICATION SERVICES, NAMELY, STREAMING OF AUDIO AND VIDEO MATERIAL VIA A GLOBAL COMPUTER NETWORK; ELECTRONIC MAIL SERVICES; ELECTRONIC TRANSMISSION OF MESSAGES AND DATA; WEBCASTING SERVICES; PROVIDING MULTIPLE-USER ACCESS TO THE INTERNET; PROVIDING ON-LINE CHAT ROOMS, ON-LINE ELECTRONIC BULLETIN BOARDS, AND ON-LINE FORUMS ALL IN THE FIELD OF BASEBALL (U.S. CLS. 100, 101 AND 104).

FIRST USE 4-8-1969; IN COMMERCE 4-8-1969.

CLASS 38—(Continued).

3,632,594. NEDELCO, INC., AURORA, NE. SN 77-412,555. PUB. 8-5-2008, FILED 3-4-2008.

SEE WHAT THEY SAY

THE MARK CONSISTS OF STANDARD CHARACTERS WITHOUT CLAIM TO ANY PARTICULAR FONT, STYLE, SIZE, OR COLOR.

FOR TELEPHONE RELAY SERVICES USING CAPTION TELEPHONE (U.S. CLS. 100, 101 AND 104).

FIRST USE 3-15-2008; IN COMMERCE 3-15-2008.

3,632,671. COX COMMUNICATIONS, INC., ATLANTA, GA. SN 77-426,402. PUB. 7-29-2008, FILED 3-19-2008.

COX DIGITAL COMMUNITY

THE MARK CONSISTS OF STANDARD CHARACTERS WITHOUT CLAIM TO ANY PARTICULAR FONT, STYLE, SIZE, OR COLOR.

OWNER OF U.S. REG. NOS. 2,189,184, 2,911,456, AND OTHERS.

NO CLAIM IS MADE TO THE EXCLUSIVE RIGHT TO USE "DIGITAL COMMUNITY", APART FROM THE MARK AS SHOWN.

FOR TELECOMMUNICATIONS SERVICES, NAMELY, LOCAL AND LONG DISTANCE TRANSMISSION OF VOICE, VIDEO AND DATA BY MEANS OF CABLE TRANSMISSIONS AND WIRELESS TELEPHONE SERVICES (U.S. CLS. 100, 101 AND 104).

FIRST USE 9-0-2008; IN COMMERCE 9-0-2008.

CLASS 38—(Continued).

3,632,778. GREENFLY NETWORKS, INC., BOZEMAN, MT. SN 77-452,898. PUB. 11-11-2008, FILED 4-20-2008.

CLASS 38—(Continued).

3,633,102. STELOR PRODUCTIONS LLC, DARNESTOWN, MD. SN 78-487,403. PUB. 12-20-2005, FILED 9-22-2004.

**CLEARPHONE**

THE MARK CONSISTS OF A STYLIZED "I" WITH A CHECK MARK ABOVE IT AND THE WORD "AGREE"; "AGREE" APPEARS ON A KIDNEY-SHAPED BACKGROUND.

FOR COMPUTER SERVICES, NAMELY, PROVIDING MULTIPLE USER ACCESS TO COMPUTER NETWORKS FOR THE TRANSFER AND DISSEMINATION OF A WIDE RANGE OF INFORMATION INTENDED FOR USE BY CHILDREN; PROVIDING ONLINE ELECTRONIC BULLETIN BOARDS FOR TRANSMISSION OF MESSAGES AMONG COMPUTER USERS CONCERNING EDUCATION AND ENTERTAINMENT OF CHILDREN (U.S. CLS. 100, 101 AND 104).

FIRST USE 11-1-2008; IN COMMERCE 11-1-2008.

THE MARK CONSISTS OF STANDARD CHARACTERS WITHOUT CLAIM TO ANY PARTICULAR FONT, STYLE, SIZE, OR COLOR.

FOR COMMUNICATIONS VIA MULTINATIONAL TELECOMMUNICATION NETWORKS; DATA TRANSMISSION AND RECEPTION SERVICES VIA TELECOMMUNICATION MEANS; ELECTRONIC EXCHANGE OF DATA STORED IN DATABASES ACCESSIBLE VIA TELECOMMUNICATION NETWORKS; HIGH BIT-RATE DATA TRANSMISSION SERVICES FOR TELECOMMUNICATION NETWORK OPERATORS; LEASING OF TELECOMMUNICATIONS LINES; PROVIDING ACCESS TO TELECOMMUNICATION NETWORKS; PROVIDING ELECTRONIC TELECOMMUNICATION CONNECTIONS; PROVIDING TELECOMMUNICATIONS CONNECTIONS TO A GLOBAL COMPUTER NETWORK; PROVIDING THIRD PARTY USERS WITH ACCESS TO TELECOMMUNICATION INFRASTRUCTURE; SIGNAL TRANSMISSION FOR ELECTRONIC COMMERCE VIA TELECOMMUNICATION SYSTEMS AND DATA COMMUNICATION SYSTEMS; TELECOMMUNICATION ACCESS SERVICES; TELECOMMUNICATION SERVICES, NAMELY, LOCAL AND LONG DISTANCE TRANSMISSION OF VOICE, DATA, GRAPHICS BY MEANS OF TELEPHONE, TELEGRAPHIC, CABLE, AND SATELLITE TRANSMISSION; TELECOMMUNICATION SERVICES, NAMELY, CALL HUNTING; TELECOMMUNICATIONS CONSULTATION; TELECOMMUNICATIONS GATEWAY SERVICES; TELECOMMUNICATIONS RESELLER SERVICES, NAMELY, PROVIDING LONG DISTANCE TELECOMMUNICATION SERVICES; TELECOMMUNICATIONS ROUTING AND JUNCTION SERVICES; TELECOMMUNICATIONS SERVICES, NAMELY, PROVIDING FIBER OPTIC NETWORK SERVICES; TRANSFER OF DATA BY TELECOMMUNICATIONS; TRANSMISSION OF INFORMATION ON OPTICAL TELECOMMUNICATION NETWORKS; WIRELESS TELEPHONE TELECOMMUNICATIONS SERVICES, NAMELY, WIRELESS MOBILE TELEPHONE CALLING PLANS (U.S. CLS. 100, 101 AND 104).

FIRST USE 6-27-2007; IN COMMERCE 6-27-2007.

3,633,195. AUTONET MOBILE, INC., SAN FRANCISCO, CA. SN 78-734,148. PUB. 1-16-2007, FILED 10-17-2005.

Autonet

THE MARK CONSISTS OF STANDARD CHARACTERS WITHOUT CLAIM TO ANY PARTICULAR FONT, STYLE, SIZE, OR COLOR.

FOR TELECOMMUNICATIONS SERVICES, NAMELY, ELECTRONIC, ELECTRIC, AND DIGITAL TRANSMISSION OF VOICE, DATA, IMAGES, SIGNALS, AND MESSAGES; ELECTRONIC MAIL SERVICES; INTERNET TELEPHONY SERVICES; BROADCASTING PROGRAMS VIA A GLOBAL COMPUTER NETWORK; VOICE-OVER IP TELEPHONE SERVICES; WIRELESS BROADBAND COMMUNICATION SERVICES; CELLULAR TELEPHONE SERVICES; SATELLITE COMMUNICATION SERVICES; MOBILE RADIO COMMUNICATION; CABLE TELEVISION TRANSMISSION, TELEVISION TRANSMISSION SERVICES; TRANSMISSION OF INFORMATION BY ELECTRONIC COMMUNICATIONS NETWORKS; MOBILE WIRELESS BROADBAND COMMUNICATION SERVICES FOR VEHICLES, BOATS, CARS, TRUCK, TRAINS (U.S. CLS. 100, 101 AND 104).

FIRST USE 8-20-2006; IN COMMERCE 8-20-2006.

CLASS 38—(Continued).

3,633,322. EVEREST PRODUCTION CORPORATION, SOMERSET, NJ. SN 78-973,145. PUB. 11-6-2007, FILED 9-13-2006.

EBRU

THE MARK CONSISTS OF STANDARD CHARACTERS WITHOUT CLAIM TO ANY PARTICULAR FONT, STYLE, SIZE, OR COLOR.

THE ENGLISH TRANSLATION OF THE TURKISH WORD "EBRU" IN THE MARK IS TURKISH PAPER MARBLING.

FOR BROADCASTING SERVICES, NAMELY, TELEVISION BROADCASTING, CABLE TELEVISION BROADCASTING, SATELLITE TELEVISION BROADCASTING, TELEVISION BROADCASTING VIA SATELLITE MASTER ANTENNA SYSTEMS, BROADCASTING OF A SUBSCRIPTION TELEVISION CHANNEL, INTERNET PROTOCOL TELEVISION BROADCASTING, BROADCASTING OF AUDIO AND VIDEO TO CELLULAR OR MOBILE PHONES, AND VIDEO ON DEMAND BROADCASTING (U.S. CLS. 100, 101 AND 104).

FIRST USE 11-22-2006; IN COMMERCE 11-22-2006.

CLASS 39—TRANSPORTATION AND STORAGE

3,632,036. MXENERGY INC., STAMFORD, CT. SN 77-181,160. PUB. 7-15-2008, FILED 5-15-2007.

EARTH FRIENDLY PARTNER

THE MARK CONSISTS OF STANDARD CHARACTERS WITHOUT CLAIM TO ANY PARTICULAR FONT, STYLE, SIZE, OR COLOR.

NO CLAIM IS MADE TO THE EXCLUSIVE RIGHT TO USE "EARTH FRIENDLY", APART FROM THE MARK AS SHOWN.

FOR DISTRIBUTION OF ENERGY, NAMELY, ELECTRICITY AND NATURAL GAS TO COMMERCIAL AND RESIDENTIAL CUSTOMERS (U.S. CLS. 100 AND 105).

FIRST USE 6-1-2007; IN COMMERCE 6-1-2007.

3,632,156. AEROVIAS DE MEXICO, S.A DE C.V., MEXICO CITY, MEXICO. SN 77-250,340. PUB. 2-12-2008, FILED 8-8-2007.

VUELO PREMIADO DE AEROMEXICO

CLASS 39—(Continued).

THE MARK CONSISTS OF STANDARD CHARACTERS WITHOUT CLAIM TO ANY PARTICULAR FONT, STYLE, SIZE, OR COLOR.

OWNER OF U.S. REG. NOS. 1,712,266, 2,606,732, AND OTHERS.

NO CLAIM IS MADE TO THE EXCLUSIVE RIGHT TO USE "VUELO PREMIADO", APART FROM THE MARK AS SHOWN.

THE ENGLISH TRANSLATION OF "VUELO PREMIADO DE AEROMEXICO" IS REWARD FLIGHT FROM AEROMEXICO.

FOR TRANSPORTATION OF PASSENGER, FREIGHT, GOODS AND MAIL BY AIR, LAND AND SEA; STORAGE OF GOODS OF ALL KINDS IN WAREHOUSES AND SHIPPING CONTAINERS; CRATING AND DELIVERY OF GOODS BY AIR; TRUCK CAR, TRAIN AND SHIP PARCEL DELIVERY (U.S. CLS. 100 AND 105).

FIRST USE 8-2-2007; IN COMMERCE 8-2-2007.

3,632,250. MORRIS VISITOR PUBLICATIONS, LLC, AUGUSTA, GA. SN 77-290,484. PUB. 1-15-2008, FILED 9-27-2007.

THE CONCIERGE PARTNER

THE MARK CONSISTS OF STANDARD CHARACTERS WITHOUT CLAIM TO ANY PARTICULAR FONT, STYLE, SIZE, OR COLOR.

FOR PROVIDING ON-LINE GEOGRAPHIC INFORMATION AND MAP IMAGES FOR CONSUMERS (U.S. CLS. 100 AND 105).

FIRST USE 3-18-2009; IN COMMERCE 3-18-2009.

CLASS 40—MATERIAL TREATMENT

3,632,225. KILLER KREATIONS INC., PHILADELPHIA, PA. SN 77-278,337. PUB. 3-4-2008, FILED 9-12-2007.

Killer Kreations

THE MARK CONSISTS OF STANDARD CHARACTERS WITHOUT CLAIM TO ANY PARTICULAR FONT, STYLE, SIZE, OR COLOR.

FOR AIR BRUSHING SERVICES (U.S. CLS. 100, 103 AND 106).

FIRST USE 8-1-1994; IN COMMERCE 4-1-2008.

CLASS 40—(Continued).

3,632,241. GLOBAL RECYCLING TECHNOLOGIES, LTD., TEMPE, AZ. SN 77-285,885. PUB. 6-24-2008, FILED 9-21-2007.



NO CLAIM IS MADE TO THE EXCLUSIVE RIGHT TO USE "GLOBAL RECYCLING", APART FROM THE MARK AS SHOWN.

THE MARK CONSISTS OF THE WORDS "GLOBAL RECYCLING" WITH A BLACK BACKGROUND OVER A DEPICTION OF THE UNIVERSAL RECYCLING SYMBOL ROTATED SLIGHTLY COUNTER-CLOCKWISE WITH LIQUID FLOWING THROUGH EACH OF THE ARROWS OF THE RECYCLING SYMBOL AND A SHADOW OF THE RECYCLING SYMBOL.

FOR RECYCLING; RECYCLING SERVICES; MATERIAL TREATMENT SERVICES IN CONNECTION WITH RECYCLING; RECLAMATION OF GLYCOL (U.S. CLS. 100, 103 AND 106).

FIRST USE 2-24-2009; IN COMMERCE 2-24-2009.

3,632,422. PERCOCO HOLDINGS, LLC, DENVER, CO. SN 77-367,729. PUB. 5-27-2008, FILED 1-9-2008.

**PERCOCO STONE FINISHING
CENTER**

THE MARK CONSISTS OF STANDARD CHARACTERS WITHOUT CLAIM TO ANY PARTICULAR FONT, STYLE, SIZE, OR COLOR.

NO CLAIM IS MADE TO THE EXCLUSIVE RIGHT TO USE "STONE FINISHING CENTER", APART FROM THE MARK AS SHOWN.

FOR APPLYING FINISHES TO NATURAL STONE AND ENGINEERED STONE (U.S. CLS. 100, 103 AND 106).

FIRST USE 6-3-2008; IN COMMERCE 6-3-2008.

CLASS 40—(Continued).

3,632,557. PRINTINGFORLESS.COM, LIVINGSTON, MT. SN 77-406,077. PUB. 7-29-2008, FILED 2-26-2008.

PFL Private Printshop

THE MARK CONSISTS OF STANDARD CHARACTERS WITHOUT CLAIM TO ANY PARTICULAR FONT, STYLE, SIZE, OR COLOR.

OWNER OF U.S. REG. NO. 3,189,427.

NO CLAIM IS MADE TO THE EXCLUSIVE RIGHT TO USE "PRIVATE PRINT SHOP", APART FROM THE MARK AS SHOWN.

FOR OFFSET PRINTING (U.S. CLS. 100, 103 AND 106).
FIRST USE 5-1-2007; IN COMMERCE 5-1-2007.

3,632,599. A SHRED 2 PIECES, LLC, IRVING, TX. SN 77-413,056. PUB. 7-22-2008, FILED 3-4-2008.



THE MARK CONSISTS OF THE DEPICTION OF SHREDDED PAPER WITH THE WORDING "A SHRED 2 PIECES" BENEATH THE IMAGE OF THE PAPER SHREDS.

FOR DOCUMENT DESTRUCTION; DOCUMENT SHREDDING SERVICES (U.S. CLS. 100, 103 AND 106).

FIRST USE 4-1-2008; IN COMMERCE 4-1-2008.

3,632,756. OLIVEIRA, LAWRENCE A. JR., ATLANTA, GA. SN 77-446,852. PUB. 9-2-2008, FILED 4-13-2008.

THE GLORY REALM

THE MARK CONSISTS OF STANDARD CHARACTERS WITHOUT CLAIM TO ANY PARTICULAR FONT, STYLE, SIZE, OR COLOR.

FOR IMPRINTING MESSAGES ON WEARING APPAREL, ACCESSORIES AND MUGS (U.S. CLS. 100, 103 AND 106).

FIRST USE 3-7-2005; IN COMMERCE 5-7-2008.

CLASS 40—(Continued).

3,632,786. SIEMENS WATER TECHNOLOGIES CORP., WAR-RENDALE, PA. SN 77-454,900. PUB. 7-8-2008, FILED 4-22-2008.

BIOFLOWSHEET+

THE MARK CONSISTS OF STANDARD CHARACTERS WITHOUT CLAIM TO ANY PARTICULAR FONT, STYLE, SIZE, OR COLOR.

FOR WASTEWATER TREATMENT SERVICE PROGRAM, NAMELY, BIOLOGICAL WASTEWATER TREATMENT PROCESS OPTIMIZATION PROGRAM (U.S. CLS. 100, 103 AND 106).

FIRST USE 10-15-2007; IN COMMERCE 10-15-2007.

3,632,875. PAR GOLF SUPPLY, INC., SCHAUMBURG, IL. SN 77-493,983. PUB. 11-4-2008, FILED 6-9-2008.



NO CLAIM IS MADE TO THE EXCLUSIVE RIGHT TO USE "GOLF TEE PRINTERS", APART FROM THE MARK AS SHOWN.

THE MARK CONSISTS OF A SIDEWAYS GOLF TEE WITH WORDING "GOLF TEE PRINTERS" ON THE LONG PART OF THE TEE.

FOR PRINTING OF ADVERTISING MATTER (U.S. CLS. 100, 103 AND 106).
FIRST USE 3-2-2009; IN COMMERCE 3-2-2009.

CLASS 40—(Continued).

3,632,876. PAR GOLF SUPPLY, INC., SCHAUMBURG, IL. SN 77-494,003. PUB. 11-4-2008, FILED 6-9-2008.



NO CLAIM IS MADE TO THE EXCLUSIVE RIGHT TO USE "GOLF TEE PRINTERS", APART FROM THE MARK AS SHOWN.

THE COLOR(S) GREEN, MEDIUM BROWN, DARK BROWN, GRAY, PINK, BLACK AND WHITE IS/ARE CLAIMED AS A FEATURE OF THE MARK.

THE MARK CONSISTS OF A CHIPMUNK THAT IS DARK BROWN, MEDIUM BROWN, GRAY, PINK AND WHITE IN COLOR STANDING ON GREEN GRASS AND HOLDING A BLACK GOLF TEE THAT IS MARKED "GOLF TEE PRINTERS". THE COLOR GREEN APPEARS IN THE GRASS; THE COLOR MEDIUM BROWN APPEARS IN THE BODY OF THE CHIPMUNK; THE COLOR DARK BROWN APPEARS IN THE BODY OF THE CHIPMUNK; THE COLOR GRAY APPEARS IN THE BODY OF THE CHIPMUNK AND IN THE TEE; THE COLOR PINK APPEARS IN THE CHIPMUNK'S EARS; THE COLOR WHITE APPEARS IN THE BODY OF THE CHIPMUNK AND IN THE WORDING "GOLF TEE PRINTERS"; THE COLOR BLACK APPEARS IN THE OUTLINING OF THE CHIPMUNK AND IN THE GOLF TEE.

FOR PRINTING OF ADVERTISING MATTER (U.S. CLS. 100, 103 AND 106).
FIRST USE 3-2-2009; IN COMMERCE 3-2-2009.

3,632,949. STAR TEK RECYCLING, LLC, MORGANTOWN, KY. SN 77-520,043. PUB. 12-9-2008, FILED 7-11-2008.

STAR TEK RECYCLING

THE MARK CONSISTS OF STANDARD CHARACTERS WITHOUT CLAIM TO ANY PARTICULAR FONT, STYLE, SIZE, OR COLOR.

NO CLAIM IS MADE TO THE EXCLUSIVE RIGHT TO USE "RECYCLING", APART FROM THE MARK AS SHOWN.

FOR RECYCLING (U.S. CLS. 100, 103 AND 106).
FIRST USE 11-1-2008; IN COMMERCE 11-1-2008.

CLASS 41—EDUCATION AND ENTERTAINMENT

CLASS 41—(Continued).

3,631,797. SIRIUS THINKING, LTD., NEW YORK, NY. SN 76-617,910. PUB. 1-31-2006, FILED 10-26-2004.

MELODY HOUNDS

THE MARK CONSISTS OF STANDARD CHARACTERS WITHOUT CLAIM TO ANY PARTICULAR FONT, STYLE, SIZE, OR COLOR.

NO CLAIM IS MADE TO THE EXCLUSIVE RIGHT TO USE "MELODY", APART FROM THE MARK AS SHOWN.

FOR EDUCATIONAL SERVICES IN THE NATURE OF MUSICAL INSTRUCTION (U.S. CLS. 100, 101 AND 107).
FIRST USE 9-30-2005; IN COMMERCE 9-30-2005.

3,631,818. CONJUNTO DESAFIO MUSICAL COUNTRY PARTNERSHIP, OXNARD, CA. SN 76-675,329. PUB. 3-4-2008, FILED 4-11-2007.

CONJUNTO
DESAFIO
MUSICAL

NO CLAIM IS MADE TO THE EXCLUSIVE RIGHT TO USE "CONJUNTO" AND "MUSICAL", APART FROM THE MARK AS SHOWN.

THE WORD "CONJUNTO DESAFIO MUSICAL" THE ENGLISH TRANSLATION IS "A CHALLENGED BAND."

FOR ENTERTAINMENT SERVICES IN THE NATURE OF LIVE PERFORMANCES BY A MUSICAL GROUP (U.S. CLS. 100, 101 AND 107).

FIRST USE 6-20-2006; IN COMMERCE 7-4-2008.

3,631,841. AMERICAN MOTORCYCLIST ASSOCIATION, PICKERINGTON, OH. SN 76-684,842. PUB. 12-30-2008, FILED 12-11-2007.

AMA DRAGBIKE

THE MARK CONSISTS OF STANDARD CHARACTERS WITHOUT CLAIM TO ANY PARTICULAR FONT, STYLE, SIZE, OR COLOR.

NO CLAIM IS MADE TO THE EXCLUSIVE RIGHT TO USE "DRAGBIKE", APART FROM THE MARK AS SHOWN.

FOR ENTERTAINMENT IN THE NATURE OF MOTORCYCLE RACES IN THE USA (U.S. CLS. 100, 101 AND 107).

FIRST USE 1-1-2008; IN COMMERCE 1-1-2008.

CLASS 41—(Continued).

3,631,842. AMERICAN MOTORCYCLIST ASSOCIATION, PICKERINGTON, OH. SN 76-684,843. PUB. 12-30-2008, FILED 12-11-2007.



NO CLAIM IS MADE TO THE EXCLUSIVE RIGHT TO USE "DRAGBIKE CHAMPIONSHIP SERIES" AND "DRAG RACING", APART FROM THE MARK AS SHOWN.

THE COLOR(S) BLACK, WHITE, RED AND BLUE IS/ARE CLAIMED AS A FEATURE OF THE MARK.

THE MARK CONSISTS OF THE BACKGROUND COLOR WHITE, WITH THE WORDS "AMA DRAGBIKE CHAMPIONSHIP" APPEARING IN BLACK, THE WORDS "AMA DRAG BIKE" APPEARING IN BLUE, A RED RECTANGLE WITH A LINE AND A BLUE RECTANGLE WITH A LINE AND A PICTURE OF A PERSON ON A MOTORCYCLE IN THE RED AND BLUE RECTANGLES OUTLINED IN WHITE.

FOR ENTERTAINMENT IN THE NATURE OF MOTORCYCLE RACES IN THE USA (U.S. CLS. 100, 101 AND 107).

FIRST USE 1-1-2008; IN COMMERCE 1-1-2008.

3,631,846. LIV SURE, LLC, LAYTON, UT. SN 76-686,620. PUB. 7-29-2008, FILED 2-7-2008.

WORLDOLGY

THE MARK CONSISTS OF STANDARD CHARACTERS WITHOUT CLAIM TO ANY PARTICULAR FONT, STYLE, SIZE, OR COLOR.

FOR EDUCATIONAL AND ENTERTAINMENT SERVICES, NAMELY, PROVIDING ONLINE INFORMATION FEATURING CONTENT ABOUT WORLD HISTORY, CULTURES AND CIVILIZATIONS, AND CURRENT EVENTS (U.S. CLS. 100, 101 AND 107).

FIRST USE 4-2-2009; IN COMMERCE 4-2-2009.

CLASS 41—(Continued).

3,631,885. FRANTZIS, BRUCE KUMAR, FAIRFAX, CA. SN 77-030,948. PUB. 5-29-2007, FILED 10-27-2006.

HEART CHI

THE MARK CONSISTS OF STANDARD CHARACTERS WITHOUT CLAIM TO ANY PARTICULAR FONT, STYLE, SIZE, OR COLOR.

FOR EDUCATIONAL SERVICES, NAMELY, CONDUCTING CLASSES, SEMINARS, RETREATS AND WORKSHOPS IN THE FIELD OF HEALING ARTS, MARTIAL ARTS, EXERCISE, STRESS RELIEF, PREVENTATIVE MEDICINE AND MEDITATION (U.S. CLS. 100, 101 AND 107).

FIRST USE 3-1-2008; IN COMMERCE 3-1-2008.

CLASS 41—(Continued).

3,631,923. PURCELLVILLE ENTERTAINMENT, INC., BEVERLY HILLS, CA. SN 77-075,361. PUB. 2-5-2008, FILED 1-3-2007.

MARTIN LAWRENCE PRESENTS
1ST AMENDMENT STAND-UP

THE MARK CONSISTS OF STANDARD CHARACTERS WITHOUT CLAIM TO ANY PARTICULAR FONT, STYLE, SIZE, OR COLOR.

NO CLAIM IS MADE TO THE EXCLUSIVE RIGHT TO USE "STAND-UP", APART FROM THE MARK AS SHOWN. THE NAME "MARTIN LAWRENCE" IDENTIFIES A LIVING INDIVIDUAL WHOSE CONSENT IS OF RECORD.

FOR ENTERTAINMENT SERVICES, NAMELY, PROVIDING A SERIES OF LIVE PERFORMANCES FEATURING COMEDIC AND/OR DRAMATIC PRESENTATIONS; ENTERTAINMENT SERVICES, NAMELY, PROVIDING A SERIES OF TELEVISION PROGRAMS IN THE FIELD OF COMEDIC AND/OR DRAMATIC PRESENTATIONS; MOTION PICTURE FILM PRODUCTION; TELEVISION PRODUCTION; PRODUCTION OF VIDEO CASSETTES, VIDEOTAPES, VIDEO COMPACT DISCS, AND DIGITAL VERSATILE DISCS (U.S. CLS. 100, 101 AND 107).

FIRST USE 8-12-2008; IN COMMERCE 8-12-2008.

3,631,991. LIFE 101, LLC, FENTON, MI. SN 77-141,306. PUB. 8-5-2008, FILED 3-27-2007.

GETLIFE101

THE MARK CONSISTS OF STANDARD CHARACTERS WITHOUT CLAIM TO ANY PARTICULAR FONT, STYLE, SIZE, OR COLOR.

FOR EDUCATIONAL SERVICES, NAMELY, TRAINING AND LIFE COACHING SERVICES IN THE NATURE OF CREDIT CARD MANAGEMENT SKILL IMPROVEMENT SERVICES, FINANCIAL PLANNING SKILL IMPROVEMENT SERVICES, MONEY MANAGEMENT SKILL IMPROVEMENT SERVICES, INSURANCE SKILL IMPROVEMENT SERVICES, MORTGAGE SKILL IMPROVEMENT SERVICES, CREDIT REPORT SKILL IMPROVEMENT SERVICES, AUTOMOBILE PURCHASE AND LEASING SKILL IMPROVEMENT SERVICES, REAL ESTATE PURCHASE SKILL IMPROVEMENT SERVICES; FACILITATING THE CREDIT CARD MANAGEMENT SKILL IMPROVEMENT SERVICES, FINANCIAL PLANNING SKILL IMPROVEMENT SERVICES, MONEY MANAGEMENT SKILL IMPROVEMENT SERVICES, INSURANCE SKILL IMPROVEMENT SERVICES, MORTGAGE SKILL IMPROVEMENT SERVICES, CREDIT REPORT SKILL IMPROVEMENT SERVICES, AUTOMOBILE PURCHASE AND LEASING SKILL IMPROVEMENT SERVICES, AND REAL ESTATE PURCHASE SKILL IMPROVEMENT SERVICES USING LIVE, ON-LINE OR SELF-STUDY CLASSES, COURSES, SEMINARS OR WORKSHOPS, AND THE DISTRIBUTION OF MULTI MEDIA INSTRUCTIONAL MATERIALS ASSOCIATED THEREWITH (U.S. CLS. 100, 101 AND 107).

FIRST USE 2-0-2008; IN COMMERCE 2-0-2008.

3,631,922. SCHAKOLAD CORPORATION, INC., ORLANDO, FL. SN 77-071,156. PUB. 12-18-2007, FILED 12-26-2006.

CHOCOLAND

THE MARK CONSISTS OF STANDARD CHARACTERS WITHOUT CLAIM TO ANY PARTICULAR FONT, STYLE, SIZE, OR COLOR.

FOR ENTERTAINMENT SERVICES, NAMELY, PROVIDING AND OPERATING A FACILITY EXHIBITING THE HISTORY AND HIGHLIGHTS OF THE CHOCOLATE INDUSTRY; CONDUCTING EDUCATIONAL AND ENTERTAINMENT EXHIBITIONS IN THE NATURE OF FACILITY AND EXHIBIT TOURS REGARDING THE HISTORY AND HIGHLIGHTS OF THE CHOCOLATE INDUSTRY (U.S. CLS. 100, 101 AND 107).

FIRST USE 3-6-2009; IN COMMERCE 3-6-2009.

CLASS 41—(Continued).

3,631,996. BLACK ENTERTAINMENT TELEVISION LLC, WASHINGTON, DC. SN 77-149,041. PUB. 9-11-2007, FILED 4-4-2007.

SUNDAY BEST

THE MARK CONSISTS OF STANDARD CHARACTERS WITHOUT CLAIM TO ANY PARTICULAR FONT, STYLE, SIZE, OR COLOR.

FOR ENTERTAINMENT SERVICES IN THE NATURE OF A CONTINUING TELEVISION TALENT SHOW ACCESSIBLE BY CABLE TELEVISION, BROADCAST TELEVISION, SATELLITE, WIRELESS AND THE INTERNET (U.S. CLS. 100, 101 AND 107).

FIRST USE 9-10-2007; IN COMMERCE 9-10-2007.

3,632,001. DAVANTZIS, THEODORE, TEMPLETON, CA. SN 77-154,684. PUB. 1-22-2008, FILED 4-12-2007.

Finally It's Friday

THE MARK CONSISTS OF STANDARD CHARACTERS WITHOUT CLAIM TO ANY PARTICULAR FONT, STYLE, SIZE, OR COLOR.

FOR ENTERTAINMENT, NAMELY, LIVE PERFORMANCES BY MUSICAL BANDS; ENTERTAINMENT IN THE NATURE OF ON-GOING TELEVISION PROGRAMS IN THE FIELD OF VARIETY; ENTERTAINMENT, NAMELY, LIVE PERFORMANCES BY A MUSICAL BAND (U.S. CLS. 100, 101 AND 107).

FIRST USE 10-4-2002; IN COMMERCE 3-9-2005.

3,632,018. MACKEY III, GRADY L., LOS ANGELES, CA. SN 77-164,150. PUB. 10-30-2007, FILED 4-24-2007.

The Spiritual Hi-Tones

THE MARK CONSISTS OF STANDARD CHARACTERS WITHOUT CLAIM TO ANY PARTICULAR FONT, STYLE, SIZE, OR COLOR.

FOR ENTERTAINMENT SERVICES IN THE NATURE OF LIVE MUSICAL PERFORMANCES BY A VOCAL ARTIST AND BY A MUSICAL GROUP (U.S. CLS. 100, 101 AND 107).

FIRST USE 1-1-2004; IN COMMERCE 1-1-2004.

CLASS 41—(Continued).

3,632,051. WORLD WRESTLING ENTERTAINMENT, INC., STAMFORD, CT. SN 77-194,082. PUB. 11-13-2007, FILED 5-31-2007.

CHERRY

THE MARK CONSISTS OF STANDARD CHARACTERS WITHOUT CLAIM TO ANY PARTICULAR FONT, STYLE, SIZE, OR COLOR.

FOR ENTERTAINMENT SERVICES, NAMELY, WRESTLING EXHIBITIONS AND PERFORMANCES BY A PROFESSIONAL WRESTLER AND ENTERTAINER; PROVIDING WRESTLING NEWS AND INFORMATION VIA A GLOBAL COMPUTER NETWORK (U.S. CLS. 100, 101 AND 107).

FIRST USE 1-19-2007; IN COMMERCE 1-19-2007.

3,632,079. UNIVERSITY SYSTEM OF MARYLAND, ADELPHI, MD. SN 77-215,764. PUB. 10-14-2008, FILED 6-26-2007.



NO CLAIM IS MADE TO THE EXCLUSIVE RIGHT TO USE "UNIVERSITY SYSTEM OF MARYLAND", APART FROM THE MARK AS SHOWN.

THE MARK CONSISTS OF THE WORDS "UNIVERSITY SYSTEM OF MARYLAND" AS A CIRCULAR BORDER AROUND A SHIELD. THE SHIELD IS BASED ON THE MARYLAND STATE FLAG. THE UPPER LEFT AND LOWER RIGHT SECTIONS REPRESENT THE CREST OF THE CALVERT FAMILY; THE OTHER SECTIONS REPRESENT THE CREST OF THE CROSSLAND FAMILY.

FOR PROVIDING ACADEMIC INFORMATION ABOUT THE UNIVERSITY SYSTEM OF MARYLAND, ITS MEMBER INSTITUTIONS AND THE EDUCATIONAL OPPORTUNITIES THAT THEY PROVIDE (U.S. CLS. 100, 101 AND 107).

FIRST USE 1-8-1997; IN COMMERCE 11-1-2004.

CLASS 41—(Continued).

3,632,096. FINANCIAL KNOWLEDGE NETWORK, LLC, CUPERTINO, CA. SN 77-225,406. PUB. 12-18-2007, FILED 7-10-2007.

**Financial Knowledge Makes
a Difference**

THE MARK CONSISTS OF STANDARD CHARACTERS WITHOUT CLAIM TO ANY PARTICULAR FONT, STYLE, SIZE, OR COLOR.

FOR EDUCATION SERVICES, NAMELY, PROVIDING LIVE AND ON-LINE CLASSES IN THE FIELD OF PERSONAL FINANCE (U.S. CLS. 100, 101 AND 107).

FIRST USE 8-1-2007; IN COMMERCE 8-1-2007.

CLASS 41—(Continued).

3,632,118. JUNKET MEDIA CORP., PEACHTREE CITY, GA. SN 77-232,039. PUB. 5-13-2008, FILED 7-17-2007.

Junket Media

THE MARK CONSISTS OF STANDARD CHARACTERS WITHOUT CLAIM TO ANY PARTICULAR FONT, STYLE, SIZE, OR COLOR.

NO CLAIM IS MADE TO THE EXCLUSIVE RIGHT TO USE "MEDIA", APART FROM THE MARK AS SHOWN.

FOR ENTERTAINMENT IN THE NATURE OF PRODUCTION AND DISTRIBUTION OF MOVIES, TELEVISION MOVIES, TELEVISION PROGRAMS; CABLE TELEVISION PROGRAMMING SERVICES; AUDIO PERFORMANCE RECORDING AND PRODUCTION (U.S. CLS. 100, 101 AND 107).

FIRST USE 7-15-2007; IN COMMERCE 8-15-2007.

3,632,102. COMPANY OF EXPERTS, INC., LAS VEGAS, NV. SN 77-227,353. PUB. 7-22-2008, FILED 7-11-2007.

WORDS CREATE WORLDS

THE MARK CONSISTS OF STANDARD CHARACTERS WITHOUT CLAIM TO ANY PARTICULAR FONT, STYLE, SIZE, OR COLOR.

FOR PROVIDING ELECTRONIC NEWSLETTERS, BOOKS, MAGAZINES AND ARTICLES RELATING TO THE PROCESS OF FACILITATING POSITIVE CHANGE IN EDUCATIONAL INSTITUTIONS, COMPANIES AND ORGANIZATIONS, VIA EMAIL AND AVAILABLE ON WEBSITES (U.S. CLS. 100, 101 AND 107).

FIRST USE 8-31-2005; IN COMMERCE 8-31-2005.

3,632,124. ALL CODES MEDIA, LLC, ST. LOUIS, MO. SN 77-234,594. PUB. 1-8-2008, FILED 7-20-2007.

MIRROR GIRL

3,632,112. VIACOM INTERNATIONAL INC., NEW YORK, NY. SN 77-230,119. PUB. 1-1-2008, FILED 7-16-2007.

VH1 BRIDGING THE GAP

THE MARK CONSISTS OF STANDARD CHARACTERS WITHOUT CLAIM TO ANY PARTICULAR FONT, STYLE, SIZE, OR COLOR.

OWNER OF U.S. REG. NOS. 2,995,834, 3,252,486, AND OTHERS.

FOR ENTERTAINMENT SERVICES IN THE NATURE OF TELEVISION SERIES, FEATURING LIVE ACTION, COMEDY AND DRAMA; PROVIDING ONLINE INFORMATION IN THE FIELD OF ENTERTAINMENT CONCERNING TELEVISION PROGRAMS (U.S. CLS. 100, 101 AND 107).

FIRST USE 10-1-2007; IN COMMERCE 10-1-2007.

THE MARK CONSISTS OF STANDARD CHARACTERS WITHOUT CLAIM TO ANY PARTICULAR FONT, STYLE, SIZE, OR COLOR.

NO CLAIM IS MADE TO THE EXCLUSIVE RIGHT TO USE "GIRL", APART FROM THE MARK AS SHOWN.

FOR ENTERTAINMENT SERVICES, NAMELY, PROVIDING A WEBSITE FEATURING, PHOTOGRAPHIC, AUDIO, VIDEO AND PROSE PRESENTATIONS FEATURING NUDE AND SEMI-NUDE MODELS (U.S. CLS. 100, 101 AND 107).

FIRST USE 3-27-2009; IN COMMERCE 3-27-2009.

CLASS 41—(Continued).

3,632,126. PRISON COMMUNITIES INTERNATIONAL, INC., KATONAH, NY. SN 77-237,282. PUB. 7-1-2008, FILED 7-24-2007.



NO CLAIM IS MADE TO THE EXCLUSIVE RIGHT TO USE "REHABILITATION THROUGH THE ARTS", APART FROM THE MARK AS SHOWN.

THE MARK CONSISTS OF A BOX THAT INCLUDES A BUTTERFLY WITH WINGS MADE FROM THUMB PRINTS AND THE WORDS "RTA REHABILITATION THROUGH THE ARTS".

FOR ARTISTIC, EDUCATIONAL AND PERSONAL GROWTH PROGRAMS, NAMELY, CLASSES, WORKSHOPS, ONE-ON-ONE MENTORING, AND SEMINARS, FOR REHABILITATION OF INCARCERATED, PAROLED AND FORMER INMATES AND INDIVIDUALS IN THE FIELD OF ART, THEATRE, DANCE, AND CREATIVE WRITING (U.S. CLS. 100, 101 AND 107).

FIRST USE 7-30-2007; IN COMMERCE 7-30-2007.

3,632,132. MARSTON COMMUNICATIONS, LLC, CHARLOTTE, NC. SN 77-239,575. PUB. 6-10-2008, FILED 7-26-2007.

CAM MARSTON

THE MARK CONSISTS OF STANDARD CHARACTERS WITHOUT CLAIM TO ANY PARTICULAR FONT, STYLE, SIZE, OR COLOR.

FOR CONDUCTING WORKSHOPS AND SEMINARS IN THE FIELDS OF SALES, BUSINESS, ORAL PRESENTATION SKILLS, AND COMMUNICATION SKILLS BETWEEN INDIVIDUALS FROM DIFFERENT GENERATIONS (U.S. CLS. 100, 101 AND 107).

FIRST USE 1-30-2009; IN COMMERCE 1-30-2009.

CLASS 41—(Continued).

3,632,146. OUTSIDE THE CLASSROOM, INC., NEEDHAM, MA. SN 77-247,753. PUB. 7-22-2008, FILED 8-6-2007.

MENTALHEALTHEDU

THE MARK CONSISTS OF STANDARD CHARACTERS WITHOUT CLAIM TO ANY PARTICULAR FONT, STYLE, SIZE, OR COLOR.

FOR PROVIDING ONLINE HEALTH AND LIFE-SKILLS COURSES IN THE FIELD OF MENTAL-HEALTH EDUCATION (U.S. CLS. 100, 101 AND 107).

FIRST USE 9-18-2007; IN COMMERCE 9-18-2007.

3,632,151. THE NEW YORK BOARD OF RABBIS, INC., NEW YORK, NY. SN 77-248,508. PUB. 6-17-2008, FILED 8-6-2007.

DAYENU!

THE MARK CONSISTS OF STANDARD CHARACTERS WITHOUT CLAIM TO ANY PARTICULAR FONT, STYLE, SIZE, OR COLOR.

THE FOREIGN WORDING IN THE MARK TRANSLATES INTO ENGLISH AS "IT WOULD SUFFICE" OR "ENOUGH".

FOR EDUCATIONAL SERVICES, NAMELY, PROVIDING CLERGY, LAY LEADERS AND COMMUNITIES, THROUGH WORKSHOPS, TRAINING SESSIONS AND SEMINARS, THE SKILLS AND KNOWLEDGE NEEDED TO ADDRESS RELIGIOUS AND CULTURAL ISSUES RELATED TO DOMESTIC AND FAMILY VIOLENCE INCLUDING COURSE MATERIALS DISTRIBUTED THEREWITH (U.S. CLS. 100, 101 AND 107).

FIRST USE 11-1-2007; IN COMMERCE 11-1-2007.

3,632,175. BETHEL GOSPEL ASSEMBLY, NEW YORK, NY. SN 77-258,859. PUB. 8-12-2008, FILED 8-19-2007.



CLASS 41—(Continued).

NO CLAIM IS MADE TO THE EXCLUSIVE RIGHT TO USE "GREAT COMMISSION CONFERENCE", APART FROM THE MARK AS SHOWN.

THE COLOR(S) BROWN, BEIGE-ORANGE AND WHITE IS/ARE CLAIMED AS A FEATURE OF THE MARK.

THE COLOR WHITE APPEARS IN THE TERM "GCC"; THE COLOR BEIGE-ORANGE APPEARS IN THE LINES IN THE GLOBE, IN THE OUTLINE OF THE GLOBE AND IN THE CROSS; THE COLOR BROWN APPEARS IN THE LANGUAGE "GREAT COMMISSION CONFERENCE" AND IN THE GLOBE.

FOR ARRANGING OF EDUCATIONAL EXHIBITIONS, SEMINARS AND CONFERENCES (U.S. CLS. 100, 101 AND 107).

FIRST USE 9-1-2005; IN COMMERCE 9-1-2005.

CLASS 41—(Continued).

3,632,273. STRAWN, JAMES, ORANGE, CA. SN 77-301,512. PUB. 3-11-2008, FILED 10-11-2007.

SLIDE

3,632,202. ATHLETES' PERFORMANCE, INC., TEMPE, AZ. SN 77-267,095. PUB. 1-22-2008, FILED 8-29-2007.

CORE PERFORMANCE

THE MARK CONSISTS OF STANDARD CHARACTERS WITHOUT CLAIM TO ANY PARTICULAR FONT, STYLE, SIZE, OR COLOR.

FOR ENTERTAINMENT, NAMELY, LIVE PERFORMANCES BY A MUSICAL BAND; ENTERTAINMENT SERVICES, NAMELY, LIVE, TELEVISED AND MOVIE APPEARANCES BY A PROFESSIONAL ENTERTAINER; ENTERTAINMENT, NAMELY, LIVE MUSIC CONCERTS (U.S. CLS. 100, 101 AND 107).

FIRST USE 1-1-1993; IN COMMERCE 2-15-1994.

THE MARK CONSISTS OF STANDARD CHARACTERS WITHOUT CLAIM TO ANY PARTICULAR FONT, STYLE, SIZE, OR COLOR.

OWNER OF U.S. REG. NOS. 3,016,023, 3,016,024, AND 3,124,046.

FOR HEALTH CLUB SERVICES, NAMELY, PROVIDING INSTRUCTION AND EQUIPMENT IN THE FIELD OF PHYSICAL EXERCISE (U.S. CLS. 100, 101 AND 107).

FIRST USE 6-1-2008; IN COMMERCE 6-1-2008.

3,632,283. RIMINI FIERA SPA, 47900 RIMINI, ITALY. SN 77-304,637. PUB. 5-13-2008, FILED 10-15-2007.

SIGEP U.S.A.

3,632,240. READABLE PRESS LLC, BLUE BELL, PA. SN 77-285,787. PUB. 3-11-2008, FILED 9-21-2007.

THE SHORTEST DISTANCE TO UNDERSTANDING FOR TAX PROFESSIONALS

THE MARK CONSISTS OF STANDARD CHARACTERS WITHOUT CLAIM TO ANY PARTICULAR FONT, STYLE, SIZE, OR COLOR.

NO CLAIM IS MADE TO THE EXCLUSIVE RIGHT TO USE "TAX PROFESSIONALS", APART FROM THE MARK AS SHOWN.

FOR PUBLISHING OF NEWSLETTERS, PAMPHLETS, BOOKS AND REFERENCE MANUALS IN THE FIELDS OF LAW, TAX LAW AND PRACTICE (U.S. CLS. 100, 101 AND 107).

FIRST USE 1-13-2009; IN COMMERCE 1-13-2009.

THE MARK CONSISTS OF STANDARD CHARACTERS WITHOUT CLAIM TO ANY PARTICULAR FONT, STYLE, SIZE, OR COLOR.

NO CLAIM IS MADE TO THE EXCLUSIVE RIGHT TO USE "U.S.A.", APART FROM THE MARK AS SHOWN.

FOR EDUCATIONAL SERVICES, NAMELY, PROVIDING TRAINING OF SUPPORT STAFF, TRAINING OF VENDORS, TRAINING OF MANAGEMENT FOR EXHIBITIONS AND FAIRS; ENTERTAINMENT, NAMELY, ORGANIZING EXHIBITIONS FOR CULTURAL AND/OR EDUCATIONAL PURPOSES (U.S. CLS. 100, 101 AND 107).

FIRST USE 4-1-2008; IN COMMERCE 4-1-2008.

CLASS 41—(Continued).

3,632,289. BR CONSULTING, INC., SEDONA, AZ. SN 77-305,516. PUB. 8-19-2008, FILED 10-16-2007.

Tao Yoga

THE MARK CONSISTS OF STANDARD CHARACTERS WITHOUT CLAIM TO ANY PARTICULAR FONT, STYLE, SIZE, OR COLOR.

NO CLAIM IS MADE TO THE EXCLUSIVE RIGHT TO USE "YOGA", APART FROM THE MARK AS SHOWN.

FOR EDUCATIONAL SERVICES, NAMELY, CONDUCTING SEMINARS, CONFERENCES, EXHIBITIONS AND CLASSES IN THE FIELDS OF MEDITATION, RELAXATION AND ENERGY HEALING (U.S. CLS. 100, 101 AND 107).

FIRST USE 3-1-2006; IN COMMERCE 3-1-2006.

3,632,292. FESTIVAL FUN PARKS, LLC, NEWPORT BEACH, CA. SN 77-306,818. PUB. 8-12-2008, FILED 10-17-2007.

ALLIGATOR AMBUSH

THE MARK CONSISTS OF STANDARD CHARACTERS WITHOUT CLAIM TO ANY PARTICULAR FONT, STYLE, SIZE, OR COLOR.

FOR ENTERTAINMENT SERVICES IN THE NATURE OF AMUSEMENT PARK RIDES AND AN AMUSEMENT PARK WATER RIDE (U.S. CLS. 100, 101 AND 107).

FIRST USE 3-28-2008; IN COMMERCE 3-28-2008.



FOR ENTERTAINMENT SERVICES IN THE NATURE OF AMUSEMENT PARK RIDES AND AN AMUSEMENT PARK WATER RIDE (U.S. CLS. 100, 101 AND 107).

FIRST USE 3-28-2008; IN COMMERCE 3-28-2008.

CLASS 41—(Continued).

3,632,304. GANDER MOUNTAIN COMPANY, ST. PAUL, MN. SN 77-316,012. PUB. 4-15-2008, FILED 10-29-2007.



OWNER OF U.S. REG. NOS. 2,864,302, 3,305,894, AND OTHERS.

NO CLAIM IS MADE TO THE EXCLUSIVE RIGHT TO USE "ROD" AND "REEL DONATION PROGRAM" OR "FOR KIDS", APART FROM THE MARK AS SHOWN.

THE MARK CONSISTS OF A BLACK RECTANGULAR BOX WITH THE WORDS "CAST AWAYS FOR KIDS ROD & REEL DONATION PROGRAM" IN WHITE, A FISHING ROD AND LURE IN BLACK ACROSS THE WORD "KIDS" AND A GRAPHIC REPRESENTATION OF A GOOSE FLYING OVER A MOUNTAIN PEAK WITH THE WORDS "GANDER MOUNTAIN" WRITTEN VERTICALLY TO THE LEFT OF THE BOX.

FOR CHARITABLE SERVICES, NAMELY, PROVIDING DONATED AND REFURBISHED FISHING RODS, REELS, AND OTHER FISHING EQUIPMENT TO CHILDREN (U.S. CLS. 100, 101 AND 107).

FIRST USE 3-31-2007; IN COMMERCE 3-31-2007.

3,632,310. KIDRO PRODUCTIONS, INC., NEW YORK, NY. SN 77-319,276. PUB. 8-26-2008, FILED 11-1-2007.



NO CLAIM IS MADE TO THE EXCLUSIVE RIGHT TO USE "PRODUCTIONS, INC.", APART FROM THE MARK AS SHOWN.

THE MARK CONSISTS OF THE WORDING "KIDRO" WHERE THE "I" IS AN EXCLAMATION POINT AND THE "O" IS A HEART, WITH THE WORDING "PRODUCTIONS, INC." BELOW. THIS WORDING APPEARS AGAINST AN IRREGULAR BACKGROUND WITH AN OVERALL RECTANGULAR SHAPE.

FOR ENTERTAINMENT SERVICES, NAMELY, ON-GOING TELEVISION AND RADIO PROGRAMS FEATURING CHILDREN'S ENTERTAINMENT; PRODUCTION AND DISTRIBUTION OF TELEVISION SHOWS, TELEVISION SPECIALS AND MOTION PICTURES (U.S. CLS. 100, 101 AND 107).

FIRST USE 9-21-2008; IN COMMERCE 9-21-2008.

CLASS 41—(Continued).

3,632,329. TIME INC., NEW YORK, NY. SN 77-327,790. PUB. 9-16-2008, FILED 11-13-2007.

TECHLAND

THE MARK CONSISTS OF STANDARD CHARACTERS WITHOUT CLAIM TO ANY PARTICULAR FONT, STYLE, SIZE, OR COLOR.

FOR ON-LINE JOURNALS, NAMELY, BLOGS FEATURING BUSINESS AND TECHNOLOGY; PROVIDING A WEB SITE FEATURING NON-DOWNLOADABLE TEXT FILES IN THE FIELD OF BUSINESS AND TECHNOLOGY, NAMELY, THE USE OF TECHNOLOGY IN BUSINESSES (U.S. CLS. 100, 101 AND 107).

FIRST USE 12-4-2007; IN COMMERCE 12-4-2007.

3,632,346. SUNDANCE CHANNEL LLC, NEW YORK, NY. SN 77-334,570. PUB. 4-22-2008, FILED 11-20-2007.

PRIME TIME FOR THE PLANET

THE MARK CONSISTS OF STANDARD CHARACTERS WITHOUT CLAIM TO ANY PARTICULAR FONT, STYLE, SIZE, OR COLOR.

FOR TELEVISION PROGRAMMING SERVICES (U.S. CLS. 100, 101 AND 107).

FIRST USE 3-10-2008; IN COMMERCE 3-10-2008.

3,632,347. JELD-WEN, INC., KLAMATH FALLS, OR. SN 77-335,022. PUB. 7-15-2008, FILED 11-21-2007.



OWNER OF U.S. REG. NOS. 1,388,339, 3,326,629, AND OTHERS.

NO CLAIM IS MADE TO THE EXCLUSIVE RIGHT TO USE "MILLWORK" AND "TRAINING MILLWORK PROFESSIONALS", APART FROM THE MARK AS SHOWN.

THE MARK CONSISTS OF THE WORDS "JELD-WEN MILLWORK UNIVERSITY" ARCHING ABOVE TWO STY-

CLASS 41—(Continued).

LIZED OLIVE BRANCHES THAT FORM A CIRCULAR DESIGN. A SHIELD/CREST APPEARS IN THE CENTER OF THE OLIVE BRANCHES WITH A SHADED RECTANGLE WITH ROUNDED CORNERS IN ITS CENTER. THE LETTERS "JW" APPEAR IN THE RECTANGLE WITH A CURVED LINE UNDERNEATH THE LETTERS. A SMALL SHADED 5-POINT STAR APPEARS JUST ABOVE THE TOP OF THE SHIELD/CREST AT ITS CENTER, AND A LARGER SHADED 5-POINT STAR APPEARS AT THE BOTTOM POINT OF THE SHIELD/CREST. A SHADED RIBBON BANNER WITH THE WORDING "TRAINING MILLWORK PROFESSIONALS" ON IT APPEARS ACROSS THE BOTTOM OF THE SHIELD/CREST ABOVE THE LARGER 5-POINT STAR.

FOR EDUCATION SERVICES, NAMELY, PROVIDING CLASSES AND SEMINARS IN THE FIELDS OF WINDOWS AND DOORS, SOFTWARE USE, SALES, SAFETY, LEGAL COMPLIANCE, CUSTOMER SERVICE, JOB PERFORMANCE, AND LEADERSHIP (U.S. CLS. 100, 101 AND 107).

FIRST USE 1-1-2008; IN COMMERCE 1-1-2008.

3,632,394. MIGHTY DOT MEDIA INC., SAN MATEO, CA. SN 77-356,425. PUB. 7-8-2008, FILED 12-20-2007.

The Registry

THE MARK CONSISTS OF STANDARD CHARACTERS WITHOUT CLAIM TO ANY PARTICULAR FONT, STYLE, SIZE, OR COLOR.

FOR MULTIMEDIA PUBLISHING OF REAL ESTATE BOOKS, MAGAZINES, JOURNALS, SOFTWARE, GAMES, MUSIC, AND ELECTRONIC PUBLICATIONS; PUBLICATION OF ELECTRONIC REAL ESTATE MAGAZINES; PUBLICATION OF REAL ESTATE MAGAZINES; PUBLISHING OF REAL ESTATE WEB MAGAZINES (U.S. CLS. 100, 101 AND 107).

FIRST USE 1-1-2008; IN COMMERCE 1-1-2008.

3,632,398. DISNEY ENTERPRISES, INC., BURBANK, CA. SN 77-357,339. PUB. 8-12-2008, FILED 12-20-2007.

DISNEY'S WILD ABOUT SAFETY

THE MARK CONSISTS OF STANDARD CHARACTERS WITHOUT CLAIM TO ANY PARTICULAR FONT, STYLE, SIZE, OR COLOR.

OWNER OF U.S. REG. NO. 2,978,787. NO CLAIM IS MADE TO THE EXCLUSIVE RIGHT TO USE "SAFETY", APART FROM THE MARK AS SHOWN.

FOR EDUCATIONAL SERVICES, NAMELY, INSTRUCTION IN THE FIELD OF SAFETY (U.S. CLS. 100, 101 AND 107).

FIRST USE 12-0-2003; IN COMMERCE 12-0-2003.

CLASS 41—(Continued).

3,632,423. KAPUSTA, STEPHEN, CELEBRATION, FL. SN 77-368,038. PUB. 7-8-2008, FILED 1-9-2008.

FragTools

THE MARK CONSISTS OF STANDARD CHARACTERS WITHOUT CLAIM TO ANY PARTICULAR FONT, STYLE, SIZE, OR COLOR.

FOR ELECTRONIC PUBLISHING SERVICES, NAMELY, PUBLICATION OF TEXT AND GRAPHIC WORKS OF OTHERS ON THE INTERNET FEATURING GAMES AND COMPUTER HARDWARE; ENTERTAINMENT SERVICES, NAMELY, PROVIDING ON-LINE REVIEWS OF COMPUTER HARDWARE, COMPUTER GAMES, CONSOLE GAMES, GAMING CONSOLE PERIPHERAL HARDWARE; MULTIMEDIA PUBLISHING OF BOOKS, MAGAZINES, JOURNALS, SOFTWARE, GAMES, MUSIC, AND ELECTRONIC PUBLICATIONS; ON-LINE PUBLICATION OF COMPUTER GAME AND HARDWARE REVIEWS; PROVIDING A WEB SITE WHERE USERS CAN POST RATINGS, REVIEWS AND RECOMMENDATIONS ON EVENTS AND ACTIVITIES IN THE FIELD OF ENTERTAINMENT AND EDUCATION; PROVIDING ON-LINE PUBLICATIONS IN THE NATURE OF REVIEWS AND EDITORIALS IN THE FIELD OF GAMES AND COMPUTER HARDWARE; PUBLICATION OF ELECTRONIC MAGAZINES; PUBLICATION OF ELECTRONIC NEWSPAPERS ACCESSIBLE VIA A GLOBAL COMPUTER NETWORK; PUBLICATION OF THE EDITORIAL CONTENT OF SITES ACCESSIBLE VIA A GLOBAL COMPUTER NETWORK; PUBLICATION OF COMPUTER GAMING MAGAZINES AND CONSOLE GAMING BOOKS; PUBLISHING OF ELECTRONIC PUBLICATIONS; PUBLISHING OF REVIEWS; WRITING OF ARTICLES FOR JOURNALS OTHER THAN FOR ADVERTISING OR PUBLICITY; WRITING OF ARTICLES FOR PROFESSIONAL JOURNALS OTHER THAN FOR ADVERTISING OR PUBLICITY; WRITING OF TEXTS (U.S. CLS. 100, 101 AND 107).
FIRST USE 9-1-2007; IN COMMERCE 1-4-2009.

3,632,433. 23ANDME, INC., MOUNTAIN VIEW, CA. SN 77-371,368. PUB. 7-22-2008, FILED 1-14-2008.

THE SPITTOON

THE MARK CONSISTS OF STANDARD CHARACTERS WITHOUT CLAIM TO ANY PARTICULAR FONT, STYLE, SIZE, OR COLOR.

FOR PROVIDING AN ONLINE RESOURCE CENTER, NAMELY, ONLINE ARTICLES IN THE FIELD OF GENETICS; PROVIDING ONLINE JOURNALS, NAMELY, BLOGS FEATURING INFORMATION IN THE FIELD OF GENETICS; PROVIDING A WEBSITE FEATURING ONLINE PUBLICATIONS IN THE NATURE OF ARTICLES AND MAGAZINES IN THE FIELD OF GENETICS (U.S. CLS. 100, 101 AND 107).
FIRST USE 1-21-2008; IN COMMERCE 1-21-2008.

CLASS 41—(Continued).

3,632,434. HALL WINES, LLC, ST. HELENA, CA. SN 77-371,437. PUB. 5-27-2008, FILED 1-14-2008.



THE MARK CONSISTS OF A SERIES OF WAVY INTERSECTING LINES IN A THREE BY THREE GRID. FOR ENTERTAINMENT SERVICES, NAMELY, WINE TASTINGS (U.S. CLS. 100, 101 AND 107).
FIRST USE 1-0-2008; IN COMMERCE 1-0-2008.

3,632,460. GEOQUEST, INC., HURRICANE, UT. SN 77-384,191. PUB. 6-17-2008, FILED 1-30-2008.

GeoQuest

THE MARK CONSISTS OF STANDARD CHARACTERS WITHOUT CLAIM TO ANY PARTICULAR FONT, STYLE, SIZE, OR COLOR.

FOR GUIDED TOURS OF HISTORICAL, GEOLOGICAL, AND RECREATIONAL SITES (U.S. CLS. 100, 101 AND 107).
FIRST USE 9-1-2008; IN COMMERCE 9-1-2008.

CLASS 41—(Continued).

3,632,461. FRANKLIN SCHOOL FOR THE PERFORMING ARTS, INC., FRANKLIN, MA. SN 77-384,214. PUB. 6-17-2008, FILED 1-30-2008.



NO CLAIM IS MADE TO THE EXCLUSIVE RIGHT TO USE "MUSIC SCHOOL", APART FROM THE MARK AS SHOWN.

THE COLOR(S) ORANGE, YELLOW, BLUE, GREEN, PURPLE, GRAY, RED, BLACK AND WHITE IS/ARE CLAIMED AS A FEATURE OF THE MARK.

THE MARK CONSISTS OF A PORTION OF A PIANO KEYBOARD WITH ORANGE, YELLOW, BLUE, GREEN, PURPLE, GRAY, AND RED BALLOONS ABOVE THE TOP AND LEFT SIDE OF THE KEYBOARD, THE WORDS "LITTLE MUSIC SCHOOL" ABOVE THE KEYBOARD AT THE TOP RIGHT SIDE THEREOF APPEAR IN BLACK, THE KEYS ON THE KEYBOARD APPEAR IN BLACK AND WHITE, THE BALLOON STRINGS APPEAR IN BLACK.

FOR PROVIDING INFORMATION ABOUT PLAYING MUSICAL INSTRUMENTS; INSTRUCTION IN THE FIELD OF MUSICAL INSTRUMENTS; PIANO INSTRUCTION (U.S. CLS. 100, 101 AND 107).

FIRST USE 7-1-2006; IN COMMERCE 7-1-2006.

3,632,462. REED ELSEVIER PROPERTIES INC., WILMINGTON, DE. SN 77-384,514. PUB. 9-23-2008, FILED 1-30-2008.

EBURGER EBURGER

THE MARK CONSISTS OF STANDARD CHARACTERS WITHOUT CLAIM TO ANY PARTICULAR FONT, STYLE, SIZE, OR COLOR.

FOR PROVIDING ONLINE NEWSLETTERS IN THE FIELD OF BARBECUE COOKING DIRECTED TO THE FOOD SERVICE INDUSTRY, NAMELY, NEWS, RECIPES, PREPARATION TIPS, FOOD TRENDS, CUSTOMER INSIGHTS AND MARKET RESEARCH (U.S. CLS. 100, 101 AND 107).

FIRST USE 10-20-2008; IN COMMERCE 10-20-2008.

CLASS 41—(Continued).

3,632,466. HARROW, SUSAN, DBA HARROW COMMUNICATIONS, SAN RAFAEL, CA. SN 77-385,321. PUB. 7-15-2008, FILED 1-31-2008.

THE COSMIC MENDING KIT

THE MARK CONSISTS OF STANDARD CHARACTERS WITHOUT CLAIM TO ANY PARTICULAR FONT, STYLE, SIZE, OR COLOR.

FOR ELECTRONIC PUBLISHING SERVICES, NAMELY, ONLINE PUBLICATION OF TEXT AND GRAPHIC WORKS OF OTHERS; ENTERTAINMENT SERVICES, NAMELY, PROVIDING A WEBSITE FEATURING WORKS OF ART, PHOTOGRAPHS, AND LITERARY WORKS OF OTHERS; ENTERTAINMENT SERVICES, NAMELY, ARRANGING CONTESTS AND COMPETITIONS IN THE FIELD OF ART, PHOTOGRAPHY, LITERATURE, MUSIC, FILM, AND POETRY (U.S. CLS. 100, 101 AND 107).

FIRST USE 3-26-2009; IN COMMERCE 3-26-2009.

3,632,467. GARDNER-WEBB UNIVERSITY, INC., BOILING SPRINGS, NC. SN 77-385,675. PUB. 7-8-2008, FILED 1-31-2008.

FAITH SERVICE LEADERSHIP

THE MARK CONSISTS OF STANDARD CHARACTERS WITHOUT CLAIM TO ANY PARTICULAR FONT, STYLE, SIZE, OR COLOR.

FOR EDUCATION AND ENTERTAINMENT SERVICES, NAMELY, PROVIDING EDUCATIONAL COURSES AT THE UNIVERSITY LEVEL AND ARRANGING AND CONDUCTING COLLEGE LEVEL MEN'S AND WOMEN'S SPORTING EVENTS, NAMELY, MEN'S AND WOMEN'S BASKETBALL, MEN'S FOOTBALL, MEN'S BASEBALL, WOMEN'S VOLLEYBALL, WOMEN'S SOFTBALL, MEN'S AND WOMEN'S TRACK AND FIELD, MEN'S AND WOMEN'S SWIMMING, MEN'S AND WOMEN'S CROSS COUNTRY, MEN'S AND WOMEN'S SOCCER, MEN'S AND WOMEN'S TENNIS AND MEN'S AND WOMEN'S GOLF (U.S. CLS. 100, 101 AND 107).

FIRST USE 8-0-2008; IN COMMERCE 8-0-2008.

CLASS 41—(Continued).

3,632,488. JOY OF GIVING SOMETHING, INC., NEW YORK, NY. SN 77-392,018. PUB. 6-24-2008, FILED 2-8-2008.

FORWARD THINKING MUSEUM

THE MARK CONSISTS OF STANDARD CHARACTERS WITHOUT CLAIM TO ANY PARTICULAR FONT, STYLE, SIZE, OR COLOR.

NO CLAIM IS MADE TO THE EXCLUSIVE RIGHT TO USE "MUSEUM", APART FROM THE MARK AS SHOWN.

FOR CONDUCTING EDUCATIONAL EXHIBITIONS IN THE NATURE OF ARTS, SCIENCE AND POLITICS AND THEIR EFFECT ON GLOBAL AFFAIRS; EDUCATIONAL SERVICES, NAMELY, CONDUCTING ON-LINE EXHIBITIONS AND DISPLAYS AND INTERACTIVE EXHIBITS IN THE FIELD OF ARTS, SCIENCE AND POLITICS AND THEIR EFFECT ON GLOBAL AFFAIRS (U.S. CLS. 100, 101 AND 107).

FIRST USE 11-2-2008; IN COMMERCE 11-20-2008.

3,632,489. JOY OF GIVING SOMETHING, INC., NEW YORK, NY. SN 77-392,021. PUB. 6-24-2008, FILED 2-8-2008.

F FORWARD THINKING MUSEUM

NO CLAIM IS MADE TO THE EXCLUSIVE RIGHT TO USE "MUSEUM", APART FROM THE MARK AS SHOWN.

THE MARK CONSISTS OF BLOCK LETTER "F" FOLLOWED BY "FORWARD THINKING MUSEUM"

FOR CONDUCTING EDUCATIONAL EXHIBITIONS IN THE NATURE OF ARTS, SCIENCE AND POLITICS AND THEIR EFFECT ON GLOBAL AFFAIRS; EDUCATIONAL SERVICES, NAMELY, CONDUCTING ON-LINE EXHIBITIONS AND DISPLAYS AND INTERACTIVE EXHIBITS IN THE FIELD OF ARTS, SCIENCE AND POLITICS AND THEIR EFFECT ON GLOBAL AFFAIRS (U.S. CLS. 100, 101 AND 107).

FIRST USE 3-0-2008; IN COMMERCE 3-0-2008.

CLASS 41—(Continued).

3,632,490. JOY OF GIVING SOMETHING, INC., NEW YORK, NY. SN 77-392,024. PUB. 6-24-2008, FILED 2-8-2008.

F FORWARD
THINKING
MUSEUM

NO CLAIM IS MADE TO THE EXCLUSIVE RIGHT TO USE "MUSEUM", APART FROM THE MARK AS SHOWN.

THE MARK CONSISTS OF BLOCK LETTER "F" FOLLOWED BY "FORWARD THINKING MUSEUM" EACH ON SEPARATE LINES.

FOR CONDUCTING EDUCATIONAL EXHIBITIONS IN THE NATURE OF ARTS, SCIENCE AND POLITICS AND THEIR EFFECT ON GLOBAL AFFAIRS; EDUCATIONAL SERVICES, NAMELY, CONDUCTING ON-LINE EXHIBITIONS AND DISPLAYS AND INTERACTIVE EXHIBITS IN THE FIELD OF ARTS, SCIENCE AND POLITICS AND THEIR EFFECT ON GLOBAL AFFAIRS (U.S. CLS. 100, 101 AND 107).

FIRST USE 11-20-2008; IN COMMERCE 11-20-2008.

3,632,528. CLOCKWORK IP, LLC, SARASOTA, FL. SN 77-399,792. PUB. 7-22-2008, FILED 2-18-2008.

CLOCKWORK
UNIVERSITY

OWNER OF U.S. REG. NOS. 3,170,839 AND 3,326,384.

NO CLAIM IS MADE TO THE EXCLUSIVE RIGHT TO USE "UNIVERSITY", APART FROM THE MARK AS SHOWN.

THE MARK CONSISTS OF THE WORDS "CLOCKWORK UNIVERSITY" ON TOP OF THE LETTER "U" CONTAINING STYLIZED GEARS.

FOR EDUCATIONAL SERVICES, NAMELY, PROVIDING CLASSES, SEMINARS, WORKSHOPS, AND ONLINE TRAINING COURSES TO HOME SERVICES CONTRACTORS IN THE FIELDS OF BUSINESS ADMINISTRATION, BUSINESS MANAGEMENT, BUSINESS DEVELOPMENT, LEADERSHIP AND BUSINESS STRATEGY DEVELOPMENT, BUDGETING, MARKETING, AND ADVERTISING, AND DISTRIBUTING COURSE MATERIALS IN CONNECTION THEREWITH (U.S. CLS. 100, 101 AND 107).

FIRST USE 4-15-2008; IN COMMERCE 4-15-2008.

CLASS 41—(Continued).

3,632,532. LIFETIME ENTERTAINMENT SERVICES, NEW YORK, NY. SN 77-401,720. PUB. 7-15-2008, FILED 2-20-2008.

HOLLYWOOD TAILS

THE MARK CONSISTS OF STANDARD CHARACTERS WITHOUT CLAIM TO ANY PARTICULAR FONT, STYLE, SIZE, OR COLOR.

NO CLAIM IS MADE TO THE EXCLUSIVE RIGHT TO USE "HOLLYWOOD", APART FROM THE MARK AS SHOWN.

FOR ENTERTAINMENT SERVICES, NAMELY, AN ON-LINE SERIES OF PROGRAMS, WEBISODES, VIDEO CLIPS AND INTERSTITIALS PROVIDED VIA THE INTERNET IN THE FIELD OF PARODY (U.S. CLS. 100, 101 AND 107).

FIRST USE 4-27-2008; IN COMMERCE 4-27-2008.

CLASS 41—(Continued).

3,632,545. RIMINI FIERA S.P.A., 47900 RIMINI, ITALY. SN 77-403,848. PUB. 7-8-2008, FILED 2-22-2008.



NO CLAIM IS MADE TO THE EXCLUSIVE RIGHT TO USE "U.S.A.", APART FROM THE MARK AS SHOWN.

THE COLOR(S) BLACK, RED, WHITE AND BLUE IS/ARE CLAIMED AS A FEATURE OF THE MARK.

THE MARK CONSISTS OF NON-STANDARD CHARACTERS, WHEREIN "S", "G", "E", AND "P" IN "SIGEP" ARE PRESENTED IN THE COLOR BLACK; "U.S.A." IS PRESENTED IN THE COLOR RED; THE "I" IN "SIGEP" CONTAINS THE COLORS RED, WHITE AND BLUE.

FOR EDUCATIONAL SERVICES, NAMELY, PROVIDING TRAINING OF SUPPORT STAFF, TRAINING OF VENDORS, TRAINING OF MANAGEMENT FOR EXHIBITIONS AND FAIRS; ENTERTAINMENT, NAMELY, ORGANIZING EXHIBITIONS FOR CULTURAL AND/OR EDUCATIONAL PURPOSES (U.S. CLS. 100, 101 AND 107).

FIRST USE 4-1-2008; IN COMMERCE 4-1-2008.

3,632,540. TEMENOS HEADQUARTERS SA, 1205 GENEVA, SWITZERLAND. SN 77-403,025. PUB. 7-15-2008, FILED 2-21-2008.



OWNER OF U.S. REG. NOS. 2,629,668, 3,325,690, AND OTHERS.

NO CLAIM IS MADE TO THE EXCLUSIVE RIGHT TO USE "CLIENT FORUM", APART FROM THE MARK AS SHOWN.

THE MARK CONSISTS OF THE WORD "TEMENOS" IN ALL CAPS, THE WORDS "CLIENT FORUM" IN INITIAL CAPS, AND A RENDERING OF A GLOBE IN THE SHAPE OF A CUBE.

THE FOREIGN WORDING IN THE MARK TRANSLATES INTO ENGLISH AS A SACRED PLACE.

FOR EDUCATIONAL SERVICES, NAMELY, ORGANIZING CONFERENCES, CONDUCTING PRACTICAL TRAINING AND DEMONSTRATIONS, AND TEACHING WORKSHOPS FOR USE IN ADMINISTRATION OF BANKING SOFTWARE FOR FINANCIAL INSTITUTIONS (U.S. CLS. 100, 101 AND 107).

FIRST USE 11-1-2007; IN COMMERCE 11-1-2007.

3,632,547. CRYSTALLIUS PRESS, LLC, MENLO PARK, CA. SN 77-404,327. PUB. 7-8-2008, FILED 2-22-2008.

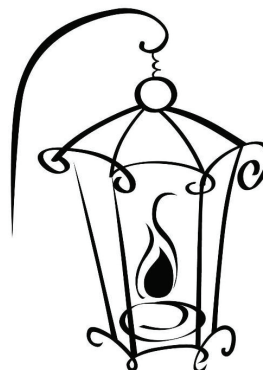

THE MARK CONSISTS OF AN IMAGE OF A LANTERN WITH A FLAME IN IT.

FOR BOOK PUBLISHING (U.S. CLS. 100, 101 AND 107). FIRST USE 4-0-2008; IN COMMERCE 4-0-2008.

CLASS 41—(Continued).

3,632,562. LAYADE, ADETUNJI, BROOKLYN, NY. SN 77-406,503. PUB. 7-15-2008, FILED 2-26-2008.

TALKING POINT FREE SPORTS
TPF

THE MARK CONSISTS OF STANDARD CHARACTERS WITHOUT CLAIM TO ANY PARTICULAR FONT, STYLE, SIZE, OR COLOR.

NO CLAIM IS MADE TO THE EXCLUSIVE RIGHT TO USE "SPORTS", APART FROM THE MARK AS SHOWN.

FOR ENTERTAINMENT SERVICES, NAMELY, PROVIDING INFORMATION IN THE FIELDS OF SPORTS RELATED NEWS AND SPORTS RELATED ENTERTAINMENT BY WAY OF A GLOBAL COMPUTER NETWORK; COMMENTARY IN THE FIELD OF SPORTS (U.S. CLS. 100, 101 AND 107).

FIRST USE 10-1-2008; IN COMMERCE 10-1-2008.

3,632,567. SOUTHLAND RACING CORPORATION, WEST MEMPHIS, AR. SN 77-407,091. PUB. 7-15-2008, FILED 2-27-2008.

BE LUCKY THAT WAY

THE MARK CONSISTS OF STANDARD CHARACTERS WITHOUT CLAIM TO ANY PARTICULAR FONT, STYLE, SIZE, OR COLOR.

FOR ENTERTAINMENT SERVICES, NAMELY, CASINO GAMING SERVICES (U.S. CLS. 100, 101 AND 107).

FIRST USE 12-31-2007; IN COMMERCE 12-31-2007.

3,632,597. FREEDOM COMMUNICATIONS, INC., DBA THE ORANGE COUNTY REGISTER, SANTA ANA, CA. SN 77-412,970. PUB. 7-15-2008, FILED 3-4-2008.



FOR ENTERTAINMENT SERVICES, NAMELY, PROVIDING INFORMATION, NEWS AND COMMENTARY VIA THE INTERNET AND TELEVISION IN THE FIELD OF ENTERTAINMENT (U.S. CLS. 100, 101 AND 107).

FIRST USE 9-8-2008; IN COMMERCE 9-8-2008.

CLASS 41—(Continued).

3,632,644. CULINARY INSTITUTE, INC., DBA CULINARY INSTITUTE ALAIN & MARIE LENOTRE, HOUSTON, TX. SN 77-419,501. PUB. 7-29-2008, FILED 3-12-2008.

CHANGING LIVES ONE CHEF
STUDENT AT A TIME

THE MARK CONSISTS OF STANDARD CHARACTERS WITHOUT CLAIM TO ANY PARTICULAR FONT, STYLE, SIZE, OR COLOR.

FOR EDUCATION SERVICES, NAMELY, PROVIDING CLASSES AND WORKSHOPS IN THE FIELD OF CULINARY ARTS AND BAKING AND DISTRIBUTION OF COURSE MATERIAL IN CONNECTION THEREWITH (U.S. CLS. 100, 101 AND 107).

FIRST USE 9-30-2008; IN COMMERCE 9-30-2008.

3,632,664. WHITEBOARDSSELLING, LLC, AUSTIN, TX. SN 77-424,648. PUB. 7-29-2008, FILED 3-18-2008.

WhiteboardSelling

THE MARK CONSISTS OF STANDARD CHARACTERS WITHOUT CLAIM TO ANY PARTICULAR FONT, STYLE, SIZE, OR COLOR.

FOR TRAINING SERVICES IN THE FIELD OF SALES (U.S. CLS. 100, 101 AND 107).

FIRST USE 7-31-2007; IN COMMERCE 7-31-2007.

3,632,665. FLYNN, LINDA, SCAPPOOSE, OR. SN 77-424,732. PUB. 7-29-2008, FILED 3-18-2008.

VIS-MEDS

THE MARK CONSISTS OF STANDARD CHARACTERS WITHOUT CLAIM TO ANY PARTICULAR FONT, STYLE, SIZE, OR COLOR.

FOR PHOTOGRAPHY SERVICES, NAMELY, PHOTOGRAPHING A TYPED LIST OF DAILY MEDICATIONS WITH THE ACTUAL MEDICATION BESIDE IT TO PROVIDE A VISUAL RECORD (PHOTO) OF DAILY MEDICATIONS FOR OTHERS (U.S. CLS. 100, 101 AND 107).

FIRST USE 3-1-2009; IN COMMERCE 3-1-2009.

CLASS 41—(Continued).

3,632,675. KNIGHT, KEITH, NEW YORK, NY. SN 77-427,341.
PUB. 9-9-2008, FILED 3-20-2008.

THE KNIGHT LIFE

THE MARK CONSISTS OF STANDARD CHARACTERS WITHOUT CLAIM TO ANY PARTICULAR FONT, STYLE, SIZE, OR COLOR.

FOR ENTERTAINMENT SERVICES, NAMELY, PUBLICATION OF COMIC STRIPS ONLINE, TO MOBILE COMMUNICATIONS DEVICES VIA GLOBAL COMPUTER NETWORKS AND WIRELESS NETWORKS, AND THROUGH OTHER ELECTRONIC VISUAL MEDIA (U.S. CLS. 100, 101 AND 107).

FIRST USE 5-5-2008; IN COMMERCE 5-5-2008.

3,632,693. CAMPANA, MICHAEL, WINDSOR, CO. SN 77-432,332. PUB. 8-5-2008, FILED 3-26-2008.

IRON FIRE

THE MARK CONSISTS OF STANDARD CHARACTERS WITHOUT CLAIM TO ANY PARTICULAR FONT, STYLE, SIZE, OR COLOR.

FOR BOOK PUBLISHING (U.S. CLS. 100, 101 AND 107).

FIRST USE 10-1-2008; IN COMMERCE 10-1-2008.

3,632,696. UPMC, PITTSBURGH, PA. SN 77-432,761. PUB. 7-15-2008, FILED 3-27-2008.

Step Up to Wellness

THE MARK CONSISTS OF STANDARD CHARACTERS WITHOUT CLAIM TO ANY PARTICULAR FONT, STYLE, SIZE, OR COLOR.

FOR PROVIDING ASSISTANCE, PERSONAL TRAINING AND PHYSICAL FITNESS CONSULTATION TO INDIVIDUALS TO HELP THEM MAKE PHYSICAL FITNESS, STRENGTH, CONDITIONING, AND EXERCISE IMPROVEMENT IN THEIR DAILY LIVING (U.S. CLS. 100, 101 AND 107).

FIRST USE 1-28-2009; IN COMMERCE 1-28-2009.

CLASS 41—(Continued).

3,632,697. UPMC, PITTSBURGH, PA. SN 77-432,766. PUB. 7-15-2008, FILED 3-27-2008.

Weigh to Wellness

THE MARK CONSISTS OF STANDARD CHARACTERS WITHOUT CLAIM TO ANY PARTICULAR FONT, STYLE, SIZE, OR COLOR.

FOR EDUCATIONAL SERVICES, NAMELY, CONDUCTING CLASSES, SEMINARS, AND WORKSHOPS IN THE FIELD OF WEIGHT MANAGEMENT AND DISTRIBUTING COURSE MATERIALS IN CONNECTION THEREWITH (U.S. CLS. 100, 101 AND 107).

FIRST USE 2-27-2009; IN COMMERCE 2-27-2009.

3,632,701. LIGHT, INC., THE, SOMERSET, NJ. SN 77-433,232. PUB. 8-5-2008, FILED 3-27-2008.

TUGHRA

THE MARK CONSISTS OF STANDARD CHARACTERS WITHOUT CLAIM TO ANY PARTICULAR FONT, STYLE, SIZE, OR COLOR.

THE MARK "TUGHRA" IS THE PHONETIC EQUIVALENT OF THE TURKISH WORD "TUGRA" WHICH MEANS "THE SULTAN'S SIGNATURE" IN ENGLISH.

FOR BOOK PUBLISHING; MAGAZINE PUBLISHING; ONLINE ELECTRONIC PUBLISHING OF BOOKS AND PERIODICALS; PUBLISHING OF BOOKS, MAGAZINES; PUBLISHING OF ELECTRONIC PUBLICATIONS; PUBLISHING OF WEB MAGAZINES; MULTIMEDIA PUBLISHING OF BOOKS, MAGAZINES, JOURNALS, SOFTWARE, GAMES, MUSIC, AND ELECTRONIC PUBLICATIONS; DIGITAL VIDEO, AUDIO, AND MULTIMEDIA PUBLISHING SERVICES (U.S. CLS. 100, 101 AND 107).

FIRST USE 5-1-2008; IN COMMERCE 5-1-2008.

CLASS 41—(Continued).

3,632,702. LIGHT, INC., THE, SOMERSET, NJ. SN 77-433,246. PUB. 8-5-2008, FILED 3-27-2008.

BLUE DOME

THE MARK CONSISTS OF STANDARD CHARACTERS WITHOUT CLAIM TO ANY PARTICULAR FONT, STYLE, SIZE, OR COLOR.

FOR BOOK PUBLISHING; MAGAZINE PUBLISHING; ONLINE ELECTRONIC PUBLISHING OF BOOKS AND PERIODICALS; PUBLISHING OF BOOKS, MAGAZINES; PUBLISHING OF ELECTRONIC PUBLICATIONS; PUBLISHING OF WEB MAGAZINES; MULTIMEDIA PUBLISHING OF BOOKS, MAGAZINES, JOURNALS, SOFTWARE, GAMES, MUSIC, AND ELECTRONIC PUBLICATIONS; DIGITAL VIDEO, AUDIO, AND MULTIMEDIA PUBLISHING SERVICES (U.S. CLS. 100, 101 AND 107).

FIRST USE 10-1-2008; IN COMMERCE 10-1-2008.

3,632,722. SANBORN THEATRES, INC., NEWPORT BEACH, CA. SN 77-437,756. PUB. 8-26-2008, FILED 4-2-2008.

CINEMAFUSION

THE MARK CONSISTS OF STANDARD CHARACTERS WITHOUT CLAIM TO ANY PARTICULAR FONT, STYLE, SIZE, OR COLOR.

FOR MOVIE THEATERS (U.S. CLS. 100, 101 AND 107). FIRST USE 6-28-2008; IN COMMERCE 6-28-2008.

CLASS 41—(Continued).

3,632,743. HOOT/INSIGHT MUSIC PUBLISHING, LLC, BOCA RATON, FL. SN 77-444,176. PUB. 8-26-2008, FILED 4-9-2008.

HOOT/INSIGHT

THE MARK CONSISTS OF STANDARD CHARACTERS WITHOUT CLAIM TO ANY PARTICULAR FONT, STYLE, SIZE, OR COLOR.

OWNER OF U.S. REG. NO. 3,280,421.

FOR MUSIC PUBLISHING SERVICES; RECORDING STUDIO SERVICES; RECORDING AND PRODUCING MUSICAL SOUND RECORDINGS AND MUSICAL VIDEO RECORDINGS; INFORMATION SERVICES RELATING TO MUSIC, MUSICAL ENTERTAINMENT AND EVENTS PROVIDED ONLINE FROM A COMPUTER DATABASE, FROM THE INTERNET OR ANY OTHER COMMUNICATION NETWORK; AND PROVIDING A WEBSITE OVER A GLOBAL COMPUTER INFORMATION NETWORK FEATURING INFORMATION ABOUT A RECORD LABEL AND A PUBLISHING COMPANY, WRITERS AND RECORDING ARTISTS ASSOCIATED WITH A RECORD LABEL AND PUBLISHING COMPANY, AND THE MUSIC OF WRITERS AND RECORDING ARTISTS ASSOCIATED WITH A RECORD LABEL AND PUBLISHING COMPANY (U.S. CLS. 100, 101 AND 107).

FIRST USE 11-7-2007; IN COMMERCE 11-7-2007.

3,632,744. MARKS INTERESTS, MIAMI, FL. SN 77-444,371. PUB. 8-26-2008, FILED 4-9-2008.

the raging jews of comedy

THE MARK CONSISTS OF STANDARD CHARACTERS WITHOUT CLAIM TO ANY PARTICULAR FONT, STYLE, SIZE, OR COLOR.

FOR PRESENTATION OF LIVE COMEDY SHOWS (U.S. CLS. 100, 101 AND 107).

FIRST USE 12-3-2008; IN COMMERCE 12-3-2008.

CLASS 41—(Continued).

3,632,753. NEW FRONTIER MEDIA, INC., BOULDER, CO. SN 77-446,157. PUB. 7-22-2008, FILED 4-11-2008.

XTSY

THE MARK CONSISTS OF STANDARD CHARACTERS WITHOUT CLAIM TO ANY PARTICULAR FONT, STYLE, SIZE, OR COLOR.

OWNER OF U.S. REG. NO. 2,971,668. FOR ENTERTAINMENT SERVICES, NAMELY, PROVIDING SEXUALLY EXPLICIT VIDEO PROGRAMMING VIA CABLE, SATELLITE AND GLOBAL INTERACTIVE NETWORKS (U.S. CLS. 100, 101 AND 107). FIRST USE 1-0-2002; IN COMMERCE 1-0-2002.

3,632,758. SCHALER, KAREN R, NEW YORK CITY, NY. SN 77-447,056. PUB. 9-2-2008, FILED 4-14-2008.

TRAVEL THERAPY

THE MARK CONSISTS OF STANDARD CHARACTERS WITHOUT CLAIM TO ANY PARTICULAR FONT, STYLE, SIZE, OR COLOR.

NO CLAIM IS MADE TO THE EXCLUSIVE RIGHT TO USE "TRAVEL", APART FROM THE MARK AS SHOWN.

FOR PUBLICATION OF BOOKS, OF MAGAZINES, OF JOURNALS, OF NEWSPAPERS, OF PERIODICALS, OF CATALOGS, OF BROCHURES; MULTIMEDIA PUBLISHING OF BOOKS, MAGAZINES, JOURNALS, SOFTWARE, GAMES, MUSIC, AND ELECTRONIC PUBLICATIONS; ONLINE ELECTRONIC PUBLISHING OF BOOKS AND PERIODICALS; PUBLISHING OF BOOKS AND REVIEWS; PUBLISHING OF BOOKS, MAGAZINES; BOOK PUBLISHING; ENTERTAINMENT SERVICES, NAMELY, PROVIDING ON-LINE REVIEWS OF TRAVEL; PUBLICATION OF BOOKS, REVIEWS; PUBLICATION OF TEXTS, BOOKS, MAGAZINES AND OTHER PRINTED MATTER (U.S. CLS. 100, 101 AND 107). FIRST USE 11-25-2008; IN COMMERCE 3-23-2009.

3,632,767. FREEDOM COMMUNICATIONS, INC., DBA THE ORANGE COUNTY REGISTER, SANTA ANA, CA. SN 77-448,769. PUB. 7-1-2008, FILED 4-15-2008.

SOCAL SPORTS NOW

THE MARK CONSISTS OF STANDARD CHARACTERS WITHOUT CLAIM TO ANY PARTICULAR FONT, STYLE, SIZE, OR COLOR.

CLASS 41—(Continued).

NO CLAIM IS MADE TO THE EXCLUSIVE RIGHT TO USE "SOCAL SPORTS", APART FROM THE MARK AS SHOWN. FOR PROVIDING A WEB SITE FEATURING INFORMATION, VIDEOS AND COMMENTARY IN THE FIELD OF SPORTS (U.S. CLS. 100, 101 AND 107).

FIRST USE 4-9-2008; IN COMMERCE 4-9-2008.

3,632,787. MICHAEL CAMPANA, WINDSOR, CO. SN 77-456,041. PUB. 8-5-2008, FILED 4-23-2008.



THE MARK CONSISTS OF "IRON" AND "FIRE" WITH A FRAME.

FOR BOOK PUBLISHING (U.S. CLS. 100, 101 AND 107). FIRST USE 10-1-2008; IN COMMERCE 10-1-2008.

3,632,802. TOY STATE INDUSTRIAL LTD., TSTE KOW-LOON, HONG KONG. SN 77-461,522. PUB. 9-30-2008, FILED 4-30-2008.

MOTOR ISLAND

THE MARK CONSISTS OF STANDARD CHARACTERS WITHOUT CLAIM TO ANY PARTICULAR FONT, STYLE, SIZE, OR COLOR.

FOR PROVIDING A WEBSITE FEATURING INTERACTIVE ACTIVITIES GAMES AND ENTERTAINMENT (U.S. CLS. 100, 101 AND 107).

FIRST USE 12-22-2008; IN COMMERCE 12-22-2008.

CLASS 41—(Continued).

3,632,873. STUDIO ONE NETWORKS, INC., NEW YORK, NY. SN 77-491,699. PUB. 9-23-2008, FILED 6-5-2008.

COMPLETELY AT HOME  The essential guide to getting the home that's right for you.

NO CLAIM IS MADE TO THE EXCLUSIVE RIGHT TO USE "HOME", APART FROM THE MARK AS SHOWN.

THE COLOR(S) DARK BLUE, LIGHT BLUE, ORANGE, GREEN AND PURPLE IS/ARE CLAIMED AS A FEATURE OF THE MARK.

THE MARK CONSISTS OF THE WORDING "COMPLETELY AT HOME," IN THE COLOR DARK BLUE, IN ALL CAPS; AND TO THE RIGHT A LIGHT BLUE TRIANGLE, ABOVE THREE CIRCLES, ONE IN EACH OF THE COLORS, ORANGE, GREEN AND PURPLE, REPRESENTING A HOUSE; FOLLOWED BY THE WORDING "THE ESSENTIAL GUIDE TO GETTING THE HOME THAT'S RIGHT FOR YOU." IN LOWER CASE, IN THE COLOR DARK BLUE.

FOR PROVIDING ON-LINE PUBLICATIONS IN THE NATURE OF MAGAZINES IN THE FIELD OF REAL ESTATE, PERSONAL FINANCE AND HOME DESIGN (U.S. CLS. 100, 101 AND 107).

FIRST USE 6-3-2008; IN COMMERCE 6-3-2008.

3,632,909. FS CHALLENGE, LLC, DBA FS CHALLENGE, ST. LOUIS, MO. SN 77-507,986. PUB. 11-25-2008, FILED 6-25-2008.



NO CLAIM IS MADE TO THE EXCLUSIVE RIGHT TO USE "CHALLENGE", APART FROM THE MARK AS SHOWN.

THE MARK CONSISTS OF "FS" IN UPPER-CASE LETTERING AT THE TOP ENCLOSED IN A PENTAGON, BORDERED ON THE BOTTOM BY A DOWNWARD ARROWED LINE, FOLLOWED BY THE WORD "CHALLENGE" IN UPPER-CASE LETTERING, WITH THE WORD "CHALLENGE" EXTENDING BEYOND THE LEFT AND RIGHT BORDERS OF THE PREVIOUSLY MENTIONED PENTAGON AND DOWNWARD ARROWED LINE, BORDERED ON THE BOTTOM BY THREE FIVE-POINTED STARS, WITH THE MIDDLE STAR APPEARING SLIGHTLY LARGER THAN THE OTHER TWO STARS, THEN BORDERED ON THE VERY BOTTOM BY TWO INCREASINGLY LARGER DOWNWARD ARROWED LINES.

FOR ENTERTAINMENT IN THE NATURE OF FANTASY SPORTS TOURNAMENTS; ENTERTAINMENT SERVICES IN THE NATURE OF FANTASY SPORTS LEAGUES; ENTERTAINMENT SERVICES, NAMELY, ARRANGING AND CONDUCTING OF COMPETITIONS FOR FANTASY SPORTS; PROVIDING A COMPUTER GAME THAT MAY BE ACCESSED NETWORK-WIDE BY NETWORK USERS; PROVIDING A WEB SITE THAT PROVIDES SPORTS LEAGUE PLAYER STATISTICS (U.S. CLS. 100, 101 AND 107).

FIRST USE 7-11-2008; IN COMMERCE 7-11-2008.

CLASS 41—(Continued).

3,632,915. FOX TELEVISION STUDIOS, INC., LOS ANGELES, CA. SN 77-510,499. PUB. 10-28-2008, FILED 6-27-2008.

THE SKINNY: FAT FREE NEWS

THE MARK CONSISTS OF STANDARD CHARACTERS WITHOUT CLAIM TO ANY PARTICULAR FONT, STYLE, SIZE, OR COLOR.

FOR ENTERTAINMENT SERVICES IN THE NATURE OF AUDIO AND VIDEO SEGMENTS FEATURING COMEDY (U.S. CLS. 100, 101 AND 107).

FIRST USE 10-9-2008; IN COMMERCE 10-9-2008.

3,632,926. PAUL, CHARSYA BIANCA, DENHAM SPRINGS, LA. SN 77-513,584. PUB. 1-13-2009, FILED 7-2-2008.



NO CLAIM IS MADE TO THE EXCLUSIVE RIGHT TO USE "MANGA", APART FROM THE MARK AS SHOWN.

THE COLOR(S) PINK, BLUE, WHITE, BLACK, AND PURPLE IS/ARE CLAIMED AS A FEATURE OF THE MARK.

THE MARK CONSISTS OF A PAWPRINT THAT IS PINK WITH A WHITE OUTLINE, THE LANGUAGE "P 2" AND "MANGA" AND THE HEARTS ON THE INSIDE OF THE PAWPRINT ARE PURPLE. THE OUTSIDE OF THE PAWPRINT IS ENCASED IN A BLACK OUTLINED CIRCLE WITH BLUE, PINK, AND PURPLE COLORS ON THE INSIDE OF THE CIRCLE.

FOR PUBLISHING OF COMIC BOOKS AND CHILDREN'S BOOKS (U.S. CLS. 100, 101 AND 107).

FIRST USE 7-3-2008; IN COMMERCE 7-3-2008.

CLASS 41—(Continued).

3,632,929. GOOD EGG STUDIOS, INC., ATLANTA, GA. SN 77-514,673. PUB. 11-25-2008, FILED 7-3-2008.

GAMING FOR GOOD

THE MARK CONSISTS OF STANDARD CHARACTERS WITHOUT CLAIM TO ANY PARTICULAR FONT, STYLE, SIZE, OR COLOR.

FOR ENTERTAINMENT SERVICES, NAMELY, PROVIDING ON-LINE COMPUTER GAMES (U.S. CLS. 100, 101 AND 107).

FIRST USE 11-4-2008; IN COMMERCE 11-4-2008.

CLASS 41—(Continued).

3,632,951. UNIVERSITY OF NORTH CAROLINA SCHOOL OF THE ARTS, WINSTON-SALEM, NC. SN 77-520,138. PUB. 12-9-2008, FILED 7-11-2008.

UNCSA

THE MARK CONSISTS OF STANDARD CHARACTERS WITHOUT CLAIM TO ANY PARTICULAR FONT, STYLE, SIZE, OR COLOR.

FOR EDUCATION SERVICES, NAMELY, PROVIDING CLASSES FOR STUDENTS FROM MIDDLE SCHOOL THROUGH GRADUATE SCHOOL OR PROFESSIONAL CAREERS IN THE FIELDS OF PERFORMING, VISUAL, FILM AND TELEVISION ARTS (U.S. CLS. 100, 101 AND 107).

FIRST USE 8-11-2008; IN COMMERCE 8-11-2008.

3,632,930. GOOD EGG STUDIOS, INC., ATLANTA, GA. SN 77-514,734. PUB. 11-25-2008, FILED 7-3-2008.

PLAY GAMES. DO GOOD.

THE MARK CONSISTS OF STANDARD CHARACTERS WITHOUT CLAIM TO ANY PARTICULAR FONT, STYLE, SIZE, OR COLOR.

FOR ENTERTAINMENT SERVICES, NAMELY, PROVIDING ON-LINE COMPUTER GAMES (U.S. CLS. 100, 101 AND 107).

FIRST USE 11-4-2008; IN COMMERCE 11-4-2008.

3,632,980. BIOELEMENTS, INC., COLORADO SPRINGS, CO. SN 77-530,233. PUB. 12-16-2008, FILED 7-24-2008.

BIOELEMENTS SkinReading

THE MARK CONSISTS OF STANDARD CHARACTERS WITHOUT CLAIM TO ANY PARTICULAR FONT, STYLE, SIZE, OR COLOR.

OWNER OF U.S. REG. NOS. 1,684,104, 2,190,960, AND OTHERS.

FOR EDUCATIONAL SERVICES, NAMELY, CONDUCTING CLASSES AND WORKSHOPS IN THE FIELD OF AESTHETIC SKIN ANALYSIS AND COURSE MATERIALS DISTRIBUTED THEREWITH (U.S. CLS. 100, 101 AND 107).

FIRST USE 4-3-2009; IN COMMERCE 4-3-2009.

3,632,940. STEVEN H. BLANCE, EXCELSIOR, MN. SN 77-518,532. PUB. 12-2-2008, FILED 7-9-2008.

Wrestlicious

THE MARK CONSISTS OF STANDARD CHARACTERS WITHOUT CLAIM TO ANY PARTICULAR FONT, STYLE, SIZE, OR COLOR.

FOR ENTERTAINMENT SERVICES IN THE NATURE OF A WRESTLING CLUB (U.S. CLS. 100, 101 AND 107).

FIRST USE 8-1-2008; IN COMMERCE 8-15-2008.

3,632,984. SIX DEGREES GAMES, INC., MARINA DEL REY, CA. SN 77-531,930. PUB. 11-25-2008, FILED 7-25-2008.



NO CLAIM IS MADE TO THE EXCLUSIVE RIGHT TO USE "ACTION", APART FROM THE MARK AS SHOWN.

THE MARK CONSISTS OF THE STYLIZED WORDS "ACTION ALLSTARS" AND A PARTIAL STAR DESIGN.

FOR ENTERTAINMENT SERVICES, NAMELY, PROVIDING AN ONLINE VIRTUAL WORLD FEATURING ONLINE COMPUTER GAMES (U.S. CLS. 100, 101 AND 107).

FIRST USE 1-1-2009; IN COMMERCE 1-1-2009.

CLASS 41—(Continued).

3,632,997. MAKO SURGICAL CORP., FORT LAUDERDALE, FL. SN 77-537,241. PUB. 12-23-2008, FILED 8-1-2008.

WHAT YOU PLAN IS WHAT YOU
GET

THE MARK CONSISTS OF STANDARD CHARACTERS WITHOUT CLAIM TO ANY PARTICULAR FONT, STYLE, SIZE, OR COLOR.

FOR EDUCATION SERVICES, NAMELY, PROVIDING AND CONDUCTING CONFERENCES, SEMINARS, WORKSHOPS, AND CLASSES IN THE FIELD OF MINIMALLY INVASIVE SURGICAL TECHNIQUES (U.S. CLS. 100, 101 AND 107).

FIRST USE 2-25-2009; IN COMMERCE 2-25-2009.

3,633,011. LEARNING UPGRADE, LLC, ESCONDIDO, CA. SN 77-542,608. PUB. 1-6-2009, FILED 8-8-2008.

ALGEBRA UPGRADE

THE MARK CONSISTS OF STANDARD CHARACTERS WITHOUT CLAIM TO ANY PARTICULAR FONT, STYLE, SIZE, OR COLOR.

OWNER OF U.S. REG. NOS. 2,554,161, 3,065,837, AND 3,211,866.

NO CLAIM IS MADE TO THE EXCLUSIVE RIGHT TO USE "ALGEBRA", APART FROM THE MARK AS SHOWN.

FOR EDUCATION SERVICES, NAMELY, PROVIDING INSTRUCTION AT THE PRIMARY AND SECONDARY LEVELS IN THE FIELD OF READING, WRITING, HISTORY, SOCIAL STUDIES, AND MATHEMATICS, AND DISTRIBUTING COURSE MATERIAL IN CONNECTION THEREWITH (U.S. CLS. 100, 101 AND 107).

FIRST USE 4-13-2009; IN COMMERCE 4-13-2009.

3,633,014. FILEDBY, INC, NASHVILLE, TN. SN 77-544,678. PUB. 12-30-2008, FILED 8-12-2008.

FILEDBY

THE MARK CONSISTS OF STANDARD CHARACTERS WITHOUT CLAIM TO ANY PARTICULAR FONT, STYLE, SIZE, OR COLOR.

FOR PROVIDING INFORMATION ON-LINE REGARDING WRITERS, AUTHORS AND THEIR WORKS (U.S. CLS. 100, 101 AND 107).

FIRST USE 12-12-2008; IN COMMERCE 12-12-2008.

CLASS 41—(Continued).

3,633,027. NATIONAL ASSOCIATION OF INSURANCE WOMEN, DBA NAIW(INTERNATIONAL), TULSA, OK. SN 77-549,036. PUB. 1-6-2009, FILED 8-18-2008.

Confidence While
Communicating

THE MARK CONSISTS OF STANDARD CHARACTERS WITHOUT CLAIM TO ANY PARTICULAR FONT, STYLE, SIZE, OR COLOR.

FOR EDUCATIONAL SERVICES, NAMELY, CONDUCTING CLASSES, SEMINARS, WORKSHOPS IN THE FIELD OF INSURANCE AND RISK MANAGEMENT (U.S. CLS. 100, 101 AND 107).

FIRST USE 4-15-2009; IN COMMERCE 4-15-2009.

3,633,034. CORPORATE DEVELOPMINT, CHARLESTON, SC. SN 77-554,729. PUB. 1-13-2009, FILED 8-25-2008.

MintAsk

THE MARK CONSISTS OF STANDARD CHARACTERS WITHOUT CLAIM TO ANY PARTICULAR FONT, STYLE, SIZE, OR COLOR.

FOR TRAINING SERVICES HELPING NON-PROFIT ORGANIZATIONS PROPERLY IMPLEMENT PHILANTHROPY TO MORE EFFICIENTLY AND EFFECTIVELY RAISE MONEY IN THE COMMUNITY (U.S. CLS. 100, 101 AND 107).

FIRST USE 6-1-2004; IN COMMERCE 6-1-2004.

CLASS 41—(Continued).

3,633,076. THIEN THANH THI NGUYEN, SHERMAN OAKS, CA. SN 77-977,069. PUB. 2-19-2008, FILED 2-12-2007.

CLASS 41—(Continued).

3,633,132. BOX 5, LLC, CAMBRIDGE, MA. SN 78-579,547. PUB. 9-30-2008, FILED 3-3-2005.

TILA TEQUILA

THE MARK CONSISTS OF STANDARD CHARACTERS WITHOUT CLAIM TO ANY PARTICULAR FONT, STYLE, SIZE, OR COLOR.

FOR SONG WRITING SERVICES; ENTERTAINMENT IN THE NATURE OF A LIVE MUSICAL PERFORMER; ENTERTAINMENT IN THE NATURE OF LIVE PERFORMANCES BY A MUSICAL ARTIST; ENTERTAINMENT IN THE NATURE OF VISUAL AND AUDIO PERFORMANCES BY A MUSICAL ARTIST; ENTERTAINMENT, NAMELY, LIVE MUSIC CONCERTS; ENTERTAINMENT, NAMELY, PERSONAL APPEARANCES BY A MUSICIAN, ENTERTAINER, MODEL, ACTRESS OR CELEBRITY; ENTERTAINMENT SERVICES, NAMELY, PROVIDING A WEB SITE FEATURING MUSICAL PERFORMANCES; ENTERTAINMENT SERVICES, NAMELY, PROVIDING PRERECORDED MUSIC ONLINE VIA A GLOBAL COMPUTER NETWORK; ENTERTAINMENT IN THE NATURE OF ON-GOING TELEVISION PROGRAMS FEATURING MUSIC, BEAUTY, FASHION, MODELING, COMEDY, DRAMATIC ACTS, AND SPOKEN WORD; TELEVISION AND CABLE TELEVISION PROGRAMS FEATURING MUSIC, BEAUTY, FASHION, MODELING, COMEDY, DRAMA, AND SPOKEN WORD (U.S. CLS. 100, 101 AND 107).
FIRST USE 12-31-2006; IN COMMERCE 12-31-2006.

3,633,131. MCDONALD'S CORPORATION, OAK BROOK, IL. SN 78-578,677. PUB. 5-9-2006, FILED 3-2-2005.

CHIEF HAPPINESS OFFICER

THE MARK CONSISTS OF STANDARD CHARACTERS WITHOUT CLAIM TO ANY PARTICULAR FONT, STYLE, SIZE, OR COLOR.

FOR EDUCATIONAL AND ENTERTAINMENT SERVICES, NAMELY, PROVIDING CLASSES AND MOTIVATIONAL SPEAKERS IN THE FIELD OF HEALTH, NUTRITION, PHYSICAL FITNESS, SAFETY, LITERACY AND ACADEMIC DEVELOPMENT AND ACHIEVEMENT (U.S. CLS. 100, 101 AND 107).
FIRST USE 8-31-2003; IN COMMERCE 8-31-2003.

BOX 5

THE MARK CONSISTS OF STANDARD CHARACTERS WITHOUT CLAIM TO ANY PARTICULAR FONT, STYLE, SIZE, OR COLOR.

FOR DISTRIBUTION OF MOTION PICTURES; ENTERTAINMENT SERVICES, NAMELY, PROVIDING A WEB SITE FEATURING, PHOTOGRAPHS, INFORMATION ABOUT FILMS, INFORMATION ABOUT FILM DISTRIBUTION, INFORMATION ABOUT FILM PRODUCTION; MOTION PICTURE AND VIDEO PRODUCTION SERVICES (U.S. CLS. 100, 101 AND 107).
FIRST USE 3-11-2005; IN COMMERCE 3-11-2005.

3,633,155. Nanci L. Bell, TRUSTEE, OR SUCCESSOR TRUSTEE, OF THE Nanci L. Bell SEPARATE PROPERTY REVOCABLE TRUST ESTABLISHED UNDER DECLARATION DATED SEPTEMBER 11, 1997, SAN LUIS OBISPO, CA. SN 78-646,249. PUB. 2-14-2006, FILED 6-8-2005.

OPAL

THE MARK CONSISTS OF STANDARD CHARACTERS WITHOUT CLAIM TO ANY PARTICULAR FONT, STYLE, SIZE, OR COLOR.

FOR EDUCATIONAL SERVICES, NAMELY, CONDUCTING SEMINARS, TRAINING PROGRAMS, WORKSHOPS AND INDIVIDUAL CLASSES IN THE FIELD OF SYMBOL IMAGERY FOR PHONEMIC AWARENESS, SIGHT WORDS AND SPELLING (U.S. CLS. 100, 101 AND 107).
FIRST USE 3-8-2005; IN COMMERCE 1-26-2006.

CLASS 41—(Continued).

3,633,157. LOOPHOLE RECORDS, LLC, PORTLAND, OR. SN 78-652,391. PUB. 10-7-2008, FILED 6-16-2005.

LOOPHOLE RECORDS

THE MARK CONSISTS OF STANDARD CHARACTERS WITHOUT CLAIM TO ANY PARTICULAR FONT, STYLE, SIZE, OR COLOR.

NO CLAIM IS MADE TO THE EXCLUSIVE RIGHT TO USE "RECORDS", APART FROM THE MARK AS SHOWN.

FOR ENTERTAINMENT SERVICES, NAMELY, PRODUCTION OF AUDIO AND VISUAL TAPES, PHONOGRAPHS RECORDS, COMPACT DISCS, DVDS AND CD-ROMS ALL FEATURING MUSIC, MUSIC VIDEOS AND MUSICAL PERFORMANCES; MUSIC PUBLISHING SERVICES (U.S. CLS. 100, 101 AND 107).

FIRST USE 12-18-2007; IN COMMERCE 12-21-2007.

3,633,158. HAAS, FRANCINE, CHICAGO, IL. AND GEORGE, BRENDAN P., DEERFIELD, IL. SN 78-654,058. PUB. 10-31-2006, FILED 6-20-2005.



FOR ORGANIZING AND ARRANGING SPORTING ACTIVITIES, INSTRUCTIONAL CLINICS AND SEMINARS IN THE FIELD OF BIKING AND WOMEN'S OUTDOOR RECREATIONAL SPORTS (U.S. CLS. 100, 101 AND 107).

FIRST USE 7-0-2004; IN COMMERCE 7-0-2004.

CLASS 41—(Continued).

3,633,160. ACCLIVUS CORPORATION, DALLAS, TX. SN 78-659,559. PUB. 3-14-2006, FILED 6-28-2005.

INSPIRING PEOPLE-ENABLING PERFORMANCE

THE MARK CONSISTS OF STANDARD CHARACTERS WITHOUT CLAIM TO ANY PARTICULAR FONT, STYLE, SIZE, OR COLOR.

FOR EDUCATIONAL SERVICES, NAMELY, CONDUCTING WORKSHOPS, LECTURES, COURSE SYMPOSIUM AND CONFERENCES IN THE FIELD OF BUSINESS MANAGEMENT, SALES COMMUNICATION AND BUILDING RELATIONSHIPS WITH CUSTOMERS, AND DISTRIBUTING COURSE MATERIALS IN CONNECTION THEREWITH (U.S. CLS. 100, 101 AND 107).

FIRST USE 6-1-2007; IN COMMERCE 6-1-2007.

3,633,162. CENTURY OF PROGRESS PRODUCTIONS, TAZANA, CA. SN 78-666,604. PUB. 7-25-2006, FILED 7-8-2005.

COURGETTE

THE MARK CONSISTS OF STANDARD CHARACTERS WITHOUT CLAIM TO ANY PARTICULAR FONT, STYLE, SIZE, OR COLOR.

FOR ENTERTAINMENT SERVICES, NAMELY, PRODUCTION OF AUDIO, VIDEO, AND AUDIO-VIDEO RECORDINGS; MUSIC PRODUCTION; VIDEO PRODUCTION; PRODUCTION OF VIDEO TAPES, COMPACT DISCS, AND DVDS; MUSIC AND BOOK PUBLISHING (U.S. CLS. 100, 101 AND 107).

FIRST USE 0-0-2006; IN COMMERCE 0-0-2007.

3,633,205. SEATTLE METROPOLITAN, LLC, SEATTLE, WA. SN 78-749,877. PUB. 7-18-2006, FILED 11-8-2005.

SEATTLE METROPOLITAN

THE MARK CONSISTS OF STANDARD CHARACTERS WITHOUT CLAIM TO ANY PARTICULAR FONT, STYLE, SIZE, OR COLOR.

NO CLAIM IS MADE TO THE EXCLUSIVE RIGHT TO USE "SEATTLE", APART FROM THE MARK AS SHOWN.

FOR ON-LINE PUBLICATIONS, NAMELY, MAGAZINES FEATURING TOPICS OF INTEREST TO RESIDENTS OF AND VISITORS TO THE PACIFIC NORTHWEST (U.S. CLS. 100, 101 AND 107).

FIRST USE 1-15-2009; IN COMMERCE 1-15-2009.

CLASS 41—(Continued).

3,633,214. OFFICE OF THE COMMISSIONER OF BASEBALL, NEW YORK, NY. SN 78-758,381. PUB. 1-23-2007, FILED 11-21-2005.



OWNER OF U.S. REG. NO. 1,357,826 AND OTHERS.
NO CLAIM IS MADE TO THE EXCLUSIVE RIGHT TO USE "LEAGUE", APART FROM THE MARK AS SHOWN.

FOR ENTERTAINMENT SERVICES, NAMELY, BASEBALL GAMES, COMPETITIONS, TOURNAMENTS AND EXHIBITIONS RENDERED LIVE AND THROUGH BROADCAST MEDIA INCLUDING TELEVISION, RADIO, SATELLITE, WIRELESS, AUDIO AND VIDEO MEDIA, TELEPHONE, FIBER OPTICS, WI-FI AND OTHER ELECTRONIC MEDIA AND VIA A GLOBAL COMPUTER NETWORK OR A COMMERCIAL ON-LINE SERVICE; INFORMATION SERVICES, NAMELY, PROVIDING INFORMATION IN THE FIELD OF SPORTS, ENTERTAINMENT AND RELATED TOPICS, AND PROVIDING FOR INFORMATIONAL MESSAGES RELATING THERETO (U.S. CLS. 100, 101 AND 107).
FIRST USE 0-0-1971; IN COMMERCE 0-0-1971.

CLASS 41—(Continued).

3,633,215. OFFICE OF THE COMMISSIONER OF BASEBALL, NEW YORK, NY. SN 78-758,419. PUB. 1-2-2007, FILED 11-21-2005.

FALL CLASSIC

THE MARK CONSISTS OF STANDARD CHARACTERS WITHOUT CLAIM TO ANY PARTICULAR FONT, STYLE, SIZE, OR COLOR.

OWNER OF U.S. REG. NOS. 1,653,242, 1,859,780, AND OTHERS.

SEC. 2(F).

FOR ENTERTAINMENT SERVICES, NAMELY, BASEBALL GAMES, COMPETITIONS, TOURNAMENTS AND EXHIBITIONS RENDERED LIVE AND THROUGH BROADCAST MEDIA INCLUDING TELEVISION, RADIO, SATELLITE, WIRELESS, AUDIO AND VIDEO MEDIA, TELEPHONE, FIBER OPTICS, WI-FI AND OTHER ELECTRONIC MEDIA AND VIA A GLOBAL COMPUTER NETWORK OR A COMMERCIAL ON-LINE SERVICE; INFORMATION SERVICES, NAMELY, PROVIDING INFORMATION IN THE FIELD OF SPORTS, ENTERTAINMENT AND RELATED TOPICS, AND PROVIDING FOR INFORMATIONAL MESSAGES RELATING THERETO; ENTERTAINMENT SERVICES, NAMELY, PRODUCTION OF PROGRAMMING BROADCAST VIA TELEVISION, RADIO AND A GLOBAL COMPUTER NETWORK OR A COMMERCIAL ON-LINE SERVICE; ORGANIZING AND CONDUCTING SPORTS CONTESTS AND SWEEPSTAKES; PROVIDING ON-LINE NEWSLETTERS IN THE FIELD OF BASEBALL (U.S. CLS. 100, 101 AND 107).

FIRST USE 0-0-1978; IN COMMERCE 0-0-1978.

3,633,218. BLIZZARD ENTERTAINMENT, INC., IRVINE, CA. SN 78-770,575. PUB. 2-13-2007, FILED 12-9-2005.

DIABLO

THE MARK CONSISTS OF STANDARD CHARACTERS WITHOUT CLAIM TO ANY PARTICULAR FONT, STYLE, SIZE, OR COLOR.

OWNER OF U.S. REG. NOS. 2,416,001 AND 2,791,742.

"THE FOREIGN WORDING IN THE MARK TRANSLATES INTO ENGLISH AS DEVIL."

FOR ENTERTAINMENT SERVICES, NAMELY, PROVIDING ON-LINE COMPUTER AND VIDEO GAMES, ON-LINE PUBLICATIONS IN THE FIELD OF TIPS AND STRATEGIES FOR COMPUTER GAMES; ARRANGING AND CONDUCTING COMPUTER GAME COMPETITIONS; AND PRODUCTION AND DISTRIBUTION OF MOTION PICTURES (U.S. CLS. 100, 101 AND 107).

FIRST USE 6-28-2000; IN COMMERCE 6-28-2000.

CLASS 41—(Continued).

3,633,222. ALOSA FOUNDATION, INC., CHESTNUT HILL, MA. SN 78-778,398. PUB. 8-22-2006, FILED 12-21-2005.

ALOSA

THE MARK CONSISTS OF STANDARD CHARACTERS WITHOUT CLAIM TO ANY PARTICULAR FONT, STYLE, SIZE, OR COLOR.

FOR EDUCATIONAL SERVICES, NAMELY, CONDUCTING CLASSES, PRESENTATIONS, SEMINARS, AND CONFERENCES CONCERNING THE DEVELOPMENT, REGULATION, RISKS AND ADVANTAGES OF VARIOUS PHARMACEUTICALS AND RESEARCH ON THE SUBJECT OF PHARMACEUTICALS (U.S. CLS. 100, 101 AND 107).

FIRST USE 1-28-2009; IN COMMERCE 1-28-2009.

3,633,238. QED INTERNATIONAL, LLC, LOS ANGELES, CA. SN 78-826,915. PUB. 7-1-2008, FILED 3-1-2006.

QED INTERNATIONAL

THE MARK CONSISTS OF STANDARD CHARACTERS WITHOUT CLAIM TO ANY PARTICULAR FONT, STYLE, SIZE, OR COLOR.

NO CLAIM IS MADE TO THE EXCLUSIVE RIGHT TO USE "INTERNATIONAL", APART FROM THE MARK AS SHOWN.

FOR ENTERTAINMENT SERVICES, NAMELY, PRODUCTION AND DISTRIBUTION OF MOTION PICTURE FILMS (U.S. CLS. 100, 101 AND 107).

FIRST USE 5-1-2006; IN COMMERCE 5-1-2006.

CLASS 41—(Continued).

3,633,260. ERMA INSTITUTE, LLC, DENVER, CO. SN 78-864,622. PUB. 7-24-2007, FILED 4-19-2006.

ERMA INSTITUTE

THE MARK CONSISTS OF STANDARD CHARACTERS WITHOUT CLAIM TO ANY PARTICULAR FONT, STYLE, SIZE, OR COLOR.

NO CLAIM IS MADE TO THE EXCLUSIVE RIGHT TO USE "INSTITUTE", APART FROM THE MARK AS SHOWN.

FOR SMALL BUSINESS ACCOUNTING TRAINING SERVICES; PROVIDING A COURSE OF INSTRUCTION AND DIPLOMA/CERTIFICATION PROGRAM IN THE FIELD OF FINANCIAL SERVICES; EDUCATIONAL SERVICES, NAMELY, PROVIDING WORKSHOPS, SEMINARS, CLASSES, COURSES OF INSTRUCTION AND ONE-ON-ONE TRAINING IN THE FIELDS OF ACCOUNTING PRINCIPALS, BUSINESS COMPUTER SOFTWARE APPLICATIONS, BUSINESS COMMUNICATIONS, BOOKKEEPING AND INFORMATION MANAGEMENT; DISTRIBUTION OF COURSE MATERIAL IN CONNECTION THEREWITH, NAMELY, PRINTED AND ELECTRONIC EDUCATIONAL AND INFORMATIONAL MATERIALS IN THE FIELDS OF ACCOUNTING AND BOOKKEEPING (U.S. CLS. 100, 101 AND 107).

FIRST USE 8-17-2007; IN COMMERCE 8-17-2007.

3,633,270. MACK, BARRY, MOUNT JULIET, TN. AND MACK, TINA, MOUNT JULIET, TN. SN 78-885,296. PUB. 12-9-2008, FILED 5-17-2006.

STARBURST RECORDS

THE MARK CONSISTS OF STANDARD CHARACTERS WITHOUT CLAIM TO ANY PARTICULAR FONT, STYLE, SIZE, OR COLOR.

NO CLAIM IS MADE TO THE EXCLUSIVE RIGHT TO USE "RECORDS", APART FROM THE MARK AS SHOWN.

FOR RECORD PRODUCTION; MUSIC PRODUCTION SERVICES; PRODUCTION OF SOUND AND MUSIC RECORDINGS (U.S. CLS. 100, 101 AND 107).

FIRST USE 9-1-2006; IN COMMERCE 9-1-2006.

CLASS 41—(Continued).

3,633,279. FOOTBALL NORTHWEST LLC, RENTON, WA. SN 78-903,375. PUB. 5-27-2008, FILED 6-7-2006.



THE MARK CONSISTS OF AN IMAGE OF THE FAN DISPLAYING THE "#1" HAND SIGN IN THE CENTER OF THE NUMBER "12".

FOR ENTERTAINMENT SERVICES, NAMELY, ARRANGING AND CONDUCTING OF COMPETITIONS FOR SPORTS FANS; ENTERTAINMENT SERVICES, NAMELY, CONDUCTING CONTESTS; FAN CLUBS; ORGANIZING EXHIBITIONS FOR FOOTBALL FANS (U.S. CLS. 100, 101 AND 107).

FIRST USE 8-15-2008; IN COMMERCE 8-15-2008.

3,633,320. TRUE NORTH CUSTOM PUBLISHING, LLC, CHATTANOOGA, TN. SN 78-971,413. PUB. 7-31-2007, FILED 9-11-2006.

CPR

THE MARK CONSISTS OF STANDARD CHARACTERS WITHOUT CLAIM TO ANY PARTICULAR FONT, STYLE, SIZE, OR COLOR.

FOR PUBLICATION OF MAGAZINES (U.S. CLS. 100, 101 AND 107).

FIRST USE 9-0-2005; IN COMMERCE 11-0-2008.

CLASS 42—SCIENTIFIC AND COMPUTER SERVICES

3,631,874. MOCANA CORPORATION, SAN FRANCISCO, CA. SN 77-017,142. PUB. 7-3-2007, FILED 10-9-2006.

MOCANA

THE MARK CONSISTS OF STANDARD CHARACTERS WITHOUT CLAIM TO ANY PARTICULAR FONT, STYLE,

CLASS 42—(Continued).

SIZE, OR COLOR.

OWNER OF U.S. REG. NO. 3,051,514.

FOR COMPUTER CONSULTATION IN THE FIELD OF COMPUTER SECURITY, SECURITY PROTOCOLS AND NETWORK SECURITY; COMPUTER CONSULTATION IN THE FIELD OF NETWORK AND COMPUTER SECURITY; COMPUTER SECURITY SERVICE, NAMELY, RESTRICTING ACCESS TO AND BY COMPUTER NETWORKS TO AND OF UNDESIRED WEB SITES, MEDIA AND INDIVIDUALS AND FACILITIES; TECHNICAL SUPPORT SERVICES, NAMELY, TROUBLESHOOTING OF COMPUTER HARDWARE AND SOFTWARE PROBLEMS; TECHNICAL SUPPORT SERVICES, NAMELY, MONITORING OF NETWORK SYSTEMS; APPLICATION SERVICE PROVIDER (ASP) FEATURING SOFTWARE IN THE FIELDS OF COMPUTERS, WIRELESS DEVICES, WIRELESS COMPUTER DEVICES, TELECOMMUNICATION, AND NETWORK SECURITY, NETWORK CONNECTIVITY AND NETWORK MANAGEMENT; PROVIDING TEMPORARY USE OF ON-LINE NON-DOWNLOADABLE DATABASE MANAGEMENT SOFTWARE IN THE FIELDS OF COMPUTERS, WIRELESS DEVICES, TELECOMMUNICATION, NETWORK SECURITY, CONNECTIVITY AND MANAGEMENT; COMPUTER AND NETWORK SECURITY SERVICES, NAMELY, COMPUTER CONSULTATION (U.S. CLS. 100 AND 101).

FIRST USE 11-1-2002; IN COMMERCE 9-3-2003.

3,631,876. LEARN.COM, INC., SUNRISE, FL. SN 77-020,015. PUB. 3-6-2007, FILED 10-12-2006.



THE MARK CONSISTS OF A CIRCLE CONTAINING A STYLIZED "X".

FOR COMPUTER SERVICES, NAMELY, HOSTING ON-LINE WEB FACILITIES FOR OTHERS FOR ORGANIZING AND CONDUCTING ONLINE MEETINGS, GATHERINGS, AND INTERACTIVE DISCUSSIONS IN THE FIELDS OF PERSONNEL AND HUMAN RESOURCE DEVELOPMENT, TRAINING, PRODUCTIVITY, AND MANAGEMENT, INCLUDING EDUCATION AND TRAINING IN SUCH FIELDS (U.S. CLS. 100 AND 101).

FIRST USE 1-17-2007; IN COMMERCE 1-17-2007.

CLASS 42—(Continued).

3,631,893. RECONNECTO, LLC, SAN ANTONIO, TX. SN 77-039,682. PUB. 7-17-2007, FILED 11-8-2006.

RECONNECTO

THE MARK CONSISTS OF STANDARD CHARACTERS WITHOUT CLAIM TO ANY PARTICULAR FONT, STYLE, SIZE, OR COLOR.

FOR PROGRAMMING OF COMMUNICATIONS EQUIPMENT, NAMELY, CELLULAR TELEPHONE UNLOCKING AND REPROGRAMMING SERVICES (U.S. CLS. 100 AND 101).

FIRST USE 4-7-2009; IN COMMERCE 4-7-2009.

3,631,951. MASTERIT LLC, BARTLETT, TN. SN 77-097,343. PUB. 6-24-2008, FILED 2-1-2007.

IT-AS-A-UTILITY

THE MARK CONSISTS OF STANDARD CHARACTERS WITHOUT CLAIM TO ANY PARTICULAR FONT, STYLE, SIZE, OR COLOR.

FOR CONSULTATION IN THE DESIGN OF COMPUTER SYSTEMS AND NETWORKS; TECHNICAL SUPPORT SERVICES, NAMELY, TROUBLESHOOTING OF COMPUTER HARDWARE AND SOFTWARE PROBLEMS; TECHNICAL SUPPORT, NAMELY, MONITORING THE PERFORMANCE OF COMPUTER NETWORKS; TECHNICAL SUPPORT, NAMELY, TROUBLESHOOTING OF COMPUTER VOICE RECOGNITION PROGRAMS AND INTERNET AND NETWORK CONNECTIVITY SYSTEMS; COMPUTER CONSULTATION IN THE FIELD OF COMPUTER SECURITY AND DATA SECURITY; HELP DESK SERVICES, NAMELY, MAINTENANCE OF COMPUTER SOFTWARE IN THE NATURE OF PERIODIC UPGRADE OF PROGRAMS, ALL FOR THIRD PARTIES (U.S. CLS. 100 AND 101).

FIRST USE 1-31-2009; IN COMMERCE 1-31-2009.

CLASS 42—(Continued).

3,632,022. CHUMBY INDUSTRIES, INC., SAN DIEGO, CA. SN 77-165,744. PUB. 11-25-2008, FILED 4-25-2007.

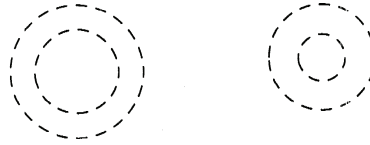

THE COLOR(S) WHITE IS/ARE CLAIMED AS A FEATURE OF THE MARK.

THE MARK CONSISTS OF TWO DIFFERENT SIZED RINGS IN WHITE. THE DOTTED LINES ARE MEANT TO INDICATE THE INNER AND OUTER BOUNDARIES OF THE MARK WHERE THE INNER CIRCLES ARE NOT PART OF THE MARK.

FOR APPLICATION SERVICE PROVIDER FEATURING SOFTWARE FOR DOWNLOADING AND PLAYING AUDIO, VIDEO AND DATA CONTENT VIA THE INTERNET AND GLOBAL COMPUTER NETWORKS; PROVIDING ONLINE NON-DOWNLOADABLE SOFTWARE FOR DOWNLOADING AND PLAYING AUDIO, VIDEO AND DATA CONTENT VIA THE INTERNET AND GLOBAL COMPUTER NETWORKS; APPLICATION SERVICE PROVIDER FEATURING SOFTWARE FOR DOWNLOADING AND STREAMING AUDIO, VIDEO AND DATA CONTENT VIA THE INTERNET AND GLOBAL COMPUTER NETWORKS; PROVIDING ONLINE NON-DOWNLOADABLE SOFTWARE FOR DOWNLOADING AND STREAMING AUDIO, VIDEO AND DATA CONTENT VIA THE INTERNET AND GLOBAL COMPUTER NETWORKS (U.S. CLS. 100 AND 101).

FIRST USE 2-0-2008; IN COMMERCE 2-0-2008.

3,632,023. CHUMBY INDUSTRIES, INC., SAN DIEGO, CA. SN 77-165,766. PUB. 11-25-2008, FILED 4-25-2007.

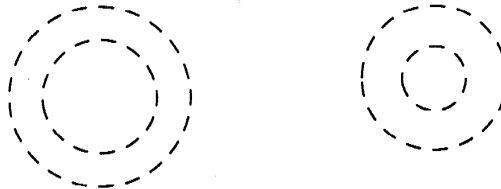

THE MARK CONSISTS OF TWO DIFFERENT SIZED RINGS. THE DOTTED LINES ARE MEANT TO INDICATE THE INNER AND OUTER BOUNDARIES OF THE MARK WHERE THE INNER CIRCLES ARE NOT PART OF THE MARK.

FOR APPLICATION SERVICE PROVIDER FEATURING SOFTWARE FOR DOWNLOADING AND PLAYING AUDIO, VIDEO AND DATA CONTENT VIA THE INTERNET AND GLOBAL COMPUTER NETWORKS; PROVIDING ONLINE NON-DOWNLOADABLE SOFTWARE FOR DOWNLOADING AND PLAYING AUDIO, VIDEO AND DATA CONTENT VIA THE INTERNET AND GLOBAL COMPUTER NETWORKS; APPLICATION SERVICE PROVIDER FEATURING SOFTWARE FOR DOWNLOADING AND STREAMING AUDIO, VIDEO AND DATA CONTENT VIA THE INTERNET AND GLOBAL COMPUTER NETWORKS; PROVIDING ONLINE NON-DOWNLOADABLE SOFTWARE FOR DOWNLOADING AND STREAMING AUDIO, VIDEO AND DATA CONTENT VIA THE INTERNET AND GLOBAL COMPUTER NETWORKS (U.S. CLS. 100 AND 101).

FIRST USE 2-0-2008; IN COMMERCE 2-0-2008.

CLASS 42—(Continued).

3,632,045. HUNTONBRADY ARCHITECTS, ORLANDO, FL. SN 77-191,895. PUB. 4-22-2008, FILED 5-29-2007.



THE MARK CONSISTS OF THE WORDS "AREATRACK" DONE IN ITC AVANT GARDE GOTHIC BT FONT WITH A CAPITAL LETTER "A" AND CAPITAL LETTER "T". THE WORDS ARE UNDERLINED WITH A THICK RECTANGULAR BOX. AT THE END OF THE RECTANGLE, IS A SQUARE WHICH APPEARS JUST UNDER THE LETTER "K" IN "TRACK".

FOR ARCHITECTURAL SPACE PROGRAMMING, NAMELY, ARCHITECTURAL DESIGN (U.S. CLS. 100 AND 101).

FIRST USE 7-23-2008; IN COMMERCE 7-23-2008.

CLASS 42—(Continued).

3,632,221. OVERGAARD, KRISTI, LAS VEGAS, NV. SN 77-277,696. PUB. 7-15-2008, FILED 9-12-2007.



NO CLAIM IS MADE TO THE EXCLUSIVE RIGHT TO USE "HOTEL", APART FROM THE MARK AS SHOWN.

THE NAME(S), PORTRAIT(S), AND/OR SIGNATURE(S) SHOWN IN THE MARK DOES NOT IDENTIFY A PARTICULAR LIVING INDIVIDUAL.

THE MARK CONSISTS OF THE WORDS "HOTEL LUCY" IN BLOCK LETTERS SURROUNDED BY SCRIBBLE LINES. FOR DESIGN FOR OTHERS IN THE FIELD OF INTERIOR DECORATING, NAMELY, FURNITURE AND ARTWORK (U.S. CLS. 100 AND 101).

FIRST USE 1-1-2008; IN COMMERCE 1-1-2008.

3,632,090. BI INCORPORATED, BOULDER, CO. SN 77-221,719. PUB. 7-29-2008, FILED 7-3-2007.



THE MARK CONSISTS OF STANDARD CHARACTERS WITHOUT CLAIM TO ANY PARTICULAR FONT, STYLE, SIZE, OR COLOR.

OWNER OF U.S. REG. NO. 2,697,736.

FOR PROVIDING TEMPORARY USE OF ON-LINE NON-DOWNLOADABLE COMPUTER SOFTWARE FOR REVIEWING REPORTS FROM MONITORING EQUIPMENT USED TO MONITOR INDIVIDUALS UNDER PROBATION, PRETRIAL DETENTION, PAROLE, HOME ARREST OR OTHER CORRECTIONAL SYSTEM MONITORING REQUIREMENTS (U.S. CLS. 100 AND 101).

FIRST USE 6-30-2008; IN COMMERCE 6-30-2008.

3,632,267. BERTOLDI, MASSIMILIANO, LATINA, ITALY. SN 77-298,658. PUB. 3-25-2008, FILED 10-8-2007.



THE MARK CONSISTS OF STANDARD CHARACTERS WITHOUT CLAIM TO ANY PARTICULAR FONT, STYLE, SIZE, OR COLOR.

FOR TESTING, ANALYSIS AND EVALUATION OF THE GOODS AND SERVICES OF OTHERS FOR THE PURPOSE OF CERTIFICATION (U.S. CLS. 100 AND 101).

FIRST USE 2-17-2009; IN COMMERCE 2-17-2009.

3,632,174. GREYSTRIPE, INC., SAN FRANCISCO, CA. SN 77-258,455. PUB. 7-8-2008, FILED 8-17-2007.



THE MARK CONSISTS OF STANDARD CHARACTERS WITHOUT CLAIM TO ANY PARTICULAR FONT, STYLE, SIZE, OR COLOR.

FOR PROVIDING TECHNICAL SUPPORT SERVICES, NAMELY, TROUBLESHOOTING OF COMPUTER SOFTWARE PROBLEMS (U.S. CLS. 100 AND 101).

FIRST USE 8-16-2006; IN COMMERCE 8-16-2006.

3,632,326. TOTALLY INTERACTIVE WEATHER LLC, AFTON, MN. SN 77-326,883. PUB. 7-22-2008, FILED 11-12-2007.



NO CLAIM IS MADE TO THE EXCLUSIVE RIGHT TO USE "WEATHER", APART FROM THE MARK AS SHOWN.

CLASS 42—(Continued).

THE COLOR(S) ORANGE AND BLACK IS/ARE CLAIMED AS A FEATURE OF THE MARK.

THE COLOR ORANGE APPEARS IN THE WORDING "WEATHER", AND THE COLOR BLACK APPEARS IN THE WORDING "MY" AND "WINDOW".

FOR PROVIDING WEATHER CONDITION INFORMATION AFFECTING SKI CONDITIONS AND ROAD CLOSURES; PROVIDING WEATHER INFORMATION; WEATHER FORECASTING; WEATHER REPORTING (U.S. CLS. 100 AND 101).

FIRST USE 4-13-2009; IN COMMERCE 4-13-2009.

3,632,353. TOTALLY INTERACTIVE WEATHER LLC, AF-TON, MN. SN 77-338,658. PUB. 7-22-2008, FILED 11-28-2007.

NO CLAIM IS MADE TO THE EXCLUSIVE RIGHT TO USE "WEATHER", APART FROM THE MARK AS SHOWN.

THE COLOR(S) ORANGE AND BLACK IS/ARE CLAIMED AS A FEATURE OF THE MARK.

THE COLOR ORANGE APPEARS IN THE WORDING "WEATHER", AND THE COLOR BLACK APPEARS IN THE WORDING "WINDOW".

FOR PROVIDING WEATHER CONDITION INFORMATION AFFECTING SKI CONDITIONS AND ROAD CLOSURES; PROVIDING WEATHER INFORMATION; WEATHER FORECASTING; WEATHER REPORTING (U.S. CLS. 100 AND 101).

FIRST USE 4-13-2008; IN COMMERCE 4-13-2008.

3,632,388. TOTAL IMMERSION SOFTWARE, INC., ALAME-DA, CA. SN 77-354,883. PUB. 6-3-2008, FILED 12-18-2007.

SIMULATIONS WITHOUT PROGRAMMERS

THE MARK CONSISTS OF STANDARD CHARACTERS WITHOUT CLAIM TO ANY PARTICULAR FONT, STYLE, SIZE, OR COLOR.

NO CLAIM IS MADE TO THE EXCLUSIVE RIGHT TO USE "SIMULATIONS", APART FROM THE MARK AS SHOWN.

FOR COMPUTER SOFTWARE DESIGN AND PROGRAMMING (U.S. CLS. 100 AND 101).

FIRST USE 0-0-2006; IN COMMERCE 0-0-2006.

CLASS 42—(Continued).

3,632,393. DIOGENIX, INC., GAITHERSBURG, MD. SN 77-356,139. PUB. 12-16-2008, FILED 12-19-2007.

DIOGENIX

THE MARK CONSISTS OF STANDARD CHARACTERS WITHOUT CLAIM TO ANY PARTICULAR FONT, STYLE, SIZE, OR COLOR.

FOR MOLECULAR DIAGNOSTIC SERVICES, NAMELY, RESEARCH AND DEVELOPMENT OF NON-INVASIVE DIAGNOSTIC, PROGNOSTIC AND DISEASE PROGRESSION AND TREATMENT RESPONSE MONITORING TESTS (U.S. CLS. 100 AND 101).

FIRST USE 5-0-2008; IN COMMERCE 5-0-2008.

3,632,505. MILITARY MAIL SOLUTIONS, QUINCY, MA. SN 77-396,085. PUB. 7-22-2008, FILED 2-13-2008.

OneNumber

THE MARK CONSISTS OF STANDARD CHARACTERS WITHOUT CLAIM TO ANY PARTICULAR FONT, STYLE, SIZE, OR COLOR.

FOR PROVIDING TEMPORARY USE OF ON-LINE NON-DOWNLOADABLE SOFTWARE FOR PERSONAL INFORMATION MANAGEMENT, NAMELY, PROVIDING A SECURE AND ANONYMOUS PERSONAL INFORMATION PROFILE THAT HOLDS PHYSICAL ADDRESSES, PHONE NUMBERS, E-MAIL ADDRESSES, PAYMENT VEHICLES, SHIPPING PREFERENCES, BUYING PREFERENCES, TRANSACTION HISTORY AND AN AGGREGATE OF OPT-IN AND OPT-OUT BEHAVIORAL ADVERTISING SETTINGS ALL FOR THE PURPOSE OF PURCHASING GOODS AND SERVICES, ARRANGING FOR SHIPPING AND DELIVERY OF PURCHASED ITEMS AND SELECTIVELY AND SECURELY PARTICIPATING IN BEHAVIOR ADVERTISING PROGRAMS (U.S. CLS. 100 AND 101).

FIRST USE 11-13-2008; IN COMMERCE 11-13-2008.

CLASS 42—(Continued).

3,632,506. MILITARY MAIL SOLUTIONS, QUINCY, MA. SN 77-396,097. PUB. 7-22-2008, FILED 2-13-2008.

OneNumber Technology

THE MARK CONSISTS OF STANDARD CHARACTERS WITHOUT CLAIM TO ANY PARTICULAR FONT, STYLE, SIZE, OR COLOR.

NO CLAIM IS MADE TO THE EXCLUSIVE RIGHT TO USE "TECHNOLOGY", APART FROM THE MARK AS SHOWN.

FOR PROVIDING TEMPORARY USE OF ON-LINE NON-DOWNLOADABLE SOFTWARE FOR PERSONAL INFORMATION MANAGEMENT, NAMELY, PROVIDING A SECURE AND ANONYMOUS PERSONAL INFORMATION PROFILE THAT HOLDS PHYSICAL ADDRESSES, PHONE NUMBERS, E-MAIL ADDRESSES, PAYMENT VEHICLES, SHIPPING PREFERENCES, BUYING PREFERENCES, TRANSACTION HISTORY AND AN AGGREGATE OF OPT-IN AND OPT-OUT BEHAVIORAL ADVERTISING SETTINGS ALL FOR THE PURPOSE OF PURCHASING GOODS AND SERVICES, ARRANGING FOR SHIPPING AND DELIVERY OF PURCHASED ITEMS AND SELECTIVELY AND SECURELY PARTICIPATING IN BEHAVIOR ADVERTISING PROGRAMS (U.S. CLS. 100 AND 101).

FIRST USE 11-13-2008; IN COMMERCE 11-13-2008.

3,632,507. MILITARY MAIL SOLUTIONS, QUINCY, MA. SN 77-396,106. PUB. 7-22-2008, FILED 2-13-2008.

OneNumber Checkout

THE MARK CONSISTS OF STANDARD CHARACTERS WITHOUT CLAIM TO ANY PARTICULAR FONT, STYLE, SIZE, OR COLOR.

NO CLAIM IS MADE TO THE EXCLUSIVE RIGHT TO USE "CHECKOUT", APART FROM THE MARK AS SHOWN.

FOR PROVIDING TEMPORARY USE OF ON-LINE NON-DOWNLOADABLE SOFTWARE FOR PERSONAL INFORMATION MANAGEMENT, NAMELY, PROVIDING A SECURE AND ANONYMOUS PERSONAL INFORMATION PROFILE THAT HOLDS PHYSICAL ADDRESSES, PHONE NUMBERS, E-MAIL ADDRESSES, PAYMENT VEHICLES, SHIPPING PREFERENCES, BUYING PREFERENCES, TRANSACTION HISTORY AND AN AGGREGATE OF OPT-IN AND OPT-OUT BEHAVIORAL ADVERTISING SETTINGS ALL FOR THE PURPOSE OF PURCHASING GOODS AND SERVICES, ARRANGING FOR SHIPPING AND DELIVERY OF PURCHASED ITEMS AND SELECTIVELY AND SECURELY PARTICIPATING IN BEHAVIOR ADVERTISING PROGRAMS (U.S. CLS. 100 AND 101).

FIRST USE 11-13-2008; IN COMMERCE 11-13-2008.

CLASS 42—(Continued).

3,632,508. MILITARY MAIL SOLUTIONS, QUINCY, MA. SN 77-396,137. PUB. 7-22-2008, FILED 2-13-2008.

OneNumber Card

THE MARK CONSISTS OF STANDARD CHARACTERS WITHOUT CLAIM TO ANY PARTICULAR FONT, STYLE, SIZE, OR COLOR.

NO CLAIM IS MADE TO THE EXCLUSIVE RIGHT TO USE "CARD", APART FROM THE MARK AS SHOWN.

FOR PROVIDING TEMPORARY USE OF ON-LINE NON-DOWNLOADABLE SOFTWARE FOR PERSONAL INFORMATION MANAGEMENT, NAMELY, PROVIDING A SECURE AND ANONYMOUS PERSONAL INFORMATION PROFILE THAT HOLDS PHYSICAL ADDRESSES, PHONE NUMBERS, E-MAIL ADDRESSES, PAYMENT VEHICLES, SHIPPING PREFERENCES, BUYING PREFERENCES, TRANSACTION HISTORY AND AN AGGREGATE OF OPT-IN AND OPT-OUT BEHAVIORAL ADVERTISING SETTINGS ALL FOR THE PURPOSE OF PURCHASING GOODS AND SERVICES, ARRANGING FOR SHIPPING AND DELIVERY OF PURCHASED ITEMS AND SELECTIVELY AND SECURELY PARTICIPATING IN BEHAVIOR ADVERTISING PROGRAMS (U.S. CLS. 100 AND 101).

FIRST USE 11-13-2008; IN COMMERCE 11-13-2008.

3,632,555. KINTZLER, JASON, RIVERTON, WY. SN 77-405,723. PUB. 9-2-2008, FILED 2-25-2008.

PitchEngine

THE MARK CONSISTS OF STANDARD CHARACTERS WITHOUT CLAIM TO ANY PARTICULAR FONT, STYLE, SIZE, OR COLOR.

FOR PROVIDING TEMPORARY USE OF NON-DOWNLOADABLE SOFTWARE FEATURING A PUBLIC RELATIONS MANAGEMENT TOOL, NAMELY, SOFTWARE FOR THE DEVELOPMENT AND STORING OF DIGITAL PRESS RELEASES (U.S. CLS. 100 AND 101).

FIRST USE 4-1-2008; IN COMMERCE 8-1-2008.

CLASS 42—(Continued).

3,632,590. MISSION LANDSCAPE COMPANIES, INC., TUSTIN, CA. SN 77-411,664. PUB. 7-22-2008, FILED 3-3-2008.



THE MARK CONSISTS OF THE WORDS "LAND ARC WEST" BELOW A FANCIFUL PERFORATED CIRCLE.. FOR LANDSCAPE ARCHITECTURAL DESIGN; LANDSCAPE LIGHTING DESIGN (U.S. CLS. 100 AND 101).

FIRST USE 2-0-2008; IN COMMERCE 2-0-2008.

3,632,615. K. MORGAN AND COMPANY, INC., PHOENIX, AZ. SN 77-414,456. PUB. 7-22-2008, FILED 3-6-2008.

Companii

THE MARK CONSISTS OF STANDARD CHARACTERS WITHOUT CLAIM TO ANY PARTICULAR FONT, STYLE, SIZE, OR COLOR.

FOR GRAPHIC DESIGN SERVICES (U.S. CLS. 100 AND 101).

FIRST USE 3-5-2008; IN COMMERCE 4-8-2009.

3,632,620. DISBURSA, LLC, CHESTERFIELD, MO. SN 77-415,158. PUB. 7-22-2008, FILED 3-6-2008.

DISBURSA

THE MARK CONSISTS OF STANDARD CHARACTERS WITHOUT CLAIM TO ANY PARTICULAR FONT, STYLE, SIZE, OR COLOR.

FOR PROVIDING TEMPORARY USE OF NON-DOWNLOADABLE, WEB-BASED SOFTWARE FOR MANAGING CONSTRUCTION PROJECTS (U.S. CLS. 100 AND 101).

FIRST USE 1-0-2000; IN COMMERCE 1-0-2000.

CLASS 42—(Continued).

3,632,641. DIOGENIX INC., GAITHERSBURG, MD. SN 77-418,820. PUB. 1-13-2009, FILED 3-11-2008.



THE COLOR(S) BLUE AND GREY IS/ARE CLAIMED AS A FEATURE OF THE MARK.

THE MARK CONSISTS OF THE WORD "DIOGENIX" WITH THE LETTERS "D", "G" AND "X" IN BLUE AND THE REMAINING LETTERS IN GREY SURMOUNTED BY A CURVED LINE ORIGINATING FROM THE LETTER "X".

FOR MOLECULAR DIAGNOSTIC SERVICES, NAMELY, RESEARCH AND DEVELOPMENT OF NON-INVASIVE DIAGNOSTIC, PROGNOSTIC AND DISEASE PROGRESSION AND TREATMENT RESPONSE MONITORING TESTS (U.S. CLS. 100 AND 101).

FIRST USE 5-0-2008; IN COMMERCE 5-0-2008.

3,632,642. CELL THERAPEUTICS, INC., SEATTLE, WA. SN 77-418,972. PUB. 7-15-2008, FILED 3-11-2008.

WE BELIEVE IN TREATMENTS
AS INDIVIDUAL AS YOU ARE

THE MARK CONSISTS OF STANDARD CHARACTERS WITHOUT CLAIM TO ANY PARTICULAR FONT, STYLE, SIZE, OR COLOR.

FOR RESEARCH AND DEVELOPMENT OF PHARMACEUTICAL PREPARATIONS; PRODUCT RESEARCH AND DEVELOPMENT FOR OTHERS IN THE FIELD OF PHARMACEUTICAL PREPARATIONS; PRODUCT RESEARCH AND DEVELOPMENT SERVICES, NAMELY, ASSESSING INTENDED TARGET RECIPIENTS OF PHARMACEUTICAL PREPARATIONS AND POSITIONING PHARMACEUTICAL PREPARATIONS FOR SUCCESS IN CLINICAL DEVELOPMENT AND COMMERCIAL USE; AND PROVIDING TECHNICAL CONSULTATION IN THE FIELD OF PHARMACEUTICAL PRODUCT RESEARCH AND DEVELOPMENT (U.S. CLS. 100 AND 101).

FIRST USE 8-28-2008; IN COMMERCE 8-28-2008.

CLASS 42—(Continued).

3,632,821. YAHOO! INC., SUNNYVALE, CA. SN 77-469,209. PUB. 8-19-2008, FILED 5-8-2008.

GLUE

THE MARK CONSISTS OF STANDARD CHARACTERS WITHOUT CLAIM TO ANY PARTICULAR FONT, STYLE, SIZE, OR COLOR.

FOR COMPUTER SERVICES, NAMELY, CREATING INDEXES OF INFORMATION, SITES, AND OTHER RESOURCES AVAILABLE ON COMPUTER NETWORKS FOR OTHERS; SEARCHING AND RETRIEVING INFORMATION, SITES, AND OTHER RESOURCES AVAILABLE ON COMPUTER NETWORKS FOR OTHERS; PROVIDING CUSTOMIZED ONLINE WEB PAGES FEATURING USER-DEFINED INFORMATION, WHICH INCLUDES SEARCH ENGINES AND ONLINE WEB LINKS TO OTHER WEBSITES (U.S. CLS. 100 AND 101).
FIRST USE 5-8-2008; IN COMMERCE 11-18-2008.

3,632,838. QWEST COMMUNICATIONS INTERNATIONAL INC., DENVER, CO. SN 77-477,915. PUB. 12-9-2008, FILED 5-19-2008.

CONNECT. SIMPLIFY. ENHANCE.

THE MARK CONSISTS OF STANDARD CHARACTERS WITHOUT CLAIM TO ANY PARTICULAR FONT, STYLE, SIZE, OR COLOR.

FOR DESIGNING, INTEGRATING, OPERATING, AND MONITORING VOICE, DATA AND VIDEO COMMUNICATIONS NETWORKS; COMPUTER SERVICES, NAMELY, VIRUS PROTECTION, DATA BACK UP AND RECOVERY SERVICES; COMPUTER SYSTEM SECURITY SERVICES, NAMELY, RESTRICTING ACCESS TO AND BY COMPUTER NETWORKS TO AND OF UNDESIRE WEB SITES, MEDIA AND INDIVIDUALS, APPLICATION SERVICES PROVIDER SERVICES, NAMELY, HOSTING SOFTWARE ON A COMPUTER SERVER FOR OTHERS FOR REMOTE ACCESS TO NETWORKS (U.S. CLS. 100 AND 101).
FIRST USE 11-6-2008; IN COMMERCE 11-6-2008.

CLASS 42—(Continued).

3,632,889. REALINVESTOR SOFTWARE, LLC, SARASOTA, FL. SN 77-498,003. PUB. 11-4-2008, FILED 6-12-2008.

REALWEBSITE

THE MARK CONSISTS OF STANDARD CHARACTERS WITHOUT CLAIM TO ANY PARTICULAR FONT, STYLE, SIZE, OR COLOR.

FOR APPLICATION SERVICE PROVIDER (ASP), NAMELY, HOSTING COMPUTER SOFTWARE APPLICATIONS OF OTHERS; DESIGN, CREATION, HOSTING, MAINTENANCE OF WEB SITES FOR OTHERS (U.S. CLS. 100 AND 101).

FIRST USE 10-1-2008; IN COMMERCE 10-1-2008.

3,632,987. BUDDY MEDIA, INC., NEW YORK, NY. SN 77-533,316. PUB. 12-9-2008, FILED 7-29-2008.

BUDDYBRAIN

THE MARK CONSISTS OF STANDARD CHARACTERS WITHOUT CLAIM TO ANY PARTICULAR FONT, STYLE, SIZE, OR COLOR.

FOR PROVIDING TEMPORARY USE OF ONLINE, NON-DOWNLOADABLE COMPUTER SOFTWARE WITH A DASHBOARD THAT ALLOWS USERS TO VIEW AND MANIPULATE ELECTRONIC DATA AND APPLICATIONS FOR USE IN REVIEWING, ANALYZING, REPORTING AND MANAGING ADVERTISING CAMPAIGNS IN THE FIELDS OF SOCIAL MEDIA AND SOCIAL NETWORKING (U.S. CLS. 100 AND 101).

FIRST USE 9-10-2008; IN COMMERCE 9-10-2008.

3,633,003. ZELAZEK, MICHAEL, TIBURON, CA. SN 77-539,882. PUB. 12-30-2008, FILED 8-5-2008.

CITTA FUTURA STUDIO

THE MARK CONSISTS OF STANDARD CHARACTERS WITHOUT CLAIM TO ANY PARTICULAR FONT, STYLE, SIZE, OR COLOR.

NO CLAIM IS MADE TO THE EXCLUSIVE RIGHT TO USE "STUDIO", APART FROM THE MARK AS SHOWN.

THE ENGLISH TRANSLATION OF "FUTURA" IN THE MARK IS FUTURE.

FOR GRAPHIC DESIGN (U.S. CLS. 100 AND 101).
FIRST USE 1-5-2009; IN COMMERCE 1-5-2009.

CLASS 42—(Continued).

3,633,010. MEDIADROIT, LLC, CHICAGO, IL. SN 77-542,435.
PUB. 12-30-2008, FILED 8-8-2008.

LEADWISE

THE MARK CONSISTS OF STANDARD CHARACTERS WITHOUT CLAIM TO ANY PARTICULAR FONT, STYLE, SIZE, OR COLOR.

FOR PROVIDING TEMPORARY USE OF ON-LINE NON-DOWNLOADABLE SOFTWARE TO STORE, MANAGE AND ANALYZE DATA IN THE FIELDS OF MARKETING, PROMOTION, SALES CUSTOMER INFORMATION, CUSTOMER RELATIONSHIP MANAGEMENT AND SALES SUPPORT (U.S. CLS. 100 AND 101).
FIRST USE 12-31-2008; IN COMMERCE 12-31-2008.

3,633,040. INXPO, INC., CHICAGO, IL. SN 77-563,687. PUB. 1-13-2009, FILED 9-5-2008.

XPOCAST

THE MARK CONSISTS OF STANDARD CHARACTERS WITHOUT CLAIM TO ANY PARTICULAR FONT, STYLE, SIZE, OR COLOR.

FOR PROVIDING ON-LINE NON-DOWNLOADABLE SOFTWARE FOR STREAMING, WEBCASTING AND DELIVERING LIVE AND PRE-RECORDED AUDIO-VISUAL CONTENT (U.S. CLS. 100 AND 101).
FIRST USE 10-15-2008; IN COMMERCE 10-15-2008.

3,633,067. KRZYWICKI, VAN B., GLEN SPEY, NY. SN 77-976,983. PUB. 7-1-2008, FILED 11-9-2007.

PEAPOD HOMES

THE MARK CONSISTS OF STANDARD CHARACTERS WITHOUT CLAIM TO ANY PARTICULAR FONT, STYLE, SIZE, OR COLOR.

NO CLAIM IS MADE TO THE EXCLUSIVE RIGHT TO USE "HOMES", APART FROM THE MARK AS SHOWN.

FOR ARCHITECTURE SERVICES, NAMELY, ARCHITECTURAL CONSULTATION AND CONSTRUCTION DRAFTING (U.S. CLS. 100 AND 101).
FIRST USE 1-0-2008; IN COMMERCE 1-0-2008.

CLASS 42—(Continued).

3,633,236. RAVENBRICK LLC, DENVER, CO. SN 78-824,471.
PUB. 12-11-2007, FILED 2-27-2006.

PROGRAMMABLE MATTER

THE MARK CONSISTS OF STANDARD CHARACTERS WITHOUT CLAIM TO ANY PARTICULAR FONT, STYLE, SIZE, OR COLOR.

FOR SCIENTIFIC RESEARCH AND DEVELOPMENT AND TECHNICAL CONSULTATION IN THE FIELD OF NANOTECHNOLOGY ENGINEERING (U.S. CLS. 100 AND 101).

FIRST USE 4-28-2008; IN COMMERCE 4-28-2008.

3,633,257. COLLEGENET, INC., PORTLAND, OR. SN 78-856,899. PUB. 7-17-2007, FILED 4-7-2006.

WHAT DO YOU THINK?

THE MARK CONSISTS OF STANDARD CHARACTERS WITHOUT CLAIM TO ANY PARTICULAR FONT, STYLE, SIZE, OR COLOR.

FOR DOCUMENT AND DATA TRANSFER AND CONVERSION SERVICES FROM ONE MEDIA TO ANOTHER, NAMELY, CONVERTING PAPER FORMS INTO ELECTRONIC FORMS (U.S. CLS. 100 AND 101).

FIRST USE 4-17-2006; IN COMMERCE 4-17-2006.

3,633,301. ROSS, GREG, FORT LAUDERDALE, FL. SN 78-936,148. PUB. 4-3-2007, FILED 7-24-2006.

GET THE 411

THE MARK CONSISTS OF STANDARD CHARACTERS WITHOUT CLAIM TO ANY PARTICULAR FONT, STYLE, SIZE, OR COLOR.

FOR LEGAL SERVICES IN THE FIELD OF PERSONAL INJURY, MEDICAL MALPRACTICE, SLIP AND FALL INJURIES; LEGAL SERVICES RENDERED TO AN INURED IN THE AREA OF WORKERS COMPENSATION AND AUTOMOBILE AND MOTORCYCLE ACCIDENTS (U.S. CLS. 100 AND 101).

FIRST USE 7-1-2008; IN COMMERCE 7-25-2008.

CLASS 43—HOTEL AND RESTAURANT SERVICES

CLASS 43—(Continued).

3,631,787. CERVECERIA MODELO, S.A. DE C.V., 11320 MEXICO, D.F., MEXICO. SN 75-875,857. PUB. 1-10-2006, FILED 12-21-1999.

Corona

OWNER OF U.S. REG. NOS. 662,347, 1,727,969, AND OTHERS.

THE ENGLISH TRANSLATION OF THE WORD "CORONA" IS "CROWN."

FOR RESTAURANT AND CAFE SERVICES; BAR AND LOUNGE SERVICES (U.S. CLS. 100 AND 101).
FIRST USE 6-0-2008; IN COMMERCE 6-0-2008.

3,631,809. HRP CREATIVE SERVICES CO., LLC, MYRTLE BEACH, SC. SN 76-655,765. PUB. 9-26-2006, FILED 2-28-2006.

EAT ME DINER

THE MARK CONSISTS OF STANDARD CHARACTERS WITHOUT CLAIM TO ANY PARTICULAR FONT, STYLE, SIZE, OR COLOR.

NO CLAIM IS MADE TO THE EXCLUSIVE RIGHT TO USE "EAT" AND "DINER", APART FROM THE MARK AS SHOWN.

FOR RESTAURANT SERVICES (U.S. CLS. 100 AND 101).
FIRST USE 11-15-2007; IN COMMERCE 11-15-2007.

3,631,858. MINETTA LANE LLC, NEW YORK, NY. SN 76-690,262. PUB. 12-16-2008, FILED 6-4-2008.

MINETTA TAVERN

THE MARK CONSISTS OF STANDARD CHARACTERS WITHOUT CLAIM TO ANY PARTICULAR FONT, STYLE, SIZE, OR COLOR.

NO CLAIM IS MADE TO THE EXCLUSIVE RIGHT TO USE "TAVERN", APART FROM THE MARK AS SHOWN.

FOR RESTAURANT AND BAR SERVICES (U.S. CLS. 100 AND 101).
FIRST USE 3-12-2009; IN COMMERCE 3-12-2009.

CLASS 43—(Continued).

3,631,921. TS ALOHA, INC., SOLANA BEACH, CA. SN 77-070,374. PUB. 7-24-2007, FILED 12-22-2006.

**STRIVING TO BE THE
FRIENDLIEST RESTAURANT
COMPANY IN AMERICA**

THE MARK CONSISTS OF STANDARD CHARACTERS WITHOUT CLAIM TO ANY PARTICULAR FONT, STYLE, SIZE, OR COLOR.

FOR RESTAURANT AND BAR SERVICES (U.S. CLS. 100 AND 101).
FIRST USE 4-30-2004; IN COMMERCE 4-30-2004.

3,631,977. PROVIDENCE COMPANIES, LLC, COLLEGEVILLE, PA. SN 77-124,112. PUB. 8-12-2008, FILED 3-7-2007.

**Providence School of Music
and WiFi Cafe**

THE MARK CONSISTS OF STANDARD CHARACTERS WITHOUT CLAIM TO ANY PARTICULAR FONT, STYLE, SIZE, OR COLOR.

NO CLAIM IS MADE TO THE EXCLUSIVE RIGHT TO USE "SCHOOL OF MUSIC AND WIFI CAFE", APART FROM THE MARK AS SHOWN.

FOR COFFEE SHOP SERVICES FOR PROVIDING FOOD AND DRINK (U.S. CLS. 100 AND 101).
FIRST USE 8-1-2007; IN COMMERCE 8-1-2007.

3,632,053. HENRY STREET HOLDINGS, LLC, SAN MARCOS, CA. SN 77-196,232. PUB. 10-21-2008, FILED 6-2-2007.

**Decanter Restaurant & Wine
Lounge**

THE MARK CONSISTS OF STANDARD CHARACTERS WITHOUT CLAIM TO ANY PARTICULAR FONT, STYLE, SIZE, OR COLOR.

NO CLAIM IS MADE TO THE EXCLUSIVE RIGHT TO USE "RESTAURANT & WINE LOUNGE", APART FROM THE MARK AS SHOWN.

FOR RESTAURANT AND BAR SERVICES (U.S. CLS. 100 AND 101).
FIRST USE 9-9-2008; IN COMMERCE 9-9-2008.

CLASS 43—(Continued).

3,632,251. CTF DEVELOPMENT, INC., CORAL GABLES, FL. SN 77-290,743. PUB. 8-19-2008, FILED 9-27-2007.

Koá  Kea

THE MARK CONSISTS OF CORAL BRANCH DESIGN. THE FOREIGN WORDING IN THE MARK TRANSLATES INTO ENGLISH AS "WHITE CORAL".

FOR HOTEL SERVICES; MAKING HOTEL RESERVATIONS FOR OTHERS; PROVISION OF TEMPORARY ACCOMMODATION; HOTEL, MOTEL AND RESORT HOTEL ACCOMMODATION SERVICES; PROVIDING FOOD AND DRINK; RESTAURANT, BAR AND CATERING SERVICES; PROVISION OF FACILITIES FOR MEETINGS, CONFERENCES, EXHIBITIONS, CONGRESSES, SEMINARS, SYMPOSIUMS AND WORKSHOPS; RESERVATION SERVICES FOR HOTEL ACCOMMODATION; FOOD AND BEVERAGE PREPARATION SERVICES (U.S. CLS. 100 AND 101).
FIRST USE 4-18-2008; IN COMMERCE 4-18-2008.

CLASS 43—(Continued).

3,632,320. PIZZA MARGHERITA, CENTREVILLE, VA. SN 77-324,521. PUB. 4-29-2008, FILED 11-8-2007.



NO CLAIM IS MADE TO THE EXCLUSIVE RIGHT TO USE "PIZZA", "NY" AND "MARGHERITA", APART FROM THE MARK AS SHOWN.

THE STIPPLING IN THE DRAWING IS FOR SHADING PURPOSES ONLY.

THE MARK CONSISTS OF A ROUND BORDER; A BANNER WITH THE TEXT "MARGHERITA" WRITTEN INSIDE. AT THE BOTTOM OF THE BANNER THERE IS THE ITALIAN FLAG, WHILE AT THE TOP OF THE BANNER THERE IS "NY" CITY ("NY" WRITTEN INSIDE; AT THE TOP OF THAT IS THE TEXT "PIZZA").

FOR RESTAURANTS (U.S. CLS. 100 AND 101).
FIRST USE 11-1-2008; IN COMMERCE 12-8-2008.

3,632,334. CULINARY CONCEPTS BY JEAN-GEORGES, LLC, NEW YORK, NY. SN 77-330,452. PUB. 4-29-2008, FILED 11-15-2007.

J & G Steakhouse

THE MARK CONSISTS OF STANDARD CHARACTERS WITHOUT CLAIM TO ANY PARTICULAR FONT, STYLE, SIZE, OR COLOR.

NO CLAIM IS MADE TO THE EXCLUSIVE RIGHT TO USE "STEAKHOUSE", APART FROM THE MARK AS SHOWN.

FOR RESTAURANT SERVICES (U.S. CLS. 100 AND 101).
FIRST USE 12-15-2008; IN COMMERCE 12-15-2008.

3,632,284. RIMINI FIERA SPA. 47900 RIMINI, ITALY. SN 77-304,643. PUB. 5-6-2008, FILED 10-15-2007.

SIGEP U.S.A.

THE MARK CONSISTS OF STANDARD CHARACTERS WITHOUT CLAIM TO ANY PARTICULAR FONT, STYLE, SIZE, OR COLOR.

NO CLAIM IS MADE TO THE EXCLUSIVE RIGHT TO USE "U.S.A.", APART FROM THE MARK AS SHOWN.

FOR PROVIDING FACILITIES FOR FAIRS AND EXHIBITIONS (U.S. CLS. 100 AND 101).
FIRST USE 4-1-2008; IN COMMERCE 4-1-2008.

3,632,401. CBCG HOLDING, LLC, HARVEY CEDARS, NJ. SN 77-358,352. PUB. 6-24-2008, FILED 12-21-2007.

CINNAMON BAY CARIBBEAN GRILL

THE MARK CONSISTS OF STANDARD CHARACTERS WITHOUT CLAIM TO ANY PARTICULAR FONT, STYLE, SIZE, OR COLOR.

NO CLAIM IS MADE TO THE EXCLUSIVE RIGHT TO USE "CARIBBEAN GRILL", APART FROM THE MARK AS SHOWN.

FOR RESTAURANT SERVICES (U.S. CLS. 100 AND 101).
FIRST USE 5-2-2008; IN COMMERCE 5-2-2008.

CLASS 43—(Continued).

3,632,402. CBCG HOLDING, LLC, HARVEY CEDARS, NJ. SN 77-358,378. PUB. 5-13-2008, FILED 12-21-2007.

CBCG

THE MARK CONSISTS OF STANDARD CHARACTERS WITHOUT CLAIM TO ANY PARTICULAR FONT, STYLE, SIZE, OR COLOR.

FOR RESTAURANT SERVICES (U.S. CLS. 100 AND 101).

FIRST USE 5-2-2008; IN COMMERCE 5-2-2008.

3,632,413. SIERRA SUITES FRANCHISE, L.P., WICHITA, KS. SN 77-365,718. PUB. 7-15-2008, FILED 1-7-2008.



OWNER OF U.S. REG. NOS. 2,562,701, 3,104,455, AND OTHERS.

NO CLAIM IS MADE TO THE EXCLUSIVE RIGHT TO USE "HOTEL", APART FROM THE MARK AS SHOWN.

THE COLOR(S) GREEN, WHITE AND BLACK IS/ARE CLAIMED AS A FEATURE OF THE MARK.

THE MARK CONSISTS OF THE LETTERS "H" AND "S" COMBINED IN THE COLOR GREEN TO THE LEFT OF THE LINEAR WORDS "HOTEL SIERRA" IN THE COLOR WHITE ON A BLACK BACKGROUND.

FOR HOTEL SERVICES; HOTEL SERVICES, NAMELY, PROVIDING ONLINE INFORMATION REGARDING HOTEL ACCOMMODATION RATES; HOTEL SERVICES FEATURING INCENTIVE PROGRAMS PROVIDING SPECIAL GUEST SERVICES, AMENITIES AND AWARDS TO MEMBERS (U.S. CLS. 100 AND 101).

FIRST USE 11-7-2007; IN COMMERCE 11-7-2007.

3,632,414. CTF DEVELOPMENT, INC., CORAL GABLES, FL. SN 77-365,855. PUB. 5-20-2008, FILED 1-7-2008.

RED SALT

THE MARK CONSISTS OF STANDARD CHARACTERS WITHOUT CLAIM TO ANY PARTICULAR FONT, STYLE, SIZE, OR COLOR.

FOR RESTAURANT AND BAR SERVICES (U.S. CLS. 100 AND 101).

FIRST USE 4-15-2009; IN COMMERCE 4-15-2009.

CLASS 43—(Continued).

3,632,418. SIERRA SUITES FRANCHISE, L.P., WICHITA, KS. SN 77-366,622. PUB. 7-15-2008, FILED 1-8-2008.



OWNER OF U.S. REG. NOS. 2,562,701, 3,104,455, AND OTHERS.

NO CLAIM IS MADE TO THE EXCLUSIVE RIGHT TO USE "HOTEL", APART FROM THE MARK AS SHOWN.

THE COLOR(S) GREEN, WHITE AND BLACK IS/ARE CLAIMED AS A FEATURE OF THE MARK.

THE MARK CONSISTS OF THE LETTERS "H" AND "S" COMBINED IN GREEN TO THE LEFT OF THE STACKED, VERTICAL WORDS "HOTEL SIERRA" IN WHITE ON A BLACK BACKGROUND.

FOR HOTEL SERVICES; HOTEL SERVICES, NAMELY, PROVIDING ONLINE INFORMATION REGARDING HOTEL ACCOMMODATION RATES; HOTEL SERVICES FEATURING INCENTIVE PROGRAMS PROVIDING SPECIAL GUEST SERVICES, AMENITIES AND AWARDS TO MEMBERS (U.S. CLS. 100 AND 101).

FIRST USE 11-7-2007; IN COMMERCE 11-7-2007.

3,632,471. ASSORTI, LLC, ARLINGTON, VA. SN 77-387,314. PUB. 7-29-2008, FILED 2-3-2008.

CAFE ASSORTI

THE MARK CONSISTS OF STANDARD CHARACTERS WITHOUT CLAIM TO ANY PARTICULAR FONT, STYLE, SIZE, OR COLOR.

NO CLAIM IS MADE TO THE EXCLUSIVE RIGHT TO USE "CAFE", APART FROM THE MARK AS SHOWN.

THE FOREIGN WORDING IN THE MARK TRANSLATES INTO ENGLISH AS TO BE WITH OR TO GO WITH ANOTHER OR OTHERS.

FOR CAFE AND RESTAURANT SERVICES (U.S. CLS. 100 AND 101).

FIRST USE 4-15-2009; IN COMMERCE 4-15-2009.

CLASS 43—(Continued).

3,632,479. TACO BELL CORP., IRVINE, CA. SN 77-389,740. PUB. 6-24-2008, FILED 2-6-2008.

**IT'S NOT JUST FOOD. IT'S
FOURTHMEAL.**

THE MARK CONSISTS OF STANDARD CHARACTERS WITHOUT CLAIM TO ANY PARTICULAR FONT, STYLE, SIZE, OR COLOR.

FOR RESTAURANT SERVICES (U.S. CLS. 100 AND 101).

FIRST USE 6-30-2007; IN COMMERCE 6-30-2007.

3,632,544. RIMINI FIERA S.P.A., 47900 RIMINI, ITALY. SN 77-403,822. PUB. 7-8-2008, FILED 2-22-2008.



NO CLAIM IS MADE TO THE EXCLUSIVE RIGHT TO USE "U.S.A.", APART FROM THE MARK AS SHOWN.

THE COLOR(S) BLACK, RED, WHITE AND BLUE IS/ARE CLAIMED AS A FEATURE OF THE MARK.

THE MARK CONSISTS OF NON-STANDARD CHARACTERS, WHEREIN "S", "G", "E", AND "P" IN "SIGEP" ARE PRESENTED IN THE COLOR BLACK; "U.S.A." IS PRESENTED IN THE COLOR RED; THE "I" IN "SIGEP" CONTAINS THE COLORS RED, WHITE, AND BLUE.

FOR PROVIDING FACILITIES FOR FAIRS AND EXHIBITIONS (U.S. CLS. 100 AND 101).

FIRST USE 4-1-2008; IN COMMERCE 4-1-2008.

3,632,558. BEST WESTERN INTERNATIONAL, INC., PHOENIX, AZ. SN 77-406,350. PUB. 8-5-2008, FILED 2-26-2008.

BWRIDER.COM

THE MARK CONSISTS OF STANDARD CHARACTERS WITHOUT CLAIM TO ANY PARTICULAR FONT, STYLE, SIZE, OR COLOR.

OWNER OF U.S. REG. NO. 3,020,526.

FOR HOTEL SERVICES FOR PREFERRED CUSTOMERS (U.S. CLS. 100 AND 101).

FIRST USE 3-16-2009; IN COMMERCE 3-16-2009.

CLASS 43—(Continued).

3,632,602. WYNDHAM TM CORP., LAS VEGAS, NV. SN 77-413,203. PUB. 7-29-2008, FILED 3-5-2008.

BYREQUEST

THE MARK CONSISTS OF STANDARD CHARACTERS WITHOUT CLAIM TO ANY PARTICULAR FONT, STYLE, SIZE, OR COLOR.

OWNER OF U.S. REG. NO. 2,550,706.

FOR HOTEL SERVICES FEATURING A FREQUENT GUEST MEMBERSHIP PROGRAM (U.S. CLS. 100 AND 101).

FIRST USE 5-1-2008; IN COMMERCE 5-1-2008.

3,632,788. THE DOWNSTREAM DEVELOPMENT AUTHORITY OF THE QUAPAW TRIBE OF OKLAHOMA (O-GAHPAH), TULSA, OK. SN 77-456,057. PUB. 7-15-2008, FILED 4-23-2008.



THE MARK CONSISTS OF A DIVIDED RECTANGLE WITH THE TOP PORTION DEPICTING A ROCKY CLIFF AND A SHORELINE AND THE BOTTOM PORTION OF THE RECTANGLE CONTAINING THE LITERAL ELEMENT OF THE MARK "DEVILS PROMENADE".

FOR BAR SERVICES (U.S. CLS. 100 AND 101).

FIRST USE 7-5-2008; IN COMMERCE 7-5-2008.

3,632,809. LASALLE HOTEL OPERATING PARTNERSHIP, L.P., BETHESDA, MD. SN 77-464,318. PUB. 11-4-2008, FILED 5-2-2008.

THE LIAISON CAPITOL HILL

THE MARK CONSISTS OF STANDARD CHARACTERS WITHOUT CLAIM TO ANY PARTICULAR FONT, STYLE,

CLASS 43—(Continued).

SIZE, OR COLOR.

NO CLAIM IS MADE TO THE EXCLUSIVE RIGHT TO USE "CAPITOL HILL", APART FROM THE MARK AS SHOWN.

FOR HOTEL AND MOTEL SERVICES; MAKING HOTEL RESERVATIONS FOR OTHERS (U.S. CLS. 100 AND 101).

FIRST USE 4-1-2008; IN COMMERCE 4-1-2008.

CLASS 43—(Continued).

NO CLAIM IS MADE TO THE EXCLUSIVE RIGHT TO USE "SPORTS BAR" & "GRILL", APART FROM THE MARK AS SHOWN.

FOR RESTAURANT AND BAR SERVICES (U.S. CLS. 100 AND 101).

FIRST USE 11-19-2008; IN COMMERCE 11-19-2008.

3,632,822. WYNDHAM TM CORP., LAS VEGAS, NV. SN 77-469,390. PUB. 7-22-2008, FILED 5-8-2008.

3,632,946. M HOLDINGS, LLC, LAS VEGAS, NV. SN 77-519,385. PUB. 12-9-2008, FILED 7-10-2008.

WYNDHAM CLEARAIR

THE MARK CONSISTS OF STANDARD CHARACTERS WITHOUT CLAIM TO ANY PARTICULAR FONT, STYLE, SIZE, OR COLOR.

OWNER OF U.S. REG. NOS. 2,096,650, 3,406,048, AND OTHERS.

FOR RESORT HOTEL AND HOTEL SERVICES (U.S. CLS. 100 AND 101).

FIRST USE 8-0-2008; IN COMMERCE 8-0-2008.



3,632,839. DD IP HOLDER LLC, CANTON, MA. SN 77-478,026. PUB. 10-14-2008, FILED 5-19-2008.

DD SMART

NO CLAIM IS MADE TO THE EXCLUSIVE RIGHT TO USE "CAFÉ", APART FROM THE MARK AS SHOWN.

THE MARK CONSISTS OF THE STYLIZED LETTER "M" OVER THE STYLIZED WORD "CAFÉ".

FOR RESTAURANT SERVICES (U.S. CLS. 100 AND 101).

FIRST USE 2-25-2009; IN COMMERCE 2-25-2009.

THE MARK CONSISTS OF STANDARD CHARACTERS WITHOUT CLAIM TO ANY PARTICULAR FONT, STYLE, SIZE, OR COLOR.

OWNER OF U.S. REG. NOS. 3,282,277, 3,394,757, AND OTHERS.

FOR RESTAURANT AND CARRYOUT FOOD SERVICES (U.S. CLS. 100 AND 101).

FIRST USE 7-30-2008; IN COMMERCE 7-30-2008.

3,632,956. DANNY OMARI, NEW YORK, NY. SN 77-521,440. PUB. 12-9-2008, FILED 7-14-2008.

3,632,935. HMSHOST CORPORATION, BETHESDA, MD. SN 77-516,478. PUB. 11-25-2008, FILED 7-8-2008.

Food Fight**MVP HOME TURF SPORTS BAR & GRILL**

THE MARK CONSISTS OF STANDARD CHARACTERS WITHOUT CLAIM TO ANY PARTICULAR FONT, STYLE, SIZE, OR COLOR.

NO CLAIM IS MADE TO THE EXCLUSIVE RIGHT TO USE "FOOD", APART FROM THE MARK AS SHOWN.

FOR RESTAURANT SERVICES (U.S. CLS. 100 AND 101).

FIRST USE 3-5-2009; IN COMMERCE 3-5-2009.

THE MARK CONSISTS OF STANDARD CHARACTERS WITHOUT CLAIM TO ANY PARTICULAR FONT, STYLE, SIZE, OR COLOR.

OWNER OF U.S. REG. NO. 3,435,786.

CLASS 43—(Continued).

3,632,969. MASIFA NY CORP., NEW YORK, NY. SN 77-526,678. PUB. 12-30-2008, FILED 7-20-2008.

CLASS 43—(Continued).

3,633,140. CR LICENSE, LLC, TUCSON, AZ. SN 78-601,595. PUB. 3-28-2006, FILED 4-4-2005.

SORA LELLA

THE MARK CONSISTS OF STANDARD CHARACTERS WITHOUT CLAIM TO ANY PARTICULAR FONT, STYLE, SIZE, OR COLOR.

THE NAME(S), PORTRAIT(S), AND/OR SIGNATURE(S) SHOWN IN THE MARK DOES NOT IDENTIFY A PARTICULAR LIVING INDIVIDUAL.

FOR BAR AND RESTAURANT SERVICES (U.S. CLS. 100 AND 101).

FIRST USE 3-16-2009; IN COMMERCE 3-6-2009.

SPA CLUB

THE MARK CONSISTS OF STANDARD CHARACTERS WITHOUT CLAIM TO ANY PARTICULAR FONT, STYLE, SIZE, OR COLOR.

OWNER OF U.S. REG. NOS. 2,498,670, 2,893,272, AND OTHERS.

SEC. 2(F).

FOR WINE BARS; PROVIDING INFORMATION ABOUT WINE CHARACTERISTICS; SOMMELIER SERVICES, NAMELY, PROVIDING ADVICE ON WINE AND WINE AND FOOD PAIRING; RESTAURANT SERVICES (U.S. CLS. 100 AND 101).

FIRST USE 11-30-2008; IN COMMERCE 11-30-2008.

3,633,006. BEST WESTERN INTERNATIONAL, INC., PHOENIX, AZ. SN 77-540,757. PUB. 12-9-2008, FILED 8-6-2008.

3,633,233. SBE LICENSING, LLC, LOS ANGELES, CA. SN 78-812,657. PUB. 7-1-2008, FILED 2-10-2006.



OWNER OF U.S. REG. NOS. 1,072,360, 1,933,830, AND OTHERS.

NO CLAIM IS MADE TO THE EXCLUSIVE RIGHT TO USE "REWARDS", APART FROM THE MARK AS SHOWN. THE COLOR(S) RED, YELLOW AND BLUE IS/ARE CLAIMED AS A FEATURE OF THE MARK.

THE COLORS BLUE, RED, AND YELLOW ARE CLAIMED AS A FEATURE OF THE MARK, WITH THE COLOR BLUE APPEARING IN THE FIVE-SIDED SHAPE AND IN THE WORDING "BEST WESTERN" ON THE RIGHT SIDE OF THE FIVE-SIDED SHAPE, THE COLOR RED APPEARING IN THE CROWN DESIGN ON THE FIVE-SIDED SHAPE, AND THE COLOR YELLOW APPEARING IN THE WORDING "BEST WESTERN" ON THE FIVE-SIDED SHAPE, IN THE BORDER OF THE FIVE-SIDED SHAPE, AND IN THE WORDING "REWARDS".

FOR HOTEL SERVICES FOR PREFERRED CUSTOMERS (U.S. CLS. 100 AND 101).

FIRST USE 12-15-2008; IN COMMERCE 12-15-2008.

KATSUYA

THE COLOR(S) GRAY IS/ARE CLAIMED AS A FEATURE OF THE MARK.

THE MARK CONSISTS OF GRAY STYLIZED WORD "KATSUYA".

FOR RESTAURANT AND BAR SERVICES (U.S. CLS. 100 AND 101).

FIRST USE 2-1-2009; IN COMMERCE 2-1-2009.

CLASS 43—(Continued).

3,633,298. SUCRE, LLC, NEW ORLEANS, LA. SN 78-933,400. PUB. 11-4-2008, FILED 7-19-2006.



NO CLAIM IS MADE TO THE EXCLUSIVE RIGHT TO USE "NEW ORLEANS", APART FROM THE MARK AS SHOWN.

THE MARK CONSISTS OF RECTANGULAR BLOCK. THE FOREIGN WORDING IN THE MARK TRANSLATES INTO ENGLISH AS "SWEETEN".

FOR RESTAURANT SERVICES, FEATURING SPECIALTY DESSERTS AND CATERING SERVICES FEATURING SPECIALTY DESSERTS (U.S. CLS. 100 AND 101). FIRST USE 4-0-2007; IN COMMERCE 4-0-2007.

CLASS 44—(Continued).

3,631,986. FIRST PLACE DENTISTRY, LLC, MILWAUKEE, WI. SN 77-135,180. PUB. 1-8-2008, FILED 3-20-2007.



NO CLAIM IS MADE TO THE EXCLUSIVE RIGHT TO USE "DENTISTRY, LLC", APART FROM THE MARK AS SHOWN.

THE MARK CONSISTS OF THE SIGN CONSISTS OF ONE LARGE ARABIC NUMBER 1 FOLLOWED BY "ST" ON TOP. FROM THE MIDDLE OF THE NUMBER 1, STARTS A DIVIDING LINE ABOVE WHICH IS THE FULL DESCRIPTION IN CAPITAL LETTERS "FIRST PLACE DENTISTRY, LLC". UNDER THE DIVIDING LINE IS THE SECOND DESCRIPTION: ENHANCING BEAUTY.

FOR DENTIST SERVICES, NAMELY, GENERAL AND AESTHETIC DENTISTRY, ORTHODONTICS SERVICES, PERIODONTICS AND DENTAL IMPLANTOLOGY (U.S. CLS. 100 AND 101).

FIRST USE 10-1-2007; IN COMMERCE 1-1-2008.

CLASS 44—MEDICAL, BEAUTY AND AGRICULTURAL SERVICES

3,631,969. CSL BEHRING AG, BERN 22, SWITZERLAND. SN 77-117,019. PUB. 3-4-2008, FILED 2-27-2007.

ZLB PLASMA

THE MARK CONSISTS OF STANDARD CHARACTERS WITHOUT CLAIM TO ANY PARTICULAR FONT, STYLE, SIZE, OR COLOR.

NO CLAIM IS MADE TO THE EXCLUSIVE RIGHT TO USE "PLASMA", APART FROM THE MARK AS SHOWN.

FOR MEDICAL TESTING AND PROCESSING OF HUMAN BLOOD PLASMA; AND COLLECTION OF HUMAN BLOOD PLASMA (U.S. CLS. 100 AND 101).

FIRST USE 1-1-2007; IN COMMERCE 1-1-2007.

3,632,047. TSAI, JANET C., NEW YORK, NY. SN 77-192,838. PUB. 7-15-2008, FILED 5-30-2007.

Herban Acupuncture

THE MARK CONSISTS OF STANDARD CHARACTERS WITHOUT CLAIM TO ANY PARTICULAR FONT, STYLE, SIZE, OR COLOR.

NO CLAIM IS MADE TO THE EXCLUSIVE RIGHT TO USE "ACUPUNCTURE", APART FROM THE MARK AS SHOWN.

FOR ACUPUNCTURE SERVICES (U.S. CLS. 100 AND 101).

FIRST USE 3-1-2003; IN COMMERCE 2-20-2008.

CLASS 44—(Continued).

3,632,167. CHOICE HOME HEALTH, INC., OKLAHOMA CITY, OK. SN 77-255,050. PUB. 7-22-2008, FILED 8-14-2007.



choice
HOME HEALTH, INC

OWNER OF U.S. REG. NOS. 3,407,841 AND 3,407,842. NO CLAIM IS MADE TO THE EXCLUSIVE RIGHT TO USE "HOME HEALTH, INC", APART FROM THE MARK AS SHOWN.

FOR HOME HEALTH CARE SERVICES, NAMELY, SKILLED NURSING, PHYSICAL THERAPY, OCCUPATIONAL THERAPY, SPEECH THERAPY, HOME HEALTH CARE PROVIDED BY CERTIFIED HOME HEALTH AIDES, NUTRITION COUNSELING, DIETITIAN SERVICES AND MEDICAL SOCIAL WORK IN THE NATURE OF PSYCHOLOGICAL COUNSELING (U.S. CLS. 100 AND 101).

FIRST USE 9-1-2007; IN COMMERCE 9-1-2007.

3,632,195. ACCURAY INCORPORATED, SUNNYVALE, CA. SN 77-265,528. PUB. 7-29-2008, FILED 8-27-2007.

RECKORD

THE MARK CONSISTS OF STANDARD CHARACTERS WITHOUT CLAIM TO ANY PARTICULAR FONT, STYLE, SIZE, OR COLOR.

FOR PROVIDING AND MAINTAINING AN ONLINE DATABASE WHERE HEALTHCARE PROFESSIONALS AND OTHER USERS OF A PROPRIETARY RADIO-SURGERY AND RADIOTHERAPY EQUIPMENT CAN STORE TREATMENT INFORMATION TO ALLOW FOR MONITORING, ANALYSIS, AND TREATMENT OPTIONS AND STRATEGIES, AND FOR STORING AND SHARING PATIENT MEDICAL HISTORIES AND THEIR CONDITIONS, INFORMATION ON PATIENT HEALTH AND PATIENT MEDICAL HISTORY TRACKING INFORMATION (U.S. CLS. 100 AND 101).

FIRST USE 1-21-2008; IN COMMERCE 1-21-2008.

CLASS 44—(Continued).

3,632,214. GOTRYBE, LLC, JOHNSTON CITY, TN. SN 77-273,085. PUB. 7-8-2008, FILED 9-6-2007.

ZOODOOS

THE MARK CONSISTS OF STANDARD CHARACTERS WITHOUT CLAIM TO ANY PARTICULAR FONT, STYLE, SIZE, OR COLOR.

FOR PROVIDING ADVICE IN THE FIELD OF NUTRITION; PROVIDING ASSISTANCE TO INDIVIDUALS TO HELP THEM MAKE HEALTH, WELLNESS AND NUTRITIONAL CHANGES IN THEIR DAILY LIVING TO IMPROVE HEALTH (U.S. CLS. 100 AND 101).

FIRST USE 12-15-2007; IN COMMERCE 12-15-2007.

3,632,274. REDICLINIC LLC, HOUSTON, TX. SN 77-301,983. PUB. 4-1-2008, FILED 10-11-2007.

**REDICLINIC HIGH-QUALITY,
AFFORDABLE, AND CONVENIENT
HEALTHCARE**

THE MARK CONSISTS OF STANDARD CHARACTERS WITHOUT CLAIM TO ANY PARTICULAR FONT, STYLE, SIZE, OR COLOR.

OWNER OF U.S. REG. NOS. 3,152,291 AND 3,280,014. NO CLAIM IS MADE TO THE EXCLUSIVE RIGHT TO USE "HIGH-QUALITY, AFFORDABLE, AND CONVENIENT HEALTHCARE", APART FROM THE MARK AS SHOWN.

FOR MEDICAL CLINIC SERVICES; MEDICAL TESTING; HEALTH SCREENING, HEALTH MAINTENANCE AND HEALTH IMPROVEMENT PROGRESS, AND HEALTH RISK APPRAISAL, NAMELY, HEALTH CARE (U.S. CLS. 100 AND 101).

FIRST USE 10-0-2007; IN COMMERCE 10-0-2007.

CLASS 44—(Continued).

3,632,468. SALON LOFTS, LLC, COLUMBUS, OH. SN 77-385,697. PUB. 6-24-2008, FILED 1-31-2008.



THE COLOR(S) ORANGE, WHITE AND SILVER IS/ARE CLAIMED AS A FEATURE OF THE MARK.

THE MARK CONSISTS OF AN ORANGE CIRCLE WITH A SILVER BORDER AND THE LETTERS "SL" IN WHITE WITHIN THE CIRCLE.

FOR BEAUTY SALONS; HAIR SALON SERVICES; NAIL CARE SALON SERVICES; SKIN CARE SALON SERVICES; MASSAGE SERVICES; HAIR EXTENSION SERVICES; COSMETIC ELECTROLYSIS; IN-PERSON MAKEUP CONSULTATION AND APPLICATION SERVICES (U.S. CLS. 100 AND 101).

FIRST USE 11-1-2007; IN COMMERCE 11-1-2007.

3,632,613. HALL, RAYMOND F., DBA DR. RAYMOND F. HALL, DC/ HALL CHIROPRACTIC, LOS ANGELES, CA. SN 77-414,391. PUB. 7-22-2008, FILED 3-6-2008.

Leading the way through
cooperative medicine

THE MARK CONSISTS OF STANDARD CHARACTERS WITHOUT CLAIM TO ANY PARTICULAR FONT, STYLE, SIZE, OR COLOR.

FOR HEALTHCARE (U.S. CLS. 100 AND 101).
FIRST USE 1-1-2009; IN COMMERCE 1-1-2009.

CLASS 44—(Continued).

3,632,782. ACACIA WALRATH, LOS GATOS, CA. AND STEVE WALRATH, LOS GATOS, CA. SN 77-453,762. PUB. 9-9-2008, FILED 4-21-2008.

Just For You

THE MARK CONSISTS OF STANDARD CHARACTERS WITHOUT CLAIM TO ANY PARTICULAR FONT, STYLE, SIZE, OR COLOR.

FOR HAIR SALON SERVICES, NAMELY, HAIR CUTTING, STYLING, COLORING, AND HAIR EXTENSION SERVICES (U.S. CLS. 100 AND 101).

FIRST USE 6-20-2007; IN COMMERCE 6-20-2007.

3,632,792. PRIMAMED PHYSICIANS ASSOCIATION, DALLAS, TX. SN 77-457,381. PUB. 9-23-2008, FILED 4-24-2008.

WHERE YOU NEED US, WHEN
YOU NEED US

THE MARK CONSISTS OF STANDARD CHARACTERS WITHOUT CLAIM TO ANY PARTICULAR FONT, STYLE, SIZE, OR COLOR.

FOR MEDICAL SERVICES AND HEALTHCARE; URGENT CARE MEDICAL SERVICES; FAMILY HEALTHCARE SERVICES; OCCUPATIONAL HEALTH MEDICAL SERVICES; PHYSICAL THERAPY; X-RAY SERVICES, NAMELY, MEDICAL RADIOLOGY SERVICES AND DIAGNOSTIC RADIOLOGY SERVICES (U.S. CLS. 100 AND 101).

FIRST USE 10-0-2000; IN COMMERCE 10-0-2000.

3,632,794. PRIMAMED PHYSICIANS ASSOCIATION, DALLAS, TX. SN 77-457,553. PUB. 9-23-2008, FILED 4-24-2008.

HEALTHCARE FOR THE WAY WE
LIVE AND WORK TODAY

THE MARK CONSISTS OF STANDARD CHARACTERS WITHOUT CLAIM TO ANY PARTICULAR FONT, STYLE, SIZE, OR COLOR.

FOR MEDICAL SERVICES AND HEALTHCARE; URGENT CARE MEDICAL SERVICES; FAMILY HEALTHCARE SERVICES; OCCUPATIONAL HEALTH MEDICAL SERVICES; PHYSICAL THERAPY; X-RAY SERVICES, NAMELY, MEDICAL RADIOLOGY SERVICES AND DIAGNOSTIC RADIOLOGY SERVICES (U.S. CLS. 100 AND 101).

FIRST USE 10-0-2000; IN COMMERCE 10-0-2000.

CLASS 44—(Continued).

3,632,803. THERAPY PRODUCTS, INC., DBA ERCHONIA MEDICAL, MCKINNEY, TX. SN 77-461,916. PUB. 10-7-2008, FILED 4-30-2008.

Zerona

THE MARK CONSISTS OF STANDARD CHARACTERS WITHOUT CLAIM TO ANY PARTICULAR FONT, STYLE, SIZE, OR COLOR.

FOR MEDICAL AND CHIROPRACTIC PROCEDURES AND THERAPIES, NAMELY, BODY CONTOURING USING A LASER (U.S. CLS. 100 AND 101).

FIRST USE 11-21-2007; IN COMMERCE 11-21-2007.

CLASS 44—(Continued).

3,632,899. SCHAEFER, RICHARD B., FOND DU LAC, WI. SN 77-503,131. PUB. 11-11-2008, FILED 6-19-2008.

TRANSFORMING LUXURY MEDICAL SERVICES

THE MARK CONSISTS OF STANDARD CHARACTERS WITHOUT CLAIM TO ANY PARTICULAR FONT, STYLE, SIZE, OR COLOR.

NO CLAIM IS MADE TO THE EXCLUSIVE RIGHT TO USE "MEDICAL SERVICES", APART FROM THE MARK AS SHOWN.

FOR SKIN TREATMENTS, NAMELY, THE INJECTION OF DERMAL FILLING AGENTS AND NEUROMUSCULAR BLOCKING AGENTS TO REDUCE THE APPEARANCE OF FACIAL LINES AND WRINKLES (U.S. CLS. 100 AND 101).

FIRST USE 1-6-2009; IN COMMERCE 1-6-2009.

3,633,012. SUPERVALU INC., EDEN PRAIRIE, MN. SN 77-543,959. PUB. 12-23-2008, FILED 8-11-2008.

HEALTHY PURSUITS

THE MARK CONSISTS OF STANDARD CHARACTERS WITHOUT CLAIM TO ANY PARTICULAR FONT, STYLE, SIZE, OR COLOR.

NO CLAIM IS MADE TO THE EXCLUSIVE RIGHT TO USE "HEALTHY", APART FROM THE MARK AS SHOWN.

FOR PROVIDING INFORMATION AND PROGRAMS IN THE FIELD OF HEALTH AND WELLNESS (U.S. CLS. 100 AND 101).

FIRST USE 9-1-2008; IN COMMERCE 9-1-2008.

3,632,836. MY HEALTH, INC., PALO ALTO, CA. SN 77-477,348. PUB. 10-7-2008, FILED 5-17-2008.

HealthConduit

THE MARK CONSISTS OF STANDARD CHARACTERS WITHOUT CLAIM TO ANY PARTICULAR FONT, STYLE, SIZE, OR COLOR.

FOR PROVIDING AN INTERNET WEB SITE FOR MEDICAL PROFESSIONALS AND MEDICAL PATIENTS THAT ALLOWS FOR THE EXCHANGE OF INFORMATION FROM REMOTE LOCATIONS USING ELECTRONIC PATIENT MONITORING DEVICES THAT FEED INFORMATION TO THE WEB SITE THAT CAN BE ACCESSED IN REAL-TIME BY MEDICAL PROFESSIONALS FOR PURPOSES OF MONITORING AND DIAGNOSING MEDICAL CONDITIONS (U.S. CLS. 100 AND 101).

FIRST USE 5-16-2008; IN COMMERCE 5-16-2008.

3,633,097. THIRTY 5 PARTNERS, LTD., NEW YORK, TX. SN 78-461,762. PUB. 12-13-2005, FILED 8-4-2004.

BE

THE MARK CONSISTS OF STANDARD CHARACTERS WITHOUT CLAIM TO ANY PARTICULAR FONT, STYLE, SIZE, OR COLOR.

FOR HEALTH SPA SERVICES, NAMELY, COSMETIC BODY CARE SERVICES; SALON SERVICES, NAMELY, PROVIDING FACIALS AND MASSAGES (U.S. CLS. 100 AND 101).

FIRST USE 8-15-2008; IN COMMERCE 8-15-2008.

CLASS 44—(Continued).

3,633,136. MEDICAL TECHNOLOGIES UNLIMITED, INC., A DELAWARE CORPORATION, MIAMI, FL. SN 78-594,035. PUB. 12-27-2005, FILED 3-24-2005.

CPREP

THE MARK CONSISTS OF STANDARD CHARACTERS WITHOUT CLAIM TO ANY PARTICULAR FONT, STYLE, SIZE, OR COLOR.

FOR MEDICAL SERVICES, NAMELY, RATING AN INDIVIDUAL'S PHYSICAL CAPABILITIES (U.S. CLS. 100 AND 101).

FIRST USE 3-24-2005; IN COMMERCE 3-12-2009.

3,633,156. SAYEG PLASTIC SURGERY CENTER, WEST BLOOMFIELD, MI. SN 78-646,266. PUB. 9-26-2006, FILED 6-8-2005.

PEBAM

THE MARK CONSISTS OF STANDARD CHARACTERS WITHOUT CLAIM TO ANY PARTICULAR FONT, STYLE, SIZE, OR COLOR.

FOR MEDICAL SERVICES, NAMELY, PERFORMING BREAST AUGMENTATION OR RECONSTRUCTIVE SURGERY (U.S. CLS. 100 AND 101).

FIRST USE 9-0-2005; IN COMMERCE 9-0-2005.

CLASS 44—(Continued).

3,633,197. FONTAINEBLEAU RESORT PROPERTIES II, LLC, LAS VEGAS, NV. SN 78-736,055. PUB. 1-2-2007, FILED 10-19-2005.

FONTAINEBLEAU

THE MARK CONSISTS OF STANDARD CHARACTERS WITHOUT CLAIM TO ANY PARTICULAR FONT, STYLE, SIZE, OR COLOR.

OWNER OF U.S. REG. NOS. 995,958 AND 3,061,814.

FOR BEAUTY SALON SERVICES; HEALTH SPA SERVICES, NAMELY, COSMETIC BODY CARE SERVICES (U.S. CLS. 100 AND 101).

FIRST USE 12-26-2008; IN COMMERCE 12-26-2008.

3,633,224. SOTTOPELLE, INC., SCOTTSDALE, AZ. SN 78-779,769. PUB. 12-19-2006, FILED 12-22-2005.

BUT IT DOESN'T HAVE TO BE THAT WAY!

THE MARK CONSISTS OF STANDARD CHARACTERS WITHOUT CLAIM TO ANY PARTICULAR FONT, STYLE, SIZE, OR COLOR.

FOR MEDICAL SERVICES, NAMELY, OBSTETRICS AND GYNECOLOGY SERVICES; AND HORMONE REPLACEMENT THERAPY (U.S. CLS. 100 AND 101).

FIRST USE 0-0-2002; IN COMMERCE 0-0-2002.

3,633,283. MEDAPPS, INC., SCOTTSDALE, AZ. SN 78-911,705. PUB. 1-30-2007, FILED 6-19-2006.

HEALTHCARE ANYWHERE

THE MARK CONSISTS OF STANDARD CHARACTERS WITHOUT CLAIM TO ANY PARTICULAR FONT, STYLE, SIZE, OR COLOR.

NO CLAIM IS MADE TO THE EXCLUSIVE RIGHT TO USE "HEALTHCARE", APART FROM THE MARK AS SHOWN.

FOR REMOTE MONITORING OF DATA INDICATIVE OF THE HEALTH OR CONDITION OF AN INDIVIDUAL OR GROUP OF INDIVIDUALS (U.S. CLS. 100 AND 101).

FIRST USE 6-19-2006; IN COMMERCE 6-19-2006.

CLASS 45—PERSONAL AND LEGAL SERVICES

CLASS 45—(Continued).

3,631,814. GREGG, VERA, PORTLAND, OR. SN 76-669,260. PUB. 1-15-2008, FILED 11-20-2006.

LOVE BUG

THE MARK CONSISTS OF STANDARD CHARACTERS WITHOUT CLAIM TO ANY PARTICULAR FONT, STYLE, SIZE, OR COLOR.

FOR MATCHING SERVICES, NAMELY, SOCIAL NETWORKING, INTRODUCTION, MATCHING, AND DATING SERVICES (U.S. CLS. 100 AND 101).

FIRST USE 11-20-2006; IN COMMERCE 11-20-2006.

3,631,918. CREDIT MARKETS REAL ESTATE CORP., NEW YORK, NY. SN 77-065,790. PUB. 12-18-2007, FILED 12-15-2006.

LUXURY. LIFE. STYLE.

THE MARK CONSISTS OF STANDARD CHARACTERS WITHOUT CLAIM TO ANY PARTICULAR FONT, STYLE, SIZE, OR COLOR.

FOR HOTEL CONCIERGE SERVICES; WEDDING CHAPEL SERVICES (U.S. CLS. 100 AND 101).

FIRST USE 3-31-2005; IN COMMERCE 3-31-2005.

3,632,227. BROWN, KEITH T., WYOMISSING, PA. SN 77-279,631. PUB. 3-4-2008, FILED 9-14-2007.

**Insuring Your Investment
Securing Your Dream**

THE MARK CONSISTS OF STANDARD CHARACTERS WITHOUT CLAIM TO ANY PARTICULAR FONT, STYLE, SIZE, OR COLOR.

FOR REAL ESTATE SETTLEMENT SERVICES; REAL ESTATE CLOSING SERVICES; TITLE SEARCHING (U.S. CLS. 100 AND 101).

FIRST USE 6-1-2007; IN COMMERCE 9-1-2007.

CLASS 45—(Continued).

3,632,618. INFOARMOR, INC., SCOTTSDALE, AZ. SN 77-414,704. PUB. 7-15-2008, FILED 3-6-2008.

SNAPD

THE MARK CONSISTS OF STANDARD CHARACTERS WITHOUT CLAIM TO ANY PARTICULAR FONT, STYLE, SIZE, OR COLOR.

FOR IDENTITY MONITORING SERVICE FOR MEASURING, MONITORING, AND SCORING IDENTITY RISK FACTORS, INCLUDING, BUT NOT LIMITED TO EVALUATING AND SCORING THE POTENTIAL RISK OF FINANCIAL, CREDIT, INSURANCE AND MEDICAL FRAUD (U.S. CLS. 100 AND 101).

FIRST USE 6-1-2007; IN COMMERCE 8-1-2007.

3,632,669. CORBIS CORPORATION, NEW YORK, NY. SN 77-425,258. PUB. 8-19-2008, FILED 3-18-2008.

GREENLIGHT

THE MARK CONSISTS OF STANDARD CHARACTERS WITHOUT CLAIM TO ANY PARTICULAR FONT, STYLE, SIZE, OR COLOR.

FOR LICENSING OF INTELLECTUAL PROPERTY, NAMELY, THE RIGHTS TO USE THE NAMES, LIKENESSES, TRADEMARKS AND IDENTIFYING CHARACTERISTICS OF PERSONS AND ENTITIES PRIMARILY IN THE FIELDS OF SPORTS, ENTERTAINMENT, HISTORY, AND POLITICS (U.S. CLS. 100 AND 101).

FIRST USE 7-19-2008; IN COMMERCE 7-19-2008.

3,633,001. TODD, JED, NEWARK, DE. AND TODD, CLAUDIA, NEWARK, DE. SN 77-539,591. PUB. 12-16-2008, FILED 8-5-2008.

Contented Critters

THE MARK CONSISTS OF STANDARD CHARACTERS WITHOUT CLAIM TO ANY PARTICULAR FONT, STYLE, SIZE, OR COLOR.

FOR PET SITTING (U.S. CLS. 100 AND 101).

FIRST USE 6-1-2008; IN COMMERCE 6-1-2008.

CLASS 45—(Continued).

3,633,105. PERSONAL ESTATE MANAGER, INC., STERLING HEIGHTS, MI. SN 78-491,019. PUB. 1-24-2006, FILED 9-28-2004.



THE MARK CONSISTS OF THE PROFILE OF A MAN WITH CURLY HAIR WEARING A WINGED HAT.
FOR COLLECTING, VIA WEBSITES ON GLOBAL COMPUTER NETWORKS, INFORMATION ABOUT AN INDIVIDUAL'S ASSETS, HEIRS OR DESIGNEES, BEQUESTS, TRACKING MORTALITY, AND DISTRIBUTING INFORMATION UPON AN INDIVIDUAL'S DEATH TO THE INDIVIDUAL'S BENEFICIARIES OR DESIGNEEES (U.S. CLS. 100 AND 101).
FIRST USE 4-30-2006; IN COMMERCE 10-17-2007.

3,633,181. LIPIN, QUINN H., NEEDHAM, MA. SN 78-698,599. PUB. 1-17-2006, FILED 8-23-2005.

RENEW

CLASS 45—(Continued).

THE MARK CONSISTS OF STANDARD CHARACTERS WITHOUT CLAIM TO ANY PARTICULAR FONT, STYLE, SIZE, OR COLOR.
FOR INTERNET BASED DATING, INTRODUCTION AND SOCIAL NETWORKING SERVICES (U.S. CLS. 100 AND 101).
FIRST USE 4-8-2009; IN COMMERCE 4-8-2009.

3,633,235. CONCIERGE DIRECT CORPORATION, MARMARONECK, NY. SN 78-821,650. PUB. 8-14-2007, FILED 2-23-2006.



NO CLAIM IS MADE TO THE EXCLUSIVE RIGHT TO USE "CONCIERGE", APART FROM THE MARK AS SHOWN.
FOR CONCIERGE SERVICES FOR OTHERS COMPRISING MAKING REQUESTED PERSONAL ARRANGEMENTS, ASSISTANCE, AND RESERVATIONS, PROVIDING CUSTOMER-SPECIFIC LOCAL INFORMATION ABOUT RESTAURANTS, ENTERTAINMENT, COMMUNITY, IN-BUILDING ACTIVITIES, AND MOVIES, TO MEET INDIVIDUAL NEEDS RENDERED TOGETHER IN APARTMENT COMPLEXES, RESIDENTIAL NEIGHBORHOODS, HOTELS, AND CONDOMINIUMS (U.S. CLS. 100 AND 101).
FIRST USE 6-1-2006; IN COMMERCE 6-1-2006.

* * * * *

PRIOR UNITED STATES CLASSIFICATION

APPLICATION IN ONE CLASS

CERTIFICATION MARKS

CLASS A—GOODS

3,632,439. SPECCERAMICS, INC., FULLERTON, CA. SN 77-374,730. PUB. 6-3-2008, FILED 1-17-2008.

THE CERTIFICATION MARK, AS INTENDED TO BE USED BY AUTHORIZED PERSONS, IS INTENDED TO CERTIFY THAT THE GOODS HAVE BEEN TESTED AND MEET THE LOW CEPHALIC STANDARDS DEVELOPED BY CERTIFIER.

FOR FOODS, BEVERAGES, AND DIETARY SUPPLEMENTS (U.S. CL. A).
FIRST USE 9-25-2008; IN COMMERCE 9-25-2008.

ECOSPEC

THE MARK CONSISTS OF STANDARD CHARACTERS WITHOUT CLAIM TO ANY PARTICULAR FONT, STYLE, SIZE, OR COLOR.

THE CERTIFICATION MARK, AS INTENDED TO BE USED BY AUTHORIZED PERSONS, IS INTENDED TO CERTIFY THE GOODS ARE MANUFACTURED IN SOUTHERN CALIFORNIA FROM CONCRETE AND 60% RECYCLED, POST-CONSUMER GLASS CONTAINERS.

FOR CEMENT BASED RECYCLED GLASS SLABS AND TILES FOR USE IN RESIDENTIAL AND COMMERCIAL CONSTRUCTION (U.S. CL. A).
FIRST USE 2-9-2009; IN COMMERCE 2-9-2009.

3,632,536. GLYCEMIC RESEARCH INSTITUTE, WASHINGTON, DC. SN 77-402,356. PUB. 7-29-2008, FILED 2-21-2008.

3,632,535. GLYCEMIC RESEARCH INSTITUTE, WASHINGTON, DC. SN 77-402,331. PUB. 7-29-2008, FILED 2-21-2008.



OWNER OF U.S. REG. NOS. 2,572,688, 3,419,072, AND OTHERS.

NO CLAIM IS MADE TO THE EXCLUSIVE RIGHT TO USE "CERTIFIED BY THE GLYCEMIC RESEARCH INSTITUTE", "LOW CEPHALIC DIET", AND "WASHINGTON, D.C.", APART FROM THE MARK AS SHOWN.

THE MARK CONSISTS OF A SEAL CONTAINING THE LITERAL ELEMENTS OF THE MARK.



OWNER OF U.S. REG. NOS. 2,572,688, 3,419,072, AND OTHERS.

NO CLAIM IS MADE TO THE EXCLUSIVE RIGHT TO USE "CERTIFIED BY THE GLYCEMIC RESEARCH INSTITUTE", "LOW CEPHALIC INDEX" AND "WASHINGTON, D.C.", APART FROM THE MARK AS SHOWN.

THE MARK CONSISTS OF A SEAL CONTAINING THE LITERAL ELEMENTS OF THE MARK.

THE CERTIFICATION MARK, AS INTENDED TO BE USED BY AUTHORIZED PERSONS, IS INTENDED TO CERTIFY THAT THE GOODS HAVE BEEN TESTED AND MEET THE LOW CEPHALIC STANDARDS DEVELOPED BY THE CERTIFIER.

FOR FOODS, BEVERAGES, AND DIETARY SUPPLEMENTS (U.S. CL. A).
FIRST USE 9-25-2008; IN COMMERCE 9-25-2008.

3,632,663. COMISION NACIONAL DE PROMOCION DE EXPORTACIONES E INVERSIONES (CONADEI), ANTI-GUO CUSCATLAN, EL SALVADOR. SN 77-424,064. PUB. 11-4-2008, FILED 3-17-2008.

CERTIFICATION MARKS

CLASS B—SERVICES

3,631,838. COMPOSITE PANEL ASSOCIATION, GAITHERSBURG, MD. SN 76-684,214. PUB. 6-17-2008, FILED 11-20-2007.



NO CLAIM IS MADE TO THE EXCLUSIVE RIGHT TO USE "AUTÉNTICO SABOR", APART FROM THE MARK AS SHOWN.

THE MARK CONSISTS OF THE WORDS "AUTÉNTICO SABOR SALVADOREÑO" WRITTEN TWICE IN A CIRCLE AROUND A HAND HOLDING A PLATE WITH THE DESIGN OF THE COUNTRY OF EL SALVADOR ABOVE THE PLATE.

THE ENGLISH TRANSLATION OF "AUTÉNTICO SABOR SALVADOREÑO" IN THE MARK IS "AUTHENTIC SALVADORIAN FLAVOR".

THE CERTIFICATION MARK, AS USED BY PERSONS AUTHORIZED BY THE CERTIFIER, CERTIFIES THAT THE GOODS PROVIDED HAVE BEEN PRODUCED IN EL SALVADOR AND ARE PRODUCED IN COMPLIANCE WITH THE QUALITY STANDARDS ADMINISTERED BY THE CERTIFIER.

FOR FROZEN FOODS; ETHNIC FOODS; BEVERAGES; CONDIMENTS; ESCENCES; JAMS AND SWEETS; BEAN SEEDS; FROZEN BEANS; TAMALES; CORN TAMALES; RIGUAS; CANNED PASTA; BREAD; SWEET BREAD; RICE; CORN; GELATIN; COFFEE GRAINS; ALFAJORES; ORGEATS AND ORGEAT FLOUR (HORCHATA); BARLEY; ATOLE SHUCO; SAUCES; ACHIOTE; HONEY; PASTA; LOROCO; CHEESE; CREAM; POWDER PREPARATIONS FOR REFRESHMENTS; SEMITA (U.S. CL. A).

FIRST USE 8-1-2008; IN COMMERCE 8-1-2008.

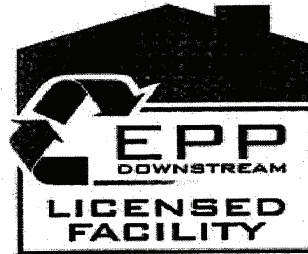

NO CLAIM IS MADE TO THE EXCLUSIVE RIGHT TO USE "EPP DOWNSTREAM LICENSED FACILITY", APART FROM THE MARK AS SHOWN.

THE CERTIFICATION MARK WILL BE USED BY AUTHORIZED PERSONS TO CERTIFY THAT 50% OF THE COMPOSITE PANEL MATERIALS PURCHASED FOR USE HAS MET THE CERTIFICATION STANDARDS WITH REGARD TO PRODUCT CONTENT AND INDUSTRY EMISSION STANDARDS.

FOR MANUFACTURE OF PARTICLEBOARD, MEDIUM DENSITY FIBERBOARD, PLYWOOD AND HARDBOARD (U.S. CL. B).

FIRST USE 5-0-2007; IN COMMERCE 6-0-2007.

* * * * *

SUPPLEMENTAL REGISTER

These registrations are not subject to opposition.

SECTION 1.— INTERNATIONAL CLASSIFICATION

The short titles associated below with the international class numbers are terms designed merely for quick identification and are not an official part of the international classification. The full names of international classes are given in section 6.1 of the trademark rules of practice.

The designation "U.S. Cl." appearing in this section refers to the U.S. class in effect prior to Sep. 1, 1973 rather than the international class which applies to applications filed on or after that date. For adoption of international classification see notice in the OFFICIAL GAZETTE of Jun. 26, 1973 (911 O.G. TM 210).

Application in more than one class

3,633,358. EFPE 2005 - FINANZIARIA FELTRINELLI S.P.A., MILANO, ITALY. SN 77-221,216. FILED P.R. 7-3-2007; AM. S.R. 4-28-2009.

3,633,369. NAVANI, GIRISH KUMAR, WESTBOROUGH, MA. SN 77-342,501. FILED P.R. 12-3-2007; AM. S.R. 4-17-2009.

FELTRINELLI

Electronic Health eXchange

THE MARK CONSISTS OF STANDARD CHARACTERS WITHOUT CLAIM TO ANY PARTICULAR FONT, STYLE, SIZE, OR COLOR.

OWNER OF ITALY REG. NO. 437524, DATED 7-8-1986, RENEWED AS REG. NO. 1122941, DATED 6-30-2008, EXPIRES 1-9-2016.

CLASS 16—PAPER GOODS AND PRINTED MATTER

FOR BOOKS, GUIDEBOOKS, MAGAZINES, BROCHURES, CATALOGS, PAMPHLETS AND MANUALS IN THE FIELD OF ARCHITECTURE, ARTS, PHOTOGRAPHY, JOURNALISM, BUSINESS, CARTOONS, CHILDREN'S ACTIVITIES, CHRISTMAS SEASONAL ACTIVITIES, COMPUTERS, COOKERY, DECORATIONS, DRAWINGS, EDUCATION, GEOGRAPHY, HISTORY, FOREIGN LANGUAGES, MUSIC, PAINTING, PHARMACEUTICALS, PICTURES, POLITICS, SCIENCE, SCHOOLS, SPORTS, FASHION, FAIRY TALES, WEDDINGS, GARDENING, NATURE, HORTICULTURE, JOBS, ANIMALS, PSYCHOLOGY, AUTOMOBILES, MOTORCYCLING, MOTORS, SEAMANSHIP, LEISURE TIME, TRAVELING, TOURISM, DRAMATIC WORKS IN THE HORROR GENRE, COLLECTING VALUABLES, CURRENT EVENTS, ROAD MAPS, CINEMA, ENTERTAINMENT SHOWS AND PERFORMANCES, COMICS, SCIENCE FICTION, ECOLOGY, SCHOLASTIC TEXTS, LITERATURE, PHILOSOPHY, ASTROLOGY, THE PARANORMAL, HUNTING, FOOTBALL, CYCLING, FISHING, HORSE-RIDING, ENOLOGY, DO-IT-YOURSELF HOMEOWNER PROJECTS, GASTRONOMY, GAMES, MOUNTAINS, SEAFARING, AND RAISING OF BABIES AND CHILDREN (U.S. CLS. 2, 5, 22, 23, 29, 37, 38 AND 50).

CLASS 41—EDUCATION AND ENTERTAINMENT

FOR PUBLISHING SERVICES, NAMELY, PUBLICATION OF BOOKS, MAGAZINES, BROCHURES, CATALOGS, PAMPHLETS AND MANUALS (U.S. CLS. 100, 101 AND 107).

THE MARK CONSISTS OF STANDARD CHARACTERS WITHOUT CLAIM TO ANY PARTICULAR FONT, STYLE, SIZE, OR COLOR.

CLASS 38—COMMUNICATION

FOR ELECTRONIC DATA TRANSMISSION, NAMELY, THE TRANSMISSION OF ELECTRONIC HEALTH RECORDS (U.S. CLS. 100, 101 AND 104).

FIRST USE 2-1-2007; IN COMMERCE 2-15-2007.

CLASS 42—SCIENTIFIC AND COMPUTER SERVICES

FOR PROVIDING ON-LINE NON-DOWNLOADABLE SOFTWARE FOR THE TRANSMISSION OF ELECTRONIC HEALTH RECORDS (U.S. CLS. 100 AND 101).

FIRST USE 2-1-2007; IN COMMERCE 2-15-2007.

3,633,376. MOSAIC INTERNATIONAL LLC, SAN RAMON, CA. SN 77-392,794. FILED P.R. 2-8-2008; AM. S.R. 4-22-2009.

SUPERHORN

THE MARK CONSISTS OF STANDARD CHARACTERS WITHOUT CLAIM TO ANY PARTICULAR FONT, STYLE, SIZE, OR COLOR.

CLASS 9—ELECTRICAL AND SCIENTIFIC APPARATUS

3,633,414. SPRINGER-VERLAG GMBH, HEIDELBERG, FED REP GERMANY. SN 77-518,911. FILED P.R. 7-10-2008; AM. S.R. 4-3-2009.

FOR GENERAL PURPOSE HORNS FOR SIGNALING AND WARNING (U.S. CLS. 21, 23, 26, 36 AND 38).
FIRST USE 4-1-2009; IN COMMERCE 4-1-2009.

CLASS 28—TOYS AND SPORTING GOODS

FOR TOY NOISEMAKERS (U.S. CLS. 22, 23, 38 AND 50).
FIRST USE 4-1-2009; IN COMMERCE 4-1-2009.

AUTHORMAPPER

3,633,388. CONCEPT DEVELOPMENT ASSOCIATES OF MARYLAND, INC., DBA LIFEWARE TEK, ST. AUGUSTINE, FL. SN 77-479,641. FILED P.R. 5-20-2008; AM. S.R. 4-22-2009.

THE MARK CONSISTS OF STANDARD CHARACTERS WITHOUT CLAIM TO ANY PARTICULAR FONT, STYLE, SIZE, OR COLOR.

PRIORITY CLAIMED UNDER SEC. 44(D) ON FED REP GERMANY APPLICATION NO. 302008041910, FILED 6-30-2008, REG. NO. 302008041910, DATED 12-1-2008, EXPIRES 6-30-2018.

DSR RADIO

THE MARK CONSISTS OF STANDARD CHARACTERS WITHOUT CLAIM TO ANY PARTICULAR FONT, STYLE, SIZE, OR COLOR.

CLASS 9—ELECTRICAL AND SCIENTIFIC APPARATUS

FOR INTERACTIVE COMPUTER SOFTWARE FEATURING PROGRAMS USED FOR ENTERTAINMENT AND EDUCATIONAL PURPOSES IN THE FIELD OF FOODSERVICE DISTRIBUTION, SALES, AND TRAINING; CD-ROMS FEATURING MULTIMEDIA SOFTWARE PROGRAMS USED FOR ENTERTAINMENT AND EDUCATION PURPOSES IN THE FIELDS OF FOODSERVICE DISTRIBUTION, SALES, AND TRAINING; CD-ROMS FEATURING SOUND AND VIDEO RECORDINGS FOR ENTERTAINMENT AND EDUCATIONAL PURPOSES IN THE FIELDS OF FOODSERVICE DISTRIBUTION, SALES, AND TRAINING; DOWNLOADABLE MP3 FILES, MP3 RECORDINGS, ONLINE DISCUSSION BOARDS, WEBCASTS AND PODCASTS FEATURING SOUND AND VIDEO RECORDINGS USED FOR ENTERTAINMENT AND EDUCATIONAL PURPOSES IN THE FIELDS OF FOODSERVICE DISTRIBUTION, SALES, AND TRAINING (U.S. CLS. 21, 23, 26, 36 AND 38).

FIRST USE 8-6-2006; IN COMMERCE 12-1-2006.

CLASS 41—EDUCATION AND ENTERTAINMENT

FOR ENTERTAINMENT SERVICES, NAMELY, PROVIDING PODCASTS IN THE FIELD OF FOODSERVICE DISTRIBUTION, SALES, AND TRAINING (U.S. CLS. 100, 101 AND 107).

FIRST USE 8-6-2006; IN COMMERCE 12-1-2006.

CLASS 9—ELECTRICAL AND SCIENTIFIC APPARATUS

FOR COMPUTER SOFTWARE FEATURING CONTENT, TEXT AND IMAGES IN THE FIELD OF SCIENCE AND SCIENTIFIC RESEARCH, ELECTRONIC DATABASES, AND ELECTRONIC PUBLICATIONS DOWNLOADABLE FROM THE INTERNET, NAMELY, JOURNALS, BOOKS, TEXT BOOKS, WORKBOOKS, MANUALS, TUTORIALS, ARTICLES, AND FILMS, ALL IN THE FIELDS OF SCIENTIFIC RESEARCH, SCIENCE, SCIENTIFIC EDUCATION AND TRAINING, MEDICINE, MEDICAL EDUCATION AND MEDICAL TRAINING (U.S. CLS. 21, 23, 26, 36 AND 38).

CLASS 16—PAPER GOODS AND PRINTED MATTER

FOR PRINTED MATTER AND PRINTED INSTRUCTIONAL AND TEACHING MATERIAL IN THE FIELDS OF SCIENCE AND MEDICINE, NAMELY, A SERIES OF NON-FICTION BOOKS, JOURNALS, TEXT BOOKS, WORKBOOKS, MANUALS, WRITTEN ARTICLES, TUTORIALS, HANDOUTS, AND WORKSHEETS, ALL IN THE FIELDS OF SCIENTIFIC RESEARCH, TECHNOLOGY, SCIENCE, MEDICINE, SCIENTIFIC EDUCATION AND TRAINING, MEDICAL EDUCATION AND MEDICAL TRAINING (U.S. CLS. 2, 5, 22, 23, 29, 37, 38 AND 50).

CLASS 41—EDUCATION AND ENTERTAINMENT

FOR EDITING AND PUBLISHING OF PRINTED MATTER IN THE FIELDS OF TECHNOLOGY, SCIENTIFIC RESEARCH, SCIENCE AND MEDICINE, AND SCIENTIFIC EDUCATION AND TRAINING; EDUCATIONAL SERVICES IN THE NATURE OF PROVIDING ONLINE TUTORIAL SESSIONS IN THE FIELDS OF TECHNOLOGY, SCIENTIFIC RESEARCH, SCIENCE AND MEDICINE; ON-LINE PUBLICATION OF ELECTRONIC BOOKS, MAGAZINES, AND JOURNALS, IN THE FIELDS OF TECHNOLOGY, SCIENTIFIC RESEARCH, SCIENCE AND MEDICINE, AND MEDICAL EDUCATION AND MEDICAL TRAINING (U.S. CLS. 100, 101 AND 107).

CLASS 42—SCIENTIFIC AND COMPUTER SERVICES

FOR PROVIDING ON-LINE, SEARCHABLE, INTERACTIVE DATABASES IN THE FIELDS OF TECHNOLOGY, SCIENTIFIC RESEARCH, SCIENCE, AND MEDICINE, FEATURING SCIENTIFIC RESEARCH, TECHNOLOGY, PUBLICATIONS, SCIENTIFIC AND TECHNOLOGICAL INFORMATION AND OTHER PERTINENT CONTENT RELATING TO SUCH RESEARCH, TECHNOLOGY, PUBLICATIONS, AND PLANS FOR THE DESIGN AND IMPLEMENTATION OF LABORATORY EXPERIMENTS, ALL RELATING TO THE LIFE, BIOLOGIC, MOLECULAR, BIOTECHNICAL, BIOMEDICAL SCIENCES, EARTH, PHYSICAL, MATHEMATICAL, MEDICAL, SOCIAL SCIENCES, AND ENGINEERING, AND TECHNOLOGIES RELATED THERETO (U.S. CLS. 100 AND 101).

3,633,415. CEMENTOS LIMA S.A., LIMA 35, PERU. SN 77-519,819. FILED P.R. 7-11-2008; AM. S.R. 4-23-2009.

CLASS 39—TRANSPORTATION AND STORAGE

FOR SUPPLY CHAIN, LOGISTICS AND REVERSE LOGISTICS SERVICES, NAMELY, TRANSPORT, PACKAGING FOR TRANSPORTATION AND STORAGE OF CEMENTS IN GENERAL, INCLUDING IN BULK AND/OR IN BAGS; RENTAL OF WAREHOUSES FOR STORAGE OF CEMENTS IN GENERAL, INCLUDING CEMENTS IN BULK AND/OR IN BAGS (U.S. CLS. 100 AND 105).

3,633,418. THOMSON, BOULOGNE-BILLANCOURT, FRANCE. SN 77-520,368. FILED P.R. 7-11-2008; AM. S.R. 3-20-2009.

Cementos Lima S.A.

Best Picture

OWNER OF PERU REG. NO. 49049, DATED 1-11-2008, EXPIRES 1-11-2018.

OWNER OF PERU REG. NO. 49057, DATED 1-11-2008, EXPIRES 1-11-2018.

OWNER OF PERU REG. NO. 134452, DATED 1-11-2008, EXPIRES 1-11-2018.

OWNER OF PERU REG. NO. 134355, DATED 1-11-2008, EXPIRES 1-11-2018.

NO CLAIM IS MADE TO THE EXCLUSIVE RIGHT TO USE "CEMENTOS" AND "S.A.", APART FROM THE MARK AS SHOWN.

THE MARK CONSISTS OF THE WORDS "CEMENTOS LIMA S.A." IN STYLIZED LETTERS.

THE FOREIGN WORDING IN THE MARK TRANSLATES INTO ENGLISH AS CEMENTS.

CLASS 16—PAPER GOODS AND PRINTED MATTER

FOR PAPER, CARDBOARD, STATIONERY; PAPER BAGS; CARDBOARD BOXES AND BAGS; PAPER FOR PACKAGING, PLASTIC BAGS AND BUBBLE PACKS AND CARDBOARD FOR PACKAGING (U.S. CLS. 2, 5, 22, 23, 29, 37, 38 AND 50).

CLASS 19—NON-METALLIC BUILDING MATERIALS

FOR CEMENTS IN GENERAL, NAMELY, PORTLAND TYPE CEMENTS AND PUZZOLANIC TYPE CEMENTS (U.S. CLS. 1, 12, 33 AND 50).

CLASS 37—CONSTRUCTION AND REPAIR

FOR BUILDING CONSTRUCTION; RENTAL OF CONSTRUCTION HAND AND POWER TOOLS, MATERIALS AND MACHINES FOR BUILDING CONSTRUCTION, QUARRYING AND MINING EXTRACTION (U.S. CLS. 100, 103 AND 106).

THE MARK CONSISTS OF STANDARD CHARACTERS WITHOUT CLAIM TO ANY PARTICULAR FONT, STYLE, SIZE, OR COLOR.

OWNER OF FRANCE REG. NO. 083552569, DATED 1-29-2008, EXPIRES 1-29-2018.

CLASS 9—ELECTRICAL AND SCIENTIFIC APPARATUS

FOR APPARATUS AND INSTRUMENTS FOR THE BROADCASTING AND COMMUNICATION OF IN-STORE INFORMATION AND ADVERTISEMENTS, NAMELY, LCD PROJECTORS USED TO DISPLAY ADVERTISEMENTS, AND VIDEO TRANSMISSION APPARATUS; SOFTWARE PLATFORMS FOR THE VIDEO MANAGEMENT AND BROADCASTING OF HIGH DEFINITION VIDEO CONTENTS FOR IN-STORE MERCHANDISING AND PROMOTION (U.S. CLS. 21, 23, 26, 36 AND 38).

CLASS 35—ADVERTISING AND BUSINESS

FOR ADVERTISING SERVICES FOR AND ON BEHALF OF THIRD PARTIES; DISTRIBUTION AND PRODUCTION OF IN-STORE ADVERTISEMENTS AND NEWS, NAMELY, PROVIDING NEWS WITHIN A STORE IN THE FIELD OF CONSUMER INFORMATION TO AID PURCHASING DECISIONS, AND PRODUCTION OF AUDIO AND VIDEO INFOMERCIALS AND TELEVISION COMMERCIALS (U.S. CLS. 100, 101 AND 102).

CLASS 38—COMMUNICATION

FOR BROADCASTING SERVICES OF HIGH DEFINITION AUDIO AND VIDEO CONTENTS, TELEVISION BROADCASTING; VIDEO AND TELEVISION BROADCASTING OF IN-STORE ADVERTISEMENTS AND NEWS (U.S. CLS. 100, 101 AND 104).

3,633,428. SPARTAN DIET, SANTA BARBARA, CA. SN 77-526,506. FILED P.R. 7-18-2008; AM. S.R. 4-13-2009.

3,633,453. MCMONIGLE, JOHN, NEWPORT, CA. SN 77-611,421. FILED P.R. 11-10-2008; AM. S.R. 4-21-2009.

SPARTAN DIET

90 DAY CERTAIN SALE

THE MARK CONSISTS OF STANDARD CHARACTERS WITHOUT CLAIM TO ANY PARTICULAR FONT, STYLE, SIZE, OR COLOR.

NO CLAIM IS MADE TO THE EXCLUSIVE RIGHT TO USE "DIET", APART FROM THE MARK AS SHOWN.

CLASS 41—EDUCATION AND ENTERTAINMENT

FOR ON-LINE JOURNALS, NAMELY, BLOGS FEATURING CONTENT IN THE FIELDS OF HOLISTIC HEALTH, NUTRITION AND LIFESTYLE WELLNESS (U.S. CLS. 100, 101 AND 107).

FIRST USE 6-30-2008; IN COMMERCE 6-30-2008.

CLASS 44—MEDICAL, BEAUTY AND AGRICULTURAL SERVICES

FOR COUNSELING SERVICES IN THE FIELDS OF HOLISTIC HEALTH, NUTRITION AND LIFESTYLE WELLNESS (U.S. CLS. 100 AND 101).

FIRST USE 7-15-2008; IN COMMERCE 7-15-2008.

THE MARK CONSISTS OF STANDARD CHARACTERS WITHOUT CLAIM TO ANY PARTICULAR FONT, STYLE, SIZE, OR COLOR.

CLASS 35—ADVERTISING AND BUSINESS

FOR REAL ESTATE AUCTIONS (U.S. CLS. 100, 101 AND 102).

FIRST USE 1-31-2009; IN COMMERCE 1-31-2009.

CLASS 36—INSURANCE AND FINANCIAL

FOR REAL ESTATE BROKERAGE; REAL ESTATE FINANCING SERVICES; REAL ESTATE INVESTMENT (U.S. CLS. 100, 101 AND 102).

FIRST USE 1-31-2009; IN COMMERCE 1-31-2009.

3,633,450. CENTENE CORPORATION, ST. LOUIS, MO. SN 77-599,104. FILED P.R. 10-23-2008; AM. S.R. 4-22-2009.

3,633,478. MEDICAL ART PROSTHETICS, LLC, MADISON, WI. SN 77-664,081. FILED P.R. 2-5-2009; AM. S.R. 4-29-2009.

SOLUTIONS SERVICES SUPPORT

Facial Anaplastology Center of Excellence

THE MARK CONSISTS OF STANDARD CHARACTERS WITHOUT CLAIM TO ANY PARTICULAR FONT, STYLE, SIZE, OR COLOR.

CLASS 41—EDUCATION AND ENTERTAINMENT

FOR CONSULTING SERVICES IN THE FIELD OF SPECIAL EDUCATION FOR MENTAL HEALTH PATIENTS; CONDUCTING SPECIAL EDUCATION PROGRAMS IN THE FIELD OF EDUCATION FOR MENTAL HEALTH PATIENTS (U.S. CLS. 100, 101 AND 107).

FIRST USE 3-0-2009; IN COMMERCE 3-0-2009.

CLASS 44—MEDICAL, BEAUTY AND AGRICULTURAL SERVICES

FOR HEALTH CARE SERVICES IN THE FIELDS OF MENTAL HEALTH; CONSULTING SERVICES IN THE FIELD OF MENTAL HEALTH CARE (U.S. CLS. 100 AND 101).

FIRST USE 3-0-2009; IN COMMERCE 3-0-2009.

THE MARK CONSISTS OF STANDARD CHARACTERS WITHOUT CLAIM TO ANY PARTICULAR FONT, STYLE, SIZE, OR COLOR.

NO CLAIM IS MADE TO THE EXCLUSIVE RIGHT TO USE "FACIAL ANAPLASTOLOGY CENTER", APART FROM THE MARK AS SHOWN.

CLASS 40—MATERIAL TREATMENT

FOR CUSTOM MANUFACTURING OF PROSTHETICS (U.S. CLS. 100, 103 AND 106).

FIRST USE 1-30-2009; IN COMMERCE 1-30-2009.

CLASS 44—MEDICAL, BEAUTY AND AGRICULTURAL SERVICES

FOR FITTING OF PROSTHETICS (U.S. CLS. 100 AND 101).
FIRST USE 1-30-2009; IN COMMERCE 1-30-2009.

* * * * *

SECTION 2.— INTERNATIONAL CLASSIFICATION

The short titles associated below with the international class numbers are terms designed merely for quick identification and are not an official part of the international classification. The full names of international classes are given in section 6.1 of the trademark rules of practice.

The designation "U.S. Cl." appearing in this section refers to the U.S. class in effect prior to Sep. 1, 1973 rather than the international class which applies to applications filed on or after that date. For adoption of international classification see notice in the OFFICIAL GAZETTE of Jun. 26, 1973 (911 O.G. TM 210).

Application in one class

CLASS 3—COSMETICS AND CLEANING PREPARATIONS

3,633,342. TRACIE MARTYN, INC., NEW YORK, NY. SN 76-615,140. FILED P.R. 10-8-2004; AM. S.R. 4-14-2009.

PURE LUXURY

THE MARK CONSISTS OF STANDARD CHARACTERS WITHOUT CLAIM TO ANY PARTICULAR FONT, STYLE, SIZE, OR COLOR.

FOR NON-MEDICATED SKIN CARE PREPARATIONS (U.S. CLS. 1, 4, 6, 50, 51 AND 52).

FIRST USE 4-28-2008; IN COMMERCE 4-28-2008.

3,633,346. PONCE, MARIAELENA, LONG BEACH, CA. SN 77-037,010. FILED P.R. 11-4-2006; AM. S.R. 4-27-2009.

ARIZONA MUD

THE MARK CONSISTS OF STANDARD CHARACTERS WITHOUT CLAIM TO ANY PARTICULAR FONT, STYLE, SIZE, OR COLOR.

NO CLAIM IS MADE TO THE EXCLUSIVE RIGHT TO USE "MUD", APART FROM THE MARK AS SHOWN.

FOR HAIR GEL (U.S. CLS. 1, 4, 6, 50, 51 AND 52).
FIRST USE 1-1-2006; IN COMMERCE 1-1-2006.

CLASS 3—(Continued).

3,633,395. PEVONIA INTERNATIONAL, LLC, DAYTONA BEACH, FL. SN 77-499,460. FILED P.R. 6-16-2008; AM. S.R. 4-24-2009.

SPATEEN

THE MARK CONSISTS OF STANDARD CHARACTERS WITHOUT CLAIM TO ANY PARTICULAR FONT, STYLE, SIZE, OR COLOR.

FOR NON-MEDICATED SKIN CARE CREAMS AND LOTIONS; FACE CREAMS; NON-MEDICATED SKIN PEELING CREAMS AND GELS; SKIN ABRASIVE PREPARATIONS; FACIAL MASKS; NON-MEDICATED FOOT CREAMS AND POWDERS; NON-MEDICATED FOOT LOTIONS; NON-MEDICATED BODY CREAMS AND POWDERS; NON-MEDICATED BODY LOTION; NON-MEDICATED BATH SALTS; AND NON-MEDICATED EYE CREAMS (U.S. CLS. 1, 4, 6, 50, 51 AND 52).
FIRST USE 11-0-2008; IN COMMERCE 11-0-2008.

3,633,403. STEARN'S PRODUCTS, INC., SIMI VALLEY, CA. SN 77-506,801. FILED P.R. 6-24-2008; AM. S.R. 3-5-2009.

VERY CLEAR

THE MARK CONSISTS OF STANDARD CHARACTERS WITHOUT CLAIM TO ANY PARTICULAR FONT, STYLE, SIZE, OR COLOR.

FOR SKIN CLEANSER CREAMS (U.S. CLS. 1, 4, 6, 50, 51 AND 52).
FIRST USE 6-18-2008; IN COMMERCE 6-18-2008.

CLASS 3—(Continued).

3,633,409. NICHOLS, DAVID, PALMER, MA. SN 77-511,207.
FILED P.R. 6-30-2008; AM. S.R. 4-16-2009.

AUSTRALIAN NATURAL

THE MARK CONSISTS OF STANDARD CHARACTERS WITHOUT CLAIM TO ANY PARTICULAR FONT, STYLE, SIZE, OR COLOR.

OWNER OF U.S. REG. NOS. 2,696,882 AND 2,765,809.
FOR BATH GELS; BODY CREAMS; FACE AND BODY LOTIONS; FACE CREAMS; SHOWER GELS; SOAPS FOR BODY CARE (U.S. CLS. 1, 4, 6, 50, 51 AND 52).
FIRST USE 1-1-2009; IN COMMERCE 1-1-2009.

3,633,441. SCHMITZ, LARRY, SANTEE, CA. SN 77-572,620.
FILED P.R. 9-17-2008; AM. S.R. 4-28-2009.

MARBLE GLOSS

THE MARK CONSISTS OF STANDARD CHARACTERS WITHOUT CLAIM TO ANY PARTICULAR FONT, STYLE, SIZE, OR COLOR.

NO CLAIM IS MADE TO THE EXCLUSIVE RIGHT TO USE "GLOSS", APART FROM THE MARK AS SHOWN.
FOR CLEANING AND POLISHING PREPARATIONS; POLISHING PREPARATIONS; POLISHING WAX; SHINING PREPARATIONS; STONE POLISHES; STONE POLISHING PREPARATIONS (U.S. CLS. 1, 4, 6, 50, 51 AND 52).
FIRST USE 0-0-2003; IN COMMERCE 0-0-2003.

3,633,471. PROCARE PRODUCTS, SUCCASUNNA, NJ. SN 77-655,649. FILED P.R. 1-23-2009; AM. S.R. 4-22-2009.

UGLY NAIL GEL FOR HEALTHY NAILS

THE MARK CONSISTS OF STANDARD CHARACTERS WITHOUT CLAIM TO ANY PARTICULAR FONT, STYLE, SIZE, OR COLOR.

NO CLAIM IS MADE TO THE EXCLUSIVE RIGHT TO USE "NAIL GEL", APART FROM THE MARK AS SHOWN.
FOR NAIL CARE PREPARATIONS; NAIL CARE PREPARATIONS, NAMELY, NAIL SOFTENERS; NAIL ENAMEL; NAIL GROOMING PRODUCTS, NAMELY, TIPS, GLUE, LACQUER AND GLITTER; NAIL HARDENERS; NAIL STRENGTHENERS; NAIL VARNISH FOR COSMETIC PURPOSES (U.S. CLS. 1, 4, 6, 50, 51 AND 52).
FIRST USE 3-31-2008; IN COMMERCE 12-15-2008.

CLASS 4—LUBRICANTS AND FUELS

3,633,354. LEED PETROLEUM LLC, LAFAYETTE, LA. SN 77-206,522. FILED P.R. 6-14-2007; AM. S.R. 4-21-2009.

LEED PETROLEUM

THE MARK CONSISTS OF STANDARD CHARACTERS WITHOUT CLAIM TO ANY PARTICULAR FONT, STYLE, SIZE, OR COLOR.

NO CLAIM IS MADE TO THE EXCLUSIVE RIGHT TO USE "PETROLEUM", APART FROM THE MARK AS SHOWN.

FOR LIQUEFIED NATURAL GAS; CRUDE OIL; NATURAL GAS; AND LIQUEFIED PETROLEUM GAS (U.S. CLS. 1, 6 AND 15).
FIRST USE 12-17-2007; IN COMMERCE 12-17-2007.

3,633,355. LEED PETROLEUM LLC, LAFAYETTE, LA. SN 77-206,568. FILED P.R. 6-14-2007; AM. S.R. 4-21-2009.

LEED

THE MARK CONSISTS OF STANDARD CHARACTERS WITHOUT CLAIM TO ANY PARTICULAR FONT, STYLE, SIZE, OR COLOR.

FOR LIQUEFIED NATURAL GAS; CRUDE OIL; NATURAL GAS; AND LIQUEFIED PETROLEUM GAS (U.S. CLS. 1, 6 AND 15).

FIRST USE 12-17-2007; IN COMMERCE 12-17-2007.

3,633,417. PACKAGING SERVICE CO., INC., PEARLAND, TX. SN 77-520,168. FILED P.R. 7-11-2008; AM. S.R. 4-29-2009.

WHISKEY BARREL

THE MARK CONSISTS OF STANDARD CHARACTERS WITHOUT CLAIM TO ANY PARTICULAR FONT, STYLE, SIZE, OR COLOR.

FOR CHARCOAL BRIQUETTES, LUMP CHARCOAL AND MIXED CHARCOAL BRIQUETTES AND LUMP CHARCOAL FOR GRILLING AND SMOKING FOOD, NATURAL CHARCOAL BRIQUETTES, WOOD CHUNKS AND CHIPS FOR SMOKING AND GRILLING (U.S. CLS. 1, 6 AND 15).
FIRST USE 4-15-2009; IN COMMERCE 4-15-2009.

CLASS 5—PHARMACEUTICALS

CLASS 5—(Continued).

3,633,348. RECKITT BENCKISER, INC., PARSIPPANY, NJ. SN 77-112,202. FILED P.R. 2-21-2007; AM. S.R. 4-3-2009.

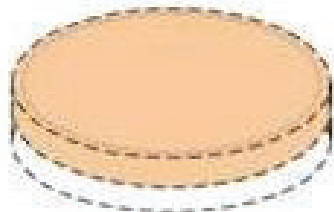

THE COLOR(S) ORANGE AND WHITE IS/ARE CLAIMED AS A FEATURE OF THE MARK.

THE MARK CONSISTS OF THE COLORS ORANGE AND WHITE AS APPLIED TO THE BI-LAYER GUAIFENENSIN AND PSEUDOEPHEDRINE EXTENDED-RELEASE TABLETS WITH ORANGE ON TOP FOR EXTENDED RELEASE AND WHITE ON BOTTOM INDICATING IMMEDIATE RELEASE. THE BROKEN LINES ONLY SERVE TO SHOW THE POSITIONING OF THE MARK ON THE PRODUCT AND THAT THE SHAPE OF THE PRODUCT IS NOT CLAIMED AS PART OF THE MARK.

FOR EXPECTORANTS (U.S. CLS. 6, 18, 44, 46, 51 AND 52).
FIRST USE 10-1-2005; IN COMMERCE 10-1-2005.

CLASS 5—(Continued).

3,633,371. AMERICAN PHARMACEUTICAL INNOVATIONS COMPANY, DARIEN, IL. SN 77-363,688. FILED P.R. 1-3-2008; AM. S.R. 4-23-2009.

AMERICAN PHARMACEUTICAL
INNOVATIONS COMPANY

THE MARK CONSISTS OF STANDARD CHARACTERS WITHOUT CLAIM TO ANY PARTICULAR FONT, STYLE, SIZE, OR COLOR.

NO CLAIM IS MADE TO THE EXCLUSIVE RIGHT TO USE "PHARMACEUTICAL" AND "COMPANY", APART FROM THE MARK AS SHOWN.

FOR NUTRITIONAL AND DIETARY SUPPLEMENTS; NUTRACEUTICALS FOR USE AS DIETARY AND NUTRITIONAL SUPPLEMENTS AND VITAMINS (U.S. CLS. 6, 18, 44, 46, 51 AND 52).

FIRST USE 10-10-2008; IN COMMERCE 10-10-2008.

3,633,489. IHERB, INC., IRWINDALE, CA. SN 77-681,830. FILED P.R. 3-2-2009; AM. S.R. 4-23-2009.

MIDORI GREENS

THE MARK CONSISTS OF STANDARD CHARACTERS WITHOUT CLAIM TO ANY PARTICULAR FONT, STYLE, SIZE, OR COLOR.

NO CLAIM IS MADE TO THE EXCLUSIVE RIGHT TO USE "GREENS", APART FROM THE MARK AS SHOWN.

THE ENGLISH TRANSLATION OF "MIDORI" IN THE MARK IS GREEN.

FOR DIETARY AND NUTRITIONAL SUPPLEMENT (U.S. CLS. 6, 18, 44, 46, 51 AND 52).

FIRST USE 2-0-2009; IN COMMERCE 2-0-2009.

3,633,349. RECKITT BENCKISER, INC., PARSIPPANY, NJ. SN 77-112,447. FILED P.R. 2-21-2007; AM. S.R. 4-3-2009.



THE COLOR(S) YELLOW & WHITE IS/ARE CLAIMED AS A FEATURE OF THE MARK.

THE MARK CONSISTS OF THE COLORS YELLOW AND WHITE AS APPLIED TO THE BI-LAYER GUAIFENENSIN AND PSEUDOEPHEDRINE EXTENDED-RELEASE TABLETS WITH YELLOW ON TOP FOR EXTENDED RELEASE AND WHITE ON BOTTOM INDICATING IMMEDIATE RELEASE. THE BROKEN LINES ONLY SERVE TO SHOW THE POSITIONING OF THE MARK ON THE PRODUCT AND THAT THE SHAPE OF THE PRODUCT IS NOT CLAIMED AS PART OF THE MARK.

FOR EXPECTORANTS (U.S. CLS. 6, 18, 44, 46, 51 AND 52).
FIRST USE 8-1-2004; IN COMMERCE 8-1-2004.

CLASS 6—METAL GOODS

3,633,352. FLOTATION SYSTEMS, INC., CULLMAN, AL. SN 77-151,392. FILED P.R. 4-8-2007; AM. S.R. 3-19-2009.

Railing Works

THE MARK CONSISTS OF STANDARD CHARACTERS WITHOUT CLAIM TO ANY PARTICULAR FONT, STYLE, SIZE, OR COLOR.

NO CLAIM IS MADE TO THE EXCLUSIVE RIGHT TO USE "RAILING", APART FROM THE MARK AS SHOWN.

FOR ALUMINUM RAILINGS FOR FENCING AND DECKING (U.S. CLS. 2, 12, 13, 14, 23, 25 AND 50).
FIRST USE 3-1-2004; IN COMMERCE 3-1-2004.

CLASS 7—MACHINERY

3,633,423. NORTH AMERICAN TILLAGE TOOLS COMPANY, HAMILTON, CANADA. SN 77-521,817. FILED P.R. 7-14-2008; AM. S.R. 4-23-2009.

EDGE CARE

THE MARK CONSISTS OF STANDARD CHARACTERS WITHOUT CLAIM TO ANY PARTICULAR FONT, STYLE, SIZE, OR COLOR.

FOR POWER OPERATED SHARPENERS; MACHINES FOR THE REMANUFACTURING AND RESTORING OF THE CUTTING SURFACES OF AGRICULTURAL IMPLEMENTS, NAMELY, BLADE SHARPENING MACHINES (U.S. CLS. 13, 19, 21, 23, 31, 34 AND 35).
FIRST USE 8-0-2007; IN COMMERCE 10-25-2007.

CLASS 8—HAND TOOLS

3,633,498. BON TOOL COMPANY, GIBSONIA, PA. SN 78-786,512. FILED P.R. 1-6-2006; AM. S.R. 7-23-2007.



THE COLOR(S) BLUE, PARTICULARLY THE SHADE OF BLUE IDENTIFIED AS PANTONE 288, IS/ARE CLAIMED AS A FEATURE OF THE MARK.

THE MARK CONSISTS OF THE COLOR BLUE, PARTICULARLY THE SHADE OF BLUE IDENTIFIED AS PANTONE 288, AS APPLIED TO THE HANDLE OF HAND TOOLS, NAMELY, MASONRY TROWELS, MASONRY TILE SETTER FLOATS, MASONRY JOINTERS, MASONRY POINTING TOOLS, NAMELY, TOOLS USED TO FORM FINISHED JOINTS IN MASONRY, CAULKING TROWELS, MASONRY SLEDRUNNERS, BRICK SETS, MASONRY CHISELS, BLOCK SPLITTERS, BRICK SPLITTERS, PAVER AND WALL SPLITTERS, WALL UNIT SPLITTERS, WALL LIFTERS, WALL UNIT LIFTERS, WALL UNIT TONGS, SAND RAKES, BASE RAKES, PAVER EXTRACTING TONGS, EXTRACTING AND ALIGNMENT BARS, SLAB MOVERS, CURB TONGS, LINE STRETCHERS, LINE TWIGS, BRICK TONGS, BRICK CARRIERS, WALL SCRAPERS, ADJUSTABLE BACKING ROD INSTALLER SETS, POST HOLE DIGGING AND TAMPING BARS, STRIPPING BARS, WRECKING BARS, SLATE BARS, JIMMY BARS, DIGGING BARS, ROCKER BARS, RIPPING BARS, UTILITY BARS, NAIL PULLERS, SHOVELS, RAKES, SHINGLE RIPPERS, ROOF ROLLERS, ROOF SEAM ROLLERS, PUNCHES, MANUALLY OPERATED CONCRETE FLOATS, CONCRETE DARBIES, CONCRETE EDGERS, CONCRETE GROOVERS, TROWELS, MANUALLY OPERATED

CLASS 8—(Continued).

SCREEDS, MANUALLY OPERATED CONCRETE TAMPERS, CONCRETE CHUTE SCRAPERS, PLACERS, CONCRETE RAKES, MANUALLY OPERATED PUMP LINE DRAGS FOR CONCRETE PLACEMENT, MESH LIFTERS, NAMELY, A MANUALLY OPERATED TOOL FOR ENABLING THE USER TO LIFT REINFORCING STEEL MESH DURING CONCRETE PLACEMENT, REBAR BENDERS, STAKE PULLERS, ASPHALT IRONS, MANUALLY OPERATED CRACK FILLING DEVICES FOR HOLDING ASPHALT FILLING COMPOSITIONS AND APPLYING THE SAME, ASPHALT RAKES, CONCRETE IMPRINT ROLLERS, CONCRETE TEXTURE ROLLERS, FLOOR COVERING TOOLS, NAMELY, FLOORING SHEARS, FLOOR SCRAPERS AND ROLLERS, CARPET STRETCHERS, KNEE KICKERS, SEAM ROLLERS, CARPET ROLLERS, GROUT COMPRESSION TOOLS, HACKSAWS, LINOLEUM ROLLERS, FLOOR SCRAPERS, LAMINATE SCORING TOOLS, LAMINATE SHEARS, DRYWALL TAPING KNIVES, DRYWALL JOINT KNIVES, DETAIL KNIVES, DRYWALL SCORING KNIFE WITH MEASURING GAUGES, HAND MIXERS, DRYWALL SAWS, DRYWALL LIFTERS, MANUALLY OPERATED SCARIFIERS FOR PLASTERING, AND STUD CHANNEL SHEARS. THE DOTTED OUTLINE OF THE GOODS IS INTENDED TO SHOW THE POSITION OF THE MARK ON THE GOODS AND IS NOT PART OF THE MARK.

FOR HAND OPERATED TOOLS, NAMELY, MASONRY TROWELS, MASONRY TILE SETTER FLOATS, MASONRY JOINTERS, MASONRY POINTING TOOLS, NAMELY, TOOLS USED TO FORM FINISHED JOINTS IN MASONRY, CAULKING TROWELS, MASONRY SLEDRUNNERS, BRICK SETS, MASONRY CHISELS, BLOCK SPLITTERS, BRICK SPLITTERS, PAVER AND WALL SPLITTERS, WALL UNIT SPLITTERS, WALL LIFTERS, WALL UNIT LIFTERS, WALL UNIT TONGS, SAND RAKES, BASE RAKES, PAVER EXTRACTING TONGS, EXTRACTING AND ALIGNMENT BARS, SLAB MOVERS, CURB TONGS, LINE STRETCHERS, LINE TWIGS, BRICK TONGS, BRICK CARRIERS, WALL SCRAPERS, ADJUSTABLE BACKING ROD INSTALLER SETS, POST HOLE DIGGING AND TAMPING BARS, STRIPPING BARS, WRECKING BARS, SLATE BARS, JIMMY BARS, DIGGING BARS, ROCKER BARS, RIPPING BARS, UTILITY BARS, NAIL PULLERS, SHOVELS, RAKES, SHINGLE RIPPERS, ROOF ROLLERS, ROOF SEAM ROLLERS, PUNCHES, MANUALLY OPERATED CONCRETE FLOATS, CONCRETE DARBIES, CONCRETE EDGERS, CONCRETE GROOVERS, TROWELS, MANUALLY OPERATED SCREEDS, MANUALLY OPERATED CONCRETE TAMPERS, CONCRETE CHUTE SCRAPERS, PLACERS, CONCRETE RAKES, MANUALLY OPERATED PUMP LINE DRAGS FOR CONCRETE PLACEMENT, MESH LIFTERS, NAMELY, A MANUALLY OPERATED TOOL FOR ENABLING THE USER TO LIFT REINFORCING STEEL MESH DURING CONCRETE PLACEMENT, REBAR BENDERS, STAKE PULLERS, ASPHALT IRONS, MANUALLY OPERATED CRACK FILLING DEVICES FOR HOLDING ASPHALT FILLING COMPOSITIONS AND APPLYING THE SAME, ASPHALT RAKES, CONCRETE IMPRINT ROLLERS, CONCRETE TEXTURE ROLLERS, FLOOR COVERING TOOLS, NAMELY, FLOORING SHEARS, FLOOR SCRAPERS AND ROLLERS, CARPET STRETCHERS, KNEE KICKERS, SEAM ROLLERS, CARPET ROLLERS, GROUT COMPRESSION TOOLS, HACKSAWS, LINOLEUM ROLLERS, FLOOR SCRAPERS, LAMINATE SCORING TOOLS, LAMINATE SHEARS, DRYWALL TAPING KNIVES, DRYWALL JOINT KNIVES, DETAIL KNIVES, DRYWALL SCORING KNIFE WITH MEASURING GAUGES, HAND MIXERS, DRYWALL SAWS, DRYWALL LIFTERS, MANUALLY OPERATED SCARIFIERS FOR PLASTERING, AND STUD CHANNEL SHEARS (U.S. CLS. 23, 28 AND 44).
FIRST USE 1-31-2000; IN COMMERCE 1-31-2000.

CLASS 9—ELECTRICAL AND SCIENTIFIC APPARATUS

CLASS 9—(Continued).

3,633,357. KUSSMAUL ELECTRONICS COMPANY, INC., WEST SAYVILLE, NY. SN 77-220,315. FILED P.R. 7-2-2007; AM. S.R. 4-29-2009.

AUTO EJECT

THE MARK CONSISTS OF STANDARD CHARACTERS WITHOUT CLAIM TO ANY PARTICULAR FONT, STYLE, SIZE, OR COLOR.

FOR ELECTRICAL RECEPTACLES (U.S. CLS. 21, 23, 26, 36 AND 38).

FIRST USE 2-1-1987; IN COMMERCE 2-1-1987.

3,633,424. ESP MUSIC DISCO LIMITED, NEWBURY, UNITED KINGDOM. SN 77-522,340. FILED P.R. 7-15-2008; AM. S.R. 4-28-2009.

DJKIT

THE MARK CONSISTS OF STANDARD CHARACTERS WITHOUT CLAIM TO ANY PARTICULAR FONT, STYLE, SIZE, OR COLOR.

OWNER OF UNITED KINGDOM REG. NO. 2452741, DATED 4-17-2007, EXPIRES 4-17-2017.

FOR APPARATUS AND INSTRUMENTS FOR RECORDING, TRANSMISSION OR REPRODUCTION OF SOUND AND IMAGES; AUDIO AND VIDEO EQUIPMENT, NAMELY, AUDIO-VIDEO RECEIVERS, AUDIO AND VIDEO CASSETTE RECORDERS, DISTRIBUTION AMPLIFIERS FOR AUDIO AND VIDEO SIGNALS, ELECTRONIC INTERCONNECTERS FOR AUDIO AND VIDEO SIGNALS, MATRIX SWITCHERS FOR AUDIO AND VIDEO SIGNALS, TRANSMITTERS AND RECEIVERS FOR AUDIO AND VIDEO SIGNALS FOR TRANSMISSION OVER TWISTED PAIR CABLES, RECORD PLAYERS, AND ELECTRONIC SOUND AND VIDEO MIXING, PROCESSING, AND SYNTHESIZING APPARATUS; MAGNETIC DATA CARRIERS, NAMELY, BLANK MAGNETIC DATA CARRIERS, AND PRERECORDED MAGNETIC DATA CARRIERS FEATURING MUSIC; RECORDING DISCS, NAMELY, BLANK RECORDABLE OPTICAL DISCS, BLANK RECORD DISCS; COMPACT DISCS, NAMELY, BLANK CD-ROMS FOR SOUND OR VIDEO RECORDING, COMPACT DISCS FEATURING MUSIC; RECORDS, NAMELY, PHONOGRAPH RECORDS FEATURING MUSIC; TAPES, NAMELY, BLANK AUDIO TAPES, BLANK VIDEO TAPES, AUDIO TAPES FEATURING MUSIC, VIDEO TAPES FEATURING MUSIC; DIGITAL MUSIC DOWNLOADABLE FROM THE INTERNET; AMPLIFIERS; CD AND MP3 PLAYERS; SOFTWARE FOR USE IN PLAYING, RECORDING, AND EDITING MP3 FILES; COMPUTER HARDWARE FOR USE IN PLAYING, RECORDING, AND EDITING MP3 FILES; SPEAKERS, NAMELY, AUDIO SPEAKERS AND LOUD SPEAKERS; MICROPHONES; DVD VIDEO EQUIPMENT, NAMELY, DVD BURNERS, DVD DRIVES, DVD MACHINES, DVD PLAYERS; SPECIAL EFFECTS EQUIPMENT, NAMELY, ELECTRONIC EFFECTS PEDALS FOR USE WITH SOUND AMPLIFIERS, GUITAR EFFECTS PROCESSORS; CONNECTION CABLES, PARTS AND FITTINGS FOR ALL THE AFORESAID GOODS (U.S. CLS. 21, 23, 26, 36 AND 38).

CLASS 9—(Continued).

3,633,429. WINDSTAR TECHNOLOGIES, INC., NORWOOD, MA. SN 77-529,471. FILED P.R. 7-23-2008; AM. S.R. 3-26-2009.

SEVIS NAVIGATOR

THE MARK CONSISTS OF STANDARD CHARACTERS WITHOUT CLAIM TO ANY PARTICULAR FONT, STYLE, SIZE, OR COLOR.

FOR COMPUTER SOFTWARE, NAMELY, SOFTWARE FOR TRANSFERRING CURRENT DATA FROM AN IMMIGRATION-RELATED GOVERNMENT DATABASE TO UPDATE NONRESIDENT ALIEN TAX PROCESSING SOFTWARE AND TO CREATE OR UPDATE THE OTHER DATABASES FOR REPORTING PURPOSES (U.S. CLS. 21, 23, 26, 36 AND 38).

FIRST USE 5-30-2008; IN COMMERCE 5-30-2008.

3,633,435. KECHELE, MATT T., DBA HURRICANE CHASERS, COCOA BEACH, FL. SN 77-543,071. FILED P.R. 8-8-2008; AM. S.R. 4-24-2009.

HURRICANE CHASERS

THE MARK CONSISTS OF STANDARD CHARACTERS WITHOUT CLAIM TO ANY PARTICULAR FONT, STYLE, SIZE, OR COLOR.

FOR PRERECORDED VIDEO TAPES AND DISCS, DVDS, MOTION PICTURE FILMS, AND HIGH DEFINITION VIDEO TAPES AND DISCS, FEATURING NATURAL DISASTERS, DRAMA, REAL LIFE SITUATION DRAMAS, SPORTS, EXTREME ADVENTURE SPORTS, ACTION, ADVENTURE, AND EDUCATIONAL MATERIALS IN THE FIELD OF TRACKING INTENSE WEATHER SYSTEMS (U.S. CLS. 21, 23, 26, 36 AND 38).

FIRST USE 4-17-2009; IN COMMERCE 4-17-2009.

CLASS 9—(Continued).

3,633,454. FOX CREEK LEATHER, INDEPENDENCE, VA. SN 77-614,323. FILED P.R. 11-14-2008; AM. S.R. 4-26-2009.



NO CLAIM IS MADE TO THE EXCLUSIVE RIGHT TO USE "LEATHER", APART FROM THE MARK AS SHOWN. THE MARK CONSISTS OF A PHONE NUMBER ON TOP OF THE WORDS "FOX CREEK LEATHER" WHICH ARE STACKED WORDS.
 FOR GOGGLES FOR SPORTS; MOTORCYCLE GOGGLES; SUNGLASSES (U.S. CLS. 21, 23, 26, 36 AND 38).
 FIRST USE 3-1-2008; IN COMMERCE 3-1-2008.

3,633,475. THE CRICKET COMPANY LLC, NOVATO, CA. SN 77-660,421. FILED P.R. 1-30-2009; AM. S.R. 4-17-2009.

FRICTION FREE

THE MARK CONSISTS OF STANDARD CHARACTERS WITHOUT CLAIM TO ANY PARTICULAR FONT, STYLE, SIZE, OR COLOR.
 FOR ELECTRIC HAIR STRAIGHTENING IRONS (U.S. CLS. 21, 23, 26, 36 AND 38).
 FIRST USE 7-15-2006; IN COMMERCE 11-15-2006.

CLASS 10—MEDICAL APPARATUS

CLASS 10—(Continued).

3,633,499. PENUMBRA, INC., SAN LEANDRO, CA. SN 78-890,229. FILED P.R. 5-23-2006; AM. S.R. 7-26-2007.

PENUMBRA SYSTEM

THE MARK CONSISTS OF STANDARD CHARACTERS WITHOUT CLAIM TO ANY PARTICULAR FONT, STYLE, SIZE, OR COLOR.
 NO CLAIM IS MADE TO THE EXCLUSIVE RIGHT TO USE "SYSTEM", APART FROM THE MARK AS SHOWN.
 FOR MEDICAL DEVICES FOR TREATMENT OF STROKES, NAMELY, DEVICES FOR REMOVAL OF THROMBOEMBOLIC MATERIAL FROM ARTERIES MEDICAL DEVICES FOR TREATMENT OF STROKES, NAMELY, DEVICES FOR REMOVAL OF THROMBOEMBOLIC MATERIAL FROM ARTERIES (U.S. CLS. 26, 39 AND 44).
 FIRST USE 8-0-2006; IN COMMERCE 8-0-2006.

CLASS 11—ENVIRONMENTAL CONTROL APPARATUS

3,633,447. HIDE, LEE, FORT MYERS, FL. SN 77-593,122. FILED P.R. 10-15-2008; AM. S.R. 4-12-2009.

solarilluminations

THE MARK CONSISTS OF STANDARD CHARACTERS WITHOUT CLAIM TO ANY PARTICULAR FONT, STYLE, SIZE, OR COLOR.
 FOR SOLAR LIGHT FIXTURES, NAMELY, INDOOR AND OUTDOOR SOLAR POWERED LIGHTING UNITS AND FIXTURES (U.S. CLS. 13, 21, 23, 31 AND 34).
 FIRST USE 10-0-2003; IN COMMERCE 10-0-2003.

CLASS 12—VEHICLES

CLASS 12—(Continued).

3,633,402. ROCKCRUSHER DIFFS 4X4 AXLE ASSEMBLIES PTY. LTD., MORNINGTON, VIC., AUSTRALIA. SN 77-506,505. FILED P.R. 6-24-2008; AM. S.R. 4-6-2009.

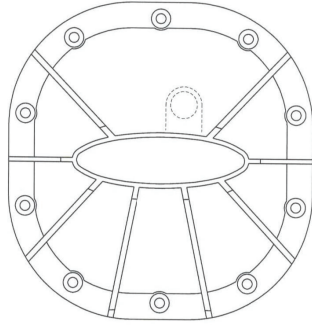

THE MARK CONSISTS OF A THREE-DIMENSIONAL DESIGN USED ON DIFFERENTIAL COVERS CONSISTING OF A CURVED PROFILE WITH AN OVAL IN THE CENTER. A PLURALITY OF BOLT HOLES APPEAR AROUND THE PERIMETER OF THE PROFILE. A PLURALITY OF RIBS EXTEND OUTWARD FROM THE OVAL. THE MATTER SHOWN IN BROKEN LINES, NAMELY, A FILL HOLE, IS NOT CLAIMED AS A FEATURE OF THE MARK.
FOR VEHICLE COMPONENTS, NAMELY, DIFFERENTIAL COVERS (U.S. CLS. 19, 21, 23, 31, 35 AND 44).
FIRST USE 0-0-2001; IN COMMERCE 0-0-2001.

3,633,495. VITRO, S.A. DE C.V., NUEVO LEON, MEXICO. SN 78-698,695. FILED P.R. 8-23-2005; AM. S.R. 8-4-2008.

THE GLASS COMPANY

THE MARK CONSISTS OF STANDARD CHARACTERS WITHOUT CLAIM TO ANY PARTICULAR FONT, STYLE, SIZE, OR COLOR.
PRIORITY CLAIMED UNDER SEC. 44(D) ON MEXICO APPLICATION NO. 29289, FILED 2-24-2005, REG. NO. 29289, DATED 2-24-2005, EXPIRES 2-24-2015.
NO CLAIM IS MADE TO THE EXCLUSIVE RIGHT TO USE "COMPANY", APART FROM THE MARK AS SHOWN.
FOR GLASS FOR AUTOMOBILES AND VEHICLES, WINDSHIELDS (U.S. CLS. 19, 21, 23, 31, 35 AND 44).

CLASS 14—JEWELRY

CLASS 14—(Continued).

3,633,419. OHIO PRECIOUS METALS, LLC, JACKSON, OH. SN 77-521,081. FILED P.R. 7-14-2008; AM. S.R. 4-22-2009.

Ru	Rh	Rd	Ag
Os	Ir	Pt	Au

Ohio Precious Metals, LLC

NO CLAIM IS MADE TO THE EXCLUSIVE RIGHT TO USE "PRECIOUS METALS, LLC", APART FROM THE MARK AS SHOWN.
THE MARK CONSISTS OF A RECTANGULAR TABLE THAT CONTAINS 8 INDIVIDUAL BOXES AND EACH BOX CONTAINS AN ELEMENT SYMBOL REPRESENTING DIFFERENT PRECIOUS METALS. BELOW THE TABLE IS THE WORD "OHIO PRECIOUS METALS, LLC" IN STYLIZED LETTERS.
FOR PRECIOUS METALS; PRECIOUS METALS AND ALLOYS THEREOF; PRECIOUS METALS AND THEIR ALLOYS (U.S. CLS. 2, 27, 28 AND 50).
FIRST USE 4-4-2003; IN COMMERCE 4-4-2003.

3,633,420. OHIO PRECIOUS METALS, LLC, JACKSON, OH. SN 77-521,102. FILED P.R. 7-14-2008; AM. S.R. 4-22-2009.

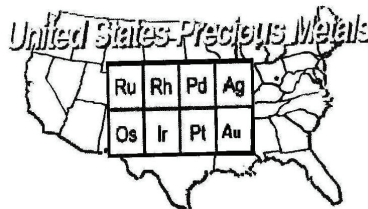

NO CLAIM IS MADE TO THE EXCLUSIVE RIGHT TO USE "PRECIOUS METALS", APART FROM THE MARK AS SHOWN.
THE MARK CONSISTS OF AN OUTLINE OF THE CONTINENTAL "UNITED STATES" WITH A RECTANGULAR TABLE SUPERIMPOSED ON TOP OF THE OUTLINE. THE TABLE CONTAINS 8 INDIVIDUAL BOXES AND EACH BOX CONTAINS AN ELEMENT SYMBOL REPRESENTING DIFFERENT PRECIOUS METALS. DIRECTLY ABOVE THE TABLE ARE THE WORDS "UNITED STATES PRECIOUS METALS" IN STYLIZED LETTERS.
FOR PRECIOUS METALS; PRECIOUS METALS AND ALLOYS THEREOF; PRECIOUS METALS AND THEIR ALLOYS (U.S. CLS. 2, 27, 28 AND 50).
FIRST USE 2-1-2005; IN COMMERCE 2-1-2005.

CLASS 14—(Continued).

3,633,421. OHIO PRECIOUS METALS, LLC, JACKSON, OH. SN 77-521,115. FILED P.R. 7-14-2008; AM. S.R. 4-22-2009.

Ohio Precious Metals, LLC

THE MARK CONSISTS OF STANDARD CHARACTERS WITHOUT CLAIM TO ANY PARTICULAR FONT, STYLE, SIZE, OR COLOR.

NO CLAIM IS MADE TO THE EXCLUSIVE RIGHT TO USE "PRECIOUS METALS, LLC", APART FROM THE MARK AS SHOWN.

FOR PRECIOUS METALS; PRECIOUS METALS AND ALLOYS THEREOF; PRECIOUS METALS AND THEIR ALLOYS (U.S. CLS. 2, 27, 28 AND 50).

FIRST USE 4-4-2003; IN COMMERCE 4-4-2003.



3,633,422. OHIO PRECIOUS METALS, LLC, JACKSON, OH. SN 77-521,169. FILED P.R. 7-14-2008; AM. S.R. 4-22-2009.

United States Precious Metals

THE MARK CONSISTS OF STANDARD CHARACTERS WITHOUT CLAIM TO ANY PARTICULAR FONT, STYLE, SIZE, OR COLOR.

NO CLAIM IS MADE TO THE EXCLUSIVE RIGHT TO USE "PRECIOUS METALS", APART FROM THE MARK AS SHOWN.

FOR PRECIOUS METALS; PRECIOUS METALS AND ALLOYS THEREOF; PRECIOUS METALS AND THEIR ALLOYS (U.S. CLS. 2, 27, 28 AND 50).

FIRST USE 2-1-2005; IN COMMERCE 2-1-2005.



CLASS 15—MUSICAL INSTRUMENTS

CLASS 15—(Continued).

3,633,363. DRUM WORKSHOP, INC., OXNARD, CA. SN 77-291,670. FILED P.R. 9-28-2007; AM. S.R. 8-21-2008.

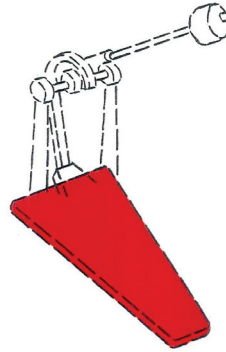

THE COLOR(S) RED IS/ARE CLAIMED AS A FEATURE OF THE MARK.

THE MARK CONSISTS OF THE COLOR RED APPLIED TO TOP AND SIDE SURFACES OF AN ELONGATED TAPERING GENERALLY FLAT PLATE. THE MATTER DEPICTED IN DOTTED LINES IS INTENDED TO SHOW THE POSITION OF THE MARK ON THE GOODS AND IS NOT PART OF THE MARK.

FOR ELONGATED TAPERING RED COLORED FLOOR PLATES BEING INTEGRAL COMPONENTS OF DRUM PEDAL UNITS (U.S. CLS. 2, 21 AND 36).

FIRST USE 1-20-1989; IN COMMERCE 1-20-1989.



CLASS 16—PAPER GOODS AND PRINTED MATTER

3,633,356. INFORM PUBLISHING GROUP LLC, SCOTTSDALE, AZ. SN 77-219,045. FILED P.R. 6-29-2007; AM. S.R. 1-9-2009.

CONSTRUCTION SUPERINTENDENT

THE MARK CONSISTS OF STANDARD CHARACTERS WITHOUT CLAIM TO ANY PARTICULAR FONT, STYLE, SIZE, OR COLOR.

FOR MAGAZINES AND JOURNALS DIRECTED TO THE CONSTRUCTION INDUSTRY (U.S. CLS. 2, 5, 22, 23, 29, 37, 38 AND 50).

FIRST USE 12-1-2008; IN COMMERCE 12-1-2008.

CLASS 16—(Continued).

3,633,378. UNIVERSITY OF BRIDGEPORT, BRIDGEPORT, CT. SN 77-403,508. FILED P.R. 2-22-2008; AM. S.R. 4-16-2009.

JOURNAL OF GLOBAL
DEVELOPMENT AND PEACE

THE MARK CONSISTS OF STANDARD CHARACTERS WITHOUT CLAIM TO ANY PARTICULAR FONT, STYLE, SIZE, OR COLOR.

FOR PUBLICATIONS, NAMELY, SCHOLARLY JOURNALS IN THE FIELDS OF INTERNATIONAL CULTURAL AND ECONOMIC DEVELOPMENT AND HUMAN SECURITY (U.S. CLS. 2, 5, 22, 23, 29, 37, 38 AND 50).
FIRST USE 4-9-2009; IN COMMERCE 4-9-2009.

3,633,400. BETTER OFFICE PRODUCTS, CANOGA PARK, CA. SN 77-504,735. FILED P.R. 6-20-2008; AM. S.R. 4-5-2009.

BETTER OFFICE GREEN

THE MARK CONSISTS OF STANDARD CHARACTERS WITHOUT CLAIM TO ANY PARTICULAR FONT, STYLE, SIZE, OR COLOR.

FOR EXPANDABLE FILES, REUSABLE ENVELOPES, TELEPHONE NUMBER/ADDRESS BOOKS, BLANK WRITING JOURNALS, NOTE PAD HOLDERS, NOTE PADS, NOTEBOOKS, DOCUMENT PORTFOLIOS, STATIONERY-TYPE PORTFOLIOS, REPORT COVERS, BINDERS, INDEX DIVIDERS, INDEX CARD CASES, CARRYING CASES FOR WRITING INSTRUMENTS, CARRYING BOXES FOR WRITING INSTRUMENTS, CARRYING POUCHES FOR WRITING INSTRUMENTS, DOCUMENT CARRY-ALLS, NAMELY, DOCUMENT PORTFOLIOS, FILE FOLDERS, SINGLE-POCKET DOCUMENT FOLDERS, MULTIPLE-POCKET DOCUMENT FOLDERS, BINDER POCKETS, STICKERS, LABELS, NAMELY, ADDRESS, ADHESIVE, BAR CODE, NAME TAG, BLANK OR PARTIALLY PRINTED, PAPER, PRINTED NOVELTY WINE, PRINTED PAPER, AND SHIPPING LABELS, CALENDARS, PLASTIC GIFT BAGS, PLASTIC PROMOTIONAL BAGS, AND PLASTIC MERCHANDISE BAGS (U.S. CLS. 2, 5, 22, 23, 29, 37, 38 AND 50).
FIRST USE 4-7-2008; IN COMMERCE 4-7-2008.

3,633,412. LATINA MEDIA VENTURES, NEW YORK, NY. SN 77-518,895. FILED P.R. 7-10-2008; AM. S.R. 4-17-2009.

CULTURA

CLASS 16—(Continued).

THE MARK CONSISTS OF STANDARD CHARACTERS WITHOUT CLAIM TO ANY PARTICULAR FONT, STYLE, SIZE, OR COLOR.

THE ENGLISH TRANSLATION OF "CULTURA" IN THE MARK IS CULTURE.

FOR SECTION OF MAGAZINE CONCERNING HEALTH ISSUES, PARENTING, FOOD AND RELATIONSHIPS (U.S. CLS. 2, 5, 22, 23, 29, 37, 38 AND 50).
FIRST USE 10-0-2003; IN COMMERCE 10-0-2003.

3,633,413. LATINA MEDIA VENTURES, NEW YORK, NY. SN 77-518,902. FILED P.R. 7-10-2008; AM. S.R. 4-17-2009.

CULTURA

THE MARK CONSISTS OF THE WORDING "CULTURA" IN STYLIZED FONT.

THE ENGLISH TRANSLATION OF "CULTURA" IN THE MARK IS CULTURE.

FOR SECTION OF MAGAZINE CONCERNING HEALTH ISSUES, PARENTING, FOOD AND RELATIONSHIPS (U.S. CLS. 2, 5, 22, 23, 29, 37, 38 AND 50).
FIRST USE 3-0-2008; IN COMMERCE 3-0-2008.

3,633,426. THE NEW YORK TIMES COMPANY, NEW YORK, NY. SN 77-522,520. FILED P.R. 7-15-2008; AM. S.R. 10-28-2008.

Social Q's

THE MARK CONSISTS OF STANDARD CHARACTERS WITHOUT CLAIM TO ANY PARTICULAR FONT, STYLE, SIZE, OR COLOR.

FOR COLUMNS ON THE SUBJECT OF ETIQUETTE, FASHION, STYLE, TRENDS, AND RELATIONSHIPS (U.S. CLS. 2, 5, 22, 23, 29, 37, 38 AND 50).

FIRST USE 6-12-2008; IN COMMERCE 6-16-2008.

3,633,467. IDI, LLC, OCEAN PINES, MD. SN 77-653,726. FILED P.R. 1-21-2009; AM. S.R. 4-16-2009.

GLOBAL PLACEMENT ASSESSMENT

CLASS 16—(Continued).

THE MARK CONSISTS OF STANDARD CHARACTERS WITHOUT CLAIM TO ANY PARTICULAR FONT, STYLE, SIZE, OR COLOR.

NO CLAIM IS MADE TO THE EXCLUSIVE RIGHT TO USE "ASSESSMENT", APART FROM THE MARK AS SHOWN.

FOR PRINTED PSYCHOLOGICAL TESTS AND REPORTS FOR ASSESSING CROSS-CULTURAL ADAPTATION, INTERCULTURAL DEVELOPMENT, INTERNATIONAL RESETTLEMENT AND EXPATRIATE ASSIGNMENTS (U.S. CLS. 2, 5, 22, 23, 29, 37, 38 AND 50).

FIRST USE 6-0-2008; IN COMMERCE 6-0-2008.

3,633,468. PHOENIX ADEPTS, INC., DBA HOMESCHOOL PROGRAMMING, INC., ALPHARETTA, GA. SN 77-654,418. FILED P.R. 1-22-2009; AM. S.R. 4-9-2009.

TeenCoder

THE MARK CONSISTS OF STANDARD CHARACTERS WITHOUT CLAIM TO ANY PARTICULAR FONT, STYLE, SIZE, OR COLOR.

FOR EDUCATIONAL PUBLICATIONS, NAMELY, EDUCATIONAL LEARNING CARDS, FLASH CARDS, ACTIVITY CARDS, WORKBOOKS, TEXTBOOKS, ACTIVITY BOOKS, STORY BOOKS, PUZZLE BOOKS, PRINTED PUZZLES, TEACHER GUIDES, MANUALS, POSTERS AND EDUCATIONAL BOOKLETS IN THE FIELD OF COMPUTER PROGRAMMING (U.S. CLS. 2, 5, 22, 23, 29, 37, 38 AND 50).

FIRST USE 12-1-2008; IN COMMERCE 12-1-2008.

CLASS 18—LEATHER GOODS

3,633,407. BRIGHT IP CONCEPTS, LLC, NOVATO, CA. SN 77-510,323. FILED P.R. 6-27-2008; AM. S.R. 4-7-2009.

SUPERCOLLAR

THE MARK CONSISTS OF STANDARD CHARACTERS WITHOUT CLAIM TO ANY PARTICULAR FONT, STYLE, SIZE, OR COLOR.

FOR COLLARS FOR ANIMALS; COLLARS FOR PETS; COLLARS FOR PETS BEARING MEDICAL INFORMATION; DOG APPAREL; DOG COLLARS; DOG COLLARS AND LEADS; DOG LEASHES (U.S. CLS. 1, 2, 3, 22 AND 41).

FIRST USE 6-27-2008; IN COMMERCE 3-22-2009.

CLASS 18—(Continued).

3,633,484. BABYBJÖRN AB, DANDERYD, SWEDEN. SN 77-665,328. FILED 2-6-2009.

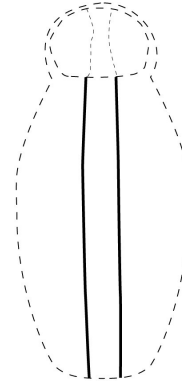

OWNER OF U.S. REG. NO. 3,469,959.

THE MARK CONSISTS OF TWO PARALLEL STRIPES ON THE FRONT PORTION OF A BABY CARRIER COVER. THE PORTIONS OF THE DRAWING SHOWN IN DOTTED LINES ARE NOT PART OF THE MARK BUT ARE MERELY INTENDED TO SHOW THE POSITION OF THE MARK.

FOR BABY CARRIER COVER (U.S. CLS. 1, 2, 3, 22 AND 41).

FIRST USE 7-31-2005; IN COMMERCE 7-31-2005.

CLASS 19—NON-METALLIC BUILDING MATERIALS

3,633,411. SEA-PAC SALES COMPANY, KENT, WA. SN 77-518,327. FILED P.R. 7-9-2008; AM. S.R. 4-8-2009.

Bel Legno

THE MARK CONSISTS OF STANDARD CHARACTERS WITHOUT CLAIM TO ANY PARTICULAR FONT, STYLE, SIZE, OR COLOR.

NO CLAIM IS MADE TO THE EXCLUSIVE RIGHT TO USE "LEGNO", APART FROM THE MARK AS SHOWN.

THE FOREIGN WORDING IN THE MARK TRANSLATES INTO ENGLISH AS BEAUTIFUL WOOD.

FOR BAMBOO FLOORING; WOODEN FLOORING (U.S. CLS. 1, 12, 33 AND 50).

FIRST USE 10-31-2008; IN COMMERCE 10-31-2008.

CLASS 20—FURNITURE AND ARTICLES NOT OTHERWISE CLASSIFIED

CLASS 20—(Continued).

3,633,481. BABYBJÖRN AB, DANDERYD, SWEDEN. SN 77-665,313. FILED 2-6-2009.

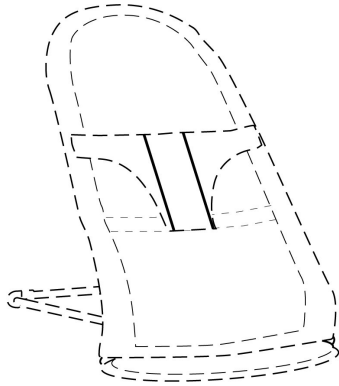

OWNER OF U.S. REG. NO. 3,469,959.
THE MARK CONSISTS OF TWO PARALLEL STRIPES ON THE FRONT PORTION OF A BABY SEAT. THE PORTIONS OF THE DRAWING SHOWN IN DOTTED LINES ARE NOT PART OF THE MARK BUT ARE MERELY INTENDED TO SHOW THE POSITION OF THE MARK.
FOR BABY SEAT (U.S. CLS. 2, 13, 22, 25, 32 AND 50).
FIRST USE 9-30-2008; IN COMMERCE 9-30-2008.

CLASS 20—(Continued).

3,633,483. BABYBJÖRN AB, DANDERYD, SWEDEN. SN 77-665,325. FILED 2-6-2009.

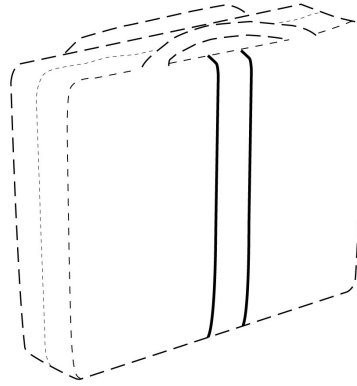

OWNER OF U.S. REG. NO. 3,469,959.
THE MARK CONSISTS OF TWO PARALLEL STRIPES ON THE FRONT PORTION OF A CARRY CASE FOR PORTABLE BABY CRIB. THE PORTIONS OF THE DRAWING SHOWN IN DOTTED LINES ARE NOT PART OF THE MARK BUT ARE MERELY INTENDED TO SHOW THE POSITION OF THE MARK.
FOR CARRY CASE FOR PORTABLE BABY CRIB (U.S. CLS. 2, 13, 22, 25, 32 AND 50).
FIRST USE 9-30-2007; IN COMMERCE 9-30-2007.

3,633,482. BABYBJÖRN AB, DANDERYD, SWEDEN. SN 77-665,318. FILED 2-6-2009.

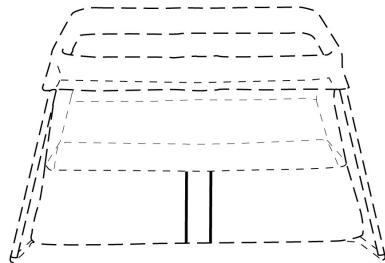

OWNER OF U.S. REG. NO. 3,469,959.
THE MARK CONSISTS OF TWO PARALLEL STRIPES ON THE FRONT PORTION OF A PORTABLE BABY CRIB. THE PORTIONS OF THE DRAWING SHOWN IN DOTTED LINES ARE NOT PART OF THE MARK BUT ARE MERELY INTENDED TO SHOW THE POSITION OF THE MARK.
FOR PORTABLE BABY CRIB (U.S. CLS. 2, 13, 22, 25, 32 AND 50).
FIRST USE 9-30-2007; IN COMMERCE 9-30-2007.

3,633,496. VITRO, S.A. DE C.V., NUEVO LEON, MEXICO. SN 78-698,716. FILED P.R. 8-23-2005; AM. S.R. 8-4-2008.

THE GLASS COMPANY

THE MARK CONSISTS OF STANDARD CHARACTERS WITHOUT CLAIM TO ANY PARTICULAR FONT, STYLE, SIZE, OR COLOR.
PRIORITY CLAIMED UNDER SEC. 44(D) ON MEXICO APPLICATION NO. 29296, FILED 2-24-2005, REG. NO. 29296, DATED 2-24-2005, EXPIRES 2-24-2015.
NO CLAIM IS MADE TO THE EXCLUSIVE RIGHT TO USE "COMPANY", APART FROM THE MARK AS SHOWN.
FOR GLASS FURNITURE, GLASS TABLE TOPS, AND MIRRORS (U.S. CLS. 2, 13, 22, 25, 32 AND 50).

CLASS 21—HOUSEWARES AND GLASS

CLASS 21—(Continued).

3,633,487. THE CRICKET COMPANY, LLC, NOVATO, CA. SN 77-672,286. FILED P.R. 2-17-2009; AM. S.R. 4-17-2009.

FRICTION FREE

THE MARK CONSISTS OF STANDARD CHARACTERS WITHOUT CLAIM TO ANY PARTICULAR FONT, STYLE, SIZE, OR COLOR.

FOR BEAUTY CARE PRODUCTS, NAMELY, HAIR COMBS AND HAIR BRUSHES (U.S. CLS. 2, 13, 23, 29, 30, 33, 40 AND 50).

FIRST USE 7-30-2006; IN COMMERCE 11-30-2006.

CLASS 24—(Continued).

3,633,451. TREND LAB, LLC, BURNSVILLE, MN. SN 77-606,192. FILED P.R. 11-3-2008; AM. S.R. 4-2-2009.

CRIBWRAP

THE MARK CONSISTS OF STANDARD CHARACTERS WITHOUT CLAIM TO ANY PARTICULAR FONT, STYLE, SIZE, OR COLOR.

FOR CRIB RAIL COVERING MADE OF CLOTH FOR TEETHING PURPOSES (U.S. CLS. 42 AND 50).

FIRST USE 2-27-2009; IN COMMERCE 2-27-2009.

CLASS 22—CORDAGE AND FIBERS

3,633,472. THE CAPE COD HAMMOCK COMPANY, N. WEYMOUTH, MA. SN 77-655,936. FILED P.R. 1-24-2009; AM. S.R. 4-27-2009.

*the
Cape Cod
Hammock Co.*

NO CLAIM IS MADE TO THE EXCLUSIVE RIGHT TO USE "HAMMOCK CO.", APART FROM THE MARK AS SHOWN.

THE MARK CONSISTS OF "THE CAPE COD HAMMOCK CO." WRITTEN IN STYLIZED LETTERS.

FOR HAMMOCKS (U.S. CLS. 1, 2, 7, 19, 22, 42 AND 50).
FIRST USE 7-5-2008; IN COMMERCE 7-5-2008.

CLASS 25—CLOTHING

3,633,365. LYDEN, ROBERT M., ALOHA, OR. SN 77-310,939. FILED P.R. 10-23-2007; AM. S.R. 4-27-2009.

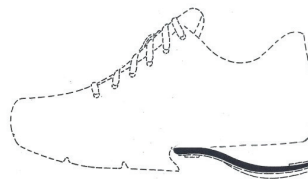

THE MARK CONSISTS OF A SPRING ELEMENT IN THE REARFOOT AREA OF FOOTWEAR.

FOR FOOTWEAR (U.S. CLS. 22 AND 39).
FIRST USE 12-31-2002; IN COMMERCE 12-31-2002.

CLASS 24—FABRICS

3,633,386. LESTHER TRUJILLO, MIRAMAR, FL. SN 77-470,233. FILED P.R. 5-9-2008; AM. S.R. 4-1-2009.

Baby Safety Towel

THE MARK CONSISTS OF STANDARD CHARACTERS WITHOUT CLAIM TO ANY PARTICULAR FONT, STYLE, SIZE, OR COLOR.

NO CLAIM IS MADE TO THE EXCLUSIVE RIGHT TO USE "BABY" OR "TOWEL", APART FROM THE MARK AS SHOWN.

FOR CHILDREN'S TOWELS (U.S. CLS. 42 AND 50).
FIRST USE 4-0-2008; IN COMMERCE 4-0-2008.

3,633,367. MILETICH, PAT, BETTENDORF, IA. SN 77-334,808. FILED P.R. 11-20-2007; AM. S.R. 4-13-2009.

Your Kung Fu is No Good Here

THE MARK CONSISTS OF STANDARD CHARACTERS WITHOUT CLAIM TO ANY PARTICULAR FONT, STYLE, SIZE, OR COLOR.

FOR CLOTHING, NAMELY, BELTS, COATS, JACKETS, JERSEYS, PANTS, RAINWEAR, SHIRTS, SHORTS, SWEAT PANTS, SWEAT SHIRTS, SWEATERS, T-SHIRTS, TANK TOPS, WIND-RESISTANT JACKETS; FOOTWEAR, HEADWEAR (U.S. CLS. 22 AND 39).

FIRST USE 4-1-2005; IN COMMERCE 4-1-2005.

CLASS 25—(Continued).

3,633,382. WRANGLER APPAREL CORP., WILMINGTON, DE. SN 77-419,554. FILED P.R. 3-12-2008; AM. S.R. 4-13-2009.



OWNER OF U.S. REG. NOS. 634,868, 3,322,277, AND OTHERS.
THE MARK CONSISTS OF THE LETTER "W" STYLIZED, OVER A HORIZONTAL DASHED LINE.
FOR BOTTOMS, NAMELY, JEANS (U.S. CLS. 22 AND 39).
FIRST USE 1-23-2009; IN COMMERCE 1-23-2009.

3,633,394. ENGINEERED LIFTING SYSTEMS, LLC, FENTON, MO. SN 77-498,121. FILED P.R. 6-13-2008; AM. S.R. 3-25-2009.

CERTIFIED CRANE CREW

THE MARK CONSISTS OF STANDARD CHARACTERS WITHOUT CLAIM TO ANY PARTICULAR FONT, STYLE, SIZE, OR COLOR.
FOR CLOTHING, NAMELY, T-SHIRTS (U.S. CLS. 22 AND 39).
FIRST USE 11-1-2006; IN COMMERCE 11-1-2006.

3,633,396. G-III LEATHER FASHIONS, INC., NEW YORK, NY. SN 77-500,118. FILED P.R. 6-16-2008; AM. S.R. 1-5-2009.



OWNER OF U.S. REG. NO. 3,424,948.
THE MARK CONSISTS OF THE WORDING "INDUSTRIAL COTTON" STYLIZED TO RESEMBLE A ROPE.
FOR CLOTHING ALL MADE IN WHOLE OR IN SUBSTANTIAL PART OF COTTON, NAMELY, BOTTOMS, SLACKS, PANTS, JEANS, CAPRIS, SHORTS, SKIRTS, AND JACKETS (U.S. CLS. 22 AND 39).
FIRST USE 10-0-2005; IN COMMERCE 10-0-2005.

CLASS 25—(Continued).

3,633,408. TIFFANY SAIDNIA, LOS ANGELES, CA. SN 77-510,538. FILED P.R. 6-27-2008; AM. S.R. 4-21-2009.



THE MARK CONSISTS OF A REPETITIVE LINEAR PATTERN CONSISTING OF A SERIES OF STITCHES.
FOR BLOUSES; DRESSES; PANTS; SKIRTS; SWEATERS; T-SHIRTS (U.S. CLS. 22 AND 39).
FIRST USE 7-12-2006; IN COMMERCE 10-1-2006.

3,633,439. ANTJUAN L. TOLBERT, PORTLAND, OR. SN 77-555,121. FILED 8-25-2008.



THE MARK CONSISTS OF THE WORDING "ST. CHANGE." A DESIGN OF A GREEK CROSS TILTED AT AN 8 DEGREE ANGLE AND A VERTICAL LINE APPEAR TO THE LEFT OF THE WORDING. THE LETTERS "A" AND "N" ARE CONNECTED, AND THE LETTERS "N" AND "G" ARE CONNECTED BY A U-SHAPED DESIGN.
FOR ATHLETIC APPAREL, NAMELY, SHIRTS, PANTS, JACKETS, FOOTWEAR, HATS AND CAPS, ATHLETIC UNIFORMS; FOOTWEAR NOT FOR SPORTS; HATS; HOODED SWEAT SHIRTS; LONG-SLEEVED SHIRTS; NECKTIES; SPORTS BRAS; SPORTS JACKETS; SPORTS JERSEYS; SPORTS SHIRTS; SPORTS SHIRTS WITH SHORT SLEEVES; T-SHIRTS; TANK TOPS; TEE SHIRTS; TOPS; TRACK JACKETS (U.S. CLS. 22 AND 39).
FIRST USE 2-5-2006; IN COMMERCE 9-5-2007.

CLASS 25—(Continued).

3,633,455. FOX CREEK LEATHER, INDEPENDENCE, VA. SN 77-614,324. FILED P.R. 11-14-2008; AM. S.R. 4-26-2009.



NO CLAIM IS MADE TO THE EXCLUSIVE RIGHT TO USE "USA", APART FROM THE MARK AS SHOWN.
 THE COLOR(S) BLUE AND RED IS/ARE CLAIMED AS A FEATURE OF THE MARK.
 THE MARK CONSISTS OF THE WORDS "FOX CREEK" IN BLUE AND "MADE IN USA" IN RED.
 FOR GLOVES (U.S. CLS. 22 AND 39).
 FIRST USE 1-1-1999; IN COMMERCE 1-1-1999.

3,633,466. AMERICAN NOSTALGIA, INC., DBA SAN DIEGO SURF COMPANY, SAN DIEGO, CA. SN 77-653,531. FILED P.R. 1-21-2009; AM. S.R. 4-10-2009.

SAN DIEGO SURF CO

THE MARK CONSISTS OF STANDARD CHARACTERS WITHOUT CLAIM TO ANY PARTICULAR FONT, STYLE, SIZE, OR COLOR.
 FOR HOODED SWEAT SHIRTS; SHORT-SLEEVED OR LONG-SLEEVED T-SHIRTS; SWEAT SHIRTS; T-SHIRTS (U.S. CLS. 22 AND 39).
 FIRST USE 12-3-2005; IN COMMERCE 12-3-2005.

3,633,500. LAMBERT, BILLIE G., SEMINOLE, FL. SN 78-905,793. FILED P.R. 6-12-2006; AM. S.R. 4-2-2009.

LICK BREAST cancer

THE MARK CONSISTS OF STANDARD CHARACTERS WITHOUT CLAIM TO ANY PARTICULAR FONT, STYLE, SIZE, OR COLOR.
 FOR SHIRTS (U.S. CLS. 22 AND 39).
 FIRST USE 11-15-2007; IN COMMERCE 11-15-2007.

CLASS 28—TOYS AND SPORTING GOODS

3,633,362. SNAPTIV, INC., SANTA MONICA, CA. SN 77-288,245. FILED P.R. 9-25-2007; AM. S.R. 9-3-2008.

WEB CARDZ

THE MARK CONSISTS OF STANDARD CHARACTERS WITHOUT CLAIM TO ANY PARTICULAR FONT, STYLE, SIZE, OR COLOR.
 NO CLAIM IS MADE TO THE EXCLUSIVE RIGHT TO USE "CARDS", APART FROM THE MARK AS SHOWN.
 FOR BOARD GAMES; CARD GAMES (U.S. CLS. 22, 23, 38 AND 50).
 FIRST USE 8-15-2008; IN COMMERCE 8-15-2008.

3,633,391. DIBBLE, ANNA D., LONDONDERRY, VT. SN 77-489,590. FILED P.R. 6-3-2008; AM. S.R. 3-18-2009.

FETCHSTIX

THE MARK CONSISTS OF STANDARD CHARACTERS WITHOUT CLAIM TO ANY PARTICULAR FONT, STYLE, SIZE, OR COLOR.
 FOR DOG TOYS (U.S. CLS. 22, 23, 38 AND 50).
 FIRST USE 10-13-2008; IN COMMERCE 10-13-2008.

CLASS 29—MEATS AND PROCESSED FOODS

CLASS 29—(Continued).

3,633,397. AVOMEX, INC., FORT WORTH, TX. SN 77-501,115.
FILED P.R. 6-17-2008; AM. S.R. 3-20-2009.

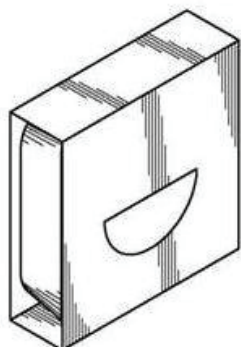

THE MARK CONSISTS OF A THREE DIMENSIONAL CONFIGURATION OF PRODUCT PACKAGING FOR THE GOODS CONSISTING OF A SLEEVE WITH A HALF CIRCLE CUT-OUT THAT SLIDES OVER A PLASTIC TUB. THE VERTICAL AND HORIZONTAL SHADING LINES WHICH APPEAR ON THE DRAWING ARE NOT CLAIMED AS PART OF THE MARK.
FOR GUACAMOLE (U.S. CL. 46).
FIRST USE 9-4-2007; IN COMMERCE 9-4-2007.

CLASS 29—(Continued).

3,633,399. AVOMEX, INC., FORT WORTH, TX. SN 77-501,163.
FILED P.R. 6-17-2008; AM. S.R. 3-20-2009.

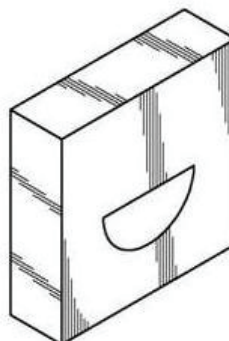

THE MARK CONSISTS OF A THREE DIMENSIONAL CONFIGURATION OF PRODUCT PACKAGING FOR THE GOODS CONSISTING OF A BOX WITH A HALF-CIRCLE CUT-OUT. THE VERTICAL AND HORIZONTAL SHADING LINES WHICH APPEAR ON THE DRAWING ARE NOT CLAIMED AS PART OF THE MARK.
FOR GUACAMOLE (U.S. CL. 46).
FIRST USE 9-4-2007; IN COMMERCE 9-4-2007.

CLASS 30—STAPLE FOODS

3,633,383. BORNAY DESSERTS S.L., 28340 VALDEMORO MADRID, SPAIN. SN 77-427,686. FILED P.R. 3-20-2008; AM. S.R. 4-7-2009.



THE MARK CONSISTS OF SPECIAL FORM OF THE WORD "MARSHMALLOW".
FOR ICE CREAM (U.S. CL. 46).
FIRST USE 11-6-2008; IN COMMERCE 11-6-2008.

3,633,398. AVOMEX, INC., FORT WORTH, TX. SN 77-501,136.
FILED P.R. 6-17-2008; AM. S.R. 3-20-2009.

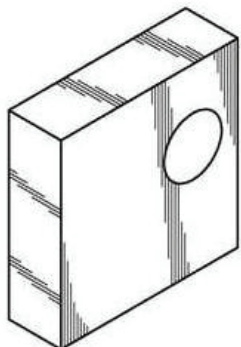

THE MARK CONSISTS OF A THREE DIMENSIONAL CONFIGURATION OF PRODUCT PACKAGING FOR THE GOODS CONSISTING OF BOX WITH A CIRCLE CUT-OUT IN THE TOP RIGHT HAND CORNER. THE VERTICAL AND HORIZONTAL SHADING LINES WHICH APPEAR ON THE DRAWING ARE NOT CLAIMED AS PART OF THE MARK.
FOR GUACAMOLE (U.S. CL. 46).
FIRST USE 9-4-2007; IN COMMERCE 9-4-2007.

3,633,477. KASCAR, LLC, GREENVILLE, SC. SN 77-663,449.
FILED P.R. 2-4-2009; AM. S.R. 4-23-2009.

The Original Cobb Salad

THE MARK CONSISTS OF STANDARD CHARACTERS WITHOUT CLAIM TO ANY PARTICULAR FONT, STYLE, SIZE, OR COLOR.

CLASS 30—(Continued).

NO CLAIM IS MADE TO THE EXCLUSIVE RIGHT TO USE "COBB SALAD", APART FROM THE MARK AS SHOWN.
FOR SALAD DRESSING (U.S. CL. 46).
FIRST USE 12-21-2007; IN COMMERCE 12-21-2007.

CLASS 32—LIGHT BEVERAGES

3,633,353. VENTURE BEVERAGE COMPANY, FORT LAUDERDALE, FL. SN 77-197,640. FILED P.R. 6-5-2007; AM. S.R. 6-13-2008.

FOR NON-ALCOHOLIC BEVERAGES CONTAINING FRUIT JUICES (U.S. CLS. 45, 46 AND 48).
FIRST USE 6-4-2007; IN COMMERCE 9-12-2007.

CLASS 33—WINES AND SPIRITS

3,633,462. JOSE J. REGINATO Y CIA S.R.L., GUAYMALLEN, ARGENTINA. SN 77-638,322. FILED P.R. 12-22-2008; AM. S.R. 4-10-2009.

REGINATO

THE MARK CONSISTS OF STANDARD CHARACTERS WITHOUT CLAIM TO ANY PARTICULAR FONT, STYLE, SIZE, OR COLOR.
FOR WINE (U.S. CLS. 47 AND 49).
FIRST USE 4-18-2008; IN COMMERCE 4-18-2008.

CLASS 34—SMOKERS' ARTICLES

3,633,437. NEW GLOBAL MARKETING, INC., STONE RIDGE, NY. SN 77-545,920. FILED P.R. 8-13-2008; AM. S.R. 4-21-2009.

MEDICI

THE MARK CONSISTS OF STANDARD CHARACTERS WITHOUT CLAIM TO ANY PARTICULAR FONT, STYLE, SIZE, OR COLOR.
FOR CIGARS (U.S. CLS. 2, 8, 9 AND 17).
FIRST USE 6-13-2008; IN COMMERCE 6-13-2008.

CLASS 34—(Continued).**SERVICE MARKS****CLASS 35—ADVERTISING AND BUSINESS**

3,633,343. SCHUETZ, ROBERT J., DALLAS, TX. SN 76-691,871. FILED P.R. 8-6-2008; AM. S.R. 4-22-2009.

FLOATSTORAGE.COM

THE MARK CONSISTS OF STANDARD CHARACTERS WITHOUT CLAIM TO ANY PARTICULAR FONT, STYLE, SIZE, OR COLOR.

FOR RETAIL STORES FEATURING STORAGE DEVICES FOR BEACH TOYS, SWIM GOGGLES, AND WATER RELATED TOYS (U.S. CLS. 100, 101 AND 102).
FIRST USE 9-1-2008; IN COMMERCE 9-1-2008.

3,633,344. SALES COACHES INTERNATIONAL, LLC, PLANO, IL. SN 76-694,247. FILED P.R. 11-14-2008; AM. S.R. 4-22-2009.

REVENUE ADVISOR

THE MARK CONSISTS OF STANDARD CHARACTERS WITHOUT CLAIM TO ANY PARTICULAR FONT, STYLE, SIZE, OR COLOR.

NO CLAIM IS MADE TO THE EXCLUSIVE RIGHT TO USE "ADVISOR", APART FROM THE MARK AS SHOWN.
FOR BUSINESS MANAGEMENT CONSULTING AND ADVISORY SERVICES, NAMELY, BUSINESS MANAGEMENT CONSULTING AND ADVISORY SERVICES IN THE FIELD OF IDENTIFYING NEW REVENUE OPTIONS AND ACCELERATING ACQUISITION OF TRADITIONAL REVENUE STREAMS THROUGH REVENUE GENERATION SYSTEMS, TOOLS, APPROACHES, SKILLS, TECHNIQUES, METHODOLOGIES AND DELIVERED THROUGH VERBAL CONSULTATION AND WRITTEN COMMUNICATION (U.S. CLS. 100, 101 AND 102).
FIRST USE 12-1-2008; IN COMMERCE 12-1-2008.

3,633,345. VANTAGE MEDIA LLC, VENICE, CA. SN 77-026,320. FILED P.R. 10-20-2006; AM. S.R. 4-1-2009.

1800COLLEGE

THE MARK CONSISTS OF STANDARD CHARACTERS WITHOUT CLAIM TO ANY PARTICULAR FONT, STYLE, SIZE, OR COLOR.

FOR REFERRALS IN THE FIELD OF SCHOOLS (U.S. CLS. 100, 101 AND 102).
FIRST USE 10-0-2006; IN COMMERCE 10-0-2006.

CLASS 35—(Continued).

3,633,347. QUADREM INTERNATIONAL, LTD, HAMILTON, BERMUDA. SN 77-068,461. FILED P.R. 12-20-2006; AM. S.R. 4-23-2009.

THE GLOBAL EMARKETPLACE

THE MARK CONSISTS OF STANDARD CHARACTERS WITHOUT CLAIM TO ANY PARTICULAR FONT, STYLE, SIZE, OR COLOR.

FOR BUSINESS SERVICES, NAMELY, BUSINESS TO BUSINESS ELECTRONIC MARKETPLACE WHICH BY MEANS OF A TRANSACTION PLATFORM AND DATA MANAGEMENT FACILITATES THE PROCUREMENT OF GOODS AND SERVICES AND OPTIMIZES THE SUPPLY CHAIN BETWEEN BUYERS AND SUPPLIERS WITHIN THE MANUFACTURING, FABRICATION, CONSTRUCTION, TRANSPORT, DISTRIBUTION, ENERGY, AND UTILITIES INDUSTRIES (U.S. CLS. 100, 101 AND 102).

FIRST USE 1-1-2007; IN COMMERCE 1-1-2007.

3,633,359. BLUE POLLEN, INC., NEW HOPE, PA. SN 77-228,337. FILED P.R. 7-12-2007; AM. S.R. 9-18-2008.

TEMPERAMENT-BASED ADVERTISING

THE MARK CONSISTS OF STANDARD CHARACTERS WITHOUT CLAIM TO ANY PARTICULAR FONT, STYLE, SIZE, OR COLOR.

NO CLAIM IS MADE TO THE EXCLUSIVE RIGHT TO USE "ADVERTISING", APART FROM THE MARK AS SHOWN.

FOR ADVERTISING AND MARKETING SERVICES FOR BUSINESSES; CONSUMER RESEARCH; ADVERTISING THROUGH ALL PUBLIC COMMUNICATIONS MEANS (U.S. CLS. 100, 101 AND 102).

FIRST USE 2-0-2007; IN COMMERCE 2-0-2007.

CLASS 35—(Continued).

3,633,360. BLUE POLLEN, INC., NEW HOPE, PA. SN 77-228,358. FILED P.R. 7-12-2007; AM. S.R. 9-18-2008.

TEMPERAMENT-BASED MARKETING

THE MARK CONSISTS OF STANDARD CHARACTERS WITHOUT CLAIM TO ANY PARTICULAR FONT, STYLE, SIZE, OR COLOR.

NO CLAIM IS MADE TO THE EXCLUSIVE RIGHT TO USE "MARKETING", APART FROM THE MARK AS SHOWN.

FOR ADVERTISING AND MARKETING SERVICES FOR BUSINESSES; CONSUMER RESEARCH; ADVERTISING THROUGH ALL PUBLIC COMMUNICATIONS MEANS (U.S. CLS. 100, 101 AND 102).

FIRST USE 2-0-2007; IN COMMERCE 2-0-2007.

3,633,384. REGIONALBEST.COM, LLC, BALA CYNWYD, PA. SN 77-445,732. FILED P.R. 4-11-2008; AM. S.R. 4-28-2009.

REGIONALBEST.COM

THE MARK CONSISTS OF STANDARD CHARACTERS WITHOUT CLAIM TO ANY PARTICULAR FONT, STYLE, SIZE, OR COLOR.

FOR ON-LINE RETAIL STORE SERVICES FEATURING FOOD (U.S. CLS. 100, 101 AND 102).

FIRST USE 7-0-2008; IN COMMERCE 7-0-2008.

3,633,385. THE GREEN WINDOW COMPANY, INC., KENNESAW, GA. SN 77-462,578. FILED P.R. 4-30-2008; AM. S.R. 2-21-2009.

THE GREEN WINDOW COMPANY

THE MARK CONSISTS OF STANDARD CHARACTERS WITHOUT CLAIM TO ANY PARTICULAR FONT, STYLE, SIZE, OR COLOR.

NO CLAIM IS MADE TO THE EXCLUSIVE RIGHT TO USE "COMPANY", APART FROM THE MARK AS SHOWN.

FOR ONLINE RETAIL STORE SERVICES FEATURING WINDOWS AND DOORS, AND ENERGY-EFFICIENT WINDOWS AND DOORS (U.S. CLS. 100, 101 AND 102).

FIRST USE 2-18-2009; IN COMMERCE 2-18-2009.

CLASS 35—(Continued).

3,633,387. MG BROWN INVESTMENT GROUP, LLC, HOUSTON, TX. SN 77-479,587. FILED P.R. 5-20-2008; AM. S.R. 4-22-2009.

THE PREMIERE PRIVATE
PRACTICE OPPORTUNITY FOR
FELLOWSHIP TRAINED HAND
SURGEONS

THE MARK CONSISTS OF STANDARD CHARACTERS WITHOUT CLAIM TO ANY PARTICULAR FONT, STYLE, SIZE, OR COLOR.

FOR FRANCHISING SERVICES, NAMELY, CONSULTATION AND ASSISTANCE IN BUSINESS MANAGEMENT, ESTABLISHMENT, ORGANIZATION AND OPERATION OF A MEDICAL OFFICE (U.S. CLS. 100, 101 AND 102).

FIRST USE 4-22-2009; IN COMMERCE 4-22-2009.

3,633,401. BOSE, ARANI, NEW YORK, NY. AND NAGY, PETER, NEW DELHI, INDIA. SN 77-505,868. FILED P.R. 6-23-2008; AM. S.R. 3-25-2009.

NATURE MORTE

THE MARK CONSISTS OF STANDARD CHARACTERS WITHOUT CLAIM TO ANY PARTICULAR FONT, STYLE, SIZE, OR COLOR.

THE ENGLISH TRANSLATION OF "NATURE MORTE" IN THE MARK IS "STILL LIFE".

FOR ART GALLERIES; COMMISSIONING OF WORKS OF ART; CONDUCTING TRADE SHOWS IN THE FIELD OF ART (U.S. CLS. 100, 101 AND 102).

FIRST USE 11-1-1997; IN COMMERCE 2-1-2005.

3,633,404. ROSSWIL, LLC, MEMPHIS, TN. SN 77-507,393. FILED P.R. 6-25-2008; AM. S.R. 4-28-2009.

LIDBID

THE MARK CONSISTS OF STANDARD CHARACTERS WITHOUT CLAIM TO ANY PARTICULAR FONT, STYLE, SIZE, OR COLOR.

FOR ARRANGING AND CONDUCTING INCENTIVE REWARD PROGRAMS TO PROMOTE THE SALE OF SMOKELESS TOBACCO (U.S. CLS. 100, 101 AND 102).

FIRST USE 2-2-2009; IN COMMERCE 2-2-2009.

CLASS 35—(Continued).

3,633,425. ESP MUSIC DISCO LIMITED, NEWBURY, UNITED KINGDOM. SN 77-522,414. FILED P.R. 7-15-2008; AM. S.R. 4-28-2009.

DJKIT

THE MARK CONSISTS OF STANDARD CHARACTERS WITHOUT CLAIM TO ANY PARTICULAR FONT, STYLE, SIZE, OR COLOR.

OWNER OF UNITED KINGDOM REG. NO. 2452741, DATED 4-17-2007, EXPIRES 4-17-2017.

FOR RETAIL STORE SERVICES, MAIL ORDER SERVICES AND RETAIL STORE SERVICES PROVIDED ONLINE OVER THE INTERNET, ALL FEATURING APPARATUS AND INSTRUMENTS FOR RECORDING, TRANSMISSION OR REPRODUCTION OF SOUND OR IMAGES, AUDIO AND VIDEO EQUIPMENT, MAGNETIC DATA CARRIERS, RECORDING DISCS, COMPACT DISCS, RECORDS, TAPES, DIGITAL MUSIC DOWNLOADABLE FROM THE INTERNET, AMPLIFIERS, CD AND MP3 PLAYERS, MP3 SOFTWARE AND HARDWARE, SPEAKERS, MICROPHONES, DVD VIDEO EQUIPMENT, SPECIAL EFFECTS EQUIPMENT, LIGHTING EQUIPMENT, MUSICAL INSTRUMENTS, KEYBOARDS, CABLES AND PARTS AND FITTINGS FOR ALL THE AFORESAID GOODS; RETAIL STORE SERVICES, MAIL ORDER SERVICES AND RETAIL STORE SERVICES PROVIDED ONLINE OVER THE INTERNET, ALL FEATURING BOOKS AND PRINTED MATTER, PRINTED MUSIC, CASES, BAGS, AND CLOTHING (U.S. CLS. 100, 101 AND 102).

3,633,430. INTEGRATED ONCOLOGY SOLUTIONS, LLC, BATON ROUGE, LA. SN 77-529,603. FILED P.R. 7-23-2008; AM. S.R. 4-24-2009.

INTEGRATED ONCOLOGY
SOLUTIONS

THE MARK CONSISTS OF STANDARD CHARACTERS WITHOUT CLAIM TO ANY PARTICULAR FONT, STYLE, SIZE, OR COLOR.

FOR BUSINESS ADMINISTRATION, ORGANIZATION AND MANAGEMENT SERVICES FOR PHYSICIANS, HOSPITALS, AND OTHER INDIVIDUALS OR ENTITIES PROVIDING CARE TO CANCER PATIENTS; ACCOUNTING SERVICES FOR PHYSICIANS, HOSPITALS, AND OTHER INDIVIDUALS OR ENTITIES PROVIDING CARE TO CANCER PATIENTS; BILLING SERVICES FOR PHYSICIANS, HOSPITALS, AND OTHER INDIVIDUALS OR ENTITIES PROVIDING CARE TO CANCER PATIENTS; ADVERTISING, MARKETING, AND PROMOTIONAL SERVICES FOR PHYSICIANS, HOSPITALS, AND OTHER INDIVIDUALS OR ENTITIES PROVIDING CARE TO CANCER PATIENTS; PERSONNEL PLACEMENT AND RECRUITING SERVICES IN THE HEALTH CARE FIELD, NAMELY, PROVIDING DOCTORS AND MEDICAL STAFF TO PHYSICIANS, HOSPITALS, AND OTHER INDIVIDUALS OR ENTITIES PROVIDING CARE TO CANCER PATIENTS (U.S. CLS. 100, 101 AND 102).

FIRST USE 6-2-2005; IN COMMERCE 6-2-2005.

CLASS 35—(Continued).

3,633,431. U.S. TRAVEL ASSOCIATION, WASHINGTON, DC. SN 77-535,994. FILED P.R. 7-31-2008; AM. S.R. 4-20-2009.

CLASS 35—(Continued).

3,633,448. IBUYER, LLC, DOVER, DE. SN 77-594,092. FILED P.R. 10-16-2008; AM. S.R. 4-20-2009.

U.S. TRAVEL ASSOCIATION

IBUYER

THE MARK CONSISTS OF STANDARD CHARACTERS WITHOUT CLAIM TO ANY PARTICULAR FONT, STYLE, SIZE, OR COLOR.

OWNER OF U.S. REG. NOS. 1,295,291 AND 1,911,966. NO CLAIM IS MADE TO THE EXCLUSIVE RIGHT TO USE "TRAVEL ASSOCIATION", APART FROM THE MARK AS SHOWN.

FOR ASSOCIATION SERVICES, NAMELY, PROMOTING THE BUSINESS AND INTERESTS OF MEMBERS BY PROMOTING TOURISM AND TRAVEL TO AND WITHIN THE BORDERS OF THE UNITED STATES (U.S. CLS. 100, 101 AND 102).

FIRST USE 1-1-2009; IN COMMERCE 1-1-2009.

THE MARK CONSISTS OF STANDARD CHARACTERS WITHOUT CLAIM TO ANY PARTICULAR FONT, STYLE, SIZE, OR COLOR.

FOR OPERATING ON-LINE MARKETPLACES FOR SELLERS OF GOODS AND/OR SERVICES; PROVIDING A WEB SITE WHEREBY BUYERS OF GOODS OR SERVICES LOCATE AND RECEIVE QUOTATIONS FROM MULTIPLE COMPETITIVE SOURCES AND SELLERS OF GOODS OR SERVICES IDENTIFY AND BID ON MULTIPLE NEW SALES OPPORTUNITIES (U.S. CLS. 100, 101 AND 102).

FIRST USE 4-16-2009; IN COMMERCE 4-16-2009.

3,633,445. LAX, SAMUEL, DBA SALA-GROUP, MISSION HILLS, CA. SN 77-583,064. FILED P.R. 10-1-2008; AM. S.R. 4-9-2009.

3,633,452. STREETLINKS NATIONAL APPRAISAL SERVICES LLC, KANSAS CITY, MO. SN 77-609,696. FILED P.R. 11-7-2008; AM. S.R. 4-16-2009.

CYBERSPACE STORE

APPRAISAL ADVOCATE

THE MARK CONSISTS OF STANDARD CHARACTERS WITHOUT CLAIM TO ANY PARTICULAR FONT, STYLE, SIZE, OR COLOR.

NO CLAIM IS MADE TO THE EXCLUSIVE RIGHT TO USE "STORE", APART FROM THE MARK AS SHOWN.

FOR ON-LINE RETAIL STORE SERVICES FEATURING CLOTHING, BAGS, JEWELRY, HEIRLOOMS, GIFTS, BELTS, BUCKLES, WATCHES, MUGS, SMOKE AND FIRE ALARMS AND DETECTORS (U.S. CLS. 100, 101 AND 102).

FIRST USE 12-31-1998; IN COMMERCE 12-31-1998.

THE MARK CONSISTS OF STANDARD CHARACTERS WITHOUT CLAIM TO ANY PARTICULAR FONT, STYLE, SIZE, OR COLOR.

NO CLAIM IS MADE TO THE EXCLUSIVE RIGHT TO USE "APPRAISAL", APART FROM THE MARK AS SHOWN.

FOR CUSTOMER SERVICE IN THE FIELD OF APPRAISAL SERVICES; PROVIDING CUSTOMER SERVICE AND PRODUCT INQUIRY SERVICES VIA TELEPHONE AND E-MAIL (U.S. CLS. 100, 101 AND 102).

FIRST USE 9-23-2008; IN COMMERCE 9-23-2008.

CLASS 35—(Continued).

3,633,465. THE PARENT BLOGGERS NETWORK LLC, PARKER, CO. SN 77-648,076. FILED P.R. 1-13-2009; AM. S.R. 4-3-2009.

PARENT BLOGGERS NETWORK

THE MARK CONSISTS OF STANDARD CHARACTERS WITHOUT CLAIM TO ANY PARTICULAR FONT, STYLE, SIZE, OR COLOR.

NO CLAIM IS MADE TO THE EXCLUSIVE RIGHT TO USE "BLOGGERS NETWORK", APART FROM THE MARK AS SHOWN.

FOR ADVERTISING AND PROMOTION SERVICES AND RELATED CONSULTING (U.S. CLS. 100, 101 AND 102).

FIRST USE 12-30-2006; IN COMMERCE 3-2-2007.

CLASS 35—(Continued).

3,633,473. INFORMATION SECURITY MEDIA GROUP, CORP., PRINCETON, NJ. SN 77-658,566. FILED P.R. 1-28-2009; AM. S.R. 4-23-2009.

CUINFOSECURITY

THE MARK CONSISTS OF STANDARD CHARACTERS WITHOUT CLAIM TO ANY PARTICULAR FONT, STYLE, SIZE, OR COLOR.

FOR ASSISTANCE IN BUSINESS MANAGEMENT AND PRODUCT COMMERCIALIZATION, WITHIN THE FRAMEWORK OF A FRANCHISE CONTRACT; BUSINESS CONSULTING AND BUSINESS INFORMATION FOR ENTERPRISES (U.S. CLS. 100, 101 AND 102).

FIRST USE 2-28-2007; IN COMMERCE 2-28-2007.

3,633,470. GREATER LAFAYETTE CHAMBER OF COMMERCE, INC., LAFAYETTE, LA. SN 77-655,023. FILED P.R. 1-23-2009; AM. S.R. 4-26-2009.

America's Energy Corridor

THE MARK CONSISTS OF STANDARD CHARACTERS WITHOUT CLAIM TO ANY PARTICULAR FONT, STYLE, SIZE, OR COLOR.

NO CLAIM IS MADE TO THE EXCLUSIVE RIGHT TO USE "ENERGY CORRIDOR", APART FROM THE MARK AS SHOWN.

FOR PROMOTING POLITICAL AND PUBLIC AWARENESS OF THE UPGRADING OF U.S. HIGHWAY 90 FROM LAFAYETTE, LOUISIANA TO NEW ORLEANS, LOUISIANA TO INTERSTATE HIGHWAY STANDARDS (U.S. CLS. 100, 101 AND 102).

FIRST USE 1-12-2009; IN COMMERCE 1-23-2009.

3,633,490. LAMPS PLUS, INC., CHATSWORTH, CA. SN 77-686,572. FILED P.R. 3-9-2009; AM. S.R. 4-22-2009.



NO CLAIM IS MADE TO THE EXCLUSIVE RIGHT TO USE "OPEN BOX", APART FROM THE MARK AS SHOWN.

THE MARK CONSISTS OF AN OPEN BOX OR CARTON TO THE LEFT OF THE WORDS "OPEN BOX".

FOR ONLINE RETAIL STORE SERVICES FEATURING ELECTRICAL LIGHTING FIXTURES, LAMPS, CEILING LIGHTS, WALL LIGHTS, OUTDOOR LIGHTS, CEILING FANS, BATHROOM EXHAUST FANS, LIGHT BULBS, UNDER-CABINET LIGHTING, LIGHT DIMMERS, LIGHT CONTROLS, AND HOME DECOR (U.S. CLS. 100, 101 AND 102).

FIRST USE 11-30-2008; IN COMMERCE 11-30-2008.

CLASS 35—(Continued).

3,633,491. LAMPS PLUS, INC., CHATSWORTH, CA. SN 77-686,580. FILED P.R. 3-9-2009; AM. S.R. 4-22-2009.



THE MARK CONSISTS OF AN OPEN BOX OR CARTON. FOR ONLINE RETAIL STORE SERVICES FEATURING ELECTRICAL LIGHTING FIXTURES, LAMPS, CEILING LIGHTS, WALL LIGHTS, OUTDOOR LIGHTS, CEILING FANS, BATHROOM EXHAUST FANS, LIGHT BULBS, UNDER-CABINET LIGHTING, LIGHT DIMMERS, LIGHT CONTROLS, AND HOME DECOR (U.S. CLS. 100, 101 AND 102).
FIRST USE 11-30-2008; IN COMMERCE 11-30-2008.

CLASS 36—INSURANCE AND FINANCIAL

3,633,373. FUNDQUEST INCORPORATED, BOSTON, MA. SN 77-374,299. FILED P.R. 1-17-2008; AM. S.R. 4-23-2009.

ACTIVEPASSIVE

THE MARK CONSISTS OF STANDARD CHARACTERS WITHOUT CLAIM TO ANY PARTICULAR FONT, STYLE, SIZE, OR COLOR.
FOR INVESTMENT ADVISORY SERVICES (U.S. CLS. 100, 101 AND 102).
FIRST USE 12-31-2007; IN COMMERCE 12-31-2007.

3,633,375. ALLSTATE INSURANCE COMPANY, NORTHBROOK, IL. SN 77-386,386. FILED P.R. 2-1-2008; AM. S.R. 4-16-2009.

SAFE DRIVING CLUB

THE MARK CONSISTS OF STANDARD CHARACTERS WITHOUT CLAIM TO ANY PARTICULAR FONT, STYLE,

CLASS 36—(Continued).

SIZE, OR COLOR.
OWNER OF U.S. REG. NOS. 3,263,842 AND 3,433,820.
FOR INSURANCE SERVICES, NAMELY, UNDERWRITING AUTOMOBILE INSURANCE POLICIES WHICH FEATURE DISCOUNTS FOR POLICY HOLDERS (U.S. CLS. 100, 101 AND 102).
FIRST USE 4-16-2009; IN COMMERCE 4-16-2009.

3,633,381. BEAULIEU GROUP, LLC, DALTON, GA. SN 77-413,418. FILED P.R. 3-5-2008; AM. S.R. 4-20-2009.

THE NICEST CARPET IN THE WORLD

THE MARK CONSISTS OF STANDARD CHARACTERS WITHOUT CLAIM TO ANY PARTICULAR FONT, STYLE, SIZE, OR COLOR.
FOR PROVIDING EXTENDED STAIN AND WEAR WARRANTIES ON CARPETS AND RUGS (U.S. CLS. 100, 101 AND 102).
FIRST USE 1-31-2008; IN COMMERCE 1-31-2008.

3,633,405. CHRISTIAN STANLEY, LLC, LOS ANGELES, CA. SN 77-509,291. FILED P.R. 6-26-2008; AM. S.R. 4-3-2009.

REVERSE-LIFE INSURANCE

THE MARK CONSISTS OF STANDARD CHARACTERS WITHOUT CLAIM TO ANY PARTICULAR FONT, STYLE, SIZE, OR COLOR.
NO CLAIM IS MADE TO THE EXCLUSIVE RIGHT TO USE "INSURANCE", APART FROM THE MARK AS SHOWN.
FOR VIATICAL AND OTHER LIFE SETTLEMENT SERVICES, NAMELY, FINANCIAL VALUATION OF LIFE INSURANCE POLICIES AND BROKERAGE OF LIFE INSURANCE POLICIES BETWEEN SELLERS AND PURCHASERS (U.S. CLS. 100, 101 AND 102).
FIRST USE 4-4-2008; IN COMMERCE 4-4-2008.

3,633,446. HUBERT F-J BROMMA, RENO, NV. SN 77-584,291. FILED P.R. 10-2-2008; AM. S.R. 3-24-2009.

The IRA Card Check

THE MARK CONSISTS OF STANDARD CHARACTERS WITHOUT CLAIM TO ANY PARTICULAR FONT, STYLE,

CLASS 36—(Continued).

SIZE, OR COLOR.

NO CLAIM IS MADE TO THE EXCLUSIVE RIGHT TO USE "IRA" AND "CHECK", APART FROM THE MARK AS SHOWN.

FOR FINANCIAL SERVICES, NAMELY, ADMINISTRATION OF TRANSACTIONS INVOLVING FUNDS DRAWN FROM SECURITIES, STOCKS, FUNDS, EQUITIES, BONDS, CASH, OR OTHER TYPES OF FINANCIAL INVESTMENTS IN RETIREMENT PLANS USING A CHECK OR NEGOTIABLE ORDER OF WITHDRAWAL OVER A GLOBAL DATA NETWORK (U.S. CLS. 100, 101 AND 102).

FIRST USE 7-28-2008; IN COMMERCE 7-28-2008.

3,633,449. ASHWORTH CREDIT UNION, WEST DES MOINES, IA. SN 77-598,690. FILED P.R. 10-23-2008; AM. S.R. 4-24-2009.

ASHWORTH CREDIT UNION

THE MARK CONSISTS OF STANDARD CHARACTERS WITHOUT CLAIM TO ANY PARTICULAR FONT, STYLE, SIZE, OR COLOR.

NO CLAIM IS MADE TO THE EXCLUSIVE RIGHT TO USE "CREDIT UNION", APART FROM THE MARK AS SHOWN.

FOR CREDIT UNION SERVICES; AND BANKING SERVICES (U.S. CLS. 100, 101 AND 102).

FIRST USE 1-1-2009; IN COMMERCE 1-1-2009.

3,633,457. MCDANIEL, TERRY, ALAMO, CA. SN 77-616,536. FILED 11-18-2008.

MoveScore

THE MARK CONSISTS OF STANDARD CHARACTERS WITHOUT CLAIM TO ANY PARTICULAR FONT, STYLE, SIZE, OR COLOR.

FOR REAL ESTATE INFORMATION SERVICES, NAMELY, PROVIDING SCORING AND SCORE ANALYSIS AS TO THE LIKELIHOOD A HOMEOWNER WILL SELL THEIR HOME (U.S. CLS. 100, 101 AND 102).

FIRST USE 7-12-2008; IN COMMERCE 7-12-2008.

CLASS 36—(Continued).

3,633,458. THE MCGRAW-HILL COMPANIES, INC., NEW YORK, NY. SN 77-623,487. FILED P.R. 12-1-2008; AM. S.R. 4-17-2009.

GLOBAL CREDIT PORTAL

THE MARK CONSISTS OF STANDARD CHARACTERS WITHOUT CLAIM TO ANY PARTICULAR FONT, STYLE, SIZE, OR COLOR.

NO CLAIM IS MADE TO THE EXCLUSIVE RIGHT TO USE "PORTAL", APART FROM THE MARK AS SHOWN.

FOR FINANCIAL INFORMATION PROVIDED OVER A GLOBAL COMPUTER NETWORK (U.S. CLS. 100, 101 AND 102).

FIRST USE 1-13-2009; IN COMMERCE 1-13-2009.

3,633,464. ADJUST MY LOAN, LLC, PHOENIX, AZ. SN 77-646,681. FILED P.R. 1-9-2009; AM. S.R. 4-23-2009.

AdjustMyLoan

THE MARK CONSISTS OF STANDARD CHARACTERS WITHOUT CLAIM TO ANY PARTICULAR FONT, STYLE, SIZE, OR COLOR.

FOR FINANCIAL LOAN CONSULTATION; FINANCIAL SERVICES, NAMELY, LOSS MITIGATION SERVICES FOR UNDER OR NON-PERFORMING MORTGAGE LOANS (U.S. CLS. 100, 101 AND 102).

FIRST USE 11-3-2008; IN COMMERCE 11-3-2008.

3,633,476. FCRC, LLC, ROCHESTER, NY. SN 77-662,722. FILED P.R. 2-3-2009; AM. S.R. 4-28-2009.

**FIDUCIARY COMPLIANCE
RESOURCE CENTER**

THE MARK CONSISTS OF STANDARD CHARACTERS WITHOUT CLAIM TO ANY PARTICULAR FONT, STYLE, SIZE, OR COLOR.

FOR INVESTMENT CONSULTATION (U.S. CLS. 100, 101 AND 102).

FIRST USE 1-1-2006; IN COMMERCE 1-1-2006.

CLASS 36—(Continued).

3,633,494. DUNDEE CORPORATION, TORONTO, ONTARIO, CANADA. SN 78-526,571. FILED P.R. 12-3-2004; AM. S.R. 12-20-2005.

PRIVATE WEALTHCARE ADVISOR

OWNER OF CANADA REG. NO. 719235, DATED 7-24-2008, EXPIRES 7-24-2023.

NO CLAIM IS MADE TO THE EXCLUSIVE RIGHT TO USE "ADVISOR", APART FROM THE MARK AS SHOWN.

FOR FINANCIAL PLANNING CONSULTING SERVICES, NAMELY, FINANCIAL PLANNING, FINANCIAL PLANNING ANALYSIS, ASSET ALLOCATION ANALYSIS, RETIREMENT PLANNING, ESTATE PLANNING AND PROVIDING PORTFOLIO RECOMMENDATIONS AND A DETAILED PERSONALIZED INVESTMENT STRATEGY (U.S. CLS. 100, 101 AND 102).

CLASS 37—CONSTRUCTION AND REPAIR

3,633,350. SKANSKA AB, SOLNA, SWEDEN. SN 77-122,629. FILED 3-5-2007.

SLATTERY

THE MARK CONSISTS OF STANDARD CHARACTERS WITHOUT CLAIM TO ANY PARTICULAR FONT, STYLE, SIZE, OR COLOR.

PRIORITY CLAIMED UNDER SEC. 44(D) ON ERP-N CMNTY TM OFC APPLICATION NO. 5724695, FILED 3-1-2007, REG. NO. 005724695, DATED 3-13-2008, EXPIRES 3-1-2017.

FOR BUILDING CONSTRUCTION, REPAIR AND MAINTENANCE OF BUILDINGS; INSTALLATION SERVICES FOR BUILDINGS, NAMELY, ELECTRICAL SYSTEMS, WINDOWS, PLUMBING; RENTAL OF MACHINES, TOOLS AND IMPLEMENTS FOR BUILDINGS, NAMELY, BUILDING EQUIPMENT, HAND AND POWER TOOLS (U.S. CLS. 100, 103 AND 106).

3,633,351. AIRLIFT SYSTEMS INTERNATIONAL, INC., ANDERSON, IN. SN 77-145,699. FILED P.R. 4-1-2007; AM. S.R. 4-3-2009.

AIRLIFT

THE MARK CONSISTS OF STANDARD CHARACTERS WITHOUT CLAIM TO ANY PARTICULAR FONT, STYLE, SIZE, OR COLOR.

FOR OIL PUMPING AND EXTRACTION (U.S. CLS. 100, 103 AND 106).
FIRST USE 7-15-2001; IN COMMERCE 7-15-2001.

CLASS 37—(Continued).

3,633,393. AVIATION REPAIR SOLUTIONS, INC., LONG BEACH, CA. SN 77-492,280. FILED P.R. 6-5-2008; AM. S.R. 3-24-2009.

**AVIATION REPAIR SOLUTIONS,
INC.**

THE MARK CONSISTS OF STANDARD CHARACTERS WITHOUT CLAIM TO ANY PARTICULAR FONT, STYLE, SIZE, OR COLOR.

NO CLAIM IS MADE TO THE EXCLUSIVE RIGHT TO USE "AVIATION REPAIR" AND "INC.", APART FROM THE MARK AS SHOWN.

FOR REPAIR AND REFURBISHMENT OF AIRCRAFT PARTS (U.S. CLS. 100, 103 AND 106).
FIRST USE 1-31-2006; IN COMMERCE 1-31-2006.

3,633,432. SOUTH MOUNTAIN RECYCLING, LLC, AGOURA HILLS, CA. SN 77-537,257. FILED P.R. 8-1-2008; AM. S.R. 2-24-2009.

**CASH FOR CLUNKERS AND
JUNKERS**

THE MARK CONSISTS OF STANDARD CHARACTERS WITHOUT CLAIM TO ANY PARTICULAR FONT, STYLE, SIZE, OR COLOR.

NO CLAIM IS MADE TO THE EXCLUSIVE RIGHT TO USE "CASH FOR CLUNKERS", APART FROM THE MARK AS SHOWN.

FOR ENVIRONMENTAL DISPOSAL SERVICES OF UNWANTED AND DISABLED VEHICLES (U.S. CLS. 100, 103 AND 106).

FIRST USE 2-3-2009; IN COMMERCE 2-3-2009.

CLASS 38—COMMUNICATION

3,633,410. DLN, LLC, CHESTERFIELD, MO. SN 77-514,607. FILED P.R. 7-3-2008; AM. S.R. 4-9-2009.

**VALENTINE'S DAY AND EVERY
DAY**

THE MARK CONSISTS OF STANDARD CHARACTERS WITHOUT CLAIM TO ANY PARTICULAR FONT, STYLE, SIZE, OR COLOR.

FOR DELIVERY OF MESSAGES AND GREETING CARDS FOR AND TO OTHERS BY ONLINE MEANS AND ELECTRONIC TRANSMISSION (U.S. CLS. 100, 101 AND 104).

FIRST USE 9-0-2008; IN COMMERCE 9-0-2008.

CLASS 39—TRANSPORTATION AND STORAGE

3,633,479. RED & WHITE FLEET EXCURSIONS, INC., SAN FRANCISCO, CA. SN 77-664,186. FILED P.R. 2-5-2009; AM. S.R. 4-27-2009.

SAN FRANCISCO CRUISES

THE MARK CONSISTS OF STANDARD CHARACTERS WITHOUT CLAIM TO ANY PARTICULAR FONT, STYLE, SIZE, OR COLOR.

OWNER OF U.S. REG. NOS. 1,180,527, 2,588,254, AND OTHERS.

NO CLAIM IS MADE TO THE EXCLUSIVE RIGHT TO USE "CRUISES", APART FROM THE MARK AS SHOWN.

FOR TOURIST SERVICES, NAMELY, PLEASURE BOAT CRUISES (U.S. CLS. 100 AND 105).

FIRST USE 12-31-2006; IN COMMERCE 12-31-2006.

3,633,497. ARMSTRONG HOSPITALITY GROUP LTD., VANCOUVER, CANADA. SN 78-713,155. FILED P.R. 9-14-2005; AM. S.R. 4-24-2009.

ARMSTRONG GROUP

THE MARK CONSISTS OF STANDARD CHARACTERS WITHOUT CLAIM TO ANY PARTICULAR FONT, STYLE, SIZE, OR COLOR.

PRIORITY CLAIMED UNDER SEC. 44(D) ON CANADA APPLICATION NO. 1271979, FILED 9-14-2005, REG. NO. TMA738324, DATED 4-17-2009, EXPIRES 4-17-2024.

NO CLAIM IS MADE TO THE EXCLUSIVE RIGHT TO USE "GROUP", APART FROM THE MARK AS SHOWN.

FOR TRANSPORTATION OF PASSENGERS AND/OR GOODS BY RAIL, BUS, CAR, BOAT AND AIR, TRANSPORTATION RESERVATION SERVICES, ORGANIZATION OF EXCURSIONS AND TOURS, COORDINATING TRAVEL ARRANGEMENTS FOR INDIVIDUALS AND FOR GROUPS, ARRANGING TRAVEL TOURS (U.S. CLS. 100 AND 105).

CLASS 41—EDUCATION AND ENTERTAINMENT

3,633,364. SELLING SOLUTIONS INC., GUELPH, CANADA. SN 77-304,024. FILED P.R. 10-15-2007; AM. S.R. 12-16-2008.

NEGOTIATING COACH**CLASS 41—(Continued).**

THE MARK CONSISTS OF STANDARD CHARACTERS WITHOUT CLAIM TO ANY PARTICULAR FONT, STYLE, SIZE, OR COLOR.

FOR EDUCATION SERVICES, NAMELY, CONDUCTING PRESENTATIONS, SEMINARS, COURSES, LEARNING WORKSHOPS, SPEAKING ENGAGEMENT SERVICES, LECTURES AND TUTORING IN THE FIELDS OF NEGOTIATION, MEDIATION, DISPUTE RESOLUTION CONSULTING AND COACHING SERVICES (U.S. CLS. 100, 101 AND 107).

FIRST USE 2-1-1995; IN COMMERCE 2-1-1995.

3,633,366. DERVAES INSTITUTE, PASADENA, CA. SN 77-326,565. FILED P.R. 11-10-2007; AM. S.R. 4-6-2009.

URBAN HOMESTEADING

THE MARK CONSISTS OF STANDARD CHARACTERS WITHOUT CLAIM TO ANY PARTICULAR FONT, STYLE, SIZE, OR COLOR.

FOR EDUCATIONAL SERVICES, NAMELY, CONDUCTING INFORMAL PROGRAMS IN THE FIELDS OF SUSTAINABLE LIVING, ORGANIC FOODS AND GARDENING, THE ENVIRONMENT, AND CONSERVATION, USING ON-LINE ACTIVITIES AND INTERACTIVE EXHIBITS; ENTERTAINMENT SERVICES, NAMELY, PROVIDING A WEB SITE FEATURING PHOTOGRAPHIC, AUDIO AND VIDEO FEATURING SUSTAINABLE LIVING, ORGANIC FOODS AND GARDENING, THE ENVIRONMENT, AND CONSERVATION; ON-LINE JOURNALS, NAMELY, BLOGS FEATURING SUSTAINABLE LIVING, ORGANIC FOODS AND GARDENING, THE ENVIRONMENT AND CONSERVATION (U.S. CLS. 100, 101 AND 107).

FIRST USE 3-6-2002; IN COMMERCE 3-6-2002.

3,633,372. PLAYGARDEN HOLDING LLC, NEW YORK, NY. SN 77-365,353. FILED P.R. 1-7-2008; AM. S.R. 4-24-2009.

PLAYGARDEN

THE MARK CONSISTS OF STANDARD CHARACTERS WITHOUT CLAIM TO ANY PARTICULAR FONT, STYLE, SIZE, OR COLOR.

FOR PROVIDING RECREATIONAL FACILITIES FOR CHILDREN, NAMELY, PROVIDING AMUSEMENT CENTERS AND INTERACTIVE PLAY AREAS; PROVIDING CLASSES FOR CHILDREN IN THE FIELDS OF TEAM SPORTS, NAMELY, SOCCER, BASEBALL, BASKETBALL AND LACROSSE, AND KARATE AND YOGA; PROVIDING CLASSES FOR CHILDREN IN THE FIELD OF THE ENVIRONMENT AND TAKING CARE OF THE PLANET (U.S. CLS. 100, 101 AND 107).

FIRST USE 1-28-2008; IN COMMERCE 1-28-2008.

CLASS 41—(Continued).

3,633,374. CASAS - COMPREHENSIVE ADULT STUDENT ASSESSMENT SYSTEMS, SAN DIEGO, CA. SN 77-384,587. FILED P.R. 1-30-2008; AM. S.R. 9-25-2008.

CLASS 41—(Continued).

3,633,406. TWEEN BRANDS INVESTMENT, LLC, NEW ALBANY, OH. SN 77-510,019. FILED P.R. 6-27-2008; AM. S.R. 3-27-2009.

QUICKSEARCH

TWEEN NETWORK

THE MARK CONSISTS OF STANDARD CHARACTERS WITHOUT CLAIM TO ANY PARTICULAR FONT, STYLE, SIZE, OR COLOR.

FOR PROVIDING AN ON-LINE SEARCHABLE COMPUTER DATABASE IN THE FIELD OF EDUCATIONAL REFERENCE MATERIALS FEATURING INFORMATION ABOUT INSTRUCTIONAL MATERIALS OBTAINED FROM COMPETENCY-BASED TEXTBOOKS, DISCS, SOFTWARE PROGRAMS AND WEBSITES FOR USE IN ESTABLISHING CURRICULA FOR ADULT AND SECONDARY EDUCATION (U.S. CLS. 100, 101 AND 107).

FIRST USE 1-1-2007; IN COMMERCE 1-1-2007.

THE MARK CONSISTS OF STANDARD CHARACTERS WITHOUT CLAIM TO ANY PARTICULAR FONT, STYLE, SIZE, OR COLOR.

OWNER OF U.S. REG. NOS. 3,289,243 AND 3,310,165.

NO CLAIM IS MADE TO THE EXCLUSIVE RIGHT TO USE "NETWORK", APART FROM THE MARK AS SHOWN.

FOR ENTERTAINMENT SERVICES, NAMELY, PROVIDING ONGOING TELEVISION PROGRAMS IN THE FIELD OF FASHION, BEAUTY, LIFESTYLE AND CELEBRITY NEWS; ENTERTAINMENT SERVICES, NAMELY, PROVIDING ONGOING TELEVISION PROGRAMS FEATURING PRERECORDED MUSIC AND VIDEO (U.S. CLS. 100, 101 AND 107).

FIRST USE 3-24-2009; IN COMMERCE 3-24-2009.

3,633,380. BUILDING SCIENCE COMMUNICATIONS LLC, SOMERVILLE, MA. SN 77-406,921. FILED P.R. 2-26-2008; AM. S.R. 4-27-2009.

3,633,416. UNIVERSITY OF NORTH CAROLINA SCHOOL OF THE ARTS, WINSTON-SALEM, NC. SN 77-520,146. FILED P.R. 7-11-2008; AM. S.R. 3-24-2009.

Building Science Press

University of North Carolina School of the Arts

THE MARK CONSISTS OF STANDARD CHARACTERS WITHOUT CLAIM TO ANY PARTICULAR FONT, STYLE, SIZE, OR COLOR.

NO CLAIM IS MADE TO THE EXCLUSIVE RIGHT TO USE "PRESS", APART FROM THE MARK AS SHOWN.

FOR PUBLISHING OF BOOKS, MAGAZINES (U.S. CLS. 100, 101 AND 107).

FIRST USE 6-1-2005; IN COMMERCE 6-1-2005.

THE MARK CONSISTS OF STANDARD CHARACTERS WITHOUT CLAIM TO ANY PARTICULAR FONT, STYLE, SIZE, OR COLOR.

FOR EDUCATION SERVICES, NAMELY, PROVIDING CLASSES FOR STUDENTS FROM MIDDLE SCHOOL THROUGH GRADUATE SCHOOL OR PROFESSIONAL CAREERS IN THE FIELDS OF PERFORMING, VISUAL, FILM AND TELEVISION ARTS (U.S. CLS. 100, 101 AND 107).

FIRST USE 8-11-2008; IN COMMERCE 8-11-2008.

CLASS 41—(Continued).

3,633,433. NEW MEDIA HOLDINGS, INC., SEATTLE, WA. SN 77-541,929. FILED P.R. 8-7-2008; AM. S.R. 4-27-2009.

The Airplanes Channel

THE MARK CONSISTS OF STANDARD CHARACTERS WITHOUT CLAIM TO ANY PARTICULAR FONT, STYLE, SIZE, OR COLOR.

NO CLAIM IS MADE TO THE EXCLUSIVE RIGHT TO USE "CHANNEL", APART FROM THE MARK AS SHOWN.

FOR PROVIDING ONLINE, NON-DOWNLOADABLE PUBLICATIONS IN THE NATURE OF ARTICLES, NEWSLETTERS, DIRECTORIES, AND REFERENCE MATERIALS IN THE NATURE OF ELECTRONIC REFERENCE BOOKS, ALL IN THE FIELDS OF AIRPLANES, GLOBAL EVENTS RELATING TO AIRPLANES, HISTORY, AIRPLANE-RELATED CLUBS, HUMAN INTEREST STORIES RELATING TO AIRPLANES, AIRPLANE-RELATED EVENTS, AIRPLANE EQUIPMENT, EXPERIMENTAL AIRCRAFT, AIRCRAFT COLLECTING, AIRCRAFT RESTORATION, TRAVEL, AND AIRCRAFT COMPETITIONS; PROVIDING A WEB SITE FEATURING VIDEOS, PHOTOGRAPHS, AND INFORMATION ABOUT AIRPLANES, NAMELY, AIRPLANE FLIGHT INSTRUCTION AND ENTERTAINMENT IN THE NATURE OF AIR SHOWS; PROVIDING NEWS AND INFORMATION ABOUT AIRPLANES, NAMELY, AIRPLANE FLIGHT INSTRUCTION AND ENTERTAINMENT IN THE NATURE OF AIR SHOWS (U.S. CLS. 100, 101 AND 107).

FIRST USE 7-15-2008; IN COMMERCE 7-15-2008.

3,633,434. NEW MEDIA HOLDINGS, INC., SEATTLE, WA. SN 77-542,007. FILED P.R. 8-7-2008; AM. S.R. 4-27-2009.

The Stock Markets Channel

THE MARK CONSISTS OF STANDARD CHARACTERS WITHOUT CLAIM TO ANY PARTICULAR FONT, STYLE, SIZE, OR COLOR.

NO CLAIM IS MADE TO THE EXCLUSIVE RIGHT TO USE "CHANNEL", APART FROM THE MARK AS SHOWN.

FOR PROVIDING ONLINE, NON-DOWNLOADABLE PUBLICATIONS IN THE NATURE OF ARTICLES, NEWSLETTERS, DIRECTORIES, AND REFERENCE MATERIALS IN THE NATURE OF ELECTRONIC REFERENCE BOOKS, ALL IN THE FIELDS OF FINANCIAL INFORMATION ABOUT STOCK MARKETS, SECURITIES, GLOBAL FINANCIAL MARKETS, HUMAN INTEREST STORIES RELATING TO FINANCE, NEWS, CURRENT EVENTS, STOCK TRADING, MANAGEMENT, STOCK SELECTION, SHAREHOLDERS, EXCHANGES, FINANCE, AND INVESTING (U.S. CLS. 100, 101 AND 107).

FIRST USE 7-15-2008; IN COMMERCE 7-15-2008.

CLASS 41—(Continued).

3,633,440. JACKSON, CORY D., SACRAMENTO, CA. SN 77-563,399. FILED P.R. 9-5-2008; AM. S.R. 4-14-2009.



NO CLAIM IS MADE TO THE EXCLUSIVE RIGHT TO USE "FOUNDATION", APART FROM THE MARK AS SHOWN.

THE MARK CONSISTS OF "ZERO TOLERANCE 4 UNDERAGE DRINKING FOUNDATION".

FOR EDUCATIONAL AND ENTERTAINMENT SERVICES, NAMELY, PROVIDING MOTIVATIONAL SPEAKING SERVICES IN THE FIELD OF UNDERAGE DRINKING (U.S. CLS. 100, 101 AND 107).

FIRST USE 1-1-2006; IN COMMERCE 1-1-2007.

3,633,442. NEW MEDIA HOLDINGS, INC., SEATTLE, WA. SN 77-573,775. FILED P.R. 9-18-2008; AM. S.R. 4-27-2009.

THE SOUTH AFRICA CHANNEL

THE MARK CONSISTS OF STANDARD CHARACTERS WITHOUT CLAIM TO ANY PARTICULAR FONT, STYLE, SIZE, OR COLOR.

NO CLAIM IS MADE TO THE EXCLUSIVE RIGHT TO USE "CHANNEL", APART FROM THE MARK AS SHOWN.

FOR PROVIDING ONLINE NON-DOWNLOADABLE PUBLICATIONS IN THE NATURE OF ARTICLES, NEWSLETTERS, DIRECTORIES, AND REFERENCE MATERIALS IN THE NATURE OF ELECTRONIC REFERENCE BOOKS, ALL IN THE FIELD OF INFORMATION ABOUT THE COUNTRY OF SOUTH AFRICA INCLUDING TRAVEL, AREA AND CITY GUIDES, ATTRACTIONS, MAPS, DESTINATIONS, SIGHT-SEEING, EVENTS, HISTORY, CULTURE, SOCIETY, BUSINESS, NEWS, WEATHER, AND HUMAN INTEREST STORIES; PROVIDING AN INTERACTIVE WEBSITE FEATURING INFORMATION ABOUT THE COUNTRY OF SOUTH AFRICA, NAMELY, INFORMATION IN THE FIELD OF ENTERTAINMENT EVENTS, ENTERTAINMENT NEWS, AND SPORTS NEWS; PROVIDING AN INTERACTIVE WEBSITE FEATURING INFORMATION ABOUT POPULAR SOCIETY AND CULTURE IN SOUTH AFRICA, NAMELY, ENTERTAINMENT INFORMATION REGARDING POPULAR MUSIC, TELEVISION, AND FILM; PROVIDING AN INTERACTIVE WEBSITE FEATURING INFORMATION ON HISTORIC FIGURES IN THE COUNTRY OF SOUTH AFRICA; ENTERTAINMENT SERVICES, NAMELY, PROVIDING INFORMATION ABOUT SOUTH AFRICA BY MEANS OF AN ONLINE EVENTS CALENDAR REGARDING ENTERTAINMENT EVENTS TAKING PLACE IN THE AFOREMENTIONED COUNTRY (U.S. CLS. 100, 101 AND 107).

FIRST USE 9-9-2008; IN COMMERCE 9-9-2008.

CLASS 41—(Continued).

3,633,443. NEW MEDIA HOLDINGS, INC., SEATTLE, WA.
SN 77-573,786. FILED P.R. 9-18-2008; AM. S.R. 4-27-2009.

CLASS 41—(Continued).

3,633,444. NEW MEDIA HOLDINGS, INC., SEATTLE, WA.
SN 77-573,822. FILED P.R. 9-18-2008; AM. S.R. 4-27-2009.

THE RUSSIA CHANNEL

THE MARK CONSISTS OF STANDARD CHARACTERS WITHOUT CLAIM TO ANY PARTICULAR FONT, STYLE, SIZE, OR COLOR.

NO CLAIM IS MADE TO THE EXCLUSIVE RIGHT TO USE "CHANNEL", APART FROM THE MARK AS SHOWN.

FOR PROVIDING ONLINE NON-DOWNLOADABLE PUBLICATIONS IN THE NATURE OF ARTICLES, NEWSLETTERS, DIRECTORIES, AND REFERENCE MATERIALS IN THE NATURE OF ELECTRONIC REFERENCE BOOKS, ALL IN THE FIELD OF INFORMATION ABOUT THE COUNTRY OF RUSSIA INCLUDING TRAVEL, AREA AND CITY GUIDES, ATTRACTIONS, MAPS, DESTINATIONS, SIGHT-SEEING, EVENTS, HISTORY, CULTURE, SOCIETY, BUSINESS, NEWS, WEATHER, AND HUMAN INTEREST STORIES; PROVIDING AN INTERACTIVE WEBSITE FEATURING INFORMATION ABOUT THE COUNTRY OF RUSSIA, NAMELY, INFORMATION IN THE FIELD OF ENTERTAINMENT EVENTS, ENTERTAINMENT NEWS, AND SPORTS NEWS; PROVIDING AN INTERACTIVE WEBSITE FEATURING INFORMATION ABOUT POPULAR SOCIETY AND CULTURE IN RUSSIA, NAMELY, ENTERTAINMENT INFORMATION REGARDING POPULAR MUSIC, TELEVISION, AND FILM; PROVIDING AN INTERACTIVE WEBSITE FEATURING INFORMATION ON HISTORIC FIGURES IN THE COUNTRY OF RUSSIA; ENTERTAINMENT SERVICES, NAMELY, PROVIDING INFORMATION ABOUT RUSSIA BY MEANS OF AN ONLINE EVENTS CALENDAR REGARDING ENTERTAINMENT EVENTS TAKING PLACE IN THE AFOREMENTIONED COUNTRY (U.S. CLS. 100, 101 AND 107).

FIRST USE 9-9-2008; IN COMMERCE 9-9-2008.

THE PUERTO RICO CHANNEL

THE MARK CONSISTS OF STANDARD CHARACTERS WITHOUT CLAIM TO ANY PARTICULAR FONT, STYLE, SIZE, OR COLOR.

NO CLAIM IS MADE TO THE EXCLUSIVE RIGHT TO USE "CHANNEL", APART FROM THE MARK AS SHOWN.

FOR PROVIDING ONLINE NON-DOWNLOADABLE PUBLICATIONS IN THE NATURE OF ARTICLES, NEWSLETTERS, DIRECTORIES, AND REFERENCE MATERIALS IN THE NATURE OF ELECTRONIC REFERENCE BOOKS, ALL IN THE FIELD OF INFORMATION ABOUT THE COMMONWEALTH OF PUERTO RICO INCLUDING TRAVEL, AREA AND CITY GUIDES, ATTRACTIONS, MAPS, DESTINATIONS, SIGHT-SEEING, EVENTS, HISTORY, CULTURE, SOCIETY, BUSINESS, NEWS, WEATHER, AND HUMAN INTEREST STORIES; PROVIDING AN INTERACTIVE WEBSITE FEATURING INFORMATION ABOUT THE COMMONWEALTH OF PUERTO RICO, NAMELY, INFORMATION IN THE FIELD OF ENTERTAINMENT EVENTS, ENTERTAINMENT NEWS, AND SPORTS NEWS; PROVIDING AN INTERACTIVE WEBSITE FEATURING INFORMATION ABOUT POPULAR SOCIETY AND CULTURE IN PUERTO RICO, NAMELY, ENTERTAINMENT INFORMATION REGARDING POPULAR MUSIC, TELEVISION, AND FILM; PROVIDING AN INTERACTIVE WEBSITE FEATURING INFORMATION ON HISTORIC FIGURES IN THE COMMONWEALTH OF PUERTO RICO; ENTERTAINMENT SERVICES, NAMELY, PROVIDING INFORMATION ABOUT PUERTO RICO BY MEANS OF AN ONLINE EVENTS CALENDAR REGARDING ENTERTAINMENT EVENTS TAKING PLACE IN THE AFOREMENTIONED COMMONWEALTH (U.S. CLS. 100, 101 AND 107).

FIRST USE 9-9-2008; IN COMMERCE 9-9-2008.

3,633,459. DRAVIS, RICHARD, WESTPORT, CT. SN 77-624,191. FILED P.R. 12-1-2008; AM. S.R. 4-26-2009.

TRAIN2SHOOT

THE MARK CONSISTS OF STANDARD CHARACTERS WITHOUT CLAIM TO ANY PARTICULAR FONT, STYLE, SIZE, OR COLOR.

FOR TRAINING SERVICES IN THE FIELD OF FIREARMS AND FIREARM SAFETY (U.S. CLS. 100, 101 AND 107).

FIRST USE 3-21-2009; IN COMMERCE 3-21-2009.

CLASS 41—(Continued).

3,633,469. FUCHS, RAFAEL, BROOKLYN, NY. SN 77-654,797. FILED P.R. 1-22-2009; AM. S.R. 4-22-2009.



THE COLOR(S) RED, YELLOW, BLUE, GRAY, WHITE AND BLACK IS/ARE CLAIMED AS A FEATURE OF THE MARK.

THE MARK CONSISTS OF THE WORDS "BUSHWICK" IN RED ON TOP OF A YELLOW AND GRAY BACKGROUND WITH THE WORD IN A BLACK BORDER. THE WORD "YEARBOOK" IN BLUE WITH WHITE AND YELLOW AND BLACK OUTLINES. BOTH WORDS ARE IN ALL CAPITALS. THE REMAINING WHITE BEHIND THE WORD "YEARBOOK" IS BACKGROUND AREA WHICH IS NOT A PART OF THE MARK.

FOR PHOTOGRAPHY; PHOTOGRAPHY SERVICES; PORTRAIT PHOTOGRAPHY (U.S. CLS. 100, 101 AND 107).

FIRST USE 4-5-2006; IN COMMERCE 8-10-2008.

3,633,480. MARC STYLES PRODUCTIONS, INC., BALDWIN, NY. SN 77-664,544. FILED P.R. 2-5-2009; AM. S.R. 4-24-2009.

SUBWAY STAR

THE MARK CONSISTS OF STANDARD CHARACTERS WITHOUT CLAIM TO ANY PARTICULAR FONT, STYLE, SIZE, OR COLOR.

FOR ENTERTAINMENT SERVICES, NAMELY, AN ONGOING REALITY-BASED TELEVISION PROGRAM FEATURING A TALENT COMPETITION (U.S. CLS. 100, 101 AND 107).

FIRST USE 1-21-2009; IN COMMERCE 1-21-2009.

3,633,486. SPANISH IN SEATTLE, TUKWILA, WA. SN 77-666,688. FILED 2-9-2009.

Spanish in Seattle

THE MARK CONSISTS OF STANDARD CHARACTERS WITHOUT CLAIM TO ANY PARTICULAR FONT, STYLE, SIZE, OR COLOR.

FOR TRANSLATION (U.S. CLS. 100, 101 AND 107). FIRST USE 1-1-2006; IN COMMERCE 12-1-2007.

CLASS 41—(Continued).

3,633,488. ACCESS INTELLIGENCE LLC, ROCKVILLE, MD. SN 77-679,733. FILED P.R. 2-27-2009; AM. S.R. 4-14-2009.

IP SATELLITE SUMMIT

THE MARK CONSISTS OF STANDARD CHARACTERS WITHOUT CLAIM TO ANY PARTICULAR FONT, STYLE, SIZE, OR COLOR.

FOR EDUCATIONAL SERVICES, NAMELY, CONDUCTING CONFERENCES ON THE TECHNOLOGY OF INTERNET PROTOCOL VIA SATELLITE, AND DISTRIBUTION OF COURSE MATERIAL IN CONNECTION THEREWITH (U.S. CLS. 100, 101 AND 107).

FIRST USE 2-9-2009; IN COMMERCE 2-9-2009.

3,633,492. SELLING SOLUTIONS INC., GUELPH, CANADA. SN 77-976,668. FILED P.R. 11-21-2007; AM. S.R. 12-16-2008.

NEGOTIATINGCOACH.COM

THE MARK CONSISTS OF STANDARD CHARACTERS WITHOUT CLAIM TO ANY PARTICULAR FONT, STYLE, SIZE, OR COLOR.

FOR EDUCATION SERVICES, NAMELY, CONDUCTING PRESENTATIONS, SEMINARS, COURSES, LEARNING WORKSHOPS, SPEAKING ENGAGEMENT SERVICES, LECTURES AND TUTORING IN THE FIELDS OF NEGOTIATION, MEDIATION, DISPUTE RESOLUTION CONSULTING AND COACHING SERVICES (U.S. CLS. 100, 101 AND 107).

FIRST USE 2-1-1995; IN COMMERCE 2-1-1995.

3,633,493. WORLD GAMES 2010 FOUNDATION, INC., LEXINGTON, KY. SN 77-977,049. FILED P.R. 5-2-2008; AM. S.R. 2-5-2009.

WORLD EQUESTRIAN GAMES

THE MARK CONSISTS OF STANDARD CHARACTERS WITHOUT CLAIM TO ANY PARTICULAR FONT, STYLE, SIZE, OR COLOR.

NO CLAIM IS MADE TO THE EXCLUSIVE RIGHT TO USE "EQUESTRIAN GAMES", APART FROM THE MARK AS SHOWN.

FOR ORGANIZING SPORTING EVENTS, NAMELY, EQUESTRIAN COMPETITIONS (U.S. CLS. 100, 101 AND 107).

FIRST USE 5-24-2007; IN COMMERCE 5-24-2007.

CLASS 42—SCIENTIFIC AND COMPUTER SERVICES

3,633,368. BANK OF AMERICA CORPORATION, CHARLOTTE, NC. SN 77-339,122. FILED P.R. 11-28-2007; AM. S.R. 4-23-2009.

QUEUE TRACKER

THE MARK CONSISTS OF STANDARD CHARACTERS WITHOUT CLAIM TO ANY PARTICULAR FONT, STYLE, SIZE, OR COLOR.
 FOR PROVIDING ONLINE, NON-DOWNLOADABLE SOFTWARE THAT UTILIZES TEMPLATES TO AUTOMATE COMPLEX WORK FLOW (U.S. CLS. 100 AND 101).

FIRST USE 1-0-2008; IN COMMERCE 1-0-2008.

CLASS 42—(Continued).

3,633,392. WEATHER DECISION TECHNOLOGIES, INC., MIDDLEBURG, VA. SN 77-489,923. FILED P.R. 6-3-2008; AM. S.R. 4-15-2009.

IMAP WEATHER

THE MARK CONSISTS OF STANDARD CHARACTERS WITHOUT CLAIM TO ANY PARTICULAR FONT, STYLE, SIZE, OR COLOR.
 NO CLAIM IS MADE TO THE EXCLUSIVE RIGHT TO USE "WEATHER", APART FROM THE MARK AS SHOWN.
 FOR WEATHER SERVICES, NAMELY, WEATHER FORECASTING, WEATHER DETECTING, WEATHER REPORTING, PROVIDING WEATHER INFORMATION BY MEANS OF COMPUTER DATABASES AND VIA A GLOBAL COMPUTER INFORMATION NETWORK AND VIA WIRED AND WIRELESS ELECTRONIC COMMUNICATION DEVICES (U.S. CLS. 100 AND 101).
 FIRST USE 6-0-2008; IN COMMERCE 6-0-2008.

3,633,390. MEDICAL EDUCATION TECHNOLOGIES, INC., SARASOTA, FL. SN 77-485,072. FILED P.R. 5-28-2008; AM. S.R. 4-16-2009.

3,633,438. UNITED STATES INFRASTRUCTURE CORPORATION, CARMEL, IN. SN 77-547,150. FILED P.R. 8-14-2008; AM. S.R. 4-6-2009.

EDOSE

UNITED STATES
 INFRASTRUCTURE CORPORATION

THE MARK CONSISTS OF STANDARD CHARACTERS WITHOUT CLAIM TO ANY PARTICULAR FONT, STYLE, SIZE, OR COLOR.
 FOR WEB-BASED NON-DOWNLOADABLE COMPUTER SOFTWARE USED IN CONJUNCTION WITH SIMULATORS, IN THE FIELD OF NURSE, DOCTOR AND MEDICAL PERSONNEL TRAINING, EDUCATION AND CLINICAL SIMULATIONS RELATED TO DOSAGE CALCULATION AND DIAGNOSTIC ASSESSMENT (U.S. CLS. 100 AND 101).
 FIRST USE 1-0-2009; IN COMMERCE 1-0-2009.

THE MARK CONSISTS OF STANDARD CHARACTERS WITHOUT CLAIM TO ANY PARTICULAR FONT, STYLE, SIZE, OR COLOR.
 NO CLAIM IS MADE TO THE EXCLUSIVE RIGHT TO USE "CORPORATION", APART FROM THE MARK AS SHOWN.
 FOR LOCATING AND MARKING PLACEMENT OF UNDERGROUND UTILITY PIPES, CABLE OR WIRES (U.S. CLS. 100 AND 101).
 FIRST USE 8-14-2008; IN COMMERCE 8-14-2008.

CLASS 42—(Continued).

3,633,460. ADF, INC., BUFFALO GROVE, IL. SN 77-628,015. FILED P.R. 12-7-2008; AM. S.R. 3-22-2009.

EBOUNDHOST

THE MARK CONSISTS OF STANDARD CHARACTERS WITHOUT CLAIM TO ANY PARTICULAR FONT, STYLE, SIZE, OR COLOR.

FOR HOSTING OF WEB SITES; HOSTING OF WEB SITES FEATURING ELECTRONIC BOOKS; COMPUTER SERVICES, NAMELY, INTERACTIVE HOSTING SERVICES WHICH ALLOW THE USER TO PUBLISH AND SHARE THEIR OWN CONTENT AND IMAGES ON-LINE (U.S. CLS. 100 AND 101).

FIRST USE 9-1-2000; IN COMMERCE 9-1-2000.

3,633,461. SMART CARD ALLIANCE, PRINCETON JUNCTION, NJ. SN 77-630,297. FILED P.R. 12-10-2008; AM. S.R. 4-2-2009.

**CERTIFIED SMART CARD
INDUSTRY PROFESSIONAL**

THE MARK CONSISTS OF STANDARD CHARACTERS WITHOUT CLAIM TO ANY PARTICULAR FONT, STYLE, SIZE, OR COLOR.

NO CLAIM IS MADE TO THE EXCLUSIVE RIGHT TO USE "CERTIFIED", APART FROM THE MARK AS SHOWN.

FOR TESTING, ANALYSIS, AND EVALUATION OF THE KNOWLEDGE, SKILLS AND ABILITIES OF OTHERS FOR THE PURPOSE OF CERTIFICATION AND RE-CERTIFICATION IN THE FIELD OF SMART CARD TECHNOLOGY (U.S. CLS. 100 AND 101).

FIRST USE 10-22-2008; IN COMMERCE 10-22-2008.

3,633,474. CYBER SECURITY RESEARCH AND SOLUTIONS CORPORATION, LA PLATA, MD. SN 77-660,213. FILED P.R. 1-30-2009; AM. S.R. 4-22-2009.

**CYBER SECURITY RESEARCH
AND SOLUTIONS CORPORATION**

THE MARK CONSISTS OF STANDARD CHARACTERS WITHOUT CLAIM TO ANY PARTICULAR FONT, STYLE, SIZE, OR COLOR.

NO CLAIM IS MADE TO THE EXCLUSIVE RIGHT TO USE "CORPORATION", APART FROM THE MARK AS SHOWN.

FOR COMPUTER TECHNOLOGY CONSULTING SERVICES (U.S. CLS. 100 AND 101).

FIRST USE 12-27-2008; IN COMMERCE 1-18-2009.

CLASS 42—(Continued).

3,633,485. DIOB LLC, BILLINGS, MT. SN 77-665,644. FILED P.R. 2-7-2009; AM. S.R. 4-29-2009.

**Tiny URL - create a
shorter link**

THE MARK CONSISTS OF STANDARD CHARACTERS WITHOUT CLAIM TO ANY PARTICULAR FONT, STYLE, SIZE, OR COLOR.

FOR PROVIDING A WEB SITE FEATURING TECHNOLOGY THAT ENABLES INTERNET USERS TO CREATE, BOOKMARK, ANNOTATE, AND PUBLICLY SHARE DATA (U.S. CLS. 100 AND 101).

FIRST USE 0-0-2006; IN COMMERCE 0-0-2007.

CLASS 43—HOTEL AND RESTAURANT SERVICES

3,633,377. VAL'S SERVICE, INC., HOMESTEAD, FL. SN 77-394,368. FILED P.R. 2-12-2008; AM. S.R. 4-1-2009.

THE CUBAN PRESS

THE MARK CONSISTS OF STANDARD CHARACTERS WITHOUT CLAIM TO ANY PARTICULAR FONT, STYLE, SIZE, OR COLOR.

FOR RESTAURANT SERVICES (U.S. CLS. 100 AND 101).

FIRST USE 2-12-2008; IN COMMERCE 3-15-2009.

CLASS 43—(Continued).

3,633,379. BARAJAS, TIMOTEO, HENDERSON, NV. AND VALENZUELA, JESUS, LAS VEGAS, NV. AND BARAJAS, RAUL, LAS VEGAS, NV. SN 77-404,549. FILED P.R. 2-23-2008; AM. S.R. 4-6-2009.

Bonito Michoacan

THE MARK CONSISTS OF STANDARD CHARACTERS WITHOUT CLAIM TO ANY PARTICULAR FONT, STYLE, SIZE, OR COLOR.

NO CLAIM IS MADE TO THE EXCLUSIVE RIGHT TO USE "BONITO", APART FROM THE MARK AS SHOWN.

FOR CATERING FOR THE PROVISION OF FOOD AND BEVERAGES; CATERING IN FAST-FOOD CAFETERIAS; CONTRACT FOOD SERVICES; PREPARATION OF FOOD AND BEVERAGES; PROVIDING OF FOOD AND DRINK; PROVIDING OF FOOD AND DRINK FOR PATIENTS AND GUESTS; RESTAURANT SERVICES, INCLUDING SIT-DOWN SERVICE OF FOOD AND TAKE-OUT RESTAURANT SERVICES; SERVING OF FOOD AND DRINK/BEVERAGES (U.S. CLS. 100 AND 101).

FIRST USE 3-0-1997; IN COMMERCE 3-0-1997.



3,633,389. SAGAMORE INSTITUTE OF THE ADIRONDACKS, RAQUETTE LAKE, NY. SN 77-485,014. FILED 5-28-2008.

GREAT CAMP SAGAMORE

THE MARK CONSISTS OF STANDARD CHARACTERS WITHOUT CLAIM TO ANY PARTICULAR FONT, STYLE, SIZE, OR COLOR.

FOR PROVIDING TEMPORARY RESIDENTIAL ACCOMMODATIONS AND PROVIDING OF FOOD AND DRINK IN DINING FACILITIES FOR PROGRAM PARTICIPANTS, INSTRUCTORS AND STAFF MEMBERS (U.S. CLS. 100 AND 101).

FIRST USE 9-24-1993; IN COMMERCE 9-24-1993.



CLASS 44—MEDICAL, BEAUTY AND AGRICULTURAL SERVICES

CLASS 44—(Continued).

3,633,370. COMMUNITY OF DOCTORS, INC., BURIEN, WA. SN 77-358,591. FILED P.R. 12-21-2007; AM. S.R. 4-23-2009.

Community of Doctors

FOR PROVIDING ONLINE INFORMATION AND NEWS IN THE FIELDS OF MEDICINE, HEALTH CARE AND PHARMACEUTICAL PRODUCTS (U.S. CLS. 100 AND 101).

FIRST USE 12-0-2008; IN COMMERCE 12-0-2008.



3,633,427. JOSEPH RHINEWINE, PHD, PC, DBA PORTLAND MINDFULNESS THERAPY, PORTLAND, OR. SN 77-525,216. FILED P.R. 7-17-2008; AM. S.R. 4-21-2009.

Portland Mindfulness

THE MARK CONSISTS OF STANDARD CHARACTERS WITHOUT CLAIM TO ANY PARTICULAR FONT, STYLE, SIZE, OR COLOR.

FOR PSYCHOLOGICAL CONSULTATION; PSYCHOLOGICAL COUNSELING; PSYCHOTHERAPY SERVICES (U.S. CLS. 100 AND 101).

FIRST USE 4-20-2009; IN COMMERCE 4-20-2009.



3,633,456. BEST HEARING CENTER, INC., WESTMONT, IL. SN 77-614,851. FILED P.R. 11-14-2008; AM. S.R. 4-28-2009.

Best Hearing Center, Inc.

THE MARK CONSISTS OF STANDARD CHARACTERS WITHOUT CLAIM TO ANY PARTICULAR FONT, STYLE, SIZE, OR COLOR.

NO CLAIM IS MADE TO THE EXCLUSIVE RIGHT TO USE "HEARING CENTER, INC.", APART FROM THE MARK AS SHOWN.

FOR HEARING AID SERVICES, NAMELY, HEARING EVALUATIONS, HEARING CONSULTATIONS, AND HEARING AID FITTINGS (U.S. CLS. 100 AND 101).

FIRST USE 2-11-2003; IN COMMERCE 2-11-2003.

CLASS 45—(Continued).

3,633,463. CROWNS ONLY DENTAL LLC, PEORIA, AZ. SN 77-640,745. FILED P.R. 12-29-2008; AM. S.R. 3-31-2009.

Crowns Only Dental

THE MARK CONSISTS OF STANDARD CHARACTERS WITHOUT CLAIM TO ANY PARTICULAR FONT, STYLE, SIZE, OR COLOR.

FOR RESTORATIVE DENTISTRY FEATURING DENTAL CROWN AND BRIDGE RESTORATIONS (U.S. CLS. 100 AND 101).

FIRST USE 7-1-2008; IN COMMERCE 7-1-2008.

CLASS 45—(Continued).

THE MARK CONSISTS OF STANDARD CHARACTERS WITHOUT CLAIM TO ANY PARTICULAR FONT, STYLE, SIZE, OR COLOR.

FOR PROVIDING INFORMATION REGARDING, AND IN THE NATURE OF, SOCIAL NETWORKING SERVICES; ONLINE SOCIAL NETWORKING SERVICES DESIGNED FOR PEOPLE WITH A COMMON DESIRE TO MEET OTHER PEOPLE WITH SIMILAR INTERESTS (U.S. CLS. 100 AND 101).

FIRST USE 5-31-2003; IN COMMERCE 5-31-2003.

3,633,436. DANIEL LEE GABBERT, HERMOSA, SD. SN 77-545,258. FILED P.R. 8-12-2008; AM. S.R. 4-23-2009.

Biblical Response Therapy

THE MARK CONSISTS OF STANDARD CHARACTERS WITHOUT CLAIM TO ANY PARTICULAR FONT, STYLE, SIZE, OR COLOR.

NO CLAIM IS MADE TO THE EXCLUSIVE RIGHT TO USE "THERAPY", APART FROM THE MARK AS SHOWN.

FOR COUNSELING SERVICES IN THE FIELD OF CHRISTIAN CONDUCT IN PERSONAL RELATIONSHIPS; GRIEF COUNSELING; MARRIAGE COUNSELING; PROVIDING BOTH IN-PERSON AND ON-LINE HOLISTIC SPIRITUAL COUNSELING SERVICES; SPIRITUAL COUNSELING (U.S. CLS. 100 AND 101).

FIRST USE 6-1-2007; IN COMMERCE 6-1-2007.

CLASS 45—PERSONAL AND LEGAL SERVICES

3,633,361. THE ROBOT CO-OP, INC., SEATTLE, WA. SN 77-264,806. FILED P.R. 8-27-2007; AM. S.R. 4-14-2009.

LISTS OF BESTS

* * * * *

TRADEMARK REGISTRATIONS RENEWED

The designation "U.S. Cl." appearing in this section refers to the U.S. class in effect prior to Sep. 1, 1973 rather than the international class which applies to applications filed on or after that date. For adoption of international classification see notice in the OFFICIAL GAZETTE of Jun. 26, 1973 (911 O.G. TM 210).

- | | | | |
|----------|--|------------|--|
| 32,982. | ROSE'S SWEETENED LIME JUICE RECONSTITUTED L. ROSE CO. LTD. ST. ALBANS, ENGLAND & THE WEST INDIES ESTD. 1805 WEST INDIA AND DESIGN. U.S. CL. 45. (INT. CL. 32). REG. 5-30-1899. | 679,699. | MOTHER'S PRIDE. U.S. CL. 46. (INT. CL. 30). REG. 6-2-1959. |
| 126,844. | FANNY FARMER (STYLIZED). U.S. CL. 46. (INT. CL. 30). REG. 10-7-1919. | 680,857. | LIF-O-GEN (STYLIZED). U.S. CL. 44. (INT. CL. 10). REG. 6-23-1959. |
| 256,535. | STERLING. U.S. CL. 16. (INT. CL. 2). REG. 5-21-1929. | 681,148. | MIKASA. U.S. CL. 30. (INT. CL. 21). REG. 6-30-1959. |
| 258,244. | TRUE TEMPER (STYLIZED). U.S. CL. 22. (INT. CLS. 16, 18, 20, 22, 25 AND 28). REG. 7-2-1929. | 682,154. | NAUTA. U.S. CL. 23. (INT. CLS. 6, 7, 8, 9, 11, 12, 16, 21 AND 28). REG. 7-21-1959. |
| 261,559. | AGUA DE FLORIDA MURRAY Y LANMAN NEW YORK. PREPARADA SOLAMENTE POR LANMAN Y KEMP AND DESIGN. U.S. CL. 51. (INT. CL. 3). REG. 9-17-1929. | 682,917. | ELECTRONIC DESIGN. U.S. CL. 38. (INT. CL. 16). REG. 8-4-1959. |
| 263,505. | CARBITOL. U.S. CL. 6. (INT. CLS. 1 AND 2). REG. 11-5-1929. | 683,100. | PALLADEX. U.S. CL. 6. (INT. CL. 1). REG. 8-11-1959. |
| 367,056. | SEE'S AND DESIGN. U.S. CL. 46. (INT. CL. 30). REG. 5-9-1939. | 684,280. | AUTRONEX. U.S. CL. 6. (INT. CL. 1). REG. 9-1-1959. |
| 373,836. | CHEROKEE. U.S. CL. 39. (INT. CL. 25). REG. 12-26-1939. | 691,390. | PENNANT. U.S. CL. 46. (INT. CL. 30). REG. 1-12-1960. |
| 438,455. | SHERWIN-WILLIAMS (STYLIZED). U.S. CL. 16. (INT. CL. 2). REG. 4-20-1948. | 850,256. | EMILIO (STYLIZED). U.S. CL. 39. (INT. CL. 25). REG. 6-4-1968. |
| 507,603. | MONARCH AND DESIGN. U.S. CL. 23. (INT. CL. 7). REG. 3-15-1949. | 858,165. | PRES GLAS. U.S. CL. 12. (INT. CL. 17). REG. 10-8-1968. |
| 508,704. | BALLANTINE'S (STYLIZED). U.S. CL. 49. (INT. CL. 33). REG. 4-19-1949. | 862,747. | MR. STRUT AND DESIGN. U.S. CL. 38. (INT. CL. 16). REG. 12-31-1968. |
| 509,419. | ROBERTSHAW. U.S. CL. 26. (INT. CL. 9). REG. 5-3-1949. | 867,818. | VICKS. U.S. CL. 18. (INT. CL. 5). REG. 4-8-1969. |
| 509,924. | MODERN MACHINE SHOP (STYLIZED). U.S. CL. 38. (INT. CL. 16). REG. 5-17-1949. | 868,170. | IS (STYLIZED). U.S. CL. 26. (INT. CL. 9). REG. 4-15-1969. |
| 510,167. | SPOON SQUID AND DESIGN. U.S. CL. 22. (INT. CL. 28). REG. 5-31-1949. | 868,314. | HOSTALUX. U.S. CL. 6. (INT. CLS. 1 AND 2). REG. 4-22-1969. |
| 510,507. | MISCELLANEOUS DESIGN. U.S. CL. 2. (INT. CLS. 6, 13, 14, 15, 16, 18, 20, 21, 22 AND 34). REG. 6-7-1949. | 868,346. | LEHIGH AND DESIGN. U.S. CL. 12. (INT. CL. 19). REG. 4-22-1969. |
| 510,918. | MOUNT HOPE. U.S. CL. 23. (INT. CL. 7). REG. 6-14-1949. | 868,408. | INSTANT-PAK. U.S. CL. 34. (INT. CL. 11). REG. 4-22-1969. |
| 510,998. | MENTOR. U.S. CL. 38. (INT. CL. 16). REG. 6-14-1949. | 868,410. | JENN-AIR. U.S. CL. 34. (INT. CL. 11). REG. 4-22-1969. |
| 511,927. | SIGNET. U.S. CL. 38. (INT. CL. 16). REG. 7-5-1949. | 868,503. | AUDIO CRAFT. U.S. CL. 100. (INT. CL. 42). REG. 4-22-1969. |
| 515,807. | FLORIDA WATER (STYLIZED). U.S. CL. 51. (INT. CLS. 3 AND 5). REG. 9-27-1949. | 868,534. | SUPER-SOFT (STYLIZED). U.S. CL. 22. (INT. CL. 9). REG. 4-22-1969. |
| 670,033. | HNM AND DESIGN. U.S. CL. 106. (INT. CL. 40). REG. 11-18-1958. | 869,541. | RR AND DESIGN. U.S. CL. 102. (INT. CL. 36). REG. 5-13-1969. |
| 670,403. | LASSIE. U.S. CL. 107. (INT. CL. 41). REG. 11-25-1958. | 870,278. | POLY B-D. INT. CL. 1. (U.S. CL. 1). REG. 6-3-1969. |
| 670,889. | EXTRACTOR. U.S. CL. 23. (INT. CL. 7). REG. 12-9-1958. | 871,548. | STYRON. INT. CL. 1. (U.S. CL. 1). REG. 6-24-1969. |
| 671,144. | GEARCHEM (STYLIZED). U.S. CL. 23. (INT. CL. 7). REG. 12-16-1958. | 876,723. | MISCELLANEOUS DESIGN. U.S. CL. 100. (INT. CL. 42). REG. 9-9-1969. |
| 673,994. | COLUMBIAN MUTUAL (STYLIZED). U.S. CL. 102. (INT. CL. 36). REG. 2-10-1959. | 877,762. | ACON AND DESIGN. U.S. CL. 27. (INT. CL. 14). REG. 9-30-1969. |
| 675,274. | GUARD-LINE AND DESIGN. U.S. CL. 39. (INT. CL. 25). REG. 3-10-1959. | 878,497. | U AND DESIGN. U.S. CL. 13. (INT. CL. 6). REG. 10-14-1969. |
| 676,842. | UNIVADINE. U.S. CL. 6. (INT. CL. 1). REG. 4-14-1959. | 878,546. | TOAST KING. U.S. CL. 21. (INT. CL. 11). REG. 10-14-1969. |
| 677,075. | COMET. U.S. CL. 46. (INT. CL. 30). REG. 4-14-1959. | 880,869. | EYE/LITE (STYLIZED). U.S. CL. 26. (INT. CL. 9). REG. 11-18-1969. |
| 677,154. | MERCEDES-BENZ. U.S. CL. 2. (INT. CL. 18). REG. 4-21-1959. | 881,406. | ZEP PLUS. U.S. CL. 52. (INT. CL. 3). REG. 11-25-1969. |
| 677,335. | SEALY AND DESIGN. U.S. CL. 32. (INT. CL. 20). REG. 4-21-1959. | 981,944. | KARON. U.S. CL. 23. (INT. CLS. 6, 7, 8, 9, 11, 12, 16, 21 AND 28). REG. 4-9-1974. |
| 677,482. | BARDAHL. U.S. CL. 52. (INT. CL. 2). REG. 4-21-1959. | 1,104,665. | MUSART. INT. CL. 9. (U.S. CL. 36). REG. 10-24-1978. |
| 677,544. | LAMPRECID. U.S. CL. 6. (INT. CL. 5). REG. 4-28-1959. | 1,106,682. | MISCELLANEOUS DESIGN. INT. CL. 19. (U.S. CL. 12). REG. 11-21-1978. |
| 678,608. | BEEFEATER. U.S. CL. 49. (INT. CL. 33). REG. 5-12-1959. | 1,107,801. | WEBSPEED. INT. CL. 7. (U.S. CL. 23). REG. 12-5-1978. |
| 679,524. | CONVERTAMATIC. U.S. CL. 21. (INT. CL. 9). REG. 6-2-1959. | 1,109,322. | MISCELLANEOUS DESIGN. INT. CL. 14. (U.S. CL. 28). REG. 12-19-1978. |
| | | 1,109,705. | WUSHOCK. INT. CL. 41. (U.S. CL. 107). REG. 12-19-1978. |
| | | 1,112,493. | WUSHOCK. INT. CL. 42. (U.S. CL. 101). REG. 1-30-1979. |
| | | 1,115,414. | -TO YOUR HEALTH!. INT. CL. 41. (U.S. CL. 107). REG. 3-20-1979. |

- 1,116,322. A ATLANTIC AND DESIGN. INT. CL. 9. (U.S. CLS. 21, 23, 26, 36 AND 38). REG. 4-10-1979.
- 1,116,411. HUDSON'S BAY. INT. CL. 24. (U.S. CL. 42). REG. 4-10-1979.
- 1,116,457. "STAGS' LEAP" AND DESIGN. INT. CL. 33. (U.S. CL. 47). REG. 4-10-1979.
- 1,116,711. THE STURDY BIRD. INT. CL. 31. (U.S. CL. 1). REG. 4-17-1979.
- 1,116,822. LUKAS. INT. CLS. 7 AND 9. (U.S. CLS. 23 AND 26). REG. 4-24-1979.
- 1,118,960. LIVE FROM LINCOLN CENTER. INT. CL. 41. (U.S. CL. 107). REG. 5-22-1979.
- 1,119,126. AM AND DESIGN. INT. CLS. 9, 14, 16, 26 AND 41 ONLY. (U.S. CLS. 28, 38, 40 AND 107). REG. 5-29-1979.
- 1,119,690. GRUNDENS (STYLIZED). INT. CL. 25. (U.S. CL. 39). REG. 6-5-1979.
- 1,120,867. WALTHER. INT. CL. 13 ONLY. (U.S. CL. 9). REG. 6-26-1979.
- 1,121,101. GOLDDIGGER. INT. CL. 29. (U.S. CL. 46). REG. 6-26-1979.
- 1,121,456. MISCELLANEOUS DESIGN. INT. CL. 25. (U.S. CL. 39). REG. 7-3-1979.
- 1,121,632. AEE AND DESIGN. INT. CL. 42. (U.S. CL. 100). REG. 7-3-1979.
- 1,122,808. TROPAR. INT. CL. 20. (U.S. CL. 50). REG. 7-24-1979.
- 1,477,513. NHT. INT. CL. 9. (U.S. CL. 21). REG. 2-23-1988.
- 1,477,863. WOOD N'STREAM AND DESIGN. INT. CL. 25. (U.S. CL. 39). REG. 2-23-1988.
- 1,489,056. HOYALUX (STYLIZED). INT. CL. 9. (U.S. CLS. 21, 23, 26, 36 AND 38). REG. 5-24-1988.
- 1,496,572. ACCUCODE. INT. CL. 9. (U.S. CL. 38). REG. 7-19-1988.
- 1,504,913. BACHRACH. INT. CLS. 25 AND 42. (U.S. CLS. 39 AND 101). REG. 9-20-1988.
- 1,508,600. THE JOFFREY BALLETT, AN AMERICAN CLASSIC. INT. CL. 41. (U.S. CL. 107). REG. 10-11-1988.
- 1,508,697. LAMBCO. INT. CLS. 1, 2 AND 19. (U.S. CLS. 1, 5, 6, 10, 12, 16, 26 AND 46). REG. 10-18-1988.
- 1,509,626. POLLO FIESTA. INT. CL. 42. (U.S. CL. 100). REG. 10-18-1988.
- 1,514,847. HAA AND DESIGN. INT. CL. 36. (U.S. CL. 102). REG. 11-29-1988.
- 1,516,200. PROCURIT. INT. CL. 5. (U.S. CL. 18). REG. 12-13-1988.
- 1,518,478. CAMPUS AMERICA. INT. CL. 42. (U.S. CLS. 100 AND 101). REG. 12-27-1988.
- 1,521,244. MISCELLANEOUS DESIGN. INT. CL. 37. (U.S. CL. 103). REG. 1-17-1989.
- 1,522,381. SANDWICH. INT. CL. 6. (U.S. CL. 13). REG. 1-31-1989.
- 1,530,624. PARR. INT. CL. 9. (U.S. CL. 26). REG. 3-21-1989.
- 1,530,821. PACIFIC BUSINESS NEWS. INT. CL. 16. (U.S. CL. 38). REG. 3-21-1989.
- 1,532,705. DISPENSEMATE AND DESIGN. INT. CL. 7. (U.S. CL. 23). REG. 4-4-1989.
- 1,532,902. BACOUNT. INT. CL. 11. (U.S. CL. 34). REG. 4-4-1989.
- 1,533,074. MORNING FRESH. INT. CL. 16. (U.S. CL. 2). REG. 4-4-1989.
- 1,533,805. NU-TRISH A/B AND DESIGN. INT. CL. 1. (U.S. CL. 6). REG. 4-11-1989.
- 1,534,229. ITRON. INT. CL. 16. (U.S. CL. 38). REG. 4-11-1989.
- 1,534,489. CAP. INT. CL. 28. (U.S. CL. 22). REG. 4-11-1989.
- 1,534,526. THE BAKER AND DESIGN. INT. CL. 30. (U.S. CL. 46). REG. 4-11-1989.
- 1,534,634. MISCELLANEOUS DESIGN. INT. CL. 36. (U.S. CLS. 100, 101 AND 102). REG. 4-11-1989.
- 1,534,650. ITRON. INT. CL. 37. (U.S. CL. 103). REG. 4-11-1989.
- 1,534,803. ORDRE-MONDIAL-DES-GOURMETS-DEGUSTATEURS VINS-EAUX-DE-VIE-LIQUEURS-SPIRITUEUX AND DESIGN. INT. CL. 42. (U.S. CL. 100). REG. 4-11-1989.
- 1,534,883. THERE IS NO BETTER. INT. CL. 16. (U.S. CL. 38). REG. 4-11-1989.
- 1,534,980. TLV (STYLIZED). INT. CLS. 7 AND 9. (U.S. CLS. 23 AND 26). REG. 4-18-1989.
- 1,535,115. AUDIOLOGIC. INT. CL. 9. (U.S. CLS. 21 AND 36). REG. 4-18-1989.
- 1,535,124. ARTIST IN RESIDENCE. INT. CL. 9. (U.S. CL. 21). REG. 4-18-1989.
- 1,535,141. ECHELON. INT. CL. 9. (U.S. CL. 38). REG. 4-18-1989.
- 1,535,177. SCHREIBER (STYLIZED). INT. CL. 11. (U.S. CLS. 23 AND 31). REG. 4-18-1989.
- 1,535,609. VERMONT COMMON CRACKERS. INT. CL. 30. (U.S. CL. 46). REG. 4-18-1989.
- 1,535,679. CALIFORNIA SECURITY AND DESIGN. INT. CLS. 35 AND 37. (U.S. CLS. 101 AND 103). REG. 4-18-1989.
- 1,535,764. ZIRCON. INT. CL. 37. (U.S. CL. 103). REG. 4-18-1989.
- 1,535,814. MAD MONEY. INT. CL. 41 ONLY. (U.S. CLS. 102 AND 107). REG. 4-18-1989.
- 1,536,075. FOX (STYLIZED). INT. CL. 7. (U.S. CLS. 13 AND 23). REG. 4-25-1989.
- 1,536,194. PROLINK. INT. CL. 9. (U.S. CL. 38). REG. 4-25-1989.
- 1,536,313. NISMO. INT. CL. 12. (U.S. CLS. 19, 21, 23, 31, 35 AND 44). REG. 4-25-1989.
- 1,536,367. MORNING FRESH AND DESIGN. INT. CL. 16. (U.S. CL. 2). REG. 4-25-1989.
- 1,536,508. ACE HI. INT. CL. 28. (U.S. CL. 22). REG. 4-25-1989.
- 1,536,604. AZTECSTANDARD CHARACTER MARK INT. CL. 30. (U.S. CL. 46). REG. 4-25-1989.
- 1,536,918. BUILDIT. INT. CL. 42. (U.S. CL. 100). REG. 4-25-1989.
- 1,536,965. REDIRECTIONS. INT. CL. 42. (U.S. CL. 100). REG. 4-25-1989.
- 1,537,097. DRYMAX. INT. CL. 2. (U.S. CL. 16). REG. 5-2-1989.
- 1,537,193. WISDOM AND DESIGN. INT. CLS. 6, 7, 8, 9 AND 22. (U.S. CLS. 7, 14, 23, 26 AND 50). REG. 5-2-1989.
- 1,537,324. URESIL. INT. CL. 10. (U.S. CLS. 26, 39 AND 44). REG. 5-2-1989.
- 1,537,584. MIDDLETON. INT. CL. 33. (U.S. CL. 49). REG. 5-2-1989.
- 1,537,662. CONNEXUS. INT. CL. 36. (U.S. CL. 102). REG. 5-2-1989.
- 1,537,715. MISCELLANEOUS DESIGN. INT. CL. 40. (U.S. CL. 106). REG. 5-2-1989.
- 1,537,719. SMG STRATEGIC MANAGEMENT GROUP, INC. (STYLIZED). INT. CLS. 41 AND 42. (U.S. CLS. 100 AND 107). REG. 5-2-1989.
- 1,537,830. BRUSH TUB. INT. CL. 16. (U.S. CL. 2). REG. 5-2-1989.
- 1,538,024. MARANTZ. INT. CL. 9. (U.S. CLS. 21, 23, 26, 36 AND 38). REG. 5-9-1989.
- 1,538,155. MISCELLANEOUS DESIGN. INT. CL. 17. (U.S. CL. 35). REG. 5-9-1989.
- 1,538,603. THE BEST LINES IN THE COUNTRY. INT. CL. 42. (U.S. CL. 101). REG. 5-9-1989.
- 1,538,855. CON6. INT. CL. 5. (U.S. CLS. 6, 18, 44, 46, 51 AND 52). REG. 5-16-1989.
- 1,539,144. PACE SETTER. INT. CL. 9. (U.S. CL. 26). REG. 5-16-1989.
- 1,539,319. HIBOSSCAL. INT. CL. 17. (U.S. CLS. 5 AND 19). REG. 5-16-1989.
- 1,539,498. TIMBER WOLF. INT. CL. 34. (U.S. CL. 17). REG. 5-16-1989.
- 1,539,632. WFTV. INT. CL. 38. (U.S. CL. 104). REG. 5-16-1989.
- 1,540,084. CRAMP-GUARD. INT. CL. 5. (U.S. CL. 18). REG. 5-23-1989.
- 1,540,432. PUGET SOUND BUSINESS JOURNAL. INT. CL. 16. (U.S. CL. 38). REG. 5-23-1989.
- 1,541,419. EASY-LOC (STYLIZED). INT. CL. 11. (U.S. CL. 13). REG. 5-30-1989.
- 1,541,828. EXPERT RESOURCES, INC.. INT. CL. 35. (U.S. CL. 101). REG. 5-30-1989.
- 1,542,127. FIREMASTER. INT. CLS. 1, 9, 17 AND 20. (U.S. CLS. 2, 6, 23, 26, 32 AND 35). REG. 6-6-1989.
- 1,542,711. APRIL O'NEIL. INT. CL. 28. (U.S. CL. 22). REG. 6-6-1989.
- 1,542,761. JOG. INT. CL. 29. (U.S. CL. 46). REG. 6-6-1989.
- 1,543,139. GIMME THE GREEN STUFF!. INT. CL. 1. (U.S. CL. 6). REG. 6-13-1989.
- 1,543,262. SELLERS. INT. CL. 7. (U.S. CL. 23). REG. 6-13-1989.
- 1,543,263. BZ. INT. CL. 7. (U.S. CL. 23). REG. 6-13-1989.
- 1,543,264. BX. INT. CL. 7. (U.S. CL. 23). REG. 6-13-1989.
- 1,543,265. B. INT. CL. 7. (U.S. CL. 23). REG. 6-13-1989.
- 1,543,364. SOLITUDES. INT. CL. 9. (U.S. CLS. 21, 23, 26, 36 AND 38). REG. 6-13-1989.
- 1,543,584. ECLIPSE. INT. CL. 21. (U.S. CL. 2). REG. 6-13-1989.
- 1,543,764. STERLING SILVER. INT. CL. 29. (U.S. CL. 46). REG. 6-13-1989.

- 1,543,766. MISCELLANEOUS DESIGN. INT. CL. 30. (U.S. CL. 46). REG. 6-13-1989.
- 1,544,731. GOLD MEDAL AND DESIGN. INT. CL. 30. (U.S. CL. 46). REG. 6-20-1989.
- 1,545,127. VERTI-FLOW. INT. CL. 7. (U.S. CL. 23). REG. 6-27-1989.
- 1,545,451. TOYS FOR LIFE AND DESIGN. INT. CL. 28. (U.S. CL. 22). REG. 6-27-1989.
- 1,545,548. CLASSIC CUSTARD. INT. CL. 30. (U.S. CL. 46). REG. 6-27-1989.
- 1,546,024. ISB-FORMULA. INT. CL. 5. (U.S. CL. 18). REG. 7-4-1989.
- 1,546,317. EZ DET. INT. CL. 13. (U.S. CL. 9). REG. 7-4-1989.
- 1,548,441. WATER JOGGER. INT. CL. 28. (U.S. CL. 22). REG. 7-18-1989.
- 1,550,145. PERFORMANCE PLUS. INT. CL. 17. (U.S. CL. 1). REG. 8-1-1989.
- 1,550,896. FLOATER. INT. CL. 12. (U.S. CLS. 19 AND 23). REG. 8-8-1989.
- 1,552,236. INTRACORP PREFERRED CARE. INT. CL. 36. (U.S. CLS. 101 AND 102). REG. 8-15-1989.
- 1,552,963. MISCELLANEOUS DESIGN. INT. CL. 25. (U.S. CL. 39). REG. 8-22-1989.
- 1,553,582. AERIALSCOPE. INT. CL. 9. (U.S. CLS. 19 AND 23). REG. 8-29-1989.
- 1,553,921. DOBBER'S. INT. CL. 30. (U.S. CL. 46). REG. 8-29-1989.
- 1,554,068. CASTLES UNLIMITED. INT. CL. 36. (U.S. CLS. 101 AND 102). REG. 8-29-1989.
- 1,555,230. ADVANCED DIGITAL DATA. INT. CL. 42. (U.S. CL. 100). REG. 9-5-1989.
- 1,555,374. HOSPITAL MOVIE CHANNEL. INT. CL. 41. (U.S. CL. 107). REG. 9-5-1989.
- 1,555,433. EAGLE BRAND AND DESIGN. INT. CL. 5. (U.S. CL. 18). REG. 9-12-1989.
- 1,556,965. RASCH QUALITY. INT. CL. 27. (U.S. CLS. 20 AND 37). REG. 9-19-1989.
- 1,557,136. SWEET VALLEY. INT. CL. 32. (U.S. CL. 45). REG. 9-19-1989.
- 1,557,539. ECO-FRESH (STYLIZED). INT. CLS. 3 AND 37. (U.S. CLS. 52 AND 103). REG. 9-26-1989.
- 1,559,741. OUTER LIMIT AND DESIGN. INT. CL. 12. (U.S. CL. 19). REG. 10-10-1989.
- 1,560,438. EARTH'S BEST. INT. CL. 5. (U.S. CL. 46). REG. 10-17-1989.
- 1,561,795. LINDUS. INT. CL. 7. (U.S. CL. 24). REG. 10-24-1989.
- 1,563,967. PET VALU. INT. CL. 42. (U.S. CL. 101). REG. 10-31-1989.
- 1,564,125. ACTIGALL. INT. CL. 5. (U.S. CL. 18). REG. 11-7-1989.
- 1,565,705. MUSIC TOGETHER. INT. CLS. 16 AND 41 ONLY. (U.S. CLS. 38 AND 107). REG. 11-14-1989.
- 1,565,756. COUNTER CURRENT. INT. CL. 11. (U.S. CL. 31). REG. 11-14-1989.
- 1,568,076. RETAIL ENGINE AND DESIGN. INT. CL. 9. (U.S. CL. 38). REG. 11-28-1989.
- 1,572,092. PONY. INT. CL. 26. (U.S. CL. 40). REG. 12-19-1989.
- 1,574,385. GOLD LINE. INT. CL. 7. (U.S. CL. 23). REG. 1-2-1990.
- 1,576,481. BLACK DIAMOND AND DESIGN. INT. CL. 25. (U.S. CL. 39). REG. 1-9-1990.
- 1,577,539. EYE TALK. INT. CL. 9. (U.S. CL. 26). REG. 1-16-1990.
- 1,578,897. MISCELLANEOUS DESIGN. INT. CL. 12. (U.S. CL. 19). REG. 1-23-1990.
- 1,581,376. QUANTUM. INT. CL. 11. (U.S. CL. 13). REG. 2-6-1990.
- 1,584,090. BAKE STOCK. INT. CL. 42. (U.S. CL. 101). REG. 2-20-1990.
- 1,585,354. IDL. INT. CL. 9. (U.S. CL. 38). REG. 3-6-1990.
- 1,585,823. AQUA BLOC. INT. CL. 25. (U.S. CL. 39). REG. 3-6-1990.
- 1,587,476. THE DESIGNER SYSTEM (STYLIZED). INT. CL. 7. (U.S. CL. 23). REG. 3-20-1990.
- 1,588,271. ACUSPORT (STYLIZED). INT. CL. 42. (U.S. CL. 101). REG. 3-20-1990.
- 1,589,234. MISCELLANEOUS DESIGN. INT. CL. 32. (U.S. CL. 48). REG. 3-27-1990.
- 1,589,739. PACIFIC. INT. CL. 7. (U.S. CL. 23). REG. 4-3-1990.
- 1,590,282. CONCERNS OF POLICE SURVIVORS C.O.P.S. INC AND DESIGN. INT. CL. 42. (U.S. CL. 100). REG. 4-3-1990.
- 1,592,536. AMERICAN COLLEGE OF RHEUMATOLOGY. INT. CL. 42. (U.S. CLS. 100 AND 107). REG. 4-17-1990.
- 1,999,052. MISCELLANEOUS DESIGN. INT. CLS. 12 AND 18. (U.S. CLS. 1, 2, 3, 19, 21, 22, 23, 31, 35, 41 AND 44). REG. 9-10-1996.
- 1,999,053. DOG WORKS. INT. CLS. 12 AND 18. (U.S. CLS. 1, 2, 3, 19, 21, 22, 23, 31, 35, 41 AND 44). REG. 9-10-1996.
- 2,042,750. GENSLER. INT. CL. 42. (U.S. CLS. 100 AND 101). REG. 3-11-1997.
- 2,133,679. SWEET INFLATIONS. INT. CLS. 28 AND 30. (U.S. CLS. 22, 23, 38, 46 AND 50). REG. 2-3-1998.
- 2,140,812. THOR. INT. CL. 13. (U.S. CLS. 2 AND 9). REG. 3-3-1998.
- 2,165,277. COACH (STYLIZED). INT. CL. 9. (U.S. CLS. 21, 23, 26, 36 AND 38). REG. 6-16-1998.
- 2,183,097. RV BUYERS GUIDE. INT. CL. 42. (U.S. CLS. 100 AND 101). REG. 8-18-1998.
- 2,189,544. EZ TILTER. INT. CL. 7. (U.S. CLS. 13, 19, 21, 23, 31, 34 AND 35). REG. 9-15-1998.
- 2,190,480. SEPCARB. INT. CL. 12 ONLY. (U.S. CLS. 19, 21, 23, 31, 35 AND 44 ONLY). REG. 9-22-1998.
- 2,190,544. A GOOD LAWYER. INT. CL. 16 ONLY. (U.S. CLS. 2, 5, 22, 23, 29, 37, 38 AND 50). REG. 9-22-1998.
- 2,195,303. EL RICO HABANO. INT. CL. 34. (U.S. CLS. 2, 8, 9 AND 17). REG. 10-13-1998.
- 2,195,886. LIFESCAPES. INT. CL. 16. (U.S. CLS. 2, 5, 22, 23, 29, 37, 38 AND 50). REG. 10-13-1998.
- 2,196,270. NANCY LEE & PERRY R BASS PERFORMANCE HALL AND DESIGN. INT. CL. 25. (U.S. CLS. 22 AND 39). REG. 10-13-1998.
- 2,197,906. 1 800 PRE-PAID. INT. CLS. 16 AND 38. (U.S. CLS. 2, 5, 22, 23, 29, 37, 38, 50, 100, 101 AND 104). REG. 10-20-1998.
- 2,198,806. SINGLE MOM & DAD SPORTSWEAR. INT. CL. 25. (U.S. CLS. 22 AND 39). REG. 10-20-1998.
- 2,198,841. CLEAN SQUEEZE. INT. CL. 11. (U.S. CLS. 13, 21, 23, 31 AND 34). REG. 10-20-1998.
- 2,199,596. AMERICAN CONNECTION. INT. CL. 39. (U.S. CLS. 100 AND 105). REG. 10-27-1998.
- 2,200,051. DOCUWORKS. INT. CL. 35. (U.S. CLS. 100, 101 AND 102). REG. 10-27-1998.
- 2,200,503. MILK AND DESIGN. INT. CL. 25. (U.S. CLS. 22 AND 39). REG. 10-27-1998.
- 2,201,883. HYDRO GRID. INT. CL. 11. (U.S. CLS. 13, 21, 23, 31 AND 34). REG. 11-3-1998.
- 2,202,145. CYBERASSISTANT. INT. CL. 9. (U.S. CLS. 21, 23, 26, 36 AND 38). REG. 11-3-1998.
- 2,205,070. 50TH ANNIVERSARY HUSKY AND DESIGN. INT. CL. 6. (U.S. CLS. 2, 12, 13, 14, 23, 25 AND 50). REG. 11-24-1998.
- 2,206,888. CIGAR SOMMELIER. INT. CL. 42. (U.S. CLS. 100 AND 101). REG. 12-1-1998.
- 2,206,993. SUPERLITE. INT. CL. 20. (U.S. CLS. 2, 13, 22, 25, 32 AND 50). REG. 12-1-1998.
- 2,206,996. EYE FIND. INT. CL. 36. (U.S. CLS. 100, 101 AND 102). REG. 12-1-1998.
- 2,207,184. ARTI-TEC. INT. CL. 10. (U.S. CLS. 26, 39 AND 44). REG. 12-1-1998.
- 2,208,483. GLODAN, INC.. INT. CL. 35. (U.S. CLS. 100, 101 AND 102). REG. 12-8-1998.
- 2,210,238. EMERGENCY ALERT SENTINEL. INT. CL. 9. (U.S. CLS. 21, 23, 26, 36 AND 38). REG. 12-15-1998.
- 2,210,839. KNOWLEDGE FORUM. INT. CLS. 9 AND 16. (U.S. CLS. 2, 5, 21, 22, 23, 26, 29, 36, 37, 38 AND 50). REG. 12-15-1998.
- 2,210,940. ASTRAL-NATURAL. INT. CL. 5. (U.S. CLS. 6, 18, 44, 46, 51 AND 52). REG. 12-15-1998.
- 2,211,559. X GAMES. INT. CL. 9. (U.S. CLS. 21, 23, 26, 36 AND 38). REG. 12-15-1998.
- 2,215,756. PRO-FIT-SHARE. INT. CL. 35. (U.S. CLS. 100, 101 AND 102). REG. 1-5-1999.
- 2,215,974. MISCELLANEOUS DESIGN. INT. CL. 42. (U.S. CLS. 100 AND 101). REG. 1-5-1999.
- 2,216,059. A BURNING DESIRE... INT. CL. 42. (U.S. CLS. 100 AND 101). REG. 1-5-1999.
- 2,216,106. A HIGHER STANDARD OF PERFORMANCE. INT. CL. 37. (U.S. CLS. 100, 103 AND 106). REG. 1-5-1999.
- 2,216,291. EASY CLIP. INT. CL. 26. (U.S. CLS. 37, 39, 40, 42 AND 50). REG. 1-5-1999.
- 2,216,530. CHICKITE. INT. CL. 30. (U.S. CL. 46). REG. 1-5-1999.

- 2,216,558. NIRVANA. NOW AVAILABLE BY THE CUP. INT. CL. 30. (U.S. CL. 46). REG. 1-5-1999.
- 2,219,771. AS SEEN ON PC. INT. CL. 35. (U.S. CLS. 100, 101 AND 102). REG. 1-19-1999.
- 2,220,426. TOCOTRIENE COMPLEX. INT. CL. 5. (U.S. CLS. 6, 18, 44, 46, 51 AND 52). REG. 1-26-1999.
- 2,220,897. OFFICIAL CHAMPAGNE OF NEW YEAR'S EVE. INT. CL. 33. (U.S. CLS. 47 AND 49). REG. 1-26-1999.
- 2,222,735. KIDSONGS AND DESIGN. INT. CL. 41. (U.S. CLS. 100, 101 AND 107). REG. 2-9-1999.
- 2,223,218. ZYMIT. INT. CL. 3. (U.S. CLS. 1, 4, 6, 50, 51 AND 52). REG. 2-9-1999.
- 2,223,950. FABRIWIN. INT. CL. 9. (U.S. CLS. 21, 23, 26, 36 AND 38). REG. 2-16-1999.
- 2,227,142. EAS EASTERN ATHLETIC SERVICES (STYLIZED). INT. CL. 35. (U.S. CLS. 100, 101 AND 102). REG. 3-2-1999.
- 2,229,386. MISCELLANEOUS DESIGN. INT. CL. 5. (U.S. CLS. 6, 18, 44, 46, 51 AND 52). REG. 3-2-1999.
- 2,229,498. DIMENSION. INT. CL. 1. (U.S. CLS. 1, 5, 6, 10, 26 AND 46). REG. 3-2-1999.
- 2,229,758. MARTIAL ARTS USA. INT. CL. 41. (U.S. CLS. 100, 101 AND 107). REG. 3-2-1999.
- 2,230,036. CANSOLV. INT. CLS. 11 AND 37. (U.S. CLS. 13, 21, 23, 31, 34, 100, 103 AND 106). REG. 3-9-1999.
- 2,230,068. WESPAY. INT. CL. 42. (U.S. CLS. 100 AND 101). REG. 3-9-1999.
- 2,230,144. URGO. INT. CL. 5. (U.S. CLS. 6, 18, 44, 46, 51 AND 52). REG. 3-9-1999.
- 2,231,258. IONPROCESSING. INT. CL. 40. (U.S. CLS. 100, 103 AND 106). REG. 3-9-1999.
- 2,231,867. STTAS. INT. CLS. 35 AND 41. (U.S. CLS. 100, 101, 102 AND 107). REG. 3-16-1999.
- 2,232,038. BLOXYGEN (STYLIZED). INT. CL. 1. (U.S. CLS. 1, 5, 6, 10, 26 AND 46). REG. 3-16-1999.
- 2,232,512. SELECT. INT. CL. 6. (U.S. CLS. 2, 12, 13, 14, 23, 25 AND 50). REG. 3-16-1999.
- 2,233,210. ALEX K AND DESIGN. INT. CL. 25. (U.S. CLS. 22 AND 39). REG. 3-23-1999.
- 2,233,258. TENTNOLOGY. INT. CLS. 9 AND 22. (U.S. CLS. 1, 2, 7, 19, 21, 22, 23, 26, 36, 38, 42 AND 50). REG. 3-23-1999.
- 2,233,455. LOGILITY PLANNING SOLUTIONS. INT. CL. 9. (U.S. CLS. 21, 23, 26, 36 AND 38). REG. 3-23-1999.
- 2,233,621. ROCKY MOUNTAIN VINEYARDS. INT. CL. 33. (U.S. CLS. 47 AND 49). REG. 3-23-1999.
- 2,233,662. GENFILM. INT. CL. 17. (U.S. CLS. 1, 5, 12, 13, 35 AND 50). REG. 3-23-1999.
- 2,234,500. HOLLYWOOD EAST PRODUCTIONS NESW AND DESIGN. INT. CL. 35. (U.S. CLS. 100, 101 AND 102). REG. 3-23-1999.
- 2,234,991. TIGHT LINES. INT. CL. 25 ONLY. (U.S. CLS. 22 AND 39). REG. 3-23-1999.
- 2,235,409. MISCELLANEOUS DESIGN. INT. CL. 33. (U.S. CLS. 47 AND 49). REG. 3-23-1999.
- 2,235,458. DOCTOR HOTLINE. INT. CL. 42. (U.S. CLS. 100 AND 101). REG. 3-23-1999.
- 2,235,606. JULIA K AND DESIGN. INT. CL. 25. (U.S. CLS. 22 AND 39). REG. 3-30-1999.
- 2,235,811. ADCARE AND DESIGN. INT. CLS. 35 AND 36. (U.S. CLS. 100, 101 AND 102). REG. 3-30-1999.
- 2,235,833. ZIQ AND DESIGN. INT. CL. 7. (U.S. CLS. 13, 19, 21, 23, 31, 34 AND 35). REG. 3-30-1999.
- 2,235,921. THERMO-COR (STYLIZED). INT. CL. 17. (U.S. CLS. 1, 5, 12, 13, 35 AND 50). REG. 3-30-1999.
- 2,235,933. GOLD CUP (STYLIZED). INT. CLS. 29, 30 AND 42. (U.S. CLS. 46, 100 AND 101). REG. 3-30-1999.
- 2,236,433. BOLAR. INT. CL. 6. (U.S. CLS. 2, 12, 13, 14, 23, 25 AND 50). REG. 4-6-1999.
- 2,236,785. DELL. INT. CL. 40. (U.S. CLS. 100, 103 AND 106). REG. 4-6-1999.
- 2,237,120. BACKWEB. INT. CL. 9. (U.S. CLS. 21, 23, 26, 36 AND 38). REG. 4-6-1999.
- 2,237,952. MAPTECH. INT. CL. 9. (U.S. CLS. 21, 23, 26, 36 AND 38). REG. 4-13-1999.
- 2,237,956. CHANGES. INT. CL. 5. (U.S. CLS. 6, 18, 44, 46, 51 AND 52). REG. 4-13-1999.
- 2,238,079. NYSEG. INT. CLS. 39, 40, 41 AND 42 ONLY. (U.S. CLS. 100, 101, 103, 105, 106 AND 107). REG. 4-13-1999.
- 2,238,208. CHILDREN'S FRIEND CARING FOR CHILDREN AND THOSE WHO LOVE THEM AND DESIGN. INT. CL. 42. (U.S. CLS. 100 AND 101). REG. 4-13-1999.
- 2,238,285. HAWAIIAN TRAVEL. INT. CLS. 39 AND 42. (U.S. CLS. 100, 101 AND 105). REG. 4-13-1999.
- 2,238,356. MISCELLANEOUS DESIGN. INT. CL. 36. (U.S. CLS. 100, 101 AND 102). REG. 4-13-1999.
- 2,238,368. THINK LIKE A KING. INT. CL. 9. (U.S. CLS. 21, 23, 26, 36 AND 38). REG. 4-13-1999.
- 2,238,466. INTERNATIONAL ASSOCIATION OF ELECTRICAL INSPECTORS. INT. CL. 41. (U.S. CLS. 100, 101 AND 107). REG. 4-13-1999.
- 2,238,560. ABYSSINIANS. INT. CL. 41. (U.S. CLS. 100, 101 AND 107). REG. 4-13-1999.
- 2,238,714. MILES DAVIS. INT. CL. 25. (U.S. CLS. 22 AND 39). REG. 4-13-1999.
- 2,238,838. AMPLEX. INT. CL. 4. (U.S. CLS. 1, 6 AND 15). REG. 4-13-1999.
- 2,238,914. SALLY LUNN'S. INT. CL. 42. (U.S. CLS. 100 AND 101). REG. 4-13-1999.
- 2,239,149. HADDON-TECSTONE. INT. CLS. 11, 19, 20, 21 AND 40. (U.S. CLS. 1, 2, 12, 13, 21, 22, 23, 25, 29, 30, 31, 32, 33, 34, 40, 50, 100, 103 AND 106). REG. 4-13-1999.
- 2,239,217. ECOLOGICAL TRUST PROPERTY. INT. CL. 20. (U.S. CLS. 2, 13, 22, 25, 32 AND 50). REG. 4-13-1999.
- 2,239,530. NATIONAL HEALTH INFORMATION NETWORK NHIN AND DESIGN. INT. CL. 42. (U.S. CLS. 100 AND 101). REG. 4-13-1999.
- 2,239,636. W (STYLIZED). INT. CL. 29. (U.S. CL. 46). REG. 4-13-1999.
- 2,239,801. BRIDES BY DEMETRIOS. INT. CL. 35. (U.S. CLS. 100, 101 AND 102). REG. 4-13-1999.
- 2,239,842. MISCELLANEOUS DESIGN. INT. CL. 19. (U.S. CLS. 1, 12, 33 AND 50). REG. 4-13-1999.
- 2,239,859. DREAM DEMO. INT. CL. 16. (U.S. CLS. 2, 5, 22, 23, 29, 37, 38 AND 50). REG. 4-13-1999.
- 2,240,080. WORLD MONUMENTS WATCH. INT. CLS. 36, 37 AND 42 ONLY. (U.S. CLS. 100, 101, 102, 103 AND 106). REG. 4-20-1999.
- 2,240,114. CIGARETTE EXPRESS. INT. CL. 35. (U.S. CLS. 100, 101 AND 102). REG. 4-20-1999.
- 2,240,280. POWER PRO AND DESIGN. INT. CL. 28. (U.S. CLS. 22, 23, 38 AND 50). REG. 4-20-1999.
- 2,240,341. ST&R AND DESIGN. INT. CL. 42. (U.S. CLS. 100 AND 101). REG. 4-20-1999.
- 2,240,462. INTERNATIONAL ASSOCIATION ELECTRICAL INSPECTORS ESTABLISHED 1928 KEYSTONE OF THE ELECTRICAL INDUSTRY AND DESIGN. INT. CL. 42. (U.S. CLS. 100 AND 101). REG. 4-20-1999.
- 2,240,463. INTERNATIONAL ASSOCIATION OF ELECTRICAL INSPECTORS. INT. CL. 42. (U.S. CLS. 100 AND 101). REG. 4-20-1999.
- 2,240,464. INTERNATIONAL ASSOCIATION ELECTRICAL INSPECTORS AND DESIGN. U.S. CL. 200. REG. 4-20-1999.
- 2,240,503. ADCARE. INT. CLS. 35 AND 36. (U.S. CLS. 100, 101 AND 102). REG. 4-20-1999.
- 2,240,598. MISCELLANEOUS DESIGN. INT. CLS. 37 AND 42. (U.S. CLS. 100, 101, 103 AND 106). REG. 4-20-1999.
- 2,240,643. TECO-SIL. INT. CL. 1. (U.S. CLS. 1, 5, 6, 10, 26 AND 46). REG. 4-20-1999.
- 2,240,713. MISCELLANEOUS DESIGN. INT. CL. 16. (U.S. CLS. 2, 5, 22, 23, 29, 37, 38 AND 50). REG. 4-20-1999.
- 2,240,783. EN CONTACTO. INT. CL. 16. (U.S. CLS. 2, 5, 22, 23, 29, 37, 38 AND 50). REG. 4-20-1999.
- 2,240,788. MUSICAL MOMMY. INT. CL. 41. (U.S. CLS. 100, 101 AND 107). REG. 4-20-1999.
- 2,240,811. MEGARAIL. INT. CL. 42. (U.S. CLS. 100 AND 101). REG. 4-20-1999.
- 2,240,817. BIOLOGIX H2O (STYLIZED). INT. CL. 37. (U.S. CLS. 100, 103 AND 106). REG. 4-20-1999.
- 2,240,818. BIOLOGIX H2O (STYLIZED). INT. CL. 1. (U.S. CLS. 1, 5, 6, 10, 26 AND 46). REG. 4-20-1999.
- 2,240,854. WANG AND DESIGN. INT. CLS. 29, 30 AND 31. (U.S. CLS. 1 AND 46). REG. 4-20-1999.
- 2,240,887. GRACE AND DESIGN. INT. CL. 41. (U.S. CLS. 100, 101 AND 107). REG. 4-20-1999.
- 2,240,896. COLOR PRINCIPAL. INT. CL. 3. (U.S. CLS. 1, 4, 6, 50, 51 AND 52). REG. 4-20-1999.
- 2,241,097. ACHILLES AND DESIGN. INT. CL. 9. (U.S. CLS. 21, 23, 26, 36 AND 38). REG. 4-20-1999.
- 2,241,130. INQUISITE. INT. CL. 9. (U.S. CLS. 21, 23, 26, 36 AND 38). REG. 4-20-1999.

- 2,241,190. LANDSCAPER. INT. CL. 9. (U.S. CLS. 21, 23, 26, 36 AND 38). REG. 4-20-1999.
- 2,241,251. PRO-SCORE. INT. CL. 7. (U.S. CLS. 13, 19, 21, 23, 31, 34 AND 35). REG. 4-20-1999.
- 2,241,409. AG LENDER. INT. CL. 16. (U.S. CLS. 2, 5, 22, 23, 29, 37, 38 AND 50). REG. 4-20-1999.
- 2,241,493. M.D. FORMULATIONS VIT-A-PLUS. INT. CL. 3. (U.S. CLS. 1, 4, 6, 50, 51 AND 52). REG. 4-27-1999.
- 2,241,535. PRO AND DESIGN. INT. CL. 35. (U.S. CLS. 100, 101 AND 102). REG. 4-27-1999.
- 2,241,541. NRSI. INT. CL. 9 ONLY. (U.S. CLS. 21, 23, 26, 36 AND 38). REG. 4-27-1999.
- 2,241,817. THE INVESTOR ADVOCATE. INT. CL. 16. (U.S. CLS. 2, 5, 22, 23, 29, 37, 38 AND 50). REG. 4-27-1999.
- 2,241,868. EARTH FRIENDLY BABY. INT. CL. 3. (U.S. CLS. 1, 4, 6, 50, 51 AND 52). REG. 4-27-1999.
- 2,241,934. TISSUEMAX THE PORTABLE ROLL TISSUE DISPENSER AND DESIGN. INT. CL. 16. (U.S. CLS. 2, 5, 22, 23, 29, 37, 38 AND 50). REG. 4-27-1999.
- 2,242,130. PROPAP. INT. CL. 5. (U.S. CLS. 6, 18, 44, 46, 51 AND 52). REG. 4-27-1999.
- 2,242,173. BANISTER SHOE STUDIO. INT. CL. 35. (U.S. CLS. 100, 101 AND 102). REG. 4-27-1999.
- 2,242,339. DELMARVA SHOREBIRDS AND DESIGN. INT. CLS. 16 AND 25. (U.S. CLS. 2, 5, 22, 23, 29, 37, 38, 39 AND 50). REG. 5-4-1999.
- 2,242,540. JACKSON STATE UNIVERSITY. INT. CLS. 6, 14, 16, 18, 20, 21, 25, 28 AND 41. (U.S. CLS. 1, 2, 3, 5, 12, 13, 14, 22, 23, 25, 27, 28, 29, 30, 32, 33, 37, 38, 39, 40, 41, 50, 100, 101 AND 107). REG. 5-4-1999.
- 2,242,672. WOOD-YOU (STYLIZED). INT. CL. 35 ONLY. (U.S. CLS. 100, 101 AND 102). REG. 5-4-1999.
- 2,242,760. SMT SPECIALIZED & INSERT MOLDING TECHNOLOGY LLC AND DESIGN. INT. CL. 40. (U.S. CLS. 100, 103 AND 106). REG. 5-4-1999.
- 2,242,977. STRATICA. INT. CLS. 19 AND 27. (U.S. CLS. 1, 12, 19, 20, 33, 37, 42 AND 50). REG. 5-4-1999.
- 2,243,055. STARWHEEL. INT. CL. 7. (U.S. CLS. 13, 19, 21, 23, 31, 34 AND 35). REG. 5-4-1999.
- 2,243,235. THE ITALIAN PIE SHOPPE AND DESIGN. INT. CL. 42. (U.S. CLS. 100 AND 101). REG. 5-4-1999.
- 2,243,707. MEDITAPES. INT. CL. 9. (U.S. CLS. 21, 23, 26, 36 AND 38). REG. 5-4-1999.
- 2,244,201. SCHOCK AND DESIGN. INT. CL. 11 ONLY. (U.S. CLS. 13, 21, 23, 31 AND 34). REG. 5-11-1999.
- 2,244,339. QUIET SOLUTIONS. INT. CL. 17. (U.S. CLS. 1, 5, 12, 13, 35 AND 50). REG. 5-11-1999.
- 2,244,411. EL CENTRO HISPANO AND DESIGN. INT. CL. 42. (U.S. CLS. 100 AND 101). REG. 5-11-1999.
- 2,244,637. LOS NETTOS. INT. CL. 42. (U.S. CLS. 100 AND 101). REG. 5-11-1999.
- 2,245,395. PERFORMER SERIES. INT. CL. 9. (U.S. CLS. 21, 23, 26, 36 AND 38). REG. 5-18-1999.
- 2,245,401. NEIGHBORCARE. INT. CLS. 35 AND 42. (U.S. CLS. 100, 101 AND 102). REG. 5-18-1999.
- 2,245,458. MISCELLANEOUS DESIGN. INT. CL. 16. (U.S. CLS. 2, 5, 22, 23, 29, 37, 38 AND 50). REG. 5-18-1999.
- 2,245,532. CERAMILL. INT. CL. 21. (U.S. CLS. 2, 13, 23, 29, 30, 33, 40 AND 50). REG. 5-18-1999.
- 2,245,632. SPEEDSCRIPT. INT. CL. 9. (U.S. CLS. 21, 23, 26, 36 AND 38). REG. 5-18-1999.
- 2,245,657. THEHOLLYWOODREPORTER. INT. CL. 41. (U.S. CLS. 100, 101 AND 107). REG. 5-18-1999.
- 2,245,774. 1ST CHAIR (STYLIZED). INT. CL. 20. (U.S. CLS. 2, 13, 22, 25, 32 AND 50). REG. 5-18-1999.
- 2,245,848. SPRINGDALE. INT. CL. 12. (U.S. CLS. 19, 21, 23, 31, 35 AND 44). REG. 5-18-1999.
- 2,245,954. SAFEWEB. INT. CL. 36. (U.S. CLS. 100, 101 AND 102). REG. 5-18-1999.
- 2,246,283. VIDEO DNA. INT. CL. 9. (U.S. CLS. 21, 23, 26, 36 AND 38). REG. 5-18-1999.
- 2,246,308. BOSCH. INT. CL. 37. (U.S. CLS. 100, 103 AND 106). REG. 5-18-1999.
- 2,246,326. VENTURA. INT. CL. 12. (U.S. CLS. 19, 21, 23, 31, 35 AND 44). REG. 5-18-1999.
- 2,246,600. AMERICAN SOCIETY FOR EXPERIMENTAL NEUROTHERAPEUTICS ASENT. INT. CL. 42. (U.S. CLS. 100 AND 101). REG. 5-18-1999.
- 2,246,941. REFLECTIONS OF NATURE. INT. CL. 9. (U.S. CLS. 21, 23, 26, 36 AND 38). REG. 5-25-1999.
- 2,246,994. FF2 (STYLIZED). INT. CL. 6. (U.S. CLS. 2, 12, 13, 14, 23, 25 AND 50). REG. 5-25-1999.
- 2,247,002. TRUE WHIRLPOOL. INT. CL. 11. (U.S. CLS. 13, 21, 23, 31 AND 34). REG. 5-25-1999.
- 2,247,437. FASTCAP. INT. CL. 20. (U.S. CLS. 2, 13, 22, 25, 32 AND 50). REG. 5-25-1999.
- 2,247,565. 700XS. INT. CL. 6. (U.S. CLS. 2, 12, 13, 14, 23, 25 AND 50). REG. 5-25-1999.
- 2,248,176. REVOLUTION. INT. CL. 28. (U.S. CLS. 22, 23, 38 AND 50). REG. 5-25-1999.
- 2,248,290. SPIRIT MOUNTAIN. INT. CL. 42. (U.S. CLS. 100 AND 101). REG. 5-25-1999.
- 2,248,313. PROPINK. INT. CL. 17. (U.S. CLS. 1, 5, 12, 13, 35 AND 50). REG. 5-25-1999.
- 2,248,352. MISCELLANEOUS DESIGN. INT. CL. 42. (U.S. CLS. 100 AND 101). REG. 5-25-1999.
- 2,248,718. VETERINARY PRACTICE MANAGER. INT. CL. 9. (U.S. CLS. 21, 23, 26, 36 AND 38). REG. 6-1-1999.
- 2,248,806. JON-DON AND DESIGN. INT. CLS. 9, 35 AND 37. (U.S. CLS. 21, 23, 26, 36, 38, 100, 101, 102, 103 AND 106). REG. 6-1-1999.
- 2,248,961. MISCELLANEOUS DESIGN. INT. CL. 41. (U.S. CLS. 100, 101 AND 107). REG. 6-1-1999.
- 2,249,537. CORMARK. INT. CL. 20. (U.S. CLS. 2, 13, 22, 25, 32 AND 50). REG. 6-1-1999.
- 2,249,540. CORMARK. INT. CL. 35. (U.S. CLS. 100, 101 AND 102). REG. 6-1-1999.
- 2,249,546. CORMARK. INT. CL. 42. (U.S. CLS. 100 AND 101). REG. 6-1-1999.
- 2,249,803. BIGCHARTS. INT. CL. 36. (U.S. CLS. 100, 101 AND 102). REG. 6-1-1999.
- 2,249,958. MISCELLANEOUS DESIGN. INT. CL. 41. (U.S. CLS. 100, 101 AND 107). REG. 6-1-1999.
- 2,250,672. MEDICAL EDUCATION TECHNOLOGIES, INC.. INT. CL. 9. (U.S. CLS. 21, 23, 26, 36 AND 38). REG. 6-1-1999.
- 2,250,777. THE SCHOOL OF THE ART INSTITUTE OF CHICAGO. INT. CL. 41. (U.S. CLS. 100, 101 AND 107). REG. 6-8-1999.
- 2,250,876. FIGHTING-WEIGHT. INT. CL. 9. (U.S. CLS. 21, 23, 26, 36 AND 38). REG. 6-8-1999.
- 2,250,955. VUCC. U.S. CL. 200. REG. 6-8-1999.
- 2,251,049. HBC AS IT SHOULD BE. INT. CL. 35. (U.S. CLS. 100, 101 AND 102). REG. 6-8-1999.
- 2,251,275. LIKE A HOME PHONE AWAY FROM HOME.. INT. CL. 38. (U.S. CLS. 100, 101 AND 104). REG. 6-8-1999.
- 2,251,753. GELFLEX. INT. CL. 9. (U.S. CLS. 21, 23, 26, 36 AND 38). REG. 6-8-1999.
- 2,251,761. WRIGHTCHECK. INT. CL. 36. (U.S. CLS. 100, 101 AND 102). REG. 6-8-1999.
- 2,252,255. PURE ESSENTIALS. INT. CL. 3. (U.S. CLS. 1, 4, 6, 50, 51 AND 52). REG. 6-15-1999.
- 2,252,529. !NNOVATIVE MARKETING SOLUTIONS, INC. (STYLIZED). INT. CLS. 40 AND 42. (U.S. CLS. 100, 101, 103 AND 106). REG. 6-15-1999.
- 2,252,777. CSAT (STYLIZED). INT. CL. 9. (U.S. CLS. 21, 23, 26, 36 AND 38). REG. 6-15-1999.
- 2,252,856. PURATEX. INT. CL. 11. (U.S. CLS. 13, 21, 23, 31 AND 34). REG. 6-15-1999.
- 2,252,976. EMERGING TRENDS IN REAL ESTATE. INT. CL. 16. (U.S. CLS. 2, 5, 22, 23, 29, 37, 38 AND 50). REG. 6-15-1999.
- 2,253,297. ULTRA-GATOR. INT. CL. 9. (U.S. CLS. 21, 23, 26, 36 AND 38). REG. 6-15-1999.
- 2,253,435. CORMARK (STYLIZED). INT. CL. 20. (U.S. CLS. 2, 13, 22, 25, 32 AND 50). REG. 6-15-1999.
- 2,253,817. MISCELLANEOUS DESIGN. INT. CL. 36. (U.S. CLS. 100, 101 AND 102). REG. 6-15-1999.
- 2,253,818. MISCELLANEOUS DESIGN. INT. CL. 36. (U.S. CLS. 100, 101 AND 102). REG. 6-15-1999.
- 2,253,880. GOLF MAGAZINE. INT. CL. 9. (U.S. CLS. 21, 23, 26, 36 AND 38). REG. 6-15-1999.
- 2,253,927. SOL BRILLANTE. INT. CL. 30. (U.S. CL. 46). REG. 6-15-1999.
- 2,254,234. WOLFERMAN'S A TRADITION OF FINE FOOD SINCE 1888 AND DESIGN. INT. CL. 30. (U.S. CL. 46). REG. 6-15-1999.
- 2,254,834. DAVKAWRITER. INT. CL. 9. (U.S. CLS. 21, 23, 26, 36 AND 38). REG. 6-22-1999.
- 2,254,835. INSPIRON. INT. CL. 9. (U.S. CLS. 21, 23, 26, 36 AND 38). REG. 6-22-1999.
- 2,255,172. NOW YOU KNOW. INT. CL. 42. (U.S. CLS. 100 AND 101). REG. 6-22-1999.
- 2,255,344. ZWORLD AND DESIGN. INT. CL. 9. (U.S. CLS. 21, 23, 26, 36 AND 38). REG. 6-22-1999.

- 2,255,361. UNICIRCLE. INT. CL. 12. (U.S. CLS. 19, 21, 23, 31, 35 AND 44). REG. 6-22-1999.
- 2,255,445. DREAMTRACKING. INT. CL. 41. (U.S. CLS. 100, 101 AND 107). REG. 6-22-1999.
- 2,255,522. PRECEPT. INT. CL. 25. (U.S. CLS. 22 AND 39). REG. 6-22-1999.
- 2,255,983. MISCELLANEOUS DESIGN. INT. CL. 14. (U.S. CLS. 2, 27, 28 AND 50). REG. 6-22-1999.
- 2,256,277. HI-TECH. INT. CLS. 1 AND 4 ONLY. (U.S. CLS. 1, 5, 6, 10, 15, 26 AND 46). REG. 6-29-1999.
- 2,256,628. ALLIANZ. INT. CL. 36. (U.S. CLS. 100, 101 AND 102). REG. 6-29-1999.
- 2,257,080. SEAQUEST. INT. CL. 1. (U.S. CLS. 1, 5, 6, 10, 26 AND 46). REG. 6-29-1999.
- 2,257,844. BOEING AND DESIGN. INT. CL. 14. (U.S. CLS. 2, 27, 28 AND 50). REG. 6-29-1999.
- 2,258,337. CSI. INT. CL. 35. (U.S. CLS. 100, 101 AND 102). REG. 7-6-1999.
- 2,258,669. ASIATTIC. INT. CL. 35. (U.S. CLS. 100, 101 AND 102). REG. 7-6-1999.
- 2,258,764. KRESKIN. INT. CL. 41. (U.S. CLS. 100, 101 AND 107). REG. 7-6-1999.
- 2,258,765. THE AMAZING KRESKIN. INT. CL. 41. (U.S. CLS. 100, 101 AND 107). REG. 7-6-1999.
- 2,258,864. POWER HITTER POWER HITTER AND DESIGN. INT. CL. 16. (U.S. CLS. 2, 5, 22, 23, 29, 37, 38 AND 50). REG. 7-6-1999.
- 2,259,407. METI. INT. CL. 9. (U.S. CLS. 21, 23, 26, 36 AND 38). REG. 7-6-1999.
- 2,260,604. TOWN AND DESIGN. INT. CL. 35. (U.S. CLS. 100, 101 AND 102). REG. 7-13-1999.
- 2,261,460. RED-LINK. INT. CL. 17. (U.S. CLS. 1, 5, 12, 13, 35 AND 50). REG. 7-13-1999.
- 2,261,573. PUREPERM. INT. CL. 11. (U.S. CLS. 13, 21, 23, 31 AND 34). REG. 7-13-1999.
- 2,262,181. PROMOXTRA!. INT. CL. 16. (U.S. CLS. 2, 5, 22, 23, 29, 37, 38 AND 50). REG. 7-20-1999.
- 2,263,145. MOUNTAIN PEOPLES WAREHOUSE. INT. CL. 35. (U.S. CLS. 100, 101 AND 102). REG. 7-20-1999.
- 2,263,326. MISCELLANEOUS DESIGN. INT. CL. 42. (U.S. CLS. 100 AND 101). REG. 7-20-1999.
- 2,265,756. EMBASSY. INT. CL. 16. (U.S. CLS. 2, 5, 22, 23, 29, 37, 38 AND 50). REG. 7-27-1999.
- 2,265,775. BBSH. INT. CL. 41. (U.S. CLS. 100, 101 AND 107). REG. 7-27-1999.
- 2,266,138. PRECISION FUNDING. INT. CL. 36. (U.S. CLS. 100, 101 AND 102). REG. 8-3-1999.
- 2,266,715. PHOTOCHROME. INT. CL. 3. (U.S. CLS. 1, 4, 6, 50, 51 AND 52). REG. 8-3-1999.
- 2,267,390. SILVER WIND. INT. CL. 39. (U.S. CLS. 100 AND 105). REG. 8-3-1999.
- 2,267,408. SILVER CLOUD. INT. CL. 39. (U.S. CLS. 100 AND 105). REG. 8-3-1999.
- 2,267,922. ASSESSMENT REFERENCE TOOL. INT. CL. 9. (U.S. CLS. 21, 23, 26, 36 AND 38). REG. 8-3-1999.
- 2,267,923. CLINICAL GUIDELINES TOOL. INT. CL. 9. (U.S. CLS. 21, 23, 26, 36 AND 38). REG. 8-3-1999.
- 2,268,022. CORAIL. INT. CL. 10. (U.S. CLS. 26, 39 AND 44). REG. 8-10-1999.
- 2,270,682. AUDIO DIMENSIONS. INT. CL. 35. (U.S. CLS. 100, 101 AND 102). REG. 8-17-1999.
- 2,270,852. FRIENDS OF THE SOCIETY. INT. CL. 39. (U.S. CLS. 100 AND 105). REG. 8-17-1999.
- 2,273,815. MEGABALL. INT. CL. 36. (U.S. CLS. 100, 101 AND 102). REG. 8-31-1999.
- 2,273,858. THE HOUSE OF IDEAS. INT. CL. 16. (U.S. CLS. 2, 5, 22, 23, 29, 37, 38 AND 50). REG. 8-31-1999.
- 2,275,466. TELEVAC. INT. CL. 10. (U.S. CLS. 26, 39 AND 44). REG. 9-7-1999.
- 2,275,822. EVIDENCE-BASED PRACTICE CENTERS AND DESIGN. INT. CL. 42. (U.S. CLS. 100 AND 101). REG. 9-7-1999.
- 2,276,614. TRAVEL ASSET. INT. CL. 16 ONLY. (U.S. CLS. 2, 5, 22, 23, 29, 37, 38 AND 50). REG. 9-7-1999.
- 2,276,901. DIRECT DRAFT PROGRAM. INT. CL. 36. (U.S. CLS. 100, 101 AND 102). REG. 9-7-1999.
- 2,277,160. MILLENNIUM HOTELS AND RESORTS AND DESIGN. INT. CL. 43. (U.S. CLS. 100 AND 101). REG. 9-14-1999.
- 2,277,688. JGB. INT. CL. 5. (U.S. CLS. 6, 18, 44, 46, 51 AND 52). REG. 9-14-1999.
- 2,277,737. KEN ONION HAWAII (STYLIZED). INT. CL. 8. (U.S. CLS. 23, 28 AND 44). REG. 9-14-1999.
- 2,278,162. TRAVEL TOOLS. INT. CL. 35. (U.S. CLS. 100, 101 AND 102). REG. 9-14-1999.
- 2,278,443. SAY IT WITH STAMPS. INT. CL. 16. (U.S. CLS. 2, 5, 22, 23, 29, 37, 38 AND 50). REG. 9-14-1999.
- 2,279,319. POLY-CAULK. INT. CL. 17. (U.S. CLS. 1, 5, 12, 13, 35 AND 50). REG. 9-21-1999.
- 2,280,714. CABLE ONE AND DESIGN. INT. CLS. 38, 41 AND 42. (U.S. CLS. 100, 101, 104 AND 107). REG. 9-28-1999.
- 2,281,446. POLYDECK. INT. CL. 2. (U.S. CLS. 6, 11 AND 16). REG. 9-28-1999.
- 2,282,928. HPS. INT. CL. 20. (U.S. CLS. 2, 13, 22, 25, 32 AND 50). REG. 10-5-1999.
- 2,283,649. CABLE ONE. INT. CLS. 38, 41 AND 42. (U.S. CLS. 100, 101, 104 AND 107). REG. 10-5-1999.
- 2,283,906. HONGO UNA PIEL-SANA AND DESIGN. INT. CL. 5. (U.S. CLS. 6, 18, 44, 46, 51 AND 52). REG. 10-5-1999.
- 2,284,279. PAINTER'S LIGHT. INT. CL. 11. (U.S. CLS. 13, 21, 23, 31 AND 34). REG. 10-5-1999.
- 2,284,455. DE LUXE IMPERIA. INT. CL. 7. (U.S. CLS. 13, 19, 21, 23, 31, 34 AND 35). REG. 10-12-1999.
- 2,284,506. OPERATION CHILL. INT. CL. 42. (U.S. CLS. 100 AND 101). REG. 10-12-1999.
- 2,284,619. PRIMEALERT. INT. CL. 9. (U.S. CLS. 21, 23, 26, 36 AND 38). REG. 10-12-1999.
- 2,285,767. DUAL MAGNUM. INT. CL. 5. (U.S. CLS. 6, 18, 44, 46, 51 AND 52). REG. 10-12-1999.
- 2,286,040. SOFT WORKS. INT. CL. 21. (U.S. CLS. 2, 13, 23, 29, 30, 33, 40 AND 50). REG. 10-12-1999.
- 2,286,139. FLOWSERVE. INT. CL. 9. (U.S. CLS. 21, 23, 26, 36 AND 38). REG. 10-12-1999.
- 2,286,648. ASSURE. INT. CL. 5. (U.S. CLS. 6, 18, 44, 46, 51 AND 52). REG. 10-12-1999.
- 2,286,987. TRADITIONAL. INT. CL. 6. (U.S. CLS. 2, 12, 13, 14, 23, 25 AND 50). REG. 10-19-1999.
- 2,287,060. GOLDEN THROATS. INT. CL. 9. (U.S. CLS. 21, 23, 26, 36 AND 38). REG. 10-19-1999.
- 2,287,410. SUR-MOOR. INT. CLS. 9 AND 20. (U.S. CLS. 2, 13, 21, 22, 23, 25, 26, 32, 36, 38 AND 50). REG. 10-19-1999.
- 2,287,674. IST & FINAL. INT. CL. 5. (U.S. CLS. 6, 18, 44, 46, 51 AND 52). REG. 10-19-1999.
- 2,287,865. BEST BUDDIES. INT. CL. 9. (U.S. CLS. 21, 23, 26, 36 AND 38). REG. 10-19-1999.
- 2,288,008. DIDN'T YOU GO TO SCHOOL WITH ONE?. INT. CL. 35. (U.S. CLS. 100, 101 AND 102). REG. 10-19-1999.
- 2,288,194. BABYLON 5. INT. CL. 9. (U.S. CLS. 21, 23, 26, 36 AND 38). REG. 10-19-1999.
- 2,289,112. BEGINNER'S BIBLE. INT. CL. 9. (U.S. CLS. 21, 23, 26, 36 AND 38). REG. 10-26-1999.
- 2,289,291. TUFECOTE. INT. CL. 6. (U.S. CLS. 2, 12, 13, 14, 23, 25 AND 50). REG. 10-26-1999.
- 2,289,710. HEATERSNFANS. INT. CL. 35. (U.S. CLS. 100, 101 AND 102). REG. 10-26-1999.
- 2,289,715. THE LIGHT PAINTER. INT. CLS. 16 AND 21. (U.S. CLS. 2, 5, 22, 23, 29, 37, 38 AND 50). REG. 11-2-1999.
- 2,290,186. SILVER LINKS. INT. CL. 39. (U.S. CLS. 100 AND 105). REG. 11-2-1999.
- 2,290,984. PERFECT VISION. INT. CL. 9. (U.S. CLS. 21, 23, 26, 36 AND 38). REG. 11-9-1999.
- 2,291,382. ENVIROLINE. INT. CL. 9. (U.S. CLS. 21, 23, 26, 36 AND 38). REG. 11-9-1999.
- 2,292,243. MISCELLANEOUS DESIGN. INT. CL. 5. (U.S. CLS. 6, 18, 44, 46, 51 AND 52). REG. 11-16-1999.
- 2,292,350. CHAMPIONITE. INT. CL. 31. (U.S. CLS. 1 AND 46). REG. 11-16-1999.
- 2,292,636. KENTUCKY REGGAE FESTIVAL. INT. CL. 41. (U.S. CLS. 100, 101 AND 107). REG. 11-16-1999.
- 2,294,315. WINNER INTERNATIONAL. INT. CL. 12. (U.S. CLS. 19, 21, 23, 31, 35 AND 44). REG. 11-23-1999.
- 2,295,124. CENTRIFLOW. INT. CL. 9. (U.S. CLS. 21, 23, 26, 36 AND 38). REG. 11-30-1999.
- 2,295,405. ELPRO. INT. CL. 18. (U.S. CLS. 1, 2, 3, 22 AND 41). REG. 11-30-1999.
- 2,297,537. CATAPULT COMMUNICATIONS AND DESIGN. INT. CLS. 9 AND 41. (U.S. CLS. 21, 23, 26, 36, 38, 100, 101 AND 107). REG. 12-7-1999.
- 2,297,899. PRO-FIT. INT. CL. 11. (U.S. CLS. 13, 21, 23, 31 AND 34). REG. 12-7-1999.
- 2,297,937. PHARMAGRAPHICS. INT. CLS. 16 AND 42. (U.S. CLS. 2, 5, 22, 23, 29, 37, 38, 50, 100 AND 101). REG. 12-7-1999.
- 2,298,813. THE CLUB. INT. CL. 6. (U.S. CLS. 2, 12, 13, 14, 23, 25 AND 50). REG. 12-7-1999.

- 2,301,187. THERAPON. INT. CL. 3 ONLY. (U.S. CLS. 1, 4, 6, 50, 51 AND 52). REG. 12-21-1999.
- 2,301,431. UNIPOL. INT. CLS. 1, 40 AND 42. (U.S. CLS. 1, 5, 6, 10, 26, 46, 100, 101, 103 AND 106). REG. 12-21-1999.
- 2,301,947. DT (STYLIZED). INT. CL. 39. (U.S. CLS. 100 AND 105). REG. 12-21-1999.
- 2,302,250. FOR PROS/BY PROS. INT. CL. 16. (U.S. CLS. 2, 5, 22, 23, 29, 37, 38 AND 50). REG. 12-21-1999.
- 2,303,269. MEMORIAL SLOAN-KETTERING CANCER CENTER. INT. CL. 41. (U.S. CLS. 100, 101 AND 107). REG. 12-28-1999.
- 2,303,270. MEMORIAL SLOAN-KETTERING CANCER CENTER ESTABLISHED 1884 AND DESIGN. INT. CL. 41. (U.S. CLS. 100, 101 AND 107). REG. 12-28-1999.
- 2,303,607. MISCELLANEOUS DESIGN. INT. CLS. 16, 17 AND 40. (U.S. CLS. 1, 2, 5, 12, 13, 22, 23, 29, 35, 37, 38, 50, 100, 103 AND 106). REG. 12-28-1999.
- 2,303,615. 3 SIGMA. INT. CLS. 16, 17 AND 40. (U.S. CLS. 1, 2, 5, 12, 13, 22, 23, 29, 35, 37, 38, 50, 100, 103 AND 106). REG. 12-28-1999.
- 2,303,906. TUFF-POLE. INT. CL. 19. (U.S. CLS. 1, 12, 33 AND 50). REG. 12-28-1999.
- 2,305,795. STONEWEAR DESIGNS. INT. CL. 25. (U.S. CLS. 22 AND 39). REG. 1-4-2000.
- 2,306,364. PHOENIX MERCURY. INT. CL. 18. (U.S. CLS. 1, 2, 3, 22 AND 41). REG. 1-4-2000.
- 2,308,946. MISCELLANEOUS DESIGN. INT. CL. 9. (U.S. CLS. 21, 23, 26, 36 AND 38). REG. 1-18-2000.
- 2,309,907. MIDRIVERS PACKAGING. INT. CL. 16. (U.S. CLS. 2, 5, 22, 23, 29, 37, 38 AND 50). REG. 1-18-2000.
- 2,310,427. CIT CHAMBER INSURANCE TRUST AND DESIGN. INT. CL. 36. (U.S. CLS. 100, 101 AND 102). REG. 1-25-2000.
- 2,313,277. THE JERICHO PROJECT. INT. CL. 42. (U.S. CLS. 100 AND 101). REG. 2-1-2000.
- 2,315,436. BASIC CHEMICAL SOLUTIONS. INT. CLS. 1 AND 39. (U.S. CLS. 1, 5, 6, 10, 26, 46, 100 AND 105). REG. 2-8-2000.
- 2,317,864. AMERICAN BUSINESS ADVISORS. INT. CLS. 35, 36 AND 41. (U.S. CLS. 100, 101, 102 AND 107). REG. 2-15-2000.
- 2,318,287. FURNITURE FIRST (STYLIZED). U.S. CL. 200. REG. 2-15-2000.
- 2,319,011. TRANSCRAFT. INT. CL. 25 ONLY. (U.S. CLS. 22 AND 39). REG. 2-15-2000.
- 2,319,776. ALL TIME GREATS. INT. CL. 30. (U.S. CL. 46). REG. 2-15-2000.
- 2,320,249. DARFORD BRAND AND DESIGN. INT. CL. 31. (U.S. CLS. 1 AND 46). REG. 2-22-2000.
- 2,320,424. MISCELLANEOUS DESIGN. INT. CL. 41. (U.S. CLS. 100, 101 AND 107). REG. 2-22-2000.
- 2,320,957. FABRI TRAK. INT. CL. 17. (U.S. CLS. 1, 5, 12, 13, 35 AND 50). REG. 2-22-2000.
- 2,322,934. COLTON'S. INT. CL. 42. (U.S. CLS. 100 AND 101). REG. 2-29-2000.
- 2,323,505. VEGGIE LOVER'S. INT. CL. 29. (U.S. CL. 46). REG. 2-29-2000.
- 2,323,945. DUG NAP. INT. CL. 16. (U.S. CLS. 2, 5, 22, 23, 29, 37, 38 AND 50). REG. 2-29-2000.
- 2,324,126. HDC. INT. CL. 17. (U.S. CLS. 1, 5, 12, 13, 35 AND 50). REG. 2-29-2000.
- 2,324,292. PARSONS BEHLE & LATIMER AND DESIGN. INT. CL. 42. (U.S. CLS. 100 AND 101). REG. 2-29-2000.
- 2,324,652. ASP. INT. CL. 37. (U.S. CLS. 100, 103 AND 106). REG. 2-29-2000.
- 2,324,974. PAGEMAX. INT. CL. 2. (U.S. CLS. 6, 11 AND 16). REG. 2-29-2000.
- 2,325,229. ANTI HYDRO. INT. CL. 42. (U.S. CLS. 100 AND 101). REG. 3-7-2000.
- 2,325,355. FOUR DIAMOND AWARD. U.S. CL. B. REG. 3-7-2000.
- 2,325,405. THE WOODLAND GROUP AND DESIGN. INT. CL. 36. (U.S. CLS. 100, 101 AND 102). REG. 3-7-2000.
- 2,325,592. THE PRESSURE'S ON US. INT. CL. 42. (U.S. CLS. 100 AND 101). REG. 3-7-2000.
- 2,325,865. CROWN JEWEL COLLECTION. INT. CL. 15. (U.S. CLS. 2, 21 AND 36). REG. 3-7-2000.
- 2,328,094. DODGE'S FRIED CHICKEN. INT. CLS. 35 AND 42. (U.S. CLS. 100, 101 AND 102). REG. 3-14-2000.
- 2,328,271. TATONKA CAPITAL CORPORATION. INT. CL. 36. (U.S. CLS. 100, 101 AND 102). REG. 3-14-2000.
- 2,328,968. STREAMING MEDIA WORLD. INT. CL. 42. (U.S. CLS. 100 AND 101). REG. 3-14-2000.
- 2,330,086. CHARLOTTE COOKS. INT. CLS. 9 AND 16. (U.S. CLS. 2, 5, 21, 22, 23, 26, 29, 36, 37, 38 AND 50). REG. 3-14-2000.
- 2,331,232. MISCELLANEOUS DESIGN. INT. CLS. 35 AND 42. (U.S. CLS. 100, 101 AND 102). REG. 3-21-2000.
- 2,331,668. PRO-Q. INT. CL. 19. (U.S. CLS. 1, 12, 33 AND 50). REG. 3-21-2000.
- 2,332,377. ACCESS SELF STORAGE AND DESIGN. INT. CL. 39. (U.S. CLS. 100 AND 105). REG. 3-21-2000.
- 2,333,161. HPI ON-LINE. INT. CL. 42. (U.S. CLS. 100 AND 101). REG. 3-21-2000.
- 2,333,654. CELL TRACE PLUS. INT. CL. 38. (U.S. CLS. 100, 101 AND 104). REG. 3-21-2000.
- 2,334,272. LAURA SCUDDER'S. INT. CL. 29. (U.S. CL. 46). REG. 3-28-2000.
- 2,334,470. EPICENTER. INT. CL. 42. (U.S. CLS. 100 AND 101). REG. 3-28-2000.
- 2,334,840. CORPORATE CARE AND DESIGN. INT. CLS. 37 AND 40. (U.S. CLS. 100, 103 AND 106). REG. 3-28-2000.
- 2,336,240. PARA TODOS AND DESIGN. INT. CL. 29. (U.S. CL. 46). REG. 3-28-2000.
- 2,336,728. PROSCAPE. INT. CL. 1. (U.S. CLS. 1, 5, 6, 10, 26 AND 46). REG. 3-28-2000.
- 2,337,509. MISCELLANEOUS DESIGN. INT. CL. 36. (U.S. CLS. 100, 101 AND 102). REG. 4-4-2000.
- 2,337,713. MISCELLANEOUS DESIGN. INT. CL. 41. (U.S. CLS. 100, 101 AND 107). REG. 4-4-2000.
- 2,337,748. NEXIS. INT. CL. 42. (U.S. CLS. 100 AND 101). REG. 4-4-2000.
- 2,337,790. MISCELLANEOUS DESIGN. INT. CL. 16. (U.S. CLS. 2, 5, 22, 23, 29, 37, 38 AND 50). REG. 4-4-2000.
- 2,339,119. FLAIR. INT. CL. 10. (U.S. CLS. 26, 39 AND 44). REG. 4-4-2000.
- 2,339,333. HENDRIX RECORDS. INT. CL. 9. (U.S. CLS. 21, 23, 26, 36 AND 38). REG. 4-4-2000.
- 2,339,620. PRO MAG. INT. CL. 7. (U.S. CLS. 13, 19, 21, 23, 31, 34 AND 35). REG. 4-11-2000.
- 2,340,565. BAM. INT. CL. 5. (U.S. CLS. 6, 18, 44, 46, 51 AND 52). REG. 4-11-2000.
- 2,340,634. REGAL FOIL. INT. CL. 16. (U.S. CLS. 2, 5, 22, 23, 29, 37, 38 AND 50). REG. 4-11-2000.
- 2,341,230. TOSTITOS. INT. CL. 30. (U.S. CL. 46). REG. 4-11-2000.
- 2,341,851. WILDLIFE PRESERVERS AND DESIGN. INT. CL. 36. (U.S. CLS. 100, 101 AND 102). REG. 4-11-2000.
- 2,342,075. MOSS. INT. CL. 10. (U.S. CLS. 26, 39 AND 44). REG. 4-18-2000.
- 2,342,354. PSI AND DESIGN. INT. CL. 42. (U.S. CLS. 100 AND 101). REG. 4-18-2000.
- 2,342,675. PROCESS ACTIVATED TRAINING SYSTEM. INT. CL. 41. (U.S. CLS. 100, 101 AND 107). REG. 4-18-2000.
- 2,343,883. CELERIS. INT. CL. 9. (U.S. CLS. 21, 23, 26, 36 AND 38). REG. 4-18-2000.
- 2,344,133. ARCTIC BREEZE. INT. CL. 3. (U.S. CLS. 1, 4, 6, 50, 51 AND 52). REG. 4-18-2000.

TRADEMARK REGISTRATIONS CANCELED

The designation "U.S. Cl." appearing in this section refers to the U.S. class in effect prior to Sep. 1, 1973 rather than the international class which applies to applications filed on or after that date. For adoption of international classification see notice in the OFFICIAL GAZETTE of Jun. 26, 1973 (911 O.G. TM 210).

SECTION 7(D)

- 2,664,034. MAX WELL MEDICAL (STYLIZED). INT. CL. 35. REG. 12-17-2002.
2,942,491. THE ULTIMATE SHIRT. INT. CL. 25. REG. 4-19-2005.

SECTION 8

- 853,039. AS AND DESIGN. U.S. CL. 13. REG. 7-23-1968.
1,413,276. CONTINENTAL. INT. CL. 12. REG. 10-14-1986.
1,441,374. BLITZ. INT. CL. 30. REG. 6-2-1987.
1,496,354. WILSON AND DESIGN. INT. CLS. 1 AND 5. REG. 7-19-1988.
1,496,356. CLEARPLAN. INT. CLS. 1 AND 5. REG. 7-19-1988.
1,496,359. WESTGUARD AND DESIGN. INT. CL. 1. REG. 7-19-1988.
1,496,361. PLATHEN. INT. CL. 1. REG. 7-19-1988.
1,496,362. SODAK GARDEN MAKER. INT. CL. 1. REG. 7-19-1988.
1,496,379. GS (STYLIZED). INT. CL. 1. REG. 7-19-1988.
1,496,381. CARBONACRYL (STYLIZED). INT. CL. 1. REG. 7-19-1988.
1,496,383. HAZCAT. INT. CL. 1. REG. 7-19-1988.
1,496,385. ALAMIN. INT. CL. 1. REG. 7-19-1988.
1,496,408. EXPEDITE. INT. CL. 1. REG. 7-19-1988.
1,496,410. MISCELLANEOUS DESIGN. INT. CL. 2. REG. 7-19-1988.
1,496,413. PRIMAZIN. INT. CL. 2. REG. 7-19-1988.
1,496,414. CREATEX AND DESIGN. INT. CL. 2. REG. 7-19-1988.
1,496,415. AQUASTAIN. INT. CL. 2. REG. 7-19-1988.
1,496,430. ORLANE AND DESIGN. INT. CL. 3. REG. 7-19-1988.
1,496,432. ACTIVE LIFE. INT. CL. 3. REG. 7-19-1988.
1,496,442. SEQUEL. INT. CL. 3. REG. 7-19-1988.
1,496,444. NOCTOSOME (STYLIZED). INT. CL. 3. REG. 7-19-1988.
1,496,453. SWEET SWEAT BY BBF AND DESIGN. INT. CL. 3. REG. 7-19-1988.
1,496,456. PERPLEX. INT. CL. 3. REG. 7-19-1988.
1,496,459. CHAMBRE (STYLIZED). INT. CL. 3. REG. 7-19-1988.
1,496,462. PURETAN. INT. CL. 3. REG. 7-19-1988.
1,496,465. BROADWAY LIGHTS. INT. CL. 3. REG. 7-19-1988.
1,496,467. ON-THE-RUN. INT. CL. 3. REG. 7-19-1988.
1,496,473. PAF. INT. CL. 4. REG. 7-19-1988.
1,496,474. CLEARCO. INT. CL. 4. REG. 7-19-1988.
1,496,475. E-Z COOL. INT. CL. 4. REG. 7-19-1988.
1,496,479. ALWAYS SAVE. INT. CL. 5. REG. 7-19-1988.
1,496,480. SEVERNAL. INT. CL. 5. REG. 7-19-1988.
1,496,487. BIOTELL. INT. CL. 5. REG. 7-19-1988.
1,496,488. ZINCARE ZM MAKES SKIN CARE A WHOLE LOT EASIER TO SWALLOW. INT. CL. 5. REG. 7-19-1988.
1,496,489. PERKACIT. INT. CL. 5. REG. 7-19-1988.
1,496,490. NAURA HAYDEN'S DOLOMINTS. INT. CL. 5. REG. 7-19-1988.
1,496,500. STRIP-'N-TAPE. INT. CL. 5. REG. 7-19-1988.
1,496,502. GRUB BUSTER AND DESIGN. INT. CL. 5. REG. 7-19-1988.
1,496,504. NOT JUST PHYSICALLY FIT - NUTRITIONALLY FIT. INT. CL. 5. REG. 7-19-1988.
1,496,507. EYL. INT. CL. 5. REG. 7-19-1988.
1,496,514. MARINER. INT. CL. 5. REG. 7-19-1988.
1,496,518. EXTRACTIVE. INT. CL. 5. REG. 7-19-1988.
1,496,522. CRITICAL MASS. INT. CL. 5. REG. 7-19-1988.
1,496,533. DERMICARE. INT. CL. 5. REG. 7-19-1988.
1,496,546. MOVADO. INT. CL. 6. REG. 7-19-1988.
1,496,547. DECK-LOCK. INT. CL. 6. REG. 7-19-1988.
1,496,561. UNI-ROD. INT. CL. 7. REG. 7-19-1988.
1,496,562. PRO BLADE. INT. CL. 7. REG. 7-19-1988.
1,496,563. LAB-LINE LLI AND DESIGN. INT. CLS. 8, 9 AND 11. REG. 7-19-1988.
1,496,564. MISCELLANEOUS DESIGN. INT. CL. 8. REG. 7-19-1988.
1,496,565. HANDY SAFETY CUTTER. INT. CL. 8. REG. 7-19-1988.
1,496,569. TEL-CHECK. INT. CLS. 9 AND 42. REG. 7-19-1988.
1,496,571. OPTIGRAPHICS. INT. CL. 9. REG. 7-19-1988.
1,496,575. SEA RANGER. INT. CLS. 9 AND 12. REG. 7-19-1988.
1,496,576. TELE TOUCH AND DESIGN. INT. CL. 9. REG. 7-19-1988.
1,496,580. CONFERENCE-MATE. INT. CL. 9. REG. 7-19-1988.
1,496,585. CATS EYES. INT. CL. 9. REG. 7-19-1988.
1,496,591. MISCELLANEOUS DESIGN. INT. CLS. 9, 11 AND 17. REG. 7-19-1988.
1,496,594. FIRST CLASS AND DESIGN. INT. CLS. 9, 11, 20 AND 21. REG. 7-19-1988.
1,496,600. MICROLITE AND DESIGN. INT. CL. 9. REG. 7-19-1988.
1,496,601. CINE-VIEW. INT. CL. 9. REG. 7-19-1988.
1,496,603. DRAGONFLY. INT. CL. 9. REG. 7-19-1988.
1,496,617. COUNTER-SYNC. INT. CL. 9. REG. 7-19-1988.
1,496,618. DESIGN/1. INT. CL. 9. REG. 7-19-1988.
1,496,619. INSTALL/1. INT. CL. 9. REG. 7-19-1988.
1,496,620. METHOD/1. INT. CL. 9. REG. 7-19-1988.
1,496,621. SILENTWRITER. INT. CL. 9. REG. 7-19-1988.
1,496,623. MICHELE (STYLIZED). INT. CL. 9. REG. 7-19-1988.
1,496,626. CEAL. INT. CL. 9. REG. 7-19-1988.
1,496,639. OMNISCAN. INT. CL. 9. REG. 7-19-1988.
1,496,640. MISCELLANEOUS DESIGN. INT. CL. 9. REG. 7-19-1988.
1,496,642. COMPU-SONIC. INT. CL. 9. REG. 7-19-1988.
1,496,643. COURTHOUSE. INT. CL. 9. REG. 7-19-1988.
1,496,647. DA VINCI SYSTEMS. INT. CL. 9. REG. 7-19-1988.
1,496,649. PRS. INT. CL. 9. REG. 7-19-1988.
1,496,650. ACROSS THE BOARDS. INT. CL. 9. REG. 7-19-1988.
1,496,652. SONOCARE. INT. CL. 10. REG. 7-19-1988.
1,496,653. CELEBRITY. INT. CL. 10. REG. 7-19-1988.
1,496,663. FLUIDOTHERAPY. INT. CL. 10. REG. 7-19-1988.
1,496,665. HVS. INT. CL. 10. REG. 7-19-1988.
1,496,670. BYCEP. INT. CL. 10. REG. 7-19-1988.
1,496,680. JUNIOR CHIL-ER (STYLIZED). INT. CL. 11. REG. 7-19-1988.
1,496,686. UCAR. INT. CL. 11. REG. 7-19-1988.

- 1,496,688. VENT-RITE. INT. CL. 11. REG. 7-19-1988.
1,496,690. HARD ROCK (STYLIZED). INT. CL. 12. REG. 7-19-1988.
1,496,691. ASCOT AND DESIGN. INT. CL. 12. REG. 7-19-1988.
1,496,693. DIABLO. INT. CL. 12. REG. 7-19-1988.
1,496,699. ORION. INT. CL. 12. REG. 7-19-1988.
1,496,705. LE LIMITEDITION (STYLIZED). INT. CL. 14. REG. 7-19-1988.
1,496,707. VICTORY. INT. CL. 14. REG. 7-19-1988.
1,496,712. MOVADO. INT. CL. 14. REG. 7-19-1988.
1,496,715. SPIEGEL (STYLIZED). INT. CLS. 16 AND 42. REG. 7-19-1988.
1,496,718. CALIFORNIA-ARIZONA FARM PRESS. INT. CL. 16. REG. 7-19-1988.
1,496,719. I&T PRODUCT FILE. INT. CL. 16. REG. 7-19-1988.
1,496,721. TRUETEST. INT. CLS. 16, 41 AND 42. REG. 7-19-1988.
1,496,722. PIZZA TODAY AND DESIGN. INT. CL. 16. REG. 7-19-1988.
1,496,726. PAGEMAKER. INT. CL. 16. REG. 7-19-1988.
1,496,728. ATSI (STYLIZED). INT. CLS. 16 AND 41. REG. 7-19-1988.
1,496,731. HOT STACK. INT. CL. 16. REG. 7-19-1988.
1,496,735. RENAISSANCE RENDERINGS. INT. CL. 16. REG. 7-19-1988.
1,496,738. OPTIMUM. INT. CL. 16. REG. 7-19-1988.
1,496,742. WORD HUNT. INT. CL. 16. REG. 7-19-1988.
1,496,744. POCKET MONTHLY. INT. CL. 16. REG. 7-19-1988.
1,496,746. SPHERE O CELL. INT. CL. 16. REG. 7-19-1988.
1,496,749. TEEN WORKS. INT. CL. 16. REG. 7-19-1988.
1,496,751. MOVADO. INT. CL. 16. REG. 7-19-1988.
1,496,753. CW COUNTERWEIGHT AND DESIGN. INT. CL. 16. REG. 7-19-1988.
1,496,754. EXCELLENCE. INT. CL. 16. REG. 7-19-1988.
1,496,757. CHARMIN BIG SQUEEZE. INT. CL. 16. REG. 7-19-1988.
1,496,760. LAMIDYNE. INT. CL. 17. REG. 7-19-1988.
1,496,767. FLEXEEN. INT. CL. 17. REG. 7-19-1988.
1,496,768. THERM-A-LECTRIC. INT. CL. 17. REG. 7-19-1988.
1,496,769. EUROSREEN. INT. CL. 17. REG. 7-19-1988.
1,496,770. W PYTHON AND DESIGN. INT. CL. 17. REG. 7-19-1988.
1,496,772. GENERAL. INT. CL. 17. REG. 7-19-1988.
1,496,773. PERFORMANCE TINT. INT. CL. 17. REG. 7-19-1988.
1,496,775. TBM. INT. CL. 17. REG. 7-19-1988.
1,496,778. JACQUELINE FERRAR. INT. CL. 18. REG. 7-19-1988.
1,496,780. INTEGRATED. INT. CL. 19. REG. 7-19-1988.
1,496,783. CASTLITE. INT. CL. 19. REG. 7-19-1988.
1,496,784. THE PREMIUM CHOICE. INT. CL. 19. REG. 7-19-1988.
1,496,786. ASHLAND AND DESIGN. INT. CL. 20. REG. 7-19-1988.
1,496,789. SPLASH CLIP. INT. CL. 20. REG. 7-19-1988.
1,496,792. CLOUDS. INT. CL. 20. REG. 7-19-1988.
1,496,793. FUTONAIR. INT. CL. 20. REG. 7-19-1988.
1,496,796. THROW-A-FIT. INT. CL. 20. REG. 7-19-1988.
1,496,801. EXCALIBUR. INT. CL. 20. REG. 7-19-1988.
1,496,802. ZEPHYR. INT. CL. 20. REG. 7-19-1988.
1,496,805. MACROCIDE. INT. CL. 20. REG. 7-19-1988.
1,496,808. DOMINION CHINA, LTD. AND DESIGN. INT. CL. 21. REG. 7-19-1988.
1,496,810. REGO AND DESIGN. INT. CL. 21. REG. 7-19-1988.
1,496,811. ENGLEWOOD. INT. CL. 21. REG. 7-19-1988.
1,496,828. SI (STYLIZED). INT. CL. 25. REG. 7-19-1988.
1,496,830. MICRON. INT. CLS. 25 AND 28. REG. 7-19-1988.
1,496,844. SMART STRAPS. INT. CL. 25. REG. 7-19-1988.
1,496,846. ATLANTIC BLEU. INT. CL. 25. REG. 7-19-1988.
1,496,851. ACCENTUETTE. INT. CL. 25. REG. 7-19-1988.
1,496,852. MILDRED & FREDDI. INT. CL. 25. REG. 7-19-1988.
1,496,854. NATURAL LIGHT AND DESIGN. INT. CL. 25. REG. 7-19-1988.
1,496,860. COLD FEET. INT. CL. 25. REG. 7-19-1988.
1,496,864. KITTENS. INT. CL. 25. REG. 7-19-1988.
1,496,865. FLORA KUNG. INT. CL. 25. REG. 7-19-1988.
1,496,866. NO COUNT. INT. CL. 26. REG. 7-19-1988.
1,496,870. METROPOLITAN. INT. CL. 27. REG. 7-19-1988.
1,496,876. HAKATA DOLL ASSOCIATION GENUINE HAKATA DOLL AND DESIGN. INT. CL. 28. REG. 7-19-1988.
1,496,885. JOHN-L. INT. CL. 28. REG. 7-19-1988.
1,496,888. SPARKLE EGGS. INT. CL. 28. REG. 7-19-1988.
1,496,890. SKILL BUILDERS. INT. CL. 28. REG. 7-19-1988.
1,496,892. ATF ADVANCED TACTICAL FIGHTER. INT. CL. 28. REG. 7-19-1988.
1,496,894. LOVE-A-BYE BABY AND DESIGN. INT. CL. 28. REG. 7-19-1988.
1,496,895. LIFE TRENDS. INT. CL. 28. REG. 7-19-1988.
1,496,898. CASH IN O. INT. CL. 28. REG. 7-19-1988.
1,496,904. MARKET SQUARE FOOD COMPANY INC. AND DESIGN. INT. CLS. 29 AND 30. REG. 7-19-1988.
1,496,906. ROCKY TOP FARMS. INT. CL. 29. REG. 7-19-1988.
1,496,912. SHARON VALLEY 778 (STYLIZED). INT. CLS. 29 AND 30. REG. 7-19-1988.
1,496,915. TUFF STUFF AND DESIGN. INT. CL. 29. REG. 7-19-1988.
1,496,917. PLUMROSE PREMIUM QUALITY AND DESIGN. INT. CL. 29. REG. 7-19-1988.
1,496,925. BARRICINI. INT. CL. 30. REG. 7-19-1988.
1,496,928. CREAMIE. INT. CL. 30. REG. 7-19-1988.
1,496,932. ROYAL COURT COOKIE COMPANY (STYLIZED). INT. CL. 30. REG. 7-19-1988.
1,496,933. J. R. SIMPLOT. INT. CL. 30. REG. 7-19-1988.
1,496,934. LAVAZZA CLUB LAVAZZA AND DESIGN. INT. CL. 30. REG. 7-19-1988.
1,496,939. COFFEE CORDIALS. INT. CL. 30. REG. 7-19-1988.
1,496,940. MISCELLANEOUS DESIGN. INT. CL. 30. REG. 7-19-1988.
1,496,941. MISCELLANEOUS DESIGN. INT. CL. 30. REG. 7-19-1988.
1,496,947. FRANKWICH. INT. CL. 30. REG. 7-19-1988.
1,496,949. P PEET'S (STYLIZED). INT. CLS. 30 AND 42. REG. 7-19-1988.
1,496,955. MONASTERY. INT. CL. 30. REG. 7-19-1988.
1,496,957. IT'S NOT EASY BEING CHEESY. INT. CL. 30. REG. 7-19-1988.
1,496,958. POONGNYUN. INT. CL. 30. REG. 7-19-1988.
1,496,959. FIT CLASS. INT. CL. 30. REG. 7-19-1988.
1,496,960. TRADITIONAL CLASSICS. INT. CL. 30. REG. 7-19-1988.
1,496,962. N NOSCO AND DESIGN. INT. CL. 31. REG. 7-19-1988.
1,496,963. FLATAZOR. INT. CL. 31. REG. 7-19-1988.
1,496,964. BACONMAKER. INT. CL. 31. REG. 7-19-1988.
1,496,965. MISCELLANEOUS DESIGN. INT. CL. 31. REG. 7-19-1988.
1,496,966. MXD. INT. CL. 31. REG. 7-19-1988.
1,496,974. MISCELLANEOUS DESIGN. INT. CL. 32. REG. 7-19-1988.
1,496,977. SAMBUCA SARTI. INT. CL. 33. REG. 7-19-1988.
1,496,983. J.P. WISER'S (STYLIZED). INT. CL. 33. REG. 7-19-1988.
1,496,988. BALBOA. INT. CL. 34. REG. 7-19-1988.
1,496,991. THE NORTH CAROLINA PERSONAL INJURY REFERRAL SERVICE AND DESIGN. INT. CL. 35. REG. 7-19-1988.
1,496,996. PRODUCTSCAN AND DESIGN. INT. CLS. 35 AND 42. REG. 7-19-1988.
1,496,997. HORIZON AND DESIGN. INT. CL. 35. REG. 7-19-1988.
1,497,001. SUPER BOWL SAVINGS SPECTACULAR NFL AND DESIGN. INT. CL. 35. REG. 7-19-1988.
1,497,003. INTERNATIONAL COMMUNICATIONS GROUP, INC.. INT. CL. 35. REG. 7-19-1988.
1,497,004. RAPID ON-LINE ROLIN INFORMATION NETWORK AND DESIGN. INT. CLS. 35 AND 42. REG. 7-19-1988.
1,497,007. MISCELLANEOUS DESIGN. INT. CL. 35. REG. 7-19-1988.
1,497,016. MISCELLANEOUS DESIGN. INT. CL. 35. REG. 7-19-1988.

- 1,497,019. BUTTERFIELD & BUTTERFIELD. INT. CLS. 35 AND 36. REG. 7-19-1988.
- 1,497,020. PS PROFESSIONAL SUPPLY NETWORK (STYLIZED). INT. CL. 35. REG. 7-19-1988.
- 1,497,022. HELPING CLIENTS SUCCEED. INT. CL. 35. REG. 7-19-1988.
- 1,497,025. SOYASCAN. INT. CL. 35. REG. 7-19-1988.
- 1,497,027. CGT CONSOLIDATED GROUP (STYLIZED). INT. CL. 36. REG. 7-19-1988.
- 1,497,028. PACIFIC EXPRESS. INT. CL. 36. REG. 7-19-1988.
- 1,497,034. REAL LIFE, REAL ANSWERS. INT. CL. 36. REG. 7-19-1988.
- 1,497,036. NYNEX. INT. CLS. 36 AND 38. REG. 7-19-1988.
- 1,497,038. MISCELLANEOUS DESIGN. INT. CLS. 36 AND 41. REG. 7-19-1988.
- 1,497,039. COMMISSION PLUS. INT. CL. 36. REG. 7-19-1988.
- 1,497,042. SECURE CARE AND DESIGN. INT. CL. 36. REG. 7-19-1988.
- 1,497,045. MERCER COUNTY BANK. INT. CL. 36. REG. 7-19-1988.
- 1,497,046. MISCELLANEOUS DESIGN. INT. CL. 36. REG. 7-19-1988.
- 1,497,048. IC (STYLIZED). INT. CL. 36. REG. 7-19-1988.
- 1,497,050. MISCELLANEOUS DESIGN. INT. CL. 36. REG. 7-19-1988.
- 1,497,056. MISCELLANEOUS DESIGN. INT. CL. 36. REG. 7-19-1988.
- 1,497,059. THE MONOGRAM BANK AND DESIGN. INT. CL. 36. REG. 7-19-1988.
- 1,497,080. BMS CAT AND DESIGN. INT. CL. 37. REG. 7-19-1988.
- 1,497,081. AUTOSTYLE (STYLIZED). INT. CL. 37. REG. 7-19-1988.
- 1,497,088. CABLEVISION AND DESIGN. INT. CL. 38. REG. 7-19-1988.
- 1,497,091. A AND DESIGN. INT. CL. 38. REG. 7-19-1988.
- 1,497,096. TELEGRAM AND DESIGN. INT. CL. 38. REG. 7-19-1988.
- 1,497,097. KTN. INT. CL. 38. REG. 7-19-1988.
- 1,497,098. ALPHATEL. INT. CL. 39. REG. 7-19-1988.
- 1,497,103. BEKINS STOR'N MOR AND DESIGN. INT. CL. 39. REG. 7-19-1988.
- 1,497,106. CON-WAY SOUTHERN EXPRESS. INT. CL. 39. REG. 7-19-1988.
- 1,497,112. CRUISE AMERICA AND DESIGN. INT. CLS. 39 AND 42. REG. 7-19-1988.
- 1,497,113. SNEAK-A-WEEK. INT. CL. 39. REG. 7-19-1988.
- 1,497,118. NATIONAL HIGH SCHOOL FINALS RODEO NHSRA AND DESIGN. INT. CL. 41. REG. 7-19-1988.
- 1,497,121. TP AND DESIGN. INT. CL. 41. REG. 7-19-1988.
- 1,497,122. FOR FATHERS ONLY AND THEIR BABIES AND DESIGN. INT. CL. 41. REG. 7-19-1988.
- 1,497,131. SPORT SENSE. INT. CL. 41. REG. 7-19-1988.
- 1,497,135. DWARF ISLAND AND DESIGN. INT. CL. 41. REG. 7-19-1988.
- 1,497,143. SHOW BIZ VIDEO. INT. CL. 41. REG. 7-19-1988.
- 1,497,144. MISCELLANEOUS DESIGN. INT. CL. 41. REG. 7-19-1988.
- 1,497,146. WOMEN OF THE CALABASH. INT. CL. 41. REG. 7-19-1988.
- 1,497,148. PROTELE. INT. CL. 41. REG. 7-19-1988.
- 1,497,153. CARETTA RACING AND DESIGN. INT. CL. 41. REG. 7-19-1988.
- 1,497,155. M.C.S. EST.-1949 AND DESIGN. INT. CL. 41. REG. 7-19-1988.
- 1,497,158. PUP CHECK. INT. CL. 41. REG. 7-19-1988.
- 1,497,162. MAJOR. INT. CL. 42. REG. 7-19-1988.
- 1,497,164. LITTLE FOLK SHOP. INT. CL. 42. REG. 7-19-1988.
- 1,497,167. POTTS' DOGGIE SHOP AND DESIGN. INT. CL. 42. REG. 7-19-1988.
- 1,497,171. GOOD SAMARITAN HOSPITAL AND DESIGN. INT. CL. 42. REG. 7-19-1988.
- 1,497,172. PARTY WORLD. INT. CL. 42. REG. 7-19-1988.
- 1,497,175. WILDWOOD AMERICA'S BEST CHICKEN AND RIBS (STYLIZED). INT. CL. 42. REG. 7-19-1988.
- 1,497,178. PCR. INT. CL. 42. REG. 7-19-1988.
- 1,497,179. PARTNERS FOR LIFE AND DESIGN. INT. CL. 42. REG. 7-19-1988.
- 1,497,183. WILLOUGHBY'S OF PALOS. INT. CL. 42. REG. 7-19-1988.
- 1,497,199. HORNE'S. INT. CL. 42. REG. 7-19-1988.
- 1,497,203. BEST VALUE (STYLIZED). INT. CL. 42. REG. 7-19-1988.
- 1,497,205. MIAMI'S AND DESIGN. INT. CL. 42. REG. 7-19-1988.
- 1,497,206. MISCELLANEOUS DESIGN. INT. CL. 42. REG. 7-19-1988.
- 1,497,210. NORMEDCO HOME CARE. INT. CL. 42. REG. 7-19-1988.
- 1,497,220. ACCIDENT COUNSELING INC. ATTORNEY FOR THE INJURED AND DESIGN. INT. CL. 42. REG. 7-19-1988.
- 1,497,223. NO PLACE ELSE IS CHILI'S HAMBURGER GRILL & BAR AND DESIGN. INT. CL. 42. REG. 7-19-1988.
- 1,497,232. DAYS LODGE AND DESIGN. INT. CL. 42. REG. 7-19-1988.
- 1,497,233. CAFFE SPASSO AND DESIGN. INT. CL. 42. REG. 7-19-1988.
- 1,497,234. CAFFE SPASSO. INT. CL. 42. REG. 7-19-1988.
- 1,497,235. PEACHTREE PLANNING CENTER. INT. CL. 42. REG. 7-19-1988.
- 1,497,247. NAA NATIONAL AGGREGATES ASSOCIATION (STYLIZED). INT. CL. 42. REG. 7-19-1988.
- 1,497,249. STONE ROWS FLECKVIEH. INT. CL. 42. REG. 7-19-1988.
- 1,497,255. MEDOHIO. INT. CL. 42. REG. 7-19-1988.
- 1,497,268. MISCELLANEOUS DESIGN. INT. CL. 42. REG. 7-19-1988.
- 1,497,271. MISCELLANEOUS DESIGN. INT. CL. 42. REG. 7-19-1988.
- 1,497,272. AM PM (STYLIZED). INT. CL. 42. REG. 7-19-1988.
- 1,497,274. CLINIC VIEW INN. INT. CL. 42. REG. 7-19-1988.
- 1,497,275. GARDEN INN. INT. CL. 42. REG. 7-19-1988.
- 1,497,278. RGM'S NUT HOUSE (STYLIZED). INT. CL. 42. REG. 7-19-1988.
- 1,497,280. MCPIGS. U.S. CL. 200. REG. 7-19-1988.
- 1,497,284. BORRIES MARKING-SYSTEMS. INT. CLS. 7 AND 8. REG. 7-19-1988.
- 1,497,286. PEEL-OFF. INT. CL. 1. REG. 7-19-1988.
- 1,497,288. ONE SCRATCH. INT. CL. 8. REG. 7-19-1988.
- 1,497,295. OBER. INT. CL. 25. REG. 7-19-1988.
- 1,497,296. BARYSHNIKOV. INT. CL. 25. REG. 7-19-1988.
- 1,497,301. OLDE HEURICH (STYLIZED). INT. CL. 32. REG. 7-19-1988.
- 1,497,302. AMERICAN YELLOW PAGE NETWORK. INT. CL. 35. REG. 7-19-1988.
- 1,497,303. GAS MART. INT. CL. 35. REG. 7-19-1988.
- 1,497,308. FISHING THE WEST. INT. CL. 39. REG. 7-19-1988.
- 1,497,541. PLANPERFECT. INT. CL. 9. REG. 7-26-1988.
- 1,497,934. RAINBOW POPS. INT. CL. 30. REG. 7-26-1988.
- 1,535,814. MAD MONEY. INT. CL. 42 ONLY. REG. 4-18-1989.
- 1,565,705. MUSIC TOGETHER. INT. CLS. 9 AND 42 ONLY. REG. 11-14-1989.
- 1,834,534. CONTOUR. INT. CL. 10. REG. 5-3-1994.
- 2,174,148. SPIKE'S TERIYAKI BOWL. INT. CL. 42. REG. 7-21-1998.
- 2,174,149. SPIKE'S AND DESIGN. INT. CL. 42. REG. 7-21-1998.
- 2,174,167. FABNET. INT. CLS. 36 AND 39. REG. 7-21-1998.
- 2,174,168. GLAMOURTOP. INT. CLS. 17 AND 19. REG. 7-21-1998.
- 2,174,189. NATURALS. INT. CL. 9. REG. 7-21-1998.
- 2,174,200. MISCELLANEOUS DESIGN. INT. CL. 6. REG. 7-21-1998.
- 2,174,206. JULIP. INT. CL. 20. REG. 7-21-1998.
- 2,174,217. MVE AND DESIGN. INT. CLS. 6 AND 12. REG. 7-21-1998.
- 2,174,234. TOTALLY ANIMALS. INT. CL. 41. REG. 7-21-1998.
- 2,174,235. CALIFORNIA WAVES. INT. CL. 25. REG. 7-21-1998.

- 2,174,239. CD SAFE AND DESIGN. INT. CL. 9. REG. 7-21-1998.
- 2,174,251. CAMOPLAST #1 IN TRACKS. INT. CLS. 12, 14, 16, 24, 25 AND 26. REG. 7-21-1998.
- 2,174,270. MRI AND DESIGN. INT. CL. 35. REG. 7-21-1998.
- 2,174,278. KRISTY. INT. CL. 21. REG. 7-21-1998.
- 2,174,284. 48 STRAIGHT. INT. CL. 36. REG. 7-21-1998.
- 2,174,286. HARLEY HAHN'S INTERNET EXPLORATION STATION. INT. CLS. 25 AND 42. REG. 7-21-1998.
- 2,174,292. FIGLA. INT. CLS. 37 AND 42. REG. 7-21-1998.
- 2,174,293. BELLE ROUGE. INT. CL. 31. REG. 7-21-1998.
- 2,174,296. UO AND DESIGN. INT. CL. 35. REG. 7-21-1998.
- 2,174,301. WITH COMPASSION. INT. CL. 16. REG. 7-21-1998.
- 2,174,307. J (STYLIZED). INT. CL. 9. REG. 7-21-1998.
- 2,174,311. THERMAL RESEARCH & DEVELOPMENT. INT. CL. 7. REG. 7-21-1998.
- 2,174,320. CELLULAR DEFENSE SHIELD. INT. CL. 3. REG. 7-21-1998.
- 2,174,330. CONSTRUCTIVE CONFRONTATION. INT. CLS. 9, 16 AND 41. REG. 7-21-1998.
- 2,174,348. PIVOT NET AND DESIGN. INT. CL. 42. REG. 7-21-1998.
- 2,174,356. MISCELLANEOUS DESIGN. INT. CL. 9. REG. 7-21-1998.
- 2,174,365. MISCELLANEOUS DESIGN. INT. CL. 35. REG. 7-21-1998.
- 2,174,380. AMATEURS XXX-POSED. INT. CL. 16. REG. 7-21-1998.
- 2,174,384. DRIV. INT. CL. 35. REG. 7-21-1998.
- 2,174,405. ASHWIN. INT. CL. 42. REG. 7-21-1998.
- 2,174,407. COWBOY TACK. INT. CL. 18. REG. 7-21-1998.
- 2,174,416. THE SWIMSUIT FIT SYSTEM AND DESIGN. INT. CL. 25. REG. 7-21-1998.
- 2,174,423. DRINK YOUR NEXT MEAL!. INT. CLS. 5, 29 AND 42. REG. 7-21-1998.
- 2,174,427. PRETTY PLEASE. INT. CL. 25. REG. 7-21-1998.
- 2,174,444. MISCELLANEOUS DESIGN. INT. CLS. 5 AND 30. REG. 7-21-1998.
- 2,174,445. PIANTO AND DESIGN. INT. CLS. 5 AND 30. REG. 7-21-1998.
- 2,174,450. MAKING COLLEGE COUNT. INT. CL. 16. REG. 7-21-1998.
- 2,174,451. YUKON PROTEC. INT. CL. 24. REG. 7-21-1998.
- 2,174,457. CADSHELL. INT. CL. 42. REG. 7-21-1998.
- 2,174,467. HEADWEST AND DESIGN. INT. CLS. 40 AND 42. REG. 7-21-1998.
- 2,174,491. GG GLASHUTTE ORIGINAL (STYLIZED). INT. CLS. 9 AND 14. REG. 7-21-1998.
- 2,174,498. TRAVELING TRUST. INT. CL. 36. REG. 7-21-1998.
- 2,174,510. BAM. INT. CLS. 1 AND 40. REG. 7-21-1998.
- 2,174,511. TOOLZALL. INT. CL. 8. REG. 7-21-1998.
- 2,174,520. USSC. INT. CL. 10. REG. 7-21-1998.
- 2,174,522. POLYFIL. INT. CL. 1. REG. 7-21-1998.
- 2,174,528. ABLE. INT. CL. 1. REG. 7-21-1998.
- 2,174,531. V GRAND VICTORIA CASINO & RESORT AND DESIGN. INT. CLS. 35, 41 AND 42. REG. 7-21-1998.
- 2,174,537. MISCELLANEOUS DESIGN. INT. CLS. 3 AND 5. REG. 7-21-1998.
- 2,174,548. FACI. INT. CLS. 6 AND 9. REG. 7-21-1998.
- 2,174,549. DA KINE DIEGO'S INSANE BURRITOS. INT. CL. 42. REG. 7-21-1998.
- 2,174,559. MISCELLANEOUS DESIGN. INT. CL. 42. REG. 7-21-1998.
- 2,174,563. PROTECT ME! WITH APC AND DESIGN. INT. CL. 9. REG. 7-21-1998.
- 2,174,566. SKILLSOURCE (STYLIZED). INT. CLS. 35 AND 41. REG. 7-21-1998.
- 2,174,577. LIMESWEET. INT. CL. 1. REG. 7-21-1998.
- 2,174,587. OUTRIDER. INT. CLS. 9 AND 41. REG. 7-21-1998.
- 2,174,592. SOUTHERN COMPANY. INT. CL. 42. REG. 7-21-1998.
- 2,174,595. REAL AND DESIGN. INT. CL. 42. REG. 7-21-1998.
- 2,174,597. BACKSTAGE PASS. INT. CL. 41. REG. 7-21-1998.
- 2,174,603. LAST TIME METAL ROOFING AND DESIGN. INT. CL. 6. REG. 7-21-1998.
- 2,174,605. ROUTE TO REFRESHMENT. INT. CL. 42. REG. 7-21-1998.
- 2,174,620. ALPHACAM. INT. CL. 9. REG. 7-21-1998.
- 2,174,632. SUREPOWER. INT. CL. 9. REG. 7-21-1998.
- 2,174,635. DIGSS VOLLEYWEAR AND DESIGN. INT. CL. 25. REG. 7-21-1998.
- 2,174,638. SCOTTY P AND DESIGN. INT. CL. 25. REG. 7-21-1998.
- 2,174,646. "HAWAIIAN SHIRT KINDA GUY:!" (COOL) REBELLIOUS IN NATURE; SHIRT REPRESENTS ATTITUDE; WILD, SOMETIMES LOUD BUT ALWAYS CASUAL; CARES MORE ABOUT COMFORT THAN SOCIETAL NORMS.. INT. CL. 25. REG. 7-21-1998.
- 2,174,649. MISCELLANEOUS DESIGN. INT. CL. 11. REG. 7-21-1998.
- 2,174,650. NASH BRIDGES. INT. CL. 41. REG. 7-21-1998.
- 2,174,653. DDBUILDER. INT. CL. 9. REG. 7-21-1998.
- 2,174,667. PEAR CUP. INT. CL. 29. REG. 7-21-1998.
- 2,174,672. PANAX GINSENG EXTRACT AND DESIGN. INT. CL. 32. REG. 7-21-1998.
- 2,174,679. WARPAIDE. INT. CL. 5. REG. 7-21-1998.
- 2,174,692. JACOB NORTH COMPANIES AND DESIGN. INT. CL. 42. REG. 7-21-1998.
- 2,174,696. MISCELLANEOUS DESIGN. INT. CL. 42. REG. 7-21-1998.
- 2,174,698. * NOMAD (STYLIZED). INT. CL. 9. REG. 7-21-1998.
- 2,174,702. S STUDIO EIGHTY FOUR (STYLIZED). INT. CL. 20. REG. 7-21-1998.
- 2,174,708. COFFEE MILL COLLECTION. INT. CL. 4. REG. 7-21-1998.
- 2,174,730. TABLE FOR SIX BILLION, PLEASE. INT. CL. 41. REG. 7-21-1998.
- 2,174,731. METROLINA TAX SERVICE AND DESIGN. INT. CL. 35. REG. 7-21-1998.
- 2,174,736. LOS MORROS DEL NORTE (STYLIZED). INT. CL. 9. REG. 7-21-1998.
- 2,174,744. INTERCOUNSEL. INT. CLS. 35 AND 42. REG. 7-21-1998.
- 2,174,747. ADI X (STYLIZED). INT. CL. 36. REG. 7-21-1998.
- 2,174,768. WEB SIDE STORY. INT. CL. 42. REG. 7-21-1998.
- 2,174,776. PASSIONS PARADISO. INT. CL. 20. REG. 7-21-1998.
- 2,174,777. PRACTICAL LAWYERS PROVIDING PRACTICAL SOLUTIONS. INT. CL. 42. REG. 7-21-1998.
- 2,174,779. WORKMIND. INT. CL. 35. REG. 7-21-1998.
- 2,174,785. DATACARE. INT. CL. 9. REG. 7-21-1998.
- 2,174,796. CELEB CENTRAL. INT. CL. 35. REG. 7-21-1998.
- 2,174,800. PACKAGING DEFINES IT! AND DESIGN. INT. CL. 16. REG. 7-21-1998.
- 2,174,803. DRI HAND. INT. CL. 21. REG. 7-21-1998.
- 2,174,812. COMPUTER WEAR. INT. CL. 20. REG. 7-21-1998.
- 2,174,813. YOU MOVE MOUNTAINS...WE KEEP THEM THERE!. INT. CL. 42. REG. 7-21-1998.
- 2,174,815. ADVENTURE FITNESS TRAINING. INT. CL. 41. REG. 7-21-1998.
- 2,174,831. VIBROMATIC COMPANY, INC. AND DESIGN. INT. CL. 7. REG. 7-21-1998.
- 2,174,838. MOONDANCE. INT. CL. 39. REG. 7-21-1998.
- 2,174,844. HITBOX. INT. CL. 42. REG. 7-21-1998.
- 2,174,849. ADD AND DESIGN. INT. CL. 9. REG. 7-21-1998.
- 2,174,856. A FOOT OF FEET. INT. CL. 30. REG. 7-21-1998.
- 2,174,857. 196. INT. CL. 38. REG. 7-21-1998.
- 2,174,859. BY THE SLICE HONEYBAKED HAM AND DESIGN. INT. CLS. 29 AND 30. REG. 7-21-1998.
- 2,174,878. PACK IT IN. INT. CL. 21. REG. 7-21-1998.
- 2,174,903. E EDGETECH BETWEEN YOU AND THE ELEMENTS. AND DESIGN. INT. CL. 17. REG. 7-21-1998.
- 2,174,906. ACCESS.AIG.COM. INT. CL. 36. REG. 7-21-1998.
- 2,174,911. ACUVISION. INT. CL. 9. REG. 7-21-1998.
- 2,174,916. DRAGON. INT. CL. 30. REG. 7-21-1998.
- 2,174,926. TRIRI AND DESIGN. INT. CL. 39. REG. 7-21-1998.
- 2,174,940. CAC. INT. CLS. 37 AND 42. REG. 7-21-1998.
- 2,174,950. TRANSITION MATTERS. INT. CL. 41. REG. 7-21-1998.
- 2,174,969. GPSOLUTION. INT. CL. 9. REG. 7-21-1998.

- 2,174,982. SUPER STAR. INT. CLS. 3, 9 AND 15. REG. 7-21-1998.
- 2,174,987. RETAIL RIGHT. INT. CL. 35. REG. 7-21-1998.
- 2,174,993. EZCATCHER. INT. CL. 28. REG. 7-21-1998.
- 2,175,000. WILBUR (STYLIZED). INT. CL. 9. REG. 7-21-1998.
- 2,175,001. RICOLA AND DESIGN. INT. CLS. 5 AND 30. REG. 7-21-1998.
- 2,175,010. STEELCASE WORKPLACE PERFORMANCE. INT. CLS. 9 AND 42. REG. 7-21-1998.
- 2,175,027. MISCELLANEOUS DESIGN. INT. CL. 36. REG. 7-21-1998.
- 2,175,030. SUNDIAL ASHANTI. INT. CL. 5. REG. 7-21-1998.
- 2,175,044. TOTAL INTEGRATION. INT. CL. 41. REG. 7-21-1998.
- 2,175,048. PATHFINDER+. INT. CL. 9. REG. 7-21-1998.
- 2,175,061. QUARTERBACK. INT. CL. 36. REG. 7-21-1998.
- 2,175,063. ALLIRICH (STYLIZED). INT. CL. 5. REG. 7-21-1998.
- 2,175,086. SITTING SAC. INT. CL. 28. REG. 7-21-1998.
- 2,175,087. TUCK ME IN'S. INT. CL. 28. REG. 7-21-1998.
- 2,175,091. SAFETGRO. INT. CL. 1. REG. 7-21-1998.
- 2,175,092. WILBUR (STYLIZED). INT. CL. 28. REG. 7-21-1998.
- 2,175,097. PORCH SWING. INT. CL. 32. REG. 7-21-1998.
- 2,175,098. I (STYLIZED). INT. CL. 42. REG. 7-21-1998.
- 2,175,099. SPINGRIP. INT. CL. 28. REG. 7-21-1998.
- 2,175,100. MURRAY. INT. CLS. 16 AND 28. REG. 7-21-1998.
- 2,175,111. NORTHERN FUNDS AND DESIGN. INT. CL. 36. REG. 7-21-1998.
- 2,175,115. KEYBANK USA AND DESIGN. INT. CL. 36. REG. 7-21-1998.
- 2,175,127. MONTANA SUNFLOWER COMPANY. INT. CL. 31. REG. 7-21-1998.
- 2,175,132. THE ONE SHOW. INT. CL. 41. REG. 7-21-1998.
- 2,175,136. SUPERCHEESE. INT. CL. 30. REG. 7-21-1998.
- 2,175,172. NULITE. INT. CL. 40. REG. 7-21-1998.
- 2,175,175. MORE VALUABLE THAN GOLD.. INT. CL. 41. REG. 7-21-1998.
- 2,175,177. FOR TRAINING THAT COUNTS. INT. CL. 41. REG. 7-21-1998.
- 2,175,178. PITA PIPER. INT. CLS. 30 AND 42. REG. 7-21-1998.
- 2,175,184. LIVINGSTON. INT. CL. 20. REG. 7-21-1998.
- 2,175,188. THE KIND OF PEOPLE YOU'D HIRE YOURSELF. INT. CL. 35. REG. 7-21-1998.
- 2,175,189. UNISURE. INT. CL. 9. REG. 7-21-1998.
- 2,175,193. SWEET BREATH SORBET. INT. CL. 3. REG. 7-21-1998.
- 2,175,195. SOUTH BEACH. INT. CL. 30. REG. 7-21-1998.
- 2,175,201. TROUBLE SPOT. INT. CL. 9. REG. 7-21-1998.
- 2,175,208. WARTHOG. INT. CL. 25. REG. 7-21-1998.
- 2,175,213. COURT OF VERSAILLES AND DESIGN. INT. CL. 27. REG. 7-21-1998.
- 2,175,214. HERBIE AND DESIGN. INT. CLS. 9, 16 AND 28. REG. 7-21-1998.
- 2,175,216. CHATEAU CHOCOLAT. INT. CL. 30. REG. 7-21-1998.
- 2,175,229. DRAKE. INT. CL. 22. REG. 7-21-1998.
- 2,175,230. PARTNERS FOR HEALTHY AGING. INT. CLS. 36 AND 42. REG. 7-21-1998.
- 2,175,239. SCANCAST 3D. INT. CLS. 9 AND 10. REG. 7-21-1998.
- 2,175,244. COMMUNITY EXCHANGE AND DESIGN. INT. CL. 35. REG. 7-21-1998.
- 2,175,246. 'FLUFFIES' AND DESIGN. INT. CL. 25. REG. 7-21-1998.
- 2,175,251. ANIMAL PLANET. INT. CL. 16. REG. 7-21-1998.
- 2,175,259. CAN-A-GRAM AND DESIGN. INT. CLS. 20 AND 30. REG. 7-21-1998.
- 2,175,264. MISCELLANEOUS DESIGN. INT. CL. 25. REG. 7-21-1998.
- 2,175,277. FIELDTECH. INT. CLS. 41 AND 42. REG. 7-21-1998.
- 2,175,297. MISCELLANEOUS DESIGN. INT. CL. 29. REG. 7-21-1998.
- 2,175,300. RESUMEROUTING. INT. CL. 9. REG. 7-21-1998.
- 2,175,301. NOMAR. INT. CL. 1. REG. 7-21-1998.
- 2,175,309. SURFWARE. INT. CL. 9. REG. 7-21-1998.
- 2,175,310. HONEY CREEK. INT. CL. 5. REG. 7-21-1998.
- 2,175,324. SOARING SPIRIT. INT. CL. 9. REG. 7-21-1998.
- 2,175,331. SPEDI*STAT. INT. CL. 9. REG. 7-21-1998.
- 2,175,332. TUMMY TAMER. INT. CL. 5. REG. 7-21-1998.
- 2,175,340. CONSULTEAM. INT. CL. 35. REG. 7-21-1998.
- 2,175,342. EUROSMARTZ. INT. CL. 9. REG. 7-21-1998.
- 2,175,346. ONE LAC. INT. CL. 31. REG. 7-21-1998.
- 2,175,389. SOFT-TECH. INT. CL. 20. REG. 7-21-1998.
- 2,175,392. XCALIBRE. INT. CL. 9. REG. 7-21-1998.
- 2,175,398. INFOWORLD ELECTRIC. INT. CL. 42. REG. 7-21-1998.
- 2,175,402. USAR AND DESIGN. INT. CL. 3. REG. 7-21-1998.
- 2,175,408. SMARTWAFER. INT. CL. 9. REG. 7-21-1998.
- 2,175,421. PEAK AND DESIGN. INT. CL. 3. REG. 7-21-1998.
- 2,175,425. LIGHTNING DEAL REVIEWER. INT. CL. 9. REG. 7-21-1998.
- 2,175,433. COMSCAPE. INT. CL. 38. REG. 7-21-1998.
- 2,175,452. FOR THE RECORD. INT. CL. 16. REG. 7-21-1998.
- 2,175,464. SPECIFIED POWER DEVICES. INT. CL. 9. REG. 7-21-1998.
- 2,175,498. LUXSONOR. INT. CL. 9. REG. 7-21-1998.
- 2,175,505. JEANETICS. INT. CL. 25. REG. 7-21-1998.
- 2,175,514. BAYRHO-D. INT. CL. 5. REG. 7-21-1998.
- 2,175,520. COFFEE DROP AND DESIGN. INT. CL. 30. REG. 7-21-1998.
- 2,175,558. SHOP WISE SUPERMARKETS. INT. CL. 35. REG. 7-21-1998.
- 2,175,565. TERAYON. INT. CL. 9. REG. 7-21-1998.
- 2,175,568. BELLA ISLA. INT. CL. 29. REG. 7-21-1998.
- 2,175,578. EVENT CASH. INT. CLS. 9 AND 36. REG. 7-21-1998.
- 2,175,606. PHYSICS PARK (STYLIZED). INT. CL. 41. REG. 7-21-1998.
- 2,175,609. CAPITAL ACROSS AMERICA. INT. CL. 36. REG. 7-21-1998.
- 2,175,613. ST. BARTHELMEH. INT. CL. 33. REG. 7-21-1998.
- 2,175,616. ATTACHE (STYLIZED). INT. CL. 16. REG. 7-21-1998.
- 2,175,621. PETSHOTEL PLUS. INT. CL. 42. REG. 7-21-1998.
- 2,175,623. MORGAN MILLS. INT. CL. 25. REG. 7-21-1998.
- 2,175,627. EVOCA. INT. CL. 9. REG. 7-21-1998.
- 2,175,644. EMDOCS. INT. CL. 42. REG. 7-21-1998.
- 2,175,648. PITT PENN. INT. CLS. 1, 3 AND 4. REG. 7-21-1998.
- 2,175,651. LEAN & FIT. INT. CL. 31. REG. 7-21-1998.
- 2,175,653. THE FASCINATION STATION CHILD CARE AND ENHANCED LEARNING CENTER. INT. CL. 42. REG. 7-21-1998.
- 2,175,657. OUTTA THE BOX (STYLIZED). INT. CL. 16. REG. 7-21-1998.
- 2,175,658. ILLUMINATOR. INT. CL. 13. REG. 7-21-1998.
- 2,175,667. STEALTH SYSTEM. INT. CL. 26. REG. 7-21-1998.
- 2,175,673. PACIFIC ECHO. INT. CL. 33. REG. 7-21-1998.
- 2,175,683. CITRAFLO. INT. CL. 1. REG. 7-21-1998.
- 2,175,694. PERIOVIEW. INT. CL. 10. REG. 7-21-1998.
- 2,175,695. DENTALVIEW. INT. CL. 10. REG. 7-21-1998.
- 2,175,715. EVENTRACK. INT. CLS. 9 AND 42. REG. 7-21-1998.
- 2,175,719. BIBLEZONE. INT. CL. 16. REG. 7-21-1998.
- 2,175,722. PACIFIC EXCHANGE. INT. CL. 36. REG. 7-21-1998.
- 2,175,728. DONNELLEY SENDD. INT. CLS. 38 AND 42. REG. 7-21-1998.
- 2,175,738. MICROHARD RECRUIT RIGHT. INT. CL. 9. REG. 7-21-1998.
- 2,175,742. ACCESS TO THE HIGHEST STANDARDS. INT. CL. 36. REG. 7-21-1998.
- 2,175,762. HAMPTON ROSE. INT. CL. 16. REG. 7-21-1998.
- 2,175,782. SUPER FUNNEL CARTRIDGE. INT. CL. 10. REG. 7-21-1998.
- 2,175,788. KIDS KEEP IT DIGITAL STUPID AND DESIGN. INT. CL. 25. REG. 7-21-1998.
- 2,175,790. BANK@HOME. INT. CL. 36. REG. 7-21-1998.
- 2,175,794. BRAND BUILDERS AND DESIGN. INT. CL. 16. REG. 7-21-1998.
- 2,175,798. CONVERGENT BILLING PLATFORM. INT. CL. 9. REG. 7-21-1998.
- 2,175,801. VOLUME GEL. INT. CL. 3. REG. 7-21-1998.

- 2,175,812. CHILDREN'S APPAREL NETWORK. INT. CL. 35. REG. 7-21-1998.
- 2,175,828. ECD. INT. CL. 7. REG. 7-21-1998.
- 2,175,833. CHEMICAL DISTRIBUTORS OF AMERICA. INT. CL. 42. REG. 7-21-1998.
- 2,175,835. NATIONAL HEALING. INT. CL. 42. REG. 7-21-1998.
- 2,175,844. HIGGINS PREMIUM PET FOODS AND DESIGN. INT. CL. 31. REG. 7-21-1998.
- 2,175,848. THE MARKET STUDY OF RETAIL TECHNOLOGY. INT. CL. 16. REG. 7-21-1998.
- 2,175,851. LAW DOS SANTOS (STYLIZED). INT. CL. 42. REG. 7-21-1998.
- 2,175,856. AMARAL (STYLIZED). INT. CL. 31. REG. 7-21-1998.
- 2,175,857. SMOOTHINGSERUM (STYLIZED). INT. CL. 3. REG. 7-21-1998.
- 2,175,858. HOTSPA. INT. CL. 10. REG. 7-21-1998.
- 2,175,859. SMOOTHINGSHAMPOO (STYLIZED). INT. CL. 3. REG. 7-21-1998.
- 2,175,864. BOTANIQUE (STYLIZED). INT. CL. 31. REG. 7-21-1998.
- 2,175,866. UDABEST. INT. CL. 25. REG. 7-21-1998.
- 2,175,867. INTERNATIONAL RICE INDUSTRY GUIDE. INT. CL. 16. REG. 7-21-1998.
- 2,175,872. MIDI CLASSICS. INT. CL. 9. REG. 7-21-1998.
- 2,175,873. IEQ STRATEGIES. INT. CL. 16. REG. 7-21-1998.
- 2,175,875. SPEED POWER PERFORMANCE. INT. CL. 9. REG. 7-21-1998.
- 2,175,877. ALLOY BOND. INT. CL. 2. REG. 7-21-1998.
- 2,175,884. ROUND TOP ARTS FESTIVAL. INT. CL. 41. REG. 7-21-1998.
- 2,190,480. SEPCARB. INT. CLS. 1, 7, 17 AND 19 ONLY. REG. 9-22-1998.
- 2,190,544. A GOOD LAWYER. INT. CL. 9 ONLY. REG. 9-22-1998.
- 2,192,911. POUCH2OASIS. INT. CL. 32. REG. 9-29-1998.
- 2,234,991. TIGHT LINES. INT. CLS. 9, 18, 20, 21 AND 24 ONLY. REG. 3-23-1999.
- 2,238,079. NYSEG. INT. CL. 35 ONLY. REG. 4-13-1999.
- 2,240,080. WORLD MONUMENTS WATCH. INT. CL. 41 ONLY. REG. 4-20-1999.
- 2,241,541. NRSI. INT. CLS. 16 AND 41 ONLY. REG. 4-27-1999.
- 2,242,672. WOOD-YOU (STYLIZED). INT. CL. 20 ONLY. REG. 5-4-1999.
- 2,244,201. SCHOCK AND DESIGN. INT. CLS. 6, 17, 19, 20 AND 22 ONLY. REG. 5-11-1999.
- 2,254,098. THEORIE (STYLIZED). INT. CL. 3. REG. 6-15-1999.
- 2,398,904. SHANNON AEROSPACE AND DESIGN. INT. CL. 12 ONLY. REG. 10-31-2000.
- 2,401,071. MAHA YOGA. INT. CL. 41. REG. 10-31-2000.
- 2,401,355. MAKING LIFESTYLE PRODUCTS FOR BETTER LIVING. INT. CLS. 5, 8, 12, 20 AND 21 ONLY. REG. 11-7-2000.
- 2,528,717. TRUE COST CALCULATOR. INT. CL. 36. REG. 1-8-2002.
- 2,540,808. EBEL (STYLIZED). INT. CL. 3. REG. 2-19-2002.
- 2,596,421. LET YOUR FINGERS DO THE WALKING WE'LL DO THE TALKING (STYLIZED). INT. CL. 35. REG. 7-23-2002.
- 2,596,427. KNOW THE WORLD. INT. CL. 28. REG. 7-23-2002.
- 2,596,429. QUICKSCAN AND DESIGN. INT. CL. 9. REG. 7-23-2002.
- 2,596,430. PATNET. INT. CL. 42. REG. 7-23-2002.
- 2,596,432. PERFORMANCE. INT. CL. 9. REG. 7-23-2002.
- 2,596,433. BUBBA'S ORIGINAL SAUCE AND DESIGN. INT. CL. 30. REG. 7-23-2002.
- 2,596,434. SHARP SHOOTERS. INT. CL. 6. REG. 7-23-2002.
- 2,596,436. NUXIL AND DESIGN. INT. CL. 5. REG. 7-23-2002.
- 2,596,438. MISCELLANEOUS DESIGN. INT. CL. 28. REG. 7-23-2002.
- 2,596,440. MKI AND DESIGN. INT. CLS. 9, 16, 35, 36, 38, 41 AND 42. REG. 7-23-2002.
- 2,596,442. BITMASTER. INT. CL. 9. REG. 7-23-2002.
- 2,596,443. MISCELLANEOUS DESIGN. INT. CLS. 6, 9, 12, 16, 19, 37, 38, 39 AND 42. REG. 7-23-2002.
- 2,596,445. DIGIZOOM. INT. CL. 10. REG. 7-23-2002.
- 2,596,446. STAR-TWIST. INT. CL. 16. REG. 7-23-2002.
- 2,596,447. OPTISET. INT. CL. 10. REG. 7-23-2002.
- 2,596,448. TREE FRIENDLY HOME STUFF. INT. CLS. 9, 14 AND 20. REG. 7-23-2002.
- 2,596,450. CAFFE DEMETRE (STYLIZED). INT. CL. 42. REG. 7-23-2002.
- 2,596,451. WORLDWIDE INTERNET CLUB, INC. THE WIC AND DESIGN. INT. CL. 35. REG. 7-23-2002.
- 2,596,453. MULTI THEMATIQUES. INT. CLS. 38, 41 AND 42. REG. 7-23-2002.
- 2,596,455. REAL LAUNDRY SYSTEM AND DESIGN. INT. CL. 25. REG. 7-23-2002.
- 2,596,457. KEYENCE AND DESIGN. INT. CL. 28. REG. 7-23-2002.
- 2,596,458. CLICK BY COLOR ME COTTON. INT. CL. 25. REG. 7-23-2002.
- 2,596,459. DIGILOK. INT. CLS. 9, 16 AND 20. REG. 7-23-2002.
- 2,596,460. VIRUS REX. INT. CLS. 9, 16, 25, 28 AND 41. REG. 7-23-2002.
- 2,596,463. LIQUID GRAPHIX. INT. CLS. 41 AND 42. REG. 7-23-2002.
- 2,596,464. BIOHOME. INT. CLS. 9, 10, 38 AND 42. REG. 7-23-2002.
- 2,596,471. TREKKING. INT. CL. 41. REG. 7-23-2002.
- 2,596,473. SWANSON CARE AND DESIGN. INT. CL. 5. REG. 7-23-2002.
- 2,596,474. CALLWEB (STYLIZED). INT. CLS. 9, 16 AND 42. REG. 7-23-2002.
- 2,596,475. GEMXPLORE (STYLIZED). INT. CLS. 9, 16, 37, 38 AND 42. REG. 7-23-2002.
- 2,596,476. FLUID ENERGY AND DESIGN. INT. CL. 25. REG. 7-23-2002.
- 2,596,477. H3D AND DESIGN. INT. CL. 9. REG. 7-23-2002.
- 2,596,478. BANDOLEROS. INT. CL. 34. REG. 7-23-2002.
- 2,596,481. SKWID. INT. CL. 7. REG. 7-23-2002.
- 2,596,483. PLUG & PLAY AND DESIGN. INT. CL. 9. REG. 7-23-2002.
- 2,596,485. BALDUCCI AND DESIGN. INT. CL. 25. REG. 7-23-2002.
- 2,596,486. AIB. INT. CL. 36. REG. 7-23-2002.
- 2,596,489. OKUMA AMERICA SUPERVISORY INFORMATION SYSTEM. INT. CL. 9. REG. 7-23-2002.
- 2,596,490. ORICA AND DESIGN. INT. CL. 37. REG. 7-23-2002.
- 2,596,500. BLUE VELVET. INT. CL. 10. REG. 7-23-2002.
- 2,596,502. THE ONES WITH THE TREASURES INSIDE. INT. CL. 4. REG. 7-23-2002.
- 2,596,504. FINTECH E-DATA E-CASH E-SOLUTIONS AND DESIGN. INT. CLS. 36 AND 38. REG. 7-23-2002.
- 2,596,505. FERTIOSCOPE. INT. CL. 10. REG. 7-23-2002.
- 2,596,506. BIG WHEEL ROSSI. INT. CL. 37. REG. 7-23-2002.
- 2,596,507. LISA'S WEIGHT WELLNESS SOLUTIONS. INT. CLS. 9, 16 AND 41. REG. 7-23-2002.
- 2,596,511. WINNING CHOICES. INT. CL. 9. REG. 7-23-2002.
- 2,596,514. WC INC AND DESIGN. INT. CL. 11. REG. 7-23-2002.
- 2,596,515. PROCLEAN PROFESSIONAL. INT. CL. 3. REG. 7-23-2002.
- 2,596,517. SUPERHEAT AND DESIGN. INT. CL. 35. REG. 7-23-2002.
- 2,596,522. MISCELLANEOUS DESIGN. INT. CL. 11. REG. 7-23-2002.
- 2,596,523. EATZA PIZZA. INT. CL. 42. REG. 7-23-2002.
- 2,596,524. PORTIA. INT. CL. 25. REG. 7-23-2002.
- 2,596,525. CYBUY AND DESIGN. INT. CLS. 35 AND 36. REG. 7-23-2002.
- 2,596,526. DOSA HUT. INT. CLS. 29, 30 AND 42. REG. 7-23-2002.
- 2,596,527. HAVAS. INT. CLS. 9, 35, 38, 41 AND 42. REG. 7-23-2002.
- 2,596,528. RAVENLOFT. INT. CL. 6. REG. 7-23-2002.
- 2,596,529. LACE ROSE EXPRESSIONS. INT. CL. 25. REG. 7-23-2002.
- 2,596,535. ROADMASTER TIRES STRADA AND DESIGN. INT. CL. 12. REG. 7-23-2002.
- 2,596,536. SOUNDADVISOR. INT. CL. 35. REG. 7-23-2002.

- 2,596,537. NICEFIT.COM. INT. CLS. 35 AND 36. REG. 7-23-2002.
- 2,596,538. MAXIM'S (STYLIZED). INT. CL. 32. REG. 7-23-2002.
- 2,596,540. KELLY'S. INT. CLS. 29 AND 30. REG. 7-23-2002.
- 2,596,542. AL SAFA CANADA'S FINEST HALAL AND DESIGN. INT. CL. 29. REG. 7-23-2002.
- 2,596,543. MISCELLANEOUS DESIGN. INT. CL. 20. REG. 7-23-2002.
- 2,596,544. CONTACT SPORTS CS AND DESIGN. INT. CL. 25. REG. 7-23-2002.
- 2,596,549. MISCELLANEOUS DESIGN. INT. CL. 5. REG. 7-23-2002.
- 2,596,552. NW NATURAL DIVIDEND EXPRESS AND DESIGN. INT. CL. 36. REG. 7-23-2002.
- 2,596,554. MISCELLANEOUS DESIGN. INT. CL. 36. REG. 7-23-2002.
- 2,596,555. VASCULAR CENTERS OF NEW JERSEY AND DESIGN. INT. CL. 42. REG. 7-23-2002.
- 2,596,557. S SEVERIN 1938 AND DESIGN. INT. CL. 14. REG. 7-23-2002.
- 2,596,559. PROGRESS THROUGH PREVENTION. INT. CL. 42. REG. 7-23-2002.
- 2,596,560. ALTERNATIVE ENTERTAINMENT NETWORK. INT. CLS. 38 AND 41. REG. 7-23-2002.
- 2,596,562. LIFEFAX. INT. CL. 42. REG. 7-23-2002.
- 2,596,563. CRUISING. INT. CL. 28. REG. 7-23-2002.
- 2,596,566. GREENDP (STYLIZED). INT. CL. 9. REG. 7-23-2002.
- 2,596,567. BSGX. INT. CL. 36. REG. 7-23-2002.
- 2,596,569. MIX FANTASY FIVE. INT. CL. 41. REG. 7-23-2002.
- 2,596,570. LASER-TRACKER AND DESIGN. INT. CL. 9. REG. 7-23-2002.
- 2,596,576. THE GREAT ELK. INT. CL. 9. REG. 7-23-2002.
- 2,596,579. PLAYA DORADA. INT. CL. 32. REG. 7-23-2002.
- 2,596,581. OUTDOOR DECOR AND DESIGN. INT. CL. 41. REG. 7-23-2002.
- 2,596,583. NEVER FEAR, NEVER QUIT. INT. CL. 41. REG. 7-23-2002.
- 2,596,584. TV GUIDE INTERACTIVE. INT. CLS. 35, 38 AND 41. REG. 7-23-2002.
- 2,596,587. BOB BURNS NO BANANAS AND DESIGN. INT. CL. 28. REG. 7-23-2002.
- 2,596,588. MISCELLANEOUS DESIGN. INT. CL. 20. REG. 7-23-2002.
- 2,596,590. SENTRY. INT. CL. 19. REG. 7-23-2002.
- 2,596,591. SAUCES DU SOLEIL AMORA 4 SAUCES CITRON FINES HERBES PROVENCALE AIOLI AND DESIGN. INT. CL. 30. REG. 7-23-2002.
- 2,596,592. OXYDIAN. INT. CLS. 9, 16, 35, 41 AND 42. REG. 7-23-2002.
- 2,596,593. TEAM. INT. CL. 35. REG. 7-23-2002.
- 2,596,594. TOTAL EVENT ASSET MANAGEMENT. INT. CL. 35. REG. 7-23-2002.
- 2,596,595. CINECITTA. INT. CL. 25. REG. 7-23-2002.
- 2,596,596. TEB AND DESIGN. INT. CL. 9. REG. 7-23-2002.
- 2,596,597. TEB. INT. CL. 9. REG. 7-23-2002.
- 2,596,600. WORKPLACE TRANSFORMATION. INT. CL. 42. REG. 7-23-2002.
- 2,596,602. SCIENCE + SUN CHEMICAL INITIATIVE FOR ENHANCING CLASSROOM EDUCATION AND DESIGN. INT. CL. 16. REG. 7-23-2002.
- 2,596,604. AUTO SHIFT. INT. CL. 11. REG. 7-23-2002.
- 2,596,606. FINGERTIP (STYLIZED). INT. CL. 9. REG. 7-23-2002.
- 2,596,607. RETIREMAX PREMIER + 1. INT. CL. 36. REG. 7-23-2002.
- 2,596,608. NO REFS. NO RULES. NO MERCY.. INT. CL. 9. REG. 7-23-2002.
- 2,596,609. FLODAC AND DESIGN. INT. CL. 35. REG. 7-23-2002.
- 2,596,616. Q-MESSAGE. INT. CLS. 9 AND 42. REG. 7-23-2002.
- 2,596,617. THE LAZY HOMEOWNER AND DESIGN. INT. CLS. 35 AND 41. REG. 7-23-2002.
- 2,596,618. IMEDEON AND DESIGN. INT. CL. 35. REG. 7-23-2002.
- 2,596,620. POWER POP. INT. CL. 9. REG. 7-23-2002.
- 2,596,621. T TILDE AND DESIGN. INT. CLS. 16 AND 41. REG. 7-23-2002.
- 2,596,623. BRIDGEPOINT. INT. CLS. 38 AND 42. REG. 7-23-2002.
- 2,596,624. WGP AND DESIGN. INT. CLS. 13, 25 AND 41. REG. 7-23-2002.
- 2,596,626. ST. INT. CL. 12. REG. 7-23-2002.
- 2,596,627. HEALTH FOOD THAT TASTES LIKE JUNK FOOD. INT. CL. 29. REG. 7-23-2002.
- 2,596,630. ATR/TREEHOUSE. INT. CLS. 35, 37, 41 AND 42. REG. 7-23-2002.
- 2,596,631. MISCELLANEOUS DESIGN. INT. CL. 28. REG. 7-23-2002.
- 2,596,632. ATR TREEHOUSE. INT. CLS. 35, 37, 41 AND 42. REG. 7-23-2002.
- 2,596,635. CATALOG.COM AND DESIGN. INT. CLS. 25, 35, 36, 38 AND 42. REG. 7-23-2002.
- 2,596,636. LIPOZONE. INT. CLS. 3 AND 5. REG. 7-23-2002.
- 2,596,637. DA CONSULTING GROUP. INT. CL. 35. REG. 7-23-2002.
- 2,596,638. BEACHBERRY. INT. CL. 33. REG. 7-23-2002.
- 2,596,640. NORM'S. INT. CL. 33. REG. 7-23-2002.
- 2,596,642. KALJI. INT. CL. 41. REG. 7-23-2002.
- 2,596,643. WATERCRYST. INT. CLS. 1 AND 11. REG. 7-23-2002.
- 2,596,646. ADACOUSTICS. INT. CLS. 35 AND 42. REG. 7-23-2002.
- 2,596,647. LINK.OPENLY. INT. CL. 9. REG. 7-23-2002.
- 2,596,648. RACONIP. INT. CL. 7. REG. 7-23-2002.
- 2,596,652. FAIR PLANET. INT. CLS. 9, 16, 25, 35, 36, 38, 41 AND 42. REG. 7-23-2002.
- 2,596,653. MLS PASSPORT. INT. CL. 9. REG. 7-23-2002.
- 2,596,654. ANASAZI INVESTMENTS LLC AND DESIGN. INT. CL. 36. REG. 7-23-2002.
- 2,596,655. TOUCHDOWN. INT. CLS. 35 AND 42. REG. 7-23-2002.
- 2,596,656. TAKE CONTROL OF YOUR TRAVEL FLY SMART FLY CHEAP!. INT. CL. 39. REG. 7-23-2002.
- 2,596,660. QUALITY AIR AND DESIGN. INT. CL. 11. REG. 7-23-2002.
- 2,596,664. FUNDSTREET.COM AND DESIGN. INT. CLS. 9, 36 AND 42. REG. 7-23-2002.
- 2,596,666. CRITTERBUGS. INT. CL. 28. REG. 7-23-2002.
- 2,596,667. SIX HATS A HOSPITALITY COMPANY AND DESIGN. INT. CLS. 35 AND 36. REG. 7-23-2002.
- 2,596,670. EVERNAL. INT. CL. 11. REG. 7-23-2002.
- 2,596,671. GRANDE SIECLE LUMIERE DU MILLENAIRE 1990 CHAMPAGNE PAR LAURENT-PERRIER MILLESIME 1990 AND DESIGN. INT. CL. 33. REG. 7-23-2002.
- 2,596,673. CENTA-STAR. INT. CL. 22. REG. 7-23-2002.
- 2,596,675. SMART ENGINE AND DESIGN. INT. CL. 38. REG. 7-23-2002.
- 2,596,676. ROOSTERHEAD ANTIQUE HEART PINE & BRICK,INC. AND DESIGN. INT. CL. 19. REG. 7-23-2002.
- 2,596,677. KELDA. INT. CLS. 37, 39, 40 AND 42. REG. 7-23-2002.
- 2,596,678. DONUTS & GOO AND DESIGN. INT. CL. 42. REG. 7-23-2002.
- 2,596,679. AMERICA'S DREAM COACH. INT. CL. 41. REG. 7-23-2002.
- 2,596,680. AMERICA'S DREAM COACH. INT. CL. 16. REG. 7-23-2002.
- 2,596,681. BF LAYING HEAD. INT. CL. 7. REG. 7-23-2002.
- 2,596,682. THE ADEA GROUP. INT. CL. 35. REG. 7-23-2002.
- 2,596,686. EINSURANCE INNOVATORS. INT. CL. 36. REG. 7-23-2002.
- 2,596,688. ASEGURANDO SU FUTURO...HOY AND DESIGN. INT. CL. 36. REG. 7-23-2002.
- 2,596,691. EUROPA. INT. CL. 12. REG. 7-23-2002.
- 2,596,693. ALASKADATA. INT. CL. 9. REG. 7-23-2002.
- 2,596,694. LEGALMATCH. INT. CL. 35. REG. 7-23-2002.
- 2,596,695. ENGENIA. INT. CL. 9. REG. 7-23-2002.
- 2,596,696. SCHOOL SPIRIT!!! AND DESIGN. INT. CL. 35. REG. 7-23-2002.

- 2,596,697. T AND DESIGN. INT. CLS. 35, 38 AND 42. REG. 7-23-2002.
- 2,596,698. TELSTRA. INT. CLS. 36, 38 AND 41. REG. 7-23-2002.
- 2,596,703. NAMCO. INT. CLS. 7, 14, 37 AND 42. REG. 7-23-2002.
- 2,596,705. ADVANCERX. INT. CL. 35. REG. 7-23-2002.
- 2,596,709. MONDO NEW LINE. INT. CL. 25. REG. 7-23-2002.
- 2,596,712. BYSECURE. INT. CLS. 37, 39 AND 42. REG. 7-23-2002.
- 2,596,713. LEGACY. INT. CL. 20. REG. 7-23-2002.
- 2,596,717. PANAGOPOULOS. INT. CL. 30. REG. 7-23-2002.
- 2,596,721. MARKETDRIVE. INT. CL. 42. REG. 7-23-2002.
- 2,596,725. MISCELLANEOUS DESIGN. INT. CL. 36. REG. 7-23-2002.
- 2,596,726. JANET. INT. CLS. 9, 16 AND 42. REG. 7-23-2002.
- 2,596,730. MOTA S.F. (STYLIZED). INT. CL. 25. REG. 7-23-2002.
- 2,596,731. S AND DESIGN. INT. CL. 35. REG. 7-23-2002.
- 2,596,732. STONE LAND AND DESIGN. INT. CLS. 19, 20 AND 21. REG. 7-23-2002.
- 2,596,733. GROVER WASHINGTON, JR.. INT. CL. 9. REG. 7-23-2002.
- 2,596,734. GROVER WASHINGTON, JR.. INT. CL. 25. REG. 7-23-2002.
- 2,596,735. BOOKHAM (STYLIZED). INT. CL. 9. REG. 7-23-2002.
- 2,596,737. E OFFICES AND DESIGN. INT. CL. 36. REG. 7-23-2002.
- 2,596,738. PARADOXART (STYLIZED). INT. CL. 20. REG. 7-23-2002.
- 2,596,740. MISCELLANEOUS DESIGN. INT. CLS. 7 AND 9. REG. 7-23-2002.
- 2,596,741. WEBFN. INT. CLS. 9, 25, 35, 36, 38, 41 AND 42. REG. 7-23-2002.
- 2,596,742. STARS ON CALL AND DESIGN. INT. CL. 36. REG. 7-23-2002.
- 2,596,746. AKATINOL. INT. CL. 5. REG. 7-23-2002.
- 2,596,747. MSR MAINTENANCE SERVICE RESOURCES, INC. AND DESIGN. INT. CL. 37. REG. 7-23-2002.
- 2,596,750. ITU. INT. CLS. 35 AND 36. REG. 7-23-2002.
- 2,596,752. TRAFFIC MART. INT. CL. 42. REG. 7-23-2002.
- 2,596,753. CONNECTING GENERATIONS SHAPED BY OUR TIMES... AND DESIGN. INT. CL. 28. REG. 7-23-2002.
- 2,596,757. SYNGO SPEAKING (STYLIZED). INT. CL. 9. REG. 7-23-2002.
- 2,596,758. EUROBOARD. INT. CLS. 16 AND 36. REG. 7-23-2002.
- 2,596,760. CHESNEY AND DESIGN. INT. CL. 25. REG. 7-23-2002.
- 2,596,761. STANLEY'S RENT TO OWN AND DESIGN. INT. CL. 42. REG. 7-23-2002.
- 2,596,763. ANTEON. INT. CLS. 41 AND 42. REG. 7-23-2002.
- 2,596,764. F.P. HUT ("FISHING POLE HOLDING UP THING"). INT. CL. 28. REG. 7-23-2002.
- 2,596,765. LANGOO.COM AND DESIGN. INT. CL. 38. REG. 7-23-2002.
- 2,596,766. EDUTORIUM. INT. CLS. 9, 16, 41 AND 42. REG. 7-23-2002.
- 2,596,768. 37.COM. INT. CL. 42. REG. 7-23-2002.
- 2,596,769. DR. SPOT'S AND DESIGN. INT. CL. 10. REG. 7-23-2002.
- 2,596,771. CREATIVITY MAGAZINE.COM (STYLIZED). INT. CL. 42. REG. 7-23-2002.
- 2,596,773. SCHINDLER NETWORKX. INT. CLS. 7, 9, 37 AND 42. REG. 7-23-2002.
- 2,596,776. KEEP UP THE PACE AND DESIGN. INT. CL. 9. REG. 7-23-2002.
- 2,596,778. M BALANCE. INT. CL. 3. REG. 7-23-2002.
- 2,596,780. 1 (800) TOW-TRUCK. INT. CLS. 35 AND 42. REG. 7-23-2002.
- 2,596,783. QL QUICKLAW AMERICA AND DESIGN. INT. CL. 42. REG. 7-23-2002.
- 2,596,785. ANIMASTERS. INT. CL. 16. REG. 7-23-2002.
- 2,596,788. POSACTION. INT. CL. 42. REG. 7-23-2002.
- 2,596,790. AMISMOK. INT. CLS. 16 AND 18. REG. 7-23-2002.
- 2,596,792. CONNECTING YOU TO WHAT'S NEXT. INT. CLS. 37, 38 AND 42. REG. 7-23-2002.
- 2,596,796. IDEACOM OUR PEOPLE PROVIDE THE IDEAS. AND DESIGN. INT. CL. 38. REG. 7-23-2002.
- 2,596,797. MR. DELICIOUS. INT. CL. 29. REG. 7-23-2002.
- 2,596,798. READERSONLY.COM. INT. CLS. 35, 38 AND 41. REG. 7-23-2002.
- 2,596,800. MISCELLANEOUS DESIGN. INT. CL. 9. REG. 7-23-2002.
- 2,596,801. HARRODS. INT. CL. 9. REG. 7-23-2002.
- 2,596,804. SAVVY DINER AND DESIGN. INT. CL. 42. REG. 7-23-2002.
- 2,596,805. EQUALIZER. INT. CL. 7. REG. 7-23-2002.
- 2,596,811. FAB FRAMES. INT. CL. 20. REG. 7-23-2002.
- 2,596,812. TRUST U.S.A. MORTGAGE CORP. AND DESIGN. INT. CL. 36. REG. 7-23-2002.
- 2,596,813. MISCELLANEOUS DESIGN. INT. CL. 42. REG. 7-23-2002.
- 2,596,815. FEED THE RAT AND DESIGN. INT. CL. 25. REG. 7-23-2002.
- 2,596,817. INNOVATION FROM THE BOTTOM UP. INT. CLS. 40 AND 42. REG. 7-23-2002.
- 2,596,820. TRACS-FN (STYLIZED). INT. CL. 9. REG. 7-23-2002.
- 2,596,821. HEARTY LIFE NATURAL FOODS HEARTY MEALS FOR HARDY PEOPLE AND DESIGN. INT. CL. 30. REG. 7-23-2002.
- 2,596,822. LEXTALK. INT. CLS. 16 AND 42. REG. 7-23-2002.
- 2,596,823. ACCELERIDER AND DESIGN. INT. CL. 28. REG. 7-23-2002.
- 2,596,824. ACTIVEGRAMS. INT. CL. 38. REG. 7-23-2002.
- 2,596,825. T-EUROPE. INT. CLS. 9, 16, 35, 36, 37, 38, 39, 41 AND 42. REG. 7-23-2002.
- 2,596,826. HANOVER FINANCIAL AND DESIGN. INT. CL. 36. REG. 7-23-2002.
- 2,596,827. B2B D2D. INT. CL. 35. REG. 7-23-2002.
- 2,596,833. AVINET AND DESIGN. INT. CL. 38. REG. 7-23-2002.
- 2,596,835. IT CAREER FAST TRACK AND DESIGN. INT. CL. 42. REG. 7-23-2002.
- 2,596,836. KEE AND DESIGN. INT. CLS. 16 AND 21. REG. 7-23-2002.
- 2,596,839. RESOURCEDESKTOP. INT. CL. 35. REG. 7-23-2002.
- 2,596,840. PARTIIBALL. INT. CL. 41. REG. 7-23-2002.
- 2,596,841. VECTRA. INT. CL. 10. REG. 7-23-2002.
- 2,596,842. READERSONLY.COM GREAT READING PLUS A WHOLE LOT MORE AND DESIGN. INT. CLS. 35, 38 AND 41. REG. 7-23-2002.
- 2,596,843. VACATION-CREATIONS.COM. INT. CLS. 39 AND 42. REG. 7-23-2002.
- 2,596,844. MISCELLANEOUS DESIGN. INT. CLS. 39 AND 42. REG. 7-23-2002.
- 2,596,845. Y-POINT. INT. CLS. 35 AND 42. REG. 7-23-2002.
- 2,596,846. A GOOD DEAL MORE. INT. CLS. 35 AND 39. REG. 7-23-2002.
- 2,596,847. ATI AMERICA TRANSFERS, INC. AND DESIGN. INT. CL. 36. REG. 7-23-2002.
- 2,596,848. I L A T C ILLINOIS ANNUAL TECHNOLOGY CONFERENCE AND DESIGN. INT. CLS. 35 AND 41. REG. 7-23-2002.
- 2,596,850. NATUR-AL. INT. CLS. 6 AND 19. REG. 7-23-2002.
- 2,596,852. SAFE HAVENS FOR YOUTH. INT. CL. 41. REG. 7-23-2002.
- 2,596,854. LOVEBROWSER. INT. CL. 42. REG. 7-23-2002.
- 2,596,855. ALWAYS THINKING. INT. CL. 41. REG. 7-23-2002.
- 2,596,856. IDEAL TECHNOLOGY SOLUTIONS U.S., INC. AND DESIGN. INT. CLS. 38, 39 AND 42. REG. 7-23-2002.
- 2,596,858. MANAGEDOPS.COM, INC. AND DESIGN. INT. CLS. 35, 37, 41 AND 42. REG. 7-23-2002.
- 2,596,860. IDEAL TECHNOLOGY SOLUTIONS. INT. CLS. 38, 39 AND 42. REG. 7-23-2002.
- 2,596,862. SERVICENTRO. INT. CLS. 35 AND 38. REG. 7-23-2002.
- 2,596,864. CONSENSUS BUILDER. INT. CL. 9. REG. 7-23-2002.

- 2,596,868. GOLDILOCKS. INT. CLS. 20 AND 21. REG. 7-23-2002.
- 2,596,871. HATSCHI-FREE (STYLIZED). INT. CL. 10. REG. 7-23-2002.
- 2,596,875. PULSE. INT. CL. 9. REG. 7-23-2002.
- 2,596,876. FIRST STAR (STYLIZED). INT. CL. 42. REG. 7-23-2002.
- 2,596,877. VENICE BEACH THE WORKOUTFIT AND DESIGN. INT. CL. 25. REG. 7-23-2002.
- 2,596,880. SHOPA SCHOOL, HOME, & OFFICE PRODUCTS ASSOCIATION AND DESIGN. INT. CLS. 35 AND 41. REG. 7-23-2002.
- 2,596,881. WU (STYLIZED). INT. CL. 3. REG. 7-23-2002.
- 2,596,882. CATFISH WILLIE'S. INT. CL. 42. REG. 7-23-2002.
- 2,596,883. SERENA SPORT AND DESIGN. INT. CL. 28. REG. 7-23-2002.
- 2,596,886. OVERSTEP YOUR BOUNDARIES. INT. CL. 9. REG. 7-23-2002.
- 2,596,892. CSK. INT. CL. 12. REG. 7-23-2002.
- 2,596,893. SHELLISEGAL. INT. CL. 25. REG. 7-23-2002.
- 2,596,899. CALIFLORIDA BOWL. INT. CL. 41. REG. 7-23-2002.
- 2,596,901. GAIL DEVERS FOUNDATION THE FORCE THAT DRIVES MINDS TO DREAM AND DESIGN. INT. CL. 42. REG. 7-23-2002.
- 2,596,902. ASPEN BUSINESS GROUP AND DESIGN. INT. CL. 35. REG. 7-23-2002.
- 2,596,903. GOVERNMENT BIDDING SOLUTIONS. INT. CL. 35. REG. 7-23-2002.
- 2,596,904. SPIKA-ICE. INT. CLS. 11, 37 AND 39. REG. 7-23-2002.
- 2,596,905. STAR-ICE. INT. CLS. 11, 37 AND 39. REG. 7-23-2002.
- 2,596,906. DPSI. INT. CL. 42. REG. 7-23-2002.
- 2,596,910. OGIO SPORT AND DESIGN. INT. CLS. 18 AND 28. REG. 7-23-2002.
- 2,596,911. AMERICA'S COUNTRY STORE AND DESIGN. INT. CL. 2. REG. 7-23-2002.
- 2,596,914. CYBEREAR. INT. CL. 9. REG. 7-23-2002.
- 2,596,915. CYBERAUDIO. INT. CL. 9. REG. 7-23-2002.
- 2,596,919. TV LISTENER (STYLIZED). INT. CL. 9. REG. 7-23-2002.
- 2,596,921. PERI'S GROVE YOU ASK IT, WE TASK IT LLC AND DESIGN. INT. CL. 42. REG. 7-23-2002.
- 2,596,924. ESA-VIEW. INT. CL. 9. REG. 7-23-2002.
- 2,596,925. 9CMC. INT. CL. 9. REG. 7-23-2002.
- 2,596,929. DURANGO & SILVERTON NARROW GAUGE RAILROAD & MUSEUM AND DESIGN. INT. CL. 41. REG. 7-23-2002.
- 2,596,930. AMORVERO PROFUMO AND DESIGN. INT. CL. 3. REG. 7-23-2002.
- 2,596,931. TRU DYNAMICS. INT. CL. 35. REG. 7-23-2002.
- 2,596,937. DXNOW.COM. INT. CL. 39. REG. 7-23-2002.
- 2,596,938. SCHOOLSPOITS AND DESIGN. INT. CLS. 16 AND 41. REG. 7-23-2002.
- 2,596,939. FCS AND DESIGN. INT. CLS. 35 AND 42. REG. 7-23-2002.
- 2,596,941. S AND DESIGN. INT. CLS. 38 AND 42. REG. 7-23-2002.
- 2,596,942. STROUDS LINEN OUTLET AND DESIGN. INT. CL. 35. REG. 7-23-2002.
- 2,596,943. RECIPROCAL OF AMERICA AND DESIGN. INT. CL. 36. REG. 7-23-2002.
- 2,596,945. REAL LEARNING FOR A VIRTUAL WORLD. INT. CLS. 41 AND 42. REG. 7-23-2002.
- 2,596,946. THE VIEW FROM C-LEVEL. INT. CL. 35. REG. 7-23-2002.
- 2,596,947. CHICK STUFF. INT. CL. 25. REG. 7-23-2002.
- 2,596,951. PENSACOLA BARRACUDAS. INT. CL. 41. REG. 7-23-2002.
- 2,596,952. ELECTROGRAPH AND DESIGN. INT. CL. 9. REG. 7-23-2002.
- 2,596,954. FRESC CO AND DESIGN. INT. CL. 42. REG. 7-23-2002.
- 2,596,955. MM (STYLIZED). INT. CLS. 16 AND 35. REG. 7-23-2002.
- 2,596,959. CAN YOU IMAGINE. INT. CLS. 9 AND 42. REG. 7-23-2002.
- 2,596,960. MOSQUITOSAFE. INT. CL. 5. REG. 7-23-2002.
- 2,596,962. OASIS GENIE. INT. CL. 9. REG. 7-23-2002.
- 2,596,963. Q QUAD/DATA SERVICES AND DESIGN. INT. CLS. 35 AND 42. REG. 7-23-2002.
- 2,596,964. FIRST KEYSTONE. THE COMMUNITY BANK FOR THE 21 ST CENTURY.. INT. CL. 36. REG. 7-23-2002.
- 2,596,968. CN8 THE COMCAST NETWORK AND DESIGN. INT. CL. 38. REG. 7-23-2002.
- 2,596,970. TOUCHDOWN THE GRAY. INT. CLS. 3 AND 21. REG. 7-23-2002.
- 2,596,972. DIGILIFE.COM. INT. CL. 10. REG. 7-23-2002.
- 2,596,974. MISCELLANEOUS DESIGN. U.S. CL. B. REG. 7-23-2002.
- 2,596,975. MISCELLANEOUS DESIGN. U.S. CL. B. REG. 7-23-2002.
- 2,596,976. 12345 AND DESIGN. U.S. CL. B. REG. 7-23-2002.
- 2,596,977. MOD. INT. CL. 9. REG. 7-23-2002.
- 2,596,978. POWERING THE KNOWLEDGE ECONOMY. INT. CL. 42. REG. 7-23-2002.
- 2,596,982. FALUN Dafa AND DESIGN. INT. CLS. 16 AND 41. REG. 7-23-2002.
- 2,596,986. PPM 2000. INT. CL. 9. REG. 7-23-2002.
- 2,596,988. ALLBRANDING. INT. CLS. 35, 38 AND 41. REG. 7-23-2002.
- 2,596,990. KDI PARAGON AND DESIGN. INT. CL. 6. REG. 7-23-2002.
- 2,596,991. SEE-PL@NET. INT. CLS. 9 AND 42. REG. 7-23-2002.
- 2,596,995. ISPHERES. INT. CL. 9. REG. 7-23-2002.
- 2,596,996. MANY MARKETS. ONE SOURCE.. INT. CLS. 9 AND 42. REG. 7-23-2002.
- 2,596,998. HOME IS A LEARNING ZONE TOO THE PARENT CONNECTION AND DESIGN. INT. CL. 9. REG. 7-23-2002.
- 2,596,999. PICCOLO. INT. CL. 39. REG. 7-23-2002.
- 2,597,000. VIA AQUA. INT. CLS. 7 AND 11. REG. 7-23-2002.
- 2,597,007. HEALTHPAQ. INT. CL. 42. REG. 7-23-2002.
- 2,597,010. LCAP. INT. CL. 35. REG. 7-23-2002.
- 2,597,014. CATALOGSOURCE.COM. INT. CLS. 40 AND 42. REG. 7-23-2002.
- 2,597,015. FD. INT. CL. 7. REG. 7-23-2002.
- 2,597,016. BARELY SURVIVING TRADING COMPANY AND DESIGN. INT. CL. 35. REG. 7-23-2002.
- 2,597,018. WESTERQUADRO. INT. CLS. 6, 11 AND 19. REG. 7-23-2002.
- 2,597,020. FINDING SOLUTIONS THAT WORK. INT. CLS. 35 AND 42. REG. 7-23-2002.
- 2,597,021. YUKON JACKPOT. INT. CL. 41. REG. 7-23-2002.
- 2,597,024. YOU NEVER KNOW WHEN A BOTTLE WILL COME IN HANDY. INT. CL. 33. REG. 7-23-2002.
- 2,597,027. INCOMEPILOT. INT. CLS. 35, 36 AND 42. REG. 7-23-2002.
- 2,597,028. PRO-CURA AND DESIGN. INT. CLS. 5 AND 10. REG. 7-23-2002.
- 2,597,029. NEKEN. INT. CL. 25. REG. 7-23-2002.
- 2,597,033. NIPPON PAPER INDUSTRIES AND DESIGN. INT. CL. 1. REG. 7-23-2002.
- 2,597,036. PLUSFUNDS. INT. CL. 36. REG. 7-23-2002.
- 2,597,037. MERCURY. INT. CL. 11. REG. 7-23-2002.
- 2,597,038. LOOKWHO.COM. INT. CL. 41. REG. 7-23-2002.
- 2,597,040. HANIF'S AND DESIGN. INT. CLS. 29 AND 30. REG. 7-23-2002.
- 2,597,043. HANIF'S. INT. CLS. 29 AND 30. REG. 7-23-2002.
- 2,597,045. DIGITAL HEAVEN. INT. CL. 9. REG. 7-23-2002.
- 2,597,051. VALUEPAK. INT. CL. 36. REG. 7-23-2002.
- 2,597,052. MEVC AND DESIGN. INT. CL. 36. REG. 7-23-2002.
- 2,597,055. FASTSTRIKE. INT. CL. 1. REG. 7-23-2002.
- 2,597,056. ENTERPRISE OFFSET. INT. CL. 16. REG. 7-23-2002.
- 2,597,058. HEART GIFT AND DESIGN. INT. CL. 35. REG. 7-23-2002.
- 2,597,059. OSSUR SILKEN (STYLIZED). INT. CLS. 1, 10 AND 40. REG. 7-23-2002.
- 2,597,063. SEWFINE INTERIOR PRODUCTS AND DESIGN. INT. CLS. 12, 27 AND 40. REG. 7-23-2002.
- 2,597,064. JAMES GANG. INT. CL. 30. REG. 7-23-2002.

- 2,597,065. SECURE ENVELOPE. INT. CLS. 9 AND 38. REG. 7-23-2002.
- 2,597,067. DI/DT. INT. CL. 9. REG. 7-23-2002.
- 2,597,068. VC VENTURE CAPITAL AND DESIGN. INT. CL. 36. REG. 7-23-2002.
- 2,597,069. DI/DT (STYLIZED). INT. CL. 9. REG. 7-23-2002.
- 2,597,073. DRIVEN BY TECHNOLOGY. INT. CL. 12. REG. 7-23-2002.
- 2,597,076. DON'T GO IT ALONE. INT. CL. 36. REG. 7-23-2002.
- 2,597,077. JACK FREEZE. INT. CL. 33. REG. 7-23-2002.
- 2,597,079. CORNER BAKERY AND DESIGN. INT. CL. 32. REG. 7-23-2002.
- 2,597,081. VIRGINIA CITY GRAND PRIX. INT. CL. 41. REG. 7-23-2002.
- 2,597,082. M (STYLIZED). INT. CL. 25. REG. 7-23-2002.
- 2,597,085. THOMAS'. INT. CL. 30. REG. 7-23-2002.
- 2,597,086. RESICON. INT. CLS. 7, 19 AND 42. REG. 7-23-2002.
- 2,597,087. THE FRUIT COMPANY AND DESIGN. INT. CLS. 29 AND 31. REG. 7-23-2002.
- 2,597,090. HAMMERHEAD. INT. CL. 9. REG. 7-23-2002.
- 2,597,095. GREENWICH TECHNOLOGY PARTNERS. INT. CL. 42. REG. 7-23-2002.
- 2,597,097. QUAD CITY STEAMWHEELERS AND DESIGN. INT. CLS. 16, 25 AND 41. REG. 7-23-2002.
- 2,597,098. EWINGSTECH. INT. CL. 38. REG. 7-23-2002.
- 2,597,100. BRIGHT START. INT. CL. 3. REG. 7-23-2002.
- 2,597,102. AIM 2010 AMERICANS IN MOTION AND DESIGN. INT. CL. 42. REG. 7-23-2002.
- 2,597,103. THE GOVERNOR'S TCC 2000 TAKE CHARGE CHALLENGE AND DESIGN. INT. CL. 42. REG. 7-23-2002.
- 2,597,105. BANKRESOURCE. INT. CL. 35. REG. 7-23-2002.
- 2,597,107. QP GROUP. INT. CL. 35. REG. 7-23-2002.
- 2,597,111. MOTHERBOARD ZONE. INT. CL. 35. REG. 7-23-2002.
- 2,597,113. THE FUTURE OF MERCHANDISING. INT. CL. 35. REG. 7-23-2002.
- 2,597,115. PASTAWARE. INT. CL. 8. REG. 7-23-2002.
- 2,597,117. GERMAINE DE CAPUCCINI AND DESIGN. INT. CL. 38. REG. 7-23-2002.
- 2,597,119. BILL MAKER. INT. CL. 9. REG. 7-23-2002.
- 2,597,122. MACHETE. INT. CLS. 35 AND 41. REG. 7-23-2002.
- 2,597,125. LOGGING THE INDUSTRIAL FOREST AND DESIGN. INT. CL. 40. REG. 7-23-2002.
- 2,597,127. SMP 2100. INT. CL. 35. REG. 7-23-2002.
- 2,597,130. OMNIACE. INT. CL. 9. REG. 7-23-2002.
- 2,597,131. WILDPHYR. INT. CL. 9. REG. 7-23-2002.
- 2,597,132. @@@@+ @@@@ @@@ @ X AND DESIGN. INT. CLS. 9, 35, 36, 38 AND 42. REG. 7-23-2002.
- 2,597,133. GEENA (STYLIZED). INT. CL. 24. REG. 7-23-2002.
- 2,597,136. BIZCAST. INT. CL. 9. REG. 7-23-2002.
- 2,597,140. A WHOLE NEW WAY TO TALK. INT. CL. 38. REG. 7-23-2002.
- 2,597,141. STOR-A-STRAP. INT. CL. 20. REG. 7-23-2002.
- 2,597,142. PACKAGINGCAREERS.COM. INT. CL. 35. REG. 7-23-2002.
- 2,597,143. ABD RACING. INT. CLS. 7 AND 12. REG. 7-23-2002.
- 2,597,148. DESKPILOT. INT. CL. 38. REG. 7-23-2002.
- 2,597,149. STOCKBRIDGE SQUARE. INT. CL. 27. REG. 7-23-2002.
- 2,597,150. WELLNESS ANGEL. INT. CLS. 9, 41 AND 42. REG. 7-23-2002.
- 2,597,151. CUSTOMFAN. INT. CL. 25. REG. 7-23-2002.
- 2,597,152. POSTAL BLUE AND DESIGN. INT. CLS. 6, 18 AND 25. REG. 7-23-2002.
- 2,597,153. UNDER TREAD-AN-A-HALF. INT. CL. 12. REG. 7-23-2002.
- 2,597,155. MYHEALTHCAREMD WWW.MYHEALTHCAREMD.NET AND DESIGN. INT. CL. 42. REG. 7-23-2002.
- 2,597,156. FFF. INT. CL. 42. REG. 7-23-2002.
- 2,597,158. FRAMERSELECT AND DESIGN. INT. CLS. 35 AND 42. REG. 7-23-2002.
- 2,597,162. CHURCH MANAGEMENT RESOURCES AND DESIGN. INT. CLS. 9 AND 42. REG. 7-23-2002.
- 2,597,164. BLUEGREEN AIR AND DESIGN. INT. CL. 36. REG. 7-23-2002.
- 2,597,165. BLUEGREEN AIR. INT. CL. 36. REG. 7-23-2002.
- 2,597,166. PLATINUM AVIATION GROUP. INT. CL. 40. REG. 7-23-2002.
- 2,597,167. FIRE IN THE HOLE! AND DESIGN. INT. CL. 30. REG. 7-23-2002.
- 2,597,168. DISTRIBUTED BY: CHEESE MONGER COMPANY CMC CHEESE SPREAD AND DESIGN. INT. CL. 29. REG. 7-23-2002.
- 2,597,171. BLACKIE'S SINCE 1946 PRIME RIB SEAFOOD FINE WINES AND DESIGN. INT. CL. 42. REG. 7-23-2002.
- 2,597,172. 555@HAND (STYLIZED). INT. CL. 35. REG. 7-23-2002.
- 2,597,178. STRICTLY BUSINESS. INT. CL. 35. REG. 7-23-2002.
- 2,597,179. SPHERICDESIGN MIND IS OPEN AND DESIGN. INT. CLS. 3, 8, 9, 11, 21 AND 26. REG. 7-23-2002.
- 2,597,180. TERRI GOLD. INT. CL. 41. REG. 7-23-2002.
- 2,597,183. THE FABRIC OF ELECTRONIC COMMERCE. INT. CL. 38. REG. 7-23-2002.
- 2,597,187. THE ORANGE ZONE. INT. CL. 35. REG. 7-23-2002.
- 2,597,188. ONE-CALL. INT. CL. 9. REG. 7-23-2002.
- 2,597,189. GOVERN YOUR DATA. INT. CL. 9. REG. 7-23-2002.
- 2,597,190. SWRI. INT. CL. 40. REG. 7-23-2002.
- 2,597,191. DESANA. INT. CLS. 35 AND 40. REG. 7-23-2002.
- 2,597,194. CYBERCSI. INT. CLS. 9 AND 37. REG. 7-23-2002.
- 2,597,200. EUROTECH. INT. CL. 7. REG. 7-23-2002.
- 2,597,204. CAVS AND DESIGN. INT. CL. 42. REG. 7-23-2002.
- 2,597,207. FOUND OBJECTS. INT. CL. 35. REG. 7-23-2002.
- 2,597,208. E-TALK CAREER HQ AND DESIGN. INT. CL. 42. REG. 7-23-2002.
- 2,597,209. CAREER EXPERTS CAREER HQ AND DESIGN. INT. CL. 42. REG. 7-23-2002.
- 2,597,212. SNPSCOUT. INT. CLS. 9 AND 42. REG. 7-23-2002.
- 2,597,213. COIN. INT. CLS. 9 AND 35. REG. 7-23-2002.
- 2,597,219. COLLEGE PATHWAYS PROJECT. INT. CL. 41. REG. 7-23-2002.
- 2,597,222. THE PROVERBS OF LEADERSHIP. INT. CL. 16. REG. 7-23-2002.
- 2,597,224. FAITES FOISONNER VOTRE TALENT WHIP UP YOUR TALENT. INT. CLS. 16, 29 AND 41. REG. 7-23-2002.
- 2,597,225. HOME SWEET HOME MOVING AND STORAGE. INT. CL. 39. REG. 7-23-2002.
- 2,597,229. ETRAVELS.NET. INT. CL. 16. REG. 7-23-2002.
- 2,597,230. OMEGA GLOW. INT. CL. 5. REG. 7-23-2002.
- 2,597,232. C-FOLDED CHANNEL AND DESIGN. INT. CL. 16. REG. 7-23-2002.
- 2,597,235. MISCELLANEOUS DESIGN. INT. CL. 38. REG. 7-23-2002.
- 2,597,239. WE'RE ALL KIDS BCNY AND DESIGN. INT. CL. 25. REG. 7-23-2002.
- 2,597,242. FU GINA. INT. CL. 38. REG. 7-23-2002.
- 2,597,243. BTE BENNETT TRUCK EQUIPMENT INCORPORATED AND DESIGN. INT. CLS. 35 AND 37. REG. 7-23-2002.
- 2,597,244. SOLERA. INT. CL. 19. REG. 7-23-2002.
- 2,597,248. LES LOUPS. INT. CL. 33. REG. 7-23-2002.
- 2,597,249. AQUAPUR. INT. CLS. 10, 21 AND 24. REG. 7-23-2002.
- 2,597,250. SBI AND DESIGN. INT. CL. 42. REG. 7-23-2002.
- 2,597,251. VENTANA INN & SPA. INT. CL. 42. REG. 7-23-2002.
- 2,597,255. TABA INCORPORATED (STYLIZED). INT. CL. 35. REG. 7-23-2002.
- 2,597,256. BLUESHIRT EXTRA. INT. CL. 41. REG. 7-23-2002.
- 2,597,257. YSLA HAIR SALON FOR MEN. INT. CL. 42. REG. 7-23-2002.
- 2,597,258. REAL MAGNET. INT. CL. 42. REG. 7-23-2002.
- 2,597,259. BODEGAS CENTENARIAS. INT. CL. 33. REG. 7-23-2002.
- 2,597,260. BLACK WIDOW. INT. CL. 14. REG. 7-23-2002.
- 2,597,261. WOOD CUTTER (STYLIZED). INT. CL. 11. REG. 7-23-2002.

- 2,597,263. VASSTV. INT. CLS. 9 AND 16. REG. 7-23-2002.
 2,597,266. COSENZA. INT. CLS. 29 AND 30. REG. 7-23-2002.
 2,597,271. ART CONNOISSEUR. INT. CL. 16. REG. 7-23-2002.
 2,597,272. AQUATICS REHAB AND DESIGN. INT. CL. 42. REG. 7-23-2002.
 2,597,273. REALABOR. INT. CL. 9. REG. 7-23-2002.
 2,597,275. SIMPLY IRASISTIBLE. INT. CL. 36. REG. 7-23-2002.
 2,597,276. FIESTA DEL MERCADO. INT. CL. 41. REG. 7-23-2002.
 2,597,279. INSTA-FREEZE. INT. CL. 11. REG. 7-23-2002.
 2,597,280. MEZQUITA. INT. CL. 32. REG. 7-23-2002.
 2,597,285. BIOWORLD ONLINE. INT. CL. 42. REG. 7-23-2002.
 2,597,288. E 3 A (STYLIZED). INT. CL. 41. REG. 7-23-2002.
 2,597,290. IM. INT. CL. 35. REG. 7-23-2002.
 2,597,291. BIFINETT. INT. CLS. 8, 11 AND 29. REG. 7-23-2002.
 2,597,292. TV FROM YESTERYEAR. INT. CL. 9. REG. 7-23-2002.
 2,597,294. SRS COMPLIANCEPARTNER. INT. CL. 42. REG. 7-23-2002.
 2,597,298. B2P (STYLIZED). INT. CLS. 35 AND 36. REG. 7-23-2002.
 2,597,299. B2P (STYLIZED). INT. CL. 42. REG. 7-23-2002.
 2,597,300. UMBRELLA ELITE S.I.R.. INT. CL. 36. REG. 7-23-2002.
 2,597,301. ARMIANSKAYA VODKA. INT. CL. 33. REG. 7-23-2002.
 2,597,302. DI-MOTRONIC MED. INT. CL. 7. REG. 7-23-2002.
 2,597,307. CARPET C.A.R.E. "CLEANING AND REPAIR EXPERTS". INT. CL. 37. REG. 7-23-2002.
 2,597,309. REGGUARD. INT. CL. 42. REG. 7-23-2002.
 2,597,310. PALADIN. INT. CL. 17. REG. 7-23-2002.
 2,597,311. CH@T. INT. CLS. 30, 32 AND 33. REG. 7-23-2002.
 2,597,313. SMILE IN A BOX. INT. CL. 16. REG. 7-23-2002.
 2,597,315. PUMP & ROLL. INT. CL. 16. REG. 7-23-2002.
 2,597,316. GESSWEIN. INT. CL. 8. REG. 7-23-2002.
 2,597,317. SKYFLOW. INT. CL. 42. REG. 7-23-2002.
 2,597,318. TEGRA OUTLOOK SUNRX. INT. CL. 9. REG. 7-23-2002.
 2,597,320. NETFUEL. INT. CL. 42. REG. 7-23-2002.
 2,597,321. DUALLY. INT. CL. 8. REG. 7-23-2002.
 2,597,323. MARKET MASTER. INT. CL. 11. REG. 7-23-2002.
 2,597,325. NEXTEP. INT. CLS. 6 AND 20. REG. 7-23-2002.
 2,597,328. IMAGICATION. INT. CL. 9. REG. 7-23-2002.
 2,597,329. LA DEMOISELLE AND DESIGN. INT. CL. 33. REG. 7-23-2002.
 2,597,330. DEMOISELLE AND DESIGN. INT. CL. 33. REG. 7-23-2002.
 2,597,331. SYSPUR-DERM. INT. CLS. 5 AND 10. REG. 7-23-2002.
 2,597,332. EXLL (STYLIZED). INT. CL. 41. REG. 7-23-2002.
 2,597,333. PLASTER MAN (STYLIZED). INT. CL. 41. REG. 7-23-2002.
 2,597,334. SAFE SURROUND AND DESIGN. INT. CLS. 18 AND 20. REG. 7-23-2002.
 2,597,336. RED CLOUD. INT. CLS. 25 AND 35. REG. 7-23-2002.
 2,597,337. THERMA-TOTE (STYLIZED). INT. CL. 21. REG. 7-23-2002.
 2,597,338. NORTHLAND FORD STORE. INT. CL. 35. REG. 7-23-2002.
 2,597,339. PLUMBMASTER. INT. CL. 11. REG. 7-23-2002.
 2,597,340. FLO-KLEAN. INT. CL. 7. REG. 7-23-2002.
 2,597,343. SYSTEM ONE. INT. CL. 9. REG. 7-23-2002.
 2,597,348. FUELGRIP. INT. CL. 17. REG. 7-23-2002.
 2,597,349. MOBYDOT. INT. CL. 42. REG. 7-23-2002.
 2,597,350. (((DIGITAL CONNECT, INC.))) (STYLIZED). INT. CL. 35. REG. 7-23-2002.
 2,597,352. HOWLING AT THE MOON PRESS. INT. CL. 16. REG. 7-23-2002.
 2,597,353. UNITED ELECTRONIC INDUSTRIES THE HIGH PERFORMANCE ALTERNATIVE. INT. CL. 9. REG. 7-23-2002.
 2,597,354. WIRED MATRIX. INT. CLS. 35 AND 42. REG. 7-23-2002.
 2,597,356. MR. DRUMHEAD. INT. CL. 28. REG. 7-23-2002.
 2,597,358. DIGITAL PRO AUDIO. INT. CL. 9. REG. 7-23-2002.
 2,597,359. THE REMNANT OF ISRAEL AND DESIGN. INT. CLS. 36 AND 42. REG. 7-23-2002.
 2,597,360. PIPES CAFE. INT. CL. 42. REG. 7-23-2002.
 2,597,365. BUSINESS JUST GOT BETTER FOR EVERYONE.. INT. CL. 35. REG. 7-23-2002.
 2,597,366. SIVA AND DESIGN. INT. CLS. 35, 41 AND 42. REG. 7-23-2002.
 2,597,368. MISCELLANEOUS DESIGN. INT. CL. 19. REG. 7-23-2002.
 2,597,369. SNACKAURANT. INT. CLS. 29, 30, 32, 33 AND 42. REG. 7-23-2002.
 2,597,370. THE IN THING IN SPEAKER INCLOSURES. INT. CL. 9. REG. 7-23-2002.
 2,597,374. 55 PAINTED BUMPER AND DESIGN. INT. CL. 12. REG. 7-23-2002.
 2,597,375. "STOW-IT" AND DESIGN. INT. CL. 20. REG. 7-23-2002.
 2,597,376. C Q MONITORING. INT. CL. 42. REG. 7-23-2002.
 2,597,377. PRECEDA. INT. CL. 12. REG. 7-23-2002.
 2,597,378. VENCASD AND DESIGN. INT. CL. 36. REG. 7-23-2002.
 2,597,379. NUSPHERE AND DESIGN. INT. CL. 41. REG. 7-23-2002.
 2,597,383. GOLDEN NAILS. INT. CL. 42. REG. 7-23-2002.
 2,597,384. GRAEWOLF. INT. CL. 12. REG. 7-23-2002.
 2,597,385. CMT HIT TRIP. INT. CL. 41. REG. 7-23-2002.
 2,597,387. PURSUIT AND DESIGN. INT. CL. 41. REG. 7-23-2002.
 2,597,391. OVATION CAPITAL. INT. CL. 36. REG. 7-23-2002.
 2,597,393. CAROSIO. INT. CL. 30. REG. 7-23-2002.
 2,597,394. CUVÉE DE L'ARBOUSIER (STYLIZED). INT. CL. 33. REG. 7-23-2002.
 2,597,395. REPLASYN. INT. CL. 5. REG. 7-23-2002.
 2,597,396. WHO REMEMBERS ANYTHING ORDINARY?. INT. CL. 42. REG. 7-23-2002.
 2,597,397. NEMA. INT. CL. 1. REG. 7-23-2002.
 2,597,399. NEWMETHOD DIRECT. INT. CL. 35. REG. 7-23-2002.
 2,597,401. RICHPEACE. INT. CL. 7. REG. 7-23-2002.
 2,597,404. UEC FLUORIDE GREAT REGULAR FLAVOR FREE TOOTHBRUSH AND DESIGN. INT. CL. 3. REG. 7-23-2002.
 2,597,406. RAPITERM. INT. CL. 9. REG. 7-23-2002.
 2,597,408. MISCELLANEOUS DESIGN. INT. CL. 41. REG. 7-23-2002.
 2,597,409. PRO-HEALTH-TEC. INT. CL. 21. REG. 7-23-2002.
 2,597,412. TANK DEMON. INT. CL. 1. REG. 7-23-2002.
 2,597,413. I OVATION CAPITAL AND DESIGN. INT. CL. 36. REG. 7-23-2002.
 2,597,414. BE CREATIVE. INT. CL. 36. REG. 7-23-2002.
 2,597,419. THE SCHOLASTIC EARLY CHILDHOOD WORKSHOP AND DESIGN. INT. CL. 16. REG. 7-23-2002.
 2,597,420. TOILE RESOURCE. INT. CL. 27. REG. 7-23-2002.
 2,597,421. BUILDING PRODUCTIVITY FOR DOCTORS ON THE GO. INT. CL. 39. REG. 7-23-2002.
 2,597,424. TOOTSIE POSIES. INT. CL. 14. REG. 7-23-2002.
 2,597,425. AND ISN'T THAT WHERE YOU WANT TO BE?. INT. CL. 35. REG. 7-23-2002.
 2,597,426. BASE MASTER. INT. CL. 28. REG. 7-23-2002.
 2,597,427. WESTCOOPER. INT. CL. 36. REG. 7-23-2002.
 2,597,428. YLC AND DESIGN. INT. CLS. 41 AND 42. REG. 7-23-2002.
 2,597,429. HEALTHCARE 21 (STYLIZED). INT. CL. 35. REG. 7-23-2002.
 2,597,430. BORA. INT. CL. 17. REG. 7-23-2002.
 2,597,431. VISIONPLUS AND DESIGN. INT. CL. 11. REG. 7-23-2002.
 2,597,433. QUADRA3. INT. CL. 9. REG. 7-23-2002.
 2,597,434. FLEUR DE DUVAL-LEROY. INT. CL. 33. REG. 7-23-2002.
 2,597,435. TRUESPECTRA AND DESIGN. INT. CL. 9. REG. 7-23-2002.
 2,597,436. AMHERST AND DESIGN. INT. CL. 35. REG. 7-23-2002.

- 2,597,437. MISCELLANEOUS DESIGN. INT. CLS. 35 AND 36. REG. 7-23-2002.
- 2,597,440. DAX & COE. INT. CL. 25. REG. 7-23-2002.
- 2,597,441. MISCELLANEOUS DESIGN. INT. CL. 36. REG. 7-23-2002.
- 2,597,442. STATE TAX TODAY. INT. CL. 42. REG. 7-23-2002.
- 2,597,443. ECG WAVE-MAVEN. INT. CL. 42. REG. 7-23-2002.
- 2,597,444. ISOURCE. INT. CL. 9. REG. 7-23-2002.
- 2,597,455. THE ALFAX ADVANTAGE. INT. CL. 35. REG. 7-23-2002.
- 2,597,456. TCADVISOR PRO. INT. CL. 36. REG. 7-23-2002.
- 2,597,457. TRICON PIPING SYSTEMS. INT. CLS. 6 AND 17. REG. 7-23-2002.
- 2,597,459. SPORTS ID.COM. INT. CL. 41. REG. 7-23-2002.
- 2,597,460. SPORTS ID. INT. CL. 41. REG. 7-23-2002.
- 2,597,464. SAMPLEMONITOR. INT. CL. 35. REG. 7-23-2002.
- 2,597,468. REEL INNOVATION. INT. CL. 20. REG. 7-23-2002.
- 2,597,470. E-HEALTHCARE SOLUTIONS AND DESIGN. INT. CL. 35. REG. 7-23-2002.
- 2,597,472. DIGITAL HEALTHCARE NETWORK. INT. CL. 35. REG. 7-23-2002.
- 2,597,473. STUDIO M AND DESIGN. INT. CL. 38. REG. 7-23-2002.
- 2,597,474. HIT N HIP.COM. INT. CL. 35. REG. 7-23-2002.
- 2,597,475. PICTURE GOLF LIKE YOU NEVER HAVE BEFORE. INT. CL. 42. REG. 7-23-2002.
- 2,597,477. PERISCOPE BEYOND IDEAS AND DESIGN. INT. CLS. 35 AND 42. REG. 7-23-2002.
- 2,597,479. VALLEY POOLS & SPAS AND DESIGN. INT. CLS. 35 AND 37. REG. 7-23-2002.
- 2,597,484. BASE YOUR SUCCESS ON UNITED GUARANTY. INT. CLS. 21 AND 36. REG. 7-23-2002.
- 2,597,485. EMPARC AND DESIGN. INT. CL. 42. REG. 7-23-2002.
- 2,597,486. GRITS. INT. CLS. 6, 9, 14, 16, 18, 20 AND 21. REG. 7-23-2002.
- 2,597,494. DUOFULATOR. INT. CLS. 11, 12 AND 13. REG. 7-23-2002.
- 2,597,495. VARIOFLATOR. INT. CLS. 11, 12 AND 13. REG. 7-23-2002.
- 2,597,496. VB CONNECTIONS. INT. CL. 35. REG. 7-23-2002.
- 2,597,497. SNAP 2000. INT. CL. 6. REG. 7-23-2002.
- 2,597,502. MCIM AND DESIGN. INT. CLS. 35 AND 41. REG. 7-23-2002.
- 2,597,505. CUISINES OF THE SUN AT MAUNA LANI BAY AND DESIGN. INT. CL. 41. REG. 7-23-2002.
- 2,597,507. CUISINES OF THE SUN. INT. CL. 41. REG. 7-23-2002.
- 2,597,510. PRINTFLEX. INT. CL. 42. REG. 7-23-2002.
- 2,597,511. PRODUCERLICENSING.COM. INT. CL. 36. REG. 7-23-2002.
- 2,597,514. PUNTO (STYLIZED). INT. CL. 12. REG. 7-23-2002.
- 2,597,516. YOURWORLD CONSULTANT GROUP AND DESIGN. INT. CL. 42. REG. 7-23-2002.
- 2,597,517. YOUR ENERGY ADVISOR.COM THE TRUSTED SOURCE FOR ALL YOUR HOUSEHOLD MANAGEMENT NEEDS AND DESIGN. INT. CL. 42. REG. 7-23-2002.
- 2,597,518. DISC SLEEVE AND DESIGN. INT. CL. 9. REG. 7-23-2002.
- 2,597,521. BROKERBASE. INT. CL. 42. REG. 7-23-2002.
- 2,597,525. FUTURE WITH FOCUS PERFORMANCE WITH PERSPECTIVE. INT. CL. 36. REG. 7-23-2002.
- 2,597,526. SPIRIT ATHLETICS. INT. CL. 35. REG. 7-23-2002.
- 2,597,527. THE BOMB. INT. CL. 31. REG. 7-23-2002.
- 2,597,528. UDE AND DESIGN. INT. CLS. 16 AND 28. REG. 7-23-2002.
- 2,597,534. MORPHICS TECHNOLOGY INC. (STYLIZED). INT. CL. 42. REG. 7-23-2002.
- 2,597,535. FINE HOST. INT. CLS. 35 AND 42. REG. 7-23-2002.
- 2,597,537. N E T G E N AND DESIGN. INT. CL. 41. REG. 7-23-2002.
- 2,597,538. ULTIMATE RACE WEEKEND. INT. CLS. 35 AND 41. REG. 7-23-2002.
- 2,597,540. M-TRON. INT. CL. 9. REG. 7-23-2002.
- 2,597,543. TC8. INT. CL. 9. REG. 7-23-2002.
- 2,597,545. GUIDECOMM. INT. CLS. 35 AND 42. REG. 7-23-2002.
- 2,597,546. 218. INT. CL. 12. REG. 7-23-2002.
- 2,597,547. PALACE AND DESIGN. INT. CL. 30. REG. 7-23-2002.
- 2,597,548. REPCONNECT. INT. CL. 42. REG. 7-23-2002.
- 2,597,550. SPORT PLUS. INT. CL. 28. REG. 7-23-2002.
- 2,597,551. CANTOLINES. INT. CL. 30. REG. 7-23-2002.
- 2,597,552. LITTLEBOT. INT. CL. 28. REG. 7-23-2002.
- 2,597,553. PAKIDO. INT. CL. 20. REG. 7-23-2002.
- 2,597,554. CORPNEX. INT. CLS. 35, 36, 37, 38 AND 42. REG. 7-23-2002.
- 2,597,556. PIERRE DE FAUVERT. INT. CL. 33. REG. 7-23-2002.
- 2,597,557. MISCELLANEOUS DESIGN. INT. CL. 35. REG. 7-23-2002.
- 2,597,559. SCANCODE LOGISTICS. INT. CLS. 37 AND 42. REG. 7-23-2002.
- 2,597,561. JUCY'S SMOKEHOUSE BAR-B-Q AND DESIGN. INT. CLS. 29 AND 42. REG. 7-23-2002.
- 2,597,563. 5S (STYLIZED). INT. CL. 30. REG. 7-23-2002.
- 2,597,566. AMAZING WOMEN. INT. CL. 16. REG. 7-23-2002.
- 2,597,569. QUALTE (STYLIZED). INT. CL. 42. REG. 7-23-2002.
- 2,597,572. GOCERTS. INT. CL. 42. REG. 7-23-2002.
- 2,597,573. MB2. INT. CL. 41. REG. 7-23-2002.
- 2,597,575. THE CREPE FACTORY. INT. CL. 42. REG. 7-23-2002.
- 2,597,576. BLOCKBUSTER GIFTCARDS. INT. CL. 16. REG. 7-23-2002.
- 2,597,577. BLOCKBUSTER FAVORITES. INT. CL. 41. REG. 7-23-2002.
- 2,597,578. LURE SEGUE. INT. CL. 42. REG. 7-23-2002.
- 2,597,583. BLADE XP. INT. CL. 9. REG. 7-23-2002.
- 2,597,585. STOP & SHOP NATURE'S SWEETEST #4016 RED DELICIOUS APPLE AND DESIGN. INT. CL. 31. REG. 7-23-2002.
- 2,597,588. CLEOPATRA'S INK. INT. CL. 42. REG. 7-23-2002.
- 2,597,589. SPARTACOM MODEMSHARE. INT. CL. 9. REG. 7-23-2002.
- 2,597,592. SMART CONTAINER. INT. CL. 21. REG. 7-23-2002.
- 2,597,594. OPEN MINDS, CUSTOM SOLUTIONS. INT. CL. 36. REG. 7-23-2002.
- 2,597,597. CASES CASES AND DESIGN. INT. CL. 35. REG. 7-23-2002.
- 2,597,598. SPRINGSTONE CHILDREN'S LEARNING CENTERS AND DESIGN. INT. CLS. 41 AND 42. REG. 7-23-2002.
- 2,597,600. BE. INT. CL. 16. REG. 7-23-2002.
- 2,597,601. MISCELLANEOUS DESIGN. INT. CLS. 16 AND 41. REG. 7-23-2002.
- 2,597,602. MUSIC FOR THE JOURNEY APRILSONGS, INC. AND DESIGN. INT. CL. 41. REG. 7-23-2002.
- 2,597,603. THE HAWAIIAN INSURANCE & GUARANTY COMPANY, LIMITED. INT. CL. 36. REG. 7-23-2002.
- 2,597,605. STUDIO 33. INT. CL. 18. REG. 7-23-2002.
- 2,597,608. ETM. INT. CLS. 9 AND 12. REG. 7-23-2002.
- 2,597,609. FERTILE HAND. INT. CL. 29. REG. 7-23-2002.
- 2,597,612. TLT-PROJECT MANAGER. INT. CL. 9. REG. 7-23-2002.
- 2,597,617. TECHNOGENESIS. INT. CL. 41. REG. 7-23-2002.
- 2,597,622. THREAT RACING. INT. CL. 25. REG. 7-23-2002.
- 2,597,627. WHITE LIGHTNING. INT. CL. 13. REG. 7-23-2002.
- 2,597,628. EVIL RULES. INT. CL. 13. REG. 7-23-2002.
- 2,597,634. LITTLE SMILES DENTISTRY FOR CHILDREN AND DESIGN. INT. CL. 42. REG. 7-23-2002.
- 2,597,637. TREE STAR. INT. CL. 5. REG. 7-23-2002.
- 2,597,640. I AND DESIGN. INT. CL. 9. REG. 7-23-2002.
- 2,597,643. MISCELLANEOUS DESIGN. INT. CL. 35. REG. 7-23-2002.
- 2,597,645. EJAI. INT. CL. 9. REG. 7-23-2002.
- 2,597,648. OYSHO. INT. CL. 18. REG. 7-23-2002.
- 2,597,649. SACK ARMIES. INT. CL. 28. REG. 7-23-2002.
- 2,597,650. T AND DESIGN. INT. CL. 28. REG. 7-23-2002.
- 2,597,652. MR. BASEBALL'S BRATS. INT. CL. 29. REG. 7-23-2002.
- 2,597,654. AIRPATH. INT. CL. 9. REG. 7-23-2002.
- 2,597,657. SOFTPEARL. INT. CL. 17. REG. 7-23-2002.

- 2,597,658. VIVID LENTICULAR. INT. CL. 17. REG. 7-23-2002.
- 2,597,660. SIERRA NEVADA HELICOPTERS, INC. AND DESIGN. INT. CL. 39. REG. 7-23-2002.
- 2,597,665. JELLY LIGHT. INT. CL. 11. REG. 7-23-2002.
- 2,597,669. MISCELLANEOUS DESIGN. INT. CLS. 16 AND 25. REG. 7-23-2002.
- 2,597,672. DOUBBLE TROUBLE. INT. CL. 41. REG. 7-23-2002.
- 2,597,678. INSTANTWRITE (STYLIZED). INT. CL. 9. REG. 7-23-2002.
- 2,597,681. MEADOWS INSTITUTE. INT. CL. 41. REG. 7-23-2002.
- 2,597,682. MEADOWS INSTITUTE. INT. CL. 35. REG. 7-23-2002.
- 2,597,685. DATABASE BOOTCAMP. INT. CL. 41. REG. 7-23-2002.
- 2,597,686. PRO 3 AND DESIGN. INT. CL. 11. REG. 7-23-2002.
- 2,597,687. DAVE MIRRA BMX SUPER TOUR. INT. CL. 41. REG. 7-23-2002.
- 2,597,690. CHARLY TEMMEL THE BEST ICE CREAM IN THEWORLD. INT. CL. 30. REG. 7-23-2002.
- 2,597,692. POLY PROCESSING. INT. CLS. 20 AND 40. REG. 7-23-2002.
- 2,597,694. ECLIPSE PACKAGING INC.. INT. CL. 40. REG. 7-23-2002.
- 2,597,695. OCEAN WAVE INTERACTIVE. INT. CL. 9. REG. 7-23-2002.
- 2,597,701. BEYOND EXPECTATION. INT. CL. 32. REG. 7-23-2002.
- 2,597,702. COLORSPLASH. INT. CL. 17. REG. 7-23-2002.
- 2,597,703. TOM'S HARDWARE GUIDE AND DESIGN. INT. CL. 42. REG. 7-23-2002.
- 2,597,704. HUMMINGBIRD ENTERPRISE INFORMATION PORTAL. INT. CL. 9. REG. 7-23-2002.
- 2,597,705. PNUTZ THE ELEPHANT AND DESIGN. INT. CL. 9. REG. 7-23-2002.
- 2,597,707. THE BOTANICAL BABIES AND DESIGN. INT. CL. 16. REG. 7-23-2002.
- 2,597,710. PORTLAND FIRE AND DESIGN. INT. CL. 38. REG. 7-23-2002.
- 2,597,711. CELLAR MATE THE KEY TO WINE CELLAR CLIMATE CONTROL AND DESIGN. INT. CL. 11. REG. 7-23-2002.
- 2,597,712. ROCKY MOUNTAIN TECHNOLOGY GROUP AND DESIGN. INT. CLS. 9, 16, 35, 41 AND 42. REG. 7-23-2002.
- 2,597,715. SWISSCARE AND DESIGN. INT. CLS. 35, 37 AND 42. REG. 7-23-2002.
- 2,597,717. HARBOR CAPITAL MANAGEMENT. INT. CL. 36. REG. 7-23-2002.
- 2,597,722. DYNASVELTE AND DESIGN. INT. CL. 30. REG. 7-23-2002.
- 2,597,723. SKYGO. INT. CLS. 9 AND 35. REG. 7-23-2002.
- 2,597,725. VECOM. INT. CL. 40. REG. 7-23-2002.
- 2,597,726. TUSCANY. INT. CL. 31. REG. 7-23-2002.
- 2,597,729. EK AND DESIGN. INT. CL. 17. REG. 7-23-2002.
- 2,597,730. BUDGETLIST.COM (STYLIZED). INT. CL. 36. REG. 7-23-2002.
- 2,597,736. NEED A SAMPLE (STYLIZED). INT. CL. 42. REG. 7-23-2002.
- 2,597,738. YOU ARE MORE THAN A FINANCIAL STATEMENT.. INT. CL. 36. REG. 7-23-2002.
- 2,597,739. ROARING GAP. INT. CL. 20. REG. 7-23-2002.
- 2,597,741. GLOWGUARD. INT. CL. 28. REG. 7-23-2002.
- 2,597,742. FACEMASKS. INT. CL. 28. REG. 7-23-2002.
- 2,597,744. FOSGATE AUDIONICS. INT. CL. 9. REG. 7-23-2002.
- 2,597,745. MISCELLANEOUS DESIGN. INT. CL. 38. REG. 7-23-2002.
- 2,597,746. UNITED TELECOM AND DESIGN. INT. CL. 38. REG. 7-23-2002.
- 2,597,748. QWEST DEX ADVANTAGE. INT. CL. 16. REG. 7-23-2002.
- 2,597,749. SAE MA UL AND DESIGN. INT. CL. 31. REG. 7-23-2002.
- 2,597,750. BAYSIDE EXPO & EXECUTIVE CONFERENCE CENTER. INT. CL. 42. REG. 7-23-2002.
- 2,597,752. EDGEWORKS. INT. CL. 16. REG. 7-23-2002.
- 2,597,755. CERTIFLEX DIMENSION. INT. CLS. 9 AND 42. REG. 7-23-2002.
- 2,597,757. UNCOMPROMISED QUALITY. UNPRECEDENTED EFFICIENCY.. INT. CL. 36. REG. 7-23-2002.
- 2,597,758. DDI ARCHITECTS, PC. INT. CL. 42. REG. 7-23-2002.
- 2,597,760. SUPERTRAK100. INT. CL. 9. REG. 7-23-2002.
- 2,597,761. SUPERSWAP. INT. CL. 9. REG. 7-23-2002.
- 2,597,766. SEE WELL ... BE WELL. INT. CL. 11. REG. 7-23-2002.
- 2,597,768. A NETWORK OF COMMUNITY BANKS BANK OF STOCKDALE A DIVISION OF VALLEY INDEPENDENT AND DESIGN. INT. CL. 36. REG. 7-23-2002.
- 2,597,769. MERCATOR ENERGY AND DESIGN. INT. CL. 42. REG. 7-23-2002.
- 2,597,771. EM AND DESIGN. INT. CL. 35. REG. 7-23-2002.
- 2,597,772. ATHLETES 1FIRST (STYLIZED). INT. CL. 35. REG. 7-23-2002.
- 2,597,773. MISCELLANEOUS DESIGN. INT. CL. 35. REG. 7-23-2002.
- 2,597,776. CLEANPAK. INT. CL. 36. REG. 7-23-2002.
- 2,597,782. GHOST IN MY SUITCASE. INT. CL. 16. REG. 7-23-2002.
- 2,597,783. OVID @HAND. INT. CL. 9. REG. 7-23-2002.
- 2,597,787. LA PLEBADA. INT. CL. 16. REG. 7-23-2002.
- 2,597,790. INFOVISION, INC. AND DESIGN. INT. CL. 35. REG. 7-23-2002.
- 2,597,792. CMD GUIDE. INT. CL. 9. REG. 7-23-2002.
- 2,597,793. TEL AIR. INT. CL. 9. REG. 7-23-2002.
- 2,597,794. KBROWSER. INT. CL. 9. REG. 7-23-2002.
- 2,597,795. CONTEMPORARY PLASTIC SURGERY AND DESIGN. INT. CL. 42. REG. 7-23-2002.
- 2,597,796. G I GARDEN IRON (STYLIZED). INT. CL. 6. REG. 7-23-2002.
- 2,597,798. INVESTOR'S ADVANTAGE PLUS. INT. CL. 36. REG. 7-23-2002.
- 2,597,800. HELL ON WHEELS. INT. CL. 16. REG. 7-23-2002.
- 2,597,802. TRES ANEJO (STYLIZED). INT. CL. 33. REG. 7-23-2002.
- 2,597,803. TRES PLATA (STYLIZED). INT. CL. 33. REG. 7-23-2002.
- 2,597,804. TRES PLATA (STYLIZED). INT. CL. 33. REG. 7-23-2002.
- 2,597,807. QUESTYS. INT. CL. 9. REG. 7-23-2002.
- 2,597,810. WARMWOMAN. INT. CL. 35. REG. 7-23-2002.
- 2,597,813. LEFT CLICK TO THE RIGHT JOB. INT. CL. 36. REG. 7-23-2002.
- 2,597,818. COSMOPOLITAN BANK AND TRUST. INT. CL. 36. REG. 7-23-2002.
- 2,597,822. OUTRAGEOUSLY INDULGENT!. INT. CLS. 30 AND 35. REG. 7-23-2002.
- 2,597,825. STRENGTHNET. INT. CL. 35. REG. 7-23-2002.
- 2,597,827. SHAKEY'S IT'S TIME. INT. CL. 42. REG. 7-23-2002.
- 2,597,828. ESTATE PLANK. INT. CL. 19. REG. 7-23-2002.
- 2,597,829. BOXWALL. INT. CL. 42. REG. 7-23-2002.
- 2,597,831. SKYBOY. INT. CL. 12. REG. 7-23-2002.
- 2,597,832. TECHDOMAIN AND DESIGN. INT. CL. 42. REG. 7-23-2002.
- 2,597,833. FARMER'S GARDEN FRESH PRODUCE AND DESIGN. INT. CL. 31. REG. 7-23-2002.
- 2,597,835. ANNA MAMMA AND DESIGN. INT. CL. 30. REG. 7-23-2002.
- 2,597,839. FAO BABY AND DESIGN. INT. CL. 35. REG. 7-23-2002.
- 2,597,841. JR JHERI RICHARDS. INT. CL. 25. REG. 7-23-2002.
- 2,597,842. STRAPSLICER. INT. CL. 7. REG. 7-23-2002.
- 2,597,845. M MASCOT AND DESIGN. INT. CL. 12. REG. 7-23-2002.
- 2,597,846. CINEBOOKS. INT. CL. 41. REG. 7-23-2002.
- 2,597,847. EVERYTHING SHOULD BE SO EASY. INT. CL. 36. REG. 7-23-2002.
- 2,597,849. STUDIO 1 STYLE. INT. CL. 41. REG. 7-23-2002.
- 2,597,854. AMFARM. INT. CL. 36. REG. 7-23-2002.

- 2,597,855. POPSDIRECT.COM AND DESIGN. INT. CL. 35. REG. 7-23-2002.
- 2,597,856. ANIMETER (STYLIZED). INT. CL. 9. REG. 7-23-2002.
- 2,597,861. EUROPEAN LIVING AND DESIGN. INT. CL. 35. REG. 7-23-2002.
- 2,597,863. TEEPE'S RIVER CITY MECHANICAL, INC.. INT. CL. 37. REG. 7-23-2002.
- 2,597,869. THE BEANS. INT. CL. 41. REG. 7-23-2002.
- 2,597,870. GROUNDBREAKING SOLUTIONS START BEFORE GROUNDBREAKING BEGINS. INT. CL. 35. REG. 7-23-2002.
- 2,597,874. D.E.N.T AND DESIGN. INT. CL. 41. REG. 7-23-2002.
- 2,597,879. INFORMED STEP PROCESSOR. INT. CL. 9. REG. 7-23-2002.
- 2,597,880. SUN COLOR. INT. CL. 3. REG. 7-23-2002.
- 2,597,882. NEOTHERM. INT. CL. 9. REG. 7-23-2002.
- 2,597,884. NO LOVE NO SKILL NO SKILL NO GAME. INT. CL. 41. REG. 7-23-2002.
- 2,597,887. SWORDCHOP. INT. CL. 29. REG. 7-23-2002.
- 2,597,889. LIVING THE EXPERIENCE. INT. CL. 41. REG. 7-23-2002.
- 2,597,891. MEMORIES COMMUNITY. INT. CL. 35. REG. 7-23-2002.
- 2,597,892. DARK SUN. INT. CL. 41. REG. 7-23-2002.
- 2,597,894. TIPS AND DESIGN. INT. CL. 9. REG. 7-23-2002.
- 2,597,898. EYE-FIVE. INT. CL. 3. REG. 7-23-2002.
- 2,597,899. WEST VIRGINIA WILD AND WONDERFUL. INT. CL. 35. REG. 7-23-2002.
- 2,597,900. MAXAM. INT. CL. 18. REG. 7-23-2002.
- 2,597,904. MISCELLANEOUS DESIGN. INT. CL. 1. REG. 7-23-2002.
- 2,597,905. B BERNARD'S SALON & DAY SPA (STYLIZED). INT. CL. 42. REG. 7-23-2002.
- 2,597,906. STACHY SHACK. INT. CL. 41. REG. 7-23-2002.
- 2,597,907. MOLD MOTEL. INT. CL. 41. REG. 7-23-2002.
- 2,597,908. BERNARD'S HAIR DESIGNS. INT. CL. 42. REG. 7-23-2002.
- 2,597,909. MINOCQUA ARBOR VITAE-WOODRUFF AND DESIGN. INT. CL. 35. REG. 7-23-2002.
- 2,597,914. POMA. INT. CL. 9. REG. 7-23-2002.
- 2,597,916. RYLAND PARK. INT. CL. 35. REG. 7-23-2002.
- 2,597,920. CLAIMADVANTAGE. INT. CL. 9. REG. 7-23-2002.
- 2,597,922. WQS WATER QUALITY SOCIETY AND DESIGN. INT. CL. 42. REG. 7-23-2002.
- 2,597,924. CSM5000. INT. CL. 9. REG. 7-23-2002.
- 2,597,925. PUZZLEDEPOT.COM. INT. CL. 41. REG. 7-23-2002.
- 2,597,926. PUZZLEDEPOT. INT. CL. 41. REG. 7-23-2002.
- 2,597,931. A WIRELESS ATTACK ON FRAUD. INT. CL. 9. REG. 7-23-2002.
- 2,597,932. SEEKS AND DESTROYS NETWORK INTRUDERS. INT. CL. 9. REG. 7-23-2002.
- 2,597,935. ISPIN. INT. CL. 7. REG. 7-23-2002.
- 2,597,936. IT'S TIME TO BELIEVE!. INT. CL. 16. REG. 7-23-2002.
- 2,597,938. MMRXCONSULTANT.COM. INT. CL. 42. REG. 7-23-2002.
- 2,597,943. SYNDICATED PLANETS. INT. CL. 28. REG. 7-23-2002.
- 2,597,945. GADZOOKS.COM. INT. CL. 35. REG. 7-23-2002.
- 2,597,946. ZOO KEEPER. INT. CL. 28. REG. 7-23-2002.
- 2,597,947. FENWICK KEATS AND DESIGN. INT. CL. 36. REG. 7-23-2002.
- 2,597,948. FAST CHART FAST CHART, INC. AND DESIGN. INT. CL. 35. REG. 7-23-2002.
- 2,597,949. MISCELLANEOUS DESIGN. INT. CLS. 35 AND 41. REG. 7-23-2002.
- 2,597,950. EMPLOYEESEMINARS.COM AND DESIGN. INT. CLS. 35 AND 41. REG. 7-23-2002.
- 2,597,954. UNIQUE MEMEC AND DESIGN. INT. CL. 35. REG. 7-23-2002.
- 2,597,955. MISCELLANEOUS DESIGN. INT. CL. 25. REG. 7-23-2002.
- 2,597,956. LIFE'S MEMORIES. INT. CL. 14. REG. 7-23-2002.
- 2,597,959. MEGA TUBE. INT. CL. 30. REG. 7-23-2002.
- 2,597,965. THE SCOTTS ADVANTAGE. INT. CL. 7. REG. 7-23-2002.
- 2,597,973. TEXMARK. INT. CL. 1. REG. 7-23-2002.
- 2,597,974. HAPPY TASTE. INT. CL. 30. REG. 7-23-2002.
- 2,597,980. SOUTHEASTERN CENTERS. INT. CL. 36. REG. 7-23-2002.
- 2,597,983. GET. INT. CL. 41. REG. 7-23-2002.
- 2,597,984. SICKENINGLY PERFECT. INT. CL. 3. REG. 7-23-2002.
- 2,597,986. "KEEP YOUR CARDS WELL!". INT. CL. 16. REG. 7-23-2002.
- 2,597,987. TIMOTHY WILLIAMS. INT. CL. 35. REG. 7-23-2002.
- 2,597,988. WIND SHEER. INT. CL. 28. REG. 7-23-2002.
- 2,597,990. SKID-Z. INT. CL. 28. REG. 7-23-2002.
- 2,597,992. REBUILDING THE WALL (STYLIZED). INT. CL. 9. REG. 7-23-2002.
- 2,598,005. HOT HOUSE. INT. CL. 16. REG. 7-23-2002.
- 2,598,007. MISCELLANEOUS DESIGN. INT. CL. 30. REG. 7-23-2002.
- 2,598,008. VALIDATION CENTRAL. INT. CL. 35. REG. 7-23-2002.
- 2,598,010. ZEUS. INT. CL. 7. REG. 7-23-2002.
- 2,598,013. STRAIGHTTALK. INT. CL. 16. REG. 7-23-2002.
- 2,598,018. KING OF TARTS. INT. CL. 28. REG. 7-23-2002.
- 2,598,022. QUALISTICS. INT. CLS. 35 AND 41. REG. 7-23-2002.
- 2,598,025. ROSE MILL AND DESIGN. INT. CL. 3. REG. 7-23-2002.
- 2,598,029. MINIJAM. INT. CL. 9. REG. 7-23-2002.
- 2,598,031. MOBILEACCESS. INT. CL. 36. REG. 7-23-2002.
- 2,598,032. LISTINGVIEW. INT. CL. 36. REG. 7-23-2002.
- 2,598,033. WIE. INT. CL. 42. REG. 7-23-2002.
- 2,598,036. NUTRIGYN. INT. CL. 5. REG. 7-23-2002.
- 2,598,037. SAVING THE WORLD'S ENERGY. INT. CL. 9. REG. 7-23-2002.
- 2,598,038. FOND MEMORIES AND DESIGN. INT. CL. 20. REG. 7-23-2002.
- 2,598,039. MOONRAKER. INT. CL. 41. REG. 7-23-2002.
- 2,598,041. MISCELLANEOUS DESIGN. INT. CL. 10. REG. 7-23-2002.
- 2,598,043. OLD MODERN. INT. CL. 9. REG. 7-23-2002.
- 2,598,044. AQUA FLARE. INT. CL. 11. REG. 7-23-2002.
- 2,598,045. HINT. INT. CL. 9. REG. 7-23-2002.
- 2,598,050. AM-VI-CO (STYLIZED). INT. CL. 2. REG. 7-23-2002.
- 2,598,051. MISCELLANEOUS DESIGN. INT. CL. 36. REG. 7-23-2002.
- 2,598,053. BURKE MERCER. INT. CL. 27. REG. 7-23-2002.
- 2,598,056. HALF & HALF BALM. INT. CL. 5. REG. 7-23-2002.
- 2,598,062. ROOTS DINER. INT. CL. 41. REG. 7-23-2002.
- 2,598,065. GOLD G GUARANTEE AND DESIGN. INT. CL. 36. REG. 7-23-2002.
- 2,598,066. AVENTURAS A TU ALCANCE. INT. CL. 39. REG. 7-23-2002.
- 2,598,068. EVERYTHING GAY. INT. CL. 35. REG. 7-23-2002.
- 2,598,073. BECAUSE SOUND TRAVELS. INT. CL. 9. REG. 7-23-2002.
- 2,598,074. E HEALTH CONNECTOR, INC. AND DESIGN. INT. CL. 42. REG. 7-23-2002.
- 2,598,075. ANIME INVASION. INT. CL. 38. REG. 7-23-2002.
- 2,598,079. MISCELLANEOUS DESIGN. INT. CL. 42. REG. 7-23-2002.
- 2,598,080. LA RANCHITA AND DESIGN. INT. CL. 18. REG. 7-23-2002.
- 2,598,081. DOT 7. INT. CL. 5. REG. 7-23-2002.
- 2,598,082. SPECIAL F/X STUNT SHOW. INT. CL. 28. REG. 7-23-2002.
- 2,598,084. BUTCH BEAR AND DESIGN. INT. CL. 9. REG. 7-23-2002.
- 2,598,085. INTERMEG. INT. CL. 42. REG. 7-23-2002.
- 2,598,086. SCHOOLSTAFF (STYLIZED). INT. CL. 35. REG. 7-23-2002.
- 2,598,088. POWER FLAG. INT. CL. 9. REG. 7-23-2002.
- 2,598,089. THEDFILMS. INT. CLS. 9 AND 41. REG. 7-23-2002.
- 2,598,090. NERDY BOOKS AND DESIGN. INT. CL. 16. REG. 7-23-2002.

- 2,598,091. SOUTHERN CROSS AND DESIGN. INT. CL. 12. REG. 7-23-2002.
- 2,598,092. DESIGN SELECT YOUR OPTIONS MANAGEMENT RESOURCE. AND DESIGN. INT. CL. 37. REG. 7-23-2002.
- 2,598,093. PEACEFUL HEALING AND DESIGN. INT. CL. 9. REG. 7-23-2002.
- 2,598,094. FIRSTGIRO YOUR GLOBAL MONEY MOVER AND DESIGN. INT. CL. 36. REG. 7-23-2002.
- 2,598,097. ECORX. INT. CL. 35. REG. 7-23-2002.
- 2,598,100. I-NETWORK AND DESIGN. INT. CL. 35. REG. 7-23-2002.
- 2,598,102. SCHMIDT SIDING & WINDOW CO. AND DESIGN. INT. CLS. 35 AND 37. REG. 7-23-2002.
- 2,598,103. THIS CAN'T BE SOY! SALT AND DESIGN. INT. CL. 29. REG. 7-23-2002.
- 2,598,104. CONNECT COMMUNICATE COLLABORATE. INT. CL. 9. REG. 7-23-2002.
- 2,598,109. FANCY MONKEY STUDIOS. INT. CLS. 9 AND 41. REG. 7-23-2002.
- 2,598,112. ARTCAR FEST AND DESIGN. INT. CL. 41. REG. 7-23-2002.
- 2,598,114. STUD DUDS. INT. CL. 25. REG. 7-23-2002.
- 2,598,116. REALO DISCOUNT DRUG STORES. INT. CL. 35. REG. 7-23-2002.
- 2,598,118. NVA NEW VISION ATHLETICS AND DESIGN. INT. CL. 41. REG. 7-23-2002.
- 2,598,120. FREEGLIDER. INT. CL. 8. REG. 7-23-2002.
- 2,598,123. KIMON. INT. CL. 9. REG. 7-23-2002.
- 2,598,124. SPUR OF THE MOMENT. INT. CL. 41. REG. 7-23-2002.
- 2,598,126. LATINCAM AND DESIGN. INT. CL. 41. REG. 7-23-2002.
- 2,598,127. OPTIONEXPRESS. INT. CL. 9. REG. 7-23-2002.
- 2,598,129. NASABA. INT. CL. 16. REG. 7-23-2002.
- 2,598,130. VIZIONING. INT. CL. 42. REG. 7-23-2002.
- 2,598,136. YOUR GATEWAY TO GETAWAYS. INT. CL. 35. REG. 7-23-2002.
- 2,598,137. BOLY. INT. CL. 9. REG. 7-23-2002.
- 2,598,138. LOVER'S EYE. INT. CL. 9. REG. 7-23-2002.
- 2,598,139. SHOP HEALTHY SWEEPSTAKES. INT. CL. 35. REG. 7-23-2002.
- 2,598,141. PROMOTIONSTAT. INT. CL. 35. REG. 7-23-2002.
- 2,598,143. CLOSAR GOLF AND DESIGN. INT. CL. 28. REG. 7-23-2002.
- 2,598,144. QUICKSITE. INT. CL. 9. REG. 7-23-2002.
- 2,598,145. NEOWORX. INT. CL. 9. REG. 7-23-2002.
- 2,598,146. DCM DATA CENTER MANAGEMENT. INT. CL. 16. REG. 7-23-2002.
- 2,598,147. WE COMPLY AND DESIGN. INT. CL. 41. REG. 7-23-2002.
- 2,598,148. RIGHT WATER SOLUTIONS AND DESIGN. INT. CL. 11. REG. 7-23-2002.
- 2,598,149. COLLEGEWISE. INT. CL. 41. REG. 7-23-2002.
- 2,598,152. SKIVVIES "NEVER GET CAUGHT WITHOUT YOUR SKIVVIES!" AND DESIGN. INT. CL. 25. REG. 7-23-2002.
- 2,598,153. LA VEREDA. INT. CL. 41. REG. 7-23-2002.
- 2,598,154. ADVOCATES ALWAYS AND DESIGN. INT. CL. 36. REG. 7-23-2002.
- 2,598,155. THUNDER (STYLIZED). INT. CL. 30. REG. 7-23-2002.
- 2,598,157. DRINKRITE. INT. CL. 11. REG. 7-23-2002.
- 2,598,158. ACROPOLIS. INT. CL. 9. REG. 7-23-2002.
- 2,598,160. HOW AMERICA SAYS MONEY. INT. CL. 36. REG. 7-23-2002.
- 2,598,161. CASH AND CARRY. INT. CL. 16. REG. 7-23-2002.
- 2,598,163. NEUROGRAM. INT. CL. 16. REG. 7-23-2002.
- 2,598,164. FA FOSGATE AUDIONICS AND DESIGN. INT. CL. 9. REG. 7-23-2002.
- 2,598,166. MAXFOLIO. INT. CL. 9. REG. 7-23-2002.
- 2,598,167. CROCOTILE AND DESIGN. INT. CL. 19. REG. 7-23-2002.
- 2,598,168. U-RULE. INT. CL. 9. REG. 7-23-2002.
- 2,598,169. MISCELLANEOUS DESIGN. INT. CL. 30. REG. 7-23-2002.
- 2,598,170. DBI BOOKS. INT. CL. 16. REG. 7-23-2002.
- 2,598,173. MISCELLANEOUS DESIGN. INT. CL. 42. REG. 7-23-2002.
- 2,598,174. NAUTI PARTS AND DESIGN. INT. CLS. 8, 9, 11 AND 28. REG. 7-23-2002.
- 2,598,176. WESTAR. INT. CL. 39. REG. 7-23-2002.
- 2,598,177. DEBBIES. INT. CL. 30. REG. 7-23-2002.
- 2,598,178. ALLEGIANCE AND DESIGN. INT. CLS. 1, 3, 5, 9, 10, 11, 21 AND 25. REG. 7-23-2002.
- 2,598,180. CERVISCAN. INT. CLS. 9 AND 10. REG. 7-23-2002.
- 2,598,181. EPOCH NETWORKS. INT. CL. 42. REG. 7-23-2002.
- 2,598,182. CTI AND DESIGN. INT. CL. 5. REG. 7-23-2002.
- 2,598,183. NETADVANTAGE. INT. CLS. 35, 37 AND 42. REG. 7-23-2002.
- 2,598,185. CARLISLE PLASTICS. INT. CLS. 40 AND 42. REG. 7-23-2002.
- 2,598,188. LABTECH ESSA. INT. CL. 9. REG. 7-23-2002.
- 2,598,190. INTERNET RESELLER WORLD. INT. CLS. 16 AND 42. REG. 7-23-2002.
- 2,598,193. PACIFIC CENTURY SBIC. INT. CL. 36. REG. 7-23-2002.
- 2,598,195. Z ZURICH AND DESIGN. INT. CL. 35. REG. 7-23-2002.
- 2,598,196. Z ZURICH RE AND DESIGN. INT. CL. 35. REG. 7-23-2002.
- 2,598,205. LIVING ASSETS. INT. CL. 41. REG. 7-23-2002.
- 2,598,208. CHINESE THEATRE AND DESIGN. INT. CL. 21. REG. 7-23-2002.
- 2,598,210. NEXTEL WORLDWIDE. INT. CLS. 9 AND 38. REG. 7-23-2002.
- 2,598,212. E-Z SKINNER. INT. CL. 8. REG. 7-23-2002.
- 2,598,213. ERGOTATION. INT. CL. 9. REG. 7-23-2002.
- 2,598,216. LUMICAD. INT. CL. 9. REG. 7-23-2002.
- 2,598,218. SCHURZENJAGER (STYLIZED). INT. CL. 9. REG. 7-23-2002.
- 2,598,223. TREE POLE. INT. CL. 9. REG. 7-23-2002.
- 2,598,224. EU-FECTIN AND DESIGN. INT. CLS. 1 AND 5. REG. 7-23-2002.
- 2,598,226. VIRTUAL GLOVE. INT. CL. 3. REG. 7-23-2002.
- 2,598,227. SAFETYRISE. INT. CL. 20. REG. 7-23-2002.
- 2,598,228. ZIP PICS. INT. CL. 9. REG. 7-23-2002.
- 2,598,229. MISCELLANEOUS DESIGN. INT. CL. 6. REG. 7-23-2002.
- 2,598,230. COSMETIC PARTY PAZAZZ. INT. CL. 28. REG. 7-23-2002.
- 2,598,231. CHAISE KIMONO. INT. CL. 24. REG. 7-23-2002.
- 2,598,234. FITNESS UNIVERSE PAGEANT. INT. CL. 41. REG. 7-23-2002.
- 2,598,235. MISCELLANEOUS DESIGN. INT. CL. 28. REG. 7-23-2002.
- 2,598,236. ENDO-STAK. INT. CL. 5. REG. 7-23-2002.
- 2,598,237. OFFICIAL SPONSOR OF MANUFACTURERS' REPRESENTATIVES FOR THE NEXT MILLENNIUM. INT. CL. 9. REG. 7-23-2002.
- 2,598,241. PATCH PLUS. INT. CL. 9. REG. 7-23-2002.
- 2,598,243. EASY CHAIN. INT. CLS. 6 AND 20. REG. 7-23-2002.
- 2,598,245. PROMAX (STYLIZED). INT. CL. 7. REG. 7-23-2002.
- 2,598,246. MANX (STYLIZED). INT. CL. 33. REG. 7-23-2002.
- 2,598,247. SERVICETV.COM. INT. CL. 41. REG. 7-23-2002.
- 2,598,249. SEMDANVER AND DESIGN. INT. CLS. 18 AND 25. REG. 7-23-2002.
- 2,598,251. E EPICURE (STYLIZED). INT. CL. 25. REG. 7-23-2002.
- 2,598,253. BOING LO GOAL. INT. CL. 28. REG. 7-23-2002.
- 2,598,254. TAPFIN. INT. CL. 9. REG. 7-23-2002.
- 2,598,255. BUILD-A-SPIRIT. INT. CLS. 40 AND 42. REG. 7-23-2002.
- 2,598,256. COLOR CONNECTIONS. INT. CL. 6. REG. 7-23-2002.
- 2,598,258. GUARDIANS FOR THE CURE. INT. CL. 36. REG. 7-23-2002.
- 2,598,261. THE SMARTER BRAND TO BUY. INT. CL. 35. REG. 7-23-2002.
- 2,598,262. CLEAN DIRT. INT. CL. 40. REG. 7-23-2002.
- 2,598,263. OFFICE EDITIONS. INT. CL. 20. REG. 7-23-2002.
- 2,598,264. MISCELLANEOUS DESIGN. INT. CL. 20. REG. 7-23-2002.

- 2,598,265. MISCELLANEOUS DESIGN. INT. CL. 42. REG. 7-23-2002.
- 2,598,267. MEPEN. INT. CL. 3. REG. 7-23-2002.
- 2,598,269. DIAGTOOLS. INT. CLS. 9 AND 16. REG. 7-23-2002.
- 2,598,273. ALPHA KIT. INT. CL. 20. REG. 7-23-2002.
- 2,598,285. UPSWING. INT. CL. 9. REG. 7-23-2002.
- 2,598,286. KP AND DESIGN. INT. CLS. 6 AND 7. REG. 7-23-2002.
- 2,598,287. KP. INT. CLS. 6 AND 7. REG. 7-23-2002.
- 2,598,289. HERITAGE VISUAL PRODUCTIONS. INT. CLS. 9 AND 41. REG. 7-23-2002.
- 2,598,295. NATURE SKO. INT. CL. 25. REG. 7-23-2002.
- 2,598,297. BAD TO THE BONE. INT. CL. 8. REG. 7-23-2002.
- 2,598,298. ASIAN TIGER CLASSIC. INT. CL. 29. REG. 7-23-2002.
- 2,598,300. SHIVER. INT. CL. 12. REG. 7-23-2002.
- 2,598,304. MEGAVIEW. INT. CL. 9. REG. 7-23-2002.
- 2,598,305. SFE CONCEPT. INT. CL. 9. REG. 7-23-2002.
- 2,598,309. MAXAIR. INT. CL. 5. REG. 7-23-2002.
- 2,598,311. GIGGLES 'N SWING. INT. CL. 28. REG. 7-23-2002.
- 2,598,312. BOLAK. INT. CL. 1. REG. 7-23-2002.
- 2,598,314. ACE/AD CREATION ENGINE AND DESIGN. INT. CL. 9. REG. 7-23-2002.
- 2,598,316. PICTRO MATCH. INT. CL. 9. REG. 7-23-2002.
- 2,598,317. NETFIX. INT. CL. 10. REG. 7-23-2002.
- 2,598,319. SNN. INT. CL. 42. REG. 7-23-2002.
- 2,598,321. TEAMSELL. INT. CL. 9. REG. 7-23-2002.
- 2,598,325. HARLEQUIN DUETS. INT. CL. 16. REG. 7-23-2002.
- 2,598,326. NUTRIBITS. INT. CL. 29. REG. 7-23-2002.
- 2,598,327. PRO SKITS AND DESIGN. INT. CL. 41. REG. 7-23-2002.
- 2,598,328. THE BACKSAVER. INT. CL. 19. REG. 7-23-2002.
- 2,598,329. CION. INT. CLS. 9 AND 35. REG. 7-23-2002.
- 2,598,332. TREGO. INT. CL. 28. REG. 7-23-2002.
- 2,598,333. BLACKDEVIL. INT. CL. 25. REG. 7-23-2002.
- 2,598,334. VISIONCORE. INT. CL. 9. REG. 7-23-2002.
- 2,598,336. SPIDER WEB DOMESTIC SECURITY SHIPMENTS AND DESIGN. INT. CL. 39. REG. 7-23-2002.
- 2,598,341. SCHWAB SIGNATURE SERVICES GOLD. INT. CL. 36. REG. 7-23-2002.
- 2,598,342. CONFLUENCE. INT. CL. 9. REG. 7-23-2002.
- 2,598,343. QUADRALINK. INT. CL. 9. REG. 7-23-2002.
- 2,598,344. ORGANIZED FOR BUSINESS. INT. CL. 16. REG. 7-23-2002.
- 2,598,346. HYBRID. INT. CLS. 4 AND 28. REG. 7-23-2002.
- 2,598,348. LIVE, LEARN, INSPIRE. INT. CLS. 16 AND 42. REG. 7-23-2002.
- 2,598,349. BOISE. IT COULDN'T BE EASIER.. INT. CLS. 16, 21, 25 AND 35. REG. 7-23-2002.
- 2,598,352. POWERSHAPER. INT. CL. 25. REG. 7-23-2002.
- 2,598,353. THERMAPAD. INT. CL. 11. REG. 7-23-2002.
- 2,598,355. ONLY A KEEPSAKE SAYS, LOVE ALWAYS. INT. CL. 14. REG. 7-23-2002.
- 2,598,356. WIZE-GUYZ. INT. CL. 25. REG. 7-23-2002.
- 2,598,358. ENIKIA. INT. CL. 9. REG. 7-23-2002.
- 2,598,363. TRIMMILIUM. INT. CL. 14. REG. 7-23-2002.
- 2,598,365. JEEPERS! RIDES GAMES BIRTHDAYS AND DESIGN. INT. CLS. 16, 18, 21, 25, 28, 41 AND 42. REG. 7-23-2002.
- 2,598,366. GALLOP-LIGHTS. INT. CL. 25. REG. 7-23-2002.
- 2,598,367. LANQA. INT. CLS. 35 AND 42. REG. 7-23-2002.
- 2,598,369. KRASOL. INT. CL. 17. REG. 7-23-2002.
- 2,598,372. SPORTEXCEL. INT. CL. 42. REG. 7-23-2002.
- 2,598,374. CHITOPLEX. INT. CL. 5. REG. 7-23-2002.
- 2,598,375. S AND DESIGN. INT. CL. 32. REG. 7-23-2002.
- 2,598,376. COVENT GARDEN GREEN WITH MINT. INT. CL. 30. REG. 7-23-2002.
- 2,598,378. BOYS NAMES WEAR YOUR GUY AND DESIGN. INT. CL. 3. REG. 7-23-2002.
- 2,598,379. TCRT. INT. CL. 9. REG. 7-23-2002.
- 2,598,384. FROM SOMEONE WHO CARES. INT. CL. 14. REG. 7-23-2002.
- 2,598,391. CITRACAL, YOUR BODYGUARD FOR YOUR BONES. INT. CL. 5. REG. 7-23-2002.
- 2,598,395. TIMES CHANGE. GREAT TV DOESN'T. INT. CL. 41. REG. 7-23-2002.
- 2,598,397. TURBO TUTOR (STYLIZED). INT. CL. 16. REG. 7-23-2002.
- 2,598,399. PLAY-A-HIT. INT. CLS. 9 AND 35. REG. 7-23-2002.
- 2,598,400. ALLIANT MEDIA. INT. CL. 41. REG. 7-23-2002.
- 2,598,401. FRENCH IMPRESSIONS. INT. CL. 26. REG. 7-23-2002.
- 2,598,403. ARRIBA. INT. CL. 9. REG. 7-23-2002.
- 2,598,405. THIN PLANET. INT. CLS. 35 AND 41. REG. 7-23-2002.
- 2,598,406. CHINEQUALIZE. INT. CL. 5. REG. 7-23-2002.
- 2,598,407. VITAMINS.COM (STYLIZED). INT. CL. 35. REG. 7-23-2002.
- 2,598,410. AUREMA. INT. CL. 9. REG. 7-23-2002.
- 2,598,411. AUREMA. INT. CL. 42. REG. 7-23-2002.
- 2,598,412. GREAT NORTHERN HARDWOOD AND DESIGN. INT. CL. 19. REG. 7-23-2002.
- 2,598,413. FACILITY ASSET OPTIMIZATION. INT. CL. 36. REG. 7-23-2002.
- 2,598,416. INTEGRATED CONTACT SYSTEMS. INT. CL. 9. REG. 7-23-2002.
- 2,598,419. CRONINSIGHT. INT. CL. 35. REG. 7-23-2002.
- 2,598,420. FAR AND WIDE. INT. CLS. 39 AND 42. REG. 7-23-2002.
- 2,598,421. LEADING COMMERCE INTO TOMORROW. INT. CL. 36. REG. 7-23-2002.
- 2,598,423. E ENG. AND DESIGN. INT. CL. 42. REG. 7-23-2002.
- 2,598,425. COILMASTER. INT. CL. 7. REG. 7-23-2002.
- 2,598,427. EBRARIAN. INT. CL. 9. REG. 7-23-2002.
- 2,598,428. PC COMPOUND. INT. CL. 5. REG. 7-23-2002.
- 2,598,429. BEVERLY CLEVERLY. INT. CLS. 9, 16 AND 28. REG. 7-23-2002.
- 2,598,430. PLANET OF THE APES. INT. CL. 21. REG. 7-23-2002.
- 2,598,431. AFTER SWIM. INT. CLS. 5 AND 10. REG. 7-23-2002.
- 2,598,432. TWINNS AND FRIENDS. INT. CLS. 28, 35 AND 40. REG. 7-23-2002.
- 2,598,433. ONE WORLD ONE PEOPLE. INT. CL. 35. REG. 7-23-2002.
- 2,598,434. BACKYARD DEPOT. INT. CL. 35. REG. 7-23-2002.
- 2,598,435. INFINITE RESOURCE GROUP. INT. CL. 35. REG. 7-23-2002.
- 2,598,436. PANGEL. INT. CL. 41. REG. 7-23-2002.
- 2,598,437. THIS IS THE SPOT AND DESIGN. INT. CL. 21. REG. 7-23-2002.
- 2,598,440. GAME RAISER. INT. CL. 28. REG. 7-23-2002.
- 2,598,442. VALUES.COM. INT. CLS. 35 AND 36. REG. 7-23-2002.
- 2,598,443. EMS WORKS. INT. CL. 9. REG. 7-23-2002.
- 2,598,444. EMS WORKS AND DESIGN. INT. CL. 9. REG. 7-23-2002.
- 2,598,445. MAR EE'S FROM PINE HOLLOW. INT. CL. 3. REG. 7-23-2002.
- 2,598,450. MISCELLANEOUS DESIGN. INT. CL. 41. REG. 7-23-2002.
- 2,598,451. CTG HEALTHCARE SOLUTIONS. INT. CL. 35. REG. 7-23-2002.
- 2,598,454. ITRUST. INT. CL. 36. REG. 7-23-2002.
- 2,598,455. SERVOFLUID. INT. CL. 7. REG. 7-23-2002.
- 2,598,458. TTT. U.S. CL. A. REG. 7-23-2002.
- 2,598,460. UNDER PRESSURE. INT. CL. 16. REG. 7-23-2002.
- 2,598,462. M&M'S INDUSTRIES. INT. CL. 28. REG. 7-23-2002.
- 2,598,463. VIOLORO. INT. CL. 14. REG. 7-23-2002.
- 2,598,465. CABLECONNECT. INT. CLS. 37 AND 42. REG. 7-23-2002.
- 2,598,466. LIBERTY ONLINE. INT. CLS. 36 AND 42. REG. 7-23-2002.
- 2,598,467. FIVE STAR CHALLENGE. INT. CL. 41. REG. 7-23-2002.
- 2,598,468. SWENSON MEATS. INT. CL. 29. REG. 7-23-2002.
- 2,598,471. MISCELLANEOUS DESIGN. INT. CL. 42. REG. 7-23-2002.
- 2,598,472. IWANTTOPLAY.COM. INT. CL. 35. REG. 7-23-2002.

- 2,598,473. VELOCITY. INT. CL. 9. REG. 7-23-2002.
 2,598,475. PFS FLOW PRODUCTS. INT. CL. 9. REG. 7-23-2002.
 2,598,476. FINGERPOINT. INT. CL. 42. REG. 7-23-2002.
 2,598,477. OAKTRAK. INT. CL. 25. REG. 7-23-2002.
 2,598,479. E-MERGING ENTERTAINMENT. INT. CLS. 38 AND 41. REG. 7-23-2002.
 2,598,482. DYNAMIC DIRECTIONS. INT. CL. 35. REG. 7-23-2002.
 2,598,483. FRAUDVIEW. INT. CL. 9. REG. 7-23-2002.
 2,598,485. HAELTH (STYLIZED). INT. CLS. 25, 35, 41 AND 42. REG. 7-23-2002.
 2,598,487. STEELMASTER. INT. CL. 7. REG. 7-23-2002.
 2,598,488. KIDZ 2000 A CRUSADE AGAINST CHILD ABUSE AND BEYOND AND DESIGN. INT. CLS. 25 AND 36. REG. 7-23-2002.
 2,598,489. R AND DESIGN. INT. CL. 16. REG. 7-23-2002.
 2,598,491. DB CAPITAL PARTNERS. INT. CL. 36. REG. 7-23-2002.
 2,598,492. ROMANCE SPECIALIST. INT. CL. 35. REG. 7-23-2002.
 2,598,502. BUYOMAHASTEAKS. INT. CL. 35. REG. 7-23-2002.
 2,598,506. THINK OUTSIDE AND DESIGN. INT. CLS. 9 AND 39. REG. 7-23-2002.
 2,598,510. ECET CLINICAL EXPERT TECHNOLOGY AND DESIGN. INT. CL. 9. REG. 7-23-2002.
 2,598,511. ASTARIS. INT. CL. 30. REG. 7-23-2002.
 2,598,512. THINKING IS DRINKING. INT. CL. 28. REG. 7-23-2002.
 2,598,513. ORDERSERVER. INT. CL. 42. REG. 7-23-2002.
 2,598,514. DURA-G. INT. CL. 10. REG. 7-23-2002.
 2,598,516. JUMPIN' JACK GAS IN A FLASH! AND DESIGN. INT. CL. 4. REG. 7-23-2002.
 2,598,517. IN A FLASH ! AND DESIGN. INT. CL. 4. REG. 7-23-2002.
 2,598,521. TRILICONE. INT. CL. 3. REG. 7-23-2002.
 2,598,525. PROSOLD. INT. CL. 35. REG. 7-23-2002.
 2,598,526. BEAUTIFUL FURNITURE EVERY DAY. INT. CL. 3. REG. 7-23-2002.
 2,598,527. CHINESE NOW!. INT. CL. 42. REG. 7-23-2002.
 2,598,528. VISIONARE SYSTEM AND DESIGN. INT. CL. 7. REG. 7-23-2002.
 2,598,529. CAPITAL 1900. INT. CL. 32. REG. 7-23-2002.
 2,598,530. SPANISH FOR SUCCESS. INT. CL. 41. REG. 7-23-2002.
 2,598,531. S4S. INT. CL. 41. REG. 7-23-2002.
 2,598,532. MISCELLANEOUS DESIGN. INT. CL. 30. REG. 7-23-2002.
 2,598,535. AAA TOUR GUIDE. INT. CL. 16. REG. 7-23-2002.
 2,598,538. REMOTE HR. INT. CL. 35. REG. 7-23-2002.
 2,598,540. UNLIMITOR. INT. CL. 28. REG. 7-23-2002.
 2,598,541. VITACIN. INT. CL. 31. REG. 7-23-2002.
 2,598,542. FULL SERVICE FOR THE NEW ECONOMY. INT. CL. 42. REG. 7-23-2002.
 2,598,545. LOFRECATOR. INT. CL. 10. REG. 7-23-2002.
 2,598,546. GROWING FAMILY. INT. CL. 41. REG. 7-23-2002.
 2,598,549. ROCK THE CASTLE. INT. CL. 41. REG. 7-23-2002.
 2,598,551. KAHRs LINNEA (STYLIZED). INT. CL. 19. REG. 7-23-2002.
 2,598,553. YAMADA AND DESIGN. INT. CL. 9. REG. 7-23-2002.
 2,598,555. SILVER APPLE IMAGES. INT. CL. 16. REG. 7-23-2002.
 2,598,558. STARTREC (STYLIZED). INT. CL. 9. REG. 7-23-2002.
 2,598,563. CLEARTRAC. INT. CL. 42. REG. 7-23-2002.
 2,598,564. LET THERE BE FUN. INT. CL. 35. REG. 7-23-2002.
 2,598,566. PINTAILTECHNOLOGIES AND DESIGN. INT. CL. 9. REG. 7-23-2002.
 2,598,567. MISCELLANEOUS DESIGN. INT. CL. 5. REG. 7-23-2002.
 2,598,568. CELLGEL. INT. CL. 3. REG. 7-23-2002.
 2,598,570. YIELDCONNECT. INT. CL. 9. REG. 7-23-2002.
 2,598,571. FIBER HEALTH. INT. CL. 5. REG. 7-23-2002.
 2,598,572. OH, THE POSSIBILITIES!. INT. CL. 35. REG. 7-23-2002.
 2,598,573. ALAVEIL (STYLIZED). INT. CL. 8. REG. 7-23-2002.
 2,598,574. LOCALITY AND DESIGN. INT. CL. 35. REG. 7-23-2002.
 2,598,577. FRENCHIE CONNECTION. INT. CL. 42. REG. 7-23-2002.
 2,598,578. PETROSOLUTIONS. INT. CL. 9. REG. 7-23-2002.
 2,598,579. NORFOLK NIGHTHAWKS. INT. CLS. 16, 25 AND 41. REG. 7-23-2002.
 2,598,580. GENTLE SLEEP FROM HEAVEN. INT. CL. 42. REG. 7-23-2002.
 2,598,582. CATCH THE READING BUG AND DESIGN. INT. CL. 41. REG. 7-23-2002.
 2,598,585. J CONSORTIUM AND DESIGN. INT. CL. 9. REG. 7-23-2002.
 2,598,588. WARRIOR SOLUTIONS. INT. CL. 9. REG. 7-23-2002.
 2,598,590. LEASEOUT. INT. CL. 35. REG. 7-23-2002.
 2,598,591. LIPPITY SPLIT. INT. CL. 3. REG. 7-23-2002.
 2,598,593. TRAINWRECK T'S SCREEN PRINTING & EMBROIDERY AND DESIGN. INT. CLS. 40 AND 42. REG. 7-23-2002.
 2,598,595. CITY YARD. INT. CLS. 1, 21, 31 AND 35. REG. 7-23-2002.
 2,598,598. FRIUL CASSETTI AND DESIGN. INT. CL. 20. REG. 7-23-2002.
 2,598,600. STENTOR. INT. CL. 9. REG. 7-23-2002.
 2,598,602. PROSOLV HD AND DESIGN. INT. CLS. 1 AND 30. REG. 7-23-2002.
 2,598,603. NIMIUS. INT. CLS. 9 AND 36. REG. 7-23-2002.
 2,598,606. CANAL SOFTWARE AND DESIGN. INT. CL. 38. REG. 7-23-2002.
 2,598,608. CLASSIC *1 AND DESIGN. INT. CL. 42. REG. 7-23-2002.
 2,598,609. EXODUS MATZOS. INT. CL. 30. REG. 7-23-2002.
 2,598,610. EVEST AND DESIGN. INT. CL. 7. REG. 7-23-2002.
 2,598,611. EVEST AND DESIGN. INT. CL. 9. REG. 7-23-2002.
 2,598,612. EDrama. INT. CLS. 9 AND 41. REG. 7-23-2002.
 2,598,613. WEBSWITCH 2000. INT. CL. 9. REG. 7-23-2002.
 2,598,614. WEBSWITCH 3000. INT. CL. 9. REG. 7-23-2002.
 2,598,615. RAPTORRAIL. INT. CL. 10. REG. 7-23-2002.
 2,598,616. FACT PLUS SELECT. INT. CL. 5. REG. 7-23-2002.
 2,598,617. FACT PLUS PRO. INT. CL. 5. REG. 7-23-2002.
 2,598,619. CLICK MATCH AND DESIGN. INT. CLS. 9 AND 42. REG. 7-23-2002.
 2,598,620. CONCEPTS 4 CASUAL LIFESTYLES. INT. CL. 21. REG. 7-23-2002.
 2,598,622. CINTAR. INT. CLS. 9 AND 16. REG. 7-23-2002.
 2,598,624. BEACH BOARDWALK. INT. CL. 28. REG. 7-23-2002.
 2,598,625. AWARDS NIGHT. INT. CL. 28. REG. 7-23-2002.
 2,598,626. MDHEAL. INT. CL. 42. REG. 7-23-2002.
 2,598,627. THE POWER OF CHOICE. INT. CL. 35. REG. 7-23-2002.
 2,598,631. MAISHA. INT. CL. 5. REG. 7-23-2002.
 2,598,634. THE PULSE OF YOUR E-BUSINESS (STYLIZED). INT. CL. 35. REG. 7-23-2002.
 2,598,638. EMPOWERING PEOPLE THROUGH E-KNOWLEDGE. INT. CL. 41. REG. 7-23-2002.
 2,598,642. UNITED MODULAR. INT. CLS. 37, 39 AND 42. REG. 7-23-2002.
 2,598,643. ULTRAMIX. INT. CL. 1. REG. 7-23-2002.
 2,598,644. LEADER. INT. CLS. 7 AND 8. REG. 7-23-2002.
 2,598,646. JEWELTRUST. INT. CL. 14. REG. 7-23-2002.
 2,598,647. FINANCEITNOW. INT. CL. 42. REG. 7-23-2002.
 2,598,648. DIGITALLY YOURS (STYLIZED). INT. CLS. 7, 9 AND 11. REG. 7-23-2002.
 2,598,650. ACCELERATION STATION. INT. CL. 9. REG. 7-23-2002.
 2,598,651. USALLIANZ ALTERITY. INT. CL. 36. REG. 7-23-2002.
 2,598,654. SK. INT. CL. 12. REG. 7-23-2002.
 2,598,658. CAMBIO HEALTH SOLUTIONS. INT. CL. 35. REG. 7-23-2002.
 2,598,659. ECU. INT. CL. 35. REG. 7-23-2002.
 2,598,660. MEDIA WITHOUT BOUNDS. INT. CL. 9. REG. 7-23-2002.
 2,598,661. SLYTHERIN. INT. CL. 28. REG. 7-23-2002.

- 2,598,662. HUFFLEPUFF. INT. CL. 16. REG. 7-23-2002.
2,598,663. RAVENCLAW. INT. CL. 28. REG. 7-23-2002.
2,598,664. HUFFLEPUFF. INT. CL. 28. REG. 7-23-2002.
2,598,665. CPL AND DESIGN. INT. CL. 11. REG. 7-23-2002.
2,598,668. INJECTX. INT. CL. 10. REG. 7-23-2002.
2,598,670. GALACTIC GUARDIAN AND DESIGN. INT. CL. 16. REG. 7-23-2002.
2,598,673. GOLD STAR. INT. CL. 36. REG. 7-23-2002.
2,598,679. BUTLER FINANCIAL SOLUTIONS. INT. CL. 36. REG. 7-23-2002.
2,598,681. V2. INT. CL. 19. REG. 7-23-2002.
2,598,684. TEL@NET. INT. CLS. 35, 37 AND 42. REG. 7-23-2002.
2,598,687. FANS NO FENCE. INT. CL. 25. REG. 7-23-2002.
2,598,688. PRO POOL TOTE-ALL. INT. CL. 22. REG. 7-23-2002.
2,598,694. QRIUM. INT. CL. 9. REG. 7-23-2002.
2,598,698. FOR THE LOVE OF KIDS, A BEECH ACRES CONFERENCE ON PRACTICAL PARENTING. INT. CL. 41. REG. 7-23-2002.
2,598,700. I-LABS. INT. CL. 35. REG. 7-23-2002.
2,598,703. POOL SERIES BY BALBOA. INT. CL. 9. REG. 7-23-2002.
2,598,704. REGAL. INT. CL. 24. REG. 7-23-2002.
2,598,705. YCK AND DESIGN. INT. CL. 28. REG. 7-23-2002.
2,598,708. METALIB. INT. CL. 42. REG. 7-23-2002.
2,598,709. BUZZARD. INT. CL. 28. REG. 7-23-2002.
2,598,710. WOW AND DESIGN. INT. CL. 42. REG. 7-23-2002.
2,598,713. MUSTARD ALGAEBLASTER. INT. CL. 7. REG. 7-23-2002.
2,598,714. EYEMODULE. INT. CLS. 9 AND 42. REG. 7-23-2002.
2,598,715. HUGGS FROM HEAVEN AND DESIGN. INT. CL. 28. REG. 7-23-2002.
2,598,719. CLEARVUE. INT. CL. 9. REG. 7-23-2002.
2,598,720. BROADWAYSURROUND. INT. CL. 41. REG. 7-23-2002.
2,598,721. STAGIONE. INT. CL. 25. REG. 7-23-2002.
2,598,727. SCRUBSAFE. INT. CL. 10. REG. 7-23-2002.
2,598,728. MY OOSOSOFT. INT. CL. 24. REG. 7-23-2002.
2,598,731. ALEXANDER JULIAN AT HOME AND DESIGN. INT. CL. 27. REG. 7-23-2002.
2,598,732. TOUCHSPRING. INT. CL. 9. REG. 7-23-2002.
2,598,733. CSA WIRELESS A TRIPOINT GLOBAL COMPANY AND DESIGN. INT. CLS. 9 AND 42. REG. 7-23-2002.
2,598,734. NOWPRINTING.COM. INT. CL. 42. REG. 7-23-2002.
2,598,735. CSA WIRELESS A TRIPOINT GLOBAL COMPANY. INT. CLS. 9 AND 42. REG. 7-23-2002.
2,598,736. PRODELIN A TRIPOINT GLOBAL COMPANY. INT. CLS. 9 AND 42. REG. 7-23-2002.
2,598,737. HOT THREADS. INT. CL. 25. REG. 7-23-2002.
2,598,740. E EMERGING ENTERTAINMENT AND DESIGN. INT. CLS. 38 AND 41. REG. 7-23-2002.
2,598,742. SPECTOR TRAILSTAR. INT. CL. 12. REG. 7-23-2002.
2,598,744. KFM. INT. CL. 25. REG. 7-23-2002.
2,598,747. OCELOT. INT. CL. 9. REG. 7-23-2002.
2,598,749. TOTALLY TECHNO. INT. CL. 28. REG. 7-23-2002.
2,598,751. MEMBERSTREET. INT. CL. 36. REG. 7-23-2002.
2,598,753. UFO (STYLIZED). INT. CL. 31. REG. 7-23-2002.
2,598,754. LIFE ACCENTS. INT. CLS. 4 AND 21. REG. 7-23-2002.
2,598,755. COMMUNICATE AND DESIGN. INT. CLS. 14 AND 16. REG. 7-23-2002.
2,598,756. MINDLEADERS.COM. INT. CLS. 9 AND 41. REG. 7-23-2002.
2,598,759. WHITE HAT OF THE MONTH. INT. CLS. 20 AND 41. REG. 7-23-2002.
2,598,762. THE CALM AFTER THE STORM. INT. CL. 36. REG. 7-23-2002.
2,598,763. NEUROPLEX. INT. CL. 10. REG. 7-23-2002.
2,598,767. TURBOZ FUN & FOOD AND DESIGN. INT. CLS. 35 AND 42. REG. 7-23-2002.
2,598,770. 5 PAW RATING SYSTEM. INT. CL. 42. REG. 7-23-2002.
2,598,771. NICOTIME. INT. CL. 30. REG. 7-23-2002.
2,598,775. PTEROCIN. INT. CL. 5. REG. 7-23-2002.
2,598,776. ROLLIN'DICE PRODUCTIONS AND DESIGN. INT. CL. 41. REG. 7-23-2002.
2,598,780. THE HOUSE THAT RUTH BUILT. INT. CLS. 14 AND 21. REG. 7-23-2002.
2,598,781. WIREFLYER AND DESIGN. INT. CLS. 39 AND 42. REG. 7-23-2002.
2,598,782. WIREFLYER. INT. CLS. 39 AND 42. REG. 7-23-2002.
2,598,783. LUCKYVILLE. INT. CL. 25. REG. 7-23-2002.
2,598,784. UNCLE BEN'S NOODLE BOWL. INT. CL. 30. REG. 7-23-2002.
2,598,786. QWEST ADVANTAGE. INT. CL. 36. REG. 7-23-2002.
2,598,787. TANGIS. INT. CL. 9. REG. 7-23-2002.
2,598,788. YOUR FRONT PAGE TO THE INFORMATION AGE. INT. CL. 16. REG. 7-23-2002.
2,598,791. JACK STONE. INT. CL. 28. REG. 7-23-2002.
2,598,792. TRIGENESIS COMMUNICATIONS AND DESIGN. INT. CLS. 9, 35 AND 41. REG. 7-23-2002.
2,598,793. JESSICA MCCLINTOCK. INT. CL. 9. REG. 7-23-2002.
2,598,797. PROPERTYMANAGERZ.COM AND DESIGN. INT. CLS. 35, 36 AND 38. REG. 7-23-2002.
2,598,798. OUT TO EAT. INT. CL. 16. REG. 7-23-2002.
2,598,800. VARIG TRAVEL VACATIONS. INT. CL. 39. REG. 7-23-2002.
2,598,803. QUIKSTOR. INT. CL. 9. REG. 7-23-2002.
2,598,804. METALTONES. INT. CLS. 11 AND 20. REG. 7-23-2002.
2,598,805. CROSSBRIDGE. INT. CL. 36. REG. 7-23-2002.
2,598,807. ACUMAN. INT. CL. 7. REG. 7-23-2002.
2,598,809. LEGAL QUESTION TREE. INT. CL. 42. REG. 7-23-2002.
2,598,810. SOURCE WIZARD. INT. CL. 9. REG. 7-23-2002.
2,598,812. MISCELLANEOUS DESIGN. INT. CLS. 18 AND 25. REG. 7-23-2002.
2,598,813. CREIGHTON. INT. CL. 9. REG. 7-23-2002.
2,598,814. QUALITY FROM GERMANY YOU DESERVE. INT. CL. 32. REG. 7-23-2002.
2,598,815. ACCESS HEALTH CHOICE. INT. CL. 36. REG. 7-23-2002.
2,598,817. WINDSWEEP. INT. CL. 24. REG. 7-23-2002.
2,598,818. FOREST GLEN APPAREL. INT. CL. 25. REG. 7-23-2002.
2,598,820. CONEY ISLAND FROZEN CUSTARD. INT. CL. 42. REG. 7-23-2002.
2,598,821. CONEY ISLAND FROZEN CUSTARD. INT. CL. 30. REG. 7-23-2002.
2,598,822. GARDEN CRUNCHERS. INT. CL. 29. REG. 7-23-2002.
2,598,823. MIDAS. INT. CL. 42. REG. 7-23-2002.
2,598,826. AMESYSTEM. INT. CL. 42. REG. 7-23-2002.
2,598,827. WWW.SPIDER.WEB. INT. CL. 35. REG. 7-23-2002.
2,598,828. USE YOUR LIFE. INT. CLS. 36, 41 AND 42. REG. 7-23-2002.
2,598,832. B SURE. INT. CL. 9. REG. 7-23-2002.
2,598,833. CORRECTCONNECT. INT. CL. 9. REG. 7-23-2002.
2,598,835. YOUR PLACE ON THE WEB. INT. CLS. 35 AND 42. REG. 7-23-2002.
2,598,836. HELPING PEOPLE MAKE THEIR LIVES BETTER, EVERYDAY. INT. CLS. 36 AND 38. REG. 7-23-2002.
2,598,837. COORDINATES. INT. CL. 16. REG. 7-23-2002.
2,598,838. MBM (STYLIZED). INT. CL. 41. REG. 7-23-2002.
2,598,840. KEY3MEDIA GROUP. INT. CL. 35. REG. 7-23-2002.
2,598,842. TEEN TEEN. INT. CL. 3. REG. 7-23-2002.
2,598,843. RELIASPAN. INT. CL. 9. REG. 7-23-2002.
2,598,844. THE THYMES. INT. CLS. 3, 4 AND 5. REG. 7-23-2002.
2,598,845. MOTIENT AND DESIGN. INT. CLS. 9, 16, 35, 38 AND 42. REG. 7-23-2002.
2,598,847. AEROMASTER. INT. CL. 18. REG. 7-23-2002.
2,598,848. PURRIFIC. INT. CLS. 21 AND 28. REG. 7-23-2002.
2,598,850. GAME CENTRE. INT. CL. 9. REG. 7-23-2002.
2,598,851. EGIS. INT. CL. 9. REG. 7-23-2002.

- 2,598,853. INTRALASE AND DESIGN. INT. CL. 10. REG. 7-23-2002.
- 2,598,856. NINA'S CREAMERY. INT. CL. 42. REG. 7-23-2002.
- 2,598,858. 2 KATAYONE ADELI. INT. CL. 25. REG. 7-23-2002.
- 2,598,860. POWERSIZE. INT. CL. 9. REG. 7-23-2002.
- 2,598,862. PEOPLE MATCH. INT. CL. 35. REG. 7-23-2002.
- 2,598,864. EA.COM AND DESIGN. INT. CLS. 38, 41 AND 42. REG. 7-23-2002.
- 2,598,865. EARTHBAND. INT. CL. 35. REG. 7-23-2002.
- 2,598,867. BALANCED LIFE. INT. CL. 36. REG. 7-23-2002.
- 2,598,868. FIRSTDOOR AND DESIGN. INT. CLS. 35 AND 36. REG. 7-23-2002.
- 2,598,869. MYBENEFITSTORE. INT. CL. 35. REG. 7-23-2002.
- 2,598,870. AAA EVERYDAY FUNDS. INT. CL. 9. REG. 7-23-2002.
- 2,598,871. RESPERATE FOR LOWER BLOOD PRESSURE AND DESIGN. INT. CLS. 10 AND 42. REG. 7-23-2002.
- 2,598,872. SAVOY FLAT. INT. CL. 19. REG. 7-23-2002.
- 2,598,873. EPIC MANUFACTURING. INT. CLS. 37 AND 40. REG. 7-23-2002.
- 2,598,874. MIDSHAFT EAF. INT. CL. 11. REG. 7-23-2002.
- 2,598,875. PRINCIPAL ASSET AND DESIGN. INT. CL. 35. REG. 7-23-2002.
- 2,598,878. THE BOOK THE PHONE COMPANY DOESN'T WANT YOU TO USE. INT. CL. 16. REG. 7-23-2002.
- 2,598,879. GROCERSCHOICE. INT. CL. 35. REG. 7-23-2002.
- 2,598,883. OPTIMIZE. INT. CL. 5. REG. 7-23-2002.
- 2,598,884. BODY GROW AND DESIGN. INT. CL. 5. REG. 7-23-2002.
- 2,598,885. COSMIC MONKEY. INT. CL. 16. REG. 7-23-2002.
- 2,598,886. COSMIC MONKEY. INT. CL. 28. REG. 7-23-2002.
- 2,598,887. THE BEST JUST GOT BETTER. INT. CL. 2. REG. 7-23-2002.
- 2,598,889. WOODEN WONDER AND DESIGN. INT. CL. 20. REG. 7-23-2002.
- 2,598,890. SPREE. INT. CL. 20. REG. 7-23-2002.
- 2,598,892. ALLURE FUSION MEDIA. INT. CL. 35. REG. 7-23-2002.
- 2,598,894. A WALK ON THE WILD SIDE. INT. CL. 28. REG. 7-23-2002.
- 2,598,895. GREATCOMMUNICATOR.COM. INT. CLS. 35, 41 AND 42. REG. 7-23-2002.
- 2,598,897. BUBBLBEUM BG USA AMERICAN FLAVOUR AND DESIGN. INT. CL. 25. REG. 7-23-2002.
- 2,598,899. (I) STRUCTURE (STYLIZED). INT. CLS. 35 AND 42. REG. 7-23-2002.
- 2,598,901. FIVEPENNIESLD. INT. CL. 38. REG. 7-23-2002.
- 2,598,902. FACE BOOST. INT. CL. 3. REG. 7-23-2002.
- 2,598,903. LOVE QUOTES. INT. CL. 40. REG. 7-23-2002.
- 2,598,904. REPORTABILITY.COM INC.. INT. CL. 42. REG. 7-23-2002.
- 2,598,905. REINVENTING THE WAY YOU STAY.. INT. CL. 42. REG. 7-23-2002.
- 2,598,906. BAKING MATTERS. INT. CL. 16. REG. 7-23-2002.
- 2,598,908. FRESH SHINE. INT. CL. 3. REG. 7-23-2002.
- 2,598,909. L Z G (STYLIZED). INT. CL. 5. REG. 7-23-2002.
- 2,598,911. CHAMPAGNE. INT. CL. 6. REG. 7-23-2002.
- 2,598,913. CEDAR SOLUTION. INT. CL. 2. REG. 7-23-2002.
- 2,598,918. AB FORCE. INT. CL. 28. REG. 7-23-2002.
- 2,598,920. SERVIDYNE GUEST SERVICES. INT. CL. 9. REG. 7-23-2002.
- 2,598,921. STARBAR100. INT. CL. 7. REG. 7-23-2002.
- 2,598,922. TOTAL-PRO. INT. CL. 42. REG. 7-23-2002.
- 2,598,923. GRANVILLE A PRESCOTT VALLEY COMMUNITY. INT. CL. 37. REG. 7-23-2002.
- 2,598,924. SCARF SECRET. INT. CL. 14. REG. 7-23-2002.
- 2,598,928. THE KERENZA COLLECTION. INT. CL. 35. REG. 7-23-2002.
- 2,598,929. SATISFACTION SET IN STONE. INT. CL. 19. REG. 7-23-2002.
- 2,598,931. DOC'S GOOFY JIG, INC. AND DESIGN. INT. CL. 28. REG. 7-23-2002.
- 2,598,932. PROTEIN INNOVATION. INT. CL. 5. REG. 7-23-2002.
- 2,598,934. CONNECTMAIL AND DESIGN. INT. CL. 38. REG. 7-23-2002.
- 2,598,935. VIVIDON. INT. CL. 9. REG. 7-23-2002.
- 2,598,937. ZOOLOGIK (STYLIZED). INT. CL. 19. REG. 7-23-2002.
- 2,598,938. EL MANDAMAS. INT. CL. 36. REG. 7-23-2002.
- 2,598,939. BUSTIN' LOOSE. INT. CL. 28. REG. 7-23-2002.
- 2,598,940. THE ONE ROD. INT. CL. 20. REG. 7-23-2002.
- 2,598,941. BIOZTECT. INT. CL. 10. REG. 7-23-2002.
- 2,598,942. GC. INT. CL. 7. REG. 7-23-2002.
- 2,598,943. LOUISVILLE SLUGGER. INT. CL. 9. REG. 7-23-2002.
- 2,598,944. LOUISVILLE SLUGGER. INT. CL. 16. REG. 7-23-2002.
- 2,598,945. CHARTERED CUSTOMER ACCESS. INT. CL. 35. REG. 7-23-2002.
- 2,598,947. WATCHMARK INSIGHT. INT. CL. 9. REG. 7-23-2002.
- 2,598,948. ADGRAM. INT. CL. 35. REG. 7-23-2002.
- 2,598,949. IWINDSURF. INT. CL. 41. REG. 7-23-2002.
- 2,598,950. EMERGEN. INT. CL. 42. REG. 7-23-2002.
- 2,598,951. HEATHER MIST. INT. CL. 5. REG. 7-23-2002.
- 2,598,954. HEALINC. INT. CL. 35. REG. 7-23-2002.
- 2,598,955. REFLEXIONS REFL BY ANDRE ASSOUS (STYLIZED). INT. CL. 25. REG. 7-23-2002.
- 2,598,958. CURL-VIVE. INT. CL. 3. REG. 7-23-2002.
- 2,598,960. PURPLE MOUNTAIN PRESS. INT. CL. 16. REG. 7-23-2002.
- 2,598,961. OYSTER ARTS. INT. CL. 41. REG. 7-23-2002.
- 2,598,963. MYLEGALPROBLEM.COM. INT. CL. 42. REG. 7-23-2002.
- 2,598,964. B J HOMEWORKS. INT. CL. 41. REG. 7-23-2002.
- 2,598,966. IPRIVACY AND DESIGN. INT. CL. 42. REG. 7-23-2002.
- 2,598,969. ABLEGUARD. INT. CL. 9. REG. 7-23-2002.
- 2,598,970. M&M'S (STYLIZED). INT. CL. 16. REG. 7-23-2002.
- 2,598,971. TRUEVIEW-UW. INT. CL. 28. REG. 7-23-2002.
- 2,598,973. THE GONGAWARE CENTER. INT. CL. 41. REG. 7-23-2002.
- 2,598,974. SURECERT. INT. CLS. 9 AND 41. REG. 7-23-2002.
- 2,598,976. POWERING BUSINESS PORTALS. INT. CL. 9. REG. 7-23-2002.
- 2,598,977. REVELATIONS. INT. CL. 16. REG. 7-23-2002.
- 2,598,978. PATCHBAY. INT. CLS. 35 AND 42. REG. 7-23-2002.
- 2,598,982. THEDOMAINDOMAIN.COM. INT. CL. 36. REG. 7-23-2002.
- 2,598,985. CHELSEA DAVIS. INT. CL. 25. REG. 7-23-2002.
- 2,598,989. ARTHROTRON. INT. CL. 10. REG. 7-23-2002.
- 2,598,990. CITA'S WORLD. INT. CL. 41. REG. 7-23-2002.
- 2,598,993. BODY SOLUTIONS AND DESIGN. INT. CL. 5. REG. 7-23-2002.
- 2,598,994. BUSINESS AS UNUSUAL. INT. CL. 35. REG. 7-23-2002.
- 2,598,995. EYED OPTIMOUSE. INT. CL. 9. REG. 7-23-2002.
- 2,598,996. RESOURCE 360. INT. CL. 35. REG. 7-23-2002.
- 2,598,997. SALOMON SMITH BARNEY MEDALLION PROGRAM. INT. CL. 36. REG. 7-23-2002.
- 2,598,999. LIGHTNING ROUTE AND DESIGN. INT. CL. 9. REG. 7-23-2002.
- 2,599,000. OMEGA. INT. CL. 7. REG. 7-23-2002.
- 2,599,003. PF PHASEFORWARD AND DESIGN. INT. CL. 9. REG. 7-23-2002.
- 2,599,004. BRANDWEB. INT. CL. 9. REG. 7-23-2002.
- 2,599,007. MISCELLANEOUS DESIGN. INT. CL. 42. REG. 7-23-2002.
- 2,599,008. S AND DESIGN. INT. CL. 36. REG. 7-23-2002.
- 2,599,009. S BLUESTREAM AND DESIGN. INT. CL. 36. REG. 7-23-2002.
- 2,599,011. FINGER POCKETS. INT. CL. 21. REG. 7-23-2002.
- 2,599,012. A GARDEN OF GEMS. INT. CL. 14. REG. 7-23-2002.
- 2,599,013. Z: AND DESIGN. INT. CL. 42. REG. 7-23-2002.
- 2,599,014. INSIDE STRATEGY. INT. CL. 35. REG. 7-23-2002.
- 2,599,015. BARLEYFEST. INT. CL. 42. REG. 7-23-2002.
- 2,599,016. GUARANTEE PLUMBING SERVICE INC. AND DESIGN. INT. CL. 37. REG. 7-23-2002.
- 2,599,019. SOFTBLADE. INT. CL. 9. REG. 7-23-2002.

- 2,599,021. A NEW KIND OF ENERGY. INT. CL. 39. REG. 7-23-2002.
- 2,599,024. I GENERATION. INT. CL. 41. REG. 7-23-2002.
- 2,599,025. PRO-LIFT. INT. CL. 16. REG. 7-23-2002.
- 2,599,027. PCAM. INT. CL. 10. REG. 7-23-2002.
- 2,599,028. EPICURELLSYN RX. INT. CL. 5. REG. 7-23-2002.
- 2,599,031. PACIFIC RESINS AND DESIGN. INT. CL. 1. REG. 7-23-2002.
- 2,599,033. AMERICAN BOARD OF EXAMINERS IN CRISIS INTERVENTION A.B.E.C.I A LOYAL AND TRUSTWORTHY MEMBER SCIENCE INTEGRITY JUSTICE AND DESIGN. INT. CL. 42. REG. 7-23-2002.
- 2,599,034. ONEBOOK. INT. CL. 9. REG. 7-23-2002.
- 2,599,035. BAKERY WITH A TAIL. INT. CL. 35. REG. 7-23-2002.
- 2,599,038. FIELDWOOD FINANCIAL. INT. CL. 36. REG. 7-23-2002.
- 2,599,039. NAP TIME. INT. CL. 25. REG. 7-23-2002.
- 2,599,040. SENSISEPT. INT. CL. 5. REG. 7-23-2002.
- 2,599,041. VESTMARC. INT. CL. 36. REG. 7-23-2002.
- 2,599,044. THE BEAUTY OF LIVING WELL.. INT. CL. 20. REG. 7-23-2002.
- 2,599,046. RODNEY RHINO. INT. CL. 25. REG. 7-23-2002.
- 2,599,047. CHARLEY CHIMP. INT. CL. 25. REG. 7-23-2002.
- 2,599,048. LOUIE LION. INT. CL. 25. REG. 7-23-2002.
- 2,599,049. GERALDINE GIRAFFE. INT. CL. 25. REG. 7-23-2002.
- 2,599,054. INERGO. INT. CL. 20. REG. 7-23-2002.
- 2,599,055. CHIP THUNDER. INT. CLS. 29 AND 30. REG. 7-23-2002.
- 2,599,057. TAKE A STEP IN THE RIGHT DIRECTION. INT. CL. 34. REG. 7-23-2002.
- 2,599,058. GOLF RECTOR. INT. CLS. 9 AND 16. REG. 7-23-2002.
- 2,599,059. HAVING A MID-LEASE CRISIS. INT. CL. 35. REG. 7-23-2002.
- 2,599,061. EDGE BMX. INT. CL. 28. REG. 7-23-2002.
- 2,599,062. SPEED FREEK. INT. CL. 28. REG. 7-23-2002.
- 2,599,063. MAD EVOLUTION. INT. CL. 9. REG. 7-23-2002.
- 2,599,068. MAXPAC. INT. CL. 42. REG. 7-23-2002.
- 2,599,069. MAX-OTVP. INT. CL. 42. REG. 7-23-2002.
- 2,599,070. WORKPLACEIQ. INT. CL. 9. REG. 7-23-2002.
- 2,599,074. H2O BABY. INT. CL. 21. REG. 7-23-2002.
- 2,599,075. ZX5. INT. CL. 12. REG. 7-23-2002.
- 2,599,076. GOURMET COOKIES FERELIS SINCE 1967 ORIGINAL RECIPE AND DESIGN. INT. CL. 30. REG. 7-23-2002.
- 2,599,077. O R T H I A (STYLIZED). INT. CL. 3. REG. 7-23-2002.
- 2,599,078. LEZARO. INT. CL. 12. REG. 7-23-2002.
- 2,599,080. SCHOOLS FIRST. INT. CL. 36. REG. 7-23-2002.
- 2,599,082. DJC. INT. CL. 14. REG. 7-23-2002.
- 2,599,084. AMBASSADORS AND DESIGN. INT. CL. 36. REG. 7-23-2002.
- 2,599,085. MAX CHECKERS. INT. CL. 35. REG. 7-23-2002.
- 2,599,086. CHECKERS. INT. CL. 35. REG. 7-23-2002.
- 2,599,087. YOUR POWER SOLUTIONS PARTNER. INT. CL. 42. REG. 7-23-2002.
- 2,599,088. IN THE THICK OF IT. INT. CL. 3. REG. 7-23-2002.
- 2,599,089. POCKUMI. INT. CL. 9. REG. 7-23-2002.
- 2,599,091. CONSYSTANT. INT. CL. 9. REG. 7-23-2002.
- 2,599,092. EMBEDDING CONFIDENCE. INT. CL. 9. REG. 7-23-2002.
- 2,599,097. MISCELLANEOUS DESIGN. INT. CL. 36. REG. 7-23-2002.
- 2,599,102. UNI-TORC. INT. CL. 8. REG. 7-23-2002.
- 2,599,103. WELLS ONELOOK. INT. CL. 36. REG. 7-23-2002.
- 2,599,104. WEBCAPTURE. INT. CL. 9. REG. 7-23-2002.
- 2,599,105. LIGHT SOURCE. INT. CL. 3. REG. 7-23-2002.
- 2,599,106. RAYLINK THE WIRELESS PEOPLE AND DESIGN. INT. CL. 9. REG. 7-23-2002.
- 2,599,107. ROLLER CRUISER II. INT. CL. 28. REG. 7-23-2002.
- 2,599,108. N NEWCOGEN AND DESIGN. INT. CL. 36. REG. 7-23-2002.
- 2,599,109. N NEWCOGEN AND DESIGN. INT. CL. 35. REG. 7-23-2002.
- 2,599,110. N (STYLIZED). INT. CL. 35. REG. 7-23-2002.
- 2,599,111. VI VO DA. INT. CL. 9. REG. 7-23-2002.
- 2,599,112. NOTHING COMES CLOSER TO THE SUN. INT. CL. 3. REG. 7-23-2002.
- 2,599,113. EIRA. U.S. CL. 200. REG. 7-23-2002.
- 2,599,115. CEASARINA. INT. CL. 16. REG. 7-23-2002.
- 2,599,116. E-JACKER. INT. CL. 9. REG. 7-23-2002.
- 2,599,117. FIREMARK AND DESIGN. INT. CL. 36. REG. 7-23-2002.
- 2,599,119. UTH 2000. INT. CL. 12. REG. 7-23-2002.
- 2,599,121. CAMEL. INT. CL. 12. REG. 7-23-2002.
- 2,599,123. MYREPAIRSHOP AND DESIGN. INT. CL. 35. REG. 7-23-2002.
- 2,599,124. MYREPAIRSHOP AND DESIGN. INT. CL. 36. REG. 7-23-2002.
- 2,599,125. MYREPAIRSHOP AND DESIGN. INT. CL. 35. REG. 7-23-2002.
- 2,599,126. MISCELLANEOUS DESIGN. INT. CL. 38. REG. 7-23-2002.
- 2,599,127. MISCELLANEOUS DESIGN. INT. CL. 36. REG. 7-23-2002.
- 2,599,128. MISCELLANEOUS DESIGN. INT. CL. 35. REG. 7-23-2002.
- 2,599,129. MYREPAIRSHOP (STYLIZED). INT. CL. 38. REG. 7-23-2002.
- 2,599,130. MYREPAIRSHOP (STYLIZED). INT. CL. 36. REG. 7-23-2002.
- 2,599,131. MYREPAIRSHOP (STYLIZED). INT. CL. 35. REG. 7-23-2002.
- 2,599,132. UNEXT. INT. CL. 41. REG. 7-23-2002.
- 2,599,133. TEXTURED TOP. INT. CL. 3. REG. 7-23-2002.
- 2,599,134. OUTER WEAR. INT. CL. 3. REG. 7-23-2002.
- 2,599,135. APPRAISINGTREE. INT. CL. 35. REG. 7-23-2002.
- 2,599,144. CAPITAL ONE AUTO FINANCE AND DESIGN. INT. CL. 36. REG. 7-23-2002.
- 2,599,145. POLSAR. INT. CL. 42. REG. 7-23-2002.
- 2,599,146. PHOENIX ZOO AND DESIGN. INT. CL. 41. REG. 7-23-2002.
- 2,599,148. STYLISH TRAVELER. INT. CLS. 16 AND 35. REG. 7-23-2002.
- 2,599,152. BAZOOKA F4. INT. CL. 28. REG. 7-23-2002.
- 2,599,154. FIRST RECOVERY. INT. CL. 9. REG. 7-23-2002.
- 2,599,155. NAUTIL. INT. CL. 28. REG. 7-23-2002.
- 2,599,156. THE OUTLET AUTHORITY. INT. CL. 35. REG. 7-23-2002.
- 2,599,157. WOOTZ EARZ. INT. CL. 31. REG. 7-23-2002.
- 2,599,158. POWERS SOLUTIONS. INT. CL. 35. REG. 7-23-2002.
- 2,599,160. TIER AND DESIGN. INT. CL. 41. REG. 7-23-2002.
- 2,599,161. SQUEEZE ME MUSIC. INT. CL. 28. REG. 7-23-2002.
- 2,599,166. ADVENTURE CROSSINGS. INT. CL. 18. REG. 7-23-2002.
- 2,599,167. URBAN CONNECTION. INT. CL. 18. REG. 7-23-2002.
- 2,599,169. MEDIANO'S CHILOSITO PEPPER SAUCE AND DESIGN. INT. CL. 30. REG. 7-23-2002.
- 2,599,172. GLASS SHINE. INT. CL. 3. REG. 7-23-2002.
- 2,599,175. HEWILLIAMS AND DESIGN. INT. CL. 11. REG. 7-23-2002.
- 2,599,176. UOMO AND DESIGN. INT. CL. 3. REG. 7-23-2002.
- 2,599,177. WISDOC. INT. CL. 42. REG. 7-23-2002.
- 2,599,181. SCHWEBCAST. INT. CL. 41. REG. 7-23-2002.
- 2,599,182. NEUSECURE. INT. CL. 9. REG. 7-23-2002.
- 2,599,184. TRANSFORMER. INT. CL. 20. REG. 7-23-2002.
- 2,599,185. FP AND DESIGN. INT. CL. 16. REG. 7-23-2002.
- 2,599,186. GENIUM. INT. CL. 9. REG. 7-23-2002.
- 2,599,187. BEE BUCKS. INT. CL. 9. REG. 7-23-2002.
- 2,599,192. MAINTAIN A RIGID STATE OF FLEXIBILITY. INT. CL. 25. REG. 7-23-2002.
- 2,599,193. ST. CHARLES. INT. CL. 11. REG. 7-23-2002.
- 2,599,198. WE'VE GOT THE POWER TO MAKE THINGS BETTER. INT. CL. 37. REG. 7-23-2002.
- 2,599,200. PETPRINTS HEALTH AND WELLNESS. INT. CLS. 16, 36 AND 42. REG. 7-23-2002.
- 2,599,202. PRIMEJOIST. INT. CL. 19. REG. 7-23-2002.
- 2,599,203. PRIMERIM. INT. CL. 19. REG. 7-23-2002.

- 2,599,206. LIFE IS BETTER WITH A BOAT AND DESIGN. INT. CL. 42. REG. 7-23-2002.
- 2,599,209. UNIVERSAL STUDIOS THEME PARKS FAN CLUB AND DESIGN. INT. CL. 42. REG. 7-23-2002.
- 2,599,212. LIFE IS BETTER WITH A BOAT. INT. CL. 42. REG. 7-23-2002.
- 2,599,214. WE SEE THE OPPORTUNITY TO CHANGE THE WORLD WITH OUR ENERGY. INT. CL. 35. REG. 7-23-2002.
- 2,599,218. MISCELLANEOUS DESIGN. INT. CL. 35. REG. 7-23-2002.
- 2,599,220. E-SAVE. INT. CL. 11. REG. 7-23-2002.
- 2,599,221. INFEC-TEES. INT. CL. 25. REG. 7-23-2002.
- 2,599,223. JUNGLE KINGDOM. INT. CL. 21. REG. 7-23-2002.
- 2,599,224. YARN CRITTERS. INT. CL. 28. REG. 7-23-2002.
- 2,599,225. BIO-PKI. INT. CL. 9. REG. 7-23-2002.
- 2,599,226. F.O.R.C.E.S.. INT. CL. 9. REG. 7-23-2002.
- 2,599,227. STRETCH & FETCH. INT. CL. 28. REG. 7-23-2002.
- 2,599,229. POCKETCHARGE. INT. CL. 9. REG. 7-23-2002.
- 2,599,230. EZ OFF LOADER. INT. CL. 7. REG. 7-23-2002.
- 2,599,234. STURDISTEP. INT. CL. 19. REG. 7-23-2002.
- 2,599,235. RUDY CAPARRINI AND DESIGN. INT. CL. 25. REG. 7-23-2002.
- 2,599,236. PUBLIXDIRECT AND DESIGN. INT. CL. 35. REG. 7-23-2002.
- 2,599,238. DULOC. INT. CL. 28. REG. 7-23-2002.
- 2,599,241. THE POSSIBILITIES ARE BOUNDLESS. INT. CL. 41. REG. 7-23-2002.
- 2,599,242. WINDOMAR. INT. CL. 36. REG. 7-23-2002.
- 2,599,244. MAKE IT THE BEST. INT. CL. 32. REG. 7-23-2002.
- 2,599,246. MEMBERLINK. INT. CL. 35. REG. 7-23-2002.
- 2,599,248. ANOTHER NAME FOR GOD'S ETERNAL LOVE AND DESIGN. INT. CL. 14. REG. 7-23-2002.
- 2,599,251. LOOKING OVER THE ONES YOU LOVE.. INT. CL. 42. REG. 7-23-2002.
- 2,599,252. TULIP HILL. INT. CL. 33. REG. 7-23-2002.
- 2,599,254. HOMEOWNER. INT. CL. 12. REG. 7-23-2002.
- 2,599,257. WE MAKE A CASKET MEAN MORE. INT. CL. 42. REG. 7-23-2002.
- 2,599,259. QUANTUM LEAP. INT. CL. 28. REG. 7-23-2002.
- 2,599,260. HANJI. INT. CL. 16. REG. 7-23-2002.
- 2,599,261. IBIS. INT. CL. 16. REG. 7-23-2002.
- 2,599,262. LIQUENT CONTENT IN MOTION AND DESIGN. INT. CL. 9. REG. 7-23-2002.
- 2,599,265. GREEN DRAGON CAFEXPRESS. INT. CL. 11. REG. 7-23-2002.
- 2,599,268. THE ANYWHERE, ANYTIME TUB. INT. CL. 11. REG. 7-23-2002.
- 2,599,269. SENTRY. INT. CL. 9. REG. 7-23-2002.
- 2,599,273. ALASKA STATEHOOD JUBILEE. INT. CL. 13. REG. 7-23-2002.
- 2,599,274. ALASKA STATEHOOD JUBILEE. INT. CL. 14. REG. 7-23-2002.
- 2,599,275. PARK R E W A R D S AND DESIGN. INT. CLS. 9 AND 35. REG. 7-23-2002.
- 2,599,276. N (STYLIZED). INT. CL. 36. REG. 7-23-2002.
- 2,599,277. MISSION RESOURCES CORPORATION. INT. CL. 42. REG. 7-23-2002.
- 2,599,281. I IMAGINGPLANET (STYLIZED). INT. CL. 9. REG. 7-23-2002.
- 2,599,282. CRYSTALTRON. INT. CL. 1. REG. 7-23-2002.
- 2,599,284. QUANTUM LEAP (STYLIZED). INT. CL. 28. REG. 7-23-2002.
- 2,599,286. GT ALL-STARS. INT. CL. 41. REG. 7-23-2002.
- 2,599,288. PLANE HEAT. INT. CL. 11. REG. 7-23-2002.
- 2,599,294. INNOVATION. INT. CL. 16. REG. 7-23-2002.
- 2,599,295. CANCER LIFE PLUS. INT. CL. 36. REG. 7-23-2002.
- 2,599,301. DORITOS, FOR THE BOLD & DARING.. INT. CL. 30. REG. 7-23-2002.
- 2,599,302. CASE IN POINT. INT. CLS. 35 AND 42. REG. 7-23-2002.
- 2,599,303. SCITECK (STYLIZED). INT. CLS. 9 AND 16. REG. 7-23-2002.
- 2,599,304. BRINGING BUSINESS INTELLIGENCE TO RESEARCH. INT. CL. 35. REG. 7-23-2002.
- 2,599,307. STARVIEW CAPITAL MANAGEMENT. INT. CL. 36. REG. 7-23-2002.
- 2,599,308. REGIONS BASIC BANKING. INT. CL. 36. REG. 7-23-2002.
- 2,599,309. REGIONS CLASSIC BANKING. INT. CL. 36. REG. 7-23-2002.
- 2,599,310. REGIONS E-SENTIAL BANKING. INT. CL. 36. REG. 7-23-2002.
- 2,599,313. EARTH RELEASE. INT. CL. 3. REG. 7-23-2002.
- 2,599,315. NATURAL SPRINGS. INT. CL. 3. REG. 7-23-2002.
- 2,599,319. PRIME-ZYME. INT. CL. 5. REG. 7-23-2002.
- 2,599,324. CHALLENGING THE LAWS OF CONVENTION. INT. CL. 42. REG. 7-23-2002.
- 2,599,325. GOLDROCK. INT. CL. 36. REG. 7-23-2002.
- 2,599,326. SOUND MASTER. INT. CL. 9. REG. 7-23-2002.
- 2,599,327. BECAUSE KIDS WILL BE KIDS. INT. CL. 27. REG. 7-23-2002.
- 2,599,328. PUSSY. INT. CL. 28. REG. 7-23-2002.
- 2,599,333. CARS FOR EVERYONE. INT. CL. 35. REG. 7-23-2002.
- 2,599,336. SATINATO. INT. CL. 19. REG. 7-23-2002.
- 2,599,339. INNERSTYLE. INT. CL. 20. REG. 7-23-2002.
- 2,599,340. HAMILTON FARM. INT. CLS. 18, 25 AND 28. REG. 7-23-2002.
- 2,599,343. WHERE YOUR JOURNEY BEGINS.... INT. CL. 35. REG. 7-23-2002.
- 2,599,348. LULLABY LIGHTS. INT. CL. 11. REG. 7-23-2002.
- 2,599,350. PET PEEVE. INT. CL. 9. REG. 7-23-2002.
- 2,599,354. CREATINE-FX. INT. CL. 5. REG. 7-23-2002.
- 2,599,355. INVESCO FUNDS. INT. CL. 36. REG. 7-23-2002.
- 2,599,357. PROCAPUI. INT. CL. 29. REG. 7-23-2002.
- 2,599,361. BEARCAT. INT. CL. 7. REG. 7-23-2002.
- 2,599,362. TRIPSPLIT. INT. CL. 39. REG. 7-23-2002.
- 2,599,363. CAPTURE COMPUTE COMMUNICATE AND DESIGN. INT. CL. 42. REG. 7-23-2002.
- 2,599,364. SIDEWALK POET. INT. CL. 28. REG. 7-23-2002.
- 2,599,366. AQUA COVER. INT. CL. 3. REG. 7-23-2002.
- 2,599,368. TRACKSTAR. INT. CL. 36. REG. 7-23-2002.
- 2,599,369. NO MORALS. INT. CL. 25. REG. 7-23-2002.
- 2,599,373. RUDE AMERICAN. INT. CL. 25. REG. 7-23-2002.
- 2,599,376. ODINKO. INT. CL. 11. REG. 7-23-2002.
- 2,599,377. APPLOCK. INT. CL. 9. REG. 7-23-2002.
- 2,599,378. DESIGNING PEACE OF MIND.. INT. CL. 9. REG. 7-23-2002.
- 2,599,379. POSTRUNNER. INT. CL. 12. REG. 7-23-2002.
- 2,599,381. MAXIM. INT. CL. 16. REG. 7-23-2002.
- 2,599,382. QUICK EASE. INT. CL. 21. REG. 7-23-2002.
- 2,599,385. METROWIDE. INT. CL. 4. REG. 7-23-2002.
- 2,599,386. CHIC-A-D ISLAND. INT. CL. 42. REG. 7-23-2002.
- 2,599,387. NOW... IT'S WATT YOU KNOW!. INT. CL. 9. REG. 7-23-2002.
- 2,599,389. VANTAGE 6000. INT. CL. 11. REG. 7-23-2002.
- 2,599,390. MERIDIAN SERIES. INT. CL. 11. REG. 7-23-2002.
- 2,599,396. WELLS FARGO OUTLOOK FUNDS. INT. CL. 36. REG. 7-23-2002.
- 2,599,397. SUNMARKE. INT. CL. 37. REG. 7-23-2002.
- 2,599,398. SEIZURE SENSE. INT. CL. 28. REG. 7-23-2002.
- 2,599,401. ASTONISH-MINTS. INT. CL. 30. REG. 7-23-2002.
- 2,599,404. UNIRAM. INT. CL. 42. REG. 7-23-2002.
- 2,599,405. BARREL O' BLUNTS. INT. CL. 34. REG. 7-23-2002.
- 2,599,406. SKINDEPTH. INT. CL. 16. REG. 7-23-2002.
- 2,599,408. BIZNET. INT. CL. 36. REG. 7-23-2002.
- 2,599,409. LILLY'S GARDEN. INT. CL. 3. REG. 7-23-2002.
- 2,599,411. AMAZONIA. INT. CL. 19. REG. 7-23-2002.
- 2,599,414. MISCELLANEOUS DESIGN. INT. CL. 28. REG. 7-23-2002.
- 2,599,417. ANGELFIRE AND DESIGN. INT. CL. 13. REG. 7-23-2002.
- 2,599,419. FULFILL. INT. CL. 42. REG. 7-23-2002.
- 2,599,420. DOUBLE KARMA. INT. CL. 30. REG. 7-23-2002.
- 2,599,422. SURGE. INT. CL. 28. REG. 7-23-2002.
- 2,599,423. RESULTS FOR WOMEN. INT. CL. 5. REG. 7-23-2002.
- 2,599,424. 7-ELEVEN VALUE+. INT. CL. 36. REG. 7-23-2002.
- 2,599,427. TEAMTRIALS. INT. CL. 42. REG. 7-23-2002.
- 2,599,429. NAMESTIX. INT. CL. 14. REG. 7-23-2002.
- 2,599,432. TRANSFORMING TECHNICAL KNOW-HOW INTO BUSINESS RESULTS. INT. CL. 35. REG. 7-23-2002.
- 2,599,433. DESKMATE. INT. CL. 11. REG. 7-23-2002.

- 2,599,434. STAR VALUE. INT. CL. 9. REG. 7-23-2002.
 2,599,436. BATIKWORLD. INT. CL. 35. REG. 7-23-2002.
 2,599,437. AGEBACK. INT. CL. 5. REG. 7-23-2002.
 2,599,439. REC TIME USA. INT. CL. 39. REG. 7-23-2002.
 2,599,440. PARLEZ-VOUS SPORTS. INT. CL. 25. REG. 7-23-2002.
 2,599,441. EQUIPE COMMUNICATIONS. INT. CL. 9. REG. 7-23-2002.
 2,599,442. CITYHEAT PRODUCTIONS. INT. CLS. 9 AND 41. REG. 7-23-2002.
 2,599,443. LOANMATCH. INT. CL. 9. REG. 7-23-2002.
 2,599,444. EMULITE. INT. CL. 9. REG. 7-23-2002.
 2,599,446. JAVA MOUNTAIN EXPRESS. INT. CL. 30. REG. 7-23-2002.
 2,599,447. MICROVESCENT TECHNIQUE. INT. CL. 42. REG. 7-23-2002.
 2,599,449. CHASING DAISIES. INT. CL. 28. REG. 7-23-2002.
 2,599,450. SKORPPPIO. INT. CL. 33. REG. 7-23-2002.
 2,599,452. GLOBAL LOUNGE. INT. CL. 38. REG. 7-23-2002.
 2,599,454. POSITIVE PRESS. INT. CL. 41. REG. 7-23-2002.
 2,599,455. 123SAUCE.COM. INT. CL. 35. REG. 7-23-2002.
 2,599,457. COLLECTIVELY INVEST COLLECTIVELY GAIN. INT. CL. 36. REG. 7-23-2002.
 2,599,458. KITCHEN KITTIES. INT. CL. 21. REG. 7-23-2002.
 2,599,459. GEYSER GUSHER. INT. CL. 28. REG. 7-23-2002.
 2,599,460. DOMAINS BY GEORGE. INT. CL. 42. REG. 7-23-2002.
 2,599,463. I AND DESIGN. INT. CL. 38. REG. 7-23-2002.
 2,599,465. N5. INT. CL. 9. REG. 7-23-2002.
 2,599,466. JESUS LOVES ME (STYLIZED). INT. CL. 25. REG. 7-23-2002.
 2,599,467. E*CARMOTORS AND DESIGN. INT. CL. 35. REG. 7-23-2002.
 2,599,468. ADVANCING SOLUTIONS. INT. CL. 10. REG. 7-23-2002.
 2,599,469. NOW I CAN. INT. CL. 10. REG. 7-23-2002.
 2,599,476. GLOBAL GOALS. INT. CL. 9. REG. 7-23-2002.
 2,599,484. SLAM DUNK HUNGER. INT. CL. 36. REG. 7-23-2002.
 2,599,485. WALL STREET FANATIC. INT. CL. 36. REG. 7-23-2002.
 2,599,487. DIAMONDS R4U. INT. CL. 14. REG. 7-23-2002.
 2,599,489. EMOGO. INT. CL. 25. REG. 7-23-2002.
 2,599,490. POWER RANGERS TIME FORCE. INT. CL. 16. REG. 7-23-2002.
 2,599,491. POWER RANGERS TIME FORCE. INT. CL. 18. REG. 7-23-2002.
 2,599,494. BEACON HILL. INT. CL. 18. REG. 7-23-2002.
 2,599,495. PIGGY PUSHERS. INT. CL. 25. REG. 7-23-2002.
 2,599,498. GEORESOURSE. INT. CL. 42. REG. 7-23-2002.
 2,599,499. GEORESOURSE REGENERATION. INT. CL. 42. REG. 7-23-2002.
 2,599,500. GEORESOURSE RENEWAL. INT. CL. 42. REG. 7-23-2002.
 2,599,501. CLASSIC AVAYA. INT. CL. 9. REG. 7-23-2002.
 2,599,503. MPLSVIEW. INT. CL. 9. REG. 7-23-2002.
 2,599,505. LADDERDILDO. INT. CL. 6. REG. 7-23-2002.
 2,599,506. IMAGEHAWK. INT. CL. 9. REG. 7-23-2002.
 2,599,507. NBS AND DESIGN. INT. CL. 25. REG. 7-23-2002.
 2,599,510. SNAPE. INT. CL. 16. REG. 7-23-2002.
 2,599,511. M&R CARESOURCE. INT. CL. 9. REG. 7-23-2002.
 2,599,513. MISCELLANEOUS DESIGN. INT. CL. 9. REG. 7-23-2002.
 2,599,515. PEOPLE RULE. INT. CL. 35. REG. 7-23-2002.
 2,599,517. PARTNERCONNECT. INT. CL. 35. REG. 7-23-2002.
 2,599,521. A BETTER QUALITY OF LIFE ON THE ROAD. INT. CLS. 35 AND 42. REG. 7-23-2002.
 2,599,523. SANECRAZY. INT. CL. 41. REG. 7-23-2002.
 2,599,524. CHILI MUNDO. INT. CL. 30. REG. 7-23-2002.
 2,599,525. COMAGINE. INT. CLS. 41 AND 42. REG. 7-23-2002.
 2,599,526. SURF LOUNGE. INT. CL. 38. REG. 7-23-2002.
 2,599,528. TOUCHDOWN MONKEY. INT. CL. 28. REG. 7-23-2002.
 2,599,531. WHITTHORNE. INT. CLS. 11, 19 AND 20. REG. 7-23-2002.
 2,599,532. REALEVENT. INT. CL. 9. REG. 7-23-2002.
 2,599,533. CORPORATE KIDS EVENTS AND DESIGN. INT. CL. 41. REG. 7-23-2002.
 2,599,534. DYNAMIC FENG SHUI. INT. CLS. 41 AND 42. REG. 7-23-2002.
 2,599,535. CRYSTAL' AIR. INT. CL. 5. REG. 7-23-2002.
 2,599,536. ENCHANTED HALLOWEEN. INT. CL. 28. REG. 7-23-2002.
 2,599,537. PERMA-LOC AND DESIGN. INT. CL. 19. REG. 7-23-2002.
 2,599,539. ANY GIFT. ANY TIME.. INT. CL. 35. REG. 7-23-2002.
 2,599,540. MALE SPECIES. INT. CL. 3. REG. 7-23-2002.
 2,599,541. MOLECULARINFO. INT. CL. 35. REG. 7-23-2002.
 2,599,543. RECOVERYSAFE. INT. CL. 9. REG. 7-23-2002.
 2,599,544. NECS. INT. CL. 35. REG. 7-23-2002.
 2,599,546. TWO FOR YOU: MOUNTAIN TOP COACHING & COLORADO ASSOCIATES FOR RELATIONSHIP ENHANCEMENT SKILLS (CARES). INT. CL. 42. REG. 7-23-2002.
 2,599,547. UNDER COVER. INT. CL. 9. REG. 7-23-2002.
 2,599,548. HELPUPLAY. INT. CL. 9. REG. 7-23-2002.
 2,599,549. ZOWIEMAIL. INT. CL. 35. REG. 7-23-2002.
 2,599,550. BETA SECRET. INT. CL. 5. REG. 7-23-2002.
 2,599,552. PINGER. INT. CL. 9. REG. 7-23-2002.
 2,599,553. MARASKINO. INT. CL. 42. REG. 7-23-2002.
 2,599,554. AROMAWERKS. INT. CL. 3. REG. 7-23-2002.
 2,599,555. "STEVE'S" STEVIA. INT. CL. 30. REG. 7-23-2002.
 2,599,556. NBDL AND DESIGN. INT. CL. 35. REG. 7-23-2002.
 2,599,557. CINNAMON ROLL. INT. CL. 3. REG. 7-23-2002.
 2,599,558. DREAM WARRIORS. INT. CL. 41. REG. 7-23-2002.
 2,599,559. META-ISM. INT. CL. 42. REG. 7-23-2002.
 2,599,561. SL PERFORMANCECALCULATOR. INT. CL. 42. REG. 7-23-2002.
 2,599,562. VIVIDLINE. INT. CL. 42. REG. 7-23-2002.
 2,599,564. HUNTER'S BAY. INT. CL. 3. REG. 7-23-2002.
 2,599,565. BALLET MASQUERADE. INT. CL. 28. REG. 7-23-2002.
 2,599,569. MOTHER-CHILD. INT. CL. 9. REG. 7-23-2002.
 2,599,572. CULTURE + . INT. CL. 35. REG. 7-23-2002.
 2,599,574. CAPITAL REWARDS. INT. CLS. 35 AND 36. REG. 7-23-2002.
 2,599,577. INSAN IT. INT. CLS. 35, 37 AND 42. REG. 7-23-2002.
 2,599,579. AIRMAN. INT. CL. 10. REG. 7-23-2002.
 2,599,580. FAMILY NEW YORK PIZZA — THE AREA'S BEST PIZZA! AND DESIGN. INT. CL. 42. REG. 7-23-2002.
 2,599,581. COMFORTLANCETS. INT. CL. 10. REG. 7-23-2002.
 2,599,582. STEAM 'N GO. INT. CL. 9. REG. 7-23-2002.
 2,599,583. RKS CYBER-I. INT. CL. 35. REG. 7-23-2002.
 2,599,587. RIOS DE GRACIA. INT. CL. 41. REG. 7-23-2002.
 2,599,588. ACUSTEP. INT. CL. 7. REG. 7-23-2002.
 2,599,589. THE EXPERIENCE TO RELY ON. INT. CL. 42. REG. 7-23-2002.
 2,599,591. TRU TRAK. INT. CL. 28. REG. 7-23-2002.
 2,599,596. DATASUL AND DESIGN. INT. CL. 9. REG. 7-23-2002.
 2,599,597. ZEONIC FRONT. INT. CL. 9. REG. 7-23-2002.
 2,599,598. SEE SPOT GO. INT. CL. 5. REG. 7-23-2002.
 2,599,599. WATER WORDS. INT. CL. 16. REG. 7-23-2002.
 2,599,602. BODY REVOLUTION. INT. CL. 25. REG. 7-23-2002.
 2,599,603. EARLY ALERT. INT. CL. 10. REG. 7-23-2002.
 2,599,604. PLANETARY LEARNING AND DESIGN. INT. CL. 16. REG. 7-23-2002.
 2,599,605. SAMBADORO. INT. CL. 32. REG. 7-23-2002.
 2,599,606. CRUISIN' WITH THE CROWD. INT. CL. 28. REG. 7-23-2002.
 2,599,608. XLS EXPRESS. INT. CL. 9. REG. 7-23-2002.
 2,599,610. LEAGUEBOSS.COM. INT. CL. 41. REG. 7-23-2002.
 2,599,611. CHILL STOPPERS. INT. CL. 25. REG. 7-23-2002.
 2,599,612. POP-OUT PEOPLE. INT. CL. 16. REG. 7-23-2002.
 2,599,613. VOX. INT. CL. 28. REG. 7-23-2002.
 2,599,614. SOPHISTICATED WEDDING. INT. CL. 28. REG. 7-23-2002.
 2,599,617. 5 DAYS TO GROW. INT. CL. 3. REG. 7-23-2002.
 2,599,620. MONSTER MESH. INT. CL. 28. REG. 7-23-2002.

- 2,599,621. BLAZE. INT. CL. 28. REG. 7-23-2002.
 2,599,623. THE RESCUE FROM ATLANTA. INT. CL. 28. REG. 7-23-2002.
 2,599,626. FORGED BY FIRE. INT. CL. 41. REG. 7-23-2002.
 2,599,628. OZ DIVE AND DESIGN. INT. CL. 39. REG. 7-23-2002.
 2,599,629. MANAGE THE POWER. INT. CL. 9. REG. 7-23-2002.
 2,599,630. L.A. SADITTE INC. AND DESIGN. INT. CL. 35. REG. 7-23-2002.
 2,599,633. MASSAGEZONE. INT. CL. 3. REG. 7-23-2002.
 2,599,634. DECORUM. INT. CLS. 3 AND 4. REG. 7-23-2002.
 2,599,635. ORDERSTAR. INT. CL. 35. REG. 7-23-2002.
 2,599,638. ENGINEERED FOR SUCCESS. INT. CL. 36. REG. 7-23-2002.
 2,599,639. ALL THE SEASONS, ALL THE TIME. INT. CL. 35. REG. 7-23-2002.
 2,599,640. ORCHARD BLOSSOM. INT. CL. 3. REG. 7-23-2002.
 2,599,641. VITRAPRIME. INT. CL. 2. REG. 7-23-2002.
 2,599,642. AUNTIE ANNE'S CRE AMO. INT. CL. 30. REG. 7-23-2002.
 2,599,646. ACTION REFLECTION LEARNING. INT. CL. 35. REG. 7-23-2002.
 2,599,647. EARNING WHILE LEARNING. INT. CL. 35. REG. 7-23-2002.
 2,599,648. HOME MADE SIMPLE AND DESIGN. INT. CLS. 3, 16 AND 37. REG. 7-23-2002.
 2,599,649. MYOMETH. INT. CL. 5. REG. 7-23-2002.
 2,599,650. EXTEND THE CHEER, PAY NEXT YEAR. INT. CL. 36. REG. 7-23-2002.
 2,599,654. HERTURN.ORG AND DESIGN. INT. CL. 5. REG. 7-23-2002.
 2,599,655. INTEXNET.NET WEBHOSTING FOR THE WORLD. INT. CL. 42. REG. 7-23-2002.
 2,599,657. CALIBRE.45. INT. CL. 33. REG. 7-23-2002.
 2,599,664. SHOT-SHAVER. INT. CL. 9. REG. 7-23-2002.
 2,599,665. FROSTED ROSE LEAF. INT. CLS. 4 AND 5. REG. 7-23-2002.
 2,599,666. TOP-FLITE. INT. CL. 18. REG. 7-23-2002.
 2,599,667. ENJOY SPEEDY SAMPLES!. INT. CLS. 18 AND 25. REG. 7-23-2002.
 2,599,668. ENJOY SPEEDY DELIVERY!. INT. CLS. 18 AND 25. REG. 7-23-2002.
 2,599,670. AFTERBURNER-LHSX. INT. CL. 9. REG. 7-23-2002.
 2,599,671. OPTVAL. INT. CL. 9. REG. 7-23-2002.
 2,599,672. AIR ALIVE! AND DESIGN. INT. CL. 28. REG. 7-23-2002.
 2,599,673. ARCH VISOR. INT. CL. 25. REG. 7-23-2002.
 2,599,674. TUF-LOC. INT. CL. 23. REG. 7-23-2002.
 2,599,675. CZR. INT. CL. 41. REG. 7-23-2002.
 2,599,676. MDX5. INT. CL. 32. REG. 7-23-2002.
 2,599,680. BISQUEKIT. INT. CL. 28. REG. 7-23-2002.
 2,599,682. PAY YOURSELF FIRST...OTHERWISE, THINGS WILL NEVER CHANGE. INT. CL. 35. REG. 7-23-2002.
 2,599,684. QUICKFLEX. INT. CL. 9. REG. 7-23-2002.
 2,599,685. MAXUM. INT. CL. 28. REG. 7-23-2002.
 2,599,686. BACTINE AND DESIGN. INT. CL. 5. REG. 7-23-2002.
 2,599,687. BACTINE AND DESIGN. INT. CL. 5. REG. 7-23-2002.
 2,599,690. KISSY KISSY HUG HUG. INT. CL. 3. REG. 7-23-2002.
 2,599,692. CTU30. INT. CL. 28. REG. 7-23-2002.
 2,599,693. KODIAK SPORTS. INT. CL. 28. REG. 7-23-2002.
 2,599,694. SCOOBY SNACKS. INT. CL. 30. REG. 7-23-2002.
 2,599,696. VENDSECURE. INT. CL. 9. REG. 7-23-2002.
 2,599,698. COLLEGEONE (STYLIZED). INT. CL. 35. REG. 7-23-2002.
 2,599,699. RESOLUTE. INT. CL. 24. REG. 7-23-2002.
 2,599,700. POINTGUARD. INT. CL. 9. REG. 7-23-2002.
 2,599,701. TOTAL PROCESS. INT. CL. 36. REG. 7-23-2002.
 2,599,702. BANDOLIER. INT. CL. 13. REG. 7-23-2002.
 2,599,703. RPSP. INT. CL. 42. REG. 7-23-2002.
 2,599,706. ELECTRONIC ORIGINAL INITIATIVE. INT. CL. 42. REG. 7-23-2002.
 2,599,707. CARBO ENERGY. INT. CL. 5. REG. 7-23-2002.
 2,599,708. BIZCARD. INT. CL. 42. REG. 7-23-2002.
 2,599,710. HOME VALUE CONSORTIUM. INT. CL. 36. REG. 7-23-2002.
 2,599,712. PERSONAL VIDEO RECORDER. INT. CL. 9. REG. 7-23-2002.
 2,599,713. SALONBIZ 2000. INT. CL. 9. REG. 7-23-2002.
 2,599,714. MISCELLANEOUS DESIGN. INT. CL. 5. REG. 7-23-2002.
 2,599,715. LUMINEUX.COM. INT. CL. 42. REG. 7-23-2002.
 2,599,716. SUPER SECTOR. INT. CL. 36. REG. 7-23-2002.
 2,599,718. E-CREDITMENU. INT. CL. 36. REG. 7-23-2002.
 2,599,720. PEO BENCHMARKER. INT. CL. 35. REG. 7-23-2002.
 2,599,723. OBJECT TELEMETRY. INT. CL. 42. REG. 7-23-2002.
 2,599,726. BRANDMEDIATOR (STYLIZED). INT. CL. 35. REG. 7-23-2002.
 2,599,727. COWBOY CODE. INT. CL. 41. REG. 7-23-2002.
 2,599,728. STEERING COLUMN. INT. CL. 16. REG. 7-23-2002.
 2,599,729. SWEET PEAR. INT. CL. 31. REG. 7-23-2002.
 2,599,730. VINUM CELLARS. INT. CL. 33. REG. 7-23-2002.
 2,599,732. SOFWEAR SHOES (STYLIZED). INT. CL. 25. REG. 7-23-2002.
 2,599,733. ANDES INTERNATIONAL, INC.. INT. CL. 20. REG. 7-23-2002.
 2,599,736. STATE TAX BAEDEKER. INT. CL. 9. REG. 7-23-2002.
 2,599,737. MS. SPRATT'S. INT. CL. 35. REG. 7-23-2002.
 2,599,738. DENTAL CARE 4 KIDS. INT. CL. 42. REG. 7-23-2002.
 2,599,740. AUTOMOTIVE CONSUMER SERVICES GROUP. INT. CL. 35. REG. 7-23-2002.
 2,599,741. VIADV. INT. CL. 9. REG. 7-23-2002.
 2,599,742. SKINGLOSS. INT. CL. 3. REG. 7-23-2002.
 2,599,744. HR ETC.. INT. CL. 35. REG. 7-23-2002.
 2,599,747. AQUAPLANT SHREDDER. INT. CL. 12. REG. 7-23-2002.
 2,599,748. TVPEOPLE (STYLIZED). INT. CL. 16. REG. 7-23-2002.
 2,599,749. EARLY PLANT. INT. CLS. 1 AND 31. REG. 7-23-2002.
 2,599,750. YOUR CHILD NUTRITION ESOURCE. INT. CL. 42. REG. 7-23-2002.
 2,599,751. ONLINEBLINDSANDDRAPERY.COM. INT. CL. 35. REG. 7-23-2002.
 2,599,752. SPICY BACON'N JACK. INT. CL. 30. REG. 7-23-2002.
 2,599,753. SMART WINCH. INT. CL. 7. REG. 7-23-2002.
 2,599,755. NEWNETCO. INT. CL. 35. REG. 7-23-2002.
 2,599,757. M-STRATEGIST. INT. CL. 42. REG. 7-23-2002.
 2,599,758. M-ANALYST. INT. CL. 42. REG. 7-23-2002.
 2,599,762. TRANSFERDIRECT. INT. CL. 36. REG. 7-23-2002.
 2,599,764. MASTERS WATER POLO. INT. CL. 28. REG. 7-23-2002.
 2,599,765. CORPORATE ENTREPRENEURSHIP. INT. CL. 35. REG. 7-23-2002.
 2,599,766. THE NATIONAL MELANOMA FOUNDATION. INT. CLS. 36 AND 42. REG. 7-23-2002.
 2,599,768. DIGITAL EDUCATION. INT. CL. 42. REG. 7-23-2002.
 2,599,770. DIRECT EMAIL EXPRESS. INT. CL. 38. REG. 7-23-2002.
 2,599,771. FRESH CUTS AND DESIGN. INT. CL. 29. REG. 7-23-2002.
 2,599,778. SMOKY MOUNTAIN CHILDREN'S HOME. INT. CL. 42. REG. 7-23-2002.
 2,599,779. HISPANIC DIRECT. INT. CL. 35. REG. 7-23-2002.
 2,599,780. SKIN SCIENCE. INT. CL. 3. REG. 7-23-2002.
 2,599,782. SLIMPOINT. INT. CL. 16. REG. 7-23-2002.
 2,599,783. THE 1ST U.V. POWDER ON WOOD SYSTEM IN NORTH AMERICA. INT. CL. 40. REG. 7-23-2002.
 2,599,784. AUTODBA. INT. CL. 9. REG. 7-23-2002.
 2,599,785. MISCELLANEOUS DESIGN. INT. CL. 8. REG. 7-23-2002.

- 2,599,786. MISCELLANEOUS DESIGN. INT. CL. 8. REG. 7-23-2002.
- 2,599,787. MISCELLANEOUS DESIGN. INT. CL. 8. REG. 7-23-2002.
- 2,599,788. MISCELLANEOUS DESIGN. INT. CL. 8. REG. 7-23-2002.
- 2,599,789. MISCELLANEOUS DESIGN. INT. CL. 8. REG. 7-23-2002.
- 2,599,790. PRIMARY CARE UPDATES. INT. CLS. 16 AND 41. REG. 7-23-2002.
- 2,599,792. HOWSMYDRIVING.COM (STYLIZED). INT. CL. 42. REG. 7-23-2002.
- 2,599,795. STEEL HOMES. INT. CL. 37. REG. 7-23-2002.
- 2,599,798. VEHICLE MILES. INT. CL. 39. REG. 7-23-2002.
- 2,599,799. WOOD CARVING ILLUSTRATED AND DESIGN. INT. CL. 16. REG. 7-23-2002.
- 2,599,802. LOCAL NEWS GATEWAY. INT. CLS. 38 AND 42. REG. 7-23-2002.
- 2,599,803. SMART BANKING. INT. CL. 16. REG. 7-23-2002.
- 2,599,805. RESTAURANT OPERATIONS INSTITUTE. INT. CL. 35. REG. 7-23-2002.
- 2,599,806. SMARTMARKS. INT. CL. 9. REG. 7-23-2002.
- 2,599,809. FUZZY PENCIL POUCH. INT. CL. 16. REG. 7-23-2002.
- 2,599,811. HI-RES MUSIC. INT. CL. 9. REG. 7-23-2002.
- 2,599,812. TENNIS SLAMS ALZHEIMER'S. INT. CL. 36. REG. 7-23-2002.
- 2,599,813. KANGA WEAR AND DESIGN. INT. CL. 25. REG. 7-23-2002.
- 2,599,816. DESIGNER SERIES. INT. CL. 9. REG. 7-23-2002.
- 2,599,818. FLEXNECK. INT. CL. 28. REG. 7-23-2002.
- 2,599,819. PART 11 COMPLIANCE REPORT. INT. CL. 16. REG. 7-23-2002.
- 2,599,820. RECALLED DRUGS. INT. CL. 42. REG. 7-23-2002.
- 2,599,821. SHORETRIPS. INT. CL. 39. REG. 7-23-2002.
- 2,599,822. NATIONAL MUD RACING ORGANIZATION. INT. CL. 41. REG. 7-23-2002.
- 2,599,823. MONTANA WATCH COMPANY. INT. CL. 14. REG. 7-23-2002.
- 2,599,826. LOANYELLOWPAGES. INT. CL. 35. REG. 7-23-2002.
- 2,599,829. WEBDESIGNSEARCHENGINE. INT. CL. 35. REG. 7-23-2002.
- 2,599,830. DENTISTSEARCH. INT. CL. 35. REG. 7-23-2002.
- 2,599,834. LETTERHEAD EMAIL. INT. CL. 9. REG. 7-23-2002.
- 2,599,835. GEL BAIT. INT. CL. 28. REG. 7-23-2002.
- 2,599,836. MEDBIZ. INT. CL. 35. REG. 7-23-2002.
- 2,599,838. WORLDWIDE MEETINGS & COMMUNICATIONS. INT. CLS. 35 AND 41. REG. 7-23-2002.
- 2,599,839. PANCREATIC CANCER ACTION NETWORK. INT. CLS. 36, 41 AND 42. REG. 7-23-2002.
- 2,599,840. E-SPECS. INT. CL. 42. REG. 7-23-2002.
- 2,599,841. THE EQUIPMENT SUPERSTORE (STYLIZED). INT. CLS. 35 AND 37. REG. 7-23-2002.
- 2,599,842. WAREHOUSE PLAN. INT. CL. 9. REG. 7-23-2002.
- 2,599,845. AS CASH. INT. CL. 9. REG. 7-23-2002.
- 2,599,846. IPBUSINESS PLAN. INT. CLS. 35, 36 AND 42. REG. 7-23-2002.
- 2,599,848. LOANSOLUTIONS. INT. CL. 36. REG. 7-23-2002.
- 2,599,850. THE CASHFLOW RECOVERY SYSTEM. INT. CL. 9. REG. 7-23-2002.
- 2,599,851. CASHFLOW MILLIONAIRE. INT. CL. 36. REG. 7-23-2002.
- 2,599,852. PROCESSOR PREFERRED. INT. CL. 31. REG. 7-23-2002.
- 2,599,853. HOLDFAST. INT. CL. 9. REG. 7-23-2002.
- 2,599,854. FULL COURT BASKETBALL. INT. CL. 25. REG. 7-23-2002.
- 2,599,856. MISCELLANEOUS DESIGN. INT. CL. 25. REG. 7-23-2002.
- 2,599,859. BY MARKETERS. FOR MARKETERS.. INT. CL. 42. REG. 7-23-2002.
- 2,599,860. BY MARKETERS. FOR MARKETERS.. INT. CL. 35. REG. 7-23-2002.
- 2,599,861. GROUNDSERVICES. INT. CL. 42. REG. 7-23-2002.
- 2,600,107. FIELDOPT. INT. CL. 9. REG. 7-30-2002.
- 2,600,843. DREAMTOWER. INT. CL. 36 ONLY. REG. 7-30-2002.
- 2,619,503. GOLDRUSH. INT. CL. 28. REG. 9-17-2002.
- 2,622,788. D&K SPORT AND DESIGN. INT. CL. 25. REG. 9-24-2002.
- 2,622,949. EUREKA. INT. CL. 32. REG. 9-24-2002.
- 2,626,681. UNLEASH THE POWER OF INSIGHT AND DESIGN. INT. CL. 35. REG. 9-24-2002.
- 2,626,740. BRUTE. INT. CL. 9. REG. 9-24-2002.
- 2,627,935. AXCESS. INT. CL. 9. REG. 10-1-2002.
- 2,633,747. MBRACE. INT. CLS. 37 AND 42 ONLY. REG. 10-15-2002.
- 2,634,012. PASCAL BIOMED. INT. CLS. 16 AND 41 ONLY. REG. 10-15-2002.
- 2,637,837. ARCHITAINMENT. INT. CLS. 9 AND 11 ONLY. REG. 10-22-2002.
- 2,637,861. G.H. BASS & CO.. INT. CLS. 16 AND 20 ONLY. REG. 10-22-2002.
- 2,637,884. ELLE & VIRE AND DESIGN. INT. CL. 30 ONLY. REG. 10-22-2002.
- 2,638,186. VORDEL. INT. CL. 38 ONLY. REG. 10-22-2002.
- 2,638,300. GSK AND DESIGN. INT. CLS. 1, 3, 10, 21, 29, 30, 32 AND 35 ONLY. REG. 10-22-2002.
- 2,638,343. MISCELLANEOUS DESIGN. INT. CLS. 9, 16 AND 42 ONLY. REG. 10-22-2002.
- 2,638,477. WILD CARROT. INT. CL. 19 ONLY. REG. 10-22-2002.
- 2,639,687. WHEATSTONEENERGY AND DESIGN. INT. CL. 35 ONLY. REG. 10-22-2002.
- 2,645,314. R AND DESIGN. INT. CL. 28 ONLY. REG. 11-5-2002.
- 2,679,839. IAAF. INT. CLS. 6, 9, 12, 14, 18, 25, 28, 32 AND 36 ONLY. REG. 1-28-2003.
- 2,703,616. D P DIGITAL PLAYGROUND AND DESIGN. INT. CL. 41 ONLY. REG. 4-8-2003.
- 2,703,703. MONDO HEDGE AND DESIGN. INT. CLS. 9, 37, 38, 41 AND 42 ONLY. REG. 4-8-2003.
- 2,705,664. MISCELLANEOUS DESIGN. INT. CL. 9 ONLY. REG. 4-15-2003.
- 2,705,760. MORE & MORE A LIFE PHILOSOPHY AND DESIGN. INT. CLS. 3, 14, 16 AND 18 ONLY. REG. 4-15-2003.
- 2,705,827. CAYENNE. INT. CLS. 9, 16, 18, 21, 24, 33 AND 42 ONLY. REG. 4-15-2003.
- 2,705,973. CAPITAL Z. INT. CL. 35 ONLY. REG. 4-15-2003.
- 2,706,001. PERFORMANCE RATED. INT. CL. 17 ONLY. REG. 4-15-2003.
- 2,706,156. TEXAS CHILDREN'S INTERNATIONAL. INT. CLS. 36 AND 39 ONLY. REG. 4-15-2003.
- 2,706,235. DAVID AUSTIN. INT. CLS. 3 AND 26 ONLY. REG. 4-15-2003.
- 2,708,292. ELYST AND DESIGN. INT. CL. 9 ONLY. REG. 4-22-2003.
- 2,708,333. PROLYSIN C. INT. CLS. 16 AND 32 ONLY. REG. 4-22-2003.
- 2,708,353. GSK. INT. CLS. 1, 21, 29, 30 AND 32 ONLY. REG. 4-22-2003.
- 2,708,364. OPERA FANATIC. INT. CLS. 16 AND 41 ONLY. REG. 4-22-2003.
- 2,708,802. MISCELLANEOUS DESIGN. INT. CL. 35 ONLY. REG. 4-22-2003.
- 2,708,867. ACTIVA LEISURE. INT. CL. 20 ONLY. REG. 4-22-2003.
- 2,708,892. CHEMICAL ABSTRACTS SERVICE. INT. CL. 38 ONLY. REG. 4-22-2003.
- 2,709,699. THAT SUCKS. INT. CL. 38 ONLY. REG. 4-22-2003.
- 2,709,957. CHUMP. INT. CLS. 18 AND 24 ONLY. REG. 4-22-2003.
- 2,710,217. THE INSTITUTE FOR FINANCIAL MARKETS. INT. CL. 9 ONLY. REG. 4-22-2003.
- 2,711,789. LUCCHESI CLASSICS. INT. CL. 18 ONLY. REG. 4-29-2003.
- 2,713,964. KIDSPOST.COM. INT. CL. 38 ONLY. REG. 5-6-2003.
- 2,726,201. ARTERIFORTE. INT. CLS. 16 AND 41 ONLY. REG. 6-17-2003.
- 2,735,728. CENTURY VILLAGE. INT. CL. 37 ONLY. REG. 7-15-2003.

- | | |
|--|--|
| 2,757,917. U-PACK. INT. CL. 17 ONLY. REG. 9-2-2003. | 2,834,406. FRED MEYER. INT. CL. 5 ONLY. REG. 4-20-2004. |
| 2,780,574. MISCELLANEOUS DESIGN. INT. CL. 20 ONLY.
REG. 11-4-2003. | |
| 2,812,991. VALUGARD AND DESIGN. INT. CL. 5 ONLY.
REG. 2-10-2004. | |
| 2,822,164. NIPS AND DESIGN. INT. CLS. 20 AND 21 ONLY.
REG. 3-16-2004. | |
| 2,828,251. BEACHBODY.COM AND DESIGN. INT. CL. 5
ONLY. REG. 3-30-2004. | |
| 2,830,811. TEAM GK. INT. CL. 28 ONLY. REG. 4-6-2004. | 287,322. "OLYMPIC CHAMPION". U.S. CL. 39. REG. 9-22-
1931. |
| 2,833,992. IRON-A-WAY. INT. CL. 21 ONLY. REG. 4-20-2004. | 2,988,718. VISIONSTANDARD CHARACTER MARK INT.
CL. 16. REG. 8-30-2005. |

SECTION 18

* * * * *

TRADEMARK REGISTRATIONS AMENDED, CORRECTED, ETC.

The designation "U.S. Cl." appearing in this section refers to the U.S. class in effect prior to Sep. 1, 1973 rather than the international class which applies to applications filed on or after that date. For adoption of international classification see notice in the OFFICIAL GAZETTE of Jun. 26, 1973 (911 O.G. TM 210).

Any change to the registration will be indicated at the bottom of each entry under ELEMENTS AMENDED, CORRECTED OR RESTRICTED. With the exception of changes to the goods and services, additions to the registration will appear in asterisks and deletions of the registration will appear in brackets. Elements which are only changed will be listed with no punctuation. As to the goods/services statement, amendments to the goods/services will appear in asterisks and deletions will appear in brackets. In addition if any change to the goods/services occurs, the element "Goods/Services" will be listed under ELEMENTS AMENDED, CORRECTED OR RESTRICTED.

419,062. REG. 2-5-1946. SWISS-AMERICAN IMPORTING COMPANY (MISSOURI CORPORATION) 4245 PAPIN ST., ST. LOUIS, MO, 63110, SN 71-472,592. FILED 7-24-1944. PRINCIPAL REGISTER.

1,316,092. REG. 1-22-1985. INTERNATIONAL FINANCE CORPORATION (UNITED STATES UNITED NATIONS AGENCY) 2121 PENNSYLVANIA AVENUE, N.W., WASHINGTON, DC, 20433, SN 73-421,714. FILED 4-15-1983. PRINCIPAL REGISTER.

DUTCH GARDEN

THE WORD "DUTCH" IS DISCLAIMED APART FROM THE MARK AS SHOWN.

INT. CLS. 1, 5, 29, 30, 31 AND 32/U.S. CL. 46

FOR GROCERIES—NAMELY, [MUSHROOM SAUCE,] TURKEY LIVER PATE, CHICKEN LIVER PATE, SMALL SOUR ONIONS, SWEET PICKLE CHIPS, SWEET PEPPER RELISH, DILL PICKELS, SPAGHETTI IN ITALIAN STYLE SAUCE, EGG NOODLE DINER, [MOSTACCIOLI (A PREPARED ANTIPASTO FOOD) IN ITALIAN STYLE SAUCE,] PREPARED MUSTARD, CHEESES, AND CHEESE SPREADS.

FIRST USE 1-0-1942; IN COMMERCE 1-0-1942.

ELEMENTS AMENDED
ASSIGNMENT/NAME CHANGE
OWNER NAME

970,866. REG. 10-16-1973. NEW WORLD PASTA COMPANY (DELAWARE CORPORATION) 85 SHANNON ROAD, HARRISBURG, PA, 17112, SN 72-411,047. FILED 12-23-1971. PRINCIPAL REGISTER.

WEDNESDAY IS PRINCE SPAGHETTI DAY

OWNER OF U.S. REG. NOS. 137,680, 784,101 AND OTHERS.

INT. CL. 30/U.S. CL. 46

FOR PASTA PRODUCTS—NAMELY, SPAGHETTI, SPAGHETTI [SAUCE (INCLUDING MARINARA, MUSHROOM, MEAT CACCIATORE AND MEATLESS), AND PIZZA SAUCE].

FIRST USE 12-30-1959; IN COMMERCE 12-30-1959.

ELEMENTS AMENDED
GOODS/SERVICES
U.S. CLASS(ES)
DATE OF FIRST USE
DATE OF FIRST USE IN COMMERCE



NO CLAIM IS MADE TO THE EXCLUSIVE RIGHT TO USE "FINANCE CORPORATION", APART FROM THE MARK AS SHOWN.

THE STIPPLING AND/OR SHADING IN THE DRAWING IS FOR CONTRAST ONLY, AND DOES NOT DENOTE ANY PARTICULAR COLOR.

SEC. 2(F).

INT. CL. 36/U.S. CLS. 100, 101 AND 102

FOR PROVIDING DEVELOPMENT FINANCING TO THE PRIVATE SECTOR IN VARIOUS COUNTRIES *, ALL OF WHICH ARE COMMEMORATIVE OF INTERNATIONAL FINANCE CORPORATION *.

FIRST USE 7-24-1956; IN COMMERCE 7-25-1956.

ELEMENTS AMENDED
CITIZENSHIP
GOODS/SERVICES

1,316,096. REG. 1-22-1985. INTERNATIONAL FINANCE CORPORATION (UNITED STATES UNITED NATIONS AGENCY) 2121 PENNSYLVANIA AVENUE, NW, WASHINGTON, DC, 20433, SN 73-422,334. FILED 4-19-1983. PRINCIPAL REGISTER.

IFC

INT. CL. 36/U.S. CLS. 100, 101 AND 102

FOR PROVIDING DEVELOPMENT FINANCING TO THE PRIVATE SECTOR IN VARIOUS COUNTRIES *ALL OF WHICH ARE COMMEMORATIVE OF INTERNATIONAL FINANCE CORPORATION *.

FIRST USE 7-24-1956; IN COMMERCE 7-25-1956.

ELEMENTS AMENDED
CITIZENSHIP
GOODS/SERVICES

1,557,654. REG. 9-26-1989. PANAMAX, INC. (CALIFORNIA CORPORATION) 150 MITCHELL BLVD., SAN RAFAEL, CA, 94903, SN 73-655,686. FILED 4-17-1987. PRINCIPAL REGISTER.

POWERMAX

INT. CL. 9/U.S. CLS. 21, 23, 26, 36 AND 38
FOR SURGE SUPPRESSORS, AND FILTERS USED AS A UNIT FOR SURGE SUPPRESSION AND FILTERING AND FOR TEMPORARY POWER BACKUP FOR ELECTRONIC DEVICES DURING INTERRUPTION OF PRIMARY AC POWER.

FIRST USE 6-3-1983; IN COMMERCE 6-3-1983.

ELEMENTS CORRECTED
OWNER NAME

1,628,478. REG. 12-18-1990. SWISS-AMERICAN IMPORTING COMPANY (MISSOURI CORPORATION) 4245 PAPIN STREET, ST. LOUIS, MO, 63110, SN 73-824,541. FILED 9-11-1989. PRINCIPAL REGISTER.

SUPER SWISS

NO CLAIM IS MADE TO THE EXCLUSIVE RIGHT TO USE "SWISS", APART FROM THE MARK AS SHOWN.

INT. CL. 29/U.S. CL. 46

FOR CHEESE.

FIRST USE 10-14-1985; IN COMMERCE 10-14-1985.

ELEMENTS CORRECTED
OWNER NAME

1,797,983. REG. 10-12-1993. SWISS-AMERICAN IMPORTING COMPANY (MISSOURI CORPORATION) 4245 PAPIN STREET, ST. LOUIS, MO, 63110, SN 74-296,027. FILED 7-20-1992. PRINCIPAL REGISTER.

NORTH LIGHT

INT. CL. 29/U.S. CL. 46

FOR CHEESE AND OTHER DAIRY PRODUCTS, EXCLUDING ICE CREAM, ICE MILK AND FROZEN YOGURT.

FIRST USE 6-1-1952; IN COMMERCE 6-1-1952.

ELEMENTS AMENDED
OWNER NAME

1,804,640. REG. 11-16-1993. SWISS-AMERICAN IMPORTING COMPANY (MISSOURI CORPORATION) 4245 PAPIN STREET, ST. LOUIS, MO, 63110, SN 74-308,184. FILED 8-24-1992. PRINCIPAL REGISTER.

CAPRICORN

INT. CL. 29/U.S. CL. 46

FOR CHEESE; DAIRY PRODUCTS, EXCLUDING ICE CREAM, ICE MILK AND FROZEN YOGURT.
FIRST USE 11-1-1981; IN COMMERCE 11-1-1981.

ELEMENTS CORRECTED
OWNER NAME

1,973,058. REG. 5-7-1996. HOME PHYSICIANS MANAGEMENT, LLC (DELAWARE LIMITED LIABILITY COMPANY) 1735 NORTH ASHLAND, CHICAGO, IL, 60061, SN 74-692,342. FILED 6-22-1995. PRINCIPAL REGISTER.



NO CLAIM IS MADE TO THE EXCLUSIVE RIGHT TO USE "HOME PHYSICIANS", APART FROM THE MARK AS SHOWN.

THE COLOR(S) PURPLE AND WHITE IS/ARE CLAIMED AS A FEATURE OF THE MARK. THE MARK CONSISTS OF THE PICTURE OF A HOUSE IN PURPLE WITH A STETHOSCOPE BOTH INSIDE AND OUTSIDE THE HOUSE, WITH THE EARPIECE AND TUBING IN PURPLE, AND THE CHESTPIECE IN A COMBINATION OF PURPLE AND WHITE, WITH THE WORDS HOME PHYSICIANS IN CAPITAL LETTERS IN PURPLE, WITH THE WORD HOME DIRECTLY ABOVE THE WORD PHYSICIANS.

INT. CL. 42/U.S. CLS. 100 AND 101

FOR HOME-BASED PHYSICIAN, [PHARMACY,] MEDICAL TESTING, AND [X-RAY TECHNICIAN] SERVICES.
FIRST USE 5-20-1995; IN COMMERCE 5-20-1995.

ELEMENTS AMENDED
DESCRIPTION OF MARK
MARK

2,026,782. REG. 12-31-1996. NEW WORLD PASTA COMPANY (DELAWARE CORPORATION) 85 SHANNON ROAD, HARRISBURG, PA, 17112, SN 75-015,747. FILED 11-7-1995. PRINCIPAL REGISTER.

EVERY DAY'S A PRINCE PASTA DAY!

INT. CL. 30/U.S. CL. 46

FOR PASTA, NAMELY, SPAGHETTI, MACARONI, [ZITI,] VERMICELLI, LINGUINE, [RIGATONI,] SHELLS, [DITALINI, MEZZANI, MACCARONCELLI, ALPHABETS,] ACINI DE PEPE, TUBETINI, ORZO, MOSTACCIOLI, [ROTINI, RADIATORE, CAVATELLI, FUSILLI, MANICOTTI, SHELLS AND CHEDDAR, TWISTS AND CHEDDAR, MACARONI AND CHEESE,] FETTUCCHINE, [EGG NOODLES, RIBBONS,] ANGEL HAIR.

FIRST USE 5-1-1995; IN COMMERCE 5-1-1995.

ELEMENTS AMENDED
GOODS/SERVICES

2,116,577. REG. 11-25-1997. COREL CORPORATION (CANADA CORPORATION) 1600 CARLING AVENUE, OTTAWA, ONTARIO, CANADA, K1Z8R7, SN 74-630,059. FILED 2-6-1995. PRINCIPAL REGISTER.

MEDIASTUDIO PRO

INT. CL. 9/U.S. CLS. 21, 23, 26, 36 AND 38
FOR COMPUTER SOFTWARE PROGRAMS FOR USE IN THE CREATING, EDITING AND CATALOGING, SEARCHING AND CONVERSION OF FILES FOR IMAGING, GRAPHICS AND MULTIMEDIA.
FIRST USE 5-1-1995; IN COMMERCE 5-1-1995.

ELEMENTS CORRECTED
[OWNER NAME]

2,142,860. REG. 3-10-1998. SWISS-AMERICAN IMPORTING COMPANY (MISSOURI CORPORATION) 4245 PAPIN STREET, ST. LOUIS, MO, 63110, SN 75-290,337. FILED 5-12-1997. PRINCIPAL REGISTER.

FIRE JACK

INT. CL. 29/U.S. CL. 46
FOR CHEESE CONTAINING HOT PEPPERS.
FIRST USE 4-1-1997; IN COMMERCE 4-1-1997.

ELEMENTS CORRECTED
OWNER NAME

2,164,295. REG. 6-9-1998. SWISS-AMERICAN IMPORTING COMPANY (MISSOURI CORPORATION) 4245 PAPIN STREET, ST. LOUIS, MO, 63110, SN 74-701,645. FILED 7-17-1995. PRINCIPAL REGISTER.

AMERICAN FARMHOUSE

INT. CL. 29/U.S. CL. 46
FOR CHEESE.
FIRST USE 1-28-1998; IN COMMERCE 1-28-1998.

ELEMENTS CORRECTED
OWNER NAME

2,200,998. REG. 11-3-1998. INDEPENDENT TRAVELER, INC., THE (NEW JERSEY CORPORATION) 2 TREE FARM ROAD, SUITE B-300, PENNINGTON, NJ, 08534, SN 75-243,385. FILED 2-18-1997. PRINCIPAL REGISTER.

Independent Traveler.com

NO CLAIM IS MADE TO THE EXCLUSIVE RIGHT TO USE "TRAVELER.COM", APART FROM THE MARK AS SHOWN.
INT. CL. 42/U.S. CLS. 100 AND 101

FOR COMPUTER SERVICES, NAMELY, PROVIDING AN INTERACTIVE COMPUTER DATABASE IN THE FIELD OF TRAVEL, IN THE NATURE OF TIPS, NEWS, BARGAINS, MESSAGE BOARDS, TRAVEL WRITING [; CHATS ON AMERICA ONLINE WITH THE WORLD WIDE WEB].

FIRST USE 12-15-1990; IN COMMERCE 12-15-1990.

ELEMENTS AMENDED
MARK
DISCLAIMER

2,205,042. REG. 11-24-1998. INTERCOMMUNICATIONS, INC. (CALIFORNIA CORPORATION) 620 NEWPORT CENTER DRIVE, SUITE 600, NEWPORT BEACH, CA, 92660, SN 75-275,732. FILED 4-15-1997. PRINCIPAL REGISTER.

INTERCOM INTERACTIVE

THE MARK CONSISTS OF STANDARD CHARACTERS WITHOUT CLAIM TO ANY PARTICULAR FONT, STYLE, SIZE, OR COLOR.

OWNER OF U.S. REG. NOS. 1,456,787 AND 1,602,704.
INT. CL. 35/U.S. CLS. 100, 101 AND 102
FOR ADVERTISING AGENCY SERVICES AND PUBLIC RELATIONS SERVICES.
FIRST USE 11-0-1996; IN COMMERCE 11-0-1996.

ELEMENTS AMENDED
MARK

2,234,409. REG. 3-23-1999. GOLDEN TEMPLE, INC. (OREGON CORPORATION) 2545 PRAIRIE RD., EUGENE, OR, 97402, SN 75-514,918. FILED 7-7-1998. PRINCIPAL REGISTER.

BREATHE DEEP

INT. CL. 30/U.S. CL. 46
FOR HERBAL TEA.
FIRST USE 9-0-1988; IN COMMERCE 9-0-1988.

ELEMENTS AMENDED
MARK
[DISCLAIMER]

2,239,055. REG. 4-13-1999. PPG INDUSTRIES OHIO, INC. (DELAWARE CORPORATION) 3800 WEST 143RD, CLEVELAND, OH, 44111, SN 74-523,744. FILED 5-11-1994. PRINCIPAL REGISTER.

DIAMOND COAT

OWNER OF U.S. REG. NOS. 1,560,349 AND 1,782,319.
NO CLAIM IS MADE TO THE EXCLUSIVE RIGHT TO USE "COAT", APART FROM THE MARK AS SHOWN.

INT. CL. 2/U.S. CLS. 6, 11 AND 16
FOR AUTOMOTIVE REFINISH COATING COMPOSITIONS.
FIRST USE 2-7-1995; IN COMMERCE 2-7-1995.

ELEMENTS CORRECTED
OWNER NAME
OWNER ADDRESS

2,245,657. REG. 5-18-1999. NIELSEN BUSINESS MEDIA, INC. (DELAWARE CORPORATION) 770 BROADWAY, NEW YORK, NY, 10003, SN 75-395,937. FILED 11-25-1997. PRINCIPAL REGISTER.

2,344,372. REG. 4-25-2000. INTERNATIONAL FINANCE CORPORATION (UNITED STATES INTERNATIONAL INSTITUTION) 2121 PENNSYLVANIA AVENUE, N.W., WASHINGTON, DC, 20433, SN 75-381,978. FILED 10-30-1997. PRINCIPAL REGISTER.

**THE HOLLYWOOD RE
PORTER**

INT. CL. 41/U.S. CLS. 100, 101 AND 107
FOR PROVIDING INFORMATION IN THE FIELD OF FILM, TELEVISION, MUSIC AND ENTERTAINMENT VIA A GLOBAL COMPUTER NETWORK.
FIRST USE 7-24-1995; IN COMMERCE 7-24-1995.

ELEMENTS AMENDED
MARK



2,302,273. REG. 12-21-1999. WHITEWAVE SERVICES, INC. (DELAWARE CORPORATION) 2515 MCKINNEY AVENUE, SUITE 1200, DALLAS, TX, 75201, SN 75-641,604. FILED 2-12-1999. PRINCIPAL REGISTER.

SILK

OWNER OF U.S. REG. NO. 2,084,789.
INT. CL. 29/U.S. CL. 46
FOR NON-DAIRY REFRIGERATED SOY PROTEIN FOODS, NAMELY, SOY-BASED BEVERAGES, [TOFU,] *AND * SOY-BASED YOGURT [, SOY-BASED AND WHEAT-GLUTEN-BASED MEAT SUBSTITUTES].
FIRST USE 1-15-1996; IN COMMERCE 1-15-1996.

ELEMENTS AMENDED
GOODS/SERVICES



2,302,310. REG. 12-21-1999. EBSCO INDUSTRIES, INC. (DELAWARE CORPORATION) 5724 HIGHWAY 280 EAST, BIRMINGHAM, AL, 35242, SN 74-429,098. FILED 8-27-1993. PRINCIPAL REGISTER.

BOO-YA

THE MARK CONSISTS OF STANDARD CHARACTERS WITHOUT CLAIM TO ANY PARTICULAR FONT, STYLE, SIZE, OR COLOR.

INT. CL. 25/U.S. CLS. 22 AND 39
FOR CLOTHING, NAMELY, SHIRTS, [PANTS,] HATS, [SHORTS,] AND T-SHIRTS.
FIRST USE 1-24-1999; IN COMMERCE 1-24-1999.

ELEMENTS AMENDED
MARK



OWNER OF U.S. REG. NOS. 1,316,092, 1,981,563 AND OTHERS.

NO CLAIM IS MADE TO THE EXCLUSIVE RIGHT TO USE "CORPORATION", APART FROM THE MARK AS SHOWN.

THE LINING SHOWN IN THE DRAWING IS A FEATURE OF THE MARK AND IS NOT INTENDED TO INDICATE COLOR.

AS TO "INTERNATIONAL FINANCE CORPORATION".
INT. CL. 16/U.S. CLS. 2, 5, 22, 23, 29, 37, 38 AND 50

FOR PRINTED MATTER AND PUBLICATIONS PERTAINING TO FINANCIAL, BANKING, ENVIRONMENTAL, ECONOMIC AND INVESTMENT SERVICES, NAMELY, FINANCIAL REPORTS, INDEXES, LEAFLETS, BROCHURES, PAMPHLETS, CATALOGUES, INSTRUCTION SHEETS, MANUALS, BOOKLETS, MAGAZINES, NEWSLETTERS, JOURNALS AND INSTRUCTIONAL TEACHING MATERIALS *, ALL OF WHICH ARE COMMEMORATIVE OF INTERNATIONAL FINANCE CORPORATION.*

FIRST USE 7-24-1956; IN COMMERCE 7-25-1956.
INT. CL. 36/U.S. CLS. 100, 101 AND 102

FOR FINANCING SERVICES PROVIDED TO THE PRIVATE SECTOR IN VARIOUS COUNTRIES; FINANCIAL SERVICES IN THE NATURE OF A STOCK INDEX, NAMELY, DETERMINATION OF A STOCK IN DEX FEATURING CALCULATION OF THE STOCK INDEX; PROVIDING FINANCIAL, BANKING, ECONOMIC AND INVESTMENT INFORMATION BY MEANS OF A GLOBAL COMPUTER NETWORK *. ALL OF WHICH ARE COMMEMORATIVE OF INTERNATIONAL FINANCE CORPORATION.*

FIRST USE 7-24-1956; IN COMMERCE 7-25-1956.
INT. CL. 42/U.S. CLS. 100 AND 101

FOR PROVIDING ENVIRONMENTAL INFORMATION BY MEANS OF A GLOBAL COMPUTER NETWORK *, ALL OF WHICH ARE COMMEMORATIVE OF INTERNATIONAL FINANCE CORPORATION.*
FIRST USE 7-24-1956; IN COMMERCE 7-25-1956.

ELEMENTS AMENDED
GOODS/SERVICES



2,347,999. REG. 5-9-2000. INTERNATIONAL FINANCE CORPORATION (UNITED STATES INTERNATIONAL INSTITUTION) 2121 PENNSYLVANIA AVENUE, N.W., WASHINGTON, DC, 20433, SN 75-381,980. FILED 10-30-1997. PRINCIPAL REGISTER.

IFC

OWNER OF U.S. REG. NOS. 1,316,092, 1,981,563 AND OTHERS.

SEC. 2(F).
INT. CL. 16/U.S. CLS. 2, 5, 22, 23, 29, 37, 38 AND 50

FOR PRINTED MATTER AND PUBLICATIONS PERTAINING TO FINANCIAL, BANKING, ENVIRONMENTAL, ECONOMIC AND INVESTMENT SERVICES, NAMELY, FINANCIAL REPORTS, INDEXES, LEAFLETS, BROCHURES, PAMPHLETS, CATALOGUES, INSTRUCTION SHEETS, MANUALS, BOOKLETS, MAGAZINES, NEWSLETTERS, JOURNALS AND INSTRUCTIONAL TEACHING MATERIALS *, ALL OF WHICH ARE COMMEMORATIVE OF INTERNATIONAL FINANCE CORPORATION *

FIRST USE 7-24-1956; IN COMMERCE 7-25-1956.
INT. CL. 36/U.S. CLS. 100, 101 AND 102

FOR FINANCING SERVICES PROVIDED TO THE PRIVATE SECTOR IN VARIOUS COUNTRIES; FINANCIAL SERVICES IN THE NATURE OF A STOCK INDEX, NAMELY, DETERMINATION OF A STOCK INDEX FEATURING CALCULATION OF THE STOCK INDEX; PROVIDING FINANCIAL, BANKING, ECONOMIC AND INVESTMENT INFORMATION BY MEANS OF A GLOBAL COMPUTER NETWORK *, ALL OF WHICH ARE COMMEMORATIVE OF INTERNATIONAL FINANCE CORPORATION*

FIRST USE 7-24-1956; IN COMMERCE 7-25-1956.
INT. CL. 42/U.S. CLS. 100 AND 101

FOR PROVIDING ENVIRONMENTAL INFORMATION BY MEANS OF A GLOBAL COMPUTER NETWORK *, ALL OF WHICH ARE COMMEMORATIVE OF INTERNATIONAL FINANCE CORPORATION *

FIRST USE 7-27-1956; IN COMMERCE 7-25-1956.

ELEMENTS AMENDED
GOODS/SERVICES

FOR FINANCING SERVICES PROVIDED TO THE PRIVATE SECTOR IN VARIOUS COUNTRIES; FINANCIAL SERVICES IN THE NATURE OF A STOCK INDEX, NAMELY, DETERMINATION OF A STOCK INDEX FEATURING CALCULATION OF THE STOCK INDEX; PROVIDING FINANCIAL, BANKING, ECONOMIC AND INVESTMENT INFORMATION BY MEANS OF A GLOBAL COMPUTER NETWORK *, ALL OF WHICH ARE COMMEMORATIVE OF INTERNATIONAL FINANCE CORPORATION*

FIRST USE 1-1-1993; IN COMMERCE 1-1-1993.
INT. CL. 42/U.S. CLS. 100 AND 101

FOR PROVIDING ENVIRONMENTAL INFORMATION BY MEANS OF A GLOBAL COMPUTER NETWORK *, ALL OF WHICH ARE COMMEMORATIVE OF INTERNATIONAL FINANCE CORPORATION*

FIRST USE 1-1-1993; IN COMMERCE 1-1-1993.

ELEMENTS AMENDED
GOODS/SERVICES

2,402,055. REG. 11-7-2000. GOFIT L.L.C. (OKLAHOMA LIMITED LIABILITY COMPANY) 12929 E. APACHE ST., TULSA, OK, 74116, SN 75-858,484. FILED 11-26-1999. PRINCIPAL REGISTER.



INT. CL. 28/U.S. CLS. 22, 23, 38 AND 50

FOR EXERCISE EQUIPMENT, NAMELY, MANUALLY OPERATED EXERCISE EQUIPMENT, WEIGHT LIFTING BENCHES, STATIONERY EXERCISE BICYCLES; AND EXERCISE ACCESSORIES, NAMELY, EXERCISE WEIGHTS, ANKLE WEIGHTS, JUMP ROPES, KNEE WRAPS AND OTHER JOINT WRAPS FOR RESISTANCE, PADS FOR USE ON ANY BODY JOINT FOR WEIGHT LIFTING, AND EXERCISE WHEELS.

FIRST USE 11-17-1999; IN COMMERCE 11-17-1999.

ELEMENTS AMENDED
OWNER ADDRESS

2,353,045. REG. 5-30-2000. INTERNATIONAL FINANCE CORPORATION (UNITED STATES INTERNATIONAL INSTITUTION) 2121 PENNSYLVANIA AVENUE, N.W., WASHINGTON, DC, 20433, SN 75-381,975. FILED 10-30-1997. PRINCIPAL REGISTER.



INTERNATIONAL FINANCE CORPORATION

OWNER OF U.S. REG. NOS. 1,316,092, 1,981,563 AND OTHERS.

NO CLAIM IS MADE TO THE EXCLUSIVE RIGHT TO USE "CORPORATION", APART FROM THE MARK AS SHOWN.

THE LINING SHOWN IN THE DRAWING IS A FEATURE OF THE MARK AND IS NOT INTENDED TO INDICATE COLOR.

AS TO "INTERNATIONAL FINANCE".

INT. CL. 16/U.S. CLS. 2, 5, 22, 23, 29, 37, 38 AND 50

FOR PRINTED MATTER AND PUBLICATIONS PERTAINING TO FINANCIAL, BANKING, ENVIRONMENTAL, ECONOMIC AND INVESTMENT SERVICES, NAMELY, FINANCIAL REPORTS, INDEXES, LEAFLETS, BROCHURES, PAMPHLETS, CATALOGUES, INSTRUCTION SHEETS, MANUALS, BOOKLETS, MAGAZINES, NEWSLETTERS, JOURNALS AND INSTRUCTIONAL TEACHING MATERIALS *, ALL OF WHICH ARE COMMEMORATIVE OF INTERNATIONAL FINANCE CORPORATION*

FIRST USE 1-1-1993; IN COMMERCE 1-1-1993.
INT. CL. 36/U.S. CLS. 100, 101 AND 102

2,481,879. REG. 8-28-2001. MORRISON & FOERSTER, LLP (CALIFORNIA LIMITED LIABILITY PARTNERSHIP) 425 MARKET STREET, SAN FRANCISCO, CA, 941052482, SN 75-936,355. FILED 3-6-2000. PRINCIPAL REGISTER.

MOFO

OWNER OF U.S. REG. NO. 2,020,689.

INT. CL. 42/U.S. CLS. 100 AND 101

FOR LEGAL SERVICES.

FIRST USE 10-10-1975; IN COMMERCE 10-10-1975.

ELEMENTS CORRECTED
CITIZENSHIP
ENTITY

2,507,912. REG. 11-13-2001. NEW WORLD PASTA COMPANY (DELAWARE CORPORATION) 85 SHANNON ROAD, HARRISBURG, PA., SN 75-831,982. FILED 10-26-1999. PRINCIPAL REGISTER.

2,604,492. REG. 8-6-2002. WINDROSE TRADING COMPANY (VIRGINIA CORPORATION) 108 SCHOOLHOUSE ROAD SUITE 104, P.O. BOX 990, MADISON, VA, 22727, SN 76-296,264. FILED 8-9-2001. PRINCIPAL REGISTER.



OWNER OF U.S. REG. NOS. 137,680, 1,238,641 AND OTHERS.
 INT. CL. 30/U.S. CL. 46
 FOR PASTA, MACARONI AND CHEESE [AND TOMATO AND NON-TOMATO BASED PASTA SAUCES].
 FIRST USE 1-1-2000; IN COMMERCE 1-1-2000.

"TRILOKA"-SANSKRIT WORD: TRI-THREE, LOKA-REALMS OR LEVELS; THE THREE REALMS ARE BHU-EARTH, BHUWAH-THE ATMOSPHERE, SWAH-SOLAR RANGE.
 INT. CL. 3/U.S. CLS. 1, 4, 6, 50, 51 AND 52
 FOR INCENSE, NAMELY, CONES, STICKS, DHOOP, LOOSE INCENSE AND SMUDGE STICKS BURNED FOR ROOM FRAGRANCE; ESSENTIAL OILS, ATTARS AND BODY OILS FOR PERFUME OR ROOM FRAGRANCE; MASSAGE OILS.
 FIRST USE 5-15-1983; IN COMMERCE 6-15-1983.

ELEMENTS AMENDED
 GOODS/SERVICES

ELEMENTS CORRECTED
 OWNER NAME

2,543,082. REG. 2-26-2002. COMMON SENSE DENTAL PRODUCTS II, INC. (MICHIGAN CORPORATION), DBA COMMON SENSE DENTAL PRODUCTS, 14998 CLEVELAND ST., SUITE A, SPRING LAKE, MI, 49456, SN 78-047,072. FILED 2-7-2001. PRINCIPAL REGISTER.

2,634,853. REG. 10-15-2002. COBRA ELECTRONICS CORPORATION (DELAWARE CORPORATION) 6500 WEST CORTLAND STREET, CHICAGO, IL, 60707, SN 76-318,497. FILED 9-27-2001. PRINCIPAL REGISTER.

LOGI BLOC

NOTHING COMES CLOSE TO A COBRA

INT. CL. 10/U.S. CLS. 26, 39 AND 44
 FOR DENTAL APPLIANCES FOR HOLDING THE MOUTH OPEN DURING DENTAL PROCEDURES.
 FIRST USE 2-1-2001; IN COMMERCE 2-1-2001.

OWNER OF U.S. REG. NOS. 1,366,377, 2,002,307 AND OTHERS.
 INT. CL. 9/U.S. CLS. 21, 23, 26, 36 AND 38
 FOR RADAR AND LASER DETECTORS; [CORDLESS TELEPHONES;] TWO-WAY RADIOS, NAMELY, CB RADIOS, FAMILY RADIO SERVICE RADIOS, GENERAL MOBILE RADIO SERVICE (GMRS) RADIOS, MARINE RADIOS, WEATHER RADIOS; AND ACCESSORIES, NAMELY, ANTENNAS, ANTENNA MOUNTS, MICROPHONES, SPEAKERS, COAXIAL CABLES, BATTERY CHARGERS AND POWER INVERTERS.
 FIRST USE 3-0-2000; IN COMMERCE 3-0-2000.

ELEMENTS CORRECTED
 DBA/AKA
 OWNER NAME
 OWNER ADDRESS
 ENTITY

ELEMENTS AMENDED
 GOODS/SERVICES

2,543,319. REG. 2-26-2002. COMMON SENSE DENTAL PRODUCTS II, INC. (MICHIGAN CORPORATION), DBA COMMON SENSE DENTAL PRODUCTS, 14998 CLEVELAND ST., SUITE A, SPRING LAKE, MI, 49456, SN 75-694,660. FILED 4-29-1999. PRINCIPAL REGISTER.

FLEXI WEDGE

2,676,153. REG. 1-21-2003. NOKIA CORPORATION (FINLAND CORPORATION) KEILALAHDENTIE 4, 02150 ESPOO, FINLAND., SN 76-083,447. FILED 7-6-2000. PRINCIPAL REGISTER.

NO CLAIM IS MADE TO THE EXCLUSIVE RIGHT TO USE WEDGE, APART FROM THE MARK AS SHOWN.
 INT. CL. 10/U.S. CLS. 26, 39 AND 44
 FOR MEDICAL DEVICES, NAMELY WEDGES USED IN DENTISTRY.
 FIRST USE 2-0-2000; IN COMMERCE 2-0-2000.

NOKIA

ELEMENTS CORRECTED
 DBA/AKA
 OWNER NAME
 OWNER ADDRESS

PRIORITY CLAIMED UNDER SEC. 44(D) ON FINLAND APPLICATION NO. T200001860, FILED 5-30-2000, REG. NO. 220980, DATED 6-15-2001.
 OWNER OF U.S. REG. NOS. 1,570,492 AND 1,734,209.
 INT. CL. 9/U.S. CLS. 21, 23, 26, 36 AND 38

FOR [TELEPHONES, CORDLESS, WIRELESS OR SATELLITE] * MOBILE * TELEPHONES, [DEDICATED NETWORK COMPUTER TERMINALS FOR TELECOMMUNICATIONS, FACSIMILES, COMMUNICATORS,] SMART PHONES, NAMELY, PHONES WITH CAPABILITY OF TRANSMITTING DATA VOICE AND IMAGES AND ACCESSING THE INTERNET, SENDING AND RECEIVING [FAXES AND] E-MAIL; [PAYPHONES, PUBLIC TELEPHONES; ANTENNAS,] BATTERIES, BATTERY CHARGERS, POWER SUPPLIES, HOUSINGS OR CASINGS OR COVERS, CLIPS, CARRYING CASES FOR MOBILE TELEPHONES [PDAS AND COMPUTERS AND CARRYING CASES FOR ACCESSORIES THEREFOR, NAMELY, MICROPHONES, SPEAKERS, HEADSETS, BATTERIES, COVERS AND BATTERY CHARGERS] ; HOLDERS, DESKTOP STANDS, [MICROPHONES, SPEAKERS, HEADSETS,] MOBILE [PHONE] * TELEPHONE * ACCESSORIES IN THE NATURE OF HANDS FREE HOLDERS, HEADSETS, MICROPHONES AND SPEAKERS FOR MOBILE PHONES; CAR KITS FOR THE ADAPTATION OF PORTABLE COMMUNICATION APPARATUS AND INSTRUMENTS FOR VEHICULAR USE, COMPRISING [ANTENNAS, ANTENNA TRANSMISSION WIRES, ANTENNA ADAPTERS,] CABLES, EARPHONES, HANDS-FREE MICROPHONES, PHONE HOLDERS, SPEAKERS, CAR CHARGERS, DATA CABLES AND ELECTRICAL WIRES; [TELEPHONE STANDS BEING PARTS OF TELEPHONES, ELECTRIC ADAPTOR CABLES, TELEPHONE CABLES, MICROPHONES, SPEAKERS AND BATTERY CHARGERS;] APPARATUS FOR RECORDING, STORING, TRANSMISSION, RECEIVING OR REPRODUCING OF DATA, SOUND, IMAGES AND/OR VIDEO, NAMELY, BASE STATIONS COMPRISING DIRECTIONAL ANTENNAS, ELECTRONIC BASE STATION CONTROLLERS, DIRECTIONAL ANTENNAS, MICROWAVE RADIOS, TELEPHONE EXCHANGES, ACCESS NODES, SWITCHES FOR TELECOMMUNICATION PURPOSES, SERVERS, ROUTERS, DATA SMART CARDS, MODEMS, MULTIPLEXERS; [ELECTRICAL CABLES AND OPTICAL FIBERS CABLES;] ELECTRONIC SYSTEMS AND APPARATUS, NAMELY, SCRAMBLERS, DESCRAMBLERS, ENCODERS AND DECODERS, FOR SCRAMBLING, DESCRAMBLING, ENCODING AND/OR DECODING OF VOICE, DATA, IMAGE AND VIDEO TRANSMISSIONS, ELECTRONIC DATA INPUT AND OUTPUT APPARATUS, NAMELY, TERMINALS, RECEIVERS, TRANSMITTERS, DECODERS, AND TRANSCEIVERS CAPABLE OF PROCESSING BROADCAST, SATELLITE, FACSIMILE, TELEVISION, TELECOMMUNICATION, NETWORK, INFRARED, VIDEO GAME, AND COMPUTER DATA SIGNALS AND FOR TRANSMISSION, REPRODUCING OR RECEIVING OF SOUND, IMAGES, VIDEO, MULTIMEDIA OR DATA; DATA PROCESSING EQUIPMENT, NAMELY, DIGITAL SIGNAL PROCESSORS; [COMPUTERS, COMPUTER SOFTWARE AND PROGRAMS USED FOR TRANSMISSION OR REPRODUCING OR RECEIVING OF SOUND, IMAGES, VIDEO OR DATA OVER A TELECOMMUNICATIONS NETWORK OR SYSTEM BETWEEN TERMINALS AND FOR ENHANCING AND FACILITATING USE AND ACCESS TO COMPUTER NETWORKS AND TELEPHONE NETWORKS AND THERE BETWEEN; COMPUTER SOFTWARE FOR USE IN GENERAL PURPOSE DATABASE MANAGEMENT; COMPUTER E-COMMERCE SOFTWARE TO ALLOW USER TO SAFELY PLACE ORDERS AND MAKE PAYMENTS IN THE FIELD OF ELECTRONIC BUSINESS TRANSACTIONS VIA A GLOBAL COMPUTER NETWORK OR TELECOMMUNICATIONS NETWORK; TRAINING AND PRODUCT SUPPORT SOFTWARE FOR COMPUTERS AND MOBILE PHONES IN THE FIELD OF COMMUNICATIONS; COMPUTER UTILITY SOFTWARE FOR PERFORMING COMPUTER MAINTENANCE WORK; COMPUTER GAME SOFTWARE;] COMPUTER SOFTWARE AND PROGRAMS FEATURING MUSIC, MOVIES, ANIMATION [ELECTRONIC BOOKS,] * AND * GAMES IN THE FIELD OF GENERAL ENTERTAINMENT; [POWER SOURCES FOR COMMUNICATION NETWORK ELEMENTS, NAMELY, BATTERIES AND POWER SUPPLIES;] SUBSTATIONS OR REPEATERS, NAMELY, SIGNAL AMPLIFIERS OR REPEATER AMPLIFIERS; [MULTIMEDIA SYSTEMS, NAMELY, SOFTWARE FOR THE DISTRIBUTION OF INFORMATION AND INTERACTIVE CONTENT CONTAINING TEXT, IMAGES, VIDEO AND SOUND TO USERS IN THE FIELD OF COMMUNICATIONS AND MULTIMEDIA TERMINALS FOR COMPUTERS; SATELLITE, CABLE AND/OR TERRESTRIAL RECEIVERS AND ANTENNAS,

SWITCHES AND MOTORS THEREOF; MONITORS,] DISPLAYS FOR MOBILE PHONES; USER INTERFACE UNITS, NAMELY, KEYBOARDS, KEYPADS, KEY ROLLS, BUTTONS, [SWITCHBOARDS] AND SCREENS; COMPUTER SOFTWARE AND PROGRAMS FOR MANAGEMENT AND OPERATION OF WIRELESS TELECOMMUNICATIONS DEVICES [] * ; * COMPUTER SOFTWARE FOR ACCESSING, SEARCHING, INDEXING AND RETRIEVING INFORMATION AND DATA FROM GLOBAL COMPUTER NETWORKS AND GLOBAL COMMUNICATION NETWORKS, AND FOR BROWSING AND NAVIGATING THROUGH WEB SITES ON SAID NETWORKS, AND COMPUTER SOFTWARE FOR SENDING AND RECEIVING SHORT MESSAGES AND ELECTRONIC MAIL [AND FOR FILTERING NON-TEXT INFORMATION FROM THE DATA] ; ANALOG AND DIGITAL RADIO TRANSCEIVERS OR RECEIVERS FOR DATA, VOICE, IMAGE AND VIDEO COMMUNICATION * SOLD AS COMPONENT PARTS OF MOBILE TELEPHONES * ; ELECTRONIC GAME SOFTWARE FOR MOBILE [HANDSETS] * TELEPHONES *; CAMERAS, NAMELY, [PHOTOGRAPHIC CAMERAS,] DIGITAL CAMERAS [MOTION PICTURE CAMERAS,] * AND *VIDEO CAMERAS *SOLD AS COMPONENT PARTS OF MOBILE TELEPHONES * ; [SYSTEMS AND APPARATUS FOR ELECTRIC MONEY TRANSACTIONS, NAMELY, SMART CARDS, SMART CARD READERS;] CALCULATORS *SOLD AS COMPONENT PARTS OF MOBILE TELEPHONES * ; [CARDS FOR COMMUNICATIONS PURPOSES, NAMELY, DATA CARDS, MODEM CARDS AND FAX MODEM CARDS FOR COMMUNICATION PURPOSES, ALL FOR USE WITH COMMUNICATIONS APPARATUS; ELECTRONIC PUBLICATIONS, NAMELY, COMPUTER USER MANUALS RECORDED ON COMPUTER MEDIA; BLANK AUDIO AND VIDEO CASSETTES, TAPES, CD'S; PRE-RECORDED AUDIO AND VIDEO CASSETTES, TAPES AND CD'S FEATURING MUSIC, MOVIES, ANIMATION, ELECTRONIC BOOKS, VIDEO GAMES; AUDIO AND VIDEO TAPE, CASSETTE, DIGITAL VIDEO DISC (DVD), VIDEO-CD (VCD), CD-I, LASER DISC, MINIDISCS, MP3 AND CD RECORDERS AND PLAYERS AND THEIR PERIPHERALS FEATURING ENTERTAINMENT, INFORMATION, MULTIMEDIA MATERIAL, MANUALS AND INSTRUCTIONAL MATERIAL; TELEVISIONS; HEADPHONES; BINOCULARS; SUNGLASSES; EYEGLASSES; MOUSE PADS; STAND ALONE VIDEO GAME MACHINES; BURGLAR AND FIRE ALARMS;] STEREO EQUIPMENT, NAMELY, [STEREO RECEIVERS AND AMPLIFIERS, CD], MP3 * PLAYERS * AND [MINIDISC PLAYERS] AND SPEAKERS *SOLD AS COMPONENT PARTS OF MOBILE TELEPHONES * .
FIRST USE ; IN COMMERCE .

ELEMENTS AMENDED
GOODS/SERVICES

2,690,628. REG. 2-25-2003. AMAZE ENTERTAINMENT, INC. (WASHINGTON CORPORATION) 12421 WILLOWS ROAD NE, #200, KIRKLAND, WA, 98034, SN 76-401,109. FILED 4-22-2002. PRINCIPAL REGISTER.

FIZZ FACTOR

THE MARK CONSISTS OF STANDARD CHARACTERS WITHOUT CLAIM TO ANY PARTICULAR FONT, STYLE, SIZE, OR COLOR.

INT. CL. 42/U.S. CLS. 100 AND 101

FOR COMPUTER SOFTWARE DESIGN FOR OTHERS; DEVELOPMENT OF COMPUTER, VIDEO, CONSOLE AND HANDHELD UNIT GAMES FOR OTHERS.

FIRST USE 3-21-2002; IN COMMERCE 3-21-2002.

ELEMENTS AMENDED
MARK

2,707,405. REG. 4-15-2003. LEONARDO'S FIFTH AVENUE, INC. (PUERTO RICO CORPORATION) CALLE FIDALGO DIAZ #413, SANTURCE, PUERTO RICO, 00910, SN 75-776,965. FILED 8-16-1999. PRINCIPAL REGISTER.

infoBoda

INT. CL. 35/U.S. CLS. 100, 101 AND 102
 FOR ADVERTISING AGENCY SERVICES, NAMELY, PROMOTING THE SERVICES OF THOSE IN THE WEDDING PLANNING INDUSTRY THROUGH THE DISTRIBUTION OF PRINTED AND AUDIO PROMOTIONAL MATERIALS AND BY RENDERING SALES PROMOTION ADVISE.
 FIRST USE 3-1-1999; IN COMMERCE 3-1-1999.
 INT. CL. 41/U.S. CLS. 100, 101 AND 107
 FOR PROVIDING INFORMATION REGARDING WEDDING PLANNING.
 FIRST USE 3-1-1999; IN COMMERCE 3-1-1999.

ELEMENTS AMENDED
 MARK

2,708,942. REG. 4-22-2003. WEAR ME OUT (CALIFORNIA LIMITED LIABILITY COMPANY) P.O. BOX 992590, SYLMAR, CA, 913922590, SN 76-384,915. FILED 3-15-2002. PRINCIPAL REGISTER.



INT. CL. 25/U.S. CLS. 22 AND 39
 FOR CLOTHING, NAMELY, TOPS, BOTTOMS, [COATS, HATS,] BRA TOPS, [TIGHTS,] SHORTS, CAPRIS, [JACKETS,] AND SWEAT SUITS [UNDERWEAR].
 FIRST USE 1-26-2002; IN COMMERCE 1-26-2002.

ELEMENTS CORRECTED
 ENTITY

2,709,784. REG. 4-22-2003. HINGLE, MEAGAN E. (UNITED STATES INDIVIDUAL) 1601 BELLE CHASSE HIGHWAY, SUITE 203, GRETNA, LA, 70056, SN 76-090,996. FILED 7-18-2000. PRINCIPAL REGISTER.

SEAT BELT SNOOZER

NO CLAIM IS MADE TO THE EXCLUSIVE RIGHT TO USE "SEAT BELT", APART FROM THE MARK AS SHOWN.
 INT. CL. 20/U.S. CLS. 2, 13, 22, 25, 32 AND 50

FOR HEAD SUPPORT SEAT BELT PILLOW FOR USE IN A VEHICLE HAVING A SHOULDER RESTRAINT STRAP.
 FIRST USE 7-24-2001; IN COMMERCE 7-26-2001.

ELEMENTS CORRECTED
 OWNER NAME

2,714,967. REG. 5-13-2003. GROUPE BOCENOR INC. (CANADA CORPORATION) 274, RUE DUCHESNAY, C.P. 1000, SAINTE-MARIE-DE-BEAUCE, QUEBEC, CANADA, G6E 3C2, SN 76-153,005. FILED 10-24-2000. PRINCIPAL REGISTER.

ECONOVER

THE MARK CONSISTS OF STANDARD CHARACTERS WITHOUT CLAIM TO ANY PARTICULAR FONT, STYLE, SIZE, OR COLOR.
 OWNER OF CANADA REG. NO. TMA316175, DATED 7-11-1986, RENEWED AS REG. NO. TMA316175, DATED 7-11-2001.
 INT. CL. 19/U.S. CLS. 1, 12, 33 AND 50
 FOR TEMPERED GLASS AND LAMINATED GLASS USED TO MAKE WINDOWS AND DOORS; SMOOTHED PLATE GLASS; NON-METAL GOODS, NAMELY, DOORS, WINDOWS, FRAMES, SHUTTERS, CURTAIN WALLS; PREFABRICATED NON-METAL GREENHOUSES; NON-METAL WINDOWS FOR GREENHOUSES.
 FIRST USE 1-0-2000; IN COMMERCE 1-0-2000.

ELEMENTS AMENDED
 MARK

2,715,928. REG. 5-13-2003. WILLIAMS-SONOMA, INC. (CALIFORNIA CORPORATION) 3250 VAN NESS AVENUE, SAN FRANCISCO, CA, 94109, SN 75-520,004. FILED 7-16-1998. PRINCIPAL REGISTER.

PBK

THE MARK CONSISTS OF STANDARD CHARACTERS WITHOUT CLAIM TO ANY PARTICULAR FONT, STYLE, SIZE, OR COLOR.
 INT. CL. 35/U.S. CLS. 100, 101 AND 102
 FOR ON-LINE RETAIL STORE SERVICES AND CATALOG MAIL ORDER SERVICES FEATURING CHILDREN'S PRODUCTS, OFFERED EXCLUSIVELY THROUGH POTTERY BARN KIDS STORES, CATALOGS, AND WEBSITES, NAMELY, BEDDING, FURNITURE, RUGS, BATH RUGS, TOWELS, SHOWER CURTAINS, WINDOW COVERINGS, LIGHTING, TOYS, BOOKS, NOVELTY HATS, SLIPPERS, AND BOOTIES, AND HOME RENOVATION PRODUCTS, NAMELY, [PAINT, STENCILS] AND HARDWARE.
 FIRST USE 1-1-1999; IN COMMERCE 1-1-1999.

ELEMENTS AMENDED
 MARK

2,743,122. REG. 7-29-2003. ARM, INC. (CALIFORNIA CORPORATION) 141 CASPIAN COURT, SUNNYVALE, CA, 940891013, SN 76-158,365. FILED 11-2-2000. PRINCIPAL REGISTER.

2,759,177. REG. 9-2-2003. WESTERWALDER BLUMENTOPF-FABRIK SPANG GMBH & CO. KG (FED REP GERMANY CORPORATION) 113-120 RHEINSTRASSE, D-56235 RANSBACH-BAUMBACH, FED REP GERMANY., SN 75-721,022. FILED 6-3-1999. PRINCIPAL REGISTER.

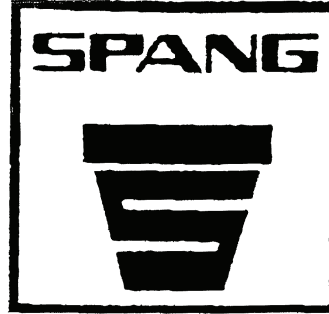

INT. CL. 9/U.S. CLS. 21, 23, 26, 36 AND 38
FOR COMPUTER SOFTWARE, NAMELY COMPILERS, MACRO ASSEMBLERS, REAL-TIME KERNELS, DEBUGGERS, SIMULATORS, INTEGRATED ENVIRONMENTS, AND EVALUATION BOARD FOR USE WITH SPECIFIC TYPES OF MICROCONTROLLER FAMILIES.
FIRST USE 1-1-1987; IN COMMERCE 1-1-1987.

PRIORITY CLAIMED UNDER SEC. 44(D) ON FED REP GERMANY APPLICATION NO. 39871089.9, FILED 12-10-1998, REG. NO. 39871089, DATED 3-2-1999, EXPIRES 12-31-2008.
INT. CL. 21/U.S. CLS. 2, 13, 23, 29, 30, 33, 40 AND 50
FOR CERAMIC PRODUCTS, NAMELY, FLOWER POTS, PLANT BOWLS, PLANT SAUCERS, AND PLANT POT HOLDERS.
FIRST USE 1-1-1971; IN COMMERCE 1-1-1986.

ELEMENTS AMENDED
MARK
DISCLAIMER

ELEMENTS CORRECTED
OWNER NAME
OWNER NAME

2,794,019. REG. 12-16-2003. SOCIETY FOR VASCULAR SURGERY (ILLINOIS CORPORATION) 633 NORTH SAINT CLAIR STREET, 24TH FLOOR, CHICAGO, IL, 60611, SN 76-440,231. FILED 8-12-2002. PRINCIPAL REGISTER.

2,752,974. REG. 8-19-2003. AMPLIFY FEDERAL CREDIT UNION (TEXAS USA NATIONAL BANKING ASSOCIATION) P.O. BOX 85300, AUSTIN, TX, 78708, SN 78-123,830. FILED 4-24-2002. PRINCIPAL REGISTER.



PLUG IN

INT. CL. 16/U.S. CLS. 2, 5, 22, 23, 29, 37, 38 AND 50
FOR PRINTED MATERIAL, NAMELY, A NEWSLETTER REGARDING CONSUMER, COMMERCIAL AND MORTGAGE BANKING SERVICES, FINANCIAL SERVICES, LOANS, SAVINGS ACCOUNTS, FINANCIAL ANALYSIS AND CONSULTATION, FINANCIAL PORTFOLIO MANAGEMENT, FINANCIAL RESEARCH, FISCAL ASSESSMENT AND EVALUATION, AND ADMINISTRATION OF EMPLOYEE BENEFIT AND PENSION PLANS.
FIRST USE 6-0-2001; IN COMMERCE 6-0-2001.

DESIGN CONSISTING OF THE UPPER HALF OF A PERSON WITH ARMS RAISED IN THE SHAPE OF A "V" AND SURROUNDED ON THREE SIDES BY A DARK BACKGROUND.
INT. CL. 41/U.S. CLS. 100, 101 AND 107
FOR EDUCATIONAL SERVICES, NAMELY, CONDUCTING PROGRAMS IN THE FIELD OF NON-CARDIAC VASCULAR DISORDERS AND DISTRIBUTION OF PRINTED MATERIALS IN CONNECTION THEREWITH.
FIRST USE 5-18-2002; IN COMMERCE 5-18-2002.

ELEMENTS AMENDED
MARK

ELEMENTS CORRECTED
OWNER ADDRESS
CITIZENSHIP

2,798,091. REG. 12-23-2003. MICROSOFT CORPORATION (WASHINGTON CORPORATION) ONE MICROSOFT WAY, REDMOND, WA, 98052, SN 75-884,368. FILED 12-30-1999. PRINCIPAL REGISTER.



OWNER OF U.S. REG. NOS. 2,014,296, 2,153,763 AND OTHERS.

THE COLOR(S) WHITE, BLUE, DARK GREEN, LIGHT GREEN, RED, ORANGE, YELLOW, AND PURPLE IS/ARE CLAIMED AS A FEATURE OF THE MARK. THE MARK COMPRISES THE LETTERS "MSN" AND A BUTTERFLY DESIGN. THE LETTERS "MSN" ARE WHITE. THE UPPER PORTION OF THE LEFT WING OF THE BUTTERFLY IS BLUE. THE CENTER PORTION DARK GREEN, AND THE LOWER PORTION IS LIGHT GREEN. THE UPPER PORTION OF THE RIGHT WING OF THE BUTTERFLY IS RED, THE MIDDLE PORTION IS ORANGE AND THE LOWER PORTION IS YELLOW. THE BODY OF THE BUTTERFLY IS PURPLE.

INT. CL. 41/U.S. CLS. 100, 101 AND 107

FOR ENTERTAINMENT SERVICES, NAMELY, PROVIDING INTERACTIVE ON-LINE COMPUTER GAMES VIA LOCAL COMPUTER NETWORKS AND GLOBAL COMMUNICATION NETWORKS; PROVIDING INFORMATION IN THE FIELDS OF MOVIES AND SPORTS VIA LOCAL COMPUTER NETWORKS AND GLOBAL COMMUNICATION NETWORKS; PROVIDING EDUCATIONAL INFORMATION FOR USE IN PREPARING LESSON PLANS IN THE FIELDS OF ART, FOREIGN LANGUAGES, HEALTH, INFORMATION TECHNOLOGY, LANGUAGE ARTS, MATH, PHILOSOPHY, PHYSICAL EDUCATION, RELIGION, SCIENCE, SOCIAL STUDIES AND VOCATIONAL EDUCATION VIA COMPUTER NETWORKS AND GLOBAL COMMUNICATION NETWORKS; ON-LINE EDUCATION SERVICES, NAMELY, PROVIDING INFORMATION ON SPECIFIC EDUCATIONAL PROGRAMS, NAMELY, INFORMATION IN THE FIELDS OF ACADEMIC PROGRAMS SUCH AS ADULT AND CONTINUING EDUCATION PROGRAMS, INFORMATION ON SPECIFIC COLLEGES AND UNIVERSITIES, COMMUNITY COLLEGES, INFORMATION ON ONLINE EDUCATIONAL COURSES, INFORMATION ON FINANCIAL AID PROGRAMS PROVIDED BY EDUCATIONAL INSTITUTIONS, INFORMATION ON GRADUATE STUDIES PROGRAMS, INFORMATION ON PROGRAMS FEATURING COURSES OF INSTRUCTION FOR K-12 EDUCATION, INFORMATION ON EDUCATIONAL EXCHANGE PROGRAMS, INFORMATION ON PROGRAMS FEATURING THEORY AND METHODS OF EDUCATION, INFORMATION ON HOME SCHOOLING PROGRAMS, ALL OFFERED VIA COMPUTER NETWORKS AND GLOBAL COMMUNICATION NETWORKS; ON-LINE INFORMATION SERVICES, NAMELY, PROVIDING REFERENCE AND ENCYCLOPEDIA INFORMATION IN THE FIELDS OF SCIENCE, TECHNOLOGY, GEOGRAPHY, HISTORY, SOCIAL SCIENCE, RELIGION, PHILOSOPHY, ART, LANGUAGE, LITERATURE, PERFORMING ARTS, SPORTS, HOBBIES AND PETS; AND PROVIDING VISITOR AND ENTERTAINMENT INFORMATION VIA LOCAL COMPUTER NETWORKS AND GLOBAL COMMUNICATION NETWORKS CONCERNING CITIES, CITY SERVICES, EVENTS AND SITES OF INTEREST LOCATED IN AND AROUND CITIES, INFORMATION AND REVIEWS ON SPORTS, MOVIES, ARTS, CULTURE AND CIVIC EVENTS AND ATTRACTIONS, AND TRANSPORTATION SERVICES.

FIRST USE 2-14-2000; IN COMMERCE 2-14-2000.

ELEMENTS AMENDED
MARK
DESCRIPTION OF MARK

2,800,500. REG. 12-30-2003. NEXTSCAN, INC. (DELAWARE CORPORATION) 1440 EAST IRON EAGLE DRIVE, EAGLE, ID, 83616, SN 78-217,389. FILED 2-21-2003. PRINCIPAL REGISTER.

ECLIPSE

INT. CL. 9/U.S. CLS. 21, 23, 26, 36 AND 38
FOR MICROFILM AND MICROFICHE SCANNERS.
FIRST USE 2-1-2003; IN COMMERCE 2-1-2003.

ELEMENTS CORRECTED
OWNER NAME
CITIZENSHIP

2,823,987. REG. 3-16-2004. MORRISON & FOERSTER, LLP (CALIFORNIA LIMITED LIABILITY PARTNERSHIP) 425 MARKET STREET, SAN FRANCISCO, CA, 941052482, SN 76-975,385. FILED 5-6-2002. PRINCIPAL REGISTER.

MOFO

INT. CL. 6/U.S. CLS. 2, 12, 13, 14, 23, 25 AND 50
FOR METAL KEY CHAINS.
FIRST USE 12-1-2002; IN COMMERCE 12-1-2002.
INT. CL. 14/U.S. CLS. 2, 27, 28 AND 50
FOR JEWELRY, WATCHES, PENDANTS AND CLOCKS.
FIRST USE 12-1-2002; IN COMMERCE 12-1-2002.
INT. CL. 16/U.S. CLS. 2, 5, 22, 23, 29, 37, 38 AND 50
FOR PENS, HIGHLIGHTERS AND PENCILS.
FIRST USE 12-1-2002; IN COMMERCE 12-1-2002.
INT. CL. 18/U.S. CLS. 1, 2, 3, 22 AND 41
FOR HANDBAGS, TOTES, BACKPACKS AND BRIEF-CASES.
FIRST USE 12-1-2002; IN COMMERCE 12-1-2002.
INT. CL. 21/U.S. CLS. 2, 13, 23, 29, 30, 33, 40 AND 50
FOR COFFEE CUPS, HOT AND COLD BEVERAGE MUGS AND DRINKING GLASSES, BOTTLE OPENERS.
FIRST USE 12-1-2002; IN COMMERCE 12-1-2002.

ELEMENTS CORRECTED
CITIZENSHIP
ENTITY

2,988,468. REG. 8-30-2005. KABUSHIKI KAISHA TOSHIBA (JAPAN CORPORATION), DBA TOSHIBA CORPORATION, 1-1, SHIBAURA 1-CHOME, MINATO-KU, TOKYO, JAPAN., SN 76-441,913. FILED 8-14-2002. PRINCIPAL REGISTER.

TOSCYCLO

OWNER OF JAPAN REG. NO. 4594430, DATED 8-9-2002, EXPIRES 8-9-2012.
INT. CL. 9/U.S. CLS. 21, 23, 26, 36 AND 38
FOR CONVERTER SYSTEM FOR ELECTRIC MOTORS.

ELEMENTS CORRECTED
FOREIGN REG. EXPIRATION DATE

3,071,081. REG. 3-21-2006. SERVICEMASTER BRANDS L.L.C. (VERMONT LIMITED LIABILITY COMPANY) 100 BANK STREET, SUITE 610, BURLINGTON, VT, 05401, SN 78-600,878. FILED 4-4-2005. PRINCIPAL REGISTER.

3,112,963. REG. 7-4-2006. SCIENTIFIC MONITORING, INC. (ARIZONA CORPORATION) SUITE 120, 8777 E. VIA DE VENTURA DRIVE, SCOTTSDALE, AZ, 85258, SN 78-496,917. FILED 10-8-2004. PRINCIPAL REGISTER.

ServiceMaster

ITREND

THE MARK CONSISTS OF STANDARD CHARACTERS WITHOUT CLAIM TO ANY PARTICULAR FONT, STYLE, SIZE, OR COLOR.

INT. CL. 9/U.S. CLS. 21, 23, 26, 36 AND 38
FOR SOFTWARE IN THE FIELD OF MAINTENANCE AND DIAGNOSTIC ANALYSIS OF AIRCRAFT, VEHICLE, SHIP, INDUSTRIAL AND MANUFACTURING EQUIPMENT .

FIRST USE 12-0-2004; IN COMMERCE 12-0-2004.

ELEMENTS AMENDED
MARK

THE MARK CONSISTS OF STANDARD CHARACTERS WITHOUT CLAIM TO ANY PARTICULAR FONT, STYLE, SIZE, OR COLOR.

OWNER OF U.S. REG. NOS. 782,584, 1,220,269 AND OTHERS.

INT. CL. 44/U.S. CLS. 100 AND 101

FOR [MAINTENANCE OF INDOOR PLANTS FOR OTHERS;] LAWN, TREE AND SHRUB CARE SERVICES; LANDSCAPE GARDENING AND DESIGN FOR OTHERS; FLOWER, TREE, SHRUB AND LAWN PLANTING AND MAINTENANCE FOR OTHERS.

FIRST USE 2-1-2003; IN COMMERCE 2-1-2003.

ELEMENTS AMENDED
GOODS/SERVICES

3,216,617. REG. 3-6-2007. VAGUE PROTOCOL, LTD. (NEVADA CORPORATION) 3510 E. POND LANE, LAKE ORION, MI, 48359, SN 78-461,665. FILED P.R. 8-4-2004; AM. S.R. 4-24-2006. SUPPLEMENTAL REGISTER.

MOBILECOUPONS

THE MARK CONSISTS OF STANDARD CHARACTERS WITHOUT CLAIM TO ANY PARTICULAR FONT, STYLE, SIZE, OR COLOR.

INT. CL. 38/U.S. CLS. 100, 101 AND 104

FOR ELECTRONIC TRANSMISSION OF DATA IN THE NATURE OF A MACHINE READABLE CODES REPRESENTING A TRANSACTION RECEIPT WHICH IS DISPLAYED ON A MOBILE DEVICE DISPLAY SCREEN.

FIRST USE 8-4-2004; IN COMMERCE 8-4-2004.

ELEMENTS AMENDED
MARK

3,097,812. REG. 5-30-2006. CCA GLOBAL PARTNERS, INC. (DELAWARE CORPORATION) 4301 EARTH CITY EXPRESSWAY, EARTH CITY, MO, 63045, SN 78-622,500. FILED 5-4-2005. PRINCIPAL REGISTER.

The **ONE** store for your perfect floor.

3,233,519. REG. 4-24-2007. CINELLISTUDIO S.R.L. (ITALY S.R.L.) VIALE MATTEUCCI 38/G, I-56124 PISA, ITALY., SN 79-002,835. FILED 3-4-2004. PRINCIPAL REGISTER.

[C]STUDIO

OWNER OF INTERNATIONAL REGISTRATION 0811485 DATED 3-13-2003, EXPIRES 3-13-2013.

THE TRADE MARK COMPRISES THE INSCRIPTION "(C)STUDIO" IN FANCY BLOCK TYPE, WITH THE LETTER "C" ENCLOSED IN SQUARE BRACKETS.

INT. CL. 25/U.S. CLS. 22 AND 39

FOR CLOTHING, NAMELY, SHORTS, SHIRTS, SOCKS, FOOTWEAR, [HEADWEAR,] JACKETS, OVERCOATS AND ANORAKS.

FIRST USE ; IN COMMERCE .

INT. CL. 35/U.S. CLS. 100, 101 AND 102

FOR CARPET DEALERSHIP SERVICES AND RETAIL STORE SERVICES IN THE FIELD OF CARPETS AND OTHER FLOOR COVERINGS.

FIRST USE 8-30-2004; IN COMMERCE 8-30-2004.

ELEMENTS CORRECTED
CITIZENSHIP

ELEMENTS CORRECTED
GOODS/SERVICES

3,259,031. REG. 7-3-2007. AMGLO KEMLITE LABORATORIES, INC. (FLORIDA CORPORATION) 8787 ENTERPRISE BLVD., LARGO, FL. 33773, SN 76-565,591. FILED 12-16-2003. PRINCIPAL REGISTER.

3,276,809. REG. 8-7-2007. COMMON SENSE DENTAL PRODUCTS II, INC. (MICHIGAN CORPORATION), DBA COMMON SENSE DENTAL PRODUCTS, 14998 CLEVELAND ST., SUITE A. SPRING LAKE, MI. 49456, SN 78-612,797. FILED 4-20-2005. PRINCIPAL REGISTER.



PREPCHECK

NO CLAIM IS MADE TO THE EXCLUSIVE RIGHT TO USE "LIGHTING CORPORATION", APART FROM THE MARK AS SHOWN.

THE MARK CONSISTS OF STANDARD CHARACTERS WITHOUT CLAIM TO ANY PARTICULAR FONT, STYLE, SIZE, OR COLOR.

INT. CL. 10/U.S. CLS. 26, 39 AND 44

FOR MEDICAL APPARATUS, NAMELY DENTAL MARKING GAUGES.

FIRST USE 1-1-2006; IN COMMERCE 1-1-2006.

INT. CL. 11/U.S. CLS. 13, 21, 23, 31 AND 34

FOR LAMPS; ELECTRIC LIGHT BULBS *, NAMELY EMERGENCY WARNING LAMPS, ARCHITECTURAL SPOT LIGHTS, SECURITY LAMPS, AIRCRAFT LIGHTING, LASER LAMPS FOR CUTTING STEEL, OBSTRUCTION TOWER LAMPS, OPERATING ROOM LAMPS FOR MEDICAL USES, PHOTOGRAPHIC LAMPS USED IN MODELING, AIRPORT RUNWAY LIGHTING LAMPS, LOCOMOTIVE LAMPS, EMERGENCY WARNING LAMPS, NOT FOR USE IN AUTOMOBILES *

FIRST USE 11-24-2006; IN COMMERCE 11-24-2006.

ELEMENTS CORRECTED

DBA/AKA

OWNER NAME

OWNER ADDRESS

ENTITY

ELEMENTS AMENDED
GOODS/SERVICES

3,291,658. REG. 9-11-2007. BLUESHIFT BIOTECHNOLOGIES, INC. (CALIFORNIA CORPORATION) 245 SANTA ANA COURT, SUNNYVALE, CA, 94085, SN 78-592,830. FILED 3-22-2005. PRINCIPAL REGISTER.

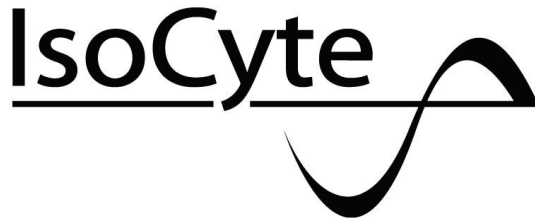

3,275,687. REG. 8-7-2007. NEUTROGENA CORPORATION (DELAWARE CORPORATION) 5760 WEST 96TH STREET, LOS ANGELES, CA, 90045, SN 76-562,148. FILED 11-26-2003. PRINCIPAL REGISTER.

INT. CL. 42/U.S. CLS. 100 AND 101

FOR RESEARCH AND DEVELOPMENT OF BIOTECHNOLOGY APPLICATIONS AND PRODUCTS.

FIRST USE 12-31-2004; IN COMMERCE 12-31-2004.

VISIBLY EVEN

ELEMENTS CORRECTED

OWNER NAME

3,324,871. REG. 10-30-2007. KABUSHIKIKAISHA XAVEL (JAPAN CORPORATION) SCALA BUILDING 6F, 1-14-17, NISHIAZABU, MINATO-KU, TOKYO 106-0031, JAPAN., SN 79-028,329. FILED 7-4-2006. PRINCIPAL REGISTER.

THE MARK CONSISTS OF STANDARD CHARACTERS WITHOUT CLAIM TO ANY PARTICULAR FONT, STYLE, SIZE, OR COLOR.

OWNER OF U.S. REG. NO. 2,530,666.

INT. CL. 3/U.S. CLS. 1, 4, 6, 50, 51 AND 52

FOR FOAMING CLEANSER AND EXFOLIATING BODY WASH AND NIGHT CREAM.

FIRST USE 6-30-2006; IN COMMERCE 6-30-2006.

F a s h i o n w a l k e r

ELEMENTS CORRECTED
GOODS/SERVICES

THE MARK CONSISTS OF STANDARD CHARACTERS WITHOUT CLAIM TO ANY PARTICULAR FONT, STYLE, SIZE, OR COLOR.

PRIORITY DATE OF 6-1-2006 IS CLAIMED.

OWNER OF INTERNATIONAL REGISTRATION 0897000 DATED 7-4-2006, EXPIRES 7-4-2016.

INT. CL. 41/U.S. CLS. 100, 101 AND 107

FOR PROVIDING COMPUTER GAMES AND INFORMATION CONCERNED THEREOF BY MEANS OF MOBILE PHONE AND OTHER TELEPHONE TOOLS; PROVIDING A WEB SITE FEATURING MUSIC, SOUND AND GRAPHICS IN THE NATURE OF MUSICAL PERFORMANCES, MUSICAL VIDEO, RELATED FILM CLIPS AND PHOTOGRAPHS BY MEANS OF A MOBILE PHONE AND OTHER TELEPHONE TOOLS; PROVIDING COMPUTER GAMES AND RELATED INFORMATION THEREOF BY MEANS OF COMPUTER NETWORK; PROVIDING A WEB SITE FEATURING MUSIC, SOUND AND GRAPHICS IN THE NATURE OF MUSICAL PERFORMANCES, MUSICAL VIDEO, RELATED FILM CLIPS AND PHOTOGRAPHS BY MEANS OF A COMPUTER NETWORK; ON-LINE LIBRARY SERVICES, NAMELY, PROVIDING ELECTRONIC LIBRARY SERVICES WHICH FEATURE BOOKS VIA AN ON-LINE COMPUTER NETWORK; ENTERTAINMENT, NAMELY PLANNING, MANAGING AND HOLDING FASHION SHOWS; EDUCATION SERVICES, NAMELY, PROVIDING CLASSES AND SEMINARS IN THE [FILED] * FIELD * OF BEAUTY ARTS AND PROVIDING INFORMATION THEREOF; MODELING FOR ARTISTS AND PROVIDING RELATED INFORMATION REGARDING MODELING FOR ARTISTS.

FIRST USE ; IN COMMERCE .

ELEMENTS CORRECTED
MARK TYPE
[GOODS/SERVICES]
[INTERNATIONAL CLASS(ES)]

3,333,053. REG. 11-6-2007. STRATEGIC CAPITAL PARTNERS, LLC (INDIANA LIMITED LIABILITY COMPANY) SUITE 160, 280 EAST 96TH STREET, INDIANAPOLIS, IN, 46240, SN 78-969,252, FILED P.R. 9-7-2006; AM. S.R. 8-8-2007. SUPPLEMENTAL REGISTER.

STRATEGIC CAPITAL PARTNERS

THE MARK CONSISTS OF STANDARD CHARACTERS WITHOUT CLAIM TO ANY PARTICULAR FONT, STYLE, SIZE, OR COLOR.

NO CLAIM IS MADE TO THE EXCLUSIVE RIGHT TO USE "PARTNERS", APART FROM THE MARK AS SHOWN. INT. CL. 36/U.S. CLS. 100, 101 AND 102

FOR INVESTMENT ADVISORY SERVICES, NAMELY, PRIVATE EQUITY INVESTMENT SERVICES AND IDENTIFYING INVESTMENT OPPORTUNITIES; VENTURE CAPITAL FUNDING SERVICES FOR EMERGING AND START UP INVESTMENT JOINT VENTURE AND INVESTMENT PARTNERSHIP COMPANIES, NAMELY, PROVIDING INVESTMENT UNDERWRITING SERVICES AND FORMATION FUNDING ASSISTANCE; AND INVESTMENT SERVICES, NAMELY, INVESTMENT MANAGEMENT AND DEVELOPMENT SERVICES; AND SUPPORTING REAL ESTATE INVESTMENTS BY PROVIDING REAL ESTATE MANAGEMENT SERVICES; * ALL OF THE ABOVE IN THE FIELD OF REAL ESTATE AND PRIVATE EQUITY *.

FIRST USE 7-7-2006; IN COMMERCE 7-7-2006.

INT. CL. 37/U.S. CLS. 100, 103 AND 106

FOR SUPPORTING REAL ESTATE INVESTMENTS BY PROVIDING REAL ESTATE DEVELOPMENT SERVICES. FIRST USE 7-7-2006; IN COMMERCE 7-7-2006.

ELEMENTS AMENDED
GOODS/SERVICES

3,335,466. REG. 11-13-2007. STEM CELL SCIENCES KK (JAPAN JOINT STOCK COMPANY) KOBE INTERNATIONAL BUSINESS, CENTER BUILDING.; 5-2, MINATOJIMA - MINAMIMACHI 5-CHOME.; CHUO-KU, KOBESHU; HYOGO 650-0047, JAPAN., SN 79-028,630, FILED 2-27-2006. PRINCIPAL REGISTER.

TherapiCell

THE MARK CONSISTS OF STANDARD CHARACTERS WITHOUT CLAIM TO ANY PARTICULAR FONT, STYLE, SIZE, OR COLOR.

PRIORITY DATE OF 11-30-2005 IS CLAIMED.

OWNER OF INTERNATIONAL REGISTRATION 0897927 DATED 2-27-2006, EXPIRES 2-27-2016.

INT. CL. 1/U.S. CLS. 1

FOR REAGENTS FOR SCIENTIFIC USE IN BIOLOGICAL PROCESSING; BIOLOGICAL PREPARATIONS FOR SCIENTIFIC USE IN CELL CULTURES; [CULTURES OF CELL MEDIA FOR SCIENTIFIC USE;] MEDIA IN THE NATURE OF GROWTH MEDIA FOR CELL CULTURE FOR USE IN NON-MEDICAL SCIENTIFIC RESEARCH LABORATORIES; MEDIA IN THE NATURE OF GROWTH MEDIA FOR CELL CULTURE FOR USE IN THE BIOTECHNOLOGICAL INDUSTRY; SERA FOR NON-MEDICAL RESEARCH PURPOSES; ANTIBODIES FOR SCIENTIFIC USE; DIAGNOSTIC PREPARATIONS FOR SCIENTIFIC USE, NAMELY, ANTIBODIES; ELISA TEST KITS, NAMELY, BIOLOGICAL REAGENTS FOR USE IN ENZYME LINKED IMMUNO-SORBENT ASSAYS FOR THE BIOCHEMICAL DETECTION OF SUBSTANCES; PRODUCTS, NAMELY, KITS CONTAINING ANTIBODIES FOR USE IN SCIENCE; [TISSUE CULTURE REAGENTS FOR SCIENTIFIC USE; CELL CULTURE REAGENTS FOR SCIENTIFIC USE;] BIOLOGICAL TEST KITS COMPOSED OF BUFFER AND STANDARD SOLUTIONS USED IN ANALYTICAL CHEMISTRY, VECTORS, CELLS AND REAGENTS FOR SCIENTIFIC RESEARCH USE .

FIRST USE ; IN COMMERCE .

INT. CL. 5/U.S. CLS. 6, 18, 44, 46, 51 AND 52

FOR BIOLOGICAL REAGENTS FOR USE IN EMBRYOLOGY; BIOLOGICAL REAGENTS FOR MEDICAL USE IN THE FIELD OF MOLECULAR BIOLOGY; REAGENTS FOR USE IN BIOLOGICAL PROCESSING FOR MEDICAL PURPOSES; REAGENTS FOR USE IN BIOLOGICAL PROCESSING FOR VETERINARY PURPOSES; AGENTS IN THE NATURE OF HORMONES, CYTOKINES, ANTIGENS, IMMUNOGLOBULINS FOR ACTIVATING CELLULAR FUNCTIONS; BIOLOGICAL PREPARATIONS FOR MEDICAL PURPOSES, NAMELY, FOR USE IN CELL CULTURES; ANTITOXIC SERA; ANTITOXIC SERA FOR IN VIVO USE FOR MEDICAL PURPOSES; ANTIBODIES FOR THE TREATMENT OF DISEASE; ANTIBODIES FOR IMMUNODIAGNOSTIC MEDICAL PURPOSES; ANTIBODIES FOR IMMUNOPROPHYLACTIC MEDICAL PURPOSES; ANTIBODIES FOR IMMUNOTHERAPEUTIC MEDICAL PURPOSES; ANTIBODIES FOR IN VIVO MEDICAL USE IN DETECTING DISEASES IN LIVESTOCK; [IMMUNOLOGICAL ANTIBODIES FOR MEDICAL USE].

FIRST USE ; IN COMMERCE .

INT. CL. 9/U.S. CLS. 21, 23, 26, 36 AND 38

FOR LABORATORY APPARATUS, NAMELY, CENTRIFUGES FOR SCIENTIFIC RESEARCH; [CELL COUNTING UNITS FOR LABORATORY USE;] CELL CULTURE APPARATUS, NAMELY, CELL CULTURE DISHES, CELL CULTURE FLASKS, CELL CULTURE PLATES, AND CELL CULTURE WELLS FOR LABORATORY USE; CELL CULTURE INSTRUMENTS, NAMELY, CELL CULTURE DISHES, CELL CULTURE FLASKS, CELL CULTURE PLATES, AND CELL CULTURE WELLS FOR LABORATORY USE; COMPUTER SOFTWARE FOR USE IN DATABASE MANAGEMENT, FOR USE AS A SPREADSHEET, AND FOR WORD PROCESSING; COMPUTER SOFTWARE FOR DATA MANAGEMENT, NAMELY, DATABASE MANAGEMENT SOFTWARE.

FIRST USE ; IN COMMERCE .

INT. CL. 42/U.S. CLS. 100 AND 101

FOR [LABORATORY SERVICES, NAMELY, LABORATORY RESEARCH IN THE FIELD OF BIOLOGY, BACTERIOLOGY, CHEMISTRY AND COSMETICS;] CELL SEPARATION RESEARCH SERVICES; CELL SEPARATION TECHNOLOGY SERVICES; STEM CELL RESEARCH SERVICES; ADVISORY SERVICES RELATING TO SCIENTIFIC RESEARCH; PHARMACEUTICAL RESEARCH SERVICES; CONTRACT RESEARCH SERVICES RELATING TO GROWTH, SELECTION, DIFFERENTIATION AND/OR PURIFICATION OF STEM CELLS; LABORATORY SERVICES RELATING TO THE PRODUCTION OF MONOCLONAL ANTIBODIES.

FIRST USE ; IN COMMERCE .

ELEMENTS CORRECTED
GOODS/SERVICES
[INTERNATIONAL CLASS(ES)]

3,335,468. REG. 11-13-2007. STEM CELL SCIENCES KK (JAPAN JOINT STOCK COMPANY) KOBE INTERNATIONAL BUSINESS, CENTER BUILDING., 5-2, MINATOJIMA - MINAMIMACHI 5-CHOME.; CHUO-KU, KOBE-SHI; HYOGO 650-0047, JAPAN., SN 79-028,674. FILED 2-27-2006. PRINCIPAL REGISTER.

AppliCell

THE MARK CONSISTS OF STANDARD CHARACTERS WITHOUT CLAIM TO ANY PARTICULAR FONT, STYLE, SIZE, OR COLOR.

PRIORITY DATE OF 11-30-2005 IS CLAIMED.

OWNER OF INTERNATIONAL REGISTRATION 0898063 DATED 2-27-2006, EXPIRES 2-27-2016.

INT. CL. 1/U.S. CLS. 1

FOR REAGENTS FOR SCIENTIFIC USE IN BIOLOGICAL PROCESSING; BIOLOGICAL PREPARATIONS FOR SCIENTIFIC USE IN CELL CULTURES; [CULTURES OF CELL MEDIA FOR SCIENTIFIC USE;] MEDIA IN THE NATURE OF GROWTH MEDIA FOR CELL CULTURE FOR USE IN NON-MEDICAL SCIENTIFIC RESEARCH LABORATORIES; MEDIA IN THE NATURE OF GROWTH MEDIA FOR CELL CULTURE FOR USE IN THE BIOTECHNOLOGICAL INDUSTRY; SERA FOR NON-MEDICAL RESEARCH PURPOSES; ANTIBODIES FOR SCIENTIFIC USE; DIAGNOSTIC PREPARATIONS FOR SCIENTIFIC USE, NAMELY, ANTIBODIES; ELISA TEST KITS, NAMELY, BIOLOGICAL REAGENTS FOR USE IN ENZYME LINKED IMMUNO-SORBENT ASSAYS FOR THE BIOCHEMICAL DETECTION OF SUBSTANCES; PRODUCTS, NAMELY, KITS CONTAINING ANTIBODIES FOR USE IN SCIENCE; TISSUE CULTURE REAGENTS FOR SCIENTIFIC USE; CELL CULTURE REAGENTS FOR SCIENTIFIC USE; BIOLOGICAL TEST KITS COMPOSED OF BUFFER AND STANDARD SOLUTIONS USED IN ANALYTICAL CHEMISTRY, VECTORS, CELLS AND REAGENTS FOR SCIENTIFIC RESEARCH USE .

FIRST USE ; IN COMMERCE .

INT. CL. 5/U.S. CLS. 6, 18, 44, 46, 51 AND 52

FOR BIOLOGICAL REAGENTS FOR USE IN EMBRYOLOGY; BIOLOGICAL REAGENTS FOR MEDICAL USE IN THE FIELD OF MOLECULAR BIOLOGY; REAGENTS FOR USE IN BIOLOGICAL PROCESSING FOR MEDICAL PURPOSES; REAGENTS FOR USE IN BIOLOGICAL PROCESSING FOR VETERINARY PURPOSES; AGENTS IN THE NATURE OF HORMONES, CYTOKINES, ANTIGENS, IMMUNOGLOBULINS FOR ACTIVATING CELLULAR FUNCTIONS; BIOLOGICAL PREPARATIONS FOR MEDICAL PURPOSES, NAMELY, FOR USE IN CELL CULTURES; ANTITOXIC SERA; ANTITOXIC SERA FOR IN VIVO USE FOR MEDICAL PURPOSES; ANTIBODIES FOR THE TREATMENT OF DISEASE; ANTIBODIES FOR IMMUNODIAGNOSTIC MEDICAL PURPOSES; ANTIBODIES FOR IMMUNOPROPHYLACTIC MEDICAL PURPOSES; ANTIBODIES FOR IMMUNOTHERAPEUTIC MEDICAL PURPOSES; ANTIBODIES FOR IN VIVO MEDICAL USE IN DETECTING DISEASES IN LIVESTOCK; [IMMUNOLOGICAL ANTIBODIES FOR MEDICAL USE] .

FIRST USE ; IN COMMERCE .

INT. CL. 9/U.S. CLS. 21, 23, 26, 36 AND 38

FOR LABORATORY APPARATUS, NAMELY, CENTRIFUGES FOR SCIENTIFIC RESEARCH; [CELL COUNTING UNITS FOR LABORATORY USE;] CELL CULTURE APPARATUS, NAMELY, CELL CULTURE DISHES, CELL CULTURE FLASKS, CELL CULTURE PLATES, AND CELL CULTURE WELLS FOR LABORATORY USE; CELL CULTURE INSTRUMENTS, NAMELY, CELL CULTURE DISHES, CELL CULTURE FLASKS, CELL CULTURE PLATES, AND CELL CULTURE WELLS FOR LABORATORY USE; COMPUTER SOFTWARE FOR USE IN DATABASE MANAGEMENT, FOR USE AS A SPREADSHEET, AND FOR WORD PROCESSING; COMPUTER SOFTWARE FOR DATA MANAGEMENT, NAMELY, DATABASE MANAGEMENT SOFTWARE.

FIRST USE ; IN COMMERCE .

INT. CL. 42/U.S. CLS. 100 AND 101

FOR [LABORATORY SERVICES, NAMELY, LABORATORY RESEARCH IN THE FIELD OF BIOLOGY, BACTERIOLOGY, CHEMISTRY AND COSMETICS;] CELL SEPARATION RESEARCH SERVICES; CELL SEPARATION TECHNOLOGY SERVICES; STEM CELL RESEARCH SERVICES; ADVISORY SERVICES RELATING TO SCIENTIFIC RESEARCH; PHARMACEUTICAL RESEARCH SERVICES; CONTRACT RESEARCH SERVICES RELATING TO GROWTH, SELECTION, DIFFERENTIATION AND/OR PURIFICATION OF STEM CELLS; LABORATORY SERVICES RELATING TO THE PRODUCTION OF MONOCLONAL ANTIBODIES.

FIRST USE ; IN COMMERCE .

ELEMENTS CORRECTED
GOODS/SERVICES
[INTERNATIONAL CLASS(ES)]

3,345,307. REG. 11-27-2007. JOHNSON & JOHNSON (NEW JERSEY CORPORATION) ONE JOHNSON & JOHNSON PLAZA, NEW BRUNSWICK, NJ, 089337001, SN 78-638,781. FILED 5-27-2005. PRINCIPAL REGISTER.

PRICARA

THE MARK CONSISTS OF STANDARD CHARACTERS WITHOUT CLAIM TO ANY PARTICULAR FONT, STYLE, SIZE, OR COLOR.

INT. CL. 5/U.S. CLS. 6, 18, 44, 46, 51 AND 52

FOR HUMAN PRESCRIPTION PHARMACEUTICAL PREPARATIONS FOR USE IN THE TREATMENT OF ACID REFLUX DISEASE, INFECTIOUS DISEASES AND FOR USE IN PAIN MANAGEMENT * EXCLUDING NUTRITIONAL SUPPLEMENTS FOR PRENATAL USE * .

FIRST USE 12-0-2006; IN COMMERCE 12-0-2006.

ELEMENTS AMENDED
GOODS/SERVICES

3,363,126. REG. 1-1-2008. ICYNENE INC. (CANADA CORPORATION) 6747 CAMPOBELLO ROAD, MISSISSAUGA, ONTARIO, CANADA, L5N 2L7, SN 78-442,421. FILED 6-28-2004. PRINCIPAL REGISTER.

3,366,968. REG. 1-8-2008. HELIX ENERGY SOLUTIONS GROUP, INC. (MINNESOTA CORPORATION) 400 N. SAM HOUSTON PARKWAY E., SUITE 400, HOUSTON, TX. 770603548, SN 78-824,368. FILED 2-27-2006. PRINCIPAL REGISTER.

GOLD SEAL 400

THE MARK CONSISTS OF STANDARD CHARACTERS WITHOUT CLAIM TO ANY PARTICULAR FONT, STYLE, SIZE, OR COLOR.

PRIORITY CLAIMED UNDER SEC. 44(D) ON CANADA APPLICATION NO. 1,206,003, FILED 2-11-2004, REG. NO. TMA658582, DATED 2-9-2006, EXPIRES 2-9-2021.

NO CLAIM IS MADE TO THE EXCLUSIVE RIGHT TO USE "400", APART FROM THE MARK AS SHOWN.

INT. CL. 1/U.S. CLS. 1

FOR CHEMICAL PREPARATIONS FOR PRODUCING INSULATION MATERIAL AND IN-SITU FOAM INSULATION; PORTABLE SPRAY PACKS CONTAINING CHEMICAL PREPARATIONS FOR PRODUCING INSULATION MATERIAL AND IN-SITU FOAM INSULATION (BASED UPON SECTION 44).

FIRST USE ; IN COMMERCE .

INT. CL. 37/U.S. CLS. 100, 103 AND 106

FOR INSTALLATION OF INDUSTRIAL, COMMERCIAL AND RESIDENTIAL BUILDING INSULATION.

FIRST USE 6-1-2006; IN COMMERCE 6-1-2006.

ELEMENTS CORRECTED
GOODS/SERVICES

3,366,050. REG. 1-8-2008. OPEL EISENACH GMBH (FED REP GERMANY LIMITED LIABILITY COMPANY) ADAM-OPEL-STRASSE 100, 99817 EISENACH, FED REP GERMANY,, SN 79-029,175. FILED 7-6-2006. PRINCIPAL REGISTER.

SIGNUM

THE MARK CONSISTS OF STANDARD CHARACTERS WITHOUT CLAIM TO ANY PARTICULAR FONT, STYLE, SIZE, OR COLOR.

OWNER OF INTERNATIONAL REGISTRATION 0674800 DATED 4-17-1997, EXPIRES 4-17-2017.

INT. CL. 12/U.S. CLS. 19, 21, 23, 31, 35 AND 44

FOR MOTOR VEHICLES, NAMELY, LAND VEHICLES AND STRUCTURAL PARTS THEREOF * NOT INCLUDING ANY TIRES FOR MOTOR VEHICLES, TUBES FOR MOTOR VEHICLES, OR PARTS AND FITTINGS FOR TIRES OR TUBES FOR MOTOR VEHICLES *.

FIRST USE ; IN COMMERCE .

ELEMENTS CORRECTED
GOODS/SERVICES

HELIX

THE MARK CONSISTS OF STANDARD CHARACTERS WITHOUT CLAIM TO ANY PARTICULAR FONT, STYLE, SIZE, OR COLOR.

INT. CL. 35/U.S. CLS. 100, 101 AND 102

FOR OPERATING MARINE STRUCTURES, MARINE EQUIPMENT, OIL AND GAS EXPLORATION AND PRODUCTION EQUIPMENT, AND OIL AND GAS WELL STRUCTURES AND EQUIPMENT FOR OTHERS.

FIRST USE 3-6-2006; IN COMMERCE 3-6-2006.

INT. CL. 37/U.S. CLS. 100, 103 AND 106

FOR UNDERWATER BUILDING AND CONSTRUCTION; MARINE CONSTRUCTION; INSTALLATION, MAINTENANCE AND REPAIR OF MARINE STRUCTURES, MARINE EQUIPMENT, AND OIL AND GAS EXPLORATION AND PRODUCTION EQUIPMENT; [REPAIR, SERVICING AND MAINTENANCE OF EQUIPMENT FOR USE IN SUBSURFACE AND OFFSHORE ENVIRONMENTS;] LAYING AND CONSTRUCTION OF PIPELINES; PIPELINE INSTALLATION AND REPAIR; CABLE INSTALLATION AND REPAIR; OIL AND GAS DRILLING; DECOMMISSIONING OF OIL AND GAS WELL STRUCTURES AND EQUIPMENT FOR OTHERS; PLUGGING AND ABANDONMENT OF OIL AND GAS WELLS; BURIAL AND REPAIR OF OIL AND GAS WELL STRUCTURES, PIPELINES, AND RELATED EQUIPMENT.

FIRST USE 3-6-2006; IN COMMERCE 3-6-2006.

INT. CL. 39/U.S. CLS. 100 AND 105

FOR UNDERWATER SALVAGE.

FIRST USE 3-6-2006; IN COMMERCE 3-6-2006.

INT. CL. 42/U.S. CLS. 100 AND 101

FOR UNDERWATER STRUCTURAL INSPECTION SERVICES; TESTING OF OIL AND GAS WELL STRUCTURES AND EQUIPMENT FOR OTHERS.

FIRST USE 3-6-2006; IN COMMERCE 3-6-2006.

ELEMENTS AMENDED
GOODS/SERVICES

3,366,973. REG. 1-8-2008. HELIX ENERGY SOLUTIONS GROUP, INC. (MINNESOTA CORPORATION) 400 N. SAM HOUSTON PARKWAY E., SUITE 400, HOUSTON, TX. 770603548, SN 78-828,871. FILED 3-3-2006. PRINCIPAL REGISTER.

3,370,185. REG. 1-15-2008. INDUSTRIAS ALEN, S.A. DE C.V. (MEXICO CORPORATION) BLVD. DIAZ ORDAZ NO. 1000, COL. LOS TREVINO, SANTA CATARINA, N.L., C.P. 66350, MEXICO., SN 78-477,664. FILED 9-2-2004. PRINCIPAL REGISTER.



THE MARK CONSISTS OF A STYLIZED REPRESENTATION OF A HELIX.

INT. CL. 35/U.S. CLS. 100, 101 AND 102

FOR OPERATING MARINE STRUCTURES, MARINE EQUIPMENT, OIL AND GAS EXPLORATION AND PRODUCTION EQUIPMENT, AND OIL AND GAS WELL STRUCTURES AND EQUIPMENT FOR OTHERS.

FIRST USE 3-6-2006; IN COMMERCE 3-6-2006.

INT. CL. 37/U.S. CLS. 100, 103 AND 106

FOR UNDERWATER BUILDING AND CONSTRUCTION; MARINE CONSTRUCTION; INSTALLATION, MAINTENANCE AND REPAIR OF MARINE STRUCTURES, MARINE EQUIPMENT, AND OIL AND GAS EXPLORATION AND PRODUCTION EQUIPMENT; [REPAIR, SERVICING AND MAINTENANCE OF EQUIPMENT FOR USE IN SUBSURFACE AND OFFSHORE ENVIRONMENTS;] LAYING AND CONSTRUCTION OF PIPELINES; PIPELINE INSTALLATION AND REPAIR; CABLE INSTALLATION AND REPAIR; OIL AND GAS DRILLING; DECOMMISSIONING OF OIL AND GAS WELL STRUCTURES AND EQUIPMENT FOR OTHERS; PLUGGING AND ABANDONMENT OF OIL AND GAS WELLS; BURIAL AND REPAIR OF OIL AND GAS WELL STRUCTURES, PIPELINES, AND RELATED EQUIPMENT.

FIRST USE 3-6-2006; IN COMMERCE 3-6-2006.

INT. CL. 39/U.S. CLS. 100 AND 105

FOR UNDERWATER SALVAGE.

FIRST USE 3-6-2006; IN COMMERCE 3-6-2006.

INT. CL. 42/U.S. CLS. 100 AND 101

FOR UNDERWATER STRUCTURAL INSPECTION SERVICES; TESTING OF OIL AND GAS WELL STRUCTURES AND EQUIPMENT FOR OTHERS.

FIRST USE 3-6-2006; IN COMMERCE 3-6-2006.

ELEMENTS AMENDED
GOODS/SERVICES

FLASH PARAISO FRUTAL

THE MARK CONSISTS OF STANDARD CHARACTERS WITHOUT CLAIM TO ANY PARTICULAR FONT, STYLE, SIZE, OR COLOR.

OWNER OF U.S. REG. NO. 2,849,604 AND OTHERS.

THE ENGLISH TRANSLATION OF THE WORDING PARAISO FRUTAL IN THE MARK IS FRUIT PARADISE.

INT. CL. 3/U.S. CLS. 1, 4, 6, 50, 51 AND 52

FOR BLEACHING, CLEANING, POLISHING, DEGREASING, SCOURING AND ABRASIVE PREPARATIONS, NAMELY, SCOURING LIQUIDS AND SCOURING POWDERS; LAUNDRY DETERGENTS AND FABRIC SOFTENERS; SOAPS; ALL OF THE ABOVE FOR HOUSEHOLD AND LAUNDRY USE *BUT SPECIFICALLY EXCLUDING FOAMING ANTIMICROBIAL CLEANSER*.

FIRST USE 2-28-2007; IN COMMERCE 2-28-2007.

ELEMENTS AMENDED
GOODS/SERVICES

3,373,792. REG. 1-22-2008. INDUSTRIAS ALEN, S.A. DE C.V. (MEXICO CORPORATION) BLVD. DIAZ ORDAZ NO. 1000, COL. LOS TREVINO, SANTA CATARINA, N.L., C.P. 66350, MEXICO., SN 78-477,656. FILED 9-2-2004. PRINCIPAL REGISTER.

FLASH PARAISO CITRICO

THE MARK CONSISTS OF STANDARD CHARACTERS WITHOUT CLAIM TO ANY PARTICULAR FONT, STYLE, SIZE, OR COLOR.

OWNER OF U.S. REG. NO. 2,849,604 AND OTHERS.

NO CLAIM IS MADE TO THE EXCLUSIVE RIGHT TO USE "CITRICO", APART FROM THE MARK AS SHOWN.

THE ENGLISH TRANSLATION OF THE WORDING PARAISO CITRICO IN THE MARK IS "CITRUS PARADISE".

INT. CL. 3/U.S. CLS. 1, 4, 6, 50, 51 AND 52

FOR BLEACHING, CLEANING, POLISHING, DEGREASING, SCOURING AND ABRASIVE PREPARATIONS, NAMELY, HOUSEHOLD LIQUID FLOOR CLEANERS; LAUNDRY DETERGENTS, LAUNDRY SOAPS AND FABRIC SOFTENERS; SOAPS FOR HOUSEHOLD USE *EXCLUDING INDUSTRIAL AND INSTITUTIONAL FOAMING ANTIMICROBIAL CLEANSER*.

FIRST USE 2-28-2007; IN COMMERCE 2-28-2007.

ELEMENTS AMENDED
GOODS/SERVICES

3,381,028. REG. 2-12-2008. COLONIAL PENN LIFE INSURANCE COMPANY (PENNSYLVANIA CORPORATION) 399 MARKET STREET, PHILADELPHIA, PA, 19181, SN 77-204,008. FILED 6-12-2007. PRINCIPAL REGISTER.

CHAMPIONSHIP LIFE

THE MARK CONSISTS OF STANDARD CHARACTERS WITHOUT CLAIM TO ANY PARTICULAR FONT, STYLE, SIZE, OR COLOR.

NO CLAIM IS MADE TO THE EXCLUSIVE RIGHT TO USE "LIFE", APART FROM THE MARK AS SHOWN.

INT. CL. 36/U.S. CLS. 100, 101 AND 102
FOR LIFE INSURANCE UNDERWRITING SERVICES.
FIRST USE 4-10-1995; IN COMMERCE 4-10-1995.

ELEMENTS AMENDED
OWNER NAME

3,404,283. REG. 4-1-2008. HERBALIFE INTERNATIONAL, INC. (NEVADA CORPORATION) 1800 CENTURY PARK EAST, LOS ANGELES, CA. 900671501, SN 77-079,192. FILED 1-9-2007. PRINCIPAL REGISTER.



OWNER OF U.S. REG. NOS. 2,002,163, 2,512,368 AND 3,120,358.

THE MARK CONSISTS OF ONE OVAL STANDING VERTICALLY, THE ENDS OF WHICH ARE POINTED, MET AT ITS BOTTOM END BY TWO OTHER OVALS, THE ENDS OF WHICH ARE ALSO POINTED, WHICH STAND AT 45 DEGREE ANGLES ON EITHER SIDE OF THE VERTICALLY STANDING OVAL, ALL ENCOMPASSED BY A CIRCLE, AND SITUATED AGAINST THE BOTTOM OF SUCH CIRCLE.

INT. CL. 9/U.S. CLS. 21, 23, 26, 36 AND 38

FOR PRE-RECORDED SOUND, VIDEO AND DATA RECORDINGS AND DATA CARRIERS, NAMELY, AUDIO CASSETTE TAPES, VIDEO TAPES, DOWNLOADABLE VIDEOGRAMS, DIGITAL AUDIO DISCS, DIGITAL VERSATILE DISCS KNOWN AS DVDS, COMPACT DISCS KNOWN AS CDS, TAPES, OPTICAL COMPACT DISCS, VIDEO DISCS, MPEGS AND DIGITAL AUDIO AND VIDEO COMPRESSION FILES ALL FEATURING ENTERTAINMENT, INSTRUCTION, EDUCATION OR NEWS IN THE FIELDS OF HEALTH, NUTRITION AND BUSINESS MANAGEMENT; PRERECORDED MOTION PICTURE FILMS AND SOUND FILMS PREPARED FOR EXHIBITION, ALL FEATURING MUSIC, ENTERTAINMENT, INSTRUCTION, EDUCATION OR NEWS; COMPUTER SOFTWARE, NAMELY, SOFTWARE FOR BROADCASTING AND FOR USE IN DELIVERING, TRANSMITTING, AND RECEIVING AUDIO AND VIDEO ON DEMAND SERVICES AND DOWNLOADING AUDIO/VIDEO STREAMS FROM A GLOBAL COMMUNICATIONS NETWORK; DOWNLOADABLE ELECTRONIC PUBLICATIONS, NAMELY, BOOKS, MAGAZINES,

NEWSLETTERS, CATALOGS, PROGRAMS AND GUIDES FEATURING ENTERTAINMENT, INSTRUCTION, EDUCATION OR NEWS IN THE FIELDS OF HEALTH, NUTRITION AND BUSINESS MANAGEMENT; CD-ROMS FEATURING ENTERTAINMENT, INSTRUCTION, EDUCATION OR NEWS IN THE FIELDS OF HEALTH, NUTRITION AND BUSINESS MANAGEMENT; ELECTRONIC INSTRUCTIONAL AND TEACHING APPARATUS AND INSTRUMENTS, NAMELY, PRE-RECORDED DISCS, TAPES, CASSETTES, CARTRIDGES AND MPEGS FEATURING INSTRUCTION, ENTERTAINMENT, EDUCATION AND INFORMATION IN THE FIELDS OF HEALTH, NUTRITION AND BUSINESS MANAGEMENT; DOWNLOADABLE SOUND AND VIDEO RECORDINGS FEATURING ENTERTAINMENT, INSTRUCTION, EDUCATION OR NEWS IN THE FIELDS OF HEALTH, NUTRITION AND BUSINESS MANAGEMENT.

FIRST USE 4-0-1995; IN COMMERCE 4-0-1995.

INT. CL. 38/U.S. CLS. 100, 101 AND 104

FOR BROADCASTING AND TRANSMISSION OF AUDIO, VIDEO, STILL AND MOVING IMAGES AND DATA IN COMPRESSED AND UNCOMPRESSED FORM IN REAL AND DELAYED TIME; BROADCASTING AND TRANSMISSION OF RADIO AND TELEVISION PROGRAMS; VIDEO BROADCASTING SERVICES; VIDEO-ON-DEMAND TRANSMISSION SERVICES; STREAMING OF AUDIO, VIDEO, DATA AND OTHER CONTENT OVER THE INTERNET AND OVER INTERCONNECTED CABLE, SATELLITE AND BROADCAST SYSTEMS; ELECTRONIC TRANSMISSION OF RADIO AND TELEVISION PROGRAMS, TEXT, INFORMATION, SOUND AND IMAGES VIA COMMUNICATION AND COMPUTER NETWORKS AND THE INTERNET; PROVIDING ACCESS TO ONLINE ELECTRONIC PUBLICATIONS.

FIRST USE 4-0-1995; IN COMMERCE 4-0-1995.

ELEMENTS CORRECTED
GOODS/SERVICES

3,410,460. REG. 4-8-2008. SWISS- AMERICAN IMPORTING COMPANY (MISSOURI CORPORATION) 4245 PAPIN STREET, ST. LOUIS, MO, 63110, SN 78-667,305. FILED 7-11-2005. PRINCIPAL REGISTER.



THE MARK CONSISTS OF A TRIANGLE WITH A SQUARE CONTAINING A PLUS SIGN AND A RECTANGLE CONTAINING A STAR.

INT. CL. 29/U.S. CL. 46

FOR GROCERIES, NAMELY, MEATS, PREPARED MEATS, DILL PICKLES, JELLIES AND JAMS; CHEESE, DAIRY PRODUCTS, EXCLUDING ICE CREAM, ICE MILK, AND FROZEN YOGURT, CHEESES AND CHEESE SPREADS; AND GIFT BASKETS AND GIFT BOARDS CONSISTING PRIMARILY OF ANY OF THE FOREGOING.

FIRST USE 5-0-2005; IN COMMERCE 5-0-2005.

ELEMENTS CORRECTED
OWNER NAME

3,412,843. REG. 4-15-2008. KING KOIL LICENSING COMPANY, INC. (DELAWARE CORPORATION) 7501 S. QUINCY STREET, SUITE 130, WILLOWBROOK, IL, 605275574. SN 78-665,463. FILED 7-7-2005. PRINCIPAL REGISTER.

3,437,434. REG. 5-27-2008. NEXBIO, INC. (CALIFORNIA CORPORATION) 10665 SORRENTO VALLEY ROAD, SAN DIEGO, CA. 92121, SN 77-224,779. FILED 7-9-2007. PRINCIPAL REGISTER.

COVERGARD

NEXBIO

THE MARK CONSISTS OF STANDARD CHARACTERS WITHOUT CLAIM TO ANY PARTICULAR FONT, STYLE, SIZE, OR COLOR.

THE MARK CONSISTS OF STANDARD CHARACTERS WITHOUT CLAIM TO ANY PARTICULAR FONT, STYLE, SIZE, OR COLOR.

INT. CL. 20/U.S. CLS. 2, 13, 22, 25, 32 AND 50
FOR BEDS, MATTRESSES AND BOX SPRINGS.
FIRST USE 1-1-2007; IN COMMERCE 1-1-2007.

INT. CL. 5/U.S. CLS. 6, 18, 44, 46, 51 AND 52
FOR PHARMACEUTICAL PREPARATIONS FOR THE TREATMENT OF ALLERGIES, CANCER, CARDIOVASCULAR DISORDERS, DERMATOLOGICAL DISORDERS, DIABETES, ENDOCRINE DISORDERS, GASTROINTESTINAL DISORDERS, HYPERTENSION, IMMUNOLOGICAL DISORDERS, INFECTIOUS DISEASES, INFLAMMATION, INFLAMMATORY DISEASES, MIGRAINES, OBESITY, PAIN, RENAL DISORDERS, RESPIRATORY DISEASES, SEPSIS, STROKE, VIRAL DISORDERS.
FIRST USE 8-19-2002; IN COMMERCE 10-22-2007.

ELEMENTS CORRECTED
CITIZENSHIP

ELEMENTS CORRECTED
MARK
DATE OF FIRST USE

3,432,080. REG. 5-20-2008. ASPEN VETERINARY RESOURCES, LTD. (COLORADO LIMITED PARTNERSHIP) P.O. BOX BB 630 "O" STREET, GREELEY, CO, 80632, SN 77-066,068. FILED 12-18-2006. PRINCIPAL REGISTER.

3,440,899. REG. 6-3-2008. FIBRO GMBH (FED REP GERMANY GMBH) AUGUST-LÄPPLÉ WEG, 74855 HABMERSHEIM, FED REP GERMANY., SN 79-033,711. FILED 10-7-2005. PRINCIPAL REGISTER.

COCCISTOP SOLUTIONS

FIBRO

THE MARK CONSISTS OF STANDARD CHARACTERS WITHOUT CLAIM TO ANY PARTICULAR FONT, STYLE, SIZE, OR COLOR.

PRIORITY DATE OF 7-26-2005 IS CLAIMED.
OWNER OF INTERNATIONAL REGISTRATION 0910509 DATED 10-7-2005, EXPIRES 10-7-2015.

INT. CL. 5/U.S. CLS. 6, 18, 44, 46, 51 AND 52
FOR VETERINARY PREPARATIONS FOR TREATMENT OF COCCIDIOSIS IN LIVESTOCK.
FIRST USE 2-2-2007; IN COMMERCE 2-2-2007.

OWNER OF U.S. REG. NOS. 1,050,559, 1,050,561 AND 1,295,708.
INT. CL. 1/U.S. CLS. 1

ELEMENTS AMENDED
OWNER NAME

FOR CYANOACRYLATE INSTANT ADHESIVES, EPOXY RESIN, ACRYLIC RESINS; HARDENERS WITH AN EPOXY RESIN BASE, NAMELY, EPOXY HARDENERS, HARDENERS FOR USE IN THE MANUFACTURE OF POLYURETHANE RUBBERS, FOAMS AND PLASTICS, ADHESIVES FOR GENERAL INDUSTRIAL USE; CHEMICAL SUBSTANCES FOR INDUSTRIAL PURPOSES, NAMELY, LEAK DETECTOR SPRAYS; SOLVENTS FOR INDUSTRIAL AND COMMERCIAL USE; ASSEMBLY ADHESIVES, NAMELY, CONSTRUCTION INDUSTRY ADHESIVES; ASSEMBLY SPRAYS, NAMELY, SPRAYS FOR THE ASSEMBLING OF MACHINES; POLYURETHANE, POLYURETHANE DEFORMATION MATERIAL, NAMELY, POLYURETHANE RESINS; QUICK CLEANERS, NAMELY, CHEMICAL CLEANERS FOR INDUSTRIAL AND COMMERCIAL USE; SEPARATING AGENTS WITH A SILICON OIL BASE, NAMELY, FORM OR MOLD RELEASING AGENTS, PARTING AGENTS FOR INDUSTRIAL AND COMMERCIAL USE; SEPARATING AGENTS WITH A WAX BASE, NAMELY, FORM OR MOLD RELEASING AGENTS, PARTING AGENTS FOR INDUSTRIAL AND COMMERCIAL USE.
FIRST USE ; IN COMMERCE .

3,432,081. REG. 5-20-2008. ASPEN VETERINARY RESOURCES, LTD. (COLORADO LIMITED PARTNERSHIP) P.O. BOX BB 630 "O" STREET, GREELEY, CO, 80632, SN 77-066,076. FILED 12-18-2006. PRINCIPAL REGISTER.

INT. CL. 7/U.S. CLS. 13, 19, 21, 23, 31, 34 AND 35

MOR-MAX

THE MARK CONSISTS OF STANDARD CHARACTERS WITHOUT CLAIM TO ANY PARTICULAR FONT, STYLE, SIZE, OR COLOR.

INT. CL. 5/U.S. CLS. 6, 18, 44, 46, 51 AND 52
FOR VETERINARY PREPARATIONS FOR DEWORMING OF GOATS.
FIRST USE 2-20-2007; IN COMMERCE 2-20-2007.

ELEMENTS AMENDED
OWNER NAME

FOR MACHINES, NAMELY, FOR AUTOMATION AND ROBOTICS, ROTARY TABLES, ROTARY INDEXING TABLES, BUILT-IN ROTARY INDEXING TABLES, NC ROTARY TABLES, ELECTROMECHANICAL ROTARY INDEXING TABLES; TURRET HEADS, NAMELY, ELECTRIC ROTARY TABLES; STANDARD MACHINES FOR THE CONSTRUCTION OF THE FOLLOWING TOOLS, MACHINE PARTS, AND MACHINE TOOLS, NAMELY, COMPRESSION SPRING TOOLS, COMPRESSION PINS, ADJUSTMENT WASHERS, STRIPPERS, EXTRACTION TOOLS, STOPPING PLATES, BOLT-ON GUIDE; STANDARD SPECIFICATIONS FOR TOOL CONSTRUCTION, NAMELY, PRESSURE SPRINGS, PRESSURE PINS, TUNING DISCS, STRIPPERS, EXTRACTION TOOL, STOPPING PLATES, BOLT-ON GUIDE PILLARS, LOCATING BOLTS FOR ROUND SPRINGS, CONTROL BARS, POT HOUSINGS FOR SPRINGS, POT HOUSINGS FOR CLIPPING PUNCHES, FEEDER PLATES FOR CLIPPING PUNCHES, EJECTOR SLEEVES, EJECTOR PINS, DELIMITING GUIDES FOR CONVEYOR BELTS, DRILL BUSHES WITH AND WITHOUT COLLAR, PIN GUIDES, LINERS, COLLAR BUSHINGS, HEAD POSTS, DATE STAMPS, DAMPING DISCS, RETAINING PLATES, DISTANCE PLATES, SPACER TUBES, SPACER BUSHES AND TUBES FOR BALL CAGES, TRIANGULAR SECTIONS, TRIANGULAR HOLLOW SECTIONS, COMPRESSION SPRINGS, COMPRESSION PLATES, COMPRESSION PINS FOR CLIPPING PUNCHES, THRUST PADS, TAPER SLEEVES, INSERTION TOOLS FOR SPRING-MOUNTED THRUST PADS, DIE SPIGOTS, INJECTION CARTRIDGES, INJECTION PISTOLS, GUIDES WITH PART POSITION CONTROL, PROGRESSION DIE SET UNITS, PANEL CASES, PROTECTIVE BELLOWS, SPRING EJECTORS, SPRING RAMS, COMBINATION SPRING AND SPACER UNITS, SPRINGS, SPRING-MOUNTED THRUST PIECES, SPRING WASHERS, SPRING PLATES, SPRING PLATE ACCESSORIES, FLAT EJECTORS PINS, FLAT SEGMENTS, SINTERED BUSHES, DIE SET UNITS FOR PROGRESSION DIES, CONVEYOR BELTS, CONVEYOR BELT ACCESSORIES, GUIDE PINS, GUIDE BUSHES, GUIDE PLATES, GUIDE STRIPS, GUIDE ELEMENTS, GUIDE BEARINGS, GUIDE PILLARS, GAS PRESSURE SPRINGS, GROUND BOARDS AND STRIPS, SLIDING ELEMENTS, SLIDE PLATES, SLIDING BLOCKS, RUBBER BELLOWS, CAST IRON DIE SETS, LINER BUSHES, LINING BLOCKS, LINING PLATES, LINERS, HARD METAL CLIPPING PUNCHES, HOLLOW ROUND SECTIONS, HOLLOW PILLARS, SLEEVES, CAGE RETAINERS, BOXES FOR TESTING PINS, SLUICE VALVES, SMALL PRESSES, BALL BEARING INSERTS, BALL BEARING GUIDES, BALL BEARING CAGES, BRASS, ELASTOMER SPRINGS, ELASTOMER PADS AND SHEETS, COUPLING SPIGOTS, HOISTING SNAP LINKS, STRIPS, PUNCHING AND STAMPING UNIT, PUNCHES, EXTRACTOR TOOLS, MATRIXES, MEASURING PINS, MEASURING PIN HOLDERS, DEMOUNTABLE PILLARS, SHOULDER SCREWS, DOWEL PINS, DOWEL PIN LININGS, PADS AND SHEETS, PNEUMATIC CONVEYOR BELTS, PNEUMATIC CONVEYORS, EMBOSSING MATERIAL, PRECISION FEELER GAUGES, PRECISION PARTS, FLAT AND SQUARE TOOL STEEL, PRESS CONSOLES, PRISMATIC GUIDES, PROFILED CLIPPING PUNCHES, RECTANGULAR MOUNTING FLANGES, RECTANGULAR PUNCHES, RING BLOCKS, RING BOLTS, ROLLER CAGES, ROLLER SLIDES, * PILLAR DIE SET * ACCESSORIES, WIPERS, PIERCING DIE BUSHES, CLIPPING PUNCHES, CLIPPING PUNCH FEEDER PLATES, QUICK CHANGE CLIPPING PUNCHES, QUICK CHANGE FRAMES, T-HEAD BOLTS, COMPRESSION SPRINGS, SHOULDER SCREWS, COUNTERSUNK SCREWS, SECURING FLANGES, SINTERED GUIDE BUSHES, SPECIAL DIE SETS, CLAMPING ELEMENTS, BOXED CLAMPING TOOL SETS, SHANKS, SPECIAL SPRINGS, SPECIAL SECURING AIDS, STEEL PLATES, STEEL DIE SETS, STANDS FOR CONVEYOR BELTS, GUIDE BUSHES FOR PUNCHES, LIFTER PINS FOR PRESS TOOL STRIPS, PUMMELS, TANK PLATE SYSTEM, WORKPIECE LIFTERS, DISC SPRINGS, LIFTING BOLTS, LIFTER HOOKS, LIFTING BOLTS, LIFTING FLANGES, LIFTER STUDS, CONVEYING AND FASTENING ELEMENTS, OVERRUN CAMS, FORMING SECTIONS, UNIVERSAL SWIVEL HOIST RINGS, URETHANE SPRINGS, URETHANE PADS AND SHEETS, VDI BUSHES, VDI PUNCHES, SCREWED SEALING PLUGS, SQUARE PUNCHES, SQUARE SECTIONS, SQUARE HOLLOW SECTIONS, SQUARE STEEL, FOUR PILLAR DIE SETS, ROLLER INSERTS, ROLLER RAILS, OILLESS GUIDE

ELEMENTS, DEMOUNTABLE GUIDE PILLARS, DIE SET UNITS FOR PROGRESSION CENTERING UNITS, TWO PILLAR DIE SETS, CYLINDER HEAD EJECTORS, CYLINDER HEAD PUNCHES, CHEESE HEAD SCREWS, STRAIGHT PIN BUSHES, STRAIGHT PINS, STRAIGHT PIN EXTRACTORS; MECHANICAL HANDLING APPARATUS FOR GRABBING, RETAINING, DEPOSITING, TRANSLATIONAL AND/OR REVOLVING MOVEMENTS AND/OR CONVEYING OF WORK PIECES, NAMELY, FOR USE IN MANUFACTURING PROCESSES, AND/OR LOADING AND DOWNLOADING OF MACHINE TOOLS; ELEMENTS OF THE AFORESAID HANDLING APPARATUS, NAMELY, GRABS, LINEAR MOVEMENT UNITS, NAMELY, CLAWS, CLUTCHES, HOOKS, NIPPERS, PINCHERS, PICKER ARMS, SINGLE ROTATING HOOKS AND OSCILLATING HOOKS; PORTAL ROBOTS FOR MACHINE TOOLS, PARTS FOR AUTOMATION AND ROBOTICS, NAMELY, SHORT-STROKE UNITS [AND SHORT-LIFTING APPARATUS,] TRANSLATION UNITS, NAMELY, TRANSLATION MACHINES, LINEAR AXES, ROTATION UNITS, NAMELY, ROTATION MACHINES, ELECTRIC MOTOR MODULES AND GRABS. FIRST USE ; IN COMMERCE .

ELEMENTS CORRECTED
GOODS/SERVICES

3,462,650, REG. 7-8-2008. THE MACALLAN DISTILLERS LIMITED (UNITED KINGDOM COMPANY) MACALLAN DISTILLERY, CRAIGELLACHIE; ABERLOUR, , BANFFSHIRE, UNITED KINGDOM, AB389RX, SN 79-042,642. FILED 6-25-2007. PRINCIPAL REGISTER.

TRIPLE CASK MATURED



PRIORITY DATE OF 6-14-2007 IS CLAIMED.
OWNER OF INTERNATIONAL REGISTRATION 0934580 DATED 6-25-2007, EXPIRES 6-25-2017.

NO CLAIM IS MADE TO THE EXCLUSIVE RIGHT TO USE TRIPLE CASK MATURED, APART FROM THE MARK AS SHOWN.

THE COLOR(S) GOLD IS/ARE CLAIMED AS A FEATURE OF THE MARK.

THE COLOR GOLD APPEARS IN THE WORDING TRIPLE CASK MATURED AND IN THE THREE CASK DESIGNS. THE COLOR WHITE IS NOT CLAIMED AS A FEATURE OF THE MARK AND IS INTENDED TO INDICATE A TRANSPARENT AREA IN THE MARK.

INT. CL. 33/U.S. CLS. 47 AND 49

FOR *SCOTCH * WHISKY.
FIRST USE ; IN COMMERCE .

ELEMENTS CORRECTED
GOODS/SERVICES

3,490,390. REG. 8-19-2008. COMMON SENSE DENTAL PRODUCTS II, INC. (MICHIGAN CORPORATION), DBA COMMON SENSE DENTAL PRODUCTS, 14998 CLEVELAND ST., SUITE A, SPRING LAKE, MI. 49456, SN 78-786,570. FILED 1-6-2006. PRINCIPAL REGISTER.

3,495,998. REG. 9-2-2008. PILLSBURY COMPANY LLC, THE (DELAWARE LIMITED LIABILITY COMPANY) NUMBER ONE GENERAL MILLS BLVD., MINNEAPOLIS, MN, 55426, SN 78-754,050. FILED 11-15-2005. PRINCIPAL REGISTER.

NUBEND 120°

THE MARK CONSISTS OF STANDARD CHARACTERS WITHOUT CLAIM TO ANY PARTICULAR FONT, STYLE, SIZE, OR COLOR.
 INT. CL. 5/U.S. CLS. 6, 18, 44, 46, 51 AND 52
 FOR DENTAL AMPOULES, NAMELY, SMALL PLASTIC VIALS CONTAINING DENTAL FILLING MATERIAL FOR USE WITH DISPENSERS TO APPLY THE DENTAL FILLING MATERIAL DURING TOOTH RESTORATIONS.
 FIRST USE 2-24-2006; IN COMMERCE 2-24-2006.

ELEMENTS CORRECTED
 DBA/AKA
 OWNER NAME
 OWNER ADDRESS
 ENTITY

3,490,448. REG. 8-19-2008. P.C. WOO, INC. DBA MEGATOYS (CALIFORNIA CORPORATION) 905 EAST SECOND STREET, LOS ANGELES, CA, 90012, SN 78-820,957. FILED 2-22-2006. PRINCIPAL REGISTER.

COFFEE BREAK

THE MARK CONSISTS OF STANDARD CHARACTERS WITHOUT CLAIM TO ANY PARTICULAR FONT, STYLE, SIZE, OR COLOR.
 NO CLAIM IS MADE TO THE EXCLUSIVE RIGHT TO USE "COFFEE", APART FROM THE MARK AS SHOWN.
 INT. CL. 30/U.S. CL. 46
 FOR GIFT SETS CONSISTING OF A DECORATIVE GIFT BOX CONTAINING PRIMARILY COFFEE, AND WHICH ALSO CONTAINS RELATED ACCESSORIES, NAMELY, COFFEE MUGS, CREAMERS, SUGAR BOWLS, AND SPOONS.
 FIRST USE 2-28-2007; IN COMMERCE 2-28-2007.

ELEMENTS CORRECTED
 OWNER NAME

Real Breakfast! Real Easy! Real Fast!

THE MARK CONSISTS OF STANDARD CHARACTERS WITHOUT CLAIM TO ANY PARTICULAR FONT, STYLE, SIZE, OR COLOR.
 INT. CL. 30/U.S. CL. 46
 FOR PASTRY FILLED WITH EGGS AND MEAT AND/OR CHEESE.
 FIRST USE 2-16-2006; IN COMMERCE 2-16-2006.

ELEMENTS CORRECTED
 OWNER NAME
 ENTITY

3,518,873. REG. 10-21-2008. L & P SWISS HOLDING COMPANY (SWITZERLAND CORPORATION) GRUNTALSTRASSE 23, WITTENBACH, SWITZERLAND, 9303, SN 77-094,682. FILED 1-30-2007. PRINCIPAL REGISTER.

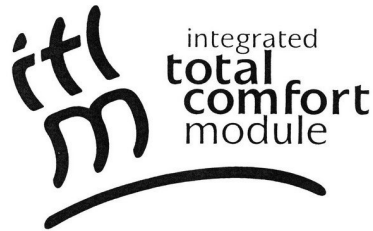

PRIORITY CLAIMED UNDER SEC. 44(D) ON FED REP GERMANY APPLICATION NO. 30647643, FILED 8-2-2006, REG. NO. 30647643, DATED 11-24-2006, EXPIRES 8-31-2016.
 NO CLAIM IS MADE TO THE EXCLUSIVE RIGHT TO USE "TOTAL COMFORT MODULE", APART FROM THE MARK AS SHOWN.
 THE MARK CONSISTS OF THE WORDS "INTEGRATED TOTAL COMFORT MODULE" AND THE LETTERS "I", "T", "C" AND "M" IN FANCIFUL SCRIPT, WITH AN INVERTED CURVED LINE UNDER ALL.
 INT. CL. 10/U.S. CLS. 26, 39 AND 44
 FOR SPECIALLY DESIGNED FURNITURE, NAMELY, CHAIRS FOR MEDICAL PURPOSES, NAMELY, FOR MEDICAL PATIENTS; ARMCHAIRS FOR MEDICAL PURPOSES, NAMELY, MEDICAL EXAMINATION; SEAT MODULES, NAMELY, SEAT INSERTS FOR SEAT FRAMES FOR MEDICAL PATIENTS; SEAT COMPONENTS, NAMELY, LUMBAR SUPPORTS AND CUSHIONS FOR MEDICAL PATIENTS; BACKRESTS FOR LORDOSIS PATIENTS; ERGONOMIC REST DEVICES; NAMELY, SEAT AND BACK CUSHIONS FOR LORDOSIS PATIENTS AND RESTS, NAMELY, CUSHIONS FOR LORDOSIS PATIENTS, THE AFOREMENTIONED GOODS DESTINED FOR SPECIALLY DESIGNED FURNITURE FOR MEDICAL PURPOSES.
 FIRST USE ; IN COMMERCE .
 INT. CL. 12/U.S. CLS. 19, 21, 23, 31, 35 AND 44

FOR VEHICLE ACCESSORIES, NAMELY, AUTOMOBILE SEAT CUSHIONS, AUTOMOBILE CARGO RACKS; VEHICLE SEATS; AUTOMOBILE SEAT MODULES, NAMELY, AUTOMOBILE SEAT CUSHIONS; AUTOMOBILE SEAT COMPONENTS, NAMELY, LUMBAR SUPPORTS AND CUSHIONS; AUTOMOBILE BACKRESTS USED FOR VEHICLE SEATS; AUTOMOBILE ERGONOMIC REST DEVICES AND RESTS, NAMELY, AUTOMOBILE SEAT CUSHIONS FOR PASSENGERS TO BE USED FOR VEHICLE SEATS; THE AFOREMENTIONED GOODS DESTINED FOR AUTOMOTIVE SEATS.
 INT. CL. 20/U.S. CLS. 2, 13, 22, 25, 32 AND 50

FOR SITTING FURNITURE; OFFICE FURNITURE; HAIR DRESSER'S FURNITURE; BACKRESTS FOR ARMCHAIRS, SEATS, AND SITTING FURNITURE; SITTING CUSHIONS; SEAT MODULES, NAMELY, SEAT CUSHIONS; SEAT COMPONENTS, NAMELY, LUMBAR SUPPORTS FOR USE WITH CHAIRS AND SEATS; ERGONOMIC REST DEVICES AND RESTS, NAMELY, SEAT CUSHIONS AND LUMBAR SUPPORTS FOR LOR- DOSIS PATIENTS, DESTINED FOR SITTING FURNI- TURE AND OFFICE FURNITURE.

3,531,138. REG. 11-11-2008. INTELLECTUAL PROPERTY HOLDINGS AS (NORWAY CORPORATION) FJORDAL- LEEN 16, N-0250 OSLO, NORWAY., SN 79-036,911. FILED 2-2-2007. PRINCIPAL REGISTER.



ELEMENTS CORRECTED
 FOREIGN APPLICATION NO.
 FOREIGN APPLICATION FILING DATE
 FOREIGN REG. DATE
 PRIORITY CLAIMED STATEMENT

PRIORITY DATE OF 9-18-2006 IS CLAIMED.
 OWNER OF INTERNATIONAL REGISTRATION 0920029 DATED 2-2-2007, EXPIRES 2-2-2017.
 OWNER OF U.S. REG. NOS. 2,652,824, 3,224,086 AND OTHERS.

NO CLAIM IS MADE TO THE EXCLUSIVE RIGHT TO USE "DRILLING", APART FROM THE MARK AS SHOWN. THE MARK CONSISTS OF THE WORDING "AKER DRILLING" AND A MISCELLANEOUS DESIGN CONSISTING OF A CURVED L-SHAPED GRAPHIC TOUCHING A CURVED L-SHAPED GRAPHIC AT THEIR RESPECTIVE CURVES.
 INT. CL. 4/U.S. CLS. 1, 6 AND 15

3,529,541. REG. 4-16-1963. TOYO ADVANCED TECHNOLOGIES CO. LTD. (JAPAN CORPORATION) 5-3-38 UJINA- HIGASHI, MINAMI-KU, HIROSHIMA, JAPAN., SN 75- 983,649. FILED 10-20-1961. PRINCIPAL REGISTER.

FOR INDUSTRIAL OILS AND GREASES; PETRO- LEUM OILS AND GASSES FOR POWER AND HEATING FUEL.

FIRST USE ; IN COMMERCE .
 INT. CL. 12/U.S. CLS. 19, 21, 23, 31, 35 AND 44
 FOR SHIPS, FAST BOATS, SEA-GOING VESSELS, AND PARTS AND FITTINGS THEREFORE.
 FIRST USE ; IN COMMERCE .

INT. CL. 37/U.S. CLS. 100, 103 AND 106
 FOR BUILDING CONSTRUCTION. CONSTRUCTION MODIFICATION, REPAIR AND INSTALLATION SER- VICES OF MECHANICAL AND AUTOMATED OIL AND GAS DRILLING AND WELL INTERVENTION EQUIP- MENT, UNITS, RIGS AND FACILITIES, AND BUILD- ING, MODIFICATION REPAIR AND INSTALLATION SERVICES OF OTHER DRILLING PROCESSING IN- STALLATIONS.
 FIRST USE ; IN COMMERCE .



INT. CL. 39/U.S. CLS. 100 AND 105
 FOR TRANSPORTATION BY SHIP AND BY AIR OF PETROLEUM OIL AND GAS DRILLING. SERVICING AND WELL INTERVENTION PROCESSING EQUIP- MENT; TRANSPORT SERVICES, NAMELY, PUMPING LOADING, STORING AND TRANSPORTATION OF OIL AND GAS PRO DUCATS, BOTH ONSHOARE AND OFFSHORE.
 FIRST USE ; IN COMMERCE .

"TOYO" MAY VARY IN MEANING, ACCORDING TO PRONUNCIATION, SUCH AS "PLENTIFUL", "FULL HAR- VEST", "ADHERENTS", "ORIENT", "APPOINT", "WORK IN HAND".

INT. CL. 7/U.S. CLS. 13, 19, 21, 23, 31, 34 AND 35
 FOR GRINDING MACHINES AND INTEGRAL PARTS OF THE FOREGOING.
 FIRST USE 10-0-1935; IN COMMERCE 10-0-1959.

INT. CL. 42/U.S. CLS. 100 AND 101
 FOR SCIENTIFIC RESEARCH, INDUSTRIAL RE- SEARCH, DESIGN AND DEVELOPMENT OF COMPU- TER PROGRAMS, AND TECHNOLOGICAL CONSULTATION SERVICES IN THE FOLLOWING PET- ROLEUM AND MARINE FIELDS: MECHANICAL AND AUTOMATED DRILLING SYSTEMS, FLOATING MAR- INE STRUCTURES AND RIGS, DOWN HOLE AND WELL INTERVENTION TECHNOLOGY, RESERVOIR TECHNOLOGY, SUBSEA TECHNOLOGY, PROCESSING, PUMPING, STORAGE AND TRANSPORTATION OF OIL AND GAS, PETROCHEMICAL AND BIOCHEMICAL PROCESS TECHNOLOGY.
 FIRST USE ; IN COMMERCE .

ELEMENTS AMENDED
 GOODS/SERVICES
 INTERNATIONAL CLASS(ES)
 DATE OF FIRST USE
 DATE OF FIRST USE IN COMMERCE

ELEMENTS CORRECTED
 GOODS/SERVICES
 CITIZENSHIP
 ENTITY

3,538,146. REG. 11-25-2008. UBS AG (SWITZERLAND CORPORATION) BAHNHOFSTRASSE 45, ZURICH, SWITZERLAND. 8001, SN 77-260,317. FILED 8-21-2007. PRINCIPAL REGISTER.



NO CLAIM IS MADE TO THE EXCLUSIVE RIGHT TO USE "OPTIMIZATION", APART FROM THE MARK AS SHOWN.

INT. CL. 36/U.S. CLS. 100, 101 AND 102

FOR ADVICE RELATING TO INVESTMENTS; INVESTMENT ADVICE; FUNDS INVESTMENT; INVESTMENT ADVISORY SERVICES; INVESTMENT BROKERAGE; MUTUAL FUND INVESTMENT; INVESTMENT OF FUNDS FOR OTHERS; INVESTMENT STRATEGY; INVESTMENT CONSULTATION; PROVIDING INFORMATION ABOUT THE ORIGINATION, DEVELOPMENT, ANALYSIS, CATEGORIZATION AND TRADING OF SECURITIES AND INVESTMENTS.

FIRST USE 12-0-2006; IN COMMERCE 12-0-2006.

ELEMENTS AMENDED
MARK
DISCLAIMER

3,559,386. REG. 1-13-2009. AMERICAN PSYCHOLOGICAL ASSOCIATION (D.C. NOT-FOR-PROFIT CORPORATION) 750 FIRST STREET NE, WASHINGTON, DC, 200024242, SN 76-683,478. FILED 10-29-2007. PRINCIPAL REGISTER.



INT. CL. 16/U.S. CLS. 2, 5, 22, 23, 29, 37, 38 AND 50

FOR PRINTED NEWSLETTERS IN THE FIELD OF PROFESSIONAL PSYCHOLOGY FOR PSYCHOLOGISTS, STUDENTS, INTERNATIONAL AND PROFESSIONAL AFFILIATES ALL DEDICATED TO PROMOTING EDUCATION, TRAINING, PRACTICE, DIVERSITY AND PUBLIC INTEREST IN PROFESSIONAL PSYCHOLOGY.

FIRST USE 1-17-2007; IN COMMERCE 1-17-2007.

ELEMENTS CORRECTED
OWNER NAME

3,545,064. REG. 12-9-2008. POLA CHEMICAL INDUSTRIES INC. (JAPAN CORPORATION) 6-48, YAYOI-CHO, SHIZUOKA-SHI, SHIZUOKA-KEN, JAPAN., SN 78-492,939. FILED 10-1-2004. PRINCIPAL REGISTER.

POLA

THE MARK CONSISTS OF STANDARD CHARACTERS WITHOUT CLAIM TO ANY PARTICULAR FONT, STYLE, SIZE, OR COLOR.

OWNER OF U.S. REG. NOS. 755,665, 2,613,004 AND OTHERS.

INT. CL. 44/U.S. CLS. 100 AND 101

FOR BEAUTY SALON SERVICES; HAIR SALON SERVICES; SKIN CARE SALON SERVICES; COSMETOLOGY AND ESTHETIC TREATMENT SERVICES; PROVIDING INFORMATION AND CONSULTING SERVICES IN THE FIELDS OF THE ABOVE-MENTIONED SERVICES.

FIRST USE 9-22-2000; IN COMMERCE 12-31-2006.

ELEMENTS CORRECTED
OWNER ADDRESS

3,561,273. REG. 1-13-2009. VIPP A/S (DENMARK CORPORATION) SNORRESGADE 22, COPENHAGEN S, DENMARK, DK2300, SN 79-046,337. FILED 8-9-2007. PRINCIPAL REGISTER.

VIPP

THE MARK CONSISTS OF STANDARD CHARACTERS WITHOUT CLAIM TO ANY PARTICULAR FONT, STYLE, SIZE, OR COLOR.

PRIORITY DATE OF 3-29-2007 IS CLAIMED.

OWNER OF INTERNATIONAL REGISTRATION 0943740 DATED 8-9-2007, EXPIRES 8-9-2017.

OWNER OF U.S. REG. NO. 3,449,665.

INT. CL. 35/U.S. CLS. 100, 101 AND 102

FOR RETAIL STORE SERVICES AND ONLINE RETAIL STORE SERVICES FEATURING [BLEACHING PREPARATIONS AND OTHER SUBSTANCES FOR LAUNDRY USE, CLEANING PREPARATIONS, POLISHING PREPARATIONS, SCOURING PREPARATIONS,] SOAPS, PERFUMERY, ESSENTIAL OILS, COSMETICS, HAIR LOTIONS, DENTIFRICES, APPARATUS FOR LIGHTING, APPARATUS FOR HEATING, APPARATUS FOR STEAM GENERATING, APPARATUS FOR COOKING, APPARATUS FOR REFRIGERATING, APPARATUS FOR DRYING, APPARATUS FOR VENTILATING, APPARATUS FOR WATER SUPPLY AND SANITARY PURPOSES, FURNITURE, MIRRORS, PICTURE FRAMES, DRAWER PULLS OF WOOD, DRAWER PULLS OF CORK, DRAWER PULLS OF REED, DRAWER PULLS OF CANE, DRAWER PULLS OF WICKER, DRAWER PULLS OF HORN, DRAWER PULLS OF BONE, DRAWER PULLS OF IVORY, DRAWER PULLS OF WHALEBONE, DRAWER PULLS OF SHELL, DRAWER PULLS OF AMBER, DRAWER PULLS OF MOTHER-OF-PEARL, GOODS OF MEERSCHAUM,

AND DRAWER PULLS OF SUBSTITUTES FOR ALL OF THESE MATERIALS, DRAWER PULLS OF PLASTICS; HOUSEHOLD OR KITCHEN UTENSILS AND CONTAINERS NOT OF PRECIOUS METAL OR COATED THEREWITH, COMBS AND SPONGES BRUSHES NOT BEING PAINT BRUSHES, BRUSH-MAKING MATERIALS, ARTICLES FOR CLEANING PURPOSES, STEEL WOOL, UNWORKED OR SEMI-WORKED GLASS NOT BEING GLASS USED IN BUILDING, DRAWER PULLS OF GLASSWARE, DRAWER PULLS OF PORCELAIN, DRAWER PULLS OF EARTHENWARE, BUCKETS, TOILET BRUSHES, SOAP DISPENSERS, LAUNDRY BASKETS, TOILET-PAPER HOLDERS, SOAP HOLDERS, SHAVING BRUSH STANDS, STORAGE HOLDERS, PAPER TOWEL DISPENSERS, TEXTILES BEING TEXTILE FABRICS FOR THE MANUFACTURE OF CLOTHING AND TEXTILE GOODS IN THE NATURE OF TOWELS, CUSHION COVERS, KITCHEN TOWELS, TEA TOWELS AND BATH LINEN, BED AND TABLE COVERS, TOWELS, TABLEMATS AND TABLECLOTHS, CLOTHING, FOOTWEAR, HEADGEAR, SWIMWEAR, BATHROBES, NIGHTSHIRTS, PYJAMAS, SHAWLS, BEACH CLOTHES AND UNDERWEAR.

FIRST USE ; IN COMMERCE .
 INT. CL. 42/U.S. CLS. 100 AND 101
 FOR INDUSTRIAL DESIGN.
 INT. CL. 44/U.S. CLS. 100 AND 101
 FOR HAIRDRESSING SALONS.

ELEMENTS CORRECTED
 GOODS/SERVICES

3,567,904. REG. 1-27-2009. CROWN CREATIVE CO., LTD. (JAPAN CORPORATION) 33-3, YANAKA 1-CHOME, ADA-CHI-KU: TOKYO, JAPAN, 1200006, SN 79-049,514. FILED 7-13-2007. PRINCIPAL REGISTER.



PRIORITY DATE OF 7-12-2007 IS CLAIMED.
 OWNER OF INTERNATIONAL REGISTRATION 0952397
 DATED 7-13-2007, EXPIRES 7-13-2017.

INT. CL. 9/U.S. CLS. 21, 23, 26, 36 AND 38
 FOR [BATTERIES; ELECTRIC FLAT IRONS; HAIR-CURLERS, ELECTRICALLY HEATED; BUZZERS, ELECTRIC;] TELECOMMUNICATIONS DEVICES, APPARATUS AND INSTRUMENTS, NAMELY, INTERCOMS, MOBILE PHONES, TELEPHONE SETS, FACSIMILE MACHINES, BROADCASTING MACHINES, NAMELY, TELEVISION AND RADIO RECEIVERS AND TRANSMITTERS, JUKE BOXES, DIGITAL CAMERAS, VIDEO CAMERAS, SOUND RECORDING INSTRUMENTS AND APPARATUS, WIRELESS COMMUNICATION DEVICE FEATURING VOICE, DATA AND IMAGE TRANSMISSION INCLUDING VOICE, TEXT AND PICTURE MESSAGING, A VIDEO AND STILL IMAGE CAMERA, ALSO FUNCTIONAL TO PURCHASE MUSIC, GAMES, VIDEO AND SOFTWARE APPLICATIONS OVER THE AIR FOR DOWNLOADING TO THE DEVICE; VIDEO FREQUENCY MACHINES AND APPARATUS, NAMELY, DIGITAL CAMERAS, VIDEO CAMERAS, DVD PLAYERS AND RECORDERS, VIDEO PLAYERS AND RECORDERS; PARTS AND ACCESSORIES FOR TELECOMMUNICATIONS DEVICES, APPARATUS AND INSTRUMENTS, NAMELY, CABINETS FOR LOUD-SPEAKERS, BLANK VIDEO TAPES, BLANK RECORDABLE DVDS, BLANK RECORD DISKS, BLANK

DIGITAL STORAGE MEDIA, BLANK ELECTRONIC MEDIA, HEADPHONES, MICROPHONES, PHONOGRAPHIC RECORD CLEANING KITS COMPRISED PRIMARILY OF REPLACEMENT STYLUS NEEDLES AND ALSO INCLUDING CLEANING SOLUTIONS AND BRUSHES; MOBILE TELEPHONE STRAPS; MOBILE TELEPHONE ACCESSORIES, NAMELY, HEADSETS, MICROPHONES AND HEADPHONES; ELECTRONIC MACHINES APPARATUS AND THEIR PARTS, NAMELY, ELECTRONIC DESK CALCULATORS, COMPUTER MOUSE AND KEYBOARDS; COMPUTER; PROGRAMS FOR COMPUTER OPERATING SYSTEMS; COMPUTER SOFTWARE FOR GAMES AND INTERACTIVE GAMES; COMPUTER SOFTWARE THAT IS DOWNLOADABLE AND ALLOWS THE USER ACCESS TO RING TONES, AUDIO FILES, MUSIC FILES, IMAGES, VIDEO IMAGES AND ELECTRONIC GAMES; [CIGAR LIGHTERS FOR AUTOMOBILES;] EYEGLASSES; GOGGLES; SPECTACLES AS OPTICS; PARTS AND ACCESSORIES FOR EYEGLASSES, GOGGLES, SPECTACLES, NAMELY, CONTAINERS, TEMPLES, PINCE-NEZ CORDS, CASES, WIPES, FRAMES, AND CONTAINERS FOR CONTACT LENSES; APPARATUS FOR GAMES ADAPTED FOR USE WITH AN EXTERNAL DISPLAY SCREEN OR MONITOR, NAMELY, CONSUMER GAME CONSOLES FOR USE WITH AN EXTERNAL DISPLAY SCREEN OR MONITOR, CONSUMER GAME JOY STICKS, VIDEO AND COMPUTER GAME PROGRAMS, VIDEO AND COMPUTER GAME CARTRIDGES AND CASSETTES; ELECTRONIC CIRCUITS AND CD-ROM RECORDED WITH PROGRAMS FOR HAND-HELD GAMES WITH LIQUID CRYSTAL DISPLAYS; WEIGHT BELTS FOR SCUBA DIVING; INFLATABLE SWIMMING FLOATS FOR SAFETY AND PROTECTION PURPOSES; PROTECTIVE HELMETS FOR SPORTS; AIR TANKS FOR SCUBA DIVING; SWIMMING FLUTTER BOARDS FOR SAFETY AND PROTECTION PURPOSES; REGULATORS FOR SCUBA DIVING; PHONOGRAPH RECORDS FEATURING MUSIC; SOUND RECORDED MAGNETIC CARDS, SHEETS AND TAPES; RECORDED COMPACT DISCS FEATURING SOUNDS, MUSIC, ANIMATION, IMAGES, VIDEO IMAGES, MOVIES, TELEVISION PROGRAMS AND INTERNET TELEVISION PROGRAMS; METRONOMES; ELECTRONIC CIRCUITS AND CD-ROMS RECORDED WITH AUTOMATIC PERFORMANCE PROGRAMS FOR ELECTRONIC MUSICAL INSTRUMENTS; DOWNLOADABLE MUSIC FILES, NAMELY, DIGITAL MUSIC FILES FROM THE INTERNET, MUSIC FILES VIA WIRELESS DEVICES, MP3 FILES, MP3 RECORDINGS, ON-LINE DISCUSSION BOARDS, WEBCASTS AND PODCASTS FEATURING MUSIC, AUDIO BOOKS AND NEWS BROADCASTS, AND MUSICAL SOUND RECORDINGS; EXPOSED CINEMATOGRAPHIC FILMS; EXPOSED SLIDE FILMS; SLIDE FILM MOUNTS; DOWNLOADABLE IMAGE FILES, NAMELY, FILES CONTAINING ARTWORK, TEXT, DIAGRAMS, PHOTOGRAPHS, GRAPHICS, VIDEO, GAMES, AND INTERNET WEB LINKS RELATING TO SUBJECTS OF GENERAL INTEREST; RECORDED VIDEO DISCS AND VIDEO TAPES FEATURING SOUNDS, MUSIC, ANIMATION, IMAGES, VIDEO IMAGES, MOVIES, TELEVISION PROGRAMS AND INTERNET TELEVISION PROGRAMS; ELECTRONIC PUBLICATIONS, NAMELY, BOOKS, MAGAZINES, NEWSLETTERS, MAPS AND COMICS FEATURING ANIMATION AND SUBJECTS OF GENERAL INTEREST; ELECTRONIC PUBLICATIONS, NAMELY, BOOKS, MAGAZINES, NEWSLETTERS, AND COMICS FEATURING MUSIC, IMAGES, VIDEO IMAGES, SOUNDS, TEXT, ANIMATION AND INFORMATION RELATED TO FICTIONAL CHARACTERS AND SUBJECTS OF GENERAL INTEREST; RECORDED MEDIA, NAMELY, EXPOSED CINEMATOGRAPHIC FILMS, VIDEO DISCS, VIDEO TAPES FEATURING ANIMATION, SPORTS, MUSIC, COMEDY; DOWNLOADABLE TEXT AND DATA FILES, MAGAZINES, BOOKS, NEWSPAPERS, MAPS, PICTURES AND DRAWINGS FEATURING IMAGES, MAPS, PICTURES, DRAWINGS, VIDEO IMAGES, AUDIO FILES, ANIMATION, SOUND FILES AND MUSIC FILES RELATED TO FICTIONAL CHARACTERS AND SUBJECTS OF GENERAL INTEREST; ELECTRONIC PUBLICATIONS, NAMELY, BOOKS, MAGAZINES, NEWSLETTERS, AND COMICS FEATURING MUSIC, IMAGES, VIDEO IMAGES, SOUNDS, TEXT, ANIMATION AND INFORMATION RELATED TO FICTIONAL CHAR-

ACTERS AND SUBJECTS OF GENERAL INTEREST; ELECTRONIC PUBLICATIONS, NAMELY, BOOKS, MAGAZINES, NEWSLETTERS, AND COMICS FEATURING MUSIC, IMAGES, VIDEO IMAGES, SOUNDS, ANIMATION, TEXT, AND INFORMATION RELATED TO FICTIONAL CHARACTERS AND SUBJECTS OF GENERAL INTEREST, RECORDED ON ELECTRONIC MEDIA, NAMELY, ENCODED ELECTRONIC CIRCUITS, IC CARDS, MAGNETIC TAPES, MAGNETIC DISCS, OPTICAL DISCS, MAGNETIC OPTICAL DISCS, CD-ROMS AND DVDS RECORDED WITH MUSIC, SOUNDS, IMAGES AND VIDEO IMAGES.

FIRST USE ; IN COMMERCE .

INT. CL. 14/U.S. CLS. 2, 27, 28 AND 50

FOR PRECIOUS METALS; KEY RINGS OF PRECIOUS METAL, IMITATION PRECIOUS METAL OR SEMI-PRECIOUS METAL; TRINKETS, NAMELY, RINGS OR WATCH FOBS OF PRECIOUS METAL, IMITATION PRECIOUS METAL OR SEMI-PRECIOUS METAL; JEWEL CASES OF PRECIOUS METAL, IMITATION PRECIOUS METAL OR SEMI-PRECIOUS METAL; PRECIOUS METAL TROPHIES BEING PRIZE CUPS; PRECIOUS METAL COMMEMORATIVE SHIELDS; PRECIOUS METAL, IMITATION PRECIOUS METAL OR SEMI-PRECIOUS METAL PERSONAL ORNAMENTS, NAMELY, JEWELRY AND IMITATION JEWELRY; CUFF LINKS; [UNWROUGHT AND SEMI-WROUGHT PRECIOUS STONES AND THEIR IMITATIONS;] SHOE ORNAMENTS OF PRECIOUS METAL; CLOCKS; WATCHES; PARTS OF CLOCKS AND WATCHES.

FIRST USE ; IN COMMERCE .

INT. CL. 16/U.S. CLS. 2, 5, 22, 23, 29, 37, 38 AND 50

FOR PASTES AND OTHER ADHESIVES FOR STATIONERY OR HOUSEHOLD PURPOSES; [SEALING WAX; PRINTERS' REGLETS; PRINTING TYPES; ADDRESSING MACHINES; INKING RIBBONS; ELECTRIC STAPLERS FOR OFFICES; ENVELOPE SEALING MACHINES FOR OFFICES; STAMP OBLITERATING MACHINES; DRAWING INSTRUMENTS; TYPEWRITERS; MIMEOGRAPHS; ROTARY DUPLICATORS; MARKING TEMPLATES; ELECTRIC PENCIL SHARPENERS; DECORATORS' PAINTBRUSHES; BABIES' DIAPER-PANTS OF PAPER, DISPOSABLE]; INDUSTRIAL PACKAGING CONTAINERS OF PAPER; [FOOD WRAPPING PLASTIC FILM FOR HOUSE HOLD USE; PATTERNS FOR MAKING CLOTHES; TAILOR'S CHALK; BANNERS OF PAPER; FLAGS OF PAPER;] HYGIENIC PAPER; TOWELS OF PAPER; TABLE NAPKINS OF PAPER; HAND TOWELS OF PAPER; HANDKERCHIEFS OF PAPER; [TABLE CLOTHS OF PAPER;] PAPER AND CARDBOARD; STATIONERY AND STUDY MATERIALS, NAMELY, SCHOOL WORK DESK BASKETS, PAINT KITS AND STUDY GUIDES; PAINTERS' ARTICLES; PRINTED MATTER, NAMELY, PICTURE POSTCARDS, POSTERS, SHEET MUSIC, CALENDARS, NEWSPAPERS, GEOGRAPHIC MAPS AND DIARIES; PRINTED MATTER, NAMELY, CATALOGS, MAGAZINES, BOOKS, NEWSLETTERS, AND LEAFLETS FEATURING ADVERTISEMENTS, COMICS, NOVELS, PRODUCTS AND INFORMATION RELATED TO FICTIONAL CHARACTERS; POSTCARDS; CATALOGUES FEATURING ADVERTISEMENTS, COMICS, NOVELS, PRODUCTS AND INFORMATION RELATED TO FICTIONAL CHARACTERS; CALENDARS; MAGAZINES FEATURING ADVERTISEMENTS, COMICS, NOVELS, PRODUCTS AND INFORMATION RELATED TO FICTIONAL CHARACTERS; BOOKS FEATURING ADVERTISEMENTS, COMICS, NOVELS, PRODUCTS AND INFORMATION RELATED TO FICTIONAL CHARACTERS; NEWSPAPERS; PAMPHLETS FEATURING ADVERTISEMENTS, COMICS, NOVELS, PRODUCTS AND INFORMATION RELATED TO FICTIONAL CHARACTERS; POSTERS; PRINTED PERIODICALS FEATURING ADVERTISEMENTS, COMICS, NOVELS, PRODUCTS AND INFORMATION RELATED TO FICTIONAL CHARACTERS; HANDBOOKS FEATURING ADVERTISEMENTS, COMICS, NOVELS, PRODUCTS AND INFORMATION RELATED TO FICTIONAL CHARACTERS; [PAINTINGS AND CALLIGRAPHIC WORKS;] PHOTOGRAPHS; AND PHOTOGRAPH STANDS.

FIRST USE ; IN COMMERCE .

INT. CL. 18/U.S. CLS. 1, 2, 3, 22 AND 41

FOR HANDBAG FRAMES; PURSE FRAMES; HORSESHOES; LEATHER ENVELOPES AND POUCHES FOR PACKAGING; CLOTHING FOR DOMESTIC PETS; COLLARS FOR ANIMALS; LEADS FOR PETS, NAMELY, DOG LEADS AND LEATHER LEADS; BOOTS AND SHOES FOR ANIMALS; BAGS, NAMELY, BACKPACKS, BOOK BAGS, SPORTS BAGS, BUM BAGS, HANDBAGS, SPORT BAGS, BELT BAGS, BOSTON BAGS, CARRY-ALL BAGS, SHOULDER BAGS, CHARM BAGS, SCHOOL CHILDREN'S BACKPACKS, BEACH BAGS, FEED BAGS FOR ANIMALS, WINE BAGS WITH HANDLES FOR CARRYING WINE, SHOE BAGS, TRUNKS AND SUITCASES; POUCHES, NAMELY, KNITTED, KILTED, LEATHER, VINYL AND CANVAS POUCHES; PURCHASED PRODUCTS, NAMELY, POUCHES FOR HOLDING SCHOOL SUPPLIES THAT FITS OVER THE BACK OF A CHAIR, POUCHES FOR HOLDING KEYS, POUCHES FOR HOLDING PET ACCESSORIES, CARD CASES, PURSES, WALLETS, AND BUSINESS CARD CASES; VANITY CASES NOT FITTED; UMBRELLAS AND THEIR PARTS; [WALKING STICKS; CANES; METAL PARTS OF CANES AND WALKING-STICKS; HANDLES OF CANES AND WALKING-STICKS; SADDLERY;] LEATHER STRAPS; RAW HIDES; RAW SKINS; TANNED LEATHER; AND FUR.

FIRST USE ; IN COMMERCE .

INT. CL. 24/U.S. CLS. 42 AND 50

FOR [WOVEN FABRICS; KNITTED FABRICS; FELT AND NON-WOVEN TEXTILES FABRICS; OILCLOTHS; GUMMED WATERPROOF CLOTHS; RUBBERIZED CLOTHS;] PERSONAL ARTICLES OF WOVEN TEXTILE NOT FOR WEAR, NAMELY, HAND TOWELS, TEXTILE HAND TOWELS, HANDKERCHIEFS, TEXTILE HANDKERCHIEFS, TOWELS AND TEXTILE TOWELS; MOSQUITO NETS; BED SHEETS; FUTON, BEING QUILTS; QUILTS; LINEN COVERS FOR FUTON, QUILTS AND QUILTS; PILLOWCASES; BED BLANKETS, BLANKET THROWS, BLANKETS FOR OUTDOOR USE, CHILDREN'S BLANKETS, AND PET BLANKETS; TABLE NAPKINS OF TEXTILES; DISH DRYING CLOTHS; SHOWER CURTAINS; TOILET SEAT COVERS OF TEXTILE; SEAT COVERS OF TEXTILE; WALL HANGINGS OF TEXTILE; CURTAINS, TABLE CLOTHS NOT OF PAPER; DRAPERIES THICK DROP CURTAINS; [BILLIARD CLOTH; AND] LABELS OF CLOTHS.

FIRST USE ; IN COMMERCE .

INT. CL. 25/U.S. CLS. 22 AND 39

FOR CLOTHING, NAMELY, BABY BODYSUITS, BABY BOTTOMS, BABY BUNTINGS, BABY DOLL PJAMAS, BABY TOPS, BATHING SUITS, BATHING SUITS FOR MEN, BATHING SUITS FOR KIDS, BEACH COVER-UPS, BEACHWEAR, BATHROBES, TEXTILE BELTS, BLOUSES, BLOUSONS, BODY LINENS, BOMBER JACKETS, CAMISOLES, CAPRI PANTS, CHILDREN'S INFANTS CLOTH BIBS, NECK TUBES, COATS, DRESS SHIRTS, DRESS SUITS, DRESSES, GOLF SHIRTS, GOLF TROUSERS, GYM SUITS, JACKETS, JEANS, JERSEYS (CLOTHING), JOGGING OUTFITS, JUMPERS, JUMPSUITS, LEATHER JACKETS, LEG WARMERS, SUITS, NURSE DRESSES, ONE PIECE OUTFITS, PANTS, RAINCOATS, RAINWEAR, ROBES, ROMPERS, SHIRTS, SILK SCARVES, SKI SUITS, SNOW SUITS, SPORT JERSEYS, TANK TOPS, TIES, VESTS, AND WIND COATS; COATS; SWEATERS, CARDIGAN SWEATERS AND VESTS; SHIRTS T-SHIRTS, SHIRT CUFFS, SHIRT COLLARS, SHIRTS, BLOUSES, POLO SHIRTS AND SWEAT SHIRTS; NIGHTWEAR; UNDERWEAR; SWIMWEAR; SWIMMING CAPS; JAPANESE TRADITIONAL CLOTHING, NAMELY, SASH BANDS FOR KIMONO OBI, BUSTLE HOLDER BANDS FOR OBI (OBIAGE), BUSTLES FOR OBI-KNOTS (OBIAGE-SHIN), WAIST STRINGS FOR KIMONOS (KOSHIMIMO), UNDERSHIRTS FOR KIMONOS (KOSHIMAKI), UNDERSHIRTS FOR KIMONOS (JUBAN), TIGHTENING-UP STRINGS FOR KIMONOS (DATEJIME), WRAP BELTS FOR KIMONOS (DATEMAKI), FULL-LENGTH KIMONOS (NAGAI), SHORT OVERCOAT FOR KIMONO (HAORI), STRING FASTENERS FOR HAORI (HAORI-HIMO), PLEATED SKIRTS FOR FORMAL KIMONOS (HAKAMA), AND DETACHABLE NECKPIECES FOR KIMONOS (HANERI); SLEEP MASKS; APRONS FOR WEAR; COLLAR PROTECTORS FOR WEAR; SOCKS AND STOCKINGS; PUTTEES AND GAITERS; FUR STOLE; SHAWLS; SCARVES; JAPANESE STYLE SOCKS AS TABI; JAPANESE STYLE SOCKS AS TABI COVERS; GLOVES AND MITTENS; BABIES' DIAPERS OF TEXTILES; NECKTIES; NECKERCHIEVES; BANDANAS; WARM-KEEPING SUPPORTS, NAMELY, LEG WARMERS, LEGGINGS, SUPPORT STOCKINGS, AND SUP-

PORT HOSE; MUFFLERS; EAR MUFFS; HOODS; SEDGE HAT (SUGE-GASA); NIGHTCAPS; HEADWEAR AND CAPS; GARTERS; SOCK SUSPENDERS; SUSPENDERS AS BRACES; WAISTBANDS; BELTS FOR CLOTHING; FOOTWEAR OTHER THAN BOOTS FOR SPORTS; SHOES AND BOOTS; SHOE DOWELS, SHOE PEGS, TONGUE OR PULL-STRAP FOR SHOES AND BOOTS; PROTECTIVE METAL MEMBERS FOR SHOES AND BOOTS; JAPANESE STYLE WOODEN CLOGS AS GETA; JAPANESE STYLE SANDALS AS ZORI; MASQUERADE COSTUMES; SPECIAL SPORTSWEAR, NAMELY, SHORTS, PANTS, SHIRTS, JACKETS, COATS, VESTS AND BATHING SUITS; SPECIAL SPORTS FOOTWEAR; AND HORSE-RIDING BOOTS.

FIRST USE ; IN COMMERCE .

INT. CL. 28/U.S. CLS. 22, 23, 38 AND 50

FOR WAX FOR SKIS; TOYS FOR DOMESTIC PETS; TOYS, NAMELY, BABY MULTIPLE ACTIVITY TOYS, BATH TOYS, BATTERY OPERATED ACTION TOYS, BENDABLE TOYS, CLOCKWORK TOYS OF PLASTIC, COLLECTABLE TOY FIGURES, DOG TOYS, DRAWING TOYS, EDUCATIONAL TOYS FOR PURPOSES OF THE DEMONSTRATION OF ALTERNATIVE ENERGY SOURCES, ELECTRIC ACTION TOYS, FANTASY CHARACTER TOYS, GIFT BASKETS CONTAINING PLUSH TOYS, INFANT TOYS, MUSICAL TOYS, PET TOYS, PLASTIC CHARACTER TOYS, PLUSH TOYS, POP UP TOYS, POSITION ABLE TOY FIGURES, PRINTING TOYS, PULL TOYS, PUSH TOYS, REMOTE CONTROL TOYS, STUFFED ANIMAL TOYS, AND GIRLS DOLLS WITH CLOTHING; DOLLS; GO GAMES; JAPANESE PLAYING CARDS AS UTAGARUTA; JAPANESE CHESS AS SHOJI GAMES; DICE; JAPANESE DICE GAMES (SUGOROKU); DICE CUPS; CHESS GAMES; CHECKERS AND CHECKER SETS; DOMINOES; PLAYING CARDS; JAPANESE PLAYING CARDS (HANAFUDA); MAH-JONG; AMUSEMENT GAME MACHINES; BILLIARD EQUIPMENT; SPORTS EQUIPMENT, NAMELY, TENNIS RACKETS, BADMINTON RACKETS, TABLE TENNIS RACKETS, GOLF BAGS, GOLF CLUBS, GOLF BALLS, GOLF BALL MARKERS, GOLF GLOVES, GOLF CLUB COVERS, SKIES, SKI CASES, SWIM FINS, SNORKELS, SKATEBOARDS, SNOWBOARDS, SNOWBOARD CASES, SURFBOARDS, AND SURFBOARD CASES; [FISHING TACKLE;] ORNAMENTS FOR CHRISTMAS TREES, EXCEPT ILLUMINATION ARTICLES AND CONFECTIONERY; PARTY FAVORS IN THE NATURE OF SMALL TOYS AND BLOW-OUTS.

FIRST USE ; IN COMMERCE .

ELEMENTS CORRECTED
GOODS/SERVICES

3,570,281. REG. 2-3-2009. DONGGUAN FUBAO SOFA MANUFACTURING CO., LTD. (CHINA CORPORATION) SHIDA ROAD, XIANGDONG INDUSTRIAL DISTRICT; DALINGSHAN TOWN; DONGGUAN CITY; GUANGDONG, CHINA., SN 79-056,375. FILED 6-24-2008. PRINCIPAL REGISTER.

Frandiss

OWNER OF INTERNATIONAL REGISTRATION 0970997 DATED 6-24-2008, EXPIRES 6-24-2018.

INT. CL. 20/U.S. CLS. 2, 13, 22, 25, 32 AND 50

FOR FURNITURE.

FIRST USE ; IN COMMERCE .

ELEMENTS CORRECTED
GOODS/SERVICES

3,571,333. REG. 2-10-2009. STOHR DISTRIBUTION & DESIGN (WASHINGTON CORPORATION) 202 S 60TH AVE, YAKIMA, WA, 98908, SN 77-332,917. FILED 11-19-2007. PRINCIPAL REGISTER.



NO CLAIM IS MADE TO THE EXCLUSIVE RIGHT TO USE "SPORTS", APART FROM THE MARK AS SHOWN.

THE MARK CONSISTS OF STYLIZED TEXT "KNUCKLE HEAD SPORTS", WITH A DRAWING OF A STYLIZED FACE.

INT. CL. 12/U.S. CLS. 19, 21, 23, 31, 35 AND 44

FOR BABY STROLLERS ; JOGGING STROLLERS; CHILD CARRYING TRAILERS FOR USE IN TRANSPORTING CHILDREN WHILE HIKING, JOGGING, WALKING, SKIING, SNOW SHOEING OR SKATING ; [BICYCLES ;] BICYCLE TRAILERS.

FIRST USE 5-0-2004; IN COMMERCE 5-0-2004.

ELEMENTS AMENDED
GOODS/SERVICES

3,572,177. REG. 2-10-2009. CELARITY, INC. (MINNESOTA CORPORATION) 7835 TELEGRAPH ROAD, BLOOMINGTON, MN, 55438, SN 77-510,490. FILED 6-27-2008. PRINCIPAL REGISTER.

CELARITY

THE MARK CONSISTS OF STANDARD CHARACTERS WITHOUT CLAIM TO ANY PARTICULAR FONT, STYLE, SIZE, OR COLOR.

INT. CL. 35/U.S. CLS. 100, 101 AND 102

FOR EMPLOYMENT HIRING, RECRUITING, PLACEMENT, STAFFING AND CAREER NETWORKING SERVICES; PERSONNEL PLACEMENT AND RECRUITMENT; PERSONNEL RECRUITMENT SERVICES AND EMPLOYMENT AGENCIES.

FIRST USE 4-0-2005; IN COMMERCE 4-0-2005.

ELEMENTS AMENDED
DATE OF FIRST USE
DATE OF FIRST USE IN COMMERCE

3,573,044. REG. 2-10-2009. KBC ADVANCED TECHNOLOGIES PLC (UNITED KINGDOM CORPORATION) 42-50 HERSHAM ROAD, WALTON ON THAMES, SURREY, UNITED KINGDOM, KT121RZ, SN 77-031,955. FILED 10-30-2006. PRINCIPAL REGISTER.

3,575,986. REG. 2-17-2009. JAD CORPORATION OF AMERICA (NEW YORK CORPORATION) 20-48 119TH STREET, COLLEGE POINT, NY, 113562123, SN 77-520,067. FILED 7-11-2008. PRINCIPAL REGISTER.

OpX

MINT-X

THE MARK CONSISTS OF STANDARD CHARACTERS WITHOUT CLAIM TO ANY PARTICULAR FONT, STYLE, SIZE, OR COLOR.

INT. CL. 16/U.S. CLS. 2, 5, 22, 23, 29, 37, 38 AND 50 FOR PLASTIC TRASH AND GARBAGE BAGS, AND GENERAL PURPOSE PLASTIC BAGS.
FIRST USE 2-27-2008; IN COMMERCE 2-27-2008.

ELEMENTS CORRECTED
CITIZENSHIP

3,575,987. REG. 2-17-2009. JAD CORPORATION OF AMERICA (NEW YORK CORPORATION) 20-48 119TH STREET, COLLEGE POINT, NY, 113562123, SN 77-520,079. FILED 7-11-2008. PRINCIPAL REGISTER.

THE MARK CONSISTS OF STANDARD CHARACTERS WITHOUT CLAIM TO ANY PARTICULAR FONT, STYLE, SIZE, OR COLOR.

INT. CL. 9/U.S. CLS. 21, 23, 26, 36 AND 38
FOR COMPUTER SOFTWARE TO SIMULATE AND MODEL PROCESS UNITS FOR USE IN CONNECTION WITH THE PROCESS AND ENERGY INDUSTRIES; COMPUTER SOFTWARE FOR USE IN DELIVERING PROFIT OPPORTUNITY IMPLEMENTATION SOLUTIONS IN THE REFINING, PETROCHEMICAL AND OTHER PROCESS INDUSTRIES.

FIRST USE 6-0-2004; IN COMMERCE 6-0-2004.
INT. CL. 35/U.S. CLS. 100, 101 AND 102
FOR MANAGEMENT CONSULTANCY SERVICES; BUSINESS ORGANIZATION SERVICES; BUSINESS ORGANIZATION INFORMATION SERVICES; ARRANGING AND CONDUCTING BUSINESS CONFERENCES.
FIRST USE 6-0-2004; IN COMMERCE 6-0-2004.

INT. CL. 40/U.S. CLS. 100, 103 AND 106
FOR CONSULTING SERVICES IN THE FIELD OF OIL REFINING.
FIRST USE 6-0-2004; IN COMMERCE 6-0-2004.

INT. CL. 41/U.S. CLS. 100, 101 AND 107
FOR EDUCATIONAL SERVICES, NAMELY, PROVISION OF TRAINING IN THE REFINING, PETROCHEMICAL, AND OTHER PROCESSING INDUSTRIES; ARRANGING AND CONDUCTING EDUCATIONAL CONFERENCES, SEMINARS, WORKSHOPS, AND CONGRESSES IN THE REFINING, PETROCHEMICAL, AND OTHER PROCESSING INDUSTRIES; WRITING AND CREATION OF TRAINING MATERIALS AND TEXTS IN BOTH HARD COPY AND ELECTRONIC FORMATS.
FIRST USE 6-0-2004; IN COMMERCE 6-0-2004.

INT. CL. 42/U.S. CLS. 100 AND 101
FOR PROVIDING ENGINEERING SERVICES AND ENGINEERING CONSULTANCY SERVICES IN CONNECTION WITH THE PROCESS INDUSTRIES; CONSULTING SERVICES IN THE PETROCHEMICAL AND OTHER PROCESS INDUSTRIES; ENGINEERING SERVICES AND ENGINEERING CONSULTANCY SERVICES; RESEARCH AND DEVELOPMENT; PROVIDING TECHNICAL CONSULTING SERVICES TO BUSINESSES FOR IMPROVING PRODUCTIVITY THEREOF, NAMELY, COMPUTER SOFTWARE DEVELOPMENT, SITE ANALYSIS, DATA EVALUATION AND ANALYSIS.
FIRST USE 6-0-2004; IN COMMERCE 6-0-2004.

ELEMENTS CORRECTED
OWNER ADDRESS

PROTECTIVE POWER OF MINT

THE MARK CONSISTS OF STANDARD CHARACTERS WITHOUT CLAIM TO ANY PARTICULAR FONT, STYLE, SIZE, OR COLOR.

INT. CL. 16/U.S. CLS. 2, 5, 22, 23, 29, 37, 38 AND 50 FOR PLASTIC TRASH AND GARBAGE BAGS, AND GENERAL PURPOSE PLASTIC BAGS.
FIRST USE 2-27-2008; IN COMMERCE 2-27-2008.

ELEMENTS CORRECTED
CITIZENSHIP

3,576,043. REG. 2-17-2009. JAD CORPORATION OF AMERICA (NEW YORK CORPORATION) 20-48 119TH STREET, COLLEGE POINT, NY, 113562123, SN 77-521,674. FILED 7-14-2008. PRINCIPAL REGISTER.



THE MARK CONSISTS OF THE WORD "MINT X" OVER A SHIELD DRAWING, WITH A SIDEWAYS TRIANGLE BETWEEN THE "T" IN "MINT" & THE "X".

INT. CL. 16/U.S. CLS. 2, 5, 22, 23, 29, 37, 38 AND 50

FOR PLASTIC TRASH AND GARBAGE BAGS, AND GENERAL PURPOSE PLASTIC BAGS.
FIRST USE 2-27-2008; IN COMMERCE 2-27-2008.

ELEMENTS CORRECTED
CITIZENSHIP

3,578,606. REG. 2-24-2009. BIONORICA AG (FED REP GERMANY CORPORATION) KERSCHENSTEINER-STRASSE 11-15, NEUMARKT, FED REP GERMANY, 92318, SN 77-302,920. FILED 10-12-2007. PRINCIPAL REGISTER.

BNO 1055

3,578,337. REG. 2-24-2009. AMERICAN PSYCHOLOGICAL ASSOCIATION (D.C. NOT-FOR-PROFIT CORPORATION) 750 FIRST STREET NE, WASHINGTON, DC, 200024242, SN 76-683,480. FILED 10-29-2007. PRINCIPAL REGISTER.



THE COLOR(S) GREEN, ORANGE, BLUE, RED AND BLACK IS/ARE CLAIMED AS A FEATURE OF THE MARK.

THE MARK CONSISTS OF THE GREEK SYMBOL PSI NEXT TO THE NUMERAL "17." THE MARK IS FRAMED IN A BLACK RECTANGLE. THE PSI CHARACTER CONSISTS OF BLUE AND GREEN "ARMS" AND AN ORANGE "BODY." THE NUMERAL "17" IS RED.

INT. CL. 9/U.S. CLS. 21, 23, 26, 36 AND 38

FOR DOWNLOADABLE ELECTRONIC PUBLICATIONS, NAMELY, NEWSLETTERS AND JOURNALS IN THE FIELD OF PSYCHOLOGY AND THE APPLICATION OF PSYCHOLOGICAL COUNSELING.

FIRST USE 1-17-2007; IN COMMERCE 1-17-2007.

INT. CL. 35/U.S. CLS. 100, 101 AND 102

FOR PROMOTING THE PUBLIC AWARENESS FOR THE IMPORTANCE OF EDUCATION, TRAINING, SCIENTIFIC INVESTIGATION, PRACTICE AND DIVERSITY AND PUBLIC INTEREST IN PROFESSIONAL PSYCHOLOGY; ASSOCIATION SERVICES, NAMELY, PROMOTING THE INTERESTS OF PSYCHOLOGISTS, STUDENTS, INTERNATIONAL AND PROFESSIONAL AFFILIATES DEDICATED TO PROMOTING EDUCATION, TRAINING, SCIENTIFIC INVESTIGATION, PRACTICE, DIVERSITY AND PUBLIC INTEREST IN PROFESSIONAL PSYCHOLOGY AND PSYCHOTHERAPY.

FIRST USE 1-17-2007; IN COMMERCE 1-17-2007.

INT. CL. 36/U.S. CLS. 100, 101 AND 102

FOR PROVIDING FELLOWSHIPS TO PROFESSIONAL PSYCHOLOGISTS AND PSYCHOTHERAPISTS.

FIRST USE 1-17-2007; IN COMMERCE 1-17-2007.

INT. CL. 41/U.S. CLS. 100, 101 AND 107

FOR ARRANGING AND CONDUCTING EDUCATIONAL CONFERENCES, EDUCATIONAL CONVENTIONS AND TRAINING IN THE FIELD OF PSYCHOLOGICAL COUNSELING, THE SOCIAL SCIENCES AND BEHAVIORAL SCIENCES; PROVIDING RECOGNITION AND INCENTIVES BY THE WAY OF AWARDS TO DEMONSTRATE EXCELLENCE IN THE FIELD OF PROFESSIONAL PSYCHOLOGY AND PSYCHOTHERAPY.

FIRST USE 1-17-2007; IN COMMERCE 1-17-2007.

INT. CL. 44/U.S. CLS. 100 AND 101

FOR PROVIDING AN INTERACTIVE WEB SITE FEATURING INFORMATION IN THE FIELD OF PSYCHOLOGY AND PSYCHOTHERAPY OF INTEREST TO PSYCHOLOGISTS, STUDENTS, INTERNATIONAL AND PROFESSIONAL AFFILIATES; PROVIDING INFORMATION IN THE FIELD OF PSYCHOLOGY AND PSYCHOTHERAPY OF INTEREST TO PSYCHOLOGISTS, STUDENTS, INTERNATIONAL AND PROFESSIONAL AFFILIATES; PROVIDING ONLINE COMPUTER DATABASE FOR MEMBERS IN THE FIELD OF PSYCHOLOGICAL COUNSELING.

FIRST USE 1-17-2007; IN COMMERCE 1-17-2007.

ELEMENTS CORRECTED
OWNER NAME

THE MARK CONSISTS OF STANDARD CHARACTERS WITHOUT CLAIM TO ANY PARTICULAR FONT, STYLE, SIZE, OR COLOR.

OWNER OF FED REP GERMANY REG. NO. 39864987, DATED 2-9-1999, RENEWED AS REG. NO. 39864987, DATED 11-30-2018, EXPIRES 11-30-2018.

INT. CL. 1/U.S. CLS. 1

FOR VEGETABLE EXTRACTS AND TINCTURES IN LIQUID, SOLID OR GASEOUS FORM FOR MANUFACTURE OF COSMETICS, FOOD AND NUTRITIONAL ADDITIVES; PLANT EXTRACTS, NAMELY, CIMICIFUGA RACEMOSA USED IN THE MANUFACTURE OF PHARMACEUTICAL PREPARATIONS, BULK PHARMACEUTICAL PREPARATIONS, AND RAW MATERIALS FOR PHARMACEUTICAL PREPARATIONS.

FIRST USE ; IN COMMERCE .

INT. CL. 3/U.S. CLS. 1, 4, 6, 50, 51 AND 52

FOR ESSENTIAL OILS FOR USE IN THE MANUFACTURE OF COSMETICS; HAIR LOTIONS; DENTIFRICES.

FIRST USE ; IN COMMERCE .

INT. CL. 5/U.S. CLS. 6, 18, 44, 46, 51 AND 52

FOR PHARMACEUTICAL PREPARATIONS FOR USE IN THE TREATMENT, CURE, MITIGATION OR PREVENTION OF GINGIVITIS, HALITOSIS, STOMATITIS, PERIODONTITIS, INFLAMMATION OF THE ORAL CAVITY AND PHARYNGEAL CAVITY, HYPERSENSITIVITY OF TEETH, ANGINA, ATHEROSCLEROSIS, BRONCHIAL ASTHMA, CIRCULATORY DISORDERS, CONSTIPATION, DIARRHEA, HEART FAILURE, HEART RHYTHM DISORDERS, HIGH BLOOD PRESSURE, INDIGESTION, INSOMNIA, MIGRAINE, MOTION SICKNESS, NAUSEA, PEPTIC ULCERS, VOMITING, ALLERGY, GYNECOLOGICAL DISORDERS AFFECTING MENSTRUATION, STERILITY, MENSTRUAL SYNDROMES, DYSMENORRHOEA, INFERTILITY, GENITAL TRACT INFECTIONS, PELVIC INFLAMMATORY DISEASES, VAGINAL DISCOMFORT DUE TO MENOPAUSAL ATROPHIC CHANGES, ANATOMICAL ABNORMALITIES, NEOPLASIA, BREAST NEOPLASM, BREAST CANCER, MAMMA, MASTOPATHY, MASTODYNIA, PREMENSTRUAL SYNDROME, CLIMACTERIC COMPLAINTS, BREAST PAIN, BLOOD CONDITIONS AND DISORDERS, BLOOD CIRCULATION DISORDERS, HIGH BLOOD PRESSURE, HYPERTENSION, PULMONARY DISEASES, HEART RHYTHM DISORDERS, HEART FAILURE, UROLOGICAL DISEASES, SEXUALLY TRANSMITTED DISEASES AND INFLAMMATORY PELVIC DISEASES, MENOPAUSAL COMPLAINTS DUE TO THERAPEUTICALLY INDUCED MENOPAUSE, TAMOXIFEN INDUCED HOT FLUSHES OF BREAST CANCER SURVIVORS, VAGINAL DISCOMFORT DUE TO MENOPAUSAL ATROPHIC CHANGES, CLIMACTIC SLEEP DISTURBANCES, DEPRESSIVE MOODS, OSTEOPROTECTIO, OSTEOPOROSIS, CENTRAL NERVOUS SYSTEM INFECTIONS, BRAIN DISEASES, CENTRAL NERVOUS SYSTEM MOVEMENT DISORDERS, OCULAR MOTILITY DISORDERS, SPINAL CORD DISEASES, PSYCHO VEGETATIVE DISORDERS, DEPRESSIVE SYNDROME, ANXIETY, NERVOUS UNREST, PERIPHERAL NERVOUS SYSTEM INFECTIONS, PERIPHERAL NERVOUS SYSTEM MOVEMENT DISORDERS, NERVE COMPRESSION SYNDROMES, NEURITIS, NEURALGIA AND REGIONAL PAIN SYNDROMES, DISEASES AND DISORDERS OF THE KIDNEY, UROLOGICAL DISORDERS, CHRONIC INFECTIONS OF THE BLADDER, CYSTITIS, PYELONEPHRITIS, GLOMERULONEPHRITIS, INTERSTITIAL NEPHRITIS, NEPHROLITHIASIS, CANCER, UROLITH PROPHYLAXIS, DIZZINESS, MIGRAINE, DEPRESSION, INFLAMMATIONS OF THE UPPER AND LOWER RESPIRATORY ORGANS, SINUSES, BRONCHITIS, TONSILLITIS, ARTHRITIS, OSTEO ARTHRITIS, FEVER, COUGH, COLD,

ALZHEIMER'S DISEASE, INFECTION OF RESPIRATORY TRACT, INFECTION OF URINARY TRACT, URINARY OBSTRUCTION, CHRONIC VENOUS INSUFFICIENCY, PROSTATE HYPERPLASIA, MUSCLE PAINS, SOFT TISSUE RHEUMATISM, MUSCULARSKETAL DISEASE, LIVER DISEASE, HEPATITIS, CIRRHOSIS OF LIVER, PERIODONTAL DISEASES AND DENTAL CARIES; PHARMACEUTICAL PREPARATIONS FOR USE AS AN ANTIDEPRESSANT, DIURETIC, HYPNOTIC, SEDATIVE, STIMULANT, AND TRANQUILIZER; HEMORRHOIDAL OINTMENT, LAXATIVE, NASAL DECONGESTANT CAPSULES, NASAL SPRAY PREPARATIONS, NON-NARCOTIC ANALGESICS, THROAT LOZENGES; MENSTRUATION CIRCULATION REGULATING TABLETS; HORMONE PREPARATIONS, HORMONE REPLACEMENT MEDICATION; PHARMACEUTICAL PREPARATIONS FOR SENSORY ORGANS, NAMELY, FOR USE IN OPHTHALMOLOGY, OTOLARYNGOLOGY AND DERMATOLOGY; PHARMACEUTICAL PREPARATIONS FOR REGULATION AND STRENGTHENING OF THE IMMUNE SYSTEM; PHARMACEUTICAL PREPARATIONS FOR TREATING TEMPORARY RELIEF OF OCCASIONAL MINOR IRRITATION, PAIN, SORE MOUTH, SORE GUMS, SORE THROAT, PAIN ASSOCIATED WITH CANKER SORES, PAIN DUE TO MINOR IRRITATION OR INJURY OF THE MOUTH AND GUMS, PAIN DUE TO MINOR DENTAL PROCEDURES, PAIN DUE TO MINOR IRRITATIONS CAUSED BY DENTURES OR ORTHODONTIC APPLIANCES, SORE GUMS DUE TO TEETHING IN INFANTS AND CHILDREN FOUR MONTHS OF AGE AND OLDER; PHARMACEUTICAL PRODUCTS, NAMELY, MEDICATED DENTAL, GUM AND MOUTH WASHES, MEDICATED DENTAL, GUM AND MOUTH RINSE, MEDICATED TOOTHPASTES, MEDICATED ORAL-CARE GELS, MEDICATED DENTAL GELS, MEDICATED LOZENGES, COUGH LOZENGES, MEDICATED CHEWING GUM, MEDICATED GELS AND FLUIDS IN THE NATURE OF DENTAL BLEACHING GELS, GUM BALMS, MEDICATED DENTAL FLOSS, MEDICATED DENTAL TAPES, MEDICATED DENTAL RIBBONS, MEDICATED TEETH WHITENER GELS, MEDICATED TOOTHPICKS, FLUORIDE CHEWING GUM AND CHEWABLE TABLETS FOR DISCLOSING DENTAL PLAQUE AND TARTAR; PREPARATIONS FOR DENTAL PURPOSES, NAMELY, PLAQUE DISCLOSING REAGENTS, PERIODONTAL DIAGNOSTIC REAGENTS FOR MEDICAL PURPOSES FOR DETECTING DERIVATIVES FROM PERIODONTAL BACTERIA, CARIES, DIAGNOSTIC REAGENTS FOR DETECTING DERIVATIVES FROM CARIES-CAUSAL BACTERIA AND MEDICINES FOR THE PREVENTION AND TREATMENT OF PERIODONTAL DISEASES, DENTAL CARIES, CANKER SORES, COLD SORES, MUCOSITIS AND ORAL AND TONGUE CANCERS; MEDICATED MOUTH SPRAYS AND DESENSITIZERS; PLANT EXTRACTS FOR VETERINARY AND PHARMACEUTICAL PURPOSES; SANITARY PREPARATIONS FOR MEDICAL USE; SANITARY PREPARATIONS FOR HYGIENE, NAMELY, ANTISEPTICS, ORAL ANTISEPTICS, DISINFECTANTS FOR HYGIENE PURPOSES; SANITARY PREPARATIONS FOR THE TREATMENT, CLEANING AND PROTECTION OF THE SKIN; DIETARY SUPPLEMENTS IN THE FORM OF TABLETS, DROPS, CAPSULES, EXTRACT PREPARATIONS, BALMS OR IN LIQUID FORM, CONTAINING PLANT EXTRACTS; DIETETIC SUBSTANCES ADAPTED FOR MEDICAL USE IN THE FORM OF TABLETS, DROPS, CAPSULES, EXTRACT PREPARATIONS, BALMS OR IN LIQUID FORM; FOOD FOR MEDICALLY RESTRICTED DIETS, FOOD FOR DIABETICS, FOOD SUPPLEMENTS CONTAINING PLANT EXTRACTS, FOOD SUPPLEMENTS DERIVED FROM PLANTS OR PLANT EXTRACTS, ALL AFORESAID GOODS IN THE FORM OF TABLETS, DROPS, CAPSULES, EXTRACT PREPARATIONS, BALMS OR IN LIQUID FORM; VITAMIN AND MINERAL SUPPLEMENTS; FOOD SUPPLEMENTS, NAMELY, HERBAL TEAS FOR MEDICINAL PURPOSES

AND MEDICINAL TEAS; NUTRITIONAL ADDITIVES FOR MEDICAL PURPOSES FOR USE IN FOODS AND DIETARY SUPPLEMENTS FOR HUMAN CONSUMPTION; DIETETIC FOOD SUPPLEMENTS; DIETARY SUPPLEMENTS; FOOD SUPPLEMENTS AND DIETARY FOOD SUPPLEMENTS; MINERAL FOOD SUPPLEMENTS, FOOD SUPPLEMENTS BASED ON AMINO ACIDS, MINERALS AND/OR TRACE ELEMENTS; FOOD SUPPLEMENTS; MEDICAL PLASTERS; MATERIALS FOR DRESSINGS, NAMELY, GAUZE AND BANDAGES; ALL PURPOSE DISINFECTANTS; MATERIAL FOR STOPPING TEETH; DENTAL WAX.

FIRST USE ; IN COMMERCE .

INT. CL. 30/U.S. CL. 46

FOR PLANT EXTRACTS, TINCTURES AND FLAVOURINGS IN LIQUID, SOLID OR GASEOUS FORM OR NON-NUTRITIONAL PURPOSES IN FOOD USED AS FLAVORINGS AND SEASONINGS, HERBAL TEAS FOR FOOD PURPOSES; PLANT EXTRACTS USED AS FLAVOURING IN LIQUID, SOLID OR GASEOUS FORM FOR FOODSTUFFS, FOOD SUPPLEMENTS AND FOOD; FOODS AND DIETETIC FOODS, NAMELY, READY TO EAT CEREAL DERIVED FOOD BARS; FLAVOURINGS IN LIQUID, SOLID OR GASEOUS FORM FOR THE MANUFACTURE OF EDIBLE COSMETICS AND FOOD; HERBAL TEAS.

FIRST USE ; IN COMMERCE .

ELEMENTS CORRECTED
GOODS/SERVICES

3,579,028. REG. 2-24-2009. WILO AG (FED REP GERMANY CORPORATION) NORTKIRCHENSTRASSE 100, DORTMUND, FED REP GERMANY, 44263, SN 77-410,963. FILED 3-3-2008. PRINCIPAL REGISTER.

CARBOCERAM

THE MARK CONSISTS OF STANDARD CHARACTERS WITHOUT CLAIM TO ANY PARTICULAR FONT, STYLE, SIZE, OR COLOR.

PRIORITY CLAIMED UNDER SEC. 44(D) ON FED REP GERMANY APPLICATION NO. 30765853.8/0, FILED 10-9-2007, REG. NO. 30765853, DATED 1-10-2008, EXPIRES 10-31-2017.

INT. CL. 7/U.S. CLS. 13, 19, 21, 23, 31, 34 AND 35

FOR PUMPS EXCEPT FOR PUMPS FOR MEDICAL PURPOSES, NAMELY, PUMPS FOR HEATING UNITS, AGRICULTURAL PUMPS, SUBMERSIBLE PUMPS, BOREHOLE PUMPS, HIGH PRESSURE CENTRIFUGAL PUMPS, PUMPS FOR BOOSTING WATER PRESSURE, HEATING INSTALLATION PUMPS, COOLING INSTALLATION PUMPS, PUMPS FOR MACHINES EXCEPT PUMPS FOR MEDICAL PURPOSES, HIGH PRESSURE PUMPS FOR WASHING APPLIANCES, AND INSTALLATIONS; BUILDING INSTALLATION PUMPS, NAMELY, PUMPS FOR HEATING INSTALLATIONS, COOLING INSTALLATIONS, FRESH WATER SUPPLY INSTALLATIONS, WASTEWATER INSTALLATIONS, SEWAGE AND FECES TREATMENT INSTALLATIONS; ELECTRICAL WATER PUMPS EXCEPT FOR PUMPS FOR MEDICAL PURPOSES, NAMELY, WATER SUPPLY PUMPS, SEWAGE TREATMENT PUMPS, PUMPS FOR SWIMMING POOLS, WHIRLPOOLS, BATHS, PONDS, WATER FILTERING UNITS; INDUSTRIAL ELECTRIC MOTORS OTHER THAN FOR LAND VEHICLES, NAMELY, ELECTRIC MOTORS FOR MACHINES AND PUMPS; SPARE PARTS FOR ELECTRIC PUMPS, NAMELY, FILTERS.

FIRST USE ; IN COMMERCE .

INT. CL. 9/U.S. CLS. 21, 23, 26, 36 AND 38

FOR REGULATING AND CONTROLLING APPARATUS, NAMELY, SWITCHING DEVICES FOR THE OPERATION OF ONE OR MORE PUMPS WITH A DRIVE MOTOR, CONTROL UNITS IN THE NATURE OF SWITCH BOXES AND OPERATING UNITS FOR THE ELECTRICAL CONNECTION OF AC AND THREE PHASE PUMPS, FLOW REGULATORS FOR COMMERCIAL AND DOMESTIC USE, ELECTRONIC FLOW AND PRESSURE CONTROLLERS; ELECTRO-TECHNICAL APPARATUS AND INSTRUMENTS, NAMELY, DRY-RUNNING PROTECTION SWITCHES, ELECTRIC PRESSURE SWITCHES, ELECTRIC FLOAT SWITCHES, IMMERSION PROBES FOR CONTROLLING AND MONITORING THE LEVEL OF LIQUID IN A VESSEL, ELECTRIC COILS, ELECTRIC TIME SWITCHES, PRESSURE SENSORS, ELECTRIC CONTROL PANELS, SWITCHGEARS FOR APPLICATION AS CONTACTOR FOR AC AND THREE-PHASE CURRENT PUMPS; REGULATING AND CONTROLLING APPARATUS, NAMELY, OPERATIONAL MONITORING SYSTEMS COMPRISED OF ELECTRONIC CONTROLS FOR PUMPS AND MOTORS, NAMELY, TEMPERATURE, CURRENT, PRESSURE, AND WATER LEVEL SENSORS FOR MONITORING AND INDICATING OPERATING STATUS OF THE PUMP OR MOTOR, AND FOR PROVIDING A WARNING SIGNAL IN CASE OF REACHING A CERTAIN MEASURED VALUE; ELECTRONIC OPERATIONAL MONITORING UNITS FOR CONTROL AND CHECK OF OPERATING STATUS OF ELECTRIC PUMPS; ELECTRICAL CONNECTION PARTS, NAMELY, INSULATED ELECTRICAL CONNECTORS.

FIRST USE ; IN COMMERCE .

3,585,463. REG. 3-10-2009. EDGE GAMES, INC. (CALIFORNIA CORPORATION) 530 SOUTH LAKE AVE, STE 171, PASADENA, CA, 91101, SN 77-352,656. FILED 12-14-2007. PRINCIPAL REGISTER.

EDGE GAMERS

THE MARK CONSISTS OF STANDARD CHARACTERS WITHOUT CLAIM TO ANY PARTICULAR FONT, STYLE, SIZE, OR COLOR.

INT. CL. 41/U.S. CLS. 100, 101 AND 107

FOR PROVIDING ORGANIZATIONS FOR ONLINE GAME ADMINISTRATORS, NAMELY, ENTERTAINMENT SERVICES IN THE NATURE OF AN ONLINE COMPUTER GAMING CLUB; PROVIDING PUBLIC FORUMS FOR ONLINE GAME ADMINISTRATORS, NAMELY, ENTERTAINMENT SERVICES IN THE NATURE OF AN ONLINE COMPUTER GAMING CLUB.

FIRST USE 7-1-2006; IN COMMERCE 7-1-2006.

ELEMENTS CORRECTED

OWNER NAME
OWNER ADDRESS
CITIZENSHIP
ENTITY

INT. CL. 11/U.S. CLS. 13, 21, 23, 31 AND 34

FOR HEATING INSTALLATIONS, NAMELY, HOT WATER HEATING INSTALLATIONS, RADIATORS, ELECTRIC HEATING CABLES, HEATING BOILERS, HEAT PUMPS, HEAT AND STEAM ACCUMULATORS, HEAT EXCHANGERS NOT BEING PARTS OF MACHINES, SOLAR COLLECTORS FOR HEATING INSTALLATIONS, HOT-WATER SPACE HEATING APPARATUS; HEATING APPARATUS, NAMELY, HEAT PUMPS FOR DOMESTIC HOT WATER CIRCULATORS, HEAT PUMPS FOR SECONDARY CIRCULATORS FOR MECHANICAL BUILDING AND INDUSTRIAL SERVICES, SOLAR THERMIC HEAT PUMPS AND PARTS THEREFOR; HOT-WATER HEATERS, NAMELY, CENTRAL HOT WATER HEATERS, HOT WATER CIRCULATING PUMPS FOR HOT WATER CIRCULATORS, SECONDARY AND SERVICE WATER HEATERS AND OPEN CONDENSATION WATER HEATERS, GLANDLESS PUMPS FOR HOT WATER HEATERS OF ALL KINDS, AIR CONDITIONING PLANTS, CLOSED CHILLED WATER CIRCULATORS, INDUSTRIAL CIRCULATORS AND PARTS THEREFOR; HOT WATER APPARATUS, NAMELY, HOT WATER TANKS, HEATING BOILERS, NAMELY, ELECTRICAL BOILERS, FURNACE BOILERS, INDUSTRIAL BOILERS; HEATING ELEMENTS, NAMELY, ELECTRICAL HEATING CABLES; AIR CONDITIONING INSTALLATIONS, NAMELY, GLANDLESS PUMPS; HEAT PUMPS; HEAT ACCUMULATORS; PRESSURE ACCUMULATORS AS PART OF HEATING AND WATER CONDUIT INSTALLATION, NAMELY, HEAT ACCUMULATORS AND STEAM ACCUMULATORS.

FIRST USE ; IN COMMERCE .

3,585,719. REG. 3-10-2009. UTICA MUTUAL INSURANCE COMPANY (NEW YORK CORPORATION), DBA UTICA NATIONAL INSURANCE GROUP, 180 GENESEE STREET, NEW HARTFORD, NY, 13413, SN 77-409,974. FILED 2-29-2008. PRINCIPAL REGISTER.

HOMEOWNERS EXTENSION PAC

THE MARK CONSISTS OF STANDARD CHARACTERS WITHOUT CLAIM TO ANY PARTICULAR FONT, STYLE, SIZE, OR COLOR.

SEC. 2(F).

INT. CL. 36/U.S. CLS. 100, 101 AND 102

FOR PROPERTY AND CASUALTY INSURANCE UNDERWRITING SERVICES.

FIRST USE 1-0-1990; IN COMMERCE 1-0-1990.

ELEMENTS CORRECTED
FOREIGN REG. DATE

ELEMENTS CORRECTED
DBA/AKA

3,587,242. REG. 3-10-2009. SOPRO (SA) (FRANCE SOCIÉTÉ ANONYME, A CONSEIL D'ADMINISTRATION) ZONE D'ACTIVITÉ COMMERCIALE ATHÉLIA IV, AVENUE DES GENEVRIERS; F-13705 LA CIOTAT, FRANCE., SN 79-041,982. FILED 4-27-2007. PRINCIPAL REGISTER.

3,587,630. REG. 3-10-2009. EXAIR CORPORATION (OHIO CORPORATION) 11510 GOLDCOAST DRIVE, CINCINNATI, OH, 45249, SN 77-023,813. FILED 10-18-2006. PRINCIPAL REGISTER.

SOPRO COMEG

THE MARK CONSISTS OF STANDARD CHARACTERS WITHOUT CLAIM TO ANY PARTICULAR FONT, STYLE, SIZE, OR COLOR.

PRIORITY DATE OF 11-23-2006 IS CLAIMED. OWNER OF INTERNATIONAL REGISTRATION 0932989 DATED 4-27-2007. EXPIRES 4-27-2017.

OWNER OF U.S. REG. NOS. 2,871,099 AND 3,215,984. THE WORDING "SOPRO COMEG" HAS NO MEANING IN ENGLISH.

INT. CL. 9/U.S. CLS. 21, 23, 26, 36 AND 38

FOR [MEDICAL ENDOSCOPES AND THEIR COMPONENTS, NAMELY, VIDEO MONITORS;] CAMERAS; OPTICAL APPARATUS, NAMELY, OPTICAL LENSES AND FIBRE OPTIC CABLES; ADAPTERS AND CABLES FOR LINKING A CAMERA TO AN ENDOSCOPE; APPARATUS FOR REPRODUCTION, TRANSMISSION AND RECORDING OF IMAGES FOR ENDOSCOPY; MICROSCOPES; MINISCOPIES OBJECTIVES FOR OPTICAL APPARATUS FOR ENDOSCOPES, NAMELY, CAMERA LENSES.

FIRST USE ; IN COMMERCE .

INT. CL. 10/U.S. CLS. 26, 39 AND 44

FOR SURGICAL AND MEDICAL APPARATUS AND INSTRUMENTS FOR USE IN GENERAL SURGERY, DENTAL SURGERY AND VETERINARY SURGERY; APPARATUS FOR MEDICAL DIAGNOSIS, NAMELY, OPTICAL MEDICINE DIAGNOSTIC IMAGING APPARATUS; CAMERA LAMPS FOR MEDICAL USE; OTOLARYNGOLOGICAL APPARATUS AND INSTRUMENTS, NAMELY, SINUSCOPIES, OTOSCOPIES, LARYNGOSCOPIES, TELESCOPES, HANDLES AND SUCTION-IRRIGATION HANDLES; UROLOGICAL APPARATUS AND INSTRUMENTS, NAMELY, CYSTOSCOPY TELESCOPES IN THE NATURE OF CYSTOSCOPIES, RESECTOSCOPIES, RENOSCOPIES, URETEROSCOPIES, NEPHROSCOPES, AND STOPCOCKS, SHEATHS, DEFLECTORS AND OBTURATORS FOR THOSE PRODUCTS; ARTHROSCOPIC APPARATUS AND INSTRUMENTS, NAMELY, TELESCOPES FOR ARTHROSCOPY IN THE NATURE OF ARTHROSCOPES, TELESCOPES FOR NEUROLOGY IN THE NATURE OF NEUROSCOPES; BIOPSY AND GRASPING FORCEPS, SCISSORS, PUNCHES FOR MEDICAL USE; SHAVERS, BLADES AND SHEATHS FOR ARTHROSCOPY; GYNECOLOGICAL APPARATUS AND INSTRUMENTS, NAMELY, TELESCOPES FOR GYNECOLOGY IN THE NATURE OF GYNAECOSCOPIES, RESECTOSCOPIES, OPERATING SHEATHS AND DEFLECTORS FOR GYNECOLOGY; LAPAROSCOPIC APPARATUS AND INSTRUMENTS, NAMELY, TELESCOPES FOR LAPAROSCOPY IN THE NATURE OF LAPAROSCOPIES, TELESCOPES FOR THORASCOPY IN THE NATURE OF THORASCOPES, SUCTION AND IRRIGATION TUBES AND GRASPING FORCEPS; PROBES FOR MEDICAL PURPOSES, NAMELY, FIBRE CABLES; LIGHTING INSTALLATIONS AND APPARATUS FOR DENTAL USE DESIGNED FOR ENDOSCOPY, NAMELY, OPTICAL LENSES, DENTAL EXAMINATION LAMPS; ARTHROSCOPY IRRIGATION PUMPS, INSUFFLATORS * MEDICAL ENDOSCOPES AND THEIR COMPONENTS *.

FIRST USE ; IN COMMERCE .

ELEMENTS CORRECTED
GOODS/SERVICES

COMPRESSED AIR INTELLIGENCE

THE MARK CONSISTS OF STANDARD CHARACTERS WITHOUT CLAIM TO ANY PARTICULAR FONT, STYLE, SIZE, OR COLOR.

NO CLAIM IS MADE TO THE EXCLUSIVE RIGHT TO USE "COMPRESSED AIR", APART FROM THE MARK AS SHOWN.

INT. CL. 7/U.S. CLS. 13, 19, 21, 23, 31, 34 AND 35

FOR COMPRESSED AIR PUMPS; VACUUM PUMPS AND CONVEYORS OPERATED BY COMPRESSED AIR; FILTERS AND FILTER SEPARATORS FOR USE IN CONNECTION WITH COMPRESSED AIR SYSTEMS; VALVES FOR USE WITH MACHINES FOR USE IN CONNECTION WITH COMPRESSED AIR SYSTEMS.

FIRST USE 10-15-2008; IN COMMERCE 10-15-2008.

INT. CL. 9/U.S. CLS. 21, 23, 26, 36 AND 38

FOR POWER SUPPLIES FOR COMPRESSED AIR AND STATIC ELIMINATOR SYSTEMS; THERMOSTATS; FLOW REGULATORS FOR USE IN CONNECTION WITH COMPRESSED AIR AND STATIC ELIMINATOR COMPONENTS; AND INSTRUMENTS FOR USE IN DETECTING LEAKS WITHIN COMPRESSED AIR SYSTEMS; ELECTRICAL STATIC ELIMINATOR OPERATED BY COMPRESSED AIR THAT NEUTRALIZE STATIC ELECTRICITY CHARGES DURING INDUSTRIAL AND MANUFACTURING PROCESSES; PRESSURE REGULATORS FOR USE IN CONNECTION WITH COMPRESSED AIR SYSTEMS.

FIRST USE 10-15-2008; IN COMMERCE 10-15-2008.

INT. CL. 11/U.S. CLS. 13, 21, 23, 31 AND 34

FOR COMPRESSED-AIR-OPERATED COMPONENTS FOR USE IN INDUSTRIAL AND COMMERCIAL COOLING, VENTILATING, BLOW-OFF AND CLEANING, NAMELY, VORTEX TUBES, PANEL COOLERS, CAMERA COOLERS, COLD GUNS, COMPONENT COOLERS, NEEDLE COOLERS, AIR AMPLIFIERS, AIR KNIVES, AIR WIPES; AIR IONIZERS, AIR JETS AND AIR NOZZLES; MOUNTING BRACKETS FOR THE FOREGOING GOODS.

FIRST USE 10-15-2008; IN COMMERCE 10-15-2008.

ELEMENTS CORRECTED
GOODS/SERVICES

3,589,920. REG. 3-17-2009. MI INDUSTRIES, INC. (NEBRASKA CORPORATION) PO BOX 29345, 6200 NORTH 56TH STREET, LINCOLN, NE, 685290345, SN 77-372,434. FILED 1-15-2008. PRINCIPAL REGISTER.

HONEY CREEK FARMS

THE MARK CONSISTS OF STANDARD CHARACTERS WITHOUT CLAIM TO ANY PARTICULAR FONT, STYLE, SIZE, OR COLOR.

INT. CL. 31/U.S. CLS. 1 AND 46

FOR [ANIMAL FOODSTUFFS;] DOG TREATS; CAT TREATS [; PET TREATS].
FIRST USE 11-30-1999; IN COMMERCE 11-30-1999.

3,593,952. REG. 3-24-2009. CHRIS RECKNOR MD PC (GEORGIA CORPORATION) 2350 LIMESTONE PARKWAY, GAINESVILLE, GA, 30501, SN 77-391,218. FILED 2-7-2008. PRINCIPAL REGISTER.

ELEMENTS CORRECTED
GOODS/SERVICES

OUTCOMES MADE SIMPLE

3,590,466. REG. 3-17-2009. HUMAN RIGHTS CAMPAIGN FOUNDATION (D.C. CORPORATION) 1640 RHODE ISLAND AVENUE, NW, WASHINGTON, DC, 20009, SN 77-507,608. FILED 6-25-2008. PRINCIPAL REGISTER.



OWNER OF U.S. REG. NOS. 2,418,646, 3,178,886 AND OTHERS.

NO CLAIM IS MADE TO THE EXCLUSIVE RIGHT TO USE "CAMP" AND "08", APART FROM THE MARK AS SHOWN.

THE COLOR(S) BLUE, WHITE AND YELLOW IS/ARE CLAIMED AS A FEATURE OF THE MARK.

THE MARK CONSISTS OF THE WORDING "CAMP EQUALITY 08 HUMAN RIGHTS CAMPAIGN" AND THE "HUMAN RIGHTS" LOGO, WHICH APPEAR ON A WHITE BACKGROUND INSIDE A BLUE RECTANGULAR CARRIER. THE WORDING IN THE MARK APPEARS IN THE COLOR BLUE AND THE "HUMAN RIGHTS" LOGO APPEARS IN THE COLORS BLUE AND YELLOW.

AS TO "HUMAN RIGHTS CAMPAIGN".
INT. CL. 41/U.S. CLS. 100, 101 AND 107
FOR EDUCATIONAL SERVICES, NAMELY, CONDUCTING AN INTERACTIVE TRAINING PROGRAM TO DEVELOP SKILLS FOR STRENGTHENING THE COMMUNITY IMPACT ON POLITICAL ELECTIONS.
FIRST USE 4-28-2008; IN COMMERCE 4-28-2008.

ELEMENTS CORRECTED
GOODS/SERVICES

THE MARK CONSISTS OF STANDARD CHARACTERS WITHOUT CLAIM TO ANY PARTICULAR FONT, STYLE, SIZE, OR COLOR.

NO CLAIM IS MADE TO THE EXCLUSIVE RIGHT TO USE "OUTCOMES", APART FROM THE MARK AS SHOWN.
INT. CL. 9/U.S. CLS. 21, 23, 26, 36 AND 38

FOR DATA PROCESSING SYSTEMS, NAMELY, SYSTEMS FOR (I) ANALYZING KEY OUTCOME DATA POINTS FROM A PATIENT WITH A MEDICAL CONDITION TO TRACK STATUS PROGRESS, GOALS AND INTERVENTIONS AND (II) ANALYZING KEY OUTCOME DATA POINTS TO TRACK STATUS AND PROGRESS OF KEY DATA POINTS ACROSS POPULATIONS WITH SPECIFIC DISEASES OR SYNDROMES.

FIRST USE 11-19-2007; IN COMMERCE 11-19-2007.

ELEMENTS CORRECTED
OWNER ADDRESS

3,594,629. REG. 3-24-2009. FARACI, MARY (UNITED STATES INDIVIDUAL) 706 E. IVY LANE, ARLINGTON HEIGHTS, IL, 60004, AND FARACI, FRANK (UNITED STATES INDIVIDUAL) 706 E. IVY LANE, ARLINGTON HEIGHTS, IL, 60004, SN 77-547,914. FILED 8-15-2008. PRINCIPAL REGISTER.

Release the Past. Embrace the Future.

THE MARK CONSISTS OF STANDARD CHARACTERS WITHOUT CLAIM TO ANY PARTICULAR FONT, STYLE, SIZE, OR COLOR.

INT. CL. 36/U.S. CLS. 100, 101 AND 102
FOR CHARITABLE FUND RAISING.
FIRST USE 8-13-2008; IN COMMERCE 8-13-2008.

ELEMENTS CORRECTED
OWNER NAME

3,591,189. REG. 3-17-2009. E. I. DU PONT DE NEMOURS AND COMPANY (DELAWARE CORPORATION) TRADE-MARK & COPYRIGHT GROUP, 1007 MARKET STREET, WILMINGTON, DE, 19898, SN 77-570,692. FILED 9-16-2008. PRINCIPAL REGISTER.

CORIAN

THE MARK CONSISTS OF STANDARD CHARACTERS WITHOUT CLAIM TO ANY PARTICULAR FONT, STYLE, SIZE, OR COLOR.

OWNER OF U.S. REG. NOS. 821,790, 827,558 AND 838,624.
INT. CL. 11/U.S. CLS. 13, 21, 23, 31 AND 34
FOR KITCHEN SINKS, [TOILET BOWLS,] LAVATORIES AND BATHROOM SINK BASINS.
FIRST USE 8-31-1984; IN COMMERCE 8-31-1984.

ELEMENTS AMENDED
GOODS/SERVICES

3,595,417. REG. 3-24-2009. VERITEC, INC. (NEVADA CORPORATION) 2445 WINNETKA AVENUE NORTH, GOLDEN VALLEY, MN, 55427, SN 77-135,803. FILED 3-20-2007. PRINCIPAL REGISTER.

VSCODE

THE MARK CONSISTS OF STANDARD CHARACTERS WITHOUT CLAIM TO ANY PARTICULAR FONT, STYLE, SIZE, OR COLOR.

INT. CL. 9/U.S. CLS. 21, 23, 26, 36 AND 38

FOR COMPUTER PROGRAMS AND SOFTWARE FOR CREATING AND DECODING BAR CODE SYMBOLS; APPARATUS THAT CREATE BAR CODE SYMBOLS, NAMELY, INK JET CARD PRINTERS, THERMAL TRANSFER PRINTERS, PHOTO PRINTERS, THERMAL PRINTERS, LASER ETCHING PRINTERS, DOT PEEN MARKERS, MICRO-ABRASIVE BLASTERS, AND LASER PRINTERS; APPARATUS THAT READ BAR CODE SYMBOLS, NAMELY, BAR CODE READERS AND BAR CODE SCANNERS; MAGNETICALLY ENCODED IDENTIFICATION CARDS CONTAINING ONE-DIMENSIONAL OR TWO-DIMENSIONAL BAR CODE SYMBOLS.

FIRST USE 4-20-2003; IN COMMERCE 4-20-2003.

ELEMENTS CORRECTED
GOODS/SERVICES

3,597,225. REG. 3-31-2009. HASTED LIMITED (IRELAND LIMITED COMPANY (LTD.)) BROOMBRIDGE STATION, 288 BANNOW ROAD, BROOMBRIDGE BUSINESS CENTRE, DUBLIN, IRELAND. 7, SN 77-324,684. FILED 11-8-2007. PRINCIPAL REGISTER.



OWNER OF ERPN CMNTY TM OFC REG. NO. 004051843, DATED 11-29-2005.

NO CLAIM IS MADE TO THE EXCLUSIVE RIGHT TO USE "VOILE" AS TO THE GOODS IN INTERNATIONAL CLASSES 18 AND 25, APART FROM THE MARK AS SHOWN.

THE MARK CONSISTS OF THE WORD "VOILE" OVER THE WORD "BLANCHE", WITH A WIDE-ANGLED "V" ABOVE BOTH WORDS, WITH A SOLID CIRCLE OVER EACH END OF THE WIDE-ANGLED "V".

THE ENGLISH TRANSLATION OF "VOILE BLANCHE" IS "WHITE SAIL".

INT. CL. 9/U.S. CLS. 21, 23, 26, 36 AND 38
FOR SPECTACLES.

INT. CL. 18/U.S. CLS. 1, 2, 3, 22 AND 41

FOR LEATHER AND IMITATIONS OF LEATHER AND GOODS MADE OF THESE MATERIALS, NAMELY, TRAVELING BAGS, SHOULDER BAGS AND HANDBAGS.

INT. CL. 25/U.S. CLS. 22 AND 39

FOR CLOTHING, NAMELY, SHIRTS, PANTS, T-SHIRTS, SWEATSHIRTS, SWEATPANTS, SWIMSUITS, SHORTS, JACKETS, DRESSES, TIES AND BELTS; FOOTWEAR, NAMELY, SHOES AND SNEAKERS; HEADGEAR, NAMELY, HATS, CAPS, HEADBANDS AND HEAD SCARVES.

ELEMENTS AMENDED
OWNER ADDRESS

3,596,672. REG. 3-24-2009. WILD GOOSE HOLDING CO., INC. (DELAWARE CORPORATION) SUITE 1300, POST OFFICE BOX 8985, 1105 NORTH MARKET STREET, WILMINGTON, DE, 19899, SN 78-875,562. FILED 5-3-2006. PRINCIPAL REGISTER.

THE WAWA GOBBLER

3,598,187. REG. 3-31-2009. FINISAR CORPORATION (DELAWARE CORPORATION) 1389 MOFFETT PARK DRIVE, SUNNYVALE, CA, 94089, SN 77-553,130. FILED 8-21-2008. PRINCIPAL REGISTER.

THE MARK CONSISTS OF STANDARD CHARACTERS WITHOUT CLAIM TO ANY PARTICULAR FONT, STYLE, SIZE, OR COLOR.

NO CLAIM IS MADE TO THE EXCLUSIVE RIGHT TO USE "GOBBLER", APART FROM THE MARK AS SHOWN.

THE ENGLISH TRANSLATION OF THE WORD "WAWA" IN THE MARK IS "WILD GOOSE".

INT. CL. 30/U.S. CL. 46

FOR HOT TURKEY SANDWICHES.

FIRST USE 9-29-2008; IN COMMERCE 9-29-2008.

ELEMENTS CORRECTED
TRANSLATION OF MARK



THE MARK CONSISTS OF A WOMEN'S FACE.
INT. CL. 41/U.S. CLS. 100, 101 AND 107

FOR EDUCATIONAL SERVICES, NAMELY, CONDUCTING COURSES, SEMINARS, AND WORKSHOPS IN THE FIELDS OF DESIGN, DEVELOPMENT, TESTING AND SUPPORT OF COMPUTER HARDWARE AND SOFTWARE FOR THE MANAGEMENT, ANALYSIS, TROUBLESHOOTING, MEASURING AND MONITORING OF STORAGE AREA NETWORKS, COMPUTER NETWORKS AND COMMUNICATION NETWORKS.

FIRST USE 0-0-2001; IN COMMERCE 0-0-2001.

INT. CL. 42/U.S. CLS. 100 AND 101

FOR TESTING SERVICES, NAMELY, PERFORMING TESTING, INTEROPERABILITY AND PERFORMANCE VERIFICATION OF PRODUCTS AND SOLUTIONS OF OTHERS, INCLUDING SERVERS, STORAGE AND NETWORKING INTERFACES, AND PROTOCOLS; AND PROVIDING SOLUTIONS TO CORRECT ERRORS FOUND IN THE PRODUCTS OF OTHERS, INCLUDING DEBUG, ANALYSIS AND REGRESSION INFORMATION.

FIRST USE 0-0-2001; IN COMMERCE 0-0-2001.

ELEMENTS CORRECTED
CITIZENSHIP

3,600,254. REG. 3-31-2009. SUCCESS APPAREL LLC (NEW YORK LIMITED LIABILITY COMPANY) 19 WEST 34TH STREET, NEW YORK, NY, 10001, SN 78-685,456. FILED 8-4-2005. PRINCIPAL REGISTER.

DECODED

THE MARK CONSISTS OF STANDARD CHARACTERS WITHOUT CLAIM TO ANY PARTICULAR FONT, STYLE, SIZE, OR COLOR.

INT. CL. 25/U.S. CLS. 22 AND 39

FOR CLOTHING FOR NEWBORNS, INFANTS, TODDLERS, CHILDREN AND ADULTS, NAMELY, T-SHIRTS, POLO SHIRTS, SPORTS SHIRTS, SWEAT-SHIRTS, SWEATPANTS, WARMUP SUITS, DRESSES, SKIRTS, BLOUSES, SWEATERS, SHORTS, COATS, JACKETS, VESTS, SUITS, RAINCOATS, HATS, VISORS, PANTS, JEANS, [BELTS,] TIES, SCARVES, GLOVES, STOCKINGS, UNDERWEAR, BRAS, BOXER SHORTS, BRIEFS, PANTIES, SLEEPWEAR, SWIMWEAR, INFANT WEAR [, AND FOOTWEAR] .

FIRST USE 1-8-2009; IN COMMERCE 1-8-2009.

ELEMENTS AMENDED
GOODS/SERVICES

3,602,412. REG. 4-7-2009. ASTELLAS PHARMA EUROPE B.V. (NETHERLANDS BESLOTEN VENNOOTSCHAP (B.V.)), FORMERLY YAMANOUCHI EUROPE B.V., ELISABETH-HOF 19, LEIDERDORP, NETHERLANDS, 2353EW, SN 77-570,184. FILED 9-15-2008. PRINCIPAL REGISTER.

LOCOID

THE MARK CONSISTS OF STANDARD CHARACTERS WITHOUT CLAIM TO ANY PARTICULAR FONT, STYLE, SIZE, OR COLOR.

OWNER OF BENELUX REG. NO. 039676, DATED 6-28-1971, EXPIRES 6-28-2018.

OWNER OF U.S. REG. NOS. 1,058,915 AND 2,136,591.

INT. CL. 5/U.S. CLS. 6, 18, 44, 46, 51 AND 52

FOR PHARMACEUTICAL STEROID PREPARATIONS FOR TOPICAL USE; TOPICAL CORTICOSTEROIDS, NAMELY, OINTMENTS, CREAMS, LOTIONS, FATTY CREAMS, MILK, ALL FOR DERMATOLOGICAL USE.

FIRST USE 9-0-1982; IN COMMERCE 9-0-1982.

ELEMENTS CORRECTED
OWNER NAME

3,602,644. REG. 4-7-2009. MARK STEPHEN MARENGO (UNITED KINGDOM INDIVIDUAL) 17 QUADRANT ARCADE., 80 REGENT STREET; LONDON W1B 5HD, UNITED KINGDOM., SN 79-044,242. FILED 7-30-2007. PRINCIPAL REGISTER.

MARK STEPHEN

PRIORITY DATE OF 2-26-2007 IS CLAIMED.

OWNER OF INTERNATIONAL REGISTRATION 0938563 DATED 7-30-2007, EXPIRES 7-30-2017.

THE NAME MARK IDENTIFIES A LIVING INDIVIDUAL WHOSE CONSENT IS OF RECORD.

INT. CL. 3/U.S. CLS. 1, 4, 6, 50, 51 AND 52

FOR BODY AND HAIR CARE PRODUCTS AND PREPARATIONS, NAMELY, BATH LOTION, BODY LOTION, HAIR CARE PREPARATIONS, HAIR CARE LOTIONS; NON-MEDICATED TOILETRIES; SHAMPOOS; SUNTAN PREPARATIONS, NAMELY, SUNTAN CREAMS, COSMETIC SUNTAN LOTIONS; TALCUM POWDERS; COSMETICS; MAKE-UP PREPARATIONS; FRAGRANT SPRAYS, NAMELY, BODY SPRAYS AND HAIR SPRAYS; PERFUMERY; AFTERSHAVES; DEODORANTS FOR PERSONAL USE; ANTIPERSPIRANTS; DEPILATORIES; DENTIFRICES; SOAPS; ESSENTIAL OILS; SHAVING CREAMS AND LOTIONS.

INT. CL. 25/U.S. CLS. 22 AND 39

FOR CLOTHING, NAMELY, [FOOTWEAR,] HEADWEAR; SUITS; COATS; SHIRTS; BELTS; FUR CLOTHING, NAMELY, COATS, HATS, CLOAKS, JACKETS; GLOVES; SCARVES; TIES; HOSIERY; SOCKS; SLIPPERS; UNDERWEAR; WOMEN'S LINGERIE.

FIRST USE ; IN COMMERCE .

INT. CL. 35/U.S. CLS. 100, 101 AND 102

FOR RETAIL, ON-LINE RETAIL, MAIL ORDER, AND CATALOG SERVICES FEATURING BODY AND HAIR CARE PRODUCTS AND PREPARATIONS, TOILETRIES, SUNTAN PREPARATIONS, TALCUM POWDERS, COSMETICS, PERFUMERY, DEODORANTS, ANTIPERSPIRANTS, DEPILATORIES, DENTIFRICES, SOAPS, ESSENTIAL OILS, SHAVING CREAMS AND LOTIONS, NON-MEDICATED TOILET PREPARATIONS, WATCHES AND CLOCKS, CUFFLINKS, KEY RINGS, JEWELRY, HOROLOGICAL AND CHRONOMETRIC INSTRUMENTS, COSTUME JEWELLERY, LEATHER AND IMITATIONS OF LEATHER, BAGS, LUGGAGE, TRUNKS, TRAVELLING BAGS AND CASES, WALLETS AND PURSES, BRIEFCASES, UMBRELLAS, PARASOLS AND WALKING STICKS, CLOTHING, FOOTWEAR, HEADGEAR, SHIRTS, SUITS, COATS AND TIES.

ELEMENTS CORRECTED
GOODS/SERVICES

3,602,748. REG. 4-7-2009. BASILEA PHARMACEUTICA AG (SWITZERLAND AKTIENGESELLSCHAFT) GRENZACHERSTRASSE 487, CH-4005 BASEL, SWITZERLAND., SN 79-052,210. FILED 2-7-2008. PRINCIPAL REGISTER.

Basilea Pharmaceuticals

THE MARK CONSISTS OF STANDARD CHARACTERS WITHOUT CLAIM TO ANY PARTICULAR FONT, STYLE, SIZE, OR COLOR.

PRIORITY DATE OF 8-17-2007 IS CLAIMED.

OWNER OF INTERNATIONAL REGISTRATION 0959593 DATED 2-7-2008, EXPIRES 2-7-2018.

NO CLAIM IS MADE TO THE EXCLUSIVE RIGHT TO USE "PHARMACEUTICALS", APART FROM THE MARK AS SHOWN.

INT. CL. 1/U.S. CLS. 1

FOR CHEMICAL SUBSTANCES FOR USE IN THE MANUFACTURE OF PHARMACEUTICAL PREPARATIONS FOR THE TREATMENT OF DERMATOLOGICAL CONDITIONS, THE TREATMENT OF INFECTIONS AND DISEASES AND IN THE RESEARCH AND DEVELOPMENT OF PHARMACEUTICALS IN THE TREATMENT OF DERMATOLOGICAL CONDITIONS, THE TREATMENT OF INFECTIONS AND DISEASES; DIAGNOSTIC PREPARATIONS FOR SCIENTIFIC CLINICAL USE; DIAGNOSTIC REAGENTS FOR CLINICAL OR MEDICAL LABORATORY USE .

FIRST USE ; IN COMMERCE .

INT. CL. 5/U.S. CLS. 6, 18, 44, 46, 51 AND 52

FOR PHARMACEUTICAL AND VETERINARY PRODUCTS AND PREPARATIONS FOR THE TREATMENT AND PREVENTION OF DERMATOLOGICAL CONDITIONS, NAMELY, ECZEMA, INFLAMMATION, INFECTION, WARTS, PSORIASIS, AGING OF THE SKIN, ULTRA VIOLET RADIATION AND CANCER; PHARMACEUTICAL AND VETERINARY PRODUCTS AND PREPARATIONS FOR THE TREATMENT AND PREVENTION OF INFECTIONS CAUSED BY BACTERIA, FUNGI, VIRUSES, AND RHEUMATOID ARTHRITIS; PHARMACEUTICAL AND VETERINARY PRODUCTS AND PREPARATIONS FOR THE TREATMENT AND PREVENTION OF DISEASES, DISORDERS AND CONDITIONS IN THE AREA OF ONCOLOGY; PHARMACEUTICAL AND VETERINARY PRODUCTS AND PREPARATIONS FOR THE TREATMENT AND PREVENTION OF DISEASES, DISORDERS AND CONDITIONS IN THE AREA OF GASTROENTEROLOGY; PHARMACEUTICAL AND VETERINARY PRODUCTS AND PREPARATIONS FOR THE TREATMENT AND PREVENTION OF DISEASES, DISORDERS AND CONDITIONS IN THE AREA OF NEUROLOGY; PHARMACEUTICAL AND VETERINARY PRODUCTS AND PREPARATIONS FOR THE TREATMENT AND PREVENTION OF DISEASES, DISORDERS AND CONDITIONS IN THE AREA OF GYNECOLOGY; PHARMACEUTICAL AND VETERINARY PRODUCTS AND PREPARATIONS FOR THE TREATMENT AND PREVENTION OF DISEASES, DISORDERS AND CONDITIONS IN THE AREA OF UROLOGY; PHARMACEUTICAL AND VETERINARY PRODUCTS AND PREPARATIONS FOR THE TREATMENT AND PRE-

VENTION OF DISEASES, DISORDERS AND CONDITIONS IN THE AREA OF CARDIOLOGY; PHARMACEUTICAL AND VETERINARY PRODUCTS AND PREPARATIONS FOR THE TREATMENT AND PREVENTION OF DISEASES, DISORDERS AND CONDITIONS IN THE AREA OF ENDOCRINOLOGY; PHARMACEUTICAL AND VETERINARY PRODUCTS AND PREPARATIONS FOR THE TREATMENT AND PREVENTION OF DISEASES, DISORDERS AND CONDITIONS IN THE AREA OF NEPHROLOGY; PHARMACEUTICAL AND VETERINARY PRODUCTS AND PREPARATIONS FOR THE TREATMENT AND PREVENTION OF DISEASES, DISORDERS AND CONDITIONS IN THE AREA OF HEMATOLOGY; PHARMACEUTICAL AND VETERINARY PRODUCTS AND PREPARATIONS FOR THE TREATMENT AND PREVENTION OF DISEASES, DISORDERS AND CONDITIONS IN THE AREA OF ALLERGY; PHARMACEUTICAL AND VETERINARY PRODUCTS AND PREPARATIONS FOR THE TREATMENT AND PREVENTION OF DISEASES, DISORDERS AND CONDITIONS IN THE AREA OF PSYCHIATRY; PHARMACEUTICAL AND VETERINARY PRODUCTS AND PREPARATIONS FOR THE TREATMENT AND PREVENTION OF DISEASES, DISORDERS AND CONDITIONS IN THE AREA OF ANESTESIOLOGY; PHARMACEUTICAL AND VETERINARY PRODUCTS AND PREPARATIONS FOR THE TREATMENT AND PREVENTION OF DISEASES, DISORDERS AND CONDITIONS IN THE AREA OF RHEUMATOLOGY; ALL OF THE AFORESAID FOR PRESCRIPTION ONLY.

FIRST USE ; IN COMMERCE .

INT. CL. 42/U.S. CLS. 100 AND 101

FOR RESEARCH AND DEVELOPMENT SERVICES FOR THIRD PARTIES IN THE FIELD OF CHEMICAL SUBSTANCES, PHARMACEUTICAL AND VETERINARY PRODUCTS AND PREPARATIONS.

ELEMENTS CORRECTED
GOODS/SERVICES

3,603,930. REG. 4-7-2009. TMP WORLDWIDE ADVERTISING & COMMUNICATIONS, LLC (NEW YORK LIMITED LIABILITY COMPANY) 205 HUDSON STREET, 5TH FLOOR, NEW YORK, NY, 10013, SN 77-394,716. FILED 2-12-2008. PRINCIPAL REGISTER.

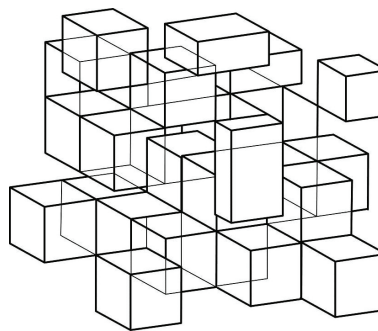

INT. CL. 35/U.S. CLS. 100, 101 AND 102

JUNE 2, 2009

U.S. PATENT AND TRADEMARK OFFICE

TM 1421

FOR ADVERTISING AGENCY SERVICES; EMPLOYMENT HIRING, RECRUITING, PLACEMENT, STAFFING AND CAREER NETWORKING SERVICES; BUSINESS MARKETING CONSULTING SERVICES; RESEARCH SERVICES IN THE FIELD OF JOB PLACEMENT; DESIGNING AND CONDUCTING EMPLOYMENT RECRUITMENT MARKETING SERVICES AND MARKETING STUDIES SERVICES VIA INTERACTIVE COMPUTER DATABASES INCLUDING A WEB SITE ON A GLOBAL COMPUTER INFORMATION NETWORK; PUBLIC RELATIONS AND EMPLOYER BRANDING SERVICES.

FIRST USE 9-30-2008; IN COMMERCE 9-30-2008.
INT. CL. 38/U.S. CLS. 100, 101 AND 104

FOR ELECTRONIC TRANSMISSION OF ADVERTISEMENTS, RESUMES AND OTHER RESPONSES TO EMPLOYMENT [RECRUITMENT] *RECRUITMENT* ADVERTISING.

FIRST USE 9-30-2008; IN COMMERCE 9-30-2008.

ELEMENTS CORRECTED
GOODS/SERVICES

* * * * *

TRADEMARK REGISTRATIONS—NEW CERTIFICATES

New Certificates issued under section 7(d) of the Trademark Act of 1946 for the unexpired term of the original registrations.

2,719,448. GANDOLFO'S NEW YORK DELICATESSEN
AND DESIGN. INT. CL. 43. GANDOLFO, PROVO, UT.
REG. 5-27-2003. NEW CERT. SEC. 7(D) TO REGISTRANT.

YSTANDARD CHARACTER MARK INT. CL. 41. THE
LUXURY MARKETING COUNCIL, INC., NEW YORK,
NY. REG. 7-31-2007. NEW CERT. SEC. 7(D) TO REGIS-
TRANT.

2,794,627. GANDOLFO'S NEW YORK DELICATESSEN.
INT. CL. 35. GANDOLFO, PROVO, UT. REG. 12-16-2003.
NEW CERT. SEC. 7(D) TO REGISTRANT.

3,593,389. AIRPORTSTANDARD CHARACTER MARK
INT. CL. 11. PARAMOUNT LEISURE INDUSTRIES,
INC., CHANDLER, AZ. REG. 3-17-2009. NEW CERT. SEC.
7(D) TO REGISTRANT.

3,147,256. OLIVERSTANDARD CHARACTER MARK INT.
CL. 7. CHUANG, BOR-YANN, TAICHUNG, TAIWAN.
REG. 9-26-2006. NEW CERT. SEC. 7(D) TO REGISTRANT.

3,593,997. MISCELLANEOUS DESIGN. INT. CLS. 9, 16 AND
41. THE EDUCATION RESOURCES INSTITUTE, INC.,
BOSTON, MA. REG. 3-24-2009. NEW CERT. SEC. 7(D) TO
REGISTRANT.

3,270,992. CONVERSATIONS WITH LEADERS IN LUXUR-

* * * * *

INDEX OF REGISTRANTS

JUNE 2, 2009

(Registered; Renewed; Canceled; Amended, Corrected, etc.; New Certificates; 12c Publications.)

The designation "U.S. Cl." appearing in this section refers to the U.S. class in effect prior to Sep. 1, 1973 rather than the international class which applies to applications filed on or after that date. For adoption of international classification see notice in the OFFICIAL GAZETTE of Jun. 26, 1973 (911 O.G. TM 210).

(GLOBAL TRADING LLC), MONTGOMERY VILLAGE, MD:
3,629,133, PUB. 3-17-2009. INT. CL. 30.

(I)STRUCTURE, LLC, BROOMFIELD, CO, DBA (I)STRUC-
TURE, LLC:
2,598,899, CANC. MULTIPLE CLASS, INT. CLS. 35 AND
42.

"DEPESCHE" VERTIEB GMBH & CO. KG, FED REP
GERMANY:
3,631,689, PUB. 3-17-2009. MULTIPLE CLASS, INT. CLS.
30, 32 AND 33.

A & H SPORTSWEAR CO., INC., STOCKERTOWN, PA:
3,632,390, INT. CL. 25.

A SHRED 2 PIECES, LLC, IRVING, TX:
3,632,599, INT. CL. 40.

A.C. DISPENSING EQUIPMENT INC., LOWER SACKVILLE,
CANADA:
3,629,307, PUB. 9-16-2008. MULTIPLE CLASS, INT. CLS.
9, 11 AND 21.

A.C.E. INTERNATIONAL COMPANY, INC., TAUNTON,
MA:
3,632,485, INT. CL. 9.

A.D.M. TAX MASTERS, INC., CLOVER, SC:
2,174,731, CANC. INT. CL. 35.

A.J. BOGGS & COMPANY, ANN ARBOR, MI:
3,630,760, PUB. 3-17-2009. INT. CL. 9.

A.J. MANUFACTURING, INC., BLOOMER, WI:
3,630,088, PUB. 3-17-2009. INT. CL. 6.

A.N.P., INC., PHOENIX, AZ, DBA ARIZONA NATURAL
PRODUCTS:
2,175,063, CANC. INT. CL. 5.

A.P. OUTDOOR PRODUCTS, ELWOOD, IL:
3,630,120, PUB. 3-17-2009. INT. CL. 1.

A.V. DENIM, INC., D/B/A A&V DENIM, INC., NEW YORK,
NY:
3,633,262, MULTIPLE CLASS, INT. CLS. 18 AND 25.

A.W. HARGROVE INSURANCE AGENCY, INC., GLEN
ALLEN, VA, DBA AUTO INSURANCE CLINIC:
1,497,050, CANC. INT. CL. 36.

A&E TELEVISION NETWORKS, NEW YORK, NY:
3,630,715, PUB. 3-17-2009. INT. CL. 41.
3,631,374, PUB. 3-17-2009. INT. CL. 41.
3,632,309, INT. CL. 36.

A&W DISTRIBUTION CENTER, BOCA RATON, FL:
3,630,056, PUB. 3-17-2009. INT. CL. 25.

AACO-A1 HEALTHCARE SERVICES, INC., SEATTLE, WA:
3,631,203, PUB. 3-17-2009. INT. CL. 44.

AARHUSKARLSHAMN AB (PUBL), SE-211 19 MALMÖ,
SWEDEN:
3,631,518, PUB. 3-17-2009. MULTIPLE CLASS, INT. CLS.
1, 3, 4, 5 AND 29.

AARON INVESTMENT COMPANY, GREENVILLE, DE:
3,629,165, PUB. 3-17-2009. MULTIPLE CLASS, INT. CLS.
35, 36, 41, 42 AND 43.

AARON MEDICAL INDUSTRIES, INC., ST. PETERSBURG,
FL:
2,598,545, CANC. INT. CL. 10.

AAXA DISCOUNT MORTGAGE, INC., WILMINGTON, NC:
3,632,942, INT. CL. 36.

AB GUSTAF KAHR, S 382 28 NYBRO, SWEDEN:
2,598,551, CANC. INT. CL. 19.

ABALENE SALES AND PROMOTIONS LTD., RICHMOND,
BRITISH COLUMBIA, CANADA:
2,175,452, CANC. INT. CL. 16.

ABANDON INTERACTIVE ENTERTAINMENT, LLC, PACI-
FIC PALISADES, CA:
3,631,810, INT. CL. 9.

ABBOTT LABORATORIES, ABBOTT PARK, IL:
2,598,514, CANC. INT. CL. 10.
2,598,616, CANC. INT. CL. 5.
2,598,617, CANC. INT. CL. 5.

ABBYY SOFTWARE LTD., NICOSIA, CYPRUS, DBA BIT
SOFTWARE, INC.:
3,629,420, PUB. 3-17-2009. INT. CL. 9.

ABRASIC 90, INC., NILES, IL, DBA CGW CAMEL GRIND-
ING WHEELS, USA:
3,630,251, PUB. 3-17-2009. INT. CL. 7.

ABRASIVE 90, INC., NILES, IL, DBA CGW CAMEL GRIND-
ING WHEELS, USA:
3,630,252, PUB. 3-17-2009. INT. CL. 7.

ABSOLUTELY SPOTLESS PROFESSIONAL CLEANING
SERVICE, LLC, LAS VEGAS, NV:
3,632,015, INT. CL. 37.

ABU DHABI NATIONAL ENERGY COMPANY PJSC, ABU
DHABI, UNITED ARAB EMIR.:
3,631,499, PUB. 3-17-2009. MULTIPLE CLASS, INT. CLS.
35 AND 36.

ACACIA WALRATH, LOS GATOS, CA AND STEVE WAL-
RATH, LOS GATOS, CA:
3,632,782, INT. CL. 44.

ACADEMY FOR PRECISION LEARNING, SEATTLE, WA:
3,631,025, PUB. 3-17-2009. INT. CL. 41.

ACCELERANT NETWORKS, BEAVERTON, OR:
2,597,131, CANC. INT. CL. 9.

ACCELERIDER CORPORATION, GLACIER, WA:
2,596,823, CANC. INT. CL. 28.

ACCESS HOUSTON CABLE CORPORATION, HOUSTON,
TX:
1,497,091, CANC. INT. CL. 38.

ACCESS INTELLIGENCE LLC, ROCKVILLE, MD:
3,633,488, INT. CL. 41.

ACCESS MANAGEMENT COMPANY, LITTLE FERRY, NJ:
2,332,377, REN. 4-30-09. INT. CL. 39.

ACCIDENT COUNSELING, INC., SACRAMENTO, CA:
1,497,220, CANC. INT. CL. 42.

ACCLIVUS CORPORATION, DALLAS, TX:
3,633,160, INT. CL. 41.

ACCO BRANDS CORPORATION, LINCOLNSHIRE, IL:
2,599,229, CANC. INT. CL. 9.

ACCOLADE LLC, PLYMOUTH MEETING, PA:
3,630,331, PUB. 3-17-2009. INT. CL. 44.

ACCREDITATION NOW, INC., COLUMBIA, MO:
3,630,316, PUB. 3-17-2009. INT. CL. 42.

ACCURA HEALTH LIMITED, IRVINE, AYRSHIRE, UNI-
TED KINGDOM:
3,632,074, INT. CL. 5.

ACCURAY INCORPORATED, SUNNYVALE, CA:
3,631,869, INT. CL. 10.
3,632,195, INT. CL. 44.

ACCURI CYTOMETERS, INC., ANN ARBOR, MI:
3,632,230, INT. CL. 9.

- ACE CAFE LONDON LIMITED, STONEBRIDGE, UNITED KINGDOM:
3,629,464, PUB. 3-17-2009. INT. CL. 25.
- ACE CO., LTD., JAPAN:
3,631,702, PUB. 3-17-2009. INT. CL. 18.
- ACE COMPANY, BOISE, ID:
2,597,842, CANC. INT. CL. 7.
- ACE CONTROLS, INC., FARMINGTON HILLS, MI:
1,574,385. REN. 4-28-09. INT. CL. 7.
- ACCELERANT INCORPORATED, VIRGINIA BEACH, VA, DBA STINGRAY TACKLE COMPANY:
3,630,389, PUB. 3-17-2009. INT. CL. 28.
- ACELL, INC., COLUMBIA, MD:
3,632,971, MULTIPLE CLASS, INT. CLS. 5 AND 10.
- ACHIEVIA DIRECT INC., DAYTONA BEACH, FL, DBA ACHIEVIA OPTICAL SOLUTIONS:
3,632,842, INT. CL. 9.
- ACHILLES CORPORATION, SHINJUKU-KU, TOKYO, JAPAN:
2,241,097. REN. 4-27-09. INT. CL. 9.
- ACORDIA, INC., CHICAGO, IL:
2,597,776, CANC. INT. CL. 36.
- ACORN PRODUCTS, INC., COLUMBUS, OH:
2,598,297, CANC. INT. CL. 8.
- ACOUSTICS ASSOCIATES, INC., GOLDEN VALLEY, MN:
2,244,339. REN. 4-27-09. INT. CL. 17.
- ACQUA DI PARMA S.R.L., ITALY:
3,631,621, PUB. 3-17-2009. MULTIPLE CLASS, INT. CLS. 3 AND 4.
- ACRES-FIORE PATENTS, LAS VEGAS, NV:
3,629,889, PUB. 3-17-2009. INT. CL. 9.
- ACROW CORPORATION OF AMERICA, PARSIPPANY, NJ:
2,247,565. REN. 4-27-09. INT. CL. 6.
- ACRYNESS, INC., MOORESVILLE, NC:
3,632,948, INT. CL. 35.
- ACS TECHNOLOGIES GROUP, INC., FLORENCE, SC:
2,988,718, CANC. INT. CL. 16.
- ACT II JEWELRY LLC, BENSENVILLE, IL:
3,630,780, PUB. 3-17-2009. INT. CL. 35.
3,630,783, PUB. 3-17-2009. INT. CL. 35.
- ACTIKARE, INC., TAMPA, FL:
3,631,365, PUB. 3-17-2009. INT. CL. 45.
- ACTRONIX, INC., FLIPPIN, AR:
3,629,965, PUB. 3-17-2009. MULTIPLE CLASS, INT. CLS. 6 AND 9.
- ACTUARIAL DATA INC., CARNEGIE, PA:
2,174,747, CANC. INT. CL. 36.
- ACUID CORPORATION LIMITED, ST.PETER PORT, GUERNSEY, BRIT IND OCN TERR:
2,599,588, CANC. INT. CL. 7.
- ACUMENT INTELLECTUAL PROPERTIES, LLC, WILMINGTON, DE:
2,174,200, CANC. INT. CL. 6.
- ACUSHNET COMPANY, FAIRHAVEN, MA:
3,632,654, INT. CL. 25.
- ACUSPORT CORPORATION, BELLEFONTAINE, OH, ACUSPORT CORPORATION, BELLEFONTAINE, OH:
1,588,271. REN. 4-24-09. INT. CL. 42.
- ACUTRACK, LIVERMORE, CA:
3,630,906, PUB. 3-17-2009. INT. CL. 40.
- ADAEQUARE INC, CHANTILLY, VA:
3,630,677, PUB. 3-17-2009. MULTIPLE CLASS, INT. CLS. 41 AND 42.
- ADAM MANAGEMENT CO., INC., SOUTHFIELD, MI:
3,630,335, PUB. 3-17-2009. INT. CL. 45.
- ADAMS BAKERY CORP., MILFORD, NJ:
1,534,526. REN. 4-24-09. INT. CL. 30.
- ADAMS LUMBER, INC., TIGARD, OR:
2,598,434, CANC. INT. CL. 35.
- ADAPTION TECHNOLOGIES VENTURES, LTD., THE WOODLANDS, TX:
3,632,212, INT. CL. 9.
- ADAPTIVE NEURAL BIOMETRICS LTD., LONDON, UNITED KINGDOM:
3,632,128, INT. CL. 9.
- ADC GMBH, 14167 BERLIN, FED REP GERMANY:
2,598,241, CANC. INT. CL. 9.
2,598,254, CANC. INT. CL. 9.
- ADCARE HEALTH SYSTEMS, INC., SPRINGFIELD, OH:
2,235,811. REN. 4-25-09. MULTIPLE CLASS, INT. CLS. 35 AND 36.
- ADCARE HEALTH SYSTEMS, INC., SPRINGFIELD, OH:
2,240,503. REN. 4-25-09. MULTIPLE CLASS, INT. CLS. 35 AND 36.
- ADDIS INTELLECTUAL CAPITAL, LLC, KING OF PRUSSIA, PA:
3,632,419, INT. CL. 16.
- ADDTEK CORP., TAIPEI CITY 105, TAIWAN:
2,174,849, CANC. INT. CL. 9.
- ADD2NET.COM, LLC, HUNTSVILLE, AL:
2,597,925, CANC. INT. CL. 41.
2,597,926, CANC. INT. CL. 41.
- ADEA SOLUTIONS, INC., IRVING, TX:
2,596,682, CANC. INT. CL. 35.
- ADECCO S.A., CH-1275 CHÈSEREX, SWITZERLAND:
3,631,557, PUB. 3-17-2009. MULTIPLE CLASS, INT. CLS. 9, 35, 41 AND 42.
- ADELI, KATAYONE, LOS ANGELES, CA:
2,598,858, CANC. INT. CL. 25.
- ADF, INC., BUFFALO GROVE, IL:
3,633,460, INT. CL. 42.
- ADI LIMITED, AUSTRALIA:
3,631,462, PUB. 3-17-2009. INT. CL. 12.
- ADIRONDACK MUSEUM OF THE ADIRONDACK HISTORICAL ASSOCIATION, THE, BLUE MOUNTAIN LAKE, NY:
1,119,126. REN. 4-30-09. MULTIPLE CLASS, INT. CLS. 9, 14, 16, 26 AND 41.
- ADJUST MY LOAN, LLC, PHOENIX, AZ:
3,633,464, INT. CL. 36.
- ADOBOE, FERDIE ATO, BELCHERTOWN, MA, DBA FERDIE'S SOCCER MAGIC:
2,597,884, CANC. INT. CL. 41.
- ADSTREAK.COM LLC, CHAPPAQUA, NY:
2,598,948, CANC. INT. CL. 35.
- ADVANCE GAMES, LLC, BATON ROUGE, LA:
3,633,009, INT. CL. 9.
- ADVANCED DIGITAL DATA, INC., FLANDERS, NJ:
1,555,230. REN. 4-27-09. INT. CL. 42.
- ADVANCED GLAZING TECHNOLOGIES LTD, SYDNEY, NOVA SCOTIA, CANADA:
2,597,244, CANC. INT. CL. 19.
- ADVANCED MEASUREMENT TECHNOLOGY, INC., OAKRIDGE, TN:
2,174,698, CANC. INT. CL. 9.
- ADVANCED MICRO DEVICES, INC., SUNNYVALE, CA:
3,629,119, PUB. 3-17-2009. INT. CL. 9.
- ADVANCED NUTRITIONAL BIOSYSTEMS, INC., ORLANDO, FL:
2,599,649, CANC. INT. CL. 5.
- ADVANCED SLEEP CONCEPTS, INC., ROME, GA:
3,632,936, INT. CL. 20.
- ADVANDX, INC., WOBURN, MA:
3,632,168, MULTIPLE CLASS, INT. CLS. 1 AND 5.
- ADVANTAGE NUTRITION & WELLNESS, LLC, BETHLEHEM, PA:
3,629,466, PUB. 3-17-2009. MULTIPLE CLASS, INT. CLS. 41 AND 44.
- ADVANTAGE RAPID RESPONSE, LP, DALLAS, TX:
3,630,314, PUB. 3-17-2009. INT. CL. 37.
- ADVENTURE FITNESS TRAINING, SANTA MONICA, CA:
2,174,815, CANC. INT. CL. 41.
- ADVERTEK, INC., LOUISVILLE, KY, DBA ADVERTEK:
3,631,071, PUB. 3-17-2009. INT. CL. 42.
- ADVP MANAGEMENT, LP, IRVING, TX:
2,596,705, CANC. INT. CL. 35.
- AEP INDUSTRIES, INC., HACKENSACK, NJ:
1,550,145. REN. 4-24-09. INT. CL. 17.
- AERO DESIGN AND MANUFACTURING COMPANY, INC., DULUTH, MN:
3,632,255, MULTIPLE CLASS, INT. CLS. 25 AND 35.
- AERO INDUSTRIES, INC., INDIANAPOLIS, IN:
3,629,838, PUB. 3-17-2009. INT. CL. 12.
- AEROGROW INTERNATIONAL, INC., BOULDER, CO:
3,632,111, INT. CL. 21.
3,633,031, INT. CL. 21.

AEROVIAS DE MEXICO, S.A DE C.V., MEXICO CITY, MEXICO:
3,632,156, INT. CL. 39.

AETHER, LLC., LOS ANGELES, CA:
3,633,069, INT. CL. 25.

AFFINITY GROUP, INC., VENTURA, CA:
2,183,097, REN. 4-29-09, INT. CL. 42.

AFFORDABLE SENIOR CARE INC., FOREST HILLS, NY, DBA ASC TRANSPORTATION:
3,630,568, PUB. 3-17-2009, INT. CL. 39.

AFP IMAGING CORPORATION, ELMSFORD, NY:
1,496,601, CANC. INT. CL. 9.

AFRIFINANCE LLC, NEW YORK, NY:
3,632,207, INT. CL. 36.

AFTERIMAGE, LLC, WATERFORD, WI:
3,631,968, INT. CL. 25.

AFTIC CORPORATION, SOUTH EL MONTE, CA:
3,630,235, PUB. 3-17-2009, INT. CL. 30.

AF2 ENTERPRISES LLC, CHICAGO, IL:
2,596,951, CANC. INT. CL. 41.
2,597,097, CANC. MULTIPLE CLASS, INT. CLS. 16, 25 AND 41.
2,598,579, CANC. MULTIPLE CLASS, INT. CLS. 16, 25 AND 41.

AG-FERTILIZER, INC., WATERTOWN, SD:
1,496,362, CANC. INT. CL. 1.

AGA AKTIEBOLAG, S-181 81 LIDINGO, SWEDEN:
2,598,643, CANC. INT. CL. 1.

AGAVE DE PLATA S.A. DE C.V., GUADALAJARA JALISCO, MEXICO:
3,631,000, PUB. 3-17-2009, INT. CL. 33.

AGAVERA CAMICHINES, S.A. DE C.V., JALISCO, C.P. 45601, MEXICO, MEXICO:
3,633,333, INT. CL. 33.

AGCONCEPTS, L.L.C., OVERLAND PARK, KS:
2,597,055, CANC. INT. CL. 1.

AGENCY FOR HEALTHCARE RESEARCH AND QUALITY, ROCKVILLE, MD:
2,275,822, REN. 4-24-09, INT. CL. 42.

AGENDIA BV, EC AMSTERDAM, NETHERLANDS:
3,631,519, PUB. 10-14-2008, MULTIPLE CLASS, INT. CLS. 5, 10 AND 44.
3,631,520, PUB. 10-14-2008, MULTIPLE CLASS, INT. CLS. 5, 10 AND 44.

AGGREGATE KNOWLEDGE, INC., SAN MATEO, CA:
3,633,321, INT. CL. 35.

AGGRESSIVE HYDRAULICS, BLAINE, MN:
3,630,676, PUB. 3-17-2009, INT. CL. 40.

AGILENT TECHNOLOGIES, INC., SANTA CLARA, CA:
2,599,444, CANC. INT. CL. 9.

AGRA GROUP A.S., CZ-387 15 STRELSKÉ HOTICE, CZECH REPUBLIC:
3,631,762, PUB. 3-17-2009, MULTIPLE CLASS, INT. CLS. 1 AND 5.

AGRAQUEST, INC., DAVIS, CA:
3,632,386, INT. CL. 5.

AGS MARKETING, INC., URBANA, IA:
3,630,934, PUB. 3-17-2009, INT. CL. 22.

AGUSTIN REYES, INC., HIALEAH, FL:
3,633,338, INT. CL. 3.

AHC MEDIA LLC, WASHINGTON, DC:
2,597,285, CANC. INT. CL. 42.

AIB FINANCIAL GROUP, INC., MIAMI, FL:
2,596,486, CANC. INT. CL. 36.

AIKEN, AMY, ST. HELENA, CA:
3,631,816, INT. CL. 33.

AIPTEK INTERNATIONAL INC., HSINCHU, TAIWAN:
3,632,866, INT. CL. 9.

AIR LIQUIDE AMERICA CORPORATION, HOUSTON, TX:
2,598,273, CANC. INT. CL. 20.

AIR SEMICONDUCTOR INC., WILMINGTON, DE:
3,631,960, INT. CL. 9.

AIR 7 SPORTS, LLC, VERNON, CA:
2,596,899, CANC. INT. CL. 41.

AIRCELL BUSINESS AVIATION SERVICES LLC, BROOMFIELD, CO:
3,631,108, PUB. 3-17-2009, INT. CL. 38.

AIRCRAFT ACCESSORIES OF AMERICA, LLC, MANCHESTER, CT:
2,599,288, CANC. INT. CL. 11.

AIRKOR HEATING AND AIR CONDITIONING, INC., COVINGTON, OH, AKA TRANSAMERICA UNDERWRITERS NATIONAL SUPPLY:
3,630,377, PUB. 3-17-2009, INT. CL. 11.

AIRLIFT SYSTEMS INTERNATIONAL, INC., ANDERSON, IN:
3,633,351, INT. CL. 37.

AIRTECH INNOVATIONS INC., TORONTO, CANADA:
3,629,425, PUB. 3-17-2009, MULTIPLE CLASS, INT. CLS. 9 AND 42.
3,629,426, PUB. 3-17-2009, MULTIPLE CLASS, INT. CLS. 9 AND 42.

AISAPACK HOLDING S.A., CH-1896 VOUVRY, SWITZERLAND:
2,597,553, CANC. INT. CL. 20.

AJINOMOTO KABUSHIKI KAISHA, CHUO-KU, TOKYO 104, JAPAN, DBA AJINOMOTO CO., INC.:
2,175,297, CANC. INT. CL. 29.

AKORN INC., LAKE FOREST, IL:
3,631,872, INT. CL. 5.

AKYEAMPONG, KWAKU APPIAH NUAMAH, LEESBURG, VA:
3,629,813, PUB. 3-17-2009, INT. CL. 35.

AKZO CHEMICALS B.V., 3818 LW AMERSFOORT, NETHERLANDS:
1,496,489, CANC. INT. CL. 5.

AKZO NOBEL COATINGS INTERNATIONAL B.V., ARNHEM, NETHERLANDS:
3,631,387, PUB. 3-17-2009, INT. CL. 2.

AL SAFA HALAL LTD., SILVER SPRING, MD:
2,596,542, CANC. INT. CL. 29.

ALADDIN TEMP-RITE, LLC, HENDERSONVILLE, TN:
3,630,249, PUB. 3-17-2009, INT. CL. 11.

ALATRON CORPORATION, SEATTLE, WA:
2,597,736, CANC. INT. CL. 42.

ALBERT ELOVITZ, INC., PITTSBURGH, PA:
2,599,539, CANC. INT. CL. 35.

ALBERTO-CULVER USA, INC., MELROSE PARK, IL:
3,631,428, PUB. 3-17-2009, INT. CL. 3.

ALBERTS, BARRY, BURBANK, CA:
1,536,918, REN. 4-29-09, INT. CL. 42.

ALCHEMY IV, LLC, SALT LAKE CITY, UT:
3,632,509, MULTIPLE CLASS, INT. CLS. 16, 21 AND 25.

ALCHYMIST, S.R.O., CZECH REPUBLIC:
3,631,695, PUB. 3-17-2009, INT. CL. 43.

ALCHYMIST, S.R.O., CZ-110 00 PRAHA 1, CZECH REPUBLIC:
3,631,709, PUB. 3-17-2009, MULTIPLE CLASS, INT. CLS. 43 AND 44.

ALDI INC., BATAVIA, IL:
1,557,136, REN. 4-30-09, INT. CL. 32.
3,632,303, INT. CL. 16.

ALDUS CORPORATION, SEATTLE, WA:
1,496,726, CANC. INT. CL. 16.

ALEXANDER JULIAN, INC., RIDGEFIELD, CT:
2,598,731, CANC. INT. CL. 27.

ALFARO DE MARON, ANA ELOISA DEL CARMEN, SAN MARCOS, EL SALVADOR, DBA LABORATORIOS COMBISA:
3,632,755, INT. CL. 5.
3,632,789, INT. CL. 5.

ALFAX FURNITURE, LLC, NEW YORK, NY:
2,597,455, CANC. INT. CL. 35.

ALFRED DUNHILL LIMITED, LONDON WIJ SQT, ENGLAND:
3,629,424, PUB. 3-17-2009, MULTIPLE CLASS, INT. CLS. 3, 9, 14, 16, 18, 25 AND 34.

ALIAS SYSTEMS CORP., MENLO PARK, CA:
2,596,959, CANC. MULTIPLE CLASS, INT. CLS. 9 AND 42.

ALL CODES MEDIA, LLC, ST. LOUIS, MO:
3,632,124, INT. CL. 41.

ALL ENTHUSIAST, INC., AMERICAN CANYON, CA:
3,630,849, PUB. 3-17-2009, INT. CL. 35.

- ALL MEDIA GUIDE, LLC, ANN ARBOR, MI:
3,631,887, MULTIPLE CLASS, INT. CLS. 9 AND 42.
- ALL STATES AG PARTS, INC., EAGAN, MN:
3,629,988, PUB. 3-17-2009. INT. CL. 35.
- ALL SURFACE RESTORATION & PRESERVATION, INC., DANIA BEACH, FL:
3,633,280, MULTIPLE CLASS, INT. CLS. 2, 37 AND 40.
- ALL 4 KIDS LLC, HUMBLE, TX, DBA CHEFS 2 B:
3,629,418, PUB. 3-17-2009. INT. CL. 41.
- ALLEGHENY COUNTY AIRPORT AUTHORITY, THE, PITTSBURGH, PA:
2,780,574, CANC. INT. CL. 20.
- ALLEGIANCE CORPORATION, MCGAW PARK, IL:
2,598,178, CANC. MULTIPLE CLASS, INT. CLS. 1, 3, 5, 9, 10, 11, 21 AND 25.
- ALLEN MEDICAL SYSTEMS, INC., BATESVILLE, IN:
2,596,500, CANC. INT. CL. 10.
- ALLEN SYSTEMS GROUP, INC., NAPLES, FL:
2,599,784, CANC. INT. CL. 9.
- ALLERGAN, INC., IRVINE, CA:
3,632,332, INT. CL. 16.
- ALLERGIK-ID, LLC, MERION STATION, PA:
3,632,067, INT. CL. 16.
- ALLGREENIT LLC, BRISTOL, CT:
3,632,752, INT. CL. 37.
- ALLIANCE GAMING CORPORATION, LAS VEGAS, NV:
2,598,334, CANC. INT. CL. 9.
- ALLIANCE LUMBER, LLC, SCOTTSDALE, AZ:
3,632,670, INT. CL. 19.
- ALLIANCE TRADING, INC., COVINGTON, LA:
3,630,959, PUB. 3-17-2009. INT. CL. 35.
- ALLIANT TECHSYSTEMS INC., EDINA, MN:
2,598,400, CANC. INT. CL. 41.
- ALLIANT TECHSYSTEMS INC., MINNEAPOLIS, MN:
3,631,944, INT. CL. 25.
3,631,945, INT. CL. 13.
- ALLIANZ SE, MUNCHEN, FED REP GERMANY:
2,256,628, REN. 4-27-09. INT. CL. 36.
2,598,651, CANC. INT. CL. 36.
- ALLIED DOMEQ SPIRITS & WINE LIMITED, LONDON, W6 9RS, ENGLAND:
508,704, REN. 4-27-09. U.S. CL. 49 (INT. CL. 33).
- ALLIED DOMEQ SPIRITS & WINE LIMITED, LONDON, W6 9RS, ENGLAND, JAMES BURROUGH LIMITED, LONDON, S.E. 11, ENGLAND:
678,608, REN. 4-27-09. U.S. CL. 49 (INT. CL. 33).
- ALLIED FORWARDING CORP., LAREDO, TX:
3,629,342, PUB. 3-17-2009. INT. CL. 35.
- ALLIED HEALTHCARE PRODUCTS, INC., ST. LOUIS, MO, LIF-O-GEN, INC., PHILADELPHIA, PA:
680,857, REN. 4-29-09. U.S. CL. 44 (INT. CL. 10).
- ALLIED INTERNATIONAL EMERGENCY, FORT WORTH, TX:
3,629,532, PUB. 3-17-2009. INT. CL. 45.
- ALLIED MINERAL PRODUCTS, INC., COLUMBUS, OH:
3,630,307, PUB. 3-17-2009. INT. CL. 19.
- ALLIED RISER OPERATIONS CORPORATION, DALLAS, TX:
2,596,792, CANC. MULTIPLE CLASS, INT. CLS. 37, 38 AND 42.
- ALLOY ENTERTAINMENT, NEW YORK, NY:
3,632,109, INT. CL. 16.
- ALLOY MARKETING & PROMOTIONS, LLC, NY, NY:
3,629,883, PUB. 3-17-2009. INT. CL. 35.
- ALLQUEST REAL ESTATE CORP., HOUSTON, TX:
3,630,379, PUB. 3-17-2009. INT. CL. 35.
- ALLSTATE INSURANCE COMPANY, NORTHBROOK, IL:
3,633,375, INT. CL. 36.
- ALLTECH, INC., NICHOLASVILLE, KY:
3,631,950, MULTIPLE CLASS, INT. CLS. 25 AND 32.
- ALLTEL COMMUNICATIONS, LLC, LITTLE ROCK, AR:
2,597,140, CANC. INT. CL. 38.
- ALLURE FUSION MEDIA, INC., ATLANTA, GA:
2,598,892, CANC. INT. CL. 35.
- ALM PROPERTIES, INC., NEW YORK, NY:
3,630,049, PUB. 3-17-2009. MULTIPLE CLASS, INT. CLS. 16 AND 41.
- ALOHA SALADS INC., KAILUA, HI, DBA ALOHA SALADS:
3,629,366, PUB. 3-17-2009. MULTIPLE CLASS, INT. CLS. 30 AND 43.
- ALOSA FOUNDATION, INC., CHESTNUT HILL, MA:
3,633,222, INT. CL. 41.
- ALPINE POWER SYSTEMS, INC., REDFORD, MI, AKA BATTERYMAX, POWERMAX, DYTRON POWER SYSTEMS, DELTA POWER SYSTEMS, SYSTEMS BY DESIGN, POWER SERVICE GROUP, EXPO POWER, SYSTEMS, ALPINE BATTERY, TFI BATTERY, MID-OHIO BATTERY, ESHELMAN POWER, MILLER-EADS TELECOM, WEST MICHIGAN BATTERY, BATTERYTESTING.COM:
3,630,964, PUB. 3-17-2009. INT. CL. 37.
- ALRED, DAVID EDWARD, BRISTOL, GREAT BRITAIN:
3,629,406, PUB. 12-23-2008. INT. CL. 41.
3,629,407, PUB. 12-23-2008. INT. CL. 41.
- ALSTOM, 75116 PARIS, FRANCE:
2,600,107, CANC. INT. CL. 9.
- ALSTOM TRANSPORT SA, LEVALLOIS-PERRET, FRANCE:
3,631,412, PUB. 3-17-2009. INT. CL. 9.
- ALTAVIEW TECHNOLOGY, INC., ALBUQUERQUE, NM:
3,629,388, PUB. 3-17-2009. MULTIPLE CLASS, INT. CLS. 9 AND 41.
- ALTERNATIVE ENTERTAINMENT NETWORK, INC., CAMARILLO, CA:
2,596,560, CANC. MULTIPLE CLASS, INT. CLS. 38 AND 41.
- ALTERNATIVE INVESTMENT RESEARCH AND TECHNOLOGIES LLC, NEW YORK, NY:
2,599,307, CANC. INT. CL. 36.
- ALTIA PLC, FINLAND:
3,631,712, PUB. 3-17-2009. INT. CL. 33.
3,631,713, PUB. 3-17-2009. INT. CL. 33.
3,631,714, PUB. 3-17-2009. INT. CL. 33.
- ALTRO LIMITED, UNITED KINGDOM:
3,631,530, PUB. 3-17-2009. INT. CL. 27.
- ALTRUISTA HEALTH, RESTON, VA:
3,631,123, PUB. 3-17-2009. INT. CL. 42.
- ALZHEIMER'S ASSOCIATION SOUTHEAST FLORIDA CHAPTER, TAMARAC, FL:
2,599,812, CANC. INT. CL. 36.
- AM DENMARK A/S, KOKKEDAL, DENMARK:
3,629,367, PUB. 3-17-2009. MULTIPLE CLASS, INT. CLS. 3 AND 21.
3,629,368, PUB. 3-17-2009. MULTIPLE CLASS, INT. CLS. 3 AND 21.
- AM-VI-CO, INC., LAS VEGAS, NV:
2,598,050, CANC. INT. CL. 2.
- AMADA AMERICA, INC., BUENA PARK, CA:
2,223,950, REN. 4-26-09. INT. CL. 9.
- AMANN, SCOTT PAUL, WINTER PARK, FL:
2,174,638, CANC. INT. CL. 25.
- AMANO USA HOLDINGS, INC., ROSELAND, NJ, FORMERLY AMANO INTERNATIONAL USA, INC. AND AMANO USA, INC.:
3,630,201, PUB. 3-17-2009. INT. CL. 9.
3,630,202, PUB. 3-17-2009. INT. CL. 9.
- AMARAL RANCHES, INC., GONZALES, CA:
2,175,856, CANC. INT. CL. 31.
- AMASOND VERTRIEBS GMBH, DORNBIERN, AUSTRIA:
3,629,465, PUB. 3-17-2009. MULTIPLE CLASS, INT. CLS. 11, 17 AND 37.
- AMAZE ENTERTAINMENT, INC., KIRKLAND, WA:
2,690,628, AM. INT. CL. 42.
- AMAZON TECHNOLOGIES, INC., RENO, NV:
3,630,077, PUB. 3-17-2009. INT. CL. 36.
- AMBITECH, INC., CANOGA PARK, CA:
2,598,237, CANC. INT. CL. 9.
- AMCOL INTERNATIONAL CORPORATION, HOFFMAN ESTATES, IL:
3,632,934, INT. CL. 1.
- AMERICA TRANSFERS, INC., IRVING, TX:
2,596,847, CANC. INT. CL. 36.
- AMERICA'S COUNTRY STORES, LLC., SHOREVIEW, MN:
2,596,911, CANC. INT. CL. 2.
- AMERICAN ACADEMY OF NEUROLOGY, THE, ST. PAUL, MN:
2,598,163, CANC. INT. CL. 16.

- AMERICAN ACADEMY OF OPHTHALMOLOGY, INC., SAN FRANCISCO, CA:
3,630,352, PUB. 3-17-2009. INT. CL. 35.
- AMERICAN ACADEMY OF PEDIATRICS, ELK GROVE VILLAGE, IL:
3,631,324, PUB. 3-17-2009. INT. CL. 41.
- AMERICAN AIRLINES, INC., FORT WORTH, TX:
2,199,596. REN. 4-30-09. INT. CL. 39.
- AMERICAN AUTOMOBILE ASSOCIATION, INC., HEATHROW, FL:
2,325,355. REN. 4-29-09. U.S. CL. B.
2,598,535, CANC. INT. CL. 16.
2,598,870, CANC. INT. CL. 9.
- AMERICAN BANKERS INSURANCE GROUP, INC., MIAMI, FL:
2,599,200, CANC. MULTIPLE CLASS, INT. CLS. 16, 36 AND 42.
- AMERICAN BIOSCIENCES, INC., BLAUVETT, NY:
3,629,315, PUB. 3-17-2009. INT. CL. 5.
- AMERICAN BUSINESS ADVISORS, INC., GREENWOOD VILLAGE, CO:
2,317,864. REN. 4-25-09. MULTIPLE CLASS, INT. CLS. 35, 36 AND 41.
- AMERICAN CHEMICAL SOCIETY, WASHINGTON, DC:
2,708,892, CANC. INT. CL. 38.
- AMERICAN COLLEGE OF RHEUMATOLOGY, ATLANTA, GA:
1,592,536. REN. 4-29-09. INT. CL. 42.
- AMERICAN COLLEGE PERSONNEL ASSOCIATION, WASHINGTON, DC:
3,630,112, PUB. 3-17-2009. MULTIPLE CLASS, INT. CLS. 16 AND 41.
- AMERICAN COMMUNICATIONS NETWORK, INC., FARMINGTON HILLS, MI:
3,629,960, PUB. 3-17-2009. MULTIPLE CLASS, INT. CLS. 35 AND 38.
- AMERICAN DEFENSE CORPORATION, BEXLEY, OH:
1,497,144, CANC. INT. CL. 41.
- AMERICAN EQUITY INSURANCE COMPANY, PHOENIX, AZ:
2,175,027, CANC. INT. CL. 36.
- AMERICAN EXPRESS MARKETING & DEVELOPMENT CORP., NEW YORK, NY:
2,599,368, CANC. INT. CL. 36.
3,633,002, INT. CL. 36.
- AMERICAN FAMILY LIFE ASSURANCE COMPANY OF COLUMBUS, COLUMBUS, GA:
3,629,958, PUB. 3-17-2009. INT. CL. 9.
- AMERICAN FARM FINANCIAL, INC., LUTZ, FL:
2,597,854, CANC. INT. CL. 36.
- AMERICAN FENCE ASSOCIATION, INC., GLEN ELLYN, IL:
3,629,282, PUB. 3-17-2009. INT. CL. 35.
- AMERICAN FIDELITY ASSURANCE COMPANY, OKLAHOMA CITY, OK:
2,596,688, CANC. INT. CL. 36.
- AMERICAN FOAM TECHNOLOGIES, INC., NEWPORT, RI:
2,235,921. REN. 4-24-09. INT. CL. 17.
- AMERICAN FORCE PROTECTION, LLC, CHATTANOOGA, TN:
3,631,234, PUB. 3-17-2009. INT. CL. 45.
- AMERICAN HEARING SYSTEMS INC., BLOOMINGTON, MN, DBA INTERTON INC.:
3,632,345, INT. CL. 10.
- AMERICAN HOME PRODUCTS CORPORATION, NEW YORK, NY:
1,497,131, CANC. INT. CL. 41.
- AMERICAN INTERNATIONAL GROUP, INC., NEW YORK, NY:
2,174,906, CANC. INT. CL. 36.
2,597,300, CANC. INT. CL. 36.
2,597,484, CANC. MULTIPLE CLASS, INT. CLS. 21 AND 36.
- AMERICAN LAND CRUISERS, INC., MIAMI, FL TO CRUISE AMERICA, INC., MIAMI, FL:
1,497,112, CANC. MULTIPLE CLASS, INT. CLS. 39 AND 42.
- AMERICAN MOTORCYCLIST ASSOCIATION, PICKERINGTON, OH:
3,631,841, INT. CL. 41.
3,631,842, INT. CL. 41.
- AMERICAN NOSTALGIA, INC., SAN DIEGO, CA, DBA SAN DIEGO SURF COMPANY:
3,633,466, INT. CL. 25.
- AMERICAN OCCUPATIONAL THERAPY ASSOCIATION, INC., BETHESDA, MD:
3,629,681, PUB. 3-17-2009. INT. CL. 16.
- AMERICAN OFFICE EQUIPMENT COMPANY, INC., BALTIMORE, MD:
3,630,557, PUB. 3-17-2009. INT. CL. 20.
3,630,574, PUB. 3-17-2009. INT. CL. 20.
- AMERICAN PACIFIC INDUSTRIES, INC., VALENCIA, CA:
2,598,742, CANC. INT. CL. 12.
- AMERICAN PHARMACEUTICAL INNOVATIONS COMPANY, DARIEN, IL:
3,633,371, INT. CL. 5.
- AMERICAN POLYMER CORPORATION, SANTA FE SPRINGS, CA, DBA POLYCOAT PRODUCTS:
2,279,319. REN. 4-24-09. INT. CL. 17.
2,281,446. REN. 4-24-09. INT. CL. 2.
- AMERICAN POWER CONVERSION CORPORATION, WEST KINGSTON, RI:
2,174,563, CANC. INT. CL. 9.
- AMERICAN PRESTO CORPORATION, ONTARIO, CA:
1,537,193. REN. 4-29-09. MULTIPLE CLASS, INT. CLS. 6, 7, 8, 9 AND 22.
- AMERICAN PSYCHOLOGICAL ASSOCIATION, WASHINGTON, DC:
3,559,386, COR. INT. CL. 16.
3,578,337, COR. MULTIPLE CLASS, INT. CLS. 9, 35, 36, 41 AND 44.
- AMERICAN RADIO RELAY LEAGUE, INCORPORATED, NEWINGTON, CT:
2,250,955. REN. 4-26-09. U.S. CL. 200.
- AMERICAN RESIDENTIAL SERVICES, L.L.C., MEMPHIS, TN:
3,632,606, INT. CL. 37.
- AMERICAN RICE, INC., HOUSTON, TX:
677,075. REN. 4-25-09. U.S. CL. 46 (INT. CL. 30).
- AMERICAN SCHOOL FOOD SERVICE ASSOCIATION, ALEXANDRIA, VA:
2,599,750, CANC. INT. CL. 42.
- AMERICAN SEATING COMPANY, GRAND RAPIDS, MI:
2,598,890, CANC. INT. CL. 20.
- AMERICAN SOCIETY FOR EXPERIMENTAL NEUROTHERAPEUTICS, THE WEST HARTFORD, WI:
2,246,600. REN. 4-30-09. INT. CL. 42.
- AMERICAN SOCIETY OF TRANSPORTATION AND LOGISTICS, INC., WASHINGTON, DC:
3,630,519, PUB. 3-17-2009. INT. CL. 16.
- AMERICAN SPORTS NETWORK, INC., ROSEMEAD, CA:
2,598,234, CANC. INT. CL. 41.
- AMERICAN VASCULAR ASSOCIATION, CHICAGO, IL:
2,794,019, COR. INT. CL. 41.
- AMERICAN WEST MEDICAL COMPANY, INC., LENEXA, KS:
1,834,534, CANC. INT. CL. 10.
- AMERICAN WOODMARK CORPORATION, WINCHESTER, VA:
2,175,184, CANC. INT. CL. 20.
- AMERICAN YELLOW PAGE NETWORK, INC., ENCINO, CA:
1,497,302, CANC. INT. CL. 35.
- AMERICAN-CIGARETTE COMPANY; (OVERSEAS) LIMITED, SWITZERLAND:
3,631,613, PUB. 3-17-2009. INT. CL. 34.
3,631,614, PUB. 3-17-2009. INT. CL. 34.
3,631,615, PUB. 3-17-2009. INT. CL. 34.
3,631,616, PUB. 3-17-2009. INT. CL. 34.
3,631,723, PUB. 3-17-2009. INT. CL. 34.
- AMERICANA FLOORS COMPANY, LLC., ANAHEIM, CA:
2,599,411, CANC. INT. CL. 19.
- AMERICANS UNITED FOR SEPARATION OF CHURCH AND STATE, WASHINGTON, DC:
3,631,370, PUB. 3-17-2009. MULTIPLE CLASS, INT. CLS.

- 35, 41 AND 45.
 AMERICREDIT CORP., FORT WORTH, TX:
 2,598,862, CANC. INT. CL. 35.
 AMERIFEE LLC, SOUTHBOROUGH, MA:
 2,598,013, CANC. INT. CL. 16.
 AMERIMARK DIRECT LLC, CLEVELAND, OH:
 3,633,108, INT. CL. 3.
 AMERIMEX POWER SYSTEMS, INC., HOUSTON, TX:
 3,629,711, PUB. 3-17-2009. MULTIPLE CLASS, INT. CLS.
 7, 9 AND 37.
 AMERINUTRITION LLC, BEAVERTON, OR:
 3,630,411, PUB. 3-17-2009. INT. CL. 5.
 AMERIQUEST MORTGAGE COMPANY, ORANGE, CA:
 2,597,738, CANC. INT. CL. 36.
 AMERLIN, INC., NORTH HOLLYWOOD, CA:
 2,598,937, CANC. INT. CL. 19.
 AMGLO KEMLITE LABORATORIES, INC., LARGO, FL:
 3,259,031, AM. INT. CL. 11.
 AMHERST, L.L.C., MERRIMACK, NH:
 2,597,436, CANC. INT. CL. 35.
 AMINI INNOVATION CORPORATION, PICO RIVERA, CA:
 3,630,024, PUB. 3-17-2009. INT. CL. 20.
 AMITY 360 LLC, POUND RIDGE, NY:
 3,630,044, PUB. 3-17-2009. INT. CL. 42.
 AMORA MAILLE, 21000 DIJON, FRANCE:
 2,596,591, CANC. INT. CL. 30.
 AMOS, PEGGY B., SARASOTA, FL:
 3,631,871, INT. CL. 25.
 AMPLIFY FEDERAL CREDIT UNION, AUSTIN, TX:
 2,752,974, AM. INT. CL. 16.
 AMRITHIKA, SAN JOSE, CA:
 3,630,267, PUB. 3-17-2009. INT. CL. 35.
 AMTICO COMPANY LIMITED, THE, COVENTRY, WAR-
 WICKSHIRE, GREAT BRITAIN:
 2,242,977, REN. 4-24-09. MULTIPLE CLASS, INT. CLS. 19
 AND 27.
 AMUROL CONFECTIONS COMPANY, YORKVILLE, IL:
 2,598,771, CANC. INT. CL. 30.
 AMVIC INC., TORONTO, ONTARIO, CANADA:
 3,632,039, INT. CL. 19.
 AMY LABOWITZ, VENICE, CA, DBA SILVER APPLE
 IMAGES:
 2,598,555, CANC. INT. CL. 16.
 ANA MARIA HENAO, EAST STROUDSBURG, PA AND
 ERIN DARBY GALLAGHER, HOBOKEN, NJ:
 3,629,341, PUB. 3-17-2009. INT. CL. 25.
 ANASAZI INVESTMENTS, LLC, ALBUQUERQUE, NM:
 2,596,654, CANC. INT. CL. 36.
 ANAZAOHEALTH CORPORATION, TAMPA, FL:
 3,632,082, MULTIPLE CLASS, INT. CLS. 3 AND 5.
 3,632,340, INT. CL. 3.
 ANCHOR FOOD PRODUCTS, INC., APPLETON, WI:
 2,598,822, CANC. INT. CL. 29.
 ANCILLA RESOURCE CORPORATION, BRADENTON, FL:
 3,631,148, PUB. 3-17-2009. INT. CL. 35.
 ANDERSEN WORLDWIDE SOCIETE COOPERATIVE, 1215
 GENEVA 15, SWITZERLAND:
 2,596,600, CANC. INT. CL. 42.
 ANDERSEN, MAIA, COSTA MESA, CA:
 3,630,151, PUB. 3-17-2009. INT. CL. 25.
 ANDERSON HENDRIX, HOMEWOOD, IL:
 3,630,294, PUB. 3-17-2009. MULTIPLE CLASS, INT. CLS.
 36 AND 42.
 ANDERSON ZURMUEHLEN & CO., P.C., HELENA, MT:
 3,630,540, PUB. 3-17-2009. MULTIPLE CLASS, INT. CLS.
 35 AND 45.
 3,630,541, PUB. 3-17-2009. INT. CL. 36.
 ANDERSON, BRIAN KENNETH, PHOENIXVILLE, PA:
 3,629,243, PUB. 3-17-2009. INT. CL. 41.
 ANDERSON, JANE E, RANCHO SANTA FE, CA AND
 RENDA, ED, RANCHO SANTA FE, CA AND CASSIDY,
 MARIE A., RANCHO SANTA FE, CA:
 3,630,137, PUB. 3-17-2009. INT. CL. 11.
 ANDERSON, KENT G, BISMARCK, ND:
 3,629,172, PUB. 3-17-2009. INT. CL. 35.
 ANDERSONS, INC., THE, MAUMEE, OH:
 1,496,502, CANC. INT. CL. 5.
 1,496,962, CANC. INT. CL. 31.
 ANDES INTERNATIONAL, INC., HIGHPOINT, NC:
 2,599,733, CANC. INT. CL. 20.
 ANDIAMO SYSTEMS, INC, SAN FRANCISCO, CA:
 3,629,152, PUB. 3-17-2009. INT. CL. 35.
 ANDO MEDIA, LLC, PROVIDENCE, RI:
 3,629,781, PUB. 3-17-2009. INT. CL. 41.
 ANDOVER HEALTHCARE, INC., SALISBURY, MA:
 2,596,769, CANC. INT. CL. 10.
 ANDRE ASSOUS, INC., NEW YORK, NY:
 2,598,955, CANC. INT. CL. 25.
 ANDREA & CO., LLC, WILMINGTON, DE:
 3,630,815, PUB. 3-17-2009. MULTIPLE CLASS, INT. CLS.
 14, 18 AND 25.
 ANDREW LANG PRODUCT DESIGN LIMITED, UNITED
 KINGDOM:
 3,631,545, PUB. 3-17-2009. INT. CL. 20.
 ANESTHESIA RESOURCES FOR CHILDREN, LLP, PLANO,
 TX:
 3,629,752, PUB. 3-17-2009. INT. CL. 44.
 ANGELO LIGHTING COMPANY, PHILADELPHIA, PA:
 2,599,193, CANC. INT. CL. 11.
 ANGELS DONATE FF MILES, VIRGINIA BEACH, VA:
 3,630,859, PUB. 3-17-2009. INT. CL. 36.
 ANGOSTURA CANADA INC., WINNIPEG, CANADA:
 2,596,640, CANC. INT. CL. 33.
 ANHEUSER-BUSCH, INCORPORATED, ST. LOUIS, MO:
 1,496,854, CANC. INT. CL. 25.
 1,589,234, REN. 4-25-09. INT. CL. 32.
 3,633,042, INT. CL. 32.
 ANHUI HONGHUI FOOD (GROUP) CORPORATION, FEI-
 DONG COUNTY; ANHUI PROVINCE, CHINA:
 3,631,634, PUB. 3-17-2009. INT. CL. 30.
 ANN ROGERS, LIVINGSTON, LA:
 3,631,091, PUB. 3-17-2009. INT. CL. 16.
 3,631,093, PUB. 3-17-2009. INT. CL. 41.
 3,631,095, PUB. 3-17-2009. INT. CL. 43.
 3,631,096, PUB. 3-17-2009. INT. CL. 43.
 ANNA'S LINENS, INC., COSTA MESA, CA:
 3,633,048, MULTIPLE CLASS, INT. CLS. 20, 24 AND 35.
 ANNE C. WILLIS ENTERPRISES, LLC, ASHEVILLE, NC:
 3,630,456, PUB. 3-17-2009. INT. CL. 3.
 3,631,308, PUB. 3-17-2009. INT. CL. 21.
 ANOXKALDNES, INC., PROVIDENCE, RI:
 3,633,168, INT. CL. 11.
 ANSILIO, THOMAS F., KINGSTON, PA:
 3,631,041, PUB. 3-17-2009. INT. CL. 35.
 ANSWER FINANCIAL INC., ENCINO, CA:
 2,596,846, CANC. MULTIPLE CLASS, INT. CLS. 35 AND
 39.
 ANTENNAS DIRECT, INC., WILDWOOD, MO:
 3,633,203, INT. CL. 9.
 ANTEON INTERNATIONAL CORPORATION, FAIRFAX,
 VA:
 2,596,763, CANC. MULTIPLE CLASS, INT. CLS. 41 AND
 42.
 ANTI-HYDRO INTERNATIONAL, INC., FLEMINGTON, NJ:
 2,325,229, REN. 4-24-09. INT. CL. 42.
 ANTIOCH UNIVERSITY, YELLOW SPRINGS, OH:
 3,630,440, PUB. 3-17-2009. INT. CL. 41.
 ANTJUAN L. TOLBERT, PORTLAND, OR:
 3,633,439, INT. CL. 25.
 ANTS SOFTWARE INC., BURLINGAME, CA:
 3,632,010, INT. CL. 9.
 ANZURI INC., SEATTLE, WA:
 3,630,386, PUB. 3-17-2009. INT. CL. 41.
 AOYAMA OPTICAL COMPANY LIMITED, SABAE-SHI,
 FUKUI-KEN, JAPAN:
 1,577,539, REN. 4-27-09. INT. CL. 9.
 APA - THE ENGINEERED WOOD ASSOCIATION, TACO-
 MA, WA:
 2,706,001, CANC. INT. CL. 17.
 APFEL, DENNIS, COMMACK, NY:
 3,633,336, INT. CL. 3.
 APLUS PNEUMATIC CORP., CHING-SUI CHEN, TAI-
 CHUNG HSIEN, TAIWAN:
 2,598,807, CANC. INT. CL. 7.
 APOSTROPHE DESIGNS, LLC, ATLANTA, GA:
 3,632,295, INT. CL. 18.

APPLE BANK FOR SAVINGS, NEW YORK, NY:
3,632,895, INT. CL. 36.

APPLICA CONSUMER PRODUCTS, INC., MIRAMAR, FL:
2,599,582, CANC. INT. CL. 9.

APPLIED INDUSTRIAL TECHNOLOGIES, INC., CLEVELAND, OH:
2,599,185, CANC. INT. CL. 16.

APPLIED MOLECULAR EVOLUTION, INC., SAN DIEGO, CA:
2,598,826, CANC. INT. CL. 42.

APRIL SONGS, INC., BABYLON, NY:
2,597,602, CANC. INT. CL. 41.

APRIL, CAROL, LOS ANGELES, CA:
3,631,098, PUB. 3-17-2009. INT. CL. 25.

APTE, INC, EVANSTON, IL:
2,165,277, REN. 4-28-09. INT. CL. 9.

AQUA MICROBICS L.L.C., HOUSTON, TX:
3,629,479, PUB. 3-17-2009. MULTIPLE CLASS, INT. CLS. 1, 35, 40 AND 42.

AQUA SMART, INC., ATLANTA, GA:
2,257,080, REN. 4-24-09. INT. CL. 1.

AQUAOX, ANDERSON, SC:
3,629,912, PUB. 3-17-2009. INT. CL. 11.

AQUBANC, LLC, BUFFALO GROVE, IL:
3,631,901, INT. CL. 9.

ARACHNE INC., LOS ANGELES, CA:
2,622,788, CANC. INT. CL. 25.

ARAMARK REFRESHMENT SERVICES OF TAMPA, LLC, PHILADELPHIA, PA:
2,235,933, REN. 4-27-09. MULTIPLE CLASS, INT. CLS. 29, 30 AND 42.

ARBITRAGE ENTERPRISES, INC., NEW YORK, NY:
3,633,263, INT. CL. 18.

ARBOR PHARMACEUTICALS, INC., RALEIGH, NC:
3,632,499, INT. CL. 5.

ARBORSYSTEMS, INC., OMAHA, NE:
3,632,197, INT. CL. 1.

ARBY'S IP HOLDER TRUST, FORT LAUDERDALE, FL:
2,599,752, CANC. INT. CL. 30.

ARCAMETRICS, LLC, DURHAM, NC:
3,630,890, PUB. 3-17-2009. INT. CL. 42.

ARCHER-DANIELS-MIDLAND COMPANY, DECATUR, IL:
3,631,791, INT. CL. 5.

ARCHIBEL SA, 5330 ASSESSE, BELGIUM:
2,174,911, CANC. INT. CL. 9.

ARES TRADING S.A., AUBONNE, SWITZERLAND:
3,629,587, PUB. 3-17-2009. INT. CL. 10.

ARGUS INDUSTRIES, INC., ELK GROVE VILLAGE, IL:
2,598,622, CANC. MULTIPLE CLASS, INT. CLS. 9 AND 16.

ARIANNA FARMS 'ONO KONA COFFEE, LLC, CAMARILLO, CA:
3,632,405, INT. CL. 30.

ARIEL CORPORATION, CRANBURY, NJ:
2,596,620, CANC. INT. CL. 9.

ARIEL RESEARCH CORPORATION, BETHESDA, MD:
2,597,309, CANC. INT. CL. 42.

ARIES ELECTRONICS, INC., FRENCHTOWN, NJ:
2,598,732, CANC. INT. CL. 9.

ARINC INCORPORATED, ANNAPOLIS, MD:
2,596,833, CANC. INT. CL. 38.

ARISCO, LAUREN, WACO, TX:
3,631,032, PUB. 3-17-2009. INT. CL. 41.

ARISTA RECORDS, INC., NEW YORK, NY:
2,599,434, CANC. INT. CL. 9.

ARITZIA LP, VANCOUVER, CANADA:
3,633,325, INT. CL. 35.
3,633,340, MULTIPLE CLASS, INT. CLS. 18 AND 25.

ARIZONA ZOOLOGICAL SOCIETY, PHOENIX, AZ, DBA THE PHOENIX ZOO:
2,599,146, CANC. INT. CL. 41.

ARLINGTON MEDICAL RESOURCES, INC., MALVERN, PA:
3,630,973, PUB. 3-17-2009. INT. CL. 9.

ARM, INC., SUNNYVALE, CA:
2,743,122, AM. INT. CL. 9.

ARMOR CORRECTIONAL HEALTH SERVICES, INC., MIAMI, FL:
3,630,578, PUB. 3-17-2009. INT. CL. 44.

ARMOUR, MICHELLE, SAN FRANCISCO, CA, DBA J.A.M. PR:
3,629,545, PUB. 2-10-2009. INT. CL. 35.

ARMSTRONG COMPANIES, DUNKIRK, MD:
3,630,897, PUB. 3-17-2009. INT. CL. 43.

ARMSTRONG HOSPITALITY GROUP LTD., VANCOUVER, CANADA:
3,633,497, INT. CL. 39.

ARNONE, MARILYN, ORIENTAL, NC:
3,630,392, PUB. 3-17-2009. INT. CL. 41.

ARNONE, MARILYN P., ORIENTAL, NC:
3,630,350, PUB. 3-17-2009. INT. CL. 41.

ART RENAISSANCE, LLC, ELGIN, IL:
3,630,857, PUB. 3-17-2009. INT. CL. 35.
3,630,860, PUB. 3-17-2009. INT. CL. 16.
3,630,861, PUB. 3-17-2009. INT. CL. 25.

ARTCAR FEST, SAN FRANCISCO, CA:
2,598,112, CANC. INT. CL. 41.

ARTEC SYSTEMS GROUP, INC., PORT WASHINGTON, NY TO L'OREAL USA CREATIVE, INC., NEW YORK, NY:
2,175,801, CANC. INT. CL. 3.

ARTEC SYSTEMS GROUP, INC., PORT WASHINGTON, NY TO L'OREAL USA CREATIVE INC., NEW YORK, NY:
2,175,857, CANC. INT. CL. 3.

ARTEC SYSTEMS GROUP, INC., PORT WASHINGTON, NY TO L'OREAL USA CREATIVE, INC., NEW YORK, NY:
2,175,859, CANC. INT. CL. 3.

ARTHUR ANDERSEN & CO., CHICAGO, IL:
1,496,618, CANC. INT. CL. 9.
1,496,619, CANC. INT. CL. 9.
1,496,620, CANC. INT. CL. 9.

ARTHUR ANDREW MEDICAL, INC, SCOTTSDALE, AZ:
3,629,481, PUB. 3-17-2009. INT. CL. 5.

ARTISANS, GLEN FLORA, WI:
2,598,818, CANC. INT. CL. 25.

ARTISTS' FRAME SERVICE, INC., CHICAGO, IL:
2,597,158, CANC. MULTIPLE CLASS, INT. CLS. 35 AND 42.

ARTOZ PAPIER AG, SWITZERLAND:
3,631,478, PUB. 3-17-2009. INT. CL. 16.

ARUZE CORPORATION, TOKYO 135-0063, JAPAN:
3,631,671, PUB. 3-17-2009. MULTIPLE CLASS, INT. CLS. 9 AND 28.

ARWIN BIO-TECH. (TAIWAN) CO., LTD., YANG MEI TOWN, TAIWAN:
3,629,849, PUB. 3-17-2009. INT. CL. 3.

AS IP HOLDCO, LLC, PISCATAWAY, NJ:
3,632,768, INT. CL. 20.

ASCEND HEALTH CORPORATION, DENTON, TX:
3,630,431, PUB. 3-17-2009. INT. CL. 44.
3,630,527, PUB. 3-17-2009. INT. CL. 44.

ASCOT SUPPLY CORPORATION, FAYETTEVILLE, GA:
1,496,691, CANC. INT. CL. 12.

ASESORIAS INTERNACIONALES, S.A., PANAMA CITY, PANAMA:
2,175,568, CANC. INT. CL. 29.

ASHER, CHARLES M., LANCASTER, CA, DBA CALIFORNIA MUFFLER SERVICE:
2,174,311, CANC. INT. CL. 7.

ASHLAND LICENSING AND INTELLECTUAL PROPERTY LLC, DUBLIN, OH:
2,599,011, CANC. INT. CL. 21.
3,630,548, PUB. 3-17-2009. INT. CL. 3.

ASHWIN-USHAS CORPORATION, INC., FREEHOLD, NJ:
2,174,405, CANC. INT. CL. 42.

ASHWORTH CREDIT UNION, WEST DES MOINES, IA:
3,633,449, INT. CL. 36.

ASI FOOD SAFETY CONSULTANTS, ST. LOUIS, MO:
3,630,800, PUB. 3-17-2009. INT. CL. 37.

ASI INDUSTRIES, L.L.C., MARSHALLTOWN, IA:
2,210,238, REN. 4-27-09. INT. CL. 9.

- ASIA PACIFIC ENVIRONMENTAL TECHNOLOGY, INC., HONOLULU, HI:
2,599,498, CANC. INT. CL. 42.
2,599,499, CANC. INT. CL. 42.
2,599,500, CANC. INT. CL. 42.
- ASIAN BISTRO - ARLINGTON INC., ANNANDALE, VA:
3,629,288, PUB. 3-17-2009. INT. CL. 43.
- ASIAN BISTRO - ARLINGTON, INC., ANNANDALE, VA:
3,629,287, PUB. 3-17-2009. INT. CL. 43.
- ASIAN MINISTRY TEAMS, HAMPTON, VA:
2,597,983, CANC. INT. CL. 41.
- ASIAN REAL ESTATE ASSOCIATION OF AMERICA, CARLSBAD, CA:
3,629,812, PUB. 3-17-2009. INT. CL. 35.
- ASICO LLC, WESTMONT, IL:
3,631,178, PUB. 3-17-2009. INT. CL. 10.
- ASPEN BUSINESS GROUP, FORT MYERS, FL:
2,596,902, CANC. INT. CL. 35.
- ASPEN CLUB LODGE PROPERTIES, LLC, WASHINGTON, DC:
3,631,377, PUB. 3-17-2009. INT. CL. 43.
- ASPEN CUSTOM TRAILERS, NISKU, CANADA:
3,629,484, PUB. 12-2-2008. INT. CL. 12.
- ASPEN PET PRODUCTS, INC., DENVER, CO:
3,631,388, PUB. 7-19-2005. INT. CL. 28.
- ASPEN PUBLISHERS, INC, NEW YORK, NY:
2,175,873, CANC. INT. CL. 16.
- ASPEN VETERINARY RESOURCES, LTD., GREELEY, CO:
3,432,080, AM. INT. CL. 5.
3,432,081, AM. INT. CL. 5.
- ASPIRING ARTISTS, LLC, SPRING LAKE, NJ:
3,629,303, PUB. 3-17-2009. INT. CL. 16.
- ASSET INTERNATIONAL, INC., GREENWICH, CT:
2,597,076, CANC. INT. CL. 36.
- ASSOCIATED RESEARCH, INC., LAKE FOREST, IL:
3,629,571, PUB. 3-17-2009. INT. CL. 9.
3,629,572, PUB. 3-17-2009. INT. CL. 9.
- ASSOCIATED WHOLESALE GROCERS, INC., KANSAS CITY, KS:
1,496,479, CANC. INT. CL. 5.
- ASSOCIATION FOR FINANCIAL PROFESSIONALS, BETHESDA, MD:
3,630,091, PUB. 12-9-2008. MULTIPLE CLASS, INT. CLS. 16 AND 41.
- ASSOCIATION OF ENERGY ENGINEERS, INC., ATLANTA, GA:
1,121,632, REN. 4-24-09. INT. CL. 42.
- ASSOCIATION OF TELEMESSAGING SERVICES INTERNATIONAL, INC., ALEXANDRIA, VA:
1,496,728, CANC. MULTIPLE CLASS, INT. CLS. 16 AND 41.
- ASSORTI, LLC, ARLINGTON, VA:
3,632,471, INT. CL. 43.
- ASSURANCE AGENCY, LTD., SCHAUMBURG, IL:
3,631,420, PUB. 4-24-2007. MULTIPLE CLASS, INT. CLS. 35, 36 AND 45.
- ASSURANT, INC., NEW YORK, NY:
3,632,777, INT. CL. 36.
- ASSURE DENTAL, TINTON FALLS, NJ:
3,630,347, PUB. 3-17-2009. INT. CL. 44.
- ASTEC INDUSTRIES, INC., CHATTANOOGA, TN:
2,598,286, CANC. MULTIPLE CLASS, INT. CLS. 6 AND 7.
2,598,287, CANC. MULTIPLE CLASS, INT. CLS. 6 AND 7.
- ASTELLAS PHARMA EUROPE B.V., LEIDERDORP, NETHERLANDS, FORMERLY YAMANOUCHI EUROPE B.V.:
3,602,412, COR. INT. CL. 5.
- ASTHEBURGERTURNS HOLDINGS, LLC, BIRMINGHAM, AL:
3,632,244, MULTIPLE CLASS, INT. CLS. 38 AND 41.
- AT&T INTELLECTUAL PROPERTY II, L.P., RENO, NV:
2,599,526, CANC. INT. CL. 38.
3,632,263, INT. CL. 38.
3,632,264, INT. CL. 38.
- AT&T WIRELESS SERVICES, INC., REDMOND, WA:
2,599,525, CANC. MULTIPLE CLASS, INT. CLS. 41 AND 42.
- ATALANTA FMA CORP., PISCATAWAY, NJ:
3,632,457, INT. CL. 25.
- ATG CORPORATION, MINNEAPOLIS, MN:
3,629,245, PUB. 3-17-2009. MULTIPLE CLASS, INT. CLS. 3 AND 11.
- ATHENA SEMICONDUCTORS, LLC, FREMONT, CA:
3,633,121, INT. CL. 9.
- ATHLETES FIRST, LLC, NEWPORT BEACH, CA:
2,597,772, CANC. INT. CL. 35.
2,597,773, CANC. INT. CL. 35.
- ATHLETES' PERFORMANCE, INC., TEMPE, AZ:
3,632,199, INT. CL. 16.
3,632,201, INT. CL. 28.
3,632,202, INT. CL. 41.
- ATHLETICS INVESTMENT GROUP LLC, OAKLAND, CA, DBA THE OAKLAND ATHLETICS BASEBALL COMPANY:
3,633,242, INT. CL. 25.
3,633,243, INT. CL. 25.
- ATI TECHNOLOGIES ULC, CALGARY, ALBERTA, CANADA:
3,632,366, INT. CL. 9.
- ATICO INTERNATIONAL USA, INC., FORT LAUDERDALE, FL:
3,631,005, PUB. 3-17-2009. MULTIPLE CLASS, INT. CLS. 11 AND 20.
- ATLANTA FINE HOMES, LLC, ATLANTA, GA:
3,633,015, INT. CL. 36.
- ATLANTIC & PACIFIC GRILL ASSOCIATES, L.L.C., NEW YORK, NY:
2,597,887, CANC. INT. CL. 29.
- ATLANTIC ALUMINUM PRODUCTS INCORPORATED, GREENWOOD, DE:
3,630,250, PUB. 3-17-2009. MULTIPLE CLASS, INT. CLS. 6, 35 AND 37.
- ATLANTIC RECORDING CORPORATION, NEW YORK, NY:
1,116,322, REN. 4-25-09. INT. CL. 9.
- ATLANTIC RICHFIELD COMPANY, LOS ANGELES, CA:
1,497,272, CANC. INT. CL. 42.
- ATLANTIC SOFTWARE EXCHANGE, INC., MEDIA, PA:
3,632,222, INT. CL. 9.
- ATLANTIS COMMUNICATIONS, LTD., WASHINGTON, DC:
2,599,523, CANC. INT. CL. 41.
- ATLANTIS PAK, ROSTOV REGION, RU 346700, RUSSIAN FED.:
2,596,790, CANC. MULTIPLE CLASS, INT. CLS. 16 AND 18.
- ATLAS SPINE, INC., JUPITER, FL:
3,629,818, PUB. 3-17-2009. INT. CL. 10.
- ATOP TECHNOLOGIES, INC., HSINCHU, TAIWAN:
2,598,969, CANC. INT. CL. 9.
- ATOTECH DEUTSCHLAND GMBH, BERLIN, FED REP GERMANY:
3,631,853, INT. CL. 1.
- ATR/TREEHOUSE, INC., JOHNSTON, RI:
2,596,630, CANC. MULTIPLE CLASS, INT. CLS. 35, 37, 41 AND 42.
2,596,632, CANC. MULTIPLE CLASS, INT. CLS. 35, 37, 41 AND 42.
- ATRONIC INTERNATIONAL GMBH, LÜBBECKE, FED REP GERMANY:
3,629,450, PUB. 3-17-2009. MULTIPLE CLASS, INT. CLS. 9 AND 41.
3,629,468, PUB. 3-17-2009. MULTIPLE CLASS, INT. CLS. 9 AND 41.
- ATTADOG ENTERTAINMENT, INC., NEW YORK, NY:
2,597,707, CANC. INT. CL. 16.
- ATTORNEYS' TITLE INSURANCE FUND, INC., ORLANDO, FL:
2,255,172, REN. 4-25-09. INT. CL. 42.
- ATUM, INC., HAMMOND, IN:
2,596,776, CANC. INT. CL. 9.
- AUDI AG, INGOLSTADT, FED REP GERMANY:
3,632,040, INT. CL. 12.
- AUDIO CRAFT COMPANY, INC., CLEVELAND, OH:
868,503, REN. 4-24-09. U.S. CL. 100 (INT. CL. 42).

AUDIO DIMENSIONS SYSTEMS CORPORATION, OKLAHOMA CITY, OK:
2,270,682. REN. 4-24-09. INT. CL. 35.

AUDIOVEND WIRELESS SYSTEMS, INC., HOUSTON, TX:
3,630,343. PUB. 3-17-2009. MULTIPLE CLASS, INT. CLS. 35, 37 AND 41.

AUERSOFT LLC, MESA, AZ:
3,629,273. PUB. 9-16-2008. INT. CL. 9.

AUGUSTA SYSTEMS, INC., MORGANTOWN, WV:
3,629,346. PUB. 3-17-2009. INT. CL. 9.

AUNTIE ANNE'S, INC., LANCASTER, PA:
2,599,642. CANC. INT. CL. 30.

AUNTIE LITER, INC., BIRMINGHAM, AL:
3,629,867. PUB. 3-17-2009. INT. CL. 35.

AUREMA PTY. LTD., CHIPPENDALE NSW 2008, AUSTRALIA:
2,598,410. CANC. INT. CL. 9.
2,598,411. CANC. INT. CL. 42.

AUSTRALIAN GOLD, INC., INDIANAPOLIS, IN:
2,344,133. REN. 4-24-09. INT. CL. 3.

AUTO SERVICES COMPANY, INC., MOUNTAIN HOME, AR:
3,630,946. PUB. 3-17-2009. INT. CL. 36.

AUTOBAHN DESIGNS, INC., RIVERSIDE, CA:
2,597,143. CANC. MULTIPLE CLASS, INT. CLS. 7 AND 12.

AUTOMATIONDIRECT.COM INC., CUMMING, GA:
3,629,935. PUB. 3-17-2009. INT. CL. 9.

AUTOMOTIVE INTERNATIONAL, INC., CINCINNATI, OH:
2,812,991. CANC. INT. CL. 5.

AUTONATION HOLDING CORP., FT. LAUDERDALE, FL:
3,632,492. INT. CL. 36.

AUTONET MOBILE, INC., SAN FRANCISCO, CA:
3,633,195. INT. CL. 38.

AUTOSTYLE, INC., GRAND RAPIDS, MI:
1,497,081. CANC. INT. CL. 37.

AUTOTRONIC CONTROLS CORPORATION, EL PASO, TX:
2,339,620. REN. 4-24-09. INT. CL. 7.

AVAYA INC., BASKING RIDGE, NJ:
2,599,501. CANC. INT. CL. 9.

AVENUE A, INC., SEATTLE, WA:
2,599,859. CANC. INT. CL. 42.
2,599,860. CANC. INT. CL. 35.

AVG TECHNOLOGIES CZ, S.R.O., BRNO, CZECH REPUBLIC:
3,629,247. PUB. 3-17-2009. MULTIPLE CLASS, INT. CLS. 9, 16 AND 42.

AVIATION REPAIR SOLUTIONS, INC., LONG BEACH, CA:
3,633,393. INT. CL. 37.

AVIENDA TECHNOLOGIES INC., ATLANTA, GA:
2,596,824. CANC. INT. CL. 38.

AVIKO B.V., STEENDEREN, NETHERLANDS:
3,631,687. PUB. 3-17-2009. INT. CL. 29.

AVOLENT, INC., SAN FRANCISCO, CA:
2,597,136. CANC. INT. CL. 9.

AVOMEX, INC., FORT WORTH, TX:
3,633,397. INT. CL. 29.
3,633,398. INT. CL. 29.
3,633,399. INT. CL. 29.

AVON PRODUCTS, INC., NEW YORK, NY:
2,599,176. CANC. INT. CL. 3.
2,599,598. CANC. INT. CL. 5.

AWANA CLUBS INTERNATIONAL, STREAMWOOD, IL:
3,633,051. MULTIPLE CLASS, INT. CLS. 9 AND 16.

AXACT FZ-LLC, DUBAI, UNITED ARAB EMIR.:
3,629,934. PUB. 3-17-2009. MULTIPLE CLASS, INT. CLS. 35 AND 42.

AXEL SPRINGER AG, FED REP GERMANY:
3,631,479. PUB. 3-17-2009. MULTIPLE CLASS, INT. CLS. 16, 35, 38 AND 41.

AXIAL GLOBALIZACION DE VINOS, S.L., 50012 ZARAGOZA, SPAIN:
3,630,458. PUB. 3-17-2009. INT. CL. 33.

AXIOM MARKETING COMMUNICATIONS, MINNEAPOLIS, MN:
2,596,617. CANC. MULTIPLE CLASS, INT. CLS. 35 AND 41.

AXON MARKETING & DESIGN, PORTLAND, ME:
3,630,732. PUB. 3-17-2009. INT. CL. 42.

AXSON TECHNOLOGIES (SOCIÉTÉ ANONYME), F-95310 ST OUEEN L'AUMONE, FRANCE:
3,631,566. PUB. 3-17-2009. INT. CL. 1.

AYOUB AND ASSOCIATES INC., RALEIGH, NC:
2,598,213. CANC. INT. CL. 9.

AZINDIES PRODUCTIONS LLC, RIVERSIDE, CA:
3,630,596. PUB. 3-17-2009. INT. CL. 41.

AZRIELANT, OFER, NEW YORK, NY:
3,632,569. INT. CL. 14.

AZTEC SHOPS LTD., SAN DIEGO, CA:
3,630,919. PUB. 3-17-2009. INT. CL. 35.

AZUMA FOODS (CANADA) CO., LTD., RICHMOND, B.C., CANADA:
3,629,227. PUB. 3-17-2009. INT. CL. 29.

AZUMA INDUSTRIAL, CO., LTD., JAPAN:
3,631,781. PUB. 3-17-2009. INT. CL. 21.

AZZOUZ NEZAR, ALBUQUERQUE, NM:
3,630,742. PUB. 3-17-2009. INT. CL. 42.

B AWARE NATION, LLC, CARSON CITY, NV:
2,598,205. CANC. INT. CL. 41.

B.A.M. MEDIA LLC, NEW YORK, NY:
3,633,065. INT. CL. 25.

B.E. MEYERS & COMPANY, INC., REDMOND, WA:
3,629,814. PUB. 3-17-2009. INT. CL. 9.

B.J. ALAN COMPANY, YOUNGSTOWN, OH:
3,630,704. PUB. 3-17-2009. INT. CL. 13.
3,630,738. PUB. 3-17-2009. INT. CL. 13.
3,630,801. PUB. 3-17-2009. INT. CL. 13.
3,630,802. PUB. 3-17-2009. INT. CL. 13.
3,630,806. PUB. 3-17-2009. INT. CL. 13.

B&B ELECTRONICS MANUFACTURING COMPANY, OTTAWA, IL:
3,633,196. INT. CL. 9.

BAAB, MATTHEW W., AUSTIN, TX:
3,630,872. PUB. 3-17-2009. INT. CL. 41.

BABBACO LLC, CHICAGO, IL:
3,630,772. PUB. 3-17-2009. INT. CL. 35.

BABCOCK POWER SERVICES INC., WORCESTER, MA:
3,632,122. MULTIPLE CLASS, INT. CLS. 37 AND 40.

BABSON COLLEGE, BABSON PARK, MA:
3,630,422. PUB. 3-17-2009. INT. CL. 41.

BABY BOOM CONSUMER PRODUCTS, INC., NEW YORK, NY:
3,629,222. PUB. 3-17-2009. INT. CL. 28.

BABY HANDS PRODUCTIONS, INC., SCOTTS VALLEY, CA:
3,630,795. PUB. 3-17-2009. INT. CL. 35.

BABYBJÖRN AB, DANDERYD, SWEDEN:
3,633,481. INT. CL. 20.
3,633,482. INT. CL. 20.
3,633,483. INT. CL. 20.
3,633,484. INT. CL. 18.

BABYGAGS, INC., SAN FRANCISCO, CA:
3,632,891. INT. CL. 25.

BABYSMART, LLC, BERNARDSVILLE, NJ:
3,629,329. PUB. 3-17-2009. MULTIPLE CLASS, INT. CLS. 20 AND 24.

BACHMAN COMPANY, THE, WYOMISSING, PA:
3,633,300. MULTIPLE CLASS, INT. CLS. 29 AND 30.

BACHRACH CLOTHING, INC., NEW YORK, NY:
1,504,913. REN. 4-30-09. MULTIPLE CLASS, INT. CLS. 25 AND 42.

BACK TO HEALTH WELLNESS CENTER, LLC, LAKE ZURICH, IL:
3,630,778. PUB. 3-17-2009. INT. CL. 44.

BACKWEB TECHNOLOGIES LTD., SAN JOSE, CA:
2,237,120. REN. 4-29-09. INT. CL. 9.

BADAEI, BARMAK, RESEDA, CA AND SAUER, JIM, LOS ANGELES, CA:
3,631,279. PUB. 3-17-2009. INT. CL. 25.
3,631,280. PUB. 3-17-2009. INT. CL. 25.

BADDOG CONCEPTS, UPLAND, CA:
2,596,678. CANC. INT. CL. 42.

BADGER METER, INC., MILWAUKEE, WI:
1,496,642. CANC. INT. CL. 9.

- BAG INNOVATIONS GROUP, LLC, CHANHASSEN, MN:
3,632,498, INT. CL. 17.
- BAGULA, MARK SCOTT, SPRING VALLEY, CA:
2,596,771, CANC. INT. CL. 42.
- BAHAMA CLIPPER, L. L. C., CHANTILLY, VA:
3,629,177, PUB. 3-17-2009. MULTIPLE CLASS, INT. CLS.
18 AND 25.
- BAIDU.COM, INC., GRAND CAYMAN, CAYMAN ISLANDS:
3,632,234, INT. CL. 9.
- BAIERL CHEVROLET, INC., WEXFORD, PA:
3,630,682, PUB. 3-17-2009. INT. CL. 35.
3,630,684, PUB. 3-17-2009. INT. CL. 35.
- BAILEY, RICHARD J, BRIGHTON, UNITED KINGDOM,
DBA TOP DECK PUBLICATIONS:
3,629,640, PUB. 3-17-2009. INT. CL. 16.
- BAIR, JAMES F., WRIGHTSVILLE, PA:
2,599,157, CANC. INT. CL. 31.
- BAKER & BAKER INC., OAK CREEK, WI:
2,598,906, CANC. INT. CL. 16.
- BALANCE ADJUSTABLE TECHNOLOGY LLC, WIND LAKE, WI:
3,632,520, INT. CL. 28.
- BALANCE ORGANIZING SERVICE CO., SAN FRANCISCO, CA:
3,630,375, PUB. 3-17-2009. INT. CL. 35.
- BALBOA INSTRUMENTS, INC., TUSIN, CA:
2,598,703, CANC. INT. CL. 9.
- BALDUCCI S.P.A., PIEVE A NIEVOLE (PISTOIA), ITALY:
2,596,485, CANC. INT. CL. 25.
- BALL STATE UNIVERSITY, MUNCIE, IN:
3,629,534, PUB. 3-17-2009. INT. CL. 41.
- BALLARD ADVANCED MATERIALS CORPORATION, BURNABY, BRITISH COLUMBIA, CANADA:
2,174,510, CANC. MULTIPLE CLASS, INT. CLS. 1 AND 40.
- BALS CORPORATION, JAPAN:
3,631,721, PUB. 3-17-2009. INT. CL. 35.
- BALTHAZAR A/S, 1749 COPENHAGEN V, DENMARK:
2,596,766, CANC. MULTIPLE CLASS, INT. CLS. 9, 16, 41 AND 42.
- BALTIMORE AIRCOIL COMPANY, INC., JESSUP, MD:
1,532,902, REN. 4-29-09. INT. CL. 11.
- BANCINSURE, INC., OKLAHOMA CITY, OK:
3,631,182, PUB. 3-17-2009. INT. CL. 36.
- BANDAI AMERICA INCORPORATED, CYPRESS, CA:
3,629,896, PUB. 3-17-2009. INT. CL. 9.
- BANG & OLUFSEN A/S, STRUER, DENMARK:
3,631,502, PUB. 3-17-2009. MULTIPLE CLASS, INT. CLS.
9, 35, 38 AND 39.
- BANK FORWARD, HANNAFORD, ND:
3,631,891, INT. CL. 36.
- BANK OF AMERICA CORPORATION, CHARLOTTE, NC:
2,599,848, CANC. INT. CL. 36.
3,633,368, INT. CL. 42.
- BANK OF AMERICA, N.A., NEW YORK, NY:
2,597,658, CANC. INT. CL. 17.
2,599,315, CANC. INT. CL. 3.
- BANK OF GUAM, AGANA, GUAM:
1,497,028, CANC. INT. CL. 36.
- BANK OF HAWAII CORPORATION, HONOLULU,, HI:
2,598,193, CANC. INT. CL. 36.
- BARABINO, BARBARA, LOS ANGELES, CA:
2,597,849, CANC. INT. CL. 41.
- BARAJAS, TIMOTEO, HENDERSON, NV AND VALENZUELA, JESUS, LAS VEGAS, NV AND BARAJAS, RAUL, LAS VEGAS, NV:
3,633,379, INT. CL. 43.
- BARBARA BRENNAN INC., BOCA RATON, FL:
2,265,775, REN. 4-24-09. INT. CL. 41.
- BARBARAS DEVELOPMENT, INC., THOUSAND OAKS, CA:
3,630,385, PUB. 3-17-2009. MULTIPLE CLASS, INT. CLS.
35, 39, 40 AND 42.
- BARBATO, A J, FT LAUDERDALE, FL:
3,632,181, INT. CL. 32.
- BARBATO, A J, OAKLAND PARK, FL:
3,632,182, INT. CL. 32.
- BARDAHL MANUFACTURING CORPORATION, SEATTLE, WA:
677,482, REN. 4-27-09. U.S. CL. 52 (INT. CL. 2).
- BARDAV INC., AGOURA HILLS, CA:
3,630,134, PUB. 3-17-2009. INT. CL. 41.
- BAREFOOT SCIENCE TECHNOLOGIES, INC., CLAREMONT, CANADA:
3,631,418, PUB. 3-17-2009. INT. CL. 10.
- BARENBRUG USA, INC., TANGENT, OR:
3,632,318, INT. CL. 31.
3,632,356, INT. CL. 31.
- BARENTHAL NORTH AMERICA, INC., RUTHERFORD, NJ:
3,632,688, INT. CL. 21.
3,632,689, INT. CL. 8.
- BARIATRIX NUTRITION INC., LACHINE, QUEBEC, CANADA:
2,174,679, CANC. INT. CL. 5.
- BARKING SOFTWARE, MERIDIAN, ID:
3,630,215, PUB. 3-17-2009. INT. CL. 9.
- BARMAK BADA EI, RESEDA, CA AND JIM SAUER, LOS ANGELES, CA:
3,631,082, PUB. 3-17-2009. INT. CL. 25.
- BARMENSEN LABS, LLC, EDISON, NJ:
3,633,327, MULTIPLE CLASS, INT. CLS. 3 AND 5.
- BARNES, JASON, LOS ANGELES, CA:
3,630,608, PUB. 3-17-2009. INT. CL. 35.
- BARNES, JESSE, SPRINGFIELD, MO:
2,289,715, REN. 4-25-09. MULTIPLE CLASS, INT. CLS. 16 AND 21.
- BARNETTE, S. RONALD, HIALEAH, FL:
2,174,168, CANC. MULTIPLE CLASS, INT. CLS. 17 AND 19.
- BARON & BUDD, P.C., DALLAS, TX:
3,631,193, PUB. 3-17-2009. INT. CL. 45.
- BARROW INDUSTRIES INC., NORWOOD, MA:
3,631,285, PUB. 3-17-2009. INT. CL. 24.
- BARRY M. MOORE, BARBARA VILUTIS, PERCIVAL T. BEACROFT, JOE N. WESTERLAGE, AND ERNESTO CALDERIN, ALL U.S. CITIZENS, AS TRUSTEES OF THE FAITH P. AND L. BYBEE FOUNDATION, ROUND TOP, TX, DBA THE TEXAS PIONEER ARTS FOUNDATION:
2,175,884, CANC. INT. CL. 41.
- BARRY, HAMLET J., DENVER, CO AND BARRY, GAIL N., DENVER, CO:
3,631,966, MULTIPLE CLASS, INT. CLS. 29 AND 30.
- BARRY, RICHARD, FAIR HAVEN, NJ:
3,632,007, INT. CL. 5.
- BARSE AND COMPANY, INC., DALLAS, TX:
3,630,558, PUB. 3-17-2009. INT. CL. 14.
- BARYSHNIKOV, MIKHAIL, NEW YORK, NY:
1,497,296, CANC. INT. CL. 25.
- BASEMENT TECHNOLOGIES, INC., NEEDHAM, MA:
3,629,184, PUB. 3-17-2009. INT. CL. 19.
- BASF AKTIENGESELLSCHAFT, LUDWIGSHAFEN, FED REP GERMANY:
1,496,413, CANC. INT. CL. 2.
- BASIC CHEMICAL SOLUTIONS, L.L.C., REDWOOD CITY, CA:
2,315,436, REN. 4-28-09. MULTIPLE CLASS, INT. CLS. 1 AND 39.
- BASILEA PHARMACEUTICA AG, SWITZERLAND:
3,602,748, COR. MULTIPLE CLASS, INT. CLS. 1, 5 AND 42.
- BASIS INTERNATIONAL LTD., ALBUQUERQUE, NM:
2,174,653, CANC. INT. CL. 9.
- BASS PRO INTELLECTUAL PROPERTY, L.L.C, SPRINGFIELD, MO:
3,632,846, INT. CL. 28.
- BATESVILLE SERVICES, INC., BATESVILLE, IN:
2,599,257, CANC. INT. CL. 42.
- BATH & BODY WORK BRAND MANAGEMENT, INC., REYNOLDSBURG, OH:
2,599,665, CANC. MULTIPLE CLASS, INT. CLS. 4 AND 5.
- BATH & BODY WORKS BRAND MANAGEMENT, INC., REYNOLDSBURG, OH:
3,632,673, MULTIPLE CLASS, INT. CLS. 3 AND 5.

BATIK WORLD, L.L.C., BATON ROUGE, LA:
2,599,436, CANC. INT. CL. 35.

BATISTE, PAUL A., METAIRIE, LA, DBA BATISTE BROTH-
ERS BAND:
3,630,798, PUB. 3-17-2009. INT. CL. 41.

BATTER UP KIDS INC., AUSTIN, TX:
3,631,153, PUB. 3-17-2009. INT. CL. 16.

BATTIATO, VICTOR J., BLOOMINGDALE, IL:
3,629,535, PUB. 3-17-2009. MULTIPLE CLASS, INT. CLS.
8, 10 AND 28.

BAUER TYPES SA, 6830 CHIASSO, SWITZERLAND:
3,631,165, PUB. 3-17-2009. INT. CL. 9.
3,631,169, PUB. 3-17-2009. INT. CL. 9.

BAUM, BRENT M, TUCSON, AZ:
2,597,408, CANC. INT. CL. 41.

BAXTER, GEORGE, TINLEY PARK, IL:
2,597,257, CANC. INT. CL. 42.

BAYER AKTIENGESELLSCHAFT, 51368 LEVERKUSEN-
BAYERWERK, FED REP GERMANY:
2,175,514, CANC. INT. CL. 5.

BAYER AKTIENGESELLSCHAFT, 51373 LEVERKUSEN,
FED REP GERMANY:
3,629,298, PUB. 3-17-2009. INT. CL. 5.

BAYER CORPORATION, PITTSBURGH, PA:
2,599,686, CANC. INT. CL. 5.
2,599,687, CANC. INT. CL. 5.
2,599,714, CANC. INT. CL. 5.

BAYER HEALTHCARE LLC, PITTSBURGH, PA:
2,598,391, CANC. INT. CL. 5.

BAYERISCHE MOTOREN WERKE AKTIENGE-
SELLSCHAFT, FED REP GERMANY:
2,597,127, CANC. INT. CL. 35.

BAYERISCHE MOTOREN WERKE AKTIENGE-
SELLSCHAFT, D-80788 MUENCHEN, FED REP GER-
MANY:
2,597,546, CANC. INT. CL. 12.

BAYOU STATE OIL CORPORATION, SHREVEPORT, LA:
3,629,874, PUB. 3-17-2009. INT. CL. 39.

BBMG GROUP CORPORATION, CHINA:
3,631,562, PUB. 3-17-2009. MULTIPLE CLASS, INT. CLS.
11, 35, 37, 42, 43 AND 45.

BBR LIMITED, GUERNSEY, CHANNEL ISLANDS:
3,631,409, PUB. 5-6-2008. INT. CL. 43.

BC BOOTCAMP LLC, TUCSON, AZ:
3,631,007, PUB. 3-17-2009. INT. CL. 41.

BCATCO ARL, ST. HELLIER, JERSEY, CHANNEL IS-
LANDS:
2,597,153, CANC. INT. CL. 12.

BCNY INTERNATIONAL INC., HICKSVILLE, NY:
2,597,239, CANC. INT. CL. 25.

BDO SEIDMAN, NEW YORK, NY:
1,497,022, CANC. INT. CL. 35.

BDT PRODUCTS, INC., IRVINE, CA:
2,598,803, CANC. INT. CL. 9.

BE INCORPORATED, MENLO PARK, CA:
2,598,471, CANC. INT. CL. 42.

BEACON FOOTWEAR, INC., WILDWOOD, MO:
2,599,732, CANC. INT. CL. 25.

BEADLE, ELEANOR, SAN DIEGO, CA AND BEADLE,
JOSHUA, SAN DIEGO, CA:
2,599,715, CANC. INT. CL. 42.

BEANS, THE, WASHINGTON, DC:
2,597,869, CANC. INT. CL. 41.

BEAR STEARNS COMPANIES INC., THE, NEW YORK, NY:
2,596,567, CANC. INT. CL. 36.

BEARY, BETH, PHOENIX, AZ:
3,630,971, PUB. 3-17-2009. MULTIPLE CLASS, INT. CLS.
18 AND 25.
3,630,976, PUB. 3-17-2009. MULTIPLE CLASS, INT. CLS.
18 AND 25.

BEAULIEU GROUP, LLC, DALTON, GA:
3,632,424, INT. CL. 27.
3,633,381, INT. CL. 36.

BEAUPRÉ, PIERRE, ST-PHILIPPE, CANADA:
3,629,438, PUB. 8-12-2008. INT. CL. 11.

BEAUTIFLSTUFF, LLC, GLENWOOD, NJ:
3,629,501, PUB. 3-17-2009. INT. CL. 14.

BEAUTY SOLUTIONS, LTD., NEW YORK, NY:
3,632,967, INT. CL. 3.

BEAUTYTRENDS INC., ST. LOUIS, MO, REVLO CON-
SUMER PRODUCTS CORPORATION, NEW YORK, NY:
2,216,291, REN. 4-28-09. INT. CL. 26.

BEAZLEY, WILLIAM H., LOS ANGELES, CA:
2,599,764, CANC. INT. CL. 28.

BECHRIS MACHINERY COMPANY, LONGWOOD, FL:
2,599,121, CANC. INT. CL. 12.

BECKER & PERAKIS, LLC, PLYMOUTH, MI:
1,545,548, REN. 4-26-09. INT. CL. 30.

BECKER, MICHAEL, BLUE POINT, NY:
3,630,505, PUB. 3-17-2009. INT. CL. 28.

BECKER'S JEWELRY CORP., WEST HARTFORD, CT:
2,598,903, CANC. INT. CL. 40.

BECKETT MEDIA LP, DALLAS, TX:
3,630,053, PUB. 3-17-2009. MULTIPLE CLASS, INT. CLS.
35, 38 AND 42.

BECKHAM BRAND LIMITED, LONDON, UNITED KING-
DOM:
3,631,399, PUB. 3-17-2009. MULTIPLE CLASS, INT. CLS.
3, 6, 9, 14, 16, 18, 21, 24, 25, 28, 29, 30, 32, 41 AND 43.

BECKHOFF AUTOMATION GMBH, D - 33415 VERL, FED
REP GERMANY:
3,631,371, PUB. 3-17-2009. INT. CL. 7.

BECKMAN, JAMES S., SPRINGDALE, AK:
2,301,187, REN. 4-27-09. INT. CL. 3.

BECKMAN, JAMES S., SPRINGDALE, AR:
3,632,737, INT. CL. 3.

BEE-ALIVE, INC., VALLEY COTTAGE, NY:
2,598,924, CANC. INT. CL. 14.

BEECH ACRES, CINCINNATI, OH:
2,598,698, CANC. INT. CL. 41.

BEER, KENNETH R., WEST PALM BEACH, FL:
3,632,145, INT. CL. 3.

BEGHELLI S.P.A., ITALY:
3,631,575, PUB. 3-17-2009. MULTIPLE CLASS, INT. CLS. 9
AND 11.
3,631,576, PUB. 3-17-2009. MULTIPLE CLASS, INT. CLS. 9
AND 11.

BEHIND THE BURNER LLC, NEW YORK, NY:
3,632,887, MULTIPLE CLASS, INT. CLS. 35, 41 AND 44.

BEHRENS ENTERPRISES, INCORPORATED, CHARLOTTE,
NC, DBA LAUNCH YOUR KID:
3,630,667, PUB. 3-17-2009. INT. CL. 41.

BEIJING SHENG WANG ACOUSTIC-ELECTRIC TECHNOL-
OGY CO.LTD, BEIJING 100029, CHINA:
3,632,896, INT. CL. 9.

BEIJING VISIONOX TECHNOLOGY CO., LTD., BEIJING,
CHINA:
3,631,680, PUB. 3-17-2009. MULTIPLE CLASS, INT. CLS.
9, 11 AND 14.

BEKINS HOLDING CORP., HILLSIDE, IL:
1,497,103, CANC. INT. CL. 39.

BEL CANTO SOCIETY, INC., NEW YORK, NY:
2,708,364, CANC. MULTIPLE CLASS, INT. CLS. 16 AND
41.

BEL-ART PRODUCTS, PEQUANNOCK, NJ:
2,599,853, CANC. INT. CL. 9.

BELKIN INTERNATIONAL INC., COMPTON, CA:
2,251,753, REN. 4-25-09. INT. CL. 9.

BELL & HOWELL MAIL AND MESSAGING TECHNOLO-
GIES COMPANY, DURHAM, NC:
2,598,942, CANC. INT. CL. 7.

BELL ALIANT REGIONAL COMMUNICATIONS, LIMITED
PARTNERSHIP, ST JOHN'S, NEWFOUNDLAND:
2,599,186, CANC. INT. CL. 9.

BELLATORE, LLC, SAN JOSE, CA:
3,629,225, PUB. 3-17-2009. MULTIPLE CLASS, INT. CLS.
36 AND 41.
3,629,226, PUB. 3-17-2009. MULTIPLE CLASS, INT. CLS.
36 AND 41.

BELLINGHAM BELLS, LLC, BELLINGHAM, WA:
3,629,721, PUB. 3-17-2009. MULTIPLE CLASS, INT. CLS.
25 AND 41.

BELLWETHER EXPLORATION COMPANY, HOUSTON,
TX:
2,599,277, CANC. INT. CL. 42.

- BELMONT ABBEY COLLEGE, INCORPORATED, BELMONT, NC:
3,630,107, PUB. 12-9-2008. MULTIPLE CLASS, INT. CLS. 9 AND 16.
- BELSHE INDUSTRICS, INC., TECUMSEH, OK:
3,630,143, PUB. 3-17-2009. INT. CL. 12.
- BELSHE INDUSTRIES, INC., TECUMSEH, OK:
3,630,141, PUB. 3-17-2009. INT. CL. 12.
- BEMIS COMPANY, INC., NEENAH, WI, BEMIS BRO. BAG COMPANY, ST. LOUIS, MO:
510,507. REN. 4-24-09. U.S. CL. 2 (INT. CLS. 6, 13, 14, 15, 16, 18, 20, 21, 22 AND 34).
- BEN WACHTER ASSOCIATES, INC., NEW YORK, NY:
3,633,151, MULTIPLE CLASS, INT. CLS. 28 AND 35.
- BENCHWORKZZ LLC, AUSTIN, TX:
3,633,217, INT. CL. 9.
- BENDER, MANFRED, BEVERLY HILLS, CA:
2,598,874, CANC. INT. CL. 11.
- BENEFIT STRATEGIES, LLC, MANCHESTER, NH:
3,629,290, PUB. 3-17-2009. INT. CL. 36.
- BENEFOOT, INC., EDGEWOOD, NY TO LANGER BIOMECHANICS, INC., DEER PARK, NY:
2,175,239, CANC. MULTIPLE CLASS, INT. CLS. 9 AND 10.
- BENNETT TRUCK EQUIPMENT, INC., ORLANDO, FL:
2,597,243, CANC. MULTIPLE CLASS, INT. CLS. 35 AND 37.
- BENT, KIM SUZANNE, MARLBOROUGH, MA:
2,598,582, CANC. INT. CL. 41.
- BENTLY NEVADA CORPORATION, MINDEN, NV:
2,598,455, CANC. INT. CL. 7.
- BEPEX INTERNATIONAL, LLC, MINNEAPOLIS, MN, RIETZ MANUFACTURING CO., SANTA ROSA, CA:
670,889. REN. 4-25-09. U.S. CL. 23 (INT. CL. 7).
- BERCHTOLD CORPORATION, CHARLESTON, SC:
2,275,466. REN. 4-30-09. INT. CL. 10.
- BERDON LLP, NEW YORK, NY:
3,630,142, PUB. 3-17-2009. MULTIPLE CLASS, INT. CLS. 35, 36 AND 45.
- BERGEVIN LANE VINEYARDS, LLC, WALLA WALLA, WA:
3,631,980, INT. CL. 33.
- BERGKESSEL, MICHAEL, MALIBU, CA:
2,175,244, CANC. INT. CL. 35.
- BERINGER BLOSS ITALIA S.R.L, ITALY:
3,631,754, PUB. 3-17-2009. INT. CL. 33.
- BERNARD G. REICH, BARRINGTON HILLS, IL:
3,632,046, INT. CL. 32.
- BERNE JEWELERS INC., MERRICK, NY:
2,599,429, CANC. INT. CL. 14.
- BERRY CHILL LLC, CHICAGO, IL:
3,632,186, INT. CL. 30.
- BERTOLDI, MASSIMILIANO, LATINA, ITALY:
3,632,267, INT. CL. 42.
- BERWANGER, INC., HOUSTON, TX:
2,596,986, CANC. INT. CL. 9.
- BESINS HEALTHCARE, INC., HERNDON, VA:
3,630,657, PUB. 3-17-2009. INT. CL. 42.
- BEST BUSINESS SYSTEMS, INC., BOWLING GREEN, KY, DBA BBS PRONET:
3,629,584, PUB. 3-17-2009. MULTIPLE CLASS, INT. CLS. 35 AND 40.
- BEST HEARING CENTER, INC., WESTMONT, IL:
3,633,456, INT. CL. 44.
- BEST PRODUCTS CO., INC., RICHMOND, VA:
1,497,203, CANC. INT. CL. 42.
- BEST WESTERN INTERNATIONAL, INC., PHOENIX, AZ:
3,632,558, INT. CL. 43.
3,633,005, INT. CL. 35.
3,633,006, INT. CL. 43.
- BETHEL GOSPEL ASSEMBLY, NEW YORK, NY:
3,632,175, INT. CL. 41.
- BETHEL HARAMBEE HISTORICAL SERVICES, LANCASTER, PA:
2,597,889, CANC. INT. CL. 41.
- BETHESDA HOSPITAL, INC., CINCINNATI, OH:
1,497,122, CANC. INT. CL. 41.
- BETTER MATTERS, INC, FRISCO, TX:
3,630,864, PUB. 3-17-2009. INT. CL. 35.
- BETTER OFFICE PRODUCTS, CANOGA PARK, CA:
3,633,400, INT. CL. 16.
- BETTERBODY FOODS & NUTRITION LLC, SALT LAKE CITY, UT:
3,630,522, PUB. 3-17-2009. INT. CL. 30.
- BETTY GIBSON ASSOCIATES, INC., BOSTON, MA, DBA PRUDENTIAL GIBSON REAL ESTATE:
2,598,982, CANC. INT. CL. 36.
- BEVERLY HILLS TEDDY BEAR COMPANY, NEWHALL, CA:
3,630,081, PUB. 3-17-2009. INT. CL. 28.
- BEYOND COFFEE & CAPPUCINO LLC, FREDERICKSBURG, VA:
3,632,416, INT. CL. 30.
- BGI ACQUISITION LLC, INDIANAPOLIS, IN:
2,598,235, CANC. INT. CL. 28.
- BHIVE.NET, LLC, CONSHOHOCKEN, PA:
2,597,437, CANC. MULTIPLE CLASS, INT. CLS. 35 AND 36.
- BI INCORPORATED, BOULDER, CO:
3,632,090, INT. CL. 42.
- BIANCO CO., LTD., TAIPEI, TAIWAN:
2,598,687, CANC. INT. CL. 25.
- BIBENDUM WINE LIMITED, LONDON, ENGLAND:
3,629,615, PUB. 3-17-2009. INT. CL. 33.
- BICYCLE CITY LLC, CINCINNATI, OH:
3,632,808, INT. CL. 37.
- BIENSEN, KELLY M., STATE CENTER, IA:
3,629,134, PUB. 3-17-2009. INT. CL. 29.
- BIG RIVER INNOVATIONS, INC., NAMPA, ID:
3,630,159, PUB. 3-17-2009. MULTIPLE CLASS, INT. CLS. 25 AND 28.
- BIG TRAIN, INC., FOOTHILL RANCH, CA:
3,632,064, INT. CL. 30.
- BIGBEE STEEL BUILDINGS, INC., MUSCLE SHOALS, AL:
3,629,525, PUB. 3-17-2009. MULTIPLE CLASS, INT. CLS. 6, 40 AND 42.
3,629,526, PUB. 3-17-2009. MULTIPLE CLASS, INT. CLS. 6, 40 AND 42.
- BIGELOW MERCHANDISING, LLC, COLUMBUS, OH:
3,633,078, INT. CL. 3.
3,633,079, INT. CL. 3.
- BIGHEAD BONDING FASTENERS LIMITED, UNITED KINGDOM:
3,631,488, PUB. 3-17-2009. MULTIPLE CLASS, INT. CLS. 6 AND 19.
- BILLY BEE PRODUCTIONS, INC., NASHUA, NH:
2,597,936, CANC. INT. CL. 16.
- BILLY GRAHAM EVANGELISTIC ASSOCIATION, CHARLOTTE, NC:
3,632,603, MULTIPLE CLASS, INT. CLS. 9, 16, 35, 38, 41 AND 45.
- BIN, LIEW, PUCHONG, MALAYSIA:
3,632,367, INT. CL. 18.
3,632,368, INT. CL. 18.
- BIO TECH NUTRIENTS, LLC, NORTH LAS VEGAS, NV:
3,630,084, PUB. 3-17-2009. INT. CL. 1.
- BIO-FOODS, LTD., WEST PATERSON, NJ:
2,598,532, CANC. INT. CL. 30.
- BIO-KEY INTERNATIONAL, INC., MARLBOROUGH, ME:
2,174,356, CANC. INT. CL. 9.
- BIO-LAB, INC., LAWRENCEVILLE, GA:
3,632,093, MULTIPLE CLASS, INT. CLS. 35, 37 AND 42.
3,633,047, INT. CL. 35.
- BIOBASED SYSTEMS, LLC, ROGERS, AR:
3,632,106, INT. CL. 17.
- BIOCENTURY, S.L., SPAIN:
3,631,631, PUB. 3-17-2009. MULTIPLE CLASS, INT. CLS. 5 AND 30.
- BIOCORP, INC., REDONDO BEACH, CA:
2,597,115, CANC. INT. CL. 8.
- BIOELEMENTS, INC., COLORADO SPRINGS, CO:
3,632,980, INT. CL. 41.

BIOIBERICA, S.A., BARCELONA, SPAIN:
 3,631,526, PUB. 3-17-2009. INT. CL. 5.
 3,631,527, PUB. 3-17-2009. INT. CL. 5.
 3,631,528, PUB. 3-17-2009. INT. CL. 5.

BIOIBERICA, S.A., SPAIN:
 3,631,529, PUB. 3-17-2009. INT. CL. 5.

BIOLOGIX SYSTEMS CORP., ST. LOUIS, MO:
 2,240,817. REN. 4-27-09. INT. CL. 37.
 2,240,818. REN. 4-27-09. INT. CL. 1.

BIOMET MANUFACTURING CORP., WARSAW, IN:
 3,629,443, PUB. 3-17-2009. INT. CL. 10.

BIONIX DEVELOPMENT CORPORATION, TOLEDO, OH:
 2,598,431, CANC. MULTIPLE CLASS, INT. CLS. 5 AND 10.

BIONORICA AG, NEUMARKT, FED REP GERMANY:
 3,578,606, COR. MULTIPLE CLASS, INT. CLS. 1, 3, 5 AND 30.

BIOPHARMA SCIENTIFIC, INC., SAN DIEGO, CA:
 3,629,458, PUB. 3-17-2009. INT. CL. 5.

BIOSENSORY, INC., PUTNAM, CT:
 3,632,630, INT. CL. 21.

BIOSYS AB, 411 34 GÖTEBORG, SWEDEN:
 2,596,464, CANC. MULTIPLE CLASS, INT. CLS. 9, 10, 38 AND 42.

BIOTEL CORPORATION, NEW YORK, NY:
 1,496,487, CANC. INT. CL. 5.

BIOVALUATION & ANALYSIS, INC., FOSTER CITY, CA:
 3,630,428, PUB. 3-17-2009. INT. CL. 42.

BIRCH TREE GROUP LTD., PRINCETON, NJ TO MUSIC TOGETHER, L.L.C., PRINCETON, NJ:
 1,565,705, CANC. MULTIPLE CLASS, INT. CLS. 9 AND 42.

BISCHOF UND KLEIN GMBH & CO. KG, D-49525 LEMBERG, FED REP GERMANY:
 2,757,917, CANC. INT. CL. 17.

BISCO INTERNATIONAL, INC., HILLSIDE, IL:
 1,496,746, CANC. INT. CL. 16.

BISHAMON INDUSTRIES CORPORATION, ONTARIO, CA:
 2,189,544. REN. 4-29-09. INT. CL. 7.
 2,599,230, CANC. INT. CL. 7.

BISIG IMPACT GROUP, INC., LOUISVILLE, KY:
 2,292,636. REN. 4-27-09. INT. CL. 41.

BISSELL HOMECARE, INC., GRAND RAPIDS, MI:
 3,629,524, PUB. 3-17-2009. INT. CL. 7.
 3,632,322, INT. CL. 21.

BIXBY ENERGY SYSTEMS, RAMSEY, MN:
 3,633,317, INT. CL. 11.

BIZANGA LTD, UNITED KINGDOM:
 3,631,534, PUB. 3-17-2009. MULTIPLE CLASS, INT. CLS. 9, 35, 37, 38 AND 42.

BLACK DIAMOND SPORTSWEAR, INC., MONTPELIER, VT, GREEN MOUNTAIN WOOLENS, INC., WAITSFIELD, VT:
 1,576,481. REN. 4-24-09. INT. CL. 25.

BLACK ENTERTAINMENT TELEVISION LLC, WASHINGTON, DC:
 2,598,990, CANC. INT. CL. 41.
 3,631,996, INT. CL. 41.

BLACK, WILSON H., ALLENTOWN, PA, DBA WILSON BLACK PHOTOGRAPHY, LLC:
 3,629,421, PUB. 3-17-2009. INT. CL. 41.

BLACKIE'S HOUSE OF BEEF, INC., WASHINGTON, DC:
 2,597,171, CANC. INT. CL. 42.

BLACKNIGHT INTERNET SOLUTIONS LTD., GRAIGUE-CULLEN, IRELAND:
 3,630,168, PUB. 3-17-2009. MULTIPLE CLASS, INT. CLS. 35, 42 AND 45.

BLACKPOWDER PRODUCTS, INC., NORCROSS, GA:
 2,175,658, CANC. INT. CL. 13.

BLACKWOOD BOATS, LLC, GROVELAND, FL:
 3,632,877, INT. CL. 12.

BLANK ROME LLP, PHILADELPHIA, PA:
 2,174,777, CANC. INT. CL. 42.

BLEX EXCHANGE III, L.P., SOMERVILLE, TX:
 3,629,460, PUB. 3-17-2009. INT. CL. 44.

BLIA CORPORATION, SAI KUNG, NEW TERRITORIES, HONG KONG, TA BLIACO:
 2,175,264, CANC. INT. CL. 25.

BLISS BROS DAIRY, INC., ATTEBORO, MA:
 3,632,314, INT. CL. 30.

BLISS WORLD LLC, NEW YORK, NY:
 3,632,999, INT. CL. 3.

BLIZZARD ENTERTAINMENT, INC., IRVINE, CA:
 3,633,218, INT. CL. 41.

BLOCKBUSTER INC., DALLAS, TX:
 2,597,576, CANC. INT. CL. 16.
 2,597,577, CANC. INT. CL. 41.
 3,629,427, PUB. 3-17-2009. MULTIPLE CLASS, INT. CLS. 35, 38 AND 41.

BLONDELL, MARYILENE, CHICAGO, IL:
 2,599,599, CANC. INT. CL. 16.

BLOODHOUND RESEARCH, LLC, NEW YORK, NY AND MOKED, NEELY, NEW YORK, NY AND MOKED, EYTAN, NEW YORK, NY:
 3,629,730, PUB. 3-17-2009. MULTIPLE CLASS, INT. CLS. 35 AND 45.

BLUE GRAPE MERCHANDISING, INC., NEW YORK, NY:
 2,597,113, CANC. INT. CL. 35.

BLUE GROTTO MEDIA, INC., WESTBURY, NY:
 3,633,209, INT. CL. 16.

BLUE KNIGHT BATTLEFIELD SEMINARS, LLC, APPLE VALLEY, MN:
 3,631,057, PUB. 3-17-2009. INT. CL. 41.

BLUE MOUNTAIN EQUIPMENT RENTAL CORPORATION, UNIONTOWN, PA:
 3,629,890, PUB. 3-17-2009. MULTIPLE CLASS, INT. CLS. 35 AND 37.

BLUE OZEAN AG, SWITZERLAND:
 3,631,763, PUB. 3-17-2009. INT. CL. 25.

BLUE POLLEN, INC., NEW HOPE, PA:
 3,633,359, INT. CL. 35.
 3,633,360, INT. CL. 35.

BLUE SKY PRODUCTIONS, LIVONIA, MI:
 3,629,549, PUB. 10-14-2008. INT. CL. 41.

BLUEGREEN CORPORATION, BOCA RATON, FL:
 2,597,164, CANC. INT. CL. 36.
 2,597,165, CANC. INT. CL. 36.

BLUELINX SERVICES INC., ATLANTA, GA:
 1,496,547, CANC. INT. CL. 6.

BLUESHIFT BIOTECHNOLOGIES, INC., SUNNYVALE, CA:
 3,291,658, COR. INT. CL. 42.

BLUESTREAM MANAGEMENT, LLC, MINNEAPOLIS, MN:
 2,599,008, CANC. INT. CL. 36.
 2,599,009, CANC. INT. CL. 36.

BLUETONGUE BREWERY PTY LIMITED, CAMERON PARK, AUSTRALIA:
 3,630,452, PUB. 3-17-2009. INT. CL. 32.

BMS CAT, INC., FORT WORTH, TX:
 1,497,080, CANC. INT. CL. 37.

BMSM LIMITED, NORTH YORKSHIRE BD24 9HE, ENGLAND:
 2,596,850, CANC. MULTIPLE CLASS, INT. CLS. 6 AND 19.

BOARD OF COUNTY COMMISSIONERS OF MESA COUNTY, COLORADO, GRAND JUNCTION, CO:
 3,629,758, PUB. 3-17-2009. MULTIPLE CLASS, INT. CLS. 35 AND 45.

BOARD OF TRUSTEES OF THE UNIVERSITY OF ILLINOIS, URBANA, IL:
 2,596,855, CANC. INT. CL. 41.

BOB JONES UNIVERSITY, INC., GREENVILLE, SC:
 2,598,964, CANC. INT. CL. 41.

BOB TRAILERS, INC., BOISE, ID:
 3,629,540, PUB. 3-17-2009. INT. CL. 12.

BOCK, KLAUS, FED REP GERMANY:
 3,631,507, PUB. 3-17-2009. MULTIPLE CLASS, INT. CLS. 7, 9 AND 20.

BODEGAS PEÑALBA LÓPEZ, S.L., E-09400 ARANDA DE DUERO (BURGOS), SPAIN:
 3,631,596, PUB. 3-17-2009. INT. CL. 33.

BODINE COMPANY, INC., THE, COLLIERVILLE, TN:
 2,597,167, CANC. INT. CL. 30.

BODY WISE INTERNATIONAL, INC, TUSTIN, CA:
 2,599,707, CANC. INT. CL. 5.

BODYPHOTAGE, INC., LONE TREE, CO:
 3,629,597, PUB. 3-17-2009. INT. CL. 41.

- BOEHM, JAMES A, SUWANEE, GA:
3,629,591, PUB. 3-17-2009. INT. CL. 41.
- BOEHRINGER INGELHEIM INTERNATIONAL GMBH,
FED REP GERMANY:
3,631,757, PUB. 3-17-2009. MULTIPLE CLASS, INT. CLS.
38, 41 AND 42.
- BOEING MANAGEMENT COMPANY, SEAL BEACH, CA:
2,255,983. REN. 4-27-09. INT. CL. 14.
2,257,844. REN. 4-27-09. INT. CL. 14.
- BOETTCHER, THOMAS D., TULSA, OK:
3,629,405, PUB. 3-17-2009. INT. CL. 16.
- BOISE CASCADE CORPORATION, BOISE, ID:
2,598,349, CANC. MULTIPLE CLASS, INT. CLS. 16, 21, 25
AND 35.
- BOLAK CO., LTD., KYUNGGI-DO, REPUBLIC OF KOREA:
2,598,312, CANC. INT. CL. 1.
- BOLY MEDIA COMMUNICATIONS INC., CUPERTINO, CA:
2,598,137, CANC. INT. CL. 9.
2,598,138, CANC. INT. CL. 9.
- BON TOOL COMPANY, GIBSONIA, PA:
3,633,498, INT. CL. 8.
- BONASOURCE INC., TORONTO, CANADA:
3,629,979, PUB. 3-17-2009. INT. CL. 42.
- BONEYARD RECYCLED CREATIONS, LLC, COLORADO
SPRINGS, CO:
3,632,011, INT. CL. 20.
- BONNIE STEPHENS, FORT WORTH, TX:
3,631,227, PUB. 3-17-2009. INT. CL. 44.
- BOOKHAM TECHNOLOGY PLC, OXFORDSHIRE OX14
4RY, UNITED KINGDOM:
2,596,735, CANC. INT. CL. 9.
- BOOT TREE LIMITED, THE, LONDON, ENGLAND:
2,598,295, CANC. INT. CL. 25.
- BORDEN CO. (PTE) LTD., BARAT, SINGAPORE:
1,555,433. REN. 4-24-09. INT. CL. 5.
- BORNAY DESSERTS S.L., 28340 VALDEMORO MADRID,
SPAIN:
3,632,657, INT. CL. 30.
3,632,658, INT. CL. 30.
3,632,659, INT. CL. 30.
3,632,679, INT. CL. 30.
3,632,761, INT. CL. 30.
3,633,383, INT. CL. 30.
- BORREGAARD INDUSTRIES LIMITED NORGE, N-1721
SARPSBORG, NORWAY:
3,631,516, PUB. 3-17-2009. INT. CL. 1.
- BOSE CORPORATION, FRAMINGHAM, MA:
2,596,536, CANC. INT. CL. 35.
- BOSE, ARANI, NEW YORK, NY AND NAGY, PETER, NEW
DELHI, INDIA:
3,633,401, INT. CL. 35.
- BOSMA, MARINUS BERNARD, TIPP CITY, OH AND
BOSMA, VIRGINIA MARIE, TIPP CITY, OH:
3,632,824, INT. CL. 9.
- BOSTIK, INC., WAUWATOSA, WI:
3,633,143, INT. CL. 17.
- BOSTON FOUNDATION, THE, BOSTON, MA:
2,597,414, CANC. INT. CL. 36.
- BOSTON SCIENTIFIC CORPORATION, WATERTOWN, MA:
1,496,670, CANC. INT. CL. 10.
- BOSTON WAREHOUSE TRADING CORP., NORWOOD,
MA:
2,598,620, CANC. INT. CL. 21.
- BOULDIN, DAVID WOOLGRIDGE, HOUSTON, TX:
2,598,713, CANC. INT. CL. 7.
- BOURGERIE, DONALD E., REDDING, CA:
2,597,375, CANC. INT. CL. 20.
- BOURJOIS, NEUILLY-SUR-SEINE, FRANCE:
3,631,705, PUB. 3-17-2009. INT. CL. 3.
- BOWMAN, DAVID J., LOS ANGELES, CA:
3,632,805, MULTIPLE CLASS, INT. CLS. 9 AND 16.
- BOWTIE, INC., IRVINE, CA:
3,633,133, MULTIPLE CLASS, INT. CLS. 16 AND 41.
- BOX 5, LLC, CAMBRIDGE, MA:
3,633,132, INT. CL. 41.
- BOXWALL SOFTWARE, INC., FAIRFIELD, CT:
2,597,829, CANC. INT. CL. 42.
- BOYNTON STUDIO INC., MORRIS, NY, DBA BOYNTON
PRO AUDIO, MUSIC SQUARE:
3,630,635, PUB. 3-17-2009. INT. CL. 35.
- BOZZELLI'S ITALIAN DELI, INC., SPRINGFIELD, VA:
3,630,438, PUB. 3-17-2009. INT. CL. 43.
- BP CORPORATION NORTH AMERICA INC., WARREN-
VILLE, IL:
3,632,619, MULTIPLE CLASS, INT. CLS. 42 AND 45.
- BPNC, INC., TEMPERANCE, MI:
3,630,589, PUB. 3-17-2009. INT. CL. 33.
- BR CONSULTING, INC., SEDONA, AZ:
3,629,228, PUB. 1-13-2009. INT. CL. 41.
3,632,289, INT. CL. 41.
- BRACCI, PAUL, MENIFEE, CA:
3,631,164, PUB. 3-17-2009. INT. CL. 19.
- BRAD CROMARTIE, MT. PLEASANT, SC:
3,632,481, INT. CL. 12.
- BRADY, PATRICK KEITH, LOVELAND, CO:
2,599,856, CANC. INT. CL. 25.
- BRAGFOLIO, INC., OCOEE, FL:
3,632,874, INT. CL. 35.
- BRAIN STATE TECHNOLOGIES, L.L.C., SCOTTSDALE, AZ:
3,629,261, PUB. 3-17-2009. MULTIPLE CLASS, INT. CLS. 9
AND 41.
- BRAND CREATIONS HOLDINGS LIMITED, APIA, SAMOA:
3,630,814, PUB. 3-17-2009. INT. CL. 35.
- BRAND NEW MARKETING & DESIGN INC, BEDMIN-
STER, NJ:
3,629,851, PUB. 3-17-2009. INT. CL. 35.
3,629,852, PUB. 3-17-2009. INT. CL. 35.
- BRAND SERVICES, INC., CHESTERFIELD, MO:
2,599,004, CANC. INT. CL. 9.
- BRANDT, MICHAEL WAYNE, DALLAS, TX:
1,557,539. REN. 4-24-09. MULTIPLE CLASS, INT. CLS. 3
AND 37.
- BRAUN GMBH, KRONBERG IM TAUNUS, FED REP
GERMANY:
2,598,120, CANC. INT. CL. 8.
- BRAUN GMBH, 61476 KRONBERG, FED REP GERMANY:
3,631,508, PUB. 3-17-2009. INT. CL. 11.
- BRAZ BRO'S INC., SATELLITE BEACH, FL:
2,174,549, CANC. INT. CL. 42.
- BREITFELD, VOLKMAR, 44227 DORTMUND, FED REP
GERMANY:
2,597,678, CANC. INT. CL. 9.
- BREITLING SA, SWITZERLAND:
3,631,463, PUB. 3-17-2009. INT. CL. 14.
- BRENDLE CLIMBING SYSTEMS, LLC, CHEYENNE, WY:
3,629,733, PUB. 3-17-2009. INT. CL. 28.
- BRENTWOOD INDUSTRIES, INC., READING, PA:
2,599,254, CANC. INT. CL. 12.
- BRETFORD MANUFACTURING, INC., FRANKLIN PARK,
IL:
2,596,713, CANC. INT. CL. 20.
- BRG INTELLECTUAL PROPERTY, LLC, NEW YORK, NY:
1,497,175, CANC. INT. CL. 42.
- BRIAN W. TURNER, LLC, DRIPPING SPRINGS, TX, DBA
INTERNATIONAL ACADEMY FOR PROFESSIONAL
DRIVING, LLC:
3,630,968, PUB. 3-17-2009. INT. CL. 41.
- BRICELINE COSMETICS SA, SWITZERLAND:
3,631,482, PUB. 3-17-2009. MULTIPLE CLASS, INT. CLS.
3, 21 AND 35.
- BRICK COMPUTER ASSOCIATES AND COMPUTER
SCIENCE INSTITUTE, INC., BRICK, NJ:
2,175,177, CANC. INT. CL. 41.
- BRIDAS CORPORATION, BUENOS AIRES, ARGENTINA:
3,629,253, PUB. 3-17-2009. MULTIPLE CLASS, INT. CLS.
37 AND 42.
- BRIDGENET SOLUTIONS, INC., CHICAGO, IL:
3,631,978, INT. CL. 9.
- BRIDGEPOINT INTERNATIONAL INC., MONTREAL,
QUEBEC, CANADA:
2,596,623, CANC. MULTIPLE CLASS, INT. CLS. 38 AND
42.
- BRIDGES, LORI A., EUGENE, OR:
3,630,469, PUB. 3-17-2009. INT. CL. 20.

BRIDGESTONE SPORTS CO., LTD., TOKYO 140-0013, JAPAN:
2,255,522, REN. 4-27-09. INT. CL. 25.

BRIDGESTONE SPORTS CO.,LTD, TOKYO 140, JAPAN:
2,598,251, CANC. INT. CL. 25.

BRIGGS & STRATTON POWER PRODUCTS GROUP, LLC,
JEFFERSON, WI:
2,175,100, CANC. MULTIPLE CLASS, INT. CLS. 16 AND
28.

BRIGGS DIGITAL MEDIA, LLC, NEWPORT COAST, CA:
3,630,166, PUB. 3-17-2009. INT. CL. 38.

BRIGHT IP CONCEPTS, LLC, NOVATO, CA:
3,633,407, INT. CL. 18.

BRIGHTPATH MORTGAGE, LLC, FAYETTESVILLE, GA:
3,632,325, INT. CL. 36.

BRIGHTPOINT, INC., PLAINFIELD, IN:
2,599,635, CANC. INT. CL. 35.

BRILL, LAURIE, CAMARILLO, CA:
2,598,378, CANC. INT. CL. 3.

BRINKER INTERNATIONAL HOLDINGS, LP, DALLAS,
TX:
2,597,079, CANC. INT. CL. 32.

BRINKMANN INSTRUMENTS, INC., WESTBURY, NY:
3,631,894, INT. CL. 9.

BRITCHES ACQUISITION CORP., LOS ANGELES, CA:
2,175,208, CANC. INT. CL. 25.

BRITE IDEAS HYDROPONICS AND ORGANICS, AUSTIN,
TX:
3,631,147, PUB. 3-17-2009. INT. CL. 1.

BRITT, TRULINDA E., PORTSMOUTH, VA, DBA TRU-
CLASS EVENTS:
3,629,943, PUB. 3-17-2009. INT. CL. 41.

BROADJUMP, INC., AUSTIN, TX:
2,596,886, CANC. INT. CL. 9.
2,598,833, CANC. INT. CL. 9.

BROADLEAF INDUSTRIES INC., COSTA MESA, CA:
3,629,139, PUB. 3-17-2009. INT. CL. 1.

BROADPOINT SOLUTIONS LLC, ESCONDIDO, CA:
3,630,356, PUB. 3-17-2009. INT. CL. 35.

BROADWAY TELEVISION NETWORK, INC., NEW YORK,
NY:
2,598,720, CANC. INT. CL. 41.

BROADWEAVE NETWORKS, INC., LEHI, UT:
3,631,408, PUB. 3-17-2009. INT. CL. 38.

BROASTER COMPANY, L.L.C., THE, BELOIT, WI:
2,216,530, REN. 4-29-09. INT. CL. 30.

BRODERSEN, BRODER, HANNOVER, FED REP GER-
MANY:
2,596,460, CANC. MULTIPLE CLASS, INT. CLS. 9, 16, 25,
28 AND 41.

BROHAN NATION APPAREL, PASADENA, CA:
3,629,993, PUB. 3-17-2009. INT. CL. 25.

BROOKLYN BOTTLING OF MILTON, NY, INC., BROOK-
LYN, NY:
3,630,068, PUB. 12-9-2008. INT. CL. 30.

BROTADURA ZRT, UJLENGYEL, HUNGARY:
2,597,085, CANC. INT. CL. 30.

BROTHER JIMMY'S NYC RESTAURANT HOLDINGS, LLC,
NEW YORK, NY:
3,629,435, PUB. 3-17-2009. MULTIPLE CLASS, INT. CLS.
25 AND 43.

BROWN COMFORT SYSTEMS, APOLLO BEACH, FL:
3,630,089, PUB. 3-17-2009. INT. CL. 9.

BROWN, KEITH T., WYOMISSING, PA:
3,632,227, INT. CL. 45.

BROWN, MICHAEL A., HINSDALE, IL AND BROWN,
BETTY L., HINSDALE, IL:
3,631,940, INT. CL. 26.

BROWN, ROGER A., DALLAS, TX:
1,496,462, CANC. INT. CL. 3.

BROWN, SALLY, INDIANAPOLIS, IN:
3,630,978, PUB. 3-17-2009. INT. CL. 41.

BROWN, THOMAS O., CAMINO, CA, DBA PARAVI VINE-
YARDS:
3,630,648, PUB. 3-17-2009. INT. CL. 33.

BROWNE, SANDRA T., GILBERT, AZ:
2,599,115, CANC. INT. CL. 16.

BROWNELL, SUSAN, SPARTA, WI:
3,632,522, MULTIPLE CLASS, INT. CLS. 9, 16, 41 AND 44.

BROYHILL FURNITURE INDUSTRIES, INC., LENOIR, NC:
2,597,739, CANC. INT. CL. 20.

BRUSKIN INTERNATIONAL LLC., VAN NUYS, CA, DBA
BELSTONE MARBLE & GRANITE:
3,630,706, PUB. 3-17-2009. INT. CL. 19.

BRV, LLC, BREMERTON, WA:
3,630,087, PUB. 3-17-2009. INT. CL. 41.

BRYAN, MATT, BURBANK, CA:
3,630,911, PUB. 3-17-2009. INT. CL. 35.

BRYANT, BRANDI VANIECE, HUNTINGTON BEACH, CA:
3,630,398, PUB. 3-17-2009. INT. CL. 25.

BRYCE CORPORATION, MEMPHIS, TN:
1,496,767, CANC. INT. CL. 17.

BRYDELS, JOHN, JR., BATON ROUGE, LA:
2,599,484, CANC. INT. CL. 36.
2,599,485, CANC. INT. CL. 36.

BT HOLDINGS (NY), INC., NEW YORK, NY:
2,598,491, CANC. INT. CL. 36.

BUCK KNIVES, INC., POST FALLS, ID:
3,629,798, PUB. 9-30-2008. INT. CL. 8.
3,633,046, INT. CL. 8.

BUCKEYE CABLEVISION, INC., TOLEDO, OH:
2,598,247, CANC. INT. CL. 41.

BUCKEYE LTD, PHOENIX, AZ:
3,629,963, PUB. 3-17-2009. INT. CL. 28.

BUDDY MEDIA, INC., NEW YORK, NY:
3,632,958, MULTIPLE CLASS, INT. CLS. 35 AND 42.
3,632,987, INT. CL. 42.

BUDGE BROWN FAMILY WINERY, GARDNERVILLE, NV:
2,599,252, CANC. INT. CL. 33.

BUILD-A-BEAR RETAIL MANAGEMENT, INC., ST. LOUIS,
MO:
2,598,255, CANC. MULTIPLE CLASS, INT. CLS. 40 AND
42.

BUILDING SCIENCE COMMUNICATIONS LLC, SOMER-
VILLE, MA:
3,633,380, INT. CL. 41.

BUMBLE AND BUMBLE, LLC, NEW YORK, NY:
3,633,159, INT. CL. 3.

BUNN-O-MATIC CORPORATION, SPRINGFIELD, IL:
3,629,504, PUB. 3-17-2009. MULTIPLE CLASS, INT. CLS.
7, 11 AND 21.

BURGET, CHRIS, SUN VALLEY, ID:
3,630,362, PUB. 3-17-2009. INT. CL. 41.

BURKE INDUSTRIAL COATINGS, VANCOUVER, WA:
2,175,877, CANC. INT. CL. 2.

BURKE INDUSTRIES, INC., SAN JOSE, CA, AKA BURKE
MERCER FLOORING PRODUCTS:
2,598,053, CANC. INT. CL. 27.

BURKHARD HANS SCHINDLER C/O IFBIO BIOENERGE-
TIKGERÄTEHANDELS GMBH, AUSTRIA:
3,631,531, PUB. 3-17-2009. MULTIPLE CLASS, INT. CLS.
9, 35, 41, 42 AND 44.

BURST MEDIA CORPORATION, BURLINGTON, MA:
2,596,839, CANC. INT. CL. 35.

BURWELL, SCOTT, ALISO VIEJO, CA:
3,632,116, INT. CL. 28.

BUSH, KENNETH M., BIRMINGHAM, AL:
2,598,577, CANC. INT. CL. 42.

BUSINESS CATALYST SYSTEMS LLC, SAN FRANCISCO,
CA:
3,629,989, PUB. 3-17-2009. INT. CL. 42.

BUSINESS GUIDES, INC., NEW YORK, NY:
2,175,848, CANC. INT. CL. 16.

BUSINESS JOURNAL PUBLICATIONS, INC, CHARLOTTE,
NC:
1,540,432, REN. 4-26-09. INT. CL. 16.

BUSINESS JOURNAL PUBLICATIONS, INC., CHARLOTTE,
NC:
1,530,821, REN. 4-26-09. INT. CL. 16.

BUSINESS PLANNING & RESEARCH INTERNATIONAL
LIMITED, LONDON, UNITED KINGDOM:
2,599,304, CANC. INT. CL. 35.

BUTCH MEDIA LTD., LAS VEGAS, NV:
2,598,084, CANC. INT. CL. 9.

- BUTLER, DOUG, LAPORTE, CO:
2,599,727, CANC. INT. CL. 41.
- BUTTAR, INC., ORLANDO, FL:
3,631,393, PUB. 3-17-2009. INT. CL. 41.
- BUTTERFIELD & BUTTERFIELD, AUCTIONEERS INC.,
SAN FRANCISCO, CA:
1,497,019, CANC. MULTIPLE CLASS, INT. CLS. 35 AND
36.
- BUY MY BIKES, INC., SAN JUAN CAPISTRANO, CA:
3,630,257, PUB. 3-17-2009. INT. CL. 37.
- BUYER'S ADVANTAGE REAL ESTATE, INC., TRAVERSE
CITY, MI:
2,597,730, CANC. INT. CL. 36.
- BUYSEASONS, INC., WAUKESHA, WI:
2,599,639, CANC. INT. CL. 35.
- BUZICA, GHEORGHE, LILBURN, GA:
3,630,737, PUB. 3-17-2009. INT. CL. 41.
- BVS ENTERTAINMENT, INC, LOS ANGELES, CA:
2,599,491, CANC. INT. CL. 18.
- BVS ENTERTAINMENT, INC., LOS ANGELES, CA:
2,599,490, CANC. INT. CL. 16.
- BY GEORGE! INC., LAKE FOREST, CA:
3,633,028, INT. CL. 28.
3,633,044, INT. CL. 16.
- BYER CALIFORNIA, SAN FRANCISCO, CA:
3,631,929, INT. CL. 25.
- B2PCOMMERCE CORP., CHICAGO, IL:
2,597,298, CANC. MULTIPLE CLASS, INT. CLS. 35 AND
36.
2,597,299, CANC. INT. CL. 42.
- C & H PACKAGING COMPANY, INC., MERRILL, WI:
2,174,800, CANC. INT. CL. 16.
- C & S NET, INC., FAIRHOPE, AL:
3,632,920, INT. CL. 35.
- C C POLLEN COMPANY, PHOENIX, AZ:
2,597,230, CANC. INT. CL. 5.
- C. R. BARD, INC., MURRAY HILL, NJ:
3,632,177, INT. CL. 10.
- C&D SCRAP METAL RECYCLERS CO., INC., HOUSTON,
TX:
3,630,787, PUB. 3-17-2009. INT. CL. 40.
- C-E MINERALS, INC., ATLANTA, GA:
2,240,643, REN. 4-24-09. INT. CL. 1.
- CABLE ONE, INC., PHOENIX, AZ:
2,280,714, REN. 4-27-09. MULTIPLE CLASS, INT. CLS. 38,
41 AND 42.
- CABLE ONE, INC., PHOENIX, AZ, CABLE ONE, INC.,
PHOENIX, AZ:
2,283,649, REN. 4-27-09. MULTIPLE CLASS, INT. CLS. 38,
41 AND 42.
- CADBURY IRELAND LIMITED, DUBLIN 5, IRELAND:
32,982, REN. 4-27-09. U.S. CL. 45 (INT. CL. 32).
- CADILLAC COFFEE COMPANY, MADISON HEIGHTS, MI:
2,599,446, CANC. INT. CL. 30.
- CAESARS WORLD, INC., LAS VEGAS, NV:
3,630,981, PUB. 3-17-2009. INT. CL. 3.
3,631,015, PUB. 3-17-2009. INT. CL. 3.
- CAFE GRATITUDE, LLC, SAN FRANCISCO, CA:
3,630,172, PUB. 3-17-2009. INT. CL. 29.
3,630,173, PUB. 3-17-2009. INT. CL. 30.
- CAFFE DEMETRE IP HOLDINGS INC., RICHMOND HILL,
ONTARIO, CANADA:
2,596,450, CANC. INT. CL. 42.
- CAGENIX, INC., MEMPHIS, TN:
3,632,572, INT. CL. 10.
- CAI GLOBAL GROUP LTD., KOWLOON, HONG KONG:
3,632,495, INT. CL. 25.
- CAL TAN, LLC, LOS ANGELES, CA:
3,632,645, INT. CL. 3.
3,632,646, INT. CL. 3.
- CALDWELL, JAMIN, NEW YORK, NY:
3,630,544, PUB. 3-17-2009. INT. CL. 28.
- CALIFORNIA CONFERENCE OF ARSON INVESTIGA-
TORS, POMONA, CA:
3,629,957, PUB. 3-17-2009. INT. CL. 41.
- CALIFORNIA CORRECTIONAL FOODS, INC., ENCINITAS,
CA:
3,633,312, MULTIPLE CLASS, INT. CLS. 29 AND 30.
- CALIFORNIA EARLY LITERACY LEARNING, RED-
LANDS, CA:
2,597,332, CANC. INT. CL. 41.
- CALIFORNIA EXOTIC NOVELTIES LLC, CHINO, CA:
3,630,181, PUB. 3-17-2009. INT. CL. 10.
- CALIFORNIA SECURITY ALARMS, INC., SAN MATEO,
CA:
1,535,679, REN. 4-27-09. MULTIPLE CLASS, INT. CLS. 35
AND 37.
- CALIFORNIA WAFFLE BAR, INC., SAN CLEMENTE, CA:
3,630,708, PUB. 3-17-2009. INT. CL. 29.
- CALLAWAY GOLF COMPANY, CARLSBAD, CA:
2,599,692, CANC. INT. CL. 28.
- CALLPOD, INC., CHICAGO, IL:
3,632,988, INT. CL. 9.
3,633,021, INT. CL. 9.
- CALLUP CORPORATION N.V., WILLEMSTAD, CURACAO,
NETHERLD ANTILLES:
2,596,638, CANC. INT. CL. 33.
- CALTRIS MEDICAL-LEGAL CONSULTING, LLC, MEL-
BOURNE BEACH, FL:
3,630,144, PUB. 3-17-2009. INT. CL. 45.
- CALZATURIFICIO CAPARRINI S.R.L., FIRENZE, ITALY:
2,599,235, CANC. INT. CL. 25.
- CAMALI INDUSTRIES (NA) INC., CAMBRIDGE ONTARIO,
MI, BIRMA PRODUCTS CORPORATION, SAYREVILLE,
NJ:
858,165, REN. 4-25-09. U.S. CL. 12 (INT. CL. 17).
- CAMBIO HEALTH SOLUTIONS, LLC, BRENTWOOD, TN:
2,598,658, CANC. INT. CL. 35.
- CAMELION ENTERPRISES LIMITED, KOWLOON, HONG
KONG:
3,631,391, PUB. 3-17-2009. INT. CL. 11.
- CAMILLE LINEN, PORTCHESTER, NY:
3,630,808, PUB. 3-17-2009. INT. CL. 16.
- CAMINO REAL LAND CORPORATION, TUSCON, AZ:
3,630,904, PUB. 3-17-2009. INT. CL. 36.
- CAMOPLAST INC., SHERBROOKE, QUEBEC, J1J 2E8,
CANADA:
2,174,251, CANC. MULTIPLE CLASS, INT. CLS. 12, 14, 16,
24, 25 AND 26.
- CAMP MAKEBELIEVE, INC., LAS VEGAS, NV:
3,630,490, PUB. 3-17-2009. INT. CL. 45.
- CAMPAIGN FOR TOBACCO-FREE KIDS, WASHINGTON,
DC:
3,630,242, PUB. 3-17-2009. MULTIPLE CLASS, INT. CLS.
35 AND 41.
3,630,243, PUB. 3-17-2009. MULTIPLE CLASS, INT. CLS.
35 AND 41.
3,630,244, PUB. 3-17-2009. MULTIPLE CLASS, INT. CLS.
35 AND 41.
- CAMPANA, MICHAEL, WINDSOR, CO:
3,632,692, INT. CL. 16.
3,632,693, INT. CL. 41.
- CAMPBELL, LISA, WESTMINSTER, CO:
3,632,847, INT. CL. 37.
- CAMPCAST, LTD., LOVELAND, OH:
3,632,503, MULTIPLE CLASS, INT. CLS. 16 AND 35.
- CANADA LIFE INSURANCE COMPANY OF NEW YORK,
ARDSLEY, NY:
2,598,867, CANC. INT. CL. 36.
- CANDESCENT TECHNOLOGIES CORPORATION, SAN
JOSE, CA:
2,598,379, CANC. INT. CL. 9.
- CANDLEMAKER AT BOARDWALK MARKET, INC., ED-
MONTON, ALBERTA, CANADA:
2,596,502, CANC. INT. CL. 4.
- CANNON, HOWARD L., STERRETT, AL:
2,599,805, CANC. INT. CL. 35.
- CANOPY FINANCIAL, INC., SAN FRANCISCO, CA:
2,708,802, CANC. INT. CL. 35.
- CANSOLV TECHNOLOGIES INC., MONTREAL, QUEBEC,
CANADA:
2,230,036, REN. 4-29-09. MULTIPLE CLASS, INT. CLS. 11
AND 37.
- CANUP, HOLLY E., COMMERCE, GA:
3,629,369, PUB. 3-17-2009. INT. CL. 16.

CANVAS ON DEMAND, LLC, RALEIGH, NC:
 3,630,691, PUB. 3-17-2009. INT. CL. 40.
 3,630,714, PUB. 3-17-2009. INT. CL. 40.
 3,630,735, PUB. 3-17-2009. INT. CL. 40.

CAP BARBELL, INC., HOUSTON, TX, CHINA ARTS & PRODUCTS, INC., HOUSTON, TX:
 1,534,489. REN. 4-24-09. INT. CL. 28.

CAPE COD SHELLFISH & SEA FOOD CO., INC., BOSTON, MA:
 3,632,409, INT. CL. 29.

CAPE CORAL CART COMPANY, INC., CAPE CORAL, FL:
 3,630,338, PUB. 3-17-2009. INT. CL. 12.

CAPEZZA, MICHELLE, MADISON, NJ, DBA MICHELLE OF MADISON:
 3,630,430, PUB. 3-17-2009. INT. CL. 14.

CAPITAL ACROSS AMERICA, INC., NASHVILLE, TN:
 2,175,609, CANC. INT. CL. 36.

CAPITAL BREWERY CO., INC., MIDDLETON, WI:
 2,598,529, CANC. INT. CL. 32.

CAPITAL GROWTH ADVISORS, LLC, ANN ARBOR, MI:
 3,630,148, PUB. 3-17-2009. INT. CL. 35.

CAPITAL ONE FINANCIAL CORPORATION, FALLS CHURCH, VA:
 2,599,144, CANC. INT. CL. 36.

CAPITAL ONE FINANCIAL CORPORATION, GLEN ALLEN, VA:
 2,599,574, CANC. MULTIPLE CLASS, INT. CLS. 35 AND 36.
 2,599,698, CANC. INT. CL. 35.

CAPITAL STREAM, INC., SEATTLE, WA:
 2,598,647, CANC. INT. CL. 42.

CAPPIELLO, DANA, WOODSIDE, CA:
 2,597,440, CANC. INT. CL. 25.

CAPSULE COMMUNICATIONS, INC., BENSALEM, PA:
 2,598,901, CANC. INT. CL. 38.

CARBITE, INC., SAN DIEGO, CA:
 2,599,591, CANC. INT. CL. 28.

CARDEAN LEARNING GROUP LLC, STAMFORD, CT:
 2,599,132, CANC. INT. CL. 41.

CARDEN, JAMES R., CULLODEN, WV:
 2,597,409, CANC. INT. CL. 21.

CARDIAC PACEMAKERS, INC., ST. PAUL, MN:
 3,631,830, INT. CL. 10.

CARDIODYNAMICS INTERNATIONAL CORPORATION, SAN DIEGO, CA:
 2,598,941, CANC. INT. CL. 10.

CARDIOVASCULAR SIMULATION INC, MOUNTAIN VIEW, CA:
 3,629,955, PUB. 3-17-2009. INT. CL. 9.

CARDPAK, INC., SOLON, OH:
 3,630,152, PUB. 3-17-2009. INT. CL. 16.

CARDSWELL, LTD., WEST BLOOMFIELD, MI:
 2,597,986, CANC. INT. CL. 16.

CARE CO INTERNATIONAL, INC., OMAHA, NE:
 3,632,575, INT. CL. 35.

CARE FOR DISABLED ANIMALS, INC., POTTER VALLEY, CA:
 3,629,749, PUB. 3-17-2009. INT. CL. 10.
 3,629,750, PUB. 3-17-2009. INT. CL. 10.

CARGILL MEAT SOLUTIONS CORPORATION, WICHITA, KS:
 1,543,764. REN. 4-27-09. INT. CL. 29.
 3,632,566, INT. CL. 29.

CARGILL, INCORPORATED, WAYZATA, MN:
 2,599,080, CANC. INT. CL. 36.
 3,632,412, INT. CL. 30.

CARIBBOUT EXPORT, CORP., INDUSTRIAL MINILLAS, PUERTO RICO:
 3,629,800, PUB. 3-17-2009. INT. CL. 32.

CARL J. SHAPIRO INSTITUTE FOR EDUCATION AND RESEARCH AT HARVARD MEDICAL SCHOOL AND BETH ISRAEL DEACONESS MEDICAL CENTER, INC., THE, BOSTON, MA:
 2,597,443, CANC. INT. CL. 42.

CARL, PETER, LONDONDERRY, NH:
 2,599,302, CANC. MULTIPLE CLASS, INT. CLS. 35 AND 42.

CARLISLE MANAGEMENT COMPANY, SYRACUSE, NY:
 2,598,185, CANC. MULTIPLE CLASS, INT. CLS. 40 AND 42.

CARLSON COMPANIES, INC., MINNEAPOLIS, MN:
 2,334,470. REN. 4-27-09. INT. CL. 42.

CARMA LABORATORIES, INC., FRANKLIN, WI:
 3,632,589, INT. CL. 3.

CARMEL, ELAINE, HIGHLAND PARK, IL:
 2,598,820, CANC. INT. CL. 42.
 2,598,821, CANC. INT. CL. 30.

CAROL NEWELL, VANCOUVER, B.C., CANADA:
 3,629,313, PUB. 3-17-2009. MULTIPLE CLASS, INT. CLS. 16 AND 41.

CAROLINA FREIGHT CARRIERS CORPORATION, CHERYVILLE, NC:
 1,497,004, CANC. MULTIPLE CLASS, INT. CLS. 35 AND 42.

CAROLINA LAND REALTY, LLC, GREENVILLE, SC:
 3,629,364, PUB. 3-17-2009. INT. CL. 37.

CAROLINA MUD DUDS INC., DAVIDSON, NC:
 3,629,270, PUB. 3-17-2009. INT. CL. 25.

CAROTECH BHD., CHEMOR, MALAYSIA:
 3,630,799, PUB. 3-17-2009. INT. CL. 1.

CARPENTER, DONALD L., DOUBLE SPRINGS, AL:
 2,599,386, CANC. INT. CL. 42.

CARPET C.A.R.E. OF SACRAMENTO, CITRUS HEIGHTS, CA:
 2,597,307, CANC. INT. CL. 37.

CARR VALLEY CHEESE COMPANY, INC., LA VALLE, WI:
 3,629,594, PUB. 3-17-2009. INT. CL. 29.
 3,629,596, PUB. 3-17-2009. INT. CL. 29.

CARRINGTON, SULTAN, SOUTH OZONE PARK, NY:
 2,596,785, CANC. INT. CL. 16.

CARROLL HALL SHELBY TRUST, COMPRISING CARROLL HALL SHELBY, A UNITED STATES CITIZEN, LOS ANGELES, CA:
 3,633,341, INT. CL. 12.

CARSON PIRIE SCOTT II, INC., YORK, PA:
 3,632,950, INT. CL. 35.

CARS4CLASSMATES, THOUSAND OAKS, CA:
 3,629,312, PUB. 12-9-2008. INT. CL. 35.

CARTER COMMUNICATIONS INTERNATIONAL, INC., NEW YORK, NY:
 3,632,349, INT. CL. 35.

CARTER, CURTIS, NEW YORK, NY:
 3,630,399, PUB. 3-17-2009. INT. CL. 45.

CARTER, NORWARD, BLOOMINGTON, IN:
 3,632,990, INT. CL. 25.

CARTTRONICS, LLC, SAN DIEGO, CA:
 3,629,898, PUB. 3-17-2009. INT. CL. 9.

CASA PIEDRA FOODS, INC., CARROLLTON, TX:
 2,599,169, CANC. INT. CL. 30.

CASAS - COMPREHENSIVE ADULT STUDENT ASSESSMENT SYSTEMS, SAN DIEGO, CA:
 3,633,374, INT. CL. 41.

CASCADE FRESH, INC., SEATTLE, WA:
 3,632,694, INT. CL. 29.

CASE, JOHN, PLYMOUTH, MI:
 3,632,316, INT. CL. 35.

CASES CASES, INCORPORATED, WAKEFIELD, MA:
 2,597,597, CANC. INT. CL. 35.

CASH-COW COUPON CENTRAL, INC., FORT MYERS, FL:
 3,630,673, PUB. 3-17-2009. INT. CL. 35.

CASINO, INC., NEWARK, DE:
 1,496,898, CANC. INT. CL. 28.

CASTER, 75008 PARIS, FRANCE:
 3,629,357, PUB. 3-17-2009. MULTIPLE CLASS, INT. CLS. 1 AND 3.

CASTLES UNLIMITED, NEWTON HIGHLANDS, MA:
 1,554,068. REN. 4-24-09. INT. CL. 36.

CATALOG.COM, INC., OKLAHOMA CITY, OK:
 2,596,635, CANC. MULTIPLE CLASS, INT. CLS. 25, 35, 36, 38 AND 42.

CATAPULT COMMUNICATIONS CORP., MOUNTAIN VIEW, CA:
 2,297,537. REN. 4-24-09. MULTIPLE CLASS, INT. CLS. 9 AND 41.

- CATEGORY CREATORS, KIRKLAND, WA:
3,630,663, PUB. 3-17-2009. INT. CL. 5.
- CATFISH WILLY'S, INC., SWEETWATER, TN, DBA CATFISH WILLIE'S:
2,596,882, CANC. INT. CL. 42.
- CATTLE DOG COFFEE ROASTERS, INC., HERNANDO, FL:
3,630,945, PUB. 3-17-2009. INT. CL. 30.
- CAVALERA, RICHARD, PHOENIX, AZ:
3,631,243, PUB. 3-17-2009. INT. CL. 25.
- CAVE DE TAIN L'HERMITAGE, UNION DES PROPRIETAIRES, TAIN L'HERMITAGE, FRANCE:
3,630,167, PUB. 12-23-2008. INT. CL. 33.
- CAVS/GUND ARENA COMPANY, CLEVELAND, OH:
2,597,204, CANC. INT. CL. 42.
- CBCG HOLDING, LLC, HARVEY CEDARS, NJ:
3,632,401, INT. CL. 43.
3,632,402, INT. CL. 43.
- CBG, INC., LAS VEGAS, NV:
3,632,497, MULTIPLE CLASS, INT. CLS. 35 AND 36.
- CBS STUDIOS INC., STUDIO CITY, CA:
3,631,924, INT. CL. 9.
- CBT SERVICES, INC., TOLEDO, OH:
1,497,056, CANC. INT. CL. 36.
- CCA GLOBAL PARTNERS, INC., EARTH CITY, MO:
3,097,812, COR. INT. CL. 35.
- CCP HF, REYKJAVIK, ICELAND:
3,630,096, PUB. 3-17-2009. INT. CL. 16.
- CCRC FARMS LLC, LAS VEGAS, NV:
2,597,726, CANC. INT. CL. 31.
- CDM CORP., TARZANA, CA:
3,629,623, PUB. 3-17-2009. INT. CL. 3.
3,629,624, PUB. 3-17-2009. INT. CL. 3.
- CE RESOURCE, INC., GRANITE BAY, CA:
3,633,169, MULTIPLE CLASS, INT. CLS. 16 AND 41.
- CEDARBERG INDUSTRIES, INC., EAGAN, MN:
2,597,141, CANC. INT. CL. 20.
- CEFLA S.C., 40026 IMOLA (BO), ITALY:
3,629,970, PUB. 3-17-2009. INT. CL. 7.
- CELARITY, INC., BLOOMINGTON, MN:
3,572,177, AM. INT. CL. 35.
- CELARTEM, INC, PORTLAND, OR, DBA EXTENSIS:
3,632,500, INT. CL. 9.
- CELEBDIRECT, INC., BEVERLY HILLS, CA:
3,632,674, MULTIPLE CLASS, INT. CLS. 10 AND 28.
3,632,729, MULTIPLE CLASS, INT. CLS. 10 AND 28.
- CELEBRATE ME HOME, INCORPORATED, TROUTDALE, OR:
3,629,712, PUB. 3-17-2009. INT. CL. 35.
- CELGENE CORPORATION, SUMMIT, NJ:
3,631,289, PUB. 3-17-2009. INT. CL. 5.
- CELL RESPONSE FORMULATIONS, LLC, JACKSON, WY:
3,631,827, INT. CL. 31.
- CELL THERAPEUTICS, INC., SEATTLE, WA:
2,598,182, CANC. INT. CL. 5.
3,632,642, INT. CL. 42.
- CELLCEUTICALS SKIN CARE INC., BEVERLY HILLS, CA:
3,633,056, INT. CL. 3.
- CELLULAR EXPRESS, INC., BEDFORD, MA:
3,629,948, PUB. 3-17-2009. MULTIPLE CLASS, INT. CLS. 9, 35 AND 42.
- CEMENTOS LIMA S.A., LIMA 35, PERU:
3,633,415, MULTIPLE CLASS, INT. CLS. 16, 19, 37 AND 39.
- CENDANT FINANCE HOLDING COMPANY LLC, PARSIPPANY, NJ:
2,599,521, CANC. MULTIPLE CLASS, INT. CLS. 35 AND 42.
- CENTENE CORPORATION, ST. LOUIS, MO:
3,633,450, MULTIPLE CLASS, INT. CLS. 41 AND 44.
- CENTER FOR ARKANSAS LEGAL SERVICES, LITTLE ROCK, AR:
3,630,892, PUB. 3-17-2009. INT. CL. 45.
- CENTER FOR HEALTH SERVICES AND POLICY RESEARCH, DENVER, CO:
2,596,962, CANC. INT. CL. 9.
- CENTRAL DETALLISTA, S.A. DE C.V., TIJUANA, B.C. 22010, MEXICO:
3,629,242, PUB. 7-31-2007. INT. CL. 35.
- CENTRAL LAKE ARMOR EXPRESS, INC., CENTRAL LAKE, MI:
3,630,175, PUB. 12-9-2008. INT. CL. 9.
- CENTRAL PIEDMONT COMMUNITY COLLEGE, CHARLOTTE, NC:
2,330,086, REN. 4-27-09. MULTIPLE CLASS, INT. CLS. 9 AND 16.
- CENTRE NATIONAL DE LA RECHERCHE SCIENTIFIQUE (CNRS), 75016 PARIS, FRANCE:
2,634,012, CANC. MULTIPLE CLASS, INT. CLS. 16 AND 41.
- CENTRIA, MOON TOWNSHIP, PA:
3,629,250, PUB. 3-17-2009. INT. CL. 6.
3,632,431, INT. CL. 9.
- CENTURY INDUSTRIES CORPORATION, NEW WATERFORD, OH:
2,331,668, REN. 4-25-09. INT. CL. 19.
- CENTURY OF PROGRESS PRODUCTIONS, TARZANA, CA:
3,633,162, INT. CL. 41.
- CENTURY VILLAGE, INC., WEST PALM BEACH, FL:
2,735,728, CANC. INT. CL. 37.
- CERAGENIX CORPORATION, DENVER, CO:
3,633,146, INT. CL. 5.
- CERES, INC, THOUSAND OAKS, CA:
3,632,190, INT. CL. 31.
- CERTIFICATION TRENDZ, LTD., BRISTOL, UNITED KINGDOM:
3,630,272, PUB. 3-17-2009. MULTIPLE CLASS, INT. CLS. 9 AND 16.
- CERTIFIED FOODS CORPORATION, CANYON LAKE, TX:
2,336,240, REN. 4-29-09. INT. CL. 29.
- CERVECERIA MODELO, S.A. DE C.V., MEXICO, D.F., MEXICO:
3,629,573, PUB. 3-17-2009. INT. CL. 32.
- CERVECERIA MODELO, S.A. DE C.V., 11320 MEXICO, D.F., MEXICO:
3,631,787, INT. CL. 43.
- CFSOFTWARE, INC., DES PLAINES, IL:
1,496,650, CANC. INT. CL. 9.
- CG ROXANE LLC, SAN FRANCISCO, CA:
3,629,575, PUB. 3-17-2009. INT. CL. 32.
- CHAMBEE COSMETIC CORPORATION, SAN ANTONIO, TX:
1,496,459, CANC. INT. CL. 3.
- CHAMELEON DENTAL PRODUCTS, INC., KANSAS CITY, KS:
3,631,018, PUB. 3-17-2009. INT. CL. 5.
- CHAMPAGNE ALAIN THIENOT, FRANCE:
3,631,484, PUB. 3-17-2009. INT. CL. 33.
- CHAMPAGNE DUVAL LEROY, 51130 VERTUS, FRANCE:
2,597,434, CANC. INT. CL. 33.
- CHAMPAGNE VRANKEN, REIMS, FRANCE:
2,597,329, CANC. INT. CL. 33.
2,597,330, CANC. INT. CL. 33.
- CHAMPION BRANDS, L.L.C., CLINTON, MO, CHAMPION ACQUISITION, L.L.C., CLINTON, MO:
2,256,277, REN. 4-24-09. MULTIPLE CLASS, INT. CLS. 1 AND 4.
- CHAMPIONS OF DISCOVERY, DALLAS, TX:
3,631,024, PUB. 3-17-2009. INT. CL. 35.
3,631,026, PUB. 3-17-2009. INT. CL. 36.
- CHAN, MICHELLE, SINGAPORE, SINGAPORE:
3,631,915, INT. CL. 35.
- CHANG, CALVIN, ANAHEIM, CA:
3,632,571, INT. CL. 30.
- CHANG, CAROL L., SAN CARLOS, CA:
2,598,154, CANC. INT. CL. 36.
- CHANNEL ONE LTD., NY, NY:
3,629,882, PUB. 3-17-2009. INT. CL. 41.
- CHANNELL COMMERCIAL CORPORATION, TEMECULA, CA:
2,324,126, REN. 4-29-09. INT. CL. 17.
- CHANTILLY MARKS, LLC, KINSTON, NC:
3,630,685, PUB. 3-17-2009. INT. CL. 33.
- CHAOTICFOX, L.L.C., MESA, AZ:
3,630,042, PUB. 3-17-2009. INT. CL. 44.
- CHARITY GLOBAL, INC., NEW YORK, NY:
3,629,509, PUB. 3-17-2009. INT. CL. 36.

- CHARLES RIVER APPAREL, INC., MEDFORD, MA:
3,629,766, PUB. 3-17-2009. INT. CL. 25.
- CHARLES SCHWAB & CO., INC., SAN FRANCISCO, CA:
2,598,341, CANC. INT. CL. 36.
2,598,473, CANC. INT. CL. 9.
2,599,181, CANC. INT. CL. 41.
- CHARLES WINSTON LUXURY GROUP, LLC, HOLLYWOOD, FL:
3,632,155, INT. CL. 14.
- CHARLESTON CONSTRUCTION COMPANY, LLC, SUMMERVILLE, SC:
2,599,795, CANC. INT. CL. 37.
- CHARLEY & SONS, INC., LAKE CITY, GA:
3,630,090, PUB. 3-17-2009. INT. CL. 29.
- CHARLY TEMMEL, INC., CULVER CITY, CA:
2,597,690, CANC. INT. CL. 30.
- CHART INC., BURNSVILLE, MN:
2,174,217, CANC. MULTIPLE CLASS, INT. CLS. 6 AND 12.
- CHASE ERGONOMICS INC., ALBUQUERQUE, NM:
3,632,041, MULTIPLE CLASS, INT. CLS. 9, 17 AND 28.
- CHATEAU MARGENE, CRESTON, CA:
3,630,169, PUB. 3-17-2009. INT. CL. 33.
- CHATEAU RAUZAN-SEGLA, MARGAUX, FRANCE:
3,631,750, PUB. 3-17-2009. INT. CL. 33.
- CHAUHAN, RAKESH, MIRAMAR BEACH, FL:
3,629,348, PUB. 3-17-2009. INT. CL. 43.
- CHAWLA, ANUJ, CHANDIGARH, INDIA:
3,632,377, INT. CL. 9.
- CHECKPOINT MORTGAGE, INC., KENNESAW, GA:
3,631,017, PUB. 3-17-2009. INT. CL. 36.
- CHECKPOINT SYSTEMS, INC., THOROFARE, NJ:
3,631,305, PUB. 3-17-2009. INT. CL. 20.
3,631,306, PUB. 3-17-2009. INT. CL. 20.
- CHEESE SPREADS UNLIMITED, L.L.C., MANASQUAN, NJ, DBA CHEESE MONGER COMPANY:
2,597,168, CANC. INT. CL. 29.
- CHESMAN, MARK M., SAN DIEGO, CA:
3,632,098, INT. CL. 20.
- CHEF-K, INC., ALAMEDA, CA:
3,630,883, PUB. 3-17-2009. INT. CL. 41.
- CHELSEA DAVIS LYNCH, LLC, LOS ANGELES, CA:
2,598,985, CANC. INT. CL. 25.
- CHEMICAL DISTRIBUTORS OF AMERICA, PLEASANT PRAIRIE, WI:
2,175,833, CANC. INT. CL. 42.
- CHEMINOVA, INC., RESEARCH TRIANGLE PARK, NC:
3,631,959, INT. CL. 5.
- CHEMNAVIGATOR, INC., SAN DIEGO, CA:
3,630,278, PUB. 3-17-2009. MULTIPLE CLASS, INT. CLS. 35 AND 42.
- CHENG, RANDY, TEMPLE CITY, CA:
3,629,408, PUB. 3-17-2009. INT. CL. 28.
3,629,409, PUB. 3-17-2009. INT. CL. 28.
- CHENGDE TRADITIONAL CHINESE MEDICINE FACTORY, CHENGDE CITY, HEBEI PROVINCE, CHINA:
2,598,567, CANC. INT. CL. 5.
- CHESAPEAKE FIELDS INSTITUTE, INC., CHESTERTOWN, MD:
3,629,684, PUB. 3-17-2009. INT. CL. 30.
- CHESAPEAKE PLC, UNITED KINGDOM:
3,631,774, PUB. 3-17-2009. INT. CL. 7.
- CHESSEN & ASSOCIATES, INC., BEVERLY HILLS, CA, DBA C&A ADVERTISING:
3,630,573, PUB. 3-17-2009. INT. CL. 35.
- CHEVRON INTELLECTUAL PROPERTY LLC, SAN RAMON, CA:
3,631,333, PUB. 3-17-2009. INT. CL. 35.
- CHICAGO HOME MORTGAGE CORPORATION, CHICAGO, IL:
2,597,813, CANC. INT. CL. 36.
- CHICLES CANEL'S S.A. DE C.V., 78040 SAN LUIS POTOSI, S.L.P., MEXICO:
2,596,579, CANC. INT. CL. 32.
- CHILDREN OF THE NATIONS, SILVERDALE, WA:
3,633,277, MULTIPLE CLASS, INT. CLS. 16, 25, 36, 41, 43 AND 44.
- CHILDREN, INC., COVINGTON, KY:
3,632,747, MULTIPLE CLASS, INT. CLS. 9 AND 35.
- CHILDREN'S APPAREL NETWORK, LTD., ELIZABETH, NJ:
2,175,812, CANC. INT. CL. 35.
- CHILDREN'S DENTAL CENTER AND BIG PEOPLE, TOO!, SAN JOSE, CA:
3,630,047, PUB. 3-17-2009. INT. CL. 44.
- CHILDREN'S FRIEND, INC., WORCESTER, MA:
2,238,208, REN. 4-29-09. INT. CL. 42.
- CHILDREN'S LEGAL SERVICES, PLLC, NOVI, MI:
3,630,767, PUB. 3-17-2009. MULTIPLE CLASS, INT. CLS. 35 AND 45.
- CHILI'S, INC., DALLAS, TX TO BRINKER INTERNATIONAL PAYROLL COMPANY, L.P., DALLAS, TX:
1,497,223, CANC. INT. CL. 42.
- CHILLY BONES, INC., SCOTTSDALE, AZ:
1,496,860, CANC. INT. CL. 25.
- CHIMNEY DOCTORS, WEST BABYLON, NY:
3,630,868, PUB. 3-17-2009. INT. CL. 37.
- CHINA BAROQUE, INC., HOUSTON, TX:
3,629,180, PUB. 3-17-2009. INT. CL. 14.
- CHINA INVESTMENT CORPORATION, DONGCHENG, BEIJING, CHINA:
3,630,628, PUB. 3-17-2009. INT. CL. 36.
- CHINA OCEAN SHIPPING (GROUP) COMPANY, BEIJING, CHINA:
3,629,631, PUB. 3-17-2009. INT. CL. 39.
- CHITAYAT, DAVID, SHANGHAI, CHINA:
3,632,829, INT. CL. 21.
- CHOCOLATE CELEBRATIONS, INC., GIBSONIA, PA:
3,629,391, PUB. 3-17-2009. INT. CL. 30.
- CHOI, MOON HEE, PALISADES, NY:
3,632,872, MULTIPLE CLASS, INT. CLS. 30 AND 43.
- CHOICE HOME HEALTH, INC., OKLAHOMA CITY, OK:
3,632,167, INT. CL. 44.
- CHOICEPOINT SERVICES INC., ALPHARETTA, GA:
2,599,710, CANC. INT. CL. 36.
- CHOOSEWHAT.COM, LLC, AUSTIN, TX:
3,630,736, PUB. 3-17-2009. INT. CL. 42.
- CHOU, YU, OCEANSIDE, NY:
3,631,121, PUB. 3-17-2009. INT. CL. 9.
- CHR. HANSEN, INC., MILWAUKEE, WI:
1,533,805, REN. 4-28-09. INT. CL. 1.
- CHRIS HARDY, HOUSTON, TX AND STEVE SMITH, ROUND ROCK, TX:
3,630,610, PUB. 3-17-2009. INT. CL. 41.
- CHRIS RECKNOR MD PC, GAINESVILLE, GA:
3,593,952, COR. INT. CL. 9.
- CHRISNA AND CO., LTD., CAUSEWAY BAY, HONG KONG:
3,632,305, INT. CL. 25.
3,632,306, INT. CL. 25.
- CHRISTIAN HOCKEY, LLC, ROSEAU, MN:
2,596,438, CANC. INT. CL. 28.
2,596,631, CANC. INT. CL. 28.
- CHRISTIAN R. SCHAARE AND JOSEPH INFANTE, NYACK, NY:
3,632,890, INT. CL. 25.
- CHRISTIAN STANLEY, LLC, LOS ANGELES, CA:
3,633,405, INT. CL. 36.
- CHRISTINA CANADA INC., MONTREAL, PROVIDENCE OF QUEBEC, CANADA:
2,174,416, CANC. INT. CL. 25.
- CHRISTNER, BART, PITTSBURGH, PA:
2,599,063, CANC. INT. CL. 9.
- CHRISTOPHER D. KING, PORTLAND, OR:
3,629,808, PUB. 3-17-2009. INT. CL. 12.
- CHROMLECH, FRANCE:
3,631,498, PUB. 3-17-2009. MULTIPLE CLASS, INT. CLS. 11 AND 42.
- CHRONOPOST (SOCIÉTÉ ANONYME), FRANCE:
3,631,651, PUB. 3-17-2009. MULTIPLE CLASS, INT. CLS. 16, 38 AND 39.
- CHRONOS INCORPORATED, BLUE BELL, PA:
2,599,708, CANC. INT. CL. 42.
- CHUANG, YI-SHUAN, TAIPING CITY, TAICHUNG COUNTY 411, TAIWAN:
3,147,256 NEW CERT. 6-2-2009. INT. CL. 7.

- CHUMBY INDUSTRIES, INC., SAN DIEGO, CA:
3,632,022, INT. CL. 42.
3,632,023, INT. CL. 42.
- CHUNG, YOUNG G., LEWISVILLE, TX, DBA SIMTECH USA:
3,629,682, PUB. 3-17-2009. INT. CL. 9.
- CHURCH & DWIGHT CO., INC., PRINCETON, NJ:
3,632,266, INT. CL. 3.
- CHURCH OF THE NATIONS, SACRAMENTO, CA:
3,629,929, PUB. 3-17-2009. INT. CL. 45.
- CHURCHILL COMMUNICATIONS CORPORATION, NEW YORK, NY:
1,497,096, CANC. INT. CL. 38.
- CIGAR CONNECTION, INC., THE, MIAMI, FL:
2,596,478, CANC. INT. CL. 34.
- CIGNA INTELLECTUAL PROPERTY, INC., CLAYMONT, DE:
1,552,236, REN. 4-27-09. INT. CL. 36.
- CIGNA INTELLECTUAL PROPERTY, INC., WILMINGTON, DE:
2,267,922, REN. 4-29-09. INT. CL. 9.
- CIGNA INTELLECTUAL PROPERTY, INC., CLAYMONT, DE:
2,267,923, REN. 4-29-09. INT. CL. 9.
- CILIAN AG, MUNSTER, FED REP GERMANY:
3,629,547, PUB. 3-17-2009. INT. CL. 5.
- CINE-MAKEUP, INC, CASTAIC, CA:
3,630,873, PUB. 3-17-2009. INT. CL. 3.
- CINE-TAL SYSTEMS, INC., INDIANAPOLIS, IN:
3,631,116, PUB. 3-17-2009. INT. CL. 9.
- CINECITTA HOLDING S.P.A., ROME, ITALY:
2,596,595, CANC. INT. CL. 25.
- CINELLISTUDIO S.R.L., ITALY:
3,233,519, COR. INT. CL. 25.
- CINEMANOW, INC., SANTA MONICA, CA:
2,598,978, CANC. MULTIPLE CLASS, INT. CLS. 35 AND 42.
- CIRCLE OF BEAUTY, INC., NEW YORK, NY:
2,596,778, CANC. INT. CL. 3.
- CIRCLE ONE GLOBAL, INC., CUTHBERT, GA:
2,597,397, CANC. INT. CL. 1.
- CIRCLE SYSTEMS, INC., SEATTLE, WA:
2,599,608, CANC. INT. CL. 9.
- CIRONE, JOSEPH L., SAN JOSE, CA:
2,598,114, CANC. INT. CL. 25.
- CISA, INC., MIAMI, FL:
2,596,514, CANC. INT. CL. 11.
- CITGO PETROLEUM CORPORATION, HOUSTON, TX:
2,238,838, REN. 4-24-09. INT. CL. 4.
- CITY PORTAL GROUP, INC, WEST FRANKFORT, IL:
3,630,987, PUB. 3-17-2009. INT. CL. 45.
- CITY TREX, LLC, SAVANNAH, GA:
3,630,015, PUB. 3-17-2009. INT. CL. 9.
- CIVIL WAR PRESERVATION TRUST, WASHINGTON, DC:
3,631,103, PUB. 3-17-2009. INT. CL. 16.
3,631,105, PUB. 3-17-2009. INT. CL. 16.
3,631,107, PUB. 3-17-2009. INT. CL. 16.
3,631,118, PUB. 3-17-2009. INT. CL. 16.
- CK TECHNOLOGIES, LLC, MONTEPELIER, OH:
3,632,581, INT. CL. 6.
- CLARA PALLARES, ROSA MARIA, BARCELONA, SPAIN:
3,629,893, PUB. 3-17-2009. INT. CL. 35.
- CLARIANT AG, SWITZERLAND:
3,631,513, PUB. 3-17-2009. MULTIPLE CLASS, INT. CLS. 1, 2, 3 AND 42.
- CLARITY IMAGING TECHNOLOGIES, INC., WALTHAM, MA, CLARITY IMAGING TECHNOLOGIES, INC., NORTH ANDOVER, MA:
2,324,974, REN. 4-28-09. INT. CL. 2.
- CLARK, JAMES E., MOREHEAD CITY, NC:
510,167, REN. 4-27-09. U.S. CL. 22 (INT. CL. 28).
- CLARK, KEVIN V., CARPINTERIA, CA:
3,631,909, INT. CL. 25.
- CLARK, RONALD, LAKESIDE, MT:
2,599,273, CANC. INT. CL. 13.
2,599,274, CANC. INT. CL. 14.
- CLARKE, LLOYD, GARDEN CITY, NY:
3,630,956, PUB. 3-17-2009. INT. CL. 41.
- CLARKWESTERN BUILDING SYSTEMS, INC., WEST CHESTER, OH:
3,630,439, PUB. 3-17-2009. INT. CL. 37.
- CLASS.COM, INC., LINCOLN, NE:
3,630,761, PUB. 3-17-2009. INT. CL. 41.
- CLASSIC BREAD COMPANY, NAMPA, ID:
3,633,149, INT. CL. 30.
- CLASSIC MEDIA, INC., NEW YORK, NY, LASSIE PROGRAMS, INC., BEVERLY HILLS, CA:
670,403, REN. 4-24-09. U.S. CL. 107 (INT. CL. 41).
- CLASSIC RAPHY'S KOSHER FOODS, VALLEY VILLAGE, CA:
3,630,400, PUB. 3-17-2009. INT. CL. 29.
- CLEAR CHANNEL BROADCASTING, INC., SAN ANTONIO, TX:
2,174,857, CANC. INT. CL. 38.
- CLEAR LIGHT INTERACTIVE CORP., NEW YORK, NY:
3,632,229, INT. CL. 35.
- CLEARCO PRODUCTS, COMPANY, PHILADELPHIA, PA:
1,496,474, CANC. INT. CL. 4.
- CLEARMEDICAL, INC., BELLEVUE, WA:
2,598,563, CANC. INT. CL. 42.
- CLEO DELAWARE, INC., WILMINGTON, DE:
2,340,634, REN. 4-29-09. INT. CL. 16.
- CLEOPATRA'S INK, INC., TAMPA, FL:
2,597,588, CANC. INT. CL. 42.
- CLEVEMED NEUROWAVE INC., CLEVELAND, OH:
3,631,979, INT. CL. 10.
- CLICK SIZE, LLC, JULIAN, CA:
3,632,323, INT. CL. 35.
- CLM/SYSTEMS, INC., TAMPA, FL:
1,496,626, CANC. INT. CL. 9.
- CLOCKWORK IP, LLC, SARASOTA, FL:
3,632,528, INT. CL. 41.
- CLOUD COMPANY, SAN LUIS OBISPO, CA:
1,543,262, REN. 4-25-09. INT. CL. 7.
1,543,263, REN. 4-25-09. INT. CL. 7.
- CLOUD COMPANY, SAN LUIS OBISPO, CA, PROSSER/ENPO INDUSTRIES, INC., PIQUA, OH:
1,543,264, REN. 4-25-09. INT. CL. 7.
- CLOUD COMPANY, SAN LUIS OBISPO, CA:
1,543,265, REN. 4-25-09. INT. CL. 7.
- CLOVER FARMS DAIRY COMPANY, READING, PA:
1,542,761, REN. 4-24-09. INT. CL. 29.
- CLUB DISPLAY, ESCONDIDO, CA, DBA HANCOCK INDUSTRIES:
2,598,709, CANC. INT. CL. 28.
- CMH RECORDS, INC., LOS ANGELES, CA:
3,629,990, PUB. 3-17-2009. INT. CL. 9.
- CMHC SYSTEMS, INC., DUBLIN, OH:
2,598,510, CANC. INT. CL. 9.
- CMMS DATA GROUP, INC., CHICAGO, IL:
3,632,392, INT. CL. 9.
- CMP MEDIA INC., MANHASSET, NY:
2,599,757, CANC. INT. CL. 42.
2,599,758, CANC. INT. CL. 42.
- COACH JOELLE INC., CLEVELAND HEIGHTS, OH:
3,629,767, PUB. 3-17-2009. INT. CL. 45.
- COACH SERVICES, INC., NEW YORK, NY:
3,633,302, INT. CL. 3.
- COASTAL DENTAL, INC., CAMARILLO, CA:
3,631,173, PUB. 3-17-2009. INT. CL. 36.
- COATES, JOHN, LONG BEACH, CA AND ZERBE, MIKE CHARLES, LONG BEACH, CA:
3,585,463, COR. INT. CL. 41.
- COBRA ELECTRONICS CORPORATION, CHICAGO, IL:
2,634,853, AM. INT. CL. 9.
- COBRAM ESTATE PTY LTD, AUSTRALIA:
3,631,691, PUB. 3-17-2009. INT. CL. 29.
- COEMINGLE INVESTMENTS LLC, REDONDO BEACH, CA AND RITTER REAL ESTATE SERVICES, INC., CARLSBAD, CA:
3,630,717, PUB. 3-17-2009. INT. CL. 36.
- COFFEE BEAN INTERNATIONAL, INC., PORTLAND, OR:
3,631,109, PUB. 3-17-2009. INT. CL. 30.
3,631,110, PUB. 3-17-2009. INT. CL. 30.
- COGNIVATION, ROLLINSFORD, NH:
3,630,395, PUB. 3-17-2009. INT. CL. 42.

COHEN, ARNOLD K., GARFIELD, NJ:
877,762. REN. 4-24-09. U.S. CL. 27 (INT. CL. 14).

COHEN, DANIEL E., CHASKA, MN:
3,632,172, MULTIPLE CLASS, INT. CLS. 9 AND 20.
3,632,173, INT. CL. 20.

COHERENT, INC., SANTA CLARA, CA:
3,632,844, INT. CL. 9.

COLD STEEL, INC., VENTURA, CA:
3,632,364, INT. CL. 8.

COLEMAN-KAMMULA, SEETHA, NEWARK, DE AND
COLEMAN, BRIAN, NEWARK, DE:
3,631,906, MULTIPLE CLASS, INT. CLS. 40 AND 42.

COLGATE-PALMOLIVE COMPANY, NEW YORK, NY:
3,633,250, INT. CL. 3.

COLLEEN P. TAYLOR PROFESSIONAL CORPORATION,
BOUNTIFUL, UT:
2,599,738, CANC. INT. CL. 42.

COLLEGENET, INC., PORTLAND, OR:
3,633,257, INT. CL. 42.

COLON, VILMA E., BURKE, VA:
2,174,950, CANC. INT. CL. 41.

COLONIAL CHEMICAL, SOUTH PITTSBURG, TN:
3,632,981, INT. CL. 1.

COLONIAL LIFE & ACCIDENT INSURANCE COMPANY,
COLUMBIA, SC:
3,632,278, INT. CL. 36.
3,632,279, INT. CL. 36.

COLONIAL PENN LIFE INSURANCE COMPANY, PHILA-
DELPHIA, PA:
3,381,028, AM. INT. CL. 36.

COLORADO BUSINESS ROUNDTABLE, DENVER, CO:
3,630,407, PUB. 3-17-2009. MULTIPLE CLASS, INT. CLS.
16 AND 41.

COLORADO SCHOOL DISTRICTS SELF INSURANCE
POOL, DENVER, CO:
3,632,879, INT. CL. 36.

COLORBOK, INC., DEXTER, MI:
2,599,224, CANC. INT. CL. 28.

COLTON'S RESTAURANT GROUP, INC., LITTLE ROCK,
AR:
2,322,934. REN. 4-29-09. INT. CL. 42.

COLUMBIA INSURANCE COMPANY, OMAHA, NE, SEE'S
CANDY SHOPS, INC., LOS ANGELES, CA:
367,056. REN. 4-24-09. U.S. CL. 46 (INT. CL. 30).

COLUMBIA INSURANCE COMPANY, OMAHA, NE:
3,630,496, PUB. 3-17-2009. INT. CL. 21.
3,630,500, PUB. 3-17-2009. INT. CL. 3.

COLUMBIA STATE BANK, TACOMA, WA:
3,629,476, PUB. 3-17-2009. INT. CL. 36.
3,629,477, PUB. 3-17-2009. INT. CL. 36.

COLUMBIAN MUTUAL LIFE INSURANCE COMPANY,
BINGHAMTON, NY:
673,994. REN. 4-25-09. U.S. CL. 102 (INT. CL. 36).

COLUMBUS COMPONENTS GROUP, LLC, COLUMBUS, IN:
2,598,887, CANC. INT. CL. 2.

COMCAST CORPORATION, PHILADELPHIA, PA:
2,596,968, CANC. INT. CL. 38.

COMERCIAL CARENADO LIMITADA, LAS CONDES, SAN-
TIAGO, CHILE:
3,630,967, PUB. 3-17-2009. INT. CL. 9.

COMET HOLDING AG, SWITZERLAND:
3,631,461, PUB. 3-17-2009. MULTIPLE CLASS, INT. CLS. 7
AND 9.

COMISION NACIONAL DE PROMOCION DE EXPORTA-
CIONES E INVERSIONES (CONADEI), ANTIGUO CUS-
CATLAN, EL SALVADOR:
3,632,663, U.S. CL. A.

COMISKEY, STEPHEN W., WASHINGTON, DC:
2,190,544. REN. 4-26-09. INT. CL. 16.
2,190,544, CANC. INT. CL. 9.

COMITÉ INTERNATIONAL OLYMPIQUE, 1007 LAU-
SANNE, SWITZERLAND:
3,630,297, PUB. 3-17-2009. MULTIPLE CLASS, INT. CLS.
9, 35, 38, 41 AND 43.

COMMERCE ONE, INC., PLEASANTON, CA:
2,596,996, CANC. MULTIPLE CLASS, INT. CLS. 9 AND
42.

COMMODITY AXIS INCORPORATION, CAMARILLO, CA:
2,597,000, CANC. MULTIPLE CLASS, INT. CLS. 7 AND
11.

COMMON SENCE DENTAL PRODUCTS II, INC., SPRING
LAKE, MI, DBA COMMON SENSE DENTAL PRODUCTS:
2,543,319, COR. INT. CL. 10.

COMMON SENSE DENTAL PRODUCTS II, INC., SPRING
LAKE, MI, DBA COMMON SENSE DENTAL PRODUCTS:
2,543,082, COR. INT. CL. 10.
3,276,809, COR. INT. CL. 10.
3,490,390, COR. INT. CL. 5.

COMMUNICATIONS DATA SERVICES, INC., DES MOINES,
IA:
3,630,421, PUB. 3-17-2009. INT. CL. 35.

COMMUNITECT, INC., LEHI, UT:
3,631,264, PUB. 3-17-2009. INT. CL. 42.
3,631,265, PUB. 3-17-2009. MULTIPLE CLASS, INT. CLS.
42 AND 45.

COMMUNITY BANK CBD, DELAVAN, WI:
3,632,191, INT. CL. 36.

COMMUNITY ISP, INC., TOLEDO, OH:
3,629,714, PUB. 3-17-2009. INT. CL. 42.

COMMUNITY OF CISTERCIANS OF THE STRICT OBSER-
VANCE, INCORPORATED, BERRYVILLE, VA:
1,496,955, CANC. INT. CL. 30.

COMMUNITY OF DOCTORS, INC., BURIEN, WA:
3,633,370, INT. CL. 44.

COMMUNITYAMERICA CREDIT UNION, LENEXA, KS:
3,630,536, PUB. 3-17-2009. INT. CL. 36.
3,630,537, PUB. 3-17-2009. INT. CL. 36.

COMODO CA LIMITED, SALFROD, UNITED KINGDOM:
3,629,706, PUB. 3-17-2009. MULTIPLE CLASS, INT. CLS.
42 AND 45.

COMPAGNIA DELL'OROLOGIO S.P.A., ITALY:
3,631,472, PUB. 3-17-2009. MULTIPLE CLASS, INT. CLS.
3, 9, 11, 14, 16, 18, 25, 35 AND 43.

COMPAGNIE FRANCAISE D'ASSURANCE POUR LE COM-
MERCE EXTERIEUR, 92800 PUTEAUX, FRANCE:
2,597,132, CANC. MULTIPLE CLASS, INT. CLS. 9, 35, 36,
38 AND 42.

COMPAGNIE GERVAIS DANONE, PARIS, FRANCE:
3,633,198, INT. CL. 29.

COMPAGNIE LAITIERE EUROPEENNE, 50890 CONDE SUR
VIE, FRANCE:
2,597,224, CANC. MULTIPLE CLASS, INT. CLS. 16, 29
AND 41.

COMPAGNIE LAITIERE EUROPEENNE, VIROFLAY,
FRANCE:
2,637,884, CANC. INT. CL. 30.

COMPAGNIE NATIONALE AIR FRANCE, PARIS,
FRANCE:
1,497,098, CANC. INT. CL. 39.

COMPANIA DE DISTRIBUCION DE SOFTWARE, S.A.,
28831 SAN FERNANDO DE HENARES (MADRID), SPAIN:
2,598,606, CANC. INT. CL. 38.

COMPANY OF EXPERTS, INC., LAS VEGAS, NV:
3,632,102, INT. CL. 41.

COMPAQ INFORMATION TECHNOLOGIES GROUP, L.P.,
HOUSTON, TX:
2,597,007, CANC. INT. CL. 42.

COMPASS DIRECTIONAL GUIDANCE, INC., HOUSTON,
TX:
3,629,203, PUB. 3-17-2009. INT. CL. 37.
3,629,204, PUB. 3-17-2009. INT. CL. 37.

COMPASSION, INCORPORATED, CLINTON, MD:
2,174,301, CANC. INT. CL. 16.

COMPETITION SPECIALTIES, INC., AUBURN, WA:
2,258,337. REN. 4-27-09. INT. CL. 35.

COMPLETE BEAUTY SOLUTIONS, INC., NEW YORK, NY:
3,629,735, PUB. 3-17-2009. INT. CL. 35.

COMPOSITE PANEL ASSOCIATION, GAITHERSBURG,
MD:
3,631,838, U.S. CL. B.

COMPUTER APPLICATIONS CORPORATION, MEMPHIS,
TN:
2,174,940, CANC. MULTIPLE CLASS, INT. CLS. 37 AND
42.

- COMPUTER SOLUTIONS INTERNATIONAL, INC., SANTA CLARA, CA:
2,597,194, CANC. MULTIPLE CLASS, INT. CLS. 9 AND 37.
- COMPUTER TASK GROUP, INC., BUFFALO, NY:
2,598,451, CANC. INT. CL. 35.
- COMPUTER WEAR, INC., BRIARCLIFF MANOR, NY:
2,174,812, CANC. INT. CL. 20.
- COMSCAPE HOLDING, INC., COLUMBUS, OH:
2,175,433, CANC. INT. CL. 38.
- COMTACTICS, MISSISSAUGA, ONTARIO L5K 2S2, CANADA:
2,598,416, CANC. INT. CL. 9.
- CON-WAY INC., SAN MATEO, CA:
1,497,106, CANC. INT. CL. 39.
2,599,269, CANC. INT. CL. 9.
- CONAGRA FOODS RDM, INC., OMAHA, NE:
2,599,420, CANC. INT. CL. 30.
- CONCENTRIC MEDICAL, INC., MOUNTAIN VIEW, CA:
3,632,204, INT. CL. 10.
- CONCEPT DEVELOPMENT ASSOCIATES OF MARYLAND, INC., ST. AUGUSTINE, FL, DBA LIFEWARE TEK:
3,633,388, MULTIPLE CLASS, INT. CLS. 9 AND 41.
- CONCEPT LABORATORIES, INC., CHICAGO, IL:
3,630,856, PUB. 3-17-2009. INT. CL. 5.
- CONCERNS OF POLICE SURVIVORS, INC., CAMDENTON, MO:
1,590,282, REN. 4-24-09. INT. CL. 42.
- CONCEVA INNOVATIVE PRODUCTS LTD., CALGARY, CANADA:
3,629,437, PUB. 3-17-2009. INT. CL. 11.
- CONCIERGE DIRECT CORPORATION, MAMARONECK, NY:
3,633,235, INT. CL. 45.
- CONCORD EFS, INC., MEMPHIS, TN:
2,598,421, CANC. INT. CL. 36.
- CONCRETE POLISHING TECHNOLOGIES, INC., FORT WORTH, TX:
3,630,325, PUB. 3-17-2009. INT. CL. 37.
- CONEXION HISPANA INC., AVENTURA, FL:
3,632,475, INT. CL. 35.
- CONEY ISLAND U.S.A., INC., BROOKLYN, NY:
2,248,961, REN. 4-29-09. INT. CL. 41.
- CONFEDERATED TRIBES OF THE GRANDE RONDE COMMUNITY OF OREGON, GRAND RONDE, OR:
2,248,290, REN. 4-27-09. INT. CL. 42.
- CONFEDERATED TRIBES OF THE GRANDE RONDE COMMUNITY OF OREGON, GRANDE RONDE, OR:
2,263,326, REN. 4-27-09. INT. CL. 42.
- CONFRIERIE DE LA CHAINE DES ROTISSEURS, LTD., MADISON, NJ:
1,534,803, REN. 4-24-09. INT. CL. 42.
- CONG TY CO PHAN MINH HUU LIEN, VIETNAM:
3,631,610, PUB. 3-17-2009. MULTIPLE CLASS, INT. CLS. 12 AND 20.
- CONG TY TRACH NHIEM HUU HAN; SENA VIET NAM, HA NOI, VIETNAM:
3,631,524, PUB. 3-17-2009. MULTIPLE CLASS, INT. CLS. 7 AND 11.
- CONGOLEUM CORPORATION, MERCERVILLE, NJ:
1,496,870, CANC. INT. CL. 27.
- CONGREGATION OF THE PRIESTS OF THE SACRED HEART, INC., CHAMBERLAIN, SD, DBA TIPI PRESS:
1,497,121, CANC. INT. CL. 41.
- CONHAR, INC., CHICAGO, IL:
2,241,535, REN. 4-25-09. INT. CL. 35.
- CONJUNTO DESAFIO MUSICAL COUNTRY PARTNERSHIP, OXNARD, CA:
3,631,818, INT. CL. 41.
- CONMED COPORATION, UTICA, NY:
1,496,500, CANC. INT. CL. 5.
- CONNECT FOR EDUCATION, INC., RESTON, VA:
3,631,346, PUB. 3-17-2009. INT. CL. 41.
- CONNECTION DISTRIBUTING COMPANY, CLEVELAND, OH:
2,174,380, CANC. INT. CL. 16.
- CONNECTMAIL, LTD., CINCINNATI, OH:
2,598,934, CANC. INT. CL. 38.
- CONNEXUS CREDIT UNION, WAUSAU, WI:
1,537,662, REN. 4-27-09. INT. CL. 36.
- CONCOPHILLIPS COMPANY, HOUSTON, TX:
2,174,605, CANC. INT. CL. 42.
- CONRAN, JASPER, LONDON, UNITED KINGDOM:
3,630,083, PUB. 3-17-2009. INT. CL. 25.
- CONSOLIDATED GRAPHICS, INC., HOUSTON, TX:
2,597,213, CANC. MULTIPLE CLASS, INT. CLS. 9 AND 35.
- CONSOLIDATED GROUP, INC., FRAMINGHAM, MA:
1,497,027, CANC. INT. CL. 36.
- CONSOLIDATED PROPERTY HOLDINGS, INC., LAS VEGAS, NV:
2,598,848, CANC. MULTIPLE CLASS, INT. CLS. 21 AND 28.
- CONSORZIO RETE INDUSTRIA, ITALY:
3,631,506, PUB. 3-17-2009. MULTIPLE CLASS, INT. CLS. 35, 36 AND 41.
- CONSTRUCTION MARKET DATA GROUP, INC., NORCROSS, GA:
2,597,792, CANC. INT. CL. 9.
- CONSTRUCTION RESEARCH & TECHNOLOGY GMBH, TROSTBERG, FED REP GERMANY:
2,633,747, CANC. MULTIPLE CLASS, INT. CLS. 37 AND 42.
3,630,186, PUB. 3-17-2009. INT. CL. 17.
- CONSTRUCTION RESEARCH & TECHNOLOGY GMBH, FED REP GERMANY:
3,631,674, PUB. 3-17-2009. INT. CL. 1.
- CONSULATE LTD., NEW YORK, NY:
3,630,058, PUB. 3-17-2009. INT. CL. 41.
- CONSUMABLE PLASMA PRODUCTS, INC., CANAAN, NH, DBA PRECISION PRODUCTS:
2,596,740, CANC. MULTIPLE CLASS, INT. CLS. 7 AND 9.
- CONSYSTANT DESIGN TECHNOLOGIES, INC., KIRKLAND, WA:
2,599,091, CANC. INT. CL. 9.
2,599,092, CANC. INT. CL. 9.
- CONTACT SPORTS INC., NEW YORK, NY:
2,596,544, CANC. INT. CL. 25.
- CONTEMPORARY PLASTIC SURGERY, EAST BRUNSWICK, NJ:
2,597,795, CANC. INT. CL. 42.
- CONTESSA PREMIUM FOODS, INC., SAN PEDRO, CA:
3,633,036, MULTIPLE CLASS, INT. CLS. 29 AND 30.
- CONTINENTAL IMPORT-EXPORT CORPORATION, COLON FREE ZONE, PANAMA TO PANAMA CIGAR COMPANY, S.A., COLON FREE ZONE, PANAMA:
1,496,988, CANC. INT. CL. 34.
- CONTITECH SCHLAUCH GMBH, HANNOVER, FED REP GERMANY:
1,538,155, REN. 4-26-09. INT. CL. 17.
- CONTRACTOR'S BEST HOLDINGS, INC., JACKSONVILLE, FL:
3,629,191, PUB. 3-17-2009. INT. CL. 35.
- CONTRACTORS REGISTER, INC., JEFFERSON VALLEY, NY:
3,630,900, PUB. 3-17-2009. INT. CL. 35.
- CONTROL4 CORPORATION, SALT LAKE CITY, UT:
3,632,012, INT. CL. 9.
- CONVERTEAM GROUP, FRANCE:
3,631,487, PUB. 3-17-2009. MULTIPLE CLASS, INT. CLS. 7 AND 9.
- COOKIN' DINNERS LICENSING COMPANY, NORWALK, CT:
3,631,988, INT. CL. 35.
- COOLTOUCH INCORPORATED, ROSEVILLE, CA:
3,632,706, INT. CL. 10.
- COOPER BRANDS, INC., HOUSTON, TX:
2,174,511, CANC. INT. CL. 8.
- COOPER TECHNOLOGIES COMPANY, HOUSTON, TX:
2,284,279, REN. 4-24-09. INT. CL. 11.
3,632,807, INT. CL. 11.
- COOPER TECHNOLOGY COMPANY, HOUSTON, TX:
3,631,270, PUB. 3-17-2009. INT. CL. 9.
- COOPER TIRE & RUBBER COMPANY, FINDLAY, OH:
2,596,535, CANC. INT. CL. 12.

COOPER, ROBERT J, NEW YORK, NY:
3,630,592, PUB. 3-17-2009. INT. CL. 37.

COOPER, THOMAS M., ELLSWORTH, MI, DBA ROCKY TOP FARMS:
1,496,906, CANC. INT. CL. 29.

COOPERVISION, INC., PLEASANTON, CA:
3,630,586, PUB. 3-17-2009. INT. CL. 9.
3,631,076, PUB. 3-17-2009. INT. CL. 9.

COOPSPORT INTERNATIONAL LP, VISTA, CA:
3,629,157, PUB. 3-17-2009. INT. CL. 28.

COPPERLEAF GOURMET FOODS, INC., LAWRENCE, KS:
3,632,605, INT. CL. 30.

CORBIS CORPORATION, NEW YORK, NY:
3,632,669, INT. CL. 45.

CORDIS CORPORATION, MIAMI LAKES, FL:
2,598,615, CANC. INT. CL. 10.

CORE CARBON GROUP APS, COPENHAGEN K, DENMARK:
3,631,544, PUB. 3-17-2009. MULTIPLE CLASS, INT. CLS. 35, 36 AND 42.

COREANA COSMETICS CO., LTD., CHEONAN-SI CHUNG-CHEONGNAM-DO, REPUBLIC OF KOREA:
2,599,077, CANC. INT. CL. 3.

COREMA S.R.L., MILANO, ITALY:
1,496,680, CANC. INT. CL. 11.

COREY COLWELL-LIPSON, ISSAQUAH, WA:
3,632,429, INT. CL. 35.

CORFMAN, CHARLES JR., EL CENTRO, CA AND DROWN, GLENN E., EL CENTRO, CA AND GRILLO, ROBERT, EL CENTRO, CA AND FARGO, JOHN S., EL CENTRO, CA:
2,597,622, CANC. INT. CL. 25.

CORGAN ASSOCIATES, INC., DALLAS, TX:
3,629,164, PUB. 3-17-2009. INT. CL. 42.

CORLIB BRAND HOLDING LTD., TORTOLA, BR.VIRGIN ISLANDS:
3,630,841, PUB. 3-17-2009. INT. CL. 29.

CORMACK, INC., DESPLAINES, IL:
2,249,537, REN. 4-29-09. INT. CL. 20.

CORMARK, INC., DESPLAINES, IL:
2,249,540, REN. 4-29-09. INT. CL. 35.

CORMARK, INC., DELPLAINES, IL:
2,249,546, REN. 4-29-09. INT. CL. 42.

CORMARK, INC., DES PLAINES, IL:
2,253,435, REN. 4-29-09. INT. CL. 20.

CORNELL, CLIFFORD B., KANSAS CITY, MO:
1,497,288, CANC. INT. CL. 8.

CORONET SCAFFOLD EQUIPMENT SUZHOU CO., LTD., SUZHOU, CHINA:
3,629,422, PUB. 3-17-2009. INT. CL. 6.

CORPORATE DEVELOPMINT, CHARLESTON, SC:
3,633,034, INT. CL. 41.

CORPORATE EXPRESS US INC., BROOMFIELD, CO:
2,597,178, CANC. INT. CL. 35.
3,629,611, PUB. 3-17-2009. MULTIPLE CLASS, INT. CLS. 3, 8, 16, 17 AND 21.

CORPORATE NETWORK ECOM, LLC, LENEXA, KS:
2,598,751, CANC. INT. CL. 36.

CORPORATE NETWORK SERVICES, INC., POOLESVILLE, MD:
3,630,782, PUB. 3-17-2009. INT. CL. 42.

CORR-JENSEN LABS, INC., CENTENNIAL, CO:
3,632,818, INT. CL. 5.
3,632,900, INT. CL. 5.
3,632,901, INT. CL. 5.
3,632,985, INT. CL. 5.

CORTAZZO, CARRIE K., SAN DIEGO, CA AND CORTAZZO, MARC W., SAN DIEGO, CA:
3,629,295, PUB. 3-17-2009. INT. CL. 37.

CORVIRTUS, INC., COLORADO SPRINGS, CO:
3,632,910, MULTIPLE CLASS, INT. CLS. 35 AND 41.

COSCIA, ROBERT, BAYSIDE, NY:
3,631,955, MULTIPLE CLASS, INT. CLS. 25 AND 34.

COSMEBIO, 26958 VALENCE CEDEX 9, FRANCE:
3,629,568, PUB. 3-17-2009. INT. CL. 3.

COSMETIC INDUSTRIAL & TRADE CORP., RIVERSIDE, CA:
3,632,301, INT. CL. 3.

COSMIC MONKEY, INC., KENDALL PARK, NJ:
2,598,885, CANC. INT. CL. 16.
2,598,886, CANC. INT. CL. 28.

COSMOPULOS, STAVROS, NORWELL, MA:
1,496,796, CANC. INT. CL. 20.

COST SYSTEMS INTERACTIVE, LLC, LOUISVILLE, KY:
2,597,273, CANC. INT. CL. 9.

COSTA ,MICHELLE, A, WILLITS, CA:
3,629,689, PUB. 3-17-2009. INT. CL. 43.

COSWAY COMPANY, INC., CARSON, CA, DBA BUREAU NUMBER FOUR:
3,630,418, PUB. 3-17-2009. INT. CL. 3.
3,630,419, PUB. 3-17-2009. INT. CL. 3.
3,630,420, PUB. 3-17-2009. INT. CL. 3.

COTTAGE WORLD, INC., SARASOTA, FL:
2,598,401, CANC. INT. CL. 26.

COTTONCASUAL B.V., NL-3743 KA BAARN, NETHERLANDS:
3,631,656, PUB. 3-17-2009. INT. CL. 25.

COUNCIL FOR RELATIONSHIPS, PHILADELPHIA, PA:
3,633,000, MULTIPLE CLASS, INT. CLS. 44 AND 45.

COUNCIL OF BETTER BUSINESS BUREAUS, INC., ARLINGTON, VA:
3,629,636, PUB. 3-17-2009. U.S. CL. B.

COUNTRY MUSIC TELEVISION, INC., NASHVILLE, TN:
2,597,385, CANC. INT. CL. 41.

COUPLES FOR CHRIST, METROPOLITAN-WASHINGTON, D.C., INCORPORATED, GAITHERSBURG, MD:
3,630,509, PUB. 3-17-2009. INT. CL. 45.

COURTHOUSE RECORDS, INC., AURORA, CO:
1,496,643, CANC. INT. CL. 9.

COVER CURL, LLC, LITTLETON, CO:
3,631,206, PUB. 3-17-2009. INT. CL. 17.

COVERX CORPORATION, SOUTHFIELD, MI:
3,629,869, PUB. 3-17-2009. INT. CL. 36.

COVEY/LINK, LLC, ALPINE, UT:
3,629,743, PUB. 3-17-2009. INT. CL. 9.

COWBOY TACK CORPORATION, FORT WORTH, TX:
2,174,407, CANC. INT. CL. 18.

COWGIRL SAVVY, LLC, GRESHAM, OR:
3,630,966, PUB. 3-17-2009. INT. CL. 25.

COWTOWN AUCTIONEERS, INC., PILESGROVE, NJ:
2,260,604, REN. 4-27-09. INT. CL. 35.

COX COMMUNICATIONS, INC., ATLANTA, GA:
3,630,118, PUB. 3-17-2009. INT. CL. 35.
3,632,671, INT. CL. 38.

CPI, FRANCE:
3,631,497, PUB. 12-9-2008. MULTIPLE CLASS, INT. CLS. 16, 35 AND 40.

CPL CARBON LINK CORPORATION, COLUMBUS, OH:
2,598,665, CANC. INT. CL. 11.

CPS GARTEN CORPORATION, IRVINE, CA:
3,631,202, PUB. 3-17-2009. INT. CL. 19.

CR CHROMCRAFT, INC., SENATOBIA, MS:
3,632,077, INT. CL. 20.

CR LICENSE, LLC, TUCSON, AZ:
3,633,140, INT. CL. 43.

CRAM CREW, INC., KATY, TX:
3,631,896, INT. CL. 16.

CRANE CO., STAMFORD, CT:
3,632,219, INT. CL. 9.

CRANE COMPOSITES, INCORPORATED, CHANNAHON, IL:
1,106,682, REN. 4-25-09. INT. CL. 19.

CRANE PRODUCTS LTD., COLUMBUS, OH:
2,599,537, CANC. INT. CL. 19.

CRAYOLA PROPERTIES, INC., EASTON, PA:
3,631,125, PUB. 3-17-2009. INT. CL. 16.
3,631,126, PUB. 3-17-2009. INT. CL. 16.
3,631,127, PUB. 3-17-2009. INT. CL. 16.
3,631,128, PUB. 3-17-2009. INT. CL. 16.
3,631,132, PUB. 3-17-2009. INT. CL. 16.
3,631,133, PUB. 3-17-2009. INT. CL. 16.

CRAYTON, SHARON L., SANTA FE, NM:
3,629,828, PUB. 3-17-2009. INT. CL. 41.

CREDIT MARKETS REAL ESTATE CORP., NEW YORK, NY:
3,631,918, INT. CL. 45.

- CREIGHTON UNIVERSITY, OMAHA, NE:
2,598,813, CANC. INT. CL. 9.
- CRESCENT REAL ESTATE EQUITIES LIMITED PARTNER-
SHIP, FORT WORTH, TX:
2,597,251, CANC. INT. CL. 42.
- CRESCENT SERVICES, INC., BLOOMFIELD, NY, DBA
CRESCENT TANK MFG:
3,630,086, PUB. 3-17-2009. INT. CL. 12.
- CRESSLINE DISTRIBUTING, INCORPORATED, CHICO,
CA, DBA KLEAN KANTEEN:
3,630,954, PUB. 3-17-2009. INT. CL. 21.
- CRESTWOOD PARTNERS, LLC, MAYFIELD VILLAGE, OH:
3,630,729, PUB. 3-17-2009. INT. CL. 8.
- CRISTINA VITIELLO, LLC, HUNTINGTON BAY, NY:
3,631,167, PUB. 3-17-2009. INT. CL. 14.
3,631,344, PUB. 3-17-2009. INT. CL. 14.
- CRONIN AND COMPANY, INCORPORATED, GLASTON-
BURY, CT:
2,598,419, CANC. INT. CL. 35.
- CROSSBRIDGE VENTURE PARTNERS LLC, SAN BRUNO,
CA:
2,598,805, CANC. INT. CL. 36.
- CROWE HORWATH LLP, SOUTH BEND, IN:
3,630,303, PUB. 3-17-2009. INT. CL. 35.
3,630,304, PUB. 3-17-2009. MULTIPLE CLASS, INT. CLS.
40, 42 AND 45.
- CROWELL, MICHAEL P., DENVER, CO:
2,198,806. REN. 4-27-09. INT. CL. 25.
- CROWLEY INVESTMENT, S.A., SPAIN:
3,631,471, PUB. 3-17-2009. INT. CL. 12.
- CROWN COFFEE SERVICES, WAKEFIELD, MA:
2,599,265, CANC. INT. CL. 11.
- CROWN CREATIVE CO., LTD., ADACHI-KU; TOKYO,
JAPAN:
3,567,904, COR. MULTIPLE CLASS, INT. CLS. 9, 14, 16,
18, 24, 25 AND 28.
- CROWN MELBOURNE LIMITED, SOUTHBANK, MEL-
BOURNE, AUSTRALIA:
3,632,091, INT. CL. 35.
- CROWNS ONLY DENTAL LLC, PEORIA, AZ:
3,633,463, INT. CL. 44.
- CRUZ, JOHN D. DELA, FREMONT, CA, DBA NEWBORN
APPLE:
3,630,625, PUB. 3-17-2009. INT. CL. 25.
- CRYSTAL CATHEDRAL MINISTRIES, GARDEN GROVE,
CA:
3,630,479, PUB. 3-17-2009. INT. CL. 45.
- CRYSTAL NATION, LLC, NEW YORK, NY:
3,630,131, PUB. 12-9-2008. INT. CL. 25.
- CRYSTALLIUS PRESS, LLC, MENLO PARK, CA:
3,632,547, INT. CL. 41.
- CSAT GESELLSCHAFT FUR COMPUTER-SYSTEME UND
AUTOMATIONS-TECHNIK MBH, 76344 EGGENSTEIN-
LEOPOLDSHAFEN, FED REP GERMANY:
2,252,777. REN. 4-24-09. INT. CL. 9.
- CSK AUTO, INC., PHOENIX, AZ:
2,596,506, CANC. INT. CL. 37.
- CSL BEHRING AG, BERN 22, SWITZERLAND:
3,631,969, INT. CL. 44.
- CTB IP, INC., WILMINGTON, DE:
3,632,372, INT. CL. 7.
- CTF DEVELOPMENT, INC., CORAL GABLES, FL:
3,632,251, INT. CL. 43.
3,632,414, INT. CL. 43.
- CTI GROUP, INC., THE, WILMINGTON, DE:
2,596,562, CANC. INT. CL. 42.
- CUBA BEVERAGE COMPANY, SAN DIEGO, CA:
3,632,032, INT. CL. 32.
3,632,033, INT. CL. 32.
3,632,034, INT. CL. 32.
- CULBERTSON, MARK SAXON, WEST HOLLYWOOD, CA:
3,631,369, PUB. 3-17-2009. MULTIPLE CLASS, INT. CLS.
16 AND 41.
- CULINARY CONCEPTS BY JEAN-GEORGES, LLC, NEW
YORK, NY:
3,632,334, INT. CL. 43.
- CULINARY INSTITUTE, INC., HOUSTON, TX, DBA CU-
LINARY INSTITUTE ALAIN & MARIE LENOTRE:
3,632,644, INT. CL. 41.
- CULLETT, DANIEL, LONG BEACH, CA, DBA DADDYS-
LAND RECORDS:
3,631,802, INT. CL. 9.
- CULTIVARIS NORTH AMERICA LLC, SAN DIEGO, CA:
3,632,321, INT. CL. 31.
- CUMBERLAND WOOD PRODUCTS, INC., TENNESSEE,
TN:
2,597,468, CANC. INT. CL. 20.
- CUMMINGS, DEBORAH, PLEASANT GARDEN, NC AND
CUMMINGS, JERRY W., PLEASANT GARDEN, NC:
2,597,974, CANC. INT. CL. 30.
- CUPID FOUNDATIONS, INC., NEW YORK, NY:
3,633,127, INT. CL. 25.
- CURRENT USA, INC., NORTH MANKATO, MN:
2,599,409, CANC. INT. CL. 3.
- CURRERI, TRACY L., REDONDO BEACH, CA:
3,630,193, PUB. 3-17-2009. INT. CL. 42.
- CURRIER ROOF TILE, L.L.C., FORT MYERS, FL:
2,598,872, CANC. INT. CL. 19.
- CUSTOM DYNAMICS, LLC, WAKE FOREST, NC:
3,630,671, PUB. 3-17-2009. INT. CL. 35.
- CUSTOM PUBLISHING & MARKETING GROUP, INC.,
JUPITER, FL:
2,599,549, CANC. INT. CL. 35.
- CUSTOM-BILT METALS, CHINO, CA:
2,174,603, CANC. INT. CL. 6.
- CVS PHARMACY, INC., WOONSOCKET, RI:
3,632,813, INT. CL. 36.
- CYBER SECURITY RESEARCH AND SOLUTIONS COR-
PORATION, LA PLATA, MD:
3,633,474, INT. CL. 42.
- CYCLES INTERNATIONAL, INC., NORTHVALE, NJ:
1,496,693, CANC. INT. CL. 12.
- CYNERGY DATA, LLC, NEW YORK, NY:
3,629,546, PUB. 3-17-2009. INT. CL. 36.
- CYNOSURE, INC., WESTFORD, MA:
3,632,415, INT. CL. 10.
- C3 SOFTWARES, INC., MINNEAPOLIS, MN, DBA C3
SOFTWARES:
3,631,229, PUB. 3-17-2009. INT. CL. 9.
- D & H COMPANY, TUPELO, MS:
2,328,094, REN. 4-24-09. MULTIPLE CLASS, INT. CLS. 35
AND 42.
2,331,232, REN. 4-24-09. MULTIPLE CLASS, INT. CLS. 35
AND 42.
- D AND M RETAIL LLC, VOORHEES, NJ:
2,599,854, CANC. INT. CL. 25.
- D.E.J. PRODUCTIONS INC., DALLAS, TX:
2,599,442, CANC. MULTIPLE CLASS, INT. CLS. 9 AND
41.
- D.H. PACE COMPANY, INC., NORTH KANSAS CITY, MO:
3,630,912, PUB. 3-17-2009. MULTIPLE CLASS, INT. CLS.
6, 19 AND 37.
3,630,916, PUB. 3-17-2009. MULTIPLE CLASS, INT. CLS.
6, 19 AND 37.
- D&B INDUSTRIAL FLOOR COATINGS, INC., MENOMO-
NEE FALLS, WI:
3,630,434, PUB. 3-17-2009. INT. CL. 1.
- D&PL TECHNOLOGY HOLDING CO., LLC, ST. LOUIS, MO:
3,630,703, PUB. 3-17-2009. INT. CL. 44.
- D-LINK SYSTEMS, INC., FOUNTAIN VALLEY, CA:
3,629,920, PUB. 3-17-2009. MULTIPLE CLASS, INT. CLS. 9
AND 42.
3,629,937, PUB. 3-17-2009. INT. CL. 9.
3,630,097, PUB. 3-17-2009. INT. CL. 9.
3,630,176, PUB. 3-17-2009. INT. CL. 9.
3,630,177, PUB. 3-17-2009. INT. CL. 9.
3,630,185, PUB. 3-17-2009. INT. CL. 9.
- D'AQUINO ITALIAN IMPORTING CO., INC., DUARTE, CA:
3,632,408, MULTIPLE CLASS, INT. CLS. 29, 30, 32 AND
33.
- D'EGIDIO, NICK, FONTANA, CA:
3,630,602, PUB. 3-17-2009. INT. CL. 41.
- D'YANS, MASHA, BRIGHTON, MA:
3,629,633, PUB. 3-17-2009. INT. CL. 16.

DA CONSULTING GROUP, INC., HOUSTON, TX:
2,596,637, CANC. INT. CL. 35.

DA DIE AGENTUR GMBH, D-88214 RAVENSBURG, FED REP GERMANY:
2,597,311, CANC. MULTIPLE CLASS, INT. CLS. 30, 32 AND 33.

DA VINCI SYSTEMS CORPORATION, RALEIGH, NC:
1,496,647, CANC. INT. CL. 9.

DABBIERO, FRANK A., BERTHOUD, CO:
2,599,440, CANC. INT. CL. 25.

DAD SERVICES, INC., OCEANSIDE, CA, DBA IN CALIFORNIA AS FINDYOURCARE.COM:
3,630,237, PUB. 3-17-2009. INT. CL. 35.

DAD'S PET CARE, MEADVILLE, PA:
2,175,651, CANC. INT. CL. 31.

DADA CORPORATION, SEOUL, REPUBLIC OF KOREA:
2,599,667, CANC. MULTIPLE CLASS, INT. CLS. 18 AND 25.
2,599,668, CANC. MULTIPLE CLASS, INT. CLS. 18 AND 25.
2,599,673, CANC. INT. CL. 25.

DAEWOO TELECOM LTD., INCHEON-SHI, REPUBLIC OF KOREA:
2,598,694, CANC. INT. CL. 9.

DAIMLER AG, 70567 STUTTGART, FED REP GERMANY:
677,154, REN. 4-25-09. U.S. CL. 2 (INT. CL. 18).

DAIMLER AG, STUTTGART, FED REP GERMANY:
2,596,626, CANC. INT. CL. 12.
2,596,892, CANC. INT. CL. 12.

DAIMLER AG, 70327 STUTTGART, FED REP GERMANY:
3,629,603, PUB. 3-17-2009. MULTIPLE CLASS, INT. CLS. 7, 9 AND 12.

DAIMLER TRUCKS NORTH AMERICA LLC, PORTLAND, OR:
3,632,403, INT. CL. 25.
3,633,139, INT. CL. 36.

DAKTRONICS, INC., BROOKINGS, SD:
3,629,300, PUB. 3-17-2009. INT. CL. 35.

DALE OTTLEY, LISA TALBERT PARTNERSHIP, THE, NORTH HOLLYWOOD, CA, DBA PROSKITS:
2,598,327, CANC. INT. CL. 41.

DALE, SUSAN, POOLVILLE, TX AND DALE, DOYLE, POOLVILLE, TX:
3,629,601, PUB. 12-9-2008. MULTIPLE CLASS, INT. CLS. 25 AND 29.

DALHOFF LARSEN & HORNEMAN, DENMARK:
3,631,673, PUB. 3-17-2009. MULTIPLE CLASS, INT. CLS. 19, 31 AND 35.

DALLASFAMILYHOMES.COM, ARLINGTON, TX, DBA DALLASFAMILYHOMES.COM:
3,630,476, PUB. 3-17-2009. INT. CL. 35.

DAMASCHINO, ELLEN L., PORTLAND, OR:
3,629,734, PUB. 3-17-2009. MULTIPLE CLASS, INT. CLS. 35 AND 41.

DAMIAN SERENA BERTOMEU, 46680 ALGEMESI, VALENCIA, SPAIN:
2,596,883, CANC. INT. CL. 28.

DAMIEN JEWELRY, INC., NEW YORK, NY:
2,599,082, CANC. INT. CL. 14.

DAN.TAKUMA TECHNOLOGIES INC., KOMAE, TOKYO, JAPAN:
2,252,856, REN. 4-29-09. INT. CL. 11.

DANA FREED, NEW YORK, NY:
3,633,107, INT. CL. 28.

DANA'S DESIGN STUDIO, L.L.C., ST. LOUIS, MO:
3,630,781, PUB. 3-17-2009. INT. CL. 42.

DANBAR INTERNATIONAL LTD., WELHAM GREEN, UNITED KINGDOM:
3,632,662, INT. CL. 28.

DANFOSS A/S, NORDBORG, DENMARK:
3,631,442, PUB. 3-17-2009. MULTIPLE CLASS, INT. CLS. 7, 9 AND 17.

DANIEL C. DIAL, SHELTON, WA:
3,631,443, PUB. 3-17-2009. INT. CL. 9.

DANIEL LEE GABBERT, HERMOSA, SD:
3,633,436, INT. CL. 45.

DANIEL PHILIPS, OXNARD, CA:
3,630,256, PUB. 3-17-2009. INT. CL. 33.

DANIEL, THOMAS, PARKVILLE, VICTORIA, AUSTRALIA AND TREVITT, ROBERT, PARKVILLE, VICTORIA, AUSTRALIA:
2,596,815, CANC. INT. CL. 25.

DANIELI & C. OFFICINE MECCANICHE SPA, 33042 BUTTRIO (UD), ITALY:
2,596,681, CANC. INT. CL. 7.

DANIELS & ASSOCIATES, INC., DENVER, CO:
1,497,088, CANC. INT. CL. 38.

DANNY OMARI, NEW YORK, NY:
3,632,956, INT. CL. 43.

DANVER & APPEX LIMITED, CHICAGO, IL:
2,598,249, CANC. MULTIPLE CLASS, INT. CLS. 18 AND 25.

DANVID, INC., CRANSTON, RI:
2,175,214, CANC. MULTIPLE CLASS, INT. CLS. 9, 16 AND 28.

DAPTIV, INC., SEATTLE, WA:
3,632,049, MULTIPLE CLASS, INT. CLS. 9, 38 AND 42.

DARF, INCORPORATED, PORTLAND, OR:
3,630,739, PUB. 3-17-2009. INT. CL. 28.

DARFORD INDUSTRIES LTD., VERNON, BRITISH COLUMBIA, CANADA:
2,320,249, REN. 4-27-09. INT. CL. 31.

DARK HORSE COMICS, INC., MILWAUKIE, OR:
2,599,612, CANC. INT. CL. 16.

DARYL BORNSTEIN AUDIO, NEW YORK, NY:
2,598,216, CANC. INT. CL. 9.

DARYL KERRIGAN CONSULTING, LTD., NEW YORK, NY:
3,631,291, PUB. 3-17-2009. INT. CL. 25.

DATA FLOW SYSTEMS, INC, MELBOURNE, FL:
3,631,339, PUB. 3-17-2009. INT. CL. 9.

DATA SOURCE OF LOUDOUN, INC., LEESBURG, VA:
3,630,727, PUB. 3-17-2009. INT. CL. 35.
3,630,728, PUB. 3-17-2009. INT. CL. 35.

DATA SWISS SOLUTIONS AG, 8590 ROMANSHORN, SWITZERLAND:
2,597,715, CANC. MULTIPLE CLASS, INT. CLS. 35, 37 AND 42.

DATACOM DESIGN GROUP, L.L.C., AUSTIN, TX, DBA DATACOM DESIGN GROUP:
3,630,149, PUB. 3-17-2009. INT. CL. 42.

DATACORE SOFTWARE CORPORATION, FORT LAUDERDALE, FL:
3,632,473, INT. CL. 9.

DATAKEY ELECTRONICS, INC., SAVAGE, MN:
3,630,262, PUB. 3-17-2009. INT. CL. 9.

DATASUL S.A., JOINVILLE, BRAZIL:
2,599,596, CANC. INT. CL. 9.

DAVANTZIS, THEODORE, TEMPLETON, CA:
3,632,001, INT. CL. 41.

DAVE GALLIGOS, MARIETTA, GA, DBA THE AD SHOPPE:
3,630,236, PUB. 3-17-2009. INT. CL. 35.

DAVE MIRRA, GREENVILLE, NC:
2,597,687, CANC. INT. CL. 41.

DAVID AUSTIN ROSES LIMITED, ALBRIGHTON, WOLVERHAMPTON, ENGLAND:
2,706,235, CANC. MULTIPLE CLASS, INT. CLS. 3 AND 26.

DAVID GROSSMAN, RICHMOND HILL, ONTARIO, CANADA:
3,629,297, PUB. 5-20-2008. INT. CL. 36.

DAVID THOMAS TOURS, INC., PHILADELPHIA, PA:
2,301,947, REN. 4-27-09. INT. CL. 39.

DAVIDUS CIGARS, LTD., MONROVIA, MD:
3,630,299, PUB. 3-17-2009. INT. CL. 34.

DAVINCI INSURANCE SERVICES, INC., WOODSTOCK, GA:
3,630,485, PUB. 3-17-2009. INT. CL. 36.

DAVIS JILES, LLC, BENTONVILLE, AR:
3,632,843, INT. CL. 28.

DAVIS, GLENN E., DALY CITY, CA:
2,258,669, REN. 4-27-09. INT. CL. 35.

DAVIS, MARY E, KANSAS CITY, MO:
3,630,936, PUB. 3-17-2009. INT. CL. 24.

DAVIS, WILLIAM, BRIAN, ARLINGTON, TX:
2,599,626, CANC. INT. CL. 41.

- DAVKA CORPORATION, SKOKIE, IL:
2,254,834. REN. 4-25-09. INT. CL. 9.
- DAWSON, STUART, PLYMOUTH, MA:
3,632,319, MULTIPLE CLASS, INT. CLS. 16, 25, 35 AND 41.
- DAY SPRING ENTERPRISES, INC., CLARENCE, NY:
1,497,934, CANC. INT. CL. 30.
- DAY-LEWIS, BRIAN, TYNGSBORO, MA:
2,598,904, CANC. INT. CL. 42.
- DAYS CORPORATION, ELKHART, IN:
3,632,938, INT. CL. 7.
- DAYS INN OF AMERICA, INC., ATLANTA, GA TO TM ACQUISITION CORP., DOVER, DE:
1,497,232, CANC. INT. CL. 42.
- DAYTON DEVELOPMENT COALITION, INC., DAYTON, OH:
3,632,373, INT. CL. 35.
3,632,420, INT. CL. 35.
3,632,421, INT. CL. 35.
- DCMS, INC., ORANGE, CA, DBA AFCOM:
2,598,146, CANC. INT. CL. 16.
- DD IP HOLDER LLC, CANTON, MA:
3,632,839, INT. CL. 43.
- DDI ARCHITECTS, PC, PHILADELPHIA, PA:
2,597,758, CANC. INT. CL. 42.
- DE JESUS DE SOUSA, JOSE, WALNUT CREEK, CA:
2,596,813, CANC. INT. CL. 42.
- DEAN DISTRIBUTORS, INC., BURLINGAME, CA:
3,629,945, PUB. 3-17-2009. MULTIPLE CLASS, INT. CLS. 30 AND 32.
- DEAN, LYDIA A., ROCHESTER, NY:
3,631,053, PUB. 3-17-2009. INT. CL. 39.
- DEANGELIS, RICHARD JAMES, LAKE LAND, FL:
3,629,665, PUB. 3-17-2009. INT. CL. 35.
- DEBRA E. ORTIZ, FELTON, CA:
3,632,115, INT. CL. 25.
- DEBRA GOODMANSON, KIRKLAND, WA:
2,598,103, CANC. INT. CL. 29.
- DECARLO, VICTORIA, ANGOLA, NY:
3,630,546, PUB. 3-17-2009. INT. CL. 18.
- DECISION MANAGEMENT COMPANY, INC., MISSION VIEJO, CA:
2,597,807, CANC. INT. CL. 9.
- DECOPAC, INC., ANOKA, MN, MCGLYNN BAKERIES, INC., MINNEAPOLIS, MN:
1,584,090. REN. 4-25-09. INT. CL. 42.
- DECORATIONS & CERAMIC CREATIONS, INC., MIDVALE, UT:
2,599,680, CANC. INT. CL. 28.
- DECORATIVE PRODUCT SOURCE, INC., GOSHEN, NY:
3,630,902, PUB. 3-17-2009. INT. CL. 11.
- DECORATIVE VENEER, INC., CLEVELAND, OH:
2,599,783, CANC. INT. CL. 40.
- DEEM, LLC, INDIANAPOLIS, IN:
3,630,852, PUB. 3-17-2009. INT. CL. 37.
3,630,853, PUB. 3-17-2009. INT. CL. 37.
- DEES ENTERTAINMENT, INC., BURBANK, CA:
3,630,514, PUB. 3-17-2009. INT. CL. 41.
- DEFRATE & PAAVOLA LLC, NEW YORK, NY:
3,633,303, INT. CL. 36.
- DEFT COMPUTERS SOLUTIONS, INC., SYRACUSE, NY:
2,597,343, CANC. INT. CL. 9.
- DEGENNARO, RAFAEL, BRANFORD, CT:
3,633,141, INT. CL. 35.
- DEJA VU CONSULTING, INC., LANSING, MI:
3,631,789, INT. CL. 32.
- DEL MONTE CORPORATION, SAN FRANCISCO, CA:
2,174,667, CANC. INT. CL. 29.
- DELAY, LAURA M, STAMFORD, NY, DBA KIDS EXERCISE AND YOGA:
3,630,046, PUB. 3-17-2009. INT. CL. 41.
- DELICIOUS FOODS, LLC, HOUSTON, TX:
2,596,797, CANC. INT. CL. 29.
- DELL COMPUTER CORPORATION, ROUND ROCK, TX:
2,599,629, CANC. INT. CL. 9.
- DELL INC., ROUND ROCK, TX:
2,236,785. REN. 4-24-09. INT. CL. 40.
2,254,835. REN. 4-24-09. INT. CL. 9.
- DELTA HEALTH TECHNOLOGIES, LLC, ALTOONA, PA:
3,629,826, PUB. 3-17-2009. MULTIPLE CLASS, INT. CLS. 9, 41 AND 42.
- DELTA PRONATURA DR. KRAUSS & DR. BECKMANN GMBH & CO., NEUISENBURG, FED REP GERMANY:
1,496,456, CANC. INT. CL. 3.
- DEMAG CRANES & COMPONENTS GMBH, WETTER, FED REP GERMANY:
2,598,425, CANC. INT. CL. 7.
2,598,487, CANC. INT. CL. 7.
- DEMATIC GMBH, 63073-OFFENBACH, FED REP GERMANY:
3,629,866, PUB. 3-17-2009. INT. CL. 9.
- DEMETRIOS LICENSING, LTD., NEW YORK, NY:
2,239,801. REN. 4-25-09. INT. CL. 35.
- DENALI CO., LLC, WAYLAND, MI:
3,631,293, PUB. 3-17-2009. INT. CL. 30.
3,631,295, PUB. 3-17-2009. INT. CL. 30.
- DENNIS GROSS, NEW YORK, NY:
3,632,048, INT. CL. 3.
- DENNIS W MILLER AND JOEL J MILLER, LINCOLN, CA, DBA OAKDOWN BOOKS:
3,630,189, PUB. 3-17-2009. INT. CL. 16.
- DENNY DURON EVANGELISTIC ASSOCIATION, INC., SHREVEPORT, LA:
2,287,865. REN. 4-24-09. INT. CL. 9.
- DENSHO, SEATTLE, WA, DBA DENSHO: THE JAPANESE AMERICAN LEGACY PROJECT:
3,630,287, PUB. 3-17-2009. INT. CL. 41.
- DENT PRODUCTIONS INC., LAKEVIEW, NY:
2,597,874, CANC. INT. CL. 41.
- DENTAL IMAGE SOLUTIONS CORP., ENCINO, CA:
3,632,089, INT. CL. 35.
- DENTALVIEW, INC., LAKE FOREST, CA:
2,175,694, CANC. INT. CL. 10.
2,175,695, CANC. INT. CL. 10.
- DENTAURUM J.P. WINKELSTROETER KG, FED REP GERMANY:
3,631,505, PUB. 3-17-2009. MULTIPLE CLASS, INT. CLS. 8 AND 10.
- DENTSPLY INTERNATIONAL INC., YORK, PA:
3,632,742, INT. CL. 5.
3,632,762, INT. CL. 10.
- DEP CORPORATION, RANCHO DOMINGUEZ, CA:
2,254,098, CANC. INT. CL. 3.
- DEPARTMENT OF DEFENSE, ALEXANDRIA, VA:
3,630,162, PUB. 3-17-2009. INT. CL. 14.
3,630,838, PUB. 3-17-2009. MULTIPLE CLASS, INT. CLS. 38 AND 41.
- DEPARTMENT OF THE ARMY, ARLINGTON, VA:
2,598,767, CANC. MULTIPLE CLASS, INT. CLS. 35 AND 42.
- DEPP GLASS INC., LONG ISLAND CITY, NY:
2,599,336, CANC. INT. CL. 19.
- DEPRAG SCHULZ GMBH U. CO, FED REP GERMANY:
3,631,682, PUB. 3-17-2009. INT. CL. 7.
- DEPUY SPINE, INC., RAYNHAM, MA:
3,633,247, INT. CL. 10.
- DEPUY, INC., WARSAW, IN:
2,268,022. REN. 4-29-09. INT. CL. 10.
- DERVAES INSTITUTE, PASADENA, CA:
3,630,230, PUB. 3-17-2009. INT. CL. 41.
3,633,366, INT. CL. 41.
- DESANA FRAGRANCES, INC., BOSTON, MA:
2,597,191, CANC. MULTIPLE CLASS, INT. CLS. 35 AND 40.
- DESERT LAKE TECHNOLOGIES, LLC, KLAMATH FALLS, OR:
3,632,711, INT. CL. 5.
- DESIGN COMPANY, THE, SAN FRANCISCO, CA:
2,596,988, CANC. MULTIPLE CLASS, INT. CLS. 35, 38 AND 41.
- DESIGN-A-KITCHEN, INC., SOUTH YARMOUTH, MA:
3,630,733, PUB. 3-17-2009. INT. CL. 9.
- DESIGNER SKIN, L.L.C., INDIANAPOLIS, IN:
3,633,142, INT. CL. 3.

DETROIT EDUCATIONAL TELEVISION FOUNDATION, DETROIT, MI:
2,174,597, CANC. INT. CL. 41.

DETROIT ENTERTAINMENT, L.L.C., DETROIT, MI:
3,630,789, PUB. 3-17-2009. INT. CL. 44.

DETROIT ZOOLOGICAL SOCIETY, THE, ROYAL OAK, MI:
2,341,851. REN. 4-29-09. INT. CL. 36.

DEUTSCHE ATOCHEM WERKE GMBH, BONN, FED REP GERMANY TO ARKEMA GMBH, DUSSELDORF, FED REP GERMANY:
1,496,361, CANC. INT. CL. 1.

DEUTSCHE BORSE AG, 60313 FRANKFURT, FED REP GERMANY:
2,596,758, CANC. MULTIPLE CLASS, INT. CLS. 16 AND 36.

DEUTSCHE TELEKOM, BONN, FED REP GERMANY:
3,629,773, PUB. 3-17-2009. INT. CL. 14.
3,629,774, PUB. 3-17-2009. INT. CL. 18.
3,629,775, PUB. 3-17-2009. INT. CL. 25.
3,629,776, PUB. 3-17-2009. INT. CL. 28.
3,629,777, PUB. 3-17-2009. INT. CL. 32.
3,629,779, PUB. 3-17-2009. INT. CL. 35.
3,629,780, PUB. 3-17-2009. INT. CL. 36.
3,629,787, PUB. 1-13-2009. INT. CL. 14.
3,629,788, PUB. 1-13-2009. INT. CL. 18.
3,629,789, PUB. 1-13-2009. INT. CL. 25.
3,629,790, PUB. 1-13-2009. INT. CL. 28.
3,629,791, PUB. 1-13-2009. INT. CL. 32.
3,629,792, PUB. 1-13-2009. INT. CL. 35.
3,629,793, PUB. 1-13-2009. INT. CL. 36.

DEUTSCHE TELEKOM AG, 53113 BONN, FED REP GERMANY:
2,596,825, CANC. MULTIPLE CLASS, INT. CLS. 9, 16, 35, 36, 37, 38, 39, 41 AND 42.
3,629,121, PUB. 10-28-2003. MULTIPLE CLASS, INT. CLS. 9, 16, 35, 36, 38, 41 AND 42.
3,629,122, PUB. 12-9-2003. MULTIPLE CLASS, INT. CLS. 9, 16, 35, 36, 38, 39, 41 AND 42.

DEUTSCHE TELEKOM AG, BONN, FED REP GERMANY:
3,631,382, PUB. 11-11-2008. INT. CL. 9.
3,631,383, PUB. 11-11-2008. INT. CL. 35.
3,631,384, PUB. 11-11-2008. INT. CL. 42.

DEUTSCHE TELEKOM, BONN, FED REP GERMANY:
3,629,554, PUB. 3-17-2009. INT. CL. 14.
3,629,555, PUB. 3-17-2009. INT. CL. 18.
3,629,556, PUB. 3-17-2009. INT. CL. 25.

DEVELOPMENT STRATEGIES LLC, TRABUCO CANYON, CA:
3,629,378, PUB. 3-17-2009. INT. CL. 37.

DEVEREAU BEACH CORPORATION, SWAMPSCOTT, MA:
3,629,238, PUB. 3-17-2009. INT. CL. 43.

DEVGEN, NAAMLOZE VENNOOTSCHAP, ZWIJNAARDE, BELGIUM:
3,629,439, PUB. 3-17-2009. MULTIPLE CLASS, INT. CLS. 1 AND 5.
3,629,440, PUB. 3-17-2009. MULTIPLE CLASS, INT. CLS. 1 AND 5.

DFR MEDIA CORP., AIRDRIE, ALBERTA, CANADA:
3,629,562, PUB. 3-17-2009. INT. CL. 28.

DIABETICSUPPLIES.COM, INC., VANCOUVER, WA:
2,599,581, CANC. INT. CL. 10.

DIAGEO CHATEAU & ESTATE WINES COMPANY, NAPA, CA:
3,629,899, PUB. 3-17-2009. INT. CL. 33.

DIAGEO NORTH AMERICA, INC., NORWALK, CT:
3,629,971, PUB. 3-17-2009. INT. CL. 32.

DIALOG COACH LLC, COOPERSBURG, PA:
3,629,949, PUB. 3-17-2009. INT. CL. 9.

DIAMOND RESORTS HOLDINGS, LAS VEGAS, NV:
3,633,049, MULTIPLE CLASS, INT. CLS. 36 AND 43.

DIBBLE, ANNA D., LONDONDERRY, VT:
3,633,391, INT. CL. 28.

DICHOS, L.L.C., TUCSON, AZ:
3,631,828, INT. CL. 30.

DICK'S SPORTING GOODS, INC., PITTSBURGH, PA:
2,248,176. REN. 4-27-09. INT. CL. 28.

DIEBOLD, INCORPORATED, NORTH CANTON, OH:
3,632,436, INT. CL. 9.

DIGGING RECORDS, INC., HOMER GLEN, IL:
3,633,230, INT. CL. 9.

DIGI INTERNATIONAL INC., MINNETONKA, MN:
2,255,344. REN. 4-26-09. INT. CL. 9.
3,629,708, PUB. 3-17-2009. INT. CL. 9.

DIGITAL COMMONS LLC, SAUSALITO, CA:
3,629,658, PUB. 3-17-2009. MULTIPLE CLASS, INT. CLS. 38, 41 AND 42.

DIGITAL CONNECT, INC., DES MOINES, IA:
2,597,350, CANC. INT. CL. 35.

DIGITAL EVOLUTION, INC., SANTA MONICA, CA:
2,597,183, CANC. INT. CL. 38.

DIGITAL PERIPHERAL SOLUTIONS, INC., ANAHEIM HILLS, CA:
3,630,768, PUB. 3-17-2009. INT. CL. 9.

DIGITAL PLAYGROUND, INC., VAN NUYS, CA:
2,703,616, CANC. INT. CL. 41.

DIGNIFIED LIVING, LLC, TEMPE, AZ:
3,630,965, PUB. 3-17-2009. INT. CL. 37.

DILLON PRECISION PRODUCTS, INC., SCOTTSDALE, AZ:
3,629,991, PUB. 3-17-2009. INT. CL. 13.
3,629,992, PUB. 3-17-2009. INT. CL. 13.
3,629,995, PUB. 3-17-2009. INT. CL. 16.

DILON TECHNOLOGIES, INC., NEWPORT NEWS, VA:
3,632,144, INT. CL. 10.

DIMENSIONS CRAFTS LLC, READING, PA:
1,496,866, CANC. INT. CL. 26.

DIMPLEX (UK) LIMITED, SOUTHAMPTON, UNITED KINGDOM:
3,629,255, PUB. 3-17-2009. MULTIPLE CLASS, INT. CLS. 7, 9 AND 11.

DIMPLEX NORTH AMERICA LIMITED, CAMBRIDGE, ONTARIO, CANADA:
3,632,766, INT. CL. 11.

DING-ZING CHEMICAL PRODUCTS CO., LTD., KAOHSIUNG, TAIWAN:
3,630,224, PUB. 12-9-2008. MULTIPLE CLASS, INT. CLS. 5, 7, 10, 17, 24, 25 AND 26.

DIOB LLC, BILLINGS, MT:
3,633,485, INT. CL. 42.

DIOPENIX INC., GAITHERSBURG, MD:
3,632,641, INT. CL. 42.

DIOPENIX, INC., GAITHERSBURG, MD:
3,632,393, INT. CL. 42.

DIOTRIN, L.L.C., ORLANDO, FL:
2,597,162, CANC. MULTIPLE CLASS, INT. CLS. 9 AND 42.

DIR GROUP, INC., CHANDLER, AZ:
2,597,038, CANC. INT. CL. 41.

DIRECT EMAIL EXPRESS, INC., LAS VEGAS, NV:
2,599,770, CANC. INT. CL. 38.

DIRECTORIESAMERICA, INC., CARY, NC:
2,596,421, CANC. INT. CL. 35.

DIRECTV GROUP, INC., EL SEGUNDO, CA:
2,599,432, CANC. INT. CL. 35.

DISBURSA, LLC, CHESTERFIELD, MO:
3,632,620, INT. CL. 42.

DISCOS MUSART, S.A. DE V.C., MEXICO D.F. 02870, MEXICO:
1,104,665. REN. 4-29-09. INT. CL. 9.

DISCOVERLINK, INC., HENDERSONVILLE, TN:
3,631,458, PUB. 3-17-2009. INT. CL. 41.
3,631,459, PUB. 3-17-2009. INT. CL. 41.

DISCOVERY COMMUNICATIONS, LLC, SILVER SPRING, MD:
2,175,251, CANC. INT. CL. 16.

DISCOVERY GREEN CONSERVANCY, HOUSTON, TX:
3,633,062, INT. CL. 28.

DISGUISE, INC., MALIBU, CA:
3,632,163, INT. CL. 28.

DISH NETWORK L.L.C., ENGLEWOOD, CO:
3,629,605, PUB. 3-17-2009. INT. CL. 9.
3,629,705, PUB. 3-17-2009. MULTIPLE CLASS, INT. CLS. 37 AND 38.
3,629,716, PUB. 3-17-2009. INT. CL. 9.

- DISNEY ENTERPRISES, INC., BURBANK, CA:
3,631,895, INT. CL. 28.
3,632,277, INT. CL. 18.
3,632,398, INT. CL. 41.
3,632,450, INT. CL. 35.
3,633,284, INT. CL. 25.
- DITEX BEDDING CORP., EAST ORANGE, NJ:
3,630,359, PUB. 3-17-2009. INT. CL. 20.
- DIVERSEY LEVER, INC., PLYMOUTH, MI:
2,599,040, CANC. INT. CL. 5.
- DIVERSIFIED BUSINESS COMMUNICATIONS CANADA, MARKHAM, ONTARIO, CANADA:
3,629,310, PUB. 3-17-2009. INT. CL. 41.
- DIVINE CHOICES, INC., TUSTIN, CA:
3,630,958, PUB. 3-17-2009. INT. CL. 45.
- DIVINE PHYSICS HOLISTIC LIFESTYLES, INC., CENTENNIAL, CO:
3,631,795, MULTIPLE CLASS, INT. CLS. 41 AND 44.
- DIVVIES LLC, SOUTH SALEM, NY:
3,630,037, PUB. 3-17-2009. INT. CL. 30.
- DIXIE, USA, INC., HOUSTON, TX:
2,596,627, CANC. INT. CL. 29.
- DIXON, MARIE, GLENDALE, CA:
3,630,653, PUB. 3-17-2009. INT. CL. 16.
- DLN, LLC, CHESTERFIELD, MO:
3,633,410, INT. CL. 38.
- DMD SYSTEMS, LLC, LOS ALAMOS, NM:
2,599,417, CANC. INT. CL. 13.
- DMI, INC., ABINGTON, PA:
1,496,617, CANC. INT. CL. 9.
- DNA DIGITAL MEDIA GROUP, CHICAGO, IL:
3,632,563, INT. CL. 9.
- DNI HOLDINGS, LTD, ST. JOHN'S, ANTIGUA & BARBUDA:
3,629,917, PUB. 3-17-2009. INT. CL. 41.
- DO RAGS, INC., HEWITT, TX:
3,629,311, PUB. 3-17-2009. INT. CL. 25.
- DOBBER'S PASTIES, INC., ESCANABA, MI:
1,553,921, REN. 4-26-09. INT. CL. 30.
- DOC'S GOOFY JIGS, INC., LARGO, FL:
2,598,931, CANC. INT. CL. 28.
- DOG WORKS, INC., TELLICO PLAINS, TN:
1,999,052, REN. 4-27-09. MULTIPLE CLASS, INT. CLS. 12 AND 18.
1,999,053, REN. 4-27-09. MULTIPLE CLASS, INT. CLS. 12 AND 18.
- DOGY BAGZ INC., MALIBU, CA:
3,632,348, MULTIPLE CLASS, INT. CLS. 5 AND 10.
- DOLE FOOD COMPANY, INC., WESTLAKE VILLAGE, CA:
3,633,294, INT. CL. 31.
- DOLLAR GENERAL MERCHANDISING, INC., GOODLETTSVILLE, TN:
2,599,690, CANC. INT. CL. 3.
- DOMARADZKI, IRENA A., BEREIA, OH:
3,631,235, PUB. 3-17-2009. INT. CL. 3.
- DOMINION CHINA, LTD., TORONTO, ONTARIO, CANADA TO EDWIN M. KNOWLES CHINA CO., THE, NILES, IL:
1,496,808, CANC. INT. CL. 21.
- DOMINION ENTERPRISES, NORFOLK, VA:
3,630,425, PUB. 3-17-2009. INT. CL. 35.
- DOMTAR PAPER COMPANY, LLC, FORT MILL, SC:
2,597,056, CANC. INT. CL. 16.
- DON MILLER & ASSOCIATES, INC., BONITA, CA:
3,633,304, INT. CL. 35.
- DON XIANGDONG HO, SOUTH EL MONTE, CA:
3,630,837, PUB. 3-17-2009. INT. CL. 25.
- DONGGUAN FUBAO; SOFA MANUFACTURING CO., LTD., CHINA:
3,570,281, COR. INT. CL. 20.
- DONGGUAN SHENGYA SANITARY WARE CO., LTD., DONGGUAN CITY, GUANGDONG PROVINCE, CHINA:
3,631,664, PUB. 3-17-2009. INT. CL. 28.
- DORE, BRAD, RICHMOND, BRITISH COLUMBIA, CANADA, DBA DORE DESIGN:
2,596,448, CANC. MULTIPLE CLASS, INT. CLS. 9, 14 AND 20.
- DOSCHER, PEGGY, KETCHUM, ID:
2,599,534, CANC. MULTIPLE CLASS, INT. CLS. 41 AND 42.
- DOTERRA HOLDINGS, LLC, OREM, UT:
3,632,893, MULTIPLE CLASS, INT. CLS. 3 AND 5.
- DOUGLASS, SUSAN UPTON, SCARSDALE, NY:
3,630,475, PUB. 3-17-2009. INT. CL. 41.
- DOVE, JAY R., GUERNEVILLE, CA:
2,598,333, CANC. INT. CL. 25.
- DOW AGROSCIENCES LLC, INDIANAPOLIS, IN:
3,631,993, INT. CL. 29.
- DOW CHEMICAL COMPANY, THE, MIDLAND, MI:
871,548, REN. 4-25-09. U.S. CL. 1 (INT. CL. 1).
- DOW JONES & COMPANY, INC., NEW YORK, NY:
3,631,273, PUB. 3-17-2009. MULTIPLE CLASS, INT. CLS. 35, 39 AND 43.
- DOWCO, INC., MANITOWOC, WI:
3,629,593, PUB. 3-17-2009. INT. CL. 12.
- DOWN LITE INTERNATIONAL, MASON, OH:
3,632,002, INT. CL. 24.
- DOWNNS, STEPHEN, BRONX, NY AND ACEVEDO, NOEL, BRONX, NY AND JIMENEZ, ROBERT, BRONX, NY AND LITTLE, CLARENCE, BRONX, NY AND SCHERMERHORN, TIM, BRONX, NY AND ALLEN, NAOMI, BRONX, NY:
2,597,800, CANC. INT. CL. 16.
- DP PET PRODUCTS, INC., ORLANDO, FL:
3,630,577, PUB. 3-17-2009. MULTIPLE CLASS, INT. CLS. 16 AND 21.
- DR. BOBS LTD, SPRINGVILLE, UT, DBA DR. BOBS LTD:
3,630,497, PUB. 3-17-2009. INT. CL. 21.
- DR. CASSELBERRY'S INTEGRATIVE HEALTH CENTER, INC., LYNDHURST, OH:
3,630,129, PUB. 3-17-2009. INT. CL. 44.
- DR. ING. H.C.F. PORSCHE AKTIENGESELLSCHAFT, 70435 STUTTGART-ZUFFENHAUSEN, FED REP GERMANY:
2,705,827, CANC. MULTIPLE CLASS, INT. CLS. 9, 16, 18, 21, 24, 33 AND 42.
- DR. JEAN BAUSCH KG, D50769 KOLN, FED REP GERMANY:
2,207,184, REN. 4-25-09. INT. CL. 10.
- DR. PREETPAL S. SANDHU, M.D., P.C., BEVERLY HILLS, CA, DBA FAMILY THERAPEUTICS:
3,630,871, PUB. 3-17-2009. INT. CL. 44.
- DR. ROBIN, INC., WEST HOLLYWOOD, CA:
3,631,863, INT. CL. 3.
- DR. SEUSS ENTERPRISES, L.P., LA JOLLA, CA:
3,631,027, PUB. 3-17-2009. INT. CL. 16.
3,631,028, PUB. 3-17-2009. INT. CL. 16.
- DR. SEUSS ENTERPRISES, L.P., LA JOLLA, CA:
3,631,021, PUB. 3-17-2009. INT. CL. 16.
- DRAKE EXTRUSION LIMITED, BRIGHLINGTON, BRADFORD, GREAT BRITAIN:
2,175,229, CANC. INT. CL. 22.
- DRAKE, THOMAS, TINLEY PARK, IL AND KASPER, DAVID, BRIDGEVIEW, IL:
2,599,135, CANC. INT. CL. 35.
- DRAPER, ALLEN, PEABODY, MA:
3,630,214, PUB. 3-17-2009. INT. CL. 41.
- DRAVIS, RICHARD, WESTPORT, CT:
3,633,459, INT. CL. 41.
- DREAMSCI INC, JUPITER, FL:
3,631,272, PUB. 3-17-2009. INT. CL. 10.
- DREAMTOWER, LLC, SANTA BARBARA, CA:
2,600,843, CANC. INT. CL. 36.
- DREAMWORKS ANIMATION L.L.C., GLENDALE, CA:
2,599,238, CANC. INT. CL. 28.
- DRIVE4LIFE, LLC, PARK CITY, UT:
2,599,792, CANC. INT. CL. 42.
- DROSSAPHARM AG, SWITZERLAND:
3,631,630, PUB. 3-17-2009. INT. CL. 5.
- DRUM WORKSHOP, INC., OXNARD, CA:
3,633,363, INT. CL. 15.
- DTX INC, MELBOURNE, FL:
3,629,523, PUB. 2-10-2009. INT. CL. 9.

- DUBOIS LIMITED, CORBY, NORTHANTS NN17 5 AE, UNITED KINGDOM TO DUBOIS LIMITED, CORBY, NORTHANTS NN17 5 AE, UNITED KINGDOM:
2,174,239, CANC. INT. CL. 9.
- DUBREUIL, TERENCE S., SEA CLIFF, NY:
2,596,738, CANC. INT. CL. 20.
- DUCKHORN WINE COMPANY, ST. HELENA, CA:
3,632,521, INT. CL. 33.
- DUCTMATE INDUSTRIES, INC., CHARLEROI, PA:
1,522,381, REN. 4-24-09, INT. CL. 6.
- DUESENBERG, LLC, MAPLE PLAIN, MN:
3,633,122, INT. CL. 14.
3,633,123, INT. CL. 28.
- DUKE ENERGY FIELD SERVICES, LLC, DENVER, CO:
2,599,021, CANC. INT. CL. 39.
- DULANTO, MARIA DEL ROSARIO ALCORTA, MIRAFLORES, LIMA, PERU:
3,630,383, PUB. 3-17-2009, INT. CL. 43.
- DULUTH TIMBER COMPANY, DULUTH, MN:
2,597,125, CANC. INT. CL. 40.
- DUMEX MEDICAL SURGICAL PRODUCTS, LTD., SCARBOROUGH, ONTARIO:
2,598,317, CANC. INT. CL. 10.
- DUMONTELLE, JOHN BRIAN, MANAGUA, NICARAGUA:
2,598,126, CANC. INT. CL. 41.
- DUNBAR ARMORED, INC, HUNT VALLEY, VA:
3,630,547, PUB. 3-17-2009, MULTIPLE CLASS, INT. CLS. 36 AND 39.
- DUNDEE CORPORATION, TORONTO, ONTARIO, CANADA:
3,629,123, PUB. 3-17-2009, INT. CL. 36.
3,629,124, PUB. 3-17-2009, INT. CL. 36.
3,631,386, PUB. 3-17-2009, INT. CL. 36.
3,633,494, INT. CL. 36.
- DUNLAP, GRUBB & WEAVER, PLLC, LEESBURG, VA, DBA DUNLAP GRUBB WEAVER:
3,630,937, PUB. 3-17-2009, INT. CL. 45.
- DUNN, RYAN M., SPOKANE, WA:
3,630,788, PUB. 3-17-2009, INT. CL. 9.
- DUNROSE TRADING 57 (PROPRIETARY) LIMITED, GAUTENG, SOUTH AFRICA:
3,631,454, PUB. 3-17-2009, INT. CL. 6.
- DURA GLOBAL TECHNOLOGIES, INC., ROCHESTER HILLS, MI:
3,629,455, PUB. 3-17-2009, INT. CL. 12.
- DURANGO & SILVERTON NARROW GAUGE RAILROAD, INC., DURANGO, CO:
2,596,929, CANC. INT. CL. 41.
- DURO-MED INDUSTRIES, INC., JESUP, GA:
2,401,355, CANC. MULTIPLE CLASS, INT. CLS. 5, 8, 12, 20 AND 21.
- DUTCHER, MICHAEL ALLEN, FORT DODGE, IA:
3,632,027, INT. CL. 30.
- DX ANTENNA COMPANY, LIMITED, HYOGO-KEN, JAPAN:
3,633,305, INT. CL. 9.
- DYNAMEX, INC., IRVING, TX:
2,596,937, CANC. INT. CL. 39.
- DYNAMIC BRANDS, LLC, RICHMOND, VA:
3,632,853, INT. CL. 28.
- DYNAMIC PROCESS SOLUTIONS, INC., TRENTON, IL:
2,596,906, CANC. INT. CL. 42.
- DYNAVET, FRANCE:
3,631,573, PUB. 3-17-2009, MULTIPLE CLASS, INT. CLS. 9 AND 18.
- DYNO NOBEL INC., SALT LAKE CITY, UT:
1,546,317, REN. 4-24-09, INT. CL. 13.
- DYNO, LLC, POMPANO BEACH, FL:
3,630,146, PUB. 3-17-2009, INT. CL. 8.
- DYSON RACING SWAG.COM, LLC, WINNETKA, IL:
3,633,199, INT. CL. 25.
- DZAMBULING IMPORTS, LLC, EL CERRITO, CA:
3,631,796, INT. CL. 32.
- E & H DISTRIBUTING CO., NORTH LAS VEGAS, NV:
2,597,266, CANC. MULTIPLE CLASS, INT. CLS. 29 AND 30.
- E. & J. GALLO WINERY, MODESTO, CA:
3,632,730, INT. CL. 33.
- E. I. DU PONT DE NEMOURS AND COMPANY, WILMINGTON, DE:
3,591,189, AM. INT. CL. 11.
3,629,404, PUB. 3-17-2009, INT. CL. 1.
3,632,073, INT. CL. 5.
3,632,684, INT. CL. 5.
3,632,748, INT. CL. 9.
- E.C. DE WITT AND COMPANY LIMITED, CHESHIRE, UNITED KINGDOM:
3,629,474, PUB. 3-17-2009, MULTIPLE CLASS, INT. CLS. 3, 5 AND 41.
- E.E. NEWCOMER ENTERPRISES, INC., NORTH KANSAS CITY, MO:
3,630,447, PUB. 3-17-2009, INT. CL. 45.
- E.G.L. COMPANY, INC., BERKELEY HEIGHTS, NJ:
2,596,925, CANC. INT. CL. 9.
- E.S. ORIGINALS, INC., NEW YORK, NY:
3,632,501, INT. CL. 25.
- E. THIRTEEN INCORPORATED, EDGARTOWN, MA:
3,632,139, INT. CL. 12.
- E*CARMOTORS, LLC, EMERYVILLE, CA:
2,599,467, CANC. INT. CL. 35.
- E-BUSINESS EXCHANGE PTE LTD, TECH VIEW, SINGAPORE:
2,597,119, CANC. INT. CL. 9.
- E-FILLIATE, INC., RANCHO CORDOVA, CA:
3,632,055, INT. CL. 9.
- E-HEALTHCARE SOLUTIONS, INC., NEWTOWN, PA:
2,597,470, CANC. INT. CL. 35.
2,597,472, CANC. INT. CL. 35.
- E-LYNXX CORPORATION, CHAMBERSBURG, PA:
3,629,569, PUB. 3-17-2009, INT. CL. 35.
- E-ONE CANADA LTD., RED DEER, CANADA:
2,597,315, CANC. INT. CL. 16.
- E-PINION CORPORATION, DALLAS, TX:
2,596,864, CANC. INT. CL. 9.
- E-Z CATCH & COMPANY, CARMEL, CA:
2,174,993, CANC. INT. CL. 28.
- EA BROEKEMA BV TRANSPORTBANDENFABRIEK, NL-9640 AB VEENDAM, NETHERLANDS:
3,631,837, INT. CL. 7.
- EADS ASTRIUM GMBH, MUENCHEN, FED REP GERMANY:
3,629,944, PUB. 3-17-2009, INT. CL. 1.
- EADS SECURE NETWORKS, FRANCE:
3,631,697, PUB. 3-17-2009, INT. CL. 9.
3,631,698, PUB. 3-17-2009, INT. CL. 9.
- EAGLE INDUSTRIES UNLIMITED, INC., FENTON, MO:
3,629,291, PUB. 10-14-2008, MULTIPLE CLASS, INT. CLS. 9, 10, 13, 18, 20, 21, 25, 35 AND 40.
3,629,492, PUB. 10-14-2008, MULTIPLE CLASS, INT. CLS. 9, 10, 13, 18, 20, 21, 25, 35 AND 40.
- EAGLE ONE GOLF PRODUCTS, INC., ANAHEIM, CA:
3,632,407, INT. CL. 19.
- EAGLE'S TRACE, LLC, ST. HELENA, CA:
3,632,677, INT. CL. 33.
- EARTH ESSENTIALS, SANTA BARBARA, CA:
2,252,255, REN. 4-25-09, INT. CL. 3.
- EARTH MAMA ANGEL BABY, LLC, CLACKAMAS, OR:
3,630,057, PUB. 3-17-2009, INT. CL. 3.
- EARTH RELEASE, JACKSONVILLE, FL:
2,599,313, CANC. INT. CL. 3.
- EARTH SOURCE TRADING, INC., EPHRATA, PA:
3,630,470, PUB. 3-17-2009, INT. CL. 31.
- EARTH-KIND, INC., STANLEY, ND:
3,630,905, PUB. 3-17-2009, INT. CL. 5.
- EARTHBAND NETWORKS, INC., BERGENFIELD, NJ:
2,598,865, CANC. INT. CL. 35.
- EAST ASIATIC COMPANY LTD. A/S, THE, 1099 COPENHAGEN K, DENMARK:
1,496,917, CANC. INT. CL. 29.
- EAST COAST GROUP NY LTD, LAURELTON, NY:
3,629,900, PUB. 3-17-2009, INT. CL. 32.
- EASTERN EXTERIOR WALL SYSTEMS, INC., ALLENTOWN, PA:
1,496,783, CANC. INT. CL. 19.

- EASTERN INSTRUMENT LABORATORIES, INC., WILMINGTON, NC:
2,295,124, REN. 4-25-09. INT. CL. 9.
- EASTERN US BUDDHA'S STUDY (FALUN DAFA) ASSOCIATION, INC., NEW YORK, NY:
2,596,982, CANC. MULTIPLE CLASS, INT. CLS. 16 AND 41.
- EASTHILL GROUP, INC., POTTSTOWN, PA:
3,629,856, PUB. 3-17-2009. INT. CL. 2.
- EASTLAND MEDICAL SYSTEMS LTD, AUSTRALIA:
3,631,553, PUB. 3-17-2009. INT. CL. 5.
- EASTMAN KODAK COMPANY, ROCHESTER, NY:
2,599,806, CANC. INT. CL. 9.
- EBAGS, INC., GREENWOOD VILLAGE, CO:
3,630,895, PUB. 3-17-2009. MULTIPLE CLASS, INT. CLS. 9 AND 18.
- EBIOSCIENCE, INC., SAN DIEGO, CA:
3,630,183, PUB. 3-17-2009. INT. CL. 1.
- EBRARY, MOUNTAIN VIEW, CA:
2,598,427, CANC. INT. CL. 9.
- EBSCO INDUSTRIES, INC., BIRMINGHAM, AL:
2,302,310, AM. INT. CL. 25.
- EBX OPTIK, L.C., MIAMI, FL:
3,632,307, INT. CL. 9.
- ECHELON CORPORATION, SAN JOSE, CA, ECHELON SYSTEMS, LOS GATOS, CA:
1,535,141, REN. 4-27-09. INT. CL. 9.
- ECHELON CORPORATION, SAN JOSE, CA:
3,629,448, PUB. 3-17-2009. INT. CL. 9.
- ECHELON RESORTS CORPORATION, LAS VEGAS, NV:
3,633,180, INT. CL. 35.
- ECHO PICTURES, LLC, TARZANA, CA:
3,630,213, PUB. 3-17-2009. INT. CL. 41.
- ECLIPSE PACKAGING, INC., STATESVILLE, NC:
2,597,694, CANC. INT. CL. 40.
- ECOLOG AG, DUSSELDORF, FED REP GERMANY:
3,631,373, PUB. 3-17-2009. INT. CL. 44.
- ECOLOGY AND ENVIRONMENT, INC., LANCASTER, NY:
3,631,833, INT. CL. 35.
- ECOSWIM USA INC., MCALLEN, TX:
3,630,156, PUB. 3-17-2009. INT. CL. 11.
- ECOWASH MOBILE INTERNATIONAL PTY LTD, PARRAMATTA NSW 2150, AUSTRALIA:
3,633,179, MULTIPLE CLASS, INT. CLS. 35 AND 37.
- ECTEL LTD., PETACH TIKVA 49130, ISRAEL:
2,598,483, CANC. INT. CL. 9.
- ED-TECH CO., LTD, KAOHSIUNG CITY, TAIWAN:
2,289,291, REN. 4-25-09. INT. CL. 6.
- EDDIE MIZRAHI, BROOKLYN, NY:
3,632,518, INT. CL. 9.
- EDDY LEON CHOCOLATE COMPANY, MOOSIC, PA TO EDDY LEON CHOCOLATE COMPANY, MOOSIC, PA:
2,175,216, CANC. INT. CL. 30.
- EDENFIELD, CARRIE, WAUCHULA, FL AND EDENFIELD, WILLIAM, WAUCHULA, FL:
3,632,493, INT. CL. 25.
- EDGE QUEST, INC., LAKE VIEW TERRACE, CA:
3,629,939, PUB. 3-17-2009. INT. CL. 25.
- EDGE TECH I.G., INC., CAMBRIDGE, OH:
2,174,903, CANC. INT. CL. 17.
- EDGEWATER MARINE INDUSTRIES, LLC, NEW BEDFORD, MA, MAPTECH, INC., AMESBURY, MA:
2,237,952, REN. 4-25-09. INT. CL. 9.
- EDGEWATER MARINE INDUSTRIES, LLC, NEW BEDFORD, MA:
2,265,756, REN. 4-25-09. INT. CL. 16.
- EDISON ELECTRIC INSTITUTE, WASHINGTON, DC:
3,629,462, PUB. 3-17-2009. INT. CL. 35.
- EDPRO CAPITAL INC., LONDON, CANADA:
3,629,338, PUB. 3-17-2009. MULTIPLE CLASS, INT. CLS. 4, 6, 7, 9 AND 20.
- EDRAMA LEARNING, INC., MONTEREY, CA:
2,598,612, CANC. MULTIPLE CLASS, INT. CLS. 9 AND 41.
- EDUCATIONAL HELP, INC., AMHERST, MA:
3,631,183, PUB. 3-17-2009. INT. CL. 9.
- EFFE 2005 - FINANZIARIA FELTRINELLI S.P.A., MILANO, ITALY:
3,633,358, MULTIPLE CLASS, INT. CLS. 16 AND 41.
- EFREIN, JOEL, LOCH SHELDRAKE, NY:
3,630,247, PUB. 3-17-2009. INT. CL. 3.
- EGE, SPOL. S R.O., CZECH REPUBLIC:
3,631,711, PUB. 3-17-2009. MULTIPLE CLASS, INT. CLS. 6, 9, 37, 41 AND 42.
- EGGETT, RICH, WEST BOUNTIFUL, UT:
3,632,906, MULTIPLE CLASS, INT. CLS. 14 AND 25.
- EGGZACK.COM, LLC, FLEMINGTON, NJ:
3,632,270, INT. CL. 35.
- EHLERT PUBLISHING GROUP, INC., MINNETONKA, MN:
2,239,859, REN. 4-25-09. INT. CL. 16.
- EILEAN SRL, ITALY:
3,631,583, PUB. 3-17-2009. MULTIPLE CLASS, INT. CLS. 12 AND 39.
- EKA PRODUCTIONS LLC, SAN DIEGO, CA:
2,175,000, CANC. INT. CL. 9.
2,175,092, CANC. INT. CL. 28.
- EL BAIK FOOD SYSTEMS COMPANY S.A., LUXEMBOURG:
3,631,565, PUB. 3-17-2009. MULTIPLE CLASS, INT. CLS. 16, 29, 30 AND 43.
- ELANTAS PDG, INC., ST. LOUIS, MO:
256,535, REN. 4-24-09. U.S. CL. 16 (INT. CL. 2).
- ELASTOGRAN GMBH, LEMFÖRDE, FED REP GERMANY:
3,631,902, INT. CL. 1.
- ELDERS, TIA M., NEW ORLEANS, LA, DBA MS. SPRATT'S:
2,599,737, CANC. INT. CL. 35.
- ELEANOR JUAREZ, IRVINE, CA, DBA "MAMA J'S":
3,632,140, INT. CL. 30.
- ELECTRIC VISUAL EVOLUTION, LLC, SAN CLEMENTE, CA:
3,632,120, INT. CL. 9.
3,633,016, INT. CL. 9.
- ELECTROGRAPH SYSTEMS, INC., TIMODIUM, MD:
2,596,952, CANC. INT. CL. 9.
- ELECTROLUX HOME CARE PRODUCTS, INC., CLEVELAND, OH:
3,631,936, INT. CL. 7.
- ELECTRONIC ARTS DRC., REDWOOD CITY, CA:
2,598,864, CANC. MULTIPLE CLASS, INT. CLS. 38, 41 AND 42.
- ELECTRONIC PRINT, INC., AMES, IA:
2,200,051, REN. 4-27-09. INT. CL. 35.
- ELECTRONIC SYSTEMS AND SOFTWARE, INC., ENCINITAS, CA:
1,496,892, CANC. INT. CL. 28.
- ELEMENT ELECTRONICS, LLC, MINNEAPOLIS, MN:
3,633,054, INT. CL. 9.
- ELESA S.P.A., MILANO, ITALY:
3,629,564, PUB. 3-17-2009. INT. CL. 7.
- ELEVEE CUSTOM CLOTHING, INC., VAN NUYS, CA:
3,631,449, PUB. 3-17-2009. INT. CL. 9.
- ELGIN RIVERBOAT RESORT, ELGIN, IL:
2,174,531, CANC. MULTIPLE CLASS, INT. CLS. 35, 41 AND 42.
- ELI LILLY AND COMPANY, INDIANAPOLIS, IN:
3,633,240, INT. CL. 5.
- ELITE LEGAL SEARCH LLC, LA JOLLA, CA:
3,631,112, PUB. 3-17-2009. INT. CL. 35.
- ELIZA JENNINGS GROUP, THE, CLEVELAND, OH:
1,496,735, CANC. INT. CL. 16.
- ELK CORPORATION OF DALLAS, DALLAS, TX:
1,496,784, CANC. INT. CL. 19.
- ELK RIDGE ALMONDS, INC., MADERA, CA:
3,633,318, INT. CL. 29.
- ELLEN LANGE, INC., SPRINGFIELD, NJ:
2,599,780, CANC. INT. CL. 3.
- ELLIS, JOWAN ELIZA, CHICAGO, IL:
3,631,417, PUB. 3-17-2009. INT. CL. 25.
- ELLMAN INNOVATIONS, LLC, OCEANSIDE, NY:
2,598,989, CANC. INT. CL. 10.
- ELMER'S RESTAURANTS, INC., PORTLAND, OR:
3,629,891, PUB. 3-17-2009. INT. CL. 43.

ELPRO INTERNATIONAL, INC., MONTREAL, QUEBEC, CANADA:
2,295,405. REN. 4-28-09. INT. CL. 18.

ELSAG NORTH AMERICA, LLC, GREENSBORO, NC:
3,630,043, PUB. 3-17-2009. INT. CL. 9.

ELSEVIER SCIENCE B.V., 1055 KV AMSTERDAM, NETHERLANDS:
2,175,644, CANC. INT. CL. 42.

ELTEKON HOLDINGS, LLC, AUSTIN, TX:
2,599,218, CANC. INT. CL. 35.

EM RESEARCH, INC., RENO, NV:
3,630,283, PUB. 2-10-2009. INT. CL. 9.

EMALANGE, FRIDA, BELLINGHAM, WA:
3,631,867, INT. CL. 3.

EMERGEN, INC., SALT LAKE CITY, UT:
2,598,950, CANC. INT. CL. 42.

EMERSON CLIMATE TECHNOLOGIES, INC., SIDNEY, OH:
2,175,048, CANC. INT. CL. 9.

EMERY-WATERHOUSE COMPANY, THE, PORTLAND, ME:
2,174,987, CANC. INT. CL. 35.

EMETER CORPORATION, REDWOOD CITY, CA:
2,598,627, CANC. INT. CL. 35.

EMHART GLASS S.A., CH-6330 CHAM, SWITZERLAND, EMHART ZURICH S.A., ZURICH, SWITZERLAND:
1,545,127. REN. 4-27-09. INT. CL. 7.

EMIL HERSCHER, BROOKLYN, NY:
3,631,085, PUB. 3-17-2009. INT. CL. 41.
3,631,088, PUB. 3-17-2009. INT. CL. 41.

EMILIO PUCCI INTERNATIONAL B. V., 3743 KB BAARN, NETHERLANDS:
850,256. REN. 4-27-09. U.S. CL. 39 (INT. CL. 25).

EMISSARY, LLC, AUSTIN, TX:
2,599,427, CANC. INT. CL. 42.

EMNACE LLC, TUKWILA, WA:
3,629,461, PUB. 3-17-2009. INT. CL. 25.

EMOGO, LLC, NEW YORK, NY:
2,599,489, CANC. INT. CL. 25.

EMORY UNIVERSITY, ATLANTA, GA:
3,631,804, MULTIPLE CLASS, INT. CLS. 25 AND 41.

EMPIRE DRIFT RECORDS, LTD., SYLVANIA, OH:
3,630,013, PUB. 3-17-2009. INT. CL. 41.

EMPIRE LABORATORIES, INC, PORTLAND, OR:
3,629,821, PUB. 3-17-2009. INT. CL. 21.

EMPIRE ROAD PRODUCTIONS, LLC, OGDEN, UT:
3,631,849, INT. CL. 16.

EMPLOYEESEMINARS.COM, INC., ALEXANDRIA, VA:
2,597,949, CANC. MULTIPLE CLASS, INT. CLS. 35 AND 41.
2,597,950, CANC. MULTIPLE CLASS, INT. CLS. 35 AND 41.

EMPLOYMENT ENTERPRISES, INC., MANASSAS, VA:
3,629,975, PUB. 3-17-2009. INT. CL. 35.
3,630,040, PUB. 3-17-2009. INT. CL. 35.

EMPLOYMENT TRADITIONS, INC., CALEDONIA, MI:
2,599,744, CANC. INT. CL. 35.

EMPLOYOU, LLC, SAN ANTONIO, TX:
3,629,200, PUB. 3-17-2009. INT. CL. 35.

EMPYREAN INTERNATIONAL LLC, ACTION, MA:
3,629,452, PUB. 3-17-2009. MULTIPLE CLASS, INT. CLS. 19 AND 42.

ENCOMPASS GROUP, LLC, MCDONOUGH, GA, DBA ALBAHEALTH LLC:
3,630,920, PUB. 3-17-2009. INT. CL. 10.

ENCORE MEDICAL ASSET CORPORATION, HENDERSON, NV:
1,496,663, CANC. INT. CL. 10.
2,596,841, CANC. INT. CL. 10.

ENDER, GEORGE, LOS ANGELES, CA:
3,632,068, INT. CL. 37.

ENDURIS, LLC, JACKSONVILLE, FL:
3,631,932, INT. CL. 19.

ENDURO SYSTEMS, INC., HOUSTON, TX, INTERNATIONAL-STANLEY CORPORATION, OMAHA, NE:
868,170. REN. 4-27-09. U.S. CL. 26 (INT. CL. 9).

ENEL S.P.A., ITALY:
3,631,782, PUB. 3-17-2009. MULTIPLE CLASS, INT. CLS. 11, 39 AND 40.
3,631,783, PUB. 3-17-2009. MULTIPLE CLASS, INT. CLS. 11, 39 AND 40.
3,631,784, PUB. 3-17-2009. MULTIPLE CLASS, INT. CLS. 11, 39 AND 40.

ENERNET, INC., REDLANDS, CA, DBA ENERPATH:
2,597,612, CANC. INT. CL. 9.

ENGENIA SOFTWARE, INC., RESTON, VA:
2,596,695, CANC. INT. CL. 9.

ENGINE MANUFACTURERS ASSOCIATION, CHICAGO, IL:
3,632,395, INT. CL. 35.

ENGINEERED LIFTING SYSTEMS, LLC, FENTON, MO:
3,633,394, INT. CL. 25.

ENIKIA INCORPORATED, WARREN, NJ:
2,598,358, CANC. INT. CL. 9.

ENOSWISS GMBH, SWITZERLAND:
3,631,710, PUB. 3-17-2009. MULTIPLE CLASS, INT. CLS. 29, 32 AND 33.

ENRICHMENT TECHNOLOGY COMPANY LIMITED, UNITED KINGDOM:
3,631,556, PUB. 3-17-2009. MULTIPLE CLASS, INT. CLS. 7, 37 AND 42.

ENTERCOM COMMUNICATIONS CORP., BALA CYNWYD, PA:
3,631,349, PUB. 3-17-2009. MULTIPLE CLASS, INT. CLS. 38 AND 41.

ENTERPRISE TRANSFORMATION SOLUTIONS INC, WASHINGTON, DC:
3,630,750, PUB. 3-17-2009. INT. CL. 35.

ENTHONE INC., WEST HAVEN, CT, SEL-REX CORPORATION, NUTLEY, NJ:
683,100. REN. 4-26-09. U.S. CL. 6 (INT. CL. 1).
684,280. REN. 4-26-09. U.S. CL. 6 (INT. CL. 1).

ENTHONE INC., WEST HAVEN, CT:
2,229,498. REN. 4-25-09. INT. CL. 1.

ENTREPIA GP III, LLC, SANTA CLARA, CA:
3,630,554, PUB. 3-17-2009. INT. CL. 36.

ENTRIX-N3 VENTURE, HOUSTON, TX:
2,598,443, CANC. INT. CL. 9.
2,598,444, CANC. INT. CL. 9.

ENTWICKLUNGSGESELLSCHAFT FÜR AKUSTIK (EFA) MIT: BESCHRÄNKTER HAFTUNG, FED REP GERMANY:
3,631,620, PUB. 3-17-2009. MULTIPLE CLASS, INT. CLS. 1, 12, 17 AND 27.

ENVIROCHECK, INC., ORANGE, CA:
3,629,861, PUB. 3-17-2009. INT. CL. 42.

ENVIRODOCK, INC., PALMER, MA:
3,632,964, INT. CL. 11.

ENVIROFINANCE GROUP, LLC, SACRAMENTO, CA:
3,630,486, PUB. 3-17-2009. INT. CL. 36.
3,631,252, PUB. 3-17-2009. INT. CL. 36.

ENVIRONMENTAL PROJECTS, INC., CASPER, WY:
2,599,282, CANC. INT. CL. 1.

ENVISION TELEPHONY, INC., SEATTLE, WA:
3,632,107, INT. CL. 9.

ENVISIONIT MEDIA, INC., CHICAGO, IL:
3,630,511, PUB. 3-17-2009. INT. CL. 35.

ENVITIA PLC, HORSHAM, UNITED KINGDOM:
3,632,215, MULTIPLE CLASS, INT. CLS. 9 AND 42.

EOFFICESUITES, INC., LOS ANGELES, CA:
2,596,737, CANC. INT. CL. 36.

EPCSOLUTIONS, INC., GREAT FALLS, VA:
3,631,009, PUB. 3-17-2009. INT. CL. 9.

EPIC SYSTEMS CORPORATION, VERONA, WI:
3,632,005, INT. CL. 9.

EPILEPSY COALITION OF NEW YORK STATE, INC., ALBANY, NY:
2,599,398, CANC. INT. CL. 28.

EQ GROUP, INC., LOS ANGELES, CA:
3,631,299, PUB. 3-17-2009. INT. CL. 36.

EQUILIBRIUM PRODUCTS LIMITED, BUCKINGHAMSHIRE HP5 3, ENGLAND:
3,631,935, INT. CL. 18.

EQUIPE COMMUNICATIONS CORPORATION, ACTON, MA:
2,599,441, CANC. INT. CL. 9.

- EQUIPMENT RELIABILITY SOLUTIONS LLC, GEORGETOWN, TX:
3,630,050, PUB. 3-17-2009. INT. CL. 37.
- EQUIPMENT SUPERSTORE, LLC, THE, WILMINGTON, OH:
2,599,841, CANC. MULTIPLE CLASS, INT. CLS. 35 AND 37.
- ERACIZM, INC., FOREST PARK, IL:
3,629,279, PUB. 3-17-2009. INT. CL. 25.
- ERIC ANTHONY D'ORAZIO, RESTON, VA:
3,629,599, PUB. 3-17-2009. INT. CL. 41.
- ERICHSON, GERALDINE RINALDI, SEARINGTOWN, NY:
2,598,838, CANC. INT. CL. 41.
- ERICSSON INC., RICHARDSON, TX:
2,598,613, CANC. INT. CL. 9.
2,598,614, CANC. INT. CL. 9.
- ERIKSFJORD, INC., HOUSTON, TX:
3,632,636, INT. CL. 9.
- ERMA INSTITUTE, LLC, DENVER, CO:
3,633,260, INT. CL. 41.
- ERN LLC, BALTIMORE, MD:
2,597,051, CANC. INT. CL. 36.
- ESAOTE, S.P.A., 15033 CASALE MONFERRATO (AL), ITALY:
2,596,924, CANC. INT. CL. 9.
- ESCHENBACH OPTIK GMBH, FED REP GERMANY:
3,631,773, PUB. 3-17-2009. INT. CL. 9.
- ESCORT SEAL CO., LTD., TAIPEI HSIEN, TAIWAN:
2,597,729, CANC. INT. CL. 17.
- ESCUDIE, JEAN-CLAUDE R., PORTLAND, OR:
3,632,869, INT. CL. 9.
- ESET, SPOL. S R.O., SLOVAKIA:
3,631,496, PUB. 3-17-2009. MULTIPLE CLASS, INT. CLS. 9, 38, 41 AND 42.
- ESMERALDA LIQUORS S.L., LLEIDA, SPAIN:
3,629,674, PUB. 3-17-2009. INT. CL. 33.
- ESP MUSIC DISCO LIMITED, NEWBURY, UNITED KINGDOM:
3,633,424, INT. CL. 9.
3,633,425, INT. CL. 35.
- ESPN RISE LLC, BRISTOL, CT:
2,596,938, CANC. MULTIPLE CLASS, INT. CLS. 16 AND 41.
- ESPN, INC., BRISTOL, CT:
2,211,559, REN. 4-27-09. INT. CL. 9.
2,248,352, REN. 4-27-09. INT. CL. 42.
- ESPOSITO, DAVID A., DOYLESTOWN, PA:
3,631,919, INT. CL. 28.
- ESPRESSO EDUCATION LIMITED, HAMMERSMITH LONDON, UNITED KINGDOM:
3,629,782, PUB. 3-17-2009. INT. CL. 41.
- ESPRIT IP LIMITED, ROAD TOWN, TORTOLA, BR. VIRGIN ISLANDS:
3,633,074, MULTIPLE CLASS, INT. CLS. 18 AND 25.
- ESPS, INC., FORT WASHINGTON, PA:
2,599,262, CANC. INT. CL. 9.
- ESSENTECH CO., LTD., INCHEON, REPUBLIC OF KOREA:
3,629,321, PUB. 3-17-2009. MULTIPLE CLASS, INT. CLS. 6, 7, 9, 11, 35 AND 40.
- ESSENTIAL ENTERTAINMENT MEDIA, LLC, LOS ANGELES, CA:
3,631,115, PUB. 3-17-2009. INT. CL. 41.
- ESSENTIAL INGREDIENTS, INC., LAWRENCEVILLE, GA:
3,629,174, PUB. 3-17-2009. INT. CL. 35.
- ESSERMAN NISSAN, LTD., MIAMI, FL:
3,629,622, PUB. 3-17-2009. INT. CL. 35.
- ESTANCIA PIEDRA, S.L., E-49800 TORO (ZAMORA), SPAIN:
3,631,627, PUB. 3-17-2009. INT. CL. 33.
- ESTEE LAUDER INC., NEW YORK, NY:
2,266,715, REN. 4-24-09. INT. CL. 3.
2,598,591, CANC. INT. CL. 3.
2,599,105, CANC. INT. CL. 3.
2,599,742, CANC. INT. CL. 3.
- ESTRATE, EVAN A., ALEXANDRIA, VA:
3,629,132, PUB. 3-17-2009. INT. CL. 28.
- ETCHEGARAY FARMS, LLC, VISALIA, CA:
3,629,230, PUB. 5-8-2007. INT. CL. 31.
3,629,231, PUB. 5-8-2007. INT. CL. 31.
3,629,232, PUB. 5-15-2007. INT. CL. 31.
- ETHICAL INTERNET RETAILERS ASSOCIATION, LLC, BEACHWOOD, OH:
2,599,113, CANC. U.S. CL. 200.
- ETHICAL PRODUCTS, INC., BLOOMFIELD, NJ:
3,632,922, INT. CL. 28.
- ETORUS FEH LLC, ENCINO, CA:
3,631,035, PUB. 3-17-2009. INT. CL. 11.
- ETTIKA, LOS ANGELES, CA:
3,630,807, PUB. 3-17-2009. INT. CL. 14.
- EUGENE WINE CELLARS, LLC, EUGENE, OR:
3,629,412, PUB. 4-22-2008. INT. CL. 33.
- EUROINVERSIONES AGUA DE SOUSAS, S.L.U., SPAIN:
3,631,659, PUB. 3-17-2009. INT. CL. 32.
- EUROPEENNE DE CONDIMENTS, F-21160 COUCHEY, FRANCE:
3,631,694, PUB. 3-17-2009. INT. CL. 30.
- EUROPHARMA, INC., GREEN BAY, WI:
3,632,570, INT. CL. 5.
- EUROSMARTZ LIMITED, CAMBRIDGE, NEW ZEALAND TO EUROSMARTZ LIMITED, CAMBRIDGE, NEW ZEALAND:
2,175,342, CANC. INT. CL. 9.
- EUROSTAR BRANDS, INC., LOS ANGELES, CA:
2,598,366, CANC. INT. CL. 25.
- EUTEK SYSTEMS, INC., HILLSBORO, OR:
3,630,125, PUB. 3-17-2009. INT. CL. 11.
- EVER COMPANION FOOD CORP., TAIPEI, TAIWAN:
3,629,304, PUB. 11-4-2008. INT. CL. 30.
- EVERDRY MARKETING & MANAGEMENT, INC., MACEDONIA, OH:
1,537,715, REN. 4-25-09. INT. CL. 40.
- EVEREST PRODUCTION CORPORATION, SOMERSET, NJ:
3,633,322, INT. CL. 38.
- EVERNAL ELECTRIC MANUFACTURING COMPANY LIMITED, KWAI CHUNG, NEW TERRITORIES, HONG KONG:
2,596,670, CANC. INT. CL. 11.
- EVERSIO, INC., SEATTLE, WA, DBA SUSTAINABLE GROUP, INC.:
3,632,058, INT. CL. 16.
3,632,059, INT. CL. 16.
- EVERT SOFTWARE, INC., CHASKA, MN:
2,599,154, CANC. INT. CL. 9.
- EVERYTHING GAY, LIGHTHOUSE POINT, FL:
2,598,068, CANC. INT. CL. 35.
- EVEST CORPORATION, TAIPEI, TAIWAN:
2,598,610, CANC. INT. CL. 7.
2,598,611, CANC. INT. CL. 9.
- EVOLUTION LASER COSMETIC SOLUTIONS LLC, GREAT NECK, NY:
3,629,618, PUB. 3-17-2009. INT. CL. 9.
- EVRIHOLDER PRODUCTS, LLC, ANAHEIM, CA:
3,632,374, INT. CL. 21.
- EWINGS TECHNOLOGIES, INC., PLANO, TX:
2,597,098, CANC. INT. CL. 38.
- EX LIBRIS GROUP LLC, MENLO PARK, CA:
2,598,708, CANC. INT. CL. 42.
- EXAIR CORPORATION, CINCINNATI, OH:
3,587,630, COR. MULTIPLE CLASS, INT. CLS. 7, 9 AND 11.
- EXEMPLAR COMPANIES, INC., BOSTON, MA:
3,630,313, PUB. 3-17-2009. MULTIPLE CLASS, INT. CLS. 35 AND 36.
- EXEMPLIS CORPORATION, CYPRESS, CA:
3,632,037, INT. CL. 20.
- EXHALE ENTERPRISES, INC., NEW YORK, NY:
3,633,072, INT. CL. 3.
- EXHIBIT A, LLC, PROVIDENCE, RI:
2,599,184, CANC. INT. CL. 20.
- EXOSUN SAS, FRANCE:
3,631,548, PUB. 3-17-2009. INT. CL. 9.
- EXOTEC, INC., SUDBURY, MA:
2,598,935, CANC. INT. CL. 9.

EXOUSA NUTRITION PRODUCTS, INC., NATIONAL CITY, CA:
2,599,550, CANC. INT. CL. 5.

EXPERIENCE HENDRIX, L.L.C., SEATTLE, WA:
2,339,333, REN. 4-27-09. INT. CL. 9.

EXPERT RESOURCES, INC., PEORIA HEIGHTS, IL:
1,541,828, REN. 4-29-09. INT. CL. 35.

EXPOSITIONS, INC., LONG BEACH, NY:
1,497,016, CANC. INT. CL. 35.

EXPROSEED CO., LTD., TOKYO, JAPAN:
3,632,593, MULTIPLE CLASS, INT. CLS. 18 AND 25.

EXTENDED TECHNOLOGIES, INC., HAMMOND, LA:
2,599,713, CANC. INT. CL. 9.

EXTREME REACH INC., NEEDHAM, MA:
3,631,362, PUB. 3-17-2009. INT. CL. 35.

EXTREME ROCK RACE ASSOCIATION, JELICO, TN:
3,632,298, INT. CL. 35.

EXXON MOBIL CORPORATION, IRVING, TX:
3,629,833, PUB. 3-17-2009. INT. CL. 42.

EYE CANDY CLOTHES, INC., NORTH RIVERSIDE, IL:
2,598,737, CANC. INT. CL. 25.

EYE KRAFT OPTICAL, INC., ST. CLOUD, MN:
880,869, REN. 4-25-09. U.S. CL. 26 (INT. CL. 9).

EYEBANDZ, LLC, CORAL SPRINGS, FL:
3,632,734, INT. CL. 9.

EYKON WALL SOURCE, INC., MEMPHIS, TN:
2,598,977, CANC. INT. CL. 16.

EZLOCAL.COM, INC., OAKBROOK TERRACE, IL:
3,629,745, PUB. 3-17-2009. INT. CL. 35.

EZWARD, LLC, DALTON, GA:
3,629,189, PUB. 3-17-2009. INT. CL. 3.

E2GROW, INC., CHAGRIN FALLS, OH:
2,598,574, CANC. INT. CL. 35.

F. KORBEL & BROS., GUERNEVILLE, CA:
2,220,897, REN. 4-25-09. INT. CL. 33.
3,631,860, INT. CL. 33.

F. VON LANGSDORFF LICENSING LIMITED, CALEDON, ONTARIO:
3,632,004, INT. CL. 19.

F.J. DESIGNS, INC., WOOSTER, OH:
2,598,038, CANC. INT. CL. 20.

F&C MANAGEMENT LIMITED, LONDON EC2A 2NY, UNITED KINGDOM:
3,631,523, PUB. 3-17-2009. INT. CL. 36.

F-MATIC, INC., LEHI, UT:
3,632,365, MULTIPLE CLASS, INT. CLS. 5 AND 35.

FABCENTRIC, INC., WELLESLEY, MA:
2,598,570, CANC. INT. CL. 9.

FABRI TRAK SYSTEMS, INC., CRANBURY, NJ:
2,320,957, REN. 4-24-09. INT. CL. 17.

FABRIKANT-TARA INTERNATIONAL LLC, NEW YORK, NY:
3,630,038, PUB. 3-17-2009. INT. CL. 14.

FABRIS INC., STONEY CREEK, CANADA:
3,630,005, PUB. 3-17-2009. MULTIPLE CLASS, INT. CLS. 7 AND 40.

FACETS IP, INC., GROVELAND, CA:
3,631,058, PUB. 3-17-2009. MULTIPLE CLASS, INT. CLS. 35, 41 AND 42.

FACI INDUSTRIES CORPORATION, BOLINGBROOK, IL:
2,174,548, CANC. MULTIPLE CLASS, INT. CLS. 6 AND 9.

FAITH COSMETIC CO., LTD., OSAKI-SHI, OSAKA, JAPAN:
3,631,903, INT. CL. 3.

FALCHI, MARCOS, NEW YORK, NY:
3,633,091, INT. CL. 18.

FAMILY FOOD DISTRIBUTOR, INC., KEARNY, NJ:
3,633,081, MULTIPLE CLASS, INT. CLS. 29, 30 AND 32.

FAMILY NEW YORK PIZZA, INC., TANNERSVILLE, PA:
2,599,580, CANC. INT. CL. 42.

FAMOUS FRAMES MI, LLC, CULVER CITY, CA:
3,629,936, PUB. 10-14-2008. INT. CL. 35.

FANCL CORPORATION, JAPAN:
3,631,747, PUB. 3-17-2009. INT. CL. 3.

FANCY MONKEY STUDIOS, INC., BURBANK, CA:
2,598,109, CANC. MULTIPLE CLASS, INT. CLS. 9 AND 41.

FANCY THAT PARTNERS, LA MESA, CA:
3,630,014, PUB. 3-17-2009. INT. CL. 17.

FANNIE MAY CONFECTIONS, INC., NORTH CANTON, OH, FANNY FARMER CANDY SHOPS, INC., ROCHESTER, NY:
126,844, REN. 4-27-09. U.S. CL. 46 (INT. CL. 30).

FAO SCHWARZ FAMILY FOUNDATION, NEW YORK, NY:
2,597,839, CANC. INT. CL. 35.

FAR & WIDE TRAVEL CORPORATION, MIAMI, FL:
2,598,420, CANC. MULTIPLE CLASS, INT. CLS. 39 AND 42.

FARACI, MARY, ARLINGTON HEIGHTS, IL AND FARACI, FRANK, ARLINGTON HEIGHTS, IL:
3,594,629, COR. INT. CL. 36.

FAREWAY STORES, INC., BOONE, IA:
3,629,379, PUB. 3-17-2009. MULTIPLE CLASS, INT. CLS. 1, 29, 30, 32 AND 35.

FARIBAULT DAIRY COMPANY, INC., FARIBAULT, MN:
3,632,923, INT. CL. 29.

FARK, INC., VERSAILLES, KY:
3,631,345, PUB. 3-17-2009. INT. CL. 41.

FARM CREDIT SERVICES OF AMERICA, ACA, OMAHA, NE:
3,630,947, PUB. 3-17-2009. INT. CL. 9.
3,630,948, PUB. 3-17-2009. INT. CL. 9.

FARMER, DIANE, CLOVERDALE, CA AND GRACE-BRAUN, VIRGINIA, CLOVERDALE, CA:
3,631,976, INT. CL. 16.

FASHION IMPORT (1986) LIMITED, MONTREAL, QUEBEC, CANADA:
3,631,403, PUB. 9-9-2008. INT. CL. 18.

FASMA, LLC, FOREST PARK, IL:
2,599,088, CANC. INT. CL. 3.

FAST BACK ROPES, INC., GRANBURY, TX:
3,630,205, PUB. 3-17-2009. INT. CL. 22.

FAST CHART, INC., DURHAM, NC:
2,597,948, CANC. INT. CL. 35.

FAST HEAT, INC., ELMHURST, IL:
2,596,875, CANC. INT. CL. 9.

FASTCAP, BELLINGHAM, WA:
2,247,437, REN. 4-24-09. INT. CL. 20.

FASTENERS FOR RETAIL, INC., CLEVELAND, OH:
3,632,941, INT. CL. 35.

FAT LAW'S FARM, INC., WAIPAHU, HI:
3,631,122, PUB. 3-17-2009. INT. CL. 31.

FAUCHER, GEORGE P, NAPLES, FL:
3,630,960, PUB. 3-17-2009. INT. CL. 9.

FAZOLI'S MANAGEMENT, INC., LEXINGTON, KY:
2,598,856, CANC. INT. CL. 42.

FBD PARTNERSHIP, LP, SAN ANTONIO, TX:
3,629,962, PUB. 3-17-2009. INT. CL. 37.

FBOP CORPORATION, OAK PARK, IL:
2,597,818, CANC. INT. CL. 36.

FCA NETWORK, INC., SHOREWOOD, IL:
3,629,840, PUB. 3-17-2009. INT. CL. 35.

FCRC, LLC, ROCHESTER, NY:
3,633,476, INT. CL. 36.

FEDERAL LEASING CORP., LIVINGSTON, NJ:
1,497,039, CANC. INT. CL. 36.

FEDERAL NATIONAL MORTGAGE ASSOCIATION, WASHINGTON, D.C., DC, DBA FANNE MAE:
2,528,717, CANC. INT. CL. 36.

FEDERAL RESERVE BANKS COMPOSED OF FEDERAL RESERVE BANK OF ATLANTA, FEDERAL RESERVE BANK OF NEW YORK, FEDERAL RESERVE BANK OF BOSTON, FEDERAL RESERVE BANK OF CHICAGO, FEDERAL RESERVE BANK OF CLEVELAND, FEDERAL RESERVE BANK OF DALLAS, FEDERAL RESERVE BANK OF KANSAS CITY, FEDERAL RESERVE BANK OF MINNEAPOLIS, FEDERAL RESERVE BANK OF PHILADELPHIA, FEDERAL RESERVE BANK OF RICHMOND, FEDERAL RESERVE BANK OF ST. LOUIS, FEDERAL RESERVE BANK OF SAN FRANCISCO, CHICAGO, IL:
3,632,226, INT. CL. 36.

FEDERAL-MOGUL WORLD WIDE INC., SOUTHFIELD, MI:
3,632,185, INT. CL. 12.

FEDERATION OF FLY FISHERS, BOZEMAN, MT:
2,597,156, CANC. INT. CL. 42.

- FEDORJAKA, JOHN, APEX, NC:
3,631,012, PUB. 3-17-2009. INT. CL. 10.
- FELA HOLDING GMBH, FED REP GERMANY:
3,631,647, PUB. 3-17-2009. MULTIPLE CLASS, INT. CLS. 9, 35 AND 40.
- FELLOWES, INC., ITASCA, IL:
2,174,189, CANC. INT. CL. 9.
- FENG, JENNY C., DIAMOND BAR, CA, DBA MARKET-
EERS CLUB:
3,630,254, PUB. 3-17-2009. INT. CL. 35.
- FENWICK-KEATS REALTY, L.L.C., NEW YORK, NY:
2,597,947, CANC. INT. CL. 36.
- FERDINAND M.J.C. WILLEMS, NETHERLANDS:
3,631,657, PUB. 3-17-2009. INT. CL. 5.
- FERELI'S S.A. DE C.V., LA LIBERTAD, EL SALVADOR:
2,599,076, CANC. INT. CL. 30.
- FERGUSON ENTERPRISES, INC., NEWPORT NEWS, VA:
3,633,319, INT. CL. 20.
- FERNDALE LABORATORIES, INC., FERNDALE, MI:
3,633,103, INT. CL. 3.
- FERRARA PAN CANDY CO., INC., FOREST PARK, IL:
3,631,230, PUB. 3-17-2009. INT. CL. 30.
- FERRARA TECHNOLOGY PARTNERS, INC., BELLEAIR
BEACH, FL:
2,599,577, CANC. MULTIPLE CLASS, INT. CLS. 35, 37
AND 42.
- FERTILE HAND, INC., THE, FAIR LAWN, NJ:
2,597,609, CANC. INT. CL. 29.
- FERTILITY FOCUS LIMITED, SUFFOLK, UNITED KING-
DOM:
2,596,505, CANC. INT. CL. 10.
- FESTIVAL FUN PARKS, LLC, NEWPORT BEACH, CA:
3,632,292, INT. CL. 41.
3,632,293, INT. CL. 41.
- FESTO AG & CO. KG, FED REP GERMANY:
3,631,561, PUB. 3-17-2009. MULTIPLE CLASS, INT. CLS. 6, 7, 9, 17 AND 20.
- FETCO HOME DECOR, INC., RANDOLPH, MA:
2,174,702, CANC. INT. CL. 20.
- FFL PRODUCTIONS, LLC, NEW YORK, NY:
3,632,516, INT. CL. 9.
- FPP, A CALIFORNIA GENERAL PARTNERSHIP, LOS
ANGELES, CA:
3,629,284, PUB. 3-17-2009. MULTIPLE CLASS, INT. CLS. 31, 39 AND 41.
- FH ORTHOPEDICS, HEIMSBRUNN, FRANCE:
3,629,964, PUB. 3-17-2009. INT. CL. 10.
- FIAT AUTO S.P.A., 10135 TORINO, ITALY:
2,597,514, CANC. INT. CL. 12.
- FIBRO GMBH, 74855 HABMERSHEIM, FED REP GER-
MANY:
3,440,899, COR. MULTIPLE CLASS, INT. CLS. 1 AND 7.
- FIDELITY NATIONAL INFORMATION SOLUTIONS, INC.,
SANTA BARBARA, CA:
2,598,031, CANC. INT. CL. 36.
2,598,032, CANC. INT. CL. 36.
- FIDELITY WARRANTY SERVICES, INC., DEERFIELD
BEACH, FL:
3,631,880, MULTIPLE CLASS, INT. CLS. 35 AND 42.
3,631,881, MULTIPLE CLASS, INT. CLS. 35 AND 42.
- FIDIA S. P. A., ABANO TERME, ITALY:
2,597,395, CANC. INT. CL. 5.
- FIDUCIARY TRUST COMPANY INTERNATIONAL, NEW
YORK, NY:
2,597,525, CANC. INT. CL. 36.
- FIELDS, GORDON IVAN, LONDON, WIN 6LD, ENGLAND:
2,596,455, CANC. INT. CL. 25.
- FIELDTECH, INC., MILWAUKEE, WI TO IMSWERV LLC,
MILWAUKEE, WI:
2,175,277, CANC. MULTIPLE CLASS, INT. CLS. 41 AND
42.
- FIELDTURF TARKETT INC., TMR-MONTREAL, CANADA:
3,629,707, PUB. 3-17-2009. INT. CL. 27.
- FIERA FOODS COMPANY, TORONTO, CANADA:
3,631,402, PUB. 9-16-2008. MULTIPLE CLASS, INT. CLS. 30
AND 40.
- FIERO EDUCATIONAL SERVICES, INC., CHICAGO, IL:
3,630,348, PUB. 3-17-2009. INT. CL. 41.
- FIESTAS MARKET SQUARE, INC., SAN ANTONIO, TX:
2,597,276, CANC. INT. CL. 41.
- FIFN, INC., SEAL BEACH, CA:
2,596,675, CANC. INT. CL. 38.
- FIFTEEN DEGREES CORP., HOUSTON, TX:
3,629,994, PUB. 3-17-2009. MULTIPLE CLASS, INT. CLS. 7,
11 AND 28.
- FIFTH THIRD BANCORP, CINCINNATI, OH, AKA FIFTH
THIRD BANK:
2,599,720, CANC. INT. CL. 35.
- FIFTH THIRD BANCORP, CINCINNATI, OH:
3,630,495, PUB. 3-17-2009. INT. CL. 45.
- FIFTYONEFIFTYCC LLC, MESA, AZ:
3,632,825, INT. CL. 25.
- FIGGIE INTERNATIONAL INC., RICHMOND, VA:
853,039, CANC. U.S. CL. 13.
- FIGHT WORLD AIDS CORP, PEMBROKE PINES, FL:
3,629,756, PUB. 3-17-2009. INT. CL. 25.
- FIGLA CO., LTD., MINATO-KU, TOKYO 105, JAPAN:
2,174,292, CANC. MULTIPLE CLASS, INT. CLS. 37 AND
42.
- FILEDBY, INC, NASHVILLE, TN:
3,633,014, INT. CL. 41.
- FILIPPO GEMELLI, ITALY:
3,631,639, PUB. 3-17-2009. MULTIPLE CLASS, INT. CLS. 7,
12, 25 AND 28.
- FINALYZ AG, ZUG, SWITZERLAND:
3,631,220, PUB. 3-17-2009. INT. CL. 36.
- FINANCIAL COMPUTER SERVICES, INC., FAIRFIELD, NJ:
2,596,939, CANC. MULTIPLE CLASS, INT. CLS. 35 AND
42.
- FINANCIAL INFORMATION TECHNOLOGIES, INC., TAM-
PA, FL:
2,596,504, CANC. MULTIPLE CLASS, INT. CLS. 36 AND
38.
- FINANCIAL KNOWLEDGE NETWORK, LLC, CUPERTINO,
CA:
3,632,096, INT. CL. 41.
- FINANCIAL ONE CORP., GRAND CAYMAN, CAYMAN
ISLANDS:
3,629,278, PUB. 3-17-2009. MULTIPLE CLASS, INT. CLS. 35
AND 36.
- FINANCIAL ONE MORTGAGE CORPORATION, COLUM-
BUS, OH:
3,630,650, PUB. 3-17-2009. INT. CL. 36.
- FINANCIAL SOFTWARE SYSTEMS, INC., HORSHAM, PA:
3,629,565, PUB. 3-17-2009. INT. CL. 9.
- FINE HOST CORPORATION, GREENWICH, CT:
2,597,535, CANC. MULTIPLE CLASS, INT. CLS. 35 AND
42.
- FINISAR CORPORATION, SUNNYVALE, CA:
3,598,187, COR. MULTIPLE CLASS, INT. CLS. 41 AND
42.
- FIREFLY ENERGY INC., PEORIA, IL:
3,632,147, INT. CL. 9.
- FIREMAN'S FUND INSURANCE COMPANY, NOVATO,
CA:
3,630,448, PUB. 3-17-2009. INT. CL. 36.
- FIREMARK GROUP, INC., THE, MORRISTOWN, NJ:
2,599,117, CANC. INT. CL. 36.
- FIRST CITIZENS NATIONAL BANK, MANSFIELD, PA:
3,630,805, PUB. 3-17-2009. INT. CL. 36.
- FIRST COLONIAL GROUP, INC., NAZARETH, PA:
1,497,046, CANC. INT. CL. 36.
- FIRST COMMERCIAL GROUP COMPANIES, LLC., HIA-
LEAH, FL:
3,632,885, INT. CL. 36.
- FIRST FINANCIAL FEDERAL CREDIT UNION, TOMS
RIVER, NJ:
3,631,200, PUB. 3-17-2009. INT. CL. 35.
- FIRST INTERNATIONAL BANK, HARTFORD, CT:
2,599,718, CANC. INT. CL. 36.
- FIRST KEYSTONE FEDERAL SAVINGS BANK, MEDIA,
PA:
2,596,964, CANC. INT. CL. 36.
- FIRST LOOK, INC., EL SEGUNDO, CA:
3,630,360, PUB. 2-10-2009. INT. CL. 42.

FIRST NATIONAL OF NEBRASKA, INC., OMAHA, NE:
3,632,878, INT. CL. 35.

FIRST PLACE DENTISTRY, LLC, MILWAUKEE, WI:
3,631,986, INT. CL. 44.

FIRST SECURITY BANK, BOZEMAN, MT:
3,632,634, INT. CL. 36.
3,632,635, INT. CL. 36.

FIRST STAR, COLLEGE PARK, MD:
2,596,876, CANC. INT. CL. 42.

FIRSTDOOR.COM, INC., KENNESAW, GA:
2,598,868, CANC. MULTIPLE CLASS, INT. CLS. 35 AND 36.

FIRSTWEB BANCORP, INC., IRVINE, CA:
2,598,094, CANC. INT. CL. 36.

FISHER, CHAD M, PEPPERELL, MA, DBA ARMORY AND KURLAND, JOSEPH, TOWNSEND, MA, DBA ARMORY:
3,629,598, PUB. 3-17-2009. INT. CL. 9.

FISHER, DONALD C., GERMANTOWN, TN:
2,342,675, REN. 4-30-09. INT. CL. 41.

FISKE, GARY S., LAKE OSWEGO, OR AND SWARTZ, PETER J., TUALATIN, OR:
2,598,342, CANC. INT. CL. 9.

FITNESS FIXX SERVICES, INC., FISHERS, IN:
3,630,394, PUB. 3-17-2009. INT. CL. 37.

FITNESS FOR ALL, LLC, CHARLESTON, SC:
3,630,432, PUB. 3-17-2009. INT. CL. 41.

FITNESS TO GO, INC., INDEPENDENCE, MO:
1,496,895, CANC. INT. CL. 28.

FITNESS4HER, INC., WELLINGTON, FL:
3,629,694, PUB. 3-17-2009. INT. CL. 41.

FIVE PHARMS, INC., BAKERSFIELD, CA, DBA MERCY PLAZA PHARMACY:
3,630,290, PUB. 3-17-2009. INT. CL. 3.

FL FOOD LION, INC., SALISBURY, NC:
2,597,538, CANC. MULTIPLE CLASS, INT. CLS. 35 AND 41.
2,597,833, CANC. INT. CL. 31.

FLAHERTY & COLLINS MANAGEMENT, INC., INDIANAPOLIS, IN:
3,631,062, PUB. 3-17-2009. INT. CL. 36.

FLAMBEAU INC., BARABOO, WI:
3,631,238, PUB. 3-17-2009. INT. CL. 28.

FLAMBEAU, INC., BARABOO, WI:
2,599,326, CANC. INT. CL. 9.

FLATIRON FINANCIAL SERVICES INC., CENTENNIAL, CO:
3,629,619, PUB. 3-17-2009. INT. CL. 36.

FLEMING, BERNE, PHOENIX, AZ:
2,596,523, CANC. INT. CL. 42.

FLEMING, DIANNE S., GARDEN CITY, NY:
2,206,993, REN. 4-25-09. INT. CL. 20.

FLETCHER LEISURE GROUP INC., ST. LAURENT, QUEBEC:
1,496,828, CANC. INT. CL. 25.

FLETCHER, JAMES D., BROWNS VALLEY, CA:
1,496,915, CANC. INT. CL. 29.

FLIGHT CLUB LOS ANGELES, LTD., LOS ANGELES, CA:
3,631,815, INT. CL. 25.

FLIPSIDE, INC., EL SEGUNDO, CA:
2,598,564, CANC. INT. CL. 35.

FLITCHAM LIMITED, LONDON, UNITED KINGDOM:
3,629,664, PUB. 3-17-2009. INT. CL. 14.

FLOAT TECH, INC., TROY, NY:
3,632,515, INT. CL. 25.

FLODAC B.V., RIJNSBURG, NETHERLANDS:
2,596,609, CANC. INT. CL. 35.

FLORACRAFT CORPORATION, LUDINGTON, MI:
3,630,423, PUB. 3-17-2009. INT. CL. 17.

FLORIDA ASSOCIATION OF CHRISTIAN COLLEGES AND SCHOOLS, INC., MIRAMAR, FL, DBA FACCS:
3,632,892, MULTIPLE CLASS, INT. CLS. 16, 35, 41 AND 42.

FLORIDA SELECT INSURANCE HOLDINGS, INC., SARASOTA, FL:
2,598,762, CANC. INT. CL. 36.

FLOTATION SYSTEMS, INC., CULLMAN, AL:
3,633,352, INT. CL. 6.

FLOW INTERNATIONAL CORPORATION, KENT, WA:
2,599,361, CANC. INT. CL. 7.

FLOWERS, INC., BOGART, GA:
2,133,679, REN. 4-24-09. MULTIPLE CLASS, INT. CLS. 28 AND 30.

FLOWERSERVE MANAGEMENT COMPANY, IRVING, TX, FLOWSERVE CORPORATION, DAYTON, OH:
2,286,139, REN. 4-25-09. INT. CL. 9.

FLUFFIES KNITWEAR INDUSTRIES, REGENCY PARK, AUSTRALIA:
2,175,246, CANC. INT. CL. 25.

FLUIDMASTER, INC., SAN JUAN CAPISTRANO, CA:
3,630,073, PUB. 3-17-2009. INT. CL. 11.

FLYING PIG GAMES, LLC, CINCINNATI, OH:
3,630,408, PUB. 3-17-2009. INT. CL. 28.

FLYNN MCNEIL RAHEB AND ASSOCIATES LIMITED, TORONTO, ONTARIO, CANADA:
2,596,432, CANC. INT. CL. 9.

FLYNN, LINDA, SCAPPOOSE, OR:
3,632,665, INT. CL. 41.

FMG INNOVATIONS, INC., SCOTTSDALE, AZ:
2,599,603, CANC. INT. CL. 10.

FOCUS BUSINESS SOLUTIONS, LLC, COLUMBUS, OH:
3,630,231, PUB. 3-17-2009. INT. CL. 36.
3,630,315, PUB. 3-17-2009. INT. CL. 36.

FOCUS ON THE FAMILY, COLORADO SPRINGS, CO:
3,631,351, PUB. 3-17-2009. INT. CL. 41.
3,631,357, PUB. 3-17-2009. INT. CL. 41.

FOLEY CONVENTION & VISITORS BUREAU, FOLEY, AL:
3,629,508, PUB. 3-17-2009. INT. CL. 41.

FONCIA, ANTONY, FRANCE:
3,631,425, PUB. 3-17-2009. INT. CL. 38.

FONDATION SAVE OUR SEAS, CH-1206 GENÈVE, SWITZERLAND:
3,631,538, PUB. 12-9-2008. MULTIPLE CLASS, INT. CLS. 9, 14, 16, 18, 24, 28, 41 AND 42.

FONDAZIONE CHAMPIONS FOR; CHILDREN O.N.L.U.S., ITALY:
3,631,490, PUB. 3-17-2009. MULTIPLE CLASS, INT. CLS. 36 AND 41.

FONT BUREAU, INC., THE, BOSTON, MA:
2,598,043, CANC. INT. CL. 9.

FONT I MAS, JUAN CARLOS, BARCELONA, SPAIN:
3,629,441, PUB. 3-17-2009. INT. CL. 5.

FONTAINEBLEAU RESORT PROPERTIES II, LLC, LAS VEGAS, NV:
3,633,197, INT. CL. 44.

FOOD SOLUTIONS, S.A. DE C.V., APODACA, N.L., MEXICO:
2,598,326, CANC. INT. CL. 29.

FOOD TRAVEL AND THE ARTS, LLC, WASHINGTON, DC:
3,629,590, PUB. 3-17-2009. MULTIPLE CLASS, INT. CLS. 16 AND 41.

FOOTBALL NORTHWEST LLC, RENTON, WA:
3,633,279, INT. CL. 41.

FORD MOTOR COMPANY, DEARBORN, MI:
2,597,338, CANC. INT. CL. 35.
2,599,075, CANC. INT. CL. 12.
2,599,740, CANC. INT. CL. 35.
3,633,125, INT. CL. 12.

FORD, AMY SUZANNE, SAN DIEGO, CA, DBA SPANISH MOSS VINTAGE:
3,630,293, PUB. 3-17-2009. INT. CL. 35.

FORGY, TERRY L., SAN LEON, TX, DBA JOE DREGS:
3,629,951, PUB. 3-17-2009. INT. CL. 35.

FORMAPILE INDUSTRIES, INC., CAPE CORAL, FL:
3,630,221, PUB. 3-17-2009. INT. CL. 19.

FORMING TECHNOLOGIES INCORPORATED, OAKVILLE, ONTARIO, CANADA:
3,629,390, PUB. 3-17-2009. INT. CL. 9.

FORTESOFT, INC., SAN FRANCISCO, CA:
2,599,723, CANC. INT. CL. 42.

FORTIFY SOFTWARE, INC., SAN MATEO, CA:
3,630,943, PUB. 3-17-2009. INT. CL. 41.

FORTISPHERE, INC., CHANTILLY, VA:
3,632,361, INT. CL. 9.
3,632,362, INT. CL. 9.
3,632,363, INT. CL. 9.

- FORTUNE PRODUCTS, INC., MARBLE FALLS, TX:
3,630,950, PUB. 3-17-2009. INT. CL. 8.
3,631,360, PUB. 3-17-2009. INT. CL. 8.
- FOSSIL, INC., RICHARDSON, TX:
2,597,260, CANC. INT. CL. 14.
- FOSTER PEPPER & SHEFELMAN PLLC, SEATTLE, WA:
2,598,489, CANC. INT. CL. 16.
- FOSTER'S WINE ESTATES AMERICAS COMPANY, NAPA, CA:
1,116,457, REN. 4-24-09. INT. CL. 33.
- FOTOFIX, LLC, SANTA BARBARA, CA:
3,629,872, PUB. 12-9-2008. INT. CL. 40.
- FOTOFIX, LLC, SANTA BARBARA, CA:
3,629,911, PUB. 12-9-2008. INT. CL. 40.
- FOUND OBJECTS, INC., CARRBORO, NC:
2,597,207, CANC. INT. CL. 35.
- FOUR PAW ENTERPRISES, INC., LOUISVILLE, KY:
2,599,035, CANC. INT. CL. 35.
- FOX CHAPEL PUBLISHING CO. INC., EAST PETERSBURG, PA:
2,599,799, CANC. INT. CL. 16.
- FOX CREEK LEATHER, INDEPENDENCE, VA:
3,633,454, INT. CL. 9.
3,633,455, INT. CL. 25.
- FOX FAMILY PROPERTIES, INC., LOS ANGELES, CA:
2,598,075, CANC. INT. CL. 38.
- FOX RIED PARTNERS, LLC, CHARLESTON, SC:
3,629,557, PUB. 3-17-2009. INT. CL. 41.
- FOX SPORTS NET, INC., LOS ANGELES, CA:
3,630,506, PUB. 3-17-2009. INT. CL. 41.
- FOX TELEVISION STUDIOS, INC., LOS ANGELES, CA:
3,632,915, INT. CL. 41.
- FOY, KEENAN T., LOUISVILLE, KY:
3,631,136, PUB. 3-17-2009. INT. CL. 39.
- FRANCES, BILLIE, SAN DIEGO, CA, DBA GUIDING MINDFUL CHANGE:
3,630,832, PUB. 3-17-2009. INT. CL. 41.
- FRANCHISE FOUNDRY, LLC, SPRINGVILLE, UT:
3,630,553, PUB. 3-17-2009. INT. CL. 35.
- FRANCHISE WINNER, INC., BROOKHAVEN, NY:
3,629,628, PUB. 3-17-2009. INT. CL. 36.
- FRANK BRUNCKHORST CO., BROOKLYN, NY:
1,496,947, CANC. INT. CL. 30.
- FRANKLIN BAKER, INC., CORDOVA, TN:
3,633,059, INT. CL. 29.
- FRANKLIN MINT COMPANY, FRANKLIN CENTER, PA:
2,598,363, CANC. INT. CL. 14.
- FRANKLIN SCHOOL FOR THE PERFORMING ARTS, INC., FRANKLIN, MA:
3,632,461, INT. CL. 41.
- FRANKLIN SPORTS, INC., STOUGHTON, MA:
3,630,117, PUB. 3-17-2009. INT. CL. 28.
- FRANKS, JUDY, HIGHLAND PARK, IL, DBA THE MARKETING DEMOCRACY:
3,630,961, PUB. 3-17-2009. INT. CL. 35.
- FRANTZIS, BRUCE KUMAR, FAIRFAX, CA:
3,631,885, INT. CL. 41.
- FRANZ WURZER, AUSTRIA:
3,631,521, PUB. 3-17-2009. MULTIPLE CLASS, INT. CLS. 6, 8 AND 28.
- FRED MEYER STORES, INC., PORTLAND, OR:
2,834,406, CANC. INT. CL. 5.
3,631,301, PUB. 3-17-2009. INT. CL. 35.
3,631,354, PUB. 3-17-2009. INT. CL. 35.
- FRED USINGER, INC, MIWAUKEE, WI:
2,597,652, CANC. INT. CL. 29.
- FREDDY PRODUCTS LIMITED, PERSHORE, UNITED KINGDOM:
3,629,589, PUB. 3-17-2009. INT. CL. 7.
- FREDERICK GOLDMAN, INC., NEW YORK, NY:
2,598,355, CANC. INT. CL. 14.
- FREE PRO MARKETING, LLC, ANAHEIM, CA:
3,631,078, PUB. 3-17-2009. INT. CL. 35.
- FREEBORDERS.COM, INC., SAN FRANCISCO, CA:
3,629,216, PUB. 3-17-2009. INT. CL. 35.
3,629,217, PUB. 3-17-2009. INT. CL. 35.
3,629,218, PUB. 3-17-2009. INT. CL. 35.
- FREEDOM COMMUNICATIONS, INC., SANTA ANA, CA, DBA THE ORANGE COUNTY REGISTER:
3,632,597, INT. CL. 41.
3,632,767, INT. CL. 41.
- FREEDOM ELECTRONICS, INC., KENNESAW, GA:
3,629,925, PUB. 3-17-2009. INT. CL. 37.
- FREEDOM GROUP, INC., THE, CEDAR RAPIDS, IA:
2,175,189, CANC. INT. CL. 9.
- FREEFORM PRODUCTIONS LIMITED, LONDON, UNITED KINGDOM:
3,633,324, MULTIPLE CLASS, INT. CLS. 9, 16, 35 AND 41.
- FREIDMAN-KLINGE CIGAR CO., ST. LOUIS, MO:
3,629,169, PUB. 3-17-2009. INT. CL. 34.
- FREMONT BANK, FREMONT, CA:
3,629,632, PUB. 3-17-2009. INT. CL. 36.
- FRESH EXPRESS INCORPORATED, SALINAS, CA:
2,323,505, REN. 4-25-09. INT. CL. 29.
- FRESHVAC, LLC, ST. LOUIS PARK, MN:
3,630,357, PUB. 3-17-2009. INT. CL. 21.
- FREYTECH INC., MIAMI, FL:
3,629,875, PUB. 3-17-2009. INT. CL. 11.
- FRICK ENTERPRISES, INC., ALEXANDRIA, VA:
2,597,987, CANC. INT. CL. 35.
- FRIEDE GOLDMAN OFFSHORE, GULFPORT, MS:
2,599,753, CANC. INT. CL. 7.
- FRIENDS OF "THE MAP", LA JOLLA, CA:
3,630,318, PUB. 3-17-2009. INT. CL. 35.
- FRITO-LAY NORTH AMERICA, INC., PLANO, TX:
1,496,957, CANC. INT. CL. 30.
2,341,230, REN. 4-27-09. INT. CL. 30.
2,599,301, CANC. INT. CL. 30.
3,631,327, PUB. 3-17-2009. INT. CL. 29.
- FRUL CASSETTI S.P.A., I-33070 MARON DI BRUGNERA (PN), ITALY:
2,598,598, CANC. INT. CL. 20.
- FRONT PORCH COMMUNICATIONS, SONORA, CA:
2,597,010, CANC. INT. CL. 35.
- FR8 SINGAPORE PTE LIMITED, SINGAPORE, SINGAPORE:
3,629,381, PUB. 3-17-2009. INT. CL. 39.
- FS CHALLENGE, LLC, ST. LOUIS, MO, DBA FS CHALLENGE:
3,632,909, INT. CL. 41.
- FSB ACQUISITION COMPANY, LLC, NORTH LAS VEGAS, NV:
2,598,460, CANC. INT. CL. 16.
- FUCHS, RAFAEL, BROOKLYN, NY:
3,633,469, INT. CL. 41.
- FUDGEY NUT, INC., THE, HUNTSVILLE, AL:
2,597,822, CANC. MULTIPLE CLASS, INT. CLS. 30 AND 35.
- FUENTE MARKETING LTD., TORTOLA, BR.VIRGIN ISLANDS:
3,630,136, PUB. 3-17-2009. INT. CL. 21.
3,631,310, PUB. 3-17-2009. INT. CL. 34.
- FUGATE MEDICAL ASSOCIATES, INCORPORATED, DU-BOIS, PA:
2,597,155, CANC. INT. CL. 42.
- FUJIAN XIANZHILU BIOLOGICAL; SCIENCE AND TECHNOLOGY CO., LTD, FUZHOU CITY, CHINA:
3,631,605, PUB. 3-17-2009. MULTIPLE CLASS, INT. CLS. 5 AND 30.
- FUJIFILM CORPORATION, TOKYO, JAPAN:
2,598,316, CANC. INT. CL. 9.
- FUJIFILM U.S.A., INC., VALHALLA, NY:
3,633,154, INT. CL. 9.
- FUJIKURA LTD., TOKYO, JAPAN:
3,632,237, INT. CL. 21.
- FUJITSU LIMITED, KANAGAWA-KEN, 211-8588, JAPAN:
3,631,998, INT. CL. 9.
- FULBRIGHT & JAWORSKI L.L.P., HOUSTON, TX:
3,632,327, MULTIPLE CLASS, INT. CLS. 9 AND 16.
- FULFILLMENT FUND, LOS ANGELES, CA:
2,597,219, CANC. INT. CL. 41.
- FULGOR EUROPE SPA, ITALY:
3,631,628, PUB. 3-17-2009. INT. CL. 11.
- FULL POINT CORPORATION S.R.L., ITALY:
3,631,715, PUB. 3-17-2009. MULTIPLE CLASS, INT. CLS.

- 20 AND 24.
 FULL SPECTRUM MARKETING & SALES CORP., SAN DIEGO, CA, DBA SURVEYEXPRESS CORPORATION:
 2,598,022, CANC. MULTIPLE CLASS, INT. CLS. 35 AND 41.
- FULLER, OSCAR P., JR., DANBURY, CT:
 2,598,889, CANC. INT. CL. 20.
- FULLING MILL LIMITED, SALFORDS, SURREY RH1 5GH, UNITED KINGDOM:
 3,631,749, PUB. 3-17-2009. MULTIPLE CLASS, INT. CLS. 28 AND 35.
- FUME-LOK PTY LTD, NORWOOD, AUSTRALIA:
 3,631,908, INT. CL. 11.
- FUNDEX GAMES, LTD., INDIANAPOLIS, IN:
 3,630,365, PUB. 3-17-2009. INT. CL. 28.
- FUNDQUEST INCORPORATED, BOSTON, MA:
 3,633,373, INT. CL. 36.
- FUNDSTREET AG, CH-8002 ZURICH, SWITZERLAND:
 2,596,664, CANC. MULTIPLE CLASS, INT. CLS. 9, 36 AND 42.
- FUNRISE TOYS LTD., TSIMSHATSUI EAST, KOWLOON, HONG KONG:
 2,598,749, CANC. INT. CL. 28.
- FURNITURE FIRST, INC., HARRISBURG, PA:
 2,318,287. REN. 4-25-09. U.S. CL. 200.
- FUSCO VINCENZO, RUBANO (PADOVA), ITALY:
 3,631,602, PUB. 3-17-2009. MULTIPLE CLASS, INT. CLS. 18 AND 25.
- FUTURE BUSINESS LEADERS OF AMERICA-PHI BETA LAMBDA, INC., RESTON, VA:
 3,629,358, PUB. 3-17-2009. INT. CL. 26.
- FUTURE FLOORS INC., CONCORD, CA, DBA DESIGN SELECT:
 2,598,092, CANC. INT. CL. 37.
- FUTURE MEDICAL DEVICES CORPORATION PTY LTD., DEAKIN WEST, ACT 2600, AUSTRALIA:
 2,598,727, CANC. INT. CL. 10.
- G. W. JR. MUSIC, INC., PHILADELPHIA, PA:
 2,596,733, CANC. INT. CL. 9.
 2,596,734, CANC. INT. CL. 25.
- G.F. HIGGINS, INC., PEMBROKE, MA:
 2,599,357, CANC. INT. CL. 29.
- G.S. LABORATORIES OF AMERICA, INC., IRVING, TX:
 3,629,480, PUB. 3-17-2009. MULTIPLE CLASS, INT. CLS. 36 AND 42.
- G+P NYC BRANDS, INC., BRONXVILLE, NY:
 3,631,303, PUB. 3-17-2009. INT. CL. 18.
- G-III LEATHER FASHIONS, INC., NEW YORK, NY:
 3,633,396, INT. CL. 25.
- GABRIEL, LEONARD JR., VANCOUVER, WA:
 3,631,949, INT. CL. 25.
- GABRIELE ROLEFF, FED REP GERMANY:
 3,631,650, PUB. 3-17-2009. INT. CL. 9.
- GADZOOKS 21, INC, LOS ANGELES, CA:
 2,597,945, CANC. INT. CL. 35.
- GAGLIARDI, MARK, SAN LEANDRO, CA:
 2,174,587, CANC. MULTIPLE CLASS, INT. CLS. 9 AND 41.
- GAIL DEVERS FOUNDATION, INC., LAWRENCEVILLE, GA:
 2,596,901, CANC. INT. CL. 42.
- GAILAND, LEO, NEW YORK, NY:
 2,598,626, CANC. INT. CL. 42.
- GALASSIA S.R.L., ITALY:
 3,631,771, PUB. 3-17-2009. INT. CL. 25.
- GALAXY DISTRIBUTION SYSTEM LTD., HONG KONG, HONG KONG:
 2,599,861, CANC. INT. CL. 42.
- GALDERMA S.A., CHAM, SWITZERLAND:
 3,633,053, INT. CL. 3.
- GALDERMA S.A., CH - 1000 LAUSANNE 30, SWITZERLAND:
 3,633,330, INT. CL. 3.
- GALE BANKS ENGINEERING, AZUSA, CA:
 3,633,077, INT. CL. 9.
- GALLAGHER MANAGEMENT SERVICES, INC., BEL AIR, MD:
 2,174,785, CANC. INT. CL. 9.
- GALLARD-SCHLESINGER INDUSTRIES, INC., CARLE PLACE, NY:
 1,496,379, CANC. INT. CL. 1.
- GALLERYROW.COM, INC., RENO, NV:
 2,597,271, CANC. INT. CL. 16.
- GALMACCI, ANDREA, LIDO DI CAMAIORE, ITALY:
 3,632,452, INT. CL. 9.
- GALVAN, MANUEL, COVINA, CA:
 3,632,243, INT. CL. 25.
- GAME HEADZ INC, HIGHLAND PARK, MI:
 3,630,289, PUB. 3-17-2009. INT. CL. 35.
- GAMELOFT S.A., PARIS, FRANCE:
 3,632,639, INT. CL. 9.
- GAMESVILLE.COM, INC, WATERTOWN, MA:
 2,597,021, CANC. INT. CL. 41.
- GAMO USA CORP., FT. LAUDERDALE, FL:
 3,632,918, INT. CL. 13.
 3,632,953, INT. CL. 13.
 3,632,954, INT. CL. 13.
- GANCIA S.P.A., CANELLI (ASTI), ITALY:
 3,629,489, PUB. 12-9-2008. INT. CL. 33.
- GANDER MOUNTAIN COMPANY, ST. PAUL, MN:
 3,632,304, INT. CL. 41.
- GANDOLFO'S DELIBOYS, LLC, LAWRENCEVILLE, GA:
 2,719,448 NEW CERT. 6-2-2009. INT. CL. 43.
 2,794,627 NEW CERT. 6-2-2009. INT. CL. 35.
- GANGI, RICHARD P, DURHAM, NY AND GANGI, ROBERT J, BOCA RATON, FL:
 2,599,674, CANC. INT. CL. 23.
- GANNETT SATELLITE INFORMATION NETWORK, INC., MCLEAN, VA:
 3,630,110, PUB. 3-17-2009. INT. CL. 16.
- GAP (APPAREL) LLC, SAN FRANCISCO, CA:
 3,633,314, INT. CL. 36.
- GAP (APPAREL), LLC, SAN FRANCISCO, CA:
 3,631,302, PUB. 3-17-2009. INT. CL. 16.
- GARAN SERVICES CORP., WILMINGTON, DE:
 2,599,046, CANC. INT. CL. 25.
 2,599,047, CANC. INT. CL. 25.
 2,599,048, CANC. INT. CL. 25.
 2,599,049, CANC. INT. CL. 25.
- GARCORT GROUP LLC, FAIRFAX, VA, AKA DON CHURRO CAFE:
 3,630,510, PUB. 3-17-2009. INT. CL. 43.
- GARDEN WRITERS ASSOCIATION, MANASSAS, VA:
 3,629,158, PUB. 3-17-2009. INT. CL. 35.
 3,629,159, PUB. 3-17-2009. INT. CL. 35.
- GARDENGENETICS, LLC, BELLEFONTE, PA:
 3,629,654, PUB. 3-17-2009. MULTIPLE CLASS, INT. CLS. 42 AND 44.
- GARDNER PUBLICATIONS, INC., CINCINNATI, OH AND GARDNER PUBLICATIONS, INC., CINCINNATI, OH:
 509,924. REN. 4-24-09. U.S. CL. 38 (INT. CL. 16).
- GARDNER-WEBB UNIVERSITY, INC., BOILING SPRINGS, NC:
 3,632,467, INT. CL. 41.
- GARNER INDUSTRIES, INC., LINCOLN, NE:
 3,629,392, PUB. 3-17-2009. INT. CL. 9.
- GASPARI NUTRITION INC., LAKEWOOD, NJ:
 3,632,811, INT. CL. 5.
- GATEWAY, INC., SAN DIEGO, CA:
 2,599,515, CANC. INT. CL. 35.
- GATLINBURG DEPARTMENT OF TOURISM, GATLINBURG, TN:
 3,631,140, PUB. 3-17-2009. INT. CL. 35.
- GAYMAR INDUSTRIES, INC., ORCHARD PARK, NY:
 3,632,564, INT. CL. 10.
- GBO INC., QUEBEC, CANADA:
 3,629,397, PUB. 3-17-2009. MULTIPLE CLASS, INT. CLS. 35, 39 AND 40.
- GE BETZ, INC., TREVISO, PA:
 1,539,144. REN. 4-27-09. INT. CL. 9.
- GE FANUC INTELLIGENT PLATFORMS, INC., CHARLOTTEVILLE, VA:
 3,631,282, PUB. 3-17-2009. MULTIPLE CLASS, INT. CLS. 9 AND 42.

- GE HEALTHCARE BIO-SCIENCES AB, UPPSALA, SWEDEN:
3,631,967, INT. CL. 7.
- GE MARQUETTE MEDICAL SYSTEMS, INC., MILWAUKEE, WI:
2,598,265, CANC. INT. CL. 42.
- GEAC ENTERPRISE SOLUTIONS, INC., SOUTHBOROUGH, MA:
2,596,653, CANC. INT. CL. 9.
- GEARBOX SOFTWARE, LLC, PLANO, TX:
3,631,050, PUB. 3-17-2009. INT. CL. 9.
- GEBR. BRASSELER GMBH & CO. KG, LEMGO, FED REP GERMANY:
3,633,288, INT. CL. 10.
3,633,289, INT. CL. 10.
3,633,310, INT. CL. 10.
3,633,311, INT. CL. 10.
- GEC-MARCONI LIMITED, ROCHESTER, KENT, ENGLAND:
1,496,585, CANC. INT. CL. 9.
- GEISHA TRADING B.V., NETHERLANDS:
3,631,735, PUB. 3-17-2009. MULTIPLE CLASS, INT. CLS. 25 AND 35.
- GEM BARCODING INC., WARWICK, RI:
3,630,918, PUB. 3-17-2009. INT. CL. 35.
- GEMPLUS S.C.A., 13705 LA CIOTAT, FRANCE:
2,596,475, CANC. MULTIPLE CLASS, INT. CLS. 9, 16, 37, 38 AND 42.
- GENERAL CONFERENCE CORPORATION OF SEVENTH-DAY ADVENTISTS, SILVER SPRING, MD:
3,630,501, PUB. 3-17-2009. MULTIPLE CLASS, INT. CLS. 16 AND 45.
- GENERAL ELECTRIC COMPANY, SCHENECTADY, NY:
3,632,024, INT. CL. 7.
- GENERAL INSTRUMENT CORPORATION, HORSHAM, PA:
2,598,183, CANC. MULTIPLE CLASS, INT. CLS. 35, 37 AND 42.
- GENERAL MILLS MARKETING, INC., MINNEAPOLIS, MN:
3,630,525, PUB. 3-17-2009. INT. CL. 30.
3,632,312, INT. CL. 30.
- GENERAL MILLS, INC., MINNEAPOLIS, MN:
1,496,753, CANC. INT. CL. 16.
1,496,940, CANC. INT. CL. 30.
1,496,941, CANC. INT. CL. 30.
1,544,731, REN. 4-28-09. INT. CL. 30.
- GENERAL MOTORS CORPORATION, DETROIT, MI:
2,599,638, CANC. INT. CL. 36.
- GENERAL WATER COMPANY, INC., SANTA ANA, CA:
2,598,157, CANC. INT. CL. 11.
- GENESIS ACQUISITION COMPANY, INC., BEND, OR:
3,629,952, PUB. 3-17-2009. INT. CL. 20.
- GENFLEX ROOFING SYSTEMS, LLC, INDIANAPOLIS, IN:
3,632,801, INT. CL. 17.
- GENOMEWEB LLC, NEW YORK, NY:
2,599,286, CANC. INT. CL. 41.
- GENSCRIPT CORPORATION, PISCATAWAY, NJ:
3,630,585, PUB. 3-17-2009. INT. CL. 1.
- GEO NORTH, LLC, ANCHORAGE, AK:
2,596,693, CANC. INT. CL. 9.
- GEODETICS, INC., LA JOLLA, CA:
3,631,410, PUB. 3-17-2009. INT. CL. 9.
- GEOQUEST, INC., HURRICANE, UT:
3,632,460, INT. CL. 41.
- GEORGE A. POWELL, SUMMERLAND, CA:
3,633,328, INT. CL. 28.
- GEORGE VERANO USA LLC, CORONA, NY:
3,630,450, PUB. 3-17-2009. INT. CL. 18.
3,630,515, PUB. 3-17-2009. INT. CL. 25.
3,630,516, PUB. 3-17-2009. INT. CL. 18.
- GEORGE'S HAPPY HOG BAR-B-Q, INC., OKLAHOMA CITY, OK:
3,631,158, PUB. 3-17-2009. INT. CL. 43.
- GEOTRACE TECHNOLOGIES, INC., HOUSTON, TX:
3,629,423, PUB. 3-17-2009. INT. CL. 42.
- GERALD PELLETIER, INC., PORTLAND, ME:
3,631,019, PUB. 3-17-2009. MULTIPLE CLASS, INT. CLS. 37, 39 AND 40.
- GERD ZIMMERMANN, FED REP GERMANY AND DR. THOMAS LEIDESCHER, FED REP GERMANY AND DR. CHRISTIAN GINZEL, FED REP GERMANY:
3,631,672, PUB. 3-17-2009. MULTIPLE CLASS, INT. CLS. 16, 41 AND 45.
- GERDAU AMERISTEEL US INC., TAMPA, FL:
2,598,921, CANC. INT. CL. 7.
- GERMAINE DE CAPUCCINI, S.A., 03800 ALCOY (ALICANTE), SPAIN:
2,597,117, CANC. INT. CL. 38.
- GET A MOVE ON, INC., WICHITA, KS:
3,630,612, PUB. 3-17-2009. INT. CL. 39.
- GETTY IMAGES (US), INC., SEATTLE, WA:
2,174,796, CANC. INT. CL. 35.
- GFS, INC., ORANGE, CT, DBA CHAMBER INSURANCE TRUST:
2,310,427, REN. 4-24-09. INT. CL. 36.
- GFTA ANALYTICS LTD., NASSAU, BAHAMAS:
3,633,269, MULTIPLE CLASS, INT. CLS. 9 AND 36.
- GHN-ONLINE, INC., DALLAS, TX:
3,630,579, PUB. 3-17-2009. INT. CL. 38.
- GL.B.I.DI. S.R.L., I-46025 POGGIO RUSCO (MANTOVA), ITALY:
3,631,707, PUB. 3-17-2009. MULTIPLE CLASS, INT. CLS. 7, 9 AND 37.
- GIBBONS, PAUL, PALM CITY, FL:
2,598,253, CANC. INT. CL. 28.
- GIBSON & BARNES, INC., EL CAJON, CA:
2,599,699, CANC. INT. CL. 24.
- GIBSON, FERRIN & RIGGS, PLC, MESA, AZ:
3,631,142, PUB. 3-17-2009. INT. CL. 45.
- GILEAD SCIENCES, INC., FOSTER CITY, CA:
3,630,622, PUB. 3-17-2009. INT. CL. 5.
- GILL RANCH STORAGE, LLC, PORTLAND, OR:
3,629,880, PUB. 3-17-2009. INT. CL. 39.
3,629,881, PUB. 3-17-2009. INT. CL. 39.
- GILROY, TIMOTHY, EAST STROUDSBURG, PA:
3,633,029, INT. CL. 25.
- GIMASGIRLS, LLC, MANCHESTER, NH:
3,631,892, INT. CL. 25.
- GIORA, LLC, ALBANY, NY:
3,631,236, PUB. 3-17-2009. INT. CL. 14.
- GIORDANO POULTRY PLAST S.P.A., CARAGLIO CN, ITALY AND LINCO ITALIA S.R.L., BRESCIA, ITALY:
3,629,876, PUB. 3-17-2009. INT. CL. 20.
- GIORGIO GIORGIS, ITALY:
3,631,599, PUB. 3-17-2009. INT. CL. 30.
- GIOVANNI'S PIZZA, INC., ASHLAND, KY:
3,631,396, PUB. 3-17-2009. INT. CL. 43.
- GISONNI, DEBBIE, REDWOOD CITY, CA:
2,598,348, CANC. MULTIPLE CLASS, INT. CLS. 16 AND 42.
- GKN DRIVELINE INTERNATIONAL GMBH, D-53797 LOHMAR, FED REP GERMANY:
2,597,608, CANC. MULTIPLE CLASS, INT. CLS. 9 AND 12.
- GLACIALTECH, INC., CHINA:
3,631,668, PUB. 3-17-2009. INT. CL. 11.
- GLACIER SALES INC., YAKIMA, WA:
3,630,165, PUB. 3-17-2009. INT. CL. 29.
- GLADSTONE, WAYNE L., SYOSSET, NY:
3,630,163, PUB. 3-17-2009. INT. CL. 41.
- GLASHUTTER UHRENBETREIB GMBH, 01768 GLASHUTTE, FED REP GERMANY:
2,174,491, CANC. MULTIPLE CLASS, INT. CLS. 9 AND 14.
- GLASSAUTOMATIC INC., MOUNT PLEASANT, PA:
3,632,549, INT. CL. 21.
- GLASSFORD HILL HOLDINGS I, LLC, PHOENIX, AZ:
2,598,923, CANC. INT. CL. 37.
- GLAXO GROUP LIMITED, GREENFORD, MIDDLESEX, UNITED KINGDOM:
2,638,300, CANC. MULTIPLE CLASS, INT. CLS. 1, 3, 10, 21, 29, 30, 32 AND 35.
2,708,353, CANC. MULTIPLE CLASS, INT. CLS. 1, 21, 29, 30 AND 32.

GLEA LLC, IRVING, TX:
3,630,405, PUB. 3-17-2009. INT. CL. 36.

GLENBARD GRAPHICS, INC., CAROL STREAM, IL:
2,597,014, CANC. MULTIPLE CLASS, INT. CLS. 40 AND 42.

GLENN BOUDREAU, ROY, UT, DBA AFTER HOURS OFFICE CLEANING:
3,630,066, PUB. 3-17-2009. INT. CL. 37.

GLENN MILLER ASSOCIATES, LOS ALAMITOS, CA:
3,632,731, INT. CL. 14.

GLOBAL AUTO MALL, NORTH PLAINFIELD, NJ:
3,631,394, PUB. 3-17-2009. MULTIPLE CLASS, INT. CLS. 35, 36 AND 39.

GLOBAL DIRECTORIES, INC., JACKSONVILLE, FL:
3,629,374, PUB. 3-17-2009. MULTIPLE CLASS, INT. CLS. 9, 16 AND 35.
3,629,376, PUB. 3-17-2009. MULTIPLE CLASS, INT. CLS. 9 AND 16.
3,629,377, PUB. 3-17-2009. INT. CL. 35.

GLOBAL HOME PRODUCTS LLC C/O CERBERUS CAPITAL MANAGEMENT, L.P., NEW YORK, NY:
1,496,811, CANC. INT. CL. 21.

GLOBAL INSIGHT COMMUNICATIONS, LLC, LAS VEGAS, NV:
3,632,131, MULTIPLE CLASS, INT. CLS. 9, 16 AND 41.

GLOBAL JUICES AND FRUITS, LLC, STAR, ID:
3,629,536, PUB. 3-17-2009. INT. CL. 32.

GLOBAL LOUNGE EXPERIENCE LLC, THE, DALLAS, TX:
2,599,452, CANC. INT. CL. 38.

GLOBAL RECYCLING TECHNOLOGIES, LTD., TEMPE, AZ:
3,632,241, INT. CL. 40.

GLOBAL REWARDS ENTERPRISES, INC., LA CANADA/FLINTRIDGE, CA, DBA REWARDPOST.COM:
3,629,495, PUB. 3-17-2009. INT. CL. 35.

GLOBAL SOFTWARE, INC., CAMPBELL, CA:
2,598,403, CANC. INT. CL. 9.

GLOBAL TRAVEL INTERNATIONAL, INC., MAITLAND, FL:
2,276,614, REN. 4-29-09. INT. CL. 16.

GLOBAL VALIDATORS INC., TROY, MI:
2,597,572, CANC. INT. CL. 42.

GLOBAL VIEWS, L.P., DALLAS, TX:
3,629,339, PUB. 3-17-2009. MULTIPLE CLASS, INT. CLS. 4, 6, 9, 11, 14, 16, 18, 19, 20, 21 AND 24.

GLOBE TELECOM, INC., MANDALUYONG CITY, PHILIPPINES:
3,629,362, PUB. 3-17-2009. INT. CL. 38.

GLOBO COMUNICAÇÃO E PARTICIPAÇÕES S.A., RIO DE JANEIRO - RJ, BRAZIL:
3,629,709, PUB. 3-17-2009. MULTIPLE CLASS, INT. CLS. 38, 41 AND 42.

GLOD, DAVID, BATAVIA, IL:
2,599,152, CANC. INT. CL. 28.

GLODAN, INC., MOUNT CARMEL, PA:
2,208,483, REN. 4-25-09. INT. CL. 35.

GLORIA SPAHN, PITTSBURG, CA:
3,632,117, INT. CL. 16.

GLOTO CORP., FULTON, MD:
3,633,167, MULTIPLE CLASS, INT. CLS. 9, 35, 38, 39 AND 42.

GLS TRANSPORT INC., ARLINGTON HEIGHTS, IL:
3,631,186, PUB. 3-17-2009. INT. CL. 39.

GLU MOBILE INC., SAN MATEO, CA:
3,632,030, MULTIPLE CLASS, INT. CLS. 9 AND 41.

GLYCEMIC RESEARCH INSTITUTE, WASHINGTON, DC:
3,632,535, U.S. CL. A.
3,632,536, U.S. CL. A.

GMA ACCESSORIES, INC., NEW YORK, NY:
2,175,086, CANC. INT. CL. 28.
2,175,087, CANC. INT. CL. 28.

GMB, INC., WINSTON-SALEM, NC:
2,599,057, CANC. INT. CL. 34.

GMH MEDIA, LTD., COLUMBUS, OH:
3,629,608, PUB. 3-17-2009. INT. CL. 41.

GOALS IN MOTION, LLC, JOHNSTON, IA:
3,631,014, PUB. 3-17-2009. INT. CL. 41.

GODIVA BRANDS, INC., NEWARK, DE:
2,598,007, CANC. INT. CL. 30.

GOFIT L.L.C., TULSA, OK:
2,402,055, AM. INT. CL. 28.

GOIN' COASTAL SEAFOOD, LLC, CANTON, GA, TA GOIN' COASTAL:
3,630,492, PUB. 3-17-2009. INT. CL. 43.

GOLBAL TOTAL OFFICE, DOWNSVIEW, ONTARIO, CANADA:
2,174,206, CANC. INT. CL. 20.

GOLDBERG CONSULTING LLC, CHASKA, MN:
2,599,133, CANC. INT. CL. 3.
2,599,134, CANC. INT. CL. 3.

GOLDEN ENTERPRISES, INC., MELBOURNE, FL:
1,496,649, CANC. INT. CL. 9.

GOLDEN GIRLS LLC, FORT MYERS, FL:
3,631,161, PUB. 3-17-2009. INT. CL. 35.

GOLDEN NAILS, INC., GREENVILLE, NC:
2,597,383, CANC. INT. CL. 42.

GOLDEN TEMPLE, INC., EUGENE, OR:
2,234,409, AM. INT. CL. 30.

GOLDEN, JILL, NEW YORK, NY, DBA FLUTTER NYC:
3,630,238, PUB. 3-17-2009. INT. CL. 14.

GOLDROCK CAPITAL MANAGEMENT, LP, NEW YORK, NY:
2,599,325, CANC. INT. CL. 36.

GOLF RACK SYSTEMS, L.L.C., FENTON, MI:
3,629,609, PUB. 3-17-2009. INT. CL. 28.

GOMEZ, PABLO, RIDGEFIELD, NJ:
3,629,148, PUB. 3-17-2009. INT. CL. 43.

GOMEZ, SALVADOR, LOS ANGELES, CA:
2,597,787, CANC. INT. CL. 16.

GOOD EARTH CORPORATION, THE, SANTA CRUZ, CA:
2,174,672, CANC. INT. CL. 32.

GOOD EGG STUDIOS, INC., ATLANTA, GA:
3,632,929, INT. CL. 41.
3,632,930, INT. CL. 41.

GOODDINE, RICHARD, DECATUR, GA:
3,631,847, INT. CL. 24.

GOODRICH CORPORATION, CHARLOTTE, NC:
3,629,233, PUB. 3-17-2009. MULTIPLE CLASS, INT. CLS. 1, 2, 6, 7, 9, 11, 12, 13, 20 AND 21.
3,631,452, PUB. 3-17-2009. MULTIPLE CLASS, INT. CLS. 1, 2, 6, 7, 9, 11, 12, 13, 20 AND 21.

GOODWAY GROUP, JENKINTOWN, PA:
3,630,483, PUB. 3-17-2009. INT. CL. 35.

GOODYEAR TIRE & RUBBER COMPANY, THE, AKRON, OH:
2,246,326, REN. 4-27-09. INT. CL. 12.
2,255,361, REN. 4-27-09. INT. CL. 12.

GOOFY FACES, ROCHESTER HILLS, MI:
3,630,909, PUB. 3-17-2009. INT. CL. 41.

GOOGENIUS, LLC, HOLLAND, MI:
3,630,493, PUB. 3-17-2009. INT. CL. 42.

GORCHOV, JOSHUA, OAKLAND, CA:
3,630,624, PUB. 3-17-2009. INT. CL. 35.

GORDINI U.S.A. INC., ESSEX JCT., VT:
1,585,823, REN. 4-27-09. INT. CL. 25.

GORGEOUS GARAGE LLC, REXBURG, ID:
3,632,108, INT. CL. 37.

GORIVER.COM, INC., LONG ISLAND CITY, NY:
2,597,521, CANC. INT. CL. 42.

GOSPEL TIDE BROADCASTING ASSOCIATION, CHAMBERSBURG, PA:
3,631,151, PUB. 3-17-2009. MULTIPLE CLASS, INT. CLS. 16, 38 AND 41.

GOSS CONTIWEB B.V., 5831 AZ BOXMEER, NETHERLANDS:
2,597,015, CANC. INT. CL. 7.

GOT ALL YOUR MARBLES, LLC, TUCSON, AZ:
3,629,262, PUB. 3-17-2009. INT. CL. 14.

GOTRYBE, LLC, JOHNSTON CITY, TN:
3,632,214, INT. CL. 44.

GOTTFRIED MEDICAL, INC., TOLEDO, OH:
3,630,334, PUB. 3-17-2009. INT. CL. 10.

GOTTO D'ORO SOCIETA COOPERATIVA, FRATTOCCHIE (ROMA), ITALY:
3,631,440, PUB. 3-17-2009. INT. CL. 33.

- GOUVEIA, GAREN, MICHAEL, GRASS VALLEY, CA:
2,599,533, CANC. INT. CL. 41.
- GOVERN SOFTWARE INC., MONTREAL, QUEBEC H2Y
1H1, CANADA:
2,597,189, CANC. INT. CL. 9.
- GOVERNOR AND COMPANY OF ADVENTURERS TRAD-
ING INTO HUDSON'S BAY, THE, TORONTO, ONTARIO,
CANADA, DBA HUDSON'S BAY COMPANY:
1,116,411, REN. 4-24-09, INT. CL. 24.
- GOWERY, DAWN M., CHASKA, MN:
2,598,231, CANC. INT. CL. 24.
- GRACE PRESBYTERIAN CHURCH, PEORIA, IL:
2,240,887, REN. 4-24-09, INT. CL. 41.
- GRAEWOLF U.S.A. INC., WILMINGTON, DE:
2,597,384, CANC. INT. CL. 12.
- GRAHAM PACKAGING COMPANY, L.P., YORK, PA:
3,632,387, INT. CL. 21.
- GRAMME CO., JAPAN:
3,631,703, PUB. 3-17-2009. MULTIPLE CLASS, INT. CLS.
14 AND 18.
- GRAND BANKS YACHTS, LTD., SEATTLE, WA:
2,596,691, CANC. INT. CL. 12.
- GRAND COMPANY INC., CODY, WY, DBA B-DAZZLED:
3,630,417, PUB. 3-17-2009, INT. CL. 14.
- GRAND TARGHEE RESORT, LLC, ALTA, WY:
3,629,411, PUB. 3-17-2009. MULTIPLE CLASS, INT. CLS.
35, 36, 37, 41, 43 AND 44.
- GRAND TRAVERSE RESORT & SPA, LLC, ACME, MI:
3,630,109, PUB. 3-17-2009, INT. CL. 43.
- GRANT STREET GROUP, INC., PITTSBURGH, PA:
3,630,969, PUB. 3-17-2009. MULTIPLE CLASS, INT. CLS.
35 AND 42.
- GRANT STREET GROUP, INC., PITTSBURGH, PA, FOR-
MERLY MUNIAUCTION, INC.:
3,631,335, PUB. 3-17-2009, INT. CL. 42.
3,631,336, PUB. 3-17-2009, INT. CL. 42.
- GRAPHIC PRODUCTS, INCORPORATED, BEAVERTON,
OR:
3,630,322, PUB. 3-17-2009, INT. CL. 9.
3,630,324, PUB. 3-17-2009, INT. CL. 9.
- GRASS VALLEY, INC., NEVADA CITY, CA:
2,598,660, CANC. INT. CL. 9.
- GRAVES, JESSE, SUNRISE, FL:
3,629,699, PUB. 3-17-2009, INT. CL. 41.
- GRAVEYARD VINEYARDS, SAN MIGUEL, CA:
3,629,850, PUB. 3-17-2009, INT. CL. 33.
- GRAVY, LLC, NEW ORLEANS, LA, DBA GRAVY:
3,629,351, PUB. 3-17-2009, INT. CL. 41.
- GREAPO POWER TOOLS (SUZHOU) CO., LTD., SUZHOU,
CHINA:
3,632,622, INT. CL. 7.
3,632,624, INT. CL. 7.
- GREAT AMERICAN DUCK RACES, INC., SCOTTSDALE,
AZ, DBA GREAT AMERICAN MERCHANDISE AND
EVENTS:
3,630,786, PUB. 3-17-2009, INT. CL. 11.
- GREAT AMERICAN FARMS, INC., POMPANO BEACH, FL:
1,496,965, CANC. INT. CL. 31.
- GREAT AMERICAN INSURANCE COMPANY, CINCINNA-
TI, OH:
2,599,728, CANC. INT. CL. 16.
- GREAT EARTH INTERNATIONAL, INC., HICKSVILLE,
NY:
1,496,504, CANC. INT. CL. 5.
- GREAT ELK COMPANY INC., THE, BUFFALO GROVE, IL:
2,596,576, CANC. INT. CL. 9.
- GREAT HARVEST FRANCHISING, INC., DILLON, MT:
3,632,019, MULTIPLE CLASS, INT. CLS. 16, 21, 25, 29, 30,
31, 35, 40 AND 43.
- GREAT TRANGO HOLDINGS, INC., LOUISVILLE, CO:
2,305,795, REN. 4-25-09, INT. CL. 25.
- GREAT-CIRCLE TECHNOLOGIES, INC., CHANTILLY, VA:
3,631,840, INT. CL. 9.
3,631,844, INT. CL. 9.
- GREAT-WEST LIFE & ANNUITY INSURANCE COMPANY,
GREENWOOD VILLAGE, CO:
3,630,932, PUB. 3-17-2009, INT. CL. 36.
- GREATER LAFAYETTE CHAMBER OF COMMERCE, INC.,
LAFAYETTE, LA:
3,633,470, INT. CL. 35.
- GREEN EARTH DETAIL, LLC, HOUSTON, TX:
3,631,228, PUB. 3-17-2009, INT. CL. 37.
- GREEN, CURTIS, BAKERSFIELD, CA:
2,599,016, CANC. INT. CL. 37.
- GREENENERGY CAPITAL HOLDINGS, LLC, NASHUA, NH:
3,630,459, PUB. 3-17-2009, INT. CL. 36.
- GREENFLY NETWORKS, INC., BOZEMAN, MT:
3,632,778, INT. CL. 38.
- GREENLEE TEXTRON INC., ROCKFORD, IL:
3,630,380, PUB. 3-17-2009, INT. CL. 8.
- GREENPAGES, INC., KITTERY, ME:
3,630,894, PUB. 3-17-2009, INT. CL. 42.
3,630,896, PUB. 3-17-2009, INT. CL. 41.
3,630,898, PUB. 3-17-2009, INT. CL. 41.
3,630,899, PUB. 3-17-2009, INT. CL. 42.
- GREENVALUE SA, LAUSANNE, SWITZERLAND:
3,631,701, PUB. 3-17-2009. MULTIPLE CLASS, INT. CLS.
2, 35, 36 AND 42.
- GREENWICH TECHNOLOGY PARTNERS, INC., WHITE
PLAINS, NY:
2,597,095, CANC. INT. CL. 42.
- GREER, DOUGLAS S., CARLSBAD, CA:
3,632,095, INT. CL. 9.
- GREGG, VERA, PORTLAND, OR:
3,631,814, INT. CL. 45.
- GREGGORY, BERNADETTE, HOLIDAY, FL, DBA SKELS-
KEY, BERNADETTE:
3,632,286, INT. CL. 35.
- GREY GLOBAL GROUP INC., NEW YORK, NY:
3,629,542, PUB. 3-17-2009. MULTIPLE CLASS, INT. CLS.
35 AND 42.
3,629,543, PUB. 3-17-2009, INT. CL. 35.
- GREYSTRIPE, INC., SAN FRANCISCO, CA:
3,632,174, INT. CL. 42.
- GRIFFINVENT INC., CARMEL, IN, DBA BAKER'S EDGE:
3,631,033, PUB. 3-17-2009, INT. CL. 21.
- GRILLAGE BOLAR (CANADA) INC., BLAINVILLE, QUE-
BEC, CANADA:
2,236,433, REN. 4-29-09, INT. CL. 6.
- GRILLSEEKERS LLC, PLAINVILLE, MA, DBA MICHAEL
PETIT AND JOHN CROATTI:
3,630,051, PUB. 3-17-2009, INT. CL. 41.
- GRIMES, ELI DAVID, ST. AUGUSTINE, FL:
3,632,977, INT. CL. 25.
- GRINDSTONEMANAGEMENT, LLC, GIG HARBOR, WA,
DBA F/K/A "ADA BLANCHE W. SCHREINER FAMILY
LLC":
3,631,376, PUB. 11-11-2008. MULTIPLE CLASS, INT. CLS.
30 AND 31.
- GRISWOLD, CAROL LEE, OAKLAND, CA:
2,598,289, CANC. MULTIPLE CLASS, INT. CLS. 9 AND
41.
- GRITS, INC., BIRMINGHAM, AL:
2,597,486, CANC. MULTIPLE CLASS, INT. CLS. 6, 9, 14,
16, 18, 20 AND 21.
- GROCERSCHOICE.COM, INC., BELLEVUE, WA:
2,598,879, CANC. INT. CL. 35.
- GROOM, JOHN F., LEESBURG, VA:
2,599,454, CANC. INT. CL. 41.
- GROSSNIKLAUS, ALICE J., WILMOT, OH:
1,497,135, CANC. INT. CL. 41.
- GROUP KAITU, LLC, RICHMOND, VA:
3,629,143, PUB. 3-17-2009, INT. CL. 35.
3,629,144, PUB. 3-17-2009, INT. CL. 41.
- GROUPE BOCENOR INC., QUEBEC, CANADA:
2,714,967, AM. INT. CL. 19.
- GROVES INTERNET CONSULTING, INC., MINNEAPOLIS,
MN, DBA SWIFT WEATHER:
3,632,856, INT. CL. 9.
- GROW LIVE LIMITED, UNITED KINGDOM:
3,631,489, PUB. 3-17-2009. MULTIPLE CLASS, INT. CLS.
35, 38 AND 42.
- GROW, INC., ESTERO, FL:
3,630,326, PUB. 3-17-2009, INT. CL. 44.
3,630,327, PUB. 3-17-2009, INT. CL. 44.

- GRUNDENS REGNKLADER AB, S-451 26 UDDEVALLA, SWEDEN:
1,119,690. REN. 4-29-09. INT. CL. 25.
- GRUNDENS REGNKLADER AB, 451 25 UDDEVALLA, SWEDEN:
1,121,456. REN. 4-29-09. INT. CL. 25.
- GRUPO I, INC., LA JOLLA, CA:
2,599,463. CANC. INT. CL. 38.
- GRUPO TECNOLOGICO E INDUSTRIAL GMV, S.A., TRES CANTOS (MADRID), SPAIN:
3,631,438. PUB. 1-13-2009. MULTIPLE CLASS, INT. CLS. 7, 9, 12, 16, 35, 37, 38, 41, 42, 44 AND 45.
- GRUPO TICHY, LLC, NORTH BARRINGTON, IL:
3,632,884. MULTIPLE CLASS, INT. CLS. 29 AND 30.
- GRUPO TICHY, LLC, NORTH BARRINGTON, IL, DBA PAIR CHOCOLATES:
3,632,898. MULTIPLE CLASS, INT. CLS. 29 AND 30.
- GS HANDELSGESELLSCHAFT M.B.H., 55543 BAD KREUZ-NACH, FED REP GERMANY:
2,175,613. CANC. INT. CL. 33.
- GSG HOLDINGS, INC., CHANDLER, AZ:
3,593,389 NEW CERT. 6-2-2009. INT. CL. 11.
- GSI COMMERCE SOLUTIONS, INC., KING OF PRUSSIA, PA:
2,597,151. CANC. INT. CL. 25.
- GTECH RHODE ISLAND CORPORATION, WEST GREENWICH, RI:
2,598,850. CANC. INT. CL. 9.
- GTFM, INC., NEW YORK, NY:
2,597,242. CANC. INT. CL. 38.
- GUANGDONG BRIGHT STAR LIGHT & ELECTRICITY CO., LTD., FOSHAN, CHINA:
3,632,013. MULTIPLE CLASS, INT. CLS. 9 AND 11.
- GUARD FINANCIAL GROUP, INC., WILKES- BARRE, PA:
2,276,901. REN. 4-25-09. INT. CL. 36.
- GUARD-LINE, INC., ATLANTA, TX, 20TH CENTURY GLOVE CORP. OF TEXAS, ATLANTA, TX:
675,274. REN. 4-28-09. U.S. CL. 39 (INT. CL. 25).
- GUERLAIN S.A. FRANCE:
3,631,617. PUB. 3-17-2009. INT. CL. 3.
- GUESTS, INC., WARRENTON, VA:
2,598,580. CANC. INT. CL. 42.
- GUIDE CORPORATION, PENDLETON, IN:
2,599,068. CANC. INT. CL. 42.
- GUIDE CORPORATION, ANDERSON, IN:
2,599,069. CANC. INT. CL. 42.
- GUIDECOMM SYSTEMS, INC., CHANTILLY, VA:
2,597,545. CANC. MULTIPLE CLASS, INT. CLS. 35 AND 42.
- GUIDER, LAWRENCE J., ROCHELLE PARK, NJ:
3,629,688. PUB. 3-17-2009. INT. CL. 35.
- GUIDO AUTOMATIC GATES, CAMERAS AND MORE, LLC, SAN ANTONIO, TX, DBA AUTOMATIC GATES, CAMERAS AND MORE:
3,630,160. PUB. 3-17-2009. INT. CL. 37.
- GUILDLINE INSTRUMENTS LTD., SMITHS FALLS, ONTARIO, CANADA:
3,629,136. PUB. 3-17-2009. MULTIPLE CLASS, INT. CLS. 9 AND 42.
- GUILIN STARS POWER; ELECTRONICS CO. LTD., CHINA:
3,631,733. PUB. 3-17-2009. MULTIPLE CLASS, INT. CLS. 7 AND 9.
- GUIMARAES, RICARDO P., SIGNAL HILL, CA:
3,629,496. PUB. 3-17-2009. INT. CL. 9.
- GULF SOUTH MEDICAL SUPPLY, INC., JACKSONVILLE, FL:
3,632,649. MULTIPLE CLASS, INT. CLS. 5 AND 10.
- GUN-MUNRO, BEVERLY JOY, WESTLAKE VILLAGE, CA, DBA FLY WRAPS:
3,630,745. PUB. 3-17-2009. INT. CL. 18.
- GUNDERSEN LUTHERAN MEDICAL FOUNDATION, INC., LA CROSSE, WI:
3,630,273. PUB. 3-17-2009. INT. CL. 41.
- GUNNESS, CLARK R., NEWBURY, NH:
2,597,086. CANC. MULTIPLE CLASS, INT. CLS. 7, 19 AND 42.
- GURU BICYCLE MANUFACTURING INC., LAVAL, CANADA:
3,629,510. PUB. 3-17-2009. INT. CL. 12.
3,629,511. PUB. 3-17-2009. INT. CL. 12.
3,629,512. PUB. 3-17-2009. INT. CL. 12.
3,629,513. PUB. 3-17-2009. INT. CL. 12.
3,629,514. PUB. 3-17-2009. INT. CL. 12.
3,631,455. PUB. 3-17-2009. INT. CL. 12.
- GUSHEN BIOLOGICAL TECHNOLOGY GROUP CO., LTD, 253500 SHANDONG, CHINA:
3,631,717. PUB. 3-17-2009. INT. CL. 29.
- GUTIERREZ, SALVADOR, NUNEZ, FREMONT, CA AND SIFUENTES, NICOLAS, SAN LORENZO, CA AND SIFUENTES, MARCO A., OAKLAND, CA AND GOMEZ, HUGO, OAKLAND, CA:
2,598,153. CANC. INT. CL. 41.
- GUY, ERIC EDWARD, WILLIAMSVILLE, NY, DBA JO APPAREL:
3,630,567. PUB. 3-17-2009. INT. CL. 25.
- G5 OUTDOORS, LLC, MEMPHIS, MI:
3,631,042. PUB. 3-17-2009. INT. CL. 28.
- GÜNTHER SPELSBERG GMBH & CO. KG, FED REP GERMANY AND MULTI-CONTACT AG, SWITZERLAND:
3,631,693. PUB. 3-17-2009. INT. CL. 9.
- H. BAHLSENS KEKSFABRIK KG, HANNOVER, FED REP GERMANY:
1,496,959. CANC. INT. CL. 30.
- H. E. WILLIAMS, CARTHAGE, MO:
2,599,175. CANC. INT. CL. 11.
- H. FOLKE SANDELIN AB, SE-591 04 MOTALA, SWEDEN:
3,631,667. PUB. 3-17-2009. MULTIPLE CLASS, INT. CLS. 7, 37 AND 42.
- H. H. FESSLER KNITTING CO., INC., OTWIGSBURG, PA:
2,598,744. CANC. INT. CL. 25.
- H.E.F., FRANCE:
3,631,643. PUB. 3-17-2009. MULTIPLE CLASS, INT. CLS. 1 AND 40.
- H&H ECO SYSTEMS, INC., NORTH BONNEVILLE, WA:
2,598,262. CANC. INT. CL. 40.
- HÄNEL GMBH & CO. KG, 74177 BAD FRIEDRICHSHALL, FED REP GERMANY:
3,631,572. PUB. 3-17-2009. INT. CL. 7.
- HAAS, FRANCINE, CHICAGO, IL AND GEORGE, BRENDAN P., DEERFIELD, IL:
3,633,158. INT. CL. 41.
- HADDONSTONE LIMITED, EAST HADDON, NORTHAMPTONSHIRE, NN6 8DB, ENGLAND:
2,239,149. REN. 4-24-09. MULTIPLE CLASS, INT. CLS. 11, 19, 20, 21 AND 40.
- HADEAN, INC., LEESBURG, VA:
3,632,928. INT. CL. 9.
- HADULLA, AXEL, D-67433 NEUSTADT, FED REP GERMANY:
2,597,369. CANC. MULTIPLE CLASS, INT. CLS. 29, 30, 32, 33 AND 42.
- HAELTH, LLC, NEW YORK, NY:
2,598,485. CANC. MULTIPLE CLASS, INT. CLS. 25, 35, 41 AND 42.
- HAHN, HARLEY, SANTA BARBARA, CA:
2,174,286. CANC. MULTIPLE CLASS, INT. CLS. 25 AND 42.
- HAIN CELESTIAL GROUP, INC., THE, MELVILLE, NY, EARTH'S BEST, INC., MIDDLEBURY, VT:
1,560,438. REN. 4-24-09. INT. CL. 5.
- HAIRART INC., LOS ANGELES, CA:
2,175,667. CANC. INT. CL. 26.
- HAITAI, INC., MONTEBELLO, CA:
1,496,958. CANC. INT. CL. 30.
- HAKATA DOLL ASSOCIATION, FUKUOKA-KEN, JAPAN:
1,496,876. CANC. INT. CL. 28.
- HALCYON MONITORING SOLUTIONS, INC., BELLEVUE, WA:
2,284,619. REN. 4-25-09. INT. CL. 9.
- HALCYONICS GMBH, 37081 GOETTINGEN, FED REP GERMANY:
2,596,977. CANC. INT. CL. 9.

- HALGO POWER, INC., PLANO, TX:
3,630,295, PUB. 3-17-2009. MULTIPLE CLASS, INT. CLS. 35 AND 37.
- HALL WINES, LLC, ST. HELENA, CA:
3,632,434, INT. CL. 41.
3,632,435, INT. CL. 33.
- HALL, ALFRED E., DALLAS, TX:
2,597,328, CANC. INT. CL. 9.
- HALL, RAYMOND F., LOS ANGELES, CA, DBA DR. RAYMOND F. HALL, DC/ HALL CHIROPRACTIC:
3,632,613, INT. CL. 44.
- HALLIBURTON ENERGY SERVICES, INC., CARROLLTON, TX:
3,632,161, INT. CL. 35.
- HALO INTERNATIONAL HOLDINGS LIMITED, ALTRINC-HAM, UNITED KINGDOM:
3,629,687, PUB. 3-17-2009. INT. CL. 18.
- HALO LABS, LLC, NEW YORK, NY:
3,632,582, MULTIPLE CLASS, INT. CLS. 5 AND 32.
- HAMILTON BEACH BRANDS, INC., GLEN ALLEN, VA:
2,596,604, CANC. INT. CL. 11.
- HAMILTON FARM REALTY HOLDING L.L.C., GLADSTONE, NJ:
2,599,340, CANC. MULTIPLE CLASS, INT. CLS. 18, 25 AND 28.
- HAMILTON SAFE COMPANY, FAIRFIELD, OH:
3,631,429, PUB. 3-17-2009. INT. CL. 9.
- HAMILTON, MARK L., JR., MERIDEN, CT:
2,234,500, REN. 4-26-09. INT. CL. 35.
- HAMLIN SENIOR MARKETING, CHERRY HILL, NJ:
3,630,071, PUB. 3-17-2009. INT. CL. 35.
- HAMMOND, DONALD R., COVINGTON, GA:
3,630,098, PUB. 3-17-2009. INT. CL. 6.
- HAMORY, NICOLE MARTIN, SALT LAKE CITY, UT:
3,630,045, PUB. 3-17-2009. INT. CL. 41.
- HAND 2 HAND ENTERTAINMENT, QUEENSVILLAGE, NY:
3,629,639, PUB. 3-17-2009. INT. CL. 9.
- HANDELSVEEM B.V., NETHERLANDS:
3,631,606, PUB. 3-17-2009. INT. CL. 39.
- HANDYMAN EXPRESS, INC., TEMPLE, TX:
2,599,085, CANC. INT. CL. 35.
2,599,086, CANC. INT. CL. 35.
- HANGER ORTHOPEDIC GROUP, INC., BETHESDA, MD:
3,630,269, PUB. 3-17-2009. INT. CL. 45.
- HANGZHOU FANGYUAN PLASTICS; MACHINERY CO., LTD, CHINA:
3,631,608, PUB. 3-17-2009. INT. CL. 7.
- HANGZHOU SUNLIGHT SANITARY; CO., LTD., HANGZHOU; 311245 ZHEJIANG, CHINA:
3,631,755, PUB. 3-17-2009. INT. CL. 20.
- HANIF'S INTERNATIONAL FOODS LTD., V3M 6M8 NORTH DELTA, BRITISH COLUMBIA, CANADA:
2,597,043, CANC. MULTIPLE CLASS, INT. CLS. 29 AND 30.
- HANIFS INTERNATIONAL FOODS LTD., V3M 6M8 NORTH DELTA, BRITISH COLUMBIA:
2,597,040, CANC. MULTIPLE CLASS, INT. CLS. 29 AND 30.
- HANNA LABS, INC., TORRANCE, CA:
3,631,246, PUB. 3-17-2009. INT. CL. 3.
- HANNA-BARBERA PRODUCTIONS, INC., BURBANK, CA:
2,599,694, CANC. INT. CL. 30.
- HANOVER FINANCIAL CORPORATION, CHICAGO, IL:
2,596,826, CANC. INT. CL. 36.
- HANSONTECH INTERNATIONAL LIMITED, CHUNG HO CITY, TAIPEI HSIEN, TAIWAN:
2,598,553, CANC. INT. CL. 9.
- HARBIN SONGJIANG COPPER TRADE (GROUP) CO., LTD., HARBIN, HEILONGJIANG, CHINA:
3,629,268, PUB. 3-17-2009. INT. CL. 6.
- HARBOR CAPITAL MANAGEMENT COMPANY, INC., BOSTON, MA:
2,597,717, CANC. INT. CL. 36.
- HARBOR PROPERTY MANAGEMENT GROUP, LLC, GREENWICH, CT:
3,630,688, PUB. 3-17-2009. INT. CL. 45.
- HARD ROCK CAFE INTERNATIONAL (USA), INC., ORLANDO, FL:
3,631,318, PUB. 3-17-2009. INT. CL. 41.
- HARDCASTLE, ASHLEY, DENTON, TX:
3,630,542, PUB. 3-17-2009. INT. CL. 41.
- HARDER, DIANE C., REDONDO BEACH, CA:
3,630,429, PUB. 3-17-2009. MULTIPLE CLASS, INT. CLS. 16 AND 21.
- HARDER, TODD, ADRIAN, MI:
3,630,836, PUB. 3-17-2009. INT. CL. 25.
- HARDI INTERNATIONAL A/S, DENMARK:
3,631,758, PUB. 3-17-2009. INT. CL. 7.
- HARDWOOD MARKET REPORT, LP, MEMPHIS, TN:
3,632,016, MULTIPLE CLASS, INT. CLS. 16, 41 AND 42.
- HARDY LIFE, LLC, LOS ANGELES, CA:
3,632,302, INT. CL. 9.
- HARI & ASSOCIATES INC., SKOKIE, IL:
1,497,153, CANC. INT. CL. 41.
- HARKLESS, MEGAN M., NEWVILLE, PA:
2,597,566, CANC. INT. CL. 16.
- HARLAND FINANCIAL SOLUTIONS, INC., PORTLAND, OR:
2,598,466, CANC. MULTIPLE CLASS, INT. CLS. 36 AND 42.
- HARLEQUIN ENTERPRISES LIMITED, DON MILLS, CANADA:
2,598,325, CANC. INT. CL. 16.
- HARMONIC HEALTH, SOMERS, NY:
3,629,941, PUB. 3-17-2009. INT. CL. 41.
- HARMONIC, INC., SUNNYVALE, CA:
3,631,997, INT. CL. 9.
- HARMONY: ATLANTA'S INTERNATIONAL YOUTH CHORUS, ATLANTA, GA:
3,630,145, PUB. 3-17-2009. INT. CL. 41.
- HARPO, INC., CHICAGO, IL:
2,598,828, CANC. MULTIPLE CLASS, INT. CLS. 36, 41 AND 42.
- HARRAH'S LICENSE COMPANY, LLC, LAS VEGAS, NV:
2,175,175, CANC. INT. CL. 41.
3,631,248, PUB. 3-17-2009. INT. CL. 41.
3,632,834, INT. CL. 35.
- HARREL, INCORPORATED, EAST NORWALK, CT:
1,496,569, CANC. MULTIPLE CLASS, INT. CLS. 9 AND 42.
- HARRIS CORPORATION, MELBOURNE, FL:
2,597,321, CANC. INT. CL. 8.
- HARRIS PUBLICATIONS, INC., NEW YORK, NY:
1,496,742, CANC. INT. CL. 16.
- HARRIS WASTE MANAGEMENT GROUP, INC., PEACHTREE CITY, GA:
3,632,480, INT. CL. 7.
- HARRODS LIMITED, LONDON, ENGLAND:
2,596,801, CANC. INT. CL. 9.
- HARROW, SUSAN, SAN RAFAEL, CA, DBA HARROW COMMUNICATIONS:
3,632,466, INT. CL. 41.
- HARRY AND DAVID, MEDFORD, OR, SARAMAR L.L.C., CHICAGO, IL:
2,239,636, REN. 4-27-09. INT. CL. 29.
- HARRY AND DAVID, MEDFORD, OR, WILLIAMS FOODS, INC., LENEXA, KS:
2,254,234, REN. 4-27-09. INT. CL. 30.
- HARRY MARK ZINSSER-KRYS, 93309 KELHEIM, FED REP GERMANY AND KURT RUHFAß, 93326 ABENSBERG, FED REP GERMANY:
3,631,734, PUB. 3-17-2009. MULTIPLE CLASS, INT. CLS. 25, 41 AND 43.
- HARTER CORPORATION, STURGIS, MI:
1,496,780, CANC. INT. CL. 19.
- HARTFORD FIRE INSURANCE COMPANY, HARTFORD, CT, DBA DBA:
3,630,270, PUB. 3-17-2009. INT. CL. 36.
- HARTFORD FIRE INSURANCE COMPANY, HARTFORD, CT:
3,630,271, PUB. 3-17-2009. INT. CL. 36.
- HARTFORD LIFE INSURANCE COMPANY, SIMSBURY, CT:
2,597,594, CANC. INT. CL. 36.

HARTZ MOUNTAIN CORPORATION, THE, SECAUCUS, NJ:
3,632,448, INT. CL. 20.

HARVESTOUN BREWERY LIMITED, ALVA, CLACKMAN-NANSHIRE, UNITED KINGDOM:
3,632,220, MULTIPLE CLASS, INT. CLS. 21 AND 32.

HASBRO, INC., PAWTUCKET, RI:
1,496,894, CANC. INT. CL. 28.
2,597,988, CANC. INT. CL. 28.
2,597,990, CANC. INT. CL. 28.
3,631,829, INT. CL. 28.
3,631,848, INT. CL. 28.
3,631,854, INT. CL. 28.
3,631,855, INT. CL. 28.

HASCO I.A. LIMITED, RENO, NV:
2,598,546, CANC. INT. CL. 41.

HASSLER ROMA S.R.L., ROME, ITALY:
2,596,930, CANC. INT. CL. 3.

HASTED LIMITED, DUBLIN, IRELAND:
3,597,225, AM. MULTIPLE CLASS, INT. CLS. 9, 18 AND 25.

HATCH, BRIAN MICHAEL, CORONA, CA:
3,630,642, PUB. 3-17-2009, INT. CL. 21.

HATCO CORPORATION, MILWAUKEE, WI:
878,546, REN. 4-25-09, U.S. CL. 21 (INT. CL. 11).

HATHCOCK, JOHN EDWARD, MEMPHIS, TN:
2,175,324, CANC. INT. CL. 9.

HAUGEN, JEFF, GILBERT, AZ:
3,630,446, PUB. 3-17-2009, INT. CL. 25.

HAVAS, 92150 SURESNES, FRANCE:
2,596,527, CANC. MULTIPLE CLASS, INT. CLS. 9, 35, 38, 41 AND 42.

HAWAII MEDICAL SERVICE ASSOCIATION, HONOLULU, HI:
3,630,104, PUB. 3-17-2009, INT. CL. 41.

HAWAIIAN INSURANCE & GUARANTY COMPANY, LIMITED, THE, HONOLULU, HI:
2,597,603, CANC. INT. CL. 36.

HAWAIIAN TRAVEL, INC., IRVING, TX:
2,238,285, REN. 4-29-09, MULTIPLE CLASS, INT. CLS. 39 AND 42.

HAWKINS, INC., MINNEAPOLIS, MN:
2,175,683, CANC. INT. CL. 1.

HAWKINS, JULES MOREAU, CANYON LAKE, CA:
2,598,152, CANC. INT. CL. 25.

HAYDEN, NAURA, NEW YORK, NY:
1,496,490, CANC. INT. CL. 5.

HAYNSWORTH SINKLER BOYD, P.A., COLUMBIA, SC:
3,631,222, PUB. 3-17-2009, INT. CL. 45.
3,631,223, PUB. 3-17-2009, INT. CL. 45.
3,631,224, PUB. 3-17-2009, INT. CL. 45.

HAYS, GARY, GRESHAM, OR:
3,632,797, INT. CL. 36.

HAZTECH SYSTEMS, INC., MOUNTAIN VIEW, CA:
1,496,383, CANC. INT. CL. 1.

HBH, CINCINNATI, OH:
2,174,859, CANC. MULTIPLE CLASS, INT. CLS. 29 AND 30.

HBI BRANDED APPAREL ENTERPRISES, LLC, WINSTON-SALEM, NC:
2,175,623, CANC. INT. CL. 25.
2,598,352, CANC. INT. CL. 25.
2,599,602, CANC. INT. CL. 25.

HDS IP HOLDING, LLC, HENDERSON, NV:
3,632,249, INT. CL. 35.

HEAD WEST INC., COMPTON, CA:
2,174,467, CANC. MULTIPLE CLASS, INT. CLS. 40 AND 42.

HEADLANDS VENTURES, LLC, SAN RAFAEL, CA:
3,629,690, PUB. 3-17-2009, INT. CL. 35.

HEALINC, LLC, BRONX, DE:
2,598,954, CANC. INT. CL. 35.

HEALTH ADVOCATE, INC., PLYMOUTH MEETING, PA:
3,630,309, PUB. 3-17-2009, MULTIPLE CLASS, INT. CLS. 35 AND 36.

HEALTH ASSOCIATES, INDIANAPOLIS, IN:
1,496,738, CANC. INT. CL. 16.

HEALTH CENTER FOR BETTER LIVING, INC., NAPLES, FL:
3,632,858, INT. CL. 3.

HEALTH WATCH INFORMATION AND PROMOTION SERVICE, INC., NEW YORK, NY:
2,174,559, CANC. INT. CL. 42.

HEALTH-TECH, INC., TOTOWA, NJ:
2,175,193, CANC. INT. CL. 3.

HEALTHCARE REGIONAL MARKETING, LLC, CINCINNATI, OH:
3,632,601, INT. CL. 16.

HEALTHCARE 21, ALHAMBRA, CA:
2,597,429, CANC. INT. CL. 35.

HEALTH THE MID-AMERICA, INC., KANSAS CITY, MO:
3,632,159, MULTIPLE CLASS, INT. CLS. 42 AND 44.

HEALTHPHONE HOLDINGS LIMITED, AUCKLAND, NEW ZEALAND:
3,629,256, PUB. 1-20-2009, MULTIPLE CLASS, INT. CLS. 9, 35 AND 44.

HEALTHQUEST LIMITED, HARROW, MIDDLESEX HA1 4TR, UNITED KINGDOM:
2,241,868, REN. 4-27-09, INT. CL. 3.

HEALTHSTAR COMMUNICATIONS, INC., CRANFORD, NJ:
2,598,435, CANC. INT. CL. 35.

HEALTHVELOCITY, PLLC, HOUSTON, TX:
2,597,757, CANC. INT. CL. 36.

HEALTHY REBATES, INC., ALPHARETTA, GA:
3,632,510, MULTIPLE CLASS, INT. CLS. 35 AND 36.

HEART GIFT CO. LTD., OSAKA-SHI, OSAKA-FU, JAPAN:
2,597,058, CANC. INT. CL. 35.

HEART OF FASHION, L.L.C., PHOENIX, AZ, DBA COMMON FATE:
3,631,254, PUB. 3-17-2009, INT. CL. 45.

HEART THOUGHTS DESIGNS, INC., WICHITA, KS:
3,631,092, PUB. 3-17-2009, INT. CL. 16.

HEARTLAND ALLIANCE FOR HUMAN NEEDS AND HUMAN RIGHTS, CHICAGO, IL:
3,631,372, PUB. 12-2-2008, MULTIPLE CLASS, INT. CLS. 41 AND 45.

HEARTS WITH HANDS, INC., ASHEVILLE, NC:
3,630,698, PUB. 3-17-2009, INT. CL. 35.

HEATCRAFT INC., GRENADA, MS:
2,597,686, CANC. INT. CL. 11.

HEIT, WARREN, MOUNT VERNON, NY AND MILLER, BARRY, BROOKFIELD, CT:
3,631,974, INT. CL. 37.

HELEN OF TROY LIMITED, ST. MICHAEL, BARBADOS:
2,286,040, REN. 4-30-09, INT. CL. 21.

HELEN OF TROY LIMITED (BARBADOS), ST. MICHAEL, BARBADOS:
2,175,858, CANC. INT. CL. 10.

HELENA HOLDING COMPANY, WILMINGTON, DE:
3,630,184, PUB. 3-17-2009, MULTIPLE CLASS, INT. CLS. 1 AND 5.

HELENE DE LATOUR DE PINS TRUST, RUTHERFORD, CA:
3,629,347, PUB. 3-17-2009, MULTIPLE CLASS, INT. CLS. 41 AND 43.

HELIOS COMMUNICATIONS, L.L.C., BANDON, OR:
2,709,699, CANC. INT. CL. 38.

HELIX ENERGY SOLUTIONS GROUP, INC., HOUSTON, TX:
3,366,968, AM. MULTIPLE CLASS, INT. CLS. 35, 37, 39 AND 42.
3,366,973, AM. MULTIPLE CLASS, INT. CLS. 35, 37, 39 AND 42.

HELLAS CONSTRUCTION, AUSTIN, TX:
3,633,101, INT. CL. 27.

HELLER EHRMAN LLP, SAN FRANCISCO, CA:
2,599,324, CANC. INT. CL. 42.

HELMET INTEGRATED SYSTEMS LIMITED, UNITED KINGDOM:
3,631,532, PUB. 3-17-2009, INT. CL. 9.

HELPUPLAY INCORPORATED, RESTON, VA:
2,599,548, CANC. INT. CL. 9.

HELVAR OY AB, 03600 KARKKILA, FINLAND:
2,637,837, CANC. MULTIPLE CLASS, INT. CLS. 9 AND

11.
 HENDERSON, J. KIRSTON, FORT WORTH, TX:
 2,240,811. REN. 4-27-09. INT. CL. 42.
- HENDERSON, LYNN, MARION, IL:
 3,630,791, PUB. 3-17-2009. INT. CL. 36.
- HENDIAZAD, ANNOUSH, MORRIS PLAINS, NJ:
 3,632,014, INT. CL. 14.
- HENDRICKSON USA, L.L.C., ITASCA, IL:
 3,633,186, INT. CL. 12.
- HENRY RAK CONSULTING PARTNERS, INC., LIBERTY-
 VILLE, IL:
 2,626,681, CANC. INT. CL. 35.
- HENRY STREET HOLDINGS, LLC, SAN MARCOS, CA:
 3,632,053, INT. CL. 43.
- HENRY TROEMNER LLC, THOROFARE, NJ:
 3,630,646, PUB. 3-17-2009. INT. CL. 9.
- HENSLEY INDUSTRIES, INC., DALLAS, TX:
 3,629,885, PUB. 3-17-2009. INT. CL. 7.
- HEPBURN, WILLIAM T., PRESCOTT, AZ:
 2,599,716, CANC. INT. CL. 36.
- HERAEUS KULZER GMBH, D-63450 HANAU, FED REP
 GERMANY:
 3,629,140, PUB. 3-17-2009. INT. CL. 5.
- HERBALIFE INTERNATIONAL, INC., LOS ANGELES, CA:
 3,404,283, COR. MULTIPLE CLASS, INT. CLS. 9 AND 38.
- HERBN TONICS, LLC, HENDERSON, NV:
 3,632,453, INT. CL. 5.
- HERITAGE PRESERVATION CORPORATION, SPARTAN-
 BURG, SC:
 2,175,728, CANC. MULTIPLE CLASS, INT. CLS. 38 AND
 42.
- HERLITZ PBS AG; PAPIER-, BÜRO UND SCHREIBWAREN,
 13507 BERLIN, FED REP GERMANY:
 3,631,546, PUB. 3-17-2009. MULTIPLE CLASS, INT. CLS.
 2, 9, 16 AND 18.
- HERMAN KAY COMPANY, INC., NEW YORK, NY:
 3,632,020, INT. CL. 25.
- HERMITAGE GROUP, INC., CHICAGO, IL:
 3,630,329, PUB. 3-17-2009. INT. CL. 16.
 3,630,332, PUB. 3-17-2009. INT. CL. 16.
- HERNANDEZ, CESAR J, BOLINGBROOK, IL:
 2,599,675, CANC. INT. CL. 41.
- HERNANDEZ, MICHELLE DAWN, PHOENIX, AZ:
 3,633,309, INT. CL. 25.
- HERSHEY CHOCOLATE & CONFECTIONERY CORPORA-
 TION, WHEAT RIDGE, CO, HERSHEY CHOCOLATE &
 CONFECTIONERY CORPORATION, WHEAT RIDGE, CO:
 2,319,776. REN. 4-30-09. INT. CL. 30.
- HERSHEY CHOCOLATE & CONFECTIONERY CORPORA-
 TION, WHEAT RIDGE, CO:
 3,631,154, PUB. 3-17-2009. INT. CL. 42.
 3,631,184, PUB. 3-17-2009. INT. CL. 30.
 3,631,239, PUB. 3-17-2009. INT. CL. 30.
 3,631,319, PUB. 3-17-2009. INT. CL. 30.
 3,631,320, PUB. 3-17-2009. INT. CL. 30.
 3,633,033, INT. CL. 30.
 3,633,208, INT. CL. 30.
- HERTURN, L.L.C., PHOENIX, AZ:
 2,599,654, CANC. INT. CL. 5.
- HERTZBERG-NEW METHOD, INC., JACKSONVILLE, IL:
 670,033. REN. 4-25-09. U.S. CL. 106 (INT. CL. 40).
- HERTZOG, DANIEL J, MANHATTAN BEACH, CA:
 2,598,512, CANC. INT. CL. 28.
- HESCO BASTION LIMITED, LEEDS, UNITED KINGDOM:
 3,629,326, PUB. 3-17-2009. MULTIPLE CLASS, INT. CLS.
 6, 19 AND 20.
- HETTICH MARKETING- UND VERTRIEBS; GMBH & CO.
 KG, FED REP GERMANY:
 3,631,704, PUB. 3-17-2009. MULTIPLE CLASS, INT. CLS. 6
 AND 20.
- HEWLETT-PACKARD COMPANY, PALO ALTO, CA:
 2,598,269, CANC. MULTIPLE CLASS, INT. CLS. 9 AND
 16.
 2,598,603, CANC. MULTIPLE CLASS, INT. CLS. 9 AND
 36.
 2,599,517, CANC. INT. CL. 35.
- HEXAWARE TECHNOLOGIES, INC., PRINCETON, NJ:
 2,596,978, CANC. INT. CL. 42.
- HEYBUTLER.COM LLC, SOLON, OH:
 3,632,313, INT. CL. 35.
- HEYMAN CORPORATION, VERNON HILLS, IL:
 2,174,803, CANC. INT. CL. 21.
- HI-RES MUSIC, LLC, CULVER CITY, CA:
 2,599,811, CANC. INT. CL. 9.
- HIDE, LEE, FORT MYERS, FL:
 3,633,447, INT. CL. 11.
- HIGGINS GROUP CORP., THE, CORAL GABLES, FL:
 2,175,844, CANC. INT. CL. 31.
- HIGH HOPES PRODUCTIONS LLC, HUNTINGTON STA-
 TION, NY:
 3,630,199, PUB. 3-17-2009. INT. CL. 41.
 3,630,200, PUB. 3-17-2009. INT. CL. 41.
- HIGH PERFORMANCE PLUS, TEMPE, AZ:
 3,630,061, PUB. 3-17-2009. INT. CL. 1.
- HIGHCROFT RACING, INC., DANBURY, CT:
 3,629,691, PUB. 3-17-2009. MULTIPLE CLASS, INT. CLS.
 25, 37 AND 41.
- HIGHMOUNT EXPLORATION & PRODUCTION HOLDING
 CORP., NEW YORK, NY:
 3,632,070, MULTIPLE CLASS, INT. CLS. 37, 40 AND 42.
- HILL, DANA, ATLANTA, GA:
 3,629,187, PUB. 3-17-2009. INT. CL. 41.
- HILL, SHERRI K., NORMAN, OK:
 3,631,052, PUB. 3-17-2009. INT. CL. 25.
- HILLERICH & BRADSBY CO., LOUISVILLE, KY:
 2,598,943, CANC. INT. CL. 9.
 2,598,944, CANC. INT. CL. 16.
- HILLSDALE COLLEGE, HILLSDALE, MI:
 3,629,163, PUB. 3-17-2009. INT. CL. 41.
- HILLSDALE FURNITURE LLC, LOUISVILLE, KY:
 3,632,072, INT. CL. 20.
- HILLYARD ENTERPRISES, INC., ST. JOSEPH, MO:
 3,630,862, PUB. 3-17-2009. INT. CL. 35.
- HINGLE, MEAGAN E., GRETNA, LA:
 2,709,784, COR. INT. CL. 20.
- HINSHAW, KEVIN D., ST. LOUIS, MO:
 2,599,027, CANC. INT. CL. 10.
- HINT CORPORATION, FREMONT, CA:
 2,598,045, CANC. INT. CL. 9.
- HIP DESIGNS LIMITED, UNITED KINGDOM:
 3,631,666, PUB. 3-17-2009. INT. CL. 28.
- HIRE CALLING, INC., MEDFORD, OR:
 2,175,188, CANC. INT. CL. 35.
- HIRED HAND SOFTWARE, LLC, CEDAR FALLS, IA:
 3,631,080, PUB. 3-17-2009. INT. CL. 42.
- HISPANIC DIRECT, INC., COLORADO SPRINGS, CO:
 2,599,779, CANC. INT. CL. 35.
- HISTO-CHEM, INC., JEFFERSON, AR:
 3,630,594, PUB. 3-17-2009. INT. CL. 1.
- HITACHI AMERICA, LTD., SAN DIEGO, CA:
 2,598,810, CANC. INT. CL. 9.
- HITCENTS.COM, BOWLING GREN, KY:
 3,630,311, PUB. 3-17-2009. INT. CL. 9.
- HK DESIGNS, NEW YORK, NY:
 3,633,292, INT. CL. 14.
- HLC SB DISTRIBUTION, S.L., SPAIN:
 3,631,649, PUB. 3-17-2009. MULTIPLE CLASS, INT. CLS.
 25 AND 28.
- HLT DOMESTIC IP LLC, BEVERLY HILLS, CA:
 1,497,275, CANC. INT. CL. 42.
- HMH PUBLISHERS LLC, WILMINGTON, DE:
 2,599,348, CANC. INT. CL. 11.
- HMI INDUSTRIES INC., STRONGSVILLE, OH:
 3,630,378, PUB. 3-17-2009. INT. CL. 11.
- HMS NATIONAL, INC., FT. LAUDERDALE, FL:
 1,514,847. REN. 4-25-09. INT. CL. 36.
- HMSHOST CORPORATION, BETHESDA, MD:
 3,632,935, INT. CL. 43.
- HO, JAMES W, WALNUT, CA:
 3,629,845, PUB. 3-17-2009. INT. CL. 9.
- HO, MAN KWONG, ARCADIA, CA:
 2,174,427, CANC. INT. CL. 25.
- HOARE, DAVE, G, LAS VEGAS, NV:
 2,598,143, CANC. INT. CL. 28.
- HOBBS BROOK MANAGEMENT LLC, WALTHAM, MA:
 3,632,751, MULTIPLE CLASS, INT. CLS. 36 AND 37.

HOCOMA AG, SWITZERLAND:
3,631,609, PUB. 3-17-2009. MULTIPLE CLASS, INT. CLS. 10 AND 28.

HODGE PRODUCTS, INC., EL CAJON, CA:
2,288,008. REN. 4-27-09. INT. CL. 35.
2,289,710. REN. 4-27-09. INT. CL. 35.
2,333,161. REN. 4-27-09. INT. CL. 42.

HODGES, RICHARD, CULVER CITY, CA:
3,632,610, INT. CL. 9.

HOEBEL FITNESS INC., NEW YORK, NY:
3,631,889, MULTIPLE CLASS, INT. CLS. 9 AND 41.

HOECHST CELANESE CORPORATION, SOMERVILLE, NJ:
1,496,467, CANC. INT. CL. 3.

HOECHST GMBH, 65926 FRANKFURT AM MAIN, FED REP GERMANY, CANADIAN HOECHST LIMITED, MONTREAL, CANADA:
868,314. REN. 4-29-09. U.S. CL. 6 (INT. CLS. 1 AND 2).

HOEI SANGYO CO., LTD., TOKYO 103, JAPAN:
2,598,558, CANC. INT. CL. 9.

HOFFMASTER GROUP, INC., INDIANAPOLIS, IN:
3,632,317, MULTIPLE CLASS, INT. CLS. 16, 21, 40 AND 42.
3,632,341, MULTIPLE CLASS, INT. CLS. 40 AND 42.

HOLDEN ADVISORS CORP., CONCORD, MA:
3,632,458, INT. CL. 35.

HOLLAND USA, INC., NORTH MANKATO, MN:
1,496,744, CANC. INT. CL. 16.

HOLLINGSWORTH & VOSE COMPANY, EAST WALPOLE, MA:
2,261,573. REN. 4-27-09. INT. CL. 11.

HOLMER, MARTHA, NEW YORK, NY:
3,632,369, INT. CL. 16.

HOLT'S COMPANY, PHILADELPHIA, PA:
3,633,130, INT. CL. 34.

HOLTZMAN'S LITTLE FOLK SHOP, INC., CITY OF INDUSTRY, CA:
1,497,164, CANC. INT. CL. 42.

HOME PHYSICIANS MANAGEMENT, LLC, CHICAGO, IL:
1,973,058, AM. INT. CL. 42.

HOME SLICE, LLC, WASHINGTON, DC:
3,629,142, PUB. 3-17-2009. MULTIPLE CLASS, INT. CLS. 29 AND 30.

HOME SWEET HOME MOVING AND STORAGE INC., HYATTSVILLE, MD:
2,597,225, CANC. INT. CL. 39.

HEMOCARE PRODUCTS, INC., ALGONA, WA:
3,632,178, INT. CL. 6.

HOMEDICS, INC., COMMERCE TOWNSHIP, MI:
2,599,044, CANC. INT. CL. 20.

HOMEFREEME, LLC, SAN DIEGO, CA:
3,629,672, PUB. 3-17-2009. INT. CL. 36.

HON HAI PRECISION INDUSTRY CO., LTD., SHENZHEN CITY, TAIWAN:
3,629,352, PUB. 3-17-2009. MULTIPLE CLASS, INT. CLS. 35, 40 AND 42.

HONEY CREEK, INC., WESTMINSTER, CO:
2,175,310, CANC. INT. CL. 5.

HONEYWELL INTERNATIONAL INC., MORRISTOWN, NJ:
2,343,883. REN. 4-24-09. INT. CL. 9.
2,599,419, CANC. INT. CL. 42.

HONG, MICHAEL, LOS ANGELES, CA:
3,631,211, PUB. 3-17-2009. INT. CL. 25.
3,631,212, PUB. 3-17-2009. INT. CL. 25.
3,631,341, PUB. 3-17-2009. INT. CL. 25.

HONOR AND REMEMBER, INC., CHESAPEAKE, VA:
3,632,806, INT. CL. 36.

HOOT/INSIGHT MUSIC PUBLISHING, LLC, BOCA RATON, FL:
3,632,743, INT. CL. 41.

HOOVER, LUZ V., MIDLOTHIAN, VA AND HOOVER, JEFFREY M., MIDLOTHIAN, VA:
2,599,559, CANC. INT. CL. 42.

HOP KEE PYROMAGIC LTD, 130-136 CONNAUGHT RD. C., HONG KONG:
2,597,627, CANC. INT. CL. 13.
2,597,628, CANC. INT. CL. 13.

HOPE FOR FAMILIES INC, MECHANICSVILLE, VA, DBA HOPE FOR FAMILIES, WORLDWIDE:
3,631,081, PUB. 3-17-2009. INT. CL. 36.

HORBLITT, ANDREA G., TRUMBULL, CT:
3,632,137, INT. CL. 25.

HORIZON MARKETING INC., MORTON GROVE, IL:
1,496,997, CANC. INT. CL. 35.

HORPHAG RESEARCH MANAGEMENT SA, 1216 COINTRIN, GENEVA, SWITZERLAND:
3,633,332, INT. CL. 3.

HORTON, WILL, CHICAGO, IL:
2,598,129, CANC. INT. CL. 16.

HORTUS USA CORP., NEW YORK, NY:
3,630,931, PUB. 3-17-2009. INT. CL. 1.

HOSHINO GAKKI CO., LTD., HIGASHI-KU, NAGOYA, 461-91, JAPAN:
2,245,774. REN. 4-30-09. INT. CL. 20.

HOSOKAWA MICRON B.V., 7005 BL DOETINCHEM, NETHERLANDS, N.V. NAUTAMIX, HAARLEM, NETHERLANDS:
682,154. REN. 4-29-09. U.S. CL. 23 (INT. CLS. 6, 7, 8, 9, 11, 12, 16, 21 AND 28).

HOSPIRA, INC., LAKE FOREST, IL:
3,630,361, PUB. 3-17-2009. INT. CL. 5.

HOT BUDDY PRODUCTS, SAN JOSE, CA:
2,598,088, CANC. INT. CL. 9.

HOT BUTTERED INTERNATIONAL PTY LTD, WARRIEWOOD, AUSTRALIA:
3,632,328, INT. CL. 9.

HOT SOFT PRETZEL COMPANY, LLC, FT. THOMAS, KY:
3,632,085, INT. CL. 30.

HOT/SHOT RADAR INSPECTIONS, LLC, LAKEWOOD, CO:
2,599,145, CANC. INT. CL. 42.

HOTANI CO., LTD., JAPAN:
3,631,737, PUB. 3-17-2009. INT. CL. 7.

HOUDINI, INC., FULLERTON, CA:
3,631,405, PUB. 3-17-2009. INT. CL. 33.
3,631,406, PUB. 3-17-2009. INT. CL. 21.

HOULBERG, MICHAEL, TUALATIN, OR, DBA HOULBERG DEVELOPMENT:
1,568,076. REN. 4-30-09. INT. CL. 9.

HOUSTON FOOD BANK, HOUSTON, TX:
3,630,161, PUB. 3-17-2009. INT. CL. 43.
3,630,164, PUB. 3-17-2009. INT. CL. 43.

HOWARD, JULES, SAN GERONIMO, CA, DBA CLUB BETWEEN:
3,630,576, PUB. 3-17-2009. INT. CL. 41.

HOWARD, SHARON D., DAYTON, OH:
3,631,912, INT. CL. 16.

HOWELL, LAUREN ASHLEY, SURREY, BRITISH COLUMBIA, CANADA, DBA CARLETON, LAUREN ASHLEY:
3,629,942, PUB. 3-17-2009. INT. CL. 21.

HOWMEDICA OSTEONICS CORP., ALLENDALE, NJ:
2,597,288, CANC. INT. CL. 41.

HOYA CORPORATION, TOKYO, JAPAN, HOYA KABUSHIKI KAISHA, TOKYO, JAPAN:
1,489,056. REN. 4-25-09. INT. CL. 9.

HRB INNOVATIONS, INC., FREEPORT, GBI, BAHAMAS:
3,629,907, PUB. 10-14-2008. INT. CL. 36.

HRP CREATIVE SERVICES CO., LLC, MYRTLE BEACH, SC:
3,631,809, INT. CL. 43.

HS MANAGEMENT PARTNERS, LLC, NEW YORK, NY:
3,632,854, INT. CL. 36.

HS ROCKS LLC, MESA, AZ:
3,630,275, PUB. 3-17-2009. INT. CL. 35.

HSIN YI CHANG INDUSTRY CO., LTD., TAINAN CITY, TAIWAN:
3,632,886, INT. CL. 12.

HUANTE, XAVIER, CARSON, CA AND HUANTE, GABRIEL, CARSON, CA:
3,629,258, PUB. 3-17-2009. INT. CL. 25.

HUB EXPO CENTERS, INC., BOSTON, MA:
2,597,750, CANC. INT. CL. 42.

HUBERT F-J BROMMA, RENO, NV:
3,633,446, INT. CL. 36.

- HUDSON ASSOCIATES CONSULTING, INC., VIRGINIA BEACH, VA:
3,630,877, PUB. 3-17-2009. INT. CL. 41.
3,630,878, PUB. 3-17-2009. INT. CL. 41.
- HUDSON NEWS COMPANY, EAST RUTHERFORD, NJ:
3,630,749, PUB. 3-17-2009. INT. CL. 35.
- HUDSON, HARVEY NUNLEY, BREMERTON, WA:
3,630,658, PUB. 3-17-2009. INT. CL. 30.
- HUESKER SYNTHETIC GMBH, FED REP GERMANY:
3,631,678, PUB. 3-17-2009. INT. CL. 19.
- HUGO BOSS; TRADE MARK MANAGEMENT GMBH & CO. KG, FED REP GERMANY:
3,631,600, PUB. 3-17-2009. INT. CL. 9.
- HULL, JERI K., BEVERLY HILLS, CA, DBA BUNNY HULL AND BRASSHEART MUSIC AND KIDS CREATIVE CLASSICS:
3,631,794, MULTIPLE CLASS, INT. CLS. 9 AND 41.
- HUMAN RIGHTS CAMPAIGN FOUNDATION, WASHINGTON, DC:
3,590,466, COR. INT. CL. 41.
- HUMANA, INC., LOUISVILLE, KY:
2,598,823, CANC. INT. CL. 42.
- HUMANERING INTERNATIONAL, INC., GREENVILLE, SC:
2,215,756, REN. 4-29-09. INT. CL. 35.
- HUMMINGBIRD LTD., NORTH YORK, ONTARIO, CANADA:
2,597,704, CANC. INT. CL. 9.
- HUNTER DOUGLAS INC., UPPER SADDLE RIVER, NJ:
1,496,792, CANC. INT. CL. 20.
2,599,339, CANC. INT. CL. 20.
- HUNTER DOUGLAS, INC., UPPER SADDLE RIVER, NJ:
2,598,227, CANC. INT. CL. 20.
- HUNTER, JERRY ANN, COLUMBIA, MD:
3,630,124, PUB. 12-9-2008. INT. CL. 44.
- HUNTINGDON MILLS (CANADA) LTD., HUNTINGDON, QUEBEC, CANADA:
2,174,451, CANC. INT. CL. 24.
- HUNTONBRADY ARCHITECTS, ORLANDO, FL:
3,632,045, INT. CL. 42.
- HUNTSMAN INTERNATIONAL LLC, THE WOODLANDS, TX, CIBA LIMITED, BASEL, SWITZERLAND:
676,842, REN. 4-25-09. U.S. CL. 6 (INT. CL. 1).
- HURRICANE BRAND HOLDINGS, LLC., STUART, FL:
3,629,146, PUB. 3-17-2009. INT. CL. 43.
- HURT, KELLY LLOYD, ALLEN, OK, DBA FREELANCE CONSULTING SERVICES, INC.:
3,630,306, PUB. 3-17-2009. INT. CL. 42.
- HUSKY CORPORATION, PACIFIC, MO:
2,205,070, REN. 4-25-09. INT. CL. 6.
- HUSSAIN, IMRAN, LEEDS, UNITED KINGDOM AND HUSSAIN, RIZWAN, LEEDS, UNITED KINGDOM AND HUSSAIN, MAARIAH, LEEDS, UNITED KINGDOM AND HUSSAIN, DANYAAL, LEEDS, UNITED KINGDOM AND HUSSAIN, ZAHRA, LEEDS, UNITED KINGDOM:
3,630,963, PUB. 3-17-2009. INT. CL. 5.
- HUTH, ALLEN S. II, SLIDELL, LA:
2,597,370, CANC. INT. CL. 9.
- HW PRODUCTIONS, INC., BURLINGAME, CA, HW PRODUCTIONS, INC., BURLINGAME, CA:
1,535,124, REN. 4-30-09. INT. CL. 9.
- HY CITE CORPORATION, MADISON, WI:
3,631,938, INT. CL. 21.
- HYATT, GRIFFIN TROY, SANTA MONICA, CA:
3,632,129, INT. CL. 5.
- HYNEK, PAUL, LOS ANGELES, CA:
3,629,894, PUB. 3-17-2009. INT. CL. 9.
- HYNIX SEMICONDUCTOR INC., KYOUNGKI-DO, REPUBLIC OF KOREA:
3,631,985, INT. CL. 9.
- H3D ENTERTAINMENT, INC., CUPERTINO, CA:
2,596,477, CANC. INT. CL. 9.
- I DID IT, INC., FAR HILLS, NJ:
3,629,131, PUB. 3-17-2009. INT. CL. 18.
- I SEE CARDS LLC, OVIEDO, FL:
3,631,030, PUB. 3-17-2009. INT. CL. 28.
- I.G.E.A.T. S.R.L., ITALY:
3,631,551, PUB. 3-17-2009. INT. CL. 25.
- I.P. HOLDINGS, GRAND PRAIRIE, TX:
3,630,504, PUB. 3-17-2009. INT. CL. 9.
- I-LABS, INC., HERNDON, VA:
2,598,700, CANC. INT. CL. 35.
- I-NETWORK CORPORATION, NEW YORK, NY:
2,598,100, CANC. INT. CL. 35.
- I'M NOT OBSESSED INC., GARDEN CITY, NY:
3,630,636, PUB. 3-17-2009. INT. CL. 41.
3,630,637, PUB. 3-17-2009. INT. CL. 41.
- IANGELIC, SAN DIEGO, CA:
3,631,214, PUB. 3-17-2009. INT. CL. 35.
- IBALANCE MEDICAL, INC., BOULDER, CO:
3,633,271, INT. CL. 10.
- IBT CONSULTANTS INC., TINLEY PARK, IL:
3,630,571, PUB. 3-17-2009. INT. CL. 11.
- IBUYER, LLC, DOVER, DE:
3,633,448, INT. CL. 35.
- IC COMM LLC, NEW YORK, NY:
2,599,572, CANC. INT. CL. 35.
- ICE MILLER, INDIANAPOLIS, IN:
2,597,290, CANC. INT. CL. 35.
- ICELAND SPRING A ISLANDI EHF, REYKJAVIK, ICELAND:
2,597,701, CANC. INT. CL. 32.
- ICL PERFORMANCE PRODUCTS LP, ST. LOUIS, MO:
2,598,511, CANC. INT. CL. 30.
- ICONECT, LLC, REDONDO BEACH, CA:
2,597,444, CANC. INT. CL. 9.
- ICRETE LLC, BEVERLY HILLS, CA:
3,632,121, INT. CL. 37.
- ICYNENE INC., MISSISSAUGA, ONTARIO, CANADA:
3,363,126, COR. MULTIPLE CLASS, INT. CLS. 1 AND 37.
- IDA, WENDY, LAKEWOOD, CA:
3,630,816, PUB. 3-17-2009. INT. CL. 41.
- IDEA FARM LLC, CULVER CITY, CA:
2,598,595, CANC. MULTIPLE CLASS, INT. CLS. 1, 21, 31 AND 35.
- IDEA INTERNATIONAL CO., LTD., TOKYO 108-0014, JAPAN:
3,631,580, PUB. 3-17-2009. INT. CL. 3.
3,631,586, PUB. 3-17-2009. INT. CL. 3.
3,631,637, PUB. 3-17-2009. INT. CL. 3.
3,631,638, PUB. 3-17-2009. INT. CL. 3.
- IDEALOGISTS LLC, AVON, CT:
2,598,018, CANC. INT. CL. 28.
- IDEASTYLE DEVELOPMENT INT'L CORP., TAIPEI COUNTY, TAIWAN:
3,630,337, PUB. 3-17-2009. INT. CL. 9.
- IDEAVILLAGE PRODUCTS CORP., WAYNE, NJ:
3,631,982, INT. CL. 9.
- IDEO INC., PALO ALTO, CA:
2,598,714, CANC. MULTIPLE CLASS, INT. CLS. 9 AND 42.
- IDEXX LABORATORIES, INC., WESTBROOK:
2,248,718, REN. 4-27-09. INT. CL. 9.
- IDEXX LABORATORIES, INC., WESTBROOK, ME:
3,632,352, INT. CL. 9.
- IDI, LLC, OCEAN PINES, MD:
3,633,467, INT. CL. 16.
- IDRATE SÄRL, SWITZERLAND:
3,631,475, PUB. 12-9-2008. MULTIPLE CLASS, INT. CLS. 32, 36, 42 AND 45.
- IDT CORPORATION, NEWARK, NJ:
2,598,136, CANC. INT. CL. 35.
- IDT NETHERLANDS, B.V. (PUERTO RICO BRANCH), SAN JUAN, PUERTO RICO:
3,633,086, INT. CL. 36.
- IERNA, RONALD F., LUTZ, FL:
3,630,487, PUB. 3-17-2009. INT. CL. 37.
- IGLESIA EVANGELICA MISIONERA DE BROOKLYN, BROOKLYN, NY:
2,599,587, CANC. INT. CL. 41.
- IGNITION NORTHWEST, SEATTLE, WA:
3,630,702, PUB. 3-17-2009. INT. CL. 41.
3,630,705, PUB. 3-17-2009. INT. CL. 41.
- IGO, INC., SCOTTSDALE, AZ:
2,598,506, CANC. MULTIPLE CLASS, INT. CLS. 9 AND 39.

IGT, RENO, NV:
 3,631,250, PUB. 3-17-2009. INT. CL. 9.
 3,632,076, INT. CL. 9.
 3,632,142, INT. CL. 9.
 3,633,117, INT. CL. 9.

IGUS GMBH, KOLN, FED REP GERMANY:
 2,598,243, CANC. MULTIPLE CLASS, INT. CLS. 6 AND 20.

IHERB, INC., IRWINDALE, CA:
 3,633,489, INT. CL. 5.

IHI CORPORATION, TOKYO, JAPAN:
 3,631,547, PUB. 3-17-2009. MULTIPLE CLASS, INT. CLS. 6, 7, 9, 10, 11, 37 AND 42.

IHU GESELLSCHAFT FUR INGENIEUR- HYDRO- UND UMWELT GEOLOGIE MBH, 99734 NORDHAUSEN, FED REP GERMANY:
 2,174,457, CANC. INT. CL. 42.

IIT RESEARCH INSTITUTE, CHICAGO, IL:
 3,629,574, PUB. 3-17-2009. INT. CL. 42.

IKONIK TECHNOLOGY CO., LTD., TAIPEI 231, TAIWAN:
 3,632,763, INT. CL. 9.

ILAN AZOURI, TEL-AVIV, ISRAEL:
 3,633,204, MULTIPLE CLASS, INT. CLS. 5, 9, 25 AND 44.

ILENE C. SHANE, INC., NEW YORK, NY:
 3,631,917, INT. CL. 30.

ILKA T. DE LEON, SAN DIEGO, CA:
 3,629,794, PUB. 3-17-2009. INT. CL. 35.

ILLINOIS TOOL WORKS, GLENVIEW, IL:
 3,629,910, PUB. 3-17-2009. INT. CL. 9.

ILLINOIS TOOL WORKS INC., GLENVIEW, IL:
 3,629,783, PUB. 3-17-2009. INT. CL. 26.
 3,629,784, PUB. 3-17-2009. INT. CL. 26.
 3,632,141, INT. CL. 17.
 3,632,704, INT. CL. 7.
 3,632,720, INT. CL. 16.

ILLION, INC., COOPERSBURG, PA:
 2,598,538, CANC. INT. CL. 35.

ILLUMINATED RESEARCH, ARLINGTON, TX:
 3,631,970, MULTIPLE CLASS, INT. CLS. 41 AND 42.

ILLVA SARONNO S.P.A., SARONNO, ITALY:
 3,633,267, INT. CL. 33.

ILS TECHNOLOGY, LLC, BOCA RATON, FL:
 3,633,183, INT. CL. 9.

IMAGEHAWK, INC., HUNTSVILLE, AL:
 2,599,506, CANC. INT. CL. 9.

IMAGEPOINT INC., KNOXVILLE, TN:
 3,630,927, PUB. 3-17-2009. INT. CL. 37.

IMAGINE LAN, INC., NASHUA, NH:
 2,599,543, CANC. INT. CL. 9.

IMANAGE, INC., SAN MATEO, CA:
 2,597,640, CANC. INT. CL. 9.

IMCLONE SYSTEMS INCORPORATED, NEW YORK, NY:
 3,629,153, PUB. 3-17-2009. INT. CL. 3.

IMED, LLC, AURORA, CO, DBA IMED COST CONTAINMENT SOLUTION:
 3,632,739, MULTIPLE CLASS, INT. CLS. 35 AND 36.

IMEDEON, INC., ALPHARETTA, GA:
 2,596,618, CANC. INT. CL. 35.

IMG LLC, ALBANY, NY:
 3,630,513, PUB. 3-17-2009. INT. CL. 35.

IMMEDIATE MEDICAL CARE OF PENNSYLVANIA, LP, WEST CHESTER, PA, DBA PIONEER URGENT CARE:
 3,631,036, PUB. 3-17-2009. INT. CL. 44.
 3,631,040, PUB. 3-17-2009. INT. CL. 44.

IMMERSIVE TECHNOLOGIES INC., SANDY, UT:
 3,632,006, INT. CL. 9.

IMPAC TECHNOLOGY, INC., WEST CHESTER, PA:
 2,598,144, CANC. INT. CL. 9.

IMPACT MANAGEMENT, INC., TAMPA, FL:
 2,599,015, CANC. INT. CL. 42.

IMPACT NATIONAL NEWS, LLC, ATLANTA, GA:
 3,630,292, PUB. 3-17-2009. INT. CL. 41.

IMPACT PRODUCTS LLC, TOLEDO, OH:
 3,631,451, PUB. 3-17-2009. INT. CL. 21.

IMPERIA S.P.A., ROMA, ITALY:
 2,284,455, REN. 4-30-09. INT. CL. 7.

IMPLANT DIRECT INT'L, LAS VEGAS, NV:
 3,632,548, INT. CL. 10.

IMPREMEDIA OPERATING COMPANY, LLC, NEW YORK, NY:
 3,629,903, PUB. 3-17-2009. MULTIPLE CLASS, INT. CLS. 35 AND 41.

IN DEMAND L.L.C., NEW YORK, NY:
 3,631,868, INT. CL. 9.

IN HIS IMAGE, INC., TULSA, OK:
 3,630,881, PUB. 3-17-2009. INT. CL. 41.

IN TOUCH MINISTRIES, INC., ATLANTA, GA:
 2,240,783, REN. 4-24-09. INT. CL. 16.

INABINETT, LAMAR, SPRINGFIELD GARDEN, NY:
 3,632,358, INT. CL. 25.

INCU PTY LIMITED, ST LEONARDS NSW 2065, AUSTRALIA:
 3,631,766, PUB. 3-17-2009. INT. CL. 25.

INDEPENDENT AUTO PARTS OF AMERICA, INC., GERMANTOWN, TN:
 2,324,652, REN. 4-28-09. INT. CL. 37.

INDEPENDENT DISTRIBUTORS ASSOCIATION, LLC, COLUMBIA, SC:
 2,596,796, CANC. INT. CL. 38.

INDEPENDENT TRAVELER, INC., THE, PENNINGTON, NJ:
 2,200,998, AM. INT. CL. 42.

INDEX DIAGNOSTICS AB, SWEDEN:
 3,631,752, PUB. 3-17-2009. INT. CL. 42.

INDIANA STATE UNIVERSITY, TERRE HAUTE, IN:
 2,598,973, CANC. INT. CL. 41.

INDIANAPOLIS COLTS, INC., THE, CHICAGO, IL:
 2,599,528, CANC. INT. CL. 28.

INDIVIDUALITEES, LLC, GREENSBORO, GA:
 3,630,797, PUB. 3-17-2009. INT. CL. 40.

INDUSTRIA DE DISENO TEXTIL, S.A., 15142 ARTEIXO A CORUNA, SPAIN, AKA INDITEX, S.A.:
 2,597,648, CANC. INT. CL. 18.

INDUSTRIA FARMACEUTICA, S.A., TEGUCIGALPA, 190, HONDURAS:
 3,630,941, PUB. 3-17-2009. INT. CL. 5.

INDUSTRIA TECNICA VALENCIANA, S. A., E-46950 CHIRIVELLA VALENCIA, SPAIN:
 2,596,904, CANC. MULTIPLE CLASS, INT. CLS. 11, 37 AND 39.

INDUSTRIA TECNICA VALENCIANA, S. A., E-46950 CHIRIVELLA (VALENCIA), SPAIN:
 2,596,905, CANC. MULTIPLE CLASS, INT. CLS. 11, 37 AND 39.

INDUSTRIAL SOFTWARE TECHNOLOGY, F-44321 NANTES CEDEX 3, FRANCE:
 3,631,765, PUB. 3-17-2009. MULTIPLE CLASS, INT. CLS. 9 AND 42.

INDUSTRIAL TECHNOLOGY RESEARCH INSTITUTE, HSIN-CHU, TAIWAN:
 3,629,488, PUB. 3-17-2009. INT. CL. 28.

INDUSTRIAS ALEN, S.A. DE C.V., SANTA CATARINA, N.L., C.P. 66350, MEXICO:
 3,373,792, AM. INT. CL. 3.

INDUSTRIAS ALEN, S.A. DE C.V., SANTA CATARINA, N.L., C.P. 66350, MEXICO:
 3,370,185, AM. INT. CL. 3.

INDUSTRIAS AUXILIARES FAUS S.L., VELENCIA, SPAIN:
 3,629,356, PUB. 3-17-2009. INT. CL. 8.

INDUSTRIAS DEL MUEBLE MARTIN, S.L., BENIPARREL, VALENCIA, SPAIN:
 2,598,264, CANC. INT. CL. 20.

INDUSTRIAS MEZQUITA, S.A. DE C.V., YUCATAN, MEXICO:
 2,597,280, CANC. INT. CL. 32.

INELCO GMBH, ROSBACH, FED REP GERMANY:
 3,629,442, PUB. 3-17-2009. INT. CL. 9.

INERGO CORPORATION, PLYMOUTH, MN:
 2,599,054, CANC. INT. CL. 20.

INFECTIOUS AWAREABLES, INC., ENCINO, CA:
 2,599,221, CANC. INT. CL. 25.

INFINEON TECHNOLOGIES AG, MUNICH, FED REP GERMANY:
 2,596,606, CANC. INT. CL. 9.

- INFINEON TECHNOLOGIES AG, 81669 MUNICH, FED REP GERMANY:
2,597,534, CANC. INT. CL. 42.
- INFINEON TECHNOLOGIES AG, NEUBIBERG, FED REP GERMANY:
3,630,847, PUB. 3-17-2009. INT. CL. 9.
- INFINITY RADIO LICENSE INC., NEW YORK, NY:
2,596,569, CANC. INT. CL. 41.
- INFINITY SOFTWARE DEVELOPMENT, INC., TALLAHASSEE, FL:
3,630,686, PUB. 3-17-2009. INT. CL. 42.
3,630,687, PUB. 3-17-2009. INT. CL. 42.
- INFINIUM REALTY GROUP, INC., SARASOTA, FL:
2,202,145, REN. 4-25-09. INT. CL. 9.
- INFOARMOR, INC., SCOTTSDALE, AZ:
3,632,568, INT. CL. 35.
3,632,618, INT. CL. 45.
- INFORM PUBLISHING GROUP LLC, SCOTTSDALE, AZ:
3,633,356, INT. CL. 16.
- INFORMATION & GRAPHICS SYSTEMS, INC., BOULDER, CO:
2,597,645, CANC. INT. CL. 9.
- INFORMATION MARKETING GROUP, INC., ROCKWALL, TX:
2,596,998, CANC. INT. CL. 9.
- INFORMATION SECURITY MEDIA GROUP, CORP., PRINCETON, NJ:
3,633,473, INT. CL. 35.
- INFORMATION, ETC., SAN ANGELO, TX:
2,598,033, CANC. INT. CL. 42.
- INFORMATIQUE GRAPHISME ENERGETIQUE-I.G.E. (S.A.), F-31770 COLOMIERS, FRANCE:
2,596,991, CANC. MULTIPLE CLASS, INT. CLS. 9 AND 42.
- INFOVISION, INC., FORT COLLINS, CO:
2,597,790, CANC. INT. CL. 35.
- INFRARED, INC., RENO, NV:
3,630,615, PUB. 3-17-2009. INT. CL. 9.
- INGENIX, INC., EDEN PRAIRIE, MN, COMMISSION ON PROFESSIONAL AND HOSPITAL ACTIVITIES, ANN ARBOR, MI:
1,496,572, REN. 4-27-09. INT. CL. 9.
- INGENUUS INDUSTRIES, BREA, CA:
3,632,962, INT. CL. 19.
- INGRAM, RAFFAELINA LYNN, WINNIPEG, MANITOBA, CANADA, TA SUGAR OF THE NILE:
3,630,384, PUB. 3-17-2009. MULTIPLE CLASS, INT. CLS. 3, 35 AND 41.
- INHABIT, LLC, SEATTLE, WA:
3,629,578, PUB. 3-17-2009. INT. CL. 35.
- INMATE TEASE LLC, WILMINGTON, NC:
3,630,913, PUB. 3-17-2009. INT. CL. 25.
- INNCOM INTERNATIONAL, INC., NANTIC, CT:
3,632,338, INT. CL. 9.
- INNOGEAR, INC., MORGAN HILL, CA:
2,598,029, CANC. INT. CL. 9.
- INNOSPEC LIMITED, UNITED KINGDOM:
3,631,729, PUB. 3-17-2009. INT. CL. 1.
- INNOVATION INTERACTIVE LLC, NEW YORK, NY:
2,596,752, CANC. INT. CL. 42.
- INNOVATIVE BEVERAGE CONCEPTS, INC., ALISO VIEJO, CA:
3,631,790, INT. CL. 5.
- INNOVATIVE BEVERAGES, L. L. C., BATON ROUGE, LA:
3,633,239, INT. CL. 5.
- INNOVATIVE MARKETING SOLUTIONS, INC., SCHAUMBURG, IL:
2,252,529, REN. 4-27-09. MULTIPLE CLASS, INT. CLS. 40 AND 42.
- INNOVIA FILMS LTD., WIGTON CUMBRIA CA79BG, UNITED KINGDOM:
2,596,446, CANC. INT. CL. 16.
- INQUISITE, INC., AUSTIN, TX:
2,241,130, REN. 4-28-09. INT. CL. 9.
- INSIDE STRATEGY, LLC, ATLANTA, GA:
2,599,014, CANC. INT. CL. 35.
- INSIGHT EQUITY A.P. X, LP, SOUTHLAKE, TX:
2,597,318, CANC. INT. CL. 9.
- INSIGHT GLOBAL, INC., ATLANTA, GA:
3,630,697, PUB. 3-17-2009. INT. CL. 35.
- INSTA-FREEZE, LLC, COLORADO CITY, CO:
2,597,279, CANC. INT. CL. 11.
- INSTITUTE FOR FINANCIAL MARKETS, WASHINGTON, DC:
2,710,217, CANC. INT. CL. 9.
- INSTITUTE FOR HIGHER EDUCATION POLICY, WASHINGTON, DC:
3,593,997 NEW CERT. 6-2-2009. MULTIPLE CLASS, INT. CLS. 9, 16 AND 41.
- INT MEDIA GROUP, INCORPORATED, DARIEN, CT:
2,598,405, CANC. MULTIPLE CLASS, INT. CLS. 35 AND 41.
- INTEGRA VENTURES, WHEATON, IL:
3,630,330, PUB. 3-17-2009. INT. CL. 35.
- INTEGRATED ASSET SERVICES, LLC, DENVER, CO:
3,630,226, PUB. 3-17-2009. INT. CL. 35.
- INTEGRATED EQUINE TECHNOLOGIES, LLC, ALLENTOWN, NJ:
3,631,933, MULTIPLE CLASS, INT. CLS. 9, 37 AND 42.
- INTEGRATED MEDICAL SYSTEMS INTERNATIONAL, INC., BIRMINGHAM, AL:
3,631,941, MULTIPLE CLASS, INT. CLS. 35, 37 AND 44.
3,631,963, INT. CL. 37.
3,632,242, INT. CL. 37.
- INTEGRATED ONCOLOGY SOLUTIONS, LLC, BATON ROUGE, LA:
3,633,430, INT. CL. 35.
- INTEGRITY FX, LLC, RIVERSIDE, CA:
3,630,620, PUB. 3-17-2009. INT. CL. 36.
- INTELLECTUAL PROPERTY HOLDINGS AS, NORWAY:
3,531,138, COR. MULTIPLE CLASS, INT. CLS. 4, 12, 37, 39 AND 42.
- INTELLIDYNE HOLDINGS, LLC, WANTAGH, NY:
2,598,037, CANC. INT. CL. 9.
- INTELLIGENCE PRESS, INC., GREAT FALLS, VA:
1,497,303, CANC. INT. CL. 35.
- INTELLIGENTSIA, INC., LOS ANGELES, CA:
3,630,796, PUB. 3-17-2009. INT. CL. 41.
- INTELLIMAT, INC., ROANOKE, VA:
3,631,962, MULTIPLE CLASS, INT. CLS. 9 AND 35.
- INTER-TEL, INC., PHOENIX, AZ:
2,627,935, CANC. INT. CL. 9.
- INTERACT ACCESSORIES, INC., HUNT VALLEY, MD:
2,597,741, CANC. INT. CL. 28.
2,597,742, CANC. INT. CL. 28.
- INTERACTIVE ADVERTISING BUREAU, INC., NEW YORK, NY:
3,629,271, PUB. 3-17-2009. MULTIPLE CLASS, INT. CLS. 16 AND 41.
- INTERACTIVE BROKERS LLC, GREENWICH, CT:
3,630,743, PUB. 3-17-2009. INT. CL. 36.
- INTERACTIVE LOT TECHNOLOGIES, INC., SOUTHAMPTON, PA:
3,632,524, MULTIPLE CLASS, INT. CLS. 9, 35 AND 42.
- INTERCOMMUNICATIONS, INC., NEWPORT BEACH, CA:
2,205,042, AM. INT. CL. 35.
- INTERCOUNSEL LLC, MATTITUCK, NY:
2,174,744, CANC. MULTIPLE CLASS, INT. CLS. 35 AND 42.
- INTERCURE INC., PRINCETON, NJ:
2,598,871, CANC. MULTIPLE CLASS, INT. CLS. 10 AND 42.
- INTERDENT SERVICE CORPORATION, EL SEGUNDO, CA:
3,631,232, PUB. 3-17-2009. INT. CL. 44.
- INTERDESIGN, INC., SOLON, OH:
3,631,877, MULTIPLE CLASS, INT. CLS. 6, 20 AND 21.
- INTERELATE, INC., EDEN PRAIRIE, MN:
2,599,007, CANC. INT. CL. 42.
- INTEREP NATIONAL RADIO SALES, INC., NEW YORK, NY:
2,598,139, CANC. INT. CL. 35.
- INTERGRAM, INC., ATLANTA, GA:
1,496,721, CANC. MULTIPLE CLASS, INT. CLS. 16, 41 AND 42.
- INTERMARTCORP., THOUSAND OAKS, CA:
2,599,845, CANC. INT. CL. 9.

INTERMATCH SWEDEN AB, STOCKHOLM, SWEDEN:
2,195,303. REN. 4-24-09. INT. CL. 34.

INTERMEDIA.NET, INC., PALO ALTO, CA:
2,597,148. CANC. INT. CL. 38.

INTERMEG CORPORATION, NEW YORK, NY:
2,598,085. CANC. INT. CL. 42.

INTERNATIONAL ACCOUNTING STANDARDS COMMITTEE FOUNDATION, LONDON, UNITED KINGDOM:
3,630,105. PUB. 3-17-2009. MULTIPLE CLASS, INT. CLS. 9, 16 AND 35.

INTERNATIONAL ALLIANCE OF LAW FIRMS, LONDON, UNITED KINGDOM:
3,629,389. PUB. 12-2-2008. INT. CL. 45.

INTERNATIONAL ASSOCIATION OF ATHLETICS FEDERATIONS, MONTE CARLO, MONACO:
2,679,839. CANC. MULTIPLE CLASS, INT. CLS. 6, 9, 12, 14, 18, 25, 28, 32 AND 36.

INTERNATIONAL ASSOCIATION OF ELECTRICAL INSPECTORS, RICHARDSON, TX:
2,238,466. REN. 4-25-09. INT. CL. 41.
2,240,462. REN. 4-25-09. INT. CL. 42.
2,240,463. REN. 4-25-09. INT. CL. 42.
2,240,464. REN. 4-25-09. U.S. CL. 200.

INTERNATIONAL BUSINESS MACHINES CORPORATION, ARMONK, NY, AKA IBM CORPORATION:
2,175,098. CANC. INT. CL. 42.
2,599,182. CANC. INT. CL. 9.

INTERNATIONAL CHAPTER P.E.O. SISTERHOOD, DES MOINES, IA:
3,630,444. PUB. 3-17-2009. INT. CL. 36.
3,630,445. PUB. 3-17-2009. INT. CL. 35.

INTERNATIONAL COMMUNICATIONS GROUP, INC., LOS ANGELES, CA:
1,497,003. CANC. INT. CL. 35.

INTERNATIONAL DATA BASE CORPORATION, ALBANY, NY:
2,596,903. CANC. INT. CL. 35.

INTERNATIONAL DATA GROUP, INC., FRAMINGHAM, MA:
2,175,398. CANC. INT. CL. 42.
2,328,968. REN. 4-30-09. INT. CL. 42.
2,598,190. CANC. MULTIPLE CLASS, INT. CLS. 16 AND 42.
3,632,198. INT. CL. 35.

INTERNATIONAL DESIGN ASSOCIATES LTD, NEW YORK, NY:
3,631,275. PUB. 3-17-2009. INT. CL. 18.
3,631,276. PUB. 3-17-2009. INT. CL. 18.
3,631,277. PUB. 3-17-2009. INT. CL. 18.
3,631,321. PUB. 3-17-2009. INT. CL. 5.

INTERNATIONAL ENTERPRISE; SINGAPORE BOARD, SINGAPORE:
3,631,542. PUB. 3-17-2009. MULTIPLE CLASS, INT. CLS. 16, 35, 38, 41 AND 42.

INTERNATIONAL EXECUTIVE CONSULTING GROUP SARL.; C/O GEMTRUST SA, SWITZERLAND:
3,631,644. PUB. 3-17-2009. MULTIPLE CLASS, INT. CLS. 35 AND 41.

INTERNATIONAL FASTENERS, INC., TAMPA, FL:
3,629,294. PUB. 3-17-2009. INT. CL. 6.

INTERNATIONAL FINANCE CORPORATION, WASHINGTON, DC:
1,316,092. AM. INT. CL. 36.
1,316,096. AM. INT. CL. 36.
2,344,372. AM. MULTIPLE CLASS, INT. CLS. 16, 36 AND 42.
2,347,999. AM. MULTIPLE CLASS, INT. CLS. 16, 36 AND 42.
2,353,045. AM. MULTIPLE CLASS, INT. CLS. 16, 36 AND 42.

INTERNATIONAL HORIZONS UNLIMITED, LTD., SAN ANTONIO, TX:
2,598,482. CANC. INT. CL. 35.

INTERNATIONAL NORTEL NETWORK USERS ASSOCIATION, CHICAGO, IL:
3,629,919. PUB. 3-17-2009. MULTIPLE CLASS, INT. CLS. 35 AND 41.

INTERNATIONAL PAPER COMPANY, STAMFORD, CT:
2,598,161. CANC. INT. CL. 16.

INTERNATIONAL PRODUCTS CORPORATION, BURLINGTON, NJ:
2,223,218. REN. 4-24-09. INT. CL. 3.

INTERNATIONAL SHARED SERVICES, INC., WEST LANGHORNE, PA:
3,633,152. MULTIPLE CLASS, INT. CLS. 9 AND 37.
3,633,153. MULTIPLE CLASS, INT. CLS. 9 AND 37.

INTERNATIONAL TENTNOLOGY CORP., SURREY, BRITISH COLUMBIA, CANADA:
2,233,258. REN. 4-26-09. MULTIPLE CLASS, INT. CLS. 9 AND 22.

INTERNATIONAL TRADE SOLUTIONS, INC., GRAND FORKS, ND:
3,633,285. INT. CL. 9.

INTERNET CONNECTIVITY GROUP, INC., LAKE FOREST, CA:
3,632,556. MULTIPLE CLASS, INT. CLS. 38 AND 42.
3,632,560. INT. CL. 9.

INTERSECTIONS INSURANCE SERVICES INC., ARLINGTON HEIGHTS, IL:
2,598,945. CANC. INT. CL. 35.

INTERSPEC, LLC, PORTLAND, ME:
2,599,840. CANC. INT. CL. 42.

INTERTHINX, INC., AGOURA HILLS, CA:
3,632,474. MULTIPLE CLASS, INT. CLS. 9 AND 41.

INTEVAC, INC., SANTA CLARA, CA:
3,631,947. INT. CL. 7.

INTEX MANAGEMENT COMPANY, LTD., GARLAND, TX:
2,599,655. CANC. INT. CL. 42.

INTIGRAL, INC., WALTON HILLS, OH, DBA EDGE SEAL TECHNOLOGIES:
3,632,258. INT. CL. 19.
3,632,259. INT. CL. 19.
3,632,276. INT. CL. 19.

INTRALASE CORP., IRVINE, CA:
2,598,853. CANC. INT. CL. 10.

INTUITIVE CIRCUITS, LLC, TROY, MI:
2,599,532. CANC. INT. CL. 9.

INVENTIO AG, 6052 HERGISWIL, SWITZERLAND:
2,596,773. CANC. MULTIPLE CLASS, INT. CLS. 7, 9, 37 AND 42.

INVENTIVE LABS CORPORATION, GREENWOOD VILLAGE, CO:
3,630,041. PUB. 3-17-2009. INT. CL. 9.

INVERNESS MEDICAL, LLC, WALTHAM, MA:
2,292,243. REN. 4-24-09. INT. CL. 5.

INVESCO FUNDS GROUP, INC., DENVER, CO:
2,599,084. CANC. INT. CL. 36.

INVESCO HOLDING COMPANY LIMITED, ATLANTA, GA:
2,599,355. CANC. INT. CL. 36.

INVESTACORP, INC., MIAMI LAKES, FL:
1,497,048. CANC. INT. CL. 36.

INVESTTOOLS INC., DRAPER, UT:
3,632,123. INT. CL. 16.

INVIVO COMMUNICATIONS INC., TORONTO, CANADA:
3,629,413. PUB. 3-17-2009. MULTIPLE CLASS, INT. CLS. 9, 16, 28, 35, 41 AND 42.

INXPO, INC., CHICAGO, IL:
3,633,040. INT. CL. 42.

IOLO TECHNOLOGIES, LLC, LOS ANGELES, CA:
3,630,988. PUB. 3-17-2009. INT. CL. 9.
3,630,992. PUB. 3-17-2009. INT. CL. 9.
3,632,125. INT. CL. 9.

IOMEDIX DEVELOPMENT INTERNATIONAL SRL, WORTHING, CHRIST CHURCH, BARBADOS:
3,629,701. PUB. 3-17-2009. INT. CL. 5.

ION MEDIA NETWORKS, INC., WEST PALM BEACH, FL:
3,632,982. MULTIPLE CLASS, INT. CLS. 38 AND 41.

IP TECHNOLOGIES HOLDINGS, LLC, WEST LIBERTY, OH:
3,632,823. INT. CL. 9.

IPCAPITAL GROUP, INC., WILLISTON, VT:
2,599,846. CANC. MULTIPLE CLASS, INT. CLS. 35, 36 AND 42.

- IPOS GESELLSCHAFT FUR INTEGRIERTE PROTHESEN-ENTWICKLUNG UND ORTHOPADIETECHNISCHEN SERVICE M.B.H. & CO. KG., D-2120 LUENEBURG, FED REP GERMANY, DBA IPOS GMBH + CO. KG:
1,496,381, CANC. INT. CL. 1.
- IPOUR, LLC, CHARLOTTE, NC:
3,632,088, INT. CL. 21.
- IPRIVACY LLC, NEW YORK, NY:
2,598,966, CANC. INT. CL. 42.
- IPSEN BIOPHARM LIMITED, UNITED KINGDOM:
3,631,476, PUB. 10-14-2008. INT. CL. 5.
- IRANIAN AMERICAN SOCIETY, PALOS VERDES ESTATE, CA:
3,629,520, PUB. 3-17-2009. INT. CL. 35.
- IRIS USA, INC., PLEASANT PRAIRIE, WI:
2,174,878, CANC. INT. CL. 21.
- IRISH DISTILLERS LIMITED, BALLSBRIDGE, DUBLIN 4, IRELAND:
1,537,584. REN. 4-29-09. INT. CL. 33.
- IRISH THUNDER, LLC, PEARL RIVER, NY:
3,632,678, INT. CL. 33.
- IRON DOG, INC., ANCHORAGE, AK:
3,630,953, PUB. 3-17-2009. MULTIPLE CLASS, INT. CLS. 25 AND 41.
3,630,955, PUB. 3-17-2009. MULTIPLE CLASS, INT. CLS. 25 AND 41.
- IRON-A-WAY INC., MORTON, IL:
2,833,992, CANC. INT. CL. 21.
- ISC CO., LTD., HIROSHIMA 731-5128, JAPAN:
3,631,756, PUB. 3-17-2009. MULTIPLE CLASS, INT. CLS. 39 AND 40.
- ISCS, INC., SAN JOSE, CA:
2,174,632, CANC. INT. CL. 9.
- ISHIHARA SANGYO KAISHA, LTD., JAPAN:
3,631,768, PUB. 3-17-2009. INT. CL. 5.
- ISI BRANDS INC., GRAND RAPIDS, MI:
1,496,507, CANC. INT. CL. 5.
- ISLE OF CAPRI CASINOS, INC., ST. LOUIS, MO:
1,535,814. REN. 4-29-09. INT. CL. 41.
1,535,814, CANC. INT. CL. 42.
3,630,560, PUB. 3-17-2009. MULTIPLE CLASS, INT. CLS. 41 AND 43.
- ISN SOFTWARE CORPORATION, DALLAS, TX:
3,630,699, PUB. 3-17-2009. INT. CL. 35.
- ISPHERES CORPORATION, OAKLAND, CA:
2,596,995, CANC. INT. CL. 9.
- ISRAEL EDIBLE PRODUCTS LTD., HAIFA, ISRAEL:
1,496,912, CANC. MULTIPLE CLASS, INT. CLS. 29 AND 30.
- ITC INCORPORATED, HOLLAND, MI:
2,598,832, CANC. INT. CL. 9.
- ITELAGEN, INC., JERSEY CITY, NJ:
3,630,415, PUB. 3-17-2009. MULTIPLE CLASS, INT. CLS. 9, 35 AND 42.
- ITERATIONS, INC., ELK RIDGE, UT, DBA VARIFIT ORTHOTICS:
3,631,298, PUB. 3-17-2009. MULTIPLE CLASS, INT. CLS. 7 AND 25.
- ITO PACKING CO., REEDLEY, CA:
2,598,753, CANC. INT. CL. 31.
- ITRAIN, LLC, BEVERLY HILLS, CA:
3,633,138, MULTIPLE CLASS, INT. CLS. 35 AND 41.
- ITRON, INC., LIBERTY LAKE, WA:
1,534,229. REN. 4-25-09. INT. CL. 16.
1,534,650. REN. 4-28-09. INT. CL. 37.
- ITT CORPORATION, WHITE PLAINS, NY:
1,585,354. REN. 4-25-09. INT. CL. 9.
- ITU VENTURES INC., LOS ANGELES, CA:
2,596,750, CANC. MULTIPLE CLASS, INT. CLS. 35 AND 36.
- IVANS, INC., STAMFORD, CT:
3,631,245, PUB. 3-17-2009. INT. CL. 38.
- IVOCLAR VIVADENT, INC., AMHERST, NY:
3,629,541, PUB. 3-17-2009. MULTIPLE CLASS, INT. CLS. 5 AND 10.
- IWANTTOPLAY.COM, INC, DALLAS, TX:
2,598,472, CANC. INT. CL. 35.
- I2W12, INC., NEWBURY, MA:
3,632,975, INT. CL. 25.
- J & B EVENT MANAGEMENT, INC., BLOOMINGTON, IN:
2,174,926, CANC. INT. CL. 39.
- J CONSORTIUM, INC., CUPERTINO, CA:
2,598,585, CANC. INT. CL. 9.
- J. C. PENNEY COMPANY, INC., PLANO, TX:
1,496,778, CANC. INT. CL. 18.
- J. F. STOFFER, INC., CANTON, OH:
2,598,804, CANC. MULTIPLE CLASS, INT. CLS. 11 AND 20.
- J. P. WISER DISTILLERY LIMITED, MONTREAL, QUEBEC, CANADA:
1,496,983, CANC. INT. CL. 33.
- J. R. SIMPLOT COMPANY, BOISE, ID:
1,496,933, CANC. INT. CL. 30.
- J. T. DESIGN STUDIO, INC., LOS ANGELES, CA:
3,632,526, INT. CL. 25.
- J.C. TOYS GROUP, INC., MIAMI, FL:
3,629,762, PUB. 3-17-2009. INT. CL. 28.
- J.H. FENNER & CO. LIMITED, EAST YORKSHIRE, UNITED KINGDOM:
3,632,257, INT. CL. 7.
- J.M. HUBER CORPORATION, EDISON, NJ:
2,174,522, CANC. INT. CL. 1.
- J&R GROUP, INC., ST. PAUL, MN, DBA THE ITALIAN PIE SHOPPE:
2,243,235. REN. 4-29-09. INT. CL. 42.
- JA MUSIC, LLC, ORANGE, CT:
3,632,772, INT. CL. 15.
- JACK DANIEL'S PROPERTIES, INC., SAN RAFAEL, CA:
2,597,077, CANC. INT. CL. 33.
- JACK ROSE, MALIBU, CA:
3,632,796, INT. CL. 32.
- JACK WHITE APPAREL, INC., DEBARY, FL:
3,629,901, PUB. 3-17-2009. INT. CL. 25.
- JACKSON RANCHERIA BAND OF MIWUK INDIANS, JACKSON, CA:
3,631,361, PUB. 3-17-2009. MULTIPLE CLASS, INT. CLS. 35, 41 AND 43.
- JACKSON STATE UNIVERSITY, JACKSON, MS:
2,242,540. REN. 4-25-09. MULTIPLE CLASS, INT. CLS. 6, 14, 16, 18, 20, 21, 25, 28 AND 41.
- JACKSON, CORY D., SACRAMENTO, CA:
3,633,440, INT. CL. 41.
- JACOB NORTH PRINTING CO., INC., LINCOLN, NE:
2,174,692, CANC. INT. CL. 42.
2,174,696, CANC. INT. CL. 42.
- JACQUELINE COY GIST, CHICAGO, IL:
3,632,795, INT. CL. 25.
- JACQUELINE SHAPIRO, NEW YORK, NY:
3,629,254, PUB. 3-17-2009. MULTIPLE CLASS, INT. CLS. 16 AND 21.
- JAD CORPORATION OF AMERICA, COLLEGE POINT, NY:
3,575,986, COR. INT. CL. 16.
3,575,987, COR. INT. CL. 16.
3,576,043, COR. INT. CL. 16.
- JAIN ALOK K, SUGAR LAND, TX AND GOYAL DEEPAK K, SUGAR LAND, TX:
3,629,785, PUB. 3-17-2009. INT. CL. 35.
- JAK MARKETING LLC, SECAUCUS, NJ:
2,233,210. REN. 4-26-09. INT. CL. 25.
2,235,606. REN. 4-26-09. INT. CL. 25.
- JAKKS PACIFIC, INC., MALIBU, CA:
2,598,894, CANC. INT. CL. 28.
3,632,094, INT. CL. 28.
- JALBERT, STEVE, SPOKANE, WA:
3,632,256, INT. CL. 7.
- JAMBA JUICE COMPANY, EMERYVILLE, CA:
2,174,423, CANC. MULTIPLE CLASS, INT. CLS. 5, 29 AND 42.
- JAME UGONE, TOPSFIELD, MA:
3,632,902, INT. CL. 21.
- JAMES CAIRD ASSET MANAGEMENT LLP, LONDON, UNITED KINGDOM:
3,629,700, PUB. 3-17-2009. INT. CL. 36.

JAMES DECRESCENZO REPORTING, LLC, PHILADELPHIA, PA:
3,632,113, INT. CL. 38.

JAMES HARDIE INTERNATIONAL FINANCE, B.V., AMSTERDAM, NETHERLANDS:
2,596,590, CANC. INT. CL. 19.

JAMES TRUSSART, LOS ANGELES, CA, DBA JAMES TRUSSART CUSTOM GUITARS:
3,630,227, PUB. 3-17-2009. INT. CL. 15.

JAMES, JALANDA, NEW YORK, NY:
3,631,415, PUB. 3-17-2009. INT. CL. 16.

JAMES, JESSE R., LINCOLN CITY, OR:
2,597,064, CANC. INT. CL. 30.

JAMF SOFTWARE, LLC, MINNEAPOLIS, MN:
3,629,375, PUB. 3-17-2009. MULTIPLE CLASS, INT. CLS. 39 AND 42.
3,629,382, PUB. 3-17-2009. INT. CL. 9.
3,629,393, PUB. 3-17-2009. INT. CL. 9.

JAMIE KELLNER, SANTA BARBARA, CA:
3,631,916, INT. CL. 33.

JAMIE KERN, BEAVERTON, OR:
3,632,708, INT. CL. 3.

JANET GESELLSCHAFT FUR INTERAKTIVE MEDIEN MBH, D-81377 MUCHENCHEN, FED REP GERMANY:
2,596,726, CANC. MULTIPLE CLASS, INT. CLS. 9, 16 AND 42.

JANICE D. ROBINSON ENTERPRISES, GREENVILLE, SC:
3,629,482, PUB. 3-17-2009. INT. CL. 41.

JAPAN POST HOLDINGS CO., LTD, TOKYO, JAPAN:
3,629,248, PUB. 3-17-2009. INT. CL. 39.

JAPIRA AG, SWITZERLAND:
3,631,676, PUB. 3-17-2009. MULTIPLE CLASS, INT. CLS. 9 AND 38.

JAS. D. EASTON, INC., VAN NUYS, CA:
2,599,685, CANC. INT. CL. 28.

JASSON INTERNATIONAL LLC, ATLANTA, GA:
3,630,064, PUB. 3-17-2009. MULTIPLE CLASS, INT. CLS. 19 AND 27.

JAY IMPORT COMPANY, INC., NEW YORK, NY:
2,599,223, CANC. INT. CL. 21.

JAZZI G, INC., SAN MARCOS, CA:
3,632,857, INT. CL. 20.

JBNI, BOTHELL, WA, DBA BIODRUX:
3,630,681, PUB. 3-17-2009. INT. CL. 5.

JCA DEVELOPMENT OF MIAMI, INC., MIAMI, FL:
3,631,262, PUB. 3-17-2009. INT. CL. 5.

JD-CMC, INC., SUN VALLEY, CA:
2,596,458, CANC. INT. CL. 25.

JEANE WAN CHING, TORONTO ONT M2H 3G6, CANADA:
3,629,729, PUB. 3-17-2009. INT. CL. 14.

JEANNE B. MCCOY COMMUNITY CENTER FOR THE ARTS, NEW ALBANY, OH:
3,632,397, MULTIPLE CLASS, INT. CLS. 35 AND 41.

JED TRADERS, INC., SANTA CRUZ, AR, DBA HAT.A.-GIRL:
3,631,208, PUB. 3-17-2009. INT. CL. 25.

JEEPERS! INC., WALTHAM, MA:
2,598,365, CANC. MULTIPLE CLASS, INT. CLS. 16, 18, 21, 25, 28, 41 AND 42.

JEFFREY JOHNSON AND MARVIN SIEPS PARTNERSHIP, THE, KIRKLAND, WA:
2,597,943, CANC. INT. CL. 28.

JELD-WEN, INC., KLAMATH FALLS, OR:
3,632,347, INT. CL. 41.

JELMA, INC., MADISON, NJ:
3,631,187, PUB. 3-17-2009. INT. CL. 33.
3,631,189, PUB. 3-17-2009. INT. CL. 33.
3,631,190, PUB. 3-17-2009. INT. CL. 33.
3,631,196, PUB. 3-17-2009. INT. CL. 33.

JEM SPORTSWEAR, INC., SAN FERNANDO, CA:
3,632,205, INT. CL. 25.
3,632,206, INT. CL. 25.

JENKINS, TERRA, CENTREVILLE, IL:
3,631,150, PUB. 3-17-2009. INT. CL. 32.

JENNIFER KAY, INC., LOS ANGELES, CA:
2,174,235, CANC. INT. CL. 25.

JENNISON GREYFOX SYSTEMS, INC., PITTSBURGH, PA:
2,598,127, CANC. INT. CL. 9.

JENZABAR, INC., BOSTON, MA, CAMPUS AMERICA, INC., KNOXVILLE, TN:
1,518,478, REN. 4-27-09. INT. CL. 42.

JERALD, INC., WATERLOO, IA:
3,629,497, PUB. 3-17-2009. INT. CL. 12.

JERDON PRODUCTS, LP, RICHARDSON, TX:
1,496,594, CANC. MULTIPLE CLASS, INT. CLS. 9, 11, 20 AND 21.

JEREMY COWAN, SAN FRANCISCO, CA:
3,630,633, PUB. 3-17-2009. INT. CL. 32.

JERICOHO PROJECT, THE, NEW YORK, NY:
2,313,277, REN. 4-24-09. INT. CL. 42.

JESS CLARKE & SONS, INC., APOLLO BEACH, FL:
1,540,084, REN. 4-24-09. INT. CL. 5.
2,219,771, REN. 4-25-09. INT. CL. 35.

JESSICA MCCLINTOCK, INC., SAN FRANCISCO, CA:
2,598,793, CANC. INT. CL. 9.

JET-PORT, INC., CHAPIN, SC:
3,630,776, PUB. 3-17-2009. INT. CL. 19.

JET-TERN MARINE COMPANY, TAO-YUAN, TAIWAN:
3,631,065, PUB. 3-17-2009. INT. CL. 12.

JETS AS, NORWAY:
3,631,601, PUB. 3-17-2009. MULTIPLE CLASS, INT. CLS. 7 AND 11.

JEUNES RESTAURATEURS D'EUROPE; (ASSOCIATION RÉGIE PAR LA LOI; DU 1ER JUILLET 1901), FRANCE:
3,631,536, PUB. 3-17-2009. MULTIPLE CLASS, INT. CLS. 35, 41 AND 43.

JEWELX NEW YORK, LTD., NEW YORK, NY:
3,632,668, INT. CL. 14.

JEWISH NATIONAL FUND (KEREN KAYEMETH LEISRAEL), INC., NEW YORK, NY:
3,629,289, PUB. 3-17-2009. MULTIPLE CLASS, INT. CLS. 36 AND 41.

JFE STEEL CORPORATION, TOKYO, JAPAN:
1,536,075, REN. 4-27-09. INT. CL. 7.

JFM CONCEPTS LLC, INDIANAPOLIS, IN:
3,629,680, PUB. 3-17-2009. INT. CL. 35.

JGA ADVERTISING, INC., CARLSTADT, NJ:
2,175,558, CANC. INT. CL. 35.

JGB, S.A., CALI, COLOMBIA:
2,277,688, REN. 4-27-09. INT. CL. 5.

JHERI RICHARDS, INC., NEW YORK, NY:
2,597,841, CANC. INT. CL. 25.

JILLMERICA, LLC, PHOENIX, AZ:
2,599,328, CANC. INT. CL. 28.

JINX PROOF LLC, NEW YORK, NY, DBA BEAUTY BAR:
3,630,840, PUB. 3-17-2009. INT. CL. 43.

JIT PARTNERS, INC, TARZANA, CA, DBA J.I.T. PARTNERS, INC.:
3,632,339, INT. CL. 25.

JITTERGRAM, INC., BEDFORD, NH:
3,630,925, PUB. 3-17-2009. INT. CL. 35.

JJE PROPERTIES LLC, GLEN ELLYN, IL:
3,632,066, INT. CL. 33.

JMB S.A.S. DI KAPLLANI BELEDINA & C., PRATO, ITALY:
3,629,246, PUB. 12-9-2008. MULTIPLE CLASS, INT. CLS. 18 AND 25.

JMBP, INC., LOS ANGELES, CA:
3,633,251, INT. CL. 9.
3,633,256, INT. CL. 35.

JME INCORPORATED, PACOIMA, CA, DBA TMB:
3,630,626, PUB. 3-17-2009. INT. CL. 11.

JNP & EG JORDAAN, TULBAGH, SOUTH AFRICA:
3,631,445, PUB. 3-17-2009. INT. CL. 33.

JO ANN LEDERMAN M.S. EDP., INC., CORAL GABLES, FL:
2,243,707, REN. 4-24-09. INT. CL. 9.

JOAQUIN T. LU, LOS ANGELES, CA:
3,632,724, INT. CL. 29.
3,632,740, INT. CL. 29.

JOBS S.P.A., PIACENZA, ITALY:
3,629,873, PUB. 3-17-2009. MULTIPLE CLASS, INT. CLS. 7 AND 9.

JOE DARDEN GROUP LLC, PORTLAND, OR:
3,630,491, PUB. 3-17-2009. INT. CL. 41.

JOFFREY BALLETT, THE, NEW YORK, NY:
1,508,600, REN. 4-27-09. INT. CL. 41.

- JOHN BESSELING, NETHERLANDS:
3,631,535, PUB. 3-17-2009. MULTIPLE CLASS, INT. CLS. 9, 16 AND 18.
- JOHN D. SHEPHERD LLC, MANHATTAN, IL:
3,630,828, PUB. 3-17-2009. INT. CL. 8.
- JOHN DOE RECORDS, LLC, COLORADO SPRINGS, CO:
3,631,226, PUB. 3-17-2009. MULTIPLE CLASS, INT. CLS. 9 AND 35.
- JOHN GJERDE AS, N-6083 GJERDSVIKA, NORWAY:
3,631,772, PUB. 3-17-2009. INT. CL. 6.
- JOHN HANCOCK MUTUAL LIFE INSURANCE COMPANY, BOSTON, MA:
1,497,034, CANC. INT. CL. 36.
- JOHN JO LEWIS AND JAY WADE PARTNERSHIP, THE, BELLINGHAM, WA:
3,633,109, MULTIPLE CLASS, INT. CLS. 12, 25, 35 AND 39.
- JOHN LEVY, LIVINGSTON, NJ, DBA GARAGE MUSICALS:
3,629,930, PUB. 3-17-2009. INT. CL. 41.
- JOHN RAYTEK WINES, HEALDSBURG, CA:
3,632,541, INT. CL. 33.
- JOHN RICH & SONS INVESTMENT HOLDING COMPANY, WILMINGTON, DE:
3,632,725, INT. CL. 25.
- JOHN WILEY & SONS, INC., HOBOKEN, NJ:
3,629,544, PUB. 3-17-2009. INT. CL. 16.
- JOHN ZABOYAN, PASADENA, CA:
1,496,705, CANC. INT. CL. 14.
- JOHNNY LINDY COMPANY, WEST LOS ANGELES, CA:
2,174,234, CANC. INT. CL. 41.
- JOHNNY VAC INC., MONTREAL, QUEBEC, CANADA:
3,629,179, PUB. 3-17-2009. INT. CL. 7.
- JOHNSON & JOHNSON, NEW BRUNSWICK, NJ:
1,496,533, CANC. INT. CL. 5.
1,516,200, REN. 4-25-09. INT. CL. 5.
3,345,307, AM. INT. CL. 5.
3,630,518, PUB. 3-17-2009. INT. CL. 42.
3,631,808, INT. CL. 5.
- JOHNSON COMPONENTS, INC., WASECA, MN TO EMERSON NETWORK POWER CONNECTIVITY SOLUTIONS, INC., WASECA, MN:
2,174,307, CANC. INT. CL. 9.
- JOHNSON CONTROLS, INC., MILWAUKEE, WI:
2,598,413, CANC. INT. CL. 36.
- JOHNSON HEALTH TECH NORTH AMERICA, INC., COTTAGE GROVE, WI:
3,631,942, INT. CL. 28.
- JOHNSON, DWAYNE, BALTIMORE, MD:
2,598,670, CANC. INT. CL. 16.
- JOHNSON, ERIC, NASHVILLE, TN:
3,631,920, INT. CL. 36.
- JOHNSON, LARRY, SCOTTSDALE, AZ:
2,174,330, CANC. MULTIPLE CLASS, INT. CLS. 9, 16 AND 41.
- JOHNSON, MARJORIE, MINNEAPOLIS, MN:
3,629,274, PUB. 3-17-2009. INT. CL. 41.
- JOHNSON, MARK TODD, GLASGOW, KY:
2,598,124, CANC. INT. CL. 41.
- JOHNSTON, JEFF, BRANSCOMB, CA AND ROBINSON, DAVID, FORT BRAGG, CA:
2,599,369, CANC. INT. CL. 25.
- JOMAR INTERNATIONAL, LTD., WARREN, MI:
1,541,419, REN. 4-27-09. INT. CL. 11.
1,543,139, REN. 4-27-09. INT. CL. 1.
- JON-DON, INC., ROSELLE, IL:
2,248,806, REN. 4-24-09. MULTIPLE CLASS, INT. CLS. 9, 35 AND 37.
- JONES, DERIK T, BRIGHTON, MI:
3,629,746, PUB. 3-17-2009. INT. CL. 12.
- JONES, RUSSELL E., KINGSTON, OH:
1,550,896, REN. 4-27-09. INT. CL. 12.
- JONESTRADING INSTITUTIONAL SERVICES LLC, WESTLAKE VILLAGE, CA:
3,632,056, INT. CL. 36.
- JONMOR INVESTMENTS, INC., WILMINGTON, DE:
3,629,403, PUB. 3-17-2009. INT. CL. 29.
3,631,244, PUB. 3-17-2009. INT. CL. 29.
- JONPAUL BOWS, INC., SALT LAKE CITY, UT:
3,629,199, PUB. 3-17-2009. INT. CL. 15.
- JOSE J. REGINATO Y CIA S.R.L., GUAYMALLEN, ARGENTINA:
3,633,462, INT. CL. 33.
- JOSEF MARTIN GMBH, BRAZ, AUSTRIA:
3,629,553, PUB. 3-17-2009. INT. CL. 7.
- JOSEPH HORNE CO., INC., PITTSBURGH, PA:
1,497,199, CANC. INT. CL. 42.
- JOSEPH RHINEWINE, PHD, PC, PORTLAND, OR, DBA PORTLAND MINDFULNESS THERAPY:
3,633,427, INT. CL. 44.
- JOSEPH, ANDREA S., BROOMALL, PA, DBA MUSICAL MOMMY PRODUCTIONS:
2,240,788, REN. 4-27-09. INT. CL. 41.
- JOSHUA PHARMACEUTICAL PTE LTD, SINGAPORE, SINGAPORE:
3,629,237, PUB. 3-17-2009. INT. CL. 5.
- JOY OF GIVING SOMETHING, INC., NEW YORK, NY:
3,632,488, INT. CL. 41.
3,632,489, INT. CL. 41.
3,632,490, INT. CL. 41.
- JOYCOS LTD., SEOUL, REPUBLIC OF KOREA:
2,598,842, CANC. INT. CL. 3.
- JOYFUL TRADING CO., LTD, TAIPEI, TAIWAN:
3,632,865, INT. CL. 25.
- JT SPORTS LLC, BENTONVILLE, AR:
2,596,624, CANC. MULTIPLE CLASS, INT. CLS. 13, 25 AND 41.
- JUBILEE BLUEBERRY FARMS, LLC, GRAND JUNCTION, MI:
3,632,065, INT. CL. 31.
- JUBILEE GROUP, INC., GROSSE POINTE WOODS, MI, DBA PROMOTION SERVICES, INC.:
2,598,467, CANC. INT. CL. 41.
- JUCY'S SMOKEHOUSE BAR-B-Q, INC., LOUISVILLE, KY:
2,597,561, CANC. MULTIPLE CLASS, INT. CLS. 29 AND 42.
- JUICY COUTURE, INC., PACOIMA, CA:
3,633,187, INT. CL. 25.
- JULIUS SÄMANN LTD., HAMILTON HM12, BERMUDA:
3,632,945, INT. CL. 5.
- JUMBO MADENI ESYA SANAYI VE TICARET ANONIM SIRKETI, BAYRAMPASA ISTANBUL, TURKEY:
2,599,785, CANC. INT. CL. 8.
2,599,786, CANC. INT. CL. 8.
2,599,787, CANC. INT. CL. 8.
2,599,788, CANC. INT. CL. 8.
2,599,789, CANC. INT. CL. 8.
- JUNE ALLEN, FITCHBURG, MA:
3,630,562, PUB. 3-17-2009. MULTIPLE CLASS, INT. CLS. 35 AND 44.
- JUNKET MEDIA CORP., PEACHTREE CITY, GA:
3,632,118, INT. CL. 41.
- JUJYL DESIGNS LLC, BROOKLYN, NY:
3,632,968, INT. CL. 25.
- JVC AMERICAS CORP., ELMWOOD PARK, NJ:
2,596,483, CANC. INT. CL. 9.
- JYMGER MARKETING AND ENGINEERING, GOSHEN, IN:
3,632,268, INT. CL. 12.
- JZJ, LLC, ATLANTA, GA:
3,629,186, PUB. 3-17-2009. INT. CL. 35.
- J2 GLOBAL HOLDINGS LIMITED, LOS ANGELES, CA:
3,631,045, PUB. 3-17-2009. INT. CL. 42.
- K & R REALTY INC MANAGEMENT INC., NEW YORK, NY:
3,630,406, PUB. 3-17-2009. INT. CL. 36.
- K. MORGAN AND COMPANY, INC., PHOENIX, AZ:
3,632,615, INT. CL. 42.
- KABELWERKE REINSHAGEN GMBH, WUPPERTAL, FED REP GERMANY:
1,496,591, CANC. MULTIPLE CLASS, INT. CLS. 9, 11 AND 17.
- KABIR INTERNATIONAL S.R.L., ITALY:
3,631,635, PUB. 3-17-2009. MULTIPLE CLASS, INT. CLS. 31 AND 44.

- KABOUREK, ILKA DANIELA, 81825 MÜNCHEN, FED REP GERMANY:
3,631,726, PUB. 3-17-2009. INT. CL. 3.
- KABUSHIKI KAISHA ALAVEIL, NIIGATA 959-1241, JAPAN:
2,598,573, CANC. INT. CL. 8.
- KABUSHIKI KAISHA D&M HOLDINGS, KAWASAKI-SHI, KANAGAWA, JAPAN, TA D&M HOLDINGS, INC., MARANTZ COMPANY, INC., CHATSWORTH, CA:
1,538,024. REN. 4-27-09. INT. CL. 9.
- KABUSHIKI KAISHA MORPHO (MORPHO, INC.), TOKYO, JAPAN:
3,629,499, PUB. 1-13-2009. INT. CL. 9.
- KABUSHIKI KAISHA PILOT CORPORATION; (ALSO TRADING AS PILOT CORPORATION), JAPAN:
3,631,730, PUB. 3-17-2009. INT. CL. 16.
- KABUSHIKI KAISHA SEGA, OHTA-KU, TOKYO, JAPAN, DBA SEGA CORPORATION:
3,633,025, INT. CL. 9.
- KABUSHIKI KAISHA TEN-ICHI SYOKUHIN SHOJI (TEN-ICHI FOODS TRADING CO., LTD.), OOTSU SHIGA, JAPAN:
3,629,816, PUB. 3-17-2009. INT. CL. 43.
- KABUSHIKI KAISHA TOSHIBA, MINATO-KU, TOKYO, JAPAN, DBA TOSHIBA CORPORATION:
2,988,468, COR. INT. CL. 9.
- KABUSHIKIKAISHA XAVEL, TOKYO 106-0031, JAPAN:
3,324,871, COR. INT. CL. 41.
- KACER, DAWN, ORLANDO, FL:
3,629,916, PUB. 3-17-2009. INT. CL. 18.
- KAGOME CO., LTD., NAKA-KU, NAGOYA, JAPAN:
2,597,835, CANC. INT. CL. 30.
- KAGOOOR NETWORKS, INC., SAN MATEO, CA:
2,599,019, CANC. INT. CL. 9.
- KAHALA FRANCHISE CORP., SCOTTSDALE, AZ:
2,598,608, CANC. INT. CL. 42.
- KAHIKI FOODS, INC., GAHANNA, OH:
3,632,370, INT. CL. 29.
- KAHLER CORPORATION, THE, ROCHESTER, MN:
1,497,274, CANC. INT. CL. 42.
- KAL-MOCHA ENTERPRISES, INC., MIAMI, FL:
3,631,813, INT. CL. 30.
- KALP MOBILYA AKSESUAR SANAYI VE TEKSTIL DIS TICARET LIMITED SIRKETI, TURKEY:
3,631,550, PUB. 3-17-2009. MULTIPLE CLASS, INT. CLS. 6 AND 20.
- KAMATICS CORPORATION, BLOOMFIELD, CT, KAMATICS CORPORATION, BLOOMFIELD, CT:
981,944. REN. 4-27-09. U.S. CL. 23 (INT. CLS. 6, 7, 8, 9, 11, 12, 16, 21 AND 28).
- KANE, JEFFREY W., CARMEL, IN:
2,599,161, CANC. INT. CL. 28.
- KANEKA CORPORATION, OSAKA, JAPAN:
3,630,082, PUB. 3-17-2009. INT. CL. 26.
- KANGAROO BRANDS, INC., MILWAUKEE, WI:
3,632,978, INT. CL. 30.
- KANSAS CITY SMALL BUSINES MONTHLY, INC., OVERLAND PARK, KS:
3,630,695, PUB. 3-17-2009. MULTIPLE CLASS, INT. CLS. 9, 16 AND 41.
- KANSAS CITY STEAK COMPANY, LLC, KANSAS CITY, KS:
3,632,235, INT. CL. 29.
- KANSAS CITY SYMPHONY, KANSAS CITY, MO:
3,630,433, PUB. 3-17-2009. MULTIPLE CLASS, INT. CLS. 9, 16, 36 AND 41.
- KAO KABUSHIKI KAISHA, TOKYO 103-8210, JAPAN, TA KAO CORPORATION:
2,599,406, CANC. INT. CL. 16.
- KAPLAN, MICHAEL T., NEW YORK, NY:
2,175,178, CANC. MULTIPLE CLASS, INT. CLS. 30 AND 42.
- KAPUSTA, STEPHEN, CELEBRATION, FL:
3,632,423, INT. CL. 41.
- KAREN VALENTINE, SHEPHERDSTOWN, WV:
3,632,158, INT. CL. 35.
- KARL MAYER TEXTILMASCHINENFABRIK GMBH, 63179 OBERTSHAUSEN, FED REP GERMANY:
3,631,683, PUB. 3-17-2009. INT. CL. 7.
3,631,684, PUB. 3-17-2009. INT. CL. 7.
- KARL STORZ IMAGING, INC., GOLETA, CA:
2,599,281, CANC. INT. CL. 9.
3,630,443, PUB. 3-17-2009. INT. CL. 10.
- KARLA ADAM, INC., NORCO, CA:
3,630,449, PUB. 3-17-2009. INT. CL. 41.
- KARO, AARON, WEST HOLLYWOOD, CA:
3,629,855, PUB. 3-17-2009. MULTIPLE CLASS, INT. CLS. 16, 41 AND 45.
- KAROUN DAIRIES, INC., SUN VALLEY, CA:
3,630,116, PUB. 3-17-2009. INT. CL. 29.
- KARPIEL, JAN, ZAKOPANE, POLAND:
3,630,147, PUB. 3-17-2009. INT. CL. 12.
- KARSTEN MANUFACTURING CORPORATION, PHOENIX, AZ:
3,633,290, INT. CL. 28.
3,633,293, INT. CL. 25.
- KARTRI SALES COMPANY, INC., FOREST CITY, PA:
3,630,731, PUB. 3-17-2009. INT. CL. 20.
- KARVOUNIS, NICHOLAS D., LAS VEGAS, NV:
2,597,672, CANC. INT. CL. 41.
- KASCAR, LLC, GREENVILLE, SC:
3,633,477, INT. CL. 30.
- KASHI COMPANY, LA JOLLA, CA, CA:
3,632,607, INT. CL. 30.
- KATHERMAN, BRIGGS & GREENBERG, LLP, YORK, PA:
3,631,290, PUB. 3-17-2009. INT. CL. 45.
- KATSANTONIS, GEORGE L., ORANGE VILLAGE, UNITED STATES:
2,599,119, CANC. INT. CL. 12.
- KAUCUK A.S., KRALUPY NAD VLTAVOU, CZECH REPUBLIC:
2,598,369, CANC. INT. CL. 17.
- KAWASHIMA INDUSTRY CO. LTD., JAPAN:
3,631,595, PUB. 3-17-2009. INT. CL. 8.
- KAY & ASSOCIATES, INC., BUFFALO, IL:
2,240,598, REN. 4-25-09. MULTIPLE CLASS, INT. CLS. 37 AND 42.
- KAYSER-ROTH CORPORATION, GREENSBORO, NC:
287,322, CANC. U.S. CL. 39.
- KB HOME, LOS ANGELES, CA:
3,630,532, PUB. 3-17-2009. INT. CL. 37.
- KBC ADVANCED TECHNOLOGIES PLC, WALTON ON THAMES, SURREY, UNITED KINGDOM:
3,573,044, COR. MULTIPLE CLASS, INT. CLS. 9, 35, 40, 41 AND 42.
- KCI COMMUNICATIONS, INC., LAKE ZURICH, IL:
3,630,712, PUB. 3-17-2009. INT. CL. 9.
- KDC PLATFORM LLC, DALLAS, TX:
3,632,888, MULTIPLE CLASS, INT. CLS. 35, 36 AND 37.
- KECHELE, MATT T., COCOA BEACH, FL, DBA HURRICANE CHASERS:
3,633,435, INT. CL. 9.
- KEE PLASTICS AB, S-601 02 NORRKPING, SWEDEN:
2,596,836, CANC. MULTIPLE CLASS, INT. CLS. 16 AND 21.
- KEEDO INTERNATIONAL (PTY) LIMITED, PAARDEN EILAND, SOUTH AFRICA:
3,631,424, PUB. 3-17-2009. MULTIPLE CLASS, INT. CLS. 24, 25 AND 35.
- KEELING, BRAD, PHOENIX, AZ, DBA ORGANIC CLEANERS LLC:
3,630,279, PUB. 3-17-2009. INT. CL. 37.
- KEERSMAEKERS GERT, BELGIUM:
3,631,642, PUB. 3-17-2009. INT. CL. 10.
- KEHRES MATERIALS COMPANY, INC., SHARON CENTER, OH:
3,631,087, PUB. 3-17-2009. INT. CL. 16.
- KEITH LAVIMODIERE, NORTH SMITHFIELD, RI:
3,631,131, PUB. 3-17-2009. INT. CL. 11.
- KELCO SUPPLY COMPANY, MINNEAPOLIS, MN:
3,632,511, INT. CL. 1.
- KELDA GROUP PLC, BRADFORD, UNITED KINGDOM:
2,596,677, CANC. MULTIPLE CLASS, INT. CLS. 37, 39, 40 AND 42.

- KELEEN LEATHERS, INC., WESTCHESTER, IL:
3,630,866, PUB. 3-17-2009. MULTIPLE CLASS, INT. CLS.
18 AND 19.
- KELLA DISTILLERS LIMITED, SULBY, ISLE OF MAN:
2,598,246, CANC. INT. CL. 33.
- KELLEY AND ABIDE COMPANY, INC., NEW ORLEANS,
LA:
3,629,151, PUB. 3-17-2009. INT. CL. 35.
- KELLEY, MICHAEL J., FORT MYERS, FL:
2,598,827, CANC. INT. CL. 35.
- KELLY, RAYMOND, VANCOUVER, WA AND MARSH,
JEFF, VANCOUVER, WA:
3,630,023, PUB. 3-17-2009. INT. CL. 37.
- KELSEY, JONATHAN, UNITED KINGDOM:
3,631,618, PUB. 3-17-2009. MULTIPLE CLASS, INT. CLS.
9, 18 AND 25.
- KELTON, HAL, SALINAS, CA:
3,632,425, INT. CL. 9.
- KENKO INTERNATIONAL, INC., LOS ANGELES, CA:
3,632,138, INT. CL. 5.
- KENNEDY & ASSOCIATES CREATIVE CONSULTANTS
GROUP, INC., CINCINNATI, OH:
3,632,623, INT. CL. 30.
- KENNETH ALLEN HOLLANDER, MALIBU, CA:
2,599,382, CANC. INT. CL. 21.
- KENNETH J. ONION, KANEHOE, HI:
2,277,737. REN. 4-24-09. INT. CL. 8.
- KEPPIES, LLC, MERION, PA:
3,629,862, PUB. 3-17-2009. INT. CL. 26.
- KEPRO S.P.A., PROVINCE OF BRESCIA, ITALY:
2,597,179, CANC. MULTIPLE CLASS, INT. CLS. 3, 8, 9, 11,
21 AND 26.
- KERDOON, DAVID, LOS ANGELES, CA:
3,632,907, INT. CL. 30.
- KERR CONCENTRATES, INC., SALEM, OR:
3,630,770, PUB. 3-17-2009. MULTIPLE CLASS, INT. CLS.
29, 30 AND 32.
- KERR DRUG, INC., DURHAM, NC:
2,598,261, CANC. INT. CL. 35.
- KEVIN & DAVID INC., FLUSHING, NY:
3,629,181, PUB. 3-17-2009. INT. CL. 43.
- KEVIN WATKINS, LEWISVILLE, NC:
2,597,892, CANC. INT. CL. 41.
- KEVIN, INC., KITTERY, ME:
3,629,634, PUB. 3-17-2009. INT. CL. 35.
3,629,635, PUB. 3-17-2009. INT. CL. 35.
- KEY TECHNOLOGIES, INC., BALTIMORE, MD:
3,629,457, PUB. 3-17-2009. INT. CL. 42.
- KEY TECHNOLOGY, INC., WALLA WALLA, WA:
3,633,185, MULTIPLE CLASS, INT. CLS. 7, 9 AND 11.
- KEYCORP, CLEVELAND, OH:
2,175,115, CANC. INT. CL. 36.
- KEYENCE CORPORATION, OSAKA, JAPAN:
2,596,457, CANC. INT. CL. 28.
- KEYS GRANITE, INC., MIAMI, FL:
2,598,929, CANC. INT. CL. 19.
- KEYSTONE MUTUAL INSURANCE COMPANY, CHESTER-
FIELD, MO:
3,632,432, INT. CL. 36.
- KEYSTONE RV COMPANY, GOSHEN, IN:
2,245,848. REN. 4-25-09. INT. CL. 12.
- KEY3MEDIA EVENTS, INC., LOS ANGELES, CA:
2,598,840, CANC. INT. CL. 35.
- KGEM POWER CORPORATION, HOUSTON, TX:
3,631,983, MULTIPLE CLASS, INT. CLS. 36 AND 40.
- KIDRO PRODUCTIONS, INC., NEW YORK, NY:
3,632,308, INT. CL. 35.
3,632,310, INT. CL. 41.
3,632,311, INT. CL. 9.
- KIDZ B KIDZ, INC., NEEDHAM, MA:
3,630,647, PUB. 3-17-2009. INT. CL. 35.
- KIDZ 2000 & BEYOND, INC., MIAMI, FL:
2,598,488, CANC. MULTIPLE CLASS, INT. CLS. 25 AND
36.
- KIGHT'S GROUP, LLC, RALEIGH, NC:
3,629,931, PUB. 3-17-2009. MULTIPLE CLASS, INT. CLS.
35 AND 44.
- KILIMANJARO CORPORATION, THE, SHERMAN OAKS,
CA:
2,597,752, CANC. INT. CL. 16.
- KILLER KREATIONS INC., PHILADELPHIA, PA:
3,632,225, INT. CL. 40.
- KILOWATTS DESIGN COMPANY INC., CALGARY, CANA-
DA:
3,629,324, PUB. 3-17-2009. INT. CL. 9.
- KIM, JEAN S., VENICE, CA:
3,631,952, INT. CL. 25.
- KIM, JESSICA NAM, CHICAGO, IL:
3,631,168, PUB. 3-17-2009. INT. CL. 35.
- KIM, MAE JA, LOS ANGELES, CA, DBA ROSE MILLS
U.S.A.:
2,598,025, CANC. INT. CL. 3.
- KIM, STACEY H., LOS ANGELES, CA, DBA VISION
AMERICA:
2,599,089, CANC. INT. CL. 9.
- KIMBERLEY'S A DAY SPA LTD., LATHAM, NY:
3,630,223, PUB. 3-17-2009. MULTIPLE CLASS, INT. CLS.
35 AND 44.
- KIMBERLY, ROBERT, COLUMBUS, OH:
3,629,155, PUB. 3-17-2009. INT. CL. 37.
- KIMC INVESTMENTS, INC., WEST PALM BEACH, FL:
3,633,004, INT. CL. 16.
- KINAXIS CORP., CHICAGO, IL:
3,629,915, PUB. 3-17-2009. INT. CL. 42.
- KINETICO INCORPORATED, NEWBURY, OH:
3,632,604, INT. CL. 11.
- KING BRAND HEALTHCARE PRODUCTS, COLLING-
WOOD, CANADA:
3,630,746, PUB. 3-17-2009. INT. CL. 10.
- KING KOIL LICENSING COMPANY, INC., WILLOW-
BROOK, IL:
3,412,843, COR. INT. CL. 20.
- KING TUNA INC., LOS ANGELES, CA:
3,632,382, INT. CL. 29.
- KING, DONALD E., DULUTH, MN:
2,598,332, CANC. INT. CL. 28.
- KING, KYLE JOHN, NORTH HOLLYWOOD, CA:
3,632,783, INT. CL. 25.
- KINGSDOWN, INC., MEBANE, NC:
2,174,776, CANC. INT. CL. 20.
- KINTZLER, JASON, RIVERTON, WY:
3,632,555, INT. CL. 42.
- KIPP, MASTIN, LOS ANGELES, CA:
3,633,334, INT. CL. 25.
- KIRKPATRICK, NICK L, WACO, TX:
3,630,477, PUB. 3-17-2009. INT. CL. 37.
- KITCHEN DESIGN WORKS, INC., LAWRENCE, NY:
2,597,861, CANC. INT. CL. 35.
- KITCHEN MARVELS LLC, FORT COLLINS, CO:
3,630,609, PUB. 3-17-2009. INT. CL. 21.
- KITS CAMERAS, INC., KENT, WA:
1,496,801, CANC. INT. CL. 20.
- KJELLBERG STIFTUNG, RECHTSFÄHIGE STIFTUNG
DES; BÜRGERLICHEN RECHTS, GIEBEN, FED REP
GERMANY:
3,631,626, PUB. 3-17-2009. MULTIPLE CLASS, INT. CLS.
7, 8 AND 9.
- KJELLBERG STIFTUNG, RECHTSFÄHIGE STIFTUNG
DES; BÜRGERLICHEN RECHTS, FED REP GERMANY:
3,631,632, PUB. 3-17-2009. MULTIPLE CLASS, INT. CLS.
7, 8 AND 9.
- KLAFTERS INC., NEW CASTLE, PA:
2,240,114, REN. 4-27-09. INT. CL. 35.
- KLEMM BOHRTECHNIK ZWEIGNIEDERLASSUNG DER
BAUER MASCHINEN GMBH, DROLSHAGEN, FED REP
GERMANY:
3,631,861, INT. CL. 37.
- KLINKER, TERRI L, CHAMPAIGN, IL, DBA BODIBRONZE
SUNLESS SPA AND KLINKER, KRISTIN J, CHAM-
PAIGN, IL, DBA BODIBRONZE SUNLESS SPA:
3,630,427, PUB. 3-17-2009. INT. CL. 44.
- KLITZNER INDUSTRIES, INC., PROVIDENCE, RI:
2,598,994, CANC. INT. CL. 35.
- KNAPP, DOUGLAS F., BURLINGTON, VT:
2,323,945, REN. 4-24-09. INT. CL. 16.

- KNAUF INSULATION GMBH, SHELBYVILLE, IN:
3,632,908, INT. CL. 17.
3,633,045, INT. CL. 17.
- KNIGHT, KEITH, NEW YORK, NY:
3,632,675, INT. CL. 41.
3,632,676, INT. CL. 16.
- KNIGHT, PATRICIA, LAS VEGAS, NV:
2,597,598, CANC. MULTIPLE CLASS, INT. CLS. 41 AND 42.
- KNIGHT, PAULA, RIVERVIEW, FL:
3,630,225, PUB. 3-17-2009. INT. CL. 41.
- KNOG PTY LTD, RICHMOND, AUSTRALIA:
3,632,104, INT. CL. 25.
- KNOTHE APPAREL GROUP, INC., NEW YORK, NY:
1,496,864, CANC. INT. CL. 25.
- KNOUSE FOODS COOPERATIVE, INC., PEACH GLEN, PA:
3,630,689, PUB. 3-17-2009. MULTIPLE CLASS, INT. CLS. 29 AND 32.
3,631,174, PUB. 3-17-2009. MULTIPLE CLASS, INT. CLS. 29 AND 32.
3,631,175, PUB. 3-17-2009. MULTIPLE CLASS, INT. CLS. 29 AND 32.
- KNOWLEDGE BUILDING CONCEPTS, INC., TORONTO, ONT M6G 2L6, CANADA:
2,210,839, REN. 4-29-09. MULTIPLE CLASS, INT. CLS. 9 AND 16.
- KNOWLEDGE NETWORKS, INC., MENLO PARK, CA:
3,632,911, INT. CL. 35.
- KNOWLEDGEBANK, INC., MCLEAN, VA:
3,629,702, PUB. 3-17-2009. INT. CL. 35.
3,629,703, PUB. 3-17-2009. MULTIPLE CLASS, INT. CLS. 35, 41 AND 45.
3,629,704, PUB. 3-17-2009. INT. CL. 41.
- KNOWLEDGEPLANET, INC., MECHANICSBURG, PA:
2,598,638, CANC. INT. CL. 41.
- KNUCKLEHEAD EMBROIDERY, INC., JOHNSON CITY, NY:
2,598,812, CANC. MULTIPLE CLASS, INT. CLS. 18 AND 25.
- KNUERR AG, ARNSTORF, FED REP GERMANY:
3,631,416, PUB. 3-17-2009. INT. CL. 9.
- KOCH EQUIPMENT LLC, KANSAS CITY, MO:
2,597,323, CANC. INT. CL. 11.
- KODIAK GROUP INC., MISSISSAUGA, ONTARIO, CANADA:
3,629,349, PUB. 3-17-2009. INT. CL. 25.
- KODIAK SPORTS, LLC, AURORA, CO:
2,599,693, CANC. INT. CL. 28.
- KOEHN, RICHARD K., SALT LAKE CITY, UT:
3,633,219, INT. CL. 5.
- KOMEX INTERNATIONAL, INC., LOS ANGELES, CA:
2,598,897, CANC. INT. CL. 25.
- KON-TIKI TOURS & TRAVEL INC., NEW YORK, NY:
3,631,347, PUB. 3-17-2009. INT. CL. 39.
- KONAMI GAMING, INC., LAS VEGAS, NV:
3,632,586, INT. CL. 9.
3,632,695, INT. CL. 9.
3,632,757, INT. CL. 9.
- KONGSBERG SIMRAD AS, 3600 KONGSBERG, NORWAY:
2,596,566, CANC. INT. CL. 9.
- KONICA MINOLTA BUSINESS TECHNOLOGIES, INC., TOKYO, JAPAN:
3,633,192, MULTIPLE CLASS, INT. CLS. 37 AND 42.
- KONICA MINOLTA MEDICAL & GRAPHIC, INC., TOKYO, JAPAN:
3,629,671, PUB. 3-17-2009. MULTIPLE CLASS, INT. CLS. 1 AND 7.
- KONINKLIJKE PHILIPS ELECTRONICS N.V., EINDHOVEN, NETHERLANDS:
2,597,431, CANC. INT. CL. 11.
2,598,600, CANC. INT. CL. 9.
- KONINKLIJKE PHILIPS ELECTRONICS N.V., NETHERLANDS:
3,631,588, PUB. 3-17-2009. MULTIPLE CLASS, INT. CLS. 9 AND 11.
- KOZLOWSKI, ANDRZEJ, SAN FRANCISCO, CA, AKA ZEJ:
3,630,662, PUB. 3-17-2009. INT. CL. 41.
- KPCHEMICAL. CORP., DONGJAK-GU, SEOUL, REPUBLIC OF KOREA:
3,633,226, INT. CL. 23.
- KRAEMER'S NURSERY, INC., MT. ANGEL, OR:
3,629,224, PUB. 3-17-2009. INT. CL. 31.
- KRAFT PIZZA COMPANY, NORTHFIELD, IL:
2,175,136, CANC. INT. CL. 30.
- KRAUSE PUBLICATIONS, INC., IOLA, WI:
2,598,170, CANC. INT. CL. 16.
- KRAUSS, LARRY C., VACAVILLE, CA, DBA UNBRANDAP-PAREL:
3,629,239, PUB. 3-17-2009. INT. CL. 25.
- KRAZY KAT SPORTSWEAR LLC, CARLSTADT, NJ:
3,630,623, PUB. 3-17-2009. INT. CL. 25.
- KRESKIN, INC., NORTH CALDWELL, NJ:
2,258,764, REN. 4-27-09. INT. CL. 41.
2,258,765, REN. 4-27-09. INT. CL. 41.
- KRETCHMER, STEVEN, PALENVILLE, NY:
2,598,463, CANC. INT. CL. 14.
- KRISCH HOTELS, INC., ROANOKE, VA:
1,497,205, CANC. INT. CL. 42.
- KRIWAN INDUSTRIE-ELEKTRONIK GMBH, FED REP GERMANY:
3,631,539, PUB. 3-17-2009. MULTIPLE CLASS, INT. CLS. 7, 9 AND 42.
- KRONENBERGER BURGOYNE, LLP, SAN FRANCISCO, CA, DBA LITMAVEN:
3,630,296, PUB. 3-17-2009. MULTIPLE CLASS, INT. CLS. 42 AND 45.
- KRUGER PRODUCTS LIMITED, MISSISSAUGA, ONTARIO:
3,631,414, PUB. 3-17-2009. MULTIPLE CLASS, INT. CLS. 16 AND 21.
- KRZYWICKI, VAN B., GLEN SPEY, NY:
3,633,067, INT. CL. 42.
- KSAR JEWELS LLC, APOLLO BEACH, FL:
3,630,028, PUB. 3-17-2009. MULTIPLE CLASS, INT. CLS. 14 AND 35.
- KSI SWISS, BURNSVILLE, MN:
3,630,373, PUB. 3-17-2009. INT. CL. 7.
- KSIN LUXEMBOURG III, S.A.R.L., L-1628, LUXEMBOURG:
3,632,491, INT. CL. 28.
- KUBOTA TRACTOR CORPORATION, TORRANCE, CA:
3,629,895, PUB. 3-17-2009. INT. CL. 36.
- KUKU'ULA DEVELOPMENT COMPANY (HAWAII), LLC, KAUAI, HI:
3,631,897, INT. CL. 35.
- KULKE & ENGELKE MARKENVERWALTUNGS GBR; (AUTHORISED TO PRESENT: PARTICIPATOR; MATHIAS KULKE, 61348 BAD HOMBURG AND; VALÉRY-CHRISTOPH ENGELKE, 60322 FRANKFURT), FED REP GERMANY:
3,631,563, PUB. 3-17-2009. INT. CL. 36.
- KUNG, FLORA, NEW HAMPTON, NH:
1,496,865, CANC. INT. CL. 25.
- KUPELIAN, CHARLES H., SHREVEPORT, LA:
3,629,732, PUB. 3-17-2009. INT. CL. 12.
- KUSHNER, RICK A., LAKEWOOD, CO:
3,632,616, MULTIPLE CLASS, INT. CLS. 41 AND 44.
- KUSSMAUL ELECTRONICS COMPANY, INC., WEST SAYVILLE, NY:
3,633,357, INT. CL. 9.
- KUYUMCUOVIC, GARO, LOS ANGELES, CA:
3,629,185, PUB. 3-17-2009. INT. CL. 35.
- KWAN, FUNG MAY, LONDON WC2N 4EH, ENGLAND:
2,596,881, CANC. INT. CL. 3.
- KWIK GOAL, LTD., QUAKERTOWN, PA:
3,631,850, INT. CL. 28.
- L & P SWISS HOLDING COMPANY, WITTENBACH, SWITZERLAND:
3,518,873, COR. MULTIPLE CLASS, INT. CLS. 10, 12 AND 20.
- L & S NATURAL, INC., LOS ANGELES, CA:
2,210,940, REN. 4-25-09. INT. CL. 5.
- L. A. SADITTE, INC., WOODLAND HILLS, CA:
2,599,630, CANC. INT. CL. 35.
- L.C. LICENSING, INC., NEW YORK, NY:
2,596,893, CANC. INT. CL. 25.

- L&I COMPANY LIMITED, KOWLOON, HONG KONG:
3,632,350, INT. CL. 9.
3,632,351, INT. CL. 9.
- L'OREAL, 75008 PARIS, FRANCE:
2,598,958, CANC. INT. CL. 3.
- L'OREAL, PARIS, FRANCE:
2,599,172, CANC. INT. CL. 3.
3,629,244, PUB. 3-17-2009. INT. CL. 3.
- L'OREAL USA CREATIVE, INC., NEW YORK, NY:
3,633,020, INT. CL. 3.
- LA DOVE, INC., HIALEAH, FL:
1,496,432, CANC. INT. CL. 3.
- LA POSTE, 92777 BOULOGNE BILLANCOURT, FRANCE:
2,596,443, CANC. MULTIPLE CLASS, INT. CLS. 6, 9, 12,
16, 19, 37, 38, 39 AND 42.
- LA PRAIRIE, INC., NEW YORK, NY:
2,174,320, CANC. INT. CL. 3.
- LA SIERRA RECORDS, INC., PANORAMA CITY, CA:
2,174,736, CANC. INT. CL. 9.
- LA TOURAINE, INC., SAN DIEGO, CA:
3,629,886, PUB. 3-17-2009. INT. CL. 41.
- LAB-LINE INSTRUMENTS, INC., MELROSE PARK, IL:
1,496,563, CANC. MULTIPLE CLASS, INT. CLS. 8, 9 AND
11.
- LABATEC PHARMA SA, CH-1217 MEYRIN MENEVE,
SWITZERLAND:
3,630,526, PUB. 3-17-2009. INT. CL. 5.
- LABORATOIRES DOLISOS, 75003 PARIS, FRANCE:
2,596,436, CANC. INT. CL. 5.
- LABORATOIRES GOEMAR, 35400 SAINT MALO, FRANCE:
2,596,636, CANC. MULTIPLE CLASS, INT. CLS. 3 AND 5.
- LABORATOIRES GYNEAS, FRANCE:
3,631,564, PUB. 3-17-2009. MULTIPLE CLASS, INT. CLS. 5
AND 10.
- LABORATORIOS LE ROY, S.A. DE C.V., COL. GRANJAS
MEXICO 08400, MEXICO:
2,597,028, CANC. MULTIPLE CLASS, INT. CLS. 5 AND
10.
- LABORATORIOS NORUEL C. POR A., LOS RIOS SANTO
DOMINGO, DOMINICAN REP:
3,631,008, PUB. 3-17-2009. INT. CL. 3.
- LABORATORIUM KOSMETYCZNE DR IRENA ERIS SPOK-
LA AKCYNA, PIASECZNO, POLAND:
3,633,050, MULTIPLE CLASS, INT. CLS. 43 AND 44.
- LABROOTS, INC., KAILUA, HI:
3,632,799, INT. CL. 35.
- LABTECH ESSA PTY LTD., BASSENDEAN, AUSTRALIA:
2,598,188, CANC. INT. CL. 9.
- LACTOSAN GMBH & CO. KG, AUSTRIA:
3,631,679, PUB. 3-17-2009. MULTIPLE CLASS, INT. CLS. 5
AND 42.
- LAERDAL MEDICAL CORPORATION, WAPPINGERS
FALLS, NY:
2,599,579, CANC. INT. CL. 10.
- LAFIN, JÖRG-RAINER, FED REP GERMANY:
3,631,568, PUB. 3-17-2009. INT. CL. 15.
- LAFRANCE MANUFACTURING CO., MARYLAND
HEIGHTS, MO:
3,630,923, PUB. 3-17-2009. INT. CL. 2.
- LAKE, MICHAEL, SEATTLE, WA:
3,632,110, INT. CL. 14.
- LAKECO ENTERPRISES, INC., CLIVE, IA, DBA TWISTED
BEAN COFFEE COMPANY:
3,629,579, PUB. 3-17-2009. INT. CL. 30.
- LAKELAND FINANCE, LLC, CHARLOTTESVILLE, VA:
3,629,871, PUB. 3-17-2009. MULTIPLE CLASS, INT. CLS.
39 AND 41.
- LALVANI, SONU, LONDON SW7 2QG, ENGLAND:
2,596,526, CANC. MULTIPLE CLASS, INT. CLS. 29, 30
AND 42.
- LAM RESEARCH CORPORATION, FREMONT, CA:
3,632,148, INT. CL. 7.
- LAMB, GEORGE, HOUSTON, TX:
2,598,384, CANC. INT. CL. 14.
- LAMBERT CORPORATION OF FLORIDA, ORLANDO, FL:
1,508,697, REN. 4-27-09. MULTIPLE CLASS, INT. CLS. 1,
2 AND 19.
- LAMBERT, BILLIE G., SEMINOLE, FL:
3,633,500, INT. CL. 25.
- LAMBERT, JOHN, VIENNA, VA:
2,597,685, CANC. INT. CL. 41.
- LAMPS PLUS, INC., CHATSWORTH, CA:
3,633,490, INT. CL. 35.
3,633,491, INT. CL. 35.
- LANART RUG INC., QUEBEC, CANADA:
3,629,398, PUB. 3-17-2009. INT. CL. 27.
- LANCE MFG LLC, CHARLOTTE, NC:
2,598,155, CANC. INT. CL. 30.
- LANCE MFG. LLC, CHARLOTTE, NC:
2,599,055, CANC. MULTIPLE CLASS, INT. CLS. 29 AND
30.
- LANCETTI COSMETICS, DEERFIELD BEACH, FL, DBA
PRESTIGE COSMETICS:
2,597,898, CANC. INT. CL. 3.
- LANCOME PARFUMS ET BEAUTE & CIE, 75008 PARIS,
FRANCE:
1,496,444, CANC. INT. CL. 3.
2,597,880, CANC. INT. CL. 3.
- LANCOME PARFUMS ET BEAUTE & CIE, PARIS, FRANCE:
3,629,353, PUB. 3-17-2009. INT. CL. 3.
3,629,560, PUB. 3-17-2009. INT. CL. 3.
- LANDEC AG, INC., MONTICELLO, IN:
2,599,749, CANC. MULTIPLE CLASS, INT. CLS. 1 AND
31.
- LANDERS MARK L, PORTLAND, OR, DBA MEDIA BLITZ
PRODUCTIONS:
3,631,086, PUB. 3-17-2009. INT. CL. 41.
- LANGLOIS, ANDREW, GLEN BURNIE, MD:
3,630,072, PUB. 3-17-2009. INT. CL. 42.
- LANGOO.COM, INC., PALO ALTO, CA:
2,596,765, CANC. INT. CL. 38.
- LANGUAGE ANALYTICS LLC, CAMBRIDGE, MA:
3,629,717, PUB. 3-17-2009. INT. CL. 42.
- LANMAN & KEMP-BARCLAY & CO. INCORPORATED,
WESTWOOD, NJ:
261,559, REN. 4-24-09. U.S. CL. 51 (INT. CL. 3).
- LANMAN & KEMP-BARCLAY & CO. INCORPRATED,
WESTWOOD, NJ:
515,807, REN. 4-24-09. U.S. CL. 51 (INT. CLS. 3 AND 5).
- LANSDON, PATRICK D., SANTA BARBARA, CA:
3,633,104, INT. CL. 35.
- LANXESS DEUTSCHLAND GMBH, LEVERKUSEN, FED
REP GERMANY:
3,630,001, PUB. 3-17-2009. INT. CL. 2.
- LANZ, INC., CULVER CITY, CA:
1,496,851, CANC. INT. CL. 25.
- LAPE'S FISH LURES, INC., LIMA, OH:
1,496,885, CANC. INT. CL. 28.
- LARGO INTERGALACTIC VIE CORPORATION, LYNN,
MA:
3,629,533, PUB. 3-17-2009. INT. CL. 28.
- LAROSA, PENILOPEE L., TULSA, OK, DBA LAROSA
INNOVATIONS, LLC:
3,629,493, PUB. 3-17-2009. INT. CL. 3.
- LARRY'S MARKETS, INC., BELLEVUE, WA:
2,598,527, CANC. INT. CL. 42.
- LARSON TEXTS, INC., ERIE, PA:
3,630,935, PUB. 3-17-2009. MULTIPLE CLASS, INT. CLS.
16 AND 41.
- LASALLE HOTEL OPERATING PARTNERSHIP, L.P.,
BETHESDA, MD:
3,632,809, INT. CL. 43.
- LATCHMAN, ROBERT, BAYONNE, NJ:
2,174,916, CANC. INT. CL. 30.
- LATERZA, JUDY, WANTAGH, NY:
2,619,503, CANC. INT. CL. 28.
- LATINA MEDIA VENTURES, NEW YORK, NY:
3,633,412, INT. CL. 16.
3,633,413, INT. CL. 16.
- LAUREATE EDUCATION, INC., BALTIMORE, MD:
3,629,641, PUB. 3-17-2009. INT. CL. 41.
3,629,642, PUB. 3-17-2009. INT. CL. 41.
- LAUREL GLEN VINEYARD, LLC, SANTA ROSA, CA:
3,631,946, INT. CL. 33.

LAUREN MANUFACTURING COMPANY, NEW PHILADELPHIA, OH:
1,496,770, CANC. INT. CL. 17.

LAURENT-PERRIER, 51150 TOURS-SUR-MAME, FRANCE:
2,596,671, CANC. INT. CL. 33.

LAVERANA GMBH, 30974 WENNIGSEN, FED REP GERMANY:
3,631,560, PUB. 3-17-2009. MULTIPLE CLASS, INT. CLS. 3, 5 AND 35.

LAWMATE TECHNOLOGY CO., LTD., TAIPEI, TAIWAN:
3,632,831, INT. CL. 9.

LAWPARTNER, LLC, RICHMOND, VA, DBA KOSCHAK LEGAL SEARCH, LLC:
3,629,552, PUB. 3-17-2009. INT. CL. 35.

LAWRENCE METAL PRODUCTS, INC., BAY SHORE, NY:
2,599,379, CANC. INT. CL. 12.

LAWRENCE RESEARCH ASSOCIATES, BOULDER, CO:
2,598,588, CANC. INT. CL. 9.

LAWTECH PUBLISHING CO., LTD., SAN CLEMENTE, CA:
3,630,157, PUB. 3-17-2009. INT. CL. 16.

LAX, SAMUEL, MISSION HILLS, CA, DBA SALA-GROUP:
3,633,445, INT. CL. 35.

LAXOR, INC, WASHINGTON, DC:
2,598,074, CANC. INT. CL. 42.

LAYADE, ADETUNJI, BROOKLYN, NY:
3,632,562, INT. CL. 41.

LDMI TELECOMMUNICATIONS, INC., SOUTHFIELD, MI:
2,596,856, CANC. MULTIPLE CLASS, INT. CLS. 38, 39 AND 42.
2,596,860, CANC. MULTIPLE CLASS, INT. CLS. 38, 39 AND 42.

LE, MICHAEL, K., MILPITAS, CA:
2,599,455, CANC. INT. CL. 35.

LEADER INTERNATIONAL CORP., ST. JOSEPH, MI:
2,598,644, CANC. MULTIPLE CLASS, INT. CLS. 7 AND 8.

LEADER WINDOW FILM CO. LTD, KAOHSIUNG, TAIWAN:
3,632,810, INT. CL. 17.

LEADERSHIP IN INTERNATIONAL MANAGEMENT, LAMBERTVILLE, NJ:
2,599,647, CANC. INT. CL. 35.

LEADERSHIP IN INTERNATIONAL MANAGEMENT, LTD., LAMBERTVILLE, NJ:
2,599,646, CANC. INT. CL. 35.

LEADING EDGE FILINGS, INC., PARK RIDGE, IL:
3,629,166, PUB. 3-17-2009. INT. CL. 45.

LEAGUEBOSS.COM LLC, PERRYSBURG, OH:
2,599,610, CANC. INT. CL. 41.

LEAPFROG ENTERPRISES, INC., EMERYVILLE, CA:
2,599,259, CANC. INT. CL. 28.
2,599,284, CANC. INT. CL. 28.

LEARN AHEAD, GURNEE, IL:
3,631,237, PUB. 3-17-2009. INT. CL. 41.

LEARN.COM, INC., SUNRISE, FL:
3,631,876, INT. CL. 42.

LEARNING LANDSCAPE, LLC, LYNNWOOD, WA:
3,630,069, PUB. 3-17-2009. INT. CL. 41.

LEARNING SOLUTIONS, INC., MARIETTA, GA:
2,598,397, CANC. INT. CL. 16.

LEARNING UNLIMITED, LLC, CARMEL, IN:
3,629,647, PUB. 3-17-2009. INT. CL. 41.

LEARNING UPGRADE, LLC, ESCONDIDO, CA:
3,633,011, INT. CL. 41.

LEASEOUT.COM, INC., TORONTO, ONTARIO M2N 6M4, CANADA:
2,598,590, CANC. INT. CL. 35.

LEASETRADING.COM INC., ROWAYTON, CT:
2,599,059, CANC. INT. CL. 35.

LEBANON SEABOARD CORPORATION, LEBANON, PA:
2,336,728, REN. 4-25-09. INT. CL. 1.

LEED PETROLEUM LLC, LAFAYETTE, LA:
3,633,354, INT. CL. 4.
3,633,355, INT. CL. 4.

LEEDSWORLD, INC., NEW KENSINGTON, PA:
3,632,719, INT. CL. 35.

LEFCOURT, JACK, NEW YORK, NY:
2,598,721, CANC. INT. CL. 25.

LEFTY'S BARBECUE UNLIMITED, INC., WALDORF, MD:
3,629,843, PUB. 3-17-2009. INT. CL. 43.

LEFTY'S SPICES, LLC, WALDORF, MD:
3,629,824, PUB. 3-17-2009. MULTIPLE CLASS, INT. CLS. 29 AND 30.

LEGAL ARTS, INC., SAN DIEGO, CA:
3,630,381, PUB. 3-17-2009. INT. CL. 42.

LEGALMATCH.COM, SAN FRANCISCO, CA:
2,596,694, CANC. INT. CL. 35.

LEGATE, KIM, NEW PORT RICHEY, FL:
2,246,283, REN. 4-27-09. INT. CL. 9.

LEGISLATIVE DEMOGRAPHIC SERVICES, INC., ARLINGTON, VA:
2,597,548, CANC. INT. CL. 42.

LEGO JURIS A/S, DK-7190 BILLUND, DENMARK:
2,598,791, CANC. INT. CL. 28.

LEGRIS S.A., RENNES, FRANCE:
3,629,683, PUB. 3-17-2009. MULTIPLE CLASS, INT. CLS. 6, 9, 11 AND 17.

LEHIGH CEMENT COMPANY, ALLENTOWN, PA:
868,346, REN. 4-25-09. U.S. CL. 12 (INT. CL. 19).

LENMAR ENTERPRISES, INC., WESTLAKE VILLAGE, CA:
2,597,882, CANC. INT. CL. 9.

LENOX CORPORATION, BRISTOL, PA:
2,174,278, CANC. INT. CL. 21.

LEONA DRUCE, ROCK SPRINGS, WY:
3,632,583, INT. CL. 25.

LEONARDO'S FIFTH AVENUE, INC., SANTURCE, PUERTO RICO:
2,707,405, AM. MULTIPLE CLASS, INT. CLS. 35 AND 41.

LES LAINAGES VICTOR LTÉE, SAINT-VICTOR, CANADA:
3,629,343, PUB. 3-17-2009. INT. CL. 24.
3,629,344, PUB. 3-17-2009. INT. CL. 24.
3,629,345, PUB. 3-17-2009. INT. CL. 24.

LES SHOEMMELIERS LLC, ST. HELENA, CA:
3,632,529, MULTIPLE CLASS, INT. CLS. 36 AND 41.

LESTHER TRUJILLO, MIRAMAR, FL:
3,633,386, INT. CL. 24.

LEUPOLD & STEVENS, INC., BEAVERTON, OR:
3,630,949, PUB. 3-17-2009. INT. CL. 9.
3,631,204, PUB. 3-17-2009. INT. CL. 9.

LEVANTINA Y ASOCIADOS DE MINERALES, S.A., SPAIN:
3,631,706, PUB. 3-17-2009. MULTIPLE CLASS, INT. CLS. 19, 20 AND 27.

LEVENFELD PEARLSTEIN GLASSBERG TUCHMAN BRIGHT GOLDSTEIN & SCHWARTZ, LLC, CHICAGO, IL:
2,596,848, CANC. MULTIPLE CLASS, INT. CLS. 35 AND 41.

LEVI, RAY & SHOUP, INC., SPRINGFIELD, IL:
3,632,800, INT. CL. 9.

LEVINE, STEPHEN K., FAR HILLS, NJ:
3,632,632, INT. CL. 21.

LEVY FAMILY ASSOCIATES, LLC, POTOMAC, MD:
3,629,182, PUB. 3-17-2009. INT. CL. 36.
3,629,183, PUB. 3-17-2009. INT. CL. 36.

LEVY PREMIUM FOODSERVICE LIMITED PARTNERSHIP, CHICAGO, IL:
3,632,440, MULTIPLE CLASS, INT. CLS. 35 AND 43.

LEVY, DONNA, SHERMAN OAKS, CA:
2,598,571, CANC. INT. CL. 5.

LEWIS JR., LORRIS, ARLINGTON, TX:
3,632,379, INT. CL. 25.

LEYNIAN LTD. CO., NEW SMYRNA BEACH, FL:
2,599,061, CANC. INT. CL. 28.
2,599,062, CANC. INT. CL. 28.

LFC, INC., SAN DIEGO, CA:
3,632,103, INT. CL. 35.

LG ELECTRONICS INC., SEOUL, REPUBLIC OF KOREA:
2,598,648, CANC. MULTIPLE CLASS, INT. CLS. 7, 9 AND 11.
3,631,930, INT. CL. 11.
3,631,943, INT. CL. 7.

LIBERATE TECHNOLOGIES, SAN CARLOS, CA:
2,598,450, CANC. INT. CL. 41.

LIBERTY BANK, MIDDLETOWN, CT:
3,631,326, PUB. 3-17-2009. INT. CL. 36.

- LICHTGITTER GESELLSCHAFT; MIT BESCHRÄNKTER HAFTUNG, FED REP GERMANY:
3,631,725, PUB. 3-17-2009. INT. CL. 6.
- LICOM SYSTEMS LTD., COVENTRY CV5 6PY, UNITED KINGDOM:
2,174,620, CANC. INT. CL. 9.
- LIDL STIFTUNG & CO. KG, D-74167 NECKARSULM, FED REP GERMANY:
2,597,249, CANC. MULTIPLE CLASS, INT. CLS. 10, 21 AND 24.
2,597,291, CANC. MULTIPLE CLASS, INT. CLS. 8, 11 AND 29.
- LIDL STIFTUNG & CO. KG, 74172 NECKARSULM, FED REP GERMANY:
2,597,393, CANC. INT. CL. 30.
2,597,394, CANC. INT. CL. 33.
2,597,547, CANC. INT. CL. 30.
2,597,556, CANC. INT. CL. 33.
- LIDL STIFTUNG & CO. KG, NECKARSULM, FED REP GERMANY:
3,631,515, PUB. 3-17-2009. INT. CL. 34.
- LIEBHERR-INTERNATIONAL AG, CH-1630 BULLE, SWITZERLAND:
3,631,633, PUB. 3-17-2009. MULTIPLE CLASS, INT. CLS. 7, 11 AND 21.
- LIEN, CRAIG, FARGO, ND:
2,598,542, CANC. INT. CL. 42.
- LIFE INSURANCE COMPANY OF THE SOUTHWEST, DALLAS, TX:
2,596,607, CANC. INT. CL. 36.
- LIFE PERSPECTIVES, INC., SAN DIEGO, CA:
3,629,771, PUB. 3-17-2009. MULTIPLE CLASS, INT. CLS. 35 AND 36.
- LIFE 101, LLC, FENTON, MI:
3,631,991, INT. CL. 41.
- LIFEGUARD AIR AMBULANCE, INC, PENSACOLA, FL:
3,629,354, PUB. 3-17-2009. MULTIPLE CLASS, INT. CLS. 35 AND 37.
- LIFESPEX, INC., BOTHELL, WA:
2,598,180, CANC. MULTIPLE CLASS, INT. CLS. 9 AND 10.
- LIFETECH RESOURCES, CHATSWORTH, CA:
3,629,908, PUB. 3-17-2009. INT. CL. 3.
- LIFETHERAPY, L.L.C., ADDISON, IL:
3,633,075, INT. CL. 3.
- LIFETIME BRANDS, INC., GARDEN CITY, NY, AMERICAN COMMERCIAL INCORPORATED, LOS ANGELES, CA:
681,148, REN. 4-27-09. U.S. CL. 30 (INT. CL. 21).
- LIFETIME ENTERTAINMENT SERVICES, NEW YORK, NY:
3,632,532, INT. CL. 41.
- LIFTED RESEARCH GROUP INC., IRVINE, CA:
3,633,134, INT. CL. 25.
- LIGHT, INC., THE, SOMERSET, NJ:
3,632,701, INT. CL. 41.
3,632,702, INT. CL. 41.
- LIGHTKULTURE.COM, LLC, SARASOTA, FL:
3,629,550, PUB. 3-17-2009. MULTIPLE CLASS, INT. CLS. 11, 14 AND 20.
- LIGHTNING BOX GAMES PTY LTD, ROSEBERY NSW 2018, AUSTRALIA:
3,631,767, PUB. 3-17-2009. MULTIPLE CLASS, INT. CLS. 9 AND 28.
- LIM, MICHAEL Z, PLAYA DEL REY, CA:
3,630,784, PUB. 3-17-2009. INT. CL. 45.
- LIMAGRAIN, FRANCE:
3,631,485, PUB. 3-17-2009. MULTIPLE CLASS, INT. CLS. 35, 41, 42 AND 44.
- LIMELIGHT INNOVATIONS L.L.C., WESTLAKE VILLAGE, CA:
3,632,882, INT. CL. 9.
- LINCAT GROUP PLC, LINCOLN LN6 3QZ, UNITED KINGDOM:
2,597,037, CANC. INT. CL. 11.
- LINCOLN CENTER FOR THE PERFORMING ARTS, INC., NEW YORK, NY:
1,118,960, REN. 4-27-09. INT. CL. 41.
- LINE ART, INC., NEW YORK, NY:
2,599,074, CANC. INT. CL. 21.
- LINEAGE OVERSEAS CORP., LOS ANGELES, CA:
3,632,265, INT. CL. 9.
- LINEN, CAMILLE, PORTCHESTER, NY:
3,630,803, PUB. 3-17-2009. INT. CL. 41.
- LINK SERVICES COMPANY, MARIETTA, GA:
2,598,097, CANC. INT. CL. 35.
- LINKPLACE LIMITED, HARROW HA2 0DH, UNITED KINGDOM, TA OAKWOOD REMEDIES:
3,632,028, MULTIPLE CLASS, INT. CLS. 3, 5 AND 21.
- LINUX SOLUTIONS PROVIDER, INC., HAZLEHURST, GA:
3,629,561, PUB. 3-17-2009. INT. CL. 25.
- LIPIN, QUINN H., NEEDHAM, MA:
3,633,181, INT. CL. 45.
- LIPMAN, SIMEON, NEW YORK, NY:
3,630,914, PUB. 3-17-2009. INT. CL. 28.
- LIPO CO., LTD., TAIPEI, TAIWAN:
2,597,232, CANC. INT. CL. 16.
- LIPS, INC., MORRISVILLE, NC:
2,597,856, CANC. INT. CL. 9.
- LIPSCHULTZ, STEPHEN ALLEN, HIGHLAND PARK, IL:
2,238,368, REN. 4-24-09. INT. CL. 9.
- LIPSCOMB SERVICES INC., SAN ANTONIO, TX:
2,596,581, CANC. INT. CL. 41.
- LIPZIPZ LLC, CENTERVILLE, UT:
3,631,965, MULTIPLE CLASS, INT. CLS. 3 AND 5.
- LIQUID GLASS ENTERPRISES, INC., TEANECK, NJ:
3,632,840, INT. CL. 3.
3,632,841, INT. CL. 4.
3,632,851, INT. CL. 3.
3,632,852, INT. CL. 4.
- LIQUID WASTE TECHNOLOGY, LLC, BALTIMORE, MD:
2,243,055, REN. 4-27-09. INT. CL. 7.
- LIQUIDMETAL TECHNOLOGIES, INC., RANCHO SANTA MARGARITA, CA:
3,633,282, MULTIPLE CLASS, INT. CLS. 9 AND 14.
- LIQUIDNET HOLDINGS, INC., NEW YORK, NY:
3,631,060, PUB. 3-17-2009. INT. CL. 36.
- LIQUIDTHOUGHT LLC, SOUTH RIDING, VA:
3,630,901, PUB. 3-17-2009. INT. CL. 42.
3,631,292, PUB. 3-17-2009. INT. CL. 9.
- LISA FRANK, INC., TUSCON, AZ:
3,629,956, PUB. 3-17-2009. INT. CL. 16.
- LISA'S WEIGHT WELLNESS SOLUTIONS INC., MISSISSAUGA, ONTARIO, CANADA:
2,596,507, CANC. MULTIPLE CLASS, INT. CLS. 9, 16 AND 41.
- LITTLE I, INC., BLAINE, WA:
3,631,297, PUB. 3-17-2009. INT. CL. 30.
3,632,903, INT. CL. 5.
- LITTLE MISS CUPCAKE LLC, NEW YORK, NY:
3,630,127, PUB. 12-9-2008. INT. CL. 30.
- LITTLE RAPIDS CORPORATION, GREEN BAY, WI:
3,632,162, INT. CL. 26.
- LIV SURE, LLC, LAYTON, UT:
3,631,846, INT. CL. 41.
- LIVBAG, 755017 PARIS, FRANCE:
2,597,494, CANC. MULTIPLE CLASS, INT. CLS. 11, 12 AND 13.
2,597,495, CANC. MULTIPLE CLASS, INT. CLS. 11, 12 AND 13.
- LIVE-360, LLC, INDIANAPOLIS, IN:
3,629,384, PUB. 3-17-2009. MULTIPLE CLASS, INT. CLS. 35 AND 41.
- LIVEBOLT IDENTITY, LLC, LAGO VISTA, TX:
3,629,980, PUB. 3-17-2009. MULTIPLE CLASS, INT. CLS. 35 AND 45.
- LIVETIME 24/7 LTD., COLWYN BAY, WALES:
3,631,890, INT. CL. 35.
- LIVING ON THE EDGE INC., WEATHERFORD, TX:
3,632,760, INT. CL. 25.
- LIVRON VITAMIN COMPANY, INC., ALLENDALE, NJ:
2,598,428, CANC. INT. CL. 5.
- LIZ EARLE BEAUTY CO., LIMITED, LONDON, UNITED KINGDOM:
3,629,334, PUB. 3-31-2009. MULTIPLE CLASS, INT. CLS.

- 3, 35 AND 44.
3,629,335, PUB. 3-31-2009. MULTIPLE CLASS, INT. CLS.
3, 35 AND 44.
- LIZA SHTRONBERG CO LLC, LOS ANGELES, CA:
3,632,060, INT. CL. 35.
- LIZA'S LEGACY FOUNDATION, INC., GUILDERLAND,
NY:
3,629,595, PUB. 10-14-2008. INT. CL. 41.
- LMG INSURANCE, LLC, WEST CONSHOCKEN, PA:
3,632,914, INT. CL. 36.
- LOBA GMBH & CO. KG, D-71254 DITZINGEN, FED REP
GERMANY:
2,598,346, CANC. MULTIPLE CLASS, INT. CLS. 4 AND
28.
- LOCALLIFE LIMITED, UNITED KINGDOM:
3,631,480, PUB. 3-17-2009. MULTIPLE CLASS, INT. CLS.
9, 16, 35, 38 AND 42.
- LOCKTON, INC., KANSAS CITY, MO:
3,630,412, PUB. 3-17-2009. INT. CL. 36.
3,630,414, PUB. 3-17-2009. INT. CL. 36.
- LOCKWOOD, HANFORD N., SAN MATEO, CA:
2,598,309, CANC. INT. CL. 5.
- LODGEWORKS, L.P., WICHITA, KS:
2,598,905, CANC. INT. CL. 42.
- LOEW-CORNELL, LLC, CINCINNATI, OH:
1,537,830, REN. 4-24-09. INT. CL. 16.
- LOGILITY, INC., ATLANTA, GA:
2,233,455, REN. 4-26-09. INT. CL. 9.
- LOGING, MARY S, APOPKA, FL, DBA MARY LOGING
DESIGNS:
3,629,720, PUB. 3-17-2009. INT. CL. 14.
- LOGO'D SOFTWARE, INC., CHESHIRE, CT, DBA LOGOS-
PORTSWEAR.COM:
3,629,953, PUB. 3-17-2009. INT. CL. 42.
- LOGO'D SOFTWARE, INC., CHESHIRE, CT, DBA TEAM-
SPORTSWEAR.COM:
3,629,954, PUB. 3-17-2009. INT. CL. 42.
- LOJER OY, 38200 VAMMALA, FINLAND:
3,631,898, MULTIPLE CLASS, INT. CLS. 10 AND 28.
- LONE STAR RESTAURANT SUPPLY, AUSTIN, TX:
3,629,283, PUB. 3-17-2009. INT. CL. 35.
- LONELY PLANET PUBLICATIONS PTY LIMITED, FOOT-
SCRAY, VICTORIA 3011, AUSTRALIA:
2,598,798, CANC. INT. CL. 16.
- LONG LIFE MAXX, INC., LOS ANGELES, CA:
2,598,374, CANC. INT. CL. 5.
- LONG VIEW ENTERPRISES, LLC, BRANDON, WI:
3,632,442, INT. CL. 6.
- LONG, DAVID, BLOOMSBURG, PA AND LONG, JOANNE,
BLOOMSBURG, PA:
3,630,115, PUB. 3-17-2009. INT. CL. 5.
- LONG, SHUNYOU, BALTIMORE, MD:
3,632,297, INT. CL. 9.
- LOOP ONE, INC., AUSTIN, TX:
2,597,643, CANC. INT. CL. 35.
- LOOPHOLE RECORDS, LLC, PORTLAND, OR:
3,633,157, INT. CL. 41.
- LORD DANIEL SPORTSWEAR, INC., SUNRISE, FL:
3,629,128, PUB. 3-17-2009. INT. CL. 25.
- LORO PIANA S.P.A., I-13017 QUARONA (VC), ITALY:
3,631,604, PUB. 3-17-2009. INT. CL. 23.
- LOS ANGELES DODGERS LLC, LOS ANGELES, CA:
3,633,244, INT. CL. 25.
- LOS ANGELES TENNIS CLUB, LOS ANGELES, CA:
3,629,386, PUB. 3-17-2009. INT. CL. 41.
- LOSCHKE, ALEXANDER, D-63834 SULZBACH, FED REP
GERMANY:
2,596,871, CANC. INT. CL. 10.
- LOUISIANA ONLINE, INC., BATON ROUGE, LA:
2,599,460, CANC. INT. CL. 42.
- LOUISIANA-PACIFIC CORPORATION, NASHVILLE, TN:
3,633,306, MULTIPLE CLASS, INT. CLS. 16, 21, 24, 25, 28
AND 41.
- LOVE CULTURE LLC, LOS ANGELES, CA:
3,633,316, MULTIPLE CLASS, INT. CLS. 14 AND 25.
- LOVELAND PRODUCTS, INC., GREELEY, CO:
2,175,091, CANC. INT. CL. 1.
- LOVER'S LANE I.P., LTD., PLYMOUTH, MI:
2,598,492, CANC. INT. CL. 35.
3,629,582, PUB. 3-17-2009. INT. CL. 35.
- LOWBORN, LLC, JERUSALEM, OH:
3,629,323, PUB. 3-17-2009. MULTIPLE CLASS, INT. CLS.
9, 25 AND 41.
- LOYAL CHRISTIAN BENEFIT ASSOCIATION, ERIE, PA:
3,631,002, PUB. 3-17-2009. INT. CL. 36.
3,631,004, PUB. 3-17-2009. INT. CL. 36.
- LOZANO ENTERPRISES, LOS ANGELES, CA, DBA LA
OPINION:
2,596,862, CANC. MULTIPLE CLASS, INT. CLS. 35 AND
38.
- LRC PRODUCTS LIMITED, LONDON, UNITED KING-
DOM:
3,631,380, PUB. 3-17-2009. INT. CL. 10.
- LS RETAIL EHF., REYKJAVIK, ICELAND:
3,633,232, MULTIPLE CLASS, INT. CLS. 9, 16 AND 42.
- LTl WHOLESALE, INC., SCHUYLKILL HAVEN, PA, DBA
LTl HOME PRODUCTS, INC.:
3,629,718, PUB. 3-17-2009. MULTIPLE CLASS, INT. CLS. 6
AND 20.
- LU, JOAQUIN T., SALEM, OR:
3,632,741, INT. CL. 29.
- LUCAS OIL PRODUCTS, INC., CORONA, CA:
3,631,812, INT. CL. 37.
- LUCASFILM LTD., SAN FRANCISCO, CA:
3,633,161, MULTIPLE CLASS, INT. CLS. 35 AND 41.
- LUCCHESI, INC., EL PASO, TX:
2,711,789, CANC. INT. CL. 18.
- LUCENT TECHNOLOGIES INC., MURRAY HILL, NY:
2,598,465, CANC. MULTIPLE CLASS, INT. CLS. 37 AND
42.
- LUCENT TECHNOLOGIES INC., MURRAY HILL, NJ:
2,598,747, CANC. INT. CL. 9.
- LUCKY BRAND DUNGAREES, INC., VERNON, CA:
2,598,783, CANC. INT. CL. 25.
- LUCKY GROUP (H. K.) LIMITED, KOWLOON, HONG
KONG:
3,632,396, INT. CL. 28.
- LUCKY LEASH, MILL CREEK, WA:
3,630,416, PUB. 3-17-2009. INT. CL. 45.
- LUIGI LAVAZZA S.P.A., TURIN, ITALY:
1,496,934, CANC. INT. CL. 30.
- LUKAS HYDRAULIK GMBH & CO. KG, D-91058 ERLAN-
GEN, FED REP GERMANY:
1,116,822, REN. 4-27-09. MULTIPLE CLASS, INT. CLS. 7
AND 9.
- LULA LU, LLC, SAN MATEO, CA:
3,632,092, MULTIPLE CLASS, INT. CLS. 25 AND 35.
- LUMI-LITE CANDLE COMPANY, INC., NORWICH, OH:
2,174,708, CANC. INT. CL. 4.
- LUMISOURCE, INC., ELK GROVE VILLAGE, IL:
2,596,522, CANC. INT. CL. 11.
- LUNCHBOX ENTERPRISES, INC., STUDIO CITY, CA:
3,631,934, MULTIPLE CLASS, INT. CLS. 16, 24, 25 AND
28.
- LURE SEGUE, LLC, CINCINNATI, OH:
2,597,578, CANC. INT. CL. 42.
- LUSA INC., SANTA BARBARA, CA:
2,597,374, CANC. INT. CL. 12.
- LUSH YOGURT, INC., WALNUT, CA:
3,629,827, PUB. 3-17-2009. INT. CL. 43.
- LUSTER CREATIONS, MILL VALLEY, CA:
3,633,112, MULTIPLE CLASS, INT. CLS. 16, 25, 29 AND
30.
3,633,113, MULTIPLE CLASS, INT. CLS. 16, 25, 29 AND
30.
- LUSTER PRODUCTS, INC., CHICAGO, IL:
3,632,814, INT. CL. 3.
3,632,817, INT. CL. 3.
- LUXCO, INC., ST. LOUIS, MO:
3,632,812, INT. CL. 33.
- LUXOTTICA U.S. HOLDINGS CORP., PORT WASHING-
TON, NY:
3,632,097, MULTIPLE CLASS, INT. CLS. 9 AND 35.
- LUXURY LIFESTYLE HOTELS, S.L., BARCELONA, SPAIN:
3,631,439, PUB. 3-17-2009. MULTIPLE CLASS, INT. CLS.

- 35, 39 AND 43.
- LYDEN, ROBERT M., ALOHA, OR:
3,633,365, INT. CL. 25.
- LYDIA JORDANE INTERNATIONAL, NEW YORK, NY:
2,598,568, CANC. INT. CL. 3.
- LYLE DEAN, INC., NORTHBROOK, IL, LEBSACK, LYLE DEAN, NORTHBROOK, IL:
1,115,414, REN. 4-26-09, INT. CL. 41.
- LYNN AB, LUND, SWEDEN:
3,630,319, PUB. 3-17-2009, INT. CL. 9.
- LYNN KALBACHER, DOVER, NJ:
2,598,005, CANC. INT. CL. 16.
- LYNX TECHNIK INC, SANTA CLARTIA, CA:
3,629,331, PUB. 3-17-2009, INT. CL. 9.
- LYONS & ASSOCIATES, ORLANDO, FL, DBA YOUR PHOTOS, INC.:
3,629,967, PUB. 3-17-2009, INT. CL. 40.
- M & JT INVESTMENTS, LLC, BOWLING GREEN, KY:
3,632,955, INT. CL. 20.
- M HOLDINGS, LLC, LAS VEGAS, NV:
3,632,946, INT. CL. 43.
- M SHIP CO., LLC., SAN DIEGO, CA:
3,629,205, PUB. 3-17-2009, INT. CL. 42.
- M. A. D. SYNERGISTICS, INC., MIAMI, FL:
3,631,287, PUB. 3-17-2009, INT. CL. 5.
- M. ARTHUR GENSLER JR. & ASSOCIATES, INC., SAN FRANCISCO, CA:
2,042,750, REN. 4-28-09, INT. CL. 42.
- M. S. INTERESTS, LTD., SCHULENBURG, TX:
3,632,081, INT. CL. 8.
- M.C.D. ENTERPRISES, INC., JOLIET, IL:
1,441,374, CANC. INT. CL. 30.
- M.D. COMMUNICATIONS, INC., PITTSBURGH, PA:
3,631,195, PUB. 3-17-2009, INT. CL. 44.
- M.J. DE BEL MANAGEMENT B.V., LH AMSTERDAM, NETHERLANDS:
3,631,612, PUB. 3-17-2009, MULTIPLE CLASS, INT. CLS. 3, 9, 14, 18 AND 25.
- M&J INDUSTRIES A/S, DENMARK:
3,631,759, PUB. 3-17-2009, MULTIPLE CLASS, INT. CLS. 7, 37 AND 40.
- M-B COMPANIES, INC., NEW HOLSTEIN, WI:
2,598,010, CANC. INT. CL. 7.
- M-PACT, INC., FREMONT, CA:
2,175,498, CANC. INT. CL. 9.
- M-REAL CORPORATION, FI-02100 ESPOO, FINLAND:
3,631,739, PUB. 3-17-2009, INT. CL. 16.
- M-TRON INDUSTRIES, INC., YANKTON, SD:
2,597,540, CANC. INT. CL. 9.
- M/C COMMUNICATIONS, LLC, BOSTON, MA:
2,599,790, CANC. MULTIPLE CLASS, INT. CLS. 16 AND 41.
- MAAX US CORP., TORONTO (ONTARIO), CANADA:
2,247,002, REN. 4-24-09, INT. CL. 11.
- MACH 5 DISTRIBUTING, INC., TAMPA, FL:
3,629,905, PUB. 3-17-2009, MULTIPLE CLASS, INT. CLS. 9 AND 41.
- MACHETE EDIT & DESIGN, LLC, CHICAGO, IL:
2,597,122, CANC. MULTIPLE CLASS, INT. CLS. 35 AND 41.
- MACINNES TOOL CORP., ROCHESTER, NY:
2,241,251, REN. 4-27-09, INT. CL. 7.
- MACINTOSH ENGINEERING & DEVELOPMENT CO., AUBURN, CA:
2,174,813, CANC. INT. CL. 42.
- MACK, BARRY, MOUNT JULIET, TN AND MACK, TINA, MOUNT JULIET, TN:
3,633,270, INT. CL. 41.
- MACKENZIE-CHILDS AURORA LLC, AURORA, NY:
3,630,539, PUB. 3-17-2009, MULTIPLE CLASS, INT. CLS. 11, 20, 21, 24 AND 27.
- MACKEY III, GRADY L., LOS ANGELES, CA:
3,632,018, INT. CL. 41.
- MACKS, ELLEN, OWINGS MILLS, MD:
2,596,742, CANC. INT. CL. 36.
- MACY'S, INC., CINCINNATI, OH:
2,596,914, CANC. INT. CL. 9.
2,596,915, CANC. INT. CL. 9.
2,598,454, CANC. INT. CL. 36.
- MADCAP LOGIC, LLC, DURANGO, CO:
3,632,537, INT. CL. 9.
- MADDENMEDIA, INC., TUCSON, AZ:
2,596,955, CANC. MULTIPLE CLASS, INT. CLS. 16 AND 35.
- MADICO, INC., WOBURN, MA:
1,496,773, CANC. INT. CL. 17.
- MADISON PARK, LLC, WILMINGTON, DE:
3,633,175, INT. CL. 32.
- MADISON SQUARE GARDEN L.P., NEW YORK, NY:
2,597,256, CANC. INT. CL. 41.
- MAF BANCORP, INC., CLARENDON HILLS, IL:
2,599,408, CANC. INT. CL. 36.
- MAG. THOMAS ROISER, MONDSEE, AUSTRIA:
3,631,879, MULTIPLE CLASS, INT. CLS. 9, 18 AND 28.
- MAGIC AMERICAN CORPORATION, CLEVELAND, OH:
1,496,789, CANC. INT. CL. 20.
- MAGNA SEATING SYSTEMS INC., AURORA, ONTARIO, CANADA:
2,596,817, CANC. MULTIPLE CLASS, INT. CLS. 40 AND 42.
- MAGNETIC POETRY, INC., MINNEAPOLIS, MN:
2,599,364, CANC. INT. CL. 28.
- MAGNIFY360, INC., LOS ANGELES, CA:
3,632,331, MULTIPLE CLASS, INT. CLS. 35 AND 42.
- MAGNUM RESEARCH, INC., FRIDLEY, MN:
3,629,795, PUB. 12-23-2008, INT. CL. 25.
3,629,796, PUB. 3-17-2009, INT. CL. 25.
- MAHER, SARA MONICA, DUNELLEN, NJ:
3,632,837, INT. CL. 26.
- MAHFAR, SINA, GREAT NECK, NY:
2,597,745, CANC. INT. CL. 38.
2,597,746, CANC. INT. CL. 38.
- MAINTENANCE RUBBER AND PUMP CO., L.L.C., CHATTANOOGA, TN:
3,632,779, INT. CL. 35.
- MAINTENANCE SUPPLY HEADQUARTERS, LP, STAFFORD, TX:
3,630,372, PUB. 3-17-2009, INT. CL. 40.
- MAISHA HEALTH SYSTEMS, INC., SHORT HILLS, NJ:
2,598,631, CANC. INT. CL. 5.
- MAISON BOUCHARD PERE ET FILS, 21200 BEAUNE, FRANCE:
2,597,248, CANC. INT. CL. 33.
- MAITAKE PRODUCTS, INC., EAST RUTHERFORD, NJ:
3,633,165, INT. CL. 5.
- MAJEED, MUHAMMED, PISCATAWAY, NJ:
2,598,775, CANC. INT. CL. 5.
- MAJID, INC., NEW YORK, NY:
3,633,060, MULTIPLE CLASS, INT. CLS. 9, 14, 18 AND 25.
- MAJLAR PRODUCTIONS CORPORATION, OJAI, CA:
3,629,728, PUB. 3-17-2009, INT. CL. 16.
- MAJOR LEAGUE BASEBALL PROPERTIES, INC., NEW YORK, NY:
3,632,542, INT. CL. 21.
3,633,190, INT. CL. 25.
3,633,191, INT. CL. 9.
- MAJOR MOTOR SUPPLY CO., INC., CHICAGO, IL:
1,497,162, CANC. INT. CL. 42.
- MAKE YOUR BET, INC., AUSTIN, TX:
2,598,781, CANC. MULTIPLE CLASS, INT. CLS. 39 AND 42.
2,598,782, CANC. MULTIPLE CLASS, INT. CLS. 39 AND 42.
- MAKO SURGICAL CORP., FORT LAUDERDALE, FL:
3,632,997, INT. CL. 41.
- MALBEC HOLDINGS, INC., LOCKWOOD, CA, DBA DAME DE LA COUR:
3,632,912, INT. CL. 33.
- MALE CHAUVINISTIC PRESERVATIONISTS INTERNATIONAL GROUP & SOCIETY, ST. PETERSBURG, FL:
1,497,280, CANC. U.S. CL. 200.

MALHOTRA SHAVING PRODUCTS PRIVATE LIMITED, BEGUMPET, HYDERABAD, INDIA:
3,629,961, PUB. 3-17-2009. INT. CL. 8.

MALLINCKRODT BAKER, INC., PHILLIPSBURG, NJ:
3,632,451, MULTIPLE CLASS, INT. CLS. 1 AND 5.

MALLINCKRODT INC., HAZELWOOD, MO:
3,632,275, INT. CL. 10.

MALPICA, BRUCE, CENTEREACH, NY:
2,598,436, CANC. INT. CL. 41.

MALT ADVOCATE, INC., EMMAUS, PA:
3,629,197, PUB. 3-17-2009. INT. CL. 16.

MANAGEDOPS.COM, INC., BEDFORD, NH:
2,596,858, CANC. MULTIPLE CLASS, INT. CLS. 35, 37, 41 AND 42.

MANAGEMENT RESOURCES INSTITUTE, INC., KNOXVILLE, TN:
2,174,270, CANC. INT. CL. 35.

MANAGEMENTSYSTEMS S.R.L., SESTO S. GIOVANNI, ITALY:
2,596,474, CANC. MULTIPLE CLASS, INT. CLS. 9, 16 AND 42.

MANASSE, GEOFF, SEATTLE, WA:
2,599,703, CANC. INT. CL. 42.

MANCHENO, JOSEPH, METUCHEN, NJ:
3,630,067, PUB. 3-17-2009. INT. CL. 25.

MANDARINO, RALPH J., GROSSE POINT FARMS, MI AND MANDARINO, EILEEN, GROSSE POINT FARMS, MI:
2,597,831, CANC. INT. CL. 12.

MANIFEST YOUR DESTINY FOUNDATION, LOS ANGELES, CA:
3,633,201, MULTIPLE CLASS, INT. CLS. 35 AND 36.

MANILAL, SALIL, NEW YORK, NY:
3,633,264, INT. CL. 14.

MANNING, DONALD, MIAMI, FL:
2,238,560, REN. 4-26-09. INT. CL. 41.

MANSFIELD PLUMBING PRODUCTS, INC., PERRYSVILLE, OH:
1,581,376, REN. 4-28-09. INT. CL. 11.

MANSFIELD PLUMBING PRODUCTS, LLC, PERRYSVILLE, OH:
2,297,899, REN. 4-28-09. INT. CL. 11.

MANUFACTURERA DE IMPLEMENTOS, S.A. DE C.V., CORDOBA, VERACRUZ, MEXICO:
3,633,089, MULTIPLE CLASS, INT. CLS. 7, 11 AND 12.

MAPLE LEAF FOODS INC., TORONTO, CANADA:
3,631,330, PUB. 3-17-2009. INT. CL. 29.

MARAK SERVICES, INC., SCOTTS VALLEY, CA:
2,598,949, CANC. INT. CL. 41.

MARATHON COMPUTER, INC., NASHVILLE, TN:
2,598,168, CANC. INT. CL. 9.

MARC A. GALLO, COMMUNICATIONS CONSULTANT, INC., DREXEL HILL, PA:
3,633,225, INT. CL. 35.

MARC SOREL, RUMFORD, RI AND RACHEL NOAH, RUMFORD, RI:
3,631,981, INT. CL. 25.

MARC STYLES PRODUCTIONS, INC., BALDWIN, NY:
3,630,985, PUB. 3-17-2009. INT. CL. 41.
3,633,480, INT. CL. 41.

MARCHESI ANTINORI S.R.L., 50123 FIRENZE, ITALY:
3,629,933, PUB. 3-17-2009. INT. CL. 33.

MARCUS SCHARZENBERGER, HUNG HOM, KOWLOON, HONG KONG:
3,629,887, PUB. 3-17-2009. INT. CL. 14.

MAREMA, FRANK A., PALMETTO BAY, FL:
3,632,617, INT. CL. 5.

MARIANNA INDUSTRIES, INC., OMAHA, NE:
3,632,859, INT. CL. 11.

MARIE, INC., PROVO, UT:
3,630,031, PUB. 3-17-2009. INT. CL. 28.
3,630,032, PUB. 3-17-2009. INT. CL. 28.
3,630,209, PUB. 3-17-2009. INT. CL. 41.

MARINE POLYMER TECHNOLOGIES, INC., DANVERS, MA:
3,633,261, INT. CL. 5.

MARK ANTHONY INTERNATIONAL SRL, ROCKLEY, CHRIST CHURCH, BARBADOS:
3,633,018, MULTIPLE CLASS, INT. CLS. 32 AND 33.
3,633,019, MULTIPLE CLASS, INT. CLS. 32 AND 33.

MARK NUTRITIONALS, INC., SAN ANTONIO, TX:
2,598,993, CANC. INT. CL. 5.

MARK STEPHEN MARENGO, UNITED KINGDOM:
3,602,644, COR. MULTIPLE CLASS, INT. CLS. 3, 25 AND 35.

MARK WILKINSON FURNITURE LIMITED, CHIPPENHAM, WILTSHIRE SN15 2HA, ENGLAND:
2,596,868, CANC. MULTIPLE CLASS, INT. CLS. 20 AND 21.

MARKET DRIVE INTERACTIVE INCORPORATED, SAUSALITO, CA:
2,596,721, CANC. INT. CL. 42.

MARKET SQUARE FOOD COMPANY, INC., HIGHLAND PARK, IL:
1,496,904, CANC. MULTIPLE CLASS, INT. CLS. 29 AND 30.

MARKETING INTELLIGENCE SERVICE, LTD., NAPLES, NY:
1,496,996, CANC. MULTIPLE CLASS, INT. CLS. 35 AND 42.

MARKETWATCH, INC., SAN FRANCISCO, CA, CONCERTO TECHNOLOGIES INC., MINNEAPOLIS, MN:
2,249,803, REN. 4-27-09. INT. CL. 36.

MARKMONITOR INC., BOISE, ID:
3,633,315, MULTIPLE CLASS, INT. CLS. 42 AND 45.

MARKS INTERESTS, MIAMI, FL:
3,632,744, INT. CL. 41.

MARKWINS BEAUTY PRODUCTS, INC., CITY OF INDUSTRY, CA:
1,496,465, CANC. INT. CL. 3.

MARQUEZ BROTHERS INTERNATIONAL, INC., SAN JOSE, CA:
3,632,193, INT. CL. 29.

MARS, INCORPORATED, MCLEAN, VA:
2,597,959, CANC. INT. CL. 30.
2,598,462, CANC. INT. CL. 28.
2,598,970, CANC. INT. CL. 16.

MARSTON COMMUNICATIONS, LLC, CHARLOTTE, NC:
3,632,132, INT. CL. 41.

MARTATOS, DANIEL, CORONA, CA:
3,632,781, INT. CL. 3.

MARTENS, ANNE E., HOBOKEN, NJ, DBA BELLA BELLIES STUDIO:
3,629,580, PUB. 3-17-2009. INT. CL. 41.

MARTHA, GARCIA, MEXICO, MEXICO:
3,630,524, PUB. 3-17-2009. INT. CL. 9.

MARTIAL ARTS USA, INC., INVERNESS, FL:
2,229,758, REN. 4-24-09. INT. CL. 41.

MARTIN UNIVERSAL DESIGN, INC., DETROIT, MI:
2,599,260, CANC. INT. CL. 16.
2,599,261, CANC. INT. CL. 16.

MARTIN, STELLA W., ATLANTA, GA:
3,633,221, INT. CL. 16.

MARUI GROUP CO., LTD., JAPAN:
3,631,619, PUB. 3-17-2009. MULTIPLE CLASS, INT. CLS. 14, 16, 18, 21, 25 AND 35.

MARUMAN & CO., LTD., TOKYO 103-0022, JAPAN:
3,631,722, PUB. 3-17-2009. MULTIPLE CLASS, INT. CLS. 18, 25 AND 28.

MARVEL CHARACTERS, INC., BEVERLY HILLS, CA:
2,273,858, REN. 4-25-09. INT. CL. 16.

MARY KAY INC., ADDISON, TX:
2,238,356, REN. 4-24-09. INT. CL. 36.

MARYLAND STATE DEPARTMENT OF EDUCATION/DIVISION OF LIBRARY DEVELOPMENT AND SERVICES, BALTIMORE, MD, DBA DIVISION OF LIBRARY DEVELOPMENT AND SERVICES:
3,630,358, PUB. 3-17-2009. INT. CL. 41.

MARYVILLE DATA SYSTEMS, INC., ST. LOUIS, MO, DBA MARYVILLE TECHNOLOGIES:
3,629,486, PUB. 3-17-2009. INT. CL. 35.
3,629,487, PUB. 3-17-2009. INT. CL. 35.

MASCO BATH CORPORATIN, MOORESTOWN, NJ:
3,632,296, INT. CL. 11.

- MASCOT CORPORATION, HONOLULU, HI, DBA MASCOT AUTO PARTS:
2,597,845, CANC. INT. CL. 12.
- MASIFA NY CORP., NEW YORK, NY:
3,632,969, INT. CL. 43.
- MASONIC HOME, INC., THE, CHARLTON, MA:
2,599,251, CANC. INT. CL. 42.
- MASSAGE ENVY LIMITED, LLC, SCOTTSDALE, AZ:
3,630,863, PUB. 3-17-2009. INT. CL. 44.
- MASSEY, KRISTINE RENE, ALBUQUERQUE, NM AND MITCHELL, JANET AILEEN, ALBUQUERQUE, NM:
3,631,075, PUB. 3-17-2009. INT. CL. 14.
- MASTER PROTECTION CORPORATION, BOCA RATON, FL, MASTER PROTECTION ENTERPRISES, LOS ANGELES, CA:
1,542,127, REN. 4-29-09. MULTIPLE CLASS, INT. CLS. 1, 9, 17 AND 20.
- MASTER'S DREDGING COMPANY, INC., THE, LAWRENCE, KS:
2,599,747, CANC. INT. CL. 12.
- MASTERIT LLC, BARTLETT, TN:
3,631,951, INT. CL. 42.
- MASTERPIECE STUDIOS, INC., NORTH MANKATO, MN:
2,598,928, CANC. INT. CL. 35.
- MASTERYWORKS, INC., FALLS CHURCH, VA:
2,195,886, REN. 4-25-09. INT. CL. 16.
- MASTRONARDI PRODUCE, LTD., SANTA BARBARA, CA:
3,629,360, PUB. 3-17-2009. INT. CL. 31.
- MATERNITY.COM, INC., UXBRIDGE, MA:
2,599,343, CANC. INT. CL. 35.
- MATTEL, INC., EL SEGUNDO, CA:
2,598,082, CANC. INT. CL. 28.
2,598,311, CANC. INT. CL. 28.
2,598,572, CANC. INT. CL. 35.
2,598,624, CANC. INT. CL. 28.
2,598,625, CANC. INT. CL. 28.
2,599,449, CANC. INT. CL. 28.
2,599,536, CANC. INT. CL. 28.
2,599,565, CANC. INT. CL. 28.
2,599,606, CANC. INT. CL. 28.
2,599,613, CANC. INT. CL. 28.
2,599,614, CANC. INT. CL. 28.
2,599,623, CANC. INT. CL. 28.
3,629,463, PUB. 3-17-2009. INT. CL. 28.
3,630,029, PUB. 3-17-2009. INT. CL. 28.
3,633,189, INT. CL. 28.
- MATTEO LLC, LOS ANGELES, CA:
3,631,177, PUB. 3-17-2009. INT. CL. 24.
- MATTHEW G. DAVIDSON, LOS ANGELES, CA:
3,632,105, INT. CL. 5.
- MATTRESS OUTLET, INC., SPOKANE, WA:
3,631,051, PUB. 3-17-2009. INT. CL. 35.
- MATZOT AVIV LTD., BENEI-BRAK 51228, ISRAEL:
2,598,609, CANC. INT. CL. 30.
- MAUNA LANI RESORT (OPERATIONS), INC., KOHALA COAST, HI:
2,597,505, CANC. INT. CL. 41.
2,597,507, CANC. INT. CL. 41.
- MAVITY, CHRISTINA L., JOHNSON CITY, TN:
2,598,321, CANC. INT. CL. 9.
- MAX LEATHER, INC., CULVER CITY, CA:
2,597,082, CANC. INT. CL. 25.
- MAX ROHR, INC., WILMINGTON, DE:
2,599,405, CANC. INT. CL. 34.
- MAX WELL MEDICAL, LLC, NASHVILLE, TN:
2,664,034, CANC. INT. CL. 35.
- MAXFIT, INC., TENAFLY, NJ:
3,631,152, PUB. 3-17-2009. INT. CL. 44.
- MAXIM'S LIMITED, LONDON SW19 4DH, UNITED KINGDOM:
2,596,538, CANC. INT. CL. 32.
- MAXIMUM HUMAN PERFORMANCE, CEDAR GROVE, NJ:
2,598,236, CANC. INT. CL. 5.
- MAXIMUM INC., OLATHE, KS:
3,630,366, PUB. 3-17-2009. INT. CL. 41.
- MAXIMUM LIVING, INC., SOULSBYVILLE, CA, DBA BAY TO BAY DISTRIBUTION, INC.:
3,629,725, PUB. 3-17-2009. INT. CL. 5.
- MAXISIT, INC., METUCHEN, NJ:
3,629,201, PUB. 3-17-2009. MULTIPLE CLASS, INT. CLS. 35, 42 AND 44.
- MAXWELL, CHRIS COLLIN, BATON ROUGE, LA:
1,497,143, CANC. INT. CL. 41.
- MAYESH WHOLESALE FLORIST, INC., LOS ANGELES, CA:
2,597,527, CANC. INT. CL. 31.
- MAYNOV PRODUCTIONS L.L.C., LONG ISLAND CITY, NY:
3,633,220, INT. CL. 35.
- MAYO HOTEL & LOFTS LIMITED PARTNERSHIP, TULSA, OK:
3,633,068, MULTIPLE CLASS, INT. CLS. 35, 36, 41 AND 43.
- MAYTAG CORPORATION, NEWTON, IA, JENN-AIR CORPORATION, INDIANAPOLIS, IN:
868,410, REN. 4-27-09. U.S. CL. 34 (INT. CL. 11).
- MBA EXCHANGE, LTD., HIGHLAND PARK, IL:
3,629,430, PUB. 3-17-2009. MULTIPLE CLASS, INT. CLS. 35 AND 41.
- MBSC SECURITIES CORPORATION, NEW YORK, NY:
2,596,725, CANC. INT. CL. 36.
- MB2 ENTERTAINMENT, LLC, TROY, MI:
2,597,573, CANC. INT. CL. 41.
- MC GREEN ENTERPRISES LLC, BOWIE, MD:
3,630,333, PUB. 3-17-2009. MULTIPLE CLASS, INT. CLS. 9 AND 41.
- MCAFEE, INC., SANTA CLARA, CA:
2,596,712, CANC. MULTIPLE CLASS, INT. CLS. 37, 39 AND 42.
- MCALLAN INNOVATIONS LIMITED, ABERDEEN, UNITED KINGDOM:
3,630,467, PUB. 3-17-2009. MULTIPLE CLASS, INT. CLS. 5 AND 21.
- MCCAULEY'S SMALL ENGINE REPAIR, LLC, LANSING, MI:
3,633,253, INT. CL. 12.
- MCCLOSKEY MECHANICAL CONTRACTORS, INC., LINDENWOLD, NJ:
3,629,214, PUB. 3-17-2009. INT. CL. 37.
- MCCLURE, TODD, HUDSONVILLE, MI:
3,630,888, PUB. 3-17-2009. INT. CL. 28.
- MCCORMICK FORENSICS, INC., VENTURA, CA:
3,631,100, PUB. 3-17-2009. INT. CL. 45.
- MCDANIEL, TERRY, ALAMO, CA:
3,633,457, INT. CL. 36.
- MCDATA CORPORATION, BROOMFIELD, CO:
2,599,589, CANC. INT. CL. 42.
- MCDONALD'S CORPORATION, OAK BROOK, IL:
876,723, REN. 4-27-09. U.S. CL. 100 (INT. CL. 42).
3,633,131, INT. CL. 41.
- MCEVOY, RICHARD, FOUNTAIN VALLEY, CA:
3,631,256, PUB. 3-17-2009. MULTIPLE CLASS, INT. CLS. 18 AND 24.
- MCGUCKEN, ELLIOT, DR., MALIBU, CA:
3,629,309, PUB. 3-17-2009. INT. CL. 25.
- MCKEE FOODS CORPORATION, COLLEGEDALE, TN:
2,596,821, CANC. INT. CL. 30.
2,598,177, CANC. INT. CL. 30.
- MCKENZIE, SEAN, NEW YORK, NY:
3,631,117, PUB. 3-17-2009. INT. CL. 25.
- MCKESSON CORPORATION, SAN FRANCISCO, CA:
3,633,287, INT. CL. 5.
- MCLEAN COUNTY HOG SERVICE, INC., LEROY, IL:
1,496,966, CANC. INT. CL. 31.
- MCLEAN, JAMES, RIVERSIDE, IL:
3,632,973, INT. CL. 9.
- MCMONIGLE, JOHN, NEWPORT, CA:
3,633,453, MULTIPLE CLASS, INT. CLS. 35 AND 36.
- MCMULLIN, KEVIN, IRVINE, CA:
2,598,149, CANC. INT. CL. 41.
- MCNAIR, JOHN, CAROLINA, PUERTO RICO:
3,631,953, INT. CL. 15.

MCNEICE, IAN, MANCHESTER, M4 1LA, UNITED KINGDOM:
2,596,854, CANC. INT. CL. 42.

MCNEIL NUTRITIONALS, LLC, FORT WASHINGTON, PA:
3,631,817, INT. CL. 5.
3,631,821, INT. CL. 5.

MCNELIS, DEBORAH, NEW BERLIN, WI:
3,630,724, PUB. 3-17-2009. INT. CL. 16.

MD FORMULATIONS, INC., SAN FRANCISCO, CA:
2,241,493, REN. 4-27-09. INT. CL. 3.

MD ORTHOPAEDICS, INC., WAYLAND, IA:
3,630,766, PUB. 3-17-2009. INT. CL. 10.

MDC PARTNERS INC., TORONTO, ONTARIO, CANADA:
3,629,209, PUB. 3-17-2009. INT. CL. 35.

MDEVERYWHERE, INC., DURHAM, NC:
2,597,421, CANC. INT. CL. 39.

MEADOWS OF WICKENBURG, L.P., THE, WICKENBURG, AZ:
2,597,681, CANC. INT. CL. 41.

MEADOWS OF WICKENBURG, LP, THE, WICKENBURG, AZ:
2,597,682, CANC. INT. CL. 35.

MEADWESTVACO CORPORATION, STAMFORD, CT:
2,598,344, CANC. INT. CL. 16.

MEADWESTVACO CORPORATION, GLEN ALLEN, VA:
3,630,234, PUB. 3-17-2009. INT. CL. 1.
3,633,147, INT. CL. 19.

MECHANICAL SERVANTS, INC., MELROSE PARK, IL:
2,251,049, REN. 4-25-09. INT. CL. 35.

MED YONES, LAS VEGAS, NV, DBA INTERNATIONAL INSTITUTE OF MANAGEMENT:
3,630,572, PUB. 3-17-2009. INT. CL. 41.

MED-I-DYNAMIX FLUID MONITORING LTD., GUSH ETZION 90433, ISRAEL:
3,631,441, PUB. 3-17-2009. MULTIPLE CLASS, INT. CLS. 10, 35 AND 44.

MEDAPPS, INC., SCOTTSDALE, AZ:
3,633,283, INT. CL. 44.

MEDCO HEALTH SOLUTIONS, INC., FRANKLIN LAKES, NJ:
2,175,230, CANC. MULTIPLE CLASS, INT. CLS. 36 AND 42.

MEDECO SECURITY LOCKS, INC., SALEM, VA:
2,599,696, CANC. INT. CL. 9.

MEDEGEN, INC., ONTARIO, CA:
3,631,826, INT. CL. 10.

MEDIA CONVERGENCE GROUP, INC., COLUMBIA, MO, DBA MEDIA CONVERGENCE GROUP, INC.:
3,631,144, PUB. 3-17-2009. INT. CL. 38.

MEDIADROIT, LLC, CHICAGO, IL:
3,633,010, INT. CL. 42.

MEDIAEDGE: CIA, LLC, NEW YORK, NY:
2,638,343, CANC. MULTIPLE CLASS, INT. CLS. 9, 16 AND 42.

MEDIAPULSE, INC., KNOXVILLE, TN:
2,598,634, CANC. INT. CL. 35.

MEDICAL ART PROSTHETICS, LLC, MADISON, WI:
3,633,478, MULTIPLE CLASS, INT. CLS. 40 AND 44.

MEDICAL EDUCATION TECHNOLOGIES, INC., SARASOTA, FL:
2,250,672, REN. 4-27-09. INT. CL. 9.
2,259,407, REN. 4-27-09. INT. CL. 9.
2,282,928, REN. 4-27-09. INT. CL. 20.
3,633,390, INT. CL. 42.

MEDICAL TECHNOLOGIES UNLIMITED, INC., A DELAWARE CORPORATION, MIAMI, FL:
3,633,136, INT. CL. 44.

MEDIMETRIKS PHARMACEUTICALS, INC., FAIRFIELD, NJ:
3,630,344, PUB. 3-17-2009. INT. CL. 5.
3,630,345, PUB. 3-17-2009. INT. CL. 5.
3,630,346, PUB. 3-17-2009. INT. CL. 5.

MEDINGENUITY, LLC, SOUTHLAKE, TX:
3,630,007, PUB. 3-17-2009. INT. CL. 35.

MEDKINETICS, LLC, FRANKLIN, TN:
3,629,666, PUB. 3-17-2009. INT. CL. 42.

MEDSHARE INC., CAMBRIDGE, ONTARIO, CANADA:
3,632,217, INT. CL. 9.

MEDTRONIC MINIMED, INC., NORTHRIDGE, CA:
2,599,468, CANC. INT. CL. 10.

MEDTRONIC MINIMED, INC., NOTHERIDGE, CA:
2,599,469, CANC. INT. CL. 10.

MEDTRONIC, INC., MINNEAPOLIS, MN:
2,598,041, CANC. INT. CL. 10.

MEDZONE CORPORATION, SUN CITY, AZ:
2,599,633, CANC. INT. CL. 3.

MEGO, INC., LOS ANGELES, CA:
3,633,206, INT. CL. 35.

MEIJER, INC., GRAND RAPIDS, MI:
2,599,401, CANC. INT. CL. 30.

MEISGEIER, CHARLES, RICHMOND, TX AND MURPHY, ELIZABETH, KELLER, TX:
3,632,157, MULTIPLE CLASS, INT. CLS. 9, 16 AND 44.

MELAS, INC., SALEM, IL:
2,597,426, CANC. INT. CL. 28.

MEMBERLINK, INC., SPRINGVILLE, UT:
2,599,246, CANC. INT. CL. 35.

MEMBERS OF CHURCHES OF CHRIST FOR SCOUTING, ABILENE, TX:
3,629,529, PUB. 3-17-2009. INT. CL. 41.

MEMEC, LLC, SAN DIEGO, CA:
2,597,954, CANC. INT. CL. 35.

MEMORIAL SLOAN-KETTERING CANCER CENTER, NEW YORK, NY:
2,303,269, REN. 4-27-09. INT. CL. 41.
2,303,270, REN. 4-27-09. INT. CL. 41.
3,630,035, PUB. 3-17-2009. INT. CL. 36.

MENTAL HEALTH AND SUBSTANCE ABUSE CORPORATIONS OF MASSACHUSETTS, INC., NATICK, MA:
3,630,211, PUB. 3-17-2009. INT. CL. 35.

MENTIS TECHNOLOGY, LLC, ENGLEWOOD, CO:
3,630,917, PUB. 3-17-2009. INT. CL. 9.

MENTOR GRAPHICS CORPORATION, WILSONVILLE, OR:
2,175,392, CANC. INT. CL. 9.

MENTOR TECHNOLOGIES GROUP, INC., ANNAPOLIS, MD:
2,596,945, CANC. MULTIPLE CLASS, INT. CLS. 41 AND 42.

MERCATOR ENERGY, LLC, DENVER, CO:
2,597,769, CANC. INT. CL. 42.

MERCHANT ADVOCATE LLC, SOUTH AMBOY, NJ:
3,632,862, INT. CL. 36.

MERCHANTS DISTRIBUTORS, INC., HICKORY, NC:
1,533,074, REN. 4-29-09. INT. CL. 16.
1,536,367, REN. 4-29-09. INT. CL. 16.

MERCK & CO., INC., WHITEHOUSE STATION, NJ:
2,242,130, REN. 4-24-09. INT. CL. 5.
3,631,975, INT. CL. 5.

MERCK-MEDCO MANAGED CARE, LLC, FRANKLIN LAKES, NJ:
2,597,938, CANC. INT. CL. 42.

MERCOSPIRITS INC., TEANECK, NJ:
2,599,605, CANC. INT. CL. 32.

MERCY SHIPS, GARDEN VALLEY, TX:
3,631,037, PUB. 3-17-2009. INT. CL. 25.
3,631,038, PUB. 3-17-2009. INT. CL. 38.

MERIAL LLC, HARLOW CM19 5QA, UNITED KINGDOM:
2,229,386, REN. 4-29-09. INT. CL. 5.

MERISANT COMPANY, CHICAGO, IL:
3,632,860, INT. CL. 30.

MERKLE INTERNATIONAL, INC., GALENA, IL:
3,632,043, MULTIPLE CLASS, INT. CLS. 7, 11, 19 AND 42.
3,632,044, MULTIPLE CLASS, INT. CLS. 7, 11, 19 AND 42.

MERLOT TARPULIN & SIDEKIT MANUFACTURING CO., INC., VERONA, PA:
3,629,738, PUB. 3-17-2009. MULTIPLE CLASS, INT. CLS. 12 AND 22.
3,629,741, PUB. 3-17-2009. MULTIPLE CLASS, INT. CLS. 12 AND 22.

MERVYNS' BRANDS, INC., MINNEAPOLIS, MN:
2,599,650, CANC. INT. CL. 36.

MERZ + CO. GMBH & CO., FED REP GERMANY:
2,596,746, CANC. INT. CL. 5.

MESHBESHER HEALTH CORPORATION, CLEARWATER, FL:
3,633,249, INT. CL. 9.

- MESO SCALE DIAGNOSTICS, LLC, GAITHERSBURG, MD:
3,630,779, PUB. 3-17-2009. INT. CL. 42.
- METABOLIC MAINTENANCE PRODUCTS, INC., SISTERS,
OR:
2,340,565, REN. 4-24-09. INT. CL. 5.
- METALTECH-OMEGA INC., LAVAL, CANADA:
3,629,305, PUB. 3-17-2009. MULTIPLE CLASS, INT. CLS. 6
AND 35.
- METHVEN LIMITED, AVONDALE, NEW ZEALAND:
3,631,385, PUB. 3-17-2009. MULTIPLE CLASS, INT. CLS.
35 AND 42.
- METPAR CORP., WESTBURY, NY:
2,598,256, CANC. INT. CL. 6.
- METRIC, LLC, IRVING, TX:
3,631,113, PUB. 3-17-2009. INT. CL. 35.
- METTLER-TOLEDO AG, GREIFENSEE, SWITZERLAND:
3,629,251, PUB. 3-17-2009. INT. CL. 9.
- MEVC.COM, INC., SAN FRANCISCO, CA:
2,597,052, CANC. INT. CL. 36.
- MG BROWN INVESTMENT GROUP, LLC, HOUSTON, TX:
3,633,387, INT. CL. 35.
- MGI LUXURY GROUP SA, 2502 BIEL, SWITZERLAND:
2,540,808, CANC. INT. CL. 3.
- MHC TT LEASING COMPANY, INC., CHICAGO, IL:
3,630,618, PUB. 3-17-2009. MULTIPLE CLASS, INT. CLS.
39 AND 43.
- MI INDUSTRIES, INC., LINCOLN, NE:
3,589,920, COR. INT. CL. 31.
- MICHAEL AKIRA WEST, MANHATTAN BEACH, CA:
3,631,251, PUB. 3-17-2009. INT. CL. 25.
- MICHAEL CAMPANA, WINDSOR, CO:
3,632,787, INT. CL. 41.
- MICHAEL G. MARSCHNER, LINWOOD, NJ:
2,599,816, CANC. INT. CL. 9.
- MICHAEL R. LIMOTTA & CO., INC., SOLVANG, CA, DBA
LIMOTTA INTERNET TECHNOLOGIES:
3,631,261, PUB. 3-17-2009. MULTIPLE CLASS, INT. CLS.
38 AND 42.
- MICHELE AUDIO CORPORATION OF AMERICA, MASSE-
NA, NY:
1,496,623, CANC. INT. CL. 9.
- MICHELIN NORTH AMERICA, INC., GREENVILLE, SC:
2,597,377, CANC. INT. CL. 12.
- MICHIGAN INTERNATIONAL SPEEDWAY, INC., DAY-
TONA BEACH, FL:
3,632,437, INT. CL. 28.
- MICRO-MEGA INTERNATIONAL MANUFACTURES, F-
25000 BESANÇON, FRANCE:
3,629,160, PUB. 3-17-2009. INT. CL. 10.
- MICROCOMPUTER SOFTWARE, INC., GRAND PRAIRIE,
TX:
2,599,664, CANC. INT. CL. 9.
- MICROHARD TECHNICAL INSTITUTE, INC., OAK
BROOK, IL:
2,175,738, CANC. INT. CL. 9.
- MICROLITE CORPORATION, PITTSBURGH, PA:
1,496,600, CANC. INT. CL. 9.
- MICROPATENT LLC, EAST HAVEN, CT:
2,596,430, CANC. INT. CL. 42.
- MICROSOFT CORPORATION, REDMOND, WA:
2,798,091, AM. INT. CL. 41.
3,631,984, MULTIPLE CLASS, INT. CLS. 9, 38 AND 42.
3,631,999, INT. CL. 9.
3,632,287, MULTIPLE CLASS, INT. CLS. 9, 39, 42 AND 44.
3,632,288, MULTIPLE CLASS, INT. CLS. 9, 39, 42 AND 44.
- MICROVAL, FRANCE:
3,631,670, PUB. 3-17-2009. INT. CL. 10.
- MID-ATLANTIC COMPANIES, INC., ROCKVILLE, MD:
3,631,806, INT. CL. 37.
- MID-SOUTH INDEPENDENT SCHOOL BUSINESS OFFI-
CERS, INC., ATLANTA, GA:
3,630,198, PUB. 3-17-2009. INT. CL. 35.
- MIDAS-KAPITI INTERNATIONAL LIMITED, WIMBLE-
DON, LONDON, SW19 4DR, UNITED KINGDOM:
2,596,440, CANC. MULTIPLE CLASS, INT. CLS. 9, 16, 35,
36, 38, 41 AND 42.
- MIDNIGHT EXPRESS POWER BOATS, INC., TOWSON, MD:
3,629,946, PUB. 3-17-2009. INT. CL. 12.
- MIDWAY HOME ENTERTAINMENT, INC., CHICAGO, IL:
2,596,608, CANC. INT. CL. 9.
- MIDWESTERN INDUSTRIES, INC., MASSILLON, OH:
1,496,561, CANC. INT. CL. 7.
- MIGHTY DOT MEDIA INC., SAN MATEO, CA:
3,632,394, INT. CL. 41.
- MIGLUS DESIGN, INC., PROVIDENCE, RI:
3,633,126, INT. CL. 24.
- MIKE LANES, L.L.C., SAN PEDRO, CA:
3,629,663, PUB. 3-17-2009. INT. CL. 25.
- MIKE LANES, LLC, SAN PEDRO, CA:
3,629,648, PUB. 3-17-2009. INT. CL. 25.
3,629,748, PUB. 3-17-2009. INT. CL. 25.
- MIKE-SELL'S, INC., DAYTON, OH:
2,596,540, CANC. MULTIPLE CLASS, INT. CLS. 29 AND
30.
- MIKEN SPORTS LLC, CALEDONIA, MN:
3,630,940, PUB. 3-17-2009. INT. CL. 28.
- MILES DAVIS PROPERTIES, L.L.C., LOS ANGELES, CA:
2,238,714, REN. 4-24-09. INT. CL. 25.
- MILES-BRAMWELL EXECUTIVE SERVICES LIMITED,
DERBYSHIRE, UNITED KINGDOM:
3,629,394, PUB. 3-17-2009. MULTIPLE CLASS, INT. CLS.
16, 41 AND 44.
- MILESTONE AV TECHNOLOGIES LLC, SAVAGE, MN:
3,632,638, MULTIPLE CLASS, INT. CLS. 6 AND 20.
- MILETICH, PAT, BETTENDORF, IA:
3,633,367, INT. CL. 25.
- MILGARD MANUFACTURING INCORPORATED, TACO-
MA, WA:
3,630,649, PUB. 3-17-2009. MULTIPLE CLASS, INT. CLS. 6
AND 19.
- MILITARY MAIL SOLUTIONS, QUINCY, MA:
3,632,505, INT. CL. 42.
3,632,506, INT. CL. 42.
3,632,507, INT. CL. 42.
3,632,508, INT. CL. 42.
- MILLENNIUM & COPTHORNE INTERNATIONAL LTD.,
CITY HOUSE, SINGAPORE:
2,277,160, REN. 4-27-09. INT. CL. 43.
- MILLER PRODUCTS COMPANY, MILWAUKEE, WI:
2,599,244, CANC. INT. CL. 32.
- MILLER SPREADER COMPANY, YOUNGSTOWN, OH:
3,629,162, PUB. 3-17-2009. INT. CL. 7.
3,629,167, PUB. 3-17-2009. INT. CL. 7.
- MILLER, ELIZABETH M., MOSCOW, ID:
3,631,056, PUB. 3-17-2009. INT. CL. 16.
- MILLIKEN & COMPANY, SPARTANBURG, SC:
2,598,817, CANC. INT. CL. 24.
- MILLIMAN, INC., SEATTLE, WA:
2,599,511, CANC. INT. CL. 9.
- MILTON E. DOWTY, WICHITA, KS:
3,630,521, PUB. 3-17-2009. INT. CL. 41.
- MILTON HERSHEY SCHOOL, HERSHEY, PA:
3,630,342, PUB. 3-17-2009. INT. CL. 41.
- MILWAUKEE BREWERS BASEBALL CLUB, MILWAUKEE,
WI:
3,633,228, INT. CL. 25.
3,633,229, INT. CL. 25.
- MIMOSA SYSTEMS, INC., SANTA CLARA, CA:
3,633,099, MULTIPLE CLASS, INT. CLS. 9 AND 42.
3,633,100, MULTIPLE CLASS, INT. CLS. 9 AND 42.
- MINDLEADERS, INC., DUBLIN, OH:
2,598,756, CANC. MULTIPLE CLASS, INT. CLS. 9 AND
41.
- MINERAL SPRINGS FARM LLC, LEXINGTON, SC:
3,630,874, PUB. 3-17-2009. INT. CL. 25.
3,630,984, PUB. 3-17-2009. INT. CL. 44.
- MINERAL TECHNOLOGIES INC., JACKSONVILLE, OR:
3,630,121, PUB. 12-9-2008. INT. CL. 40.
- MINETTA LANE LLC, NEW YORK, NY:
3,631,858, INT. CL. 43.
- MINI BAZAAR & CO LLC, TERRETON, ID:
3,629,669, PUB. 3-17-2009. INT. CL. 35.
- MINNESOTA GREENSTAR, MINNEAPOLIS, MN:
3,629,518, PUB. 3-17-2009. MULTIPLE CLASS, INT. CLS.
41 AND 42.

MINNESOTA PUBLIC RADIO, ST. PAUL, MN:
3,631,300, PUB. 3-17-2009. INT. CL. 41.

MINNOVATION LIMITED, WAKEFIELD, UNITED KING-
DOM:
3,630,353, PUB. 3-17-2009. INT. CL. 7.

MINNPAR LLC, MINNEAPOLIS, MN:
3,630,034, PUB. 3-17-2009. INT. CL. 7.

MINOCQUA ARBOR VITAE-WOODRUFF AREA CHAM-
BER OF COMMERCE, INC., MINOCQUA, WI:
2,597,909, CANC. INT. CL. 35.

MINOS MEDICAL, INC., IRVINE, CA:
3,631,882, INT. CL. 10.

MINRAD INC., ORCHARD PARK, NY:
3,633,061, INT. CL. 5.

MINTIE TECHNOLOGIES, INC., LOS ANGELES, CA:
3,631,864, INT. CL. 11.

MINTLING, DENNIS LESLIE, ERIE, CO:
2,599,192, CANC. INT. CL. 25.

MINTON, CHARLES, UNION, NJ:
2,206,888, REN. 4-28-09. INT. CL. 42.
2,216,059, REN. 4-28-09. INT. CL. 42.

MIONIX CORPORATION, ROUND ROCK, TX:
3,631,822, INT. CL. 5.

MIRAGE STUDIOS, HAYDENVILLE, MA:
1,542,711, REN. 4-27-09. INT. CL. 28.

MIRANDA, FRANCES, LOS ANGELES, CA:
3,630,990, PUB. 3-17-2009. INT. CL. 9.

MIRANT INTELLECTUAL ASSET MANAGEMENT AND
MARKETING, LLC, ATLANTA, GA:
2,599,214, CANC. INT. CL. 35.

MIROGLIO S.P.A., ALBA, CUNEO, ITALY:
3,632,337, INT. CL. 25.

MIRZA TANNERS LIMITED, KANPUR 208001, INDIA:
2,598,477, CANC. INT. CL. 25.

MIRZAAE, TERESA DBA AMA JEWELS, TORONTO, ON-
TARIO, CANADA:
3,631,401, PUB. 3-17-2009. INT. CL. 14.

MISSION CITY PRESS, INC., SAN ANTONIO, TX:
2,289,112, REN. 4-24-09. INT. CL. 9.

MISSION LANDSCAPE COMPANIES, INC., TUSTIN, CA:
3,632,590, INT. CL. 42.

MISSONI S.P.A., SUMIRAGO, VARESE, ITALY:
3,631,884, INT. CL. 3.

MISTURA INC., OTTAWA, CANADA:
3,629,292, PUB. 3-17-2009. INT. CL. 3.

MITCHELL INTERNATIONAL, INC., SAN DIEGO, CA:
2,597,771, CANC. INT. CL. 35.

MITCHELL, LINDBERG AND TAYLOR, INC., CLARK-
STON, GA:
3,629,661, PUB. 3-17-2009. INT. CL. 35.

MITSUBISHI PENCIL CO., LTD., TOKYO, JAPAN:
3,632,209, INT. CL. 16.

MITY-LITE, INC., OREM, UT:
3,632,913, INT. CL. 19.

MIZUNO CORPORATION, OSAKA, JAPAN:
3,632,826, INT. CL. 25.
3,632,827, INT. CL. 25.

MIZUNO USA, INC., NORCROSS, GA:
3,632,009, INT. CL. 28.

MLP FINANZDIENSTLEISTUNGEN AG, 69126 HEIDEL-
BERG, FED REP GERMANY:
2,597,027, CANC. MULTIPLE CLASS, INT. CLS. 35, 36
AND 42.

MOBICIOUS, INC., NEEDHAM, MA:
3,631,170, PUB. 3-17-2009. INT. CL. 42.

MOBILE DREAMS FACTORY S.L., MADRID, SPAIN:
3,631,077, PUB. 3-17-2009. INT. CL. 35.

MOBILESPORTS, LLC, FARMINGTON, CT:
3,630,674, PUB. 3-17-2009. INT. CL. 41.
3,631,328, PUB. 3-17-2009. INT. CL. 9.

MOBILING AMERICA'S YOUTH, INC., BERKELEY, CA:
3,630,700, PUB. 3-17-2009. INT. CL. 41.

MOCANA CORPORATION, SAN FRANCISCO, CA:
3,631,874, INT. CL. 42.

MOCANI (PTY) LTD, RANDBURG, SOUTH AFRICA:
2,596,481, CANC. INT. CL. 7.

MOCHILD, INC., WEST MIFFLIN, PA:
1,497,278, CANC. INT. CL. 42.

MOCKOVAK, RICHARD M., CARMEL, IN:
2,599,818, CANC. INT. CL. 28.

MODTECH HOLDINGS, INC., PERRIS, CA:
2,598,642, CANC. MULTIPLE CLASS, INT. CLS. 37, 39
AND 42.

MOELLEKEN, BRENT R.W., BEVERLY HILLS, CA:
3,630,865, PUB. 3-17-2009. INT. CL. 44.

MOEN, CARROLL W., GRANTS PASS, OR AND MOEN,
NANCY L., GRANTS PASS, OR:
2,597,016, CANC. INT. CL. 35.

MOFFAT PTY LIMITED, MULGRAVE, AUSTRALIA:
3,631,444, PUB. 3-17-2009. INT. CL. 7.

MOHAWK BRANDS, INC., WILMINGTON, DE:
3,630,980, PUB. 3-17-2009. INT. CL. 42.
3,631,049, PUB. 3-17-2009. INT. CL. 27.

MOJO REPUBLIK LLC, LAS VEGAS, NV:
3,630,192, PUB. 3-17-2009. INT. CL. 41.

MOLINO DI FERRO S.P.A., FANZOLO DE VEDEL, ITALY:
3,629,370, PUB. 8-5-2008. MULTIPLE CLASS, INT. CLS. 5
AND 29.

MOMENTUM ADVANCED SOLUTIONS INC., THORN-
HILL, CANADA:
3,629,359, PUB. 3-17-2009. INT. CL. 42.

MOMENTUM BAY LLC, HOUSTON, TX:
3,629,145, PUB. 3-17-2009. INT. CL. 35.

MOMO S.R.L., I-20146 MILANO, ITALY:
3,631,785, PUB. 3-17-2009. INT. CL. 9.

MONDAY CLASSICS, INC., HIALEAH, FL:
1,496,846, CANC. INT. CL. 25.

MONDERA WHEELS, LONG BEACH, CA:
2,599,078, CANC. INT. CL. 12.

MONDO NEW LINE INC., LONG ISLAND CITY, NY:
2,596,709, CANC. INT. CL. 25.

MONDO USA, INC., GRAPEVINE, TX:
3,633,174, INT. CL. 19.

MONDOHEDGE S.P.A., MILAN 20124, ITALY:
2,703,703, CANC. MULTIPLE CLASS, INT. CLS. 9, 37, 38,
41 AND 42.

MONESSEN HEARTH SYSTEMS COMPANY, PARIS, KY:
3,630,891, PUB. 3-17-2009. INT. CL. 11.

MONEYMATTERS NETWORK INC., RENO, NV:
2,599,850, CANC. INT. CL. 9.
2,599,851, CANC. INT. CL. 36.

MONEYSOFT, INC., SAN DIEGO, CA:
2,175,425, CANC. INT. CL. 9.

MONEYTEL, INC., MIAMI BEACH, FL:
2,598,938, CANC. INT. CL. 36.

MONOGRAM BANK, THE, BLUE ASH, OH:
1,497,059, CANC. INT. CL. 36.

MONSANTO TECHNOLOGY LLC, ST. LOUIS, MO:
2,599,852, CANC. INT. CL. 31.

MONSIEUR FABIEN OUDOT, F-75012 PARIS, FRANCE:
3,631,522, PUB. 3-17-2009. MULTIPLE CLASS, INT. CLS.
41, 42 AND 43.

MONSOON, INC., PORTLAND, OR:
3,631,137, PUB. 3-17-2009. INT. CL. 9.
3,631,138, PUB. 3-17-2009. INT. CL. 9.
3,631,141, PUB. 3-17-2009. INT. CL. 35.

MONSTER CABLE PRODUCTS, INC., BRISBANE, CA:
2,245,395, REN. 4-27-09. INT. CL. 9.

MONTANA PRODUCTS, INC., ORRVILLE, OH:
3,631,437, PUB. 3-17-2009. INT. CL. 2.

MONTANA SUNFLOWER COMPANY, LLC, DENTON, MT:
2,175,127, CANC. INT. CL. 31.

MONTANA WATCH COMPANY LLC, LIVINGSTON, MT:
2,599,823, CANC. INT. CL. 14.

MONTERIS MEDICAL INC., WINNIPEG, MANITOBA, CA-
NADA:
3,631,925, INT. CL. 10.

MONTERIS MEDICAL INC., WINNIPEG, MB, CANADA:
3,631,948, INT. CL. 10.

MOO & OINK, INC., CHICAGO, IL:
3,629,220, PUB. 3-17-2009. INT. CL. 35.
3,629,221, PUB. 3-17-2009. INT. CL. 35.

MOODY STREET KIDS PTY LTD, BALWYN NORTH VIC,
AUSTRALIA:
3,631,469, PUB. 3-17-2009. MULTIPLE CLASS, INT. CLS.
9, 16, 25, 28 AND 41.

- MOODY, HELEN F., CORRALES, NM:
2,240,713, REN. 4-27-09. INT. CL. 16.
- MOONDANCE ADVENTURES, INC., ATLANTA, GA:
2,174,838, CANC. INT. CL. 39.
- MOONRAKER PARTNERSHIP, THE, BRIGHTON, MA:
2,598,039, CANC. INT. CL. 41.
- MOORE, DARIAN, CANTON, MI:
3,630,529, PUB. 3-17-2009. INT. CL. 36.
- MORALES, JOSE NICHOLAS, PLATTEVILLE, CO AND
MORALES, MANUAL, CASTLE ROCK, CO:
3,629,655, PUB. 3-17-2009. INT. CL. 43.
- MORASSE, LINDA, SUNCOOK, NH:
2,596,543, CANC. INT. CL. 20.
- MORE & MORE TEXTILVERTRIEBS GMBH, 82319 STARN-
BERG, FED REP GERMANY:
2,705,760, CANC. MULTIPLE CLASS, INT. CLS. 3, 14, 16
AND 18.
- MORE CUPCAKES, LLC, CHICAGO, IL:
3,632,832, INT. CL. 25.
- MORELAND, BILL D., BUFORD, CA:
2,597,142, CANC. INT. CL. 35.
- MORGAN CRUCIBLE COMPANY PLC, THE, BERKSHIRE
SL4 1EP, ENGLAND:
1,496,775, CANC. INT. CL. 17.
- MORGAN STANLEY, NEW YORK, NY:
3,632,733, INT. CL. 35.
- MORGAN, JERRY L., BROOKFIELD, WI AND HURLEY,
JAMES C., WOODBURY, MN:
3,632,512, INT. CL. 31.
- MORI SEIKI U.S.A., INC., ROLLING MEADOWS, IL:
3,629,695, PUB. 3-17-2009. INT. CL. 41.
- MORINAGA MILK INDUSTRY CO., LTD., TOKYO, JAPAN:
2,175,346, CANC. INT. CL. 31.
- MORNINGSTAR, INC., CHICAGO, IL:
2,596,974, CANC. U.S. CL. B.
2,596,975, CANC. U.S. CL. B.
2,596,976, CANC. U.S. CL. B.
- MORRIS VISITOR PUBLICATIONS, LLC, AUGUSTA, GA:
3,632,250, INT. CL. 39.
- MORRISON & FOERSTER, LLP, SAN FRANCISCO, CA:
2,481,879, COR. INT. CL. 42.
2,823,987, COR. MULTIPLE CLASS, INT. CLS. 6, 14, 16, 18
AND 21.
- MORRISON, ERIC M., BETHESDA, MD:
2,597,485, CANC. INT. CL. 42.
- MORSE PLC, BRENTFORD, TAIWAN:
3,629,260, PUB. 3-17-2009. MULTIPLE CLASS, INT. CLS.
36, 41 AND 45.
- MORTGAGE RESEARCH CENTER, LLC, COLUMBIA, MO:
3,630,812, PUB. 3-17-2009. INT. CL. 41.
- MOSAIC INTERNATIONAL LLC, SAN RAMON, CA:
3,633,376, MULTIPLE CLASS, INT. CLS. 9 AND 28.
- MOSCOSO, VICTOR, WOODACRE, CA:
3,630,951, PUB. 3-17-2009. INT. CL. 16.
- MOSES, NATALIE LOUISE, KIRRAWEE, AUSTRIA:
2,599,466, CANC. INT. CL. 25.
- MOSHE INC, LOS ANGELES, CA, DBA SCENT-SATION:
3,629,432, PUB. 3-17-2009. INT. CL. 3.
3,629,433, PUB. 3-17-2009. INT. CL. 3.
- MOSLER INC., HAMILTON, OH:
2,597,793, CANC. INT. CL. 9.
- MOSS TUBES, INC., WEST SAND LAKE, NY, MOSS TUBES,
INC., WEST SAND LAKE, NY:
2,342,075, REN. 4-29-09. INT. CL. 10.
- MOTA S.F., SAN FRANCISCO, CA:
2,596,730, CANC. INT. CL. 25.
- MOTHERBEARWARE, INC., GILROY, CA:
3,629,879, PUB. 3-17-2009. INT. CL. 25.
- MOTHERBOARDZONE.COM, LLC, CEDAR PARK, TX:
2,597,111, CANC. INT. CL. 35.
- MOTIENT CORPORATION, RESTON, VA:
2,598,845, CANC. MULTIPLE CLASS, INT. CLS. 9, 16, 35,
38 AND 42.
- MOUNTAIN STATE UNIVERSITY, INC., BECKLEY, WV:
3,629,652, PUB. 3-17-2009. INT. CL. 41.
- MOUNTANOS BROTHERS COFFEE COMPANY, INC.,
SOUTH SAN FRANCISCO, CA:
3,632,716, INT. CL. 30.
- MOUTTET, PAUL G., MIAMI, FL:
2,292,350, REN. 4-24-09. INT. CL. 31.
- MOVING BOX STUDIOS, ITHACA, NY:
3,630,870, PUB. 3-17-2009. INT. CL. 41.
- MOZO, INC., PARKER, CO:
3,630,108, PUB. 3-17-2009. INT. CL. 25.
- MPOWER LABS, INC., AUSTIN, TX:
3,632,871, INT. CL. 36.
- MR. ELECTRIC CORP., WACO, TX:
2,599,198, CANC. INT. CL. 37.
- MR. HANDYMAN INTERNATIONAL, LLC, ANN ARBOR,
MI:
3,632,573, INT. CL. 35.
- MR. SHOWER DOOR, INC., STRATFORD, CT:
1,521,244, REN. 4-28-09. INT. CL. 37.
- MS. MOANA C. MEYER, HONOLULU, HI:
2,175,866, CANC. INT. CL. 25.
- MSB WEST LLC, LOS ANGELES, CA:
2,597,749, CANC. INT. CL. 31.
- MSNBC CABLE L.L.C., NEW YORK, NY:
3,630,999, PUB. 3-17-2009. INT. CL. 9.
- MT MANUFACTURING, INC., SOLON, OH:
3,630,829, PUB. 3-17-2009. INT. CL. 3.
- MTS PRODUCTS, NORTHRIDGE, CA:
2,597,334, CANC. MULTIPLE CLASS, INT. CLS. 18 AND
20.
- MTTM WORLDWIDE, LLC, LAKE SUCCESS, NY:
3,631,337, PUB. 3-17-2009. INT. CL. 25.
3,631,342, PUB. 3-17-2009. INT. CL. 25.
- MUBIO PRODUCTS B.V., NL-6229 EV MAASTRICHT,
NETHERLANDS:
3,631,675, PUB. 3-17-2009. INT. CL. 5.
- MUD-THROWERS, LLC, WAMEGO, KS:
3,630,587, PUB. 3-17-2009. INT. CL. 35.
- MUELLER SPORTS MEDICINE, INC., PRAIRIE DU SAC,
WI:
2,598,056, CANC. INT. CL. 5.
- MULLICAN FLOORING, L.P., HAMBURG, NY:
3,630,100, PUB. 3-17-2009. INT. CL. 19.
- MULTI THEMATIQUES, 92659 BOULOGNE BILLAN-
COURT, FRANCE:
2,596,453, CANC. MULTIPLE CLASS, INT. CLS. 38, 41
AND 42.
- MULTI-HOLDING AG, SWITZERLAND:
3,631,578, PUB. 3-17-2009. INT. CL. 9.
- MULTI-HOLDING AG, CH-4123 ALLSCHWIL, SWITZER-
LAND:
3,631,579, PUB. 3-17-2009. INT. CL. 9.
- MULTIMEDIA GAMES, INC., AUSTIN, TX:
3,632,380, INT. CL. 9.
3,632,683, INT. CL. 9.
- MUNNY JOURNEY LLC, COEUR D'ALENE, ID:
3,631,958, MULTIPLE CLASS, INT. CLS. 16 AND 41.
- MURAK, GERALD E., WILLIAMSVILLE, NY:
3,633,110, INT. CL. 16.
- MURALO COMPANY, INC., THE, BAYONNE, NJ:
2,598,913, CANC. INT. CL. 2.
- MURATA MACHINERY, LTD., KYOTO, JAPAN:
3,632,785, INT. CL. 2.
- MURCHISON, DENNIS, RICHMOND, CA:
3,629,192, PUB. 3-17-2009. INT. CL. 19.
- MURPHY & COMPANY, INC., ST. LOUIS, MO:
2,599,803, CANC. INT. CL. 16.
- MURPHY PRODUCTS, INC., OKLAHOMA CITY, OK:
3,630,063, PUB. 3-17-2009. INT. CL. 7.
- MURPHY, BARRY JOSEPH, NAPA, CA, DBA SILVERPOINT
CELLARS LLC:
3,632,769, INT. CL. 33.
- MURRAY, KENNETH R., GOTHAM, FL:
3,630,075, PUB. 3-17-2009. INT. CL. 41.
- MUSIC TOGETHER, L.L.C., PRINCETON, NJ, BIRCH TREE
GROUP LTD., PRINCETON, NJ:
1,565,705, REN. 4-28-09. MULTIPLE CLASS, INT. CLS. 16
AND 41.
- MUSICBOOTH LLC, THE, NEW ROCHELLE, NY:
2,596,646, CANC. MULTIPLE CLASS, INT. CLS. 35 AND
42.

- MUSICIANS INSTITUTE INCORPORATED, HOLLYWOOD, CA:
3,630,655, PUB. 3-17-2009. MULTIPLE CLASS, INT. CLS. 9, 16, 21 AND 25.
3,630,659, PUB. 3-17-2009. MULTIPLE CLASS, INT. CLS. 9, 16, 21 AND 25.
- MUTT LYNCH WINERY, INC., CALISTOGA, CA, DBA MUTT LYNCH WINERY:
3,630,265, PUB. 3-17-2009. INT. CL. 33.
- MUX INDUSTRIES INC., BURBANK, CA:
3,630,719, PUB. 3-17-2009. INT. CL. 19.
- MVI STUDIOS, INC., SHERMAN OAKS, CA:
2,597,473, CANC. INT. CL. 38.
- MVP HEALTH PLAN, INC., SCHENECTADY, NY:
2,597,847, CANC. INT. CL. 36.
- MXENERGY INC., STAMFORD, CT:
3,632,036, INT. CL. 39.
- MXP4, F-75009 PARIS, FRANCE:
3,631,594, PUB. 3-17-2009. MULTIPLE CLASS, INT. CLS. 9, 15 AND 28.
- MY HEALTH, INC., PALO ALTO, CA:
3,632,836, INT. CL. 44.
- MY STOCKS ENTERPRISES LLC, BRIGHTON, MI:
3,631,216, PUB. 3-17-2009. INT. CL. 42.
- MY TWINN, INC., DENVER, CO:
2,598,432, CANC. MULTIPLE CLASS, INT. CLS. 28, 35 AND 40.
- MYAUTONETWORK, INC., TEMPE, AZ:
3,629,778, PUB. 3-17-2009. INT. CL. 35.
3,630,039, PUB. 3-17-2009. INT. CL. 35.
- MYFIFIDENT FOUNDATION, ALPHARETTA, GA:
3,631,240, PUB. 3-17-2009. INT. CL. 42.
- MYLEGALPROBLEM, INC., PITTSBURGH, PA:
2,598,809, CANC. INT. CL. 42.
2,598,963, CANC. INT. CL. 42.
- MYREPAIRSHOP, INC., HOUSTON, TX:
2,599,123, CANC. INT. CL. 35.
2,599,124, CANC. INT. CL. 36.
2,599,125, CANC. INT. CL. 35.
2,599,126, CANC. INT. CL. 38.
2,599,127, CANC. INT. CL. 36.
2,599,128, CANC. INT. CL. 35.
2,599,129, CANC. INT. CL. 38.
2,599,130, CANC. INT. CL. 36.
2,599,131, CANC. INT. CL. 35.
- MYSAPCE INC., BEVERLY HILLS, CA:
3,629,478, PUB. 3-17-2009. INT. CL. 41.
- MYSTAKAS, GEORGE, LEBANON, PA:
3,633,337, MULTIPLE CLASS, INT. CLS. 18, 25, 41 AND 44.
- MÖLNLYCKE HEALTH CARE AB, SWEDEN:
3,631,753, PUB. 3-17-2009. INT. CL. 5.
- M2 INTERNATIONAL, LTD., MAITLAND, FL:
3,630,933, PUB. 3-17-2009. INT. CL. 36.
- N.V. SUMATRA TOBACCO TRADING COMPANY, SUMATERA UTARA, INDONESIA:
3,629,966, PUB. 1-13-2009. INT. CL. 34.
- NAIDU, MAHENDRAN, LEXINGTON, KY:
2,597,832, CANC. INT. CL. 42.
- NALCO COMPANY, NAPERVILLE, IL:
3,632,428, INT. CL. 1.
3,632,449, INT. CL. 1.
- NAMASTE LABORATORIES, L.L.C., BLUE ISLAND, IL:
3,632,021, INT. CL. 3.
3,632,038, INT. CL. 3.
- NAMCO BANDAI GAMES AMERICA INC., SANTA CLARA, CA:
2,599,597, CANC. INT. CL. 9.
- NAMEZERO.COM INC., LOS GATOS, CA:
2,598,835, CANC. MULTIPLE CLASS, INT. CLS. 35 AND 42.
- NAMIBIAN MINERALS CORPORATION, WHITEHORSE, YUKON, CANADA:
2,596,703, CANC. MULTIPLE CLASS, INT. CLS. 7, 14, 37 AND 42.
- NAN YANG FABRIC CO., LTD, AMBOL KHOA-YOI, THAILAND:
3,632,061, INT. CL. 25.
- NANCI L. BELL, TRUSTEE, OR SUCCESSOR TRUSTEE, OF THE NANCI L. BELL SEPARATE PROPERTY REVOCABLE TRUST ESTABLISHED UNDER DECLARATION DATED SEPTEMBER 11, 1997, SAN LUIS OBISPO, CA:
3,633,155, INT. CL. 41.
- NANNI'S LITTLE SMILES DENTISTRY FOR CHILDREN, P.A., BOERNE, TX:
2,597,634, CANC. INT. CL. 42.
- NANO GATE AG, FED REP GERMANY:
3,631,587, PUB. 3-17-2009. MULTIPLE CLASS, INT. CLS. 7, 9 AND 11.
- NARMA LV AS, ESTONIA:
3,631,746, PUB. 3-17-2009. INT. CL. 27.
- NATALIE CHANIN, FLORENCE, AL:
3,629,451, PUB. 3-17-2009. MULTIPLE CLASS, INT. CLS. 14, 25, 35 AND 41.
- NATHAN SAWAYA, INC., NEW YORK, NY:
3,631,181, PUB. 3-17-2009. INT. CL. 16.
- NATIONAL ACADEMY OF RECORDING ARTS & SCIENCES, INC., SANTA MONICA, CA:
3,630,822, PUB. 3-17-2009. INT. CL. 41.
3,630,823, PUB. 3-17-2009. INT. CL. 41.
3,630,825, PUB. 3-17-2009. INT. CL. 41.
3,630,826, PUB. 3-17-2009. INT. CL. 41.
3,630,827, PUB. 3-17-2009. INT. CL. 41.
- NATIONAL AGGREGATES ASSOCIATION, SILVER SPRING, MD:
1,497,247, CANC. INT. CL. 42.
- NATIONAL ALFALFA AND FORAGE ALLIANCE, KENNEWICK, WA:
3,630,276, PUB. 3-17-2009. U.S. CL. 200.
- NATIONAL ALLIANCE OF FOREST OWNERS, WASHINGTON, DC:
3,632,759, INT. CL. 35.
- NATIONAL ASBESTOS FLOORING ENCASMENT SYSTEMS, INC., PLACERVILLE, CA:
3,632,133, INT. CL. 6.
- NATIONAL ASSOCIATION OF INSURANCE WOMEN, TULSA, OK, DBA NAIW(INTERNATIONAL):
3,633,027, INT. CL. 41.
- NATIONAL CENTER FOR FAMILY LITERACY, INC., LOUISVILLE, KY:
3,632,712, INT. CL. 36.
- NATIONAL CENTER FOR PREVENTION AND RESEARCH SOLUTIONS, INC., SOUTH DAYTONA, FL:
3,631,359, PUB. 3-17-2009. MULTIPLE CLASS, INT. CLS. 35 AND 41.
- NATIONAL CHILD SAFETY COUNCIL, JACKSON, MI:
1,497,158, CANC. INT. CL. 41.
- NATIONAL COUNCIL ON FAMILY RELATIONS, MINNEAPOLIS, MN, DBA NCFR:
3,631,364, PUB. 3-17-2009. INT. CL. 35.
- NATIONAL CUSTOMS BROKERS AND FORWARDERS ASSOCIATION OF AMERICA, INC., NEW YORK, NY:
2,174,167, CANC. MULTIPLE CLASS, INT. CLS. 36 AND 39.
- NATIONAL DIRECTORY COMPANY, TUSTIN, CA:
2,598,878, CANC. INT. CL. 16.
- NATIONAL ENDOWMENT FOR FINANCIAL EDUCATION, GREENWOOD VILLAGE, CO:
3,632,170, MULTIPLE CLASS, INT. CLS. 35, 36 AND 41.
- NATIONAL ENERGY CONTROL SERVICES INC., JASPER, IN:
2,599,544, CANC. INT. CL. 35.
- NATIONAL FEDERATION OF STATE HIGH SCHOOL ASSOCIATIONS, INDIANAPOLIS, IN:
3,629,984, PUB. 3-17-2009. INT. CL. 41.
- NATIONAL FOOTBALL LEAGUE, NEW YORK, NY:
1,497,001, CANC. INT. CL. 35.
- NATIONAL GEOGRAPHIC SOCIETY, WASHINGTON, DC:
3,633,090, INT. CL. 21.
- NATIONAL HEALING CORPROATION, BOCA RATON, FL:
2,175,835, CANC. INT. CL. 42.
- NATIONAL HEALTH SYSTEMS, INC., FORTH WORTH, TX:
2,239,530, REN. 4-24-09. INT. CL. 42.
- NATIONAL HIGH SCHOOL RODEO ASSOCIATION, THE, DENVER, CO:
1,497,118, CANC. INT. CL. 41.

- NATIONAL HISTORIC CHEESEMAKING CENTER, INC., MONROE, WI:
3,630,552, PUB. 3-17-2009. INT. CL. 41.
- NATIONAL HOME LIFE ASSURANCE COMPANY, FRAZER, PA:
1,497,042, CANC. INT. CL. 36.
- NATIONAL MARINE MANUFACTURERS ASSOCIATION, INC., CHICAGO, IL:
2,599,206, CANC. INT. CL. 42.
2,599,212, CANC. INT. CL. 42.
- NATIONAL MELANOMA FOUNDATION, THE, PHILADELPHIA, PA:
2,599,766, CANC. MULTIPLE CLASS, INT. CLS. 36 AND 42.
- NATIONAL MULTIPLE SCLEROSIS SOCIETY, NEW YORK, NY:
3,632,519, INT. CL. 36.
3,632,681, INT. CL. 36.
3,632,682, INT. CL. 36.
- NATIONAL NETWORK OF DIGITAL SCHOOLS MANAGEMENT FOUNDATION, BEAVER, PA:
3,632,626, MULTIPLE CLASS, INT. CLS. 16 AND 41.
- NATIONAL PROPANE GAS ASSOCIATION, WASHINGTON, DC:
3,629,129, PUB. 3-17-2009. U.S. CL. 200.
3,629,130, PUB. 3-17-2009. INT. CL. 35.
- NATIONAL READING STYLES INSTITUTE, INC., SYOSSET, NY:
2,241,541, REN. 4-29-09. INT. CL. 9.
2,241,541, CANC. MULTIPLE CLASS, INT. CLS. 16 AND 41.
- NATIONAL SOCIETY OF PROFESSIONAL SURVEYORS INC, GAITHERSBURG, MD:
3,630,006, PUB. 3-17-2009. INT. CL. 35.
- NATIONAL STONE, SAND & GRAVEL ASSOCIATION, ALEXANDRIA, VA:
3,632,530, INT. CL. 35.
3,632,533, INT. CL. 35.
- NATIONAL WATER SERVICES, INC., ESCONDIDO, CA:
3,630,388, PUB. 3-17-2009. INT. CL. 37.
- NATIONWIDE BIWEEKLY ADMINISTRATION, INC., XENIA, OH:
3,632,705, INT. CL. 36.
- NATIONWIDE CHILDREN'S HOSPITAL, COLUMBUS, OH:
3,633,096, MULTIPLE CLASS, INT. CLS. 9, 16 AND 41.
- NATURADE OPERATING CORP., ANAHEIM, CA:
2,598,406, CANC. INT. CL. 5.
- NATURAL MERCHANTS, LLC., ROGUE RIVER, OR:
3,632,932, INT. CL. 33.
- NATURAL PLANTATION INC., MARGO SASKATCHEWAN, CANADA:
3,629,336, PUB. 9-2-2008. INT. CL. 3.
- NATURAL SUPPLEMENT ASSOCIATION, INCORPORATED, GOLDEN, CO, DBA EXPERIMENTAL AND APPLIED SCIENCES, INC.:
2,599,423, CANC. INT. CL. 5.
- NATURALE LTD., GREAT NECK, NY:
2,596,960, CANC. INT. CL. 5.
- NATURE AMERICA, INC., NEW YORK, NY:
3,633,052, INT. CL. 9.
- NATURE'S INTENT ENVIRONMENTAL PRODUCTS, INC., TONASKET, WA:
2,174,577, CANC. INT. CL. 1.
- NATURE'S WAY PRODUCTS, INC., SPRINGVILLE, UT:
1,496,518, CANC. INT. CL. 5.
- NAUTICAL PARTS OF U.S.A., INC., MIAMI, FL:
2,598,174, CANC. MULTIPLE CLASS, INT. CLS. 8, 9, 11 AND 28.
- NAV TECHNOLOGIES, INC., NEWARK, NJ:
2,599,276, CANC. INT. CL. 36.
- NAVAJO NATION, THE, WINDOW ROCK, AZ:
1,497,097, CANC. INT. CL. 38.
- NAVANI, GIRISH KUMAR, WESTBOROUGH, MA:
3,633,369, MULTIPLE CLASS, INT. CLS. 38 AND 42.
- NAVY FEDERAL CREDIT UNION, MERRIFIELD, VA:
3,629,868, PUB. 3-17-2009. INT. CL. 36.
- NBA PROPERTIES, INC., NEW YORK, NY:
2,599,556, CANC. INT. CL. 35.
- NBG RADIO NETWORK, INC., PORTLAND, OR:
2,598,123, CANC. INT. CL. 9.
- NBTY, INC., BOHEMIA, NY:
2,599,354, CANC. INT. CL. 5.
- NCI GROUP, INC., HOUSTON, TX:
2,286,987, REN. 4-29-09. INT. CL. 6.
3,631,843, INT. CL. 9.
- NCMX, INC., SEATTLE, WA:
2,598,367, CANC. MULTIPLE CLASS, INT. CLS. 35 AND 42.
- NCO HOLDINGS, INC., WILMINGTON, DE:
3,629,904, PUB. 3-17-2009. MULTIPLE CLASS, INT. CLS. 35 AND 36.
- NCS PEARSON, INC., BLOOMINGTON, MN:
3,632,025, INT. CL. 35.
- NDG INVESTMENT GROUP L.L.C., SEATTLE, WA:
3,631,067, PUB. 3-17-2009. INT. CL. 36.
3,631,068, PUB. 3-17-2009. INT. CL. 36.
- NEC SAN-EI INSTRUMENTS, LTD., TOKYO 190-0012, JAPAN:
2,597,130, CANC. INT. CL. 9.
- NEDELCO, INC., AURORA, NE:
3,632,594, INT. CL. 38.
- NEEDLE INDUSTRIES (INDIA) LIMITED, NILGIRIS, TAMILNADU, INDIA:
1,572,092, REN. 4-27-09. INT. CL. 26.
- NEEDLE ROCK RANCH ENTERPRISES INC., CRAWFORD, CO, DBA PARADISE ON A HANGER:
2,174,646, CANC. INT. CL. 25.
- NEEDS, INC., SYRACUSE, NY:
2,599,319, CANC. INT. CL. 5.
- NEIGHBORE CARE HOLDINGS, INC., BALTIMORE, MD:
2,245,401, REN. 4-29-09. MULTIPLE CLASS, INT. CLS. 35 AND 42.
- NELIX, INC., SCHAUMBURG, IL:
3,629,444, PUB. 3-17-2009. MULTIPLE CLASS, INT. CLS. 36 AND 42.
- NELSON JEWELLERY ARTS CO. LTD., HUNGHOM KOWLOON, HONG KONG:
3,632,294, INT. CL. 14.
- NELSON, MADELEINE YAYODELE, NEW YORK, NY:
1,497,146, CANC. INT. CL. 41.
- NELSON, RONALD J., CONROE, TX, DBA RJN MOTORSPORTS:
2,598,939, CANC. INT. CL. 28.
- NELVANA LIMITED, TORONTO, ONTARIO, CANADA:
3,629,819, PUB. 3-17-2009. INT. CL. 16.
- NEMIROFF; INTELLECTUAL PROPERTY ESTABLISHMENT, LIECHTENSTEIN:
3,631,570, PUB. 3-17-2009. MULTIPLE CLASS, INT. CLS. 33 AND 35.
- NEOGEN CORPORATION, LANSING, MI:
2,174,537, CANC. MULTIPLE CLASS, INT. CLS. 3 AND 5.
- NEOPARADIGM LABS, INC., MILPITAS, CA:
2,599,111, CANC. INT. CL. 9.
- NEOSAEJ CORPORATION, BURLINGTON, MA:
3,632,454, INT. CL. 35.
- NEOWORX, INC., DAYTON, OH:
2,598,145, CANC. INT. CL. 9.
- NERDY BOOKS, LLC, FLEMINGTON, NJ:
2,598,090, CANC. INT. CL. 16.
- NETCESSITIES, LLC, LOGANSPOET, IN:
3,632,224, INT. CL. 18.
- NETFUEL, INC., LOS GATOS, CA:
2,597,320, CANC. INT. CL. 42.
- NETGEN LEARNING SYSTEMS, INC., COLUMBIA, SC:
2,597,537, CANC. INT. CL. 41.
- NETIFICE COMMUNICATIONS, INC., NORCROSS, GA:
2,598,181, CANC. INT. CL. 42.
- NETWORK CAPITAL FUNDING CORPORATION, IRVINE, CA:
3,630,924, PUB. 3-17-2009. INT. CL. 36.
- NEUMEDICINE TECHNOLOGIES, INC., NOVI, MI, AKA NEUMEDICINE INTERNATIONAL:
3,631,316, PUB. 3-17-2009. INT. CL. 44.

- NEUMO ARMATURENFABRIK-APPARATEBAU-METALLGIEßEREI: GMBH + CO. KG, 75438 KNITTLINGEN, FED REP GERMANY:
3,631,494, PUB. 3-17-2009. MULTIPLE CLASS, INT. CLS. 6, 7, 9, 11 AND 20.
- NEURAL INFORMATION PROCESSING SYSTEMS FOUNDATION, INC., LA JOLLA, CA:
3,629,940, PUB. 3-17-2009. MULTIPLE CLASS, INT. CLS. 35 AND 41.
- NEUROMATION STUDIO, LLC, WALTHAM, MA:
3,632,750, INT. CL. 35.
- NEUTROGENA CORPORATION, LOS ANGELES, CA:
3,275,687, COR. INT. CL. 3.
- NEVILLE MICHAEL, BLOOMFIELD HILLS, MI, DBA OZBADGE:
3,630,747, PUB. 3-17-2009. INT. CL. 20.
- NEW ARMY, INC., WAYNESBORO, PA:
3,633,227, MULTIPLE CLASS, INT. CLS. 25 AND 35.
- NEW BALANCE ATHLETIC SHOE, INC., BOSTON, MA:
3,632,727, INT. CL. 25.
- NEW BELGIUM BREWING COMPANY, INC., FORT COLLINS, CO:
2,175,097, CANC. INT. CL. 32.
- NEW EARTH, RICHMOND, VA:
3,629,583, PUB. 3-17-2009. INT. CL. 25.
- NEW ENGLAND TEA & COFFEE CO., INC., MALDEN, MA:
3,632,426, INT. CL. 37.
- NEW FAT INC., BRONX, NY:
3,629,870, PUB. 3-17-2009. INT. CL. 39.
- NEW FLUID SOLUTIONS, INC, HOUSTON, TX:
3,629,577, PUB. 3-17-2009. INT. CL. 1.
- NEW FRONTIER MEDIA, INC., BOULDER, CO:
3,632,753, INT. CL. 41.
- NEW GLOBAL MARKETING, INC., STONE RIDGE, NY:
3,633,437, INT. CL. 34.
- NEW LINE PRODUCTIONS, INC., NEW YORK, NY:
3,632,042, INT. CL. 9.
- NEW MEDIA HOLDINGS, INC., SEATTLE, WA:
3,633,433, INT. CL. 41.
3,633,434, INT. CL. 41.
3,633,442, INT. CL. 41.
3,633,443, INT. CL. 41.
3,633,444, INT. CL. 41.
- NEW MILFORD HOSPITAL, NEW MILFORD, CT:
3,630,661, PUB. 3-17-2009. INT. CL. 25.
- NEW NAME, INC., LOS ANGELES, CA:
3,629,473, PUB. 3-17-2009. INT. CL. 25.
- NEW NET COMPANIES, INC., GUILFORD, CT:
2,599,755, CANC. INT. CL. 35.
- NEW ORDER ORGANIZERS LLC, MENTOR, OH:
3,632,494, INT. CL. 16.
- NEW PENDULUM CORP., WILMINGTON, DE:
3,632,845, INT. CL. 27.
- NEW TECHNOLOGY PARTNERS, INC., NASHUA, NH:
3,631,304, PUB. 3-17-2009. INT. CL. 9.
- NEW VIEW GIFTS & ACCESSORIES, LTD., MEDIA, PA:
2,596,811, CANC. INT. CL. 20.
- NEW VISION ATHLETICS, INC., LAKE BLUFF, IL:
2,598,118, CANC. INT. CL. 41.
- NEW WORLD PASTA COMPANY, HARRISBURG, PA:
970,866, AM. U.S. CL. 30.
2,026,782, AM. INT. CL. 30.
2,507,912, AM. INT. CL. 30.
- NEW YORK LIFE INSURANCE COMPANY, NEW YORK, NY:
2,597,275, CANC. INT. CL. 36.
- NEW YORK STATE ELECTRIC & GAS CORPORATION, BINGHAMTON, NY:
2,238,079, REN. 4-28-09. MULTIPLE CLASS, INT. CLS. 39, 40, 41 AND 42.
2,238,079, CANC. INT. CL. 35.
- NEW YORK YANKEES PARTNERSHIP, BRONX, NY:
2,598,780, CANC. MULTIPLE CLASS, INT. CLS. 14 AND 21.
- NEW ZEALAND DAIRY BOARD, WELLINGTON, NEW ZEALAND:
1,496,385, CANC. INT. CL. 1.
- NEWCOGEN GROUP INC., CAMBRIDGE, MA:
2,599,108, CANC. INT. CL. 36.
2,599,109, CANC. INT. CL. 35.
2,599,110, CANC. INT. CL. 35.
- NEWDOMINION FINANCIAL CORPORATION, CHARLOTTE, NC:
3,632,534, INT. CL. 36.
- NEWELL OPERATING COMPANY, FREEPORT, IL:
1,496,786, CANC. INT. CL. 20.
- NEWFIELD PUBLICATIONS, INC.:
1,496,749, CANC. INT. CL. 16.
- NEWFLORA LLC, CENTRAL POINT, OR:
3,631,286, PUB. 3-17-2009. INT. CL. 31.
- NEWMETHOD DIRECT, LLC, ENGLEWOOD, CO:
2,597,399, CANC. INT. CL. 35.
- NEWS AMERICA MARKETING PROPERTIES, LLC, CHICAGO, IL:
3,630,701, PUB. 3-17-2009. INT. CL. 35.
- NEWSPAPER ASSOCIATION OF AMERICA, INC., ARLINGTON, VA:
2,599,802, CANC. MULTIPLE CLASS, INT. CLS. 38 AND 42.
- NEWSTAR PRODUCTIONS, LLC, SYLVANIA, OH:
2,599,558, CANC. INT. CL. 41.
- NEXAL CORPORATION, ISSAQUAH, WA:
2,599,034, CANC. INT. CL. 9.
- NEXBIO, INC., SAN DIEGO, CA:
3,437,434, COR. INT. CL. 5.
- NEXTCEA, INC., WOBURN, MA:
3,632,998, INT. CL. 9.
- NEXTEP-MIYAMA, INC., OXNARD, CA:
2,597,325, CANC. MULTIPLE CLASS, INT. CLS. 6 AND 20.
- NEXTEP, INC., RENO, NV:
3,631,288, PUB. 3-17-2009. INT. CL. 16.
- NEXTHAUS CORPORATION, FORT LAUDERDALE, FL:
3,631,006, PUB. 3-17-2009. INT. CL. 9.
- NEXTSCAN, INC, GARDEN VALLEY, ID:
2,800,500, COR. INT. CL. 9.
- NEXUS ESTATES PLC, LONDON EC3V 4QT, ENGLAND:
2,597,554, CANC. MULTIPLE CLASS, INT. CLS. 35, 36, 37, 38 AND 42.
- NG, KENNY KA WAH, MONTEREY PARK, CA, DBA CCS:
3,629,638, PUB. 3-17-2009. INT. CL. 11.
- NHT AUDIO, LLC, BENICIA, CA:
1,477,513, REN. 4-29-09. INT. CL. 9.
- NICHOLS, DAVID, PALMER, MA:
3,633,409, INT. CL. 3.
- NICHOLS, NICOL, JEAN, SAN DIEGO, CA:
2,598,080, CANC. INT. CL. 18.
- NIEDUZAK, ANDRZEJ, DUESSELDORF, FED REP GERMANY:
2,599,569, CANC. INT. CL. 9.
- NIELSEN BUSINESS MEDIA, INC., NEW YORK, NY:
2,245,657, REN. 4-24-09. INT. CL. 41.
2,245,657, AM. INT. CL. 41.
- NIENHUIS MONTESSORI INTERNATIONAL B.V., BL ZELHEM, NETHERLANDS:
1,545,451, REN. 4-27-09. INT. CL. 28.
- NIETO, ANDREAS, BEVERLY HILLS, CA:
3,632,863, INT. CL. 30.
- NIKE, INC., BEAVERTON, OR:
1,496,830, CANC. MULTIPLE CLASS, INT. CLS. 25 AND 28.
- NIKKISO CO., LTD., TOKYO, JAPAN:
3,631,413, PUB. 3-17-2009. MULTIPLE CLASS, INT. CLS. 7, 9, 10, 11, 12, 37 AND 42.
- NIKON INC., MELVILLE, NY:
1,496,576, CANC. INT. CL. 9.
- NILFISK-ADVANCE, INC., PLYMOUTH, MN, ADVANCE MACHINE COMPANY, MINNEAPOLIS, MN:
679,524, REN. 4-27-09. U.S. CL. 21 (INT. CL. 9).
- NINE WEST DEVELOPMENT CORPORATION, WILMINGTON, DE:
2,242,173, REN. 4-27-09. INT. CL. 35.
- NINGBO TIANBO GANGLIAN; ELECTRONICS CO., LTD., CHINA:
3,631,640, PUB. 3-17-2009. INT. CL. 9.

- NINGBO WAYWELL INTERNATIONAL CO., LTD., ZHEJIANG PROVINCE, CHINA:
3,632,672, INT. CL. 11.
- NINGBO ZHONGBIN FASTENER; MANUFACTURE CO., LTD.; (NINGBO ZHONGBIN JINGUJIAN; ZHIZAO YOUXIAN GONGSI), CHINA AND NINGBO ZHONGLIAN FASTENER; MANUFACTURE CO., LTD.; (NINGBOSHI ZHONGLIAN JINGUJIAN; ZHIZAO YOUXIAN GONGSI), CHINA AND NINGBO ZHONGJIE METAL PRODUCT; CO., LTD.; (NINGBO ZHONGJIE JINSHU; ZHIPIN YOUXIAN GONGSI), CHINA AND NINGBO ZHENHAI TONGBIAO; INDUSTRIAL GENERAL COMPANY; (NINGBOSHI ZHENHAI TONGBIAO; SHIYE ZONGGONGSI), CHINA AND NINGBO ZHENHAI LIANTONG; SCREW MANUFACTURE CO., LTD.; (NINGBOSHI ZHENHAI LIANTONG; LUOSI ZHIZAO YOUXIAN GONGSI), CHINA:
3,631,525, PUB. 3-17-2009. INT. CL. 6.
- NINTENDO OF AMERICA INC., REDMOND, WA:
3,633,323, INT. CL. 25.
- NIPPON DENKI KABUSHIKI KAISHA, TOKYO, JAPAN:
1,496,621, CANC. INT. CL. 9.
- NIPPON KAGAKU KOGYO KABUSHIKI KAISHA, TOKYO, JAPAN, DBA NIPPON CHEMICAL INDUSTRIAL CO., LTD.:
3,629,469, PUB. 3-17-2009. INT. CL. 1.
- NIPPON PAPER INDUSTRIES CO., LTD., OJI, KITA-KU, TOKYO, JAPAN:
2,597,033, CANC. INT. CL. 1.
- NIPPON SUISAN KABUSHIKI KAISHA, CHIYODA-KU, TOKYO, JAPAN, TA NIPPON SUISAN KAISHA, LTD.:
3,630,762, PUB. 3-17-2009. INT. CL. 29.
- NIPS ORDNUNGSSYSTEME GMBH, D-93055 REGENSBURG, FED REP GERMANY:
2,822,164, CANC. MULTIPLE CLASS, INT. CLS. 20 AND 21.
- NISSAN JIDOSHA KABUSHIKI KAISHA (A.T.A. NISSAN MOTOR CO., LTD), KANAGAWA-KEN, JAPAN:
1,536,313, REN. 4-28-09. INT. CL. 12.
- NMM PRODUCTIONS, WICHITA, KS:
3,629,581, PUB. 3-17-2009. INT. CL. 41.
- NOBEL LEARNING COMMUNITIES INC., WEST CHESTER, PA:
1,497,155, CANC. INT. CL. 41.
- NOGUCHI MEDICAL RESEARCH INSTITUTE, PHILADELPHIA, PA:
2,235,458, REN. 4-26-09. INT. CL. 42.
- NOKIA CORPORATION, 02150 ESPOO, FINLAND:
2,676,153, AM. INT. CL. 9.
- NOKIA CORPORATION, FINLAND:
3,631,751, PUB. 3-17-2009. MULTIPLE CLASS, INT. CLS. 9, 38 AND 39.
- NOLAN, PHILIP, FOREST PARK, IL:
2,598,971, CANC. INT. CL. 28.
- NOMIX-CHIPMAN LIMITED, STAPLE HILL, BRISTOL BS16 4PS, ENGLAND:
1,496,408, CANC. INT. CL. 1.
- NOMOS GLASHÜTTE/SA ROLAND SCHWERTNER KG, FED REP GERMANY:
3,631,778, PUB. 3-17-2009. INT. CL. 14.
- NORCROSS SAFETY PRODUCTS L.L.C., ROCK ISLAND, IL:
2,250,876, REN. 4-27-09. INT. CL. 9.
- NORD FEDER GMBH & CO. KG WOHNTEXTILIEN, 70327 STUTTGART-UNTERTURKHEIM, FED REP GERMANY:
2,596,673, CANC. INT. CL. 22.
- NORDOST CORPORATION, ASHLAND, MA:
3,632,200, INT. CL. 9.
- NORDSKOG, ERIK, WOODLAND HILLS, CA AND SINGER, RANDY, WOODLAND HILLS, CA:
3,629,558, PUB. 3-17-2009. INT. CL. 25.
- NORDSON CORPORATION, VISTA, CA:
1,532,705, REN. 4-24-09. INT. CL. 7.
- NORFORD, DAVID A., KING GEORGE, VA:
3,633,252, INT. CL. 37.
- NORMAND, GAUDRY, CHARLESBOURG, QUEBEC, CANADA:
1,496,793, CANC. INT. CL. 20.
- NORTECH LABORATORIES, INC., FARMINGDALE, NY:
3,629,625, PUB. 3-17-2009. INT. CL. 18.
- NORTH AMERICAN INSURANCE AGENCY, INC., OKLAHOMA CITY, OK:
3,629,740, PUB. 3-17-2009. MULTIPLE CLASS, INT. CLS. 35 AND 36.
- NORTH AMERICAN RESCUE PRODUCTS, INC., GREER, SC, DBA NORTH AMERICAN RESCUE:
3,629,645, PUB. 3-17-2009. INT. CL. 35.
- NORTH AMERICAN TILLAGE TOOLS COMPANY, HAMILTON, CANADA:
3,633,423, INT. CL. 7.
- NORTH AMERICAN WATCH CORPORATION, LYNDHURST, NJ:
1,496,546, CANC. INT. CL. 6.
1,496,712, CANC. INT. CL. 14.
1,496,751, CANC. INT. CL. 16.
- NORTH CAROLINA A&T STATE UNIVERSITY, GREENSBORO, NC:
3,631,803, INT. CL. 6.
- NORTH CAROLINA GRANITE CORORATION, THE, MOUNT AIRY, NC, NORTH CAROLINA GRANITE CORPORATION, MOUNT AIRY, NC:
1,116,711, REN. 4-27-09. INT. CL. 31.
- NORTH CENTRAL MANAGEMENT, INC., MIDDLETON, WI:
3,629,506, PUB. 3-17-2009. MULTIPLE CLASS, INT. CLS. 35 AND 37.
- NORTH COAST CONSULTANTS, INC., CHICAGO, IL:
2,598,549, CANC. INT. CL. 41.
- NORTH COLORADO MEDICAL CENTER, INC., GREELEY, CO:
1,497,210, CANC. INT. CL. 42.
- NORTHEAST TIER BEN FRANKLIN TECHNOLOGY CENTER, BETHLEHEM, PA:
1,497,038, CANC. MULTIPLE CLASS, INT. CLS. 36 AND 41.
- NORTHERN MASSACHUSETTS TELEPHONE WORKERS CREDIT UNION, LOWELL, MA:
3,630,268, PUB. 3-17-2009. INT. CL. 36.
- NORTHERN TRUST CORPORATION, CHICAGO, IL:
2,175,111, CANC. INT. CL. 36.
- NORTHGATE AVIATION, INC., CHICO, CA:
3,630,616, PUB. 3-17-2009. INT. CL. 37.
- NORTHSTAR PRODUCTIONS, LLC, TREASURE ISLAND, FL:
3,633,272, INT. CL. 9.
- NORTHWEST AGRICULTURAL PRODUCTS, PASCO, WA:
3,631,176, PUB. 3-17-2009. INT. CL. 1.
3,631,352, PUB. 3-17-2009. INT. CL. 1.
- NORTHWEST GEMOLOGICAL LABORATORY, INC., BELLEVUE, WA:
3,630,111, PUB. 3-17-2009. INT. CL. 36.
- NORTHWEST NATURAL GAS COMPANY, PORTLAND, OR, DBA NW NATURAL:
2,596,552, CANC. INT. CL. 36.
- NORTHWEST OUTFITTERS SUPPLY CO., PORTLAND, OR:
1,497,308, CANC. INT. CL. 39.
- NORTHWIRE, INC., OSCEOLA, WI:
3,629,173, PUB. 3-17-2009. INT. CL. 40.
- NORTON COMPANY, WORCESTER, MA:
1,496,768, CANC. INT. CL. 17.
- NORWOLF TOOL WORKS, WESTWOOD, NJ:
2,599,102, CANC. INT. CL. 8.
- NOTIONS MARKETING CORPORATION, GRAND RAPIDS, MI:
3,632,709, INT. CL. 23.
- NOVA RESEARCH, INC., SOLVANG, CA:
3,633,114, INT. CL. 9.
- NOVALAR PHARMACEUTICALS, INC., SAN DIEGO, CA:
3,632,280, MULTIPLE CLASS, INT. CLS. 5 AND 10.
- NOVAMED-USA INC., ELMSFORD, NY:
3,629,978, PUB. 3-17-2009. INT. CL. 9.
- NOVARTIS AG, BASEL, SWITZERLAND:
3,633,266, INT. CL. 5.
- NOVATEL INC., CALGARY, ALBERTA, CANADA:
2,174,969, CANC. INT. CL. 9.

NOVELIS DEUTSCHLAND GMBH, GOETTINGEN, FED REP GERMANY:
2,246,994. REN. 4-25-09. INT. CL. 6.

NOVEN PHARMACEUTICALS, INC., MIAMI, FL:
2,598,081, CANC. INT. CL. 5.

NOVUS BIOLOGICALS, LLC, LITTLETON, CO:
3,631,039, PUB. 3-17-2009. INT. CL. 1.

NOWPRINTING.COM, INC., CARLSTADT, NJ:
2,598,734, CANC. INT. CL. 42.

NOXELL CORPORATION, HUNT VALLEY, MD:
3,632,726, INT. CL. 3.

NPC, INC., MILFORD, NH:
3,632,463, INT. CL. 6.

NRI, INC., WASHINGTON, DC:
3,630,690, PUB. 3-17-2009. INT. CL. 35.

NTELOS INC., WAYNESBORO, VA:
2,251,275. REN. 4-24-09. INT. CL. 38.

NTS INTERACTIVE, LLC, LAS VEGAS, NV, DBA NAPKIN-NIGHTS.COM:
3,630,502, PUB. 3-17-2009. MULTIPLE CLASS, INT. CLS. 35 AND 41.
3,630,503, PUB. 3-17-2009. MULTIPLE CLASS, INT. CLS. 35 AND 41.

NU VAN TECHNOLOGY, INC., MANSFIELD, TX:
2,597,073, CANC. INT. CL. 12.

NUANCE COMMUNICATIONS, INC., BURLINGTON, MA:
3,633,223, MULTIPLE CLASS, INT. CLS. 9 AND 42.

NUCASA MILLING COMPANY LIMITED, BURNABY, BRITISH COLUMBIA, CANADA:
3,631,432, PUB. 1-13-2009. MULTIPLE CLASS, INT. CLS. 1, 2, 19, 35, 37, 40 AND 42.
3,631,433, PUB. 1-13-2009. MULTIPLE CLASS, INT. CLS. 1, 2, 19, 20, 35, 37, 40 AND 42.

NUGENT, STEVEN F., BLACK BUTTE RANCH, OR, DBA EMPIRICAL AUDIO:
3,630,709, PUB. 3-17-2009. INT. CL. 9.

NUKOTE INTERNATIONAL, INC., ROCHESTER, NY:
3,632,584, INT. CL. 37.

NUMEDICA, L.L.C., TULSA, OK, FORMERLY XYMOGEN NUMEDICA:
3,631,247, PUB. 3-17-2009. INT. CL. 5.

NUSPHERE CORPORATION, RENO, NV:
2,597,379, CANC. INT. CL. 41.

NUTRAMAX LABORATORIES, INC., EDGEWOOD, MD:
3,633,176, INT. CL. 5.
3,633,177, INT. CL. 5.

NUTRIGYN, LLC, CORAL SPRINGS, FL:
2,598,036, CANC. INT. CL. 5.

NUTRITEL FOOD TECHNOLOGIES INC., CALEDON, CANADA:
3,629,236, PUB. 3-17-2009. INT. CL. 30.

NUTRITION CENTER, INC., DOUGLAS, WY:
1,546,024. REN. 4-29-09. INT. CL. 5.

NUTRITION PROFESSIONALS, INC., SPRINGVILLE, UT:
1,496,522, CANC. INT. CL. 5.

NUTRITIONAL SERVICES CONSULTING, LAUREL, MS:
3,630,818, PUB. 3-17-2009. INT. CL. 5.

NUTRO PRODUCTS, INC., FRANKLIN, TN:
3,631,807, INT. CL. 31.
3,631,836, INT. CL. 31.

NUTS ABOUT NEW YORK, INC, DIX HILLS, NY:
3,631,001, PUB. 3-17-2009. INT. CL. 29.

NUVISION WATER, LLC, WINTER PARK, FL:
3,630,180, PUB. 3-17-2009. INT. CL. 32.

NUVO NETWORK MANAGEMENT INC., AUSTIN, TX:
3,631,395, PUB. 4-29-2008. MULTIPLE CLASS, INT. CLS. 42 AND 45.

NYCOMED GMBH, KONSTANZ, FED REP GERMANY:
3,631,350, PUB. 3-17-2009. INT. CL. 36.

NYKO TECHNOLOGIES, LOS ANGELES, CA:
3,630,288, PUB. 3-17-2009. INT. CL. 9.

NYNEX CORPORATION, NEW YORK, NY:
1,497,036, CANC. MULTIPLE CLASS, INT. CLS. 36 AND 38.

O'BRIEN, KEVIN, CINCINNATI, OH:
2,598,356, CANC. INT. CL. 25.

O'BYRNE, KRISTIN KOETTING, LEAWOOD, KS:
3,633,329, MULTIPLE CLASS, INT. CLS. 14, 25 AND 41.

O'NEILL DEVELOPMENTS, INC., ATLANTA, GA:
2,597,980, CANC. INT. CL. 36.

O'REILLY AUTOMOTIVE, INC., SPRINGFIELD, MO:
3,629,620, PUB. 3-17-2009. INT. CL. 35.
3,629,621, PUB. 3-17-2009. INT. CL. 25.

OBER-DIFFUSION SA, PARIS, FRANCE:
1,497,295, CANC. INT. CL. 25.

OCEAN WAVE INTERACTIVE, MT. PLEASANT, TX:
2,597,695, CANC. INT. CL. 9.

OCEANWORKS INTERNATIONAL, INC., HOUSTON, TX:
3,629,723, PUB. 3-17-2009. MULTIPLE CLASS, INT. CLS. 40 AND 42.
3,629,724, PUB. 3-17-2009. INT. CL. 9.

OCELOT ENGINEERING, INC., SAN BERNARDINO, CA:
3,629,503, PUB. 3-17-2009. INT. CL. 9.

OCHOA, SYLVIA F., GLENDALE, AZ, DBA GAY PRIDE FASHIONS:
3,632,732, INT. CL. 25.

OCTOMOD, INC., DANIA, FL:
3,629,922, PUB. 3-17-2009. INT. CL. 36.

ODIORNE POINT GOLF COMPANY, INC., NEWBURYPORT, MA:
2,597,955, CANC. INT. CL. 25.

ODYSSEY, L.P., SAN FRANCISCO, CA:
3,632,248, INT. CL. 35.

OELERICH, KEITH, KISSIMMEE, FL:
3,630,300, PUB. 3-17-2009. INT. CL. 20.

OERLIKON TEXTILE GMBH & CO. KG., REMSCHEID, FED REP GERMANY:
2,235,833. REN. 4-27-09. INT. CL. 7.

OFF LEASE ONLY, INC., LAKE WORTH, FL, DBA E&M MOTORS:
3,629,566, PUB. 3-17-2009. INT. CL. 35.

OFFICE OF THE COMMISSIONER OF BASEBALL, NEW YORK, NY:
3,633,210, INT. CL. 25.
3,633,211, INT. CL. 25.
3,633,212, INT. CL. 25.
3,633,213, INT. CL. 25.
3,633,214, INT. CL. 41.
3,633,215, INT. CL. 41.

OFFINGER MANAGEMENT CO., INC., ZANESVILLE, OH:
2,597,891, CANC. INT. CL. 35.

OGDEMLI/FELDMAN DESIGN, INC., VALLEY VILLAGE, CA:
2,596,666, CANC. INT. CL. 28.

OGIO INTERNATIONAL, INC., SALT LAKE CITY, UT:
2,596,910, CANC. MULTIPLE CLASS, INT. CLS. 18 AND 28.

OHIO HEALTH CHOICE, CLEVELAND, OH:
2,598,815, CANC. INT. CL. 36.

OHIO PRECIOUS METALS, LLC, JACKSON, OH:
3,633,419, INT. CL. 14.
3,633,420, INT. CL. 14.
3,633,421, INT. CL. 14.
3,633,422, INT. CL. 14.

OHIO STATE UNIVERSITY, THE, COLUMBUS, OH:
1,497,255, CANC. INT. CL. 42.

OKARSKI, JOSEPH F., LUVERNE, MN:
2,175,201, CANC. INT. CL. 9.

OKKATOTS LLC, OREM, UT:
3,632,330, INT. CL. 18.

OKUMA AMERICA CORPORATION, CHARLOTTE, NC:
2,596,489, CANC. INT. CL. 9.

OKYANUS KIMYA HIRDAVAT ELEKTRIKLI; EL ALETLE-RI VE ELEKTRONIK MALZEMELERI; ITHALAT IHRA-CAT; SANAYI TICARET LIMITED SIRKETI, TURKEY:
3,631,464, PUB. 3-17-2009. MULTIPLE CLASS, INT. CLS. 1, 2, 4 AND 17.

OLD EUROPEAN BREWERY COMPANY, SAN DIEGO, CA:
2,622,949, CANC. INT. CL. 32.

OLD FOUR STEAM, LLC, JACKSONVILLE, OR, DBA GARY WEST MEATS:
3,629,997, PUB. 3-17-2009. INT. CL. 29.

OLD FRIENDS HOLDINGS, LLC, CANOGA PARK, CA:
3,630,003, PUB. 3-17-2009. MULTIPLE CLASS, INT. CLS. 29 AND 30.

- OLD HOME FOODS, INC., ST. PAUL, MN:
3,630,583, PUB. 3-17-2009. INT. CL. 29.
3,630,614, PUB. 3-17-2009. INT. CL. 29.
- OLD WORLD INDUSTRIES, INC., NORTHBROOK, IL:
2,175,421, CANC. INT. CL. 3.
- OLDCASTLE BUILDING PRODUCTS CANADA, INC., NEW BRUNSWICK, CANADA:
3,629,419, PUB. 3-17-2009. INT. CL. 19.
3,629,434, PUB. 3-17-2009. INT. CL. 19.
- OLDE HEURICH BREWING COMPANY, THE, WASHINGTON, DC:
1,497,301, CANC. INT. CL. 32.
- OLINDA ELIZABETH LOPEZ DE GALILEA, ASUNCION, PARAGUAY:
3,629,763, PUB. 3-17-2009. INT. CL. 25.
- OLIT INC., WARWICK, RI:
2,599,248, CANC. INT. CL. 14.
- OLIVADOTI, RICHARD C., NEW YORK, NY:
2,598,437, CANC. INT. CL. 21.
- OLIVEIRA, LAWRENCE A. JR., ATLANTA, GA:
3,632,756, INT. CL. 40.
- OLSEN, MATTHEW E., NEWPORT BEACH, CA:
3,632,084, INT. CL. 25.
- OLYMPIC OPTICAL COMPANY, LLC, ST. CHARLES, MO:
2,626,740, CANC. INT. CL. 9.
- OM BRANDS LICENSIVE LICENCIAMENTOS LTDA., RIO DE JANEIRO, CEP 20940-180 - RJ, BRAZIL:
3,633,200, INT. CL. 24.
- OMAHA STEAKS INTERNATIONAL, INC., OMAHA, NE:
2,598,502, CANC. INT. CL. 35.
- OMAHA WORLD-HERALD COMPANY, OMAHA, NE:
2,598,788, CANC. INT. CL. 16.
- OMEGA CREATIONS, LLC, DALLAS, TX:
3,633,129, MULTIPLE CLASS, INT. CLS. 41 AND 42.
- OMEGA GROUP OF HIGHLAND BEACH, LP, WARWICK, RI:
3,629,265, PUB. 3-17-2009. INT. CL. 37.
- OMEGA SEWMAC INC., WESTON, ONTARIO, CANADA:
2,599,000, CANC. INT. CL. 7.
- OMNI BROKERAGE, INC., SOUTH JORDAN, UT:
3,632,406, INT. CL. 36.
- OMNI ENTERTAINMENT GROUP, INC., NORTH HOLLYWOOD, CA, DBA DJFRANCE:
3,630,179, PUB. 3-17-2009. INT. CL. 41.
- OMNISOLV, INC., SALISBURY, NC:
3,631,904, INT. CL. 35.
3,631,905, INT. CL. 35.
- OMNOVA SOLUTIONS INC., FAIRLAWN, OH:
2,233,662, REN. 4-27-09. INT. CL. 17.
- OMRON NETWORK PRODUCTS, LLC, SCHAUMBURG, IL:
2,599,670, CANC. INT. CL. 9.
- OMS INVESTMENTS, INC., WILMINGTON, DE:
2,597,904, CANC. INT. CL. 1.
2,597,965, CANC. INT. CL. 7.
- OMS INVESTMENTS, INC., LOS ANGELES, CA:
3,632,062, INT. CL. 1.
3,633,064, INT. CL. 5.
- OMX, INC., LAS VEGAS, NV:
2,598,263, CANC. INT. CL. 20.
- ON LINE BLIND FACTORY.COM, INC., SARASOTA, FL:
2,599,751, CANC. INT. CL. 35.
- ON THE WALL PRODUCTIONS, INC., UNIVERSITY CITY, MO:
2,597,356, CANC. INT. CL. 28.
- ON-COURT TENNIS, BATON ROUGE, LA:
3,629,646, PUB. 3-17-2009. INT. CL. 35.
- ONBOARD MEDIA, INC., MIAMI BEACH, FL:
2,599,148, CANC. MULTIPLE CLASS, INT. CLS. 16 AND 35.
- ONDRASIK, JOHN, LOS ANGELES, CA:
3,632,335, INT. CL. 36.
3,632,336, INT. CL. 36.
- ONE CLUB FOR ART & COPY, INC., THE, NEW YORK, NY:
2,175,132, CANC. INT. CL. 41.
- ONE DOT SOURCE, LLC, NORWALK, CT:
2,599,166, CANC. INT. CL. 18.
2,599,167, CANC. INT. CL. 18.
- ONE ECONOMY CORPORATION, WASHINGTON, DC:
3,630,217, PUB. 3-17-2009. INT. CL. 42.
3,630,218, PUB. 3-17-2009. INT. CL. 35.
- ONE SUN SOLAR SYSTEMS INC., EDMONTON, CANADA:
3,629,235, PUB. 3-17-2009. MULTIPLE CLASS, INT. CLS. 14, 16, 18 AND 25.
- ONE VALLEY BANCORP OF WEST VIRGINIA, INC., CHARLESTON, WV:
1,497,045, CANC. INT. CL. 36.
- ONE WORLD TRADE NETWORKS INTEGRATED TECHNOLOGIES, INC., LOS ANGELES, CA:
2,598,433, CANC. INT. CL. 35.
- ONLINE BUDDIES, INC., CAMBRIDGE, MA:
3,629,515, PUB. 3-17-2009. INT. CL. 45.
- OOO "HIDEX", RU-143401 MOSCOVSKAYA OBLAST, RUSSIAN FED.:
3,631,495, PUB. 3-17-2009. MULTIPLE CLASS, INT. CLS. 18, 19 AND 25.
- OPALTONE INKJET PTY. LTD., ASHMORE QLD, AUSTRALIA:
3,633,022, INT. CL. 2.
3,633,023, INT. CL. 2.
- OPEL EISENACH GMBH, FED REP GERMANY:
3,366,050, COR. INT. CL. 12.
- OPEN ENTERPRISES, INC., SAN FRANCISCO, CA:
3,631,427, PUB. 3-17-2009. MULTIPLE CLASS, INT. CLS. 3, 5, 9, 10, 16, 18, 28 AND 30.
- OPENLY INFORMATICS, INC., MONTCLAIR, NJ:
2,596,647, CANC. INT. CL. 9.
- OPERATIC EXPERIENCE, INC., FAIR LAWN, NJ, DBA ITALIAN OPERATIC EXPERIENCE:
3,631,029, PUB. 3-17-2009. INT. CL. 41.
- OPHIR-SPIRICON INC., LOGAN, UT:
3,632,976, INT. CL. 9.
- OPTAMETRA, LLC, VERONA, WI:
3,632,989, INT. CL. 9.
- OPTEOS, INC., ANN ARBOR, MI:
3,629,522, PUB. 3-17-2009. INT. CL. 42.
- OPTIGRAPHICS CORPORATION, SAN DIEGO, CA:
1,496,571, CANC. INT. CL. 9.
- OPTIMIST INTERNATIONAL, ST. LOUIS, MO:
3,629,660, PUB. 3-17-2009. INT. CL. 16.
- OPTIQUE CAPITAL MANAGEMENT, RACINE, WI:
3,632,299, INT. CL. 36.
3,632,300, INT. CL. 36.
- OPTURO INC., WATERTOWN, MA:
3,630,893, PUB. 3-17-2009. INT. CL. 42.
- ORB NETWORKS, INC., OAKLAND, CA:
3,633,118, INT. CL. 9.
- ORBAN, GEORGE A, JIM THORPE, PA:
2,599,437, CANC. INT. CL. 5.
- ORBEXCORP (ASIA) PTE. LTD., SINGAPORE:
3,631,541, PUB. 3-17-2009. INT. CL. 35.
- ORCAWEST HOLDINGS, LLC, GLENDALE, CO:
3,632,713, INT. CL. 10.
- OREGON BREWING COMPANY, NEWPORT, OR:
3,630,569, PUB. 3-17-2009. INT. CL. 32.
- OREGON CHAI, INC., PORTLAND, OR:
2,216,558, REN. 4-29-09. INT. CL. 30.
- OREGON HEALTH & SCIENCE UNIVERSITY, PORTLAND, OR:
3,629,266, PUB. 3-17-2009. MULTIPLE CLASS, INT. CLS. 41, 42 AND 44.
- ORENDA INTERNATIONAL LLC, TEMPE, AZ:
3,632,203, INT. CL. 3.
- ORGANIC HAND, LLC, SIMSBURY, CT:
3,632,629, MULTIPLE CLASS, INT. CLS. 29 AND 30.
- ORGANIC REACTIONS, URBANA, IL:
3,629,446, PUB. 3-17-2009. INT. CL. 42.
- ORGANIZATION OF AMERICAN STATES, WASHINGTON, DC:
3,631,334, PUB. 3-17-2009. INT. CL. 16.
- ORGANIZE THE ESSENTIALS, LLC, DUNEDIN, FL:
3,630,645, PUB. 3-17-2009. INT. CL. 9.
- ORICA AUSTRALIA PTY LTD, MELBOURNE, VICTORIA, 3000, AUSTRALIA:
2,596,490, CANC. INT. CL. 37.

- ORIGINAL TOWN ASSOCIATION, INC., NORTH PLATTE, NE:
3,630,880, PUB. 3-17-2009. INT. CL. 35.
- ORION IMAGES CORPORATION, WESTMINSTER, CA:
3,633,296, INT. CL. 9.
- ORION SEAFOOD INTERNATIONAL, INC., PORTSMOUTH, NH:
3,632,559, INT. CL. 29.
- ORION-YHTYMA OY, 02101 ESPOO, FINLAND:
1,496,480, CANC. INT. CL. 5.
- ORKIN EXPANSION, INC., WILMINGTON, DE:
3,632,700, INT. CL. 37.
- ORLANDO SCIENCE CENTER, INC., ORLANDO, FL:
2,175,606, CANC. INT. CL. 41.
- ORLANE S.A., PARIS, FRANCE:
1,496,430, CANC. INT. CL. 3.
- OROMO LIBERATION FRONT, WASHINGTON, DC:
3,631,296, PUB. 3-17-2009. INT. CL. 35.
- ORTHO TECHNOLOGY, INC., TAMPA, FL:
3,632,359, INT. CL. 10.
- ORTHO-TAIN, INC., TOA ALTA, PUERTO RICO:
3,633,248, INT. CL. 10.
- ORTHOSPORTS & AQUATIC PHYSICAL THERAPY, PC, NEEDHAM, MA:
3,631,811, INT. CL. 10.
- ORVIS/CUSHMAN & WAKEFIELD RANCH AND RECREATIONAL PROPERTIES, LLC, COLORADO SPRINGS, CO:
3,630,426, PUB. 3-17-2009. INT. CL. 36.
- OS ASSET, INC., TAMPA, FL:
3,633,024, INT. CL. 35.
- OSAKA TITANIUM TECHNOLOGIES CO., LTD., JAPAN:
3,631,554, PUB. 3-17-2009. MULTIPLE CLASS, INT. CLS. 1, 2, 6, 7, 9, 10, 11, 40 AND 42.
- OSBURN, ANDREW, NUEVO, CA AND VINEYARD, JEREMY, NUEVO, CA AND ZIEMER, SEAN, NUEVO, CA AND SCHORNACK, STEVE, NUEVO, CA:
3,630,641, PUB. 3-17-2009. INT. CL. 41.
- OSCAR MEDINA, ONTARIO, CA:
3,629,519, PUB. 3-17-2009. MULTIPLE CLASS, INT. CLS. 9 AND 41.
- OSOTSPA CO., LTD., BANGKOK, THAILAND:
3,632,496, INT. CL. 32.
- OSSUR HF, REYKJAVIK, ICELAND:
2,597,059, CANC. MULTIPLE CLASS, INT. CLS. 1, 10 AND 40.
- OSSUR HF., REYKJAVIK, ICELAND:
3,632,596, INT. CL. 10.
- OSTEOMETER MEDITECH, INC., HAWTHORNE, CA:
3,631,134, PUB. 3-17-2009. INT. CL. 10.
- OSTEOMETER MEDITECH, INC., HAWTHORNE, CA:
3,631,139, PUB. 3-17-2009. INT. CL. 9.
- OTICON A/S, 2900 HELLERUP, DENMARK:
2,596,972, CANC. INT. CL. 10.
- OTIS ELEVATOR COMPANY, FARMINGTON, CT:
3,629,267, PUB. 3-17-2009. INT. CL. 9.
- OTKRYTOE AKTSIONERNOE: OBSHESTVO "SIBUR - RUSSKIE SHINY", RUSSIAN FED.:
3,631,645, PUB. 3-17-2009. INT. CL. 12.
- OTO MEDICINE, ANN ARBOR, MI:
3,630,851, PUB. 3-17-2009. INT. CL. 5.
- OTSUKA PHARMACEUTICAL FACTORY, INC., TOKUSHIMA-KEN, JAPAN:
3,631,571, PUB. 3-17-2009. INT. CL. 5.
- OTSUKA TAKASHI, TOKYO 146-0094, JAPAN:
3,631,742, PUB. 3-17-2009. INT. CL. 28.
- OTTER PRODUCTS, LLC, FORT COLLINS, CO:
3,632,231, INT. CL. 9.
- OTTO BORRIES KG, LEINFELDEN-ECHTERDINGEN, FED REP GERMANY:
1,497,284, CANC. MULTIPLE CLASS, INT. CLS. 7 AND 8.
- OUTBOARD MARINE CORPORATION, WAUGAN, IL:
1,413,276, CANC. INT. CL. 12.
- OUTSET, INC., CHANHASSEN, MN:
3,629,897, PUB. 3-17-2009. MULTIPLE CLASS, INT. CLS. 4, 9 AND 21.
- OUTSIDE THE CLASSROOM, INC., NEEDHAM, MA:
3,632,146, INT. CL. 41.
- OUTSOURCEONE, INC., MINNEAPOLIS, MN:
3,631,831, INT. CL. 36.
- OUTTA THE BOX DISPENSERS, LLC., DAYTON, OH:
2,175,657, CANC. INT. CL. 16.
- OVATION CAPITAL MANAGEMENT, LLC, WHITE PLAINS, NY:
2,597,391, CANC. INT. CL. 36.
2,597,413, CANC. INT. CL. 36.
- OVERGAARD, KRISTI, LAS VEGAS, NV:
3,632,221, INT. CL. 42.
- OVERSEE.NET, LOS ANGELES, CA:
3,629,316, PUB. 3-17-2009. MULTIPLE CLASS, INT. CLS. 35 AND 42.
- OVERWATCH SYSTEMS, LTD., AUSTIN, TX:
3,629,686, PUB. 3-17-2009. INT. CL. 9.
- OVID TECHNOLOGIES, INC., NEW YORK, NY:
2,597,783, CANC. INT. CL. 9.
- OWENS CORNING INTELLECTUAL CAPITAL, LLC, TOLEDO, OH:
2,248,313, REN. 4-27-09. INT. CL. 17.
- OWENS, CHRISTOPHER DAVID, MYSTIC, CT:
3,630,403, PUB. 3-17-2009. MULTIPLE CLASS, INT. CLS. 41 AND 43.
3,630,404, PUB. 3-17-2009. MULTIPLE CLASS, INT. CLS. 41 AND 43.
- OXFORD INDUSTRIES, INC., ATLANTA, GA:
2,942,491, CANC. INT. CL. 25.
- OXYDIAN, SOCIETE ANONYME, 92130 ISSY-LES-MOULINEAUX, FRANCE:
2,596,592, CANC. MULTIPLE CLASS, INT. CLS. 9, 16, 35, 41 AND 42.
- OXYWIPES LLC., BIXBY, OK:
3,630,261, PUB. 3-17-2009. INT. CL. 3.
- OYAMA, WAYNE K., WAHIAWA, HI:
2,597,349, CANC. INT. CL. 42.
- OYSTER ARTS, INC., NEW YORK, NY:
2,598,961, CANC. INT. CL. 41.
- O2 HOLDINGS, LLC, NEW YORK, NY:
3,632,552, INT. CL. 35.
- P.C. WOO, INC. DBA MEGATOYS, LOS ANGELES, CA:
3,490,448, COR. INT. CL. 30.
- P-MAX APPAREL, INC., SOUTH SAN FRANCISCO, CA:
3,629,211, PUB. 3-17-2009. INT. CL. 25.
- PA ACQUISITION COMPANY, COMMERCE CITY, CO, AKA NULITE LIGHTING, INC.:
2,175,172, CANC. INT. CL. 40.
- PA DISTRIBUTORS LLC, NEWPORT BEACH, CA:
2,175,742, CANC. INT. CL. 36.
- PACELINE PRODUCTS, INC., PLEASANT VALLEY, MO:
3,632,261, INT. CL. 5.
- PACIFIC CENTURY, LLC, WASHINGTON, DC:
3,631,063, PUB. 3-17-2009. INT. CL. 9.
- PACIFIC CYCLE, LLC, MADISON, WI, AMERICAN RE-CREATION GROUP, COMMACK, NY:
1,559,741, REN. 4-27-09. INT. CL. 12.
- PACIFIC ELEMENTS, LLC, TURLOCK, CA:
3,631,835, INT. CL. 5.
- PACIFIC EXCHANGE, INC., SAN FRANCISCO, CA TO PACIFIC EXCHANGE, INC., SAN FRANCISCO, CA:
2,175,722, CANC. INT. CL. 36.
- PACIFIC HANDY CUTTER, INC., COSTA MESA, CA:
1,496,565, CANC. INT. CL. 8.
- PACIFIC INTERNATIONAL LINES (PRIVATE) LIMITED, SINGAPORE, SINGAPORE:
3,629,276, PUB. 3-17-2009. MULTIPLE CLASS, INT. CLS. 35 AND 39.
3,629,277, PUB. 3-17-2009. MULTIPLE CLASS, INT. CLS. 35 AND 39.
- PACIFIC INTERNATIONAL VEGETABLE MARKETING, INC., SALINAS, CA:
3,630,952, PUB. 3-17-2009. INT. CL. 31.
- PACIFIC PRESS TECHNOLOGIES, INC., MT. CARMEL, IL:
1,589,739, REN. 4-24-09. INT. CL. 7.
- PACIFIC UNIVERSITY, FOREST GROVE, OR:
3,629,842, PUB. 3-17-2009. INT. CL. 21.

- PACIFICA, INC., PORTLAND, OR:
3,630,793, PUB. 3-17-2009. INT. CL. 3.
3,630,794, PUB. 3-17-2009. INT. CL. 3.
3,630,831, PUB. 3-17-2009. MULTIPLE CLASS, INT. CLS. 3
AND 4.
- PACKAGING SERVICE CO., INC., PEARLAND, TX:
3,633,417, INT. CL. 4.
- PACTIV CORPORATION, LAKE FOREST, IL:
1,543,584. REN. 4-24-09. INT. CL. 21.
- PACWEST FUNDING, INC., EUGENE, OR, DBA PRECI-
SION FUNDING, PACWEST FUNDING, INC., EUGENE,
OR, DBA PRECISION FUNDING:
2,266,138. REN. 4-27-09. INT. CL. 36.
- PADRES L.P., SAN DIEGO, CA:
3,632,400, INT. CL. 38.
- PAGAN, ENRIQUE, BRONX, NY AND PAGAN, YOLANDA,
BRONX, NY:
2,598,705, CANC. INT. CL. 28.
- PAGES BBDO, S.A., SANTO DOMINGO, DOMINICAN REP:
3,632,134, INT. CL. 35.
- PALERMO, ANTHONY, CHESTERLAND, OH:
2,241,934. REN. 4-24-09. INT. CL. 16.
- PALFINGER AG, AUSTRIA:
3,631,677, PUB. 3-17-2009. INT. CL. 7.
- PALLET SOLUTION, BOISE, ID:
3,631,159, PUB. 3-17-2009. INT. CL. 20.
- PALLMANN MASCHINENFABRIK; GMBH & CO. KG, 66482
ZWEIBRÜCKEN, FED REP GERMANY:
3,631,592, PUB. 3-17-2009. INT. CL. 7.
- PALM BEACH STEAMSHIP AGENCY, INC., RIVIERA
BEACH, FL:
3,629,815, PUB. 3-17-2009. INT. CL. 39.
- PALM BREWERIES,; NAAMLOZE VENNOOTSCHAP, BEL-
GIUM:
3,631,552, PUB. 12-9-2008. INT. CL. 32.
- PALM WINDOW FASHIONS, LLC, FORT MEYERS, FL:
3,630,052, PUB. 3-17-2009. INT. CL. 35.
- PALMER MARINE OF WASHINGTON, INC., PORT ORCH-
ARD, WA:
2,598,654, CANC. INT. CL. 12.
- PALMER, CORNELIA G., PROVIDENCE, RI AND PALMER,
ROBERT PARK JR., PROVIDENCE, RI AND PALMER,
ROBERT PARK, PROVIDENCE, RI:
2,599,505, CANC. INT. CL. 6.
- PALMER, KARI, FORTUNA, CA, DBA RESULTS FIT CAMP
AND AGUIAR, SANDY, FORTUNA, CA, DBA RESULTS
FIT CAMP:
3,630,101, PUB. 3-17-2009. INT. CL. 41.
- PALOMBO, GINO, CHESTERLAND, OH:
3,630,810, PUB. 3-17-2009. INT. CL. 25.
- PALOS VERDES FOOTWEAR, INC., CARSON, CA:
3,630,867, PUB. 3-17-2009. INT. CL. 25.
- PAN AMERICAN COFFEE CO., INC., HOBOKEN, NJ:
3,629,332, PUB. 3-17-2009. INT. CL. 30.
- PAN.PRO VERTRIEBS AG, SALZBURG, AUSTRIA:
3,631,397, PUB. 3-17-2009. MULTIPLE CLASS, INT. CLS.
9, 10, 28, 35, 41, 42 AND 44.
3,631,398, PUB. 3-17-2009. MULTIPLE CLASS, INT. CLS.
9, 10, 28, 35, 41, 42 AND 44.
- PANAGO PIZZA INC., ABBOTSFORD, BRITISH COLUM-
BIA, CANADA:
2,596,717, CANC. INT. CL. 30.
- PANAMAX, INC., SAN RAFAEL, CA:
1,557,654, COR. INT. CL. 9.
- PANCREATIC CANCER ACTION NETWORK, INC., TOR-
RANCE, CA:
2,599,839, CANC. MULTIPLE CLASS, INT. CLS. 36, 41
AND 42.
- PANEL REY, S.A., MONTERREY, MEXICO:
3,631,453, PUB. 2-12-2008. INT. CL. 19.
- PANLINE USA, NORTHVALE, NJ:
2,599,809, CANC. INT. CL. 16.
- PANORAMA TECHNOLOGIES, INC., HOUSTON, TX:
3,633,295, INT. CL. 9.
- PANS & COMPANY INTERNATIONAL, S.L., BARCELONA,
E-08190, SPAIN:
2,596,954, CANC. INT. CL. 42.
- PANTELLOS CORPORATION, THE WOODLANDS, TX:
2,597,365, CANC. INT. CL. 35.
- PANTIM WOOD PRODUCTS, INC, PORTLAND, ME:
2,598,412, CANC. INT. CL. 19.
- PANTONE, INC., CARLSTADT, NJ:
3,632,054, MULTIPLE CLASS, INT. CLS. 16 AND 42.
- PAPER MAGIC GROUP, INC., THE, WILMINGTON, DE:
1,496,888, CANC. INT. CL. 28.
- PAR GOLF SUPPLY, INC., SCHAUMBURG, IL:
3,632,875, INT. CL. 40.
3,632,876, INT. CL. 40.
- PAR-SIVA CORPORATION, NEW HARTFORD, NY:
2,597,366, CANC. MULTIPLE CLASS, INT. CLS. 35, 41
AND 42.
- PARADISE ADVENTURE GROUP LLC, DALLAS, TX:
2,599,628, CANC. INT. CL. 39.
- PARADISE ROASTERS INC, RAMSEY, MN:
3,630,551, PUB. 3-17-2009. INT. CL. 30.
- PARADOX 21, INC., SOLON, IA:
2,596,583, CANC. INT. CL. 41.
- PARAMOUNT BEVERAGE, INC., SALT LAKE CITY, UT:
2,192,911, CANC. INT. CL. 32.
- PARAMOUNT LEISURE INDUSTRIES, INC., CHANDLER,
AZ:
3,629,630, PUB. 3-17-2009. INT. CL. 11.
- PARATEX, 59700 MARCQ-EN-BAROEUL, FRANCE:
2,596,549, CANC. INT. CL. 5.
- PARENTAL SOLUTIONS, INC., MENDON, NY:
3,631,456, PUB. 3-17-2009. INT. CL. 24.
- PARFUMS CHRISTIAN DIOR, FRANCE:
3,631,741, PUB. 3-17-2009. INT. CL. 3.
- PARI PHARMA GMBH, STARNBERG, FED REP GER-
MANY:
3,633,032, INT. CL. 10.
- PARIS BUSINESS PRODUCTS, INC., WESTAMPTON, NJ:
3,632,904, INT. CL. 16.
- PARK HOSPITALITY, LLC, MINNEAPOLIS, MN:
2,599,275, CANC. MULTIPLE CLASS, INT. CLS. 9 AND
35.
- PARK, IN JAE, SEOUL, REPUBLIC OF KOREA:
3,632,355, MULTIPLE CLASS, INT. CLS. 9 AND 15.
- PARK, MICHAEL K., PIEDMONT, CA:
2,599,836, CANC. INT. CL. 35.
- PARK, SOON HWA, ROWLAND HEIGHTS, CA, DBA
PARK'S ACUPUNCTURE & HERBS:
2,598,884, CANC. INT. CL. 5.
- PARKING COMPANY OF AMERICA AIRPORTS, LLC,
DOWNEY, CA:
2,596,999, CANC. INT. CL. 39.
- PARR INSTRUMENT CO., MOLINE, IL:
1,530,624. REN. 4-26-09. INT. CL. 9.
- PARR LUMBER COMPANY, HILLSBORO, OR:
3,630,390, PUB. 3-17-2009. MULTIPLE CLASS, INT. CLS.
37 AND 40.
3,630,391, PUB. 3-17-2009. INT. CL. 37.
- PARSONS BEHLE & LATIMER, SALT LAKE CITY, UT:
2,324,292. REN. 4-27-09. INT. CL. 42.
- PARTIBALL PTY LTD, MARSFIELD 2122 NEW SOUTH
WALES, AUSTRALIA:
2,596,840, CANC. INT. CL. 41.
- PARTY WORLD, INC., NORTHRIDGE, CA:
1,497,172, CANC. INT. CL. 42.
- PARTYPAINTER, BRUNSWICK, ME:
3,630,751, PUB. 3-17-2009. INT. CL. 41.
- PASSARELLI, MADELINE, NEW YORK, NY:
3,632,650, INT. CL. 25.
- PATEL DEVIYANI, NORTH BERGEN, NJ:
3,632,707, INT. CL. 14.
- PATEL, RAKESH, BONITA SPRINGS, FL:
3,630,611, PUB. 3-17-2009. INT. CL. 34.
- PATHFINDERS INTERNATIONAL, LLC, ATLANTA, GA:
3,629,918, PUB. 10-14-2008. MULTIPLE CLASS, INT. CLS.
44 AND 45.
- PATHWAY INVESTMENT CORPORATION, WYCKOFF, NJ:
3,629,924, PUB. 3-17-2009. INT. CL. 21.
- PATRIOT'S BOLD BARBEQUE, LLC, DANIEL ISLAND, SC:
3,630,498, PUB. 3-17-2009. INT. CL. 30.

PATTIE BROCKWELL, DRACUT, MA AND STEPHEN JESUS, DRACUT, MA:
3,632,917, INT. CL. 21.

PAUL H. GESSWEIN & CO., INC., BRIDGEPORT, CT:
2,597,316, CANC. INT. CL. 8.

PAUL, CHARSYA BIANCA, DENHAM SPRINGS, LA:
3,632,926, INT. CL. 41.

PAUMIER, KATHRYN, FREMONT, CA:
3,629,878, PUB. 3-17-2009. INT. CL. 35.

PAVE TECH, INC., PRIOR LAKE, MN:
3,632,633, INT. CL. 19.

PAXAR AMERICAS, INC., MIAMISBURG, OH, MONARCH MARKING SYSTEM COMPANY, THE, DAYTON, OH:
507,603. REN. 4-29-09. U.S. CL. 23 (INT. CL. 7).

PAYLESS SHOESOURCE WORLDWIDE, INC., TOPEKA, KS:
2,599,564, CANC. INT. CL. 3.

PBP LLC, BALTIMORE, MD:
3,630,939, PUB. 3-17-2009. INT. CL. 30.

PC PITSTOP L.L.C., SIOUX CITY, IA:
3,629,120, PUB. 3-17-2009. INT. CL. 42.

PCORDER.COM, INC., AUSTIN, TX:
2,598,513, CANC. INT. CL. 42.

PEACE STORE, INC., SANTA BARBARA, CA:
3,631,862, INT. CL. 35.

PEACHTREE DISTRIBUTING INC., SMYRNA, GA:
3,630,915, PUB. 3-17-2009. INT. CL. 11.

PEACHTREE DOORS, INC., NORCROSS, GA:
1,497,235, CANC. INT. CL. 42.

PEAK POTENTIALS TRAINING, INC., NORTH VANCOUVER, CANADA:
3,630,070, PUB. 12-9-2008. INT. CL. 41.

PEARSON DENTAL SUPPLIES, INC., SYLMAR, CA:
3,632,830, INT. CL. 10.

PECA VERBUNDTECHNIK GMBH, FED REP GERMANY:
3,631,577, PUB. 3-17-2009. INT. CL. 6.

PEEK...AREN'T YOU CURIOUS, INC, SAN FRANCISCO, CA:
3,630,078, PUB. 3-17-2009. INT. CL. 25.
3,630,079, PUB. 3-17-2009. INT. CL. 25.

PEERLESS-WINSMITH, INC., WARREN, OH:
1,496,639, CANC. INT. CL. 9.
1,496,640, CANC. INT. CL. 9.

PEET'S COFFEE AND TEA, INC., EMERYVILLE, CA TO PEET'S COFFEE AND TEA, INC., SEATTLE, WA:
1,496,949, CANC. MULTIPLE CLASS, INT. CLS. 30 AND 42.

PELICAN COVE INN, INC., CARLSBAD, CA:
3,630,748, PUB. 3-17-2009. INT. CL. 43.

PELICAN'S WHARF, INC., AUSTIN, TX:
1,497,206, CANC. INT. CL. 42.

PELLA CORPORATION, PELLA, IA:
2,232,512. REN. 4-24-09. INT. CL. 6.

PELONIS USA LTD., MALVERN, PA:
2,599,220, CANC. INT. CL. 11.

PENGUIN BOOKS USA INC., NEW YORK, NY, NEW AMERICAN LIBRARY OF WORLD LITERATURE, INC., THE, NEW YORK, NY:
510,998. REN. 4-29-09. U.S. CL. 38 (INT. CL. 16).

PENGUIN GROUP (USA) INC., NEW YORK, NY, NEW AMERICAN LIBRARY OF WORLD LITERATURE, INC., THE, NEW YORK, NY:
511,927. REN. 4-29-09. U.S. CL. 38 (INT. CL. 16).

PENNANT FOODS COMPANY, ITASCA, IL, UNITED BISCUIT COMPANY OF AMERICA, MELROSE PARK, IL:
691,390. REN. 4-26-09. U.S. CL. 46 (INT. CL. 30).

PENNY & GILES DRIVES TECHNOLOGY LIMITED, CHRISTCHURCH, DORSET, UNITED KINGDOM:
2,598,851, CANC. INT. CL. 9.

PENSA COMMUNICATIONS, INC., NEW YORK, NY:
2,598,479, CANC. MULTIPLE CLASS, INT. CLS. 38 AND 41.
2,598,740, CANC. MULTIPLE CLASS, INT. CLS. 38 AND 41.

PENSELS LTD., EAST NORTHPORT, NY:
3,630,654, PUB. 3-17-2009. INT. CL. 3.

PENTAGON PROTECTION USA, LLC, DUBLIN, OH:
3,630,678, PUB. 3-17-2009. INT. CL. 6.

PENTAIR POOL PRODUCTS, INC., LAGRANGEVILLE, NY:
2,596,990, CANC. INT. CL. 6.

PENTAIR WATER POOL AND SPA, INC., SANFORD, NC:
3,632,710, INT. CL. 9.

PENTON BUSINESS MEDIA, INC., NEW YORK, NY:
1,496,718, CANC. INT. CL. 16.
1,496,719, CANC. INT. CL. 16.
2,262,181, REN. 4-29-09. INT. CL. 16.
3,629,314, PUB. 3-17-2009. MULTIPLE CLASS, INT. CLS. 16 AND 41.
3,630,298, PUB. 3-17-2009. MULTIPLE CLASS, INT. CLS. 16 AND 41.
3,633,041, MULTIPLE CLASS, INT. CLS. 35 AND 41.

PENTON MEDIA, INC., CLEVELAND, OH:
682,917. REN. 4-24-09. U.S. CL. 38 (INT. CL. 16).

PENUMBRA, INC., SAN LEANDRO, CA:
3,633,499, INT. CL. 10.

PENWEST PHARMACEUTICALS CO., PATTERSON, NY:
2,598,602, CANC. MULTIPLE CLASS, INT. CLS. 1 AND 30.

PEOPLECLICK, INC., RALEIGH, NC:
3,629,926, PUB. 3-17-2009. INT. CL. 9.
3,629,974, PUB. 3-17-2009. INT. CL. 9.

PEORIA UNIFIED SCHOOL DISTRICT, PEORIA, AZ:
3,630,993, PUB. 3-17-2009. INT. CL. 35.

PEOTAGRAFX, INC., CHICAGO, IL:
2,598,228, CANC. INT. CL. 9.

PEPINIERES ET ROSERAIES GEORGES DELBARD, MALICORNE - 03600 COMMENTRY, FRANCE:
2,174,293, CANC. INT. CL. 31.

PEPPERWOOD INTERNATIONAL CORPORATION, WASHINGTON, COLOMBIA, DBA HANNAFORD ENTERPRISES, INC.:
2,598,895, CANC. MULTIPLE CLASS, INT. CLS. 35, 41 AND 42.

PEPSICO, INC., PURCHASE, NY:
2,599,676, CANC. INT. CL. 32.

PERAGALLO PIPE ORGAN CO., PATERSON, NJ:
3,630,008, PUB. 3-17-2009. INT. CL. 37.
3,630,009, PUB. 3-17-2009. INT. CL. 39.
3,630,010, PUB. 3-17-2009. INT. CL. 15.
3,630,011, PUB. 3-17-2009. INT. CL. 37.
3,630,012, PUB. 3-17-2009. INT. CL. 15.

PERAITA, JOSE A., NEW YORK, NY:
3,632,718, INT. CL. 28.

PERCOCO HOLDINGS, LLC, DENVER, CO:
3,632,422, INT. CL. 40.

PERFECT SENSE GREETING GIFT CARDS, INC., CINCINNATI, OH:
3,633,308, INT. CL. 9.

PERFECT 10 ANTENNA COMPANY INC., NORTH LITTLE ROCK, AR:
2,290,984. REN. 4-25-09. INT. CL. 9.

PERFECTION FENCE CORPORATION, MARSHFIELD, MA:
3,630,997, PUB. 3-17-2009. INT. CL. 6.

PERFORMING ARTS FORT WORTH, INC., FORT WORTH, TX:
2,196,270. REN. 4-28-09. INT. CL. 25.

PERI'S GROVE LLC, FAIRFIELD, CT:
2,596,921, CANC. INT. CL. 42.

PERINATAL RESOURCES OF CALIFORNIA, INC., SAN DIEGO, CA:
2,598,710, CANC. INT. CL. 42.

PERISCOPE, L.L.C., AUSTIN, TX:
2,597,477, CANC. MULTIPLE CLASS, INT. CLS. 35 AND 42.

PERSEVERANCE ENTERTAINMENT, INC., BROOKLYN, NY:
2,598,329, CANC. MULTIPLE CLASS, INT. CLS. 9 AND 35.

PERSONAL ESTATE MANAGER, INC., STERLING HEIGHTS, MI:
3,633,105, INT. CL. 45.

PET ANGEL WORLD SERVICES, LLC, WILBRAHAM, MA:
3,630,833, PUB. 3-17-2009. INT. CL. 35.

- PET DISTRICT CORPORATION, CHARLOTTE, NC, AKA PET DISTRICT:
3,630,336, PUB. 3-17-2009. INT. CL. 35.
3,630,349, PUB. 3-17-2009. INT. CL. 35.
- PET VALU CANADA INC., MARKHAM ONTARIO L3R 3L3, CANADA, HOLT DISTRIBUTORS LIMITED, SCARBOROUGH, ONTARIO, CANADA:
1,563,967. REN. 4-24-09. INT. CL. 42.
- PETE GARCIA COMPANY, ATLANTA, GA:
1,538,603. REN. 4-24-09. INT. CL. 42.
- PETER GILES, UNITED KINGDOM AND YASMINE GILES, SURREY KT10 0PD, UNITED KINGDOM:
3,631,611, PUB. 3-17-2009. MULTIPLE CLASS, INT. CLS. 9 AND 41.
- PETER J. LISTRO ASSOCIATES, LTD., NEW YORK, NY:
2,596,919, CANC. INT. CL. 9.
- PETER KUBASCH, LÜBECK, FED REP GERMANY:
3,631,716, PUB. 3-17-2009. INT. CL. 35.
- PETLAND, INC., CHILLICOTHE, OH:
3,630,305, PUB. 3-17-2009. INT. CL. 18.
3,630,367, PUB. 3-17-2009. INT. CL. 5.
- PETREE, CHAD, SANTA MONICA, CA AND DAWSON, JEREMY, SANTA MONICA, CA:
3,629,176, PUB. 3-17-2009. MULTIPLE CLASS, INT. CLS. 9 AND 41.
- PETRO-POWER INCORPORATED, GLENDALE, CA:
2,597,412, CANC. INT. CL. 1.
- PETROFERM INC., FERNANDINA BEACH, FL:
1,496,473, CANC. INT. CL. 4.
- PETSMART STORE SUPPORT GROUP INC., PHOENIX, AZ:
2,175,621, CANC. INT. CL. 42.
- PEVONIA INTERNATIONAL, LLC, DAYTONA BEACH, FL:
3,633,395, INT. CL. 3.
- PEZZIOL B.V., HAARLEM, NETHERLANDS:
1,496,977, CANC. INT. CL. 33.
- PFEIFER, DAVID J., PITTSBURGH, PA:
3,632,443, INT. CL. 28.
- PFIZER INC., NEW YORK, NY:
3,632,187, INT. CL. 5.
- PGA TOUR, INC., PONTE VEDRA BEACH, FL:
2,249,958. REN. 4-29-09. INT. CL. 41.
- PGI, INCORPORATED, ARLINGTON, VA:
2,596,593, CANC. INT. CL. 35.
2,596,594, CANC. INT. CL. 35.
- PHARMATROPIC, LTD., NEWTOWN, PA:
3,629,252, PUB. 3-17-2009. INT. CL. 11.
- PHARMAVITE CORPORATION, MISSION HILLS, CA:
2,598,883, CANC. INT. CL. 5.
- PHASE FORWARD INCORPORATED, WALTHAM, MA:
2,599,003, CANC. INT. CL. 9.
- PHASE FOUR, LLC, MARCO ISLAND, FL:
3,631,792, INT. CL. 16.
- PHASHOW INC., TORONTO, ONTARIO, CANADA:
3,631,064, PUB. 3-17-2009. MULTIPLE CLASS, INT. CLS. 9, 16, 25, 28 AND 41.
- PHEBRA PTY LTD, LANE COVE, AUSTRALIA:
3,631,559, PUB. 3-17-2009. MULTIPLE CLASS, INT. CLS. 5, 10 AND 42.
- PHIFER INCORPORATED, TUSCALOOSA, AL:
1,496,769, CANC. INT. CL. 17.
- PHILIP MORRIS USA INC., RICHMOND, VA:
3,629,972, PUB. 3-17-2009. INT. CL. 34.
3,632,780, INT. CL. 34.
- PHILIPP W. MARX, UNITED STATES:
3,631,509, PUB. 3-17-2009. MULTIPLE CLASS, INT. CLS. 9, 37, 41 AND 42.
- PHILLIPS FOODS, INC., BALTIMORE, MD:
3,629,229, PUB. 3-17-2009. INT. CL. 29.
- PHILLIPS PRODUCTS CO., LLC, PRINCETON, MN:
2,235,409. REN. 4-29-09. INT. CL. 33.
- PHILLIPS-VAN HEUSEN CORPORATION, NEW YORK, NY:
2,637,861, CANC. MULTIPLE CLASS, INT. CLS. 16 AND 20.
- PHILLIPS, PETER R., CLAREMONT, ONTARIO, CANADA:
2,596,427, CANC. INT. CL. 28.
- PHILOSOPHY, INC., PHOENIX, AZ:
3,633,115, INT. CL. 28.
- PHOENIX ADEPTS, INC., ALPHARETTA, GA, DBA HOME-SCHOOL PROGRAMMING, INC.:
3,633,468, INT. CL. 16.
- PHOENIX LANDING FOUNDATION, ASHEVILLE, NC:
3,629,753, PUB. 3-17-2009. INT. CL. 39.
- PHOENIX MULTIMEDIA, INC., HUNTSVILLE, AL:
2,599,768, CANC. INT. CL. 42.
- PHOTO MARKETING ASSOCIATION INTERNATIONAL, JACKSON, MI:
3,630,575, PUB. 3-17-2009. INT. CL. 9.
- PHOTON TECHNOLOGY INTERNATIONAL, INC., BIRMINGHAM, NJ:
3,633,234, INT. CL. 9.
- PHYSICIANS FORMULA COSMETICS, INC., AZUSA, CA:
2,598,226, CANC. INT. CL. 3.
2,599,366, CANC. INT. CL. 3.
2,599,557, CANC. INT. CL. 3.
- PIA GROUP, LLC, STAMFORD, CT:
3,629,837, PUB. 3-17-2009. INT. CL. 25.
- PIAGGIO & C. S.P.A., I-56025 PONTEDERA (PISA), ITALY:
3,631,567, PUB. 3-17-2009. INT. CL. 12.
- PICCIRILLO, DANA, TUCKER, GA:
3,630,382, PUB. 3-17-2009. INT. CL. 44.
- PICIS, INC., WAKEFIELD, MA:
3,630,093, PUB. 3-17-2009. INT. CL. 9.
3,630,094, PUB. 3-17-2009. INT. CL. 9.
- PICTORIAL, INC., INDIANAPOLIS, IN:
2,597,511, CANC. INT. CL. 36.
- PICTURE FOR UNITY LTD., LONDON EC1A 4JQ, UNITED KINGDOM:
3,631,468, PUB. 3-17-2009. INT. CL. 41.
- PICTUREU PROMOTIONS, INC., ATLANTA, GA:
3,631,055, PUB. 3-17-2009. INT. CL. 35.
3,631,061, PUB. 3-17-2009. INT. CL. 35.
3,631,267, PUB. 3-17-2009. INT. CL. 35.
- PIERRE BALMAIN SA, 75008 PARIS, FRANCE:
3,631,786, INT. CL. 25.
- PIERRE FOODS, INC., CINCINNATI, OH, PIERRE FROZEN FOODS, INC., CINCINNATI, OH:
1,121,101. REN. 4-24-09. INT. CL. 29.
- PIGGY PUSHERS, LLC, HOLLAND, MI:
2,599,495, CANC. INT. CL. 25.
- PILSEN STEEL S.R.O., CZECH REPUBLIC:
3,631,517, PUB. 3-17-2009. MULTIPLE CLASS, INT. CLS. 6, 7, 12, 35, 39, 40 AND 42.
- PILYUGIN, ANDREY B, BARNAUL, RUSSIAN FED.:
3,633,026, INT. CL. 9.
- PINCKNEY, JANE G., SAVANNAH, GA:
2,599,813, CANC. INT. CL. 25.
- PINELAWN CEMETERY, FARMINGDALE, NY:
3,631,003, PUB. 3-17-2009. MULTIPLE CLASS, INT. CLS. 44 AND 45.
- PINK UNICORN PRODUCTIONS LLC, ROOSEVELT, NY:
3,631,079, PUB. 3-17-2009. INT. CL. 9.
- PINKERTON TOBACCO CO., L.P., OWENSBORO, KY:
1,539,498. REN. 4-24-09. INT. CL. 34.
- PINNACLE TELECOMMUNICATIONS, INC., LOOMIS, CA:
3,630,716, PUB. 3-17-2009. MULTIPLE CLASS, INT. CLS. 37 AND 38.
- PINTAIL TECHNOLOGIES, INC., PLANO, TX:
2,598,566, CANC. INT. CL. 9.
- PIPER COMMUNICATIONS, INC., IRVINE, CA:
3,632,164, INT. CL. 35.
3,632,165, INT. CL. 35.
- PIPES CAFE, INC., CARDIFF BY THE SEA, CA:
2,597,360, CANC. INT. CL. 42.
- PISCITELLI, JOSEPH, HOPEWELL JUNCTION, NY:
3,630,720, PUB. 3-17-2009. INT. CL. 35.
- PITA KING, INC., ASTORIA, NY:
3,630,835, PUB. 3-17-2009. MULTIPLE CLASS, INT. CLS. 25 AND 43.
- PITA STOP, INC, WHEELING, IL:
3,630,182, PUB. 3-17-2009. INT. CL. 43.
- PITT PENN OIL CO., LLC, CREIGHTON, PA:
2,175,648, CANC. MULTIPLE CLASS, INT. CLS. 1, 3 AND 4.
- PIVOTAL PARKER COMMERCIAL, LLC, PHOENIX, AZ:
2,599,397, CANC. INT. CL. 37.

PIXELWORKS, INC., PORTLAND, OR:
 3,631,995, INT. CL. 9.
 PIZZA HUT, INC., DALLAS, TX:
 3,632,820, INT. CL. 30.
 PIZZA MARGHERITA, CENTREVILLE, VA:
 3,632,320, INT. CL. 43.
 PJ DREAMWEAR, ANAHEIM, CA:
 3,632,381, INT. CL. 25.
 PJS & RHS EXPERIENCES LLC, CHARLOTTE, NC:
 3,631,043, PUB. 3-17-2009. INT. CL. 35.
 PLACEMARK INVESTMENTS, INC., DALLAS, TX:
 2,599,701, CANC. INT. CL. 36.
 PLAID ENTERPRISES, INC., NORCROSS, GA, ANM AC-
 QUSITION CORP., NORCROSS, GA:
 2,278,443. REN. 4-24-09. INT. CL. 16.
 PLANET HOLLYWOOD (REGION IV), INC., ORLANDO, FL:
 3,632,399, INT. CL. 25.
 PLANET RETAIL STUDIOS, LLC, SEATTLE, WA:
 2,597,396, CANC. INT. CL. 42.
 PLANGEA INC., VISTA, CA:
 3,630,666, PUB. 3-17-2009. INT. CL. 35.
 PLASTIC SPECIALTIES AND TECHNOLOGIES, INC., RID-
 GEFIELD, NJ:
 2,597,702, CANC. INT. CL. 17.
 PLATEAU MUSIC LLC, WHITE HOUSE, TN:
 3,629,355, PUB. 3-17-2009. INT. CL. 9.
 PLATINUM AVIATION GROUP, INC., RENO, NV:
 2,597,166, CANC. INT. CL. 40.
 PLAYGARDEN HOLDING LLC, NEW YORK, NY:
 3,633,372, INT. CL. 41.
 PLOUGMANN & VINGTOFT A/S, DENMARK:
 3,631,764, PUB. 3-17-2009. MULTIPLE CLASS, INT. CLS.
 35 AND 42.
 PLU HOLDING SAS, FRANCE:
 3,631,692, PUB. 3-17-2009. MULTIPLE CLASS, INT. CLS. 6
 AND 19.
 PLUMBMASTER, INC., IRVING, TX:
 2,597,339, CANC. INT. CL. 11.
 PLURAL HOLDINGS, LLC, NEW YORK, NY:
 3,632,804, INT. CL. 36.
 PLUS COMMUNICATIONS, INC., LAKE MARY, FL, DBA
 STRANG COMMUNICATIONS COMPANY:
 3,633,084, INT. CL. 16.
 PLUSFUNDS GROUP, INC., NEW YORK, NY:
 2,597,036, CANC. INT. CL. 36.
 PLUVIOSE, PATRICK, BROOKLYN, NY:
 2,597,029, CANC. INT. CL. 25.
 POD PACK INTERNATIONAL, LTD., BATON ROUGE, LA:
 3,630,474, PUB. 3-17-2009. INT. CL. 30.
 PODI, LLC, CHICAGO, IL:
 3,633,092, INT. CL. 25.
 POINT CREATIVE, INC., BEAVERTON, OR:
 3,632,655, INT. CL. 9.
 POLA CHEMICAL INDUSTRIES INC., SHIZUOKA-SHI,
 SHIZUOKA-KEN, JAPAN:
 3,545,064, COR. INT. CL. 44.
 POLLARD BANKNOTE LIMITED PARTNERSHIP, WINNI-
 PEG, MANITOBA, CANADA:
 3,630,248, PUB. 3-17-2009. INT. CL. 28.
 POLLO FIESTA, INC., DALLAS, TX:
 1,509,626. REN. 4-27-09. INT. CL. 42.
 POLY PROCESSING COMPANY, LLC, MONROE, LA:
 2,597,692, CANC. MULTIPLE CLASS, INT. CLS. 20 AND
 40.
 POLY-TAK PROTECTION SYSTEMS, INC., IRVINE, CA:
 3,629,485, PUB. 3-17-2009. INT. CL. 27.
 POLY-TEX, INC., CASTLE ROCK, MN:
 2,597,497, CANC. INT. CL. 6.
 POLYGUARD PRODUCTS, INC., ENNIS, TX:
 3,630,499, PUB. 3-17-2009. INT. CL. 17.
 POLYMER GROUP, LLC, MADISON, MS, DBA POLYCON
 MANUFACTURING DIVISION OF POLYMER GROUP:
 3,632,514, INT. CL. 19.
 POMWONDERFUL LLC, LOS ANGELES, CA:
 3,633,116, INT. CL. 32.
 PONCE, MARIAELENA, LONG BEACH, CA:
 3,633,346, INT. CL. 3.
 PONDBIZ, INC., CANOGA PARK, CA:
 3,630,559, PUB. 3-17-2009. INT. CL. 35.
 PONZIO, FRANK, MANTOLOKING, NJ:
 2,175,788, CANC. INT. CL. 25.
 POOLE, DELMA, REDONDO BEACH, CA:
 3,630,790, PUB. 3-17-2009. INT. CL. 35.
 POPSDIRECT, INC., GLENVIEW, IL:
 2,597,855, CANC. INT. CL. 35.
 PORT-A-COOL, LLC, DALLAS, TX:
 3,629,786, PUB. 3-17-2009. INT. CL. 11.
 PORTA-NAILS, INC., CURRIE, NC:
 3,631,155, PUB. 3-17-2009. INT. CL. 7.
 PORTABLE JOHN, INC., ATLANTA, GA:
 2,597,669, CANC. MULTIPLE CLASS, INT. CLS. 16 AND
 25.
 PORTABLE PRACTICAL EDUCATIONAL PREPARATION,
 INC., TUCSON, AZ:
 3,629,801, PUB. 3-17-2009. INT. CL. 36.
 PORTLAND TRAILS, PORTLAND, ME:
 3,630,126, PUB. 3-17-2009. INT. CL. 42.
 POSITEC GROUP LIMITED, HONG KONG ADM. REGION,
 CHINA:
 3,632,625, INT. CL. 9.
 POSITROL, INC., CINCINNATI, OH:
 3,629,969, PUB. 3-17-2009. INT. CL. 6.
 POTHOS, INC, SAN DIEGO, CA:
 3,630,598, PUB. 3-17-2009. INT. CL. 35.
 POTRERO MEDIA CORPORATION, SAN FRANCISCO, CA:
 3,629,727, PUB. 3-17-2009. INT. CL. 35.
 POTTS' HOT DOGS, INC., FT. MYERS, FL:
 1,497,167, CANC. INT. CL. 42.
 POWER MONITORS, INC., MOUNT CRAWFORD, VA:
 3,632,447, INT. CL. 9.
 POWER TACKLE INC., SEGUIN, TX:
 3,631,162, PUB. 3-17-2009. INT. CL. 28.
 POWER-ONE, INC., CAMARILLO, CA:
 2,597,067, CANC. INT. CL. 9.
 2,597,069, CANC. INT. CL. 9.
 POWERS MANAGEMENT, LLC, NASHVILLE, TN:
 2,599,158, CANC. INT. CL. 35.
 POWERWERX, INC., BREA, CA:
 3,630,665, PUB. 3-17-2009. INT. CL. 8.
 PPG INDUSTRIES, INC., PITTSBURGH, PA:
 2,239,055, COR. INT. CL. 2.
 PRACTICAL PRODUCTS, LLC, SAN DIEGO, CA:
 3,630,884, PUB. 3-17-2009. INT. CL. 20.
 PRAGER WINERY & PORT WORKS, INC., ST. HELENA,
 CA:
 3,631,274, PUB. 3-17-2009. INT. CL. 33.
 PRAKASH, KARUN SHASHI, SEASIDE, CA:
 3,632,591, INT. CL. 25.
 PRANA GYANA, CHANDLER, AZ:
 3,630,033, PUB. 3-17-2009. INT. CL. 44.
 PRECARE CORP., WEST BABYLON, NY, DBA PREMIER
 CARE INDUSTRIES:
 3,629,521, PUB. 3-17-2009. INT. CL. 5.
 PRECHEL, SHERI, MISSION, CANADA:
 3,630,979, PUB. 3-17-2009. INT. CL. 25.
 PRECISE SOLUTION CORPORATION, TROY, MI:
 2,597,200, CANC. INT. CL. 7.
 PRECISION TWIST DRILL CO., CRYSTAL LAKE, IL:
 3,631,431, PUB. 3-17-2009. MULTIPLE CLASS, INT. CLS. 7
 AND 8.
 PREDATOR SYSTEMS INC., BOCA RATON, FL:
 2,325,592. REN. 4-27-09. INT. CL. 42.
 2,342,354. REN. 4-27-09. INT. CL. 42.
 PREFERRED HOME BUYERS NETWORK, INC., EXCEL-
 SIOR, MN:
 3,631,157, PUB. 3-17-2009. INT. CL. 35.
 3,631,209, PUB. 3-17-2009. INT. CL. 36.
 3,631,322, PUB. 3-17-2009. MULTIPLE CLASS, INT. CLS.
 35 AND 36.
 PREMIER ENTREPRENEUR PROGRAMS, INC., DENVER,
 CO:
 2,599,765, CANC. INT. CL. 35.
 PREMIER RESEARCH LABORATORIES, ROUND ROCK,
 TX:
 2,220,426. REN. 4-30-09. INT. CL. 5.

- PREMIER, INC., SAN DIEGO, CA:
3,630,777, PUB. 3-17-2009. MULTIPLE CLASS, INT. CLS. 9 AND 41.
- PREMIERE VISION, LYON, FRANCE:
3,632,228, MULTIPLE CLASS, INT. CLS. 35 AND 45.
- PRENATAL PRESCHOOL, INC., BOCA RATON, FL:
3,632,561, INT. CL. 9.
- PRENTISS, LUKE S. RICHMOND, TX:
3,631,171, PUB. 3-17-2009. INT. CL. 41.
- PREPAK PRODUCTS, INC., OCEANSIDE, CA:
3,632,153, MULTIPLE CLASS, INT. CLS. 16 AND 44.
- PREVENT CANCER FOUNDATION, ALEXANDRIA, VA:
2,596,559, CANC. INT. CL. 42.
- PROGRESSIVE CONCRETE WORKS, INC., PHOENIX, AZ:
3,630,229, PUB. 3-17-2009. INT. CL. 19.
- PRICELINE.COM INCORPORATED, NORWALK, CT:
2,596,656, CANC. INT. CL. 39.
- PRICEWATERHOUSECOOPERS LLP, NEW YORK, NY:
2,252,976, REN. 4-29-09. INT. CL. 16.
- PRIMA TECHNOLOGIES, INCORPORATED, NESCONSET, NY:
3,632,574, INT. CL. 3.
- PRIMAMED PHYSICIANS ASSOCIATION, DALLAS, TX:
3,632,792, INT. CL. 44.
3,632,794, INT. CL. 44.
- PRIMARY FLOW SIGNAL, INC., WARWICK, RI:
2,598,475, CANC. INT. CL. 9.
- PRIMAVERA LIFE GMBH, SULZBERG, FED REP GERMANY:
3,632,484, MULTIPLE CLASS, INT. CLS. 3, 21 AND 35.
- PRIME CHOICE AUTO PARTS, INC., OTTAWA, CANADA:
3,629,275, PUB. 3-17-2009. MULTIPLE CLASS, INT. CLS. 7, 9, 11, 12 AND 35.
- PRIME NUMBERS TECHNOLOGY, LLC, MEDFIELD, MA:
3,632,260, INT. CL. 35.
- PRIME, SPYDER, TAMPA, FL:
3,630,983, PUB. 3-17-2009. INT. CL. 41.
- PRIMELINK INC., GARDEN GROVE, CA:
3,631,083, PUB. 3-17-2009. INT. CL. 35.
- PRIMESOURCE BUILDING PRODUCTS, INC., CARROLLTON, TX:
2,599,202, CANC. INT. CL. 19.
2,599,203, CANC. INT. CL. 19.
- PRIMIZIE, INC., AUSTIN, TX:
3,630,675, PUB. 3-17-2009. INT. CL. 43.
- PRIMO SPORT, INC., NEWARK, DE:
3,632,791, INT. CL. 17.
- PRINCETON TECTONICS, INC., BORDENTOWN, NJ:
2,598,044, CANC. INT. CL. 11.
- PRINCIPAL ASSET, LLC, NEW YORK, NY:
2,598,875, CANC. INT. CL. 35.
- PRINCIPAL FINANCIAL SERVICES, INC., DES MOINES, IA:
1,534,634, REN. 4-24-09. INT. CL. 36.
- PRINDABLE, JAMES, BELLEVILLE, IL:
2,598,525, CANC. INT. CL. 35.
- PRINT COMMUNICATION RESEARCH, INCORPORATED, SAN FRANCISCO, CA TO EILS, LEE C. III, SAN FRANCISCO, CA:
1,497,178, CANC. INT. CL. 42.
- PRINTINGFORLESS.COM, LIVINGSTON, MT:
3,632,557, INT. CL. 40.
- PRISCO A. MONACO & ASSOCIATES, LLC, STANFORDVILLE, NY, DBA PRISCO A. MONACO & ASSOCIATES, LLC:
3,630,371, PUB. 3-17-2009. INT. CL. 35.
- PRISMA CONSULTING LLC, POMPANO BEACH, FL, DBA HOME BURGER USA:
3,630,584, PUB. 3-17-2009. INT. CL. 43.
- PRISON COMMUNITIES INTERNATIONAL, INC., KATONAH, NY:
3,632,126, INT. CL. 41.
- PRISON DHARMA NETWORK, BOULDER, CO:
3,629,531, PUB. 3-17-2009. INT. CL. 41.
- PRITCHETT, KAREEM, HILLSBOROUGH, NJ AND PINE-DO, VICTOR, EAST WINDSOR, NJ:
3,629,588, PUB. 3-17-2009. U.S. CL. 200.
- PRIVATE NATIONAL MORTGAGE ACCEPTANCE COMPANY, LLC, CALABASAS, CA:
3,631,074, PUB. 3-17-2009. INT. CL. 36.
- PRO EBIZ LLC, BOISE, ID:
3,631,149, PUB. 3-17-2009. INT. CL. 9.
- PRO TECH PUBLISHING AND COMMUNICATIONS, INC., NEW ALBANY, IN, DBA PRO TECH PUBLISHING INC.:
1,496,722, CANC. INT. CL. 16.
- PRO WASH MOBILE CAR WASH SERVICE, LLC, AVENTURA, FL:
3,630,670, PUB. 3-17-2009. INT. CL. 12.
- PRO-LIFT FINGERPRINT COLLECTION SYSTEM, INC., BRADENTON, FL:
2,599,025, CANC. INT. CL. 16.
- PROBUILD HOLDINGS, INC., DENVER, CO:
3,631,873, MULTIPLE CLASS, INT. CLS. 37 AND 40.
- PROCARE PRODUCTS, SUCCASUNNA, NJ:
3,633,471, INT. CL. 3.
- PROCEDANT INSURANCE COMPANY, SCOTTSDALE, AZ:
3,629,498, PUB. 3-17-2009. INT. CL. 36.
- PROCESADORA DE LA ALIMENTOS KRIS, S.A., GAUTEMALA, GUATEMALA, AKA PRAKSA:
3,630,970, PUB. 3-17-2009. INT. CL. 30.
- PROCESADORA DE LA ALIMENTOS KRIS, S.A., GUATEMALA, GUATEMALA, AKA PRAKSA:
3,630,974, PUB. 3-17-2009. INT. CL. 32.
3,630,977, PUB. 3-17-2009. INT. CL. 32.
- PROCONEX, INC., ROYERSFORD, PA:
2,215,974, REN. 4-25-09. INT. CL. 42.
- PROCTER & GAMBLE COMPANY, THE, CINCINNATI, OH:
1,496,757, CANC. INT. CL. 16.
2,599,648, CANC. MULTIPLE CLASS, INT. CLS. 3, 16 AND 37.
- PROCURESTAFF, LTD., NEW YORK, NY:
3,632,919, INT. CL. 36.
- PRODUCT PARTNERS, L.L.C., SANTA MONICA, CA:
2,828,251, CANC. INT. CL. 5.
- PRODUCTOS CAPPUCINO S.A., BARREAL DE HEREDIA, COSTA RICA:
2,175,520, CANC. INT. CL. 30.
- PRODUCTOS GENUINOS DE TEQUILA, GUADALAJARA, MEXICO:
2,599,657, CANC. INT. CL. 33.
- PROFESSIONAL AUDIO CONCEPTS, INC., ORANGE, CA:
2,597,358, CANC. INT. CL. 9.
- PROFESSIONAL SUPPLY NETWORK, INC., MACOMB, IL:
1,497,020, CANC. INT. CL. 35.
- PROFESSOR DR. MED. HERMANN HOLZHÜTER, FED REP GERMANY:
3,631,732, PUB. 3-17-2009. MULTIPLE CLASS, INT. CLS. 29, 30 AND 43.
- PROFITS RUN, INC., WIXOM, MI:
3,629,802, PUB. 3-17-2009. MULTIPLE CLASS, INT. CLS. 9 AND 16.
3,629,803, PUB. 3-17-2009. MULTIPLE CLASS, INT. CLS. 9 AND 16.
- PROFORCE MARKETING, INC., PRESCOTT, AZ:
3,631,089, PUB. 3-17-2009. INT. CL. 35.
3,631,090, PUB. 3-17-2009. INT. CL. 35.
- PROGRESS SOFTWARE CORPORATION, BEDFORD, MA:
2,245,632, REN. 4-24-09. INT. CL. 9.
- PROGRESSIVE LABORATORIES, INC., IRVING, TX:
3,630,926, PUB. 3-17-2009. INT. CL. 5.
3,630,930, PUB. 3-17-2009. INT. CL. 5.
- PROGRESSUS THERAPY, LLC, BALTIMORE, MD:
3,630,207, PUB. 3-17-2009. INT. CL. 35.
3,630,208, PUB. 3-17-2009. INT. CL. 35.
- PROJECT OPUS TECHNOLOGIES INC., VANCOUVER, CANADA:
3,631,407, PUB. 3-17-2009. MULTIPLE CLASS, INT. CLS. 35 AND 38.
- PROJECT WABASH LLC, CHICAGO, IL:
3,629,698, PUB. 3-17-2009. INT. CL. 41.
- PROJEKT202, LP, AUSTIN, TX:
3,631,201, PUB. 3-17-2009. INT. CL. 42.
- PROJETIX LTD., BG-2700 BLAGOEVGRAD, BULGARIA:
3,631,769, PUB. 3-17-2009. INT. CL. 42.

PROMEDICA INTERNATIONAL, A CALIFORNIA CORPORATION, COSTA MESA, CA:
1,536,194. REN. 4-27-09. INT. CL. 9.

PROMEGA CORPORATION, MADISON, WI:
2,597,935, CANC. INT. CL. 7.
2,598,224, CANC. MULTIPLE CLASS, INT. CLS. 1 AND 5.

PROMISE TECHNOLOGY, INC., MILPITAS, CA:
2,597,761, CANC. INT. CL. 9.

PROMISE TECHNOLOGY, INC., MILPITAS, CA:
2,597,760, CANC. INT. CL. 9.

PROMOTION COMPANY, INC., THE, INDIANAPOLIS, IN:
2,599,822, CANC. INT. CL. 41.

PROMOTIONSTAT, INC., FORT LEE, NJ:
2,598,141, CANC. INT. CL. 35.

PROMUTUAL GROUP, INC., BOSTON, MA:
3,632,517, INT. CL. 36.

PRONATURAMEX, INC., SANTA FE, CA:
3,629,299, PUB. 3-17-2009. MULTIPLE CLASS, INT. CLS. 3, 5 AND 35.

PROPERTY MUSIC GROUP, LLC, HOUSTON, TX:
3,632,867, INT. CL. 9.

PROPERTYMANAGERZ.COM, INC., KIRKLAND, WA:
2,598,797, CANC. MULTIPLE CLASS, INT. CLS. 35, 36 AND 38.

PROSKALO INC., CALABASAS, CA:
3,629,563, PUB. 3-17-2009. INT. CL. 42.

PROTEAM, INC., BOISE, ID:
3,631,278, PUB. 3-17-2009. INT. CL. 7.

PROTECH CHEMICALS LTD/PROTECH CHIMIE LTEE, SAINT-LAURENT, QUEBEC, CANADA:
3,631,436, PUB. 3-17-2009. INT. CL. 2.

PROUDFIT, CHARLES L., CINCINNATI, OH, DBA SKILL-SOURCE:
2,174,566, CANC. MULTIPLE CLASS, INT. CLS. 35 AND 41.

PROVIDENCE COMPANIES, LLC, COLLEGEVILLE, PA:
3,631,977, INT. CL. 43.

PRUDEAUX, MARK, NORTHRIDGE, CA:
3,633,148, INT. CL. 25.

PRUITT, MIKE, LIMA, OH, DBA LIMA FORD, INC.:
2,598,673, CANC. INT. CL. 36.

PSC INC., WEBSTER, NY:
2,596,429, CANC. INT. CL. 9.

PSIBER DATA SYSTEMS, INC., SAN DIEGO, CA:
2,599,552, CANC. INT. CL. 9.

PST PRODUCTS, INC., ATLANTA, GA:
2,597,188, CANC. INT. CL. 9.

PSYCHIATRIC SOLUTIONS, INC., FRANKLIN, TN:
3,630,989, PUB. 3-17-2009. INT. CL. 35.

PSYOP, INC., NEW YORK, NY:
3,629,644, PUB. 3-17-2009. MULTIPLE CLASS, INT. CLS. 35 AND 41.

PUBLIGROUPE S.A., LAUSANNE, SWITZERLAND:
2,597,502, CANC. MULTIPLE CLASS, INT. CLS. 35 AND 41.

PUBLIX SUPER MARKETS, INC., LAKELAND, FL:
2,599,236, CANC. INT. CL. 35.

PULIDO, LUIS, LOS ANGELES, CA:
2,200,503. REN. 4-24-09. INT. CL. 25.

PULLEY WORKS ENTERPRISES, INC., GRAY, TN, DBA PARAFROG AIRSOFT, INC.:
3,630,520, PUB. 3-17-2009. INT. CL. 35.

PULSAFEEDER, INC., ROCHESTER, NY, ECO ENGINEERING COMPANY, DIVISION OF ECONOMY FAUCET COMPANY, NEWARK, NJ:
671,144. REN. 4-28-09. U.S. CL. 23 (INT. CL. 7).

PUNZ TEC SRL, ITALY:
3,631,623, PUB. 3-17-2009. INT. CL. 7.

PURATOS BAKERY SUPPLY, INC., CHERRY HILL, NJ:
2,253,927. REN. 4-25-09. INT. CL. 30.

PURCELLVILLE ENTERTAINMENT, INC., BEVERLY HILLS, CA:
3,631,923, INT. CL. 41.

PURE & NATURAL COMPANY, SCOTTSDALE, AZ:
2,598,951, CANC. INT. CL. 5.

PURE FISHING, INC., SPIRIT LAKE, IA:
2,599,155, CANC. INT. CL. 28.

PURI COMPANY LIMITED, BANGKOK 10400, THAILAND:
3,629,768, PUB. 3-17-2009. INT. CL. 3.

PURITY ORGANICS, INC., FRESNO, CA:
3,633,150, MULTIPLE CLASS, INT. CLS. 35 AND 40.

PURPLE MOUNTAIN PRESS MEDIA COMPANY, PORTLAND, OR:
2,598,960, CANC. INT. CL. 16.

PURSUIT SOCCER CLUB, INC., SPRING, TX:
2,597,387, CANC. INT. CL. 41.

PWB-RUHLATEC INDUSTRIEPRODUKTE GMBH, FED REP GERMANY:
3,631,720, PUB. 3-17-2009. MULTIPLE CLASS, INT. CLS. 7, 9, 16, 35 AND 42.

PYNG MEDICAL CORP., RICHMOND, B.C., CANADA:
3,631,066, PUB. 3-17-2009. INT. CL. 10.

PYRAMID BREWERIES INC., SEATTLE, WA:
3,630,660, PUB. 3-17-2009. INT. CL. 32.

QDIRECT VENTURES, INC., WEST CHESTER, PA:
2,599,241, CANC. INT. CL. 41.

QED INTERNATIONAL, LLC, LOS ANGELES, CA:
3,633,238, INT. CL. 41.

QHEMET BIOLOGICS, INC., TAMPA, FL:
3,633,299, INT. CL. 3.

QIAQIA FOOD CO., LTD., HEFEI, ANHUI, CHINA:
3,631,486, PUB. 3-17-2009. INT. CL. 31.

QINGWEN XU, LOS ANGELES, CA:
3,630,591, PUB. 3-17-2009. INT. CL. 18.

QLIKTECH INTERNATIONAL AB, SE-223 70 LUND, SWEDEN:
3,631,718, PUB. 3-17-2009. MULTIPLE CLASS, INT. CLS. 9 AND 42.

QPA L.L.C., MONTVILLE, NJ:
2,597,107, CANC. INT. CL. 35.

QSR INTERNATIONAL PTY LTD (ACN 006 357 213), BUNDOORA, AUSTRALIA:
2,599,465, CANC. INT. CL. 9.

QUAD/GRAPHICS, INC., SUSSEX, WI:
2,596,963, CANC. MULTIPLE CLASS, INT. CLS. 35 AND 42.

QUADRANT HEALTHCOM INC., CHATHAM, NJ:
2,598,792, CANC. MULTIPLE CLASS, INT. CLS. 9, 35 AND 41.

QUADRANT INFORMATION SERVICES, LLC, RENO, NV:
3,630,062, PUB. 3-17-2009. INT. CL. 36.

QUADRANT STRUCTURED PRODUCTS COMPANY, LTD., NORWALK, CT:
3,630,694, PUB. 3-17-2009. INT. CL. 36.

QUADREM INTERNATIONAL, LTD, HAMILTON, BERMUDA:
3,633,347, INT. CL. 35.

QUALCOMM INCORPORATED, SAN DIEGO, CA:
2,597,924, CANC. INT. CL. 9.
3,631,990, MULTIPLE CLASS, INT. CLS. 35, 38 AND 41.

QUALITY DAIRY COMPANY, LANSING, MI:
3,629,198, PUB. 3-17-2009. INT. CL. 30.

QUALITY OF LIFE LABS, PURCHASE, NY:
3,632,828, INT. CL. 5.
3,632,925, INT. CL. 5.

QUALTE, LOS ANGELES, CA:
2,597,569, CANC. INT. CL. 42.

QUANTUM3D, SAN JOSE, CA:
3,629,612, PUB. 3-17-2009. INT. CL. 9.

QUEUE SYSTEMS, INC., COLUMBIA, SC:
2,596,616, CANC. MULTIPLE CLASS, INT. CLS. 9 AND 42.

QUICK FITTING, INC., TIVERTON, RI:
3,630,854, PUB. 3-17-2009. MULTIPLE CLASS, INT. CLS. 6 AND 11.

QUICK SILVER ASSOC., INC, CHICAGO, IL:
2,599,684, CANC. INT. CL. 9.

QUICK TICK INTERNATIONAL, INC., HOUSTON, TX:
2,598,079, CANC. INT. CL. 42.

QUICKEN LOANS INC., LIVONIA, MI:
3,629,416, PUB. 3-17-2009. INT. CL. 36.

QUICKLAW AMERICA INC., BETHPAGE, NY:
2,596,783, CANC. INT. CL. 42.

QUICKLY CORPORATION, HAYWARD, CA:
3,629,863, PUB. 3-17-2009. INT. CL. 43.

- QUIETFLEX MANUFACTURING COMPANY, L.P., HOUSTON, TX:
2,598,328, CANC. INT. CL. 19.
- QVD USA LLC, BELLEVUE, WA:
3,630,119, PUB. 3-17-2009. INT. CL. 29.
- QWEST COMMUNICATIONS INTERNATIONAL INC., DENVER, CO, U S WEST, INC., DENVER, CO:
2,333,654, REN. 4-27-09. INT. CL. 38.
- QWEST COMMUNICATIONS INTERNATIONAL INC., DENVER, CO:
2,597,748, CANC. INT. CL. 16.
2,598,786, CANC. INT. CL. 36.
3,629,337, PUB. 3-17-2009. MULTIPLE CLASS, INT. CLS. 3 AND 25.
3,632,838, INT. CL. 42.
- R + A DESIGN, LLC, CHICAGO, IL:
3,633,331, MULTIPLE CLASS, INT. CLS. 24 AND 35.
- R.A. ALLEN COMPANY, INC., VERO BEACH, FL:
3,632,233, INT. CL. 12.
- R.L. HUDSON & COMPANY, BROKEN ARROW, OK, DBA RL HUDSON:
3,629,361, PUB. 3-17-2009. MULTIPLE CLASS, INT. CLS. 7, 12, 17 AND 40.
- R& B LEASING, FRUITA, CO:
3,632,588, INT. CL. 37.
- R-P PACKAGING, INC., COLUMBUS, GA:
1,496,772, CANC. INT. CL. 17.
- RADALINK, INC., ATLANTA, GA:
3,629,285, PUB. 3-17-2009. INT. CL. 9.
- RADIANT OPTICS, INC., WOODINVILLE, WA:
3,630,858, PUB. 3-17-2009. INT. CL. 11.
- RADIO SPIRITS, INC., CEDAR KNOLLS, NJ:
2,597,292, CANC. INT. CL. 9.
- RADIOLOGICAL IMAGING TECHNOLOGY, INC., COLORADO SPRINGS, CO:
3,632,565, MULTIPLE CLASS, INT. CLS. 9, 42 AND 44.
- RADIX INTERNATIONAL LLC, EAST ALTON, IL:
3,632,160, MULTIPLE CLASS, INT. CLS. 35, 36 AND 42.
- RAE SYSTEMS INC., SAN JOSE, CA:
3,631,135, PUB. 3-17-2009. INT. CL. 9.
- RAE, SHARA, CHICAGO, IL:
3,630,765, PUB. 3-17-2009. INT. CL. 41.
- RAGE RECORDS INC, KERHONKSON, NY, DBA ROSALIE SENDELBACH IMPORTS:
3,629,825, PUB. 3-17-2009. INT. CL. 33.
- RAGE WRAPS, INC., BARTLETT, IL:
3,629,719, PUB. 3-17-2009. INT. CL. 42.
- RAGEVOL LLC, TORRANCE, CA:
3,631,034, PUB. 3-17-2009. INT. CL. 25.
- RAINBOW CAPITAL GMBH, FED REP GERMANY:
3,631,569, PUB. 3-17-2009. INT. CL. 25.
- RAINMAKER MARKETING, INC., RALEIGH, NC:
1,496,991, CANC. INT. CL. 35.
- RAISIN SOCIAL LIMITED, GODSTONE, UNITED KINGDOM:
2,597,024, CANC. INT. CL. 33.
- RALINK TECHNOLOGY CORPORATION, HSIN-CHU, TAIWAN:
3,629,417, PUB. 3-17-2009. INT. CL. 42.
- RAMISCH, ROLF P., D-47800 KREFELD, FED REP GERMANY:
2,596,648, CANC. INT. CL. 7.
- RAPID PACKAGING INC., MINNEAPOLIS, MN:
2,174,365, CANC. INT. CL. 35.
- RAPID SHEET METAL INC., NASHUA, NH:
3,630,402, PUB. 3-17-2009. INT. CL. 40.
- RAPOI, INC., LAKE OSWEGO, OR:
3,632,577, MULTIPLE CLASS, INT. CLS. 16 AND 22.
3,632,578, MULTIPLE CLASS, INT. CLS. 16 AND 22.
- RATH, MATTHIAS, CAPE TOWN, SOUTH AFRICA:
2,708,333, CANC. MULTIPLE CLASS, INT. CLS. 16 AND 32.
2,726,201, CANC. MULTIPLE CLASS, INT. CLS. 16 AND 41.
- RAVE SPORTS, INC., VADNAIS HEIGHTS, MN:
3,629,832, PUB. 3-17-2009. INT. CL. 28.
- RAVEN'S BREW COFFEE, INC., TUMWATER, WA:
3,630,197, PUB. 3-17-2009. INT. CL. 30.
- RAVENBRICK LLC, DENVER, CO:
3,633,236, INT. CL. 42.
- RAWLINGS SPORTING GOODS COMPANY, INC., TULLAHOMA, TN:
3,630,076, PUB. 3-17-2009. INT. CL. 28.
- RAY MARKS CO. LLC, NEW YORK, NY:
3,632,445, INT. CL. 31.
3,632,446, INT. CL. 31.
- RAY, KALI, MALIBU, CA:
2,596,642, CANC. INT. CL. 41.
- RAYLINK INC., BALDWIN PARK, CA:
2,599,106, CANC. INT. CL. 9.
- RAYMA COMPANIES CO., CARROLLTON, VA, DBA LUXURY TRESS BY MARCIA:
3,629,371, PUB. 3-17-2009. INT. CL. 26.
- RAYMER, ROBIN, CANTON, IL:
2,597,333, CANC. INT. CL. 41.
- RAYMOND JAMES FINANCIAL, INC., ST. PETERSBURG, FL:
3,632,417, INT. CL. 36.
- RAYOVAC CANADA INC., BRIDGETON, MO:
1,496,354, CANC. MULTIPLE CLASS, INT. CLS. 1 AND 5.
- RAYPAK, INC., OXNARD, CA, RAYPAK COMPANY, INC., SOUTH EL MONTE, CA:
868,408, REN. 4-30-09. U.S. CL. 34 (INT. CL. 11).
- RAYSPAN CORPORATION, SAN DIEGO, CA:
3,632,652, INT. CL. 9.
3,632,653, INT. CL. 9.
- RDSP ACQUISITION, INC., HOUSTON, TX:
2,598,578, CANC. INT. CL. 9.
- REA, KATHRYN TURNER, VISTA, CA:
2,597,313, CANC. INT. CL. 16.
- READABLE PRESS LLC, BLUE BELL, PA:
3,632,240, INT. CL. 41.
- READER'S DIGEST ASSOCIATION, INC., THE, PLEASANTVILLE, NY:
2,596,798, CANC. MULTIPLE CLASS, INT. CLS. 35, 38 AND 41.
- READER'S DIGEST ASSOCIATION, INC., THE, PLEASANTVILLE, NY:
2,596,842, CANC. MULTIPLE CLASS, INT. CLS. 35, 38 AND 41.
- REAL ESTATE BUSINESS SERVICES, INC., LOS ANGELES, CA:
3,630,228, PUB. 3-17-2009. INT. CL. 9.
- REAL MAGNET, LLC, WASHINGTON, DC:
2,597,258, CANC. INT. CL. 42.
- REAL WASABI, LLC, HILTON HEAD ISLAND, SC:
3,633,135, INT. CL. 30.
- REALINVESTOR SOFTWARE, LLC, SARASOTA, FL:
3,632,889, INT. CL. 42.
- REALNETWORKS, INC., SEATTLE, WA:
2,174,595, CANC. INT. CL. 42.
2,599,513, CANC. INT. CL. 9.
- REALO DISCOUNT DRUG STORES, INC, KINSTON, NC:
2,598,116, CANC. INT. CL. 35.
- REBEL VISIONS INCORPORATED, WHITE PLAINS, NY:
2,597,705, CANC. INT. CL. 9.
- RECALLED PRODUCTS, INC., NEWPORT BEACH, CA:
2,599,820, CANC. INT. CL. 42.
- RECETAS PARA LA VIDA LLC, SAN DIEGO, CA:
3,630,886, PUB. 3-17-2009. INT. CL. 16.
- RECIPROCAL OF AMERICA, GLEN ALLEN, VA:
2,596,943, CANC. INT. CL. 36.
2,599,097, CANC. INT. CL. 36.
- RECK, GARY, SPARKS, NV:
2,598,212, CANC. INT. CL. 8.
- RECKITT BENCKISER INC., PARSIPPANY, NJ:
2,598,526, CANC. INT. CL. 3.
- RECKITT BENCKISER INC., WAYNE, NJ:
2,599,535, CANC. INT. CL. 5.
- RECKITT BENCKISER N.V., HOOFFDORP, NETHERLANDS:
2,599,640, CANC. INT. CL. 3.
- RECKITT BENCKISER, INC., PARSIPPANY, NJ:
3,629,797, PUB. 3-17-2009. INT. CL. 5.
3,633,348, INT. CL. 5.
3,633,349, INT. CL. 5.

RECONNECTO, LLC, SAN ANTONIO, TX:
3,631,893, INT. CL. 42.

RECRUIT CO., LTD., TOKYO, JAPAN:
3,631,607, PUB. 3-17-2009. MULTIPLE CLASS, INT. CLS. 16, 35, 43 AND 45.

RED & WHITE FLEET EXCURSIONS, INC., SAN FRANCISCO, CA:
3,633,479, INT. CL. 39.

RED BOY FRANCHISING CORP., SAN RAFAEL, CA:
1,497,271, CANC. INT. CL. 42.

RED CLOUD, LLC, FULLERTON, CA:
2,597,336, CANC. MULTIPLE CLASS, INT. CLS. 25 AND 35.

RED JACKET MOUNTAIN VIEW, LLC, NORTH CONWAY, NH:
3,630,651, PUB. 3-17-2009. INT. CL. 41.

RED LIGHT, LLC, TOLLAND, CT:
3,630,233, PUB. 3-17-2009. INT. CL. 9.

RED RACING PARTS D.I.; DI GIOVANNI BERTONE, ITALY:
3,631,501, PUB. 3-17-2009. INT. CL. 12.

RED SPRING COMMUNICATIONS, INC., SARATOGA SPRINGS, NY:
2,597,600, CANC. INT. CL. 16.

REDICLINIC LLC, HOUSTON, TX:
3,632,274, INT. CL. 44.

REDIRECTIONS, INC., WESTMONT, IL:
1,536,965, REN. 4-27-09. INT. CL. 42.

REDLINE, ENGLEWOOD, CO:
3,629,600, PUB. 3-17-2009. MULTIPLE CLASS, INT. CLS. 36 AND 41.

REDSHIRTIMAGING, LLC, DECATUR, GA:
2,598,763, CANC. INT. CL. 10.

REDSTONE GROUP, LTD., HOUSTON, TX:
2,599,038, CANC. INT. CL. 36.

REEBOK INTERNATIONAL LTD., CANTON, MA:
3,633,058, INT. CL. 25.
3,633,335, MULTIPLE CLASS, INT. CLS. 18, 25 AND 28.

REECE, CONNIE, AUSTIN, TX:
3,629,606, PUB. 3-17-2009. INT. CL. 36.

REED ELSEVIER PROPERTIES INC., WILMINGTON, DE:
2,337,748, REN. 4-24-09. INT. CL. 42.
2,596,822, CANC. MULTIPLE CLASS, INT. CLS. 16 AND 42.
3,630,059, PUB. 3-17-2009. INT. CL. 42.
3,632,462, INT. CL. 41.

REEF CHECK FOUNDATION, PACIFIC PALISADES, CA:
3,629,744, PUB. 3-17-2009. INT. CL. 35.

REFINEMENT CANADA INC., RICHMOND HILL, ONTARIO, CANADA:
3,632,029, INT. CL. 28.

REFUND REALTY & MORTGAGE, LLC, HOUSTON, TX:
3,629,161, PUB. 3-17-2009. INT. CL. 36.

REFUSE2COMPROMISE, LLC, ANDERSON, SC:
3,631,213, PUB. 3-17-2009. INT. CL. 25.

REGAN, PETER, J, BARRINGTON, RI:
2,598,166, CANC. INT. CL. 9.

REGIONAL BOND DEALERS ASSOCIATION, INC., ALEXANDRIA, VA:
3,629,212, PUB. 3-17-2009. INT. CL. 35.

REGIONALBEST.COM, LLC, BALA CYNWYD, PA:
3,633,384, INT. CL. 35.

REGIONS ASSET COMPANY, WILMINGTON, DE:
2,599,308, CANC. INT. CL. 36.
2,599,309, CANC. INT. CL. 36.
2,599,310, CANC. INT. CL. 36.

REGIS INC., MINNEAPOLIS, MN:
3,630,441, PUB. 3-17-2009. INT. CL. 44.

REGUS MANAGEMENT LIMITED, CHERTSEY, SURREY, KT16 ORS, UNITED KINGDOM:
2,596,655, CANC. MULTIPLE CLASS, INT. CLS. 35 AND 42.

REHABCARE GROUP, INC., ST. LOUIS, MO:
3,630,472, PUB. 3-17-2009. INT. CL. 35.
3,630,473, PUB. 3-17-2009. INT. CL. 35.

REHRIG PACIFIC COMPANY, LOS ANGELES, CA:
1,496,805, CANC. INT. CL. 20.

REICH, JOSEF, 60596 FRANKFURT AM MAIN, FED REP GERMANY, DBA FAIR PLANET:
2,596,652, CANC. MULTIPLE CLASS, INT. CLS. 9, 16, 25, 35, 36, 38, 41 AND 42.

REID, DEBORAH, ROCKPORT, MA:
3,630,480, PUB. 3-17-2009. INT. CL. 44.

RELAXACIZOR PRODUCTS, INC., ATLANTA, GA:
3,630,351, PUB. 3-17-2009. INT. CL. 10.

RELIANCE ORTHODONTIC PRODUCTS, INC., ITASCA, IL:
2,286,648, REN. 4-28-09. INT. CL. 5.
2,287,674, REN. 4-27-09. INT. CL. 5.

REMNANT FELLOWSHIP, BRENTWOOD, TN:
2,597,992, CANC. INT. CL. 9.

REMNANT OF ISRAEL, INC., SAVANAH, GA:
2,597,359, CANC. MULTIPLE CLASS, INT. CLS. 36 AND 42.

REMOTIS TECHNOLOGIES LLC, ALPHARETTA, GA:
3,632,502, MULTIPLE CLASS, INT. CLS. 9 AND 42.

REMPAC L.L.C., ROCHELLE PARK, NJ:
3,630,775, PUB. 3-17-2009. INT. CL. 21.

RENAULT S.A.S., BOULOGNE-BILLANCOURT, FRANCE:
2,705,664, CANC. INT. CL. 9.

RENTAL LINK, LLC, FORT MYERS, FL:
3,631,832, INT. CL. 36.

REPLAY SOLUTIONS, INC., REDWOOD CITY, CA:
3,632,026, MULTIPLE CLASS, INT. CLS. 9 AND 42.

REPROS THERAPEUTICS INC, THE WOODLANDS, TX:
3,629,764, PUB. 3-17-2009. INT. CL. 42.

REPUBLIC BANK & TRUST COMPANY, LOUISVILLE, KY:
3,630,758, PUB. 3-17-2009. INT. CL. 36.

RESORT LIVE, INC., BEVERLY HILLS, CA:
2,599,024, CANC. INT. CL. 41.

RESOURCE 360, INC., NORCROSS, GA:
2,598,996, CANC. INT. CL. 35.

RESTIVO, SANDRA, KANSAS CITY, MO AND NUCKOLLS, DEBBIE, KANSAS CITY, MO:
3,629,415, PUB. 3-17-2009. INT. CL. 25.

RESTORATION SERVICES, INC., SACRAMENTO, CA:
2,597,906, CANC. INT. CL. 41.
2,597,907, CANC. INT. CL. 41.

RETAIL ROYALTY COMPANY, LAS VEGAS, NV:
3,633,124, INT. CL. 25.

RETAIL SOLUTION CENTER, INC., FREEPORT, NY:
3,629,141, PUB. 3-17-2009. INT. CL. 20.

RETINA CONSULTANTS OF SOUTHWEST FLORIDA, P.A., FORT MYERS, FL:
3,631,010, PUB. 3-17-2009. INT. CL. 44.

RETROFITNESS IP, LLC, COLTS NECK, NJ:
3,630,668, PUB. 3-17-2009. INT. CL. 41.

REUSS, DAVID, NEW YORK, NY:
3,630,153, PUB. 3-17-2009. INT. CL. 42.

REUVENI, ABRAHAM, VAN NUYS, CA, DBA ROYAL COURT COOKIE COMPANY AND REUVENI, KAREN, VAN NUYS, CA, DBA ROYAL COURT COOKIE COMPANY:
1,496,932, CANC. INT. CL. 30.

REVIVE PARTNERSHIP, NASHVILLE, TN:
3,630,018, PUB. 3-17-2009. INT. CL. 9.
3,630,019, PUB. 3-17-2009. INT. CL. 41.

REVLON CONSUMER PRODUCTS CORPORATION, NEW YORK, NY:
2,599,617, CANC. INT. CL. 3.
3,632,188, INT. CL. 3.

REXAM CLOSURE SYSTEMS INC., PERRYSBURG, OH:
3,631,883, INT. CL. 20.

REXROTH STAR GMBH, SCHWEINFURT, FED REP GERMANY:
3,631,375, PUB. 3-17-2009. MULTIPLE CLASS, INT. CLS. 6 AND 20.

REZENERATION, INC., LOS ANGELES, CA:
3,629,327, PUB. 3-17-2009. INT. CL. 44.

RFD INC, EDEN PRAIRIE, MN:
2,599,227, CANC. INT. CL. 28.

RFD, INC., MINNETRISTA, MN:
2,598,267, CANC. INT. CL. 3.

RGB SYSTEMS, INC., ANAHEIM, CA:
3,632,587, INT. CL. 9.

- RHEE, JUNG HUN, KANGDONG-KU; SEOUL, REPUBLIC OF KOREA:
3,631,779, PUB. 3-17-2009. INT. CL. 25.
- RHEON AUTOMATIC MACHINERY CO., LTD., UTSUNOMIYA CITY, JAPAN:
3,632,035, MULTIPLE CLASS, INT. CLS. 30 AND 43.
- RHINO ENTERTAINMENT COMPANY, BURBANK, CA:
2,287,060. REN. 4-29-09. INT. CL. 9.
- RHINO LININGS USA, INC., SAN DIEGO, CA:
3,629,380, PUB. 3-17-2009. MULTIPLE CLASS, INT. CLS. 2 AND 40.
- RHK, INC, BOULDER, CO:
2,596,667, CANC. MULTIPLE CLASS, INT. CLS. 35 AND 36.
- RHYTHM & BLUE INC. LIMITED, WEST SUSSEX, UNITED KINGDOM:
3,630,132, PUB. 3-17-2009. INT. CL. 3.
- RIBBIT CORPORATION, MOUNTAIN VIEW, CA, DBA DUALITY, INC.:
3,629,401, PUB. 3-17-2009. MULTIPLE CLASS, INT. CLS. 38 AND 39.
3,629,402, PUB. 3-17-2009. MULTIPLE CLASS, INT. CLS. 38 AND 39.
- RICE INVESTMENTS, LP, HANOVER, PA:
3,632,933, INT. CL. 30.
- RICE, DOUGLAS R., DALLAS, TX, DBA THE FITWIT GROUP, LLC:
3,629,325, PUB. 3-17-2009. INT. CL. 44.
- RICE, MARK, CUMMING, GA:
2,597,946, CANC. INT. CL. 28.
- RICH TASTE, INC., LAS VEGAS, NV:
3,629,387, PUB. 3-17-2009. INT. CL. 25.
- RICHARD E. THIBAUT, INC., NEWARK, NJ:
2,597,420, CANC. INT. CL. 27.
- RICHARDS, FIONA MCGREGOR, KATY, TX, DBA PRIVILEGED PETS LLC AND RICHARDS, JOHN P, KATY, TX, DBA PRIVILEGED PETS LLC:
3,630,533, PUB. 3-17-2009. INT. CL. 45.
- RICHARDSON-VICKS INC., CINCINNATI, OH:
867,818. REN. 4-24-09. U.S. CL. 18 (INT. CL. 5).
- RICHEMONT ITALIA S.P.A., ITALY:
3,631,636, PUB. 3-17-2009. INT. CL. 16.
- RICHMOND, BRODICK G, SOUTH HOLLAND, IL:
3,630,903, PUB. 3-17-2009. INT. CL. 41.
- RICHPEACE TECHNOLOGY LIMITED, VERNON, CA:
2,597,401, CANC. INT. CL. 7.
- RICK MERITT INVESTMENTS, LTD., GILMER, TX:
3,629,190, PUB. 3-17-2009. MULTIPLE CLASS, INT. CLS. 7 AND 21.
- RICK SEIM REAL ESTATE, L.L.C., KIRKLAND, WA:
2,598,051, CANC. INT. CL. 36.
- RICNO TECHNOLOGIES, INC., RANCHO CUCAMONGA, CA:
3,630,869, PUB. 3-17-2009. INT. CL. 40.
- RICOLA AG, LAUFEN, SWITZERLAND:
2,175,001, CANC. MULTIPLE CLASS, INT. CLS. 5 AND 30.
- RICOS INTELLECTUAL PROPERTY, LTD., SAN ANTONIO, TX:
3,630,286, PUB. 3-17-2009. MULTIPLE CLASS, INT. CLS. 29 AND 30.
- RIENZI & RIENZI COMMUNICATIONS, INC., MONTVILLE, NJ:
3,631,312, PUB. 3-17-2009. INT. CL. 35.
- RIGGS, RANDALL S., SEATTLE, WA:
2,174,779, CANC. INT. CL. 35.
- RIGO S.R.L., ITALY:
3,631,760, PUB. 3-17-2009. MULTIPLE CLASS, INT. CLS. 7 AND 8.
- RIMINI FIERA S.P.A., 47900 RIMINI, ITALY:
3,632,544, INT. CL. 43.
3,632,545, INT. CL. 41.
3,632,546, INT. CL. 16.
- RIMINI FIERA SPA, 47900 RIMINI, ITALY:
3,632,281, INT. CL. 16.
3,632,282, INT. CL. 35.
3,632,283, INT. CL. 41.
3,632,284, INT. CL. 43.
- RIMROCK AUTOMATION INC., FORT COLLINS, CO:
3,629,722, PUB. 3-17-2009. INT. CL. 7.
- RINK, DONNA M., ELGIN, IL AND RINK, DEBORAH M., ELGIN, IL:
3,632,149, INT. CL. 28.
- RISESMART, INC., SUNNYVALE, CA:
3,632,189, MULTIPLE CLASS, INT. CLS. 35 AND 41.
- RITA'S WATER ICE FRANCHISE COMPANY, LLC, TREVISO, PA:
3,631,989, INT. CL. 35.
- RKM PARTNERS IN TRUST, INC., SAN DIEGO, CA:
2,598,869, CANC. INT. CL. 35.
- RKS RESEARCH & CONSULTING, NORTH SALEM, NY:
2,599,583, CANC. INT. CL. 35.
- ROARING SPRING PAPER PRODUCTS CO., ROARING SPRING, PA:
2,599,381, CANC. INT. CL. 16.
- ROBBINS WEALTHPARTNERS LLC, BROOKFIELD, WI:
3,629,602, PUB. 3-17-2009. INT. CL. 36.
- ROBERT BOSCH GMBH, STUTTGART, FED REP GERMANY:
2,246,308. REN. 4-24-09. INT. CL. 37.
- ROBERT BOSCH GMBH, D-70839 GERLINGEN, FED REP GERMANY:
2,597,302, CANC. INT. CL. 7.
2,597,406, CANC. INT. CL. 9.
- ROBERT GRAHAM HOLDINGS LLC, NEW YORK, NY:
3,633,268, INT. CL. 25.
- ROBERT J. BURNS, APPLETON, WI:
2,596,587, CANC. INT. CL. 28.
- ROBERT L. O'BLOCK REVOCABLE TRUST, SPRINGFIELD, MO:
2,599,033, CANC. INT. CL. 42.
- ROBERT WOOD JOHNSON UNIVERSITY HOSPITAL, INC., NEW BRUNSWICK, NJ:
2,596,555, CANC. INT. CL. 42.
- ROBERTSHAW CONTROLS COMPANY, CAROL STREAM, IL, ROBERTSHAW-FULTON CONTROLS COMPANY, YOUNGWOOD, PA:
509,419. REN. 4-27-09. U.S. CL. 26 (INT. CL. 9).
- ROBERTSON-CECO II CORPORATION, CHICAGO, IL:
3,629,168, PUB. 3-17-2009. MULTIPLE CLASS, INT. CLS. 37 AND 42.
- ROBERTSON'S HAMS, INC., MARIETTA, OK:
3,629,301, PUB. 3-17-2009. INT. CL. 29.
- ROBINSON, JAMES G., PHILADELPHIA, PA:
3,629,318, PUB. 3-17-2009. INT. CL. 29.
- ROBINSON, TAMLA CLAUDETTE, BEVERLY HILLS, CA:
2,599,507, CANC. INT. CL. 25.
- ROCCHIO, ANTHONY, PROVIDENCE, RI:
2,598,619, CANC. MULTIPLE CLASS, INT. CLS. 9 AND 42.
- ROCK ON MOTORSPORTS MANAGEMENT, INC., ORANGE, CA:
3,629,651, PUB. 3-17-2009. INT. CL. 41.
- ROCKCRUSHER DIFFS 4X4 AXLE ASSEMBLIES PTY. LTD., MORNINGTON, VIC., AUSTRALIA:
3,633,402, INT. CL. 12.
- ROCKFORD CORPORATION, TEMPE, AZ:
2,597,744, CANC. INT. CL. 9.
2,598,164, CANC. INT. CL. 9.
- ROCKVIEW DAIRIES, INC., DOWNEY, CA:
3,632,861, MULTIPLE CLASS, INT. CLS. 29 AND 30.
- ROCKWARE, INC., GOLDEN, CO:
3,630,092, PUB. 3-17-2009. MULTIPLE CLASS, INT. CLS. 9, 41 AND 42.
- ROCKWOOD PIGMENTS NA, INC., BELTSVILLE, MD:
1,537,097. REN. 4-29-09. INT. CL. 2.
- ROCKY MOUNTAIN TECHNOLOGY GROUP, INC., BILLINGS, MT:
2,597,712, CANC. MULTIPLE CLASS, INT. CLS. 9, 16, 35, 41 AND 42.
- RODIN, JOHN B., CHESTERLAND, OH:
3,631,956, INT. CL. 21.
- RODRIGUEZ INTERNATIONAL PICTURES, L.P., AUSTIN, TX:
3,631,899, MULTIPLE CLASS, INT. CLS. 9 AND 41.

RODRIGUEZ, MOISES, MORENO VALLEY, CA:
3,630,451, PUB. 3-17-2009. INT. CL. 37.

RODRIGUEZ, RODRIGO, THE WOODLANDS, TX AND
RODRIGUEZ, BEATRIZ G., THE WOODLANDS, TX:
2,599,450, CANC. INT. CL. 33.

ROGERS, JIMY, WHEELING, IL:
3,630,158, PUB. 3-17-2009. INT. CL. 25.

ROLAND MEINL MUSIKINSTRUMENTE GMBH & CO. KG,
91413 NEUSTADT, AISCH, FED REP GERMANY:
3,629,241, PUB. 12-9-2008. MULTIPLE CLASS, INT. CLS. 9
AND 15.

ROLLIN' DICE PRODUCTIONS, LOS ANGELES, CA:
2,598,776, CANC. INT. CL. 41.

ROMAN DECORATING PRODUCTS, INC., CALUMET
CITY, IL:
3,632,135, INT. CL. 2.

ROMANO, JULIO MARIO, LOS ANGELES, CA:
3,633,088, INT. CL. 3.

RON ROBINSON, INC., LOS ANGELES, CA:
3,630,106, PUB. 12-9-2008. INT. CL. 25.

RONALD TRAHAN ASSOCIATES, INC., WESTWOOD, MA:
3,630,317, PUB. 3-17-2009. INT. CL. 9.

ROONEY, MICHELLE, GILBERT, AZ:
3,630,887, PUB. 3-17-2009. INT. CL. 35.

ROOSTERHEAD ANTIQUE HEART PINE & BRICK, INC.,
ROME, GA:
2,596,676, CANC. INT. CL. 19.

ROPER HOLDINGS, INC., WILMINGTON, DE:
3,629,928, PUB. 3-17-2009. INT. CL. 9.

RORAJ TRADE, LLC, NEW YORK, NY:
3,629,685, PUB. 3-17-2009. INT. CL. 18.

ROSANA BAMONTE AND M. VERONICA YZETA PART-
NERSHIP, THE, ALBUQUERQUE, NM:
2,599,554, CANC. INT. CL. 3.

ROSARIO, MIGUEL, BRIARWOOD, NY:
3,630,074, PUB. 3-17-2009. INT. CL. 41.

ROSE, CHARLIE, COSTA MESA, CA:
3,631,048, PUB. 3-17-2009. INT. CL. 41.

ROSEN ENTERTAINMENT SYSTEMS, L.P., CORONA, CA:
2,598,719, CANC. INT. CL. 9.

ROSEN, ALICE, CONCORD, MA:
3,630,722, PUB. 3-17-2009. INT. CL. 41.

ROSENBERG, JOAN, NEW YORK, NY:
2,598,902, CANC. INT. CL. 3.

ROSENTHAL & ROSENTHAL, INC., NEW YORK, NY:
869,541, REN. 4-26-09. U.S. CL. 102 (INT. CL. 36).

ROSS, GREG, FORT LAUDERDALE, FL:
3,633,301, INT. CL. 42.

ROSS, STEVEN HOPKINS, BRENTWOOD, CA:
2,401,071, CANC. INT. CL. 41.

ROSSANO, ANTHONY C., CHERRY HILL, NJ:
2,597,905, CANC. INT. CL. 42.
2,597,908, CANC. INT. CL. 42.

ROSSON, SALLY BAIN, BONDI BEACH, 2026 NSW, AUS-
TRALIA:
3,629,372, PUB. 3-17-2009. MULTIPLE CLASS, INT. CLS.
16, 25, 41 AND 45.

ROSSWIL, LLC, MEMPHIS, TN:
3,633,404, INT. CL. 35.

ROXY ENTERTAINMENT, BLOOMINGTON, IN:
2,598,062, CANC. INT. CL. 41.

ROYAL CARIBBEAN CRUISES LTD., MIAMI, FL:
2,598,066, CANC. INT. CL. 39.

ROYAL COPENHAGEN A/S, 2600 GLOSTRUP, DENMARK,
DEN KONGELIGE PORCELAINSFABRIK A/S, DK 2000
COPENHAGEN F, DENMARK, DBA ROYAL COPENHA-
GEN PORCELAIN MANUFACTORY LTD.:
1,109,322, REN. 4-28-09. INT. CL. 14.

ROYAL COUTURE, INC., LAS VEGAS, NV:
3,630,590, PUB. 3-17-2009. INT. CL. 26.

ROYAL RICH (CHINA) LTD., SHEUNG WAN, HONG
KONG:
3,629,470, PUB. 3-17-2009. INT. CL. 11.

ROYER, DANIEL, COURTENAY, CANADA:
3,630,908, PUB. 3-17-2009. INT. CL. 5.

RSMR GLOBAL RESOURCES, INC., CHICAGO, IL:
2,597,020, CANC. MULTIPLE CLASS, INT. CLS. 35 AND
42.

RUBBER STAMP MANAGEMENT, INCORPORATED,
BROWNS POINT, WA:
3,630,523, PUB. 3-17-2009. INT. CL. 35.
3,630,588, PUB. 3-17-2009. INT. CL. 35.

RUBBERMAID OFFICE PRODUCTS INC., MARYVILLE,
TN:
1,496,731, CANC. INT. CL. 16.

RUBYELLEN N. BRATCHER, CORONA, CA, DBA RU-
BYELLEN C. NAVALES:
3,629,810, PUB. 3-17-2009. INT. CL. 41.

RUDE AMERICAN MOTORCYCLE COMPANY, INC., HEN-
DERSON, NV:
2,599,373, CANC. INT. CL. 25.

RUFF WEAR, INC., BEND, OR:
3,630,484, PUB. 3-17-2009. INT. CL. 18.

RUIZ, JOSEPH R., SANTA MONICA, CA:
3,631,215, PUB. 3-17-2009. INT. CL. 35.

RUMSEY INDIAN RANCHERIA OF WINTUN INDIANS OF
CALIFORNIA, BROOKS, CA:
3,632,114, INT. CL. 33.

RUNBERG, INC., EASTON, PA, DBA ZEPHYRS:
3,632,598, INT. CL. 3.

RUNMYERRAND, INC., CHARLESTOWN, MA:
3,630,656, PUB. 3-17-2009. INT. CL. 35.

RUSSELL BRANDS, LLC, ALEXANDER CITY, AL:
1,496,890, CANC. INT. CL. 28.
2,598,440, CANC. INT. CL. 28.
2,645,314, CANC. INT. CL. 28.

RUSTIC ROOSTER, INC., ENCINITAS, CA:
3,630,986, PUB. 3-17-2009. MULTIPLE CLASS, INT. CLS.
20, 35 AND 42.

RUTKOFF, ANANDA CHARLES, PALM SPRINGS, CA:
2,599,476, CANC. INT. CL. 9.

RX SYSTEMS, INC., ST. CHARLES, MO:
2,309,907, REN. 4-27-09. INT. CL. 16.

RXR PROPERTY MANAGEMENT LLC, UNIONDALE, NY:
3,632,793, MULTIPLE CLASS, INT. CLS. 36 AND 37.

RYAN BASICS LLC, NEW YORK, NY:
3,633,326, MULTIPLE CLASS, INT. CLS. 3, 14, 18, 35 AND
44.

RYAN NEEDLES, LAKESIDE, CA:
3,630,757, PUB. 3-17-2009. INT. CL. 25.

RYSER ENTERTAINMENT, L.L.C., SANTA MONICA, CA:
2,174,650, CANC. INT. CL. 41.

S & J ASSOCIATES, INC., MOUNDS VIEW, MN, DBA STEIN
LITE TECHNOLOGIES, INC. AND MAGIC DISPLAY:
3,630,171, PUB. 3-17-2009. INT. CL. 35.

S A S SAFETY CORP., LONG BEACH, CA:
3,633,278, INT. CL. 9.

S. C. JOHNSON & SON, INC., RACINE, WI:
3,630,713, PUB. 3-17-2009. INT. CL. 21.

S. S. ADAMS, L.L.C., NEPTUNE, NJ:
3,631,294, PUB. 3-17-2009. INT. CL. 28.

S.A. BISCUITS CANTREAU, 85206 FONTENAY LE COMTE
CEDEX, FRANCE:
2,597,551, CANC. INT. CL. 30.

S.A. MAXWELL CO., MUNDELEIN, IL:
2,598,837, CANC. INT. CL. 16.

S.A.S. VENTURES, INC., LYNDHURST, OH:
1,534,883, REN. 4-24-09. INT. CL. 16.

S.P.C.M. SA, F-42000 SAINT-ETIENNE, FRANCE:
3,631,777, PUB. 3-17-2009. INT. CL. 1.

S.S. TARIS ZEYTIN VE ZEYTINYAGI TARIM SATIS
KOOPERATIFLERI BIRLIGI, ALSANCAK-IZMIR, TUR-
KEY:
3,631,378, PUB. 3-17-2009. MULTIPLE CLASS, INT. CLS.
1, 2, 3, 29, 30, 32, 39 AND 40.

S&S BRANDS, INC., WILMINGTON, DE:
2,597,585, CANC. INT. CL. 31.

S&S PROCESSING INCORPORATED, WEST PITTSBURG,
PA:
3,629,985, PUB. 3-17-2009. INT. CL. 19.

S-N MERGER CORP., RESTON, VA:
2,598,210, CANC. MULTIPLE CLASS, INT. CLS. 9 AND
38.

SABATINE, PHILIP J., WEATOGUE, CT, DBA MIDI CLAS-
SICS:
2,175,872, CANC. INT. CL. 9.

- SABEMO SA, CH-4002 BASEL, SWITZERLAND:
2,597,212, CANC. MULTIPLE CLASS, INT. CLS. 9 AND 42.
- SABERTOOTH MOTORCYCLES, LLC, PIEDMONT, SC:
3,630,879, PUB. 3-17-2009. INT. CL. 12.
- SABIC HOLDING EUROPE BV, NETHERLANDS:
3,631,597, PUB. 3-17-2009. MULTIPLE CLASS, INT. CLS. 1 AND 17.
- SABINE DEBRUS, GLONS, BELGIUM:
3,632,970, INT. CL. 14.
- SABRE GOLF LLC, UNIONTOWN, OH:
2,175,099, CANC. INT. CL. 28.
- SACILOTTO, ROBERT C., STANARDSVILLE, VA, DBA BOTANIQUE:
2,175,864, CANC. INT. CL. 31.
- SACRED HEART APOSTOLATE, INC., SYRACUSE, NY:
3,629,196, PUB. 3-17-2009. INT. CL. 45.
- SAEKS, FORD, WICHITA, KS:
3,630,139, PUB. 12-16-2008. INT. CL. 41.
- SAFARILAND, LLC, JACKSONVILLE, FL:
2,598,343, CANC. INT. CL. 9.
- SAFE STEP WALK IN TUB CO., NASHVILLE, TN:
3,630,113, PUB. 3-17-2009. INT. CL. 11.
3,630,114, PUB. 3-17-2009. INT. CL. 11.
- SAFEAWAKE, LLC, COLUMBIA, MD:
3,633,178, INT. CL. 9.
- SAFETY CORPORATION OF AMERICA, COMMERCE CITY, CO:
2,598,167, CANC. INT. CL. 19.
- SAFETY HARBOR FIREARMS, INC., SAFETY HARBOR, FL:
3,630,811, PUB. 3-17-2009. INT. CL. 35.
- SAFFORD, EDWARD W, SAN DIEGO, CA:
2,599,058, CANC. MULTIPLE CLASS, INT. CLS. 9 AND 16.
- SAFRAN, PARIS, FRANCE:
2,190,480, REN. 4-26-09. INT. CL. 12.
2,190,480, CANC. MULTIPLE CLASS, INT. CLS. 1, 7, 17 AND 19.
- SAGAMORE INSTITUTE OF THE ADIRONDACKS, RAQUETTE LAKE, NY:
3,633,389, INT. CL. 43.
- SAGEM SECURITE, PARIS, FRANCE:
3,630,617, PUB. 3-17-2009. INT. CL. 9.
- SAGINAW CONTROL & ENGINEERING, INC., SAGINAW, MI:
2,291,382, REN. 4-29-09. INT. CL. 9.
- SAGINAW MACHINES SYSTEMS, INC, SAGINAW, MI:
3,632,815, INT. CL. 7.
- SAHARA SAM'S OASIS, LLC, WEST BERLIN, NJ:
3,633,166, MULTIPLE CLASS, INT. CLS. 35 AND 41.
- SAHAREX INC., CITY OF COMMERCE, CA:
2,597,301, CANC. INT. CL. 33.
- SAID, SAED, IRVINE, CA AND SAID, SEPEHR, IRVINE, CA:
3,629,806, PUB. 3-17-2009. INT. CL. 35.
3,629,807, PUB. 3-17-2009. INT. CL. 35.
- SAIL STAR INC., TORTOLA, BR. VIRGIN ISLANDS:
1,561,795, REN. 4-24-09. INT. CL. 7.
- SAILOR CORPORATION OF AMERICA, INC., FAYETTEVILLE, GA:
2,599,294, CANC. INT. CL. 16.
- SAINT LUKE'S HOSPITAL OF BETHLEHEM, PENNSYLVANIA, BETHLEHEM, PA:
3,630,310, PUB. 3-17-2009. INT. CL. 44.
- SAINT LUKE'S HOSPITAL OF BETHLEHEM, PENNSYLVANIA, BETHLEHEM, PA:
3,630,312, PUB. 3-17-2009. INT. CL. 44.
- SAINT MAXIMUS LLC, PHILADELPHIA, PA:
3,632,994, INT. CL. 33.
- SAINT-GOBAIN CERAMICS & PLASTICS, INC., WORCESTER, MA:
2,175,408, CANC. INT. CL. 9.
3,631,332, PUB. 3-17-2009. INT. CL. 9.
- SAINT, ROXANNE, WEST HOLLYWOOD, CA:
3,631,447, PUB. 3-27-2007. INT. CL. 41.
- SAKAMURA INDUSTRIES INC., KYOTO 613, JAPAN:
2,598,229, CANC. INT. CL. 6.
- SALES COACHES INTERNATIONAL, LLC, PLANO, IL:
3,633,344, INT. CL. 35.
- SALES CONSULTANTS OF LAKE OSWEGO, LLC, LAKE OSWEGO, OR, DBA UNITED HUMAN CAPITAL SOLUTIONS:
3,632,927, INT. CL. 35.
- SALESTRONG LLC, ROCKVILLE, MD:
3,629,296, PUB. 10-14-2008. INT. CL. 42.
- SALINA VORTEX CORPORATION, SALINA, KS:
3,631,419, PUB. 10-30-2007. INT. CL. 7.
- SALLY LUNN'S, INC., CHESTER, NJ:
2,238,914, REN. 4-24-09. INT. CL. 42.
- SALOMON SMITH BARNEY INC., NEW YORK, NY:
2,598,997, CANC. INT. CL. 36.
- SALON LOFTS, LLC, COLUMBUS, OH:
3,632,468, INT. CL. 44.
- SALVATORE FERRAGAMO ITALIA S.P.A., ITALY:
3,631,593, PUB. 3-17-2009. INT. CL. 14.
- SAM ASH MUSIC CORPORATION, HICKSVILLE, NY:
3,632,595, MULTIPLE CLASS, INT. CLS. 15 AND 35.
- SAMBUSAC LLC, NAPLES, FL:
3,631,258, PUB. 3-17-2009. INT. CL. 30.
- SAMJIN GLOBALNET CO. LTD., SEOUL, REPUBLIC OF KOREA:
2,240,854, REN. 4-27-09. MULTIPLE CLASS, INT. CLS. 29, 30 AND 31.
- SAMPLES, J. DWAYNE, ROSWELL, GA:
3,630,468, PUB. 3-17-2009. INT. CL. 35.
- SAMSON, BERNARD F., HOUSTON, TX:
2,596,764, CANC. INT. CL. 28.
- SAMSONITE CORPORATION, DENVER, CO:
2,599,494, CANC. INT. CL. 18.
- SAMSUNG ELECTRONICS CO., LTD., GYEONGGI-DO, REPUBLIC OF KOREA:
3,629,567, PUB. 3-17-2009. INT. CL. 9.
- SAMSUNG ELECTRONICS CO., LTD., SUWON-SI, GYEONGGI-DO, REPUBLIC OF KOREA:
3,632,944, INT. CL. 9.
3,632,959, INT. CL. 9.
- SAMSUNG OPTO-ELECTRONICS AMERICA, INC., SECAUCUS, NJ:
2,175,627, CANC. INT. CL. 9.
- SAMUDRA CORPORATION, SANTA MONICA, CA:
2,599,555, CANC. INT. CL. 30.
- SAN FRANCISCO FORTY NINERS, LIMITED, SANTA CLARA, CA:
3,630,972, PUB. 3-17-2009. INT. CL. 41.
3,630,975, PUB. 3-17-2009. MULTIPLE CLASS, INT. CLS. 9, 25 AND 28.
- SANBORN THEATRES, INC., NEWPORT BEACH, CA:
3,632,722, INT. CL. 41.
- SANDERS, ANNE B., COVINGTON, LA:
2,597,272, CANC. INT. CL. 42.
- SANDLER & TRAVIS TRADE ADVISORY SERVICES, INC., MIAMI, FL:
2,231,867, REN. 4-24-09. MULTIPLE CLASS, INT. CLS. 35 AND 41.
- SANDLER, TRAVIS & ROSENBERG, P.A., MIAMI, FL:
2,240,341, REN. 4-24-09. INT. CL. 42.
- SANDRO HUGO CILINGO, BUENOS AIRES, ARGENTINA:
3,630,755, PUB. 3-17-2009. INT. CL. 41.
- SANDUSKY DISTRIBUTING COMPANY, INC., STREETS-BORO, OH:
2,598,399, CANC. MULTIPLE CLASS, INT. CLS. 9 AND 35.
- SANITORS, INC., SAN ANTONIO, TX:
2,596,747, CANC. INT. CL. 37.
- SANKO HOLDING ANONIM SIRKETI, SEHITKAMIL-GAZIANTEP, TURKEY:
3,632,052, MULTIPLE CLASS, INT. CLS. 25, 27, 29 AND 30.
- SANOFI-AVENTIS, FRANCE:
3,631,669, PUB. 3-17-2009. MULTIPLE CLASS, INT. CLS. 41 AND 44.
3,631,775, PUB. 3-17-2009. INT. CL. 5.
3,631,776, PUB. 3-17-2009. INT. CL. 5.
3,631,780, PUB. 3-17-2009. INT. CL. 5.

SANOFI-AVENTIS DEUTSCHLAND GMBH, 65926 FRANKFURT AM MAIN, FED REP GERMANY:
2,596,447, CANC. INT. CL. 10.

SANOY INC., NEW YORK, NY:
3,629,610, PUB. 3-17-2009. INT. CL. 14.

SANTA CRUZ BICYCLES, INC., SANTA CRUZ, CA:
3,631,044, PUB. 3-17-2009. INT. CL. 12.

SANTOS, EDWARD DOS, PHOENIX, AZ, DBA EDWARD DOS SANTOS, P.C.:
2,175,851, CANC. INT. CL. 42.

SANYANG INDUSTRY CO., LTD., HUKOU HSINCHU, TAIWAN:
3,632,176, MULTIPLE CLASS, INT. CLS. 4 AND 11.

SAPELEM; (SOCIÉTÉ PAR ACTIONS SIMPLIFIÉE), FRANCE:
3,631,629, PUB. 3-17-2009. INT. CL. 7.

SARA LEE BAKERY GROUP, INC., DOWNERS GROVE, IL:
3,631,900, INT. CL. 30.

SARA LEE DE/N.V., 3532 AD UTRECHT, NETHERLANDS:
3,633,082, INT. CL. 11.

SARAMAR CORPORATION, WILMINGTON, DE:
1,496,939, CANC. INT. CL. 30.

SARATOGA INSTITUTE, INC., SANTA CLARA, CA:
2,596,946, CANC. INT. CL. 35.

SARTOMER TECHNOLOGY COMPANY, INC., WILMINGTON, DE, SINCLAIR OIL CORPORATION, NEW YORK, NY:
870,278, REN. 4-27-09. U.S. CL. 1 (INT. CL. 1).

SARTORIA SAINT ANDREWS; MILANO S.P.A., ITALY:
3,631,648, PUB. 3-17-2009. MULTIPLE CLASS, INT. CLS. 3, 9 AND 18.

SASSY PRODUCT DEVELOPMENT AND MARKETING, INC., LAFAYETTE, CA:
2,599,459, CANC. INT. CL. 28.

SAULL, JEFFREY, PALM BEACH GARDENS, FL:
2,598,754, CANC. MULTIPLE CLASS, INT. CLS. 4 AND 21.

SAVILLE SYSTEMS PLC, GALWAY, IRELAND:
2,175,798, CANC. INT. CL. 9.

SAVING OPUS ONE, LLC, MARIETTA, GA, TA SOYGO:
3,630,478, PUB. 3-17-2009. INT. CL. 29.

SAVVYDINER.COM, INC., SEATTLE, WA:
2,596,804, CANC. INT. CL. 42.

SAWA AMANA & JAHA, INC., FAIRFIELD, CA:
3,632,855, MULTIPLE CLASS, INT. CLS. 9, 16, 18, 24 AND 25.

SAYEG PLASTIC SURGERY CENTER, WEST BLOOMFIELD, MI:
3,633,156, INT. CL. 44.

SAYEGH, JOSEPH, CORONA DEL MAR, CA:
3,629,668, PUB. 3-17-2009. INT. CL. 19.

SBE LICENSING, LLC, LOS ANGELES, CA:
3,633,233, INT. CL. 43.

SBI INC., SALT LAKE CITY, UT:
2,597,250, CANC. INT. CL. 42.

SBS TECHNOLOGIES, INC., ST. PAUL, MN:
2,598,843, CANC. INT. CL. 9.

SC INTERNATIONAL ENTERPRISES INC., VANCOUVER, BRITISH COLUMBIA, CANADA:
3,632,192, MULTIPLE CLASS, INT. CLS. 25 AND 35.

SCALE AUTO, REDMOND, WA:
3,630,055, PUB. 3-17-2009. INT. CL. 28.

SCALLO, DIANE, WESTWOOD, NJ:
3,632,717, MULTIPLE CLASS, INT. CLS. 5, 35 AND 44.

SCAN FOUNDATION, INC., ATLANTA, GA:
3,630,122, PUB. 12-9-2008. INT. CL. 35.

SCANA CORPORATION, COLUMBIA, SC:
3,633,313, INT. CL. 35.

SCANCODE SYSTEMS INC., FENELON FALLS, ONTARIO:
2,597,559, CANC. MULTIPLE CLASS, INT. CLS. 37 AND 42.

SCANSOURCE, INC., GREENVILLE, SC:
3,632,333, INT. CL. 35.

SCANTLIN, EUGENEIA, GLADSTONE, MO:
2,598,445, CANC. INT. CL. 3.

SCHABOW, JOHN, MAUMEE, OH, DBA SUPER STAR PRODUCTS:
2,174,982, CANC. MULTIPLE CLASS, INT. CLS. 3, 9 AND 15.

SCHAEFER, RICHARD B., FOND DU LAC, WI:
3,632,899, INT. CL. 44.

SCHAKOLAD CORPORATION, INC., ORLANDO, FL:
3,631,922, INT. CL. 41.

SCHALER, KAREN R., NEW YORK CITY, NY:
3,632,758, INT. CL. 41.

SCHARFFENBERGER CELLARS, INC., PHILO, CA:
2,175,673, CANC. INT. CL. 33.

SCHAUER, RICHARD L., FRISCO, NC AND SCHAUER, JULIE R., FRISCO, NC, DBA BUBBA'S BAR-B-Q:
2,596,433, CANC. INT. CL. 30.

SCHEER, RAINER, HOLMES BEACH, FL:
3,629,428, PUB. 3-17-2009. INT. CL. 41.

SCHERER, MICHAEL D., DECATUR, IL, DBA DREAMVISION PRODUCTIONS:
3,630,734, PUB. 3-17-2009. INT. CL. 41.

SCHERING CORPORATION, KENILWORTH, NJ:
3,629,670, PUB. 3-17-2009. INT. CL. 5.

SCHERING-PLOUGH HEALTHCARE PRODUCTS, INC., MEMPHIS, TN:
2,599,112, CANC. INT. CL. 3.
3,631,343, PUB. 3-17-2009. INT. CL. 25.
3,632,179, INT. CL. 10.
3,632,180, MULTIPLE CLASS, INT. CLS. 10 AND 25.

SCHICK, STEVEN WAYNE, ALISO VIEJO, CA:
2,599,447, CANC. INT. CL. 42.

SCHIFF NUTRITION INTERNATIONAL, INC., SALT LAKE CITY, UT:
3,632,376, INT. CL. 5.

SCHILLER CARD & GIFT LLC, SAN MATEO, CA:
3,632,614, INT. CL. 16.

SCHLAGE LOCK COMPANY, SAN FRANCISCO, CA:
2,598,911, CANC. INT. CL. 6.

SCHMIDT SIDING & WINDOW, INC., MANKATO, MN:
2,598,102, CANC. MULTIPLE CLASS, INT. CLS. 35 AND 37.

SCHMITZ, LARRY, SANTEE, CA:
3,633,441, INT. CL. 3.

SCHNEIDER, DAVID L., SAN DIEGO, CA:
2,599,826, CANC. INT. CL. 35.
2,599,829, CANC. INT. CL. 35.
2,599,830, CANC. INT. CL. 35.

SCHOCH, JUAN VICENTE, SOUTH DAYTONA, FL:
2,598,423, CANC. INT. CL. 42.

SCHOCK GMBH, REGEN, FED REP GERMANY:
2,244,201, REN. 4-29-09. INT. CL. 11.
2,244,201, CANC. MULTIPLE CLASS, INT. CLS. 6, 17, 19, 20 AND 22.

SCHOLARSHIP AMERICA, INC., ST. PETER, MN:
3,629,877, PUB. 3-17-2009. MULTIPLE CLASS, INT. CLS. 36 AND 41.

SCHOLASTIC INC., NEW YORK, NY:
2,597,419, CANC. INT. CL. 16.

SCHOOL & HOME OFFICE PRODUCTS ASSOCIATION, DAYTON, OH, DBA SHOPA:
2,596,880, CANC. MULTIPLE CLASS, INT. CLS. 35 AND 41.

SCHOOL OF THE ART INSTITUTE OF CHICAGO, THE, CHICAGO, IL:
2,250,777, REN. 4-24-09. INT. CL. 41.

SCHOOL SPECIALTY, INC., APPLETON, WI:
3,630,004, PUB. 3-17-2009. INT. CL. 16.

SCHOOL SPIRIT!!!, GRANDVILLE, MI:
2,596,696, CANC. INT. CL. 35.

SCHOOLHOUSE OUTFITTERS, LLC, NORWOOD, OH:
3,630,889, PUB. 3-17-2009. INT. CL. 35.

SCHOOLSTAFF, INC., PENNINGTON, NJ:
2,598,086, CANC. INT. CL. 35.

SCHOUTEN, ERIK, LITITZ, PA:
3,632,465, INT. CL. 6.

SCHREIBER, LLC, TRUSSVILLE, AL:
1,535,177, REN. 4-27-09. INT. CL. 11.
1,565,756, REN. 4-27-09. INT. CL. 11.
2,198,841, REN. 4-27-09. INT. CL. 11.
2,201,883, REN. 4-27-09. INT. CL. 11.

SCHUETZ, ROBERT J., DALLAS, TX:
3,633,343, INT. CL. 35.

- SCHULTZ JR., DONALD F., HUNTINGTON BEACH, CA:
3,631,073, PUB. 3-17-2009. INT. CL. 25.
- SCHURHAMMER MANUFACTURING, INC., WABASHA, MN:
3,631,845, INT. CL. 14.
- SCHWARZHEIDER KUNSTSTOFF- UND VERARBEITUNGSGESELLSCHAFT MBH, 02994 BERNSDORF, FED REP GERMANY:
2,597,331, CANC. MULTIPLE CLASS, INT. CLS. 5 AND 10.
- SCHWEITZER ENGINEERING LABORATORIES, INC., PULLMAN, WA:
3,630,460, PUB. 3-17-2009. INT. CL. 9.
3,630,461, PUB. 3-17-2009. INT. CL. 9.
3,630,465, PUB. 3-17-2009. INT. CL. 9.
3,630,466, PUB. 3-17-2009. INT. CL. 9.
3,632,966, INT. CL. 9.
- SCHÜCO INTERNATIONAL KG, BIELEFELD, FED REP GERMANY:
3,629,804, PUB. 3-17-2009. MULTIPLE CLASS, INT. CLS. 6, 9, 11 AND 19.
- SCHÜTZ GMBH & CO. KGAA, D-56242 SELTERS, FED REP GERMANY:
3,633,265, MULTIPLE CLASS, INT. CLS. 6, 20 AND 37.
- SCIENCE CENTER, PHILADELPHIA, PA:
3,632,916, INT. CL. 35.
- SCIENTIFIC IMAGE CENTER MANAGEMENT, L.L.C., TROY, MI:
3,629,662, PUB. 3-17-2009. INT. CL. 35.
- SCIENTIFIC MONITORING, INC., SCOTTSDALE, AZ:
3,112,963, AM. INT. CL. 9.
- SCITECK, INC., ARDEN, NC:
2,599,303, CANC. MULTIPLE CLASS, INT. CLS. 9 AND 16.
- SCOOTER SUPERSTORE OF AMERICA, INC., HOLLYWOOD, FL:
3,629,286, PUB. 3-17-2009. INT. CL. 12.
- SCOTT G. KELBY, OLDSMAR, FL:
3,631,156, PUB. 3-17-2009. INT. CL. 41.
- SCREAMING EAGLE WEB SOLUTIONS, LLC, LEHIGHTON, PA:
3,630,128, PUB. 3-17-2009. INT. CL. 39.
- SCRI HOLDINGS, LLC, NASHVILLE, TN:
3,629,675, PUB. 3-17-2009. MULTIPLE CLASS, INT. CLS. 35 AND 42.
- SCT PERFORMANCE, LLC, LONGWOOD, FL:
3,632,383, INT. CL. 9.
- SEA & GREEN, LLC, TOMS RIVER, NJ:
3,632,223, INT. CL. 35.
- SEA-PAC SALES COMPANY, KENT, WA:
3,633,411, INT. CL. 19.
- SEABIOTICS, INC., PROSPER, TX:
3,632,150, INT. CL. 5.
- SEAGATE TECHNOLOGY LLC, SCOTTS VALLEY, CA:
3,632,745, INT. CL. 9.
- SEAGRAVE FIRE APPARATUS, LLC, CLINTONVILLE, WI:
1,553,582, REN. 4-28-09. INT. CL. 9.
- SEALY TECHNOLOGY LLC, TRINITY, NC, SEALY, INCORPORATED, CHICAGO, IL:
677,335, REN. 4-24-09. U.S. CL. 32 (INT. CL. 20).
- SEALY TECHNOLOGY LLC, TRINITY, NC:
3,632,728, INT. CL. 20.
- SEARS BRANDS, LLC, HOFFMAN ESTATES, IL:
3,630,204, PUB. 3-17-2009. INT. CL. 35.
3,631,185, PUB. 3-17-2009. INT. CL. 35.
- SEARS PH.D., BARRY D., DANVERS, MA:
3,631,379, PUB. 3-17-2009. INT. CL. 39.
- SEARS, ROEBUCK AND CO., HOFFMAN ESTATES, IL:
2,596,529, CANC. INT. CL. 25.
2,599,611, CANC. INT. CL. 25.
- SEATTLE METROPOLITAN, LLC, SEATTLE, WA:
3,633,205, INT. CL. 41.
- SEATTLE'S BEST COFFEE, LLC, SEATTLE, WA:
3,633,202, INT. CL. 30.
- SEAY, DIANNA J., TULSA, OK, DBA HOWLING AT THE MOON PRESS:
2,597,352, CANC. INT. CL. 16.
- SEB S.A., FRANCE:
3,631,662, PUB. 3-17-2009. MULTIPLE CLASS, INT. CLS. 35, 37 AND 41.
- SECNOLOGY (USA), INC., EL GRANADA, CA:
3,630,566, PUB. 3-17-2009. INT. CL. 9.
- SECONDHAND CONCEPTS, INC., FAYETTEVILLE, NC:
3,630,220, PUB. 3-17-2009. INT. CL. 35.
- SECOS, INC., IRVINE, CA:
2,597,931, CANC. INT. CL. 9.
2,597,932, CANC. INT. CL. 9.
- SECUGEN CORPORATION, SAN JOSE, CA:
2,598,995, CANC. INT. CL. 9.
- SECURE-IT, INC., EAST LONGMEADOW, MA:
3,632,483, INT. CL. 9.
- SEGMA POWER PRODUCTS CO., CORTLAND, IL:
3,630,174, PUB. 2-10-2009. INT. CL. 7.
- SEIDNER ENTERPRISES, LLC, COVINA, CA, DBA BERT'S MEGA MALL:
3,630,195, PUB. 3-17-2009. INT. CL. 35.
3,630,196, PUB. 3-17-2009. INT. CL. 35.
- SELCO COMMUNITY CREDIT UNION, EUGENE, OR:
3,630,368, PUB. 3-17-2009. INT. CL. 36.
- SELECTHEALTH, INC., SALT LAKE CITY, UT:
3,629,854, PUB. 3-17-2009. INT. CL. 36.
- SELLING SOLUTIONS INC., GUELPH, CANADA:
3,633,364, INT. CL. 41.
3,633,492, INT. CL. 41.
- SELLINGER, ART, ROANOKE, TX:
3,630,424, PUB. 3-17-2009. INT. CL. 25.
- SELSEK MATTHIEU, FRANCE:
3,631,724, PUB. 3-17-2009. INT. CL. 9.
- SEMI SECRET SOFTWARE LLC, AUSTIN, TX:
3,630,644, PUB. 3-17-2009. INT. CL. 9.
- SEMICONDUCTOR ENERGY LABORATORY CO., LTD., KANAGAWA-KEN, 243-0036, JAPAN:
3,629,127, PUB. 3-17-2009. INT. CL. 9.
- SENIOR CONNECTIONS, INC., CHAMBLEE, GA:
3,630,155, PUB. 3-17-2009. INT. CL. 41.
- SENIOR EXPRESS LIMITED LIABILITY COMPANY, LAKE-LAND, FL:
3,630,982, PUB. 3-17-2009. INT. CL. 45.
- SENSIBLE LINES, LLC, LITHIA, FL, FORMERLY SLIM LINES, LLC:
3,629,809, PUB. 3-17-2009. INT. CL. 10.
- SENSORMATIC ELECTRONICS CORPORATION, BOCA RATON, FL:
2,253,297, REN. 4-24-09. INT. CL. 9.
- SEQUA CHEMICALS, INC., CHESTER, SC:
2,175,301, CANC. INT. CL. 1.
- SEQUEL PRODUCTS, INC., CHICAGO, IL:
1,496,442, CANC. INT. CL. 3.
- SERA WERKE HEIMTIERBEDARF; J. RAVNAK GMBH & CO. KG, FED REP GERMANY:
3,631,681, PUB. 3-17-2009. INT. CL. 1.
- SERCEL, CARQUEFOU, FRANCE:
3,631,465, PUB. 3-17-2009. MULTIPLE CLASS, INT. CLS. 9, 12 AND 42.
- SERENTEC, INC., RALEIGH, NC:
2,598,008, CANC. INT. CL. 35.
- SERRA MELANIE L, ATLANTA, GA, DBA INTERIOR REVIVALS INC.:
3,630,102, PUB. 3-17-2009. INT. CL. 42.
- SERVICE MERCHANDISE COMPANY, INC., BRENTWOOD, TN:
2,597,956, CANC. INT. CL. 14.
- SERVICE STRATEGIES CORPORATION, SAN DIEGO, CA:
3,632,252, MULTIPLE CLASS, INT. CLS. 16, 41 AND 42.
3,632,253, MULTIPLE CLASS, INT. CLS. 16, 41 AND 42.
3,632,254, MULTIPLE CLASS, INT. CLS. 16, 41 AND 42.
- SERVICEMASTER BRANDS L.L.C., BURLINGTON, VT:
3,071,081, AM. INT. CL. 44.
- SERVICIOS DE FRANQUICIA PARDO'S S. A. C., LIMA 27, PERU:
3,629,125, PUB. 3-17-2009. INT. CL. 43.
- SERVIDYNE, INC., ATLANTA, GA:
2,598,920, CANC. INT. CL. 9.
2,639,687, CANC. INT. CL. 35.

SESAME WORKSHOP, NEW YORK, NY:
 3,633,098, MULTIPLE CLASS, INT. CLS. 9 AND 16.
 SEVEN BRIDGES MANAGEMENT, L.P., NEW YORK, NY:
 3,630,848, PUB. 3-17-2009. INT. CL. 36.
 SEVERIN MONTRES AG, 3001 BERN, SWITZERLAND:
 2,596,557, CANC. INT. CL. 14.
 SEW FUN, LLC, CHARLOTTE, CA:
 3,630,957, PUB. 3-17-2009. INT. CL. 41.
 SEWING CENTER SUPPLY CO., INC., PORTLAND, OR:
 3,629,676, PUB. 3-17-2009. INT. CL. 18.
 3,629,677, PUB. 3-17-2009. MULTIPLE CLASS, INT. CLS.
 20 AND 26.
 SF INVESTMENTS, INC., WILMINGTON, DE:
 3,631,926, INT. CL. 29.
 3,631,927, INT. CL. 29.
 3,631,928, INT. CL. 29.
 SFE GESELLSCHAFT FUR STRUKTURANALYSE MBH,
 13355 BERLIN, FED REP GERMANY:
 2,598,305, CANC. INT. CL. 9.
 SHADY LADY, INC., BRYN MAWR, PA:
 3,629,857, PUB. 12-9-2008. INT. CL. 42.
 SHAGHAL, LTD., LOS ANGELES, CA:
 3,633,111, INT. CL. 11.
 SHAH SAFARI, INC., SEATTLE, WA:
 2,175,505, CANC. INT. CL. 25.
 SHAKE-N-GO FASHION, INC., PORT WASHINGTON, NY:
 3,631,972, INT. CL. 26.
 SHAKER SPORT APPAREL CO., CLEVELAND, OH:
 1,496,852, CANC. INT. CL. 25.
 SHAKESPEARE COMPANY, LLC, COLUMBIA, SC:
 3,630,374, PUB. 3-17-2009. INT. CL. 28.
 SHAKESPEARE COMPOSITE STRUCTURES LLC, NEW-
 BERRY, SC:
 2,303,906. REN. 4-29-09. INT. CL. 19.
 SHAKEY'S INCORPORATED, GARDEN GROVE, CA:
 2,597,827, CANC. INT. CL. 42.
 SHANA CORPORATION, EDMONTON, ALBERTA T6E 5C5,
 CANADA:
 2,597,879, CANC. INT. CL. 9.
 SHANDONG LIULIUSHUN FOODS CO., LTD., SHAN-
 DONG, CHINA:
 3,630,652, PUB. 3-17-2009. INT. CL. 30.
 SHANNON AEROSPACE LIMITED, COUNTY CLARE, IRE-
 LAND:
 2,398,904, CANC. INT. CL. 12.
 SHAPIRO, JEROME, FT. LEE, NJ:
 2,599,748, CANC. INT. CL. 16.
 SHARPER IMAGE ACQUISITION LLC, NEW YORK, NY:
 2,599,350, CANC. INT. CL. 9.
 SHAW INDUSTRIES, INC., DALTON, GA:
 2,599,327, CANC. INT. CL. 27.
 SHAWNEE MILLING COMPANY, SHAWNEE, OK, DOING
 BUSINESS AS OKEENE MILLING COMPANY:
 679,699. REN. 4-24-09. U.S. CL. 46 (INT. CL. 30).
 SHC DIRECT, LLC, DOWNERS GROVE, IL:
 3,629,195, PUB. 3-17-2009. INT. CL. 35.
 SHEA RADIANCE, ELLICOTT CITY, MD:
 3,631,188, PUB. 3-17-2009. INT. CL. 3.
 SHEEX, LLC, MYRTLE BEACH, SC:
 3,632,848, INT. CL. 24.
 3,632,849, INT. CL. 24.
 3,632,850, INT. CL. 24.
 SHEFSIEK, MARK, PITTSBURGH, PA:
 2,175,044, CANC. INT. CL. 41.
 SHENUI INC., ISSAQUAH, WA:
 3,632,375, INT. CL. 3.
 SHENYANG SBT TECHNOLOGY; & DEVELOPMENT CO.,
 LTD., CHINA:
 3,631,661, PUB. 3-17-2009. INT. CL. 34.
 SHENZHEN GRAND WING; INVESTMENT, INC., CHINA:
 3,631,555, PUB. 3-17-2009. INT. CL. 28.
 SHERIDAN HEALTHCARE, INC., SUNRISE, FL:
 3,632,476, MULTIPLE CLASS, INT. CLS. 35 AND 44.
 SHERMAN, DAVE, PITTSBURG, CA:
 2,597,518, CANC. INT. CL. 9.
 SHERMAN, DEBORAH K., LAGUNA BEACH, CA:
 2,599,458, CANC. INT. CL. 21.
 SHERWIN-WILLIAMS COMPANY, THE, CLEVELAND, OH:
 3,632,986, INT. CL. 20.
 SHIELD INDUSTRIES, INC., WOODSTOCK, GA, DBA
 SHIELD INDUSTRIES, INC:
 3,631,307, PUB. 3-17-2009. INT. CL. 3.
 SHIELDS, COLLEEN M., ANNAPOLIS, MD:
 3,629,643, PUB. 3-17-2009. INT. CL. 41.
 SHIMABUKURO, KYLE, HONOLULU, HI, DBA HI LIFE
 CLOTHING CO.:
 3,630,370, PUB. 3-17-2009. MULTIPLE CLASS, INT. CLS.
 25 AND 28.
 SHIMADZU CORPORATION, KYOTO, JAPAN:
 3,631,448, PUB. 1-13-2009. INT. CL. 9.
 SHIMANO AMERICAN CORPORATION, IRVINE, CA:
 2,240,280. REN. 4-24-09. INT. CL. 28.
 SHIN NIPPON SEITETSU KABUSHIKI KAISHA; (ALSO
 DOING BUSINESS AS; NIPPON STEEL CORPORATION),
 JAPAN:
 3,631,510, PUB. 3-17-2009. MULTIPLE CLASS, INT. CLS.
 1, 2, 4, 6, 7, 9, 11, 17, 19, 37 AND 42.
 SHISEIDO COMPANY, LTD., TOKYO 104-8010, JAPAN:
 2,597,563, CANC. INT. CL. 30.
 SHIVASHADE, MERRICK, NY, DBA SHIVASHADE INC:
 3,630,369, PUB. 3-17-2009. INT. CL. 1.
 SHODHAN, SHYAMAL, AHMEDABAD-380 015, INDIA:
 3,629,751, PUB. 3-17-2009. INT. CL. 25.
 SHOGUN (USA) PYROTECHNICS LTD., KOWLOON, HONG
 KONG:
 2,599,702, CANC. INT. CL. 13.
 SHOKROLA, GEORGE, LOS ANGELES, CA:
 3,631,022, PUB. 3-17-2009. INT. CL. 42.
 3,631,023, PUB. 3-17-2009. INT. CL. 45.
 SHOP IT TO ME, INC., SAN FRANCISCO, CA:
 3,631,114, PUB. 3-17-2009. INT. CL. 35.
 SHORETRIPS, LLC, BROWN DEER, WI:
 2,599,821, CANC. INT. CL. 39.
 SHORT, PATRICIA L., INDIAN LAND, SC:
 3,632,527, INT. CL. 25.
 SHOWCRAFT, INC., BURNSVILLE, MN:
 3,629,453, PUB. 5-6-2008. INT. CL. 9.
 SHROFF GARY, HICKSVILLE, NY:
 3,632,404, INT. CL. 16.
 SHUFFLE MASTER, INC., LAS VEGAS, NV:
 3,630,813, PUB. 3-17-2009. INT. CL. 9.
 SHURTLEFF, WILLIAM, LAFAYETTE, CA:
 1,497,025, CANC. INT. CL. 35.
 SIBeam, INC., SUNNYVALE, CA:
 3,633,188, MULTIPLE CLASS, INT. CLS. 9 AND 42.
 SID HAUSEN, MERRICK, NY:
 3,631,368, PUB. 3-17-2009. INT. CL. 20.
 SIDOTI, NICK, GRAND ISLAND, NY:
 3,630,364, PUB. 3-17-2009. INT. CL. 41.
 SIEMENS AKTIENGESELLSCHAFT, MUNICH, FED REP
 GERMANY:
 2,596,757, CANC. INT. CL. 9.
 SIEMENS AUDIOLOGISCHE TECHNIK GMBH, FED REP
 GERMANY:
 3,631,590, PUB. 3-17-2009. INT. CL. 10.
 SIEMENS AUDIOLOGISCHE TECHNIK GMBH, ERLAN-
 GEN, FED REP GERMANY:
 3,631,654, PUB. 3-17-2009. INT. CL. 10.
 SIEMENS AUDIOLOGISCHE TECHNIK GMBH, FED REP
 GERMANY:
 3,631,770, PUB. 3-17-2009. INT. CL. 10.
 SIEMENS BUSINESS COMMUNICATIONS SYSTEMS, INC.,
 SANTA CLARA, CA:
 2,175,300, CANC. INT. CL. 9.
 SIEMENS HEALTHCARE DIAGNOSTICS INC., DEER-
 FIELD, IL:
 1,538,855. REN. 4-24-09. INT. CL. 5.
 SIEMENS MEDICAL SOLUTIONS USA, INC., MALVERN,
 PA:
 3,633,194, INT. CL. 9.
 SIEMENS WATER TECHNOLOGIES CORP., WARREN-
 DALE, PA:
 3,632,786, INT. CL. 40.
 SIEPKA, SCOTT L, ALGONQUIN, IL:
 3,632,960, INT. CL. 36.

- SIERINGER, SVEN, FED REP GERMANY AND STÖWER, JENS, FED REP GERMANY:
3,631,503, PUB. 3-17-2009. MULTIPLE CLASS, INT. CLS. 16 AND 31.
- SIERRA NEVADA HELICOPTERS, INC., RENO, NV:
2,597,660, CANC. INT. CL. 39.
- SIERRA ON-LINE, INC., LOS ANGELES, CA:
2,598,158, CANC. INT. CL. 9.
- SIERRA POINT PARTNERS, LLC, PLEASANT HILL, CA:
2,599,387, CANC. INT. CL. 9.
- SIERRA SUITES FRANCHISE, L.P., WICHITA, KS:
3,632,413, INT. CL. 43.
3,632,418, INT. CL. 43.
- SIERRA WIRELESS, INC., RICHMOND, BRITISH COLUMBIA V6V 3A4, CANADA:
2,597,654, CANC. INT. CL. 9.
- SIEVER, BRYAN T., GOLETA, CA:
2,175,340, CANC. INT. CL. 35.
- SIGHTRON, INC., YOUNGSDALE, NC:
3,632,152, INT. CL. 9.
- SIGMA ALIMENTOS, S.A. DE C.V., SAN PEDRO GARZA GARCIA, MEXICO:
3,632,647, INT. CL. 29.
- SIGMA-TAU PHARMACEUTICALS, INC., GAITHERSBURG, MD:
3,630,021, PUB. 3-17-2009. INT. CL. 5.
3,630,022, PUB. 3-17-2009. INT. CL. 5.
3,630,025, PUB. 3-17-2009. INT. CL. 5.
- SIGMATEK GMBH & CO KG, LAMPRECHTSHAUSEN, AUSTRIA:
3,630,302, PUB. 3-17-2009. MULTIPLE CLASS, INT. CLS. 7, 9 AND 42.
- SIGMUND, ROY P., VANCOUVER, BRITISH COLUMBIA, CANADA:
2,599,028, CANC. INT. CL. 5.
- SIGNAPAY, LTD., IRVING, TX:
3,629,805, PUB. 3-17-2009. INT. CL. 36.
- SIGNATURE ESTATE & INVESTMENT ADVISORS, LLC, LOS ANGELES, CA:
3,630,462, PUB. 3-17-2009. INT. CL. 36.
- SILICON LABS CP, INC., AUSTIN, TX:
2,599,363, CANC. INT. CL. 42.
- SILVA, TEA, MIAMI, FL:
3,629,436, PUB. 3-17-2009. INT. CL. 25.
- SILVER HORDE FISHING SUPPLIES, INC., LYNNWOOD, WA:
1,536,508, REN. 4-27-09. INT. CL. 28.
- SILVERBACK, LLC, FORT WORTH, TX:
3,633,182, INT. CL. 35.
- SILVERSEA CRUISES LTD., FORT LAUDERDALE, FL:
2,267,390, REN. 4-24-09. INT. CL. 39.
2,267,408, REN. 4-24-09. INT. CL. 39.
2,270,852, REN. 4-24-09. INT. CL. 39.
2,290,186, REN. 4-24-09. INT. CL. 39.
- SIMBA TOYS GMBH & CO. KG, FED REP GERMANY:
3,631,745, PUB. 3-17-2009. INT. CL. 28.
- SIMEK'S, SAINT PAUL PARK, MN:
3,630,130, PUB. 3-17-2009. INT. CL. 35.
- SIMON DE WINTER GROUP PTY LIMITED, MELBOURNE, VICTORIA, AUSTRALIA:
3,633,245, INT. CL. 25.
- SIMPLE HOME SOLUTIONS, MIAMI, FL:
3,630,817, PUB. 3-17-2009. INT. CL. 37.
- SIMPLICITY VENTURES INC, AURORA, OH:
3,629,449, PUB. 3-17-2009. INT. CL. 43.
- SINGLETON FISHERIES, INC., VERNON, CA:
2,598,298, CANC. INT. CL. 29.
- SIR AUBREY'S TEA COMPANY, SCOTTSDALE, AZ:
2,598,376, CANC. INT. CL. 30.
- SIRIUS THINKING, LTD., NEW YORK, NY:
3,631,797, INT. CL. 41.
- SISSON, PAMELA W., ACTON, MA:
2,598,093, CANC. INT. CL. 9.
- SIX DEGREES GAMES, INC., MARINA DEL REY, CA:
3,632,984, INT. CL. 41.
- SJB ENTERPRISES, LLC, DENVER, CO:
3,630,824, PUB. 3-17-2009. INT. CL. 41.
- SKANSKA AB, SOLNA, SWEDEN:
3,633,350, INT. CL. 37.
- SKAT BLAST, INC., CANFIELD, OH:
3,629,193, PUB. 3-17-2009. INT. CL. 7.
- SKIDMORE FOUR WHEEL DRIVE LIMITED, WEST MIDLANDS, UNITED KINGDOM:
3,629,319, PUB. 3-17-2009. INT. CL. 9.
- SKIHEART INC., AMBLER, PA:
3,632,798, INT. CL. 35.
- SKINNY LITTLE THINGS, LLC, WOODSIDE, CA:
3,632,354, MULTIPLE CLASS, INT. CLS. 9 AND 25.
- SKINNYMINNYMEDIA, LLC, JOPPA, MD:
3,630,725, PUB. 3-17-2009. INT. CL. 42.
3,630,726, PUB. 3-17-2009. INT. CL. 9.
- SKIPPER DIPPER, LLC, BROOKLYN, NY:
3,630,804, PUB. 3-17-2009. INT. CL. 43.
- SKIS DYNASTAR, INC., WILLISTON, VT:
2,599,422, CANC. INT. CL. 28.
- SKUNKIES, LLC, VOORHEES, NJ:
3,631,210, PUB. 3-17-2009. INT. CL. 5.
- SKYFLOW, INC., EMERYVILLE, CA:
2,597,317, CANC. INT. CL. 42.
- SKYGO.COM, INC., REDWOOD CITY, CA:
2,597,723, CANC. MULTIPLE CLASS, INT. CLS. 9 AND 35.
- SK8BRDKRW, LLC, LOS ANGELES, CA:
3,633,297, INT. CL. 16.
- SLADE, SANDY, DEL MAR, CA:
3,629,932, PUB. 3-17-2009. INT. CL. 28.
- SLC SKINCARE, INC., CALABASAS, CA:
3,633,093, INT. CL. 3.
- SLEDGE USA, INC., LOS ANGELES, CA:
3,630,253, PUB. 3-17-2009. INT. CL. 25.
- SLICK RIDES, INC, AMARILLO, TX, DBA SEWFINE INTERIOR PRODUCTS:
2,597,063, CANC. MULTIPLE CLASS, INT. CLS. 12, 27 AND 40.
- SMART CARD ALLIANCE, PRINCETON JUNCTION, NJ:
3,633,461, INT. CL. 42.
- SMART CARD SOLUTIONS, LLC, HARTLAND, WI:
2,175,578, CANC. MULTIPLE CLASS, INT. CLS. 9 AND 36.
2,175,715, CANC. MULTIPLE CLASS, INT. CLS. 9 AND 42.
- SMART POWER SYSTEMS, INC., HOUSTON, TX:
2,598,285, CANC. INT. CL. 9.
- SMARTFORCE PLC, CLONSKEAGH, DUBLIN 4, IRELAND:
2,598,974, CANC. MULTIPLE CLASS, INT. CLS. 9 AND 41.
- SMG BRANDS, INC., WILMINGTON, DE:
3,630,138, PUB. 3-17-2009. INT. CL. 31.
- SMITH & CHAMBERS, L.L.C., FORT SCOTT, KS:
2,598,593, CANC. MULTIPLE CLASS, INT. CLS. 40 AND 42.
- SMITH INTERNATIONAL, INC., HOUSTON, TX:
3,632,539, INT. CL. 7.
- SMOKY MOUNTAIN CHILDREN'S HOME, SEVIERVILLE, TN:
2,599,778, CANC. INT. CL. 42.
- SMT, L.L.C., NAPERVILLE, IL:
2,242,760, REN. 4-29-09. INT. CL. 40.
- SNAP-ON EQUIPMENT GMBH, FED REP GERMANY:
3,631,740, PUB. 3-17-2009. MULTIPLE CLASS, INT. CLS. 7, 9 AND 37.
- SNAP-ON INCORPORATED, KENOSHA, WI:
3,629,950, PUB. 3-17-2009. INT. CL. 9.
3,631,358, PUB. 3-17-2009. INT. CL. 9.
- SNAPT V, INC., SANTA MONICA, CA:
3,633,362, INT. CL. 28.
- SNELL & WILCOX LIMITED, PETERSFIELD, HAMPSHIRE GU31 5AZ, ENGLAND:
2,596,442, CANC. INT. CL. 9.
- SNIFFEN, R. DONN, WELLINGTON, FL:
3,629,150, PUB. 3-17-2009. INT. CL. 21.
- SNIPI, INC., PHILADELPHIA, PA:
3,632,943, MULTIPLE CLASS, INT. CLS. 35, 39 AND 45.
- SNOLA, INC., LOS ANGELES, CA:
3,632,210, MULTIPLE CLASS, INT. CLS. 30 AND 35.

SOAPBOX LLC, WASHINGTON, DC, DBA SOAPBOX CONSULTING LLC:
3,630,036, PUB. 3-17-2009. MULTIPLE CLASS, INT. CLS. 35 AND 41.

SOCCERTOTS INCORPORATED, SPOKANE, WA:
3,629,259, PUB. 3-17-2009. INT. CL. 41.
3,629,272, PUB. 3-17-2009. INT. CL. 41.

SOCIAL & SCIENTIFIC SYSTEMS, INC., BETHESDA, MD:
2,599,838, CANC. MULTIPLE CLASS, INT. CLS. 35 AND 41.

SOCIEDAD ANONIMA VINA SANTA RITA, SANTIAGO, CHILE:
2,597,259, CANC. INT. CL. 33.

SOCIETE DE DEVELOPPEMENT ET DE RECHERCHE INDUSTRIELLE, CHENOVE, FRANCE:
2,230,144, REN. 4-24-09. INT. CL. 5.

SOCIETE DES PRODUITS NESTLE, S.A., 1800 VEVEY, SWITZERLAND:
3,631,973, INT. CL. 30.

SOCIETE POUR LES TRANSPORTS DE L'INDUSTRIE NUCLEAIRE - TRANSNUCLEAIRE, 75008 PARIS, FRANCE:
2,597,430, CANC. INT. CL. 17.

SOCIETY OF DERMATOLOGY PHYSICIAN ASSISTANTS, INCORPORATED, GASTONIA, NC:
3,631,119, PUB. 3-17-2009. INT. CL. 35.

SOCIOUS, INC., GILBERT, AZ:
3,630,543, PUB. 3-17-2009. INT. CL. 42.

SOFLUSION LLC, MIAMI, FL:
3,629,431, PUB. 3-17-2009. INT. CL. 41.

SOFTBOX SYSTEMS LIMITED, LONG CRENDON AYLESBURY, UNITED KINGDOM:
3,629,257, PUB. 3-17-2009. MULTIPLE CLASS, INT. CLS. 16, 17, 20 AND 22.

SOLAR TIME LIMITED, KOWLOON, HONG KONG:
3,630,455, PUB. 3-17-2009. INT. CL. 14.

SOLAREH, SOCIETE POUR L' AVANCEMENT DES RESSOURCES HUMAINES INC., VILLE ST-LAURENT, QUEBEC, CANADA:
2,596,788, CANC. INT. CL. 42.

SOLAS SCIENCE & ENGINEERING CO., LTD., TAICHUNG, TAIWAN:
3,629,559, PUB. 3-17-2009. MULTIPLE CLASS, INT. CLS. 7 AND 12.

SOLO CUP OPERATING CORPORATION, HIGHLAND PARK, IL:
1,496,564, CANC. INT. CL. 8.

SOLSTICE OUTDOOR, INC., PORTLAND, OR:
3,632,735, INT. CL. 25.

SOLUXURY HMC, FRANCE:
3,631,582, PUB. 3-17-2009. INT. CL. 43.

SOLVAY BIOLOGICALS B.V., NETHERLANDS:
3,631,581, PUB. 3-17-2009. INT. CL. 5.

SOMERSET ENTERTAINMENT LTD, TORONTO, ONTARIO, CANADA:
2,246,941, REN. 4-24-09. INT. CL. 9.

SOMERSET ENTERTAINMENT LTD., TORONTO, ONTARIO, CANADA:
1,543,364, REN. 4-24-09. INT. CL. 9.

SONEXAYSANA, SENG DEUANE, MOUNTLAKE TERRACE, WA:
2,598,909, CANC. INT. CL. 5.

SONG, SOOK HEE, CERRITOS, CA:
3,629,947, PUB. 3-17-2009. INT. CL. 43.

SONIC INTEGRITY CANADA LTD., MISSISSAUGA, ONTARIO, CANADA:
3,632,553, INT. CL. 20.

SONLIGHT CURRICULUM, LTD., LITTLETON, CO:
2,337,790, REN. 4-25-09. INT. CL. 16.

SONOCARE, INC., SKANEATELES, NY:
1,496,652, CANC. INT. CL. 10.

SONOVA HOLDING AG, STAEFA, SWITZERLAND:
2,596,445, CANC. INT. CL. 10.

SONOVA HOLDING AG, CH-8712 STÄFA, SWITZERLAND:
3,631,646, PUB. 3-17-2009. MULTIPLE CLASS, INT. CLS. 9, 10, 42 AND 44.

SONY CORPORATION, TOKYO, JAPAN:
3,632,389, INT. CL. 9.

SONY ERICSSON MOBILE COMMUNICATIONS AB, LUND, SWEDEN:
3,632,194, INT. CL. 9.

SONYGOOD INDUSTRIES CO., LTD., MIAO LI HSIEN, TAIWAN:
3,630,301, PUB. 3-17-2009. INT. CL. 18.

SOPRAL, 35670 PLECHATTEL, FRANCE:
1,496,963, CANC. INT. CL. 31.

SOPRIS WEST EDUCATIONAL SERVICES, INC., LONGMONT, CO:
2,598,650, CANC. INT. CL. 9.

SOPRO (SA), FRANCE:
3,587,242, COR. MULTIPLE CLASS, INT. CLS. 9 AND 10.

SORORITY GOURMET, DANA POINT, CA:
3,630,885, PUB. 3-17-2009. INT. CL. 43.

SOTICO PTY LTD, PERTH, WESTERN AUSTRALIA, AUSTRALIA:
2,597,368, CANC. INT. CL. 19.

SOTTOPELLE, INC., SCOTTSDALE, AZ:
3,633,224, INT. CL. 44.

SOUL OVERHAUL CORP, MIAMI, FL:
3,630,054, PUB. 3-17-2009. INT. CL. 45.

SOUND BACK PACK, INC., BROWNSVILLE, TX:
2,598,073, CANC. INT. CL. 9.

SOUND SURGICAL TECHNOLOGIES LLC., LOUISVILLE, CO:
3,629,154, PUB. 3-17-2009. INT. CL. 10.

SOUNDS OF CUBA, INC., NEW YORK, NY, DBA SON CUBANO:
3,630,944, PUB. 3-17-2009. INT. CL. 43.

SOURCE ADVANTAGE, LLC, CINCINNATI, OH, DBA RED CARPET STUDIOS, INC.:
3,629,761, PUB. 3-17-2009. INT. CL. 25.

SOURCE ENTERPRISES, INC., NEW YORK, NY:
3,631,163, PUB. 3-17-2009. INT. CL. 16.

SOURCE GLOBAL ENTERPRISES, INC., BRONX, NY:
2,598,940, CANC. INT. CL. 20.

SOURCE ONE GLOBAL PARTNERS, CHICAGO, IL:
3,632,961, INT. CL. 5.
3,633,007, INT. CL. 5.
3,633,008, INT. CL. 5.

SOUTH ALLIANCE, INC., LAS VEGAS, NV:
3,632,538, INT. CL. 25.

SOUTH BEACH BEVERAGE COMPANY, INC., NORWALK, CT:
2,175,195, CANC. INT. CL. 30.

SOUTH CONE, INC., CARLSBAD, CA:
3,631,788, INT. CL. 32.

SOUTH MOUNTAIN RECYCLING, LLC, AGOURA HILLS, CA:
3,633,432, INT. CL. 37.

SOUTH TEXAS AUTO REBUILDERS, INC., LAREDO, TX:
3,630,792, PUB. 3-17-2009. INT. CL. 37.

SOUTHEND INTERACTIVE AB, MALMÖ, SWEDEN:
3,629,736, PUB. 3-17-2009. INT. CL. 9.

SOUTHERN COMPANY, THE, ATLANTA, GA:
2,174,592, CANC. INT. CL. 42.

SOUTHERN CROSS YACHTS INTERNATIONAL INC., FORT LAUDERDALE, FL:
2,598,091, CANC. INT. CL. 12.

SOUTHERN NEVADA WATER AUTHORITY, LAS VEGAS, NV:
3,631,046, PUB. 3-17-2009. INT. CL. 16.
3,631,070, PUB. 3-17-2009. MULTIPLE CLASS, INT. CLS. 8, 14, 16, 26 AND 28.
3,631,231, PUB. 3-17-2009. MULTIPLE CLASS, INT. CLS. 16, 35 AND 40.
3,631,259, PUB. 3-17-2009. INT. CL. 16.

SOUTHERN WIRE PTY LTD., BASSENDEAN, AUSTRALIA:
3,632,196, INT. CL. 6.

SOUTHINT PROPERTIES, IBC, TAMPA, FL:
2,597,235, CANC. INT. CL. 38.

SOUTHLAND RACING CORPORATION, WEST MEMPHIS, AR:
3,632,567, INT. CL. 41.

SOUTHWEST RESEARCH INSTITUTE, SAN ANTONIO, TX:
2,597,190, CANC. INT. CL. 40.

- SOUTHWEST STRATEGIES LLC., SAN DIEGO, CA:
3,629,853, PUB. 3-17-2009. INT. CL. 35.
- SOUTHWORTH COMPANY, AGAWAM, MA:
2,175,762, CANC. INT. CL. 16.
- SOWER, FORREST D., ANDERSON ISLAND, WA:
2,596,570, CANC. INT. CL. 9.
- SPAFINDER, INC., NEW YORK, NY:
3,632,870, INT. CL. 16.
- SPALDING SPORTS WORLDWIDE, INC., CHICOPEE, MA:
2,599,666, CANC. INT. CL. 18.
- SPAN TECH LLC, GLASGOW, KY, SPAN TECH, INC.,
GLASGOW, KY:
1,587,476, REN. 4-27-09. INT. CL. 7.
- SPANISH BROADCASTING SYSTEM, INC., COCONUT
GROVE, FL:
3,629,657, PUB. 3-17-2009. INT. CL. 41.
- SPANISH FOR SUCCESS, LLC, PITTSBURGH, PA:
2,598,530, CANC. INT. CL. 41.
2,598,531, CANC. INT. CL. 41.
- SPANISH IN SEATTLE, TUKWILA, WA:
3,633,486, INT. CL. 41.
- SPARKPEOPLE, INC., CINCINNATI, OH:
3,629,996, PUB. 3-17-2009. MULTIPLE CLASS, INT. CLS.
41 AND 44.
- SPARTACOM TECHNOLOGIES, INC., TUCSON, AZ:
2,597,589, CANC. INT. CL. 9.
- SPARTAN DIET, SANTA BARBARA, CA:
3,633,428, MULTIPLE CLASS, INT. CLS. 41 AND 44.
- SPD GROUP, INC., LIGHTHOUSE POINT, FL, DBA JR
DUNN JEWELERS:
3,633,017, INT. CL. 14.
- SPEAKERCRAFT, INC., RIVERSIDE, CA:
3,632,391, INT. CL. 9.
- SPEARS ABACUS ADVISORS LLC, NEW YORK, NY:
3,632,897, INT. CL. 36.
- SPECCERAMICS, INC., FULLERTON, CA:
3,632,439, U.S. CL. A.
- SPECCOMM INTERNATIONAL, INC., RALEIGH, NC:
2,175,867, CANC. INT. CL. 16.
- SPECIAL PRODUCTS CORPORATION "SPECO", GRAND
DUCHY, LUXEMBOURG:
2,174,444, CANC. MULTIPLE CLASS, INT. CLS. 5 AND
30.
- SPECIAL PRODUCTS CORPORATION "SPECO", L-9780
WINCRANGE 10, LUXEMBOURG:
2,174,445, CANC. MULTIPLE CLASS, INT. CLS. 5 AND
30.
- SPECIAL PRODUCTS LIMITED, LONDON EC4A 1RS, UNI-
TED KINGDOM:
3,631,655, PUB. 3-17-2009. INT. CL. 5.
- SPECIAL SHAPES REFRACTORY COMPANY, INC., BESSE-
MER, AL:
3,630,170, PUB. 3-17-2009. INT. CL. 1.
- SPECIALIZED BICYCLE COMPONENTS, INC., MORGAN
HILL, CA:
1,496,690, CANC. INT. CL. 12.
- SPECIALIZED PRODUCTS COMPANY, SOUTHLAKE, TX:
3,632,272, INT. CL. 8.
- SPECIALTY & CUSTOM FIBERS, LLC, CLEMSON, SC:
3,629,363, PUB. 3-17-2009. INT. CL. 17.
- SPECTRA CINE RESEARCH CORPORATION, BURBANK,
CA, DBA SPECTRA CINE:
3,630,437, PUB. 3-17-2009. INT. CL. 9.
- SPECTRA NAIL SYSTEMS, INC., MEMPHIS, TN:
2,599,547, CANC. INT. CL. 9.
- SPECTRUM PET CARE, INC., MONTGOMERY CITY, MO:
3,631,160, PUB. 3-17-2009. INT. CL. 31.
- SPEEDO INTERNATIONAL LIMITED, LONDON, UNITED
KINGDOM:
3,632,993, INT. CL. 9.
- SPEEDWAY PROPERTIES COMPANY, LLC, RENO, NV:
2,320,424, REN. 4-25-09. INT. CL. 41.
- SPELL C. LLC, VAN NUYS, CA:
373,836, REN. 4-24-09. U.S. CL. 39 (INT. CL. 25).
- SPENCER GIFTS L.L.C., EGG HARBOR TOWNSHIP, NJ:
3,632,667, MULTIPLE CLASS, INT. CLS. 3, 5, 6, 9, 10, 14,
20, 21 AND 24.
- SPENCER, CHERYL V, VALLEY STREAM, NY:
3,633,273, INT. CL. 28.
- SPENCER, KEVIN, LYNCHBURG, VA:
3,630,910, PUB. 3-17-2009. INT. CL. 41.
- SPENSA DEVELOPMENT GROUP, LLC, MINNETONKA,
MN:
3,630,323, PUB. 2-10-2009. INT. CL. 39.
- SPEX CERTIPREP, INC., METUCHEN, NJ:
3,632,661, INT. CL. 1.
- SPIDER WEB OF AMERICA, INC., NEW YORK, NY:
2,598,336, CANC. INT. CL. 39.
- SPIEGEL CATALOG HOLDINGS CORPORATION, NEW
YORK, NY:
1,496,715, CANC. MULTIPLE CLASS, INT. CLS. 16 AND
42.
- SPIETH ANDERSON USA, INC., FORT WORTH, TX:
2,597,550, CANC. INT. CL. 28.
- SPIKE'S RESTAURANTS, INC., COVINA, CA:
2,174,148, CANC. INT. CL. 42.
2,174,149, CANC. INT. CL. 42.
- SPILLER, MANUEL, SIEGSDORF, FED REP GERMANY:
3,629,472, PUB. 3-17-2009. INT. CL. 3.
- SPIN PRODUCTS, INC., CHINO, CA, DBA BURLINGHAM
SPORTS:
3,629,505, PUB. 12-9-2008. INT. CL. 28.
- SPINA BIFIDA ASSOCIATION OF AMERICA, WASHING-
TON, DC:
3,629,306, PUB. 3-17-2009. U.S. CL. 200.
- SPINSIX STRATEGIC MARKETING DESIGN, LLC,
SCOTTSDALE, AZ:
3,630,570, PUB. 3-17-2009. INT. CL. 35.
3,630,753, PUB. 3-17-2009. INT. CL. 42.
- SPINTOP MEDIA, INC., VANCOUVER, CANADA:
3,632,154, INT. CL. 9.
- SPIRIT ATHLETICS, INC., MADISON, WI:
2,597,526, CANC. INT. CL. 35.
- SPIRITUALITY IS SEXY, LLC, FRISCO, TX:
3,631,101, PUB. 3-17-2009. INT. CL. 45.
- SPITZER, LISA ANN, NEWARK, DE:
2,175,653, CANC. INT. CL. 42.
- SPORT CARRIERS, INC., CORONA, CA, DBA SPORT PLUS
ACCESSORIES:
2,596,731, CANC. INT. CL. 35.
- SPORT ELLE, INC., NEW YORK, NY:
3,630,002, PUB. 3-17-2009. INT. CL. 25.
- SPORTEXCEL, INC., PHOENIX, AZ:
2,598,372, CANC. INT. CL. 42.
- SPORTS ID, INC., LAFAYETTE, CA:
2,597,459, CANC. INT. CL. 41.
2,597,460, CANC. INT. CL. 41.
- SPORTS ONE INCORPORATED, WOODBRIDGE, CT:
3,630,785, PUB. 3-17-2009. INT. CL. 5.
- SPORTS RESEARCH CORPORATION, SAN PEDRO, CA:
1,496,453, CANC. INT. CL. 3.
- SPORTS SCHOLARSHIPS USA, LLC, AGOURA HILLS, CA:
3,630,769, PUB. 3-17-2009. INT. CL. 36.
- SPORTSWEAR COMPANY - S.P.A.; (IN SIGLA SPW S.P.A.),
I-40124 BOLOGNA, ITALY:
3,631,477, PUB. 3-17-2009. MULTIPLE CLASS, INT. CLS.
3, 9, 14, 18 AND 25.
- SPRADLING HOLDINGS, INC., PELHAM, AL:
3,632,947, INT. CL. 1.
- SPRING LEAF CONCEPTS & DESIGN, WACONIA, MN:
3,629,726, PUB. 3-17-2009. INT. CL. 16.
- SPRING, WALTER, LONDON SW20, UNITED KINGDOM:
2,599,177, CANC. INT. CL. 42.
- SPRINGER-VERLAG GMBH, HEIDELBERG, FED REP
GERMANY:
3,633,414, MULTIPLE CLASS, INT. CLS. 9, 16, 41 AND 42.
- SPRINGS GLOBAL US, INC., FORT MILL, SC:
2,598,704, CANC. INT. CL. 24.
- SPRINT COMMUNICATIONS COMPANY L.P., OVERLAND
PARK, KS:
2,174,348, CANC. INT. CL. 42.
- SPRUCE MEADOWS, CALGARY, CANADA:
3,631,426, PUB. 1-13-2009. MULTIPLE CLASS, INT. CLS.
9, 25 AND 41.

SPS TECHNOLOGIES, LLC, JENKINTOWN, PA:
3,630,232, PUB. 3-17-2009. MULTIPLE CLASS, INT. CLS. 7
AND 8.
3,630,255, PUB. 3-17-2009. MULTIPLE CLASS, INT. CLS. 7
AND 8.

SPX COOLING TECHNOLOGIES, INC., OVERLAND PARK,
KS:
3,629,913, PUB. 3-17-2009. INT. CL. 7.

SQUG, LLC, GROTON, MA:
3,630,481, PUB. 3-17-2009. INT. CL. 28.

SR 2003 CORP, NEW YORK, NY:
3,629,322, PUB. 3-17-2009. INT. CL. 14.

ST. BARTHOLOMEW'S CHURCH IN THE CITY OF NEW
YORK, NEW YORK, NY:
3,633,258, INT. CL. 16.

ST. LUKE'S HOSPITAL, MILWAUKEE, WI:
1,497,179, CANC. INT. CL. 42.

ST. MARY'S HEALTH CARE SYSTEM, INC., ATHENS, GA:
2,598,173, CANC. INT. CL. 42.

STAAR SURGICAL COMPANY, INC., MONROVIA, CA:
2,175,782, CANC. INT. CL. 10.

STAB-THE-CAT INTERNATIONAL, INC., WEST PALM
BEACH, FL:
3,629,202, PUB. 3-17-2009. INT. CL. 25.

STACIA, INC., SANTA MONICA, CA:
3,630,613, PUB. 3-17-2009. MULTIPLE CLASS, INT. CLS.
18, 25 AND 35.

STAEDTLER & UHL KG, FED REP GERMANY:
3,631,500, PUB. 3-17-2009. INT. CL. 7.

STALLINGS, ZACK, FAYETVILLE, GA:
2,598,688, CANC. INT. CL. 22.

STANLEY LOGISTICS, INC., NEW BRITAIN, CT:
2,596,434, CANC. INT. CL. 6.

STANLEY, CRAIG, CLAREMORE, OK, DBA STANLEY'S
RENT-TO-OWN:
2,596,761, CANC. INT. CL. 42.

STAPLES THE OFFICE SUPERSTORE, LLC, FRAMING-
HAM, MA:
3,633,119, INT. CL. 16.

STAR BRITE, INC, FORT LAUDERDALE, FL:
3,632,083, INT. CL. 3.

STAR SCIENTIFIC, INC., PETERSBURG, VA:
3,630,643, PUB. 3-17-2009. INT. CL. 34.

STAR TEK RECYCLING, LLC, MORGANTOWN, KY:
3,632,949, INT. CL. 40.

STARFESTIVAL, INC., CAMBRIDGE, MA:
2,596,800, CANC. INT. CL. 9.

STARKEY LABORATORIES, INC., EDEN PRAIRIE, MN:
1,496,653, CANC. INT. CL. 10.

STARLIGHT CHILDREN'S FOUNDATION, LOS ANGELES,
CA:
3,630,531, PUB. 3-17-2009. INT. CL. 36.

STARLIGHT R & D LIMITED, ABERDEEN, HONG KONG,
RANDIX INDUSTRIES, LTD., MILFORD, MA:
1,535,115, REN. 4-27-09. INT. CL. 9.

STARS 4 STUDENTS, INC., NEW YORK, NY:
3,633,128, MULTIPLE CLASS, INT. CLS. 35 AND 41.

STARWAY CO., LTD., MINATO-KU, TOKYO, JAPAN:
3,632,714, INT. CL. 16.

STATE BAR OF CALIFORNIA, THE, SAN FRANCISCO, CA:
2,597,601, CANC. MULTIPLE CLASS, INT. CLS. 16 AND
41.

STATE OF FLORIDA, DEPARTMENT OF THE LOTTERY,
TALLAHASSEE, FL, AKA FLORIDA LOTTERY:
2,273,815, REN. 4-24-09. INT. CL. 36.

STATE STREET CORPORATION, BOSTON, MA:
2,599,561, CANC. INT. CL. 42.

STATE SWIM SYSTEMS PTY LTD, KENT TOWN SA 5067,
AUSTRALIA:
3,631,574, PUB. 3-17-2009. INT. CL. 41.

STATESIDE INTERNATIONAL INC., SAN CLEMENTE, CA:
1,496,699, CANC. INT. CL. 12.

STEARNS PRODUCTS, INC., SIMI VALLEY, CA:
3,633,403, INT. CL. 3.

STEELCASE INC., GRAND RAPIDS, MI:
2,175,010, CANC. MULTIPLE CLASS, INT. CLS. 9 AND
42.

STEEP, PORTSMOUTH, NH:
2,598,375, CANC. INT. CL. 32.

STEIFENSAND, GERNOT M., 90530 WENDELSTEIN, FED
REP GERMANY:
3,629,350, PUB. 10-7-2008. INT. CL. 20.

STEINWAY, INC., LONG ISLAND CITY, NY:
2,325,865, REN. 4-28-09. INT. CL. 15.

STELLATO & SCHWARTZ, LTD., CHICAGO, IL:
3,631,016, PUB. 3-17-2009. INT. CL. 45.

STELOR PRODUCTIONS LLC, DARNESTOWN, MD:
3,633,102, INT. CL. 38.

STEM CELL SCIENCES HOLDINGS LIMITED, EDIN-
BURGH, UNITED KINGDOM:
3,629,475, PUB. 3-17-2009. MULTIPLE CLASS, INT. CLS. 1
AND 5.

STEM CELL SCIENCES KK, JAPAN:
3,335,466, COR. MULTIPLE CLASS, INT. CLS. 1, 5, 9
AND 42.
3,335,468, COR. MULTIPLE CLASS, INT. CLS. 1, 5, 9
AND 42.

STEMCO LP, LONGVIEW, TX, COLTEC NORTH CAROLI-
NA INC., CHARLOTTE, NC:
2,216,106, REN. 4-29-09. INT. CL. 37.

STEMMERMAN, JANE, HALLANDALE BEACH, FL:
3,632,723, INT. CL. 3.

STEP 1, INC., OVERLAND PARK, KS:
2,596,835, CANC. INT. CL. 42.

STEPPING STONES MUSEUM FOR CHILDREN, INC.,
NORWALK, CT:
3,630,489, PUB. 3-17-2009. INT. CL. 41.

STERIS INC., TEMECULA, CA:
3,632,239, MULTIPLE CLASS, INT. CLS. 10 AND 11.

STERLING INTERNATIONAL INC., SPOKANE, WA:
3,633,080, INT. CL. 21.

STERLING PRODUCTS LTD., KOWLOON, HONG KONG:
3,629,447, PUB. 3-17-2009. MULTIPLE CLASS, INT. CLS.
24, 25 AND 40.

STETON TECHNOLOGY GROUP, INC., ST. GEORGE, UT:
3,631,143, PUB. 3-17-2009. INT. CL. 9.

STEVEN H. BLANCE, EXCELSIOR, MN:
3,632,940, INT. CL. 41.

STEVEN ROBERTS ORIGINAL DESSERTS, DENVER, CO:
3,630,809, PUB. 3-17-2009. INT. CL. 30.

STEVEN S. ZAWALICK, SAN LUIS OBISPO, CA, DBA
IRONWOOD DESIGNS:
2,232,038, REN. 4-27-09. INT. CL. 1.

STEVEN VENDING, INC., TOLEDO, OH:
2,599,385, CANC. INT. CL. 4.

STEVENSON, MICHAEL J., CLARKDALE, AZ:
3,631,834, INT. CL. 1.
3,632,290, INT. CL. 16.
3,632,291, INT. CL. 16.
3,632,357, MULTIPLE CLASS, INT. CLS. 2 AND 16.
3,632,411, INT. CL. 16.

STEWART, SCOTT H, BANGOR, ME:
2,599,439, CANC. INT. CL. 39.

STG PRODUCTS, LLC., WOODBURY, NY:
3,631,870, INT. CL. 3.

STILES, JACKIE, WICHITA, KS:
3,630,534, PUB. 3-17-2009. INT. CL. 41.

STOHR DISTRIBUTION & DESIGN, YAKIMA, WA:
3,571,333, AM. INT. CL. 12.

STOKELY-VAN CAMP, INC., CHICAGO, IL:
3,632,469, INT. CL. 32.

STONE ROWS FLECKVIEH, INC., COLORADO SPRINGS,
CO:
1,497,249, CANC. INT. CL. 42.

STONE-LAND GMBH, D-91183 ABENBERG, FED REP
GERMANY:
2,596,732, CANC. MULTIPLE CLASS, INT. CLS. 19, 20
AND 21.

STOWE WOODWARD LICENSING INC., YOUNGSVILLE,
NC, MOUNT HOPE MACHINERY COMPANY, TAUN-
TON, MA:
510,918, REN. 4-27-09. U.S. CL. 23 (INT. CL. 7).

STOXX AG, SWITZERLAND:
3,631,598, PUB. 3-17-2009. MULTIPLE CLASS, INT. CLS.
35 AND 41.

- STRATAGENE CALIFORNIA, LA JOLLA, CA:
2,174,528, CANC. INT. CL. 1.
- STRATASYS, INC., EDEN PRAIRIE, MN:
3,631,859, INT. CL. 7.
- STRATEGIC CAPITAL PARTNERS, LLC, INDIANAPOLIS, IN:
3,333,053, AM. MULTIPLE CLASS, INT. CLS. 36 AND 37.
- STRATEGIC HEALTHCARE CONSULTING INC., COLORADO SPRINGS, CO:
2,599,604, CANC. INT. CL. 16.
- STRATEGIC MANAGEMENT GROUP, INC., PHILADELPHIA, PA:
1,537,719, REN. 4-27-09. MULTIPLE CLASS, INT. CLS. 41 AND 42.
- STRATEGIC RISK SERVICES, L.L.C., CHARLOTTE, MI:
2,597,294, CANC. INT. CL. 42.
- STRATHMORE PARTNERS LP, CONCORD, NH:
2,597,100, CANC. INT. CL. 3.
- STRAUSS, ROSEMARY B., OMAHA, NE:
2,598,429, CANC. MULTIPLE CLASS, INT. CLS. 9, 16 AND 28.
- STRAWN, JAMES, ORANGE, CA:
3,632,273, INT. CL. 41.
- STREETLINKS NATIONAL APPRAISAL SERVICES LLC, KANSAS CITY, MO:
3,633,452, INT. CL. 35.
- STRENGTHNET ENTERTAINMENT, LLC, RESTON, VA:
2,597,825, CANC. INT. CL. 35.
- STRETCH-O-RAMA, INC., NEW YORK, NY:
3,631,355, PUB. 3-17-2009. INT. CL. 25.
- STROUDS ACQUISITION CORPORATION, CITY OF INDUSTRY, CA:
2,596,942, CANC. INT. CL. 35.
- STROZAR, INC, WESTPORT, CT:
3,631,460, PUB. 3-17-2009. MULTIPLE CLASS, INT. CLS. 14, 18 AND 25.
- STRUMBONO II, L.L.C., HOUSTON, TX:
2,334,840, REN. 4-27-09. MULTIPLE CLASS, INT. CLS. 37 AND 40.
- STRYKER CORPORATION, KALAMAZOO, MI:
3,632,691, INT. CL. 9.
- STUDENT SUCCESS, INC., GREEN BAY, WI:
2,174,450, CANC. INT. CL. 16.
- STUDIO DROR, NEW YORK, NY:
3,630,730, PUB. 3-17-2009. INT. CL. 42.
- STUDIO ONE NETWORKS, INC., NEW YORK, NY:
3,632,873, INT. CL. 41.
- STURM FOODS, INC., MANAWA, WI:
3,631,331, PUB. 3-17-2009. MULTIPLE CLASS, INT. CLS. 30, 32 AND 40.
- STUSSY, INC., IRVINE, CA:
3,632,208, INT. CL. 34.
- STUTH, WILLIAM L., SR., KENT, WA:
3,629,765, PUB. 3-17-2009. MULTIPLE CLASS, INT. CLS. 37 AND 42.
- SUBARU OF AMERICA, INC., WEST CHERRY HILL, NJ:
3,632,651, INT. CL. 37.
- SUBMARINA, INC., SAN MARCOS, CA:
3,630,150, PUB. 3-17-2009. MULTIPLE CLASS, INT. CLS. 29, 30 AND 43.
- SUCCESS APPAREL LLC, NEW YORK, NY:
3,600,254, AM. INT. CL. 25.
- SUCCESS PROMOTIONS, INC., WEST PALM BEACH, FL:
1,497,007, CANC. INT. CL. 35.
- SUCCESS STRATEGIES, INC., MODESTO, CA:
3,630,239, PUB. 3-17-2009. MULTIPLE CLASS, INT. CLS. 35 AND 36.
3,630,240, PUB. 3-17-2009. MULTIPLE CLASS, INT. CLS. 35 AND 36.
3,630,241, PUB. 3-17-2009. INT. CL. 36.
- SUCESORES PEDRO CORTES, INC., SAN JUAN, PUERTO RICO:
3,629,865, PUB. 3-17-2009. INT. CL. 30.
- SUCRE, LLC, NEW ORLEANS, LA:
3,633,298, INT. CL. 43.
- SUDBERRY PROPERTIES/ENTITLEMENT, L.P., SAN DIEGO, CA:
3,629,834, PUB. 3-17-2009. INT. CL. 37.
3,629,835, PUB. 3-17-2009. INT. CL. 37.
- SUDDEN DEALS, LLC, MENDOTA HEIGHTS, MN:
3,630,030, PUB. 3-17-2009. INT. CL. 35.
- SUFFRIDGE & TRENI COMMUNICATIONS, INC., RIDGEWOOD, NJ:
1,496,580, CANC. INT. CL. 9.
- SUGAR SWEET SUNSHINE, INC., NEW YORK, NY:
3,630,085, PUB. 12-9-2008. MULTIPLE CLASS, INT. CLS. 30 AND 43.
- SUGARS BY SHARON, SUISUN CITY, CA:
3,631,218, PUB. 3-17-2009. INT. CL. 30.
- SUISSE PROGRAMME LIMITED, GIBRALTAR, GIBRALTAR:
3,631,392, PUB. 10-2-2007. INT. CL. 5.
- SULLIVAN, MICHELLE, SAN RAFAEL, CA:
3,629,592, PUB. 3-17-2009. INT. CL. 5.
- SUMITOMO ELECTRIC INDUSTRIES, LTD., OSAKA, JAPAN:
3,629,395, PUB. 3-17-2009. INT. CL. 9.
- SUMMIT CONSULTING AND APEX PLANNING INC., VALLEY STREAM, NY, DBA R & G BRENNER INCOME TAX CENTERS:
3,630,839, PUB. 3-17-2009. INT. CL. 35.
- SUMNER, RICHARD, HUNTINGTON BEACH, CA:
2,175,309, CANC. INT. CL. 9.
- SUN CHEMICAL CORPORATION, PARSIPPANY, NJ:
2,596,602, CANC. INT. CL. 16.
3,632,648, INT. CL. 2.
3,632,764, INT. CL. 2.
3,632,765, INT. CL. 2.
- SUN STATE ELECTRIC COMPANY, INC., KENNESAW, GA:
3,630,942, PUB. 3-17-2009. INT. CL. 37.
- SUN STEEL TREATING, INC., SOUTH LYON, MI:
2,231,258, REN. 4-29-09. INT. CL. 40.
- SUN-RYPE PRODUCTS LTD., KELOWNA, CANADA:
3,632,438, INT. CL. 29.
- SUNBEAM PRODUCTS, INC., BOCA RATON, FL:
3,632,543, INT. CL. 24.
- SUNDANCE CHANNEL LLC, NEW YORK, NY:
3,632,346, INT. CL. 41.
- SUNDIAL HERBAL PRODUCTS, BRONX, NY:
2,175,030, CANC. INT. CL. 5.
- SUNJEEN, INC., FULLERTON, CA, DBA PROTEC:
3,631,084, PUB. 3-17-2009. MULTIPLE CLASS, INT. CLS. 9 AND 15.
- SUNJEEN, INC., FULLERTON, CA:
3,631,253, PUB. 3-17-2009. INT. CL. 15.
- SUNKARA, SWAMY, CINCINNATI, OH:
3,633,083, INT. CL. 28.
- SUNMARKS, LLC, WILMINGTON, DE:
3,632,790, INT. CL. 4.
- SUNOPTA INGREDIENTS, INC., BEDFORD, MA:
3,632,459, INT. CL. 1.
- SUNOVIA ENERGY TECHNOLOGIES, INC., SARASOTA, FL:
3,632,075, INT. CL. 9.
- SUNRISE AND RAINBOW, LOS ANGELES, CA, DBA TREE STAR MINERALS, INC.:
2,597,637, CANC. INT. CL. 5.
- SUNRISE LED INC., PLEASANT HILL, CA:
3,631,852, INT. CL. 9.
- SUNRISE MEDICAL HHG INC., LONGMONT, CO:
3,632,979, INT. CL. 12.
- SUNSHINE MAKERS, INC., HUNTINGTON HARBOUR, CA:
3,629,604, PUB. 3-17-2009. INT. CL. 35.
- SUNTORY FLOWERS LIMITED, TOKYO, JAPAN:
3,631,851, INT. CL. 31.
- SUNTRUST BANKS, INC., ORLANDO, FL:
2,597,798, CANC. INT. CL. 36.
- SUPA DUPA FLY, INC., VIRGINIA BEACH, VA:
3,629,811, PUB. 3-17-2009. INT. CL. 25.
- SUPERCIRCUITS, INC., AUSTIN, TX:
3,632,551, INT. CL. 9.

SUPERIOR PERFORMERS, INC., DANVILLE, VA:
3,630,048, PUB. 3-17-2009. INT. CL. 36.

SUPERNUTRIENT CORPORATION, AIKEN, SC:
3,629,902, PUB. 3-17-2009. INT. CL. 5.

SUPERVALU INC., EDEN PRAIRIE, MN:
3,633,012, INT. CL. 44.

SURFACE BALANCE NORWAY LTD, STRØMMEN, NORWAY:
3,631,736, PUB. 3-17-2009. INT. CL. 20.

SURFACE TECHNOLOGIES, INC., KANSAS CITY, MO:
3,630,619, PUB. 3-17-2009. INT. CL. 20.

SURGICAL NAVIGATION SPECIALISTS INC., MISSISSAUGA, ONTARIO, CANADA:
2,598,319, CANC. INT. CL. 42.

SURREY NANOSYSTEMS LIMITED, NEWHAVEN, EAST SUSSEX BN9 ODQ, UNITED KINGDOM:
3,631,492, PUB. 3-17-2009. MULTIPLE CLASS, INT. CLS. 7 AND 9.
3,631,493, PUB. 3-17-2009. MULTIPLE CLASS, INT. CLS. 7 AND 9.

SURRY LICENSING LLC, KEENE, NH:
2,597,557, CANC. INT. CL. 35.

SURVIVING SUNRISE, INC., NEW YORK, NY:
3,631,207, PUB. 3-17-2009. MULTIPLE CLASS, INT. CLS. 9 AND 41.

SUSAN G. KOMEN BREAST CANCER FOUNDATION, THE, DALLAS, TX:
2,598,258, CANC. INT. CL. 36.

SUSSMAN-AUTOMATIC CORPORATION, LONG ISLAND CITY, NY:
3,632,285, INT. CL. 9.

SUZUKI MOTOR CORPORATION, HAMAMATSU-SHI, JAPAN:
3,629,293, PUB. 8-5-2008. INT. CL. 9.

SVILAND, ELEN, JERSEY CITY, NJ:
2,599,376, CANC. INT. CL. 11.

SWAN ENTERPRISES, INC., RENO, NV:
3,632,531, MULTIPLE CLASS, INT. CLS. 18 AND 25.

SWANK LIGHTING LP, AUSTIN, TX:
3,630,664, PUB. 3-17-2009. INT. CL. 11.

SWANK MOTION PICTURES, INC., ST. LOUIS, MO:
1,555,374, REN. 4-24-09. INT. CL. 41.

SWANSON HEALTH PRODUCTS, INC., FARGO, ND:
2,596,473, CANC. INT. CL. 5.

SWANSON TOOL CO., INC., FRANKFORT, IL:
3,633,071, INT. CL. 9.

SWEET PEOPLE APPAREL, INC., LOS ANGELES, CA:
3,633,237, INT. CL. 16.

SWENSON LAND & CATTLE CO., DALLAS, TX:
2,598,468, CANC. INT. CL. 29.

SWIM, W. R., IOWA CITY, IA, DBA TRAINING RESEARCH SERVICES:
2,174,384, CANC. INT. CL. 35.

SWIMC, INC., WILMINGTON, DE:
438,455, REN. 4-29-09. U.S. CL. 16 (INT. CL. 2).
2,239,842, REN. 4-24-09. INT. CL. 19.
2,596,515, CANC. INT. CL. 3.

SWIMC, NIC., WILMINGTON, DE:
2,596,805, CANC. INT. CL. 7.

SWISS-AMERICAN IMPORTING COMPANY, ST. LOUIS, MO TO SWISS-AMERICAN IMPORTING COMPANY, ST. LOUIS, MO:
419,062, AM. U.S. CL. 46.

SWISS-AMERICAN IMPORTING COMPANY, ST. LOUIS, MO:
1,628,478, COR. INT. CL. 29.
1,797,983, AM. INT. CL. 29.
1,804,640, COR. INT. CL. 29.
2,142,860, COR. INT. CL. 29.
2,164,295, COR. INT. CL. 29.
3,410,460, COR. INT. CL. 29.

SWITZER RESOURCE GROUP, INC., SHAWNEE, KS:
3,631,069, PUB. 3-17-2009. INT. CL. 41.

SY KESSLER SALES, INC., DALLAS, TX:
3,631,266, PUB. 3-17-2009. INT. CL. 7.

SYDNEY IVF LIMITED, SYDNEY NSW, AUSTRALIA:
3,631,466, PUB. 3-17-2009. MULTIPLE CLASS, INT. CLS. 5, 42 AND 44.
3,631,467, PUB. 3-17-2009. MULTIPLE CLASS, INT. CLS. 42 AND 44.

SYED, JAWED, MISSISSAUGA, ONTARIO, CANADA:
3,630,065, PUB. 3-17-2009. INT. CL. 30.

SYL, LLC, WILMINGTON, DE:
3,632,057, INT. CL. 25.

SYLMARK HOLDINGS LIMITED, DUBLIN 2, IRELAND:
3,632,680, INT. CL. 10.

SYMBOL MATTRESS COMPANY, RICHMOND, VA:
3,632,482, INT. CL. 20.

SYNAPSE BIOMEDICAL, INC., OBERLIN, OH:
3,632,660, INT. CL. 10.

SYNCHRONIZED DYNAMICS, INC., ASTORIA, NY:
2,596,941, CANC. MULTIPLE CLASS, INT. CLS. 38 AND 42.

SYNCHRONOUS MEDIA INTERNATIONAL, LTD., LANSING, MI, DBA MESSAGE MAKERS:
3,630,396, PUB. 3-17-2009. INT. CL. 35.

SYNGENTA INVESTMENT CORPORATION, GREENSBORO, NC, NAVARITIS FINANCE CORPORATION, SUMMIT, NJ:
2,285,767, REN. 4-24-09. INT. CL. 5.

SYPRIS ELECTRONICS, LLC, TAMPA, FL:
3,633,291, INT. CL. 9.

SYSTEM WIDE SOLUTIONS, INC., COLUMBIA, SC:
3,632,472, INT. CL. 16.

T & T INTERNATIONAL SEAFOOD, INC., NORCROSS, GA:
3,629,400, PUB. 4-1-2008. INT. CL. 29.

T TIME SOLUTIONS, CALDWELL, ID:
3,630,549, PUB. 3-17-2009. INT. CL. 41.

T.E.B. L.B., 21590 SANTENAY, FRANCE:
2,596,596, CANC. INT. CL. 9.
2,596,597, CANC. INT. CL. 9.

T.O.W., INC., LOS ANGELES, CA:
3,629,317, PUB. 3-17-2009. INT. CL. 25.

T-MOBILE USA, INC., BELLEVUE, WA:
3,632,991, INT. CL. 9.
3,632,992, INT. CL. 9.

TA OPERATING LLC, WESTLAKE, OH:
3,630,219, PUB. 3-17-2009. INT. CL. 36.

TABA INCORPORATED, POTOMAC, MD:
2,597,255, CANC. INT. CL. 35.

TABLETOPS UNLIMITED, INC., CARSON, CA:
3,630,026, PUB. 3-17-2009. INT. CL. 21.

TABRIO COMMUNICATIONS INC., VANCOUVER, CANADA:
3,632,627, MULTIPLE CLASS, INT. CLS. 9, 35 AND 38.
3,632,628, MULTIPLE CLASS, INT. CLS. 9, 35 AND 38.

TACO BELL CORP., IRVINE, CA:
3,629,938, PUB. 3-17-2009. INT. CL. 43.
3,632,479, INT. CL. 43.

TADY LURE CORPORATION, CITY OF INDUSTRY, CA:
3,630,027, PUB. 3-17-2009. MULTIPLE CLASS, INT. CLS. 25 AND 28.

TAHOE INTERNET CORP, HOUSTON, TX:
2,596,686, CANC. INT. CL. 36.

TAIWAN LIPOSOME CO., LTD., TAIPEI, NANKANG DISTRICT, TAIWAN:
3,631,124, PUB. 3-17-2009. INT. CL. 5.

TAJ CELLARS, LLC, SANTA ROSA, CA:
3,631,072, PUB. 3-17-2009. INT. CL. 33.

TAKAHASHI, TSUYOSHI, TONE-GUN, JAPAN:
3,631,054, PUB. 3-17-2009. INT. CL. 25.

TAKE-TWO INTERACTIVE SOFTWARE, INC., NEW YORK, NY:
3,631,311, PUB. 3-17-2009. INT. CL. 25.
3,633,063, INT. CL. 16.
3,633,070, INT. CL. 16.
3,633,073, INT. CL. 16.

TALIERI, PETER, SANTA MONICA, CA:
3,630,830, PUB. 3-17-2009. INT. CL. 35.

TALKING TABS, L.L.C., MAITLAND, FL:
3,629,986, PUB. 3-17-2009. MULTIPLE CLASS, INT. CLS. 25 AND 41.
3,629,987, PUB. 3-17-2009. MULTIPLE CLASS, INT. CLS. 25 AND 41.

- TAMAYA GOURMET S.A., SANTIAGO, CHILE:
3,629,637, PUB. 3-17-2009. INT. CL. 29.
- TAMER INTERNATIONAL, LTD., SEATTLE, WA TO TAMER INTERNATIONAL, LTD., SEATTLE, WA:
2,175,332, CANC. INT. CL. 5.
- TAMPA SWEETHEARTS CIGAR COMPANY, TAMPA, FL:
3,632,972, INT. CL. 34.
3,633,043, INT. CL. 34.
- TANDEM ENTREPRENEUR MANAGEMENT SERVICES, LLC, MENLO PARK, CA:
3,629,328, PUB. 3-17-2009. INT. CL. 36.
- TANK CONNECTION, L.L.C., PARSONS, KS:
3,630,995, PUB. 3-17-2009. INT. CL. 6.
- TANK DESIGN, NEW YORK, NY:
3,630,190, PUB. 3-17-2009. INT. CL. 16.
- TAO GROUP LIMITED, EARLEY, READING, UNITED KINGDOM:
2,597,045, CANC. INT. CL. 9.
- TAPETENFABRIK GEBR. RASCH GMBH & CO., BRAMCHE, FED REP GERMANY:
1,556,965, REN. 4-29-09. INT. CL. 27.
- TAPPED OUT, LLC, GRANDA HILLS, CA:
3,631,910, INT. CL. 18.
- TAPPED OUT, LLC, GRANADA HILLS, CA:
3,631,913, INT. CL. 16.
- TARANACE ENTERPRISES, LLC, SAN ANTONIO, TX:
3,631,260, PUB. 3-17-2009. INT. CL. 30.
- TARGET 250 INC., MORRISTOWN, NJ:
3,630,882, PUB. 3-17-2009. MULTIPLE CLASS, INT. CLS. 35 AND 41.
- TASTEFULLY SIMPLE, INC., ALEXANDRIA, MN:
3,631,381, PUB. 3-17-2009. INT. CL. 29.
- TASTY BAKING COMPANY, PHILADELPHIA, PA:
1,496,928, CANC. INT. CL. 30.
- TAT MAKARNACILIK; SANAYI VE TICARET ANONIM SIRKETI, TURKEY:
3,631,653, PUB. 3-17-2009. INT. CL. 30.
- TATAMI SCHUH GMBH, 53604 BAD HONNEF, FED REP GERMANY:
3,631,663, PUB. 3-17-2009. MULTIPLE CLASS, INT. CLS. 9, 10, 18 AND 25.
- TATONKA CAPITAL CORPORATION, DENVER, CO:
2,328,271, REN. 4-29-09. INT. CL. 36.
- TAUNTON TRADE COMPANY, INC., THE, NEWTOWN, CT:
2,302,250, REN. 4-24-09. INT. CL. 16.
- TAUREAN SYSTEMS LIMITED, HUNTINGDON, UNITED KINGDOM:
3,629,626, PUB. 3-17-2009. MULTIPLE CLASS, INT. CLS. 3 AND 5.
- TAX ANALYSTS, ARLINGTON, VA:
2,597,442, CANC. INT. CL. 42.
2,599,736, CANC. INT. CL. 9.
- TAYLOR MADE GROUP, INC., GLOVERSVILLE, NY:
2,287,410, REN. 4-24-09. MULTIPLE CLASS, INT. CLS. 9 AND 20.
- TAYLOR-DIMONTE ENTERPRISES INC., THORNHILL, ONTARIO, CANADA:
2,596,563, CANC. INT. CL. 28.
- TAYLOR, JENNIFER, BURBANK, CA:
3,632,576, INT. CL. 16.
- TAYLOR, SCOTT, INDIANAPOLIS, IN:
3,632,921, INT. CL. 36.
- TAYLOR, WILLARD GREGG, SILVER SPRING, MD:
2,597,516, CANC. INT. CL. 42.
- TBB GLOBAL LOGISTICS, INC., NEW FREEDOM, PA:
3,631,179, PUB. 3-17-2009. MULTIPLE CLASS, INT. CLS. 35 AND 39.
3,631,180, PUB. 3-17-2009. MULTIPLE CLASS, INT. CLS. 35 AND 39.
- TCC, LCC, LENEXA, KS:
2,597,103, CANC. INT. CL. 42.
- TD WATERHOUSE GROUP, INC., NEW YORK, NY:
2,599,762, CANC. INT. CL. 36.
- TDI, INC., WASHINGTON, DC:
3,631,931, INT. CL. 13.
- TEA LIFE, LLC, MANHASSET, NY:
3,629,576, PUB. 3-17-2009. INT. CL. 4.
- TEACHERS COLLEGE, COLUMBIA UNIVERSITY, NEW YORK, NY:
3,629,614, PUB. 3-17-2009. INT. CL. 41.
- TEAM ATHLETIC GOODS, INC., CHESTERFIELD, MO:
3,631,129, PUB. 3-17-2009. INT. CL. 28.
3,631,130, PUB. 3-17-2009. INT. CL. 28.
- TEAM PRODUCTS INTERNATIONAL, BOOTON, NJ:
2,597,665, CANC. INT. CL. 11.
- TEAMQUEST CORPORATION, CLEAR LAKE, IA:
3,629,820, PUB. 3-17-2009. INT. CL. 9.
3,629,823, PUB. 3-17-2009. INT. CL. 9.
3,629,884, PUB. 3-17-2009. INT. CL. 9.
- TEAR-N-IT UP DEMOLITION, HAYWARD, CA:
3,630,680, PUB. 3-17-2009. INT. CL. 37.
- TEC LABORATORIES, INC., ALBANY, OR:
3,630,756, PUB. 3-17-2009. INT. CL. 5.
- TECH CONFERENCES, INC., MONROE, CT:
2,597,496, CANC. INT. CL. 35.
- TECH ELECTRONICS, INC., NORCROSS, GA:
2,598,104, CANC. INT. CL. 9.
- TECHEDU, LONG BRANCH, NJ:
3,629,570, PUB. 3-17-2009. INT. CL. 39.
- TECHNETIX GROUP LIMITED, WEST SUSSEX, UNITED KINGDOM:
3,629,365, PUB. 10-7-2008. INT. CL. 9.
- TECHNICAL INNOVATIONS, INC., DRAYTON PLAINS, MI:
1,497,286, CANC. INT. CL. 1.
- TECHNIFAB PRODUCTS, INC., BRAZIL, IN:
3,630,482, PUB. 3-17-2009. INT. CL. 7.
- TECHNISAT DIGITAL GMBH, FED REP GERMANY:
3,631,549, PUB. 3-17-2009. INT. CL. 9.
- TECHNOGYM S.R.L., I - 47035 GAMBETTOLA, ITALY:
2,597,150, CANC. MULTIPLE CLASS, INT. CLS. 9, 41 AND 42.
- TECHRADIUM INC., SUGAR LAND, TX:
3,631,197, PUB. 3-17-2009. INT. CL. 42.
- TECO ENERGY, INC., TAMPA, FL:
3,629,383, PUB. 3-17-2009. MULTIPLE CLASS, INT. CLS. 35 AND 39.
- TED SQUIRES, LLC, HERMITAGE, TN:
2,598,755, CANC. MULTIPLE CLASS, INT. CLS. 14 AND 16.
- TEDDI TOYS, INC., CHICAGO, IL:
2,830,811, CANC. INT. CL. 28.
- TEENAIN CO., LTD, SEOUL, REPUBLIC OF KOREA:
3,631,992, INT. CL. 3.
- TEG STAFFING, INC., SAN DIEGO, CA:
3,630,453, PUB. 3-17-2009. INT. CL. 45.
- TEKNOR APEX COMPANY, PAWTUCKET, RI:
3,631,315, PUB. 3-17-2009. INT. CL. 17.
- TELE-PRO CORP., RONKONKOMA, NY:
2,598,684, CANC. MULTIPLE CLASS, INT. CLS. 35, 37 AND 42.
- TELEBRANDS CORP., FAIRFIELD, NJ:
2,598,918, CANC. INT. CL. 28.
- TELEDYNE INDUSTRIES, INC., LOS ANGELES, CA:
1,496,760, CANC. INT. CL. 17.
- TELEFLEX INCORPORATED, LIMERICK, PA:
1,496,410, CANC. INT. CL. 2.
- TELEMANAGEMENT FORUM, MORRISTOWN, NJ:
3,632,143, INT. CL. 9.
- TELEPERFORMANCE, PARIS, FRANCE:
3,631,514, PUB. 3-17-2009. MULTIPLE CLASS, INT. CLS. 35, 38 AND 41.
- TELEVISA, S.A. DE C.V., COLONIA ZEDEC SANTA FE, MEXICO, D.F, MEXICO:
3,631,446, PUB. 3-17-2009. INT. CL. 41.
- TELEVISA, S.A. DE C.V., COLONIA ZEDEC SANTA FE, MEXICO:
3,631,971, INT. CL. 28.
- TELSTRA CORPORATION LIMITED, MELBOURNE, VIC, AUSTRALIA:
2,596,697, CANC. MULTIPLE CLASS, INT. CLS. 35, 38 AND 42.
- TELSTRA CORPORATION LIMITED, MELBOURNE, VIC, 3000, AUSTRALIA:
2,596,698, CANC. MULTIPLE CLASS, INT. CLS. 36, 38

- AND 41.
 TEMENOS HEADQUARTERS SA, 1205 GENEVA, SWITZERLAND:
 3,632,540, INT. CL. 41.
- TENGFEL, INC., BALTIMORE, MD:
 3,630,991, PUB. 3-17-2009. INT. CL. 29.
- TENNECO AUTOMOTIVE OPERATING COMPANY INC., LAKE FOREST, IL:
 3,632,924, INT. CL. 7.
- TENNECO MARZOCCHI SRL, BOLOGNA (BO), ITALY:
 2,598,300, CANC. INT. CL. 12.
- TENNESSEE MEDIATION ARBITRATION SERVICES, INC., BRENTWOOD, TN:
 3,631,820, MULTIPLE CLASS, INT. CLS. 16 AND 41.
- TEQUILA SAUZA, S.A. DE C.V., JALISCO, JAL. 44100 GUADALAJARA, MEXICO:
 2,597,802, CANC. INT. CL. 33.
 2,597,803, CANC. INT. CL. 33.
 2,597,804, CANC. INT. CL. 33.
- TERAYON COMMUNICATION SYSTEMS, SANTA CLARA, CA TO TERAYON COMMUNICATION SYSTEMS INC., SANTA CLARA, CA:
 2,175,565, CANC. INT. CL. 9.
- TERENCE JEFFERY LAPIDGE, BEACON HILL, AUSTRALIA:
 3,631,470, PUB. 3-17-2009. INT. CL. 21.
- TERESA, GRAPHOS TESSA, MOSS POINT, MS:
 3,630,266, PUB. 3-17-2009. INT. CL. 41.
- TEREX ADVANCE MIXER, INC., WESTPORT, CT:
 2,598,873, CANC. MULTIPLE CLASS, INT. CLS. 37 AND 40.
- TESTAMERICA LABORATORIES, INC., ASHEVILLE, NC:
 2,597,090, CANC. INT. CL. 9.
- TETHYS TECHNOLOGY, NEW YORK, NY:
 3,629,757, PUB. 3-17-2009. INT. CL. 42.
 3,629,759, PUB. 3-17-2009. INT. CL. 42.
- TETRA TECHNOLOGIES, INC., THE WOODLANDS, TX:
 3,629,692, PUB. 3-17-2009. MULTIPLE CLASS, INT. CLS. 1 AND 5.
- TEXAS CHILDREN'S HOSPITAL, HOUSTON, TX:
 2,706,156, CANC. MULTIPLE CLASS, INT. CLS. 36 AND 39.
- TEXAS DEPARTMENT OF TRANSPORTATION, AUSTIN, TX:
 3,630,512, PUB. 3-17-2009. INT. CL. 35.
- TEXAS INSTRUMENTS INCORPORATED, DALLAS, TX:
 3,631,866, INT. CL. 9.
- TEXMARK CHEMICALS, INC., GALENA PARK, TX:
 2,597,973, CANC. INT. CL. 1.
- TEYDO HOLDING INC., POTOMAC FALLS, VA:
 3,629,507, PUB. 12-9-2008. MULTIPLE CLASS, INT. CLS. 9 AND 38.
- TFC SYSTEMS, INC., JACKSONVILLE, FL:
 3,631,225, PUB. 3-17-2009. INT. CL. 35.
- THAKKAR, INC., HOUSTON, TX:
 3,630,581, PUB. 3-17-2009. INT. CL. 9.
 3,630,582, PUB. 3-17-2009. INT. CL. 11.
- THALASSA TALLER DE VINO, S.L., BARCELONA, SPAIN:
 3,629,340, PUB. 3-17-2009. MULTIPLE CLASS, INT. CLS. 35 AND 41.
- THALES TRACS LIMITED, BRACKNELL, ENGLAND:
 2,596,820, CANC. INT. CL. 9.
- THC SYSTEMS, INC., MELVILLE, NY:
 1,496,810, CANC. INT. CL. 21.
- THE ACE CARD COMPANY, NOIDA, INDIA:
 3,630,212, PUB. 3-17-2009. INT. CL. 28.
- THE AGAPE ALLIANCE, LLC, CHELSEA, MA:
 3,631,255, PUB. 3-17-2009. INT. CL. 25.
- THE AMYOTROPHIC LATERAL SCLEROSIS ASSOCIATION, CALABASAS HILLS, CA:
 3,632,211, MULTIPLE CLASS, INT. CLS. 35 AND 36.
- THE ANNIE E. CASEY FOUNDATION, INC., BALTIMORE, MD:
 3,630,683, PUB. 3-17-2009. INT. CL. 41.
- THE ARMOR ALL/STP PRODUCTS COMPANY, OAKLAND, CA:
 3,632,640, INT. CL. 9.
 3,632,703, INT. CL. 7.
 3,632,833, INT. CL. 3.
- THE AVALON CONSULTING GROUP, INC., WASHINGTON, DC:
 3,629,528, PUB. 3-17-2009. INT. CL. 35.
- THE BALTIMORE LIFE INSURANCE COMPANY, BALTIMORE, MD:
 3,632,324, INT. CL. 36.
- THE BANK OF MIAMI, NATIONAL ASSOCIATION, CORAL GABLES, FL:
 3,630,284, PUB. 3-17-2009. INT. CL. 36.
- THE BIENMOYO FOUNDATION, INC., BROOKLINE, MA:
 3,630,875, PUB. 3-17-2009. INT. CL. 44.
- THE BIG LEAD, LLC, BROOKLYN, NY:
 3,629,548, PUB. 3-17-2009. INT. CL. 41.
- THE BRADBURY CO., INC., MOUNDRIDGE, KS:
 3,630,095, PUB. 3-17-2009. MULTIPLE CLASS, INT. CLS. 7 AND 9.
- THE CALIFORNIA ENDOWMENT, LOS ANGELES, CA:
 3,629,517, PUB. 3-17-2009. MULTIPLE CLASS, INT. CLS. 36 AND 44.
- THE CAPE COD HAMMOCK COMPANY, N. WEYMOUTH, MA:
 3,633,472, INT. CL. 22.
- THE CARTER CENTER, INC., ATLANTA, GA:
 3,630,016, PUB. 3-17-2009. MULTIPLE CLASS, INT. CLS. 36 AND 41.
 3,630,017, PUB. 3-17-2009. MULTIPLE CLASS, INT. CLS. 36 AND 41.
- THE CARTOON NETWORK, INC., ATLANTA, GA:
 3,633,170, INT. CL. 9.
- THE CARTOON NETWORK, INC., ATLANTA, GA:
 3,632,003, INT. CL. 25.
 3,633,163, INT. CL. 18.
 3,633,171, INT. CL. 14.
 3,633,172, INT. CL. 16.
 3,633,193, INT. CL. 25.
- THE CHIEF OF NAVAL INFORMATION, THE DEPARTMENT OF THE NAVY, ARLINGTON, VA:
 3,631,094, PUB. 3-17-2009. INT. CL. 14.
- THE CITY OF MESQUITE, MESQUITE, TX:
 3,630,463, PUB. 3-17-2009. INT. CL. 35.
- THE COAST DISTRIBUTION SYSTEM, INC., MORGAN HILL, CA:
 3,632,378, INT. CL. 7.
- THE COMMUNICATIONS DOCTOR, INC., CHAPEL HILL, NC:
 3,629,713, PUB. 3-17-2009. INT. CL. 41.
- THE CRICKET COMPANY LLC, NOVATO, CA:
 3,633,475, INT. CL. 9.
- THE CRICKET COMPANY, LLC, NOVATO, CA:
 3,633,487, INT. CL. 21.
- THE DELFIELD COMPANY LLC, WILMINGTON, DE:
 2,599,389, CANC. INT. CL. 11.
 2,599,390, CANC. INT. CL. 11.
- THE DEVI CLINIC, LLC, NASHVILLE, TN:
 3,629,760, PUB. 3-17-2009. MULTIPLE CLASS, INT. CLS. 41 AND 44.
- THE DMSE FOUNDATION, INC., NORTH ANDOVER, MA:
 2,597,102, CANC. INT. CL. 42.
- THE DOW CHEMICAL COMPANY, MIDLAND, MI:
 3,633,145, INT. CL. 1.
- THE DOWNSTREAM DEVELOPMENT AUTHORITY OF THE QUAPAW TRIBE OF OKLAHOMA (O-GAH-PAH), TULSA, OK:
 3,632,788, INT. CL. 43.
- THE ECJC GRANTOR TRUST, WOODLAND HILLS, CA:
 3,629,585, PUB. 3-17-2009. INT. CL. 15.
- THE EUCLID CHEMICAL COMPANY, CLEVELAND, OH:
 1,496,415, CANC. INT. CL. 2.
- THE EXTREME PITA FRANCHISING USA, INC., MISSISSAUGA, CANADA:
 3,629,914, PUB. 3-17-2009. INT. CL. 43.
- THE FLUID LIFE COMPANY, EDMONTON, CANADA:
 3,631,435, PUB. 1-6-2009. INT. CL. 9.

- THE FORT WAYNE-ALLEN COUNTY AIRPORT AUTHORITY, FORT WAYNE, IN:
3,629,175, PUB. 3-17-2009. INT. CL. 39.
- THE FRAGRANCE FACTORY, LLC, GAHANNA, OH:
3,630,773, PUB. 3-17-2009. INT. CL. 16.
- THE FRUIT COMPANY, INC., HOOD RIVER, OR:
2,597,087, CANC. MULTIPLE CLASS, INT. CLS. 29 AND 31.
- THE GARLAND COMPANY, INC., CLEVELAND, OH:
3,632,410, INT. CL. 19.
- THE GLASS GURU FRANCHISE SYSTEMS INC., SACRAMENTO, CA:
3,632,441, INT. CL. 3.
- THE GOOD SAMARITAN HOSPITAL OF CINCINNATI, OHIO, CINCINNATI, OH:
1,497,171, CANC. INT. CL. 42.
- THE GREEN WINDOW COMPANY, INC., KENNESAW, GA:
3,633,385, INT. CL. 35.
- THE HARTZ MOUNTAIN CORPORATION, SECAUCUS, NJ:
3,632,579, INT. CL. 21.
3,632,621, INT. CL. 28.
3,632,774, INT. CL. 31.
3,632,775, INT. CL. 31.
3,632,776, INT. CL. 28.
3,632,784, INT. CL. 5.
- THE ILLUMEN GROUP, INC., DENVER, CO:
3,630,454, PUB. 3-17-2009. INT. CL. 38.
- THE IMAGINARY PET COMPANY, LLC, HOLLYWOOD, FL:
3,630,707, PUB. 3-17-2009. INT. CL. 28.
- THE INSTITUTIONAL LIFE MARKETS ASSOCIATION, INC., WASHINGTON, DC:
3,629,927, PUB. 3-17-2009. INT. CL. 35.
- THE ISOPURE COMPANY, LLC, HAUPPAUGE, NY:
2,598,932, CANC. INT. CL. 5.
- THE JACK RABBIT COLLECTION, LOS ANGELES, CA:
3,629,471, PUB. 3-17-2009. INT. CL. 18.
- THE JAM CATS, ROCKAWAY, NJ:
3,631,172, PUB. 3-17-2009. INT. CL. 41.
- THE KAVLI FOUNDATION, OXNARD, CA:
3,630,080, PUB. 3-17-2009. INT. CL. 41.
- THE LAURA SCUDDER'S COMPANY, NEWPORT BEACH, CA:
2,334,272, REN. 4-25-09. INT. CL. 29.
- THE LUXURY MARKETING COUNCIL, LLC, NEW YORK, NY:
3,270,992 NEW CERT. 6-2-2009. INT. CL. 41.
- THE MACALLAN DISTILLERS LIMITED, BANFFSHIRE, UNITED KINGDOM:
3,462,650, COR. INT. CL. 33.
- THE MCGRAW-HILL COMPANIES, INC., NEW YORK, NY:
3,633,458, INT. CL. 36.
- THE MEGA SHED PTY LTD, SALISBURY, AUSTRALIA:
3,632,513, INT. CL. 2.
- THE MINI SOCIAL, GLENDALE, CA:
3,630,123, PUB. 3-17-2009. INT. CL. 35.
- THE MOORE COMPANY, WESTERLY, RI:
2,596,588, CANC. INT. CL. 20.
- THE MOST HONORABLE ORDER OF CHRISTIAN KNIGHTS OF THE ROSE, SEASIDE, CA:
3,631,964, MULTIPLE CLASS, INT. CLS. 35 AND 36.
- THE MURALO COMPANY, INC., BAYONNE, NJ:
3,630,464, PUB. 3-17-2009. INT. CL. 2.
- THE NEW YORK BOARD OF RABBIS, INC., NEW YORK, NY:
3,632,151, INT. CL. 41.
- THE NEW YORK TIMES COMPANY, NEW YORK, NY:
3,633,426, INT. CL. 16.
- THE NORTH FACE APPAREL CORP, WILMINGTON, DE:
3,630,550, PUB. 3-17-2009. INT. CL. 25.
3,630,564, PUB. 3-17-2009. INT. CL. 35.
3,630,565, PUB. 3-17-2009. INT. CL. 25.
3,630,629, PUB. 3-17-2009. INT. CL. 20.
3,630,846, PUB. 3-17-2009. INT. CL. 25.
3,630,850, PUB. 3-17-2009. INT. CL. 25.
- THE OCCASIONS GROUP, INC., NORTH MANKATO, MN:
3,633,274, INT. CL. 16.
- THE ONE FOUR ALL FOUNDATION; C/O RITTER RECHTSANWÄLTE, SWITZERLAND:
3,631,473, PUB. 3-17-2009. MULTIPLE CLASS, INT. CLS. 14, 16, 25, 28, 32, 35, 41 AND 43.
- THE OZONE MAN, INC., BEVERLY HILLS, CA:
3,629,959, PUB. 3-17-2009. MULTIPLE CLASS, INT. CLS. 7, 40 AND 42.
- THE PARENT BLOGGERS NETWORK LLC, PARKER, CO:
3,633,465, INT. CL. 35.
- THE PENNEY GROUP, INC., MIAMI, FL:
3,630,285, PUB. 3-17-2009. MULTIPLE CLASS, INT. CLS. 35 AND 42.
- THE PILLSBURY COMPANY, MINNEAPOLIS, MN:
3,495,998, COR. INT. CL. 30.
- THE POINSETT CLUB, GREENVILLE, SC:
3,630,842, PUB. 3-17-2009. INT. CL. 41.
- THE PORTABLE BABY, INC., SARATOGA, CA:
3,630,621, PUB. 3-17-2009. INT. CL. 35.
- THE POWDER GROUP, LLC, NEW YORK, NY:
3,630,133, PUB. 3-17-2009. INT. CL. 35.
- THE PROCTER & GAMBLE COMPANY, CINCINNATI, OH:
3,629,909, PUB. 3-17-2009. INT. CL. 29.
3,632,580, MULTIPLE CLASS, INT. CLS. 3 AND 21.
3,632,699, INT. CL. 16.
3,632,738, MULTIPLE CLASS, INT. CLS. 3 AND 37.
3,633,013, INT. CL. 37.
- THE RANCH SALONS, ROSS, CA:
3,631,233, PUB. 3-17-2009. INT. CL. 44.
- THE RED REPORT, LLC, HENDERSON, NV:
3,632,071, INT. CL. 16.
- THE ROBOT CO-OP, INC., SEATTLE, WA:
3,633,361, INT. CL. 45.
- THE ROYAL BANK OF SCOTLAND GROUP PLC, EDINBURGH EH2 2YB, UNITED KINGDOM:
3,631,743, PUB. 3-17-2009. MULTIPLE CLASS, INT. CLS. 9, 16, 35, 36, 38 AND 42.
- THE SCARLET TASSEL, INC., ATLANTA, GA:
3,629,234, PUB. 3-17-2009. INT. CL. 35.
- THE SHAWE FOUNDATION, NEW YORK, NY:
3,630,413, PUB. 3-17-2009. INT. CL. 25.
- THE SHERWIN-WILLIAMS COMPANY, CLEVELAND, OH:
2,599,641, CANC. INT. CL. 2.
3,632,086, INT. CL. 17.
- THE SKY FACTORY, L.C., FAIRFIELD, IA:
3,629,527, PUB. 3-17-2009. MULTIPLE CLASS, INT. CLS. 6, 19 AND 42.
- THE SUNBELT SOWER COMPANIES, INC, HOUSTON, TX, DBA DMN3:
3,629,467, PUB. 3-17-2009. INT. CL. 35.
- THE SY-KLONE COMPANY, JACKSONVILLE, FL:
3,631,839, INT. CL. 11.
- THE TAPLOW GROUP S.A., LUXEMBOURG:
3,631,533, PUB. 3-17-2009. MULTIPLE CLASS, INT. CLS. 35, 41 AND 42.
- THE TEXAS LICE SQUAD RN LLC, MISSOURI CITY, TX:
3,630,435, PUB. 3-17-2009. INT. CL. 44.
- THE TRUSTEES OF PRINCETON UNIVERSITY, PRINCETON, NJ:
3,630,907, PUB. 3-17-2009. INT. CL. 41.
- THE TRUSTEES OF THE UNIVERSITY OF PENNSYLVANIA, PHILADELPHIA, PA:
3,630,135, PUB. 3-17-2009. MULTIPLE CLASS, INT. CLS. 16, 41, 42 AND 44.
- THE U.S. SECRET SERVICE UNIFORMED DIVISION BENEFIT FUND, WASHINGTON, DC:
3,633,207, INT. CL. 25.
- THE W. W. HENRY COMPANY, L.P., ALIQUIPPA, PA:
3,633,241, INT. CL. 19.
- THE WEINSTEIN COMPANY LLC, NEW YORK, NY:
3,630,844, PUB. 3-17-2009. INT. CL. 41.
- THE WELLCARE MANAGEMENT GROUP, INC., TAMPA, FL:
3,629,737, PUB. 3-17-2009. INT. CL. 44.
3,629,846, PUB. 3-17-2009. INT. CL. 35.
- THE WINE GROUP LLC, TRACY, CA:
3,632,262, INT. CL. 33.
- THE WOODLAND SERVICES GROUP, INC., SPARTA, NJ:
2,325,405, REN. 4-24-09. INT. CL. 36.

THED LENSSEN HOLDING B.V., AMSTERDAM, NETHERLANDS:
 2,598,089, CANC. MULTIPLE CLASS, INT. CLS. 9 AND 41.

THERADOC, INC., SALT LAKE CITY, UT:
 3,633,137, INT. CL. 9.

THERAPY PRODUCTS, INC., MCKINNEY, TX, DBA ERCHONIA MEDICAL:
 3,632,803, INT. CL. 44.

THERATIVE, INC., LIVERMORE, CA:
 3,631,205, PUB. 3-17-2009. INT. CL. 10.

THERMAL CORP., GEORGETOWN, DE:
 2,598,353, CANC. INT. CL. 11.

THERMO-TECHNOLOGIES, LLC, BISMARCK, ND:
 3,631,823, INT. CL. 1.

THIELE TECHNOLOGIES, INC., MINNEAPOLIS, MN:
 3,630,222, PUB. 3-17-2009. INT. CL. 7.

THIEN THANH THI NGUYEN, SHERMAN OAKS, CA:
 3,633,076, INT. CL. 41.

THIERRY MUGLER PARFUMS S.A.S., NEUILLY-SUR-SEINE, FRANCE:
 3,633,087, INT. CL. 3.

THINKSTREET, AUSTIN, TX:
 3,629,215, PUB. 3-17-2009. INT. CL. 35.
 3,629,219, PUB. 3-17-2009. INT. CL. 35.

THINKWELL GROUP INC., BURBANK, CA:
 3,630,263, PUB. 3-17-2009. INT. CL. 37.

THINKWELL GROUP INC., BURBANK, CA:
 3,630,264, PUB. 3-17-2009. INT. CL. 37.

THINKWELL GROUP INC., BURBANK, CA:
 3,630,376, PUB. 3-17-2009. INT. CL. 42.

THIRSTY FISH PTY LTD, SANDRINGHAM VIC 3191, AUSTRALIA:
 3,631,603, PUB. 3-17-2009. MULTIPLE CLASS, INT. CLS. 9, 25 AND 28.

THIRTY 5 PARTNERS, LTD., NEW YORK, TX:
 3,633,097, INT. CL. 44.

THOMAS & BETTS INTERNATIONAL, INC., WILMINGTON, DE:
 3,631,323, PUB. 3-17-2009. INT. CL. 9.

THOMAS E MCAULIFFE ENTERPRISES, STERLING, VA:
 3,630,308, PUB. 3-17-2009. INT. CL. 41.

THOMAS LIAM MURPHY, ATLANTA, GA:
 3,629,973, PUB. 3-17-2009. INT. CL. 32.

THOMAS NELSON, INC., NASHVILLE, TN:
 2,308,946. REN. 4-24-09. INT. CL. 9.
 2,337,713. REN. 4-24-09. INT. CL. 41.

THOMAS, DAVID C, LOS GATOS, CA, DBA FAQTORS:
 3,632,995, INT. CL. 35.

THOMAS, RICKY JAMES, TAMPA, FL:
 2,596,760, CANC. INT. CL. 25.

THOMASON, SCOTT L., FAIRFIELD, CA:
 2,599,333, CANC. INT. CL. 35.

THOMPSON, BRIAN, HOUSTON, TX:
 3,633,038, INT. CL. 9.

THOMSON, BOULOGNE-BILLANCOURT, FRANCE:
 3,633,418, MULTIPLE CLASS, INT. CLS. 9, 35 AND 38.

THOR TECH, INC., SAGINAW, MI, NEW GOSHEN COACH CORPORATION, ELKHART, IN:
 1,578,897. REN. 4-29-09. INT. CL. 12.

THORNE, CHRISTAN, ATLANTA, GA:
 3,632,078, INT. CL. 25.

THORNHAM INCORPORATED, HALIFAX, CANADA:
 3,632,384, INT. CL. 36.
 3,632,385, INT. CL. 36.

THORO'BRED RACING PLATE CO., INC., ANAHEIM, CA:
 3,630,693, PUB. 3-17-2009. INT. CL. 8.

THOROWGOOD LIMITED, WEST MIDLANDS WS3 2XJ, UNITED KINGDOM:
 2,597,900, CANC. INT. CL. 18.

THYMES LIMITED, THE, MINNEAPOLIS, MN:
 2,598,844, CANC. MULTIPLE CLASS, INT. CLS. 3, 4 AND 5.

TI GOLF HOLDINGS INC., NEW YORK, NY:
 2,253,880. REN. 4-27-09. INT. CL. 9.
 2,597,475, CANC. INT. CL. 42.

TIANJIN BOATGEM ORGANIC FOOD MANUFACTURING CO., LTD, TIANJIN, CHINA:
 3,630,545, PUB. 3-17-2009. INT. CL. 30.

TIANJIN UNITED TIRE & RUBBER; INTERNATIONAL CO., LTD, CHINA:
 3,631,708, PUB. 3-17-2009. INT. CL. 12.

TIBOR RUMSZAUER, D-81739 MUNCHEN, FED REP GERMANY:
 3,629,333, PUB. 3-17-2009. MULTIPLE CLASS, INT. CLS. 18, 21, 25 AND 32.

TIE COMMERCE, INC., BURLINGTON, MA:
 2,175,331, CANC. INT. CL. 9.

TIEN YUEN MACHINERY MFG. CO., LTD., TAICHUNG, TAIWAN:
 3,632,905, INT. CL. 12.

TIER ONE TUTORS, VAN NUYS, CA:
 3,631,020, PUB. 3-17-2009. INT. CL. 41.

TIER TECHNOLOGIES, INC., WALNUT CREEK, CA:
 2,599,160, CANC. INT. CL. 41.

TIFFANY SAIDNIA, LOS ANGELES, CA:
 3,633,408, INT. CL. 25.

TILDE PTY LIMITED ACN 078 809 659, MANLY NSW 1655, AUSTRALIA:
 2,596,621, CANC. MULTIPLE CLASS, INT. CLS. 16 AND 41.

TIMBERLAND COMPANY, THE, STRATHAM, NH:
 1,552,963. REN. 4-27-09. INT. CL. 25.

TIMCAL SA (TIMCAL AG) (TIMCAL LTD), SWITZERLAND:
 3,631,624, PUB. 3-17-2009. INT. CL. 1.

TIME FOR GOOD FOOD INC., SAINT LEONARD, MD:
 3,629,147, PUB. 3-17-2009. MULTIPLE CLASS, INT. CLS. 30 AND 43.

TIME INC., NEW YORK, NY:
 3,631,257, PUB. 3-17-2009. INT. CL. 41.
 3,632,329, INT. CL. 41.

TIME WARNER ENTERTAINMENT COMPANY, L.P., NEW YORK, NY:
 2,598,661, CANC. INT. CL. 28.
 2,598,662, CANC. INT. CL. 16.
 2,598,663, CANC. INT. CL. 28.
 2,598,664, CANC. INT. CL. 28.
 2,599,510, CANC. INT. CL. 16.

TIMEGATE STUDIOS, INC., SUGAR LAND, TX:
 3,631,097, PUB. 3-17-2009. INT. CL. 9.

TIMELESS PALATES WINE LLC, SAN PEDRO, CA:
 3,629,968, PUB. 3-17-2009. INT. CL. 33.

TIMEX CORPORATION, MIDDLEBURY, CT:
 1,496,707, CANC. INT. CL. 14.

TIMMONS, FRANK R., DENVER, CO AND TIMMONS, KAREN J., DENVER, CO:
 2,599,546, CANC. INT. CL. 42.

TIMONIUM MOBIL, INC., HUNT VALLEY, MD:
 2,227,142. REN. 4-24-09. INT. CL. 35.

TIMOTHY'S COFFEES OF THE WORLD INC., TORONTO, ONTARIO:
 3,632,080, INT. CL. 30.

TINA FOUNTAIN, INC., MARIETTA, GA:
 3,630,528, PUB. 3-17-2009. INT. CL. 36.
 3,631,338, PUB. 3-17-2009. INT. CL. 36.

TINSLEY ROBOR PLC, CHICHESTER WEST SUSSEX PO20 6EW, ENGLAND:
 2,596,459, CANC. MULTIPLE CLASS, INT. CLS. 9, 16 AND 20.

TINY PRINTS, INC., MOUNTAIN VIEW, CA:
 3,629,373, PUB. 3-17-2009. MULTIPLE CLASS, INT. CLS. 16, 35, 40 AND 42.

TIPS EXPORTS INC., EDISON, NJ:
 2,597,894, CANC. INT. CL. 9.

TIRECO, INC., COMPTON, CA:
 3,632,592, INT. CL. 12.

TISHCON CORP, WESTBURY, NY:
 3,632,894, INT. CL. 5.

TITAN WRECKING & ENVIRONMENTAL, LLC, KENMORE, NY:
 3,630,627, PUB. 3-17-2009. MULTIPLE CLASS, INT. CLS. 37 AND 40.

- TIVO BRANDS LLC, ALVISO, CA:
2,599,712, CANC. INT. CL. 9.
- TL ENTERPRISES LLC, PHILADELPHIA, PA:
3,633,039, INT. CL. 30.
- TLV CO., LTD., KAKOGAWA-SHI, HYOGO-KEN, JAPAN:
1,534,980. REN. 4-27-09. MULTIPLE CLASS, INT. CLS. 7 AND 9.
- TM ACQUISITION CORP., PARSIPPANY, NJ:
2,598,065, CANC. INT. CL. 36.
- TMI PROMOTIONS INC., NEW BERLIN, WI:
3,632,609, INT. CL. 35.
- TMP NEVADA, INC., LAS VEGAS, NV:
3,631,242, PUB. 3-17-2009. INT. CL. 5.
- TMP WORLDWIDE ADVERTISING & COMMUNICATIONS, LLC, NEW YORK, NY:
3,603,930, COR. MULTIPLE CLASS, INT. CLS. 35 AND 38.
- TMW SYSTEMS, INC., BEACHWOOD, OH:
3,633,120, INT. CL. 9.
- TNS CUSTOM RESEARCH, INC., HORSHAM, PA:
2,597,464, CANC. INT. CL. 35.
- TOASTMASTER INC., COLUMBIA, MO:
2,175,389, CANC. INT. CL. 20.
- TODD, JED, NEWARK, DE AND TODD, CLAUDIA, NEWARK, DE:
3,633,001, INT. CL. 45.
- TOG SHOP, INC., THE, AMERICUS, GA:
2,597,916, CANC. INT. CL. 35.
- TOGETHER AGAIN VIDEO PRODUCTIONS, INC., LOS ANGELES, CA:
2,222,735. REN. 4-29-09. INT. CL. 41.
- TOLDRIAN, THOMAS P., ROSS, CA:
1,496,754, CANC. INT. CL. 16.
- TOM'S GUIDES PUBLISHING AG, D-85622 FELDKIRCHEN, FED REP GERMANY:
2,597,703, CANC. INT. CL. 42.
- TOMTEC, INC., HAMDEN, CT:
2,597,433, CANC. INT. CL. 9.
- TONOS ENTERTAINMENT, INC., LOS ANGELES, CA:
2,597,543, CANC. INT. CL. 9.
- TOO MARKER PRODUCTS, INC., SHIBUYA-KU TOKYO, JAPAN:
3,629,617, PUB. 3-17-2009. INT. CL. 16.
- TOO SOFT, LLC, HAMBURG, NJ:
3,629,308, PUB. 3-17-2009. INT. CL. 35.
- TOP CREATION (ASIA) LTD., WANCHAI, HONG KONG:
3,631,434, PUB. 3-17-2009. INT. CL. 21.
- TOP 20 REALTY INC., TUSTIN, CA:
3,632,643, INT. CL. 36.
- TOPCO ASSOCIATES, LLC, SKOKIE, IL:
3,633,144, INT. CL. 21.
- TOPCO ENERGY SAVING SYSTEM CORPORATION, DAN DISTRICT, TAIPEI, TAIWAN:
3,630,328, PUB. 3-17-2009. INT. CL. 11.
- TOPTST GMBH, CH-8001 ZÜRICH, SWITZERLAND:
3,631,537, PUB. 3-17-2009. MULTIPLE CLASS, INT. CLS. 35, 38, 41, 42 AND 45.
- TORRES, EDGAR, BROWNSTOWN, MI:
3,632,430, INT. CL. 25.
- TORRES, LOUIS, MALIBU, CA:
3,629,817, PUB. 3-17-2009. INT. CL. 40.
- TOTAL IMMERSION SOFTWARE, INC., ALAMEDA, CA:
3,632,388, INT. CL. 42.
- TOTAL PROFESSIONAL SERVICES GROUP, LTD., NEW YORK, NY:
2,598,922, CANC. INT. CL. 42.
- TOTAL SYSTEM SERVICES, INC., COLUMBUS, GA:
3,632,715, MULTIPLE CLASS, INT. CLS. 9 AND 16.
- TOTALLY INTERACTIVE WEATHER LLC, AFTON, MN:
3,632,326, INT. CL. 42.
3,632,353, INT. CL. 42.
- TOUCH NETWORKS, INC., BELLEVUE, WA:
3,631,198, PUB. 3-17-2009. INT. CL. 9.
- TOUCHTONE CORP., COSTA MESA, CA:
2,596,537, CANC. MULTIPLE CLASS, INT. CLS. 35 AND 36.
- TOWATCH B.V., VOORBURG, NETHERLANDS:
3,633,307, MULTIPLE CLASS, INT. CLS. 9, 35 AND 38.
- TOWER TECHNOLOGY, INC, BOSTON, MA:
2,599,104, CANC. INT. CL. 9.
- TOWN COMPASS, LLC, SEATTLE, WA:
2,598,476, CANC. INT. CL. 42.
- TOWNSEND & O'LEARY ENTERPRISES INC., IRVINE, CA:
2,597,187, CANC. INT. CL. 35.
- TOWNSITE PARTNERS, LLC, MADISON, NC:
3,630,820, PUB. 3-17-2009. INT. CL. 35.
- TOXICELL APS, DENMARK:
3,631,491, PUB. 3-17-2009. MULTIPLE CLASS, INT. CLS. 5, 9 AND 42.
- TOY STATE INDUSTRIAL LTD., TSTE KOWLOON, HONG KONG:
3,632,802, INT. CL. 41.
- TOY TIPS, INC., FRANKLIN, WI:
2,598,458, CANC. U.S. CL. A.
- TOYO ADVANCED TECHNOLOGIES CO. LTD., HIROSHIMA, JAPAN:
3,529,541, AM. INT. CL. 7.
- TOYO BOSEKI KABUSHIKI KAISHA, OSAKA, JAPAN:
2,597,133, CANC. INT. CL. 24.
- TOYOTA JIDOSHA KABUSHIKI KAISHA, TOYOTA-SHI, JAPAN, TA TOYOTA MOTOR CORPORATION:
3,631,340, PUB. 3-17-2009. INT. CL. 36.
- TOZER SEEDS AMERICA, LLC, SANTA MARIA, CA:
3,632,868, INT. CL. 31.
- TP MECHANICAL CONTRACTORS, INC., CINCINNATI, OH:
2,597,863, CANC. INT. CL. 37.
- TRACFONE WIRELESS, INC., MIAMI, FL:
3,630,321, PUB. 3-17-2009. INT. CL. 38.
- TRACIE MARTYN, INC., NEW YORK, NY:
3,631,798, INT. CL. 3.
3,633,342, INT. CL. 3.
- TRACKING PROJECT, INC., THE, CORRALES, NM:
2,255,445. REN. 4-27-09. INT. CL. 41.
- TRACTO-TECHNIK GMBH & CO. KG, FED REP GERMANY:
3,631,474, PUB. 3-17-2009. INT. CL. 7.
- TRADITIONAL MEDICINALS, INC., ROHNERT PARK, CA:
1,496,960, CANC. INT. CL. 30.
- TRAINA-SEPE, DONNA, M, MIDLOTHIAN, VA:
2,599,682, CANC. INT. CL. 35.
- TRAMPLANCOMPANY MUSIKPRODUKTION UND WERBEGES. M.B.H., 6290 MAYRHOFEN, AUSTRIA:
2,598,218, CANC. INT. CL. 9.
- TRANS-SCRIPTO (PTY) LTD, MILNERTON 7441, SOUTH AFRICA:
3,633,173, INT. CL. 33.
- TRANSACTIONDRIVERS LLC, LOS ANGELES, CA:
3,630,929, PUB. 3-17-2009. INT. CL. 42.
- TRASCRAFT CORPORATION, ANNA, IL:
2,319,011. REN. 4-27-09. INT. CL. 25.
- TRANSTECTOR SYSTEMS, INC., HAYDEN LAKE, ID:
2,175,464, CANC. INT. CL. 9.
- TRAU & LOEVNER OPERATING CO., INC., PITTSBURGH, PA:
2,709,957, CANC. MULTIPLE CLASS, INT. CLS. 18 AND 24.
- TRAVEL TOOLS, INC., ARDSLEY, NY:
2,278,162. REN. 4-24-09. INT. CL. 35.
- TRAVELERS INDEMNITY COMPANY, THE, HARFORD, CT:
2,245,954. REN. 4-25-09. INT. CL. 36.
- TRAVELERS INDEMNITY COMPANY, THE, HARTFORD, CT:
3,632,169, INT. CL. 36.
- TRAVELPRO INTERNATIONAL, INC., BOCA RATON, FL:
2,598,847, CANC. INT. CL. 18.
- TRAVIS BELL, MISSISSAUGA, CANADA:
3,632,184, INT. CL. 32.
- TRC RECREATION, LP, WICHITA FALLS, TX, SCHEUER, ROBERT S., WICHITA FALLS, TX, DBA TEXAS WATER CRAFTERS:
868,534. REN. 4-27-09. U.S. CL. 22 (INT. CL. 9).
- TRC RECREATION, LP, WICHITA FALLS, TX:
1,548,441. REN. 4-27-09. INT. CL. 28.

TREASURE GARDEN INC., BALDWIN PARK, CA:
2,708,867, CANC. INT. CL. 20.

TREE OF LIFE CARE GROUP, LLC, AUSTIN, TX:
3,631,059, PUB. 3-17-2009. INT. CL. 43.

TREGASKIS, FRED, SHARON, CT, DBA NEW ENGLAND
WINE CELLARS AND CELLAR MATE:
2,597,711, CANC. INT. CL. 11.

TREK BICYCLE CORPORATION, WATERLOO, WI:
2,596,471, CANC. INT. CL. 41.
3,631,284, PUB. 3-17-2009. INT. CL. 12.

TREMONT ELECTRIC LLC, CLEVELAND, OH:
3,632,099, INT. CL. 7.
3,632,100, INT. CL. 7.
3,632,101, INT. CL. 7.

TREND LAB, LLC, BURNSVILLE, MN:
3,633,451, INT. CL. 24.

TRENDMASTERS, INC., ST. LOUIS, MO:
2,597,552, CANC. INT. CL. 28.
2,598,230, CANC. INT. CL. 28.
2,598,540, CANC. INT. CL. 28.

TRESSA, INC., ERLANGER, KY:
3,632,957, INT. CL. 3.

TRI-STATE HOSPITAL SUPPLY CORPORATION, HOWELL,
MI:
2,597,337, CANC. INT. CL. 21.

TRI-TRONICS, INC., TUCSON, AZ:
3,632,819, INT. CL. 9.

TRIAD PARTNERS, LLC, CROSSVILLE, TN:
3,632,996, INT. CL. 36.

TRIAENA TRAVEL AND TOURISM, INC., NEW YORK, NY:
1,497,113, CANC. INT. CL. 39.

TRIANGLE HOME FASHIONS LLC, CRANBURY, NJ:
3,632,585, INT. CL. 24.

TRICERASOFT, BRAMPTON, ONTARIO, CANADA:
3,630,103, PUB. 3-17-2009. INT. CL. 9.

TRICON PIPING SYSTEMS, INC., SYRACUSE, NY:
2,597,457, CANC. MULTIPLE CLASS, INT. CLS. 6 AND
17.

TRIDENT MICROSYSTEMS, INC., SANTA CLARA, CA:
2,597,583, CANC. INT. CL. 9.

TRIOLOGY MARKETING GROUP, ORINDA, CA:
3,631,199, PUB. 3-17-2009. INT. CL. 35.

TRINDIGO LLC, TAMPA, FL:
3,631,031, PUB. 3-17-2009. INT. CL. 42.

TRINITY 3 INTERNATIONAL, ALISO VIEJO, CA:
3,630,996, PUB. 3-17-2009. INT. CL. 25.

TRIO SOLUTIONS, INC., MOUNT PLEASANT, SC:
3,630,845, PUB. 3-17-2009. INT. CL. 35.

TRIP SPLIT, INC., ST. PAUL, MN:
2,599,362, CANC. INT. CL. 39.

TRIPLE CROWN DOG ACADEMY, INC., HUTTO, TX:
2,598,770, CANC. INT. CL. 42.

TRIPLE SN LPA, WHEAT RIDGE, CO, DBA MAZARAKIS &
ASSOCIATES AND RAINES, CLAIRE, DENVER, CO:
2,596,753, CANC. INT. CL. 28.

TRIPLETHEGIFT LLC, BROOKEVILLE, MD:
3,630,921, PUB. 3-17-2009. INT. CL. 35.

TRIPPOINT GLOBAL COMMUNICATIONS, INC., NEW
YORK, NY:
2,598,733, CANC. MULTIPLE CLASS, INT. CLS. 9 AND
42.
2,598,735, CANC. MULTIPLE CLASS, INT. CLS. 9 AND
42.
2,598,736, CANC. MULTIPLE CLASS, INT. CLS. 9 AND
42.

TRIRIGA INC., LAS VEGAS, NV:
2,597,870, CANC. INT. CL. 35.
3,629,747, PUB. 3-17-2009. MULTIPLE CLASS, INT. CLS.
9, 36 AND 42.

TROIA, ARLENE B., CRANSTON, RI, DBA TRAV ENTER-
PRISES:
2,598,715, CANC. INT. CL. 28.

TROIKA INTERNATIONAL, INC., DUARTE, CA:
3,631,145, PUB. 3-17-2009. INT. CL. 26.

TROLEX CORPORATION, ELMWOOD PARK, NJ:
3,629,410, PUB. 3-17-2009. INT. CL. 11.

TROPAR MANUFACTURING CO., INC., FLORHAM PARK,
NJ, TROPAR TROPHY MANUFACTURING CO., INC.,
FLORHAM PARK, NJ:
1,122,808, REN. 4-24-09. INT. CL. 20.

TROPICAL NUT & FRUIT CO., CHARLOTTE, NC:
3,630,187, PUB. 3-17-2009. INT. CL. 29.
3,630,280, PUB. 3-17-2009. INT. CL. 29.
3,630,281, PUB. 3-17-2009. INT. CL. 29.
3,630,387, PUB. 3-17-2009. INT. CL. 29.
3,632,736, MULTIPLE CLASS, INT. CLS. 29 AND 30.

TROPICAL TOBACCO, INC., MIAMI, FL:
3,632,487, INT. CL. 34.

TRU DYNAMICS, INC., SCOTTSDALE, AZ:
2,596,931, CANC. INT. CL. 35.

TRUCKPROTECT LIMITED, UNITED KINGDOM:
3,631,589, PUB. 3-17-2009. MULTIPLE CLASS, INT. CLS.
6, 12, 20 AND 35.

TRUDELL MEDICAL INTERNATIONAL, LONDON, ON-
TARIO, CANADA:
3,632,236, INT. CL. 10.

TRUE NORTH CUSTOM PUBLISHING, LLC, CHATTA-
NOOGA, TN:
3,633,320, INT. CL. 41.

TRUE TEMPER SPORTS, INC., MEMPHIS, TN, AMERICAN
FORK & HOE COMPANY, THE, CLEVELAND, OH:
258,244, REN. 4-28-09. U.S. CL. 22 (INT. CLS. 16, 18, 20, 22,
25 AND 28).

TRUE VALUE COMPANY, CHICAGO, IL:
3,632,360, INT. CL. 11.

TRUESPECTRA, INC., BURLINGAME, CA:
2,597,435, CANC. INT. CL. 9.

TRUMPETTE, INC., RANCHO CORDOVA, CA:
3,629,799, PUB. 3-17-2009. MULTIPLE CLASS, INT. CLS.
18, 25, 28 AND 35.

TRUST COMPANY OF AMERICA, ENGLEWOOD, CO:
2,597,456, CANC. INT. CL. 36.

TRUST U.S.A. MORTGAGE CORP., NORTH MIAMI
BEACH, FL:
2,596,812, CANC. INT. CL. 36.

TRUSTAR, INCORPORATED, PEARLAND, TX:
3,630,938, PUB. 3-17-2009. INT. CL. 7.

TRUSTEE OF THE SAMI LADEKI TRUST, LA JOLLA, CA:
2,599,553, CANC. INT. CL. 42.

TRUSTEES OF THE STEVENS INSTITUTE OF TECHNOL-
OGY, THE, HOBOKEN, NJ:
2,597,617, CANC. INT. CL. 41.

TRUTH HARDWARE CORPORATION, OWATONNA, MN:
3,632,063, INT. CL. 6.

TRUTZSCHLER GMBH & CO. KG, D-41199 MONCHEN-
GLADBACH, FED REP GERMANY:
1,107,801, REN. 4-25-09. INT. CL. 7.

TRYG SYSTEMS LLC, BROOKLYN, NY:
2,599,443, CANC. INT. CL. 9.

TS ALOHA, INC., SOLANA BEACH, CA:
3,631,921, INT. CL. 43.

TSA CORPORATE SERVICES, INC., ENGLEWOOD, CO:
2,599,107, CANC. INT. CL. 28.
2,599,156, CANC. INT. CL. 35.

TSAI, JANET C., NEW YORK, NY:
3,632,047, INT. CL. 44.

TSAI, NIECO MING HUAN, VERNON, CA:
2,599,116, CANC. INT. CL. 9.

TSI HEALTH SCIENCES, INC., MISSOULA, MT:
2,599,031, CANC. INT. CL. 1.

TSN LABS, INC., MURRAY, UT:
3,630,436, PUB. 3-17-2009. INT. CL. 5.
3,631,011, PUB. 3-17-2009. INT. CL. 5.

TSS PHOTOGRAPHY, INC., DULUTH, GA:
3,631,268, PUB. 3-17-2009. MULTIPLE CLASS, INT. CLS.
16 AND 41.
3,631,269, PUB. 3-17-2009. MULTIPLE CLASS, INT. CLS.
16 AND 41.

TSUCHIYA CO., LTD., NAKA-KU, NAGOYA, AICHI, JA-
PAN:
1,539,319, REN. 4-25-09. INT. CL. 17.

TT 648 LLC, PASADENA, MD:
3,631,423, PUB. 3-17-2009. INT. CL. 43.

- TTI TURNER TECHNOLOGY INSTRUMENTS INC., OTTAWA, CANADA:
3,631,404, PUB. 3-17-2009. MULTIPLE CLASS, INT. CLS. 10 AND 42.
- TTOOLS, LLC, PROVIDENCE, RI:
2,599,782, CANC. INT. CL. 16.
- TUCEL INDUSTRIES, INC., FORESTDALE, VT:
2,597,592, CANC. INT. CL. 21.
- TUCKER DESIGNS, LTD., KENNER, LA:
3,629,836, PUB. 3-17-2009. INT. CL. 20.
- TUGBOAT ENTERPRISES LTD., POWELL RIVER, B.C., CANADA:
3,631,911, MULTIPLE CLASS, INT. CLS. 9 AND 42.
- TUGGEY ROSENTHAL PAUERSTEIN SANDOLOSKI AGATHER LLP, SAN ANTONIO, TX:
3,629,656, PUB. 3-17-2009. INT. CL. 45.
- TULLIS, ERIC, MASON, OH:
3,632,939, INT. CL. 8.
- TUMBLEWEED COMMUNICATIONS CORP., REDWOOD CITY, CA:
2,597,065, CANC. MULTIPLE CLASS, INT. CLS. 9 AND 38.
- TUMMY SHIELD COMPANY PTY LTD, AUSTRALIA:
3,631,625, PUB. 3-17-2009. INT. CL. 12.
- TURN IT UP MEDIA, LLC, BRENTWOOD, TN:
3,632,983, MULTIPLE CLASS, INT. CLS. 9 AND 35.
- TURTLE WAX, INC., CHICAGO, IL:
2,598,521, CANC. INT. CL. 3.
2,598,908, CANC. INT. CL. 3.
- TUSTIN BARBEQUES, INC., IRVINE, CA:
2,597,261, CANC. INT. CL. 11.
- TV GUIDE MAGAZINE GROUP, INC., NEW YORK, NY:
2,596,584, CANC. MULTIPLE CLASS, INT. CLS. 35, 38 AND 41.
2,597,846, CANC. INT. CL. 41.
- TV WINNERS, INC., MADISON, NJ:
3,630,774, PUB. 3-17-2009. INT. CL. 26.
- TWEEN BRANDS INVESTMENT, LLC, NEW ALBANY, OH:
2,597,984, CANC. INT. CL. 3.
3,633,406, INT. CL. 41.
- TWENTIETH CENTURY FOX FILM CORPORATION, LOS ANGELES, CA:
2,598,430, CANC. INT. CL. 21.
- TWIN STAR INTERNATIONAL, INC., DELRAY BEACH, FL:
3,631,805, INT. CL. 20.
- TWIN TIGER WORLD MARKETS, LTD., VANCOUVER, CANADA:
3,632,444, INT. CL. 25.
- TWINSIES INC., LOS ANGELES, CA:
2,597,424, CANC. INT. CL. 14.
- TWISTHINK, LLC, HOLLAND, MI:
3,630,669, PUB. 3-17-2009. INT. CL. 42.
- TWO LITTLE FISHIES, MIAMI, FL:
3,629,858, PUB. 3-17-2009. INT. CL. 31.
3,629,859, PUB. 3-17-2009. INT. CL. 21.
- TYCO ELECTRONICS CORPORATION, BERWYN, PA:
3,632,816, INT. CL. 9.
- TYCO HEALTHCARE GROUP LP, NORWALK, CT:
2,174,520, CANC. INT. CL. 10.
- TYCOM CORPORATION, IRVINE, CA:
2,598,528, CANC. INT. CL. 7.
- TYE, TAYLOR, DENTON, TX:
2,599,524, CANC. INT. CL. 30.
- TYLER CANDLE COMPANY, L.L.C., TYLER, TX:
3,630,580, PUB. 3-17-2009. MULTIPLE CLASS, INT. CLS. 3 AND 4.
3,630,597, PUB. 3-17-2009. MULTIPLE CLASS, INT. CLS. 3 AND 4.
3,630,599, PUB. 3-17-2009. MULTIPLE CLASS, INT. CLS. 3 AND 4.
3,630,600, PUB. 3-17-2009. MULTIPLE CLASS, INT. CLS. 3 AND 4.
3,630,603, PUB. 3-17-2009. MULTIPLE CLASS, INT. CLS. 3 AND 4.
3,630,604, PUB. 3-17-2009. MULTIPLE CLASS, INT. CLS. 3 AND 4.
3,630,605, PUB. 3-17-2009. INT. CL. 4.
3,630,606, PUB. 3-17-2009. MULTIPLE CLASS, INT. CLS. 3 AND 4.
3,630,607, PUB. 3-17-2009. INT. CL. 4.
3,630,638, PUB. 3-17-2009. MULTIPLE CLASS, INT. CLS. 3 AND 4.
3,630,639, PUB. 3-17-2009. INT. CL. 4.
3,630,640, PUB. 3-17-2009. INT. CL. 4.
- TYRANNY GAMES LLC, MILWAUKEE, WI:
2,597,649, CANC. INT. CL. 28.
2,597,650, CANC. INT. CL. 28.
- TYSON DELI, INC., SPRINGDALE, AR:
2,599,771, CANC. INT. CL. 29.
- U S VITA LABORATORIES CORP., MIAMI, FL:
2,283,906, REN. 4-29-09. INT. CL. 5.
- U. D. TESTING, INC., MARCO ISLAND, FL:
2,597,376, CANC. INT. CL. 42.
- U. O. D., INC., WILMINGTON, DE:
2,174,296, CANC. INT. CL. 35.
2,599,039, CANC. INT. CL. 25.
- U. S. INTELL, INC., GLENVIEW, IL:
1,497,268, CANC. INT. CL. 42.
- U.S. BANK N.A., MINNEAPOLIS, MN:
2,253,817, REN. 4-27-09. INT. CL. 36.
2,253,818, REN. 4-27-09. INT. CL. 36.
2,337,509, REN. 4-27-09. INT. CL. 36.
3,632,685, INT. CL. 36.
3,632,686, INT. CL. 36.
3,632,687, INT. CL. 36.
- U.S. MILLS, LLC, NEEDHAM, MA:
1,536,604, REN. 4-28-09. INT. CL. 30.
- U.S. MORTGAGE EXCHANGE, L.L.C., WEST ORANGE, NJ:
2,598,160, CANC. INT. CL. 36.
- U.S. PANDA FOODS & BEVERAGES, INC, CLAREMONT, CA:
3,631,314, PUB. 3-17-2009. INT. CL. 30.
- U.S. RISK INSURANCE GROUP, INC., DALLAS, TX:
3,632,770, INT. CL. 36.
- U.S. TECHNICAL SERVICES, INC., BREWSTER, NY:
3,629,269, PUB. 9-4-2007. INT. CL. 41.
- U.S. TRAVEL ASSOCIATION, WASHINGTON, DC:
3,633,431, INT. CL. 35.
- U-NGOEN U-THONG LTD., PARTNERSHIPS, DISTRICT PHAKHAI, THAILAND:
3,632,952, MULTIPLE CLASS, INT. CLS. 3, 5 AND 30.
- UBE INDUSTRIES, LTD., YAMAGUCHI-KEN 755-8633, JAPAN:
3,631,591, PUB. 3-17-2009. INT. CL. 1.
- UBE INDUSTRIES, LTD., UBE-SHI, YAMAGUCHI-KEN, JAPAN:
3,631,641, PUB. 3-17-2009. INT. CL. 1.
- UBIDYNE, INC., WILMINGTON, DE:
3,629,829, PUB. 3-17-2009. INT. CL. 9.
3,629,830, PUB. 3-17-2009. INT. CL. 38.
3,629,831, PUB. 3-17-2009. INT. CL. 42.
3,629,847, PUB. 3-17-2009. INT. CL. 9.
3,629,848, PUB. 3-17-2009. INT. CL. 38.
- UBIQUE HOLDINGS LP, LIGHTHOUSE POINT, FL:
3,629,976, PUB. 3-17-2009. INT. CL. 35.
- UBS AG, ZURICH, SWITZERLAND:
3,538,146, AM. INT. CL. 36.
- UBURG CORP, MENLO PARK, CA, TA WWW.UBURG.-COM:
3,633,030, INT. CL. 35.
- UHLIG, LLC, OVERLAND PARK, KS:
3,629,302, PUB. 4-29-2008. MULTIPLE CLASS, INT. CLS. 16, 35, 39 AND 41.
- UI HOLDING CO., CONKLIN, NY:
2,598,304, CANC. INT. CL. 9.
- ULEAD SYSTEMS, INC., TORRANCE, CA:
2,116,577, COR. INT. CL. 9.
- ULTIMATE GENETICS, LLC, WHELOCK, TX:
3,631,937, INT. CL. 5.
- UMAREX SPORTWAFFEN GMBH & CO., KG, 59757 ARNSBERG, FED REP GERMANY, CARL WALTHER, 7900 ULM/DONAU, FED REP GERMANY:
1,120,867, REN. 4-24-09. INT. CL. 13.

UMICORE AG & CO. KG, HANAU, FED REP GERMANY:
2,708,292, CANC. INT. CL. 9.

UNCLE BEN'S, INC., HOUSTON, TX:
2,598,784, CANC. INT. CL. 30.

UNDER ARMOUR, INC., BALTIMORE, MD:
3,630,507, PUB. 3-17-2009. INT. CL. 25.
3,630,517, PUB. 3-17-2009. INT. CL. 25.

UNI-SELECT INC., BOUCHERVILLE, CANADA:
3,629,530, PUB. 3-17-2009. INT. CL. 35.

UNILEVER N.V., ZUG, SWITZERLAND:
1,496,356, CANC. MULTIPLE CLASS, INT. CLS. 1 AND 5.

UNILEVER SUPPLY CHAIN, INC., CLINTON, CT:
3,631,994, INT. CL. 3.

UNILIN FLOORING NC, LLC, CALHOUN, GA:
2,597,828, CANC. INT. CL. 19.

UNIMEX INDUSTRIES, INC., WOODS CROSS, UT, DBA
BRIDGewater INTERNATIONAL:
3,631,961, INT. CL. 11.

UNIMILLS B.V., NL-3336 LE ZWIJNDRECHT, NETHER-
LANDS:
3,631,688, PUB. 3-17-2009. INT. CL. 29.

UNIMILLS B.V., NETHERLANDS:
3,631,700, PUB. 3-17-2009. INT. CL. 29.

UNION BANK OF CALIFORNIA, N.A., SAN FRANCISCO,
CA TO UNION BANK OF CALIFORNIA, N.A., SAN
FRANCISCO, CA:
2,175,790, CANC. INT. CL. 36.

UNION CARBIDE CORPORATION, MIDLAND, MI, CAR-
BIDE & CARBON CHEMICALS CORPORATION, NEW
YORK, NY:
263,505, REN. 4-27-09. U.S. CL. 6 (INT. CLS. 1 AND 2).

UNION CARBIDE CORPORATION, DANBURY, CT:
1,496,686, CANC. INT. CL. 11.

UNION CARBIDE CORPORATION, MIDLAND, MI:
2,261,460, REN. 4-27-09. INT. CL. 17.
2,301,431, REN. 4-27-09. MULTIPLE CLASS, INT. CLS. 1,
40 AND 42.

UNION DISTRIBUTING COMPANY OF TUCSON, TUCSON,
AZ:
2,598,516, CANC. INT. CL. 4.
2,598,517, CANC. INT. CL. 4.

UNION PACIFIC RAILROAD COMPANY, OMAHA, NE:
3,630,320, PUB. 3-17-2009. INT. CL. 39.

UNION/OSG, LLC, LONG BEACH, CA:
3,629,739, PUB. 3-17-2009. INT. CL. 9.

UNIQUE RENEWABLES LLC, PEACHTREE CITY, GA:
3,630,354, PUB. 3-17-2009. INT. CL. 40.

UNIRAM TECHNOLOGY, INC., SANTA CLARA, CA:
2,599,404, CANC. INT. CL. 42.

UNISEcurity, INC., SAN JOSE, CA:
2,599,225, CANC. INT. CL. 9.
2,599,226, CANC. INT. CL. 9.

UNISTRUT INTERNATIONAL CORPORATION, WAYNE,
MI:
862,747, REN. 4-24-09. U.S. CL. 38 (INT. CL. 16).

UNITED AIR LINES, INC., ELK GROVE TOWNSHIP, IL:
2,599,798, CANC. INT. CL. 39.

UNITED AMERICAN INSURANCE COMPANY, MCKIN-
NEY, TX:
3,630,282, PUB. 3-17-2009. INT. CL. 44.

UNITED BUSINESS MEDIA LLC, MANHASSET, NY, DBA
EVERYTHING CHANNEL:
2,597,425, CANC. INT. CL. 35.

UNITED BUSINESS MEDIA LLC, MANHASSET, NY:
3,629,494, PUB. 3-17-2009. MULTIPLE CLASS, INT. CLS.
41 AND 42.

UNITED COATINGS, INC., CHICAGO, IL:
1,496,414, CANC. INT. CL. 2.

UNITED CONCORDIA COMPANIES, INC., PITTSBURGH,
PA:
3,630,277, PUB. 3-17-2009. INT. CL. 36.

UNITED CONSUMERS CREDIT UNION, INDEPENDENCE,
MO:
3,630,258, PUB. 3-17-2009. INT. CL. 36.

UNITED ELECTRONIC INDUSTRIES, INC., WATERTOWN,
MA:
2,597,353, CANC. INT. CL. 9.

UNITED EXCHANGE CORPORATION, CERRITOS, CA:
2,597,404, CANC. INT. CL. 3.

UNITED HARDWARE DISTRIBUTING CO., PLYMOUTH,
MN:
3,632,883, INT. CL. 35.

UNITED KENNEL CLUB, INC., KALAMAZOO, MI:
3,630,843, PUB. 3-17-2009. INT. CL. 35.
3,630,855, PUB. 3-17-2009. INT. CL. 35.

UNITED METHODIST PUBLISHING HOUSE, THE, NASH-
VILLE, TN:
2,175,719, CANC. INT. CL. 16.

UNITED NATURAL FOODS, INC., DAYVILLE, CT:
2,263,145, REN. 4-25-09. INT. CL. 35.

UNITED NEGRO COLLEGE FUND, INC., FAIRFAX, VA:
3,629,240, PUB. 3-17-2009. INT. CL. 36.

UNITED OF OMAHA LIFE INSURANCE COMPANY, OMA-
HA, NE:
2,599,295, CANC. INT. CL. 36.

UNITED PHOSPHORUS LIMITED, MUMBAI, INDIA:
1,496,514, CANC. INT. CL. 5.

UNITED STATES FENCING ASSOCIATION, COLORADO
SPRINGS, CO:
3,630,593, PUB. 3-17-2009. INT. CL. 35.

UNITED STATES FOUNDATION FOR INSPIRATION AND
RECOGNITION OF SCIENCE AND TECHNOLOGY,
MANCHESTER, NH, AKA FIRST:
3,631,146, PUB. 3-17-2009. INT. CL. 41.

UNITED STATES FOUNDATION FOR INSPIRATION AND
RECOGNITION OF SCIENCE AND TECHNOLOGY,
MANCHESTER, NH:
3,631,356, PUB. 3-17-2009. INT. CL. 41.
3,631,363, PUB. 3-17-2009. INT. CL. 41.
3,631,366, PUB. 3-17-2009. INT. CL. 41.

UNITED STATES INFRASTRUCTURE CORPORATION,
CARMEL, IN:
3,633,438, INT. CL. 42.

UNITED STATES OLYMPIC COMMITTEE, COLORADO
SPRINGS, CO:
3,631,348, PUB. 3-17-2009. INT. CL. 35.
3,631,353, PUB. 3-17-2009. INT. CL. 35.

UNITED STATES POSTAL SERVICE, WASHINGTON, DC:
2,597,152, CANC. MULTIPLE CLASS, INT. CLS. 6, 18
AND 25.
3,631,367, PUB. 3-17-2009. INT. CL. 41.

UNITED STATES STEEL CORPORATION, PITTSBURGH,
PA:
3,629,537, PUB. 3-17-2009. MULTIPLE CLASS, INT. CLS.
35, 36, 37 AND 41.
3,629,539, PUB. 3-17-2009. MULTIPLE CLASS, INT. CLS.
35, 36, 37 AND 41.

UNITED SUPER ACCOUNT PROGRAM, INC., BAY SHORE,
NY, DBA PHYSICIANS HEALTH PROGRAM:
3,630,191, PUB. 3-17-2009. INT. CL. 35.

UNITED SUPERMARKETS, L.L.C., LUBBOCK, TX:
3,630,535, PUB. 3-17-2009. INT. CL. 35.
3,630,538, PUB. 3-17-2009. INT. CL. 35.
3,631,411, PUB. 3-17-2009. INT. CL. 41.

UNITED VISION OF NEW YORK CORPORATION, NEW
YORK, NY:
3,632,504, MULTIPLE CLASS, INT. CLS. 9 AND 10.

UNITED WAY OF SONOMA-MENDOCINO-LAKE, SANTA
ROSA, CA:
2,596,852, CANC. INT. CL. 41.

UNITHER DEVELOPPEMENT, F-80080 AMIENS, FRANCE:
3,629,454, PUB. 3-17-2009. MULTIPLE CLASS, INT. CLS.
5, 10 AND 42.

UNIVERSAL ABC INTERNATIONAL INC., BROOKLYN,
NY:
3,629,171, PUB. 3-17-2009. INT. CL. 3.

UNIVERSAL CITY STUDIOS, INC., UNIVERSAL CITY, CA:
2,599,209, CANC. INT. CL. 42.

UNIVERSAL HEALTH CARD, LLC, CANTON, OH:
3,632,937, MULTIPLE CLASS, INT. CLS. 16 AND 36.

UNIVERSAL HOSIERY INC, VALENCIA, CA, DBA UNI-
VERSAL HOSIERY:
3,630,998, PUB. 3-17-2009. INT. CL. 25.

UNIVERSAL METAL PRODUCTS, INC., WICKLIFFE, OH:
878,497, REN. 4-24-09. U.S. CL. 13 (INT. CL. 6).

- UNIVERSAL REMOTE CONTROL, INC., HARRISON, NY:
3,629,207, PUB. 3-17-2009. INT. CL. 9.
3,629,208, PUB. 3-17-2009. INT. CL. 9.
- UNIVERSITY OF BRIDGEPORT, BRIDGEPORT, CT:
3,633,378, INT. CL. 16.
- UNIVERSITY OF CINCINNATI FOUNDATION, THE, CINCINNATI, OH:
3,632,963, MULTIPLE CLASS, INT. CLS. 35, 36 AND 41.
- UNIVERSITY OF MIAMI, CORAL GABLES, FL:
3,629,399, PUB. 3-17-2009. INT. CL. 44.
- UNIVERSITY OF NORTH CAROLINA SCHOOL OF THE ARTS, WINSTON-SALEM, NC:
3,632,951, INT. CL. 41.
3,633,416, INT. CL. 41.
- UNIVERSITY OF NOTRE DAME DU LAC, NOTRE DAME, IN:
3,631,309, PUB. 3-17-2009. INT. CL. 25.
- UNIVERSITY OF SOUTHERN CALIFORNIA, LOS ANGELES, CA:
2,244,637, REN. 4-24-09. INT. CL. 42.
- UNIVERSITY SYSTEM OF MARYLAND, ADELPHI, MD:
3,632,079, INT. CL. 41.
- UNIVEST CORPORATION OF PENNSYLVANIA, SOUDERTON, PA:
3,631,099, PUB. 3-17-2009. INT. CL. 36.
3,631,317, PUB. 3-17-2009. INT. CL. 36.
- UNIVISA, S.A., MEXICO CITY, DF, MEXICO TO UNIVISA, INC.:
1,497,148, CANC. INT. CL. 41.
- UNIVISION COMMUNICATIONS INC., LOS ANGELES, CA:
3,630,710, PUB. 3-17-2009. INT. CL. 41.
- UNLIMITED TECHNOLOGIES, INC., ASHEVILLE, NC:
2,175,828, CANC. INT. CL. 7.
- UPI INC., GUELPH, ONTARIO, CANADA:
2,596,517, CANC. INT. CL. 35.
- UPMC, PITTSBURGH, PA:
3,632,696, INT. CL. 41.
3,632,697, INT. CL. 41.
- UPPER DECK COMPANY, LLC, THE, CARLSBAD, CA:
2,597,528, CANC. MULTIPLE CLASS, INT. CLS. 16 AND 28.
- UPROAR, INC., SEATTLE, WA:
3,629,459, PUB. 3-17-2009. MULTIPLE CLASS, INT. CLS. 35 AND 42.
- URBAN PANTRY LLC, DENVER, CO:
3,631,241, PUB. 3-17-2009. INT. CL. 43.
- URBAN REPUBLIC CLOTHING, ANAHEIM, CA:
3,632,965, INT. CL. 25.
- URBAN TREE SPECIALISTS, LLC, PARKVILLE, MO:
3,630,672, PUB. 3-17-2009. INT. CL. 44.
- URESIL, LLC, SKOKIE, IL:
1,537,324, REN. 4-30-09. INT. CL. 10.
- URIBE, PABLO, SAN ANTONIO, TX:
3,630,154, PUB. 3-17-2009. INT. CL. 35.
- US AIRWAYS, INC., TEMPE, AZ:
2,175,616, CANC. INT. CL. 16.
- US VISUAL INCITE, LLC, FLOWER MOUND, TX, DBA VISUAL INCITE:
3,630,206, PUB. 3-17-2009. INT. CL. 35.
- USA DISCOUNTERS, LTD., VIRGINIA BEACH, VA:
3,632,656, INT. CL. 35.
- USA PEACE SIGNAL EQUIPMENT LLC, NEW CASTLE, DE:
3,632,880, INT. CL. 9.
- USADVISORS INSURANCE AGENCY, LLC, EDEN PRAIRIE, MN:
3,629,330, PUB. 3-17-2009. MULTIPLE CLASS, INT. CLS. 35 AND 36.
- USGI MEDICAL, INC., SAN CLEMENTE, CA:
3,633,164, INT. CL. 10.
- USMLEWORLD, LLC, TOWSON, MD:
3,630,721, PUB. 3-17-2009. INT. CL. 42.
- USPEAKWETYPE TECHNOLOGIES LLC, TRAVERSE CITY, MI:
3,630,494, PUB. 3-17-2009. INT. CL. 42.
- UTA PIPPIG, BOCA RATON, FL:
3,631,907, INT. CL. 36.
- UTAH MEDICAL PRODUCTS, INC., MIDVALE, UT:
3,629,206, PUB. 3-17-2009. INT. CL. 10.
- UTICA MUTUAL INSURANCE COMPANY, NEW HARTFORD, NY, DBA UTICA NATIONAL INSURANCE GROUP:
3,585,719, COR. INT. CL. 36.
- UTILITY ENGINEERING, AMARILLO, TX:
2,599,087, CANC. INT. CL. 42.
- UTILITY TRAILER MANUFACTURING CO., CITY OF INDUSTRY, CA:
3,630,363, PUB. 3-17-2009. INT. CL. 12.
- UTRAFILTER INTERNATIONAL AG, 42781 HAAN, FED REP GERMANY:
2,596,660, CANC. INT. CL. 11.
- UZIN UTZ AKTIENGESELLSCHAFT, FED REP GERMANY:
3,631,511, PUB. 3-17-2009. MULTIPLE CLASS, INT. CLS. 1, 2, 8, 9, 12, 17, 19, 21, 37, 41 AND 42.
- V. MANE FILS, FRANCE:
3,631,481, PUB. 3-17-2009. MULTIPLE CLASS, INT. CLS. 3 AND 30.
- VACATION-CREATIONS.COM, INC., WILLIAMSBURG, VA:
2,596,843, CANC. MULTIPLE CLASS, INT. CLS. 39 AND 42.
2,596,844, CANC. MULTIPLE CLASS, INT. CLS. 39 AND 42.
- VACCARO, HENRY S., BRADENTON, FL:
3,633,094, INT. CL. 9.
- VAGUE PROTOCOL, LTD., LAKE ORION, MI:
3,216,617, AM. INT. CL. 38.
- VAIL, WILLIAM BANNING III, BOTHELL, WA:
2,239,217, REN. 4-24-09. INT. CL. 20.
- VAISALA OYJ, VANTAA, FINLAND:
3,631,389, PUB. 8-8-2006. MULTIPLE CLASS, INT. CLS. 9, 37 AND 42.
3,631,390, PUB. 2-28-2006. MULTIPLE CLASS, INT. CLS. 9, 37 AND 42.
- VAL'S SERVICE, INC., HOMESTEAD, FL:
3,633,377, INT. CL. 43.
- VALENT BIOSCIENCES CORPORATION, LIBERTYVILLE, IL:
3,631,283, PUB. 3-17-2009. INT. CL. 1.
- VALLEY INDEPENDENT BANK, EL CENTRO, CA:
2,597,768, CANC. INT. CL. 36.
- VALLEY POOLS, INC., BURNSVILLE, MN:
2,597,479, CANC. MULTIPLE CLASS, INT. CLS. 35 AND 37.
- VALMONT INDUSTRIES, INC., VALLEY, NE:
2,598,223, CANC. INT. CL. 9.
- VALTRA, INC., PICO RIVERA, CA:
3,629,839, PUB. 3-17-2009. INT. CL. 8.
- VALUEGATE HOLDINGS LIMITED, TORTOLA, BR. VIRGIN ISLANDS:
3,632,031, INT. CL. 36.
- VALUES.COM INC., HAUPPAUGE, NY:
2,598,442, CANC. MULTIPLE CLASS, INT. CLS. 35 AND 36.
- VAN AIR SYSTEMS INC., LAKE CITY, PA:
2,599,700, CANC. INT. CL. 9.
- VAN BEURDEN INSURANCE SERVICES, INC., KINGSBURG, CA:
3,631,865, MULTIPLE CLASS, INT. CLS. 35, 36 AND 44.
- VAN CORT INSTRUMENTS, INC., NORTHAMPTON, MA:
1,496,603, CANC. INT. CL. 9.
- VAN DAAZ, MONTREAL, CANADA:
2,599,487, CANC. INT. CL. 14.
- VAN DIEST SUPPLY COMPANY, WEBSTER CITY, IA:
3,629,223, PUB. 3-17-2009. INT. CL. 1.
- VAN DORN DEMAG CORPORATION, STRONGSVILLE, OH:
3,630,630, PUB. 3-17-2009. INT. CL. 9.
- VAN GILLUWE, FRANK, L., MOUNTAIN VIEW, CA, DBA FAQWARE:
3,630,723, PUB. 3-17-2009. INT. CL. 42.
- VAN OTIS CHOCOLATES, LLC, MANCHESTER, NH:
3,629,178, PUB. 3-17-2009. MULTIPLE CLASS, INT. CLS. 30, 33, 35 AND 45.

VANCE COMMUNICATIONS CANADA, CALGARY, CANADA:
3,631,104, PUB. 3-17-2009. INT. CL. 41.

VANCE PUBLISHING CORPORATION, LINCOLNSHIRE, IL:
2,241,409. REN. 4-24-09. INT. CL. 16.

VANCEINFO TECHNOLOGIES INC., GEORGE TOWN, CAYMAN ISLANDS:
3,632,232, MULTIPLE CLASS, INT. CLS. 35, 41 AND 42.

VANDERVEER, LLC, DBA THE VANDERVEER CENTER, PORTLAND, OR:
3,629,385, PUB. 3-17-2009. INT. CL. 44.

VANDIVER GROUP, INC., ST. LOUIS, MO:
3,629,538, PUB. 3-17-2009. INT. CL. 41.

VANGUARD INDUSTRIES EAST, INC., NORFOLK, VA:
2,599,414, CANC. INT. CL. 28.

VANITY FAIR, INC., BOWLING GREEN, KY:
3,632,523, INT. CL. 25.

VANTAGE MEDIA LLC, VENICE, CA:
3,633,345, INT. CL. 35.

VANTAGEMED CORPORATION, RANCHO CORDOVA, CA:
2,597,920, CANC. INT. CL. 9.

VARIABLE LUMINAIRE CORP., SHULIN CITY, TAIWAN:
3,632,371, INT. CL. 11.

VARIG, S.A., RIO DE JANEIRO, BRAZIL:
2,598,800, CANC. INT. CL. 39.

VASCULAR SOLUTIONS, INC., MINNEAPOLIS, MN:
3,632,771, INT. CL. 5.

VASS, JEROME R., TELLURIDE, CO, DBA THE VASS COMPANY:
2,597,263, CANC. MULTIPLE CLASS, INT. CLS. 9 AND 16.

VAUGHAN, SARABETH, LAFAYETTE, IN:
2,599,012, CANC. INT. CL. 14.

VB HOLDING LLC, IRVING, TX:
3,629,138, PUB. 3-17-2009. INT. CL. 5.

VC EXPERTS, NEW YORK, NY:
2,597,068, CANC. INT. CL. 36.

VDOTEK, INC, MIAMI, FL:
3,632,069, INT. CL. 9.

VECHERA, SVITLANA, WEST HILLS, CA:
3,630,355, PUB. 3-17-2009. INT. CL. 3.

VECOM METAL TREATMENT TECHNOLOGY B.V., 3144 NA MAASSLUIS, NETHERLANDS:
2,597,725, CANC. INT. CL. 40.

VECTOR PRODUCTS, INC., FT. LAUDERDALE, FL:
2,599,433, CANC. INT. CL. 11.

VEEDER-ROOT COMPANY, SIMSBURY, CT:
3,631,013, PUB. 3-17-2009. INT. CL. 9.

VEEV SPIRITS, LLC, BEVERLY HILLS, CA:
3,629,844, PUB. 3-17-2009. INT. CL. 33.

VEGA, RUTH GORMAN, CHARLOTTE, NC:
2,244,411. REN. 4-24-09. INT. CL. 42.

VEGAS.COM, LLC, HENDERSON, NV:
3,629,770, PUB. 3-17-2009. INT. CL. 41.
3,629,772, PUB. 3-17-2009. INT. CL. 35.

VELOCITI ALLIANCE NORTH AMERICA, INC., GREENVILLE, SC:
3,633,254, MULTIPLE CLASS, INT. CLS. 9 AND 42.

VELTRI, BARBARA TORRE, SCOTTSDALE, AZ:
2,258,864. REN. 4-25-09. INT. CL. 16.

VENCAST, INC., NEW YORK, NY:
2,597,378, CANC. INT. CL. 36.

VENERABLE, VINCENT E., EL DORADO HILLS, CA AND MIRANDA, GLENDA L., EL DORADO HILLS, CA:
2,598,148, CANC. INT. CL. 11.

VENICE BEACH GMBH, HAMBURG, FED REP GERMANY:
2,596,877, CANC. INT. CL. 25.

VENNETTI, RALPH S., BENSENVILLE, IL:
2,597,510, CANC. INT. CL. 42.

VENT-RITE VALVE CORPORATION, NORWOOD, MA:
1,496,688, CANC. INT. CL. 11.

VENTEX TECHNOLOGY, INC., JUPITER, FL:
3,631,857, INT. CL. 9.

VENTRITEX, INC., SUNNYVALE, CA:
1,496,665, CANC. INT. CL. 10.

VENTURE BEVERAGE COMPANY, FORT LAUDERDALE, FL:
3,633,353, INT. CL. 32.

VERDOONER, STEVEN, GRANITE BAY, CA AND YVONNE COLEBANK, NEW YORK, NY:
3,630,259, PUB. 12-9-2008. INT. CL. 42.

VERES, RICHARD, BAY VILLAGE, OH:
2,241,817. REN. 4-24-09. INT. CL. 16.

VERIDIAM, INC., EL CAJON, CA:
3,631,957, INT. CL. 6.

VERILUX, INC., STAMFORD, CT:
2,597,766, CANC. INT. CL. 11.

VERITAS V, LLC, SALINAS, CA:
3,631,886, INT. CL. 31.

VERITEC, INC., GOLDEN VALLEY, MN:
3,595,417, COR. INT. CL. 9.

VERITY, INC., SUNNYVALE, CA:
2,598,976, CANC. INT. CL. 9.

VERMONT COMMON FOODS LLC, NORTH CLARENDON, VT:
1,535,609. REN. 4-24-09. INT. CL. 30.

VERO CAPITAL MANAGEMENT, LLC, NEW YORK, NY:
3,629,263, PUB. 3-17-2009. INT. CL. 36.

VERSAILLES FOUNDATION, INC., THE, NEW YORK, NY:
2,175,213, CANC. INT. CL. 27.

VERSATILE GROUP, INC., THE, DALLAS, TX:
2,597,755, CANC. MULTIPLE CLASS, INT. CLS. 9 AND 42.

VERSTANDIG, BRUCE D., NEW YORK, NY:
2,598,646, CANC. INT. CL. 14.

VERTIS, INC., BALTIMORE, MD:
2,596,463, CANC. MULTIPLE CLASS, INT. CLS. 41 AND 42.
2,598,314, CANC. INT. CL. 9.

VERVE PUBLIC RELATIONS, INC., PLAYA DEL REY, CA:
3,631,457, PUB. 3-17-2009. INT. CL. 35.

VERYFINE PRODUCTS, INC., LITTLETON, MA:
1,496,974, CANC. INT. CL. 32.

VESTA CORPORATION, PORTLAND, OR:
2,197,906. REN. 4-28-09. MULTIPLE CLASS, INT. CLS. 16 AND 38.

VESTMARC, L.L.C., FLOWER MOUND, TX:
2,599,041, CANC. INT. CL. 36.

VETVISION, INC., DAVIS, CA:
3,629,742, PUB. 3-17-2009. INT. CL. 35.
3,629,755, PUB. 3-17-2009. INT. CL. 35.

VEYANCE TECHNOLOGIES, INC., AKRON, OH:
2,597,310, CANC. INT. CL. 17.
2,597,348, CANC. INT. CL. 17.

VHA INC., IRVING, TX:
3,631,281, PUB. 3-17-2009. INT. CL. 41.

VIÑA IJALBA S.A., LOGROÑO, SPAIN:
3,630,962, PUB. 3-17-2009. INT. CL. 33.

VIACOM INTERNATIONAL INC., NEW YORK, NY:
2,598,395, CANC. INT. CL. 41.
3,632,112, INT. CL. 41.

VIADV, INC., MERIDIAN, ID:
2,599,741, CANC. INT. CL. 9.

VIATRAN, INC., AUSTIN, TX:
2,174,635, CANC. INT. CL. 25.

VIBA FIMA, INC., BUFFALO GROVE, IL:
2,598,659, CANC. INT. CL. 35.

VIBE LABS, INC., BLAINE, WA:
3,629,769, PUB. 3-17-2009. INT. CL. 9.

VIBE SMG US, LLC, TORONTO, ONTARIO, CANADA:
3,629,754, PUB. 3-17-2009. MULTIPLE CLASS, INT. CLS. 35 AND 42.

VIBROMATIC COMPANY, INC., NOBLESVILLE, IN:
2,174,831, CANC. INT. CL. 7.

VICENZI BISCOTTI S.P.A., ITALY:
3,631,686, PUB. 3-17-2009. INT. CL. 30.

VICTORIA PRINCIPAL PRODUCTIONS, INC., NASHVILLE, TN, PRINCIPAL, VICTORIA, LOS ANGELES, CA:
2,240,896. REN. 4-27-09. INT. CL. 3.

VICTORIA'S SECRET STORES BRAND MANAGEMENT, INC., REYNOLDSBURG, OH:
3,631,914, INT. CL. 3.

- VICTORINOX AG, IBACH-SCHWYZ, SWITZERLAND:
3,632,835, INT. CL. 35.
- VICTORY ENERGY OPERATIONS, L.L.C., COLLINSVILLE, OK:
3,632,455, INT. CL. 11.
3,632,456, INT. CL. 11.
3,632,464, INT. CL. 11.
- VIDEO SECURITY SPECIALISTS, INC., BURBANK, CA:
3,629,983, PUB. 3-17-2009. INT. CL. 9.
- VIGILOS, INC., SEATTLE, WA:
3,629,693, PUB. 3-17-2009. INT. CL. 9.
- VIKER MANUFACTURE CO LTD., RICHMOND, CANADA:
3,630,397, PUB. 3-17-2009. INT. CL. 5.
- VIKING INTERWORKS, INC., RANCHO SANTA MARGARITA, CA:
2,175,875, CANC. INT. CL. 9.
- VILLA JULIE COLLEGE, STEVENSON, MD:
2,597,208, CANC. INT. CL. 42.
2,597,209, CANC. INT. CL. 42.
- VILLAGE PANTRY, LLC, INDIANAPOLIS, IN:
3,632,881, INT. CL. 35.
3,632,974, INT. CL. 21.
- VINELAND CORPORATION, THE, PALISADE, CO:
2,233,621, REN. 4-28-09. INT. CL. 33.
- VINO TABI, INC., SANTA CRUZ, CA:
3,632,343, INT. CL. 33.
- VINTAGE ENTERPRISES, INC., EAST STROUDSBURG, PA:
3,631,825, INT. CL. 34.
- VINUM CELLARS, SAN FRANCISCO, CA:
2,599,730, CANC. INT. CL. 33.
- VIPP A/S, COPENHAGEN S, DENMARK:
3,561,273, COR. MULTIPLE CLASS, INT. CLS. 35, 42 AND 44.
- VIRCIGLIO JR., JOHN B., BESSEMER, AL:
3,629,280, PUB. 10-14-2008. INT. CL. 41.
- VIRCO MGMT. CORPORATION, TORRANCE, CA:
3,633,057, INT. CL. 20.
- VIRTUAL HOLD TECHNOLOGY, LLC, AKRON, OH:
3,630,555, PUB. 3-17-2009. INT. CL. 9.
- VIRTUAL IMAGING, INC., DEERFIELD BEACH, FL:
3,629,731, PUB. 3-17-2009. INT. CL. 10.
- VISAN, CORNEL, BORING, OR:
3,633,339, MULTIPLE CLASS, INT. CLS. 35 AND 41.
- VISCOT MEDICAL, LLC, EAST HANOVER, NJ:
3,630,740, PUB. 3-17-2009. INT. CL. 10.
- VISION OPTICS TECHNOLOGIES LTD., LOUISVILLE, KY:
3,630,442, PUB. 3-17-2009. INT. CL. 2.
- VISION QUEST MEDIA, INC., LOS ANGELES, CA:
3,630,556, PUB. 3-17-2009. INT. CL. 9.
- VISION SISTEMAS DE LOCALIZACION, S.L., ESPARTINAS SEVILLA, SPAIN:
3,630,178, PUB. 3-17-2009. MULTIPLE CLASS, INT. CLS. 9, 35 AND 38.
- VISION WHEEL, INC., DECATUR, AL:
3,630,601, PUB. 3-17-2009. INT. CL. 12.
- VISIONBANK OF IOWA, WEST DES MOINES, IA:
3,631,875, INT. CL. 36.
- VISKO TEEPAAK BELGIUM NV, B-3920 LOMMEL, BELGIUM:
3,631,584, PUB. 3-17-2009. INT. CL. 18.
3,631,585, PUB. 3-17-2009. INT. CL. 18.
- VISUAL MANUAL LLC, SANTA BARBARA, CA, DBA IL FUSTINO:
3,633,037, MULTIPLE CLASS, INT. CLS. 29 AND 30.
- VITAL PHARMACEUTICALS, INC., DAVIE, FL:
3,632,666, INT. CL. 5.
- VITALITY SELECT, INC., PROVO, UT:
3,629,998, PUB. 3-17-2009. INT. CL. 44.
3,629,999, PUB. 3-17-2009. INT. CL. 44.
- VITALSMARTS, LLC, PROVO, UT:
3,629,659, PUB. 3-17-2009. INT. CL. 41.
- VITAMINS.COM, LLC, FALLS CHURCH, VA:
2,598,407, CANC. INT. CL. 35.
- VITAQUEST INTERNATIONAL, LLC, WEST CALDWELL, NJ:
2,237,956, REN. 4-24-09. INT. CL. 5.
- VITRO, S.A. DE C.V., NUEVO LEON, MEXICO:
3,633,495, INT. CL. 12.
3,633,496, INT. CL. 20.
- VIVA! CHOICES, INC., MARYSVILLE, CA:
3,631,888, MULTIPLE CLASS, INT. CLS. 39, 41 AND 45.
- VIVERAE, DALLAS, TX:
3,630,203, PUB. 3-17-2009. MULTIPLE CLASS, INT. CLS. 35 AND 44.
- VIVIDLINE INC., SAN DIEGO, CA:
2,599,562, CANC. INT. CL. 42.
- VIVONET INCORPORATED, BELLINGHAM, WA:
3,632,216, MULTIPLE CLASS, INT. CLS. 9, 42 AND 45.
- VIZIONING, INC., DULUTH, GA:
2,598,130, CANC. INT. CL. 42.
- VIZNMETA4, LLC, SAN JOSE, CA:
3,630,140, PUB. 3-17-2009. MULTIPLE CLASS, INT. CLS. 16 AND 28.
- VLASSARA, HELEN, NEW YORK, NY:
3,633,095, INT. CL. 29.
- VLINX.COM INC., NORTH VANCOUVER, CANADA:
2,596,827, CANC. INT. CL. 35.
- VNU BUSINESS MEDIA, INC., NEW YORK, NY:
2,175,794, CANC. INT. CL. 16.
- VOICE CLOUD, INC., SAN DIEGO, CA:
3,632,554, INT. CL. 35.
- VOIGT & SCHWEITZER, INC., COLUMBUS, OH:
3,630,561, PUB. 3-17-2009. INT. CL. 40.
3,630,563, PUB. 3-17-2009. INT. CL. 40.
- VOLKSWAGEN GROUP OF AMERICA, INC., AUBURN HILLS, MI:
3,631,819, INT. CL. 35.
- VOLOMEDIA, INC., SUNNYVALE, CA:
3,629,456, PUB. 3-17-2009. MULTIPLE CLASS, INT. CLS. 35 AND 42.
3,629,483, PUB. 3-17-2009. MULTIPLE CLASS, INT. CLS. 35 AND 42.
- VOMELA SPECIALTY COMPANY, ST. PAUL, MN:
3,629,629, PUB. 3-17-2009. MULTIPLE CLASS, INT. CLS. 40 AND 42.
- VORDEL LIMITED, DUBLIN 2, IRELAND:
2,638,186, CANC. INT. CL. 38.
- VORTRAN MEDICAL TECHNOLOGY1, INC., SACRAMENTO, CA:
3,631,102, PUB. 3-17-2009. INT. CL. 10.
3,631,106, PUB. 3-17-2009. INT. CL. 10.
3,631,111, PUB. 3-17-2009. INT. CL. 10.
- VOUGHLOHN, DEE, FAIRVIEW, OR AND THOMPSON, DON, ESTACADA, OR AND HARTUNG, STAN, ESTACADA, OR:
3,631,263, PUB. 3-17-2009. INT. CL. 9.
- VRL INTERNATIONAL LTD., GEORGETOWN, CAYMAN ISLANDS:
3,631,191, PUB. 3-17-2009. INT. CL. 35.
3,631,192, PUB. 3-17-2009. INT. CL. 35.
3,631,194, PUB. 3-17-2009. INT. CL. 35.
- VSM GROUP AB, HUSKVARNA, SWEDEN:
3,632,486, INT. CL. 7.
- V2 COMPOSITES, INC., AUBURN, AL:
2,598,681, CANC. INT. CL. 19.
- W M MEDICAL MANAGEMENT, INC., LA QUINTA, CA:
3,629,678, PUB. 3-17-2009. INT. CL. 35.
3,629,679, PUB. 3-17-2009. INT. CL. 35.
- W.E.T. AUTOMOTIVE SYSTEMS AG, FED REP GERMANY:
3,631,540, PUB. 3-17-2009. MULTIPLE CLASS, INT. CLS. 10, 11, 17 AND 24.
- W.T. GIVEN & DAUGHTER, INC., LAS VEGAS, NV:
2,598,541, CANC. INT. CL. 31.
- WACHOVIA EDUCATION FINANCE INC., RANCHO CORDOVA, CA:
2,174,284, CANC. INT. CL. 36.
2,175,061, CANC. INT. CL. 36.
- WACKER NEUSON CORPORATION, MEMONONEE FALLS, WI:
3,630,471, PUB. 3-17-2009. INT. CL. 11.
- WAGMAN METAL PRODUCTS, INC., DALLASTOWN, PA:
1,496,562, CANC. INT. CL. 7.
- WAGNER, ANNE MCGEE, NEW CANAAN, CT:
3,633,106, MULTIPLE CLASS, INT. CLS. 16 AND 41.

WAHLUND, BILL, EDEN PRAIRIE, MN:
2,206,996, REN. 4-25-09. INT. CL. 36.

WAL-MART STORES, INC., BENTONVILLE, AR:
3,631,271, PUB. 3-17-2009. INT. CL. 35.
3,632,773, MULTIPLE CLASS, INT. CLS. 35 AND 43.

WALDMAN, OWEN, SCOTTSDALE, AZ:
3,633,035, INT. CL. 16.

WALL, JIM, CHARLOTTE, NC:
2,597,105, CANC. INT. CL. 35.

WALLACH MARK S, SAN JUAN CAPISTRANO, CA:
3,633,246, INT. CL. 28.

WALLACH, MARK S., SAN JUAN CAPISTRANO, CA:
3,632,130, INT. CL. 28.

WALRUS BRANDS, LLC, CHICAGO, IL:
3,629,491, PUB. 3-17-2009. MULTIPLE CLASS, INT. CLS.
10 AND 25.

WALSH, TIMOTHY, DAYTON, OH, DBA THE PROBLEM
SOLVERS LLC:
3,630,401, PUB. 3-17-2009. INT. CL. 37.

WAN HAI LINES, LTD., TAIPEI, TAIWAN, DBA WAN HAI
LINES, LTD.:
3,630,245, PUB. 3-17-2009. MULTIPLE CLASS, INT. CLS.
6, 12 AND 39.
3,630,246, PUB. 3-17-2009. MULTIPLE CLASS, INT. CLS. 6
AND 39.

WANDL, INC., BOUND BROOK, NJ:
2,599,503, CANC. INT. CL. 9.

WANDRIAN, INC., WHITE PLAINS, NY:
3,631,430, PUB. 3-17-2009. MULTIPLE CLASS, INT. CLS.
35, 39 AND 42.

WANG, ANDREW C, HONOLULU, HI, DBA IDUMPLING-
COM:
3,631,217, PUB. 3-17-2009. INT. CL. 42.

WANG, JING XIN, HACIENDA HEIGHTS, CA:
3,630,763, PUB. 3-17-2009. INT. CL. 12.

WANG, SHUI MU, TAICHUNG HSIEN, TAIWAN:
2,597,657, CANC. INT. CL. 17.

WANG, ZHAOMING, WUHAN, HUBEI, CHINA:
3,632,611, INT. CL. 18.
3,632,612, INT. CL. 9.

WARD MACHINERY CO., INC., HUNT VALLEY, MD:
3,631,954, INT. CL. 9.

WARD, JOHNNY, COLLEGE STATION, TX:
3,633,275, INT. CL. 24.

WARE INDUSTRIES, INC., SOUTH PLAINFIELD, NJ, DBA
MARINO WARE:
3,629,649, PUB. 3-17-2009. INT. CL. 6.

WAREHOUSE PLAN, INC., FORT LAUDERDALE, FL:
2,599,842, CANC. INT. CL. 9.

WARMWOMAN, LLC, OREGON, WI:
2,597,810, CANC. INT. CL. 35.

WARNACO INC., NEW YORK, NY:
1,496,844, CANC. INT. CL. 25.

WARNACO U.S., INC., MILFORD, CT:
3,632,608, INT. CL. 25.

WARNER BROS. ENTERTAINMENT INC., BURBANK, CA:
2,288,194, REN. 4-25-09. INT. CL. 9.
3,632,864, INT. CL. 25.

WARRANTTECH CORPORATION, BEDFORD, TX:
2,598,679, CANC. INT. CL. 36.

WARREN MILLER COMPANY, LLC, SEATTLE, WA:
3,631,166, PUB. 3-17-2009. INT. CL. 25.

WARRIOR SPORTS, INC., WARREN, MI:
2,599,620, CANC. INT. CL. 28.
2,599,621, CANC. INT. CL. 28.

WARSKOW, HELEN M., PHOENIX, AZ, DBA HELENS'
DESIGNS:
2,598,728, CANC. INT. CL. 24.

WARSTEINER BRAUEREI HAUS CRAMER KG., DOMR-
ING, FED REP GERMANY:
2,598,814, CANC. INT. CL. 32.

WASHINGTON BUSINESS INFORMATION, INC., FALLS
CHURCH, VA:
2,599,819, CANC. INT. CL. 16.

WASHINGTON MUTUAL, INC., SEATTLE, WA:
3,630,020, PUB. 3-17-2009. INT. CL. 36.

WASHINGTONPOST.NEWSWEEK INTERACTIVE COM-
PANY, LLC, ARLINGTON, VA:
2,713,964, CANC. INT. CL. 38.

WATCH AND PRAY MINISTRIES, INC., LANHAM, MD:
3,629,210, PUB. 3-17-2009. INT. CL. 41.

WATCHGUARD TECHNOLOGIES, INC., SEATTLE, WA:
2,599,377, CANC. INT. CL. 9.
2,599,378, CANC. INT. CL. 9.

WATCHMARK CORP., BELLEVUE, WA:
2,598,947, CANC. INT. CL. 9.

WATER QUALITY ASSOCIATION, LISLE, IL:
2,597,922, CANC. INT. CL. 42.

WATERBOR BURN AND CANCER FOUNDATION, THE,
NEW YORK, NY:
2,597,441, CANC. INT. CL. 36.

WATERCRYST CHEMIEFREIE WASSERBEHANDLUNG
GMBH, KURT-SCHWARZKOPFSTR. 1, AUSTRIA:
2,596,643, CANC. MULTIPLE CLASS, INT. CLS. 1 AND
11.

WATERS, CAROLINE, CULVER CITY, CA:
3,629,673, PUB. 3-17-2009. INT. CL. 41.

WATKINS MANUFACTURING CORPORATION, VISTA,
CA:
2,599,268, CANC. INT. CL. 11.
3,629,627, PUB. 3-17-2009. INT. CL. 9.

WATKINS, MEEGAN, DRURY, & COMPANY, L.L.C.,
BETHESDA, MD:
3,629,864, PUB. 3-17-2009. INT. CL. 36.

WATSON PHARMACEUTICALS, INC., CORONA, CA:
1,564,125, REN. 4-28-09. INT. CL. 5.

WATSON, BENNETT, COLLIGAN, JOHNSON & SCHECH-
TER, LLP, BUFFALO, NY:
3,630,340, PUB. 3-17-2009. INT. CL. 45.

WAUSAU PAPER TOWEL & TISSUE, LLC, MOSINEE, WI:
3,631,799, INT. CL. 16.
3,631,800, INT. CL. 16.
3,631,801, INT. CL. 16.

WAVESAT INC., DORVAL, QUEBEC, CANADA:
3,629,429, PUB. 3-17-2009. MULTIPLE CLASS, INT. CLS. 9
AND 42.

WAXLESS SURFBOARD SYSTEMS INC., SAN CLEMENTE,
CA:
3,629,921, PUB. 10-14-2008. INT. CL. 2.

WAYNE K KNOLL JR, ANNAPOLIS, MD:
3,629,613, PUB. 12-9-2008. INT. CL. 5.

WAYNE STEPHEN RESLOW, WESTFORD, MA, DBA TCOB
ASSOCIATES:
3,629,822, PUB. 3-17-2009. INT. CL. 28.

WEAR ME OUT, SYLMAR, CA:
2,708,942, COR. INT. CL. 25.

WEATHER DECISION TECHNOLOGIES, INC., MIDDLE-
BURG, VA:
3,633,392, INT. CL. 42.

WEATHERBILL INC., SAN FRANCISCO, CA:
3,629,264, PUB. 3-17-2009. INT. CL. 36.

WEATHEREXTREME LTD., ZEPHYR COVE, NV:
3,629,490, PUB. 3-17-2009. MULTIPLE CLASS, INT. CLS.
42 AND 45.

WEATHERFORYOU.COM LLC, GRANTS PASS, OR:
3,630,711, PUB. 3-17-2009. INT. CL. 42.

WEAVER, STEPHEN K., FORT WAYNE, IN:
2,175,259, CANC. MULTIPLE CLASS, INT. CLS. 20 AND
30.

WEBER & WEBER GMBH & CO. KG, INNING, FED REP
GERMANY:
3,630,188, PUB. 3-17-2009. INT. CL. 5.

WEBFN.COM, LLC, CHICAGO, IL:
2,596,741, CANC. MULTIPLE CLASS, INT. CLS. 9, 25, 35,
36, 38, 41 AND 42.

WEBOOK, INC., BETHESDA, MD:
3,629,923, PUB. 10-14-2008. INT. CL. 41.
3,629,977, PUB. 10-14-2008. INT. CL. 42.

WEBSIDESTORY, INC., SAN DIEGO, CA:
2,174,768, CANC. INT. CL. 42.
2,174,844, CANC. INT. CL. 42.

WEBSTER VALVE, INC., NORTH ANDOVER, MA:
2,598,860, CANC. INT. CL. 9.

- WECOMPLY, INC., MOUNT KISCO, NY:
2,598,147, CANC. INT. CL. 41.
- WEEDPRO, INC., ALPHARETTA, GA:
3,630,488, PUB. 3-17-2009. INT. CL. 44.
- WEEKDAY AB, SWEDEN:
3,631,665, PUB. 3-17-2009. MULTIPLE CLASS, INT. CLS. 3, 14 AND 35.
- WEEKDAY BRANDS AB, SWEDEN:
3,631,652, PUB. 3-17-2009. MULTIPLE CLASS, INT. CLS. 3, 14 AND 35.
- WEINBRENNER SHOE COMPANY, INC., MERRILL, WI:
1,477,863, REN. 4-25-09. INT. CL. 25.
- WEINSTEIN, SUSAN, SANTA MONICA, CA:
2,596,947, CANC. INT. CL. 25.
- WEISZ, JAMES S., COTO DE CAZA, CA:
2,174,498, CANC. INT. CL. 36.
- WELLCOMET GMBH, FED REP GERMANY:
3,631,719, PUB. 3-17-2009. INT. CL. 10.
- WELLPOINT, INC., INDIANAPOLIS, IN:
3,633,259, MULTIPLE CLASS, INT. CLS. 35, 36 AND 44.
3,633,286, MULTIPLE CLASS, INT. CLS. 35, 36 AND 44.
- WELLS FARGO & COMPANY, MINNEAPOLIS, MN:
2,599,103, CANC. INT. CL. 36.
2,599,396, CANC. INT. CL. 36.
- WELLS LAMONT CORPORATION, NILES, IL:
3,630,819, PUB. 3-17-2009. INT. CL. 9.
3,630,821, PUB. 3-17-2009. INT. CL. 9.
- WELLS, WILLIAM, VENTURA, CA:
3,629,841, PUB. 3-17-2009. MULTIPLE CLASS, INT. CLS. 8 AND 9.
- WEMA VOGTLAND GMBH, PLAUEN, FED REP GERMANY:
3,629,607, PUB. 1-13-2009. INT. CL. 7.
- WESLEY COLLEGE, DOVER, DE:
3,633,231, MULTIPLE CLASS, INT. CLS. 21, 25 AND 41.
- WEST COOPER ASSET MANAGEMENT GROUP, LLC, PHILADELPHIA, PA:
2,597,427, CANC. INT. CL. 36.
- WEST ELECTRIC GROUP, INC., COLORADO SPRINGS, CO:
3,630,679, PUB. 3-17-2009. INT. CL. 37.
- WEST MARINE IHC I, INC., WATSONVILLE, CA:
1,496,575, CANC. MULTIPLE CLASS, INT. CLS. 9 AND 12.
- WEST VIRGINIA DIVISION OF TOURISM, CHARLESTON, WV:
2,597,899, CANC. INT. CL. 35.
- WEST VIRGINIA EMPLOYER'S MUTUAL INSURANCE COMPANY, CHARLESTON, WV:
3,629,500, PUB. 3-17-2009. INT. CL. 35.
- WEST VIRGINIA EMPLOYERS' MUTUAL INSURANCE COMPANY, CHARLESTON, WV:
3,629,502, PUB. 3-17-2009. INT. CL. 35.
- WEST, WHITNEY C., STUDIO CITY, CA:
2,234,991, REN. 4-26-09. INT. CL. 25.
2,234,991, CANC. MULTIPLE CLASS, INT. CLS. 9, 18, 20, 21 AND 24.
- WESTA-HOLDING GMBH & CO. KG, D-33334 GUTER-SLOH, FED REP GERMANY:
2,597,018, CANC. MULTIPLE CLASS, INT. CLS. 6, 11 AND 19.
- WESTECH AEROSOL CORPORATION, PORT ORCHARD, WA:
3,629,697, PUB. 3-17-2009. INT. CL. 1.
- WESTERFIELD, JAMES, FREEBURG, IL:
2,599,729, CANC. INT. CL. 31.
- WESTERN DAIRY SPECIALTIES, LLC, RENO, NV:
3,633,066, INT. CL. 29.
- WESTERN PACIFIC STORAGE SOLUTIONS, INC., SAN DIMAS, CA:
3,630,410, PUB. 3-17-2009. INT. CL. 20.
- WESTERN PAYMENTS ALLIANCE, SAN FRANCISCO, CA:
2,230,068, REN. 4-25-09. INT. CL. 42.
- WESTERN RESOURCES, INC., TOPEKA, KS:
2,598,176, CANC. INT. CL. 39.
- WESTERN STATES RACING ASSOCIATION, RENO, NV:
2,597,081, CANC. INT. CL. 41.
- WESTERN TEXTILE CO., INC., CHICAGO, IL:
1,496,359, CANC. INT. CL. 1.
- WESTERN UNION HOLDINGS, INC., ENGLEWOOD, CO:
2,598,836, CANC. MULTIPLE CLASS, INT. CLS. 36 AND 38.
- WESTERN UNITED FISH COMPANY INC., SEATTLE, WA:
3,629,981, PUB. 3-17-2009. INT. CL. 29.
3,629,982, PUB. 3-17-2009. INT. CL. 29.
- WESTERWALDER BLUMENTOPF-FABRIK SPANG GMBH & CO. KG, D-56235 RANSBACH-BAUMBACH, FED REP GERMANY:
2,759,177, COR. INT. CL. 21.
- WESTLAKE INDUSTRIES, INC., GREENSBORO, NC:
2,297,937, REN. 4-24-09. MULTIPLE CLASS, INT. CLS. 16 AND 42.
- WESTMINSTER & YORK, LTD, WILLIAMSBURG, VA:
3,629,653, PUB. 3-17-2009. INT. CL. 9.
- WESTROM PHARMA, HASSELT, BELGIUM:
2,597,722, CANC. INT. CL. 30.
- WESTWAY MACHINERY LTD., MISSISSAUGA, CANADA:
3,629,906, PUB. 12-2-2008. INT. CL. 35.
- WEYERHAEUSER COMPANY, FEDERAL WAY, WA:
2,599,234, CANC. INT. CL. 19.
- WEYLICHEM FRANKFURT GMBH, FRANKFURT, FED REP GERMANY, FARBERWERKE HOECHST AKTIENGSELLSCHAFT VORMALS MEISTER LUCIUS & BRUNING, FRANKFURT AM MAIN, FED REP GERMANY:
677,544, REN. 4-25-09. U.S. CL. 6 (INT. CL. 5).
- WF CINEMA HOLDINGS, L.P., BURBANK, CA:
2,598,208, CANC. INT. CL. 21.
- WFTV, INC., ATLANTA, GA, WFTV, INC., ATLANTA, GA:
1,539,632, REN. 4-27-09. INT. CL. 38.
- WGBH EDUCATIONAL FOUNDATION, BOSTON, MA:
3,632,166, MULTIPLE CLASS, INT. CLS. 9, 38 AND 41.
3,632,183, MULTIPLE CLASS, INT. CLS. 9, 38 AND 41.
- WHALEY, ROBERT E., CHAPEL HILL, NC:
2,599,671, CANC. INT. CL. 9.
- WHEELER, RICHARD A., NEW YORK, NY:
3,629,667, PUB. 3-17-2009. INT. CL. 25.
- WHELAN, JOAN MARIE, CORONA DEL MAR, CA:
3,630,508, PUB. 3-17-2009. INT. CL. 41.
- WHIRLPOOL PROPERTIES, INC., ST. JOSEPH, MI:
3,632,525, INT. CL. 35.
- WHITE DOG ENTERPRISES, INC., PHILADELPHIA, PA:
2,174,730, CANC. INT. CL. 41.
- WHITE HOUSE TELEVISION PRODUCTION, L.L.C., SPRINGFIELD, MO:
3,632,008, MULTIPLE CLASS, INT. CLS. 38 AND 41.
- WHITE'S PLUMBING SUPPLIES, INC., WEST HAVEN, CT:
3,629,715, PUB. 3-17-2009. INT. CL. 11.
- WHITEBOARDSELLING, LLC, AUSTIN, TX:
3,632,664, INT. CL. 41.
- WHITEHAT.COM, INC., TEMPE, AZ:
2,598,759, CANC. MULTIPLE CLASS, INT. CLS. 20 AND 41.
- WHITEWAVE SERVICES, INC., WILMINGTON, DE:
1,496,925, CANC. INT. CL. 30.
- WHITEWAVE SERVICES, INC., DALLAS, TX:
2,302,273, AM. INT. CL. 29.
- WHITINGTON, MITCHEL, GARLAND, TX:
2,597,782, CANC. INT. CL. 16.
- WHITTHORNE, LLC, ATLANTA, GA:
2,599,531, CANC. MULTIPLE CLASS, INT. CLS. 11, 19 AND 20.
- WHIZ BRANDS PTY LTD, AUSTRALIA:
3,631,744, PUB. 3-17-2009. INT. CL. 3.
- WICHITA STATE UNIVERSITY-INTERCOLLEGIATE ATHLETIC ASSOCIATION, WICHITA, KS:
1,112,493, REN. 4-29-09. INT. CL. 42.
- WICHITA STATE UNIVERSITY, INTERCOLLEGIATE ATHLETIC ASSOCIATION, WICHITA, KS:
1,109,705, REN. 4-24-09. INT. CL. 41.
- WIEDER, MARCIA, SAN FRANCISCO, CA:
2,596,679, CANC. INT. CL. 41.
2,596,680, CANC. INT. CL. 16.
- WIENER BÖRSE AG, A-1010 WIEN, AUSTRIA:
3,631,761, PUB. 3-17-2009. MULTIPLE CLASS, INT. CLS. 9, 16, 35, 36, 37, 41 AND 42.
- WIL I S INC, VIDALIA, GA:
3,630,922, PUB. 3-17-2009. INT. CL. 9.

WILCOM PTY LIMITED, AUSTRALIA:
 3,631,622, PUB. 3-17-2009. INT. CL. 9.
 WILD CARROT CREATIONS INC., BLAINE, WA:
 2,638,477, CANC. INT. CL. 19.
 WILD GOOSE HOLDING CO., INC., WILMINGTON, DE:
 3,596,672, COR. INT. CL. 30.
 WILDERNESS ATHLETE, INC., ALEXANDRIA, MN:
 3,629,892, PUB. 3-17-2009. INT. CL. 5.
 WILEX AG, 81675 MÜNCHEN, FED REP GERMANY:
 3,631,748, PUB. 3-17-2009. MULTIPLE CLASS, INT. CLS. 5
 AND 42.
 WILEY PUBLISHING, INC., HOBOKEN, NJ, IDG BOOKS
 WORLDWIDE, INC., FOSTER CITY, CA:
 2,245,458, REN. 4-27-09. INT. CL. 16.
 WILHELMINA INTERNATIONAL, LTD., NEW YORK, NY:
 3,630,928, PUB. 3-17-2009. INT. CL. 35.
 WILKERSON, DAVID, ESSEX, CT:
 2,597,796, CANC. INT. CL. 6.
 WILKERSON, OWEN MICHAEL, TULSA, OK:
 3,630,194, PUB. 3-17-2009. INT. CL. 9.
 WILLIAM E. PROUDFORD SICKLE CELL FUND, INC.,
 DOVER, DE:
 3,630,210, PUB. 3-17-2009. INT. CL. 36.
 WILLIAM S. THOMAS, SIMSBURY, CT:
 3,631,047, PUB. 3-17-2009. INT. CL. 16.
 WILLIAMS-SONOMA, INC., SAN FRANCISCO, CA:
 2,715,928, AM. INT. CL. 35.
 WILLIAMS, CAITLIN, LOS GATOS, CA:
 3,631,939, MULTIPLE CLASS, INT. CLS. 9, 16, 35, 38 AND
 41.
 WILLIAMS, JOSEPH J., SHILOH, IL, TA LEAD-TEK LLC:
 3,630,393, PUB. 3-17-2009. INT. CL. 42.
 WILLIAMS, MICHAEL O., GULFPORT, MS:
 3,629,149, PUB. 3-17-2009. INT. CL. 10.
 WILLIAMS, RACHEL ANN, WHARTON, TX:
 3,629,586, PUB. 3-17-2009. MULTIPLE CLASS, INT. CLS.
 35 AND 42.
 WILLIS, STEVEN, NASHVILLE, TN:
 2,597,222, CANC. INT. CL. 16.
 WILLOUGHBY'S OF PALOS, INC., PALOS HEIGHTS, IL:
 1,497,183, CANC. INT. CL. 42.
 WILLTECH (PRC) LTD., KWAI CHUNG, NEW TERRI-
 TORIES, HONG KONG:
 2,599,672, CANC. INT. CL. 28.
 WILO AG, DORTMUND, FED REP GERMANY:
 3,579,028, COR. MULTIPLE CLASS, INT. CLS. 7, 9 AND
 11.
 WINANS, LOUIS A., ENDICOTT, NY:
 3,629,156, PUB. 3-17-2009. INT. CL. 28.
 WINDRELLA PRODUCTS CORP., BOYNTON BEACH, FL:
 3,630,339, PUB. 3-17-2009. INT. CL. 18.
 WINDOMAR, INC., DENVER, CO:
 2,599,242, CANC. INT. CL. 36.
 WINDOVER, LLC, MANCHESTER, MA:
 3,630,631, PUB. 3-17-2009. INT. CL. 37.
 3,630,632, PUB. 3-17-2009. INT. CL. 37.
 WINDROSE TRADING COMPANY, MADISON, VA:
 2,604,492, COR. INT. CL. 3.
 WINDSOR SMITH HOMES, INC., BRENTWOOD, CA:
 3,631,824, INT. CL. 20.
 WINDSTAR TECHNOLOGIES, INC., NORWOOD, MA:
 3,633,429, INT. CL. 9.
 WINE ISLANDS VINTNERS ASSOCIATION, COBBLE HILL,
 B.C., CANADA:
 3,629,860, PUB. 3-17-2009. INT. CL. 35.
 WINEASE, LLC, EAGAN, MN, WINEASE, LLC, EAGAN,
 MN:
 2,339,119, REN. 4-27-09. INT. CL. 10.
 WINEBOW, INC., MONTVALE, NJ:
 3,630,759, PUB. 3-17-2009. INT. CL. 33.
 WING CHEUNG JIAN, CHAMBLEE, GA:
 3,629,414, PUB. 3-17-2009. INT. CL. 9.
 WING WAH FOOD MANUFACTORY LIMITED, NEW
 TERRITORIES, HONG KONG, TRIPLE EIGHT TRADING
 INC, TORONTO, CANADA:
 1,543,766, REN. 4-30-09. INT. CL. 30.
 WINN INCORPORATED, HUNTINGTON BEACH, CA:
 3,629,888, PUB. 3-17-2009. INT. CL. 28.
 WINNER INTERNATIONAL ROYALTY LLC, SHARON, PA,
 WINNER INTERNATIONAL ROYALTY LLC, SHARON,
 PA:
 2,294,315, REN. 4-27-09. INT. CL. 12.
 2,298,813, REN. 4-27-09. INT. CL. 6.
 WINNING CHOICES, INC., HOLLAND, MI:
 2,596,511, CANC. INT. CL. 9.
 WINNING FACE, LLC, LAS VEGAS, NV, DBA MALE
 SPECIES:
 2,599,540, CANC. INT. CL. 3.
 WINSPUR, FRANK, GLENWOOD, FL:
 3,631,878, INT. CL. 28.
 WINTECH AMERICA, INC., NORWALK, CA:
 3,632,269, INT. CL. 17.
 WIRED MATRIX, INC., CHICAGO, IL:
 2,597,354, CANC. MULTIPLE CLASS, INT. CLS. 35 AND
 42.
 WISCONSIN HOUSING AND ECONOMIC DEVELOPMENT
 AUTHORITY, MADISON, WI, DBAWHEDA:
 3,629,616, PUB. 3-17-2009. INT. CL. 36.
 WISCONSIN HOUSING AND ECONOMIC DEVELOPMENT
 AUTHORITY, MADISON, WI, DBA WHEDA:
 3,629,650, PUB. 3-17-2009. INT. CL. 36.
 WISDOM 3 CONSULTING, INC., BRADENTON, FL:
 3,630,771, PUB. 3-17-2009. INT. CL. 35.
 WITCO CORPORATION:
 1,496,475, CANC. INT. CL. 4.
 WIZARDS OF THE COAST, INC., RENTON, WA:
 2,596,528, CANC. INT. CL. 6.
 WM. WRIGLEY JR. COMPANY, CHICAGO, IL:
 2,598,169, CANC. INT. CL. 30.
 WMF WUERTEMBERGISCHE METALLWARENFABRIK
 AKTIENGESELLSCHAFT, D-73309 GEISLINGEN
 (STEIGE), FED REP GERMANY:
 2,245,532, REN. 4-27-09. INT. CL. 21.
 WMS GAMING INC., WAUKEGAN, IL:
 2,599,187, CANC. INT. CL. 9.
 WNBA ENTERPRISES, LLC, SECAUCUS, NJ:
 2,306,364, REN. 4-29-09. INT. CL. 18.
 2,597,710, CANC. INT. CL. 38.
 3,633,085, INT. CL. 25.
 WNS NORTH AMERICA, INC., NEW YORK, NY:
 3,629,249, PUB. 4-1-2008. INT. CL. 35.
 WOLPA, MARK, BERKELEY, CA:
 2,174,856, CANC. INT. CL. 30.
 WOLVERINE ADVANCED MATERIALS L.L.C., INKSTER,
 MI:
 3,630,457, PUB. 3-17-2009. INT. CL. 17.
 WOMEN OF WRESTLING, INC., INDIANAPOLIS, IN:
 2,597,180, CANC. INT. CL. 41.
 WOMEN'S HEALTH AMERICA, INC., MADISON, WI:
 3,629,137, PUB. 3-17-2009. MULTIPLE CLASS, INT. CLS.
 35 AND 42.
 WONDERLAND BAKERY, INC, CORONA DEL MAR, CA:
 3,629,516, PUB. 3-17-2009. MULTIPLE CLASS, INT. CLS.
 16 AND 28.
 WONG, SENG, FREMONT, CA:
 3,629,135, PUB. 9-30-2008. INT. CL. 5.
 WOO, HO-HYUNG, LOS ANGELES, CA:
 2,599,541, CANC. INT. CL. 35.
 WOOD LYNN FARMS, LIMITED, DELAWARE, ONTARIO,
 CANADA:
 1,496,964, CANC. INT. CL. 31.
 WOOD WORLDWIDE, INC., NEW YORK, NY:
 2,599,726, CANC. INT. CL. 35.
 WOOD YOU DISTRIBUTORS, INC., JACKSONVILLE, FL,
 DBA WOOD YOU:
 2,242,672, REN. 4-24-09. INT. CL. 35.
 2,242,672, CANC. INT. CL. 20.
 WOODBURY-SCHMIDT, INC., KUNKLETOWN, PA:
 3,632,600, INT. CL. 3.
 WOODHOUSE FAMILY CELLARS, INC., WOODINVILLE,
 WA:
 3,631,329, PUB. 3-17-2009. INT. CL. 33.
 WOODLEAF CORPORATION, LOS ANGELES, CA:
 2,596,970, CANC. MULTIPLE CLASS, INT. CLS. 3 AND
 21.

- WOODMEISTER MASTER BUILDERS, INC., HOLDEN, MA:
3,629,188, PUB. 3-17-2009. INT. CL. 37.
- WORDJEMS INC., NEW YORK, NY:
3,630,752, PUB. 3-17-2009. INT. CL. 9.
- WORDPERFECT CORPORATION, OREM, UT:
1,497,541, CANC. INT. CL. 9.
- WORK FORCE, INC., STOUGHTON, MA:
3,629,213, PUB. 3-17-2009. INT. CL. 25.
- WORKING COW HOMEMADE, INC., ST. PETERSBURG, FL:
3,630,764, PUB. 3-17-2009. INT. CL. 30.
- WORKPLACE HEARING, INC., GREENSBORO, NC:
3,632,550, INT. CL. 9.
- WORKPLACELQ, INC., BOSTON, MA:
2,599,070, CANC. INT. CL. 9.
- WORLD BUSINESS CROSSING, INC., TAYLOR, MI:
2,599,457, CANC. INT. CL. 36.
- WORLD CONNECT AG, STEINHAUSEN, SWITZERLAND:
3,629,445, PUB. 3-17-2009. MULTIPLE CLASS, INT. CLS. 9 AND 18.
- WORLD FISHING NETWORK LTD., TORONTO, ONTARIO, CANADA:
3,631,421, PUB. 3-17-2009. MULTIPLE CLASS, INT. CLS. 35, 38 AND 41.
3,631,422, PUB. 3-17-2009. MULTIPLE CLASS, INT. CLS. 35, 38 AND 41.
- WORLD GAMES 2010 FOUNDATION, INC., LEXINGTON, KY:
3,633,493, INT. CL. 41.
- WORLD MONUMENTS FUND, NEW YORK, NY:
2,240,080, REN. 4-29-09. MULTIPLE CLASS, INT. CLS. 36, 37 AND 42.
2,240,080, CANC. INT. CL. 41.
- WORLD WRESTLING ENTERTAINMENT, INC., STAMFORD, CT:
3,632,051, INT. CL. 41.
- WORLDWIDE DREAMS, LLC., NEW YORK, NY:
2,597,605, CANC. INT. CL. 18.
- WORLDWIDE INTERNET CLUB, INC., KIRTLAND, OH:
2,596,451, CANC. INT. CL. 35.
- WORLDWISE, INC., SN RAFAEL, CA:
3,632,631, INT. CL. 28.
- WOSTENBERG, MICHELLE L, LADERA RANCH, CA, DBA SOMETHING TO WEAR, STYLE CONSULTING:
3,631,219, PUB. 3-17-2009. INT. CL. 45.
- WOUND SYSTEMS, LLC, ATLANTA, GA:
3,632,245, INT. CL. 10.
3,632,246, INT. CL. 10.
3,632,247, INT. CL. 10.
- WOVEN SOFTWARE CORPORATION, WHEATON, IL:
3,630,099, PUB. 3-17-2009. INT. CL. 35.
- WOWWEE GROUP LIMITED, TSIM SHA TSUI EAST, KOWLOON, HONG KONG:
3,632,218, INT. CL. 28.
- WRANGLER APPAREL CORP., WILMINGTON, DE:
3,632,119, INT. CL. 18.
3,632,213, INT. CL. 25.
3,632,238, INT. CL. 20.
3,632,698, INT. CL. 25.
3,632,721, INT. CL. 24.
3,633,382, INT. CL. 25.
- WRIGHT GROUP ENTERPRISES, INC, SACRAMENTO, CA:
3,632,427, INT. CL. 25.
- WRIGHT-PATT CREDIT UNION, INC., FAIRBORN, OH:
2,251,761, REN. 4-24-09. INT. CL. 36.
- WRIGHT, JOHN, THOMAS, LONG BEACH, CA:
2,599,835, CANC. INT. CL. 28.
- WRIGHT, RICHARD K., KENNEWICK, WA:
3,632,754, MULTIPLE CLASS, INT. CLS. 9, 16, 41 AND 44.
- WRITE HOOK, LLC, WHITEFISH BAY, WI:
3,632,342, INT. CL. 16.
- WU QIHU, LUJIANG, CHINA:
3,631,738, PUB. 3-17-2009. INT. CL. 25.
- WU, WEN CHEN K, PORT WASHINGTON, NY:
3,632,136, INT. CL. 14.
- WULFTEC INTERNATIONAL INC., AYER'S CLIFF, CANADA:
3,629,696, PUB. 3-17-2009. INT. CL. 7.
- WUNDERLOOP S.A., LUXEMBOURG:
3,631,727, PUB. 3-17-2009. MULTIPLE CLASS, INT. CLS. 35, 36, 38, 41, 42 AND 45.
- WVGH B.V., NETHERLANDS:
3,631,658, PUB. 3-17-2009. MULTIPLE CLASS, INT. CLS. 35, 36 AND 45.
- WYCKOFF CONSULTING LLC, ARVADA, CO:
3,630,696, PUB. 3-17-2009. INT. CL. 35.
- WYNDHAM TM CORP., LAS VEGAS, NV:
3,632,602, INT. CL. 43.
3,632,822, INT. CL. 43.
- W2BI, INC., UNION, NJ:
3,632,087, INT. CL. 9.
- XANADU - SOCIETÀ PER AZIONI, ITALY:
3,631,728, PUB. 3-17-2009. INT. CL. 25.
- XCO LLC, NEW YORK, NY:
2,596,525, CANC. MULTIPLE CLASS, INT. CLS. 35 AND 36.
- XD INC., SEATTLE, WA:
2,598,787, CANC. INT. CL. 9.
- XENOBIOTIC DETECTION SYSTEMS INTERNATIONAL, INC., DURHAM, NC:
3,630,994, PUB. 3-17-2009. INT. CL. 42.
- XENOSEP TECHNOLOGIES LLC, BOONTON, NJ:
3,630,274, PUB. 3-17-2009. INT. CL. 16.
- XI'AN SENSHE ELECTRONIC TECHNOLOGY; CORPORATION, HITECH ZONE, 710075 XI'AN SH ANXI, CHINA:
3,631,558, PUB. 3-17-2009. INT. CL. 9.
- XIAO, YAN, ARCADIA, CA:
3,632,271, INT. CL. 19.
- XIAOMING HU, 317200 ZHEJIANG, CHINA:
3,631,696, PUB. 3-17-2009. INT. CL. 12.
- XNATION INC., SALT LAKE CITY, UT:
3,631,793, INT. CL. 25.
- XSB, INC., STONY BROOK, NY:
3,630,260, PUB. 3-17-2009. INT. CL. 42.
- XYBERNAUT CORPORATION, CHANTILLY, VA:
2,597,914, CANC. INT. CL. 9.
- Y-POINT, INC., HAZLET, NJ:
2,596,845, CANC. MULTIPLE CLASS, INT. CLS. 35 AND 42.
- YA FASHION, INC., MONTEREY PARK, CA:
3,632,017, INT. CL. 25.
- YABAN CHAIN INDUSTRIAL CO., LTD., TAINAN HSIEN, TAIWAN:
3,631,450, PUB. 3-17-2009. INT. CL. 12.
- YAHOO! INC., SUNNYVALE, CA:
3,632,821, INT. CL. 42.
- YAHRAUS, RYAN ANDREW, SARASOTA, FL:
2,596,476, CANC. INT. CL. 25.
- YAMADA, MERILYNN, LOS ANGELES, CA:
3,629,710, PUB. 3-17-2009. INT. CL. 44.
- YANG QINGBO, JIAMUSI CITY; HEILONGJIANG PROVINCE, CHINA:
3,631,660, PUB. 3-17-2009. INT. CL. 18.
- YB COMPANY INC., BROOKLYN, NY, DBA KPD:
3,630,718, PUB. 3-17-2009. INT. CL. 5.
- YCI INC, SANTA FE SPGS, CA:
2,598,245, CANC. INT. CL. 7.
- YELL-O-GLOW CORPORATION, EVERETT, MA:
3,629,170, PUB. 3-17-2009. INT. CL. 31.
- YELLOWSPACES INC., HOWARD BEACH, NY:
3,630,530, PUB. 3-17-2009. INT. CL. 35.
3,631,221, PUB. 3-17-2009. INT. CL. 35.
3,631,313, PUB. 3-17-2009. INT. CL. 35.
3,631,325, PUB. 3-17-2009. INT. CL. 35.
- YENMAK MOTOR GÖMLEKLERI; SANAYI VE TICARET; ANONIM SİRKETİ, KONYA, TURKEY:
3,631,731, PUB. 3-17-2009. MULTIPLE CLASS, INT. CLS. 7 AND 12.
- YERGE, HENOCK MEKONNEN, CLARKSTON, GA, DBA YESHI INJERA:
3,631,120, PUB. 3-17-2009. INT. CL. 30.
- YI, JOON TAE, DENVILLE, NJ:
3,629,281, PUB. 3-17-2009. INT. CL. 7.
- YIFENG, ZHENG, ZHUJI, CHINA:
3,633,184, INT. CL. 14.

YKK CORPORATION OF AMERICA, MARIETTA, GA:
3,632,000, MULTIPLE CLASS, INT. CLS. 6 AND 19.

YMG CAPITAL MANAGEMENT INC., TORONTO, ONTARIO, CANADA:
2,596,554, CANC. INT. CL. 36.

YOGA DEVA, GILBERT, AZ:
3,630,876, PUB. 3-17-2009. INT. CL. 41.

YOGA WHAT LLC, TEMPE, AZ:
3,630,595, PUB. 3-17-2009. INT. CL. 35.

YOGAGLO, LLC, MANHATTAN BEACH, CA:
3,630,409, PUB. 3-17-2009. INT. CL. 41.

YOGURT MONKEY, LLC, SACRAMENTO, CA:
3,630,634, PUB. 3-17-2009. INT. CL. 35.

YOON, HO HOUN, NEW YORK, NY:
2,597,474, CANC. INT. CL. 35.

YORK WALLCOVERINGS, INC., YORK, PA:
2,597,149, CANC. INT. CL. 27.

YOSWIRL, FREMONT, CA:
3,632,690, INT. CL. 30.

YOUGHIOGHENY COMMUNICAITONS-IP, LLC, SAN ANTONIO, TX:
3,630,692, PUB. 3-17-2009. INT. CL. 35.

YOUMAIL, INC., IRVINE, CA:
3,629,396, PUB. 3-17-2009. INT. CL. 38.

YOUNG LEADERSHIP COUNCIL, NEW ORLEANS, LA:
2,597,428, CANC. MULTIPLE CLASS, INT. CLS. 41 AND 42.

YOUNG LIM ENTERPRISE CO., LTD., SEO-GU INCHEON 404-190, REPUBLIC OF KOREA:
3,631,400, PUB. 3-17-2009. MULTIPLE CLASS, INT. CLS. 29 AND 30.

YOUNGGU ART CO., LTD., REPUBLIC OF KOREA:
3,631,512, PUB. 3-17-2009. MULTIPLE CLASS, INT. CLS. 3, 6, 9, 14, 16, 18, 20, 24, 25, 26, 28, 29, 30, 32, 34, 41 AND 43.

YOUNGMAN AUTOMOBILE; GROUP CO.,LTD., CHINA:
3,631,543, PUB. 3-17-2009. INT. CL. 12.

YOUR ENERGY ADVISOR.COM, INC., UNION, NJ:
2,597,517, CANC. INT. CL. 42.

YXLON INTERNATIONAL GMBH, FED REP GERMANY:
3,631,699, PUB. 3-17-2009. MULTIPLE CLASS, INT. CLS. 9, 37 AND 42.

Z, LINDA, BRYN MAWR, PA:
3,630,000, PUB. 3-17-2009. INT. CL. 36.

ZAK'S MONOGRAMMING INC., SPRING LAKE, NJ, DBA INITIAL IMPACT EMBROIDERY:
3,630,341, PUB. 3-17-2009. INT. CL. 25.

ZAK'S MONOGRAMMING INC., SPRING LAKE, NJ, DBA INITIAL IMPACT EMBROIDERY:
3,630,291, PUB. 3-17-2009. INT. CL. 25.

ZAPP IT BOWLING PRODUCTS, DALLAS, TX:
3,630,216, PUB. 3-17-2009. INT. CL. 3.

ZARAGOZAZARAGOZA, INC., NEW YORK, NY:
2,599,634, CANC. MULTIPLE CLASS, INT. CLS. 3 AND 4.

ZATHYUS NETWORKS, INC., BOWIE, MD:
3,629,194, PUB. 3-17-2009. INT. CL. 42.

ZELAZEK, MICHAEL, TIBURON, CA:
3,633,003, INT. CL. 42.

ZELCO INDUSTRIES, INC., NEW YORK, NY:
3,631,987, INT. CL. 6.

ZEN WORLD ENTERTAINMENT, INC., UPLAND, CA:
3,632,470, INT. CL. 35.

ZENITH SPECIALTIES, L.P., CLINTON, MO, DBA ZENITH SPECIALTIES:
2,140,812, REN. 4-30-09. INT. CL. 13.

ZEP IP HOLDING LLC, ATLANTA, GA:
881,406, REN. 4-24-09. U.S. CL. 52 (INT. CL. 3).

ZEPHYR SYSTEMS, INC., RIVERSIDE, CA:
1,496,802, CANC. INT. CL. 20.

ZERODAY ENTERPRISES, LLC, WILSONVILLE, OR:
3,632,171, MULTIPLE CLASS, INT. CLS. 1, 11 AND 40.

ZHEJIANG HENGYOU; MACHINE & ELECTRON CO., LTD, CHINA:
3,631,690, PUB. 3-17-2009. INT. CL. 7.

ZHOUYONGSHENG, CHINA:
3,631,483, PUB. 3-17-2009. MULTIPLE CLASS, INT. CLS. 9 AND 12.

ZICCARDI, CAMILLE, CHICAGO, IL:
2,175,402, CANC. INT. CL. 3.

ZIFF DAVIS PUBLISHING HOLDINGS INC., NEW YORK, NY:
2,597,229, CANC. INT. CL. 16.

ZIMET, GARY, WASHINGTONVILLE, NY:
2,597,575, CANC. INT. CL. 42.

ZIMMER GMBH, WINTERTHUR, SWITZERLAND:
3,632,749, INT. CL. 10.

ZIMMERMANN WEAR PTY LTD, AUSTRALIA:
3,631,685, PUB. 3-17-2009. MULTIPLE CLASS, INT. CLS. 9, 18, 25, 35 AND 42.

ZING ENTERPRISES, LLC, OSWEGO, IL:
3,631,249, PUB. 3-17-2009. INT. CL. 19.

ZINPRO CORPORATION, EDINA, MN:
1,496,488, CANC. INT. CL. 5.

ZIONS BANCORPORATION, SALT LAKE CITY, UT:
3,632,746, INT. CL. 35.

ZIPPMARK, INC., WILMINGTON, DE:
2,174,649, CANC. INT. CL. 11.

ZIRCON CORPORATION, COLLIERVILLE, TN:
1,535,764, REN. 4-24-09. INT. CL. 37.

ZMARK, INC., VENTURA, CA:
3,632,315, INT. CL. 9.

ZOE SAKOUTIS, LLC, NEW YORK, NY, DBA BLUEPRINT CLEANSE:
3,630,834, PUB. 3-17-2009. INT. CL. 32.

ZOOM SEWER & DRAIN CLEANING SERVICE, INC., NORRISTOWN, PA:
3,630,754, PUB. 3-17-2009. INT. CL. 37.

ZOTAC INTERNATIONAL (MCO) LIMITED, FO TAN, SHATIN, N.T., HONG KONG:
3,632,050, INT. CL. 9.

ZPROMPT INC., IRVINE, CA:
2,599,013, CANC. INT. CL. 42.

ZUPANCIC, DEREK J., WEST HILLS, CA, DBA HYDRO-ELECTRICPOWER LLC:
3,629,551, PUB. 3-17-2009. INT. CL. 11.

ZURICH AMERICAN INSURANCE COMPANY, SCHAUMBURG, IL:
2,598,195, CANC. INT. CL. 35.
2,598,196, CANC. INT. CL. 35.

ZURICH INSURANCE COMPANY, 8022 ZURICH, SWITZERLAND:
2,705,973, CANC. INT. CL. 35.

ZWEZ-CHEMIE GMBH, FED REP GERMANY:
3,631,504, PUB. 3-17-2009. MULTIPLE CLASS, INT. CLS. 1, 2, 3 AND 4.

ZYLTEC, INC., ISSAQUAH, WA:
3,633,216, MULTIPLE CLASS, INT. CLS. 9 AND 16.

1 (800) TOW-TRUCK, INC., NEWARK, NJ:
2,596,780, CANC. MULTIPLE CLASS, INT. CLS. 35 AND 42.

1197217 ONTARIO LIMITED, CHATHAM, CANADA:
3,632,127, INT. CL. 30.

152310 CANADA, MONTREAL, CANADA, DBA AS HANGING SYSTEMS:
3,630,741, PUB. 3-17-2009. INT. CL. 20.
3,630,744, PUB. 3-17-2009. INT. CL. 16.

1660929 ONTARIO LIMITED, TORONTO, CANADA:
3,633,255, INT. CL. 5.

1660929 ONTARIO LIMITED, OAKVILLE, ONTARIO, CANADA:
3,633,276, INT. CL. 5.
3,633,281, INT. CL. 5.

168700 CANADA INC., DOLLARD-DES-ORMEAUX, QUEBEC, CANADA, DBA SACHA GROUP:
2,596,524, CANC. INT. CL. 25.

2000 INJECTX INC., SAN JOSE, CA:
2,598,668, CANC. INT. CL. 10.

23ANDME, INC., MOUNTAIN VIEW, CA:
3,632,433, INT. CL. 41.

24/8 LLC, NEW YORK, NY:
3,633,055, INT. CL. 3.

3 SIGMA CORPORATION, TROY, OH:
2,303,615, REN. 4-24-09. MULTIPLE CLASS, INT. CLS. 16, 17 AND 40.

- 3 SIGNA CORPORATION, TROY, OH:
2,303,607, REN. 4-27-09. MULTIPLE CLASS, INT. CLS. 16,
17 AND 40.
- 3*6*5 PRODUCTIONS LTD., MASON, OH:
3,629,320, PUB. 4-22-2008. INT. CL. 16.
- 3M COMPANY, ST. PAUL, MN:
2,241,190, REN. 4-27-09. INT. CL. 9.
- 3M COMPANY, SAINT PAUL, MN:
2,597,340, CANC. INT. CL. 7.
- 3MV BANCORP, INC., OMAHA, NE:
3,631,856, INT. CL. 36.
- 37.COM INC., WILMINGTON, DE:
2,596,768, CANC. INT. CL. 42.
- 4 CAV CO. INC., CARLE PLACE, NY, DBA CAFFE SPASSO:
1,497,233, CANC. INT. CL. 42.
1,497,234, CANC. INT. CL. 42.
- 4 MY MOM, FRANKLIN LAKES, NJ:
3,632,477, MULTIPLE CLASS, INT. CLS. 16, 18, 20, 24
AND 25.
3,632,478, MULTIPLE CLASS, INT. CLS. 16, 18, 20, 24
AND 25.
3,632,637, MULTIPLE CLASS, INT. CLS. 16, 18, 20, 24
AND 25.
- 4-U COMPUTING, LLC, FT. WAYNE, IN:
2,598,999, CANC. INT. CL. 9.
- 4PM INVESTMENTS LTD., VICTORIA BRITISH COLUMBIA,
CANADA:
2,599,834, CANC. INT. CL. 9.
- 4THPASS INC., SEATTLE, WA:
2,597,794, CANC. INT. CL. 9.
- 413, INC., CORONA, CA:
3,630,060, PUB. 12-9-2008. MULTIPLE CLASS, INT. CLS. 9
AND 41.
- 5TH GENERATION MESSAGING LTD., HENLEY ON
THAMES, RG9 5AB, GREAT BRITAIN:
2,599,706, CANC. INT. CL. 42.
- 555-1212.COM, INC., SAN FRANCISCO, CA:
2,597,172, CANC. INT. CL. 35.
- 649355 B.C. LTD., VANCOUVER, BRITISH COLUMBIA,
CANADA:
3,629,126, PUB. 1-13-2009. INT. CL. 5.
- 7 DIGITAL INCORPORATED, LONDON, UNITED KING-
DOM, DBA 7 DIGITAL MEDIA LIMITED:
3,632,344, MULTIPLE CLASS, INT. CLS. 9, 35, 38, 41 AND
42.
- 7-ELEVEN, INC., DALLAS, TX:
2,284,506, REN. 4-29-09. INT. CL. 42.
2,599,424, CANC. INT. CL. 36.
- 7TH INNING STRETCH, LLC, SALISBURY, MD:
2,242,339, REN. 4-25-09. MULTIPLE CLASS, INT. CLS. 16
AND 25.
- 901 VINYL, L.L.C., CHICAGO, IL:
3,632,931, INT. CL. 35.

* * * * *